

# IDT79R3081™ RISController™



Hardware  
User's Manual



INTEGRATED DEVICE TECHNOLOGY, INC.

**The IDT79R3081<sup>TM</sup>**  
**RISController<sup>TM</sup>**  
**Hardware User's Manual**

**Revision 1.2**

**December 11, 1992**

## ***ABOUT THIS MANUAL***

This manual provides a qualitative description of the operation of members of the IDT R3081 integrated RISController.

A quantitative description of the processor electrical interface is provided in the data sheet for this product. Also included in the data sheet is the mechanical descriptions of the part, including packaging and pin-out.

Additional information on development tools, complementary support chips, and the use of this product in various applications, is provided in separate data sheets and applications notes.

Additional information on other family members can be found in the documentation for those devices.

Any of this information is readily available from your local IDT sales representative.

## **CONTENTS OVERVIEW**

**Chapter 1** contains an overview description of the R3081 integrated RISControllers, including a brief discussion of development tools and a family overview.

**Chapter 2** describes the instruction set architecture of the R3081.

**Chapter 3** describes the instruction set architecture of the on-chip hardware floating point unit of the R3081.

**Chapter 4** describes the on-chip cache of the R3081.

**Chapter 5** discusses the memory management capabilities of the R3081.

**Chapter 6** describes the exception interface and handling capabilities of the processor.

**Chapter 7** provides an overview of the bus interface of the R3081, including signal description and transaction priority model.

**Chapter 8** describes the read interface of the R3081.

**Chapter 9** describes the write interface of the R3081.

**Chapter 10** describes the DMA Arbiter interface.

**Chapter 11** describes the reset, mode initialization, and clocking of the processor.

**Chapter 12** describes various debug features of the processor.

**Appendix A** describes design considerations for systems which may interchange among the R3041, R3051, R3052, and R3081 processors.

Integrated Device Technology, Inc. reserves the right to make changes to its products or specifications at any time, without notice, in order to improve design or performance and to supply the best possible product. IDT does not assume any responsibility for use of any circuitry described other than the circuitry embodied in an IDT product. The Company makes no representations that circuitry described herein is free from patent infringement or other rights of third parties which may result from its use. No license is granted by implication or otherwise under any patent, patent rights or other rights, of Integrated Device Technology, Inc.

#### **LIFE SUPPORT POLICY**

**Integrated Device Technology's products are not authorized for use as critical components in life support devices or systems unless a specific written agreement pertaining to such intended use is executed between the manufacturer and an officer of IDT.**

- 1. Life support devices or systems are devices or systems which (a) are intended for surgical implant into the body or (b) support or sustain life and whose failure to perform, when properly used in accordance with instructions for use provided in the labeling, can be reasonably expected to result in a significant injury to the user.**
- 2. A critical component is any components of a life support device or system whose failure to perform can be reasonably expected to cause the failure of the life support device or system, or to affect its safety or effectiveness.**

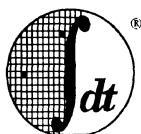

Integrated Device Technology, Inc.

## TABLE OF CONTENTS

<b>Family Overview</b>	<b>1-1</b>
Introduction	1-1
Features	1-1
Device Overview	1-2
CPU Core	1-3
System Control Co-Processor	1-4
Floating Point Co-Processor	1-4
Clock Generator Unit	1-4
Instruction Cache	1-4
Data Cache	1-5
Bus Interface Unit	1-5
System Usage	1-6
Development Support	1-8
Performance Overview	1-10
<b>Family Instruction Set Architecture</b>	<b>2-1</b>
Introduction	2-1
R3051 Family Processor Features Overview	2-1
CPU Registers Overview	2-1
Instruction Set Overview	2-2
Programming Model	2-4
Data Formats and Addressing	2-4
CPU General Registers	2-6
CPO Special Registers	2-6
Operating Modes	2-7
Pipeline Architecture	2-7
Pipeline Hazards	2-8
Instruction Set Summary	2-10
Instruction Formats	2-10
Instruction Notational Conventions	2-10
Load and Store Instructions	2-10
Computational Instructions	2-13
Jump and Branch Instructions	2-15
Special Instructions	2-16
Co-processor Instructions	2-17
System Control Co-processor Instructions	2-18
Opcode Encoding	2-18
<b>R3081 Floating Point Accelerator</b>	<b>3-1</b>
Introduction	3-1
FPA Features	3-1
FPA Programming Model	3-2
Floating-Point General Registers	3-2
Floating-Point Registers	3-2
Floating-Point Control Registers	3-3
Control/Status Register (Read and Write)	3-3
Control/Status Register Condition Bit	3-4
Control/Status Register Exception Bits	3-4
Control/Status Register Exception Bits	3-5
Control/Status Register TrapEnable Bits	3-5
Control/Status Register Rounding Mode Control Bits	3-5
Implementation and Revision Register (Read Only)	3-5

---

Floating-Point Formats	3-6
Number Definitions	3-7
Normalized Numbers	3-7
Denormalized Numbers	3-7
Infinity	3-7
Zero	3-7
Co-Processor Operation	3-8
Load, Store and Move Operations	3-8
Floating-Point Operations	3-8
Exceptions	3-8
Instruction Set Overview	3-8
Instruction Set Summary	3-10
Load, Store and Move Operations	3-10
Floating-Point Computational Instructions	3-10
Floating-Point Relational Instructions	3-13
Branch On FPA Condition Instructions	3-14
FPA Opcode Encoding	3-15
The Instruction Pipeline	3-16
Instruction Execution Times	3-18
Overlapping FPA Instructions	3-19
<b>R3081 Cache Architecture</b>	4-1
Introduction	4-1
Fundamentals of Cache Operation	4-1
R3081 Cache Organization	4-2
Basic Cache Operation	4-2
Memory Address to Cache Location Mapping	4-2
Cache Addressing	4-3
Write Policy	4-3
Partial Word Writes	4-3
Instruction Cache Line Size	4-3
Data Cache Line Size	4-4
Cache Configurability	4-5
Cache Construction Summary	4-5
Cache Operation	4-6
Basic Cache Fetch Operation	4-6
Cache Miss Processing	4-6
Instruction Streaming	4-7
Cacheable References	4-7
Software Directed Cache Operations	4-7
Cache Sizing	4-8
Cache Flushing	4-8
Forcing Data Into Caches	4-9
Summary	4-9
<b>Memory Management</b>	<b>5-1</b>
Introduction	5-1
Virtual Memory In the R3051 Family	5-1
Privilege States	5-2
User Mode Virtual Addressing	5-2
Kernel Mode Virtual Addressing	5-2
Base Versions Address Translation	5-3
Extended Versions Address Translation	5-5
TLB Entries	5-6
EntryHi and EntryLo Registers	5-6
Virtual Address Translation	5-7
The Index Register	5-8
The Random Register	5-9
TLB Instructions	5-9
TLB Shutdown	5-10

---

---

Summary	5-10
<b>Exception Handling</b>	<b>6-1</b>
Introduction	6-1
R3051 Family Exception Model	6-1
Precise vs. Imprecise Exceptions	6-2
Exception Processing	6-3
Exception Handling Registers	6-3
The Cause Register	6-4
The EPC Register	6-5
Bad VAddr Register	6-5
Context Register	6-5
The Status Register	6-6
The Config Register	6-8
Lock:	6-8
Slow Bus	6-8
FPInt:	6-9
DB Refill:	6-9
RF:	6-9
Halt:	6-9
Alt Cache:	6-10
Reserved:	6-10
PrId Register	6-10
Exception Vector Locations	6-10
Exception Prioritization	6-11
Exception Latency	6-12
Interrupts in the R3051 Family	6-12
Using The BrCond Inputs	6-14
Interrupt Handling	6-14
Interrupt Servicing	6-15
Basic Software Techniques for Handling Interrupts	6-15
Preserving Context	6-16
Determining the Cause of the Exception	6-17
Return From Exceptions	6-18
Special Techniques for Interrupt Handling	6-19
Interrupt Masking	6-19
Using the BrCond for Fast Response	6-19
Nested Interrupts	6-21
Catastrophic Exceptions	6-22
Handling Specific Exceptions	6-23
Address Error Exception	6-23
Breakpoint Exception	6-24
Bus Error Exception	6-25
Co-processor-Unusable Exception	6-26
Interrupt Exception	6-27
Overflow Exception	6-28
Reserved Instruction Exception	6-29
Reset Exception	6-30
System Call Exception	6-31
TLB Miss Exceptions	6-32
TLB Miss Exception	6-33
TLB Modified Exception	6-34
UTLB Miss Exception	6-35
Floating-Point Exceptions	6-36
Exception Trap Processing	6-37
Inexact Exception	6-39
Invalid Operation Exception (V)	6-39
Division-By-Zero Exception	6-40
Underflow Exception	6-40

---



---

Unimplemented Operation Exception (E)	6-40
Saving and Restoring State	6-41
<b>Interface Overview</b>	<b>7-1</b>
Multiple Operations	7-2
Execution Engine Fundamentals	7-4
Execution Core Cycles	7-4
Cycles	7-4
Run Cycles	7-4
Stall Cycles	7-4
Multiple Stalls	7-5
Pin Description	7-6
<b>Read Interface</b>	<b>8-1</b>
Introduction	8-1
Types of Read Transactions	8-1
Read Interface Signals	8-2
Read Interface Timing Overview	8-4
Initiation of Read Request	8-4
Memory Addressing	8-6
Bus Turn Around	8-6
Bringing Data into the Processor	8-7
Terminating the Read	8-8
Latency Between Processor Operations	8-9
Processor Internal Activity	8-11
Read Timing Diagrams	8-13
Single Word Reads	8-13
Block Reads	8-15
Bus Error Operation	8-20
<b>Write Interface</b>	<b>9-1</b>
Introduction	9-1
Importance of Writes in R3081 Systems	9-1
Types of Write Transactions	9-2
Partial Word Writes	9-2
Write Interface Signals	9-3
Write Interface Timing Overview	9-5
Initiating the write	9-5
Memory Addressing	9-6
Data Phase	9-7
Terminating the Write	9-8
Latency Between Processor Operations	9-8
Write buffer Full Operation	9-9
Write Timing Diagrams	9-10
Basic Write	9-10
Bus Error Operation	9-12
<b>DMA Interface and Cache Coherency</b>	<b>10-1</b>
Introduction	10-1
Interface Overview	10-1
DMA Arbiter Interface Signals	10-2
Non-Coherent DMA Arbitration Timing Diagrams	10-3
Initiation of DMA Mastership	10-3
Relinquishing Mastership Back to the CPU	10-4
Hardware-Based Cache Coherency	10-5
Cache Coherency Interface Signals	10-6
Cache Coherency Operations Timing	10-7
Initiating Coherent DMA	10-7
Capturing Write Target Address	10-9
Invalidating the Data Cache Word	10-10
Ending the Current Write	10-11
Terminating the Coherent DMA	10-12

---

<b>Reset Initialization and Input Clocking</b>	<b>11-1</b>
Introduction	11-1
Reset Timing	11-1
Mode Selectable Features	11-1
CoherentDMAEn	11-1
IxClockEn	11-1
Half-Frequency Bus	11-2
DBlockRefill	11-2
Tri-State	11-2
BigEndian	11-2
R3000A Equivilant Modes	11-2
Reset Behavior	11-3
Boot Software Requirements	11-3
Detailed Reset Timing Diagrams	11-4
Reset Pulse Width	11-4
Mode Initialization Timing Requirements	11-5
Reset Setup Time Requirements	11-6
ClkIn Requirements	11-6
<b>Debug Mode Features</b>	<b>12-1</b>
Introduction	12-1
Overview of Features	12-1
Debug Mode Activation	12-1
Address Display	12-2
Run Status Display	12-2
Forcing Cache Misses	12-4
<b>Compatibility Among R3051 Family Devices</b>	<b>A-1</b>
Introduction	A-1
Software Considerations	A-1
Hardware Considerations	A-2
R3041 Unique Features	A-2
R3081 Unique Features	A-3
Pin Description Differences	A-3
Reset Mode Selection	A-4
Reserved No-Connect Pins	A-5
DIAG Pins	A-5
BrCond(1:0), SBrCond(3:2)	A-5
Slow Bus Turn Around Mode	A-6
The R3081 FPA Interrupt	A-6
Half-Frequency Bus Mode	A-6
Reduced Frequency/Halt Capability	A-6
DMA Issues	A-6
Debug Features	A-7
WrNear Page Size	A-7
Hardware Compatibility Summary	A-7
Summary	A-8
<b>List of Figures</b>	
1.1. Block Diagram	1-3
1.2. System Diagram	1-7
1.3. Development Support	1-9
2.1. CPU Registers	2-1
2.2. Instruction Encoding	2-2
2.3. Byte Ordering Conventions	2-5
2.4. Unaligned Words	2-5
2.5. 5-Stage Pipeline	2-7
2.6. 5-Instructions per Clock Cycle	2-8
2.7. Load Delay	2-9

---

2.8. Branch Delay	2-9
3.1. On-Chip FPA Functional Block Diagram	3-1
3.2. FPA Registers	3-2
3.3. Control/Status Register Bit Assignments	3-3
3.4. Control/Status Register Exception/Sticky/Trap Enable Bits	3-4
3.5. Implementation/Revision Register	3-5
3.6. Single Precision Floating Point Format	3-6
3.7. Double Precision Floating Point Format	3-6
3.8. FPA Instruction Execution Sequence	3-16
3.9. FPA Instruction Pipeline	3-17
3.10. An FPA Pipeline Stall	3-17
3.11. FPA Instruction Execution Times	3-18
3.12. Overlapping FPA Instructions	3-19
3.13. Overlapped Instructions in FPA Pipeline	3-20
4.1. Cache Line Selection	4-2
4.2. R3081 Execution Core and Cache Interface	4-4
4.3. R3081 Execution Core and Cache Interface	4-5
4.4. Phased Access of Instruction and Data Caches	4-6
5.1. Virtual Address Format	5-1
5.2. Virtual to Physical Address Translation in Base Versions	5-2
5.3. Virtual to Physical Address Mapping of Extended Archit.	5-4
5.4. The System Co-Processor Registers	5-5
5.5. Format of a TLB Entry	5-6
5.6. The TLB EntryLo and EntryHi Registers	5-6
5.7. TLB Address Translation	5-7
5.8. Virtual to Physical TLB Translation	5-8
5.9. The Index Register	5-9
5.10. The Random Register	5-9
6.1. The CPO Execution Handling Registers	6-3
6.2. The Cause Register	6-4
6.3. Context Register	6-5
6.4. The Status Register	6-6
6.5. R3081 Config Register	6-8
6.6. Format of Prid Register	6-10
6.7. Pipelining in the R3051 Family	6-11
6.8. Synchronized Interrupt Operation	6-13
6.9. Direxct Interrupt Operation	6-13
6.10. Synchronized BrCond Inputs	6-14
6.11. Direct BrCond Inputs	6-14
6.12. Kernal and Interrupt Status Being Saved on Interrupts	6-15
6.13. Code Sequence to Initialize Exception Vectors	6-16
6.14. Preserving Processor Context	6-17
6.15. Exception Cause Decoding	6-17
6.16. Exception Service Branch Table	6-18
6.17. Returning from Exception	6-18
6.18. Polling System Using BrCond	6-20
6.19. Using BrCond for Fast Interrupt Decoding	6-21
6.20. TLB Miss Exceptions	6-32
6.21. User TLB Refill Code	6-35
6.22. FPA Control/Status Register	6-36
8.1(a). CPU Latency to Start of Read (Full Frequency Mode)	8-4
8.1(b). CPU Latency to start of Read (Half Frequency Mode)	8-5
8.2. Start of Bus Read Operation	8-7
8.3. Data Sampling on R3051/52	8-8
8.4. Read Cycle Termination	8-9
8.5. Use of DataEn as Output Enable Control	8-10
8.6(a). Internal Processor States on Burst Read (Full Freq. Mode)	8-11
8.6(b). Internal Processor States on Burst Read (Half Freq. Mode)	8-11

---

8.7. Instruction Streaming Example (Full Freq. Mode)	8-12
8.8. Single Word Read Without Bus Wait Cycles	8-13
8.9. Single Word Read With Bus Wait Cycles	8-14
8.10. Burst Read With No Wait Cycle	8-15
8.11(a). Start of Burst Read with Initial Wait Cycles	8-16
8.11(b). End of Burst Read	8-17
8.12(a). First Two Words of "Throttled" Quad Word Read	8-18
8.12(b). End of Throttled Quad Word Read	8-19
8.13. Single Word Read Terminated by Bus Error	8-20
8.14. Block Read Terminated by Bus Error	8-21
9.1(a). Start of Write Operation—BIU Arbitration	9-5
9.1(b). Start of Write Arbitration—Half-frequency Mode	9-6
9.2. Memory addressing and Start of Write	9-7
9.3. End of Write	9-8
9.4. Write Buffer Full Operation	9-9
9.5. Bus Write with No Wait Cycles	9-10
9.6. Write with Bus Wait Cycles	9-11
9.7. Bus Error on Write	9-12
10.1. Bus Grant and Start of DMA Transaction	10-3
10.2. Regaining Bus Mastership	10-4
10.3. Requesting Coherent DMA	10-8
10.4. Capturing Write Target Address During Coherent DMA	10-9
10.5. Invalidating Current Data Cache Word and Incrementing Invalidate Address	10-10
10.6. Terminating a Coherent Write Sequence	10-11
10.7. Terminating Coherent DMA	10-12
11.1. Cold Start	11-4
11.2. Warm Reset	11-4
11.3. R3081 Internal Mode Vector Logic	11-5
11.4. Mode Vector Timing	11-5
11.5. Reset Timing	11-6
11.6(a). R3081 Family Clocking (1x ClkIn, Full Frequency)	11-6
11.6(b). R3081 Family Clocking (1x ClkIn, Half Frequency)	11-6
11.6(c). R3081 Family Clocking (2x ClkIn, Full Frequency)	11-7
11.6(d). R3081 Family Clocking (2x ClkIn, Half Frequency)	11-7
12.1(a). R3051 Debug Mode Instruction Address Display	12-3
12.1(b). R3051 Debug Mode Instruction Address Display	12-3
12.1(c). Instruction Cache Miss Sequence in Address Display Mode	12-3
12.3. Forcing an Instruction Cache Miss in Debug Mode	12-4

### **Listing of Tables**

1.1. Pin-, Socket-, and Software-Compatible R3051 Family	1-2
2.1. Instruction Set Mnemonics	2-4
2.2. CPO Registers	2-6
2.3. Byte Addressing in Load/Store Operations	2-11
2.4. Load and Store Instructions	2-12
2.5(a). ALU Immediate Operations	2-13
2.5(b). Three Operand Register-Type Operations	2-14
2.5(c). Shift Operations	2-14
2.5(d). Multiply and Divide Operations	2-15
2.6(a). Jump Instructions	2-16
2.6(b). Branch Instructions	2-16
2.7. Special Instructions	2-17
2.8. Co-Processor Operations	2-17
2.9. System Control Co-Processor (CPO) Operations	2-18
2.10. OpCode Encoding	2-19
3.1. Floating Point General Registers	3-3
3.2. Rounding Mode Bit Decoding	3-5

---

3.3. Equations for Calculating Values in Floating-Point Format	3-6
3.4. Floating Point Parameter Values	3-7
3.5. Floating Point Instruction Summary	3-9
3.6. Floating Point Load, Store, and Move Instruction Summary	3-11
3.7. Floating Point Computational Instruction Summary	3-12
3.8. Relationship Mnemonic Definitions	3-13
3.9. Floating Point Relational Operators	3-14
3.10. Branch on FPA Condition Instructions	3-14
3.11. FPA OpCode Encoding	3-15
5.1. Virtual and Physical Address Relationships in Base Versions	5-4
5.2. TLB Instructions	5-9
6.1. R3051 Family Exceptions	6-2
6.2. Co-Processor O Register addressing	6-4
6.3. Cause Register Exception Codes	6-5
6.4. Encoding of FPInt Field of Config Register	6-9
6.5. Exception Vectors When BEV = 0	6-10
6.6. Exception Vectors When BEV = 1	6-10
6.7. Exception Priority	6-12
6.8. FPA Exception Causing Codes	6-37
6.9. FPA Exception Causing Conditions	6-38
11.1. R3081 Mode Selectable Features	11-1
A.1. CPO Registers in the R3051 Family	A-1
A.2. Pin Considerations Among R3051 Family Members	A-3
A.3. Reset Mode Vectors of R3041, R3051/52, and R3081	A-4
A.4. Rsvd Pins of R3041, 3051/52, and R3081	A-5
A.5. Summary of Hardware Design Considerations	A-7

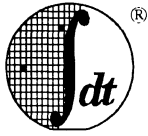

Integrated Device Technology, Inc.

### INTRODUCTION

The IDTR3051 family is a series of high-performance 32-bit microprocessors featuring a high-level of integration, and targeted to high-performance but cost sensitive processing applications. The R3051 family is designed to bring the high-performance inherent in the MIPS RISC architecture into low-cost, simplified, power sensitive applications.

Thus, functional units have been integrated onto the CPU core in order to reduce the total system cost, rather than to increase the inherent performance of the integer engine. Nevertheless, the R3051 family is able to offer 35 MIPS of integer performance at 40 MHz without requiring external SRAM or caches.

The R3081 extends the capabilities of the R3051, by integrating additional resources into the same pin-out. The R3081 thus extends the range of applications addressed by the R3051 family, and allows designers to implement a single, base system and software set capable of accepting a wide variety of CPUs, according to the price performance goals of the end system.

In addition to the embedded applications served by the R3051 family, the R3081 allows low-cost, entry level computer systems to be constructed. These systems will offer many times the performance of traditional PC systems, yet cost approximately the same. The R3081 is able to run any of the various operating systems ported to the MIPS R3000 architecture. Thus, the R3081 can be used to build a low-cost high-performance computer systems, further widening the range of performance solutions of the MIPS architecture.

This manual describes the 79R3081 and 79R3081E devices; the 79R3041, and 79R3051/52, are described in separate manuals. Appendix A describes design considerations for those wishing to interchange various R3051 family CPUs in a given design.

### FEATURES

- Instruction set compatible with IDT 79R3000A RISC CPU
- High level of integration minimizes system cost
- 35 MIPS at 40 MHz
- Low cost 84-pin packaging
- Large on-chip instruction and data caches with user configurability
- Parity protection over on-chip caches
- On-chip R3010A compatible Floating Point Accelerator
- Flexible bus interface allows simple, low cost designs.
- Optional half-frequency bus mode allows high-execution rate with low cost, low-speed system interface
- Optional 1X clock input with 45-55% duty cycle tolerance or R3051 compatible 2x clock
- 20 through 40 MHz operation
- Superset Pin- and Software- compatible with R3041, R3051, R3052
- Multiplexed bus interface with support for low cost, low speed memory systems with a high-speed CPU
- On-chip 4-deep write buffer eliminates memory write stalls
- On-chip 4-deep read buffer supports burst or simple block reads
- On-chip DMA arbiter
- Hardware-based Cache Coherency Support

## DEVICE OVERVIEW

The R3051 family offers a wide range of functionality in a pin-compatible interface. The R3051 family allows the system designer to implement a single base system, and utilize interface-compatible processors of various complexity to achieve the price-performance goals of the particular end system.

Differences among the various family members pertain to the on-chip resources of the processor, as illustrated in Table 1.1. Current family members include:

- The R3041, which incorporates 2kB of instruction cache, 512B of data cache, and a flexible system interface suited to low cost memory systems. The R3041 does not feature an on-chip MMU, but is fully address map compatible with the base versions of the R3051 family.
- The R3052E, which incorporates an 8kB instruction cache, a 2kB data cache, and full function memory management unit (MMU) including 64-entry fully associative Translation Lookaside Buffer (TLB).
- The R3052, which also incorporates an 8kB instruction cache and 2kB data cache, but does not include the TLB, and instead uses a simpler virtual to physical address mapping.
- The R3051E, which incorporates 4kB of instruction cache and 2kB of data cache, along with the full function MMU/TLB of the R3000A.
- The R3051, which incorporates 4kB of instruction cache and 2kB of data cache, but omits the TLB, and instead uses a simpler virtual to physical address mapping.
- The R3081E, which incorporates a 16kB instruction cache, a 4kB data cache, and full function memory management unit (MMU) including 64-entry fully associative Translation Lookaside Buffer (TLB). The cache on the R3081E is user configurable to an 8kB Instruction Cache and 8kB Data Cache.
- The R3081, which incorporates a 16kB instruction cache, a 4kB data cache, but uses the simpler memory mapping of the R3051/52, and thus omits the TLB. The cache on the R3081 is user configurable to an 8kB Instruction Cache and 8kB Data Cache.

Figure 1.1 shows a block level representation of the functional units within the R3081E. The R3081E could be viewed as the embodiment of a discrete solution built around the R3000A and R3010A. However, by integrating this functionality on a single chip, dramatic cost and power reductions are achieved.

An overview of these blocks is presented here, with detailed information on each block found in subsequent chapters.

Device Name	Instruction Cache	Data Cache	Floating Point	Bus Options
R3041	2kB	512B	Software emulation	8-, 16-, and 32-bit port width support Programmable timing support
R3051	4kB	2kB	Software emulation	32-bit Mux'ed Address/Data
R3052	8kB	2kB	Software emulation	32-bit Mux'ed Address/Data
R3081	16kB Or 8kB	4kB or 8kB	On-chip Hardware	1/2 frequency bus option

Table 1.1. Pin-, Socket-, and Software- Compatible R3051 Family

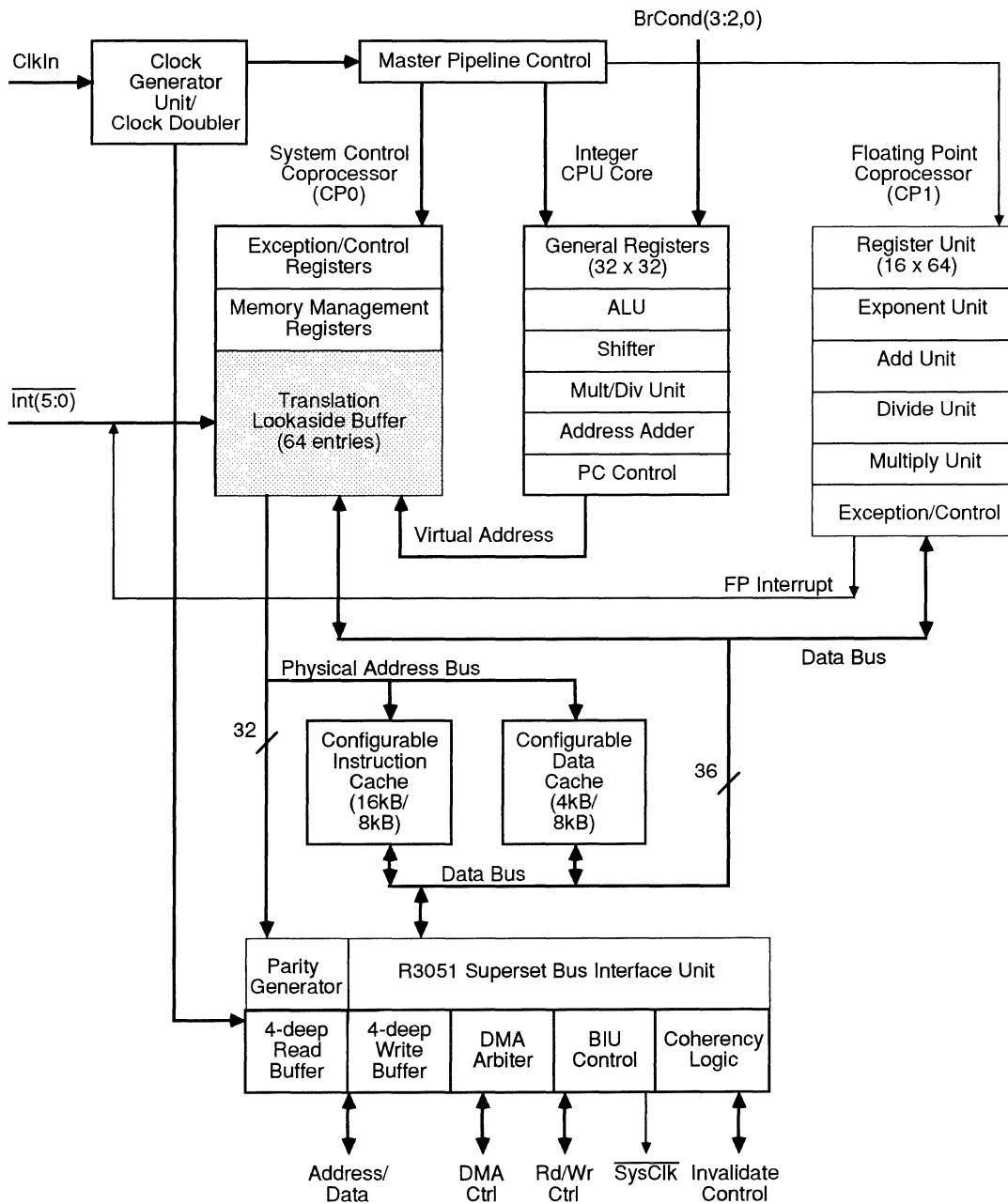

Figure 1.1. Block Diagram

**CPU Core**

The CPU core is a full 32-bit RISC integer execution engine, capable of sustaining close to single cycle execution rate. The CPU core contains a five stage pipeline, and 32 orthogonal 32-bit registers. The R3081 uses the same basic integer execution core as the entire R3051 family, which is the R3000A implementation of the MIPS instruction set. Thus, the R3081 family is binary compatible with the R3051, R3052, R3000A, R3001, and R3500 CPUs. In addition, the R4000 represents an upwardly software compatible migration path to still higher levels of performance.



### **System Control Co-Processor**

The R3081 family also integrates on-chip the System Control Co-processor, CP0. CP0 manages both the exception handling capability of the R3081, as well as the virtual to physical address mapping. These topics are discussed in subsequent chapters.

As with the R3051 and R3052, the R3081 family offers two versions of memory management and virtual to physical address mapping: the extended architecture versions, the R3051E, R3052E, and R3081E, incorporate the same MMU as the R3000A and R3001. These versions contain a fully associative 64-entry TLB which maps 4kB virtual pages into the physical address space. The virtual to physical mapping thus includes kernel segments which are hard-mapped to physical addresses, and kernel and user segments which are mapped page by page by the TLB into anywhere in the 4GB physical address space. In this TLB, 8 pages can be “locked” by the kernel to insure deterministic response in real-time applications.

R3051 family base versions (the R3051, R3052, and R3081) remove the TLB and institute a fixed address mapping for the various segments of the virtual address space. These devices still support distinct kernel and user mode operation, but do not require page management software, leading to a simpler software model.

### **Floating Point Co-Processor**

The R3081 also integrates an R3010A compatible floating point accelerator. The R3010A is a high performance floating point co-processor (co-processor 1 to the CPU) providing separate add, multiply, and divide functional units for single and double precision floating point arithmetic. The floating point accelerator features low latency operations, and autonomous functional units which allow differing types of floating point operations to function concurrently with integer operations. The R3010A appears to the software programmer as a simple extension of the integer execution unit, with 16 dedicated 64-bit floating point registers (software references these as 32 32-bit registers when performing loads or stores).

### **Clock Generator Unit**

The R3081 is driven from a single input clock which can either be at twice the execution rate (2x clock mode) or exactly at the execution rate (1x clock mode). On-chip, the clock generator unit is responsible for managing the interaction of the CPU core, caches, and bus interface. The R3081 includes an on-chip clock doubler to provide higher frequency signals to the internal execution core. Thus, the R3081 can be used either with a R3051 compatible 2x clock input, or can use a lower frequency 1x clock input.

### **Instruction Cache**

The R3081 implements a 16kB Instruction Cache. The system may choose to repartition the on-chip caches, so that the instruction cache is reduced to 8kB but the data cache is increased to 8kB. The instruction cache is organized with a line size of 16 bytes (four 32-bit entries). This large cache achieves hit rates in excess of 98% in most applications, and substantially contributes to the performance inherent in the R3081. The cache is implemented as a direct mapped cache, and is capable of caching instructions from anywhere within the 4GB physical address space. The cache is implemented using physical addresses and physical tags (rather than virtual addresses or tags), and thus does not require flushing on context switch.

The on-chip instruction cache is parity protected over both the instruction word and tag fields. The read buffer will generate proper parity into the cache during cache refills; on cache references, the parity will be checked. If a parity error is detected, a cache miss will be processed.

**Data Cache**

The R3081 incorporates an on-chip data cache of 4kB, organized as a line size of 4 bytes (one word). The R3081 allows the system to reconfigure the on-chip cache from the default 16kB I-Cache/4kB D-Cache to 8kB of Instruction and 8kB of Data caches.

The relatively large data cache achieves hit rates in excess of 95% in most applications, and contributes substantially to the performance inherent in the R3081. As with the instruction cache, the data cache is implemented as a direct mapped physical address cache. The cache is capable of mapping any word within the 4GB physical address space.

The data cache is implemented as a write through cache, to insure that main memory is always consistent with the internal cache. In order to minimize processor stalls due to data write operations, the bus interface unit incorporates a 4-deep write buffer which captures address and data at the processor execution rate, allowing it to be retired to main memory at a much slower rate without impacting system performance. Further, support has been provided to allow hardware based data cache coherency in a multi-master environment, such as one utilizing DMA from I/O to memory.

The on-chip data cache is parity protected over both the data and tag fields. The read buffer will generate proper parity into the cache during cache refills; on cache references, the parity will be checked. If a parity error is detected, a cache miss will be processed.

**Bus Interface Unit**

The R3081 uses its large internal caches to provide the majority of the bandwidth requirements of the execution engine, and thus can utilize a simple bus interface connected to slower memory devices. Alternately, a high-performance, low cost secondary cache can be implemented, allowing the processor to increase performance in systems where bus bandwidth is a performance limitation.

The R3051 family bus interface utilizes a 32-bit address and data bus multiplexed onto a single set of pins. The bus interface unit also provides an ALE (Address Latch Enable) output signal to de-multiplex the A/D bus, and simple handshake signals to process CPU read and write requests. In addition to the read and write interface, the R3051 family incorporates a DMA arbiter, to allow an external master to control the external bus. The R3081 can be used in a multi-master system using hardware-based cache coherency.

The R3081 incorporates a 4-deep write buffer to decouple the speed of the execution engine from the speed of the memory system. The write buffers capture and FIFO processor address and data information in store operations, and present it to the bus interface as write transactions at the rate the memory system can accommodate.

The R3081 read interface performs both single word reads and quad word reads. Single word reads work with a simple handshake, and quad word reads can either utilize the simple handshake (in lower performance, simple systems) or utilize a tighter timing mode when the memory system can burst data at the processor clock rate. Thus, the system designer can choose to utilize page or nibble mode DRAMs (and possibly use interleaving, if desired, in high-performance systems), or use simpler techniques to reduce complexity. During cache refills, the bus interface unit generates parity over the incoming data values, and places the parity in the on-chip caches.

In order to accommodate slower quad word reads, the R3081 incorporates a 4-deep read buffer FIFO, so that the external interface can queue up data within the processor before releasing it to perform a burst fill of the internal caches.

The R3081 is R3051 superset compatible in its bus interface. Specifically, the R3081 has additional support to simplify the design of very high frequency systems. This support includes the ability to run the bus interface at one-half the processor execution rate, as well as the ability to slow the transitions between reads and writes to provide extra buffer disable time for the memory interface.

## **SYSTEM USAGE**

The IDT R3051 family has been specifically designed to allow a wide variety of memory systems. Low cost systems can use slow speed memories and simple controllers, while other designers may choose to incorporate higher frequencies, faster memories, and techniques such as DMA to achieve maximum performance. The R3081 includes specific support for high performance systems, including signals necessary to implement external secondary caches, and the ability to perform hardware based cache coherency in multi-master systems.

Figure 1.2 shows a typical system implementation using off-the-shelf logic devices. Transparent latches are used to de-multiplex the R3081 address and data busses from the A/D bus. The data paths between the memory system elements and the R3051/52 family A/D bus is managed by simple octal devices. A small set of simple PALs is used to control the various data path elements, and to control the handshake between the memory devices and the R3051/52. IDT has implemented the R3720/21 support chip set specifically tailored to R3051 family systems. This chip set directly interfaces the processor to DRAM, simplifying design and eliminating discrete logic chips and PAL devices.

Depending on the cost vs. performance tradeoffs appropriate to a given application, the system design engineer could include true burst support from the DRAM to provide for high-performance cache miss processing, or utilize a simpler, lower performance memory system to reduce cost and simplify the design. Similarly, the system designer could choose to implement techniques such as external secondary cache, or DMA, to further improve system performance.

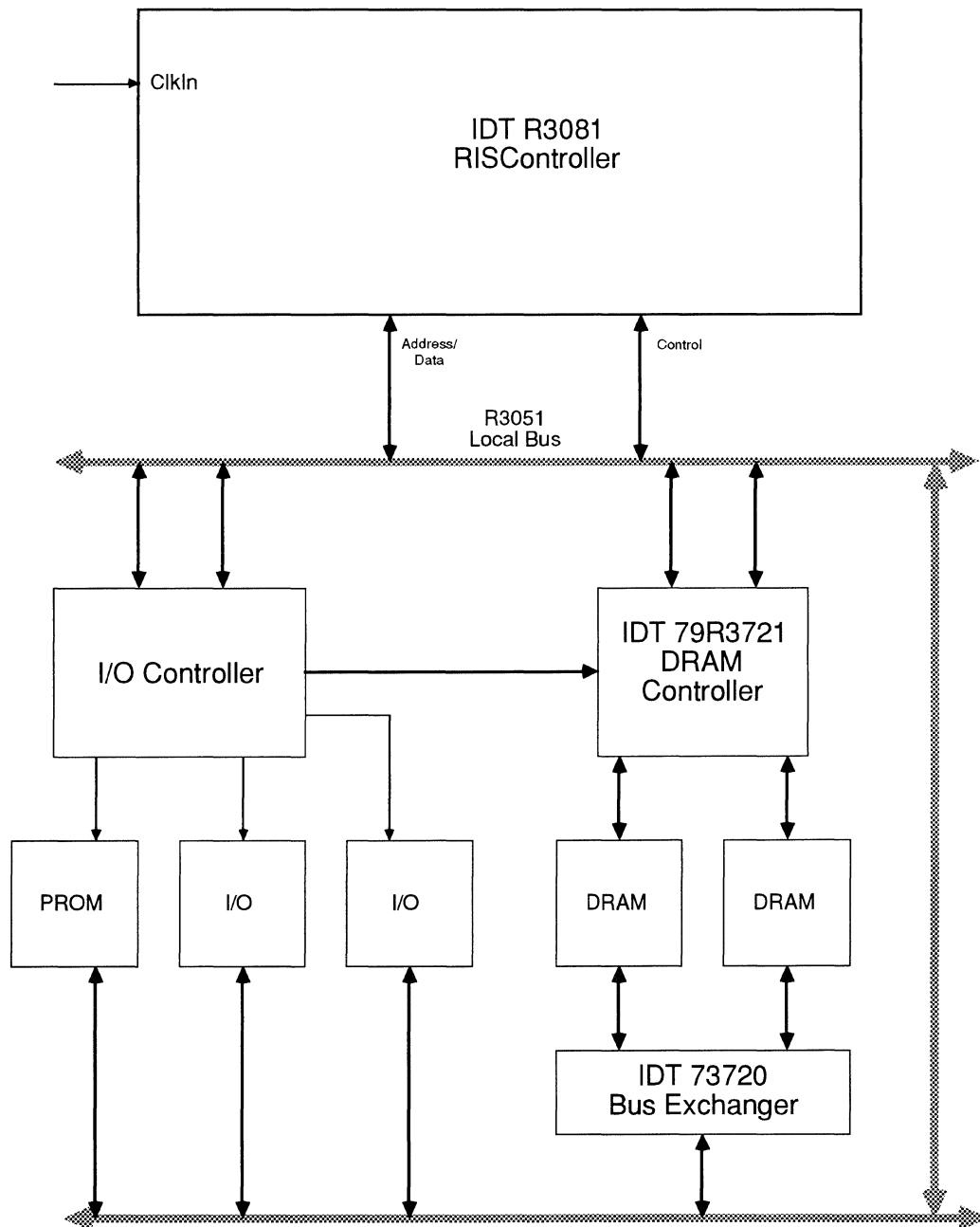

Figure 1.2. System Diagram

## DEVELOPMENT SUPPORT

The IDT R3051 family is supported by a rich set of development tools, ranging from system simulation tools through PROM monitor and debug support, applications software and utility libraries, logic analysis tools, sub-system modules, and shrink wrap operating systems. The R3081, which is pin and software compatible with the R3051, can directly utilize these existing tools to reduce time to market.

Figure 1.3 is an overview of the system development process typically used when developing R3051 family applications. The R3051 family is supported in all phases of project development. These tools allow timely, parallel development of hardware and software for R3051 family based applications, and include tools such as:

- A program, Cache-R3081, which allows the performance of an R3081 family system to be modeled and understood without requiring actual hardware.
- Sable, an instruction set simulator.
- Optimizing compilers from MIPS, the acknowledged leader in optimizing compiler technology. The compilers are available in both native and cross environments.
- Cross development tools, available in a variety of development environments.
- The high-performance IDT floating point library software, including transcendental functions and IEEE compliant exception handlers.
- The IDT Evaluation Board, which includes RAM, EPROM, I/O, and the IDT PROM Monitor.
- The IDT 79S389 Adobe Reference Printer system, which directly drives a low-cost print engine, and runs PostScript™ software from Adobe.
- IDT/sim, which implements a full prom monitor (diagnostics, remote debug support, peek/poke, etc.).
- IDT/kit, which implements a run-time support package for R3051 family systems.

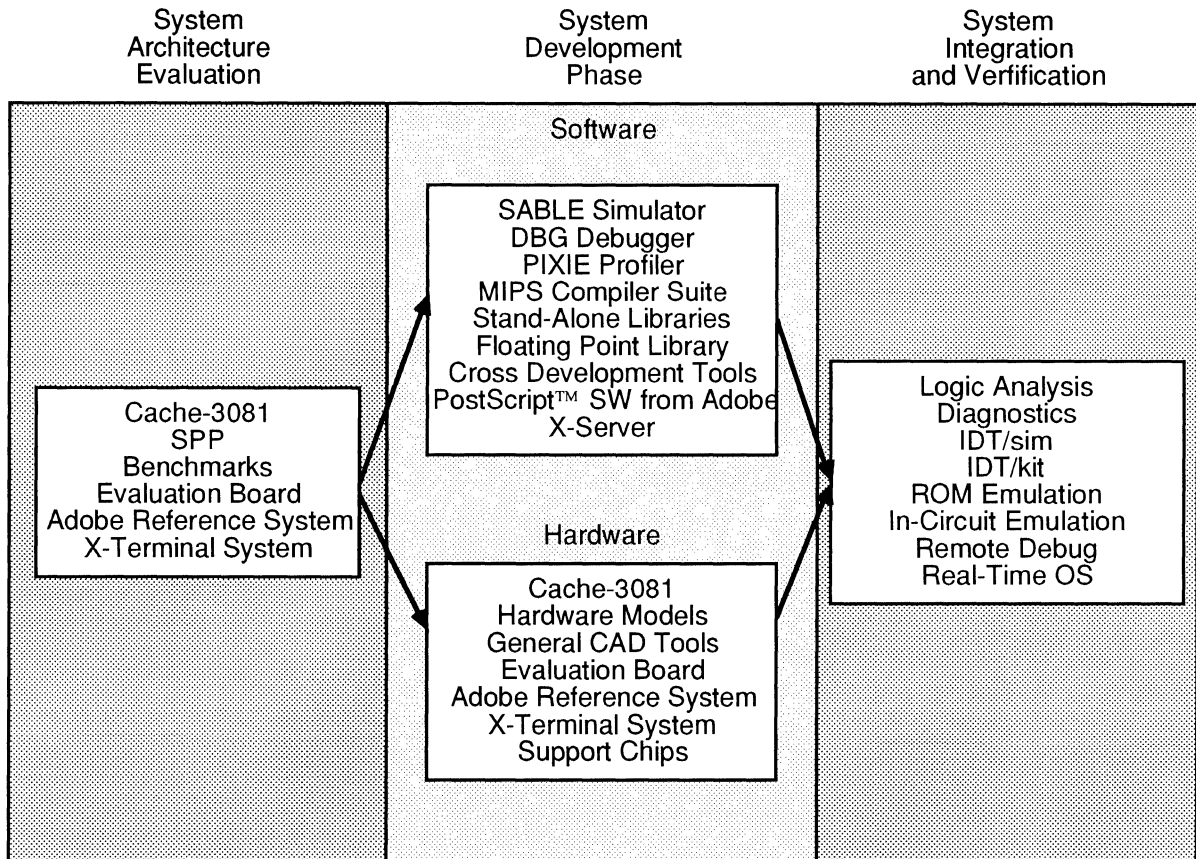

Figure 1.3. Development Support

## PERFORMANCE OVERVIEW

The R3081 achieves a very high-level of performance. This performance is based on:

- An efficient execution engine. The CPU performs ALU operations and store operations in single cycle, and has an effective load time of 1.3 cycles, and branch execution rate of 1.5 cycles (based on the ability of the compilers to avoid software interlocks). Thus, the execution engine achieves over 35 MIPS performance when operating out of cache.
- A full featured floating point accelerator/co-processor. The R3081 incorporates the R3010A floating point accelerator on-chip, with independent ALUs for floating point add, multiply, and divide. The floating point unit is fully hardware interlocked, and features overlapped operation and precise exceptions. The FPA allows floating point adds, multiplies, and divides to occur concurrently with each other, as well as concurrently with integer operations.
- Large on-chip caches. The R3081 contains caches which are substantially larger than those on the majority of today's microprocessors. These large caches minimize the number of bus transactions required, and allow the R3051 family to achieve actual sustained performance very close to its peak execution rate. The R3081 doubles the cache available on the R3052, making it a suitable engine for many general purpose computing applications, such as ARC compliant systems.
- Autonomous multiply and divide operations. The R3081 features an on-chip integer multiplier/divide unit which is separate from the other ALU. This allows the CPU to perform multiply or divide operations in parallel with other integer operations, using a single multiply or divide instruction rather than "step" operations.
- Integrated write buffer. The R3081 features a four deep write buffer, which captures store target addresses and data at the processor execution rate and retires it to main memory at the slower main memory access rate. Use of on-chip write buffers eliminates the need for the processor to stall when performing store operations.
- Burst read support. The R3081 enables the system designer to utilize page mode or nibble mode RAMs when performing read operations to minimize the main memory read penalty and increase the effective cache hit rates.

These techniques combine to allow the processor to achieve over 28 MIPS integer performance, 11MFlops of Linpack performance, and 64,000 dhrystones without the use of external caches or zero wait-state memory devices.

The performance differences amongst the various family members depends on the application software and the design of the memory system. The impact of the various cache sizes, and the hardware floating point, can be accurately modeled using Cache-3051. Since the R3041, R3051, R3052, and R3081 are all pin and software compatible, the system designer has maximum freedom in trading between performance and cost. A system can be designed, and later the appropriate CPU inserted into the board, depending on the desired system performance.



## INTRODUCTION

The IDT R3051 family contains the same basic execution core as the IDT/MIPS R3000A. In addition to being able to run software written for either of this processor family, this enables the R3051 family to achieve dramatic levels of performance, based on the efficiency of the execution engine. The R3081 includes the same integer execution unit as does all members of the R3051 family, and thus is fully binary compatible with applications for that processor. The floating point accelerator included in the R3081 acts as an extension to the CPU, and is described in chapter 3.

This chapter gives an overview of the MIPS architecture implemented in the R3051 family, and discusses the programmers' model for this device. Further detail is available in the book "mips RISC Architecture", available from IDT.

## R3051 FAMILY PROCESSOR FEATURES OVERVIEW

The R3051 family has many of the same attributes of the IDT R3000A, at a higher level of integration geared to lower system cost. These features include:

- **Full 32-bit Operation.** The R3051 family contains thirty-two 32-bit integer registers, and all instructions and addresses are 32 bits.
- **Efficient Pipelining.** The CPU utilizes a 5-stage pipeline design to achieve an execution rate approaching one instruction per cycle. Pipeline stalls, hazards, and exceptional events are handled precisely and efficiently.
- **Large On-Chip Instruction and Data Caches.** The R3051 family utilizes large on-chip caches to provide high-bandwidth to the execution engine. The large size of the caches insures high hit rates, minimizing stalls due to cache miss processing and dramatically contributing to overall performance. Both the instruction and data cache can be accessed during a single CPU cycle.
- **On-chip Memory Management.** The IDT Extended Architecture versions of the R3051 family (the R3051E, R3052E, and R3081E) utilize the same memory management scheme as the R3000A, providing a 64-entry fully-associative TLB to provide fast virtual to physical address translation of the 4GB address space. The base versions of the family (the R3041, R3051, R3052, and R3081) do not utilize the TLB, but perform fixed segment-based mapping of the virtual space to physical addresses.

## CPU REGISTERS OVERVIEW

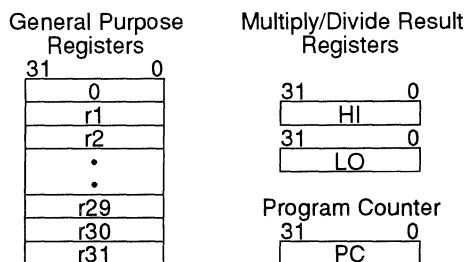

Figure 2.1. CPU Registers <sup>4000 drw 01</sup>



The IDT R3051 family CPU engine provides 32 general purpose 32-bit registers, a 32-bit Program Counter, and two dedicated 32-bit registers which hold the result of an integer multiply or divide operation. The CPU registers, illustrated in Figure 2.1, are discussed later in this chapter.

Note that the MIPS architecture does not use a traditional Program Status Word (PSW) register. The functions normally provided by such a register are instead provided through the use of “Set” instructions and conditional branches. By avoiding the use of traditional condition codes, the architecture can be more finely pipelined. This, coupled with the fine granularity of the instruction set, allows the compilers to achieve dramatically higher levels of optimizations than for traditional architectures.

Overflow and exceptional conditions are then handled through the use of the on-chip *Status* and *Cause* registers, which reside on-chip as part of the System Control Co-Processor (Co-Processor 0). These registers contain information about the run-time state of the machine, and any exceptional conditions it has encountered.

### INSTRUCTION SET OVERVIEW

All instructions are 32-bits long, and there are only three basic instruction formats. This approach dramatically simplifies instruction decoding, permitting higher frequency operation. More complicated (but less frequently used) operations and addressing modes are synthesized by the assembler, using sequences of the basic instruction set. This approach enables object code optimizations at a finer level of resolution than achievable in micro-coded CPU architectures.

Figure 2.2 shows the instruction set encoding used by the MIPS architecture. This approach simplifies instruction decoding in the CPU.

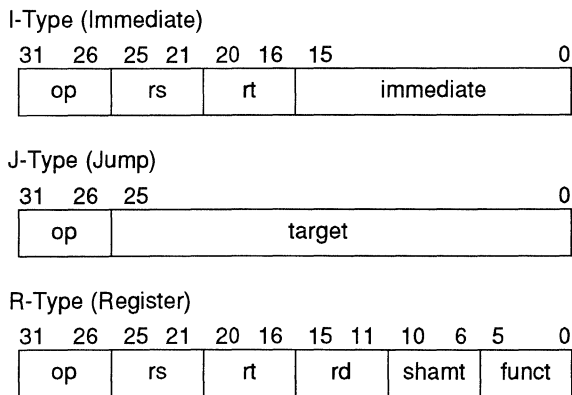

where:

op	is a 6-bit operation code
rs	is a five bit source register specifier
rt	is a 5-bit target register or branch condition
immediate	is a 16-bit immediate, or branch or address displacement
target	is a 26-bit jump target address
rd	is a 5-bit destination register specifier
shamt	is a 5-bit shift amount
funct	is a 6-bit function field

4000 drw 02

**Figure 2.2. Instruction Encoding**

The instruction set can be divided into the following basic groups:

- **Load/Store** instructions move data between memory and the general registers. They are all encoded as “I-Type” instructions, and the only addressing mode implemented is base register plus signed, immediate offset. This directly enables the use of three distinct addressing modes: register plus offset; register direct; and immediate.
- **Computational** instructions perform arithmetic, logical, and shift operations on values in registers. They are encoded as either “R-Type” instructions, when both source operands as well as the result are general registers, and “I-Type”, when one of the source operands is a 16-bit immediate value. Computational instructions use a three address format, so that operations don’t needlessly interfere with the contents of source registers.
- **Jump and Branch** instructions change the control flow of a program. A Jump instruction can be encoded as a “J-Type” instruction, in which case the Jump target address is a paged absolute address formed by combining the 26-bit immediate value with four bits of the Program Counter. This form is used for subroutine calls.

Alternately, Jumps can be encoded using the “R-Type” format, in which case the target address is a 32-bit value contained in one of the general registers. This form is typically used for returns and dispatches.

Branch operations are encoded as “I-Type” instructions. The target address is formed from a 16-bit displacement relative to the Program Counter.

The Jump and Link instructions save a return address in Register r31. These are typically used as subroutine calls, where the subroutine return address is stored into r31 during the call operation.

- **Co-Processor** instructions perform operations on the co-processor set. Co-Processor Loads and Stores are always encoded as “I-Type” instructions; co-processor operational instructions have co-processor dependent formats.

In the R3051 family, the System Control Co-Processor (CP0) contains registers which are used in memory management and exception handling. In the R3081, the floating point accelerator also resides on-chip, and operates as Co-Processor 1 (CP1)

Additionally, the R3051 family implements BrCond inputs. Software can use the Branch on Co-Processor Condition instructions to test the state of these external inputs, and thus they may be used like general purpose input ports. In the R3081, BrCond(1) is used internally by the Floating Point Unit, and thus is not available externally.

- **Special** instructions perform a variety of tasks, including movement of data between special and general registers, system calls, and breakpoint operations. They are always encoded as “R-Type” instructions.

Table 2.1 lists the instruction set mnemonics of the R3051 family. More detail on these operations is presented later in this chapter. For further detail, consult “mips RISC Architecture”, or one of the language programming guides, available from IDT.

OP	Description	OP	Description
	<b>Load/Store Instructions</b>		<b>Multiply/Divide Instructions</b>
LB	Load Byte	MULT	Multiply
LBU	Load Byte Unsigned	MULTU	Multiply Unsigned
LH	Load Halfword	DIV	Divide
LHU	Load Halfword Unsigned	DIVU	Divide Unsigned
LW	Load Word		
LWL	Load Word Left	MFHI	Move From HI
LWR	Load Word Right	MTHI	Move To HI
SB	Store Byte	MFLO	Move From LO
SH	Store Halfword	MTLO	Move To LO
SW	Store Word		
SWL	Store Word Left		<b>Jump and Branch Instructions</b>
SWR	Store Word Right	J	Jump
	<b>Arithmetic Instructions (ALU Immediate)</b>	JAL	Jump and Link
ADDI	Add Immediate	JR	Jump to Register
ADDIU	Add Immediate Unsigned	JALR	Jump and Link Register
SLTI	Set on Less Than Immediate	BEQ	Branch on Equal
SLTIU	Set on Less Than Immediate Unsigned	BNE	Branch on Not Equal
ANDI	AND Immediate	BLEZ	Branch on Less than or Equal to Zero
ORI	OR Immediate	BGTZ	Branch on Greater Than Zero
XORI	Exclusive OR Immediate	BLTZ	Branch on Less Than Zero
LUI	Load Upper Immediate	BGEZ	Branch on Greater Than or Equal to Zero
	<b>Arithmetic Instructions (3-operand, register-type)</b>	BLTZAL	Branch on Less Than Zero and Link
ADD	Add	BGEZAL	Branch on Greater Than or Equal to Zero and Link
ADDU	Add Unsigned		<b>Special Instructions</b>
SUB	Subtract	SYSCALL	System Call
SUBU	Subtract Unsigned	BREAK	Break
SLT	Set on Less Than		<b>Coprocessor Instructions</b>
SLTU	Set on Less Than Unsigned	LWCz	Load Word from Coprocessor
AND	AND	SWCz	Store Word to Coprocessor
OR	OR	MTCz	Move To Coprocessor
XOR	Exclusive OR	MFCz	Move From Coprocessor
NOR	NOR	CTCz	Move Control To Coprocessor
	<b>Shift Instructions</b>	CFCz	Move Control From Coprocessor
SLL	Shift Left Logical	COPz	Coprocessor Operation
SRL	Shift Right Logical	BCzT	Branch on Coprocessor z True
SRA	Shift Right Arithmetic	BCzF	Branch on Coprocessor z False
SLLV	Shift Left Logical Variable		<b>System Control Coprocessor (CPO) Instructions</b>
SRLV	Shift Right Logical Variable	MTC0	Move To CPO
SRAV	Shift Right Arithmetic Variable	MFC0	Move From CPO
		TLBR	Read indexed TLB entry
		TLBWI	Write indexed TLB entry
		TLBWR	Write Random TLB entry
		TLBP	Probe TLB for matching entry
		RFE	Restore From Exception

4000 tbl 01

Table 2.1. Instruction Set Mnemonics

## PROGRAMMING MODEL

This section describes the organization of data in the general registers and in memory, and discusses the set of general registers available. A summary description of all of the CPU registers is presented. The Floating Point Registers are discussed in Chapter 3.

### Data Formats and Addressing

The R3051 family defines a word as 32-bits, a half-word as 16-bits, and a byte as 8-bits. The byte ordering convention is configurable during hardware reset (Chapter 11) into either a *big-endian* or *little-endian* convention.

When configured as a big-endian system, byte 0 is always the most significant (leftmost) byte in a word. This is the order used in MC680x0® microprocessors, and systems from MIPS.

When configured as a little-endian system, byte 0 is always the least significant (rightmost) byte in a word. This is compatible with the iAPX® x86 microprocessors and systems from Digital Equipment Corporation.

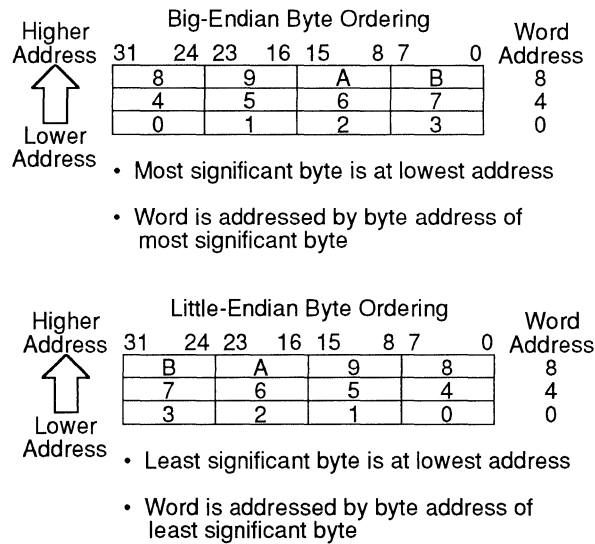

4000 drw 03

Figure 2.3. Byte Ordering Conventions

Figure 2.3 shows the ordering of bytes within words and the ordering of words within multiple word structures for the big-endian and little-endian conventions.

The R3051 family uses byte addressing for all accesses, including half-word and word. The MIPS architecture has alignment constraints that require half-word access to be aligned on an even byte boundary, and word access to be aligned on a modulo-4 byte boundary. Thus, in big-endian systems, the address of a multiple-byte data item is the address of the most-significant byte, while in little-endian systems it is the address of the least-significant byte of the structure.

For compatibility with older programs written for 8- or 16-bit machines, the MIPS instruction set provides special instructions for addressing 32-bit words which are not aligned on 4-byte boundaries. These instructions, which are Load/Store Left/Right, are used in pairs to provide addressing of misaligned words. This effectively means that these types of data movements require only one-additional instruction cycle over that required for properly aligned words, and provides a much more efficient way of dealing with this case than is possible using sequences of loads/stores and shift operations. Figure 2.4 shows the bytes accessed when addressing a mis-aligned word with a byte address of 3, for each of the two byte ordering conventions.

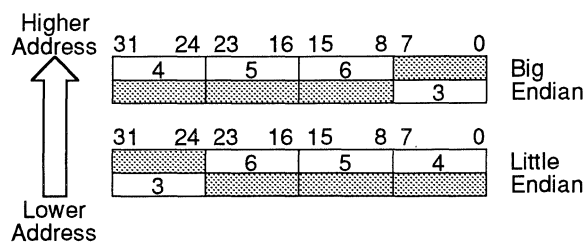

4000 drw 04

Figure 2.4. Unaligned Words

### CPU General Registers

The R3051 family contains 32-general registers, each containing a single 32-bit word. The 32 general registers are treated symmetrically (orthogonally), with two notable exceptions: general register r0 is hardwired to a zero value, and r31 is used as the link register in Jump and Link instructions

Register r0 maintains the value zero under all conditions when used as a source register, and discards data written to it. Thus, instructions which attempt to write to it may be used as No-Op Instructions. The use of a register wired to the zero value allows the simple synthesis of different addressing modes, no-ops, register or memory clear operations, etc., without requiring expansion of the basic instruction set.

Register r31 is used as the link register in jump and link instructions. These instructions are used in subroutine calls, and the subroutine return address is placed in register r31. This register can be written to or read as a normal register in other operations.

In addition to the general registers, the CPU contains two registers (HI and LO) which store the double-word, 64-bit result of integer multiply operations, and the quotient and remainder of integer divide operations.

### CP0 Special Registers

In addition to the general CPU registers, the R3051 family contains a number of special registers on-chip. These registers logically reside in the on-chip System Control Co-processor CP0, and are used in memory management and exception handling. There may be some differences in the set of CP0 registers across the various R3051 family members; it is recommended that applications perform a CPU identification routine at boot-up, and perform a device specific initialization routine, to preserve interchangeability among the various family members.

Table 2.2 shows the logical CP0 address of each of the registers in the R3081. The format of each of these registers, and their use, is discussed in Chapter 5 (Memory Management), and Chapter 6 (Exception Handling). Note that the Config register is unique to the R3081; it is used to allow software to control a number of system hardware options. Its use is discussed in chapter 6.

Number	Mnemonic	Description
0	Index	Programmable pointer into on-chip TLB array
1	Random	Pseudo-random pointer into on-chip TLB array (read only)
2	EntryLo	Low-half of TLB entry
3	Config*	Hardware configuration register
4	Context	Pointer to kernel virtual Page Table Entry Table
5-7	Reserved	
8	BadVAddr	Bad virtual address
9	Reserved	
10	EntryHi	High-half of TLB entry
11	Reserved	
12	SR	Status Register
13	Cause	Cause of last exception
14	EPC	Exception Program Counter
15	PRId	Processor Revision Identifier
16-31	Reserved	

\*: This register is only present in the R3081 devices.

**Table 2.2. CP0 Registers**

### Operating Modes

The R3051 family supports two different operating modes: *User* and *Kernel* modes. The processor normally operates in User mode until an exception is detected, forcing it into kernel mode. It remains in Kernel mode until a Return From Exception (RFE) instruction is executed, returning it to its previous operation mode.

The processor supports these levels of protection by segmenting the 4GB virtual address space into 4 distinct segments. One segment is accessible from either the User state or the Kernel mode, and the other three segments are only accessible from kernel mode.

In addition to providing memory address protection, the kernel can protect the co-processors from access or modification by the user task.

Finally, the R3081 supports the execution of user programs with the opposite byte ordering (Reverse Endianness) of the kernel, facilitating the exchange of programs and data between dissimilar machines.

Chapter 5 discusses the memory management facilities of the processor.

### Pipeline Architecture

The IDT R3051 family uses the same basic pipeline structure as that implemented in the R3000A. Thus, the execution of a single instruction is performed in five distinct steps.

- **Instruction Fetch (IF).** In this stage, the instruction virtual address is translated to a physical address and the instruction is read from the internal Instruction Cache.
- **Read (RD).** During this stage, the instruction is decoded and required operands are read from the on-chip register file.
- **ALU.** The required operation is performed on the instruction operands.
- **Memory Access (MEM).** If the instruction was a load or store, the Data Cache is accessed. Note that there is a skew between the instruction cycle which fetches the instruction and the one in which the required data transfer occurs. This skew is a result of the intervening pipestages.
- **Write Back (WB).** During the write back pipestage, the results of the ALU stage operation are updated into the on-chip register file.

Each of these pipestages requires approximately one CPU cycle, as shown in Figure 2.5. Parts of some operations lap into the next cycle, while other operations require only 1/2 cycle.

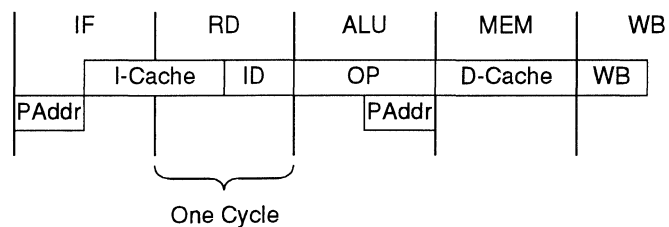

4000 drw 05

Figure 2.5. 5-Stage Pipeline

The net effect of the pipeline structure is that a new instruction can be initiated every clock cycle. Thus, the execution of five instructions at a time is overlapped, as shown in Figure 2.6.

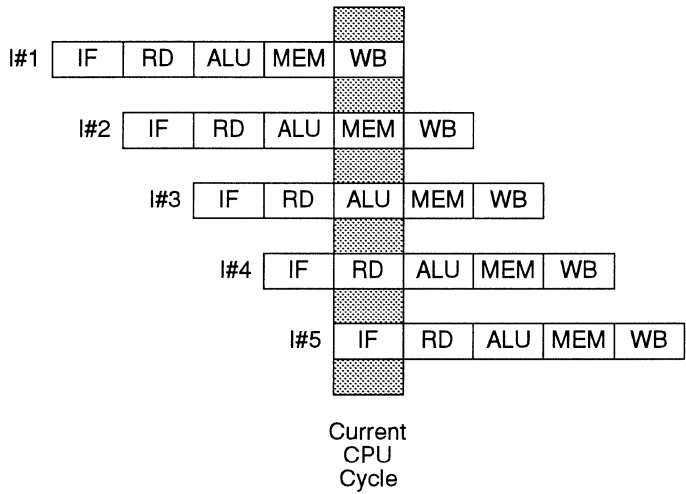

4000 drw 06

Figure 2.6. 5-Instructions per Clock Cycle

The pipeline operates efficiently, because different CPU resources such as address and data bus access, ALU operations, and the register file, are utilized on a non-interfering basis.

**Pipeline Hazards**

In a pipelined machine such as an R3051 family CPU, there are certain instructions which, based on the pipeline structure, can potentially disrupt the smooth operation of the pipeline. The basic problem is that the current pipestage of an instruction may require the result of a previous instruction, still in the pipeline, whose result is not yet available. This class of problems is referred to as pipeline hazards.

An example of a potential pipeline hazard occurs when a computational instruction (instruction n+1) requires the result of the immediately prior instruction (instruction n). Instruction n+1 wants to access the register file during the RF pipestage. However, instruction n has not yet completed its register writeback operation, and thus the current value is not available directly from the register file. In this case, special logic within the execution engine forwards the result of instruction n's ALU operation to instruction n+1, prior to the true writeback operation. The pipeline is undisturbed, and no pipeline stalls need to occur.

Another example of a pipeline hazard handled in hardware is the integer multiply and divide operations. If an instruction attempts to access the HI or LO registers prior to the completion of the multiply or divide, that instruction will be *interlocked* (held off) until the multiply or divide operation completes. Thus, the programmer is isolated from the actual execution time of this operation. The optimizing compilers attempt to schedule as many instructions as possible between the start of the multiply/divide and the access of its result, to minimize stalls.

However, not all pipeline hazards are handled in hardware. There are two categories of instructions which utilize software intervention to insure logical operation. The optimizing compilers (and peephole scheduler of the assembler) are capable of insuring proper execution. These two instruction classes are:

- Load instructions have a delay, or latency, of one cycle before the data loaded from memory is available another instruction. This is because the ALU stage of the immediately subsequent instruction is processed simultaneously with the Data Cache access of the load operation. Figure 2.7 illustrates the cause of this delay slot.

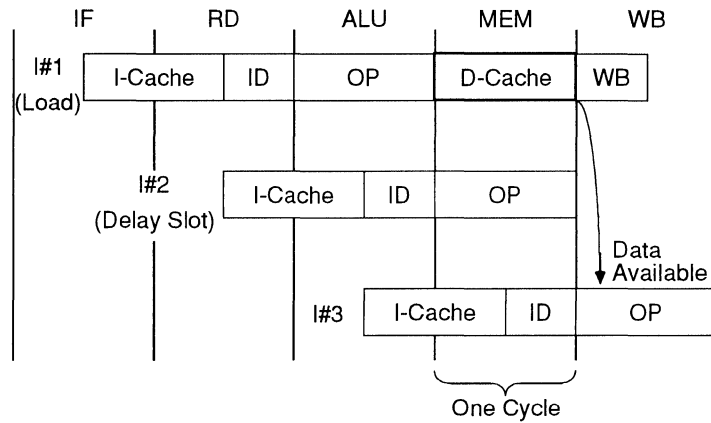

4000 drw 07

Figure 2.7. Load Delay

- Jump and Branch instructions have a delay of one cycle before the program flow change can occur. This is due to the fact that the next instruction is fetched prior to the decode and ALU stage of the jump/branch operation. Figure 2.8 illustrates the cause of this delay slot.

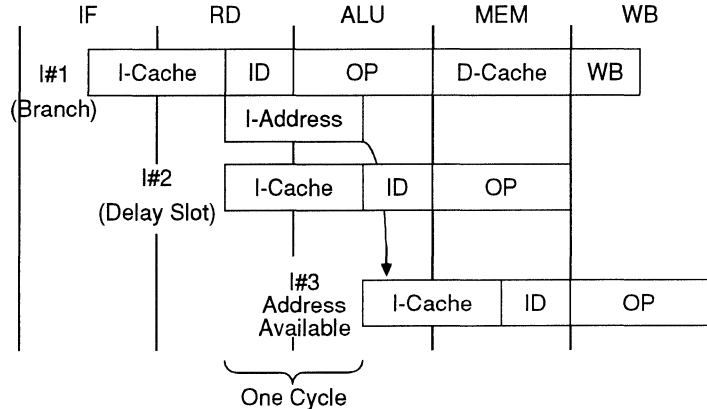

4000 drw 08

Figure 2.8. Branch Delay

The CPU continues execution, despite the delay in the operation. Thus, loads, jumps and branches do not disrupt the pipeline flow of instructions, and the processor always executes the instruction immediately following one of these “delayed” instructions.



Rather than include extensive pipeline control logic, the CPU gives responsibility for dealing with “delay slots” to software. Thus, the peephole optimizer (which can be performed as part of compilation or assembly) can re-order the code to insure that the instruction in the delay slot does not require the logical result of the “delayed” instruction. In the worst case, a NOP can be inserted to guarantee proper software execution.

Chapter 6 discusses the impact of pipelining on exception handling. In general, when an instruction causes an exception, it is desirable for all instructions initiated prior to that instruction to complete, and all subsequent instructions to abort. This insures that the machine state presented to the exception handler reflects the logical state that existed at the time the exception was detected. In addition, it is desirable to avoid requiring software to explicitly manage the pipeline when handling or returning from exceptions. The IDT R3051 family CPU pipeline is designed to properly manage exceptional events.

## INSTRUCTION SET SUMMARY

This section provides an overview of the R3051 family instruction set by presenting each category of instructions in a tabular summary form. Refer to the “mips RISC Architecture” reference for a detailed description of each instruction.

### Instruction Formats

Every instruction consists of a single word (32 bits) aligned on a word boundary. There are only three instruction formats as shown in Figure 2.2. This approach simplifies instruction decoding. More complicated (less frequently used) operations and addressing modes are synthesized by the compilers.

### Instruction Notational Conventions

In this manual, all variable sub-fields in an instruction format (such as *rs*, *rt*, *immediate*, and so on) are shown in lower-case names.

For the sake of clarity, an alias is sometimes used for a variable sub-field in the formats of specific instructions. For example, “*base*” rather than “*rs*” is used in the format for Load and Store instructions. Such an alias is always lower case, since it refers to a variable sub-field.

Instruction opcodes are shown in all upper case.

The actual bit encoding for all the mnemonics is specified at the end of this chapter.

### Load and Store Instructions

**Load/Store** instructions move data between memory and general registers. They are all I-type instructions. The only addressing mode directly supported is base register plus 16-bit signed immediate offset. This can be used to directly implement immediate addressing (using the *r0* register) or register direct (using an immediate offset value of zero).

All load operations have a latency of one instruction. That is, the data being loaded from memory into a register is not available to the instruction that immediately follows the load instruction: the data is available to the second instruction after the load instruction. An exception is the target register for the “load word left” and “load word right” instructions, which may be specified as the same register used as the destination of a load instruction that immediately precedes it.

**Big-Endian**

Size	AdrLo(1)	AdrLo(0)	BE(3) Data(31:24)	BE(2) Data(23:16)	BE(1) Data(15:8)	BE(0) Data(7:0)
Word	0	0	Yes	Yes	Yes	Yes
Tri-Byte	0	0	Yes	Yes	Yes	No
Tri-Byte	0	1	No	Yes	Yes	Yes
16-Bit	0	0	Yes	Yes	No	No
16-Bit	1	0	No	No	Yes	Yes
Byte	0	0	Yes	No	No	No
Byte	0	1	No	Yes	No	No
Byte	1	0	No	No	Yes	No
Byte	1	1	No	No	No	Yes

**Little-Endian**

Size	AdrLo(1)	AdrLo(0)	BE(3) Data(31:24)	BE(2) Data(23:16)	BE(1) Data(15:8)	BE(0) Data(7:0)
Word	0	0	Yes	Yes	Yes	Yes
Tri-Byte	0	0	No	Yes	Yes	Yes
Tri-Byte	0	1	Yes	Yes	Yes	No
16-Bit	0	0	No	No	Yes	Yes
16-Bit	1	0	Yes	Yes	No	No
Byte	0	0	No	No	No	Yes
Byte	0	1	No	No	Yes	No
Byte	1	0	No	Yes	No	No
Byte	1	1	Yes	No	No	No

4000 tbl 03

**Table 2.3. Byte Addressing in Load/Store Operations**

The Load/Store instruction opcode determines the size of the data item to be loaded or stored as shown in Table 2.1. Regardless of access type or byte-numbering order (endian-ness), the address specifies the byte which has the smallest byte address of all bytes in the addressed field. For a big-endian access, this is the most significant byte; for a little-endian access, this is the least significant byte. Note that in an R3051 family system, the endianness of a given access is dynamic, in that the RE (Reverse Endianness) bit of the Status Register can be used to force user space accesses of the opposite byte convention of the kernel.

The bytes within the addressed word that are used can be determined directly from the access size and the two low-order bits of the address, as shown in Table 2.3. Note that certain combinations of access type and low-order address bits can never occur: only the combinations shown in Table 2.3 are permissible. The R3051 family indicates which bytes are being accessed by the byte-enable ( $\overline{BE}$ ) bus.

Table 2.4 shows the load/store instructions supported by the MIPS ISA.

Instruction	Format and Description
Load Byte	LB <i>rt</i> , <i>offset (base)</i> Sign-extend 16-bit <i>offset</i> and add to contents of register <i>base</i> to form address. Sign-extend contents of addressed byte and load into <i>rt</i> .
Load Byte Unsigned	LBU <i>rt</i> , <i>offset (base)</i> Sign-extend 16-bit <i>offset</i> and add to contents of register <i>base</i> to form address. Zero-extend contents of addressed byte and load into <i>rt</i> .
Load Halfword	LH <i>rt</i> , <i>offset (base)</i> Sign-extend 16-bit <i>offset</i> and add to contents of register <i>base</i> to form address. Sign-extend contents of addressed byte and load into <i>rt</i> .
Load Halfword Unsigned	LHU <i>rt</i> , <i>offset (base)</i> Sign-extend 16-bit <i>offset</i> and add to contents of register <i>base</i> to form address. Zero-extend contents of addressed byte and load into <i>rt</i> .
Load Word	LW <i>rt</i> , <i>offset (base)</i> Sign-extend 16-bit <i>offset</i> and add to contents of register <i>base</i> to form address. Load contents of addressed word into register <i>rt</i> .
Load Word Left	LWL <i>rt</i> , <i>offset (base)</i> Sign-extend 16-bit <i>offset</i> and add to contents of register <i>base</i> to form address. Shift addressed word left so that addressed byte is leftmost byte of a word. Merge bytes from memory with contents of register <i>rt</i> and load result into register <i>rt</i> .
Load Word Right	LWR <i>rt</i> , <i>offset (base)</i> Sign-extend 16-bit <i>offset</i> and add to contents of register <i>base</i> to form address. Shift addressed word right so that addressed byte is rightmost byte of a word. Merge bytes from memory with contents of register <i>rt</i> and load result into register <i>rt</i> .
Store Byte	SB <i>rt</i> , <i>offset (base)</i> Sign-extend 16-bit <i>offset</i> and add to contents of register <i>base</i> to form address. Store least significant byte of register <i>rt</i> at addressed location.
Store Halfword	SH <i>rt</i> , <i>offset (base)</i> Sign-extend 16-bit <i>offset</i> and add to contents of register <i>base</i> to form address. Store least significant halfword of register <i>rt</i> at addressed location.
Store Word	SW <i>rt</i> , <i>offset (base)</i> Sign-extend 16-bit <i>offset</i> and add to contents of register <i>base</i> to form address. Store least significant word of register <i>rt</i> at addressed location.
Store Word Left	SWL <i>rt</i> , <i>offset (base)</i> Sign-extend 16-bit <i>offset</i> and add to contents of register <i>base</i> to form address. Shift contents of register <i>rt</i> right so that leftmost byte of the word is in position of addressed byte. Store bytes containing original data into corresponding bytes at addressed byte.
Store Word Right	SWR <i>rt</i> , <i>offset (base)</i> Sign-extend 16-bit <i>offset</i> and add to contents of register <i>base</i> to form address. Shift contents of register <i>rt</i> left so that rightmost byte of the word is in position of addressed byte. Store bytes containing original data into corresponding bytes at addressed byte.

4000 tbl 04

Table 2.4. Load and Store Instructions

### Computational Instructions

**Computational** instructions perform arithmetic, logical and shift operations on values in registers. They occur in both R-type (both operands are registers) and I-type (one operand is a 16-bit immediate) formats. There are four categories of computational instructions:

- **ALU Immediate** instructions are summarized in Table 2.5a.
- **3-Operand Register-Type** instructions are summarized in Table 2.5b.
- **Shift** instructions are summarized in Table 2.5c.
- **Multiply/Divide** instructions are summarized in Table 2.5d.

Instruction	Format and Description
ADD Immediate	ADDI <i>rt, rs, immediate</i> Add 16-bit sign-extended <i>immediate</i> to register <i>rs</i> and place 32-bit result in register <i>rt</i> . Trap on two's complement overflow.
ADD Immediate Unsigned	ADDIU <i>rt, rs, immediate</i> Add 16-bit sign-extended <i>immediate</i> to register <i>rs</i> and place 32-bit result in register <i>rt</i> . Do not trap on overflow.
Set on Less Than Immediate	SLTI <i>rt, rs, immediate</i> Compare 16-bit sign-extended <i>immediate</i> with register <i>rs</i> as signed 32-bit integers. Result = 1 if <i>rs</i> is less than <i>immediate</i> ; otherwise result = 0. Place result in register <i>rt</i> .
Set on Less Than Unsigned Immediate	SLTIU <i>rt, rs, immediate</i> Compare 16-bit sign-extended <i>immediate</i> with register <i>rs</i> as unsigned 32-bit integers. Result = 1 if <i>rs</i> is less than <i>immediate</i> ; otherwise result = 0. Place result in register <i>rt</i> . Do not trap on overflow.
AND Immediate	ANDI <i>rt, rs, immediate</i> Zero-extend 16-bit <i>immediate</i> , AND with contents of register <i>rs</i> and place result in register <i>rt</i> .
OR Immediate	ORI <i>rt, rs, immediate</i> Zero-extend 16-bit <i>immediate</i> , OR with contents of register <i>rs</i> and place result in register <i>rt</i> .
Exclusive OR Immediate	XORI <i>rt, rs, immediate</i> Zero-extend 16-bit <i>immediate</i> , exclusive OR with contents of register <i>rs</i> and place result in register <i>rt</i> .
Load Upper Immediate	LUI <i>rt, immediate</i> Shift 16-bit <i>immediate</i> left 16 bits. Set least significant 16 bits of word to zeroes. Store result in register <i>rt</i> .

4000 tbl 05

**Table 2.5a. ALU Immediate Operations**

Instruction	Format and Description
Add	ADD <i>rd, rs, rt</i> Add contents of registers <i>rs</i> and <i>rt</i> and place 32-bit result in register <i>rd</i> . Trap on two's complement overflow.
ADD Unsigned	ADDU <i>rd, rs, rt</i> Add contents of registers <i>rs</i> and <i>rt</i> and place 32-bit result in register <i>rd</i> . Do not trap on overflow.
Subtract	SUB <i>rd, rs, rt</i> Subtract contents of registers <i>rt</i> and <i>rs</i> and place 32-bit result in register <i>rd</i> . Trap on two's complement overflow.
Subtract Unsigned	SUBU <i>rd, rs, rt</i> Subtract contents of registers <i>rt</i> and <i>rs</i> and place 32-bit result in register <i>rd</i> . Do not trap on overflow.
Set on Less Than	SLT <i>rd, rs, rt</i> Compare contents of register <i>rt</i> to register <i>rs</i> (as signed 32-bit integers). If register <i>rs</i> is less than <i>rt</i> , result = 1; otherwise, result = 0.
Set on Less Than Unsigned	SLTU <i>rd, rs, rt</i> Compare contents of register <i>rt</i> to register <i>rs</i> (as unsigned 32-bit integers). If register <i>rs</i> is less than <i>rt</i> , result = 1; otherwise, result = 0.
AND	AND <i>rd, rs, rt</i> Bit-wise AND contents of registers <i>rs</i> and <i>rt</i> and place result in register <i>rd</i> .
OR	OR <i>rd, rs, rt</i> Bit-wise OR contents of registers <i>rs</i> and <i>rt</i> and place result in register <i>rd</i> .
Exclusive OR	XOR <i>rd, rs, rt</i> Bit-wise Exclusive OR contents of registers <i>rs</i> and <i>rt</i> and place result in register <i>rd</i> .
NOR	NOR <i>rd, rs, rt</i> Bit-wise NOR contents of registers <i>rs</i> and <i>rt</i> and place result in register <i>rd</i> .

4000 tbl 06

**Table 2.5b. Three Operand Register-Type Operations**

Instruction	Format and Description
Shift Left Logical	SLL <i>rd, rt, shamt</i> Shift contents of register <i>rt</i> left by <i>shamt</i> bits, inserting zeroes into low order bits. Place 32-bit result in register <i>rd</i> .
Shift Right Logical	SRL <i>rd, rt, shamt</i> Shift contents of register <i>rt</i> right by <i>shamt</i> bits, inserting zeroes into high order bits. Place 32-bit result in register <i>rd</i> .
Shift Right Arithmetic	SRA <i>rd, rt, shamt</i> Shift contents of register <i>rt</i> right by <i>shamt</i> bits, sign-extending the high order bits. Place 32-bit result in register <i>rd</i> .
Shift Left Logical Variable	SLLV <i>rd, rt, rs</i> Shift contents of register <i>rt</i> left. Low-order 5 bits of register <i>rs</i> specify number of bits to shift. Insert zeroes into low order bits of <i>rt</i> and place 32-bit result in register <i>rd</i> .
Shift Right Logical Variable	SRLV <i>rd, rt, rs</i> Shift contents of register <i>rt</i> right. Low-order 5 bits of register <i>rs</i> specify number of bits to shift. Insert zeroes into high order bits of <i>rt</i> and place 32-bit result in register <i>rd</i> .
Shift Right Arithmetic Variable	SRAV <i>rd, rt, rs</i> Shift contents of register <i>rt</i> right. Low-order 5 bits of register <i>rs</i> specify number of bits to shift. Sign-extend the high order bits of <i>rt</i> and place 32-bit result in register <i>rd</i> .

4000 tbl 07

**Table 2.5c. Shift Operations**

Instruction	Format and Description
Multiply	MULT <i>rs, rt</i> Multiply contents of registers <i>rs</i> and <i>rt</i> as twos complement values. Place 64-bit result in special registers HI/LO
Multiply Unsigned	MULTU <i>rs, rt</i> Multiply contents of registers <i>rs</i> and <i>rt</i> as unsigned values. Place 64-bit result in special registers HI/LO
Divide	DIV <i>rs, rt</i> Divide contents of register <i>rs</i> by <i>rt</i> treating operands as twos complements values. Place 32-bit quotient in special register LO, and 32-bit remainder in HI.
Divide Unsigned	DIVU <i>rs, rt</i> Divide contents of register <i>rs</i> by <i>rt</i> treating operands as unsigned values. Place 32-bit quotient in special register LO, and 32-bit remainder in HI.
Move From HI	MFHI <i>rd</i> Move contents of special register HI to register <i>rd</i> .
Move From LO	MFLO <i>rd</i> Move contents of special register LO to register <i>rd</i> .
Move To HI	MTHI <i>rd</i> Move contents of special register <i>rd</i> to special register HI.
Move To LO	MTLO <i>rd</i> Move contents of register <i>rd</i> to special register LO.

4000 tbl 08

Table 2.5d. Multiply and Divide Operations

### Jump and Branch Instructions

**Jump and Branch** instructions change the control flow of a program. All Jump and Branch instructions occur with a one instruction delay: that is, the instruction immediately following the jump or branch is always executed while the target instruction is being fetched from storage, regardless of whether the branch is to be taken.

An assembler has several possibilities for utilizing the branch delay slot productively:

- It can insert an instruction that logically precedes the branch instruction in the delay slot since the instruction immediately following the jump/branch effectively belongs to the block preceding the transfer instruction.
- It can replicate the instruction that is the target of the branch/jump into the delay slot provided that no side-effects occur if the branch falls through.
- It can move an instruction up from below the branch into the delay slot, provided that no side-effects occur if the branch is taken.
- If no other instruction is available, it can insert a NOP instruction in the delay slot.

The J-type instruction format is used for both jumps and jump-and-links for subroutine calls. In this format, the 26-bit target address is shifted left two bits, and combined with high-order 4 bits of the current program counter to form a 32-bit absolute address.

The R-type instruction format which takes a 32-bit byte address contained in a register is used for returns, dispatches, and cross-page jumps.

Branches have 16-bit offsets relative to the program counter (I-type). Jump-and-Link and Branch-and-Link instructions save a return address in register 31.

Table 2.6a summarizes the Jump instructions and Table 2.6b summarizes the Branch instructions.

Instruction	Format and Description
Jump	J target Shift 26-bit target address left two bits, combine with high-order 4 bits of PC and jump to address with a one instruction delay.
Jump and Link	JAL target Shift 26-bit target address left two bits, combine with high-order 4 bits of PC and jump to address with a one instruction delay. Place address of instruction following delay slot in r31 (link register).
Jump Register	JR <i>rs</i> Jump to address contained in register <i>rs</i> with a one instruction delay.
Jump and Link Register	JALR <i>rs, rd</i> Jump to address contained in register <i>rs</i> with a one instruction delay. Place address of instruction following delay slot in <i>rd</i> .

4000 tbl 09

Table 2.6a. Jump Instructions

Instruction	Format and Description
	<b>Branch Target:</b> All Branch instruction target addresses are computed as follows: Add address of instruction in delay slot and the 16-bit offset (shifted left two bits and sign-extended to 32 bits). All branches occur with a delay of one instruction.
Branch on Equal	BEQ <i>rs, rt, offset</i> Branch to target address if register <i>rs</i> equal to <i>rt</i>
Branch on Not Equal	BNE <i>rs, rt, offset</i> Branch to target address if register <i>rs</i> not equal to <i>rt</i> .
Branch on Less than or Equal Zero	BLEZ <i>rs, offset</i> Branch to target address if register <i>rs</i> less than or equal to 0.
Branch on Greater Than Zero	BGTZ <i>rs, offset</i> Branch to target address if register <i>rs</i> greater than 0.
Branch on Less Than Zero	BLTZ <i>rs, offset</i> Branch to target address if register <i>rs</i> less than 0.
Branch on Greater than or Equal Zero	BGEZ <i>rs, offset</i> Branch to target address if register <i>rs</i> greater than or equal to 0.
Branch on Less Than Zero And Link	BLTZAL <i>rs, offset</i> Place address of instruction following delay slot in register r31 (link register). Branch to target address if register <i>rs</i> less than 0.
Branch on greater than or Equal Zero And Link	BGEZAL <i>rs, offset</i> Place address of instruction following delay slot in register r31 (link register). Branch to target address if register <i>rs</i> is greater than or equal to 0.

4000 tbl 10

Table 2.6b. Branch Instructions

### Special Instructions

The two **Special** instructions let software initiate traps. They are always R-type. Table 2.7 summarizes the Special instructions.

Instruction	Format and Description
System Call	SYSCALL Initiates system call trap, immediately transferring control to exception handler.
Breakpoint	BREAK Initiates breakpoint trap, immediately transferring control to exception handler.

4000 tbl 11

Table 2.7. Special Instructions

### Co-processor Instructions

**Co-processor** instructions perform operations in the co-processors. Co-processor Loads and Stores are I-type. Co-processor computational instructions have co-processor-dependent formats; Chapter 3 discusses the operation of the on-chip Floating Point Accelerator, which is Co-Processor 1.

The R3051 family may use certain co-processor instructions to utilize the BrCond inputs. Specifically, the BCzT/F instructions are used to test the state of the BrCond inputs. Other operations to CP2 and CP3 have undefined results.

A special set of co-processor operations are used to manage the on-chip system control co-processor, CP0.

Table 2.8 summarizes the Co-processor Instruction Set of the MIPS ISA.

Instruction	Format and Description
Load Word to Co-processor	LWCz <i>rt, offset (base)</i> Sign-extend 16-bit <i>offset</i> and add to <i>base</i> to form address. Load contents of addressed word into co-processor register <i>rt</i> of co-processor unit <i>z</i> .
Store Word from Co-processor	SWCz <i>rt, offset (base)</i> Sign-extend 16-bit <i>offset</i> and add to <i>base</i> to form address. Store contents of co-processor register <i>rt</i> from co-processor unit <i>z</i> at addressed memory word.
Move To Co-processor	MTCz <i>rt, rd</i> Move contents of CPU register <i>rt</i> into co-processor register <i>rd</i> of co-processor unit <i>z</i> .
Move from Co-processor	MFCz <i>rt, rd</i> Move contents of co-processor register <i>rd</i> from co-processor unit <i>z</i> to CPU register <i>rt</i> .
Move Control To Co-processor	CTCz <i>rt, rd</i> Move contents of CPU register <i>rt</i> into co-processor control register <i>rd</i> of co-processor unit <i>z</i> .
Move Control From Co-processor	CFCz <i>rt, rd</i> Move contents of control register <i>rd</i> of co-processor unit <i>z</i> into CPU register <i>rt</i> .
Co-processor Operation	COPz <i>cofun</i> Co-processor <i>z</i> performs an operation. The state of the R3051/52 is not modified by a co-processor operation.
Branch on Co-processor <i>z</i> True	BCzT <i>offset</i> Compute a branch target address by adding address of instruction in the 16-bit <i>offset</i> (shifted left two bits and sign-extended to 32-bits). Branch to the target address (with a delay of one instruction) if co-processor <i>z</i> 's condition line is true.
Branch on Co-processor <i>z</i> False	BCzF <i>offset</i> Compute a branch target address by adding address of instruction in the 16-bit <i>offset</i> (shifted left two bits and sign-extended to 32-bits). Branch to the target address (with a delay of one instruction) if co-processor <i>z</i> 's condition line is false.

4000 tbl 12

Table 2.8. Co-Processor Operations



### System Control Co-processor (CPO) Instructions

**Co-processor 0** instructions perform operations on the System Control Co-processor (CPO) registers to manipulate the memory management and exception handling facilities of the processor. Memory Management is discussed in chapter 5; exception handling is covered in detail in chapter 6.

Table 2.9 summarizes the instructions available to work with CPO.

Instruction	Format and Description
Move To CPO	MTCO <i>rt, rd</i> Store contents of CPU register <i>rt</i> into register <i>rd</i> of CPO. This follows the convention of store operations.
Move From CPO	MFCO <i>rt, rd</i> Load CPU register <i>rt</i> with contents of CPO register <i>rd</i> .
Read Indexed TLB Entry	TLBR Load <i>EntryHi</i> and <i>EntryLo</i> registers with TLB entry pointed at by <i>Index</i> register.
Write Indexed TLB Entry	TLBWI Load TLB entry pointed at by <i>Index</i> register with contents of <i>EntryHi</i> and <i>EntryLo</i> registers.
Write Random TLB Entry	TLBWR Load TLB entry pointed at by <i>Random</i> register with contents of <i>EntryHi</i> and <i>EntryLo</i> registers.
Probe TLB for Matching Entry	TLBP Load <i>Index</i> register with address of TLB entry whose contents match <i>EntryHi</i> and <i>EntryLo</i> . If no TLB entry matches, set high-order bit of <i>Index</i> register.
Restore From Exception	RFE Restore previous interrupt mask and mode bits of <i>status</i> register into current status bits. Restore old status bits into previous status bits.

4000 tbl 13

**Table 2.9. System Control Co-Processor (CPO) Operations**

### OPCODE ENCODING

Table 2.10 shows the opcode encoding for the R3051 family.

28..26		OPCODE						
31..29	0	1	2	3	4	5	6	7
0	SPECIAL	BCOND	J	JAL	BEQ	BNE	BLEZ	BGTZ
1	ADDI	ADDIU	SLTI	SLTIU	ANDI	ORI	XORI	LUI
2	COP0	COP1	COP2	COP3	†	†	†	†
3	†	†	†	†	†	†	†	†
4	LB	LH	LWL	LW	LBU	LHU	LWR	†
5	SB	SH	SWL	SW	†	†	SWR	†
6	LWC0	LWC1	LWC2	LWC3	†	†	†	†
7	SWC0	SWC1	SWC2	SWC3	†	†	†	†

2..0		SPECIAL						
5..3	0	1	2	3	4	5	6	7
0	SLL	†	SRL	SRA	SLLV	†	SRLV	SRAV
1	JR	JALR	†	†	SYSCALL	BREAK	†	†
2	MFHI	MTHI	MFLO	MTLO	†	†	†	†
3	MULT	MULTU	DIV	DIVU	†	†	†	†
4	ADD	ADDU	SUB	SUBU	AND	OR	XOR	NOR
5	†	†	SLT	SLTU	†	†	†	†
6	†	†	†	†	†	†	†	†
7	†	†	†	†	†	†	†	†

18..16		BCOND						
20..19	0	1	2	3	4	5	6	7
0	BLTZ	BGEZ						
1								
2	BLTZAL	BGEZAL						
3								
4								

23..21		COPz						
25..24	0	1	2	3	4	5	6	7
0	MF		CF		MT		CT	
1	BC	†	†	†	†	†	†	†
2	<b>Co-Processor Specific</b>							
3	<b>Operations</b>							

18..16		BCzT						
20..19	0	1	2	3	4	5	6	7
0	BCzF	BCzT						
1								
2								
3								

2..0		CPO						
4..3	0	1	2	3	4	5	6	7
0		TLBR	TLBWI				TLBWR	
1	TLBP							
2	RFE							
3								

4000 tbl 14

Table 2.10. Opcode Encoding





## INTRODUCTION

The R3081 family contains an on-chip Floating-Point Accelerator (FPA), which operates as a coprocessor for the R3000A integer processor and extends the instruction set to perform arithmetic operations on values in floating-point representations. The FPA, with associated system software, fully conforms to the requirements of ANSI/IEEE Standard 754-1985, "IEEE Standard for Binary Floating-Point Arithmetic." In addition, the MIPS architecture fully supports the standard's recommendations. Figure 3.1 illustrates the functional organization of the FPA.

## FPA FEATURES

- **Full 64-bit Operation.** The FPA contains sixteen, 64-bit registers that can each be used to hold single-precision or double-precision values. The FPA also includes a 32-bit status/control register that provides access to all IEEE-Standard exception handling capabilities.
- **Load/Store Instruction Set.** Like the Integer Processor, the FPA uses a load/store-oriented instruction set, with single-cycle loads and stores. Floating-point operations are started in a single cycle and their execution is overlapped with other fixed point or floating-point operations.
- **Tightly-coupled Coprocessor Interface.** The FPA connects with the Integer Processor to form a tightly-coupled unit with a seamless integration of floating-point and fixed-point instruction sets. Since each unit receives and executes instructions in parallel, some floating-point instructions can execute at the same single-cycle per instruction rate as fixed point-instructions.

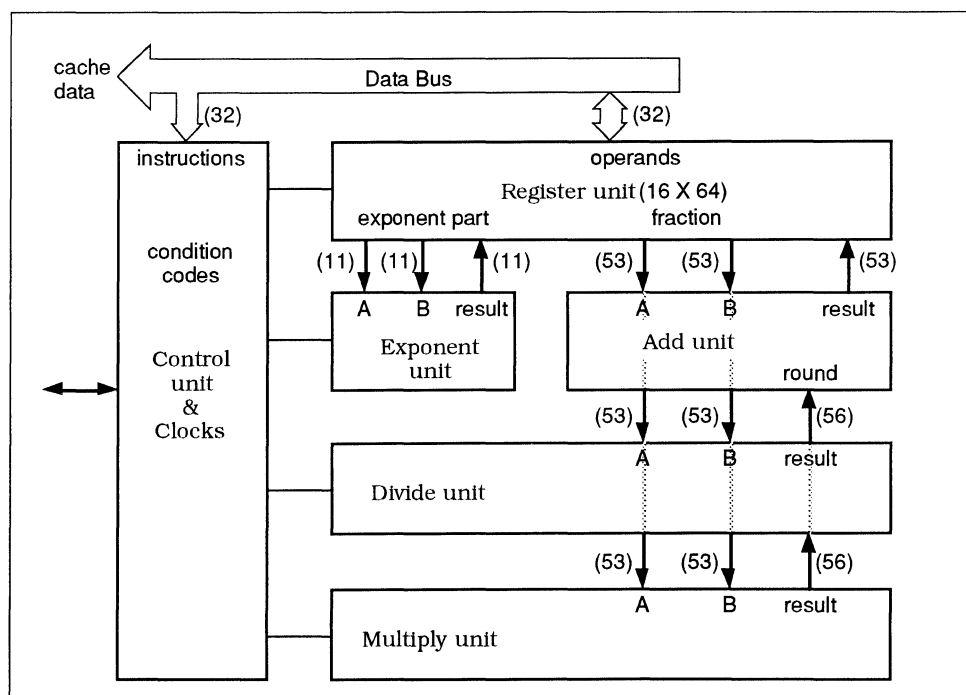

Figure 3.1. On-Chip FPA Functional Block Diagram

## FPA PROGRAMMING MODEL

This section describes the organization of data in registers and in memory and the set of general registers available. This section also gives a summary description of all the FPA registers

The FPA provides three types of registers as shown in Figure 3.2:

- Floating-Point General-Purpose Registers (FGR)
- Floating-Point Registers (FPR)
- Floating-Point Control Registers (FCR)

*Floating-Point General Registers (FGR)* are directly addressable, physical registers. The FPA provides thirty-two 32-bit FGRs.

*Floating-Point Registers (FPR)* are logical registers used to store data values during floating-point operations. Each of the 16 FPRs is 64 bits wide and is formed by concatenating two adjacent FGRs. Depending on the requirements of an operation, FPRs hold either single- or double-precision floating-point values.

*Floating-Point Control Registers (FCR)* are used for rounding mode control, exception handling, and state saving. The FCRs include the Control/Status register and the Implementation/Revision register.

### Floating-Point General Registers

The 32 Floating-Point General Registers (FGRs) on the FPA are directly addressable 32-bit registers used in floating point operations and individually accessible via move, load, and store instructions. The FGRs are listed in Table 3.1, and the Floating Point Registers (FPRs) that are logically formed by the general registers are described in the section that follows.

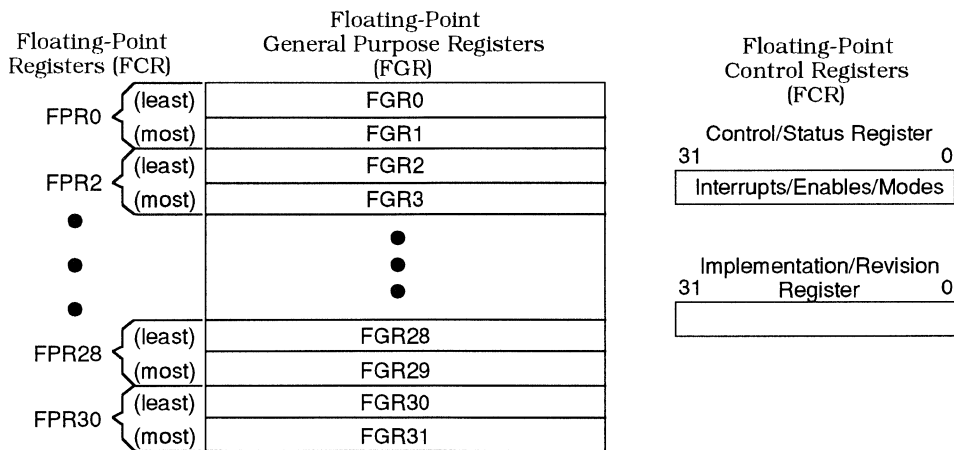

Figure 3.2. FPA Registers

### Floating-Point Registers

The FPA produces 16 Floating-Point Registers (FPR). These logical 64-bit registers hold floating-point values during floating-point operations and are physically formed from the General-Purpose Registers (FGR).

The FPRs hold values in either single- or double-precision floating-point format. Only even numbers are used to address FPRs: odd FPR register numbers are invalid. During single-precision floating-point operations, only the even-numbered (least) general registers are used, and during double-precision floating-point operations, the general registers are accessed in double pairs. Thus, in a double-precision operation, selecting Floating-Point Register 0 (FPR0) addresses adjacent Floating-Point General-Purpose Registers FGR0 and FGR1.

FGR Number	Usage
0	FPR 0 (least)
1	FPR 0 (most)
2	FPR 2 (least)
3	FPR 2 (most)
•	•
•	•
•	•
28	FPR 28 (least)
29	FPR 28 (most)
30	FPR 30 (least)
31	FPR 30 (most)

Table 3.1. Floating Point General Registers

**Floating-Point Control Registers**

MIPS coprocessors can have as many as 32 control registers. The FPA coprocessor implements two Floating-Point Control Registers (FCRs). These registers can be accessed only by Move operations and contain the following:

- The *Control/Status Register* (FCR31), is used to control and monitor exceptions, hold result of compare operations, and establish rounding modes; and
- The *Implementation/Revision Register* (FCR0), holds revision information about the FPA.

**Control/Status Register (Read and Write)**

The Control/Status Register, FCR31, contains control and status data and can be accessed by instructions running in either Kernel or User mode. It controls the arithmetic rounding mode and the enabling of exceptions. It also indicates exceptions that occurred in the most recently executed instruction, and all exceptions that have occurred since the register was cleared. Figure 3.3 shows the bit assignments.

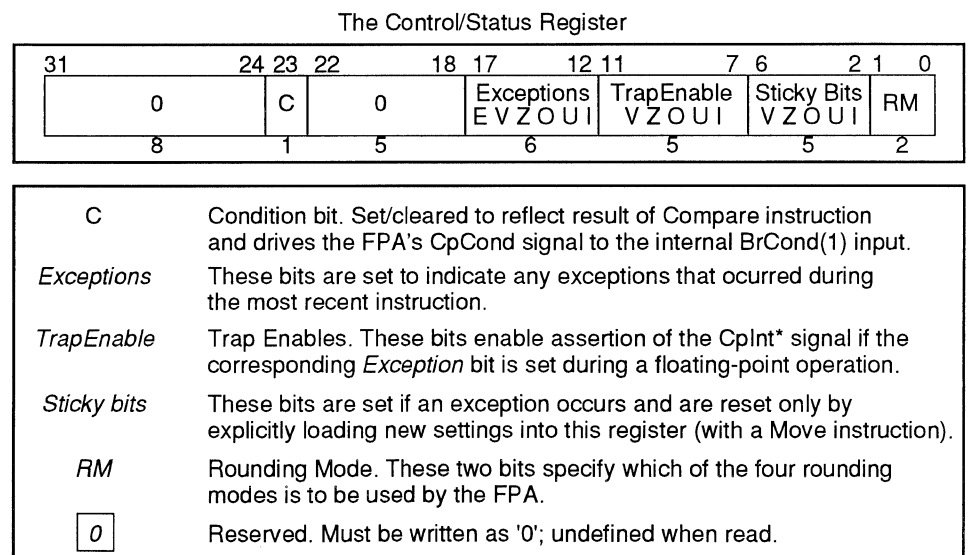

Figure 3.3. Control/Status Register Bit Assignments

When the Control/Status Register is read using a *Move Control From Coprocessor 1* (CFC1) instruction, all unfinished instructions in the pipeline are completed before the contents of the register are moved to the main processor. If a floating-point exception occurs as the pipeline empties, the exception is taken and the CFC1 instruction can be re-executed after the exception is serviced.

The bits in the Control/Status Register can be set or cleared by writing to the register using a *Move Control To Coprocessor 1* (CTC1) instruction. This register must only be written to when the FPA is not actively executing floating-point operations: this can be assured by first reading the contents of the register to empty the pipeline.

### Control/Status Register Condition Bit

Bit 23 of the Control/Status Register is the *Condition* bit. When a floating-point *Compare* operation takes place, the detected condition is placed at bit 23, so that the state of the condition line may be saved or restored. The “C” bit is set (1) if the condition is true and cleared (0) if the condition is false. Bit 23 is affected only by *Compare* and *Move Control To FPA* instructions.

### Control/Status Register Exception Bits

Bits 17:12 in the Control/Status Register contain *Exception* bits as shown in Figure 3.4 that reflect the results of the most recently executed instruction. These bits are appropriately set or cleared after each floating-point operation. Exception bits are set for instructions that cause one of the five IEEE standard exceptions or the Unimplemented Operation exception.

If two exceptions occur together in one instruction, both of the appropriate bits in the exception bit field will be set. When an exception occurs, both the corresponding *Exception* and *Sticky* bits are set. Refer to **Chapter 6, Exceptions**, for a complete description of floating-point exceptions.

The Unimplemented Operation exception is not one of the standard IEEE-defined floating-point exceptions. It is provided to permit software implementation of IEEE standard operations and exceptions that are not fully supported by the FPA. Note that trapping on this exception cannot be disabled: there is no *TrapEnable* bit for E.

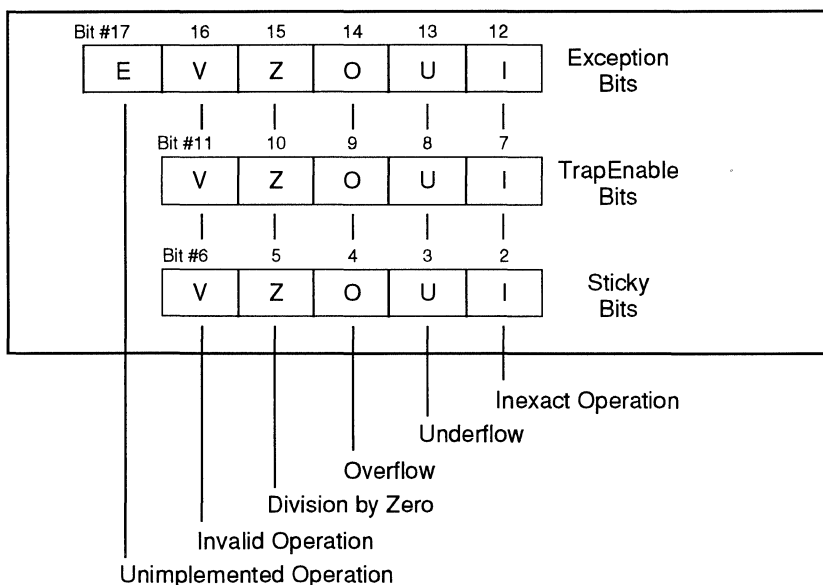

Figure 3.4. Control/Status Register Exception/Sticky/Trap Enable Bits

**Control/Status Register Sticky Bits**

The *Sticky* bits shown in Figure 3.4 hold the accumulated or accrued exception bits required by the IEEE standard for *trap disabled* operation. These bits are set whenever an FPA operation result causes one of the corresponding *Exception* bits to be set. However, unlike the *Exception* bits, the *Sticky* bits are never cleared as a side-effect of floating-point operations; they can be cleared only by writing a new value into the Control/Status Register, using the *Move Control To Coprocessor 1 (CTC1)* instruction.

**Control/Status Register TrapEnable Bits**

The *TrapEnable* bits shown in Figure 3.4 are used to enable a user trap when an exception occurs during a floating-point operation. If the *TrapEnable* bit corresponding to the exception is set it causes assertion of the FPA's  $\overline{FpInt}$  signal. The processor responds to the  $\overline{FpInt}$  signal by taking an interrupt exception which can then be used to implement trap handling of the FPA exception.

**Control/Status Register Rounding Mode Control Bits**

Bits 1 and 0 in the Control/Status Register comprise the Rounding Mode (*RM*) field. These bits specify the rounding mode that the FPA will use for all floating-point operations as shown in Table 3.2.

RM Bits	Mnemonic	Rounding Mode Description
00	RN	Rounds result to nearest representable value; round to value with least significant bit zero when the two nearest representable values are equally near.
01	RZ	Rounds result toward zero; round to value closest to and not greater in magnitude than the infinitely precise result.
10	RP	Rounds toward $+\infty$ ; round to value closest to and not less than the infinitely precise result.
11	RM	Rounds toward $-\infty$ ; round to value closest to and not greater than the infinitely precise result.

Table 3.2. Rounding Mode Bit Decoding

**Implementation and Revision Register (Read Only)**

The FPA control register zero (FCR0) contains values that define the implementation and revision number of the FPA. This information can be used to determine the coprocessor revision and performance level and can also be used by diagnostic software.

Only the low-order bytes of the implementation and revision register are defined. Bits 15 through 8 identify the implementation and bits 7 through 0 identify the revision number as shown in Figure 3.5.

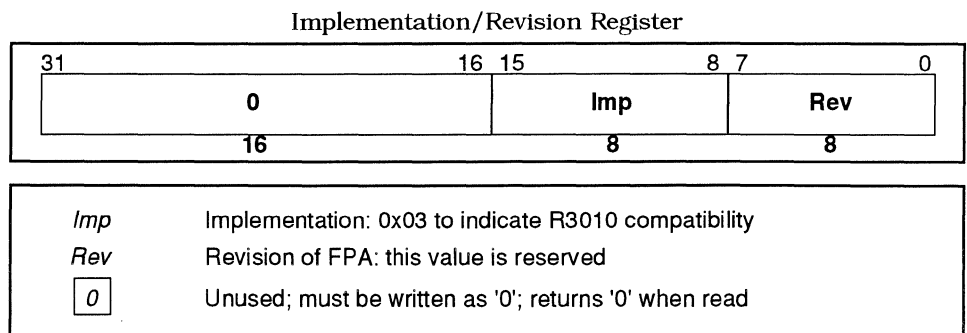

Figure 3.5. Implementation/Revision Register



## FLOATING-POINT FORMATS

The FPA performs both 32-bit (single-precision) and 64-bit (double-precision) IEEE standard floating-point operations. The 32-bit format has a 24-bit signed-magnitude fraction field and an 8-bit exponent, as shown in Figure 3.6.

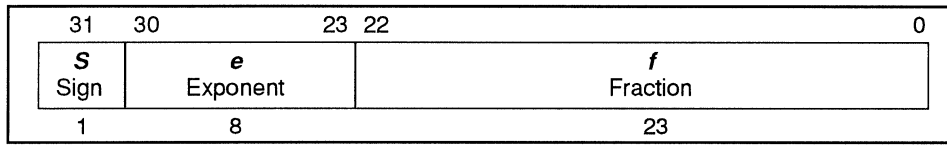

Figure 3.6. Single Precision Floating Point Format

The 64-bit format has a 53-bit signed-magnitude fraction field and an 11-bit exponent, as shown in Figure 3.7.

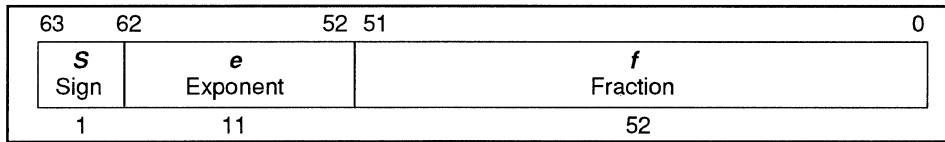

Figure 3.7. Double Precision Floating Point Format

Numbers in the single-precision and double-precision floating-point formats (extended and quad formats are not supported by the FPA) are composed of three fields:

- A 1-bit sign:  $s$ ,
- A biased exponent:  $e = E + bias$ , and
- A fraction:  $f = .b_1b_2 \dots bp_{-1}$

The range of the unbiased exponent  $E$  includes every integer between two values  $E_{min}$  and  $E_{max}$  inclusive, and also two other reserved values:  $E_{min} - 1$  to encode  $\pm 0$  and denormalized numbers, and  $E_{max} + 1$  to encode  $\pm \infty$  and NaNs (Not a Number). For single- and double-precision formats, each representable non-zero numerical value has just one encoding.

For single- and double-precision formats, the value of a number,  $v$ , is determined by the equations shown in Table 3.3

(1)	if $E = E_{max} + 1$ and $f \neq 0$ , then $v$ is NaN, regardless of $s$ .
(2)	if $E = E_{max} + 1$ and $f = 0$ , then $v = (-1)^s \infty$ .
(3)	if $E_{min} \leq E \leq E_{max}$ , then $v = (-1)^s 2^E(1.f)$ .
(4)	if $E = E_{min} - 1$ and $f \neq 0$ , then $v = (-1)^s 2^{E_{min}}(0.f)$ .
(5)	if $E = E_{min} - 1$ and $f = 0$ , then $v = (-1)^s 0$ .

Table 3.3. Equations for Calculating Values in Floating-Point Format

For all floating-point formats, if  $v$  is NaN, the most significant bit of  $f$  determines whether the value is a signaling or quiet NaN.  $v$  is a signaling NaN if the most significant bit of  $f$  is set; otherwise  $v$  is a quiet NaN.

Table 3.4 defines the values for the format parameters in the preceding description.

Parameter	Single	Double
P	24	53
$E_{\max}$	+127	+1023
$E_{\min}$	-126	-1022
exponent bias	+127	+1023
exponent width in bits	8	11
integer bit	hidden	hidden
fraction width in bits	23	52
format width in bits	32	64

Table 3.4. Floating Point Parameter Values

## NUMBER DEFINITIONS

This subsection contains a definition of the following number types specified in the IEEE 754 standard:

- Normalized Numbers
- Denormalized Numbers
- Infinity
- Zero

For more information, refer to the *ANSI/IEEE Std. 754-1985 IEEE Standard for Binary Floating-Point Arithmetic*.

### Normalized Numbers

Most floating-point calculations are performed on normalized numbers. For single-precision operations, normalized numbers have a biased exponent that ranges from 1 to 254 (-126 to +127 unbiased) and a normalized fraction field, meaning that the leftmost, or hidden, bit is one. In decimal notation, this allows representation of a range of positive and negative numbers from approximately  $10^{38}$  to  $10^{-38}$ , with accuracy to 7 decimal places.

### Denormalized Numbers

Denormalized numbers have a zero exponent and a denormalized (hidden bit equal to zero) non-zero fraction field.

### Infinity

Infinity has an exponent of all ones and a fraction field equal to zero. Both positive and negative infinity are supported.

### Zero

Zero has an exponent of zero, a hidden bit equal to zero, and a value of zero in the fraction field. Both +0 and -0 are supported.

## COPROCESSOR OPERATION

The FPA continually monitors the Integer Processor instruction stream. If an instruction does not apply to the coprocessor, it is ignored; if an instruction does apply to the coprocessor, the FPA executes that instruction and transfers necessary result and exception data synchronously to the main processor.

The FPA performs three types of operations:

- Loads and Stores;
- Moves;
- Two- and three-register floating-point operations.

### Load, Store, and Move Operations

Load, Store, and Move operations move data between memory or the Integer Processor registers and the FPA registers. These operations perform no format conversions and cause no floating-point exceptions. Load, Store, and Move operations reference a single 32-bit word of either the Floating-Point General Registers (FGR) or the Floating-Point Control Registers (FCR).

### Floating-Point Operations

The FPA supports the following single- and double-precision format floating-point operations:

- Add
- Subtract
- Multiply
- Divide
- Absolute Value
- Move
- Negate
- Compare

In addition, the FPA supports conversion between single- and double-precision floating-point formats and fixed-point formats.

### Exceptions

The FPA supports all five IEEE standard exceptions:

- Invalid Operation
- Inexact Operation
- Division by Zero
- Overflow
- Underflow

The FPA also supports the optional, Unimplemented Operation exception that allows unimplemented instructions to trap to software emulation routines.

## INSTRUCTION SET OVERVIEW

All FPA instructions are 32 bits long and they can be divided into the following groups:

- **Load/Store and Move** instructions move data between memory, the main processor and the FPA general registers.
- **Computational** instructions perform arithmetic operations on floating point values in the FPA registers.
- **Conversion** instructions perform conversion operations between the various data formats.
- **Compare** instructions perform comparisons of the contents of registers and set a condition bit based on the results.

Table 3.5 lists the instruction set of the FPA.

OP	Description	OP	Description
	Load/Store/Move Instructions		Computational Instructions
LWC1	Load Word to FPA	ADD.fmt	Floating-point Add
SWC1	Store Word from FPA	SUB.fmt	Floating-point Subtract
MTC1	Move word to FPA	MUL.fmt	Floating-point Multiply
MFC1	Move word from FPA	DIV.fmt	Floating-point Divide
CTC1	Move Control word to FPA	ABS.fmt	Floating-point Absolute value
CFC1	Move Control word from FPA	MOV.fmt	Floating-point Move
	Conversion Instructions	NEG.fmt	Floating-point Negate
CVT.S.fmt	Floating-point Convert to Single FP		Compare Instructions
CVT.D.fmt	Floating-point Convert to Double FP	C.cond.fmt	Floating-point Compare
CVT.W.fmt	Floating-point Convert to fixed-point		

Table 3.5. Floating Point Instruction Summary

## INSTRUCTION SET SUMMARY

The floating point instructions supported by the FPA are all implemented using the coprocessor unit 1 (CP1) operation instructions of the Processor instruction set. The basic operations performed by the FPA are:

- Load and store operations from/to the FPA registers
- Moves between FPA and CPU registers
- Computational operations including floatation-point add, subtract, multiply, divide, and convert instructions
- Floating point comparisons

### Load, Store, and Move Instructions

All movement of data between the FPA and memory is accomplished by load word to coprocessor 1 (LWC1) and store word to coprocessor 1 (SWC1) instructions which reference a single 32-bit word of the FPA's general registers. These loads and stores are unformatted; no format conversions are performed and therefore no floating-point exceptions occur due to these operations.

Data may also be directly moved between the FPA and the Integer Processor by *move to coprocessor 1* (MTC1) and *move from coprocessor 1* (MFC1) instructions. Like the floating-point load and store operations, these operations perform no format conversions and never cause floating-point exceptions.

The *load* and *move to* operations have a latency of one instruction. That is, the data being loaded from memory or the CPU into an FPA register is not available to the instruction that immediately follows the load instruction: the data is available to the second instruction after the load instruction.

### Floating Point Computational Instructions

Computational instructions perform arithmetic operations on floating-point values in registers. There are four categories of computational instructions summarized in Table 3.7:

- **3-Operand Register-Type** instructions that perform floating point addition, subtraction, multiplication, and division operations
- **2-Operand Register-Type** instructions that perform floating point absolute value, move, and negate operations
- **Convert** instructions that perform conversions between the various data formats
- **Compare** instructions that perform comparisons of the contents of two registers and set or clear a condition signal based on the result of the comparison.

In the instruction formats shown in Table 3.7, the *fmt* term appended to the instruction op code is the data format specifier: *s* specifies Single-precision binary floating-point, *d* specifies Double-precision binary floating-point, and *w* specifies binary fixed-point. For example, an **ADD.d** specifies that the operands for the addition operation are double-precision binary floating-point values. NOTE: when *fmt* is single-precision or binary fixed point, the odd register of the destination is undefined.

<b>Instruction</b>	<b>Format and Description</b>
Load Word to FPA (coprocessor 1)	<i>LWC1 ft,offset(base)</i> Sign-extend 16-bit <i>offset</i> and add to contents of CPU register <i>base</i> to form address. Load contents of addressed word into FPA general register <i>ft</i> .
Store Word from FPA (coprocessor 1)	<i>SWC1 ft,offset(base)</i> Sign-extend 16-bit <i>offset</i> and add to contents of CPU register <i>base</i> to form address. Store 32-bit contents of FPA general register <i>ft</i> at addressed location
Move Word to FPA (coprocessor 1)	<i>MTC1 rt,fs</i> Move contents of CPU general register <i>rt</i> into FPA register <i>fs</i> .
Move Word from FPA (coprocessor 1)	<i>MFC1 rt,fs</i> Move contents of FPA general register <i>fs</i> into CPU register <i>rt</i> .
Move Control Word to FPA (coprocessor 1)	<i>CTC rt,fs</i> Move contents of CPU register <i>rt</i> into FPA control register <i>fs</i> .
Move Control Word from FPA (coprocessor 1)	<i>CFC1, rt,fs</i> Move contents of FPA control register <i>fs</i> into CPU register <i>rt</i> .

Table 3.6. Floating Point Load, Store, and Move Instruction Summary

Instruction	Format and Description
Floating-point Add	<i>ADD.fmt fd,fs,ft</i> Interpret contents of FPA registers <i>fs</i> and <i>ft</i> in specified format ( <i>fmt</i> ) and add arithmetically. Place rounded result in FPA register <i>fd</i> .
Floating-point Subtract	<i>SUB.fmt fd,fs,ft</i> Interpret contents of FPA registers <i>fs</i> and <i>ft</i> in specified format ( <i>fmt</i> ) and arithmetically subtract <i>ft</i> from <i>fs</i> . Place result in FPA register <i>fd</i> .
Floating-point Multiply	<i>MUL.fmt fd,fs,ft</i> Interpret contents of FPA registers <i>fs</i> and <i>ft</i> in specified format ( <i>fmt</i> ) and arithmetically multiply <i>ft</i> and <i>fs</i> . Place result in FPA register <i>fd</i> .
Floating-point Divide	<i>DIV.fmt fd,fs,ft</i> Interpret contents of FPA registers <i>fs</i> and <i>ft</i> in specified format ( <i>fmt</i> ) and arithmetically divide <i>fs</i> by <i>ft</i> . Place rounded result in register <i>fd</i> .
Floating-point Absolute Value	<i>ABS.fmt fd,fs</i> Interpret contents of FPA register <i>fs</i> in specified format ( <i>fmt</i> ) and take arithmetic absolute value. Place result in FPA register <i>fd</i> .
Floating-point Move	<i>Move.fmt fd,fs</i> Interpret contents of FPA register <i>fs</i> in specified format ( <i>fmt</i> ) and copy into FPA register <i>fd</i> .
Floating-point Negate	<i>NEG.fmt fd,fs</i> Interpret contents of FPA register <i>fs</i> in specified format ( <i>fmt</i> ) and take arithmetic negation. Place result in FPA register <i>fd</i> .
Floating-point Convert to Single FP Format	<i>CVT.S.fmt fd,fs</i> Interpret contents of FPA register <i>fs</i> in specified format ( <i>fmt</i> ) and arithmetically convert to the single binary floating point format. Place rounded result in FPA register <i>fd</i> .
Floating-point Convert to Double FP Format	<i>CVT.D.fmt fd,fs</i> Interpret contents of FPA register <i>fs</i> in specified format ( <i>fmt</i> ) and arithmetically convert to the double binary floating point format. Place rounded result in FPA register <i>fd</i> .
Floating-point Convert to Single Fixed-Point Format	<i>CVT.W.fmt fd,fs</i> Interpret contents of FPA register <i>fs</i> in specified format ( <i>fmt</i> ) and arithmetically convert to the single fixed-point format. Place result in FPA register <i>fd</i> .
Floating-point Compare	<i>C.cond.fmt fs,ft</i> Interpret contents of FPA registers <i>fs</i> , and <i>ft</i> in specified format ( <i>fmt</i> ) and arithmetically compare. The result is determined by the comparison and the specified condition ( <i>cond</i> ). After a one instruction delay, the condition is available for testing by the with the <i>branch on floating-point coprocessor condition (BC1T, BC1F)</i> instructions.

Table 3.7. Floating Point Computational Instruction Summary

**Floating Point Relational Operations**

The Floating-point compare (*C,fmt,cond*) instructions interpret the contents of two FPA registers in the specified format (*fmt*) and arithmetically compares them. A result is determined based on the comparison and conditions (*cond*) specified in the instruction. Table 3.8 lists the conditions that can be specified for the Compare instruction and Table 3.9 summarizes the floating-point relational operations that are performed.

Table 3.9 is derived from the similar table in the IEEE floating point standard and describes the 26 predicates named in the standard. The table includes six additional predicates (for a total of 32) to round out the set of possible predicates based on the conditions tested by a comparison. Four mutually exclusive relations are possible: less than, equal, greater than, and unordered. Note that invalid operation exceptions occur only when comparisons include the *less than* (<) or *greater than* (>) characters but not the *unordered* (?) character in the ad hoc form of the predicate.

<b>Mnemonic</b>	<b>Definition</b>	<b>Mnemonic</b>	<b>Definition</b>
<b>F</b>	False	<b>T</b>	True
<b>UN</b>	Unordered	<b>OR</b>	Ordered
<b>EQ</b>	Equal	<b>NEQ</b>	Not Equal
<b>UEQ</b>	Unordered or Equal	<b>OLG</b>	Ordered or Less than or Greater than
<b>OLT</b>	Ordered Less Than	<b>UGE</b>	Unordered or Greater than or Equal
<b>ULT</b>	Unordered or Less Than	<b>OGE</b>	Ordered Greater Than
<b>OLE</b>	Ordered Less than or Equal	<b>UGT</b>	Unordered or Greater Than
<b>ULE</b>	Unordered or Less than or Equal	<b>OGT</b>	Ordered Greater Than
<b>SF</b>	Signaling False	<b>ST</b>	Signal True
<b>NGLE</b>	Not Greater than or Less than or Equal	<b>GLE</b>	Greater than, or Less than or Equal
<b>SEQ</b>	Signaling Equal	<b>SNE</b>	Signaling Not Equal
<b>NGL</b>	Not Greater than or Less than	<b>GL</b>	Greater Than or Less Than
<b>LT</b>	Less Than	<b>NLT</b>	Not Less Than
<b>NGE</b>	Not Greater then or Equal	<b>GE</b>	Greater Than or Equal
<b>LE</b>	Less than or Equal	<b>NLE</b>	Not Less Than or Equal
<b>NGT</b>	Not Greater Than	<b>GT</b>	Greater Than

**Table 3.8. Relationship Mnemonic Definitions**



PREDICATES			RELATIONS				Invalid Operation Exception if Unordered
Condition Mnemonic	ad hoc	FORTTRAN	Greater Than	Less Than	Equal	Un-ordered	
F	false		F	F	F	F	no
UN	?		F	F	F	T	no
EQ	=	.EQ.	F	F	T	F	no
UEQ	?=	.UE.	F	F	T	T	no
OLT	NOT(?>=)	.NOT. .UG.	F	T	F	F	no
ULT	?<	.UL.	F	T	F	T	no
OLE	NOT(?>)	.NOT. .UG.	F	T	T	F	no
ULE	?<=	.ULE.	F	T	T	T	no
OGT	NOT(?<=)	.NOT. .ULE.	T	F	F	F	no
UGT	?>	.UGT.	T	F	F	T	no
OGE	NOT(?<)	.NOT. .UL.	T	F	T	F	no
UGE	?>=	.UGE.	T	F	T	T	no
OLG	NOT(?=)		T	T	F	F	no
NEQ	NOT(=)	.NE.	T	T	F	T	no
OR	NOT(?)		T	T	T	F	no
T	true		T	T	T	T	no
SF			F	F	F	F	yes
NGLE	NOT(<=>)	.NOT. .LEG.	F	F	F	T	yes
SEQ			F	F	T	F	yes
NGL	NOT(<>)	.NOT. .LG.	F	F	T	T	yes
LT	<	.LT.	F	T	F	F	yes
NGE	NOT(>=)	.NOT. .GE.	F	T	F	T	yes
LE	<=	.LE.	F	T	T	F	yes
NGT	NOT(>)	.NOT. .GT.	F	T	T	T	yes
GT	>	.GT.	T	F	F	F	yes
NLE	NOT(<=)	.NOT. .LE.	T	F	F	T	yes
GE	>=	.GE.	T	F	T	F	yes
NLT	NOT(<)	.NOT. .LT.	T	F	T	T	yes
GL	<>	.LG.	T	T	F	F	yes
SNE			T	T	F	T	yes
GLE	<=>	.LEG.	T	T	T	F	yes
ST			T	T	T	T	yes

Table 3.9. Floating Point Relational Operators

**Branch on FPA Condition Instructions**

Table 3.10 summarized the two branch on FPA (coprocessor unit 1) condition instructions that can be used to test the result of the FPA Compare (C.cond) instructions. In this table, the phrase *delay slot* refers to the instruction immediately following the branch instruction. Refer to chapter 2 for a discussion of the branch delay slot.

Instruction	Format and Description
Branch on FPA True	<i>BCIT</i> Compare a branch target address by adding address of instruction in the delay slot and the 16-bit <i>offset</i> (shifted left two bits and sign-extended to 32 bits). Branch to the target address (with a delay of one instruction) if the FPA's CpCond signal is true.
Branch on FPA False	<i>BCIF</i> Compute a branch target address by adding address of instruction in the delay slot and the 16-bit <i>offset</i> (shifted left two bits and sign-extended to 32 bits). Branch to the target address (with a delay of one instruction) if the FPA's CpCond signal is false.

Table 3.10. Branch on FPA Condition Instructions

		28..26							
		OPCODE							
31..29		0	1	2	3	4	5	6	7
0									
1									
2			COP1						
3									
4									
5									
6			LWC1						
7			SWC1						

		23..21							
		fmt							
24		0	1	2	3	4	5	6	7
6		Single	Double	†	†	†	†	†	†
7		†	†	†	†	†	†	†	†

		25..23							
		COP1							
22,16		0	1	2	3	4	5	6	7
0, 0		MF	MT	BCF		CO			
0, 1	BCT								
1, 0		CF	CT						
1, 1									

		2..0							
		function							
5..3		0	1	2	3	4	5	6	7
0		ADD.fmt	SUB.fmt	MUL.fmt	DIV.fmt	†	ABS.fmt	MOV.fmt	NEG.fmt
1		†	†	†	†	†	†	†	†
2		†	†	†	†	†	†	†	†
3		†	†	†	†	†	†	†	†
4		CVT.S	CVT.D	†	†	CVT.W	†	†	†
5		†	†	†	†	†	†	†	†
6		C.F	C.UN	C.EQ	C.UEQ	C.OLT	C.ULT	C.OLE	C.ULE
7		C.SF	C.NGLE	C.SEQ	C.NGL	C.LT	C.NGE	C.LE	C.NGT

Table 3.11. FPA Opcode Encoding

**FPA Opcode Encoding**

Table 3.11 shows the encoding of the R3081 FPA instructions.

**THE INSTRUCTION PIPELINE**

The FPA provides an instruction pipeline that parallels that of the Integer Processor. The FPA, however, has a 6-stage pipeline instead of the 5-stage pipeline of the Integer CPU: the additional FPA pipe stage is used to provide efficient coordination of exception responses between the FPA and main processor. Figure 3.8 illustrates the six stages of the FPA instruction pipeline. The six stages of the FPA instruction pipeline are used as follows:

- 1) IF - Instruction Fetch. The CPU calculates the instruction address required to read an instruction from the I-Cache. The instruction address is generated and output during phase 2 of this pipe stage. No action is required of the FPA during this pipe stage since the main processor is responsible for address generation. Note that the instruction is not actually read into the processor until the beginning (phase 1) of the RD pipe stage.
- 2) RD - The instruction is present on data bus during phase 1 of this pipe stage and the FPA decodes the data on the bus to determine if it is an instruction for the FPA. The FPA reads any required operands from its registers (RF = Register Fetch) while decoding the instruction.
- 3) ALU - If the instruction is one for the FPA, execution commences during this pipe stage. If the instruction causes an exception, the FPA notifies the main processor of the exception during this pipe stage by asserting the  $\overline{FpInt}$  signal. If the FPA determines that it requires additional time to complete this instruction, it initiates a stall during this pipe stage.
- 4) MEM - If this is a coprocessor load or store instruction, the FPA presents or captures the data during phase 2 of this pipe stage. If an interrupt is taken by the main processor, it notifies the FPA during phase 2 of this pipe stage (via the on-chip  $\overline{Exception}$  signal).
- 5) WB - If the instruction that is currently in the write back (WB) stage caused an exception, the main processor notifies the FPA by asserting the on-chip  $\overline{Exception}$  signal during this pipe state. Thus, the FPA uses this pipe stage solely to deal with exceptions.
- 6) FWB - The FPA uses this stage to write back ALU results to its register file. This stage is the equivalent of the WB stage in the main processor.

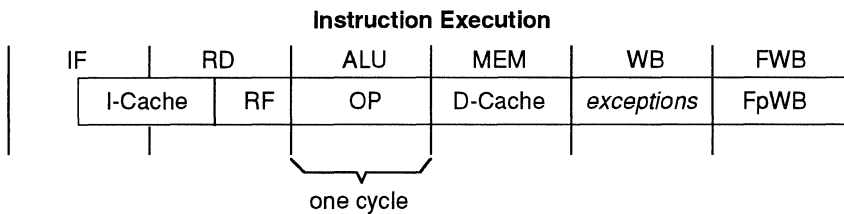

**Figure 3.8. FPA Instruction Execution Sequence**

Figure 3.9 illustrates how the six instructions would be overlapped in the FPA pipeline.

This figure presumes that each instruction can be completed in a single cycle. Most FPA instructions, however, require more than one cycle to execute. Therefore, the FPA must stall the pipeline if an instruction's execution cannot proceed because of register or resource conflicts due to prior FPA operations. Figure 3.10 illustrates the effect of a three-cycle stall on the FPA pipeline.

To mitigate the performance impact that would result from frequently stalling the instruction pipeline, the FPA allows overlapping of instructions so that instruction execution can proceed so long as there are no resource conflicts, data dependencies or exception conditions. The sections that follow describe and illustrate the timing and overlapping of FPA instructions.

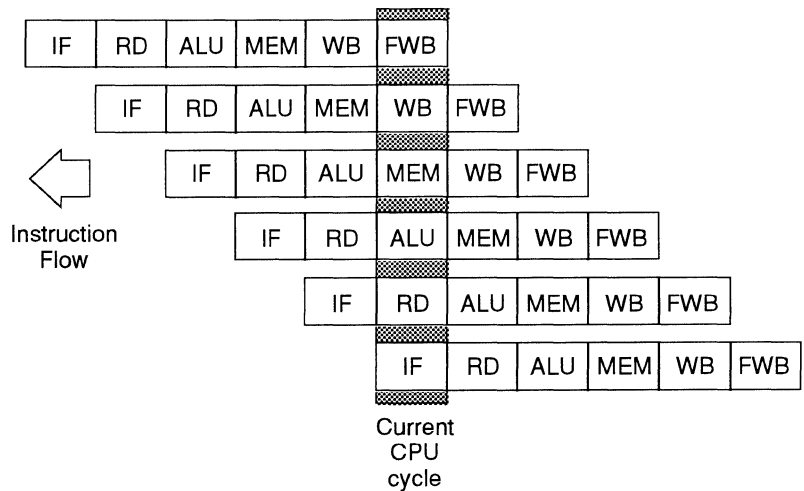

Figure 3.9. FPA Instruction Pipeline

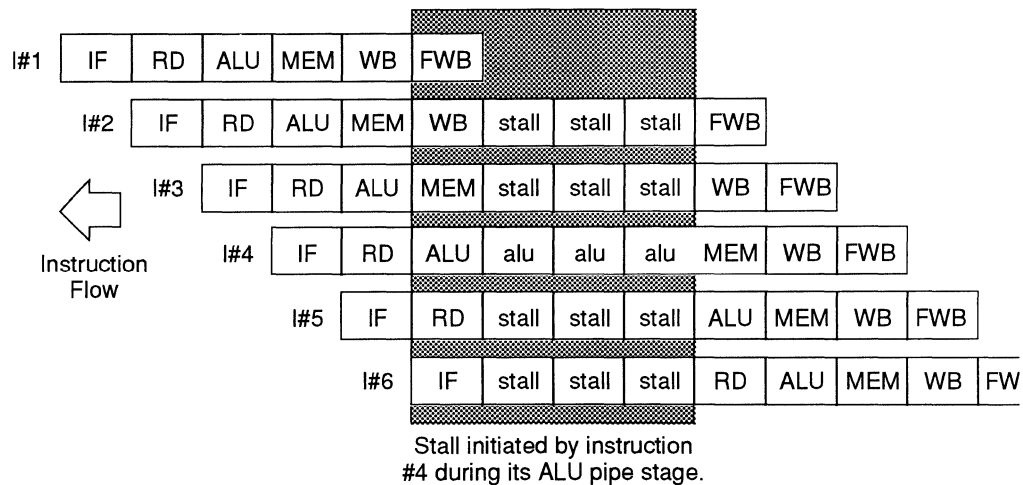

Figure 3.10. An FPA Pipeline Stall

**Instruction Execution Times**

Unlike the Integer Processor which executes almost all instructions in a single cycle, the time required to execute FPA instructions ranges from one cycle to 19 cycles. Figure 3.11 illustrates the number of cycles required to execute each of the FPA instructions.

In Figure 3.11, the cycles of an instruction's execution time that are darkly shaded require exclusive access to an FPA resource (such as buses or ALU) that precludes the concurrent use by another instruction and therefore prohibits overlapping execution of another FPA instruction. (Note that load and store operations can be overlapped with these cycles.) Those instruction cycles that are lightly shaded, however, are placing minimal demands on the FPA resources, and other instructions can be overlapped (with some restrictions) to obtain simultaneous execution of instructions without stalling the instruction pipeline.

For example, an instruction such as DIV.D that requires a large number of cycles to complete could begin execution, and another instruction such as ADD.D could be initiated and completed while the DIV.D instruction is still being executed. Note that only one multiply instruction is still being executed. Note that only one multiply instruction can be running at a time and only one divide instruction can run at a time.

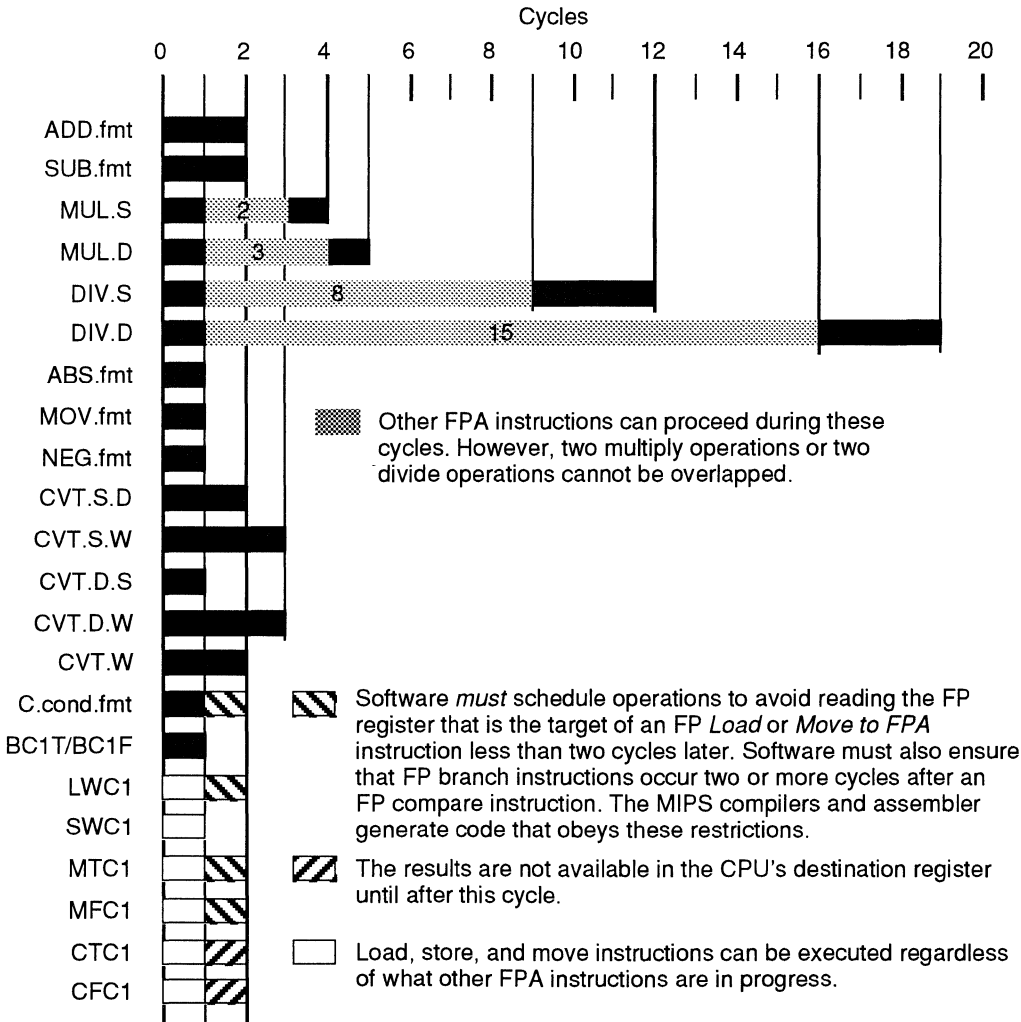

**Figure 3.11. FPA Instruction Execution Times**

**Overlapping FPA Instructions**

Figure 3.12 illustrates the overlapping of several FPA (and non-FPA) instructions. In this figure, the first instruction (DIV.S) requires a total of 12 cycles for execution but only the first cycle and last three cycles preclude the simultaneous execution of other FPA instructions. Similarly, the second instruction (MUL.S) has 2 cycles in the middle of its total of 4 required cycles that can be used to advance the execution of the third (ADD.S) and fourth instructions shown in the figure.

Note that although processing of a single instruction consists of six pipe stages, the FPA does not require that an instruction actually be completed within six cycles to avoid stalling the instruction pipeline. If a subsequent instruction does not require FPA resources being used by a preceding instruction and has no data dependencies on preceding instruction and has no data dependencies on preceding uncompleted instructions, then execution continues.

Figure 3.13 illustrates the progression of the FPA instruction pipeline with some overlapped FPA instructions. The first instruction (DIV.S) in this figure requires eight additional cycles beyond its FWB pipe stage before it is completed. The pipeline need not be stalled, however, because the way in which the FPA instructions are overlapped avoids resource conflicts.

Figure 3.13 also presumes that there are no data dependencies between the instructions that would stall the pipeline. For example, if any instruction before I#13 required the results of the DIV.S (I#1) instruction, then the pipeline would be stalled until those results were available.

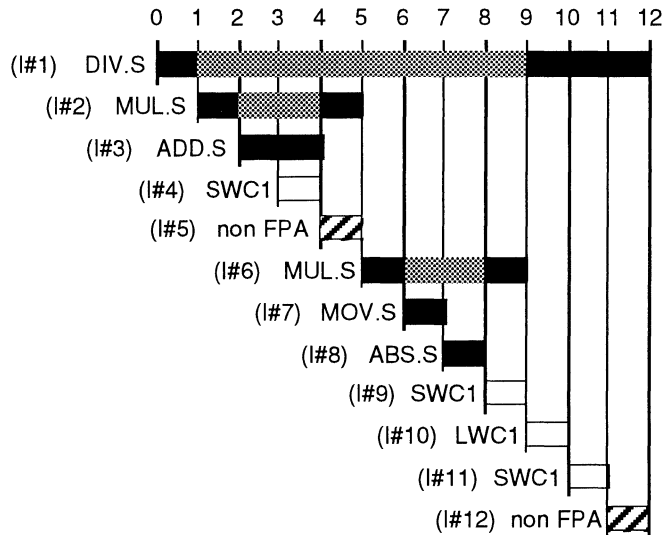

**Figure 3.12. Overlapping FPA Instructions**

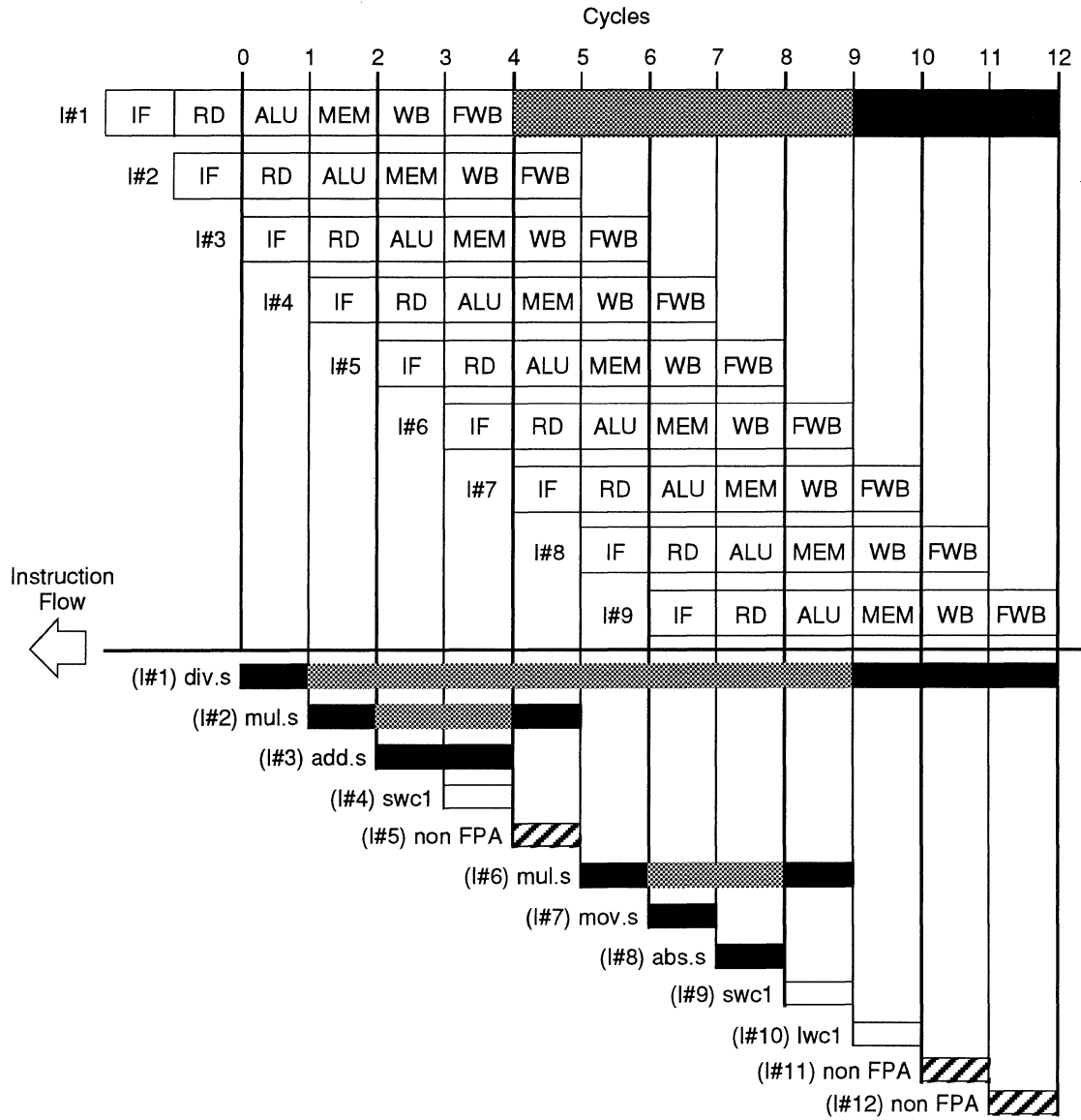

Figure 3.13. Overlapped Instructions in FPA Pipeline



Integrated Device Technology, Inc.

## **R3081 CACHE ARCHITECTURE**

## **CHAPTER 4**

### **INTRODUCTION**

The R3051 family achieves its high standard of performance by combining a fast, efficient execution engine (the R3000A) with high-memory bandwidth, supplied from its large internal instruction and data caches. These caches insure that the majority of processor execution occurs at the rate of one instruction per clock cycle, and serve to decouple the high-speed execution engine from slower, external memory resources.

Portions of this chapter review the fundamentals of general cache operation, and may be skipped by readers already familiar with these concepts. This chapter also discusses the particular organization of the on-chip caches of the R3051 family in general, and the R3081 specifically. However, as these caches are managed by the CPU itself, the system designer does not typically need to be explicitly aware of this structure.

### **FUNDAMENTALS OF CACHE OPERATION**

High-performance microprocessor based systems frequently borrow from computer architecture principles long used in mini-computers and mainframes. These principles include instruction execution pipelining (discussed in Chapter 2) and instruction and data caching.

A cache is a high-speed memory store which contains the instructions and data most likely to be needed by the processor. That is, rather than implement the entire memory system with zero wait-state memory devices, a small zero wait-state memory is implemented. This memory, called a cache, then contains the instructions/data most likely to be referenced by the processor. If indeed the processor issues a reference to an item contained in the cache, then a zero wait-state access is made; if the reference is not contained in the cache, then the longer latency associated with the true system memory is incurred. The processor will achieve its maximum performance as long as its references "hit" (are resident) in the cache.

Caches rely on the principles of locality of software. These principles state that when a data/instruction element is used by a processor, it and its close neighbors are likely to be used again soon. The cache is then constructed to keep a copy of instructions and data referenced by the processor, so that subsequent references occur with zero wait-states.

Since the cache is typically many orders of magnitude smaller than main memory or virtual address space, each cache element must contain both the data (or instruction) required by the processor, as well as information which can be used to determine whether a cache "hit" occurs. This information, called the cache "TAG", is typically some or all of the address in main memory of the data item contained in that cache element as well as a "Valid" flag for that cache element. Thus, when the processor issues an address for a reference, the cache controller compares the TAG with the processor address to determine whether a hit occurs.





### Cache Addressing

The address presented to the cache and cache controller is that of the physical (main) memory element to be accessed. That is, the virtual address to physical address translation is performed by the memory management unit prior to the processor issuing its reference address.

Some microprocessors utilize virtual indexing in the cache, where the processor virtual address is used to specify the cache element to be retrieved. This type of cache structure complicates software and slows embedded applications:

- When the processor performs a context switch, a virtually indexed cache must be flushed. This is because two different tasks can use the same virtual address but mean totally different physical addresses. Cache flushing for a large cache dramatically slows context switch performance.
- Software must be aware of and specifically manage against “aliasing” problems. An alias occurs when two different virtual addresses correspond to the same physical address. If that occurs in a virtually indexed cache, then the same data element may be present in two different cache locations. If one virtual address is used to change the value of that memory location, and a different address used to read it later, then the second reference will not get the current value of that data item.

By providing for the memory management unit in the processor pipeline, physical cache addressing is used with no inherent speed penalty.

### Write Policy

The R3051 family utilizes a write through cache. That is, whenever the processor performs a write operation to memory, then both the cache (data and TAG fields) and main memory are written. If the reference is uncacheable, then only main memory is written.

To minimize the delays associated with updating main memory, the R3081 contains a 4 element write buffer. The write buffer captures the target address and data value in a single processor clock cycle, and subsequently performs the main memory write at its own, slower rate. The write buffer can FIFO up to 4 pending writes, as described in a later chapter.

### Partial Word Writes

In the case of partial word writes, the R3081 operates by performing a read-modify-write sequence in the cache: the store target address is used to perform a cache fetch; if the cache “hits”, then the partial word data is merged with the cache and the cache is updated. If the cache read results in a hit, the memory interface will see the full word write, rather than the partial word. This allows the designer to observe the actual activity of the cache.

If the cache lookup of a partial word write “misses” in the cache, then only main memory is updated.

### Instruction Cache Line Size

The “line size” of a cache refers to the number of cache elements mapped by a single TAG element. In the R3081, the instruction cache line size is 16 bytes, or four words.

This means that each cache line contains four adjacent words from main memory. In order to accommodate this, an instruction cache miss is processed by performing a quad word (block) read from the main memory, as discussed in a later chapter. This insures that a cache line contains four adjacent memory locations. Note that since the instruction cache is typically never written into directly by user software, the larger line size is permissible. If software does explicitly store into the instruction cache (perform store operations

with the caches “swapped”), the programmer must insure that either the written lines are left invalidated, or that they contain four adjacent instructions.

Block refill uses the principle of locality of reference. Since instructions typically execute sequentially, there is a high probability that the instruction address immediately after the current instruction will be the next instruction. Block refill then brings into the cache those instructions immediately near the current instruction, resulting in a higher instruction cache hit rate.

Block refill also takes advantage of the difference between memory latency and memory bandwidth. Memory latency refers to the amount of time required to perform a processor request, while bandwidth refers to the rate at which subsequent data elements are available. Factors that affect memory latency include address decoding, bus arbitration, and memory pre-charge requirements; factors which maximize bandwidth include the use of page mode or nibble mode accesses, memory interleaving, and burst memory devices.

The processing of a quad word read is discussed in a later chapter; however, it is worth noting that the R3051 family can support either true burst accesses or can utilize a simpler, slower memory protocol for quad word reads.

During the quad word read sequence, the processor can simultaneously update its on-chip caches and execute the incoming instruction stream. This process is commonly called streaming, and results in a 5% to 10% performance improvement over the alternative of refilling and then executing.

**Data Cache Line Size**

The data cache line size is different from that of the instruction cache, based on differences in their uses. The data cache is organized as a line size of one word (four bytes).

This is optimal for the write policy of the data cache: since an individual cache word may be written by a software store instruction, the cache controller cannot guarantee that four adjacent words in the cache are from adjacent memory locations. Thus each word is individually tagged. The partial word writes (less than 4 bytes) are handled as a read-modify-write sequence, as described above.

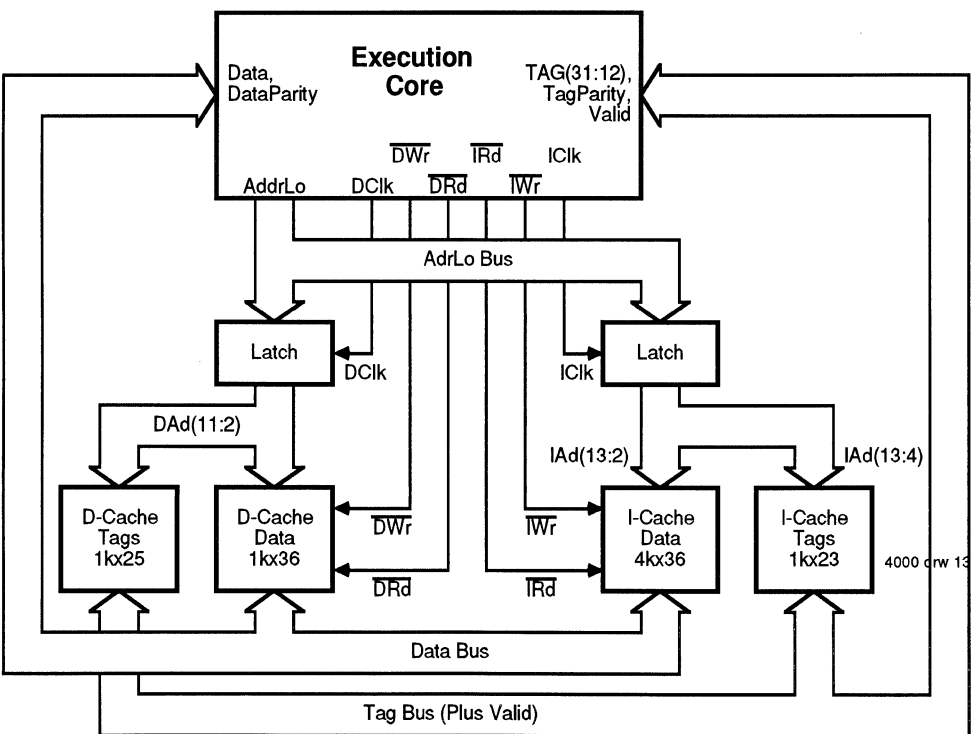

**Figure 4.2. R3081 Execution Core and Cache Interface (Configured as 16kB Instruction Cache, 4kB Data Cache)**

Although the data cache line size is one word, the system may elect to perform data cache updates using quad word reads (block refill). The performance of the data cache update options can be simulated using Cache-305x; some systems may achieve higher performance through the use of data cache burst fill. No “streaming” occurs on data cache refills. Note that for the R3081, software can dynamically select the data cache block refill size (one or four words) using the on-chip Config register. This allows the programmer to optimize the algorithms for key sections of the code, such as window copying into and out of the frame buffer.

**Cache Configurability**

The R3081 allows the system designer to select (via software) from two different cache organizations. The default organization provides 16kB of Instruction Cache, and 4kB of Data Cache. This organization is illustrated in figure 4.2.

If the Alternative Cache Size bit of the CPO Config register is set, the internal cache organization will be changed to 8kB of Instruction Cache, and 8kB of data cache, as shown in figure 4.3. The write-through, direct mapped, and line size characteristics of the cache remain unchanged. When re-configuring the cache, the programmer must use software operating out of the uncacheable address space; further, both the instruction and data caches must be flushed after re-configuring the caches, prior to their use in normal operation. Note that the ability to dynamically switch between cache organizations may be of particular benefit to some applications. Specifically, the default organization may be chosen when performing certain tasks such as data movement of graphics windows (where D-Cache is of reduced benefit), while the alternative organization may be used when performing data base manipulation or calculation on a large array (where the larger D-Cache will gain substantial performance).

**Cache Construction Summary**

The on-chip caches of the R3051 family can be thought of as constructed from discrete devices around the R3000A. The R3081 allows the system designer to select either a 16kB Instruction Cache/4kB Data Cache organization, or an 8kB Instruction Cache/8kB Data Cache organization.

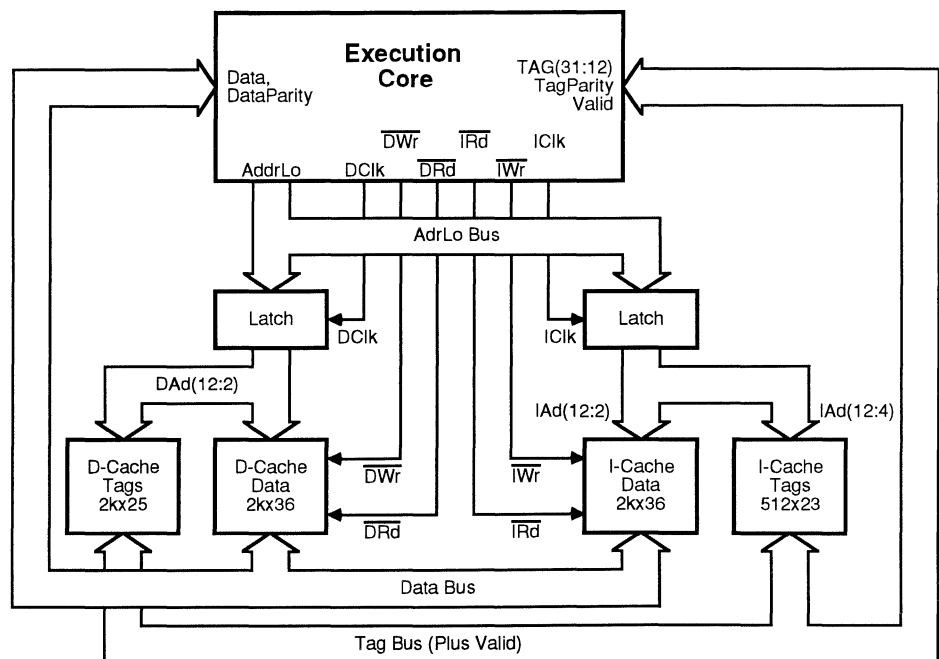

**Figure 4.3. R3081 Execution Core and Cache Interface (Configured as 8kB Instruction Cache, 8kB Data Cache)**

## CACHE OPERATION

The operation of the on-chip caches is very straightforward, and is automatically handled by the processor.

### Basic Cache Fetch Operation

As with the R3000A, the R3081 can access both the instruction and data caches in a single clock cycle, resulting in 320 MB/sec bandwidth to the execution core at 40MHz. It does this by time multiplexing the cycle in the cache interface:

- During the first phase, a data cache address is presented, and a previous instruction cache read is completed.
- During the second phase, the data cache is read into the processor (or written by the processor). Also, the instruction cache is addressed with the next desired instruction.
- During the first phase of the next cycle, the instruction fetch begun in the previous phase is completed and a new data transaction is initiated.

This operation is illustrated in Figure 4.4. As long as the processor hits in the cache, and no internal stall conditions are encountered, it will continue to execute *run* cycles. A run cycle is defined to be a clock cycle in which forward progress in the processor pipeline occurs.

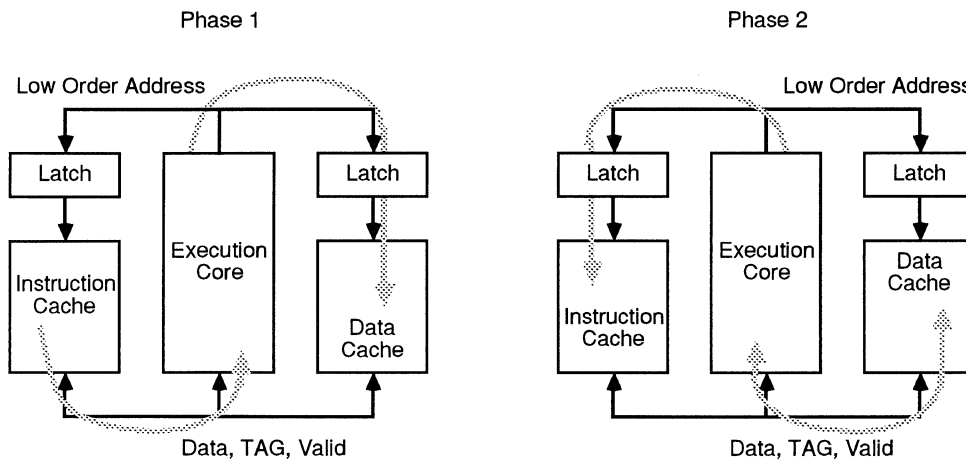

4000 drw 14

Figure 4.4. Phased Access of Instruction and Data Caches

### Cache Miss Processing

In the case of a cache miss (due to either a failed tag comparison, the detection of an internal parity error on the data or tag field of the cache word, or because the processor issued an uncacheable reference), the main memory interface (discussed in a later chapter) is invoked. If, during a given clock cycle, both the instruction and data cache miss, the data reference will be resolved before the instruction cache miss is processed.

While the processor is waiting for a cache miss to be processed, it will enter *stall* cycles until the bus interface unit indicates that it has obtained the necessary data.

When the bus interface unit returns the data from main memory, it is simultaneously brought to the execution unit and written into the on-chip caches. This is performed in a processor *fixup* cycle.

During a fixup cycle, the processor re-issues the cache access that failed; this occurs by having the processor re-address the instruction and data caches, so that the data may be written into the caches. If the cache miss was due to an uncacheable reference, the write is not performed, although a fixup cycle does occur.

### **Instruction Streaming**

A special feature of the R3051 family is utilized when performing block reads for instruction cache misses. This process is called *instruction streaming*. Instruction streaming is simultaneous instruction execution and cache refill.

As the block is brought into the chip, the processor refills the instruction cache. Execution of the instructions within the block begins when the instruction corresponding to the cache miss is returned by the bus interface unit to the execution core. Execution continues until the end of the block is reached (in which case normal execution is resumed), or until some event forces the processor core to discontinue execution of that stream. These events include:

- Taken branches
- Data cache miss
- Internal stalls (TLB miss, multiply/divide interlock)
- Exceptions

When one of these events occur, the processor re-enters simple cache refill until the rest of the block has been written into the cache.

### **CACHEABLE REFERENCES**

Chapter 5 on memory management explains how the processor determines whether a particular reference (either instruction or data) is to a memory location that may reside in the cache. The fundamental mechanism is that certain virtual addresses are considered to be “cacheable”. If the processor attempts to make a reference to a cacheable address, then it will employ its cache management protocol through that reference. Otherwise, the cache will be bypassed, and the execution engine core will directly communicate with the bus interface unit to process the reference.

Whether a given reference should be cacheable or not depends very much on the application, and on the target of the reference. Generally, I/O devices should be referenced as uncacheable data; for example, if software was polling a status register, and that register was cached, then it would never see the I/O device update the status (note that the compiler suite supports the “volatile” data type to insure that the I/O device status register value in this case never gets allocated into an internal register).

There may be other instances where the uncacheable attribute is appropriate. For example, software which directly manipulates or flushes the caches can not be cached; similarly, boot software can not rely on the state of the caches, and thus must operate uncached at least until the caches are initialized.

### **SOFTWARE DIRECTED CACHE OPERATIONS**

In order to support certain system requirements, the R3051 family provides mechanisms for software to explicitly manipulate the caches. These mechanisms support diagnostics, cache and memory sizing, and cache flushing. In general, these mechanisms are enabled/disabled through the use of the Status Register in CPO.

The primary mechanisms for supporting these operations are cache swapping and cache isolation. Cache swapping forces the processor to use the data cache as an instruction cache, and vice versa. It is useful for allowing the processor to issue store instructions which cause the instruction cache to be written. Cache isolation causes the current data cache to be “isolated” from memory; stores do not cause main memory to be written, and all loads “hit” in the data cache. These operations are described in chapter 6.

These mechanisms are enabled through the use of the “IsC” (Isolate Cache) and SwC (Swap Cache) bits of the status register, which resides in the on-chip System Control Co-Processor (CPO). Instructions which immediately precede and succeed these operations must not be cacheable, so that the actual swapping/isolation of the cache does not disrupt operation.

In addition to these general mechanisms, the R3081 allows software to select between two cache organizations, through the use of the Alternate Cache bit of the Config register in CPO.

### Cache Sizing

It is possible for software to determine the amount of cache on-chip. This may be desirable when the application may be running on either an R3051, R3052, or R3081; in this case, software can perform simple diagnostics to determine the amount of cache (and thus how much cache must be flushed).

Cache sizing in an R3051 family CPU is performed much like traditional memory sizing algorithms, but with the cache isolated. This avoids side-effects in memory from the sizing algorithm, and allows the software to use the “Cache Miss” bit of the status register in the sizing algorithm.

To determine the size of the on-chip cache, software must:

- 1: Swap Caches (not needed for D-Cache sizing)
- 2: Isolate Caches
- 3: Write a value at location 8000\_0000
- 4: Write a value at location 8000\_0200 (8000\_0000 + 512B)  
Read location 8000\_0000.  
Examine the CM (Cache Miss) bit of the status register; if it indicates a cache miss, then the cache is 512B; if the CM bit is negated, the cache is 1kB or larger.
- 5: Write a value at location 8000\_0400 (8000\_0000 + 1kB)  
Read location 8000\_0000.  
Examine the CM (Cache Miss) bit of the status register; if it indicates a cache miss, then the cache is 1kB; if the CM bit is negated, the cache is 2kB or larger.
- 6: etc...

Other algorithms could be developed. However, any algorithm will probably include the Swap and Isolate of the Instruction Cache, and the use of the Cache Miss bit. Sizing the data cache is done with a similar algorithm, although the caches need not be swapped.

Note that this software should operate as uncached. Once this algorithm is done, software should return the caches to their normal state by performing either a complete cache flush or an invalidate of those cache lines modified by the sizing algorithm.

### Cache Flushing

Cache flushing refers to the act of invalidating (indicating a line does not have valid contents) lines within either the instruction or data caches. Flushing must be performed before the caches are first used as real caches, and might also be performed during main memory page swapping or at certain context switches (note that the R3051 family implements physical caches, so that cache flushing at context switch time is not generally required).

The basic concept behind cache flushing is to have the “Valid” bit of each cache line set to indicate invalid. This is done in the R3051 family by having the cache isolated, and then writing a partial word quantity into the current data cache. Under these conditions, the R3051/52 will negate the “Valid” bit of the target cache line.

Again, this software should operate as uncached. To flush the data cache:

- 1: Isolate Caches
- 2: Perform a byte write every 4 bytes, starting at location 0, until all words of the D-Cache have been flushed (128 writes for a 512B cache; 512 writes for a 2kB cache; 1024 writes for a 4kB cache; 2048 writes when the cache is configured as 8kB).
- 3: Return the data cache to its normal state by clearing the IsC function.

To flush the instruction cache:

- 1: Swap Caches
- 2: Isolate Caches
- 3: Perform a byte write every 16 bytes (based on the instruction cache line size of 16 bytes). This should be done until each line (128 lines for the R3041; 256 lines in the R3051, 512 in the R3052; 1024 or 2048 for the R3081, depending on the cache organization selected) have been invalidated. Note that always invalidating the instruction cache as though it contains 16kB is acceptable although less efficient.
- 4: Return the caches to their normal state (unswapped and not isolated).

To minimize the execution time of the cache flush, this software should probably use an “unrolled” loop. That is, rather than have one iteration of the loop invalidate only one cache line, each iteration should invalidate multiple lines. This spreads the overhead of the loop flow control over more cache line invalidates, thus reducing execution time.

Also, it is recommended that the cache sizing algorithm described above to determine the number of lines to flush. It is acceptable to flush more lines than are actually in the cache, but this is not particularly efficient.

### **Forcing Data into the Caches**

Using these basic tools, it is possible to have software directly place values into the caches. When combined with appropriate memory management techniques, this could be used to “lock” values into the on-chip caches, by insuring that software does not issue other address references which may displace these locked values.

In order to force values into a cache, the cache should be Isolated. If software is trying to write instructions into the instruction cache, then the caches should also be swapped.

When forcing values into the instruction cache, software must take care with regards to the line size of the instruction cache. Specifically, a single TAG and Valid field describe four words in the instruction cache; software must then insure that any instruction cache line tagged as Valid actually contains valid data from all four words of the block.

### **SUMMARY**

The on-chip caches of the R3081 are key to the inherent performance of the processor. The R3051 family design, however, does not require the system designer (either software or hardware) to explicitly manage this important resource, other than to correctly choose virtual addresses which may or may not be cached, and to flush the caches at system boot. This contributes to both the simplicity and performance of an R3051 family system.





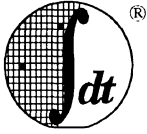

INTRODUCTION

The R3051 family provides two basic flavors of memory management. The base versions (the R3041, R3051, R3052, and R3081) provide segment-based virtual to physical address translation, and support the segregation of kernel and user tasks without requiring extensive virtual page management. The extended versions (the R3051E, R3052E, and R3081E) provide a full featured memory management unit (MMU) identical to the MMU structure of the R3000A. The extended MMU uses an on-chip translation lookaside buffer (TLB) and dedicated registers in CP0 to provide for software management of page tables.

This chapter describes the operating states of the processor (kernel and user), and describes the virtual to physical address translation mechanisms provided in both versions of the architecture.

VIRTUAL MEMORY IN THE R3051 FAMILY

There are two primary purposes of the memory management capabilities of the R3051 family.

- Various areas of main memory can have individual sets of attributes associated with them. For example, some segments may be indicated as requiring kernel status to be accessed; others may have cacheable or uncacheable attributes. The virtual to physical address translation establishes the rules appropriate for a given virtual address.
• The virtual memory system can be used to logically expand the physical memory space of the processor, by translating addresses composed in a large virtual address space into the physical address space of the system. This is particularly important in applications where software may not be explicitly aware of the hardware resources of the processor system, and includes applications such as ARC-compliant systems and X-Window display systems. These types of applications are better served by the "E" (extended architecture) versions of the processor.

Figure 5.1 shows the form of an R3051 family virtual address. The most significant 20 bits of the 32-bit virtual address are called the virtual page number, or VPN. In the extended architecture versions, the VPN allows mapping of virtual addresses based on 4k Byte pages; in the base versions, only the three highest bits (segment number) are involved in the virtual to physical address translation.

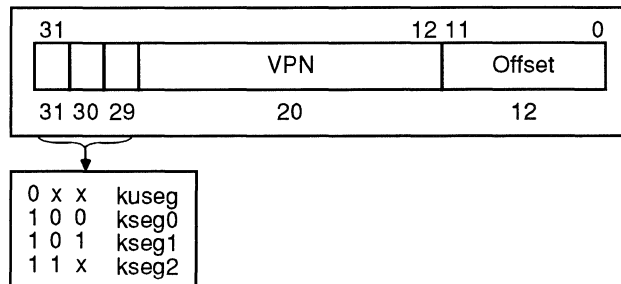

4000 drw 15

Figure 5.1. Virtual Address Format

In all versions, the three most significant bits of the virtual address identify which virtual address segment the processor is currently referencing; these segments have associated with them the mapping algorithm to be employed, and whether virtual addresses in that segment may reside in the cache. The translation of the virtual address to an equivalent privilege level/segment is the same for the base and extended versions of the architecture.

## PRIVILEGE STATES

The R3051 family provides for two unique privilege states: the “Kernel” mode, which is analogous to the “supervisory” mode provided in many systems, and the “User” mode, where non-supervisory programs are executed. Kernel mode is entered whenever the processor detects an exception; when a Restore From Exception (RFE) instruction is executed, the processor will return either to its previous privilege mode or to User mode, depending on the state of the machine and when the exception was detected.

### User Mode Virtual Addressing

While the processor is operating in User mode, a single, uniform virtual address space (**kuseg**) of 2 GBytes is available for Users. All valid user-mode virtual addresses have the most significant bit of the virtual address cleared to 0. An attempt to reference a Kernel address (most significant bit of the virtual address set to 1) while in User mode will cause an Address Error Exception (see chapter 5). Kuseg begins at virtual address 0 and extends linearly for 2 GBytes. This segment is typically used to hold user code and data, and the current user processes. The virtual to physical address translation depends on whether the processor is a base or extended architecture version.

### Kernel Mode Virtual Addressing

When the processor is operating in Kernel mode, four distinct virtual address segments are simultaneously available. The segments are:

- **kuseg**. The kernel may assert the same virtual address as a user process, and have the same virtual to physical address translation performed for it as the translation for the user task. This facilitates the kernel having direct access to user memory regions. The virtual to physical address translation depends on whether the processor is a base or extended architecture version.
- **kseg0**. Kseg0 is a 512 MByte segment, beginning at virtual address 0x8000\_0000. This segment is always translated to a linear 512 MByte region of the physical address space starting at physical address 0. All references through this segment are cacheable.

When the most significant three bits of the virtual address are “100”, the virtual address resides in kseg0. The physical address is constructed by replacing these three bits of the virtual address with the value “000”. As these references are cacheable, kseg0 is typically used for kernel executable code and some kernel data.

- **kseg1**. Kseg1 is a 512 MByte segment, beginning at virtual address 0xa000\_0000. This segment is also translated directly to the 512 MByte physical address space starting at address 0. All references through this segment are uncacheable.

When the most significant three bits of the virtual address are “101”, the virtual address resides in kseg1. The physical address is constructed by replacing these three bits of the virtual address with the value “000”. Unlike kseg0, references through kseg1 are not cacheable. This segment is typically used for I/O registers, boot ROM code, and operating system data areas such as disk buffers.

- **kseg2.** This segment is analogous to kuseg, but is accessible only from kernel mode. This segment contains 1 GByte of linear addresses, beginning at virtual address 0xc000\_0000. As with kuseg, the virtual to physical address translation depends on whether the processor is a base or extended architecture version.

When the two most significant bits of the virtual address are “11”, the virtual address resides in the 1024 MByte segment kseg2. The virtual to physical translation is done either through the TLB (extended versions of the processor) or through a direct segment mapping (base versions). An operating system would typically use this segment for stacks, per-process data that must be re-mapped at context switch, user page tables, and for some dynamically allocated data areas.

Thus, in both the base and extended versions of the processor, kseg0 and kseg1 are always mapped in the same fashion, to the lowest 512 MBytes of the physical address space. In both versions of the architecture, kseg0 references may reside in the on-chip cache, while kseg1 references may never reside in the on-chip caches.

The mapping of kuseg and kseg2 from virtual to physical addresses depends on whether the processor is a base or extended version of the architecture.

A base version is distinguishable from an extended version in software by examining the TS (TLB Shutdown) bit of the Status Register after reset, before the TLB is used. If the TS bit is set (1) immediately after reset, indicating that the TLB is non-functional, then the current processor is a base version of the architecture. If the TS bit is cleared after reset, then the software is executing on an extended architecture version of the processor.

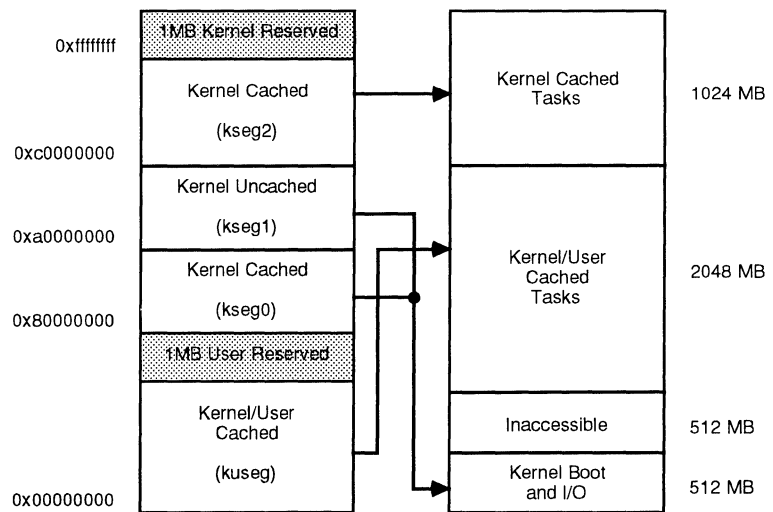

4000 drw 16

Figure 5.2. Virtual to Physical Address Translation in Base Versions

### BASE VERSIONS ADDRESS TRANSLATION

Processors which only implement the base versions of memory management perform direct segment mapping of virtual to physical addresses, as illustrated in Figure 5.2. Thus, the mapping of kuseg and kseg2 is performed as follows:

- Kuseg is always translated to a contiguous 2 GByte region of the physical address space, beginning at location 0x4000\_0000. That is, the value “00” in the two highest order bits of the virtual address space are translated to the value “01”, with the remaining 30 bits of the virtual address unchanged.
- Virtual addresses in kseg2 are directly output as physical addresses; that is, references to kseg2 occur with the physical address unchanged from the virtual address.

- The upper 1 MByte of each of Kuseg and Kseg2 should not be used. This region is being reserved for compatibility with future revisions of the chip, which may include on-chip resources which map to these virtual addresses.

The base versions of the architecture allow kernel software to be protected from user mode accesses, without requiring virtual page management software. User references to kernel virtual address will result in an address error exception.

Some systems may elect to protect external physical memory as well. That is, the system may include distinct memory devices which can only be accessed from kernel mode. The physical address output determines whether the reference occurred from kernel or user mode, according to Table 5.1.

Physical Address (31:29)	Virtual Address Segment
'000'	Kseg0 or Kseg1
'001'	Inaccessible
'01x'	Kuseg
'10x'	Kuseg
'11x'	Kseg2

4000 tbl 15

**Table 5.1. Virtual and Physical Address Relationships in Base Versions**

Thus, some systems may wish to limit accesses to some memory or I/O devices to those physical address bits which correspond to kernel mode virtual addresses.

Alternately, some systems may wish to have the kernel and user tasks share common areas of memory. Those systems could choose to have their address decoder ignore the high-order physical address bits, and compress all of memory into the lower region of physical memory. The high-order physical address bits may be useful as privilege mode status outputs in these systems.

Note that for base version CPUs, the CPO registers associated with the TLB are undefined. That is, writes to these registers do not alter the memory mapping, and the value of the registers when read is undefined/reserved.

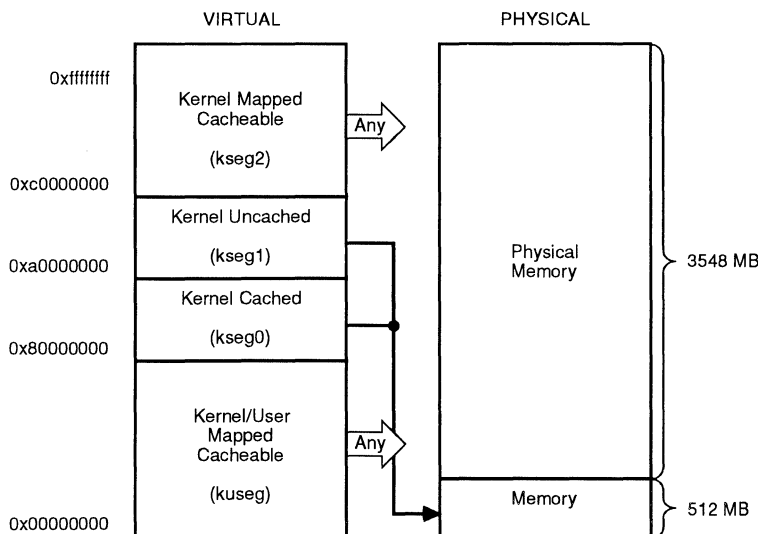

4000 drw 17

**Figure 5.3. Virtual to Physical Address Mapping of Extended Architecture**

**EXTENDED VERSIONS ADDRESS TRANSLATION**

The extended versions of the architecture use a full featured MMU, like that found in the R3000A, to manage the virtual to physical address translation of kuseg and kseg2. This MMU maps 4kByte virtual pages to 4kByte physical pages, and controls the attribute of these pages on a page by page basis. The extended versions of the architecture map the virtual address space as illustrated in Figure 5.3.

Note that kuseg and kseg2 may be mapped anywhere in the 4GByte physical address space. Thus, the external memory system may not be able to examine the physical address outputs from the processor to determine the virtual segment origin of the reference. Software in such a system will be much more responsible for managing the separation of kernel and user resources.

Pages are mapped by substituting a 20-bit physical frame number (PFN) for the 20-bit virtual page number field of the virtual address. This substitution is performed through the use of the on-chip Translation Lookaside Buffer (TLB). The TLB is a fully associative memory that holds 64 entries to provide a mapping of 64 4kByte pages. When a virtual reference to kuseg or kseg2 occurs, each TLB entry is probed to see if it maps the corresponding VPN.

The mapping function is provided as part of the on-chip System Control Co-Processor, CP0. CP0 supports address translation, exception handling, and other privileged transactions. CP0 contains the TLB and the other registers shown in Figure 5.4.

The sections that follow describes the virtual to physical address mapping performed by the TLB.

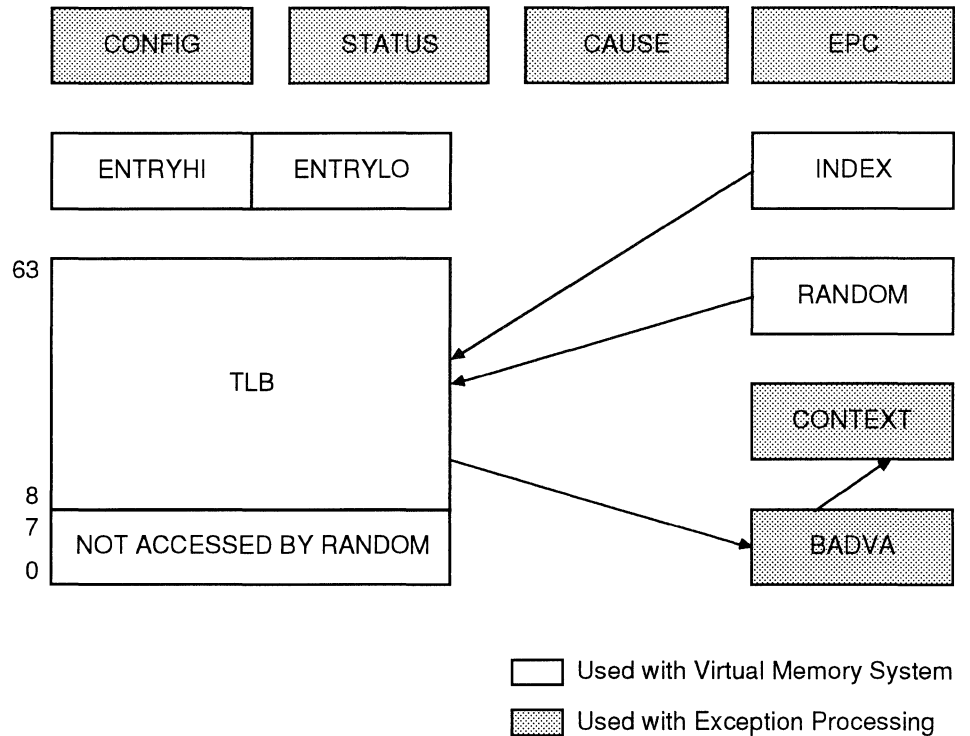

**Figure 5.4. The System Coprocessor Registers**

**TLB Entries**

Each TLB entry is 64 bits wide, and its format is illustrated in Figure 5.5. Each field of a TLB entry has a corresponding field in the EntryHi/EntryLo register pair (described next). Figure 5.6 describes each of the fields of a TLB entry.

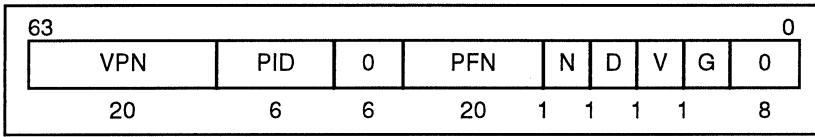

4000 drw 19

**Figure 5.5. Format of a TLB Entry**

**EntryHi and EntryLo Registers**

These two registers provide the data path for operations which read, write, or probe the TLB file. The format of these registers is the same as the format of a TLB entry, and is illustrated in Figure 5.6.

For maximum software efficiency, operating system software could use the format of EntryLo to describe a Page Table Entry in the operating system Page Table; however, since PTE's are managed through software algorithms, rather than hardware, an operating system could choose a different format than that of EntryLo.

TLB EntryHi Register

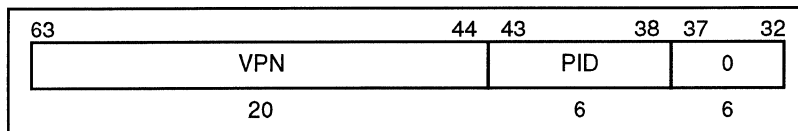

- VPN* Virtual Page Number. Bits 31..12 of virtual address.
- PID* Process ID field. A 6-bit field which lets multiple processes share the TLB while each process has a distinct mapping of otherwise identical virtual page numbers.
- 0 Reserved. Must be written as '0'; returns zero when read.

TLB EntryLo Register

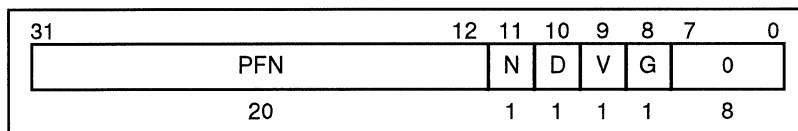

- PFN* Page Frame Number. Bits 31..12 of the physical address. The R3051/52"E" maps a virtual page to the PFN.
- N* Non-cacheable. If this bit is set, the page is marked as non-cacheable and the R3081"E" directly accesses main memory instead of first accessing the cache.
- D* Dirty. If this bit is set, the page is marked as "dirty" and therefore writable. This bit is actually a "write-protect" bit that software can use to prevent alteration of data. If an entry is accessed for a write operation when the D bit is cleared, the R3081"E" causes a TLB Mod trap. The TLB entry is not modified on such a trap.
- V* Valid. If this bit is set, it indicates that the TLB entry is valid; otherwise, a TLBL or TLBS Miss occurs.
- G* Global. If this bit is set, the R3081"E" ignores the PID match requirement for valid translation. In kseg2, the Global bit lets the kernel access all mapped data without requiring it to save or restore PID (Process ID) values.
- 0 Reserved. Must be written as '0', returns '0' when read.

**Figure 5.6. The TLB EntryLo and EntryHi Registers**

4000 drw 20

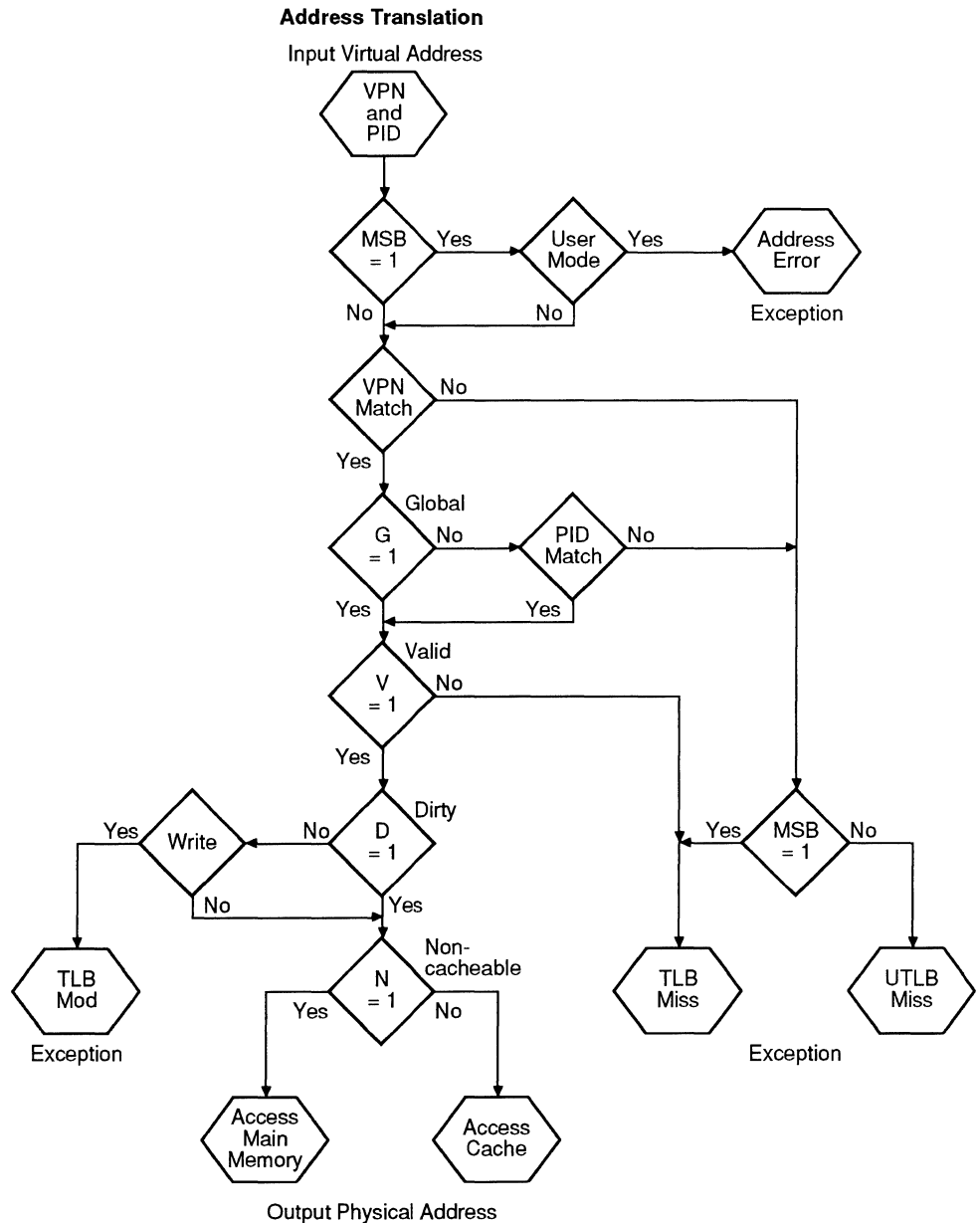

4000 drw 21

Figure 5.7. TLB Address Translation

**Virtual Address Translation**

During a virtual to physical address translation in kuseg or kseg2, extended architecture CPUs compare the PID and the highest 20 bits of the virtual address (the VPN) to the contents of each TLB entry. A generalized algorithm for this mapping is illustrated in Figure 5.7.

A virtual address matches (is mapped by) a TLB entry if:

- the VPN of the virtual address matches the VPN field of a TLB entry
- either the “G” (global) bit of the TLB entry is set, or the PID field of the virtual address (stored in the EntryHi register) matches the PID field of the TLB entry.

If a match is found, then the corresponding physical address (PFN) field of the TLB entry is retrieved from the matching entry, along with the access control bits (N, D, and V). If no match is found, then either a TLB or UTLB miss exception will occur. Figure 5.8 shows the generation of a physical address from a specific virtual address mapped by the TLB.



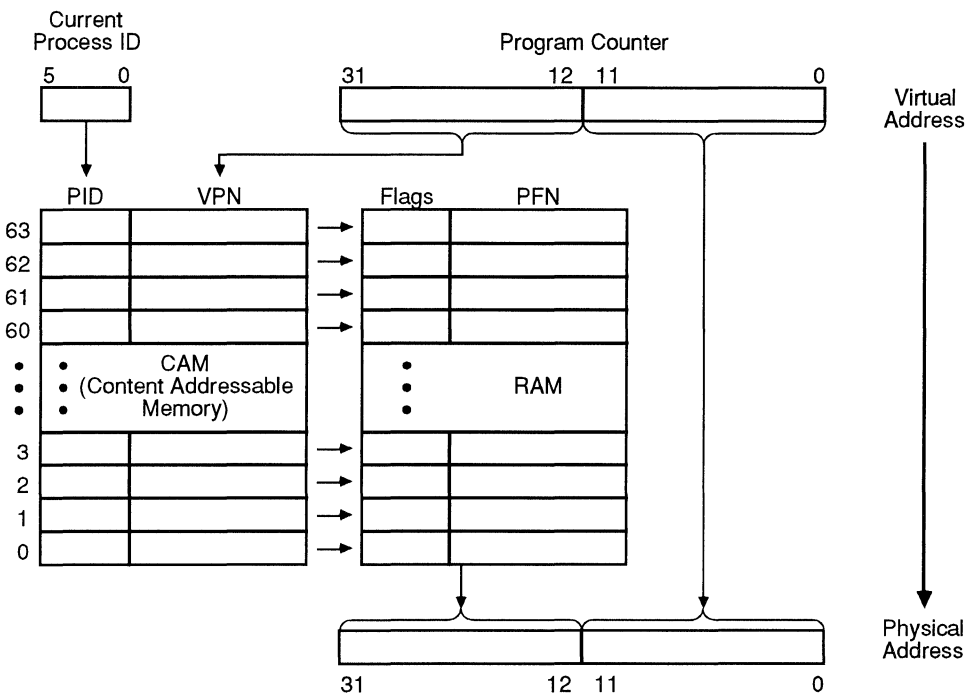

Figure 5.8. Virtual to Physical TLB Translation 4000 drw 22

If the access control bits (D and V) indicate that the access is not valid (either the TLB entry is not valid, or the page is write protected or not yet dirty), then a TLB modification or TLB miss exception will occur. If the N (Non-cacheable) bit is set, then the processor will not look in its caches for the data, but rather will directly use the bus interface unit to retrieve the word from main memory.

**The Index Register**

The *Index* register is a 32-bit, read-write register, which has a 6-bit field used to index to a specific entry in the 64-entry TLB file. The high-order bit of the register is a status bit which reflects the success or failure of a **TLB Probe (tlbp)** instruction, described later in this chapter.

The Index register also specifies the TLB entry that will be affected by the **TLB Read (tlbr)** and **TLB Write Index (tlbwi)** instructions. Figure 5.9 shows the format of the Index register.

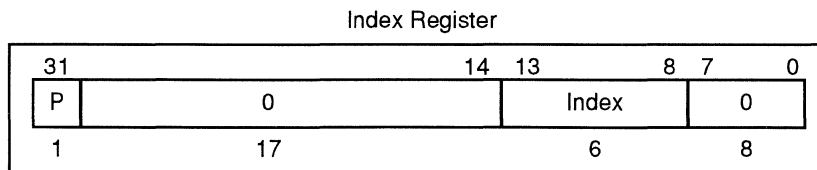

<i>P</i>	Probe failure. Set to 1 when the last TLBProbe (tlbp) instruction was unsuccessful.
<i>Index</i>	Index to the TLB entry that will be affected by the TLBRead and TLBWrite instructions.
0	Reserved. Must be written as zero, returns zero when read.

4000 drw 23

Figure 5.9. The Index Register

**The Random Register**

The *Random* register is a 32-bit read-only register. The format of the Random register is shown in figure 5.10.

The six-bit Random field indexes a Random entry in the TLB. It is basically a counter which decrements on every clock cycle, but which is constrained to count in the range of 63 to 8. That is, software is guaranteed that the Random register will never index into the first 8 TLB entries. These entries can be “locked” by software into the TLB file, guaranteeing that no TLB miss exceptions will occur in operations which use those virtual address. This is useful for particularly critical areas of the operating system.

The Random register is typically used in the processing of a TLB miss exception. The Random register provides software with a “suggested” TLB entry to be written with the correct translation; although slightly less efficient than a Least Recently Used (LRU) algorithm, Random replacement offers substantially similar performance while allowing dramatically simpler hardware and software management. To perform a TLB replacement, the **TLB Write Random (tlbwr)** instruction is used to write the TLB entry indexed by this register.

At reset, this counter is preset to the value ‘63’. Thus, it is possible for two processors to operate in “lock-step”, even when using the Random TLB replacement algorithm. Also, software may directly read this register, although this feature probably has little utility outside of device testing and diagnostics.

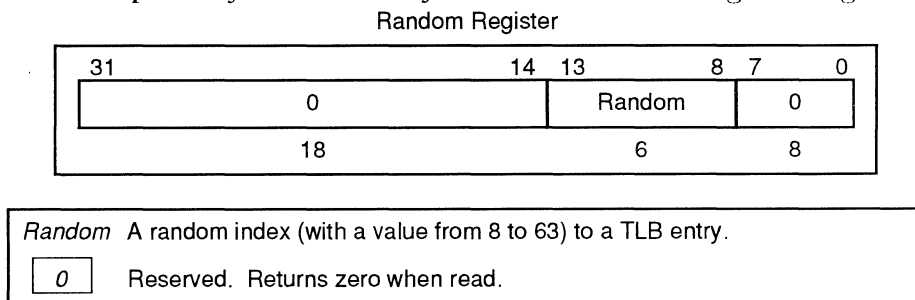

Figure 5.10. The Random Register

4000 drw 24

**TLB Instructions**

Extended architecture CPUs provide instructions for working with the TLB, as listed in Table 5.2. These instructions are described briefly below. Their operation in base versions of the R3051 family architecture is undefined.

**Translation Lookaside Buffer Probe (tlbp).** This instruction “probes” the TLB to see if an entry matches the EntryHi register contents. If a match occurs, the CPU loads the Index register with the index of the entry that matched. If no match exists, the processor will set the high order bit (the *P* bit) of the Index Register.

**Translation Lookaside Buffer Read (tlbr).** This instruction loads the EntryHi and EntryLo registers with the contents of the TLB entry pointed to by the Index register.

Op Code	Description
tlbp	Translation Lookaside Buffer Probe
tlbr	Translation Lookaside Buffer Read
tlbwi	Translation Lookaside Buffer Write at Index
tlbwr	Translation Lookaside Buffer Write at Random

4000 tbl 16

Table 5.2. TLB Instructions

**Translation Lookaside Buffer Write at Index (tlbwi).** This instruction loads the TLB entry pointed to by the Index register with the current values of the EntryHi and EntryLo register.

**Translation Lookaside Buffer Write at Random (tlbwr).** This instruction loads the TLB entry pointed to by the Random register with the current values of the EntryHi and EntryLo register.

### **TLB Shutdown**

The status register contains a single bit which indicates whether the TLB is operating properly. This bit, once set, may only be cleared by a device reset.

There are two reasons this bit might be set:

- If this bit is set at device reset, prior to the actual use of the TLB for address mapping, then this is not an “Extended” version of the R3051 family architecture, and thus no TLB is present.
- If this bit is cleared at reset, but set subsequently, then the TLB detected multiple virtual to physical mappings for the same VPN. This is either the result of improper software, or of improper operation of the TLB. If this condition is detected, the TLB will be shutdown, prohibiting further virtual to physical address mappings through the TLB. The virtual to physical translation of kuseg and kseg2 is undefined under these conditions.

### **SUMMARY**

The R3051 family provides two models of memory management: a very simple, segment based mapping, found in the base versions of the architecture, and a more sophisticated, TLB-based page mapping scheme, present in the extended versions of the architecture. Each scheme has advantages to different applications.

For example, many stand-alone applications have no need for paging, as the memory requirements of the application are absolutely determined when the system is designed. Examples of these types of systems include data communications applications, navigation, and process control.

Other applications may have unpredictable memory requirements, since the target system can not predict the resource requirements of the various tasks which operate on it. This is the classic model for virtual memory management in general purpose computers. Additionally, this model is increasingly appropriate in a number of embedded applications, such as X-Window Terminals. Applications such as these may be connected on a network to numerous hosts, each of which presents tasks to the system without explicit awareness of the resource utilization of other hosts. Virtual memory management in such applications may then be appropriate, with the unmapped segments (kseg0 and kseg1) used for the application operating system and I/O channels. For applications such as X-servers and ARC compliant systems, the extended architecture versions of the family are appropriate.



## **INTRODUCTION**

Processors in general execute code in a highly-directed fashion. The instruction immediately subsequent to the current instruction is fetched and then executed; if that instruction is a branch instruction, the program execution is diverted to the specified location. Thus, program execution is relatively straightforward and predictable.

Exceptions are a mechanism used to break into this execution stream and to force the processor to begin handling another task, typically related to either the system state or to the erroneous or undesirable execution of the program stream. Thus, exceptions typically are viewed by programmers as asynchronous interruptions of their program. (Note that exceptions are not necessarily unpredictable or asynchronous, in that the events which cause the exception may be exactly repeatable by the same software executing on the same data; however, the programmer does not typically "expect" an exception to occur when and where it does, and thus will view exceptions as asynchronous events).

The R3051 family architecture provides for extremely fast, flexible interrupt and exception handling. The processor makes no assumptions about interrupt causes or handling techniques, and allows the system designer to build his own model of the best response to exception conditions. However, the processor provides enough information and resources to minimize both the amount of time required to begin handling the specific cause of the exception, and to minimize the amount of software required to preserve processor state information so that the normal instruction stream may be resumed.

This chapter discusses exception handling issues in R3051 family systems. The topics examined are: the exception model, the machine state to be saved on an exception, and nested exceptions. Representative software examples of exception handlers are also provided, as are techniques and issues appropriate to specific classes of exceptions.

## **R3051 FAMILY EXCEPTION MODEL**

The exception processing capability of the R3051 family is provided to assure an orderly transfer of control from an executing program to the kernel. Exceptions may be broadly divided into two categories: they can be caused by an instruction or instruction sequence, including an unusual condition arising during its execution; or can be caused by external events such as interrupts. When an R3051 family processor detects an exception, the normal sequence of instruction flow is suspended; the processor is forced to kernel mode where it can respond to the abnormal or asynchronous event. Table 6.1 lists the exceptions recognized by the R3051 family.

Exception	Mnemonic	Cause
<b>Reset</b>	Reset	Assertion of the Reset signal causes an exception that transfers control to the special vector at virtual address 0xbfc0_0000.
<b>UTLB Miss</b>	UTLB	User TLB Miss. A reference is made (in either kernel or user mode) to a page in <i>kuseg</i> that has no matching TLB entry. This can occur only in extended architecture versions of the processor.
<b>TLB Miss</b>	TLBL (Load) TLBS (Store)	A referenced TLB entry's Valid bit isn't set, or there is a reference to a <i>kseg2</i> page that has no matching TLB entry. This can occur only in extended architecture versions of the processor.
<b>TLB Modified</b>	Mod	During a store instruction, the Valid bit is set but the dirty bit is not set in a matching TLB entry. This can occur only in extended architecture versions of the processor.
<b>Bus Error</b>	IBE (Instruction) DBE (Data)	Assertion of the Bus Error input during a read operation, due to such external events as bus timeout, backplane memory errors, invalid physical address, or invalid access types.
<b>Address Error</b>	AdEL (Load) AdES (Store)	Attempt to load, fetch, or store an unaligned word; that is, a word or halfword at an address not evenly divisible by four or two, respectively. Also caused by reference to a virtual address with most significant bit set while in User Mode.
<b>Overflow</b>	Ovf	Twos complement overflow during add or subtract.
<b>System Call</b>	Sys	Execution of the SYSCALL Trap Instruction
<b>Breakpoint</b>	Bp	Execution of the break instruction
<b>Reserved Instruction</b>	RI	Execution of an instruction with an undefined or reserved major operation code (bits 31:26), or a special instruction whose minor opcode (bits 5:0) is undefined.
<b>Co-processor Unusable</b>	CpU	Execution of a co-processor instruction when the CU (Co-processor Usable) bit is not set for the target co-processor.
<b>Interrupt</b>	Int	Assertion of one of the six hardware interrupt inputs or setting of one of the two software interrupt bits in the Cause register.

4000 tbl 17

Table 6.1. R3051 Family Exceptions

### Precise vs. Imprecise Exceptions

One classification of exceptions refers to the precision with which the exception cause and processor context can be determined. That is, some exceptions are precise in their nature, while others are "imprecise."

In a **precise exception**, much is known about the system state at the exact instance the exception is caused. Specifically, the exact processor context and the exact cause of the exception are known. The processor thus maintains its exact state before the exception was generated, and can accurately handle the exception, allowing the instruction stream to resume when the situation is corrected. Additionally, in a precise exception model, the processor can not advance state once an exception condition occurs; that is, subsequent instructions, which may already be in the processor pipeline, are not allowed to change the state of the machine.

Many real-time applications greatly benefit from a processor model which guarantees precise exception context and cause information. The MIPS architecture, including the R3051 family, implements a precise exception model for all exceptional events, including long-latency floating point operations.

**EXCEPTION PROCESSING**

The R3051 family's exception handling system efficiently handles machine exceptions, including Translation Lookaside Buffer (TLB) misses, arithmetic overflows (integer or floating point), I/O interrupts, system calls, breakpoints, reset, and co-processor unusable conditions. Any of these events interrupt the normal execution flow; the processor aborts the instruction causing the exception and also aborts all those following in the exception pipeline which have already begun, thus not modifying processor context. The processor then performs a direct jump into a designated exception handler routine. This insures that the processor is always consistent with the precise exception model.

Note that the on-chip floating point unit uses one of the general processor interrupts to signal that an exception occurred in a floating point operation. Software then examines the status register of the FPA to determine the exact nature of the exception. Since even floating point exceptions are precise, the Exception Program Counter (EPC, described later) will indicate which floating point instruction was responsible for the exception.

**EXCEPTION HANDLING REGISTERS**

The system co-processor (CPO) registers contain information pertinent to exception processing. Software can examine these registers during exception processing to determine the cause of the exception and the state of the processor when it occurred. There are six registers handling exception processing, shown in shaded boxes in Figure 6.1. These are the *Cause* register, the *EPC* register, the *Status* register, the *BadVAddr* register, the *Context* register, and the *Config* register. Note that the configuration register is unique

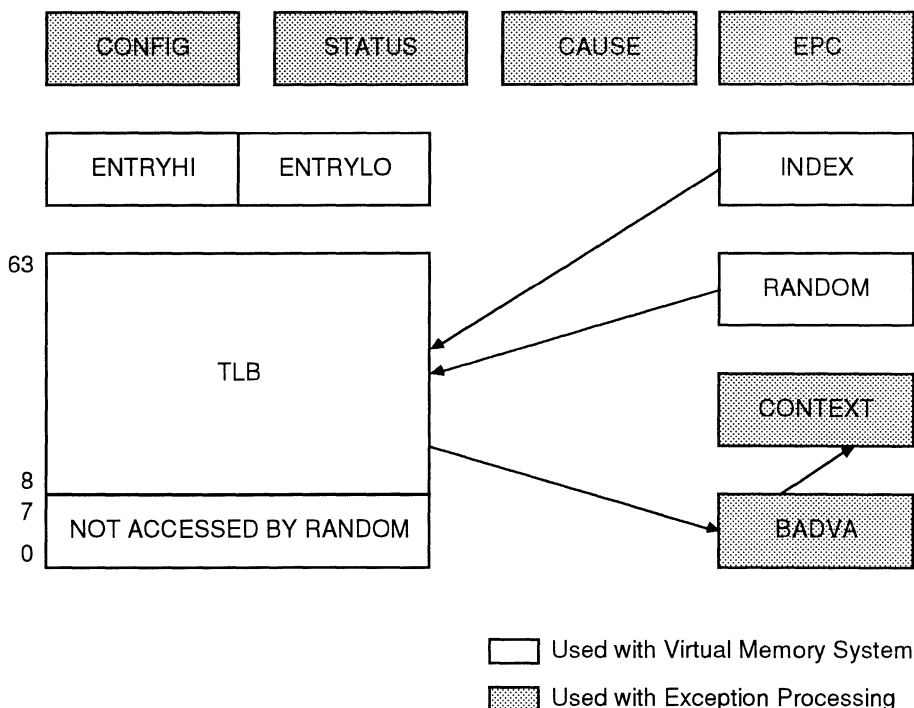

Figure 6.1. The CPO Execution Handling Registers

to the R3081; it is provided to allow the system designer more flexibility. However, the register powers up into a rational state, and thus many operating systems will never need to read or write the register. Thus, software compatibility with the R3000A and R3051 is maintained, even for operating system kernels and boot proms. A brief description of each of these registers follows.

Table 6.2 lists the register address of each of the CPO registers (as used in CPO operations); the register number is used by software when issuing co-processor load and store instructions.

Register Name	Register Number (Decimal)
Status	\$12
Cause	\$13
Exception PC	\$14
TLB Entry Hi	\$10
TLB Entry Lo	\$2
Index	\$0
Random	\$1
Context	\$4
Bad Virtual Address	\$8
Config	\$3
PrId	\$15
Reserved	\$5-\$7, \$9, \$11, \$16-\$31

4000 tbl 18

Table 6.2. Co-processor 0 Register Addressing

**The Cause Register**

The contents of the Cause register describe the last exception. A 5-bit exception code indicates the cause of the current exception; the remaining fields contain detailed information specific to certain exceptions.

All bits in this register, with the exception of the SW bits, are read-only. The SW bits can be written to set or reset software interrupts. Figure 6.2 illustrates the format of the Cause register. Table 6.3 details the meaning of the various exception codes.

The meaning of the other bits of the cause register is as follows:

- BD** The Branch Delay bit is set (1) if the last exception was taken while the processor was executing in the branch delay slot. If so, then the EPC will be rolled back to point to the branch instruction, so that it can be re-executed and the branch direction re-determined.
- CE** The Co-processor Error field captures the co-processor unit number referenced when a Co-processor Unusable exception is detected.
- IP** The Interrupt Pending field indicates which interrupts are pending. Regardless of which interrupts are masked, the IP field can be used to determine which interrupts are pending.

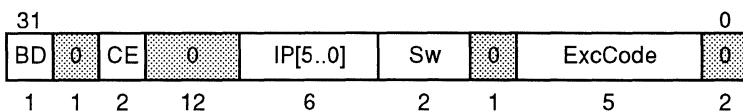

BD: BRANCH DELAY  
 CE: COPROCESSOR ERROR  
 IP: INTERRUPTS PENDING  
 Sw: SOFTWARE INTERRUPTS\*

ExcCode: EXCEPTION CODE FIELD

 : RESERVED  
 Must Be Written as 0  
 Returns 0 when Read

\*READ AND WRITE. THE REST ARE READ-ONLY.

Figure 6.2. The Cause Register

4000 drw 26

**SW** The Software interrupt bits can be thought of as the logical extension of the IP field. The SW interrupts can be written to to force an interrupt to be pending to the processor, and are useful in the prioritization of exceptions. To set a software interrupt, a “1” is written to the appropriate SW bit, and a “0” will clear the pending interrupt. There are corresponding interrupt mask bits in the status register for these interrupts.

**ExcCode** The exception code field encodes the cause of the most recently taken exception. The values of this field are shown in table 6.3.

Number	Mnemonic	Description
0	Int	External Interrupt
1	MOD	TLB Modification Exception
2	TLBL	TLB miss Exception (Load or instruction fetch)
3	TLBS	TLB miss exception (Store)
4	AdEL	Address Error Exception (Load or instruction fetch)
5	AdES	Address Error Exception (Store)
6	IBE	Bus Error Exception (for Instruction Fetch)
7	DBE	Bus Error Exception (for data Load or Store)
8	Sys	SYSCALL Exception
9	Bp	Breakpoint Exception
10	RI	Reserved Instruction Exception
11	CpU	Co-Processor Unusable Exception
12	Ovf	Arithmetic Overflow Exception
13-31	-	Reserved

4000 tbl 19

Table 6.3. Cause Register Exception Codes

### The EPC (Exception Program Counter) Register

The 32-bit EPC register contains the virtual address of the instruction which took the exception, from which point processing resumes after the exception has been serviced. When the virtual address of the instruction resides in a branch delay slot, the EPC contains the virtual address of the instruction immediately preceding the exception (that is, the EPC points to the Branch or Jump instruction).

### Bad VAddr Register

The Bad VAddr register saves the entire bad virtual address for any addressing exception.

### Context Register

The Context register duplicates some of the information in the BadVAddr register, but provides this information in a form that may be more useful for a software TLB exception handler.

Figure 6.3 illustrates the layout of the Context register. The Context register is used to allow software to quickly determine the main memory address of the page table entry corresponding to the bad virtual address, and allows the TLB to be updated by software very quickly (using a nine-instruction code sequence).

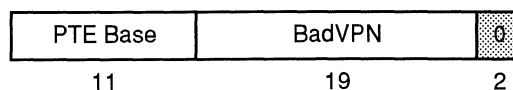

0: RESERVED: READ AS 0, MUST BE WRITTEN AS 0

BadVPN: FAILING VIRTUAL PAGE NUMBER (SET BY HARDWARE;  
READ ONLY FIELD DERIVED FROM BADVADDR REGISTER)

PTE Base: BASE ADDRESS OF PAGE TABLE ENTRY;  
SET BY KERNEL SOFTWARE

Figure 6.3. Context Register

4000 drw 27



## The Status Register

The Status register contains all the major status bits; any exception puts the system in Kernel mode. All bits in the status register, with the exception of the TS (TLB Shutdown) bit, are readable and writable; the TS bit is read-only. Figure 6.4 shows the functionality of the various bits in the status register.

The status register contains a three level stack (current, previous, and old) of the kernel/user mode bit (KU) and the interrupt enable (IE) bit. The stack is pushed when each exception is taken, and popped by the Restore From Exception instruction. These bits may also be directly read or written.

At reset, the SWc, KUc, and IEc bits are set to zero; BEV is set to one; and the value of the TS bit depends on whether the device is an Extended Architecture version (TS = 0) or base version (TS = 1). The rest of the bit fields are undefined after reset.

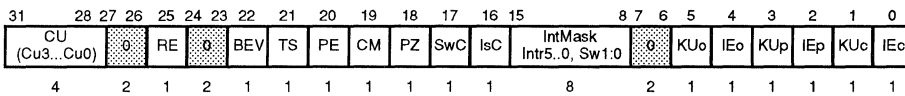

CU: COPROCESSOR USABILITY  
 BEV: BOOTSTRAP EXCEPTION VECTOR  
 TS: TLB SHUTDOWN  
 PE: PARITY ERROR  
 CM: CACHE MISS  
 PZ: PARITY ZERO  
 SwC: SWAP CACHES  
 IsC: ISOLATE CACHE  
 RE: REVERSE ENDIANNESS

IntMASK: INTERRUPT MASK  
 KUo: KERNEL/USER MODE, OLD  
 IEo: INTERRUPT ENABLE, OLD  
 KUp: KERNEL/USER MODE, PREVIOUS  
 IEp: INTERRUPT ENABLE, PREVIOUS  
 KUc: KERNEL/USER MODE, CURRENT  
 IEc: INTERRUPT ENABLE, CURRENT  
 0: RESERVED: READ AS ZERO  
 MUST BE WRITTEN AS ZERO

Figure 6.4. The Status Register

4000 drw 28

The various bits of the status register are defined as follows:

- CU** Co-processor Useability. These bits individually control user level access to co-processor operations, including the polling of the BrCond input port and the manipulation of the System Control Co-processor.
- RE** Reverse Endianness. The R3051 family allows the system to determine the byte ordering convention for the Kernel mode, and the default setting for user mode, at reset time. If this bit is cleared, the endianness defined at reset is used for the current user task. If this bit is set, then the user task will operate with the opposite byte ordering convention from that determined at reset. This bit has no effect on kernel mode operation.
- BEV** Bootstrap Exception Vector. The value of this bit determines the locations of the exception vectors of the processor. If BEV = 1, then the processor is in “Bootstrap” mode, and the exception vectors reside in uncacheable space. If BEV = 0, then the processor is in normal mode, and the exception vectors reside in cacheable space.
- TS** TLB Shutdown. This bit reflects whether the TLB is functioning. At reset, this bit can be used to determine whether the current processor is a base or extended architecture version. In extended architecture versions, this bit will also reflect whether the TLB is operating normally, as described in Chapter 5.
- PE** Parity Error. This bit is set if a cache parity error has occurred. Since the R3081 transparently recovers from parity errors by processing a cache miss to access main memory, this bit is only intended for diagnostic purposes. Software can use this bit to log cache parity errors, and diagnostics can use it to verify proper functioning of the cache parity bits and parity trees. To clear this bit, write a '1' to PE;

writing a zero does not affect its value. At boot time, this bit should be cleared by software.

- CM** Cache Miss. This bit is set if a cache miss occurred while the cache was isolated. It is useful in determining the size and operation of the internal cache subsystem.
- PZ** Parity Zero. If this bit is set, outgoing cache parity bits (for both the data and tag fields) for store instructions are set to '0', regardless of the data pattern. This bit is used for diagnostics.
- SwC** Swap Caches. Setting this bit causes the execution core to use the on-chip instruction cache as a data cache and vice-versa. Resetting the bit to zero unswaps the caches. This is useful for certain operations such as instruction cache flushing. This bit is not intended for normal operation.
- IsC** Isolate Cache. If this bit is set, the data cache is "isolated" from main memory; that is, store operations modify the data cache but do not cause a main memory write to occur, and load operations return the data value from the cache whether or not a cache hit occurred. This bit is also useful in various operations such as flushing, as described in Chapter 4.
- IM** Interrupt Mask. This 8-bit field can be used to mask the hardware and software interrupts to the execution engine (that is, not allow them to cause an exception). IM(1:0) are used to mask the software interrupts, and IM (7:2) mask the 6 external interrupts. A value of '0' disables a particular interrupt, and a '1' enables it. Note that the IE bit is a global interrupt enable; that is, if the IE is used to disable interrupts, the value of particular mask bits is irrelevant; if IE enables interrupts, then a particular interrupt is selectively masked by this field.
- KUo** Kernel/User old. This is the privilege state two exceptions previously. A '0' indicates kernel mode.
- IEo** Interrupt Enable old. This is the global interrupt enable state two exceptions previously. A '1' indicates that interrupts were enabled, subject to the IM mask.
- KUp** Kernel/User previous. This is the privilege state prior to the current exception. A '0' indicates kernel mode.
- IEp** Interrupt Enable old. This is the global interrupt enable state prior to the current exception. A '1' indicates that interrupts were enabled, subject to the IM mask.
- KUc** Kernel/User current. This is the current privilege state. A '0' indicates kernel mode.
- IEc** Interrupt Enable current. This is the current global interrupt enable state. A '1' indicates that interrupts are enabled, subject to the IM mask.
- '0'** Fields indicated as '0' are reserved; they must be written as '0', and will return '0' when read.

## Config Register

The Config register is unique to the R3081 family. It is provided to allow the system designer more flexibility in the CPU interface to the rest of the system. Functions included in this register are the FPA to CPU interrupt assignment, the data cache refill block size, and power reduction logic. The format for this register is shown in Figure 6.5. In general, software should allow a minimum of 10 instruction cycles before relying on a change to any of these bit fields resulting in a change in the processor's behavior.

There are two important notes for this register with respect to software compatibility with the R3000A and R3051:

- The individual bit fields of the register are reset into a known, useful, and compatible state. Thus, shrink wrap operating systems which do not access the register will still operate properly on the R3081.
- The register contains a "Lock" bit feature. This bit, once set, inhibits future writes to the register. Only a processor reset can clear the lock.

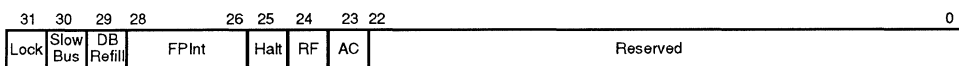

Lock: 1 -> Ignore subsequent writes to this register  
 Slow Bus: 1 -> Extra time for bus turnaround  
 DB Refill: 1 -> 4 word refill  
 FPInt: Power of two encoding of FPInt <-> CPU Interrupt  
 Halt: 1 -> Stall CPU until reset or interrupt  
 RF: 1 -> Divide frequency by 16  
 AC: 1 -> 8kB per cache configuration  
 Reserved: Must be written as 0; returns 0 when read

**Figure 6.5. R3081 Config Register**

The individual bit fields of this register include:

### Lock:

A '1' written to this bit field forces all subsequent writes to the Config register to be ignored. Note that values written to the other bit fields of the config register in the same store operation used to "lock" the register will be accepted, but future attempts to change those values will be ignored.

A processor Reset clears this bit to "0"

### Slow Bus:

This bit affects the bus turnaround characteristics of the multiplexed A/D bus of the processor. Specifically, this bit affects the minimum amount of time allowed in transitioning the bus from being driven externally (i.e. read data) to being driven by the processor (i.e. providing an address for a subsequent transfer). Currently, the R3051 family samples data on the falling edge of  $\overline{\text{SysClk}}$ , and can begin driving a new address on the immediately subsequent rising edge of the clock.

If the bus is operating at full processor frequency, the only case where such a rapid transition can occur is in a read followed by a write; the internal processor fixup cycle insures a minimum of one additional cycle between reads. Thus, if slow bus turnaround is desired, software must set this bit prior to executing any main memory writes. When half-frequency bus mode is selected, the default value for this bit is "1", corresponding to a slow bus. If this bit is set to a "1", the R3081 will insure an additional cycle (minimum of 1.5 cycles total) for transitioning between bus sources. If this bit is cleared to a "0", R3051 compatible operation will result.

At Reset, the initial value of this bit is determined by the value of the half-frequency bus option; if a full frequency bus is selected, the initial value of this bit is "0"; if a half frequency bus is selected, the initial value of this bit is "1".

**FPInt:**

This three bit field determines which of the six integer unit Interrupt inputs is used for the floating point interrupt signal. This field allows the system designer to establish the interrupt priority scheme appropriate to the target application.

Table 6.4 shows the encoding of this three bit field.

At reset, the default value of this field is '011'; thus, the on-chip floating point unit uses processor interrupt input (3), corresponding to IP(5) of the CP0 status register (the software interrupts are IP(1:0)). This is in keeping with the recommendations of the MIPS Architecture reference manual.

Note that the interrupt input pin corresponding to the floating point to CPU connection will be ignored. That is, external transitions on this pin will not cause the processor to take an interrupt exception.

**DB Refill:**

This bit selects the type of read transfer used to satisfy misses in the on-chip data cache. Specifically, a value of '0' will cause all data cache misses to be processed as single word reads; a value of '1' will cause data cache misses to use quad word read cycles.

This bit allows software to dynamically change the refill characteristics of the system. Algorithms to manipulate a frame buffer may choose different refill characteristics than algorithms to manage the network interface.

The initial value of this bit is determined at reset, via the DBlockRefill mode vector.

FPInt(2:0)	CPU Interrupt
000	Int(0)
001	Int(1)
010	Int(2)
011	Int(3)
100	Int(4)
101	Int(5)
11x	Reserved

**Table 6.4. Encoding of FPInt field of Config Register**

**RF:**

This bit can cause the processor to operate at reduced frequency, in order to reduce power consumption.

If this bit is cleared ("0"), the processor will operate at the frequency provided at its clock input. If this bit is set ("1"), the processor will divide the input clock frequency by 16; this will reduce the internal operation, and the bus clock, by 16 .

Note that this function can only be used in systems operating above 33 MHz, so that the minimum clock frequency specification will not be violated.

**Halt:**

This bit is used to force the processor to enter a stall. The processor will remain stalled until it is either reset, or an interrupt input is asserted (regardless of the current masking state). Writing a '1' to this bit causes the processor to stall. At reset, this bit is cleared.

**Alt Cache:**

This bit is used to select between the two cache configurations supported by the R3081. At reset, this bit is cleared ("0"), corresponding to the 16kB Instruction/4kB Data cache configuration.

Writing a "1" to this bit re-configures the on-chip caches as 8kB of Instruction and 8kB of Data cache. The cache can be dynamically changed between the two configurations. After changing the cache configuration, both caches must be fully flushed to insure proper operation.

**Reserved:**

This field must be written with the value "0". This field will return "0" when read.

**PrId Register**

This register is useful to software in determining which revision of the processor is executing the code. The format of this register is illustrated in Figure 6.6; the value currently returned is 0x0000\_0230, which is the same as the R3000A.

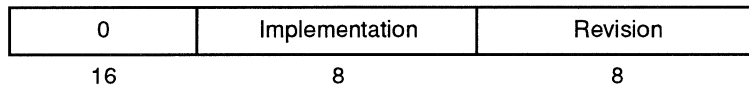

0: READ AS 0, MUST BE WRITTEN AS 0

Implementation: EXECUTION ENGINE IMPLEMENTATION CODE

Revision: REVISION LEVEL FOR THIS IMPLEMENTATION

4000 drw 29

**Figure 6.6. Format of PrId Register**

**EXCEPTION VECTOR LOCATIONS**

The R3051 family separates exceptions into three vector spaces. The value of each vector depends on the BEV (Boot Exception Vector) bit of the status register, which allows two alternate sets of vectors (and thus two different pieces of code) to be used. Typically, this is used to allow diagnostic tests to occur before the functionality of the cache is validated; processor reset forces the value of the BEV bit to a 1. Tables 6.5 and 6.6 list the exception vectors for the R3051 family for the two different modes.

Exception	Virtual Address	Physical Address
<b>Reset</b>	0xbfc0_0000	0x1fc0_0000
<b>UTLB Miss</b>	0x8000_0000	0x0000_0000
<b>General</b>	0x8000_0080	0x0000_0080

4000 tbl 20

**Table 6.5. Exception Vectors When BEV = 0**

Exception	Virtual Address	Physical Address
<b>Reset</b>	0xbfc0_0000	0x1fc0_0000
<b>UTLB Miss</b>	0xbfc0_0100	0x1fc0_0100
<b>General</b>	0xbfc0_0180	0x1fc0_0180

4000 tbl 21

**Table 6.6. Exception Vectors When BEV = 1**

## EXCEPTION PRIORITIZATION

It is important to understand the structure of the R3051 family instruction execution unit in order to understand the exception priority model of the processor. The R3051 family runs instructions through a five stage pipeline, illustrated in Figure 6.7. The pipeline stages are:

- **IF:** Instruction Fetch. This cycle contains two parts: the IVA (Instruction Virtual Address) phase, which generates the virtual instruction address of the next instruction to be fetched, and the ITLB phase, which performs the virtual to physical translation of the address.
- **RD:** Read and Decode. This phase obtains the required data from the internal registers and also decodes the instruction.
- **ALU:** This phase either performs the desired arithmetic or logical operation, or generates the address for the upcoming data operation. For data operations, this phase contains both the data virtual address stage, which generates the desired virtual address, and the data TLB stage, which performs the virtual to physical translation.
- **MEM:** Memory. This phase performs the data load or store transaction.
- **WB:** Write Back. This stage updates the registers with the result data.

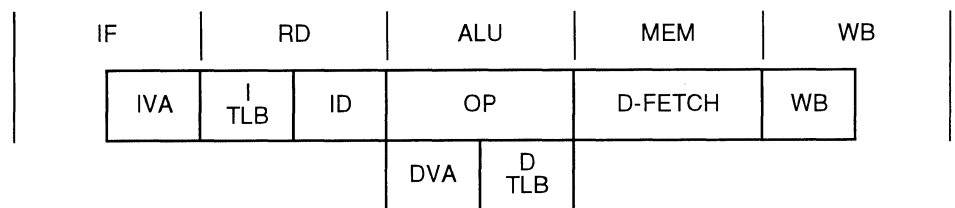

4000 drw 30

**Figure 6.7. Pipelining in the R3051 Family**

High performance is achieved because five instructions are operating concurrently, each in a different stage of the pipeline. However, since multiple instructions are operating concurrently, it is possible that multiple exceptions are generated concurrently. If so, the processor must decide which exception to process, basing this decision on the stage of the pipeline that detected the exception. The processor will then flush all preceding pipeline stages to avoid altering processor context, thus implementing precise exceptions. This determines the relative priority of the exceptions.

For example, an illegal instruction exception can only be detected in the instruction decode stage of the processor; an Instruction Bus Error can only be determined in the I-Fetch pipe stage. Since the illegal instruction was fetched before the instruction which generated the bus error was fetched, and since it is conceivable that handling this exception might have avoided the second exception, it is important that the processor handle the illegal instruction before the bus error. Therefore the exception detected in the latest pipeline stage has priority over exceptions detected in earlier pipeline stages. All instructions fetched subsequent to this (all preceding pipeline stages) are flushed to avoid altering state information, maintaining the precise exception model.

Table 6.7 lists the priority of exceptions from highest first to lowest.

Mnemonic	Pipestage
Reset	Any
AdEL	Memory (Load instruction)
AdES	Memory (Store instruction)
DBE	Memory (Load or store)
MOD	ALU (Data TLB)
TLBL	ALU (DTLB Miss)
TLBS	ALU (DTLB Miss)
Int	ALU
Ovf	ALU
Sys	RD (Instruction Decode)
Bp	RD (Instruction Decode)
RI	RD (Instruction Decode)
CpU	RD (Instruction Decode)
TLBL	I-Fetch (ITLB Miss)
AdEL	IVA (Instruction Virtual Address)
IBE	RD (end of I-Fetch)

4000 tbl 22

Table 6.7. Exception Priority

## EXCEPTION LATENCY

A critical measurement of a processor's throughput in interrupt driven systems is the interrupt "latency" of the system. Interrupt latency is a measurement of the amount time from the assertion of an interrupt until software begins handling that interrupt. Often included when discussing latency is the amount of overhead associated with restoring context once the exception is handled, although this is typically less critical than the initial latency.

In systems where the processor is responsible for managing a number of time-critical operations in real time, it is important that the processor minimize interrupt latency. That is, it is more important that *every* interrupt be handled at a rate above some given value, rather than *occasionally* handle an interrupt at very high speed.

Factors which affect the interrupt latency of a system include the types of operations it performs (that is, systems which have long sequences of operations during which interrupts can not be accepted have long latency), how much information must be stored and restored to preserve and restore processor context, and the priority scheme of the system.

Table 6.7 illustrates which pipestage recognizes which exceptions. As mentioned above, all instructions less advanced in the pipeline are flushed from the pipeline to avoid altering state execution. Those instructions will be restarted when the exception handler completes.

Once the exception is recognized, the address of the appropriate exception vector will be the next instruction to be fetched. In general, the latency to the exception handler is one instruction cycle, and at worst the longest stall cycle in that system.

## INTERRUPTS IN THE R3051 FAMILY

The R3051 family features two types of interrupt inputs: synchronized internally and non-synchronized, or direct.

The  $\overline{\text{SInt}}(2:0)$  bus (Synchronized Interrupts) allow the system designer to connect unsynchronized interrupt sources to the processor. The processor includes special logic on these inputs to avoid meta-stable states associated with switching inputs right at the processor sampling point. Because of this logic, these interrupt sources have slightly longer latency from the  $\overline{\text{SInt}}(n)$  pin to the exception vector than the non-synchronized inputs. The operation of the synchronized interrupts is illustrated in Figure 6.8.

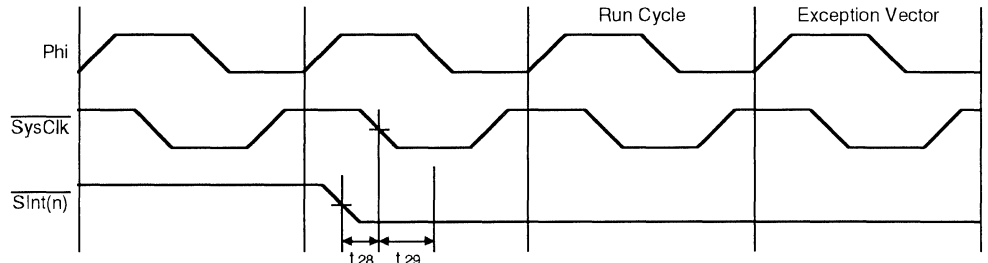

Figure 6.8. Synchronized Interrupt Operation

4000 drw 31

The other interrupts,  $\overline{\text{Int}}(5:3)$ , do not contain this synchronization logic, and thus have slightly better latency to the exception vector. However, the interrupting agent must guarantee that it always meets the interrupt input set-up and hold time requirements of the processor. These inputs are useful for interrupting agents which operate off of the  $\overline{\text{SysClk}}$  output of the processor. The operation of these interrupts is illustrated in Figure 6.9.

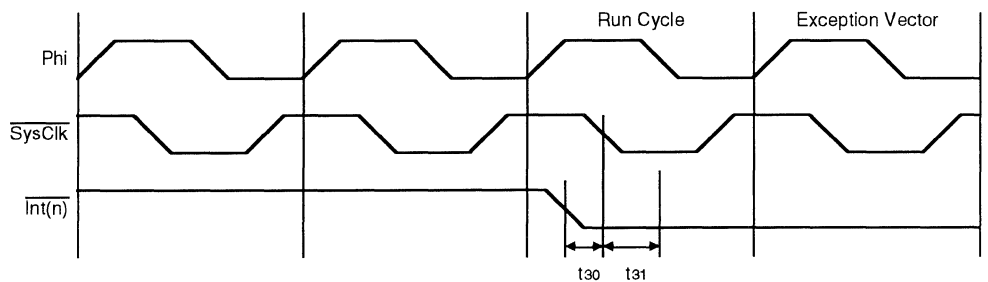

Figure 6.9. Direct Interrupt Operation

4000 drw 32

Note that one of the processor interrupt inputs will be used for the internal floating point unit, as determined by the Config register. The external input pin corresponding to the selected interrupt path for the floating point will be ignored. The system must provide a pull-up at the corresponding pin.

Since the interrupt exception is detected during the ALU stage of the instruction currently in the processor pipeline, at least one run cycle must occur between (or at) the assertion of the external interrupt input and the fetch of the exception vector. Thus, if the processor is in a stall cycle when an external agent sends an interrupt, it will execute at least one run cycle before beginning exception processing. In this instance, there would be no difference in the latency of synchronized and direct interrupt inputs.

All of the interrupts are level-sensitive and active low. They continue to be sampled after an interrupt exception has occurred, and are not latched within the processor when an interrupt exception occurs. It is important that the external interrupting agent maintain the interrupt line until software acknowledges the interrupt.

Each of the eight interrupts (6 hardware and 2 software) can be individually masked by clearing the corresponding bit in the Interrupt Mask field of the Status Register. All eight interrupts can be masked at once by clearing the IEC bit in the Status Register.

On the synchronized interrupts, care should be taken to allow at least two clock cycles between the negation of the interrupt input and the re-enabling of the interrupt mask for that bit.



The value shown in the interrupt pending bits of the Cause register reflects the current state of the interrupt pins and floating point interrupt of the processor. These bits are not latched (except for sampling from the data bus to guarantee that they are stable when examined), and the masking of specific interrupt inputs does not mask the bits from being read.

## USING THE BrCond INPUTS

In addition to the interrupt pins themselves, many systems can use the BrCond input port pins in their exception model. These pins can be directly tested by software, and can be used for polling or fast interrupt decoding.

As with the interrupt bus, there are two versions of the BrCond pins. BrCond(1:0) are direct inputs, and thus the set-up and hold requirements of the processor must be met. BrCond(3:2) are synchronized inputs, and thus may be driven by asynchronous sources. The timing requirements of the BrCond inputs are illustrated in Figure 6.10 and Figure 6.11.

In the R3081, BrCond(1) is used by the internal floating point unit. Thus, this pin is a "no connect" on these devices; when software performs a Branch on the value of CpCond(1), the outcome of the branch is determined by the state of the floating point unit, rather than the value of this external pin.

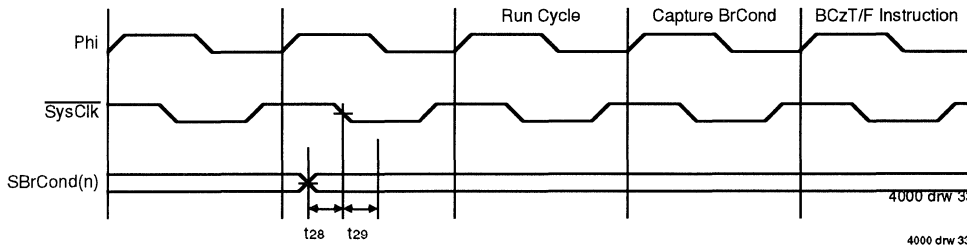

Figure 6.10. Synchronized BrCond Inputs

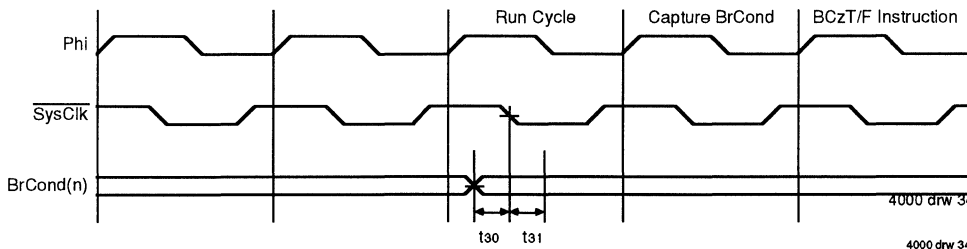

Figure 6.11. Direct BrCond Inputs

Similar to the interrupt inputs, at least one instruction must be executed (in the ALU stage) of the instruction pipeline prior to software being able to detect a change in one of these inputs. This is because the processor actually captures the value of these flags one instruction prior to the branch on co-processor instruction. Thus, if the processor is in a stall when the flag changes, there will be no difference in the time required for the processor to recognize synchronized or direct BrCond inputs.

## INTERRUPT HANDLING

The assertion of an unmasked interrupt input causes the R3051 family to branch to the general exception vector at virtual address 0x8000\_0080, and write the 'Int' code in the Cause register. The IP field of the Cause register shows which of the six hardware interrupts are pending and the SW field in the Cause register show which of the two software interrupts are pending. Multiple interrupts can be pending at the same time, with no priority assumed by the processor.

When an interrupt occurs, the KUp, IEp, KUc and IEc bits of the Status register are saved in the KUo, IEo, KUp, IEp bit fields in the Status register, respectively, as illustrated in Figure 6.12. The current kernel status bit KUc and the interrupt bit IEc are cleared. This masks all the interrupts and places the processor in kernel mode. This sequence will be reversed by the execution of an rfe (restore from exception) instruction.

### INTERRUPT SERVICING

In case of a hardware interrupt, the interrupt must be cleared by deasserting the interrupt line, which has to be done by alleviating the external conditions that caused the interrupt. Software interrupts have to be cleared by clearing the corresponding bits, SW(1:0), in the Cause register to zero.

If the case where the interrupt to be serviced corresponds to the on-chip floating point, software in general will examine the floating point status register to determine the exact nature of the floating point exception. Later in this chapter, specific techniques for handling floating point exceptions will be discussed. Note that IDT has software libraries available which will perform the interrupt servicing of the on-chip floating point unit.

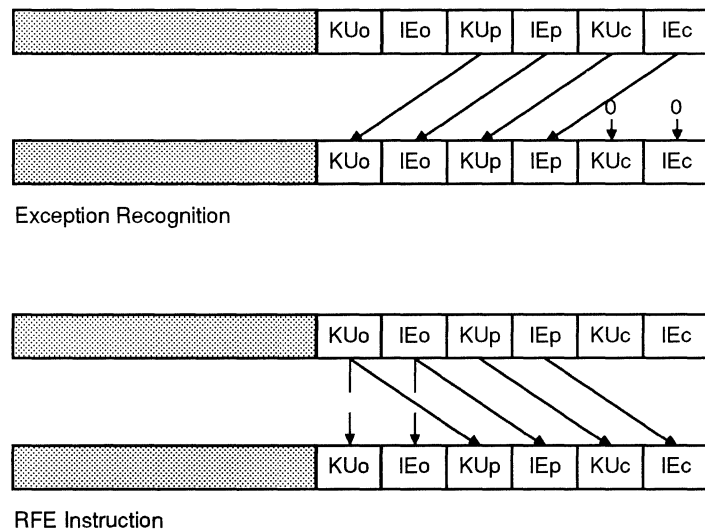

Figure 6.12. Kernel and Interrupt Status Being Saved on Interrupts

### BASIC SOFTWARE TECHNIQUES FOR HANDLING INTERRUPTS

Once an exception is detected the processor suspends the current task, enters kernel mode, disables interrupts, and begins processing at the exception vector location. The EPC is loaded with the address the processor will return to once the exception event is handled.

The specific actions of the processor depend on the cause of the exception being handled. The R3051 family classifies exceptions into three distinct classes: RESET, UTLB Miss, and General.

Coming out of reset, the processor initializes the state of the machine. In addition to initializing system peripherals, page tables, the TLB, and the caches, software clears both STATUS and CAUSE registers, and initializes the exception vectors.

The code located at the exception vector may be just a branch to the actual exception code; however, in more time critical systems the instructions located at the exception vector may perform the actual exception processing. In order to cause the exception vector location to branch to the appropriate exception handler (presuming that such a jump is appropriate), a short code sequence such as that illustrated in Figure 6.13 may be used.

```

.set      noreorder          # tells the assembler not to reorder the code
/*
**   code sequence copied to UTLB exception vector
*/
    la     k0,excep_utlb     #address of utlb excp. handler
    j      k0                # jump via reg k0
    nop

/*
**   code sequence copied to general exception vector
*/
    la     k0,excep_general  #address of general excp. handler
    j      k0                # jump via reg k0
    nop

```

4000 drw 36

**Figure 6.13. Code Sequence to Initialize Exception Vectors**

It should be noted the the contents of register k0 are not preserved. This is not a problem for software, since MIPS compiler and assembler conventions reserve k0 for kernel processes, and do not use it for user programs. For the system developer it is advised that the use of k0 be reserved for use by the exception handling code exclusively. This will make debugging and development much easier.

## PRESERVING CONTEXT

The R3051 family has the following registers related to exception processing:

1. The *Cause* register
2. The *EPC* (exception program counter) register
3. The *Status* register
4. The *BadVAddr* (bad virtual address) register
5. The *Context* register
6. The *Config* register

Typical exception handlers preserve the status, cause, and EPC registers in general registers (or on the system stack). If the exception cause is due to a TLB miss, software may also preserve the bad virtual address and context registers for later processing.

Note that not all systems need to preserve this information. Since the R3051 family disables subsequent interrupts, it is possible for software to directly process the exception while leaving the processor context in the CP0 registers. Care must be taken to insure that the execution of the exception handler does not generate subsequent exceptions.

Preserving the context in general registers (and on the stack) does have the advantage that interrupts can be re-enabled while the original exception is handled, thus allowing a priority interrupt model to be built.

A typical code sequence to preserve processor context is shown in Figure 6.14. This code sequence preserves the context into an area of memory pointed to by the k0 kernel register. This register points to a block of memory capable of storing processor context. Constants identified by name (such as *R\_EPC*) are used to indicate the offset of a particular register from the start of that memory area.

```

la      k0,except_regs      # fetch address of reg save array
sw      AT,R_AT*4(k0)      # save register AT
sw      v0,R_V0*4(k0)      # save register v0
sw      v1,R_V1*4(k0)      # save register v1
mfc0    v0,C0_EPC          # fetch the epc register
mfc0    v1,C0_SR           # fetch the status register
sw      v0,R_EPC*4(k0)     # save the epc
mfc0    v0,C0_CAUSE        # fetch the cause register
sw      v1,R_SR*4(k0)      # save status register

/*      The above code is about the minimum required
**      The user specific code would follow
*/

```

4000 drw 37

Figure 6.14. Preserving Processor Context

It should be noted that this sequence for fetching the co-processor zero registers is required because there is a one clock delay in the register value actually being loaded into the general registers after the execution of the mfc0 instruction.

### DETERMINING THE CAUSE OF THE EXCEPTION

The cause register indicates the reason the exception handler was invoked. Thus, to invoke the appropriate exception service routine, software merely needs to examine the cause register, and use its contents to direct a branch to the appropriate handler.

One method of decoding the jump to an appropriate software routine to handle the exception and cause is shown in Figure 6.15. Register v0 contains the cause register, and register k0 still points to the register save array.

```

.set    noreorder
sw      a0,R_A0*4(k0)      # save register a0
and     v1,v0,EXCMASK      # isolate exception code
lw      a0,cause_table(v1) # get address of interrupt routine.
sw      a1,R_A1*4(k0)      # use delay slot to save register a1
j       a0
sw      k1,R_K1*4(sp)      # save k1 register
.set    reorder           # re-enable pipeline scheduling

```

4000 drw 38

Figure 6.15. Exception Cause Decoding

The above sequence of instructions extracts the exception code from the cause register and uses that code to index into the table of pointers to functions (the *cause\_table*). The *cause\_table* data structure is shown in Figure 6.16.

```

int (*cause_table[16])() = {
    int_extern,           /* External interrupts          */
    int_tlbmod,          /* TLB modification error      */
    int_tlbmiss,         /* load or instruction fetch    */
    int_tlbmiss,         /* write miss                   */
    int_addrerr,         /* load or instruction fetch    */
    int_addrerr,         /* write address error          */
    int_ibe,             /* Bus error - Instruction fetch*/
    int_dbe,             /* Bus error - load or store data*/
    int_syscall,         /* SYSCALL exception           */
    int_breakpoint,     /* breakpoint instruction       */
    int_trap,           /* Reserved instruction        */
    int_cpunuse,        /* coprocessor unusable        */
    int_trap,           /* Arithmetic overflow         */
    int_unexp,          /* Reserved                     */
    int_unexp,          /* Reserved                     */
    int_unexp,          /* Reserved                     */
};

```

4000 drw 39

Figure 6.16. Exception Service Branch Table

Each of the entries in this table point to a function for processing the particular type of interrupt detected. The specifics of the code contained in each of these functions is unique for a given application; all registers used in these functions must be saved and restored.

## RETURNING FROM EXCEPTIONS

Returning from the exception routine is made through the *rfe* instruction. When the exception first occurs the processor automatically saves some of the processor context, the current value of the interrupt enable bit is saved into the field for the previous interrupt enable bit, and the kernel/user mode context is preserved.

The *IE* interrupt enable bit must be asserted (a one) for external interrupts to be recognized. The *KU* kernel mode bit must be a zero in kernel mode. When an exception occurs, external interrupts are disabled and the processor is forced into kernel mode. When the *rfe* instruction is executed at completion of exception handling, the state of the mode bits is restored to what it was when the exception was recognized (presuming the programmer restored the status register to its value when the exception occurred). This is done by “popping” the old/previous/current *KU* and *IE* bits of the status register.

The code sequence in Figure 6.17 is an example of exiting an interrupt handler. The assumption is that registers and context were saved as outlined above.

```

gen_excp_exit:
    .set    noreorder
                # by the time we have gotten here
                # all general registers have been
                # restored (except of k0 and v0)
                # reg. AT points to the reg save array

    lw     k0,C0_SR*4(AT)    # fetch status reg. contents
    lw     v0,R_V0*4(AT)    # restore reg. v0
    mtc0   k0,C0_SR        # restore the status reg. contents
    lw     k0,R_EPC*4(AT)   # Get the return address
    lw     AT,R_AT*4(AT)    # restore AT in load delay
    j      k0               # return from int. via jump reg.
    rfe                    # the rfe instr. is executed in the
                # branch delay slot

    .set    reorder

```

4000 drw 40

Figure 6.17. Returning from Exception

This code sequence must either be replicated in each of the cause handling functions, or each of them must branch to this code sequence to properly exit from exception handling.

Note that this code sequence must be executed with interrupts disabled. If the exception handler routine re-enables interrupts they must be disabled when the CP0 registers are being restored.

## **SPECIAL TECHNIQUES FOR INTERRUPT HANDLING**

There are a number of techniques which take advantage of the R3051 family architecture to minimize exception latency and maximize throughput in interrupt driven systems. This section discusses a number of those techniques.

### **Interrupt Masking**

Only the six external and two software interrupts are maskable exceptions. The mask for these interrupts are in the status register.

To enable a given external interrupt, the corresponding bit in the status register must be set. The IEC bit in the status register must also be set. It follows that by setting and clearing these bits within the interrupt handler that interrupt priorities can be established. The general mechanism for doing this is performed within the external interrupt-handler portion of the exception handler.

The interrupt handler preserves the current mask value when the status register is preserved. The interrupt handler then calculates which (if any) external interrupts have priority, and sets the interrupt mask bit field of the status register accordingly. Once this is done, the IEC bit is changed to allow higher priority interrupts. Note that all interrupts must again be disabled when the return from exception is processed.

### **Using BrCond For Fast Response**

The R3051 family instruction set contains mechanisms to allow external or internal co-processors to operate as an extension of the main CPU. Some of these features may also be used in an interrupt-driven system to provide the highest levels of response.

Specifically, the R3051 family has external input port signals, the BrCond(3:0) signals. These signals are used by external agents to report status back to the processor. The instruction set contains instructions which allow the external bits to be tested, and branches to be executed depending on the value of BrCond. Note that for the R3081, BrCond(1) is actually used by the on-chip floating point unit, and thus is not available externally.

An interrupt-driven system can use these BrCond signals, and the corresponding instructions, to implement an input port for time-critical interrupts. Rather than mapping an input port in memory (which requires external logic), the BrCond signals can be examined by software to control interrupt handling.

There are actually two methods of advantageously using this. One method uses these signals to perform interrupt polling; in this method, the processor continually examines these signals, waiting for an appropriate value before handling the interrupt. A sample code sequence is shown in Figure 6.18.

```

.set      noreorder      # prevents the assembler from
                        # reordering the code below

polling_loop:
    bc2f    polling_loop  # branch to yourself until
                        # BrCond(2) is asserted
    nop

                        # Once BrCond(2) is asserted, fall through
                        # and begin processing the external event
fast_response_cp2:

                        # code sequence that would do the
                        # event processing

    b      polling_loop  # return to polling

```

4000 drw 41

**Figure 6.18. Polling System Using BrCond**

The software in this system is very compact, and easily resides in the on-chip cache of the processor. Thus, the latency to the interrupt service routine in this system is minimized, allowing the fastest interrupt service capabilities.

A second method utilizes external interrupts combined with the BrCond signals. In this method, both the BrCond signal and one of the external interrupt lines are asserted when an external event occurs. This configuration allows the CPU to perform normal tasks while waiting for the external event.

For example, assume that a valve must be closed and then normal processing continued when BrCond(2) is asserted TRUE. The valve is controlled by a register that is memory-mapped to address 0xaffe\_0020 and writing a one to this location closes the valve. The software in Figure 6.19 accomplishes this, using BrCond(2) to aid in cause decoding.

The number of cycles for a deterministic system is five cycles between the time the interrupt occurred and it was serviced. Interrupts were re-enabled in four additional cycles. Note that none of the processor context needs to be preserved and restored for this routine.

```

.set    noreorder          # prevents the assembler from reordering
                               # the code sequences below

/* This section of code is placed at the general exception
** vector location 0x8000_0080. When an external interrupt is
** asserted execution begins here.
*/

        bc2t    close_valve    # test for emergency condition and
        li      k0,1           # jump to close valve if TRUE
        la      k0,gen_exp_hand # otherwise,
        j       k0             # jump to general exc. handler
        nop                                # and process less critical excepts.

/* This is the close valve routine - its sole purpose is to close the
** valve as quickly as possible. The registers 'k0' and 'k1' are reserved
** for kernel use and therefore need not be saved when a client or
** user program is interrupted. It should be noted that the value to
** write to the valve close register was put in reg 'k0' in the
** branch delay slot above - so by the time we get here it is
** ready to output to the close register.
*/
close_valve:
        la      k1,0xaffe0020    # the address of the close register
        sw      k0,0(k1)         # write the value to the close register
        mfc0    k0,C0_EPC        # get the return address to cont processing
        nop
        j       k0               # return to normal processing
        rfe                                # restore previous interrupt mask
                                           # and kernel/user mode bits of the
                                           # status register.

.set    reorder

```

4000 drw 42

Figure 6.19. Using BrCond for Fast Interrupt Decoding

### Nested Interrupts

Note that the processor does not automatically stack processor context when an exception occurs; thus, to allow nested exceptions it is important that software perform this stacking.

Most of the software illustrated above also applies to a nested exception system. However, rather than using just one register (pointed to by k0) as a save area, a stacking area must be implemented and managed by software. Also, since interrupts are automatically disabled once an exception is detected, the interrupt handling routine must mask the interrupt it is currently servicing, re-enable other interrupts (once context is preserved) through the IEC bit.

The use of Interrupt Mask bits of the status register to implement an interrupt prioritization scheme was discussed earlier. An analogous technique can be performed by using an external interrupt encoder to allow more interrupt sources to be presented to the processor.

Software interrupts can also be used as part of the prioritization of interrupts. If the interrupt service routine desires to service the interrupting agent, but not completely perform the interrupt service, it can cause the external agent to negate the interrupt input but leave interrupt service pending through the use of the SW bits of the Cause register.



**Catastrophic Exceptions**

There are certain types of exceptions that indicate fundamental problems with the system. Although there is little the software can do to handle such events, they are worth discussing. Exceptions such as these are typically associated with faulty systems, such as in the initial debugging or development of the system.

Potential problems can arise because the processor does not automatically stack context information when an exception is detected. If the processor context has not been preserved when another exception is recognized, the value of the status, cause, and EPC registers are lost and thus the original task can not be resumed.

An example of this occurring is an exception handler performing a memory reference that results in a bus error (for example, when attempting to preserve context). The bus error forces execution to the exception vector location, overwriting the status, cause, and context registers. Proper operation cannot be resumed.

## HANDLING SPECIFIC EXCEPTIONS

This section documents some specific issues and techniques for handling particular R3051 family exceptions.

### Address Error Exception

#### Cause

This exception occurs when an attempt is made to load, fetch, or store a word that is not aligned on a word boundary. Attempting to load or store a half-word that is not aligned on a half-word boundary will also cause this exception. The exception also occurs in User mode if a reference is made to a virtual address whose most significant bit is set (a kernel address). This exception is not maskable.

#### Handling

The R3051 family branches to the General Exception vector for this exception. When the exception occurs, the processor sets the ADEL or ADES code in the Cause register ExcCode field to indicate whether the address error occurred during an instruction fetch or a load operation (ADEL) or a store operation (ADES).

The EPC register points at the instruction that caused the exception, unless the instruction is in a branch delay slot: in that case, the EPC register points at the branch instruction that preceded the exception-causing instruction and sets the BD bit of the Cause register.

The processor saves the KUp, IEp, KUc, and IEc bits of the Status register in the KUo, IEo, KUp, and IEp bits, respectively and clears the KUc and IEc bits.

When this exception occurs, the BadVAddr register contains the virtual address that was not properly aligned or that improperly addressed kernel data while in User mode. The contents of the VPN field of the Context and EntryHi registers are undefined.

#### Servicing

A kernel should hand the executing process a segmentation violation signal. Such an error is usually fatal although an alignment error might be handled by simulating the instruction that caused the error.

## Breakpoint Exception

### Cause

This exception occurs when the processor executes the BREAK instruction. This exception is not maskable.

### Handling

The processor branches to the General Exception vector for the exception and sets the BP code in the CAUSE register ExcCode field.

The processor saves the *KUp*, *IEp*, *KUc*, and *IEc* bits of the Status register in the *KUo*, *KUp*, and *IEp* bits, respectively, and clears the *KUc* and *IEc* bits.

The *EPC* register points at the BREAK instruction that caused the exception, unless the instruction is in a branch delay slot: in that case, the *EPC* register points at the BRANCH instruction that preceded the BREAK instruction and sets the *BD* bit of the Cause register.

### Service

The breakpoint exception is typically handled by a dedicated system routine. Unused bits of the BREAK instruction (bits 25..6) can be used pass additional information. To examine these bits, load the contents of the instruction pointed at by the *EPC* register. NOTE: If the instruction resides in the branch delay slot, add four to the contents of the *EPC* register to find the instruction.

To resume execution, change the *EPC* register so that the processor does not execute the BREAK instruction again. To do this, add four to the *EPC* register before returning. NOTE: If a BREAK instruction is in the branch delay slot, the BRANCH instruction must be interpreted in order to resume execution.

## Bus Error Exception

### Cause

This exception occurs when the Bus Error input to the CPU is asserted by external logic during a read operation. For example, events like bus time-outs, backplane bus parity errors, and invalid physical memory addresses or access types can signal exception. This exception is not maskable.

This exception is used for synchronously occurring events such as cache miss refills. The general interrupt mechanism must be used to report a bus error that results from asynchronous events such as a buffered write transaction.

### Handling

The processor branches to the General Exception vector for this exception. When exception occurs, the processor sets the *IBE* or *DBE* code in the CAUSE register ExcCode field to indicate whether the error occurred during an instruction fetch reference (IBE) or during a data load or store reference (DBE).

The EPC register points at the instruction that caused the exception, unless the instruction is in a branch delay slot; in that case, the EPC register points at the BRANCH instruction that preceded the exception-causing instruction and sets the BD bit of the cause register.

The processor saves the KUp, IEp, KUc, and IEc bits of the Status register in the KUo, IEo, KUp, and IEp bits, respectively, and clears the KUc and IEc bits.

### Servicing

The physical address where the fault occurred can be computed from the information in the CPO registers:

- If the Cause register's IBE code is set (showing an instruction fetch reference), the virtual address resides in the EPC register.
- If the Cause register's DBE exception code is set (specifying a load or store reference), the instruction that caused the exception is at the virtual address contained in the EPC register (if the BD bit of the cause register is set, add four to the contents of the EPC register). Interpret the instruction to get the virtual address of the load or store reference and then use the TLBProbe (tlbp) instruction and read EntryLo to compute the physical page number.

A kernel should hand the executing process a bus error when this exception occurs. Such an error is usually fatal.

## Co-processor Unusable Exception

### Cause

This exception occurs due to an attempt to execute a co-processor instruction when the corresponding co-processor unit has not been marked usable (the appropriate CU bit in the status register has not been set). For CP0 instructions, this exception occurs when the unit has not been marked usable and the process is executing in User mode; CP0 is always usable from Kernel mode regardless of the setting of the CP0 bit in the status register. This exception is not maskable.

### Handling

The processor branches to the General Exception vector for this exception. It sets the CPU code in the CAUSE register ExcCode field. Only one co-processor can fail at a time.

The contents of the cause register's CE (Co-processor Error) field show which of the four coprocessors (3,2,1, or 0) the processor referenced when the exception occurred.

The EPC register points at the co-processor instruction that caused the exception, unless the instruction is in a branch delay slot: in that case, the EPC register points at the branch instruction that preceded the co-processor instruction and sets the BD bit of the Cause register.

The processor saves the KUp, IEp, KUc, and IEc bits of the status register in the KUo, IEo, KUp, and IEp bits, respectively, and clears the KUc and IEc bits.

### Servicing

To identify the co-processor unit that was referenced, examine the contents of the Cause register's CE field. If the process is entitled to access, mark the co-processor usable and restore the corresponding user state to the co-processor.

If the process is entitled to access to the co-processor, but the co-processor is known not to exist or to have failed, the system could interpret the co-processor instruction. If the BD bit is set in the Cause register, the BRANCH instruction must be interpreted; then, the co-processor instruction could be emulated with the EPC register advanced past the co-processor instruction.

If the process is not entitled to access to the co-processor, the process executing at the time should be handed an illegal instruction/privileged instruction fault signal. Such an error is usually fatal.

---

## Interrupt Exception

### Cause

This exception occurs when one of eight interrupt conditions (software generates two, hardware generates six) occurs.

Each of the eight external interrupts can be individually masked by clearing the corresponding bit in the IntMask field of the status register. All eight of the interrupts can be masked at once by clearing the IEC bit in the status register.

### Handling

The processor branches to the General Exception vector for this exception. The processor sets the INT code in the Cause register's ExcCode field.

The IP field in the Cause register show which of six external interrupts are pending, and the SW field in the cause register shows which two software interrupts are pending. More than one interrupt can be pending at a time.

The processor saves the KUp, IEp, KUc, and IEC bits of the status register in the KUo, IEo, KUp, and IEp bits, respectively, and clears the KUc and IEC bits.

### Servicing

If software generates the interrupt, clear the interrupt condition by setting the corresponding Cause register bit (SW1:0) to zero.

If external hardware generated the interrupt, clear the interrupt condition by alleviating the conditions that assert the interrupt signal.

If the interrupt corresponds to the on-chip FPA interrupt, service according to the discussion later in this chapter.

## Overflow Exception

### Cause

This exception occurs when an **ADD ADDI, SUB, or SUBI** instruction results in two's complement overflow. This exception is not maskable.

### Handling

The processor branches to the General Exception vector for this exception. The processor sets the OV code in the CAUSE register.

The EPC register points at the instruction that caused the exception, unless the instruction is in a branch delay slot: in that case, the EPC register points at the Branch instruction that preceded the exception-causing instruction and sets the BD bit of the CAUSE register.

The processor saves the KUp, IEp, KUc, and IEc bits of the status register in the KUo, IEo, KUp, and IEp bits, respectively, and clears the KUc and IEc bits.

### Servicing

A kernel should hand the executing process a floating point exception or integer overflow error when the exception occurs. Such an error is usually fatal.

---

## Reserved Instruction Exception

### Cause

This exception occurs when the processor executes an instruction whose major opcode (bits 31..26) is undefined or a Special instruction whose minor opcode (bits 5..0) is undefined.

This exception provides a way to interpret instructions that might be added to or removed from the processor architecture.

### Handling

The processor branches to the General Exception vector for this exception. It sets the RI code of the Cause register's ExcCode field.

The EPC register points at the instruction that caused the exception, unless the instruction is in a branch delay slot: in that case, the EPC register points at the Branch instruction that preceded the reserved instruction and sets the BD bit of the CAUSE register.

The processor saves the KUp, IEp, KUc, and IEc bits of the status register in the KUo, IEo, KUp, and IEp bits, respectively, and clears the KUc and IEc bits.

### Servicing

If instruction interpretation is not implemented, the kernel should hand the executing process an illegal instruction/reserved operand fault signal. Such an error is usually fatal.

An operating system can interpret the undefined instruction and pass control to a routine that implements the instruction in software. If the undefined instruction is in the branch delay slot, the routine that implements the instruction is responsible for simulating the branch instruction after the undefined instruction has been "executed". Simulation of the branch instruction includes determining if the conditions of the branch were met and transferring control to the branch target address (if required) or to the instruction following the delay slot if the branch is not taken. If the branch is not taken, the next instruction's address is  $[EPC] + 8$ . If the branch is taken, the branch target address is calculated as  $[EPC] + 4 + (\text{Branch Offset} * 4)$ .

Note that the target address is relative to the address of the instruction in the delay slot, not the address of the branch instruction. Refer to the description of branch instruction for details on how branch target addresses are calculated.



## Reset Exception

### Cause

This exception occurs when the processor RESET signal is asserted and then de-asserted.

### Handling

The processor provides a special exception vector for this exception. The Reset vector resides in the processor's unmapped and uncached address space; Therefore the hardware need not initialize the Translation Lookaside Buffer (TLB) or the cache to handle this exception. The processor can fetch and execute instructions while the caches and virtual memory are in an undefined state.

The contents of all registers in the processor are undefined when this exception occurs except for the following:

- The SWc, KUc, and IEc bits of the Status register are cleared to zero.
- The BEV bit of the Status register is set to one.
- The Random register is initialized to 63.
- For extended versions of the architecture, the TS bit is cleared to zero.
- For base versions of the architecture, the TS bit is frozen at one.
- The Config register is initialized and unlocked.

### Servicing

The reset exception is serviced by initializing all processor registers, co-processor registers, the caches, and the memory system. Typically, diagnostics would then be executed and the operating system bootstrapped. The reset exception vector is selected to appear in the uncached, unmapped memory space of the machine so that instructions can be fetched and executed while the cache and virtual memory system are still in an undefined state.

---

## System Call Exception

### Cause

This exception occurs when the processor executes a SYSCALL instruction.

### Handling

The processor branches to the General Exception vector for this exception and sets the SYS code in the CAUSE register's ExcCode field.

The EPC register points at the SYSCALL instruction that caused the exception, unless the SYSCALL instruction is in a branch delay slot: in that case, the EPC register points at the branch instruction that preceded the SYSCALL instruction and the BD bit of the CAUSE register is set.

The processor saves the KUp, IEp, KUC, and IEC bits of the status register in the KUo, IEo, KUp, and IEp bits, respectively, and clears the KUC and IEC bits.

### Servicing

The operating system transfers control to the applicable system routine. To resume execution, alter the EPC register so that the SYSCALL instruction does not execute again. To do this, add four to the EPC register before returning.

NOTE: If a SYSCALL instruction is in a branch delay slot, the branch instruction must be interpreted in order to resume execution.

**TLB Miss Exceptions**

There are three different types of TLB misses that can occur:

- If the input Virtual Page Number (VPN) does not match the VPN of any TLB entry, or if the Process Identifier (PID) in EntryHi does not match the TLB entry's PID (and the Global bit is not set), a miss occurs. For KUSEG references, a UTLB Miss exception is taken. For KSEG2 references, a TLB Miss occurs.
- If everything matches, but the valid bit of the matching TLB entry is not set, a TLB Miss occurs.
- If the dirty bit in a matching TLB entry is not set and the access is a write, a TLB MOD exception occurs.

Figure 6.20 (a simplified version of TLB address translation figure used in Chapter 5) illustrates how the three different kinds of TLB miss exceptions are generated. Each of the exceptions is described in detail in the pages that follow.

The TLB exceptions obviously only occur in extended architecture versions of the processor.

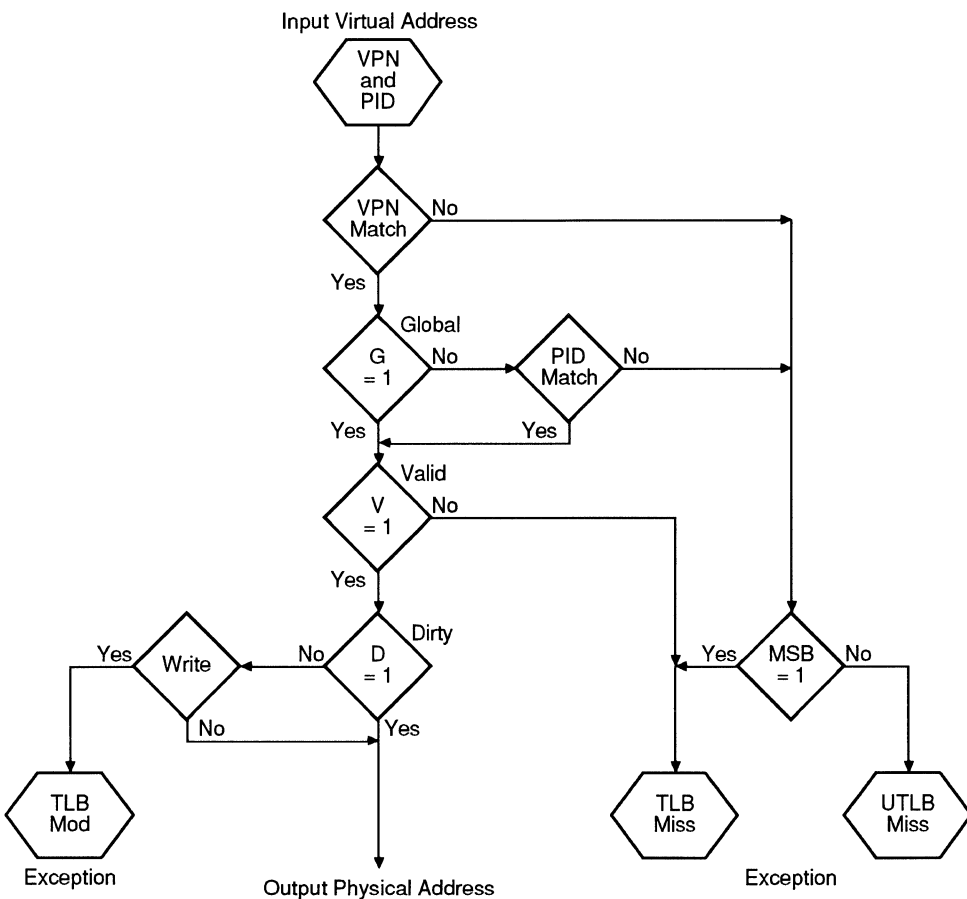

4000 drw 43

**Figure 6.20. TLB Miss Exceptions**

## TLB Miss Exception

### Cause

This exception occurs when a Kernel mode virtual address reference to memory is not mapped, when a User mode virtual address reference to memory matches an invalid TLB entry, or when a Kernel mode reference to user memory space matches an invalid TLB entry.

### Handling

The processor branches to the General Exception vector for this exception. When the exception occurs, the processor sets the TLBL or TLBS code in the CAUSE register's ExcCode field to indicate whether the miss was due to an instruction fetch or a load operation (TLBL) or a store operation (TLBS).

The EPC register points at the instruction that caused the exception, unless the instruction is in a branch delay slot: in that case, the EPC register points at the Branch instruction that preceded the exception-causing instruction and sets the BD bit of the Cause register. The processor saves the KUp, IEp, KUc, and IEc bits of the status register in the KUo, IEo, KUp, and IEp bits, respectively, and clears the KUc and IEc bits.

When this exception occurs, the BadVAddr, Context, and EntryHi register contain the virtual address that failed address translation. The PID field of EntryHi remains unchanged by this exception. The Random register normally specifies the pseudo-random location where the processor can put a replacement TLB entry.

### Servicing

The failing virtual address or virtual page number identifies the corresponding PTE. The operating system should load EntryLo with the appropriate PTE that contains the physical page frame and access control bits and also write the contents of EntryLo and EntryHi into the TLB.

### Servicing Multiple (nested) TLB Misses

Within a UTLB Miss handler, the virtual address that specifies the PTE contains physical address and access control information that might not be mapped in the TLB. Then, a TLB Miss exception occurs. This case is recognized by noting that the EPC register points within the UTLB Miss handler. The operating system might interpret the event as an address error (when the virtual address falls outside the valid region for the process) or as a TLB Miss on the page mapping table.

This second TLB miss obscures the contents of the BadVAddr, Context, and EntryHi registers as they were within the UTLB Miss handler. As a result, the exact virtual address whose translation caused the first fault is not known unless the UTLB Miss handler specifically saved this address. You can only observe the failing PTE virtual address. The BadVAddr register now contains the original contents of the Context register within the UTLB Miss handler, which is the PTE for the original faulting address.

If the operating system interprets the exception as a TLB Miss on the page table, it constructs a TLB entry to map the page table and writes the entry into the TLB. Then, the operating system can determine the original faulting virtual page number, but not the complete address. The operating system uses this information to fetch the PTE that contains the physical address and access control information. It also writes this information into the TLB.

The UTLB Miss handler must save the EPC in a way that allows the second miss to find it. The EPC register information that the UTLB Miss handler saved gives the correct address at which to resume execution. The "old" KUo and IEo bits of the status register contain the correct mode after the processor services a double miss. NOTE: You neither need nor want to return to the UTLB Miss handler at this point.

## TLB Modified Exception

### Cause

This exception occurs when the virtual address target of a store operation matches a TLB entry is marked valid, but not marked dirty. This exception is not maskable.

### Handling

The processor branches to the General Exception vector for this exception and sets the MOD exception code in the CAUSE register's ExcCode field.

When this exception occurs, the BadVAddr, Context, and EntryHi registers contain the virtual address that failed address translation. EntryHi also contains the PID from which the translation fault occurred.

The EPC register points at the instruction that caused the exception, unless the instruction is in a branch delay slot: in that case, the EPC register points at the Branch instruction that preceded the exception-causing instruction and sets the BD bit of the Cause register.

The processor saves the KUp, IEp, KUc, and IEc bits of the status register in the KUo, IEo, KUp, and IEp bits, respectively, and clears the KUc and IEc bits.

### Servicing

A kernel should use the failing virtual address or virtual page number to identify the corresponding access control information. The identified page might or might not permit write accesses. (Typically, software maintains the "real" write protection in other memory areas.) If the page does not permit write access, a "Write Protection Violation" occurs.

If the page does permit write accesses, the kernel should mark the page frame as dirty in its own data structures. Use the TLBProbe (tlbp) instruction to put the index of the TLB entry that must be altered in the Index register. Then load the EntryLo register with a word that contains the physical page frame and access control bits (with the data bit D set). Finally, use the TLBWrite Indexed (tlbwi) instruction to write EntryHi and EntryLo into the TLB.

## UTLB Miss Exception

### Cause

This exception occurs from User or Kernel mode references to user memory space when no TLB entry matches both the VPN and the PID. Invalid entries cause a TLB Miss rather than a UTLB Miss. This exception is not maskable.

### Handling

The processor uses the special UTLB Miss interrupt vector for this exception. When the exception occurs, the processor sets the TLBL or TLBS code in the Cause register ExcCode field to indicate whether the miss was due to an instruction fetch or a load operation (TLBL) or a store operation (TLBS).

The EPC register points at the instruction that caused the exception, unless the instruction is in a branch delay slot: in that case, the EPC register points at the Branch instruction that preceded the exception-causing instruction and sets the BD bit of the Cause register.

The processor saves the KUp, IEp, KUc, and IEc bits of the status register in the KUo, IEo, KUo, and IEp bits, respectively, and clears the KUc and IEc bits.

The virtual address that failed translation is held in the BadVAddr, Context, and EntryHi registers. The EntryHi register also contains the PID (Process Identifier) from which the translation fault occurred. The Random register contains a valid pseudo-random location in which to put a replacement TLB entry.

### Servicing

The contents of the Context register can be used as the virtual address of the memory word that contains the physical page frame and the access control bits (a Page Table Entry, or PTE) for the failing reference. An operating system should put the memory word in EntryLo and write the contents of EntryHi and EntryLo into the TLB by using a TLB Write Random (tlbwr) assembly instruction.

The PTE virtual address might be on a page that is not resident in the TLB. Therefore, before an operating system can reference the PTE virtual address, it should save the EPC register's contents in a general register reserved for kernel use or in a physical memory location. If the reference is not mapped in the TLB, a TLB Miss exception would occur within the UTLB Miss handler.

A short routine (nine instructions, one load) to service a UTLB miss is shown in figure 6.21.

mfc0	k0, C0_CTX	# get address of PTE
mfc0	k1, C0_EPC	# get address of failed reference
lw	k0, 0(k0)	# fetch PTE
nop		# load delay slot
mtc0	k0, C0_TLBLO	# write EntryLo (EntryHi set by chip hardware)
nop		# effective delay slot due to CP0 move
c0	C0_WriteR	# tlbwr; write random TLB entry
j	k1	# return to EPC
rfe		# restore context from exception

4000 drw 44

Figure 6.21. User TLB Refill Code

## FLOATING POINT EXCEPTIONS

This section describes how the FPA handles floating point exceptions. A floating point exception occurs whenever the FPA cannot handle the operands or results of a floating point operation in the normal way. The FPA responds either by generating a CPU interrupt to initiate a software trap or by setting a status flag. The Control/Status register described in Chapter 3 contains a *trap enable* bit for each exception type that determines whether an exception will cause the FPA to initiate a trap or just set a status flag. If a trap is taken, the FPA remains in the state found at the beginning of the operation, and a software exception handling routine is executed. If no trap is taken, an appropriate value is written into the FPA destination register and execution continues.

The FPA supports the five IEEE exception types— inexact (I), overflow (O), underflow (U), divide by zero (Z), and invalid operation (V) — with exception bits, trap enables, and sticky bits (status flags). The FPA adds a sixth exception type, unimplemented operation (E), to be used in those cases where the FPA itself cannot implement the standard MIPS floating-point architecture, including cases where the FPA cannot determine the correct exception behavior. This exception indicates that a software implementation must be used. The unimplemented operation exception has no trap enable or sticky bit; whenever this exception occurs, an unimplemented exception trap is taken (if the FPA's interrupt input to the CPU is enabled).

Figure 6.22 illustrates the Control/Status register bits used to support exceptions.

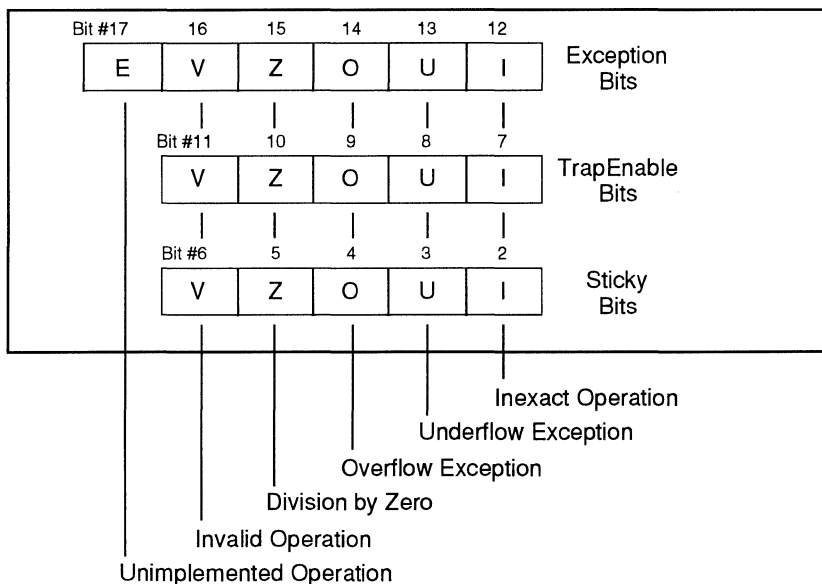

**Figure 6.22. FPA Control/Status Register**

Each of the five IEEE exceptions (V, Z, O, U, I) is associated with a trap under user control which is enabled by setting one of the five *TrapEnable* bits. When an exception occurs, both the corresponding Exception and Sticky bits are set. If the corresponding *TrapEnable* bit is set, the FPA generates an interrupt to the main processor and the subsequent exception processing allows a trap to be taken.

### Exception Trap Processing

When a floating-point exception trap is taken, the Processor's Cause register indicates that an external interrupt from the FPA is the cause of the exception and the EPC (Exception Program Counter) contains the address of the instruction that caused the exception trap.

For each IEEE standard exception, a status flag (Sticky bit) is provided that is set on any occurrence of the corresponding exception condition with no corresponding exception trap signaled. The Sticky bits may be reset by writing a new value into the Control/Status register and may be saved and restored individually, or as a group, by software.

When no exception trap is signaled, a default action is taken by the FPA, which provides a substitute value for the original, exceptional, result of the floating-point operation. The default action taken depends on the type of exception, and in the case of the Overflow exception, the current rounding mode. Table 6.7 lists the default action taken by the FPA for each of the IEEE exceptions.

Exception		Rounding Mode	Default Action (no exception trap signaled)
V	Invalid Operation	—	Supply a quiet NaN
Z	Division by zero	—	Supply a properly signed $\infty$ .
O	Overflow	RN	Modify overflow values to $\infty$ with the sign of the intermediate result
		RZ	Modify overflow values to the format's largest finite number with the sign of the intermediate result.
		RP	Modify negative overflows to the format's most negative finite number. Modify positive overflows to $+\infty$ .
		RM	Modify positive overflows to the format's largest finite number. Modify negative overflows to $-\infty$ .
U	Underflow	—	Generate an Unimplemented exception.
I	Inexact	—	Supply a rounded result

Table 6.8. FPA Exception Causing Codes

The FPA internally detects eight different conditions that can cause exceptions. When the FPA encounters one of these unusual situations, it will cause either an IEEE exception or an Unimplemented Operation exception (E). Table 6.8 lists the exception-causing situations and contrasts the behavior of the FPA with the IEEE standard's requirements.



<b>FPA internal result</b>	<b>IEEE Stndrd</b>	<b>Trap Enab.</b>	<b>Trap Disab.</b>	<b>Note</b>
Inexact result	I	I	I	loss of accuracy
Exponent overflow	O I*	O I	O I	normalized exponent > Emax
Divide by zero	Z	Z	Z	zero is (exponent = Emin-1, mantissa = 0)
Overflow on convert	V	V	E	source out of integer range
Signaling NaN source	V	V	E	quiet NaN source produces quiet NaN result
Invalid operation	V	V	E	0/0 etc.
Exponent underflow	U	E	E	normalized exponent < Emin
Denormalized source	none	E	E	exponent = Emin-1 and mantissa <> 0

\*Standard specifies inexact exception on overflow only if overflow trap is disabled.

**Table 6.9 FPA Exception-causing Conditions**

The sections that follow describe the conditions that cause the FPA to generate each of its six exceptions and details the FPA's response to each of these exception-causing situations.

**Inexact Exception (I)**

The FPA generates this exception if the rounded result of an operation is not exact or if it overflows.

**NOTE:** The FPA usually examines the operands of floating point operation before execution actually begins to determine (based on the exponent values of the operands) if the operation can possibly cause an exception. If there is a possibility of an instruction causing an exception trap, then the FPA uses a coprocessor stall mechanism to execute the instruction. It is impossible, however, for the FPA to predetermine if an instruction will produce an inexact result. Therefore, if inexact exception traps are enabled, the FPA uses the coprocessor stall mechanism to execute all floating point operations that require more than one cycle. Since this mode of execution can impact performance, inexact exception traps should be enabled only when necessary.

**Trap Enabled Results:** If inexact exception traps are enabled, the result register is not modified and the source registers are preserved.

**Trap Disabled Results:** The rounded or overflowed result is delivered to the destination register if no other software trap occurs.

**Invalid Operation Exception (V)**

The invalid operation exception is signaled if one or both of the operands are invalid for an implemented operation. The invalid operations are:

- 1) Addition or subtraction: magnitude subtraction of infinities, such as:  $(-\infty) - (+\infty)$
- 2) Multiplication: 0 times  $\infty$ , with any signs
- 3) Division:  $0 \div 0$ , or  $\infty \div \infty$ , with any signs
- 4) Conversion of a floating point number to a fixed-point format when an overflow, or operand value of infinity or NaN, precludes a faithful representation in that format
- 5) Comparison of predicates involving  $<$  or  $>$  without  $?$ , when the operands are "unordered"
- 6) Any arithmetic operation on a signaling NaN. Note that a move (MOV) operation is not considered to be an arithmetic operation, but that ABS and NEG are considered to be arithmetic operations and will cause this exception if one or both operands is a signaling NaN.

Software may simulate this exception for other operations that are invalid for the given source operands. Examples of these operations include IEEE-specified functions implemented in software, such as Remainder:  $x \text{ REM } y$ , where  $y$  is zero or  $x$  is infinite; conversion of a floating-point number to a decimal format whose value causes an overflow or is infinity or NaN; and transcendental functions, such as  $\ln(-5)$  or  $\cos^{-1}(3)$ .

**Trap Enabled Results:** The original operand values are undisturbed.

**Trap Disabled Results:** The FPA always signals an Unimplemented exception because it does not create the NaN that the Standard specifies should be returned under these circumstances.

**Division-by-Zero Exception (Z)**

The division by zero exception is signaled on a divide operation if the divisor is zero and the dividend is a finite non-zero number.

**Trap Enabled Results:** The result register is not modified, and the source registers are preserved.

**Trap Disabled Results:** The result, when no trap occurs, is a correctly signed infinity.

**Overflow Exception (O)**

The overflow exception is signaled when what would have been the magnitude of the rounded floating-point result, were the exponent range unbounded, is larger than the destination format's largest finite number. (This exception also sets the Inexact exception and sticky bits.)

**Trap Enabled Results:** The result register is not modified, and the source registers are preserved.

**Trap Disabled Results:** The result, when no trap occurs, is determined by the rounding mode and the sign of the intermediate result (as listed in Table 6.7).

**Underflow Exception (U)**

The FPA never generates an Underflow exception and never sets the U bit in either the *Exceptions* field or *Sticky* field of the Control/Status register. If the FPA detects a condition that could be either an underflow or a loss of accuracy, it generates an Unimplemented exception.

**Unimplemented Operation Exception (E)**

The FPA generates this exception when it attempts to execute an instruction with an OpCode (bits 31-26) or format code (bits 24-21) which has been reserved for future use.

This exception is not maskable: the trap is always enabled. When an Unimplemented Operation is signaled, an interrupt is sent to the Integer Processor so that the operation can be emulated in software. When the operation is emulated in software, any of the IEEE exceptions may arise; these exceptions must, in turn, be simulated.

This exception is also generated when any of the following exceptions are detected by the FPA.

- Denormalized Operand
- Not-a-Number (NaN) Operand
- Invalid operation with trap disabled
- Denormalized Result
- Underflow

**Trap Enabled Results:** The original operand values are undisturbed.

**Trap Disabled Results:** This trap cannot not be disabled.

**Saving and Restoring State**

Thirty-two coprocessor load or store instructions will save or restore the FPA's floating-point register state in memory. The contents of the Control/Status register can be saved using the "move to/from coprocessor control register" instructions (CTC1/CFC1). Normally, the Control/Status register contents are saved first and restored last.

If the Control/Status register is read when the coprocessor is executing one or more floating-point instructions, the instructions in progress (in the pipeline) are completed before the contents of the register are moved to the main processor. If an exception occurs during one of the in-progress instructions, that exception is written into the Control/Status register *Exceptions* field.

Note that the *Exceptions* field of the control/Status register holds the results of only one instruction: the FPA examines source operands before an operation is initiated to determine if the instruction can possibly cause an exception. If an exception is possible, the FPA executes the instruction in "stall" mode to ensure that no more than one instruction can possibly cause an exception. If an exception is possible, the FPA executes the instruction in "stall" mode to ensure that no more than one instruction at a time is executed that might cause an exception.

All of the bits in the *Exceptions* field can be cleared by writing a zero value to this field. This permits restarting of normal processing after the Control/Status register state is restored.



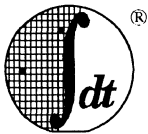

The IDT R3051 family utilizes a simple, flexible bus interface to its external memory and I/O resources. The interface uses a single, multiplexed 32-bit address and data bus and a simple set of control signals to manage read and write operations. Complementing the basic read and write interface is a DMA Arbiter interface which allows an external agent to gain control of the memory interface to transfer data.

The R3081 is superset pin-compatible with the R3051. That is, most systems which employ the R3051 can remove that CPU and replace it with an R3081, with no changes to the board. Alternately, the system designer could choose to take advantage of new features in the R3081, such as the half-frequency bus mode or cache coherency capability.

The R3081 supports the following types of operations on its interface:

- **Read Operations:** The processor executes read operations as the result of either a cache miss or an uncacheable reference. As with the write interface, the read interface has been designed to accommodate a wide variety of memory system strategies. There are two types of reads performed by the processor:

Quad word reads occur when the processor requests a contiguous block of four words from memory. These reads occur in response to instruction cache misses, and may occur in response to a data cache miss. The processor incorporates an on-chip 4-deep read buffer which may be used to “queue up” the read response before passing it through to the high-bandwidth cache and execution core. Read buffering is appropriate in systems which require wait states between adjacent words of a block read. On the other hand, systems which use high-bandwidth memory techniques (such as page mode, static column, nibble mode, or memory interleaving) can effectively bypass the read buffer by bursting words of the block at the processor clock rate. Note that the choice of burst vs. read buffering is independent of the initial latency of the memory; that is, burst mode can be used even if multiple wait states are required to access the first word of the block.

Single word reads are used for uncacheable references (such as I/O or boot code) and may be used in response to a data cache miss. The processor is capable of retiring a single word read in as few as two clock cycles.

The read interface of the R3081 is described in detail in Chapter 8.

- **Write Operations:** The R3081 utilizes an on-chip write buffer to isolate the execution core from the speed of external memory during write operations. The write interface of the R3081 is designed to allow a variety of write strategies, from fast 2-cycle write operations through multiple wait-state writes.

The R3081 supports the use of fast page mode writes by providing an output indicator,  $\overline{WrNear}$ , to indicate that the current write may be retired using a page mode access. This facilitates the rapid “flushing” of the on-chip write buffer to main memory, since the majority of processor writes will occur within a localized area of memory.

The write interface is described in detail in Chapter 9.

- **DMA Operations:** The R3081 includes a DMA arbiter which allows an external agent to gain full control of the processor read and write interface. DMA is useful in systems which need to move significant amounts of data within memory (e.g. BitBlT operations) or move data between memory and I/O channels.

The R3051 family utilizes a very simple handshake to transfer control of its interface bus. This handshake is described in detail in chapter 10.

The R3081 adds the capability to perform hardware based data cache coherency during DMA cycles. This capability includes the capability of performing hardware invalidation of specific data cache lines, as well as the capability of performing burst invalidations during burst DMA writes. This capability is also described in chapter 10.

## MULTIPLE OPERATIONS

It is possible for the R3081 to have multiple interface activities pending. Specifically, there may be data in the write buffer, a read request (e.g. due to a cache miss), a DMA mastership request, and an ongoing transaction all occurring simultaneously.

In establishing the order in which the requests are processed, the R3051 family is sensitive to possible conflicts and data coherency issues. For example, if the on-chip write buffer contains data which has not yet been written to memory, and the processor issues a read request to the target address of one of the write buffer entries, then the processor strategy must insure that the read request is satisfied by the new, current value of the data.

Note that there are two levels of prioritization: that performed by the CPU engine internal to the R3081, and that performed by the bus interface unit. The internal execution engine can be viewed as making requests to the bus interface unit. In the case of multiple requests in the same clock cycle, the CPU core will:

- 1: Perform the data request first. That is, if both the data cache and instruction cache miss in the same clock cycle, the processor core will request a read to satisfy the data cache first. Similarly, a write buffer full stall will be processed before an instruction cache miss.
- 2: Perform a read due to an instruction cache miss.

This prioritization is important in maintaining the precise exception model of the MIPS architecture. Since data references are the result of instructions which entered the pipeline earlier, they must be processed (and any exceptions serviced) before subsequent instructions (and their exceptions) are serviced.

Once the processor core internally decides which type of request to make to the bus interface unit, it then presents that request to the bus interface unit.

Thus, in the R3081 Bus Interface Unit, multiple operations are serviced in the following order:

- 1: Ongoing transactions are completed without interruption.
- 2: DMA requests not requiring cache coherency are serviced.
- 3: Instruction cache misses are processed.
- 4: Pending writes are processed.
- 5: DMA requests indicating possible coherency are processed.
- 6: Data cache misses or uncacheable reads are processed.

This service order has been designed to achieve maximum performance, minimize complexity, and solve the data coherency problem possible in write buffer systems.

Note that this order assumes that the write buffer does not contain instructions which the processor may wish to execute. The processor does not write directly into the instruction cache: store instructions generate data writes which may change only the data cache. The only way in which an instruction reference may reside in the write buffer is in the case of self modifying code, generated with the caches swapped. However, in order to unswap the caches, an uncacheable instruction which modifies CPO must be executed; the fetch of this instruction would cause the write buffer to be flushed to memory. Thus, this ordering enforces strong ordering of operations in hardware, even for self modifying code. Of course, software could perform an uncacheable reference to flush the write buffer at any time, thus achieving memory synchronization with software.

The final consideration in the priority structure has to do with cache coherency operations. Specifically, the R3081 bus interface unit insures that memory is completely current with the on-chip caches by retiring all pending writes to memory, and further insures that an ongoing read has updated the on-chip caches. Only after these conditions are met is the coherent DMA request granted.

Specifically, when a coherent DMA request is detected, the R3081 will complete its current bus cycle, and then insure that memory is consistent with the on-chip caches. It will bring data out of the read buffer and into the caches; if the read response data contains instructions to be executed, then those instructions will be streamed normally, and may generate additional data values into the write buffer.

Once the read buffer is brought into the cache, the CPU core is stalled and pending writes are retired to memory. Any additional writes generated during streaming will also be updated to the main memory. Since the processor core is stalled, no additional read requests will be generated.

At this point, the processor core will be stalled in anticipation of potential invalidates, the read buffer is empty, and the memory is current with the on-chip caches. The R3081 will then grant the bus to the DMA requester.



## EXECUTION ENGINE FUNDAMENTALS

This section describes the fundamentals of the processor read interface and its interaction with the execution core. These fundamentals will help to explain the relationship between design tradeoffs in the system interface and the performance achieved in R3081 based systems.

### Execution Core Cycles

The R3081 execution core utilizes many of the same operation fundamentals as does the R3000A processor. Thus, much of the terminology used to describe the activity of the R3081 is derived from the terminology used to describe the R3000A. In many instances, the activity of the execution core is independent of that of the bus interface unit.

### Cycles

A cycle is the basic timing reference of the R3081 execution core. Cycles in which forward progress is made (the processor pipeline advances) are called *Run* cycles. Cycles in which no forward progress occurs are called *Stall* cycles. Stall cycles are used for resolving exigencies such as cache misses, write stalls, and other types of events. All cycles can be classified as either run or stall cycles. Note that the bus cycle rate may differ from the execution cycle rate, due to half-frequency bus mode.

### Run Cycles

Run cycles are characterized by the transfer of an instruction into the processor core, and the optional transfer of data into or out of the execution core. Thus, each run cycle can be thought of as having an instruction and data, or ID, pair.

There are actually two types of run cycles: cache run cycles, and refill run cycles. Cache run cycles (typically referred to as just run cycles) occur while the execution core is executing out of its on chip cache; these are the principal execution mechanism.

Refill run cycles, referred to as streaming cycles, occur when the execution core is executing instructions as they are brought into the on-chip cache. For the R3081, streaming cycles are defined as cycles in which data is brought out of the on-chip read buffer into the execution core (rather than defining them as cycles in which data is brought from the memory interface to the read buffer).

### Stall Cycles

There are three types of stall cycles:

**Wait Stall Cycles.** These are commonly referred to simply as stall cycles.

During wait stall cycles, the execution core maintains a state consistent with resolving a stall causing event. No cache activity will occur during wait stalls.

**Refill Stall Cycles.** These occur only during memory reads, and are used to transfer data from the on-chip read buffer into the caches.

**Fixup Stall Cycles.** Fixup cycles occur during the final cycle of a stall; that is, one cycle before entering a run cycle or entering another stall. During the final fixup cycle (the one which occurs before finally re-entering run operation), the ID pair which should have been processed during the last run cycle is handled by the processor. The fixup cycle is used to restart the processor and co-processor pipelines, and in general to fixup conditions which caused the stall.

The basic causes of stalls include:

**Read Busy Stalls:** If the processor is utilizing its read interface, either to process a cache miss or an uncacheable reference, then it will be stalled until the read data is brought back to the execution core.

**Write Busy Stalls:** If the processor attempts to perform a store operation while the on-chip write buffer is already full, then the processor will stall until a write transaction is begun on the interface to free up room in the write buffer for the new address and data.

**Multiply/Divide Busy Stalls:** If software attempts to read the result registers of the integer multiply/divide unit (the HI and LO registers) while a multiply or divide operation is underway, the processor execution core will stall until the results are available.

**Coprocessor Busy Stalls:** These stalls originate when the CPU makes a request of the FPA co-processor, but the requested resource is unavailable. Examples of such events include: references to an FPA register currently being used for another operation, and requesting an arithmetic operation when the required ALU is still busy with another instruction. In these cases, the FPA will stall the main processor until the requested resource is available.

**Micro-TLB Fill Stalls:** These stalls can occur when an instruction translation misses in the instruction TLB cache (the micro-TLB, which is a two-entry cache of the main TLB used to translate instruction references). When such an event occurs, the execution core will stall for one cycle, in order to refill the micro-TLB from the main TLB. Since this is a single-cycle stall, it is of necessity a fixup cycle.

**Multi-processor Stalls:** These stalls occur during coherent DMA. The execution core is stalled, leaving the on-chip caches free for potential invalidations.

### Multiple Stalls

Multiple stalls are possible whenever more than one stall initiating event occurs within a single run cycle. An example of such activity is when a single cycle results in both an instruction cache miss and a data cache miss.

The most important characteristic of any multiple stall cycle is the validity of the ID pair processed in the final fixup cycle. The R3081 execution core keeps track of nested stalls to insure that orderly operation is resumed once all of the stall causing events are processed.

For the general case of multiple stalls, the service order is:

- 1: Micro-TLB Miss, Multi-processor and Partial Word Stores
- 2: Halt requested through Config register.
- 3: Data Cache Miss or Write Busy Stall
- 4: Co-processor Busy Stall
- 5: Instruction Cache Miss
- 6: Multiply/Divide Unit Busy

## PIN DESCRIPTION

This section describes the signals used in the above interfaces. More detail on the actual use of these pins is found in other chapters. Note that many of the signals have multiple definitions which are de-multiplexed either by the ALE signal or the  $\overline{\text{Rd}}$  and  $\overline{\text{Wr}}$  control signals. Note that signals indicated with an overbar are active low.

### System Bus Interface Signals

These signals are used by the bus interface to perform read and write operations.

#### Address and Data Path

#### A/D(31:0)      I/O

**Address/Data:** A 32-bit, time multiplexed bus which indicates the desired address for a bus transaction in one cycle, and which is used to transmit data between this device and external memory resources on other cycles.

Bus transactions on this bus are logically separated into two phases: during the first phase, information about the transfer is presented to the memory system to be captured using the ALE output. This information consists of:

**Address(31:4):** The high-order address for the transfer is presented.

**$\overline{\text{BE}}(3:0)$ :** These strobes indicating which bytes of the 32-bit bus will be involved in the transfer.  $\overline{\text{BE}}(3)$  indicates that AD(31:24) is used;  $\overline{\text{BE}}(2)$  indicates that AD(23:16) is used;  $\overline{\text{BE}}(1)$  indicates that AD(15:8) is used; and  $\overline{\text{BE}}(0)$  indicates that AD(7:0) is used.

During write cycles, the bus contains the data to be stored and is driven from the internal write buffer. On read cycles, the bus receives the data from the external resource, in either a single word transaction or in a burst of four words, and places it into the on-chip read buffer.

During cache coherency operations, the R3081 monitors the A/D bus at the start of a DMA write to capture the write target address for potential data cache invalidates.

#### Addr(3:2)      I/O

**Low Address (3:2)** A 2-bit bus which indicates which word is currently expected by the processor. Specifically, this two bit bus presents either the address bits for the single word to be transferred (writes or single word reads) or functions as a two bit counter starting at '00' for burst read operations.

During cache coherency operations, the R3081 monitors the Addr bus at the start of a DMA write to capture the write target address for potential data cache invalidates.

### Read and Write Control Signals

#### ALE      I/O

**Address Latch Enable:** Used to indicate that the A/D bus contains valid address information for the bus transaction. This signal is used by external logic (transparent latches) to capture the address for the transfer.

During cache coherency operations, the R3081 monitors ALE at the start of a DMA write to capture the write target address for potential data cache invalidates.

**$\overline{\text{DataEn}}$**                       **O**

**Data Input Enable:** This signal indicates that the AD bus is no longer being driven by the processor during read cycles, and thus the external memory system may enable the drivers of the memory system onto this bus without having a bus conflict occur. During write cycles, or when no bus transaction is occurring, this signal is negated.

**$\overline{\text{Burst/}}$   
 **$\text{WrNear}$**                       **O****

**Burst Transfer:** On read transactions, this signal indicates that the current bus read is requesting a block of four contiguous words from memory (a burst read). This signal is asserted only in read cycles due to cache misses; it is asserted for all I-Cache miss read cycles, and for D-Cache miss read cycles if selected at device reset time.

**Write Near:** On write transactions, this output tells the external memory system that the bus interface unit is performing back-to-back write transactions to an address within the same 512 entry memory "page" as the prior write transaction. This signal is useful in memory systems which employ page mode or static column DRAMs.

**$\overline{\text{Rd}}$**                                       **O**

**Read:** An output which indicates that the current bus transaction is a read.

**$\overline{\text{Wr}}$**                                       **I/O**

**Write:** An output which indicates that the current bus transaction is a write. During coherent DMA, the R3081 monitors this input to detect DMA write operations.

**$\overline{\text{Ack}}$**                                       **I**

**Acknowledge:** An input which indicates to the device that the memory system has sufficiently processed the bus transaction, and that the processor may either advance to the next write buffer entry or release the execution core to process the read data.

During coherent DMA, the R3081 monitors this input to detect the completion of DMA write transfers.

**$\overline{\text{RdCEn}}$**                                 **I**

**Read Buffer Clock Enable:** An input which indicates to the device that the memory system has placed valid data on the AD bus, and that the processor may move the data into the on-chip Read Buffer.

**$\overline{\text{BusError}}$**                               **I**

**Bus Error:** Input to the bus interface unit to terminate a bus transaction due to an external bus error. This signal is only sampled during read and write

operations. If the bus transaction is a read operation, then the CPU will also take a bus error exception.

### Status Information

#### Diag(1)      O

**Diagnostic Pin 1.** This output indicates whether the current bus read transaction is due to an on-chip cache miss, and also presents part of the miss address. During reads, the value output on this pin is time multiplexed:

**Cached:** During the phase in which the A/D bus presents address information, this pin is an active high output which indicates whether the current read is a result of a cache miss.

**Miss Address (3):** During the remainder of the read operation, this output presents address bit (3) of the address the processor was attempting to reference when the cache miss occurred. Regardless of whether a cache miss is being processed, this pin reports the transfer address during this time.

On write cycles, this output signals whether the data being written was retained in the on-chip data cache. The value of this pin is time multiplexed:

**Cached:** During the address phase of write operations, this signal is an active high output which indicates that the store data was retained in the on-chip data cache.

**Reserved:** The value of this pin during the data phase of writes is reserved.

#### Diag(0)      O

**Diagnostic Pin 0.** This output distinguishes cache misses due to instruction references from those due to data references, and presents the remaining bit of the miss address. During read cycles, the value output on this pin is also time multiplexed:

**I/ $\bar{D}$ :** If the “Cached” Pin indicates a cache miss, then a high on this pin at this time indicates an instruction reference, and a low indicates a data reference. If the read is not due to a cache miss but rather an uncached reference (“Cached” is negated), then this pin is undefined during this phase.

**Miss Address (2):** During the remainder of the read operation, this output presents address bit (2) of the address the processor was attempting to reference when the cache miss occurred. Regardless of whether a cache miss is being processed, this pin reports the transfer address during this time.

During write cycles, the value of this pin during both the address and data phase is reserved.

## Interrupt Interface

Chapter 6 discusses the exception model of the R3051 family.

### **BrCond(0)** **SBrCond(3:2) I**

**Branch Condition Port:** These external signals are available as an input port to the processor, which can use the Branch on Co-Processor Condition instructions to test their polarity. The SBrCond bus is synchronized by the R3081, and thus may be driven by an asynchronous source; BrCond(0) is directly tied to the execution core, and thus must be generated synchronously. Note that BrCond(1) is used for the on-chip floating point co-processor, CP1, and thus is not available externally.

### **SInt(2:0)** **Int(5:3) I**

**Processor Interrupt:** During operation, these signals are the same as the Int(5:0) signals of the R3000. During processor reset, these signals perform mode initialization of the processor. The Synchronized interrupt inputs are internally synchronized by the R3081, and thus may be generated by an asynchronous interrupt agent; the direct interrupts must be externally synchronized by the interrupt agent. Note that the interrupt selected in the Config register to correspond to the floating point co-processor interrupt is not available externally; the value of the signal will be ignored. The system designer must tie this signal to a valid logic level anyway.

## DMA Arbiter Interface

These signals are involved when the processor exchanges bus mastership with an external agent. This operation is described in chapter 10.

### **BusReq I**

**DMA Arbiter Bus Request:** An input to the device which requests that the processor tri-state its bus interface signals so that they may be driven by an external master. The negation of this input releases the bus back to the R3081.

### **BusGnt O**

**DMA Arbiter Bus Grant.** An output from the R3081 used to acknowledge that a  $\overline{\text{BusReq}}$  has been granted, and that the bus is relinquished to the external master.

## Cache Coherency Interface

These signals are involved when the processor exchanges bus mastership with an external agent, and the cache coherency interface is invoked. This operation is described in chapter 10.

**IvdReq** I

**Invalidate Request:** This input is used to cause the R3081 to invalidate the currently indicated data cache word during a coherent DMA write sequence. During memory cycles in which an external DMA master controls the processor bus, the R3081 monitors  $\overline{\text{ALE}}$ ,  $\overline{\text{Wr}}$ , and the address bus. If the current DMA write also signals an  $\overline{\text{IvdReq}}$ , the R3081 will cause the corresponding Data cache word to be invalidated, as described in chapter 10. This signal is only monitored during coherent DMA write cycles. This signal shares the same pin as  $\text{Diag}(0)$ .

**CohReq** I

**Coherent DMA Request:** This input is sampled along with  $\overline{\text{BusReq}}$  to indicate that the currently requested DMA transfer may involve cache coherency operations. In this case, the R3081 will fully complete any ongoing reads and update the main memory from the write buffer prior to granting the DMA request, as described earlier in this chapter. Once the coherent DMA request is granted, the memory system can then use  $\overline{\text{IvdReq}}$  to request that the cache line corresponding to the current address be invalidated, as described in chapter 10. This input signal uses the pin designated as  $\text{Rsvd}(0)$  in the R3051. In systems which do not use cache coherency (as indicated at reset), this input is ignored, and need not be connected.

**Reset and Clocking****ClkIn** I

**Master clock Input:** This is an input clock which will be either at the processor execution frequency (1x clock mode) or at twice the cycle rate (2x clock mode).

**SysClk** O

**System Reference Clock:** An output from the processor which reflects the clock used to perform bus interface functions. This clock is used to control state transitions in the read buffer, write buffer, memory controller, and bus interface unit. It should be used as a timing reference by the external memory system. The frequency of this clock will be either the same as the CPU cycle rate, or one-half that frequency, depending on the reset initialization mode selected. There is no guaranteed AC timing relationship between this clock and the input clock.

**Reset** I

**Master Processor Reset:** This signal initializes the processor. Optional features of the processor are established during the last cycle of reset using the interrupt inputs.

**Miscellaneous****Rsvd(4:1)** I/O

**Reserved:** These four signal pins are reserved for testing and for future revisions of this device. Users must not connect these pins. Note that  $\text{Rsvd}(0)$  on the R3051 is used for  $\text{CohReq}$  on the R3081.

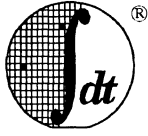

## **INTRODUCTION**

The R3051 family read protocol has been designed to interface to a wide variety of memory and I/O devices. Particular care has been taken in the definition of the control signals available to the system designer. These signals allow the system designer to implement a memory interface appropriate to the cost and performance goals of the end application. The R3081 uses the same protocol as the R3051 and R3052. However, new features have been added which maintain pin compatibility but which simplify the design of high-frequency systems. These features include the slow bus turn-around mode and half-frequency bus mode.

This chapter includes both an overview of the read interface as well as provides detailed timing diagrams of the read interface.

## **TYPES OF READ TRANSACTIONS**

The majority of the execution engine read requests are never seen at the memory interface, but rather are satisfied by the internal cache resources of the processor. Only in the cases of uncacheable references or cache misses do read transactions occur on the bus.

In general, there are only two types of read transactions: quad word reads and single word reads. Note that partial word reads of less than 32-bits can be thought of as a simple subset of the single word read, with only some of the byte enable strobes asserted. As part of the read response processing, the R3081 bus interface unit will generate parity over the incoming words for protection over the on-chip caches. Quad word reads occur only in response to cache misses. All instruction cache misses are processed as quad word reads; data cache misses may be processed as quad word reads or single word reads, depending on the current value of the DBRefill bit of the Config register.

In processing reads, there are two parameters of interest. The first parameter is the initial latency to the first word of the read. This latency is influenced by the overall system architecture as well as the type of memory system being addressed: time required to perform address decoding, and perform bus arbitration, memory pre-charge requirements, and memory control requirements, as well as memory access time. The initial latency is the only parameter of interest in single word reads.

The second parameter of interest (only in quad word refills) is the repeat rate of data. Factors which influence the repeat rate include the memory system architecture, the types and speeds of devices used, and the sophistication of the memory controller: memory interleaving, the use of page mode, and faster devices all serve to increase the repeat rate.

The R3051 family has been designed to accommodate a wide variety of memory system designs, including no wait state operations (first word available in two cycles) and true burst operation (adjacent words every clock cycle), through simpler, slower systems incorporating many bus wait states to the first word and multiple clock cycles between adjacent words (this is accomplished by use of the on-chip read buffer).

The R3081 adds slow bus turnaround and half-frequency bus operation. Both of these modes are fully compatible with the types of operations performed by the R3051: slow bus turnaround merely affects the spacing of bus operations, not the protocol of those operations. Similarly, half-frequency mode has been designed to present the appearance of a processor running at one-half the frequency; the system designer, and the system interface, is not explicitly aware that this mode is active.



## READ INTERFACE SIGNALS

The read interface uses the signals listed below. Signal names indicated with an overbar are active low. Timing is always with respect to the  $\overline{\text{SysClk}}$  output, which will be either at the CPU frequency, or at one-half the CPU frequency.

### $\overline{\text{Rd}}$            0

This output indicates that a read operation is occurring.

### A/D (31:0)    I/O

During read operations, this bus is used to transmit the read target address to the memory system, and is used by the memory system to return the required data back to the processor. Its function is demultiplexed using other control signals.

During the addressing portion of the read transaction, this bus contains the following:

Address(31:4)    The upper 28 bits of the read address are presented on A/D (31:4).

$\overline{\text{BE}}(3:0)$         The byte strobes for the read transaction are presented on A/D(3:0).

### ALE                0

This output signal is typically connected directly to the latch enable of transparent latches. Latches are typically used to de-multiplex the address and Byte Enable information from the A/D bus.

### Addr(3:2)        0

The remaining bits of the transfer address are presented directly on these outputs. In the case of quad word reads, these pins function as a two bit counter starting at '00', and are used to perform the quad word transfer. In the case of single datum reads, these pins contain Address (3:2) of the transfer address.

### $\overline{\text{DataEn}}$        0

This output indicates that the A/D bus is no longer being driven by the processor, and thus the output drivers of the memory system may be enabled.

Special logic on the CPU guarantees the following:

The A/D bus is driven to guarantee hold time from the negation of ALE.  
The A/D bus output drivers will be disabled before the assertion of  $\overline{\text{DataEn}}$ .

Thus, the system designer is assured that ALE can be used to directly control the latch enable of a transparent latch. Similarly,  $\overline{\text{DataEn}}$  can be used to directly control the output enable of memory system drivers.

### $\overline{\text{Burst}}$            0

This output distinguishes between quad word and single datum reads.

**$\overline{\text{RdCEn}}$**       **I**

Read Buffer Clock Enable is used by the external memory system to cause the processor to capture the contents of the A/D bus. In the case of quad word reads, this causes the contents of the A/D bus to be strobed into the on-chip read buffer; in the case of single datum reads, this causes the processor to capture the read data and may also terminate the read operation.

 **$\overline{\text{Ack}}$**       **I**

Acknowledge is used by the memory system to indicate that it has sufficiently processed the read transaction, and that the internal execution core may begin processing the read data. Thus,  $\overline{\text{Ack}}$  can be used by the external memory system to cause the execution core to begin processing the read data simultaneously with the memory system bringing in additional words of the burst refill. The timing of the assertion of  $\overline{\text{Ack}}$  by the memory system must be constructed to insure that words not yet retrieved from the memory will be brought in before they are required by the execution core.

When the memory system is able to supply words at the rate of one per clock cycle (after the initial latency),  $\overline{\text{Ack}}$  can be asserted simultaneous with the initial  $\overline{\text{RdCEn}}$  to achieve the highest levels of performance.

Other systems, which utilize simpler memory system strategies, may ignore the use of  $\overline{\text{Ack}}$  in read transactions. The processor will recognize the implicit termination of a read operation by the assertion of the appropriate number (one or four) of  $\overline{\text{RdCEn}}$ . While this approach is simpler to design, a loss of performance will result.

 **$\overline{\text{BusError}}$**       **I**

This input can be used to terminate a read operation. It will also cause the processor to take a BusError exception. Read transactions terminated by  $\overline{\text{BusError}}$  do not require the assertion of  $\overline{\text{Ack}}$  or  $\overline{\text{RdCEn}}$ .

**Diag(1)**      **O**

During the address phase of the read transaction, this output indicates whether the read is a result of a cache miss or an uncacheable reference.

During the remainder of the transfer, this output indicates Address(3) of the actual address reference which missed in the cache.

This pin is useful in the initial debug of R3051 family based systems.

**Diag(0)**      **O**

During the address phase of the read transaction, this output indicates whether the read is a result of an instruction or data reference.

During the remainder of the transfer, this output indicates Address(2) of the actual address reference which missed in the cache.

This pin is useful in the initial debug of R3051 family based systems.

### READ INTERFACE TIMING OVERVIEW

The read interface is designed to allow a variety of memory strategies. An overview of how data is transmitted from memory and I/O devices to the processor is discussed below. Note that multiplexing the address and data bus does not slow down read transactions: the address is on the A/D bus for only one-half clock cycle, so the data drivers can be enabled quickly; memory and I/O devices initiate their transfers based on addressing and chip enable, not on the availability of the bus. Thus, memory does not need to “wait” for the bus, and no performance penalty occurs.

#### Initiation of Read Request

A read transaction occurs when the processor internally performs a run cycle which is not satisfied by the internal caches. Immediately after the run cycle, the processor enters a stall cycle and asserts the internal control signal  $\overline{\text{MemRd}}$ . This signals to the internal bus interface unit arbiter that a read transaction is pending.

Assuming that the read transaction can be immediately processed (that is, there are no ongoing bus operations, and no higher priority operations pending), the processor will initiate a bus read transaction on rising edge of  $\overline{\text{SysClk}}$ , which occurs during phase 2 of the processor stall cycle. Higher priority operations would have the effect of delaying the start of the read by inserting additional processor stall cycles.

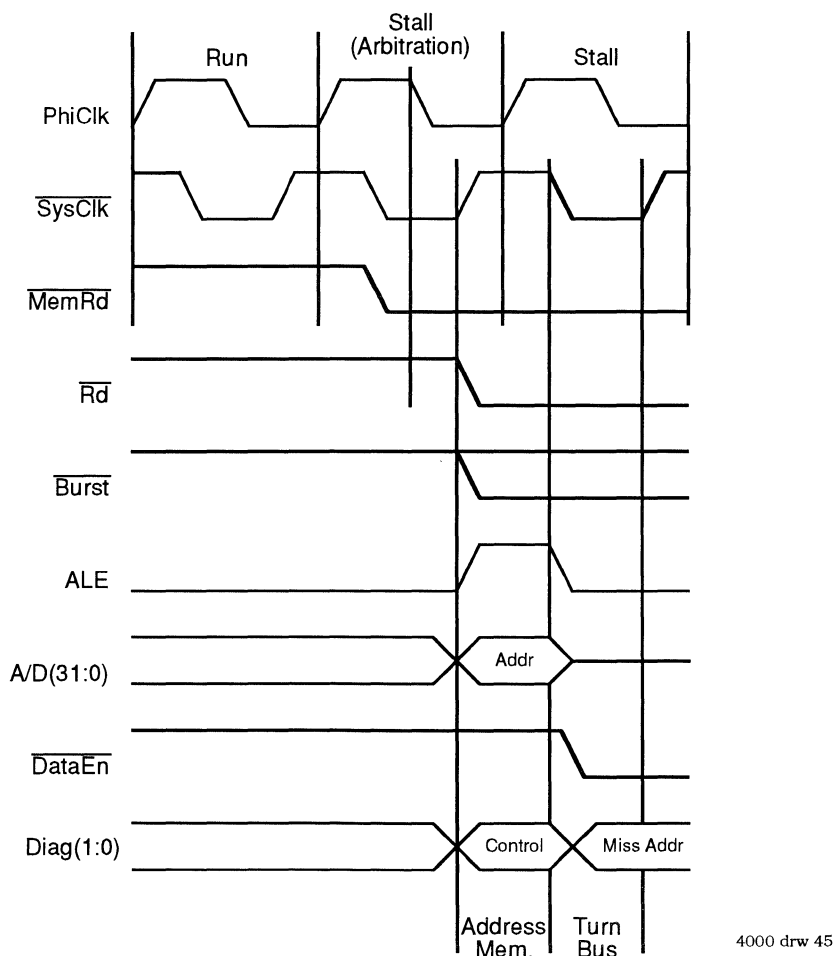

Figure 8.1(a). CPU Latency to Start of Read (Full Frequency Mode)

Figure 8.1(a, b) illustrates the initiation of a read transaction, based on the internal assertion of the  $\overline{\text{MemRd}}$  control signal. This figure is useful in determining the overall latency of cache misses on processor operation. Figure 8.1(a) shows the arbitration in full frequency mode; figure 8.1(b) shows the arbitration in half-frequency mode.

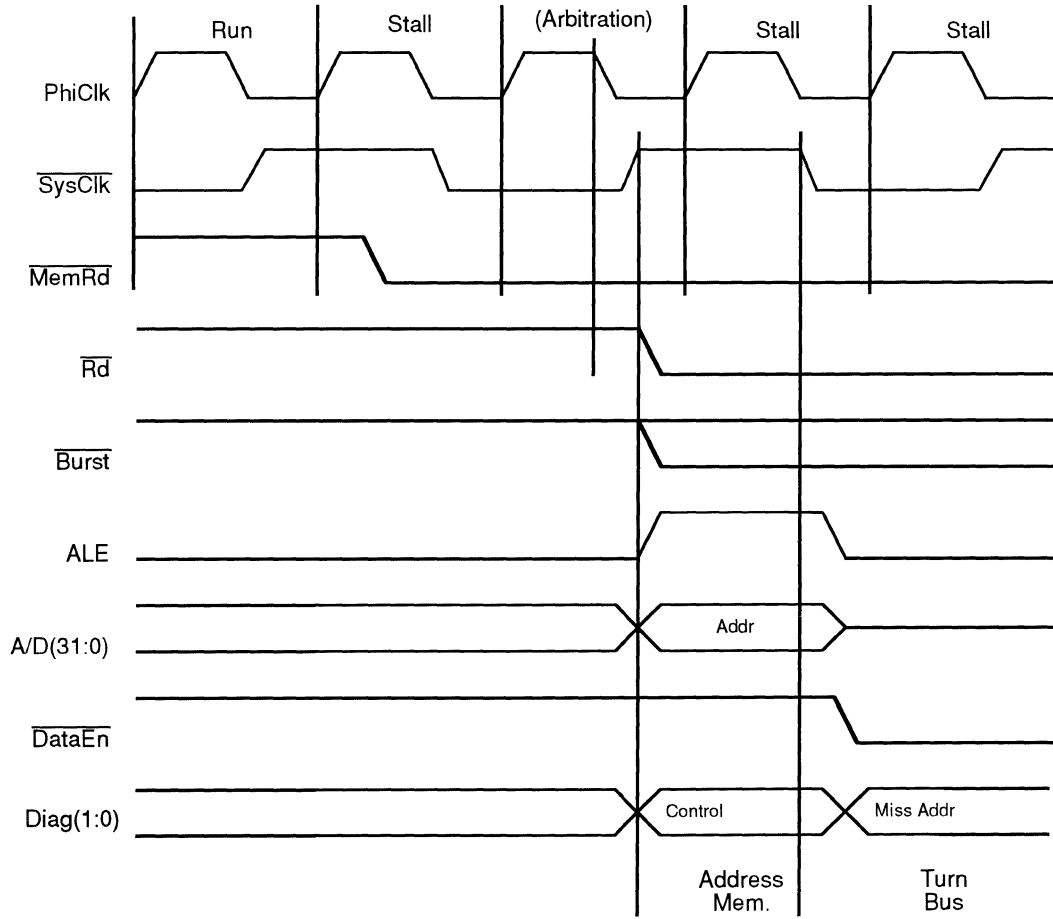

Figure 8.1(b). CPU Latency to Start of Read (Half Frequency Mode)

### Memory Addressing

A read transaction begins when the processor asserts its  $\overline{Rd}$  control output, and also drives the address and other control information onto the A/D and memory interface bus. Figure 8.2 illustrates the start of a processor read transaction, including the addressing of memory and the bus turn around. Note that all of this timing is with respect to the CPU  $\overline{SysClk}$  output, and thus applies in either half- or full-frequency mode.

The addressing occurs in a half-cycle of the  $\overline{SysClk}$  output. At the rising edge of  $\overline{SysClk}$ , the processor will drive the read target address onto the A/D bus. At this time, ALE will also be asserted, to allow an external transparent latch to capture the address. Depending on the system design, address decoding could occur in parallel with address de-multiplexing (that is, the decoder could start on the assertion of ALE, and the output of the decoder captured by ALE), or could occur on the output side of the transparent latches. During this phase,  $\overline{DataEn}$  will be held high indicating that memory drivers should not be enabled onto the A/D bus.

Concurrent with driving addresses on the A/D bus, the processor will indicate whether the read transaction is a quad word read or single word read, by driving  $\overline{Burst}$  to the appropriate polarity (low for a quad word read). If a quad word read is indicated, the Addr(3:2) lines will drive '00' (the start of the block); if a single datum is indicated, the Addr(3:2) lines will indicate the word address for the transfer. The functioning of the counter during quad words is described later.

### Bus Turn Around

Once the A/D bus has presented the address for the transfer, it is "turned around" by the processor to accept the incoming data. This occurs in the second phase of the first clock cycle of the read transaction, as illustrated in Figure 8.2.

The processor turns the bus around by carefully performing the following sequence of events:

- It negates ALE, causing the transparent address latches to capture the contents of the A/D bus.
- It disables its output drivers on the A/D bus, allowing it to be driven by an external agent. The processor design guarantees that the ALE is negated prior to tri-stating the A/D bus.
- The processor then asserts  $\overline{DataEn}$ , to indicate that the bus may be now driven by the external memory resource. The processor design insures that the A/D bus is released prior to  $\overline{DataEn}$  being asserted.  $\overline{DataEn}$  may be directly connected to the output enable of external memory, and no bus conflicts will occur.

Thus, the processor A/D bus is ready to be driven by the end of the second phase of the read transaction. At this time, it begins to look for the end of the read cycle.

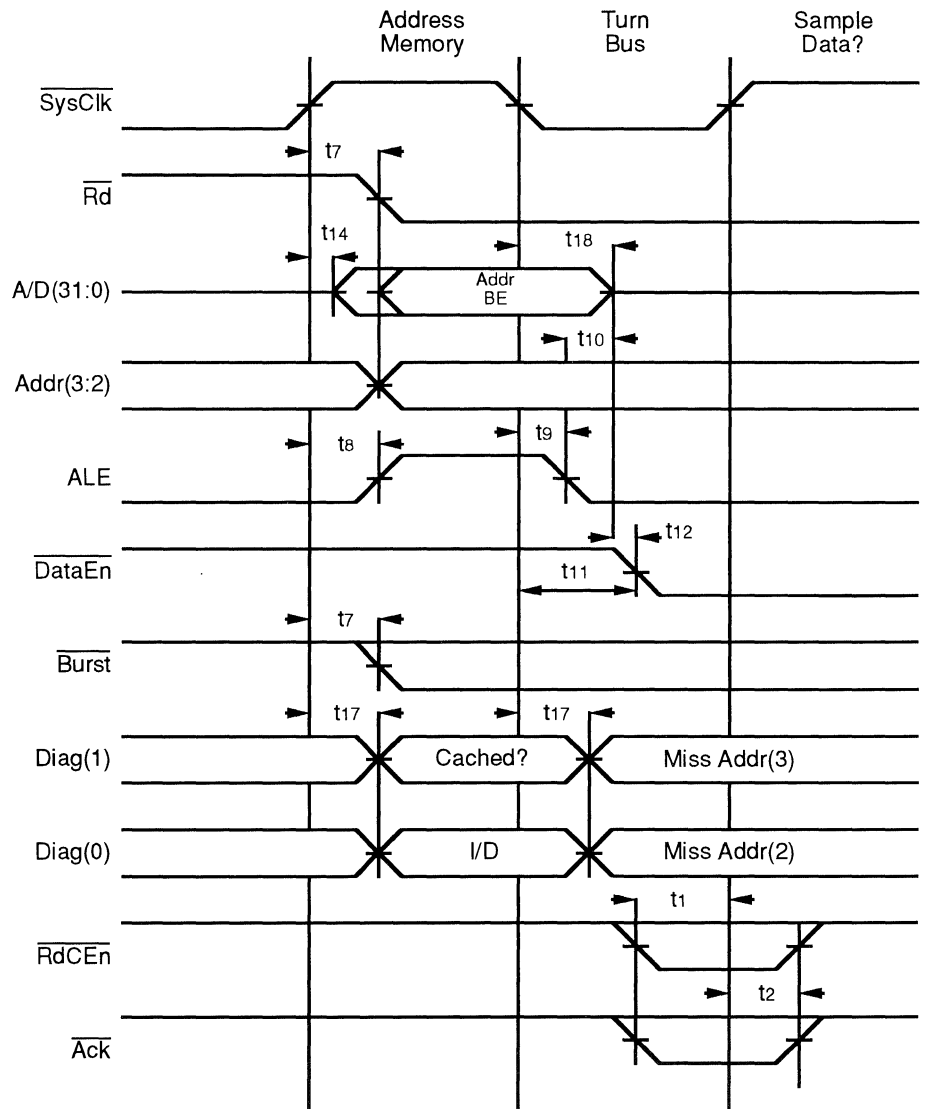

4000 drw 46

Figure 8.2. Start of Bus Read Operation

**Bringing Data into the Processor**

Regardless of whether the transfer is a quad word read or a single word transfer, the basic mechanism for transferring data presented on the A/D bus into the processor is the same.

Although there are two control signals involved in terminating read operations, only the  $\overline{\text{RdCEn}}$  signal is used to cause data to be captured from the bus.

The memory system asserts  $\overline{\text{RdCEn}}$  to indicate to the processor that it has (or will have) data on the A/D bus to be sampled. The earliest that  $\overline{\text{RdCEn}}$  can be detected by the processor is the rising edge of  $\overline{\text{SysClk}}$  after it has turned the bus around (start of phase 1 of the second clock cycle of the read).

If  $\overline{\text{RdCEn}}$  is detected as asserted (with adequate setup and hold time to the rising edge of  $\overline{\text{SysClk}}$ ), the processor will capture (with proper setup and hold time) the contents of the A/D bus on the immediately subsequent falling edge of  $\overline{\text{SysClk}}$ . This captures the data in the internal read buffer for later processing by the execution core/cache subsystem.

Figure 8.3 illustrates the sampling of data by an R3081.

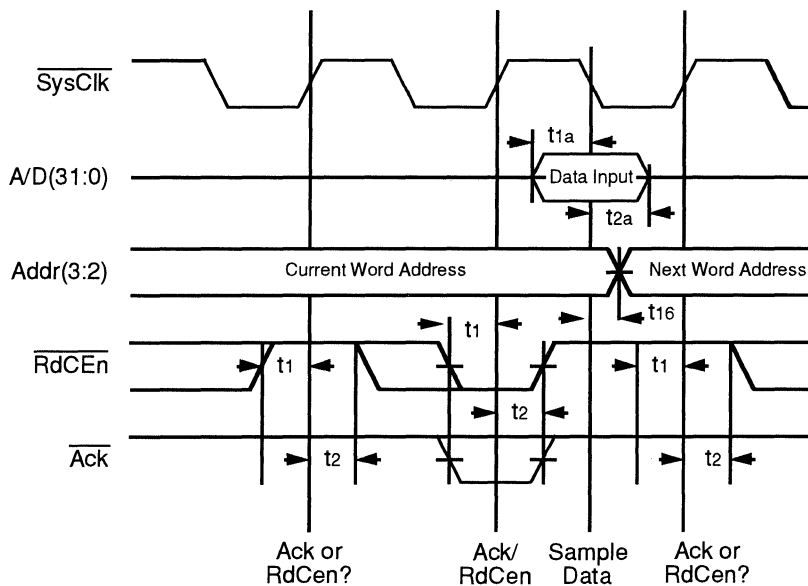

4000 drw 47

Figure 8.3. Data Sampling on R3051/52

### Terminating the Read

There are actually three methods for the external memory system to terminate an ongoing read operation:

- It can supply an  $\overline{\text{Ack}}$  (acknowledge) to the processor, to indicate that it has sufficiently processed the read request and has or will supply the requested data in a timely fashion. Note that  $\overline{\text{Ack}}$  may be signalled to the processor “early”, to enable it to begin processing the read data even while additional data is brought from the A/D bus. This is applicable only in quad word read operations. To simplify design, half-frequency mode has been constructed to reference  $\overline{\text{Ack}}$  in bus cycles. That is, the system will return  $\overline{\text{Ack}}$  in half-frequency mode with the same timing as it would for a processor running in full-frequency mode but at half the clock rate. The processor will internally synchronize the  $\overline{\text{Ack}}$  signal to compensate for the speed difference between the CPU and the bus.
- It can supply a  $\overline{\text{BusError}}$  to the processor, to indicate that the requested data transfer has “failed” on the bus, and force the processor to take a bus error exception. Although the system interface behavior of the processor when  $\overline{\text{BusError}}$  is presented is similar to the behavior when  $\overline{\text{Ack}}$  is presented, no data will actually be written into the on-chip cache. Rather, the cache line will either remain unchanged, or will be invalidated by the processor, depending on how much of the read has already been processed.
- The external memory system can supply the requested data, using  $\overline{\text{RdCEn}}$  to enable the processor to capture data from the bus. The processor will “count” the number of times  $\overline{\text{RdCEn}}$  is asserted; once the processor counts that the memory system has returned the desired amount of data (one or four words), it will implicitly “acknowledge” the read at the same time that it samples the last required  $\overline{\text{RdCEn}}$ . This approach leads to a simpler memory design at the cost of lower performance.

Throughout this chapter, method one will be illustrated. The other cases can easily be extrapolated from these diagrams (for example, the system designer

can assume that  $\overline{\text{Ack}}$  is asserted simultaneous with the last  $\overline{\text{RdCEn}}$  of a read transfer).

There are actually two phases of terminating the read: there is the phase where the memory system indicates to the processor that it has sufficiently processed the read request, and the internal read buffer can be released to begin refilling the internal caches; and there is the phase in which the read control signals are negated by the processor bus interface unit. The difference between these phases is due to block refill: it is possible for the memory system to “release” the execution core even though additional words of the block are still required; in that case, the processor will continue to assert the external read control signals until all four words are brought into the read buffer, while simultaneously refilling/executing based on the data already brought on board.

Figure 8.4 shows the timing of the control signals when the read cycle is being terminated. This figure applies regardless of the bus-frequency setting.

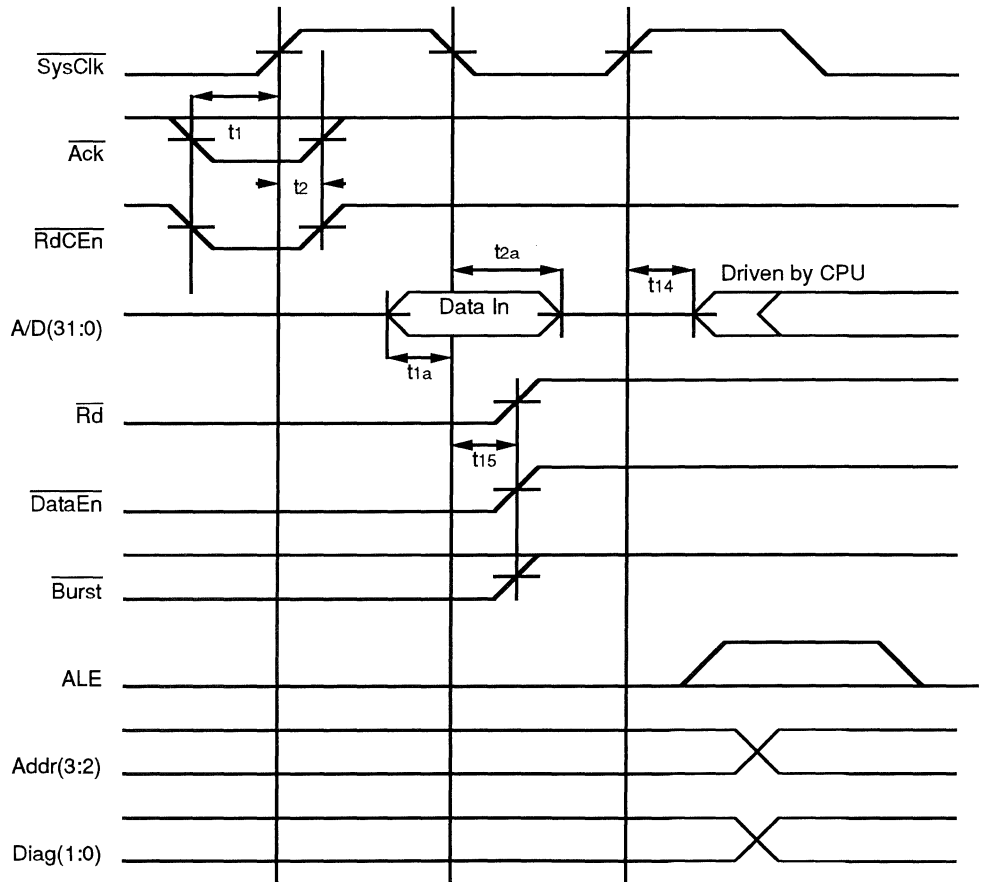

4000 drw 48

Figure 8.4. Read Cycle Termination

**Latency Between Processor Operations**

In general, the processor may begin a new bus activity in the phase immediately after the termination of the read cycle. This operation may logically be either a read, write, or bus grant. In full-frequency mode, there are no cases where a read operation can be signalled by the internal execution core in order to cause a read to start in the very next cycle after a read is terminated. However, a write may occur in this cycle. Similarly, in half-frequency mode, the cycle immediately after a read may be either a read or a write.

It is important that the external memory system cease to drive the bus prior to this clock edge used to begin a new transaction. In order to simplify design,



the processor provides the  $\overline{\text{DataEn}}$  output, which can be used to control either the Output Enable of the memory device (presuming its tri-state time is fast enough), or to control the Output Enable of a buffer or transceiver between the memory device data bus and the processor A/D bus. The use of this signal is illustrated in Figure 8.5.

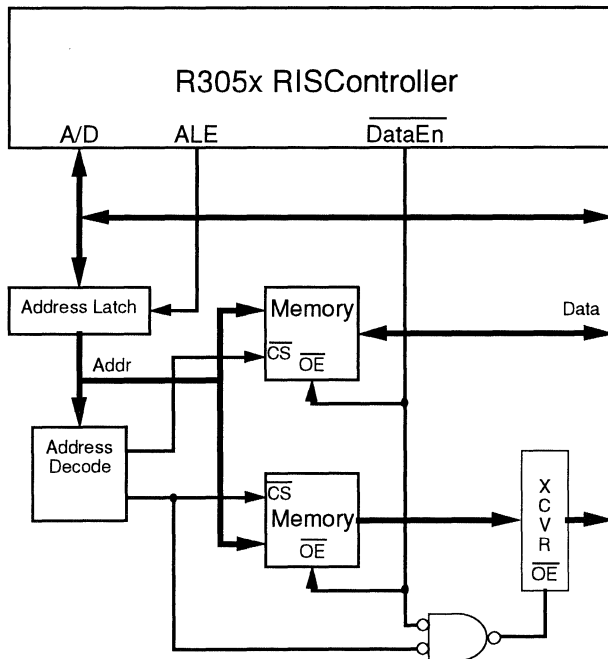

4000 drw 49

**Figure 8.5. Use of DataEn as Output Enable Control**

In addition, the system designer can choose to enable the slow bus turnaround mode of the R3081, through the Config register. If this mode is enabled, the processor will guarantee a minimum of one idle clock cycle after a read and before another transaction is begun.

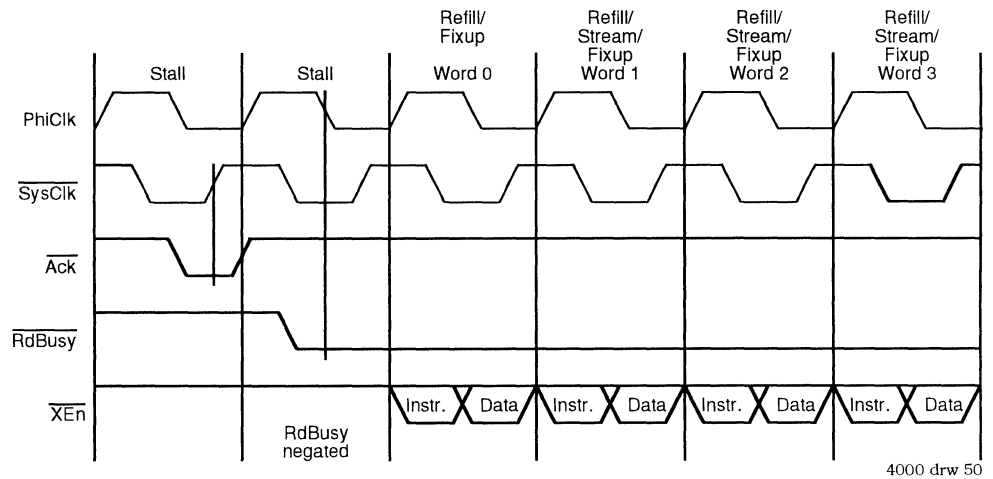

Figure 8.6(a). Internal Processor States on Burst Read (Full Frequency Mode)

**Processor Internal Activity**

In general, the processor will execute stall cycles until  $\overline{\text{Ack}}$  is detected. It will then begin the process of refilling the internal caches from the read buffer. Note that in the case of half-frequency mode, the processor uses an internal  $\overline{\text{IAck}}$  to control this event.  $\overline{\text{IAck}}$  is generated from the external  $\overline{\text{Ack}}$  with timing that depends on the type of transfer. In general, if the timing of the external  $\overline{\text{Ack}}$  is proper for a full frequency bus with a processor at half the speed, the internal  $\overline{\text{Ack}}$  will insure proper timing of the read-buffer/cache interface. The  $\overline{\text{IAck}}$  signal is internally delayed by  $n$  processor clock periods from the external  $\overline{\text{Ack}}$ , where  $n$  is the number of data items read (one or four).

The system designer should consider the difference between the time when the memory interface has completed the read, and when the processor core has completed the read. The bus interface may have successfully returned all of the required data, but the processor core may still require additional clock cycles to bring the data out of the read buffer and into the caches. Figure 8.6 (a, b) illustrates the relationship between  $\overline{\text{Ack}}$  and the internal activity for a block read. Figure 8.6 (a) shows the timing for a full frequency interface; figure 8.6 (b) shows the timing for a half-frequency bus interface, and shows the relationship of  $\overline{\text{IAck}}$  to  $\overline{\text{Ack}}$ .

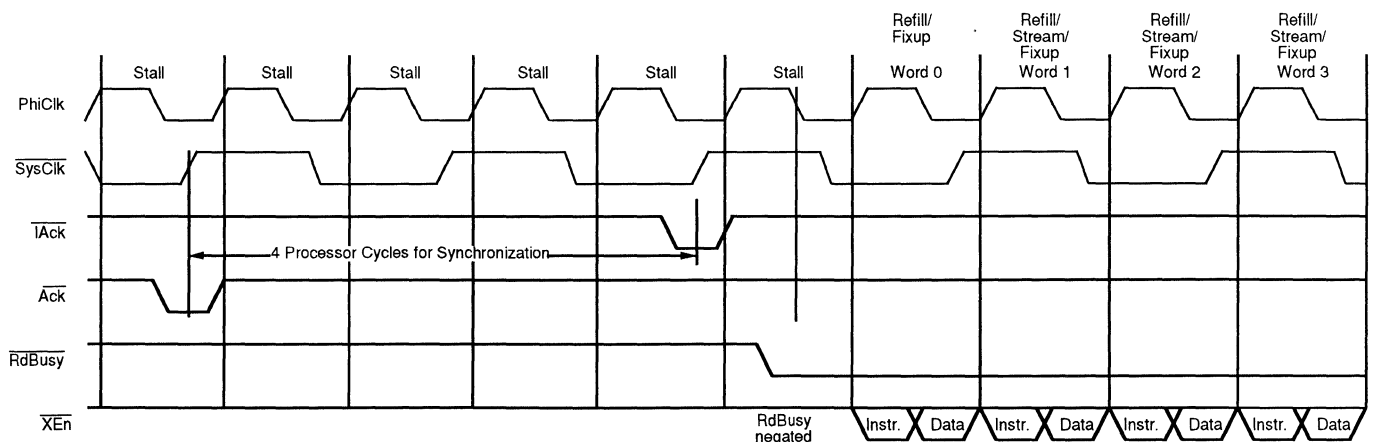

Figure 8.6(b). Internal Processor States on Burst Read (Half Frequency Mode)

These figures illustrate that the processor may perform either a stream, fixup, or refill cycle in cycles in which data is brought from the read buffer. The difference between these cycles is defined as:

- **Refill.** A refill cycle is a clock cycle in which data is brought out of the read buffer and placed into the internal processor cache. The processor does not execute on this data.
- **Fixup.** A fixup cycle is a cycle in which the processor transitions into executing the incoming data. It can be thought of as a “retry” of the cache cycle which resulted in a miss.
- **Stream.** A stream cycle is a cycle in which the processor simultaneously refills the internal cache and executes the instruction brought out of the read buffer.

When reading the block from the read buffer, the processor will use the following rules:

For uncacheable references, the processor will bring the single word out of the read buffer using a fixup cycle.

For data cache refill, it will execute either one or four refill cycles, followed by a fixup cycle.

For instruction cache refill, it will execute refill cycles starting at word zero until it encounters the miss address, and then transition to a fixup cycle. It will then execute stream cycles until either the entire block is processed, or an event stops execution. If something causes execution to stop, the processor will process the remainder of the block using simple refill cycles. For example, Figure 8.7 illustrates the refill/fixup/stream sequence appropriate for a miss which occurs on the second word of the block (word address 1).

Although this operation is transparent to the external memory system, it is important to understand this operation to gauge the impact of design trade-offs on performance.

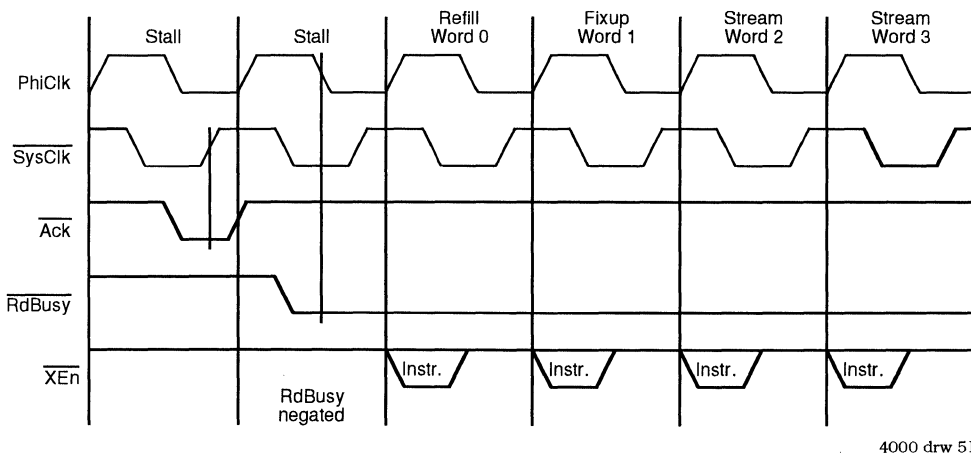

**Figure 8.7. Instruction Streaming Example (Full Frequency Mode)**

### READ TIMING DIAGRAMS

This section illustrates a number of timing diagrams applicable to R3081 read transactions. These diagrams reference AC parameters whose values are contained in the R3081 data sheet. Many of these timing diagrams also show the internal processor activity, assuming full frequency bus mode. In half-frequency mode, additional stall cycles would be incurred; however, the external timing shown would be unchanged.

#### Single Word Reads

Figure 8.8 illustrates the case of a single word read which did not require wait states. Thus, Ack was detected at the rising edge of SysClk which occurred exactly one clock cycle after the rising edge of SysClk which asserted Rd. Data was sampled one phase later, and Rd and DataEn disabled from that falling edge of SysClk. Thus, in full frequency mode, the execution core required three stall cycles and a fixup to process the internal data.

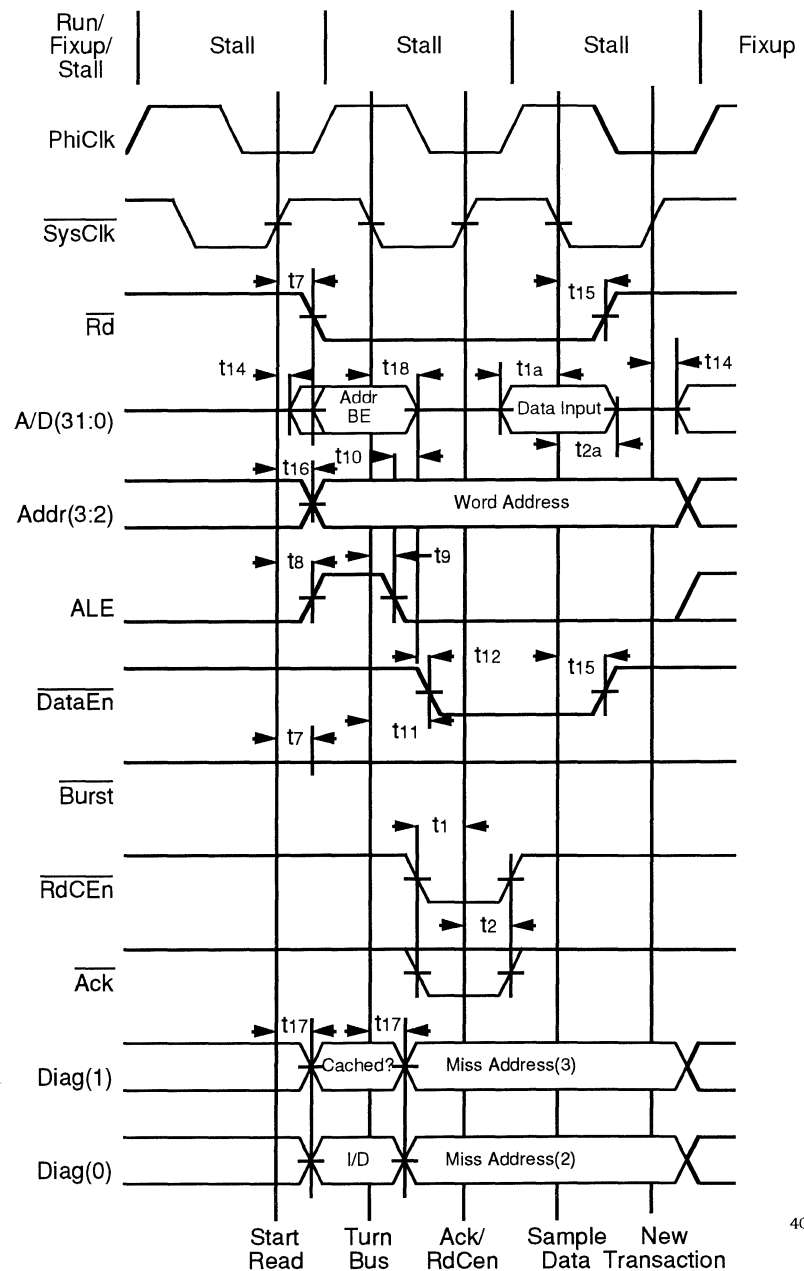

4000 drw 52

Figure 8.8. Single Word Read Without Bus Wait Cycles

Figure 8.9 also illustrates the case of a single word read. However, in this figure, two bus wait cycles were required before the data was returned. Thus, two rising edges of  $\overline{\text{SysClk}}$  occurred where neither  $\overline{\text{RdCEn}}$  or  $\overline{\text{Ack}}$  were asserted. On the third rising edge of  $\overline{\text{SysClk}}$ ,  $\overline{\text{RdCEn}}$  was asserted. Optionally,  $\overline{\text{Ack}}$  could also be asserted at this time, although it is not strictly necessary.

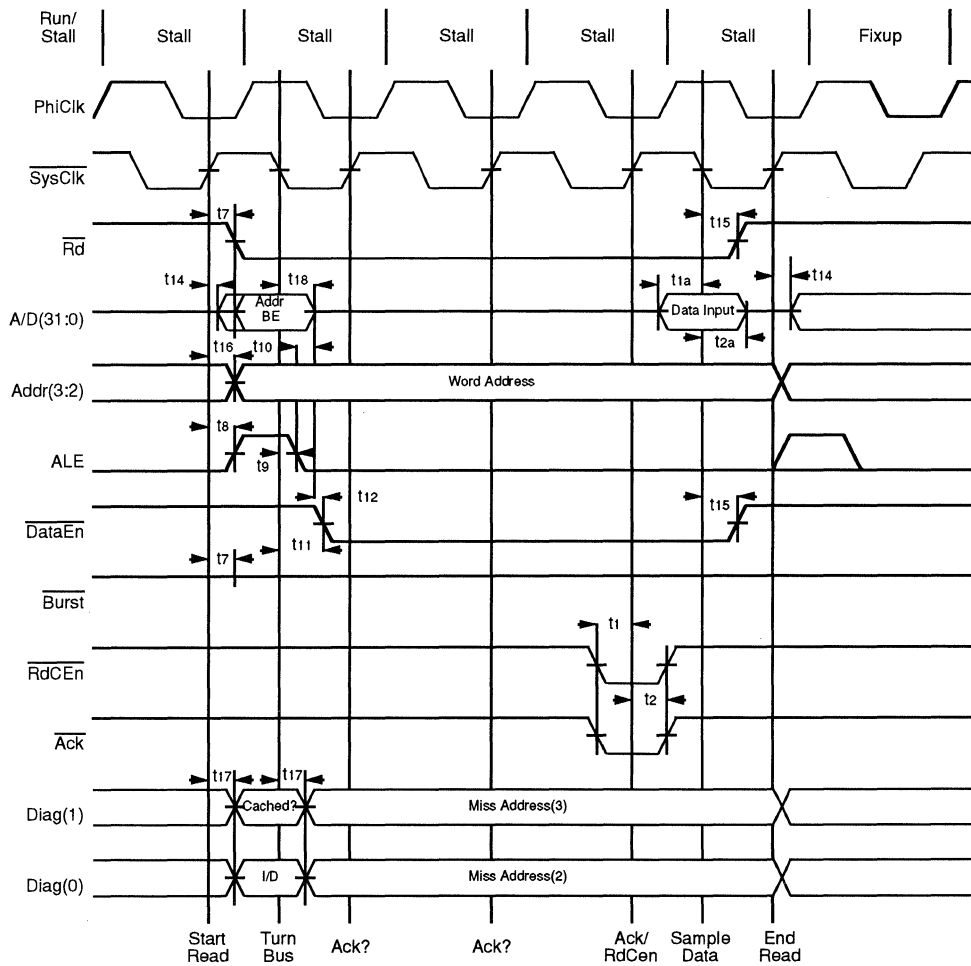

4000 drw 53

Figure 8.9. Single Word Read With Bus Wait Cycles

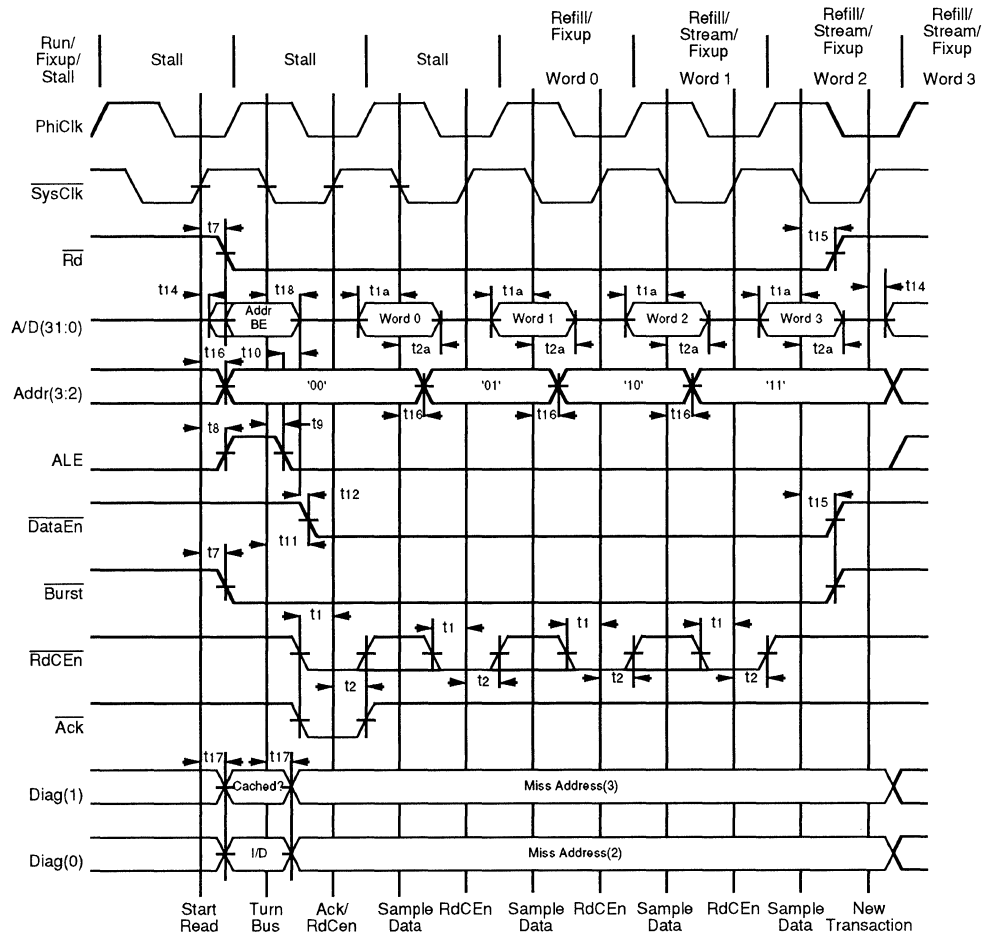

Figure 8.10. Burst Read With No Wait Cycles

4000 drw 54

### Block Reads

Figure 8.10 illustrates the absolute fastest block read. The first word of the block is returned in the second cycle of the read; each additional word is returned in the immediately subsequent clock cycle. Thus, Ack can be returned simultaneously with the first RdCEn, to minimize the number of processor stall cycles.

Note that although Ack is brought in the first data cycle, a number of clock cycles are required before the processor negates the Rd control output. Thus, the system designer is assured that Rd remains active as long as the processor continues to expect data.

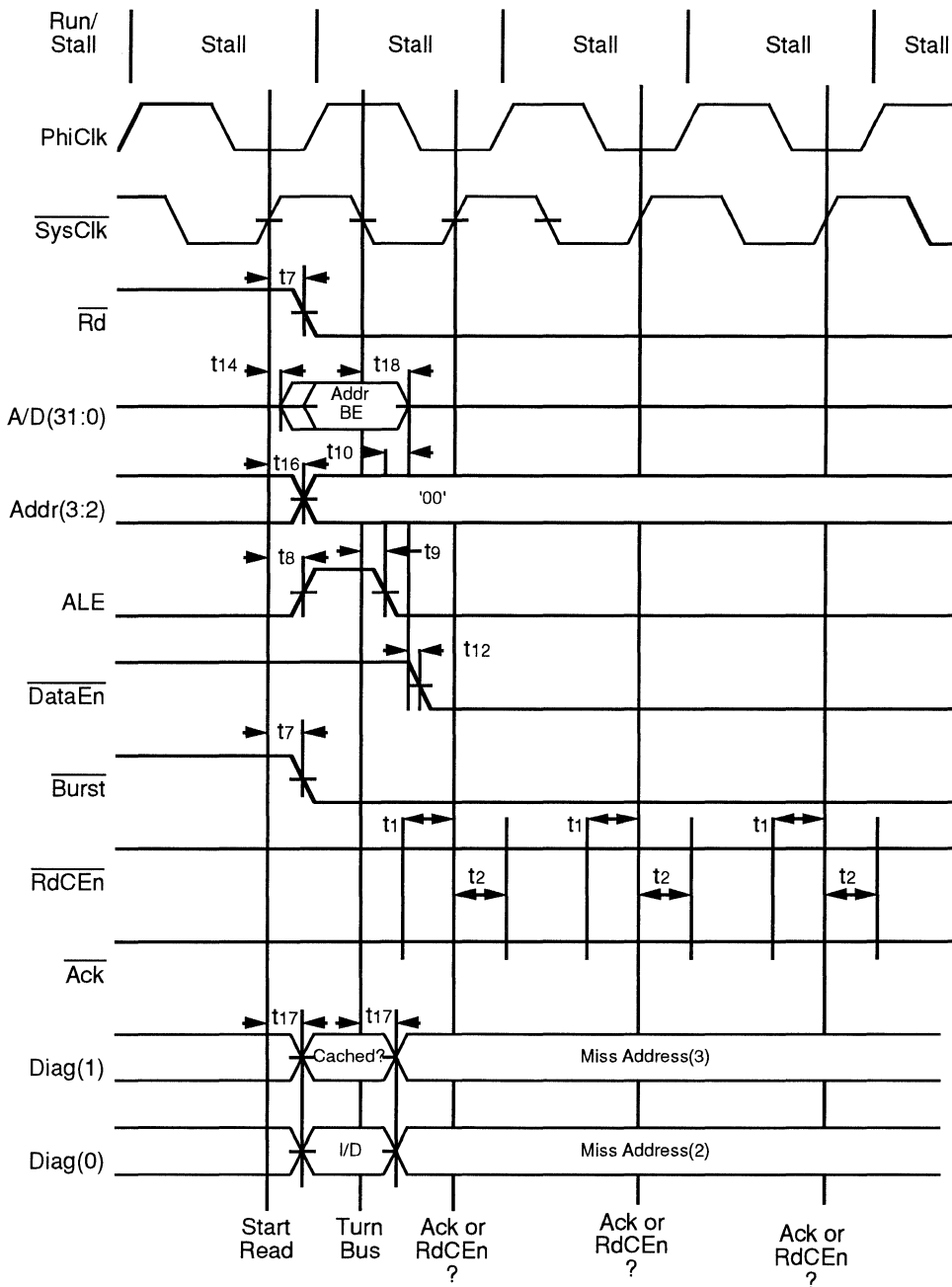

4000 drw 55

Figure 8.11(a). Start of Burst Read With Initial Wait Cycles

Figure 8.11 (a, b) illustrates a block read in which bus wait cycles are required before the first word is brought to the processor, but in which additional words can be brought in at the bus clock rate. Thus, as with the no wait cycle operation, Ack is returned simultaneously with the first RdCEn. Figure 8.11 (a) illustrates the start of the block read, including initial wait cycles to the first word; Figure 8.11 (b) illustrates the activity which occurs as data is brought onto the chip and the read is terminated.

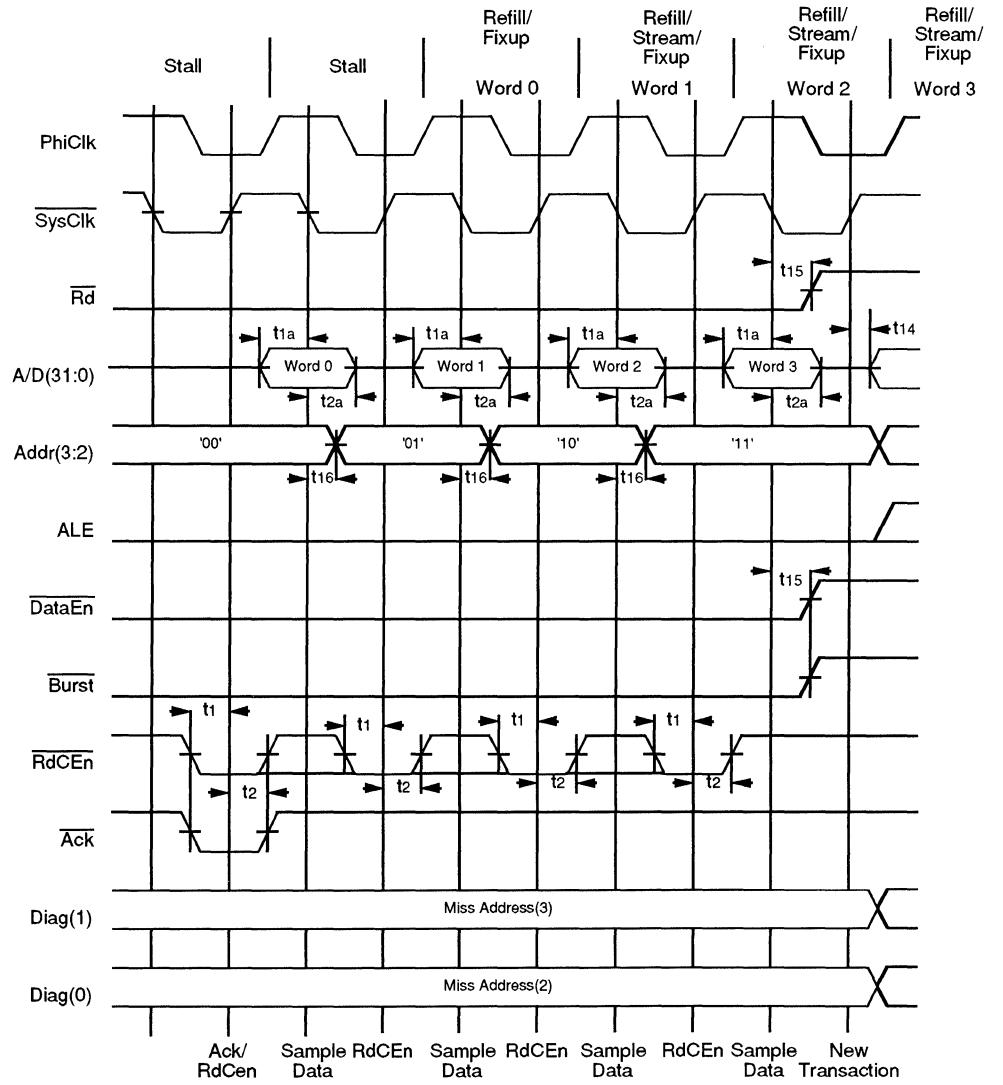

4000 drw 56

Figure 8.11(b). End of Burst Read



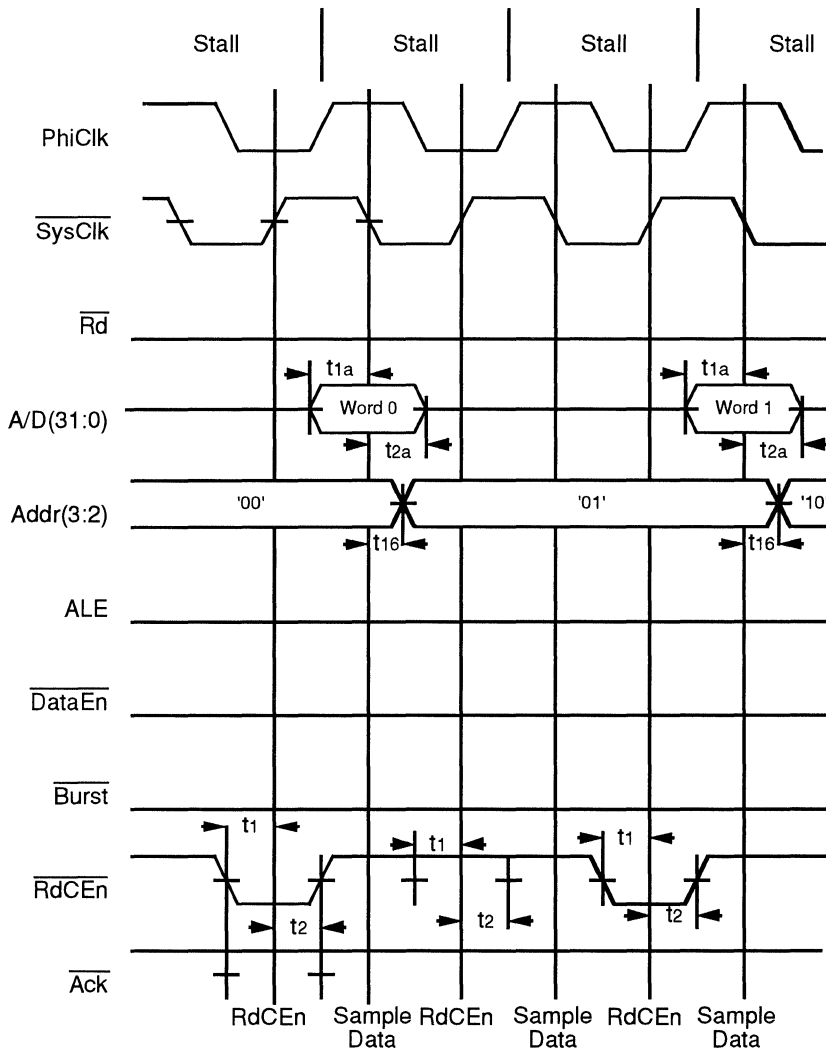

4000 drw 57

**Figure 8.12(a). First Two Words of "Throttled" Quad Word Read**

Figure 8.12 (a, b) illustrates a block read in which bus wait cycles are required before the first word is returned, and in which wait cycles are required between subsequent words: figure 8.12 (a) illustrates the the first two words of the block being brought on chip; figure 8.12 (b) illustrates the last two words of the read, including the optimum timing of Ack, and the negation of the read control signals.

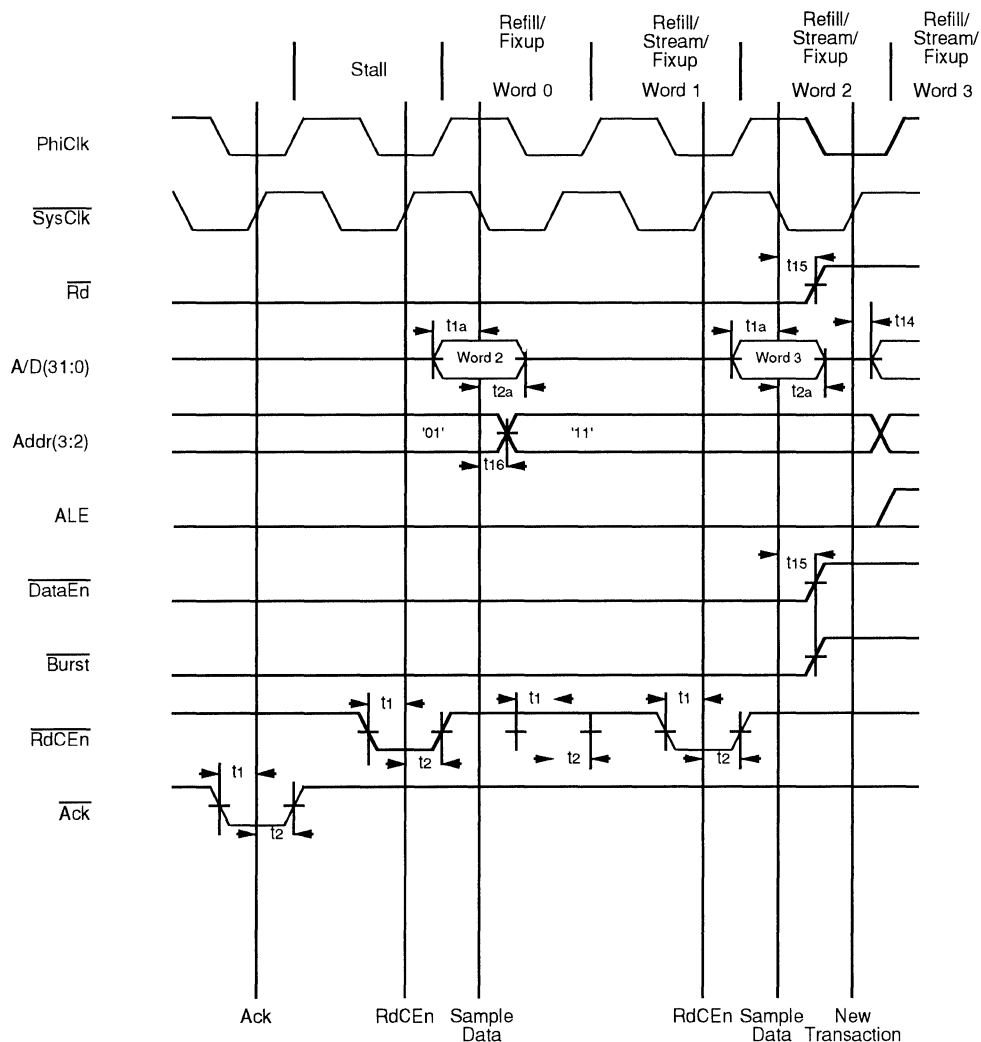

4000 drw 58

Figure 8.12(b). End of Throttled Quad Word Read

In this diagram, the memory system returns  $\overline{\text{Ack}}$  according to when the processor will empty the read buffer (assuming full frequency bus mode). As shown in figure 8.12(b), the optimum time for the memory system to return  $\overline{\text{Ack}}$  is five cycles prior to when the execution core requires the fourth word (in full frequency mode). That is, for a quad word read,  $\overline{\text{Ack}}$  should be returned four cycles before the fourth word is provided by the memory system to the read buffer. This "four-cycles" rule applies regardless of the bus frequency setting selected. As a final note, the system designer should also insure that the third, second, etc. words of the read cycle are available to the read buffer before the execution core removes them to the caches.

**Bus Error Operation**

Figure 8.13 is a modified version of Figure 8.9 (single word read with wait cycles), in which  $\overline{\text{BusError}}$  is used to terminate the read cycle. In this diagram, note that  $\overline{\text{RdCEn}}$  does not need to be asserted, since the processor will insure that the contents of the A/D bus do not get written into the cache or executed. In single word reads,  $\overline{\text{BusError}}$  can be asserted anytime up until  $\overline{\text{Ack}}$  is asserted. If  $\overline{\text{BusError}}$  and  $\overline{\text{Ack}}$  are asserted simultaneously, the  $\overline{\text{BusError}}$  will be processed; if  $\overline{\text{BusError}}$  is asserted after  $\overline{\text{Ack}}$  is sampled, it will be ignored.

Figure 8.14 shows the impact of  $\overline{\text{BusError}}$  on block reads. The assertion of  $\overline{\text{BusError}}$  is allowed up until the assertion of  $\overline{\text{Ack}}$ . Once  $\overline{\text{BusError}}$  is asserted (sampled on a rising edge of  $\overline{\text{SysClk}}$ ), the read cycle will be terminated immediately, regardless of how many words have been written into the read buffer. Note that this means that the external memory system should stop cycling  $\overline{\text{RdCEn}}$  at this time, since a late  $\overline{\text{RdCEn}}$  may be erroneously detected as part of a subsequent read. Note that if  $\overline{\text{BusError}}$  and  $\overline{\text{Ack}}$  are asserted simultaneously,  $\overline{\text{BusError}}$  processing will occur. If  $\overline{\text{BusError}}$  is asserted after  $\overline{\text{Ack}}$ , the  $\overline{\text{BusError}}$  will be ignored.

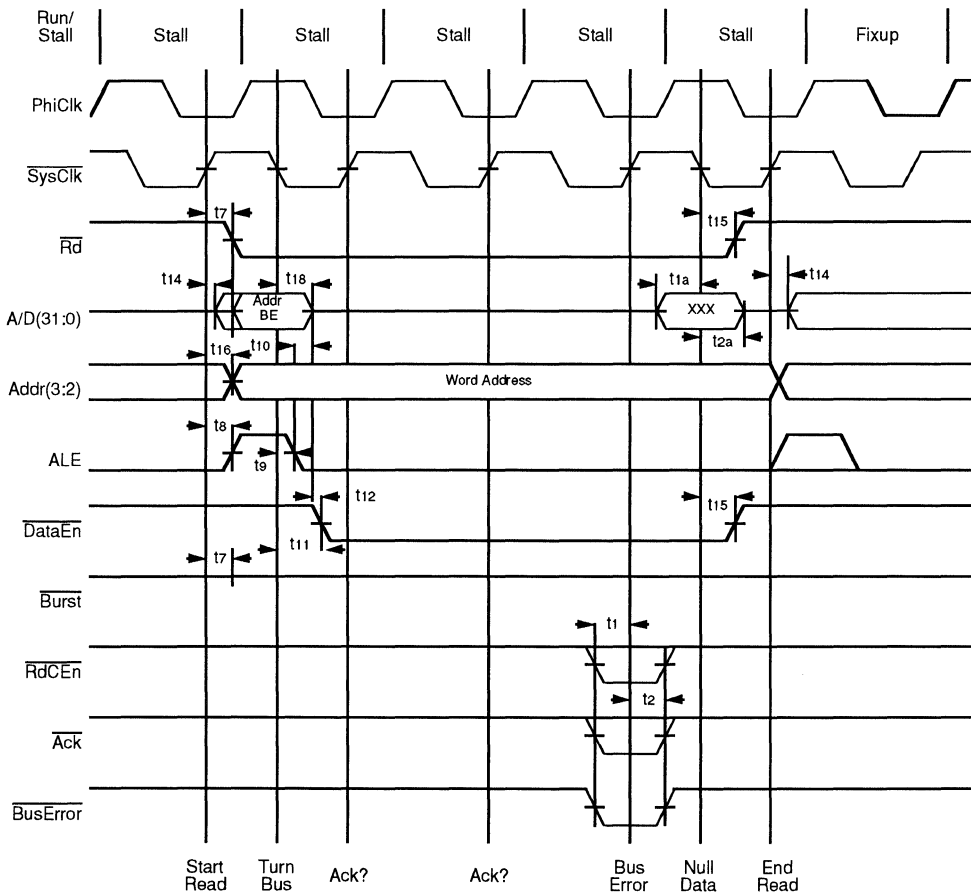

4000 drw 59

**Figure 8.13. Single Word Read Terminated by Bus Error**

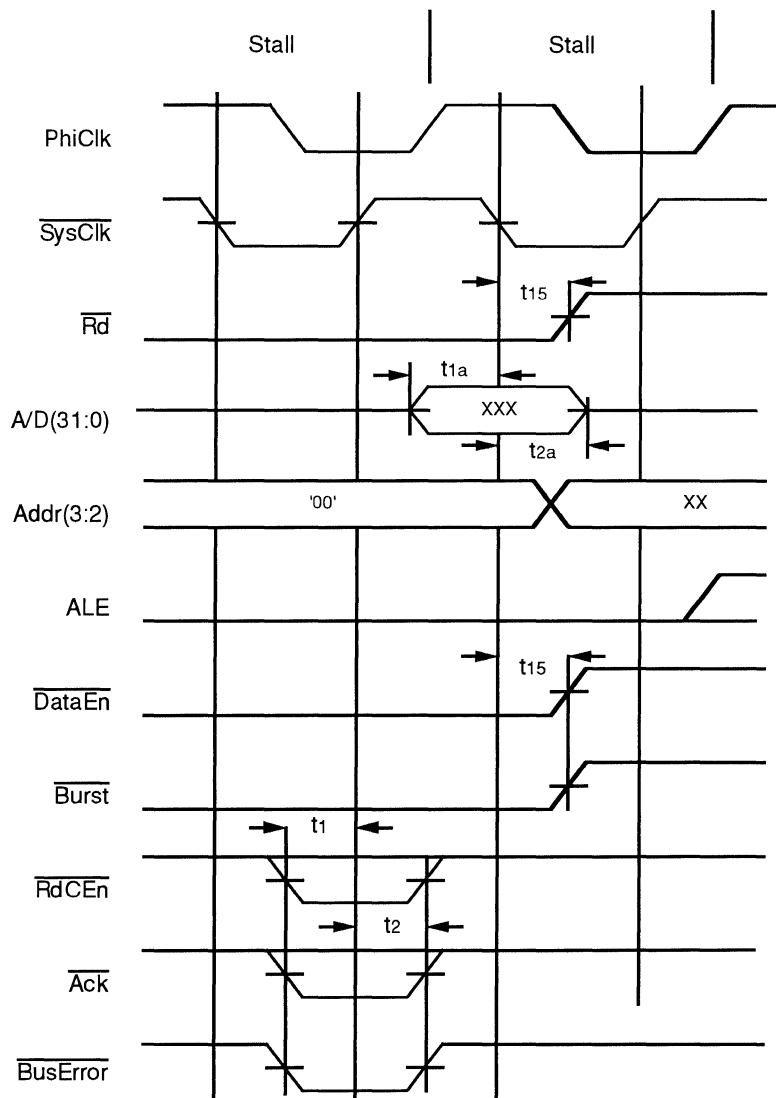

4000 drw 60

Figure 8.14. Block Read Terminated by Bus Error





**INTRODUCTION**

The write protocol of the R3081 has been designed to complement the read interface of the processor. Many of the same signals are used for both reads and writes, simplifying the design of the memory system control logic.

This chapter includes both an overview of the write interface as well as provides detailed timing diagrams of the write interface.

**IMPORTANCE OF WRITES IN R3081 SYSTEMS**

The design goal of the write interface was to achieve two things:

Insure that a relatively slow write cycle does not unduly degrade the performance of the processor. To this end, a four deep write buffer has been incorporated on chip. The role of the write buffer is to decouple the speed of the memory interface from the speed of the execution engine. The write buffer captures store information (data, address, and transaction size) from the processor at its clock rate, and later presents it to the memory interface at the rate it can perform the writes. Four such buffer entries are incorporated, thus allowing the processor to continue execution even when performing a quick succession of writes. Only when the write buffer is filled must the processor stall; simulations have shown that significantly less than 1% of processor clock cycles are lost to write buffer full stalls.

Allow the memory system to optimize for fast writes. To this end, a number of design decisions were made: the  $\overline{WrNear}$  signal is provided to allow page mode writes to be used in even simple memory systems; the A/D bus presents the data to be written in the second phase of the first clock cycle of a write transaction; and writes can be performed in as few as two clock cycles.

Although it may be counter-intuitive, the majority of bus traffic will in fact be processor writes to memory. This can be demonstrated if one assumes the following:

**Instruction Mix:**

ALU Operations	55%
Branch Operations	15%
Load Operations	20%
Store Operations	10%

**Cache Performance**

Instruction Hit Rate	98%
Data Hit Rate	96%

Under these assumptions, in 100 instructions, the processor would perform:

- 2 Reads to process instruction cache misses on instruction fetches
- 4% x 20 = 0.8 reads to process data cache misses on loads
- 10 store operations to the write through cache
- Total: 2.8 reads and 10 writes

Thus, in this example, over 75% of the bus transactions are write operations, even though only 10 instructions were store operations, vs. 100 instruction fetches and 20 data fetches.

## TYPES OF WRITE TRANSACTIONS

Unlike instruction fetches and data loads, which are usually satisfied by the on-chip caches and thus are not seen at the bus interface, all write activity is seen at the bus interface as single write transactions. There is no such thing as a “burst write”; the processor performs a word or subword write as a single autonomous bus transaction; however, the  $\overline{\text{WrNear}}$  output does allow successive write transactions to be processed using page mode writes. This is particularly important when “flushing” the write buffer before performing a data read.

Thus, there really is only one type of write transaction: however, the memory system may elect to take advantage of the assertion of  $\overline{\text{WrNear}}$  during a write to perform quicker write operations than would otherwise be performed. Alternately, a high-performance DRAM controller may utilize a different strategy for performing page mode transactions (read or write) to the DRAM.

In processing writes, there is only one parameter of interest: the latency of the write. This latency is influenced by the overall system architecture as well as the type of memory system being addressed: time required to perform address decoding and bus arbitration, memory pre-charge requirements, and memory control requirements, as well as memory access time.  $\overline{\text{WrNear}}$  may be used to reduce the latency of successive write operations within the same DRAM page.

The R3051 family has been designed to accommodate a wide variety of memory system designs, including no wait cycle operations (write completed in two cycles) through simpler, slower systems incorporating many bus wait cycles.

### Partial Word Writes

When the processor issues a store instruction which stores less than a 32-bit quantity, a partial word store occurs. The R3051 family processes partial word stores using a two clock cycle sequence:

It attempts a cache read to see if the store address is cache resident. If it is, it will merge the partial word with the word read from the cache, and write the resulting word back into the cache.

It will use a second clock cycle to allow the write buffer to capture the data and target address and update the cache if appropriate. If the store target word was cache resident, a full word write will be processed. Otherwise, only the partial word write will be seen on the bus.

**WRITE INTERFACE SIGNALS**

The write interface uses the following signals:

**$\overline{Wr}$**                       **O**

This output indicates that a write operation is occurring.

**A/D (31:0)**                **O**

During write operations, this bus is used to transmit the write target address to the memory system, and is also used to transmit the store data to the memory system. Its function is de-multiplexed using other control signals.

During the addressing portion of the write transaction, this bus contains the following:

Address(31:4)      The upper 28 bits of the write address are presented on A/D (31:4).

$\overline{BE}$ (3:0)              The byte strobes for the write transaction are presented on A/D(3:0).

During the data portion of the write transaction, the A/D bus contains the store data on the appropriate data lines, as indicated by the  $\overline{BE}$  strobes during the addressing phase.

**ALE**                              **O**

This output signal is typically connected directly to the latch enable of transparent latches. Latches are typically used to de-multiplex the address and Byte Enable information from the A/D bus.

**Addr(3:2)**                    **O**

The remaining bits of the transfer address are presented directly on these outputs. During write transactions, these pins contain Address (3:2) of the transfer address.

**Diag(1)**                        **O**

**Diagnostic Pin 1.** On write cycles, this output signals whether the data being written was retained in the on-chip data cache. The value of this pin is time multiplexed:

**Cached:**                      During the address phase of write operations, this signal is an active high output which indicates that the store data was retained in the on-chip data cache.

**Reserved:**                    The value of this pin during the data phase of writes is reserved.

**Diag(0)**                        **O**

**Diagnostic Pin 0.** During write cycles, the value of this pin during both the address and data phase is reserved.



**$\overline{\text{DataEn}}$**       **O**

This output will remain high throughout the write transaction. It is typically used by the memory system to enable output drivers; the CPU will maintain this output as high throughout write transactions, thus disabling memory system output drivers.

 **$\overline{\text{WrNear}}$**       **O**

This output is driven valid during the addressing phase of the write transaction. It is asserted if:

- 1: The store target address of this write operation has the same Addr(31:11) as the previous write transaction, and
- 2: No read or DMA transaction has occurred since the last write.

If one or both of these conditions are not met, the  $\overline{\text{WrNear}}$  output will not be asserted during the write transaction.

 **$\overline{\text{Ack}}$**       **I**

Acknowledge is used by the memory system to indicate that it has sufficiently processed the write transaction, and that the CPU may terminate the write transaction (and cease driving the write data).

 **$\overline{\text{BusError}}$**       **I**

This input can also be used to terminate a write operation.  $\overline{\text{BusError}}$  asserted during a write will not cause the processor to take a **BusError** exception. If the system designer would like the occurrence of a  $\overline{\text{BusError}}$  to cause a processor exception, he must use it to externally generate an interrupt to the processor. Write transactions terminated by  $\overline{\text{BusError}}$  do not require the assertion of  $\overline{\text{Ack}}$ .  $\overline{\text{BusError}}$  can be asserted at any time the processor is looking for  $\overline{\text{Ack}}$  to be asserted, up to and including the cycle in which the memory system does signal  $\overline{\text{Ack}}$ .

### WRITE INTERFACE TIMING OVERVIEW

The protocol for transmitting data from the processor to memory and I/O devices is discussed below. Note that the choice between half- and full-frequency mode for the bus interface does not affect the timing diagrams.

#### Initiating the Write

A write transaction occurs when the processor has placed data into the write buffer, and the bus interface is either free, or write has the highest priority. Internally, the processor bus arbiter uses the NotEmpty indicator from the write buffer to indicate that a write is being requested.

Assuming that the write transaction can be processed (that is, there are no ongoing bus operations, and no higher priority operations pending), the processor will initiate a bus write transaction on the next rising edge of SysClk. Higher priority operations would have the effect of delaying the start of the write.

Figure 9.1 (a) illustrates the initiation of a write transaction, based on the internal negation of the  $\overline{\text{WbEmpty}}$  control signal. This figure applies when the processor is performing a write, and the write buffer is otherwise empty, and further assumes that the bus interface uses the full frequency mode of operation. In half-frequency mode, the  $\overline{\text{MemWr}}$  and  $\overline{\text{WbEmpty}}$  signals would still be asserted with the timing shown in figure 9.1; however, the bus interface unit arbitration would actually take place in the next PhiClk, and thus the write would not be begun until one cycle later. This is shown in figure 9.1 (b).

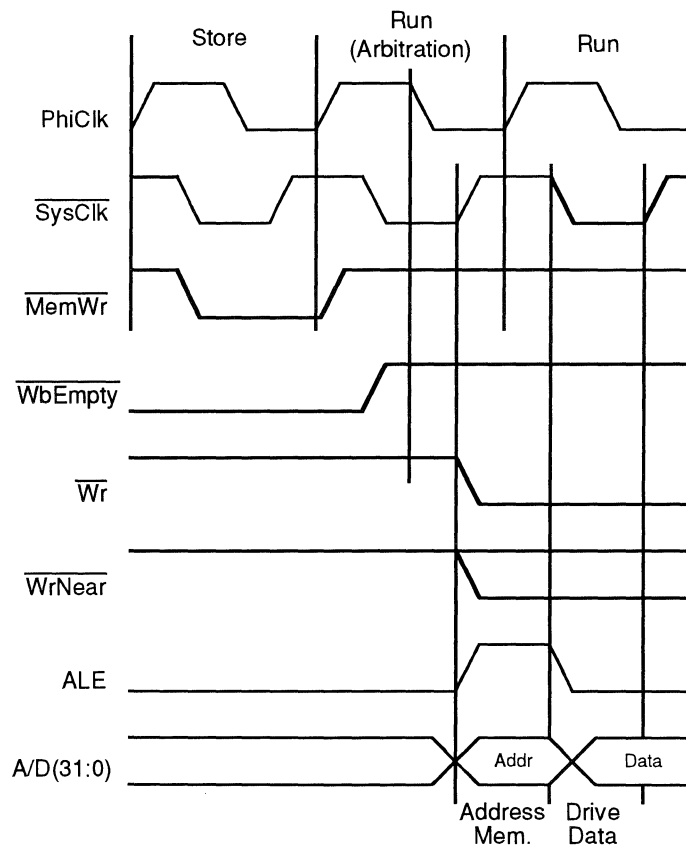

4000 drw 61

Figure 9.1 (a). Start of Write Operation – BIU Arbitration

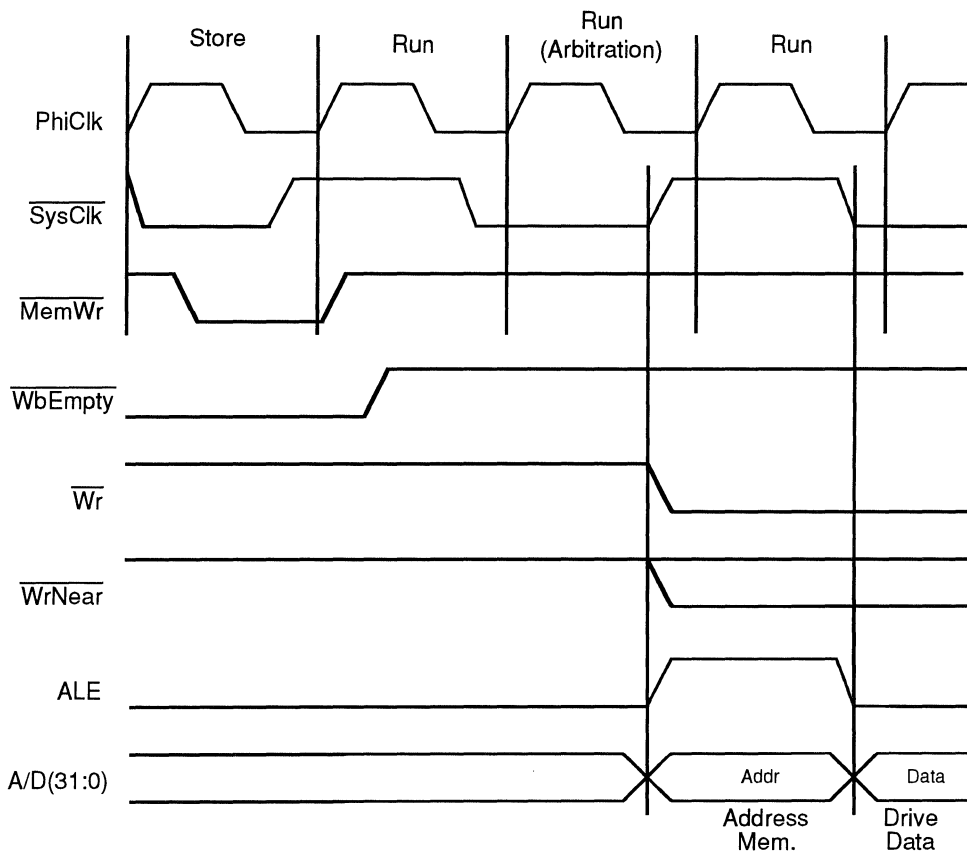

Figure 9.1 (b). Start of Write Arbitration - Half-frequency Mode

If the write buffer already had data in it, it would continually request the use of the bus until it was emptied; it would be up to the bus interface unit arbiter to decide the priority of the request relative to other pending requests. Additional stores would be captured by other write buffer entries, until the write buffer was filled.

### Memory Addressing

A write transaction begins when the processor asserts its  $\overline{Wr}$  control output, and also drives the address and other control information onto the A/D and memory interface bus. Figure 9.2 illustrates the start of a processor write transaction, including the addressing of memory and presenting the store data on the A/D bus.

The addressing occurs in a half-cycle of the  $\overline{SysClk}$  output. At the rising edge of  $\overline{SysClk}$ , the processor will drive the write target address onto the A/D bus. At this time, ALE will also be asserted, to allow an external transparent latch to capture the address. Depending on the system design, address decoding could occur in parallel with address de-multiplexing (that is, the decoder could start on the assertion of ALE, and the output of the decoder captured by ALE), or could occur on the output side of the transparent latches. During this phase,  $\overline{WrNear}$  will also be determined and driven out by the processor.

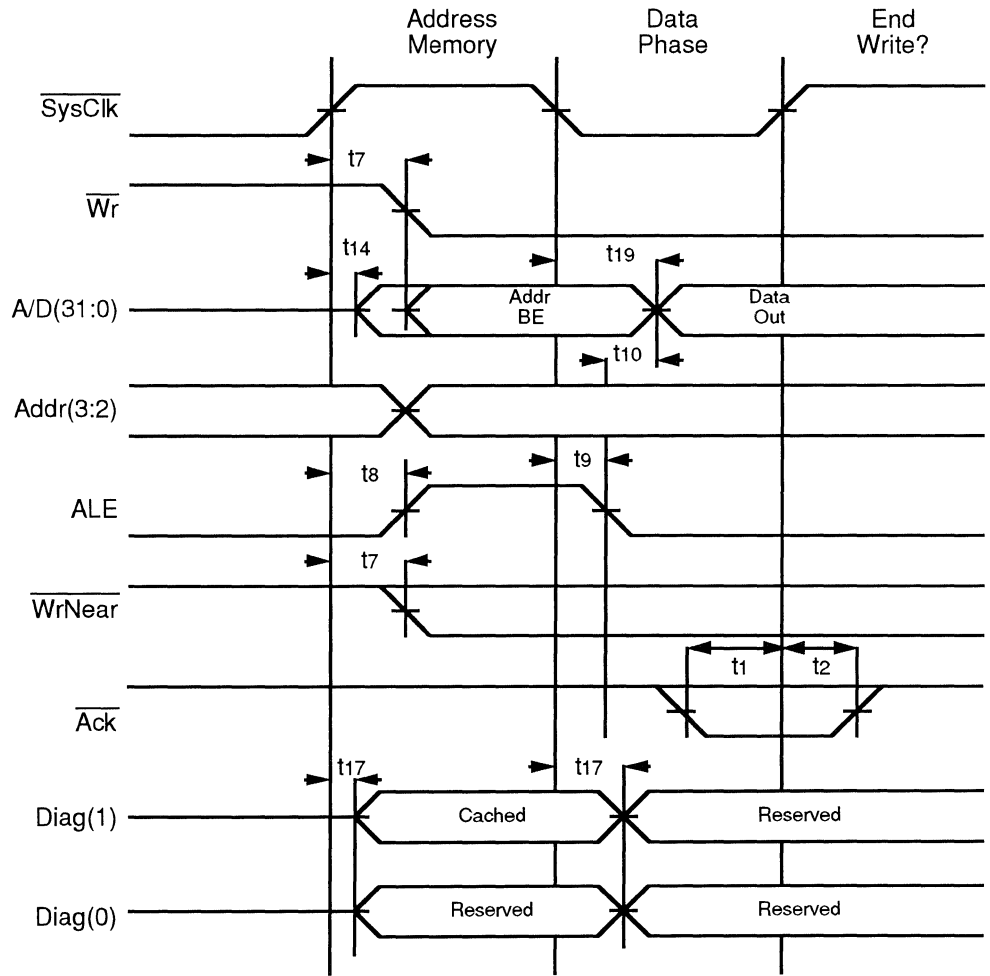

Figure 9.2. Memory Addressing and Start of Write

**Data Phase**

Once the A/D bus has presented the address for the transfer, the address is replaced on the A/D bus by the store data. This occurs in the second phase of the first bus clock cycle of the write transaction, as illustrated in Figure 9.2.

The processor enters the data phase by performing the following sequence of events:

- It negates ALE, causing the transparent address latches to capture the contents of the A/D bus.
- It internally captures the data in a register in the bus interface unit, and enables this register onto its output drivers on the A/D bus. The processor design guarantees that the ALE is negated prior to the address being removed from the A/D bus.

Thus, the processor A/D bus is driving the store data by the end of the second phase of the write transaction. At this time, it begins to look for the end of the write cycle.

**Terminating the Write**

There are only two methods for the external memory system to terminate a write operation:

- It can supply an  $\overline{\text{Ack}}$  (acknowledge) to the processor, to indicate that it has sufficiently processed the write request, and the processor may terminate the write.
- It can supply a  $\overline{\text{BusError}}$  to the processor, to indicate that the requested data transfer has “failed” on the bus. The system interface behavior of the processor when  $\overline{\text{BusError}}$  is presented is identical to the behavior when  $\overline{\text{Ack}}$  is asserted. In the case of writes terminated by  $\overline{\text{BusError}}$ , no exception is taken, and the data transfer cannot be retried.

Figure 9.3 shows the timing of the control signals when the write cycle is being terminated.

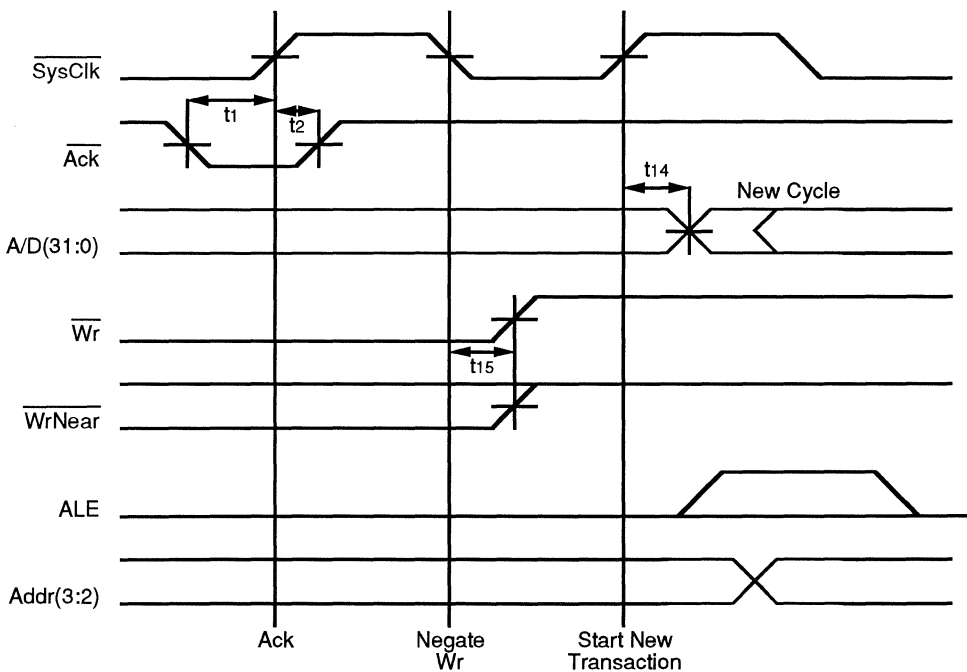

Figure 9.3. End of Write

4000 drw 63

**Latency Between Processor Operations**

In general, the processor may begin a new bus activity in the phase immediately after the termination of the write cycle. This operation may be either a read, write, or bus grant.

Since a new operation may begin one clock cycle after  $\overline{\text{Ack}}$  is sampled, it is important that the external memory system not rely on the store data still being present on the bus at this time.

Note that the slow bus turn-around mode does not impact the latency after a write cycle. This is because the R3081 retains control of the A/D bus during the entire write cycle, and thus there is no concern about one driver turning off before another turns on.

**Write Buffer Full Operation**

It is possible that the execution core on occasion may be able to fill the on-chip write buffer. If the processor core attempts to perform a store to the write buffer while the buffer is full, the execution core will be stalled by the write buffer until a space is available. Once space is made available, the execution core will use a fixup cycle to “retry” the store, allowing the data to be captured by the write buffer. It will then resume execution.

The write buffer can actually be thought of as “four and one-half” entries: it contains a special data buffer which captures the data being presented by an ongoing bus write transaction. Thus, when the bus interface unit begins a write transaction, the write buffer slot containing the data for that write is freed up in the second phase of the write transaction. If the processor was in a write busy stall, it will be released to write into the now available slot at this time, regardless of how long it takes the memory system to retire the ongoing write.

This operation is illustrated in figure 9.4 for a full-frequency bus unit. At half-frequency, the  $\overline{WbFull}$  is negated one PhiClk later (based on the longer address phase), and thus one extra stall cycle is encountered.

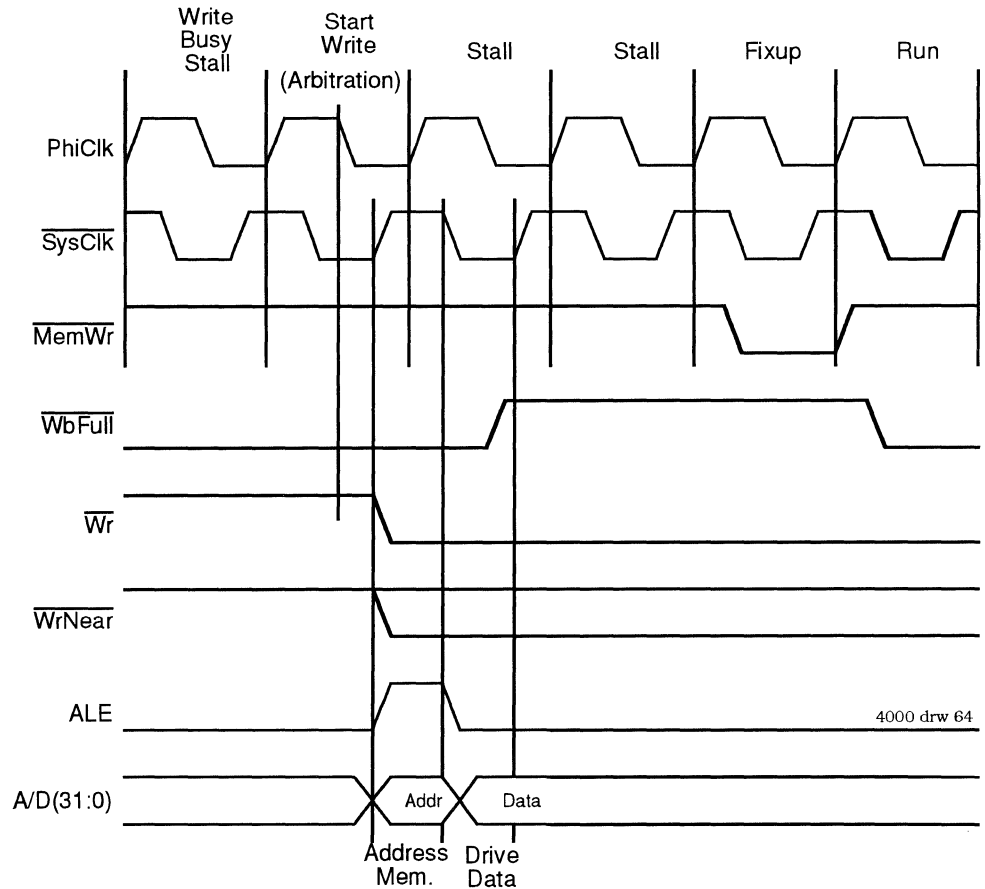

**Figure 9.4. Write Buffer Full Operation**

**WRITE TIMING DIAGRAMS**

This section illustrates a number of timing diagrams applicable to R3051 family writes. The values for the AC parameters referenced are contained in the R3081 data sheet.

**Basic Write**

Figure 9.5 illustrates the case of a write operation which did not require bus wait states. Thus,  $\overline{\text{Ack}}$  was detected at the rising edge of  $\overline{\text{SysClk}}$  which occurred exactly one clock cycle after the rising edge of  $\overline{\text{SysClk}}$  which asserted  $\overline{\text{Wr}}$ .

Figure 9.6 also illustrates the case of a basic write. However, in this figure, two bus wait cycles were required before the data was retired. Thus, two rising edges of  $\overline{\text{SysClk}}$  occurred where  $\overline{\text{Ack}}$  was not asserted. On the third rising edge of  $\overline{\text{SysClk}}$ ,  $\overline{\text{Ack}}$  was asserted, and the write operation was terminated.

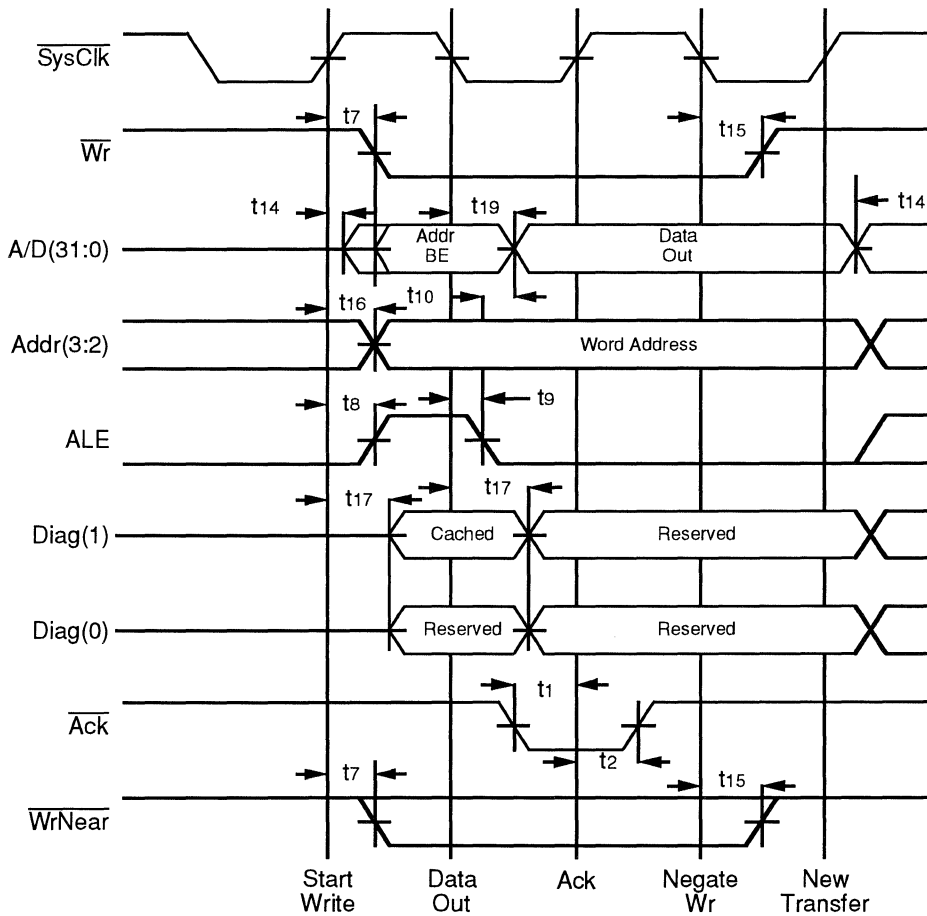

**Figure 9.5. Bus Write With No Wait Cycles**

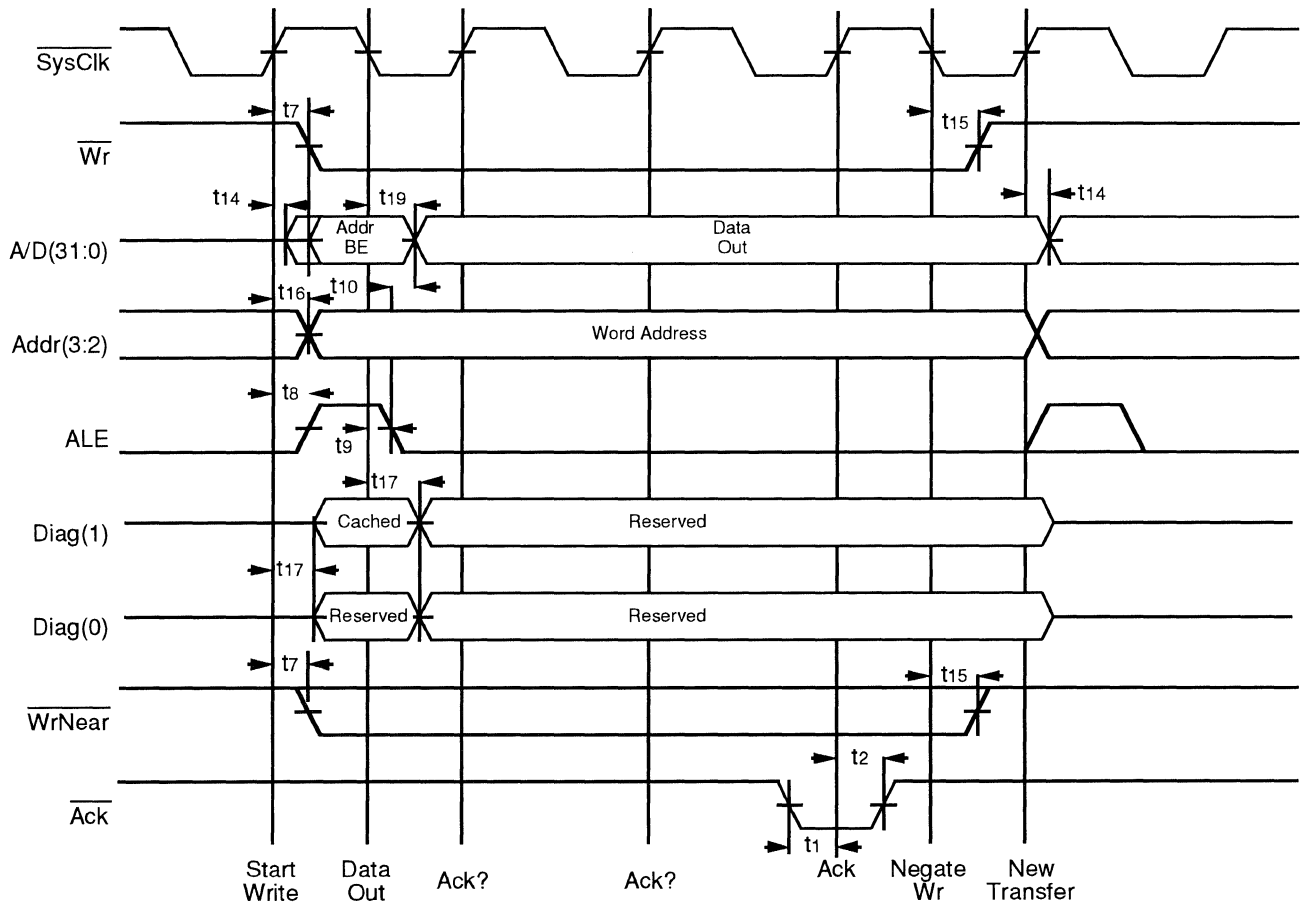

Figure 9.6. Write With Bus Wait Cycles



**Bus Error Operation**

Figure 9.7 is a modified version of Figure 9.6 (basic write with wait cycles), in which  $\overline{\text{BusError}}$  is used to terminate the write cycle. If  $\overline{\text{BusError}}$  and  $\overline{\text{Ack}}$  are asserted simultaneously, the  $\overline{\text{BusError}}$  will be processed.

No exception is taken because such an exception would violate the precise exception model of the processor. Since writes are buffered, the processor program counter will no longer be pointing to the address of the store instruction which requested the write, and other state information of the processor may have been changed. Thus, if the system designer would like the processor core to take an exception as a result of the bus error, he should externally latch the  $\overline{\text{BusError}}$  signal, and use the output of the latch to cause an interrupt to the processor.

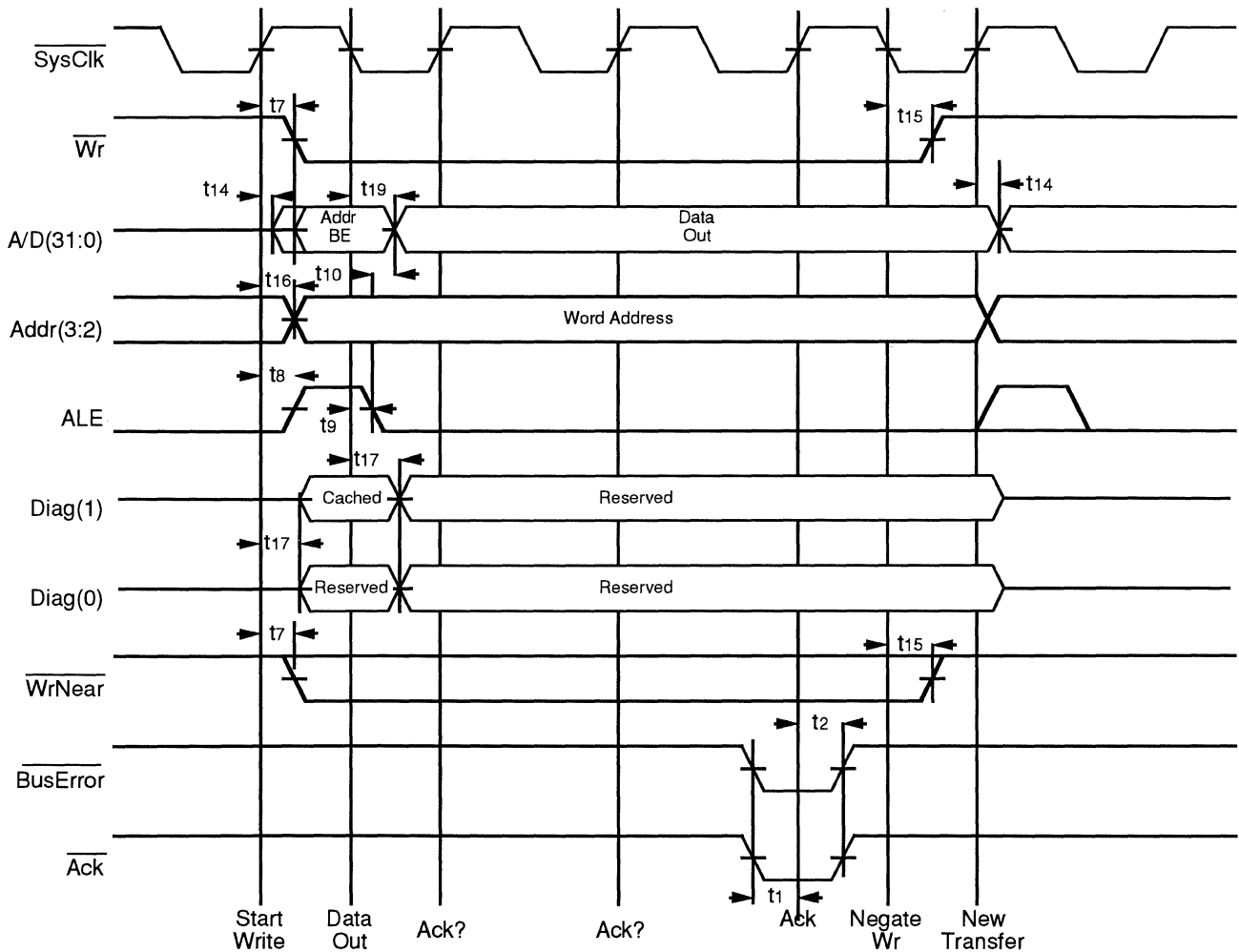

**Figure 9.7. Bus Error on Write**



Integrated Device Technology, Inc.

## DMA INTERFACE and CACHE COHERENCY

## CHAPTER 10

### INTRODUCTION

The R3081 contains provisions to allow an external agent to remove the processor from its memory bus, and thus perform transfers (DMA). These provisions use the DMA arbiter to coordinate the external request for mastership with the CPU read and write interface.

The DMA arbiter interface uses a simple two signal protocol to allow an external agent to obtain mastership of the external system bus. Logic internal to the CPU synchronizes the external interface to the internal arbiter unit to insure that no conflicts between the internal synchronous requesters (read and write engines) and external asynchronous (DMA) requester occurs.

The R3081 also allows the system designer to utilize hardware based cache coherency. Thus, if an external DMA master updates main memory, appropriate lines in the processor data cache may be invalidated, insuring that there is no stale data, and avoiding software directed cache flushing. The cache coherency mechanisms of the R3081 are also described in this chapter.

### INTERFACE OVERVIEW

An external agent indicates the desire to perform DMA requests by asserting the  $\overline{\text{BusReq}}$  input to the processor. Non-coherent DMA requests have the highest priority, and thus, once the request is detected, is guaranteed to gain mastership at the next arbitration; for coherent DMA requests, the read buffer must be emptied to the caches and the write buffer contents written to main memory before the bus is granted, to insure memory coherency.

The CPU indicates that the external DMA cycle may begin by asserting its  $\overline{\text{BusGnt}}$  output on the rising edge of  $\text{SysClk}$ . During DMA cycles, the processor holds the following memory interface signals in tri-state:

- A/D Bus
- $\text{Addr}(3:2)$
- Interface control signals:  $\overline{\text{Rd}}$ ,  $\overline{\text{Wr}}$ ,  $\overline{\text{DataEn}}$ ,  $\overline{\text{Burst/WrNear}}$ , and ALE
- $\text{Diag}(1:0)$

Thus, the DMA master can use the same memory control logic as that used by the CPU; it may use  $\overline{\text{Burst}}$ , for example, to obtain a burst of data from the memory; it may use  $\overline{\text{RdCEn}}$  to detect whether the memory has satisfied its request, etc. Thus, DMA can occur at the same speed at which the R3081 allows data transfers on its bus (a peak of one word per clock cycle). During DMA cycles, the processor can continue to operate out of cache until it requires the bus; alternately, hardware based cache coherency can be used to avoid stale data; however, the execution core will be stalled to allow maximum invalidation bandwidth.

The external agent indicates that the DMA transfer has terminated by negating the  $\overline{\text{BusReq}}$  input to the processor, which is sampled on the rising edge of  $\text{SysClk}$ .  $\overline{\text{BusGnt}}$  is negated on a falling edge of  $\text{SysClk}$ , so that it will be negated before the assertion of  $\overline{\text{Rd}}$  or  $\overline{\text{Wr}}$  for a subsequent transfer. On the next rising edge of  $\text{SysClk}$ , the processor will resume driving tri-stated signals.

**DMA ARBITER INTERFACE SIGNALS****BusReq      I**

This signal is an input to the processor, used to request mastership of the external interface bus. Mastership is granted according to the assertion of this input, and taken back based on its negation.

**BusGnt      O**

This signal is an output from the processor, used to indicate that it has relinquished mastership of the external interface bus.

**NON-COHERENT DMA ARBITRATION TIMING DIAGRAMS**

These figures reference AC timing parameters whose values are contained in the R3081 data sheet.

**Initiation of DMA Mastership**

Figure 10.1 shows the beginning of a DMA cycle. Note that if  $\overline{\text{BusReq}}$  were asserted while the processor was performing a read or write operation,  $\overline{\text{BusGnt}}$  would be delayed until the next bus slot after the read or write operation is completed.

To initiate DMA, the processor must detect the assertion of  $\overline{\text{BusReq}}$  with proper set-up time to  $\text{SysClk}$ . Once  $\overline{\text{BusReq}}$  is detected, and the bus is free, the processor will grant control to the requesting agent by asserting its  $\overline{\text{BusGnt}}$  output, and tri-stating its output drivers, from a rising edge of  $\text{SysClk}$ . The bus will remain in the control of the external master until it negates  $\overline{\text{BusReq}}$ , indicating that the processor is once again the bus master.

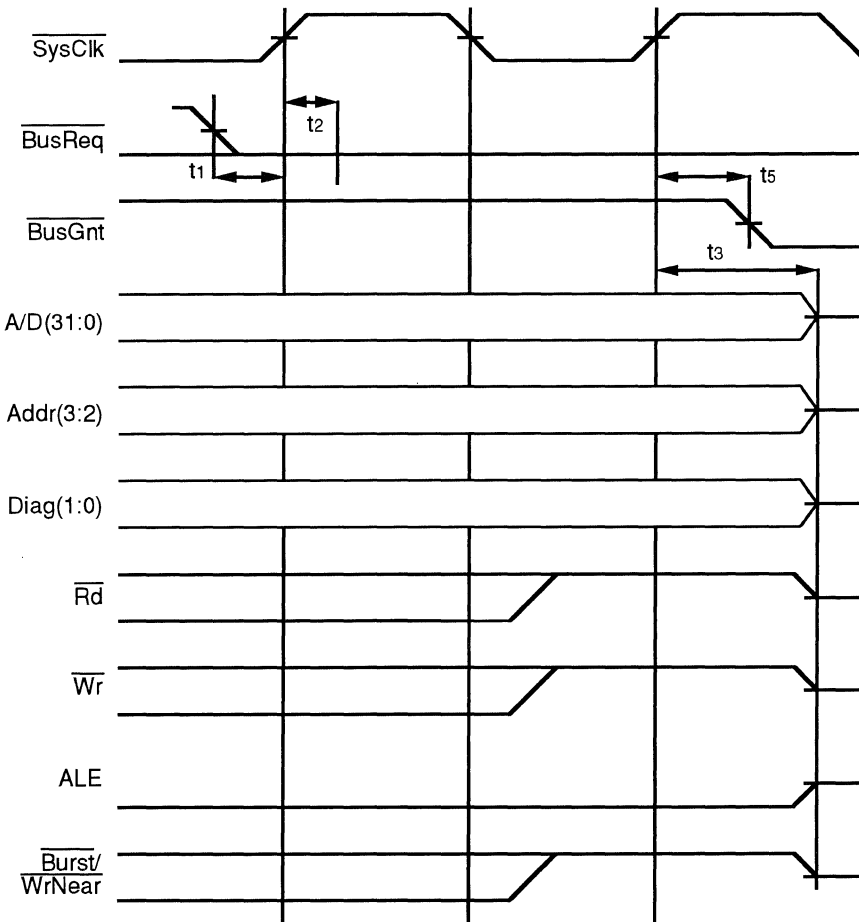
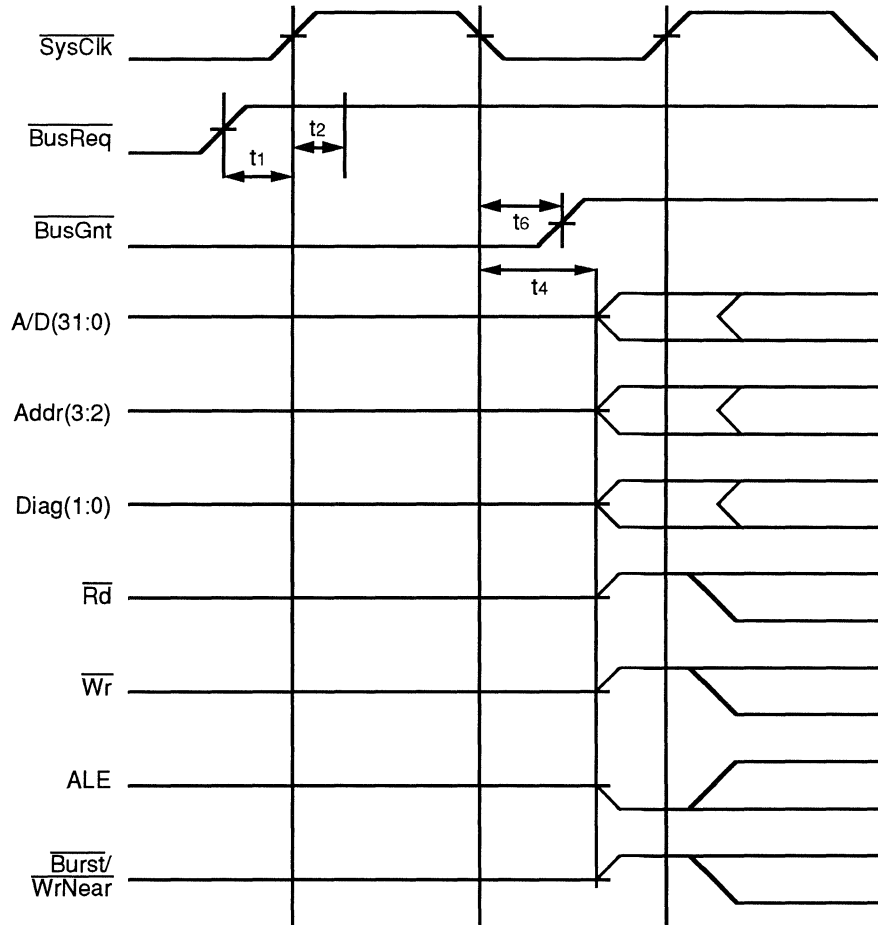

**Figure 10.1. Bus Grant and Start of DMA Transaction**

**Relinquishing Mastership Back to the CPU**

Figure 10.2 shows the end of a DMA cycle. The next rising edge of  $\overline{\text{SysClk}}$  after the negation of  $\overline{\text{BusReq}}$  is sampled may actually be the beginning of a processor read or write operation.

To terminate DMA, the external master must negate the processor  $\overline{\text{BusReq}}$  input. Once this is detected (with proper setup and hold time), the processor will negate its  $\overline{\text{BusGnt}}$  output on the next falling edge of  $\overline{\text{SysClk}}$ . It will also re-enable its output drivers. Thus, the external agent must disable its output drivers by this clock edge, to avoid bus conflicts.



4000 drw 69

**Figure 10.2. Regaining Bus Mastership**

## HARDWARE-BASED CACHE COHERENCY

The R3081 provides support for hardware based cache coherency. Specifically, during DMA writes, the processor can be directed to invalidate the cache line(s) corresponding to the current DMA writes. Thus, when the DMA master updates main memory, software referencing the memory will miss in the cache, and thus get the current value from memory.

The cache coherency mechanisms of the R3081 were designed principally to support cache coherency in a multi-master, DMA environment. Tightly coupled symmetric multiprocessing requires a great deal more support, and is best performed by the R4000MC processor.

The basic operation of the R3081 coherency involves the use of two input signals, used to signal to the R3081 that it should invalidate a given data cache line.

The system designer selects cache coherency by enabling the coherent DMA feature at reset time. If this feature is not enabled, the R3081 will continue to operate out of its internal cache during DMA, until it needs access to the external bus, thus maintaining strict compatibility with the R3051. In this case, the coherency interface signals will not be monitored, and the system designer does not need to worry about driving them to a particular polarity.

If the coherent interface is enabled, the processor will stall to allow maximum cache invalidation bandwidth. During DMA cycles, it will monitor the ALE signal, and capture the external address (A/D and Addr busses) at the start of a write transfer. It will then monitor the  $\overline{\text{IvdReq}}$  input; if the  $\overline{\text{IvdReq}}$  input is asserted, the processor will invalidate the data cache word corresponding to the current DMA write target address.

The R3081 also supports invalidation during burst DMA write transfers. A burst DMA write will use a single address cycle and multiple data cycles, thus achieving maximum write bandwidth. The R3081 will capture the starting address at the initiation of the transfer cycle. Every time the memory system signals  $\overline{\text{Ack}}$  (to indicate that the current word has been written), the current write target address inside the R3081 will be incremented. Thus, the R3081 always knows the current write target address.

During burst DMA writes, if the memory system asserts the  $\overline{\text{IvdReq}}$ , the R3081 will then invalidate the data cache line corresponding to the current write target address. Thus, the cache coherency mechanism can be used to invalidate a sequence of data cache lines during burst DMA writes.

System performance will be augmented if an external secondary cache is used. This cache would be constructed to be a superset of the on-chip caches; thus, cache line snoop would occur in the secondary cache. The system could then request that only lines it knows to be cache resident would be invalidated.

Alternately, the system designer could hold  $\overline{\text{IvdReq}}$  low during all coherent DMA writes; the R3081 will then blindly invalidate cache lines that may (or may not) be affected by the current DMA write.

## CACHE COHERENCY INTERFACE SIGNALS

The following signals are used by the R3081 cache coherency mechanism: These signals are in addition to the DMA arbitration signals described earlier.

### **ALE** I

**Address Latch Enable:** This signal is used by the external DMA controller to indicate that a DMA target address is currently available on the A/D bus. The R3081 uses the trailing edge of ALE to capture the write target address, and uses that as the target address for the potential cache invalidate.

### **$\overline{Wr}$** I

**Write:** This signal is used by the external DMA controller to signal that the current transfer is a DMA write. The processor only performs cache coherency operations during cycles in which the DMA controller is updating main memory (writing).

### **$\overline{Ack}$** I

**Acknowledge:** This signal is used by the memory system to indicate that it has retired the current write. During burst DMA writes, the processor uses this information to advance its burst invalidate address counter.

### **A/D(31:0)** I

**Address/Data:** This bus contains part of the target address for the DMA transfer. At the start of a DMA write, the R3081 captures the target address on the falling edge of ALE.

### **Addr(3:2)** I

**Address/Data:** This 32-bit bus contains the target address for the DMA transfer. At the start of a DMA write, the R3081 captures the target address on the falling edge of ALE.

### **$\overline{IvdReq}$** I

**Invalidate Request:** This input signals to the R3081 that it must invalidate the data cache line corresponding to the current DMA write. This input, which is the same signal pin as Diag(0), is only sampled under the following conditions:

- Coherent DMA enabled via reset vector
- Current DMA request indicated potential coherency requests
- Current DMA transfer is a write ( $\overline{Wr}$  is asserted)
- In the current cycle,  $\overline{Ack}$  is also asserted to indicate completion of the current DMA write transfer.

If all of these conditions are met, the corresponding data cache word will be invalidated.

### **$\overline{CohReq}$** I

**Coherent DMA Request:** This input is sampled along with the  $\overline{BusReq}$  input, to request external mastership of the R3081 bus. Coherent DMA requests differ from other DMA requests in that the processor will:

- Update the cache with the contents of the read buffer
- Update memory with all pending writes
- Stall the execution core

All of this activity will occur prior to asserting the  $\overline{BusGnt}$  output to the external requester. Note that this signal uses the pin indicated as Rsvd(0) in the R3051. This input is only sampled if Coherent DMA is enabled at reset time.

## CACHE COHERENCY OPERATIONS TIMING

The following timing diagrams reference AC parameters contained in the R3081 data sheet.

### Initiating Coherent DMA

Coherent DMA is requested at the same time the external DMA master requests bus mastership. Coherent DMA is requested by asserting the  $\overline{\text{CohReq}}$  input at the same time that the  $\overline{\text{BusReq}}$  input is asserted, as shown in figure 10.3. In the case of a coherent DMA request, the R3081 must perform some memory system housekeeping before granting bus mastership, in order to insure that the caches and main memory are consistent with each other and the current program state, and to support maximum cache invalidation bandwidth.

If a coherent DMA request is detected, the R3081 will complete its current bus cycle, and then insure that memory is made consistent with the on-chip caches before the bus is granted. Thus, the R3081 will insure that data pending in the read buffer is brought into the cache; if that data was the result of an instruction cache miss, normal instruction streaming will occur, and in fact the processor may generate additional store data.

Once the read buffer is brought into the cache, the CPU core is stalled and pending writes are retired to memory. During streaming, additional writes may have been generated; the R3081 will insure that these too are updated into main memory. Note that since the processor core is effectively stalled, no other read requests can be generated.

At this point, the processor core is stalled in anticipation of potential invalidates, the read buffer is empty, and memory is current with the on-chip caches. The R3081 will then assert  $\overline{\text{BusGnt}}$  as for a normal DMA mastership grant.

The assertion of  $\overline{\text{BusGnt}}$  after  $\overline{\text{BusReq}}$  is thus highly dependent on the internal state of the processor when the coherent DMA request was asserted, as well as the speed with which memory can retire the pending writes.

Note that once  $\overline{\text{BusReq}}$  is asserted, the value of  $\overline{\text{CohReq}}$  must be stable until the request is granted, and until  $\overline{\text{BusReq}}$  is negated to end the external mastership.



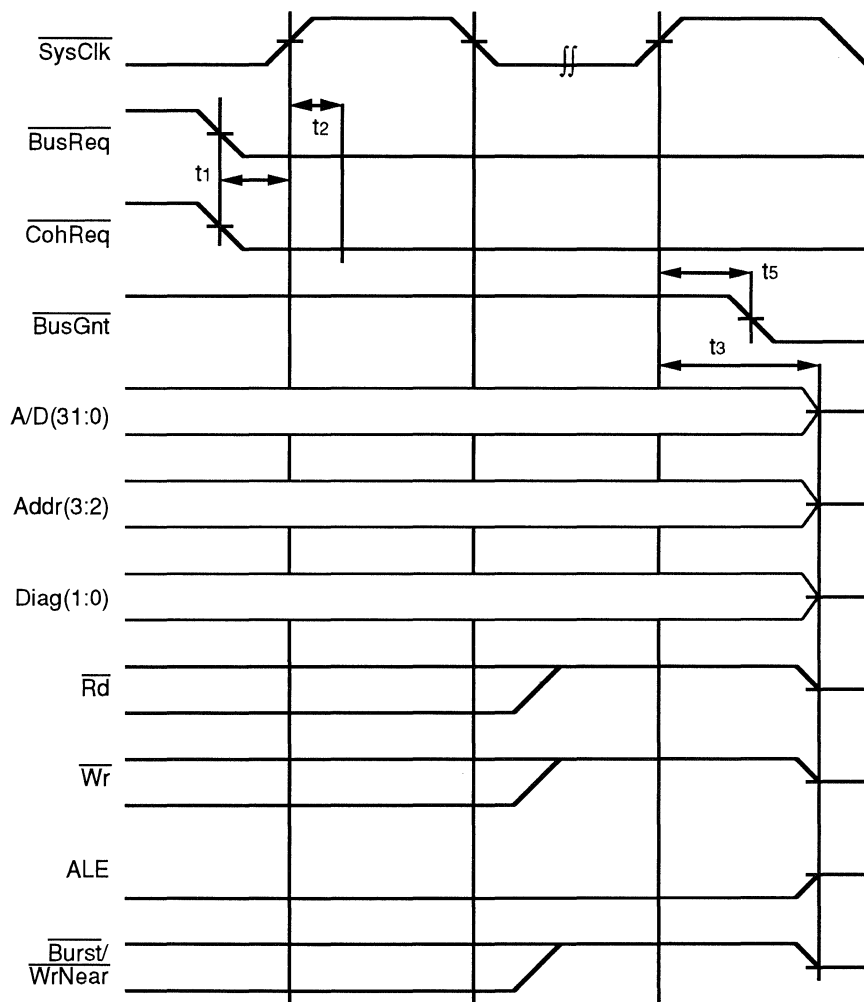

Figure 10.3. Requesting Coherent DMA

### Capturing Write Target Address

The R3081 will monitor the address bus (specifically A/D(12:4) and Addr(3:2)) during coherent DMA cycles. If, in a given cycle, ALE and  $\overline{Wr}$  are asserted, the R3081 will capture the contents of the address bus in its internal invalidate address counter, according to figure 10.4. Note that the timing used by the R3081 is basically compatible with its own bus timing; that is, if the DMA master uses timing similar to the timing of the R3081, the R3081 is guaranteed to be able to capture the A/D bus.

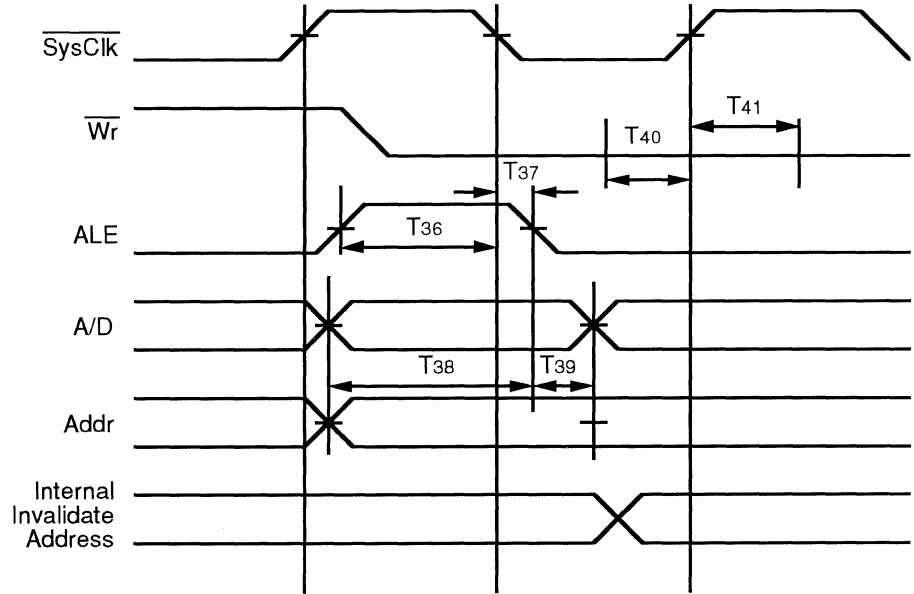

Figure 10.4. Capturing Write Target Address During Coherent DMA

**Invalidating the Data Cache Word**

If the external memory system determines that the data cache word corresponding to the current write should be invalidated, it will assert its  $\overline{\text{IvdReq}}$  input in the same cycle the memory system asserts  $\overline{\text{Ack}}$ , as shown in figure 10.5. The DMA master may determine that an invalidate is required by examining an external snoop cache; alternately, it may blindly assert the  $\overline{\text{IvdReq}}$  input based on address decoding, preprogramming, or some other system specific rule.

Requesting an invalidation causes the R3081 to invalidate the corresponding data cache word, as shown in figure 10.5.

Regardless of whether an invalidation was requested,  $\overline{\text{Ack}}$  will cause the R3081 to increment its internal invalidate counter, as shown in figure 10.5. Of course, if an invalidate was also requested, the R3081 will insure that the appropriate data cache word is invalidated before the address is incremented.

This feature is provided to support burst invalidation during burst DMA writes. Although the R3081 bus does not explicitly define a burst write protocol, one could easily be built from the bus protocol in place. The R3081 assumes that a burst write protocol would involve a single ALE cycle to establish the initial address, and an  $\overline{\text{Ack}}$  provided with each word transferred. The R3081 cache coherency protocol thus uses  $\overline{\text{Ack}}$  to increment the current invalidate address. The protocol is flexible enough to support burst writes of any length. A single word write is a subset of this burst write protocol.

The R3081 supports an invalidation per bus cycle during burst DMA writes. During single DMA writes, the R3081 cache coherency protocol will support the maximum write rate of the R3081; that is, a single word write in a minimum of two cycles, with a new single word write initiated immediately after the completion of the current write. Obviously, slower write protocols can also be supported.

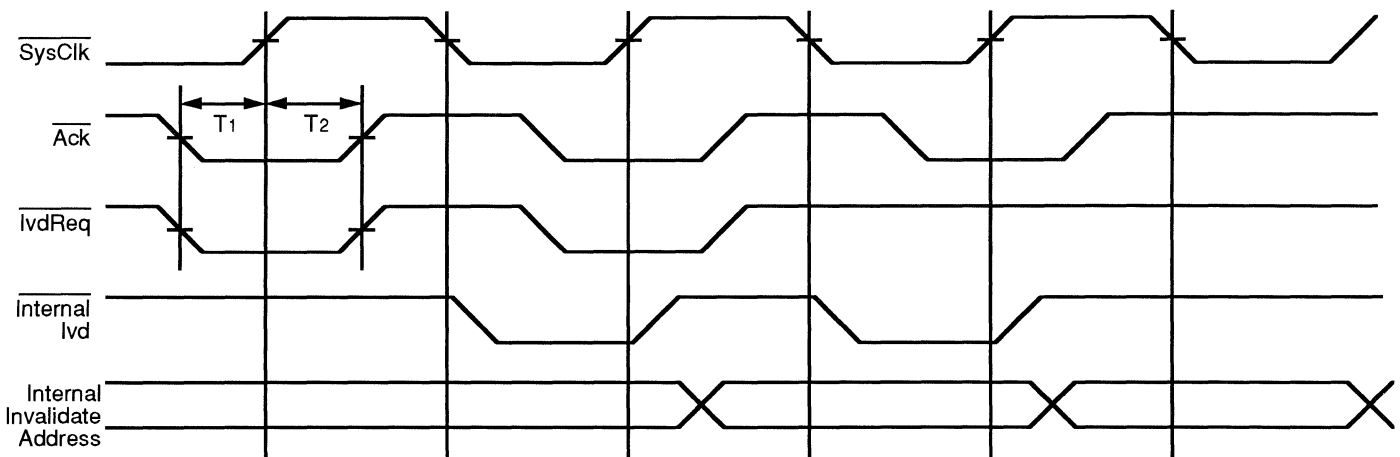

**Figure 10.5. Invalidating Current Data Cache Word and Incrementing Invalidate Address**

**Ending the Current Write**

Once a coherent DMA request has been made, it is possible for the memory system to perform multiple reads and writes within one arbitration. The R3081 must recognize the end of the write cycle, to avoid spurious invalidations of the Data cache. Thus, the DMA master must insure that the  $\overline{Wr}$  signal is negated with proper setup and hold time characteristics, as shown in Figure 10.6.

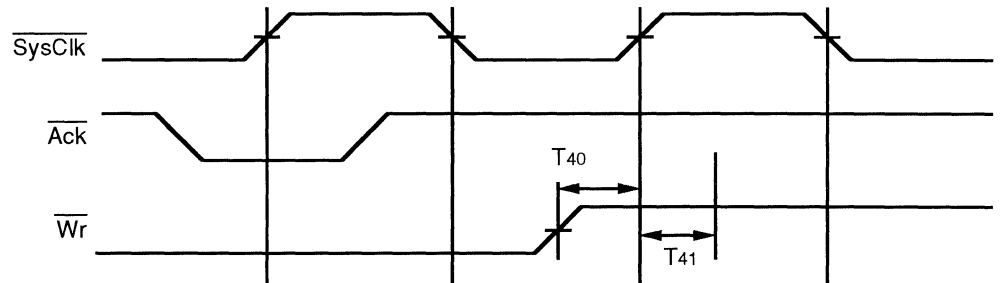
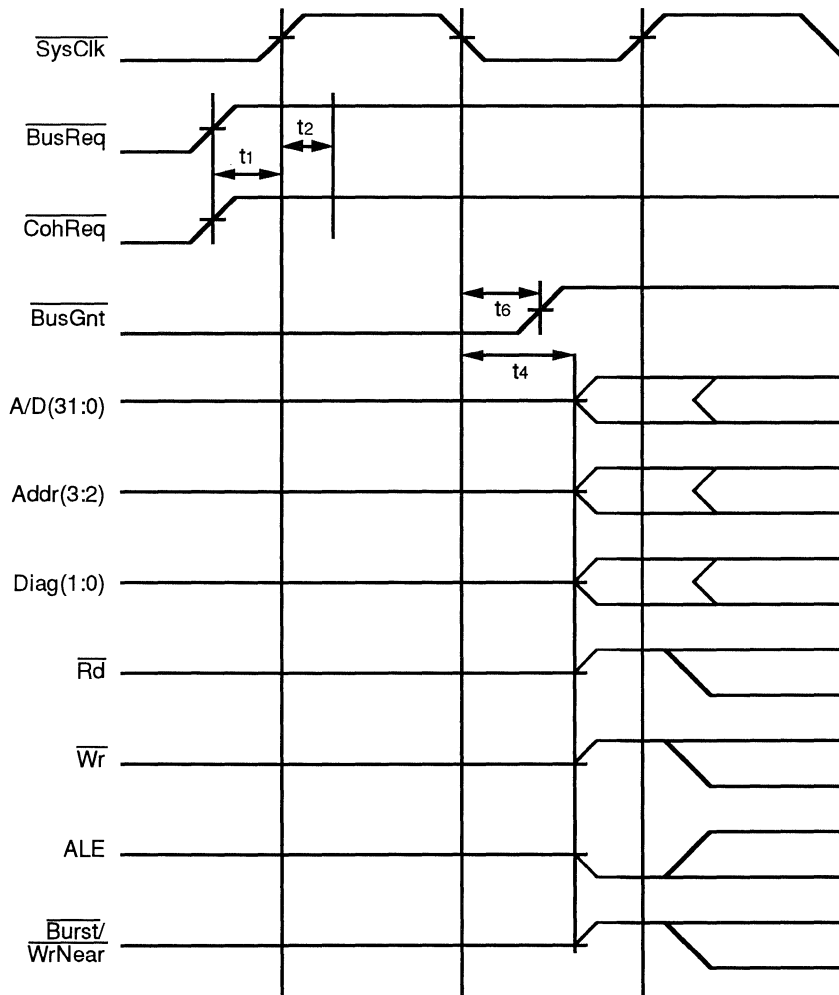

Figure 10.6. Terminating a Coherent Write Sequence

**Terminating the Coherent DMA**

The R3081 requires that the  $\overline{\text{CohReq}}$  input remain stable through the entire DMA mastership cycle; that is, if the initial DMA request also indicated coherency,  $\overline{\text{CohReq}}$  must remain asserted the entire time that  $\overline{\text{BusReq}}$  is asserted.

Figure 10.7 shows the negation of  $\overline{\text{BusReq}}$  and  $\overline{\text{CohReq}}$ .



**Figure 10.7. Terminating Coherent DMA**



**INTRODUCTION**

This chapter discusses the reset initialization sequence required by the R3081. Also included is a discussion of the mode selectable features of the processor, and of the software requirements of the boot program.

There are a small number of selectable features in the R3081. These mode selectable features are determined by the polarity of the appropriate Interrupt inputs when the rising edge of Reset occurs.

**RESET TIMING**

Unlike the R3000, which requires the use of a state machine during the last four cycles of reset to initialize the device and perform mode selection, the R3081 requires a very simple reset sequence. There are only two concerns for the system designer:

- The set-up time and hold requirements of the interrupt inputs (mode selectable features) with respect to the rising edge of  $\overline{\text{Reset}}$  are met.
- The minimum  $\overline{\text{Reset}}$  pulse width is satisfied.

**MODE SELECTABLE FEATURES**

The R3081 has features which are determined at reset time. This is done using a latch internal to the CPU: this latch samples the contents of the Interrupt bus ( $\overline{\text{Int}}(5:3)$  and  $\overline{\text{SInt}}(2:0)$ ) at the negating edge of  $\overline{\text{Reset}}$ . The encoding of the mode selectable features on the interrupt bus is described in Table 11.1.

Interrupt Pin	Mode Feature
$\overline{\text{Int}}(5)$	$\overline{\text{CoherentDMAEn}}$
$\overline{\text{Int}}(4)$	$\overline{\text{1xClockEn}}$
$\overline{\text{Int}}(3)$	Half-frequency Bus
$\overline{\text{SInt}}(2)$	DBlockRefill
$\overline{\text{SInt}}(1)$	Tri-State
$\overline{\text{SInt}}(0)$	BigEndian

4000 tbl 23

Table 11.1. R3081 Mode Selectable Features

**CoherentDMAEn**

If asserted (active low), then the cache coherent interface described in chapter 10 is enabled. If negated (high), then R3051 compatible DMA is performed, and the coherent DMA signals are ignored. In R3051 systems, this mode vector was reserved and thus this will be high, insuring R3051 compatibility.

**1xClockEn**

If asserted (active low), the input clock is a 1x clock at the processor execution rate. If negated (high), then the input clock is a 2x clock at twice the execution rate. This mode vector was reserved in the R3051, and thus those systems will have this vector selected as high, corresponding to an R3051 compatible 2x clock input.

### Half-Frequency Bus

If asserted (active low), the bus interface will be operated at one-half the frequency of the internal processor. If negated, the bus interface will operate at the processor frequency. During  $\overline{\text{Reset}}$ , this value should be held stable for 128 clock cycles, to avoid clock glitches in the R3081 bus interface unit and to allow the external memory controllers to stabilize to the final frequency.

### DBlockRefill

If asserted (active high), data cache misses will be processed using quad word refills. If negated, data cache misses will be processed using single word reads. This mode bit does not affect the processing of instruction cache misses (always handled as quad word reads) or uncacheable references (always handled as single word reads).

### Tri-State

If asserted (active low) at the end of reset, all CPU outputs (except  $\overline{\text{SysClk}}$ ) will remain in tri-state after reset. They will remain in tri-state until another reset occurs (with tri-state disabled).

This mode input has the unique feature that it can be used to force the CPU outputs to tri-state during the entire reset period. That is, if  $\overline{\text{Tri-State}}$  is asserted while  $\overline{\text{Reset}}$  is asserted, the processor outputs will be tri-stated through the reset period. If  $\overline{\text{Tri-State}}$  is negated during reset, the output drivers will be enabled. Again, note that the Tri-State mode does not affect  $\overline{\text{SysClk}}$ , which is driven regardless of the tri-state mode.

Thus, it is possible to hold tri-state low during the majority of reset, and bring it high only during the last four cycles of reset. The CPU outputs would be tri-state through the reset, but the processor would operate normally after reset. This is useful in board testing, and also for in-circuit emulators.

### BigEndian

If asserted (active high), the processor will operate as a big-endian machine, and the RE bit of the status register would then allow little-endian tasks to operate in a big-endian system. If negated, the processor will operate as a little-endian machine, and the RE bit will allow big-endian tasks to operate on a little-endian machine.

### R3000A Equivalent Modes

The R3000A features a number of modes, which are selected at Reset time. Although most of those modes are irrelevant, a number of equivalences can be made:

- IBlkSize = 4 word refill.
- DBlkSize = 1 or 4 word refill, depending on the DBlockRefill mode selected.
- Reverse Endianness capability enabled.
- Instruction Streaming enabled.
- Partial Word Stores enabled.
- MP enabled.

Other modes of the R3000A primarily pertain to its cache interface, which is incorporated within the R3081 and thus transparent to users of these processors.

## RESET BEHAVIOR

While  $\overline{\text{Reset}}$  is asserted and  $\overline{\text{Tri-State}}$  negated, the processor maintains its interface in a state which allows the rest of the system to also be reset. Specifically:

- $\overline{\text{A/D}}$  is tri-stated
- $\overline{\text{SysClk}}$  operates.
- $\text{Addr}(3:2)$  and  $\text{Diag}(1:0)$  are driven (reserved value).
- $\overline{\text{ALE}}$  is driven negated (low).
- $\overline{\text{DataEn}}$ ,  $\overline{\text{Burst/WrNear}}$ ,  $\overline{\text{BusGnt}}$ ,  $\overline{\text{Rd}}$ , and  $\overline{\text{Wr}}$  are driven negated (high).

The R3051 family samples for the negation of  $\overline{\text{Reset}}$  relative to a falling edge of  $\overline{\text{SysClk}}$ . The processor will initiate a read request for the instruction located at the Reset Vector at the 6th rising edge of  $\overline{\text{SysClk}}$  after the negation of  $\overline{\text{Reset}}$  is detected. These cycles are a result of:

- $\overline{\text{Reset}}$  input synchronization performed by the CPU. The  $\overline{\text{Reset}}$  input uses special synchronization logic, thus allowing  $\overline{\text{Reset}}$  to be negated asynchronously to the processor. This synchronization logic introduces a two cycle delay between the external negation of  $\overline{\text{Reset}}$  and the negation of  $\overline{\text{Reset}}$  to the execution core.
- Internal clock cycles in which the execution core flushes its pipeline, before it attempts to read the exception vector.
- One additional cycle for the read request to propagate from the internal execution core to the read interface, as described in Chapter 8.

## BOOT SOFTWARE REQUIREMENTS

Basic mode selection is performed using hardware during the reset sequence, as discussed in the mode initialization section. However, there are certain aspects of the boot sequence that must be performed by software.

The assertion and subsequent negation of reset forces the CPU to begin execution at the reset vector, which is address  $0x1FC0\_0000$ . This address resides in uncached, unmapped memory, and thus does not require that the caches or TLB be initialized for the processor to execute boot code.

The processor needs to perform the following activities during boot:

- **Initialize the CPO Status Register**

The processor must be assured of having the kernel enabled to perform the boot sequence. Specifically, co-processor useable bits, and cache control bits, must be set to the desired value for diagnostics and initialization to occur.

- **Initialize the CPO Config Register**

If the system requires the floating point interrupt to be re-mapped from its default, or if the system is to be operated with the alternative cache configuration, or if the system desires slow bus turnaround, the Config register must be written. The system could also choose to "lock" this register at this time.

- **Initialize the caches**

The processor needs to determine the sizes of the on-chip caches, and flush each entry, as discussed in Chapter 4. This must be done before the processor attempts to execute cacheable code.

- **Initialize the TLB**

The processor needs to examine the TLB Shutdown bit to determine if a TLB is present. If this is an extended architecture version of the processor, software must sequence through all 64 TLB entries, giving them either a valid translation, or marking them as not Valid. This must be done before software attempts to reference through mapped space.



- **Initialize CPO Registers**

The processor should establish appropriate values in various CPO registers, including:

The PID field of EntryHi.

The IM bits of the status register.

The BEV bit.

Initialize KUp/IEp so that user state can be entered using a RFE instruction

- **Enter User State**

Branch to the first user task, and perform an RFE.

### DETAILED RESET TIMING DIAGRAMS

The timing requirements of the processor reset sequence are illustrated below. The timing diagrams reference AC parameters whose values are contained in the R3081 data sheet.

#### Reset Pulse Width

There are two parameters to be concerned with: the power on reset pulse width, and the warm reset pulse width.

Figure 11.1 illustrates the power on reset requirements of the R3081.

Figure 11.2 illustrates the warm reset requirements of the processor.

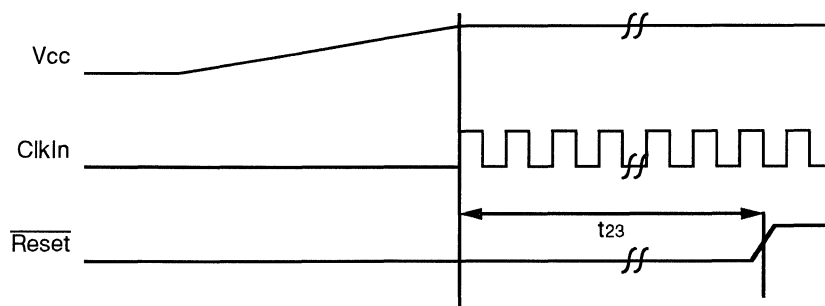

Figure 11.1. Cold Start

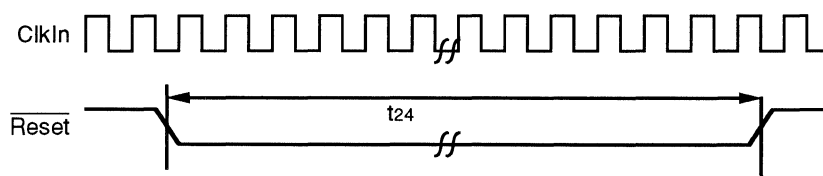
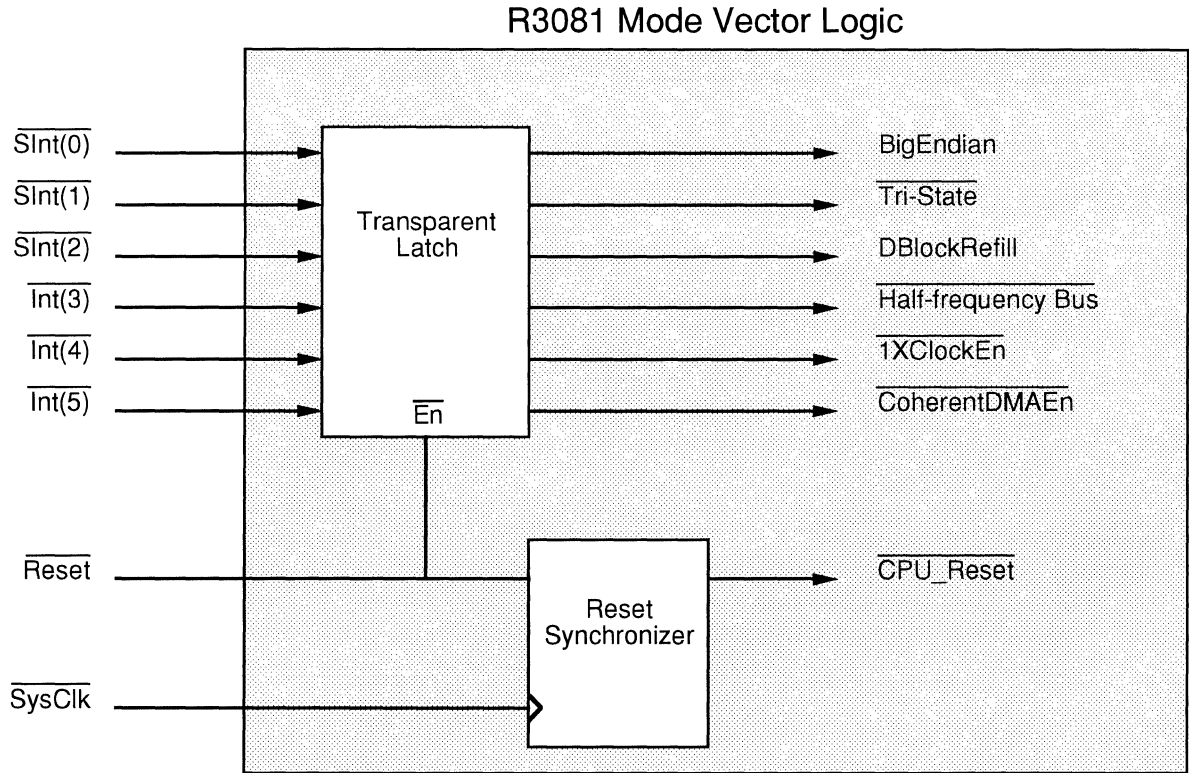

Figure 11.2. Warm Reset

**Mode Initialization Timing Requirements**

The mode initialization vectors are sampled by a transparent latch, whose output enable is directly controlled by the  $\overline{\text{Reset}}$  input of the processor. The internal structure of the processor is illustrated in Figure 11.3.

Thus, the mode vectors have a set-up and hold time with respect to the rising edge of  $\overline{\text{Reset}}$ , as illustrated in Figure 11.4.



**Figure 11.3. R3081 Internal Mode Vector Logic**

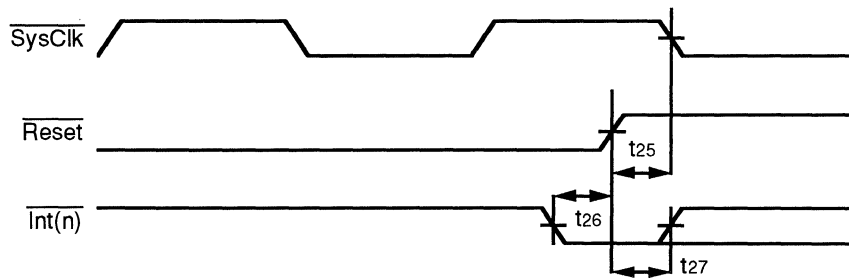

**Figure 11.4. Mode Vector Timing**

**Reset Setup Time Requirements**

The reset signal incorporates special synchronization logic which allows it to be driven from an asynchronous source. This is done to allow the processor Reset signal to be derived from a simple circuit, such as an RC network with a time constant long enough to guarantee the reset pulse width requirement is met.

The Reset set-up time parameter can then be thought of as the amount of time Reset must be negated before the rising edge of SysClk for it to be guaranteed to be recognized; failure to meet this requirement will not result in improper operation, but rather will have the effect of delaying the internal recognition of the end of reset by one clock cycle. This does not affect the timing of the sampling of the mode initialization vectors.

Figure 11.5 illustrates the set-up time parameter of the R3081.

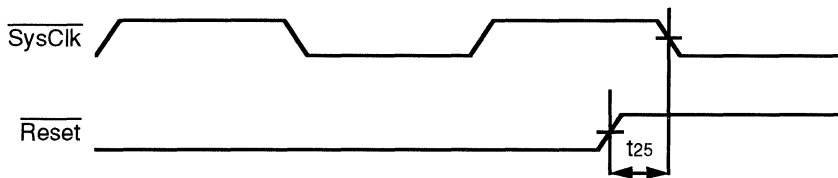

**Figure 11.5. Reset Timing**

**ClkIn Requirements**

The input clock timing requirements are illustrated in Figure 11.6 (a, b, c, d). The system designer does not need to be explicitly aware of the timing relationship between ClkIn and SysClk, and no timing relationship is guaranteed. Note that SysClk is driven even during the Reset period, (regardless of the Tri-state mode), as long as ClkIn is provided. However, the Reset signal logic should not require SysClk to assert at power up.

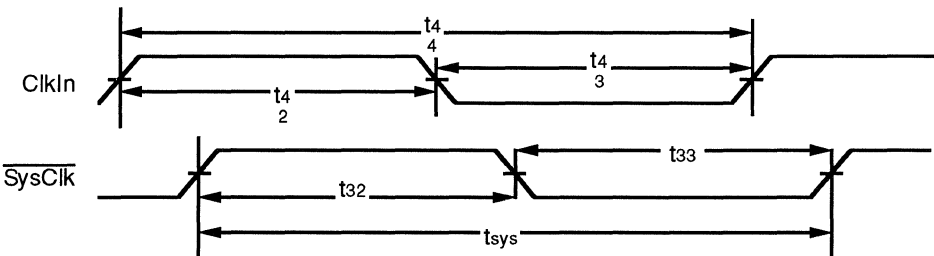

**Figure 11.6 (a). R3081 Family Clocking (1x ClkIn, Full-Frequency Bus Mode)**

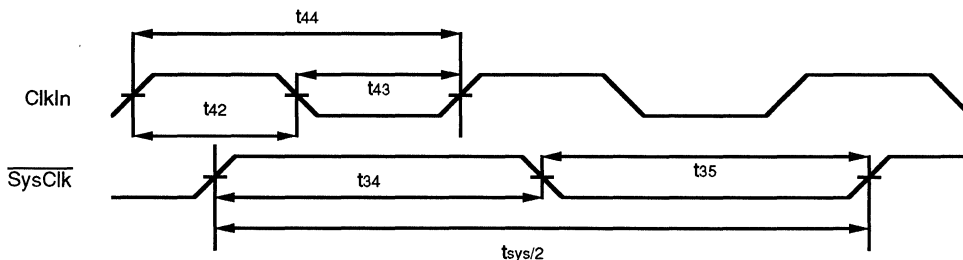

**Figure 11.6 (b). R3081 Family Clocking (1x ClkIn, Half-Frequency Bus Mode)**

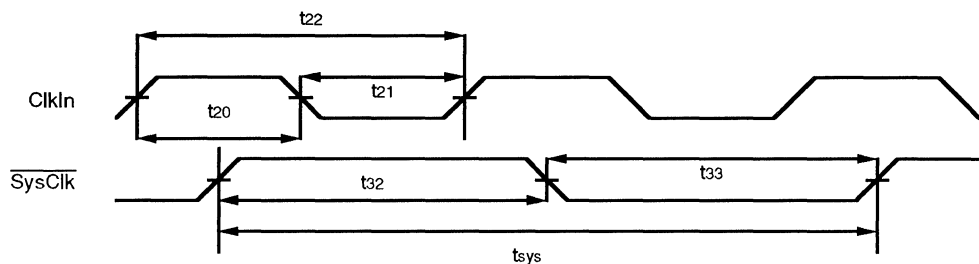

Figure 11.6 (c). R3081 Family Clocking (2x ClkIn, Full-Frequency Bus Mode)

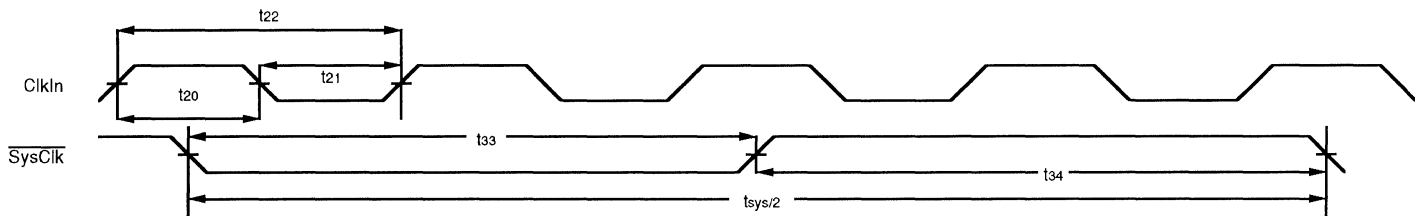
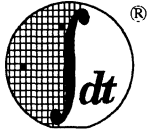

Figure 11.6 (d). R3081 Family Clocking (2x ClkIn, Half-Frequency Bus Mode)





Integrated Device Technology, Inc.

## **INTRODUCTION**

This chapter discusses particular features of the R3081 included to facilitate debugging of R3081-based systems. Although many of these features are intended to be used by an In-Circuit Emulator, the features documented in this chapter are also useful in environments which use a logic analyzer or similar tool.

## **OVERVIEW OF FEATURES**

The features described in this chapter include:

- The ability of the processor to display internal instruction addresses on its A/D bus during idle bus cycles. This mode facilitates the trace of instruction streams operating out of the internal cache.
- The ability of the processor to have instruction cache misses forced, thus allowing control to be brought to the bus interface. This mode is useful for breaking into infinite loops, and is also useful for “jamming” an alternate instruction stream (such as a debug monitor) into the instruction stream.

Other features useful in debug and In-Circuit Emulation are contained in the definition of the DIAG pins, described in an earlier chapter.

Note that the features described in this chapter are performed on the “Reserved” pins of the processor. Thus, other R3051 family members may or may not incorporate these features in the same fashion. The features described in this chapter are intended for initial debug, rather than continued use in a production system.

## **DEBUG MODE ACTIVATION**

Debug mode in the R3081 is activated by driving the Reserved(2) pin high. This mode can be selected any time that the part is running, or may be selected while the part is being reset. Again, it is not recommended that logic driving Reserved(2) be placed on the production board, since other R3051 family members may use this signal for a different function.

## ADDRESS DISPLAY

Activating the debug mode forces the CPU to display Instruction stream addresses on its A/D bus during idle bus cycles. Refer to figure 12.1 (a, b) regarding the timing relationship between instruction initiation in the on-chip cache and the output address. Even in half-frequency bus mode, the R3081 will display internal addresses at the execution engine rate. Note that the address is driven out, but ALE is not asserted. This is to reduce the impact of this mode on system designs which may use the initiation of ALE to start a state machine to process the bus cycle. Instead of ALE, external logic should use the rising edge of SysClk (full-frequency mode) or both edges of SysClk (half-frequency mode) to latch the current contents of the address bus.

The address displayed is determined by capturing the low order address bits used to address the instruction cache (AddrLo), and then capturing the TAG response from the cache one-half clock cycle later. As described in Chapter 4, cache accesses occur by separating the physical address into two portions: AddrLo, used to index the specific cache entry to check for a hit, and TAG, which is the high-order address bits indicating the value currently cached by that cache line. The on-chip cache controller compares the TAG returned by the cache with the high-order bits of the physical address currently referenced by the CPU. These address lines are concatenated, and presented as follows (Note AddrLo(1:0) will be '00' in all Instruction Cache cycles):

- A/D(31:12) displays TAG(31:12)
- A/D(11:4) displays AddrLo(11:4)
- A/D(3:2) displays AddrLo(13:12)
- A/D(1:0) is reserved for future use.
- Addr(3:2) displays AddrLo(3:2)

This mode is intended to allow gross, rather than fine, instruction trace. Specifically, branches taken while a write or DMA operation occurs may not be displayed, and there is no indication that an exception has occurred (and thus that initiated instructions have been aborted). Additionally, erroneous addresses may be presented in cycles where internal processor stalls occur, such as those for integer multiply/divide interlocks or  $\mu$ TLB misses.

Finally, note that the two cycles immediately before a main memory read may contain erroneous addresses. Specifically, if the memory read is due to an instruction cache miss, the address displayed two cycles before the assertion of Rd will be that of the cache contents, rather than the current program counter, as illustrated in figure 12.2.

Finally, note that the cycle immediately after a memory read or write may not produce the address with appropriate timing. It is recommended that these cycles be ignored when tracing execution.

## RUN STATUS DISPLAY

In addition to displaying the current address, the R3081 will provide an output signal called "Run" during debug mode. This output indicates whether the execution core is in a run cycle or in a stall cycle, and is useful in system debug to determine the activity of the execution core.

Since Run indicates the status of the execution core, its basic timing is dependent on the internal PhiClk. However, the R3081 uses the rising edge of SysClk to synchronize the Run output, and the falling edge to transition the output; thus, external logic should use the rising edge of SysClk as a timing reference. In one-half frequency bus mode, Run is driven from both edges of SysClk, and thus should be sampled with On's hold time from each edge.

The BrCond(1) pin, which is otherwise unused by the R3081, is used as the Run output pin during address display mode.

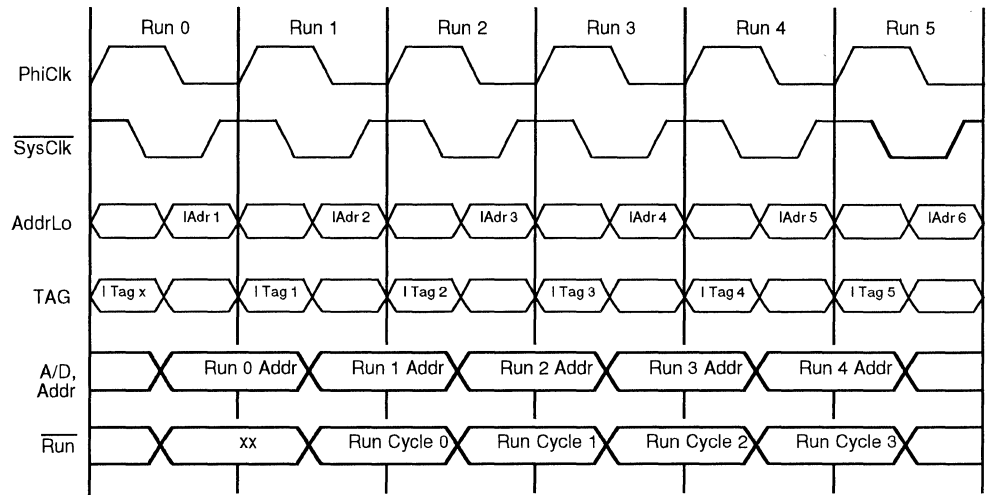

Figure 12.1 (a). R3051 Debug Mode Instruction Address Display (Full-Frequency Mode)

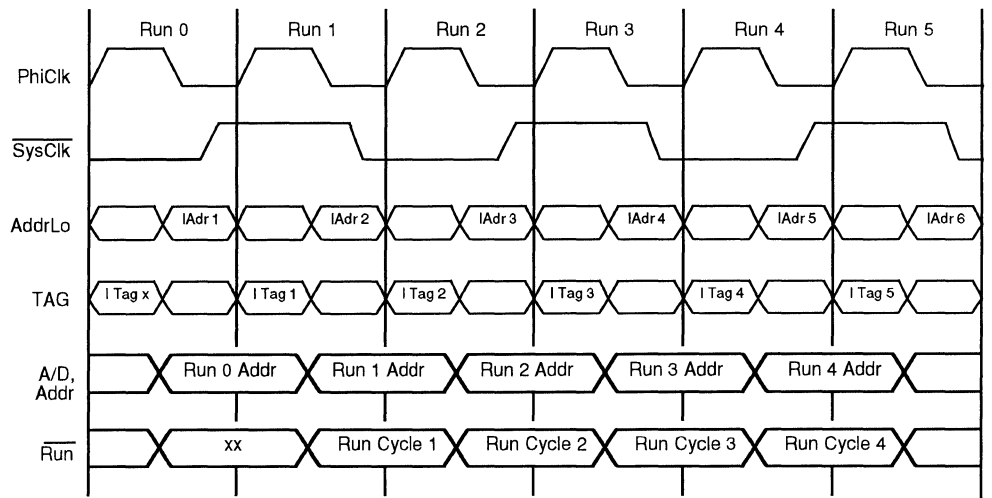

Figure 12.1 (b). R3051 Debug Mode Instruction Address Display (Half-Frequency Mode)

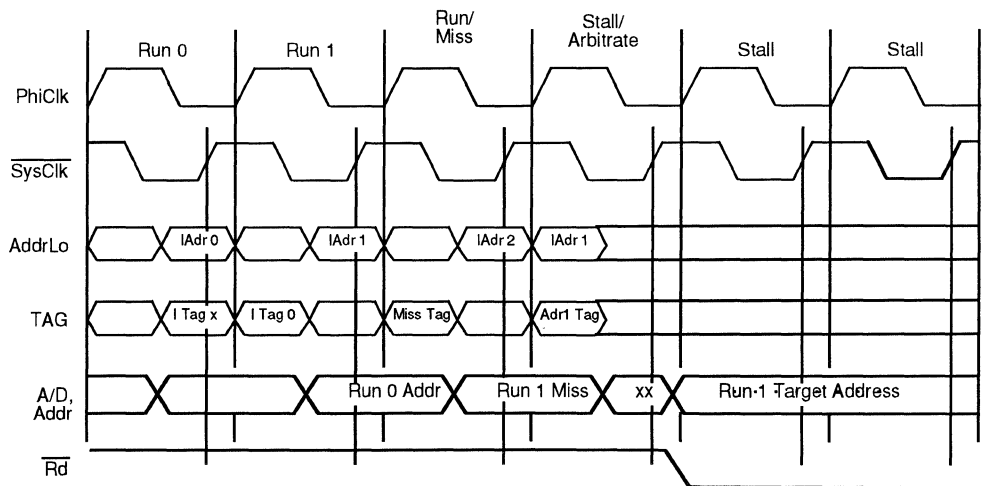

Figure 12.2. Instruction Cache Miss Sequence in Address Display Mode (full frequency bus)



## FORCING CACHE MISSES

Another feature for debugging is the ability to force a cache miss from an external signal pin. As with debug mode itself, this mode is not intended for use in a production environment.

Forcing a cache miss is a relatively simple operation with the R3081. With the device in debug mode (Reserved(2) high), drive Reserved(1) high, to be sampled on a falling edge of  $\overline{\text{SysClk}}$ . This will force the next cache reference to “miss”, forcing a read operation to the bus. Diag(1:0) can be used to determine that the memory cycle was due to a cache miss, and whether an instruction cache or data cache miss occurred. Figure 12.3 illustrates a “jam” operation.

When jamming the cache, a couple of things must be considered:

- The “Jam” input is sampled relative to the falling edge of  $\overline{\text{SysClk}}$ . However, IDT does not guarantee the setup and hold time parameters for this signal—it is recommended that a relatively conservative design be used here, since the set-up and hold time of this input are probably slightly larger than the parameters for other inputs.
- Due to the possibility of other bus activities (such as writes), the “Jam” input should be asserted at least until a read is detected on the bus.
- The Jam input does not affect the value of the Valid bit written into the cache on cache line refill. However, it is recommended that the Jam input be negated prior to the Acknowledge of the read (either implicit, by  $\overline{\text{RdCEn}}$ , or explicit, by  $\overline{\text{Ack}}$ ), to avoid unwanted subsequent miss cycles.
- If an instruction other than the target of the read is forced onto the A/D bus for an instruction cache miss read, it is the responsibility of that debug monitor to use software cache operations to fix-up the internal instruction cache before resuming normal execution.

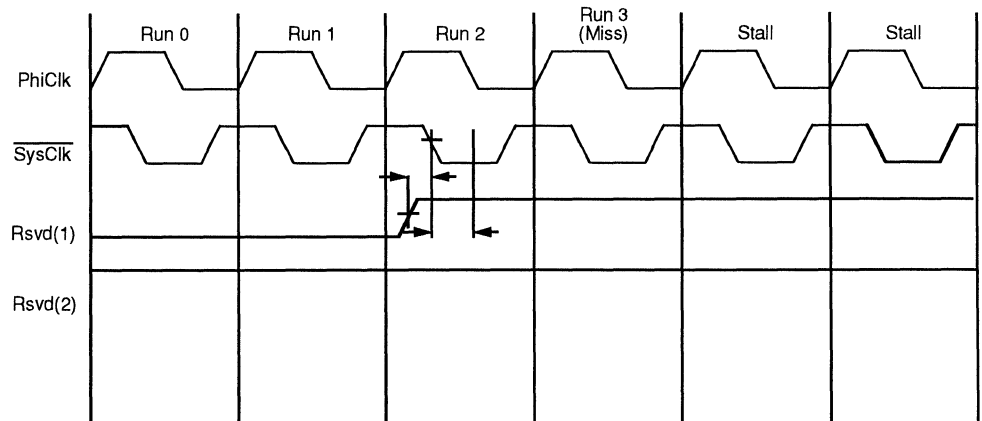

Figure 12.3. Forcing an Instruction Cache Miss in Debug Mode



**INTRODUCTION**

One of the unique advantages of the IDT R3051 family is the high level of pin, socket, and software compatibility across a very wide price-performance range. Although some devices do offer features not found in other family members, in general it is very straightforward to design a single system and set of software capable of using either the R3041, R3051, R3052, or R3081; the decision as to which processor to use can be made at board manufacturing time (as opposed to at design time) or as a program of field upgrades.

This appendix discusses compatibility issues among the various R3051 family members. The goal of this chapter is to provide the system designer with the understanding necessary to be able to interchange various R3051 family members in a single design environment, and with a single set of software tools.

**SOFTWARE CONSIDERATIONS**

In general, software considerations among the various family members can be summarized into the following areas:

- **Cache Size differences.** One of the obvious differences among the devices is the amount of instruction and data cache integrated on chip. Although the cache size is typically transparent to the applications software, the kernel must typically know how much cache to flush, etc. during system boot up. This manual presents an algorithm for determining the amount of cache on the executing processor; to insure compatibility, software should be written to dynamically determine the amount of cache on-chip.
- **Differences in CP0 registers.** Another area where the various family members differ slightly is in their implementation of CP0 registers. Table A.1 summarizes the CP0 registers of the various family members.

In general, these differences are only relevant at system start-up. The start-up code should determine which device is running, and branch to a CPU specific CP0 initialization routine. Determining which CPU is executing is straightforward, and can be accomplished by reading the PrID register (to determine the presence of an R3041) and/or performing floating point diagnostics (to determine the presence of a R3081).

Register	R3041	R3051/52	R3081
\$0	rsvd	Index	Index
\$1	rsvd	Random	Random
\$2	BusCtrl	EntryLo	EntryLo
\$3	CacheConfig	rsvd	Config
\$4	rsvd	Context	Context
\$5-\$7	rsvd	rsvd	rsvd
\$8	BadVA	BadVA	BadVA
\$9	Count	rsvd	rsvd
\$10	PortSize	EntryHi	EntryHi
\$11	Compare	rsvd	rsvd
\$12	Status	Status	Status
\$13	Cause	Cause	Cause
\$14	EPC	EPC	EPC
\$15	PrID	PrID	PrID

**Table A.1. CP0 Registers in the R3051 Family**

- "E" vs. "non-E" parts. In general, few applications will freely interchange devices with TLB's with those that do not. However, a given kernel source tree may be used across multiple applications; in this case, the start-up code should examine the "TS" bit of the status register after reset to determine the presence of an on-chip TLB, and initialize the TLB if needed.
- Hardware vs. Software Floating Point. The R3081 offers a very high-performance floating point accelerator on-chip, while the R3041 and R3051/52 do not. In this case, it may be advantageous to generate two distinct binaries from the same source tree (one for hardware floating point and one for software). However, the R3051 architecture does support the ability to trap on floating point instructions (for later emulation), by negating the CP1 usable bit. Thus, initialization software may wish to determine the presence of an on-chip FPA, and initialize the CP1 usable bit accordingly.

## HARDWARE CONSIDERATIONS

In general, the R3041, R3051/52, and R3081 offer the same system interface and pin-out, simplifying the interchange of the various family members. However, both the R3041 and the R3081 offer some device specific features, which should be considered when designing a common board. The differences among the devices are summarized below.

### R3041 Unique Features

The R3041 includes features targeting reduced system cost. Systems may wish to take full advantage of these features, in which case they may sacrifice the ability to readily interchange various CPUs in the design. Specifically, the R3041 can be interchanged with an R3051 or R3081 only in systems which implement a full 32-bit wide memory interface to the CPU, since the R3051 and R3081 do not offer the variable port width interface found in the R3041.

In general, the areas of differences between the R3041 and the R3051 are summarized below:

- The R3041 has a unique processor ID (PRId) of 0x0000\_0700.
- The R3041 has the base address translation memory map only (w/o TLB).
- Different Instruction and Data Cache sizes.
- The R3041 software selects the DBlockRefill mode, rather than as a reset mode.
- The R3041 does not externally connect the BrCond(1:0) input pins.
- Diag(1:0) are not available on the R3041. Similar information is available with the Diag pin.
- The R3041 WtNear page size is decreased.
- The R3041 has additional/different reset modes.
- The R3041 includes new Co-processor 0 Config Registers.
- The R3041 can configure SBrCond(3:2) as outputs.
- The R3041 uses pins that are Reserved as no-connects on the R3051/ R3081.
- The R3041 has an Extended Address Hold mode.
- The R3041 has a Slow Bus Turnaround mode with programmable bus wait timing.
- The R3041 has 8-bit and 16-bit ports with appropriately sized bus cycles. The R3041 can boot directly from an 8- or 16-bit wide PROM.
- The R3041 has additional outputs for  $\overline{BE16}(1:0)$ ,  $\overline{Last}$ ,  $\overline{MemStrobe}$ ,  $\overline{ExtDataEn}$ , and  $\overline{IOStrobe}$ , and  $\overline{TC}$ .
- The R3041 has a read/write mask for  $\overline{BE}(3:0)$ .
- The R3041 has an on-chip Timer with Count and Compare registers in CP0.
- The R3041 has a DMA protocol option.

### R3081 Unique Features

The R3081 includes features targeted to simplifying its use in high-frequency, high-performance systems. Systems may wish to take advantage of these features, in which case they may sacrifice some level of interchangeability with other CPUs. Key differences between the R3081 and the R3051 are summarized below:

- The R3081 includes an on-chip FPA.
- The R3081 features larger caches, which are configurable.
- The R3081 on-chip FPA uses one of the six CPU interrupts; the corresponding input pin is logically not connected.
- The R3081 implements Half-frequency bus mode.
- The R3081 features Hardware cache coherency capability during DMA.
- The R3081 can use an optional 1x (rather than 2x) clock input.
- The R3081  $\overline{\text{WrNear}}$  page size is increased.
- The R3081 implements an additional CP0 Config register.
- The R3081 implements a power down (reduced frequency, halt) option.
- The R3081 features a dynamic data cache miss refill option.
- The R3081 BrCond(1) input is not available externally. It may be used as a "Run" output indicator.
- The R3081 implements additional reset mode vectors.
- The R3081 differs slightly in its use of the reserved pins.

In general, the similarities in features allow the R3041 to use the same DRAM, I/O, and peripheral controllers that the R3051/81 use. It is possible by only using a subset of the interface features of the R3041 to also use the same system board socket as the R3051/81. However, many of these features, for instance the Extended Address Hold mode and the BootProm8 mode, allow inexpensive interface alternatives that often will justify a dedicated system board design.

### Pin Description Differences

Table A.2 lists the significant R3051, R3081, and R3081 pin differences. These differences can easily be accommodated in a single board design, as described in this chapter.

R3051	R3081	R3041
Rsvd(0)	$\overline{\text{CohReq}}$	Addr(0)
Rsvd(1)	Rsvd(1)	Addr(1)
Rsvd(2)	Rsvd(2)	$\overline{\text{BE16(0)}}$
Rsvd(3)	Rsvd(3)	$\overline{\text{BE16(1)}}$
Rsvd(4)	Rsvd(4)	$\overline{\text{TriState}}$
BrCond(0)	BrCond(0)	$\overline{\text{MemStrobe}}$
BrCond(1)	unused/ $\overline{\text{Run}}$	$\overline{\text{TC}}$
Diag(0)	Diag(0)	$\overline{\text{Last}}$
Diag(1)	Diag(1)	Diag

Table A.2. Pin Considerations Among R3051 Family Members

### Reset Mode Selection

Table A.3 shows the various reset mode vectors available in the various family members. As can be seen from the table, there are differences in the mode vector options available in the different devices.

Designing a board which accommodates these differences is very straightforward:

- Use pull-up resistors on Addr(3:2). These pull-ups will have no effect on the R3051 or R3081; in the R3041, they will cause the device to boot from a 32-bit wide EPROM, which is compatible with the R3051 and R3081.
- Do not connect anything to the R3051 reserved pins. This will insure that the R3051 and R3081 function properly. In the R3041, this will negate the Extended Address Hold feature, causing the address to data transition of the processor A/D bus to be compatible with the R3051 and R3081.
- Use dip-switches with a MUX or 3-state buffer to select the reset initialization presented on the interrupt pins. Thus, selecting different reset mode vectors merely involves setting the dip switches.

Note that many systems may not need to do this either. For example, using pull-ups on the interrupt inputs will result in a BigEndian system for all devices, and in general disable the various device specific modes of the R3081 and R3041.

Pin	R3041	R3051/52	R3081
$\overline{\text{Int}}(5)$	Rsvd	Rsvd	$\overline{\text{CoherentDMA}}$
$\overline{\text{Int}}(4)$	Rsvd	Rsvd	$\overline{\text{TxClkEn}}$
$\overline{\text{Int}}(3)$	$\overline{\text{AddrDisplay}}$	Rsvd	$\overline{\text{I}/2\text{FreqBus}}$
$\overline{\text{SInt}}(2)$	Rsvd	DBlockRefill	DBlkRefill
$\overline{\text{SInt}}(1)$	Rsvd	$\overline{\text{Tri-State}}$	$\overline{\text{Tri-State}}$
$\overline{\text{SInt}}(0)$	BigEndian	BigEndian	BigEndian
Addr(3)	$\overline{\text{BootProm16}}$	N/A	N/A
Addr(2)	$\overline{\text{BootProm8}}$	N/A	N/A
Rsvd(4)	$\overline{\text{Tri-State}}(*)$	NC	NC
Rsvd(3)	Rsvd(*)	NC	NC
Rsvd(2)	Rsvd(*)	NC	NC
Rsvd(1)	Rsvd(*)	NC	NC
Rsvd(0)	$\overline{\text{ExtAddrHold}}(*)$	NC	NC

#### NOTES:

- Rsvd: Must be driven high  
 N/A: Must not be driven  
 NC: Must not be connected  
 \*: Contains an internal pull-up

**Table A.3. Reset Mode Vectors of R3041, R3051/52, and R3081**

### Reserved No-Connect Pins

The R3051/81 contain not-to-be-connected reserved pins that R3041 systems may use. Table A.4 illustrates the different uses of the reserved pins.

To insure compatibility in systems using the same physical socket, various options exist:

- Use the internal pull-ups of the R3041 by extending the length of warm resets to be the same as that of power-up resets.
- Use external pull-ups which can be removed when an R3051/81 is used. This is so the R3051/81 Reserved pins have no chance of being driven.
- Use a tri-statable device to drive the reset configuration mode pins during reset and which then tri-state after reset when the R3041 is used, but which can be removed when the R3051/81 is used.

Of these options, the first is obviously the simplest; by not connecting the reserved pins, the R3051 and R3081 specifications will be met, and the extended features of the R3041 will not be accessed.

Pin	R3041	R3051/52	R3081
Rsvd(4)	Tri-State	Rsvd	Rsvd
Rsvd(3)	$\overline{BE16(1)}$	Rsvd	Rsvd
Rsvd(2)	$\overline{BE16(0)}$	Rsvd	Rsvd
Rsvd(1)	Addr(1)	Rsvd	Rsvd
Rsvd(0)	Addr(0)	Rsvd	$\overline{CohReq}$

Table A.4. Rsvd Pins of R3041, R3051/52, and R3081

### DIAG Pins

The R3051 features a pair of DIAG output pins which can be used during system debug. There are subtle differences in these pins in the various family members:

- The R3081 indicates the cacheability of data on writes, to simplify cache coherency. Since the R3041 and R3051 do not feature cache coherency, this feature would not be used in systems which wish to interchange the various family members.
- The R3041 uses a single DIAG pin (on the same physical pin as DIAG(1), to report the cacheability of an access. The other pin is used as the "Last" output of the R3041. Since the "Last" output is not available on the R3051 or R3081, systems designed to interchange CPUs will not use this output.

In general, the DIAG pins will only be used in system debug, rather than used to control some aspect of board operation. Thus, the differences in these pins will not impact the interchangeability of various CPUs.

### BrCond(1:0), SBrCond(3:2)

There are also some differences among the devices in their treatment of the BrCond input pins. Specifically:

- The R3051 allows software to access all of BrCond(3:0).
- The R3081 uses BrCond(1) internally for the FPA. Software can access the BrCond(3:2) and BrCond(0) inputs.
- The R3041 does not provide access to the BrCond(1:0) pins, which instead are used for other functions. Additionally, the R3041 defaults to using the SBrCond(3:2) pins as inputs on reset, although they can be used to provide other functions.

Thus, to insure CPU interchangeability, the system designer should provide pull-ups on BrCond(1:0), and only use BrCond(3:2). Of course, if these are also not used, pull-ups should be provided.

### **Slow Bus Turn Around Mode**

Slow bus turn around on the R3041 allows extra cycles between changes in A/D bus direction. The R3081 also has a bus turn around feature, but the maximum number of extra cycles is fewer. Note that with the bus turnaround slowed, the R3041 continues to operate in a 100% compatible fashion with the R3051 (there is no R3051 transaction that guarantees a "quick" bus turnaround).

Note that there is a hardware solution to bus turnaround in the R3051, which will also work with the R3041/81. This involves using the DMA arbiter to prevent the R3041/51/81 from issuing a bus cycle, and is explained in an applications note available from IDT.

Most systems that are using an R3041 and R3051 in the same socket may want to immediately reprogram the Bus Turn Around Control bits in the Bus Control CP0 register to '00' to match up exactly with the R3051 (and thus increase performance), instead of the default '11' which is used at reset, although it is not strictly necessary.

### **The R3081 FPA Interrupt**

The on-chip FPA of the R3081 reports exceptions to the CPU using one of the general purpose interrupts. The corresponding input pin is ignored. Systems desiring to interchange an R3041 with an R3081 must reserve an interrupt pin for the FPA, and provide a pull-up for that signal. The R3081 Config register allows software to select any of the 6 interrupts; at reset, the default used is interrupt 3.

### **Half-Frequency Bus Mode**

The R3081 allows the bus to operate at one-half the CPU frequency. When enabled, the bus will operate as for an R3041/51 operating at half the frequency of the R3081 CPU. Thus, this mode is entirely compatible with an R3041/51 at one-half the R3081 frequency.

In the R3081, this feature is enabled as a reset option. Systems may choose to employ a jumper on this value, so that this feature may be selectively enabled when a R3081 is used, but the pin may be pulled-high or pulled-low when an R3041 is used.

### **Reduced Frequency/Halt Capability**

This R3081 mode is incorporated to reduce power consumption when waiting for an interrupt or other external event. This mode is unavailable in an R3041/51.

Note that reduced frequency mode will appear to merely reduce the bus frequency of the R3081; most R3041/51 systems should operate correctly under this circumstance. However, the DRAM refresh timer, and other real-time timers, should either use a clock source other than the SysClk output, or reprogram their time constants, when this feature is used.

The R3041/51 does not offer the software stall capability of the R3081. Software executing on an R3041/51 which attempts to halt the processor will product no effect, and thus may result in erroneous software operation.

### **DMA Issues**

Each of the CPUs can operate using R3051 compatible DMA. In these systems, the processor will attempt to continue execution out of on-chip cache during bus DMA; however, once the CPU core needs the bus, it will wait for the external master to relinquish the bus.

The R3081 allows hardware cache coherency during DMA writes. This capability may be disabled using the Coherent DMA Enable feature of the processor.

The R3041 implements a DMA Pulse Protocol, whereby the R3041 may negate BusGnt during an external DMA cycle to indicate that it wishes to regain bus mastership. This feature is not available on the other family members, and can be enabled or disabled via the R3041 CP0 registers.

To insure CPU compatibility, systems should disable both the R3081 cache coherency mode, and the R3041 Pulse Protocol, so that all devices will operate in R3051 compatible fashion.

### Debug Features

Debug and in-circuit emulator features are not compatible between the R3041 and the R3051/81. These debug features are intended for initial development and manufacturing tests and are not recommended for functional use on fielded end-user systems. These features include the Diag pin(s), Tri-State mode, AddrDisplay mode, and ForceCacheMiss mode.

### WrNear Page Size

The various processors implement different choices for the size of the address compared for  $\overline{\text{WrNear}}$  output assertion:

- The R3051 compares Address(31:10), compatible with 64k x 4 and larger DRAMs.
- The R3081 compares Address(31:11), compatible with 256k x 4 and larger DRAMs.
- The R3041 compares Address(31:8), compatible with 64k x 4 and larger DRAMs in an 8-bit wide memory port.

To insure proper operation, the system designer can make one of two choices:

- Ignore the  $\overline{\text{WrNear}}$  output, which simplifies system design but sacrifices performance.
- Always use 256k x 4 or larger DRAMs.

### Hardware Compatibility Summary

It is very simple to design a board capable of using any of the 4 CPUs described above. Table A.5 provides a summary of the design considerations to insure CPU interchangeability. In general, any board designed around the R3051 can easily be migrated up in performance to the R3081, or down in cost to the R3041.

Design Consideration	Compatible Solution
WrNear page size	Use 256kx4 or larger DRAM
Rsvd Pins	Leave unconnected
BrCond pins	Use only BrCond(3:2); Pullups on BrCond(1:0)
R3081 FPA Interrupt	Reserve one CPU interrupt for FPA; Use external Pull-up
DIAG pins	Use only for system debug; not a production function
Reset Logic	Pull -ups on Addr(3:2); no connects on reserved lines Dip switches and mux on Interrupt lines
DMA options	Use R3051 compatible DMA
Bus Turn-around	Meet R3051 timing or use DMA to add time

Table A.5. Summary of Hardware Design Considerations



**SUMMARY**

The R3051 family offers a unique level of compatibility among various CPUs, offering a wide range of price performance options for a single design. This capability extends not only to the signal interface, but to the actual footprint of the device itself. Using advanced packaging techniques, the 84-pin PLCC footprint is available across the entire family, including the entire frequency range of the family.

Although some systems will find it advantageous to use the features particular to a given CPU; others will find advantage in the ability to offer a single design, with real value added manufacturing and field upgrade capability. This choice is unique among high-performance embedded processors.



**Integrated  
Device Technology, Inc.**

2975 Stender Way  
P.O. Box 58015  
Santa Clara, CA 95052-8015  
(408) 727-6116  
FAX 408-492-8674