

PHILIPS

HE4000B logic family - CMOS

IC04 1986

PHILIPS

Data handbook



Electronic
components
and materials

Integrated circuits

Book IC04

1986

HE4000B logic family

CMOS

**HE4000B LOGIC FAMILY
CMOS**

| | <i>page</i> |
|--|-------------|
| Selection guide | 1 |
| Functional index | 3 |
| Numerical index | 6 |
| General | 9 |
| Rating systems | 11 |
| Handling MOS devices | 13 |
| CECC qualified products | 14 |
| Burn-in options | 17 |
| Ordering information | 18 |
| Package outlines | 21 |
| Functional diagrams | 39 |
| Pin designations | 73 |
| HE4000B family – introduction | 87 |
| Family specifications | 101 |
| Device data | 111 |

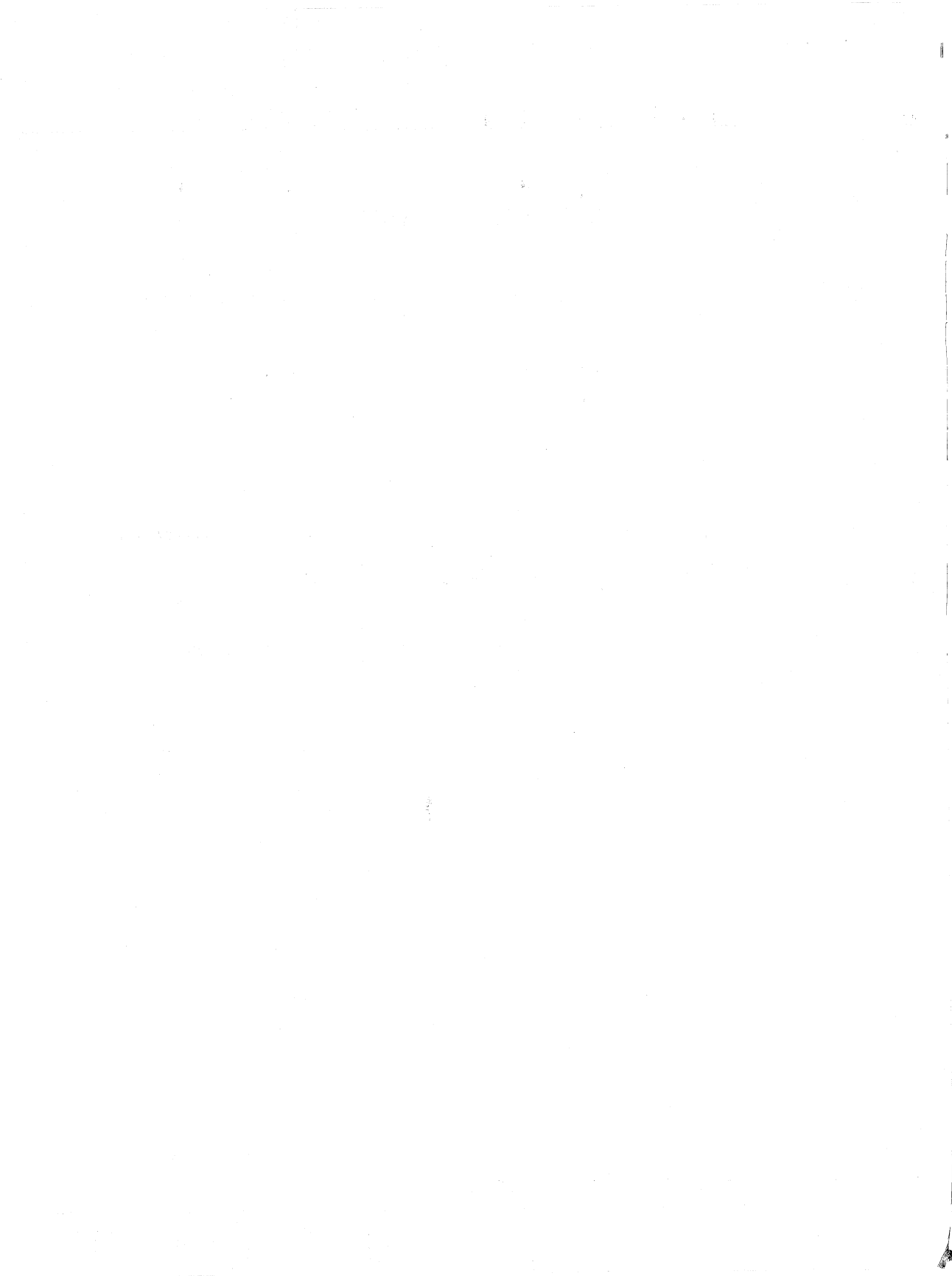

DATA HANDBOOK SYSTEM

Our Data Handbook System comprises more than 60 books with specifications on electronic components, subassemblies and materials. It is made up of four series of handbooks:

| | |
|--------------------------|--------|
| ELECTRON TUBES | BLUE |
| SEMICONDUCTORS | RED |
| INTEGRATED CIRCUITS | PURPLE |
| COMPONENTS AND MATERIALS | GREEN |

The contents of each series are listed on pages iv to viii.

The data handbooks contain all pertinent data available at the time of publication, and each is revised and reissued periodically.

When ratings or specifications differ from those published in the preceding edition they are indicated with arrows in the page margin. Where application information is given it is advisory and does not form part of the product specification.

Condensed data on the preferred products of Philips Electronic Components and Materials Division is given in our Preferred Type Range catalogue (issued annually).

Information on current Data Handbooks and on how to obtain a subscription for future issues is available from any of the Organizations listed on the back cover.

Product specialists are at your service and enquiries will be answered promptly.

ELECTRON TUBES (BLUE SERIES)

The blue series of data handbooks comprises:

- T1** **Tubes for r.f. heating**
- T2a** **Transmitting tubes for communications, glass types**
- T2b** **Transmitting tubes for communications, ceramic types**
- T3** **Klystrons**
- T4** **Magnetrons for microwave heating**
- T5** **Cathode-ray tubes**
Instrument tubes, monitor and display tubes, C.R. tubes for special applications
- T6** **Geiger-Müller tubes**
- T8** **Colour display systems**
Colour TV picture tubes, colour data graphic display tube assemblies, deflection units
- T9** **Photo and electron multipliers**
- T10** **Plumbicon camera tubes and accessories**
- T11** **Microwave semiconductors and components**
- T12** **Vidicon and Newvicon camera tubes**
- T13** **Image intensifiers and infrared detectors**
- T15** **Dry reed switches**
- T16** **Monochrome tubes and deflection units**
Black and white TV picture tubes, monochrome data graphic display tubes, deflection units

SEMICONDUCTORS (RED SERIES)

The red series of data handbooks comprises:

- S1 Diodes**
Small-signal silicon diodes, voltage regulator diodes (< 1,5 W), voltage reference diodes, tuner diodes, rectifier diodes
- S2a Power diodes**
- S2b Thyristors and triacs**
- S3 Small-signal transistors**
- S4a Low-frequency power transistors and hybrid modules**
- S4b High-voltage and switching power transistors**
- S5 Field-effect transistors**
- S6 R.F. power transistors and modules**
- S7 Surface mounted semiconductors**
- S8a Light-emitting diodes**
- S8b Devices for optoelectronics**
Optocouplers, photosensitive diodes and transistors, infrared light-emitting diodes and infrared sensitive devices, laser and fibre-optic components
- S9 Power MOS transistors**
- S10 Wideband transistors and wideband hybrid IC modules**
- S11 Microwave transistors**
- S12 Surface acoustic wave devices**
- S13 Semiconductor sensors**

INTEGRATED CIRCUITS (PURPLE SERIES)

The NEW SERIES of handbooks is now completed. With effect from the publication date of this handbook the "N" in the handbook code number will be deleted. Handbooks to be replaced during 1986 are shown below.

The purple series of handbooks comprises:

| | | |
|----------------------------|--|---------------------------------|
| IC01 | Radio, audio and associated systems Bipolar, MOS | new issue 1986 IC01N 1985 |
| IC02a/b | Video and associated systems Bipolar, MOS | new issue 1986 IC02Na/b 1985 |
| IC03 | Integrated circuits for telephony Bipolar, MOS | new issue 1986 IC03N 1985 |
| IC04 | HE4000B logic family CMOS | new issue 1986 IC4 1983 |
| IC05N | HE4000B logic family – uncased ICs CMOS | published 1984 |
| IC06N | High-speed CMOS; PC74HC/HCT/HCU Logic family | published 1986 |
| IC08 | ECL 10K and 100K logic families | New issue 1986 IC08N 1984 |
| IC09N | TTL logic series | published 1986 |
| IC10 | Memories MOS, TTL, ECL | new issue 1986 IC7 1982 |
| IC11N | Linear LSI | published 1985 |
| Supplement to IC11N | Linear LSI | published 1986 |
| IC12 | I²C-bus compatible ICs | not yet issued |
| IC13 | Semi-custom Programmable Logic Devices (PLD) | new issue 1986 IC13N 1985 |
| IC14N | Microprocessors, microcontrollers and peripherals Bipolar, MOS | published 1985 |
| IC15 | FAST TTL logic series | new issue 1986 IC15N 1985 |
| IC16 | CMOS integrated circuits for clocks and watches | first issue 1986 |
| IC17 | Integrated Services Digital Networks (ISDN) | not yet issued |
| IC18 | Microprocessors and peripherals | new issue 1986* |

* The Microprocessors were included in handbook IC14N 1985, so IC18 will replace that part of IC14N.

COMPONENTS AND MATERIALS (GREEN SERIES)

The green series of data handbooks comprises:

- C2** Television tuners, coaxial aerial input assemblies, surface acoustic wave filters
- C3** Loudspeakers
- C4** Ferroxcube potcores, square cores and cross cores
- C5** Ferroxcube for power, audio/video and accelerators
- C6** Synchronous motors and gearboxes
- C7** Variable capacitors
- C8** Variable mains transformers
- C9** Piezoelectric quartz devices
- C11** Varistors, thermistors and sensors
- C12** Potentiometers, encoders and switches
- C13** Fixed resistors
- C14** Electrolytic and solid capacitors
- C15** Ceramic capacitors
- C16** Permanent magnet materials
- C17** Stepping motors and associated electronics
- C18** Direct current motors
- C19** Piezoelectric ceramics
- C20** Wire-wound components for TVs and monitors
- C22** Film capacitors

SELECTION GUIDE

Functional index

Numerical index

Maintenance type list

FUNCTIONAL INDEX

| | | | page |
|-----------------------|-----------|---|------|
| NAND gates | HEF4011B | quadruple 2-input NAND gate | 145 |
| | HEF4011UB | quadruple 2-input NAND gate; unbuffered | 147 |
| | HEF4012B | dual 4-input NAND gate | 155 |
| | HEF4023B | triple 3-input NAND gate | 219 |
| | HEF4068B | 8-input NAND gate | 371 |
| AND gates | HEF4073B | triple 3-input AND gate | 385 |
| | HEF4081B | quadruple 2-input AND gate | 399 |
| | HEF4082B | dual 4-input AND gate | 401 |
| NOR gates | HEF4000B | dual 3-input NOR gate and inverter | 113 |
| | HEF4001B | quadruple 2-input NOR gate | 117 |
| | HEF4001UB | quadruple 2-input NOR gate; unbuffered | 119 |
| | HEF4002B | dual 4-input NOR gate | 127 |
| | HEF4025B | triple 3-input NOR gate | 225 |
| | HEF4078B | 8-input NOR gate | 397 |
| OR gates | HEF4071B | quadruple 2-input OR gate | 381 |
| | HEF4072B | dual 4-input OR gate | 383 |
| | HEF4075B | triple 3-input OR gate | 387 |
| Inverters and buffers | HEF4007UB | dual complementary pair and inverter | 133 |
| | HEF4041B | quadruple true/complement buffer | 269 |
| | HEF4049B | hex inverting buffers | 313 |
| | HEF4050B | hex non-inverting buffers | 315 |
| | HEF4069UB | hex inverter | 373 |
| | HEF4502B | strobed hex inverter/buffer | 427 |
| | HEF40097B | 3-state hex non-inverting buffer | 721 |
| | HEF40098B | 3-state hex inverting buffer | 725 |
| Complex gates | HEF4030B | quadruple EXCLUSIVE-OR gate | 249 |
| | HEF4070B | quadruple EXCLUSIVE-OR gate | 379 |
| | HEF4077B | quadruple EXCLUSIVE-NOR gate | 395 |
| | HEF4085B | dual 2-wide 2-input AND-OR-invert gate | 403 |
| | HEF4086B | 4-wide 2-input AND-OR-invert gate | 405 |
| Flip-flops | HEF4013B | dual D-type flip-flop | 157 |
| | HEF4027B | dual JK flip-flop | 227 |
| | HEF4076B | quadruple D-type register with 3-state outputs | 389 |
| | HEF40174B | hex D-type flip-flop | 775 |
| | HEF40175B | quadruple D-type flip-flop | 779 |
| Counters | HEF4017B | 5-stage Johnson counter | 181 |
| | HEF4018B | presettable divide-by-n counter | 189 |
| | HEF4020B | 14-stage binary counter | 199 |
| | HEF4022B | 4-stage divide-by-8 Johnson counter | 211 |
| | HEF4024B | 7-stage binary counter | 221 |
| | HEF4029B | synchronous up/down counter, binary/decade counter | 237 |
| | HEF4040B | 12-stage binary counter | 265 |

FUNCTIONAL INDEX

| | | | page |
|------------------------------------|--------------------------------|---|--------------------------------|
| Counters (continued) | HEF4059B | programmable divide-by-n counter | 341 |
| | HEF4060B | 14-stage ripple-carry binary counter/divider and oscillator | 347 |
| | HEF4510B | BCD up/down counter | 447 |
| | HEF4516B | binary up/down counter | 479 |
| | HEF4518B | dual BCD counter | 497 |
| | HEF4520B | dual binary counter | 507 |
| | HEF4521B | 24-stage frequency divider | 513 |
| | HEF4522B | programmable 4-bit BCD down counter | 523 |
| | HEF4526B | programmable 4-bit binary down counter | 533 |
| | HEF4534B | real time 5-decade counter | 569 |
| | HEF4737B; V | quadruple static decade counters | 649 |
| | HEF4751V | universal divider | 681 |
| | HEF40160B | 4-bit synchronous decade counter with asynchronous reset | 735 |
| | HEF40161B | 4-bit synchronous binary counter with asynchronous reset | 745 |
| | HEF40162B | 4-bit synchronous decade counter with synchronous reset | 755 |
| | HEF40163B | 4-bit synchronous binary counter with synchronous reset | 765 |
| | HEF40192B | 4-bit up/down decade counter | 783 |
| | HEF40193B | 4-bit up/down binary counter | 791 |
| | Registers | HEF4006B | 18-stage static shift register |
| HEF4014B | | 8-bit static shift register | 163 |
| HEF4015B | | dual 4-bit static shift register | 169 |
| HEF4021B | | 8-bit static shift register | 205 |
| HEF4031B | | 64-stage static shift register | 251 |
| HEF4035B | | 4-bit universal shift register | 257 |
| HEF4076B | | quadruple D-type register with 3-state outputs | 389 |
| HEF4094B | | 8-stage shift-and-store bus register | 415 |
| HEF4517B | | dual 64-bit static shift register | 489 |
| HEF4557B | | 1-to-64 bit variable length shift register | 611 |
| HEF4731B; V | | quadruple 64-bit static shift register | 645 |
| HEF40194B | | 4-bit bidirectional universal shift register | 799 |
| HEF40195B | 4-bit universal shift register | 805 | |
| Decoders and demultiplexers | HEF4028B | 1-of-10 decoder | 233 |
| | HEF4511B | BCD to 7-segment latch/decoder/driver | 457 |
| | HEF4514B | 1-of-16 decoder/demultiplexer with input latches | 471 |
| | HEF4515B | 1-of-16 decoder/demultiplexer with input latches | 475 |
| | HEF4543B | BCD to 7-segment latch/decoder/driver | 597 |
| | HEF4555B | dual 1-of-4 decoder/demultiplexer | 603 |
| | HEF4556B | dual 1-of-4 decoder/demultiplexer | 607 |
| Digital multiplexers | HEF4019B | quadruple 2-input multiplexer | 195 |
| | HEF4512B | 8-input multiplexer with 3-state output | 465 |
| | HEF4519B | quadruple 2-input multiplexer | 503 |
| | HEF4539B | dual 4-input multiplexer | 585 |

FUNCTIONAL INDEX

| | | | page |
|--|-------------|---|------|
| Analogue switches and multiplexers/demultiplexers | HEF4016B | quadruple bilateral switches | 173 |
| | HEF4051B | 8-channel analogue multiplexer/demultiplexer | 317 |
| | HEF4052B | dual 4-channel analogue multiplexer/demultiplexer | 325 |
| | HEF4053B | triple 2-channel analogue multiplexer/demultiplexer | 333 |
| | HEF4066B | quadruple bilateral switches | 355 |
| | HEF4067B | 16-channel analogue multiplexer/demultiplexer | 363 |
| Latches | HEF4042B | quadruple D-latch | 271 |
| | HEF4043B | quadruple R/S latch with 3-state outputs | 277 |
| | HEF4044B | quadruple R/S latch with 3-state outputs | 281 |
| | HEF4508B | dual 4-bit latch | 439 |
| | HEF4724B | 8-bit addressable latch | 639 |
| Multivibrators and timers | HEF4047B | monostable/astable multivibrator | 299 |
| | HEF4528B | dual monostable multivibrator | 551 |
| | HEF4538B | dual precision monostable multivibrator | 577 |
| | HEF4541B | programmable timer | 589 |
| | HEF4753B | universal timer module | 695 |
| Arithmetic units | HEF4008B | 4-bit binary full adder | 141 |
| | HEF4531B | 13-input parity checker/generator | 557 |
| | HEF4532B | 8-input priority encoder | 561 |
| | HEF4585B | 4-bit magnitude comparator | 617 |
| Schmitt triggers | HEF4093B | quadruple 2-input NAND Schmitt trigger | 409 |
| | HEF40106B | hex Schmitt trigger | 729 |
| Memories | HEF4505B | 64-bit, 1-bit per word read/write RAM | 431 |
| | HEF4720B; V | 256-bit, 1-bit per word RAM | 623 |
| Special functions | HEF4046B | phase-locked loop | 285 |
| | HEF4104B | quadruple low-to-high voltage translator with 3-state outputs | 423 |
| | HEF4527B | BCD rate multiplier | 543 |
| | HEF4738V | IEC/IEEE bus interface | 657 |
| | HEF4750V | frequency synthesizer | 665 |
| | HEF4752V | a.c. motor control circuit | 691 |
| | HEF4754V | 18-element bar graph LCD driver | 703 |
| | HEF4755V | transceiver for serial data communication | 709 |
| Octal circuits | HEF40240B | octal buffers with 3-state outputs | 813 |
| | HEF40244B | octal buffers with 3-state outputs | 819 |
| | HEF40245B | octal bus transceiver with 3-state outputs | 825 |
| | HEF40373B | octal transparent latch with 3-state outputs | 831 |
| | HEF40374B | octal D-type flip-flop with 3-state outputs | 837 |

NUMERICAL INDEX

| type number | function | category | pins | suffix * | page |
|-------------|---|------------|------|----------|------|
| HEF4000B | dual 3-input NOR gate and inverter | gates | 14 | D, P, T | 113 |
| HEF4001B | quadruple 2-input NOR gate | gates | 14 | D, P, T | 117 |
| HEF4001UB | quadruple 2-input NOR gate; unbuffered | gates | 14 | D, P, T | 119 |
| HEF4002B | dual 4-input NOR gate | gates | 14 | D, P, T | 127 |
| HEF4006B | 18-stage static shift register | MSI | 14 | D, P, T | 129 |
| HEF4007UB | dual complementary pair and inverter | gates | 14 | D, P, T | 133 |
| HEF4008B | 4-bit binary full adder | MSI | 16 | D, P, T | 141 |
| HEF4011B | quadruple 2-input NAND gate | gates | 14 | D, P, T | 145 |
| HEF4011UB | quadruple 2-input NAND gate; unbuffered | gates | 14 | D, P, T | 147 |
| HEF4012B | dual 4-input NAND gate | gates | 14 | D, P, T | 155 |
| HEF4013B | dual D-type flip-flop | flip-flops | 14 | D, P, T | 157 |
| HEF4014B | 8-bit static shift register | MSI | 16 | D, P, T | 163 |
| HEF4015B | dual 4-bit static shift register | MSI | 16 | D, P, T | 169 |
| HEF4016B | quadruple bilateral switches | gates | 14 | D, P, T | 173 |
| HEF4017B | 5-stage Johnson counter | MSI | 16 | D, P, T | 181 |
| HEF4018B | presettable divide-by-n counter | MSI | 16 | D, P, T | 189 |
| HEF4019B | quadruple 2-input multiplexer | MSI | 16 | D, P, T | 195 |
| HEF4020B | 14-stage binary counter | MSI | 16 | D, P, T | 199 |
| HEF4021B | 8-bit static shift register | MSI | 16 | D, P, T | 205 |
| HEF4022B | 4-stage divide-by-8 Johnson counter | MSI | 16 | D, P, T | 211 |
| HEF4023B | triple 3-input NAND gate | gates | 14 | D, P, T | 219 |
| HEF4024B | 7-stage binary counter | MSI | 14 | D, P, T | 221 |
| HEF4025B | triple 3-input NOR gate | gates | 14 | D, P, T | 225 |
| HEF4027B | dual JK flip-flop | flip-flops | 16 | D, P, T | 227 |
| HEF4028B | 1-of-10 decoder | MSI | 16 | D, P, T | 233 |
| HEF4029B | synchronous up/down — binary/decade counter | MSI | 16 | D, P, T | 237 |
| HEF4030B | quadruple EXCLUSIVE-OR gate | gates | 14 | D, P, T | 249 |
| HEF4031B | 64-stage static shift register | MSI | 16 | D, P, T | 251 |
| HEF4035B | 4-bit universal shift register | MSI | 16 | D, P, T | 257 |
| HEF4040B | 12-stage binary counter | MSI | 16 | D, P, T | 265 |
| HEF4041B | quadruple true/complement buffer | buffers | 14 | D, P, T | 269 |
| HEF4042B | quadruple D-latch | MSI | 16 | D, P, T | 271 |
| HEF4043B | quadruple R/S latch with 3-state outputs | MSI | 16 | D, P, T | 277 |
| HEF4044B | quadruple R/S latch with 3-state outputs | MSI | 16 | D, P, T | 281 |
| HEF4046B | phase-locked loop | MSI | 16 | D, P, T | 285 |
| HEF4047B | monostable/astable multivibrator | MSI | 14 | D, P, T | 299 |
| HEF4049B | hex inverting buffers | buffers | 16 | D, P, T | 313 |
| HEF4050B | hex non-inverting buffers | buffers | 16 | D, P, T | 315 |
| HEF4051B | 8-channel analogue multiplexer/demultiplexer | MSI | 16 | D, P, T | 317 |
| HEF4052B | dual 4-channel analogue multiplexer/demultiplexer | MSI | 16 | D, P, T | 325 |

* Add the suffix to the type number on all orders.

D:ceramic (cerdip) package (DIL).

P:plastic package (DIL).

T:plastic mini-pack (SO-package).

NUMERICAL INDEX

| type number | function | category | pins | suffix * | page |
|-------------|--|----------|------|----------|------|
| HEF4053B | triple 2-channel analogue multiplexer/demultiplexer | MSI | 16 | D, P, T | 333 |
| HEF4059B | programmable divide-by-n counter | MSI | 24 | D, P, T | 341 |
| HEF4060B | 14-stage ripple-carry binary counter/divider and oscillator | MSI | 16 | D, P, T | 347 |
| HEF4066B | quadruple bilateral switches | gates | 14 | D, P, T | 355 |
| HEF4067B | 16-channel analogue multiplexer/demultiplexer | MSI | 24 | D, P, T | 363 |
| HEF4068B | 8-input NAND gate | gates | 14 | D, P, T | 371 |
| HEF4069UB | hex inverter | gates | 14 | D, P, T | 373 |
| HEF4070B | quadruple EXCLUSIVE-OR gate | gates | 14 | D, P, T | 379 |
| HEF4071B | quadruple 2-input OR gate | gates | 14 | D, P, T | 381 |
| HEF4072B | dual 4-input OR gate | gates | 14 | D, P, T | 383 |
| HEF4073B | triple 3-input AND gate | gates | 14 | D, P, T | 385 |
| HEF4075B | triple 3-input OR gate | gates | 14 | D, P, T | 387 |
| HEF4076B | quadruple D-type register with 3-state outputs | MSI | 16 | D, P, T | 389 |
| HEF4077B | quadruple EXCLUSIVE-NOR gate | gates | 14 | D, P, T | 395 |
| HEF4078B | 8-input NOR gate | gates | 14 | D, P, T | 397 |
| HEF4081B | quadruple 2-input AND gate | gates | 14 | D, P, T | 399 |
| HEF4082B | dual 4-input AND gate | gates | 14 | D, P, T | 401 |
| HEF4085B | dual 2-wide 2-input AND-OR-invert gate | gates | 14 | D, P, T | 403 |
| HEF4086B | 4-wide 2-input AND-OR-invert gate | gates | 14 | D, P, T | 405 |
| HEF4093B | quadruple 2-input NAND Schmitt trigger | gates | 14 | D, P, T | 409 |
| HEF4094B | 8-stage shift-and-store bus register | MSI | 16 | D, P, T | 415 |
| HEF4104B | quadruple low to high voltage translator; 3-state | MSI | 16 | D, P, T | 423 |
| HEF4502B | strobed hex inverter/buffer | buffers | 16 | D, P, T | 427 |
| HEF4505B | 64-bit static read/write RAM | LSI | 14 | D, P | 431 |
| HEF4508B | dual 4-bit latch | MSI | 24 | D, P, T | 439 |
| HEF4510B | BCD up/down counter | MSI | 16 | D, P, T | 447 |
| HEF4511B | BCD to 7-segment latch/decoder/driver | MSI | 16 | D, P, T | 457 |
| HEF4512B | 8-input multiplexer with 3-state output | MSI | 16 | D, P, T | 465 |
| HEF4514B | 1-of-16 decoder/demultiplexer with input latches | MSI | 24 | D, P, T | 471 |
| HEF4515B | 1-of-16 decoder/demultiplexer with input latches | MSI | 24 | D, P, T | 475 |
| HEF4516B | binary up/down counter | MSI | 16 | D, P, T | 479 |
| HEF4517B | dual 64-bit static shift register | LSI | 16 | D, P, T | 489 |
| HEF4518B | dual BCD counter | MSI | 16 | D, P, T | 497 |
| HEF4519B | quadruple 2-input multiplexer | MSI | 16 | D, P, T | 503 |
| HEF4520B | dual binary counter | MSI | 16 | D, P, T | 507 |
| HEF4521B | 24-stage frequency divider | MSI | 16 | D, P, T | 513 |
| HEF4522B | programmable 4-bit BCD down counter | MSI | 16 | D, P, T | 523 |
| HEF4526B | programmable 4-bit binary down counter | MSI | 16 | D, P, T | 533 |
| HEF4527B | BCD rate multiplier | MSI | 16 | D, P, T | 543 |
| HEF4528B | dual monostable multivibrator | MSI | 16 | D, P, T | 551 |

* Add the suffix to the type number on all orders.
D:ceramic (cerdip) package (DIL).
P:plastic package (DIL).
T:plastic mini-pack (SO-package).

NUMERICAL INDEX

| type number | function | category | pins | suffix * | page |
|-------------|--|----------|------|----------|------|
| HEF4531B | 13-input parity checker/generator | MSI | 16 | D, P, T | 557 |
| HEF4532B | 8-input priority encoder | MSI | 16 | D, P, T | 561 |
| HEF4534B | real time 5-decade counter | LSI | 24 | D, P, T | 569 |
| HEF4538B | dual precision monostable multivibrator | MSI | 16 | D, P, T | 577 |
| HEF4539B | dual 4-input multiplexer | MSI | 16 | D, P, T | 585 |
| HEF4541B | programmable timer | MSI | 14 | D, P, T | 589 |
| HEF4543B | BCD to 7-segment latch/decoder/driver | MSI | 16 | D, P, T | 597 |
| HEF4555B | dual 1-of-4 decoder/demultiplexer | MSI | 16 | D, P, T | 603 |
| HEF4556B | dual 1-of-4 decoder/demultiplexer | MSI | 16 | D, P, T | 607 |
| HEF4557B | 1-to-64 bit variable length shift register | LSI | 16 | D, P, T | 611 |
| HEF4585B | 4 bit magnitude comparator | MSI | 16 | D, P, T | 617 |
| HEF4720B;V | 256-bit, 1-bit per word RAM | LSI | 16 | D, P, T | 623 |
| HEF4724B | 8-bit addressable latch | MSI | 16 | D, P, T | 639 |
| HEF4731B;V | quadruple 64-bit static shift register | LSI | 14 | D, P | 645 |
| HEF4737B;V | quadruple static decade counters | LSI | 18 | D, P | 649 |
| HEF4738V | IEC/IEEE bus interface | LSI | 40 | P | 657 |
| HEF4750V | frequency synthesizer | LSI | 28 | D | 665 |
| HEF4751V | universal divider | LSI | 28 | D, P, T | 681 |
| HEF4752V | a.c. motor control circuit | LSI | 28 | D, P, T | 691 |
| HEF4753B | universal timer module | LSI | 18 | D, P | 695 |
| HEF4754V | 18-element bar graph LCD driver | LSI | 28 | D, P, T | 703 |
| HEF4755V | transceiver for serial data communication | LSI | 28 | D, P, T | 709 |
| HEF40097B | 3-state hex non-inverting buffer | buffers | 16 | D, P, T | 721 |
| HEF40098B | 3-state hex inverting buffer | buffers | 16 | D, P, T | 725 |
| HEF40106B | hex inverting Schmitt trigger | gates | 14 | D, P, T | 729 |
| HEF40160B | 4-bit synchronous decade counter; asynchronous reset | MSI | 16 | D, P, T | 735 |
| HEF40161B | 4-bit synchronous binary counter; asynchronous reset | MSI | 16 | D, P, T | 745 |
| HEF40162B | 4-bit synchronous decade counter; synchronous reset | MSI | 16 | D, P, T | 755 |
| HEF40163B | 4-bit synchronous binary counter; synchronous reset | MSI | 16 | D, P, T | 765 |
| HEF40174B | hex D-type flip-flop | MSI | 16 | D, P, T | 775 |
| HEF40175B | quadruple D-type flip-flop | MSI | 16 | D, P, T | 779 |
| HEF40192B | 4-bit up/down decade counter | MSI | 16 | D, P, T | 783 |
| HEF40193B | 4-bit up/down binary counter | MSI | 16 | D, P, T | 791 |
| HEF40194B | 4-bit bidirectional universal shift register | MSI | 16 | D, P, T | 799 |
| HEF40195B | 4-bit universal shift register | MSI | 16 | D, P, T | 805 |
| HEF40240B | octal buffers with 3-state outputs | buffers | 20 | P, T | 813 |
| HEF40244B | octal buffers with 3-state outputs | buffers | 20 | P, T | 819 |
| HEF40245B | octal bus transceiver with 3-state outputs | buffers | 20 | P, T | 825 |
| HEF40373B | octal transparent latch with 3-state outputs | MSI | 20 | P, T | 831 |
| HEF40374B | octal D-type flip-flop with 3-state outputs | MSI | 20 | P, T | 837 |

* : Add the suffix to the type number on all orders.

D : ceramic (cerdip) package (DIL).

P : plastic package (DIL).

T : plastic mini-pack (SO-package).

GENERAL

Rating systems

Handling MOS devices

CECC qualified products

Burn-in options

Ordering information

RATING SYSTEMS

The rating systems described are those recommended by the International Electrotechnical Commission (IEC) in its Publication 134.

DEFINITIONS OF TERMS USED

Electronic device. An electronic tube or valve, transistor or other semiconductor device.

Note

This definition excludes inductors, capacitors, resistors and similar components.

Characteristic. A characteristic is an inherent and measurable property of a device. Such a property may be electrical, mechanical, thermal, hydraulic, electro-magnetic, or nuclear, and can be expressed as a value for stated or recognized conditions. A characteristic may also be a set of related values, usually shown in graphical form.

Bogey electronic device. An electronic device whose characteristics have the published nominal values for the type. A bogey electronic device for any particular application can be obtained by considering only those characteristics which are directly related to the application.

Rating. A value which establishes either a limiting capability or a limiting condition for an electronic device. It is determined for specified values of environment and operation, and may be stated in any suitable terms.

Note

Limiting conditions may be either maxima or minima.

Rating system. The set of principles upon which ratings are established and which determine their interpretation.

Note

The rating system indicates the division of responsibility between the device manufacturer and the circuit designer, with the object of ensuring that the working conditions do not exceed the ratings.

ABSOLUTE MAXIMUM RATING SYSTEM

Absolute maximum ratings are limiting values of operating and environmental conditions applicable to any electronic device of a specified type as defined by its published data, which should not be exceeded under the worst probable conditions.

These values are chosen by the device manufacturer to provide acceptable serviceability of the device, taking no responsibility for equipment variations, environmental variations, and the effects of changes in operating conditions due to variations in the characteristics of the device under consideration and of all other electronic devices in the equipment.

The equipment manufacturer should design so that, initially and throughout life, no absolute maximum value for the intended service is exceeded with any device under the worst probable operating conditions with respect to supply voltage variation, equipment component variation, equipment control adjustment, load variations, signal variation, environmental conditions, and variations in characteristics of the device under consideration and of all other electronic devices in the equipment.

DESIGN MAXIMUM RATING SYSTEM

Design maximum ratings are limiting values of operating and environmental conditions applicable to a bogey electronic device of a specified type as defined by its published data, and should not be exceeded under the worst probable conditions.

These values are chosen by the device manufacturer to provide acceptable serviceability of the device, taking responsibility for the effects of changes in operating conditions due to variations in the characteristics of the electronic device under consideration.

The equipment manufacturer should design so that, initially and throughout life, no design maximum value for the intended service is exceeded with a bogey device under the worst probable operating conditions with respect to supply voltage variation, equipment component variation, variation in characteristics of all other devices in the equipment, equipment control adjustment, load variation, signal variation and environmental conditions.

DESIGN CENTRE RATING SYSTEM

Design centre ratings are limiting values of operating and environmental conditions applicable to a bogey electronic device of a specified type as defined by its published data, and should not be exceeded under normal conditions.

These values are chosen by the device manufacturer to provide acceptable serviceability of the device in average applications, taking responsibility for normal changes in operating conditions due to rated supply voltage variation, equipment component variation, equipment control adjustment, load variation, signal variation, environmental conditions, and variations in the characteristics of all electronic devices.

The equipment manufacturer should design so that, initially, no design centre value for the intended service is exceeded with a bogey electronic device in equipment operating at the stated normal supply voltage.

HANDLING MOS DEVICES

Though all our MOS integrated circuits incorporate protection against electrostatic discharges, they can nevertheless be damaged by accidental over-voltages. In storing and handling them, the following precautions are recommended.

Caution

Testing or handling and mounting call for special attention to personal safety. Personnel handling MOS devices should normally be connected to ground via a resistor.

Storage and transport

Store and transport the circuits in their original packing. Alternatively, use may be made of a conductive material or special IC carrier that either short-circuits all leads or insulates them from external contact.

Testing or handling

Work on a conductive surface (e.g. metal table top) when testing the circuits or transferring them from one carrier to another. Electrically connect the person doing the testing or handling to the conductive surface, for example by a metal bracelet and a conductive cord or chain. Connect all testing and handling equipment to the same surface.

Signals should not be applied to the inputs while the device power supply is off. All unused input leads should be connected to either the supply voltage or ground.

Mounting

Mount MOS integrated circuits on printed circuit boards *after* all other components have been mounted. Take care that the circuits themselves, metal parts of the board, mounting tools, and the person doing the mounting are kept at the same electric (ground) potential. If it is impossible to ground the printed-circuit board the person mounting the circuits should touch the board before bringing MOS circuits into contact with it.

Soldering

Soldering iron tips, including those of low-voltage irons, or soldering baths should also be kept at the same potential as the MOS circuits and the board.

Static charges

Dress personnel in clothing of non-electrostatic material (no wool, silk or synthetic fibres). After the MOS circuits have been mounted on the board proper handling precautions should still be observed. Until the sub-assemblies are inserted into a complete system in which the proper voltages are supplied, the board is no more than an extension of the leads of the devices mounted on the board. To prevent static charges from being transmitted through the board wiring to the device it is recommended that conductive clips or conductive tape be put on the circuit board terminals.

Transient voltages

To prevent permanent damage due to transient voltages, do not insert or remove MOS devices, or printed-circuit boards with MOS devices, from test sockets or systems with power on.

Voltage surges

Beware of voltage surges due to switching electrical equipment on or off, relays and d.c. lines.

CECC QUALIFIED PRODUCTS

INTRODUCTION

The basis of the quality assessment of the CMOS ICs described in this handbook is formed by the rules and procedures of the well known CECC system (European system of quality assessment for electronic components). As a consequence, all CMOS manufacturing activities are now fully qualified and supervised by independent, internationally recognized, National Inspectorates (e.g. KEMA for The Netherlands).

Our CMOS ICs are homologated according to the CECC 90 000 Specification.

CECC - WHAT DO CUSTOMERS GET?

- Products, wholly manufactured in CECC approved premises.
- Products, released by an Inspection Organization which is approved by the National Supervising Inspectorate (NSI).
- Products, released in accordance with CECC adopted specifications.
- Mandatory sample life tests and environmental tests.
- Delivery in packages, which are sealed with the mark of conformity under supervision of the NSI.
- Certified test records compiled every six months and available on request.
- Audits of the production facilities by the NSI.

THE CECC SCHEME

CECC is a scheme for providing electronic components of assessed quality controlled by the National Supervising Inspectorate (NSI, e.g. KEMA). It is set up by the CENELEC (European Committee for Electrotechnical Standardization) Electronic Components Committee (CECC) and the International Electrotechnical Commission (IEC).

The CECC scheme includes two essential features of any Quality Assurance Scheme:

- a specification system,
- a certification procedure supported by an independent inspectorate.

CECC IN OPERATION

The CECC scheme operates essentially in three parts.

Part 1: the plant qualification

Part 2: the device qualification

Part 3: quality conformance inspection of deliveries

Part 1

Established to the satisfaction of the NSI that the organization has adequate quality systems, procedures and standards to control the manufacturing of electronic components to the minimum standard as defined in the CECC system.

Part 2

Established by demonstration to the NSI that the electronic components are capable of meeting the requirements of detail specifications which are prepared in accordance with the CECC system. This is accomplished by performing the qualification activity.

Part 3

Established on a lot-by-lot and periodic sampling basis such, that the devices are in conformance with the specifications to which they were initially qualified. Data on the results of these tests are provided as Certified Test Records (CTRs), certified by a representative of the NSI and they are published at six-monthly intervals.

At this stage, if any lot should be classified as rejected, it will become disqualified from being released as a CECC device. Re-submission of rejected lots is not permitted.

CECC - QUALIFICATION FEATURES

Lot-by-lot tests

Group A inspection

Group A prescribes the visual examination and electrical measurements to be made on a lot-by-lot basis to assess the principal electrical properties of a circuit (see CECC 00 107).

Group A inspection is divided into appropriate Sub-Groups.

Group B inspection

Group B prescribes the procedures to be used on a lot-by-lot basis to assess certain additional properties of the circuit, including environmental and endurance tests which can be completed in less than one week (see CECC 00 107).

Group B inspection is divided into appropriate Sub-Groups.

Periodic tests

Group C inspection

Group C prescribes the procedures to be used on a periodic basis to assess certain properties of the circuit including environmental and endurance tests which are appropriate for checking at intervals of 3 months.

Group C inspection is divided into appropriate Sub-Groups.

Group D inspection

Group D prescribes the procedures to be used on a periodic basis at intervals of 12 months.

CECC - QUALIFICATION PROCEDURE

- Raise detail specification in accordance with appropriate rules.
- Detail specification approved by NSI and NAI (National Authorized Institution).
- Submit 3 separate lots for qualification.
- Pass all group A and B tests on each of the 3 lots.
- Pass all group C tests on a combined sample from the 3 lots.
- Pass all group C tests, except test C8 (endurance).
- Pass C8 endurance test at 1000 hours, submit test records countersigned by supervising inspector and apply for provisional approval.

CECC - PRODUCTS

Our CMOS products are available up to the highest assessment level R. Products qualified by CECC are recognized by the symbol  on the individual data sheets in this handbook. The appropriate CECC detail specification number is also given.

BURN-IN OPTIONS

Production quality control ensures that the quality inherent in a design is realized during manufacture of our CMOS integrated circuits. This is achieved by monitoring the quality, both conformity and reliability, of finished ICs; by inspection of the materials and components to be used in the process; by calibration of the equipment; and by monitoring the temperature, humidity and dust content of the manufacturing area.

Careful integration of the production and quality-control functions is essential for good and improving quality.

The BURN-IN option is an additional feature and is available on all our plastic and ceramic (cerdip) DIL packaged CMOS ICs. The features are:

- reduced infant mortality
- reduced printed-circuit board and system re-design
- reduced equipment down-time
- reduced field failures

Flow-charts

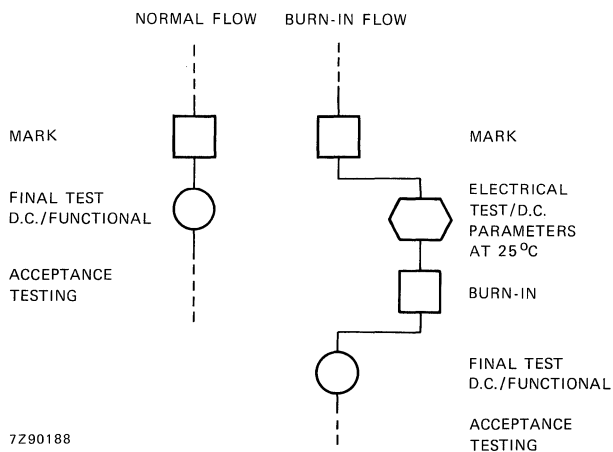

Burn-in is performed under the following conditions:

| | | |
|-----------|-----------|-----------------|
| V_{DD} | 15 V | } or equivalent |
| T_{amb} | 125 °C | |
| time | 168 hours | |
| bias | static | |

ORDERING INFORMATION

TYPE DESIGNATION

HEX4512BXX

| | |
|------|--|
| HE | family identification |
| X | operating temperature range (C = full, F = limited) |
| 4512 | device number |
| B | JEDEC "B" series CMOS specification |
| X | package code (P = plastic, D = ceramic (cerdip), T = plastic SO mini-pack) |
| X | screening class (B = burn-in; see also chapter BURN-IN OPTIONS) |

Example: HEF4512BDB

MARKING

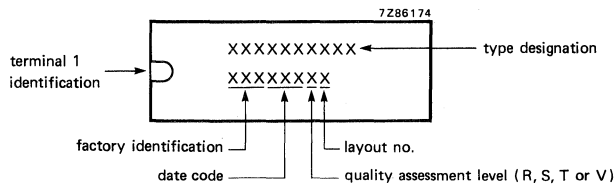

ORDERING

N (a) integrated circuit HEF (b) 4512B, R (c) level, B class (d), D (e) package, following NL-CECC 90 104-066, Issue 1.

Complete type number: HEF4512BDB

Note: Always use the complete type number when ordering (see above). Complete type number are given in the device data sheets.

- a: quantity
- b: operating temperature range (HEF or HEC)
- c: quality assessment level (R)
- d: screening class, burn-in (optional)
- e: package code D = ceramic (cerdip); P = plastic; T = plastic SO mini-pack

PACKAGE OUTLINES

14-LEAD DUAL IN-LINE; PLASTIC (SOT-27K,M,T)

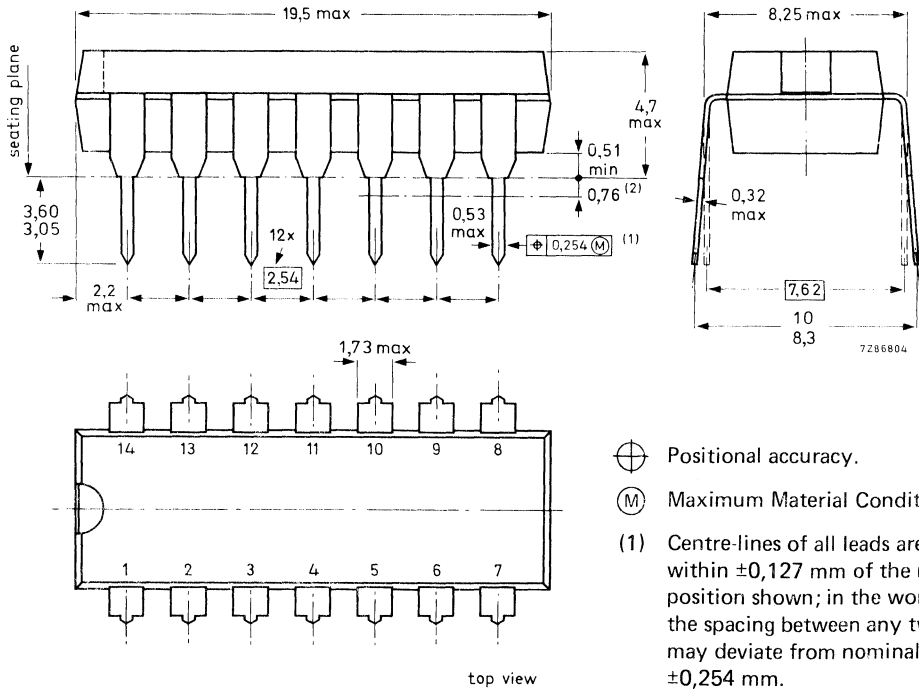

- ⊕ Positional accuracy.
- Ⓜ Maximum Material Condition.
- (1) Centre-lines of all leads are within $\pm 0,127$ mm of the nominal position shown; in the worst case, the spacing between any two leads may deviate from nominal by $\pm 0,254$ mm.
- (2) Lead spacing tolerances apply from seating plane to the line indicated.

Dimensions in mm

SOLDERING

1. By hand

Apply the soldering iron below the seating plane (or not more than 2 mm above it). If its temperature is below 300 °C it must not be in contact for more than 10 seconds; if between 300 °C and 400 °C, for not more than 5 seconds.

2. By dip or wave

The maximum permissible temperature of the solder is 260 °C; this temperature must not be in contact with the joint for more than 5 seconds. The total contact time of successive solder waves must not exceed 5 seconds.

The device may be mounted up to the seating plane, but the temperature of the plastic body must not exceed the specified storage maximum. If the printed-circuit board has been pre-heated, forced cooling may be necessary immediately after soldering to keep the temperature within the permissible limit.

3. Repairing soldered joints

The same precautions and limits apply as in (1) above.

16-LEAD DUAL IN-LINE; PLASTIC (SOT-38Z)

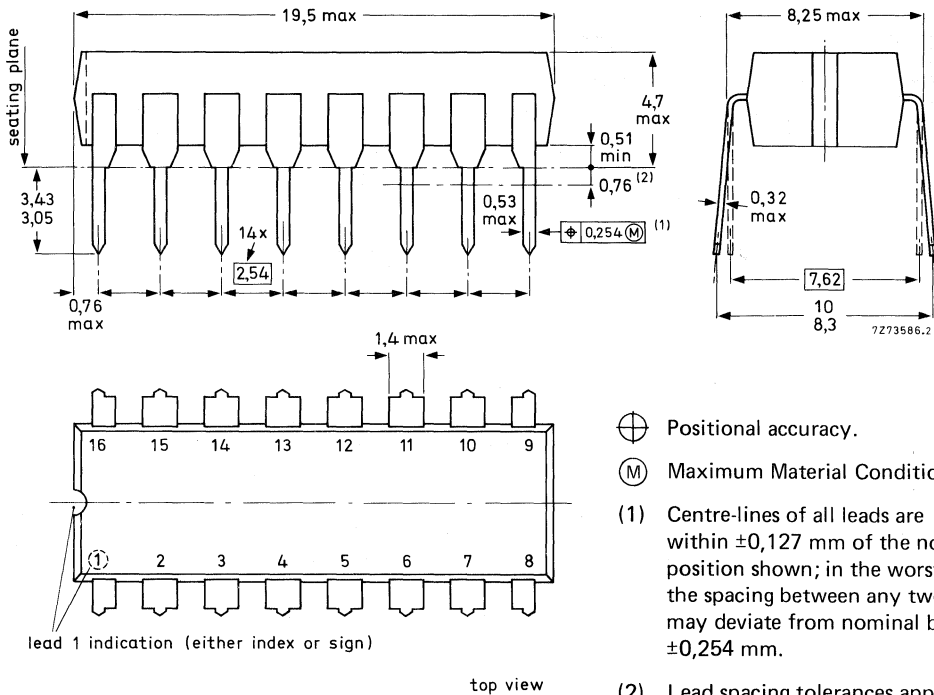

Dimensions in mm

SOLDERING

1. By hand

Apply the soldering iron below the seating plane (or not more than 2 mm above it). If its temperature is below 300 °C it must not be in contact for more than 10 seconds; if between 300 °C and 400 °C, for not more than 5 seconds.

2. By dip or wave

The maximum permissible temperature of the solder is 260 °C; this temperature must not be in contact with the joint for more than 5 seconds. The total contact time of successive solder waves must not exceed 5 seconds.

The device may be mounted up to the seating plane, but the temperature of the plastic body must not exceed the specified storage maximum. If the printed-circuit board has been pre-heated, forced cooling may be necessary immediately after soldering to keep the temperature within the permissible limit.

3. Repairing soldered joints

The same precautions and limits apply as in (1) above.

14-LEAD DUAL IN-LINE; CERAMIC (CERDIP) (SOT-73A,B,C)

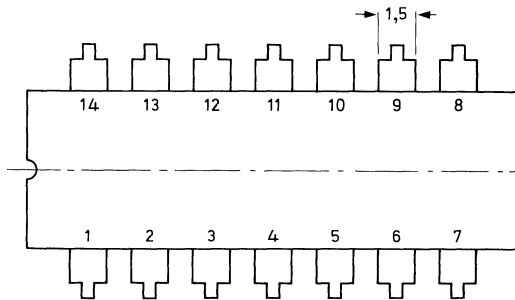
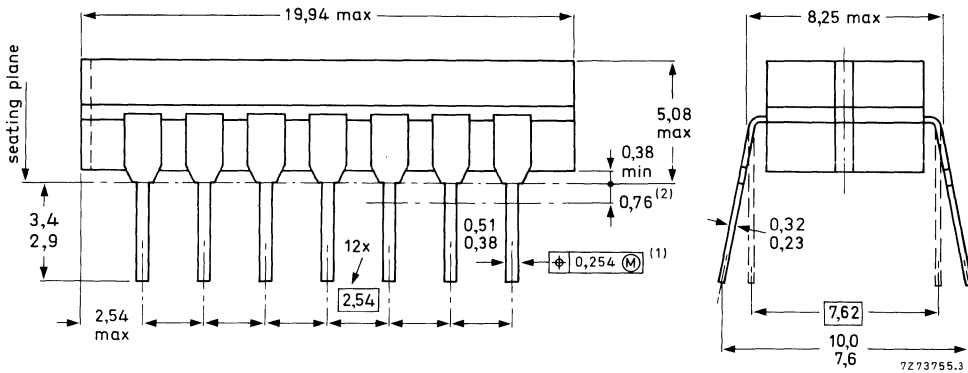

top view

⊕ Positional accuracy.

Ⓜ Maximum Material Condition.

(1) Centre-lines of all leads are within $\pm 0,127$ mm of the nominal position shown; in the worst case, the spacing between any two leads may deviate from nominal by $\pm 0,254$ mm.

(2) Lead spacing tolerances apply from seating plane to the line indicated.

Dimensions in mm

16-LEAD DUAL IN-LINE; CERAMIC (CERDIP) (SOT-74A,B,C)

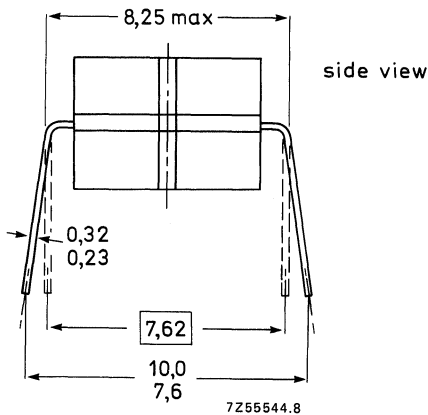
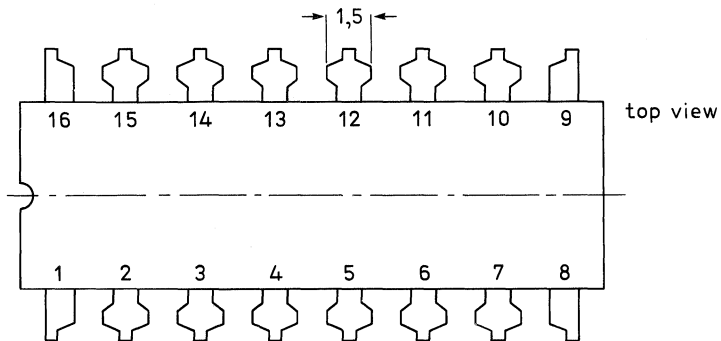
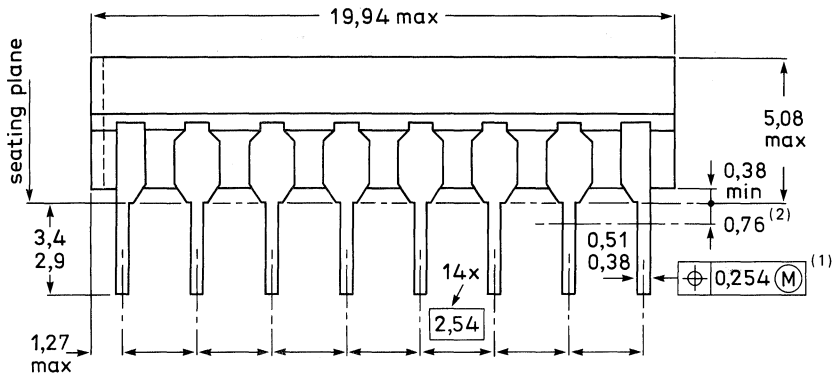

- ⊕ Positional accuracy.
- Ⓜ Maximum Material Condition.

- (1) Centre-lines of all leads are within $\pm 0,127$ mm of the nominal position shown; in the worst case, the spacing between any two leads may deviate from nominal by $\pm 0,254$ mm.
- (2) Lead spacing tolerances apply from seating plane to the line indicated.

Dimensions in mm

24-LEAD DUAL IN-LINE; CERAMIC (CERDIP) (SOT-94)

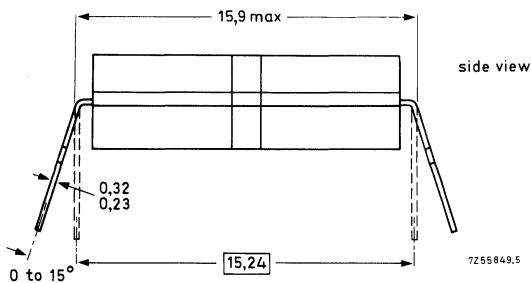
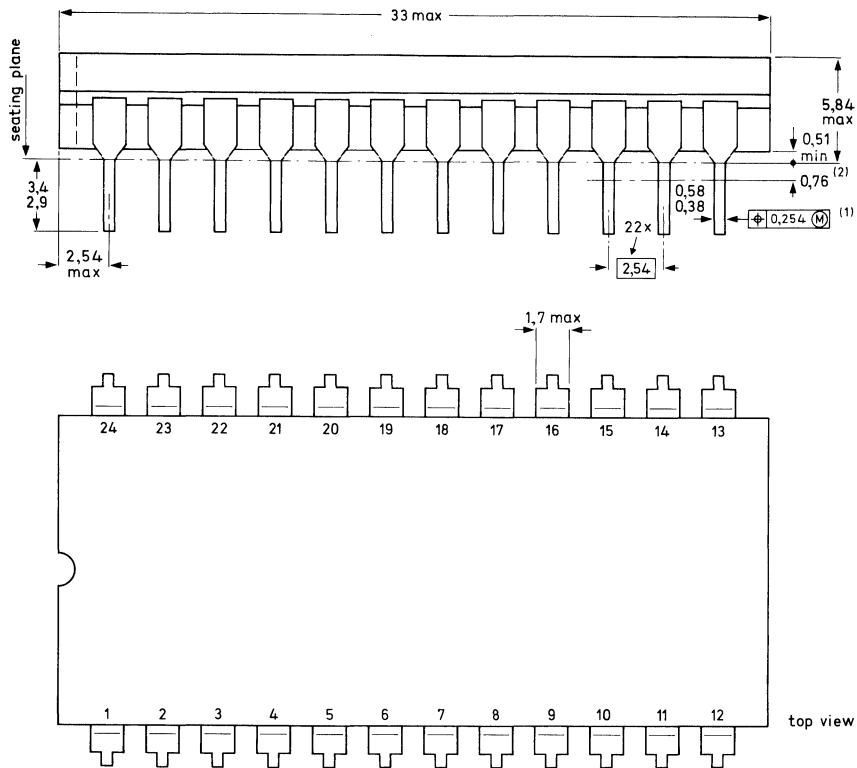

⊕ Positional accuracy.

Ⓜ Maximum Material Condition.

(1) Centre-lines of all leads are within $\pm 0,127$ mm of the nominal position shown; in the worst case, the spacing between any two leads may deviate from nominal by $\pm 0,254$ mm.

(2) Lead spacing tolerances apply from seating plane to the line indicated.

Dimensions in mm

24-LEAD DUAL IN-LINE; PLASTIC (SOT-101A)

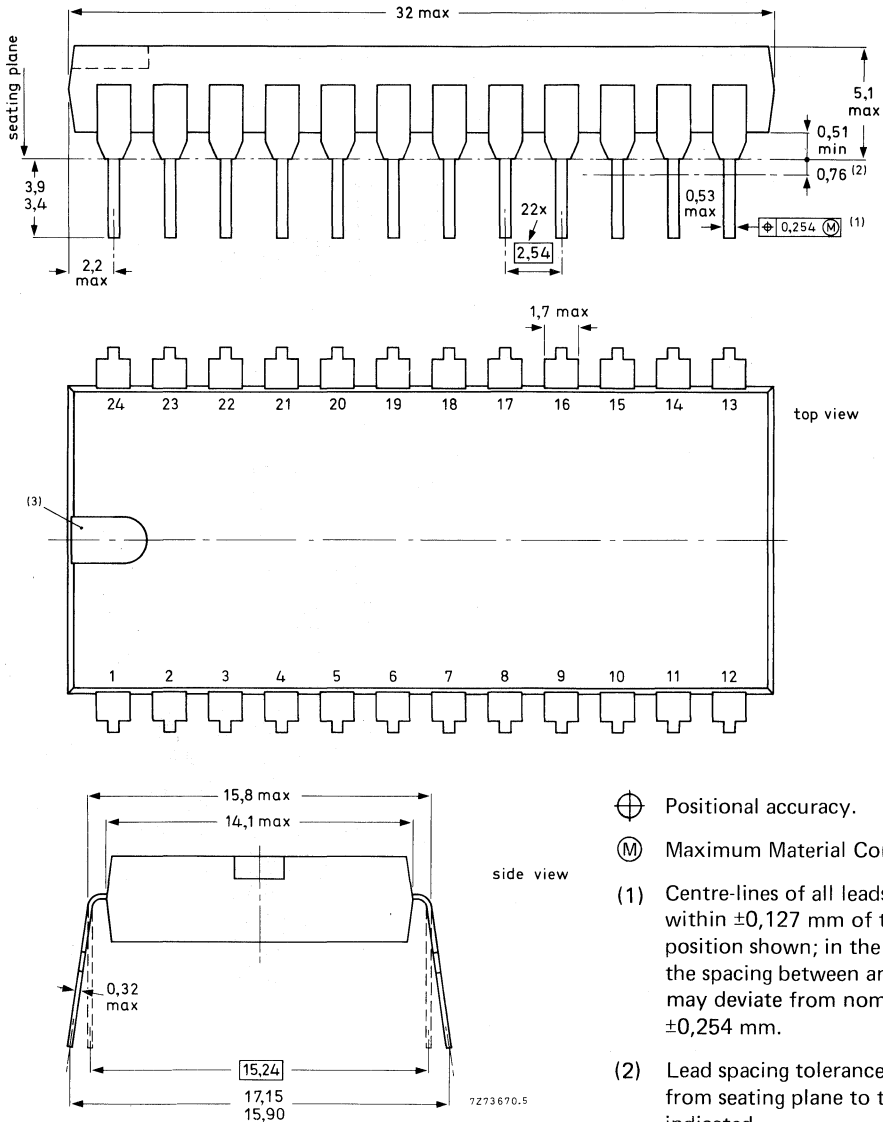

- ⊕ Positional accuracy.
- Ⓜ Maximum Material Condition.

- (1) Centre-lines of all leads are within $\pm 0,127$ mm of the nominal position shown; in the worst case, the spacing between any two leads may deviate from nominal by $\pm 0,254$ mm.
- (2) Lead spacing tolerances apply from seating plane to the line indicated.
- (3) Index may be horizontal as shown, or vertical.

Dimensions in mm

18-LEAD DUAL IN-LINE; PLASTIC (SOT-102)

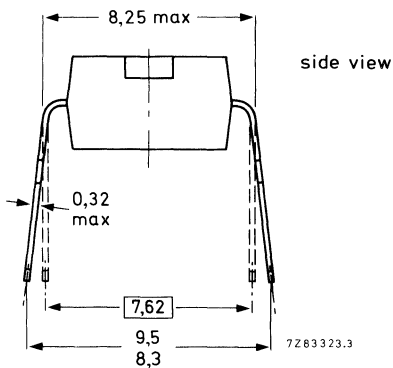
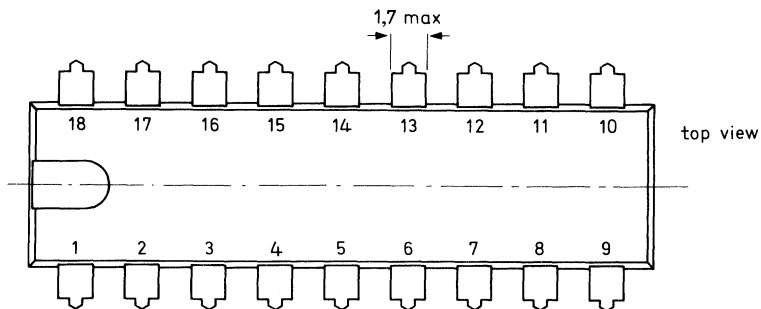
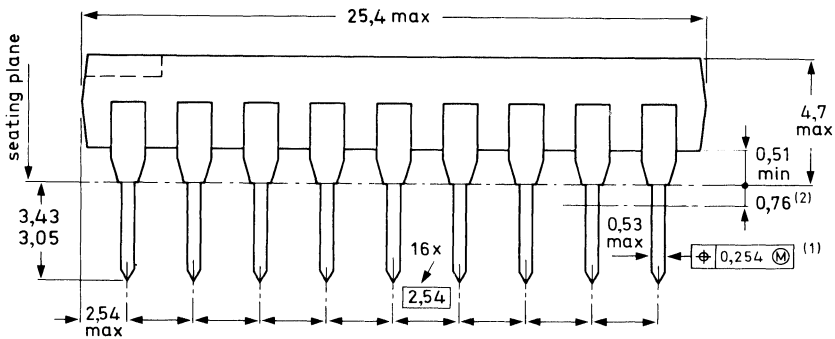

⊕ Positional accuracy.

Ⓜ Maximum Material Condition.

(1) Centre-lines of all leads are within $\pm 0,127$ mm of the nominal position shown; in the worst case, the spacing between any two leads may deviate from nominal by $\pm 0,254$ mm.

(2) Lead spacing tolerances apply from seating plane to the line indicated.

Dimensions in mm

PACKAGE OUTLINES

14-LEAD MINI-PACK; PLASTIC (SO-14; SOT-108A)

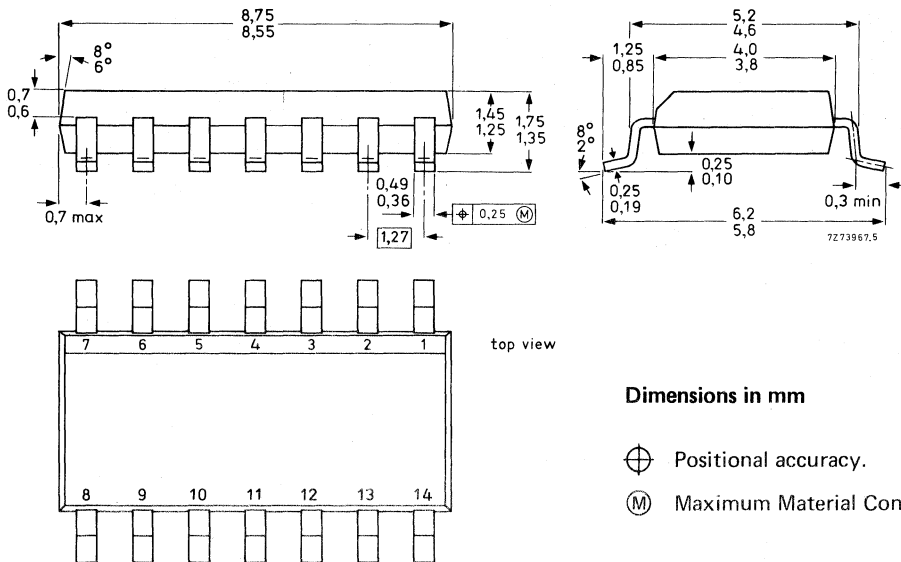

Dimensions in mm

- ⊕ Positional accuracy.
- (M) Maximum Material Condition.

SOLDERING

The reflow solder technique

The preferred technique for mounting miniature components on hybrid thick or thin-film circuits is reflow soldering. Solder is applied to the required areas on the substrate by dipping in a solder bath or, more usually, by screen printing a solder paste. Components are put in place and the solder is reflowed by heating.

Solder pastes consist of very finely powdered solder and flux suspended in an organic liquid binder. They are available in various forms depending on the specification of the solder and the type of binder used. For hybrid circuit use, a tin-lead solder with 2 to 4% silver is recommended. The working temperature of this paste is about 220 to 230 °C when a mild flux is used.

For printing the paste onto the substrate a stainless steel screen with a mesh of 80 to 105 μm is used for which the emulsion thickness should be about 50 μm . To ensure that sufficient solder paste is applied to the substrate, the screen aperture should be slightly larger than the corresponding contact area.

The contact pins are positioned on the substrate, the slight adhesive force of the solder paste being sufficient to keep them in place. The substrate is heated to the solder working temperature preferably by means of a controlled hot plate. The soldering process should be kept as short as possible: 10 to 15 seconds is sufficient to ensure good solder joints and evaporation of the binder fluid. After soldering, the substrate must be cleaned of any remaining flux.

16-LEAD MINI-PACK; PLASTIC (SO-16; SOT-109A)

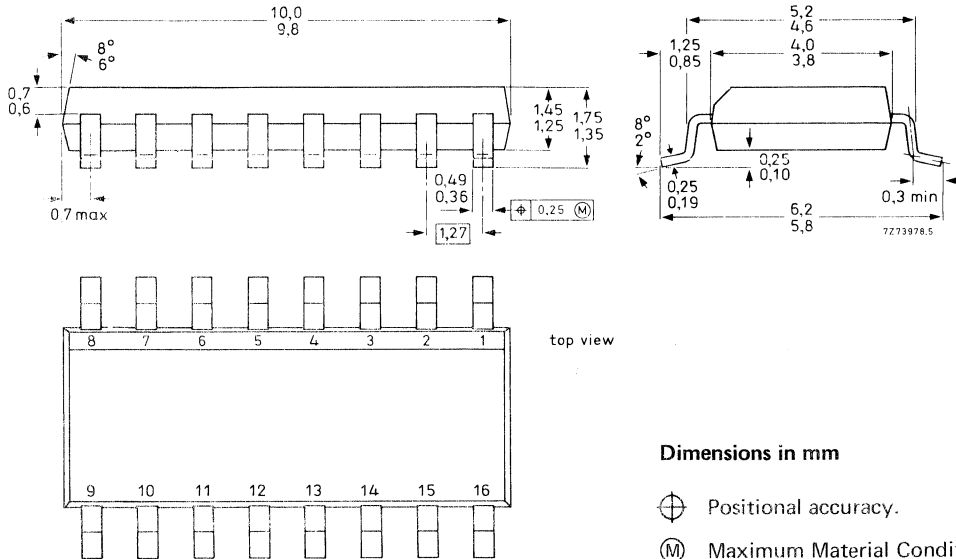

SOLDERING

The reflow solder technique

The preferred technique for mounting miniature components on hybrid thick or thin-film circuits is reflow soldering. Solder is applied to the required areas on the substrate by dipping in a solder bath or, more usually, by screen printing a solder paste. Components are put in place and the solder is reflowed by heating.

Solder pastes consist of very finely powdered solder and flux suspended in an organic liquid binder. They are available in various forms depending on the specification of the solder and the type of binder used. For hybrid circuit use, a tin-lead solder with 2 to 4% silver is recommended. The working temperature of this paste is about 220 to 230 °C when a mild flux is used.

For printing the paste onto the substrate a stainless steel screen with a mesh of 80 to 105 μm is used for which the emulsion thickness should be about 50 μm. To ensure that sufficient solder paste is applied to the substrate, the screen aperture should be slightly larger than the corresponding contact area.

The contact pins are positioned on the substrate, the slight adhesive force of the solder paste being sufficient to keep them in place. The substrate is heated to the solder working temperature preferably by means of a controlled hot plate. The soldering process should be kept as short as possible: 10 to 15 seconds is sufficient to ensure good solder joints and evaporation of the binder fluid.

After soldering, the substrate must be cleaned of any remaining flux.

PACKAGE OUTLINES

28-LEAD DUAL IN-LINE; PLASTIC (SOT-117)

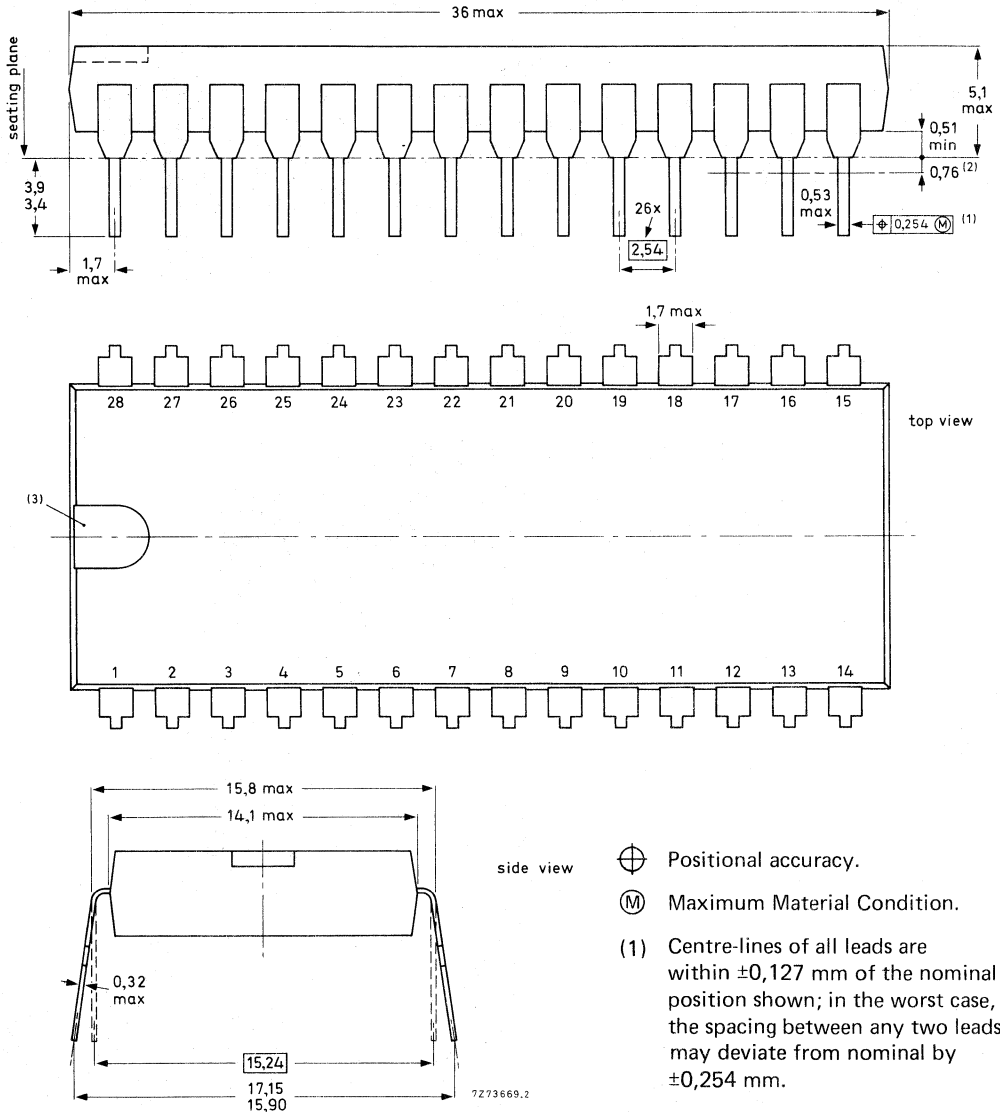

Dimensions in mm

side view

⊕ Positional accuracy.

Ⓜ Maximum Material Condition.

- (1) Centre-lines of all leads are within $\pm 0,127$ mm of the nominal position shown; in the worst case, the spacing between any two leads may deviate from nominal by $\pm 0,254$ mm.
- (2) Lead spacing tolerances apply from seating plane to the line indicated.
- (3) Index may be horizontal as shown, or vertical.

40-LEAD DUAL IN-LINE; PLASTIC (SOT-129)

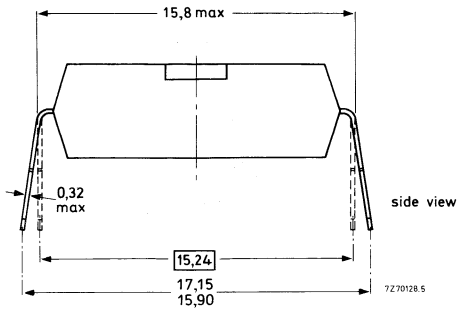
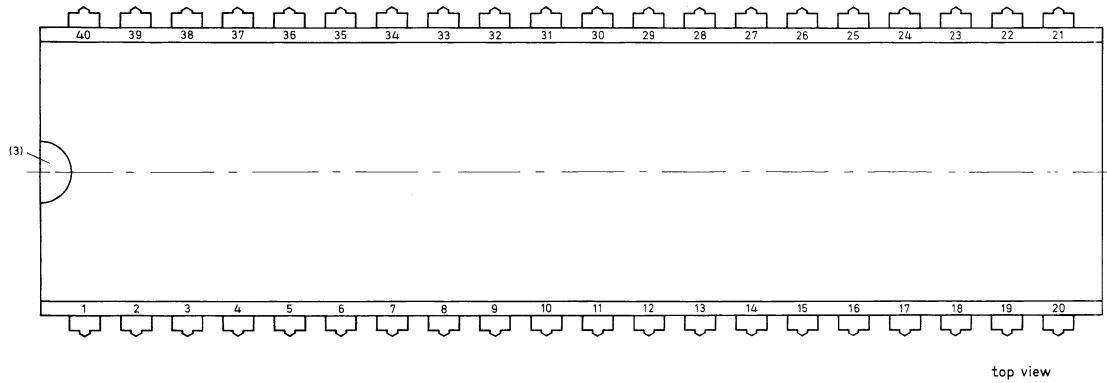
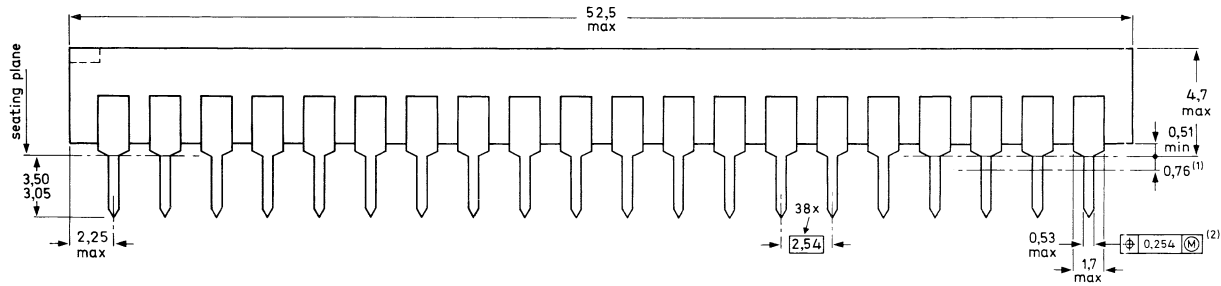

⊕ Positional accuracy.

Ⓜ Maximum Material Condition.

(1) Centre-lines of all leads are within $\pm 0,127$ mm of the nominal position shown; in the worst case, the spacing between any two leads may deviate from nominal by $\pm 0,254$ mm.

(2) Lead spacing tolerances apply from seating plane to the line indicated.

(3) Index may be horizontal as shown, or vertical.

Dimensions in mm

PACKAGE
OUTLINES

PACKAGE OUTLINES

18-LEAD DUAL IN-LINE; CERAMIC (CERDIP) (SOT-133A,B)

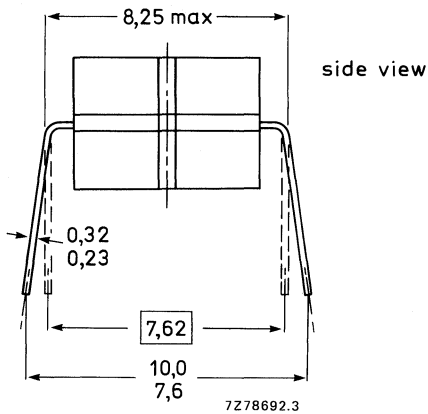
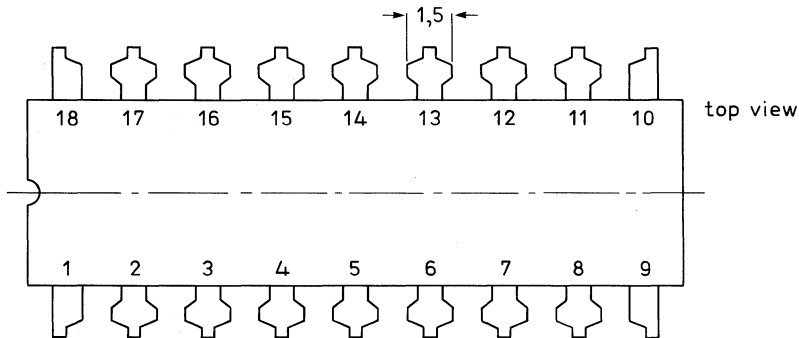
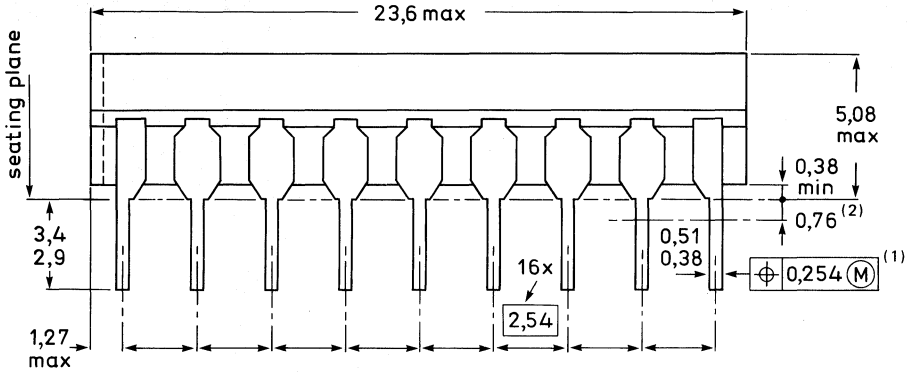

- ⊕ Positional accuracy.
- (M) Maximum Material Condition.

- (1) Centre-lines of all leads are within $\pm 0,127$ mm of the nominal position shown; in the worst case, the spacing between any two leads may deviate from nominal by $\pm 0,254$ mm.
- (2) Lead spacing tolerances apply from seating plane to the line indicated.

Dimensions in mm

28-LEAD DUAL IN-LINE; CERAMIC (CERDIP) (SOT-135A)

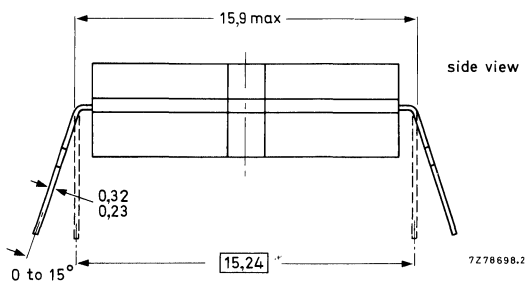
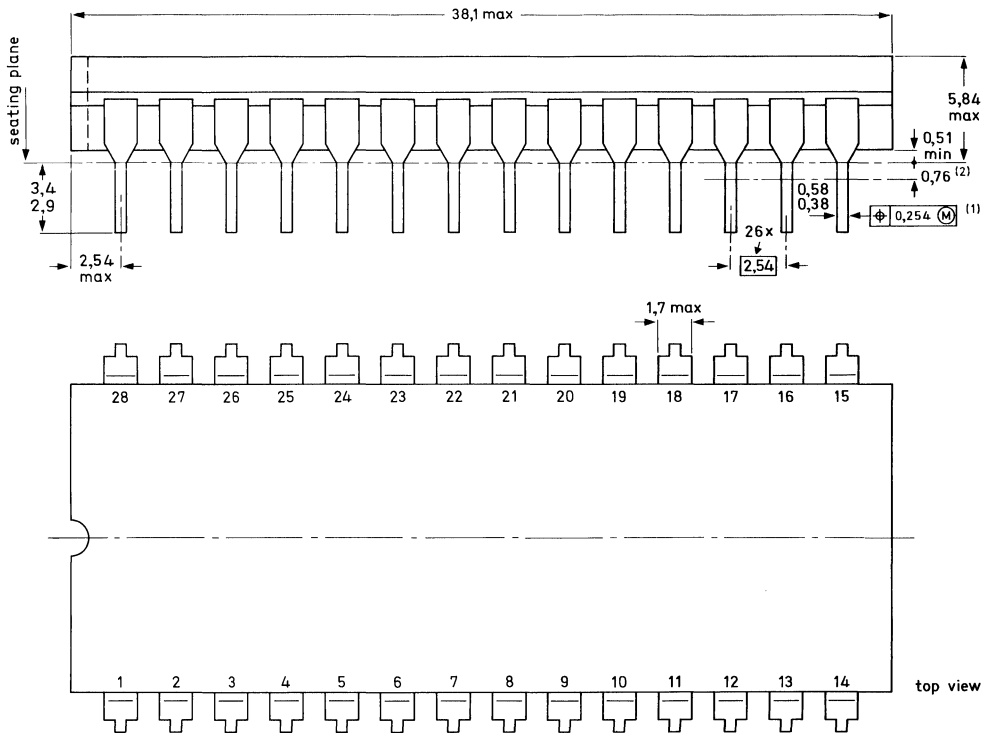

\oplus Positional accuracy.

\textcircled{M} Maximum Material Condition.

(1) Centre-lines of all leads are within $\pm 0,127$ mm of the nominal position shown; in the worst case, the spacing between any two leads may deviate from nominal by $\pm 0,254$ mm.

(2) Lead spacing tolerances apply from seating plane to the line indicated.

Dimensions in mm

PACKAGE OUTLINES

20-LEAD DUAL IN-LINE; PLASTIC (SOT-146; 146C1)

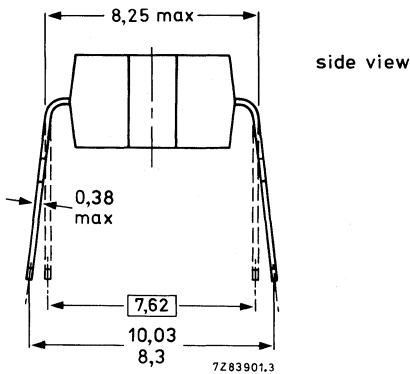
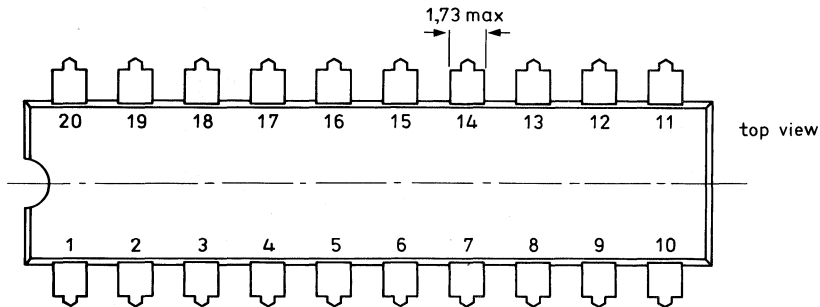
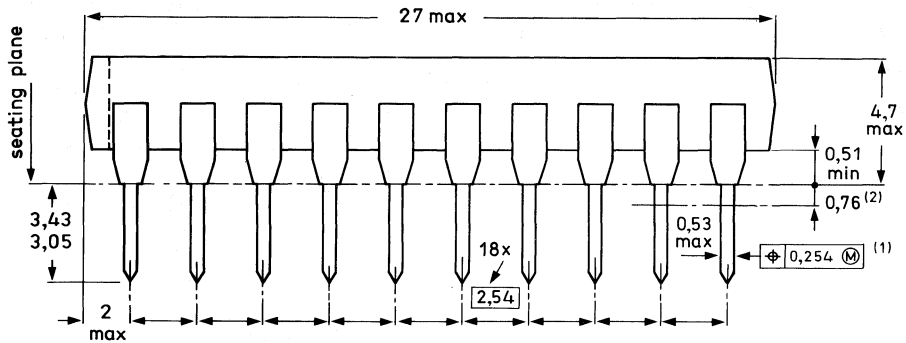

⊕ Positional accuracy.

(M) Maximum Material Condition.

(1) Centre-lines of all leads are within $\pm 0,127$ mm of the nominal position shown; in the worst case, the spacing between any two leads may deviate from nominal by $\pm 0,254$ mm.

(2) Lead spacing tolerances apply from seating plane to the line indicated.

Dimensions in mm

16-LEAD MINI-PACK; PLASTIC (SO-16L; SOT-162A)

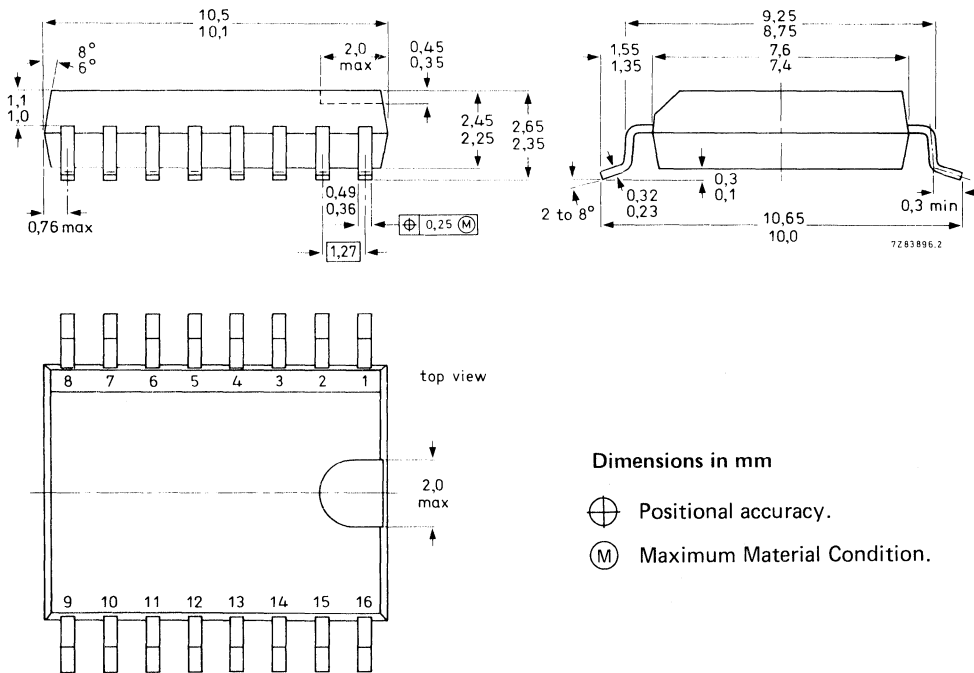

SOLDERING

The reflow solder technique

The preferred technique for mounting miniature components on hybrid thick or thin-film circuits is reflow soldering. Solder is applied to the required areas on the substrate by dipping in a solder bath or, more usually, by screen printing a solder paste. Components are put in place and the solder is reflowed by heating.

Solder pastes consist of very finely powdered solder and flux suspended in an organic liquid binder. They are available in various forms depending on the specification of the solder and the type of binder used. For hybrid circuit use, a tin-lead solder with 2 to 4% silver is recommended. The working temperature of this paste is about 220 to 230 °C when a mild flux is used.

For printing the paste onto the substrate a stainless steel screen with a mesh of 80 to 105 μm is used for which the emulsion thickness should be about 50 μm . To ensure that sufficient solder paste is applied to the substrate, the screen aperture should be slightly larger than the corresponding contact area.

The contact pins are positioned on the substrate, the slight adhesive force of the solder paste being sufficient to keep them in place. The substrate is heated to the solder working temperature preferably by means of a controlled hot plate. The soldering process should be kept as short as possible: 10 to 15 seconds is sufficient to ensure good solder joints and evaporation of the binder fluid. After soldering, the substrate must be cleaned of any remaining flux.

20-LEAD MINI-PACK; PLASTIC (SO-20; SOT-163A)

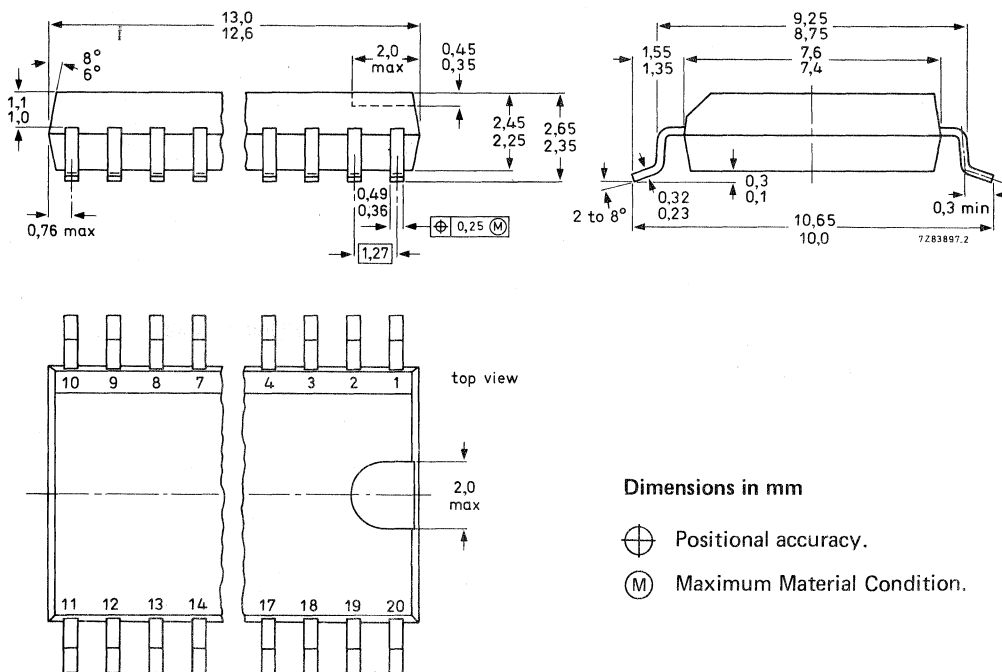

Dimensions in mm

- ⊕ Positional accuracy.
- Ⓜ Maximum Material Condition.

SOLDERING

The reflow solder technique

The preferred technique for mounting miniature components on hybrid thick or thin-film circuits is reflow soldering. Solder is applied to the required areas on the substrate by dipping in a solder bath or, more usually, by screen printing a solder paste. Components are put in place and the solder is reflowed by heating.

Solder pastes consist of very finely powdered solder and flux suspended in an organic liquid binder. They are available in various forms depending on the specification of the solder and the type of binder used. For hybrid circuit use, a tin-lead solder with 2 to 4% silver is recommended. The working temperature of this paste is about 220 to 230 °C when a mild flux is used.

For printing the paste onto the substrate a stainless steel screen with a mesh of 80 to 105 μm is used for which the emulsion thickness should be about 50 μm. To ensure that sufficient solder paste is applied to the substrate, the screen aperture should be slightly larger than the corresponding contact area.

The contact pins are positioned on the substrate, the slight adhesive force of the solder paste being sufficient to keep them in place. The substrate is heated to the solder working temperature preferably by means of a controlled hot plate. The soldering process should be kept as short as possible: 10 to 15 seconds is sufficient to ensure good solder joints and evaporation of the binder fluid. After soldering, the substrate must be cleaned of any remaining flux.

FUNCTIONAL DIAGRAMS

FUNCTIONAL DIAGRAMS

HEF4000B

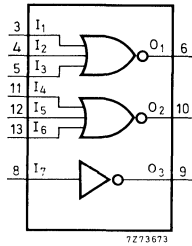

Dual 3-input NOR gate and inverter.

HEF4001B

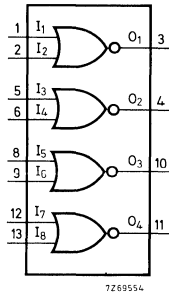

Quadruple 2-input NOR gate.

HEF4001UB

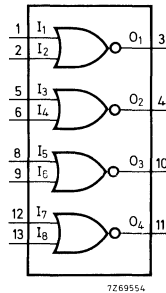

Quadruple 2-input NOR gate; unbuffered.

HEF4002B

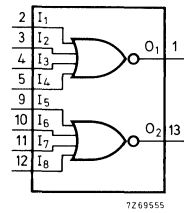

Dual 4-input NOR gate.

HEF4006B

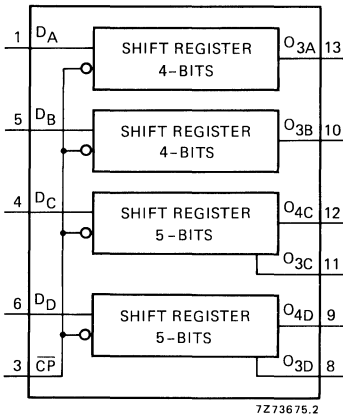

18-stage static shift register.

HEF4008B

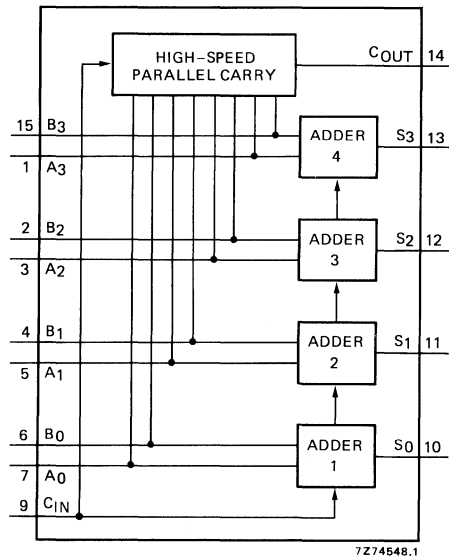

4-bit binary full adder.

HEF4007UB

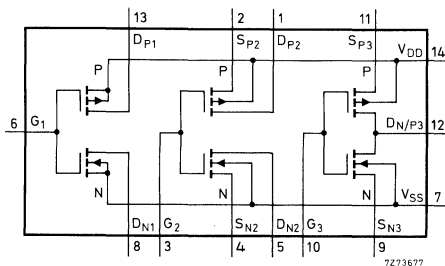

Dual complementary pair and inverter; unbuffered.

FUNCTIONAL DIAGRAMS

HEF4011B

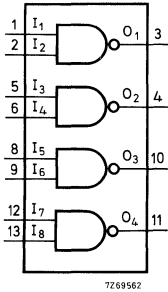

7269562

Quadruple 2-input NAND gate.

HEF4011UB

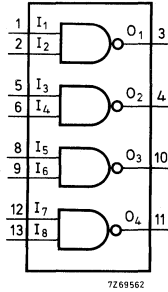

7269562

Quadruple 2-input NAND gate; unbuffered.

HEF4012B

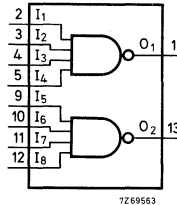

7269563

Dual 4-input NAND gate.

HEF4013B

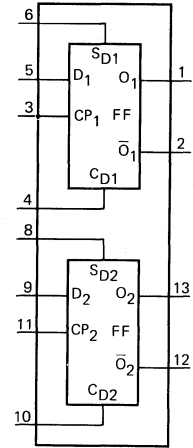

7269524.1

Dual D-type flip-flop.

HEF4014B

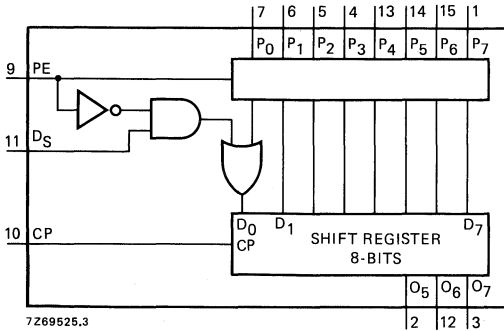

7269525.3

8-bit static shift register.

HEF4015B

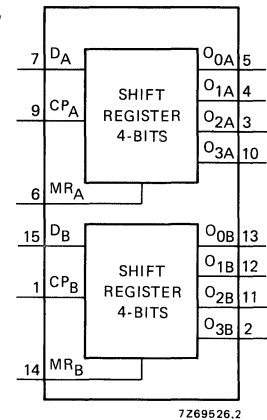

7269526.2

Dual 4-bit static shift register

HEF4016B

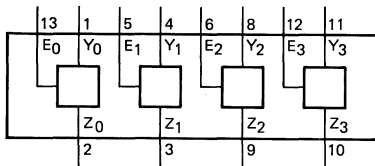

7269571.2

Quadruple bilateral switches.

HEF4017B

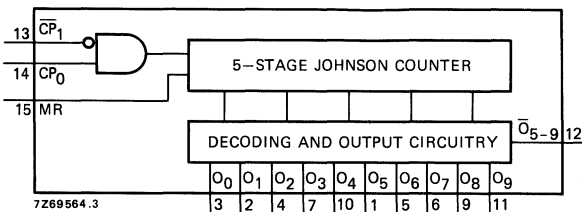

7269564.3

5-stage Johnson counter.

HEF4018B

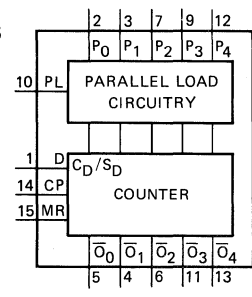

7269527.3

Presetable divide-by-n counter.

FUNCTIONAL DIAGRAMS

HEF4019B

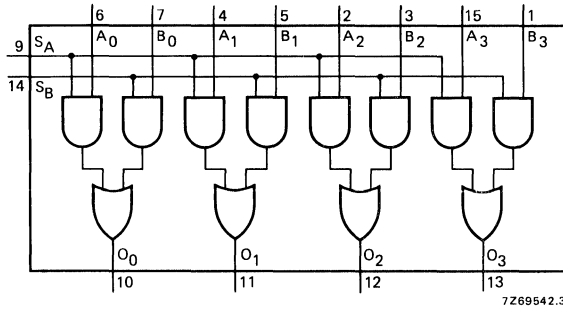

Quadruple 2-input multiplexer.

HEF4020B

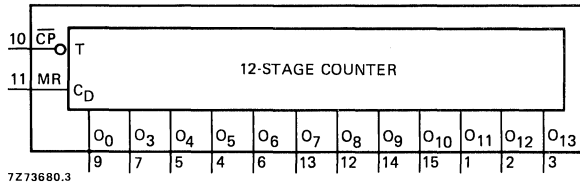

14-stage binary counter.

HEF4021B

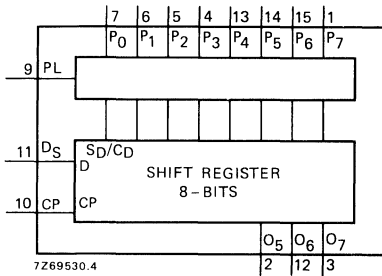

8-bit static shift register.

HEF4022B

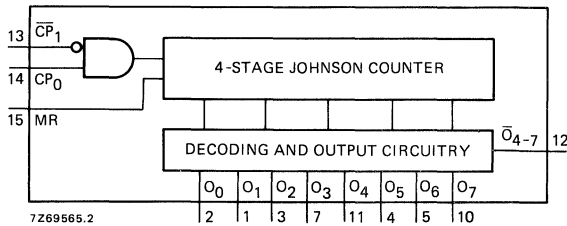

4-stage divide-by-8 Johnson counter.

HEF4023B

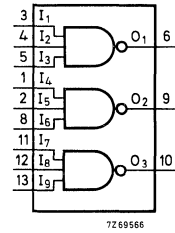

Triple 3-input NAND gate.

HEF4025B

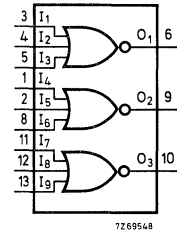

Triple 3-input NOR gate.

HEF4024B

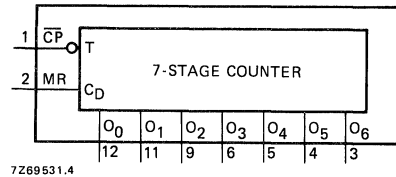

7-stage binary counter.

HEF4027B

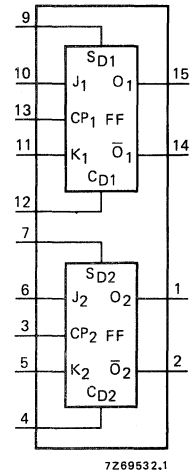

Dual JK flip-flop.

FUNCTIONAL DIAGRAMS

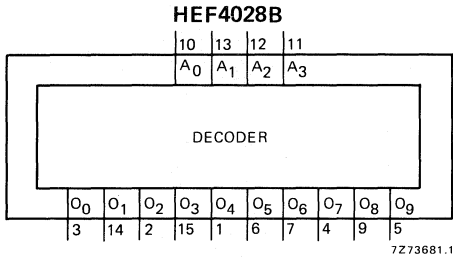

1-of-10 decoder.

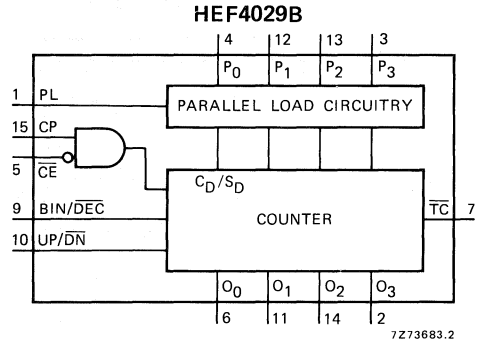

Synchronous up/down counter, binary/decade counter.

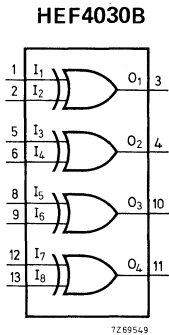

Quadruple EXCLUSIVE-OR gate.

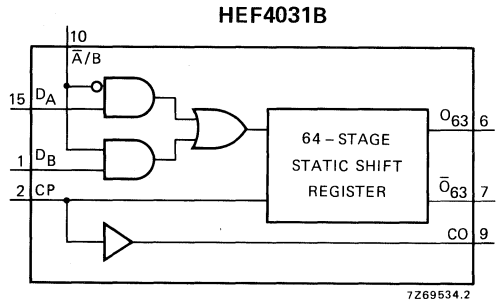

64-stage static shift register.

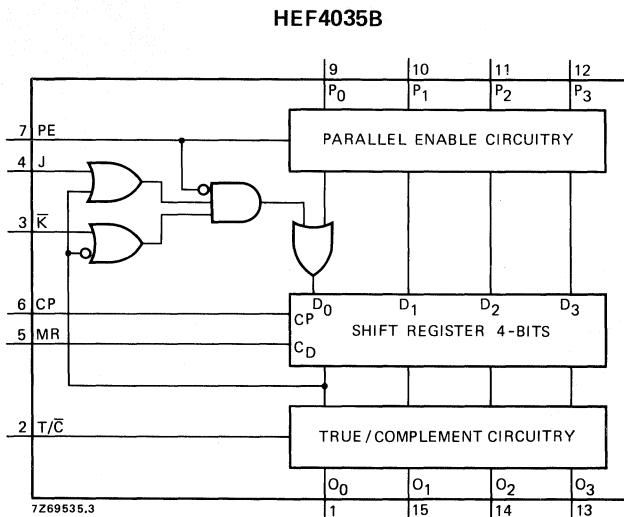

4-bit universal shift register.

HEF4040B

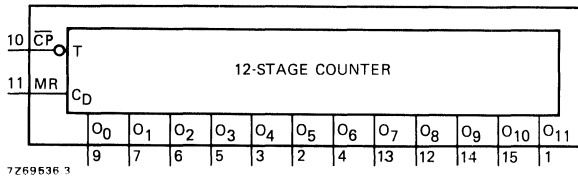

7269536.3

12-stage binary counter.

HEF4041B

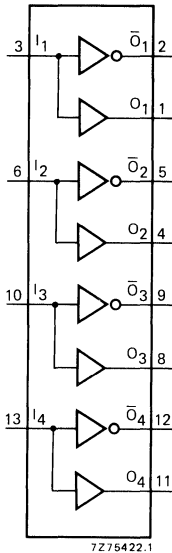

7275422.1

Quadruple true/complement
buffer.

HEF4043B

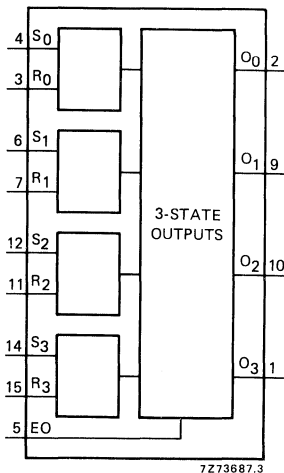

7273687.3

Quadruple R/S latch with 3-state outputs.

HEF4042B

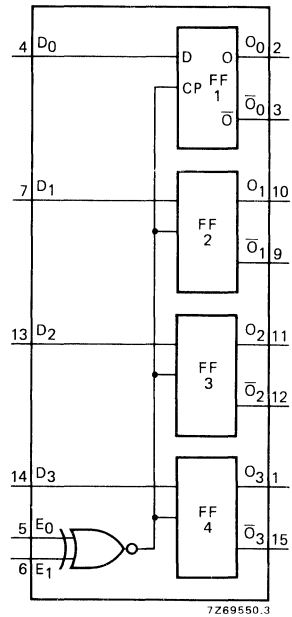

7269550.3

Quadruple D-latch.

HEF4044B

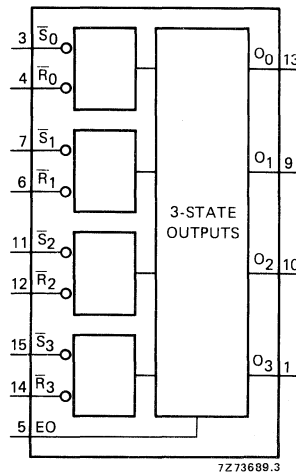

7273689.3

Quadruple R/S latch with 3-state outputs.

FUNCTIONAL DIAGRAMS

HEF4046B

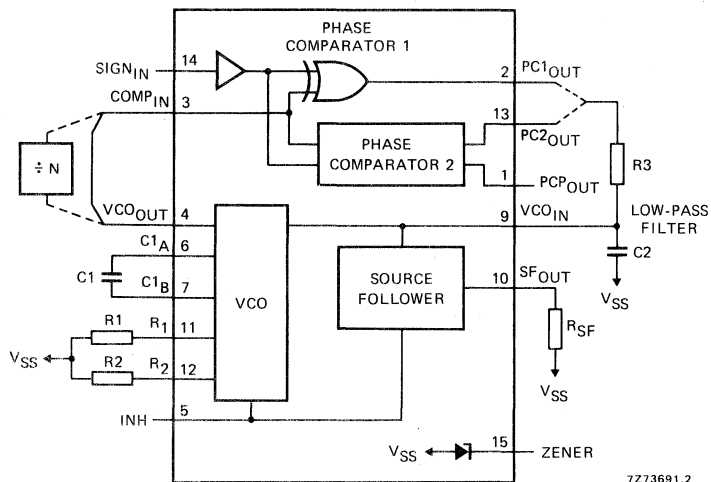

7273691.2

Phase-locked loop.

HEF4047B

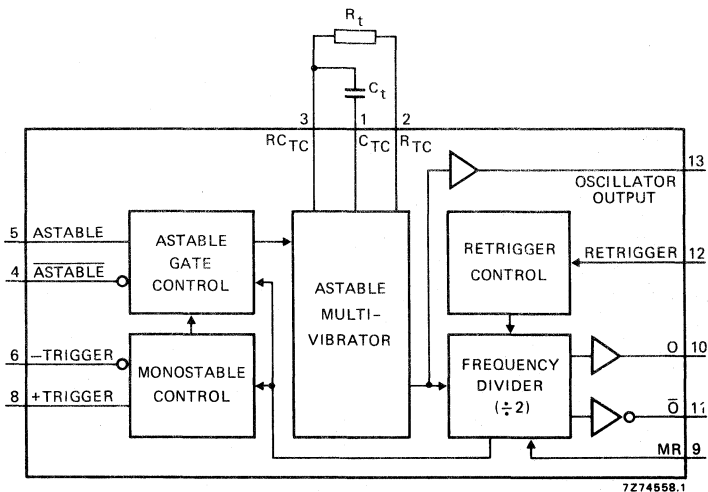

7274568.1

Monostable/astable multivibrator.

HEF4049B

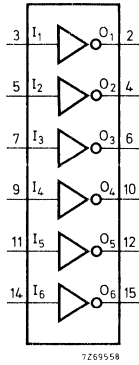

Hex inverting buffers.

HEF4050B

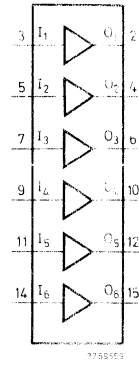

Hex non-inverting buffers.

HEF4051B

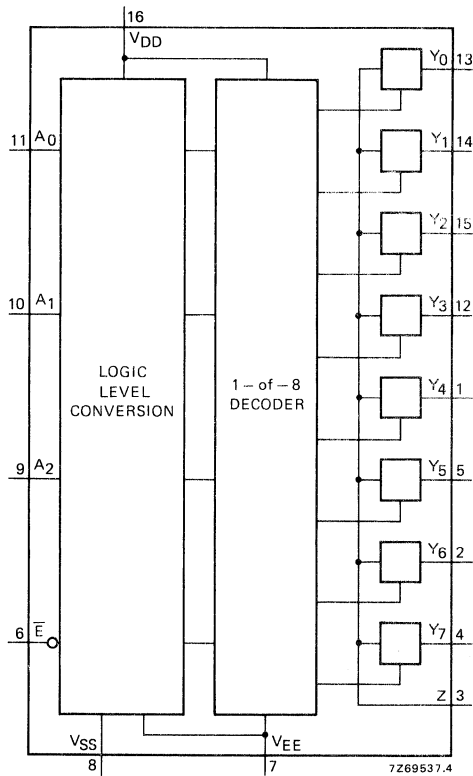

8-channel analogue multiplexer/demultiplexer.

HEF4053B

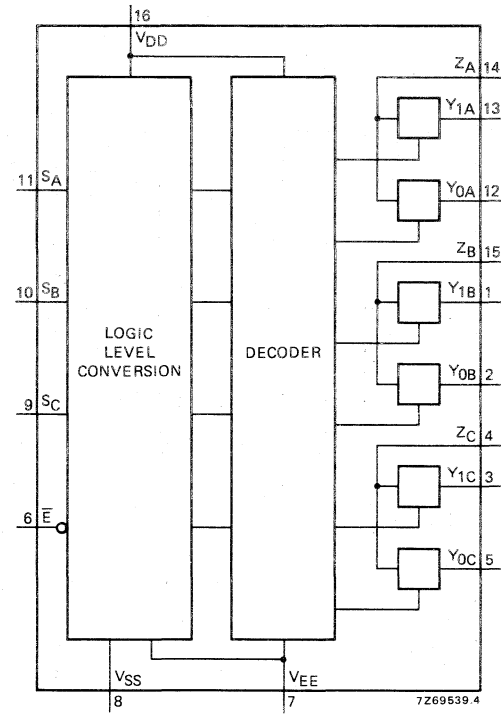

Triple 2-channel analogue multiplexer/demultiplexer.

HEF4052B

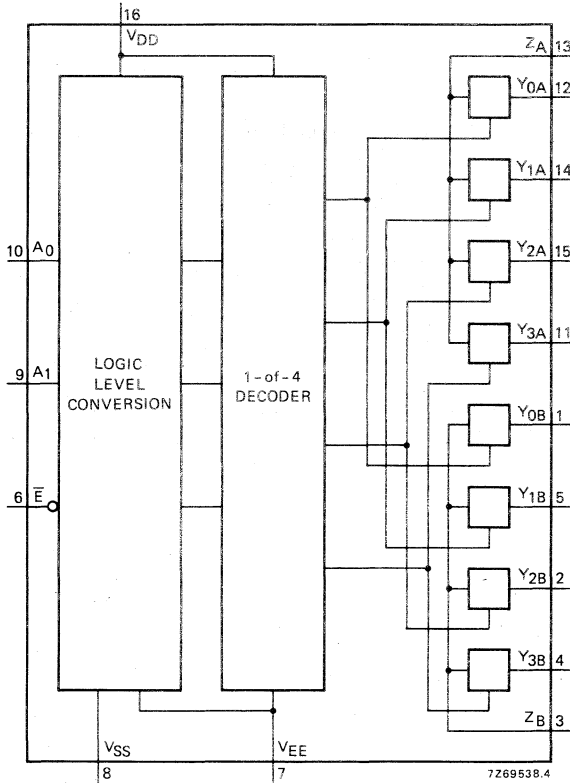

Dual 4-channel analogue multiplexer/demultiplexer.

HEF4059B

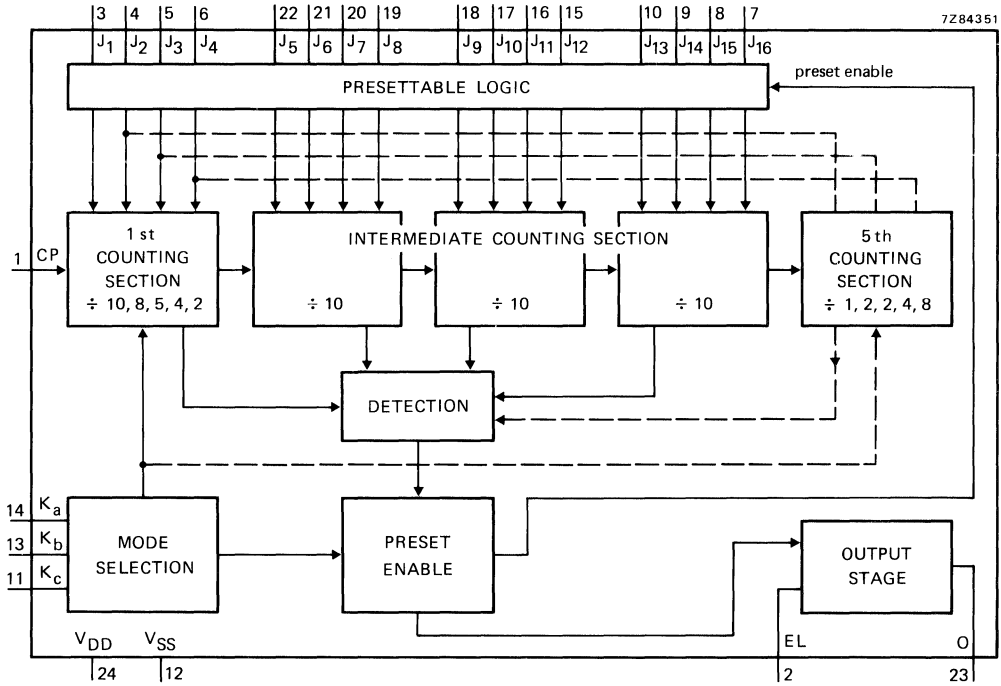

Programmable divide-by-n counter.

HEF4060B

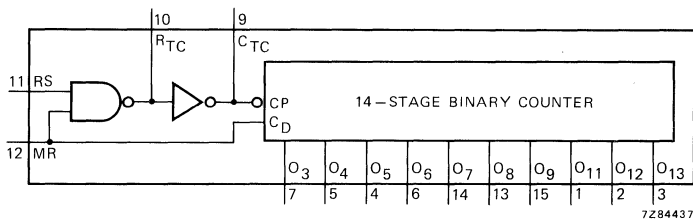

14-stage ripple-carry binary counter/divider and oscillator.

HEF4066B

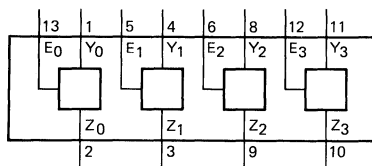

Quadruple bilateral switches.

FUNCTIONAL DIAGRAMS

HEF4067B

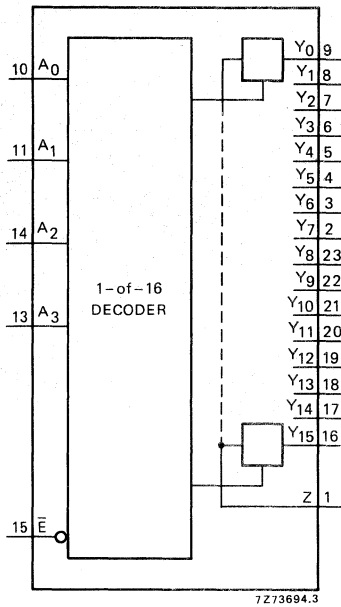

16-channel analogue multiplexer/demultiplexer.

HEF4068B

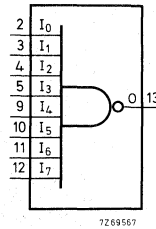

8-input NAND gate.

HEF4069UB

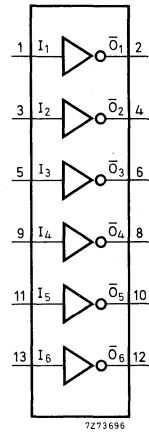

Hex inverter; unbuffered.

HEF4070B

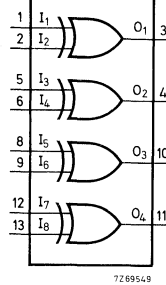

Quadruple EXCLUSIVE-OR gate.

HEF4071B

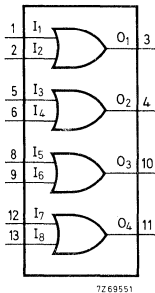

Quadruple 2-input OR gate

HEF4072B

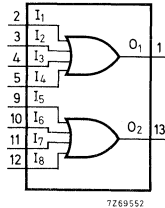

Dual 4-input OR gate.

HEF4073B

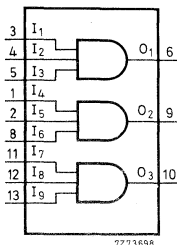

Triple 3-input AND gate.

HEF4075B

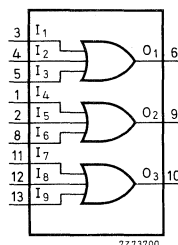

Triple 3-input OR gate.

HEF4076B

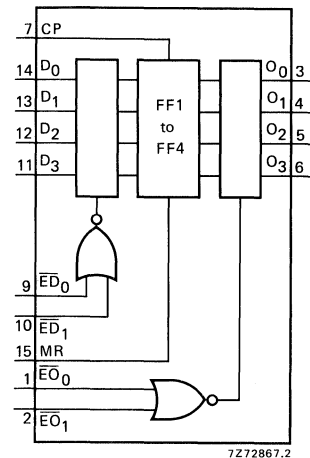

Quadruple D-type register with 3-state outputs.

FUNCTIONAL DIAGRAMS

HEF4077B

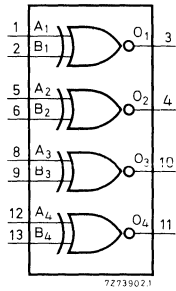

Quadruple EXCLUSIVE-NOR gate.

HEF4078B

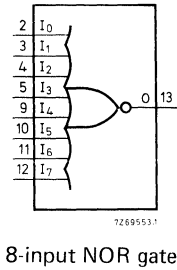

8-input NOR gate.

HEF4081B

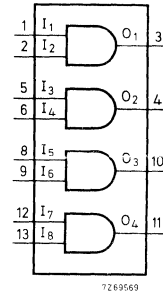

Quadruple 2-input AND gate.

HEF4082B

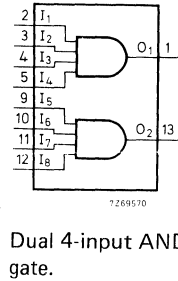

Dual 4-input AND gate.

HEF4085B

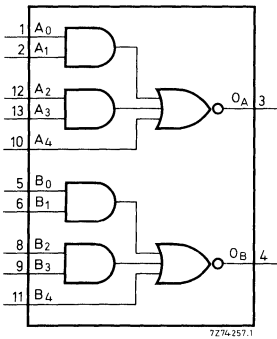

Dual 2-wide 2-input AND-OR-INVERT gate.

HEF4086B

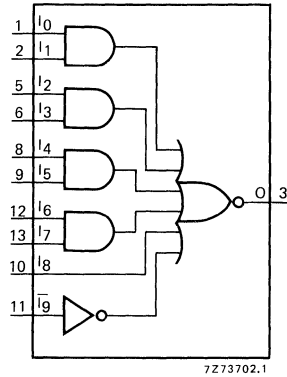

4-wide 2-input AND-OR-INVERT gate.

HEF4093B

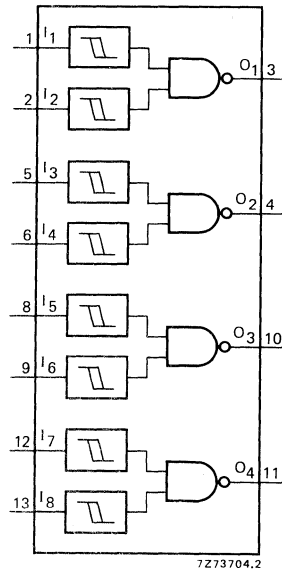

Quadruple 2-input NAND Schmitt trigger.

HEF4094B

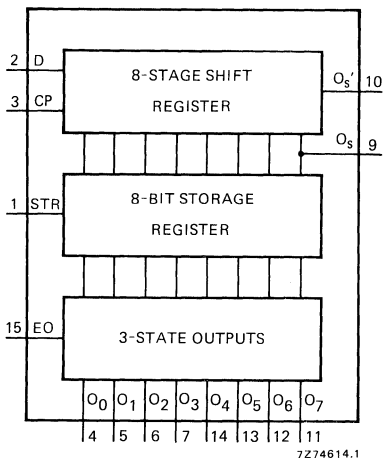

8-stage shift-and-store bus register.

FUNCTIONAL DIAGRAMS

HEF4104B

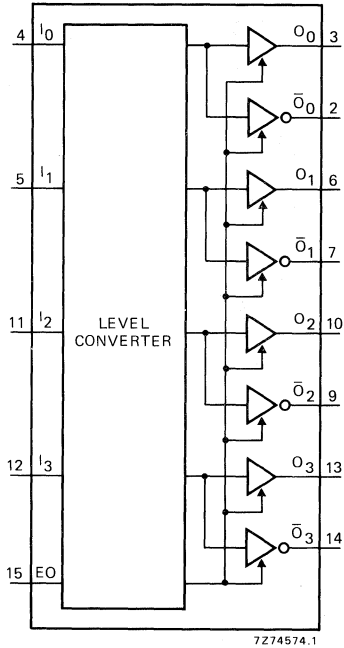

7Z74574.1

Quadruple low-to-high voltage translator with 3-state outputs.

HEF4502B

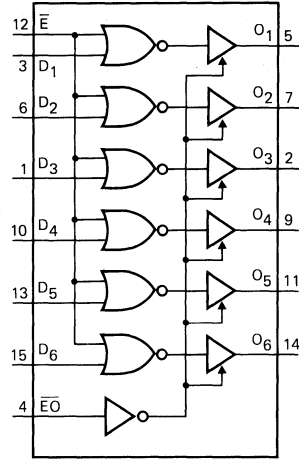

7Z75372.2

Strobed hex inverter/buffer.

HEF4505B

64-bit, 1-bit per word random access read/write memory.

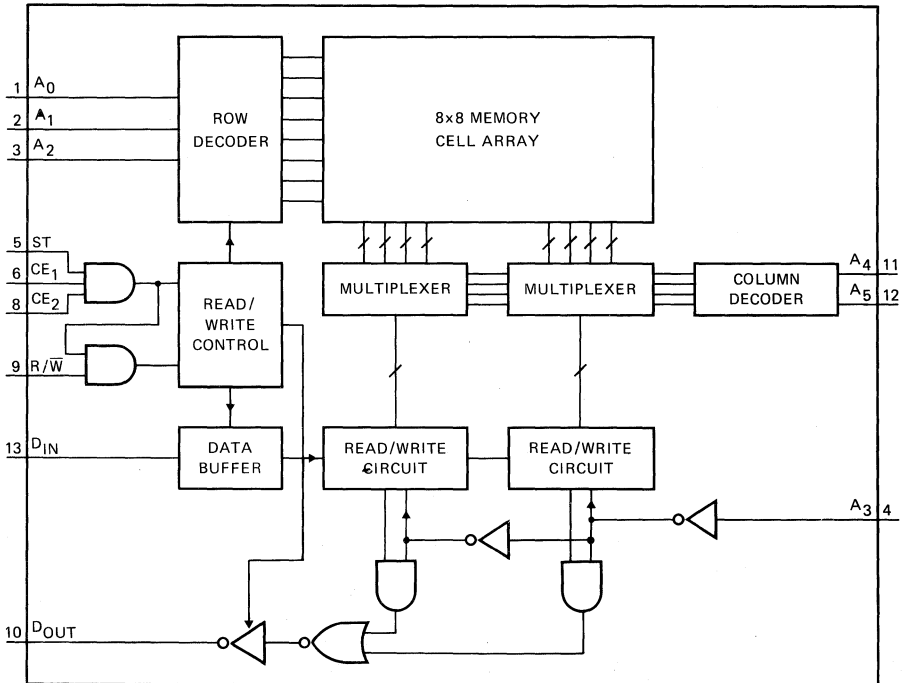

7Z74630.2

FUNCTIONAL DIAGRAMS

HEF4508B

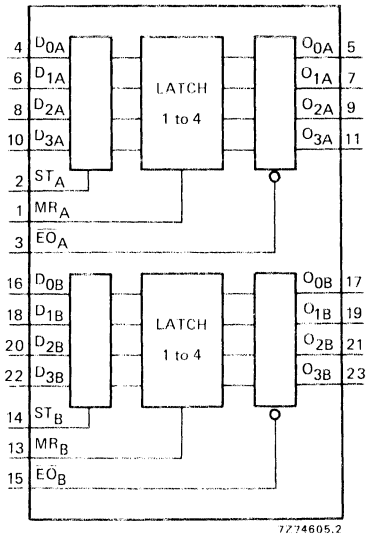

Dual 4-bit latch.

HEF4511B

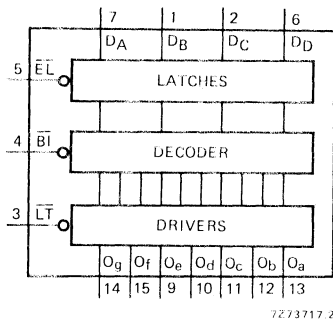

BCD to 7 segment latch/decoder/driver.

HEF4510B

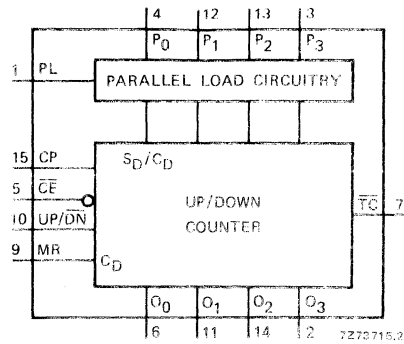

BCD up/down counter.

HEF4512B

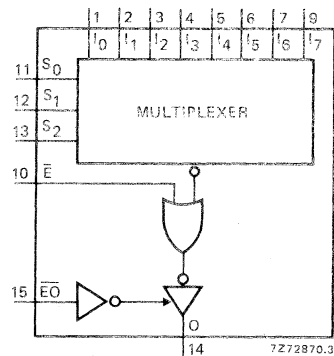

8-input multiplexer with 3-state output.

HEF4514B

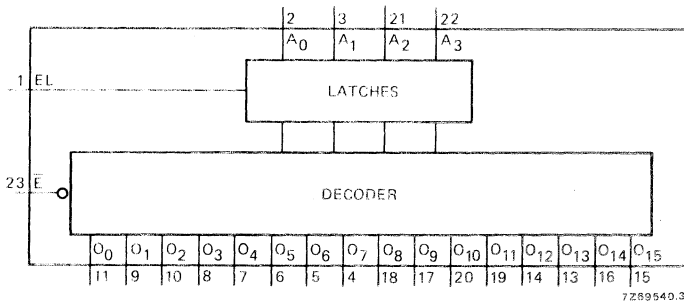

1-of-16 decoder/demultiplexer with input latches.

FUNCTIONAL DIAGRAMS

HEF4515B

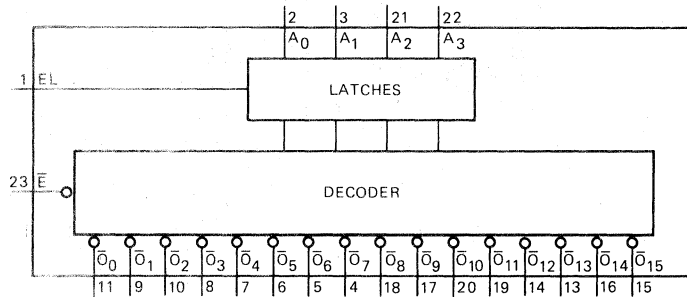

1-of-16 decoder/demultiplexer with input latches.

7284275

HEF4516B

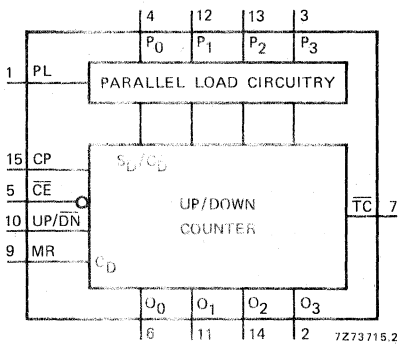

Binary up/down counter.

7273715.2

HEF4517B

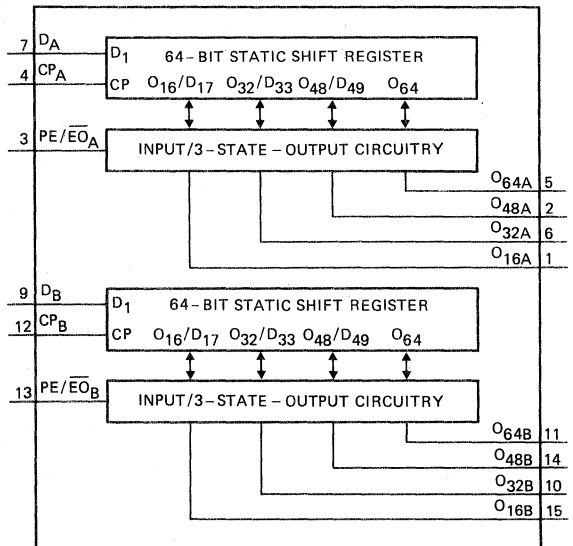

Dual 64-bit static shift register.

7274669.1

HEF4518B

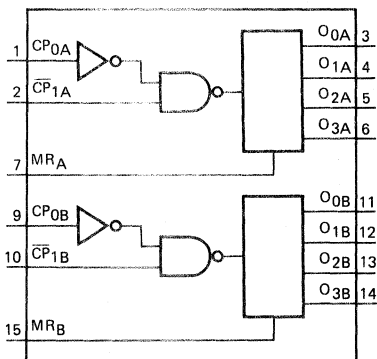

Dual BCD counter.

7269556.1

HEF4519B

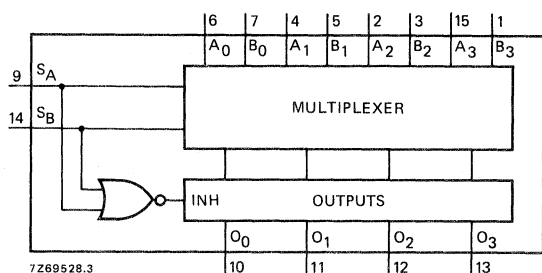

Quadruple 2-input multiplexer.

7269528.3

HEF4520B

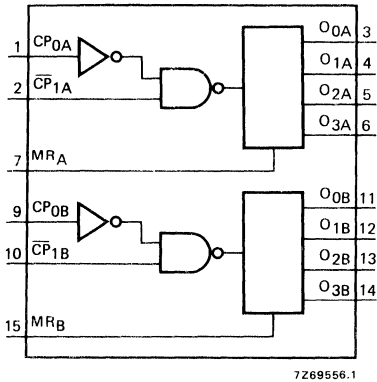

7Z69556.1

Dual binary counter.

HEF4521B

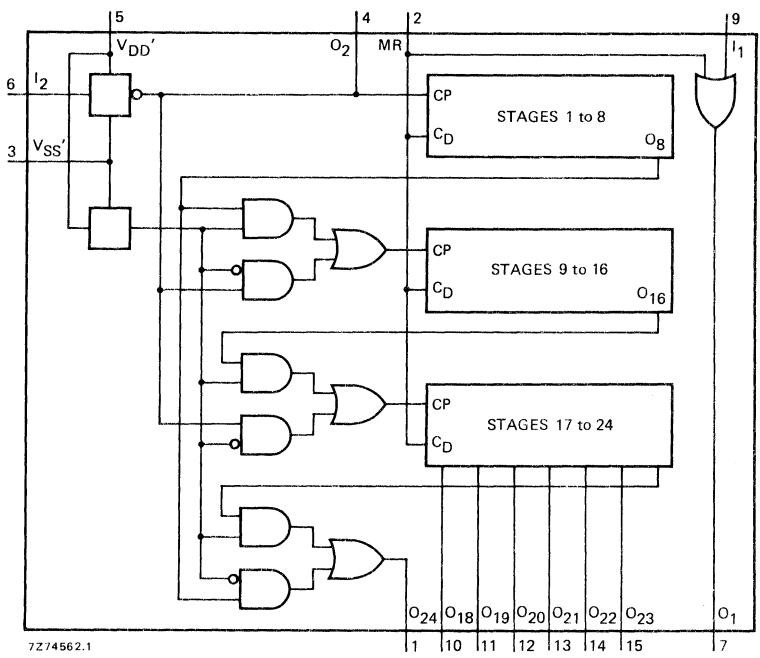

7Z74562.1

24-stage frequency divider.

FUNCTIONAL DIAGRAMS

HEF4522B

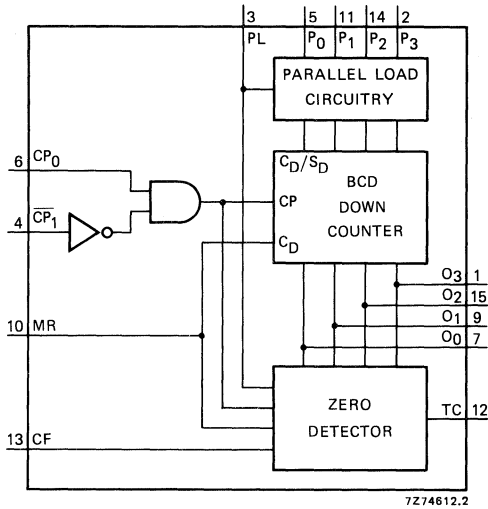

Programmable 4-bit BCD down counter.

HEF4526B

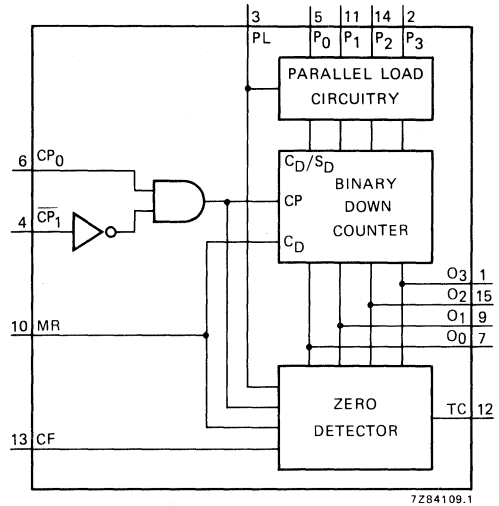

Programmable 4-bit binary down counter.

HEF4527B

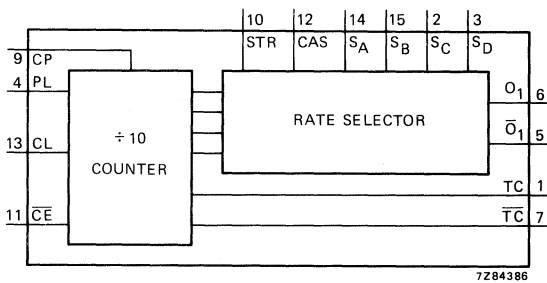

BCD rate multiplier.

HEF4528B

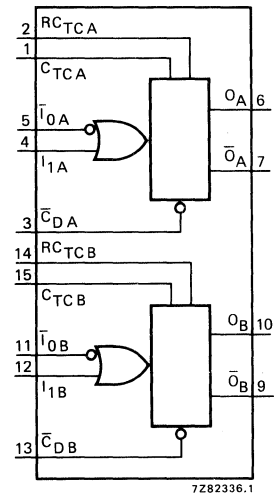

Dual monostable multivibrator.

HEF4531B

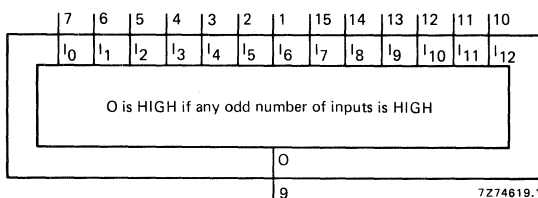

13-input parity checker/generator.

HEF4532B

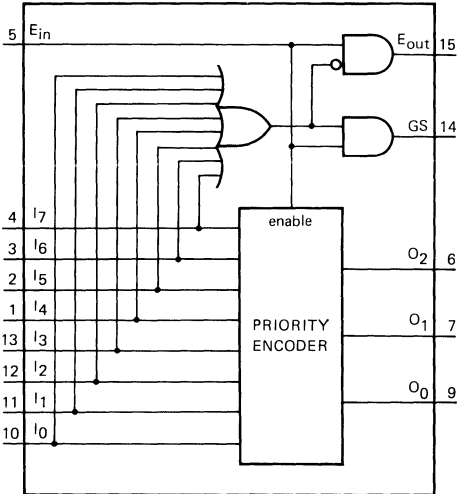

7275371.1

8-input priority encoder.

FUNCTIONAL DIAGRAMS

HEF4534B

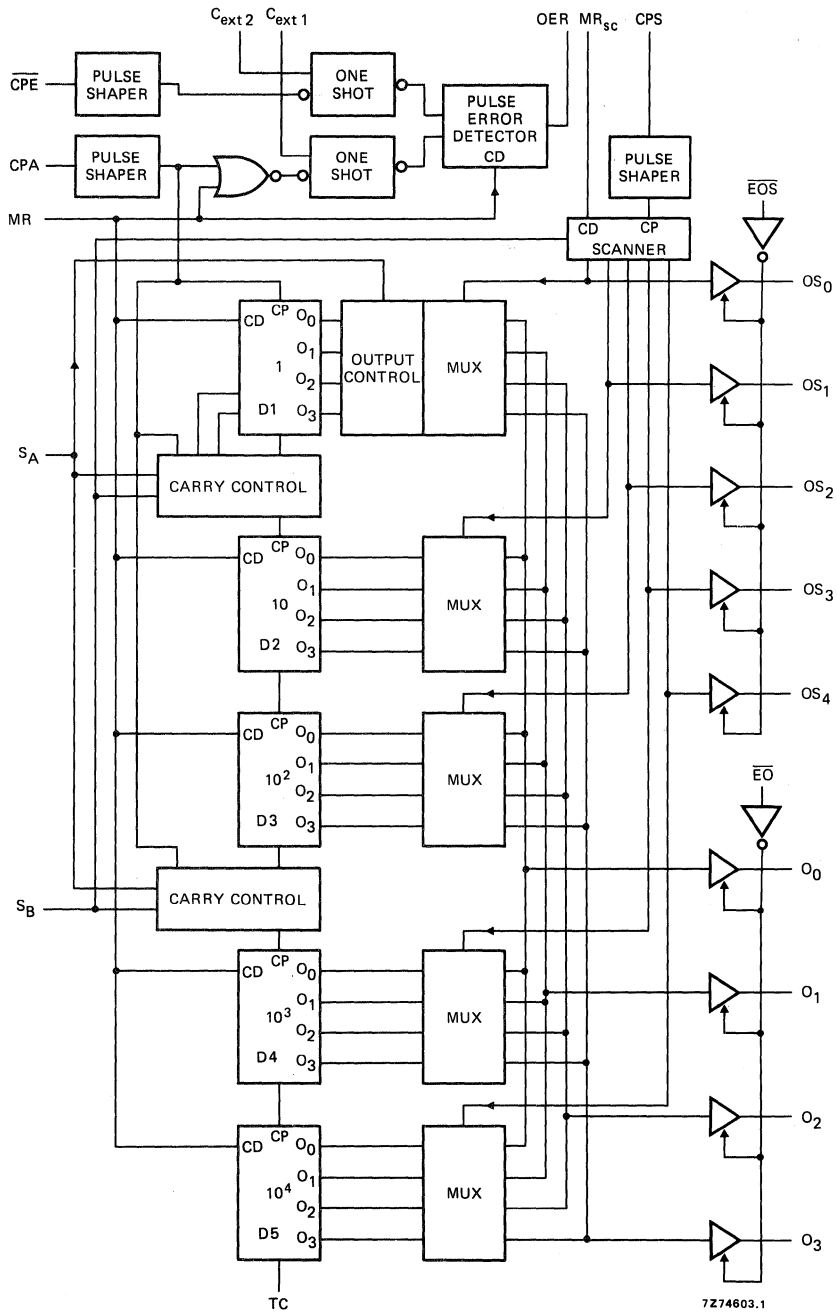

Real time 5-decade counter.

FUNCTIONAL DIAGRAMS

HEF4538B

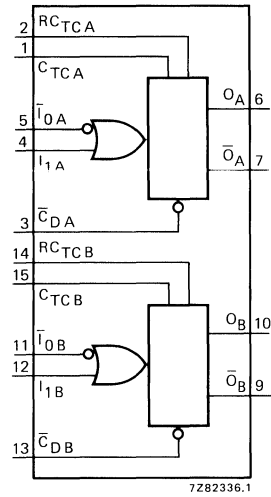

Dual precision monostable multivibrator.

HEF4539B

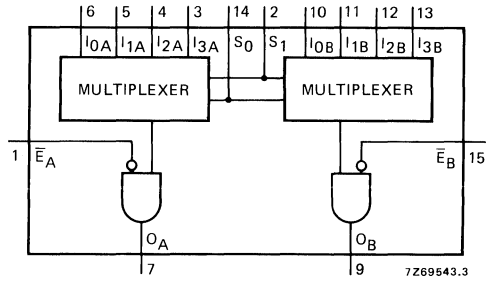

Dual 4-input multiplexer.

HEF4541B

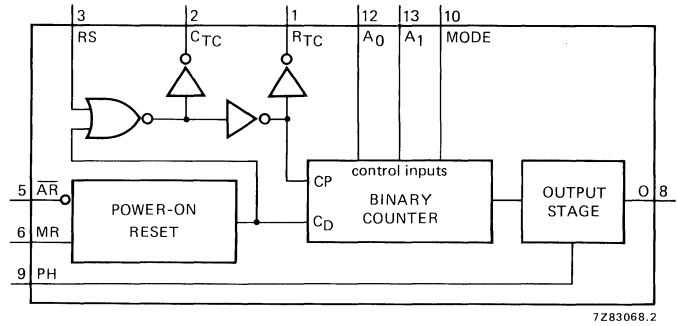

Programmable timer.

HEF4543B

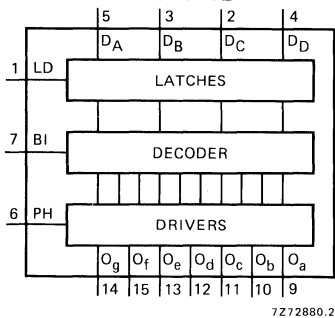

BCD to 7-segment latch/decoder/driver.

HEF4555B

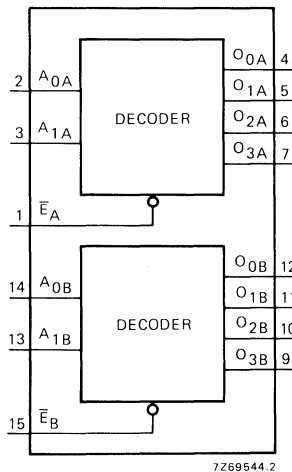

Dual 1-of-4 decoder/demultiplexer.

HEF4556B

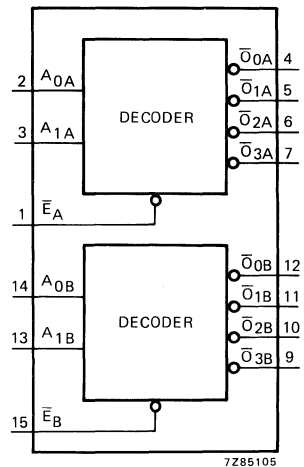

Dual 1-of-4 decoder/demultiplexer.

FUNCTIONAL DIAGRAMS

HEF4557B

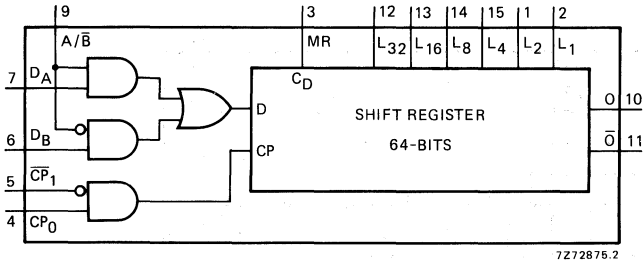

1-to-16 bit variable length shift register.

HEF4585B

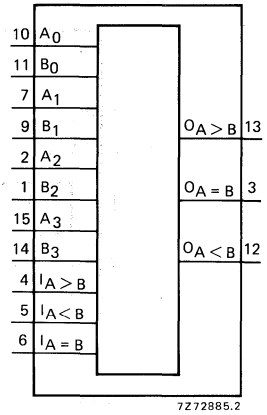

4-bit magnitude comparator.

HEF4720B; V

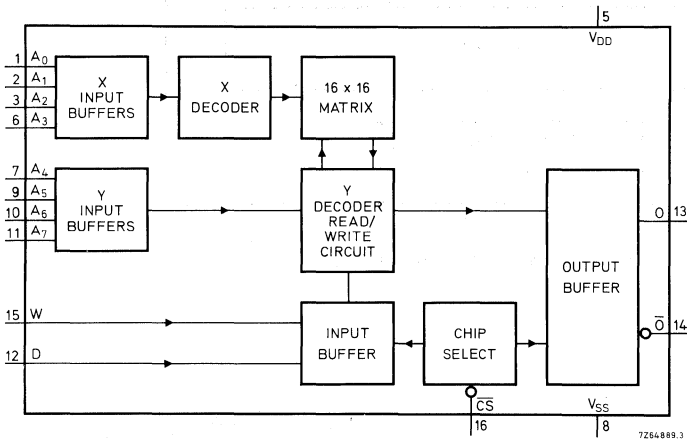

256-bit, 1-bit per word RAM.

HEF4724B

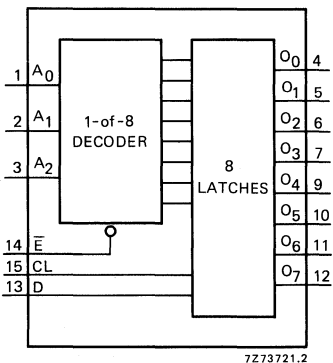

8-bit addressable latch.

HEF4731B; V

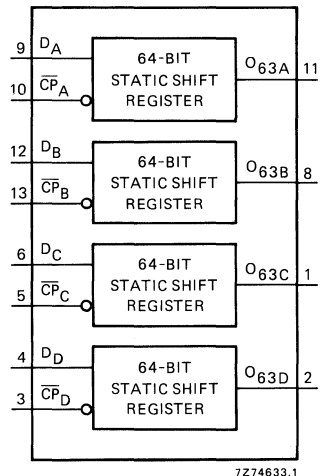

Quadruple 64-bit static shift register.

HEF4737B; V

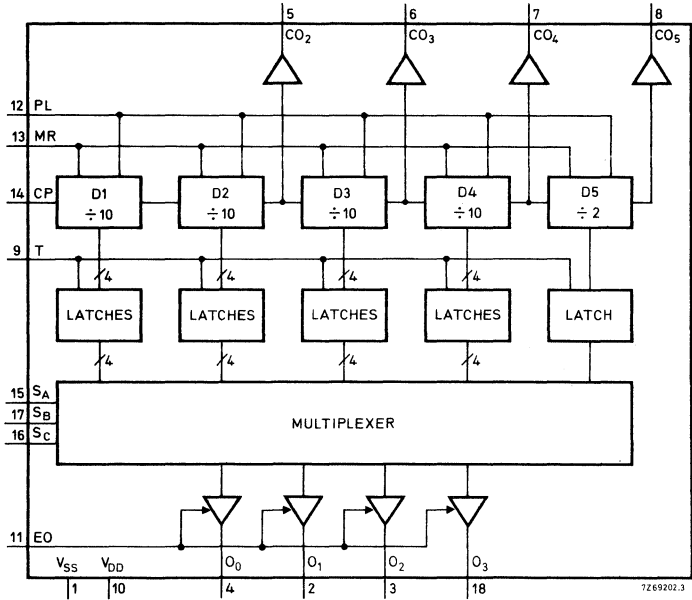

Quadruple static decade counter.

HEF4738V

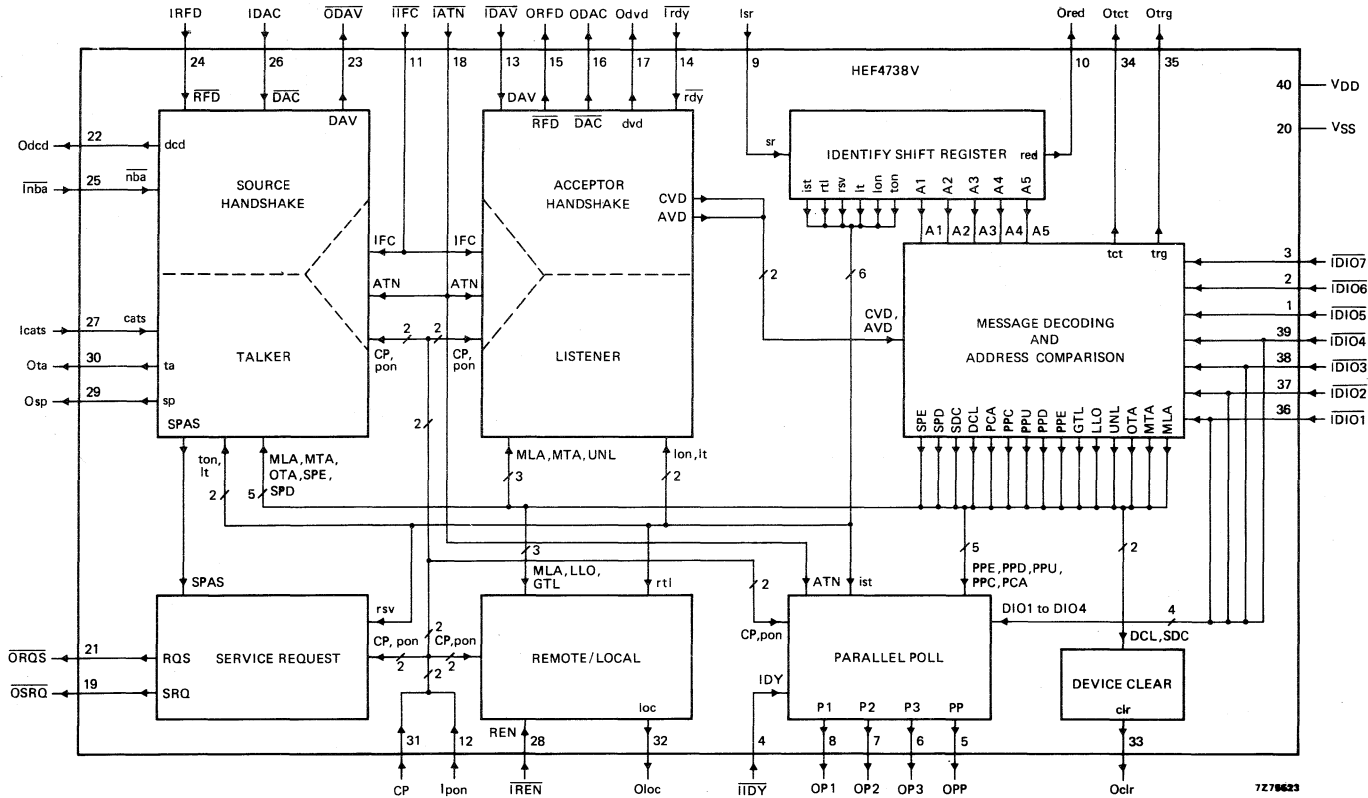

7278623

IEC/IEEE bus interface.

HEF4750V

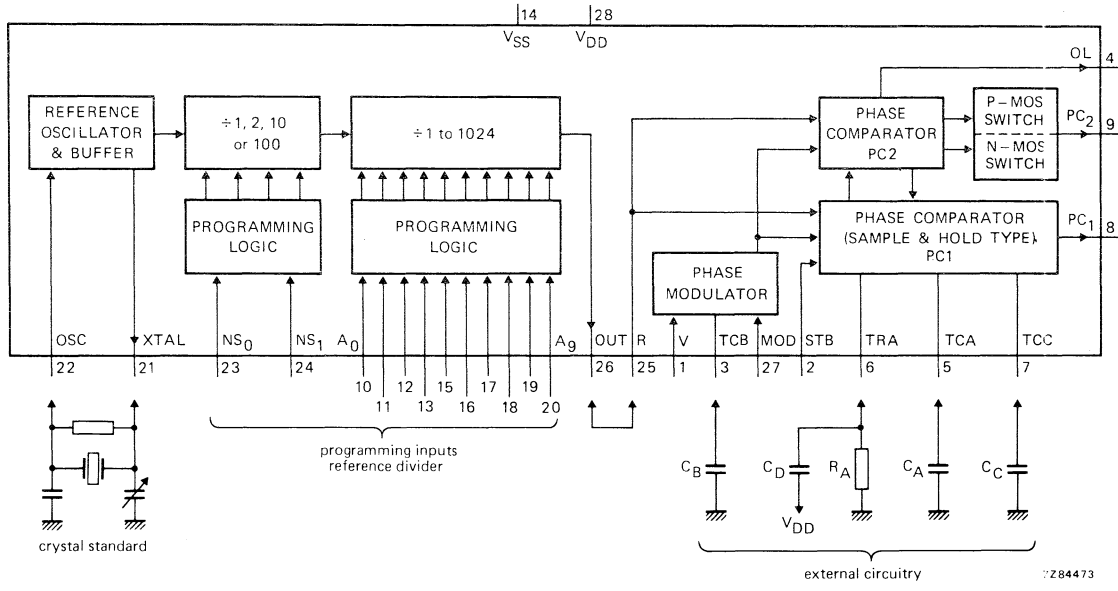

Frequency synthesizer.

FUNCTIONAL DIAGRAMS

HEF4751V

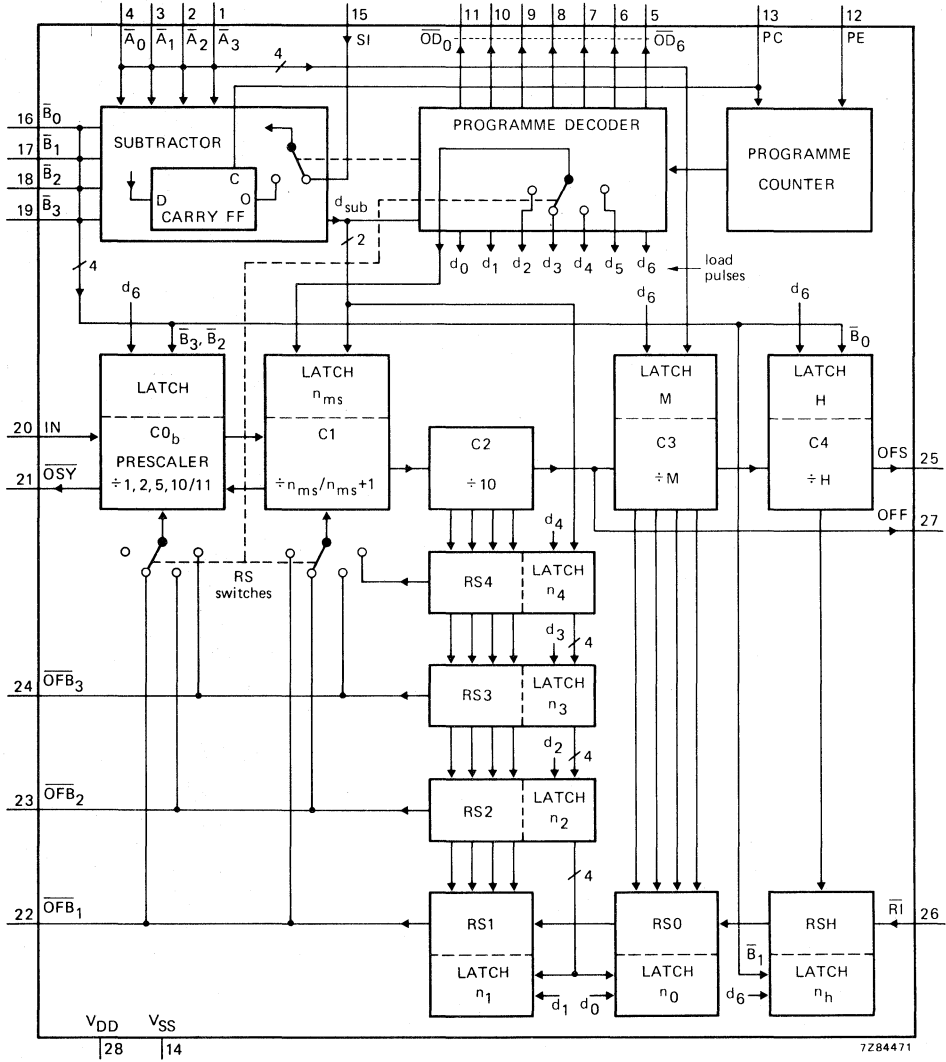

Universal divider.

HEF4753B

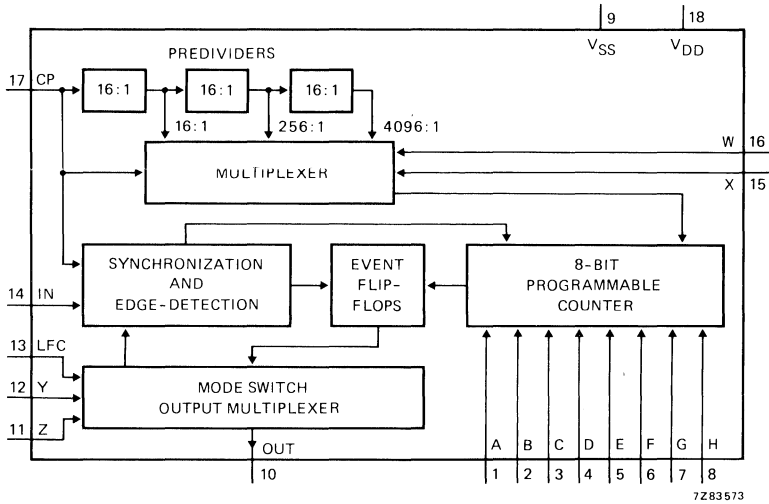

Universal timer module.

HEF4754V

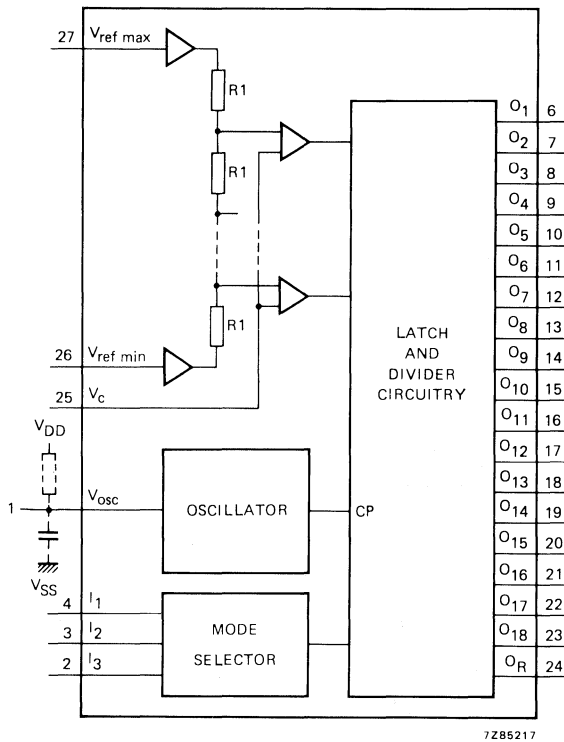

18-element bargraph LCD driver.

FUNCTIONAL DIAGRAMS

HEF4755V

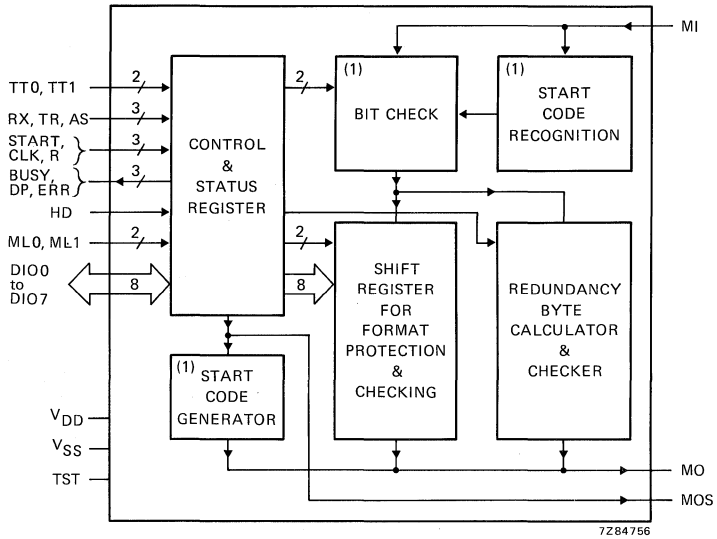

(1) Only used in the asynchronous mode.

Transceiver for serial data communication.

HEF40097B

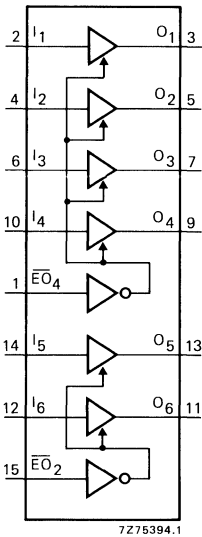

3-state hex non-inverting buffer.

HEF40098B

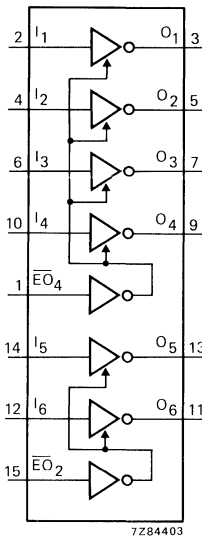

3-state hex inverting buffer.

HEF40106B

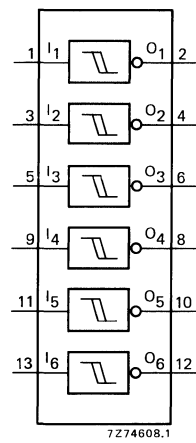

Hex Schmitt trigger.

HEF40160B

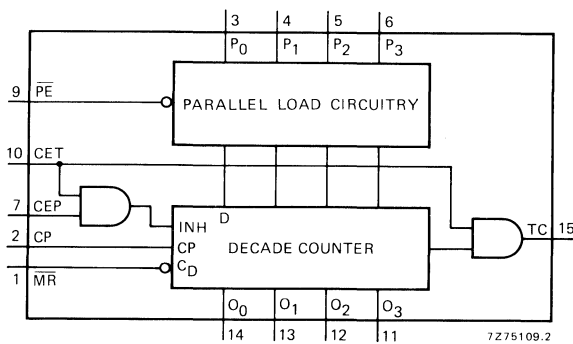

4-bit synchronous decade counter with asynchronous reset.

FUNCTIONAL DIAGRAMS

HEF40161B

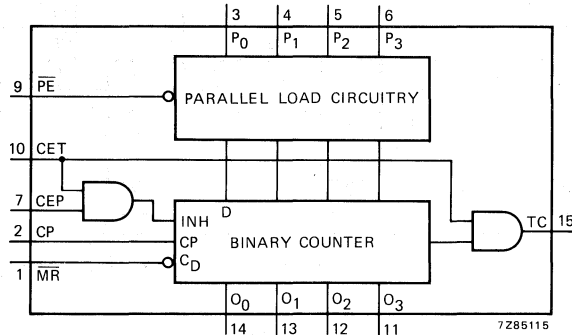

4-bit synchronous binary counter
with asynchronous reset.

HEF40162B

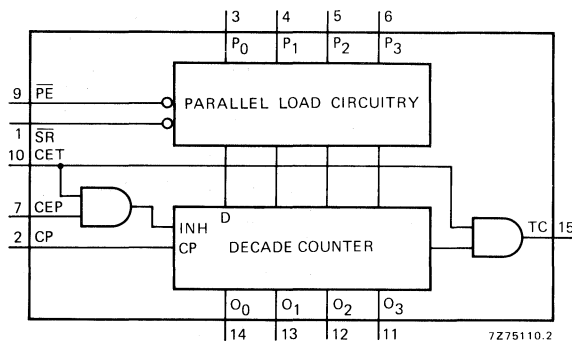

4-bit synchronous decade counter
with synchronous reset.

HEF40163B

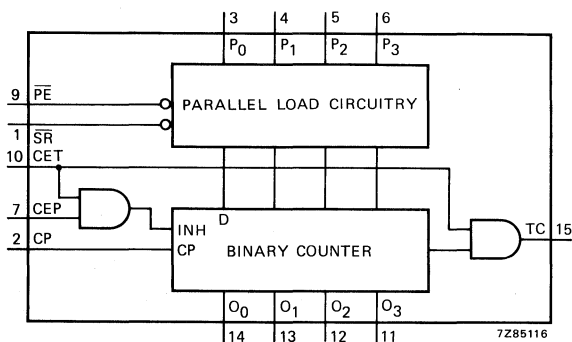

4-bit synchronous binary counter
with synchronous reset.

HEF40174B

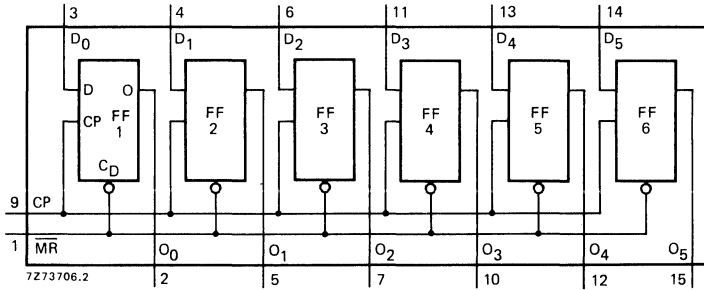

Hex D-type flip-flop.

HEF40175B

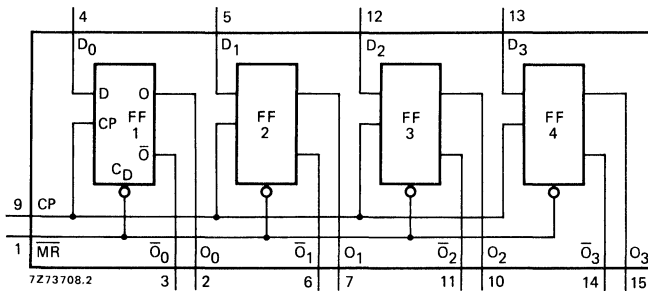

Quadruple D-type flip-flop.

HEF40192B

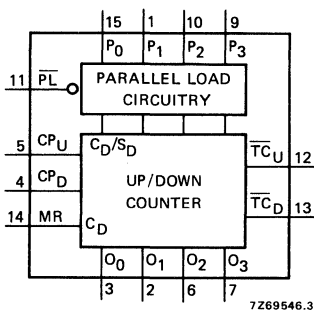

4-bit up/down decade counter.

HEF40193B

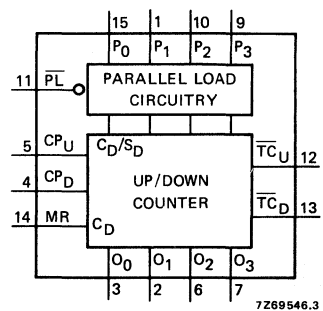

4-bit up/down binary counter.

FUNCTIONAL DIAGRAMS

HEF40194B

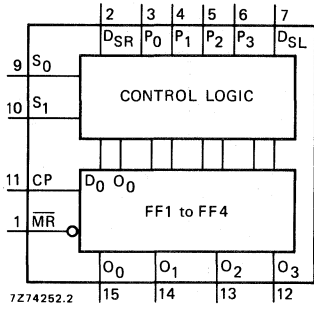

4-bit bidirectional universal shift register.

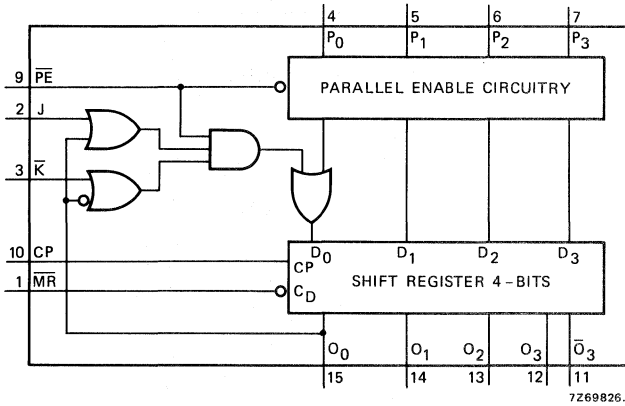

HEF40195B

4-bit universal
shift register.

HEF40240B

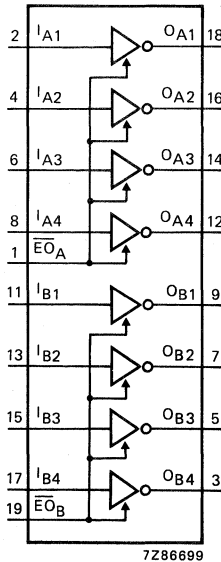

7Z86699

Octal buffers with 3-state outputs.

HEF40244B

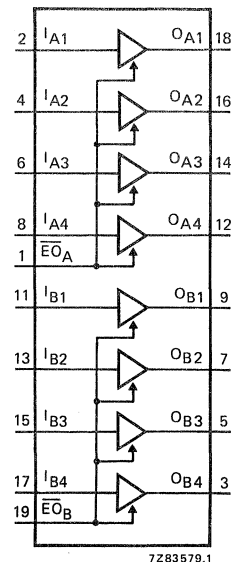

7Z83579.1

Octal buffers with 3-state outputs.

HEF40245B

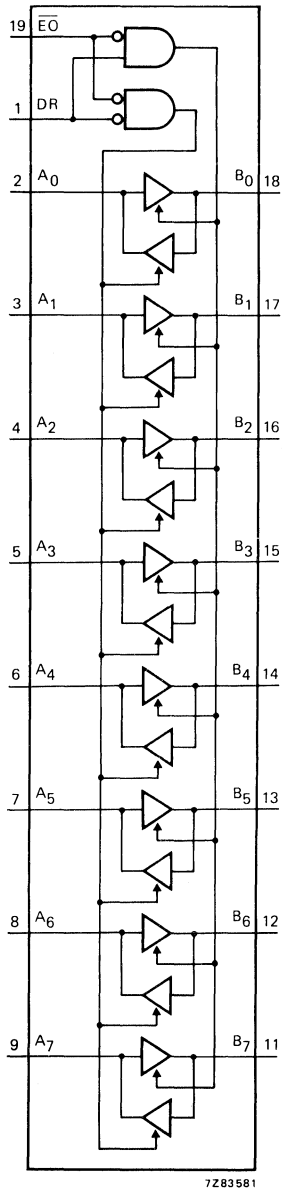

Octal bus transceiver with
3-state outputs.

HEF40373B

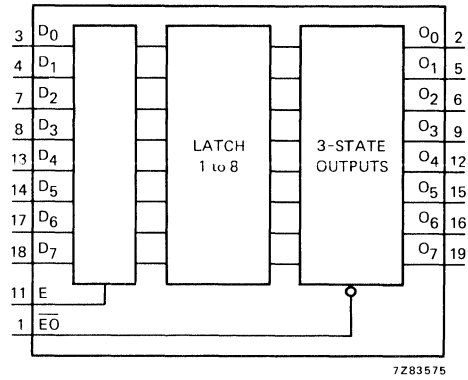

Octal transparent latch with 3-state outputs.

HEF40374B

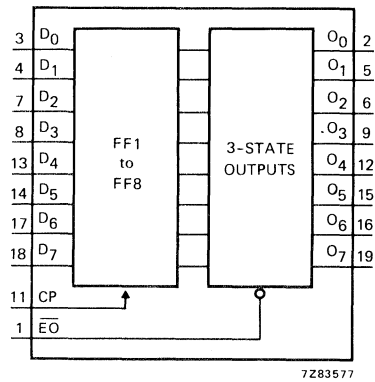

Octal D-type flip-flop with 3-state outputs.

PIN DESIGNATIONS

PIN DESIGNATIONS

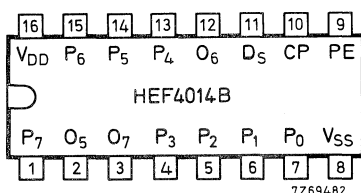
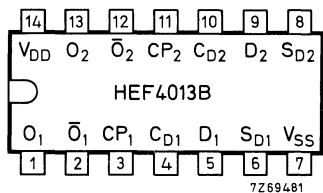
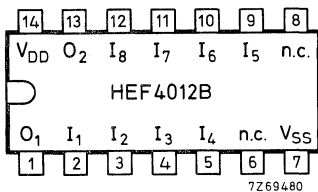
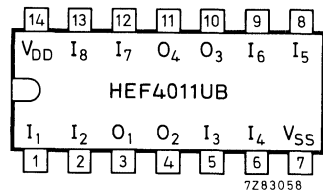
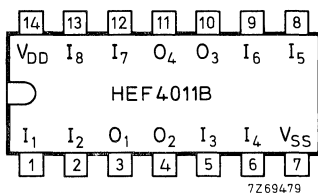
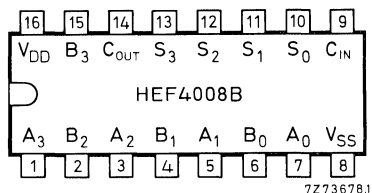
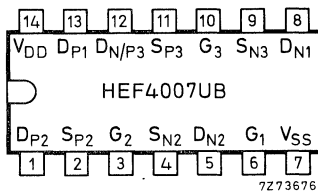
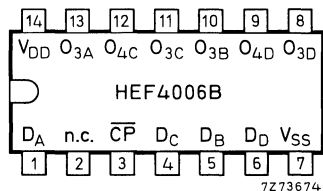
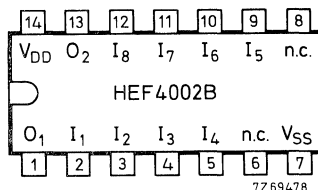
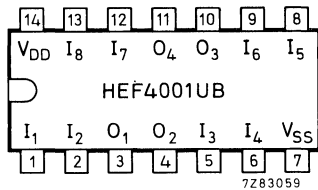
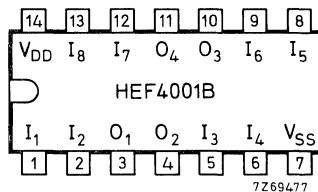
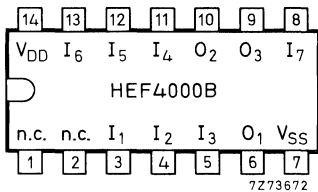

PIN DESIGNATIONS

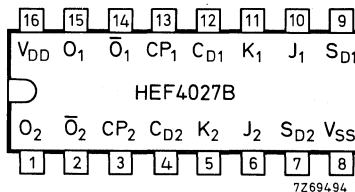
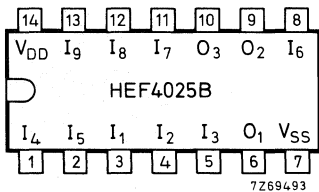
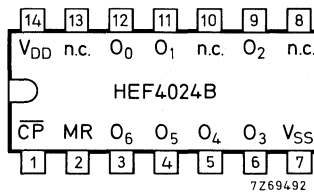
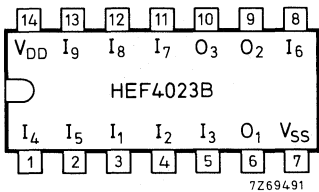
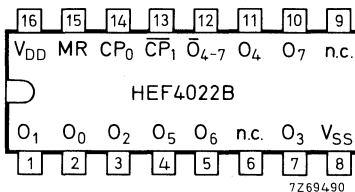
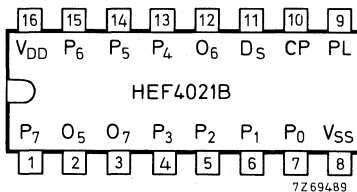
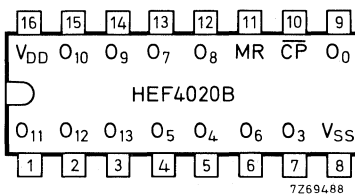
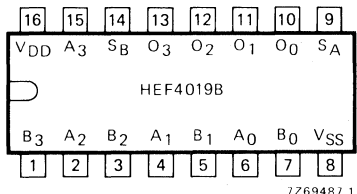
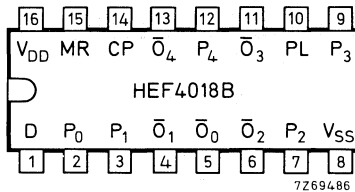
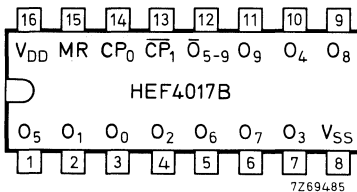
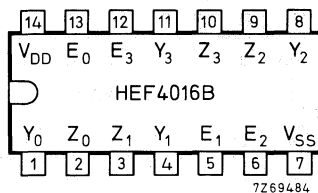

PIN DESIGNATIONS

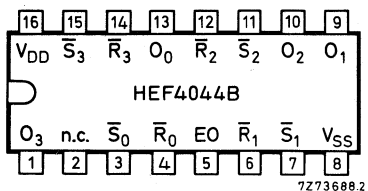
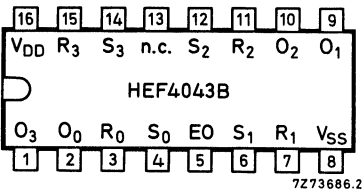
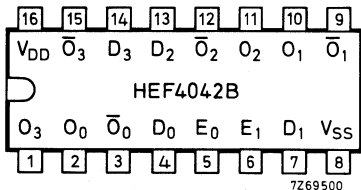
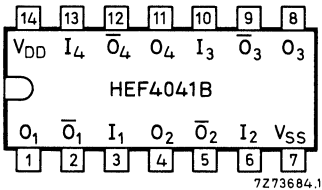
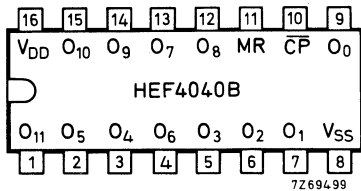
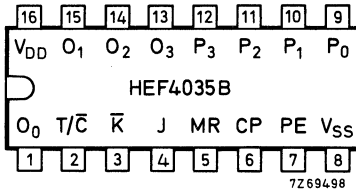
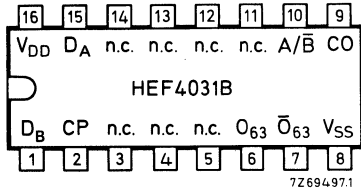
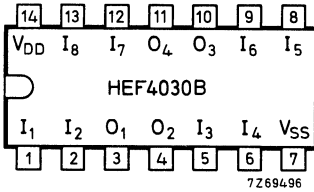
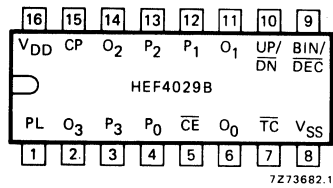

PIN DESIGNATIONS

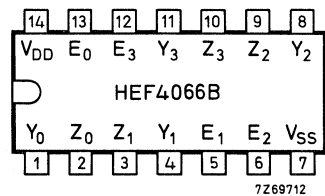
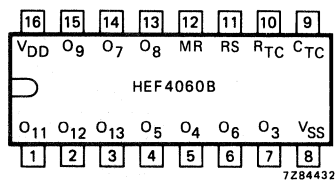
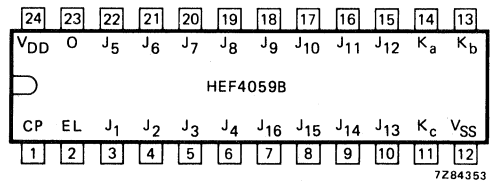
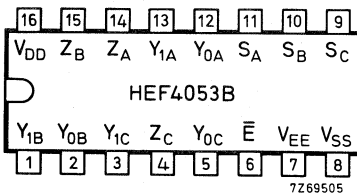
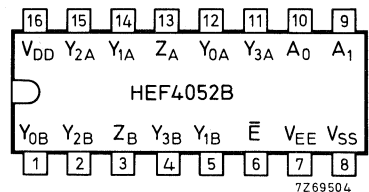
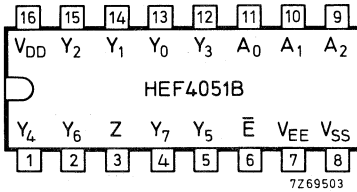
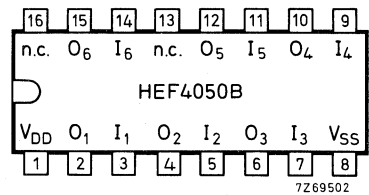
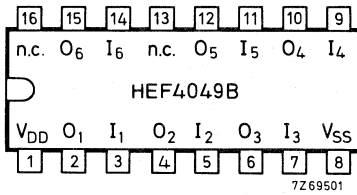
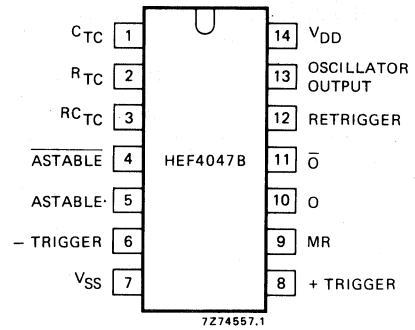
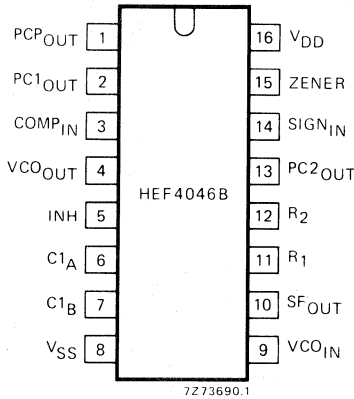

PIN DESIGNATIONS

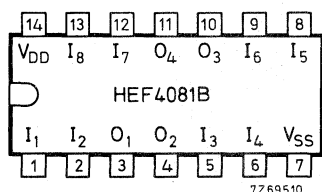
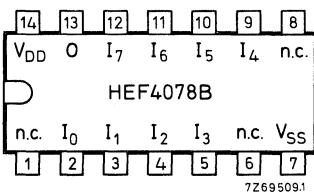
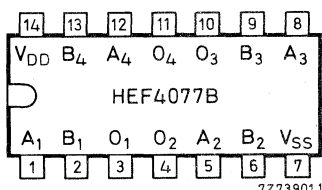
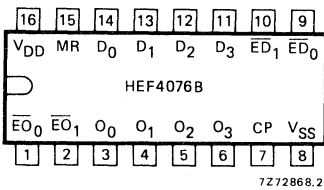
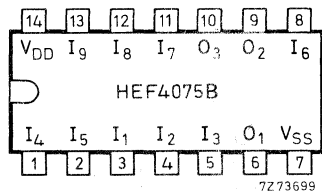
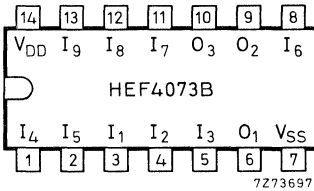
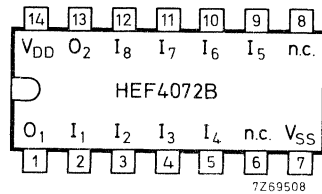
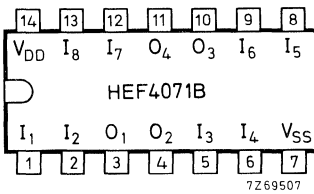
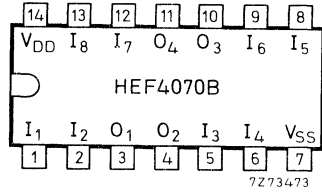
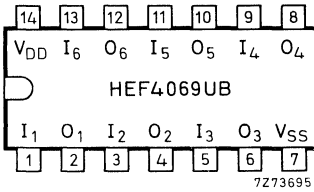
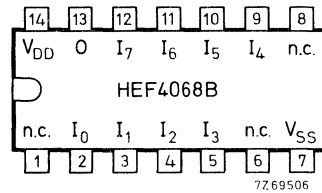
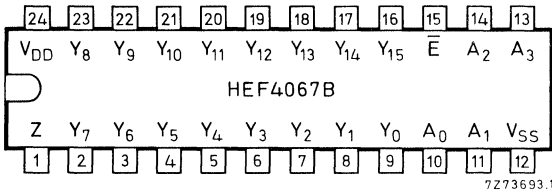

PIN DESIGNATIONS

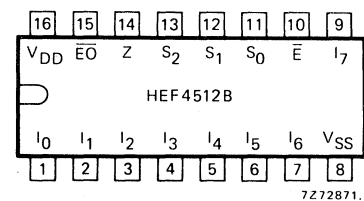
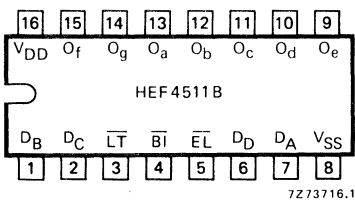
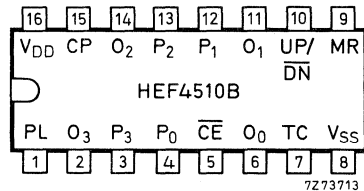
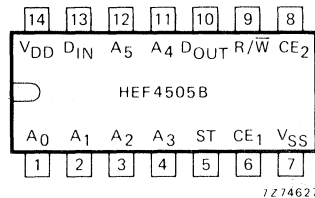
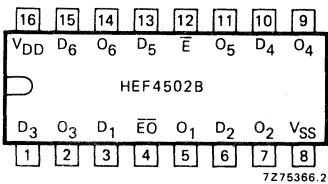
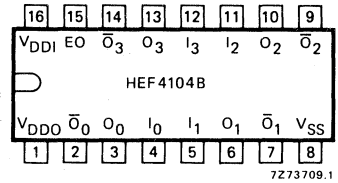
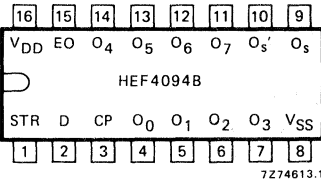
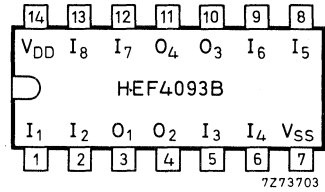
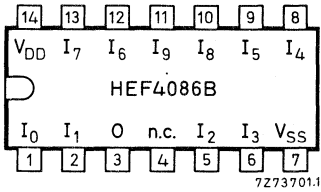
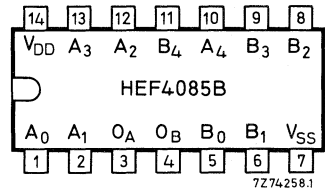
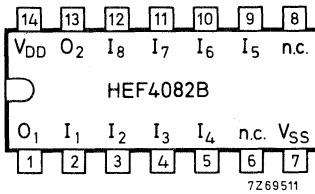

PIN DESIGNATIONS

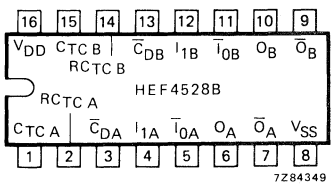
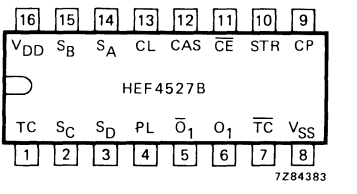
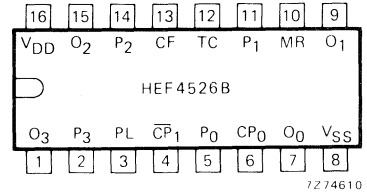
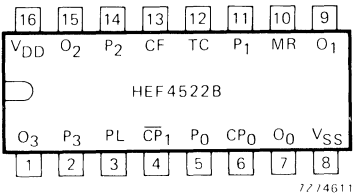
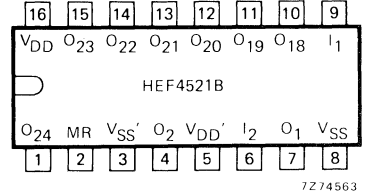
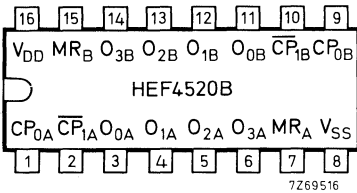
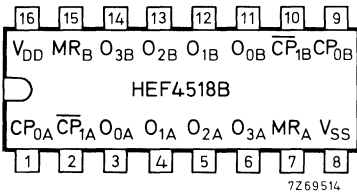
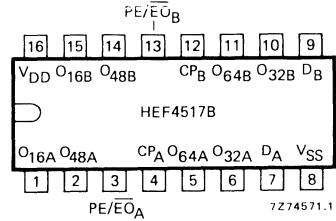
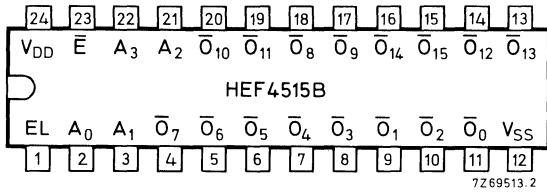
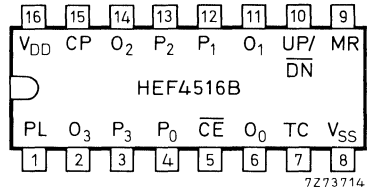
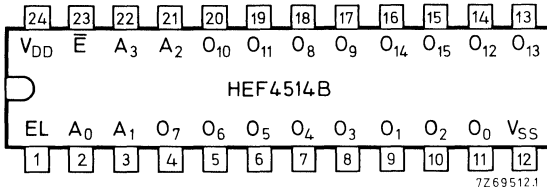

PIN DESIGNATIONS

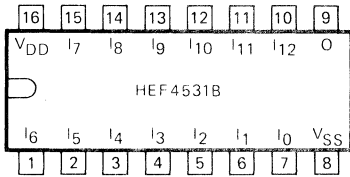

727461B

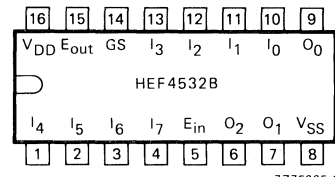

7275365.1

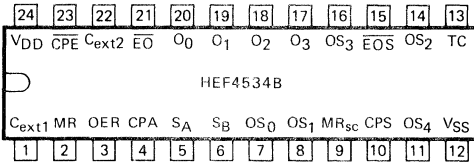

7274602.1

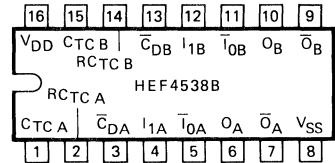

7282335.1

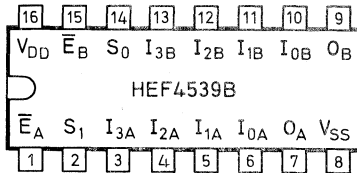

7269517

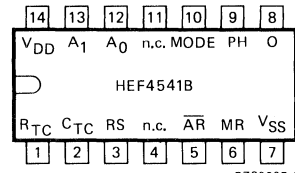

7283067.1

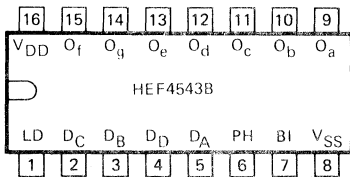

7272881.1

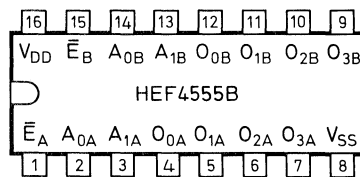

7269518

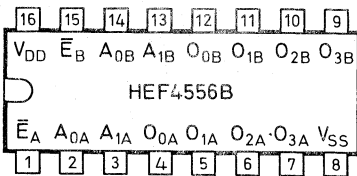

7269519

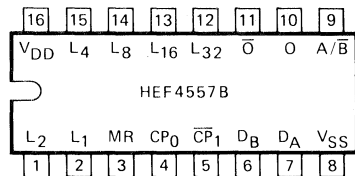

7272876.1

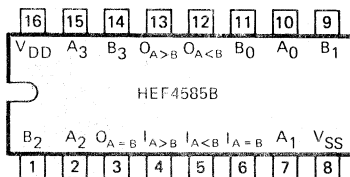

7272886

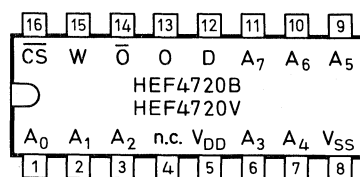

7274260.2

PIN DESIGNATIONS

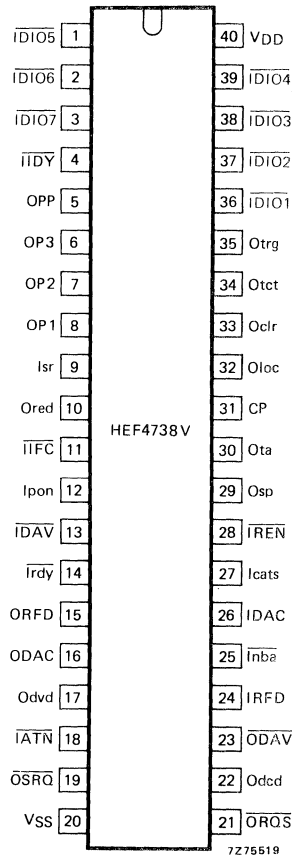
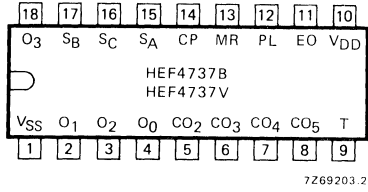
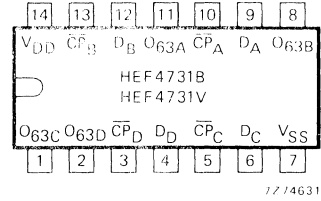
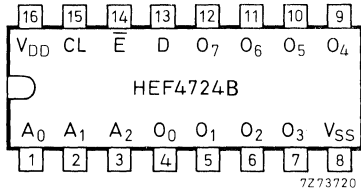

PIN DESIGNATIONS

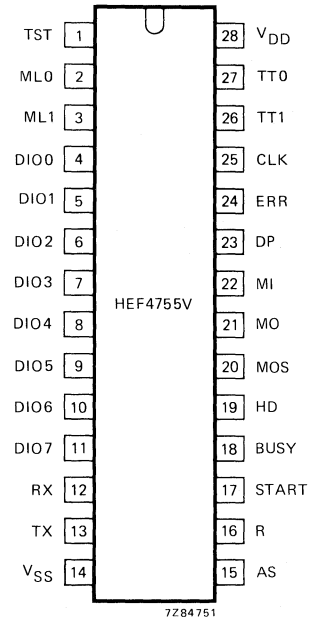
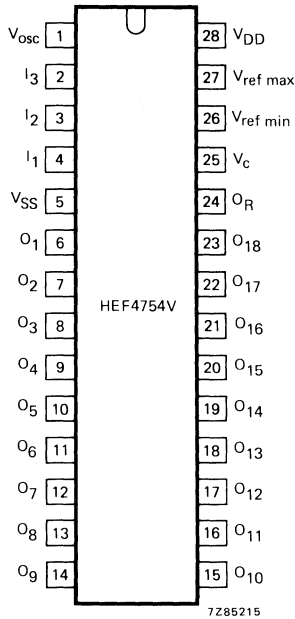
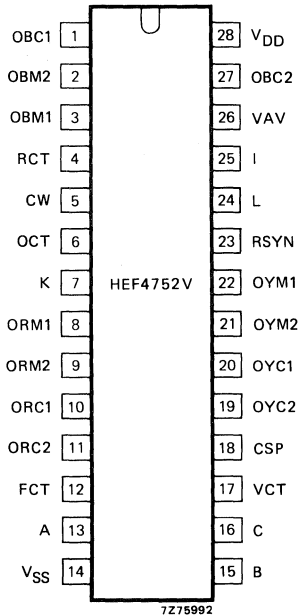
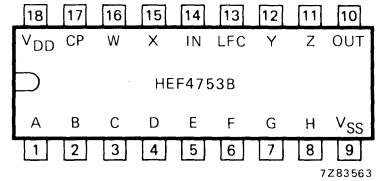
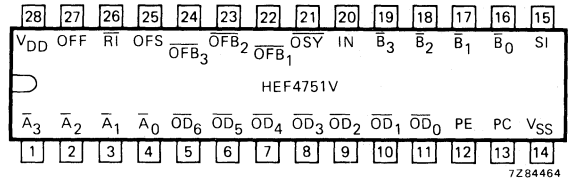
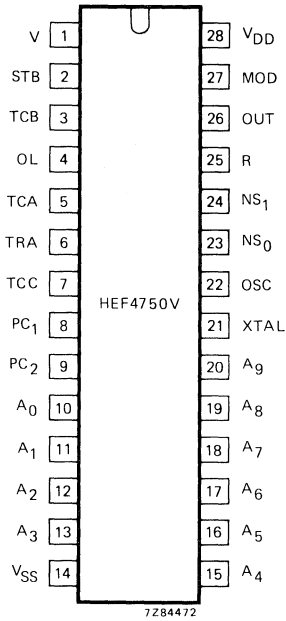

PIN DESIGNATIONS

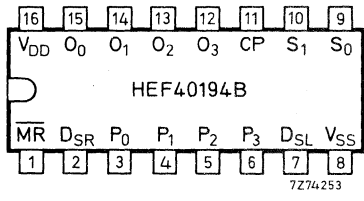
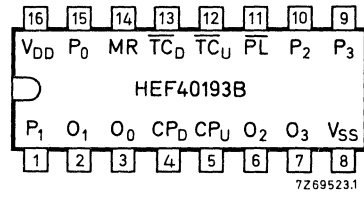
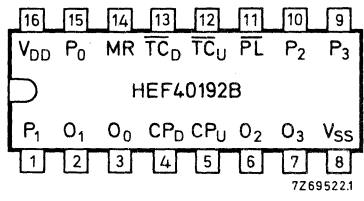
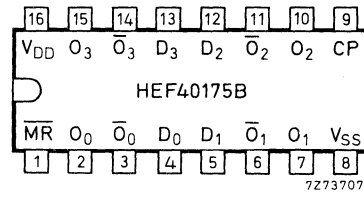
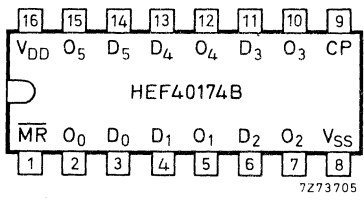
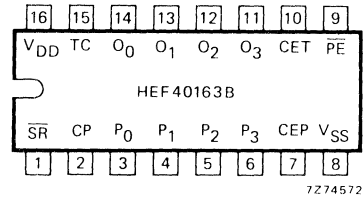
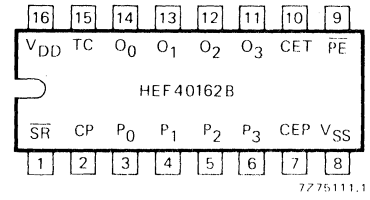
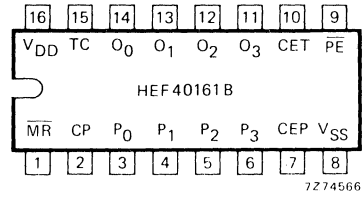
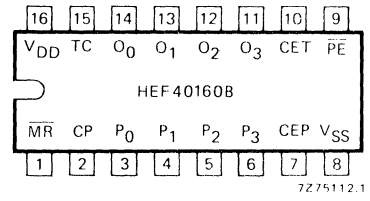
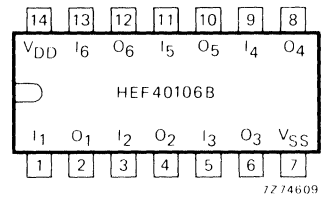
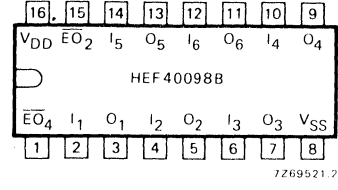
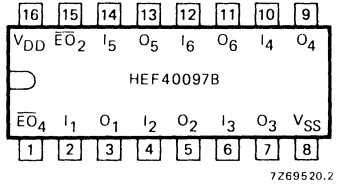

PIN DESIGNATIONS

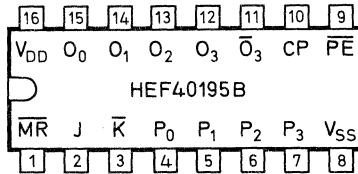

7Z69827

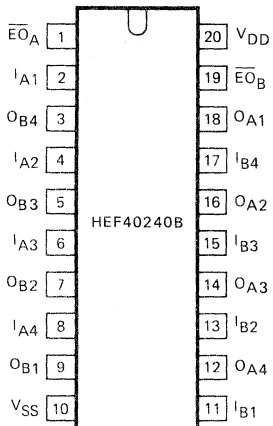

7Z86700

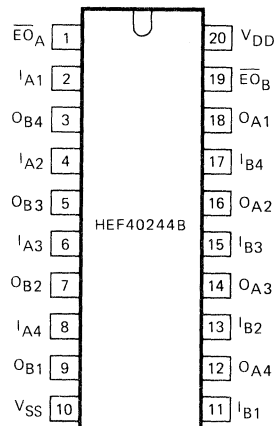

7Z83578.1

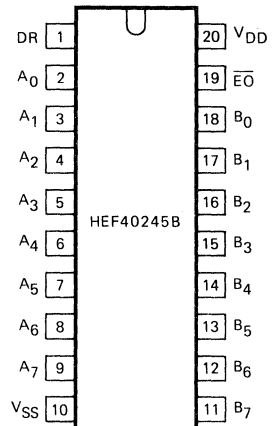

7Z83580

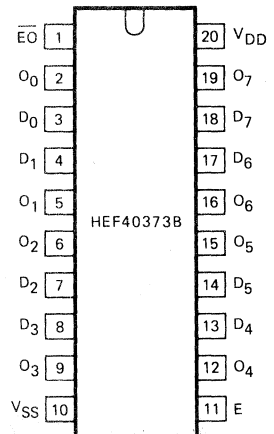

7Z83574

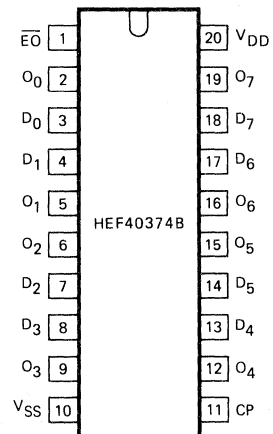

7Z83576

HE4000B FAMILY-INTRODUCTION

INTRODUCTION TO THE HE4000B FAMILY DATA SHEETS

The LOCMOS HE4000B range is a fully buffered digital integrated circuit family which meets the Jedec-B specification. The members of this family are pin-compatible with the well-known C-MOS 4000 and 14500 ranges. The HE family has the same advantages as conventional C-MOS circuits, plus the additional LOCMOS advantages.

LOCMOS means: Local Oxidation Complementary MOS.

The main effect of LOCMOS is a considerable reduction in the chip area required for a given function. Also important is the reduction in stray capacitance due to the smaller contact areas - hence the higher switching speed. Another benefit, brought about by the manufacturing process, is the self-alignment of the source and drain diffusions. This means that tolerance margins in the diffusions are unnecessary, thus further reducing the stray capacitances.

Advantages of C-MOS:

- low power dissipation - typically 10 nW per gate (static);
- wide operating supply voltage range;
- wide operating temperature range - -40 to $+85$ °C;
- high d.c. fan-out;
- inputs and outputs are protected against electrostatic voltages.

In addition to these, the LOCMOS HE4000B range has:

- buffered outputs on **all** circuits;
- higher speed;
- higher packing density - essential for MSI/LSI;
- excellent noise immunity.

The HE family is designed with standardized output drive characteristics which, combined with relative insensitivity to output capacitance loading, simplify system design.

Note

On page 1 of most of the device data sheets are shown a pinning diagram together with a functional diagram. In addition to this functional diagram, a more detailed logic diagram is given, which also shows the buffered outputs.

BUFFERED OUTPUTS

To minimize any pattern sensitivity of propagation delay, and to standardize delay and output drive, all HE family devices have an output buffer stage (see Fig. 1). Buffering improves the static noise immunity because the increased voltage gain gives nearly ideal transfer characteristics and the low output impedance gives significant improvement of the dynamic noise immunity. Significant pulse shaping is obtained because output transitions are virtually independent of input rise and fall times.

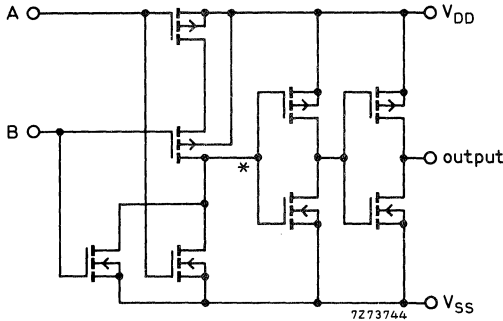

Fig. 1 Two-input NOR gate with fully buffered output; a typical LOCMOS circuit. In an unbuffered device the output would be taken from the point marked*.

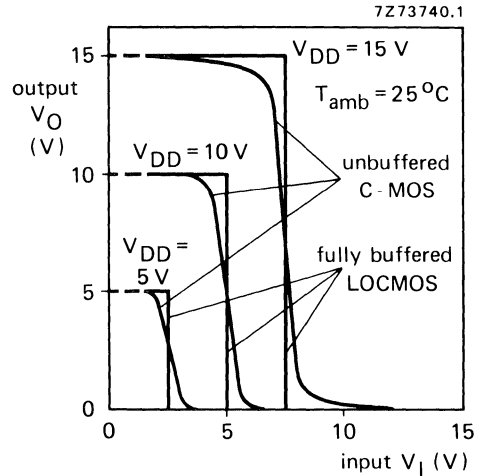
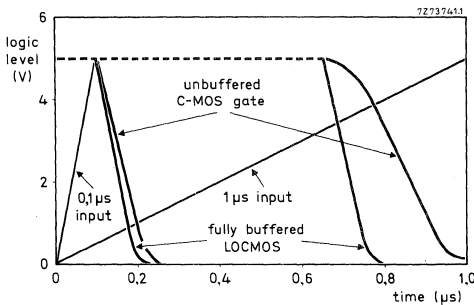
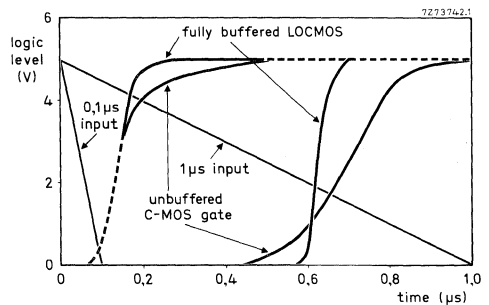

Fig. 2 Typical transfer characteristic showing improvement in buffered LOCMOS device as compared with unbuffered C-MOS device.



(a)



(b)

Fig. 3 The two graphs show how the output transitions are independent of input rise time (a) and fall time (b).

DESIGN CONSIDERATIONS

General

Local Oxidation Complementary MOS digital integrated circuits of SSI and MSI complexity have been hailed as the ideal logic family. A few LOCMOS devices, such as bidirectional analogue switches, exploit the unique feature of C-MOS technology; some take advantage of the smaller device size and higher potential packing density to achieve true LSI complexity, and perform logic functions that have been available in TTL for many years. Therefore, it is both helpful and practical to compare the performance of LOCMOS with that of the more familiar TTL (see table below).

LOCMOS speed is about three to six times lower than TTL or low-power Schottky (LS-TTL). Static noise immunity and fan-out are almost ideal, supply voltage is non-critical, and the quiescent power consumption is close to zero – several orders of magnitude lower than for any competing technology. For dynamic noise immunity, see NOISE IMMUNITY.

| | standard TTL | low-power Schottky | 4000 LOCMOS 5 V | 4000 LOCMOS 10 V | 4000 LOCMOS 15 V |
|--|-----------------|-----------------------|-----------------------|------------------------|------------------------|
| propagation delay $C_L = 15 \text{ pF}$ | 10 ns | 10 ns | 40 ns | 20 ns | 15 ns |
| flip-flop clock frequency | 35 MHz | 45 MHz | 8 MHz | 16 MHz | 20 MHz |
| quiescent power | 10 mW | 2 mW | 10 nW | 10 nW | 10 nW |
| noise immunity | 1 V | 0,8 V | 2,25 V | 4,5 V | 6,75 V |
| fan-out | 10 | 10 | 50 * | 50 * | 50 * |

* Or as determined by permissible propagation delay.

Supply voltage range

LOCMOS is guaranteed to function over the unprecedented range of 3 to 15 V supply voltage. Characteristics are guaranteed for 5, 10 and 15 V operation and can be extrapolated for any voltage in between. Operation below 4,5 V is not very meaningful because of the increase in delay (loss of speed), the increase in output impedance and the loss of noise immunity. Operation above 15 V is not recommended because of high dynamic power consumption and risk of noise spikes on the power supply exceeding the breakdown voltage (typ. > 20 V), causing SCR-latch-up and destroying the device unless the current is externally limited.

The lower limit of power supply voltage, including ripple, is determined by the required noise immunity, propagation delay or interface to TTL. The upper limit of supply voltage, including ripple and transients, is determined by power dissipation or direct interface to other logic. The HEF4049B, HEF4050B and HEF4104B provide level transition between TTL and LOCMOS when LOCMOS supply voltages over 5 V are used.

Low static power consumption combined with wide supply voltage range make LOCMOS the ideal logic family for battery-operated equipment.

Power consumption

Under static conditions, the p-channel and the n-channel transistors are not conducting simultaneously, thus only leakage current flows from the positive (V_{DD}) to the negative (V_{SS}) supply connection. This leakage current is typically 0,5 nA per gate, resulting in a very attractive low power consumption of 2,5 nW per gate (at 5 V).

Whenever a LOCMOS circuit is exercised, when data or clock inputs change, additional power is consumed to charge and discharge capacitances (on-chip parasitic capacitances as well as load capacitances). Moreover, there is a short time during the transition when both the p-channel and n-channel transistors are partially conducting. This dynamic power consumption is obviously proportional to the frequency at which the circuit is exercised, to the load capacitance and to the square of the supply voltage. As shown in Fig. 4, the power consumption of a LOCMOS gate exceeds that of a low-power Schottky gate somewhere between 500 kHz and 2 MHz of actual output frequency. Comparing the power consumption of more complex devices (MSI) in various technologies may show a different result.

In any complex design, only a small fraction of the gates actually switch at the full clock frequency, most gates operate at a much lower average rate and therefore consume much less power. A realistic comparison of power consumption between different technologies involves a thorough analysis of the average switching speed of each gate in the circuit.

The maximum values of the quiescent device current (I_{DD}) are given in the Family Specifications, the typical dynamic power dissipation is given in the individual data sheets. The total device power dissipation is the sum of the quiescent and dynamic power dissipation.

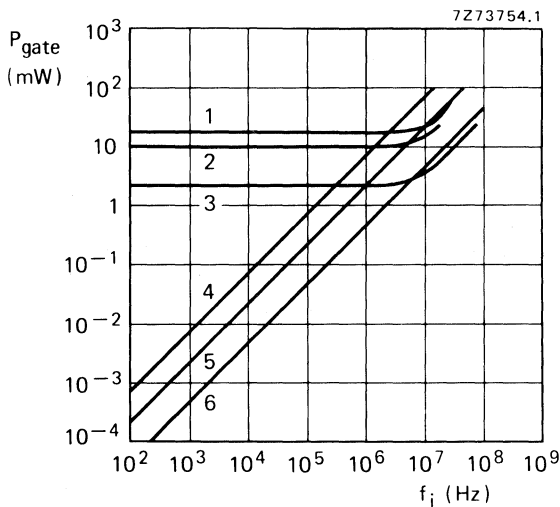

Fig. 4 Typical power dissipation per gate as a function of input frequency for several logic families.

- 1 Schottky TTL
- 2 Standard TTL
- 3 Low-power Schottky
- 4 LOCMOS ($V_{DD} = 15$ V)
- 5 LOCMOS ($V_{DD} = 10$ V)
- 6 LOCMOS ($V_{DD} = 5$ V)

Additional power consumption (due to slow input rise and fall times)

As long as the input voltage of a LOC MOS circuit is below the N-transistor threshold voltage, or higher than the supply voltage minus the P-transistor threshold voltage, one of the input transistors is always in the OFF-state and no 'through' current flows in the input stage.

When the input voltage equals the N-transistor threshold voltage (typ. 1.5 V), the N-transistor starts conducting and a drain current starts to flow.

Figure 5 shows the drain current as a function of the input voltage for a typical LOC MOS input.

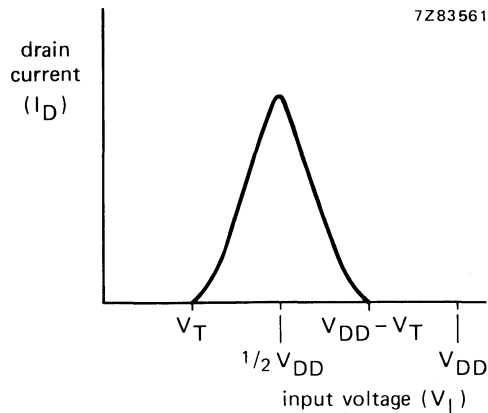

Fig. 5 Drain current as a function of input voltage.

This drain current reaches a maximum at $1/2 V_{DD}$ and the peak value depends on the geometrics of the transistors used. This current is proportional to V_{DD}^n , in which $n > 2$.

For Schmitt triggers, unbuffered types, and circuits comprising a single stage inverter, typical current transfer characteristics are given in the device data sheets.

When squaring up slow pulses by means of Schmitt triggers, the through current gives additional power consumption.

By applying RC-oscillators, or oscillators constructed with Schmitt triggers, the phenomenon described gives a frequency-independent power consumption.

Propagation delay

Compared to TTL and LS-TTL, all C-MOS devices are slow and very sensitive to capacitance loading (see Fig. 6).

The HE family uses both advanced processing (LOC MOS) and improved circuit design (buffered gates) to achieve propagation delays and output transition times that are superior to any other junction-isolated C-MOS design.

LOC MOS processing achieves lower parasitic capacitances which reduce the on-chip delay and increase the maximum clock frequency of flip-flops, registers and counters. Buffering all outputs, even on gates, results in lower output impedance and thus reduces the effect of capacitive loading.

Propagation delay is affected by three parameters: capacitive loading, supply voltage, and temperature.

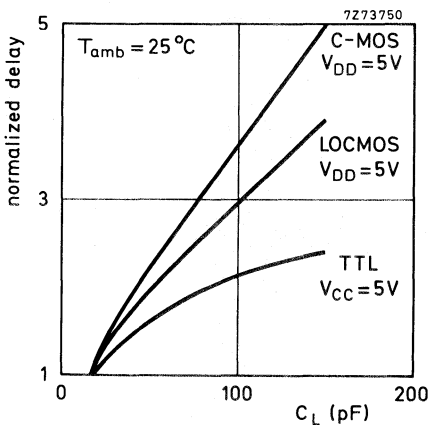

Fig. 6 Normalized propagation delay as a function of load capacitance for TTL, C-MOS and LOC MOS.

Capacitive loading effect

Historically, semiconductor manufacturers have always specified the propagation delay at an output load of 15 pF, not because this was considered a representative systems environment, but rather because it was the lowest practical test-jig capacitance. It also generated the most impressive specifications. For example, TTL with an output impedance in the LOW state of typically 25 Ω is little affected by an increase in capacitive loading. LOC MOS, however, with an output impedance of typically 250 Ω (at 5 V) is 10 times more sensitive to capacitive loading. As an example Fig. 7 shows the positive and negative-going delays as functions of load capacitance for the HEF4011B and Fig. 8 shows the output transition times for standard output stages. For detailed information see Family Specifications and the individual data sheets. It should be noted that most unbuffered gates have an even higher output impedance, a larger dependence on output loading, and do not show the same symmetry.

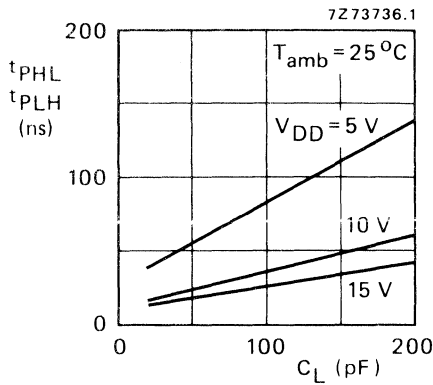

Fig. 7 Positive and negative-going propagation delay as functions of load capacitance for the HEF4011B.

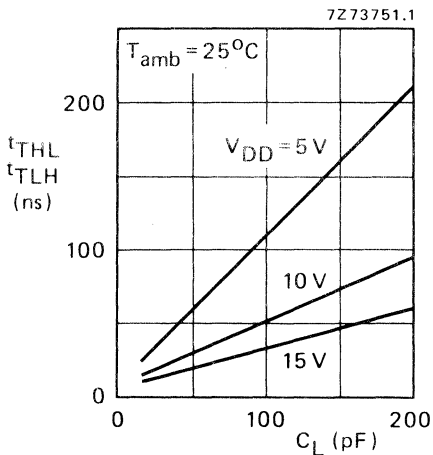

Fig. 8 Output transition times as functions of load capacitance.

Supply voltage effect

1. Speed; Fig. 9 shows propagation delays as functions of supply voltage. The best choice for slow applications is 5 V. For reasonably fast systems, choose 10 or 12 V. Any application requiring 15 V to achieve short delays and fast operation should be investigated for excessive power dissipation and should be weighed against an LS-TTL approach.
2. Noise immunity; improves with higher supply voltage (see NOISE IMMUNITY).

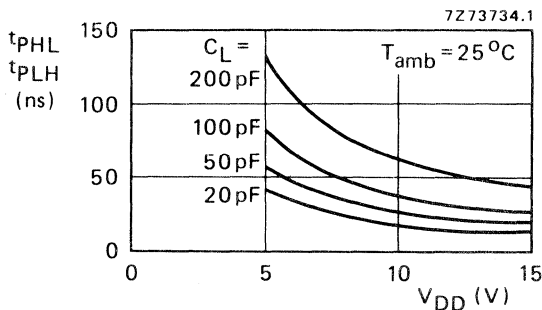

Fig. 9 Propagation delays (symmetrical) as functions of power supply voltage for the HEF4011B.

Temperature effect

The temperature dependence of LOC MOS is much simpler than with TTL, where three factors contribute: increase of beta with temperature, increase of resistor value with temperature, and decrease of junction forward voltage drop with increasing temperature. In LOC MOS, essentially only the carrier mobility changes, thus increasing the impedance, and hence the delay, with temperature. For more details see Family Specifications and the individual data sheets, for example see Fig. 10.

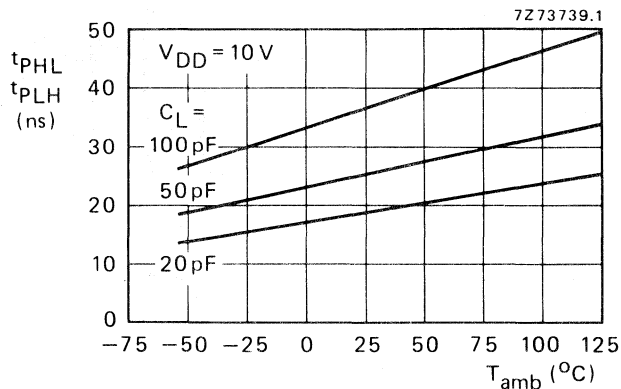

Fig. 10 Propagation delays as functions of ambient temperature, with $V_{DD} = 10$ V for HEF4011B.

Noise immunity

One of the most advertised and also misunderstood C-MOS features is noise immunity. The input threshold of a C-MOS gate is approximately 50% of the supply voltage and the voltage transfer curve is almost ideal. As a result, LOC MOS can claim very good voltage noise immunity, typically 45% of the supply voltage, i.e., 2,25 V in a 5 V system, 4,5 V in a 10 V system and 6,75 V in a 15 V system. Compare this with the TTL transfer curve in Fig. 11 and its resultant 1 V noise immunity in a lightly loaded system and only 0,4 V worst case. Fig. 12 shows the transfer characteristic between -55 and $+125$ °C.

Since LOC MOS output impedance, output voltage and input threshold are symmetrical with respect to the supply voltage, the LOW and HIGH level noise immunities are practically equal. Therefore, a LOC MOS system can tolerate ground or V_{DD} drops and noise on these supply lines of more than 1 V, even in a 5 V system. Moreover, the inherent LOC MOS delays act as a noise filter; 10 ns spikes tend to disappear in a chain of LOC MOS gates, but are amplified in a chain of TTL gates. Because of these features, LOC MOS is very popular with designers of industrial control equipment that must operate in an electrically and electromagnetically 'polluted' environment.

Unfortunately these impressive noise margin specifications disregard one important fact: the output impedance of LOC MOS is 3 to 10 times higher than that of TTL. C-MOS interconnections are therefore less 'stiff' and more susceptible to capacitively coupled noise. In terms of such current-injected crosstalk from high noise voltages through small coupling capacitances, the tables on the next page give a comparison between LOC MOS and TTL/LS-TTL.

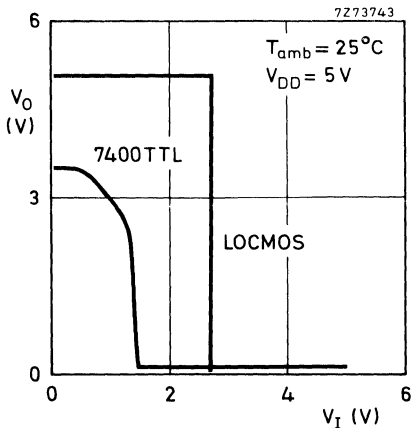

Fig. 11 Typical transfer characteristic for TTL and LOCMOS.

LOCMOS/TTL (normalized to TTL)

| | | | |
|----------|-----|------|------|
| V_{DD} | 5 V | 10 V | 15 V |
| factor | 0,5 | 1 | 2 |

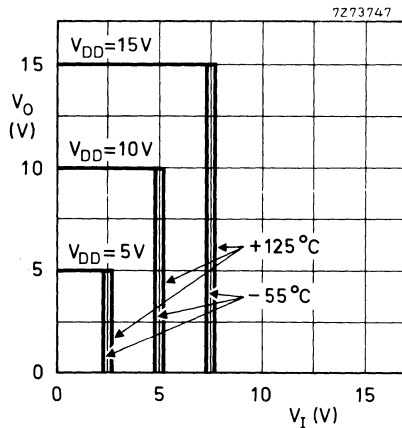

Fig. 12 Voltage transfer characteristic over -55 to $+125$ °C range.

LOCMOS/LS-TTL (normalized to LS-TTL)

| | | | |
|----------|-----|------|------|
| V_{DD} | 5 V | 10 V | 15 V |
| factor | 1 | 3 | 5 |

From the tables can be seen that LOCMOS operating at $V_{DD} = 10$ V has a dynamic noise immunity which is comparable with TTL and 3 times as good as LS-TTL.

In terms of voltage injected noise the nearly ideal transfer characteristic and the relatively slow response of LOCMOS circuits make them at least 5 times less sensitive to magnetically coupled noise than TTL/LS-TTL.

Input protection

The gate input to any MOS transistor appears like a small value (< 1 pF), very low leakage (< 1 pA) capacitor. Without special precautions, such inputs could be electrostatically charged to a high voltage, causing a destructive breakdown of the dielectric and permanently damaging the device. Therefore, all LOCMOS inputs are protected by a combination of series resistor and shunt diodes. Different manufacturers have different approaches; some use a single diode, others use two diodes, and some use a resistor with a parasitic substrate diode.

With the exception of a few devices, each member of the HE family utilizes a series resistor, nominally 400Ω , and two diodes, one to V_{DD} , and the other to V_{SS} (see Fig. 13). The resistor is a polysilicon 'true resistor' without a parasitic substrate diode. This ensures that the input impedance is always at least 400Ω under all biasing conditions, even when V_{DD} is short-circuited to V_{SS} . A parasitic substrate diode would represent a poorly defined shunt to V_{SS} in this particular case.

The diodes exhibit typical forward voltage drops of $0,9$ V at 1 mA and reverse breakdown voltages of 20 V. For certain special applications such as oscillators, the diodes actually conduct during normal operation, in this case the current should be limited to 1 mA. Input currents averaging 10 mA or more may destroy the device.

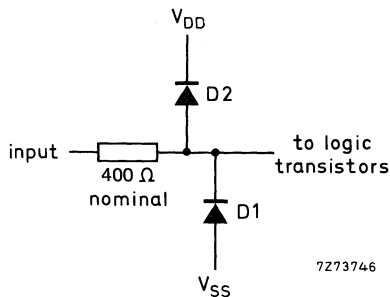

Fig. 13 Standard HE family LOCMOS input protection circuit.

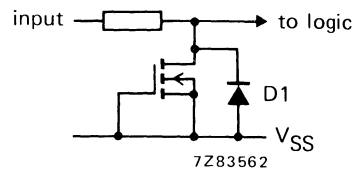

Fig. 14 The input protection for the HEF4049B and HEF4050B.

Figure 14 shows the input protection for the types HEF4049B and HEF4050B. Diode D1 is the inherent drain to V_{SS} diode of the protection device. Under operational conditions, this input may exceed the supply voltage V_{DD} .

Power supply regulation and decoupling

The LOCMOS technology suggests that any supply voltage between 3 and 15 V will do, thus rendering supply voltage regulation unnecessary. However, it must be realized that the supply voltage has influence on the system speed (see Fig. 9), noise immunity (see Figs 11 and 12) and dissipation (see Fig. 4) and see text concerning all these Figures.

Any dynamic system generates voltage spikes on the supply line. These spikes influence the noise immunity, they may damage the circuit, or may have a negative influence on proper operation of the circuit. Therefore a matched decoupling of the supply line is necessary. Generally an electrolytic capacitor of $3 \mu\text{F}$ per 10 devices is sufficient. However, some circuits require special attention:

1. HEF4511B: BCD to 7-segment latch/decoder/driver; an electrolytic capacitor of $3 \mu\text{F}$ should be added to each device to avoid excessive voltage spikes due to high di/dt .
2. HEF4528B: dual retriggerable/resettable monostable multivibrator; for circuits of this nature it is recommended to use proper decoupling to avoid pulse length variations due to supply line ripple.
3. Circuits that operate in the linear mode, such as RC or crystal oscillators, a minimum supply voltage of at least 4 V is recommended.

3-state outputs

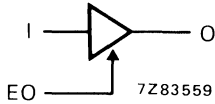

Fig. 15 Logic symbol of a 3-state output.

Function table

| inputs | | output |
|--------|----|--------|
| I | EO | O |
| X | L | Z |
| L | H | L |
| H | H | H |

H = HIGH state (the more positive voltage)
 L = LOW state (the less positive voltage)
 X = state is immaterial
 Z = high impedance OFF-state

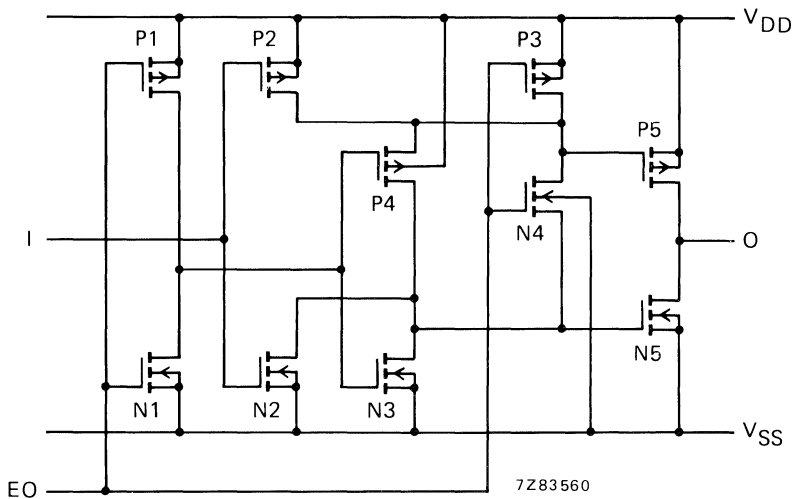

Fig. 16 Circuit diagram of 3-state output.

When EO is HIGH, the output is enabled and the transistors P4 and N4 act as a transmission gate, and they connect the gates of the output transistors together. A LOW level at EO puts the output in the high impedance OFF-state; transistors P3 and N3 function as pull-up and pull-down transistors respectively.

FAMILY SPECIFICATIONS



These specifications cover the common electrical characteristics of the entire HE4000B family, unless otherwise specified in the individual device data sheet.

The LOCMOS HE4000B family devices will operate over a recommended V_{DD} power supply range of 3 to 15 V, as referenced to V_{SS} (usually ground). Parametric limits are guaranteed for V_{DD} of 5, 10 and 15 V. Because of the wide operating voltage range, power supply regulation is less critical than with other types of logic. The lower limit of the supply voltage is 3 V, or as determined by required system speed and/or noise immunity or interface to other logic. The recommended upper limit is 15 V or as determined by power dissipation constraints or interface to other logic. Unused inputs must be connected to V_{DD} , V_{SS} or another input. Inputs and outputs are protected against electrostatic effects in a wide variety of device-handling situations. However, to be totally safe, it is desirable to take handling precautions into account.

RATINGS

Limiting values in accordance with the Absolute Maximum System (IEC 134)

| | | | |
|---|-----------|--------------------------------|---|
| Supply voltage | V_{DD} | -0,5 to + 18 V | |
| Voltage on any input | V_I | -0,5 to $V_{DD} + 0,5$ V | |
| D.C. current into any input or output | $\pm I$ | max. 10 mA | |
| Power dissipation per package (for plastic and ceramic DIL) | | | |
| for $T_{amb} = -40$ to $+70$ °C | P_{tot} | max. 500 mW | ← |
| for $T_{amb} = +70$ to $+85$ °C | | derate linearly with 8 mW/K | ← |
| Power dissipation per package (for plastic SO mini-pack) | | | |
| for $T_{amb} = -40$ to $+70$ °C | P_{tot} | max. 400 mW | ← |
| for $T_{amb} = +70$ to $+85$ °C | | derate linearly with 6 mW/K | ← |
| Power dissipation per output | P | max. 100 mW | |
| Storage temperature | T_{stg} | -65 to $+150$ °C | |
| Operating ambient temperature | T_{amb} | -40 to $+85$ °C | |

D.C. CHARACTERISTICS $V_{SS} = 0$ V; for all devices unless otherwise specified

| parameter | V_{DD} V | symbol | T_{amb} (°C) | | | | | | unit | conditions | |
|--|---------------|----------|----------------|------|-------|------|-------|------|---------|--|--|
| | | | -40 | | + 25 | | + 85 | | | | |
| | | | min. | max. | min. | max. | min. | max. | | | |
| Quiescent device current | | | | | | | | | | | |
| gates | 5 | I_{DD} | - | 1,0 | - | 1,0 | - | 7,5 | μA | all valid input combinations; $V_I = V_{SS}$ or V_{DD} | |
| | 10 | | - | 2,0 | - | 2,0 | - | 15,0 | μA | | |
| | 15 | | - | 4,0 | - | 4,0 | - | 30,0 | μA | | |
| buffers, flip-flops | 5 | I_{DD} | - | 4,0 | - | 4,0 | - | 30 | μA | | |
| | 10 | | - | 8,0 | - | 8,0 | - | 60 | μA | | |
| | 15 | | - | 16,0 | - | 16,0 | - | 120 | μA | | |
| MSI | 5 | I_{DD} | - | 20 | - | 20 | - | 150 | μA | | |
| | 10 | | - | 40 | - | 40 | - | 300 | μA | | |
| | 15 | | - | 80 | - | 80 | - | 600 | μA | | |
| LSI | 5 | I_{DD} | - | 50 | - | 50 | - | 375 | μA | | |
| | 10 | | - | 100 | - | 100 | - | 750 | μA | | |
| | 15 | | - | 200 | - | 200 | - | 1500 | μA | | |
| Output voltage LOW | 5 | V_{OL} | - | 0,05 | - | 0,05 | - | 0,05 | V | | $V_I = V_{SS}$ or V_{DD} ; $ I_O < 1 \mu A$ |
| | 10 | | - | 0,05 | - | 0,05 | - | 0,05 | V | | |
| | 15 | | - | 0,05 | - | 0,05 | - | 0,05 | V | | |
| Output voltage HIGH | 5 | V_{OH} | 4,95 | - | 4,95 | - | 4,95 | - | V | $V_I = V_{SS}$ or V_{DD} ; $ I_O < 1 \mu A$ | |
| | 10 | | 9,95 | - | 9,95 | - | 9,95 | - | V | | |
| | 15 | | 14,95 | - | 14,95 | - | 14,95 | - | V | | |
| Input voltage LOW (buffered stages only) | 5 | V_{IL} | - | 1,5 | - | 1,5 | - | 1,5 | V | $V_O = 0,5$ V or 4,5 V $V_O = 1,0$ V or 9,0 V $V_O = 1,5$ V or 13,5 V $ I_O < 1 \mu A$ | |
| | 10 | | - | 3,0 | - | 3,0 | - | 3,0 | V | | |
| | 15 | | - | 4,0 | - | 4,0 | - | 4,0 | V | | |
| Input voltage HIGH (buffered stages only) | 5 | V_{IH} | 3,5 | - | 3,5 | - | 3,5 | - | V | $V_O = 0,5$ V or 4,5 V $V_O = 1,0$ V or 9,0 V $V_O = 1,5$ V or 13,5 V $ I_O < 1 \mu A$ | |
| | 10 | | 7,0 | - | 7,0 | - | 7,0 | - | V | | |
| | 15 | | 11,0 | - | 11,0 | - | 11,0 | - | V | | |

D.C. CHARACTERISTICS (continued) $V_{SS} = 0$ V; for all devices unless otherwise specified

| parameter | V_{DD} V | symbol | T_{amb} (°C) | | | | | | unit | conditions | |
|---|---------------|--------------|----------------|------|------|------|------|------|---------|--|---------------------|
| | | | -40 | | + 25 | | + 85 | | | | |
| | | | min. | max. | min. | max. | min. | max. | | | |
| Input voltage LOW (unbuffered stages only) | 5 | V_{IL} | - | 1 | - | 1 | - | 1 | V | $V_O = 0,5$ V or 4,5 V $V_O = 1,0$ V or 9,0 V $V_O = 1,5$ V or 13,5 V | $ I_O < 1$ μ A |
| | 10 | | - | 2 | - | 2 | - | 2 | V | | |
| | 15 | | - | 2,5 | - | 2,5 | - | 2,5 | V | | |
| Input voltage HIGH (unbuffered stages only) | 5 | V_{IH} | 4 | - | 4 | - | 4 | - | V | $V_O = 0,5$ V or 4,5 V $V_O = 1,0$ V or 9,0 V $V_O = 1,5$ V or 13,5 V | $ I_O < 1$ μ A |
| | 10 | | 8 | - | 8 | - | 8 | - | V | | |
| | 15 | | 12,5 | - | 12,5 | - | 12,5 | - | V | | |
| Output (sink) current LOW | 5 | I_{OL} | 0,52 | - | 0,44 | - | 0,36 | - | mA | $V_O = 0,4$ V; $V_I = 0$ or 5 V $V_O = 0,5$ V; $V_I = 0$ or 10 V $V_O = 1,5$ V; $V_I = 0$ or 15 V | |
| | 10 | | 1,3 | - | 1,1 | - | 0,9 | - | mA | | |
| | 15 | | 3,6 | - | 3,0 | - | 2,4 | - | mA | | |
| Output (source) current HIGH | 5 | $-I_{OH}$ | 0,52 | - | 0,44 | - | 0,36 | - | mA | $V_O = 4,6$ V; $V_I = 0$ or 5 V $V_O = 9,5$ V; $V_I = 0$ or 10 V $V_O = 13,5$ V; $V_I = 0$ or 15 V | |
| | 10 | | 1,3 | - | 1,1 | - | 0,9 | - | mA | | |
| | 15 | | 3,6 | - | 3,0 | - | 2,4 | - | mA | | |
| Output (source) current HIGH | 5 | $-I_{OH}$ | 1,7 | - | 1,4 | - | 1,1 | - | mA | $V_O = 2,5$ V; $V_I = 0$ or 5 V | |
| Input leakage current | 15 | $\pm I_{IN}$ | - | 0,3 | - | 0,3 | - | 1,0 | μ A | $V_I = 0$ or 15 V | |
| 3-state output leakage current; HIGH | 15 | I_{OZH} | - | 1,6 | - | 1,6 | - | 12,0 | μ A | output returned to V_{DD} | |
| 3-state output leakage current; LOW | 15 | $-I_{OZL}$ | - | 1,6 | - | 1,6 | - | 12,0 | μ A | output returned to V_{SS} | |

FAMILY SPECIFICATIONS

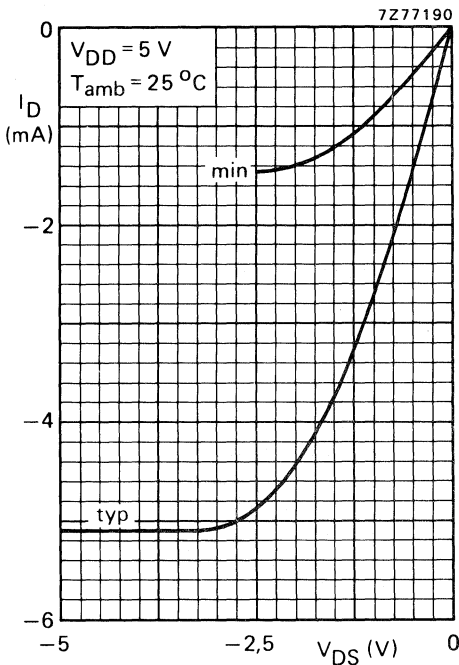

P-channel drain characteristics (source)

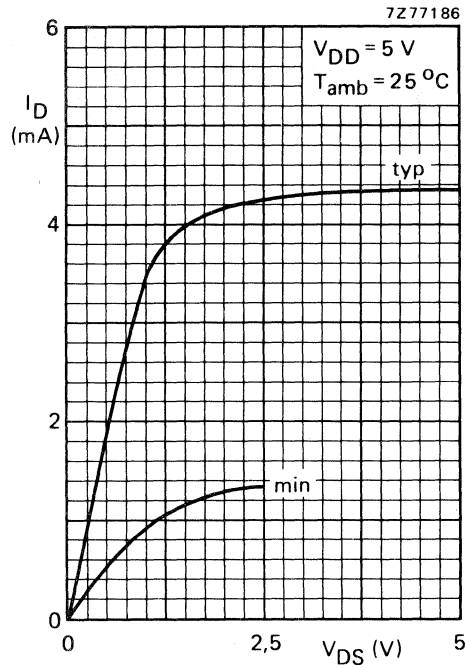

N-channel drain characteristics (sink)

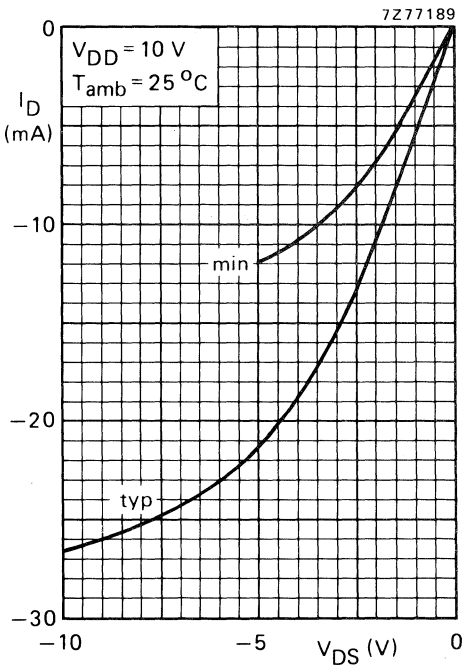

P-channel drain characteristics (source)

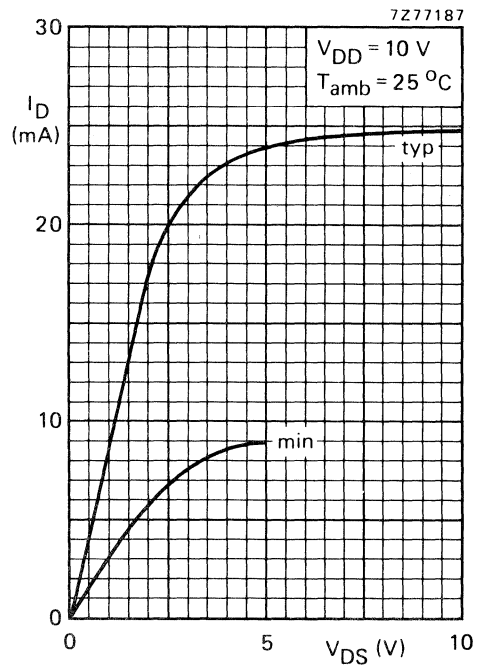

N-channel drain characteristics (sink)

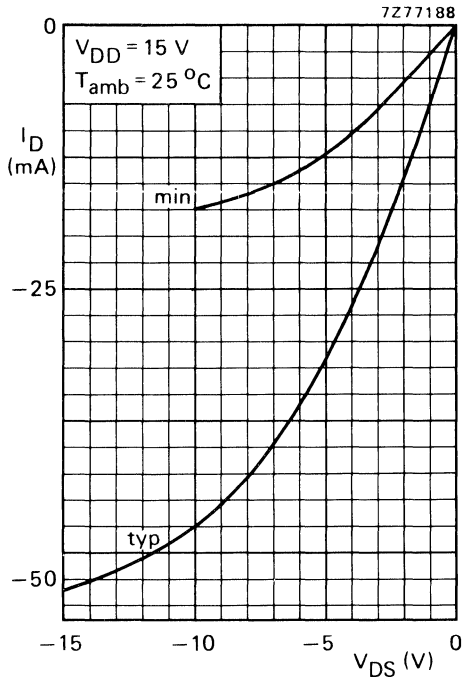

P-channel drain characteristics (source)

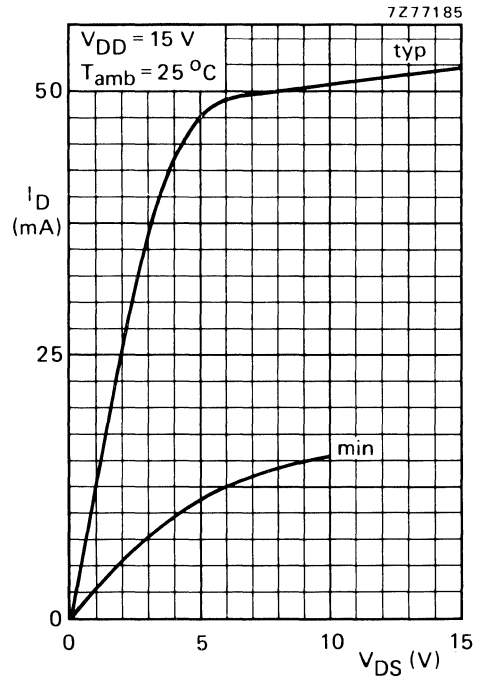

N-channel drain characteristics (sink)

Note

Temperature coefficient: $-0,4\%/^\circ\text{C}$.

A.C. CHARACTERISTICS

Clock input rise and fall times (t_r , t_f)

The upper limits on t_r and t_f vary widely from device to device and with supply voltage. Unless otherwise specified in the individual data sheets it is recommended that input rise and fall times be less than 15 μ s for $V_{DD} = 5$ V; 4 μ s for $V_{DD} = 10$ V; 1 μ s for $V_{DD} = 15$ V.

Output transition times (t_{TLH} , t_{THL})

$V_{SS} = 0$ V; $T_{amb} = 25$ °C; $C_L = 50$ pF; input transition times ≤ 20 ns

| | V_{DD} V | symbol | min. | typ. | max. | typical extrapolation formula | |
|--|---------------|-----------|------|------|------|----------------------------------|---------------------------|
| Output transition times HIGH to LOW | 5 | t_{THL} | | 60 | 120 | ns | 10 ns + (1,0 ns/pF) C_L |
| | 10 | | 30 | 60 | ns | 9 ns + (0,42 ns/pF) C_L | |
| | 15 | | 20 | 40 | ns | 6 ns + (0,28 ns/pF) C_L | |
| LOW to HIGH | 5 | t_{TLH} | | 60 | 120 | ns | 10 ns + (1,0 ns/pF) C_L |
| | 10 | | 30 | 60 | ns | 9 ns + (0,42 ns/pF) C_L | |
| | 15 | | 20 | 40 | ns | 6 ns + (0,28 ns/pF) C_L | |

Temperature coefficient (typical values)

Propagation delays +0,35%/°C
 Output transition times +0,35%/°C

Input capacitance (digital inputs)

Maximum input capacitance $C_i = 7,5$ pF.

Set-up times, hold times, recovery times and propagation delays for sequential logic circuits.

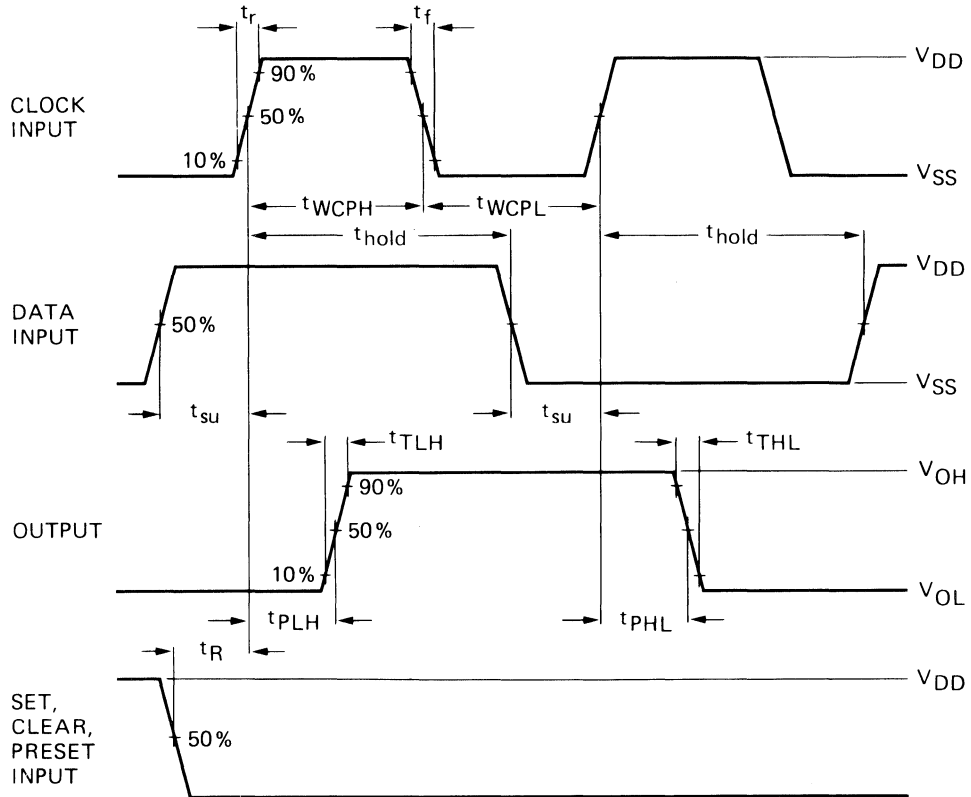

7Z75375

Note

In the waveforms above the active transition of the clock input is going from LOW to HIGH and the active level of the forcing signals (SET, CLEAR and PRESET) is HIGH.

The actual direction of the active transition of the clock input and the actual active levels of the forcing signals are specified in the individual device data sheet.

FAMILY SPECIFICATIONS

Propagation delays of 3-state outputs.

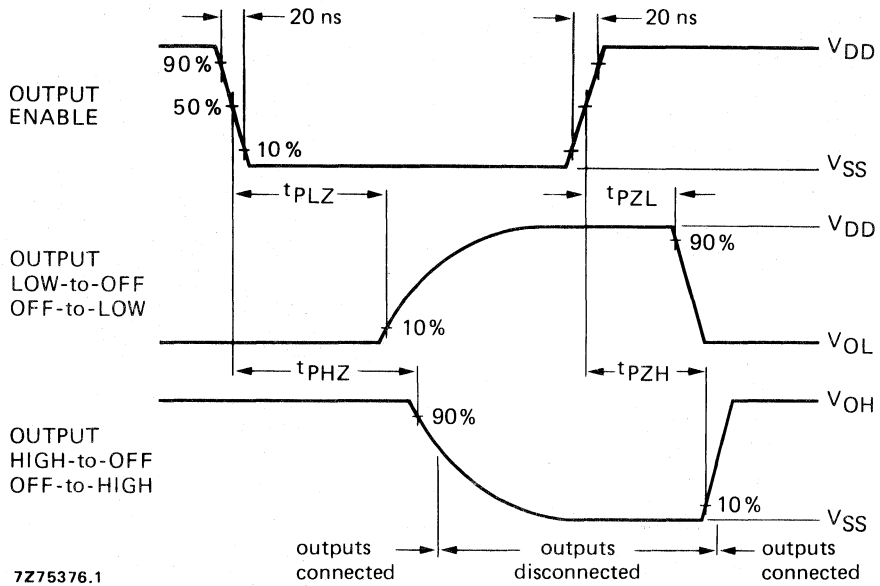

Test circuit of 3-state output ICs.

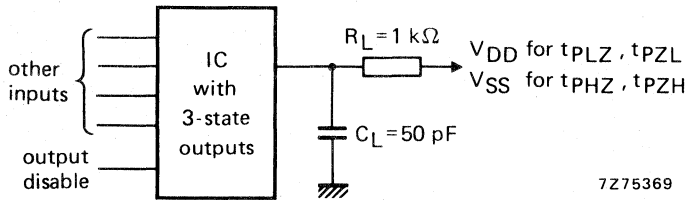

DEFINITION OF SYMBOLS AND TERMS USED IN DATA SHEETS

Currents

Positive current is defined as conventional current flow into a device. Negative current is defined as conventional current flow out of a device.

| | |
|-----------|--|
| I_{IN} | Input current; the current flowing into a device at specified input voltage and V_{DD} . |
| I_{OH} | Output current HIGH; the drive current flowing out of the device at specified HIGH output voltage and V_{DD} . |
| I_{OL} | Output current LOW; the drive current flowing into a device at specified LOW output voltage and V_{DD} . |
| I_{DD} | Quiescent power supply current; the current flowing into the V_{DD} lead at specified input and V_{DD} conditions. |
| I_{OZ} | Output OFF current; the leakage current flowing into or out of the output of a 3-state device in the OFF state when the output is connected to V_{DD} or V_{SS} . |
| I_{IL} | Input current LOW; the current flowing into a device at a specified LOW level input voltage and a specified V_{DD} . |
| I_{IH} | Input current HIGH; the current flowing into a device at a specified HIGH level input voltage and a specified V_{DD} . |
| I_{DDL} | Quiescent power supply current LOW; the current flowing into the V_{DD} lead with a specified LOW level input voltage on all inputs and specified V_{DD} conditions. |
| I_{DDH} | Quiescent power supply current HIGH; the current flowing into the V_{DD} lead with a specified HIGH level input voltage on all inputs and specified V_{DD} conditions. |
| I_Z | OFF state leakage current; the leakage current flowing into the output of a 3-state device in the OFF state at a specified output voltage and V_{DD} . |

Voltages

All voltages are referenced to V_{SS} , which is the most negative potential applied to the device.

| | |
|----------|---|
| V_{DD} | Supply voltage; the most positive potential on the device. |
| V_{SS} | Supply voltage; for a device with a single negative power supply, the most negative power supply, used as the reference level for other voltages; typically ground. |
| V_{EE} | Supply voltage; one of two (V_{SS} and V_{EE}) negative power supplies. For a device with dual negative power supply, the most negative power supply as a reference level for other voltages. |
| V_{IH} | Input voltage HIGH; the range of input voltages that represents a logic HIGH level in the system. |
| V_{IL} | Input voltage LOW; the range of input voltages that represents a logic LOW level in the system. |
| V_{OH} | Output voltage HIGH; the range of voltages at an output terminal with specified output loading and supply voltage. Device inputs are conditioned to establish a HIGH level at the output. |
| V_{OL} | Output voltage LOW; the range of voltages at an output terminal with specified output loading and supply voltage. Device inputs are conditioned to establish a LOW level at the output. |
| V_P | Trigger threshold voltage; positive-going signal. |
| V_N | Trigger threshold voltage; negative-going signal. |

Analogue terms

| | |
|-----------------|---|
| R_{ON} | ON resistance; the effective ON state resistance of an analogue transmission gate, at specified input voltage, output load and V_{DD} . |
| ΔR_{ON} | Δ ON resistance; the difference in effective ON resistance between any two transmission gates of an analogue device at specified input voltage, output load and V_{DD} . |

A.C. switching parameters

| | |
|------------|---|
| f_i | Input frequency; for combinatorial logic devices the maximum number of inputs and outputs switching in accordance with the device truth table. For sequential logic devices the clock frequency using alternate HIGH and LOW for data input or using the toggle mode, whichever is applicable. |
| f_o | Output frequency; each output. |
| f_{max} | Clock frequency; clock input waveform should have a 50% duty cycle and be such as to cause the outputs to be switching from 10% V_{DD} to 90% V_{DD} in accordance with the device truth table. |
| t_r, t_f | Clock input rise and fall times; 10% to 90% value. |
| t_{PLH} | Propagation delay time; the time between the specified reference points, normally 50% points on the input and output waveforms, with the output changing from the defined LOW level to the defined HIGH level. |
| t_{PHL} | Propagation delay time; the time between the specified reference points, normally 50% points on the input and output waveforms, with the output changing from the defined HIGH level to the defined LOW level. |
| t_{TLH} | Transition time, LOW-to-HIGH; the time between two specified reference points on a waveform, normally 10% and 90% points, that is changing from LOW to HIGH. |
| t_{THL} | Transition time, HIGH-to-LOW; the time between two specified reference points on a waveform, normally 90% and 10% points, that is changing from HIGH to LOW. |
| t_W | Pulse width; the time between 50% amplitude points on the leading and trailing edges of pulse. |
| t_{hold} | Hold time; the interval immediately following the active transition of the timing pulse (usually the clock pulse) or following the transition of the control input to its latching level, during which interval the data to be recognized must be maintained at the input to ensure their continued recognition. A negative hold time indicates that the correct logic level may be released prior to the timing pulse and still be recognized. |
| t_{su} | Set-up time; the interval immediately preceding the active transition of the timing pulse (usually the clock pulse) or preceding the transition of the control input to its latching level, during which interval the data to be recognized must be maintained at the input to ensure their recognition. A negative set-up time indicates that the correct logic level may be initiated sometime after the active transition of the timing pulse and still be recognized. |
| t_{PHZ} | 3-state output disable time, HIGH to Z; the time between the specified reference points, normally the 50% point on the output enable input voltage waveform and a point representing a 0,1 V_{OH} drop on the output voltage waveform of a 3-state device, with the output changing from the output HIGH level (V_{OH}) to a high impedance OFF-state. |
| t_{PLZ} | 3-state output disable time, LOW to Z; the time between the specified reference points, normally the 50% point on the output enable input voltage waveform and a point representing a 0,1 ($V_{DD}-V_{OL}$) rise on the output voltage waveform of a 3-state device, with the output changing from the output LOW level (V_{OL}) to a high impedance OFF-state. |
| t_{PZH} | 3-state output enable time, Z to HIGH; the time between the specified reference points, normally 50% point on the output enable input voltage waveform and a point representing 0,1 V_{OH} voltage rise on the output voltage waveform of a 3-state device, with the output changing from a high impedance OFF-state to the output HIGH level (V_{OH}). |
| t_{PZL} | 3-state output enable time, Z to LOW; the time between the specified reference points, normally the 50% point on the output enable input voltage waveform and a point representing 0,1 ($V_{DD}-V_{OL}$) voltage drop on the output voltage waveform of a 3-state device, with the output changing from a high impedance OFF-state to the output LOW level (V_{OL}). |
| t_R | Recovery time; the time between the end of an overriding asynchronous input, typically a clear or reset input, and the earliest permissible beginning of a synchronous control input, typically a clock input, normally measured at 50% points on both input voltage waveforms. |

DEVICE DATA



DUAL 3-INPUT NOR GATE AND INVERTER

The HEF4000B provides the positive dual 3-input NOR function. A single stage inverting function with standard output performance is also accomplished. The outputs are fully buffered for highest noise immunity and pattern insensitivity of output impedance.

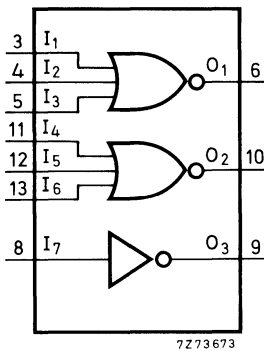

Fig. 1 Functional diagram.

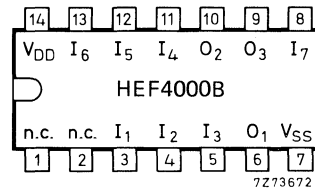

Fig. 2 Pinning diagram.

HEF4000BP : 14-lead DIL; plastic (SOT-27K, M, T).
 HEF4000BD : 14-lead DIL; ceramic (cerdip) (SOT-73).
 HEF4000BT : 14-lead mini-pack; plastic (SO-14; SOT-108A).

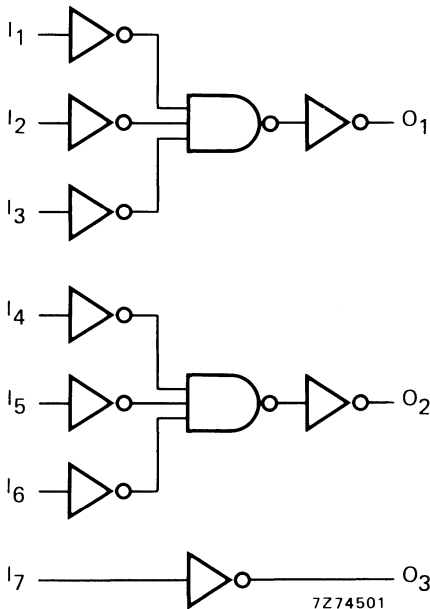

Fig. 3 Logic diagram.

FAMILY DATA

I_{DD} LIMITS category GATES

see Family Specifications

HEF4000B

gates

D.C. CHARACTERISTICS

For the single inverter stage (I_7/O_3):

see Family Specifications for input voltages HIGH and LOW (unbuffered stages only).

A.C. CHARACTERISTICS

$V_{SS} = 0\text{ V}$; $T_{amb} = 25\text{ }^\circ\text{C}$; $C_L = 50\text{ pF}$; input transition times $\leq 20\text{ ns}$

| | V_{DD} V | symbol | typ. | max. | | typical extrapolation formula |
|--|---------------|--------------------|------|------|----|--|
| Propagation delays $I_1 \text{ to } I_6 \rightarrow O_1, O_2$ | 5 | $t_{PHL}; t_{PLH}$ | 70 | 140 | ns | $43\text{ ns} + (0,55\text{ ns/pF}) C_L$ |
| | 10 | | 35 | 70 | ns | $24\text{ ns} + (0,23\text{ ns/pF}) C_L$ |
| | 15 | | 30 | 55 | ns | $22\text{ ns} + (0,16\text{ ns/pF}) C_L$ |
| $I_7 \rightarrow O_3$ (unbuffered output) | 5 | $t_{PHL}; t_{PLH}$ | 45 | 90 | ns | $18\text{ ns} + (0,55\text{ ns/pF}) C_L$ |
| | 10 | | 25 | 50 | ns | $14\text{ ns} + (0,23\text{ ns/pF}) C_L$ |
| | 15 | | 20 | 40 | ns | $12\text{ ns} + (0,16\text{ ns/pF}) C_L$ |
| Output transition times HIGH to LOW | 5 | t_{THL} | 60 | 120 | ns | $10\text{ ns} + (1,0\text{ ns/pF}) C_L$ |
| | 10 | | 30 | 60 | ns | $9\text{ ns} + (0,42\text{ ns/pF}) C_L$ |
| | 15 | | 20 | 40 | ns | $6\text{ ns} + (0,28\text{ ns/pF}) C_L$ |
| LOW to HIGH | 5 | t_{TLH} | 60 | 120 | ns | $10\text{ ns} + (1,0\text{ ns/pF}) C_L$ |
| | 10 | | 30 | 60 | ns | $9\text{ ns} + (0,42\text{ ns/pF}) C_L$ |
| | 15 | | 20 | 40 | ns | $6\text{ ns} + (0,28\text{ ns/pF}) C_L$ |

| | V_{DD} V | typical formula for P (μW) | where f_i = input freq. (MHz) f_o = output freq. (MHz) C_L = load capacitance (pF) $\Sigma(f_o C_L)$ = sum of outputs V_{DD} = supply voltage (V) |
|---|---------------|---|--|
| Dynamic power dissipation per package (P) | 5 | $1\ 000 f_i + \Sigma(f_o C_L) \times V_{DD}^2$ | |
| | 10 | $7\ 700 f_i + \Sigma(f_o C_L) \times V_{DD}^2$ | |
| | 15 | $28\ 700 f_i + \Sigma(f_o C_L) \times V_{DD}^2$ | |

APPLICATION INFORMATION

The following information (Figs 4 to 7) is only for the single inverter stage (I_7/O_3).

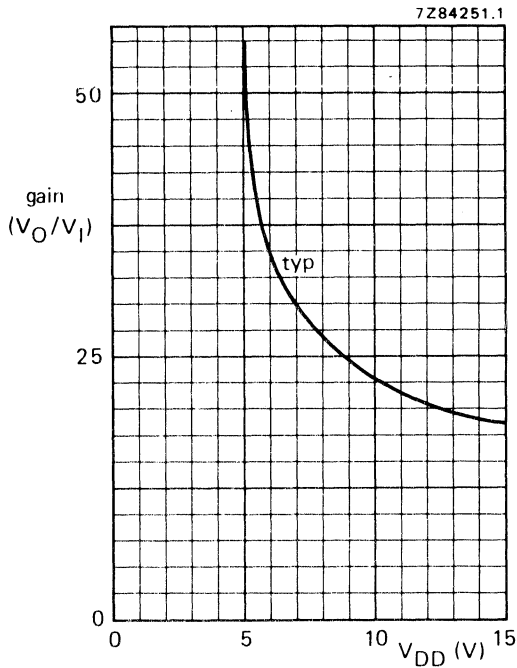

Fig. 4 Voltage gain (V_O/V_I) as a function of supply voltage.

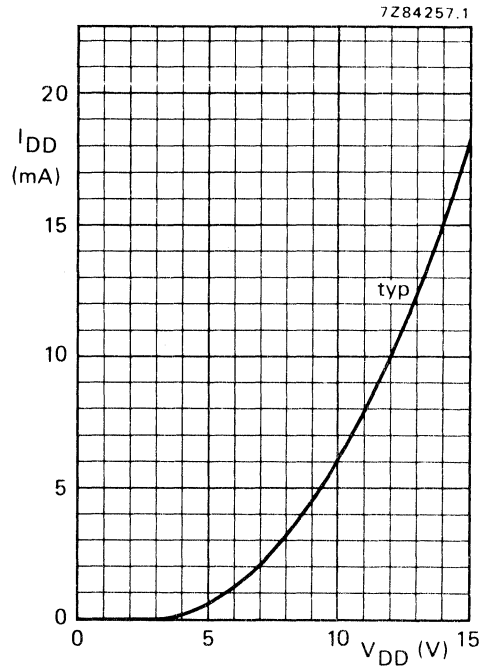

Fig. 5 Supply current as a function of supply voltage.

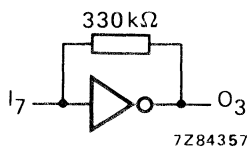

Fig. 6 Test set-up for measuring graphs of Figs 4 and 5.

This is also an example of an analogue amplifier using the single inverter stage (I_7/O_3) of the HEF4000B.

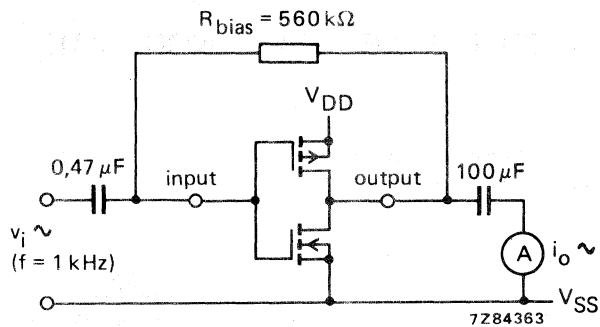
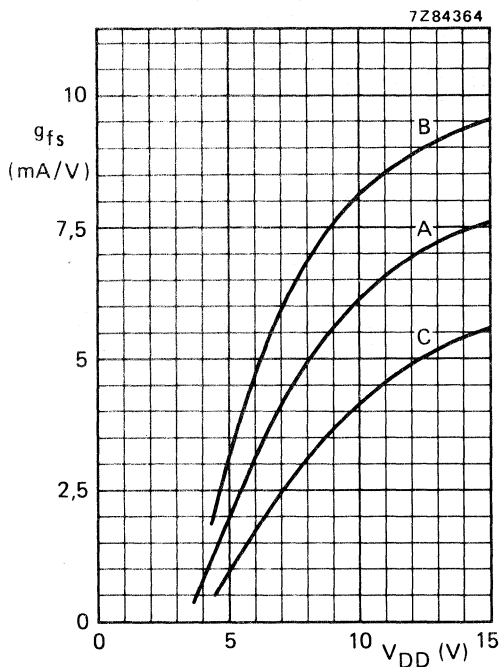

Fig. 7 Test set-up for measuring forward transconductance $g_{fs} = di_o/dv_i$ at v_o is constant (see also graph Fig. 8).



Curves in Fig. 8:

A: average

B: average + 2 s,

C: average - 2 s, in where:

's' is the observed standard deviation.

Fig. 8 Typical forward transconductance g_{fs} as a function of the supply voltage at $T_{amb} = 25\text{ }^{\circ}\text{C}$.

QUADRUPLE 2-INPUT NOR GATE



The HEF4001B provides the positive quadruple 2-input NOR function. The outputs are fully buffered for highest noise immunity and pattern insensitivity of output impedance.

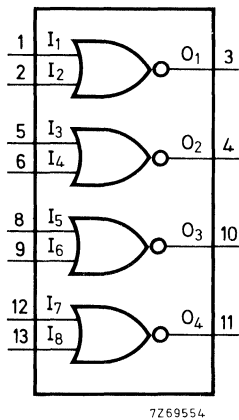

Fig. 1 Functional diagram.

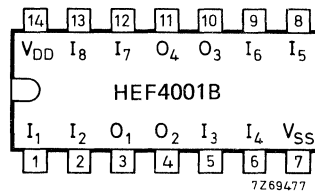

Fig. 2 Pinning diagram.

HEF4001BP : 14-lead DIL; plastic (SOT-27K, M, T).
 HEF4001BD : 14-lead DIL; ceramic (cerdip) (SOT-73).
 HEF4001BT : 14-lead mini-pack; plastic (SO-14; SOT-108A).

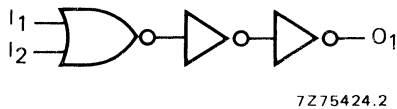

Fig. 3 Logic diagram (one gate).

FAMILY DATA

I_{DD} LIMITS category GATES

see Family Specifications

HEF4001B

gates

A.C. CHARACTERISTICS

$V_{SS} = 0\text{ V}$; $T_{amb} = 25\text{ }^{\circ}\text{C}$; $C_L = 50\text{ pF}$; input transition times $\leq 20\text{ ns}$

| | V_{DD} V | symbol | typ | max | | typical extrapolation formula |
|--|---------------|-----------|-----|-----|----|--|
| Propagation delays $I_n \rightarrow O_n$ HIGH to LOW | 5 | t_{PHL} | 60 | 120 | ns | $33\text{ ns} + (0,55\text{ ns/pF}) C_L$ |
| | 10 | | 25 | 50 | ns | $14\text{ ns} + (0,23\text{ ns/pF}) C_L$ |
| | 15 | | 20 | 40 | ns | $12\text{ ns} + (0,16\text{ ns/pF}) C_L$ |
| LOW to HIGH | 5 | t_{PLH} | 50 | 100 | ns | $23\text{ ns} + (0,55\text{ ns/pF}) C_L$ |
| | 10 | | 25 | 45 | ns | $14\text{ ns} + (0,23\text{ ns/pF}) C_L$ |
| | 15 | | 20 | 35 | ns | $12\text{ ns} + (0,16\text{ ns/pF}) C_L$ |
| Output transition times HIGH to LOW | 5 | t_{THL} | 60 | 120 | ns | $10\text{ ns} + (1,0\text{ ns/pF}) C_L$ |
| | 10 | | 30 | 60 | ns | $9\text{ ns} + (0,42\text{ ns/pF}) C_L$ |
| | 15 | | 20 | 40 | ns | $6\text{ ns} + (0,28\text{ ns/pF}) C_L$ |
| LOW to HIGH | 5 | t_{TLH} | 60 | 120 | ns | $10\text{ ns} + (1,0\text{ ns/pF}) C_L$ |
| | 10 | | 30 | 60 | ns | $9\text{ ns} + (0,42\text{ ns/pF}) C_L$ |
| | 15 | | 20 | 40 | ns | $6\text{ ns} + (0,28\text{ ns/pF}) C_L$ |

| | V_{DD} V | typical formula for P (μW) | where f_i = input freq. (MHz) f_o = output freq. (MHz) C_L = load capacitance (pF) $\Sigma(f_o C_L)$ = sum of outputs V_{DD} = supply voltage (V) |
|---|---------------|---|--|
| Dynamic power dissipation per package (P) | 5 | $1100 f_i + \Sigma(f_o C_L) \times V_{DD}^2$ | |
| | 10 | $5000 f_i + \Sigma(f_o C_L) \times V_{DD}^2$ | |
| | 15 | $14\,200 f_i + \Sigma(f_o C_L) \times V_{DD}^2$ | |

QUADRUPLE 2-INPUT NOR GATE



The HEF4001UB is a quadruple 2-input NOR gate. This unbuffered single stage version provides a direct implementation of the NOR function. The output impedance and output transition time depends on the input voltage and input rise and fall times applied.

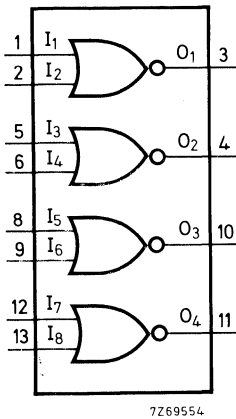

Fig. 1 Functional diagram.

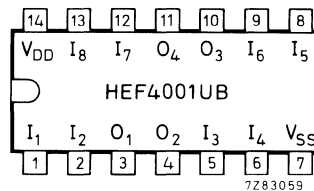

Fig. 2 Pinning diagram.

HEF4001UBP : 14-lead DIL; plastic (SOT-27K, M, T).
 HEF4001UBD : 14-lead DIL; ceramic (cerdip) (SOT-73).
 HEF4001UBT : 14-lead mini-pack; plastic (SO-14; SOT-108A).

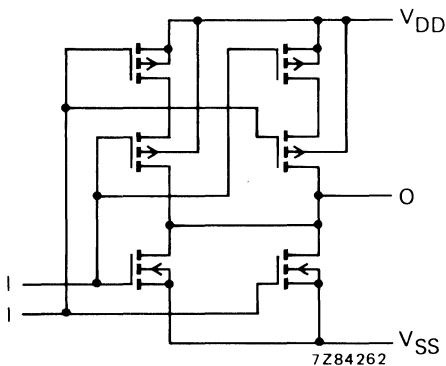

Fig. 3 Schematic diagram (one gate). The splitting-up of the p-transistors provide identical inputs.

FAMILY DATA

I_{DD} LIMITS category GATES

see Family Specifications for V_{IH}/V_{IL} unbuffered stages

HEF4001UB

gates

A.C. CHARACTERISTICS

$V_{SS} = 0 \text{ V}$; $T_{amb} = 25 \text{ }^\circ\text{C}$; $C_L = 50 \text{ pF}$; input transition times $\leq 20 \text{ ns}$

| | V_{DD} V | symbol | typ. | max. | | typical extrapolation formula | |
|--|---------------|-----------|-----------|------|-----|--|--|
| Propagation delays $I_n \rightarrow O_n$ HIGH to LOW | 5 | t_{PHL} | 65 | 130 | ns | $30 \text{ ns} + (0,70 \text{ ns/pF}) C_L$ | |
| | 10 | | 30 | 60 | ns | $17 \text{ ns} + (0,27 \text{ ns/pF}) C_L$ | |
| | 15 | | 25 | 50 | ns | $15 \text{ ns} + (0,20 \text{ ns/pF}) C_L$ | |
| LOW to HIGH | 5 | t_{PLH} | 40 | 80 | ns | $13 \text{ ns} + (0,55 \text{ ns/pF}) C_L$ | |
| | 10 | | 20 | 40 | ns | $9 \text{ ns} + (0,23 \text{ ns/pF}) C_L$ | |
| | 15 | | 15 | 30 | ns | $7 \text{ ns} + (0,16 \text{ ns/pF}) C_L$ | |
| Output transition times | 5 | t_{THL} | 75 | 150 | ns | $15 \text{ ns} + (1,20 \text{ ns/pF}) C_L$ | |
| | 10 | | 30 | 60 | ns | $6 \text{ ns} + (0,48 \text{ ns/pF}) C_L$ | |
| | 15 | | 20 | 40 | ns | $4 \text{ ns} + (0,32 \text{ ns/pF}) C_L$ | |
| | HIGH to LOW | 5 | t_{TLH} | 60 | 110 | ns | $10 \text{ ns} + (1,00 \text{ ns/pF}) C_L$ |
| | | 10 | | 30 | 60 | ns | $9 \text{ ns} + (0,42 \text{ ns/pF}) C_L$ |
| | | 15 | | 20 | 40 | ns | $6 \text{ ns} + (0,28 \text{ ns/pF}) C_L$ |
| Input capacitance | | C_{IN} | — | 10 | pF | | |

| | V_{DD} V | typical formula for P (μW) | where |
|---|---------------|---|------------------------------------|
| Dynamic power dissipation per package (P) | 5 | $500 f_i + \Sigma(f_o C_L) \times V_{DD}^2$ | f_i = input freq. (MHz) |
| | 10 | | f_o = output freq. (MHz) |
| | 15 | | C_L = load capacitance (pF) |
| | | | $\Sigma(f_o C_L)$ = sum of outputs |
| | | | V_{DD} = supply voltage (V) |

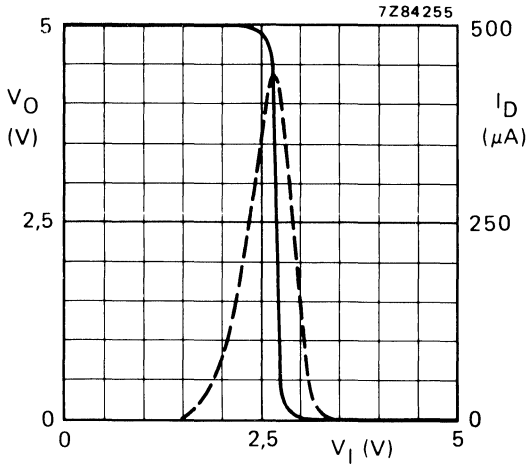

Fig. 4 Typical transfer characteristics; one input, the other input connected to V_{SS} ; — V_O ; - - - I_D (drain current); $I_O = 0$; $V_{DD} = 5 V$.

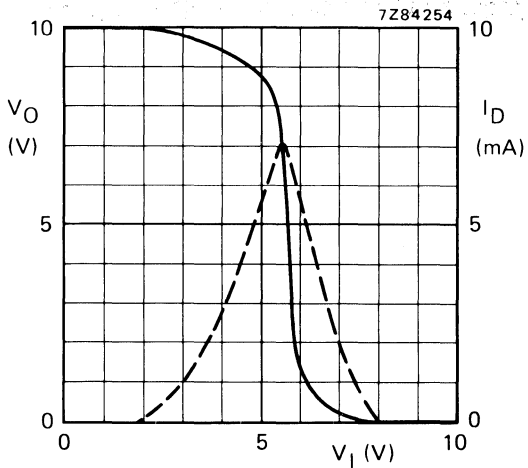

Fig. 5 Typical transfer characteristics; one input, the other input connected to V_{SS} ; — V_O ; - - - I_D (drain current); $I_O = 0$; $V_{DD} = 10 V$.

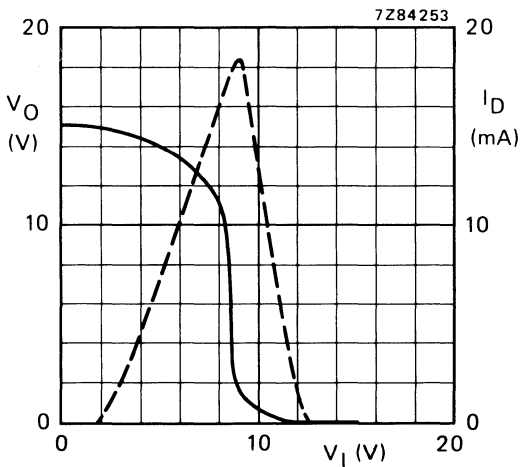

Fig. 6 Typical transfer characteristics; one input, the other input connected to V_{SS} ; — V_O ; - - - I_D (drain current); $I_O = 0$; $V_{DD} = 15 V$.

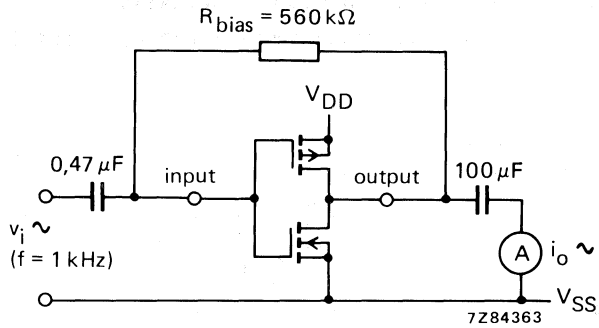
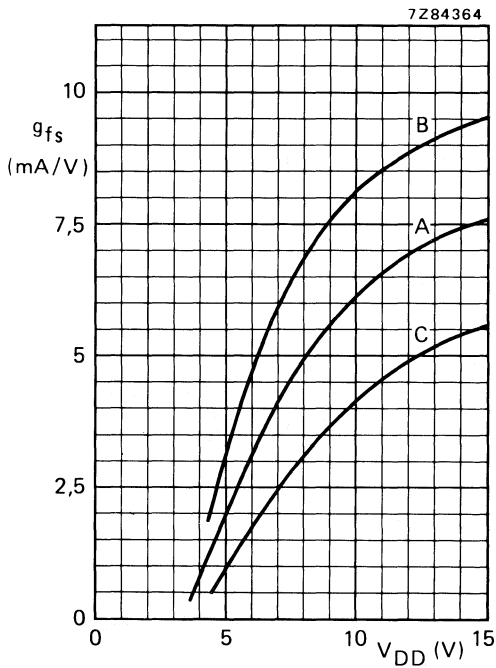

Fig. 7 Test set-up for measuring forward transconductance $g_{fs} = di_o/dv_i$ at v_o is constant (see also graph Fig. 8).



Curves in Fig. 8:

- A : average,
- B : average + 2 s,
- C : average - 2 s, in where:
's' is the observed standard deviation.

Fig. 8 Typical forward transconductance g_{fs} as a function of the supply voltage at $T_{amb} = 25$ °C.

APPLICATION INFORMATION

Some examples of applications for the HEF4001UB are shown below.

Because of the fact that this circuit is unbuffered, it is suitable for use in (partly) analogue circuits.

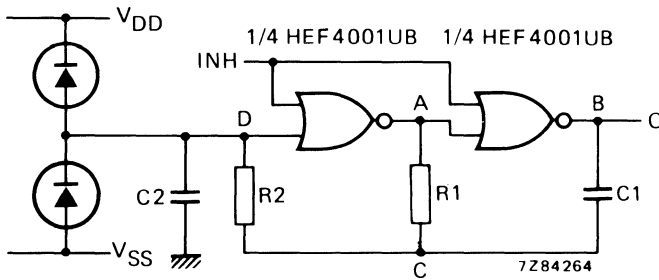

| | |
|-----|-----|
| INH | O |
| H | L |
| L | OSC |

(a)

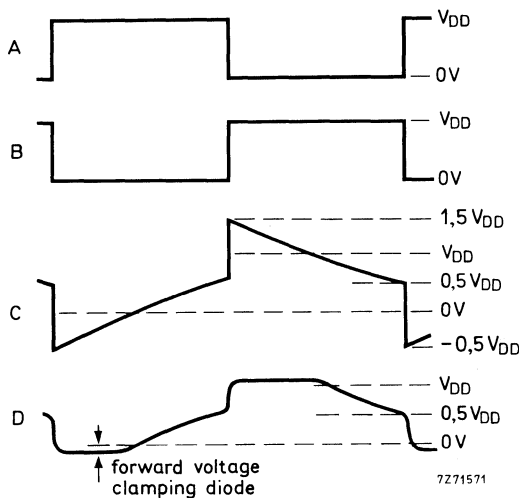

(b)

Fig. 9(a) Astable relaxation oscillator using two HEF4001UB gates; the diodes may be BAW62; C2 is a parasitic capacitance. (b) Waveforms at the points marked A, B, C and D in the circuit diagram.

In Fig. 9 the oscillation frequency is mainly determined by R1C1, provided $R1 \ll R2$ and $R2C2 \ll R1C1$.

The function of R2 is to minimize the influence of the forward voltage across the protection diodes on the frequency; C2 is a stray (parasitic) capacitance. The period T_p is given by $T_p = T_1 + T_2$, in which

$$T_1 = R1C1 \ln \frac{V_{DD} + V_{ST}}{V_{ST}} \text{ and } T_2 = R1C1 \ln \frac{2V_{DD} - V_{ST}}{V_{DD} - V_{ST}} \text{ where}$$

V_{ST} is the signal threshold level of the gate. The period is fairly independent of V_{DD} , V_{ST} and temperature. The duty factor, however, is influenced by V_{ST} .

HEF4001UB
gates

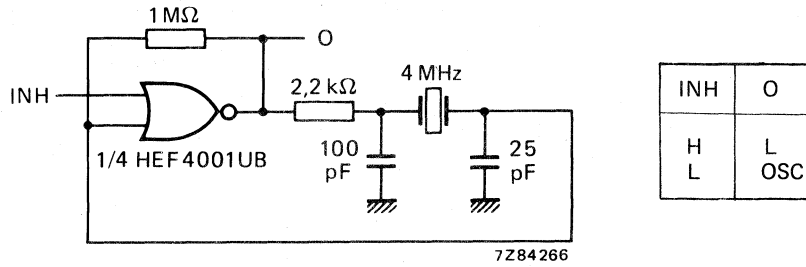

Fig. 10 Example of a crystal oscillator using one HEF4001UB gate.

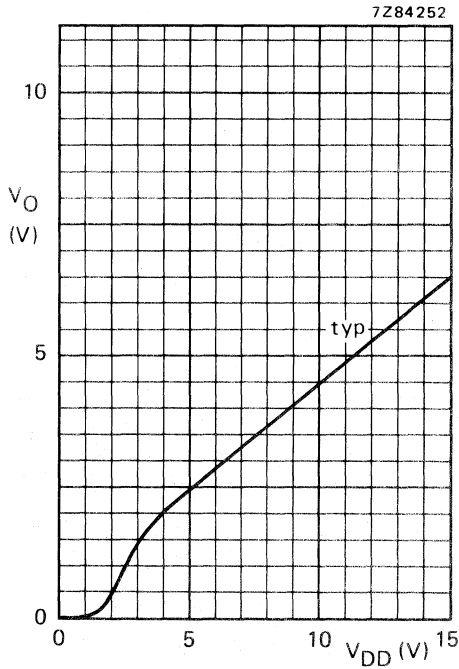

Fig. 11 Output voltages as a function of supply voltage.

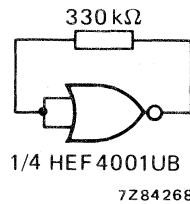

Fig. 12 Test set-up for measuring graph of Fig. 11. Condition: all other inputs connected to ground.

NOTES

If a gate is just used as an amplifying inverter, there are two possibilities:

- Connecting the inputs together gives simpler wiring, but makes the device output not completely symmetrical.
- Connecting one input to V_{SS} will give the device a symmetrical output.

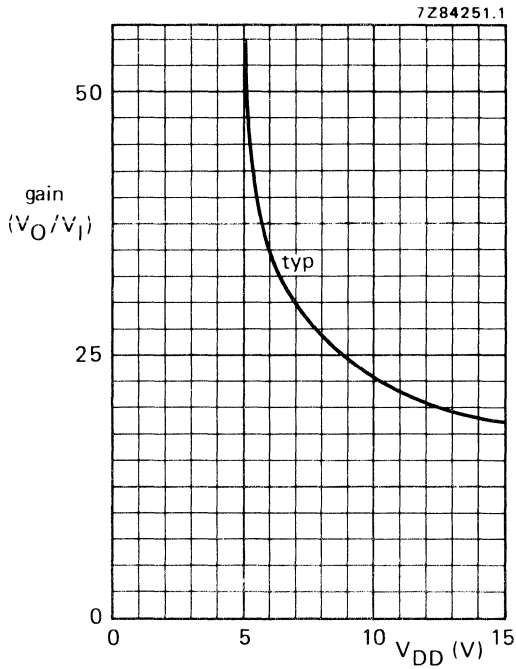

Fig. 13 Voltage gain (V_O/V_I) as a function of supply voltage.

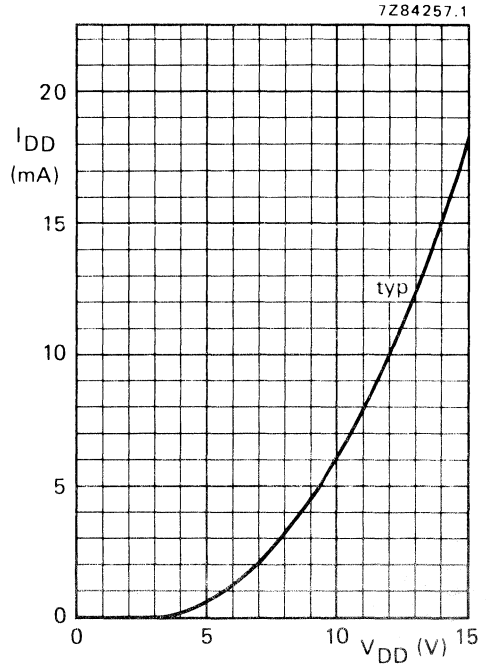
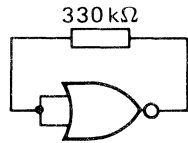

Fig. 14 Supply current as a function of supply voltage.



7Z84268

Fig. 15 Test set-up for measuring graphs of Figs 13 and 14. Condition: all other inputs connected to ground.

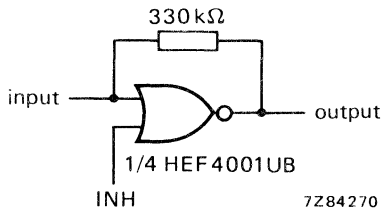

Fig. 16 Example of an analogue amplifier with inhibit using one HEF4001UB gate.



DUAL 4-INPUT NOR GATE

The HEF4002B provides the positive dual 4-input NOR function. The outputs are fully buffered for highest noise immunity and pattern insensitivity of output impedance.

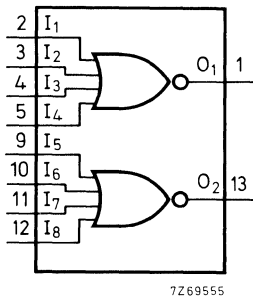

Fig. 1 Functional diagram.

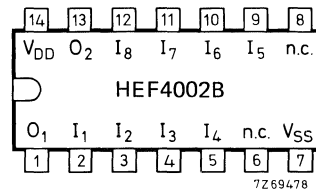

Fig. 2 Pinning diagram.

HEF4002BP : 14-lead DIL; plastic (SOT-27K, M, T).
HEF4002BD : 14-lead DIL; ceramic (cerdip) (SOT-73).
HEF4002BT : 14-lead mini-pack; plastic (SO-14; SOT-108A).

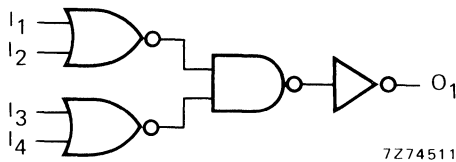

Fig. 3 Logic diagram (one gate).

FAMILY DATA

see Family Specifications

I_{DD} LIMITS category GATES

HEF4002B

gates

A.C. CHARACTERISTICS

$V_{SS} = 0\text{ V}$; $T_{amb} = 25\text{ }^{\circ}\text{C}$; $C_L = 50\text{ pF}$; input transition times $\leq 20\text{ ns}$

| | V_{DD} V | symbol | typ. | max. | | typical extrapolation formula |
|---|---------------|--------------------|------|------|----|--|
| Propagation delays $I_n \rightarrow O_n$ | 5 | | 60 | 120 | ns | $33\text{ ns} + (0,55\text{ ns/pF}) C_L$ |
| | 10 | $t_{PHL}; t_{PLH}$ | 25 | 50 | ns | $14\text{ ns} + (0,23\text{ ns/pF}) C_L$ |
| | 15 | | 20 | 40 | ns | $12\text{ ns} + (0,16\text{ ns/pF}) C_L$ |
| Output transition times HIGH to LOW | 5 | | 60 | 120 | ns | $10\text{ ns} + (1,0\text{ ns/pF}) C_L$ |
| | 10 | t_{THL} | 30 | 60 | ns | $9\text{ ns} + (0,42\text{ ns/pF}) C_L$ |
| | 15 | | 20 | 40 | ns | $6\text{ ns} + (0,28\text{ ns/pF}) C_L$ |
| LOW to HIGH | 5 | | 60 | 120 | ns | $10\text{ ns} + (1,0\text{ ns/pF}) C_L$ |
| | 10 | t_{TLH} | 30 | 60 | ns | $9\text{ ns} + (0,42\text{ ns/pF}) C_L$ |
| | 15 | | 20 | 40 | ns | $6\text{ ns} + (0,28\text{ ns/pF}) C_L$ |

| | V_{DD} V | typical formula for P (μW) | where |
|---|---------------|---|------------------------------------|
| Dynamic power dissipation per package (P) | 5 | $1050 f_i + \Sigma(f_o C_L) \times V_{DD}^2$ | f_i = input freq. (MHz) |
| | 10 | $4300 f_i + \Sigma(f_o C_L) \times V_{DD}^2$ | f_o = output freq. (MHz) |
| | 15 | $11\,700 f_i + \Sigma(f_o C_L) \times V_{DD}^2$ | C_L = load capacitance (pF) |
| | | | $\Sigma(f_o C_L)$ = sum of outputs |
| | | | V_{DD} = supply voltage (V) |

18-STAGE STATIC SHIFT REGISTER



The HEF4006B is an 18-stage shift register arranged as two 4-stage and two 5-stage shift registers with a common clock input (\overline{CP}). The two 4-stage shift registers each have a data input (D_A , D_B) and a data output (O_{3A} , O_{3B}); the two 5-stage shift registers each have a data input (D_C , D_D) and data outputs from the fourth and fifth stages (O_{3C} , O_{4C} , O_{3D} , O_{4D}).

The registers can be operated in parallel or interconnected to form a single shift register of up to 18 bits. Data are shifted into the first register position of each register from the data inputs (D_A to D_D) and all the data in each register are shifted one position to the right on the HIGH to LOW transition of \overline{CP} .

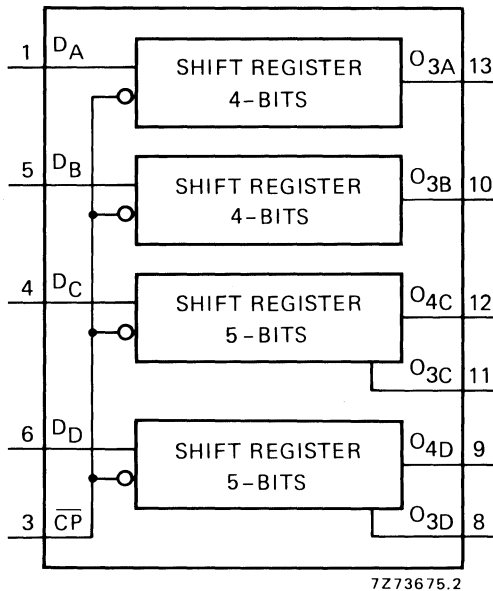

Fig. 1 Functional diagram.

PINNING

D_A to D_D data inputs
 \overline{CP} clock input (HIGH to LOW; edge-triggered)
 O_{3A} to O_{3D} ; O_{4C} ; O_{4D} data outputs

FAMILY DATA

I_{DD} LIMITS category MSI

} see Family Specifications

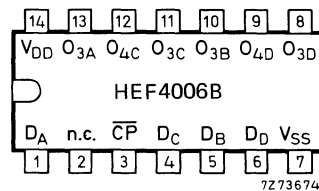

Fig. 2 Pinning diagram.

HEF4006BP : 14-lead DIL; plastic (SOT-27K, M, T).
 HEF4006BD: 14-lead DIL; ceramic (cerdip) (SOT-73).
 HEF4006BT : 14-lead mini-pack; plastic (SO-14; SOT-108A).

FUNCTION TABLE

| D_n | \overline{CP} | O_n^* |
|-------|-----------------|-----------|
| D_1 | \nearrow | D_1 |
| X | \searrow | no change |

X = state is immaterial
 \nearrow = positive-going transition
 \searrow = negative-going transition
 D_1 = either HIGH or LOW

* The moment D_1 appears at O depends on the register length.

HEF4006B
MSI

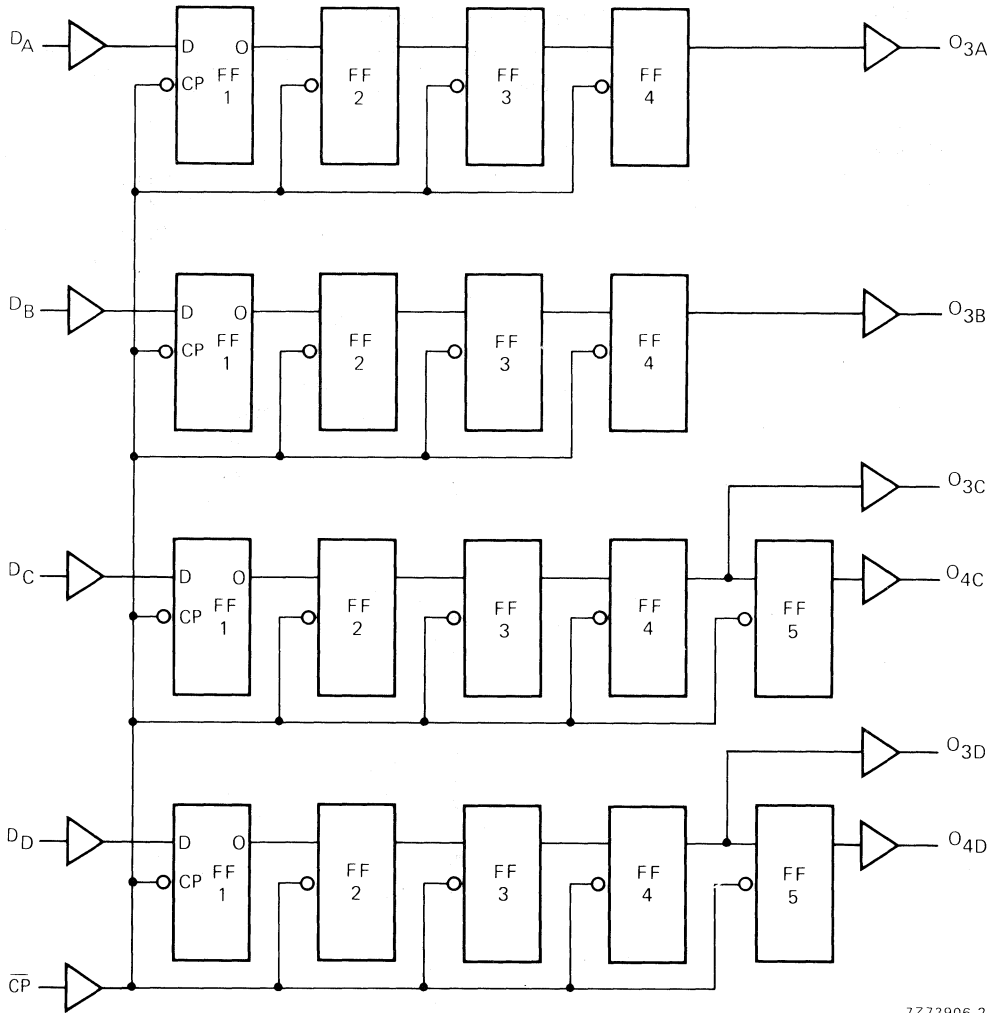

7273906.2

Fig. 3 Logic diagram.

A.C. CHARACTERISTICS

$V_{SS} = 0\text{ V}$; $T_{amb} = 25\text{ }^\circ\text{C}$; $C_L = 50\text{ pF}$; input transition times $\leq 20\text{ ns}$

| | V_{DD} V | symbol | min | typ | max | typical extrapolation formula |
|---|---------------|------------|-----|-------|--|--|
| Propagation delays $CP \rightarrow O_n$ HIGH to LOW | 5 | t_{PHL} | | 90 | 180 ns | $63\text{ ns} + (0,55\text{ ns/pF}) C_L$ |
| | 10 | | 40 | 80 ns | $29\text{ ns} + (0,23\text{ ns/pF}) C_L$ | |
| | 15 | | 30 | 60 ns | $22\text{ ns} + (0,16\text{ ns/pF}) C_L$ | |
| LOW to HIGH | 5 | t_{PLH} | | 90 | 180 ns | $63\text{ ns} + (0,55\text{ ns/pF}) C_L$ |
| | 10 | | 40 | 85 ns | $29\text{ ns} + (0,23\text{ ns/pF}) C_L$ | |
| | 15 | | 35 | 70 ns | $27\text{ ns} + (0,16\text{ ns/pF}) C_L$ | |
| Output transition times HIGH to LOW | 5 | t_{THL} | | 60 | 120 ns | $10\text{ ns} + (1,0\text{ ns/pF}) C_L$ |
| | 10 | | 30 | 60 ns | $9\text{ ns} + (0,42\text{ ns/pF}) C_L$ | |
| | 15 | | 20 | 40 ns | $6\text{ ns} + (0,28\text{ ns/pF}) C_L$ | |
| LOW to HIGH | 5 | t_{TLH} | | 60 | 120 ns | $10\text{ ns} + (1,0\text{ ns/pF}) C_L$ |
| | 10 | | 30 | 60 ns | $9\text{ ns} + (0,42\text{ ns/pF}) C_L$ | |
| | 15 | | 20 | 40 ns | $6\text{ ns} + (0,28\text{ ns/pF}) C_L$ | |
| Minimum clock pulse width; HIGH | 5 | t_{WCPH} | 60 | 30 | ns | } see also waveforms Fig. 4 |
| | 10 | | 40 | 20 | ns | |
| | 15 | | 30 | 15 | ns | |
| Set-up time $D_n \rightarrow \overline{CP}$ | 5 | t_{su} | 20 | 10 | ns | |
| | 10 | | 10 | 5 | ns | |
| | 15 | | 5 | 0 | ns | |
| Hold time $D_n \rightarrow \overline{CP}$ | 5 | t_{hold} | 5 | -5 | ns | |
| | 10 | | 5 | 0 | ns | |
| | 15 | | 5 | 0 | ns | |
| Maximum clock pulse frequency | 5 | f_{max} | 9 | 18 | MHz | |
| | 10 | | 15 | 30 | MHz | |
| | 15 | | 18 | 36 | MHz | |

| | V_{DD} V | typical formula for P (μW) | where f_i = input freq. (MHz) f_o = output freq. (MHz) C_L = load capacitance (pF) $\Sigma(f_o C_L)$ = sum of outputs V_{DD} = supply voltage (V) |
|---|---------------|---|--|
| Dynamic power dissipation per package (P) | 5 | $600 f_i + \Sigma(f_o C_L) \times V_{DD}^2$ | |
| | 10 | $3200 f_i + \Sigma(f_o C_L) \times V_{DD}^2$ | |
| | 15 | $11\,600 f_i + \Sigma(f_o C_L) \times V_{DD}^2$ | |

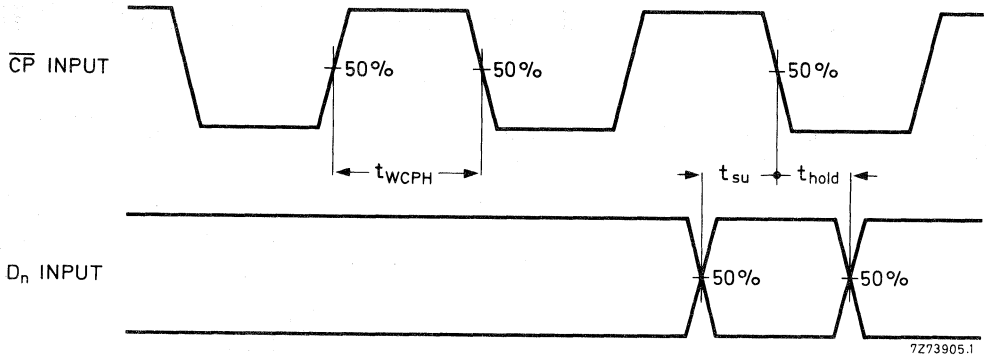

Fig. 4 Waveforms showing minimum clock pulse width, and set-up and hold-times for D_n to \overline{CP} . Set-up and hold times are shown as positive values but may be specified as negative values.

DUAL COMPLEMENTARY PAIR AND INVERTER



The HEF4007UB is a dual complementary pair and an inverter with access to each device. It has three n-channel and three p-channel enhancement mode MOS transistors.

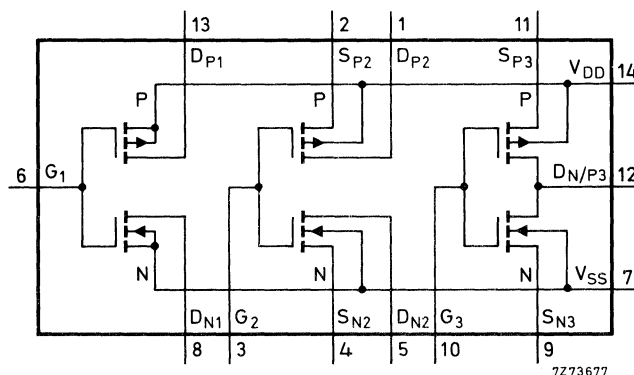

Fig. 1 Schematic diagram.

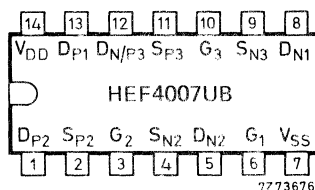

Fig. 2 Pinning diagram.

HEF4007UBP: 14-lead DIL; plastic (SOT-27K, M, T).

HEF4007UBD: 14-lead DIL; ceramic (cerdip) (SOT-73).

HEF4007UBT: 14-lead mini-pack; plastic
(SO-14; SOT-108A).

PINNING

- Sp₂, Sp₃ source connections to 2nd and 3rd p-channel transistors
 Dp₁, Dp₂ drain connections from the 1st and 2nd p-channel transistors
 Dn₁, Dn₂ drain connections from the 1st and 2nd n-channel transistors
 Sn₂, Sn₃ source connections to the 2nd and 3rd n-channel transistors
 Dn/P₃ common connection to the 3rd p-channel and n-channel transistor drains
 G₁ to G₃ gate connections to n-channel and p-channel of the three transistor pairs

FAMILY DATA

I_{DD} LIMITS category GATES

see Family Specifications for V_{IH}/V_{IL} unbuffered stages

HEF4007UB

gates

A.C. CHARACTERISTICS

$V_{SS} = 0 \text{ V}$; $T_{amb} = 25 \text{ }^\circ\text{C}$; $C_L = 50 \text{ pF}$; input transition times $\leq 20 \text{ ns}$

| | V_{DD} V | symbol | typ. | max. | | typical extrapolation formula |
|--|---------------|-----------|------|------|----|--|
| Propagation delays $G_n \rightarrow D_N$; D_p HIGH to LOW | 5 | t_{PHL} | 40 | 80 | ns | $13 \text{ ns} + (0,55 \text{ ns/pF}) C_L$ |
| | 10 | | 20 | 40 | ns | $9 \text{ ns} + (0,23 \text{ ns/pF}) C_L$ |
| | 15 | | 15 | 30 | ns | $7 \text{ ns} + (0,16 \text{ ns/pF}) C_L$ |
| LOW to HIGH | 5 | t_{PLH} | 40 | 75 | ns | $13 \text{ ns} + (0,55 \text{ ns/pF}) C_L$ |
| | 10 | | 20 | 40 | ns | $9 \text{ ns} + (0,23 \text{ ns/pF}) C_L$ |
| | 15 | | 15 | 30 | ns | $7 \text{ ns} + (0,16 \text{ ns/pF}) C_L$ |
| Output transition times HIGH to LOW | 5 | t_{THL} | 60 | 120 | ns | $10 \text{ ns} + (1,0 \text{ ns/pF}) C_L$ |
| | 10 | | 30 | 60 | ns | $9 \text{ ns} + (0,42 \text{ ns/pF}) C_L$ |
| | 15 | | 20 | 40 | ns | $6 \text{ ns} + (0,28 \text{ ns/pF}) C_L$ |
| LOW to HIGH | 5 | t_{TLH} | 60 | 120 | ns | $10 \text{ ns} + (1,0 \text{ ns/pF}) C_L$ |
| | 10 | | 30 | 60 | ns | $9 \text{ ns} + (0,42 \text{ ns/pF}) C_L$ |
| | 15 | | 20 | 40 | ns | $6 \text{ ns} + (0,28 \text{ ns/pF}) C_L$ |

| | V_{DD} V | typical formula for P (μW) | where |
|---|---------------|--|------------------------------------|
| Dynamic power dissipation per package (P) | 5 | $4500 f_i + \Sigma(f_o C_L) \times V_{DD}^2$ | f_i = input freq. (MHz) |
| | 10 | | f_o = output freq. (MHz) |
| | 15 | | C_L = load capacitance (pF) |
| | | | $\Sigma(f_o C_L)$ = sum of outputs |
| | | | V_{DD} = supply voltage (V) |

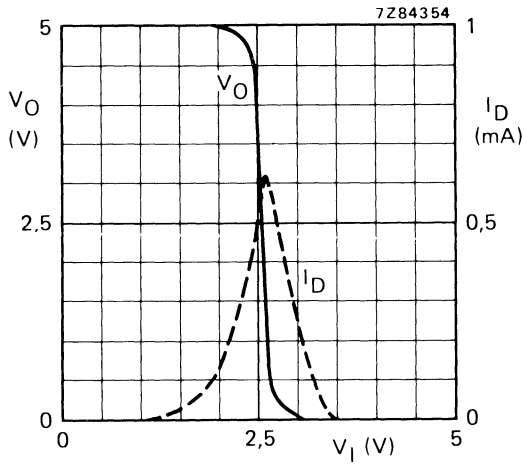

Fig. 3 Typical drain current I_D and output voltage V_O as functions of input voltage; $V_{DD} = 5$ V; $T_{amb} = 25$ °C.

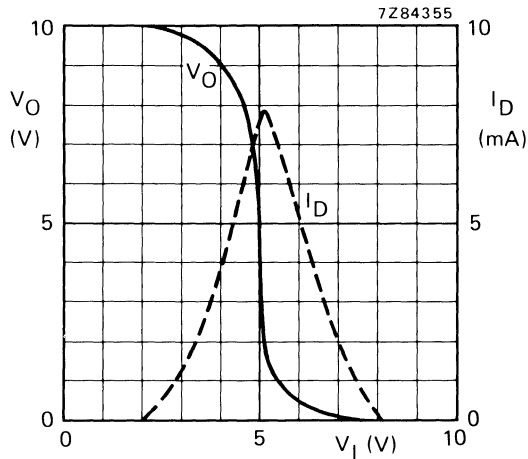

Fig. 4 Typical drain current I_D and output voltage V_O as functions of input voltage; $V_{DD} = 10$ V; $T_{amb} = 25$ °C.

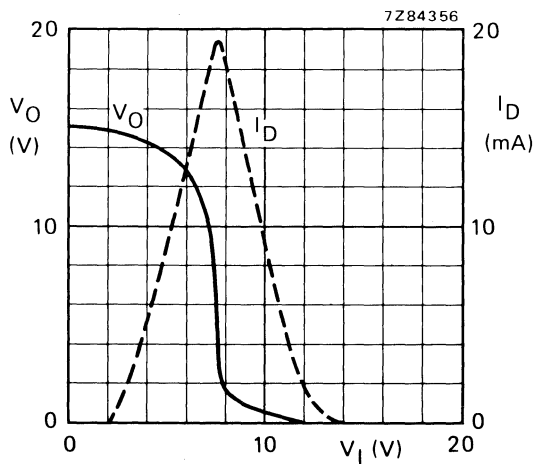

Fig. 5 Typical drain current I_D and output voltage V_O as functions of input voltage; $V_{DD} = 15$ V; $T_{amb} = 25$ °C.

APPLICATION INFORMATION

Some examples of applications for the HEF4007UB are:

- High input impedance amplifiers
- Linear amplifiers
- (Crystal) oscillators
- High-current sink and source drivers
- High impedance buffers.

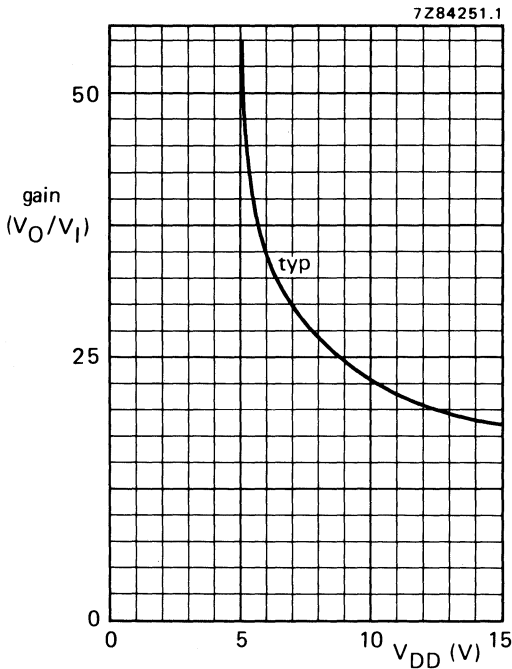

Fig. 6 Voltage gain (V_O/V_I) as a function of supply voltage.

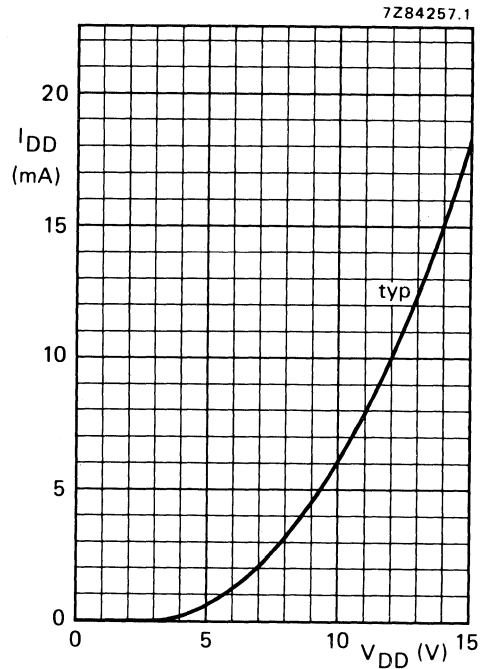

Fig. 7 Supply current as a function of supply voltage.

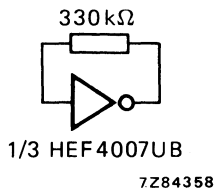

Fig. 8 Test set-up for measuring graphs of Figs 6 and 7.

This is also an example of an analogue amplifier using one HEF4007UB gate.

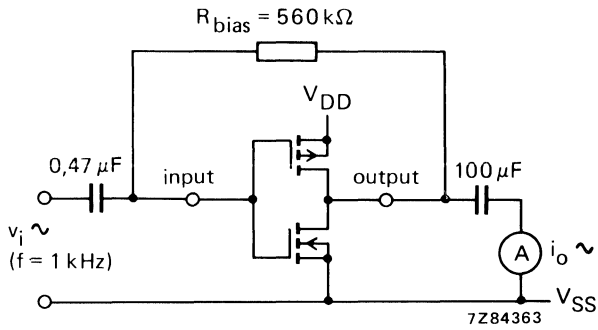
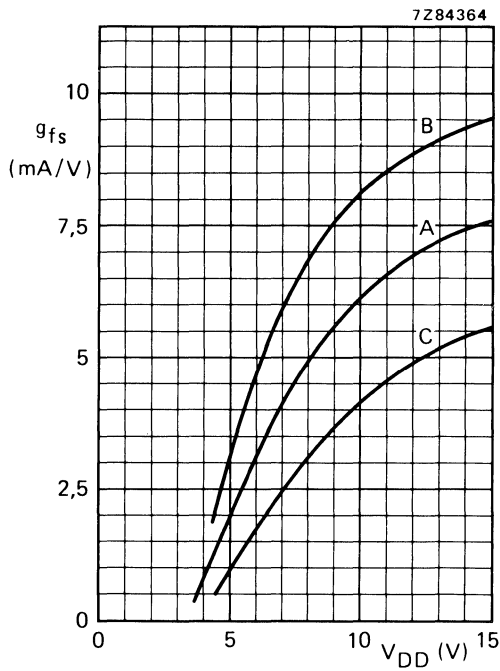

Fig. 9 Test set-up for measuring forward transconductance $g_{fs} = di_o/dv_i$ at v_o is constant (see also graph Fig. 10).



Curves in Fig. 10:

- A: average,
- B: average + 2 s,
- C: average - 2 s, in where 's' is the observed standard deviation.

Fig. 10 Typical forward transconductance g_{fs} as a function of the supply voltage at $T_{amb} = 25\text{ }^\circ\text{C}$.

APPLICATION INFORMATION (continued)

Figures 11 to 14 show some applications in which the HEF4007UB is used.

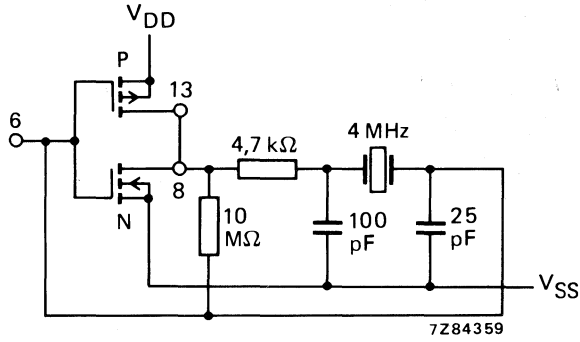

Fig. 11 4 MHz crystal oscillator.

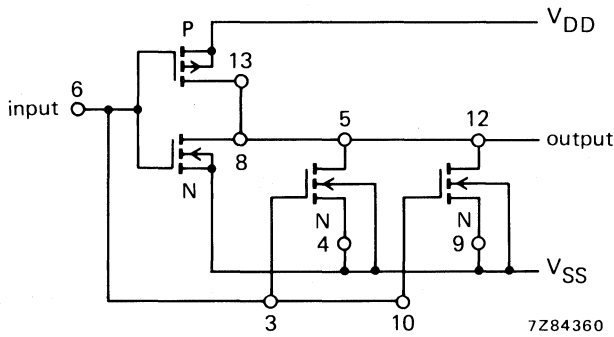

Fig. 12 High current sink driver.

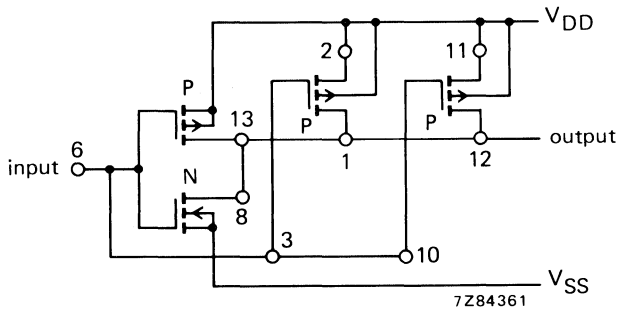

Fig. 13 High current source driver.

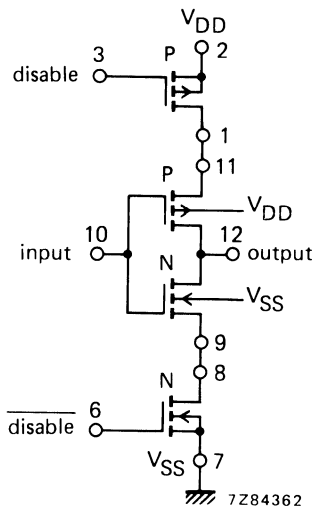

Fig. 14 High impedance buffer.

FUNCTION TABLE for Fig. 14.

| input | disable | output |
|-------|---------|--------|
| H | L | L |
| L | L | H |
| X | H | open |

H = HIGH state (the more positive voltage)

L = LOW state (the less positive voltage)

X = state is immaterial

NOTE

Rules for maintaining electrical isolation between transistors and monolithic substrate:

Pin number 14 must be maintained at the most positive (or equally positive) potential with respect to any other pin of the HEF4007UB.

Pin number 7 must be maintained at the most negative (or equally negative) potential with respect to any other pin of the HEF4007UB.

Violation of these rules will result in improper transistor operation and/or possible permanent damage to the HEF4007UB.



4-BIT BINARY FULL ADDER

The HEF4008B is a 4 bit binary full adder with two 4-bit data inputs (A_0 to A_3 , B_0 to B_3), a carry input (C_{IN}), four sum outputs (S_0 to S_3), and a carry output (C_{OUT}). The IC uses full look-ahead across 4-bits to generate C_{OUT} . This minimizes the necessity for extensive look-ahead and carry-cascading circuits.

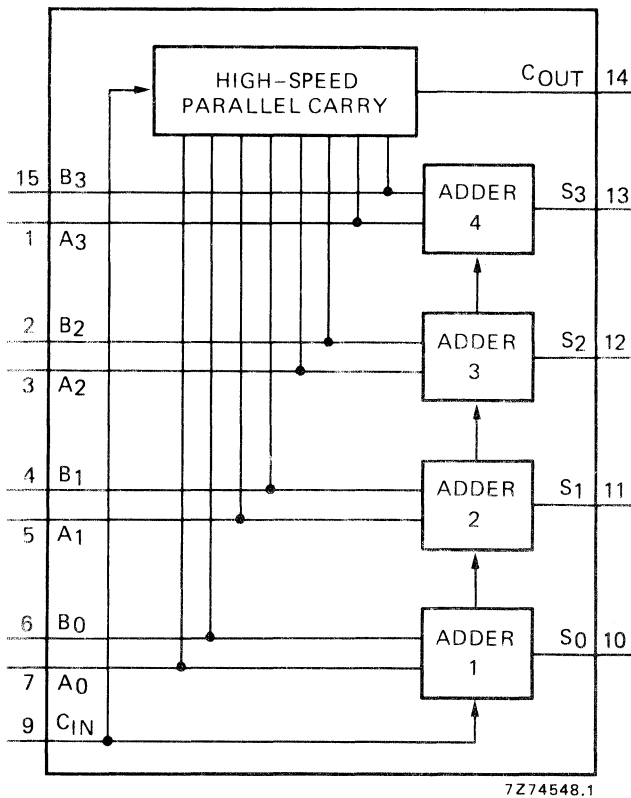

Fig. 1 Functional diagram.

HEF4008BP : 16-lead DIL; plastic (SOT-38Z).
 HEF4008BD: 16-lead DIL; ceramic (cerdip) (SOT-74).
 HEF4008BT : 16-lead mini-pack; plastic (SO-16; SOT-109A).

FAMILY DATA

I_{DD} LIMITS category MSI

} see Family Specifications

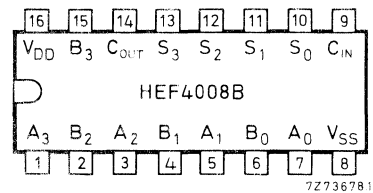

Fig. 2 Pinning diagram.

PINNING

- A_0 to A_3 data inputs
- B_0 to B_3 data inputs
- S_0 to S_3 sum outputs
- C_{IN} carry input
- C_{OUT} carry output

TRUTH TABLE (one adder)

| C_{IN} | A | B | C_{OUT} | S |
|----------|---|---|-----------|---|
| L | L | L | L | L |
| L | L | H | L | H |
| L | H | L | L | H |
| L | H | H | H | L |
| H | L | L | L | H |
| H | L | H | H | L |
| H | H | L | H | L |
| H | H | H | H | H |

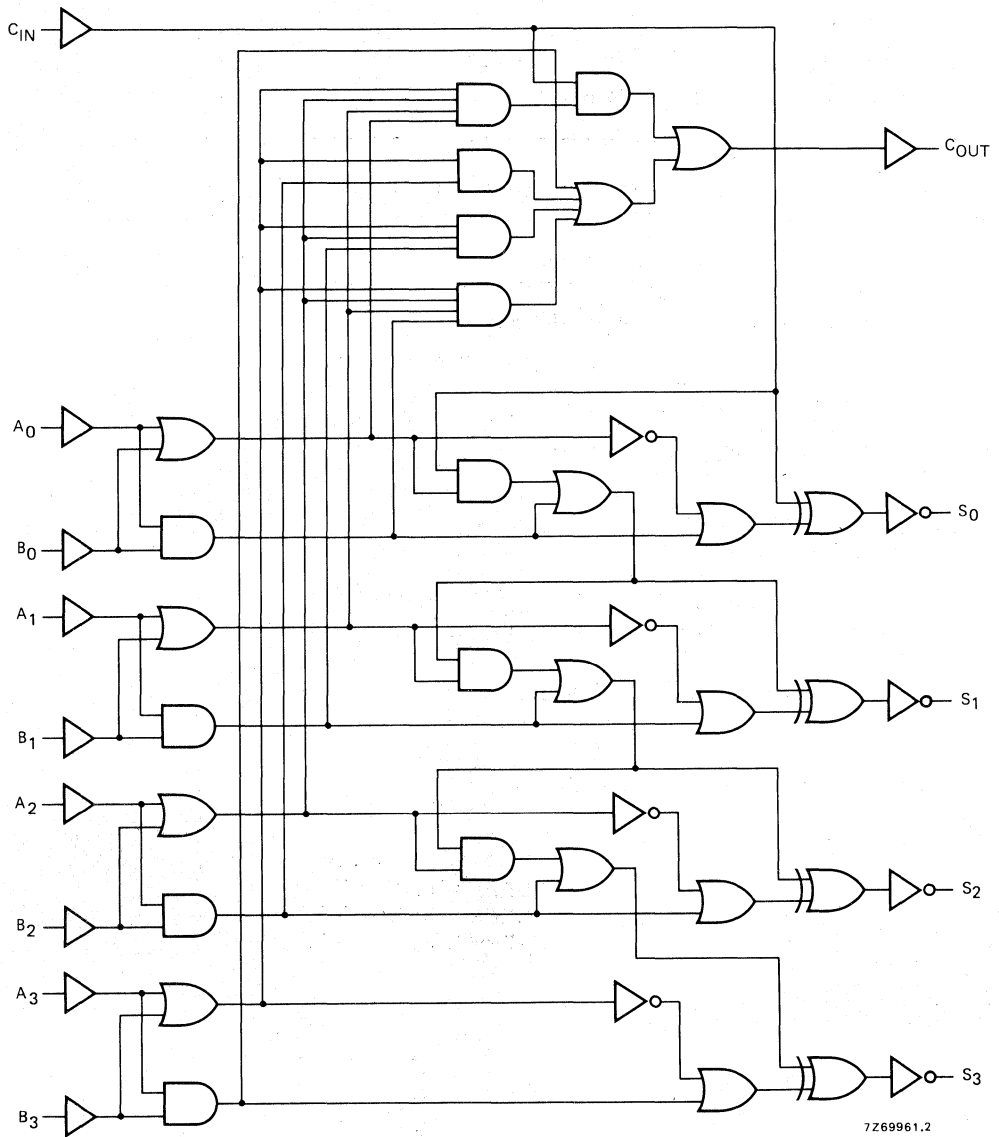

Fig. 3 Logic diagram.

A.C. CHARACTERISTICS

 $V_{SS} = 0 \text{ V}$; $T_{amb} = 25 \text{ }^\circ\text{C}$; $C_L = 50 \text{ pF}$; input transition times $\leq 20 \text{ ns}$

| | V_{DD} V | symbol | min. | typ. | max. | typical extrapolation formula |
|---|---------------|------------------|------|--------|-------------------------------------|--------------------------------------|
| Propagation delays sum in \rightarrow sum out HIGH to LOW | 5 | t _{PHL} | | 150 | 300 ns | 123 ns + (0,55 ns/pF) C _L |
| | 10 | | 55 | 110 ns | 44 ns + (0,23 ns/pF) C _L | |
| | 15 | | 40 | 80 ns | 32 ns + (0,16 ns/pF) C _L | |
| LOW to HIGH | 5 | t _{PLH} | | 135 | 270 ns | 108 ns + (0,55 ns/pF) C _L |
| | 10 | | 55 | 110 ns | 44 ns + (0,23 ns/pF) C _L | |
| | 15 | | 40 | 80 ns | 32 ns + (0,16 ns/pF) C _L | |
| sum in \rightarrow C _{OUT} HIGH to LOW | 5 | t _{PHL} | | 125 | 250 ns | 98 ns + (0,55 ns/pF) C _L |
| | 10 | | 50 | 100 ns | 39 ns + (0,23 ns/pF) C _L | |
| | 15 | | 35 | 70 ns | 27 ns + (0,16 ns/pF) C _L | |
| LOW to HIGH | 5 | t _{PLH} | | 100 | 200 ns | 73 ns + (0,55 ns/pF) C _L |
| | 10 | | 45 | 90 ns | 34 ns + (0,23 ns/pF) C _L | |
| | 15 | | 30 | 60 ns | 22 ns + (0,16 ns/pF) C _L | |
| C _{IN} \rightarrow sum out HIGH to LOW | 5 | t _{PHL} | | 130 | 260 ns | 103 ns + (0,55 ns/pF) C _L |
| | 10 | | 50 | 100 ns | 39 ns + (0,23 ns/pF) C _L | |
| | 15 | | 35 | 70 ns | 27 ns + (0,16 ns/pF) C _L | |
| LOW to HIGH | 5 | t _{PLH} | | 115 | 230 ns | 88 ns + (0,55 ns/pF) C _L |
| | 10 | | 50 | 100 ns | 39 ns + (0,23 ns/pF) C _L | |
| | 15 | | 35 | 70 ns | 27 ns + (0,16 ns/pF) C _L | |
| C _{IN} \rightarrow C _{OUT} HIGH to LOW | 5 | t _{PHL} | | 90 | 180 ns | 63 ns + (0,55 ns/pF) C _L |
| | 10 | | 35 | 70 ns | 24 ns + (0,23 ns/pF) C _L | |
| | 15 | | 25 | 50 ns | 17 ns + (0,16 ns/pF) C _L | |
| LOW to HIGH | 5 | t _{PLH} | | 75 | 150 ns | 48 ns + (0,55 ns/pF) C _L |
| | 10 | | 35 | 70 ns | 24 ns + (0,23 ns/pF) C _L | |
| | 15 | | 25 | 50 ns | 17 ns + (0,16 ns/pF) C _L | |
| Output transition times HIGH to LOW | 5 | t _{THL} | | 60 | 120 ns | 10 ns + (1,0 ns/pF) C _L |
| | 10 | | 30 | 60 ns | 9 ns + (0,42 ns/pF) C _L | |
| | 15 | | 20 | 40 ns | 6 ns + (0,28 ns/pF) C _L | |
| LOW to HIGH | 5 | t _{TLH} | | 60 | 120 ns | 10 ns + (1,0 ns/pF) C _L |
| | 10 | | 30 | 60 ns | 9 ns + (0,42 ns/pF) C _L | |
| | 15 | | 20 | 40 ns | 6 ns + (0,28 ns/pF) C _L | |

| | V_{DD} V | typical formula for P (μW) | where f _i = input freq. (MHz) f _o = output freq. (MHz) C _L = load capacitance (pF) $\Sigma(f_o C_L)$ = sum of outputs V _{DD} = supply voltage (V) |
|---|---------------|---|--|
| Dynamic power dissipation per package (P) | 5 | $1\,500 f_i + \Sigma(f_o C_L) \times V_{DD}^2$ | |
| | 10 | $6\,000 f_i + \Sigma(f_o C_L) \times V_{DD}^2$ | |
| | 15 | $13\,500 f_i + \Sigma(f_o C_L) \times V_{DD}^2$ | |

APPLICATION INFORMATION

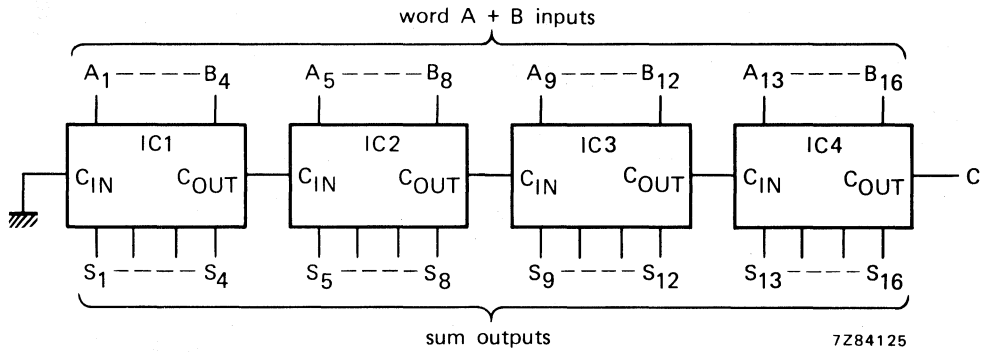

Fig. 4 Example of a 16-bit full adder using 4 HEF4008B ICs.

QUADRUPLE 2-INPUT NAND GATE



The HEF4011B provides the positive quadruple 2-input NAND function. The outputs are fully buffered for highest noise immunity and pattern insensitivity of output impedance.

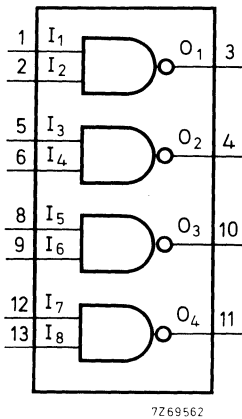

Fig. 1 Functional diagram.

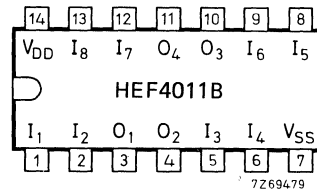

Fig. 2 Pinning diagram.

HEF4011BP : 14-lead DIL; plastic (SOT-27K, M, T).
HEF4011BD : 14-lead DIL; ceramic (cerdip) (SOT-73).
HEF4011BT : 14-lead mini-pack; plastic (SO-14; SOT-108A).

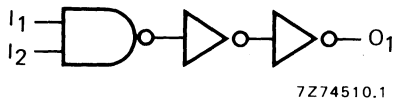

Fig. 3 Logic diagram (one gate).

FAMILY DATA

I_{DD} LIMITS category GATES

} see Family Specifications

HEF4011B

gates

A.C. CHARACTERISTICS

$V_{SS} = 0\text{ V}$; $T_{amb} = 25\text{ }^{\circ}\text{C}$; $C_L = 50\text{ pF}$; input transition times $\leq 20\text{ ns}$

| | V_{DD} V | symbol | typ | max | | typical extrapolation formula | |
|---|---------------|-------------------------------------|-----|-----|----|--|---|
| Propagation delays $I_n \rightarrow O_n$ | 5 | t _{PHL} ; t _{PLH} | 55 | 110 | ns | $28\text{ ns} + (0,55\text{ ns/pF}) C_L$ | |
| | 10 | | 25 | 45 | ns | $14\text{ ns} + (0,23\text{ ns/pF}) C_L$ | |
| | 15 | | 20 | 35 | ns | $12\text{ ns} + (0,16\text{ ns/pF}) C_L$ | |
| Output transition times | HIGH to LOW | t _{THL} | 60 | 120 | ns | $10\text{ ns} + (1,0\text{ ns/pF}) C_L$ | |
| | | | 10 | 30 | 60 | ns | $9\text{ ns} + (0,42\text{ ns/pF}) C_L$ |
| | | | 15 | 20 | 40 | ns | $6\text{ ns} + (0,28\text{ ns/pF}) C_L$ |
| | LOW to HIGH | t _{TLH} | 60 | 120 | ns | $10\text{ ns} + (1,0\text{ ns/pF}) C_L$ | |
| | | | 10 | 30 | 60 | ns | $9\text{ ns} + (0,42\text{ ns/pF}) C_L$ |
| | | | 15 | 20 | 40 | ns | $6\text{ ns} + (0,28\text{ ns/pF}) C_L$ |

| | V_{DD} V | typical formula for P (μW) | where |
|---|---------------|---|------------------------------------|
| Dynamic power dissipation per package (P) | 5 | $1300 f_i + \Sigma(f_o C_L) \times V_{DD}^2$ | f_i = input freq. (MHz) |
| | 10 | $6000 f_i + \Sigma(f_o C_L) \times V_{DD}^2$ | f_o = output freq. (MHz) |
| | 15 | $20100 f_i + \Sigma(f_o C_L) \times V_{DD}^2$ | C_L = load capacitance (pF) |
| | | | $\Sigma(f_o C_L)$ = sum of outputs |
| | | | V_{DD} = supply voltage (V) |

QUADRUPLE 2-INPUT NAND GATE



The HEF4011UB is a quadruple 2-input NAND gate. This unbuffered single stage version provides a direct implementation of the NAND function. The output impedance and output transition time depends on the input voltage and input rise and fall times applied.

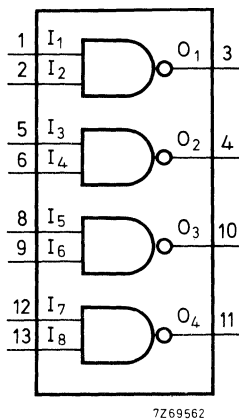

Fig. 1 Functional diagram.

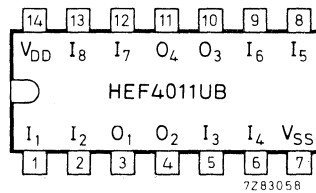

Fig. 2 Pinning diagram.

HEF4011UBP : 14-lead DIL; plastic (SOT-27K, M, T).
 HEF4011UBD : 14-lead DIL; ceramic (cerdip) (SOT-73).
 HEF4011UBT : 14-lead mini-pack; plastic (SO-14; SOT-108A).

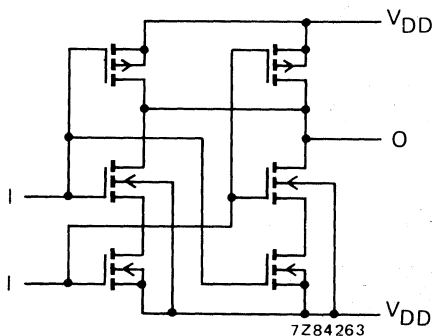

Fig. 3 Schematic diagram (one gate). The splitting-up of the n-transistors provide identical inputs.

FAMILY DATA

I_{DD} LIMITS category GATES

see Family Specifications for V_{IH}/V_{IL} unbuffered stages

HEF4011UB

gates

A.C. CHARACTERISTICS

$V_{SS} = 0 \text{ V}$; $T_{amb} = 25 \text{ }^\circ\text{C}$; $C_L = 50 \text{ pF}$; input transition times $\leq 20 \text{ ns}$

| | V_{DD} V | symbol | typ. | max. | | typical extrapolation formula | |
|--|---------------|------------------|------------------|------|-----|-------------------------------------|-------------------------------------|
| Propagation delays $I_n \rightarrow O_n$ HIGH to LOW | 5 | t _{PHL} | 60 | 120 | ns | 25 ns + (0,70 ns/pF) C _L | |
| | 10 | | 25 | 50 | ns | 12 ns + (0,27 ns/pF) C _L | |
| | 15 | | 20 | 40 | ns | 10 ns + (0,20 ns/pF) C _L | |
| | LOW to HIGH | 5 | t _{PLH} | 35 | 70 | ns | 8 ns + (0,55 ns/pF) C _L |
| | | 10 | | 20 | 40 | ns | 9 ns + (0,23 ns/pF) C _L |
| | | 15 | | 17 | 35 | ns | 9 ns + (0,16 ns/pF) C _L |
| Output transition times HIGH to LOW | 5 | t _{THL} | 75 | 150 | ns | 15 ns + (1,20 ns/pF) C _L | |
| | 10 | | 30 | 60 | ns | 6 ns + (0,48 ns/pF) C _L | |
| | 15 | | 20 | 40 | ns | 4 ns + (0,32 ns/pF) C _L | |
| | LOW to HIGH | 5 | t _{TLH} | 60 | 110 | ns | 10 ns + (1,00 ns/pF) C _L |
| | | 10 | | 30 | 60 | ns | 9 ns + (0,42 ns/pF) C _L |
| | | 15 | | 20 | 40 | ns | 6 ns + (0,28 ns/pF) C _L |
| Input capacitance | | C _{IN} | | 10 | pF | | |

| | V_{DD} V | typical formula for P (μW) | where f _i = input freq. (MHz) f _o = output freq. (MHz) C _L = load capacitance (pF) $\Sigma(f_o C_L)$ = sum of outputs V _{DD} = supply voltage (V) |
|---|---------------|---|--|
| Dynamic power dissipation per package (P) | 5 | $500 f_i + \Sigma(f_o C_L) \times V_{DD}^2$ | |
| | 10 | | |
| | 15 | | |

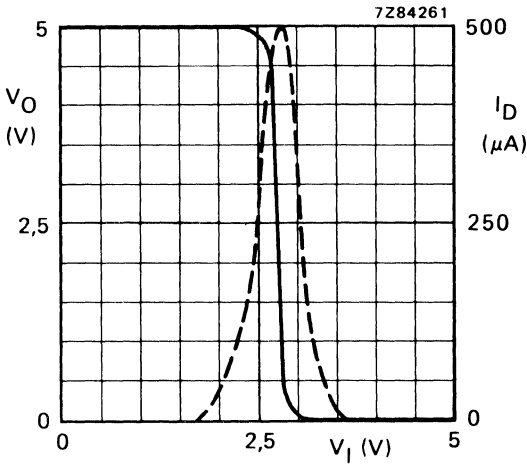

Fig. 4 Typical transfer characteristics;
one input, the other input connected to V_{DD} ;
— V_O ; - - - I_D (drain current); $I_O = 0$;
 $V_{DD} = 5$ V.

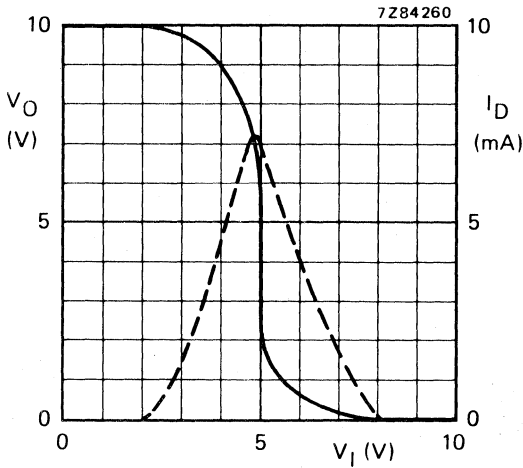

Fig. 5 Typical transfer characteristics;
one input, the other input connected to V_{DD} ;
— V_O ; - - - I_D (drain current); $I_O = 0$;
 $V_{DD} = 10$ V.

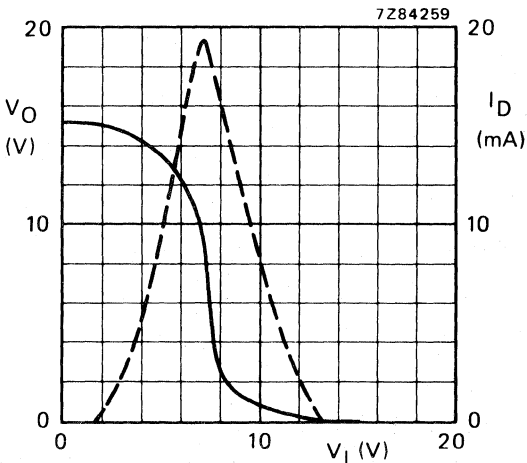

Fig. 6 Typical transfer characteristics;
one input, the other input connected to V_{DD} ;
— V_O ; - - - I_D (drain current); $I_O = 0$;
 $V_{DD} = 15$ V.

HEF4011UB

gates

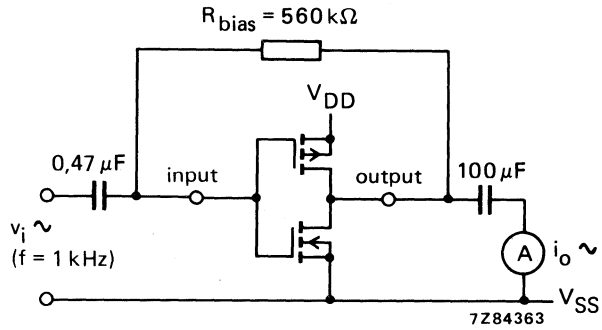

Fig. 7 Test set-up for measuring forward transconductance $g_{fs} = di_o/dv_i$ at v_o is constant (see also graph Fig. 8).

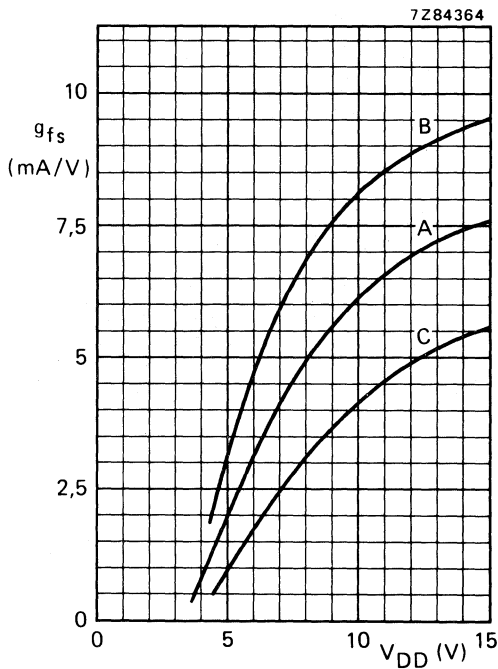

Fig. 8 Typical forward transconductance g_{fs} as a function of the supply voltage at $T_{amb} = 25\text{ }^{\circ}\text{C}$.

Curves in Fig. 8:

- A : average,
- B : average + 2 s,
- C : average - 2 s, in where:
's' is the observed standard deviation.

APPLICATION INFORMATION

Some examples of applications for the HEF4011UB are shown below.

Because of the fact that this circuit is unbuffered, it is suitable for use in (partly) analogue circuits.

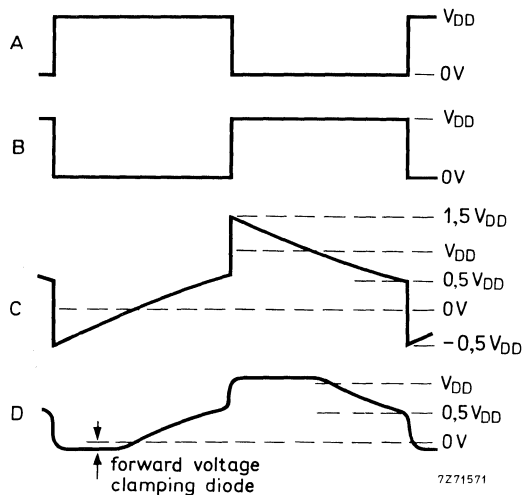
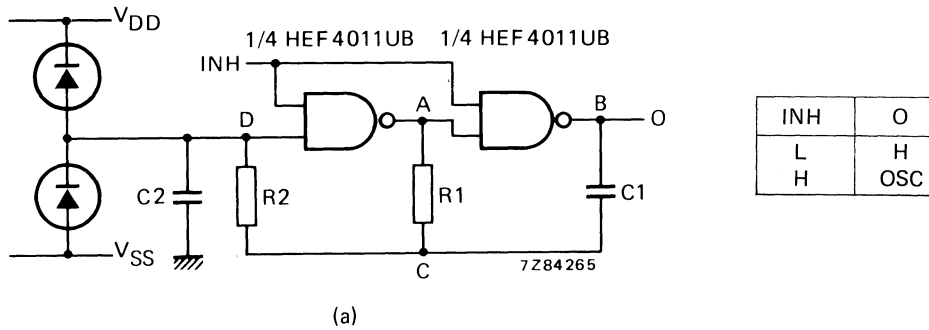

Fig. 9(a) Astable relaxation oscillator using two HEF4011UB gates; the diodes may be BAW62; C2 is a parasitic capacitance. (b) Waveforms at the points marked A, B, C and D in the circuit diagram.

In Fig. 9 the oscillation frequency is mainly determined by $R1C1$, provided $R1 \ll R2$ and $R2C2 \ll R1C1$.

The function of R2 is to minimize the influence of the forward voltage across the protection diodes on the frequency; C2 is a stray (parasitic) capacitance. The period T_p is given by $T_p = T_1 + T_2$, in which

$$T_1 = R1C1 \ln \frac{V_{DD} + V_{ST}}{V_{ST}} \quad \text{and} \quad T_2 = R1C1 \ln \frac{2V_{DD} - V_{ST}}{V_{DD} - V_{ST}} \quad \text{where}$$

V_{ST} is the signal threshold level of the gate. The period is fairly independent of V_{DD} , V_{ST} and temperature. The duty factor, however, is influenced by V_{ST} .

HEF4011UB
gates

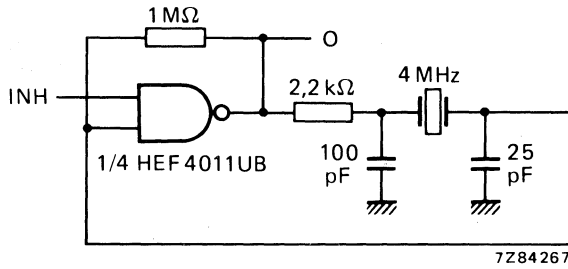

| | |
|-----|-----|
| INH | O |
| L | H |
| H | OSC |

Fig. 10 Example of a crystal oscillator using one HEF4011UB gate.

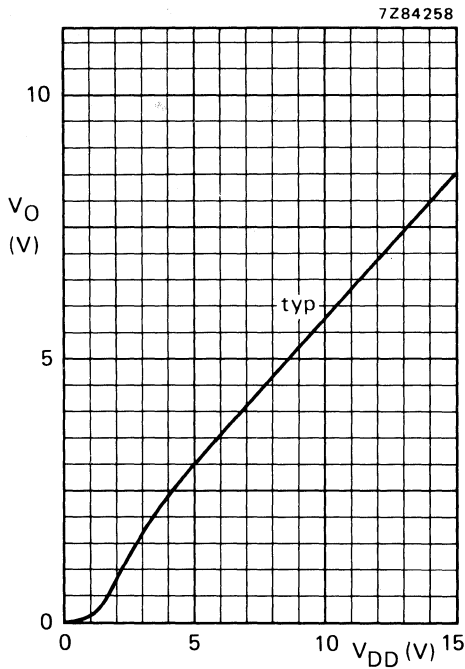
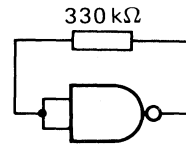

Fig. 11 Output voltage as a function of supply voltage.



1/4 HEF4011UB
7Z84269

Fig. 12 Test set-up for measuring graph of Fig. 11. Condition: all other inputs connected to ground.

NOTES

If a gate is just used as an amplifying inverter, there are two possibilities:

- Connecting the inputs together gives simpler wiring, but makes the device output not completely symmetrical.
- Connecting one input to V_{DD} will give the device a symmetrical output.

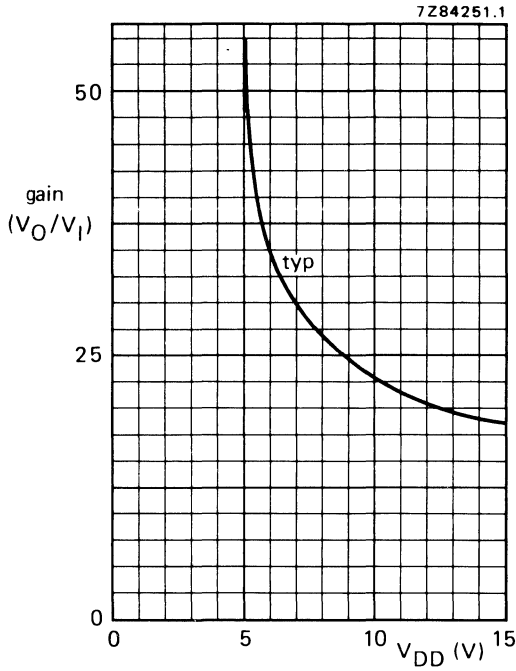

Fig. 13 Voltage gain (V_O/V_I) as a function of supply voltage.

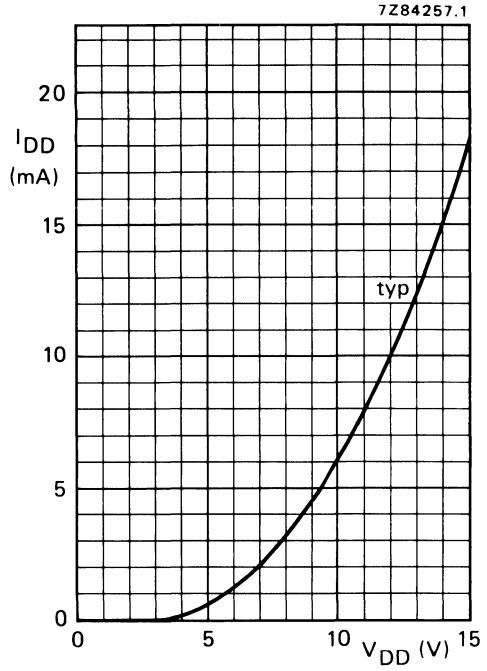

Fig. 14 Supply current as a function of supply voltage.

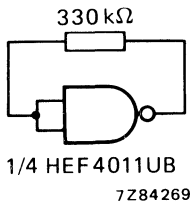

Fig. 15 Test set-up for measuring graphs of Figs 13 and 14. Condition: all other inputs connected to ground.

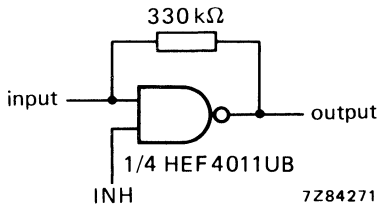

Fig. 16 Example of an analogue amplifier with inhibit using one HEF4011UB gate.

DUAL 4-INPUT NAND GATE



The HEF4012B provides the positive dual 4-input NAND function. The outputs are fully buffered for highest noise immunity and pattern insensitivity of output impedance.

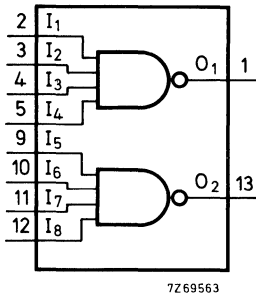

Fig. 1 Functional diagram.

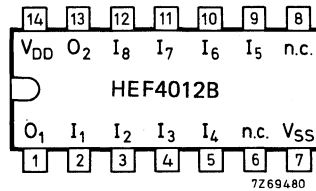

Fig. 2 Pinning diagram.

HEF4012BP : 14-lead DIL; plastic (SOT-27K, M, T).
HEF4012BD : 14-lead DIL; ceramic (cerdip) (SOT-73).
HEF4012BT : 14-lead mini-pack; plastic (SO-14; SOT-108A).

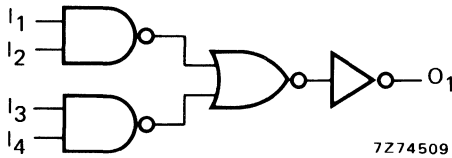

Fig. 3 Logic diagram (one gate).

FAMILY DATA

I_{DD} LIMITS category GATES

} see Family Specifications

HEF4012B

gates

A.C. CHARACTERISTICS

$V_{SS} = 0\text{ V}$; $T_{amb} = 25\text{ }^{\circ}\text{C}$; $C_L = 50\text{ pF}$; input transition times $\leq 20\text{ ns}$

| | V_{DD} V | symbol | typ | max | | typical extrapolation formula |
|--|---------------|------------------|-----|-----|----|--|
| Propagation delays $I_n \rightarrow O_n$ HIGH to LOW | 5 | t _{PHL} | 70 | 135 | ns | $43\text{ ns} + (0,55\text{ ns/pF}) C_L$ |
| | 10 | | 25 | 50 | ns | $14\text{ ns} + (0,23\text{ ns/pF}) C_L$ |
| | 15 | | 20 | 35 | ns | $12\text{ ns} + (0,16\text{ ns/pF}) C_L$ |
| LOW to HIGH | 5 | t _{PLH} | 70 | 140 | ns | $43\text{ ns} + (0,55\text{ ns/pF}) C_L$ |
| | 10 | | 30 | 60 | ns | $19\text{ ns} + (0,23\text{ ns/pF}) C_L$ |
| | 15 | | 25 | 50 | ns | $17\text{ ns} + (0,16\text{ ns/pF}) C_L$ |
| Output transition times HIGH to LOW | 5 | t _{THL} | 60 | 120 | ns | $10\text{ ns} + (1,0\text{ ns/pF}) C_L$ |
| | 10 | | 30 | 60 | ns | $9\text{ ns} + (0,42\text{ ns/pF}) C_L$ |
| | 15 | | 20 | 40 | ns | $6\text{ ns} + (0,28\text{ ns/pF}) C_L$ |
| LOW to HIGH | 5 | t _{TLH} | 60 | 120 | ns | $10\text{ ns} + (1,0\text{ ns/pF}) C_L$ |
| | 10 | | 30 | 60 | ns | $9\text{ ns} + (0,42\text{ ns/pF}) C_L$ |
| | 15 | | 20 | 40 | ns | $6\text{ ns} + (0,28\text{ ns/pF}) C_L$ |

| | V_{DD} V | typical formula for P (μW) | where |
|---|---------------|---|------------------------------------|
| Dynamic power dissipation per package (P) | 5 | $1100 f_i + \Sigma(f_o C_L) \times V_{DD}^2$ | f_i = input freq. (MHz) |
| | 10 | $4400 f_i + \Sigma(f_o C_L) \times V_{DD}^2$ | f_o = output freq. (MHz) |
| | 15 | $12900 f_i + \Sigma(f_o C_L) \times V_{DD}^2$ | C_L = load capacitance (pF) |
| | | | $\Sigma(f_o C_L)$ = sum of outputs |
| | | | V_{DD} = supply voltage (V) |



DUAL D-TYPE FLIP-FLOP

The HEF4013B is a dual D-type flip-flop which features independent set direct (S_D), clear direct (C_D), clock inputs (CP) and outputs (O, \bar{O}). Data is accepted when CP is LOW and transferred to the output on the positive-going edge of the clock. The active HIGH asynchronous clear-direct (C_D) and set-direct (S_D) are independent and override the D or CP inputs. The outputs are buffered for best system performance. Schmitt-trigger action in the clock input makes the circuit highly tolerant to slower clock rise and fall times.

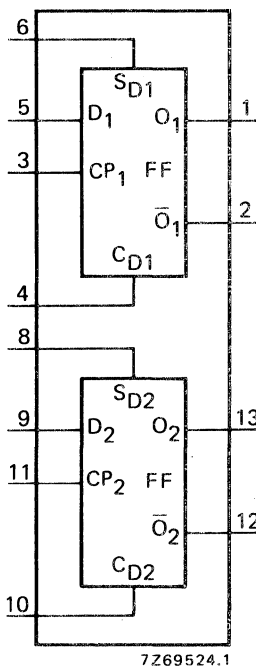

Fig. 1 Functional diagram.

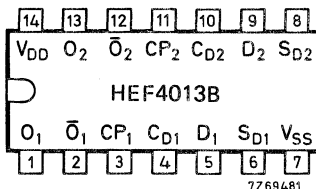

Fig. 2 Pinning diagram.

FUNCTION TABLES

| inputs | | | | outputs | |
|--------|-------|----|---|---------|-----------|
| S_D | C_D | CP | D | O | \bar{O} |
| H | L | X | X | H | L |
| L | H | X | X | L | H |
| H | H | X | X | H | H |

| inputs | | | | outputs | |
|--------|-------|----|---|-----------|-----------------|
| S_D | C_D | CP | D | O_{n+1} | \bar{O}_{n+1} |
| L | L | / | L | L | H |
| L | L | / | H | H | L |

- H = HIGH state (the more positive voltage)
- L = LOW state (the less positive voltage)
- X = state is immaterial
- / = positive-going transition
- O_{n+1} = state after clock positive transition

PINNING

- D data inputs
- CP clock input (L to H edge-triggered)
- S_D asynchronous set-direct input (active HIGH)
- C_D asynchronous clear-direct input (active HIGH)
- O true output
- \bar{O} complement output

- HEF4013BP : 14-lead DIL; plastic (SOT-27K, M, T).
- HEF4013BD : 14-lead DIL; ceramic (cerdip) (SOT-73).
- HEF4013BT : 14-lead mini-pack; plastic (SO-14; SOT-108A).

FAMILY DATA

I_{DD} LIMITS category FLIP-FLOPS

} see Family Specifications

HEF4013B
flip-flops

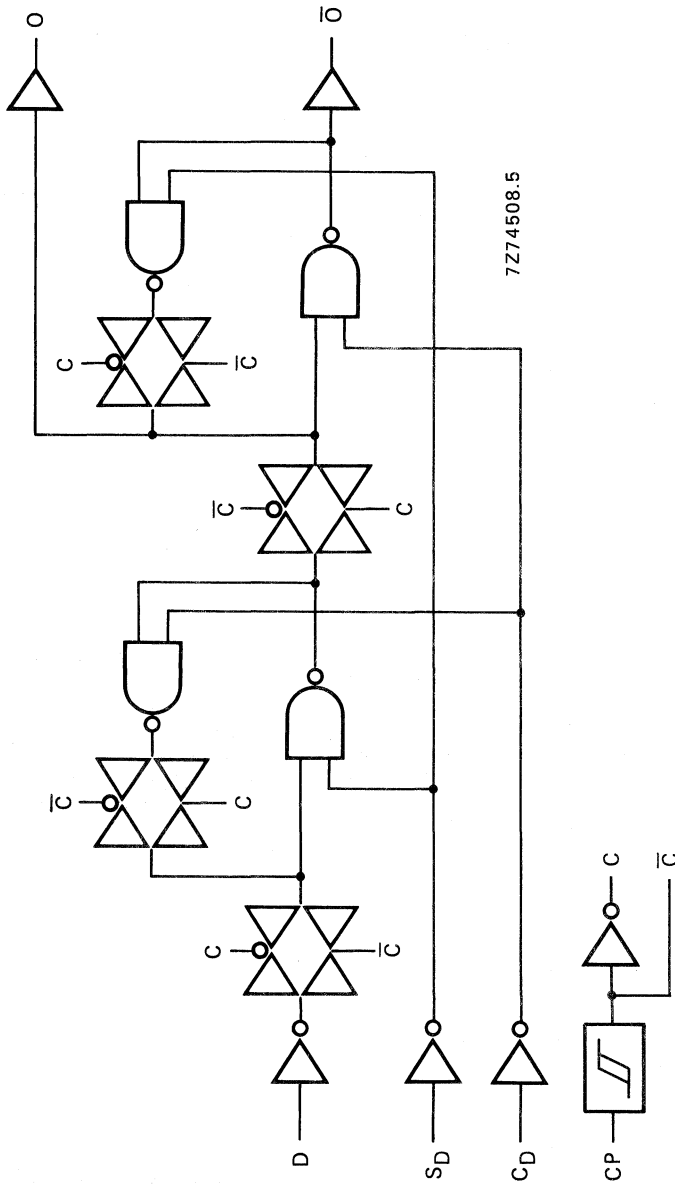

Fig. 3 Logic diagram (one flip-flop).

A.C. CHARACTERISTICS

 $V_{SS} = 0 \text{ V}$; $T_{amb} = 25 \text{ }^\circ\text{C}$; $C_L = 50 \text{ pF}$; input transition times $\leq 20 \text{ ns}$

| | V_{DD} V | symbol | min. | typ. | max. | typical extrapolation formula | |
|--|---------------|-----------|------|------|------|---|---|
| Propagation delays $CP \rightarrow O, \bar{O}$ HIGH to LOW | 5 | t_{PHL} | | 110 | 220 | ns | $83 \text{ ns} + (0,55 \text{ ns/pF})C_L$ |
| | 10 | | 45 | 90 | ns | $34 \text{ ns} + (0,23 \text{ ns/pF})C_L$ | |
| | 15 | | 30 | 60 | ns | $22 \text{ ns} + (0,16 \text{ ns/pF})C_L$ | |
| LOW to HIGH | 5 | t_{PLH} | | 95 | 190 | ns | $68 \text{ ns} + (0,55 \text{ ns/pF})C_L$ |
| | 10 | | 40 | 80 | ns | $29 \text{ ns} + (0,23 \text{ ns/pF})C_L$ | |
| | 15 | | 30 | 60 | ns | $22 \text{ ns} + (0,16 \text{ ns/pF})C_L$ | |
| $S_D \rightarrow \bar{O}$ HIGH to LOW | 5 | t_{PHL} | | 100 | 200 | ns | $73 \text{ ns} + (0,55 \text{ ns/pF})C_L$ |
| | 10 | | 40 | 80 | ns | $29 \text{ ns} + (0,23 \text{ ns/pF})C_L$ | |
| | 15 | | 30 | 60 | ns | $22 \text{ ns} + (0,16 \text{ ns/pF})C_L$ | |
| $S_D \rightarrow O$ LOW to HIGH | 5 | t_{PLH} | | 75 | 150 | ns | $48 \text{ ns} + (0,55 \text{ ns/pF})C_L$ |
| | 10 | | 35 | 70 | ns | $24 \text{ ns} + (0,23 \text{ ns/pF})C_L$ | |
| | 15 | | 25 | 50 | ns | $17 \text{ ns} + (0,16 \text{ ns/pF})C_L$ | |
| $C_D \rightarrow O$ HIGH to LOW | 5 | t_{PHL} | | 100 | 200 | ns | $73 \text{ ns} + (0,55 \text{ ns/pF})C_L$ |
| | 10 | | 40 | 80 | ns | $29 \text{ ns} + (0,23 \text{ ns/pF})C_L$ | |
| | 15 | | 30 | 60 | ns | $22 \text{ ns} + (0,16 \text{ ns/pF})C_L$ | |
| $C_D \rightarrow \bar{O}$ LOW to HIGH | 5 | t_{PLH} | | 60 | 120 | ns | $33 \text{ ns} + (0,55 \text{ ns/pF})C_L$ |
| | 10 | | 30 | 60 | ns | $19 \text{ ns} + (0,23 \text{ ns/pF})C_L$ | |
| | 15 | | 20 | 40 | ns | $12 \text{ ns} + (0,16 \text{ ns/pF})C_L$ | |
| Output transition times HIGH to LOW | 5 | t_{THL} | | 60 | 120 | ns | $10 \text{ ns} + (1,0 \text{ ns/pF}) C_L$ |
| | 10 | | 30 | 60 | ns | $9 \text{ ns} + (0,42 \text{ ns/pF}) C_L$ | |
| | 15 | | 20 | 40 | ns | $6 \text{ ns} + (0,28 \text{ ns/pF}) C_L$ | |
| LOW to HIGH | 5 | t_{TLH} | | 60 | 120 | ns | $10 \text{ ns} + (1,0 \text{ ns/pF}) C_L$ |
| | 10 | | 30 | 60 | ns | $9 \text{ ns} + (0,42 \text{ ns/pF}) C_L$ | |
| | 15 | | 20 | 40 | ns | $6 \text{ ns} + (0,28 \text{ ns/pF}) C_L$ | |

HEF4013B

flip-flops

A.C. CHARACTERISTICS

$V_{SS} = 0\text{ V}$; $T_{amb} = 25\text{ }^\circ\text{C}$; $C_L = 50\text{ pF}$; input transition times $\leq 20\text{ ns}$

| | V_{DD} V | symbol | min. | typ. | max. | |
|------------------------------------|---------------|------------|------|------|------|------------------------------------|
| Set-up time D \rightarrow CP | 5 | t_{su} | 40 | 20 | ns | see also waveforms Figs 4 and 5 |
| | 10 | | 25 | 10 | ns | |
| | 15 | | 15 | 5 | ns | |
| Hold time D \rightarrow CP | 5 | t_{hold} | 20 | 0 | ns | |
| | 10 | | 20 | 0 | ns | |
| | 15 | | 15 | 0 | ns | |
| Minimum clock pulse width; LOW | 5 | t_{WCPL} | 60 | 30 | ns | |
| | 10 | | 30 | 15 | ns | |
| | 15 | | 20 | 10 | ns | |
| Minimum S_D pulse width; HIGH | 5 | t_{WSDH} | 50 | 25 | ns | |
| | 10 | | 24 | 12 | ns | |
| | 15 | | 20 | 10 | ns | |
| Minimum C_D pulse width; HIGH | 5 | t_{WCDH} | 50 | 25 | ns | |
| | 10 | | 24 | 12 | ns | |
| | 15 | | 20 | 10 | ns | |
| Recovery time for S_D | 5 | t_{RSD} | 15 | -5 | ns | |
| | 10 | | 15 | 0 | ns | |
| | 15 | | 15 | 0 | ns | |
| Recovery time for C_D | 5 | t_{RCD} | 40 | 25 | ns | |
| | 10 | | 25 | 10 | ns | |
| | 15 | | 25 | 10 | ns | |
| Maximum clock pulse frequency | 5 | f_{max} | 7 | 14 | MHz | |
| | 10 | | 14 | 28 | MHz | |
| | 15 | | 20 | 40 | MHz | |

| | V_{DD} V | typical formula for P (μW) | where f_i = input freq. (MHz) f_o = output freq. (MHz) C_L = total load cap. (pF) $\Sigma(f_o C_L)$ = sum of outputs V_{DD} = supply voltage (V) |
|---|---------------|--|---|
| Dynamic power dissipation per package (P) | 5 | $850 f_i + \Sigma(f_o C_L) \times V_{DD}^2$ | |
| | 10 | $3\,600 f_i + \Sigma(f_o C_L) \times V_{DD}^2$ | |
| | 15 | $9\,000 f_i + \Sigma(f_o C_L) \times V_{DD}^2$ | |

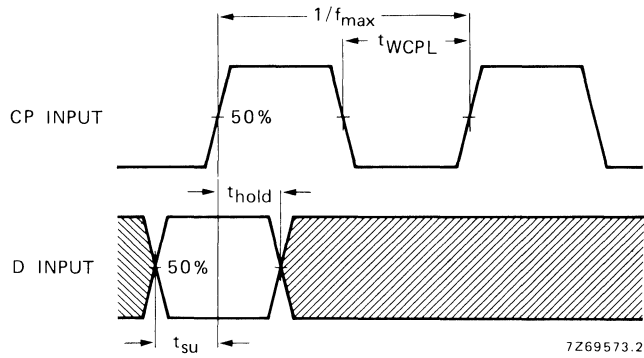

Fig. 4 Waveforms showing set-up times, hold times and minimum clock pulse width. Set-up and hold times are shown as positive values but may be specified as negative values.

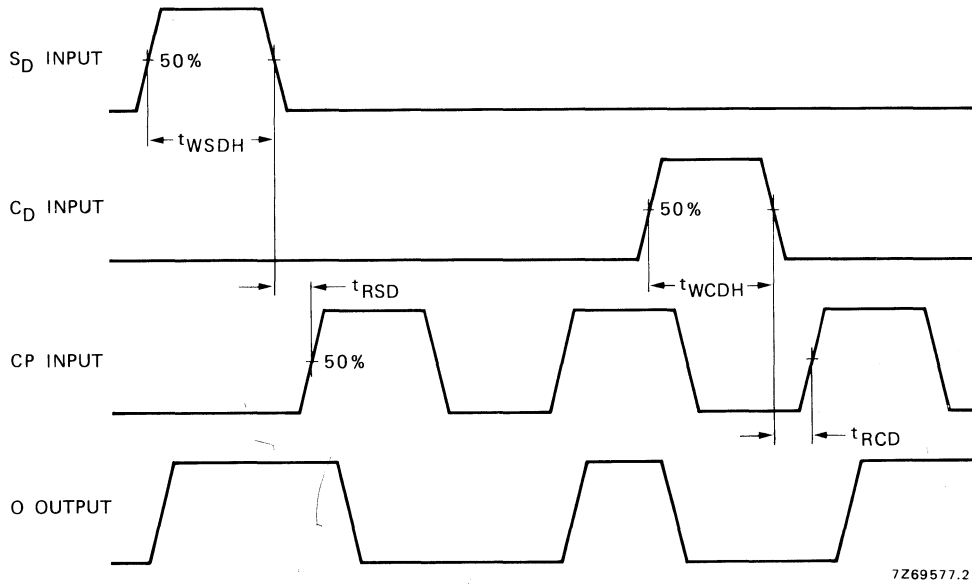

Fig. 5 Waveforms showing recovery times for S_D and C_D; minimum S_D and C_D pulse widths.

APPLICATION INFORMATION

Some examples of applications for the HEF4013B are:

- Counters/dividers
- Registers
- Toggle flip-flops

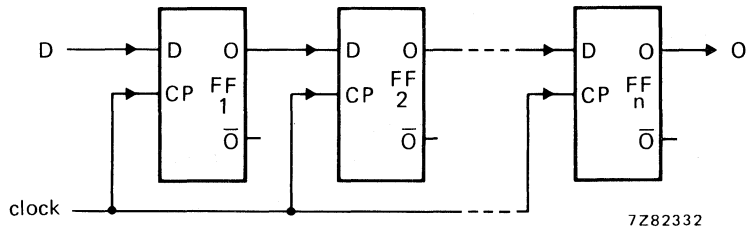

Fig. 6 Typical application of the HEF4013B in an n-stage shift register.

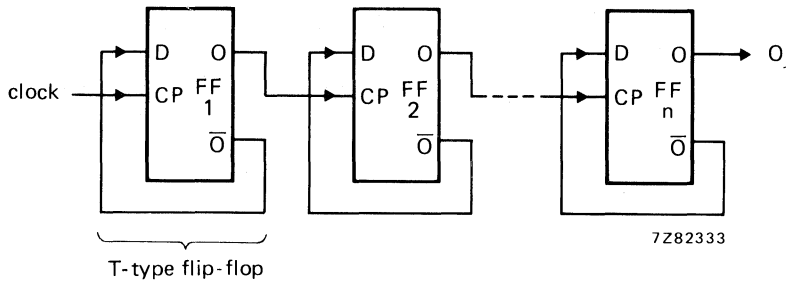

Fig. 7 Typical application of the HEF4013B in a binary ripple up-counter; divide-by- 2^n .

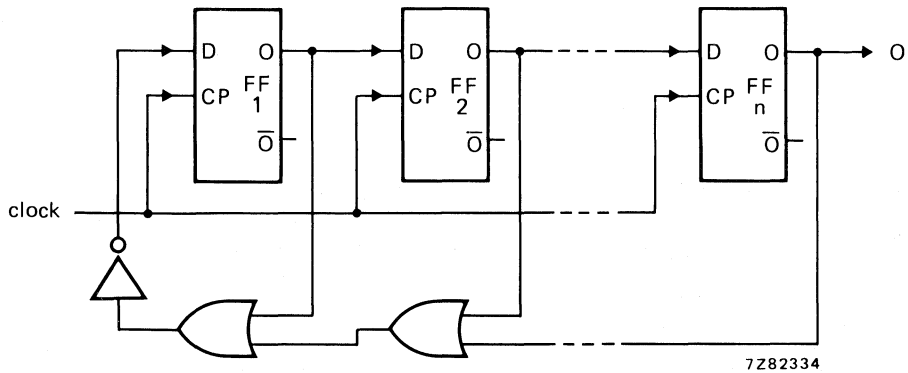

Fig. 8 Typical application of the HEF4013B in a modified ring counter; divide-by-(n + 1).



8-BIT STATIC SHIFT REGISTER

The HEF4014B is a fully synchronous edge-triggered 8-bit static shift register with eight synchronous parallel inputs (P_0 to P_7), a synchronous serial data input (D_S), a synchronous parallel enable input (PE), a LOW to HIGH edge-triggered clock input (CP) and buffered parallel outputs from the last three stages (O_5 to O_7).

Operation is synchronous and the device is edge-triggered on the LOW to HIGH transition of CP. Each register stage is of a D-type master-slave flip-flop. When PE is HIGH, data is loaded into the register from P_0 to P_7 on the LOW to HIGH transition of CP. When PE is LOW, data is shifted to the first position from D_S , and all the data in the register is shifted one position to the right on the LOW to HIGH transition of CP. Schmitt-trigger action in the clock input makes the circuit highly tolerant to slower clock rise and fall times

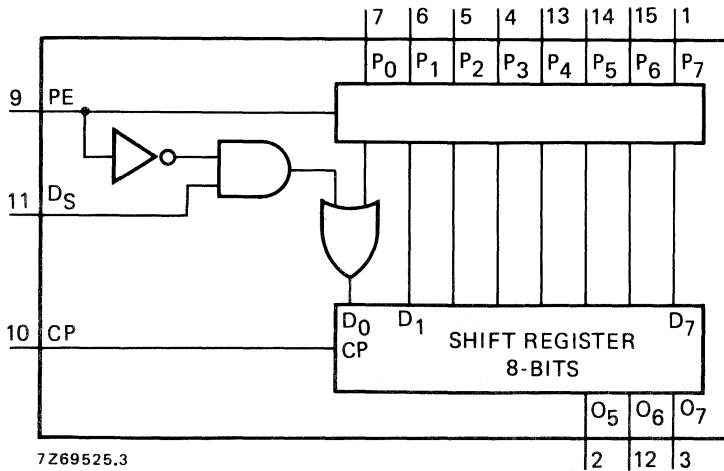

Fig. 1 Functional diagram.

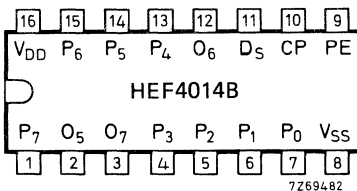

Fig. 2 Pinning diagram.

HEF4014BP : 16-lead DIL; plastic (SOT-38Z).
HEF4014BD : 16-lead DIL; ceramic (cerdip) (SOT-74).
HEF4014BT : 16-lead mini-pack; plastic (SO-16; SOT-109A).

FAMILY DATA

I_{DD} LIMITS category MSI

} see Family Specifications

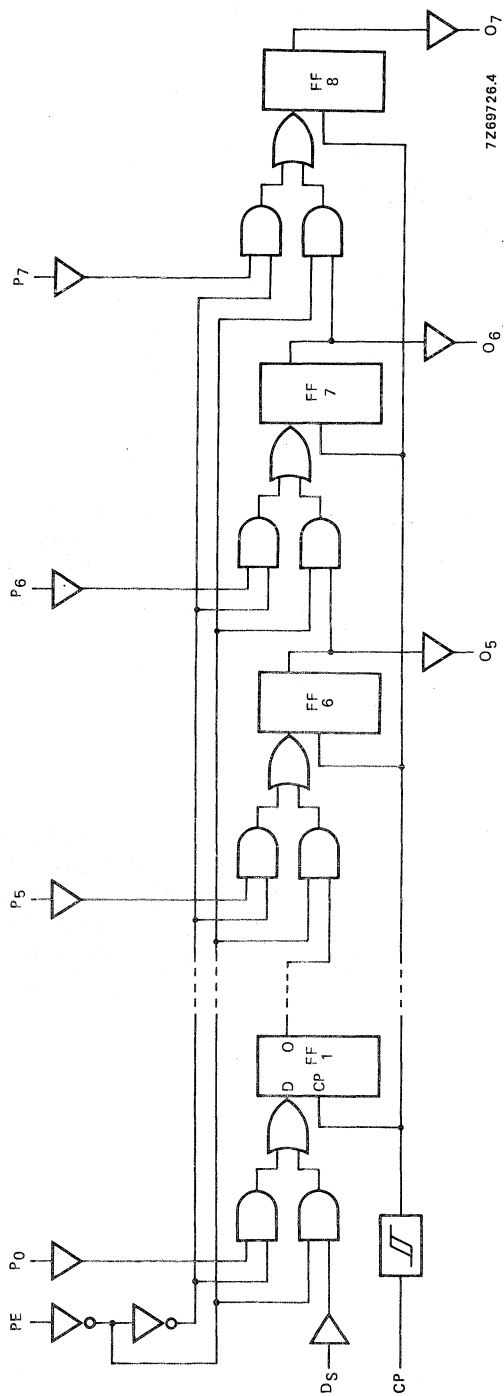

Fig. 3 Logic diagram.

PINNING

- PE parallel enable input
 P₀ to P₇ parallel data inputs
 D_S serial data input
 CP clock input (LOW to HIGH edge-triggered)
 O₅ to O₇ buffered parallel outputs from the last three stages

FUNCTION TABLES

Serial operation

| n | inputs | | | outputs | | |
|---|--------|----------------|----|----------------|----------------|----------------|
| | CP | D _S | PE | O ₅ | O ₆ | O ₇ |
| 1 | ∩ | D ₁ | L | X | X | X |
| 2 | ∩ | D ₂ | L | X | X | X |
| 3 | ∩ | D ₃ | L | X | X | X |
| 6 | ∩ | X | L | D ₁ | X | X |
| 7 | ∩ | X | L | D ₂ | D ₁ | X |
| 8 | ∩ | X | L | D ₃ | D ₂ | D ₁ |
| | ∩ | X | X | no change | | |

Parallel operation

| n | inputs | | | outputs | | |
|---|--------|----------------|----|----------------|----------------|----------------|
| | CP | D _S | PE | O ₅ | O ₆ | O ₇ |
| 1 | ∩ | X | H | P ₅ | P ₆ | P ₇ |
| | ∩ | X | X | no change | | |

H = HIGH state (the more positive voltage)

L = LOW state (the less positive voltage)

X = state is immaterial

∩ = positive-going transition

∩ = negative-going transition

D_n = either HIGH or LOW

n = number of clock pulse transitions

A.C. CHARACTERISTICS

V_{SS} = 0 V; T_{amb} = 25 °C; C_L = 50 pF; input transition times ≤ 20 ns

| | V _{DD} V | typical formula for P (μW) | where f _i = input freq. (MHz) f _o = output freq. (MHz) C _L = load cap. (pF) Σ(f _o C _L) = sum of outputs V _{DD} = supply voltage (V) |
|---|----------------------|--|---|
| Dynamic power dissipation per package (P) | 5 | 900 f _i + Σ(f _o C _L) × V _{DD} ² | |
| | 10 | 4 300 f _i + Σ(f _o C _L) × V _{DD} ² | |
| | 15 | 12 000 f _i + Σ(f _o C _L) × V _{DD} ² | |

A.C. CHARACTERISTICS

 $V_{SS} = 0\text{ V}$; $T_{amb} = 25\text{ }^{\circ}\text{C}$; $C_L = 50\text{ pF}$; input transition times $\leq 20\text{ ns}$

| | V_{DD} V | symbol | min. | typ. | max. | typical extrapolation formula | |
|--------------------------------|---------------|------------|------|------|------|----------------------------------|---|
| Propagation delays | | | | | | | |
| $C_p \rightarrow O_n$ | 5 | | | 130 | 260 | ns | $103\text{ ns} + (0,55\text{ ns/pF}) C_L$ |
| HIGH to LOW | 10 | t_{PHL} | | 55 | 110 | ns | $44\text{ ns} + (0,23\text{ ns/pF}) C_L$ |
| | 15 | | | 40 | 80 | ns | $32\text{ ns} + (0,16\text{ ns/pF}) C_L$ |
| LOW to HIGH | 5 | | | 115 | 230 | ns | $88\text{ ns} + (0,55\text{ ns/pF}) C_L$ |
| | 10 | t_{PLH} | | 50 | 100 | ns | $39\text{ ns} + (0,23\text{ ns/pF}) C_L$ |
| | 15 | | | 40 | 80 | ns | $32\text{ ns} + (0,16\text{ ns/pF}) C_L$ |
| Output transition times | | | | | | | |
| HIGH to LOW | 5 | | | 60 | 120 | ns | $10\text{ ns} + (1,0\text{ ns/pF}) C_L$ |
| | 10 | t_{THL} | | 30 | 60 | ns | $9\text{ ns} + (0,42\text{ ns/pF}) C_L$ |
| | 15 | | | 20 | 40 | ns | $6\text{ ns} + (0,28\text{ ns/pF}) C_L$ |
| LOW to HIGH | 5 | | | 60 | 120 | ns | $10\text{ ns} + (1,0\text{ ns/pF}) C_L$ |
| | 10 | t_{TLH} | | 30 | 60 | ns | $9\text{ ns} + (0,42\text{ ns/pF}) C_L$ |
| | 15 | | | 20 | 40 | ns | $6\text{ ns} + (0,28\text{ ns/pF}) C_L$ |
| Set-up times | | | | | | | |
| $PE \rightarrow CP$ | 5 | | 40 | 10 | | ns | |
| | 10 | t_{su} | 25 | 5 | | ns | |
| | 15 | | 15 | 0 | | ns | |
| $D_S \rightarrow CP$ | 5 | | 35 | -5 | | ns | |
| | 10 | t_{su} | 25 | -5 | | ns | |
| | 15 | | 25 | 0 | | ns | |
| $P_n \rightarrow CP$ | 5 | | 35 | -5 | | ns | |
| | 10 | t_{su} | 25 | -5 | | ns | |
| | 15 | | 25 | 0 | | ns | |
| Hold times | | | | | | | |
| $PE \rightarrow CP$ | 5 | | 25 | -5 | | ns | |
| | 10 | t_{hold} | 20 | 0 | | ns | |
| | 15 | | 15 | 0 | | ns | |
| $D_S \rightarrow CP$ | 5 | | 30 | 15 | | ns | |
| | 10 | t_{hold} | 20 | 10 | | ns | |
| | 15 | | 15 | 7 | | ns | |
| $P_n \rightarrow CP$ | 5 | | 30 | 15 | | ns | |
| | 10 | t_{hold} | 20 | 10 | | ns | |
| | 15 | | 15 | 7 | | ns | |
| Minimum clock pulse width; LOW | 5 | | 70 | 35 | | ns | |
| | 10 | t_{WCPL} | 30 | 15 | | ns | |
| | 15 | | 24 | 12 | | ns | |
| Maximum clock pulse frequency | 5 | | 6 | 13 | | MHz | |
| | 10 | f_{max} | 15 | 30 | | MHz | |
| | 15 | | 20 | 40 | | MHz | |

see also waveforms
Fig. 4

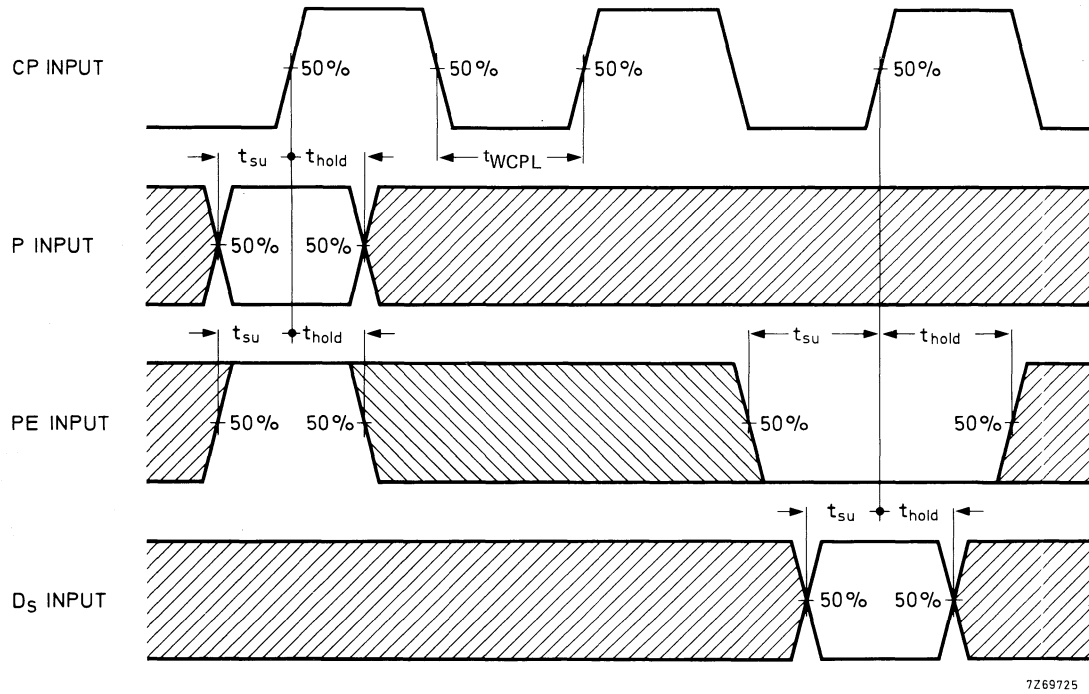

Fig. 4 Waveforms showing minimum clock pulse width, and set-up and hold times for PE to CP, D_S to CP, and P to CP. Set-up and hold times are shown as positive values but may be specified as negative values.

APPLICATION INFORMATION

Some examples of applications for the HEF4014B are:

- Parallel-to-serial converter
- Serial data queueing
- General purpose register



DUAL 4-BIT STATIC SHIFT REGISTER

The HEF4015B is a dual edge-triggered 4-bit static shift register (serial-to-parallel converter). Each shift register has a serial data input (D), a clock input (CP), four fully buffered parallel outputs (O_0 to O_3) and an overriding asynchronous master reset input (MR). Information present on D is shifted to the first register position, and all the data in the register is shifted one position to the right on the LOW-to-HIGH transition of CP. A HIGH on MR clears the register and forces O_0 to O_3 to LOW, independent of CP and D. Schmitt-trigger action in the clock input makes the circuit highly tolerant to slower clock rise and fall times.

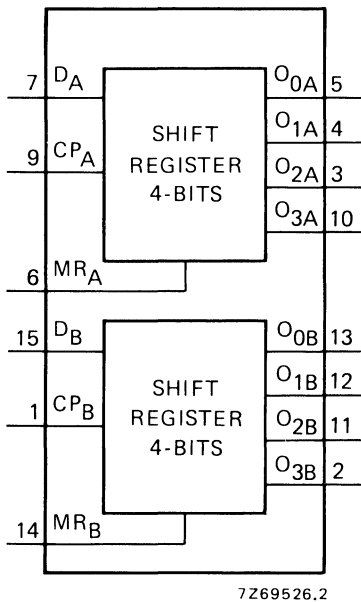

Fig. 1 Functional diagram.

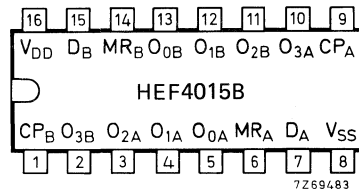

Fig. 2 Pinning diagram.

HEF4015BP : 16-lead DIL; plastic (SOT-38Z).

HEF4015BD : 16-lead DIL; ceramic (cerdip) (SOT-74).

HEF4015BT : 16-lead mini-pack; plastic (SO-16; SOT-109A).

PINNING

| | |
|---|--|
| D_A , D_B | serial data input |
| MR_A , MR_B | master reset input (active HIGH) |
| CP_A , CP_B | clock input (LOW-to-HIGH edge-triggered) |
| O_{0A} , O_{1A} , O_{2A} , O_{3A} | parallel outputs |
| O_{0B} , O_{1B} , O_{2B} , O_{3B} | parallel outputs |

APPLICATION INFORMATION

Some examples of applications for the HEF4015B are:

- Serial-to-parallel converter
- Buffer stores
- General purpose register

FAMILY DATA

} see Family Specifications

I_{DD} LIMITS category MSI

LOGIC DIAGRAM (one register)

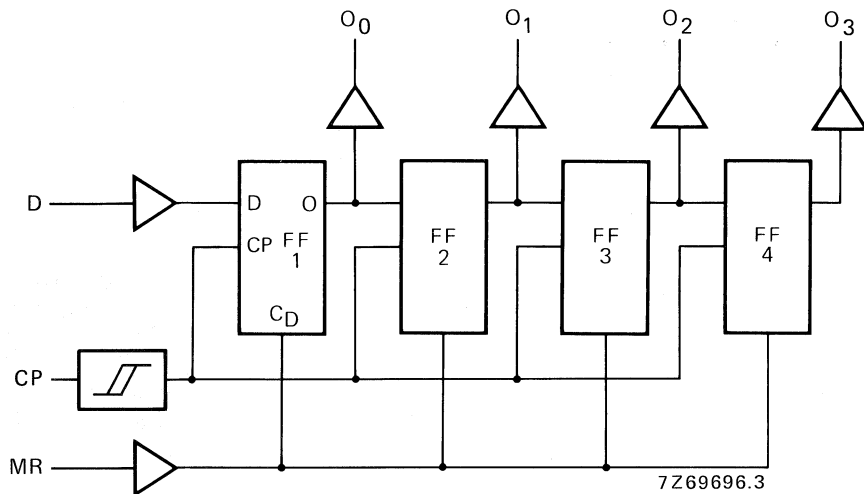

Fig. 3 Logic diagram.

FUNCTION TABLE

| n | inputs | | | outputs | | | |
|---|--------|----------------|----|----------------|----------------|----------------|----------------|
| | CP | D | MR | O ₀ | O ₁ | O ₂ | O ₃ |
| 1 | / | D ₁ | L | D ₁ | X | X | X |
| 2 | / | D ₂ | L | D ₂ | D ₁ | X | X |
| 3 | / | D ₃ | L | D ₃ | D ₂ | D ₁ | X |
| 4 | / | D ₄ | L | D ₄ | D ₃ | D ₂ | D ₁ |
| | \ | X | L | no change | | | |
| | X | X | H | L | L | L | L |

H = HIGH state (the more positive voltage)
 L = LOW state (the less positive voltage)
 X = state is immaterial
 / = positive-going transition
 \ = negative-going transition
 D_n = either HIGH or LOW
 n = number of clock pulse transitions

A.C. CHARACTERISTICS

 $V_{SS} = 0\text{ V}$; $T_{amb} = 25\text{ }^{\circ}\text{C}$; $C_L = 50\text{ pF}$; input transition times $\leq 20\text{ ns}$

| | V_{DD} V | symbol | min. | typ. | max. | typical extrapolation formula | |
|---|---------------|------------|------|------|------|--|---|
| Propagation delays CP \rightarrow O_n HIGH to LOW | 5 | t_{PHL} | | 130 | 260 | ns | $103\text{ ns} + (0,55\text{ ns/pF}) C_L$ |
| | 10 | | 55 | 110 | ns | $44\text{ ns} + (0,23\text{ ns/pF}) C_L$ | |
| | 15 | | 40 | 80 | ns | $32\text{ ns} + (0,16\text{ ns/pF}) C_L$ | |
| LOW to HIGH | 5 | t_{PLH} | | 120 | 240 | ns | $93\text{ ns} + (0,55\text{ ns/pF}) C_L$ |
| | 10 | | 55 | 110 | ns | $44\text{ ns} + (0,23\text{ ns/pF}) C_L$ | |
| | 15 | | 40 | 80 | ns | $32\text{ ns} + (0,16\text{ ns/pF}) C_L$ | |
| MR \rightarrow O_n HIGH to LOW | 5 | t_{PHL} | | 105 | 210 | ns | $78\text{ ns} + (0,55\text{ ns/pF}) C_L$ |
| | 10 | | 45 | 90 | ns | $34\text{ ns} + (0,23\text{ ns/pF}) C_L$ | |
| | 15 | | 35 | 70 | ns | $27\text{ ns} + (0,16\text{ ns/pF}) C_L$ | |
| Output transition times HIGH to LOW | 5 | t_{THL} | | 60 | 120 | ns | $10\text{ ns} + (1,0\text{ ns/pF}) C_L$ |
| | 10 | | 30 | 60 | ns | $9\text{ ns} + (0,42\text{ ns/pF}) C_L$ | |
| | 15 | | 20 | 40 | ns | $6\text{ ns} + (0,28\text{ ns/pF}) C_L$ | |
| LOW to HIGH | 5 | t_{TLH} | | 60 | 120 | ns | $10\text{ ns} + (1,0\text{ ns/pF}) C_L$ |
| | 10 | | 30 | 60 | ns | $9\text{ ns} + (0,42\text{ ns/pF}) C_L$ | |
| | 15 | | 20 | 40 | ns | $6\text{ ns} + (0,28\text{ ns/pF}) C_L$ | |
| Set-up time D \rightarrow CP | 5 | t_{su} | 25 | -15 | | ns | see waveforms Figs 4 and 5 |
| | 10 | | 25 | -10 | | ns | |
| | 15 | | 20 | -5 | | ns | |
| Hold time D \rightarrow CP | 5 | t_{hold} | 40 | 20 | | ns | |
| | 10 | | 20 | 10 | | ns | |
| | 15 | | 15 | 8 | | ns | |
| Minimum clock pulse width; LOW | 5 | t_{WCPL} | 60 | 30 | | ns | |
| | 10 | | 30 | 15 | | ns | |
| | 15 | | 20 | 10 | | ns | |
| Minimum MR pulse width; HIGH | 5 | t_{WMRH} | 80 | 40 | | ns | |
| | 10 | | 30 | 15 | | ns | |
| | 15 | | 24 | 12 | | ns | |
| Recovery time for MR | 5 | t_{RMR} | 50 | 20 | | ns | |
| | 10 | | 30 | 10 | | ns | |
| | 15 | | 20 | 5 | | ns | |
| Maximum clock pulse frequency | 5 | f_{max} | 7 | 15 | | MHz | |
| | 10 | | 15 | 30 | | MHz | |
| | 15 | | 22 | 44 | | MHz | |

| | V_{DD} V | typical formula for P (μW) | where f_i = input freq. (MHz) f_o = output freq. (MHz) C_L = load capacitance (pF) $\Sigma(f_o C_L)$ = sum of outputs V_{DD} = supply voltage (V) |
|---|---------------|---|--|
| Dynamic power dissipation per package (P) | 5 | $1\,500 f_i + \Sigma(f_o C_L) \times V_{DD}^2$ | |
| | 10 | $6\,300 f_i + \Sigma(f_o C_L) \times V_{DD}^2$ | |
| | 15 | $17\,000 f_i + \Sigma(f_o C_L) \times V_{DD}^2$ | |

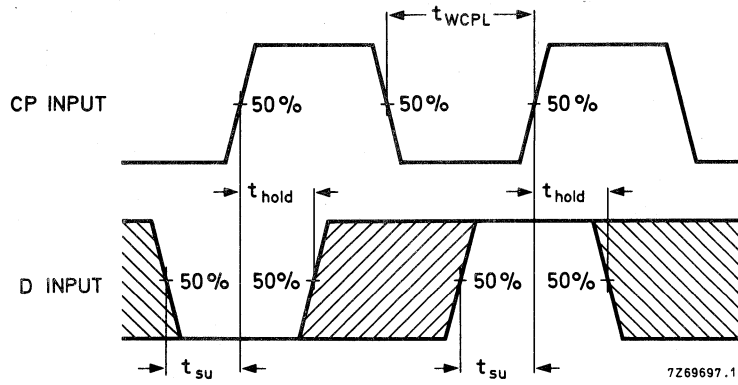

Fig. 4 Waveforms showing set-up times, hold times and minimum clock pulse width. Set-up and hold times are shown as positive values but may be specified as negative values.

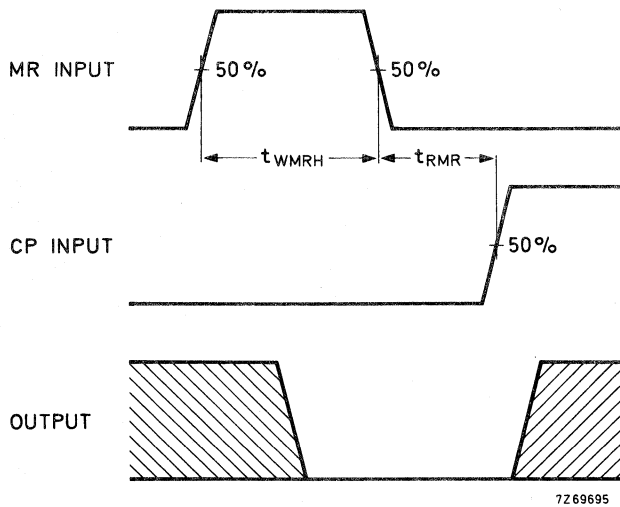

Fig. 5 Waveforms showing recovery time for MR and minimum MR pulse width.

QUADRUPLE BILATERAL SWITCHES



The HEF4016B has four independent analogue switches (transmission gates). Each switch has two input/output terminals (Y/Z) and an active HIGH enable input (E). When E is connected to V_{DD} a low impedance bidirectional path between Y and Z is established (ON condition). When E is connected to V_{SS} the switch is disabled and a high impedance between Y and Z is established (OFF condition). Current through a switch will not cause additional V_{DD} current provided the voltage at the terminals of the switch is maintained within the supply voltage range; $V_{DD} \geq (V_Y, V_Z) \geq V_{SS}$. Inputs Y and Z are electrically equivalent terminals.

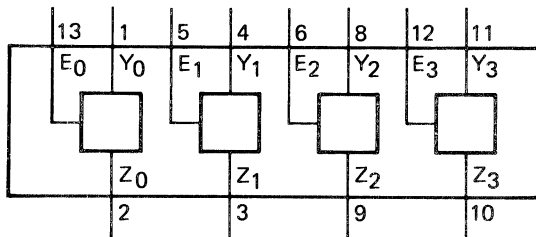

Fig. 1 Functional diagram.

7Z69571.2

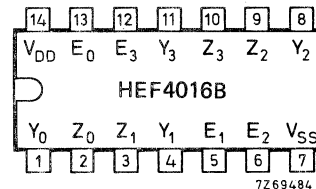

Fig. 2 Pinning diagram.

HEF4016BP : 14-lead DIL; plastic (SOT-27K, M, T).

HEF4016BD: 14-lead DIL; ceramic (cerdip) (SOT-73).

HEF4016BT: 14-lead mini-pack; plastic (SO-14; SOT-108A).

PINNING

E_0 to E_3 enable inputs

Y_0 to Y_3 input/output terminals

Z_0 to Z_3 input/output terminals

APPLICATION INFORMATION

Some examples of applications for the HEF4016B are:

- Signal gating
- Modulation
- Demodulation
- Chopper

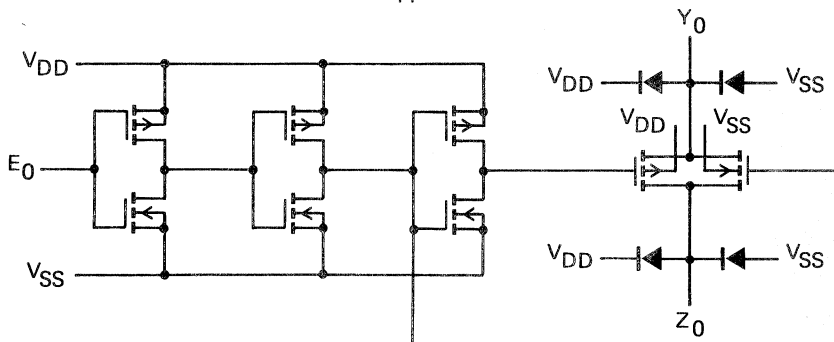

7Z69694.3

Fig. 3 Schematic diagram (one switch).

RATINGS

Limiting values in accordance with the Absolute Maximum System (IEC 134)

Power dissipation per switch

P max. 100 mW

For other RATINGS see Family Specifications

D.C. CHARACTERISTICS

 $T_{amb} = 25\text{ }^{\circ}\text{C}$; $V_{SS} = 0\text{ V}$ (unless otherwise specified)

| parameter | V_{DD} V | symbol | typ. | max. | unit | conditions |
|---|---------------|-----------------|------|------|----------|---|
| ON resistance | 5 | R_{ON} | 8000 | — | Ω | E_n at V_{IH} $V_{is} = 0$ to V_{DD} see Fig. 4 |
| | 10 | | 230 | 690 | Ω | |
| | 15 | | 115 | 350 | Ω | |
| ON resistance | 5 | R_{ON} | 140 | 425 | Ω | E_n at V_{IH} $V_{is} = V_{SS}$ see Fig. 4 |
| | 10 | | 65 | 195 | Ω | |
| | 15 | | 50 | 145 | Ω | |
| ON resistance | 5 | R_{ON} | 170 | 515 | Ω | E_n at V_{IH} $V_{is} = V_{DD}$ see Fig. 4 |
| | 10 | | 95 | 285 | Ω | |
| | 15 | | 75 | 220 | Ω | |
| ' Δ ' ON resistance between any two channels | 5 | ΔR_{ON} | 200 | — | Ω | E_n at V_{IH} $V_{is} = 0$ to V_{DD} see Fig. 4 |
| | 10 | | 15 | — | Ω | |
| | 15 | | 10 | — | Ω | |

| parameter | V_{DD} V | symbol | T_{amb} ($^{\circ}\text{C}$) | | | unit | condition | | |
|---|---------------|--------------|----------------------------------|-------------|-------------|------|-----------|------|--|
| | | | —40 min. | +25 max. | +85 min. | | | max. | |
| Quiescent device current | 5 | I_{DD} | — | 1,0 | — | 1,0 | — | 7,5 | μA $V_{SS} = 0$; all valid input combinations; $V_I = V_{SS}$ or V_{DD} |
| | 10 | | — | 2,0 | — | 2,0 | — | 15,0 | |
| | 15 | | — | 4,0 | — | 4,0 | — | 30,0 | |
| Input leakage current at E_n | 15 | $\pm I_{IN}$ | — | — | — | 300 | — | 1000 | nA E_n at V_{SS} or V_{DD} |
| OFF-state leakage current, any channel OFF | 5 | I_{OZ} | — | — | — | — | — | — | nA E_n at V_{IL} ; $V_{is} = V_{SS}$ or V_{DD} ; $V_{os} = V_{DD}$ or V_{SS} |
| | 10 | | — | — | — | — | — | — | |
| | 15 | | — | — | — | 200 | — | — | |
| E_n input voltage LOW | 5 | V_{IL} | — | 1,5 | — | 1,5 | — | 1,5 | V switch OFF; see Fig. 9 for I_{OZ} |
| | 10 | | — | 3,0 | — | 3,0 | — | 3,0 | |
| | 15 | | — | 4,0 | — | 4,0 | — | 4,0 | |
| E_n input voltage HIGH | 5 | V_{IH} | 3,5 | — | 3,5 | — | 3,5 | — | V low-impedance between Y and Z (ON condition) see R_{ON} switch |
| | 10 | | 7,0 | — | 7,0 | — | 7,0 | — | |
| | 15 | | 11,0 | — | 11,0 | — | 11,0 | — | |

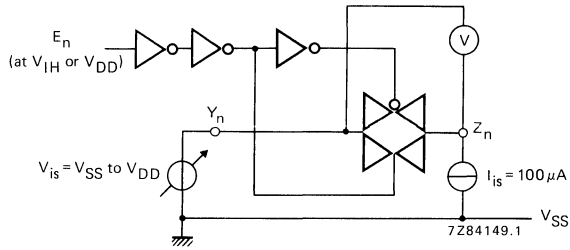

Fig. 4 Test set-up for measuring R_{ON} .

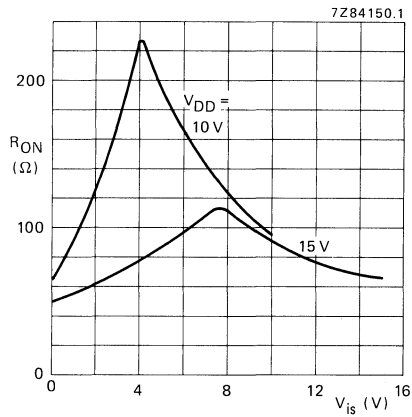

Fig. 5 Typical R_{ON} as a function of input voltage.

$E_n > V_{IH}$
 $I_{is} = 100 \mu A$
 $V_{SS} = 0 V$

A.C. CHARACTERISTICS $V_{SS} = 0 \text{ V}$; $T_{amb} = 25 \text{ }^\circ\text{C}$; input transition times $\leq 20 \text{ ns}$

| | V_{DD} V | symbol | typ. | max. | | |
|--|---------------|--|------------------------------------|------|-----|----------|
| Propagation delays $V_{is} \rightarrow V_{os}$ HIGH to LOW | 5 | tPHL | 25 | 50 | ns | } note 1 |
| | 10 | | 10 | 20 | ns | |
| | 15 | | 5 | 10 | ns | |
| LOW to HIGH | 5 | tPLH | 20 | 40 | ns | } note 1 |
| | 10 | | 10 | 20 | ns | |
| | 15 | | 5 | 10 | ns | |
| Output disable times $E_n \rightarrow V_{os}$ HIGH | 5 | tPHZ | 40 | 80 | ns | } note 2 |
| | 10 | | 30 | 60 | ns | |
| | 15 | | 25 | 50 | ns | |
| LOW | 5 | tPLZ | 35 | 70 | ns | } note 2 |
| | 10 | | 25 | 50 | ns | |
| | 15 | | 25 | 50 | ns | |
| Output enable times $E_n \rightarrow V_{os}$ HIGH | 5 | tPZH | 40 | 80 | ns | } note 2 |
| | 10 | | 20 | 40 | ns | |
| | 15 | | 15 | 30 | ns | |
| LOW | 5 | tPZL | 40 | 80 | ns | } note 2 |
| | 10 | | 20 | 40 | ns | |
| | 15 | | 15 | 30 | ns | |
| Distortion, sine-wave response | 5 | | — | | % | } note 3 |
| | 10 | | 0,08 | | % | |
| | 15 | | 0,04 | | % | |
| Crosstalk between any two channels | 5 | | — | | MHz | } note 4 |
| | 10 | | 1 | | MHz | |
| | 15 | | — | | MHz | |
| Crosstalk; enable input to output | 5 | | — | | mV | } note 5 |
| | 10 | | 50 | | mV | |
| | 15 | | — | | mV | |
| OFF-state feed-through | 5 | | — | | MHz | } note 6 |
| | 10 | | 1 | | MHz | |
| | 15 | | — | | MHz | |
| ON-state frequency response | 5 | | — | | MHz | } note 7 |
| | 10 | | 90 | | MHz | |
| | 15 | | — | | MHz | |
| | V_{DD} V | typical formula for P (μW) | where | | | |
| Dynamic power dissipation per package (P)* | 5 | $550 f_i + \Sigma(f_o C_L) \times V_{DD}^2$ | f_i = input freq. (MHz) | | | |
| | 10 | $2600 f_i + \Sigma(f_o C_L) \times V_{DD}^2$ | f_o = output freq. (MHz) | | | |
| | 15 | $6500 f_i + \Sigma(f_o C_L) \times V_{DD}^2$ | C_L = load capacitance (pF) | | | |
| | | | $\Sigma(f_o C_L)$ = sum of outputs | | | |
| | | | V_{DD} = supply voltage (V) | | | |

* All enable inputs switching.

NOTES

V_{is} is the input voltage at a Y or Z terminal, whichever is assigned as input.

V_{os} is the output voltage at a Y or Z terminal, whichever is assigned as output.

1. $R_L = 10\text{ k}\Omega$ to V_{SS} ; $C_L = 50\text{ pF}$ to V_{SS} ; $E_n = V_{DD}$; $V_{is} = V_{DD}$ (square-wave); see Figs 6 and 10.
2. $R_L = 10\text{ k}\Omega$; $C_L = 50\text{ pF}$ to V_{SS} ; $E_n = V_{DD}$ (square-wave);
 $V_{is} = V_{DD}$ and R_L to V_{SS} for t_{PHZ} and t_{PZH} ;
 $V_{is} = V_{SS}$ and R_L to V_{DD} for t_{PLZ} and t_{PZL} ; see Figs 6 and 11.
3. $R_L = 10\text{ k}\Omega$; $C_L = 15\text{ pF}$; $E_n = V_{DD}$; $V_{is} = \frac{1}{2}V_{DD}$ (p-p) (sine-wave, symmetrical about $\frac{1}{2}V_{DD}$);
 $f_{is} = 1\text{ kHz}$; see Fig. 7.
4. $R_L = 1\text{ k}\Omega$; $V_{is} = \frac{1}{2}V_{DD}$ (p-p) (sine-wave, symmetrical about $\frac{1}{2}V_{DD}$);
 $20 \log \frac{V_{os}(B)}{V_{is}(A)} = -50\text{ dB}$; $E_n(A) = V_{SS}$; $E_n(B) = V_{DD}$; see Fig. 8.
5. $R_L = 10\text{ k}\Omega$ to V_{SS} ; $C_L = 15\text{ pF}$ to V_{SS} ; $E_n = V_{DD}$ (square-wave); crosstalk is $|V_{os}|$ (peak value);
 see Fig. 6.
6. $R_L = 1\text{ k}\Omega$; $C_L = 5\text{ pF}$; $E_n = V_{SS}$; $V_{is} = \frac{1}{2}V_{DD}$ (p-p) (sine-wave, symmetrical about $\frac{1}{2}V_{DD}$);
 $20 \log \frac{V_{os}}{V_{is}} = -50\text{ dB}$; see Fig. 7.
7. $R_L = 1\text{ k}\Omega$; $C_L = 5\text{ pF}$; $E_n = V_{DD}$; $V_{is} = \frac{1}{2}V_{DD}$ (p-p) (sine-wave, symmetrical about $\frac{1}{2}V_{DD}$);
 $20 \log \frac{V_{os}}{V_{is}} = -3\text{ dB}$; see Fig. 7.

HEF4016B
gates

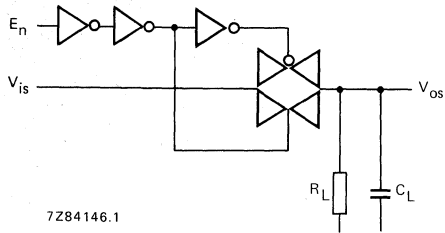

Fig. 6.

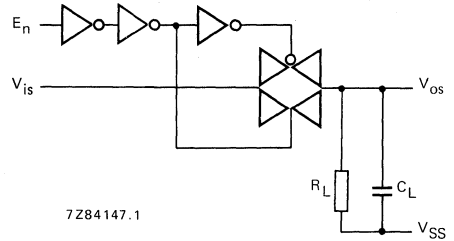

Fig. 7.

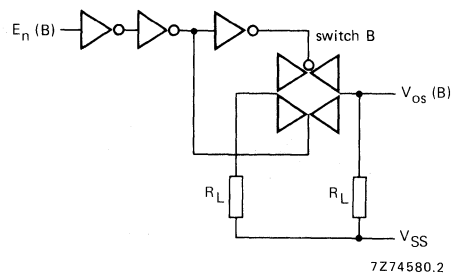
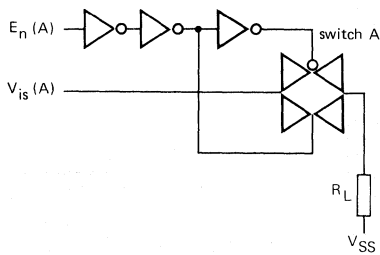

Fig. 8.

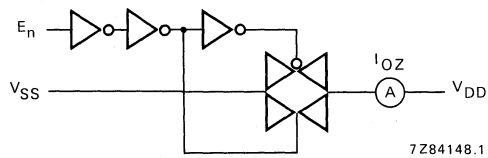

Fig. 9.

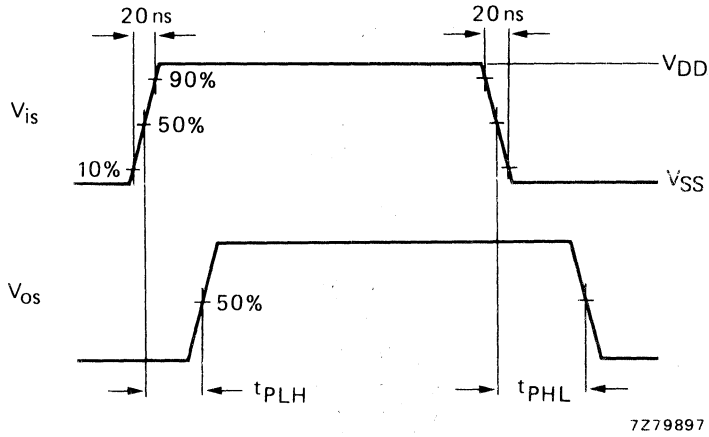
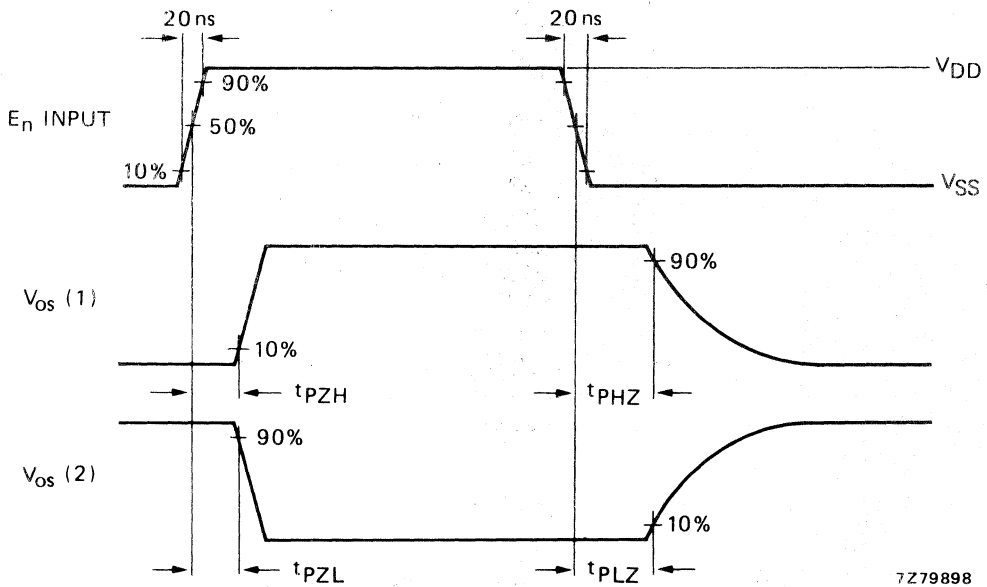

Fig. 10 Waveforms showing propagation delays from V_{is} to V_{os} .



(1) V_{is} at V_{DD} ; (2) V_{is} at V_{SS} .

Fig. 11 Waveforms showing output disable and enable times.

5-STAGE JOHNSON COUNTER



The HEF4017B is a 5-stage Johnson decade counter with ten spike-free decoded active HIGH outputs (O_0 to O_9), an active LOW output from the most significant flip-flop (\bar{O}_{5-9}), active HIGH and active LOW clock inputs (CP_0, \bar{CP}_1) and an overriding asynchronous master reset input (MR).

The counter is advanced by either a LOW to HIGH transition at CP_0 while \bar{CP}_1 is LOW or a HIGH to LOW transition at \bar{CP}_1 while CP_0 is HIGH (see also function table).

When cascading counters, the \bar{O}_{5-9} output, which is LOW while the counter is in states 5, 6, 7, 8 and 9, can be used to drive the CP_0 input of the next counter.

A HIGH on MR resets the counter to zero ($O_0 = \bar{O}_{5-9} = \text{HIGH}$; O_1 to $O_9 = \text{LOW}$) independent of the clock inputs (CP_0, \bar{CP}_1).

Automatic code correction of the counter is provided by an internal circuit: following any illegal code the counter returns to a proper counting mode within 11 clock pulses.

Schmitt-trigger action in the clock input makes the circuit highly tolerant to slower clock rise and fall times.

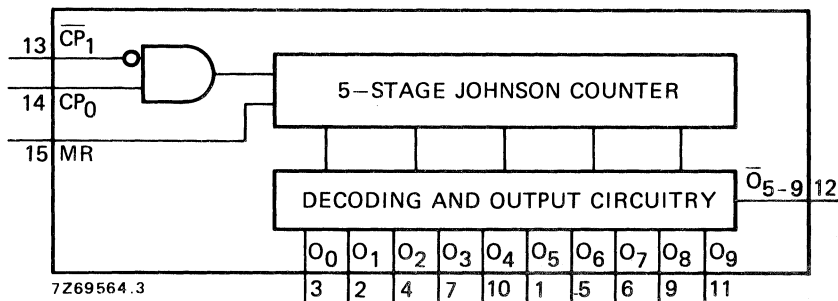

Fig. 1 Functional diagram.

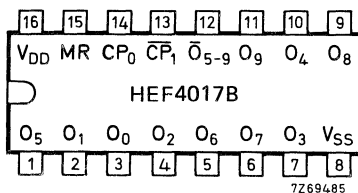

Fig. 2 Pinning diagram.

HEF4017BP : 16-lead DIL; plastic (SOT-38Z).

HEF4017BD : 16-lead DIL; ceramic (cerdip) (SOT-74).

HEF4017BT : 16-lead mini-pack; plastic (SO-16; SOT-109A).

PINNING

| | |
|-----------------|-------------------------------------|
| CP_0 | clock input (LOW to HIGH triggered) |
| CP_1 | clock input (HIGH to LOW triggered) |
| MR | master reset input |
| O_0 to O_9 | decoded outputs |
| \bar{O}_{5-9} | carry output (active LOW) |

FAMILY DATA

} see Family Specifications

I_{DD} LIMITS category MSI

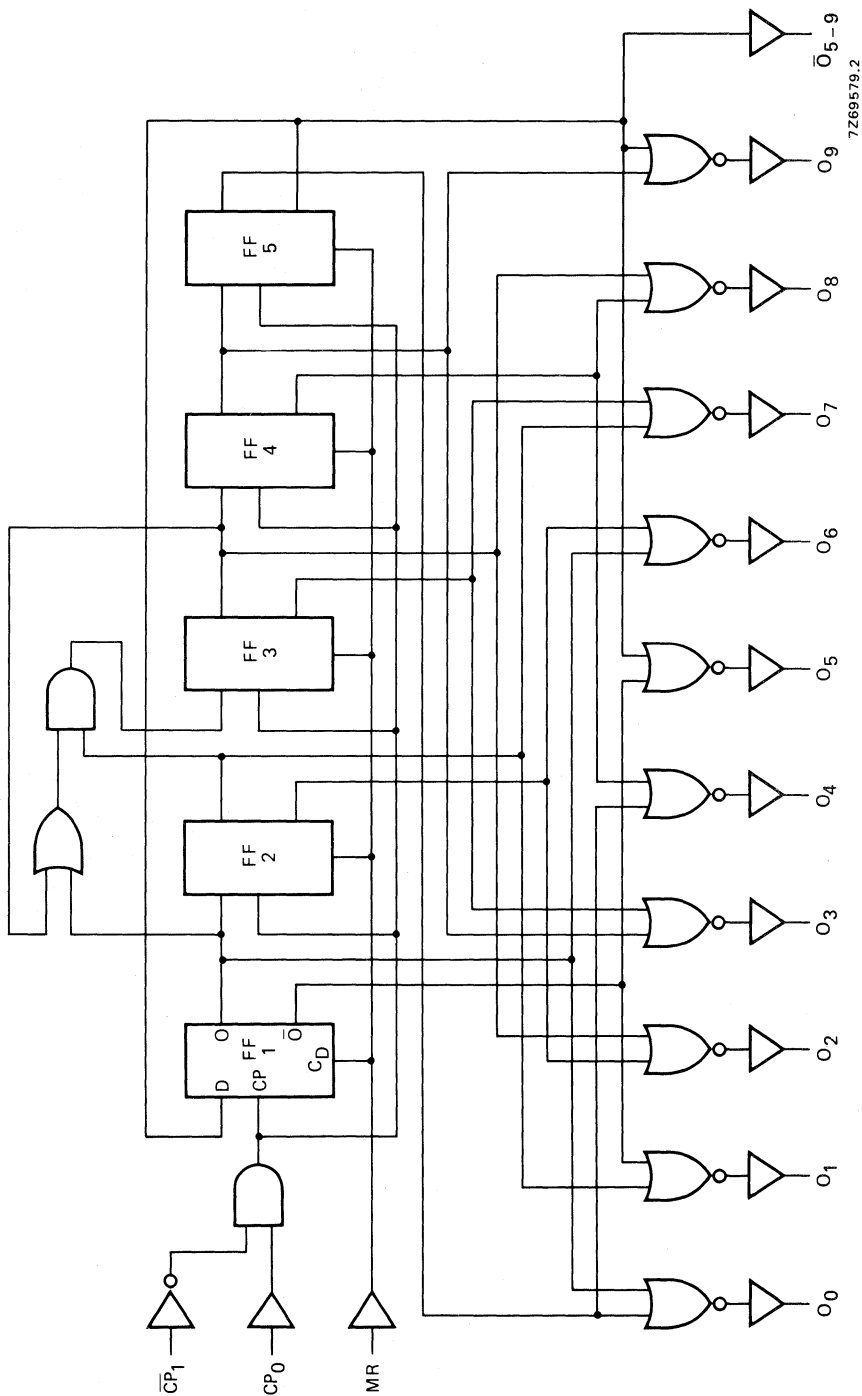

Fig. 3 Logic diagram.

FUNCTION TABLE

| MR | CP ₀ | \overline{CP}_1 | operation |
|----|-----------------|-------------------|---|
| H | X | X | $O_0 = \overline{O}_{5-9} = H$; O_1 to $O_9 = L$ |
| L | H | \searrow | Counter advances |
| L | \swarrow | L | Counter advances |
| L | L | X | No change |
| L | X | H | No change |
| L | H | \swarrow | No change |
| L | \searrow | L | No change |

H = HIGH state (the more positive voltage)

L = LOW state (the less positive voltage)

X = state is immaterial

 \swarrow = positive-going transition \searrow = negative-going transition

A.C. CHARACTERISTICS

 $V_{SS} = 0$ V; $T_{amb} = 25$ °C; $C_L = 50$ pF; input transition times ≤ 20 ns

| | V_{DD} V | symbol | min. | typ. | max. | typical extrapolation formula | |
|---|---------------|------------------|------|------|------|-------------------------------------|--------------------------------------|
| Propagation delays | | | | | | | |
| CP ₀ , CP ₁ → O ₀ to O ₉ HIGH to LOW | 5 | t _{PHL} | | 140 | 280 | ns | 113 ns + (0,55 ns/pF) C _L |
| | 10 | | 55 | 110 | ns | 44 ns + (0,23 ns/pF) C _L | |
| | 15 | | 40 | 80 | ns | 32 ns + (0,16 ns/pF) C _L | |
| LOW to HIGH | 5 | t _{PLH} | | 125 | 250 | ns | 98 ns + (0,55 ns/pF) C _L |
| | 10 | | 50 | 100 | ns | 39 ns + (0,23 ns/pF) C _L | |
| | 15 | | 40 | 80 | ns | 32 ns + (0,16 ns/pF) C _L | |
| CP ₀ , \overline{CP}_1 → \overline{O}_{5-9} HIGH to LOW | 5 | t _{PHL} | | 145 | 290 | ns | 118 ns + (0,55 ns/pF) C _L |
| | 10 | | 55 | 110 | ns | 44 ns + (0,23 ns/pF) C _L | |
| | 15 | | 40 | 80 | ns | 32 ns + (0,16 ns/pF) C _L | |
| LOW to HIGH | 5 | t _{PLH} | | 125 | 250 | ns | 98 ns + (0,55 ns/pF) C _L |
| | 10 | | 50 | 100 | ns | 39 ns + (0,23 ns/pF) C _L | |
| | 15 | | 40 | 80 | ns | 32 ns + (0,16 ns/pF) C _L | |
| MR → O ₁ to O ₉ HIGH to LOW | 5 | t _{PHL} | | 115 | 230 | ns | 88 ns + (0,55 ns/pF) C _L |
| | 10 | | 50 | 100 | ns | 39 ns + (0,23 ns/pF) C _L | |
| | 15 | | 35 | 70 | ns | 27 ns + (0,16 ns/pF) C _L | |
| MR → \overline{O}_{5-9} LOW to HIGH | 5 | t _{PLH} | | 110 | 220 | ns | 83 ns + (0,55 ns/pF) C _L |
| | 10 | | 45 | 90 | ns | 34 ns + (0,23 ns/pF) C _L | |
| | 15 | | 35 | 70 | ns | 27 ns + (0,16 ns/pF) C _L | |
| MR → O ₀ LOW to HIGH | 5 | t _{PLH} | | 130 | 260 | ns | 103 ns + (0,55 ns/pF) C _L |
| | 10 | | 55 | 105 | ns | 44 ns + (0,23 ns/pF) C _L | |
| | 15 | | 40 | 75 | ns | 32 ns + (0,16 ns/pF) C _L | |
| Output transition times | | | | | | | |
| HIGH to LOW | 5 | t _{THL} | | 60 | 120 | ns | 10 ns + (1,0 ns/pF) C _L |
| | 10 | | 30 | 60 | ns | 9 ns + (0,42 ns/pF) C _L | |
| | 15 | | 20 | 40 | ns | 6 ns + (0,28 ns/pF) C _L | |
| LOW to HIGH | 5 | t _{TLH} | | 60 | 120 | ns | 10 ns + (1,0 ns/pF) C _L |
| | 10 | | 30 | 60 | ns | 9 ns + (0,42 ns/pF) C _L | |
| | 15 | | 20 | 40 | ns | 6 ns + (0,28 ns/pF) C _L | |

HEF4017B

MSI

A.C. CHARACTERISTICS

$V_{SS} = 0\text{ V}$; $T_{amb} = 25\text{ }^{\circ}\text{C}$; $C_L = 50\text{ pF}$; input transition times $\leq 20\text{ ns}$

| | V_{DD} V | symbol | min. | typ. | max. | | |
|---|------------------------------------|--------------|------------|------|------|------------------------------------|----|
| Hold times $CP_0 \rightarrow \overline{CP}_1$ | 5 | t_{hold} | 90 | 45 | ns | see also waveforms Figs 4 and 5 | |
| | 10 | | 40 | 20 | ns | | |
| | 15 | | 20 | 10 | ns | | |
| | $\overline{CP}_1 \rightarrow CP_0$ | 5 | t_{hold} | 80 | 40 | | ns |
| | | 10 | | 40 | 20 | | ns |
| | | 15 | | 30 | 10 | | ns |
| Minimum clock pulse width: $CP_0 = \text{LOW}$; $\overline{CP}_1 = \text{HIGH}$ | 5 | $t_{WCPL} =$ | 80 | 40 | ns | | |
| | 10 | | 40 | 20 | ns | | |
| | 15 | t_{WCPH} | 30 | 15 | ns | | |
| Minimum MR pulse width; HIGH | 5 | t_{WMRH} | 50 | 25 | ns | | |
| | 10 | | 30 | 15 | ns | | |
| | 15 | | 20 | 10 | ns | | |
| Recovery time for MR | 5 | t_{RMR} | 60 | 30 | ns | | |
| | 10 | | 30 | 15 | ns | | |
| | 15 | | 20 | 10 | ns | | |
| Maximum clock pulse frequency | 5 | f_{max} | 6 | 12 | MHz | | |
| | 10 | | 12 | 24 | MHz | | |
| | 15 | | 15 | 30 | MHz | | |

| | V_{DD} V | typical formula for P (μW) | where f_i = input freq. (MHz) f_o = output freq. (MHz) C_L = load cap. (pF) $\Sigma(f_o C_L)$ = sum of outputs V_{DD} = supply voltage (V) |
|---|---------------|--|---|
| Dynamic power dissipation per package (P) | 5 | $500 f_i + \Sigma(f_o C_L) \times V_{DD}^2$ | |
| | 10 | $2200 f_i + \Sigma(f_o C_L) \times V_{DD}^2$ | |
| | 15 | $6000 f_i + \Sigma(f_o C_L) \times V_{DD}^2$ | |

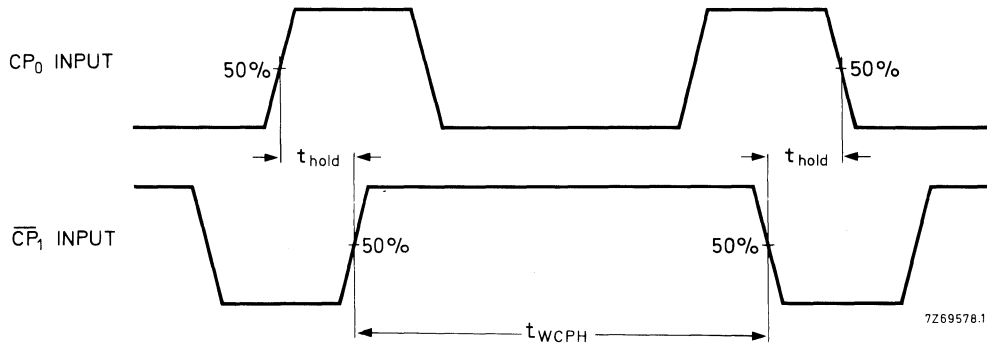

Fig. 4 Waveforms showing hold times for CP_0 to \overline{CP}_1 and \overline{CP}_1 to CP_0 . Hold times are shown as positive values, but may be specified as negative values.

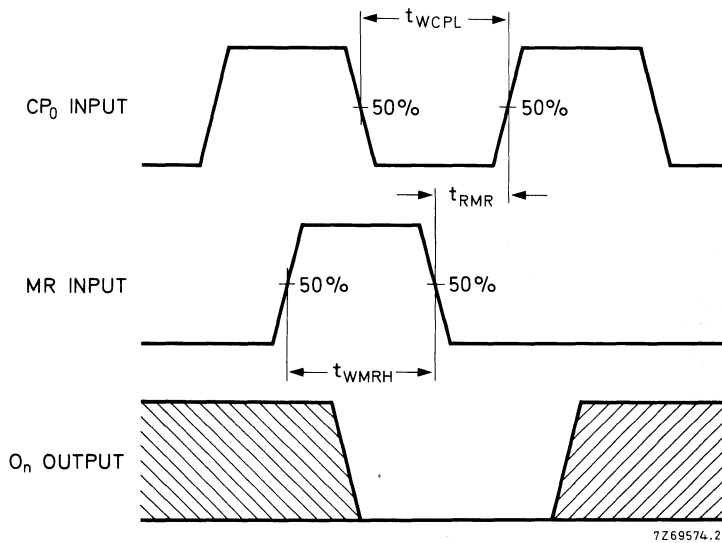

Fig. 5 Waveforms showing recovery time for MR; minimum CP_0 and MR pulse widths. Conditions: $\overline{CP}_1 = \text{LOW}$ while CP_0 is triggered on a LOW to HIGH transition. t_{WCP} and t_{RMR} also apply when $CP_0 = \text{HIGH}$ and \overline{CP}_1 is triggered on a HIGH to LOW transition.

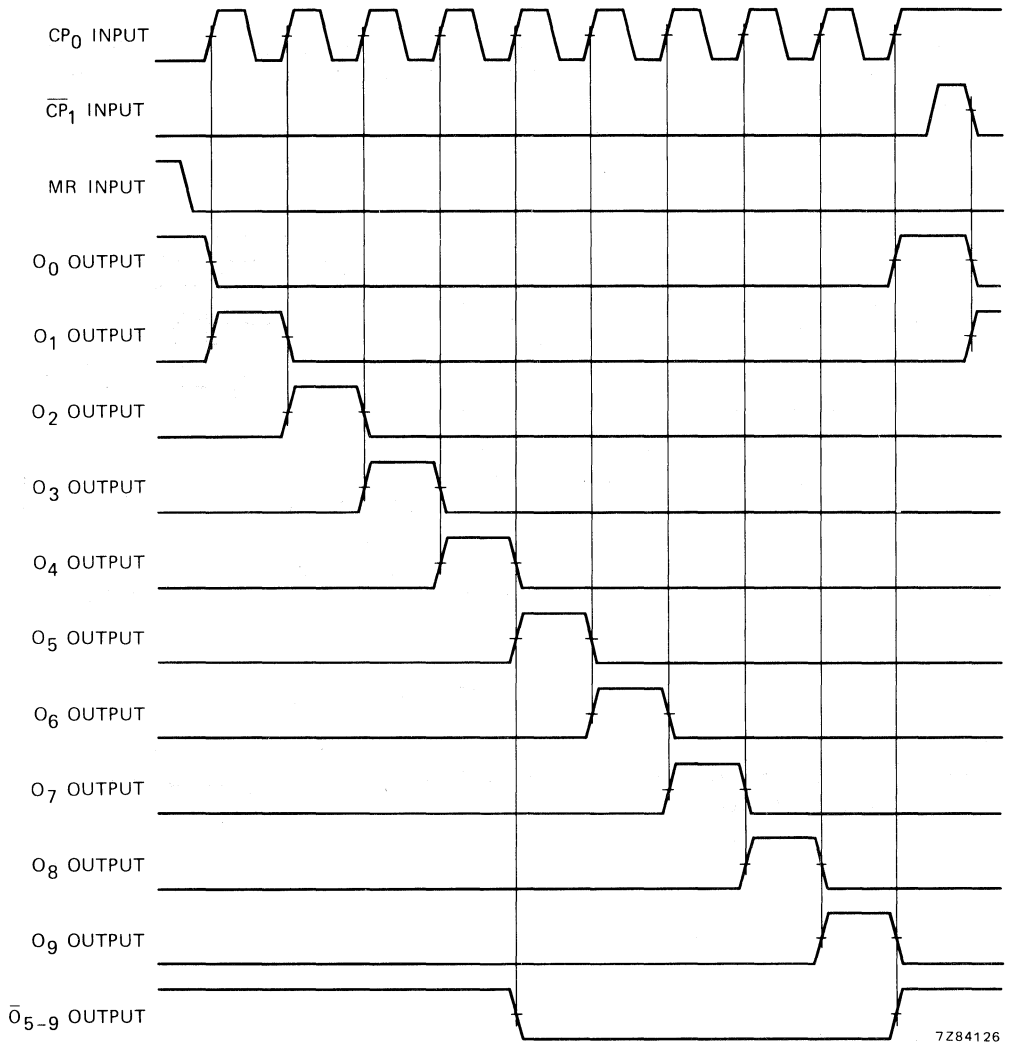

Fig. 6 Timing diagram.

APPLICATION INFORMATION

Some examples of applications for the HEF4017B are:

- Decade counter with decimal decoding
- 1 out of n decoding counter (when cascaded)
- Sequential controller
- Timer.

Figure 7 shows a technique for extending the number of decoded output states for the HEF4017B. Decoded outputs are sequential within each stage and from stage to stage, with no dead time (except propagation delay).

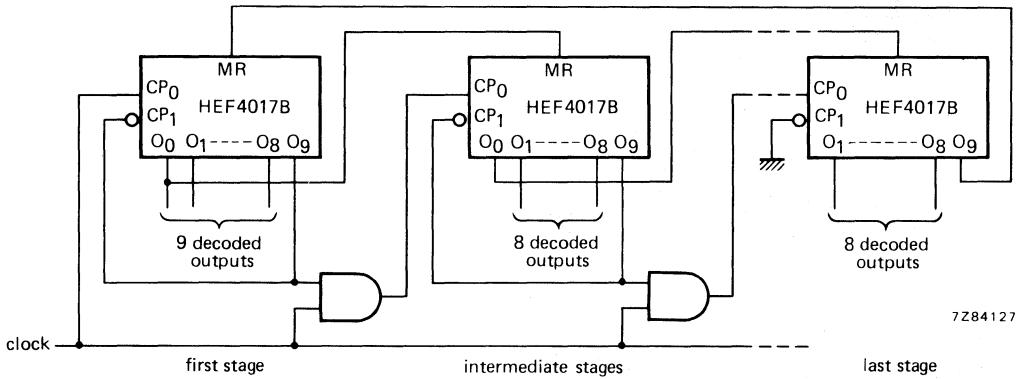

Fig. 7 Counter expansion.

Note

It is essential not to enable the counter on \overline{CP}_1 when CP_0 is HIGH, or on CP_0 when \overline{CP}_1 is LOW, as this would cause an extra count.



PRESETTABLE DIVIDE-BY-N COUNTER

The HEF4018B is a 5-stage Johnson counter with a clock input (CP), a data input (D), an asynchronous parallel load input (PL), five parallel inputs (P_0 to P_4), five active LOW buffered outputs (\bar{O}_0 to \bar{O}_4), and an overriding asynchronous master reset input (MR).

Information on P_0 to P_4 is asynchronously loaded into the counter while PL is HIGH, independent of CP and D inputs. When P_L is LOW, the counter advances on the LOW to HIGH transition of CP. By connecting \bar{O}_0 to \bar{O}_4 to D, the counter operates as a divide-by-n counter ($n = 2$ to 10 ; see also function selection below). Each register stage is a D-type master-slave flip-flop with a set-direct/clear-direct input. An internal code correction circuit provides automatic code correction of the counter. From any illegal code the counter is in a proper counting mode within 11 clock pulses.

A HIGH on MR resets the counter (\bar{O}_0 to $\bar{O}_4 = \text{HIGH}$) independent of all other inputs.

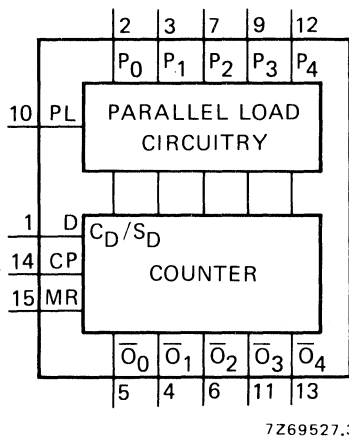

Fig. 1 Functional diagram.

FUNCTION SELECTION

| counter mode; divide by | connect D input to | remarks |
|-------------------------|--|--|
| 10 8 6 4 2 | \bar{O}_4 \bar{O}_3 \bar{O}_2 \bar{O}_1 \bar{O}_0 | no external components needed |
| 9 7 5 3 | $\bar{O}_3 \cdot \bar{O}_4$ $\bar{O}_2 \cdot \bar{O}_3$ $\bar{O}_1 \cdot \bar{O}_2$ $\bar{O}_0 \cdot \bar{O}_1$ | AND gate needed; counter skips all HIGH states |

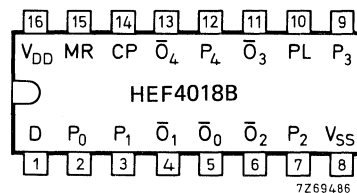

Fig. 2 Pinning diagram.

HEF4018BP : 16-lead DIL; plastic (SOT-38Z).
HEF4018BD : 16-lead DIL; ceramic (cerdip) (SOT-74).
HEF4018BT : 16-lead mini-pack; plastic (SO-16; SOT-109A).

PINNING

PL parallel load input
 P_0 to P_4 parallel inputs
D data input
CP clock input (LOW to HIGH edge triggered)
MR master reset input
 \bar{O}_0 to \bar{O}_4 buffered output (active LOW)

APPLICATION INFORMATION

Some examples of applications for the HEF4018B are:

- Programmable divide-by-n counter
- Programmable frequency division
- Timers

FAMILY DATA

I_{DD} LIMITS category MSI

see Family Specifications

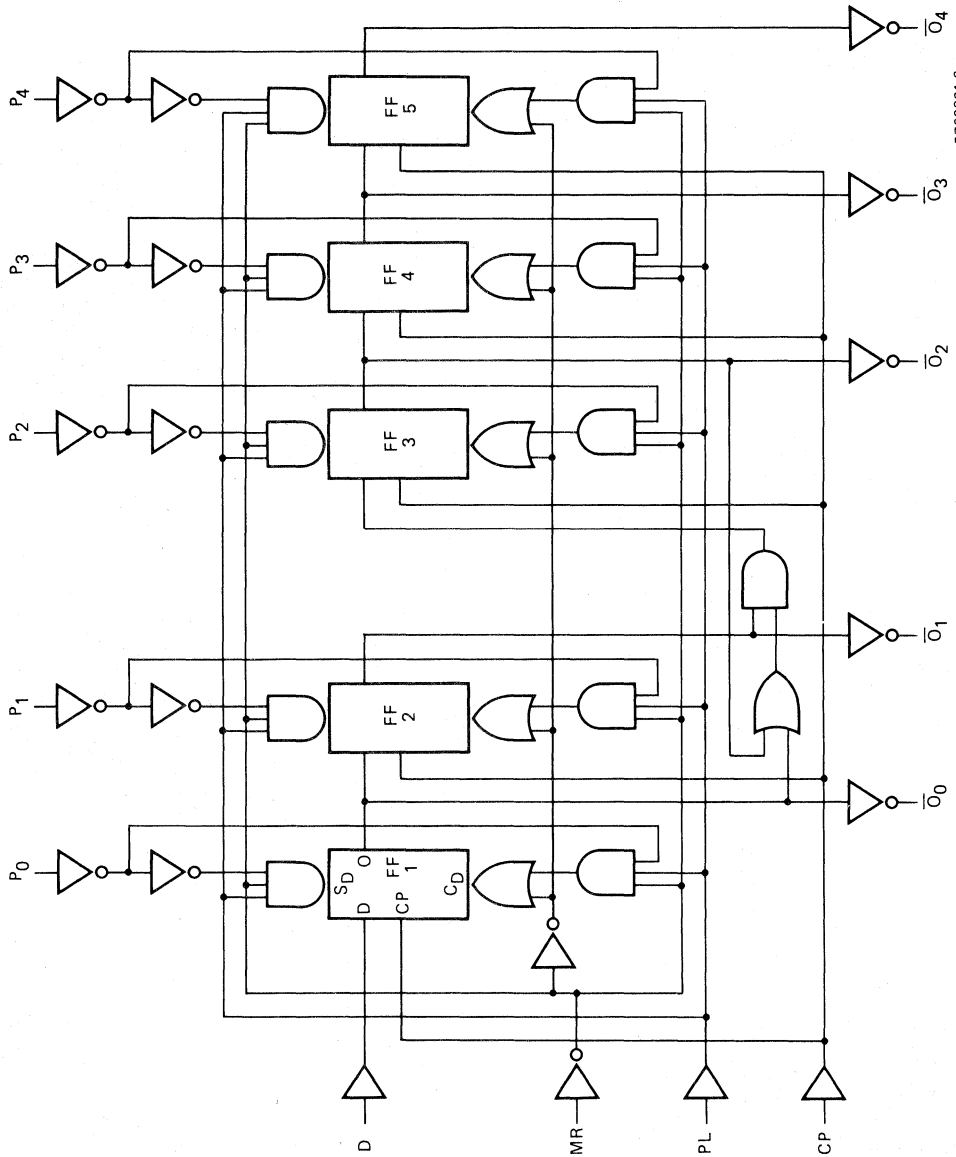

7Z69821.2

Fig. 3 Logic diagram.

A.C. CHARACTERISTICS

V_{SS} = 0 V; T_{amb} = 25 °C; input transition times ≤ 20 ns

| | V _{DD} V | typical formula for P (μW) | where |
|---|----------------------|---|--|
| Dynamic power dissipation per package (P) | 5 | $700 f_i + \Sigma(f_o C_L) \times V_{DD}^2$ | f _i = input freq. (MHz) |
| | 10 | $3450 f_i + \Sigma(f_o C_L) \times V_{DD}^2$ | f _o = output freq. (MHz) |
| | 15 | $10\,300 f_i + \Sigma(f_o C_L) \times V_{DD}^2$ | C _L = load capacitance (pF) Σ(f _o C _L) = sum of outputs V _{DD} = supply voltage (V) |

A.C. CHARACTERISTICS

V_{SS} = 0 V; T_{amb} = 25 °C; C_L = 50 pF; input transition times ≤ 20 ns

| | V _{DD} V | symbol | min. | typ. | max. | typical extrapolation formula | |
|---|----------------------|-------------------|------|------|------|-------------------------------------|--------------------------------------|
| Propagation delays CP → \bar{O} HIGH to LOW | 5 | t _{PHL} | | 185 | 370 | ns | 158 ns + (0,55 ns/pF) C _L |
| | 10 | | 65 | 135 | ns | 54 ns + (0,23 ns/pF) C _L | |
| | 15 | | 50 | 95 | ns | 42 ns + (0,16 ns/pF) C _L | |
| LOW to HIGH | 5 | t _{PLH} | | 145 | 295 | ns | 118 ns + (0,55 ns/pF) C _L |
| | 10 | | 55 | 110 | ns | 44 ns + (0,23 ns/pF) C _L | |
| | 15 | | 40 | 85 | ns | 32 ns + (0,16 ns/pF) C _L | |
| PL → \bar{O} HIGH to LOW | 5 | t _{PHL} | | 205 | 415 | ns | 178 ns + (0,55 ns/pF) C _L |
| | 10 | | 70 | 140 | ns | 59 ns + (0,23 ns/pF) C _L | |
| | 15 | | 50 | 105 | ns | 42 ns + (0,16 ns/pF) C _L | |
| LOW to HIGH | 5 | t _{PLH} | | 175 | 350 | ns | 148 ns + (0,55 ns/pF) C _L |
| | 10 | | 65 | 125 | ns | 54 ns + (0,23 ns/pF) C _L | |
| | 15 | | 50 | 95 | ns | 42 ns + (0,16 ns/pF) C _L | |
| MR → \bar{O} LOW to HIGH | 5 | t _{PLH} | | 140 | 280 | ns | 113 ns + (0,55 ns/pF) C _L |
| | 10 | | 55 | 105 | ns | 44 ns + (0,23 ns/pF) C _L | |
| | 15 | | 40 | 80 | ns | 32 ns + (0,16 ns/pF) C _L | |
| Output transition times HIGH to LOW | 5 | t _{THL} | | 60 | 120 | ns | 10 ns + (1,0 ns/pF) C _L |
| | 10 | | 30 | 60 | ns | 9 ns + (0,42 ns/pF) C _L | |
| | 15 | | 20 | 40 | ns | 6 ns + (0,28 ns/pF) C _L | |
| LOW to HIGH | 5 | t _{T LH} | | 60 | 120 | ns | 10 ns + (1,0 ns/pF) C _L |
| | 10 | | 30 | 60 | ns | 9 ns + (0,42 ns/pF) C _L | |
| | 15 | | 20 | 40 | ns | 6 ns + (0,28 ns/pF) C _L | |

A.C. CHARACTERISTICS

$V_{SS} = 0\text{ V}$; $T_{amb} = 25\text{ }^{\circ}\text{C}$; $C_L = 50\text{ pF}$; input transition times $\leq 20\text{ ns}$

| | V_{DD} V | symbol | min. | typ. | max. | typical extrapolation formula |
|-----------------------------------|---------------|------------|------|------|------|---------------------------------------|
| Set-up time D \rightarrow CP | 5 | t_{su} | 130 | 65 | ns | see also waveforms Figs 4, 5 and 6 |
| | 10 | | 40 | 20 | ns | |
| | 15 | | 30 | 15 | ns | |
| Hold time D \rightarrow CP | 5 | t_{hold} | 20 | -45 | ns | |
| | 10 | | 5 | -15 | ns | |
| | 15 | | 5 | -10 | ns | |
| Minimum clock pulse width; LOW | 5 | t_{WCPL} | 140 | 70 | ns | |
| | 10 | | 50 | 25 | ns | |
| | 15 | | 40 | 20 | ns | |
| Minimum MR pulse width; HIGH | 5 | t_{WMRH} | 100 | 50 | ns | |
| | 10 | | 35 | 20 | ns | |
| | 15 | | 25 | 15 | ns | |
| Minimum PL pulse width; HIGH | 5 | t_{WPLH} | 145 | 75 | ns | |
| | 10 | | 50 | 25 | ns | |
| | 15 | | 35 | 20 | ns | |
| Recovery time for MR | 5 | t_{RMR} | 135 | 70 | ns | |
| | 10 | | 40 | 20 | ns | |
| | 15 | | 25 | 15 | ns | |
| Recovery time for PL | 5 | t_{RPL} | 170 | 85 | ns | |
| | 10 | | 55 | 30 | ns | |
| | 15 | | 40 | 20 | ns | |
| Maximum clock pulse frequency | 5 | f_{max} | 2 | 4 | MHz | |
| | 10 | | 6 | 11 | MHz | |
| | 15 | | 8 | 16 | MHz | |

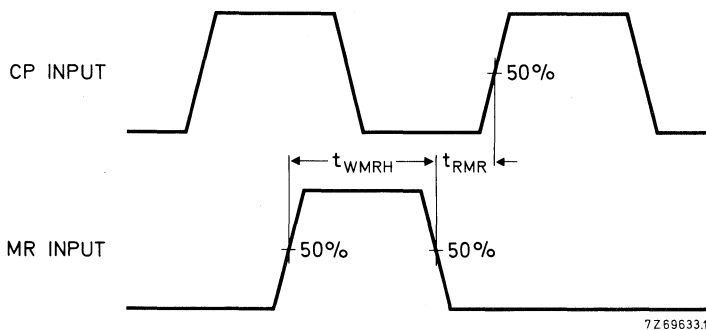

Fig. 4 Waveforms showing minimum MR pulse width and MR recovery time.

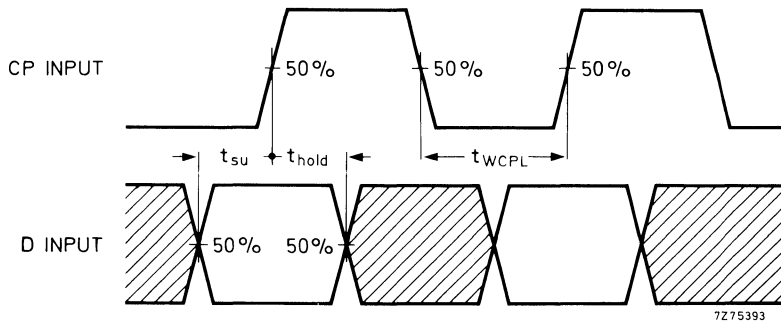

Fig. 5 Waveforms showing minimum clock pulse width, set-up time and hold time for CP and D.

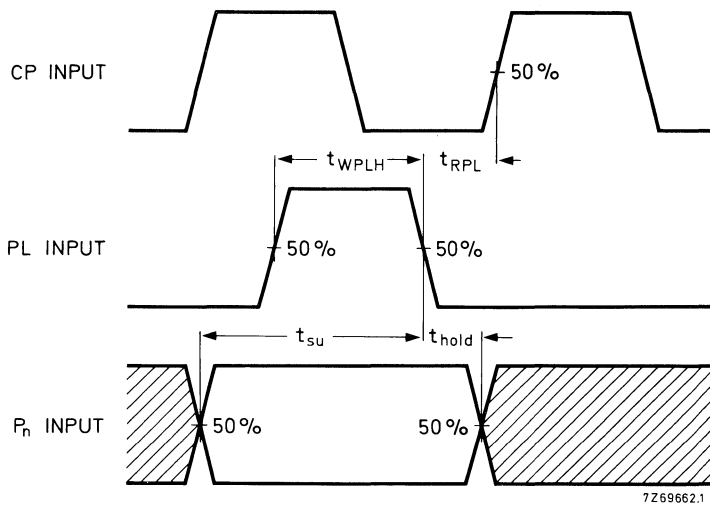

Fig. 6 Waveforms showing minimum PL pulse width, recovery time for PL, and set-up and hold times for P_n to PL. Set-up and hold times are shown as positive values but may be specified as negative values.

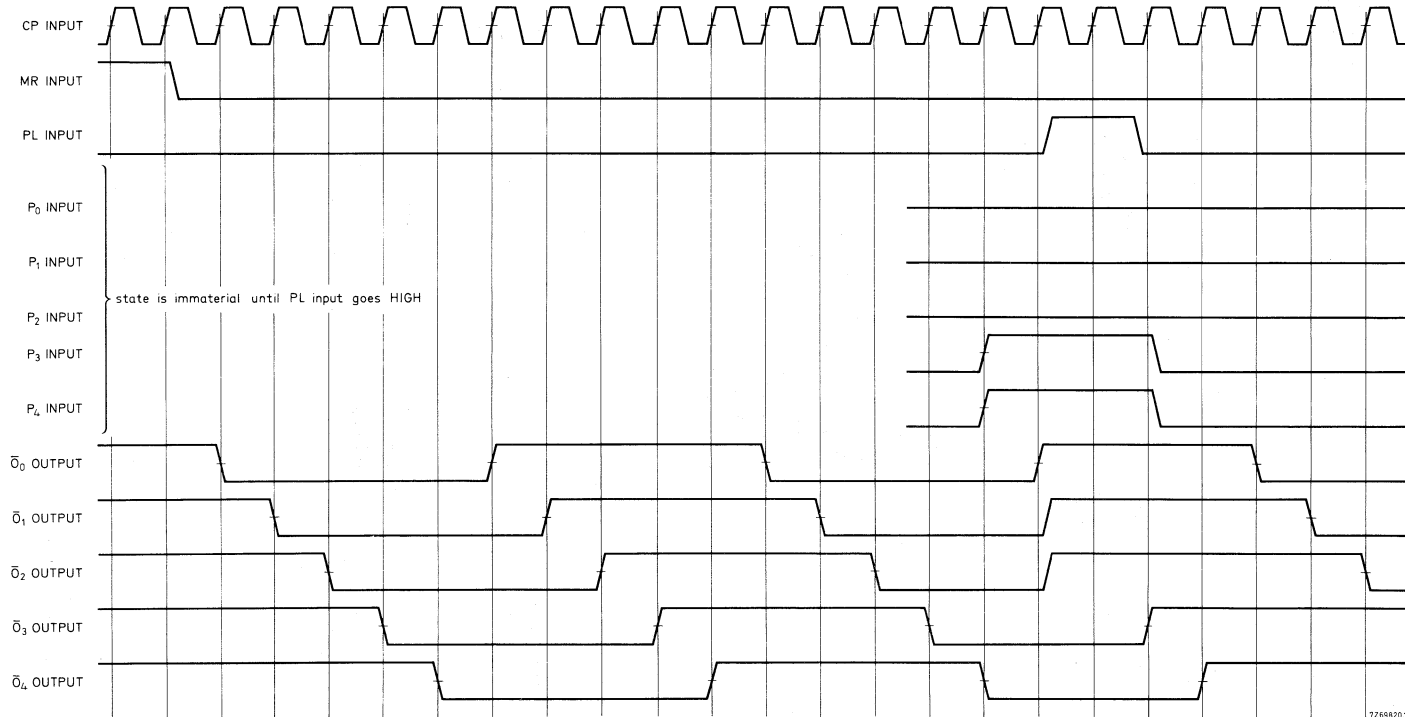

Fig. 7 Timing diagram.

Note

D input connected to \bar{O}_4 for decade counter configuration.

QUADRUPLE 2-INPUT MULTIPLEXER



The HEF4019B provides four multiplexing circuits with common select inputs (S_A , S_B); each circuit contains two inputs (A_n , B_n) and one output (O_n). It may be used to select four bits of information from one of two sources.

The A inputs are selected when S_A is HIGH, the B inputs when S_B is HIGH. When S_A and S_B are HIGH, output (O_n) is the logical OR of the A_n and B_n inputs ($O_n = A_n + B_n$). When S_A and S_B are LOW, output (O_n) is LOW independent of the multiplexer inputs.

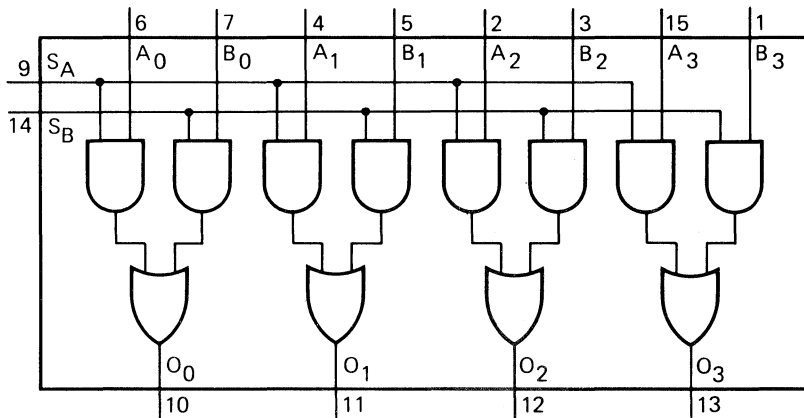

7Z69542.3

Fig. 1 Functional diagram.

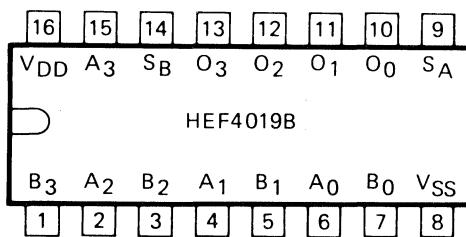

7Z69487.1

HEF4019BP : 16-lead DIL; plastic (SOT-38Z).

HEF4019BD : 16-lead DIL; ceramic (cerdip) (SOT-74).

HEF4019BT : 16-lead mini-pack; plastic (SO-16; SOT-109A).

Fig. 2 Pinning diagram.

PINNING

 S_A , S_B select inputs (active HIGH) B_0 to B_3 multiplexer inputs

multiplexer inputs

 A_0 to A_3 multiplexer inputs O_0 to O_3 multiplexer outputs

multiplexer outputs

FAMILY DATA

I_{DD} LIMITS category MSI

} see Family Specifications

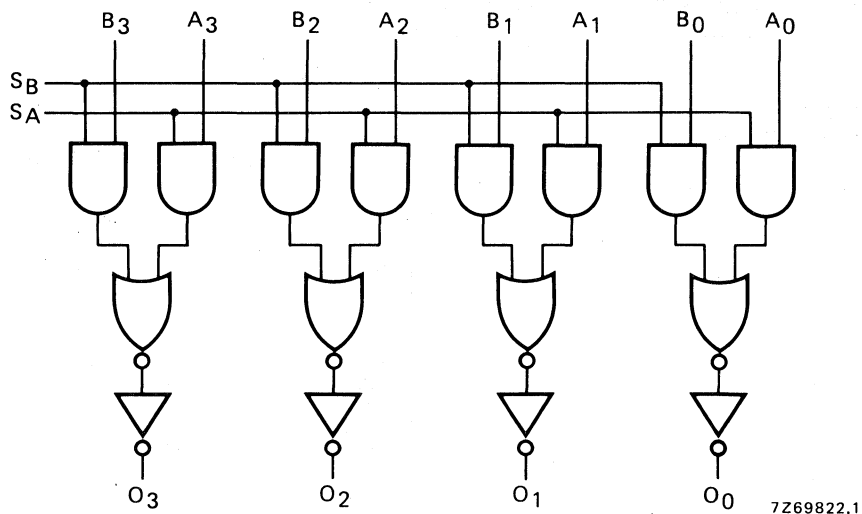

Fig. 3 Logic diagram.

TRUTH TABLE

| select | | inputs | | output |
|----------------|----------------|----------------|----------------|----------------|
| S _A | S _B | A _n | B _n | O _n |
| L | L | X | X | L |
| H | L | L | X | L |
| H | L | H | X | H |
| L | H | X | L | L |
| L | H | X | H | H |
| H | H | H | X | H |
| H | H | X | H | H |
| H | H | L | L | L |

H = HIGH state (the more positive voltage)

L = LOW state (the less positive voltage)

X = state is immaterial

A.C. CHARACTERISTICS

$V_{SS} = 0\text{ V}$; $T_{amb} = 25\text{ }^{\circ}\text{C}$; $C_L = 50\text{ pF}$; input transition times $\leq 20\text{ ns}$

| | V_{DD} V | symbol | typ. | max. | | typical extrapolation formula |
|---|---------------|--------|------|------|----|--|
| Propagation delays $A_n, B_n, S_A, S_B \rightarrow O_n$ HIGH to LOW | 5 | tPHL | 70 | 145 | ns | $43\text{ ns} + (0,55\text{ ns/pF}) C_L$ |
| | 10 | | 30 | 60 | ns | $19\text{ ns} + (0,23\text{ ns/pF}) C_L$ |
| | 15 | | 25 | 50 | ns | $17\text{ ns} + (0,16\text{ ns/pF}) C_L$ |
| LOW to HIGH | 5 | tPLH | 60 | 130 | ns | $33\text{ ns} + (0,55\text{ ns/pF}) C_L$ |
| | 10 | | 25 | 50 | ns | $14\text{ ns} + (0,23\text{ ns/pF}) C_L$ |
| | 15 | | 15 | 35 | ns | $7\text{ ns} + (0,16\text{ ns/pF}) C_L$ |
| Output transition times HIGH to LOW | 5 | tTHL | 60 | 120 | ns | $10\text{ ns} + (1,0\text{ ns/pF}) C_L$ |
| | 10 | | 30 | 60 | ns | $9\text{ ns} + (0,42\text{ ns/pF}) C_L$ |
| | 15 | | 20 | 40 | ns | $6\text{ ns} + (0,28\text{ ns/pF}) C_L$ |
| LOW to HIGH | 5 | tTLH | 60 | 120 | ns | $10\text{ ns} + (1,0\text{ ns/pF}) C_L$ |
| | 10 | | 30 | 60 | ns | $9\text{ ns} + (0,42\text{ ns/pF}) C_L$ |
| | 15 | | 20 | 40 | ns | $6\text{ ns} + (0,28\text{ ns/pF}) C_L$ |

| | V_{DD} V | typical formula for P (μW) | where f_i = input freq. (MHz) f_o = output freq. (MHz) C_L = load capacitance (pF) $\Sigma(f_o C_L)$ = sum of outputs V_{DD} = supply voltage (V) |
|---|---------------|---|--|
| Dynamic power dissipation per package (P) | 5 | $1200 f_i + \Sigma(f_o C_L) \times V_{DD}^2$ | |
| | 10 | $5100 f_i + \Sigma(f_o C_L) \times V_{DD}^2$ | |
| | 15 | $18\,700 f_i + \Sigma(f_o C_L) \times V_{DD}^2$ | |

APPLICATION INFORMATION

An example of an application for the HEF4019B is:

- True/complement selection.

14-STAGE BINARY COUNTER



The HEF4020B is a 14-stage binary ripple counter with a clock input (\overline{CP}), an overriding asynchronous master reset input (MR) and twelve fully buffered outputs (O_0 , O_3 to O_{13}). The counter advances on the HIGH to LOW transition of \overline{CP} . A HIGH on MR clears all counter stages and forces all outputs LOW, independent of the state of \overline{CP} . Each counter stage is a static toggle flip-flop. A feature of the HEF4020B is: high speed (typ. 35 MHz at $V_{DD} = 15$ V).

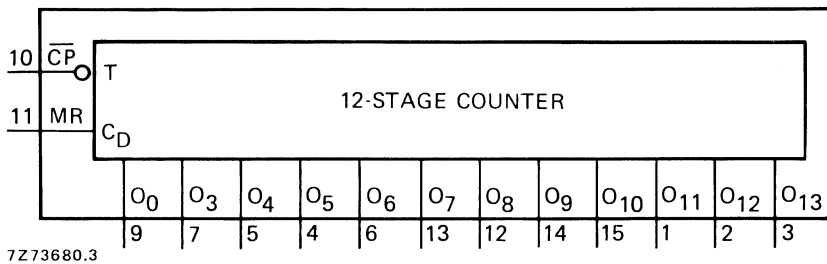

Fig. 1 Functional diagram.

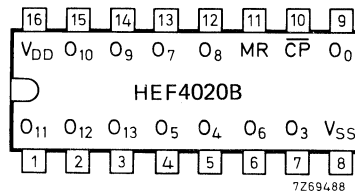

Fig. 2 Pinning diagram.

HEF4020BP: 16-lead DIL; plastic (SOT-38Z).
 HEF4020BD: 16-lead DIL; ceramic (cerdip) (SOT-74).
 HEF4020BT: 16-lead mini-pack; plastic (SO-16; SOT-109A).

PINNING

\overline{CP} clock input (HIGH to LOW edge triggered)
 MR master reset input (active HIGH)
 O_0 , O_3 to O_{13} parallel outputs

FAMILY DATA

I_{DD} LIMITS category MSI

} see Family Specifications

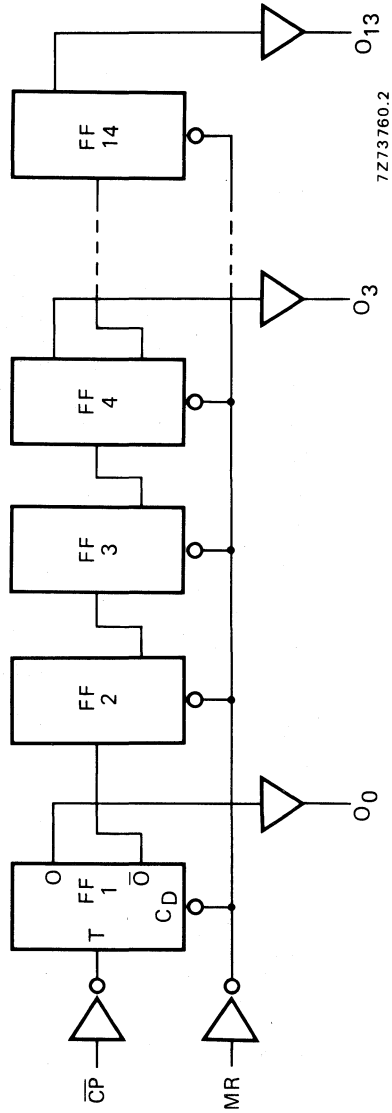

Fig. 3 Logic diagram.

A.C. CHARACTERISTICS

$V_{SS} = 0\text{ V}$; $T_{amb} = 25\text{ }^{\circ}\text{C}$; $C_L = 50\text{ pF}$; input transition times $\leq 20\text{ ns}$; see also waveforms Fig. 4

| | V_{DD} V | symbol | min. | typ. | max. | typical extrapolation formula | |
|--|---------------|------------------|------|------|------|--|---|
| Propagation delays $\overline{CP} \rightarrow O_0$ HIGH to LOW | 5 | tPHL | | 105 | 210 | ns | $78\text{ ns} + (0,55\text{ ns/pF}) C_L$ |
| | 10 | | 45 | 90 | ns | $34\text{ ns} + (0,23\text{ ns/pF}) C_L$ | |
| | 15 | | 30 | 65 | ns | $22\text{ ns} + (0,16\text{ ns/pF}) C_L$ | |
| LOW to HIGH | 5 | tPLH | | 105 | 210 | ns | $78\text{ ns} + (0,55\text{ ns/pF}) C_L$ |
| | 10 | | 50 | 95 | ns | $39\text{ ns} + (0,23\text{ ns/pF}) C_L$ | |
| | 15 | | 35 | 70 | ns | $27\text{ ns} + (0,16\text{ ns/pF}) C_L$ | |
| $O_n \rightarrow O_{n+1}$ HIGH to LOW | 5 | tPHL | | 80 | 160 | ns | $53\text{ ns} + (0,55\text{ ns/pF}) C_L$ |
| | 10 | | 30 | 60 | ns | $19\text{ ns} + (0,23\text{ ns/pF}) C_L$ | |
| | 15 | | 20 | 40 | ns | $12\text{ ns} + (0,16\text{ ns/pF}) C_L$ | |
| LOW to HIGH | 5 | tPLH | | 70 | 140 | ns | $43\text{ ns} + (0,55\text{ ns/pF}) C_L$ |
| | 10 | | 25 | 50 | ns | $14\text{ ns} + (0,23\text{ ns/pF}) C_L$ | |
| | 15 | | 20 | 40 | ns | $12\text{ ns} + (0,16\text{ ns/pF}) C_L$ | |
| MR $\rightarrow O_n$ HIGH to LOW | 5 | tPHL | | 180 | 360 | ns | $153\text{ ns} + (0,55\text{ ns/pF}) C_L$ |
| | 10 | | 90 | 180 | ns | $79\text{ ns} + (0,23\text{ ns/pF}) C_L$ | |
| | 15 | | 70 | 140 | ns | $62\text{ ns} + (0,16\text{ ns/pF}) C_L$ | |
| Output transition times HIGH to LOW | 5 | tTHL | | 60 | 120 | ns | $10\text{ ns} + (1,0\text{ ns/pF}) C_L$ |
| | 10 | | 30 | 60 | ns | $9\text{ ns} + (0,42\text{ ns/pF}) C_L$ | |
| | 15 | | 20 | 40 | ns | $6\text{ ns} + (0,28\text{ ns/pF}) C_L$ | |
| LOW to HIGH | 5 | tTLH | | 60 | 120 | ns | $10\text{ ns} + (1,0\text{ ns/pF}) C_L$ |
| | 10 | | 30 | 60 | ns | $9\text{ ns} + (0,42\text{ ns/pF}) C_L$ | |
| | 15 | | 20 | 40 | ns | $6\text{ ns} + (0,28\text{ ns/pF}) C_L$ | |
| Minimum clock pulse width; HIGH | 5 | tWCPH | 50 | 25 | | ns | |
| | 10 | | 25 | 15 | | ns | |
| | 15 | | 20 | 10 | | ns | |
| Minimum MR pulse width; HIGH | 5 | tWMRH | 130 | 65 | | ns | |
| | 10 | | 95 | 50 | | ns | |
| | 15 | | 90 | 45 | | ns | |
| Recovery time for MR | 5 | tRMR | 115 | 60 | | ns | |
| | 10 | | 65 | 35 | | ns | |
| | 15 | | 55 | 25 | | ns | |
| Maximum clock pulse frequency | 5 | f _{max} | 5 | 10 | | MHz | |
| | 10 | | 13 | 25 | | MHz | |
| | 15 | | 18 | 35 | | MHz | |

| | V_{DD} V | typical formula for P (μW) | where |
|---|---------------|---|------------------------------------|
| Dynamic power dissipation per package (P) | 5 | $600 f_i + \Sigma(f_o C_L) \times V_{DD}^2$ | f_i = input freq. (MHz) |
| | 10 | | f_o = output freq. (MHz) |
| | 15 | | C_L = load cap. (pF) |
| | | | $\Sigma(f_o C_L)$ = sum of outputs |
| | | | V_{DD} = supply voltage (V) |

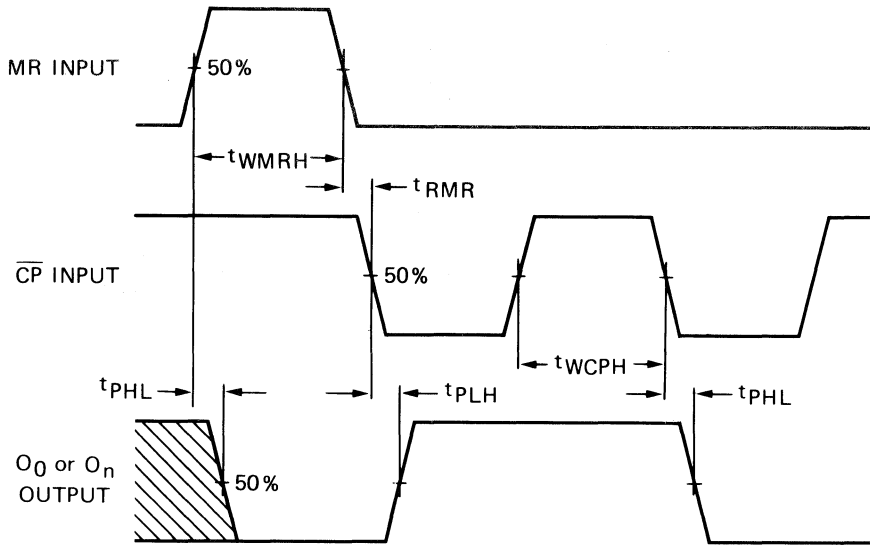

7Z75389

Fig. 4 Waveforms showing propagation delays for MR to O_n and CP to O₀, minimum MR and CP pulse widths.

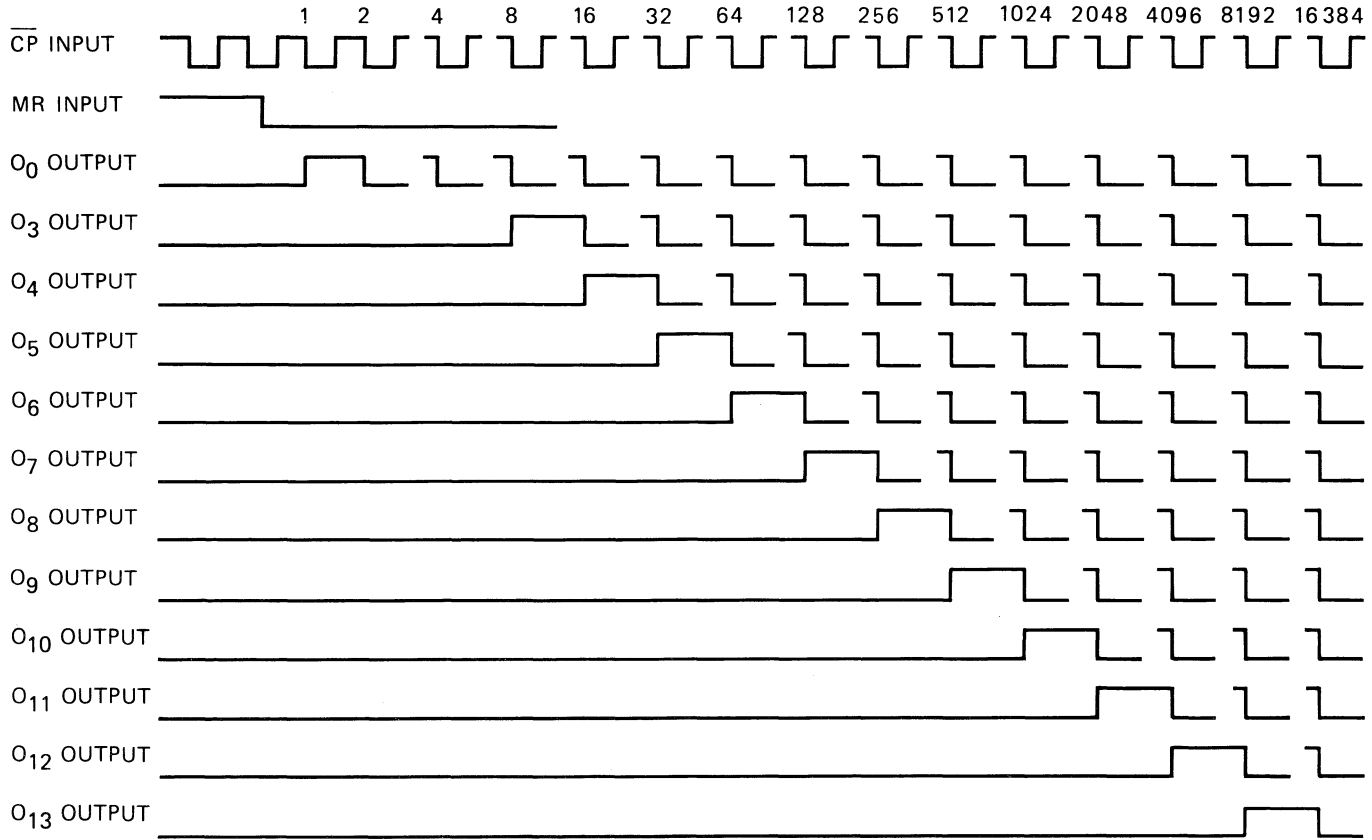

7282340

Fig. 5 Timing diagram.



8-BIT STATIC SHIFT REGISTER

The HEF4021B is an 8-bit static shift register (parallel-to-serial converter) with a synchronous serial data input (D_S), a clock input (CP), an asynchronous active HIGH parallel load input (PL), eight asynchronous parallel data inputs (P_0 to P_7) and buffered parallel outputs from the last three stages (O_5 to O_7).

Each register stage is a D-type master-slave flip-flop with a set direct/clear direct input. Information on P_0 to P_7 is asynchronously loaded into the register while PL is HIGH, independent of CP and D_S . When PL is LOW, data on D_S is shifted into the first register position and all the data in the register is shifted one position to the right on the LOW to HIGH transition of CP. Schmitt-trigger action in the clock input makes the circuit highly tolerant to slower clock rise and fall times.

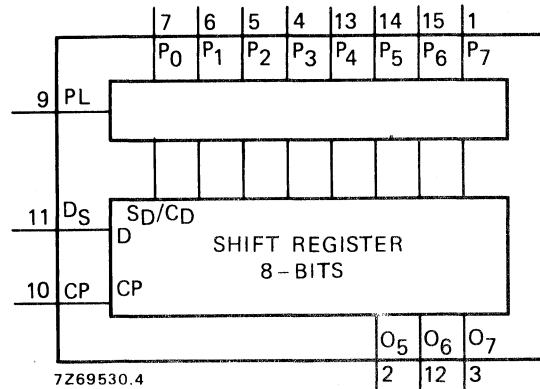

Fig. 1 Functional diagram.

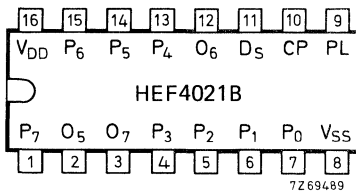

Fig. 2 Pinning diagram.

HEF4021BP : 16-lead DIL; plastic (SOT-38Z).
HEF4021BD : 16-lead DIL; ceramic (cerdip) (SOT-74).
HEF4021BT : 16-lead mini-pack; plastic (SO-16; SOT-109A).

PINNING

PL parallel load input
 P_0 to P_7 parallel data inputs
 D_S serial data input
CP clock input (LOW to HIGH edge-triggered)
 O_5 to O_7 buffered parallel outputs from the last three stages

FAMILY DATA

I_{DD} LIMITS category MSI

} see Family Specifications

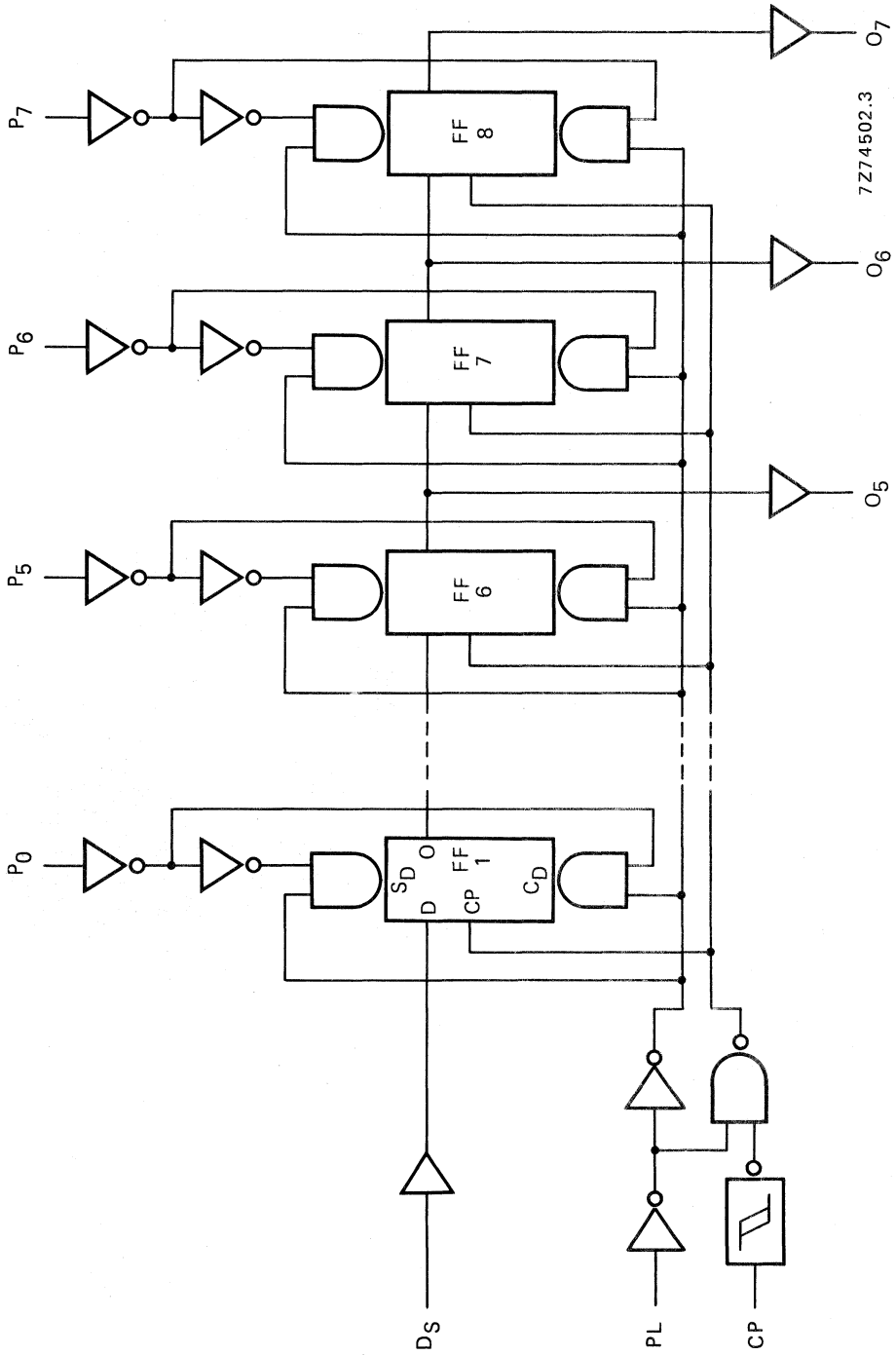

Fig. 3 Logic diagram.

FUNCTION TABLES

Serial operation

| n | inputs | | | outputs | | |
|---|--------|----------------|----|----------------|----------------|----------------|
| | CP | D _S | PL | O ₅ | O ₆ | O ₇ |
| 1 | ∩ | D ₁ | L | X | X | X |
| 2 | ∩ | D ₂ | L | X | X | X |
| 3 | ∩ | D ₃ | L | X | X | X |
| 6 | ∩ | X | L | D ₁ | X | X |
| 7 | ∩ | X | L | D ₂ | D ₁ | X |
| 8 | ∩ | X | L | D ₃ | D ₂ | D ₁ |
| | ∩ | X | L | no change | | |

Parallel operation

| n | inputs | | | outputs | | |
|---|--------|----------------|----|----------------|----------------|----------------|
| | CP | D _S | PL | O ₅ | O ₆ | O ₇ |
| | X | X | H | P ₅ | P ₆ | P ₇ |

H = HIGH state (the more positive voltage)

L = LOW state (the less positive voltage)

X = state is immaterial

∩ = positive-going transition

∩ = negative-going transition

D_n = either HIGH or LOW

n = number of clock pulse transitions

A.C. CHARACTERISTICS

V_{SS} = 0 V; T_{amb} = 25 °C; C_L = 50 pF; input transition times ≤ 20 ns

| | V _{DD} V | symbol | min. | typ. | max. | typical extrapolation formula | |
|--|----------------------|------------------|------|------|------|------------------------------------|------------------------------------|
| Propagation delays CP → O _n HIGH to LOW | 5 | t _{PHL} | | 125 | 250 | ns | 98 ns + (0,55 ns/pF)C _L |
| | 10 | | 55 | 110 | ns | 44 ns + (0,23 ns/pF)C _L | |
| | 15 | | 40 | 80 | ns | 32 ns + (0,16 ns/pF)C _L | |
| LOW to HIGH | 5 | t _{PLH} | | 115 | 230 | ns | 88 ns + (0,55 ns/pF)C _L |
| | 10 | | 50 | 100 | ns | 39 ns + (0,23 ns/pF)C _L | |
| | 15 | | 40 | 80 | ns | 32 ns + (0,16 ns/pF)C _L | |
| PL → O _n HIGH to LOW | 5 | t _{PHL} | | 120 | 240 | ns | 93 ns + (0,55 ns/pF)C _L |
| | 10 | | 55 | 110 | ns | 44 ns + (0,23 ns/pF)C _L | |
| | 15 | | 40 | 80 | ns | 32 ns + (0,16 ns/pF)C _L | |
| LOW to HIGH | 5 | t _{PLH} | | 105 | 210 | ns | 78 ns + (0,55 ns/pF)C _L |
| | 10 | | 50 | 100 | ns | 39 ns + (0,23 ns/pF)C _L | |
| | 15 | | 40 | 80 | ns | 32 ns + (0,16 ns/pF)C _L | |
| Output transition times HIGH to LOW | 5 | t _{THL} | | 60 | 120 | ns | 10 ns + (1,0 ns/pF) C _L |
| | 10 | | 30 | 60 | ns | 9 ns + (0,42 ns/pF) C _L | |
| | 15 | | 20 | 40 | ns | 6 ns + (0,28 ns/pF) C _L | |
| LOW to HIGH | 5 | t _{TLH} | | 60 | 120 | ns | 10 ns + (1,0 ns/pF) C _L |
| | 10 | | 30 | 60 | ns | 9 ns + (0,42 ns/pF) C _L | |
| | 15 | | 20 | 40 | ns | 6 ns + (0,28 ns/pF) C _L | |

HEF4021B

MSI

A.C. CHARACTERISTICS

$V_{SS} = 0\text{ V}$; $T_{amb} = 25\text{ }^{\circ}\text{C}$; $C_L = 50\text{ pF}$; input transition times $\leq 20\text{ ns}$

| | V_{DD} V | symbol | min. | typ. | max. | |
|--------------------------------------|---------------|------------|------|------|------|------------------------------------|
| Set-up times $D_S \rightarrow CP$ | 5 | t_{su} | 25 | -15 | ns | see also waveforms Figs 4 and 5 |
| | 10 | | 25 | -10 | ns | |
| | 15 | | 15 | -5 | ns | |
| $P_n \rightarrow PL$ | 5 | t_{su} | 50 | 25 | ns | |
| | 10 | | 30 | 10 | ns | |
| | 15 | | 20 | 5 | ns | |
| Hold times $D_S \rightarrow CP$ | 5 | t_{hold} | 40 | 20 | ns | |
| | 10 | | 20 | 10 | ns | |
| | 15 | | 15 | 8 | ns | |
| $P_n \rightarrow PL$ | 5 | t_{hold} | 15 | -10 | ns | |
| | 10 | | 15 | 0 | ns | |
| | 15 | | 15 | 0 | ns | |
| Minimum clock pulse width; LOW | 5 | t_{WCPL} | 70 | 35 | ns | |
| | 10 | | 30 | 15 | ns | |
| | 15 | | 24 | 12 | ns | |
| Minimum PL pulse width; HIGH | 5 | t_{WPLH} | 70 | 35 | ns | |
| | 10 | | 30 | 15 | ns | |
| | 15 | | 24 | 12 | ns | |
| Recovery time for PL | 5 | t_{RPL} | 50 | 10 | ns | |
| | 10 | | 40 | 5 | ns | |
| | 15 | | 35 | 5 | ns | |
| Maximum clock pulse frequency | 5 | f_{max} | 6 | 13 | MHz | |
| | 10 | | 15 | 30 | MHz | |
| | 15 | | 20 | 40 | MHz | |

| | V_{DD} V | typical formula for P (μW) | where |
|---|---------------|---|------------------------------------|
| Dynamic power dissipation per package (P) | 5 | $900 f_i + \Sigma(f_o C_L) \times V_{DD}^2$ | f_i = input freq. (MHz) |
| | 10 | | f_o = output freq. (MHz) |
| | 15 | | C_L = load capacitance (pF) |
| | | | $\Sigma(f_o C_L)$ = sum of outputs |
| | | | V_{DD} = supply voltage (V) |

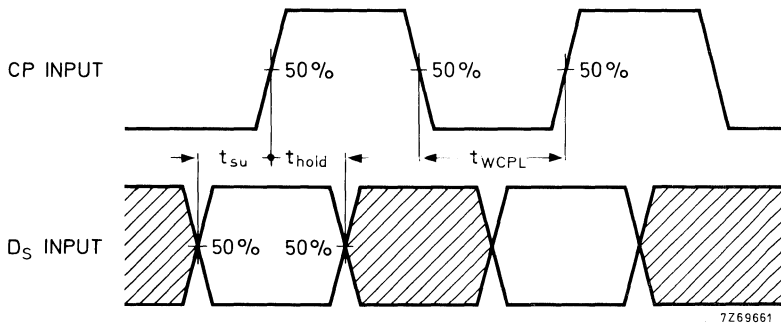

Fig. 4 Waveforms showing minimum clock pulse width, set-up time and hold time for CP and D_S.

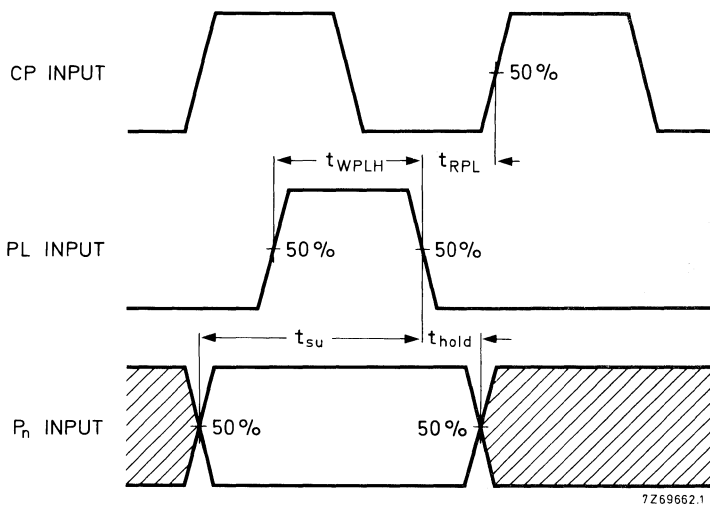

Fig. 5 Waveforms showing minimum PL pulse width, recovery time for PL, and set-up and hold times for P_n to PL. Set-up and hold times are shown as positive values but may be specified as negative values.

4-STAGE DIVIDE-BY-8 JOHNSON COUNTER



The HEF4022B is a 4-stage divide-by-8 Johnson counter with eight spike-free decoded active HIGH outputs (O_0 to O_7), an active LOW output from the most significant flip-flop (\bar{O}_{4-7}), active HIGH and active LOW clock inputs (CP_0 , \bar{CP}_1) and an overriding asynchronous master reset input (MR).

The counter is advanced by either a LOW to HIGH transition at CP_0 while \bar{CP}_1 is LOW or a HIGH to LOW transition at \bar{CP}_1 while CP_0 is HIGH (see also function table). Either CP_0 or \bar{CP}_1 may be used as clock input to the counter and the other clock input may be used as a clock enable input. When cascading counters, the \bar{O}_{4-7} output, which is LOW while the counter is in states, 4, 5, 6 and 7, can be used to drive the CP_0 input of the next counter.

A HIGH on MR resets the counter to zero ($O_0 = \bar{O}_{4-7} = \text{HIGH}$; O_1 to $O_7 = \text{LOW}$) independent of the clock inputs (CP_0 , \bar{CP}_1).

Automatic code correction of the counter is provided by an internal circuit, following any illegal code the counter returns to a proper counting mode within 11 clock pulses.

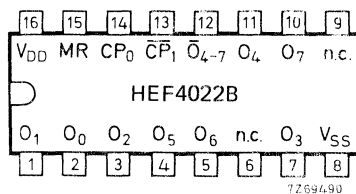
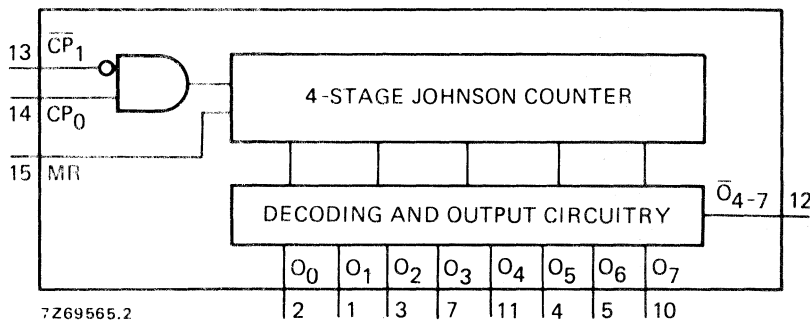

Fig. 2 Pinning diagram.

Fig. 1 Functional diagram.

HEF4022BP : 16-lead DIL; plastic (SOT-38Z).
HEF4022BD : 16-lead DIL; ceramic (cerdip) (SOT-74).
HEF4022BT : 16-lead mini-pack; plastic (SO-16; SOT-109A).

PINNING

CP_0 clock input (LOW to HIGH; edge-triggered)
 \bar{CP}_1 clock input (HIGH to LOW; edge-triggered)
MR master reset input
 O_0 to O_7 decoded outputs
 \bar{O}_{4-7} carry output (active LOW)

FAMILY DATA

I_{DD} LIMITS category MSI

} see Family Specifications

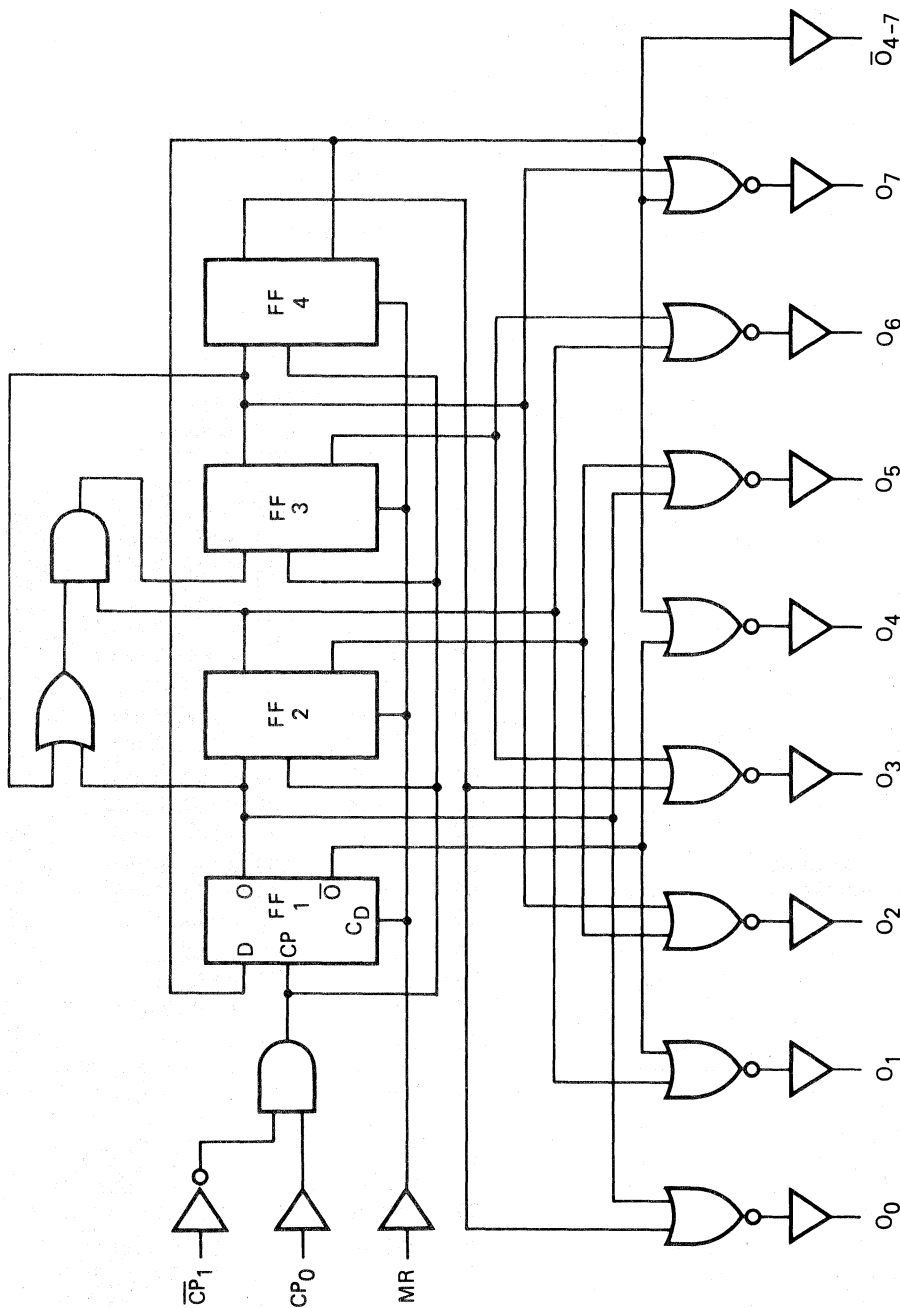

7Z69804.2

Fig. 3 Logic diagram.

FUNCTION TABLE

| MR | CP ₀ | \overline{CP}_1 | operation |
|----|-----------------|-------------------|---|
| H | X | X | $O_0 = \overline{O}_{4-7} = H$; O_1 to $O_7 = L$ |
| L | H | \ | Counter advances |
| L | / | L | Counter advances |
| L | L | X | No change |
| L | X | H | No change |
| L | H | / | No change |
| L | \ | L | No change |

H = HIGH state (the more positive voltage)

L = LOW state (the less positive voltage)

X = state is immaterial

/ = positive-going transition

\ = negative-going transition

A.C. CHARACTERISTICS

 $V_{SS} = 0\text{ V}$; $T_{amb} = 25\text{ }^\circ\text{C}$; $C_L = 50\text{ pF}$; input transition times $\leq 20\text{ ns}$

| | V_{DD} V | symbol | min. | typ. | max. | typical extrapolation formula |
|---|---------------|--------|------|--------|--|---|
| Propagation delays $CP_0, CP_1 \rightarrow O_n$ HIGH to LOW | 5 | tPHL | | 195 | 390 ns | $168\text{ ns} + (0,55\text{ ns/pF}) C_L$ |
| | 10 | | 75 | 145 ns | $64\text{ ns} + (0,23\text{ ns/pF}) C_L$ | |
| | 15 | | 50 | 100 ns | $42\text{ ns} + (0,16\text{ ns/pF}) C_L$ | |
| LOW to HIGH | 5 | tPLH | | 245 | 485 ns | $218\text{ ns} + (0,55\text{ ns/pF}) C_L$ |
| | 10 | | 95 | 195 ns | $84\text{ ns} + (0,23\text{ ns/pF}) C_L$ | |
| | 15 | | 60 | 125 ns | $52\text{ ns} + (0,16\text{ ns/pF}) C_L$ | |
| $CP_0, \overline{CP}_1 \rightarrow \overline{O}_{4-7}$ HIGH to LOW | 5 | tPHL | | 245 | 485 ns | $218\text{ ns} + (0,55\text{ ns/pF}) C_L$ |
| | 10 | | 90 | 185 ns | $79\text{ ns} + (0,23\text{ ns/pF}) C_L$ | |
| | 15 | | 60 | 120 ns | $52\text{ ns} + (0,16\text{ ns/pF}) C_L$ | |
| LOW to HIGH | 5 | tPLH | | 190 | 380 ns | $163\text{ ns} + (0,55\text{ ns/pF}) C_L$ |
| | 10 | | 75 | 145 ns | $64\text{ ns} + (0,23\text{ ns/pF}) C_L$ | |
| | 15 | | 50 | 105 ns | $42\text{ ns} + (0,16\text{ ns/pF}) C_L$ | |
| MR $\rightarrow O_1$ to O_7 HIGH to LOW | 5 | tPHL | | 130 | 260 ns | $103\text{ ns} + (0,55\text{ ns/pF}) C_L$ |
| | 10 | | 55 | 105 ns | $44\text{ ns} + (0,23\text{ ns/pF}) C_L$ | |
| | 15 | | 40 | 75 ns | $32\text{ ns} + (0,16\text{ ns/pF}) C_L$ | |
| MR $\rightarrow O_0$ LOW to HIGH | 5 | tPLH | | 130 | 260 ns | $103\text{ ns} + (0,55\text{ ns/pF}) C_L$ |
| | 10 | | 55 | 105 ns | $44\text{ ns} + (0,23\text{ ns/pF}) C_L$ | |
| | 15 | | 40 | 75 ns | $32\text{ ns} + (0,16\text{ ns/pF}) C_L$ | |
| MR $\rightarrow \overline{O}_{4-7}$ LOW to HIGH | 5 | tPLH | | 110 | 220 ns | $83\text{ ns} + (0,55\text{ ns/pF}) C_L$ |
| | 10 | | 45 | 90 ns | $34\text{ ns} + (0,23\text{ ns/pF}) C_L$ | |
| | 15 | | 35 | 70 ns | $27\text{ ns} + (0,16\text{ ns/pF}) C_L$ | |
| Output transition times HIGH to LOW | 5 | tTHL | | 60 | 120 ns | $10\text{ ns} + (1,0\text{ ns/pF}) C_L$ |
| | 10 | | 30 | 60 ns | $9\text{ ns} + (0,42\text{ ns/pF}) C_L$ | |
| | 15 | | 20 | 40 ns | $6\text{ ns} + (0,28\text{ ns/pF}) C_L$ | |
| LOW to HIGH | 5 | tTLH | | 60 | 120 ns | $10\text{ ns} + (1,0\text{ ns/pF}) C_L$ |
| | 10 | | 30 | 60 ns | $9\text{ ns} + (0,42\text{ ns/pF}) C_L$ | |
| | 15 | | 20 | 40 ns | $6\text{ ns} + (0,28\text{ ns/pF}) C_L$ | |

HEF4022B

MSI

A.C. CHARACTERISTICS

$V_{SS} = 0 \text{ V}$; $T_{amb} = 25 \text{ }^\circ\text{C}$; $C_L = 50 \text{ pF}$; input transition times $\leq 20 \text{ ns}$

| | V_{DD} V | symbol | min. | typ. | max. | |
|--|---------------|------------|------|------|------|------------------------------------|
| Hold times $CP_0 \rightarrow \overline{CP}_1$ | 5 | t_{hold} | 140 | 70 | ns | see also waveforms Figs 4 and 5 |
| | 10 | | 50 | 25 | ns | |
| | 15 | | 30 | 15 | ns | |
| $\overline{CP}_1 \rightarrow CP_0$ | 5 | t_{hold} | 170 | 85 | ns | |
| | 10 | | 60 | 30 | ns | |
| | 15 | | 40 | 20 | ns | |
| Minimum clock pulse width | 5 | t_{WCP} | 75 | 35 | ns | |
| | 10 | | 30 | 15 | ns | |
| | 15 | | 20 | 10 | ns | |
| Minimum MR pulse width; HIGH | 5 | t_{WMRH} | 70 | 35 | ns | |
| | 10 | | 30 | 15 | ns | |
| | 15 | | 20 | 10 | ns | |
| Recovery time for MR | 5 | t_{RMR} | 30 | 10 | ns | |
| | 10 | | 15 | 5 | ns | |
| | 15 | | 10 | 5 | ns | |
| Maximum clock pulse frequency | 5 | f_{max} | 3 | 6 | MHz | |
| | 10 | | 8 | 16 | MHz | |
| | 15 | | 12 | 24 | MHz | |

| | V_{DD} V | typical formula for P (μW) | where f_i = input freq. (MHz) f_o = output freq. (MHz) C_L = load capacitance (pF) $\Sigma(f_o C_L)$ = sum of outputs V_{DD} = supply voltage (V) |
|---|---------------|--|--|
| Dynamic power dissipation per package (P) | 5 | $475 f_i + \Sigma(f_o C_L) \times V_{DD}^2$ | |
| | 10 | $2400 f_i + \Sigma(f_o C_L) \times V_{DD}^2$ | |
| | 15 | $6700 f_i + \Sigma(f_o C_L) \times V_{DD}^2$ | |

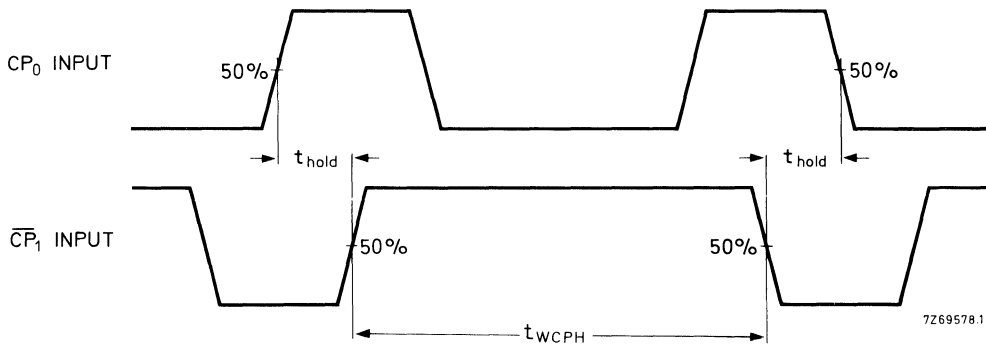

Fig. 4 Waveforms showing hold times for CP_0 to \overline{CP}_1 and \overline{CP}_1 to CP_0 . Hold times are shown as positive values, but may be specified as negative values.

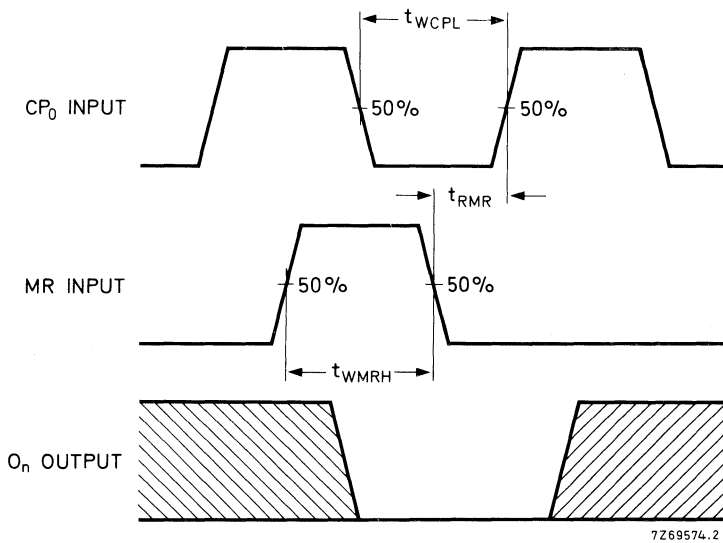
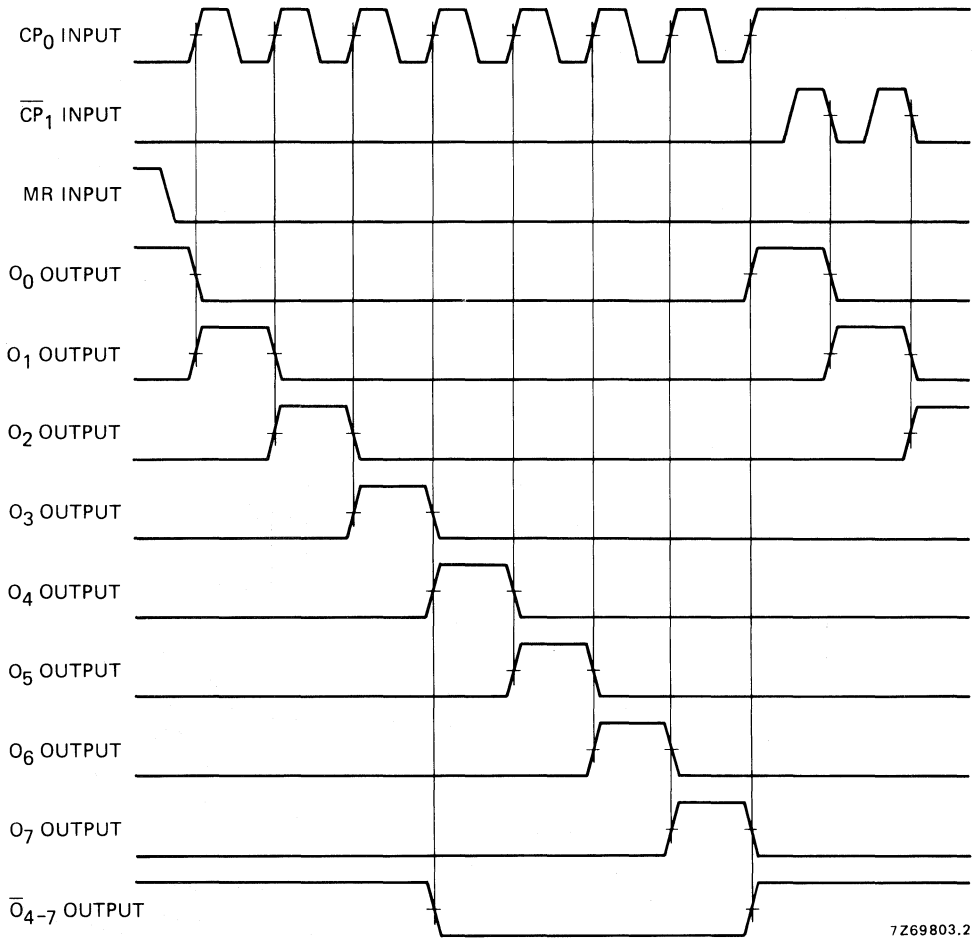

Fig. 5 Waveforms showing recovery time for MR; minimum CP_0 and MR pulse widths. Conditions: $\overline{CP}_1 = \text{LOW}$ while CP_0 is triggered on a LOW to HIGH transition. t_{WCP} and t_{RMR} also apply when $CP_0 = \text{HIGH}$ and \overline{CP}_1 is triggered on a HIGH to LOW transition.



7Z69803.2

Fig. 6 Timing diagram.

APPLICATION INFORMATION

Some of the features of the HEF4022B are:

- High speed
- Spike-free decoded outputs
- Carry output for cascading

Figure 7 shows a technique for extending the number of decoded output states for the HEF4022B. Decoded outputs are sequential within each stage and from stage to stage, with no dead time (except propagation delay).

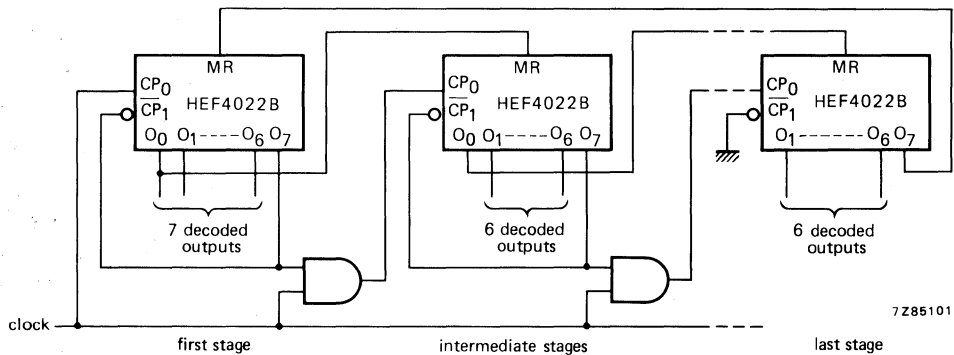

Fig. 7 Counter expansion.

TRIPLE 3-INPUT NAND GATE



The HEF4023B provides the positive triple 3-input NAND function. The outputs are fully buffered for highest noise immunity and pattern insensitivity of output impedance.

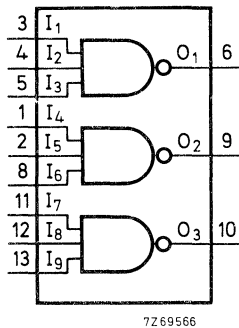

Fig. 1 Functional diagram.

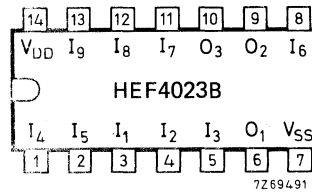

Fig. 2 Pinning diagram.

HEF4023BP : 14-lead DIL; plastic (SOT-27K, M, T).
 HEF4023BD : 14-lead DIL; ceramic (cerdip) (SOT-73).
 HEF4023BT : 14-lead mini-pack; plastic (SO-14; SOT-108A).

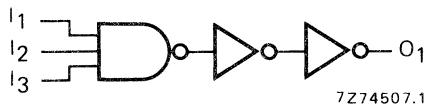

Fig. 3 Logic diagram (one gate).

FAMILY DATA

I_{DD} LIMITS category GATES

} see Family Specifications

HEF4023B

gates

A.C. CHARACTERISTICS

$V_{SS} = 0\text{ V}$; $T_{amb} = 25\text{ }^{\circ}\text{C}$; $C_L = 50\text{ pF}$; input transition times $\leq 20\text{ ns}$

| | V_{DD} V | symbol | typ. | max. | | typical extrapolation formula | |
|--|---------------|------------------|------|------|-----|--|---|
| Propagation delays $I_n \rightarrow O_n$ HIGH to LOW | 5 | t _{PHL} | 65 | 135 | ns | $38\text{ ns} + (0,55\text{ ns/pF}) C_L$ | |
| | 10 | | 25 | 50 | ns | $14\text{ ns} + (0,23\text{ ns/pF}) C_L$ | |
| | 15 | | 15 | 30 | ns | $7\text{ ns} + (0,16\text{ ns/pF}) C_L$ | |
| LOW to HIGH | 5 | t _{PLH} | 65 | 130 | ns | $38\text{ ns} + (0,55\text{ ns/pF}) C_L$ | |
| | 10 | | 30 | 60 | ns | $19\text{ ns} + (0,23\text{ ns/pF}) C_L$ | |
| | 15 | | 25 | 45 | ns | $17\text{ ns} + (0,16\text{ ns/pF}) C_L$ | |
| Output transition times | HIGH to LOW | t _{THL} | 5 | 60 | 120 | ns | $10\text{ ns} + 1,0\text{ ns/pF}) C_L$ |
| | | | 10 | 30 | 60 | ns | $9\text{ ns} + (0,42\text{ ns/pF}) C_L$ |
| | | | 15 | 20 | 40 | ns | $6\text{ ns} + (0,28\text{ ns/pF}) C_L$ |
| | LOW to HIGH | t _{TLH} | 5 | 60 | 120 | ns | $10\text{ ns} + (1,0\text{ ns/pF}) C_L$ |
| | | | 10 | 30 | 60 | ns | $9\text{ ns} + (0,42\text{ ns/pF}) C_L$ |
| | | | 15 | 20 | 40 | ns | $6\text{ ns} + (0,28\text{ ns/pF}) C_L$ |

| | V_{DD} V | typical formula for P (μW) | where |
|---|---------------|--|------------------------------------|
| Dynamic power dissipation per package (P) | 5 | $1200 f_i + \Sigma(f_o C_L) \times V_{DD}^2$ | f_i = input freq. (MHz) |
| | 10 | | f_o = output freq. (MHz) |
| | 15 | | C_L = load capacitance (pF) |
| | | | $\Sigma(f_o C_L)$ = sum of outputs |
| | | | V_{DD} = supply voltage (V) |

7-STAGE BINARY COUNTER



The HEF4024B is a 7-stage binary ripple counter with a clock input (\overline{CP}), and overriding asynchronous master reset input (MR) and seven fully buffered parallel outputs (O_0 to O_6). The counter advances on the HIGH to LOW transition of \overline{CP} . A HIGH on MR clears all counter stages and forces all outputs LOW, independent of \overline{CP} . Each counter stage is a static toggle flip-flop.

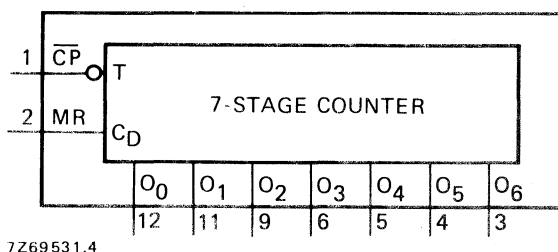

Fig. 1 Functional diagram.

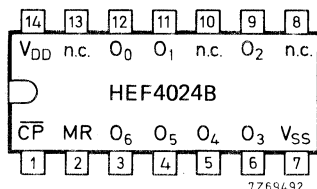

Fig. 2 Pinning diagram.

HEF4024BP : 14-lead DIL; plastic (SOT-27K, M, T).
 HEF4024BD : 14-lead DIL; ceramic (cerdip) (SOT-73).
 HEF4024BT : 14-lead mini-pack; plastic
 (SO-14; SOT-108A).

PINNING

\overline{CP} clock input (HIGH to LOW triggered)
 MR master reset input
 O_0 to O_6 buffered parallel outputs

APPLICATION INFORMATION

Some examples of applications for the HEF4024B are:

- Frequency dividers
- Time delay circuits

FAMILY DATA

I_{DD} LIMITS category MSI

} see Family Specifications

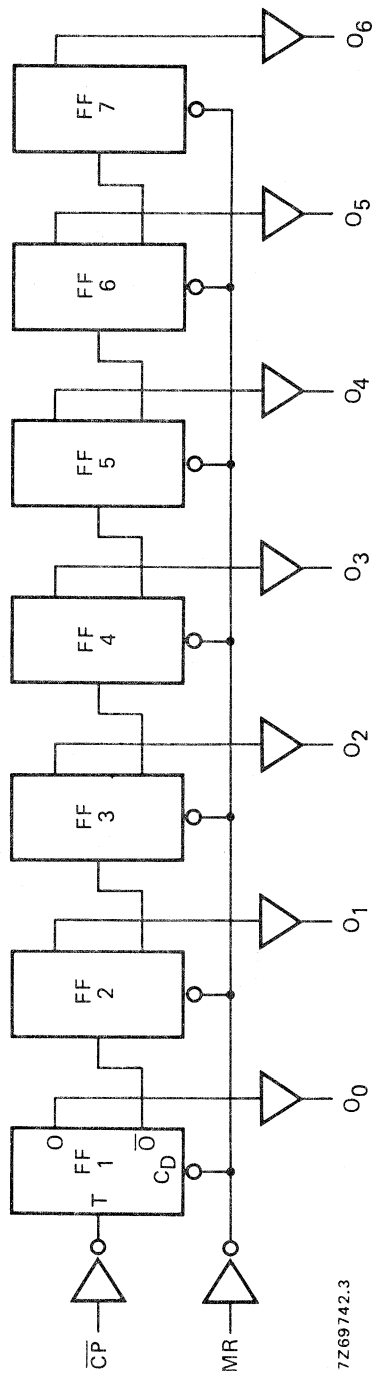

Fig. 3 Logic diagram.

A.C. CHARACTERISTICS

$V_{SS} = 0$ V; $T_{amb} = 25$ °C; $C_L = 50$ pF; input transition times ≤ 20 ns; see also waveforms Fig. 4

| | V_{DD} V | symbol | min. | typ. | max. | typical extrapolation formula | |
|--|---------------|-------------------|------|------|------|----------------------------------|--|
| Propagation delays $\overline{CP} \rightarrow O_0$ HIGH to LOW | 5 | | | 100 | 200 | ns | $73 \text{ ns} + (0,55 \text{ ns/pF}) C_L$ |
| | 10 | t _{PHL} | | 40 | 75 | ns | $29 \text{ ns} + (0,23 \text{ ns/pF}) C_L$ |
| | 15 | | | 25 | 50 | ns | $17 \text{ ns} + (0,16 \text{ ns/pF}) C_L$ |
| LOW to HIGH | 5 | | | 105 | 210 | ns | $78 \text{ ns} + (0,55 \text{ ns/pF}) C_L$ |
| | 10 | t _{PLH} | | 45 | 85 | ns | $34 \text{ ns} + (0,23 \text{ ns/pF}) C_L$ |
| | 15 | | | 30 | 60 | ns | $22 \text{ ns} + (0,16 \text{ ns/pF}) C_L$ |
| $O_n \rightarrow O_{n+1}$ HIGH to LOW | 5 | | | 60 | 120 | ns | $33 \text{ ns} + (0,55 \text{ ns/pF}) C_L$ |
| | 10 | t _{PHL} | | 25 | 50 | ns | $14 \text{ ns} + (0,23 \text{ ns/pF}) C_L$ |
| | 15 | | | 20 | 40 | ns | $12 \text{ ns} + (0,16 \text{ ns/pF}) C_L$ |
| LOW to HIGH | 5 | | | 50 | 100 | ns | $23 \text{ ns} + (0,55 \text{ ns/pF}) C_L$ |
| | 10 | t _{PLH} | | 20 | 40 | ns | $9 \text{ ns} + (0,23 \text{ ns/pF}) C_L$ |
| | 15 | | | 15 | 30 | ns | $7 \text{ ns} + (0,16 \text{ ns/pF}) C_L$ |
| MR $\rightarrow O_n$ HIGH to LOW | 5 | | | 120 | 240 | ns | $93 \text{ ns} + (0,55 \text{ ns/pF}) C_L$ |
| | 10 | t _{PHL} | | 45 | 90 | ns | $34 \text{ ns} + (0,23 \text{ ns/pF}) C_L$ |
| | 15 | | | 30 | 60 | ns | $22 \text{ ns} + (0,16 \text{ ns/pF}) C_L$ |
| Output transition times HIGH to LOW | 5 | | | 60 | 120 | ns | $10 \text{ ns} + (1,0 \text{ ns/pF}) C_L$ |
| | 10 | t _{THL} | | 30 | 60 | ns | $9 \text{ ns} + (0,42 \text{ ns/pF}) C_L$ |
| | 15 | | | 20 | 40 | ns | $6 \text{ ns} + (0,28 \text{ ns/pF}) C_L$ |
| LOW to HIGH | 5 | | | 60 | 120 | ns | $10 \text{ ns} + (1,0 \text{ ns/pF}) C_L$ |
| | 10 | t _{TLH} | | 30 | 60 | ns | $9 \text{ ns} + (0,42 \text{ ns/pF}) C_L$ |
| | 15 | | | 20 | 40 | ns | $6 \text{ ns} + (0,28 \text{ ns/pF}) C_L$ |
| Minimum clock pulse width; HIGH | 5 | | 60 | 30 | | ns | |
| | 10 | t _{WCPH} | 30 | 15 | | ns | |
| | 15 | | 20 | 10 | | ns | |
| Minimum MR pulse width; HIGH | 5 | | 80 | 40 | | ns | |
| | 10 | t _{WMRH} | 35 | 20 | | ns | |
| | 15 | | 25 | 15 | | ns | |
| Recovery time for MR | 5 | | 20 | 10 | | ns | |
| | 10 | t _{RMR} | 15 | 5 | | ns | |
| | 15 | | 15 | 5 | | ns | |
| Maximum clock pulse frequency | 5 | | 5 | 10 | | MHz | |
| | 10 | f _{max} | 13 | 25 | | MHz | |
| | 15 | | 18 | 35 | | MHz | |

| | V_{DD} V | typical formula for P (μ W) | where f _i = input freq. (MHz) f _o = output freq. (MHz) C _L = load cap. (pF) $\Sigma(f_o C_L)$ = sum of outputs V _{DD} = supply voltage (V) |
|---|---------------|--|---|
| Dynamic power dissipation per package (P) | 5 | $500 f_i + \Sigma(f_o C_L) \times V_{DD}^2$ | |
| | 10 | $2100 f_i + \Sigma(f_o C_L) \times V_{DD}^2$ | |
| | 15 | $5200 f_i + \Sigma(f_o C_L) \times V_{DD}^2$ | |

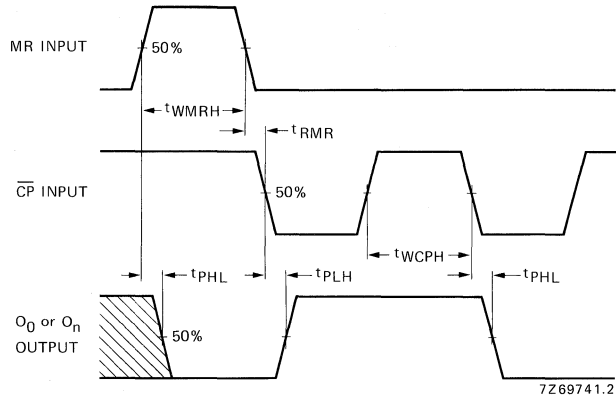

Fig. 4 Waveforms showing propagation delays for MR to O_n and \overline{CP} to O_0 , minimum MR and \overline{CP} pulse widths and recovery time for MR.

TRIPLE 3-INPUT NOR GATE



The HEF4025B provides the positive triple 3-input NOR function. The outputs are fully buffered for highest noise immunity and pattern insensitivity of output impedance.

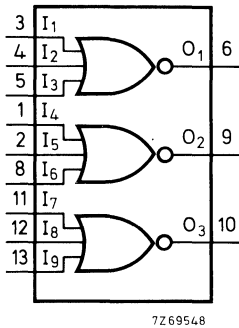

Fig. 1 Functional diagram.

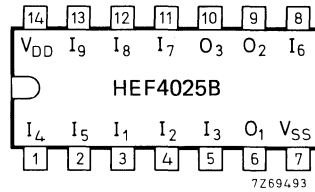

Fig. 2 Pinning diagram.

HEF4025BP : 14-lead DIL; plastic (SOT-27K, M, T).
HEF4025BD : 14-lead DIL; ceramic (cerdip) (SOT-73).
HEF4025BT : 14-lead mini-pack; plastic (SO-14; SOT-108A).

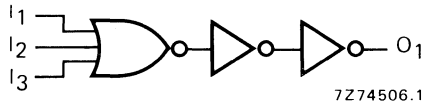

Fig. 3 Logic diagram (one gate).

FAMILY DATA

I_{DD} LIMITS category GATES

} see Family Specifications

A.C. CHARACTERISTICS

$V_{SS} = 0\text{ V}$; $T_{amb} = 25\text{ }^\circ\text{C}$; $C_L = 50\text{ pF}$; input transition times $\leq 20\text{ ns}$

| | V_{DD} V | symbol | typ. | max. | | typical extrapolation formula |
|--|---------------|--------|------|------|----|--|
| Propagation delays $I_n \rightarrow O_n$ HIGH to LOW | 5 | tPHL | 70 | 135 | ns | $43\text{ ns} + (0,55\text{ ns/pF}) C_L$ |
| | 10 | | 25 | 55 | ns | $14\text{ ns} + (0,23\text{ ns/pF}) C_L$ |
| | 15 | | 20 | 40 | ns | $12\text{ ns} + (0,16\text{ ns/pF}) C_L$ |
| LOW to HIGH | 5 | tPLH | 60 | 120 | ns | $33\text{ ns} + (0,55\text{ ns/pF}) C_L$ |
| | 10 | | 25 | 50 | ns | $14\text{ ns} + (0,23\text{ ns/pF}) C_L$ |
| | 15 | | 15 | 35 | ns | $7\text{ ns} + (0,16\text{ ns/pF}) C_L$ |
| Output transition times HIGH to LOW | 5 | tTHL | 60 | 120 | ns | $10\text{ ns} + (1,0\text{ ns/pF}) C_L$ |
| | 10 | | 30 | 60 | ns | $9\text{ ns} + (0,42\text{ ns/pF}) C_L$ |
| | 15 | | 20 | 40 | ns | $6\text{ ns} + (0,28\text{ ns/pF}) C_L$ |
| LOW to HIGH | 5 | tTLH | 60 | 120 | ns | $10\text{ ns} + (1,0\text{ ns/pF}) C_L$ |
| | 10 | | 30 | 60 | ns | $9\text{ ns} + (0,42\text{ ns/pF}) C_L$ |
| | 15 | | 20 | 40 | ns | $6\text{ ns} + (0,28\text{ ns/pF}) C_L$ |

| | V_{DD} V | typical formula for P (μW) | where f_i = input freq. (MHz) f_o = output freq. (MHz) C_L = load capacitance (pF) $\Sigma(f_o C_L)$ = sum of outputs V_{DD} = supply voltage (V) |
|---|---------------|---|--|
| Dynamic power dissipation per package (P) | 5 | $900 f_i + \Sigma(f_o C_L) \times V_{DD}^2$ | |
| | 10 | $4000 f_i + \Sigma(f_o C_L) \times V_{DD}^2$ | |
| | 15 | $10\ 900 f_i + \Sigma(f_o C_L) \times V_{DD}^2$ | |



DUAL JK FLIP-FLOP

The HEF4027B is a dual JK flip-flop which is edge-triggered and features independent set direct (S_D), clear direct (C_D), clock (CP) inputs and outputs (O, \bar{O}). Data is accepted when CP is LOW, and transferred to the output on the positive-going edge of the clock. The active HIGH asynchronous clear-direct (C_D) and set-direct (S_D) are independent and override the J, K, and CP inputs. The outputs are buffered for best system performance. Schmitt-trigger action in the clock input makes the circuit highly tolerant to slower clock rise and fall times.

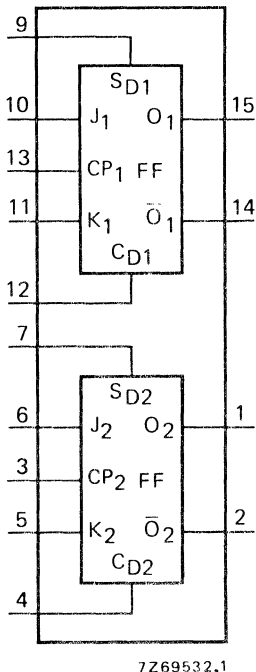

Fig. 1 Functional diagram.

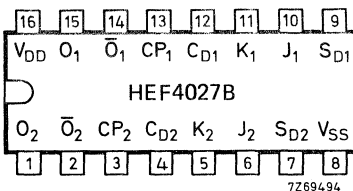

Fig. 2 Pinning diagram.

FUNCTION TABLES

| inputs | | | | | outputs | |
|--------|-------|----|---|---|---------|-----------|
| S_D | C_D | CP | J | K | O | \bar{O} |
| H | L | X | X | X | H | L |
| L | H | X | X | X | L | H |
| H | H | X | X | X | H | H |

| inputs | | | | | outputs | |
|--------|-------|------------|---|---|-------------|-----------------|
| S_D | C_D | CP | J | K | O_{n+1} | \bar{O}_{n+1} |
| L | L | \nearrow | L | L | no change | |
| L | L | \nearrow | H | L | H | L |
| L | L | \nearrow | L | H | L | H |
| L | L | \nearrow | H | H | \bar{O}_n | O_n |

H = HIGH state (the more positive voltage)

L = LOW state (the less positive voltage)

X = state is immaterial

\nearrow = positive-going transition

O_{n+1} = state after clock positive transition

PINNING

J,K synchronous inputs

CP clock input (L to H edge-triggered)

S_D asynchronous set-direct input (active HIGH)

C_D asynchronous clear-direct input (active HIGH)

O true output

\bar{O} complement output

HEF4027BP : 16-lead DIL; plastic (SOT-38Z).

HEF4027BD : 16-lead DIL; ceramic (cerdip) (SOT-74).

HEF4027BT : 16-lead mini-pack; plastic (SO-16; SOT-109A).

FAMILY DATA

I_{DD} LIMITS category FLIP-FLOPS

see Family Specifications

HEF4027B
flip-flops

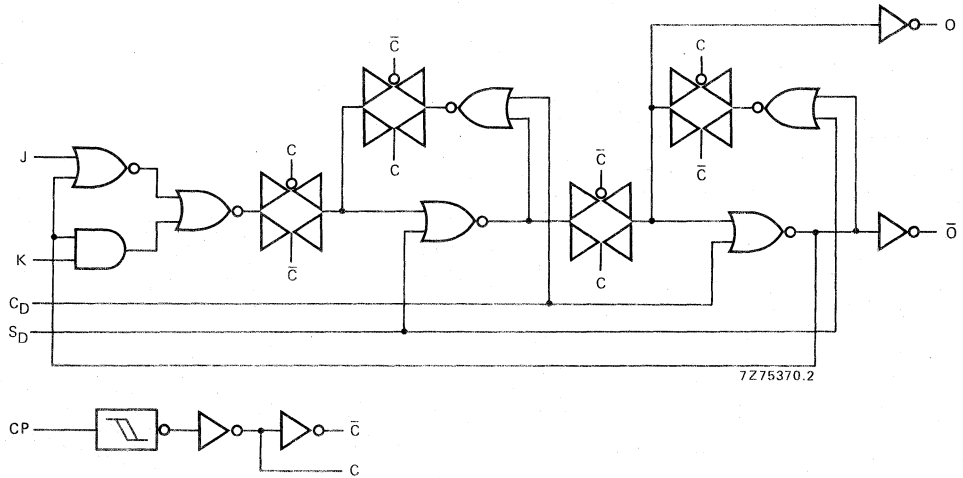

Fig. 3 Logic diagram (one flip-flop).

A.C. CHARACTERISTICS

 $V_{SS} = 0 \text{ V}$; $T_{amb} = 25 \text{ }^\circ\text{C}$; $C_L = 50 \text{ pF}$; input transition times $\leq 20 \text{ ns}$

| | V_{DD} V | symbol | min. | typ. | max. | typical extrapolation formula | |
|--|---------------|--------------------------------------|------|------|------|----------------------------------|--------------------------------------|
| Propagation delays CP \rightarrow O, \bar{O} HIGH to LOW | 5 | t _{PHL} | | 105 | 210 | ns | 78 ns + (0,55 ns/pF) C _L |
| | 10 | | | 40 | 80 | ns | 29 ns + (0,23 ns/pF) C _L |
| | 15 | | | 30 | 60 | ns | 22 ns + (0,16 ns/pF) C _L |
| LOW to HIGH | 5 | t _{PLH} | | 85 | 170 | ns | 58 ns + (0,55 ns/pF) C _L |
| | 10 | | | 35 | 70 | ns | 27 ns + (0,23 ns/pF) C _L |
| | 15 | | | 30 | 60 | ns | 22 ns + (0,16 ns/pF) C _L |
| S _D \rightarrow O LOW to HIGH | 5 | t _{PLH} | | 70 | 140 | ns | 43 ns + (0,55 ns/pF) C _L |
| | 10 | | | 30 | 60 | ns | 19 ns + (0,23 ns/pF) C _L |
| | 15 | | | 25 | 50 | ns | 17 ns + (0,16 ns/pF) C _L |
| C _D \rightarrow O HIGH to LOW | 5 | t _{PHL} | | 120 | 240 | ns | 93 ns + (0,55 ns/pF) C _L |
| | 10 | | | 45 | 90 | ns | 33 ns + (0,23 ns/pF) C _L |
| | 15 | | | 35 | 70 | ns | 27 ns + (0,16 ns/pF) C _L |
| S _D \rightarrow \bar{O} HIGH to LOW | 5 | t _{PHL} | | 140 | 280 | ns | 113 ns + (0,55 ns/pF) C _L |
| | 10 | | | 55 | 110 | ns | 44 ns + (0,23 ns/pF) C _L |
| | 15 | | | 40 | 80 | ns | 32 ns + (0,16 ns/pF) C _L |
| C _D \rightarrow \bar{O} LOW to HIGH | 5 | t _{PLH} | | 75 | 150 | ns | 48 ns + (0,55 ns/pF) C _L |
| | 10 | | | 35 | 70 | ns | 24 ns + (0,23 ns/pF) C _L |
| | 15 | | | 25 | 50 | ns | 17 ns + (0,16 ns/pF) C _L |
| Output transition times HIGH to LOW | 5 | t _{THL} | | 60 | 120 | ns | 10 ns + (1,0 ns/pF) C _L |
| | 10 | | | 30 | 60 | ns | 9 ns + (0,42 ns/pF) C _L |
| | 15 | | | 20 | 40 | ns | 6 ns + (0,28 ns/pF) C _L |
| LOW to HIGH | 5 | t _{TLH} | | 60 | 120 | ns | 10 ns + (1,0 ns/pF) C _L |
| | 10 | | | 30 | 60 | ns | 9 ns + (0,42 ns/pF) C _L |
| | 15 | | | 20 | 40 | ns | 6 ns + (0,28 ns/pF) C _L |
| Set-up time J, K \rightarrow CP | 5 | t _{su} | 50 | 25 | | ns | see also waveforms Figs 4 and 5 |
| | 10 | | 30 | 10 | | ns | |
| | 15 | | 20 | 5 | | ns | |
| Hold time J, K \rightarrow CP | 5 | t _{hold} | 25 | 0 | | ns | |
| | 10 | | 20 | 0 | | ns | |
| | 15 | | 15 | 5 | | ns | |
| Minimum clock pulse width; LOW | 5 | t _{WCPL} | 80 | 40 | | ns | |
| | 10 | | 30 | 15 | | ns | |
| | 15 | | 24 | 12 | | ns | |
| Minimum S _D , C _D pulse width; HIGH | 5 | t _{WSDH} | 90 | 45 | | ns | |
| | 10 | t _{WCDH} | 40 | 20 | | ns | |
| | 15 | t _{WCDH} | 30 | 15 | | ns | |
| Recovery time for S _D , C _D | 5 | t _{RS} , t _{RD} | 20 | -15 | | ns | |
| | 10 | | 15 | -10 | | ns | |
| | 15 | | 10 | -5 | | ns | |

HEF4027B

flip-flops

A.C. CHARACTERISTICS

$V_{SS} = 0\text{ V}$; $T_{amb} = 25\text{ }^\circ\text{C}$; $C_L = 50\text{ pF}$; input transition times $\leq 20\text{ ns}$

| | V_{DD} V | symbol | min | typ | max | |
|---|---------------|-----------|-----|-----|-----|--------------------------------|
| Maximum clock pulse frequency J = K = HIGH | 5 | f_{max} | 4 | 8 | MHz | } see also waveforms Fig. 4 |
| | 10 | | 12 | 25 | MHz | |
| | 15 | | 15 | 30 | MHz | |

| | V_{DD} V | typical formula for P (μW) | where |
|---|---------------|---|------------------------------------|
| Dynamic power dissipation per package (P) | 5 | $900 f_i + \Sigma(f_o C_L) \times V_{DD}^2$ | f_i = input freq. (MHz) |
| | 10 | $4\,500 f_i + \Sigma(f_o C_L) \times V_{DD}^2$ | f_o = output freq. (MHz) |
| | 15 | $13\,200 f_i + \Sigma(f_o C_L) \times V_{DD}^2$ | C_L = load capacitance (pF) |
| | | | $\Sigma(f_o C_L)$ = sum of outputs |
| | | | V_{DD} = supply voltage (V) |

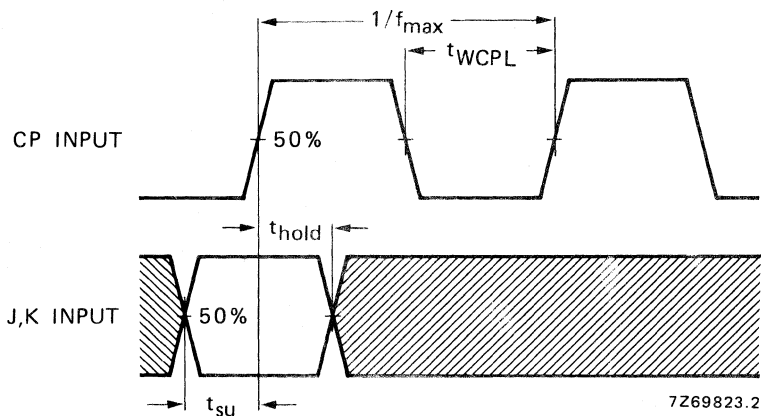

Fig. 4 Waveforms showing set-up times, hold times and minimum clock pulse width. Set-up and hold times are shown as positive values but may be specified as negative values.

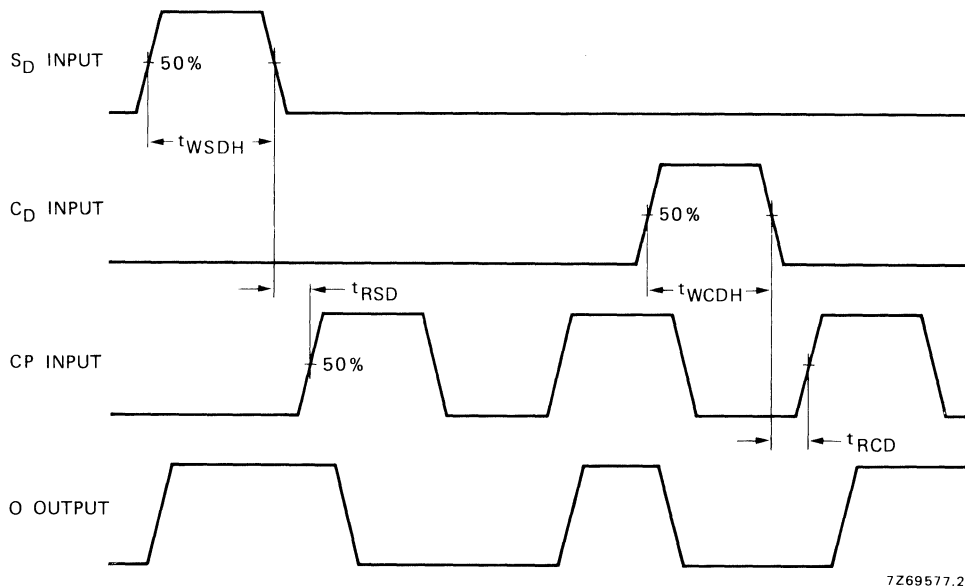

Fig. 5 Waveforms showing recovery times for S_D and C_D; minimum S_D and C_D pulse widths.

APPLICATION INFORMATION

Some examples of applications for the HEF4027B are:

- Registers
- Counters
- Control circuits

1-OF-10 DECODER



The HEF4028B is a 4-bit BCD to 1-of-10 active HIGH decoder. A 1-2-4-8 BCD code applied to inputs A_0 to A_3 causes the selected output to be HIGH, the other nine will be LOW. If desired, the device may be used as a 1-of-8 decoder with enable; 3-bit octal inputs are applied to inputs A_0 , A_1 and A_2 selecting an output O_0 to O_7 . Input A_3 then becomes an active LOW enable, forcing the selected output LOW when A_3 is HIGH. The HEF4028B may also be used as an 8-output (O_0 to O_7) demultiplexer with A_0 to A_2 as address inputs and A_3 as an active LOW data input. The outputs are fully buffered for best performance.

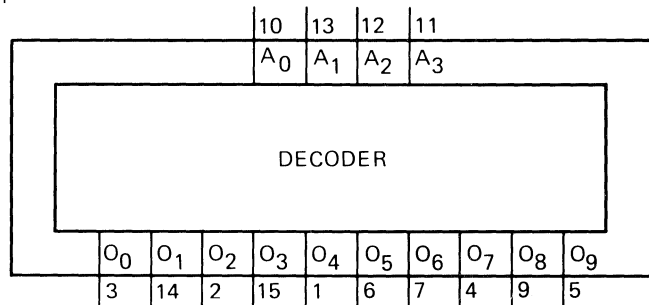
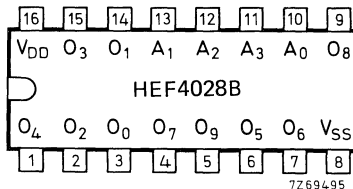

Fig.1 Functional diagram.

7Z73681.1



7Z69495

Fig.2 Pinning diagram

HEF4028BP : 16-lead DIL; plastic (SOT-38Z).

HEF4028BD : 16-lead DIL; ceramic (cerdip) (SOT-74).

HEF4028BT : 16-lead mini-pack; plastic (SO-16; SOT-109A).

PINNING

 A_0 to A_3 address inputs, 1-2-4-8 BCD O_0 to O_9 outputs (active HIGH)

FAMILY DATA

} see Family Specifications

 I_{DD} LIMITS category MSI

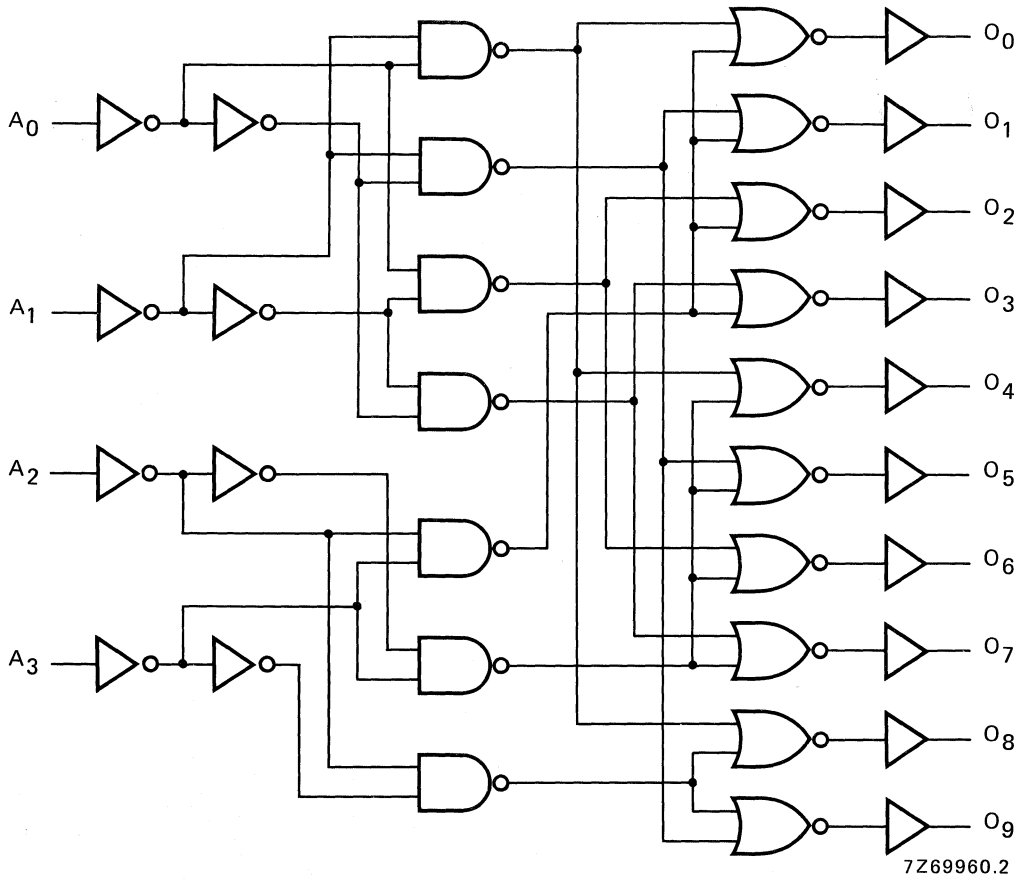

Fig. 3 Logic diagram.

TRUTH TABLE

| inputs | | | | outputs | | | | | | | | | |
|----------------|----------------|----------------|----------------|----------------|----------------|----------------|----------------|----------------|----------------|----------------|----------------|----------------|----------------|
| A ₃ | A ₂ | A ₁ | A ₀ | O ₀ | O ₁ | O ₂ | O ₃ | O ₄ | O ₅ | O ₆ | O ₇ | O ₈ | O ₉ |
| L | L | L | L | H | L | L | L | L | L | L | L | L | L |
| L | L | L | H | L | H | L | L | L | L | L | L | L | L |
| L | L | H | L | L | L | H | L | L | L | L | L | L | L |
| L | L | H | H | L | L | L | H | L | L | L | L | L | L |
| L | H | L | L | L | L | L | L | H | L | L | L | L | L |
| L | H | L | H | L | L | L | L | L | H | L | L | L | L |
| L | H | H | L | L | L | L | L | L | L | H | L | L | L |
| L | H | H | H | L | L | L | L | L | L | L | H | L | L |
| H | L | L | L | L | L | L | L | L | L | L | L | H | L |
| H | L | L | H | L | L | L | L | L | L | L | L | L | H |
| H | L | H | L | L | L | L | L | L | L | L | L | L | L |
| H | L | H | H | L | L | L | L | L | L | L | L | L | L |
| H | H | L | L | L | L | L | L | L | L | L | L | L | L |
| H | H | L | H | L | L | L | L | L | L | L | L | L | L |
| H | H | H | L | L | L | L | L | L | L | L | L | L | L |
| H | H | H | H | L | L | L | L | L | L | L | L | L | L |
| H | H | H | L | L | L | L | L | L | L | L | L | L | L |
| H | H | H | H | L | L | L | L | L | L | L | L | L | L |
| H | H | H | H | L | L | L | L | L | L | L | L | L | L |
| H | H | H | H | L | L | L | L | L | L | L | L | L | L |
| H | H | H | H | L | L | L | L | L | L | L | L | L | L |

H = HIGH state (the more positive voltage)

L = LOW state (the less positive voltage)

* Extraordinary states.

HEF4028B

MSI

A.C. CHARACTERISTICS

$V_{SS} = 0\text{ V}$; $T_{amb} = 25\text{ }^{\circ}\text{C}$; $C_L = 50\text{ pF}$; input transition times $\leq 20\text{ ns}$

| | V_{DD} V | symbol | typ. | max. | | typical extrapolation formula | |
|--|---------------|-----------|-----------|------|-----|--|--|
| Propagation delays $A_n \rightarrow O_n$ HIGH to LOW | 5 | t_{PHL} | 100 | 200 | ns | $73\text{ ns} + (0,55\text{ ns/pF}) C_L$ | |
| | 10 | | 40 | 80 | ns | $29\text{ ns} + (0,23\text{ ns/pF}) C_L$ | |
| | 15 | | 30 | 60 | ns | $22\text{ ns} + (0,16\text{ ns/pF}) C_L$ | |
| | LOW to HIGH | 5 | t_{PLH} | 90 | 180 | ns | $63\text{ ns} + (0,55\text{ ns/pF}) C_L$ |
| | | 10 | | 40 | 80 | ns | $29\text{ ns} + (0,23\text{ ns/pF}) C_L$ |
| | | 15 | | 30 | 60 | ns | $22\text{ ns} + (0,16\text{ ns/pF}) C_L$ |
| Output transition times | HIGH to LOW | t_{THL} | 60 | 120 | ns | $10\text{ ns} + (1,0\text{ ns/pF}) C_L$ | |
| | | | 10 | 30 | 60 | ns | $9\text{ ns} + (0,42\text{ ns/pF}) C_L$ |
| | | | 15 | 20 | 40 | ns | $6\text{ ns} + (0,28\text{ ns/pF}) C_L$ |
| | LOW to HIGH | t_{TLH} | 60 | 120 | ns | $10\text{ ns} + (1,0\text{ ns/pF}) C_L$ | |
| | | | 10 | 30 | 60 | ns | $9\text{ ns} + (0,42\text{ ns/pF}) C_L$ |
| | | | 15 | 20 | 40 | ns | $6\text{ ns} + (0,28\text{ ns/pF}) C_L$ |

| | V_{DD} V | typical formula for P (μW) | where |
|---|---------------|---|------------------------------------|
| Dynamic power dissipation per package (P) | 5 | $350 f_i + \Sigma(f_o C_L) \times V_{DD}^2$ | f_i = input freq. (MHz) |
| | 10 | | f_o = output freq. (MHz) |
| | 15 | | C_L = load capacitance (pF) |
| | | | $\Sigma(f_o C_L)$ = sum of outputs |
| | | | V_{DD} = supply voltage (V) |

SYNCHRONOUS UP/DOWN COUNTER, BINARY/DECADE COUNTER



The HEF4029B is a synchronous edge-triggered up/down 4-bit binary/BCD decade counter with a clock input (CP), an active LOW count enable input (\overline{CE}), an up/down control input (UP/ \overline{DN}), a binary/decade control input (BIN/ \overline{DEC}), an overriding asynchronous active HIGH parallel load input (PL), four parallel data inputs (P_0 to P_3), four parallel buffered outputs (O_0 to O_3) and an active LOW terminal count output (\overline{TC}).

Information on P_0 to P_3 is asynchronously loaded into the counter while PL is HIGH, independent of CP.

The counter is advanced one count on the LOW to HIGH transition of CP when \overline{CE} and PL are LOW. The \overline{TC} signal is normally HIGH and goes LOW when the counter reaches its maximum count in the UP mode, or the minimum count in the DOWN mode provided \overline{CE} is LOW.

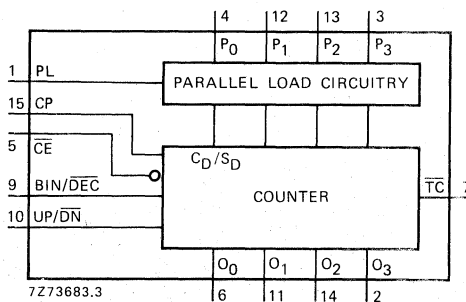

Fig. 1 Functional diagram.

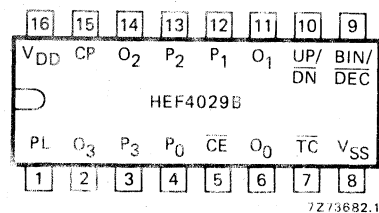

Fig. 2 Pinning diagram.

PINNING

- PL parallel load input
- P_0 to P_3 parallel data inputs
- BIN/ \overline{DEC} binary/decade control input
- UP/ \overline{DN} up/down control input
- \overline{CE} count enable input (active LOW)
- CP clock input (LOW to HIGH, edge triggered)
- O_0 to O_3 buffered parallel outputs
- \overline{TC} terminal count output (active LOW)

- HEF4029BP: 16-lead DIL; plastic (SOT-382).
- HEF4029BD: 16-lead DIL; ceramic (cerdip) (SOT-74).
- HEF4029BT: 16-lead mini-pack; plastic (SO-16; SOT-109A).

FAMILY DATA

I_{DD} LIMITS category MSI

} see Family Specifications

HEF4029B
MSI

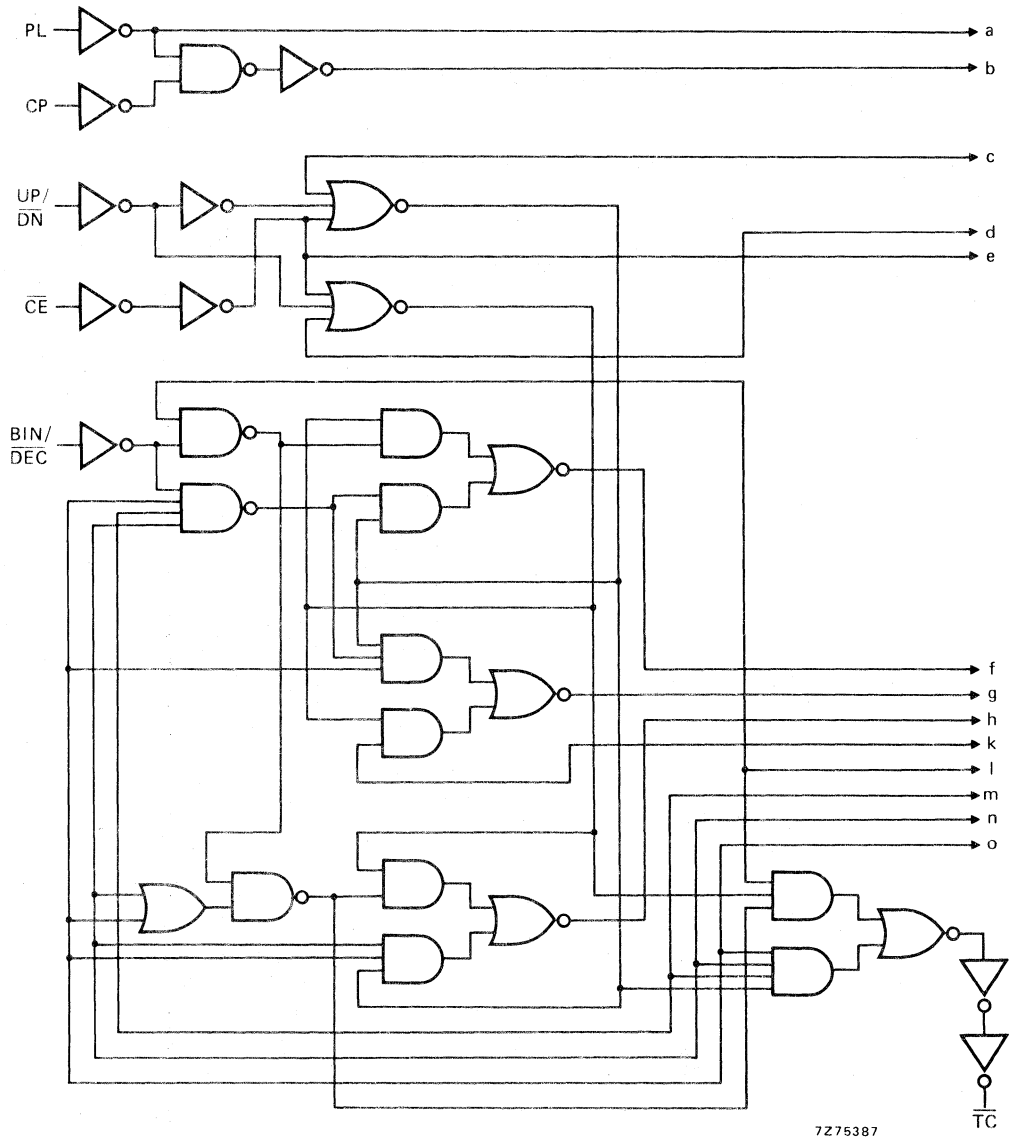
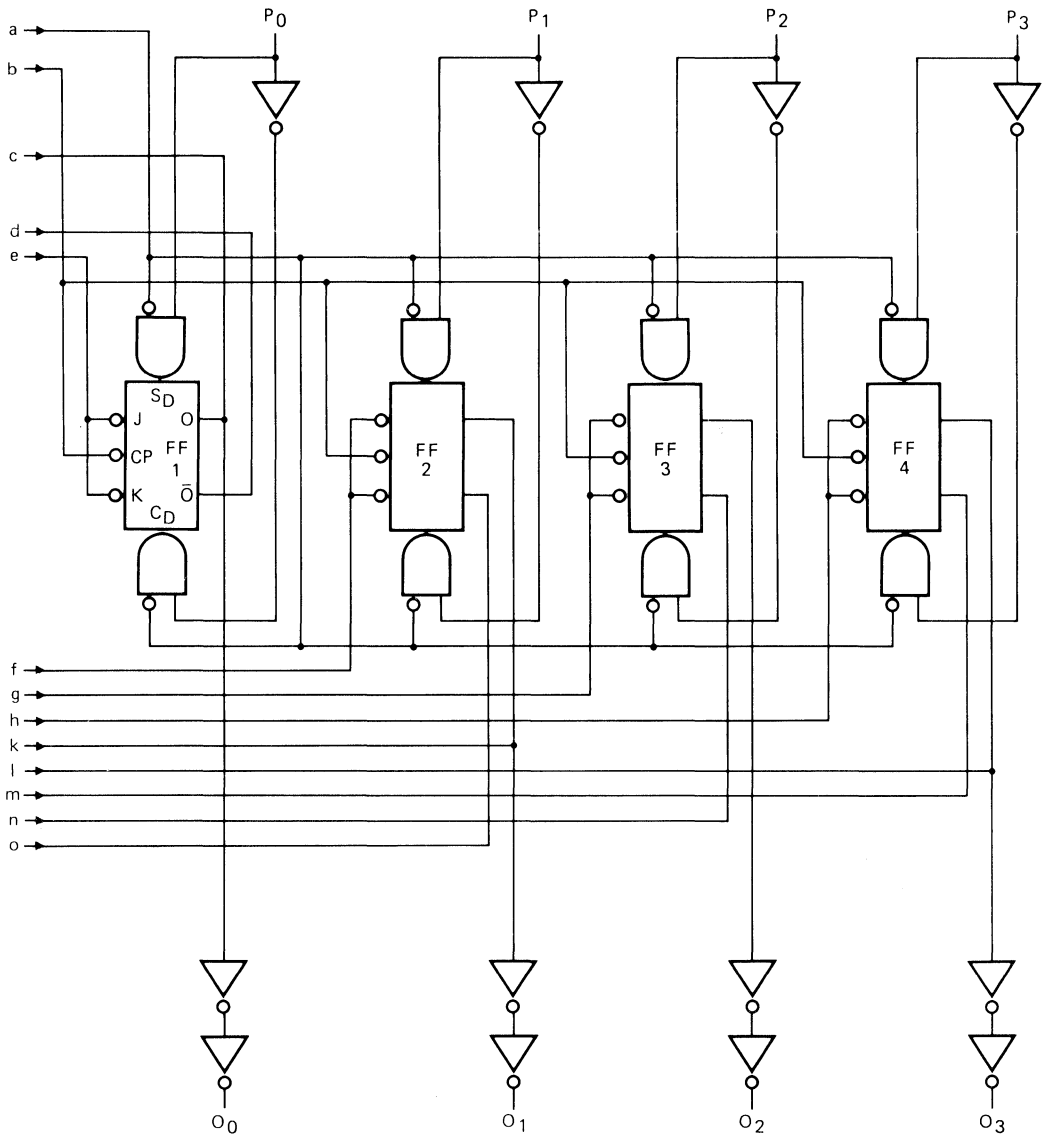

Fig. 3a Logic diagram (continued in Fig. 3b).



7275388

Fig. 3b Logic diagram (continued from Fig. 3a).

FUNCTION TABLE

| PL | BIN/DEC | UP/DN | \overline{CE} | CP | mode |
|----|---------|-------|-----------------|------------|---|
| H | X | X | X | X | parallel load ($P_n \rightarrow O_n$) |
| L | X | X | H | X | no change |
| L | L | L | L | \nearrow | count-down, decade |
| L | L | H | L | \nearrow | count-up, decade |
| L | H | L | L | \nearrow | count-down, binary |
| L | H | H | L | \nearrow | count-up, binary |

H = HIGH state (the more positive voltage)

L = LOW state (the less positive voltage)

X = state is immaterial

\nearrow = positive-going clock pulse edge

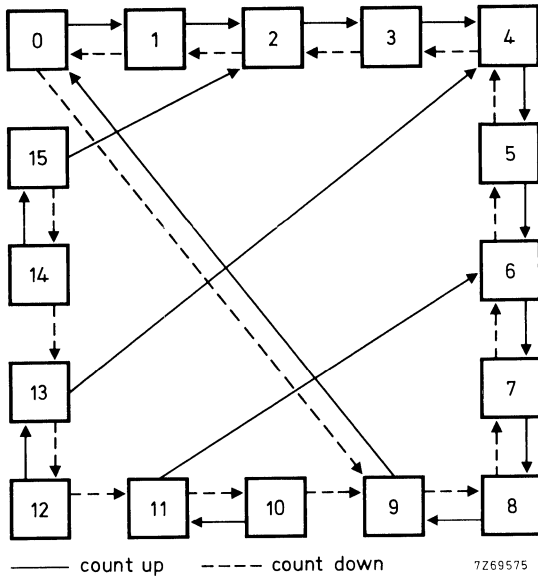

Fig. 4 State diagram; $\text{BIN}/\overline{\text{DEC}} = \text{LOW}$.

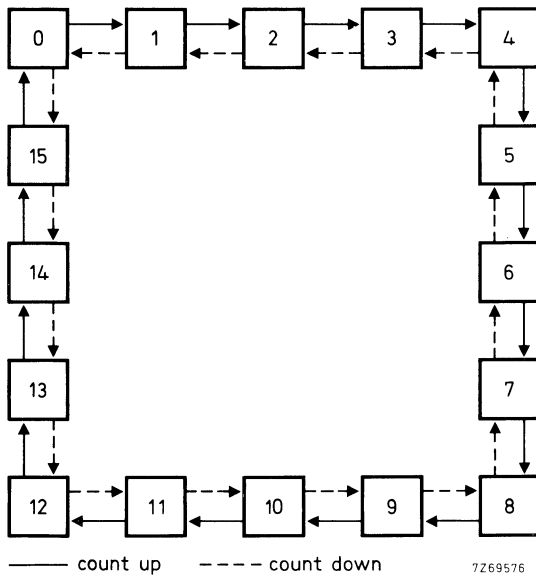

Fig. 5 State diagram; $\text{BIN}/\overline{\text{DEC}} = \text{HIGH}$.

Logic equation for terminal count:

$$\text{TC} = \overline{\text{CE}} (\text{BIN}/\overline{\text{DEC}} \cdot \text{UP}/\overline{\text{DN}} \cdot \overline{\text{O}}_0 \cdot \overline{\text{O}}_1 \cdot \overline{\text{O}}_2 \cdot \overline{\text{O}}_3 + \text{BIN}/\overline{\text{DEC}} \cdot \text{UP}/\overline{\text{DN}} \cdot \overline{\text{O}}_0 \cdot \overline{\text{O}}_1 \cdot \overline{\text{O}}_2 \cdot \overline{\text{O}}_3 + \text{BIN}/\overline{\text{DEC}} \cdot \text{UP}/\overline{\text{DN}} \cdot \overline{\text{O}}_0 \cdot \overline{\text{O}}_3 + \text{BIN}/\overline{\text{DEC}} \cdot \text{UP}/\overline{\text{DN}} \cdot \overline{\text{O}}_0 \cdot \overline{\text{O}}_1 \cdot \overline{\text{O}}_2 \cdot \overline{\text{O}}_3)$$

HEF4029B

MSI

A.C. CHARACTERISTICS

$V_{SS} = 0\text{ V}$; $T_{amb} = 25\text{ }^\circ\text{C}$; input transition times $\leq 20\text{ ns}$

| | V_{DD} V | typical formula for P (μW) | where f_i = input freq. (MHz) f_o = output freq. (MHz) C_L = load capacitance (pF) $\Sigma(f_o C_L)$ = sum of outputs V_{DD} = supply voltage (V) |
|---|---------------|---|--|
| Dynamic power dissipation per package (P) | 5 | $1000 f_i + \Sigma(f_o C_L) \times V_{DD}^2$ | |
| | 10 | $4500 f_i + \Sigma(f_o C_L) \times V_{DD}^2$ | |
| | 15 | $11\,500 f_i + \Sigma(f_o C_L) \times V_{DD}^2$ | |

A.C. CHARACTERISTICS

$V_{SS} = 0\text{ V}$; $T_{amb} = 25\text{ }^\circ\text{C}$; $C_L = 50\text{ pF}$; input transition times $\leq 20\text{ ns}$

| | V_{DD} V | symbol | min. | typ. | max. | typical extrapolation formula | |
|---|---------------|--------|------|------|------|-------------------------------|---|
| Propagation delays $CP \rightarrow O_n$ HIGH to LOW | 5 | tPHL | | 145 | 290 | ns | $118\text{ ns} + (0,55\text{ ns/pF}) C_L$ |
| | 10 | | | 55 | 110 | ns | $44\text{ ns} + (0,23\text{ ns/pF}) C_L$ |
| | 15 | | | 40 | 75 | ns | $32\text{ ns} + (0,16\text{ ns/pF}) C_L$ |
| LOW to HIGH | 5 | tPLH | | 160 | 315 | ns | $133\text{ ns} + (0,55\text{ ns/pF}) C_L$ |
| | 10 | | | 60 | 120 | ns | $49\text{ ns} + (0,23\text{ ns/pF}) C_L$ |
| | 15 | | | 40 | 80 | ns | $32\text{ ns} + (0,16\text{ ns/pF}) C_L$ |
| $CP \rightarrow \overline{TC}$ HIGH to LOW | 5 | tPHL | | 280 | 560 | ns | $253\text{ ns} + (0,55\text{ ns/pF}) C_L$ |
| | 10 | | | 105 | 205 | ns | $94\text{ ns} + (0,23\text{ ns/pF}) C_L$ |
| | 15 | | | 70 | 140 | ns | $62\text{ ns} + (0,16\text{ ns/pF}) C_L$ |
| LOW to HIGH | 5 | tPLH | | 195 | 385 | ns | $168\text{ ns} + (0,55\text{ ns/pF}) C_L$ |
| | 10 | | | 75 | 150 | ns | $64\text{ ns} + (0,23\text{ ns/pF}) C_L$ |
| | 15 | | | 55 | 105 | ns | $47\text{ ns} + (0,16\text{ ns/pF}) C_L$ |
| $PL \rightarrow O_n$ HIGH to LOW | 5 | tPHL | | 120 | 240 | ns | $93\text{ ns} + (0,55\text{ ns/pF}) C_L$ |
| | 10 | | | 50 | 100 | ns | $39\text{ ns} + (0,23\text{ ns/pF}) C_L$ |
| | 15 | | | 35 | 70 | ns | $27\text{ ns} + (0,16\text{ ns/pF}) C_L$ |
| LOW to HIGH | 5 | tPLH | | 170 | 335 | ns | $143\text{ ns} + (0,55\text{ ns/pF}) C_L$ |
| | 10 | | | 65 | 130 | ns | $54\text{ ns} + (0,23\text{ ns/pF}) C_L$ |
| | 15 | | | 45 | 90 | ns | $37\text{ ns} + (0,16\text{ ns/pF}) C_L$ |
| $\overline{CE} \rightarrow \overline{TC}$ HIGH to LOW | 5 | tPHL | | 180 | 360 | ns | $153\text{ ns} + (0,55\text{ ns/pF}) C_L$ |
| | 10 | | | 70 | 140 | ns | $59\text{ ns} + (0,23\text{ ns/pF}) C_L$ |
| | 15 | | | 50 | 100 | ns | $42\text{ ns} + (0,16\text{ ns/pF}) C_L$ |
| LOW to HIGH | 5 | tPLH | | 170 | 335 | ns | $143\text{ ns} + (0,55\text{ ns/pF}) C_L$ |
| | 10 | | | 65 | 135 | ns | $54\text{ ns} + (0,23\text{ ns/pF}) C_L$ |
| | 15 | | | 50 | 100 | ns | $42\text{ ns} + (0,16\text{ ns/pF}) C_L$ |
| Output transition times HIGH to LOW | 5 | tTHL | | 60 | 120 | ns | $10\text{ ns} + (1,0\text{ ns/pF}) C_L$ |
| | 10 | | | 30 | 60 | ns | $9\text{ ns} + (0,42\text{ ns/pF}) C_L$ |
| | 15 | | | 20 | 40 | ns | $6\text{ ns} + (0,28\text{ ns/pF}) C_L$ |
| LOW to HIGH | 5 | tTLH | | 60 | 120 | ns | $10\text{ ns} + (1,0\text{ ns/pF}) C_L$ |
| | 10 | | | 30 | 60 | ns | $9\text{ ns} + (0,42\text{ ns/pF}) C_L$ |
| | 15 | | | 20 | 40 | ns | $6\text{ ns} + (0,28\text{ ns/pF}) C_L$ |

A.C. CHARACTERISTICS

 $V_{SS} = 0 \text{ V}$; $T_{amb} = 25 \text{ }^\circ\text{C}$; $C_L = 50 \text{ pF}$; input transition times $\leq 20 \text{ ns}$

| | V_{DD} V | symbol | min | typ | max | |
|--|---------------|------------|-----|------|-----|------------------------------------|
| Minimum clock pulse width; LOW | 5 | | 110 | 55 | ns | see also waveforms Figs 6 and 7 |
| | 10 | t_{WCPL} | 35 | 20 | ns | |
| | 15 | | 25 | 15 | ns | |
| Minimum PL pulse width; HIGH | 5 | | 160 | 80 | ns | |
| | 10 | t_{WPLH} | 55 | 25 | ns | |
| | 15 | | 35 | 15 | ns | |
| Recovery time for PL | 5 | | 150 | 75 | ns | |
| | 10 | t_{RPL} | 50 | 25 | ns | |
| | 15 | | 35 | 20 | ns | |
| Set-up times BIN/ \overline{DEC} \rightarrow CP | 5 | | 270 | 135 | ns | |
| | 10 | t_{su} | 90 | 45 | ns | |
| | 15 | | 60 | 30 | ns | |
| UP/ \overline{DN} \rightarrow CP | 5 | | 300 | 150 | ns | |
| | 10 | t_{su} | 105 | 55 | ns | |
| | 15 | | 75 | 35 | ns | |
| \overline{CE} \rightarrow CP | 5 | | 120 | 60 | ns | |
| | 10 | t_{su} | 45 | 25 | ns | |
| | 15 | | 35 | 20 | ns | |
| P_n \rightarrow PL | 5 | | 70 | 35 | ns | |
| | 10 | t_{su} | 20 | 10 | ns | |
| | 15 | | 10 | 5 | ns | |
| Hold times BIN/ \overline{DEC} \rightarrow CP | 5 | | 45 | -90 | ns | |
| | 10 | t_{hold} | 15 | -30 | ns | |
| | 15 | | 10 | -20 | ns | |
| UP/ \overline{DN} \rightarrow CP | 5 | | 15 | -135 | ns | |
| | 10 | t_{hold} | 0 | -50 | ns | |
| | 15 | | -5 | -35 | ns | |
| \overline{CE} \rightarrow CP | 5 | | 30 | -30 | ns | |
| | 10 | t_{hold} | 10 | -10 | ns | |
| | 15 | | 5 | -10 | ns | |
| P_n \rightarrow PL | 5 | | 15 | -20 | ns | |
| | 10 | t_{hold} | 0 | -10 | ns | |
| | 15 | | 0 | -5 | ns | |
| Maximum clock pulse frequency | 5 | | 4 | 8 | MHz | |
| | 10 | f_{max} | 12 | 25 | MHz | |
| | 15 | | 18 | 35 | MHz | |

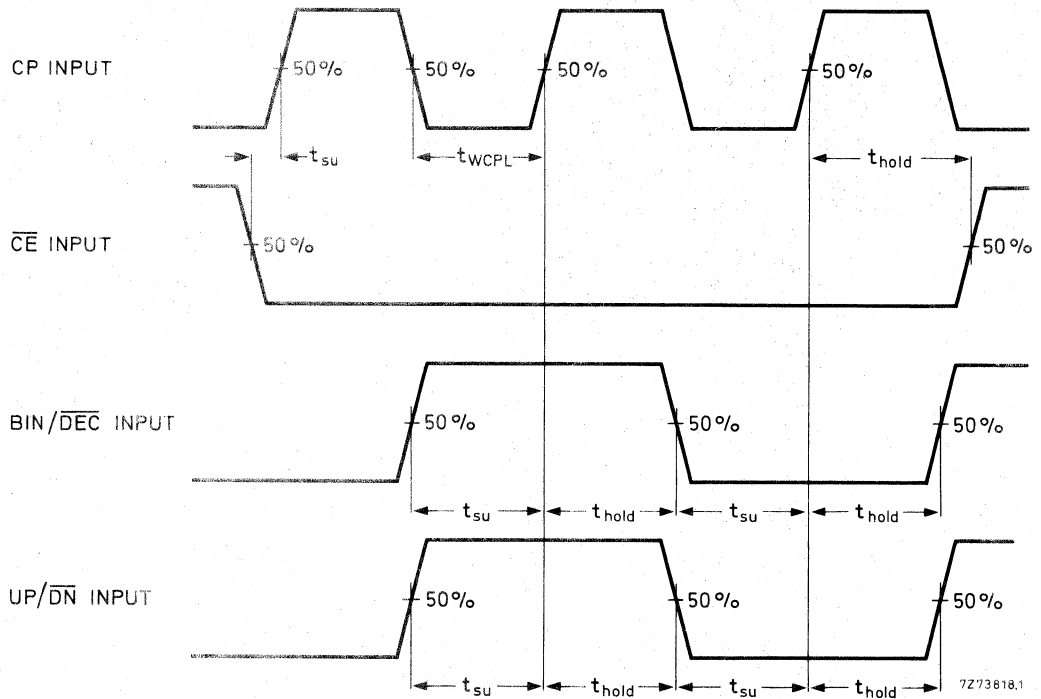

Fig. 6 Waveforms showing minimum pulse width for CP, set-up and hold times for \overline{CE} to CP, BIN/ \overline{DEC} to CP and UP/ \overline{DN} to CP. Set-up and hold times are shown as positive values but may be specified as negative values.

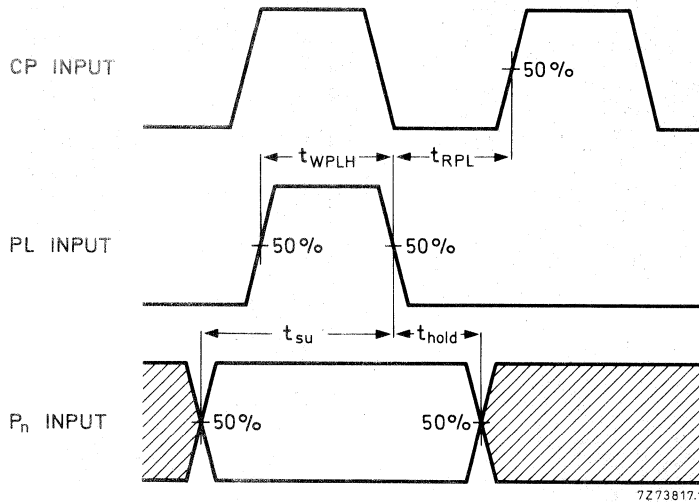

Fig. 7 Waveforms showing minimum pulse width for PL, recovery time for PL, and set-up and hold times for P_n to PL. Set-up and hold times are shown as positive values but may be specified as negative values.

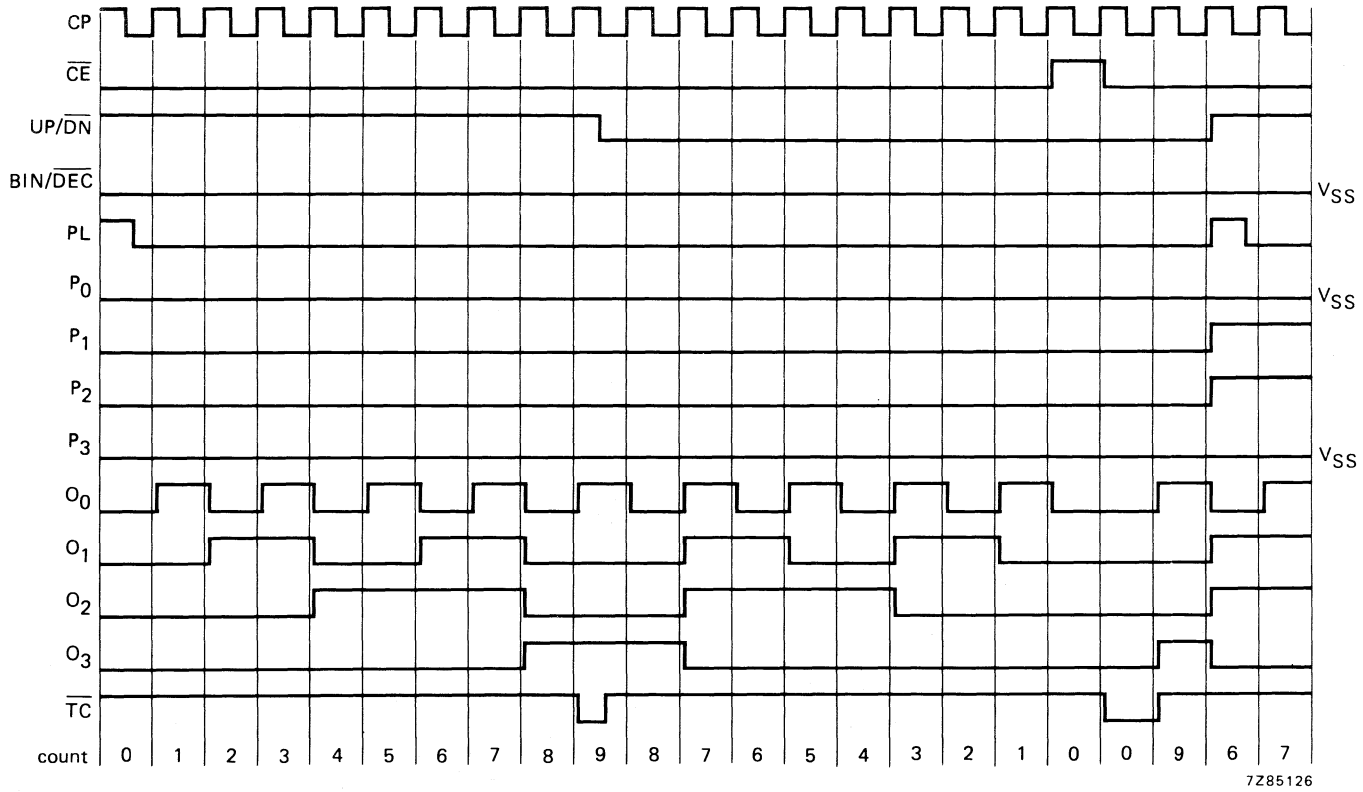
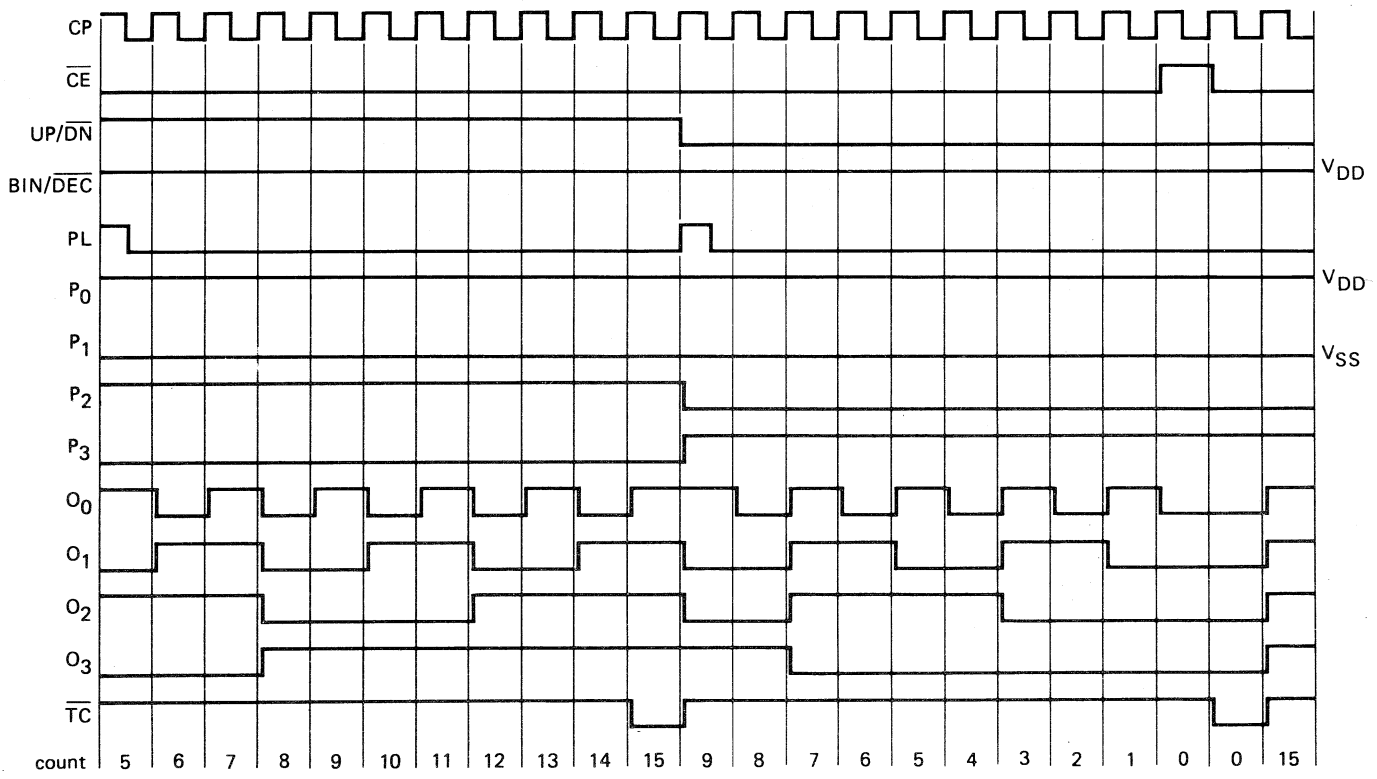

Fig. 8 Timing diagram; decade mode; $P_0 = \text{LOW}$; $P_3 = \text{LOW}$; $\overline{BIN/DEC} = \text{LOW}$.



7285127

Fig. 9 Timing diagram; binary mode; P₀ = HIGH; P₁ = LOW; BIN/ \overline{DEC} = HIGH.

APPLICATION INFORMATION

Some examples of applications for the HEF4029B are:

- Programmable binary and decade counting/frequency synthesizers - BCD output.
- Analogue-to-digital and digital-to-analogue conversion.
- Up/down binary counting.
- Magnitude and sign generation.
- Up/down decade counting.
- Difference counting.

APPLICATION INFORMATION (continued)

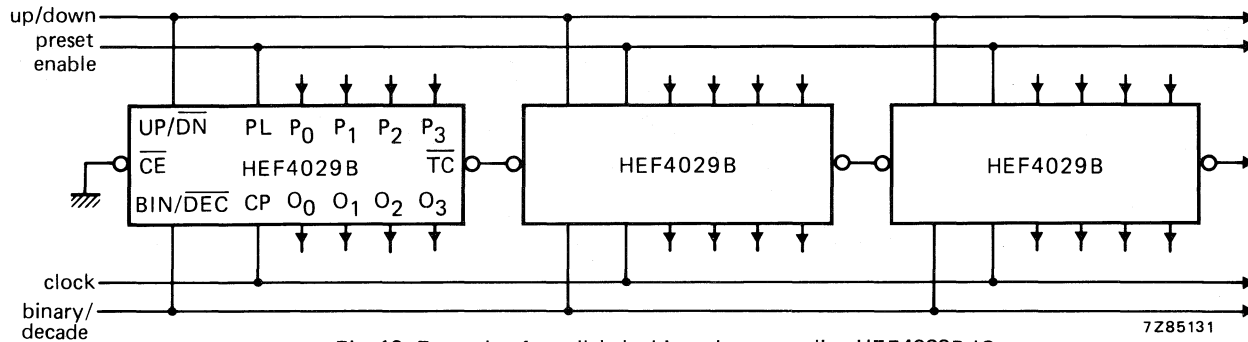

Fig. 10 Example of parallel clocking when cascading HEF4029B ICs.

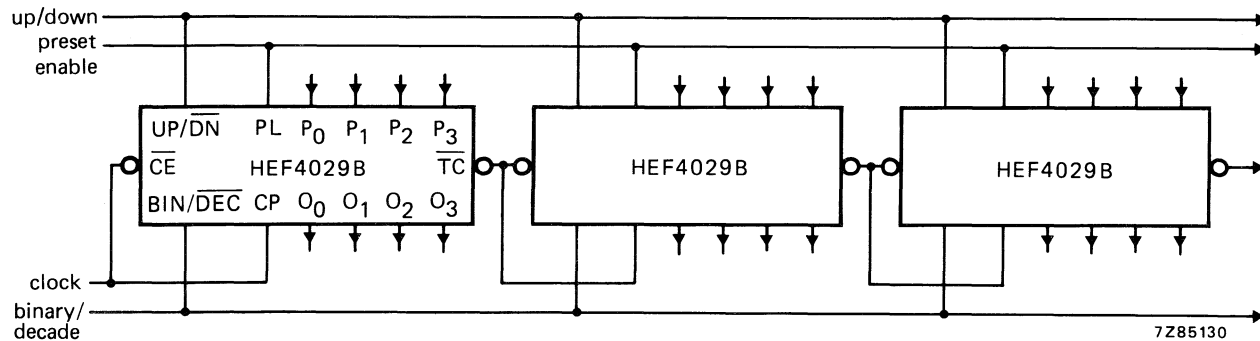

Fig. 11 Example of ripple clocking when cascading HEF4029B ICs. Ripple clocking mode: the up/down control can be changed at any count; the only restriction on changing the up/down control is that the clock input to the first counting stage must be HIGH.

Note

\overline{TC} lines at all stages after the first may have a negative-going glitch pulse resulting from differential delays of different HEF4029B ICs. These negative-going glitches do not affect proper HEF4029B operation; however if the \overline{TC} signals are used to trigger other edge-sensitive logic devices, such as flip-flops or counters, the \overline{TC} signals should be gated with the clock signal using a 2-input OR gate such as HEF4071B.

7Z85131

7Z85130

QUADRUPLE EXCLUSIVE-OR GATE



The HEF4030B provides the positive quadruple exclusive-OR function. The outputs are fully buffered for highest noise immunity and pattern insensitivity of output impedance.

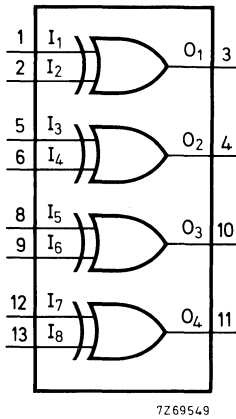

Fig. 1 Functional diagram.



Fig. 2 Pinning diagram.

HEF4030BP : 14-lead DIL; plastic (SOT-27K, M, T).
HEF4030BD: 14-lead DIL; ceramic (cerdip) (SOT-73).
HEF4030BT : 14-lead mini-pack; plastic (SO-14; SOT-108A).

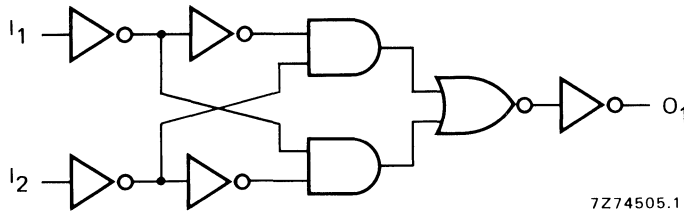

Fig. 3 Logic diagram (one gate).

TRUTH TABLE

| I ₁ | I ₂ | O ₁ |
|----------------|----------------|----------------|
| L | L | L |
| H | L | H |
| L | H | H |
| H | H | L |

H = HIGH state (the more positive voltage)

L = LOW state (the less positive voltage)

FAMILY DATA

I_{DD} LIMITS category GATES

} see Family Specifications

HEF4030B

gates

A.C. CHARACTERISTICS

$V_{SS} = 0\text{ V}$; $T_{amb} = 25\text{ }^{\circ}\text{C}$; $C_L = 50\text{ pF}$; input transition times $\leq 20\text{ ns}$

| | V_{DD} V | symbol | typ. | max. | | typical extrapolation formula |
|--|---------------|------------------|------|------|----|-------------------------------------|
| Propagation delays $I_n \rightarrow O_n$ HIGH to LOW | 5 | t _{PHL} | 85 | 175 | ns | 57 ns + (0,55 ns/pF) C _L |
| | 10 | | 35 | 75 | ns | 24 ns + (0,23 ns/pF) C _L |
| | 15 | | 30 | 55 | ns | 22 ns + (0,16 ns/pF) C _L |
| LOW to HIGH | 5 | t _{PLH} | 75 | 150 | ns | 47 ns + (0,55 ns/pF) C _L |
| | 10 | | 30 | 65 | ns | 19 ns + (0,23 ns/pF) C _L |
| | 15 | | 25 | 50 | ns | 17 ns + (0,16 ns/pF) C _L |
| Output transition times HIGH to LOW | 5 | t _{THL} | 60 | 120 | ns | 10 ns + (1,0 ns/pF) C _L |
| | 10 | | 30 | 60 | ns | 9 ns + (0,42 ns/pF) C _L |
| | 15 | | 20 | 40 | ns | 6 ns + (0,28 ns/pF) C _L |
| LOW to HIGH | 5 | t _{TLH} | 60 | 120 | ns | 10 ns + (1,0 ns/pF) C _L |
| | 10 | | 30 | 60 | ns | 9 ns + (0,42 ns/pF) C _L |
| | 15 | | 20 | 40 | ns | 6 ns + (0,28 ns/pF) C _L |

| | V_{DD} V | typical formula for P (μW) | where f _i = input freq. (MHz) f _o = output freq. (MHz) C _L = load capacitance (pF) $\Sigma(f_o C_L)$ = sum of outputs V _{DD} = supply voltage (V) |
|---|---------------|---|--|
| Dynamic power dissipation per package (P) | 5 | $1\ 100 f_i + \Sigma(f_o C_L) \times V_{DD}^2$ | |
| | 10 | $4\ 900 f_i + \Sigma(f_o C_L) \times V_{DD}^2$ | |
| | 15 | $14\ 400 f_i + \Sigma(f_o C_L) \times V_{DD}^2$ | |

64-STAGE STATIC SHIFT REGISTER



The HEF4031B is an edge-triggered 64-stage static shift register with two serial data inputs (D_A , D_B), a data select input \bar{A}/B , a clock input (CP), a buffered clock output (CO), and buffered outputs from the 64th bit position (O_{63} , \bar{O}_{63}). The output O_{63} is capable of driving one TTL load.

Data from D_A or D_B , as determined by the state of \bar{A}/B , is shifted into the first shift register position and all the data in the register is shifted one position to the right on the LOW to HIGH transition of CP. D_A is selected by a LOW, and D_B by a HIGH on \bar{A}/B . Registers can be cascaded either by connecting all CP inputs together or by driving CP of the most right-hand register with the system clock and connecting CO to CP of the preceding register. When the second technique is used in the recirculating mode, a flip-flop must be used to store O_{63} of the most right-hand register until the most left-hand register is clocked.

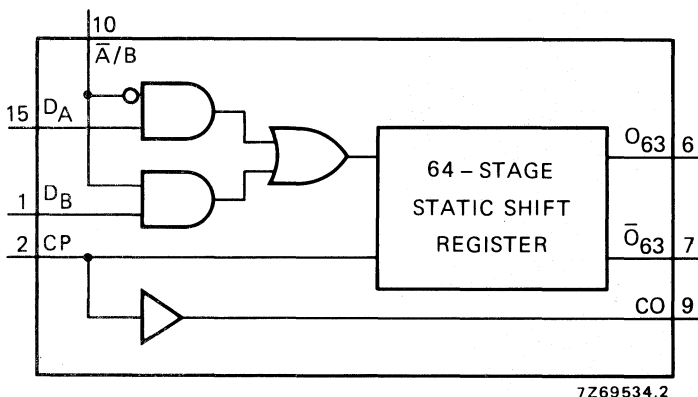

Fig. 1 Functional diagram.

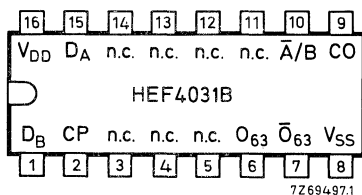

Fig. 2 Pinning diagram.

PINNING

- D_A , D_B data inputs
- \bar{A}/B data select input
- CP clock input (LOW to HIGH edge-triggered)
- CO buffered clock output
- O_{63} buffered output from the 64th stage
- \bar{O}_{63} complementary buffered output from the 64th stage

HEF4031BP : 16-lead DIL; plastic (SOT-38Z).
 HEF4031BD : 16-lead DIL; ceramic (cerdip) (SOT-74).
 HEF4031BT : 16-lead mini-pack; plastic
 (SO-16; SOT-109A).

FAMILY DATA

I_{DD} LIMITS category MSI

} see Family Specifications.

HEF4031B
MSI

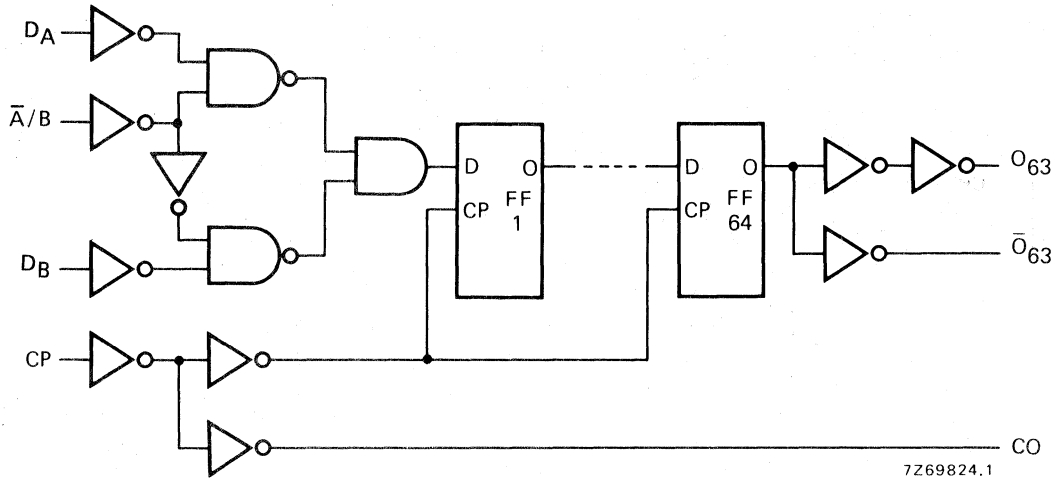

Fig. 3 Logic diagram.

D.C. CHARACTERISTICS

$V_{SS} = 0\text{ V}$; $V_I = V_{SS}$ or V_{DD}

| | V_{DD} V | V_{OH} V | V_{OL} V | symbol | T_{amb} (°C) | | | |
|--|---------------|---------------|---------------|-----------|----------------|-------------|-------------|-------------|
| | | | | | -40 min. | +25 max. | +85 min. | +85 max. |
| Output (source) current HIGH; O_{63} | 5 | 4,6 | | | 1,0 | 0,85 | 0,65 | mA |
| | 10 | 9,5 | | $-I_{OH}$ | 3,0 | 2,5 | 2,0 | mA |
| | 15 | 13,5 | | | 10,0 | 8,5 | 6,5 | mA |
| HIGH; \bar{O}_{63} | 5 | 2,5 | | $-I_{OH}$ | 3,0 | 2,5 | 2,0 | mA |
| Output (sink) current LOW; O_{63} | 4,75 | | 0,4 | | 2,7 | 2,3 | 1,8 | mA |
| | 10 | | 0,5 | I_{OL} | 9,5 | 8,0 | 6,3 | mA |
| | 15 | | 1,5 | | 24,0 | 20,0 | 16,0 | mA |

A.C. CHARACTERISTICS

 $V_{SS} = 0\text{ V}$; $T_{amb} = 25\text{ }^{\circ}\text{C}$; $C_L = 50\text{ pF}$; input transition times $\leq 20\text{ ns}$

| | V_{DD} V | symbol | min. | typ. | max. | typical extrapolation formula |
|--|---------------|------------------|------|--------|----------------------------|----------------------------------|
| Propagation delays CP \rightarrow O_{63} HIGH to LOW | 5 | t _{PHL} | | 180 | 360 ns | 167 ns + (0,26 ns/pF) C_L |
| | 10 | | 65 | 130 ns | 57 ns + (0,16 ns/pF) C_L | |
| | 15 | | 45 | 90 ns | 40 ns + (0,11 ns/pF) C_L | |
| LOW to HIGH | 5 | t _{PLH} | | 170 | 340 ns | 148 ns + (0,45 ns/pF) C_L |
| | 10 | | 65 | 130 ns | 56 ns + (0,19 ns/pF) C_L | |
| | 15 | | 45 | 90 ns | 39 ns + (0,13 ns/pF) C_L | |
| CP \rightarrow \bar{O}_{63} HIGH to LOW | 5 | t _{PHL} | | 190 | 380 ns | 163 ns + (0,55 ns/pF) C_L |
| | 10 | | 75 | 150 ns | 64 ns + (0,23 ns/pF) C_L | |
| | 15 | | 50 | 100 ns | 42 ns + (0,16 ns/pF) C_L | |
| LOW to HIGH | 5 | t _{PLH} | | 190 | 380 ns | 163 ns + (0,55 ns/pF) C_L |
| | 10 | | 75 | 150 ns | 64 ns + (0,23 ns/pF) C_L | |
| | 15 | | 50 | 100 ns | 42 ns + (0,16 ns/pF) C_L | |
| CP \rightarrow CO HIGH to LOW | 5 | t _{PHL} | | 70 | 140 ns | 43 ns + (0,55 ns/pF) C_L |
| | 10 | | 35 | 70 ns | 24 ns + (0,23 ns/pF) C_L | |
| | 15 | | 25 | 50 ns | 17 ns + (0,16 ns/pF) C_L | |
| LOW to HIGH | 5 | t _{PLH} | | 55 | 110 ns | 28 ns + (0,55 ns/pF) C_L |
| | 10 | | 30 | 60 ns | 19 ns + (0,23 ns/pF) C_L | |
| | 15 | | 25 | 50 ns | 17 ns + (0,16 ns/pF) C_L | |
| Output transition times; O_{63} HIGH to LOW | 5 | t _{THL} | | 25 | 50 ns | 5 ns + (0,40 ns/pF) C_L |
| | 10 | | 12 | 24 ns | 3 ns + (0,18 ns/pF) C_L | |
| | 15 | | 8 | 16 ns | 2 ns + (0,13 ns/pF) C_L | |
| LOW to HIGH | 5 | t _{TLH} | | 40 | 80 ns | 8 ns + (0,65 ns/pF) C_L |
| | 10 | | 20 | 40 ns | 5 ns + (0,30 ns/pF) C_L | |
| | 15 | | 13 | 26 ns | 3 ns + (0,20 ns/pF) C_L | |
| Output transition times; \bar{O}_{63} , CO HIGH to LOW | 5 | t _{THL} | | 60 | 120 ns | 10 ns + (1,0 ns/pF) C_L |
| | 10 | | 30 | 60 ns | 9 ns + (0,42 ns/pF) C_L | |
| | 15 | | 20 | 40 ns | 6 ns + (0,28 ns/pF) C_L | |
| LOW to HIGH | 5 | t _{TLH} | | 60 | 120 ns | 10 ns + (1,0 ns/pF) C_L |
| | 10 | | 30 | 60 ns | 9 ns + (0,42 ns/pF) C_L | |
| | 15 | | 20 | 40 ns | 6 ns + (0,28 ns/pF) C_L | |

A.C. CHARACTERISTICS

V_{SS} = 0 V; T_{amb} = 25 °C; C_L = 50 pF; input transition times ≤ 20 ns

| | V _{DD} V | symbol | min. | typ. | max. | typical extrapolation formula |
|--|----------------------|-------------------|------|------|------|----------------------------------|
| Set-up times D _A , D _B → CP | 5 | t _{su} | 25 | 0 | ns | } see also waveforms Fig. 4 |
| | 10 | | 25 | -5 | ns | |
| | 15 | | 10 | -10 | ns | |
| \bar{A}/B → CP | 5 | t _{su} | 30 | 10 | ns | |
| | 10 | | 15 | 0 | ns | |
| | 15 | | 10 | -5 | ns | |
| Hold times D _A , D _B → CP | 5 | t _{hold} | 40 | 10 | ns | |
| | 10 | | 40 | 10 | ns | |
| | 15 | | 40 | 10 | ns | |
| \bar{A}/B → CP | 5 | t _{hold} | 40 | 10 | ns | |
| | 10 | | 40 | 10 | ns | |
| | 15 | | 40 | 10 | ns | |
| Minimum clock pulse width; LOW | 5 | t _{WCPL} | 180 | 90 | ns | |
| | 10 | | 70 | 35 | ns | |
| | 15 | | 50 | 25 | ns | |
| Maximum clock pulse frequency | 5 | f _{max} | 2,5 | 5 | MHz | |
| | 10 | | 7 | 14 | MHz | |
| | 15 | | 10 | 20 | MHz | |

A.C. CHARACTERISTICS

V_{SS} = 0 V; T_{amb} = 25 °C; input transition times ≤ 20 ns

| | V _{DD} V | typical formula for P (μW) | where f _i = input freq. (MHz) f _o = output freq. (MHz) C _L = load capacitance (pF) Σ(f _o C _L) = sum of outputs V _{DD} = supply voltage (V) |
|---|----------------------|--|--|
| Dynamic power dissipation per package (P) | 5 | 4000 f _i + Σ(f _o C _L) × V _{DD} ² | |
| | 10 | 19 000 f _i + Σ(f _o C _L) × V _{DD} ² | |
| | 15 | 54 000 f _i + Σ(f _o C _L) × V _{DD} ² | |

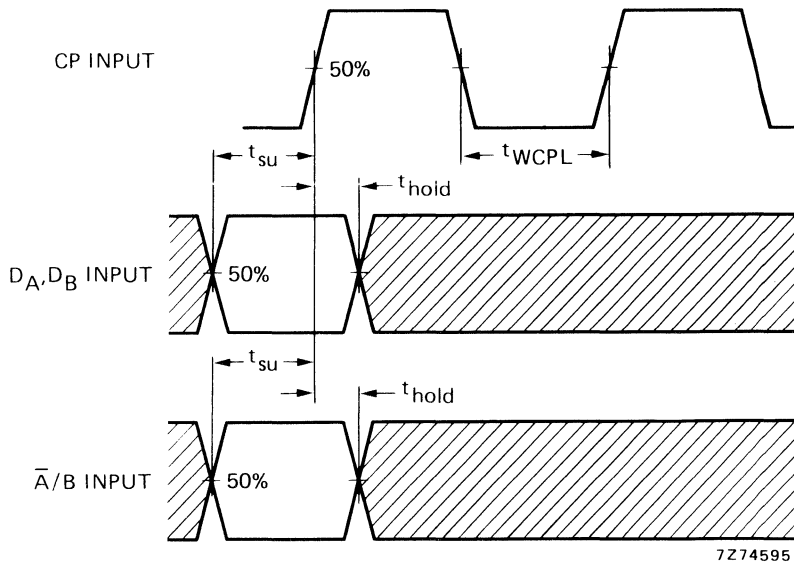

Fig. 4 Waveforms showing minimum clock pulse width, set-up and hold times for D_A , D_B to CP and \bar{A}/B to CP. Set-up and hold times are shown as positive values but may be specified as negative values.

APPLICATION INFORMATION

An example of an application for the HEF4031B is:

- Serial shift register.

APPLICATION INFORMATION

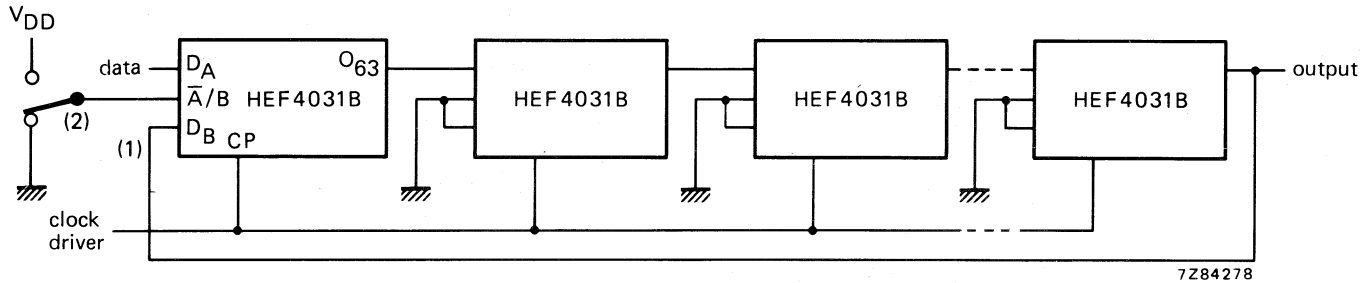

(1) Recirculating input.

(2) Mode control: V_{DD} = recirculation; ground (V_{SS}) = new data.

Fig. 5 Cascading using direct clocking for high speed operation (see clock rise and fall time requirements).

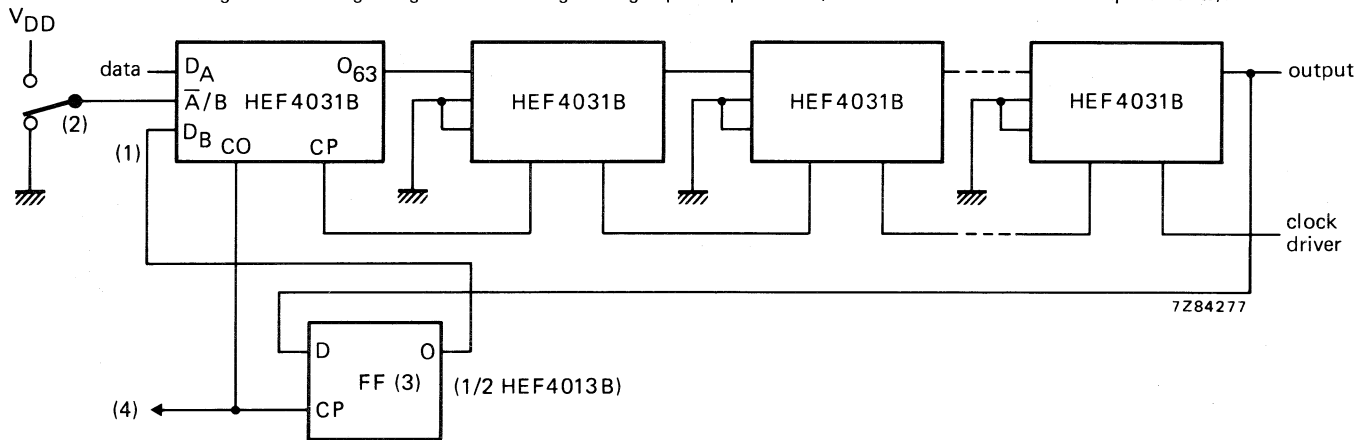

(1) Recirculating input.

(2) Mode control: V_{DD} = recirculation; ground (V_{SS}) = new data.

(3) For recirculation mode only, FF to delay data until first register delayed clocking has occurred.

(4) Delayed clock-to-clock; new data into first register.

Fig. 6 Cascading using delayed clocking for reduced clock drive requirements.

4-BIT UNIVERSAL SHIFT REGISTER



The HEF4035B is a fully synchronous edge-triggered 4-bit shift register with a clock input (CP), four synchronous parallel data inputs (P_0 to P_3), two synchronous serial data inputs (J, \bar{K}), a synchronous parallel enable input (PE), buffered parallel outputs from all 4-bit positions (O_0 to O_3), a true/complement input (T/\bar{C}) and an overriding asynchronous master reset input (MR).

Each register is of a D-type master-slave flip-flop.

Operation is synchronous (except for MR) and is edge-triggered on the LOW to HIGH transition of the CP input. When PE is HIGH, data is loaded into the register from P_0 to P_3 on the LOW to HIGH transition of CP.

When PE is LOW, data is shifted into the first register position from J and \bar{K} and all the data in the register is shifted one position to the right on the LOW to HIGH transition of CP. D-type entry is obtained by interconnecting J and \bar{K} . When J = HIGH and \bar{K} = LOW the first stage is in the toggle mode. When J = LOW and \bar{K} = HIGH the first stage is in the hold mode.

The outputs (O_0 to O_3) are either inverting or non-inverting, depending on T/\bar{C} state. With T/\bar{C} HIGH, O_0 to O_3 are non-inverting (active HIGH) and when T/\bar{C} is LOW, O_0 to O_3 are inverting (active LOW). A HIGH on MR resets all four bit positions (O_0 to O_3 = LOW if T/\bar{C} = HIGH, O_0 to O_3 = HIGH if T/\bar{C} = LOW) independent of all other input conditions.

Schmitt-trigger action in the clock input makes the circuit highly tolerant to slower clock rise and fall times.

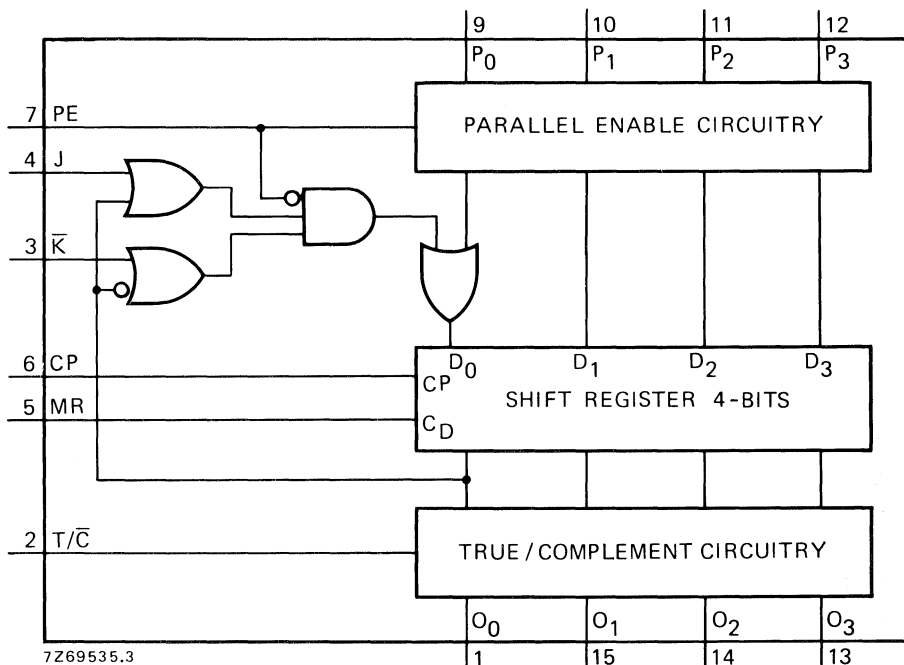

Fig. 1 Functional diagram.

FAMILY DATA

I_{DD} LIMITS category MSI

see Family Specifications



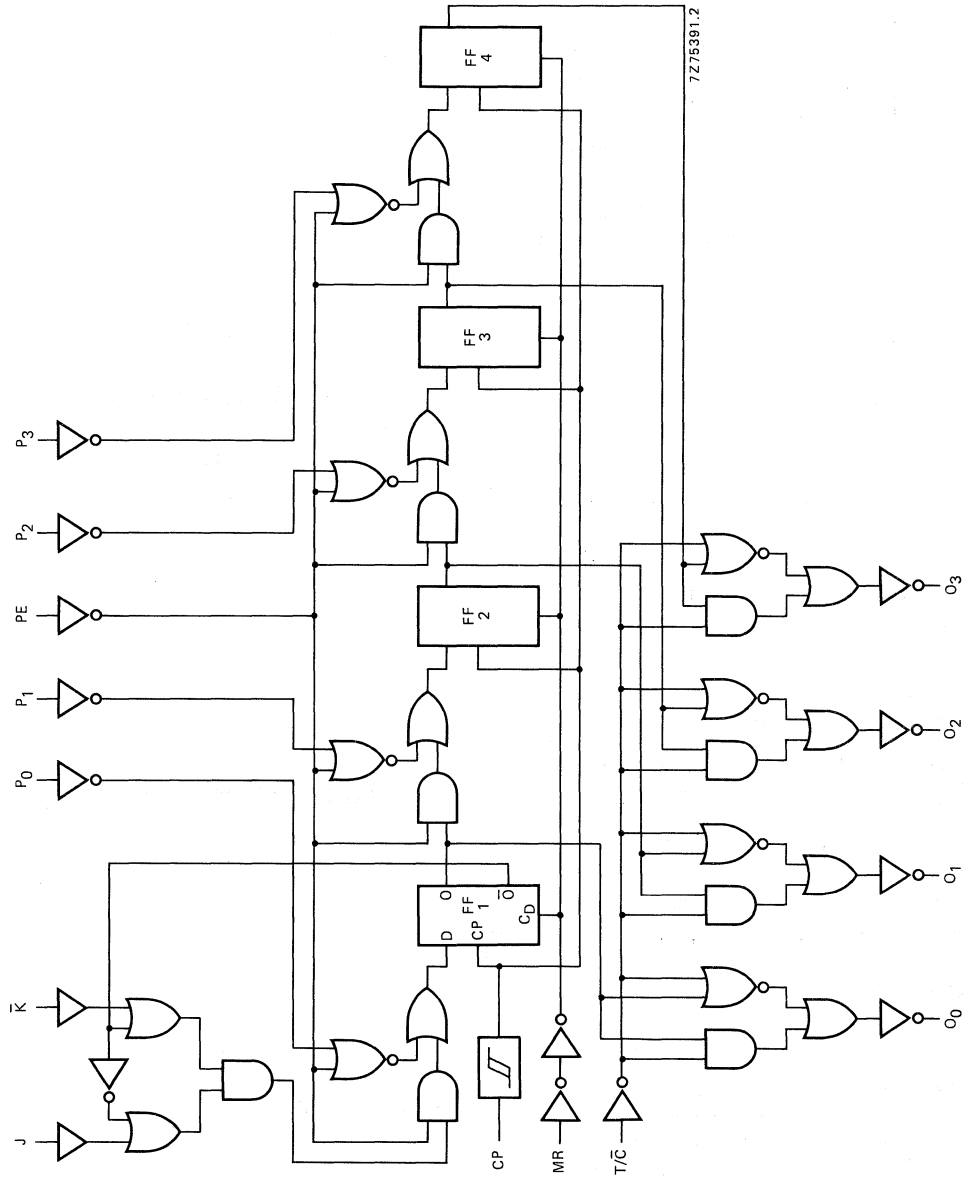

Fig. 2 Logic diagram.

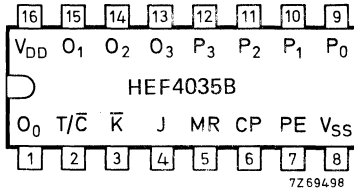

Fig. 3 Pinning diagram.

HEF4035BP : 16-lead DIL; plastic (SOT-38Z).
 HEF4035BD: 16-lead DIL; ceramic (cerdip) (SOT-74).
 HEF4035BT : 16-lead mini-pack; plastic (SO-16; SOT-109A).

PINNING

- | | | | |
|----------------------------------|-----------------------------------|----------------------------------|--|
| PE | parallel enable input | CP | clock input (LOW to HIGH edge-triggered) |
| P ₀ to P ₃ | parallel data inputs | T/ \bar{C} | true/complement input |
| J | first stage J-input (active HIGH) | MR | master reset input |
| \bar{K} | first stage K-input (active LOW) | O ₀ to O ₃ | buffered parallel outputs |

FUNCTION TABLES

Serial operation first stage

| inputs | | | | output | mode of operation |
|------------|---|-----------|----|------------------|-------------------|
| CP | J | \bar{K} | MR | O ₀₊₁ | |
| \nearrow | H | H | L | H | D flip-flop |
| \nearrow | L | L | L | L | D flip-flop |
| \nearrow | H | L | L | \bar{O}_0 | toggle |
| \nearrow | L | H | L | O ₀ | no change |
| X | X | X | H | L | reset |

T/ \bar{C} = HIGH; PE = LOW

Parallel operation

| CP | inputs | | | | outputs | | | |
|------------|----------------|----------------|----------------|----------------|----------------|----------------|----------------|----------------|
| | P ₀ | P ₁ | P ₂ | P ₃ | O ₀ | O ₁ | O ₂ | O ₃ |
| \nearrow | H | H | H | H | H | H | H | H |
| \nearrow | L | L | L | L | L | L | L | L |

T/ \bar{C} = HIGH; PE = HIGH; MR = LOW

- \nearrow = positive-going transition
- H = HIGH state (the more positive voltage)
- L = LOW state (the less positive voltage)
- X = state is immaterial

A.C. CHARACTERISTICS

 $V_{SS} = 0 \text{ V}$; $T_{amb} = 25 \text{ }^\circ\text{C}$; $C_L = 50 \text{ pF}$; input transition times $\leq 20 \text{ ns}$

| | V_{DD} V | symbol | min. | typ. | max. | typical extrapolation formula |
|---|---------------|--------|------|------|--------|---|
| Propagation delays CP \rightarrow O_n HIGH to LOW | 5 | tPHL | | 170 | 340 ns | $143 \text{ ns} + (0,55 \text{ ns/pF}) C_L$ |
| | 10 | | | 70 | 140 ns | $59 \text{ ns} + (0,23 \text{ ns/pF}) C_L$ |
| | 15 | | | 50 | 100 ns | $42 \text{ ns} + (0,16 \text{ ns/pF}) C_L$ |
| LOW to HIGH | 5 | tPLH | | 150 | 300 ns | $123 \text{ ns} + (0,55 \text{ ns/pF}) C_L$ |
| | 10 | | | 65 | 130 ns | $54 \text{ ns} + (0,23 \text{ ns/pF}) C_L$ |
| | 15 | | | 50 | 100 ns | $42 \text{ ns} + (0,16 \text{ ns/pF}) C_L$ |
| MR \rightarrow O_n HIGH to LOW | 5 | tPHL | | 115 | 230 ns | $88 \text{ ns} + (0,55 \text{ ns/pF}) C_L$ |
| | 10 | | | 50 | 100 ns | $39 \text{ ns} + (0,23 \text{ ns/pF}) C_L$ |
| | 15 | | | 40 | 80 ns | $32 \text{ ns} + (0,16 \text{ ns/pF}) C_L$ |
| LOW to HIGH | 5 | tPLH | | 115 | 230 ns | $88 \text{ ns} + (0,55 \text{ ns/pF}) C_L$ |
| | 10 | | | 50 | 100 ns | $39 \text{ ns} + (0,23 \text{ ns/pF}) C_L$ |
| | 15 | | | 40 | 80 ns | $32 \text{ ns} + (0,16 \text{ ns/pF}) C_L$ |
| $T/\bar{C} \rightarrow O_n$ HIGH to LOW | 5 | tPHL | | 105 | 210 ns | $78 \text{ ns} + (0,55 \text{ ns/pF}) C_L$ |
| | 10 | | | 50 | 100 ns | $39 \text{ ns} + (0,23 \text{ ns/pF}) C_L$ |
| | 15 | | | 35 | 70 ns | $27 \text{ ns} + (0,16 \text{ ns/pF}) C_L$ |
| LOW to HIGH | 5 | tPLH | | 85 | 170 ns | $58 \text{ ns} + (0,55 \text{ ns/pF}) C_L$ |
| | 10 | | | 45 | 90 ns | $34 \text{ ns} + (0,23 \text{ ns/pF}) C_L$ |
| | 15 | | | 35 | 70 ns | $27 \text{ ns} + (0,16 \text{ ns/pF}) C_L$ |
| Output transition times HIGH to LOW | 5 | tTHL | | 60 | 120 ns | $10 \text{ ns} + (1,0 \text{ ns/pF}) C_L$ |
| | 10 | | | 30 | 60 ns | $9 \text{ ns} + (0,42 \text{ ns/pF}) C_L$ |
| | 15 | | | 20 | 40 ns | $6 \text{ ns} + (0,28 \text{ ns/pF}) C_L$ |
| LOW to HIGH | 5 | tTLH | | 60 | 120 ns | $10 \text{ ns} + (1,0 \text{ ns/pF}) C_L$ |
| | 10 | | | 30 | 60 ns | $9 \text{ ns} + (0,42 \text{ ns/pF}) C_L$ |
| | 15 | | | 20 | 40 ns | $6 \text{ ns} + (0,28 \text{ ns/pF}) C_L$ |

A.C. CHARACTERISTICS

V_{SS} = 0 V; T_{amb} = 25 °C; C_L = 50 pF; input transition times ≤ 20 ns

| | V _{DD} V | symbol | min. | typ. | max. | |
|-------------------------------------|----------------------|-------------------|------|------|------|--------------------------------------|
| Minimum clock pulse width; LOW | 5 | t _{WCPL} | 80 | 40 | ns | } see also waveforms Figs 4 and 5 |
| | 10 | | 40 | 20 | ns | |
| | 15 | | 30 | 15 | ns | |
| Minimum MR pulse width; HIGH | 5 | t _{WMRH} | 50 | 25 | ns | |
| | 10 | | 30 | 15 | ns | |
| | 15 | | 20 | 10 | ns | |
| Recovery time for MR | 5 | t _{RMR} | 50 | 20 | ns | |
| | 10 | | 40 | 15 | ns | |
| | 15 | | 25 | 10 | ns | |
| Set-up times P _n → CP | 5 | t _{su} | 40 | 5 | ns | |
| | 10 | | 25 | 0 | ns | |
| | 15 | | 15 | 0 | ns | |
| PE → CP | 5 | t _{su} | 50 | 25 | ns | |
| | 10 | | 35 | 15 | ns | |
| | 15 | | 30 | 10 | ns | |
| J, \bar{K} → CP | 5 | t _{su} | 55 | 40 | ns | |
| | 10 | | 35 | 15 | ns | |
| | 15 | | 25 | 10 | ns | |
| Hold times P _n → CP | 5 | t _{hold} | 25 | 10 | ns | |
| | 10 | | 20 | 10 | ns | |
| | 15 | | 20 | 10 | ns | |
| PE → CP | 5 | t _{hold} | 15 | -5 | ns | |
| | 10 | | 10 | -5 | ns | |
| | 15 | | 5 | -5 | ns | |
| J, \bar{K} → CP | 5 | t _{hold} | 10 | -5 | ns | |
| | 10 | | 10 | 0 | ns | |
| | 15 | | 10 | 0 | ns | |
| Maximum clock pulse frequency | 5 | f _{max} | 5 | 10 | MHz | |
| | 10 | | 12 | 25 | MHz | |
| | 15 | | 15 | 30 | MHz | |

| | V _{DD} V | typical formula for P (μW) | where f _i = input freq. (MHz) f _o = output freq. (MHz) C _L = load cap. (pF) Σ(f _o C _L) = sum of outputs V _{DD} = supply voltage (V) |
|---|----------------------|--|---|
| Dynamic power dissipation per package (P) | 5 | 1 000 f _i + Σ(f _o C _L) × V _{DD} ² | |
| | 10 | 6 000 f _i + Σ(f _o C _L) × V _{DD} ² | |
| | 15 | 20 000 f _i + Σ(f _o C _L) × V _{DD} ² | |

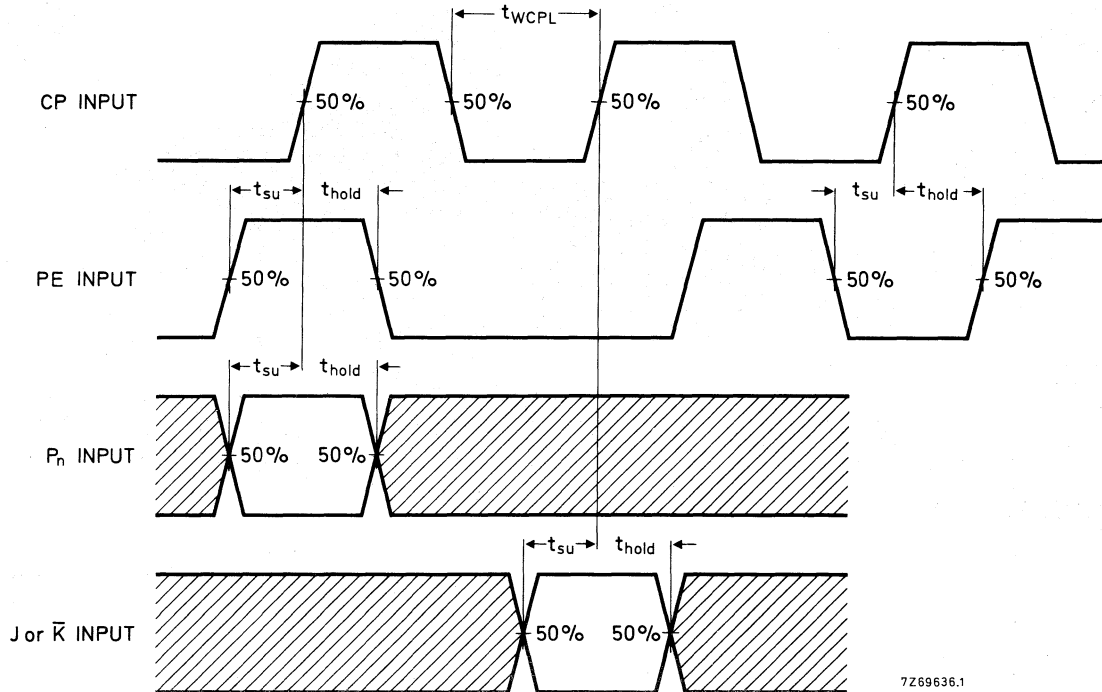

Fig. 4 Waveforms showing minimum clock pulse width, set-up times, hold times. Set-up times and hold times are shown as positive values but may be specified as negative values.

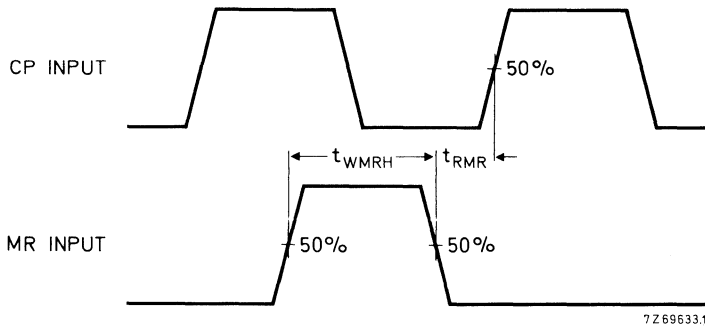

Fig. 5 Waveforms showing minimum MR pulse width and MR recovery time.

APPLICATION INFORMATION

Some examples of applications for the HEF4035B are:

- Counters, registers, arithmetic-unit registers, shift-left/shift-right registers.
- Serial-to-parallel/parallel-to-serial conversions.
- Sequence generation.
- Control circuits.
- Code conversion.

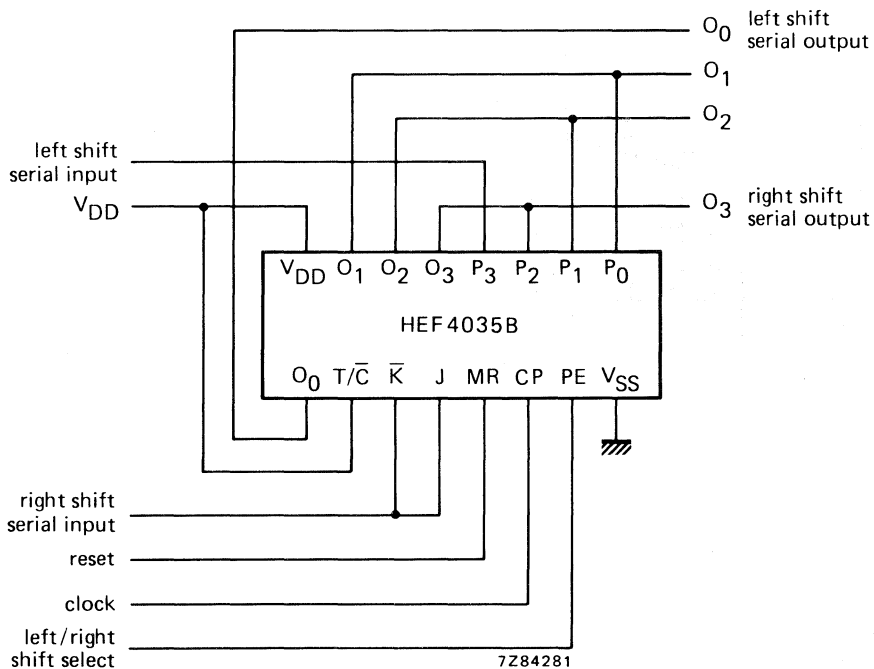

Fig. 6 Shift-left/shift-right register.

12-STAGE BINARY COUNTER



The HEF4040B is a 12-stage binary ripple counter with a clock input (\overline{CP}), an overriding asynchronous master reset input (MR) and twelve fully buffered outputs (O_0 to O_{11}). The counter advances on the HIGH to LOW transition of \overline{CP} . A HIGH on MR clears all counter stages and forces all outputs LOW, independent of \overline{CP} . Each counter stage is a static toggle flip-flop. Schmitt-trigger action in the clock input makes the circuit highly tolerant to slower clock rise and fall times.

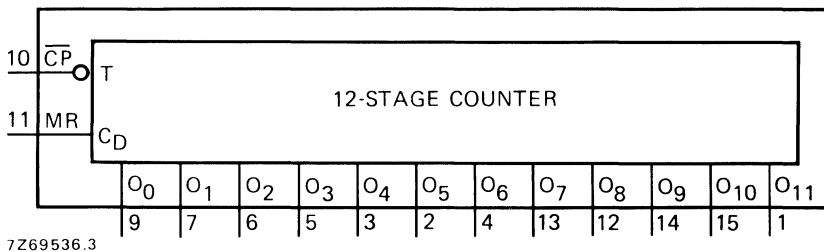

Fig. 1 Functional diagram.

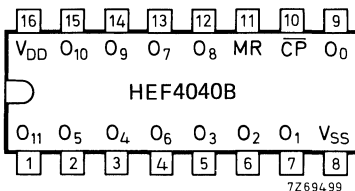

Fig. 2 Pinning diagram.

HEF4040BP : 16-lead DIL; plastic (SOT-38Z);
 HEF4040BD : 16-lead DIL; ceramic (cerdip) (SOT-74).
 HEF4040BT : 16-lead mini-pack; plastic
 (SO-16; SOT-109A).

PINNING

\overline{CP} clock input (HIGH to LOW edge-triggered)
 MR master reset input (active HIGH)
 O_0 to O_{11} parallel outputs

APPLICATION INFORMATION

Some examples of applications for the HEF4040B are:

- Frequency dividing circuits
- Time delay circuits
- Control counters

FAMILY DATA

I_{DD} LIMITS category MSI

} see Family Specifications

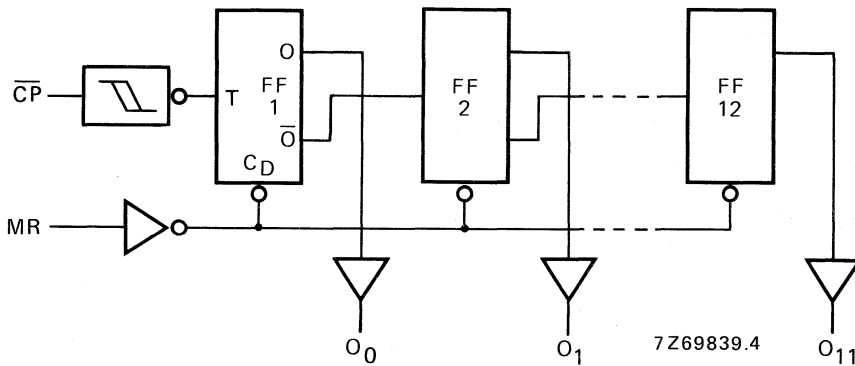

Fig. 3 Logic diagram.

A.C. CHARACTERISTICS

$V_{SS} = 0\text{ V}$; $T_{amb} = 25\text{ }^{\circ}\text{C}$; $C_L = 50\text{ pF}$; input transition times $\leq 20\text{ ns}$

| | V_{DD} V | symbol | min. | typ. | max. | typical extrapolation formula | |
|--|---------------|-----------|------|------|------|--|--|
| Propagation delays $\overline{CP} \rightarrow O_0$ HIGH to LOW | 5 | t_{PHL} | | 105 | 210 | ns | $78\text{ ns} + (0,55\text{ ns/pF}) C_L$ |
| | 10 | | 45 | 90 | ns | $34\text{ ns} + (0,23\text{ ns/pF}) C_L$ | |
| | 15 | | 35 | 70 | ns | $27\text{ ns} + (0,16\text{ ns/pF}) C_L$ | |
| | 5 | | 85 | 170 | ns | $58\text{ ns} + (0,55\text{ ns/pF}) C_L$ | |
| | 10 | | 40 | 80 | ns | $29\text{ ns} + (0,23\text{ ns/pF}) C_L$ | |
| | 15 | | 30 | 60 | ns | $22\text{ ns} + (0,16\text{ ns/pF}) C_L$ | |
| LOW to HIGH | 5 | t_{PLH} | | 35 | 70 | ns | note $(0,55\text{ ns/pF}) C_L$ |
| | 10 | | 15 | 30 | ns | note $(0,23\text{ ns/pF}) C_L$ | |
| | 15 | | 10 | 20 | ns | note $(0,16\text{ ns/pF}) C_L$ | |
| | 5 | | 35 | 70 | ns | note $(0,55\text{ ns/pF}) C_L$ | |
| | 10 | | 15 | 30 | ns | note $(0,23\text{ ns/pF}) C_L$ | |
| | 15 | | 10 | 20 | ns | note $(0,16\text{ ns/pF}) C_L$ | |
| $O_n \rightarrow O_{n+1}$ HIGH to LOW | 5 | t_{PHL} | | 90 | 180 | ns | $63\text{ ns} + (0,55\text{ ns/pF}) C_L$ |
| | 10 | | 40 | 80 | ns | $29\text{ ns} + (0,23\text{ ns/pF}) C_L$ | |
| | 15 | | 30 | 60 | ns | $22\text{ ns} + (0,16\text{ ns/pF}) C_L$ | |
| | 5 | | 35 | 70 | ns | note $(0,55\text{ ns/pF}) C_L$ | |
| | 10 | | 15 | 30 | ns | note $(0,23\text{ ns/pF}) C_L$ | |
| | 15 | | 10 | 20 | ns | note $(0,16\text{ ns/pF}) C_L$ | |
| MR $\rightarrow O_n$ HIGH to LOW | 5 | t_{PHL} | | 90 | 180 | ns | $63\text{ ns} + (0,55\text{ ns/pF}) C_L$ |
| | 10 | | 40 | 80 | ns | $29\text{ ns} + (0,23\text{ ns/pF}) C_L$ | |
| | 15 | | 30 | 60 | ns | $22\text{ ns} + (0,16\text{ ns/pF}) C_L$ | |
| | 5 | | 60 | 120 | ns | $10\text{ ns} + (1,0\text{ ns/pF}) C_L$ | |
| | 10 | | 30 | 60 | ns | $9\text{ ns} + (0,42\text{ ns/pF}) C_L$ | |
| | 15 | | 20 | 40 | ns | $6\text{ ns} + (0,28\text{ ns/pF}) C_L$ | |
| Output transition times HIGH to LOW | 5 | t_{THL} | | 60 | 120 | ns | $10\text{ ns} + (1,0\text{ ns/pF}) C_L$ |
| | 10 | | 30 | 60 | ns | $9\text{ ns} + (0,42\text{ ns/pF}) C_L$ | |
| | 15 | | 20 | 40 | ns | $6\text{ ns} + (0,28\text{ ns/pF}) C_L$ | |
| | 5 | | 60 | 120 | ns | $10\text{ ns} + (1,0\text{ ns/pF}) C_L$ | |
| | 10 | | 30 | 60 | ns | $9\text{ ns} + (0,42\text{ ns/pF}) C_L$ | |
| | 15 | | 20 | 40 | ns | $6\text{ ns} + (0,28\text{ ns/pF}) C_L$ | |
| LOW to HIGH | 5 | t_{TLH} | | 60 | 120 | ns | $10\text{ ns} + (1,0\text{ ns/pF}) C_L$ |
| | 10 | | 30 | 60 | ns | $9\text{ ns} + (0,42\text{ ns/pF}) C_L$ | |
| | 15 | | 20 | 40 | ns | $6\text{ ns} + (0,28\text{ ns/pF}) C_L$ | |

Note

For other loads than 50 pF at the n^{th} output, use the slope given.

A.C. CHARACTERISTICS

$V_{SS} = 0\text{ V}$; $T_{amb} = 25\text{ }^\circ\text{C}$; $C_L = 50\text{ pF}$; input transition times $\leq 20\text{ ns}$

| | V_{DD} V | symbol | min. | typ. | max. | |
|---------------------------------|---------------|------------|------|------|------|-----------------------------|
| Minimum clock pulse width; HIGH | 5 | t_{WCPH} | 50 | 25 | ns | } see also waveforms Fig. 4 |
| | 10 | | 30 | 15 | ns | |
| | 15 | | 20 | 10 | ns | |
| Minimum MR pulse width; HIGH | 5 | t_{WMRH} | 40 | 20 | ns | |
| | 10 | | 30 | 15 | ns | |
| | 15 | | 20 | 10 | ns | |
| Recovery time for MR | 5 | t_{RMR} | 40 | 20 | ns | |
| | 10 | | 30 | 15 | ns | |
| | 15 | | 20 | 10 | ns | |
| Maximum clock pulse frequency | 5 | f_{max} | 10 | 20 | MHz | |
| | 10 | | 15 | 30 | MHz | |
| | 15 | | 25 | 50 | MHz | |

| | V_{DD} V | typical formula for P (μW) | where f_i = input freq. (MHz) f_o = output freq. (MHz) C_L = load cap. (pF) $\Sigma(f_o C_L)$ = sum of outputs V_{DD} = supply voltage (V) |
|---|---------------|--|---|
| Dynamic power dissipation per package (P) | 5 | $400 f_i + \Sigma(f_o C_L) \times V_{DD}^2$ | |
| | 10 | $2\,000 f_i + \Sigma(f_o C_L) \times V_{DD}^2$ | |
| | 15 | $5\,200 f_i + \Sigma(f_o C_L) \times V_{DD}^2$ | |

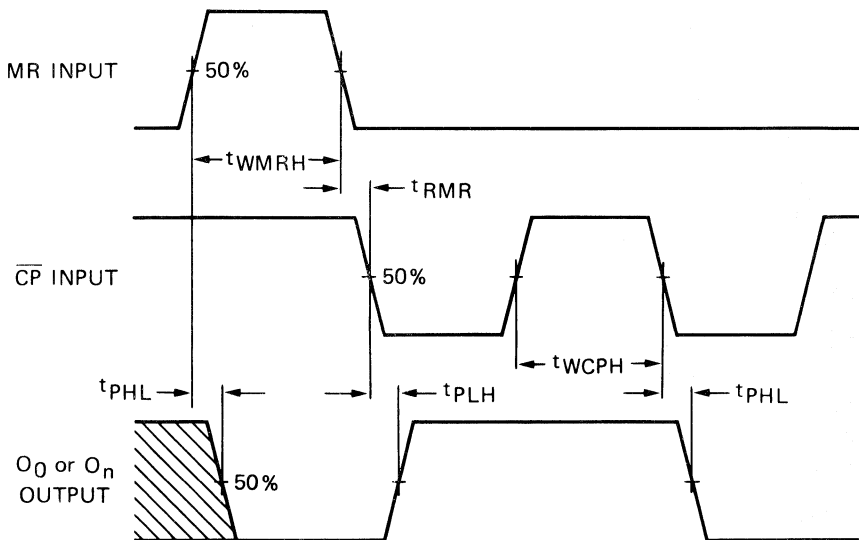

7275389

Fig. 4 Waveforms showing propagation delays for MR to O_n and CP to O₀, minimum MR and CP pulse widths.

QUADRUPLE TRUE/COMPLEMENT BUFFER



The HEF4041B is a quadruple true/complement buffer which provides both an inverted active LOW output (\bar{O}) and a non-inverted active HIGH output (O) for each input (I).
The buffers exhibit high current output capability suitable for driving TTL or high capacitive loads.

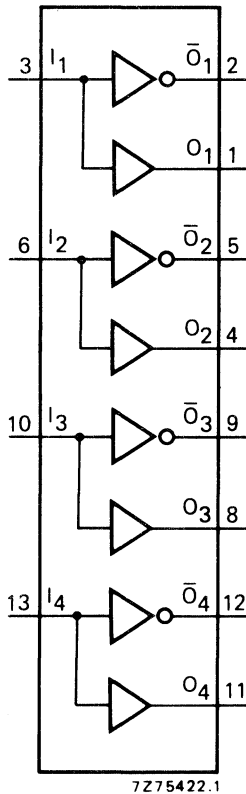

Fig. 1 Functional diagram.

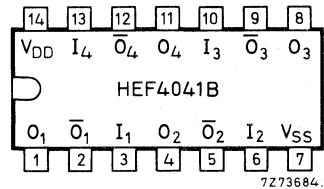

Fig. 2 Pinning diagram.

HEF4041BP : 14-lead DIL; plastic (SOT-27K, M, T).
HEF4041BD : 14-lead DIL; ceramic (cerdip) (SOT-73).
HEF4041BT : 14-lead mini-pack; plastic (SO-14; SOT-108A).

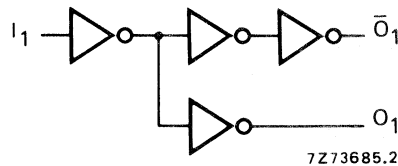

Fig. 3 Logic diagram (one buffer).

APPLICATION INFORMATION

Some examples of applications for the HEF4041B are:

- LOCMOS to DTL/TTL converter
- High current sink and source driver

FAMILY DATA

I_{DD} LIMITS category BUFFERS

} see Family Specifications

HEF4041B

buffers

D.C. CHARACTERISTICS

$V_{SS} = 0\text{ V}$; $V_I = V_{SS}$ or V_{DD}

| | V_{DD} V | V_{OH} V | V_{OL} V | symbol | T_{amb} (°C) | | | | | |
|---------------------------------|---------------|---------------|---------------|-----------|----------------|------|------|------|------|------|
| | | | | | -40 | | +25 | | +85 | |
| | | | | | min. | max. | min. | typ. | min. | max. |
| Output (source) current HIGH | 5 | 4,6 | | | 1,6 | | 1,3 | 2,6 | 1,0 | mA |
| | 10 | 9,5 | | $-I_{OH}$ | 4,5 | | 3,6 | 7,0 | 2,7 | mA |
| | 15 | 13,5 | | | 16,0 | | 14,0 | 30,0 | 10,0 | mA |
| HIGH | 5 | 2,5 | | $-I_{OH}$ | 5,0 | | 4,0 | 8,0 | 3,0 | mA |
| Output (sink) current LOW | 4,75 | | 0,4 | | 2,0 | | 1,7 | 4,0 | 1,35 | mA |
| | 10 | | 0,5 | I_{OL} | 7,5 | | 6,0 | 12,0 | 4,5 | mA |
| | 15 | | 1,5 | | 23,0 | | 20,0 | 35,0 | 15,0 | mA |

A.C. CHARACTERISTICS

$V_{SS} = 0\text{ V}$; $T_{amb} = 25\text{ °C}$; $C_L = 50\text{ pF}$; input transition times $\leq 20\text{ ns}$

| | V_{DD} V | symbol | | | | typical extrapolation formula | | |
|--|---------------|-----------|-----------|------|------|----------------------------------|--|--|
| | | | min. | typ. | max. | | | |
| Propagation delays $I_n \rightarrow O_n$ HIGH to LOW | 5 | | | 30 | 65 | ns | $17\text{ ns} + (0,27\text{ ns/pF}) C_L$ | |
| | 10 | t_{PHL} | | 20 | 40 | ns | $14\text{ ns} + (0,11\text{ ns/pF}) C_L$ | |
| | 15 | | | 15 | 30 | ns | $12\text{ ns} + (0,08\text{ ns/pF}) C_L$ | |
| | 5 | | | 30 | 55 | ns | $17\text{ ns} + (0,27\text{ ns/pF}) C_L$ | |
| | LOW to HIGH | 10 | t_{PLH} | | 15 | 30 | ns | $9\text{ ns} + (0,11\text{ ns/pF}) C_L$ |
| | | 15 | | | 10 | 20 | ns | $7\text{ ns} + (0,08\text{ ns/pF}) C_L$ |
| 5 | | | | 35 | 75 | ns | $22\text{ ns} + (0,27\text{ ns/pF}) C_L$ | |
| $I_n \rightarrow \bar{O}_n$ HIGH to LOW | 10 | t_{PHL} | | 20 | 40 | ns | $14\text{ ns} + (0,11\text{ ns/pF}) C_L$ | |
| | 15 | | | 15 | 30 | ns | $12\text{ ns} + (0,08\text{ ns/pF}) C_L$ | |
| | 5 | | | 35 | 75 | ns | $22\text{ ns} + (0,27\text{ ns/pF}) C_L$ | |
| | LOW to HIGH | 10 | t_{PLH} | | 20 | 40 | ns | $14\text{ ns} + (0,11\text{ ns/pF}) C_L$ |
| | | 15 | | | 15 | 30 | ns | $12\text{ ns} + (0,08\text{ ns/pF}) C_L$ |
| | | 5 | | | 25 | 50 | ns | $5\text{ ns} + (0,40\text{ ns/pF}) C_L$ |
| Output transition times $O_n \rightarrow \bar{O}_n$ HIGH to LOW | 10 | t_{THL} | | 12 | 25 | ns | $2\text{ ns} + (0,21\text{ ns/pF}) C_L$ | |
| | 15 | | | 8 | 20 | ns | $1\text{ ns} + (0,14\text{ ns/pF}) C_L$ | |
| | 5 | | | 25 | 45 | ns | $5\text{ ns} + (0,40\text{ ns/pF}) C_L$ | |
| | LOW to HIGH | 10 | t_{TLH} | | 12 | 25 | ns | $2\text{ ns} + (0,21\text{ ns/pF}) C_L$ |
| | | 15 | | | 8 | 20 | ns | $1\text{ ns} + (0,14\text{ ns/pF}) C_L$ |
| | | 5 | | | 25 | 45 | ns | $5\text{ ns} + (0,40\text{ ns/pF}) C_L$ |

| | V_{DD} V | typical formula for P (μW) | where |
|---|---------------|---|------------------------------------|
| Dynamic power dissipation per package (P) | 5 | $3100 f_i + \Sigma(f_o C_L) \times V_{DD}^2$ | f_i = input freq. (MHz) |
| | 10 | $12\ 700 f_i + \Sigma(f_o C_L) \times V_{DD}^2$ | f_o = output freq. (MHz) |
| | 15 | $33\ 800 f_i + \Sigma(f_o C_L) \times V_{DD}^2$ | C_L = load capacitance (pF) |
| | | | $\Sigma(f_o C_L)$ = sum of outputs |
| | | | V_{DD} = supply voltage (V) |

QUADRUPLE D-LATCH



The HEF4042B is a 4-bit latch with four data inputs (D_0 to D_3), four buffered latch outputs (O_0 to O_3), four buffered complementary latch outputs (\bar{O}_0 to \bar{O}_3) and two common enable inputs (E_0 and E_1). Information on D_0 to D_3 is transferred to O_0 to O_3 while both E_0 and E_1 are in the same state, either HIGH or LOW. O_0 to O_3 follow D_0 to D_3 as long as both E_0 and E_1 remain in the same state. When E_0 and E_1 are different, D_0 to D_3 do not affect O_0 to O_3 and the information in the latch is stored.

\bar{O}_0 to \bar{O}_3 are always the complement of O_0 to O_3 . The exclusive-OR input structure allows the choice of either polarity for E_0 and E_1 . With one enable input HIGH, the other enable input is active HIGH; with one enable input LOW, the other enable input is active LOW.

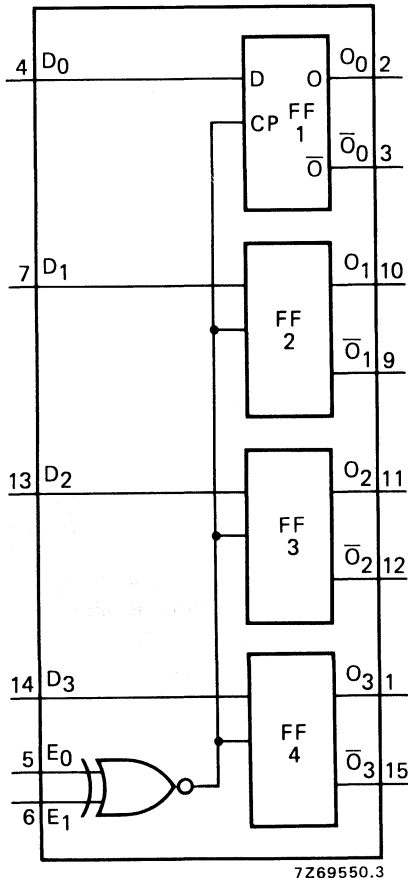

FAMILY DATA

I_{DD} LIMITS category MSI

} see Family Specifications

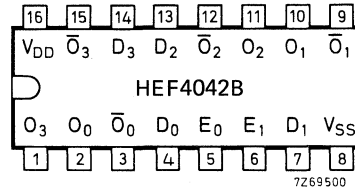

Fig. 2 Pinning diagram.

HEF4042BP : 16-lead DIL; plastic (SOT-38Z).

HEF4042BD: 16-lead DIL; ceramic (cerdip) (SOT-74).

HEF4042BT: 16-lead mini-pack; plastic (SO-16; SOT-109A).

PINNING

- D_0 to D_3 data inputs
- E_0 and E_1 enable inputs
- O_0 to O_3 parallel latch outputs
- \bar{O}_0 to \bar{O}_3 complementary parallel latch outputs

APPLICATION INFORMATION

Some examples of applications for the HEF4042B are:

- Buffer storage
- Holding register

Fig. 1 Functional diagram.

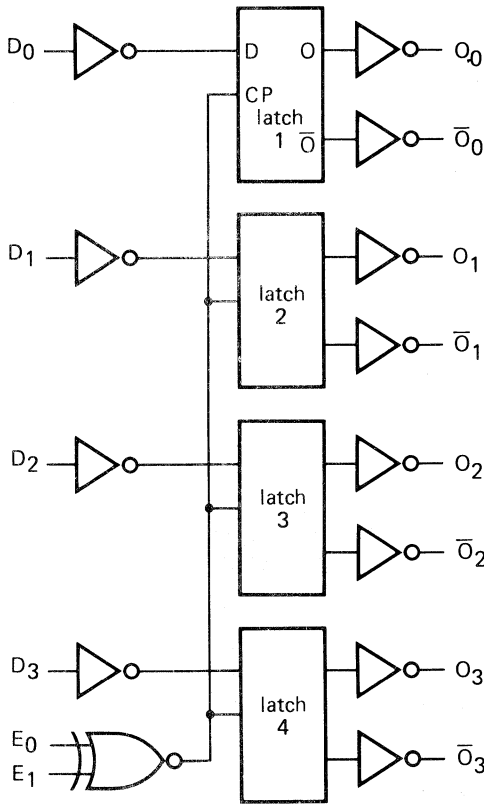

7Z69746.2

Fig. 3 Logic diagram.

FUNCTION TABLE

| E ₀ | E ₁ | output O _n |
|----------------|----------------|-----------------------|
| L | L | D _n |
| L | H | latched |
| H | L | latched |
| H | H | D _n |

H = HIGH state (the more positive voltage)
L = LOW state (the less positive voltage).

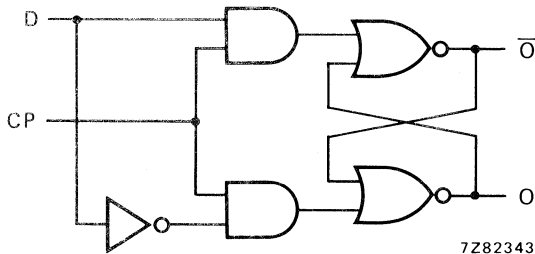

7Z82343

Fig. 4 Logic diagram (one latch).

A.C. CHARACTERISTICS

V_{SS} = 0 V; T_{amb} = 25 °C; C_L = 50 pF; input transition times ≤ 20 ns

| | V _{DD} V | symbol | min. | typ. | max. | typical extrapolation formula | |
|---|----------------------|-------------------|------|------|------|-------------------------------------|--------------------------------------|
| Propagation delays D → O, \bar{O} HIGH to LOW | 5 | t _{PHL} | | 95 | 190 | ns | 67 ns + (0,55 ns/pF) C _L |
| | 10 | | 40 | 80 | ns | 28 ns + (0,23 ns/pF) C _L | |
| | 15 | | 30 | 55 | ns | 22 ns + (0,16 ns/pF) C _L | |
| LOW to HIGH | 5 | t _{PLH} | | 85 | 175 | ns | 57 ns + (0,55 ns/pF) C _L |
| | 10 | | 40 | 75 | ns | 28 ns + (0,23 ns/pF) C _L | |
| | 15 | | 30 | 60 | ns | 22 ns + (0,16 ns/pF) C _L | |
| E → O, \bar{O} HIGH to LOW | 5 | t _{PHL} | | 130 | 260 | ns | 102 ns + (0,55 ns/pF) C _L |
| | 10 | | 50 | 105 | ns | 38 ns + (0,23 ns/pF) C _L | |
| | 15 | | 35 | 75 | ns | 27 ns + (0,16 ns/pF) C _L | |
| LOW to HIGH | 5 | t _{PLH} | | 120 | 245 | ns | 92 ns + (0,55 ns/pF) C _L |
| | 10 | | 50 | 105 | ns | 38 ns + (0,23 ns/pF) C _L | |
| | 15 | | 35 | 75 | ns | 27 ns + (0,16 ns/pF) C _L | |
| Output transition times HIGH to LOW | 5 | t _{THL} | | 60 | 120 | ns | 10 ns + (1,0 ns/pF) C _L |
| | 10 | | 30 | 60 | ns | 9 ns + (0,42 ns/pF) C _L | |
| | 15 | | 20 | 40 | ns | 6 ns + (0,28 ns/pF) C _L | |
| LOW to HIGH | 5 | t _{TLH} | | 60 | 120 | ns | 10 ns + (1,0 ns/pF) C _L |
| | 10 | | 30 | 60 | ns | 9 ns + (0,42 ns/pF) C _L | |
| | 15 | | 20 | 40 | ns | 6 ns + (0,28 ns/pF) C _L | |
| Set-up time D → E | 5 | t _{su} | 30 | 10 | | ns | see also waveforms Figs 5 and 6 |
| | 10 | | 20 | 5 | | ns | |
| | 15 | | 20 | 5 | | ns | |
| Hold time D → E | 5 | t _{hold} | 15 | -5 | | ns | |
| | 10 | | 15 | 0 | | ns | |
| | 15 | | 15 | 0 | | ns | |
| Minimum enable pulse width | 5 | t _{WE} | 90 | 45 | | ns | |
| | 10 | | 40 | 20 | | ns | |
| | 15 | | 30 | 15 | | ns | |

| | V _{DD} V | typical formula for P (W) | where |
|---|----------------------|--|--|
| Dynamic power dissipation per package (P) | 5 | 3800 f _i + Σ(f _o C _L) × V _{DD} ² | f _i = input freq. (MHz) |
| | 10 | 15 700 f _i + Σ(f _o C _L) × V _{DD} ² | f _o = output freq. (MHz) |
| | 15 | 41 100 f _i + Σ(f _o C _L) × V _{DD} ² | C _L = load capacitance (pF) |
| | | | Σ(f _o C _L) = sum of outputs |
| | | | V _{DD} = supply voltage (V) |

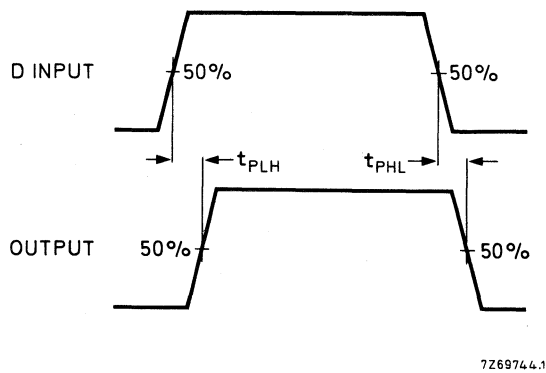
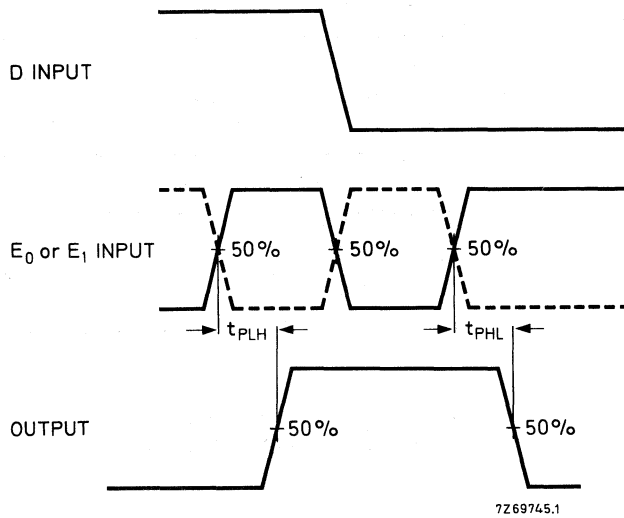

Fig. 5 Waveforms showing propagation delays for D to O, with latch enabled.

Note

Either E₀ or E₁ is held HIGH or LOW while the other enable input is pulsed as the function table shows.

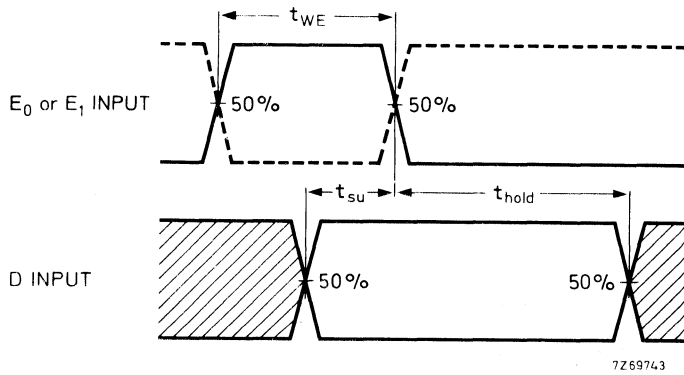

Fig. 6 Waveforms showing minimum enable pulse width, set-up time and hold time for E and D. Set-up and hold-times are shown as positive values but may be specified as negative values.

QUADRUPLE R/S LATCH WITH 3-STATE OUTPUTS



The HEF4043B is a quadruple R/S latch with 3-state outputs with a common output enable input (EO). Each latch has an active HIGH set input (S_0 to S_3), an active HIGH reset input (R_0 to R_3) and an active HIGH 3-state output (O_0 to O_3).

When EO is HIGH, the state of the latch output (O_n) can be determined from the function table below. When EO is LOW, the latch outputs are in the high impedance OFF-state. EO does not affect the state of the latch.

The high impedance off-state feature allows common busing of the outputs.

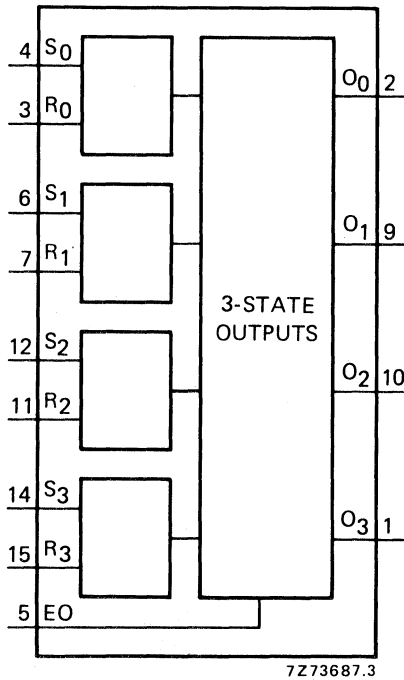

Fig. 1 Functional diagram.

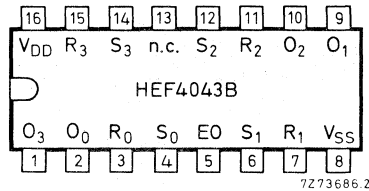

Fig. 2 Pinning diagram.

HEF4043BP : 16-lead DIL; plastic (SOT-38Z).
HEF4043BD : 16-lead DIL; ceramic (cerdip) (SOT-74).
HEF4043BT : 16-lead mini-pack; plastic (SO-16; SOT-109A).

PINNING

- EO common output enable input
- S_0 to S_3 set inputs (active HIGH)
- R_0 to R_3 reset inputs (active HIGH)
- O_0 to O_3 3-state buffered latch outputs

FUNCTION TABLE

| EO | inputs | | output O_n |
|----|--------|-------|--------------|
| | S_n | R_n | |
| L | X | X | Z |
| H | L | H | L |
| H | H | X | H |
| H | L | L | latched |

H = HIGH state (the more positive voltage)
L = LOW state (the less positive voltage)
X = state immaterial
Z = high impedance state

FAMILY DATA

I_{DD} LIMITS category MSI

} see Family Specifications

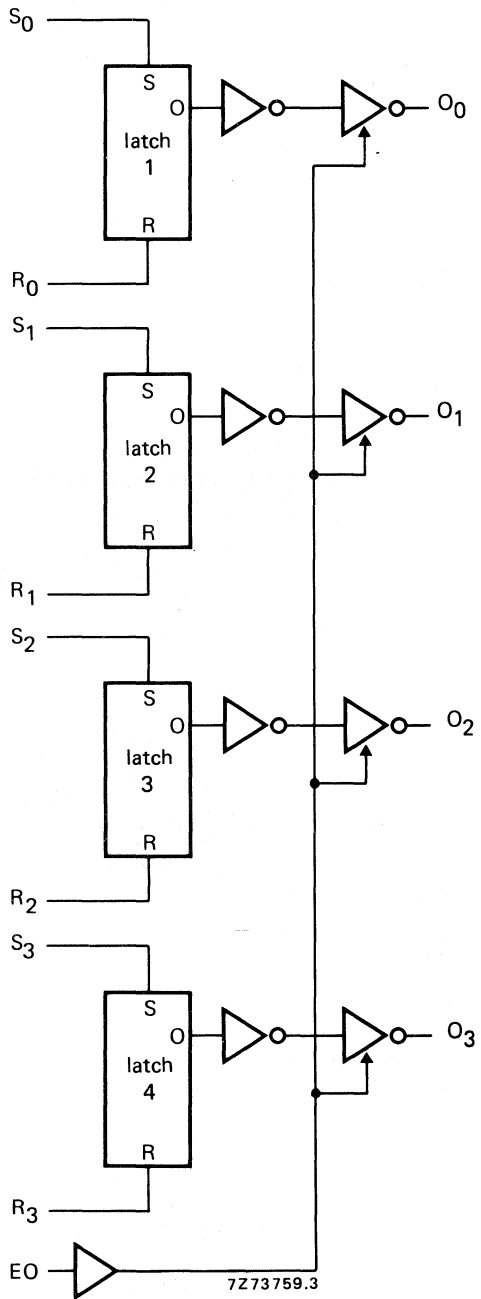

Fig. 3 Logic diagram.

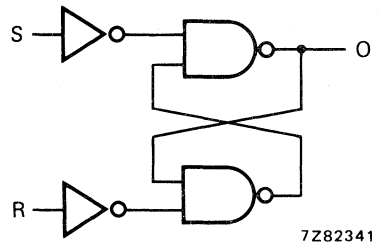

Fig. 4 Logic diagram (one latch).

A.C. CHARACTERISTICS

V_{SS} = 0 V; T_{amb} = 25 °C; C_L = 50 pF; input transition times ≤ 20 ns

| | V _{DD} V | symbol | min. | typ. | max. | typical extrapolation formula |
|--|----------------------|--------|------|-------|-------------------------------------|-------------------------------------|
| Propagation delays R _n → O _n HIGH to LOW | 5 | tPHL | | 90 | 180 ns | 63 ns + (0,55 ns/pF) C _L |
| | 10 | | 35 | 70 ns | 24 ns + (0,23 ns/pF) C _L | |
| | 15 | | 25 | 50 ns | 17 ns + (0,16 ns/pF) C _L | |
| S _n → O _n LOW to HIGH | 5 | tPLH | | 65 | 135 ns | 38 ns + (0,55 ns/pF) C _L |
| | 10 | | 25 | 50 ns | 14 ns + (0,23 ns/pF) C _L | |
| | 15 | | 15 | 35 ns | 7 ns + (0,16 ns/pF) C _L | |
| Output transition times HIGH to LOW | 5 | tTHL | | 60 | 120 ns | 10 ns + (1,0 ns/pF) C _L |
| | 10 | | 30 | 60 ns | 9 ns + (0,42 ns/pF) C _L | |
| | 15 | | 20 | 40 ns | 6 ns + (0,28 ns/pF) C _L | |
| LOW to HIGH | 5 | tTLH | | 60 | 120 ns | 10 ns + (1,0 ns/pF) C _L |
| | 10 | | 30 | 60 ns | 9 ns + (0,42 ns/pF) C _L | |
| | 15 | | 20 | 40 ns | 6 ns + (0,28 ns/pF) C _L | |
| 3-state propagation delays | | | | | | |
| Output disable times EO → O _n HIGH | 5 | tPHZ | | 45 | 90 ns | |
| | 10 | | 20 | 35 ns | | |
| | 15 | | 10 | 25 ns | | |
| LOW | 5 | tPLZ | | 50 | 100 ns | |
| | 10 | | 20 | 40 ns | | |
| | 15 | | 10 | 25 ns | | |
| Output enable times EO → O _n HIGH | 5 | tPZH | | 25 | 50 ns | |
| | 10 | | 15 | 30 ns | | |
| | 15 | | 10 | 25 ns | | |
| LOW | 5 | tPZL | | 40 | 80 ns | |
| | 10 | | 20 | 45 ns | | |
| | 15 | | 15 | 35 ns | | |
| Minimum S _n pulse width; HIGH | 5 | tWSH | 30 | 15 | ns | } see also waveforms Fig. 5 |
| | 10 | | 20 | 10 | ns | |
| | 15 | | 16 | 8 | ns | |
| Minimum R _n pulse width; HIGH | 5 | tWRH | 30 | 15 | ns | |
| | 10 | | 20 | 10 | ns | |
| | 15 | | 16 | 8 | ns | |

| | V _{DD} V | typical formula for P (μW) | where f _i = input freq. (MHz) f _o = output freq. (MHz) C _L = load capacitance (pF) Σ(f _o C _L) = sum of outputs V _{DD} = supply voltage (V) |
|---|----------------------|--|--|
| Dynamic power dissipation per package (P) | 5 | 1100 f _i + Σ(f _o C _L) × V _{DD} ² | |
| | 10 | 4400 f _i + Σ(f _o C _L) × V _{DD} ² | |
| | 15 | 11 400 f _i + Σ(f _o C _L) × V _{DD} ² | |

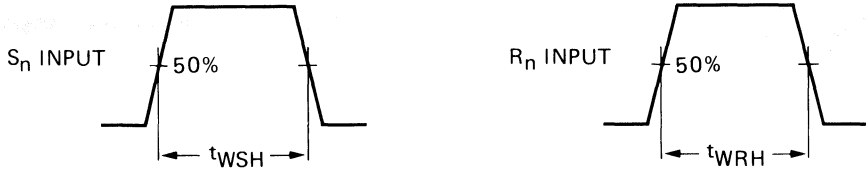

7273758.1

Fig. 5 Waveforms showing minimum S_n and R_n pulse widths.

APPLICATION INFORMATION

An example of application for the HEF4043B is:

- Four-bit storage with output enable

QUADRUPLE R/S LATCH WITH 3-STATE OUTPUTS



The HEF4044B is a quadruple R/S latch with 3-state outputs with a common output enable input (EO). Each latch has an active LOW set input (\bar{S}_0 to \bar{S}_3), an active LOW reset input (\bar{R}_0 to \bar{R}_3) and an active HIGH 3-state output (O_0 to O_3).

When EO is HIGH, the state of the latch output (O_n) can be determined from the function table below. When EO is LOW, the latch outputs are in the high impedance OFF-state. EO does not affect the state of the latch.

The high impedance off-state feature allows common busing of the outputs.

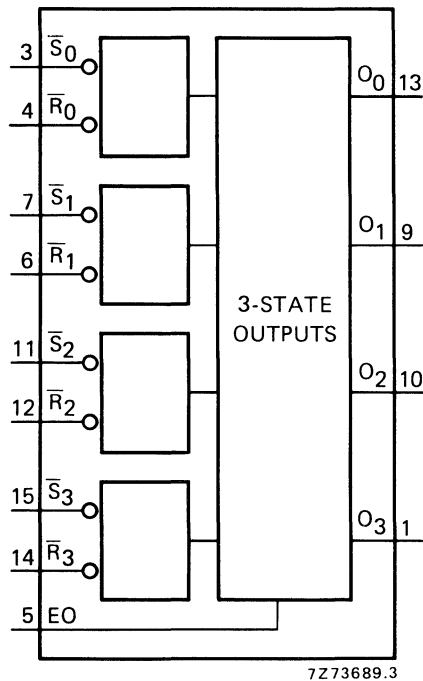

Fig. 1 Functional diagram.

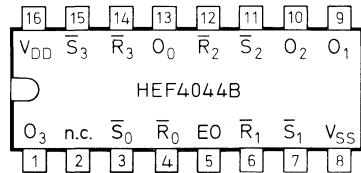

Fig. 2 Pinning diagram.

HEF4044BP : 16-lead DIL; plastic (SOT-38Z).

HEF4044BD : 16-lead DIL; ceramic (cerdip) (SOT-74).

HEF4044BT : 16-lead mini-pack; plastic (SO-16; SOT-109A).

PINNING

EO common output enable input
 \bar{S}_0 to \bar{S}_3 set inputs (active LOW)
 \bar{R}_0 to \bar{R}_3 reset inputs (active LOW)
 O_0 to O_3 3-state buffered latch outputs

FUNCTION TABLE

| EO | inputs | | output O_n |
|----|-------------|-------------|-----------------|
| | \bar{S}_n | \bar{R}_n | |
| L | X | X | Z |
| H | L | H | H |
| H | X | L | L |
| H | H | H | latched |

H = HIGH state (the more positive voltage)

L = LOW state (the less positive voltage)

X = state immaterial

Z = high impedance OFF-state

FAMILY DATA

I_{DD} LIMITS category MSI

} see Family Specifications

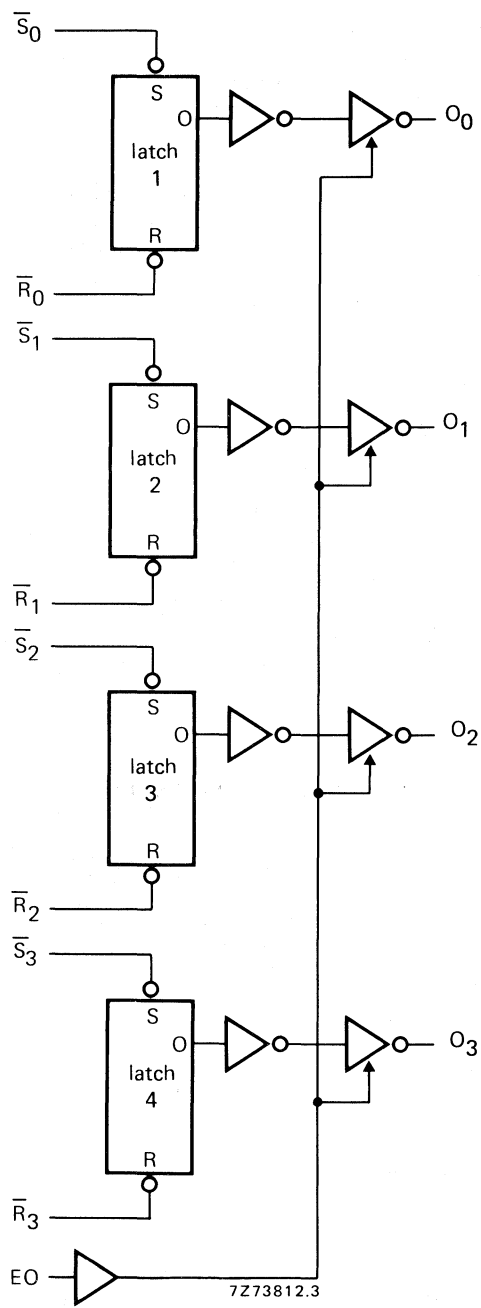

Fig. 3 Logic diagram.

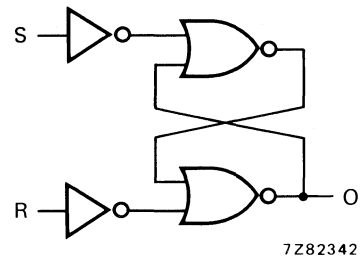

Fig. 4 Logic diagram (one latch).

A.C. CHARACTERISTICS

$V_{SS} = 0\text{ V}$; $T_{amb} = 25\text{ }^\circ\text{C}$; $C_L = 50\text{ pF}$; input transition times $\leq 20\text{ ns}$

| | V_{DD} V | symbol | min. | typ. | max. | typical extrapolation formula | |
|--|---------------|--------|------|------|------|--|--|
| Propagation delays $\bar{R}_n \rightarrow O_n$ HIGH to LOW | 5 | tPHL | | 90 | 185 | ns | $63\text{ ns} + (0,55\text{ ns/pF}) C_L$ |
| | 10 | | 40 | 80 | ns | $29\text{ ns} + (0,23\text{ ns/pF}) C_L$ | |
| | 15 | | 30 | 60 | ns | $22\text{ ns} + (0,16\text{ ns/pF}) C_L$ | |
| $\bar{S}_n \rightarrow O_n$ LOW to HIGH | 5 | tPLH | | 90 | 180 | ns | $63\text{ ns} + (0,55\text{ ns/pF}) C_L$ |
| | 10 | | 40 | 80 | ns | $29\text{ ns} + (0,23\text{ ns/pF}) C_L$ | |
| | 15 | | 30 | 60 | ns | $22\text{ ns} + (0,16\text{ ns/pF}) C_L$ | |
| Output transition times HIGH to LOW | 5 | tTHL | | 60 | 120 | ns | $10\text{ ns} + (1,0\text{ ns/pF}) C_L$ |
| | 10 | | 30 | 60 | ns | $9\text{ ns} + (0,42\text{ ns/pF}) C_L$ | |
| | 15 | | 20 | 40 | ns | $6\text{ ns} + (0,28\text{ ns/pF}) C_L$ | |
| LOW to HIGH | 5 | tTLH | | 60 | 120 | ns | $10\text{ ns} + (1,0\text{ ns/pF}) C_L$ |
| | 10 | | 30 | 60 | ns | $9\text{ ns} + (0,42\text{ ns/pF}) C_L$ | |
| | 15 | | 20 | 40 | ns | $6\text{ ns} + (0,28\text{ ns/pF}) C_L$ | |
| 3-state propagation delays | | | | | | | |
| Output disable times $EO \rightarrow O_n$ HIGH | 5 | tPHZ | | 50 | 100 | ns | } see also waveforms Fig. 5 |
| | 10 | | 30 | 60 | ns | | |
| | 15 | | 25 | 50 | ns | | |
| LOW | 5 | tPLZ | | 30 | 60 | ns | |
| | 10 | | 25 | 45 | ns | | |
| | 15 | | 20 | 40 | ns | | |
| Output enable times $EO \rightarrow O_n$ HIGH | 5 | tPZH | | 50 | 100 | ns | |
| | 10 | | 25 | 50 | ns | | |
| | 15 | | 20 | 40 | ns | | |
| LOW | 5 | tPZL | | 50 | 95 | ns | |
| | 10 | | 25 | 45 | ns | | |
| | 15 | | 20 | 35 | ns | | |
| Minimum \bar{S}_n pulse width; LOW | 5 | tWSL | 30 | 15 | | ns | |
| | 10 | | 20 | 10 | | ns | |
| | 15 | | 16 | 8 | | ns | |
| Minimum \bar{R}_n pulse width; LOW | 5 | tWRL | 30 | 15 | | ns | |
| | 10 | | 20 | 10 | | ns | |
| | 15 | | 16 | 8 | | ns | |

| | V_{DD} V | typical formula for P (μW) | where f_i = input freq. (MHz) f_o = output freq. (MHz) C_L = load capacitance (pF) $\Sigma(f_o C_L)$ = sum of outputs V_{DD} = supply voltage (V) |
|---|---------------|---|--|
| Dynamic power dissipation per package (P) | 5 | $1300 f_i + \Sigma(f_o C_L) \times V_{DD}^2$ | |
| | 10 | $5200 f_i + \Sigma(f_o C_L) \times V_{DD}^2$ | |
| | 15 | $12\ 900 f_i + \Sigma(f_o C_L) \times V_{DD}^2$ | |

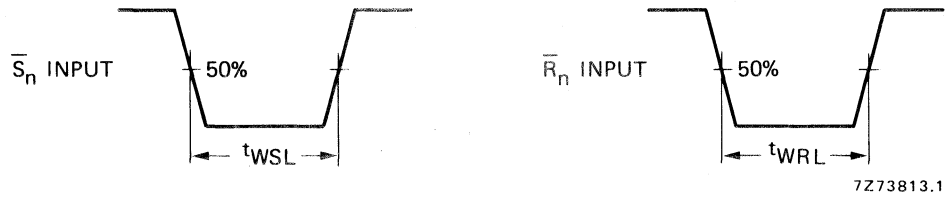

Fig. 5 Waveforms showing minimum \bar{S}_n and \bar{R}_n pulse widths.

APPLICATION INFORMATION

An example of application for the HEF4044B is:

- Four-bit storage with output enable

PHASE-LOCKED LOOP



The HEF4046B is a phase-locked loop circuit that consists of a linear voltage controlled oscillator (VCO) and two different phase comparators with a common signal input amplifier and a common comparator input. A 7 V regulator (zener) diode is provided for supply voltage regulation if necessary. For functional description see further on in this data.

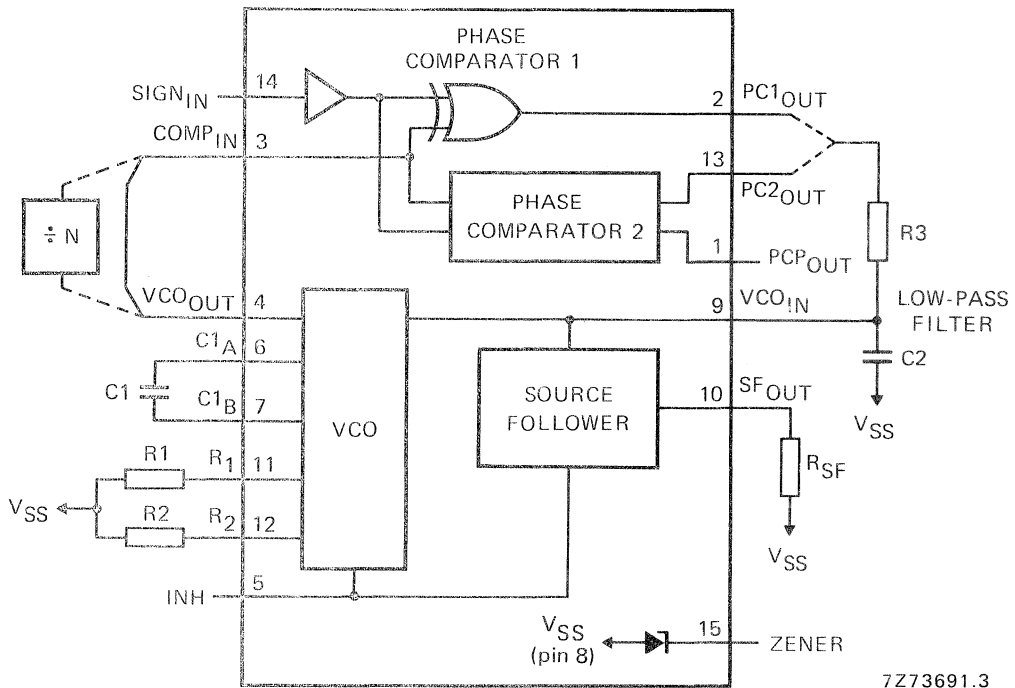

7273691.3

Fig. 1 Functional diagram.

HEF4046BP : 16-lead DIL; plastic (SOT-38Z).

HEF4046BD: 16-lead DIL; ceramic (cerdip) (SOT-74).

HEF4046BT : 16-lead mini-pack; plastic (SO-16; SOT-109A).

FAMILY DATA: see Family Specifications

I_{DD} LIMITS category MSI: see further on in this data.

HEF4046B

MSI

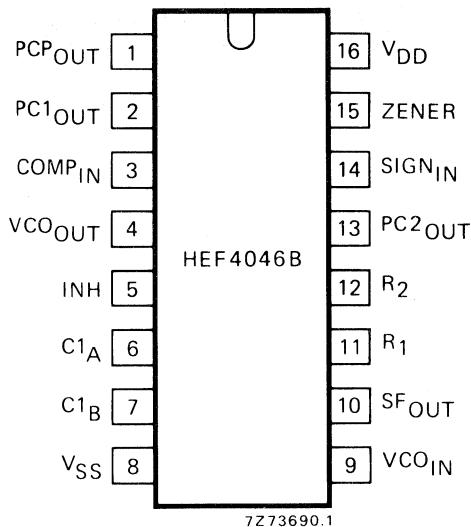

Fig. 2 Pinning diagram.

PINNING

1. Phase comparator pulse output
2. Phase comparator 1 output
3. Comparator input
4. VCO output
5. Inhibit input
6. Capacitor C1 connection A
7. Capacitor C1 connection B
8. V_{SS}
9. VCO input
10. Source-follower output
11. Resistor R1 connection
12. Resistor R2 connection
13. Phase comparator 2 output
14. Signal input
15. Zener diode input for regulated supply.

FUNCTIONAL DESCRIPTION

VCO part

The VCO requires one external capacitor (C1) and one or two external resistors (R1 or R1 and R2). Resistor R1 and capacitor C1 determine the frequency range of the VCO. Resistor R2 enables the VCO to have a frequency off-set if required. The high input impedance of the VCO simplifies the design of low-pass filters; it permits the designer a wide choice of resistor/capacitor ranges. In order not to load the low-pass filter, a source-follower output of the VCO input voltage is provided at pin 10. If this pin (SF_{OUT}) is used, a load resistor (R_{SF}) should be connected from this pin to V_{SS} ; if unused, this pin should be left open. The VCO output (pin 4) can either be connected directly to the comparator input (pin 3) or via a frequency divider. A LOW level at the inhibit input (pin 5) enables the VCO and the source follower, while a HIGH level turns off both to minimize stand-by power consumption.

Phase comparators

The phase-comparator signal input (pin 14) can be direct-coupled, provided the signal swing is between the standard HE4000B family input logic levels. The signal must be capacitively coupled to the self-biasing amplifier at the signal input in case of smaller swings. Phase comparator 1 is an EXCLUSIVE-OR network. The signal and comparator input frequencies must have a 50% duty factor to obtain the maximum lock range. The average output voltage of the phase comparator is equal to $\frac{1}{2} V_{DD}$ when there is no signal or noise at the signal input. The average voltage to the VCO input is supplied by the low-pass filter connected to the output of phase comparator 1. This also causes the VCO to oscillate at the centre frequency (f_0). The frequency capture range ($2 f_c$) is defined as the frequency range of input signals on which the PLL will lock if it was initially out of lock. The frequency lock range ($2 f_L$) is defined as the frequency range of input signals on which the loop will stay locked if it was initially in lock. The capture range is smaller or equal to the lock range.

With phase comparator 1, the range of frequencies over which the PLL can acquire lock (capture range) depends on the low-pass filter characteristics and this range can be made as large as the lock range. Phase comparator 1 enables the PLL system to remain in lock in spite of high amounts of noise in the input signal. A typical behaviour of this type of phase comparator is that it may lock onto input

frequencies that are close to harmonics of the VCO centre frequency. Another typical behaviour is, that the phase angle between the signal and comparator input varies between 0° and 180° and is 90° at the centre frequency. Figure 3 shows the typical phase-to-output response characteristic.

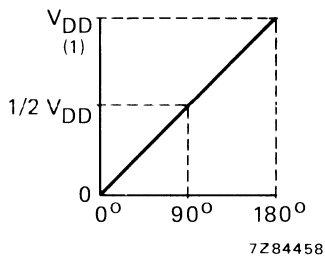

(1) Average output voltage.

Fig. 3 Signal-to-comparator inputs phase difference for comparator 1.

Figure 4 shows the typical waveforms for a PLL employing phase comparator 1 in locked condition of f_0 .

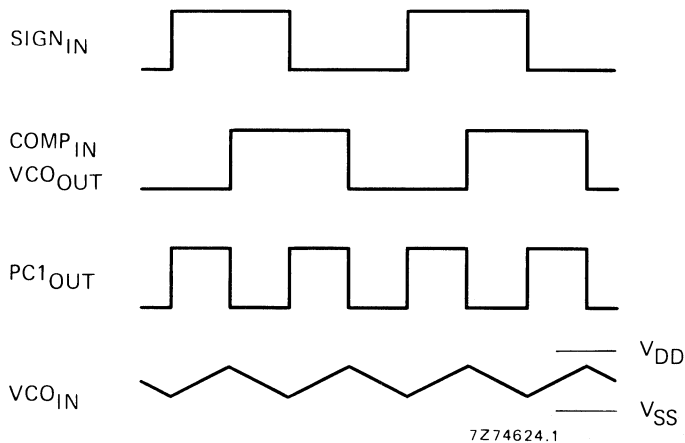

Fig. 4 Typical waveforms for phase-locked loop employing phase comparator 1 in locked condition of f_0 .

FUNCTIONAL DESCRIPTION (continued)

Phase comparator 2 is an edge-controlled digital memory network. It consists of four flip-flops, control gating and a 3-state output circuit comprising p and n-type drivers having a common output node. When the p-type or n-type drivers are ON, they pull the output up to V_{DD} or down to V_{SS} respectively. This type of phase comparator only acts on the positive-going edges of the signals at $SIGN_{IN}$ and $COMP_{IN}$. Therefore, the duty factors of these signals are not of importance.

If the signal input frequency is higher than the comparator input frequency, the p-type output driver is maintained ON most of the time, and both the n and p-type drivers are OFF (3-state) the remainder of the time. If the signal input frequency is lower than the comparator input frequency, the n-type output driver is maintained ON most of the time, and both the n and p-type drivers are OFF the remainder of the time. If the signal input and comparator input frequencies are equal, but the signal input lags the comparator input in phase, the n-type output driver is maintained ON for a time corresponding to the phase difference. If the comparator input lags the signal input in phase, the p-type output driver is maintained ON for a time corresponding to the phase difference. Subsequently, the voltage at the capacitor of the low-pass filter connected to this phase comparator is adjusted until the signal and comparator inputs are equal in both phase and frequency. At this stable point, both p and n-type drivers remain OFF and thus the phase comparator output becomes an open circuit and keeps the voltage at the capacitor of the low-pass filter constant.

Moreover, the signal at the phase comparator pulse output (PCP_{OUT}) is a HIGH level which can be used for indicating a locked condition. Thus, for phase comparator 2 no phase difference exists between the signal and comparator inputs over the full VCO frequency range. Moreover, the power dissipation due to the low-pass filter is reduced when this type of phase comparator is used because both p and n-type output drivers are OFF for most of the signal input cycle. It should be noted that the PLL lock range for this type of phase comparator is equal to the capture range, independent of the low-pass filter. With no signal present at the signal input, the VCO is adjusted to its lowest frequency for phase comparator 2. Figure 5 shows typical waveforms for a PLL employing this type of phase comparator in locked condition.

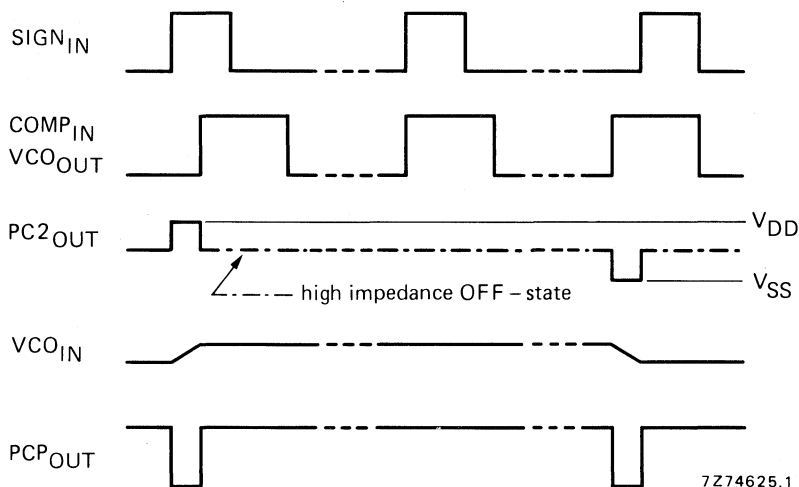
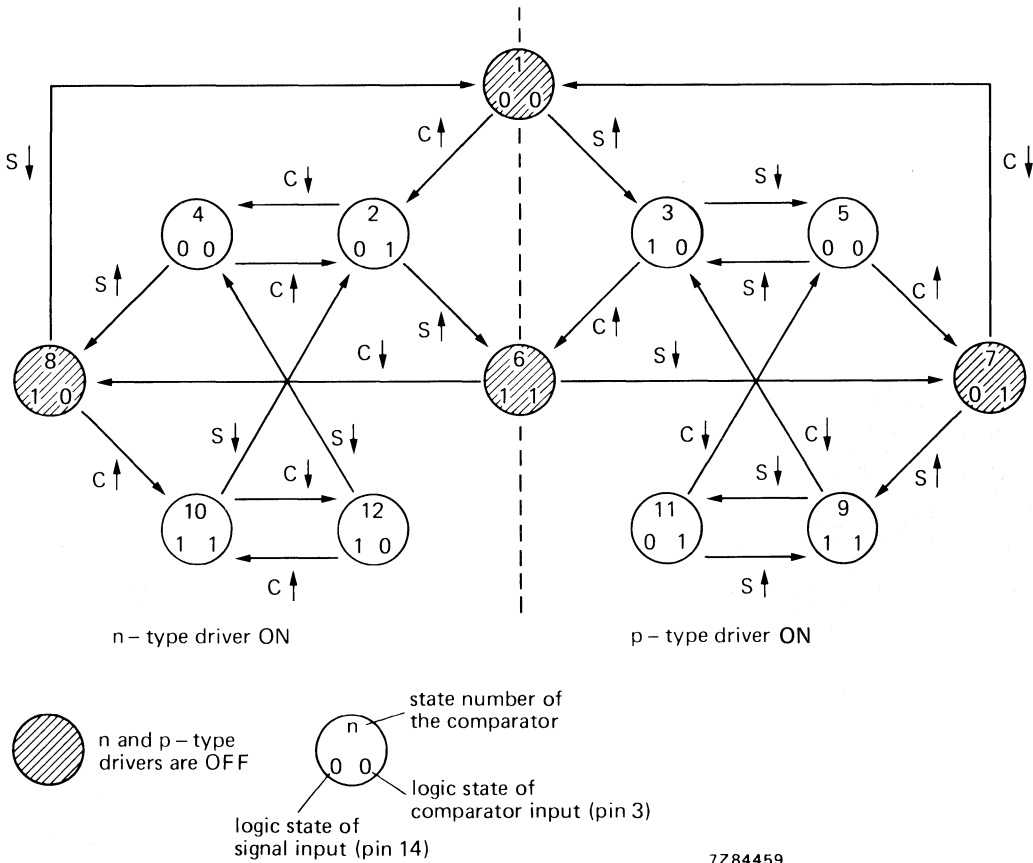

Fig. 5 Typical waveforms for phase-locked loop employing phase comparator 2 in locked condition.

Figure 6 shows the state diagram for phase comparator 2. Each circle represents a state of the comparator. The number at the top, inside each circle, represents the state of the comparator, while the logic state of the signal and comparator inputs are represented by a '0' for a logic LOW or a '1' for a logic HIGH, and they are shown in the left and right bottom of each circle.

The transitions from one to another result from either a logic change at the signal input (S) or the comparator input (C). A positive-going and a negative-going transition are shown by an arrow pointing up or down respectively.

The state diagram assumes, that only one transition on either the signal input or comparator input occurs at any instant. States 3, 5, 9 and 11 represent the condition at the output when the p-type driver is ON, while states 2, 4, 10 and 12 determine the condition when the n-type driver is ON. States 1, 6, 7 and 8 represent the condition when the output is in its high impedance OFF state; i.e. both p and n-type drivers are OFF, and the PCP_{OUT} output is HIGH. The condition at output PCP_{OUT} for all other states is LOW.



S ↑ : 0 to 1 transition at the signal input.
 C ↓ : 1 to 0 transition at the comparator input.

Fig. 6 State diagram for comparator 2.

D.C. CHARACTERISTICS

$V_{SS} = 0\text{ V}$

| | V_{DD} V | symbol | T_{amb} (°C) | | | | | | |
|--------------------------------------|---------------|----------|----------------|------|------|------|------|------|---------------|
| | | | -40 | | +25 | | +85 | | |
| | | | typ. | max. | typ. | max. | typ. | max. | |
| Supply current (note 1) | 5 | I_D | - | - | 20 | - | - | - | μA |
| | 10 | | - | - | 300 | - | - | - | μA |
| | 15 | | - | - | 750 | - | - | - | μA |
| Quiescent device current (note 2) | 5 | I_{DD} | - | 20 | - | 20 | - | 150 | μA |
| | 10 | | - | 40 | - | 40 | - | 300 | μA |
| | 15 | | - | 80 | - | 80 | - | 600 | μA |

Notes

- Pin 15 open; pin 5 at V_{DD} ; pins 3 and 9 at V_{SS} ; pin 14 open.
- Pin 15 open; pin 5 at V_{DD} ; pins 3 and 9 at V_{SS} ; pin 14 at V_{DD} ; input current pin 14 not included.

A.C. CHARACTERISTICS

$V_{SS} = 0\text{ V}$; $T_{amb} = 25\text{ °C}$; $C_L = 50\text{ pF}$; input transition times $\leq 20\text{ ns}$

| | V_{DD} V | symbol | min. | typ. | max. | |
|--|---------------|-----------|------|------|------------------|--|
| Phase comparators | | | | | | |
| Operating supply voltage | | V_{DD} | 3 | | 15 V | |
| Input resistance at $SIGN_{IN}$ | 5 | R_{IN} | | 750 | $\text{k}\Omega$ | } at self-bias operating point |
| | 10 | | | 220 | $\text{k}\Omega$ | |
| | 15 | | | 140 | $\text{k}\Omega$ | |
| A.C. coupled input sensitivity at $SIGN_{IN}$ | 5 | V_{IN} | | 150 | mV | } peak-to-peak values; $R_1 = 10\text{ k}\Omega$; $R_2 = \infty$; $C_1 = 100\text{ pF}$; independent of the lock range |
| | 10 | | | 150 | mV | |
| | 15 | | | 200 | mV | |
| D.C. coupled input sensitivity at $SIGN_{IN}$; $COMP_{IN}$ LOW level | 5 | V_{IL} | | | 1,5 V | } full temperature range |
| | 10 | | | | 3,0 V | |
| | 15 | | | | 4,0 V | |
| HIGH level | 5 | V_{IH} | 3,5 | | V | } |
| | 10 | | 7,0 | | V | |
| | 15 | | 11,0 | | V | |
| Input current at $SIGN_{IN}$ | 5 | $+I_{IN}$ | | 7 | μA | } $SIGN_{IN}$ at V_{DD} |
| | 10 | | | 30 | μA | |
| | 15 | | | 70 | μA | |
| | 5 | $-I_{IN}$ | | 3 | μA | } $SIGN_{IN}$ at V_{SS} |
| | 10 | | | 18 | μA | |
| | 15 | | | 45 | μA | |

A.C. CHARACTERISTICS $V_{SS} = 0\text{ V}$; $T_{amb} = 25\text{ }^{\circ}\text{C}$; $C_L = 50\text{ pF}$; input transition times $\leq 20\text{ ns}$

| | V_{DD} V | symbol | min. | typ. | max. | |
|--|---------------|-----------|-------------------|-------------------------------------|---|--|
| VCO | | | | | | |
| Operating supply voltage | | V_{DD} | 3 5 | | 15 15 | V V as fixed oscillator only phase-locked loop operation |
| Power dissipation | 5 10 15 | P | | 150 2500 9000 | μW μW μW | $f_o = 10\text{ kHz}$; $R_1 = 1\text{ M}\Omega$; $R_2 = \infty$; V_{COIN} at $\frac{1}{2} V_{DD}$; see also Figs 10 and 11 |
| Maximum operating frequency | 5 10 15 | f_{max} | 0,5 1,0 1,3 | 1,0 2,0 2,7 | MHz MHz MHz | V_{COIN} at V_{DD} ; $R_1 = 10\text{ k}\Omega$; $R_2 = \infty$; $C_1 = 50\text{ pF}$ |
| Temperature/frequency stability | 5 10 15 | | | 0,22–0,30 0,04–0,05 0,01–0,05 | %/ $^{\circ}\text{C}$ %/ $^{\circ}\text{C}$ %/ $^{\circ}\text{C}$ | no frequency offset ($f_{min} = 0$); see also note 1 |
| | 5 10 15 | | | 0–0,22 0–0,04 0–0,01 | %/ $^{\circ}\text{C}$ %/ $^{\circ}\text{C}$ %/ $^{\circ}\text{C}$ | with frequency offset ($f_{min} > 0$); see also note 1 |
| Linearity | 5 10 15 | | | 0,50 0,25 0,25 | % % % | $R_1 > 10\text{ k}\Omega$ $R_1 > 400\text{ k}\Omega$ $R_1 = 1\text{ M}\Omega$ } see Fig. 13 and Figs 14 15 and 16 |
| Duty factor at V_{COOUT} | 5 10 15 | δ | | 50 50 50 | % % % | |
| Input resistance at V_{COIN} | 5 10 15 | R_{IN} | | 10^6 10^6 10^6 | $\text{M}\Omega$ $\text{M}\Omega$ $\text{M}\Omega$ | |
| Source follower | | | | | | |
| Offset voltage V_{COIN} minus S_{FOUT} | 5 10 15 | | | 1,7 2,0 2,1 | V V V | $R_{SF} = 10\text{ k}\Omega$; V_{COIN} at $\frac{1}{2} V_{DD}$ |
| | 5 10 15 | | | 1,5 1,7 1,8 | V V V | $R_{SF} = 50\text{ k}\Omega$; V_{COIN} at $\frac{1}{2} V_{DD}$ |
| Linearity | 5 10 15 | | | 0,3 1,0 1,3 | % % % | $R_{SF} > 50\text{ k}\Omega$; see Fig. 13 |
| Zener diode | | | | | | |
| Zener voltage | | V_Z | | 7,3 | V | $I_Z = 50\text{ }\mu\text{A}$ |
| Dynamic resistance | | R_Z | | 25 | Ω | $I_Z = 1\text{ mA}$ |

Notes

- Over the recommended component range.

DESIGN INFORMATION

| characteristic | using phase comparator 1 | using phase comparator 2 |
|---|--|---|
| No signal on $SIGN_{IN}$ | VCO in PLL system adjusts to centre frequency (f_0) | VCO in PLL system adjusts to min. frequency (f_{min}) |
| Phase angle between $SIGN_{IN}$ and $COMP_{IN}$ | 90° at centre frequency (f_0), approaching 0° and 180° at ends of lock range ($2 f_L$) | always 0° in lock (positive-going edges) |
| Locks on harmonics of centre frequency | yes | no |
| Signal input noise rejection | high | low |
| Lock frequency range ($2 f_L$) | the frequency range of the input signal on which the loop will stay locked if it was initially in lock; $2 f_L$ = full VCO frequency range = $f_{max} - f_{min}$ | |
| Capture frequency range ($2 f_C$) | the frequency range of the input signal on which the loop will lock if it was initially out of lock depends on low-pass filter characteristics; $f_C < f_L$ $f_C = f_L$ | |
| Centre frequency (f_0) | the frequency of the VCO when VCO_{IN} at $\frac{1}{2}V_{DD}$ | |

VCO component selection

Recommended range for R1 and R2: 10 k Ω to 1 M Ω ; for C1: 50 pF to any practical value.

1. VCO without frequency offset ($R2 = \infty$).

- Given f_0 : use f_0 with Fig. 7 to determine R1 and C1.
- Given f_{max} : calculate f_0 from $f_0 = \frac{1}{2} f_{max}$; use f_0 with Fig. 7 to determine R1 and C1.

2. VCO with frequency offset.

- Given f_0 and f_L : calculate f_{min} from the equation $f_{min} = f_0 - f_L$; use f_{min} with Fig. 8 to determine R2 and C1; calculate

$$\frac{f_{max}}{f_{min}} \text{ from the equation } \frac{f_{max}}{f_{min}} = \frac{f_0 + f_L}{f_0 - f_L}; \text{ use } \frac{f_{max}}{f_{min}} \text{ with Fig. 9 to determine the ratio } R2/R1 \text{ to}$$

obtain R1.

- Given f_{min} and f_{max} : use f_{min} with Fig. 8 to determine R2 and C1; calculate $\frac{f_{max}}{f_{min}}$; use $\frac{f_{max}}{f_{min}}$

with Fig. 9 to determine R2/R1 to obtain R1.

728462

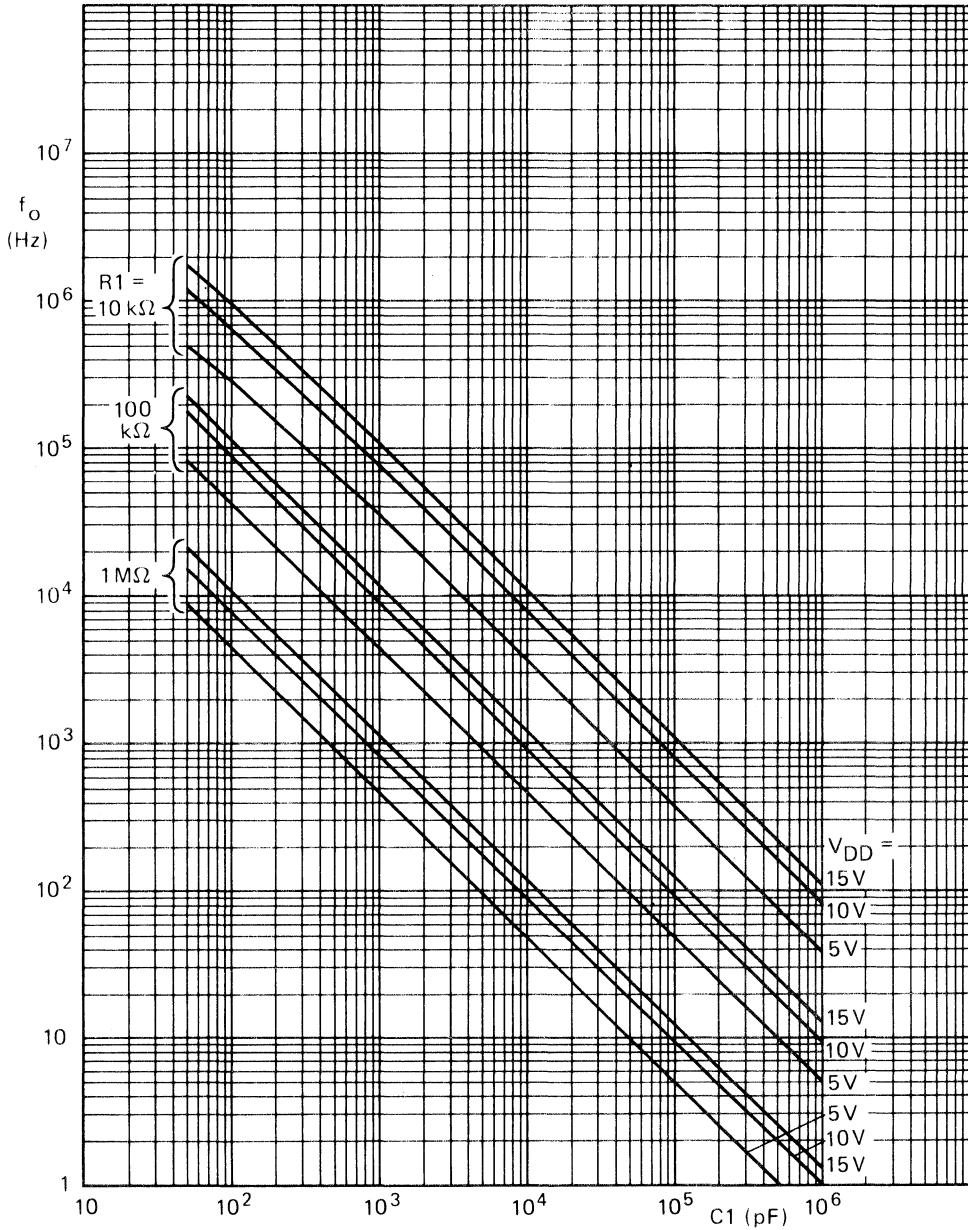

Fig. 7 Typical centre frequency as a function of capacitor C_1 ; $T_{amb} = 25\text{ }^\circ\text{C}$; $V_{CO\text{IN}}$ at $\frac{1}{2} V_{DD}$; INH at V_{SS} ; $R_2 = \infty$.

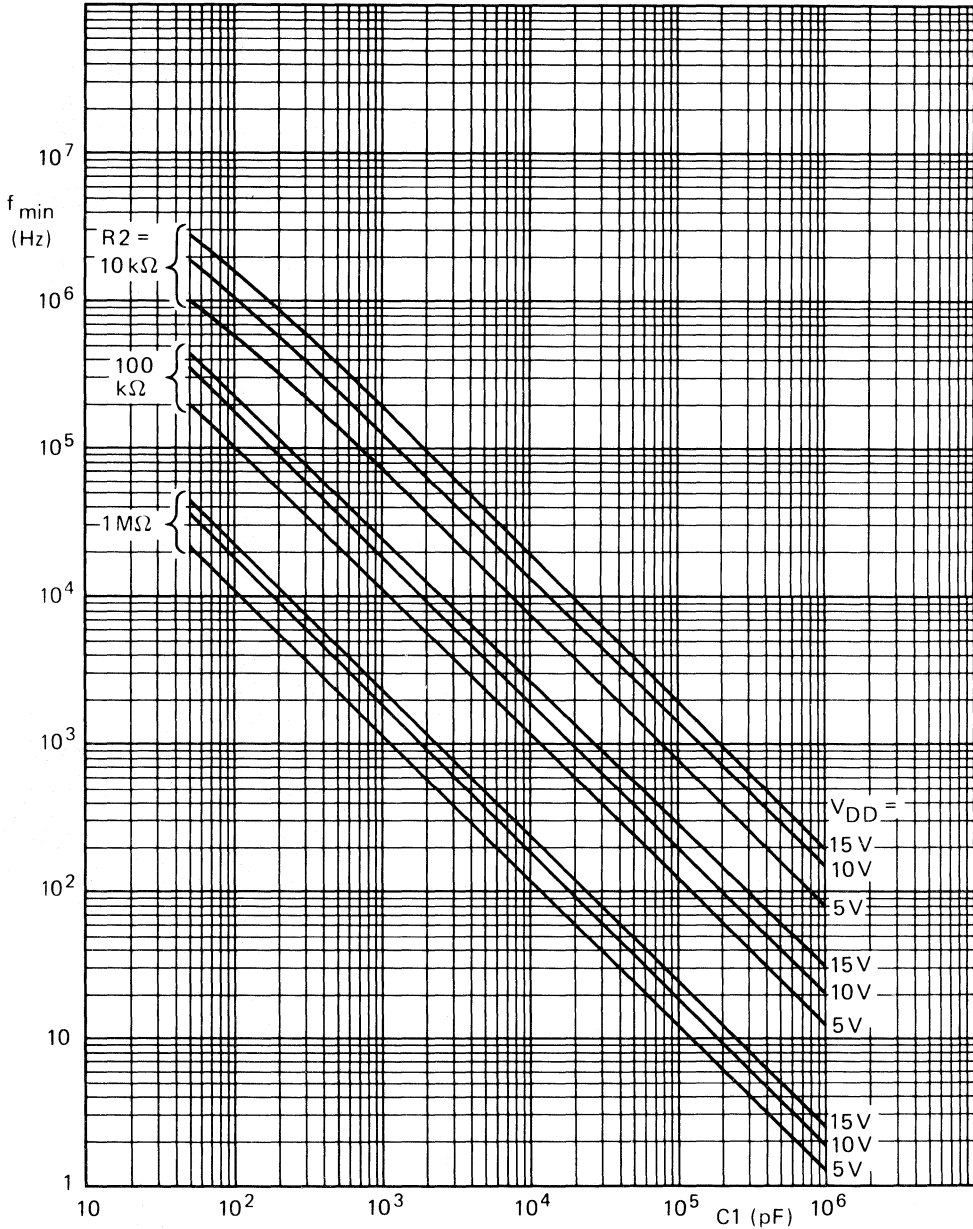

Fig. 8 Typical frequency offset as a function of capacitor $C1$; $T_{amb} = 25\text{ }^\circ\text{C}$; V_{COIN} at V_{SS} ; INH at V_{SS} ; $R1 = \infty$.

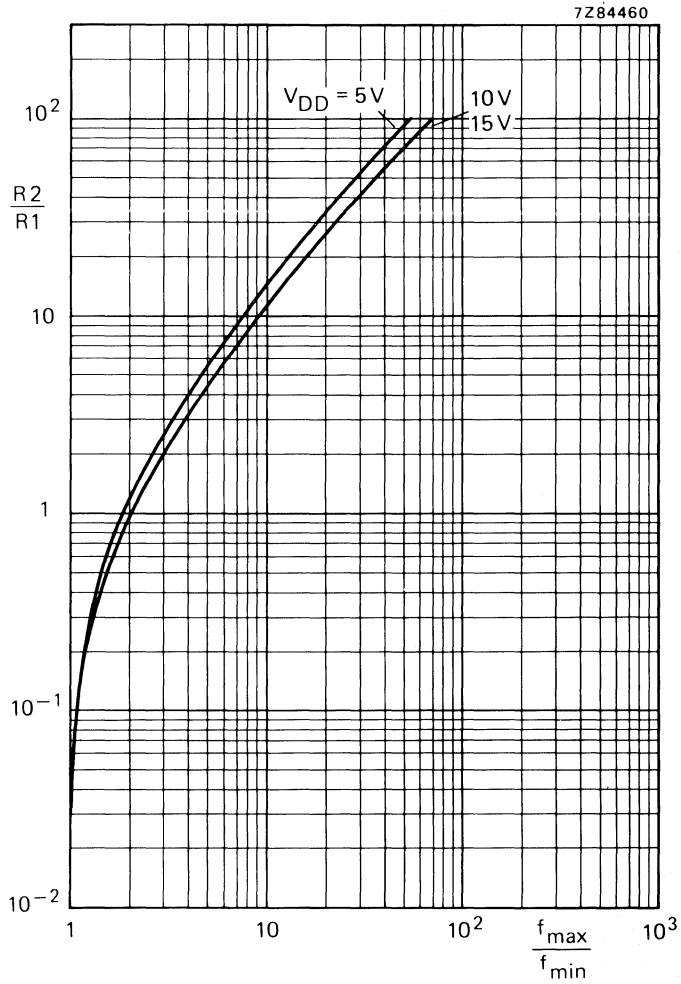

Fig. 9 Typical ratio of R2/R1 as a function of the ratio f_{\max}/f_{\min} .

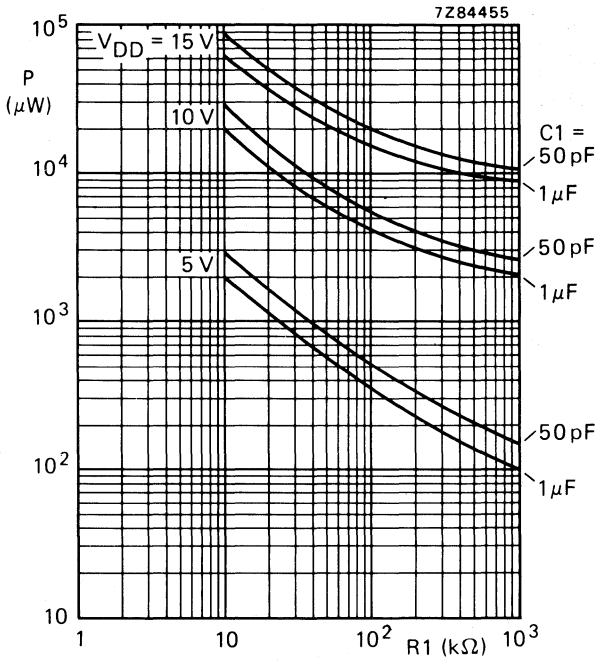

Fig. 10 Power dissipation as a function of R1; R2 = ∞ ; VCO_{IN} at $\frac{1}{2}$ V_{DD}; C_L = 50 pF.

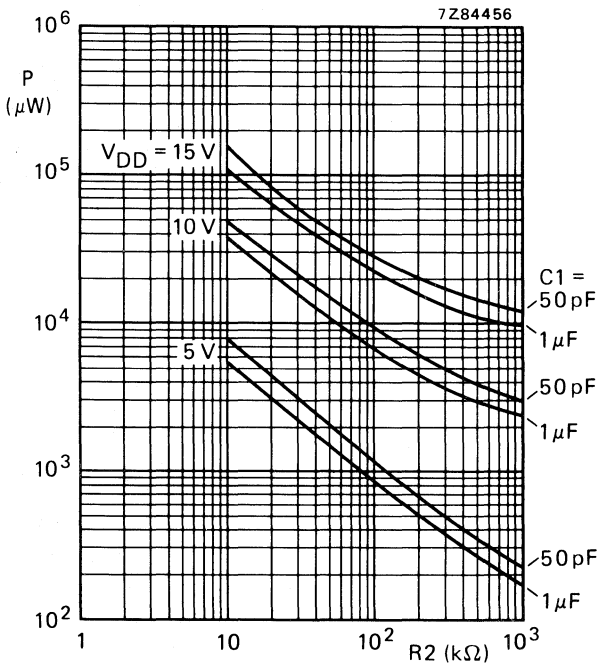

Fig. 11 Power dissipation as a function of R2; R1 = ∞ ; VCO_{IN} at V_{SS} (0 V); C_L = 50 pF.

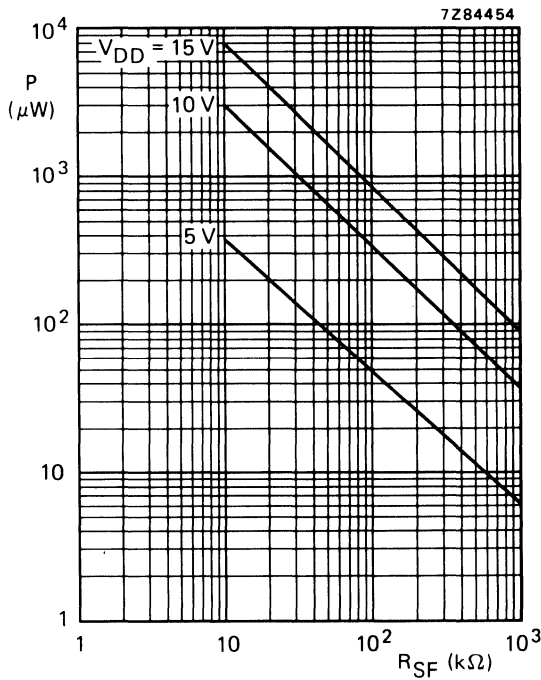

Fig. 12 Power dissipation of source follower as a function of R_{SF} ; VCO_{IN} at $\frac{1}{2} V_{DD}$; $R1 = \infty$; $R2 = \infty$.

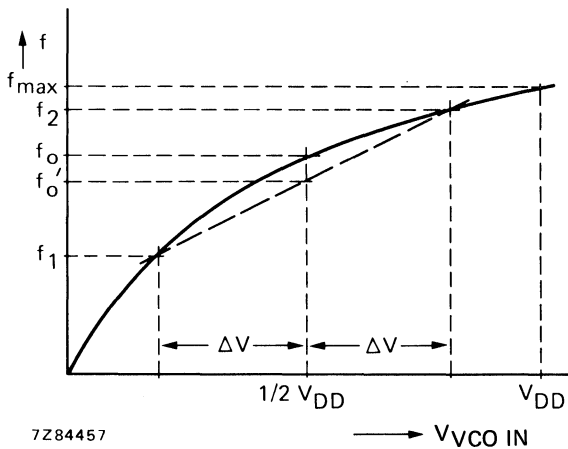

Fig. 13 Definition of linearity (see a.c. characteristics).

For VCO linearity:

$$f'_0 = \frac{f_1 + f_2}{2}$$

$$\text{lin.} = \frac{f'_0 - f_0}{f'_0} \times 100\%$$

Figure 13 and the above formula also apply to source follower linearity: substitute $V_{SF OUT}$ for f .

$\Delta V = 0,3 V$ at $V_{DD} = 5 V$

$\Delta V = 2,5 V$ at $V_{DD} = 10 V$

$\Delta V = 5 V$ at $V_{DD} = 15 V$

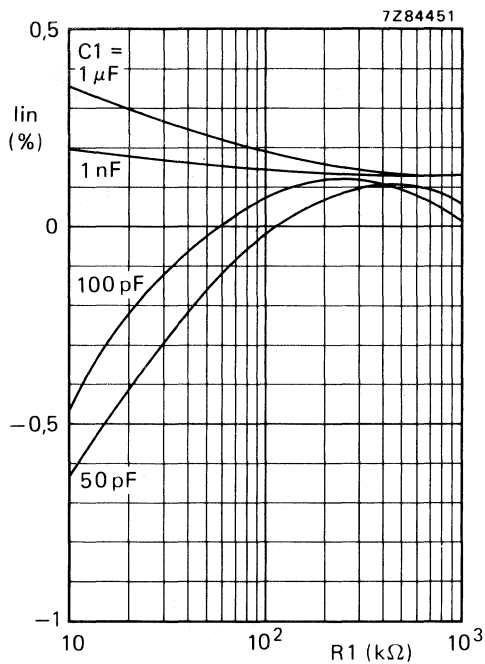

Fig. 14 VCO frequency linearity as a function of R1; R2 = ∞; V_{DD} = 5 V.

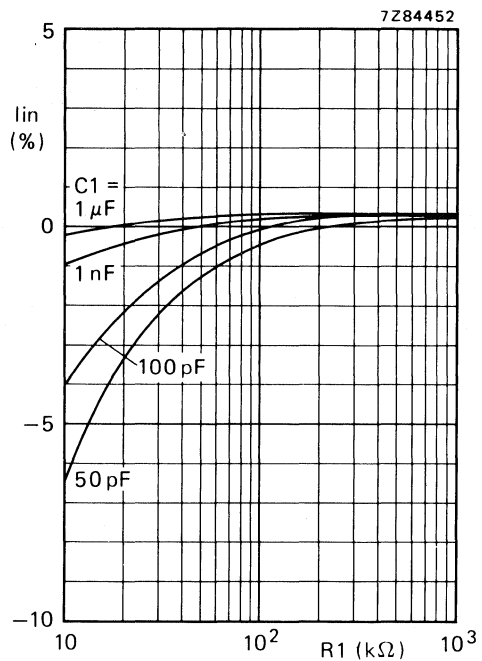

Fig. 15 VCO frequency linearity as a function of R1; R2 = ∞; V_{DD} = 10 V.

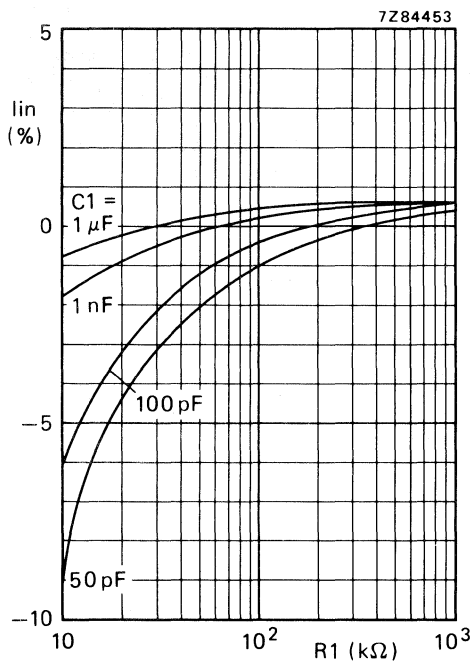

Fig. 16 VCO frequency linearity as a function of R1; R2 = ∞; V_{DD} = 15 V.

MONOSTABLE/ASTABLE MULTIVIBRATOR



The HEF4047B consists of a gatable astable multivibrator with logic techniques incorporated to permit positive or negative edge-triggered monostable multivibrator action with retriggering and external counting options.

Inputs include + TRIGGER, - TRIGGER, ASTABLE, $\overline{\text{ASTABLE}}$, RETRIGGER and MR (Master Reset). Buffered outputs are O, $\overline{\text{O}}$ and OSCILLATOR OUTPUT. In all modes of operation an external capacitor (C_t) must be connected between C_{TC} and R_{TC} , and an external resistor (R_t) must be connected between R_{TC} and R_{TC} (continued on next page).

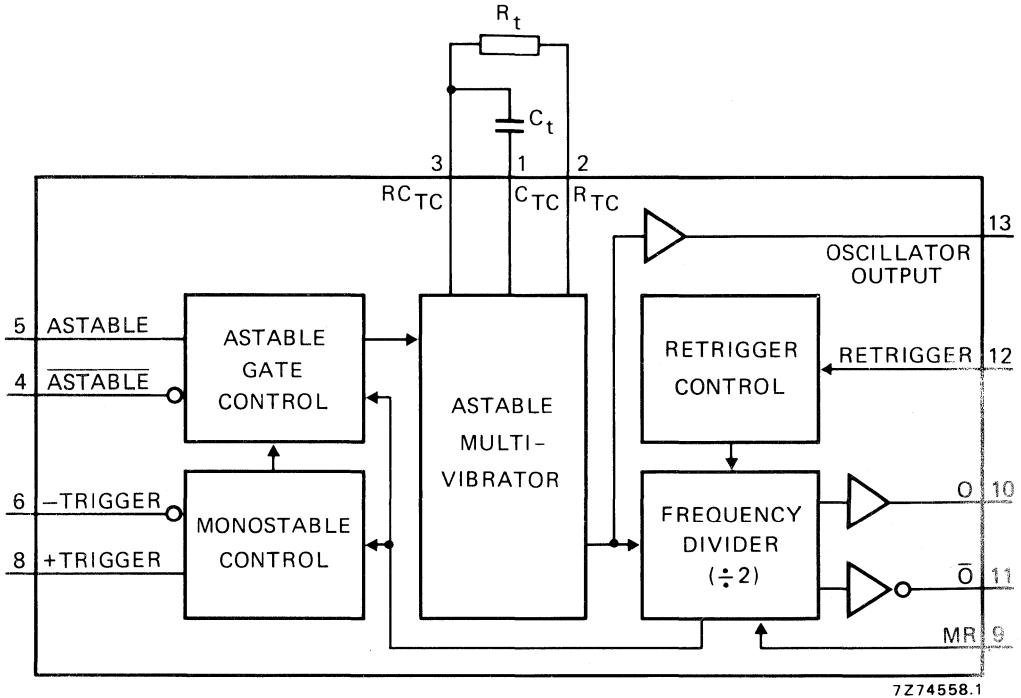

Fig. 1 Functional diagram.

FAMILY DATA

I_{DD} LIMITS category MSI

} see Family Specifications

HEF4047B

MSI

Astable operation is enabled by a HIGH level on the ASTABLE input. The period of the square wave at O and \bar{O} outputs is a function of the external components employed. 'True' input pulses on the ASTABLE or 'complement' pulses on the $\bar{ASTABLE}$ input, allow the circuit to be used as a gatable multivibrator. The OSCILLATOR OUTPUT period will be half of the O output in the astable mode. However, a 50% duty factor is not guaranteed at this output.

In the monostable mode, positive edge-triggering is accomplished by applying a leading-edge pulse to the + TRIGGER input and a LOW level to the - TRIGGER input. For negative edge-triggering, a trailing-edge pulse is applied to the - TRIGGER and a HIGH level to the + TRIGGER. Input pulses may be of any duration relative to the output pulse. The multivibrator can be retriggered (on the leading-edge only) by applying a common pulse to both the RETRIGGER and + TRIGGER inputs. In this mode the output pulse remains HIGH as long as the input pulse period is shorter than the period determined by the RC components.

An external count down option can be implemented by coupling O to an external 'N' counter and resetting the counter with the trigger pulse. The counter output pulse is fed back to the $\bar{ASTABLE}$ input and has a duration equal to N times the period of the multivibrator. A HIGH level on the MR input assures no output pulse during an ON-power condition. This input can also be activated to terminate the output pulse at any time. In the monostable mode, a HIGH level or power-ON reset pulse must be applied to MR, whenever V_{DD} is applied.

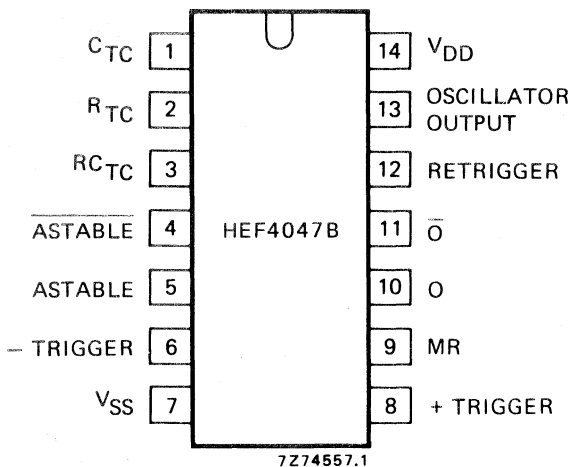
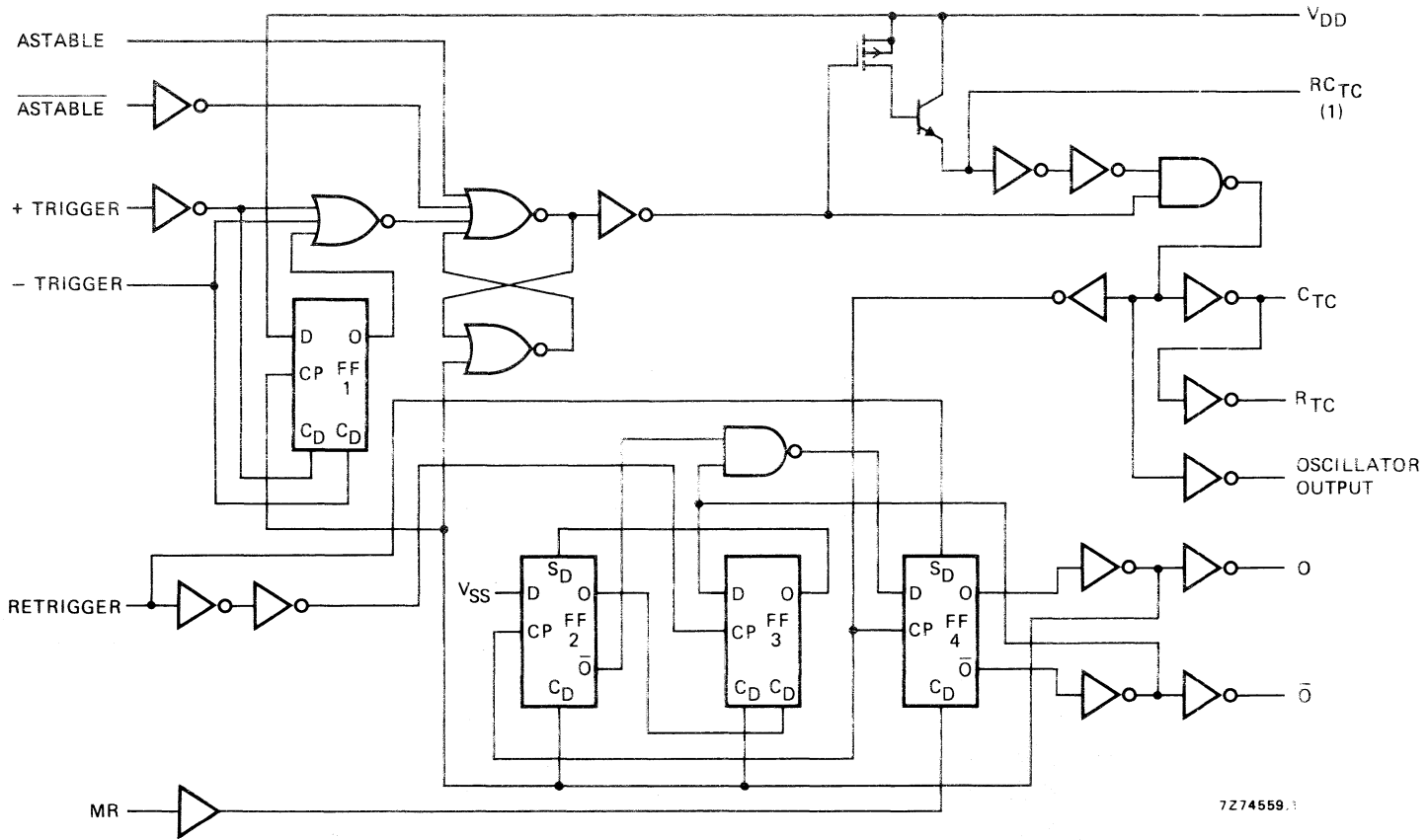

Fig. 2 Pinning diagram.

HEF4047BP : 14-lead DIL; plastic (SOT-27K, M, T).

HEF4047BD: 14-lead DIL; ceramic (cerdip) (SOT-73).

HEF4047BT: 14-lead mini-pack; plastic (SO-14; SOT-108A).



(1) Special input protection that allows operating input voltages outside the supply voltage lines. Compared to the standard input protection pin 3 is more sensitive to static discharge; extra handling precautions are recommended.

Fig. 3 Logic diagram.

FUNCTIONAL CONNECTIONS

| function | pins connected to | | | output pulse from pins | output period or pulse width |
|---------------------------------|-------------------|-------------------|-------------|------------------------|---|
| | V _{DD} | V _{SS} | input pulse | | |
| astable multivibrator | | | | | |
| free running | 4, 5, 6, 14 | 7, 8, 9, 12 | — | 10, 11, 13 | at pins 10, 11: t _A = 4,40 R _t C _t at pin 13: t _A = 2,20 R _t C _t |
| true gating | 4, 6, 14 | 7, 8, 9, 12 | 5 | 10, 11, 13 | |
| complement gating | 6, 14 | 5, 7, 8, 9, 12 | 4 | 10, 11, 13 | |
| monostable multivibrator | | | | | |
| pos. edge-triggering | 4, 14 | 5, 6, 7, 9, 12 | 8 | 10, 11 | at pins 10, 11: t _M = 2,48 R _t C _t |
| neg. edge-triggering | 4, 8, 14 | 5, 7, 9, 12 | 6 | 10, 11 | |
| retriggerable | 4, 14 | 5, 6, 7, 9 | 8, 12 | 10, 11 | |
| external count down* | 14 | 5, 6, 7, 8, 9, 12 | — | 10, 11 | |

* Input pulse to RESET of external counting chip; external counting chip output to pin 4.

Note

In all cases, external resistor between pins 2 and 3, external capacitor between pins 1 and 3.

D.C. CHARACTERISTICS

V_{SS} = 0 V; inputs at V_{SS} or V_{DD}

| | V _{DD} V | symbol | T _{amb} (°C) | | | | |
|--|----------------------|----------------|-----------------------|-------------|-------------|-------------|--|
| | | | -40 max. | +25 min. | +85 max. | +85 max. | |
| Leakage current pin 3; output transistor OFF | 15 | I ₃ | 0,3 | — | 0,3 | 1 μA | pin 3 at V _{DD} or V _{SS} |

A.C. CHARACTERISTICS

 $V_{SS} = 0\text{ V}$; $T_{amb} = 25\text{ }^{\circ}\text{C}$; $C_L = 50\text{ pF}$; input transition times $\leq 20\text{ ns}$

| | V_{DD} V | symbol | min. typ. max. | typical extrapolation formula |
|--|---------------|-----------|----------------|---|
| Propagation delays | | | | |
| ASTABLE, $\overline{\text{ASTABLE}}$ | | | | |
| → OSC. OUTPUT | 5 | | 95 190 | $68\text{ ns} + (0,55\text{ ns/pF}) C_L$ |
| HIGH to LOW | 10 | t_{PHL} | 45 90 | $43\text{ ns} + (0,23\text{ ns/pF}) C_L$ |
| | 15 | | 30 60 | $22\text{ ns} + (0,16\text{ ns/pF}) C_L$ |
| LOW to HIGH | 5 | | 85 170 | $58\text{ ns} + (0,55\text{ ns/pF}) C_L$ |
| | 10 | t_{PLH} | 40 80 | $29\text{ ns} + (0,23\text{ ns/pF}) C_L$ |
| | 15 | | 30 60 | $22\text{ ns} + (0,16\text{ ns/pF}) C_L$ |
| ASTABLE, $\overline{\text{ASTABLE}}$ | | | | |
| → O, $\overline{\text{O}}$ | 5 | | 150 300 | $123\text{ ns} + (0,55\text{ ns/pF}) C_L$ |
| HIGH to LOW | 10 | t_{PHL} | 65 130 | $54\text{ ns} + (0,23\text{ ns/pF}) C_L$ |
| | 15 | | 50 100 | $42\text{ ns} + (0,16\text{ ns/pF}) C_L$ |
| LOW to HIGH | 5 | | 130 260 | $103\text{ ns} + (0,55\text{ ns/pF}) C_L$ |
| | 10 | t_{PLH} | 60 120 | $49\text{ ns} + (0,23\text{ ns/pF}) C_L$ |
| | 15 | | 45 90 | $37\text{ ns} + (0,16\text{ ns/pF}) C_L$ |
| +/- TRIGGER | | | | |
| → O, $\overline{\text{O}}$ | 5 | | 160 320 | $133\text{ ns} + (0,55\text{ ns/pF}) C_L$ |
| HIGH to LOW | 10 | t_{PHL} | 65 130 | $54\text{ ns} + (0,23\text{ ns/pF}) C_L$ |
| | 15 | | 50 100 | $42\text{ ns} + (0,16\text{ ns/pF}) C_L$ |
| LOW to HIGH | 5 | | 155 310 | $128\text{ ns} + (0,55\text{ ns/pF}) C_L$ |
| | 10 | t_{PLH} | 65 130 | $54\text{ ns} + (0,23\text{ ns/pF}) C_L$ |
| | 15 | | 50 100 | $42\text{ ns} + (0,16\text{ ns/pF}) C_L$ |
| + TRIGGER, RETRIGGER → $\overline{\text{O}}$ | | | | |
| HIGH to LOW | 5 | | 65 130 | $38\text{ ns} + (0,55\text{ ns/pF}) C_L$ |
| | 10 | t_{PHL} | 30 60 | $19\text{ ns} + (0,23\text{ ns/pF}) C_L$ |
| | 15 | | 25 50 | $17\text{ ns} + (0,16\text{ ns/pF}) C_L$ |
| + TRIGGER, RETRIGGER → O | | | | |
| LOW to HIGH | 5 | | 95 190 | $68\text{ ns} + (0,55\text{ ns/pF}) C_L$ |
| | 10 | t_{PLH} | 40 80 | $29\text{ ns} + (0,23\text{ ns/pF}) C_L$ |
| | 15 | | 30 60 | $22\text{ ns} + (0,16\text{ ns/pF}) C_L$ |
| MR → O | | | | |
| HIGH to LOW | 5 | | 100 200 | $83\text{ ns} + (0,55\text{ ns/pF}) C_L$ |
| | 10 | t_{PHL} | 45 90 | $34\text{ ns} + (0,23\text{ ns/pF}) C_L$ |
| | 15 | | 35 70 | $27\text{ ns} + (0,16\text{ ns/pF}) C_L$ |
| MR → $\overline{\text{O}}$ | | | | |
| LOW to HIGH | 5 | | 100 200 | $83\text{ ns} + (0,55\text{ ns/pF}) C_L$ |
| | 10 | t_{PLH} | 45 90 | $34\text{ ns} + (0,23\text{ ns/pF}) C_L$ |
| | 15 | | 35 70 | $27\text{ ns} + (0,16\text{ ns/pF}) C_L$ |

A.C. CHARACTERISTICS (continued)

 $V_{SS} = 0\text{ V}$; $T_{amb} = 25\text{ }^{\circ}\text{C}$; $C_L = 50\text{ pF}$; input transition times $\leq 20\text{ ns}$

| | V_{DD} V | symbol | min. | typ. | max. | typical extrapolation formula | |
|--|---------------|------------|------|------|------|----------------------------------|---|
| Output transition times HIGH to LOW | 5 | t_{THL} | | 60 | 120 | ns | $10\text{ ns} + (1,0\text{ ns/pF}) C_L$ $9\text{ ns} + (0,42\text{ ns/pF}) C_L$ $6\text{ ns} + (0,28\text{ ns/pF}) C_L$ |
| | 10 | | 30 | 60 | ns | | |
| | 15 | | 20 | 40 | ns | | |
| LOW to HIGH | 5 | t_{TLH} | | 60 | 120 | ns | $10\text{ ns} + (1,0\text{ ns/pF}) C_L$ $9\text{ ns} + (0,42\text{ ns/pF}) C_L$ $6\text{ ns} + (0,28\text{ ns/pF}) C_L$ |
| | 10 | | 30 | 60 | ns | | |
| | 15 | | 20 | 40 | ns | | |
| Minimum MR pulse width; HIGH | 5 | t_{WMRH} | 60 | 30 | | ns | |
| | 10 | | 30 | 15 | | ns | |
| | 15 | | 20 | 10 | | ns | |
| Minimum input pulse width; any input except MR | 5 | t_W | 220 | 110 | | ns | |
| | 10 | | 100 | 50 | | ns | |
| | 15 | | 70 | 35 | | ns | |

APPLICATION INFORMATION

General features:

- Monostable (one-shot) or astable (free-running) operation
- True and complemented buffered outputs
- Only one external R and C required

Monostable multivibrator features:

- Positive- or negative-edge triggering
- Output pulse width independent of trigger pulse duration
- Retriggerable option for pulse-width expansion
- Long pulse width possible using small RC components by means of external counter provision
- Fast recovery time essentially independent of pulse width
- Pulse-width accuracy maintained at duty cycles approaching 100%

Astable multivibrator features:

- Free-running or gatable operating modes
- 50% duty cycle
- Oscillator output available

1. Astable mode design information

a. Unit-to-unit transfer-voltage variations

The following analysis presents worst-case variations from unit-to-unit as a function of transfer-voltage (V_{TR}) shift for free running (astable) operation.

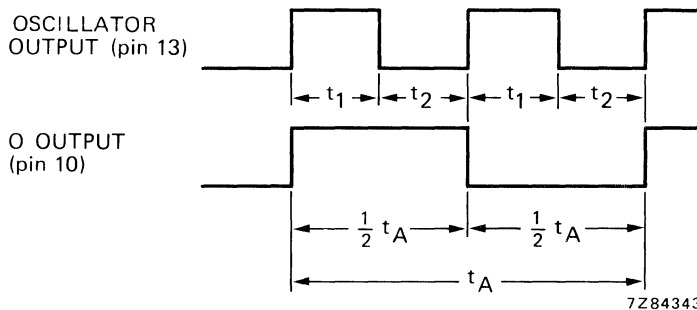

Fig. 4 Astable mode waveforms.

$$t_1 = -R_t C_t \ln \frac{V_{TR}}{V_{DD} + V_{TR}}$$

$$t_2 = -R_t C_t \ln \frac{V_{DD} - V_{TR}}{2V_{DD} - V_{TR}}$$

$$t_A = 2(t_1 + t_2) = -2R_t C_t \ln \frac{(V_{TR})(V_{DD} - V_{TR})}{(V_{DD} + V_{TR})(2V_{DD} - V_{TR})}, \text{ where } t_A = \text{Astable mode pulse width.}$$

Values for t_A are:

| | |
|---------------------------------------|---|
| | typ. : $V_{TR} = 0,5 V_{DD}$; $t_A = 4,40 R_t C_t$ |
| $V_{DD} = 5 \text{ or } 10 \text{ V}$ | { min. : $V_{TR} = 0,3 V_{DD}$; $t_A = 4,71 R_t C_t$ |
| | { max. : $V_{TR} = 0,7 V_{DD}$; $t_A = 4,71 R_t C_t$ |
| $V_{DD} = 15 \text{ V}$ | { min. : $V_{TR} = 4 \text{ V}$; $t_A = 4,84 R_t C_t$ |
| | { max. : $V_{TR} = 11 \text{ V}$; $t_A = 4,84 R_t C_t$ |

thus if $t_A = 4,40 R_t C_t$ is used, the maximum variation will be (+ 7,0%; -0,0%) at 10 V.

APPLICATION INFORMATION (continued)

b. Variations due to changes in V_{DD}

In addition to variations from unit-to-unit, the astable period may vary as a function of frequency with respect to V_{DD} .

Typical variations are presented graphically in Figs 5 and 6 with 10 V as a reference.

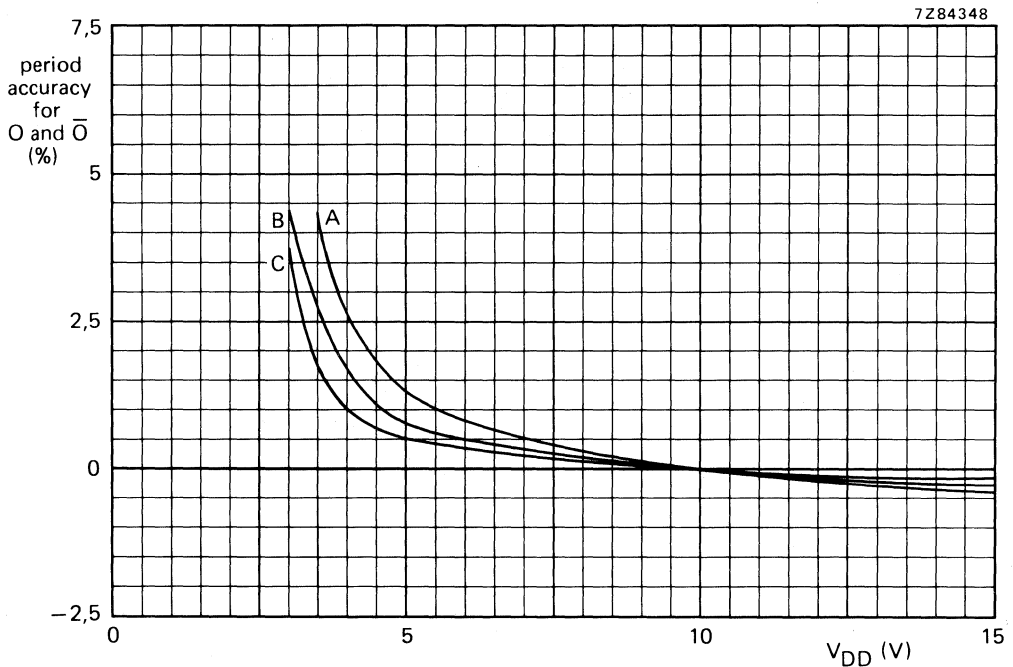

Fig. 5 Typical O and \bar{O} period accuracy as a function of supply voltage; astable mode; $T_{amb} = 25^\circ\text{C}$.

| curve | f_o kHz | C_t pF | R_t k Ω |
|-------|--------------|-------------|---------------------|
| A | 10 | 100 | 220 |
| B | 5 | 100 | 470 |
| C | 1 | 1000 | 220 |

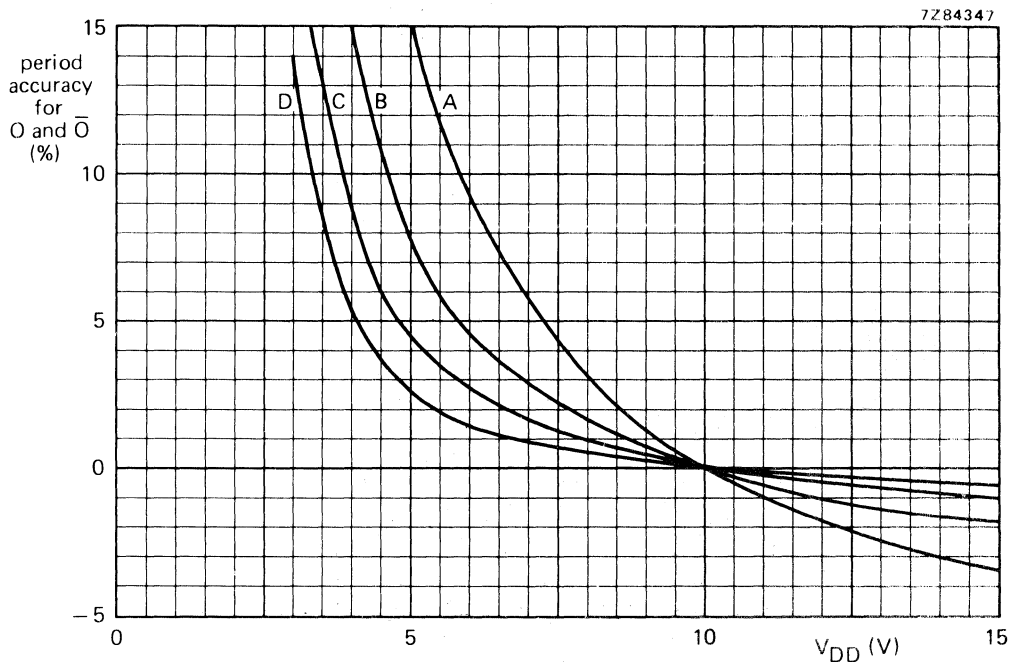

Fig. 6 Typical O and \bar{O} period accuracy as a function of supply voltage; astable mode; $T_{amb} = 25^\circ\text{C}$.

| curve | f_o kHz | C_t pF | R_t k Ω |
|-------|--------------|-------------|---------------------|
| A | 500 | 10 | 47 |
| B | 225 | 100 | 10 |
| C | 100 | 100 | 22 |
| D | 50 | 100 | 47 |

APPLICATION INFORMATION (continued)

2. Monostable mode design information

The following analysis presents worst case variations from unit-to-unit as a function of transfer-voltage (V_{TR}) shift for one-shot (monostable) operation.

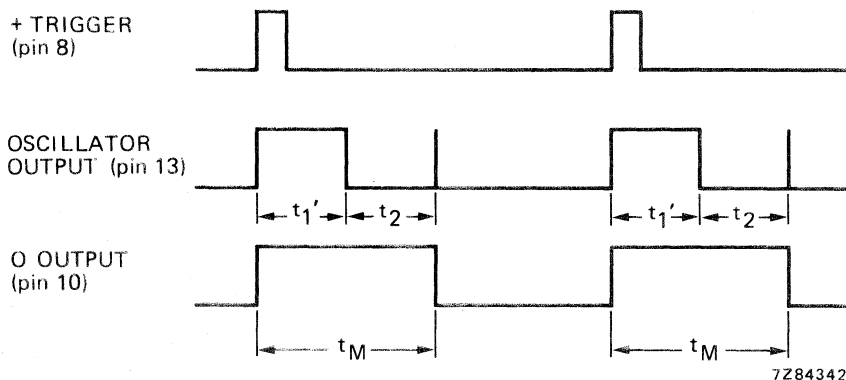

Fig. 7 Monostable waveforms.

$$t_1' = -R_t C_t \ln \frac{V_{TR}}{2V_{DD}}$$

$$t_M = (t_1' + t_2)$$

$$t_M = -R_t C_t \ln \frac{(V_{TR})(V_{DD} - V_{TR})}{(2V_{DD} - V_{TR})(2V_{DD})}, \text{ where } t_M = \text{Monostable mode pulse width.}$$

Values for t_M are:

| | |
|---------------------------------------|---|
| | typ. : $V_{TR} = 0,5 V_{DD}$; $t_M = 2,48 R_t C_t$ |
| $V_{DD} = 5 \text{ to } 10 \text{ V}$ | { min. : $V_{TR} = 0,3 V_{DD}$; $t_M = 2,78 R_t C_t$ |
| | { max. : $V_{TR} = 0,7 V_{DD}$; $t_M = 2,52 R_t C_t$ |
| $V_{DD} = 15 \text{ V}$ | { min. : $V_{TR} = 4 \text{ V}$; $t_M = 2,88 R_t C_t$ |
| | { max. : $V_{TR} = 11 \text{ V}$; $t_M = 2,56 R_t C_t$ |

thus if $t_M = 2,48 R_t C_t$ is used, the maximum variation will be (+ 12%; -0,0%) at 10 V.

Note

In the astable mode, the first positive half cycle has a duration of t_M ; succeeding durations are $\frac{1}{2} t_A$.

3. Retrigger mode operation

The HEF4047B can be used in the retrigger mode to extend the output pulse duration, or to compare the frequency of an input signal with that of the internal oscillator. In the retrigger mode the input pulse is applied to pins 8 and 12, and the output is taken from pin 10 or 11. Normal monostable action is obtained when one retrigger pulse is applied (Fig. 8).

Extended pulse duration is obtained when more than one pulse is applied. For two input pulses, $t_{RE} = t_1' + t_1 + 2t_2$. For more than two pulses, t_{RE} (output O), terminates at some variable time, t_D , after the termination of the last retrigger pulse; t_D is variable because t_{RE} (output O) terminates after the second positive edge of the oscillator output appears at flip-flop 4.

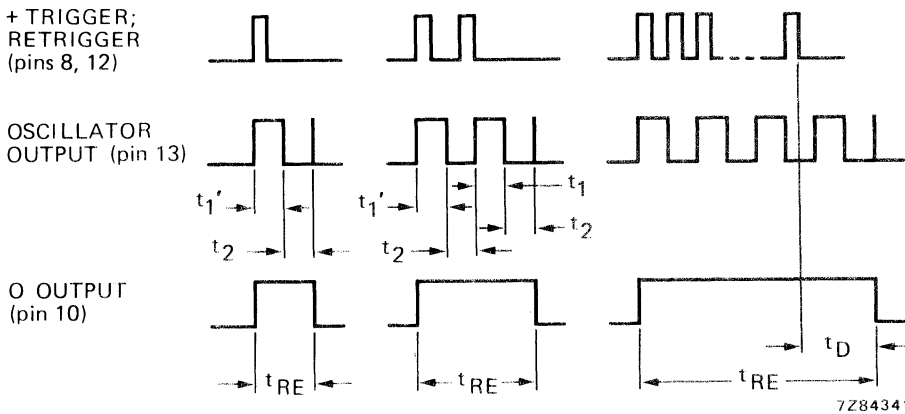

Fig. 8 Retrigger mode waveforms.

4. External counter option

Time t_M can be extended by any amount with the use of external counting circuitry. Advantages include digitally controlled pulse duration, small timing capacitors for long time periods, and extremely fast recovery time. A typical implementation is shown in Fig. 9.

The pulse duration at the output is:

$$t_{ext} = (N - 1)(t_A) + (t_M + \frac{1}{2} t_A)$$

Where t_{ext} = pulse duration of the circuitry, and N is the number of counts used.

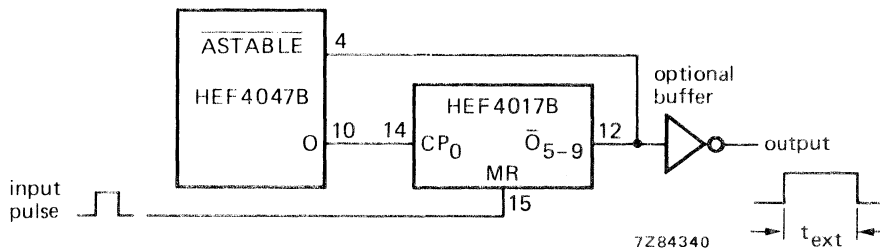

Fig. 9 Implementation of external counter option.

APPLICATION INFORMATION (continued)**5. Timing component limitations**

The capacitor used in the circuit should be non-polarized and have low leakage (i.e. the parallel resistance of the capacitor should be an order of magnitude greater than the external resistor used).

There is no upper or lower limit for either R_t or C_t value to maintain oscillation.

However, in consideration of accuracy, C_t must be much larger than the inherent stray capacitance in the system (unless this capacitance can be measured and taken into account).

R_t must be much larger than the LOC MOS 'ON' resistance in series with it, which typically is hundreds of ohms.

The recommended values for R_t and C_t to maintain agreement with previously calculated formulae without trimming should be:

$$C_t \geq 100 \text{ pF, up to any practical value,}$$

$$10 \text{ k}\Omega \leq R_t \leq 1 \text{ M}\Omega.$$

6. Power consumption

In the standby mode (monostable or astable), power dissipation will be a function of leakage current in the circuit.

For dynamic operation, the power needed to charge the external timing capacitor C_t is given by the following formulae:

$$\text{Astable mode: } P = 2 C_t V^2 f \text{ (f at output pin 13)}$$

$$P = 4 C_t V^2 f \text{ (f at output pins 10 and 11)}$$

$$\text{Monostable mode: } P = \frac{(2.9 C_t V^2)(\text{duty cycle})}{T} \text{ (f at output pins 10 and 11)}$$

Because the power dissipation does not depend on R_t , a design for minimum power dissipation would be a small value of C_t . The value of R would depend on the desired period (within the limitations discussed previously).

Typical power consumption in astable mode is shown in Figs 10, 11 and 12.

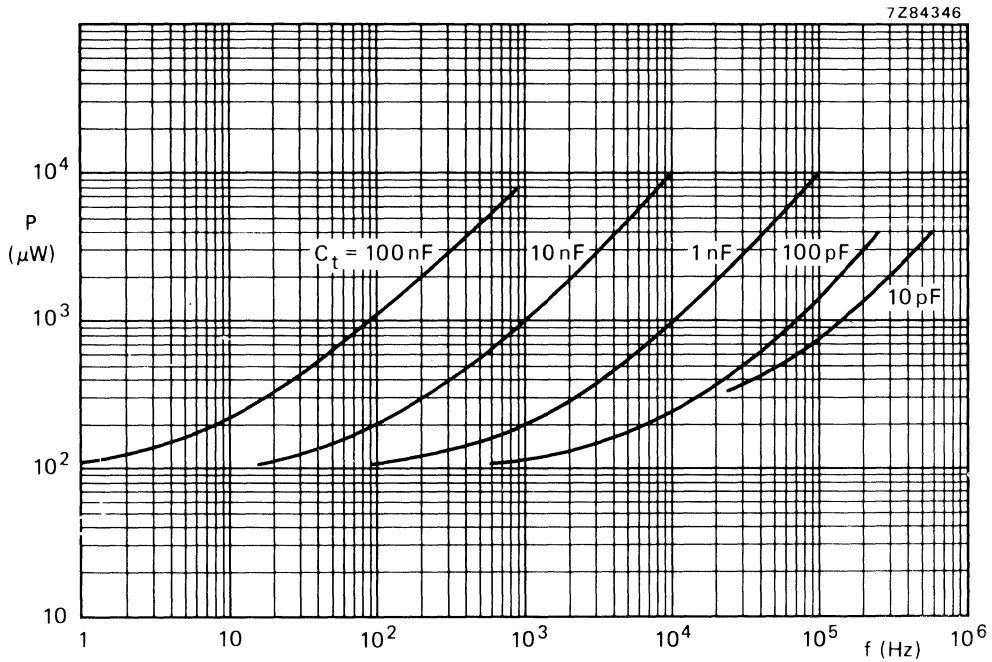

Fig. 10 Power consumption as a function of the output frequency at O or \bar{O} ; $V_{DD} = 5\text{V}$; astable mode.

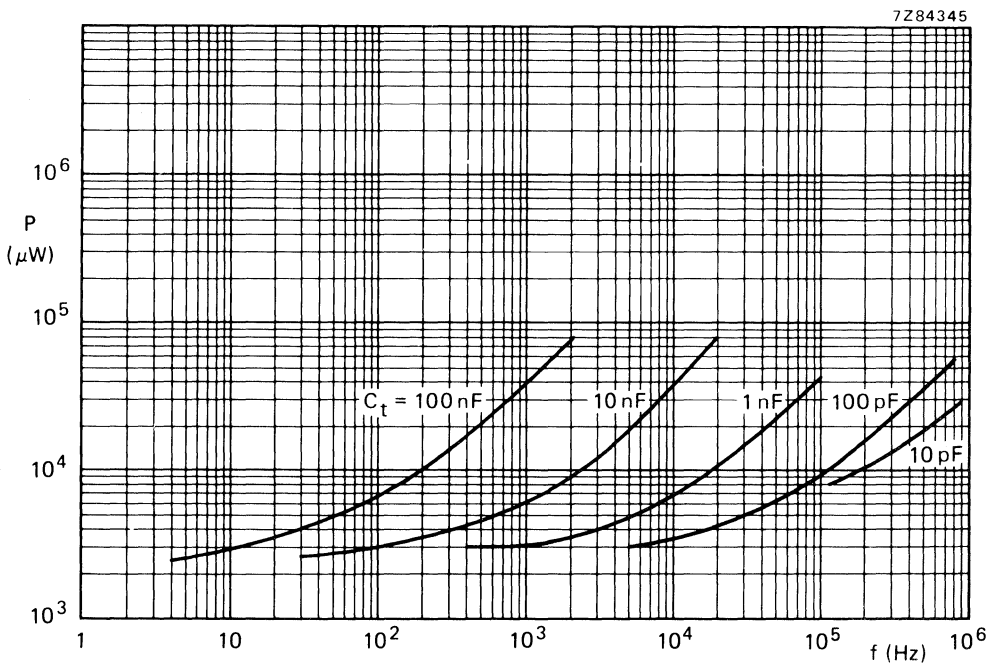

Fig. 11 Power consumption as a function of the output frequency at O or \bar{O} ; $V_{DD} = 10\text{V}$; astable mode.

APPLICATION INFORMATION (continued)

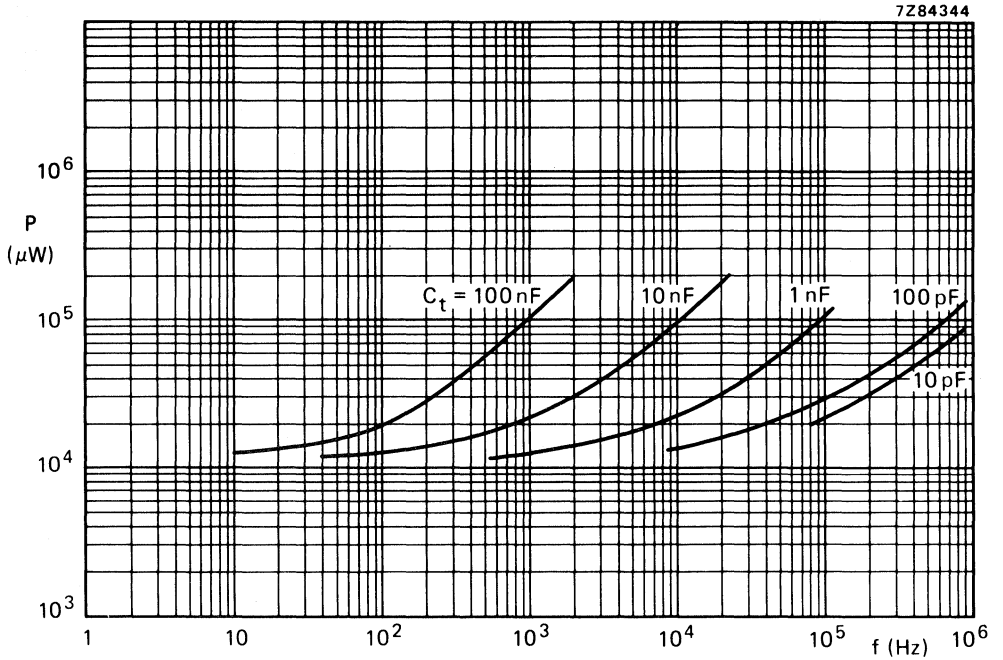

Fig. 12 Power consumption as a function of the output frequency at O or \bar{O} ; $V_{DD} = 15 \text{ V}$; astable mode.

HEX INVERTING BUFFERS



The HEF4049B provides six inverting buffers with high current output capability suitable for driving TTL or high capacitive loads. Since input voltages in excess of the buffers' supply voltage are permitted, the buffers may also be used to convert logic levels of up to 15 V to standard TTL levels. Their guaranteed fan-out into common bipolar logic elements is shown in the table on next page.

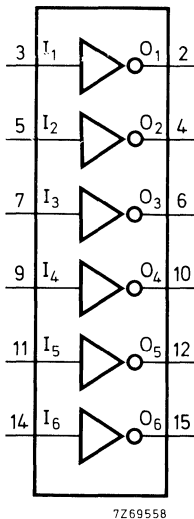

Fig. 1 Functional diagram.

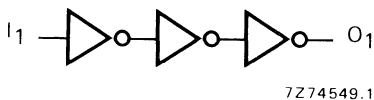

Fig. 3 Logic diagram (one gate).

APPLICATION INFORMATION

Some examples of applications for the HEF4049B are:

- LOCMOS to DTL/TTL converter
- HIGH sink current for driving 2 TTL loads
- HIGH-to-LOW level logic conversion

FAMILY DATA

I_{DD} LIMITS category BUFFERS

} see Family Specifications

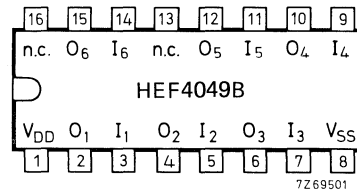

Fig. 2 Pinning diagram.

HEF4049BP : 16-lead DIL; plastic (SOT-38Z).
 HEF4049BD : 16-lead DIL; ceramic (cerdip) (SOT-74).
 HEF4049BT : 16-lead mini-pack; plastic (SO-16; SOT-109A).

HEF4049B

buffers

Guaranteed fan-out in common logic families

| driven element | guaranteed fan-out |
|----------------|--------------------|
| standard TTL | 2 |
| 74LS | 9 |
| 74L | 16 |

Input protection

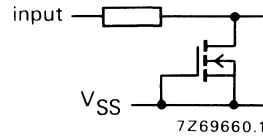

Fig. 4 Input protection circuit that allows input voltages in excess of V_{DD} .

D.C. CHARACTERISTICS $V_{SS} = 0\text{ V}$; $V_I = V_{SS}$ or V_{DD}

| | V_{DD} V | V_O V | symbol | $T_{amb}(^{\circ}\text{C})$ | | | | | | |
|---------------------------------|---------------|------------|-----------|-----------------------------|------|------|------|------|------|----|
| | | | | -40 | | +25 | | +85 | | |
| | | | | min. | max. | min. | max. | min. | max. | |
| Output (sink) current LOW | 4,75 | 0,4 | I_{OL} | 3,5 | — | 2,9 | — | 2,3 | — | mA |
| | 10 | 0,5 | | 12,0 | — | 10,0 | — | 8,0 | — | mA |
| | 15 | 1,5 | | 24,0 | — | 20,0 | — | 16,0 | — | mA |
| Output (source) current HIGH | 5 | 4,6 | $-I_{OH}$ | 0,52 | — | 0,44 | — | 0,36 | — | mA |
| | 10 | 9,5 | | 1,3 | — | 1,1 | — | 0,9 | — | mA |
| | 15 | 13,5 | | 3,6 | — | 3,0 | — | 2,4 | — | mA |
| Output (source) current HIGH | 5 | 2,5 | $-I_{OH}$ | 1,7 | — | 1,4 | — | 1,1 | — | mA |

A.C. CHARACTERISTICS $V_{SS} = 0\text{ V}$; $T_{amb} = 25^{\circ}\text{C}$; $C_L = 50\text{ pF}$; input transition times $\leq 20\text{ ns}$

| | V_{DD} V | symbol | | | | typical extrapolation formula |
|--|---------------|-----------|------|------|----|--|
| | | | typ. | max. | | |
| Propagation delays $I_n \rightarrow O_n$ HIGH to LOW | 5 | t_{PHL} | 35 | 70 | ns | $26\text{ ns} + (0,18\text{ ns/pF}) C_L$ |
| | 10 | | 15 | 30 | ns | $11\text{ ns} + (0,08\text{ ns/pF}) C_L$ |
| | 15 | | 12 | 25 | ns | $9\text{ ns} + (0,05\text{ ns/pF}) C_L$ |
| LOW to HIGH | 5 | t_{PLH} | 50 | 100 | ns | $23\text{ ns} + (0,55\text{ ns/pF}) C_L$ |
| | 10 | | 25 | 50 | ns | $14\text{ ns} + (0,23\text{ ns/pF}) C_L$ |
| | 15 | | 20 | 40 | ns | $12\text{ ns} + (0,16\text{ ns/pF}) C_L$ |
| Output transition times HIGH to LOW | 5 | t_{THL} | 20 | 40 | ns | $3\text{ ns} + (0,35\text{ ns/pF}) C_L$ |
| | 10 | | 10 | 20 | ns | $3\text{ ns} + (0,14\text{ ns/pF}) C_L$ |
| | 15 | | 7 | 14 | ns | $2\text{ ns} + (0,09\text{ ns/pF}) C_L$ |
| LOW to HIGH | 5 | t_{TLH} | 60 | 120 | ns | $10\text{ ns} + (1,0\text{ ns/pF}) C_L$ |
| | 10 | | 30 | 60 | ns | $9\text{ ns} + (0,42\text{ ns/pF}) C_L$ |
| | 15 | | 20 | 40 | ns | $6\text{ ns} + (0,28\text{ ns/pF}) C_L$ |

| | V_{DD} V | typical formula for P (μW) | where |
|---|---------------|--|------------------------------------|
| Dynamic power dissipation per package (P) | 5 | $2500 f_i + \Sigma(f_o C_L) \times V_{DD}^2$ | f_i = input freq. (MHz) |
| | 10 | | f_o = output freq. (MHz) |
| | 15 | | C_L = load capacitance (pF) |
| | | | $\Sigma(f_o C_L)$ = sum of outputs |
| | | | V_{DD} = supply voltage (V) |

HEX NON-INVERTING BUFFERS



The HEF4050B provides six non-inverting buffers with high current output capability suitable for driving TTL or high capacitive loads. Since input voltages in excess of the buffers' supply voltage are permitted, the buffers may also be used to convert logic levels of up to 15 V to standard TTL levels. Their guaranteed fan-out into common bipolar logic elements is shown in the table on next page.

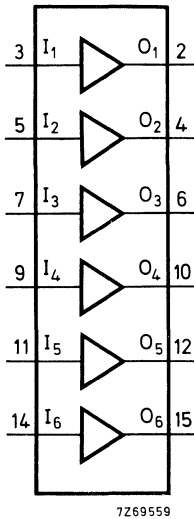

Fig. 1 Functional diagram.

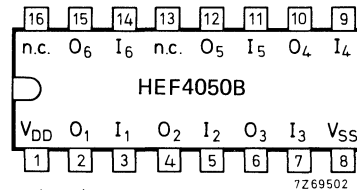

Fig. 2 Pinning diagram.

HEF4050BP : 16-lead DIL; plastic (SOT-38Z).
HEF4050BD : 16-lead DIL; ceramic (cerdip) (SOT-74).
HEF4050BT : 16-lead mini-pack; plastic (SO-16; SOT-109A).

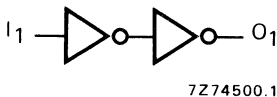

Fig. 3 Logic diagram (one gate).

APPLICATION INFORMATION

Some examples of applications for the HEF4050B are:

- LOCMOS to DTL/TTL converter
- HIGH sink current for driving 2 TTL loads
- HIGH-to-LOW level logic conversion

FAMILY DATA

I_{DD} LIMITS category BUFFERS

} see Family Specifications

HEF4050B

buffers

Guaranteed fan-out in common logic families

| driven element | guaranteed fan-out |
|----------------|--------------------|
| standard TTL | 2 |
| 74LS | 9 |
| 74L | 16 |

Input protection

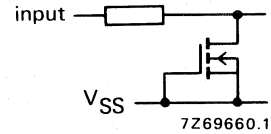

Fig.4 Input protection circuit that allows input voltages in excess of V_{DD} .

D.C. CHARACTERISTICS $V_{SS} = 0\text{ V}$; $V_I = V_{SS}$ or V_{DD}

| | V_{DD} V | V_O V | symbol | $T_{amb}(^{\circ}\text{C})$ | | | | | | |
|---------------------------------|---------------|------------|-----------|-----------------------------|------|------|------|------|------|----|
| | | | | -40 | | +25 | | +85 | | |
| | | | | min. | max. | min. | max. | min. | max. | |
| Output (sink) current LOW | 4,75 | 0,4 | I_{OL} | 3,5 | — | 2,9 | — | 2,3 | — | mA |
| | 10 | 0,5 | | 12,0 | — | 10,0 | — | 8,0 | — | mA |
| | 15 | 1,5 | | 24,0 | — | 20,0 | — | 16,0 | — | mA |
| Output (source) current HIGH | 5 | 4,6 | $-I_{OH}$ | 0,52 | — | 0,44 | — | 0,36 | — | mA |
| | 10 | 9,5 | | 1,3 | — | 1,1 | — | 0,9 | — | mA |
| | 15 | 13,5 | | 3,6 | — | 3,0 | — | 2,4 | — | mA |
| Output (source) current HIGH | 5 | 2,5 | $-I_{OH}$ | 1,7 | — | 1,4 | — | 1,1 | — | mA |

A.C. CHARACTERISTICS $V_{SS} = 0\text{ V}$; $T_{amb} = 25^{\circ}\text{ C}$; $C_L = 50\text{ pF}$; input transition times $\leq 20\text{ ns}$

| | V_{DD} V | symbol | typ. | max. | typical extrapolation formula |
|--|---------------|-----------|------|--------|---|
| Propagation delays I_n O_n HIGH to LOW | 5 | t_{PHL} | 35 | 70 ns | $26\text{ ns} + (0,18\text{ ns/pF})C_L$ |
| | 10 | | 20 | 35 ns | $16\text{ ns} + (0,08\text{ ns/pF})C_L$ |
| | 15 | | 15 | 30 ns | $12\text{ ns} + (0,05\text{ ns/pF})C_L$ |
| LOW to HIGH | 5 | t_{PLH} | 55 | 110 ns | $28\text{ ns} + (0,55\text{ ns/pF})C_L$ |
| | 10 | | 25 | 55 ns | $14\text{ ns} + (0,23\text{ ns/pF})C_L$ |
| | 15 | | 20 | 40 ns | $12\text{ ns} + (0,16\text{ ns/pF})C_L$ |
| Output transition times HIGH to LOW | 5 | t_{THL} | 25 | 50 ns | $7\text{ ns} + (0,35\text{ ns/pF})C_L$ |
| | 10 | | 10 | 20 ns | $3\text{ ns} + (0,14\text{ ns/pF})C_L$ |
| | 15 | | 7 | 14 ns | $2\text{ ns} + (0,09\text{ ns/pF})C_L$ |
| LOW to HIGH | 5 | t_{TLH} | 60 | 120 ns | $10\text{ ns} + (1,0\text{ ns/pF})C_L$ |
| | 10 | | 30 | 60 ns | $9\text{ ns} + (0,42\text{ ns/pF})C_L$ |
| | 15 | | 20 | 40 ns | $6\text{ ns} + (0,28\text{ ns/pF})C_L$ |

| | V_{DD} V | typical formula for P (μW) | where |
|---|---------------|---|------------------------------------|
| Dynamic power dissipation per package (P) | 5 | $3\ 800 f_i + \Sigma (f_o C_L) \times V_{DD}^2$ | f_i = input freq. (MHz) |
| | 10 | | f_o = output freq. (MHz) |
| | 15 | | C_L = load capacitance (pF) |
| | | | $\Sigma(f_o C_L)$ = sum of outputs |
| | | | V_{DD} = supply voltage (V) |

8-CHANNEL ANALOGUE MULTIPLEXER/DEMULTIPLEXER

The HEF4051B is an 8-channel analogue multiplexer/demultiplexer with three address inputs (A_0 to A_2), an active LOW enable input (\bar{E}), eight independent inputs/outputs (Y_0 to Y_7) and a common input/output (Z).

The device contains eight bidirectional analogue switches, each with one side connected to an independent input/output (Y_0 to Y_7) and the other side connected to a common input/output (Z).

With \bar{E} LOW, one of the eight switches is selected (low impedance ON-state) by A_0 to A_2 . With \bar{E} HIGH, all switches are in the high impedance OFF-state, independent of A_0 to A_2 .

V_{DD} and V_{SS} are the supply voltage connections for the digital control inputs (A_0 to A_2 , and \bar{E}). The V_{DD} to V_{SS} range is 3 to 15 V. The analogue inputs/outputs (Y_0 to Y_7 , and Z) can swing between V_{DD} as a positive limit and V_{EE} as a negative limit. $V_{DD}-V_{EE}$ may not exceed 15 V.

For operation as a digital multiplexer/demultiplexer, V_{EE} is connected to V_{SS} (typically ground).

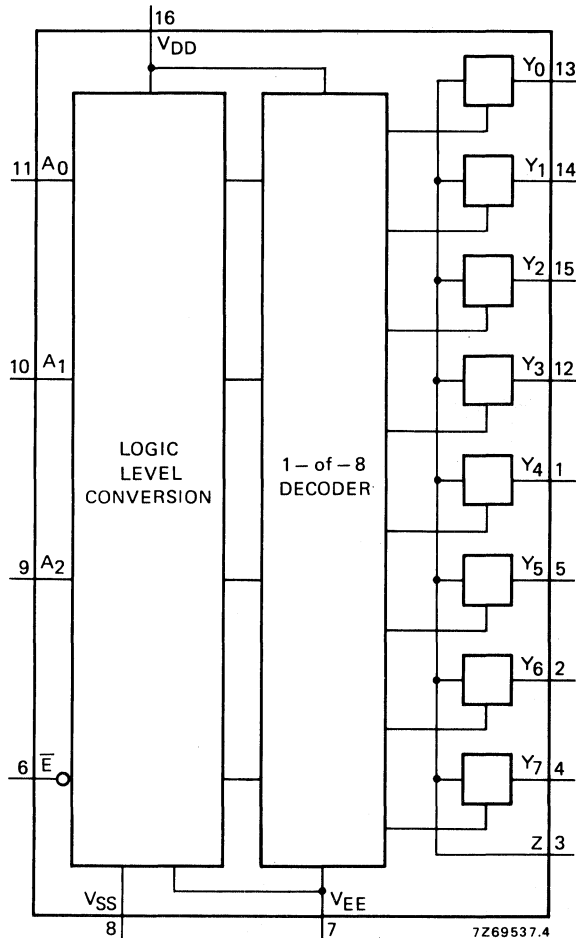

Fig. 1 Functional diagram.

FAMILY DATA

I_{DD} LIMITS category MSI
see Family Specifications

HEF4051B

MSI

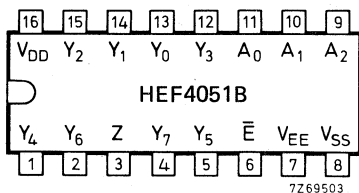

Fig. 2 Pinning diagram.

HEF4051BP: 16-lead DIL; plastic (SOT-38Z).

HEF4051BD: 16-lead DIL; ceramic (cerdip) (SOT-74).

HEF4051BT: 16-lead mini-pack; plastic (SO-16; SOT-109A).

PINNING

- Y₀ to Y₇ independent inputs/outputs
- A₀ to A₂ address inputs
- \bar{E} enable input (active LOW)
- Z common input/output

Fig. 3 Schematic diagram (one switch).

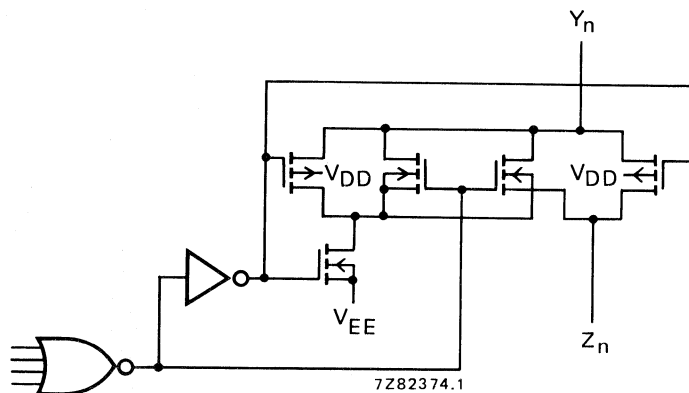

FUNCTION TABLE

| inputs | | | | channel ON |
|-----------|----------------|----------------|----------------|-------------------|
| \bar{E} | A ₂ | A ₁ | A ₀ | |
| L | L | L | L | Y ₀ -Z |
| L | L | L | H | Y ₁ -Z |
| L | L | H | L | Y ₂ -Z |
| L | L | H | H | Y ₃ -Z |
| L | H | L | L | Y ₄ -Z |
| L | H | L | H | Y ₅ -Z |
| L | H | H | L | Y ₆ -Z |
| L | H | H | H | Y ₇ -Z |
| H | X | X | X | none |

- H = HIGH state (the more positive voltage)
- L = LOW state (the less positive voltage)
- X = state is immaterial

RATINGS

Limiting values in accordance with the Absolute Maximum System (IEC 134)

Supply voltage (with reference to V_{DD})

V_{EE} -18 to +0,5 V

NOTE

To avoid drawing V_{DD} current out of terminal Z, when switch current flows into terminals Y, the voltage drop across the bidirectional switch must not exceed 0,4 V. If the switch current flows into terminal Z, no V_{DD} current will flow out of terminals Y, in this case there is no limit for the voltage drop across the switch, but the voltages at Y and Z may not exceed V_{DD} or V_{EE}.

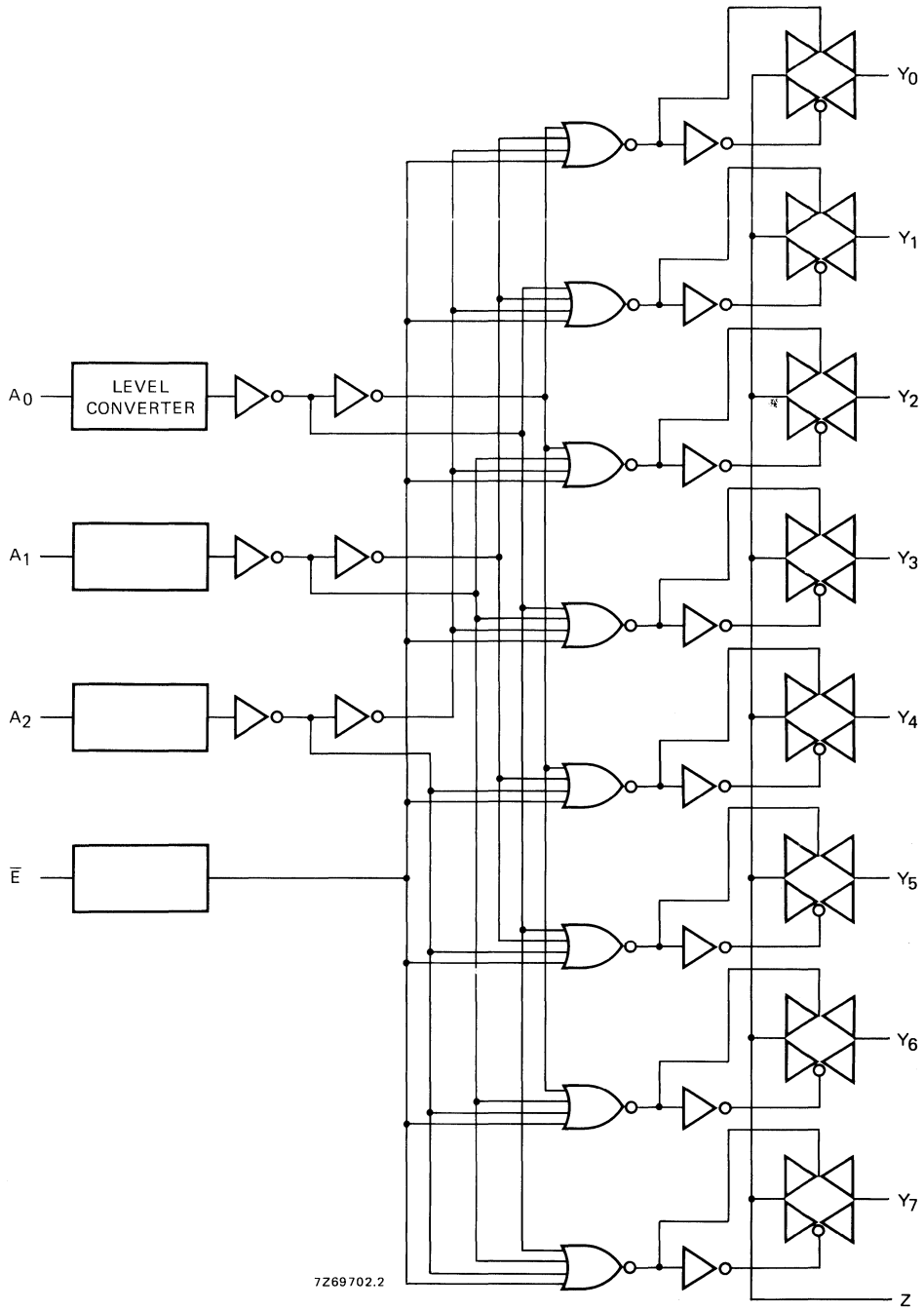

Fig. 4 Logic diagram.

D.C. CHARACTERISTICS

T_{amb} = 25 °C

| | $V_{DD}-V_{EE}$ V | symbol | typ. | max. | conditions | |
|---|----------------------|------------------|------|------|---|----|
| ON resistance | 5 | R _{ON} | 350 | 2500 | } V _{is} = 0 to V _{DD} -V _{EE} see Fig. 6 | |
| | 10 | | 80 | 245 | | Ω |
| | 15 | | 60 | 175 | | Ω |
| ON resistance | 5 | R _{ON} | 115 | 340 | } V _{is} = 0 see Fig. 6 | |
| | 10 | | 50 | 160 | | Ω |
| | 15 | | 40 | 115 | | Ω |
| ON resistance | 5 | R _{ON} | 120 | 365 | } V _{is} = V _{DD} -V _{EE} see Fig. 6 | |
| | 10 | | 65 | 200 | | Ω |
| | 15 | | 50 | 155 | | Ω |
| 'Δ' ON resistance between any two channels | 5 | ΔR _{ON} | 25 | — | } V _{is} = 0 to V _{DD} -V _{EE} see Fig. 6 | |
| | 10 | | 10 | — | | Ω |
| | 15 | | 5 | — | | Ω |
| OFF-state leakage current, all channels OFF | 5 | I _{OZZ} | — | — | } \bar{E} at V _{DD} V _{SS} = V _{EE} | |
| | 10 | | — | — | | nA |
| | 15 | | — | 1000 | | nA |
| OFF-state leakage current, any channel | 5 | I _{OZY} | — | — | } \bar{E} at V _{SS} V _{SS} = V _{EE} | |
| | 10 | | — | — | | nA |
| | 15 | | — | 200 | | nA |

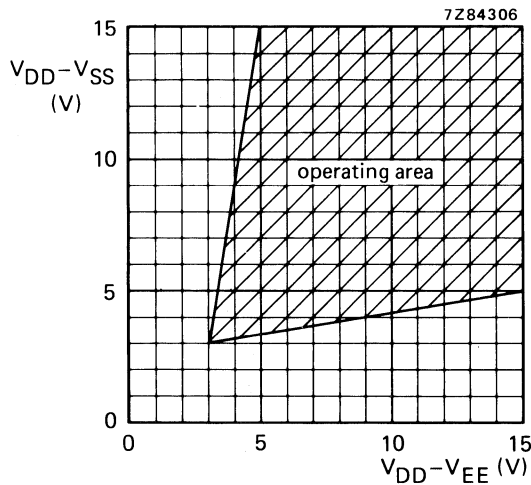

Fig. 5 Operating area as a function of the supply voltages.

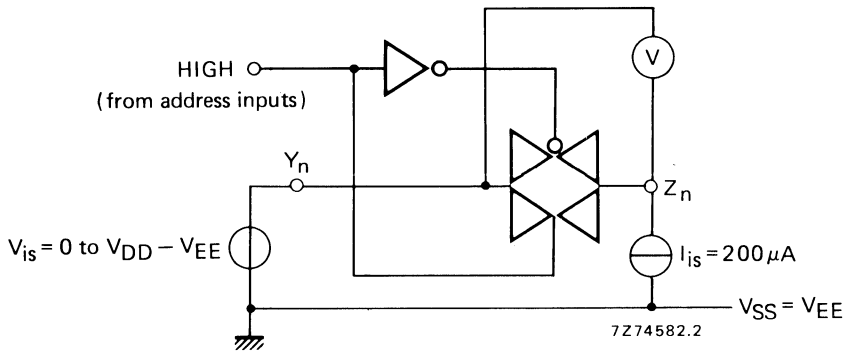

Fig. 6 Test set-up for measuring R_{ON} .

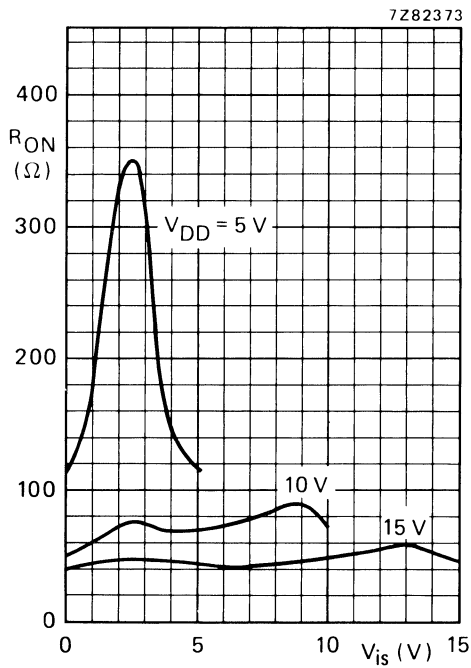

Fig. 7 Typical R_{ON} as a function of input voltage.

$I_{is} = 200 \mu A$
 $V_{SS} = V_{EE} = 0 V$

HEF4051B

MSI

A.C. CHARACTERISTICS

$V_{EE} = V_{SS} = 0\text{ V}$; $T_{amb} = 25\text{ }^{\circ}\text{C}$; input transition times $\leq 20\text{ ns}$

| | V_{DD} V | typical formula for P (μW) | where f_i = input freq. (MHz) f_o = output freq. (MHz) C_L = load capacitance (pF) $\Sigma(f_o C_L)$ = sum of outputs V_{DD} = supply voltage (V) |
|---|---------------|---|--|
| Dynamic power dissipation per package (P) | 5 | $1\ 000 f_i + \Sigma(f_o C_L) \times V_{DD}^2$ | |
| | 10 | $5\ 500 f_i + \Sigma(f_o C_L) \times V_{DD}^2$ | |
| | 15 | $15\ 000 f_i + \Sigma(f_o C_L) \times V_{DD}^2$ | |

A.C. CHARACTERISTICS

$V_{EE} = V_{SS} = 0\text{ V}$; $T_{amb} = 25\text{ }^{\circ}\text{C}$; input transition times $\leq 20\text{ ns}$

| | V_{DD} V | symbol | typ. | max. | |
|--|---------------|------------------|------|------|-------------|
| Propagation delays $V_{is} \rightarrow V_{os}$ HIGH to LOW | 5 | t _{PHL} | 15 | 30 | ns } note 1 |
| | 10 | | 5 | 10 | |
| | 15 | | 5 | 10 | |
| LOW to HIGH | 5 | t _{PLH} | 15 | 30 | ns } note 1 |
| | 10 | | 5 | 10 | |
| | 15 | | 5 | 10 | |
| $A_n \rightarrow V_{os}$ HIGH to LOW | 5 | t _{PHL} | 150 | 300 | ns } note 2 |
| | 10 | | 60 | 120 | |
| | 15 | | 45 | 90 | |
| LOW to HIGH | 5 | t _{PLH} | 150 | 300 | ns } note 2 |
| | 10 | | 65 | 130 | |
| | 15 | | 45 | 90 | |
| Output disable times $\bar{E} \rightarrow V_{os}$ HIGH | 5 | t _{PHZ} | 120 | 240 | ns } note 3 |
| | 10 | | 90 | 180 | |
| | 15 | | 85 | 170 | |
| LOW | 5 | t _{PLZ} | 145 | 290 | ns } note 3 |
| | 10 | | 120 | 240 | |
| | 15 | | 115 | 230 | |
| Output enable times $\bar{E} \rightarrow V_{os}$ HIGH | 5 | t _{PZH} | 140 | 280 | ns } note 3 |
| | 10 | | 55 | 110 | |
| | 15 | | 40 | 80 | |
| LOW | 5 | t _{PZL} | 140 | 280 | ns } note 3 |
| | 10 | | 55 | 110 | |
| | 15 | | 40 | 80 | |

A.C. CHARACTERISTICS

$V_{EE} = V_{SS} = 0\text{ V}$; $T_{amb} = 25\text{ }^{\circ}\text{C}$; input transition times $\leq 20\text{ ns}$

| | V_{DD} V | symbol | typ. | max. | |
|--|---------------|--------|------|------|----------|
| Distortion, sine-wave response | 5 | | 0,25 | % | } note 4 |
| | 10 | | 0,04 | % | |
| | 15 | | 0,04 | % | |
| Crosstalk between any two channels | 5 | | — | MHz | } note 5 |
| | 10 | | 1 | MHz | |
| | 15 | | — | MHz | |
| Crosstalk; enable or address input to output | 5 | | — | mV | } note 6 |
| | 10 | | 50 | mV | |
| | 15 | | — | mV | |
| OFF-state feed-through | 5 | | — | MHz | } note 7 |
| | 10 | | 1 | MHz | |
| | 15 | | — | MHz | |
| ON-state frequency response | 5 | | 13 | MHz | } note 8 |
| | 10 | | 40 | MHz | |
| | 15 | | 70 | MHz | |

NOTES

V_{is} is the input voltage at a Y or Z terminal, whichever is assigned as input.

V_{os} is the output voltage at a Y or Z terminal, whichever is assigned as output.

- $R_L = 10\text{ k}\Omega$ to V_{EE} ; $C_L = 50\text{ pF}$ to V_{EE} ; $\bar{E} = V_{SS}$; $V_{is} = V_{DD}$ (square-wave); see Fig. 8.
- $R_L = 10\text{ k}\Omega$; $C_L = 50\text{ pF}$ to V_{EE} ; $\bar{E} = V_{SS}$; $A_n = V_{DD}$ (square-wave); $V_{is} = V_{DD}$ and R_L to V_{EE} for t_{PLH} ; $V_{is} = V_{EE}$ and R_L to V_{DD} for t_{PHL} ; see Fig. 8.
- $R_L = 10\text{ k}\Omega$; $C_L = 50\text{ pF}$ to V_{EE} ; $\bar{E} = V_{DD}$ (square-wave); $V_{is} = V_{DD}$ and R_L to V_{EE} for t_{PHZ} and t_{PZH} ; $V_{is} = V_{EE}$ and R_L to V_{DD} for t_{PLZ} and t_{PZL} ; see Fig. 8.
- $R_L = 10\text{ k}\Omega$; $C_L = 15\text{ pF}$; channel ON; $V_{is} = \frac{1}{2} V_{DD(p-p)}$ (sine-wave, symmetrical about $\frac{1}{2} V_{DD}$); $f_{is} = 1\text{ kHz}$; see Fig. 9.
- $R_L = 1\text{ k}\Omega$; $V_{is} = \frac{1}{2} V_{DD(p-p)}$ (sine-wave, symmetrical about $\frac{1}{2} V_{DD}$); $20 \log \frac{V_{os}}{V_{is}} = -50\text{ dB}$; see Fig. 10.
- $R_L = 10\text{ k}\Omega$ to V_{EE} ; $C_L = 15\text{ pF}$ to V_{EE} ; \bar{E} or $A_n = V_{DD}$ (square-wave); crosstalk is $|V_{os}|$ (peak value); see Fig. 8.
- $R_L = 1\text{ k}\Omega$; $C_L = 5\text{ pF}$; channel OFF; $V_{is} = \frac{1}{2} V_{DD(p-p)}$ (sine-wave, symmetrical about $\frac{1}{2} V_{DD}$); $20 \log \frac{V_{os}}{V_{is}} = -50\text{ dB}$; see Fig. 9.
- $R_L = 1\text{ k}\Omega$; $C_L = 5\text{ pF}$; channel ON; $V_{is} = \frac{1}{2} V_{DD(p-p)}$ (sine-wave, symmetrical about $\frac{1}{2} V_{DD}$); $20 \log \frac{V_{os}}{V_{is}} = -3\text{ dB}$; see Fig. 9.

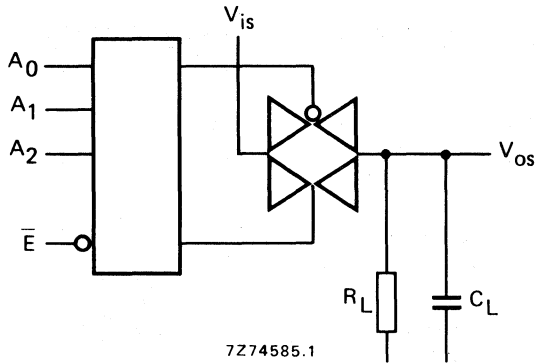

Fig. 8.

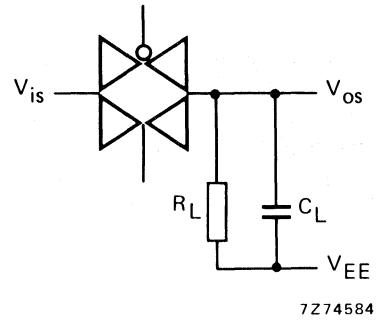

Fig. 9.

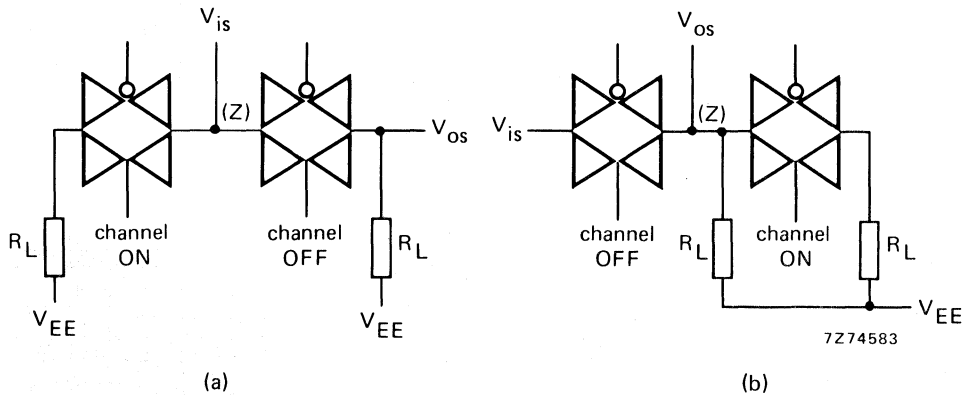

Fig. 10.

APPLICATION INFORMATION

Some examples of applications for the HEF4051B are:

- Analogue multiplexing and demultiplexing.
- Digital multiplexing and demultiplexing.
- Signal gating.

NOTE

If break before make is needed, then it is necessary to use the enable input.

DUAL 4-CHANNEL ANALOGUE MULTIPLEXER/DEMULTIPLEXER

The HEF4052B is a dual 4-channel analogue multiplexer/demultiplexer with common channel select logic. Each multiplexer/demultiplexer has four independent inputs/outputs (Y_0 to Y_3) and a common input/output (Z). The common channel select logic includes two address inputs (A_0 and A_1) and an active LOW enable input (\bar{E}).

Both multiplexers/demultiplexers contain four bidirectional analogue switches, each with one side connected to an independent input/output (Y_0 to Y_3) and the other side connected to a common input/output (Z).

With \bar{E} LOW, one of the four switches is selected (low impedance ON-state) by A_0 and A_1 . With \bar{E} HIGH, all switches are in the high impedance OFF-state, independent of A_0 and A_1 .

V_{DD} and V_{SS} are the supply voltage connections for the digital control inputs (A_0 , A_1 and \bar{E}). The V_{DD} to V_{SS} range is 3 to 15 V. The analogue inputs/outputs (Y_0 to Y_3 , and Z) can swing between V_{DD} as a positive limit and V_{EE} as a negative limit. $V_{DD} - V_{EE}$ may not exceed 15 V.

For operation as a digital multiplexer/demultiplexer, V_{EE} is connected to V_{SS} (typically ground).

Fig. 1 Functional diagram.

FAMILY DATA

I_{DD} LIMITS category MSI
see Family Specifications

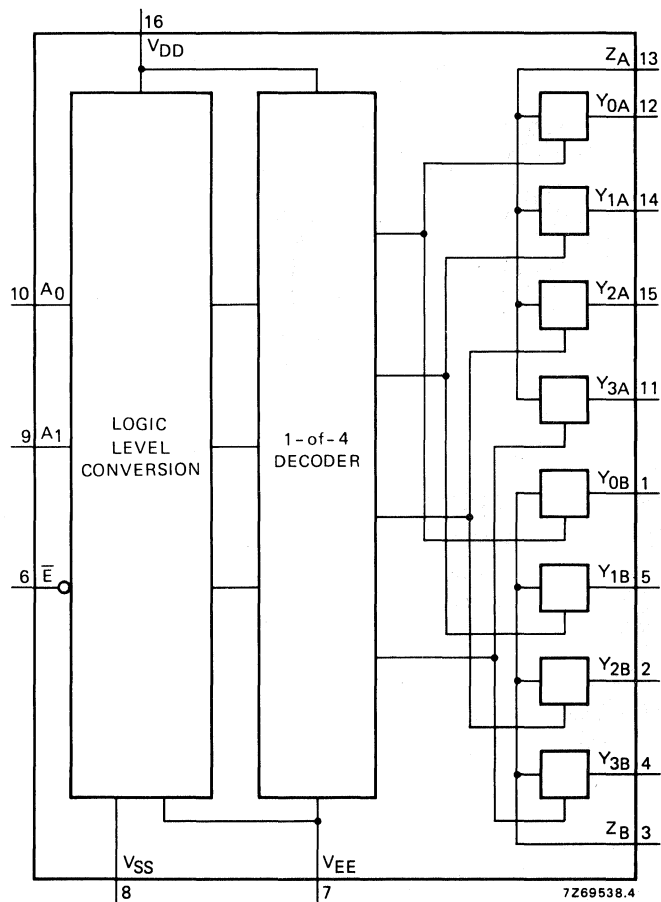

HEF4052B

MSI

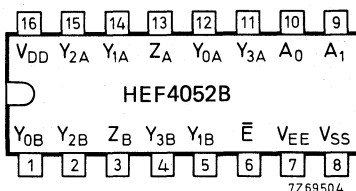

Fig. 2 Pinning diagram.

PINNING

- Y_{0A} to Y_{3A} independent inputs/outputs
- Y_{0B} to Y_{3B} independent inputs/outputs
- A₀, A₁ address inputs
- \bar{E} enable input (active LOW)
- Z_A, Z_B common inputs/outputs

- HEF4052BP : 16-lead DIL; plastic (SOT-38Z).
- HEF4052BD : 16-lead DIL; ceramic (cerdip) (SOT-74).
- HEF4052BT : 16-lead mini-pack; plastic (SO-16; SOT-109A).

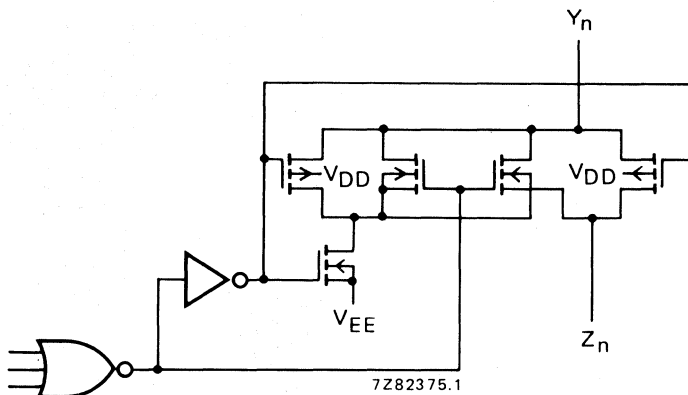

Fig. 3 Schematic diagram (one switch).

FUNCTION TABLE

| inputs | | | channel ON |
|-----------|----------------|----------------|---|
| \bar{E} | A ₁ | A ₀ | |
| L | L | L | Y _{0A} -Z _A ; Y _{0B} -Z _B |
| L | L | H | Y _{1A} -Z _A ; Y _{1B} -Z _B |
| L | H | L | Y _{2A} -Z _A ; Y _{2B} -Z _B |
| L | H | H | Y _{3A} -Z _A ; Y _{3B} -Z _B |
| H | X | X | none |

- H = HIGH state (the more positive voltage)
- L = LOW state (the less positive voltage)
- X = state is immaterial

RATINGS

Limiting values in accordance with the Absolute Maximum System (IEC 134)

Supply voltage (with reference to V_{DD})

V_{EE} -18 to +0,5 V

NOTE

To avoid drawing V_{DD} current out of terminal Z, when switch current flows into terminals Y, the voltage drop across the bidirectional switch must not exceed 0,4 V. If the switch current flows into terminal Z, no V_{DD} current will flow out of terminals Y, in this case there is no limit for the voltage drop across the switch, but the voltages at Y and Z may not exceed V_{DD} or V_{EE}.

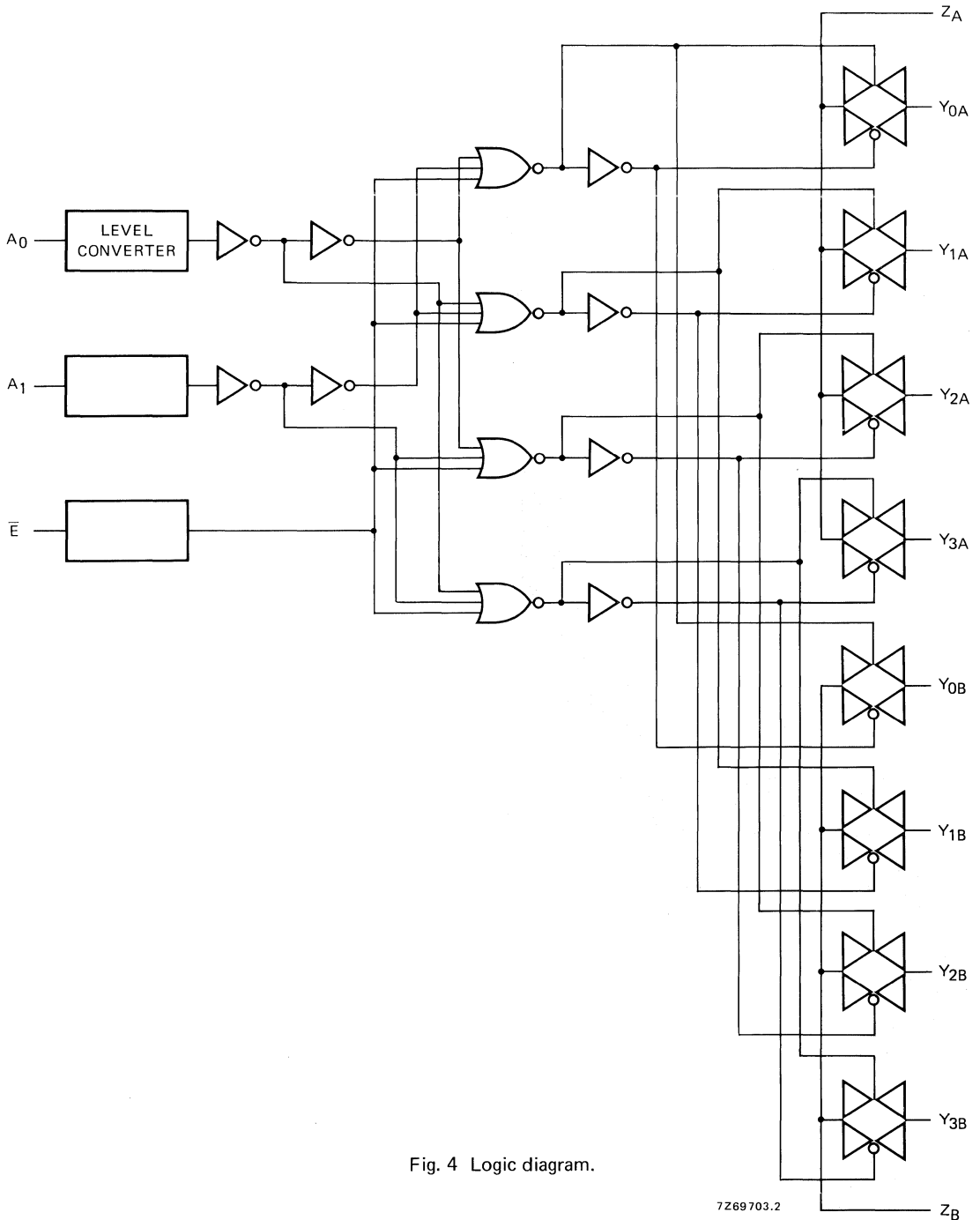

Fig. 4 Logic diagram.

D.C. CHARACTERISTICS

 $T_{amb} = 25\text{ }^{\circ}\text{C}$

| | $V_{DD}-V_{EE}$ V | symbol | typ. | max. | conditions |
|---|----------------------|-----------------|------|------|--|
| ON resistance | 5 | R_{ON} | 350 | 2500 | Ω } $V_{is} = 0$ to $V_{DD}-V_{EE}$ see Fig. 6 |
| | 10 | | 80 | 245 | |
| | 15 | | 60 | 175 | |
| ON resistance | 5 | R_{ON} | 115 | 340 | Ω } $V_{is} = 0$ see Fig. 6 |
| | 10 | | 50 | 160 | |
| | 15 | | 40 | 115 | |
| ON resistance | 5 | R_{ON} | 120 | 365 | Ω } $V_{is} = V_{DD}-V_{EE}$ see Fig. 6 |
| | 10 | | 65 | 200 | |
| | 15 | | 50 | 155 | |
| ' Δ ' ON resistance between any two channels | 5 | ΔR_{ON} | 25 | — | Ω } $V_{is} = 0$ to $V_{DD}-V_{EE}$ see Fig. 6 |
| | 10 | | 10 | — | |
| | 15 | | 5 | — | |
| OFF-state leakage current, all channels OFF | 5 | I_{OZZ} | — | — | nA } \bar{E} at V_{DD} |
| | 10 | | — | — | |
| | 15 | | — | 1000 | |
| OFF-state leakage current, any channel | 5 | I_{OZY} | — | — | nA } \bar{E} at V_{SS} |
| | 10 | | — | — | |
| | 15 | | — | 200 | |

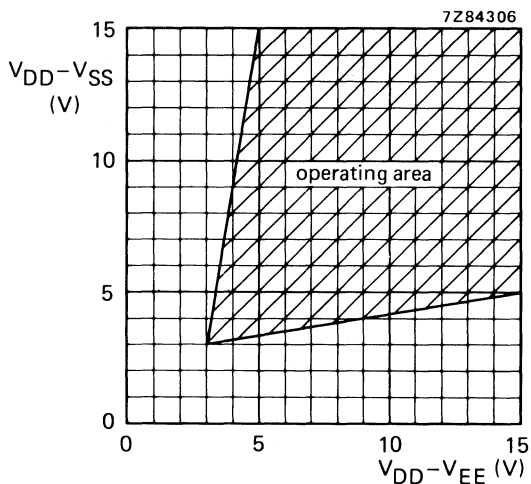

Fig. 5 Operating area as a function of the supply voltages.

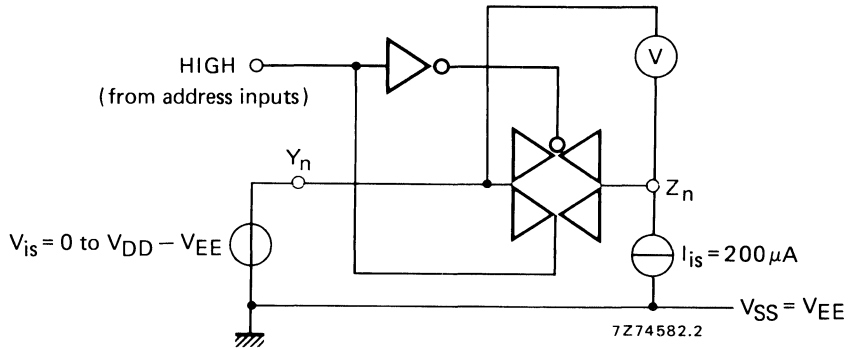

Fig. 6 Test set-up for measuring R_{ON} .

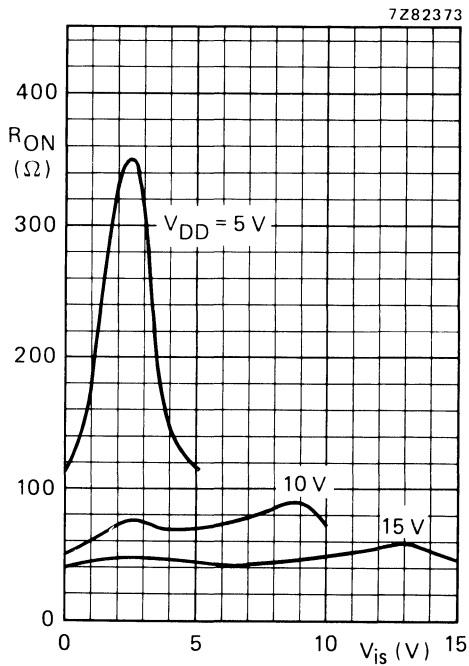

Fig. 7 Typical R_{ON} as a function of input voltage.

$I_{is} = 200 \mu A$
 $V_{SS} = V_{EE} = 0 V$

A.C. CHARACTERISTICS

 $V_{EE} = V_{SS} = 0 \text{ V}$; $T_{amb} = 25 \text{ }^\circ\text{C}$; input transition times $\leq 20 \text{ ns}$

| | V_{DD} V | typical formula for P (μW) | where f_i = input freq. (MHz) f_o = output freq. (MHz) C_L = load capacitance (pF) $\Sigma(f_o C_L)$ = sum of outputs V_{DD} = supply voltage (V) |
|---|---------------|---|--|
| Dynamic power dissipation per package (P) | 5 | $1\,300 f_i + \Sigma(f_o C_L) \times V_{DD}^2$ | |
| | 10 | $6\,100 f_i + \Sigma(f_o C_L) \times V_{DD}^2$ | |
| | 15 | $15\,600 f_i + \Sigma(f_o C_L) \times V_{DD}^2$ | |

A.C. CHARACTERISTICS

 $V_{EE} = V_{SS} = 0 \text{ V}$; $T_{amb} = 25 \text{ }^\circ\text{C}$; input transition times $\leq 20 \text{ ns}$

| | V_{DD} V | symbol | typ. | max. | | | |
|--|---------------|--------|------|------|-----|----------|----------|
| Propagation delays $V_{is} \rightarrow V_{os}$ HIGH to LOW | 5 | tPHL | 10 | 20 | ns | } note 1 | |
| | 10 | | 5 | 10 | | | |
| | 15 | | 5 | 10 | | | |
| | LOW to HIGH | 5 | tPLH | 10 | 20 | ns | } note 1 |
| | | 10 | | 5 | 10 | | |
| | | 15 | | 5 | 10 | | |
| $A_n \rightarrow V_{os}$ HIGH to LOW | 5 | tPHL | 150 | 305 | ns | } note 2 | |
| | 10 | | 65 | 135 | | | |
| | 15 | | 50 | 100 | | | |
| | LOW to HIGH | 5 | tPLH | 150 | 300 | ns | } note 2 |
| | | 10 | | 75 | 150 | | |
| | | 15 | | 50 | 100 | | |
| Output disable times $\bar{E} \rightarrow V_{os}$ HIGH | 5 | tPHZ | 95 | 190 | ns | } note 3 | |
| | 10 | | 90 | 180 | | | |
| | 15 | | 90 | 180 | | | |
| | LOW | 5 | tPLZ | 100 | 205 | ns | } note 3 |
| | | 10 | | 90 | 180 | | |
| | | 15 | | 90 | 180 | | |
| Output enable times $\bar{E} \rightarrow V_{os}$ HIGH | 5 | tPZH | 130 | 260 | ns | } note 3 | |
| | 10 | | 55 | 115 | | | |
| | 15 | | 45 | 85 | | | |
| | LOW | 5 | tPZL | 120 | 240 | ns | } note 3 |
| | | 10 | | 50 | 100 | | |
| | | 15 | | 35 | 75 | | |

A.C. CHARACTERISTICS

$V_{EE} = V_{SS} = 0\text{ V}$; $T_{amb} = 25\text{ }^{\circ}\text{C}$; input transition times $\leq 20\text{ ns}$

| | V_{DD} V | symbol | typ. | max. | |
|--|---------------|--------|------|------|----------|
| Distortion, sine-wave response | 5 | | 0,25 | % | } note 4 |
| | 10 | | 0,04 | % | |
| | 15 | | 0,04 | % | |
| Crosstalk between any two channels | 5 | | — | MHz | } note 5 |
| | 10 | | 1 | MHz | |
| | 15 | | — | MHz | |
| Crosstalk; enable or address input to output | 5 | | — | mV | } note 6 |
| | 10 | | 50 | mV | |
| | 15 | | — | mV | |
| OFF-state feed-through | 5 | | — | MHz | } note 7 |
| | 10 | | 1 | MHz | |
| | 15 | | — | MHz | |
| ON-state frequency response | 5 | | 13 | MHz | } note 8 |
| | 10 | | 40 | MHz | |
| | 15 | | 70 | MHz | |

NOTES

V_{is} is the input voltage at a Y or Z terminal, whichever is assigned as input.

V_{os} is the output voltage at a Y or Z terminal, whichever is assigned as output.

- $R_L = 10\text{ k}\Omega$ to V_{EE} ; $C_L = 50\text{ pF}$ to V_{EE} ; $\bar{E} = V_{SS}$; $V_{is} = V_{DD}$ (square-wave); see Fig. 8.
- $R_L = 10\text{ k}\Omega$; $C_L = 50\text{ pF}$ to V_{EE} ; $\bar{E} = V_{SS}$; $A_n = V_{DD}$ (square-wave); $V_{is} = V_{DD}$ and R_L to V_{EE} for t_{PLH} ; $V_{is} = V_{EE}$ and R_L to V_{DD} for t_{PHL} ; see Fig. 8.
- $R_L = 10\text{ k}\Omega$; $C_L = 50\text{ pF}$ to V_{EE} ; $\bar{E} = V_{DD}$ (square-wave); $V_{is} = V_{DD}$ and R_L to V_{EE} for t_{PHZ} and t_{PZH} ; $V_{is} = V_{EE}$ and R_L to V_{DD} for t_{PLZ} and t_{PZL} ; see Fig. 8.
- $R_L = 10\text{ k}\Omega$; $C_L = 15\text{ pF}$; channel ON; $V_{is} = \frac{1}{2} V_{DD(p-p)}$ (sine-wave, symmetrical about $\frac{1}{2} V_{DD}$); $f_{is} = 1\text{ kHz}$; see Fig. 9.
- $R_L = 1\text{ k}\Omega$; $V_{is} = \frac{1}{2} V_{DD(p-p)}$ (sine-wave, symmetrical about $\frac{1}{2} V_{DD}$); $20 \log \frac{V_{os}}{V_{is}} = -50\text{ dB}$; see Fig. 10.
- $R_L = 10\text{ k}\Omega$ to V_{EE} ; $C_L = 15\text{ pF}$ to V_{EE} ; \bar{E} or $A_n = V_{DD}$ (square-wave); crosstalk is $|V_{os}|$ (peak value); see Fig. 8.
- $R_L = 1\text{ k}\Omega$; $C_L = 5\text{ pF}$; channel OFF; $V_{is} = \frac{1}{2} V_{DD(p-p)}$ (sine-wave, symmetrical about $\frac{1}{2} V_{DD}$); $20 \log \frac{V_{os}}{V_{is}} = -50\text{ dB}$; see Fig. 9.
- $R_L = 1\text{ k}\Omega$; $C_L = 5\text{ pF}$; channel ON; $V_{is} = \frac{1}{2} V_{DD(p-p)}$ (sine-wave, symmetrical about $\frac{1}{2} V_{DD}$); $20 \log \frac{V_{os}}{V_{is}} = -3\text{ dB}$; see Fig. 9.

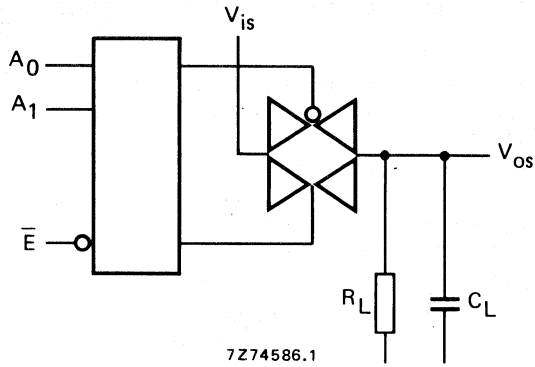

Fig. 8.

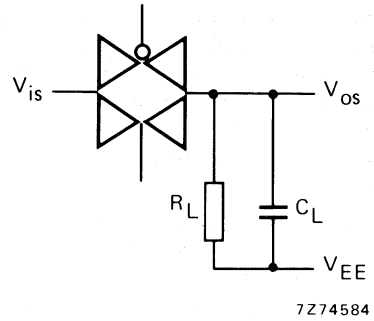

Fig. 9.

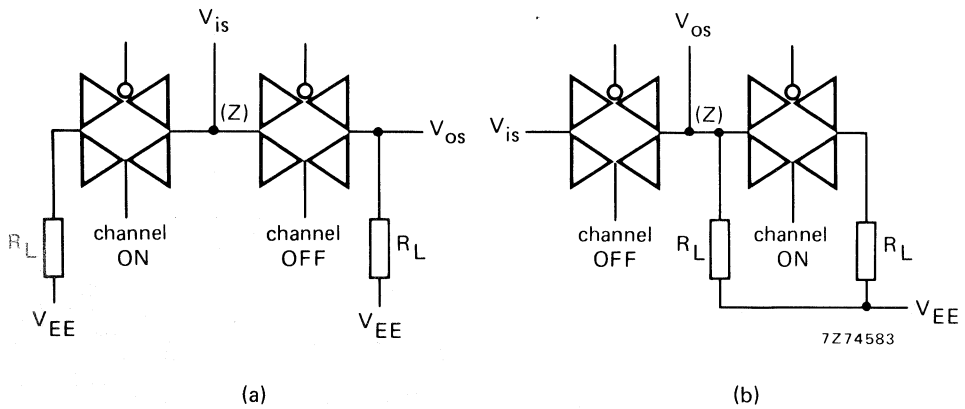

Fig. 10.

APPLICATION INFORMATION

Some examples of applications for the HEF4052B are:

- Analogue multiplexing and demultiplexing.
- Digital multiplexing and demultiplexing.
- Signal gating.

NOTE

If break before make is needed, then it is necessary to use the enable input.

TRIPLE 2-CHANNEL ANALOGUE MULTIPLEXER/DEMULTIPLEXER



The HEF4053B is a triple 2-channel analogue multiplexer/demultiplexer with a common enable input (\bar{E}). Each multiplexer/demultiplexer has two independent inputs/outputs (Y_0 and Y_1), a common input/output (Z), and select inputs (S_n). Each also contains two-bidirectional analogue switches, each with one side connected to an independent input/output (Y_0 and Y_1) and the other side connected to a common input/output (Z).

With \bar{E} LOW, one of the two switches is selected (low impedance ON-state) by S_n . With \bar{E} HIGH, all switches are in the high impedance OFF-state, independent of S_A to S_C .

V_{DD} and V_{SS} are the supply voltage connections for the digital control inputs (S_A to S_C and \bar{E}). The V_{DD} to V_{SS} range is 3 to 15 V. The analogue inputs/outputs (Y_0 , Y_1 and Z) can swing between V_{DD} as a positive limit and V_{EE} as a negative limit. $V_{DD}-V_{EE}$ may not exceed 15 V.

For operation as a digital multiplexer/demultiplexer, V_{EE} is connected to V_{SS} (typically ground).

Fig. 1 Functional diagram.

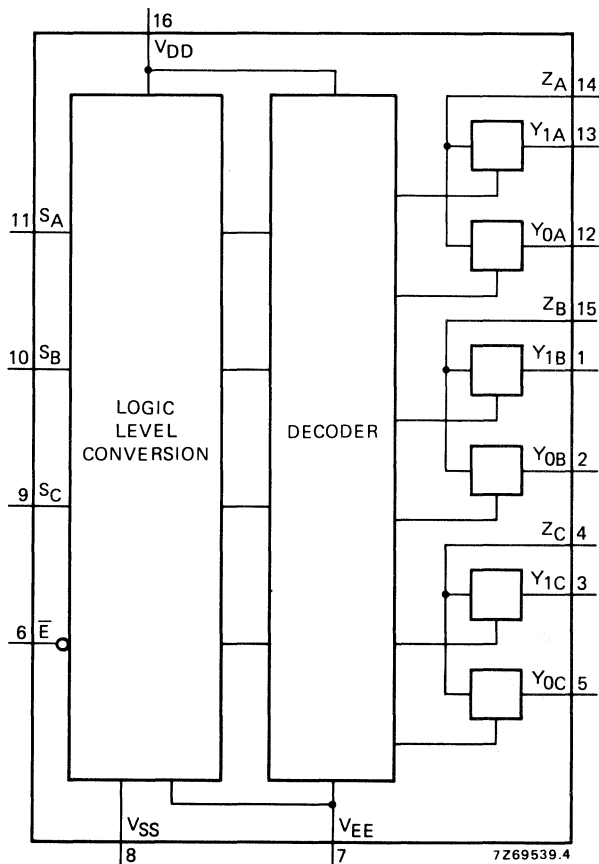

FAMILY DATA

I_{DD} LIMITS category MSI
see Family Specifications

HEF4053B

MSI



Fig. 2 Pinning diagram.

PINNING

| | |
|------------------------------------|----------------------------|
| Y _{0A} to Y _{0C} | independent inputs/outputs |
| Y _{1A} to Y _{1C} | independent inputs/outputs |
| S _A to S _C | select inputs |
| \bar{E} | enable input (active LOW) |
| Z _A to Z _C | common inputs/outputs |

HEF4053BP : 16-lead DIL; plastic (SOT-38Z).
 HEF4053BD: 16-lead DIL; ceramic (cerdip) (SOT-74).
 HEF4053BT : 16-lead mini-pack; plastic (SO-16; SOT-109A).

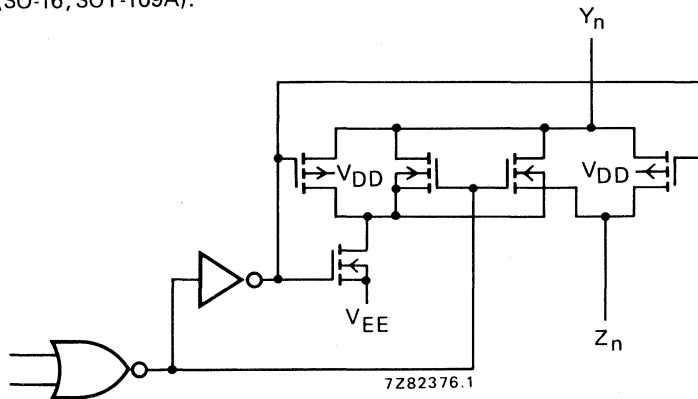

Fig. 3 Schematic diagram (one switch).

FUNCTION TABLE

| inputs | | channel ON |
|-----------|----------------|---------------------------------|
| \bar{E} | S _n | |
| L | L | Y _{0n} -Z _n |
| L | H | Y _{1n} -Z _n |
| H | X | none |

H = HIGH state (the more positive voltage)
 L = LOW state (the less positive voltage)
 X = state is immaterial

RATINGS

Limiting values in accordance with the Absolute Maximum System (IEC 134)

Supply voltage (with reference to V_{DD}) V_{EE} -18 to +0,5 V

NOTE

To avoid drawing V_{DD} current out of terminal Z, when switch current flows into terminals Y, the voltage drop across the bidirectional switch must not exceed 0,4 V. If the switch current flows into terminal Z, no V_{DD} current will flow out of terminals Y, in this case there is no limit for the voltage drop across the switch, but the voltages at Y and Z may not exceed V_{DD} or V_{EE}.

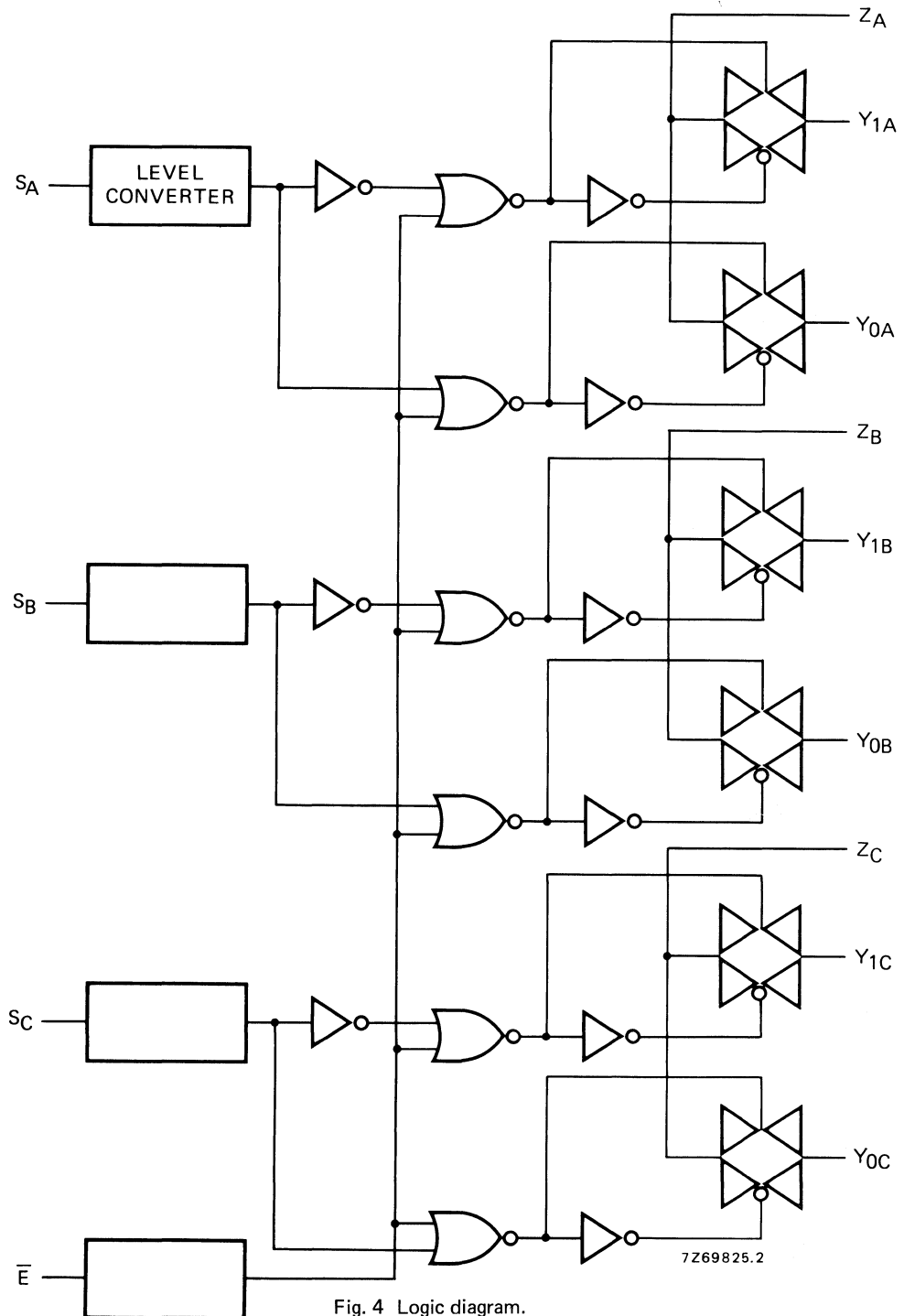

Fig. 4 Logic diagram.

D.C. CHARACTERISTICS

T_{amb} = 25 °C

| | V _{DD} -V _{EE} V | symbol | typ. | max. | conditions |
|---|---------------------------------------|------------------|------|------|---|
| ON resistance | 5 | R _{ON} | 350 | 2500 | } V _{is} = 0 to V _{DD} -V _{EE} see Fig. 6 |
| | 10 | | 80 | 245 | |
| | 15 | | 60 | 175 | |
| ON resistance | 5 | R _{ON} | 115 | 340 | } V _{is} = 0 see Fig. 6 |
| | 10 | | 50 | 160 | |
| | 15 | | 40 | 115 | |
| ON resistance | 5 | R _{ON} | 120 | 365 | } V _{is} = V _{DD} -V _{EE} see Fig. 6 |
| | 10 | | 65 | 200 | |
| | 15 | | 50 | 155 | |
| 'Δ' ON resistance between any two channels | 5 | ΔR _{ON} | 25 | — | } V _{is} = 0 to V _{DD} -V _{EE} see Fig. 6 |
| | 10 | | 10 | — | |
| | 15 | | 5 | — | |
| OFF-state leakage current, all channels OFF | 5 | I _{OZZ} | — | — | } \bar{E} at V _{DD} |
| | 10 | | — | — | |
| | 15 | | — | 1000 | |
| OFF-state leakage current, any channel | 5 | I _{OZY} | — | — | } \bar{E} at V _{SS} |
| | 10 | | — | — | |
| | 15 | | — | 200 | |

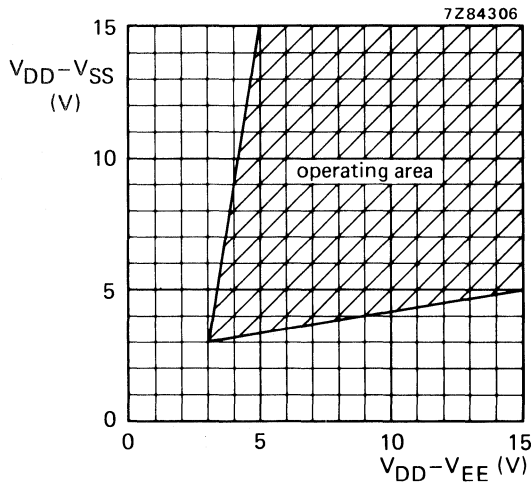

Fig. 5 Operating area as a function of the supply voltages.

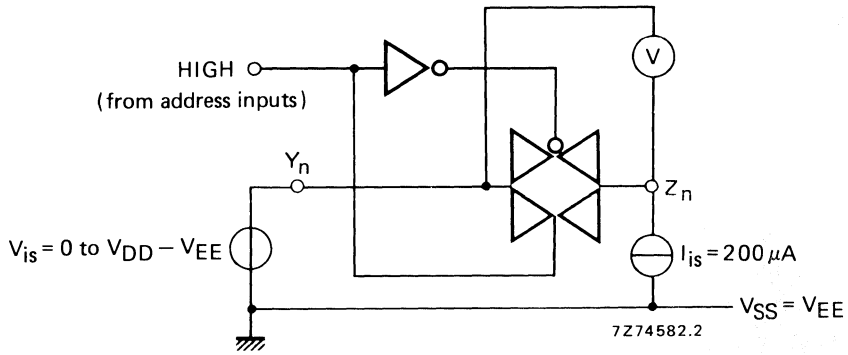

Fig. 6 Test set-up for measuring R_{ON} .

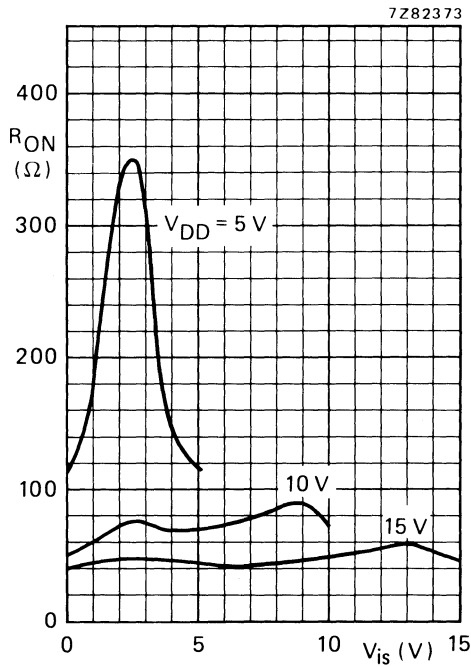

Fig. 7 Typical R_{ON} as a function of input voltage.

$I_{is} = 200 \mu A$
 $V_{SS} = V_{EE} = 0 V$

HEF4053B

MSI

A.C. CHARACTERISTICS

$V_{EE} = V_{SS} = 0\text{ V}$; $T_{amb} = 25\text{ }^\circ\text{C}$; input transition times $\leq 20\text{ ns}$

| | V_{DD} V | typical formula for P (μW) | where f_i = input freq. (MHz) f_o = output freq. (MHz) C_L = load capacitance (pF) $\Sigma(f_o C_L)$ = sum of outputs V_{DD} = supply voltage (V) |
|---|---------------|---|--|
| Dynamic power dissipation per package (P) | 5 | $2\,500 f_i + \Sigma(f_o C_L) \times V_{DD}^2$ | |
| | 10 | $11\,500 f_i + \Sigma(f_o C_L) \times V_{DD}^2$ | |
| | 15 | $29\,000 f_i + \Sigma(f_o C_L) \times V_{DD}^2$ | |

A.C. CHARACTERISTICS

$V_{EE} = V_{SS} = 0\text{ V}$; $T_{amb} = 25\text{ }^\circ\text{C}$; input transition times $\leq 20\text{ ns}$

| | V_{DD} V | symbol | typ. | max. | |
|--|---------------|--------|------|------|-------------|
| Propagation delays $V_{is} \rightarrow V_{os}$ HIGH to LOW | 5 | tPHL | 10 | 20 | ns } note 1 |
| | 10 | | 5 | 10 | |
| | 15 | | 5 | 10 | |
| LOW to HIGH | 5 | tPLH | 15 | 30 | ns } note 1 |
| | 10 | | 5 | 10 | |
| | 15 | | 5 | 10 | |
| $S_n \rightarrow V_{os}$ HIGH to LOW | 5 | tPHL | 200 | 400 | ns } note 2 |
| | 10 | | 85 | 170 | |
| | 15 | | 65 | 130 | |
| LOW to HIGH | 5 | tPLH | 275 | 555 | ns } note 2 |
| | 10 | | 100 | 200 | |
| | 15 | | 65 | 130 | |
| Output disable times $\bar{E} \rightarrow V_{os}$ HIGH | 5 | tPHZ | 200 | 400 | ns } note 3 |
| | 10 | | 115 | 230 | |
| | 15 | | 110 | 220 | |
| LOW | 5 | tPLZ | 200 | 400 | ns } note 3 |
| | 10 | | 120 | 245 | |
| | 15 | | 110 | 215 | |
| Output enable times $\bar{E} \rightarrow V_{os}$ HIGH | 5 | tPZH | 260 | 525 | ns } note 3 |
| | 10 | | 95 | 190 | |
| | 15 | | 65 | 130 | |
| LOW | 5 | tPZL | 280 | 565 | ns } note 3 |
| | 10 | | 105 | 205 | |
| | 15 | | 70 | 140 | |

A.C. CHARACTERISTICS

 $V_{EE} = V_{SS} = 0 \text{ V}$; $T_{amb} = 25 \text{ }^\circ\text{C}$; input transition times $\leq 20 \text{ ns}$

| | V_{DD} V | symbol | typ. | max. | |
|--|---------------|--------|------|------|----------|
| Distortion, sine-wave response | 5 | | 0,25 | % | } note 4 |
| | 10 | | 0,04 | % | |
| | 15 | | 0,04 | % | |
| Crosstalk between any two channels | 5 | | — | MHz | } note 5 |
| | 10 | | 1 | MHz | |
| | 15 | | — | MHz | |
| Crosstalk; enable or address input to output | 5 | | — | mV | } note 6 |
| | 10 | | 50 | mV | |
| | 15 | | — | mV | |
| OFF-state feed-through | 5 | | — | MHz | } note 7 |
| | 10 | | 1 | MHz | |
| | 15 | | — | MHz | |
| ON-state frequency response | 5 | | 13 | MHz | } note 8 |
| | 10 | | 40 | MHz | |
| | 15 | | 70 | MHz | |

NOTES

 V_{is} is the input voltage at a Y or Z terminal, whichever is assigned as input.

 V_{os} is the output voltage at a Y or Z terminal, whichever is assigned as output.

- $R_L = 10 \text{ k}\Omega$ to V_{EE} ; $C_L = 50 \text{ pF}$ to V_{EE} ; $\bar{E} = V_{SS}$; $V_{is} = V_{DD}$ (square-wave); see Fig. 8.
- $R_L = 10 \text{ k}\Omega$; $C_L = 50 \text{ pF}$ to V_{EE} ; $\bar{E} = V_{SS}$; $S_n = V_{DD}$ (square-wave); $V_{is} = V_{DD}$ and R_L to V_{EE} for t_{PLH} ; $V_{is} = V_{EE}$ and R_L to V_{DD} for t_{PHL} ; see Fig. 8.
- $R_L = 10 \text{ k}\Omega$; $C_L = 50 \text{ pF}$ to V_{EE} ; $\bar{E} = V_{DD}$ (square-wave); $V_{is} = V_{DD}$ and R_L to V_{EE} for t_{PHZ} and t_{PZH} ; $V_{is} = V_{EE}$ and R_L to V_{DD} for t_{PLZ} and t_{PZL} ; see Fig. 8.
- $R_L = 10 \text{ k}\Omega$; $C_L = 15 \text{ pF}$; channel ON; $V_{is} = \frac{1}{2} V_{DD}(\text{p-p})$ (sine-wave, symmetrical about $\frac{1}{2} V_{DD}$); $f_{is} = 1 \text{ kHz}$; see Fig. 9.
- $R_L = 1 \text{ k}\Omega$; $V_{is} = \frac{1}{2} V_{DD}(\text{p-p})$ (sine-wave, symmetrical about $\frac{1}{2} V_{DD}$); $20 \log \frac{V_{os}}{V_{is}} = -50 \text{ dB}$; see Fig. 10.
- $R_L = 10 \text{ k}\Omega$ to V_{EE} ; $C_L = 15 \text{ pF}$ to V_{EE} ; \bar{E} or $S_n = V_{DD}$ (square-wave); crosstalk is $|V_{os}|$ (peak value); see Fig. 8.
- $R_L = 1 \text{ k}\Omega$; $C_L = 5 \text{ pF}$; channel OFF; $V_{is} = \frac{1}{2} V_{DD}(\text{p-p})$ (sine-wave, symmetrical about $\frac{1}{2} V_{DD}$); $20 \log \frac{V_{os}}{V_{is}} = -50 \text{ dB}$; see Fig. 9.
- $R_L = 1 \text{ k}\Omega$; $C_L = 5 \text{ pF}$; channel ON; $V_{is} = \frac{1}{2} V_{DD}(\text{p-p})$ (sine-wave, symmetrical about $\frac{1}{2} V_{DD}$); $20 \log \frac{V_{os}}{V_{is}} = -3 \text{ dB}$; see Fig. 9.

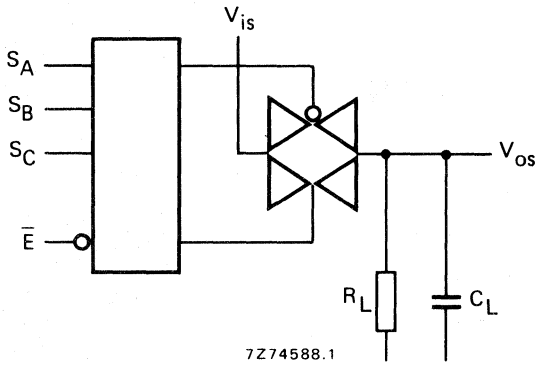

Fig. 8.

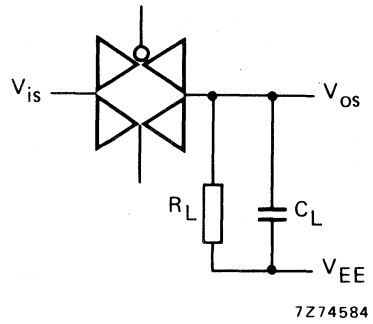

Fig. 9.

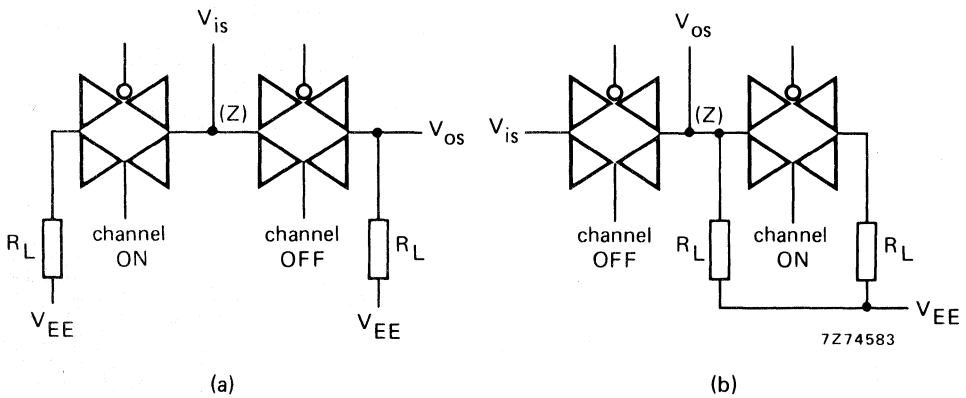

Fig. 10.

APPLICATION INFORMATION

Some examples of applications for the HEF4053B are:

- Analogue multiplexing and demultiplexing.
- Digital multiplexing and demultiplexing.
- Signal gating.

NOTE

If break before make is needed, then it is necessary to use the enable input.

PROGRAMMABLE DIVIDE-BY-N COUNTER

The HEF4059B is a divide-by-n counter which can be programmed to divide an input frequency by any number n from 3 to 15999. The output signal is a one clock-cycle wide pulse and occurs at a rate equal to the input frequency divided by n . The single output (O) has TTL drive capability. The down counter is preset by means of 16 jam inputs (J1 to J16); continued on next page.

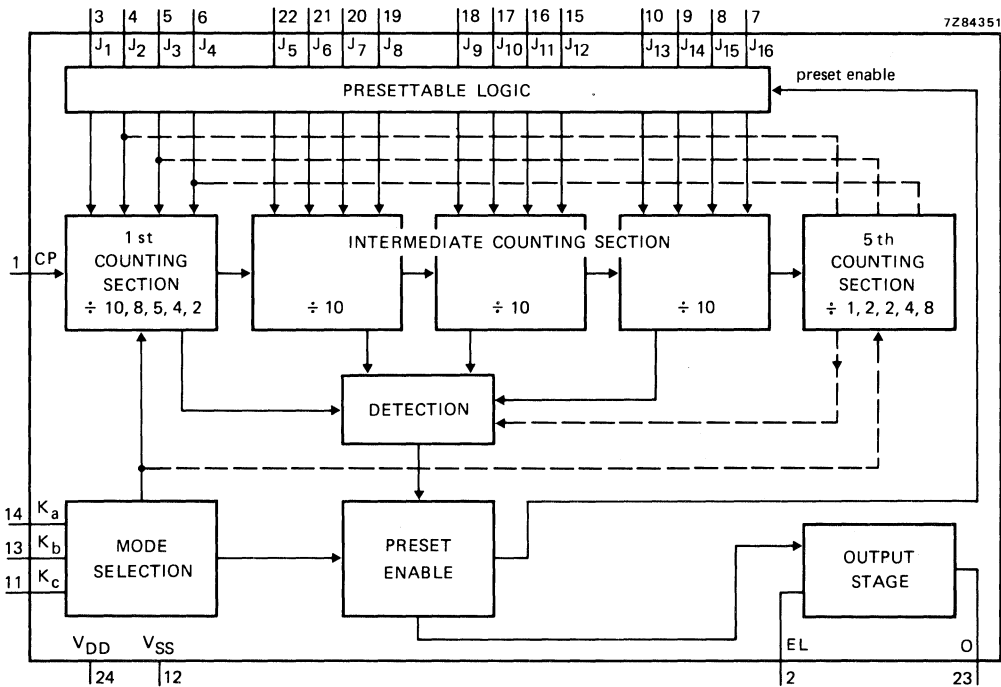
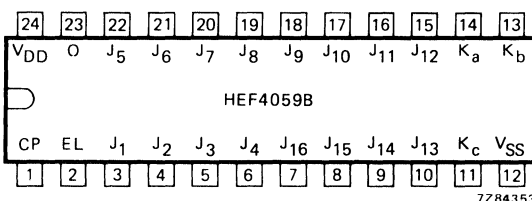

Fig. 1 Functional block diagram.



PINNING

- CP clock input
- K_a, K_b, K_c mode select inputs
- J_1 to J_{16} programmable jam inputs (BCD)
- EL latch enable input
- O divide-by-n output

Fig. 2 Pinning diagram.

- HEF4059BP : 24-lead DIL; plastic (SOT-101A).
- HEF4059BD: 24-lead DIL; ceramic (cerdip) (SOT-94).
- HEF4059BT : 24-lead mini-pack; plastic (SO-24; SOT-137A).

FAMILY DATA

I_{DD} LIMITS category MSI

see Family Specifications

The three mode selection inputs K_a , K_b and K_c determine the modulus ('divide-by' number) of the first and last counting sections in accordance with Table 1.

Every time the first (fastest) counting section goes through one cycle, it reduces, by 1, the number that has been preset (jammed) into the three decades of the intermediate counting section and into the last counting section (which consists of flip-flops that are not needed for operating the first counting section).

For example, in the $\div 2$ mode, only one flip-flop is needed in the first counting section. Therefore the last (5th) counting section has three flip-flops that can be preset to a maximum count of seven with a place value of thousands.

This counting mode is selected when K_a , K_b and K_c are set to HIGH. In this case input J_1 is used to preset the first counting section and J_2 to J_4 are used to preset the last (5th) counting section.

If $\div 10$ mode is desired for the first section, K_a is set HIGH, K_b to HIGH and K_c to LOW. The jam inputs J_1 to J_4 are used to preset the first counting section and there is no last counting section. The intermediate counting section consists of three cascaded BCD decade ($\div 10$) counters, presettable by means of the jam inputs J_5 to J_{16} .

When clock pulses are applied to the clock input after a number n has been preset into the counter, the counter counts down until the DETECTION circuit detects the zero state. At this time the PRESET ENABLE circuit is enabled to preset again the number n into the counter and to produce an output pulse.

The preset of the counter to a desired $\div n$ is achieved as follows:

$$n = (\text{MODE}^*) (1000 \times \text{decade 5 preset} + 100 \times \text{decade 4 preset} + 10 \times \text{decade 3 preset} + 1 \times \text{decade 2 preset}) + \text{decade 1 preset.}$$

$$* \text{MODE} = \text{first counting section divider (10, 8, 5, 4 or 2).}$$

To calculate preset values for any n count, divide the n count by the selected mode. The resultant is the corresponding preset values of the 5th to the 2nd decade with the remainder being equal to the 1st decade value.

$$\text{preset value} = \frac{n}{\text{mode}}.$$

If $n = 8479$, and the selected mode = 5, the preset value = $8479 \div 5 = 1695$ with a remainder of 4, thus the jam inputs must be set as follows:

| | | | | | | | | | | | | | | | |
|-------|-------|-------|-------|-------|-------|-------|-------|-------|----------|----------|----------|----------|----------|----------|----------|
| 4 | 1 | 5 | | | | 9 | | | | 6 | | | | | |
| J_1 | J_2 | J_3 | J_4 | J_5 | J_6 | J_7 | J_8 | J_9 | J_{10} | J_{11} | J_{12} | J_{13} | J_{14} | J_{15} | J_{16} |
| L | L | H | H | H | L | H | L | H | L | L | H | L | H | H | L |

The mode select inputs permit frequency-synthesizer channel separations of 10, 12.5, 20, 25 and 50 parts. These inputs set the maximum value of n at 9999 (when the first counting section divides by 5 or 10) or at 15 999 (when the first counting section divides by 8, 4 or 2).

The three decades of the intermediate counting section can be preset to a binary 15 instead of a binary 9. In this case the first cycle of a counter consists of 15 count pulses, the next cycles consisting of 10 count pulses. Thus the place value of the three decades are still 1, 10 and 100. For example, in the $\div 8$ mode, the number from which the intermediate counting section begins to count-down can be preset to:

$$\begin{array}{r} \text{3rd decade: } 1500 \\ \text{2nd decade: } 150 \\ \text{1st decade: } 15 \\ \hline 1665 \end{array}$$

The last counting section can be preset to a maximum of 1, with a place value of 1000. The total of these numbers (2665) times 8 equals 21 320. The first counting section can be preset to a maximum of 7. Therefore, 21 327 is the maximum possible count in the $\div 8$ mode. The highest count of the various modes is shown in Table 1, in the column entitled 'extended counter range'. Control inputs K_B and K_C can be used to initiate and lock the counter in the 'master preset' mode. In this condition the flip-flops in the counter are preset in accordance with the jam inputs and the counter remains in that mode as long as K_B and K_C both remain LOW. The counter begins to run down from the preset state when a counting mode other than the 'master preset' mode is selected. Whenever the 'master preset' mode is used, control signals $K_B = L$ and $K_C = L$ must be applied for at least 3 full clock pulses. After the master preset mode inputs have been changed to one of the counting modes, the next positive-going clock transition changes an internal flip-flop so that the count-down can begin at the second positive-going clock transition. Thus, after a 'master preset' mode, there is always one extra count before the output goes HIGH. Figure 3 illustrates the operation of the counter in mode $\div 8$ starting from the preset state 3.

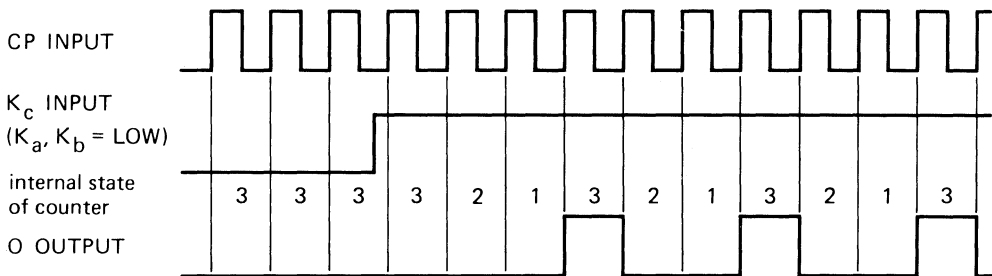

7Z84352

Fig. 3 Total count of 3.

If the 'master preset' mode is started two clock cycles or less before an output pulse, the output pulse will appear at the time due. If the 'master preset' mode is not used the counter is preset in accordance with the 'jam inputs' when the output pulse appears. A HIGH level at the latch enable input (EL) will cause the counter output to remain in the HIGH state until EL input returns to LOW. If the EL input is LOW, the output pulse will remain HIGH for only one cycle of the clock input signal.

When $K_a = L, K_b = H, K_c = L$ and $EL = L$, the counter operates in the 'preset inhibit' mode, with which the dividend of the counter is fixed to 10 000, independent of the state of the jam inputs.

When in the same state of mode select inputs $EL = H$, the counter operates in the normal $\div 10$ mode, however, without the latch operation at the output.

Schmitt-trigger action in the clock input makes the circuit highly tolerant to slower clock rise and fall times.

Table 1

| latch enable input | mode select inputs | | | first counting section | | | last counting section | | | counter range | |
|--------------------|--------------------|----------------|----------------|------------------------|-------------------|---|-----------------------|-------------------|--|---------------|---------------|
| | K _a | K _b | K _c | MODE divides by | max. preset state | jam inputs used | MODE divides by | max. preset state | jam inputs used | design max. | extended max. |
| X | H | H | H | 2 | 1 | J ₁ | 8 | 7 | J ₂ J ₃ J ₄ | 15 999 | 17 331 |
| X | L | H | H | 4 | 3 | J ₁ J ₂ | 4 | 3 | J ₃ J ₄ | 15 999 | 18 663 |
| X | H | L | H | 5 | 4 | J ₁ J ₂ J ₃ | 2 | 1 | J ₄ | 9 999 | 13 329 |
| X | L | L | H | 8 | 7 | J ₁ J ₂ J ₃ | 2 | 1 | J ₄ | 15 999 | 21 327 |
| X | H | H | L | 10 | 9 | J ₁ J ₂ J ₃ J ₄ | 1 | 0 | — | 9 999 | 16 659 |
| H | L | H | L | 10 | 9 | J ₁ J ₂ J ₃ J ₄ | 1 | 0 | — | 9 999 | 16 659 |
| L | L | H | L | preset inhibit | | | preset inhibit | | | fixed 10 000 | — |
| X | X | L | L | master preset | | | master preset | | | — | — |

D.C. CHARACTERISTICS V_{SS} = 0 V

| | V _{DD} V | symbol | T _{amb} (°C) | | | unit | |
|---------------------------------|----------------------|------------------|-----------------------|-------------|-------------|------|--|
| | | | -40 min. | +25 min. | +85 min. | | |
| Output (sink) current LOW | 4,75 | I _{OL} | 2,7 | 2,3 | 1,8 | mA | V _O = 0,4 V; V _I = 0 or 4,75 V |
| | 10 | | 9,5 | 8 | 6,3 | mA | V _O = 0,5 V; V _I = 0 or 10 V |
| | 15 | | 24 | 20 | 16 | mA | V _O = 1,5 V; V _I = 0 or 15 V |
| Output (source) current HIGH | 5 | -I _{OH} | 0,8 | 0,7 | 0,5 | mA | V _O = 4,6 V; V _I = 0 or 5 V |
| | 10 | | 2,4 | 2 | 1,6 | mA | V _O = 9,5 V; V _I = 0 or 10 V |
| | 15 | | 8,4 | 7 | 5,6 | mA | V _O = 13,5 V; V _I = 0 or 15 V |
| Output (source) current HIGH | 5 | -I _{OH} | 2,4 | 2 | 1,6 | mA | V _O = 2,5 V; V _I = 0 or 5 V |

A.C. CHARACTERISTICS

$V_{SS} = 0\text{ V}$; $T_{amb} = 25\text{ }^{\circ}\text{C}$; input transition times $\leq 20\text{ ns}$

| | V_{DD} V | typical formula for P (μW) | |
|--|---------------|--|--|
| Dynamic power dissipation per package (P); n = 3 | 5 | $1\ 100\ f_i + \Sigma(f_o C_L) \times V_{DD}^2$ | where f_i = input freq. (MHz) f_o = output freq. (MHz) C_L = load capacitance (pF) $\Sigma(f_o C_L)$ = sum of outputs V_{DD} = supply voltage (V) |
| | 10 | $5\ 500\ f_i + \Sigma(f_o C_L) \times V_{DD}^2$ | |
| | 15 | $15\ 000\ f_i + \Sigma(f_o C_L) \times V_{DD}^2$ | |
| n = 1000 | 5 | $500\ f_i + \Sigma(f_o C_L) \times V_{DD}^2$ | |
| | 10 | $3\ 500\ f_i + \Sigma(f_o C_L) \times V_{DD}^2$ | |
| | 15 | $9\ 000\ f_i + \Sigma(f_o C_L) \times V_{DD}^2$ | |

A.C. CHARACTERISTICS

$V_{SS} = 0\text{ V}$; $T_{amb} = 25\text{ }^{\circ}\text{C}$; $C_L = 50\text{ pF}$; input transition times $\leq 20\text{ ns}$

| | V_{DD} V | symbol | min. | typ. | max. | typical extrapolation formula | | |
|---|---------------|------------------|------------------|------|------|---|---|---|
| Propagation delays CP \rightarrow O HIGH to LOW | 5 | t _{PHL} | | 90 | 180 | ns | $78\text{ ns} + (0,25\text{ ns/pF})\ C_L$ | |
| | 10 | | 45 | 90 | ns | $40\text{ ns} + (0,10\text{ ns/pF})\ C_L$ | | |
| | 15 | | 35 | 70 | ns | $32\text{ ns} + (0,07\text{ ns/pF})\ C_L$ | | |
| LOW to HIGH | 5 | t _{PLH} | | 100 | 200 | ns | $76\text{ ns} + (0,48\text{ ns/pF})\ C_L$ | |
| | 10 | | 50 | 100 | ns | $40\text{ ns} + (0,20\text{ ns/pF})\ C_L$ | | |
| | 15 | | 40 | 80 | ns | $33\text{ ns} + (0,15\text{ ns/pF})\ C_L$ | | |
| Output transition times HIGH to LOW | 5 | t _{THL} | | 30 | 60 | ns | $10\text{ ns} + (0,40\text{ ns/pF})\ C_L$ | |
| | 10 | | 15 | 30 | ns | $6\text{ ns} + (0,18\text{ ns/pF})\ C_L$ | | |
| | 15 | | 10 | 20 | ns | $4\text{ ns} + (0,13\text{ ns/pF})\ C_L$ | | |
| | LOW to HIGH | 5 | t _{TLH} | | 45 | 90 | ns | $10\text{ ns} + (0,70\text{ ns/pF})\ C_L$ |
| | | 10 | | 25 | 50 | ns | $9\text{ ns} + (0,33\text{ ns/pF})\ C_L$ | |
| | | 15 | | 16 | 32 | ns | $5\text{ ns} + (0,23\text{ ns/pF})\ C_L$ | |
| Maximum clock pulse frequency | 5 | f _{max} | 3,5 | 7 | | MHz | | |
| | 10 | | 7,5 | 15 | | MHz | | |
| | 15 | | 10,0 | 20 | | MHz | | |

14-STAGE RIPPLE-CARRY BINARY COUNTER/DIVIDER AND OSCILLATOR

The HEF4060B is a 14-stage ripple-carry binary counter/divider and oscillator with three oscillator terminals (RS, R_{TC} and C_{TC}), ten buffered outputs (O_3 to O_9 and O_{11} to O_{13}) and an overriding asynchronous master reset input (MR). The oscillator configuration allows design of either RC or crystal oscillator circuits. The oscillator may be replaced by an external clock signal at input RS. The counter advances on the negative-going transition of RS. A HIGH level on MR resets the counter (O_3 to O_9 and O_{11} to O_{13} = LOW), independent of other input conditions.

Schmitt-trigger action in the clock input makes the circuit highly tolerant to slower clock rise and fall times.

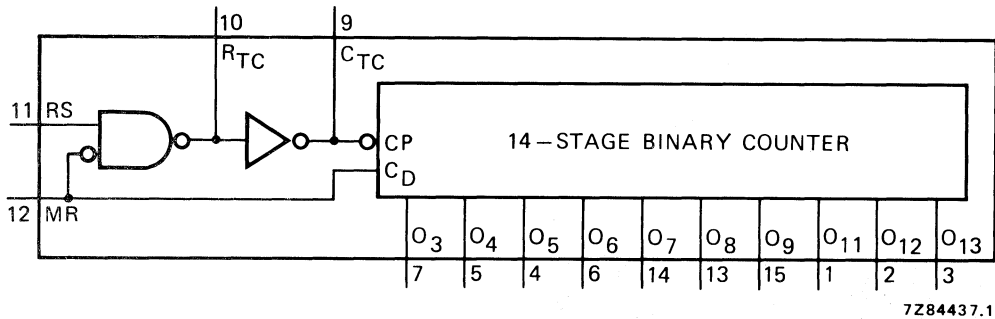
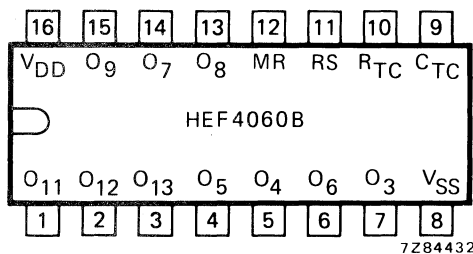

Fig. 1 Functional diagram.



PINNING

| | |
|----------------------|-------------------------------|
| MR | master reset |
| RS | clock input/oscillator pin |
| R_{TC} | oscillator pin |
| C_{TC} | external capacitor connection |
| O_3 to O_9 | } counter outputs |
| O_{11} to O_{13} | |

Fig. 2 Pinning diagram.

HEF4060BP : 16-lead DIL; plastic (SOT-38Z).
 HEF4060BD : 16-lead DIL; ceramic (cerdip) (SOT-74).
 HEF4060BT : 16-lead mini-pack; plastic (SO-16; SOT-109A).

FAMILY DATA

I_{DD} LIMITS category MSI

} see Family Specifications

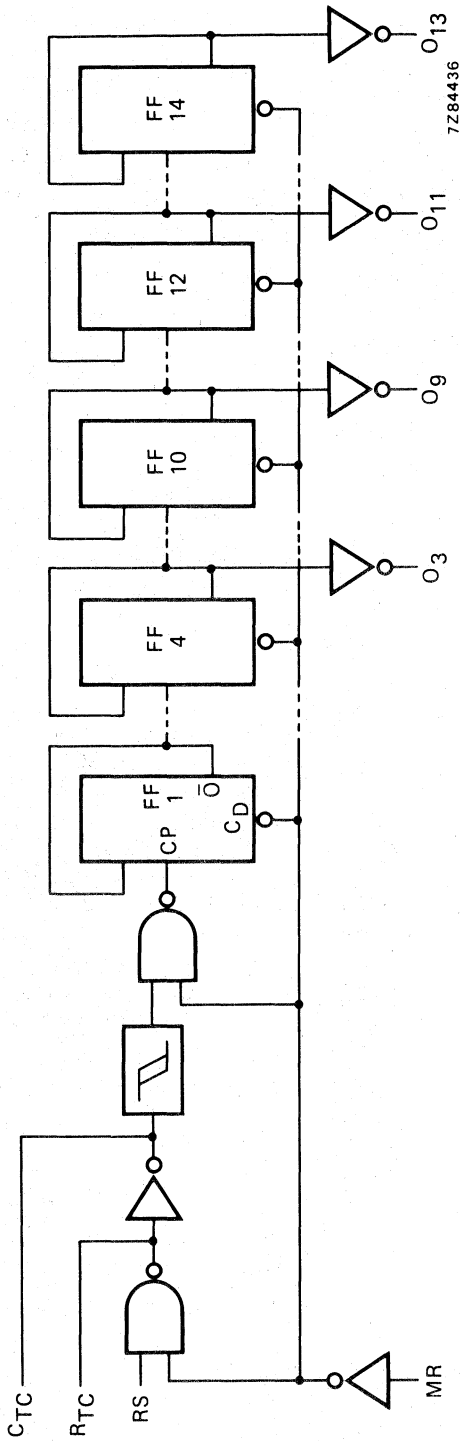

Fig. 3 Logic diagram.

A.C. CHARACTERISTICS

 $V_{SS} = 0\text{ V}$; $T_{amb} = 25\text{ }^{\circ}\text{C}$; $C_L = 50\text{ pF}$; input transition times $\leq 20\text{ ns}$

| | V_{DD} V | symbol | min. | typ. | max. | typical extrapolation formula |
|--|---------------|-------------------|------|--------|-------------------------------------|--------------------------------------|
| Propagation delays RS \rightarrow O ₃ HIGH to LOW | 5 | t _{PHL} | | 210 | 420 ns | 183 ns + (0,55 ns/pF) C _L |
| | 10 | | 80 | 160 ns | 69 ns + (0,23 ns/pF) C _L | |
| | 15 | | 50 | 100 ns | 42 ns + (0,16 ns/pF) C _L | |
| LOW to HIGH | 5 | t _{PLH} | | 210 | 420 ns | 183 ns + (0,55 ns/pF) C _L |
| | 10 | | 80 | 160 ns | 69 ns + (0,23 ns/pF) C _L | |
| | 15 | | 50 | 100 ns | 42 ns + (0,16 ns/pF) C _L | |
| O _n \rightarrow O _{n+1} HIGH to LOW | 5 | t _{PHL} | | 25 | 50 ns | |
| | 10 | | 10 | 20 ns | | |
| | 15 | | 6 | 12 ns | | |
| LOW to HIGH | 5 | t _{PLH} | | 25 | 50 ns | |
| | 10 | | 10 | 20 ns | | |
| | 15 | | 6 | 12 ns | | |
| MR \rightarrow O _n HIGH to LOW | 5 | t _{PHL} | | 100 | 200 ns | 73 ns + (0,55 ns/pF) C _L |
| | 10 | | 40 | 80 ns | 29 ns + (0,23 ns/pF) C _L | |
| | 15 | | 30 | 60 ns | 22 ns + (0,16 ns/pF) C _L | |
| Output transition times HIGH to LOW | 5 | t _{THL} | | 60 | 120 ns | 10 ns + (1,0 ns/pF) C _L |
| | 10 | | 30 | 60 ns | 9 ns + (0,42 ns/pF) C _L | |
| | 15 | | 20 | 40 ns | 6 ns + (0,28 ns/pF) C _L | |
| LOW to HIGH | 5 | t _{TLH} | | 60 | 120 ns | 10 ns + (1,0 ns/pF) C _L |
| | 10 | | 30 | 60 ns | 9 ns + (0,42 ns/pF) C _L | |
| | 15 | | 20 | 40 ns | 6 ns + (0,28 ns/pF) C _L | |
| Minimum clock pulse width input RS HIGH | 5 | t _{WRSH} | 120 | 60 | ns | |
| | 10 | | 50 | 25 | ns | |
| | 15 | | 30 | 15 | ns | |
| Minimum MR pulse width; HIGH | 5 | t _{WMRH} | 50 | 25 | ns | |
| | 10 | | 30 | 15 | ns | |
| | 15 | | 20 | 10 | ns | |
| Recovery time for MR | 5 | t _{RMR} | 160 | 80 | ns | |
| | 10 | | 80 | 40 | ns | |
| | 15 | | 60 | 30 | ns | |
| Maximum clock pulse frequency input RS | 5 | f _{max} | 4 | 8 | MHz | |
| | 10 | | 10 | 20 | MHz | |
| | 15 | | 15 | 30 | MHz | |

A.C. CHARACTERISTICS

$V_{SS} = 0 \text{ V}$; $T_{amb} = 25 \text{ }^\circ\text{C}$; input transition times $\leq 20 \text{ ns}$

| | V_{DD} V | typical formula for P (μW)* |
|---|---------------|--|
| Dynamic power dissipation per package (P) | 5 | $700 f_i + f_o C_L V_{DD}^2$ |
| | 10 | $3300 f_i + f_o C_L V_{DD}^2$ |
| | 15 | $8900 f_i + f_o C_L V_{DD}^2$ |
| Total power dissipation when using the on-chip oscillator (P) | 5 | $700 f_{osc} + f_o C_L V_{DD}^2 + 2C_t V_{DD}^2 f_{osc} + 690 V_{DD}$ |
| | 10 | $3300 f_{osc} + f_o C_L V_{DD}^2 + 2C_t V_{DD}^2 f_{osc} + 6900 V_{DD}$ |
| | 15 | $8900 f_{osc} + f_o C_L V_{DD}^2 + 2C_t V_{DD}^2 f_{osc} + 22000 V_{DD}$ |

* where:

- f_i = input frequency (MHz)
- f_o = output frequency (MHz)
- C_L = load capacitance (pF)
- V_{DD} = supply voltage (V)
- C_t = timing capacitance (pF)
- f_{osc} = oscillator frequency (MHz)

RC oscillator

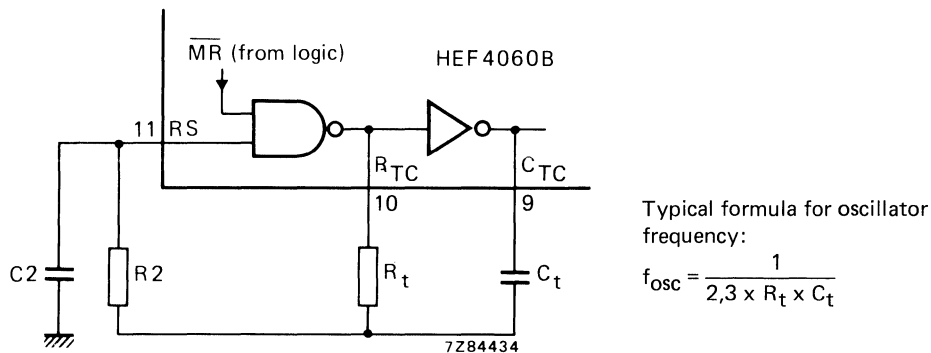

Fig. 4 External component connection for RC oscillator.

Timing component limitations

The oscillator frequency is mainly determined by $R_t C_t$, provided $R_t \ll R_2$ and $R_2 C_2 \ll R_t C_t$. The function of R_2 is to minimize the influence of the forward voltage across the input protection diodes on the frequency. The stray capacitance C_2 should be kept as small as possible. In consideration of accuracy, C_t must be larger than the inherent stray capacitance. R_t must be larger than the LOCMOS 'ON' resistance in series with it, which typically is 500 Ω at $V_{DD} = 5$ V, 300 Ω at $V_{DD} = 10$ V and 200 Ω at $V_{DD} = 15$ V.

The recommended values for these components to maintain agreement with the typical oscillation formula are:

- $C_t \geq 100$ pF, up to any practical value,
- 10 k $\Omega \leq R_t \leq 1$ M Ω .

Typical crystal oscillator circuit

In Fig. 5, R_2 is the power limiting resistor. For starting and maintaining oscillation a minimum transconductance is necessary.

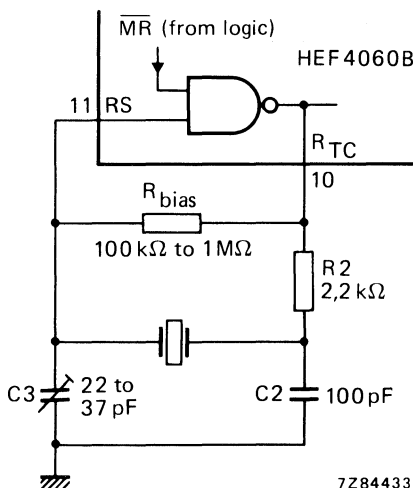

Fig. 5 External component connection for crystal oscillator.

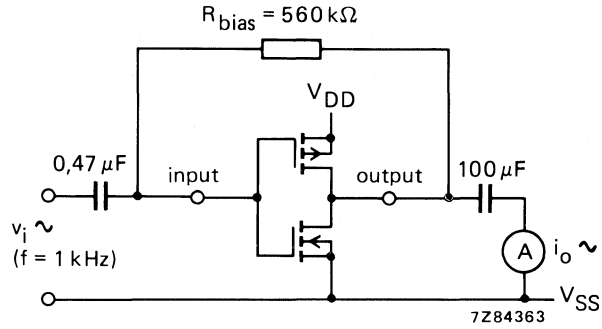
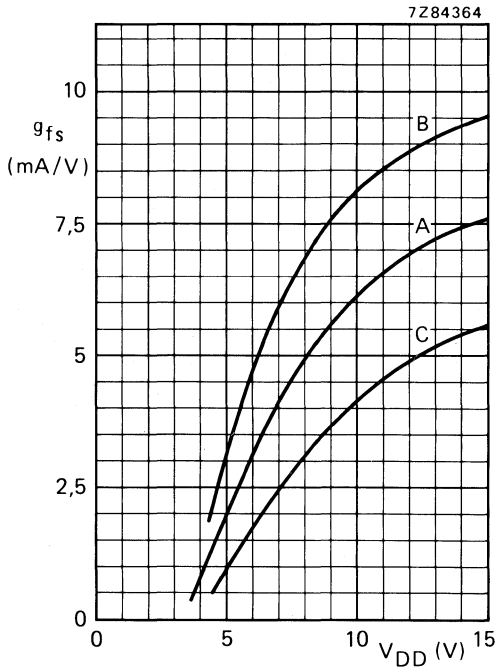

Fig. 6 Test set-up for measuring forward transconductance $g_{fs} = di_o/dv_i$ at v_o is constant (see also graph Fig. 7); MR = LOW.



Curves in Fig. 7:

- A: average
- B: average + 2 s,
- C: average - 2 s, in where:
's' is the observed standard deviation.

Fig. 7 Typical forward transconductance g_{fs} as a function of the supply voltage at $T_{amb} = 25\text{ }^{\circ}\text{C}$.

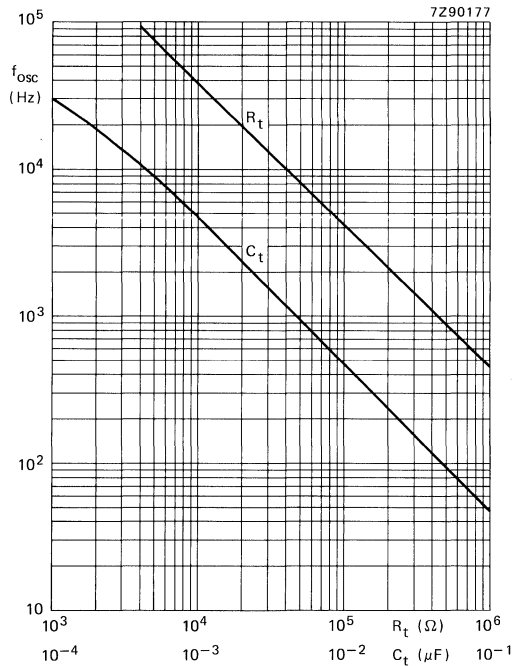

Fig. 8 RC oscillator frequency as a function of R_t and C_t at $V_{DD} = 5$ to 15 V; $T_{amb} = 25$ °C.

C_t curve at $R_t = 100$ k Ω ; $R_2 = 470$ k Ω .

R_t curve at $C_t = 1$ nF; $R_2 = 5 R_t$.

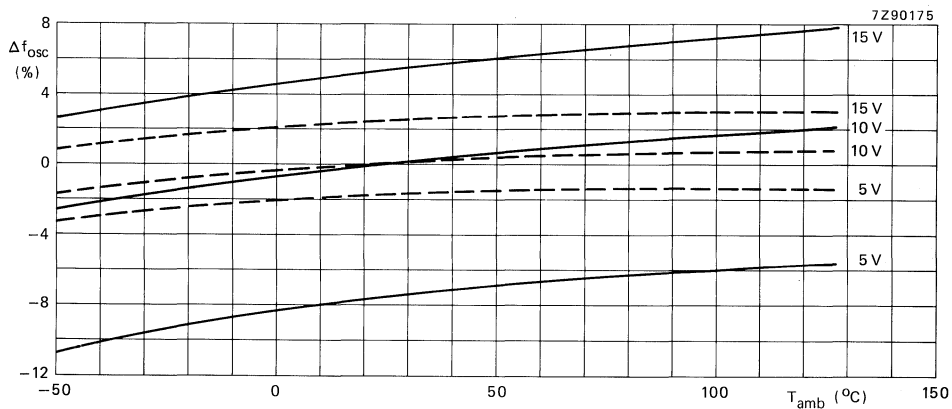

Fig. 9 Oscillator frequency deviation (Δf_{osc}) as a function of ambient temperature; referenced at: f_{osc} at $T_{amb} = 25$ °C and $V_{DD} = 10$ V.

— $R_t = 100$ k Ω ; $C_t = 1$ nF; $R_2 = 0$.

- - - $R_t = 100$ k Ω ; $C_t = 1$ nF; $R_2 = 300$ k Ω .

QUADRUPLE BILATERAL SWITCHES



The HEF4066B has four independent bilateral analogue switches (transmission gates). Each switch has two input/output terminals (Y/Z) and an active HIGH enable input (E). When E is connected to V_{DD} a low impedance bidirectional path between Y and Z is established (ON condition). When E is connected to V_{SS} the switch is disabled and a high impedance between Y and Z is established (OFF condition).

The HEF4066B is pin compatible with the HEF4016B but exhibits a much lower ON resistance. In addition the ON resistance is relatively constant over the full input signal range.

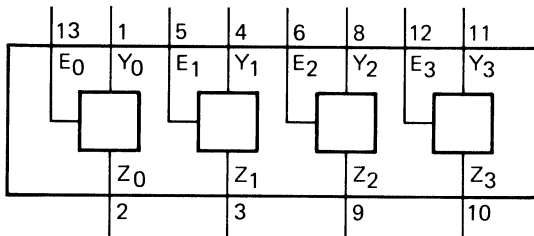

7269571.2

Fig. 1 Functional diagram.

PINNING

E_0 to E_3 enable inputs

Y_0 to Y_3 input/output terminals

Z_0 to Z_3 input/output terminals

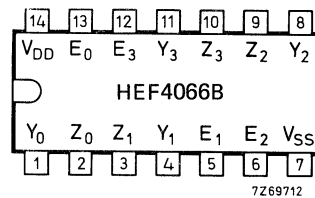

Fig. 2 Pinning diagram.

HEF4066BP : 14-lead DIL; plastic (SOT-27K, M, T).
 HEF4066BD : 14-lead DIL; ceramic (cerdip) (SOT-73).
 HEF4066BT : 14-lead mini-pack; plastic
 (SO-14; SOT-108A).

APPLICATION INFORMATION

An example of application for the HEF4066B is:

- Analogue and digital switching

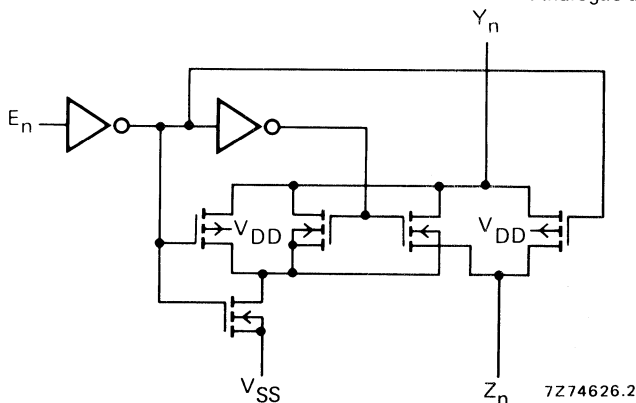

7274626.2

Fig. 3 Schematic diagram (one switch).

HEF4066B

gates

RATINGS

Limiting values in accordance with the Absolute Maximum System (IEC 134)

Power dissipation per switch

P max. 100 mW

For other RATINGS see Family Specifications

D.C. CHARACTERISTICS

T_{amb} = 25 °C

| | V _{DD} V | symbol | min. | typ. | max. | conditions |
|--|----------------------|------------------|------|------|------|---|
| ON resistance | 5 | R _{ON} | — | 350 | 2500 | } E _n at V _{DD} V _{is} = V _{SS} to V _{DD} see Fig. 4 |
| | 10 | | — | 80 | 245 | |
| | 15 | | — | 60 | 175 | |
| ON resistance | 5 | R _{ON} | — | 115 | 340 | } E _n at V _{DD} V _{is} = V _{SS} see Fig. 4 |
| | 10 | | — | 50 | 160 | |
| | 15 | | — | 40 | 115 | |
| ON resistance | 5 | R _{ON} | — | 120 | 365 | } E _n at V _{DD} V _{is} = V _{DD} see Fig. 4 |
| | 10 | | — | 65 | 200 | |
| | 15 | | — | 50 | 155 | |
| 'Δ' ON resistance between any two channels | 5 | ΔR _{ON} | — | 25 | — | } E _n at V _{DD} V _{is} = V _{SS} to V _{DD} see Fig. 4 |
| | 10 | | — | 10 | — | |
| | 15 | | — | 5 | — | |
| OFF state leakage current, any channel OFF | 5 | I _{OZ} | — | — | — | } E _n at V _{SS} |
| | 10 | | — | — | — | |
| | 15 | | — | — | 200 | |
| E _n input voltage LOW | 5 | V _{IL} | — | 2,25 | 1 | } I _{is} = 10 μA see Fig. 9 |
| | 10 | | — | 4,50 | 2 | |
| | 15 | | — | 6,75 | 2 | |

| | V _{DD} V | symbol | T _{amb} (°C) | | | conditions |
|--|----------------------|-------------------|-----------------------|-------------|-------------|--|
| | | | −40 max. | +25 max. | +85 max. | |
| Quiescent device current | 5 | I _{DD} | 1,0 | 1,0 | 7,5 | } V _{SS} = 0; all valid input combinations; V _I = V _{SS} or V _{DD} |
| | 10 | | 2,0 | 2,0 | 15,0 | |
| | 15 | | 4,0 | 4,0 | 30,0 | |
| Input leakage current at E _n | 15 | ± I _{IN} | — | 300 | 1000 | E _n at V _{SS} or V _{DD} |

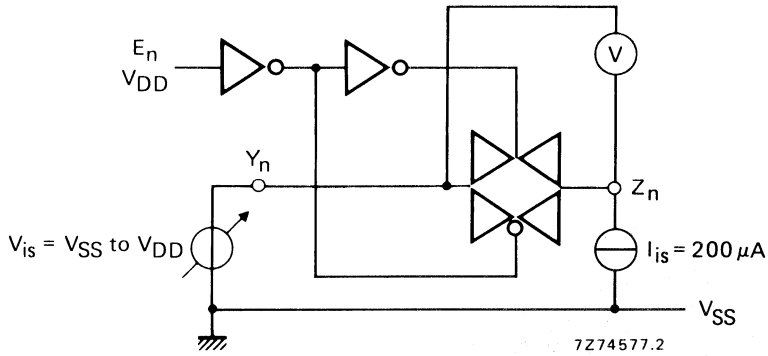

Fig. 4 Test set-up for measuring R_{ON} .

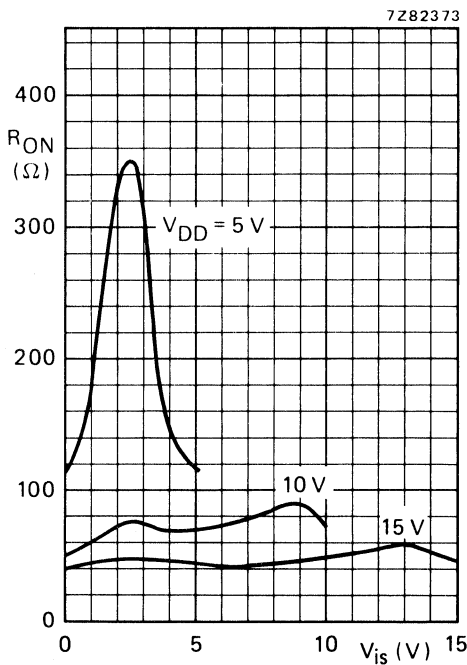

Fig. 5 Typical R_{ON} as a function of input voltage.

E_n at V_{DD}
 $I_{is} = 200 \mu A$
 $V_{SS} = 0 V$

NOTE

To avoid drawing V_{DD} current out of terminal Z, when switch current flows into terminals Y, the voltage drop across the bidirectional switch must not exceed 0,4 V. If the switch current flows into terminal Z, no V_{DD} current will flow out of terminals Y, in this case there is no limit for the voltage drop across the switch, but the voltages at Y and Z may not exceed V_{DD} or V_{SS} .

A.C. CHARACTERISTICS

 $V_{SS} = 0\text{ V}$; $T_{amb} = 25\text{ }^{\circ}\text{C}$; input transition times $\leq 20\text{ ns}$

| | V_{DD} V | symbol | typ. | max. | |
|--|---------------|---|--|------|-----|
| Propagation delays $V_{is} \rightarrow V_{os}$ HIGH to LOW | 5 | t _{PHL} | 10 | 20 | ns |
| | 10 | | 5 | 10 | ns |
| | 15 | | 5 | 10 | ns |
| LOW to HIGH | 5 | t _{PLH} | 10 | 20 | ns |
| | 10 | | 5 | 10 | ns |
| | 15 | | 5 | 10 | ns |
| Output disable times $E_n \rightarrow V_{os}$ HIGH | 5 | t _{PHZ} | 80 | 160 | ns |
| | 10 | | 65 | 130 | ns |
| | 15 | | 60 | 120 | ns |
| LOW | 5 | t _{PLZ} | 80 | 160 | ns |
| | 10 | | 70 | 140 | ns |
| | 15 | | 70 | 140 | ns |
| Output enable times $E_n \rightarrow V_{os}$ HIGH | 5 | t _{PZH} | 40 | 80 | ns |
| | 10 | | 20 | 40 | ns |
| | 15 | | 15 | 30 | ns |
| LOW | 5 | t _{PZL} | 45 | 90 | ns |
| | 10 | | 20 | 40 | ns |
| | 15 | | 15 | 30 | ns |
| Distortion, sine-wave response | 5 | | 0,25 | | % |
| | 10 | | 0,04 | | % |
| | 15 | | 0,04 | | % |
| Crosstalk between any two channels | 5 | | — | | MHz |
| | 10 | | 1 | | MHz |
| | 15 | | — | | MHz |
| Crosstalk; enable input to output | 5 | | — | | mV |
| | 10 | | 50 | | mV |
| | 15 | | — | | mV |
| OFF-state feed-through | 5 | | — | | MHz |
| | 10 | | 1 | | MHz |
| | 15 | | — | | MHz |
| ON-state frequency response | 5 | | — | | MHz |
| | 10 | | 90 | | MHz |
| | 15 | | — | | MHz |
| | V_{DD} V | typical formula for P (μW) | where f_i = input freq. (MHz) f_o = output freq. (MHz) C_L = load capacitance (pF) $\Sigma(f_o C_L)$ = sum of outputs V_{DD} = supply voltage (V) | | |
| Dynamic power dissipation per package (P) | 5 | $800 f_i + \Sigma(f_o C_L) \times V_{DD}^2$ | | | |
| | 10 | $3\,500 f_i + \Sigma(f_o C_L) \times V_{DD}^2$ | | | |
| | 15 | $10\,100 f_i + \Sigma(f_o C_L) \times V_{DD}^2$ | | | |

NOTES

V_{is} is the input voltage at a Y or Z terminal, whichever is assigned as input.

V_{os} is the output voltage at a Y or Z terminal, whichever is assigned as output.

1. $R_L = 10\text{ k}\Omega$ to V_{SS} ; $C_L = 50\text{ pF}$ to V_{SS} ; $E_n = V_{DD}$; $V_{is} = V_{DD}$ (square-wave); see Figs 6 and 10.
2. $R_L = 10\text{ k}\Omega$; $C_L = 50\text{ pF}$ to V_{SS} ; $E_n = V_{DD}$ (square-wave);
 $V_{is} = V_{DD}$ and R_L to V_{SS} for t_{pHZ} and t_{pZH} ;
 $V_{is} = V_{SS}$ and R_L to V_{DD} for t_{pLZ} and t_{pZL} ; see Figs 6 and 11.
3. $R_L = 10\text{ k}\Omega$; $C_L = 15\text{ pF}$; $E_n = V_{DD}$; $V_{is} = \frac{1}{2} V_{DD}(p-p)$ (sine-wave, symmetrical about $\frac{1}{2} V_{DD}$);
 $f_{is} = 1\text{ kHz}$; see Fig. 7.
4. $R_L = 1\text{ k}\Omega$; $V_{is} = \frac{1}{2} V_{DD}(p-p)$ (sine-wave, symmetrical about $\frac{1}{2} V_{DD}$);
 $20 \log \frac{V_{os} (B)}{V_{is} (A)} = -50\text{ dB}$; $E_n (A) = V_{SS}$; $E_n (B) = V_{DD}$; see Fig. 8.
5. $R_L = 10\text{ k}\Omega$ to V_{SS} ; $C_L = 15\text{ pF}$ to V_{SS} ; $E_n = V_{DD}$ (square-wave); crosstalk is $|V_{os}|$ (peak value);
 see Fig. 6.
6. $R_L = 1\text{ k}\Omega$; $C_L = 5\text{ pF}$; $E_n = V_{SS}$; $V_{is} = \frac{1}{2} V_{DD}(p-p)$ (sine-wave, symmetrical about $\frac{1}{2} V_{DD}$);
 $20 \log \frac{V_{os}}{V_{is}} = -50\text{ dB}$; see Fig. 7.
7. $R_L = 1\text{ k}\Omega$; $C_L = 5\text{ pF}$; $E_n = V_{DD}$; $V_{is} = \frac{1}{2} V_{DD}(p-p)$ (sine-wave, symmetrical about $\frac{1}{2} V_{DD}$);
 $20 \log \frac{V_{os}}{V_{is}} = -3\text{ dB}$; see Fig. 7.

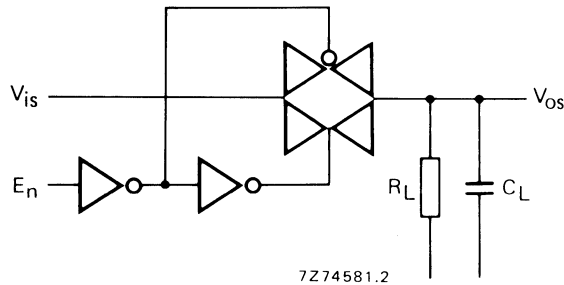

Fig. 6.

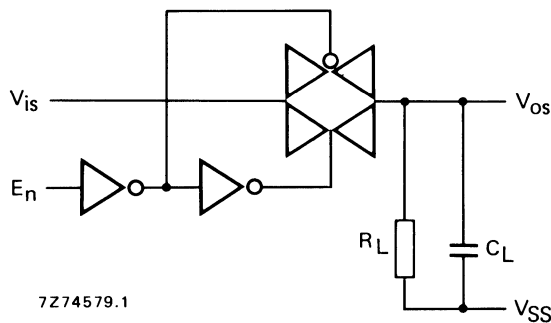

Fig. 7.

HEF4066B
gates

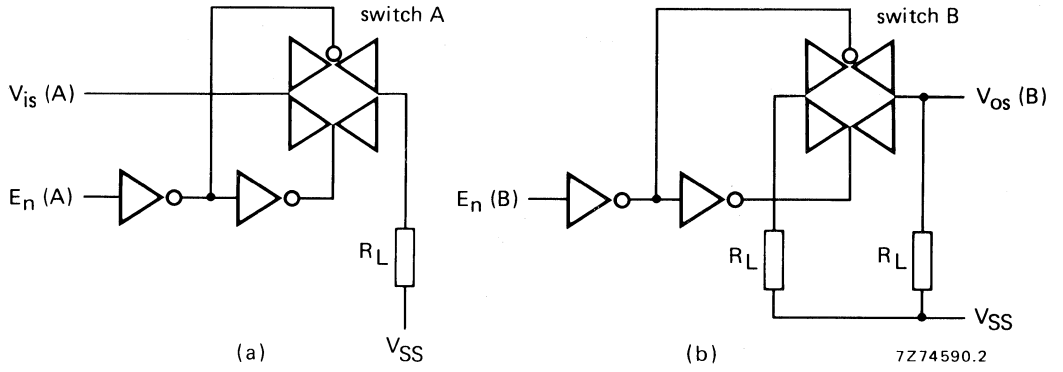

Fig. 8.

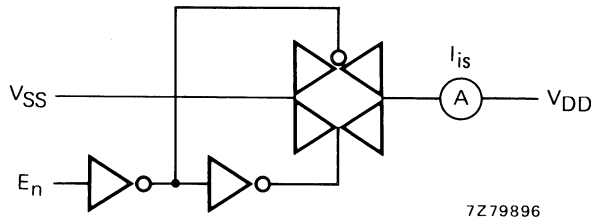

Fig. 9.

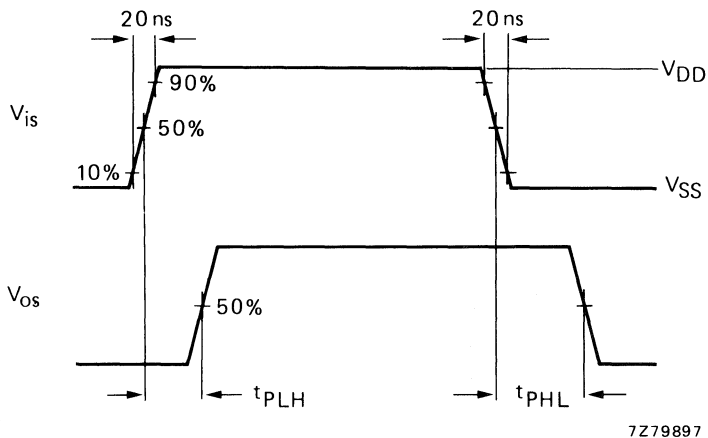
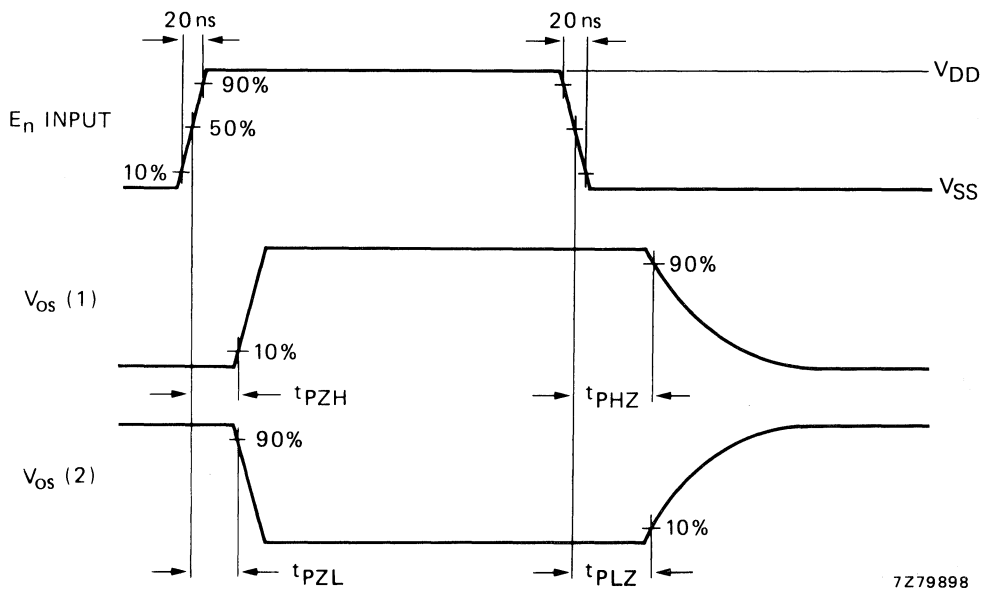

Fig. 10 Waveforms showing propagation delays from V_{is} to V_{os} .



(1) V_{is} at V_{DD} ; (2) V_{is} at V_{SS} .

Fig. 11 Waveforms showing output disable and enable times.

16-CHANNEL ANALOGUE MULTIPLEXER/DEMULTIPLEXER



The HEF4067B is a 16-channel analogue multiplexer/demultiplexer with four address inputs (A_0 to A_3), an active LOW enable input (\bar{E}), sixteen independent inputs/outputs (Y_0 to Y_{15}) and a common input/output (Z).

The device contains sixteen bidirectional analogue switches, each with one side connected to an independent input/output (Y_0 to Y_{15}) and the other side connected to the common input/output (Z).

With \bar{E} LOW, one of the sixteen switches is selected (low impedance ON-state) by A_0 to A_3 . All unselected switches are in the high impedance OFF-state. With \bar{E} HIGH all switches are in the high impedance OFF-state, independent of A_0 to A_3 .

The analogue inputs/outputs (Y_0 to Y_{15} and Z) can swing between V_{DD} as a positive limit and V_{SS} as a negative limit. V_{DD} to V_{SS} may not exceed 15 V.

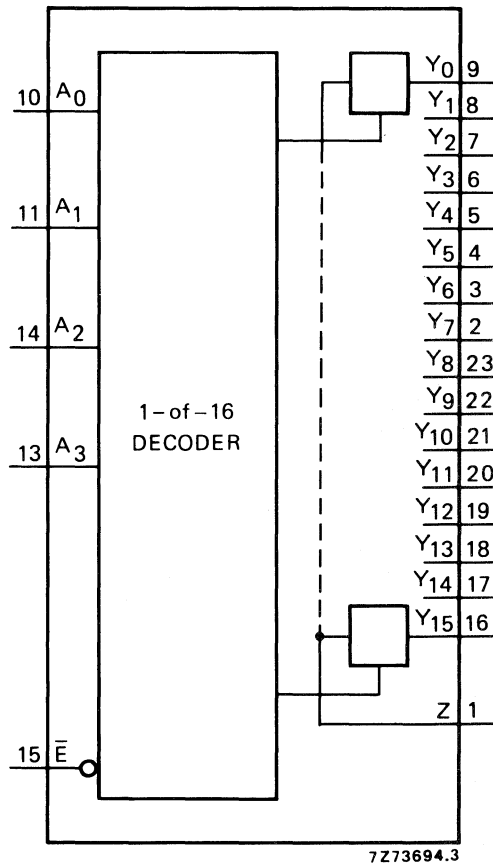

Fig. 1 Functional diagram.

FAMILY DATA

I_{DD} LIMITS category MSI
see Family Specifications

7273694.3

HEF4067B
MSI

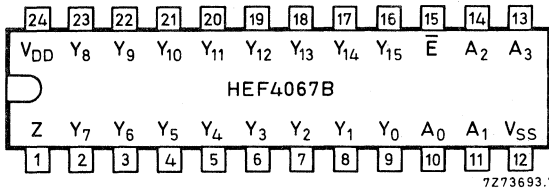

HEF4067BP : 24-lead DIL; plastic (SOT-101A).
 HEF4067BD: 24-lead DIL; ceramic (cerdip) (SOT-94).
 HEF4067BT: 24-lead mini-pack; plastic (SO-24; SOT-137A).

Fig. 2 Pinning diagram.

PINNING

Y₀ to Y₁₅ independent inputs/outputs
 A₀ to A₃ address inputs
 E-bar enable input (active LOW)
 Z common input/output

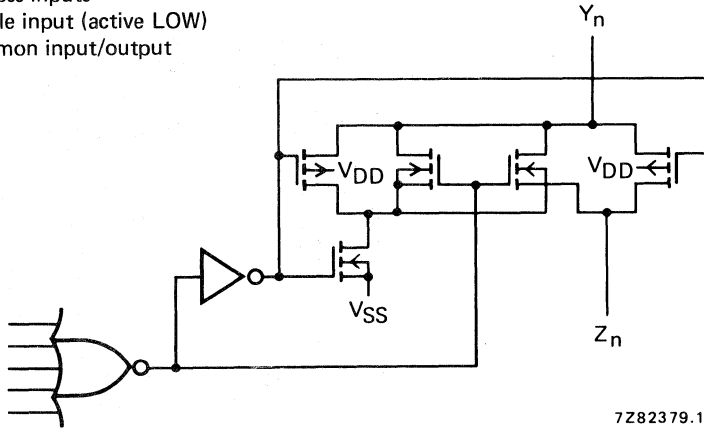

Fig. 3 Schematic diagram (one switch).

FUNCTION TABLE

| inputs | | | | | channel ON |
|--------|----------------|----------------|----------------|----------------|---------------------|
| E | A ₃ | A ₂ | A ₁ | A ₀ | |
| L | L | L | L | L | Y ₀ - Z |
| L | L | L | L | H | Y ₁ - Z |
| L | L | L | H | L | Y ₂ - Z |
| L | L | L | H | H | Y ₃ - Z |
| L | L | H | L | L | Y ₄ - Z |
| L | L | H | L | H | Y ₅ - Z |
| L | L | H | H | L | Y ₆ - Z |
| L | L | H | H | H | Y ₇ - Z |
| L | H | L | L | L | Y ₈ - Z |
| L | H | L | L | H | Y ₉ - Z |
| L | H | L | H | L | Y ₁₀ - Z |
| L | H | L | H | H | Y ₁₁ - Z |
| L | H | H | L | L | Y ₁₂ - Z |
| L | H | H | L | H | Y ₁₃ - Z |
| L | H | H | H | L | Y ₁₄ - Z |
| L | H | H | H | H | Y ₁₅ - Z |
| H | X | X | X | X | none |

H = HIGH state (the more positive voltage)
 L = LOW state (the less positive voltage)
 X = state is immaterial

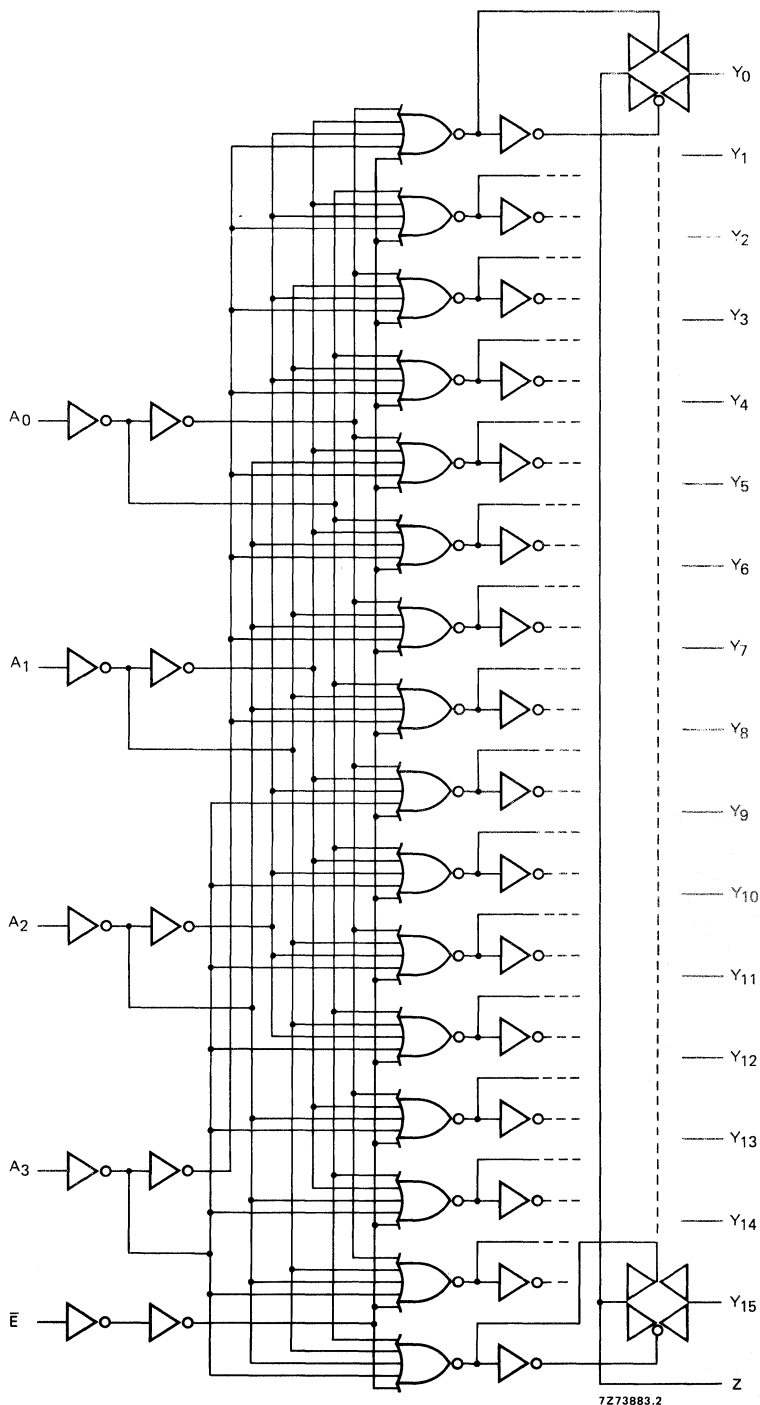

Fig. 4 Logic diagram.

D.C. CHARACTERISTICS

 $T_{amb} = 25\text{ }^{\circ}\text{C}$

| | V_{DD} V | symbol | typ. | max. | conditions |
|---|---------------|------------------|------|------|---|
| ON resistance | 5 | R _{ON} | 350 | 2500 | } $V_{is} = V_{SS}$ to V_{DD} see Fig. 5 |
| | 10 | | 80 | 245 | |
| | 15 | | 60 | 175 | |
| ON resistance | 5 | R _{ON} | 115 | 340 | } $V_{is} = V_{SS}$ see Fig. 5 |
| | 10 | | 50 | 160 | |
| | 15 | | 40 | 115 | |
| ON resistance | 5 | R _{ON} | 120 | 365 | } $V_{is} = V_{DD}$ see Fig. 5 |
| | 10 | | 65 | 200 | |
| | 15 | | 50 | 155 | |
| 'Δ' ON resistance between any two channels | 5 | ΔR _{ON} | 25 | — | } $V_{is} = V_{SS}$ to V_{DD} see Fig. 5 |
| | 10 | | 10 | — | |
| | 15 | | 5 | — | |
| OFF-state leakage current, all channels OFF | 5 | I _{OZZ} | — | — | } \bar{E} at V_{DD} |
| | 10 | | — | — | |
| | 15 | | — | 1000 | |
| OFF-state leakage current, any channel | 5 | I _{OZY} | — | — | } \bar{E} at V_{SS} |
| | 10 | | — | — | |
| | 15 | | — | 200 | |

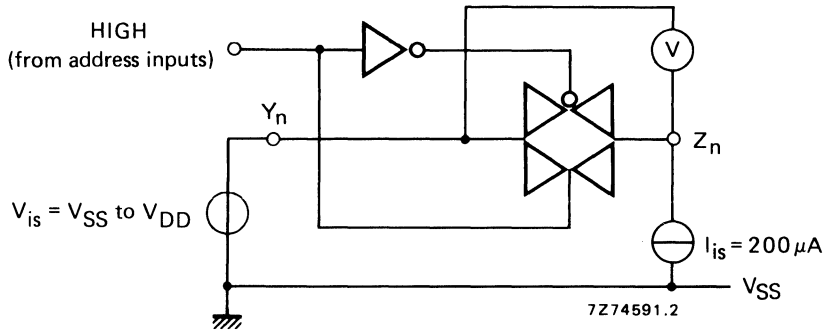

Fig. 5 Test set-up for measuring R_{ON} .

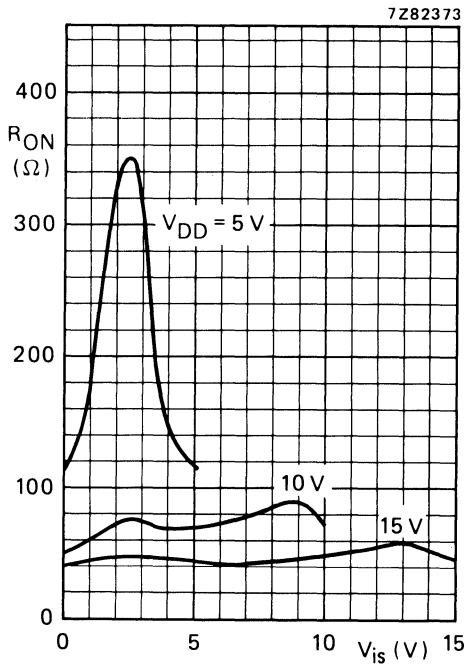

Fig. 6 Typical R_{ON} as a function of input voltage.

$I_{is} = 200 \mu A$
 $V_{SS} = 0 V$

NOTE

To avoid drawing V_{DD} current out of terminal Z, when switch current flows into terminals Y, the voltage drop across the bidirectional switch must not exceed 0,4 V. If the switch current flows into terminal Z, no V_{DD} current will flow out of terminals Y, in this case there is no limit for the voltage drop across the switch, but the voltages at Y and Z may not exceed V_{DD} or V_{SS} .

A.C. CHARACTERISTICS

 $V_{SS} = 0 \text{ V}$; $T_{amb} = 25 \text{ }^\circ\text{C}$; input transition times $\leq 20 \text{ ns}$

| | V_{DD} V | typical formula for P (μW) | where f_i = input freq. (MHz) f_o = output freq. (MHz) C_L = load capacitance (pF) $\Sigma(f_o C_L)$ = sum of outputs V_{DD} = supply voltage (V) |
|---|---------------|---|--|
| Dynamic power dissipation per package (P) | 5 | $1\ 100 f_i + \Sigma(f_o C_L) \times V_{DD}^2$ | |
| | 10 | $5\ 000 f_i + \Sigma(f_o C_L) \times V_{DD}^2$ | |
| | 15 | $13\ 300 f_i + \Sigma(f_o C_L) \times V_{DD}^2$ | |

A.C. CHARACTERISTICS

 $V_{SS} = 0 \text{ V}$; $T_{amb} = 25 \text{ }^\circ\text{C}$; input transition times $\leq 20 \text{ ns}$

| | V_{DD} V | symbol | typ. | max. | | |
|--|---------------|-----------|------|------|----|----------|
| Propagation delays $V_{is} \rightarrow V_{os}$ HIGH to LOW | 5 | t_{PHL} | 30 | 60 | ns | } note 1 |
| | 10 | | 15 | 25 | ns | |
| | 15 | | 10 | 20 | ns | |
| LOW to HIGH | 5 | t_{PLH} | 25 | 50 | ns | } note 1 |
| | 10 | | 10 | 20 | ns | |
| | 15 | | 10 | 20 | ns | |
| $A_n \rightarrow V_{os}$ HIGH to LOW | 5 | t_{PHL} | 190 | 380 | ns | } note 2 |
| | 10 | | 70 | 145 | ns | |
| | 15 | | 50 | 100 | ns | |
| LOW to HIGH | 5 | t_{PLH} | 175 | 345 | ns | } note 2 |
| | 10 | | 70 | 140 | ns | |
| | 15 | | 50 | 100 | ns | |
| Output disable times $\bar{E} \rightarrow V_{os}$ HIGH | 5 | t_{PHZ} | 195 | 385 | ns | } note 3 |
| | 10 | | 140 | 280 | ns | |
| | 15 | | 130 | 260 | ns | |
| LOW | 5 | t_{PLZ} | 215 | 435 | ns | } note 3 |
| | 10 | | 180 | 355 | ns | |
| | 15 | | 170 | 340 | ns | |
| Output enable times $\bar{E} \rightarrow V_{os}$ HIGH | 5 | t_{PZH} | 155 | 315 | ns | } note 3 |
| | 10 | | 70 | 135 | ns | |
| | 15 | | 50 | 100 | ns | |
| LOW | 5 | t_{PZL} | 170 | 340 | ns | } note 3 |
| | 10 | | 70 | 140 | ns | |
| | 15 | | 50 | 100 | ns | |

A.C. CHARACTERISTICS

$V_{SS} = 0\text{ V}$; $T_{amb} = 25\text{ }^{\circ}\text{C}$; input transition times $\leq 20\text{ ns}$

| | V_{DD} V | symbol | typ. | max. | |
|--|---------------|--------|------|------|----------|
| Distortion, sine-wave response | 5 | | 0,25 | % | } note 4 |
| | 10 | | 0,04 | % | |
| | 15 | | 0,04 | % | |
| Crosstalk between any two channels | 5 | | — | MHz | } note 5 |
| | 10 | | 1 | MHz | |
| | 15 | | — | MHz | |
| Crosstalk; enable or address input to output | 5 | | — | mV | } note 6 |
| | 10 | | 50 | mV | |
| | 15 | | — | mV | |
| OFF-state feed-through | 5 | | — | MHz | } note 7 |
| | 10 | | 1 | MHz | |
| | 15 | | — | MHz | |
| ON-state frequency response | 5 | | 13 | MHz | } note 8 |
| | 10 | | 40 | MHz | |
| | 15 | | 70 | MHz | |

NOTES

V_{is} is the input voltage at a Y or Z terminal, whichever is assigned as input.

V_{os} is the output voltage at a Y or Z terminal, whichever is assigned as output.

- $R_L = 10\text{ k}\Omega$ to V_{SS} ; $C_L = 50\text{ pF}$ to V_{SS} ; $\bar{E} = V_{SS}$; $V_{is} = V_{DD}$ (square-wave); see Fig. 7.
- $R_L = 10\text{ k}\Omega$; $C_L = 50\text{ pF}$ to V_{SS} ; $\bar{E} = V_{SS}$; $A_n = V_{DD}$ (square-wave); $V_{is} = V_{DD}$ and R_L to V_{SS} for t_{PLH} ; $V_{is} = V_{SS}$ and R_L to V_{DD} for t_{PHL} ; see Fig. 7.
- $R_L = 10\text{ k}\Omega$; $C_L = 50\text{ pF}$ to V_{SS} ; $\bar{E} = V_{DD}$ (square-wave); $V_{is} = V_{DD}$ and R_L to V_{SS} for t_{PHZ} and t_{PZH} ; $V_{is} = V_{SS}$ and R_L to V_{DD} for t_{PLZ} and t_{PZL} ; see Fig. 7.
- $R_L = 10\text{ k}\Omega$; $C_L = 15\text{ pF}$; channel ON; $V_{is} = \frac{1}{2} V_{DD(p-p)}$ (sine-wave, symmetrical about $\frac{1}{2} V_{DD}$); $f_{is} = 1\text{ kHz}$; see Fig. 8.
- $R_L = 1\text{ k}\Omega$; $V_{is} = \frac{1}{2} V_{DD(p-p)}$ (sine-wave, symmetrical about $\frac{1}{2} V_{DD}$); $20 \log \frac{V_{os}}{V_{is}} = -50\text{ dB}$; see Fig. 9.
- $R_L = 10\text{ k}\Omega$ to V_{SS} ; $C_L = 15\text{ pF}$ to V_{SS} ; \bar{E} or $A_n = V_{DD}$ (square-wave); crosstalk is $|V_{os}|$ (peak value); see Fig. 7.
- $R_L = 1\text{ k}\Omega$; $C_L = 5\text{ pF}$; channel OFF; $V_{is} = \frac{1}{2} V_{DD(p-p)}$ (sine-wave, symmetrical about $\frac{1}{2} V_{DD}$); $20 \log \frac{V_{os}}{V_{is}} = -50\text{ dB}$; see Fig. 8.
- $R_L = 1\text{ k}\Omega$; $C_L = 5\text{ pF}$; channel ON; $V_{is} = \frac{1}{2} V_{DD(p-p)}$ (sine-wave, symmetrical about $\frac{1}{2} V_{DD}$); $20 \log \frac{V_{os}}{V_{is}} = -3\text{ dB}$; see Fig. 8.

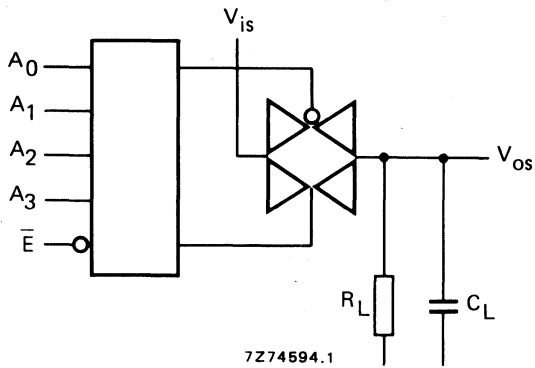

Fig. 7.

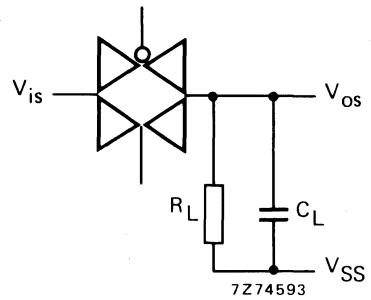

Fig. 8.

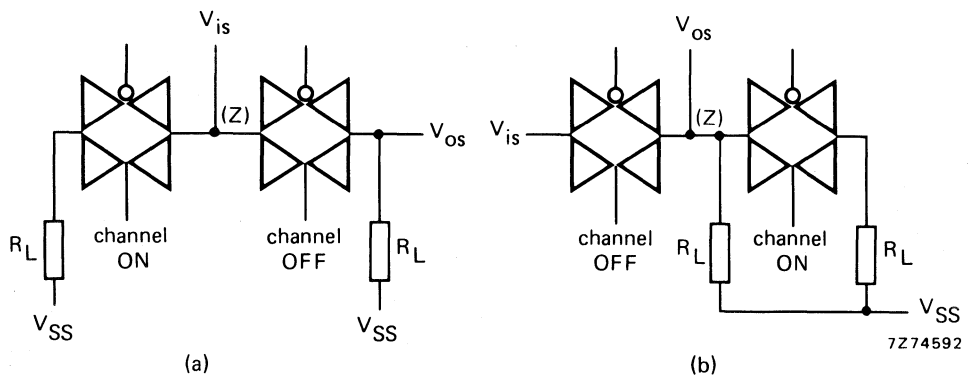

Fig. 9.

APPLICATION INFORMATION

Some examples of applications for the HEF4067B are:

- Analogue multiplexing and demultiplexing.
- Digital multiplexing and demultiplexing.
- Signal gating.

NOTE

If break before make is needed, then it is necessary to use the enable input.

8-INPUT NAND GATE



The HEF4068B provides the 8-input NAND function. The outputs are fully buffered for highest noise immunity and pattern insensitivity of output impedance.

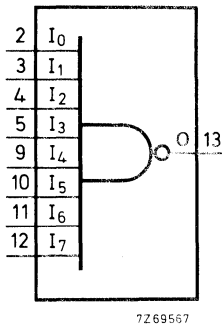

Fig. 1 Functional diagram.

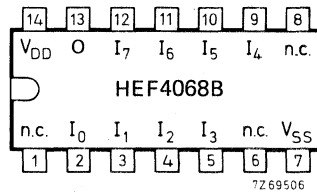

Fig. 2 Pinning diagram.

HEF4068BP : 14-lead DIL; plastic (SOT-27K, M, T).
 HEF4068BD : 14-lead DIL; ceramic (cerdip) (SOT-73).
 HEF4068BT : 14-lead mini-pack; plastic (SO-14; SOT-108A).

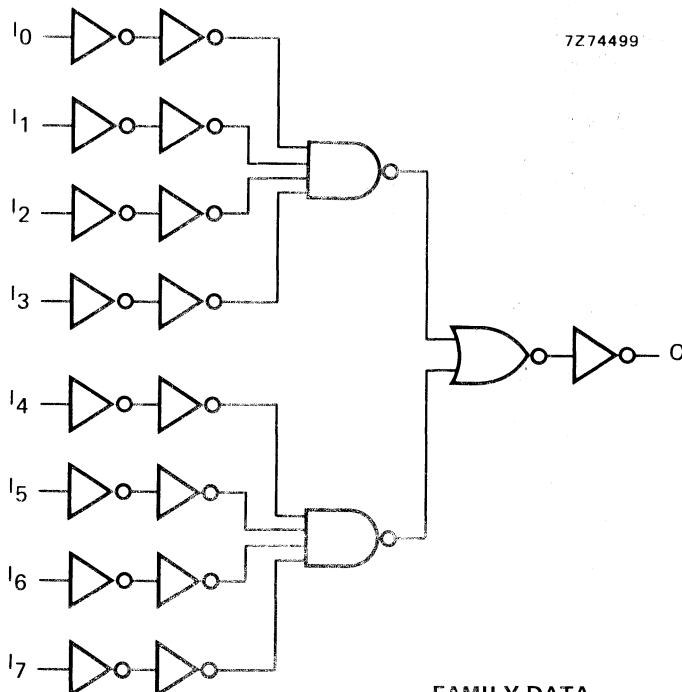

Fig. 3 Logic diagram.

FAMILY DATA

I_{DD} LIMITS category GATES

} see Family Specifications

HEF4068B

gates

A.C. CHARACTERISTICS

$V_{SS} = 0 \text{ V}$; $T_{amb} = 25 \text{ }^\circ\text{C}$; $C_L = 50 \text{ pF}$; input transition times $\leq 20 \text{ ns}$

| | V_{DD} V | symbol | typ. | max. | | typical extrapolation formula |
|--|---------------|-----------|------|------|----|--|
| Propagation delays $I_n \rightarrow 0$ HIGH to LOW | 5 | t_{PHL} | 95 | 195 | ns | $68 \text{ ns} + (0,55 \text{ ns/pF}) C_L$ |
| | 10 | | 40 | 85 | ns | $29 \text{ ns} + (0,23 \text{ ns/pF}) C_L$ |
| | 15 | | 30 | 65 | ns | $22 \text{ ns} + (0,16 \text{ ns/pF}) C_L$ |
| LOW to HIGH | 5 | t_{PLH} | 80 | 165 | ns | $53 \text{ ns} + (0,55 \text{ ns/pF}) C_L$ |
| | 10 | | 35 | 70 | ns | $24 \text{ ns} + (0,23 \text{ ns/pF}) C_L$ |
| | 15 | | 30 | 60 | ns | $22 \text{ ns} + (0,16 \text{ ns/pF}) C_L$ |
| Output transition times HIGH to LOW | 5 | t_{THL} | 60 | 120 | ns | $10 \text{ ns} + (1,0 \text{ ns/pF}) C_L$ |
| | 10 | | 30 | 60 | ns | $9 \text{ ns} + (0,42 \text{ ns/pF}) C_L$ |
| | 15 | | 20 | 40 | ns | $6 \text{ ns} + (0,28 \text{ ns/pF}) C_L$ |
| LOW to HIGH | 5 | t_{TLH} | 60 | 120 | ns | $10 \text{ ns} + (1,0 \text{ ns/pF}) C_L$ |
| | 10 | | 30 | 60 | ns | $9 \text{ ns} + (0,42 \text{ ns/pF}) C_L$ |
| | 15 | | 20 | 40 | ns | $6 \text{ ns} + (0,28 \text{ ns/pF}) C_L$ |

| | V_{DD} V | typical formula for P (μW) | where |
|---|---------------|--|------------------------------------|
| Dynamic power dissipation per package (P) | 5 | $700 f_i + \Sigma(f_o C_L) \times V_{DD}^2$ | f_i = input freq. (MHz) |
| | 10 | $2900 f_i + \Sigma(f_o C_L) \times V_{DD}^2$ | f_o = output freq. (MHz) |
| | 15 | $7200 f_i + \Sigma(f_o C_L) \times V_{DD}^2$ | C_L = load capacitance (pF) |
| | | | $\Sigma(f_o C_L)$ = sum of outputs |
| | | | V_{DD} = supply voltage (V) |

HEX INVERTER



The HEF4069UB is a general purpose hex inverter. Each of the six inverters is a single stage.

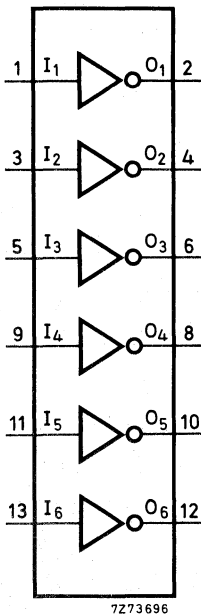

Fig. 1 Functional diagram.

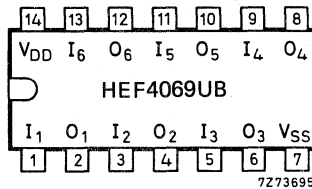

Fig. 2 Pinning diagram.

HEF4069UBP : 14-lead DIL; plastic (SOT-27K, M, T).
 HEF4069UBD : 14-lead DIL; ceramic (cerdip) (SOT-73).
 HEF4069UBT : 14-lead mini-pack; plastic (SO-14; SOT-108A).

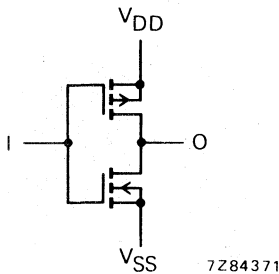

Fig. 3 Schematic diagram (one inverter).

FAMILY DATA

I_{DD} LIMITS category GATES

see Family Specifications for V_{IH}/V_{IL} unbuffered stages



HEF4069UB

gates

A.C. CHARACTERISTICS

$V_{SS} = 0 \text{ V}$; $T_{amb} = 25 \text{ }^\circ\text{C}$; $C_L = 50 \text{ pF}$; input transition times $\leq 20 \text{ ns}$

| | V_{DD} V | symbol | typ. | max. | typical extrapolation formula |
|--|---------------|---|------|------------------------------------|--|
| Propagation delays $I_n \rightarrow O_n$ HIGH to LOW | 5 | t_{PHL} | 45 | 90 ns | $18 \text{ ns} + (0,55 \text{ ns/pF}) C_L$ |
| | 10 | | 20 | 40 ns | $9 \text{ ns} + (0,23 \text{ ns/pF}) C_L$ |
| | 15 | | 15 | 25 ns | $7 \text{ ns} + (0,16 \text{ ns/pF}) C_L$ |
| LOW to HIGH | 5 | t_{PLH} | 40 | 80 ns | $13 \text{ ns} + (0,55 \text{ ns/pF}) C_L$ |
| | 10 | | 20 | 40 ns | $9 \text{ ns} + (0,23 \text{ ns/pF}) C_L$ |
| | 15 | | 15 | 30 ns | $7 \text{ ns} + (0,16 \text{ ns/pF}) C_L$ |
| Output transition times HIGH to LOW | 5 | t_{THL} | 60 | 120 ns | $10 \text{ ns} + (1,0 \text{ ns/pF}) C_L$ |
| | 10 | | 30 | 60 ns | $9 \text{ ns} + (0,42 \text{ ns/pF}) C_L$ |
| | 15 | | 20 | 40 ns | $6 \text{ ns} + (0,28 \text{ ns/pF}) C_L$ |
| LOW to HIGH | 5 | t_{TLH} | 60 | 120 ns | $10 \text{ ns} + (1,0 \text{ ns/pF}) C_L$ |
| | 10 | | 30 | 60 ns | $9 \text{ ns} + (0,42 \text{ ns/pF}) C_L$ |
| | 15 | | 20 | 40 ns | $6 \text{ ns} + (0,28 \text{ ns/pF}) C_L$ |
| | V_{DD} V | typical formula for P (μW) | | where | |
| Dynamic power dissipation per package (P) | 5 | $600 f_i + \Sigma(f_o C_L) \times V_{DD}^2$ | | f_i = input freq. (MHz) | |
| | 10 | $4\,000 f_i + \Sigma(f_o C_L) \times V_{DD}^2$ | | f_o = output freq. (MHz) | |
| | 15 | $22\,000 f_i + \Sigma(f_o C_L) \times V_{DD}^2$ | | C_L = load capacitance (pF) | |
| | | | | $\Sigma(f_o C_L)$ = sum of outputs | |
| | | | | V_{DD} = supply voltage (V) | |

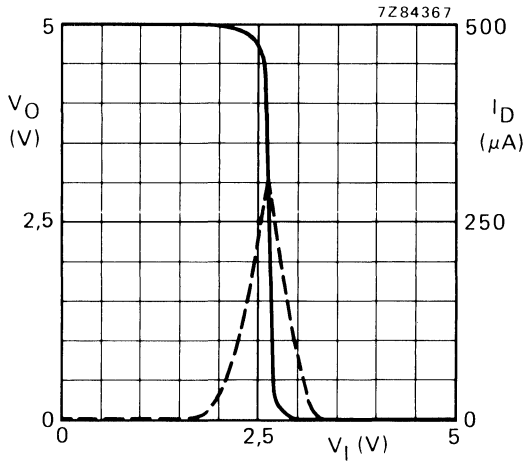

Fig. 4 Typical transfer characteristics;
 — V_O ; - - - I_D (drain current); $I_O = 0$;
 $V_{DD} = 5\text{ V}$.

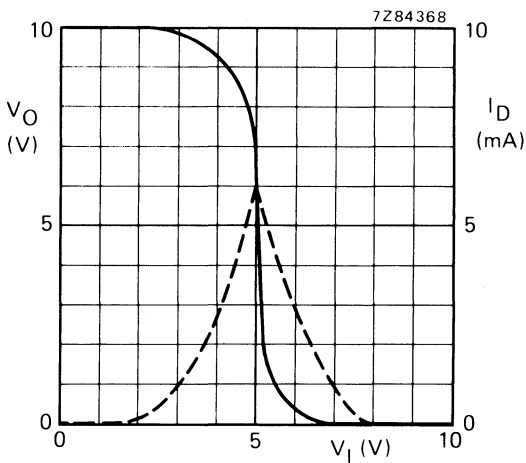

Fig. 5 Typical transfer characteristics;
 — V_O ; - - - I_D (drain current); $I_O = 0$;
 $V_{DD} = 10\text{ V}$.

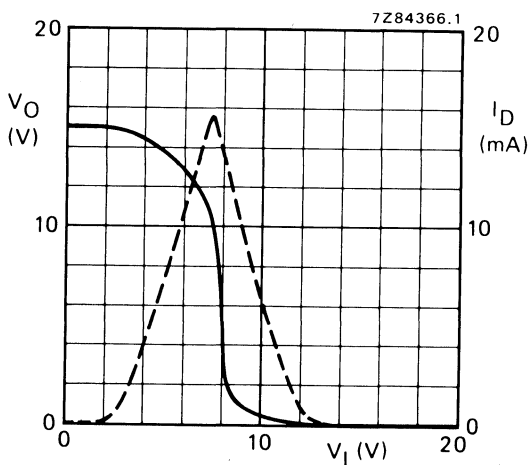
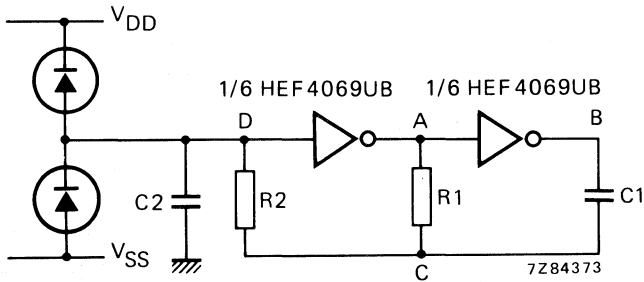

Fig. 6 Typical transfer characteristics;
 — V_O ; - - - I_D (drain current) $I_O = 0$;
 $V_{DD} = 15\text{ V}$.

APPLICATION INFORMATION

Some examples of applications for the HEF4069UB are shown below.

In Fig. 7 an astable relaxation oscillator is given. The oscillation frequency is mainly determined by $R1C1$, provided $R1 \ll R2$ and $R2C2 \ll R1C1$.



(a)

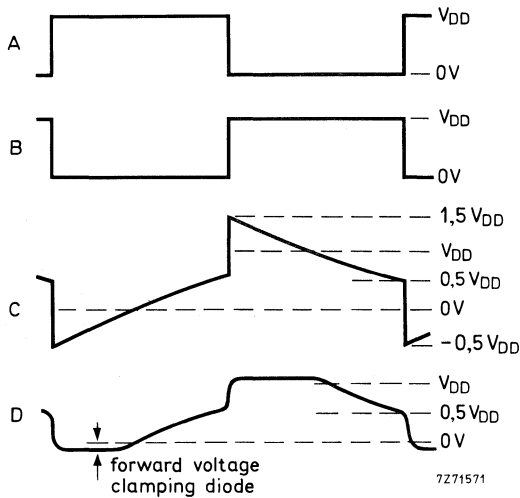

(b)

Fig. 7(a) Astable relaxation oscillator using two HEF4069UB inverters; the diodes may be BAW62; C2 is a parasitic capacitance. (b) Waveforms at the points marked A, B, C and D in the circuit diagram.

The function of R2 is to minimize the influence of the forward voltage across the protection diodes on the frequency; C2 is a stray (parasitic) capacitance. The period T_p is given by $T_p = T_1 + T_2$, in which

$$T_1 = R1C1 \ln \frac{V_{DD} + V_{ST}}{V_{ST}} \quad \text{and} \quad T_2 = R1C1 \ln \frac{2V_{DD} - V_{ST}}{V_{DD} - V_{ST}} \quad \text{where}$$

V_{ST} is the signal threshold level of the inverter. The period is fairly independent of V_{DD} , V_{ST} and temperature. The duty factor, however, is influenced by V_{ST} .

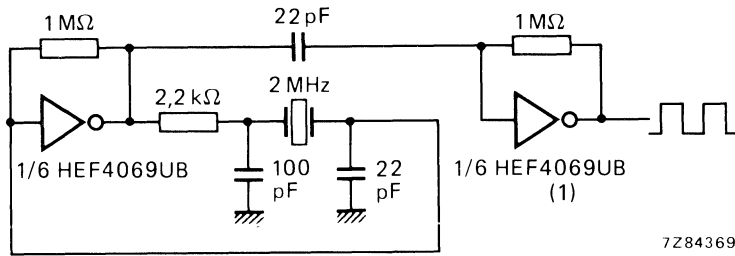

7Z84369

(1) This inverter is added to amplify the oscillator output voltage to a level sufficient to drive other LOCMOS circuits.

Fig. 8 Crystal oscillator for frequencies up to 10 MHz, using two HEF4069UB inverters.

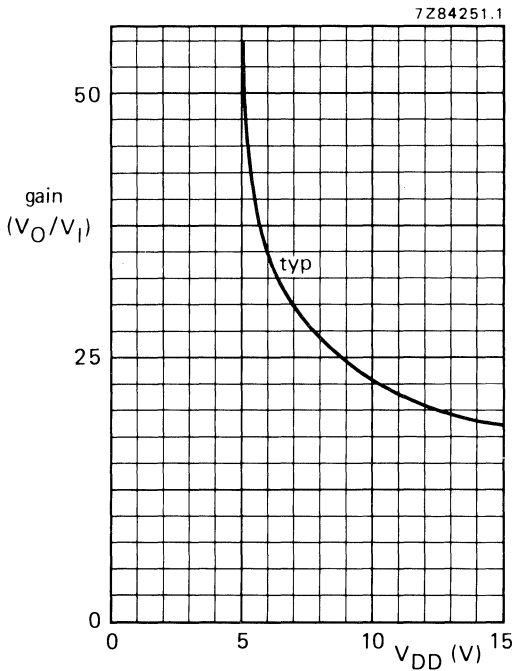

Fig. 9 Voltage gain (V_O/V_I) as a function of supply voltage.

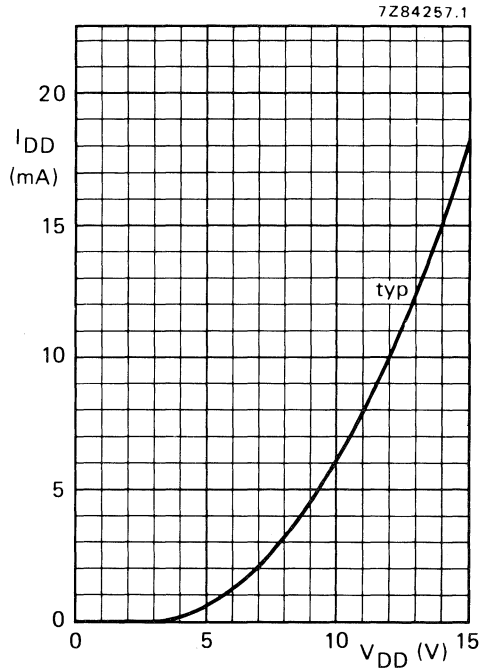
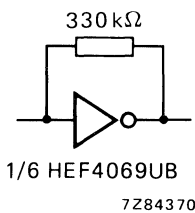

Fig. 10 Supply current as a function of supply voltage.



7Z84370

Fig. 11 Test set-up for measuring graphs of Figs 9 and 10.

It is also an example of an analogue amplifier using one HEF4069UB.

APPLICATION INFORMATION (continued)

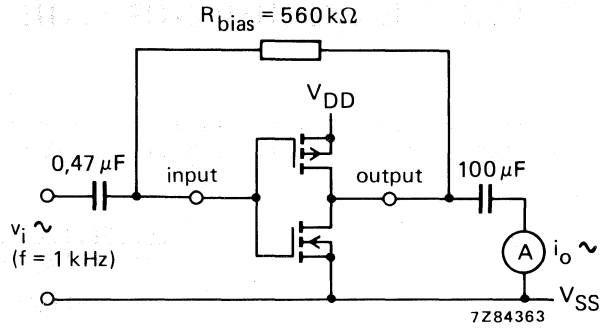
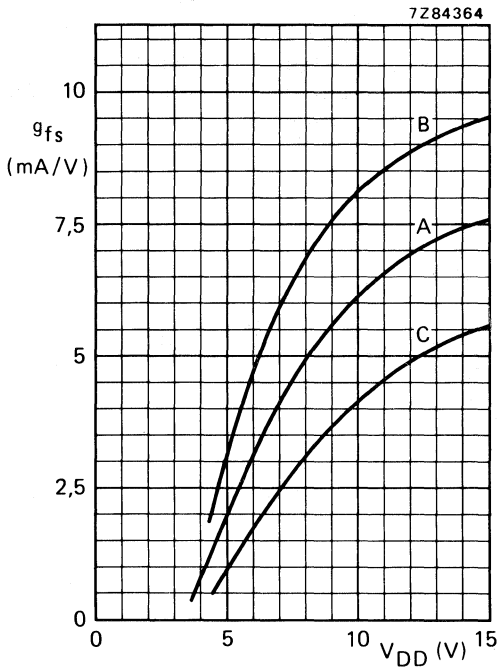

Fig. 12 Test set-up for measuring forward transconductance $g_{fs} = di_o/dv_i$ at v_o is constant (see also graph Fig. 13).



Curves in Fig. 13:

- A : average,
- B : average + 2 s,
- C : average - 2 s, in where:
's' is the observed standard deviation.

Fig. 13 Typical forward transconductance g_{fs} as a function of the supply voltage at $T_{amb} = 25\text{ }^{\circ}\text{C}$.

QUADRUPLE EXCLUSIVE-OR GATE



The HEF4070B provides the positive quadruple exclusive-OR function. The outputs are fully buffered for highest noise immunity and pattern insensitivity of output impedance.

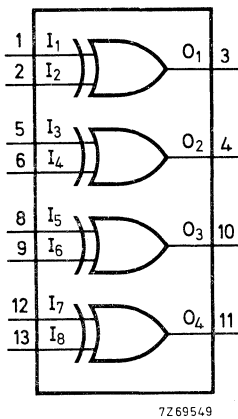

Fig. 1 Functional diagram.

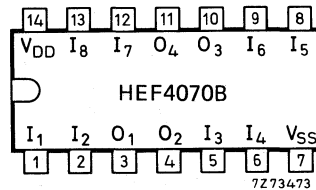

Fig. 2 Pinning diagram.

HEF4070BP : 14-lead DIL; plastic (SOT-27K, M, T).
 HEF4070BD : 14-lead DIL; ceramic (cerdip) (SOT-73).
 HEF4070BT : 14-lead mini-pack; plastic (SO-14; SOT-108A).

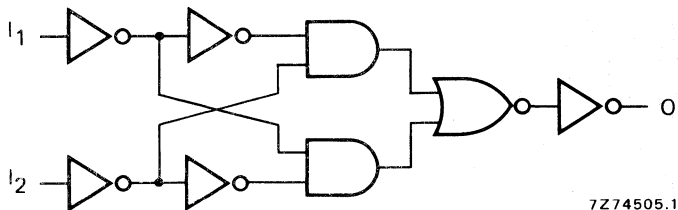

Fig. 3 Logic diagram (one gate).

APPLICATION INFORMATION

Some examples of applications for the HEF4070B are:

- Logical comparators
- Parity checkers and generators

TRUTH TABLE

| I ₁ | I ₂ | O ₁ |
|----------------|----------------|----------------|
| L | L | L |
| H | L | H |
| L | H | H |
| H | H | L |

H = HIGH state (the more positive voltage)

L = LOW state (the less positive voltage)

FAMILY DATA

I_{DD} LIMITS category GATES

} see Family Specifications

HEF4070B

gates

A.C. CHARACTERISTICS

$V_{SS} = 0\text{ V}$; $T_{amb} = 25\text{ }^{\circ}\text{C}$; $C_L = 50\text{ pF}$; input transition times $\leq 20\text{ ns}$

| | V_{DD} V | symbol | typ. | max. | | typical extrapolation formula | |
|--|---------------|------------------|------------------|------|-----|--|--|
| Propagation delays $I_n \rightarrow O_n$ HIGH to LOW | 5 | t _{PHL} | 85 | 175 | ns | $58\text{ ns} + (0,55\text{ ns/pF}) C_L$ | |
| | 10 | | 35 | 75 | ns | $24\text{ ns} + (0,23\text{ ns/pF}) C_L$ | |
| | 15 | | 30 | 55 | ns | $21\text{ ns} + (0,16\text{ ns/pF}) C_L$ | |
| | LOW to HIGH | 5 | t _{PLH} | 75 | 150 | ns | $48\text{ ns} + (0,55\text{ ns/pF}) C_L$ |
| | | 10 | | 30 | 65 | ns | $19\text{ ns} + (0,23\text{ ns/pF}) C_L$ |
| | | 15 | | 25 | 50 | ns | $17\text{ ns} + (0,16\text{ ns/pF}) C_L$ |
| Output transition times | 5 | t _{THL} | 60 | 120 | ns | $10\text{ ns} + (1,0\text{ ns/pF}) C_L$ | |
| | 10 | | 30 | 60 | ns | $9\text{ ns} + (0,42\text{ ns/pF}) C_L$ | |
| | 15 | | 20 | 40 | ns | $6\text{ ns} + (0,28\text{ ns/pF}) C_L$ | |
| | LOW to HIGH | 5 | t _{TLH} | 60 | 120 | ns | $10\text{ ns} + (1,0\text{ ns/pF}) C_L$ |
| | | 10 | | 30 | 60 | ns | $9\text{ ns} + (0,42\text{ ns/pF}) C_L$ |
| | | 15 | | 20 | 40 | ns | $6\text{ ns} + (0,28\text{ ns/pF}) C_L$ |

| | V_{DD} V | typical formula for P (μW) | where f_i = input freq. (MHz) f_o = output freq. (MHz) C_L = load capacitance (pF) $\Sigma(f_o C_L)$ = sum of outputs V_{DD} = supply voltage (V) |
|---|---------------|---|--|
| Dynamic power dissipation per package (P) | 5 | $1100 f_i + \Sigma(f_o C_L) \times V_{DD}^2$ | |
| | 10 | $4900 f_i + \Sigma(f_o C_L) \times V_{DD}^2$ | |
| | 15 | $14\,400 f_i + \Sigma(f_o C_L) \times V_{DD}^2$ | |

QUADRUPLE 2-INPUT OR GATE



The HEF4071B is a positive logic quadruple 2-input OR gate. The outputs are fully buffered for highest noise immunity and pattern insensitivity of output impedance.

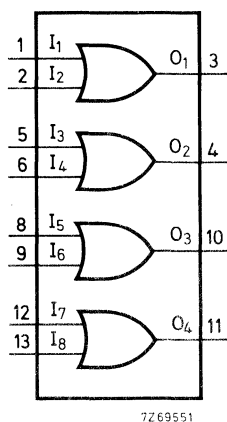

Fig. 1 Functional diagram.

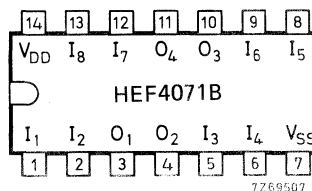

Fig. 2 Pinning diagram.

HEF4071BP : 14-lead DIL; plastic (SOT-27K, M, T).
 HEF4071BD : 14-lead DIL; ceramic (cerdip) (SOT-73).
 HEF4071BT : 14-lead mini-pack; plastic (SO-14; SOT-108A).

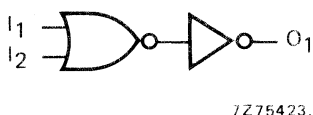

Fig. 3 Logic diagram (one gate).

FAMILY DATA

I_{DD} LIMITS category GATES

} see Family Specifications

A.C. CHARACTERISTICS

$V_{SS} = 0$ V; $T_{amb} = 25$ °C; $C_L = 50$ pF; input transition times ≤ 20 ns

| | V_{DD} V | symbol | typ. | max. | | typical extrapolation formula |
|--|---------------|-----------|------|------|----|--|
| Propagation delays $I_n \rightarrow O_n$ HIGH to LOW | 5 | t_{PHL} | 55 | 115 | ns | $28 \text{ ns} + (0,55 \text{ ns/pF}) C_L$ |
| | 10 | | 25 | 50 | ns | $15 \text{ ns} + (0,23 \text{ ns/pF}) C_L$ |
| | 15 | | 20 | 35 | ns | $12 \text{ ns} + (0,16 \text{ ns/pF}) C_L$ |
| LOW to HIGH | 5 | t_{PLH} | 45 | 90 | ns | $18 \text{ ns} + (0,55 \text{ ns/pF}) C_L$ |
| | 10 | | 20 | 45 | ns | $9 \text{ ns} + (0,23 \text{ ns/pF}) C_L$ |
| | 15 | | 15 | 30 | ns | $7 \text{ ns} + (0,16 \text{ ns/pF}) C_L$ |
| Output transition times HIGH to LOW | 5 | t_{THL} | 60 | 120 | ns | $10 \text{ ns} + (1,0 \text{ ns/pF}) C_L$ |
| | 10 | | 30 | 60 | ns | $9 \text{ ns} + (0,42 \text{ ns/pF}) C_L$ |
| | 15 | | 20 | 40 | ns | $6 \text{ ns} + (0,28 \text{ ns/pF}) C_L$ |
| LOW to HIGH | 5 | t_{TLH} | 60 | 120 | ns | $10 \text{ ns} + (1,0 \text{ ns/pF}) C_L$ |
| | 10 | | 30 | 60 | ns | $9 \text{ ns} + (0,42 \text{ ns/pF}) C_L$ |
| | 15 | | 20 | 40 | ns | $6 \text{ ns} + (0,28 \text{ ns/pF}) C_L$ |

| | V_{DD} V | typical formula for P (μ W) | where |
|---|---------------|---|------------------------------------|
| Dynamic power dissipation per package (P) | 5 | $1150 f_i + \Sigma(f_o C_L) \times V_{DD}^2$ | f_i = input freq. (MHz) |
| | 10 | $4800 f_i + \Sigma(f_o C_L) \times V_{DD}^2$ | f_o = output freq. (MHz) |
| | 15 | $19\,700 f_i + \Sigma(f_o C_L) \times V_{DD}^2$ | C_L = load capacitance (pF) |
| | | | $\Sigma(f_o C_L)$ = sum of outputs |
| | | | V_{DD} = supply voltage (V) |



DUAL 4-INPUT OR GATE

The HEF4072B provides the positive dual 4-input OR function. The outputs are fully buffered for highest noise immunity and pattern insensitivity of output impedance.

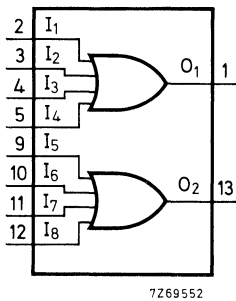

Fig. 1 Functional diagram.

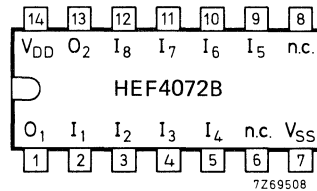

Fig. 2 Pinning diagram.

HEF4072BP : 14-lead DIL; plastic (SOT-27K, M, T).
HEF4072BD: 14-lead DIL; ceramic (cerdip) (SOT-73).
HEF4072BT : 14-lead mini-pack; plastic (SO-14; SOT-108A).

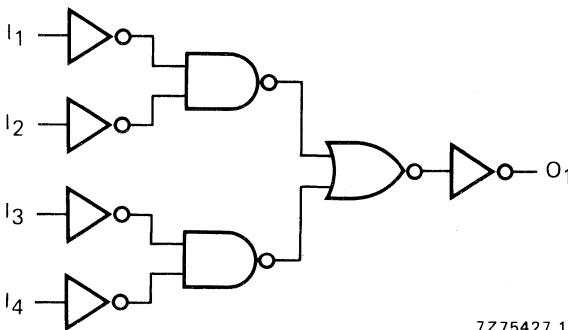

Fig. 3 Logic diagram (one gate).

FAMILY DATA

I_{DD} LIMITS category GATES

} see Family Specifications

HEF4072B

gates

A.C. CHARACTERISTICS

$V_{SS} = 0\text{ V}$; $T_{amb} = 25\text{ }^\circ\text{C}$; $C_L = 50\text{ pF}$; input transition times $\leq 20\text{ ns}$

| | V_{DD} V | symbol | typ. | max. | | typical extrapolation formula |
|--|---------------|-----------|------|------|----|--|
| Propagation delays $I_n \rightarrow O_n$ HIGH to LOW | 5 | t_{PHL} | 80 | 155 | ns | $53\text{ ns} + (0,55\text{ ns/pF}) C_L$ |
| | 10 | | 35 | 70 | ns | $24\text{ ns} + (0,23\text{ ns/pF}) C_L$ |
| | 15 | | 25 | 55 | ns | $17\text{ ns} + (0,16\text{ ns/pF}) C_L$ |
| LOW to HIGH | 5 | t_{PLH} | 75 | 145 | ns | $48\text{ ns} + (0,55\text{ ns/pF}) C_L$ |
| | 10 | | 35 | 70 | ns | $24\text{ ns} + (0,23\text{ ns/pF}) C_L$ |
| | 15 | | 25 | 55 | ns | $17\text{ ns} + (0,16\text{ ns/pF}) C_L$ |
| Output transition times HIGH to LOW | 5 | t_{THL} | 60 | 120 | ns | $10\text{ ns} + (1,0\text{ ns/pF}) C_L$ |
| | 10 | | 30 | 60 | ns | $9\text{ ns} + (0,42\text{ ns/pF}) C_L$ |
| | 15 | | 20 | 40 | ns | $6\text{ ns} + (0,28\text{ ns/pF}) C_L$ |
| LOW to HIGH | 5 | t_{TLH} | 60 | 120 | ns | $10\text{ ns} + (1,0\text{ ns/pF}) C_L$ |
| | 10 | | 30 | 60 | ns | $9\text{ ns} + (0,42\text{ ns/pF}) C_L$ |
| | 15 | | 20 | 40 | ns | $6\text{ ns} + (0,28\text{ ns/pF}) C_L$ |

| | V_{DD} V | typical formula for P (μW) | where |
|---|---------------|---|------------------------------------|
| Dynamic power dissipation per package (P) | 5 | $950 f_i + \Sigma(f_o C_L) \times V_{DD}^2$ | f_i = input freq. (MHz) |
| | 10 | $4500 f_i + \Sigma(f_o C_L) \times V_{DD}^2$ | f_o = output freq. (MHz) |
| | 15 | $13\,700 f_i + \Sigma(f_o C_L) \times V_{DD}^2$ | C_L = load capacitance (pF) |
| | | | $\Sigma(f_o C_L)$ = sum of outputs |
| | | | V_{DD} = supply voltage (V) |

TRIPLE 3-INPUT AND GATE



The HEF4073B provides the positive triple 3-input AND function. The outputs are fully buffered for highest noise immunity and pattern insensitivity of output impedance.

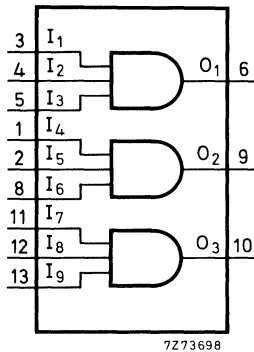

Fig.1 Functional diagram.

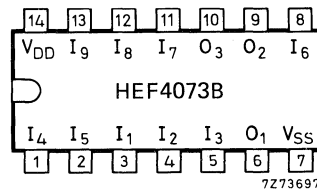

Fig.2 Pinning diagram.

HEF4073BP : 14-lead DIL; plastic (SOT-27K, M, T).
 HEF4073BD : 14-lead DIL; ceramic (cerdip) (SOT-73).
 HEF4073BT : 14-lead mini-pack; plastic
 (SO-14; SOT-108A).

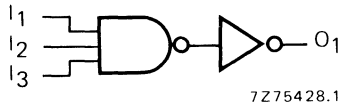

Fig.3 Logic diagram (one gate).

FAMILY DATA

I_{DD} LIMITS category GATES

} see Family Specifications

HEF4073B

gates

A.C. CHARACTERISTICS

$V_{SS} = 0\text{ V}$; $T_{amb} = 25\text{ }^\circ\text{C}$; $C_L = 50\text{ pF}$; input transition times $\leq 20\text{ ns}$

| | V_{DD} V | symbol | typ. | max. | | typical extrapolation formula | |
|--|---------------|--------|------|------|-----|--|--|
| Propagation delays $I_n \rightarrow O_n$ HIGH to LOW | 5 | tPHL | 55 | 110 | ns | $23\text{ ns} + (0,55\text{ ns/pF}) C_L$ | |
| | 10 | | 25 | 50 | ns | $14\text{ ns} + (0,23\text{ ns/pF}) C_L$ | |
| | 15 | | 20 | 40 | ns | $12\text{ ns} + (0,16\text{ ns/pF}) C_L$ | |
| | LOW to HIGH | 5 | tPLH | 45 | 90 | ns | $13\text{ ns} + (0,55\text{ ns/pF}) C_L$ |
| | | 10 | | 20 | 40 | ns | $9\text{ ns} + (0,23\text{ ns/pF}) C_L$ |
| | | 15 | | 15 | 30 | ns | $7\text{ ns} + (0,16\text{ ns/pF}) C_L$ |
| Output transition times | HIGH to LOW | tTHL | 5 | 60 | 120 | ns | $10\text{ ns} + (1,0\text{ ns/pF}) C_L$ |
| | | | 10 | 30 | 60 | ns | $9\text{ ns} + (0,42\text{ ns/pF}) C_L$ |
| | | | 15 | 20 | 40 | ns | $6\text{ ns} + (0,28\text{ ns/pF}) C_L$ |
| | LOW to HIGH | tTLH | 5 | 60 | 120 | ns | $10\text{ ns} + (1,0\text{ ns/pF}) C_L$ |
| | | | 10 | 30 | 60 | ns | $9\text{ ns} + (0,42\text{ ns/pF}) C_L$ |
| | | | 15 | 20 | 40 | ns | $6\text{ ns} + (0,28\text{ ns/pF}) C_L$ |

| | V_{DD} V | typical formula for P (μW) | where |
|---|---------------|--|------------------------------------|
| Dynamic power dissipation per package (P) | 5 | $600 f_i + \Sigma(f_o C_L) \times V_{DD}^2$ | f_i = input freq. (MHz) |
| | 10 | $2700 f_i + \Sigma(f_o C_L) \times V_{DD}^2$ | f_o = output freq. (MHz) |
| | 15 | $8400 f_i + \Sigma(f_o C_L) \times V_{DD}^2$ | C_L = load capacitance (pF) |
| | | | $\Sigma(f_o C_L)$ = sum of outputs |
| | | | V_{DD} = supply voltage (V) |



TRIPLE 3-INPUT OR GATE

The HEF4075B provides the positive triple 3-input OR function. The outputs are fully buffered for highest noise immunity and pattern insensitivity of output impedance.

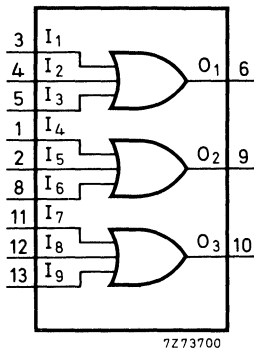

Fig.1 Functional diagram.

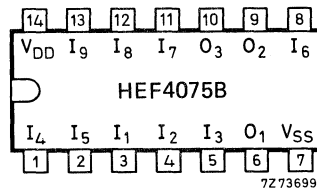

Fig.2 Pinning diagram.

HEF4075BP : 14-lead DIL; plastic (SOT-27K, M, T).
HEF4075BD: 14-lead DIL; ceramic (cerdip) (SOT-73).
HEF4075BT: 14-lead mini-pack; plastic (SO-14; SOT-108A).

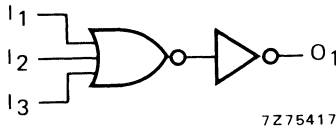

Fig.3 Logic diagram (one gate).

FAMILY DATA

I_{DD} LIMITS category GATES

} see Family Specifications

A.C. CHARACTERISTICS

 $V_{SS} = 0 \text{ V}$; $T_{amb} = 25 \text{ }^\circ\text{C}$; $C_L = 50 \text{ pF}$; input transition times $\leq 20 \text{ ns}$

| | V_{DD} V | symbol | typ. | max. | | typical extrapolation formula |
|--|---------------|--------|------|------|----|--|
| Propagation delays $I_n \rightarrow O_n$ HIGH to LOW | 5 | tPHL | 65 | 130 | ns | $38 \text{ ns} + (0,55 \text{ ns/pF}) C_L$ |
| | 10 | | 30 | 60 | ns | $19 \text{ ns} + (0,23 \text{ ns/pF}) C_L$ |
| | 15 | | 20 | 40 | ns | $12 \text{ ns} + (0,16 \text{ ns/pF}) C_L$ |
| LOW to HIGH | 5 | tPLH | 65 | 130 | ns | $38 \text{ ns} + (0,55 \text{ ns/pF}) C_L$ |
| | 10 | | 30 | 60 | ns | $19 \text{ ns} + (0,23 \text{ ns/pF}) C_L$ |
| | 15 | | 25 | 50 | ns | $17 \text{ ns} + (0,16 \text{ ns/pF}) C_L$ |
| Output transition times HIGH to LOW | 5 | tTHL | 60 | 120 | ns | $10 \text{ ns} + (1,0 \text{ ns/pF}) C_L$ |
| | 10 | | 30 | 60 | ns | $9 \text{ ns} + (0,42 \text{ ns/pF}) C_L$ |
| | 15 | | 20 | 40 | ns | $6 \text{ ns} + (0,28 \text{ ns/pF}) C_L$ |
| LOW to HIGH | 5 | tTLH | 60 | 120 | ns | $10 \text{ ns} + (1,0 \text{ ns/pF}) C_L$ |
| | 10 | | 30 | 60 | ns | $9 \text{ ns} + (0,42 \text{ ns/pF}) C_L$ |
| | 15 | | 20 | 40 | ns | $6 \text{ ns} + (0,28 \text{ ns/pF}) C_L$ |

| | V_{DD} V | typical formula for P (μW) | where |
|---|---------------|---|------------------------------------|
| Dynamic power dissipation per package (P) | 5 | $750 f_i + \Sigma(f_o C_L) \times V_{DD}^2$ | f_i = input freq. (MHz) |
| | 10 | $3\ 600 f_i + \Sigma(f_o C_L) \times V_{DD}^2$ | f_o = output freq. (MHz) |
| | 15 | $11\ 200 f_i + \Sigma(f_o C_L) \times V_{DD}^2$ | C_L = load capacitance (pF) |
| | | | $\Sigma(f_o C_L)$ = sum of outputs |
| | | | V_{DD} = supply voltage (V) |

QUADRUPLE D-TYPE REGISTER WITH 3-STATE OUTPUTS

The HEF4076B is a quadruple edge-triggered D-type flip-flop with four data inputs (D_0 to D_3), two active LOW data enable inputs (\overline{ED}_0 and \overline{ED}_1), a common clock input (CP), four 3-state outputs (O_0 to O_3), two active LOW output enable inputs (\overline{EO}_0 and \overline{EO}_1), and an overriding asynchronous master reset input (MR).

Information on D_0 to D_3 is stored in the four flip-flops on the LOW to HIGH transition of CP if both \overline{ED}_0 and \overline{ED}_1 are LOW. A HIGH on either \overline{ED}_0 or \overline{ED}_1 prevents the flip-flops from changing on the LOW to HIGH transition of CP, independent of the information on D_0 to D_3 . When both \overline{EO}_0 and \overline{EO}_1 are LOW, the contents of the four flip-flops are available at O_0 to O_3 . A HIGH on either \overline{EO}_0 or \overline{EO}_1 forces O_0 to O_3 into the high impedance OFF-state. A HIGH on MR resets all four flip-flops, independent of all other input conditions.

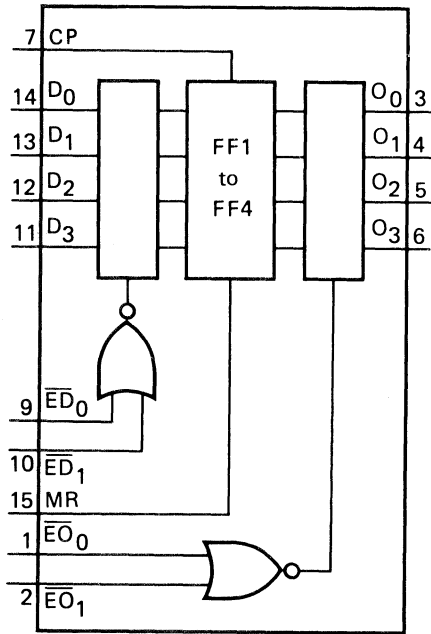

Fig. 1 Functional diagram.

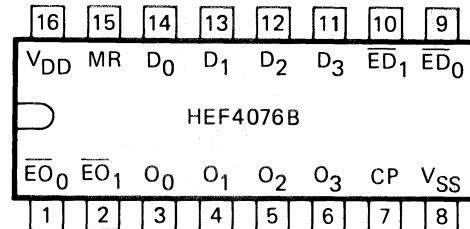

Fig. 2 Pinning diagram.

HEF4076BP : 16-lead DIL; plastic (SOT-38Z).
 HEF4076BD : 16-lead DIL; ceramic (cerdip) (SOT-74).
 HEF4076BT : 16-lead mini-pack; plastic
 (SO-16; SOT-109A).

PINNING

| | |
|---------------------------------------|---|
| D_0 to D_3 | data inputs |
| \overline{ED}_0 , \overline{ED}_1 | data enable inputs (active LOW) |
| \overline{EO}_0 , \overline{EO}_1 | output enable inputs (active LOW) |
| CP | clock input (LOW to HIGH, edge-triggered) |
| MR | master reset input |
| O_0 to O_3 | data outputs |

FAMILY DATA

I_{DD} LIMITS category MSI

} see Family Specifications

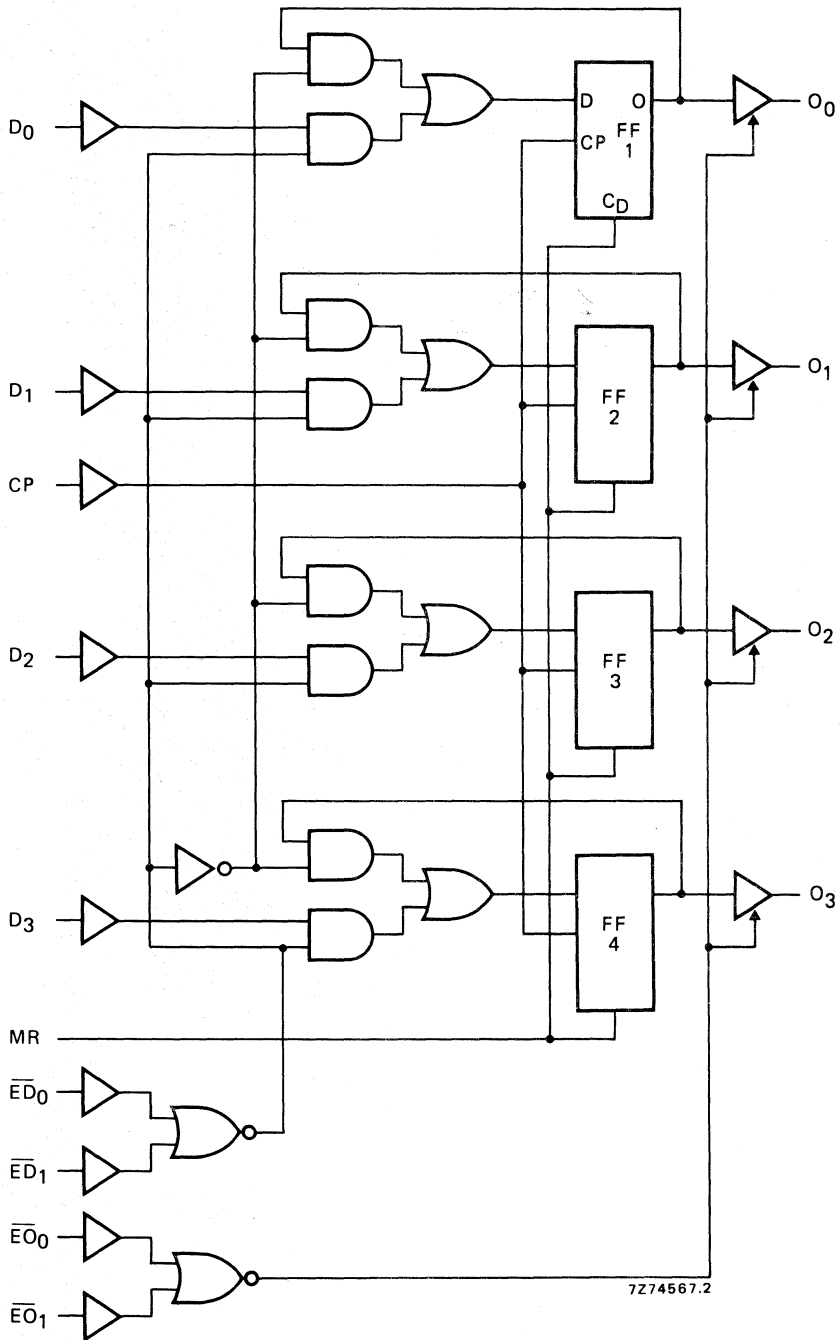

Fig. 3 Logic diagram.

FUNCTION TABLE

| inputs | | | | | outputs |
|--------|----|-------------------|-------------------|-------|-----------|
| MR | CP | $\overline{E}D_0$ | $\overline{E}D_1$ | D_n | O_n |
| H | X | X | X | X | L |
| L | / | H | X | X | no change |
| L | / | X | H | X | no change |
| L | / | L | L | H | H |
| L | / | L | L | L | L |
| L | \ | X | X | X | no change |

$\overline{E}O_0 = \overline{E}O_1 = \text{LOW}$

When either $\overline{E}O_0$ or $\overline{E}O_1$ is HIGH, the outputs are disabled (high impedance OFF-state).

H = HIGH state (the more positive voltage)

L = LOW state (the less positive voltage)

X = state is immaterial

/ = positive-going transition

\ = negative-going transition

A.C. CHARACTERISTICS

$V_{SS} = 0\text{ V}$; $T_{amb} = 25\text{ }^\circ\text{C}$; $C_L = 50\text{ pF}$; input transition times $\leq 20\text{ ns}$; see also waveforms Fig. 4

| | V_{DD} V | symbol | min. | typ. | max. | typical extrapolation formula |
|---|---------------|------------------|------|--------|-------------------------------------|--------------------------------------|
| Propagation delays | | | | | | |
| CP \rightarrow O_n HIGH to LOW | 5 | t _{PHL} | | 150 | 305 ns | 123 ns + (0,55 ns/pF) C _L |
| | 10 | | 60 | 120 ns | 49 ns + (0,23 ns/pF) C _L | |
| | 15 | | 45 | 85 ns | 37 ns + (0,16 ns/pF) C _L | |
| LOW to HIGH | 5 | t _{PLH} | | 160 | 320 ns | 133 ns + (0,55 ns/pF) C _L |
| | 10 | | 65 | 130 ns | 54 ns + (0,23 ns/pF) C _L | |
| | 15 | | 45 | 90 ns | 37 ns + (0,16 ns/pF) C _L | |
| MR \rightarrow O_n HIGH to LOW | 5 | t _{PHL} | | 95 | 190 ns | 68 ns + (0,55 ns/pF) C _L |
| | 10 | | 40 | 85 ns | 29 ns + (0,23 ns/pF) C _L | |
| | 15 | | 30 | 65 ns | 22 ns + (0,16 ns/pF) C _L | |
| Output transition times | | | | | | |
| HIGH to LOW | 5 | t _{THL} | | 60 | 120 ns | 10 ns + (1,0 ns/pF) C _L |
| | 10 | | 30 | 60 ns | 9 ns + (0,42 ns/pF) C _L | |
| | 15 | | 20 | 40 ns | 6 ns + (0,28 ns/pF) C _L | |
| LOW to HIGH | 5 | t _{TLH} | | 60 | 120 ns | 10 ns + (1,0 ns/pF) C _L |
| | 10 | | 30 | 60 ns | 9 ns + (0,42 ns/pF) C _L | |
| | 15 | | 20 | 40 ns | 6 ns + (0,28 ns/pF) C _L | |
| 3-state propagation delays | | | | | | |
| Output disable times | | | | | | |
| $\overline{E}O_n \rightarrow O_n$ HIGH | 5 | t _{PHZ} | | 50 | 105 ns | |
| | 10 | | 35 | 70 ns | | |
| | 15 | | 30 | 65 ns | | |
| LOW | 5 | t _{PLZ} | | 45 | 90 ns | |
| | 10 | | 30 | 65 ns | | |
| | 15 | | 30 | 60 ns | | |
| Output enable times | | | | | | |
| $\overline{E}O_n \rightarrow O_n$ HIGH | 5 | t _{PZH} | | 65 | 130 ns | |
| | 10 | | 30 | 55 ns | | |
| | 15 | | 20 | 40 ns | | |
| LOW | 5 | t _{PZL} | | 60 | 120 ns | |
| | 10 | | 25 | 50 ns | | |
| | 15 | | 20 | 35 ns | | |

A.C. CHARACTERISTICS

 $V_{SS} = 0 \text{ V}$; $T_{amb} = 25 \text{ }^\circ\text{C}$; $C_L = 50 \text{ pF}$; input transition times $\leq 20 \text{ ns}$

| | V_{DD} V | symbol | min. | typ. | max. | typical extrapolation formula |
|-----------------------------------|---------------|------------|------|------|------|----------------------------------|
| Set-up times | 5 | | 10 | -15 | ns | see also waveforms Fig. 4 |
| $D_n \rightarrow CP$ | 10 | t_{su} | 0 | -10 | ns | |
| | 15 | | 0 | -5 | ns | |
| $\overline{ED}_n \rightarrow CP$ | 5 | | 0 | -50 | ns | |
| | 10 | t_{su} | 0 | -20 | ns | |
| | 15 | | 0 | -15 | ns | |
| Hold times | 5 | | 55 | 30 | ns | |
| $D_n \rightarrow CP$ | 10 | t_{hold} | 20 | 10 | ns | |
| | 15 | | 15 | 10 | ns | |
| $\overline{ED}_n \rightarrow CP$ | 5 | | 25 | -25 | ns | |
| | 10 | t_{hold} | 10 | -10 | ns | |
| | 15 | | 5 | -5 | ns | |
| Minimum clock pulse width; LOW | 5 | | 120 | 60 | ns | |
| | 10 | t_{WCPL} | 45 | 20 | ns | |
| | 15 | | 30 | 15 | ns | |
| Minimum MR pulse width; HIGH | 5 | | 55 | 25 | ns | |
| | 10 | t_{WMRH} | 30 | 15 | ns | |
| | 15 | | 20 | 10 | ns | |
| Recovery time for MR | 5 | | 90 | 45 | ns | |
| | 10 | t_{RMR} | 35 | 15 | ns | |
| | 15 | | 20 | 10 | ns | |
| Maximum clock pulse frequency | 5 | | 4 | 8 | MHz | |
| | 10 | f_{max} | 11 | 22 | MHz | |
| | 15 | | 16 | 32 | MHz | |

| | V_{DD} V | typical formula for P (μW) | where f_i = input freq. (MHz) f_o = output freq. (MHz) C_L = load capacitance (pF) $\Sigma(f_o C_L)$ = sum of outputs V_{DD} = supply voltage (V) |
|---|---------------|---|--|
| Dynamic power dissipation per package (P) | 5 | $2200 f_i + \Sigma(f_o C_L) \times V_{DD}^2$ | |
| | 10 | $9300 f_i + \Sigma(f_o C_L) \times V_{DD}^2$ | |
| | 15 | $24\,500 f_i + \Sigma(f_o C_L) \times V_{DD}^2$ | |

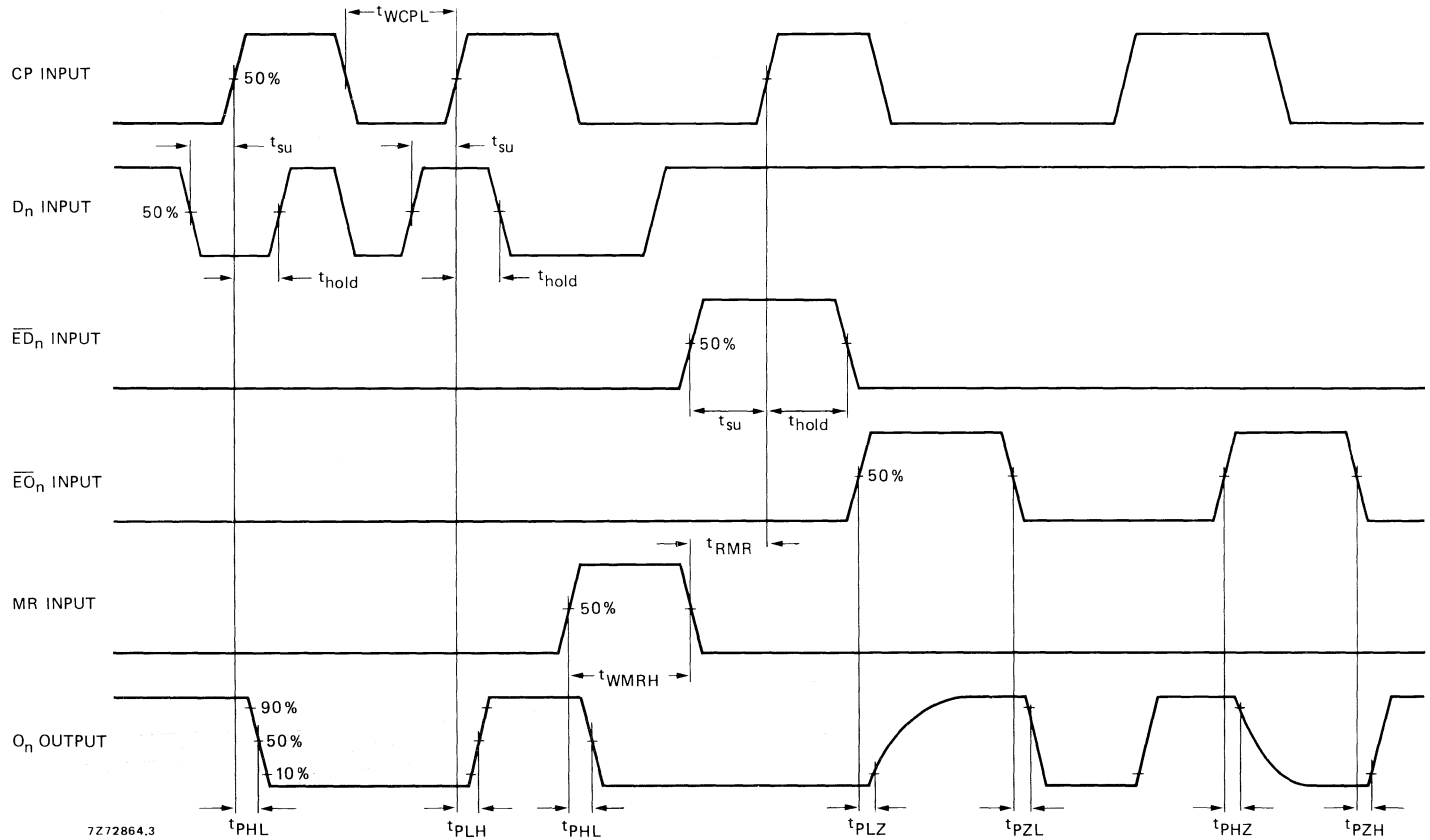

Fig. 4 Waveforms showing propagation delays, output disable/enable times, minimum CP and MR pulse widths, set-up and hold times for D_n to CP and $\overline{E}D_n$ to CP, and recovery time for MR. Set-up and hold times are shown as positive values but may be specified as negative values.

QUADRUPLE EXCLUSIVE-NOR GATE



The HEF4077B provides the exclusive-NOR function. The outputs are fully buffered for best performance.

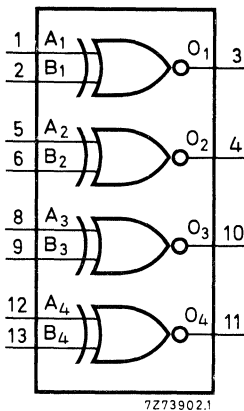

Fig. 1 Functional diagram.

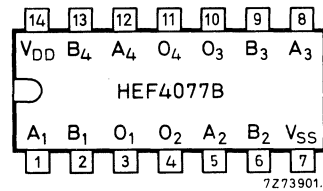

Fig. 2 Pinning diagram.

HEF4077BP : 14-lead DIL; plastic (SOT-27K, M, T).
 HEF4077BD : 14-lead DIL; ceramic (cerdip) (SOT-73).
 HEF4077BT : 14-lead mini-pack; plastic (SO-14; SOT-108A).

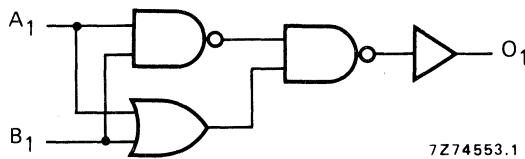

Fig. 3 Logic diagram (one gate).

TRUTH TABLE

| A _n | B _n | O _n |
|----------------|----------------|----------------|
| L | L | H |
| L | H | L |
| H | L | L |
| H | H | H |

H = HIGH state (the more positive voltage)
 L = LOW state (the less positive voltage)

FAMILY DATA

I_{DD} LIMITS category GATES

} see Family Specifications

A.C. CHARACTERISTICS

$V_{SS} = 0\text{ V}$; $T_{amb} = 25\text{ }^\circ\text{C}$; $C_L = 50\text{ pF}$; input transition times $\leq 20\text{ ns}$

| | V_{DD} V | symbol | typ. | max. | | typical extrapolation formula | |
|---|---------------|--------|------|------|-----|--|--|
| Propagation delays $A_n, B_n \rightarrow O_n$ HIGH to LOW | 5 | tPHL | 75 | 150 | ns | $48\text{ ns} + (0,55\text{ ns/pF}) C_L$ | |
| | 10 | | 35 | 70 | ns | $24\text{ ns} + (0,23\text{ ns/pF}) C_L$ | |
| | 15 | | 30 | 55 | ns | $22\text{ ns} + (0,16\text{ ns/pF}) C_L$ | |
| | LOW to HIGH | 5 | tPLH | 70 | 145 | ns | $43\text{ ns} + (0,55\text{ ns/pF}) C_L$ |
| | | 10 | | 30 | 60 | ns | $19\text{ ns} + (0,23\text{ ns/pF}) C_L$ |
| | | 15 | | 25 | 50 | ns | $17\text{ ns} + (0,16\text{ ns/pF}) C_L$ |
| Output transition times | HIGH to LOW | tTHL | 5 | 60 | 120 | ns | $10\text{ ns} + (1,0\text{ ns/pF}) C_L$ |
| | | | 10 | 30 | 60 | ns | $9\text{ ns} + (0,42\text{ ns/pF}) C_L$ |
| | | | 15 | 20 | 40 | ns | $6\text{ ns} + (0,28\text{ ns/pF}) C_L$ |
| | LOW to HIGH | tTLH | 5 | 60 | 120 | ns | $10\text{ ns} + (1,0\text{ ns/pF}) C_L$ |
| | | | 10 | 30 | 60 | ns | $9\text{ ns} + (0,42\text{ ns/pF}) C_L$ |
| | | | 15 | 20 | 40 | ns | $6\text{ ns} + (0,28\text{ ns/pF}) C_L$ |

| | V_{DD} V | typical formula for P (μW) | where |
|---|---------------|---|------------------------------------|
| Dynamic power dissipation per package (P) | 5 | $850 f_i + \Sigma(f_o C_L) \times V_{DD}^2$ | f_i = input freq. (MHz) |
| | 10 | | f_o = output freq. (MHz) |
| | 15 | | C_L = load capacitance (pF) |
| | | | $\Sigma(f_o C_L)$ = sum of outputs |
| | | | V_{DD} = supply voltage (V) |

8-INPUT NOR GATE



The HEF4078B provides the positive 8-input NOR function. The outputs are fully buffered for highest noise immunity and pattern insensitivity of output impedance.

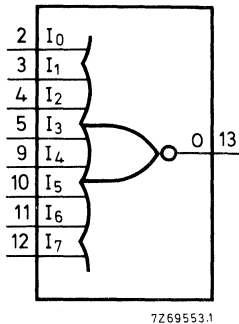

Fig. 1 Functional diagram.

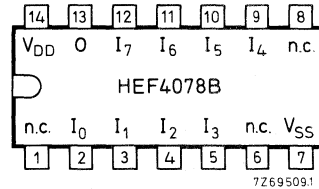

Fig. 2 Pinning diagram.

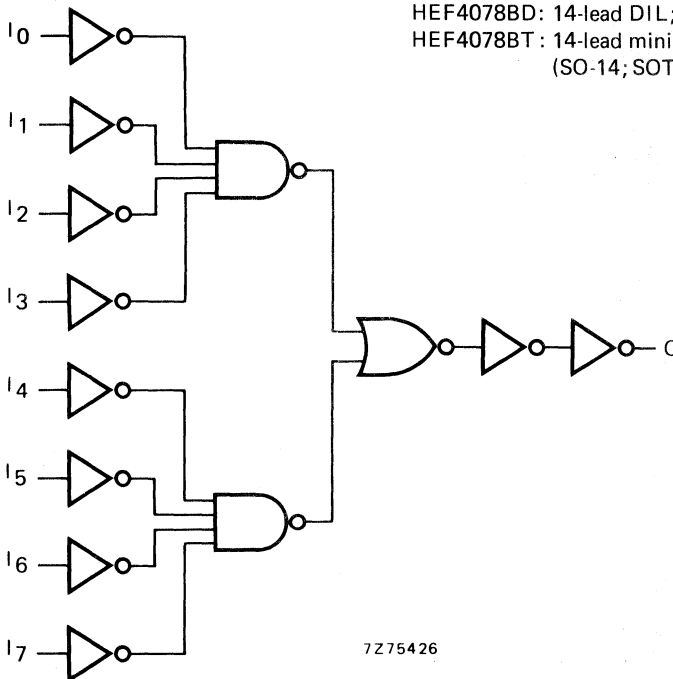

Fig. 3 Logic diagram.

HEF4078BP : 14-lead DIL; plastic (SOT-27K, M, T).
 HEF4078BD : 14-lead DIL; ceramic (cerdip) (SOT-73).
 HEF4078BT : 14-lead mini-pack; plastic (SO-14; SOT-108A).

FAMILY DATA

I_{DD} LIMITS category GATES

} see Family Specifications

A.C. CHARACTERISTICS

 $V_{SS} = 0 \text{ V}$; $T_{amb} = 25 \text{ }^\circ\text{C}$; $C_L = 50 \text{ pF}$; input transition times $\leq 20 \text{ ns}$

| | V_{DD} V | symbol | typ. | max. | | typical extrapolation formula | |
|--|---------------|--|------------------|-------------------------------|------------------------------------|--|--|
| Propagation delays $I_n \rightarrow O_n$ HIGH to LOW | 5 | t _{PHL} | 80 | 160 | ns | $53 \text{ ns} + (0,55 \text{ ns/pF}) C_L$ | |
| | 10 | | 35 | 70 | ns | $24 \text{ ns} + (0,23 \text{ ns/pF}) C_L$ | |
| | 15 | | 25 | 50 | ns | $17 \text{ ns} + (0,16 \text{ ns/pF}) C_L$ | |
| | LOW to HIGH | 5 | t _{PLH} | 80 | 160 | ns | $53 \text{ ns} + (0,55 \text{ ns/pF}) C_L$ |
| | | 10 | | 35 | 70 | ns | $24 \text{ ns} + (0,23 \text{ ns/pF}) C_L$ |
| | | 15 | | 25 | 50 | ns | $17 \text{ ns} + (0,16 \text{ ns/pF}) C_L$ |
| Output transition times | 5 | t _{THL} | 60 | 120 | ns | $10 \text{ ns} + (1,0 \text{ ns/pF}) C_L$ | |
| | 10 | | 30 | 60 | ns | $9 \text{ ns} + (0,42 \text{ ns/pF}) C_L$ | |
| | 15 | | 20 | 40 | ns | $6 \text{ ns} + (0,28 \text{ ns/pF}) C_L$ | |
| | LOW to HIGH | 5 | t _{TLH} | 60 | 120 | ns | $10 \text{ ns} + (1,0 \text{ ns/pF}) C_L$ |
| | | 10 | | 30 | 60 | ns | $9 \text{ ns} + (0,42 \text{ ns/pF}) C_L$ |
| | | 15 | | 20 | 40 | ns | $6 \text{ ns} + (0,28 \text{ ns/pF}) C_L$ |
| | V_{DD} V | typical formula for P (μW) | | where | | | |
| Dynamic power dissipation per package (P) | 5 | $750 f_i + \Sigma(f_o C_L) \times V_{DD}^2$ | | f_i = input freq. (MHz) | | | |
| | 10 | $2800 f_i + \Sigma(f_o C_L) \times V_{DD}^2$ | | f_o = output freq. (MHz) | | | |
| | 15 | $7500 f_i + \Sigma(f_o C_L) \times V_{DD}^2$ | | C_L = load capacitance (pF) | | | |
| | | | | | $\Sigma(f_o C_L)$ = sum of outputs | | |
| | | | | | V_{DD} = supply voltage (V) | | |

QUADRUPLE 2-INPUT AND GATE



The HEF4081B provides the positive quadruple 2-input AND function. The outputs are fully buffered for highest noise immunity and pattern insensitivity of output impedance.

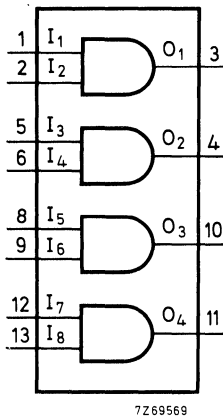

Fig.1 Functional diagram.

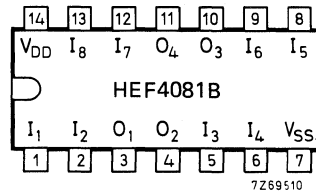

Fig.2 Pinning diagram.

HEF4081BP : 14-lead DIL; plastic (SOT-27K, M, T).
 HEF4081BD : 14-lead DIL; ceramic (cerdip) (SOT-73).
 HEF4081BT : 14-lead mini-pack; plastic (SO-14; SOT-108A).

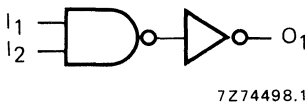

Fig.3 Logic diagram (one gate).

FAMILY DATA

I_{DD} LIMITS category GATES

} see Family Specifications

HEF4081B

gates

A.C. CHARACTERISTICS

$V_{SS} = 0\text{ V}$; $T_{amb} = 25\text{ }^{\circ}\text{C}$; $C_L = 50\text{ pF}$; input transition times $\leq 20\text{ ns}$

| | V_{DD} V | symbol | typ. | max. | | typical extrapolation formula | |
|--|---------------|-----------|-----------|------|-----|--|--|
| Propagation delays $I_n \rightarrow O_n$ HIGH to LOW | 5 | t_{PHL} | 55 | 110 | ns | $28\text{ ns} + (0,55\text{ ns/pF}) C_L$ | |
| | 10 | | 25 | 50 | ns | $14\text{ ns} + (0,23\text{ ns/pF}) C_L$ | |
| | 15 | | 20 | 40 | ns | $12\text{ ns} + (0,16\text{ ns/pF}) C_L$ | |
| | LOW to HIGH | 5 | t_{PLH} | 45 | 90 | ns | $18\text{ ns} + (0,55\text{ ns/pF}) C_L$ |
| | | 10 | | 20 | 40 | ns | $9\text{ ns} + (0,23\text{ ns/pF}) C_L$ |
| | | 15 | | 15 | 30 | ns | $7\text{ ns} + (0,16\text{ ns/pF}) C_L$ |
| Output transition times HIGH to LOW | 5 | t_{THL} | 60 | 120 | ns | $10\text{ ns} + (1,0\text{ ns/pF}) C_L$ | |
| | 10 | | 30 | 60 | ns | $9\text{ ns} + (0,42\text{ ns/pF}) C_L$ | |
| | 15 | | 20 | 40 | ns | $6\text{ ns} + (0,28\text{ ns/pF}) C_L$ | |
| | LOW to HIGH | 5 | t_{TLH} | 60 | 120 | ns | $10\text{ ns} + (1,0\text{ ns/pF}) C_L$ |
| | | 10 | | 30 | 60 | ns | $9\text{ ns} + (0,42\text{ ns/pF}) C_L$ |
| | | 15 | | 20 | 40 | ns | $6\text{ ns} + (0,28\text{ ns/pF}) C_L$ |

| | V_{DD} V | typical formula for P (μW) | where f_i = input freq. (MHz) f_o = output freq. (MHz) C_L = load capacitance (pF) $\Sigma(f_o C_L)$ = sum of outputs V_{DD} = supply voltage (V) |
|---|---------------|---|--|
| Dynamic power dissipation per package (P) | 5 | $450 f_i + \Sigma(f_o C_L) \times V_{DD}^2$ | |
| | 10 | $2900 f_i + \Sigma(f_o C_L) \times V_{DD}^2$ | |
| | 15 | $11700 f_i + \Sigma(f_o C_L) \times V_{DD}^2$ | |

DUAL 4-INPUT AND GATE



The HEF4082B provides the positive dual 4-input AND function. The outputs are fully buffered for highest noise immunity and pattern insensitivity of output impedance.

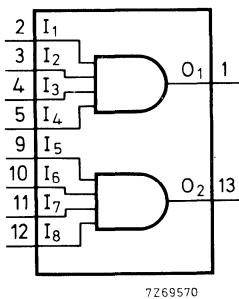

Fig. 1 Functional diagram.

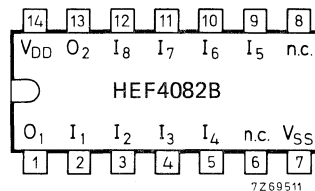

Fig. 2 Pinning diagram.

HEF4082BP : 14-lead DIL; plastic (SOT-27K, M, T).
HEF4082BD : 14-lead DIL; ceramic (cerdip) (SOT-73).
HEF4082BT : 14-lead mini-pack; plastic (SO-14; SOT-108A).

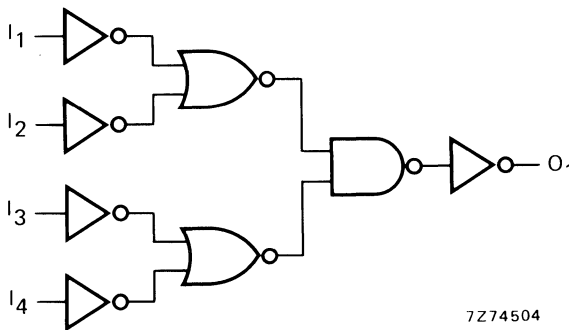

Fig. 3 Logic diagram (one gate).

FAMILY DATA

I_{DD} LIMITS category GATES

} see Family Specifications

HEF4082B

gates

A.C. CHARACTERISTICS

$V_{SS} = 0 \text{ V}$; $T_{amb} = 25 \text{ }^\circ\text{C}$; $C_L = 50 \text{ pF}$; input transition times $\leq 20 \text{ ns}$

| | V_{DD} V | symbol | typ. | max. | | typical extrapolation formula |
|---|---------------|--------------------|------|------|----|--|
| Propagation delays $I_n \rightarrow O_n$ | 5 | $t_{PHL}; t_{PLH}$ | 65 | 125 | ns | $38 \text{ ns} + (0,55 \text{ ns/pF}) C_L$ |
| | 10 | | 30 | 60 | ns | $19 \text{ ns} + (0,23 \text{ ns/pF}) C_L$ |
| | 15 | | 25 | 45 | ns | $17 \text{ ns} + (0,16 \text{ ns/pF}) C_L$ |
| Output transition times HIGH to LOW | 5 | t_{THL} | 60 | 120 | ns | $10 \text{ ns} + (1,0 \text{ ns/pF}) C_L$ |
| | 10 | | 30 | 60 | ns | $9 \text{ ns} + (0,42 \text{ ns/pF}) C_L$ |
| | 15 | | 20 | 40 | ns | $6 \text{ ns} + (0,28 \text{ ns/pF}) C_L$ |
| LOW to HIGH | 5 | t_{TLH} | 60 | 120 | ns | $10 \text{ ns} + (1,0 \text{ ns/pF}) C_L$ |
| | 10 | | 30 | 60 | ns | $9 \text{ ns} + (0,42 \text{ ns/pF}) C_L$ |
| | 15 | | 20 | 40 | ns | $6 \text{ ns} + (0,28 \text{ ns/pF}) C_L$ |

| | V_{DD} V | typical formula for P (μW) | where f_i = input freq. (MHz) f_o = output freq. (MHz) C_L = load capacitance (pF) $\Sigma(f_o C_L)$ = sum of outputs V_{DD} = supply voltage (V) |
|---|---------------|---|--|
| Dynamic power dissipation per package (P) | 5 | $1500 f_i + \Sigma(f_o C_L) \times V_{DD}^2$ | |
| | 10 | $6700 f_i + \Sigma(f_o C_L) \times V_{DD}^2$ | |
| | 15 | $16800 f_i + \Sigma(f_o C_L) \times V_{DD}^2$ | |

DUAL 2-WIDE 2-INPUT AND-OR-INVERT GATE



The HEF4085B is a dual 2 wide 2 input AND-OR-invert gate, each with an additional input (A_4 or B_4) which can be used as either an expander input or an inhibit input. A HIGH on A_4 or B_4 forces the output (O_A or O_B) LOW independent of the other inputs (A_0 to A_3 or B_0 to B_3). The outputs O_A and O_B are fully buffered for highest noise immunity and pattern insensitivity of output impedance.

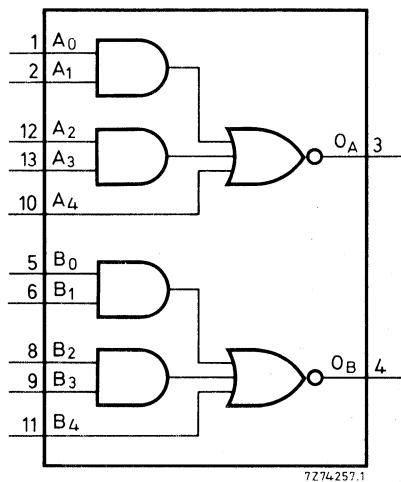

Fig. 1 Functional diagram.

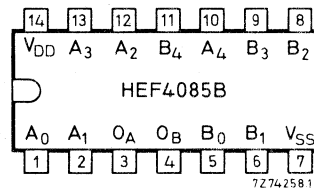

Fig. 2 Pinning diagram.

HEF4085BP : 14-lead DIL; plastic (SOT-27K, M, T).
 HEF4085BD : 14-lead DIL; ceramic (cerdip) (SOT-73).
 HEF4085BT : 14-lead mini-pack; plastic
 (SO-14; SOT-108A).

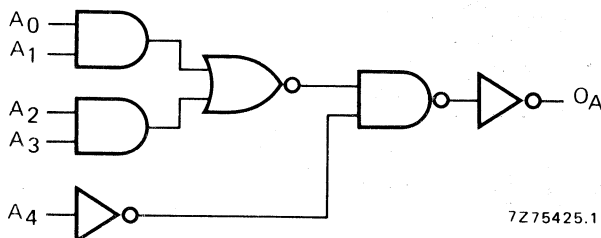

Fig. 3 Logic diagram (one gate).

LOGIC FUNCTION

$$O_A = \overline{A_0 \cdot A_1 + A_2 \cdot A_3 + A_4}$$

$$O_B = \overline{B_0 \cdot B_1 + B_2 \cdot B_3 + B_4}$$

FAMILY DATA

IDD LIMITS category GATES

} see Family Specifications

HEF4085B

gates

A.C. CHARACTERISTICS

$V_{SS} = 0 \text{ V}$; $T_{amb} = 25 \text{ }^\circ\text{C}$; $C_L = 50 \text{ pF}$; input transition times $\leq 20 \text{ ns}$

| | V_{DD} V | symbol | typ. | max. | | typical extrapolation formula | |
|---|---------------|-----------|-----------|------|-----|--|--|
| Propagation delays $A_n, B_n \rightarrow O_n$ HIGH to LOW | 5 | t_{PHL} | 75 | 155 | ns | $48 \text{ ns} + (0,55 \text{ ns/pF}) C_L$ | |
| | 10 | | 30 | 60 | ns | $19 \text{ ns} + (0,23 \text{ ns/pF}) C_L$ | |
| | 15 | | 20 | 40 | ns | $12 \text{ ns} + (0,16 \text{ ns/pF}) C_L$ | |
| | LOW to HIGH | 5 | t_{PLH} | 65 | 135 | ns | $38 \text{ ns} + (0,55 \text{ ns/pF}) C_L$ |
| | | 10 | | 30 | 55 | ns | $19 \text{ ns} + (0,23 \text{ ns/pF}) C_L$ |
| | | 15 | | 20 | 40 | ns | $12 \text{ ns} + (0,16 \text{ ns/pF}) C_L$ |
| Output transition times | HIGH to LOW | t_{THL} | 5 | 60 | 120 | ns | $10 \text{ ns} + (1,0 \text{ ns/pF}) C_L$ |
| | | | 10 | 30 | 60 | ns | $9 \text{ ns} + (0,42 \text{ ns/pF}) C_L$ |
| | | | 15 | 20 | 40 | ns | $6 \text{ ns} + (0,28 \text{ ns/pF}) C_L$ |
| | LOW to HIGH | t_{TLH} | 5 | 60 | 120 | ns | $10 \text{ ns} + (1,0 \text{ ns/pF}) C_L$ |
| | | | 10 | 30 | 60 | ns | $9 \text{ ns} + (0,42 \text{ ns/pF}) C_L$ |
| | | | 15 | 20 | 40 | ns | $6 \text{ ns} + (0,28 \text{ ns/pF}) C_L$ |

| | V_{DD} V | typical formula for P (μW) | where |
|---|---------------|---|------------------------------------|
| Dynamic power dissipation per package (P) | 5 | $750 f_i + \Sigma(f_o C_L) \times V_{DD}^2$ | f_i = input freq. (MHz) |
| | 10 | | f_o = output freq. (MHz) |
| | 15 | | C_L = load capacitance (pF) |
| | | | $\Sigma(f_o C_L)$ = sum of outputs |
| | | | V_{DD} = supply voltage (V) |

4-WIDE 2-INPUT AND-OR-INVERT GATE



The HEF4086B is a 4-wide 2-input AND-OR-invert (AOI) gate with two additional inputs (I_8 and \bar{I}_9) which can be used as either expander or inhibit inputs by connecting them to any standard LOCMOS output. A HIGH on I_8 or a LOW on \bar{I}_9 forces the output (O) LOW independent of the other eight inputs (I_0 to I_7). The output (O) is fully buffered for highest noise immunity and pattern insensitivity of output impedance.

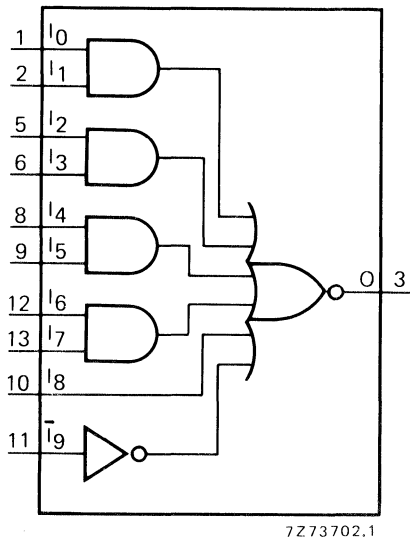

Fig. 1 Functional diagram.

PINNING

- I_0 to I_8 gate inputs
- \bar{I}_9 gate input (active LOW)
- O output (active LOW)

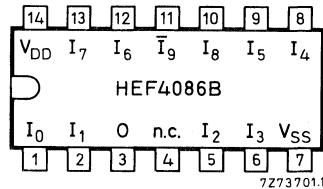

Fig. 2 Pinning diagram.

- HEF4086BP : 14-lead DIL; plastic (SOT-27K, M, T).
- HEF4086BD: 14-lead DIL; ceramic (cerdip) (SOT-73).
- HEF4086BT: 14-lead mini-pack; plastic (SO-14; SOT-108A).

FAMILY DATA

I_{DD} LIMITS category GATES

} see Family Specifications

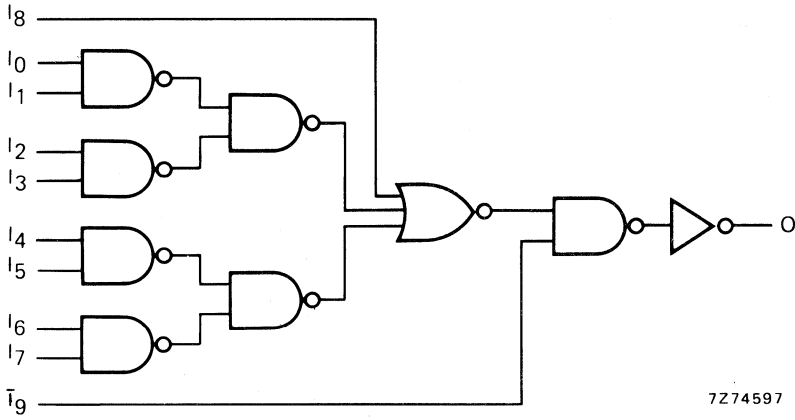

7274597

Fig. 3 Logic diagram.

LOGIC EQUATION

$$O = I_0 \cdot I_1 + I_2 \cdot I_3 + I_4 \cdot I_5 + I_6 \cdot I_7 + I_8 + I_9$$

A.C. CHARACTERISTICS

$V_{SS} = 0\text{ V}$; $T_{amb} = 25\text{ }^{\circ}\text{C}$; $C_L = 50\text{ pF}$; input transition times $\leq 20\text{ ns}$

| | V_{DD} V | symbol | typ. | max. | | typical extrapolation formula |
|---|---------------|--------|------|------|----|--|
| Propagation delays I_0 to $I_7 \rightarrow 0$ HIGH to LOW | 5 | tPHL | 90 | 180 | ns | $63\text{ ns} + (0,55\text{ ns/pF}) C_L$ |
| | 10 | | 30 | 65 | ns | $19\text{ ns} + (0,23\text{ ns/pF}) C_L$ |
| | 15 | | 20 | 40 | ns | $12\text{ ns} + (0,16\text{ ns/pF}) C_L$ |
| LOW to HIGH | 5 | tPLH | 80 | 155 | ns | $53\text{ ns} + (0,55\text{ ns/pF}) C_L$ |
| | 10 | | 30 | 60 | ns | $19\text{ ns} + (0,23\text{ ns/pF}) C_L$ |
| | 15 | | 20 | 40 | ns | $12\text{ ns} + (0,16\text{ ns/pF}) C_L$ |
| $I_8 \rightarrow 0$ HIGH to LOW | 5 | tPHL | 70 | 140 | ns | $43\text{ ns} + (0,55\text{ ns/pF}) C_L$ |
| | 10 | | 25 | 55 | ns | $14\text{ ns} + (0,23\text{ ns/pF}) C_L$ |
| | 15 | | 20 | 40 | ns | $12\text{ ns} + (0,16\text{ ns/pF}) C_L$ |
| LOW to HIGH | 5 | tPLH | 55 | 115 | ns | $28\text{ ns} + (0,55\text{ ns/pF}) C_L$ |
| | 10 | | 20 | 40 | ns | $9\text{ ns} + (0,23\text{ ns/pF}) C_L$ |
| | 15 | | 15 | 25 | ns | $7\text{ ns} + (0,16\text{ ns/pF}) C_L$ |
| $\bar{I}_9 \rightarrow 0$ HIGH to LOW | 5 | tPHL | 55 | 105 | ns | $28\text{ ns} + (0,55\text{ ns/pF}) C_L$ |
| | 10 | | 20 | 45 | ns | $9\text{ ns} + (0,23\text{ ns/pF}) C_L$ |
| | 15 | | 15 | 30 | ns | $7\text{ ns} + (0,16\text{ ns/pF}) C_L$ |
| LOW to HIGH | 5 | tPLH | 45 | 90 | ns | $18\text{ ns} + (0,55\text{ ns/pF}) C_L$ |
| | 10 | | 15 | 35 | ns | $4\text{ ns} + (0,23\text{ ns/pF}) C_L$ |
| | 15 | | 10 | 25 | ns | $2\text{ ns} + (0,16\text{ ns/pF}) C_L$ |
| Output transition times HIGH to LOW | 5 | tTHL | 60 | 120 | ns | $10\text{ ns} + (1,0\text{ ns/pF}) C_L$ |
| | 10 | | 30 | 60 | ns | $9\text{ ns} + (0,42\text{ ns/pF}) C_L$ |
| | 15 | | 20 | 40 | ns | $6\text{ ns} + (0,28\text{ ns/pF}) C_L$ |
| LOW to HIGH | 5 | tTLH | 60 | 120 | ns | $10\text{ ns} + (1,0\text{ ns/pF}) C_L$ |
| | 10 | | 30 | 60 | ns | $9\text{ ns} + (0,42\text{ ns/pF}) C_L$ |
| | 15 | | 20 | 40 | ns | $6\text{ ns} + (0,28\text{ ns/pF}) C_L$ |

| | V_{DD} V | typical formula for P (μW) | where |
|---|---------------|---|------------------------------------|
| Dynamic power dissipation per package (P) | 5 | $525 f_i + \Sigma(f_o C_L) \times V_{DD}^2$ | f_i = input freq. (MHz) |
| | 10 | | f_o = output freq. (MHz) |
| | 15 | | C_L = load capacitance (pF) |
| | | | $\Sigma(f_o C_L)$ = sum of outputs |
| | | | V_{DD} = supply voltage (V) |

HEF4086B

gates

APPLICATION INFORMATION

Figure 4 shows two HEF4086B ICs connected to obtain an 8-wide 2-input AOI function. The output (O_A) of the first IC is fed directly into the $\overline{I_{9B}}$ gate input of the second IC. Similarly, any NAND gate output can be fed directly into the $\overline{I_9}$ gate input to obtain a 5-wide AOI function. In addition, any AND gate output can be fed directly into the I_8 gate input with the same result.

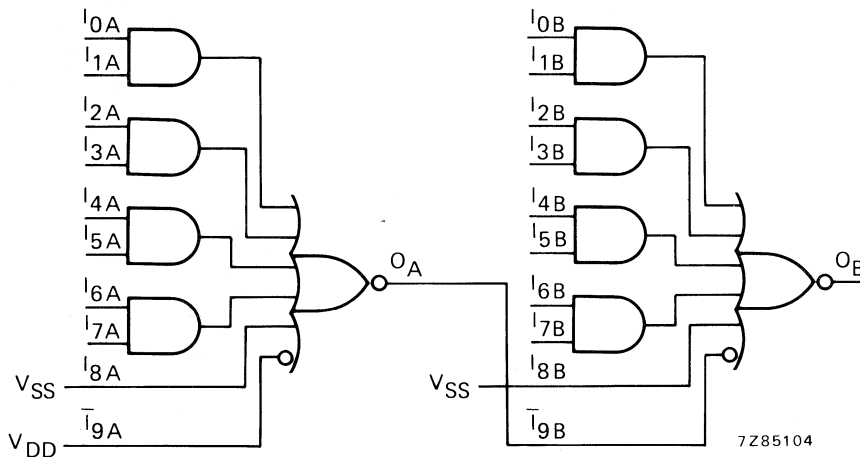

Fig. 4 Two HEF4086B ICs connected as an 8-wide 2-input AOI gate.

Logic equation for Fig. 4:

$$O_B = \overline{I_{0A} \cdot I_{1A} + I_{2A} \cdot I_{3A} + I_{4A} \cdot I_{5A} + I_{6A} \cdot I_{7A} + I_{0B} \cdot I_{1B} + I_{2B} \cdot I_{3B} + I_{4B} \cdot I_{5B} + I_{6B} \cdot I_{7B}}$$

QUADRUPLE 2-INPUT NAND SCHMITT TRIGGER



The HEF4093B consists of four Schmitt-trigger circuits. Each circuit functions as a two-input NAND gate with Schmitt-trigger action on both inputs. The gate switches at different points for positive and negative-going signals. The difference between the positive voltage (V_P) and the negative voltage (V_N) is defined as hysteresis voltage (V_H).

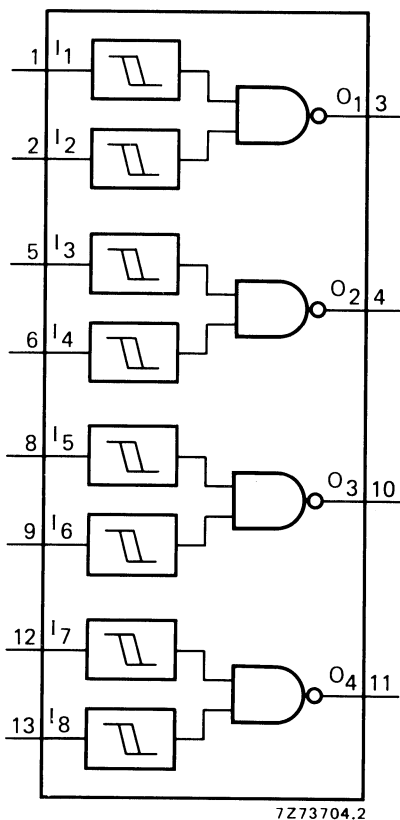

Fig. 1 Functional diagram.



Fig. 2 Pinning diagram.

HEF4093BP : 14-lead DIL; plastic (SOT-27K, M, T).
 HEF4093BD : 14-lead DIL; ceramic (cerdip) (SOT-73).
 HEF4093BT : 14-lead mini-pack; plastic
 (SO-14; SOT-108A).

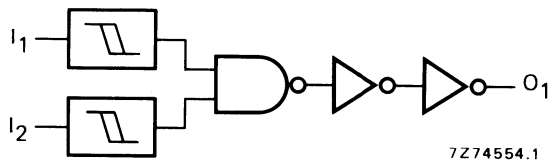

Fig. 3 Logic diagram (one gate).

FAMILY DATA

I_{DD} LIMITS category GATES

see Family Specifications

D.C. CHARACTERISTICS

$V_{SS} = 0\text{ V}; T_{amb} = 25\text{ }^\circ\text{C}$

| | V_{DD} V | symbol | min. | typ. | max. | |
|---|---------------|--------|------|------|------|---|
| Hysteresis voltage | 5 | V_H | 0,4 | 0,7 | — | V |
| | 10 | | 0,6 | 1,0 | — | V |
| | 15 | | 0,7 | 1,3 | — | V |
| Switching levels positive-going input voltage | 5 | V_P | 1,9 | 2,9 | 3,5 | V |
| | 10 | | 3,6 | 5,2 | 7 | V |
| | 15 | | 4,7 | 7,3 | 11 | V |
| negative-going input voltage | 5 | V_N | 1,5 | 2,2 | 3,1 | V |
| | 10 | | 3 | 4,2 | 6,4 | V |
| | 15 | | 4 | 6,0 | 10,3 | V |

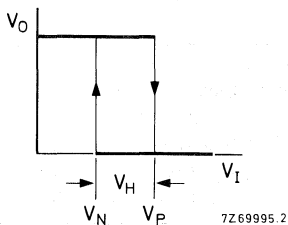

Fig. 4 Transfer characteristic.

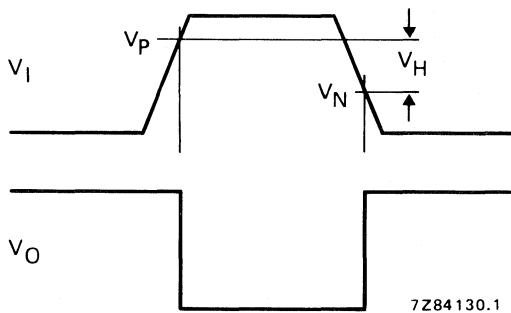

Fig. 5 Waveforms showing definition of V_P , V_N and V_H ; where V_N and V_P are between limits of 30% and 70%.

A.C. CHARACTERISTICS

$V_{SS} = 0\text{ V}$; $T_{amb} = 25\text{ }^{\circ}\text{C}$; $C_L = 50\text{ pF}$; input transition times $\leq 20\text{ ns}$

| | V_{DD} V | symbol | typ. | max. | | typical extrapolation formula |
|--|---------------|------------------|------|------|----|-------------------------------------|
| Propagation delays $I_n \rightarrow O_n$ HIGH to LOW | 5 | t _{PHL} | 90 | 185 | ns | 63 ns + (0,55 ns/pF) C _L |
| | 10 | | 40 | 80 | ns | 29 ns + (0,23 ns/pF) C _L |
| | 15 | | 30 | 60 | ns | 22 ns + (0,16 ns/pF) C _L |
| LOW to HIGH | 5 | t _{PLH} | 85 | 170 | ns | 58 ns + (0,55 ns/pF) C _L |
| | 10 | | 40 | 80 | ns | 29 ns + (0,23 ns/pF) C _L |
| | 15 | | 30 | 60 | ns | 22 ns + (0,16 ns/pF) C _L |
| Output transition times HIGH to LOW | 5 | t _{THL} | 60 | 120 | ns | 10 ns + (1,0 ns/pF) C _L |
| | 10 | | 30 | 60 | ns | 9 ns + (0,42 ns/pF) C _L |
| | 15 | | 20 | 40 | ns | 6 ns + (0,28 ns/pF) C _L |
| LOW to HIGH | 5 | t _{TLH} | 60 | 120 | ns | 10 ns + (1,0 ns/pF) C _L |
| | 10 | | 30 | 60 | ns | 9 ns + (0,42 ns/pF) C _L |
| | 15 | | 20 | 40 | ns | 6 ns + (0,28 ns/pF) C _L |

| | V_{DD} V | typical formula for P (μW) | where |
|---|---------------|---|------------------------------------|
| Dynamic power dissipation per package (P) | 5 | $1300 f_i + \Sigma(f_o C_L) \times V_{DD}^2$ $6400 f_i + \Sigma(f_o C_L) \times V_{DD}^2$ $18\,700 f_i + \Sigma(f_o C_L) \times V_{DD}^2$ | f_i = input freq. (MHz) |
| | 10 | | f_o = output freq. (MHz) |
| | 15 | | C_L = load capacitance (pF) |
| | | | $\Sigma(f_o C_L)$ = sum of outputs |
| | | | V_{DD} = supply voltage (V) |

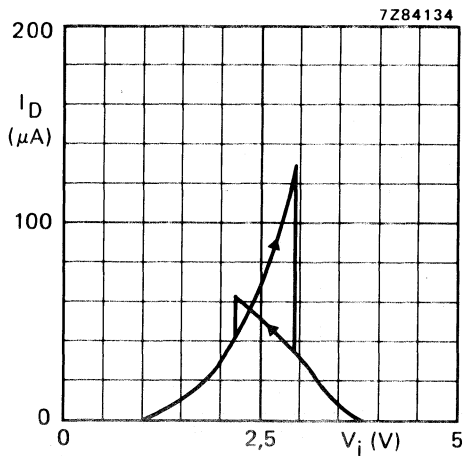

Fig. 6 Typical drain current as a function of input voltage; $V_{DD} = 5V$; $T_{amb} = 25^\circ C$.

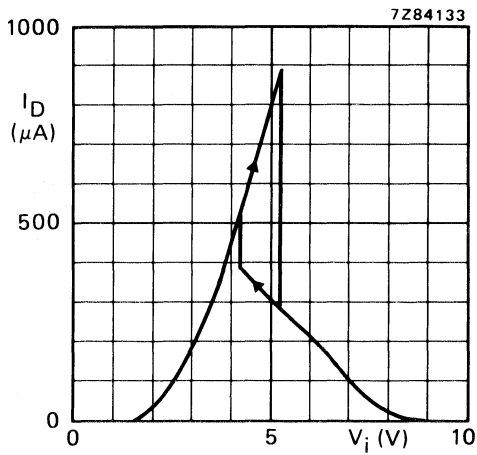

Fig. 7 Typical drain current as a function of input voltage; $V_{DD} = 10V$; $T_{amb} = 25^\circ C$.

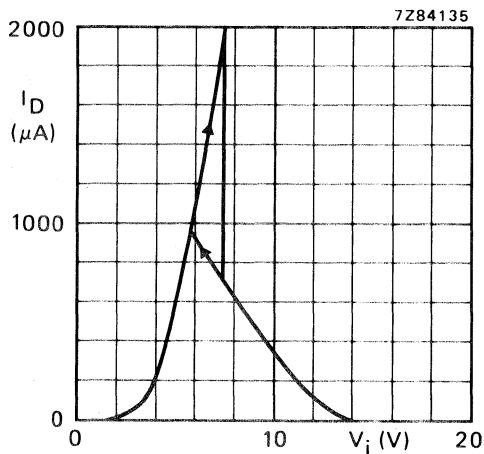

Fig. 8 Typical drain current as a function of input voltage; $V_{DD} = 15V$; $T_{amb} = 25^\circ C$.

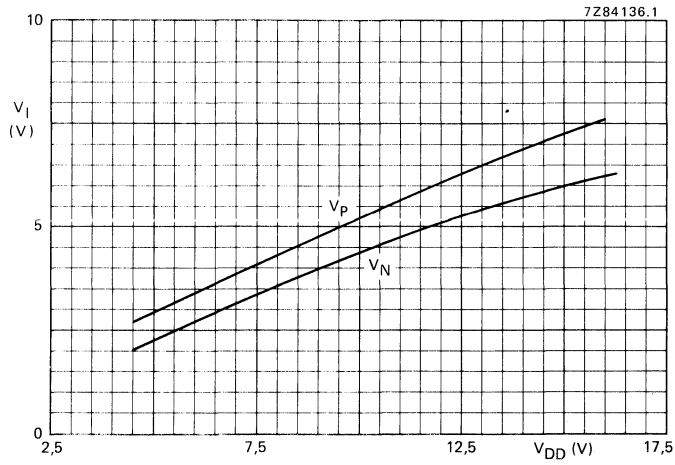

Fig. 9 Typical switching levels as a function of supply voltage V_{DD} ; $T_{amb} = 25^\circ\text{C}$.

APPLICATION INFORMATION

Some examples of applications for the HEF4093B are:

- Wave and pulse shapers
- Astable multivibrators
- Monostable multivibrators.

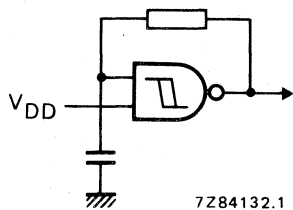

Fig. 10 The HEF4093B used as a astable multivibrator.

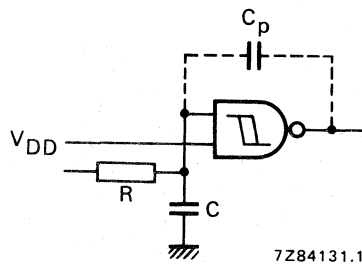

Fig. 11 Schmitt trigger driven via a high impedance ($R > 1 \text{ k}\Omega$).

If a Schmitt trigger is driven via a high impedance ($R > 1 \text{ k}\Omega$) then it is necessary to incorporate a capacitor C of such value that: $\frac{C}{C_p} > \frac{V_{DD}-V_{SS}}{V_H}$, otherwise oscillation can occur on the edges of a pulse.

C_p is the external parasitic capacitance between inputs and output; the value depends on the circuit board layout.

Note

The two inputs may be connected together, but this will result in a larger through-current at the moment of switching.

8-STAGE SHIFT-AND-STORE BUS REGISTER



The HEF4094B is an 8-stage serial shift register having a storage latch associated with each stage for strobing data from the serial input to parallel buffered 3-state outputs O_0 to O_7 . The parallel outputs may be connected directly to common bus lines. Data is shifted on positive-going clock transitions. The data in each shift register stage is transferred to the storage register when the strobe (STR) input is HIGH. Data in the storage register appears at the outputs whenever the output enable (EO) signal is HIGH.

Two serial outputs (O_s and O'_s) are available for cascading a number of HEF4094B devices. Data is available at O_s on positive-going clock edges to allow high-speed operation in cascaded systems in which the clock rise time is fast. The same serial information is available at O'_s on the next negative-going clock edge and provides cascading HEF4094B devices when the clock rise time is slow.

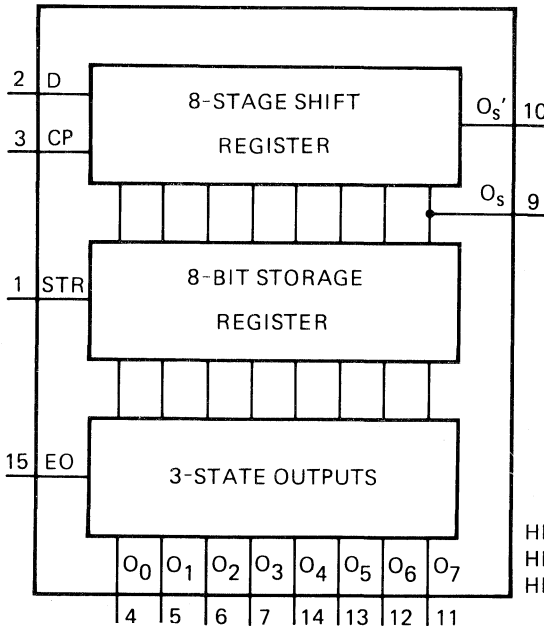

Fig. 1 Functional diagram.

7274614.1

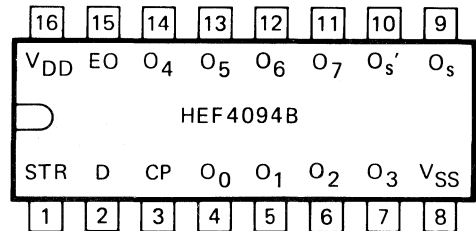

Fig. 2 Pinning diagram.

7274613.1

HEF4094BP : 16-lead DIL; plastic (SOT-38Z).
HEF4094BD : 16-lead DIL; ceramic (cerdip) (SOT-74).
HEF4094BT : 16-lead mini-pack; plastic (SO-16; SOT-109A).

PINNING

| | | | |
|-----|--------------|----------------|---------------------|
| D | data input | EO | output enable input |
| CP | clock input | O_s, O'_s | serial outputs |
| STR | strobe input | O_0 to O_7 | parallel outputs |

FAMILY DATA

I_{DD} LIMITS category MSI

} see Family Specifications

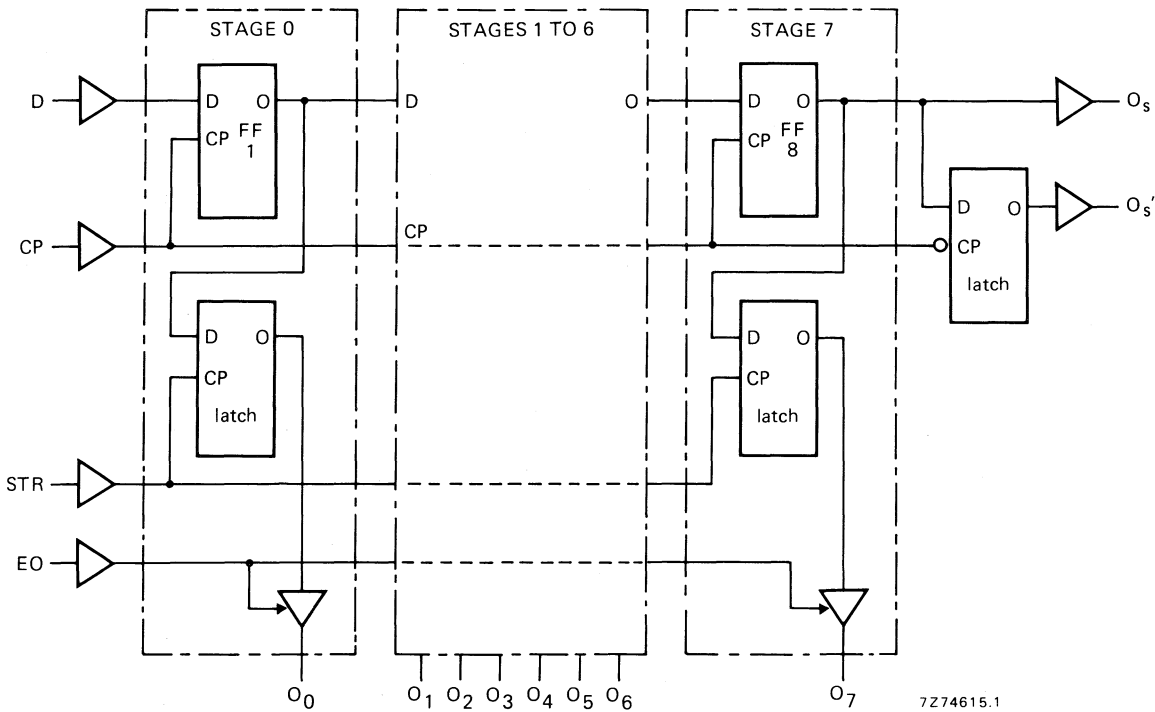

Fig. 3a Logic diagram.

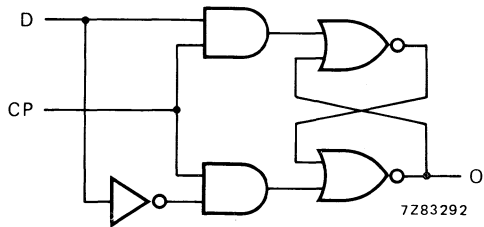

Fig. 3b One D-latch.

FUNCTION TABLE

| inputs | | | | parallel outputs | | serial outputs | |
|--------|----|-----|---|------------------|------------------|-----------------|-----------------|
| CP | EO | STR | D | O ₀ | O _n | O _s | O' _s |
| ∕ | L | X | X | Z | Z | O' ₆ | nc |
| ∖ | L | X | X | Z | Z | nc | O ₇ |
| ∕ | H | L | X | nc | nc | O' ₆ | nc |
| ∕ | H | H | L | L | O _{n-1} | O' ₆ | nc |
| ∕ | H | H | H | H | O _{n-1} | O' ₆ | nc |
| ∖ | H | H | H | nc | nc | nc | O ₇ |

H = HIGH state (the more positive voltage)

L = LOW state (the less positive voltage)

X = state is immaterial

∕ = positive-going transition

∖ = negative-going transition

Z = high impedance off state

nc = no change

O'₆ = the information in the seventh shift register stage

At the positive clock edge the information in the 7th register stage is transferred to the 8th register stage and the O_s output.

A.C. CHARACTERISTICS

V_{SS} = 0 V; T_{amb} = 25 °C; input transition times ≤ 20 ns

| | V _{DD} V | typical formula for P (μW) | where f _i = input freq. (MHz) f _o = output freq. (MHz) C _L = load capacitance (pF) Σ(f _o C _L) = sum of outputs V _{DD} = supply voltage (V) |
|---|----------------------|--|--|
| Dynamic power dissipation per package (P) | 5 | 2100 f _i + Σ(f _o C _L) × V _{DD} ² | |
| | 10 | 9700 f _i + Σ(f _o C _L) × V _{DD} ² | |
| | 15 | 26 000 f _i + Σ(f _o C _L) × V _{DD} ² | |

HEF4094B

MSI

A.C. CHARACTERISTICS

 $V_{SS} = 0 \text{ V}$; $T_{amb} = 25 \text{ }^\circ\text{C}$; $C_L = 50 \text{ pF}$; input transition times $\leq 20 \text{ ns}$

| | V_{DD} V | symbol | typ. | max. | | typical extrapolation formula |
|----------------------------|---------------|-----------|------|------|----|---|
| Propagation delays | | | | | | |
| CP \rightarrow O_s | 5 | | 135 | 270 | ns | $108 \text{ ns} + (0,55 \text{ ns/pF}) C_L$ |
| HIGH to LOW | 10 | t_{PHL} | 65 | 130 | ns | $54 \text{ ns} + (0,23 \text{ ns/pF}) C_L$ |
| | 15 | | 50 | 100 | ns | $42 \text{ ns} + (0,16 \text{ ns/pF}) C_L$ |
| | 5 | | 105 | 210 | ns | $78 \text{ ns} + (0,55 \text{ ns/pF}) C_L$ |
| LOW to HIGH | 10 | t_{PLH} | 50 | 100 | ns | $39 \text{ ns} + (0,23 \text{ ns/pF}) C_L$ |
| | 15 | | 40 | 80 | ns | $32 \text{ ns} + (0,16 \text{ ns/pF}) C_L$ |
| CP \rightarrow O'_s | 5 | | 105 | 210 | ns | $78 \text{ ns} + (0,55 \text{ ns/pF}) C_L$ |
| HIGH to LOW | 10 | t_{PHL} | 50 | 100 | ns | $39 \text{ ns} + (0,23 \text{ ns/pF}) C_L$ |
| | 15 | | 40 | 80 | ns | $32 \text{ ns} + (0,16 \text{ ns/pF}) C_L$ |
| | 5 | | 105 | 210 | ns | $78 \text{ ns} + (0,55 \text{ ns/pF}) C_L$ |
| LOW to HIGH | 10 | t_{PLH} | 50 | 100 | ns | $39 \text{ ns} + (0,23 \text{ ns/pF}) C_L$ |
| | 15 | | 40 | 80 | ns | $32 \text{ ns} + (0,16 \text{ ns/pF}) C_L$ |
| CP \rightarrow O_n | 5 | | 165 | 330 | ns | $138 \text{ ns} + (0,55 \text{ ns/pF}) C_L$ |
| HIGH to LOW | 10 | t_{PHL} | 75 | 150 | ns | $64 \text{ ns} + (0,23 \text{ ns/pF}) C_L$ |
| | 15 | | 55 | 110 | ns | $47 \text{ ns} + (0,16 \text{ ns/pF}) C_L$ |
| | 5 | | 150 | 300 | ns | $123 \text{ ns} + (0,55 \text{ ns/pF}) C_L$ |
| LOW to HIGH | 10 | t_{PLH} | 70 | 140 | ns | $59 \text{ ns} + (0,23 \text{ ns/pF}) C_L$ |
| | 15 | | 55 | 110 | ns | $47 \text{ ns} + (0,16 \text{ ns/pF}) C_L$ |
| STR \rightarrow O_n | 5 | | 110 | 220 | ns | $83 \text{ ns} + (0,55 \text{ ns/pF}) C_L$ |
| HIGH to LOW | 10 | t_{PHL} | 50 | 100 | ns | $39 \text{ ns} + (0,23 \text{ ns/pF}) C_L$ |
| | 15 | | 35 | 70 | ns | $27 \text{ ns} + (0,16 \text{ ns/pF}) C_L$ |
| | 5 | | 100 | 200 | ns | $73 \text{ ns} + (0,55 \text{ ns/pF}) C_L$ |
| LOW to HIGH | 10 | t_{PLH} | 45 | 90 | ns | $34 \text{ ns} + (0,23 \text{ ns/pF}) C_L$ |
| | 15 | | 35 | 70 | ns | $27 \text{ ns} + (0,16 \text{ ns/pF}) C_L$ |
| Output transition times | | | | | | |
| HIGH to LOW | 5 | | 60 | 120 | ns | $10 \text{ ns} + (1,0 \text{ ns/pF}) C_L$ |
| | 10 | t_{THL} | 30 | 60 | ns | $9 \text{ ns} + (0,42 \text{ ns/pF}) C_L$ |
| | 15 | | 20 | 40 | ns | $6 \text{ ns} + (0,28 \text{ ns/pF}) C_L$ |
| | 5 | | 60 | 120 | ns | $10 \text{ ns} + (1,0 \text{ ns/pF}) C_L$ |
| LOW to HIGH | 10 | t_{TLH} | 30 | 60 | ns | $9 \text{ ns} + (0,42 \text{ ns/pF}) C_L$ |
| | 15 | | 20 | 40 | ns | $6 \text{ ns} + (0,28 \text{ ns/pF}) C_L$ |

A.C. CHARACTERISTICS

 $V_{SS} = 0 \text{ V}$; $T_{amb} = 25 \text{ }^\circ\text{C}$; $C_L = 50 \text{ pF}$; input transition times $\leq 20 \text{ ns}$

| | V_{DD} V | symbol | min. | typ. | max. |
|-------------------------------|---------------|--------------------|------|------|--------|
| 3-state propagation delays | | | | | |
| Output enable times | 5 | | | 40 | 80 ns |
| EO \rightarrow O_n | 10 | t _{PZH} | | 25 | 50 ns |
| HIGH | 15 | | | 20 | 40 ns |
| LOW | 5 | | | 40 | 80 ns |
| | 10 | t _{PZL} | | 25 | 50 ns |
| | 15 | | | 20 | 40 ns |
| | 5 | | | 40 | 80 ns |
| Output disable times | 5 | | | 75 | 150 ns |
| EO \rightarrow O_n | 10 | t _{PHZ} | | 40 | 80 ns |
| HIGH | 15 | | | 30 | 60 ns |
| LOW | 5 | | | 80 | 160 ns |
| | 10 | t _{PLZ} | | 40 | 80 ns |
| | 15 | | | 30 | 60 ns |
| | 5 | | | 60 | 120 ns |
| Minimum clock pulse width | 5 | | 60 | 30 | ns |
| LOW | 10 | t _{WCPL} | 30 | 15 | ns |
| | 15 | | 24 | 12 | ns |
| Minimum strobe pulse width | 5 | | 40 | 20 | ns |
| HIGH | 10 | t _{WSTRH} | 30 | 15 | ns |
| | 15 | | 24 | 12 | ns |
| Set-up times | 5 | | 60 | 30 | ns |
| D \rightarrow CP | 10 | t _{su} | 20 | 10 | ns |
| | 15 | | 15 | 5 | ns |
| Hold times | 5 | | 5 | -15 | ns |
| D \rightarrow CP | 10 | t _{hold} | 20 | 5 | ns |
| | 15 | | 20 | 5 | ns |
| Maximum clock pulse frequency | 5 | | 5 | 10 | MHz |
| | 10 | f _{max} | 11 | 22 | MHz |
| | 15 | | 14 | 28 | MHz |

HEF4094B
MSI

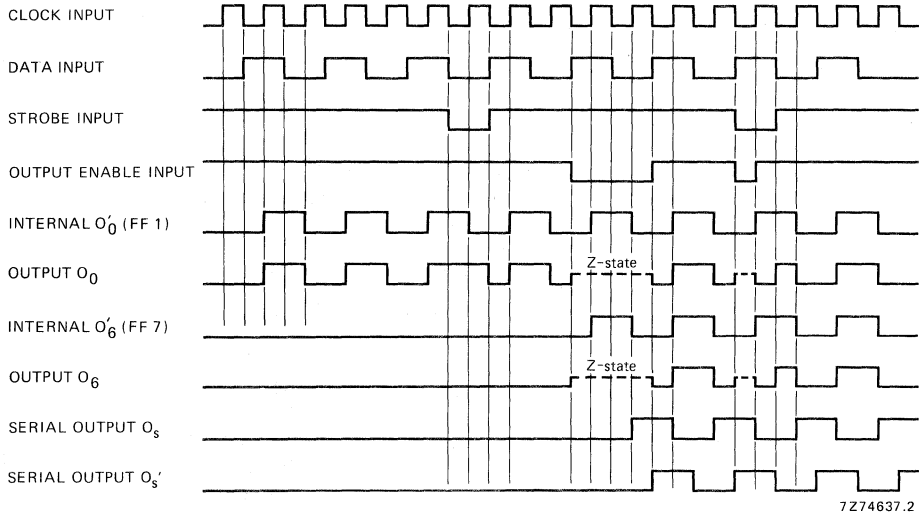

Fig. 4 Timing diagram.

APPLICATION INFORMATION

Some examples of applications for the HEF4094B are:

- Serial-to-parallel data conversion
- Remote control holding register

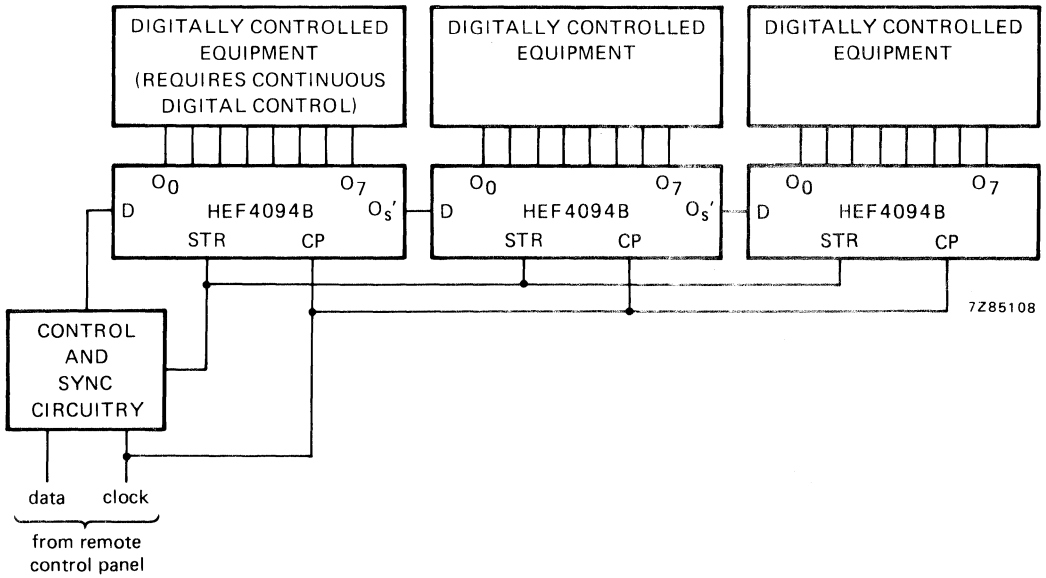

Fig. 5 Remote control holding register.

QUADRUPLE LOW TO HIGH VOLTAGE TRANSLATOR WITH 3-STATE OUTPUTS



The HEF4104B quadruple low voltage to high voltage translator with 3-state outputs provides the capability of interfacing low voltage circuits to high voltage circuits, such as low voltage LOC MOS and TTL to high voltage LOC MOS. It has four data inputs (I_0 to I_3), an active HIGH output enable input (EO), four data outputs (O_0 to O_3) and their complements (\bar{O}_0 to \bar{O}_3).

With EO HIGH, O_0 to O_3 and \bar{O}_0 to \bar{O}_3 are in the low impedance ON-state, either HIGH or LOW as determined by I_0 to I_3 ; with EO LOW, O_0 to O_3 and \bar{O}_0 to \bar{O}_3 are in the high impedance OFF-state.

The device uses a common negative supply (V_{SS}) and separate positive supplies for inputs (V_{DD1}) and outputs (V_{DD0}). V_{DD1} must always be less than or equal to V_{DD0} , even during power turn-on and turn-off. For the permissible operating range of V_{DD1} and V_{DD0} see graph Fig. 4.

Each input protection circuit is terminated between V_{DD0} and V_{SS} . This allows the input signals to be driven from any potential between V_{DD0} and V_{SS} , without regard to current limiting. When driving from potentials greater than V_{DD0} or less than V_{SS} , the current at each input must be limited to 10 mA.

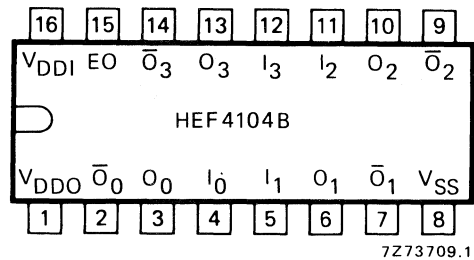
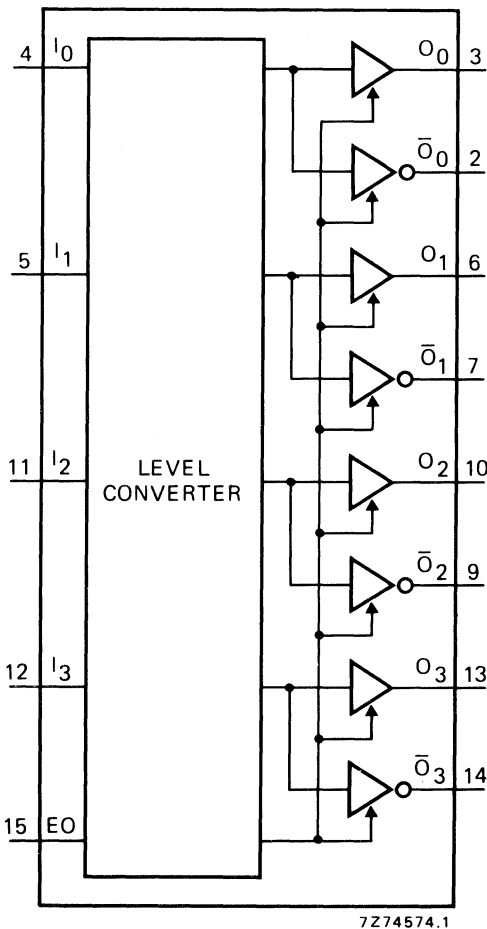

Fig. 2 Pinning diagram.

HEF4104BP : 16-lead DIL; plastic (SOT-38Z).
HEF4104BD : 16-lead DIL; ceramic (cerdip) (SOT-74).
HEF4104BT : 16-lead mini-pack; plastic
(SO-16; SOT-109A).

PINNING

I_0 to I_3 data inputs
EO output enable input
 O_0 to O_3 data outputs
 \bar{O}_0 to \bar{O}_3 complementary data outputs

Fig. 1 Functional diagram.

FAMILY DATA

I_{DD} LIMITS category MSI

} see Family Specifications

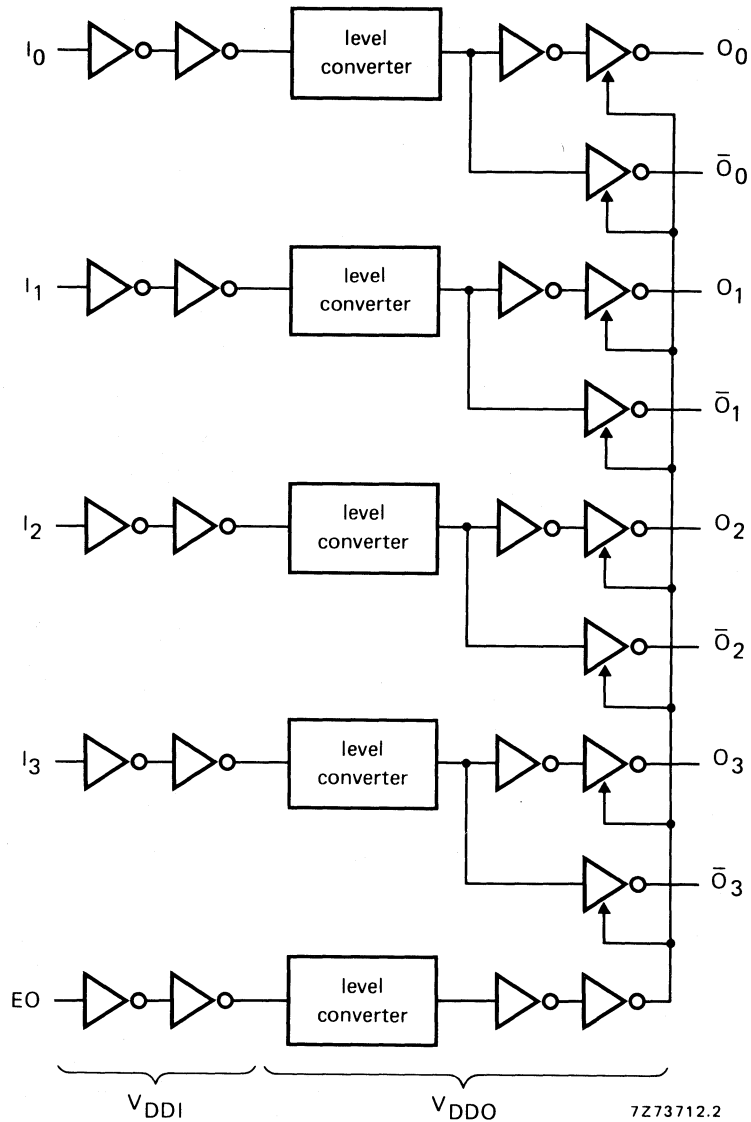

Fig. 3 Logic diagram.

A.C. CHARACTERISTICS

V_{SS} = 0 V; T_{amb} = 25 °C; C_L = 50 pF; input transition times ≤ 20 ns

| | V _{DD} V | symbol | typ. | max. | | typical extrapolation formula | |
|---|----------------------|------------------|------------------|------|-----|--------------------------------------|--------------------------------------|
| Propagation delays I _n → O _n , $\overline{O_n}$ HIGH to LOW | 5 | t _{PHL} | 170 | 340 | ns | 143 ns + (0,55 ns/pF) C _L | |
| | 10 | | 80 | 160 | ns | 69 ns + (0,23 ns/pF) C _L | |
| | 15 | | 65 | 135 | ns | 57 ns + (0,16 ns/pF) C _L | |
| | LOW to HIGH | 5 | t _{PLH} | 170 | 340 | ns | 143 ns + (0,55 ns/pF) C _L |
| | | 10 | | 80 | 160 | ns | 69 ns + (0,23 ns/pF) C _L |
| | | 15 | | 70 | 140 | ns | 62 ns + (0,16 ns/pF) C _L |
| Output transition times | 5 | t _{THL} | 60 | 120 | ns | 10 ns + (1,0 ns/pF) C _L | |
| | | | 10 | 30 | 60 | ns | 9 ns + (0,42 ns/pF) C _L |
| | | | 15 | 20 | 40 | ns | 6 ns + (0,28 ns/pF) C _L |
| | LOW to HIGH | t _{TLH} | 60 | 120 | ns | 10 ns + (1,0 ns/pF) C _L | |
| | | | 10 | 30 | 60 | ns | 9 ns + (0,42 ns/pF) C _L |
| | | | 15 | 20 | 40 | ns | 6 ns + (0,28 ns/pF) C _L |
| 3-state propagation delays | 5 | t _{PHZ} | 70 | 135 | ns | | |
| | | | 10 | 55 | 110 | ns | |
| | | | 15 | 60 | 120 | ns | |
| | LOW | t _{PLZ} | 70 | 135 | ns | | |
| | | | 10 | 55 | 105 | ns | |
| | | | 15 | 55 | 110 | ns | |
| Output enable times EO → O _n , $\overline{O_n}$ | 5 | t _{PZH} | 195 | 395 | ns | | |
| | | | 10 | 95 | 195 | ns | |
| | | | 15 | 80 | 165 | ns | |
| | LOW | t _{PZL} | 195 | 395 | ns | | |
| | | | 10 | 95 | 190 | ns | |
| | | | 15 | 80 | 160 | ns | |

| | V _{DD} V | typical formula for P (μW) | where |
|---|----------------------|--|--|
| Dynamic power dissipation per package (P) | 5 | 3 000 f _i + Σ(f _o C _L) × V _{DD} ² | f _i = input freq. (MHz) |
| | 10 | 12 200 f _i + Σ(f _o C _L) × V _{DD} ² | f _o = output freq. (MHz) |
| | 15 | 31 000 f _i + Σ(f _o C _L) × V _{DD} ² | C _L = load capacitance (pF) |
| | | | Σ(f _o C _L) = sum of outputs |
| | | | V _{DD} = supply voltage (V) |

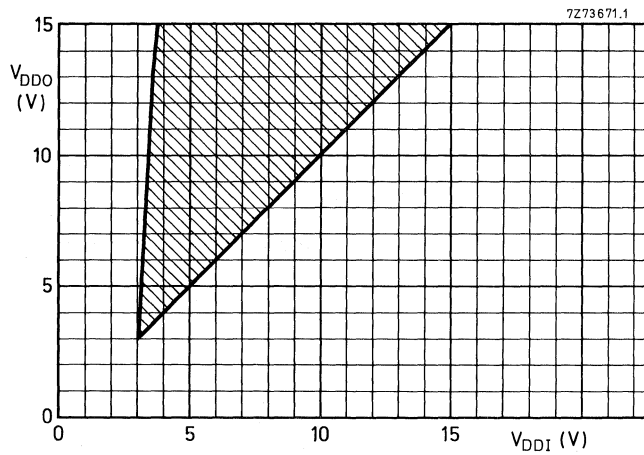

Fig. 4 V_{DDO} as a function of V_{DDI} ; the shaded area shows the permissible operating range.

STROBED HEX INVERTER/BUFFER



The HEF4502B consists of six inverter/buffers with 3-state outputs. When the output enable input (\overline{EO}) is HIGH all six outputs (O_1 to O_6) are in the high impedance OFF-state. When the enable input (\overline{E}) is HIGH all six outputs are switched to LOW. The outputs have a 2-TTL load drive capability.

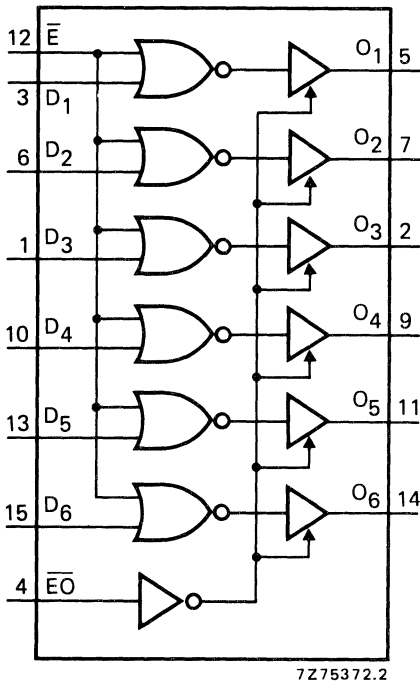

Fig. 1 Functional diagram.

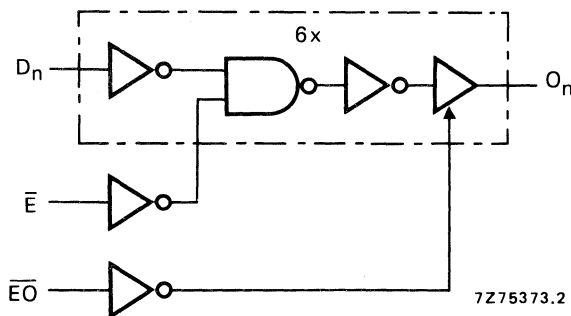

Fig. 3 Logic diagram.

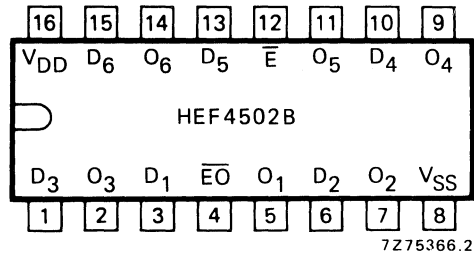

Fig. 2 Pinning diagram.

HEF4502BP : 16-lead DIL; plastic (SOT-38Z).
 HEF4502BD : 16-lead DIL; ceramic (cerdip) (SOT-74).
 HEF4502BT : 16-lead mini-pack; plastic (SO-16; SOT-109A).

PINNING

- D_1 to D_6 data inputs
- \overline{E} enable input
- \overline{EO} output enable input
- O_1 to O_6 3-state outputs

TRUTH TABLE

| inputs | | | output |
|--------|----------------|-----------------|--------|
| D_n | \overline{E} | \overline{EO} | O_n |
| L | L | L | H |
| H | L | L | L |
| X | H | L | L |
| X | X | H | Z |

H = HIGH state (the more pos. voltage)
 L = LOW state (the less pos. voltage)
 X = state is immaterial
 Z = high impedance off state

FAMILY DATA

I_{DD} LIMITS category BUFFERS } see Family Specifications

HEF4502B

buffers

D.C. CHARACTERISTICS

$V_{SS} = 0 \text{ V}$

| | V_{DD} V | V_{OH} V | V_{OL} V | symbol | $T_{amb} \text{ (}^\circ\text{C)}$ | | | | | | |
|------------------------|---------------|---------------|---------------|-----------|------------------------------------|------|------|------|------|------|----|
| | | | | | -40 | | +25 | | +85 | | mA |
| | | | | | min. | max. | min. | max. | min. | max. | |
| Output current HIGH | 5 | 4,6 | | $-I_{OH}$ | 1,2 | 1,0 | 0,8 | | | | mA |
| | 10 | 9,5 | | | 3,8 | 3,2 | 2,5 | | | | mA |
| | 15 | 13,5 | | | 12,0 | 10,0 | 8,0 | | | | mA |
| Output current HIGH | 5 | 2,5 | | $-I_{OH}$ | 3,8 | 3,2 | 2,5 | | | | mA |
| Output current LOW | 4,75 | | 0,4 | I_{OL} | 3,5 | 2,9 | 2,3 | | | | mA |
| | 10 | | 0,5 | | 12,0 | 10,0 | 8,0 | | | | mA |
| | 15 | | 1,5 | | 24,0 | 20,0 | 16,0 | | | | mA |

A.C. CHARACTERISTICS

$V_{SS} = 0 \text{ V}$; $T_{amb} = 25 \text{ }^\circ\text{C}$; input transition times $\leq 20 \text{ ns}$

| | V_{DD} V | typical formula for P (μW) | where |
|---|---------------|---|------------------------------------|
| Dynamic power dissipation per package (P) | 5 | $5\,000 f_i + \Sigma(f_o C_L) \times V_{DD}^2$ | f_i = output freq. (MHz) |
| | 10 | $25\,000 f_i + \Sigma(f_o C_L) \times V_{DD}^2$ | f_o = output freq. (MHz) |
| | 15 | $85\,000 f_i + \Sigma(f_o C_L) \times V_{DD}^2$ | C_L = load capacitance (pF) |
| | | | $\Sigma(f_o C_L)$ = sum of outputs |
| | | | V_{DD} = supply voltage (V) |

A.C. CHARACTERISTICS

 $V_{SS} = 0 \text{ V}$; $T_{amb} = 25 \text{ }^\circ\text{C}$; $C_L = 50 \text{ pF}$; input transition times $\leq 20 \text{ ns}$

| | V_{DD} V | symbol | typ. | max. | typical extrapolation formula |
|---|---------------|--------|------|--------|--|
| Propagation delays $D_n, \bar{E} \rightarrow O_n$ HIGH to LOW | 5 | tPHL | 85 | 170 ns | $77 \text{ ns} + (0,17 \text{ ns/pF}) C_L$ |
| | 10 | | 40 | 80 ns | $37 \text{ ns} + (0,06 \text{ ns/pF}) C_L$ |
| | 15 | | 35 | 70 ns | $33 \text{ ns} + (0,04 \text{ ns/pF}) C_L$ |
| LOW to HIGH | 5 | tPLH | 80 | 160 ns | $66 \text{ ns} + (0,28 \text{ ns/pF}) C_L$ |
| | 10 | | 35 | 70 ns | $28 \text{ ns} + (0,13 \text{ ns/pF}) C_L$ |
| | 15 | | 30 | 60 ns | $25 \text{ ns} + (0,10 \text{ ns/pF}) C_L$ |
| Output transition times HIGH to LOW | 5 | tTHL | 25 | 50 ns | $10 \text{ ns} + (0,30 \text{ ns/pF}) C_L$ |
| | 10 | | 12 | 24 ns | $7 \text{ ns} + (0,11 \text{ ns/pF}) C_L$ |
| | 15 | | 8 | 15 ns | $5 \text{ ns} + (0,07 \text{ ns/pF}) C_L$ |
| LOW to HIGH | 5 | tTLH | 30 | 60 ns | $5 \text{ ns} + (0,50 \text{ ns/pF}) C_L$ |
| | 10 | | 15 | 30 ns | $3 \text{ ns} + (0,24 \text{ ns/pF}) C_L$ |
| | 15 | | 12 | 24 ns | $3 \text{ ns} + (0,18 \text{ ns/pF}) C_L$ |
| 3-state propagation delays | | | | | |
| Output disable times $\bar{E}O \rightarrow O_n$ HIGH | 5 | tPHZ | 60 | 160 ns | |
| | 10 | | 55 | 140 ns | |
| | 15 | | 55 | 140 ns | |
| LOW | 5 | tPLZ | 50 | 100 ns | |
| | 10 | | 35 | 70 ns | |
| | 15 | | 30 | 60 ns | |
| Output enable times $\bar{E}O \rightarrow O_n$ HIGH | 5 | tPZH | 60 | 120 ns | |
| | 10 | | 35 | 70 ns | |
| | 15 | | 30 | 60 ns | |
| LOW | 5 | tPZL | 55 | 110 ns | |
| | 10 | | 25 | 50 ns | |
| | 15 | | 20 | 40 ns | |

64-BIT, 1-BIT PER WORD RANDOM ACCESS READ/WRITE MEMORY



The HEF4505B is a 64-bit, 1-bit per word, fully decoded and completely static, random access memory. The memory is strobed for reading or writing only when the strobe input (ST), chip enable inputs (CE₁ and CE₂) are HIGH simultaneously. The output data is available at the data output (D_{OUT}) only when the memory is strobed, the read/write input (R/W) is HIGH and after the read access time has passed. Note that the three-state output is initially disabled and always goes to the LOW state before data is valid. The output is disabled in the high-impedance OFF-state, when the memory is not strobed or R/W is LOW. R/W may remain HIGH during a read cycle or LOW during a write cycle. The output data has the same polarity as the input data.

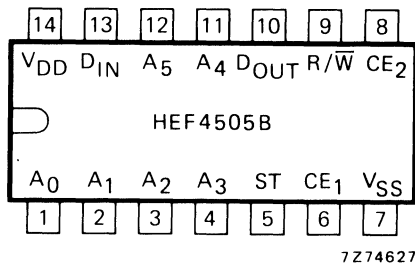

HEF4505BP : 14-lead DIL; plastic (SOT-27K, M, T).
HEF4505BD : 14-lead DIL; ceramic (cerdip) (SOT-73).

Fig. 1 Pinning diagram.

PINNING

A₀ to A₅ address inputs
CE₁, CE₂ chip enable inputs
R/W read/write input
ST strobe input
D_{IN} data input
D_{OUT} data output

FUNCTION TABLE

| ST, CE ₁ , CE ₂ | R/W | D _{OUT} | mode |
|---------------------------------------|-----|----------------------|----------|
| L | L | Z | disabled |
| H | L | Z | write |
| L | H | Z | disabled |
| H | H | equal to memory data | read |

H = HIGH state (the more positive voltage)
L = LOW state (the less positive voltage)
Z = high-impedance OFF-state

FAMILY DATA

I_{DD} LIMITS category LSI

} see Family Specifications

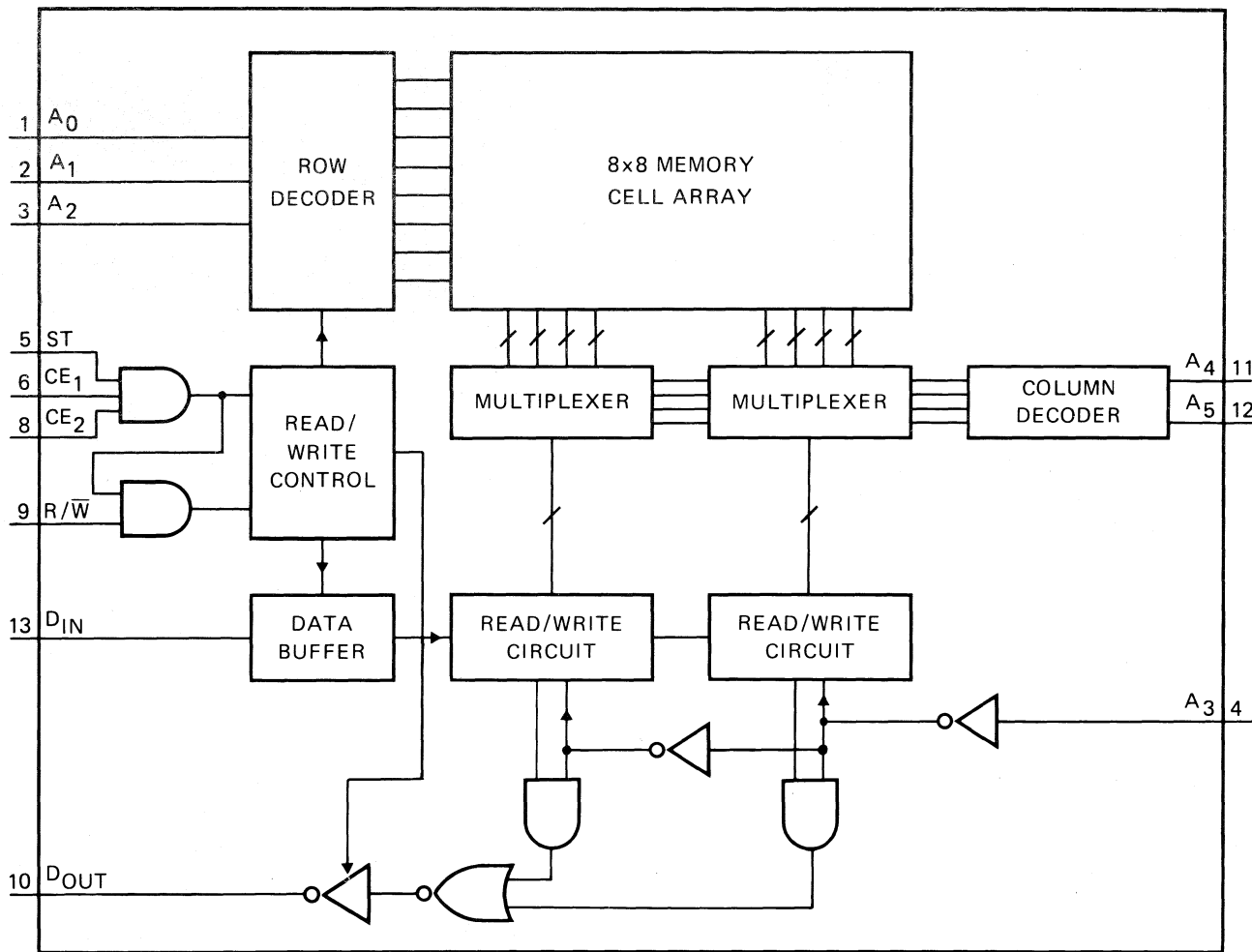

Fig. 2 Functional diagram.

7Z74630.2

A.C. CHARACTERISTICS

 $V_{SS} = 0\text{ V}$; $T_{amb} = 25\text{ }^{\circ}\text{C}$; $C_L = 50\text{ pF}$; input transition times $\leq 20\text{ ns}$

| | V_{DD} V | symbol | min. | typ. | max. | typical extrapolation formula | |
|------------------------------------|---------------|-------------|------|------|------|----------------------------------|---|
| Minimum strobe pulse width; LOW | 5 | t_{STL} | 75 | 35 | ns | | |
| | 10 | | 45 | 22 | ns | | |
| | 15 | | 30 | 15 | ns | | |
| Read cycle time | 5 | t_{RC} | | 350 | 700 | | ns |
| | 10 | | 250 | 500 | ns | | |
| | 15 | | 210 | 420 | ns | | |
| Write cycle time | 5 | t_{WC} | | 220 | 440 | | ns |
| | 10 | | 125 | 250 | ns | | |
| | 15 | | 75 | 150 | ns | | |
| Read access time | 5 | t_{ACC} | | 330 | 660 | | ns |
| | 10 | | 135 | 270 | ns | | |
| | 15 | | 100 | 200 | ns | | |
| Address recovery time | 5 | t_{AR} | 80 | 40 | ns | | $303\text{ ns} + (0,55\text{ ns/pF}) C_L$ |
| | 10 | | 40 | 20 | ns | | $124\text{ ns} + (0,23\text{ ns/pF}) C_L$ |
| | 15 | | 25 | 10 | ns | | $92\text{ ns} + (0,16\text{ ns/pF}) C_L$ |
| Read recovery time | 5 | t_{RR} | 180 | 90 | ns | | |
| | 10 | | 120 | 60 | ns | | |
| | 15 | | 90 | 45 | ns | | |
| Write recovery time | 5 | t_{WR} | 75 | 35 | ns | | |
| | 10 | | 45 | 25 | ns | | |
| | 15 | | 40 | 20 | ns | | |
| 3-state propagation delays | | | | | | | |
| Output disable times | 5 | t_{PHZ} , | | 105 | 210 | ns | |
| | 10 | | 60 | 125 | ns | | |
| | 15 | t_{PLZ} | | 55 | 115 | ns | |
| Set-up times | | | | | | | |
| $A_n \rightarrow ST$ | 5 | t_{suA} | -20 | -40 | ns | | |
| | 10 | | -10 | -20 | ns | | |
| | 15 | | -5 | -10 | ns | | |
| $R/\bar{W} \rightarrow ST$ | 5 | t_{suR} | -30 | -60 | ns | | |
| | 10 | | -15 | -30 | ns | | |
| | 15 | | -5 | -10 | ns | | |
| $D_{IN} \rightarrow ST$ | 5 | t_{suD} | 160 | 80 | ns | | |
| | 10 | | 75 | 35 | ns | | |
| | 15 | | 45 | 20 | ns | | |
| $R/\bar{W} \rightarrow ST$ | 5 | t_{suW} | 240 | 120 | ns | | |
| | 10 | | 100 | 50 | ns | | |
| | 15 | | 75 | 35 | ns | | |
| Hold time | | | | | | | |
| $D_{IN} \rightarrow ST$ | 5 | t_{holdD} | -20 | -40 | ns | | |
| | 10 | | 5 | -10 | ns | | |
| | 15 | | 10 | 0 | ns | | |

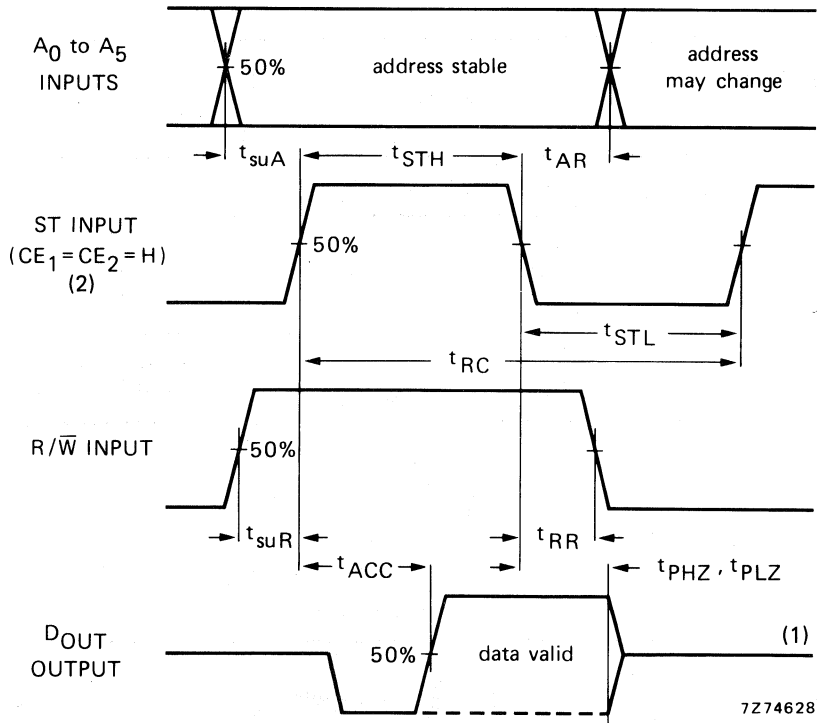

7274628

- (1) Output in high impedance OFF-state.
- (2) $t_{STHmin} = t_{RCmax} - t_{STLmin}$.

Fig. 3 Read cycle timing diagram.

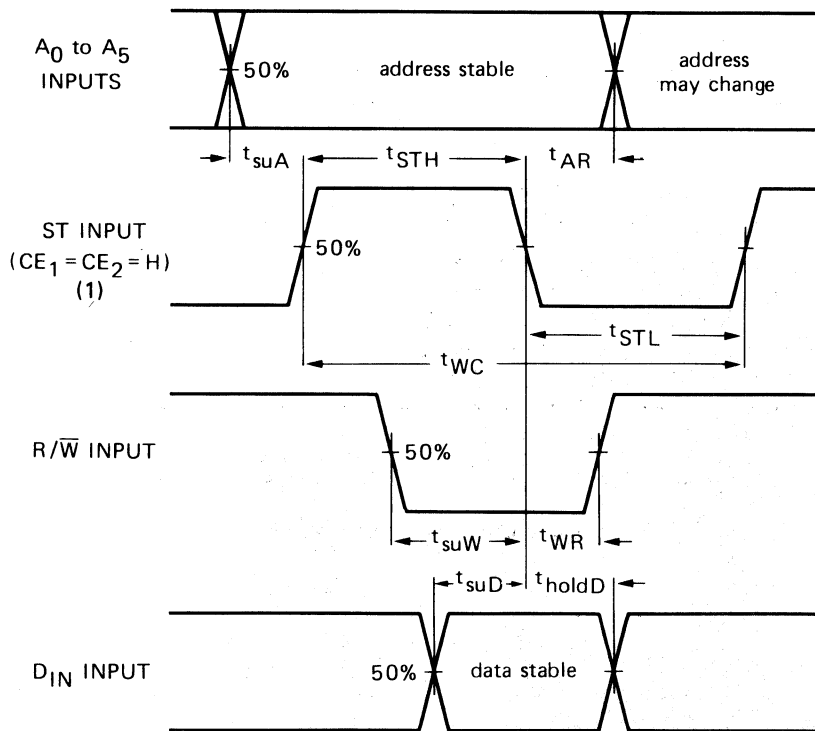

7274629

(1) $t_{STHmin} = t_{WCmax} - t_{STLmin}$

Fig. 4 Write cycle timing diagram.

APPLICATION INFORMATION

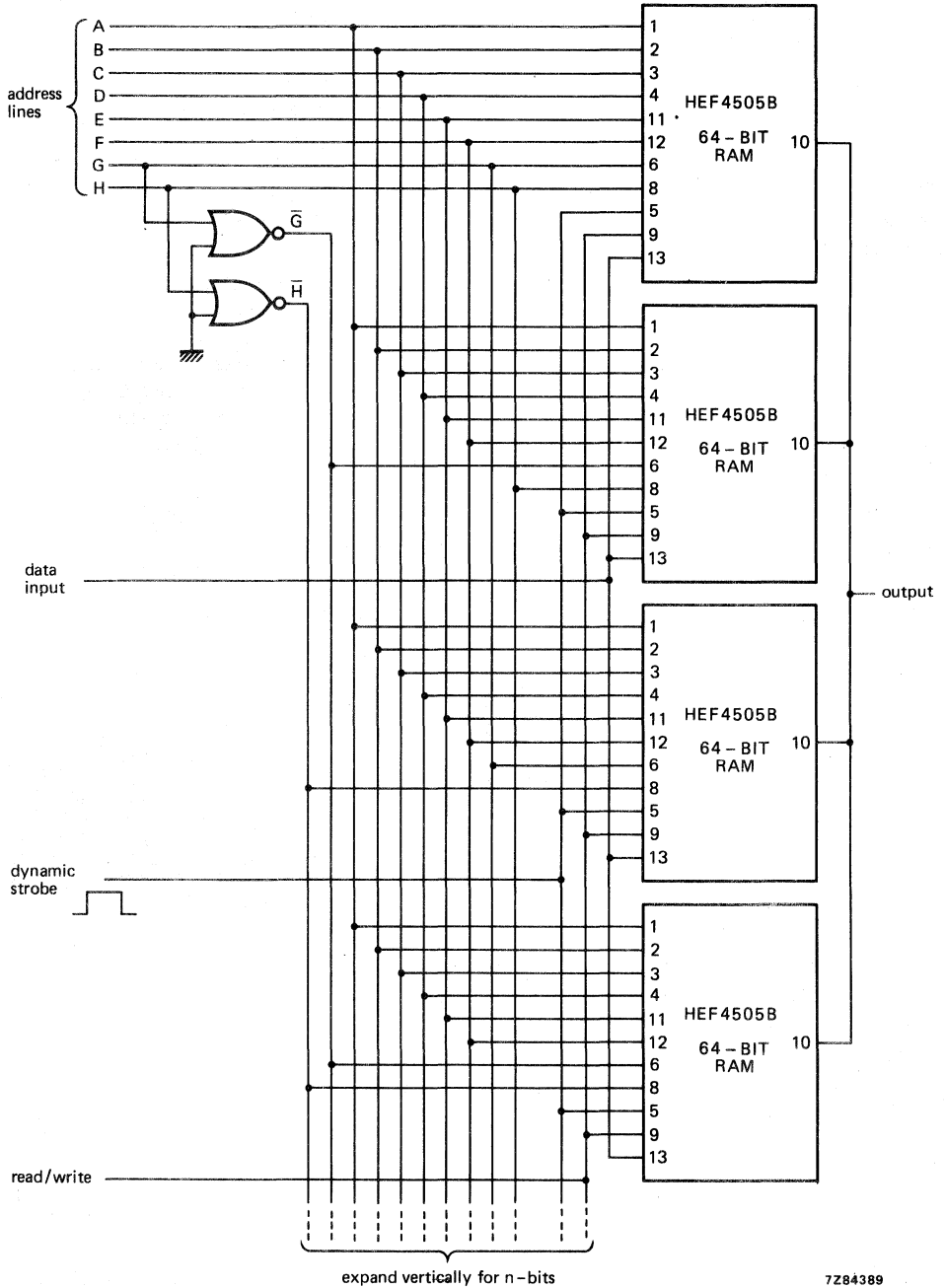

Fig. 5 256-word by n-bit static read/write memory using HEF4505B ICs.

Figure 5 shows a 256-word by n-bit static RAM system. The outputs of the four HEF4505B circuits are tied together to form 256 words by 1-bit. Additional bits are attained by paralleling the inputs in groups of four. Memories of larger words can be attained by decoding the most significant bits of the address and AND-ing them with the strobe input.

Fan-in and fan-out of the memory are limited only by speed requirements. The extremely low input and output leakage currents keep the output voltage levels from changing significantly as more outputs are tied together. With the output levels independent of fan-out, most of the power supply range is available as logic swing, regardless of the number of units wired together. As a result, high noise immunity is maintained under all conditions.

The memory system shown in Fig. 5 can be interfaced directly with other ICs of the LOCMOS HE family. No external components are required.

Non-volatile information storage is allowed due to very low power dissipation when the memory is powered by a small standby battery. Figure 6 shows an optional standby power supply circuit for making a LOCMOS memory 'non-volatile'. When the usual power fails, a battery is used to sustain operation or maintain stored information. While normal power supply voltage is present, the battery is trickle-charged through a resistor (R) which sets the charging rate. In Fig. 6 the sustaining voltage is V_B , and +V is the ordinary voltage from a power supply. V_{DD} is connected to the power supply pin of the memory. Low-leakage diodes are recommended to conserve battery power.

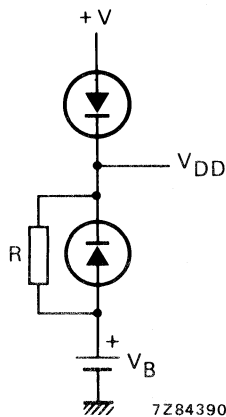

Fig. 6 Standby battery circuit.



DUAL 4-BIT LATCH

The HEF4508B is a dual 4-bit latch, which consists of two identical independent 4-bit latches with separate strobe (ST), master reset (MR), output-enable input (\overline{EO}) and 3-state outputs (O).

With the ST input in the HIGH state, the data on the D inputs appear at the corresponding outputs provided \overline{EO} is LOW. Changing the ST input to the LOW state locks the data into the latch. A HIGH on the reset line forces the outputs to a LOW level regardless of the state of the ST input. The 3-state outputs are controlled by the output-enable input. A HIGH on \overline{EO} causes the outputs to assume a high impedance OFF-state regardless of other input conditions. This allows the outputs to interface directly with bus orientated systems. When \overline{EO} is LOW the contents of the latches are available at the outputs.

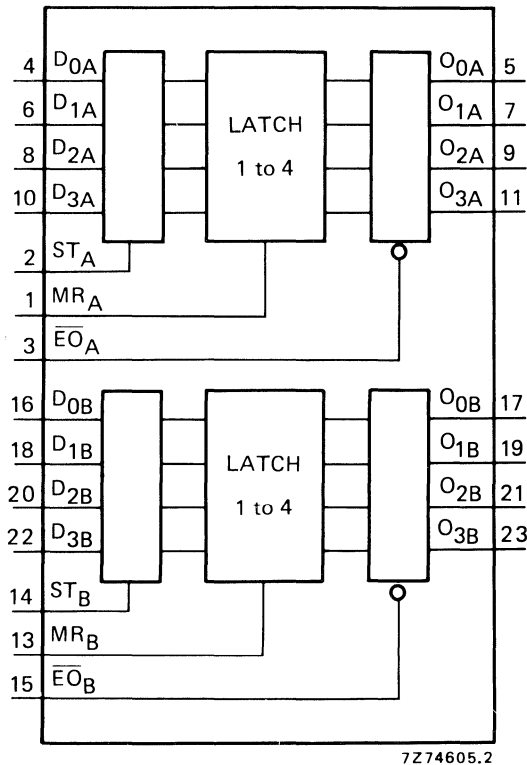

Fig. 1 Functional diagram.

FAMILY DATA

I_{DD} LIMITS category MSI

} see Family Specifications

HEF4508B
MSI

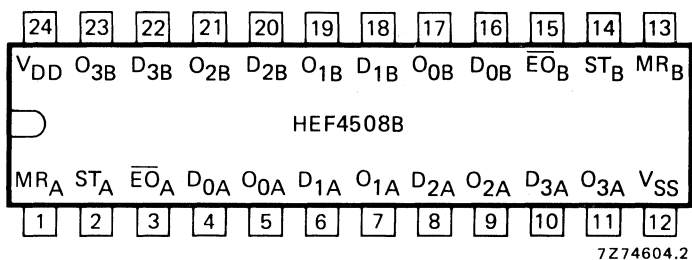

Fig. 2 Pinning diagram.

HEF4508BP : 24-lead DIL; plastic (SOT-101A).
 HEF4508BD: 24-lead DIL; ceramic (cerdip) (SOT-94).
 HEF4508BT : 24-lead mini-pack; plastic
 (SO-24; SOT-137A).

PINNING

D_{0A} to D_{3A}, D_{0B} to D_{3B} data inputs
 ST_A, ST_B strobe inputs
 MR_A, MR_B master reset inputs
 $\overline{E}O_A$, $\overline{E}O_B$ output enable inputs
 O_{0A} to O_{3A}, O_{0B} to O_{3B} 3-state outputs

FUNCTION TABLE

| inputs | | | | output |
|--------|----|-----------------|----------------|----------------|
| MR | ST | $\overline{E}O$ | D _n | O _n |
| L | H | L | H | H |
| L | H | L | L | L |
| L | L | L | X | latched |
| H | X | L | X | L |
| X | X | H | X | Z |

H = HIGH state (the more positive voltage)
 L = LOW state (the less positive voltage)
 X = state is immaterial
 Z = high impedance OFF state

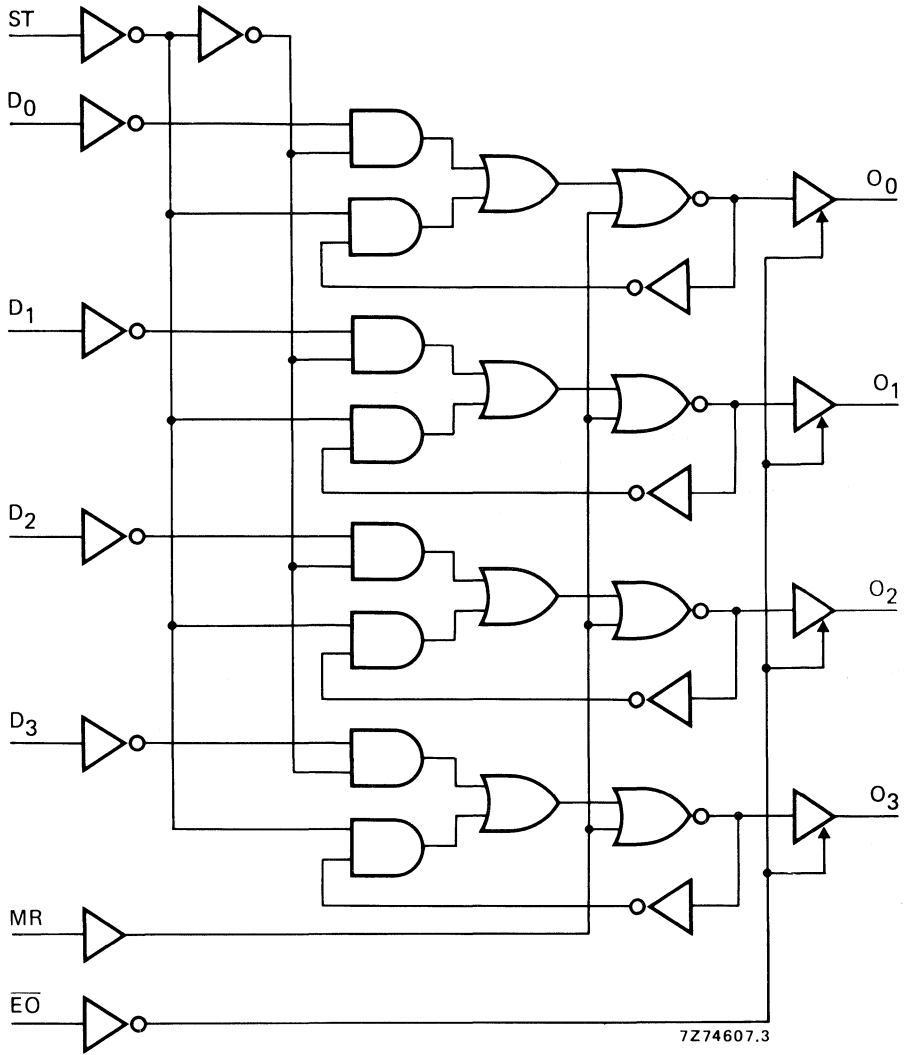

Fig. 3 Logic diagram (one 4-bit latch).

A.C. CHARACTERISTICS

$V_{SS} = 0\text{ V}$; $T_{amb} = 25\text{ }^{\circ}\text{C}$; $C_L = 50\text{ pF}$; input transition times $\leq 20\text{ ns}$; see also waveforms Fig. 4.

| | V_{DD} V | symbol | min. | typ. | max. | typical extrapolation formula | |
|---------------------------------|---------------|------------------|------|------|------|----------------------------------|----------------------------|
| Propagation delays | | | | | | | |
| ST \rightarrow O_n | 5 | | | 115 | 230 | ns | 88 ns + (0,55 ns/pF) C_L |
| HIGH to LOW | 10 | t _{PHL} | | 50 | 100 | ns | 39 ns + (0,23 ns/pF) C_L |
| | 15 | | | 35 | 70 | ns | 27 ns + (0,16 ns/pF) C_L |
| | 5 | | | 115 | 230 | ns | 88 ns + (0,55 ns/pF) C_L |
| LOW to HIGH | 10 | t _{PLH} | | 50 | 100 | ns | 39 ns + (0,23 ns/pF) C_L |
| | 15 | | | 35 | 70 | ns | 27 ns + (0,16 ns/pF) C_L |
| | 5 | | | 95 | 190 | ns | 68 ns + (0,55 ns/pF) C_L |
| $D_n \rightarrow$ O_n | 5 | | | 95 | 190 | ns | 68 ns + (0,55 ns/pF) C_L |
| HIGH to LOW | 10 | t _{PHL} | | 40 | 80 | ns | 29 ns + (0,23 ns/pF) C_L |
| | 15 | | | 30 | 60 | ns | 22 ns + (0,16 ns/pF) C_L |
| | 5 | | | 95 | 190 | ns | 68 ns + (0,55 ns/pF) C_L |
| LOW to HIGH | 10 | t _{PLH} | | 40 | 80 | ns | 29 ns + (0,23 ns/pF) C_L |
| | 15 | | | 30 | 60 | ns | 22 ns + (0,16 ns/pF) C_L |
| | 5 | | | 100 | 200 | ns | 73 ns + (0,55 ns/pF) C_L |
| MR \rightarrow O_n | 5 | | | 100 | 200 | ns | 73 ns + (0,55 ns/pF) C_L |
| HIGH to LOW | 10 | t _{PHL} | | 40 | 80 | ns | 29 ns + (0,23 ns/pF) C_L |
| | 15 | | | 30 | 60 | ns | 22 ns + (0,16 ns/pF) C_L |
| | 5 | | | 60 | 120 | ns | 10 ns + (1,0 ns/pF) C_L |
| Output transition times | 5 | | | 60 | 120 | ns | 10 ns + (1,0 ns/pF) C_L |
| HIGH to LOW | 10 | t _{THL} | | 30 | 60 | ns | 9 ns + (0,42 ns/pF) C_L |
| | 15 | | | 20 | 40 | ns | 6 ns + (0,28 ns/pF) C_L |
| | 5 | | | 60 | 120 | ns | 10 ns + (1,0 ns/pF) C_L |
| LOW to HIGH | 10 | t _{TLH} | | 30 | 60 | ns | 9 ns + (0,42 ns/pF) C_L |
| | 15 | | | 20 | 40 | ns | 6 ns + (0,28 ns/pF) C_L |
| | 5 | | | 45 | 90 | ns | |
| 3-state propagation delays | | | | | | | |
| Output enable times | | | | | | | |
| $\overline{E}O \rightarrow O_n$ | 5 | | | 45 | 90 | ns | |
| HIGH | 10 | t _{PZH} | | 20 | 40 | ns | |
| | 15 | | | 18 | 36 | ns | |
| | 5 | | | 45 | 90 | ns | |
| LOW | 10 | t _{PZL} | | 20 | 40 | ns | |
| | 15 | | | 18 | 36 | ns | |
| | 5 | | | 35 | 70 | ns | |
| Output disable times | | | | | | | |
| $\overline{E}O \rightarrow O_n$ | 5 | | | 35 | 70 | ns | |
| HIGH | 10 | t _{PHZ} | | 20 | 40 | ns | |
| | 15 | | | 18 | 36 | ns | |
| | 5 | | | 45 | 90 | ns | |
| LOW | 10 | t _{PLZ} | | 20 | 40 | ns | |
| | 15 | | | 18 | 36 | ns | |

A.C. CHARACTERISTICS

$V_{SS} = 0\text{ V}$; $T_{amb} = 25\text{ }^{\circ}\text{C}$; $C_L = 50\text{ pF}$; input transition times $\leq 20\text{ ns}$

| | V_{DD} V | symbol | min. | typ. | max. | |
|--------------------------------------|---------------|------------|------|------|------|--------------------------------|
| Minimum ST pulse width; HIGH | 5 | t_{WSTH} | 50 | 25 | ns | } see also waveforms Fig. 4 |
| | 10 | | 30 | 15 | ns | |
| | 15 | | 20 | 10 | ns | |
| Minimum MR pulse width; HIGH | 5 | t_{WMRH} | 40 | 20 | ns | |
| | 10 | | 24 | 12 | ns | |
| | 15 | | 20 | 10 | ns | |
| Recovery time for MR | 5 | t_{RMR} | 20 | 0 | ns | |
| | 10 | | 20 | 0 | ns | |
| | 15 | | 15 | 0 | ns | |
| Set-up times $D_n \rightarrow ST$ | 5 | t_{su} | 35 | 10 | ns | |
| | 10 | | 25 | 5 | ns | |
| | 15 | | 20 | 0 | ns | |
| Hold times $D_n \rightarrow ST$ | 5 | t_{hold} | 20 | 0 | ns | |
| | 10 | | 20 | 0 | ns | |
| | 15 | | 15 | 0 | ns | |

| | V_{DD} V | typical formula for P (μW) | where |
|---|---------------|---|------------------------------------|
| Dynamic power dissipation per package (P) | 5 | $2\,000 f_i + \Sigma(f_o C_L) \times V_{DD}^2$ | f_i = input freq. (MHz) |
| | 10 | $9\,000 f_i + \Sigma(f_o C_L) \times V_{DD}^2$ | f_o = output freq. (MHz) |
| | 15 | $25\,000 f_i + \Sigma(f_o C_L) \times V_{DD}^2$ | C_L = load capacitance (pF) |
| | | | $\Sigma(f_o C_L)$ = sum of outputs |
| | | | V_{DD} = supply voltage (V) |

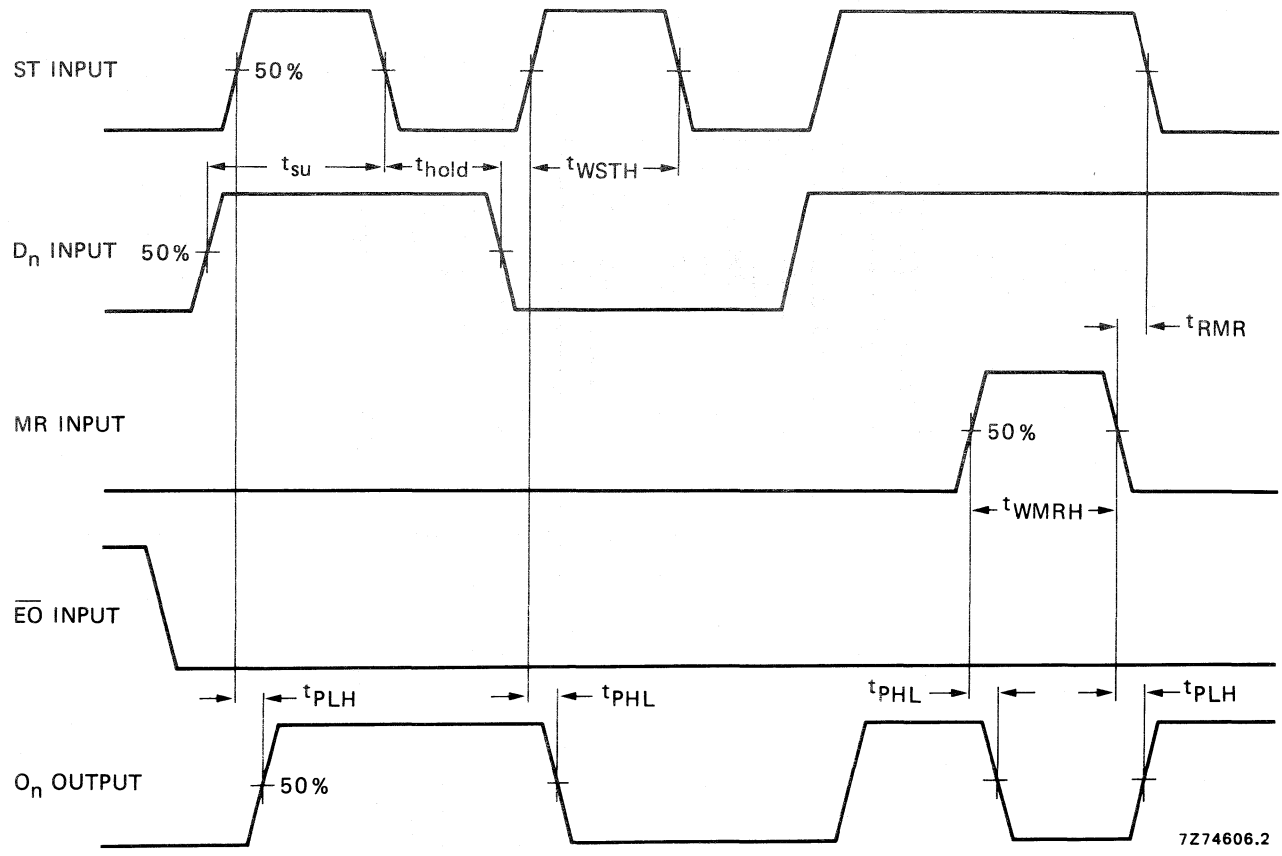

Fig. 4 Waveforms showing minimum ST and MR pulse widths, set-up and hold times for D_n to ST, recovery time for MR and propagation delays from ST to O_n, D_n to O_n and MR to O_n.

APPLICATION INFORMATION

Some examples of application for the HEF4508B are:

- Buffer storage
- Holding registers
- Data storage and multiplexing

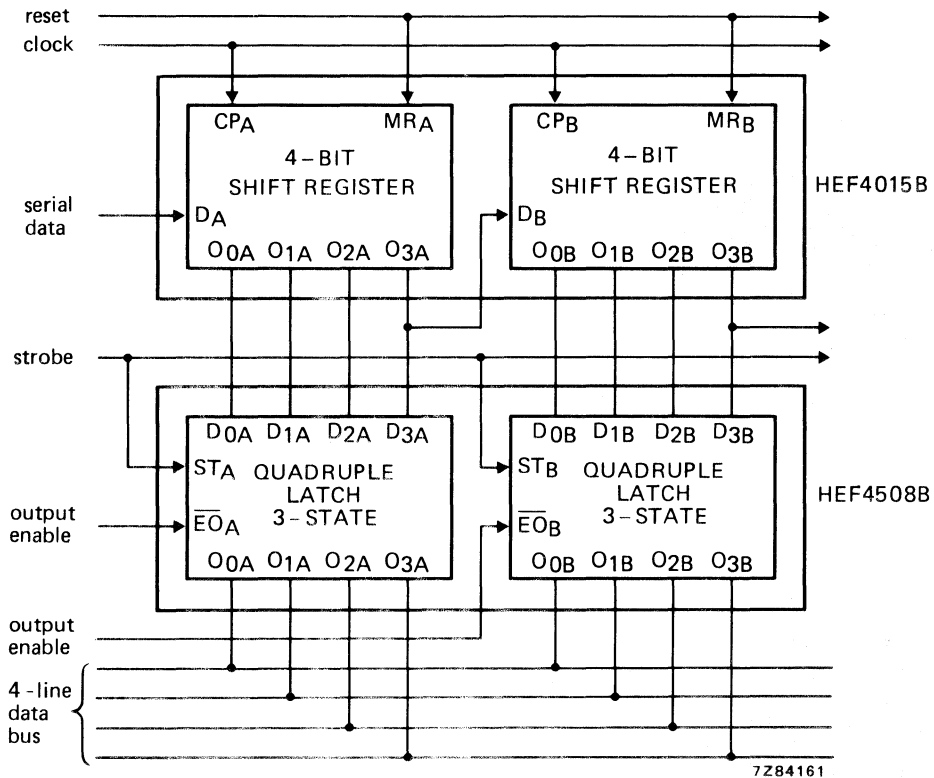

Fig. 5 Example of a bus register using HEF4508B and HEF4015B.

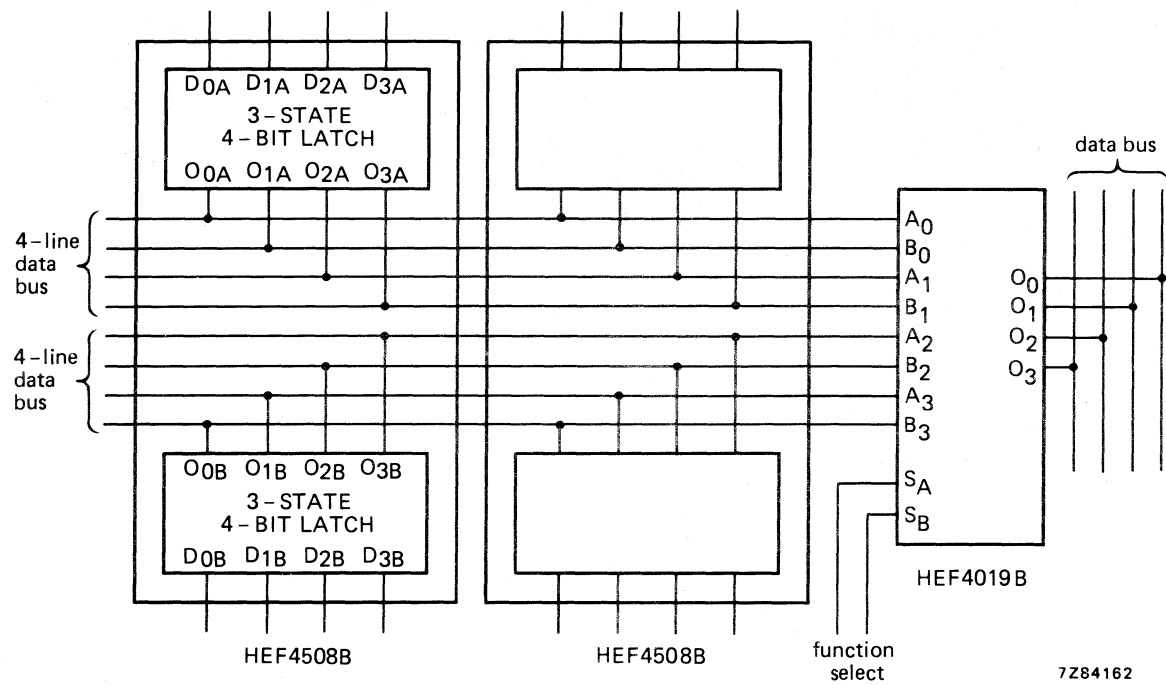

Fig. 6 Example of a dual multiplexed bus register with function select using two HEF4508B and one HEF4019B.

FUNCTION SELECT

| S _A | S _B | function |
|----------------|----------------|---------------------------------|
| L | L | inhibit (all L) |
| H | L | select A bus |
| L | H | select B bus |
| H | H | A ₁ + B ₁ |

BCD UP/DOWN COUNTER



The HEF4510B is an edge-triggered synchronous up/down BCD counter with a clock input (CP), an up/down count control input (UP/DN), an active LOW count enable input (\overline{CE}), an asynchronous active HIGH parallel load input (PL), four parallel inputs (P_0 to P_3), four parallel outputs (O_0 to O_3), an active LOW terminal count output (\overline{TC}), and an overriding asynchronous master reset input (MR).

Information on P_0 to P_3 is loaded into the counter while PL is HIGH, independent of all other input conditions except the MR input, which must be LOW. With PL LOW, the counter changes on the LOW to HIGH transition of CP if \overline{CE} is LOW. UP/DN determines the direction of the count, HIGH for counting up, LOW for counting down. When counting up, \overline{TC} is LOW when O_0 and O_3 are HIGH and \overline{CE} is LOW. When counting down, \overline{TC} is LOW when O_0 to O_3 and \overline{CE} are LOW. A HIGH on MR resets the counter (O_0 to $O_3 = \text{LOW}$) independent of all other input conditions.

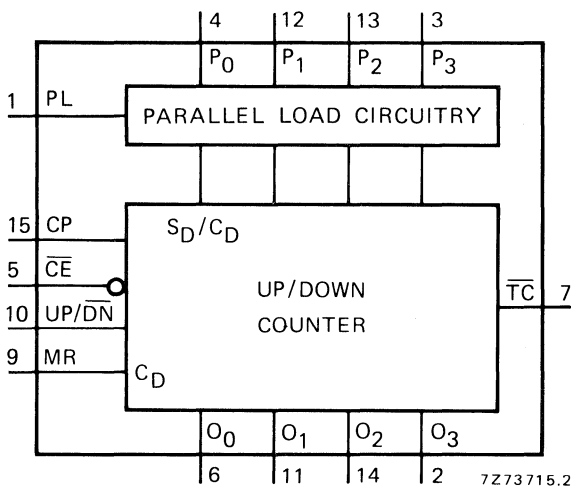

Fig. 1 Functional diagram.

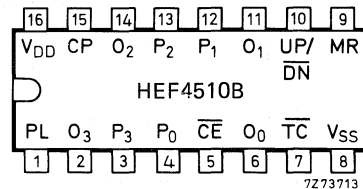

Fig. 2 Pinning diagram.

HEF4510BP : 16-lead DIL; plastic (SOT-38Z).
 HEF4510BD: 16-lead DIL; ceramic (cerdip) (SOT-74).
 HEF4510BT : 16-lead mini-pack; plastic (SO-16; SOT-109A).

PINNING

| | | | |
|-----------------|---|-----------------|------------------------------------|
| PL | parallel load input (active HIGH) | UP/DN | up/down count control input |
| P_0 to P_3 | parallel inputs | MR | master reset input |
| \overline{CE} | count enable input (active LOW) | \overline{TC} | terminal count output (active LOW) |
| CP | clock pulse input (LOW to HIGH, edge triggered) | O_0 to O_3 | parallel outputs |

FAMILY DATA

} see Family Specifications

I_{DD} LIMITS category MSI

HEF4510B
MSI

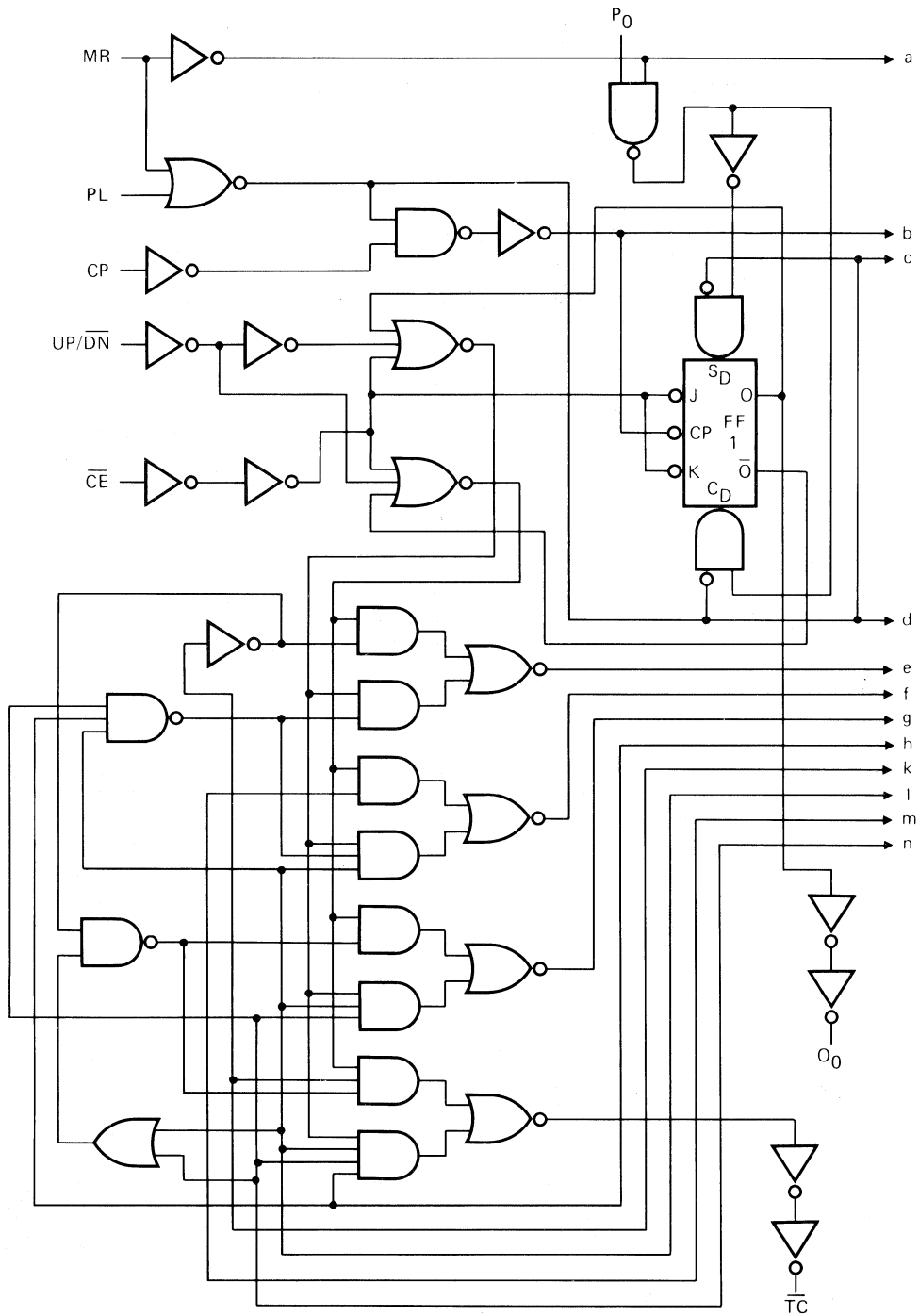

7275079.1

Fig. 3a Logic diagram (continued in Fig. 3b).

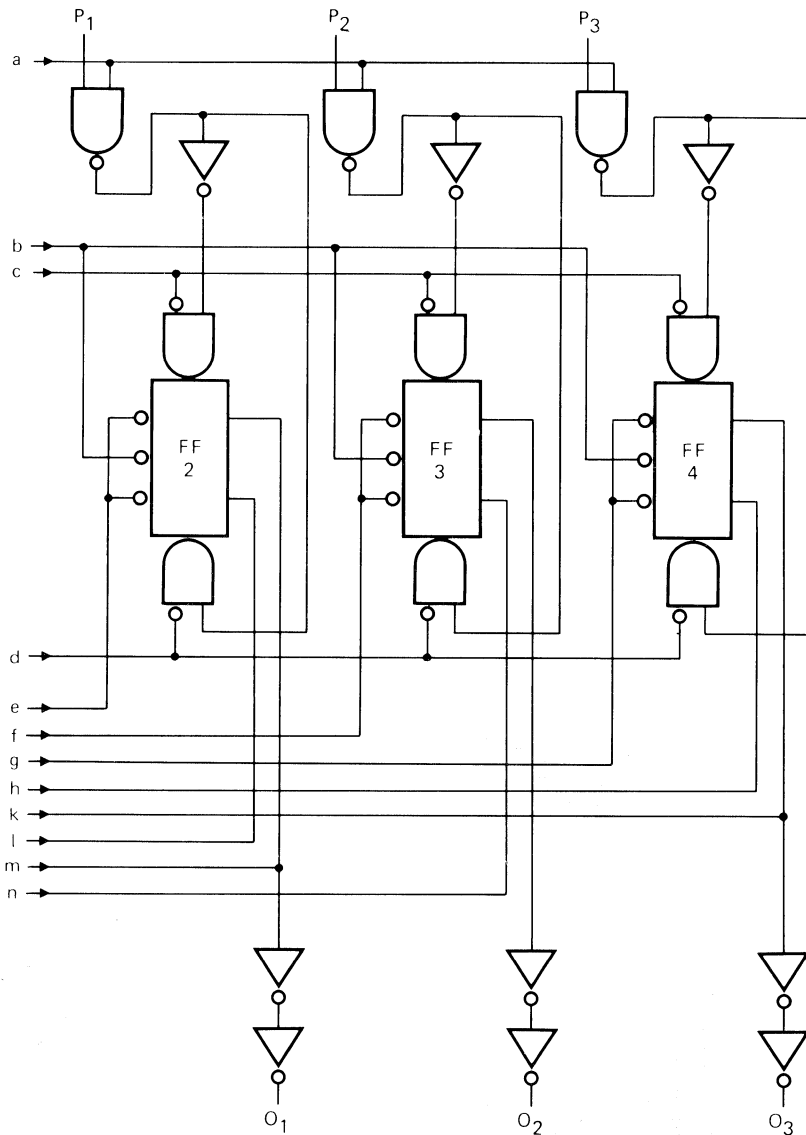

7275080.1

Fig. 3b Logic diagram (continued from Fig. 3a).

FUNCTION TABLE

| MR | PL | UP/DN | CE | CP | mode |
|----|----|-------|----|----|---------------|
| L | H | X | X | X | parallel load |
| L | L | X | H | X | no change |
| L | L | L | L | ∕ | count down |
| L | L | H | L | ∕ | count up |
| H | X | X | X | X | reset |

H = HIGH state (the more positive voltage)

L = LOW state (the less positive voltage)

X = state is immaterial

∕ = positive-going transition

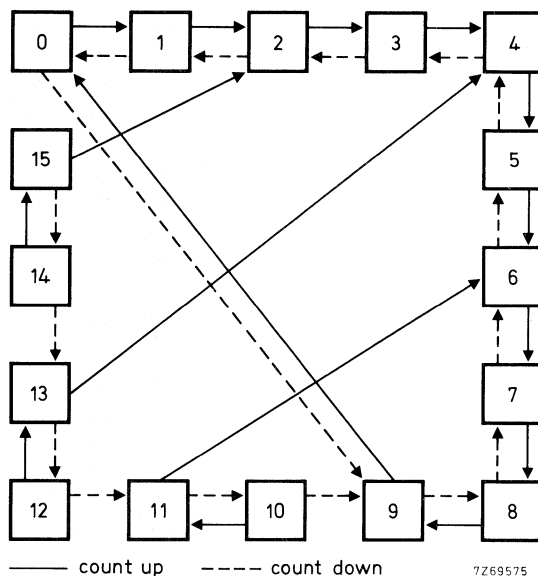

Fig. 4 State diagram.

Logic equation for terminal count:

$$\overline{TC} = \overline{CE} \cdot \{ (UP/DN) \cdot O_0 \cdot O_3 + (UP/DN) \cdot \overline{O_0} \cdot \overline{O_1} \cdot \overline{O_2} \cdot \overline{O_3} \}$$

A.C. CHARACTERISTICS

V_{SS} = 0 V; T_{amb} = 25 °C; input transition times ≤ 20 ns

| | V _{DD} V | typical formula for P (μW) | where |
|---|----------------------|--|--|
| Dynamic power dissipation per package (P) | 5 | 1000 f _i + Σ(f _o C _L) × V _{DD} ² | f _i = input freq. (MHz) |
| | 10 | 4500 f _i + Σ(f _o C _L) × V _{DD} ² | f _o = output freq. (MHz) |
| | 15 | 11 200 f _i + Σ(f _o C _L) × V _{DD} ² | C _L = load capacitance (pF) |
| | | | Σ(f _o C _L) = sum of outputs |
| | | | V _{DD} = supply voltage (V) |

A.C. CHARACTERISTICS

 $V_{SS} = 0 \text{ V}$; $T_{amb} = 25 \text{ }^\circ\text{C}$; $C_L = 50 \text{ pF}$; input transition times $\leq 20 \text{ ns}$

| | V_{DD} V | symbol | min. | typ. | max. | typical extrapolation formula | |
|---|---------------|------------------|------|------|------|----------------------------------|---|
| Propagation delays $CP \rightarrow O_n$ HIGH to LOW | 5 | t _{PHL} | | 145 | 290 | ns | $118 \text{ ns} + (0,55 \text{ ns/pF}) C_L$ |
| | 10 | | | 60 | 120 | ns | $49 \text{ ns} + (0,23 \text{ ns/pF}) C_L$ |
| | 15 | | | 45 | 90 | ns | $37 \text{ ns} + (0,16 \text{ ns/pF}) C_L$ |
| LOW to HIGH | 5 | t _{PLH} | | 155 | 310 | ns | $128 \text{ ns} + (0,55 \text{ ns/pF}) C_L$ |
| | 10 | | | 65 | 130 | ns | $54 \text{ ns} + (0,23 \text{ ns/pF}) C_L$ |
| | 15 | | | 45 | 90 | ns | $37 \text{ ns} + (0,16 \text{ ns/pF}) C_L$ |
| $CP \rightarrow \overline{TC}$ HIGH to LOW | 5 | t _{PHL} | | 260 | 525 | ns | $233 \text{ ns} + (0,55 \text{ ns/pF}) C_L$ |
| | 10 | | | 105 | 210 | ns | $94 \text{ ns} + (0,23 \text{ ns/pF}) C_L$ |
| | 15 | | | 75 | 150 | ns | $67 \text{ ns} + (0,16 \text{ ns/pF}) C_L$ |
| LOW to HIGH | 5 | t _{PLH} | | 180 | 360 | ns | $153 \text{ ns} + (0,55 \text{ ns/pF}) C_L$ |
| | 10 | | | 75 | 150 | ns | $64 \text{ ns} + (0,23 \text{ ns/pF}) C_L$ |
| | 15 | | | 55 | 115 | ns | $47 \text{ ns} + (0,16 \text{ ns/pF}) C_L$ |
| $PL \rightarrow O_n$ HIGH to LOW | 5 | t _{PHL} | | 125 | 255 | ns | $98 \text{ ns} + (0,55 \text{ ns/pF}) C_L$ |
| | 10 | | | 55 | 110 | ns | $44 \text{ ns} + (0,23 \text{ ns/pF}) C_L$ |
| | 15 | | | 40 | 85 | ns | $32 \text{ ns} + (0,16 \text{ ns/pF}) C_L$ |
| LOW to HIGH | 5 | t _{PLH} | | 170 | 340 | ns | $143 \text{ ns} + (0,55 \text{ ns/pF}) C_L$ |
| | 10 | | | 70 | 140 | ns | $59 \text{ ns} + (0,23 \text{ ns/pF}) C_L$ |
| | 15 | | | 50 | 105 | ns | $42 \text{ ns} + (0,16 \text{ ns/pF}) C_L$ |
| $PL \rightarrow \overline{TC}$ HIGH to LOW | 5 | t _{PHL} | | 250 | 500 | ns | $223 \text{ ns} + (0,55 \text{ ns/pF}) C_L$ |
| | 10 | | | 110 | 220 | ns | $99 \text{ ns} + (0,23 \text{ ns/pF}) C_L$ |
| | 15 | | | 80 | 160 | ns | $72 \text{ ns} + (0,16 \text{ ns/pF}) C_L$ |
| LOW to HIGH | 5 | t _{PLH} | | 250 | 500 | ns | $223 \text{ ns} + (0,55 \text{ ns/pF}) C_L$ |
| | 10 | | | 110 | 220 | ns | $99 \text{ ns} + (0,23 \text{ ns/pF}) C_L$ |
| | 15 | | | 80 | 160 | ns | $72 \text{ ns} + (0,16 \text{ ns/pF}) C_L$ |
| $\overline{CE} \rightarrow \overline{TC}$ HIGH to LOW | 5 | t _{PHL} | | 165 | 330 | ns | $138 \text{ ns} + (0,55 \text{ ns/pF}) C_L$ |
| | 10 | | | 65 | 135 | ns | $54 \text{ ns} + (0,23 \text{ ns/pF}) C_L$ |
| | 15 | | | 50 | 100 | ns | $42 \text{ ns} + (0,16 \text{ ns/pF}) C_L$ |
| LOW to HIGH | 5 | t _{PLH} | | 145 | 290 | ns | $118 \text{ ns} + (0,55 \text{ ns/pF}) C_L$ |
| | 10 | | | 60 | 125 | ns | $49 \text{ ns} + (0,23 \text{ ns/pF}) C_L$ |
| | 15 | | | 45 | 95 | ns | $37 \text{ ns} + (0,16 \text{ ns/pF}) C_L$ |
| $MR \rightarrow O_n, \overline{TC}$ HIGH to LOW | 5 | t _{PHL} | | 205 | 405 | ns | $178 \text{ ns} + (0,55 \text{ ns/pF}) C_L$ |
| | 10 | | | 65 | 130 | ns | $54 \text{ ns} + (0,23 \text{ ns/pF}) C_L$ |
| | 15 | | | 45 | 85 | ns | $37 \text{ ns} + (0,16 \text{ ns/pF}) C_L$ |
| $MR \rightarrow \overline{TC}$ LOW to HIGH | 5 | t _{PLH} | | 225 | 450 | ns | $198 \text{ ns} + (0,55 \text{ ns/pF}) C_L$ |
| | 10 | | | 75 | 150 | ns | $64 \text{ ns} + (0,23 \text{ ns/pF}) C_L$ |
| | 15 | | | 50 | 100 | ns | $42 \text{ ns} + (0,16 \text{ ns/pF}) C_L$ |

A.C. CHARACTERISTICS

 $V_{SS} = 0 \text{ V}$; $T_{amb} = 25 \text{ }^\circ\text{C}$; $C_L = 50 \text{ pF}$; input transition times $\leq 20 \text{ ns}$

| | V_{DD} V | symbol | min. | typ. | max. | typical extrapolation formula |
|---|---------------|------------|------|------|--------|---|
| Output transition times HIGH to LOW | 5 | t_{THL} | | 60 | 120 ns | $10 \text{ ns} + (1,0 \text{ ns/pF}) C_L$ $9 \text{ ns} + (0,42 \text{ ns/pF}) C_L$ $6 \text{ ns} + (0,28 \text{ ns/pF}) C_L$ |
| | 10 | | | 30 | 60 ns | |
| | 15 | | | 20 | 40 ns | |
| LOW to HIGH | 5 | t_{TLH} | | 60 | 120 ns | $10 \text{ ns} + (1,0 \text{ ns/pF}) C_L$ $9 \text{ ns} + (0,42 \text{ ns/pF}) C_L$ $6 \text{ ns} + (0,28 \text{ ns/pF}) C_L$ |
| | 10 | | | 30 | 60 ns | |
| | 15 | | | 20 | 40 ns | |
| Minimum clock pulse width; LOW | 5 | t_{WCPL} | 95 | 45 | ns | see also waveforms Figs 5 and 6 |
| | 10 | | 35 | 20 | ns | |
| | 15 | | 25 | 15 | ns | |
| Minimum PL pulse width; HIGH | 5 | t_{WPLH} | 105 | 55 | ns | |
| | 10 | | 45 | 25 | ns | |
| | 15 | | 35 | 15 | ns | |
| Minimum MR pulse width; HIGH | 5 | t_{WMRH} | 120 | 60 | ns | |
| | 10 | | 50 | 25 | ns | |
| | 15 | | 40 | 20 | ns | |
| Recovery time for MR | 5 | t_{RMR} | 130 | 65 | ns | |
| | 10 | | 45 | 20 | ns | |
| | 15 | | 30 | 15 | ns | |
| Recovery time for PL | 5 | t_{RPL} | 150 | 75 | ns | |
| | 10 | | 50 | 25 | ns | |
| | 15 | | 30 | 15 | ns | |
| Set-up times $P_n \rightarrow PL$ | 5 | t_{su} | 100 | 50 | ns | |
| | 10 | | 50 | 25 | ns | |
| | 15 | | 40 | 20 | ns | |
| $UP/\overline{DN} \rightarrow CP$ | 5 | t_{su} | 250 | 125 | ns | |
| | 10 | | 100 | 50 | ns | |
| | 15 | | 75 | 35 | ns | |
| $\overline{CE} \rightarrow PL$ | 5 | t_{su} | 120 | 60 | ns | |
| | 10 | | 40 | 20 | ns | |
| | 15 | | 25 | 10 | ns | |
| Hold times $P_n \rightarrow PL$ | 5 | t_{hold} | 10 | -40 | ns | |
| | 10 | | 5 | -20 | ns | |
| | 15 | | 0 | -20 | ns | |
| $UP/\overline{DN} \rightarrow CP$ | 5 | t_{hold} | 35 | -90 | ns | |
| | 10 | | 15 | -35 | ns | |
| | 15 | | 15 | -25 | ns | |
| $\overline{CE} \rightarrow CP$ | 5 | t_{hold} | 20 | -40 | ns | |
| | 10 | | 5 | -15 | ns | |
| | 15 | | 5 | -10 | ns | |
| Maximum clock pulse frequency | 5 | f_{max} | 5 | 10 | MHz | |
| | 10 | | 12 | 24 | MHz | |
| | 15 | | 17 | 34 | MHz | |

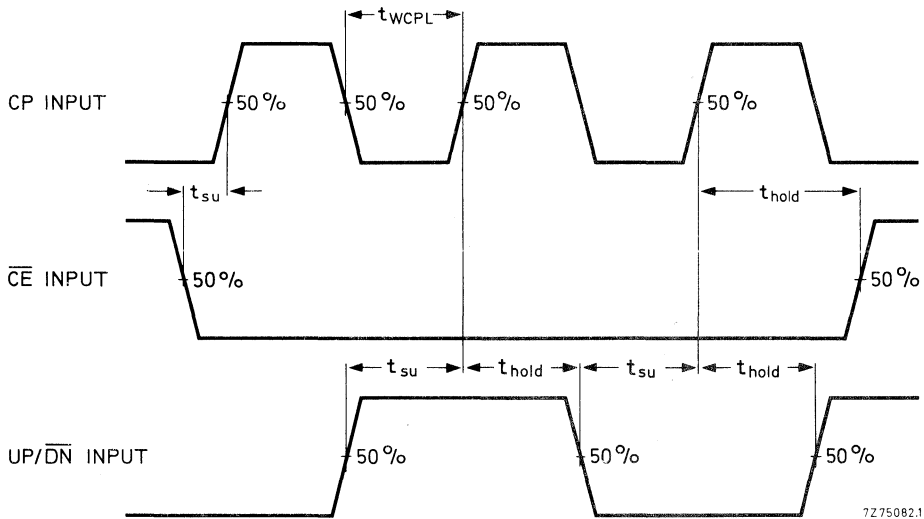

Fig. 5 Waveforms showing minimum pulse width for CP, set-up and hold times for \overline{CE} to CP and UP/ \overline{DN} to CP.

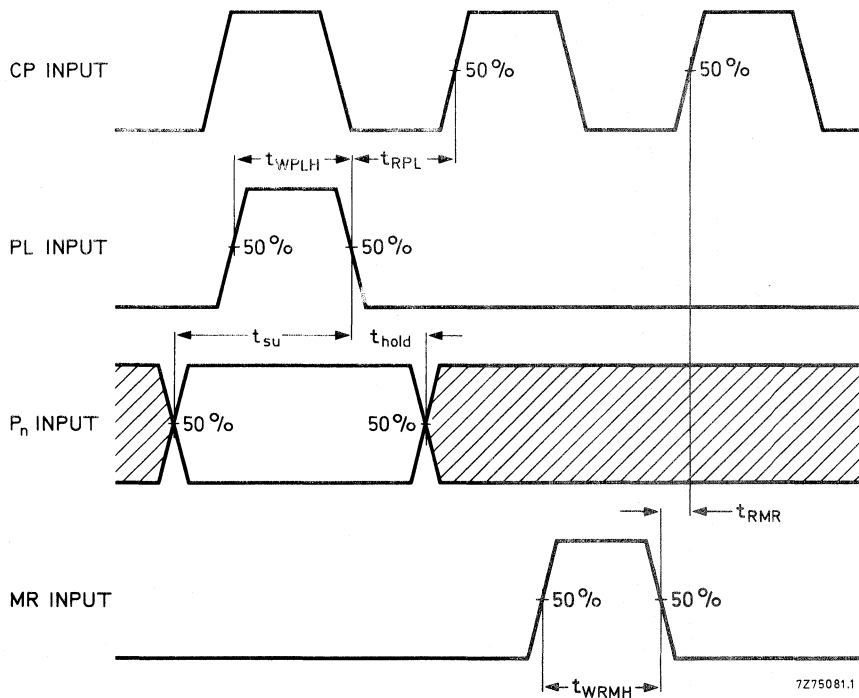
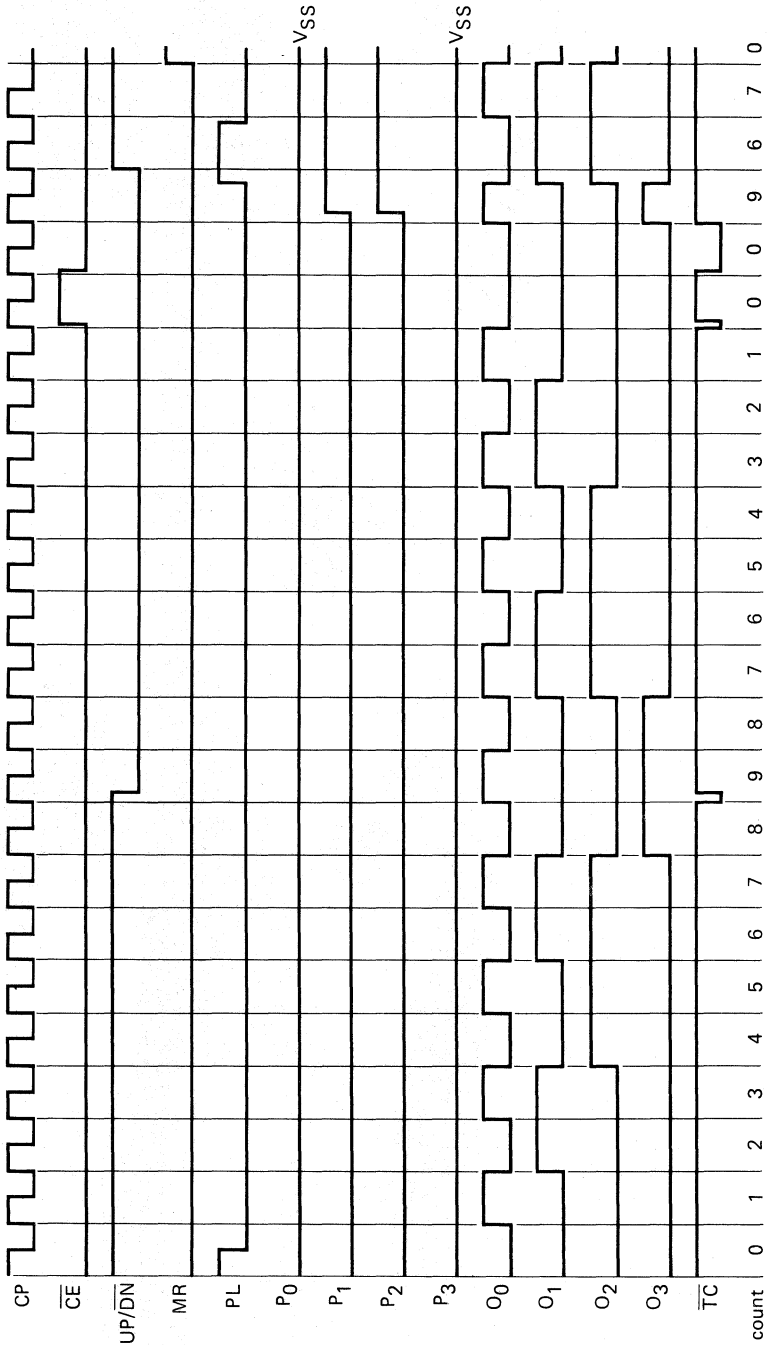

Fig. 6 Waveforms showing minimum pulse width for PL and MR, recovery time for PL and MR and set-up and hold times for P_n to PL.



7285122

Fig. 7 Timing diagram.

BCD TO 7-SEGMENT LATCH/DECODER/DRIVER



The HEF4511B is a BCD to 7-segment latch/decoder/driver with four address inputs (D_A to D_D), an active LOW latch enable input (\overline{EL}), an active LOW ripple blanking input (\overline{BI}), an active LOW lamp test input (\overline{LT}), and seven active HIGH n-p-n bipolar transistor segment outputs (O_a to O_g).

When \overline{EL} is LOW, the state of the segment outputs (O_a to O_g) is determined by the data on D_A to D_D . When \overline{EL} goes HIGH, the last data present on D_A to D_D are stored in the latches and the segment outputs remain stable. When \overline{LT} is LOW, all the segment outputs are HIGH independent of all other input conditions. With \overline{LT} HIGH, a LOW on \overline{BI} forces all segment outputs LOW. The inputs \overline{LT} and \overline{BI} do not affect the latch circuit.

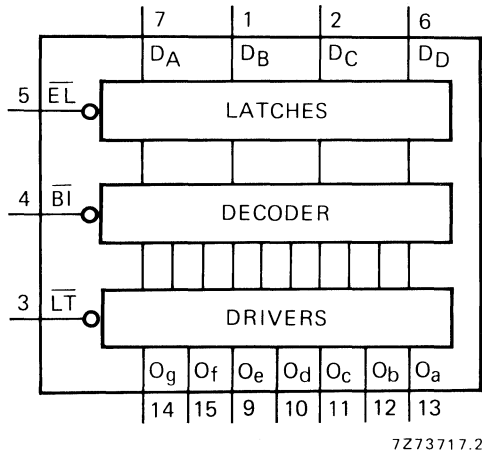

Fig. 1 Functional diagram.

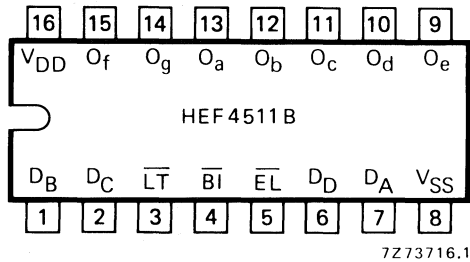

Fig. 2 Pinning diagram.

HEF4511BP: 16-lead DIL; plastic (SOT-38Z).
HEF4511BD: 16-lead DIL; ceramic (cerdip) (SOT-74).
HEF4511BT: 16-lead mini-pack; plastic (SO-16; SOT-109A).

PINNING

- D_A to D_D address (data) inputs
- \overline{EL} latch enable input (active LOW)
- \overline{BI} ripple blanking input (active LOW)
- \overline{LT} lamp test input (active LOW)
- O_a to O_g segment outputs

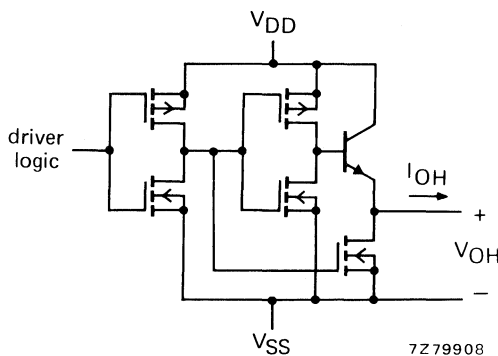

Fig. 3 Schematic diagram of output stage.

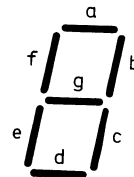

Fig. 4 Segment designation.

FAMILY DATA

I_{DD} LIMITS category MSI

} see Family Specifications

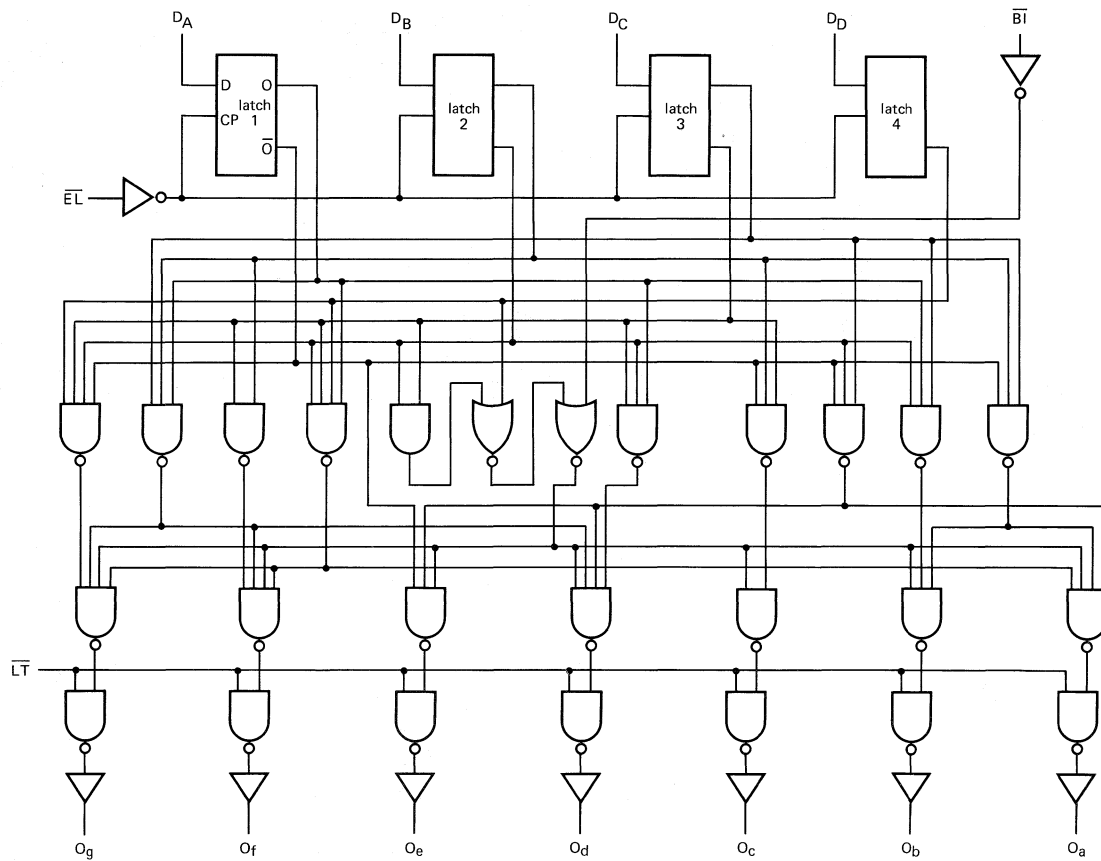

Fig. 5 Logic diagram; for one latch see Fig. 6.

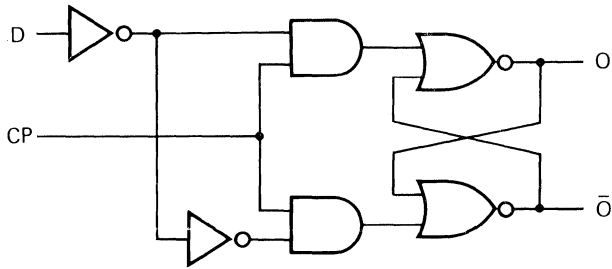

Fig. 6 Logic diagram (one latch); see also Fig. 5. 7Z79901

FUNCTION TABLE

| inputs | | | | | | | outputs | | | | | | | |
|-----------------|-----------------|-----------------|-------|-------|-------|-------|---------|-------|-------|-------|-------|-------|-------|---------|
| \overline{EL} | \overline{BI} | \overline{LT} | D_D | D_C | D_B | D_A | O_a | O_b | O_c | O_d | O_e | O_f | O_g | display |
| X | X | L | X | X | X | X | H | H | H | H | H | H | H | 8 |
| X | L | H | X | X | X | X | L | L | L | L | L | L | L | blank |
| L | H | H | L | L | L | L | H | H | H | H | H | H | L | 0 |
| L | H | H | L | L | L | H | L | H | H | L | L | L | L | 1 |
| L | H | H | L | L | H | L | H | H | L | H | H | L | H | 2 |
| L | H | H | L | L | H | H | H | H | H | H | L | L | H | 3 |
| L | H | H | L | H | L | L | L | H | H | L | L | H | H | 4 |
| L | H | H | L | H | L | H | H | L | H | H | L | H | H | 5 |
| L | H | H | L | H | H | L | L | L | H | H | H | H | H | 6 |
| L | H | H | L | H | H | H | H | H | H | L | L | L | L | 7 |
| L | H | H | H | L | L | L | H | H | H | H | H | H | H | 8 |
| L | H | H | H | L | L | L | H | H | H | L | L | H | H | 9 |
| L | H | H | H | L | H | L | L | L | L | L | L | L | L | blank |
| L | H | H | H | L | H | H | L | L | L | L | L | L | L | blank |
| L | H | H | H | H | L | L | L | L | L | L | L | L | L | blank |
| L | H | H | H | H | L | H | L | L | L | L | L | L | L | blank |
| L | H | H | H | H | H | L | L | L | L | L | L | L | L | blank |
| L | H | H | H | H | H | H | L | L | L | L | L | L | L | blank |
| H | H | H | X | X | X | X | | | * | | | | | * |

H = HIGH state (the more positive voltage)

L = LOW state (the less positive voltage)

X = state is immaterial

* Depends upon the BCD code applied during the LOW to HIGH transition of \overline{EL} .

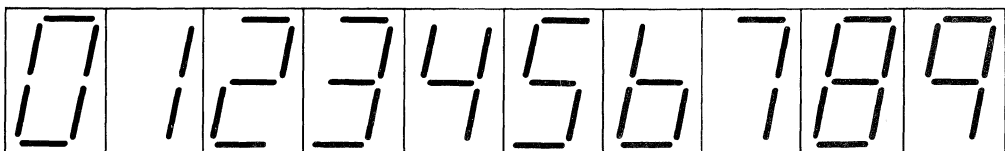

Fig. 7 Display.

7Z72856

RATINGS

Limiting values in accordance with the Absolute Maximum System (IEC 134).

Output (source) current HIGH

$-I_{OH}$ max. 25 mA

For other RATINGS see Family Specifications.

Note

A destructive high current mode may occur if V_I and V_O are not constrained to the range $V_{SS} \leq V_I$ or $V_O \leq V_{DD}$.

D.C. CHARACTERISTICS

$V_{SS} = 0$ V

| | V_{DD} V | I_{OH} mA | symbol | T_{amb} (°C) | | | | | |
|------------------------|---------------|----------------|----------|----------------|-------|-------|-------|------|------|
| | | | | -40 | | +25 | | +85 | |
| | | | | min. | max. | min. | typ. | min. | max. |
| Output voltage HIGH | 5 | 0 | V_{OH} | 4,10 | 4,10 | 4,40 | 4,10 | | V |
| | 10 | 0 | | 9,10 | 9,10 | 9,40 | 9,10 | | V |
| | 15 | 0 | | 14,10 | 14,10 | 14,40 | 14,10 | | V |
| Output voltage HIGH | 5 | 5 | V_{OH} | | | 4,20 | | | V |
| | 10 | 5 | | | | 9,20 | | | V |
| | 15 | 5 | | | | 14,20 | | | V |
| Output voltage HIGH | 5 | 10 | V_{OH} | 3,60 | 3,60 | 4,05 | 3,30 | | V |
| | 10 | 10 | | 8,75 | 8,75 | 9,10 | 8,45 | | V |
| | 15 | 10 | | 13,75 | 13,75 | 14,10 | 13,45 | | V |
| Output voltage HIGH | 5 | 15 | V_{OH} | | | 4,00 | | | V |
| | 10 | 15 | | | | 9,00 | | | V |
| | 15 | 15 | | | | 14,00 | | | V |
| Output voltage HIGH | 5 | 20 | V_{OH} | 2,80 | 2,80 | 3,80 | 2,50 | | V |
| | 10 | 20 | | 8,10 | 8,10 | 9,00 | 7,80 | | V |
| | 15 | 20 | | 13,10 | 13,10 | 14,00 | 12,80 | | V |
| Output voltage HIGH | 5 | 25 | V_{OH} | | | 3,70 | | | V |
| | 10 | 25 | | | | 8,90 | | | V |
| | 15 | 25 | | | | 14,00 | | | V |

A.C. CHARACTERISTICS

$V_{SS} = 0$ V; $T_{amb} = 25$ °C; input transition times ≤ 20 ns

| | V_{DD} V | typical formula for P (μ W) | where |
|---|---------------|---|------------------------------------|
| Dynamic power dissipation per package (P) | 5 | $1\,000 f_i + \Sigma(f_o C_L) \times V_{DD}^2$ | f_i = input freq. (MHz) |
| | 10 | $4\,000 f_i + \Sigma(f_o C_L) \times V_{DD}^2$ | f_o = output freq. (MHz) |
| | 15 | $10\,000 f_i + \Sigma(f_o C_L) \times V_{DD}^2$ | C_L = load capacitance (pF) |
| | | | $\Sigma(f_o C_L)$ = sum of outputs |
| | | | V_{DD} = supply voltage (V) |

A.C. CHARACTERISTICS

 $V_{SS} = 0\text{ V}$; $T_{amb} = 25\text{ }^{\circ}\text{C}$; $C_L = 50\text{ pF}$; input transition times $\leq 20\text{ ns}$

| | V_{DD} V | symbol | min. | typ. | max. | typical extrapolation formula |
|---|---------------|------------|------|------|--------|---|
| Propagation delays | | | | | | |
| $D_n \rightarrow O_n$ | 5 | | | 155 | 310 ns | $128\text{ ns} + (0,55\text{ ns/pF}) C_L$ |
| HIGH to LOW | 10 | t_{PHL} | | 60 | 120 ns | $49\text{ ns} + (0,23\text{ ns/pF}) C_L$ |
| | 15 | | | 40 | 80 ns | $32\text{ ns} + (0,16\text{ ns/pF}) C_L$ |
| LOW to HIGH | 5 | | | 135 | 270 ns | $108\text{ ns} + (0,55\text{ ns/pF}) C_L$ |
| | 10 | t_{PLH} | | 55 | 110 ns | $44\text{ ns} + (0,23\text{ ns/pF}) C_L$ |
| | 15 | | | 40 | 80 ns | $32\text{ ns} + (0,16\text{ ns/pF}) C_L$ |
| $\overline{EL} \rightarrow O_n$ | 5 | | | 160 | 320 ns | $133\text{ ns} + (0,55\text{ ns/pF}) C_L$ |
| HIGH to LOW | 10 | t_{PHL} | | 60 | 120 ns | $49\text{ ns} + (0,23\text{ ns/pF}) C_L$ |
| | 15 | | | 45 | 90 ns | $37\text{ ns} + (0,16\text{ ns/pF}) C_L$ |
| LOW to HIGH | 5 | | | 160 | 320 ns | $133\text{ ns} + (0,55\text{ ns/pF}) C_L$ |
| | 10 | t_{PLH} | | 70 | 140 ns | $59\text{ ns} + (0,23\text{ ns/pF}) C_L$ |
| | 15 | | | 50 | 100 ns | $42\text{ ns} + (0,16\text{ ns/pF}) C_L$ |
| $\overline{BI} \rightarrow O_n$ | 5 | | | 120 | 240 ns | $93\text{ ns} + (0,55\text{ ns/pF}) C_L$ |
| HIGH to LOW | 10 | t_{PHL} | | 50 | 100 ns | $39\text{ ns} + (0,23\text{ ns/pF}) C_L$ |
| | 15 | | | 35 | 70 ns | $27\text{ ns} + (0,16\text{ ns/pF}) C_L$ |
| LOW to HIGH | 5 | | | 105 | 210 ns | $78\text{ ns} + (0,55\text{ ns/pF}) C_L$ |
| | 10 | t_{PLH} | | 40 | 80 ns | $29\text{ ns} + (0,23\text{ ns/pF}) C_L$ |
| | 15 | | | 30 | 60 ns | $22\text{ ns} + (0,16\text{ ns/pF}) C_L$ |
| $\overline{LT} \rightarrow O_n$ | 5 | | | 80 | 160 ns | $52\text{ ns} + (0,55\text{ ns/pF}) C_L$ |
| HIGH to LOW | 10 | t_{PHL} | | 30 | 60 ns | $19\text{ ns} + (0,23\text{ ns/pF}) C_L$ |
| | 15 | | | 20 | 40 ns | $12\text{ ns} + (0,16\text{ ns/pF}) C_L$ |
| LOW to HIGH | 5 | | | 60 | 120 ns | $33\text{ ns} + (0,55\text{ ns/pF}) C_L$ |
| | 10 | t_{PLH} | | 30 | 60 ns | $19\text{ ns} + (0,23\text{ ns/pF}) C_L$ |
| | 15 | | | 25 | 50 ns | $17\text{ ns} + (0,16\text{ ns/pF}) C_L$ |
| Output transition times | | | | | | |
| HIGH to LOW | 5 | | | 60 | 120 ns | $10\text{ ns} + (1,0\text{ ns/pF}) C_L$ |
| | 10 | t_{THL} | | 30 | 60 ns | $9\text{ ns} + (0,42\text{ ns/pF}) C_L$ |
| | 15 | | | 20 | 40 ns | $6\text{ ns} + (0,28\text{ ns/pF}) C_L$ |
| LOW to HIGH | 5 | | | 25 | 50 ns | $20\text{ ns} + (0,1\text{ ns/pF}) C_L$ |
| | 10 | t_{TLH} | | 16 | 32 ns | $13\text{ ns} + (0,06\text{ ns/pF}) C_L$ |
| | 15 | | | 13 | 26 ns | $10\text{ ns} + (0,06\text{ ns/pF}) C_L$ |
| Minimum \overline{EL} pulse width; LOW | 5 | | 80 | 40 | ns | see also waveforms Fig. 8 |
| | 10 | t_{WELL} | 40 | 20 | ns | |
| | 15 | | 35 | 17 | ns | |
| Set-up time | | | | | | |
| $D_n \rightarrow \overline{EL}$ | 5 | | 50 | 25 | ns | see also waveforms Fig. 8 |
| | 10 | t_{su} | 25 | 12 | ns | |
| | 15 | | 20 | 9 | ns | |
| Hold time | | | | | | |
| $D_n \rightarrow \overline{EL}$ | 5 | | 60 | 30 | ns | see also waveforms Fig. 8 |
| | 10 | t_{hold} | 30 | 15 | ns | |
| | 15 | | 25 | 12 | ns | |

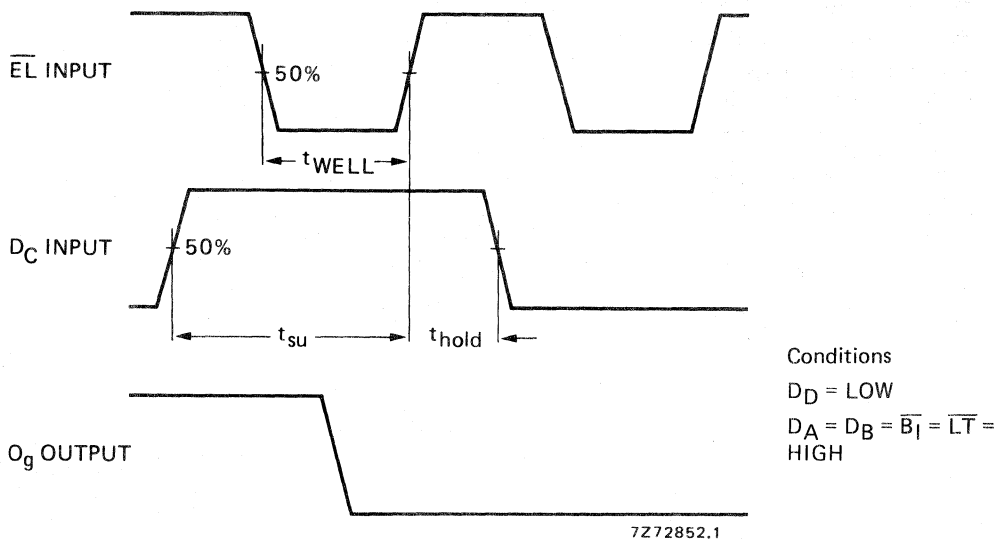

Fig. 8 Waveforms showing minimum \overline{EL} pulse width, set-up and hold time for D_C to \overline{EL} .

APPLICATION INFORMATION

Some examples of applications for the HEF4511B are:

- Driving LED displays.
- Driving incandescent displays.
- Driving fluorescent displays.
- Driving LCD displays.
- Driving gas discharge displays.

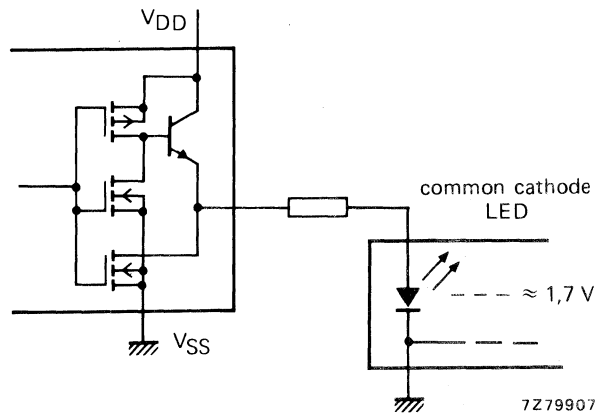

Fig. 9 Connection to common cathode LED display readout.

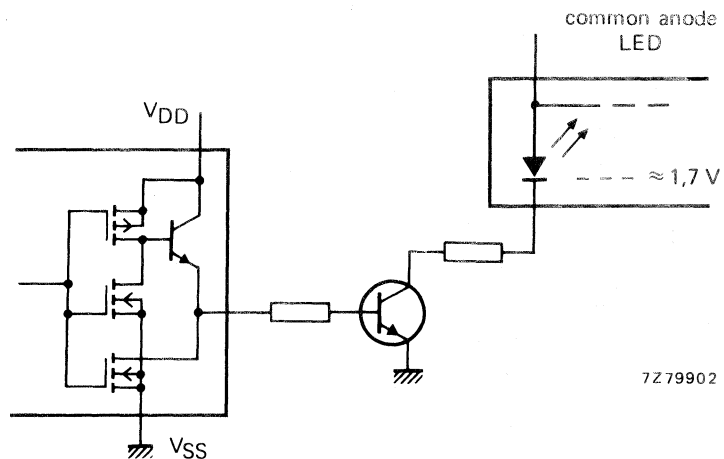
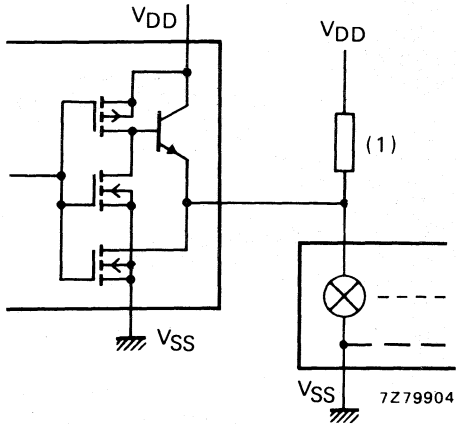

Fig. 10 Connection to common anode LED display readout.



(1) A filament pre-warm resistor is recommended to reduce filament thermal shock and increase the effective cold resistance of the filament.
Fig. 11 Connection to incandescent display readout.

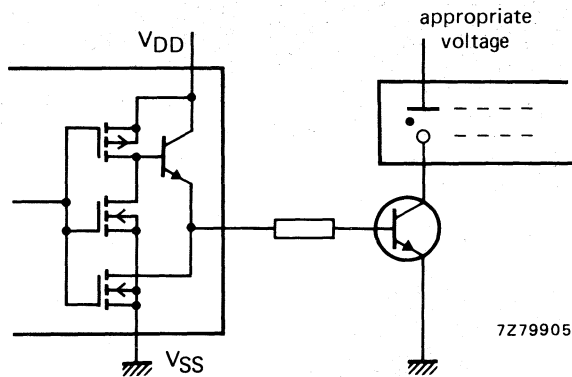

Fig. 13 Connection to gas discharge display readout.

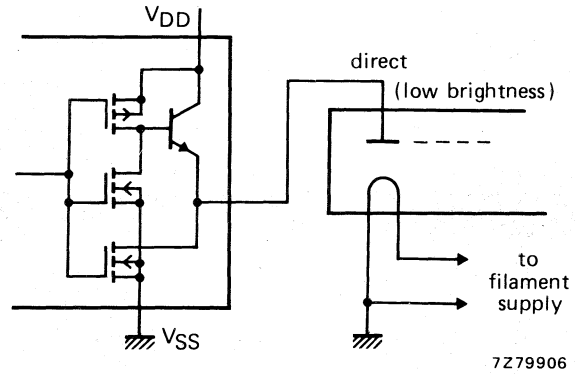

Fig. 12 Connection to fluorescent display readout.

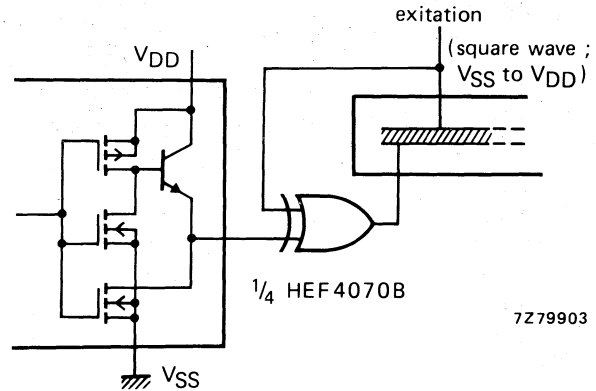

Fig. 14 Connection to liquid crystal (LCD) display readout. Direct d.c. drive of LCDs not recommended for life of LCD readouts.

8-INPUT MULTIPLEXER WITH 3-STATE OUTPUT



The HEF4512B is an 8-input multiplexer with 8 binary inputs (I_0 to I_7), an enable input (\bar{E}) and an output enable input (\bar{EO}). One of eight binary inputs is selected by select inputs S_0 , S_1 and S_2 , and is routed to the output O . A HIGH on \bar{EO} causes O to assume a high impedance OFF-state, regardless of other input conditions. This allows the output to interface directly with bus oriented systems (3-state). When the active LOW enable (\bar{E}) is HIGH, it forces the output LOW provided \bar{EO} is LOW. By proper manipulation of the inputs, the device can provide any logic functions of four variables. It cannot be used to multiplex analogue signals.

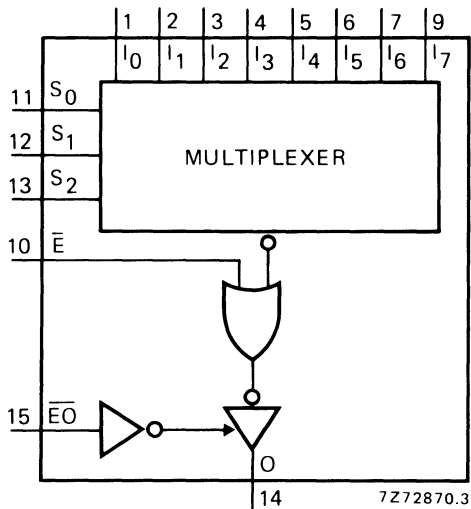

Fig. 1 Functional diagram.

PINNING

- S_0, S_1, S_2 select inputs
- \bar{EO} output enable (active LOW)
- \bar{E} enable (active LOW)
- I_0 to I_7 multiplexer inputs
- O multiplexer output

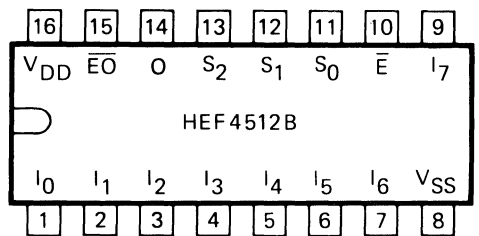

Fig. 2 Pinning diagram.

- HEF4512BP : 16-lead DIL; plastic (SOT-38Z).
- HEF4512BD : 16-lead DIL; ceramic (cerdip) (SOT-74).
- HEF4512BT : 16-lead mini-pack; plastic (SO-16; SOT-109A).

FAMILY DATA

I_{DD} LIMITS category MSI

see Family Specifications

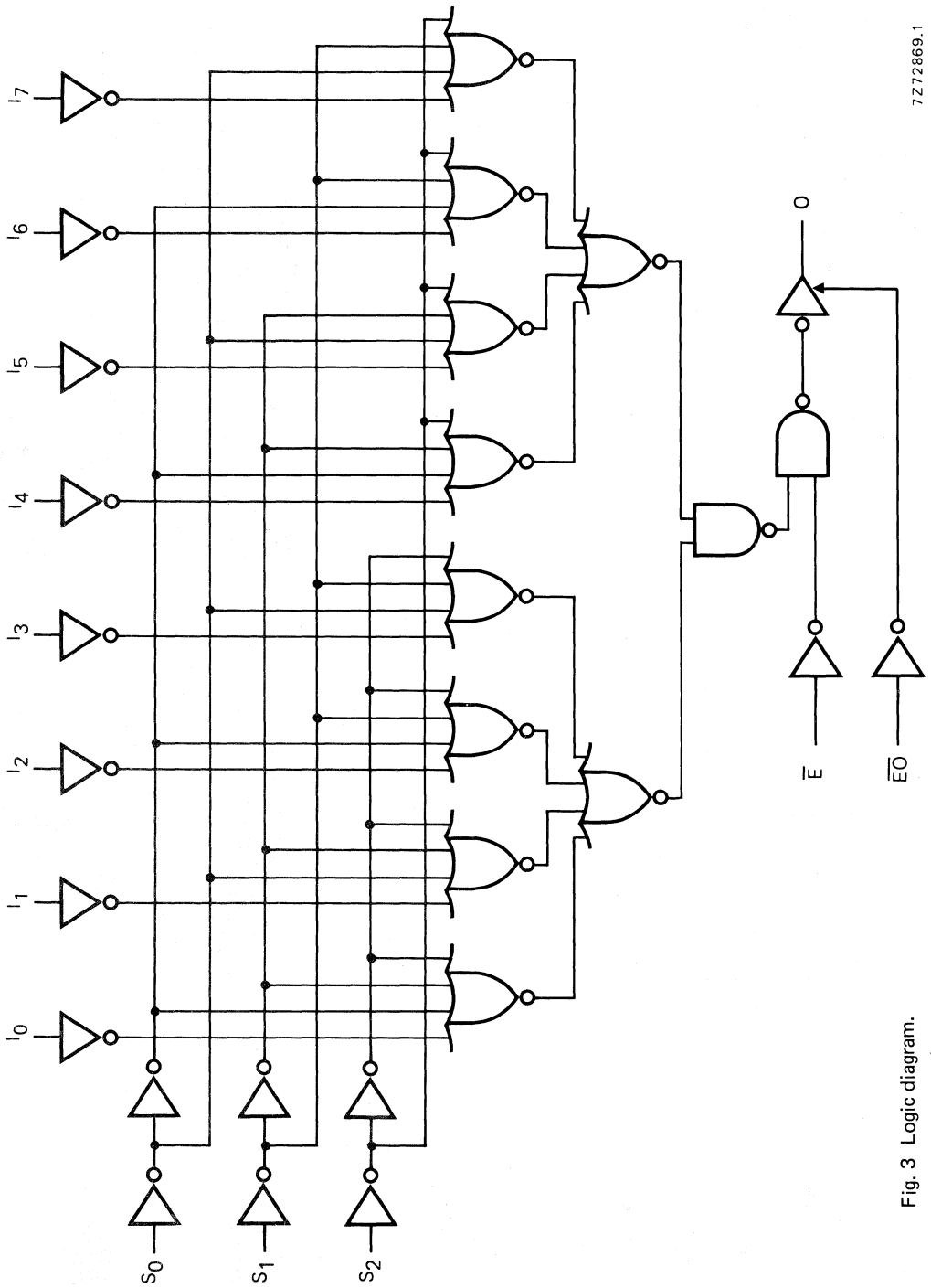

7Z72869.1

Fig. 3 Logic diagram.

TRUTH TABLE

| | | inputs | | | | | | | | | | | output |
|-----------------|----------------|----------------|----------------|----------------|----------------|----------------|----------------|----------------|----------------|----------------|----------------|----------------|--------|
| $\overline{E}O$ | \overline{E} | S ₂ | S ₁ | S ₀ | I ₀ | I ₁ | I ₂ | I ₃ | I ₄ | I ₅ | I ₆ | I ₇ | O |
| L | H | X | X | X | X | X | X | X | X | X | X | X | L |
| L | L | L | L | L | L | X | X | X | X | X | X | X | L |
| L | L | L | L | L | H | X | X | X | X | X | X | X | H |
| L | L | L | L | H | X | L | X | X | X | X | X | X | L |
| L | L | L | L | H | X | H | X | X | X | X | X | X | H |
| L | L | L | H | L | X | X | L | X | X | X | X | X | L |
| L | L | L | H | L | X | X | H | X | X | X | X | X | H |
| L | L | L | H | H | X | X | X | L | X | X | X | X | L |
| L | L | L | H | H | X | X | X | H | X | X | X | X | H |
| L | L | H | L | L | X | X | X | X | L | X | X | X | L |
| L | L | H | L | L | X | X | X | X | H | X | X | X | H |
| L | L | H | L | H | X | X | X | X | X | L | X | X | L |
| L | L | H | L | H | X | X | X | X | X | H | X | X | H |
| L | L | H | H | L | X | X | X | X | X | X | L | X | L |
| L | L | H | H | L | X | X | X | X | X | X | H | X | H |
| L | L | H | H | H | X | X | X | X | X | X | X | L | L |
| L | L | H | H | H | X | X | X | X | X | X | X | H | H |
| H | X | X | X | X | X | X | X | X | X | X | X | X | Z |

H = HIGH state (the more positive voltage)

L = LOW state (the less positive voltage)

X = state is immaterial

Z = high impedance OFF-state

A.C. CHARACTERISTICS $V_{SS} = 0\text{ V}$; $T_{amb} = 25\text{ }^{\circ}\text{C}$; input transition times $\leq 20\text{ ns}$

| | V_{DD} V | typical formula for P (μW) | where f _i = input freq. (MHz) f _o = output freq. (MHz) C _L = load capacitance (pF) $\Sigma(f_o C_L)$ = sum of outputs V _{DD} = supply voltage (V) |
|---|---------------|--|--|
| Dynamic power dissipation per package (P) | 5 | $500 f_i + \Sigma(f_o C_L) \times V_{DD}^2$ | |
| | 10 | $2100 f_i + \Sigma(f_o C_L) \times V_{DD}^2$ | |
| | 15 | $5800 f_i + \Sigma(f_o C_L) \times V_{DD}^2$ | |

A.C. CHARACTERISTICS

 $V_{SS} = 0\text{ V}$; $T_{amb} = 25\text{ }^{\circ}\text{C}$; $C_L = 50\text{ pF}$; input transition times $\leq 20\text{ ns}$

| | V_{DD} V | symbol | typ. | max. | | typical extrapolation formula |
|---|---------------|--------|------|------|----|----------------------------------|
| Propagation delays $I_n \rightarrow O$ HIGH to LOW | 5 | tPHL | 100 | 200 | ns | 73 ns + (0,55 ns/pF) C_L |
| | 10 | | 40 | 80 | ns | 29 ns + (0,23 ns/pF) C_L |
| | 15 | | 30 | 60 | ns | 22 ns + (0,16 ns/pF) C_L |
| LOW to HIGH | 5 | tPLH | 100 | 200 | ns | 73 ns + (0,55 ns/pF) C_L |
| | 10 | | 40 | 80 | ns | 29 ns + (0,23 ns/pF) C_L |
| | 15 | | 30 | 60 | ns | 22 ns + (0,16 ns/pF) C_L |
| $S_n \rightarrow O$ HIGH to LOW | 5 | tPHL | 140 | 280 | ns | 113 ns + (0,55 ns/pF) C_L |
| | 10 | | 55 | 110 | ns | 44 ns + (0,23 ns/pF) C_L |
| | 15 | | 40 | 80 | ns | 32 ns + (0,16 ns/pF) C_L |
| LOW to HIGH | 5 | tPLH | 150 | 300 | ns | 123 ns + (0,55 ns/pF) C_L |
| | 10 | | 60 | 120 | ns | 49 ns + (0,23 ns/pF) C_L |
| | 15 | | 40 | 80 | ns | 32 ns + (0,16 ns/pF) C_L |
| $\bar{E} \rightarrow O$ HIGH to LOW | 5 | tPHL | 60 | 120 | ns | 33 ns + (0,55 ns/pF) C_L |
| | 10 | | 25 | 50 | ns | 14 ns + (0,23 ns/pF) C_L |
| | 15 | | 20 | 40 | ns | 12 ns + (0,16 ns/pF) C_L |
| LOW to HIGH | 5 | tPLH | 55 | 110 | ns | 28 ns + (0,55 ns/pF) C_L |
| | 10 | | 25 | 50 | ns | 14 ns + (0,23 ns/pF) C_L |
| | 15 | | 20 | 40 | ns | 12 ns + (0,16 ns/pF) C_L |
| Output transition times HIGH to LOW | 5 | tTHL | 60 | 120 | ns | 10 ns + (1,0 ns/pF) C_L |
| | 10 | | 30 | 60 | ns | 9 ns + (0,42 ns/pF) C_L |
| | 15 | | 20 | 40 | ns | 6 ns + (0,28 ns/pF) C_L |
| LOW to HIGH | 5 | tTLH | 60 | 120 | ns | 10 ns + (1,0 ns/pF) C_L |
| | 10 | | 30 | 60 | ns | 9 ns + (0,42 ns/pF) C_L |
| | 15 | | 20 | 40 | ns | 6 ns + (0,28 ns/pF) C_L |
| 3-state propagation delays Output disable times $\bar{E}O \rightarrow O$ HIGH | 5 | tPHZ | 35 | 70 | ns | |
| | 10 | | 20 | 40 | ns | |
| | 15 | | 15 | 30 | ns | |
| LOW | 5 | tPLZ | 35 | 70 | ns | |
| | 10 | | 15 | 30 | ns | |
| | 15 | | 10 | 20 | ns | |
| Output enable times $\bar{E}O \rightarrow O$ HIGH | 5 | tPZH | 35 | 70 | ns | |
| | 10 | | 15 | 30 | ns | |
| | 15 | | 10 | 20 | ns | |
| LOW | 5 | tPZL | 35 | 70 | ns | |
| | 10 | | 20 | 40 | ns | |
| | 15 | | 15 | 30 | ns | |

APPLICATION INFORMATION

Some examples of applications for the HEF4512B are:

- Signal gating
- Digital multiplexing
- Number sequence generation

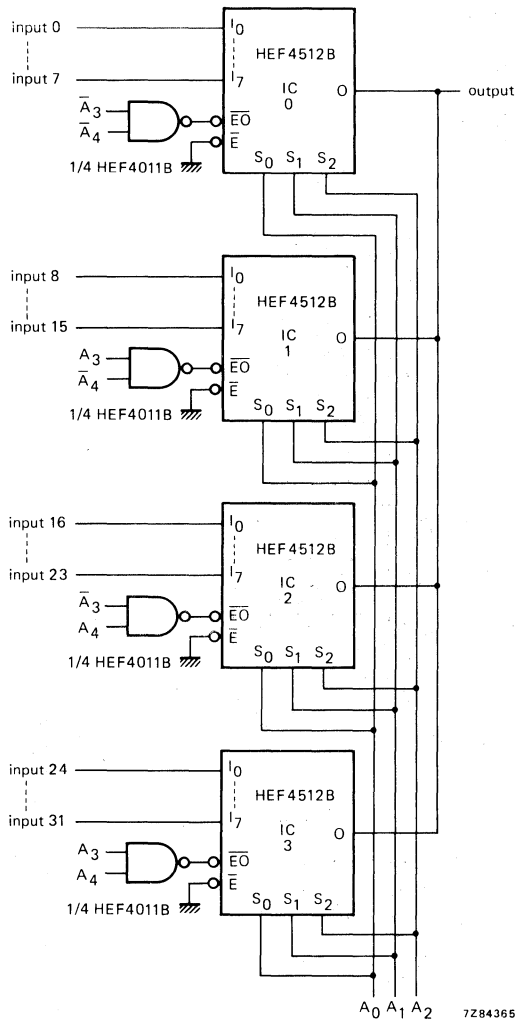

TRUTH TABLE for Fig. 4

| A ₄ | A ₃ | A ₂ | A ₁ | A ₀ | input conn. to output |
|----------------|----------------|----------------|----------------|----------------|-----------------------|
| L | L | L | L | L | 0 |
| L | L | L | L | H | 1 |
| L | L | L | H | L | 2 |
| L | L | L | H | H | 3 |
| L | L | H | L | L | 4 |
| L | L | H | L | H | 5 |
| L | L | H | H | L | 6 |
| L | L | H | H | H | 7 |
| L | H | L | L | L | 8 |
| L | H | L | L | H | 9 |
| L | H | L | H | L | 10 |
| L | H | L | H | H | 11 |
| L | H | H | L | L | 12 |
| L | H | H | L | H | 13 |
| L | H | H | H | L | 14 |
| L | H | H | H | H | 15 |
| H | L | L | L | L | 16 |
| H | L | L | L | H | 17 |
| H | L | L | H | L | 18 |
| H | L | L | H | H | 19 |
| H | L | H | L | L | 20 |
| H | L | H | L | H | 21 |
| H | L | H | H | L | 22 |
| H | L | H | H | H | 23 |
| H | H | L | L | L | 24 |
| H | H | L | L | H | 25 |
| H | H | L | H | L | 26 |
| H | H | L | H | H | 27 |
| H | H | H | L | L | 28 |
| H | H | H | L | H | 29 |
| H | H | H | H | L | 30 |
| H | H | H | H | H | 31 |

Fig. 4 32-input multiplexer using 4 x HEF4512B and 1 x HEF4011B. The input is selected by 5-bit address (A₄ to A₀) and presented at the output.

1-OF-16 DECODER/DEMULTIPLEXER WITH INPUT LATCHES 

The HEF4514B is a 1-of-16 decoder/demultiplexer, having four binary weighted address inputs (A_0 to A_3), a latch enable input (EL), and an active LOW enable input (\bar{E}). The 16 outputs (O_0 to O_{15}) are mutually exclusive active HIGH. When EL is HIGH, the selected output is determined by the data on A_n . When EL goes LOW, the last data present at A_n are stored in the latches and the outputs remain stable. When \bar{E} is LOW, the selected output, determined by the contents of the latch, is HIGH. At \bar{E} HIGH, all outputs are LOW. The enable input (\bar{E}) does not affect the state of the latch. When the HEF4514B is used as a demultiplexer, \bar{E} is the data input and A_0 to A_3 are the address inputs.

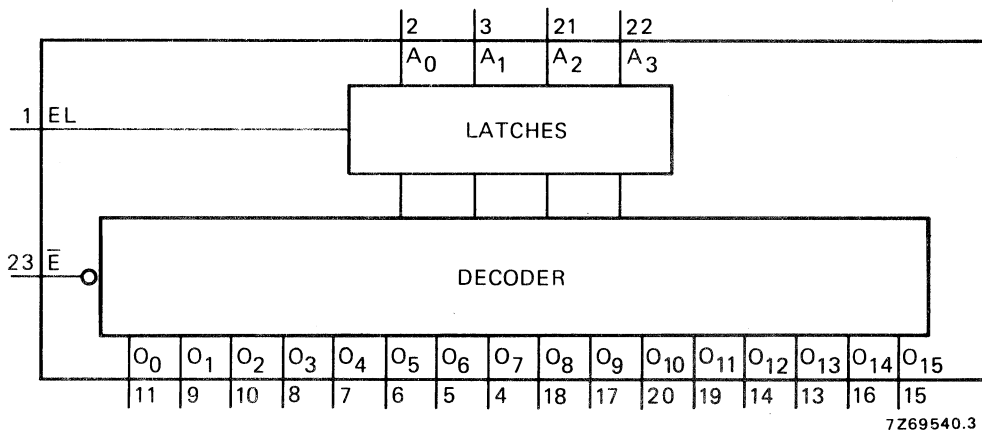

7269540.3

Fig. 1 Functional diagram.

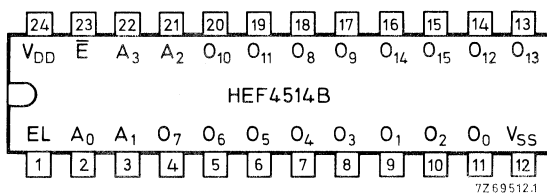

7269512.1

Fig. 2 Pinning diagram.

PINNING

| | |
|-------------------|---------------------------|
| A_0 to A_3 | address inputs |
| \bar{E} | enable input (active LOW) |
| EL | latch enable input |
| O_0 to O_{15} | outputs (active HIGH) |

HEF4514BP : 24-lead DIL; plastic (SOT-101A).
 HEF4514BD : 24-lead DIL; ceramic (cerdip) (SOT-94).
 HEF4514BT : 24-lead mini-pack; plastic (SO-24; SOT-137A).

APPLICATION INFORMATION

Some examples of applications for the HEF4514B are:

- Digital multiplexing.
- Address decoding.
- Hexadecimal/BCD decoding.

FAMILY DATA

I_{DD} LIMITS category MSI

} see Family Specifications

HEF4514B

MSI

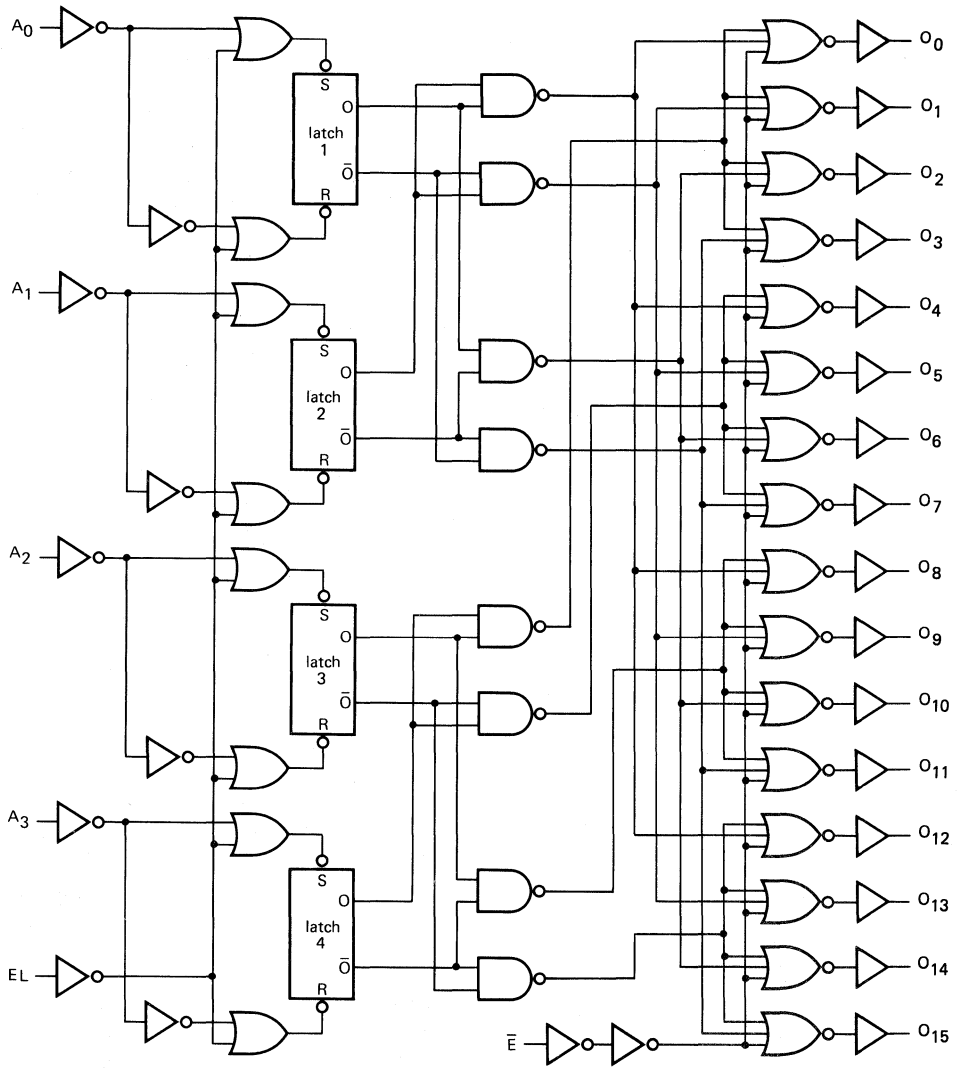

Fig. 3 Logic diagram.

7Z69769.3

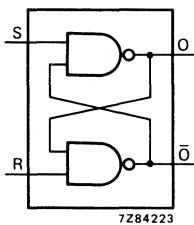

Fig. 4 Logic diagram (one latch).

7Z84223

TRUTH TABLE

| inputs | | | | | outputs | | | | | | | | | | | | | | | | |
|-----------|----------------|----------------|----------------|----------------|----------------|----------------|----------------|----------------|----------------|----------------|----------------|----------------|----------------|----------------|-----------------|-----------------|-----------------|-----------------|-----------------|-----------------|---|
| \bar{E} | A ₀ | A ₁ | A ₂ | A ₃ | O ₀ | O ₁ | O ₂ | O ₃ | O ₄ | O ₅ | O ₆ | O ₇ | O ₈ | O ₉ | O ₁₀ | O ₁₁ | O ₁₂ | O ₁₃ | O ₁₄ | O ₁₅ | |
| H | X | X | X | X | L | L | L | L | L | L | L | L | L | L | L | L | L | L | L | L | L |
| L | L | L | L | L | H | L | L | L | L | L | L | L | L | L | L | L | L | L | L | L | L |
| L | H | L | L | L | L | H | L | L | L | L | L | L | L | L | L | L | L | L | L | L | L |
| L | L | H | L | L | L | L | H | L | L | L | L | L | L | L | L | L | L | L | L | L | L |
| L | L | L | H | L | L | L | L | H | L | L | L | L | L | L | L | L | L | L | L | L | L |
| L | H | L | H | L | L | L | L | L | L | H | L | L | L | L | L | L | L | L | L | L | L |
| L | L | H | H | L | L | L | L | L | L | H | L | L | L | L | L | L | L | L | L | L | L |
| L | H | H | H | L | L | L | L | L | L | L | H | L | L | L | L | L | L | L | L | L | L |
| L | L | L | L | H | L | L | L | L | L | L | L | H | L | L | L | L | L | L | L | L | L |
| L | H | L | L | H | L | L | L | L | L | L | L | L | H | L | L | L | L | L | L | L | L |
| L | L | H | L | H | L | L | L | L | L | L | L | L | L | L | H | L | L | L | L | L | L |
| L | H | H | L | H | L | L | L | L | L | L | L | L | L | L | L | H | L | L | L | L | L |
| L | L | L | H | H | L | L | L | L | L | L | L | L | L | L | L | H | L | L | L | L | L |
| L | H | L | H | H | L | L | L | L | L | L | L | L | L | L | L | L | H | L | L | L | L |
| L | L | H | H | H | L | L | L | L | L | L | L | L | L | L | L | L | L | H | L | L | L |
| L | H | H | H | H | L | L | L | L | L | L | L | L | L | L | L | L | L | L | H | L | L |

EL = HIGH
 H = HIGH state (the more positive voltage)
 L = LOW state (the less positive voltage)
 X = state is immaterial

A.C. CHARACTERISTICS

V_{SS} = 0 V; T_{amb} = 25 °C; C_L = 50 pF; input transition times ≤ 20 ns

| | V _{DD} V | symbol | typ. | max. | | typical extrapolation formula |
|---|----------------------|------------------|------|------|----|--------------------------------------|
| Propagation delays A _n , EL → O _n HIGH to LOW | 5 | t _{PHL} | 260 | 520 | ns | 233 ns + (0,55 ns/pF) C _L |
| | 10 | | 95 | 190 | ns | 84 ns + (0,23 ns/pF) C _L |
| | 15 | | 65 | 130 | ns | 57 ns + (0,16 ns/pF) C _L |
| LOW to HIGH | 5 | t _{PLH} | 270 | 550 | ns | 243 ns + (0,55 ns/pF) C _L |
| | 10 | | 95 | 190 | ns | 84 ns + (0,23 ns/pF) C _L |
| | 15 | | 65 | 130 | ns | 57 ns + (0,16 ns/pF) C _L |
| \bar{E} → O _n HIGH to LOW | 5 | t _{PHL} | 175 | 350 | ns | 148 ns + (0,55 ns/pF) C _L |
| | 10 | | 65 | 130 | ns | 54 ns + (0,23 ns/pF) C _L |
| | 15 | | 45 | 90 | ns | 37 ns + (0,16 ns/pF) C _L |
| LOW to HIGH | 5 | t _{PLH} | 200 | 400 | ns | 173 ns + (0,55 ns/pF) C _L |
| | 10 | | 70 | 140 | ns | 59 ns + (0,23 ns/pF) C _L |
| | 15 | | 50 | 100 | ns | 42 ns + (0,16 ns/pF) C _L |

A.C. CHARACTERISTICS

$V_{SS} = 0\text{ V}$; $T_{amb} = 25\text{ }^\circ\text{C}$; $C_L = 50\text{ pF}$; input transition times $\leq 20\text{ ns}$

| | V_{DD} V | symbol | min. | typ. | max. | typical extrapolation formula | |
|---|---------------|------------|------|------|------|--|---|
| Output transition times HIGH to LOW | 5 | t_{THL} | | 90 | 180 | ns | $40\text{ ns} + (1,0\text{ ns/pF}) C_L$ |
| | 10 | | 35 | 65 | ns | $14\text{ ns} + (0,42\text{ ns/pF}) C_L$ | |
| | 15 | | 25 | 50 | ns | $11\text{ ns} + (0,28\text{ ns/pF}) C_L$ | |
| LOW to HIGH | 5 | t_{TLH} | | 85 | 170 | ns | $35\text{ ns} + (1,0\text{ ns/pF}) C_L$ |
| | 10 | | 35 | 70 | ns | $14\text{ ns} + (0,42\text{ ns/pF}) C_L$ | |
| | 15 | | 25 | 50 | ns | $11\text{ ns} + (0,28\text{ ns/pF}) C_L$ | |
| Set-up time $A_n \rightarrow EL$ | 5 | t_{su} | 120 | 60 | | ns | } see also waveforms Fig. 5 |
| | 10 | | 40 | 20 | | ns | |
| | 15 | | 30 | 15 | | ns | |
| Hold time $A_n \rightarrow EL$ | 5 | t_{hold} | 0 | 60 | | ns | |
| | 10 | | 0 | 20 | | ns | |
| | 15 | | 0 | 15 | | ns | |
| Minimum EL pulse width; HIGH | 5 | t_{WELH} | 120 | 60 | | ns | |
| | 10 | | 40 | 20 | | ns | |
| | 15 | | 30 | 15 | | ns | |

| | V_{DD} V | typical formula for P (μW) | where |
|---|---------------|---|------------------------------------|
| Dynamic power dissipation per package (P) | 5 | $1100 f_i + \Sigma(f_o C_L) \times V_{DD}^2$ | f_i = input freq. (MHz) |
| | 10 | $5500 f_i + \Sigma(f_o C_L) \times V_{DD}^2$ | f_o = output freq. (MHz) |
| | 15 | $16\,000 f_i + \Sigma(f_o C_L) \times V_{DD}^2$ | C_L = load capacitance (pF) |
| | | | $\Sigma(f_o C_L)$ = sum of outputs |
| | | | V_{DD} = supply voltage (V) |

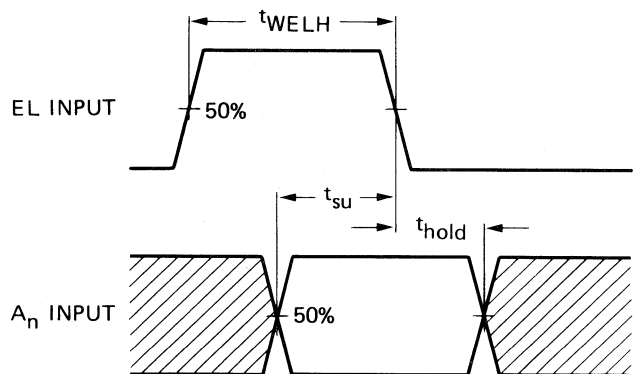

7274552

Fig. 5 Waveforms showing minimum pulse width for EL, set-up and hold times for A_n to EL. Set-up and hold times are shown as positive values but may be specified as negative values.

1-OF-16 DECODER/DEMULTIPLEXER WITH INPUT LATCHES 

The HEF4515B is a 1-of-16 decoder/demultiplexer, having four binary weighted address inputs (A_0 to A_3), a latch enable input (EL), and an active LOW enable input (\bar{E}). The 16 outputs (\bar{O}_0 to \bar{O}_{15}) are mutually exclusive active LOW. When EL is HIGH, the selected output is determined by the data on A_n . When EL goes LOW, the last data present at A_n are stored in the latches and the outputs remain stable. When \bar{E} is LOW, the selected output, determined by the contents of the latch, is LOW. At \bar{E} HIGH, all outputs are HIGH. The enable input (\bar{E}) does not affect the state of the latch. When the HEF 4515B is used as a demultiplexer, \bar{E} is the data input and A_0 to A_3 are the address inputs.

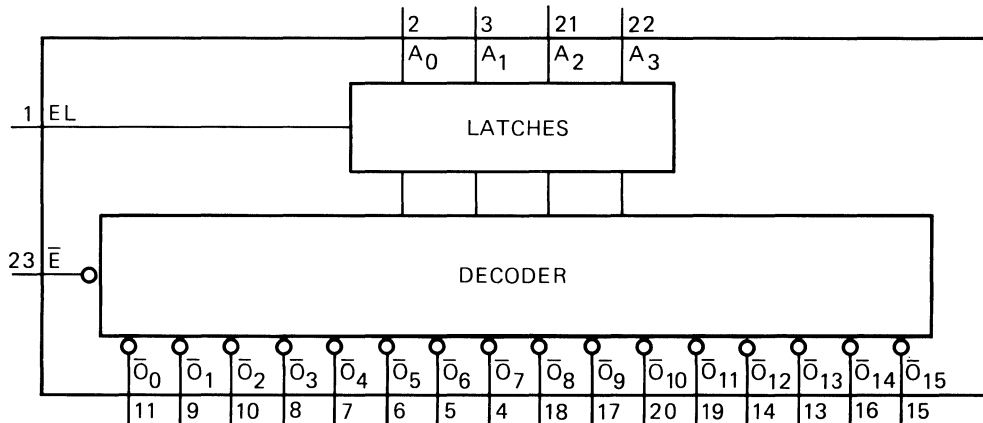

7Z84275

Fig. 1 Functional diagram.

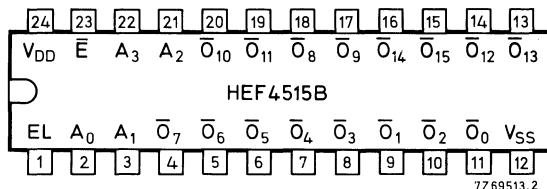

PINNING

A_0 to A_3 address inputs
 \bar{E} enable input (active LOW)
 EL latch enable input
 \bar{O}_0 to \bar{O}_{15} outputs (active LOW)

Fig. 2 Pinning diagram.

HEF4515BP : 24-lead DIL; plastic (SOT-101A).

HEF4515BD: 24-lead DIL; ceramic (cerdip) (SOT-94).

HEF4515BT : 24-lead mini-pack; plastic (SO-24; SOT-137A).

APPLICATION INFORMATION

Some examples of applications for the HEF4515B are:

- Digital multiplexing.
- Address decoding.
- Hexadecimal/BCD decoding.

FAMILY DATA

I_{DD} LIMITS category MSI

} see Family Specifications

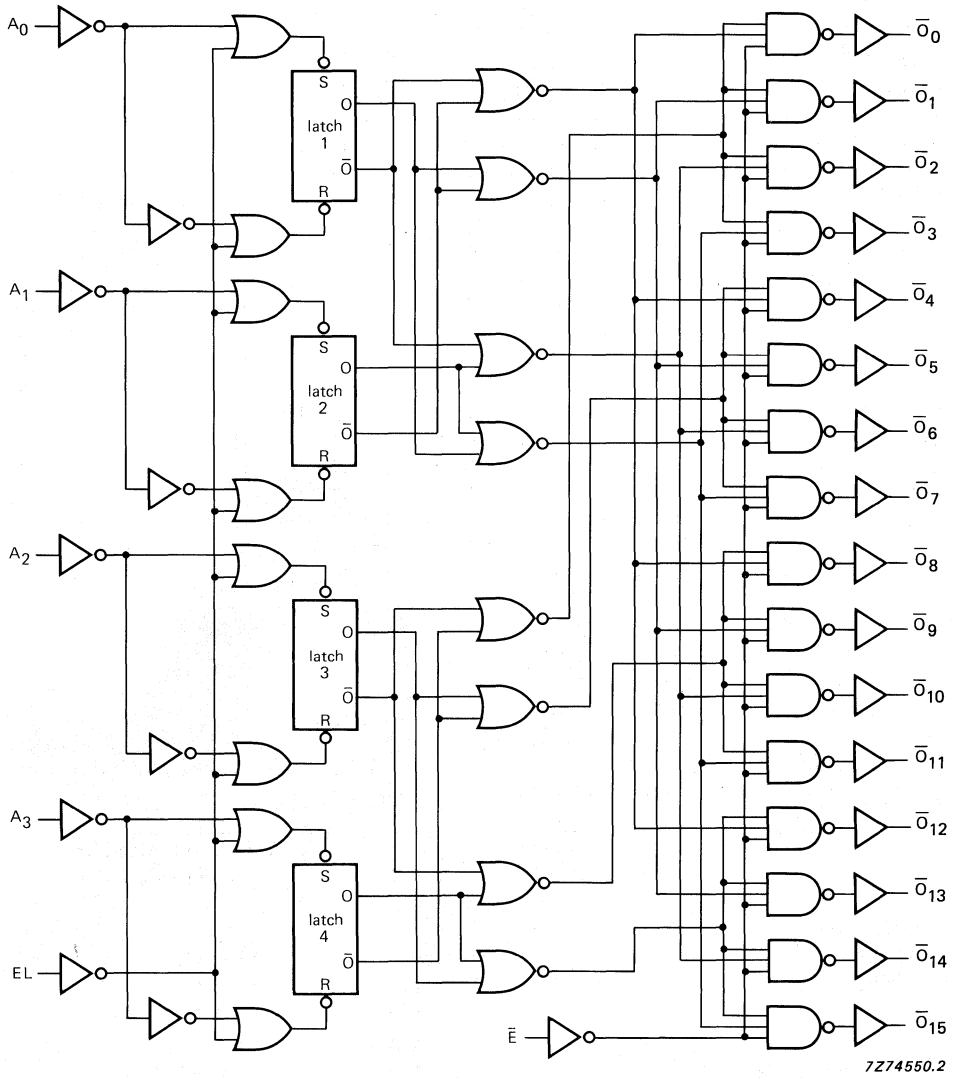

Fig. 3 Logic diagram.

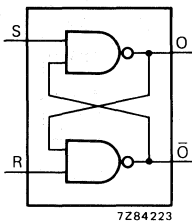

Fig. 4 Logic diagram (one latch).

TRUTH TABLE

| inputs | | | | | outputs | | | | | | | | | | | | | | | | |
|-----------|----------------|----------------|----------------|----------------|-------------|-------------|-------------|-------------|-------------|-------------|-------------|-------------|-------------|-------------|----------------|----------------|----------------|----------------|----------------|----------------|---|
| \bar{E} | A ₀ | A ₁ | A ₂ | A ₃ | \bar{O}_0 | \bar{O}_1 | \bar{O}_2 | \bar{O}_3 | \bar{O}_4 | \bar{O}_5 | \bar{O}_6 | \bar{O}_7 | \bar{O}_8 | \bar{O}_9 | \bar{O}_{10} | \bar{O}_{11} | \bar{O}_{12} | \bar{O}_{13} | \bar{O}_{14} | \bar{O}_{15} | |
| H | X | X | X | X | H | H | H | H | H | H | H | H | H | H | H | H | H | H | H | H | H |
| L | L | L | L | L | L | H | H | H | H | H | H | H | H | H | H | H | H | H | H | H | H |
| L | H | L | L | L | H | L | H | H | H | H | H | H | H | H | H | H | H | H | H | H | H |
| L | L | H | L | L | H | H | L | H | H | H | H | H | H | H | H | H | H | H | H | H | H |
| L | H | H | L | L | H | H | H | L | H | H | H | H | H | H | H | H | H | H | H | H | H |
| L | L | L | H | L | H | H | H | H | L | H | H | H | H | H | H | H | H | H | H | H | H |
| L | H | L | H | L | H | H | H | H | H | L | H | H | H | H | H | H | H | H | H | H | H |
| L | L | H | H | L | H | H | H | H | H | L | H | H | H | H | H | H | H | H | H | H | H |
| L | H | H | H | L | H | H | H | H | H | H | L | H | H | H | H | H | H | H | H | H | H |
| L | L | L | H | H | H | H | H | H | H | H | H | H | H | H | H | H | L | H | H | H | H |
| L | H | L | H | H | H | H | H | H | H | H | H | H | H | H | H | H | H | L | H | H | H |
| L | L | H | H | H | H | H | H | H | H | H | H | H | H | H | H | H | H | L | H | H | H |
| L | H | H | H | H | H | H | H | H | H | H | H | H | H | H | H | H | H | H | L | H | H |
| L | H | H | H | H | H | H | H | H | H | H | H | H | H | H | H | H | H | H | H | L | H |
| L | H | H | H | H | H | H | H | H | H | H | H | H | H | H | H | H | H | H | H | H | L |

EL = HIGH
 H = HIGH state (the more positive voltage)
 L = LOW state (the less positive voltage)
 X = state is immaterial

A.C. CHARACTERISTICS

V_{SS} = 0 V; T_{amb} = 25 °C; C_L = 50 pF; input transition times ≤ 20 ns

| | V _{DD} V | symbol | typ. | max. | | typical extrapolation formula |
|--|----------------------|------------------|------|------|----|--------------------------------------|
| Propagation delays A _n , EL → \bar{O}_n HIGH to LOW | 5 | t _{PHL} | 260 | 520 | ns | 233 ns + (0,55 ns/pF) C _L |
| | 10 | | 95 | 190 | ns | 84 ns + (0,23 ns/pF) C _L |
| | 15 | | 65 | 130 | ns | 57 ns + (0,16 ns/pF) C _L |
| LOW to HIGH | 5 | t _{PLH} | 270 | 550 | ns | 243 ns + (0,55 ns/pF) C _L |
| | 10 | | 95 | 190 | ns | 84 ns + (0,23 ns/pF) C _L |
| | 15 | | 65 | 130 | ns | 57 ns + (0,16 ns/pF) C _L |
| \bar{E} → \bar{O}_n HIGH to LOW | 5 | t _{PHL} | 175 | 350 | ns | 148 ns + (0,55 ns/pF) C _L |
| | 10 | | 65 | 130 | ns | 54 ns + (0,23 ns/pF) C _L |
| | 15 | | 45 | 90 | ns | 37 ns + (0,16 ns/pF) C _L |
| LOW to HIGH | 5 | t _{PLH} | 200 | 400 | ns | 173 ns + (0,55 ns/pF) C _L |
| | 10 | | 70 | 140 | ns | 59 ns + (0,23 ns/pF) C _L |
| | 15 | | 50 | 100 | ns | 42 ns + (0,16 ns/pF) C _L |

A.C. CHARACTERISTICS

V_{SS} = 0 V; T_{amb} = 25 °C; C_L = 50 pF; input transition times ≤ 20 ns

| | V _{DD} V | symbol | min. | typ. | max. | typical extrapolation formula |
|---|----------------------|-------------------|------|------|-------------------------------------|------------------------------------|
| Output transition times HIGH to LOW | 5 | t _{THL} | | 90 | 180 | 40 ns + (1,0 ns/pF) C _L |
| | 10 | | 35 | 65 | 14 ns + (0,42 ns/pF) C _L | |
| | 15 | | 25 | 50 | 11 ns + (0,28 ns/pF) C _L | |
| LOW to HIGH | 5 | t _{TLH} | | 85 | 170 | 35 ns + (1,0 ns/pF) C _L |
| | 10 | | 35 | 70 | 14 ns + (0,42 ns/pF) C _L | |
| | 15 | | 25 | 50 | 11 ns + (0,28 ns/pF) C _L | |
| Set-up time A _n → EL | 5 | t _{su} | 120 | 60 | | } see also waveforms Fig. 5 |
| | 10 | | 40 | 20 | | |
| | 15 | | 30 | 15 | | |
| Hold time A _n → EL | 5 | t _{hold} | 0 | 60 | | |
| | 10 | | 0 | 20 | | |
| | 15 | | 0 | 15 | | |
| Minimum EL pulse width; HIGH | 5 | t _{WELH} | 120 | 60 | | |
| | 10 | | 40 | 20 | | |
| | 15 | | 30 | 15 | | |

| | V _{DD} V | typical formula for P (μW) | where f _i = input freq. (MHz) f _o = output freq. (MHz) C _L = load capacitance (pF) Σ(f _o C _L) = sum of outputs V _{DD} = supply voltage (V) |
|---|----------------------|--|--|
| Dynamic power dissipation per package (P) | 5 | 1100 f _i + Σ(f _o C _L) × V _{DD} ² | |
| | 10 | 5500 f _i + Σ(f _o C _L) × V _{DD} ² | |
| | 15 | 16 000 f _i + Σ(f _o C _L) × V _{DD} ² | |

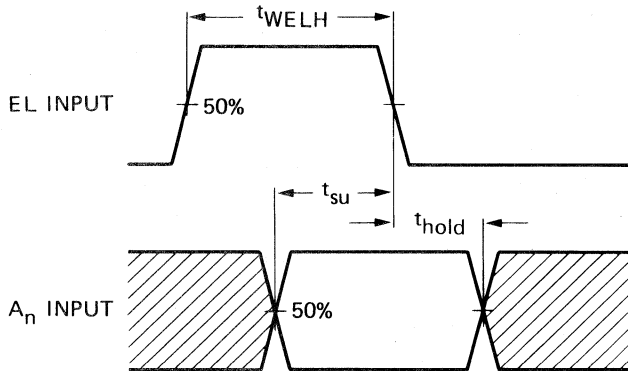

7Z74552

Fig. 5 Waveforms showing minimum pulse width for EL, set-up and hold times for A_n to EL. Set-up and hold times are shown as positive values but may be specified as negative values.

BINARY UP/DOWN COUNTER



The HEF4516B is an edge-triggered synchronous up/down 4-bit binary counter with a clock input (CP), an up/down count control input (UP/DN), an active LOW count enable input (\overline{CE}), an asynchronous active HIGH parallel load input (PL), four parallel inputs (P_0 to P_3), four parallel outputs (O_0 to O_3), an active LOW terminal count output (\overline{TC}), and an overriding asynchronous master reset input (MR).

Information on P_0 to P_3 is loaded into the counter while PL is HIGH, independent of all other input conditions except MR which must be LOW. When PL and \overline{CE} are LOW, the counter changes on the LOW to HIGH transition of CP. Input UP/DN determines the direction of the count, HIGH for counting up, LOW for counting down. When counting up, \overline{TC} is LOW when O_0 to O_3 are HIGH and \overline{CE} is LOW. When counting down, \overline{TC} is LOW when O_0 to O_3 and \overline{CE} are LOW. A HIGH on MR resets the counter (O_0 to $O_3 = \text{LOW}$) independent of all other input conditions.

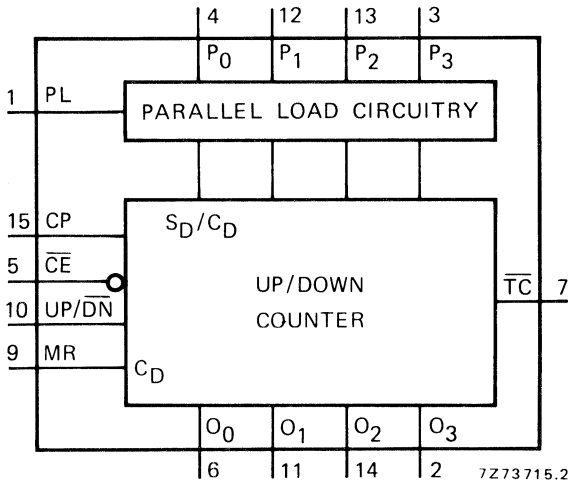

Fig. 1 Functional diagram.

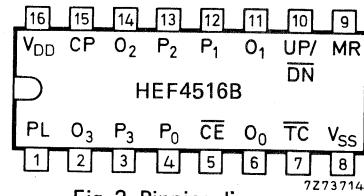

Fig. 2 Pinning diagram.

HEF4516BP : 16-lead DIL; plastic (SOT-38Z).

HEF4516BD : 16-lead DIL; ceramic (cerdip) (SOT-74).

HEF4516BT : 16-lead mini-pack; plastic (SO-16; SOT-109A).

PINNING

| | | | |
|-----------------|---|-----------------|------------------------------------|
| PL | parallel load input (active HIGH) | UP/DN | up/down count control input |
| P_0 to P_3 | parallel inputs | MR | master reset input |
| \overline{CE} | count enable input (active LOW) | \overline{TC} | terminal count output (active LOW) |
| CP | clock pulse input (LOW to HIGH, edge triggered) | O_0 to O_3 | parallel outputs |

FAMILY DATA

I_{DD} LIMITS category MSI

} see Family Specifications

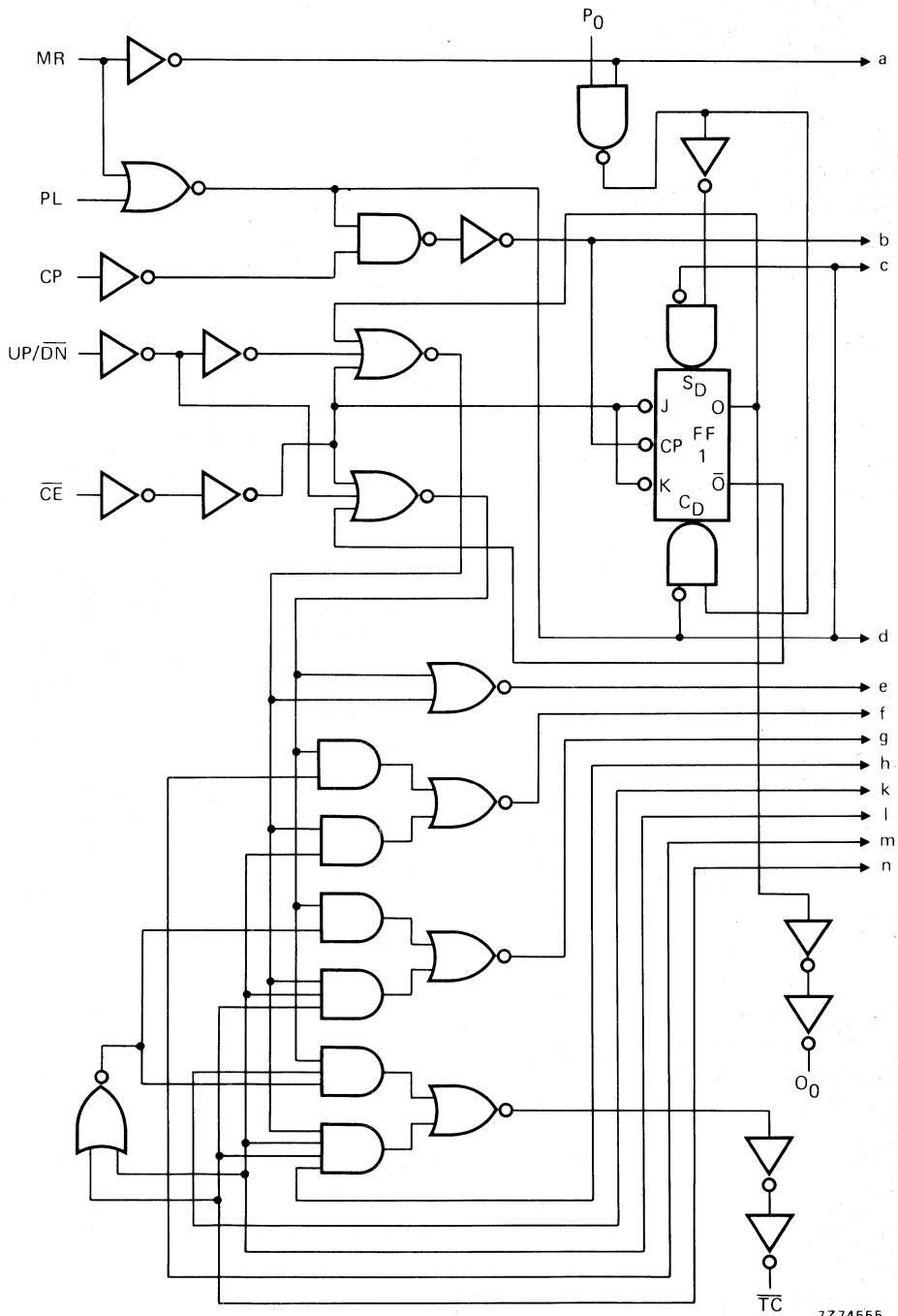

7274555

Fig. 3a Logic diagram (continued in Fig. 3b).

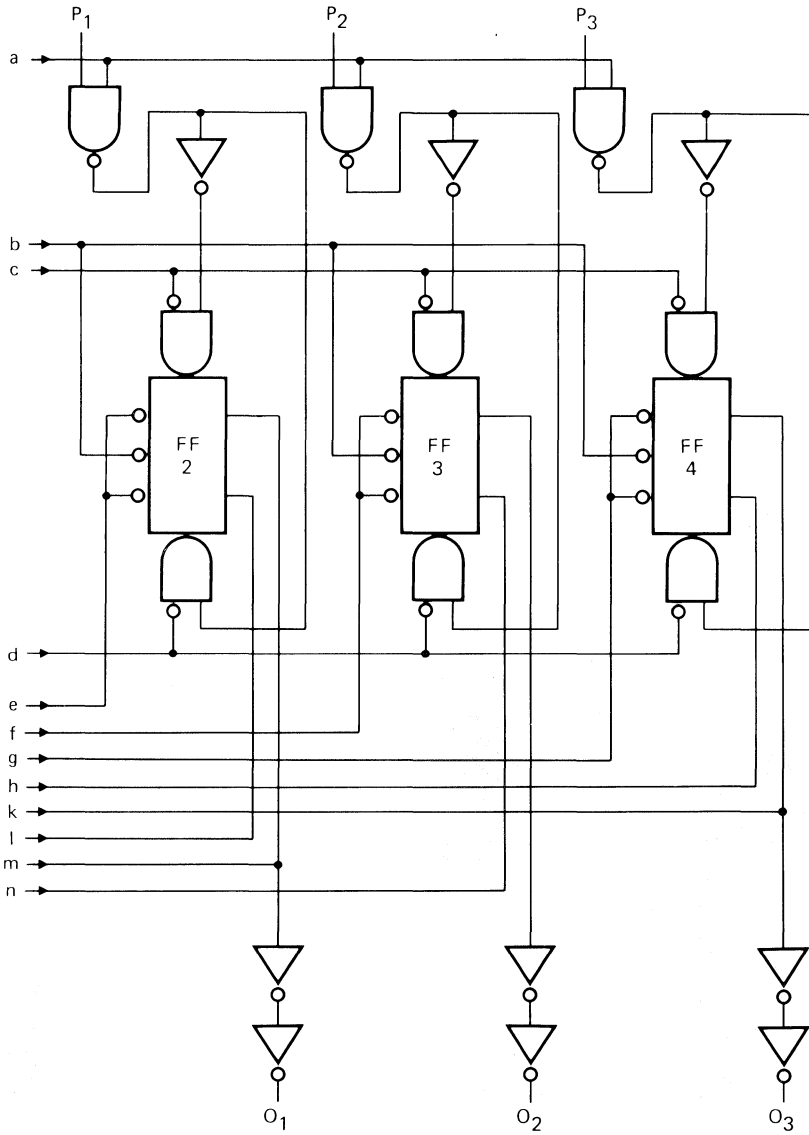

7274556

Fig. 3b Logic diagram (continued from Fig. 3a).

FUNCTION TABLE

| MR | PL | UP/DN | \overline{CE} | CP | mode |
|----|----|-------|-----------------|------------|---------------|
| L | H | X | X | X | parallel load |
| L | L | X | H | X | no change |
| L | L | L | L | \nearrow | count down |
| L | L | H | L | \nearrow | count up |
| H | X | X | X | X | reset |

H = HIGH state (the more positive voltage)

L = LOW state (the less positive voltage)

X = state is immaterial

\nearrow = positive-going transition

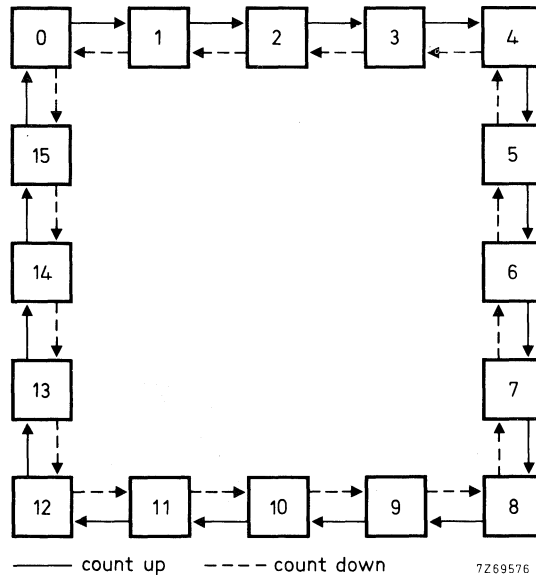

Fig. 4 State diagram.

Logic equation for terminal count:

$$\overline{TC} = \overline{\overline{CE}} \cdot \{ (\overline{UP/DN}) \cdot O_0 \cdot O_1 \cdot O_2 \cdot O_3 + (\overline{UP/DN}) \cdot \overline{O_0} \cdot \overline{O_1} \cdot \overline{O_2} \cdot \overline{O_3} \}$$

A.C. CHARACTERISTICS

$V_{SS} = 0$ V; $T_{amb} = 25$ °C; input transition times ≤ 20 ns

| | V_{DD} V | typical formula for P (μ W) | where f_i = input freq. (MHz) f_o = output freq. (MHz) C_L = load capacitance (pF) $\Sigma(f_o C_L)$ = sum of outputs V_{DD} = supply voltage (V) |
|---|---------------|---|--|
| Dynamic power dissipation per package (P) | 5 | $1000 f_i + \Sigma(f_o C_L) \times V_{DD}^2$ | |
| | 10 | $4500 f_i + \Sigma(f_o C_L) \times V_{DD}^2$ | |
| | 15 | $11\,200 f_i + \Sigma(f_o C_L) \times V_{DD}^2$ | |

A.C. CHARACTERISTICS

 $V_{SS} = 0 \text{ V}$; $T_{amb} = 25 \text{ }^\circ\text{C}$; $C_L = 50 \text{ pF}$; input transition times $\leq 20 \text{ ns}$

| | V_{DD} V | symbol | min. | typ. | max. | typical extrapolation formula |
|---|---------------|--------|------|--------|--|---|
| Propagation delays $CP \rightarrow O_n$ HIGH to LOW | 5 | tPHL | | 145 | 290 ns | $118 \text{ ns} + (0,55 \text{ ns/pF}) C_L$ |
| | 10 | | 60 | 120 ns | $49 \text{ ns} + (0,23 \text{ ns/pF}) C_L$ | |
| | 15 | | 45 | 90 ns | $37 \text{ ns} + (0,16 \text{ ns/pF}) C_L$ | |
| LOW to HIGH | 5 | tPLH | | 155 | 310 ns | $128 \text{ ns} + (0,55 \text{ ns/pF}) C_L$ |
| | 10 | | 65 | 130 ns | $54 \text{ ns} + (0,23 \text{ ns/pF}) C_L$ | |
| | 15 | | 45 | 90 ns | $37 \text{ ns} + (0,16 \text{ ns/pF}) C_L$ | |
| $CP \rightarrow \overline{TC}$ HIGH to LOW | 5 | tPHL | | 260 | 525 ns | $233 \text{ ns} + (0,55 \text{ ns/pF}) C_L$ |
| | 10 | | 105 | 210 ns | $94 \text{ ns} + (0,23 \text{ ns/pF}) C_L$ | |
| | 15 | | 75 | 150 ns | $67 \text{ ns} + (0,16 \text{ ns/pF}) C_L$ | |
| LOW to HIGH | 5 | tPLH | | 180 | 360 ns | $153 \text{ ns} + (0,55 \text{ ns/pF}) C_L$ |
| | 10 | | 75 | 150 ns | $64 \text{ ns} + (0,23 \text{ ns/pF}) C_L$ | |
| | 15 | | 55 | 115 ns | $47 \text{ ns} + (0,16 \text{ ns/pF}) C_L$ | |
| $PL \rightarrow O_n$ HIGH to LOW | 5 | tPHL | | 125 | 255 ns | $98 \text{ ns} + (0,55 \text{ ns/pF}) C_L$ |
| | 10 | | 55 | 110 ns | $44 \text{ ns} + (0,23 \text{ ns/pF}) C_L$ | |
| | 15 | | 40 | 85 ns | $32 \text{ ns} + (0,16 \text{ ns/pF}) C_L$ | |
| LOW to HIGH | 5 | tPLH | | 170 | 340 ns | $143 \text{ ns} + (0,55 \text{ ns/pF}) C_L$ |
| | 10 | | 70 | 140 ns | $59 \text{ ns} + (0,23 \text{ ns/pF}) C_L$ | |
| | 15 | | 50 | 105 ns | $42 \text{ ns} + (0,16 \text{ ns/pF}) C_L$ | |
| $PL \rightarrow \overline{TC}$ HIGH to LOW | 5 | tPHL | | 250 | 500 ns | $223 \text{ ns} + (0,55 \text{ ns/pF}) C_L$ |
| | 10 | | 110 | 220 ns | $99 \text{ ns} + (0,23 \text{ ns/pF}) C_L$ | |
| | 15 | | 80 | 160 ns | $72 \text{ ns} + (0,16 \text{ ns/pF}) C_L$ | |
| LOW to HIGH | 5 | tPLH | | 250 | 500 ns | $223 \text{ ns} + (0,55 \text{ ns/pF}) C_L$ |
| | 10 | | 110 | 220 ns | $99 \text{ ns} + (0,23 \text{ ns/pF}) C_L$ | |
| | 15 | | 80 | 160 ns | $72 \text{ ns} + (0,16 \text{ ns/pF}) C_L$ | |
| $\overline{CE} \rightarrow \overline{TC}$ HIGH to LOW | 5 | tPHL | | 165 | 330 ns | $138 \text{ ns} + (0,55 \text{ ns/pF}) C_L$ |
| | 10 | | 65 | 135 ns | $54 \text{ ns} + (0,23 \text{ ns/pF}) C_L$ | |
| | 15 | | 50 | 100 ns | $42 \text{ ns} + (0,16 \text{ ns/pF}) C_L$ | |
| LOW to HIGH | 5 | tPLH | | 145 | 290 ns | $118 \text{ ns} + (0,55 \text{ ns/pF}) C_L$ |
| | 10 | | 60 | 125 ns | $49 \text{ ns} + (0,23 \text{ ns/pF}) C_L$ | |
| | 15 | | 45 | 95 ns | $37 \text{ ns} + (0,16 \text{ ns/pF}) C_L$ | |
| $MR \rightarrow O_n, \overline{TC}$ HIGH to LOW | 5 | tPHL | | 205 | 405 ns | $178 \text{ ns} + (0,55 \text{ ns/pF}) C_L$ |
| | 10 | | 65 | 130 ns | $54 \text{ ns} + (0,23 \text{ ns/pF}) C_L$ | |
| | 15 | | 45 | 85 ns | $37 \text{ ns} + (0,16 \text{ ns/pF}) C_L$ | |
| $MR \rightarrow \overline{TC}$ LOW to HIGH | 5 | tPLH | | 225 | 450 ns | $198 \text{ ns} + (0,55 \text{ ns/pF}) C_L$ |
| | 10 | | 75 | 150 ns | $64 \text{ ns} + (0,23 \text{ ns/pF}) C_L$ | |
| | 15 | | 50 | 100 ns | $42 \text{ ns} + (0,16 \text{ ns/pF}) C_L$ | |

A.C. CHARACTERISTICS

 $V_{SS} = 0\text{ V}$; $T_{amb} = 25\text{ }^{\circ}\text{C}$; $C_L = 50\text{ pF}$; input transition times $\leq 20\text{ ns}$

| | V_{DD} V | symbol | min. | typ. | max. | typical extrapolation formula | | |
|---|---------------|------------|-----------|------|------|---|---|---|
| Output transition times HIGH to LOW | 5 | t_{THL} | | 60 | 120 | ns | $10\text{ ns} + (1,0\text{ ns/pF}) C_L$ | |
| | 10 | | 30 | 60 | ns | $9\text{ ns} + (0,42\text{ ns/pF}) C_L$ | | |
| | 15 | | 20 | 40 | ns | $6\text{ ns} + (0,28\text{ ns/pF}) C_L$ | | |
| | LOW to HIGH | 5 | t_{TLH} | | 60 | 120 | ns | $10\text{ ns} + (1,0\text{ ns/pF}) C_L$ |
| | | 10 | | 30 | 60 | ns | $9\text{ ns} + (0,42\text{ ns/pF}) C_L$ | |
| | | 15 | | 20 | 40 | ns | $6\text{ ns} + (0,28\text{ ns/pF}) C_L$ | |
| Minimum clock pulse width; LOW | 5 | t_{WCPL} | 95 | 45 | | ns | | |
| | 10 | | 35 | 20 | | ns | | |
| | 15 | | 25 | 15 | | ns | | |
| Minimum PL pulse width; HIGH | 5 | t_{WPLH} | 105 | 55 | | ns | | |
| | 10 | | 45 | 25 | | ns | | |
| | 15 | | 35 | 15 | | ns | | |
| Minimum MR pulse width; HIGH | 5 | t_{WMRH} | 120 | 60 | | ns | | |
| | 10 | | 50 | 25 | | ns | | |
| | 15 | | 40 | 20 | | ns | | |
| Recovery time for MR | 5 | t_{RMR} | 130 | 65 | | ns | | |
| | 10 | | 45 | 20 | | ns | | |
| | 15 | | 30 | 15 | | ns | | |
| Recovery time for PL | 5 | t_{RPL} | 150 | 75 | | ns | | |
| | 10 | | 50 | 25 | | ns | | |
| | 15 | | 30 | 15 | | ns | | |
| Set-up times $P_n \rightarrow PL$ | 5 | t_{su} | 100 | 50 | | ns | see also waveforms Figs 5 and 6 | |
| | 10 | | 50 | 25 | | ns | | |
| | 15 | | 40 | 20 | | ns | | |
| $UP/\overline{DN} \rightarrow CP$ | 5 | t_{su} | 250 | 125 | | ns | | |
| | 10 | | 100 | 50 | | ns | | |
| | 15 | | 75 | 35 | | ns | | |
| $\overline{CE} \rightarrow CP$ | 5 | t_{su} | 120 | 60 | | ns | | |
| | 10 | | 40 | 20 | | ns | | |
| | 15 | | 25 | 10 | | ns | | |
| Hold times $P_n \rightarrow PL$ | 5 | t_{hold} | 10 | -40 | | ns | | |
| | 10 | | 5 | -20 | | ns | | |
| | 15 | | 0 | -20 | | ns | | |
| $UP/\overline{DN} \rightarrow CP$ | 5 | t_{hold} | 35 | -90 | | ns | | |
| | 10 | | 15 | -35 | | ns | | |
| | 15 | | 15 | -25 | | ns | | |
| $\overline{CE} \rightarrow CP$ | 5 | t_{hold} | 20 | -40 | | ns | | |
| | 10 | | 5 | -15 | | ns | | |
| | 15 | | 5 | -10 | | ns | | |
| Maximum clock pulse frequency | 5 | f_{max} | 3 | 6 | | MHz | | |
| | 10 | | 7 | 14 | | MHz | | |
| | 15 | | 9 | 18 | | MHz | | |

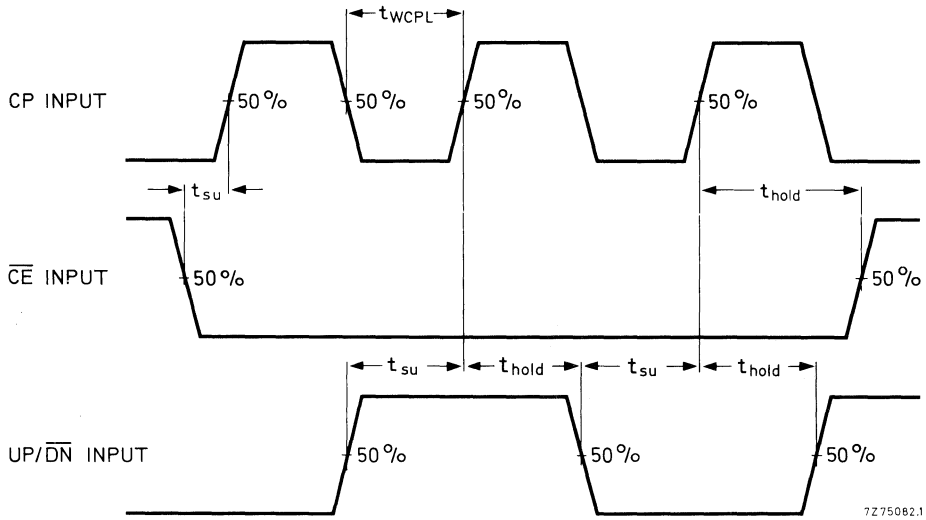

Fig. 5 Waveforms showing minimum pulse width for CP, set-up and hold times for \overline{CE} to CP and UP/ \overline{DN} to CP.

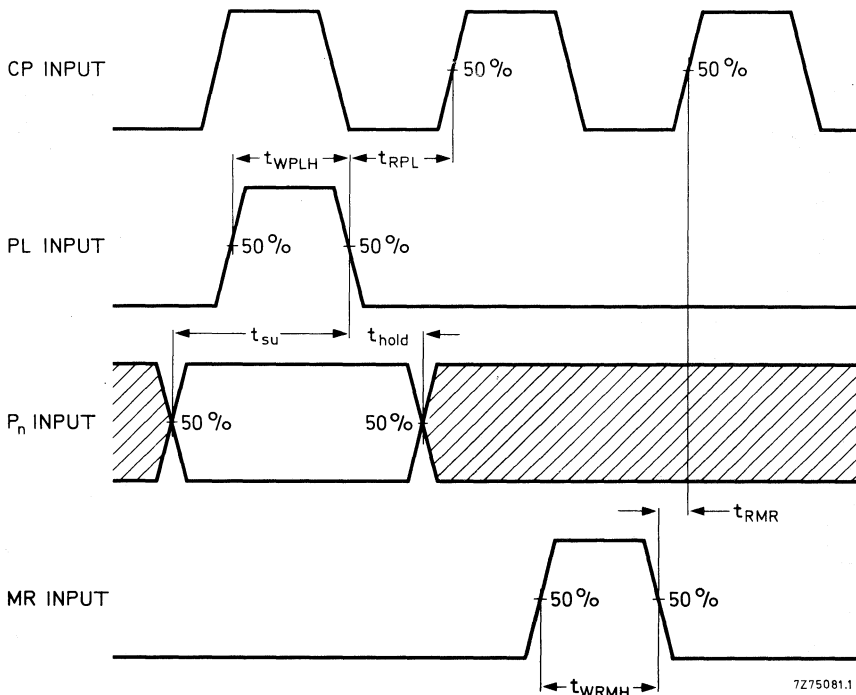
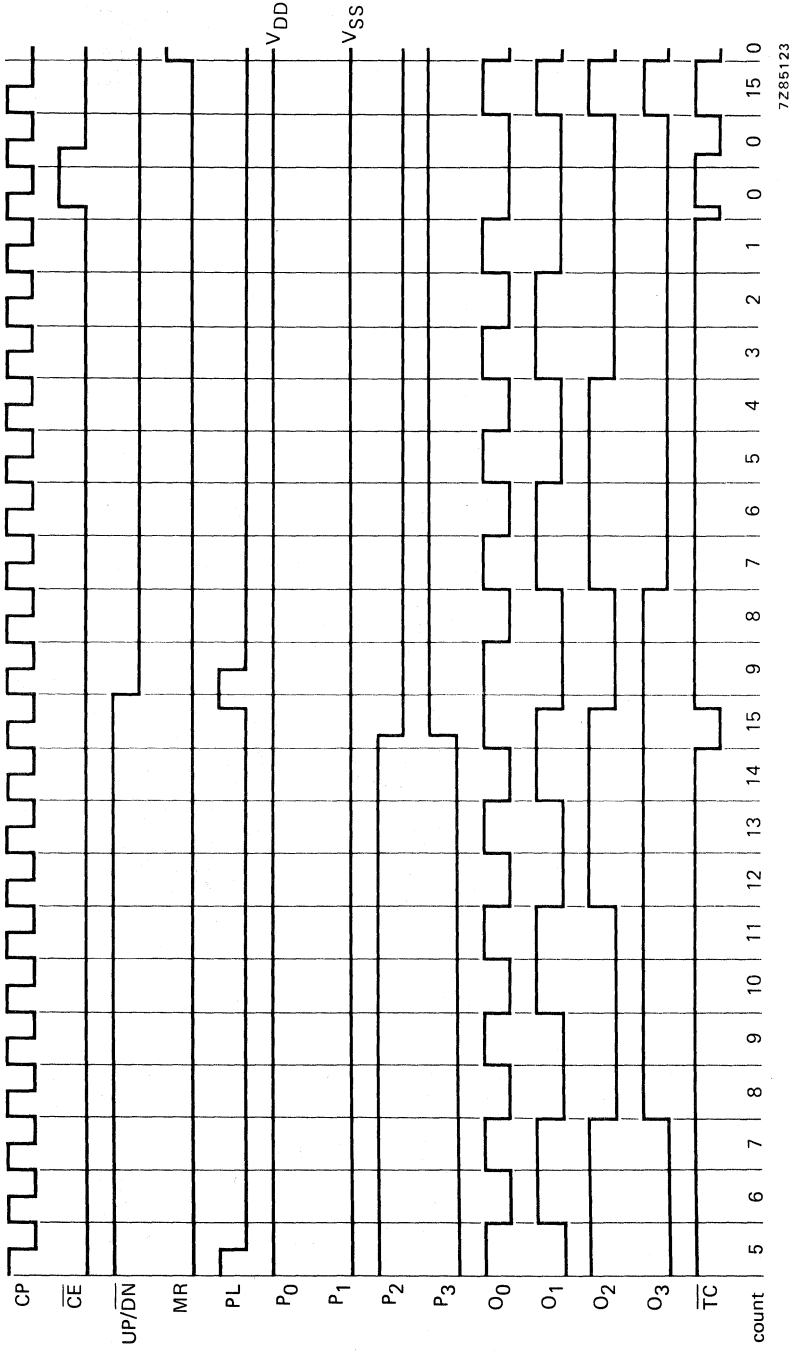

Fig. 6 Waveforms showing minimum pulse width for PL and MR, recovery time for PL and MR and set-up and hold times for P_n to PL.



7285123

Fig. 7 Timing diagram.

DUAL 64-BIT STATIC SHIFT REGISTER



The HEF4517B consists of two identical, independent 64-bit static shift registers. Each register has separate clock (CP), data input (D), parallel input-enable/output-enable (PE/\overline{EO}) and four 3-state outputs of the 16th, 32nd, 48th and 64th bit positions (O_{16} to O_{64}). Data at the D input is entered into the first bit on the LOW to HIGH transition of the clock, regardless of the state of PE/\overline{EO} .

When PE/\overline{EO} is LOW the outputs are enabled and the device is in the 64-bit serial mode.

When PE/\overline{EO} is HIGH the outputs are disabled (high impedance OFF-state), the 64-bit shift register is divided into four 16-bit shift registers with D, O_{16} , O_{32} and O_{48} as data inputs of the 1st, 17th, 33rd, and 49th bit respectively. Schmitt-trigger action in the clock input makes the circuit highly tolerant to slower clock rise and fall times.

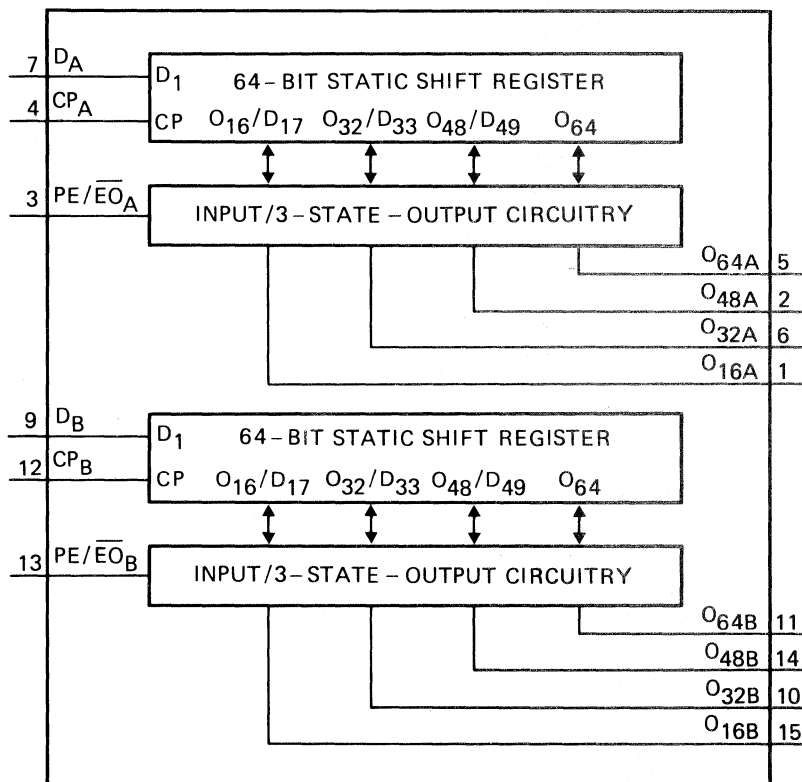

Fig. 1 Functional diagram.

7274569.1

FAMILY DATA

I_{DD} LIMITS category LSI

} see Family Specifications

HEF4517B
LSI

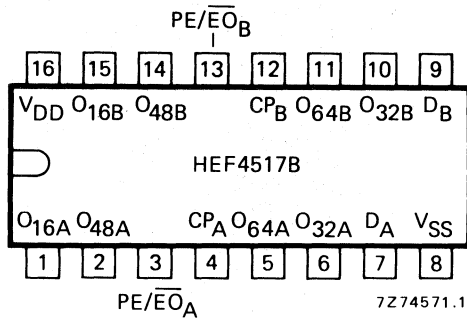

Fig. 2 Pinning diagram.

- HEF4517BP : 16-lead DIL; plastic (SOT-38Z).
- HEF4517BD: 16-lead DIL; ceramic (cerdip) (SOT-74).
- HEF4517BT : 16-lead mini-pack; plastic (SO-16L; SOT-162A).

PINNING

| | |
|--|--|
| CP_A, CP_B | clock inputs |
| $PE/\overline{EO}_A, PE/\overline{EO}_B$ | parallel input-enable/output-enable inputs |
| D_A, D_B | data inputs |
| $O_{16A}, O_{32A}, O_{48A}$ | 3-state outputs/inputs |
| $O_{16B}, O_{32B}, O_{48B}$ | 3-state outputs/inputs |
| O_{64A}, O_{64B} | 3-state outputs |

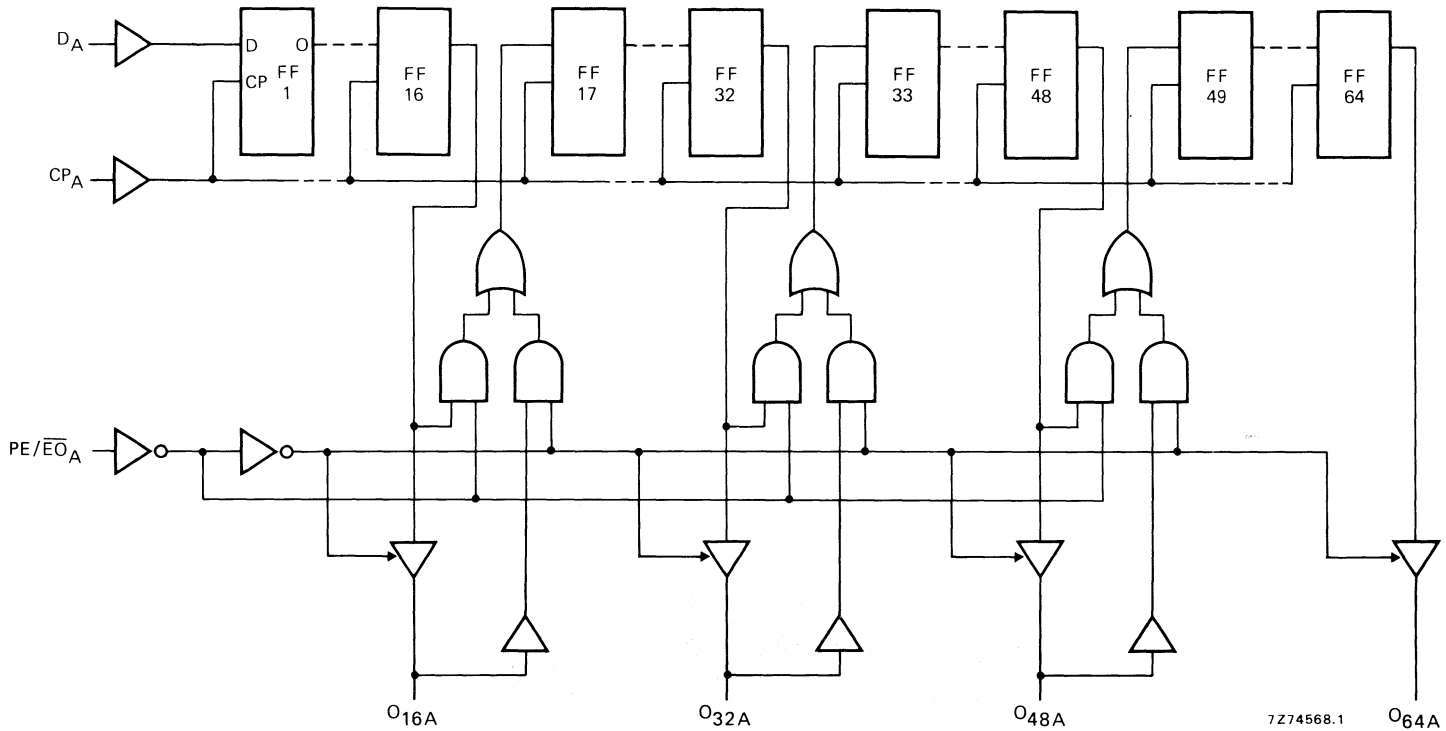

Fig. 3 Logic diagram (one shift register).

FUNCTION TABLE

| inputs | | | inputs/outputs | | | | mode |
|-------------|---------------------------|---------------------|---|---|---|-------------------------------|---|
| CP | D | PE/ $\overline{E0}$ | O ₁₆ | O ₃₂ | O ₄₈ | O ₆₄ | |
| \int | data entered into 1st bit | L | content of 16th bit displayed | content of 32nd bit displayed | content of 48th bit displayed | content of 64th bit displayed | One 64-bit shift register. The content of the shift register is shifted over one stage |
| \int | data entered into 1st bit | H | data at O ₁₆ entered into 17th bit | data at O ₃₂ entered into 33rd bit | data at O ₄₈ entered into 49th bit | remains in 'Z' state | Four 16-bit shift register. The content of the shift registers is shifted over one stage. |
| \setminus | X | L | no change | no change | no change | no change | no change |
| \setminus | X | H | Z | Z | Z | Z | no change |

H = HIGH state (the more positive voltage)

L = LOW state (the less positive voltage)

X = state is immaterial

Z = high impedance state

 \int = positive-going transition \setminus = negative-going transition

A.C. CHARACTERISTICS

$V_{SS} = 0 \text{ V}$; $T_{amb} = 25 \text{ }^\circ\text{C}$; input transition times $\leq 20 \text{ ns}$

| | V_{DD} V | typical formula for P (μW) | where f_i = input freq. (MHz) f_o = output freq. (MHz) C_L = load capacitance (pF) $\Sigma(f_o C_L)$ = sum of outputs V_{DD} = supply voltage (V) |
|---|---------------|---|--|
| Dynamic power dissipation per package (P) | 5 | $7\,000 f_i + \Sigma(f_o C_L) \times V_{DD}^2$ | |
| | 10 | $28\,000 f_i + \Sigma(f_o C_L) \times V_{DD}^2$ | |
| | 15 | $70\,000 f_i + \Sigma(f_o C_L) \times V_{DD}^2$ | |

A.C. CHARACTERISTICS

$V_{SS} = 0 \text{ V}$; $T_{amb} = 25 \text{ }^\circ\text{C}$; $C_L = 50 \text{ pF}$; input transition times $\leq 20 \text{ ns}$

| | V_{DD} V | symbol | min. | typ. | max. | typical extrapolation formula | |
|---|---------------|-----------|------|------|------|--|---|
| Propagation delays CP \rightarrow O_n HIGH to LOW | 5 | t_{PHL} | | 220 | 440 | ns | $193 \text{ ns} + (0,55 \text{ ns/pF}) C_L$ |
| | 10 | | 85 | 170 | ns | $74 \text{ ns} + (0,23 \text{ ns/pF}) C_L$ | |
| | 15 | | 60 | 120 | ns | $52 \text{ ns} + (0,16 \text{ ns/pF}) C_L$ | |
| LOW to HIGH | 5 | t_{PLH} | | 190 | 380 | ns | $163 \text{ ns} + (0,55 \text{ ns/pF}) C_L$ |
| | 10 | | 75 | 150 | ns | $64 \text{ ns} + (0,23 \text{ ns/pF}) C_L$ | |
| | 15 | | 50 | 100 | ns | $42 \text{ ns} + (0,16 \text{ ns/pF}) C_L$ | |
| Output transition times HIGH to LOW | 5 | t_{THL} | | 60 | 120 | ns | $10 \text{ ns} + (1,0 \text{ ns/pF}) C_L$ |
| | 10 | | 30 | 60 | ns | $9 \text{ ns} + (0,42 \text{ ns/pF}) C_L$ | |
| | 15 | | 20 | 40 | ns | $6 \text{ ns} + (0,28 \text{ ns/pF}) C_L$ | |
| LOW to HIGH | 5 | t_{TLH} | | 60 | 120 | ns | $10 \text{ ns} + (1,0 \text{ ns/pF}) C_L$ |
| | 10 | | 30 | 60 | ns | $9 \text{ ns} + (0,42 \text{ ns/pF}) C_L$ | |
| | 15 | | 20 | 40 | ns | $6 \text{ ns} + (0,28 \text{ ns/pF}) C_L$ | |

A.C. CHARACTERISTICS

$V_{SS} = 0\text{ V}$; $T_{amb} = 25\text{ }^{\circ}\text{C}$; $C_L = 50\text{ pF}$; input transition times $\leq 20\text{ ns}$

| | V_{DD} V | symbol | min. | typ. | max. | |
|---|---------------|------------------|------|------|------|-----|
| Minimum clock pulse width; LOW | 5 | $t_{WCP\bar{L}}$ | | 95 | 190 | ns |
| | 10 | | | 40 | 80 | ns |
| | 15 | | | 30 | 60 | ns |
| Set-up times $O_n, D \rightarrow CP$ | 5 | t_{su} | 30 | 10 | | ns |
| | 10 | | 25 | 5 | | ns |
| | 15 | | 20 | 5 | | ns |
| Hold time $O_n, D \rightarrow CP$ | 5 | t_{hold} | 45 | 15 | | ns |
| | 10 | | 30 | 10 | | ns |
| | 15 | | 25 | 10 | | ns |
| 3-state propagation delays | | | | | | |
| Output disable times $PE/\bar{E}O \rightarrow O_n$ HIGH | 5 | t_{PHZ} | | 40 | 80 | ns |
| | 10 | | | 30 | 60 | ns |
| | 15 | | | 25 | 50 | ns |
| LOW | 5 | t_{PLZ} | | 50 | 100 | ns |
| | 10 | | | 30 | 60 | ns |
| | 15 | | | 25 | 50 | ns |
| Output enable times $PE/\bar{E}O \rightarrow O_n$ HIGH | 5 | t_{PZH} | | 45 | 90 | ns |
| | 10 | | | 25 | 50 | ns |
| | 15 | | | 20 | 40 | ns |
| LOW | 5 | t_{PZL} | | 60 | 120 | ns |
| | 10 | | | 30 | 60 | ns |
| | 15 | | | 25 | 50 | ns |
| Maximum clock pulse frequency | 5 | f_{max} | 2 | 5 | | MHz |
| | 10 | | 6 | 12 | | MHz |
| | 15 | | 8 | 16 | | MHz |

see also waveforms
Fig. 4.

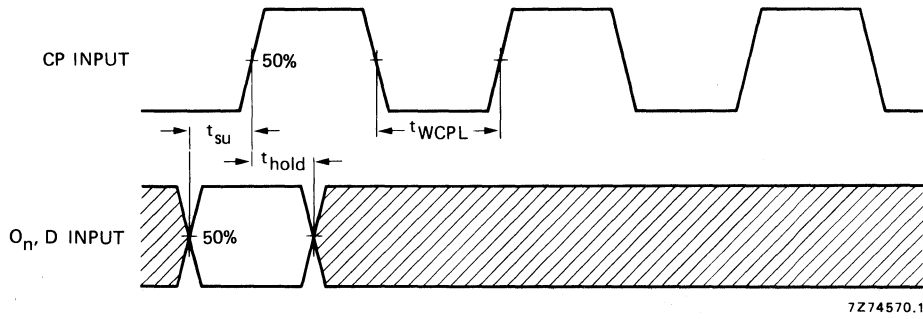

Fig. 4 Waveforms showing minimum clock pulse width, set-up and hold times for O_n (as data input) and D to CP.

DUAL BCD COUNTER



The HEF4518B is a dual 4-bit internally synchronous BCD counter. The counter has an active HIGH clock input (CP_0) and an active LOW clock input (\overline{CP}_1), buffered outputs from all four bit positions (O_0 to O_3) and an active HIGH overriding asynchronous master reset input (MR). The counter advances on either the LOW to HIGH transition of the CP_0 input if \overline{CP}_1 is HIGH or the HIGH to LOW transition of the \overline{CP}_1 input if CP_0 is LOW. Either CP_0 or \overline{CP}_1 may be used as the clock input to the counter and the other clock input may be used as a clock enable input. A HIGH on MR resets the counter (O_0 to $O_3 = \text{LOW}$) independent of CP_0 , \overline{CP}_1 . Schmitt-trigger action in the clock input makes the circuit highly tolerant to slower clock rise and fall times.

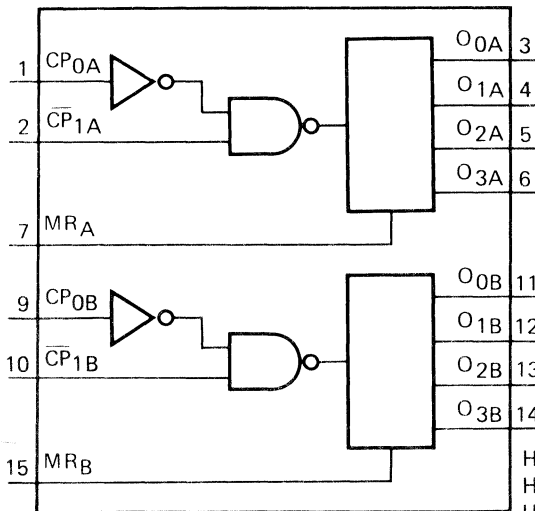

Fig. 1 Functional diagram.

7Z69556.1

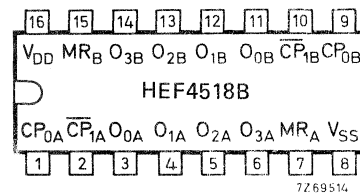

Fig. 2 Pinning diagram.

HEF4518BP : 16-lead DIL; plastic (SOT-38Z).

HEF4518BD : 16-lead DIL; ceramic (cerdip) (SOT-74).

HEF4518BT : 16-lead mini-pack; plastic (SO-16; SOT-109A).

PINNING

 CP_{0A} , CP_{0B} clock inputs (L to H triggered) \overline{CP}_{1A} , \overline{CP}_{1B} clock inputs (H to L triggered) MR_A , MR_B master reset inputs O_{0A} to O_{3A} outputs O_{0B} to O_{3B} outputs

APPLICATION INFORMATION

Some examples of applications for the HEF4518B are:

- Multistage synchronous counting.
- Multistage asynchronous counting.
- Frequency dividers.

FAMILY DATA

I_{DD} LIMITS category MSI

} see Family Specifications

A.C. CHARACTERISTICS

 $V_{SS} = 0 \text{ V}$; $T_{amb} = 25 \text{ }^\circ\text{C}$; $C_L = 50 \text{ pF}$; input transition times $\leq 20 \text{ ns}$

| | V_{DD} V | symbol | min. | typ. | max. | typical extrapolation formula | |
|---|---------------|------------|------|------|--------|--|----|
| Propagation delays $CP_0, CP_1 \rightarrow O_n$ HIGH to LOW | 5 | t_{PHL} | | 120 | 240 ns | $93 \text{ ns} + (0,55 \text{ ns/pF}) C_L$ | |
| | 10 | | | 55 | 110 ns | $44 \text{ ns} + (0,23 \text{ ns/pF}) C_L$ | |
| | 15 | | | 40 | 80 ns | $32 \text{ ns} + (0,16 \text{ ns/pF}) C_L$ | |
| LOW to HIGH | 5 | t_{PLH} | | 120 | 240 ns | $93 \text{ ns} + (0,55 \text{ ns/pF}) C_L$ | |
| | 10 | | | 55 | 110 ns | $44 \text{ ns} + (0,23 \text{ ns/pF}) C_L$ | |
| | 15 | | | 40 | 80 ns | $32 \text{ ns} + (0,16 \text{ ns/pF}) C_L$ | |
| MR $\rightarrow O_n$ HIGH to LOW | 5 | t_{PHL} | | 75 | 150 ns | $48 \text{ ns} + (0,55 \text{ ns/pF}) C_L$ | |
| | 10 | | | 35 | 70 ns | $24 \text{ ns} + (0,23 \text{ ns/pF}) C_L$ | |
| | 15 | | | 25 | 50 ns | $17 \text{ ns} + (0,16 \text{ ns/pF}) C_L$ | |
| Output transition times HIGH to LOW | 5 | t_{THL} | | 60 | 120 ns | $10 \text{ ns} + (1,0 \text{ ns/pF}) C_L$ | |
| | 10 | | | 30 | 60 ns | $9 \text{ ns} + (0,42 \text{ ns/pF}) C_L$ | |
| | 15 | | | 20 | 40 ns | $6 \text{ ns} + (0,28 \text{ ns/pF}) C_L$ | |
| LOW to HIGH | 5 | t_{TLH} | | 60 | 120 ns | $10 \text{ ns} + (1,0 \text{ ns/pF}) C_L$ | |
| | 10 | | | 30 | 60 ns | $9 \text{ ns} + (0,42 \text{ ns/pF}) C_L$ | |
| | 15 | | | 20 | 40 ns | $6 \text{ ns} + (0,28 \text{ ns/pF}) C_L$ | |
| Minimum CP_0 pulse width; LOW | 5 | t_{WCPL} | 60 | 30 | ns | | |
| | 10 | | | 30 | 15 | ns | |
| | 15 | | | 20 | 10 | ns | |
| Minimum \overline{CP}_1 pulse width; HIGH | 5 | t_{WCPH} | 60 | 30 | ns | | |
| | 10 | | | 30 | 15 | ns | |
| | 15 | | | 20 | 10 | ns | |
| Minimum MR pulse width; HIGH | 5 | t_{WMRH} | 30 | 15 | ns | | |
| | 10 | | | 20 | 10 | ns | |
| | 15 | | | 16 | 8 | ns | |
| Recovery time for MR | 5 | t_{RMR} | 50 | 25 | ns | see also waveforms Figs 4 and 5 | |
| | 10 | | | 30 | 15 | | ns |
| | 15 | | | 20 | 10 | | ns |
| Set-up times $CP_0 \rightarrow \overline{CP}_1$ | 5 | t_{su} | 50 | 25 | ns | | |
| | 10 | | | 30 | 15 | ns | |
| | 15 | | | 20 | 10 | ns | |
| $\overline{CP}_1 \rightarrow CP_0$ | 5 | t_{su} | 50 | 25 | ns | | |
| | 10 | | | 30 | 15 | ns | |
| | 15 | | | 20 | 10 | ns | |
| Maximum clock pulse frequency | 5 | f_{max} | 8 | 16 | MHz | | |
| | 10 | | | 15 | 30 | MHz | |
| | 15 | | | 20 | 40 | MHz | |

A.C. CHARACTERISTICS

$V_{SS} = 0\text{ V}$; $T_{amb} = 25\text{ }^{\circ}\text{C}$; input transition times $\leq 20\text{ ns}$

| | V_{DD} V | typical formula for P (μW) | where f_i = input freq. (MHz) f_o = output freq. (MHz) C_L = load capacitance (pF) $\Sigma(f_o C_L)$ = sum of outputs V_{DD} = supply voltage (V) |
|---|---------------|--|--|
| Dynamic power dissipation per package (P) | 5 | $750 f_i + \Sigma(f_o C_L) \times V_{DD}^2$ | |
| | 10 | $3300 f_i + \Sigma(f_o C_L) \times V_{DD}^2$ | |
| | 15 | $8000 f_i + \Sigma(f_o C_L) \times V_{DD}^2$ | |

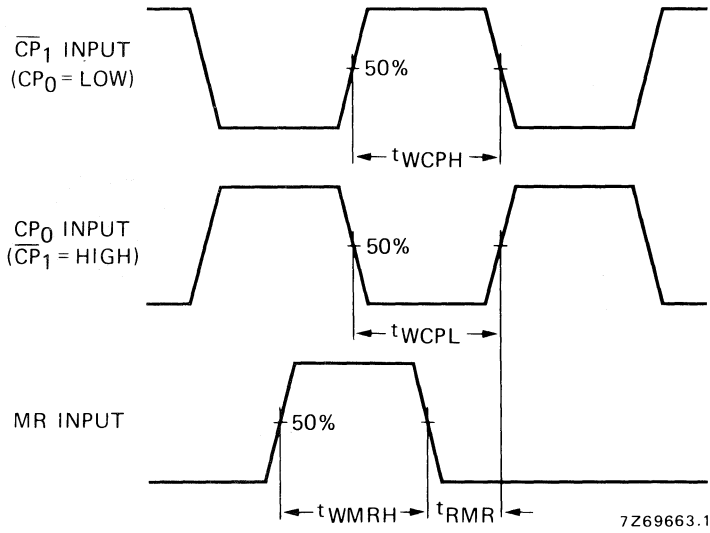

Fig. 4 Waveforms showing recovery time for MR; minimum CP_0 , \overline{CP}_1 and MR pulse widths.

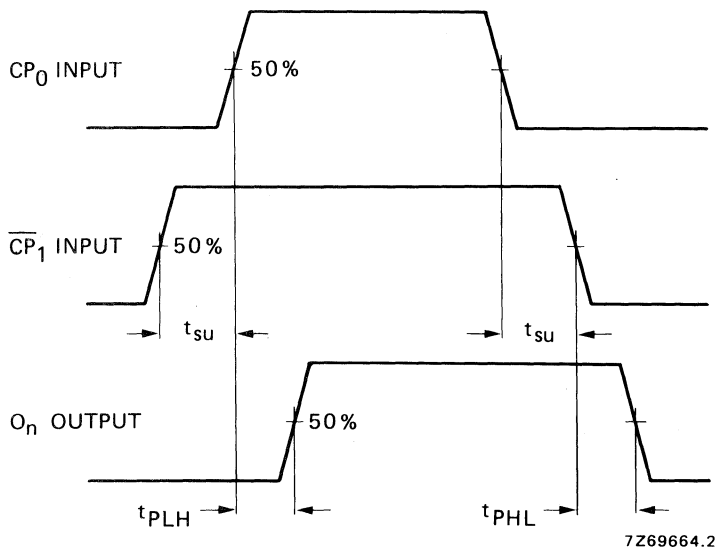

Fig. 5 Waveforms showing set-up times for CP_0 to \overline{CP}_1 and \overline{CP}_1 to CP_0 , and propagation delays.

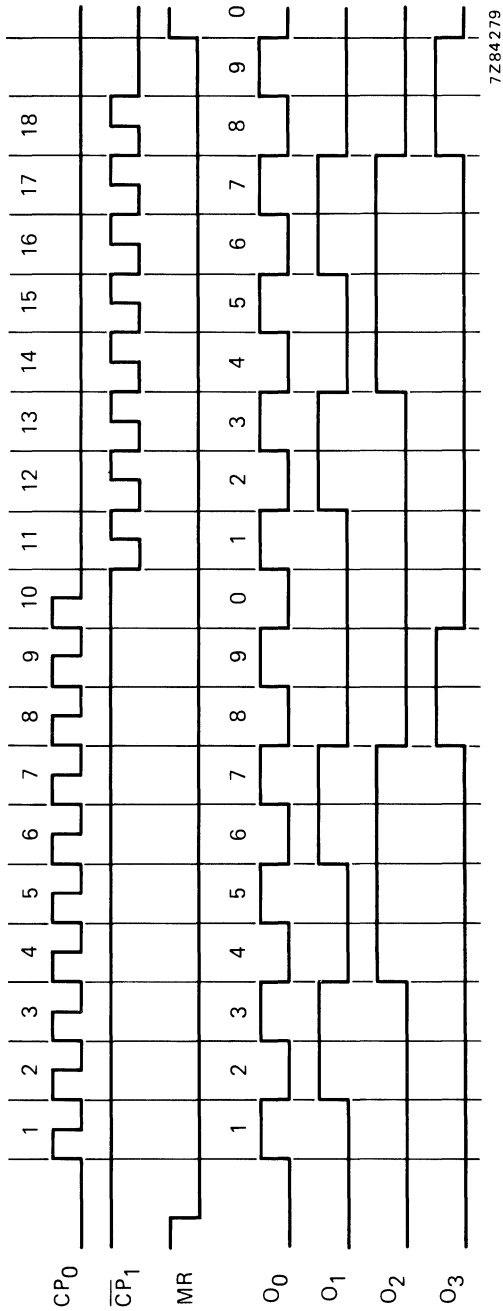

Fig. 6 Timing diagram.

QUADRUPLE 2-INPUT MULTIPLEXER



The HEF4519B provides four multiplexing circuits with common select inputs (S_A , S_B); each circuit contains two inputs (A_n , B_n) and one output (O_n). It may be used to select four bits of information from one of two sources.

The 'A' inputs are selected when S_A is HIGH, the 'B' inputs when S_B is HIGH. When S_A and S_B are HIGH, the output (O_n) is the logical EXCLUSIVE-NOR of the A_n and B_n inputs ($O_n = A_n \odot B_n$).

When S_A and S_B are LOW, the output (O_n) is LOW, independent of the multiplexer inputs (A_n and B_n).

The HEF4519B cannot be used to multiplex analogue signals. The outputs utilize standard buffers for best performance.

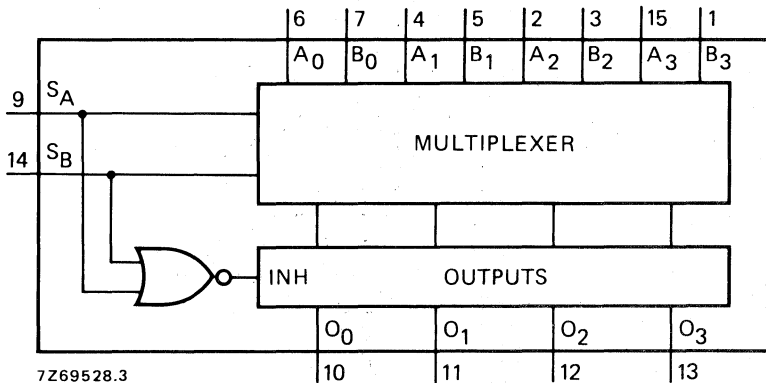

Fig. 1 Functional diagram.

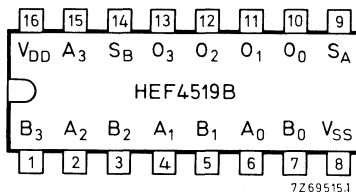

Fig. 2 Pinning diagram.

HEF4519BP : 16-lead DIL; plastic (SOT-38Z).
 HEF4519BD : 16-lead DIL; ceramic (cerdip) (SOT-74).
 HEF4519BT : 16-lead mini-pack; plastic
 (SO-16; SOT-109A).

PINNING

S_A , S_B selects inputs (active HIGH)
 A_0 to A_3 multiplexer inputs
 B_0 to B_3 multiplexer inputs
 O_0 to O_3 multiplexer outputs

FAMILY DATA

I_{DD} LIMITS category MSI

} see Family Specifications

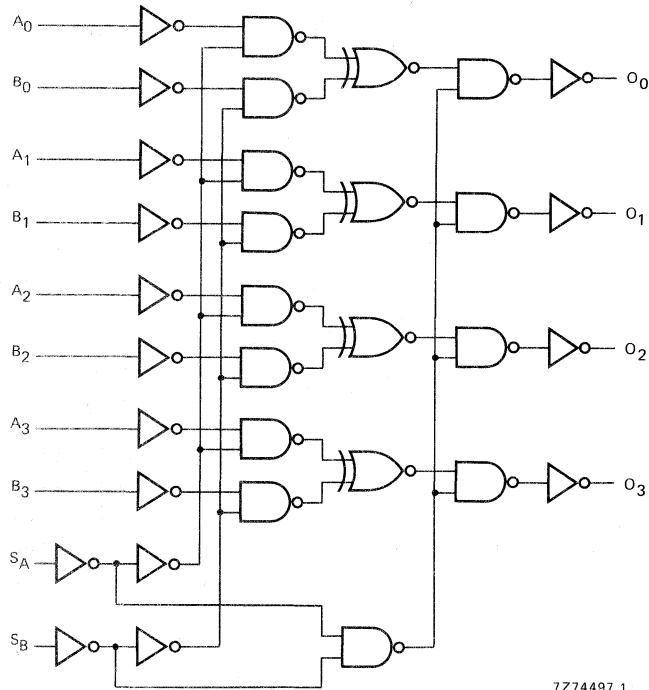

7274497.1

Fig. 3 Logic diagram.

FUNCTION TABLE

| inputs | | | | output |
|----------------|----------------|----------------|----------------|----------------|
| S _A | S _B | A _n | B _n | O _n |
| L | L | X | X | L |
| H | L | A _n | X | A _n |
| L | H | X | B _n | B _n |
| H | H | L | L | H |
| H | H | H | L | L |
| H | H | L | H | L |
| H | H | H | H | H |

H = HIGH state (the more positive voltage)
L = LOW state (the less positive voltage)
X = state is immaterial

A.C. CHARACTERISTICS

$V_{SS} = 0\text{ V}$; $T_{amb} = 25\text{ }^\circ\text{C}$; $C_L = 50\text{ pF}$; input transition times $\leq 20\text{ ns}$

| | V_{DD} V | symbol | typ. | max. | | typical extrapolation formula | |
|---|---------------|------------------|------|------|----|---|---|
| Propagation delays $A_n, B_n \rightarrow O_n$ HIGH to LOW | 5 | t _{PHL} | 95 | 190 | ns | $68\text{ ns} + (0,55\text{ ns/pF})C_L$ | |
| | 10 | | 40 | 80 | ns | | $29\text{ ns} + (0,23\text{ ns/pF})C_L$ |
| | 15 | | 30 | 60 | ns | | $22\text{ ns} + (0,16\text{ ns/pF})C_L$ |
| LOW to HIGH | 5 | t _{PLH} | 80 | 160 | ns | $53\text{ ns} + (0,55\text{ ns/pF})C_L$ | |
| | 10 | | 40 | 80 | ns | | $29\text{ ns} + (0,23\text{ ns/pF})C_L$ |
| | 15 | | 30 | 60 | ns | | $22\text{ ns} + (0,16\text{ ns/pF})C_L$ |
| $S_A, S_B \rightarrow O_n$ HIGH to LOW | 5 | t _{PHL} | 95 | 190 | ns | $68\text{ ns} + (0,55\text{ ns/pF})C_L$ | |
| | 10 | | 40 | 80 | ns | | $29\text{ ns} + (0,23\text{ ns/pF})C_L$ |
| | 15 | | 30 | 55 | ns | | $22\text{ ns} + (0,16\text{ ns/pF})C_L$ |
| LOW to HIGH | 5 | t _{PLH} | 85 | 165 | ns | $58\text{ ns} + (0,55\text{ ns/pF})C_L$ | |
| | 10 | | 40 | 80 | ns | | $29\text{ ns} + (0,23\text{ ns/pF})C_L$ |
| | 15 | | 30 | 60 | ns | | $22\text{ ns} + (0,16\text{ ns/pF})C_L$ |
| Output transition times HIGH to LOW | 5 | t _{THL} | 60 | 120 | ns | $10\text{ ns} + (1,0\text{ ns/pF}) C_L$ | |
| | 10 | | 30 | 60 | ns | | $9\text{ ns} + (0,42\text{ ns/pF}) C_L$ |
| | 15 | | 20 | 40 | ns | | $6\text{ ns} + (0,28\text{ ns/pF}) C_L$ |
| LOW to HIGH | 5 | t _{TLH} | 60 | 120 | ns | $10\text{ ns} + (1,0\text{ ns/pF}) C_L$ | |
| | 10 | | 30 | 60 | ns | | $9\text{ ns} + (0,42\text{ ns/pF}) C_L$ |
| | 15 | | 20 | 40 | ns | | $6\text{ ns} + (0,28\text{ ns/pF}) C_L$ |

| | V_{DD} V | typical formula for P (μW) | where f_i = input freq. (MHz) f_o = output freq. (MHz) C_L = load capacitance (pF) $\Sigma(f_o C_L)$ = sum of outputs V_{DD} = supply voltage (V) |
|---|---------------|---|--|
| Dynamic power dissipation per package (P) | 5 | $1000 f_i + \Sigma(f_o C_L) \times V_{DD}^2$ | |
| | 10 | $6000 f_i + \Sigma(f_o C_L) \times V_{DD}^2$ | |
| | 15 | $17\ 000 f_i + \Sigma(f_o C_L) \times V_{DD}^2$ | |

APPLICATION INFORMATION

Some examples of applications for the HEF4519B are:

- 2-input multiplexers.
- True/complement selectors.

DUAL BINARY COUNTER



The HEF4520B is a dual 4-bit internally synchronous binary counter. The counter has an active HIGH clock input (CP_0) and an active LOW clock input (\overline{CP}_1), buffered outputs from all four bit positions (O_0 to O_3) and an active HIGH overriding asynchronous master reset input (MR). The counter advances on either the LOW to HIGH transition of the CP_0 input if \overline{CP}_1 is HIGH or the HIGH to LOW transition of the \overline{CP}_1 input if CP_0 is LOW. Either CP_0 or \overline{CP}_1 may be used as the clock input to the counter and the other clock input may be used as a clock enable input. A HIGH on MR resets the counter (O_0 to $O_3 = \text{LOW}$) independent of CP_0 , \overline{CP}_1 .

Schmitt-trigger action in the clock input makes the circuit highly tolerant to slower clock rise and fall times.

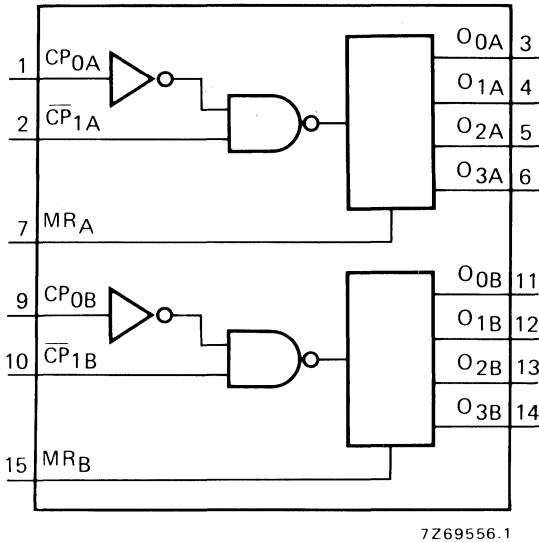

Fig. 1 Functional diagram.

PINNING

CP_{0A} , CP_{0B} clock inputs (L to H triggered)
 \overline{CP}_{1A} , \overline{CP}_{1B} clock inputs (H to L triggered)
 MR_A , MR_B master reset inputs
 O_{0A} to O_{3A} outputs
 O_{0B} to O_{3B} outputs

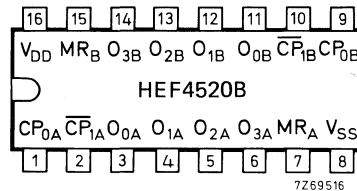

Fig. 2 Pinning diagram.

HEF4520BP : 16-lead DIL; plastic (SOT-38Z).

HEF4520BD : 16-lead DIL; ceramic (cerdip) SOT-74).

HEF4520BT : 16-lead mini-pack; plastic
(SO-16; SOT-109A).

FAMILY DATA

I_{DD} LIMITS category MSI

} see Family Specifications

A.C. CHARACTERISTICS

 $V_{SS} = 0 \text{ V}$; $T_{amb} = 25 \text{ }^\circ\text{C}$; $C_L = 50 \text{ pF}$; input transition times $\leq 20 \text{ ns}$

| | V_{DD} V | symbol | min. | typ. | max. | typical extrapolation formula | |
|--|---------------|------------------|------|------|------|--|--|
| Propagation delays $CP_0, \overline{CP}_1 \rightarrow O_n$ HIGH to LOW | 5 | tPHL | | 110 | 220 | ns | $83 \text{ ns} + (0,55 \text{ ns/pF}) C_L$ |
| | 10 | | 50 | 100 | ns | $39 \text{ ns} + (0,23 \text{ ns/pF}) C_L$ | |
| | 15 | | 40 | 80 | ns | $32 \text{ ns} + (0,16 \text{ ns/pF}) C_L$ | |
| LOW to HIGH | 5 | tPLH | | 110 | 220 | ns | $83 \text{ ns} + (0,55 \text{ ns/pF}) C_L$ |
| | 10 | | 50 | 100 | ns | $39 \text{ ns} + (0,23 \text{ ns/pF}) C_L$ | |
| | 15 | | 40 | 80 | ns | $32 \text{ ns} + (0,16 \text{ ns/pF}) C_L$ | |
| MR $\rightarrow O_n$ HIGH to LOW | 5 | tPHL | | 75 | 150 | ns | $48 \text{ ns} + (0,55 \text{ ns/pF}) C_L$ |
| | 10 | | 35 | 70 | ns | $24 \text{ ns} + (0,23 \text{ ns/pF}) C_L$ | |
| | 15 | | 25 | 50 | ns | $17 \text{ ns} + (0,16 \text{ ns/pF}) C_L$ | |
| Output transition times HIGH to LOW | 5 | tTHL | | 60 | 120 | ns | $10 \text{ ns} + (1,0 \text{ ns/pF}) C_L$ |
| | 10 | | 30 | 60 | ns | $9 \text{ ns} + (0,42 \text{ ns/pF}) C_L$ | |
| | 15 | | 20 | 40 | ns | $6 \text{ ns} + (0,28 \text{ ns/pF}) C_L$ | |
| LOW to HIGH | 5 | tTLH | | 60 | 120 | ns | $10 \text{ ns} + (1,0 \text{ ns/pF}) C_L$ |
| | 10 | | 30 | 60 | ns | $9 \text{ ns} + (0,42 \text{ ns/pF}) C_L$ | |
| | 15 | | 20 | 40 | ns | $6 \text{ ns} + (0,28 \text{ ns/pF}) C_L$ | |
| Minimum CP_0 pulse width; LOW | 5 | tWCPL | 60 | 30 | | ns | |
| | 10 | | 30 | 15 | | ns | |
| | 15 | | 20 | 10 | | ns | |
| Minimum \overline{CP}_1 pulse width; HIGH | 5 | tWCPH | 60 | 30 | | ns | |
| | 10 | | 30 | 15 | | ns | |
| | 15 | | 20 | 10 | | ns | |
| Minimum MR pulse width; HIGH | 5 | tWMRH | 30 | 15 | | ns | |
| | 10 | | 20 | 10 | | ns | |
| | 15 | | 16 | 8 | | ns | |
| Recovery time for MR | 5 | tRMR | 50 | 25 | | ns | see also waveforms Figs 4 and 5 |
| | 10 | | 30 | 15 | | ns | |
| | 15 | | 20 | 10 | | ns | |
| Set-up times $CP_0 \rightarrow \overline{CP}_1$ | 5 | t _{su} | 50 | 25 | | ns | |
| | 10 | | 30 | 15 | | ns | |
| | 15 | | 20 | 10 | | ns | |
| $\overline{CP}_1 \rightarrow CP_0$ | 5 | t _{su} | 50 | 25 | | ns | |
| | 10 | | 30 | 15 | | ns | |
| | 15 | | 20 | 10 | | ns | |
| Maximum clock pulse frequency | 5 | f _{max} | 8 | 16 | | MHz | |
| | 10 | | 15 | 30 | | MHz | |
| | 15 | | 20 | 40 | | MHz | |

A.C. CHARACTERISTICS

$V_{SS} = 0\text{ V}$; $T_{amb} = 25\text{ }^\circ\text{C}$; input transition times $\leq 20\text{ ns}$

| | V_{DD} V | typical formula for P (μW) | where f_i = input freq. (MHz) f_o = output freq. (MHz) C_L = load capacitance (pF) $\Sigma(f_o C_L)$ = sum of outputs V_{DD} = supply voltage (V) |
|---|---------------|--|--|
| Dynamic power dissipation per package (P) | 5 | $850f_i + \Sigma(f_o C_L) \times V_{DD}^2$ | |
| | 10 | $3800f_i + \Sigma(f_o C_L) \times V_{DD}^2$ | |
| | 15 | $10200f_i + \Sigma(f_o C_L) \times V_{DD}^2$ | |

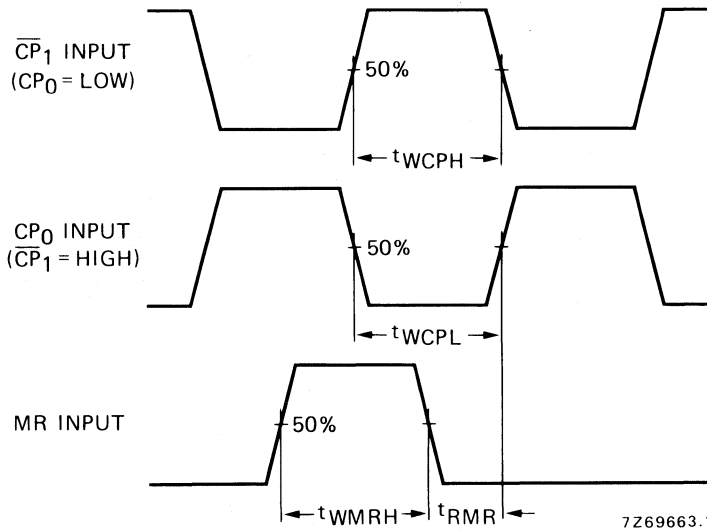

7269663.1

Fig. 4 Waveforms showing recovery time for MR; minimum CP_0 , \overline{CP}_1 and MR pulse widths.

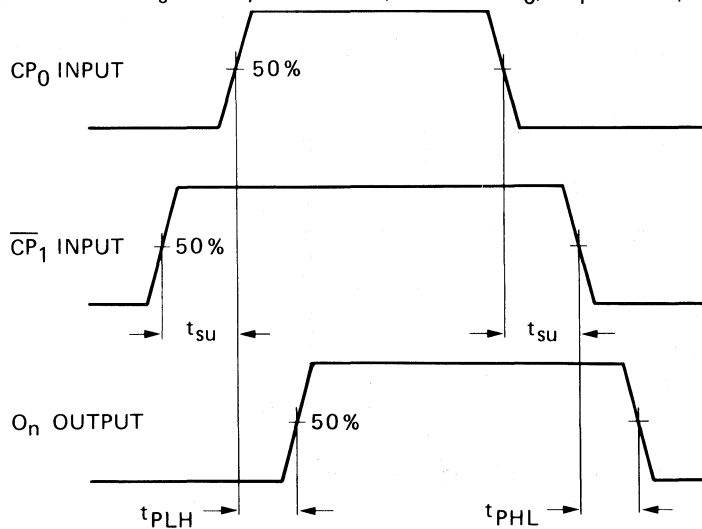

7269664.2

Fig. 5 Waveforms showing set-up times for CP_0 to \overline{CP}_1 and \overline{CP}_1 to CP_0 , and propagation delays.

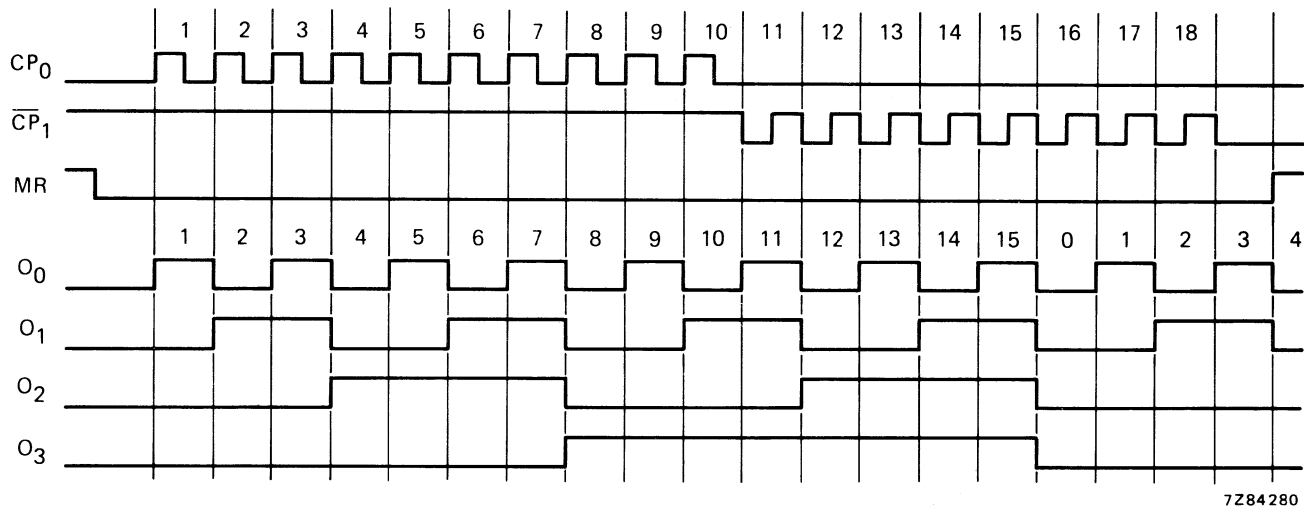

Fig. 6 Timing diagram.

24-STAGE FREQUENCY DIVIDER



The HEF4521B consists of a chain of 24 toggle flip-flops with an overriding asynchronous master reset input (MR), and an input circuit that allows three modes of operation. The single inverting stage (I_2/O_2) will function as a crystal oscillator, or in combination with I_1 as an RC oscillator, or as an input buffer for an external oscillator. Low-power operation as a crystal oscillator is enabled by connecting external resistors to pins 3 (V_{SS}') and 5 (V_{DD}'). Each flip-flop divides the frequency of the previous flip-flop by two, consequently the HEF4521B will count up to $2^{24} = 16\,777\,216$. The counting advances on the HIGH to LOW transition of the clock (I_2). The outputs of the last seven stages are available for additional flexibility.

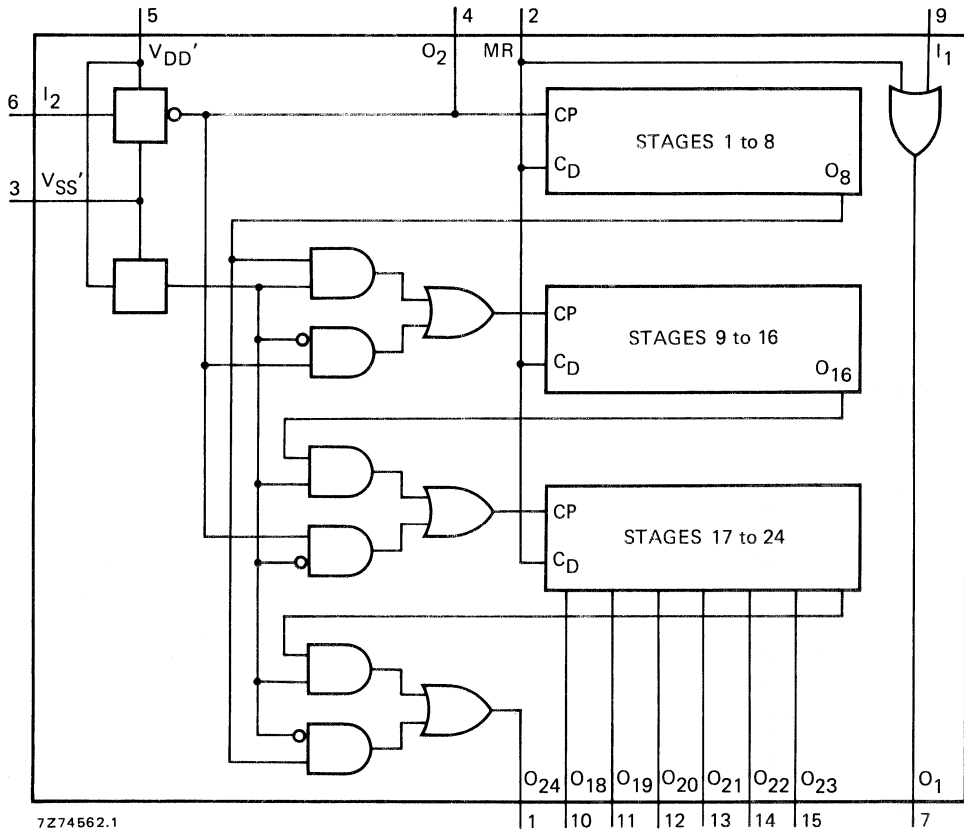

Fig. 1 Functional diagram.

FAMILY DATA
 I_{DD} LIMITS category MSI } see Family Specifications

HEF4521B

MSI

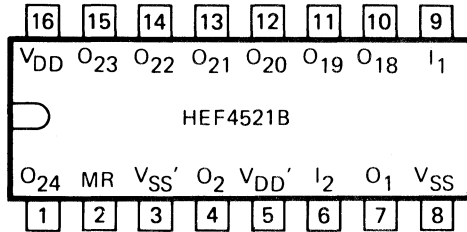

Fig. 2 Pinning diagram.

7Z74563

HEF4521BP : 16-lead DIL; plastic (SOT-38Z).
 HEF4521BD : 16-lead DIL; ceramic (cerdip) (SOT-74).
 HEF4521BT : 16-lead mini-pack; plastic (SO-16; SOT-109A).

COUNT CAPACITY

| output | count capacity |
|-----------------|------------------------------|
| O ₁₈ | 2 ¹⁸ = 262 144 |
| O ₁₉ | 2 ¹⁹ = 524 288 |
| O ₂₀ | 2 ²⁰ = 1 048 576 |
| O ₂₁ | 2 ²¹ = 2 097 152 |
| O ₂₂ | 2 ²² = 4 194 304 |
| O ₂₃ | 2 ²³ = 8 388 608 |
| O ₂₄ | 2 ²⁴ = 16 777 216 |

FUNCTIONAL TEST SEQUENCE

| inputs | | control terminals | | | outputs | remarks |
|--------|----------------|-------------------|-------------------|-------------------|------------------------------------|---|
| MR | I ₂ | O ₂ | V _{SS} ' | V _{DD} ' | O ₁₈ to O ₂₄ | |
| H | L | L | V _{DD} | V _{SS} | L | counter is in three 8-stage sections in parallel mode; I ₂ and O ₂ are interconnected (O ₂ is now input); counter is reset by MR |
| L | ⌈ | ⌈ | V _{DD} | V _{SS} | H | 255 pulses are clocked into I ₂ , O ₂ (the counter advances on the LOW to HIGH transition) |
| L | L | L | V _{SS} | V _{SS} | H | V _{SS} ' is connected to V _{SS} |
| L | H | L | V _{SS} | V _{SS} | H | the input I ₂ is made HIGH |
| L | H | L | V _{SS} | V _{DD} | H | V _{DD} ' is connected to V _{DD} ; O ₂ is now made floating and becomes an output; the device is now in the 2 ²⁴ mode |
| L | ⌋ | | V _{SS} | V _{DD} | L | counter ripples from an all HIGH state to an all LOW state |

A test function has been included for the reduction of the test time required to exercise all 24 counter stages. This test function divides the counter into three 8-stage sections by connecting V_{SS}' to V_{DD} and V_{DD}' to V_{SS}. Via I₂ (connected to O₂) 255 counts are loaded into each of the 8-stage sections in parallel. All flip-flops are now at a HIGH state. The counter is now returned to the normal 24-stage in series configuration by connecting V_{SS}' to V_{SS} and V_{DD}' to V_{DD}. One more pulse is entered into input I₂, which will cause the counter to ripple from an all HIGH state to an all LOW state.

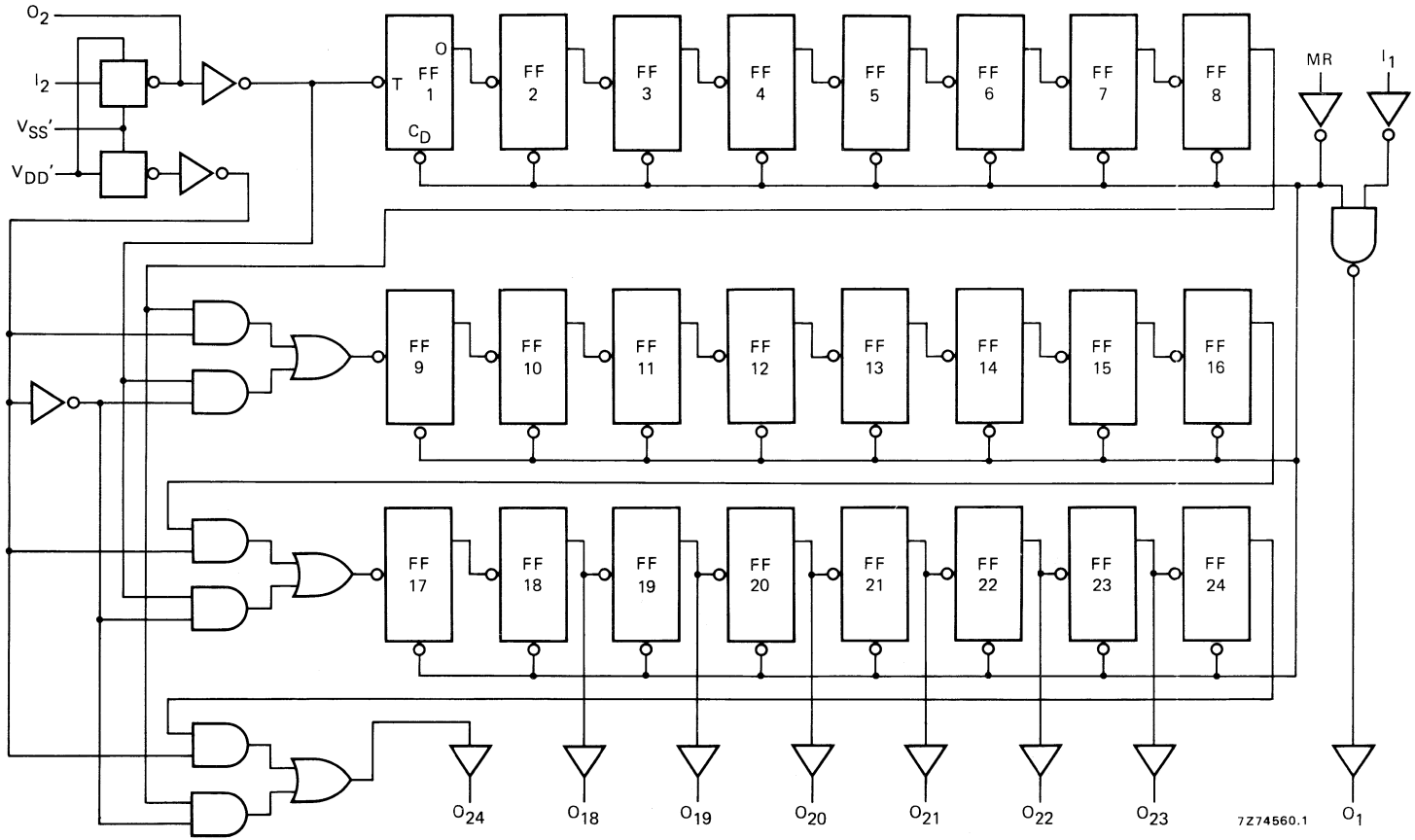

Fig. 3 Logic diagram; for schematic diagram of clock circuit see Fig. 4.

7274560.1

HEF4521B
MSI

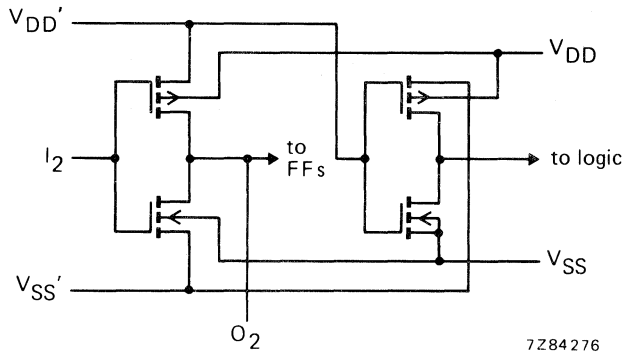

Fig. 4 Schematic diagram of clock input circuitry.

A.C. CHARACTERISTICS

$V_{SS} = 0\text{ V}$; $T_{amb} = 25\text{ }^\circ\text{C}$; $C_L = 50\text{ pF}$; input transition times $\leq 20\text{ ns}$

| | V_{DD} V | symbol | min. | typ. | max. | typical extrapolation formula |
|---|---------------|--------|------|--------|-----------------------------|----------------------------------|
| Propagation delays $I_2 \rightarrow O_{18}$ HIGH to LOW | 5 | tPHL | | 950 | 1900 ns | 923 ns + (0,55 ns/pF) C_L |
| | 10 | | 350 | 700 ns | 339 ns + (0,23 ns/pF) C_L | |
| | 15 | | 220 | 440 ns | 212 ns + (0,16 ns/pF) C_L | |
| LOW to HIGH | 5 | tPLH | | 950 | 1900 ns | 923 ns + (0,55 ns/pF) C_L |
| | 10 | | 350 | 700 ns | 339 ns + (0,23 ns/pF) C_L | |
| | 15 | | 220 | 440 ns | 212 ns + (0,16 ns/pF) C_L | |
| $O_n \rightarrow O_{n+1}$ HIGH to LOW | 5 | tPHL | | 40 | 80 ns | 13 ns + (0,55 ns/pF) C_L |
| | 10 | | 15 | 30 ns | 4 ns + (0,23 ns/pF) C_L | |
| | 15 | | 10 | 20 ns | 2 ns + (0,16 ns/pF) C_L | |
| LOW to HIGH | 5 | tPLH | | 40 | 80 ns | 13 ns + (0,55 ns/pF) C_L |
| | 10 | | 15 | 30 ns | 4 ns + (0,23 ns/pF) C_L | |
| | 15 | | 10 | 20 ns | 2 ns + (0,16 ns/pF) C_L | |
| MR $\rightarrow O_n$ HIGH to LOW | 5 | tPHL | | 120 | 240 ns | 93 ns + (0,55 ns/pF) C_L |
| | 10 | | 55 | 110 ns | 44 ns + (0,23 ns/pF) C_L | |
| | 15 | | 40 | 80 ns | 32 ns + (0,16 ns/pF) C_L | |
| $I_1 \rightarrow O_1$ HIGH to LOW | 5 | tPHL | | 90 | 180 ns | 63 ns + (0,55 ns/pF) C_L |
| | 10 | | 35 | 70 ns | 24 ns + (0,23 ns/pF) C_L | |
| | 15 | | 25 | 50 ns | 17 ns + (0,16 ns/pF) C_L | |
| LOW to HIGH | 5 | tPLH | | 60 | 120 ns | 33 ns + (0,55 ns/pF) C_L |
| | 10 | | 30 | 60 ns | 19 ns + (0,23 ns/pF) C_L | |
| | 15 | | 20 | 40 ns | 12 ns + (0,16 ns/pF) C_L | |
| Output transition times HIGH to LOW | 5 | tTHL | | 60 | 120 ns | 10 ns + (1,0 ns/pF) C_L |
| | 10 | | 30 | 60 ns | 9 ns + (0,42 ns/pF) C_L | |
| | 15 | | 20 | 40 ns | 6 ns + (0,28 ns/pF) C_L | |
| LOW to HIGH | 5 | tTLH | | 60 | 120 ns | 10 ns + (1,0 ns/pF) C_L |
| | 10 | | 30 | 60 ns | 9 ns + (0,42 ns/pF) C_L | |
| | 15 | | 20 | 40 ns | 6 ns + (0,28 ns/pF) C_L | |

A.C. CHARACTERISTICS

$V_{SS} = 0\text{ V}$; $T_{amb} = 25\text{ }^{\circ}\text{C}$; $C_L = 50\text{ pF}$; input transition times $\leq 20\text{ ns}$

| | V_{DD} V | symbol | min. | typ. | max. | |
|---------------------------------|---------------|------------|------|------|------|-----------------------------|
| Minimum I_2 pulse width; HIGH | 5 | t_{WI2H} | 80 | 40 | ns | } see also waveforms Fig. 5 |
| | 10 | | 40 | 20 | ns | |
| | 15 | | 30 | 15 | ns | |
| Minimum MR pulse width; HIGH | 5 | t_{WMRH} | 70 | 35 | ns | |
| | 10 | | 40 | 20 | ns | |
| | 15 | | 30 | 15 | ns | |
| Recovery time for MR | 5 | t_{RMR} | 20 | -10 | ns | |
| | 10 | | 15 | -5 | ns | |
| | 15 | | 15 | 0 | ns | |
| Maximum clock pulse frequency | 5 | f_{max} | 6 | 12 | MHz | |
| | 10 | | 12 | 25 | MHz | |
| | 15 | | 17 | 35 | MHz | |

| | V_{DD} V | typical formula for P (μW) | where |
|---|---------------|---|----------------------------------|
| Dynamic power dissipation per package (P) | 5 | $1\,200 f_i + \sum(f_o C_L) \times V_{DD}^2$ | f_i = input freq. (MHz) |
| | 10 | $5\,100 f_i + \sum(f_o C_L) \times V_{DD}^2$ | f_o = output freq. (MHz) |
| | 15 | $13\,050 f_i + \sum(f_o C_L) \times V_{DD}^2$ | C_L = load capacitance (pF) |
| | | | $\sum(f_o C_L)$ = sum of outputs |
| | | | V_{DD} = supply voltage (V) |

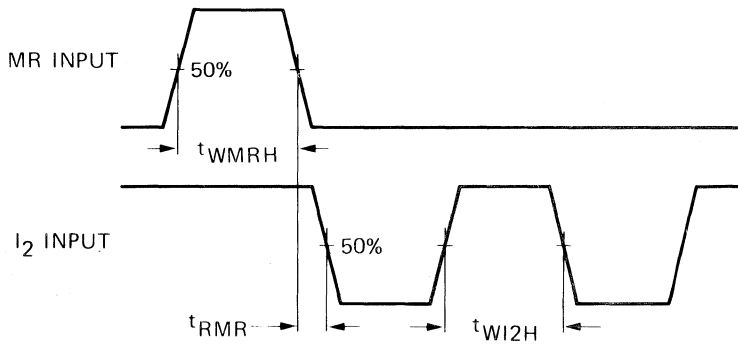
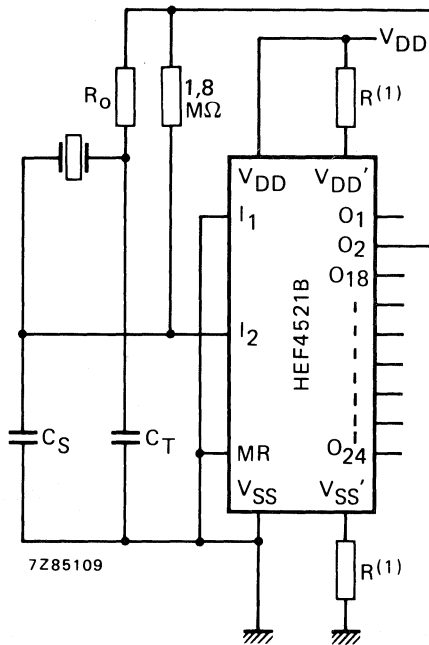

Fig. 5 Waveforms showing minimum pulse widths for MR and I_2 , recovery time for MR.

APPLICATION INFORMATION



(1) Optional for low power operation.

Fig. 6 Crystal oscillator circuit.

Typical characteristics for crystal oscillator circuit (Fig. 6):

| | 500 kHz circuit | 50 kHz circuit | unit |
|------------------------------------|-----------------|----------------|------------|
| Crystal characteristics | | | |
| resonance frequency | 500 | 50 | kHz |
| crystal cut | S | N | — |
| equivalent resistance; R_S | 1 | 6,2 | k Ω |
| External resistor/capacitor values | | | |
| R_O | 47 | 750 | k Ω |
| C_T | 82 | 82 | pF |
| C_S | 20 | 20 | pF |

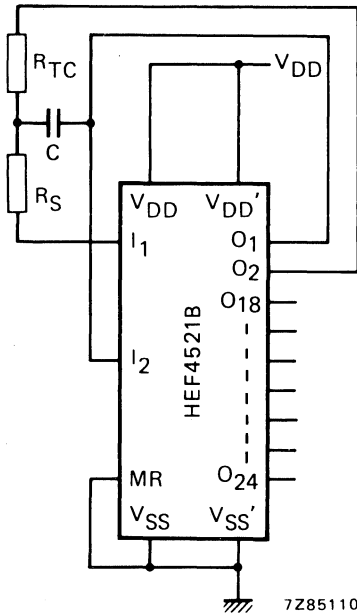

Fig. 7 RC oscillator circuit;

$$f \approx \frac{1}{2,3 \times R_{TC} \times C}; R_S \geq 2 R_{TC}, \text{ in which:}$$

f in Hz, R in Ω , C in F.

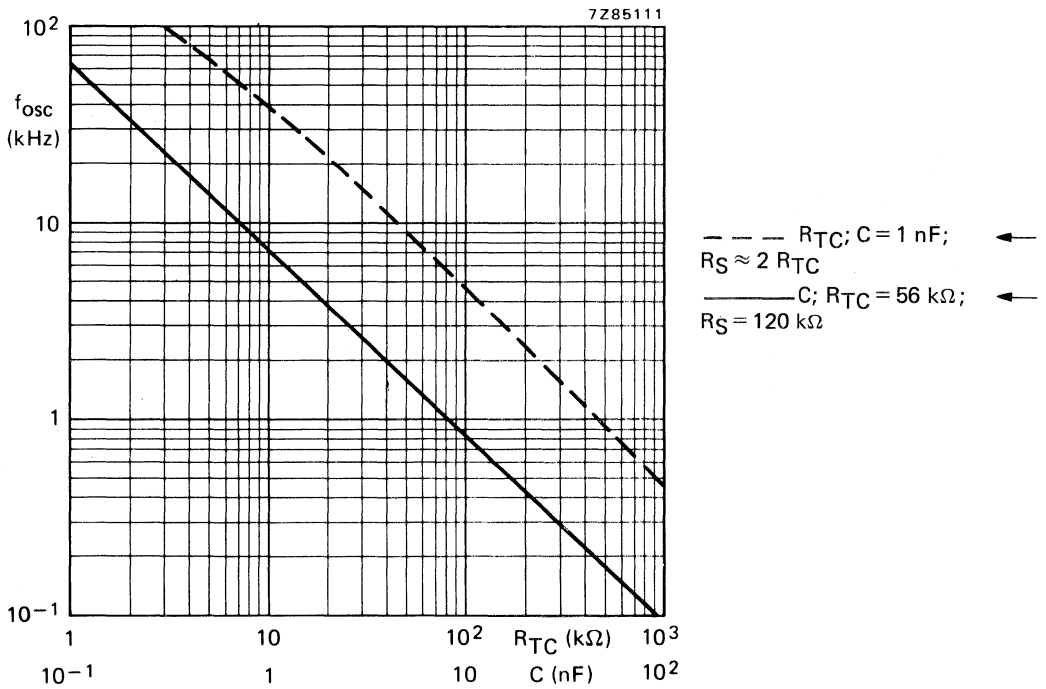

Fig. 8 Oscillator frequency as a function of R_{TC} and C; $V_{DD} = 10 \text{ V}$; test circuit is Fig. 7.

APPLICATION INFORMATION (continued)

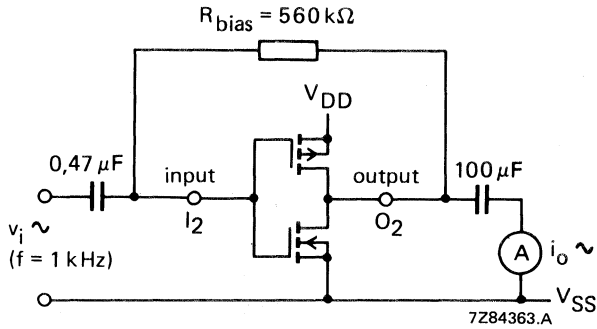
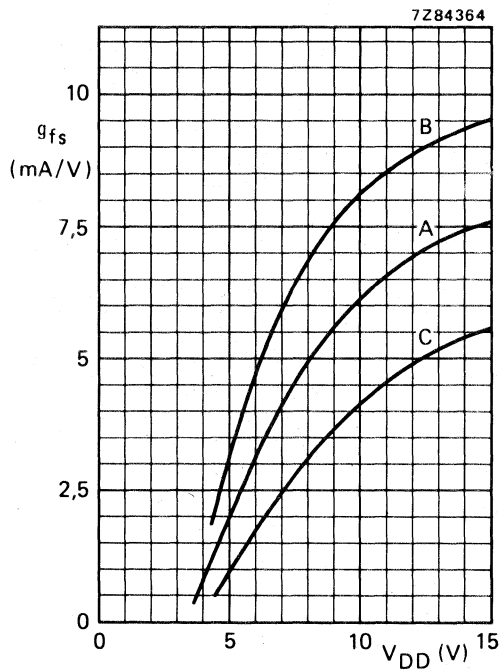

Fig. 9 Test set-up for measuring forward transconductance $g_{fs} = di_o/dv_i$ at v_o is constant (see also graph Fig. 10).



Curves in Fig. 10:

- A: average,
- B: average + 2 s,
- C: average - 2 s, in which:
's' is the observed standard deviation.

Fig. 10 Typical forward transconductance g_{fs} as a function of the supply voltage at $T_{amb} = 25^\circ\text{C}$.

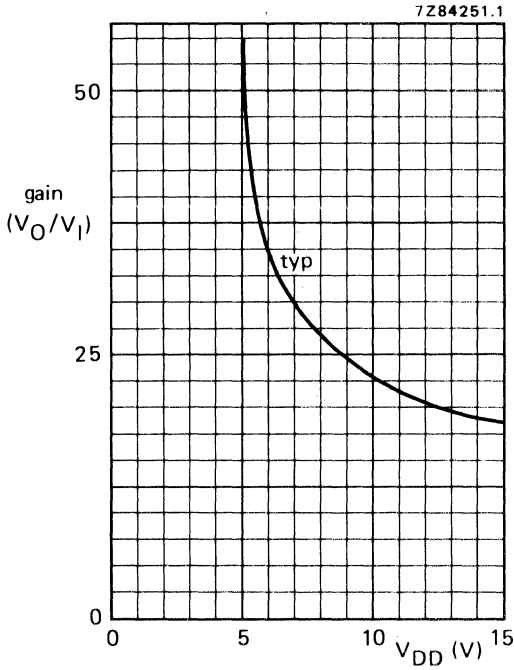

Fig. 11 Voltage gain (V_O/V_I) as a function of supply voltage.

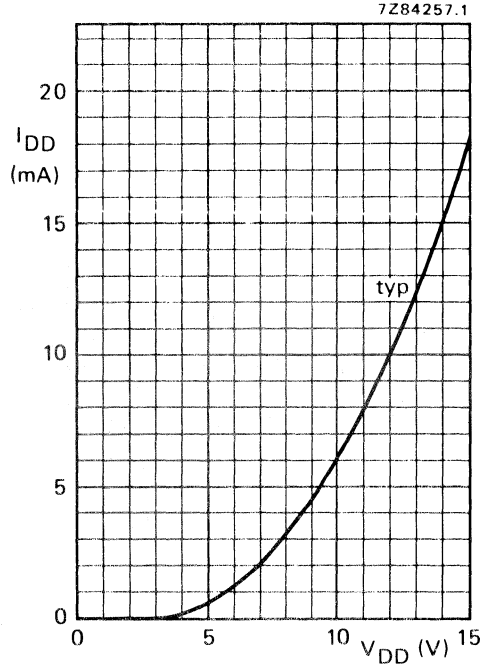

Fig. 12 Supply current as a function of supply voltage.

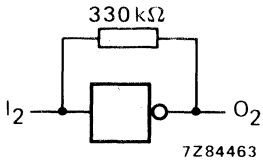

Fig. 13 Test set-up for measuring graphs of Figs 11 and 12.

PROGRAMMABLE 4-BIT BCD DOWN COUNTER



The HEF4522B is a synchronous programmable 4-bit BCD down counter with an active HIGH and an active LOW clock input (CP_0 , \overline{CP}_1), an asynchronous parallel load input (PL), four parallel inputs (P_0 to P_3), a cascade feedback input (CF), four buffered parallel outputs (O_0 to O_3), a terminal count output (TC) and an overriding asynchronous master reset input (MR).

This device is a programmable, cascadable down counter with a decoded TC output for divide-by-n applications. In single stage applications the TC output is connected to PL. CF allows cascade divide-by-n operation with no additional gates required.

Information on P_0 to P_3 is loaded into the counter while PL is HIGH, independent of all other input conditions except MR, which must be LOW. When PL and \overline{CP}_1 are LOW, the counter advances on a LOW to HIGH transition of CP_0 . When PL is LOW and CP_0 is HIGH, the counter advances on a HIGH to LOW transition of \overline{CP}_1 . TC is HIGH when the counter is in the zero state ($O_0 = O_1 = O_2 = O_3 = \text{LOW}$) and CF is HIGH and PL is LOW. A HIGH on MR resets the counter (O_0 to $O_3 = \text{LOW}$) independent of other input conditions.

Schmitt-trigger action in the clock input makes the circuit highly tolerant to slower clock rise and fall times.

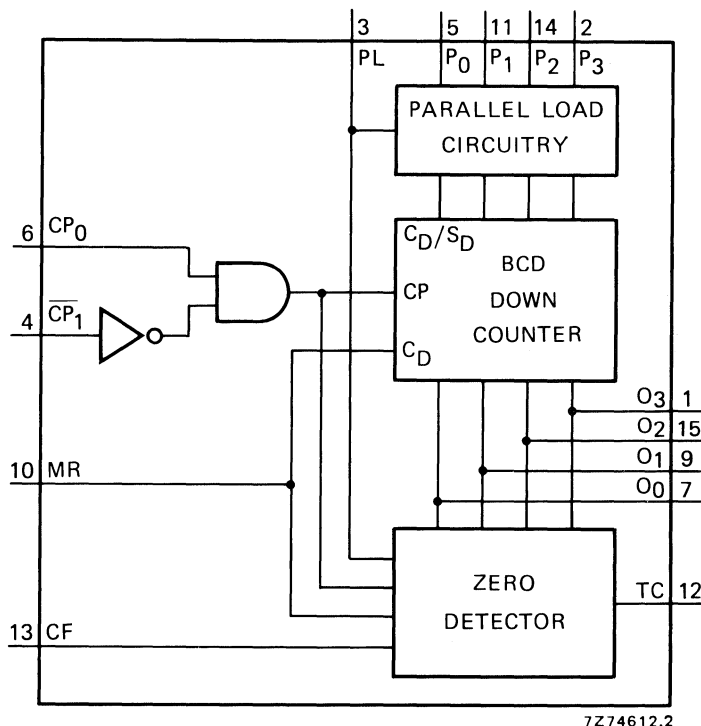

Fig. 1 Functional diagram.

FAMILY DATA

I_{DD} LIMITS category MSI

} see Family Specifications

HEF4522B

MSI

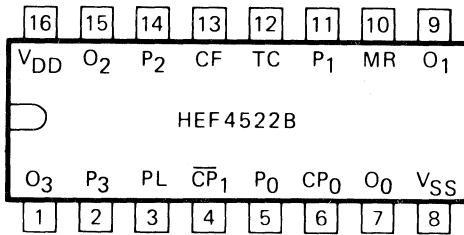

7274611

HEF4522BP : 16-lead DIL; plastic (SOT-38Z).
 HEF4522BD : 16-lead DIL; ceramic (cerdip) (SOT-74).
 HEF4522BT : 16-lead mini-pack; plastic (SO-16; SOT-109A).

Fig. 2 Pinning diagram.

PINNING

- PL parallel load input
- P₀ to P₃ parallel inputs
- CF cascade feedback input
- CP₀ clock input (LOW to HIGH, triggered)
- \overline{CP}_1 clock input (HIGH to LOW, triggered)
- MR asynchronous master reset input
- TC terminal count output
- O₀ to O₃ buffered parallel outputs

COUNTING MODE

CF = HIGH; PL = LOW; MR = LOW

FUNCTION TABLE

| count | outputs | | | |
|-------|----------------|----------------|----------------|----------------|
| | O ₃ | O ₂ | O ₁ | O ₀ |
| 9 | H | L | L | H |
| 8 | H | L | L | L |
| 7 | L | H | H | H |
| 6 | L | H | H | L |
| 5 | L | H | L | H |
| 4 | L | H | L | L |
| 3 | L | L | H | H |
| 2 | L | L | H | L |
| 1 | L | L | L | H |
| 0 | L | L | L | L |

| MR | PL | CP ₀ | \overline{CP}_1 | mode |
|----|----|-----------------|-------------------|-----------------------|
| H | X | X | X | reset (asynchronous) |
| L | H | X | X | preset (asynchronous) |
| L | L | / | H | no change |
| L | L | L | \ | no change |
| L | L | \ | X | no change |
| L | L | X | / | no change |
| L | L | / | L | counter advances |
| L | L | H | \ | counter advances |

H = HIGH state (the more positive voltage)
 L = LOW state (the less positive voltage)
 X = state is immaterial
 / = positive-going transition
 \ = negative-going transition

SINGLE STAGE OPERATION

Divide-by-n; MR = LOW; CF = HIGH; \overline{CP}_1 = LOW

| PL | P ₃ | P ₂ | P ₁ | P ₀ | divide by | TC output pulse width |
|----|----------------|----------------|----------------|----------------|--------------|-----------------------|
| L | X | X | X | X | 10 | one clock period |
| TC | H | H | H | H | 15 | clock pulse HIGH |
| TC | H | H | H | L | 14 | |
| TC | H | H | L | H | 13 | |
| TC | H | H | L | L | 12 | |
| TC | H | L | H | H | 11 | |
| TC | H | L | H | L | 10 | |
| TC | H | L | L | H | 9 | |
| TC | H | L | L | L | 8 | |
| TC | L | H | H | H | 7 | |
| TC | L | H | H | L | 6 | |
| TC | L | H | L | H | 5 | |
| TC | L | H | L | L | 4 | |
| TC | L | L | H | H | 3 | |
| TC | L | L | H | L | 2 | |
| TC | L | L | L | H | 1 | |
| TC | L | L | L | L | no operation | |

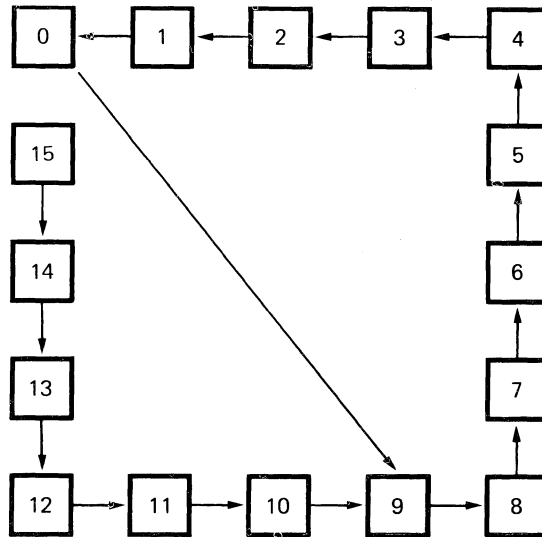

7274617

Fig. 3 State diagram.

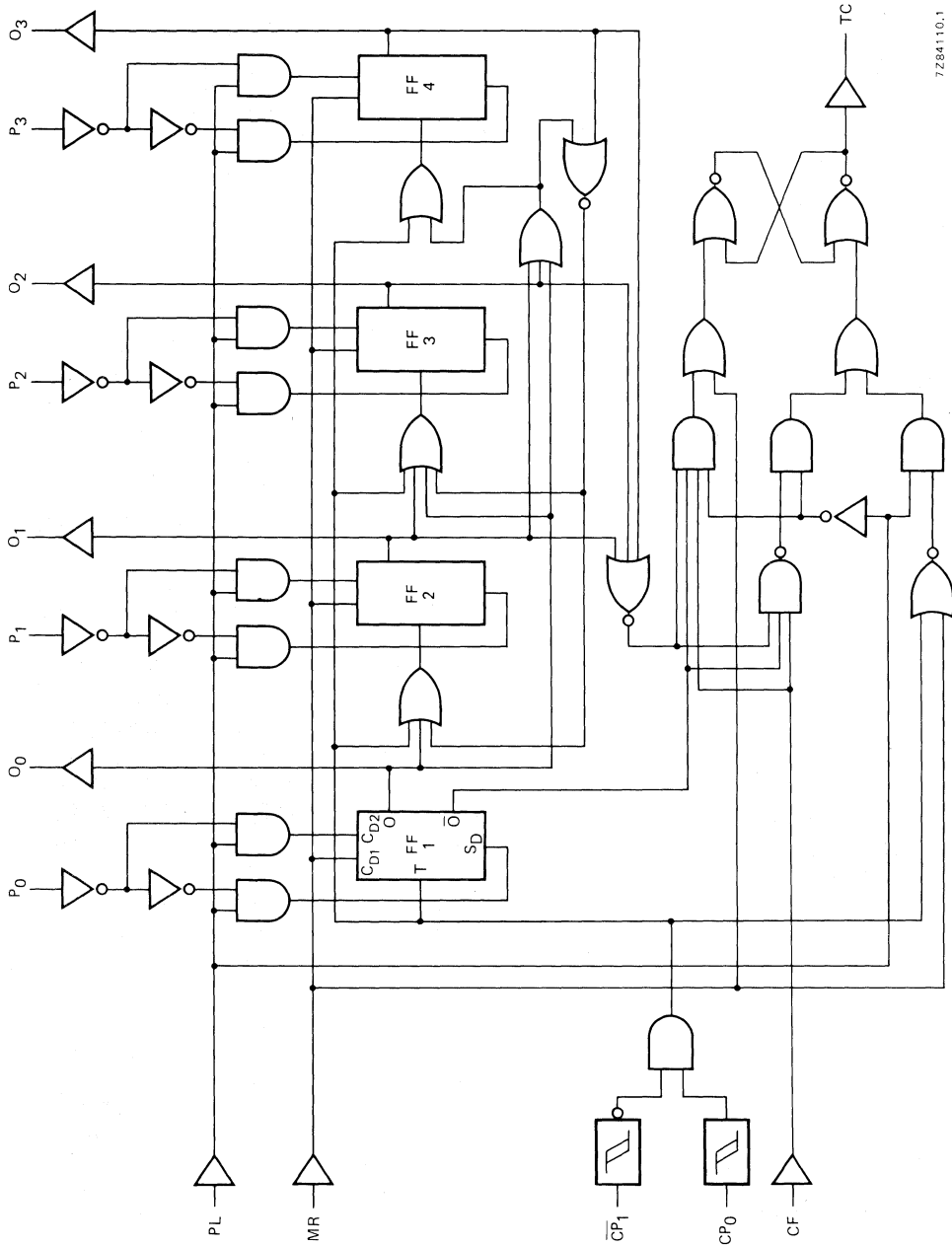

7284110.1

Fig. 4 Logic diagram.

A.C. CHARACTERISTICS

$V_{SS} = 0\text{ V}$; $T_{amb} = 25\text{ }^\circ\text{C}$; input transition times $\leq 20\text{ ns}$

| | V_{DD} V | typical formula for P (μW) | where f_i = input freq. (MHz) f_o = output freq. (MHz) C_L = load capacitance (pF) $\Sigma(f_o C_L)$ = sum of outputs V_{DD} = supply voltage (V) |
|---|---------------|---|--|
| Dynamic power dissipation per package (P) | 5 | $1000 f_i + \Sigma(f_o C_L) \times V_{DD}^2$ | |
| | 10 | $4000 f_i + \Sigma(f_o C_L) \times V_{DD}^2$ | |
| | 15 | $10000 f_i + \Sigma(f_o C_L) \times V_{DD}^2$ | |

A.C. CHARACTERISTICS

$V_{SS} = 0\text{ V}$; $T_{amb} = 25\text{ }^\circ\text{C}$; $C_L = 50\text{ pF}$; input transition times $\leq 20\text{ ns}$

| | V_{DD} V | symbol | min. | typ. | max. | typical extrapolation formula |
|--|---------------|------------------|------|--------|--|---|
| Propagation delays $CP_0, \overline{CP}_1 \rightarrow O_n$ HIGH to LOW | 5 | t _{PHL} | | 150 | 300 ns | $123\text{ ns} + (0,55\text{ ns/pF}) C_L$ |
| | 10 | | 65 | 130 ns | $54\text{ ns} + (0,23\text{ ns/pF}) C_L$ | |
| | 15 | | 50 | 100 ns | $42\text{ ns} + (0,16\text{ ns/pF}) C_L$ | |
| LOW to HIGH | 5 | t _{PLH} | | 150 | 300 ns | $123\text{ ns} + (0,55\text{ ns/pF}) C_L$ |
| | 10 | | 65 | 130 ns | $54\text{ ns} + (0,23\text{ ns/pF}) C_L$ | |
| | 15 | | 50 | 100 ns | $42\text{ ns} + (0,16\text{ ns/pF}) C_L$ | |
| $CP_0, \overline{CP}_1 \rightarrow TC$ HIGH to LOW | 5 | t _{PHL} | | 210 | 420 ns | $183\text{ ns} + (0,55\text{ ns/pF}) C_L$ |
| | 10 | | 90 | 180 ns | $79\text{ ns} + (0,23\text{ ns/pF}) C_L$ | |
| | 15 | | 70 | 140 ns | $62\text{ ns} + (0,16\text{ ns/pF}) C_L$ | |
| LOW to HIGH | 5 | t _{PLH} | | 210 | 420 ns | $183\text{ ns} + (0,55\text{ ns/pF}) C_L$ |
| | 10 | | 90 | 180 ns | $79\text{ ns} + (0,23\text{ ns/pF}) C_L$ | |
| | 15 | | 70 | 140 ns | $62\text{ ns} + (0,16\text{ ns/pF}) C_L$ | |
| $PL \rightarrow O_n$ HIGH to LOW | 5 | t _{PHL} | | 200 | 400 ns | $173\text{ ns} + (0,55\text{ ns/pF}) C_L$ |
| | 10 | | 80 | 160 ns | $69\text{ ns} + (0,23\text{ ns/pF}) C_L$ | |
| | 15 | | 60 | 120 ns | $52\text{ ns} + (0,16\text{ ns/pF}) C_L$ | |
| LOW to HIGH | 5 | t _{PLH} | | 180 | 360 ns | $153\text{ ns} + (0,55\text{ ns/pF}) C_L$ |
| | 10 | | 70 | 140 ns | $59\text{ ns} + (0,23\text{ ns/pF}) C_L$ | |
| | 15 | | 50 | 100 ns | $42\text{ ns} + (0,16\text{ ns/pF}) C_L$ | |
| $MR \rightarrow O_n$ HIGH to LOW | 5 | t _{PHL} | | 140 | 280 ns | $113\text{ ns} + (0,55\text{ ns/pF}) C_L$ |
| | 10 | | 55 | 110 ns | $44\text{ ns} + (0,23\text{ ns/pF}) C_L$ | |
| | 15 | | 40 | 80 ns | $32\text{ ns} + (0,16\text{ ns/pF}) C_L$ | |
| Output transition times HIGH to LOW | 5 | t _{THL} | | 60 | 120 ns | $10\text{ ns} + (1,0\text{ ns/pF}) C_L$ |
| | 10 | | 30 | 60 ns | $9\text{ ns} + (0,42\text{ ns/pF}) C_L$ | |
| | 15 | | 20 | 40 ns | $6\text{ ns} + (0,28\text{ ns/pF}) C_L$ | |
| LOW to HIGH | 5 | t _{TLH} | | 60 | 120 ns | $10\text{ ns} + (1,0\text{ ns/pF}) C_L$ |
| | 10 | | 30 | 60 ns | $9\text{ ns} + (0,42\text{ ns/pF}) C_L$ | |
| | 15 | | 20 | 40 ns | $6\text{ ns} + (0,28\text{ ns/pF}) C_L$ | |

A.C. CHARACTERISTICS

 $V_{SS} = 0\text{ V}$; $T_{amb} = 25\text{ }^{\circ}\text{C}$; $C_L = 50\text{ pF}$; input transition times $\leq 20\text{ ns}$

| | V_{DD} V | symbol | min. | typ. | max. | |
|---|---------------|------------|------|------|------|--------------------------------------|
| Minimum clock pulse width; CP_0 LOW | 5 | t_{WCPL} | 80 | 40 | ns | } see also waveforms Figs 5 and 6 |
| | 10 | | 40 | 20 | ns | |
| | 15 | | 30 | 15 | ns | |
| Minimum clock pulse width; CP_1 HIGH | 5 | t_{WCPH} | 80 | 40 | ns | |
| | 10 | | 40 | 20 | ns | |
| | 15 | | 30 | 15 | ns | |
| Minimum PL pulse width; HIGH | 5 | t_{WPLH} | 100 | 50 | ns | |
| | 10 | | 40 | 20 | ns | |
| | 15 | | 32 | 16 | ns | |
| Minimum MR pulse width; HIGH | 5 | t_{WMRH} | 130 | 65 | ns | |
| | 10 | | 50 | 25 | ns | |
| | 15 | | 40 | 20 | ns | |
| Hold time $P_n \rightarrow PL$ | 5 | t_{hold} | 30 | 5 | ns | |
| | 10 | | 20 | 5 | ns | |
| | 15 | | 15 | 5 | ns | |
| Set-up time $P_n \rightarrow PL$ | 5 | t_{su} | 30 | 0 | ns | |
| | 10 | | 20 | 0 | ns | |
| | 15 | | 15 | 0 | ns | |
| Maximum clock pulse frequency PL = LOW | 5 | f_{max} | 6 | 12 | MHz | } see note |
| | 10 | | 12 | 25 | MHz | |
| | 15 | | 16 | 32 | MHz | |

Note

In the divide-by-n mode (PL connected to TC), one has to observe the maximum HIGH to LOW propagation delay for CP to TC, before applying the next clock pulse.

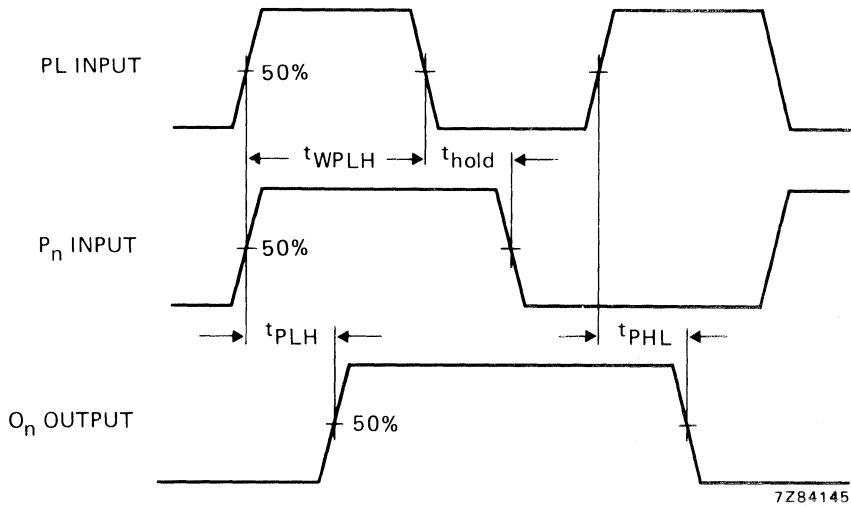

Fig. 5 Waveforms showing minimum PL pulse width, propagation delays for PL, P_n to O_n and hold time for PL to P_n.

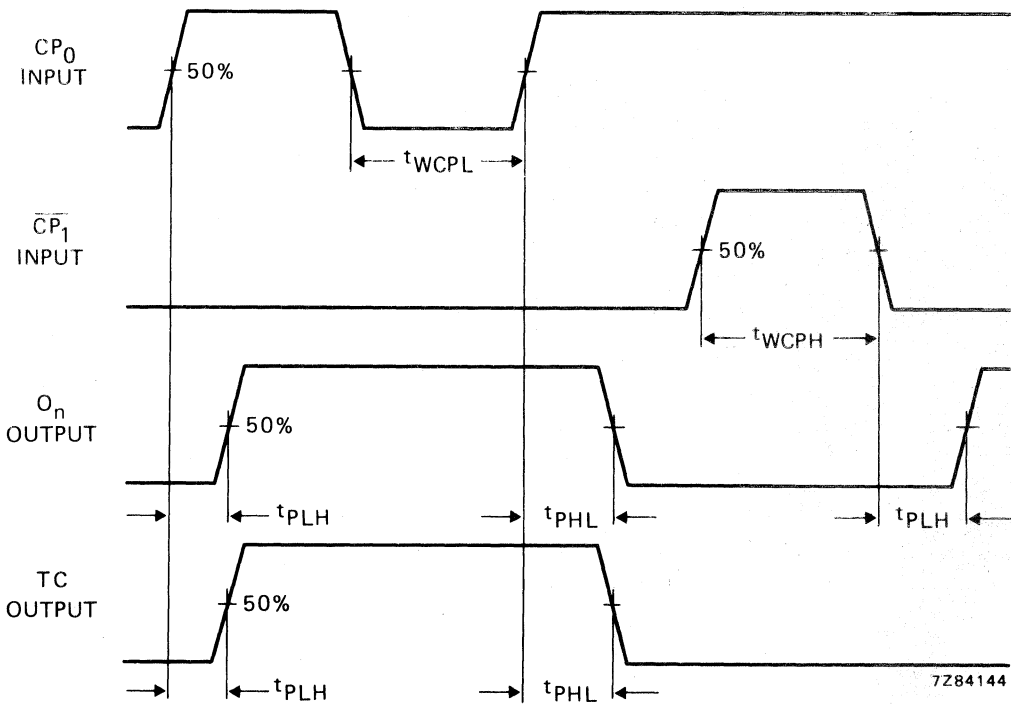

Fig. 6 Waveforms showing minimum CP₀ and CP₁ pulse widths, propagation delays for CP₀, CP₁ to O_n and TC.

HEF4522B

MSI

APPLICATION INFORMATION

Some examples of applications for the HEF4522B are:

- Divide-by-n counter
- Programmable frequency divider

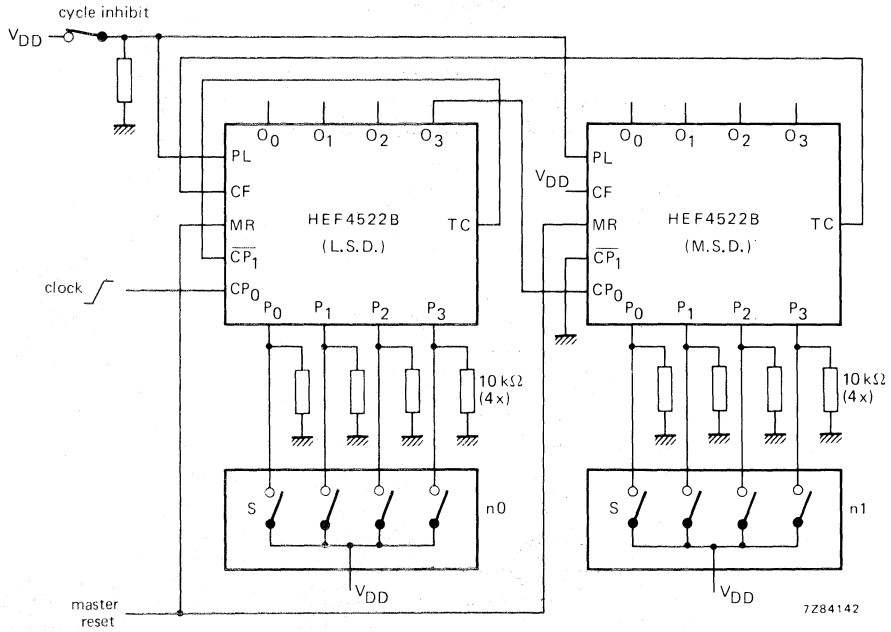
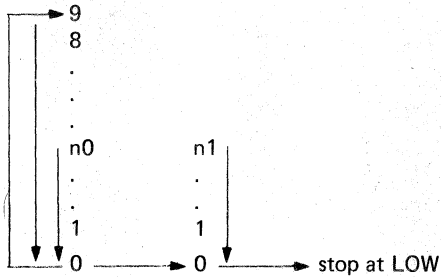

Fig. 7 Typical application of two HEF4522B circuits in a 2-stage programmable down counter (one cycle). S are thumbwheel switches; when open: LOW state.

Counting cycle:



L.S.D. counter

M.S.D. counter

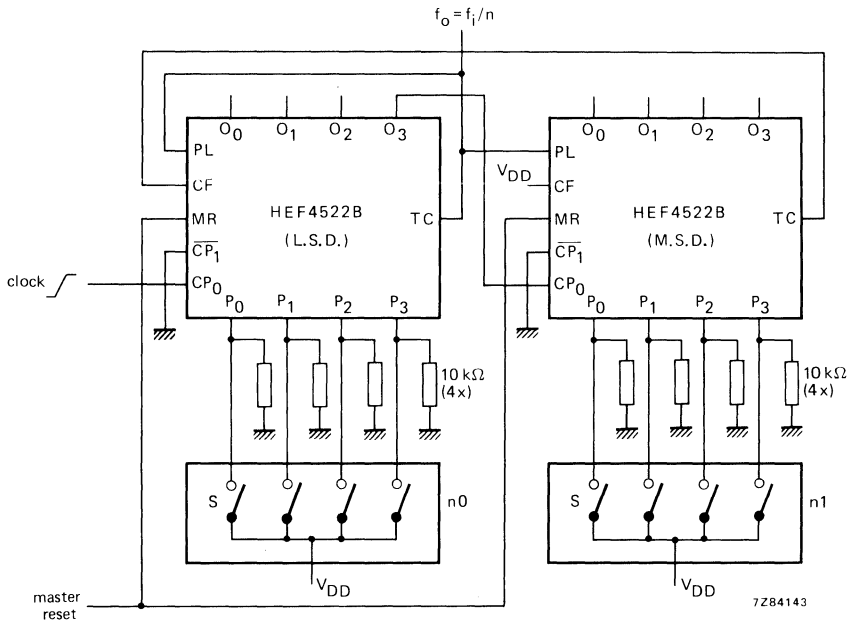
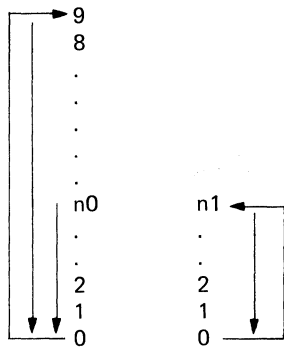

Fig. 8 Typical application of two HEF4522B circuits in a 2-stage programmable frequency divider. S are thumbwheel switches; when open: LOW state.

Counting cycle:



L.S.D. counter

M.S.D. counter

PROGRAMMABLE 4-BIT BINARY DOWN COUNTER



The HEF4526B is a synchronous programmable 4-bit binary down counter with an active HIGH and an active LOW clock input (CP_0 , \overline{CP}_1), an asynchronous parallel load input (PL), four parallel inputs (P_0 to P_3), a cascade feedback input (CF), four buffered parallel outputs (O_0 to O_3), a terminal count output (TC) and an overriding asynchronous master reset input (MR).

This device is a programmable, cascadable down counter with a decoded TC output for divide-by-n applications. In single stage applications the TC output is connected to PL. CF allows cascade divide-by-n operation with no additional gates required.

Information on P_0 to P_3 is loaded into the counter while PL is HIGH, independent of all other input conditions except MR, which must be LOW. When PL and \overline{CP}_1 are LOW, the counter advances on a LOW to HIGH transition of CP_0 . When PL is LOW and CP_0 is HIGH, the counter advances on a HIGH to LOW transition of \overline{CP}_1 . TC is HIGH when the counter is in the zero state ($O_0 = O_1 = O_2 = O_3 = \text{LOW}$) and CF is HIGH and PL is LOW. A HIGH on MR resets the counter (O_0 to $O_3 = \text{LOW}$) independent of other input conditions.

Schmitt-trigger action in the clock input makes the circuit highly tolerant to slower clock rise and fall times.

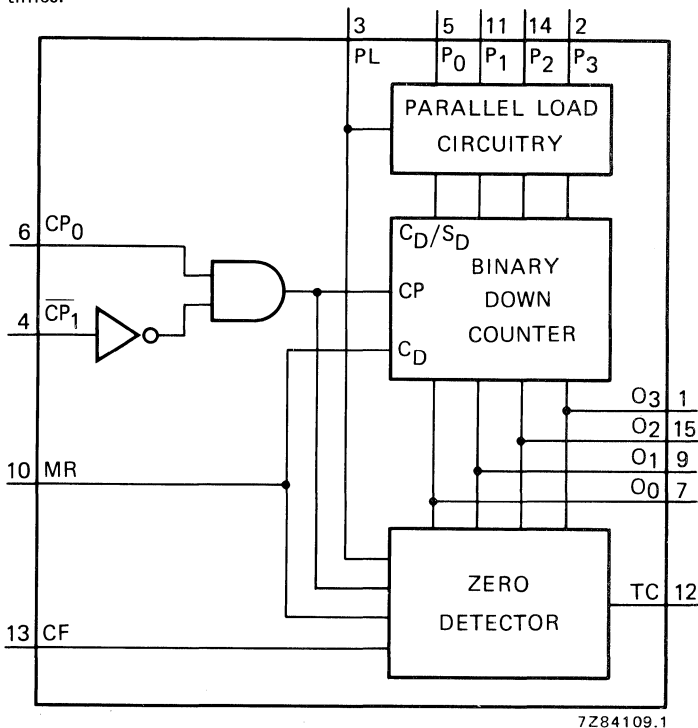

Fig. 1 Functional diagram.

FAMILY DATA

I_{DD} LIMITS category MSI

} see Family Specifications

HEF4526B

MSI

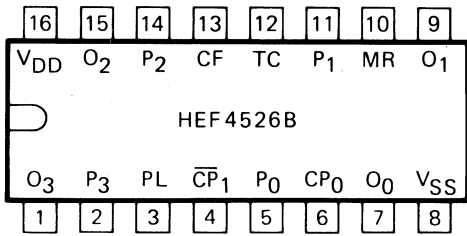

7274610

HEF4526BP : 16-lead DIL; plastic (SOT-38Z).
 HEF4526BD : 16-lead DIL; ceramic (cerdip) (SOT-74).
 HEF4526BT : 16-lead mini-pack; plastic (SO-16; SOT-109A).

Fig. 2 Pinning diagram.

PINNING

- PL parallel load input
- P₀ to P₃ parallel inputs
- CF cascade feedback input
- CP₀ clock input (LOW to HIGH, triggered)
- \overline{CP}_1 clock input (HIGH to LOW, triggered)
- MR asynchronous master reset input
- TC terminal count output
- O₀ to O₃ buffered parallel outputs

COUNTING MODE

CF = HIGH; PL = LOW; MR = LOW

FUNCTION TABLE

| count | outputs | | | |
|-------|----------------|----------------|----------------|----------------|
| | O ₃ | O ₂ | O ₁ | O ₀ |
| 15 | H | H | H | H |
| 14 | H | H | H | L |
| 13 | H | H | L | H |
| 12 | H | H | L | L |
| 11 | H | L | H | H |
| 10 | H | L | H | L |
| 9 | H | L | L | H |
| 8 | H | L | L | L |
| 7 | L | H | H | H |
| 6 | L | H | H | L |
| 5 | L | H | L | H |
| 4 | L | H | L | L |
| 3 | L | L | H | H |
| 2 | L | L | H | L |
| 1 | L | L | L | H |
| 0 | L | L | L | L |

| MR | PL | CP ₀ | \overline{CP}_1 | mode |
|----|----|-----------------|-------------------|-----------------------|
| H | X | X | X | reset (asynchronous) |
| L | H | X | X | preset (asynchronous) |
| L | L | / | H | no change |
| L | L | L | \ | no change |
| L | L | \ | X | no change |
| L | L | X | / | no change |
| L | L | / | L | counter advances |
| L | L | H | \ | counter advances |

- H = HIGH state (the more positive voltage)
- L = LOW state (the less positive voltage)
- X = state is immaterial
- / = positive-going transition
- \ = negative-going transition

SINGLE STAGE OPERATION

Divide-by-n; MR = LOW; CF = HIGH; \overline{CP}_1 = LOW

| PL | P ₃ | P ₂ | P ₁ | P ₀ | divide by | TC output pulse width |
|----|----------------|----------------|----------------|----------------|--------------|-----------------------|
| L | X | X | X | X | 16 | one clock period |
| TC | H | H | H | H | 15 | clock pulse HIGH |
| TC | H | H | H | L | 14 | |
| TC | H | H | L | H | 13 | |
| TC | H | H | L | L | 12 | |
| TC | H | L | H | H | 11 | |
| TC | H | L | H | L | 10 | |
| TC | H | L | L | H | 9 | |
| TC | H | L | L | L | 8 | |
| TC | L | H | H | H | 7 | |
| TC | L | H | H | L | 6 | |
| TC | L | H | L | H | 5 | |
| TC | L | H | L | L | 4 | |
| TC | L | L | H | H | 3 | |
| TC | L | L | H | L | 2 | |
| TC | L | L | L | H | 1 | |
| TC | L | L | L | L | no operation | |

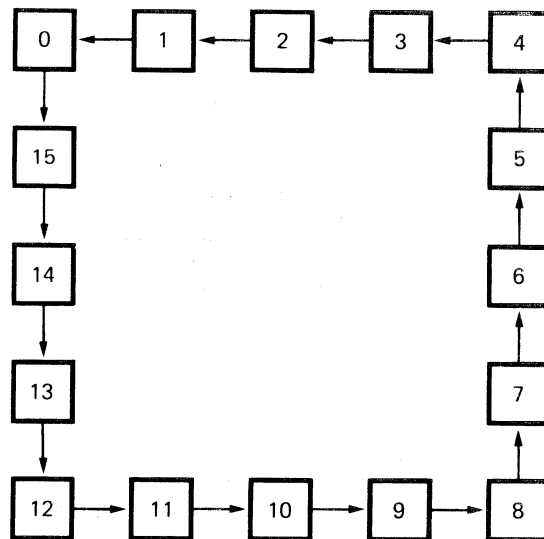

7274616

Fig. 3 State diagram.

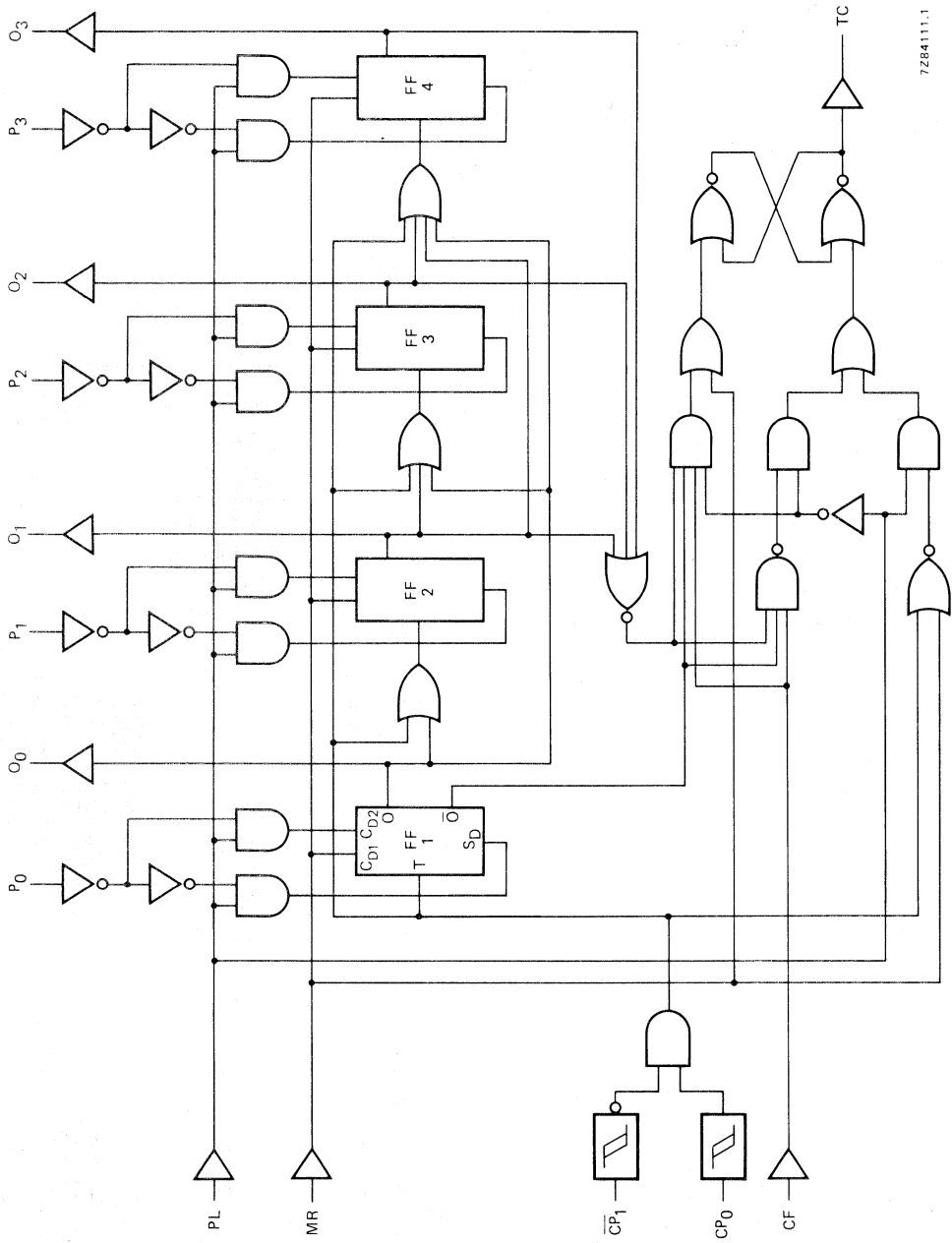

Fig. 4 Logic diagram.

A.C. CHARACTERISTICS

V_{SS} = 0 V; T_{amb} = 25 °C; input transition times ≤ 20 ns

| | V _{DD} V | typical formula for P (μW) | where f _i = input freq. (MHz) f _o = output freq. (MHz) C _L = load capacitance (pF) Σ(f _o C _L) = sum of outputs V _{DD} = supply voltage (V) |
|---|----------------------|--|--|
| Dynamic power dissipation per package (P) | 5 | 1000 f _i + Σ(f _o C _L) × V _{DD} ² | |
| | 10 | 4000 f _i + Σ(f _o C _L) × V _{DD} ² | |
| | 15 | 10 000 f _i + Σ(f _o C _L) × V _{DD} ² | |

A.C. CHARACTERISTICS

V_{SS} = 0 V; T_{amb} = 25 °C; C_L = 50 pF; input transition times ≤ 20 ns

| | V _{DD} V | symbol | min. | typ. | max. | typical extrapolation formula |
|--|----------------------|------------------|------|------|------|--------------------------------------|
| Propagation delays CP ₀ , $\overline{CP}_1 \rightarrow O_n$ HIGH to LOW | 5 | t _{PHL} | 150 | 300 | ns | 123 ns + (0,55 ns/pF) C _L |
| | 10 | | 65 | 130 | ns | 54 ns + (0,23 ns/pF) C _L |
| | 15 | | 50 | 100 | ns | 42 ns + (0,16 ns/pF) C _L |
| LOW to HIGH | 5 | t _{PLH} | 150 | 300 | ns | 123 ns + (0,55 ns/pF) C _L |
| | 10 | | 65 | 130 | ns | 54 ns + (0,23 ns/pF) C _L |
| | 15 | | 50 | 100 | ns | 42 ns + (0,16 ns/pF) C _L |
| CP ₀ , $\overline{CP}_1 \rightarrow TC$ HIGH to LOW | 5 | t _{PHL} | 210 | 420 | ns | 183 ns + (0,55 ns/pF) C _L |
| | 10 | | 90 | 180 | ns | 79 ns + (0,23 ns/pF) C _L |
| | 15 | | 70 | 140 | ns | 62 ns + (0,16 ns/pF) C _L |
| LOW to HIGH | 5 | t _{PLH} | 210 | 420 | ns | 183 ns + (0,55 ns/pF) C _L |
| | 10 | | 90 | 180 | ns | 79 ns + (0,23 ns/pF) C _L |
| | 15 | | 70 | 140 | ns | 62 ns + (0,16 ns/pF) C _L |
| PL → O _n HIGH to LOW | 5 | t _{PHL} | 200 | 400 | ns | 173 ns + (0,55 ns/pF) C _L |
| | 10 | | 80 | 160 | ns | 69 ns + (0,23 ns/pF) C _L |
| | 15 | | 60 | 120 | ns | 52 ns + (0,16 ns/pF) C _L |
| LOW to HIGH | 5 | t _{PLH} | 180 | 360 | ns | 153 ns + (0,55 ns/pF) C _L |
| | 10 | | 70 | 140 | ns | 59 ns + (0,23 ns/pF) C _L |
| | 15 | | 50 | 100 | ns | 42 ns + (0,16 ns/pF) C _L |
| MR → O _n HIGH to LOW | 5 | t _{PHL} | 140 | 280 | ns | 113 ns + (0,55 ns/pF) C _L |
| | 10 | | 55 | 110 | ns | 44 ns + (0,23 ns/pF) C _L |
| | 15 | | 40 | 80 | ns | 32 ns + (0,16 ns/pF) C _L |
| Output transition times HIGH to LOW | 5 | t _{THL} | 60 | 120 | ns | 10 ns + (1,0 ns/pF) C _L |
| | 10 | | 30 | 60 | ns | 9 ns + (0,42 ns/pF) C _L |
| | 15 | | 20 | 40 | ns | 6 ns + (0,28 ns/pF) C _L |
| LOW to HIGH | 5 | t _{TLH} | 60 | 120 | ns | 10 ns + (1,0 ns/pF) C _L |
| | 10 | | 30 | 60 | ns | 9 ns + (0,42 ns/pF) C _L |
| | 15 | | 20 | 40 | ns | 6 ns + (0,28 ns/pF) C _L |

A.C. CHARACTERISTICS

 $V_{SS} = 0\text{ V}$; $T_{amb} = 25\text{ }^{\circ}\text{C}$; $C_L = 50\text{ pF}$; input transition times $\leq 20\text{ ns}$

| | V_{DD} V | symbol | min. | typ. | max. | |
|--|---------------|------------|------|------|------|--------------------------------------|
| Minimum clock pulse width CP_0 LOW | 5 | t_{WCPL} | 80 | 40 | ns | } see also waveforms Figs 5 and 6 |
| | 10 | | 40 | 20 | ns | |
| | 15 | | 30 | 15 | ns | |
| Minimum clock pulse width \overline{CP}_1 HIGH | 5 | t_{WCPH} | 80 | 40 | ns | |
| | 10 | | 40 | 20 | ns | |
| | 15 | | 30 | 15 | ns | |
| Minimum PL pulse width; HIGH | 5 | t_{WPLH} | 100 | 50 | ns | |
| | 10 | | 40 | 20 | ns | |
| | 15 | | 32 | 16 | ns | |
| Minimum MR pulse width; HIGH | 5 | t_{WMRH} | 130 | 65 | ns | |
| | 10 | | 50 | 25 | ns | |
| | 15 | | 40 | 20 | ns | |
| Hold time $P_n \rightarrow PL$ | 5 | t_{hold} | 30 | 5 | ns | |
| | 10 | | 20 | 5 | ns | |
| | 15 | | 15 | 5 | ns | |
| Set-up time $P_n \rightarrow PL$ | 5 | t_{su} | 30 | 0 | ns | |
| | 10 | | 20 | 0 | ns | |
| | 15 | | 15 | 0 | ns | |
| Maximum clock pulse frequency PL = LOW | 5 | f_{max} | 6 | 12 | MHz | } see note |
| | 10 | | 12 | 25 | MHz | |
| | 15 | | 16 | 32 | MHz | |

Note

In the divide-by-n mode (PL connected to TC), one has to observe the maximum HIGH to LOW propagation delay for CP to TC, before applying the next clock pulse.

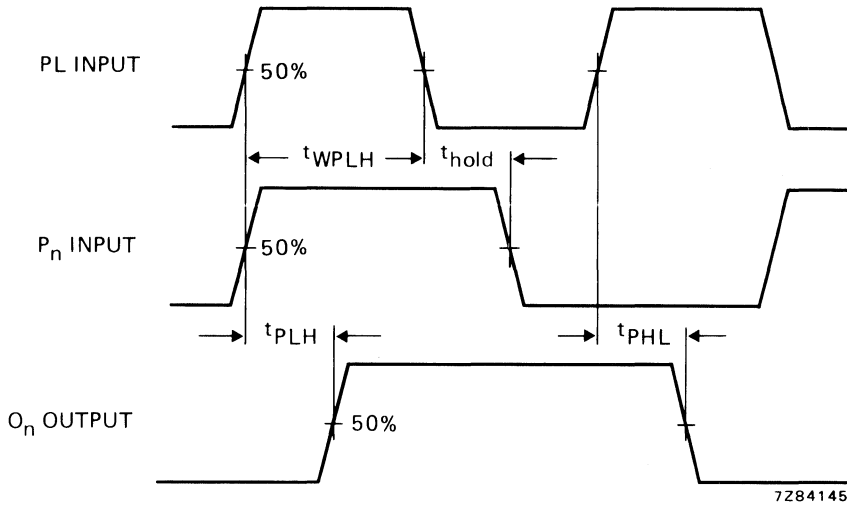

7284145

Fig. 5 Waveforms showing minimum PL pulse width, propagation delays for PL, P_n to O_n and hold time for PL to P_n.

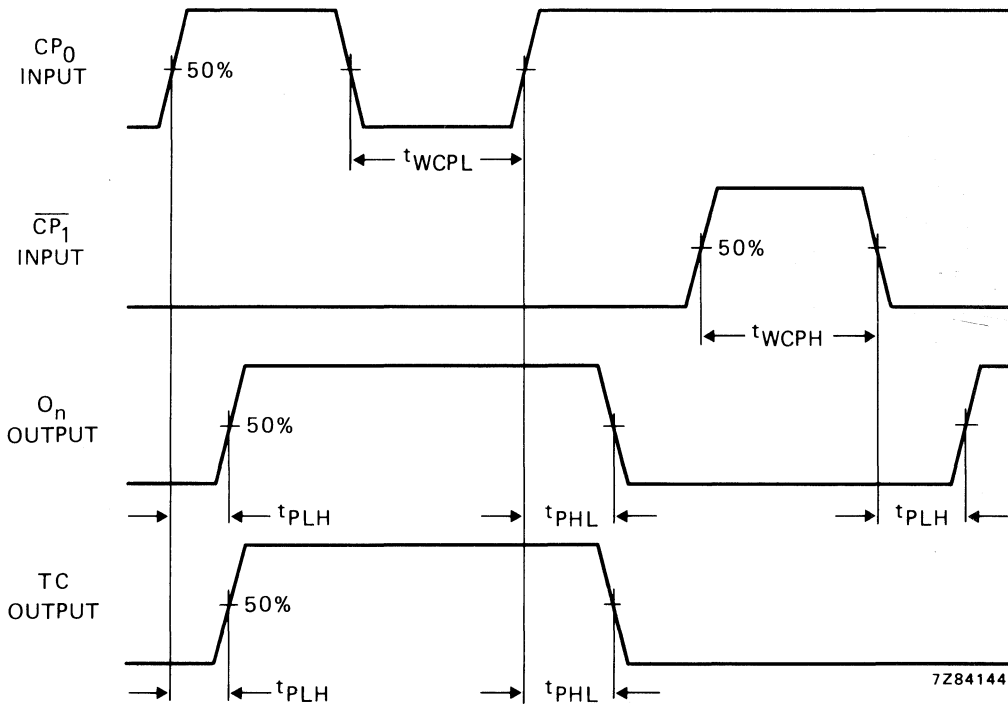

7284144

Fig. 6 Waveforms showing minimum CP₀ and CP₁ pulse widths, propagation delays for CP₀, CP₁ to O_n and TC.

HEF4526B

MSI

APPLICATION INFORMATION

Some examples of applications for the HEF4526B are:

- Divide-by-n counter
- Programmable frequency divider

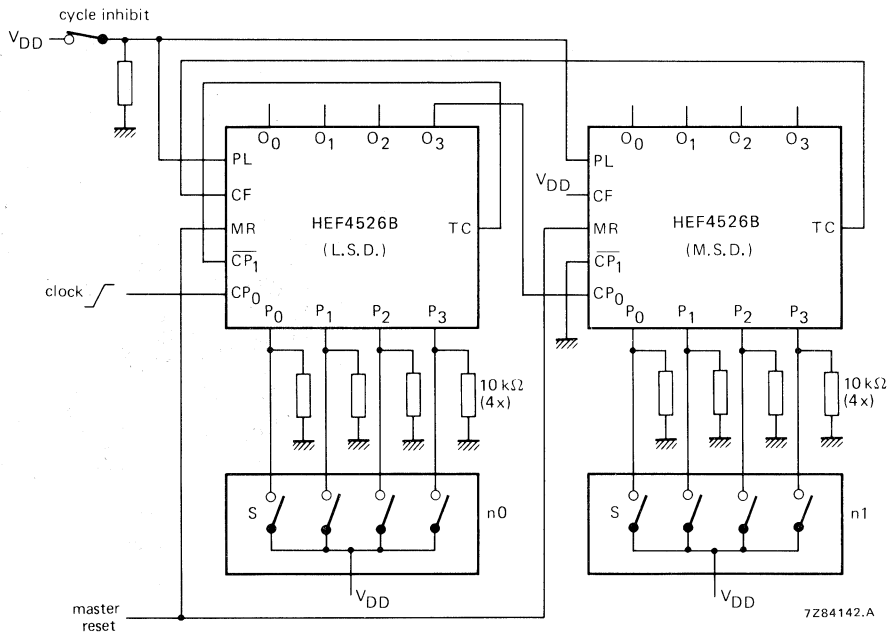
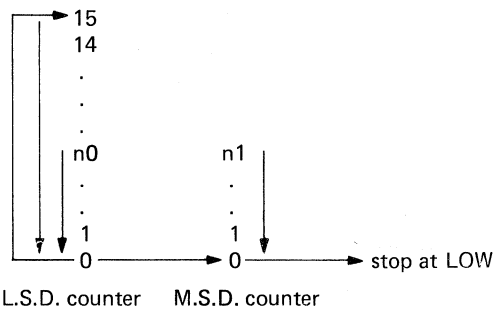

Fig. 7 Typical application of two HEF4526B circuits in a 2-stage programmable down counter (one cycle). S are thumbwheel switches; when open: LOW state.

Counting cycle:



L.S.D. counter M.S.D. counter

BCD RATE MULTIPLIER

The HEF4527B is a BCD rate multiplier with two buffered rate outputs (O_1 and \bar{O}_1), two buffered terminal count outputs (TC and \bar{TC}), four BCD rate select inputs (S_A, S_B, S_C, S_D), a common clock input (CP), a preset input (PL), an overriding asynchronous clear input (CL), a strobe input (STR), a cascade input (CAS) and an active LOW count enable input (\bar{CE}).

The BCD rate multiplier provides an output pulse rate based upon the BCD input number. For example, if 6 is the BCD number, there will be six output pulses for every ten clock input pulses. The output is clocked on the negative-going transition of the clock.

When \bar{CE} , STR, CAS, CL and PL are LOW, the rate pulses are available at the outputs O_1 and \bar{O}_1 , the terminal count pulses at TC and \bar{TC} .

A HIGH on CL resets the counter, independent of all other input conditions and a rate of 10 pulses is available at O_1 and \bar{O}_1 when S_D is HIGH. When \bar{CE} is HIGH, the counter is disabled, the state of the outputs (O_1, \bar{O}_1) depend on the content of the counter.

A HIGH on PL sets the counter in the '9' state and TC becomes HIGH.

A HIGH on STR inhibits the outputs O_1 and \bar{O}_1 . A HIGH on CAS forces the output O_1 to HIGH, while the state of \bar{O}_1 depends on the inputs S_A to S_D (see lines 1 to 16 of function table).

This device may be used to perform arithmetic operations. For the add mode and multiply mode see Figs 5 and 6.

Schmitt-trigger action in the clock input makes the circuit highly tolerant to slower clock rise and fall times.

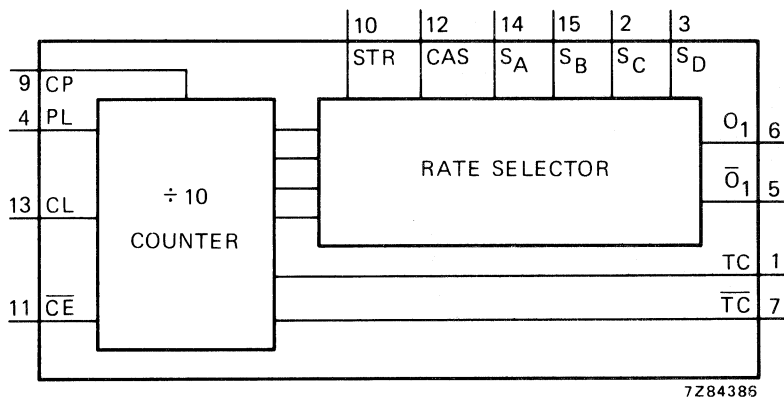

Fig. 1 Functional diagram.

FAMILY DATA

I_{DD} LIMITS category MSI

see Family Specifications

HEF4527B

MSI

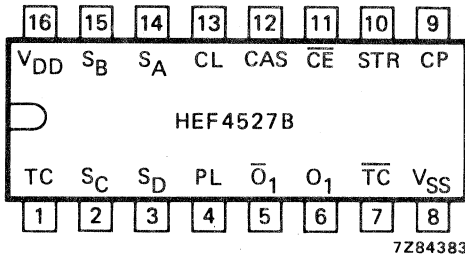

HEF4527BP : 16-lead DIL; plastic (SOT-38Z).
HEF4527BD : 16-lead DIL; ceramic (cerdip) (SOT-74).
HEF4527BT : 16-lead mini-pack; plastic (SO-16; SOT-109A).

Fig. 2 Pinning diagram.

PINNING

| | |
|---|-------------------------------------|
| CP | clock input |
| PL | preset to '9' input |
| CL | counter clear input |
| C _E | count enable input (active LOW) |
| STR | strobe input |
| CAS | cascade input |
| S _A to S _D | rate select inputs |
| O ₁ to O ₁ (with overbar) | rate outputs |
| TC | terminal count output (active HIGH) |
| T _C (with overbar) | terminal count output (active LOW) |

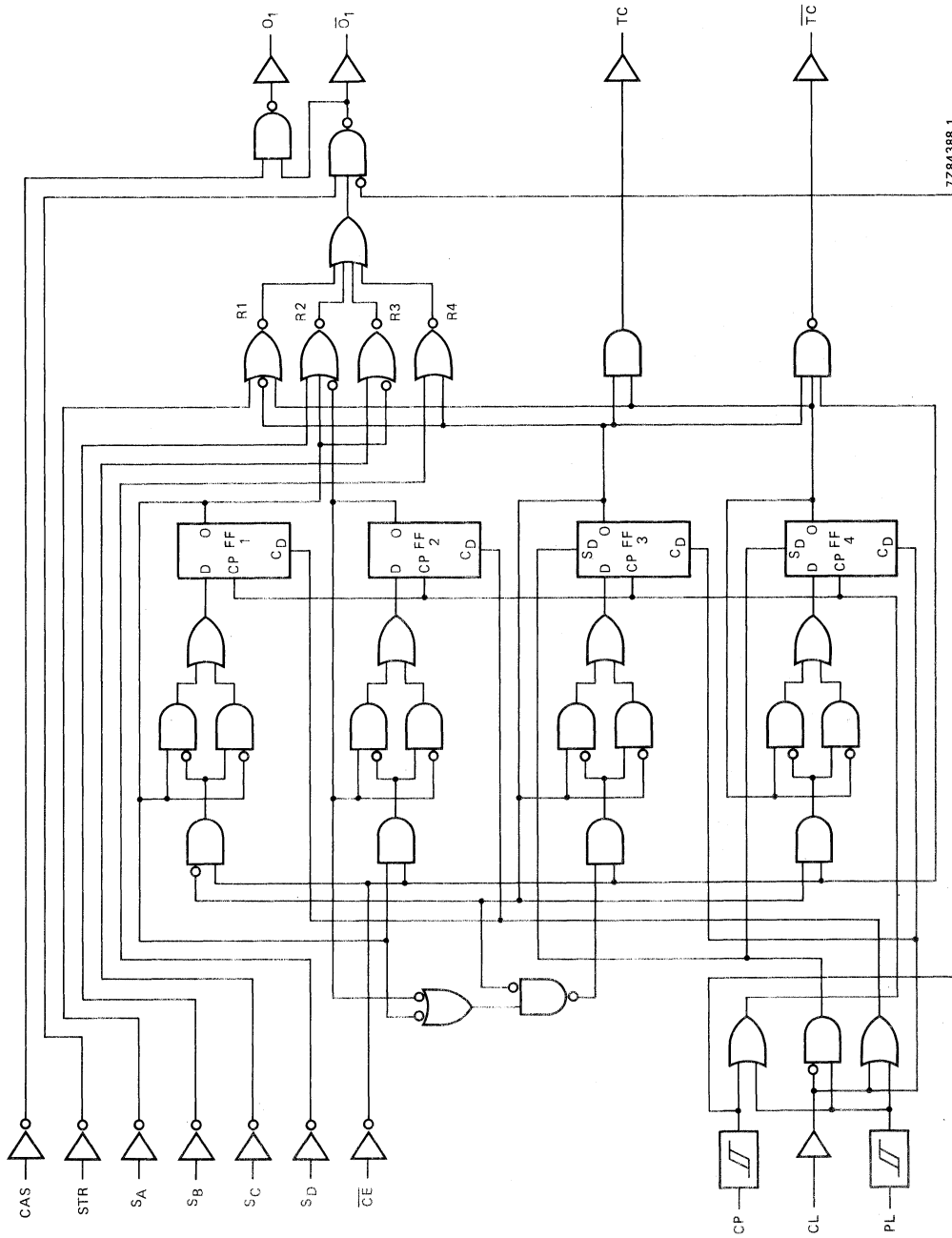

7284388.1

Fig. 3 Logic diagram.

FUNCTION TABLE

| inputs | | | | | | | | | | outputs | | | | mode of operation |
|---------------------------------|----------------|----------------|----------------|----|------------------------|-----|-----|----|----|---------------------------------|-------------------------|------------------------|----|--|
| number of pulses or logic level | | | | | | | | | | number of pulses or logic level | | | | |
| S _D | S _C | S _B | S _A | CP | $\overline{\text{CE}}$ | STR | CAS | CL | PL | O ₁ | $\overline{\text{O}}_1$ | $\overline{\text{TC}}$ | TC | |
| L | L | L | L | 10 | L | L | L | L | L | L | H | 1 | 1 | rate pulses at the outputs depend on the BCD input number at S _A to S _D |
| L | L | L | H | 10 | L | L | L | L | L | 1 | 1 | 1 | 1 | |
| L | L | H | L | 10 | L | L | L | L | L | 2 | 2 | 1 | 1 | |
| L | L | H | H | 10 | L | L | L | L | L | 3 | 3 | 1 | 1 | |
| L | H | L | L | 10 | L | L | L | L | L | 4 | 4 | 1 | 1 | |
| L | H | L | H | 10 | L | L | L | L | L | 5 | 5 | 1 | 1 | |
| L | H | H | L | 10 | L | L | L | L | L | 6 | 6 | 1 | 1 | |
| L | H | H | H | 10 | L | L | L | L | L | 7 | 7 | 1 | 1 | |
| H | L | L | L | 10 | L | L | L | L | L | 8 | 8 | 1 | 1 | |
| H | L | L | H | 10 | L | L | L | L | L | 9 | 9 | 1 | 1 | |
| H | L | H | L | 10 | L | L | L | L | L | 8 | 8 | 1 | 1 | |
| H | L | H | H | 10 | L | L | L | L | L | 9 | 9 | 1 | 1 | |
| H | H | L | L | 10 | L | L | L | L | L | 8 | 8 | 1 | 1 | |
| H | H | L | H | 10 | L | L | L | L | L | 9 | 9 | 1 | 1 | |
| H | H | H | L | 10 | L | L | L | L | L | 8 | 8 | 1 | 1 | |
| H | H | H | H | 10 | L | L | L | L | L | 9 | 9 | 1 | 1 | |
| X | X | X | X | X | H | L | L | L | L | ▲ | ▲ | H | ▲ | $\overline{\text{CE}}$ = H; counter disabled outputs O ₁ and O ₂ disabled output O ₁ disabled CL = H counter reset PL = H; preset to '9' |
| X | X | X | X | 10 | L | H | L | L | L | L | H | 1 | 1 | |
| X | X | X | X | 10 | L | L | H | L | L | H | * | 1 | 1 | |
| H | X | X | X | 10 | L | L | L | H | X | 10 | 10 | H | L | |
| L | X | X | X | X | L | L | L | H | X | L | H | H | L | |
| X | X | X | X | X | L | L | L | L | H | L | H | L | H | |

H = HIGH state (the more positive voltage)

L = LOW state (the less positive voltage)

X = state is immaterial

* Same output as the first 16 lines of this function table (depends on the values of S_A to S_D).

▲ Depends on internal state of the counter.

A.C. CHARACTERISTICS $V_{SS} = 0\text{ V}$; $T_{amb} = 25\text{ }^{\circ}\text{C}$; $C_L = 50\text{ pF}$; input transition times $\leq 20\text{ ns}$.

| parameter | V_{DD} V | symbol | min. | typ. | max. | unit | typical extrapolation formula |
|--|---------------|--------|------|------|------|--|---|
| Propagation delays CP \rightarrow O_1, \bar{O}_1 HIGH to LOW | 5 | tPHI | | 130 | 260 | ns | $103\text{ ns} + (0,55\text{ ns/pF}) C_L$ |
| | 10 | | 50 | 100 | ns | $39\text{ ns} + (0,23\text{ ns/pF}) C_L$ | |
| | 15 | | 35 | 70 | ns | $27\text{ ns} + (0,16\text{ ns/pF}) C_L$ | |
| LOW to HIGH | 5 | tPLH | | 130 | 260 | ns | $103\text{ ns} + (0,55\text{ ns/pF}) C_L$ |
| | 10 | | 50 | 50 | ns | $39\text{ ns} + (0,23\text{ ns/pF}) C_L$ | |
| | 15 | | 35 | 35 | ns | $27\text{ ns} + (0,16\text{ ns/pF}) C_L$ | |
| CP \rightarrow TC HIGH to LOW | 5 | tPHL | | 175 | 350 | ns | $148\text{ ns} + (0,55\text{ ns/pF}) C_L$ |
| | 10 | | 65 | 130 | ns | $54\text{ ns} + (0,23\text{ ns/pF}) C_L$ | |
| | 15 | | 45 | 90 | ns | $37\text{ ns} + (0,16\text{ ns/pF}) C_L$ | |
| LOW to HIGH | 5 | tPLH | | 160 | 320 | ns | $133\text{ ns} + (0,55\text{ ns/pF}) C_L$ |
| | 10 | | 65 | 130 | ns | $54\text{ ns} + (0,23\text{ ns/pF}) C_L$ | |
| | 15 | | 45 | 90 | ns | $37\text{ ns} + (0,16\text{ ns/pF}) C_L$ | |
| CP \rightarrow \bar{TC} HIGH to LOW | 5 | tPHL | | 175 | 350 | ns | $148\text{ ns} + (0,55\text{ ns/pF}) C_L$ |
| | 10 | | 65 | 130 | ns | $54\text{ ns} + (0,23\text{ ns/pF}) C_L$ | |
| | 15 | | 50 | 100 | ns | $42\text{ ns} + (0,16\text{ ns/pF}) C_L$ | |
| LOW to HIGH | 5 | tPLH | | 150 | 300 | ns | $123\text{ ns} + (0,55\text{ ns/pF}) C_L$ |
| | 10 | | 60 | 120 | ns | $49\text{ ns} + (0,23\text{ ns/pF}) C_L$ | |
| | 15 | | 45 | 90 | ns | $37\text{ ns} + (0,16\text{ ns/pF}) C_L$ | |
| CAS \rightarrow O_1 HIGH to LOW | 5 | tPHL | | 90 | 180 | ns | $63\text{ ns} + (0,55\text{ ns/pF}) C_L$ |
| | 10 | | 35 | 70 | ns | $24\text{ ns} + (0,23\text{ ns/pF}) C_L$ | |
| | 15 | | 25 | 50 | ns | $17\text{ ns} + (0,16\text{ ns/pF}) C_L$ | |
| LOW to HIGH | 5 | tPLH | | 70 | 140 | ns | $43\text{ ns} + (0,55\text{ ns/pF}) C_L$ |
| | 10 | | 30 | 60 | ns | $19\text{ ns} + (0,23\text{ ns/pF}) C_L$ | |
| | 15 | | 25 | 50 | ns | $17\text{ ns} + (0,16\text{ ns/pF}) C_L$ | |
| STR \rightarrow O_1, \bar{O}_1 HIGH to LOW | 5 | tPHL | | 100 | 200 | ns | $73\text{ ns} + (0,55\text{ ns/pF}) C_L$ |
| | 10 | | 40 | 80 | ns | $29\text{ ns} + (0,23\text{ ns/pF}) C_L$ | |
| | 15 | | 30 | 60 | ns | $22\text{ ns} + (0,16\text{ ns/pF}) C_L$ | |
| LOW to HIGH | 5 | tPLH | | 85 | 170 | ns | $58\text{ ns} + (0,55\text{ ns/pF}) C_L$ |
| | 10 | | 35 | 70 | ns | $24\text{ ns} + (0,23\text{ ns/pF}) C_L$ | |
| | 15 | | 25 | 50 | ns | $17\text{ ns} + (0,16\text{ ns/pF}) C_L$ | |
| $\bar{CE} \rightarrow \bar{TC}$ HIGH to LOW | 5 | tPHL | | 95 | 190 | ns | $68\text{ ns} + (0,55\text{ ns/pF}) C_L$ |
| | 10 | | 35 | 70 | ns | $24\text{ ns} + (0,23\text{ ns/pF}) C_L$ | |
| | 15 | | 25 | 50 | ns | $17\text{ ns} + (0,16\text{ ns/pF}) C_L$ | |
| LOW to HIGH | 5 | tPLH | | 65 | 130 | ns | $38\text{ ns} + (0,55\text{ ns/pF}) C_L$ |
| | 10 | | 30 | 60 | ns | $19\text{ ns} + (0,23\text{ ns/pF}) C_L$ | |
| | 15 | | 20 | 40 | ns | $12\text{ ns} + (0,16\text{ ns/pF}) C_L$ | |
| CL \rightarrow O_1 HIGH to LOW | 5 | tPHL | | 145 | 290 | ns | $118\text{ ns} + (0,55\text{ ns/pF}) C_L$ |
| | 10 | | 55 | 110 | ns | $44\text{ ns} + (0,23\text{ ns/pF}) C_L$ | |
| | 15 | | 40 | 80 | ns | $32\text{ ns} + (0,16\text{ ns/pF}) C_L$ | |
| CL \rightarrow \bar{O}_1 LOW to HIGH | 5 | tPLH | | 145 | 290 | ns | $118\text{ ns} + (0,55\text{ ns/pF}) C_L$ |
| | 10 | | 55 | 110 | ns | $44\text{ ns} + (0,23\text{ ns/pF}) C_L$ | |
| | 15 | | 40 | 80 | ns | $32\text{ ns} + (0,16\text{ ns/pF}) C_L$ | |

A.C. CHARACTERISTICS (continued)V_{SS} = 0 V; T_{amb} = 25 °C; C_L = 50 pF; input transition times ≤ 20 ns.

| parameter | V _{DD} V | symbol | min. | typ. | max. | unit | typical extrapolation formula |
|--|----------------------|-------------------|------|------|------|-------------------------------------|--------------------------------------|
| Propagation delays PL → O ₁ , \bar{O}_1 HIGH to LOW | 5 | t _{PHL} | | 260 | 520 | ns | 233 ns + (0,55 ns/pF) C _L |
| | 10 | | 100 | 200 | ns | 89 ns + (0,23 ns/pF) C _L | |
| | 15 | | 70 | 140 | ns | 62 ns + (0,16 ns/pF) C _L | |
| LOW to HIGH | 5 | t _{PLH} | | 235 | 470 | ns | 208 ns + (0,55 ns/pF) C _L |
| | 10 | | 90 | 180 | ns | 79 ns + (0,23 ns/pF) C _L | |
| | 15 | | 50 | 100 | ns | 42 ns + (0,16 ns/pF) C _L | |
| Minimum clock pulse width HIGH | 5 | t _{WCPH} | | 45 | 90 | ns | |
| | 10 | | 18 | 36 | ns | | |
| | 15 | | 12 | 24 | ns | | |
| Minimum CL pulse width; HIGH | 5 | t _{WCLH} | | 20 | 40 | ns | |
| | 10 | | 12 | 24 | ns | | |
| | 15 | | 10 | 20 | ns | | |
| Minimum PL pulse width; HIGH | 5 | t _{WPLH} | | 50 | 100 | ns | |
| | 10 | | 20 | 40 | ns | | |
| | 15 | | 15 | 30 | ns | | |
| Set-up times CE → CP | 5 | t _{su} | 30 | 15 | | ns | |
| | 10 | | 20 | 10 | | ns | |
| | 15 | | 12 | 5 | | ns | |
| Recovery times CL → CP | 5 | t _{RCL} | 20 | 10 | | ns | |
| | 10 | | 16 | 8 | | ns | |
| | 15 | | 10 | 5 | | ns | |
| PL → CP | 5 | t _{RPL} | 80 | 40 | | ns | |
| | 10 | | 36 | 18 | | ns | |
| | 15 | | 25 | 10 | | ns | |
| Maximum clock pulse frequency | 5 | f _{max} | 4,5 | 9 | | MHz | |
| | 10 | | 11 | 22 | | MHz | |
| | 15 | | 16 | 32 | | MHz | |

A.C. CHARACTERISTICSV_{SS} = 0 V; T_{amb} = 25 °C; input transition times ≤ 20 ns

| | V _{DD} V | typical formula for P (μW) | where |
|---|----------------------|--|--|
| Dynamic power dissipation per package (P) | 5 | 1 050 f _i + Σ(f _o C _L) × V _{DD} ² | f _i = input freq. (MHz) |
| | 10 | 4 500 f _i + Σ(f _o C _L) × V _{DD} ² | f _o = output freq. (MHz) |
| | 15 | 10 500 f _i + Σ(f _o C _L) × V _{DD} ² | C _L = load capacitance (pF) Σ(f _o C _L) = sum of outputs V _{DD} = supply voltage (V) |

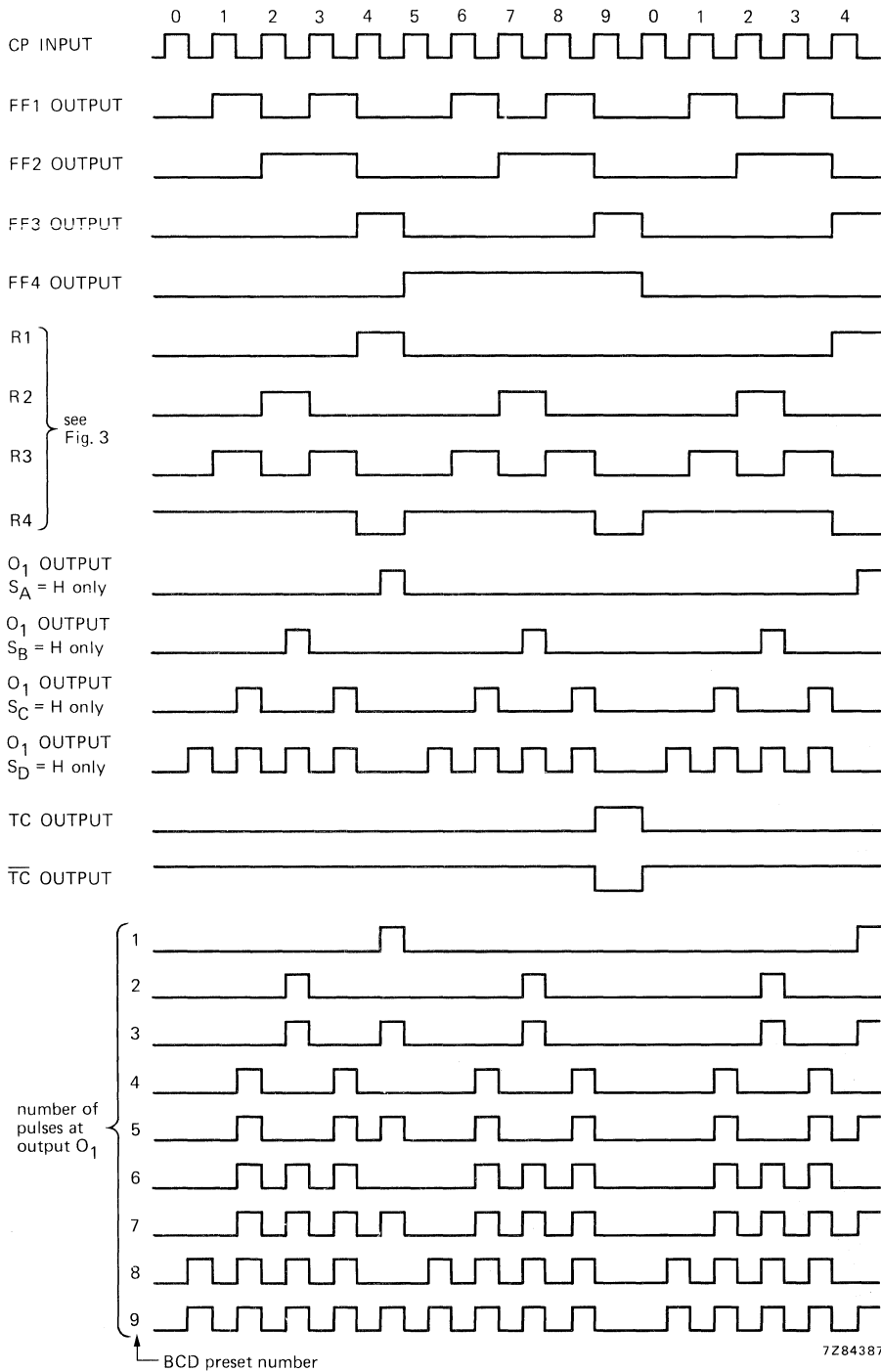

7Z84387

Fig. 4 Timing diagram.

APPLICATION INFORMATION

Add mode

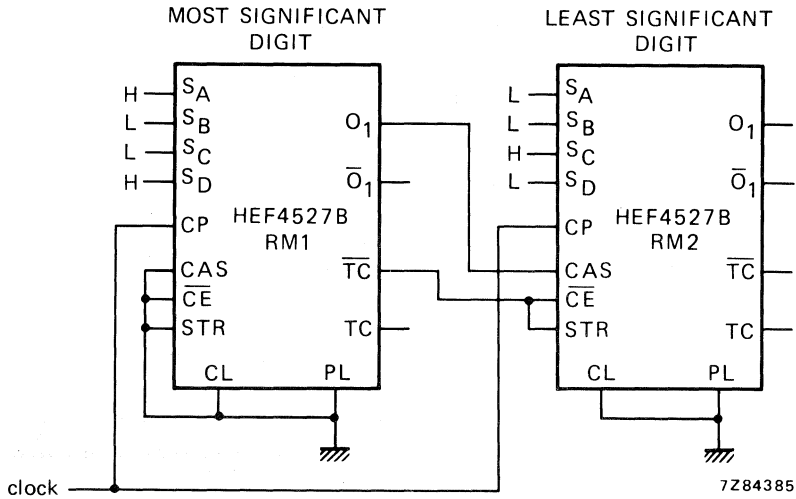

Fig. 5 Two HEF4527B cascaded in the add mode.
Output rate = $10^n (0,1 \text{ BCD}_1 + 0,01 \text{ BCD}_2 + 0,01 \text{ BCD}_3 + \dots)$, in where n = number of cascaded RMs. Example: RM1 preset to 9 and RM2 preset to 4, output rate is $10^2 (0,1 \times 9 \times 0,01 \times 4) = 94$.

Multiply mode

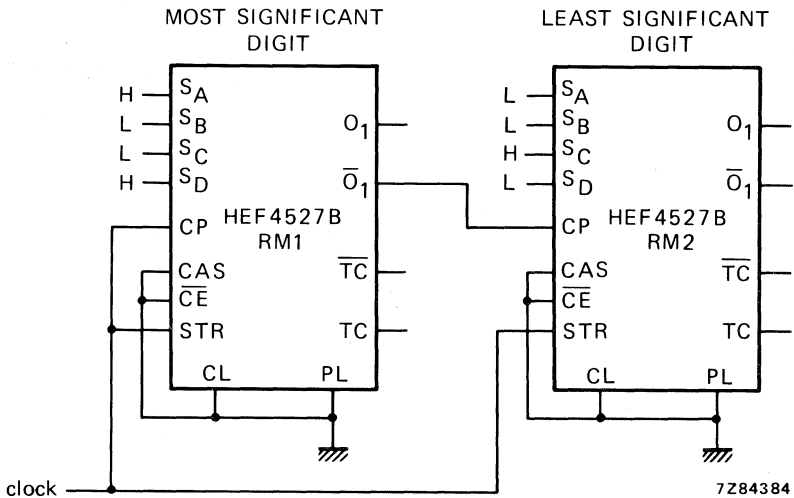

Fig. 6 Two HEF4527B cascaded in the multiply mode.
Output rate = $10^n (0,1 \text{ BCD}_1 \times 0,1 \text{ BCD}_2 \times 0,1 \text{ BCD}_3 \times \dots)$, in where n = number of cascaded RMs. Example: RM1 preset to 9 and RM2 preset to 4, output rate is $10^2 (0,1 \times 9 \times 0,1 \times 4) = 36$.

DUAL MONOSTABLE MULTIVIBRATOR



The HEF4528B is a dual retriggerable-resettable monostable multivibrator. Each multivibrator has an active LOW input (\bar{I}_0), and active HIGH input (I_1), an active LOW clear direct input (\bar{C}_D), an output (O) and its complement (\bar{O}), and two pins for connecting the external timing components (C_{TC} ,* R_{TC}).

An external timing capacitor (C_t) must be connected between C_{TC} and R_{TC} and an external resistor (R_t) must be connected between R_{TC} and V_{DD} . The duration of the output pulse is determined by the external timing components C_t and R_t .

A HIGH to LOW transition on \bar{I}_0 when I_1 is LOW or a LOW to HIGH transition on I_1 when \bar{I}_0 is HIGH produces a positive pulse (LOW-HIGH-LOW) on O and a negative pulse (HIGH-LOW-HIGH) on \bar{O} if the \bar{C}_D is HIGH. A LOW on \bar{C}_D forces O LOW, \bar{O} HIGH and inhibits any further pulses until \bar{C}_D is HIGH.

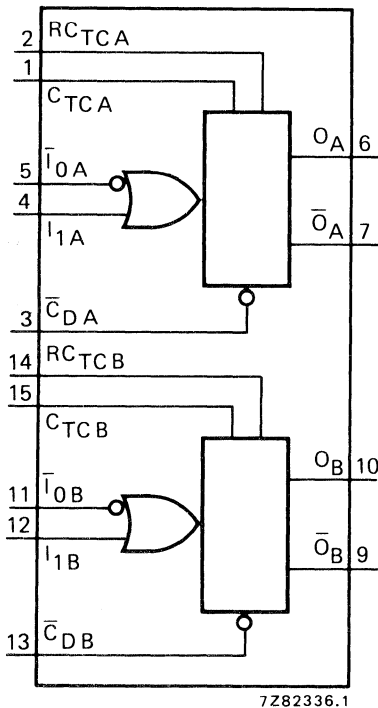

Fig. 1 Functional diagram.

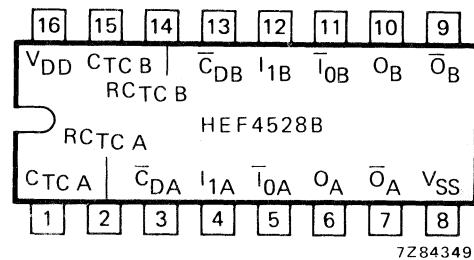

Fig. 2 Pinning diagram.

HEF4528BP : 16-lead DIL; plastic (SOT-38Z).
HEF4528BD : 16-lead DIL; ceramic (cerdip) (SOT-74).
HEF4528BT : 16-lead mini-pack; plastic (SO-16; SOT-109A).

PINNING

$\bar{I}_{0A}, \bar{I}_{0B}$ input (HIGH to LOW triggered)
 I_{1A}, I_{1B} input (LOW to HIGH triggered)
 $\bar{C}_{DA}, \bar{C}_{DB}$ clear direct input (active LOW)
 O_A, O_B output
 \bar{O}_A, \bar{O}_B complementary output (active LOW)
 C_{TCA}, C_{TCB} external capacitor connections*
 R_{TCA}, R_{TCB} external capacitor/
resistor connections

* Always connected to ground.

FAMILY DATA

I_{DD} LIMITS category MSI

see Family Specifications

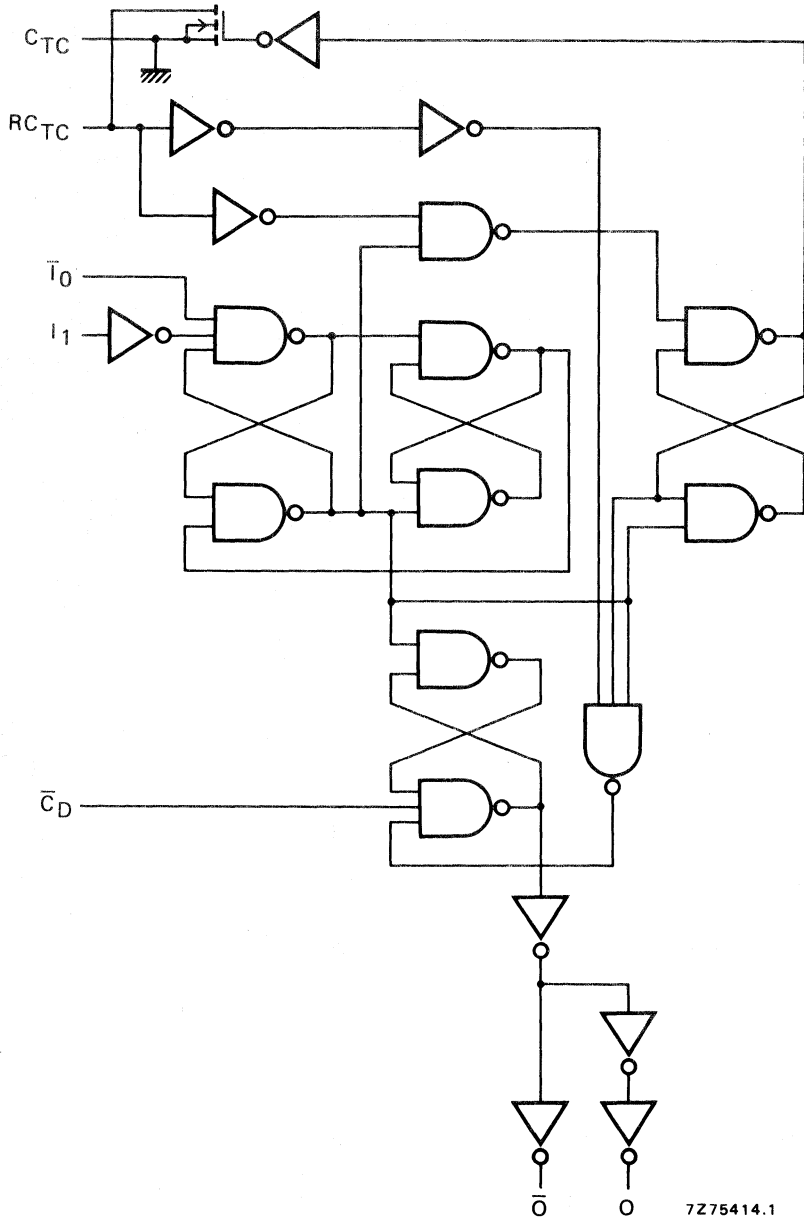

Fig. 3 Logic diagram (one monostable multivibrator).

FUNCTION TABLE

| inputs | | | outputs | |
|-------------|-------|-------------|---------|-----------|
| \bar{T}_0 | I_1 | \bar{C}_D | O | \bar{O} |
| L | L | H | | |
| H | | H | | |
| X | X | L | L | H |

H = HIGH state (the more positive voltage)

L = LOW state (the less positive voltage)

X = state is immaterial

= positive-going transition

= negative-going transition

= positive or negative output pulse; width is determined by C_t and R_t

A.C. CHARACTERISTICS

$V_{SS} = 0\text{ V}$; $T_{amb} = 25\text{ }^\circ\text{C}$; $C_L = 50\text{ pF}$; input transition times $\leq 20\text{ ns}$

| | V_{DD} V | symbol | min. | typ. | max. | typical extrapolation formula | |
|---|---------------|-----------|------|------|------|--|---|
| Propagation delays $\bar{T}_0, I_1 \rightarrow \bar{O}$ HIGH to LOW | 5 | t_{PHL} | | 140 | 280 | ns | $113\text{ ns} + (0,55\text{ ns/pF}) C_L$ |
| | 10 | | 50 | 100 | ns | $39\text{ ns} + (0,23\text{ ns/pF}) C_L$ | |
| | 15 | | 35 | 70 | ns | $27\text{ ns} + (0,16\text{ ns/pF}) C_L$ | |
| $\bar{T}_0, I_1 \rightarrow O$ LOW to HIGH | 5 | t_{PLH} | | 155 | 305 | ns | $128\text{ ns} + (0,55\text{ ns/pF}) C_L$ |
| | 10 | | 60 | 115 | ns | $49\text{ ns} + (0,23\text{ ns/pF}) C_L$ | |
| | 15 | | 40 | 80 | ns | $32\text{ ns} + (0,16\text{ ns/pF}) C_L$ | |
| $\bar{C}_D \rightarrow O$ HIGH to LOW | 5 | t_{PHL} | | 105 | 210 | ns | $78\text{ ns} + (0,55\text{ ns/pF}) C_L$ |
| | 10 | | 40 | 85 | ns | $29\text{ ns} + (0,23\text{ ns/pF}) C_L$ | |
| | 15 | | 30 | 60 | ns | $22\text{ ns} + (0,16\text{ ns/pF}) C_L$ | |
| $\bar{C}_D \rightarrow \bar{O}$ LOW to HIGH | 5 | t_{PLH} | | 120 | 240 | ns | $93\text{ ns} + (0,55\text{ ns/pF}) C_L$ |
| | 10 | | 50 | 105 | ns | $39\text{ ns} + (0,23\text{ ns/pF}) C_L$ | |
| | 15 | | 35 | 70 | ns | $27\text{ ns} + (0,16\text{ ns/pF}) C_L$ | |
| Output transition times HIGH to LOW | 5 | t_{THL} | | 60 | 120 | ns | $10\text{ ns} + (1,0\text{ ns/pF}) C_L$ |
| | 10 | | 30 | 60 | ns | $9\text{ ns} + (0,42\text{ ns/pF}) C_L$ | |
| | 15 | | 20 | 40 | ns | $6\text{ ns} + (0,28\text{ ns/pF}) C_L$ | |
| LOW to HIGH | 5 | t_{TLH} | | 60 | 120 | ns | $10\text{ ns} + (1,0\text{ ns/pF}) C_L$ |
| | 10 | | 30 | 60 | ns | $9\text{ ns} + (0,42\text{ ns/pF}) C_L$ | |
| | 15 | | 20 | 40 | ns | $6\text{ ns} + (0,28\text{ ns/pF}) C_L$ | |

A.C. CHARACTERISTICS

$V_{SS} = 0\text{ V}$; $T_{amb} = 25\text{ }^\circ\text{C}$; input transition times $\leq 20\text{ ns}$; $R_t = 5\text{ k}\Omega$; $C_t = 15\text{ pF}$

| | V_{DD} V | typical formula for P (μW) | where f_i = input freq. (MHz) f_o = output freq. (MHz) C_L = load capacitance (pF) $\Sigma(f_o C_L)$ = sum of outputs V_{DD} = supply voltage (V) |
|---|---------------|---|--|
| Dynamic power dissipation per package (P) | 5 | $4000 f_i + \Sigma(f_o C_L) \times V_{DD}^2$ | |
| | 10 | $20\,000 f_i + \Sigma(f_o C_L) \times V_{DD}^2$ | |
| | 15 | $59\,000 f_i + \Sigma(f_o C_L) \times V_{DD}^2$ | |

A.C. CHARACTERISTICS

$V_{SS} = 0\text{ V}$; $T_{amb} = 25\text{ }^{\circ}\text{C}$; $C_L = 50\text{ pF}$; input transition times $\leq 20\text{ ns}$; see also waveforms Fig. 5.

| | V_{DD} V | symbol | min. | typ. | max. | |
|---|---------------|-----------------|-----------|---------|-----------------|---|
| Recovery time for \bar{C}_D | 5 | t_{RCD} | 0 | -75 | ns | <div style="display: flex; flex-direction: column; align-items: center;"> <div style="margin-bottom: 10px;">} to avoid change in output</div> <div style="margin-bottom: 10px;">} note 1</div> <div style="margin-bottom: 10px;">} note 2</div> <div style="margin-bottom: 10px;">} note 3</div> <div style="margin-bottom: 10px;">} $V_{DD} \pm 5\%$</div> </div> |
| | 10 | | 0 | -30 | ns | |
| | 15 | | 0 | -25 | ns | |
| Minimum \bar{I}_0 pulse width; LOW | 5 | t_{WI0L} | 50 | 25 | ns | |
| | 10 | | 30 | 15 | ns | |
| | 15 | | 20 | 10 | ns | |
| Minimum I_1 pulse width; HIGH | 5 | t_{WI1H} | 50 | 25 | ns | |
| | 10 | | 30 | 15 | ns | |
| | 15 | | 20 | 10 | ns | |
| Minimum \bar{C}_D pulse width; LOW | 5 | t_{WCDL} | 60 | 30 | ns | |
| | 10 | | 35 | 15 | ns | |
| | 15 | | 25 | 10 | ns | |
| Set-up time $\bar{C}_D \rightarrow \bar{I}_0$ or I_1 | 5 | t_{su} | 0 | -105 | ns | |
| | 10 | | 0 | -40 | ns | |
| | 15 | | 0 | -25 | ns | |
| Output O pulse width; HIGH | 5 | t_{WOH} | - | 235 | ns | |
| | 10 | | - | 155 | ns | |
| | 15 | | - | 140 | ns | |
| Output O pulse width; HIGH | 5 | t_{WOH} | - | 5,45 | μs | |
| | 10 | | - | 4,95 | μs | |
| | 15 | | - | 4,85 | μs | |
| Change in output O pulse width over temperature | 5 | Δt_{WO} | - | ± 3 | % | |
| | 10 | | - | ± 2 | % | |
| | 15 | | - | ± 2 | % | |
| Change in output O pulse width over V_{DD} | 5 | Δt_{WO} | - | ± 2 | % | |
| | 10 | | - | ± 1 | % | |
| | 15 | | - | ± 1 | % | |
| External timing resistor | 5 | R_t | 5 | - | 2000 k Ω | |
| | 10 | | 5 | - | 2000 k Ω | |
| | 15 | | 5 | - | 2000 k Ω | |
| External timing capacitor | 5 | C_t | no limits | | | |
| | 10 | | no limits | | | |
| | 15 | | no limits | | | |

Notes

- $R_t = 5\text{ k}\Omega$; $C_t = 15\text{ pF}$; for other R_t , C_t combinations and $C_t < 0,01\text{ }\mu\text{F}$ see graph Fig. 4.
- $R_t = 10\text{ k}\Omega$; $C_t = 1000\text{ pF}$; for other R_t , C_t combinations and $C_t > 0,01\text{ }\mu\text{F}$ use formula $t_{WO} = K \cdot R_t \cdot C_t$.

where: t_{WO} = output pulse width (s)

R_t = external timing resistor (Ω)

C_t = external timing capacitor (F)

$K = 0,42$ for $V_{DD} = 5\text{ V}$

$K = 0,32$ for $V_{DD} = 10\text{ V}$

$K = 0,30$ for $V_{DD} = 15\text{ V}$

- $T_{amb} = -40$ to $+85\text{ }^{\circ}\text{C}$; Δt_{WO} is referenced to t_{WO} at $T_{amb} = 25\text{ }^{\circ}\text{C}$.

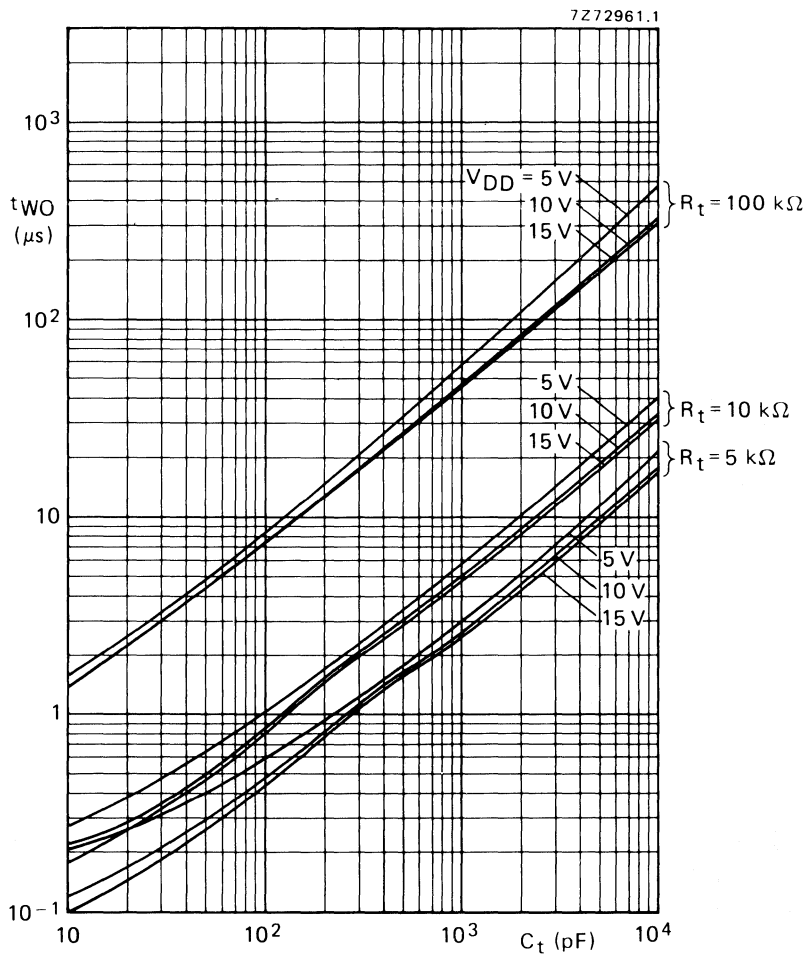
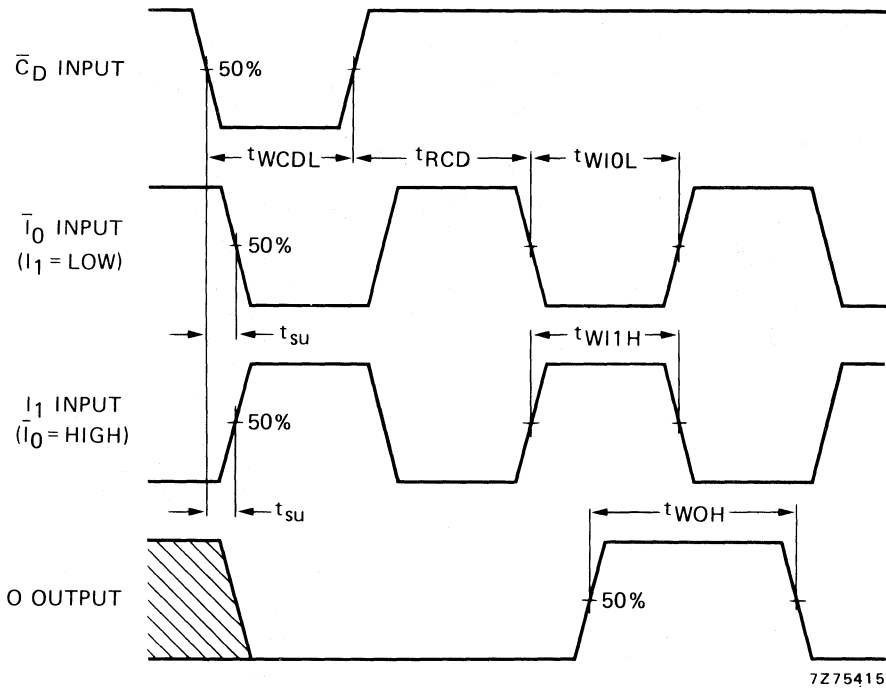

Fig. 4 Output pulse width (t_{WO}) as a function of external timing capacitor (C_t).



7275415

Fig. 5 Waveforms showing minimum \bar{I}_0 , I_1 and O pulse widths, set-up and recovery times. Set-up and recovery times are shown as positive values but may be specified as negative values.

APPLICATION INFORMATION

An example of an application for the HEF4528B is:

- Non-retriggerable monostable multivibrator

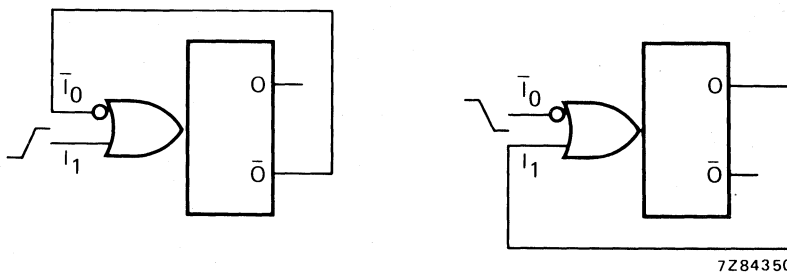

7284350

Fig. 6 Two examples for a non-retriggerable monostable multivibrator using half of HEF4528B (LOW to HIGH and HIGH to LOW triggered).

13-INPUT PARITY CHECKER/GENERATOR



The HEF4531B is a parity checker/generator with 13 parity inputs (I_0 to I_{12}) and a parity output (O). When the number of parity inputs that are HIGH is even, the output is LOW. When the number of parity inputs that are HIGH is odd, the output is HIGH. For words of 12 bits or less, the output can be used to generate either odd or even parity by appropriate termination of the unused parity input(s). For words of 14 or more bits, the devices can be cascaded by connecting the output of one device to any parity input of another device. When cascading devices, it is recommended that the output of one device be connected to the I_{12} input of the other device since there is less delay to the output from the I_{12} input than from any other input (I_0 to I_{11}).

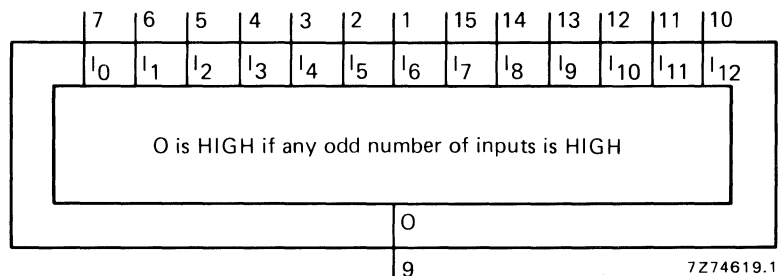

Fig. 1 Functional diagram.

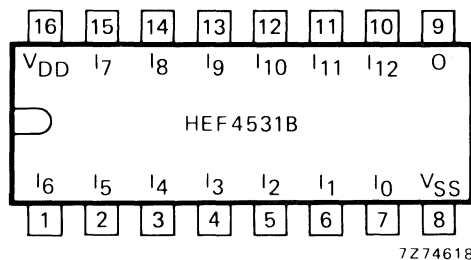

Fig. 2 Pinning diagram.

HEF4531BP : 16-lead DIL; plastic (SOT-38Z).
 HEF4531BD : 16-lead DIL; ceramic (cerdip) (SOT-74).
 HEF4531BT : 16-lead mini-pack; plastic
 (SO-16; SOT-109A).

FAMILY DATA

I_{DD} LIMITS category MSI

} see Family Specifications

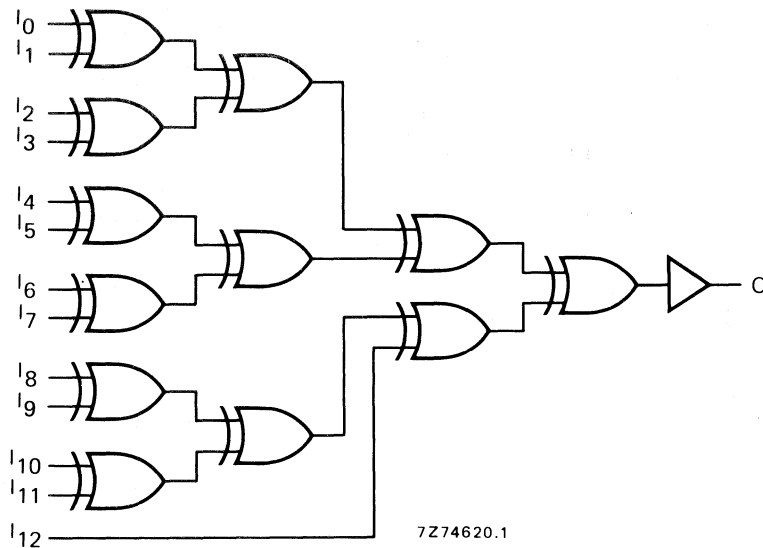

Fig. 3 Logic diagram.

FUNCTION TABLE

| inputs | | | | | | | | | | | | | output |
|--------------------------------|----------------|----------------|----------------|----------------|----------------|----------------|----------------|----------------|----------------|-----------------|-----------------|-----------------|--------|
| I ₀ | I ₁ | I ₂ | I ₃ | I ₄ | I ₅ | I ₆ | I ₇ | I ₈ | I ₉ | I ₁₀ | I ₁₁ | I ₁₂ | O |
| L | L | L | L | L | L | L | L | L | L | L | L | L | L |
| any odd number of inputs HIGH | | | | | | | | | | | | | H |
| any even number of inputs HIGH | | | | | | | | | | | | | L |
| H | H | H | H | H | H | H | H | H | H | H | H | H | H |

H = HIGH state (the more positive voltage)

L = LOW state (the less positive voltage)

A.C. CHARACTERISTICS

 $V_{SS} = 0\text{ V}$; $T_{amb} = 25\text{ }^{\circ}\text{C}$; input transition times $\leq 20\text{ ns}$

| | V_{DD} V | typical formula for P (μW) | where f_i = input freq. (MHz) f_o = output freq. (MHz) C_L = load capacitance (pF) $\Sigma(f_o C_L)$ = sum of outputs V_{DD} = supply voltage (V) |
|---|---------------|--|--|
| Dynamic power dissipation per package (P) | 5 | $425 f_i + \Sigma(f_o C_L) \times V_{DD}^2$ | |
| | 10 | $2\,400 f_i + \Sigma(f_o C_L) \times V_{DD}^2$ | |
| | 15 | $7\,700 f_i + \Sigma(f_o C_L) \times V_{DD}^2$ | |

A.C. CHARACTERISTICS

$V_{SS} = 0$ V; $T_{amb} = 25$ °C; $C_L = 50$ pF; input transition times ≤ 20 ns

| | V_{DD} V | symbol | typ. | max. | | typical extrapolation formula |
|--|---------------|-----------|------|------|----|---|
| Propagation delays I_0 to $I_{11} \rightarrow 0$ HIGH to LOW | 5 | t_{PHL} | 145 | 290 | ns | $118 \text{ ns} + (0,55 \text{ ns/pF}) C_L$ |
| | 10 | | 60 | 120 | ns | $49 \text{ ns} + (0,23 \text{ ns/pF}) C_L$ |
| | 15 | | 45 | 90 | ns | $37 \text{ ns} + (0,16 \text{ ns/pF}) C_L$ |
| LOW to HIGH | 5 | t_{PLH} | 135 | 270 | ns | $108 \text{ ns} + (0,55 \text{ ns/pF}) C_L$ |
| | 10 | | 55 | 110 | ns | $44 \text{ ns} + (0,23 \text{ ns/pF}) C_L$ |
| | 15 | | 45 | 90 | ns | $37 \text{ ns} + (0,16 \text{ ns/pF}) C_L$ |
| $I_{12} \rightarrow 0$ HIGH to LOW | 5 | t_{PHL} | 105 | 210 | ns | $78 \text{ ns} + (0,55 \text{ ns/pF}) C_L$ |
| | 10 | | 45 | 90 | ns | $34 \text{ ns} + (0,23 \text{ ns/pF}) C_L$ |
| | 15 | | 35 | 70 | ns | $27 \text{ ns} + (0,16 \text{ ns/pF}) C_L$ |
| LOW to HIGH | 5 | t_{PLH} | 85 | 170 | ns | $58 \text{ ns} + (0,55 \text{ ns/pF}) C_L$ |
| | 10 | | 35 | 70 | ns | $24 \text{ ns} + (0,23 \text{ ns/pF}) C_L$ |
| | 15 | | 25 | 50 | ns | $17 \text{ ns} + (0,16 \text{ ns/pF}) C_L$ |
| Output transition times HIGH to LOW | 5 | t_{THL} | 60 | 120 | ns | $10 \text{ ns} + (1,0 \text{ ns/pF}) C_L$ |
| | 10 | | 30 | 60 | ns | $9 \text{ ns} + (0,42 \text{ ns/pF}) C_L$ |
| | 15 | | 20 | 40 | ns | $6 \text{ ns} + (0,28 \text{ ns/pF}) C_L$ |
| LOW to HIGH | 5 | t_{TLH} | 60 | 120 | ns | $10 \text{ ns} + (1,0 \text{ ns/pF}) C_L$ |
| | 10 | | 30 | 60 | ns | $9 \text{ ns} + (0,42 \text{ ns/pF}) C_L$ |
| | 15 | | 20 | 40 | ns | $6 \text{ ns} + (0,28 \text{ ns/pF}) C_L$ |



8-INPUT PRIORITY ENCODER

The HEF4532B is an 8-input priority encoder with eight active HIGH priority inputs (I_0 to I_7), three active HIGH outputs (O_0 to O_2), an active HIGH enable input (E_{in}), an active HIGH enable output (E_{out}) and an active HIGH group select output (GS).

Data is accepted on inputs I_0 to I_7 . The binary code corresponding to the highest priority input (I_0 to I_7) which is HIGH, is generated on O_0 to O_2 if E_{in} is HIGH. Input I_7 is assigned the highest priority. GS is HIGH when one or more priority inputs and E_{in} are HIGH. E_{out} is HIGH when I_0 to I_7 are LOW and E_{in} is HIGH. E_{in} , when LOW, forces all outputs (O_0 to O_2 , GS, E_{out}) LOW.

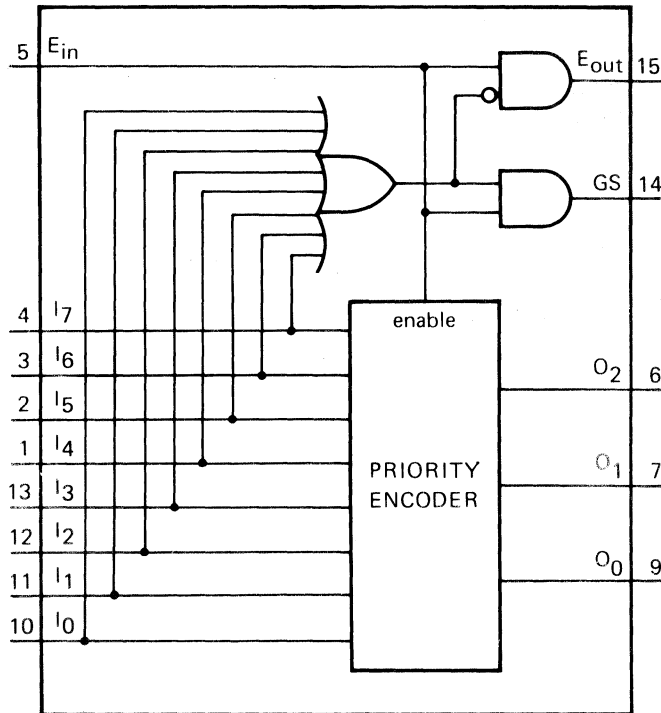

Fig. 1 Functional diagram.

7Z75371.1

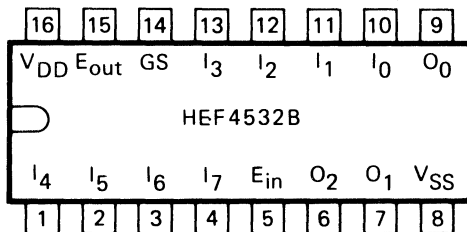

Fig. 2 Pinning diagram.

7Z75365.1

HEF4532BP: 16-lead DIL; plastic (SOT-38Z).

HEF4532BD: 16-lead DIL; ceramic (cerdip) (SOT-74).

HEF4532BT: 16-lead mini-pack; plastic (SO-16; SOT-109A).

PINNING

| | |
|----------------|---------------------|
| I_0 to I_7 | priority inputs |
| E_{in} | enable input |
| E_{out} | enable output |
| GS | group select output |
| O_0 to O_2 | outputs |

FAMILY DATA

 I_{DD} LIMITS category MSI

see Family Specifications

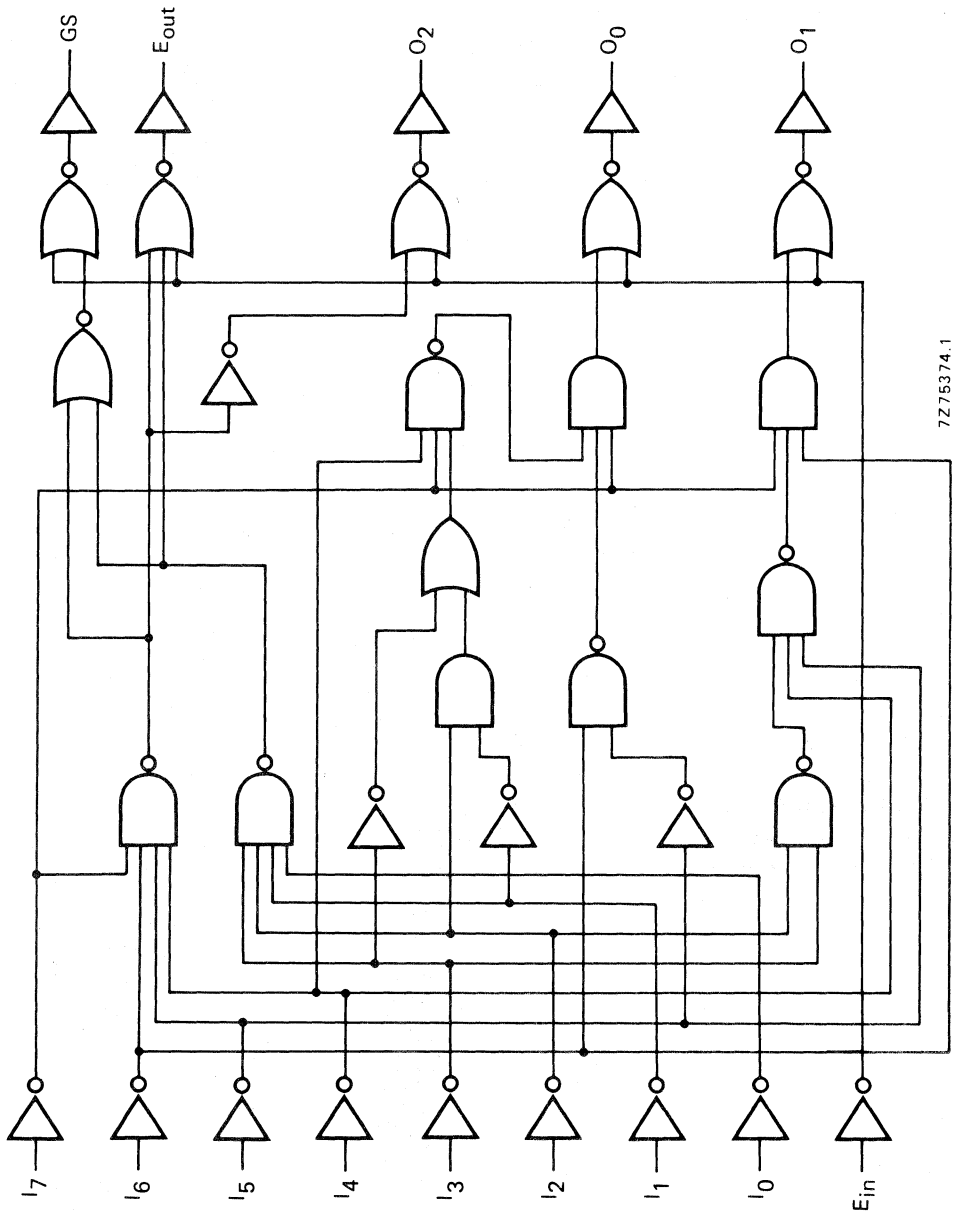

Fig. 3 Logic diagram.

TRUTH TABLE

| inputs | | | | | | | | | outputs | | | | |
|-----------------|----------------|----------------|----------------|----------------|----------------|----------------|----------------|----------------|---------|----------------|----------------|----------------|------------------|
| E _{in} | I ₇ | I ₆ | I ₅ | I ₄ | I ₃ | I ₂ | I ₁ | I ₀ | GS | O ₂ | O ₁ | O ₀ | E _{out} |
| L | X | X | X | X | X | X | X | X | L | L | L | L | L |
| H | L | L | L | L | L | L | L | L | L | L | L | L | H |
| H | H | X | X | X | X | X | X | X | H | H | H | H | L |
| H | L | H | X | X | X | X | X | X | H | H | H | L | L |
| H | L | L | H | X | X | X | X | X | H | H | L | H | L |
| H | L | L | L | H | X | X | X | X | H | H | L | L | L |
| H | L | L | L | L | H | X | X | X | H | L | H | H | L |
| H | L | L | L | L | L | H | X | X | H | L | H | L | L |
| H | L | L | L | L | L | L | H | X | H | L | L | H | L |
| H | L | L | L | L | L | L | L | H | H | L | L | L | L |

H = HIGH state (the more positive voltage)

L = LOW state (the less positive voltage)

X = state is immaterial

LOGIC EQUATIONS

$$O_2 = E_{in} \cdot (I_4 + I_5 + I_6 + I_7)$$

$$O_1 = E_{in} \cdot (I_2 \cdot \bar{I}_4 \cdot \bar{I}_5 + I_3 \cdot \bar{I}_4 \cdot \bar{I}_5 + I_6 + I_7)$$

$$O_0 = E_{in} \cdot (I_1 \cdot \bar{I}_2 \cdot \bar{I}_4 \cdot \bar{I}_6 + I_3 \cdot \bar{I}_4 \cdot \bar{I}_6 + I_5 \cdot \bar{I}_6 + I_7)$$

$$E_{out} = E_{in} \cdot \bar{I}_0 \cdot \bar{I}_1 \cdot \bar{I}_2 \cdot \bar{I}_3 \cdot \bar{I}_4 \cdot \bar{I}_5 \cdot \bar{I}_6 \cdot \bar{I}_7$$

$$GS = E_{in} \cdot (I_0 + I_1 + I_2 + I_3 + I_4 + I_5 + I_6 + I_7)$$

A.C. CHARACTERISTICS

V_{SS} = 0 V; T_{amb} = 25 °C; input transition times ≤ 20 ns

| | V _{DD} V | typical formula for P (μW) | where f _i = input freq. (MHz) f _o = output freq. (MHz) C _L = load capacitance (pF) Σ(f _o C _L) = sum of outputs V _{DD} = supply voltage (V) |
|---|----------------------|--|--|
| Dynamic power dissipation per package (P) | 5 | 1 620 f _i + Σ(f _o C _L) × V _{DD} ² | |
| | 10 | 6 600 f _i + Σ(f _o C _L) × V _{DD} ² | |
| | 15 | 15 970 f _i + Σ(f _o C _L) × V _{DD} ² | |

A.C. CHARACTERISTICS

$V_{SS} = 0\text{ V}$; $T_{amb} = 25\text{ }^{\circ}\text{C}$; $C_L = 50\text{ pF}$; input transition times $\leq 20\text{ ns}$; see also waveforms Fig. 4

| | V_{DD} V | symbol | min. | typ. | max. | typical extrapolation formula | |
|---|---------------|--------|------|------|------|--|--|
| Propagation delays $E_{in} \rightarrow E_{out}$ HIGH to LOW | 5 | tPHL | | 95 | 190 | ns | $68\text{ ns} + (0,55\text{ ns/pF}) C_L$ |
| | 10 | | 45 | 90 | ns | $34\text{ ns} + (0,23\text{ ns/pF}) C_L$ | |
| | 15 | | 35 | 70 | ns | $27\text{ ns} + (0,16\text{ ns/pF}) C_L$ | |
| LOW to HIGH | 5 | tPLH | | 80 | 160 | ns | $53\text{ ns} + (0,55\text{ ns/pF}) C_L$ |
| | 10 | | 35 | 70 | ns | $24\text{ ns} + (0,23\text{ ns/pF}) C_L$ | |
| | 15 | | 30 | 60 | ns | $22\text{ ns} + (0,16\text{ ns/pF}) C_L$ | |
| $E_{in} \rightarrow GS$ HIGH to LOW | 5 | tPHL | | 85 | 170 | ns | $58\text{ ns} + (0,55\text{ ns/pF}) C_L$ |
| | 10 | | 45 | 90 | ns | $34\text{ ns} + (0,23\text{ ns/pF}) C_L$ | |
| | 15 | | 35 | 70 | ns | $27\text{ ns} + (0,16\text{ ns/pF}) C_L$ | |
| LOW to HIGH | 5 | tPLH | | 80 | 160 | ns | $53\text{ ns} + (0,55\text{ ns/pF}) C_L$ |
| | 10 | | 40 | 80 | ns | $29\text{ ns} + (0,23\text{ ns/pF}) C_L$ | |
| | 15 | | 30 | 60 | ns | $22\text{ ns} + (0,16\text{ ns/pF}) C_L$ | |
| $E_{in} \rightarrow O_n$ HIGH to LOW | 5 | tPHL | | 80 | 160 | ns | $53\text{ ns} + (0,55\text{ ns/pF}) C_L$ |
| | 10 | | 40 | 80 | ns | $29\text{ ns} + (0,23\text{ ns/pF}) C_L$ | |
| | 15 | | 30 | 60 | ns | $22\text{ ns} + (0,16\text{ ns/pF}) C_L$ | |
| LOW to HIGH | 5 | tPLH | | 85 | 170 | ns | $58\text{ ns} + (0,55\text{ ns/pF}) C_L$ |
| | 10 | | 40 | 80 | ns | $29\text{ ns} + (0,23\text{ ns/pF}) C_L$ | |
| | 15 | | 30 | 60 | ns | $22\text{ ns} + (0,16\text{ ns/pF}) C_L$ | |
| $I_n \rightarrow O_n$ HIGH to LOW | 5 | tPHL | | 115 | 230 | ns | $88\text{ ns} + (0,55\text{ ns/pF}) C_L$ |
| | 10 | | 50 | 100 | ns | $39\text{ ns} + (0,23\text{ ns/pF}) C_L$ | |
| | 15 | | 35 | 70 | ns | $27\text{ ns} + (0,16\text{ ns/pF}) C_L$ | |
| LOW to HIGH | 5 | tPLH | | 115 | 230 | ns | $88\text{ ns} + (0,55\text{ ns/pF}) C_L$ |
| | 10 | | 50 | 100 | ns | $39\text{ ns} + (0,23\text{ ns/pF}) C_L$ | |
| | 15 | | 35 | 70 | ns | $27\text{ ns} + (0,16\text{ ns/pF}) C_L$ | |
| $I_n \rightarrow GS$ HIGH to LOW | 5 | tPHL | | 115 | 230 | ns | $88\text{ ns} + (0,55\text{ ns/pF}) C_L$ |
| | 10 | | 50 | 100 | ns | $39\text{ ns} + (0,23\text{ ns/pF}) C_L$ | |
| | 15 | | 40 | 80 | ns | $32\text{ ns} + (0,16\text{ ns/pF}) C_L$ | |
| LOW to HIGH | 5 | tPLH | | 115 | 230 | ns | $88\text{ ns} + (0,55\text{ ns/pF}) C_L$ |
| | 10 | | 50 | 100 | ns | $39\text{ ns} + (0,23\text{ ns/pF}) C_L$ | |
| | 15 | | 40 | 80 | ns | $32\text{ ns} + (0,16\text{ ns/pF}) C_L$ | |
| Output transition times HIGH to LOW | 5 | tTHL | | 60 | 120 | ns | $10\text{ ns} + (1,0\text{ ns/pF}) C_L$ |
| | 10 | | 30 | 60 | ns | $9\text{ ns} + (0,42\text{ ns/pF}) C_L$ | |
| | 15 | | 20 | 40 | ns | $6\text{ ns} + (0,28\text{ ns/pF}) C_L$ | |
| LOW to HIGH | 5 | tTLH | | 60 | 120 | ns | $10\text{ ns} + (1,0\text{ ns/pF}) C_L$ |
| | 10 | | 30 | 60 | ns | $9\text{ ns} + (0,42\text{ ns/pF}) C_L$ | |
| | 15 | | 20 | 40 | ns | $6\text{ ns} + (0,28\text{ ns/pF}) C_L$ | |

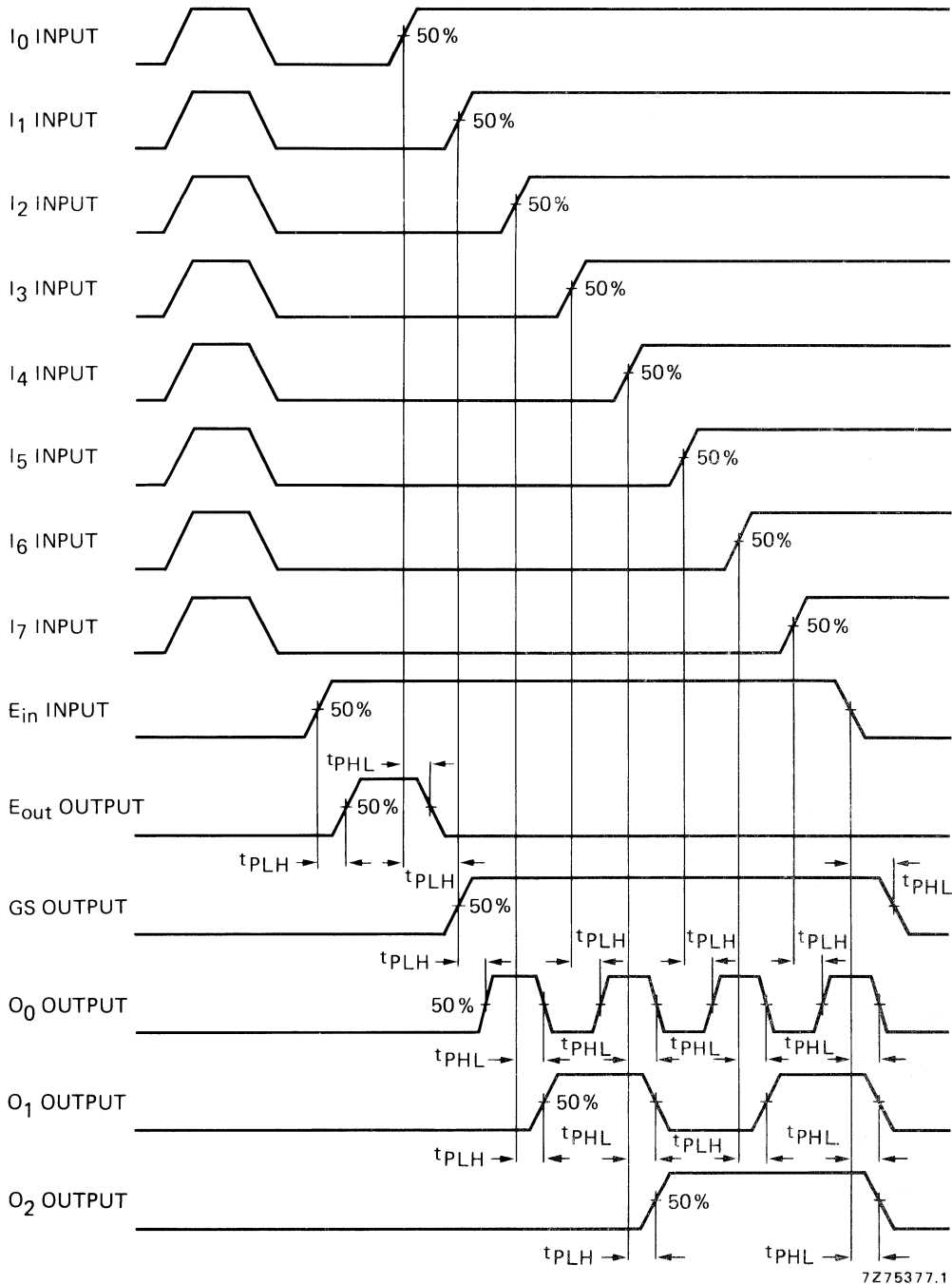

Fig. 4 Waveforms showing propagation delays from inputs to outputs.

APPLICATION INFORMATION

Some examples of applications for the HEF4532B are:

- Priority encoder
- Keyboard encoder

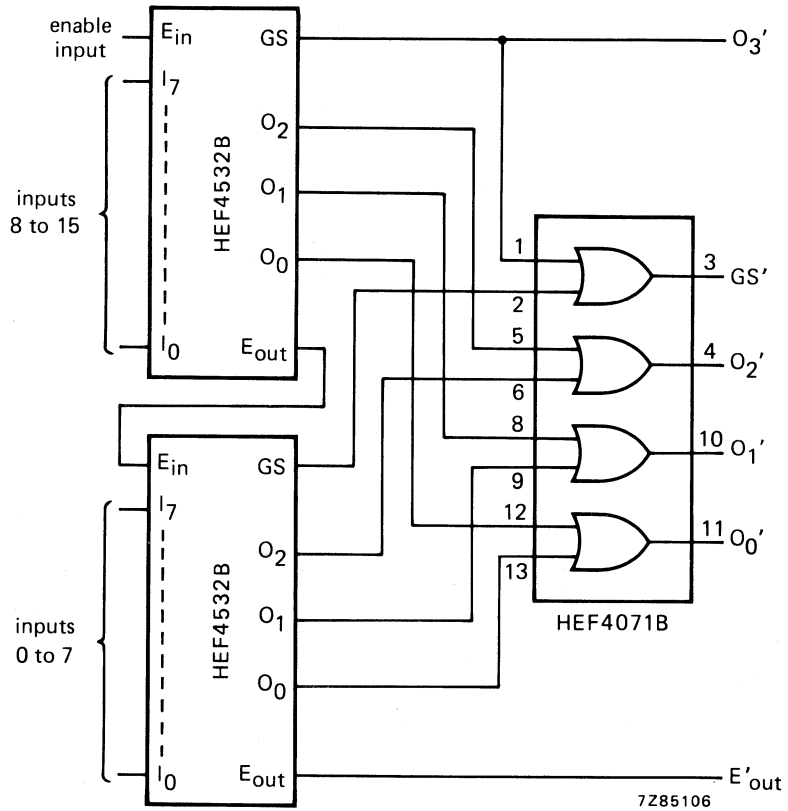

Fig. 5 16-level priority encoder.

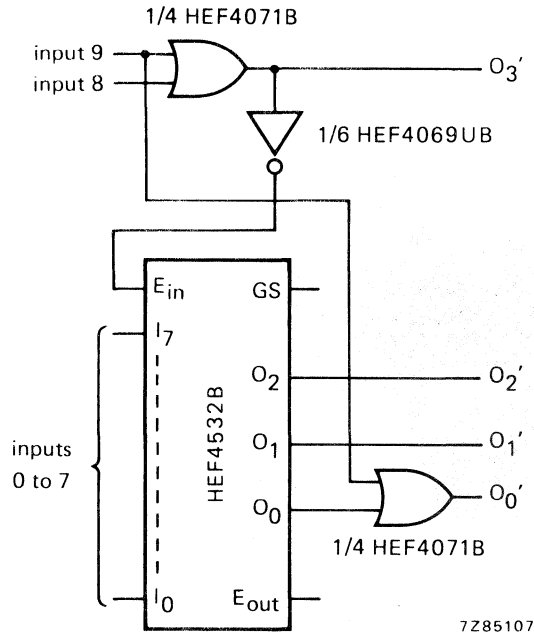

Fig. 6 0-to-9 keyboard encoder.

TRUTH TABLE (for Fig. 6)

| inputs | | | | | | | | | | outputs | | | | |
|--------|---|---|---|---|---|---|---|---|---|---------|------------------|------------------|------------------|------------------|
| 9 | 8 | 7 | 6 | 5 | 4 | 3 | 2 | 1 | 0 | GS | O ₃ ' | O ₂ ' | O ₁ ' | O ₀ ' |
| H | X | X | X | X | X | X | X | X | X | L | H | L | L | H |
| L | H | X | X | X | X | X | X | X | X | L | H | L | L | L |
| L | L | H | X | X | X | X | X | X | X | H | L | H | H | H |
| L | L | L | H | X | X | X | X | X | X | H | L | H | H | L |
| L | L | L | L | H | X | X | X | X | X | H | L | H | L | H |
| L | L | L | L | L | H | X | X | X | X | H | L | H | L | L |
| L | L | L | L | L | L | H | X | X | X | H | L | L | H | H |
| L | L | L | L | L | L | L | H | X | X | H | L | L | L | L |
| L | L | L | L | L | L | L | L | H | X | H | L | L | L | H |
| L | L | L | L | L | L | L | L | L | H | H | L | L | L | L |

H = HIGH state (the more positive voltage)

L = LOW state (the less positive voltage)

X = state is immaterial

REAL TIME 5-DECADE COUNTER



The HEF4534B is a 5-decade ripple counter. The binary outputs of the decade counters are time-multiplexed by an internal scanner on four BCD outputs (O_0 to O_3). The selected decade is indicated by a logic HIGH on the appropriate digit select output (OS_0 : units, 1; OS_1 : tens, 10; OS_2 : hundreds, 10^2 ; OS_3 : thousands, 10^3 ; OS_4 : ten thousands, 10^4).

The binary outputs (O_0 to O_3) and the select outputs (OS_0 to OS_4) are 3-state controlled via enable inputs \overline{EO} and \overline{EOS} respectively, allowing interface with other bus orientated devices. Cascading may be accomplished by using the carry out (TC). The counter is triggered by a LOW to HIGH transition on the decade clock (CPA) and is reset by a HIGH level on the master reset (MR). The scanner is triggered by a LOW to HIGH transition on the scanner clock (CPS) and is reset (select ten thousand counter) by a HIGH level on the scanner reset (MR_{sc}).

The counter can operate in four modes depending on the state of the mode select inputs (S_A , S_B). The error detector will detect an error when a positive edge on CPA is not accompanied by a negative edge on the error detector clock \overline{CPE} or vice versa, within time limits adjusted by external capacitors connected to C_{ext1} and C_{ext2} . Three or more detected errors result in a HIGH level on the error output (OER). The error detector is reset by a HIGH level on MR.

Schmitt-trigger action in the clock inputs makes the circuit highly tolerant to slower clock rise and fall times.

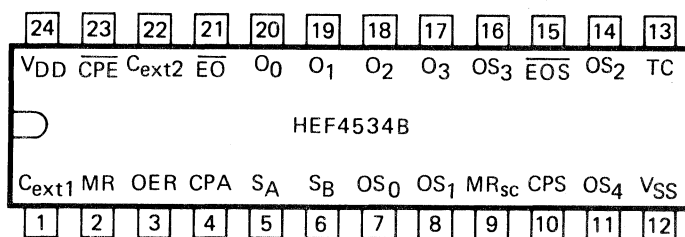

7Z74602.1

Fig. 1 Pinning diagram.

HEF4534BP : 24-lead DIL; plastic (SOT-101A).

HEF4534BD: 24-lead DIL; ceramic (cerdip) (SOT-94).

HEF4534BT: 24-lead mini-pack; plastic (SO-24; SOT-137A).

PINNING

| | | | |
|------------------|----------------------|------------------|----------------------------|
| O_1 to O_3 | BCD outputs | \overline{CPE} | error detector clock input |
| OS_0 to OS_3 | digit select outputs | S_A , S_B | mode select inputs |
| OER | error output | MR | master reset input |
| CPA | decade clock input | MR_{sc} | scanner reset input |
| CPS | scanner clock input | TC | carry out |

FAMILY DATA

I_{DD} LIMITS category LSI

} see Family Specifications

HEF4534B

LSI

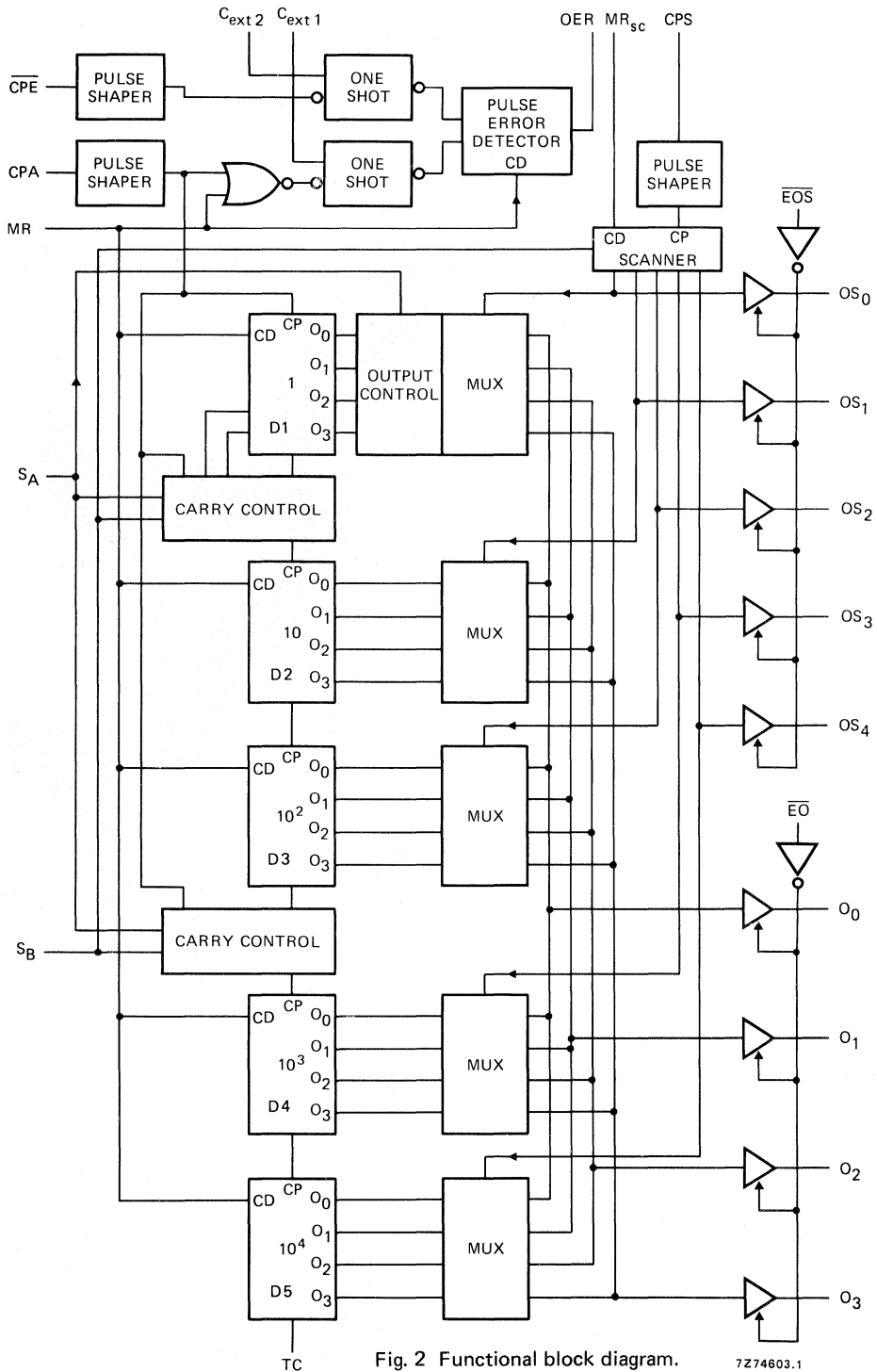

Fig. 2 Functional block diagram.

7274603.1

MODE CONTROL FUNCTION TABLE

| select inputs | | 1st decade output | carry to 2nd stage | carry to 4th stage | mode |
|----------------|----------------|---|--|--|---|
| S _A | S _B | | | | |
| L | L | normal count and display | at 9 to 0 transition of the 1st decade | at 9 to 0 transition of the 3rd decade | 5-decade counter |
| L | H | inhibited | input clock | input clock | test purposes: clock directly into stages 1, 2 and 4 |
| H | H | inhibited | at 4 to 5 transition of the 1st decade | at 9 to 0 transition of the 3rd decade | 4-decade counter with ÷10 and round-off at front end |
| H | L | display counts: 3, 4, 5, 6, 7 = 5 8, 9, 0, 1, 2 = 0 | at 7 to 8 transition of the 1st decade | at 9 to 0 transition of the 3rd decade | 4-decade counter; ½-pence capability |

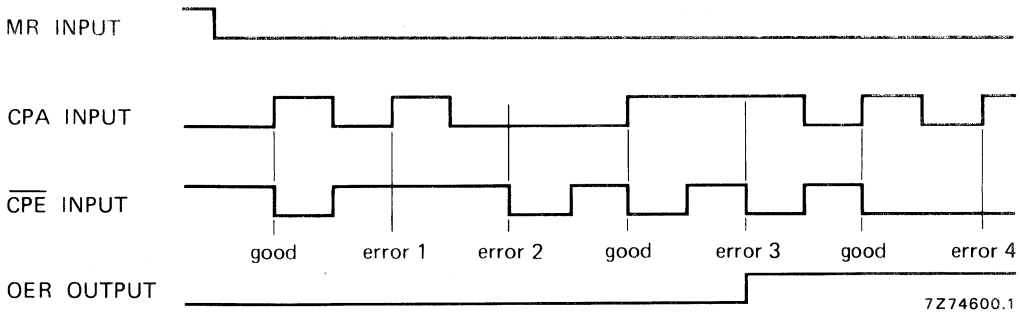

Fig. 3 Error detection timing diagram.

The skew time is the time difference between the LOW to HIGH transition of CPA and the HIGH to LOW transition of CPE or vice versa (see Fig. 4). The skew time is typically proportional to the external capacitor (C_{ext}) connected from C_{ext1} and C_{ext2} (pins 1 and 22) to V_{SS} . The error detector will count an error when a positive edge on the counter clock CPA is not succeeded by a negative edge on the error detector clock CPE within a skew time t_{SK1} (adjustable by C_{ext1} at pin 1). The same holds for a negative edge at CPE succeeded by a positive on CPA within a skew time t_{SK2} (adjustable by C_{ext2} at pin 22). If error detection is not needed, CPE must be either HIGH or LOW and no C_{ext} is applied. For further information see Fig. 5.

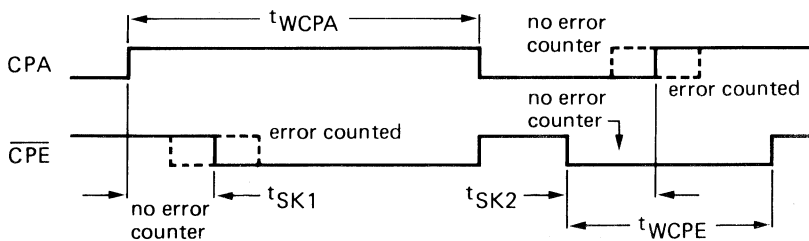

Fig. 4 Skew times timing diagram; $t_{WCPA} > t_{SK1}$; $t_{WCE} > t_{SK2}$.

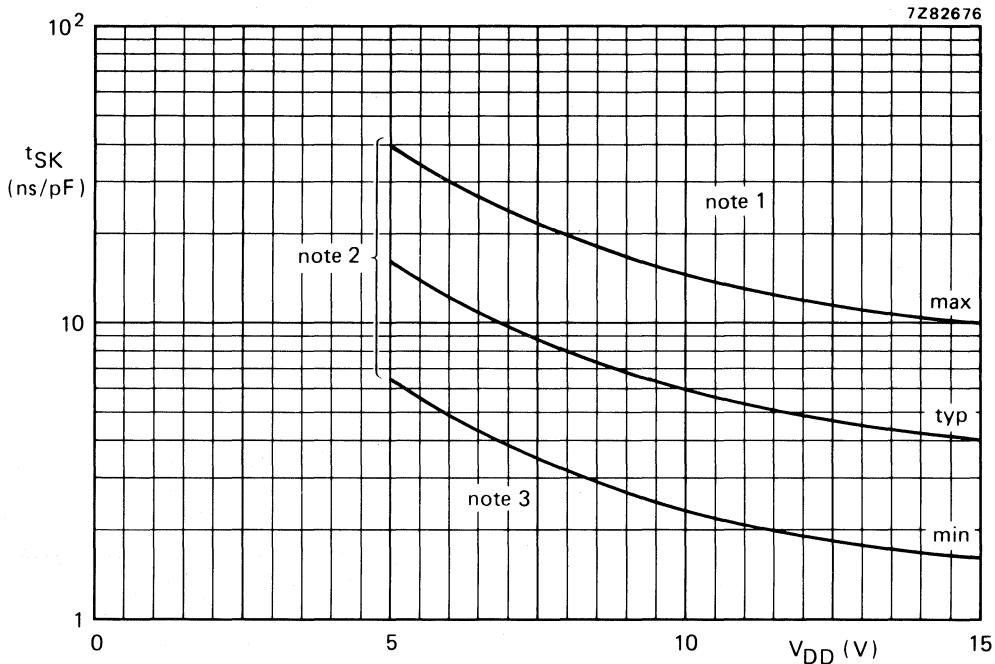

Fig. 5 Typical clock skew as a function of the supply voltage. This graph is accurate for $C_{ext} \geq 100$ pF and $T_{amb} = 25$ °C.

Notes to Fig. 5

1. Skew in this area results in counted error.
2. Skew in the area between max. and min. curves may or may not result in counted error.
3. Skew in this area results in no error counted.

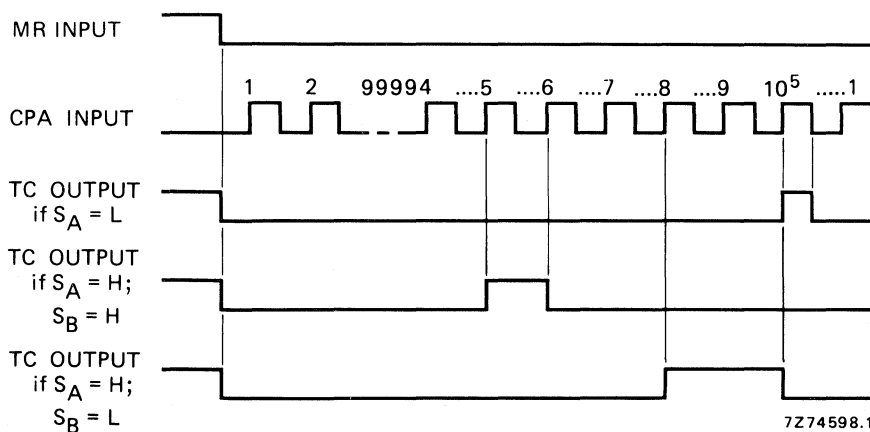

Fig. 6 Carry timing diagram.

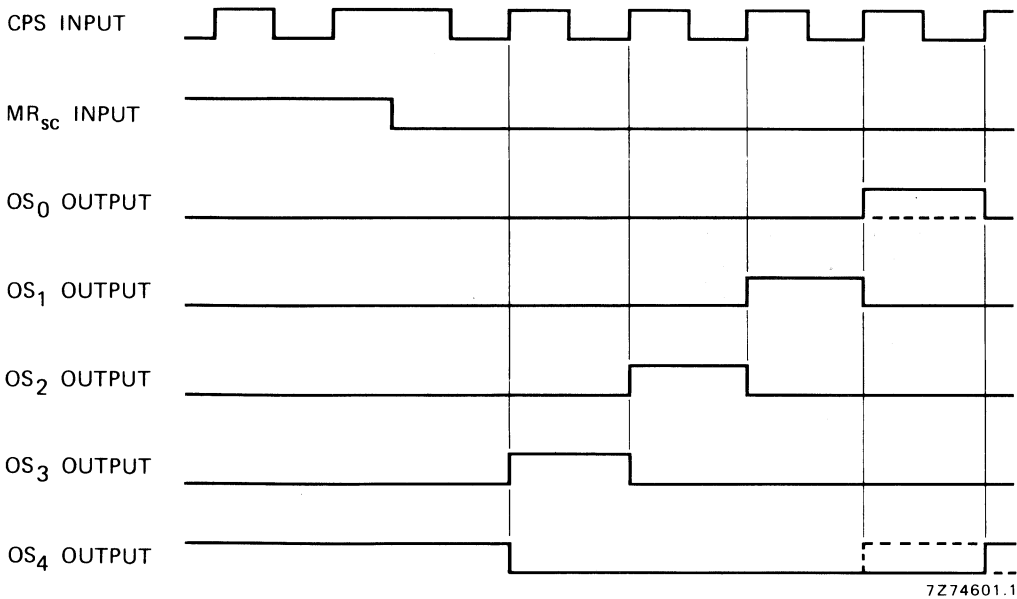

Fig. 7 Scanner timing diagram.

Note: If $S_B = H$, the 1st decade is inhibited and the cycle will be shortened to four stages (see dotted lines).

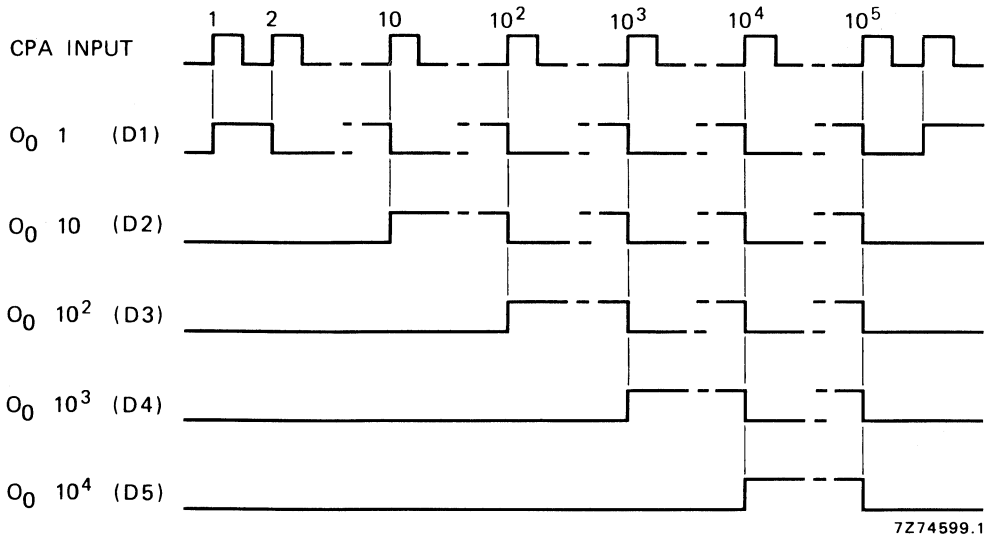

Fig. 8 Counter timing diagram.

A.C. CHARACTERISTICS

 $V_{SS} = 0 \text{ V}$; $T_{amb} = 25 \text{ }^\circ\text{C}$; $C_L = 50 \text{ pF}$; input transition times $\leq 20 \text{ ns}$

| | V_{DD} V | symbol | min. | typ. | max. | typical extrapolation formula | |
|--------------------------|---------------|-----------|------|------|------|----------------------------------|-----------------------------|
| Propagation delays | | | | | | | |
| CPA \rightarrow O_n | 5 | | | 300 | 600 | ns | 283 ns + (0,55 ns/pF) C_L |
| D1 selected | 10 | t_{PHL} | | 130 | 260 | ns | 119 ns + (0,23 ns/pF) C_L |
| HIGH to LOW | 15 | | | 95 | 190 | ns | 87 ns + (0,16 ns/pF) C_L |
| | 5 | | | 240 | 480 | ns | 213 ns + (0,55 ns/pF) C_L |
| LOW to HIGH | 10 | t_{PLH} | | 100 | 200 | ns | 89 ns + (0,23 ns/pF) C_L |
| | 15 | | | 75 | 150 | ns | 67 ns + (0,16 ns/pF) C_L |
| CPA \rightarrow O_n | 5 | | | 550 | 1100 | ns | 523 ns + (0,55 ns/pF) C_L |
| D5 selected | 10 | t_{PHL} | | 230 | 460 | ns | 219 ns + (0,23 ns/pF) C_L |
| HIGH to LOW | 15 | | | 170 | 340 | ns | 162 ns + (0,16 ns/pF) C_L |
| | 5 | | | 550 | 1100 | ns | 523 ns + (0,55 ns/pF) C_L |
| LOW to HIGH | 10 | t_{PLH} | | 230 | 460 | ns | 219 ns + (0,23 ns/pF) C_L |
| | 15 | | | 170 | 340 | ns | 162 ns + (0,16 ns/pF) C_L |
| CPA \rightarrow TC | 5 | | | 420 | 840 | ns | 393 ns + (0,55 ns/pF) C_L |
| LOW to HIGH | 10 | t_{PLH} | | 190 | 380 | ns | 179 ns + (0,23 ns/pF) C_L |
| | 15 | | | 140 | 280 | ns | 132 ns + (0,16 ns/pF) C_L |
| MR \rightarrow O_n | 5 | | | 200 | 400 | ns | 173 ns + (0,55 ns/pF) C_L |
| HIGH to LOW | 10 | t_{PHL} | | 85 | 170 | ns | 74 ns + (0,23 ns/pF) C_L |
| | 15 | | | 60 | 120 | ns | 52 ns + (0,16 ns/pF) C_L |
| MR \rightarrow OER | 5 | | | 140 | 280 | ns | 113 ns + (0,55 ns/pF) C_L |
| HIGH to LOW | 10 | t_{PHL} | | 65 | 130 | ns | 54 ns + (0,23 ns/pF) C_L |
| | 15 | | | 50 | 100 | ns | 42 ns + (0,16 ns/pF) C_L |
| CPS \rightarrow O_n | 5 | | | 225 | 450 | ns | 198 ns + (0,55 ns/pF) C_L |
| HIGH to LOW | 10 | t_{PHL} | | 95 | 190 | ns | 84 ns + (0,23 ns/pF) C_L |
| | 15 | | | 70 | 140 | ns | 62 ns + (0,16 ns/pF) C_L |
| | 5 | | | 225 | 450 | ns | 198 ns + (0,55 ns/pF) C_L |
| LOW to HIGH | 10 | t_{PLH} | | 95 | 190 | ns | 84 ns + (0,23 ns/pF) C_L |
| | 15 | | | 70 | 140 | ns | 62 ns + (0,16 ns/pF) C_L |
| CPS \rightarrow OS_n | 5 | | | 170 | 340 | ns | 143 ns + (0,55 ns/pF) C_L |
| HIGH to LOW | 10 | t_{PHL} | | 70 | 140 | ns | 59 ns + (0,23 ns/pF) C_L |
| | 15 | | | 50 | 100 | ns | 42 ns + (0,16 ns/pF) C_L |
| CPA \rightarrow OS_n | 5 | | | 170 | 340 | ns | 143 ns + (0,55 ns/pF) C_L |
| LOW to HIGH | 10 | t_{PLH} | | 70 | 140 | ns | 59 ns + (0,23 ns/pF) C_L |
| | 15 | | | 50 | 100 | ns | 42 ns + (0,16 ns/pF) C_L |
| Output transition times | | | | | | | |
| | 5 | | | 60 | 120 | ns | 10 ns + (1,0 ns/pF) C_L |
| HIGH to LOW | 10 | t_{THL} | | 30 | 60 | ns | 9 ns + (0,42 ns/pF) C_L |
| | 15 | | | 20 | 40 | ns | 6 ns + (0,28 ns/pF) C_L |
| | 5 | | | 60 | 120 | ns | 10 ns + (1,0 ns/pF) C_L |
| LOW to HIGH | 10 | t_{TLH} | | 30 | 60 | ns | 9 ns + (0,42 ns/pF) C_L |
| | 15 | | | 20 | 40 | ns | 6 ns + (0,28 ns/pF) C_L |

A.C. CHARACTERISTICS

$V_{SS} = 0\text{ V}$; $T_{amb} = 25\text{ }^\circ\text{C}$; $C_L = 50\text{ pF}$; input transition times $\leq 20\text{ ns}$

| | V_{DD} V | symbol | min. | typ. | max. | |
|--|---------------|------------------|------|------|------|-----|
| 3-state propagation delays | | | | | | |
| Output disable times | | | | | | |
| $\overline{EO} \rightarrow O_n$; $\overline{EOS} \rightarrow OS_n$ | 5 | tPHZ | | 30 | 60 | ns |
| HIGH | 10 | | | 25 | 50 | ns |
| | 15 | | | 20 | 40 | ns |
| LOW | 5 | tPLZ | | 40 | 80 | ns |
| | 10 | | | 25 | 50 | ns |
| | 15 | | | 20 | 40 | ns |
| Output enable times | | | | | | |
| $\overline{EO} \rightarrow O_n$; $\overline{EOS} \rightarrow OS_n$ | 5 | tPZH | | 35 | 70 | ns |
| HIGH | 10 | | | 20 | 40 | ns |
| | 15 | | | 15 | 30 | ns |
| LOW | 5 | tPZL | | 50 | 100 | ns |
| | 10 | | | 25 | 50 | ns |
| | 15 | | | 15 | 30 | ns |
| Minimum clock pulse width; CPA, CPS | 5 | tWCPH | 70 | 35 | | ns |
| HIGH | 10 | | | 40 | 20 | ns |
| | 15 | | | 30 | 15 | ns |
| Minimum reset pulse width; MR, MR _{sc} | 5 | tWMRH | 90 | 45 | | ns |
| HIGH | 10 | | | 60 | 30 | ns |
| | 15 | | | 40 | 20 | ns |
| Recovery time for MR | 5 | tRMR | 120 | 60 | | ns |
| | 10 | | | 60 | 30 | ns |
| | 15 | | | 50 | 25 | ns |
| Recovery time for MR _{sc} | 5 | tRMR | 60 | 30 | | ns |
| | 10 | | | 40 | 20 | ns |
| | 15 | | | 30 | 15 | ns |
| Maximum clock pulse frequency | 5 | f _{max} | 2,5 | 5 | | MHz |
| CPA and CPS | 10 | | | 6 | 12 | MHz |
| | 15 | | | 8 | 16 | MHz |

| | V_{DD} V | typical formula for P (μW) | where f _i = input freq. (MHz) f _o = output freq. (MHz) C _L = load cap. (pF) $\Sigma(f_o C_L)$ = sum of outputs V _{DD} = supply voltage (V) |
|--|---------------|--|---|
| Dynamic power dissipation per package (P)* | 5 | $1\ 100\ f_i + \Sigma(f_o C_L) \times V_{DD}^2$ | |
| | 10 | $4\ 800\ f_i + \Sigma(f_o C_L) \times V_{DD}^2$ | |
| | 15 | $12\ 000\ f_i + \Sigma(f_o C_L) \times V_{DD}^2$ | |

* C_{ext} = 0.

APPLICATION INFORMATION

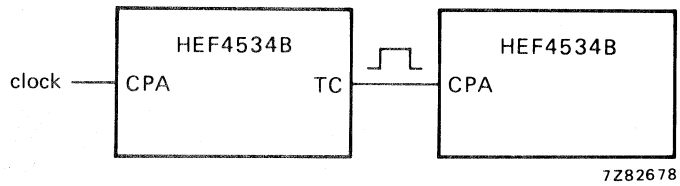

Fig. 9 Two HEF4534B ICs connected for cascade operation. TC is HIGH for a single clock period when all five BCD decades go to zero. TC also goes HIGH when MR is applied.

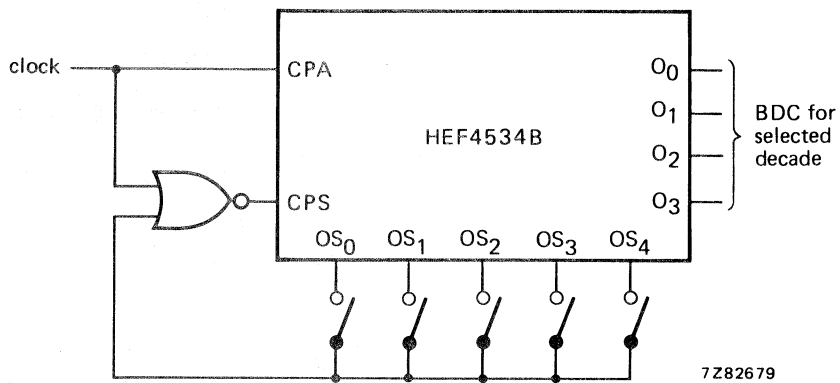

Fig. 10 Forcing a decade to the O_n outputs. When the O_n outputs of a given decade are required, this configuration will lock-up the selected decade within four clock cycles. The select line feed back may be hardwired or switched.

DUAL PRECISION MONOSTABLE MULTIVIBRATOR

The HEF4538B is a dual retriggerable-resettable monostable multivibrator. Each multivibrator has an active LOW trigger/retrigger input (\bar{I}_0), an active HIGH trigger/retrigger input (I_1), an overriding active LOW direct reset input (\bar{C}_D), an output (O) and its complement (\bar{O}), and two pins (C_{TC} , R_{TC}) for connecting the external timing components C_t and R_t . Typical pulse width variation over temperature range is $\pm 0,2\%$.

The HEF4538B may be triggered by either the positive or the negative edges of the input pulse and will produce an accurate output pulse with a pulse width range of $10 \mu s$ to infinity. The duration and accuracy of the output pulse are determined by the external timing components C_t and R_t . The output pulse width (T) is equal to $R_t \times C_t$. The linear design techniques in LOC MOS guarantee precise control of the output pulse width.

A LOW level at \bar{C}_D terminates the output pulse immediately. The minimum reset pulse width depends on the value of the external timing capacitor C_t .

Schmitt-trigger action in the trigger inputs makes the circuit highly tolerant to slower rise and fall times.

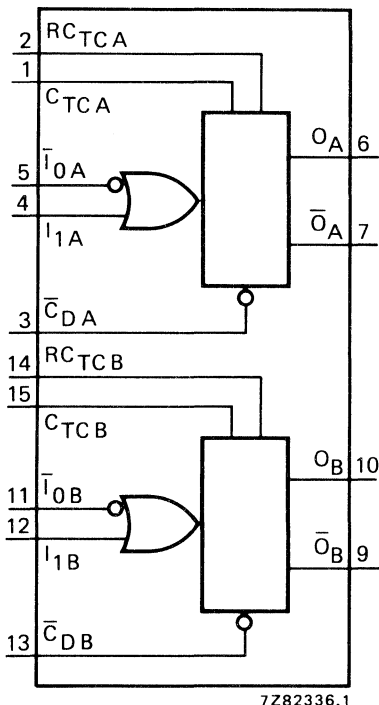

Fig. 1 Functional diagram.

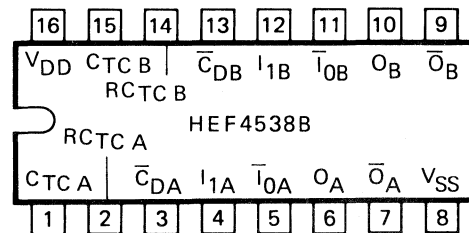

Fig. 2 Pinning diagram.

HEF4538BP : 16-lead DIL; plastic (SOT-38Z).
HEF4538BD : 16-lead DIL; ceramic (cerdip) (SOT-74).
HEF4538BT : 16-lead mini-pack; plastic (SO-16; SOT-109A).

PINNING

$\bar{I}_{0A}, \bar{I}_{0B}$ input (HIGH to LOW triggered)
 I_{1A}, I_{1B} input (LOW to HIGH triggered)
 $\bar{C}_{DA}, \bar{C}_{DB}$ direct reset input (active LOW)
 O_A, O_B output
 \bar{O}_A, \bar{O}_B complementary output (active LOW)
 $C_{TC A}, C_{TC B}$ external capacitor connections*

$R_{TC A}, R_{TC B}$ external capacitor/
resistor connections

* Always connected to ground.

FAMILY DATA; I_{DD} LIMITS category MSI: see Family specifications.

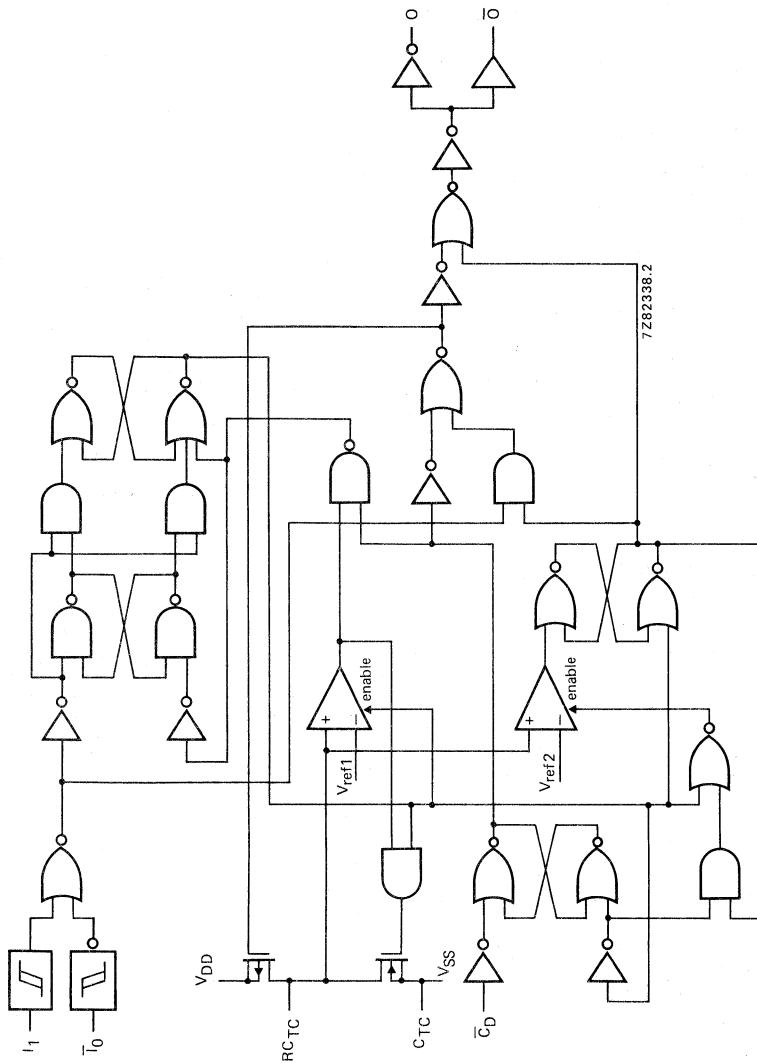

Fig. 3 Logic diagram.

FUNCTION TABLE

| inputs | | | outputs | |
|-------------|------------|-------------|------------|--------------|
| \bar{I}_0 | I_1 | \bar{C}_D | O | \bar{O} |
| \searrow | L | H | \uparrow | \downarrow |
| H | \swarrow | H | \uparrow | \downarrow |
| X | X | L | L | H |

H = HIGH state (the more positive voltage)
 L = LOW state (the less positive voltage)
 X = state is immaterial
 \swarrow = positive-going transition
 \searrow = negative-going transition
 \uparrow = positive output pulse
 \downarrow = negative output pulse

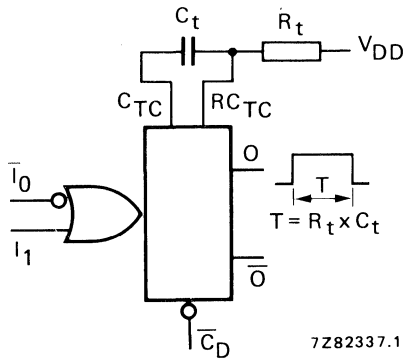

Fig. 4 Connection of the external timing components R_t and C_t .

D.C. CHARACTERISTICS

$V_{SS} = 0\text{ V}$

| | V_{DD} V | symbol | T_{amb} (°C) | | | | | |
|--|---------------|--------------|----------------|------|------|------|------|---------------|
| | | | -40 | | +25 | | +85 | |
| | | | typ. | max. | typ. | max. | typ. | max. |
| Supply current active state (see note) | 5 | I_D | | | 55 | | | μA |
| | 10 | | | | 150 | | | μA |
| | 15 | | | | 220 | | | μA |
| Input leakage current (pins 2 and 14) | 15 | $\pm I_{IN}$ | | | 300 | 1000 | | nA |

Note

Only one monostable is switching: current present during output pulse (output O is HIGH).

A.C. CHARACTERISTICS

 $V_{SS} = 0\text{ V}$; $T_{amb} = 25\text{ }^{\circ}\text{C}$; $C_L = 50\text{ pF}$; input transition times $\leq 20\text{ ns}$

| | V_{DD} V | symbol | min. | typ. | max. | typical extrapolation formula | |
|--|---------------|------------|------|------|------|----------------------------------|---|
| Propagation delays $\overline{T}_0, I_1 \rightarrow 0$ HIGH to LOW | 5 | t_{PHL} | | 200 | 460 | ns | $173\text{ ns} + (0,55\text{ ns/pF}) C_L$ |
| | 10 | | | 90 | 180 | ns | $79\text{ ns} + (0,23\text{ ns/pF}) C_L$ |
| | 15 | | | 60 | 120 | ns | $52\text{ ns} + (0,16\text{ ns/pF}) C_L$ |
| $\overline{T}_0, I_1 \rightarrow \overline{0}$ LOW to HIGH | 5 | t_{PLH} | | 220 | 440 | ns | $193\text{ ns} + (0,55\text{ ns/pF}) C_L$ |
| | 10 | | | 85 | 190 | ns | $74\text{ ns} + (0,23\text{ ns/pF}) C_L$ |
| | 15 | | | 60 | 120 | ns | $52\text{ ns} + (0,16\text{ ns/pF}) C_L$ |
| $\overline{C}_D \rightarrow 0$ HIGH to LOW | 5 | t_{PHL} | | 125 | 250 | ns | $98\text{ ns} + (0,55\text{ ns/pF}) C_L$ |
| | 10 | | | 55 | 110 | ns | $44\text{ ns} + (0,23\text{ ns/pF}) C_L$ |
| | 15 | | | 40 | 80 | ns | $32\text{ ns} + (0,16\text{ ns/pF}) C_L$ |
| $\overline{C}_D \rightarrow \overline{0}$ LOW to HIGH | 5 | t_{PLH} | | 125 | 250 | ns | $98\text{ ns} + (0,55\text{ ns/pF}) C_L$ |
| | 10 | | | 55 | 110 | ns | $44\text{ ns} + (0,23\text{ ns/pF}) C_L$ |
| | 15 | | | 40 | 80 | ns | $32\text{ ns} + (0,16\text{ ns/pF}) C_L$ |
| Recovery times $\overline{C}_D \rightarrow \overline{T}_0, I_1$ | 5 | t_{RCD} | | 20 | 40 | ns | |
| | 10 | | | 10 | 20 | ns | |
| | 15 | | | 5 | 10 | ns | |
| Retrigger times $0, \overline{0} \rightarrow \overline{T}_0, I_1$ | 5 | t_{RO} | 0 | | | ns | |
| | 10 | | 0 | | | ns | |
| | 15 | | 0 | | | ns | |
| Minimum \overline{T}_0 pulse width; LOW | 5 | t_{WI0L} | | 45 | 90 | ns | |
| | 10 | | | 15 | 30 | ns | |
| | 15 | | | 12 | 24 | ns | |
| Minimum I_1 pulse width; HIGH | 5 | t_{WI1H} | | 25 | 50 | ns | |
| | 10 | | | 12 | 24 | ns | |
| | 15 | | | 10 | 20 | ns | |
| Output 0 or $\overline{0}$ pulse width | 5 | t_{WO} | 218 | 230 | 242 | μs | $\left\{ \begin{array}{l} R_t = 100\text{ k}\Omega \\ C_t = 0,002\text{ }\mu\text{F} \end{array} \right.$ |
| | 10 | | 213 | 224 | 235 | μs | |
| | 15 | | 211 | 223 | 234 | μs | |
| Output 0 or $\overline{0}$ pulse width | 5 | t_{WO} | 10,3 | 10,8 | 11,3 | ms | $\left\{ \begin{array}{l} R_t = 100\text{ k}\Omega \\ C_t = 0,1\text{ }\mu\text{F} \end{array} \right.$ |
| | 10 | | 10,2 | 10,7 | 11,2 | ms | |
| | 15 | | 10,1 | 10,6 | 11,1 | ms | |
| Output 0 or $\overline{0}$ pulse width | 5 | t_{WO} | 1,01 | 1,09 | 1,11 | s | $\left\{ \begin{array}{l} R_t = 100\text{ k}\Omega \\ C_t = 10\text{ }\mu\text{F} \end{array} \right.$ |
| | 10 | | 0,99 | 1,04 | 1,09 | s | |
| | 15 | | 0,99 | 1,04 | 1,09 | s | |

A.C. CHARACTERISTICS

 $V_{SS} = 0 \text{ V}$; $T_{amb} = 25 \text{ }^\circ\text{C}$; $C_L = 50 \text{ pF}$; input transition times $\leq 20 \text{ ns}$

| | V_{DD} V | symbol | min. | typ. | max. | |
|---|---------------|-----------------|------|-----------|-----------|-----------|
| Change in output O pulse width over temperature (T_{amb}) | 5 | Δt_{WO} | | $\pm 0,2$ | | % |
| | 10 | | | $\pm 0,2$ | | % |
| | 15 | | | $\pm 0,2$ | | % |
| Change in output O pulse width over V_{DD} range 5 to 15 V | | Δt_{WO} | | $\pm 1,5$ | | % |
| Pulse width variation between circuits in same package | 5 | Δt_{WO} | | ± 1 | | % |
| | 10 | | | ± 1 | | % |
| | 15 | | | ± 1 | | % |
| External timing resistor | | R_t | 5 | — | * | $k\Omega$ |
| External timing capacitor | | C_t | 2000 | — | no limits | pF |
| Input capacitance (pin 2 or 14) | | C_{IN} | | 15 | | pF |

 $\left\{ \begin{array}{l} R_t = 100 \text{ k}\Omega \\ C_t = 2 \text{ nF to } 10 \mu\text{F} \end{array} \right.$

* The maximum permissible resistance R_t , which holds the specified accuracy of t_{WO} , depends on the leakage current of the capacitor C_t and the leakage of the HEF4538B.

HEF4538B
MSI

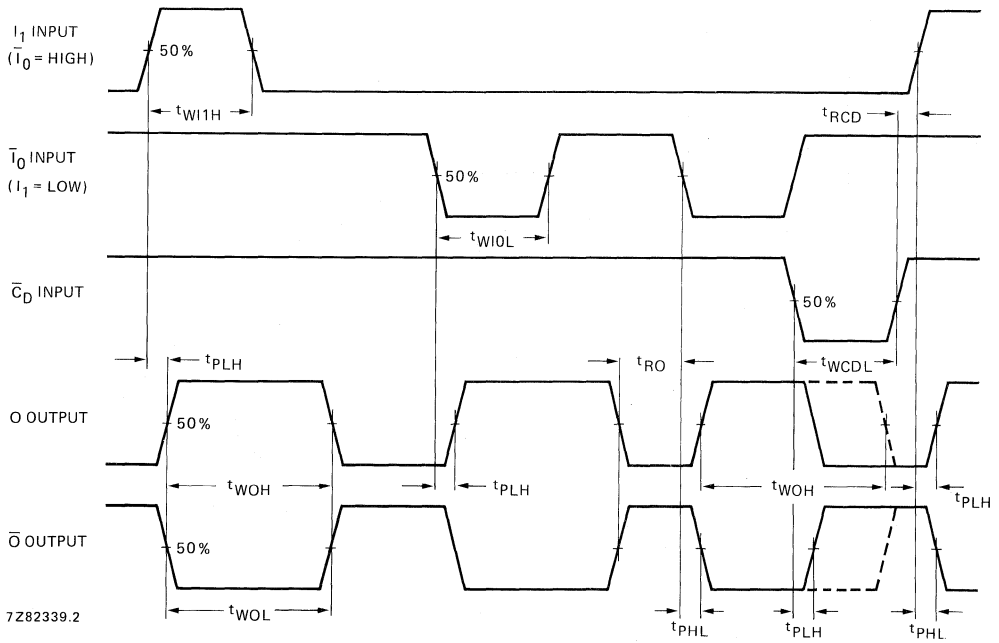
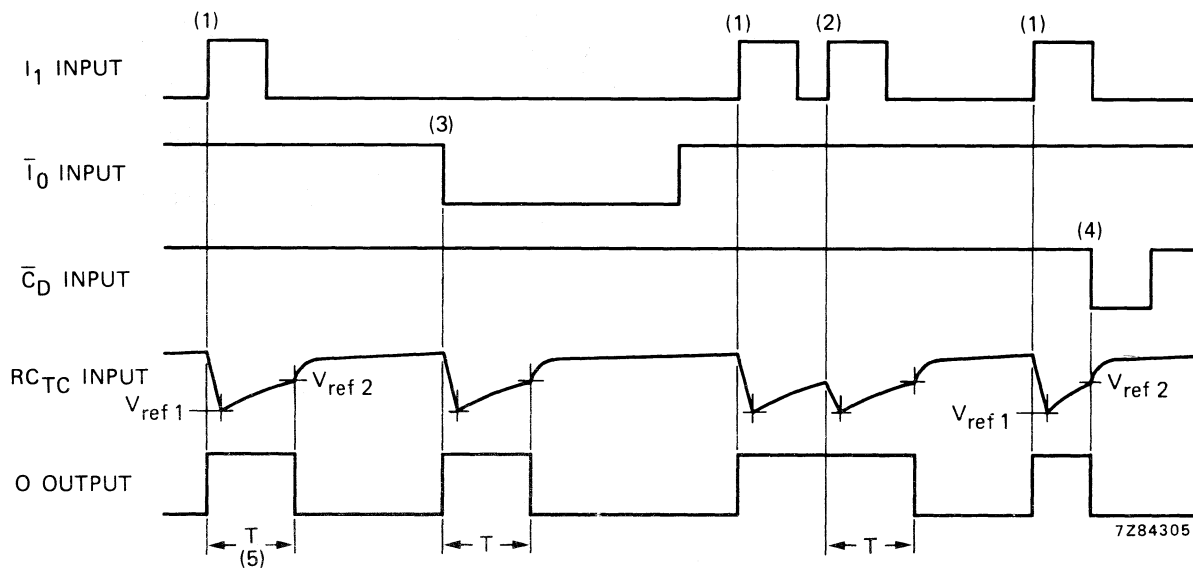
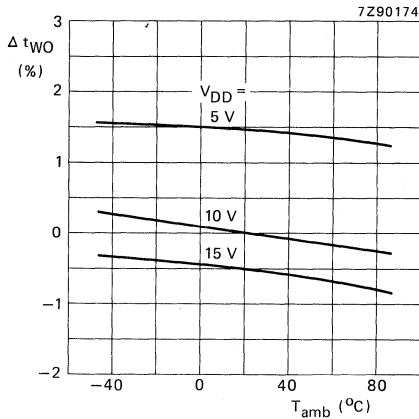

Fig. 5 Waveforms showing minimum \bar{I}_0 , I_1 , O and \bar{C}_D pulse widths, recovery times and propagation delays.



- (1) Positive edge triggering.
- (2) Positive edge re-triggering (pulse lengthening).
- (3) Negative edge triggering.
- (4) Reset (pulse shortening).
- (5) $T = R_t \times C_t$.

Fig. 6 Timing diagram.



(a)

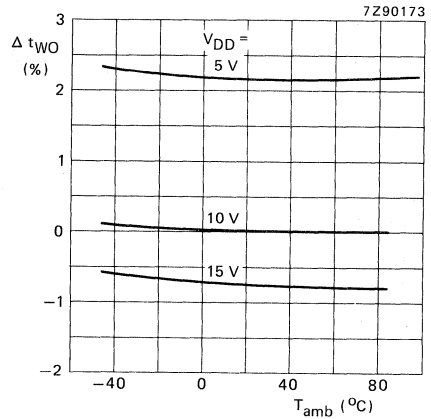

(b)

Fig. 7 Typical normalized change in output pulse width as a function of ambient temperature; 0% at $V_{DD} = 10\text{ V}$ and $T_{amb} = 25\text{ }^\circ\text{C}$.

(a) $R_t = 100\text{ k}\Omega$; $C_t = 100\text{ nF}$. (b) $R_t = 100\text{ k}\Omega$; $C_t = 2\text{ nF}$.

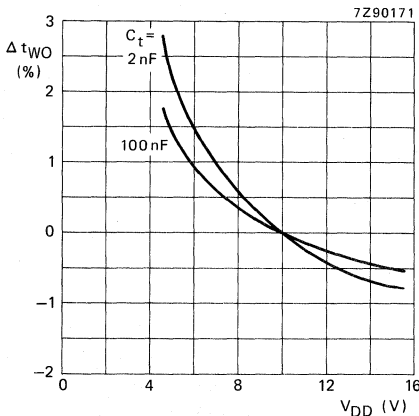

Fig. 8 Typical normalized change in output pulse width as a function of the supply voltage at $T_{amb} = 25\text{ }^\circ\text{C}$; 0% at $V_{DD} = 10\text{ V}$; $R_t = 100\text{ k}\Omega$.

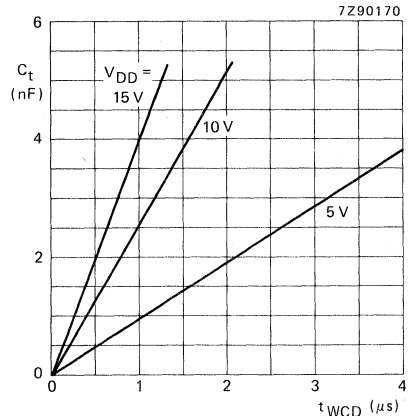
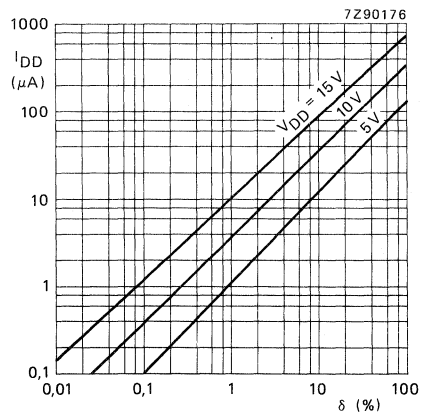

Fig. 9 Typical minimum reset pulse width as a function of C_t ; $R_t = 2\text{ k}\Omega$.

Fig. 10 Total supply current as a function of the output duty factor; $R_t = 100\text{ k}\Omega$; $C_t = 100\text{ nF}$; $C_L = 50\text{ pF}$. One monostable multivibrator switching only.



DUAL 4-INPUT MULTIPLEXER



The HEF4539B is a dual 4-input multiplexer with common select logic. Each multiplexer has four multiplexer inputs (I_0 to I_3), an active LOW enable input (\bar{E}) and a multiplexer output (O). When HIGH, \bar{E} forces O of the respective multiplexer LOW, independent of the select inputs (S_0 and S_1) and I_0 to I_3 . When \bar{E} is LOW, S_0 and S_1 determine which multiplexer input (I_0 to I_3) on each of the multiplexers is routed to the respective multiplexer output (O).

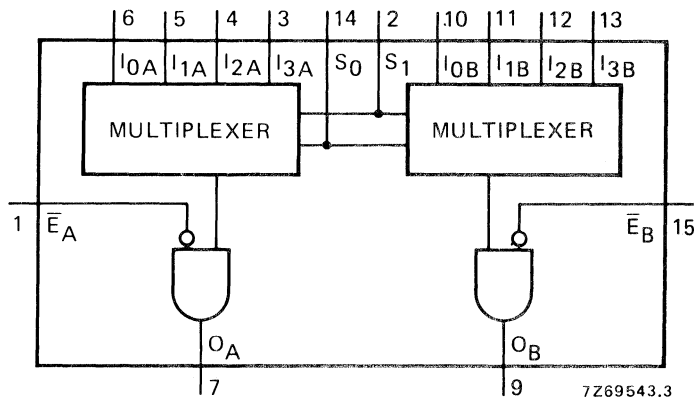

Fig. 1 Functional diagram.

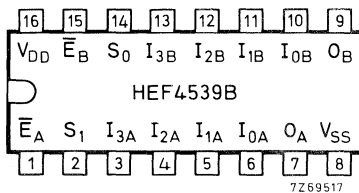

Fig. 2 Pinning diagram.

PINNING

| | |
|---|----------------------------|
| I_{0A} , I_{1A} , I_{2A} , I_{3A} | multiplexer inputs |
| I_{0B} , I_{1B} , I_{2B} , I_{3B} | multiplexer inputs |
| S_0 , S_1 | select inputs |
| \bar{E}_A , \bar{E}_B | enable inputs (active LOW) |
| O_A , O_B | multiplexer outputs |

FAMILY DATA

I_{DD} LIMITS category MSI

} see Family Specifications

HEF4539BP : 16-lead DIL; plastic (SOT-38Z).
 HEF4539BD : 16-lead DIL; ceramic (cerdip) (SOT-74).
 HEF4539BT : 16-lead mini-pack; plastic (SO-16; SOT-109A).



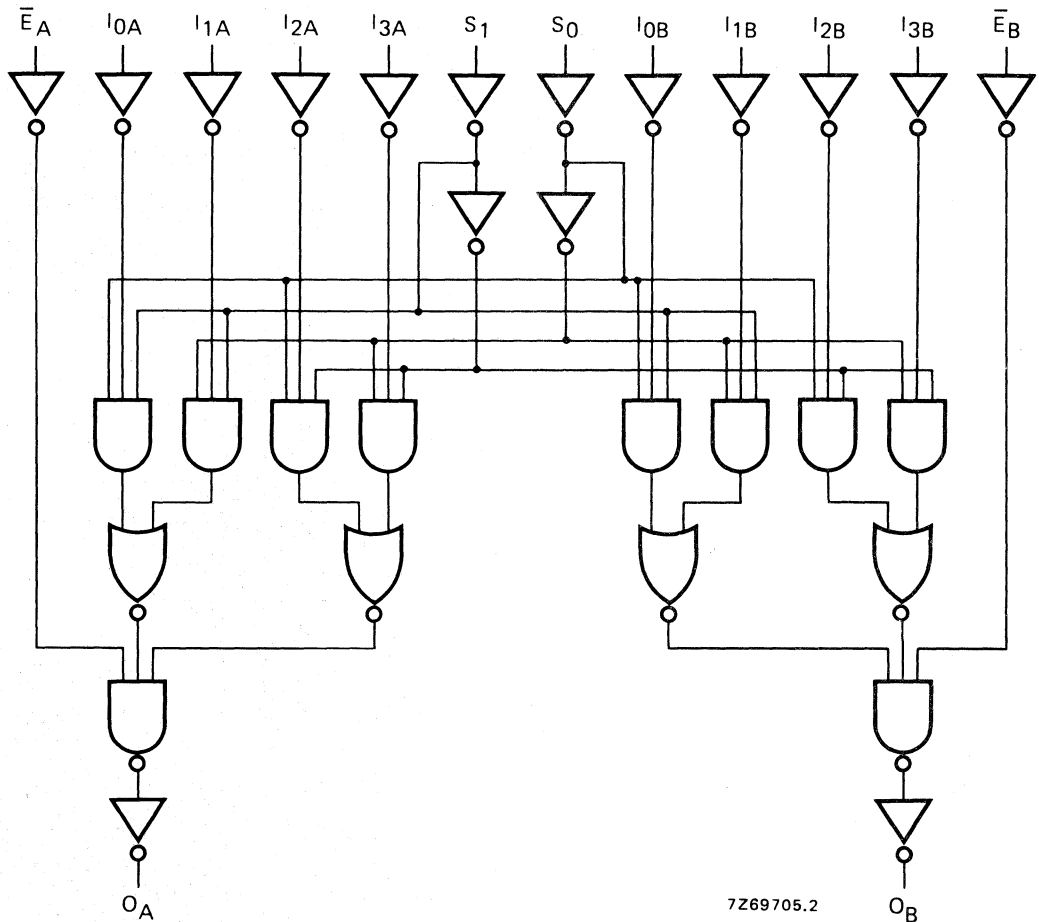

Fig. 3 Logic diagram.

FUNCTION TABLE

| inputs | | | output |
|----------------|----------------|-------------|----------------|
| S ₀ | S ₁ | \bar{E}_n | O _n |
| X | X | H | L |
| L | L | L | I ₀ |
| H | L | L | I ₁ |
| L | H | L | I ₂ |
| H | H | L | I ₃ |

H = HIGH state (the more positive voltage)
L = LOW state (the less positive voltage)
X = state is immaterial

A.C. CHARACTERISTICS

 $V_{SS} = 0\text{ V}$; $T_{amb} = 25\text{ }^{\circ}\text{C}$; $C_L = 50\text{ pF}$; input transition times $\leq 20\text{ ns}$

| | V_{DD} V | symbol | min. | typ. | max. | typical extrapolation formula | |
|--|---------------|-----------|------|------|------|--|---|
| Propagation delays $I_n \rightarrow O_n$ HIGH to LOW | 5 | t_{PHL} | | 120 | 240 | ns | $93\text{ ns} + (0,55\text{ ns/pF}) C_L$ |
| | 10 | | 45 | 90 | ns | $34\text{ ns} + (0,23\text{ ns/pF}) C_L$ | |
| | 15 | | 30 | 60 | ns | $22\text{ ns} + (0,16\text{ ns/pF}) C_L$ | |
| LOW to HIGH | 5 | t_{PLH} | | 120 | 245 | ns | $93\text{ ns} + (0,55\text{ ns/pF}) C_L$ |
| | 10 | | 50 | 100 | ns | $39\text{ ns} + (0,23\text{ ns/pF}) C_L$ | |
| | 15 | | 35 | 65 | ns | $27\text{ ns} + (0,16\text{ ns/pF}) C_L$ | |
| $S_n \rightarrow O_n$ HIGH to LOW | 5 | t_{PHL} | | 165 | 330 | ns | $138\text{ ns} + (0,55\text{ ns/pF}) C_L$ |
| | 10 | | 65 | 125 | ns | $54\text{ ns} + (0,23\text{ ns/pF}) C_L$ | |
| | 15 | | 40 | 80 | ns | $32\text{ ns} + (0,16\text{ ns/pF}) C_L$ | |
| LOW to HIGH | 5 | t_{PLH} | | 155 | 310 | ns | $128\text{ ns} + (0,55\text{ ns/pF}) C_L$ |
| | 10 | | 60 | 120 | ns | $49\text{ ns} + (0,23\text{ ns/pF}) C_L$ | |
| | 15 | | 40 | 80 | ns | $32\text{ ns} + (0,16\text{ ns/pF}) C_L$ | |
| $\bar{E}_n \rightarrow O_n$ HIGH to LOW | 5 | t_{PHL} | | 100 | 200 | ns | $73\text{ ns} + (0,55\text{ ns/pF}) C_L$ |
| | 10 | | 40 | 80 | ns | $29\text{ ns} + (0,23\text{ ns/pF}) C_L$ | |
| | 15 | | 30 | 55 | ns | $22\text{ ns} + (0,16\text{ ns/pF}) C_L$ | |
| LOW to HIGH | 5 | t_{PLH} | | 100 | 200 | ns | $73\text{ ns} + (0,55\text{ ns/pF}) C_L$ |
| | 10 | | 40 | 80 | ns | $29\text{ ns} + (0,23\text{ ns/pF}) C_L$ | |
| | 15 | | 30 | 55 | ns | $22\text{ ns} + (0,16\text{ ns/pF}) C_L$ | |
| Output transition times HIGH to LOW | 5 | t_{THL} | | 60 | 120 | ns | $10\text{ ns} + (1,0\text{ ns/pF}) C_L$ |
| | 10 | | 30 | 60 | ns | $9\text{ ns} + (0,42\text{ ns/pF}) C_L$ | |
| | 15 | | 20 | 40 | ns | $6\text{ ns} + (0,28\text{ ns/pF}) C_L$ | |
| LOW to HIGH | 5 | t_{TLH} | | 60 | 120 | ns | $10\text{ ns} + (1,0\text{ ns/pF}) C_L$ |
| | 10 | | 30 | 60 | ns | $9\text{ ns} + (0,42\text{ ns/pF}) C_L$ | |
| | 15 | | 20 | 40 | ns | $6\text{ ns} + (0,28\text{ ns/pF}) C_L$ | |

| | V_{DD} V | typical formula for P (μW) | where f_i = input freq. (MHz) f_o = output freq. (MHz) C_L = load capacitance (pF) $\Sigma(f_o C_L)$ = sum of outputs V_{DD} = supply voltage (V) |
|---|---------------|--|--|
| Dynamic power dissipation per package (P) | 5 | $700 f_i + \Sigma(f_o C_L) \times V_{DD}^2$ | |
| | 10 | $2900 f_i + \Sigma(f_o C_L) \times V_{DD}^2$ | |
| | 15 | $8100 f_i + \Sigma(f_o C_L) \times V_{DD}^2$ | |

APPLICATION INFORMATION

Some examples of applications for the HEF4539B are:

- Data selectors.
- Data multiplexers.

PROGRAMMABLE TIMER



The HEF4541B is a programmable timer which consists of a 16-stage binary counter, an integrated oscillator to be used with external timing components, an automatic power-on reset and output control logic. The frequency of the oscillator is determined by the external components R_T and C_T within the frequency range 1 Hz to 100 kHz. This oscillator may be replaced by an external clock signal at input RS, the timer advances on the positive-going transition of RS. A LOW on the auto reset input (\overline{AR}) and a LOW on the master reset input (MR) enables the internal power-on reset. A HIGH level at input MR resets the counter independent on all other inputs. Resetting disables the oscillator to provide no active power dissipation.

A HIGH at input \overline{AR} turns off the power-on reset to provide a low quiescent power dissipation of the timer. The 16-stage counter divides the oscillator frequency by 2^8 , 2^{10} , 2^{13} or 2^{16} depending on the state of the address inputs (A_0 , A_1). The divided oscillator frequency is available at output O. The phase input (PH) features a complementary output signal. If the mode select input (MODE) is LOW or HIGH the timer can be used respectively as a single transition timer or 2^n frequency divider.

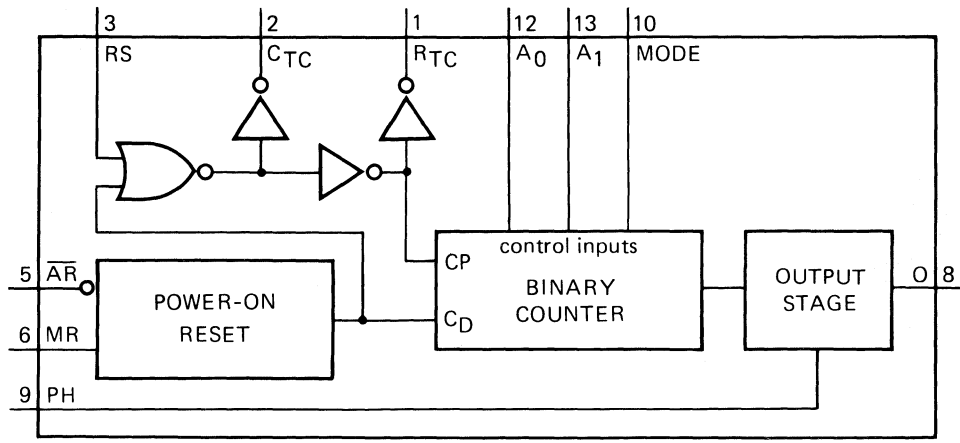

7Z83068.2

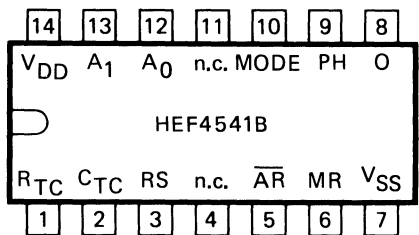

7Z83067.1

Fig. 2 Pinning diagram.

Fig. 1 Functional diagram.

- HEF4541BP : 14-lead DIL; plastic (SOT-27K, M, T).
- HEF4541BD: 14-lead DIL; ceramic (cerdip) (SOT-73).
- HEF4541BT: 14-lead mini-pack; plastic (SO-14; SOT-108A).

FAMILY DATA

see Family Specifications

I_{DD} LIMITS category MSI

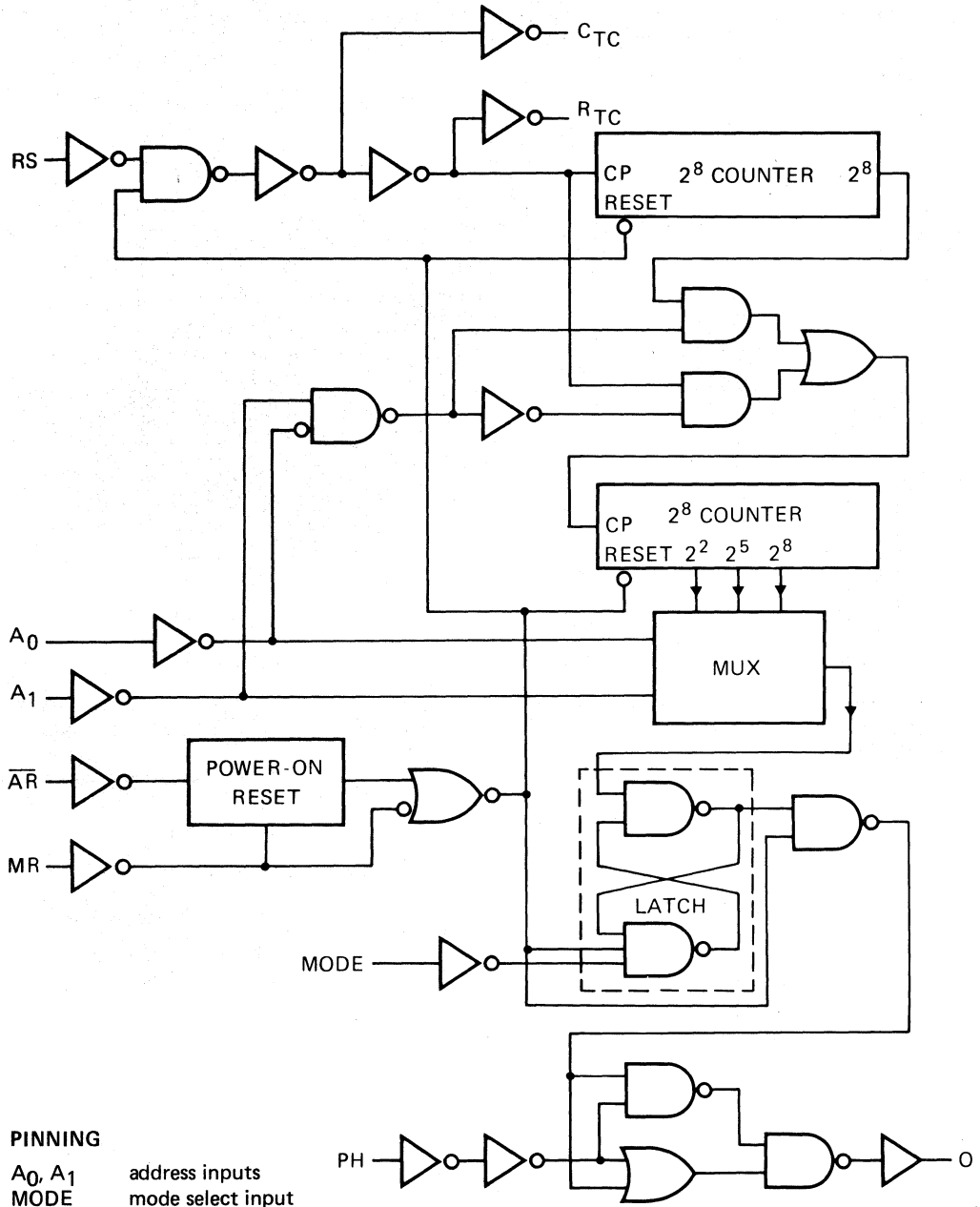

7283070.2

PINNING

- A₀, A₁ address inputs
- MODE mode select input
- AR auto reset input
- MR master reset input
- PH phase input
- R_{TC} external resistor connection (R_T)
- C_{TC} external capacitor connection (C_T)
- RS external resistor connection (R_S) or external clock input

Fig. 3 Logic diagram.

FREQUENCY SELECTION TABLE

| A ₀ | A ₁ | number of counter stages n | $\frac{f_{osc}}{f_{out}} = 2^n$ |
|----------------|----------------|-------------------------------|---------------------------------|
| L | L | 13 | 8 192 |
| L | H | 10 | 1 024 |
| H | L | 8 | 256 |
| H | H | 16 | 65 536 |

FUNCTION TABLE

| inputs | | | | mode |
|-----------------|----|----|------|---------------------------------------|
| \overline{AR} | MR | PH | MODE | |
| H | L | X | X | auto reset disabled |
| L | L | X | X | auto reset enabled |
| X | H | X | X | master reset active |
| X | L | X | H | normal operation selected |
| X | L | X | L | division to output |
| X | L | L | X | single-cycle mode* |
| X | L | L | X | output initially LOW, after reset |
| X | L | H | X | output initially HIGH, after reset |

H = HIGH state (the more positive voltage)
 L = LOW state (the less positive voltage)
 X = state is immaterial

* The timer is initialized on a reset pulse and the output changes state after 2^{n-1} counts and remains in that state (latched). Reset of this latch is obtained by master reset or by a LOW to HIGH transition on the MODE input.

RC oscillator

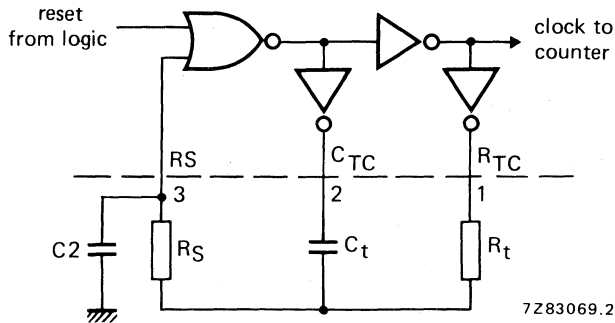

Typical formula for oscillator frequency:

$$f_{osc} = \frac{1}{2,3 \times R_t \times C_t}$$

Fig. 4 External component connection for RC oscillator; $R_S \approx 2R_t$.

Timing component limitations

The oscillator frequency is mainly determined by $R_t C_t$, provided $R_t \ll R_S$ and $R_S C_2 \ll R_t C_t$. The function of R_S is to minimize the influence of the forward voltage across the input protection diodes on the frequency. The stray capacitance C_2 should be kept as small as possible. In consideration of accuracy, C_t must be larger than the inherent stray capacitance. R_t must be larger than the LOCMOS 'ON' resistance in series with it, which typically is 500Ω at $V_{DD} = 5 \text{ V}$, 300Ω at $V_{DD} = 10 \text{ V}$ and 200Ω at $V_{DD} = 15 \text{ V}$.

The recommended values for these components to maintain agreement with the typical oscillation formula are:

$$C_t \geq 100 \text{ pF, up to any typical value,}$$

$$10 \text{ k}\Omega \leq R_t \leq 1 \text{ M}\Omega.$$

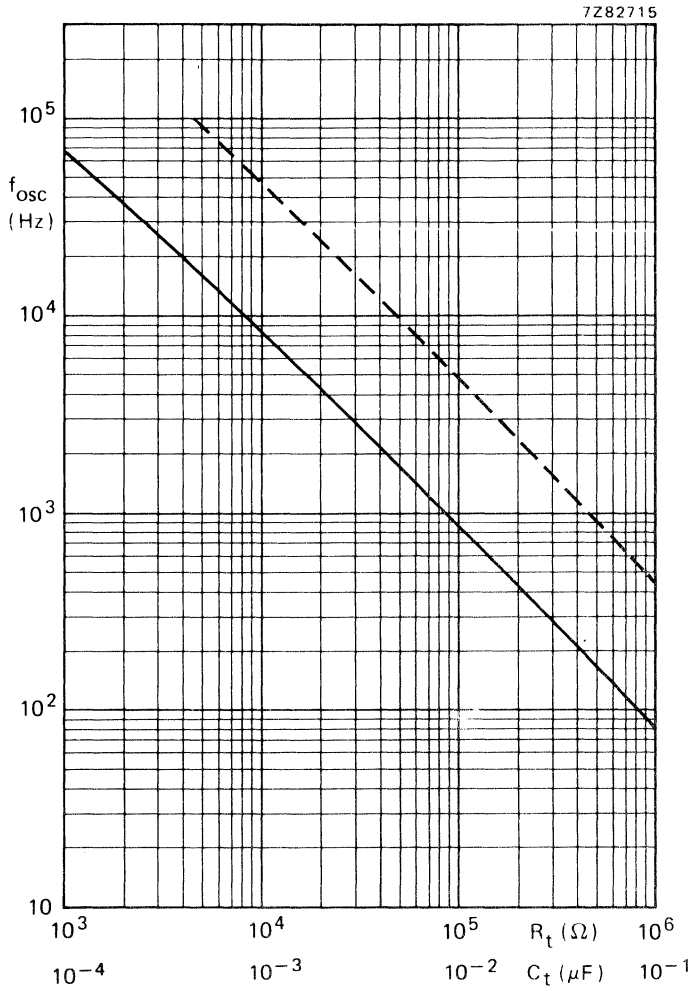

Fig. 5 RC oscillator frequency as a function of R_t and C_t at $V_{DD} = 5$ to 15 V ; $T_{amb} = 25 \text{ }^\circ\text{C}$.

- C_t curve at $R_t = 56 \text{ k}\Omega$; $R_S = 120 \text{ k}\Omega$.
- - - R_t curve at $C_t = 1 \text{ nF}$; $R_S = 2R_t$.

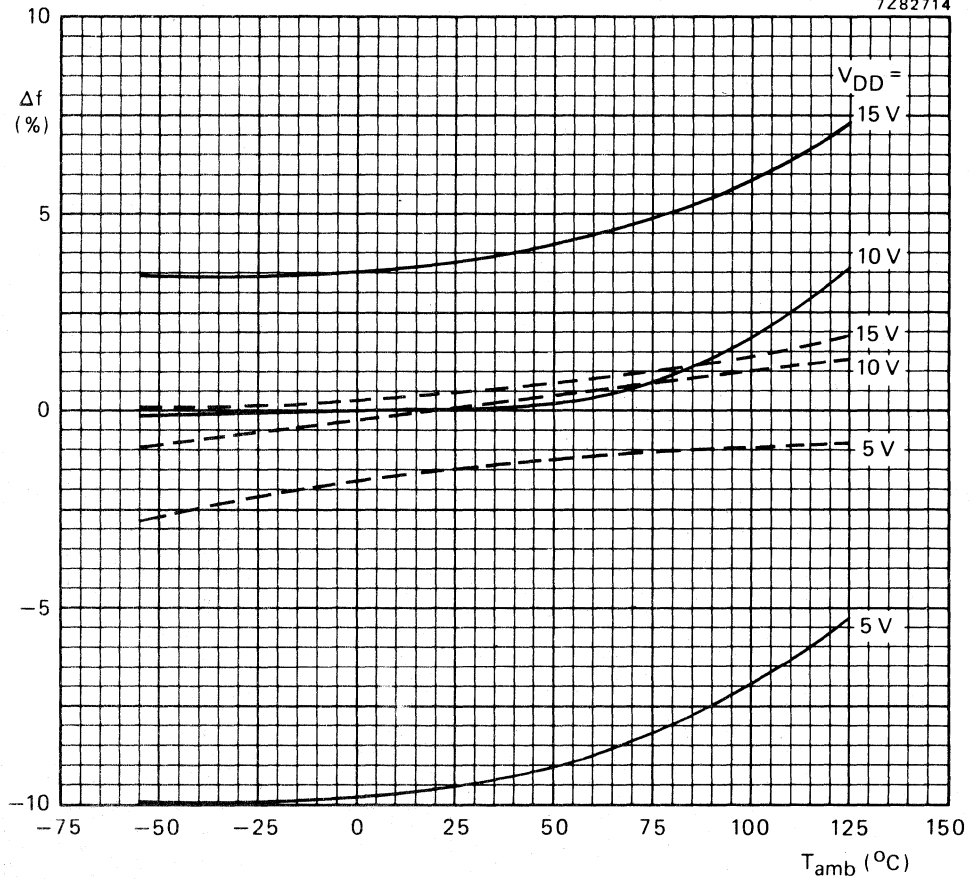

Fig. 6 Frequency deviation (Δf) as a function of ambient temperature; referenced at : f_{osc} at $T_{amb} = 25 \text{ }^\circ\text{C}$ and $V_{DD} = 10 \text{ V}$.

- $R_t = 56 \text{ k}\Omega$; $C_t = 1 \text{ nF}$; $R_S = 0$.
- - - $R_t = 56 \text{ k}\Omega$; $C_t = 1 \text{ nF}$; $R_S = 120 \text{ k}\Omega$.

D.C. CHARACTERISTICS

V_{SS} = 0 V

| | V _{DD} V | V _{OL} V | V _{OH} V | symbol | T _{amb} (°C) | | | | | | |
|---|----------------------|----------------------|----------------------|------------------|-----------------------|------|------|------|------|------|------|
| | | | | | -40 | | +25 | | +85 | | |
| | | | | | min. | max. | min. | typ. | max. | min. | max. |
| Supply current power-on reset enabled (note) | 5 | | | I _D | - | 80 | - | 20 | 80 | - | 230 |
| | 10 | | | | - | 750 | - | 250 | 600 | - | 700 |
| | 15 | | | | - | 1600 | - | 500 | 1300 | - | 1500 |
| Supply voltage for automatic reset initialization (note) | | | | V _{DD} | - | - | 8,5 | 5 | - | - | - |
| Output current HIGH; C _{TC} , R _{TC} | 5 | | 4,6 | -I _{OH} | 0,5 | - | 0,4 | - | - | 0,3 | - |
| | 10 | | 9,5 | | 1,4 | - | 1,2 | - | - | 0,95 | - |
| | 15 | | 13,5 | | 4,8 | - | 4,0 | - | - | 3,2 | - |
| Output current LOW; C _{TC} , R _{TC} | 5 | | 2,5 | I _{OL} | 1,4 | - | 1,2 | - | - | 0,95 | - |
| | 5 | 0,4 | | | 0,33 | - | 0,27 | - | - | 0,20 | - |
| | 10 | 0,5 | | | 1,00 | - | 0,85 | - | - | 0,68 | - |
| 15 | 1,5 | | 3,20 | - | 2,70 | - | - | - | 2,30 | - | |

Note

All inputs at 0 V or V_{DD}, except input \overline{AR} = input MR = 0 V (power-on reset active).

A.C. CHARACTERISTICS

V_{SS} = 0 V; T_{amb} = 25 °C; input transition times ≤ 20 ns

| | V _{DD} V | typical formula for P (μW)* |
|---|----------------------|--|
| Dynamic power dissipation per package (P) | 5 | 1 300 f _i + f _o C _L V _{DD} ² |
| | 10 | 5 300 f _i + f _o C _L V _{DD} ² |
| | 15 | 12 000 f _i + f _o C _L V _{DD} ² |
| Total power dissipation when using the on-chip oscillator (P) | 5 | 1 300 f _{osc} + f _o C _L V _{DD} ² + 2C _t V _{DD} ² f _{osc} + 10 V _{DD} |
| | 10 | 5 300 f _{osc} + f _o C _L V _{DD} ² + 2C _t V _{DD} ² f _{osc} + 100 V _{DD} |
| | 15 | 12 000 f _{osc} + f _o C _L V _{DD} ² + 2C _t V _{DD} ² f _{osc} + 400 V _{DD} |

* where:

- f_i = input frequency (MHz)
- f_o = output frequency (MHz)
- C_L = load capacitance (pF)
- V_{DD} = supply voltage (V)
- C_t = timing capacitance (pF)
- f_{osc} = oscillator frequency (MHz)

HEF4541B

MSI

A.C. CHARACTERISTICS

$V_{SS} = 0\text{ V}$; $T_{amb} = 25\text{ }^{\circ}\text{C}$; $C_L = 50\text{ pF}$; input transition times $\leq 20\text{ ns}$

| | V_{DD} V | symbol | min. | typ. | max. | typical extrapolation formula | |
|---|---------------|--|------|------|---------|--|-----|
| Propagation delays RS \rightarrow O 2 ⁸ selected | 5 | t _{PHL} ; t _{PLH} | | 375 | 750 ns | 348 ns + (0,55 ns/pF) C _L 139 ns + (0,23 ns/pF) C _L 102 ns + (0,16 ns/pF) C _L | |
| | 10 | | | 150 | 300 ns | | |
| | 15 | | | 110 | 220 ns | | |
| RS \rightarrow O 2 ¹⁰ selected | 5 | t _{PHL} ; t _{PLH} | | 425 | 850 ns | 398 ns + (0,55 ns/pF) C _L 154 ns + (0,23 ns/pF) C _L 112 ns + (0,16 ns/pF) C _L | |
| | 10 | | | 165 | 330 ns | | |
| | 15 | | | 120 | 240 ns | | |
| RS \rightarrow O 2 ¹³ selected | 5 | t _{PHL} ; t _{PLH} | | 510 | 1020 ns | 483 ns + (0,55 ns/pF) C _L 179 ns + (0,23 ns/pF) C _L 127 ns + (0,16 ns/pF) C _L | |
| | 10 | | | 190 | 380 ns | | |
| | 15 | | | 135 | 270 ns | | |
| RS \rightarrow O 2 ¹⁶ selected | 5 | t _{PHL} ; t _{PLH} | | 575 | 1150 ns | 548 ns + (0,55 ns/pF) C _L 199 ns + (0,23 ns/pF) C _L 142 ns + (0,16 ns/pF) C _L | |
| | 10 | | | 210 | 420 ns | | |
| | 15 | | | 150 | 300 ns | | |
| Minimum clock pulse width; LOW | 5 | t _{WRSL} | 60 | 30 | ns | | |
| | 10 | | | 30 | 15 | | ns |
| | 15 | | | 24 | 12 | | ns |
| Minimum reset pulse width; HIGH | 5 | t _{WMRH} | 60 | 30 | ns | | |
| | 10 | | | 30 | 15 | | ns |
| | 15 | | | 24 | 12 | | ns |
| Maximum clock pulse frequency | 5 | f _{max} | 8 | 16 | MHz | | |
| | 10 | | | 15 | 30 | | MHz |
| | 15 | | | 18 | 36 | | MHz |
| Oscillator frequency | 5 | f _{osc} | | 90 | kHz | } R _t = 5 kΩ } C _t = 1 nF } R _S = 10 kΩ | |
| | 10 | | | | 90 | | kHz |
| | 15 | | | | 90 | | kHz |
| Oscillator frequency | 5 | f _{osc} | | 8 | kHz | } R _t = 56 kΩ } C _t = 1 nF } R _S = 120 kΩ | |
| | 10 | | | | 8 | | kHz |
| | 15 | | | | 8 | | kHz |

BCD TO 7-SEGMENT LATCH/DECODER/DRIVER



The HEF4543B is a BCD to 7-segment latch/decoder/driver for liquid crystal and LED displays. It has four address inputs (D_A to D_D), an active HIGH latch disable input (LD), an active HIGH blanking input (BI), an active HIGH phase input (PH) and seven buffered segment outputs (O_a to O_g).

The circuit provides the function of a 4-bit storage latch and an 8-4-2-1 BCD to 7-segment decoder/driver. It can invert the logic levels of the output combination. The phase (PH), blanking (BI) and latch disable (LD) inputs are used to reverse the function table phase, blank the display and store a BCD code, respectively.

For liquid crystal displays a square-wave is applied to PH and the electrical common back-plane of the display. The outputs of the device are directly connected to the segments of the liquid crystal.

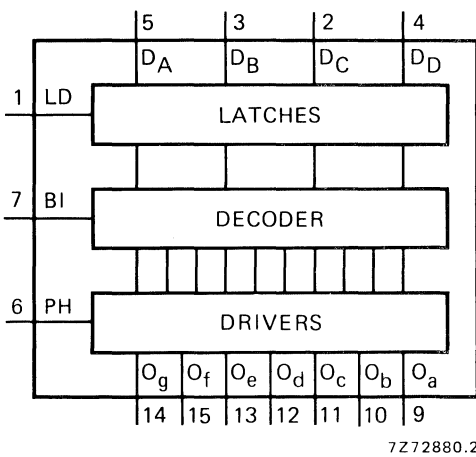

Fig. 1 Functional diagram.

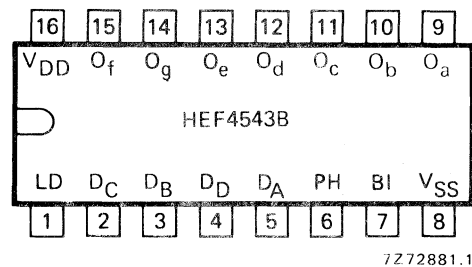

Fig. 2 Pinning diagram.

HEF4543BP : 16-lead-DIL; plastic (SOT-38Z).

HEF4543BD : 16-lead-DIL; ceramic (cerdip) (SOT-74).

HEF4543BT : 16-lead mini-pack; plastic (SO-16; SOT-109A).

PINNING

- D_A to D_D address (data) inputs
 PH phase input (active HIGH)
 BI blanking input (active HIGH)
 LD latch disable input (active HIGH)
 O_a to O_g segment outputs



Fig. 3 Segment designation.

FAMILY DATA

} see Family Specifications

I_{DD} LIMITS category MSI

HEF4543B
MSI

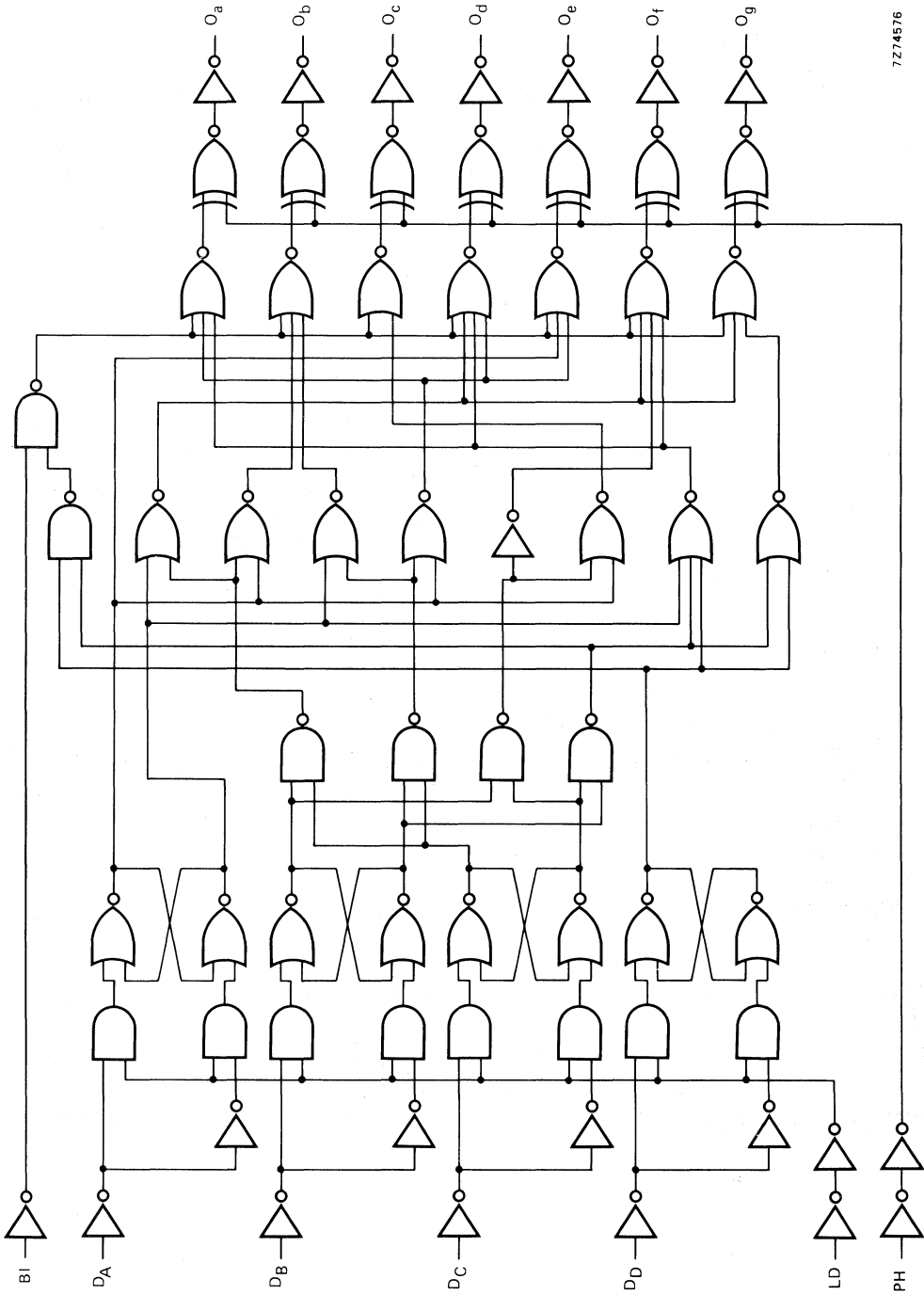

7Z74576

Fig. 4 Logic diagram.

FUNCTION TABLE

| inputs | | | | | | | outputs | | | | | | | |
|----------|----|------|----------------|----------------|----------------|----------------|------------------|----------------|----------------|----------------|----------------|----------------|----------------|----------|
| LD | BI | PH * | D _D | D _C | D _B | D _A | O _a | O _b | O _c | O _d | O _e | O _f | O _g | display |
| X | H | L | X | X | X | X | L | L | L | L | L | L | L | blank |
| H | L | L | L | L | L | L | H | H | H | H | H | H | L | 0 |
| H | L | L | L | L | L | H | L | H | H | L | L | L | L | 1 |
| H | L | L | L | L | H | L | H | H | L | H | H | L | H | 2 |
| H | L | L | L | L | H | H | H | H | H | H | L | L | H | 3 |
| H | L | L | L | H | L | L | L | H | H | L | L | H | H | 4 |
| H | L | L | L | H | L | H | H | L | H | H | L | H | H | 5 |
| H | L | L | L | H | H | L | H | L | H | H | H | H | H | 6 |
| H | L | L | L | H | H | H | H | H | H | L | L | L | L | 7 |
| H | L | L | H | L | L | L | H | H | H | H | H | H | H | 8 |
| H | L | L | H | L | L | H | H | H | H | H | L | H | H | 9 |
| H | L | L | H | L | H | L | L | L | L | L | L | L | L | blank |
| H | L | L | H | L | H | H | L | L | L | L | L | L | L | blank |
| H | L | L | H | H | L | L | L | L | L | L | L | L | L | blank |
| H | L | L | H | H | H | L | L | L | L | L | L | L | L | blank |
| H | L | L | H | H | H | H | L | L | L | L | L | L | L | blank |
| L | L | L | X | X | X | X | | | | | | | | ** |
| as above | | H | as above | | | | inverse of above | | | | | | | as above |

H = HIGH state (the more positive voltage)

L = LOW state (the less positive voltage)

X = state is immaterial

* For liquid crystal displays, apply a square-wave to PH.

For common cathode LED displays, select PH = LOW.

For common anode LED displays, select PH = HIGH.

** Depends upon the BCD-code previously applied when LD = HIGH.

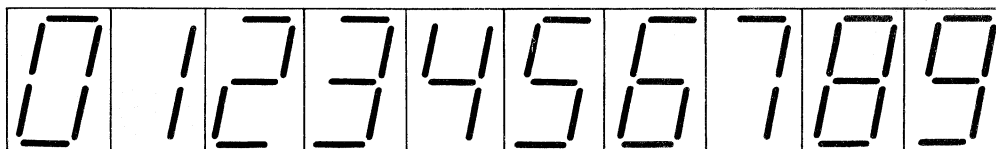

7272882

Fig. 5 Display.

A.C. CHARACTERISTICS

 $V_{SS} = 0 \text{ V}$; $T_{amb} = 25 \text{ }^\circ\text{C}$; $C_L = 50 \text{ pF}$; input transition times $\leq 20 \text{ ns}$

| | V_{DD} V | symbol | min. | typ. | max. | typical extrapolation formula | | |
|-------------------------------------|--------------------------------------|-------------|------|------|------|---|---|---|
| Propagation delays | $D_n \rightarrow O_n$ HIGH to LOW | tPHL | 5 | 180 | 360 | ns | $153 \text{ ns} + (0,55 \text{ ns/pF}) C_L$ | |
| | | | 10 | 75 | 150 | ns | $64 \text{ ns} + (0,23 \text{ ns/pF}) C_L$ | |
| | | | 15 | 55 | 110 | ns | $47 \text{ ns} + (0,16 \text{ ns/pF}) C_L$ | |
| | LOW to HIGH | tPLH | 5 | 180 | 360 | ns | $153 \text{ ns} + (0,55 \text{ ns/pF}) C_L$ | |
| | | | 10 | 75 | 150 | ns | $64 \text{ ns} + (0,23 \text{ ns/pF}) C_L$ | |
| | | | 15 | 55 | 110 | ns | $47 \text{ ns} + (0,16 \text{ ns/pF}) C_L$ | |
| | $LD \rightarrow O_n$ HIGH to LOW | tPHL | 5 | 170 | 340 | ns | $143 \text{ ns} + (0,55 \text{ ns/pF}) C_L$ | |
| | | | 10 | 80 | 160 | ns | $69 \text{ ns} + (0,23 \text{ ns/pF}) C_L$ | |
| | | | 15 | 60 | 120 | ns | $52 \text{ ns} + (0,16 \text{ ns/pF}) C_L$ | |
| | | LOW to HIGH | tPLH | 5 | 190 | 380 | ns | $163 \text{ ns} + (0,55 \text{ ns/pF}) C_L$ |
| | | | | 10 | 80 | 160 | ns | $69 \text{ ns} + (0,23 \text{ ns/pF}) C_L$ |
| | | | | 15 | 60 | 120 | ns | $52 \text{ ns} + (0,16 \text{ ns/pF}) C_L$ |
| $BI \rightarrow O_n$ HIGH to LOW | tPHL | 5 | 145 | 290 | ns | $118 \text{ ns} + (0,55 \text{ ns/pF}) C_L$ | | |
| | | 10 | 65 | 130 | ns | $54 \text{ ns} + (0,23 \text{ ns/pF}) C_L$ | | |
| | | 15 | 45 | 90 | ns | $37 \text{ ns} + (0,16 \text{ ns/pF}) C_L$ | | |
| | LOW to HIGH | tPLH | 5 | 125 | 250 | ns | $98 \text{ ns} + (0,55 \text{ ns/pF}) C_L$ | |
| | | | 10 | 55 | 110 | ns | $54 \text{ ns} + (0,23 \text{ ns/pF}) C_L$ | |
| | | | 15 | 40 | 80 | ns | $32 \text{ ns} + (0,16 \text{ ns/pF}) C_L$ | |
| Output transition times | HIGH to LOW | tTHL | 5 | 60 | 120 | ns | $10 \text{ ns} + (1,0 \text{ ns/pF}) C_L$ | |
| | | | 10 | 30 | 60 | ns | $9 \text{ ns} + (0,42 \text{ ns/pF}) C_L$ | |
| | | | 15 | 20 | 40 | ns | $6 \text{ ns} + (0,28 \text{ ns/pF}) C_L$ | |
| | LOW to HIGH | tTLH | 5 | 60 | 120 | ns | $10 \text{ ns} + (1,0 \text{ ns/pF}) C_L$ | |
| | | | 10 | 30 | 60 | ns | $9 \text{ ns} + (0,42 \text{ ns/pF}) C_L$ | |
| | | | 15 | 20 | 40 | ns | $6 \text{ ns} + (0,28 \text{ ns/pF}) C_L$ | |
| Minimum LD pulse width; HIGH | tWLDH | 5 | 60 | 30 | ns | | | |
| | | 10 | 30 | 15 | ns | | | |
| | | 15 | 20 | 10 | ns | | | |
| Set-up time $D_n \rightarrow LD$ | t _{su} | 5 | 40 | 20 | ns | | | |
| | | 10 | 20 | 5 | ns | | | |
| | | 15 | 15 | 0 | ns | | | |
| Hold time $D_n \rightarrow LD$ | t _{hold} | 5 | 0 | -15 | ns | | | |
| | | 10 | 15 | 0 | ns | | | |
| | | 15 | 20 | 5 | ns | | | |

| | V_{DD} V | typical formula for P (μW) | where f_i = input freq. (MHz) f_o = output freq. (MHz) C_L = load capacitance (pF) $\Sigma(f_o C_L)$ = sum of outputs V_{DD} = supply voltage (V) |
|---|---------------|---|--|
| Dynamic power dissipation per package (P) | 5 | $2\,200 f_i + \Sigma(f_o C_L) \times V_{DD}^2$ | |
| | 10 | $10\,400 f_i + \Sigma(f_o C_L) \times V_{DD}^2$ | |
| | 15 | $33\,000 f_i + \Sigma(f_o C_L) \times V_{DD}^2$ | |

APPLICATION INFORMATION

Some examples of applications for the HEF4543B are:

- Driving LCD displays.
- Driving LED displays.
- Driving fluorescent displays
- Driving incandescent displays.
- Driving gas discharge displays.

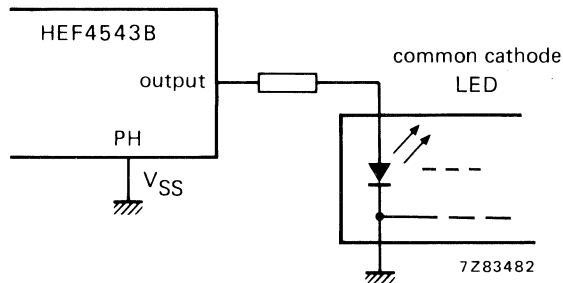

Fig. 6 Connection to common cathode LED display readout.

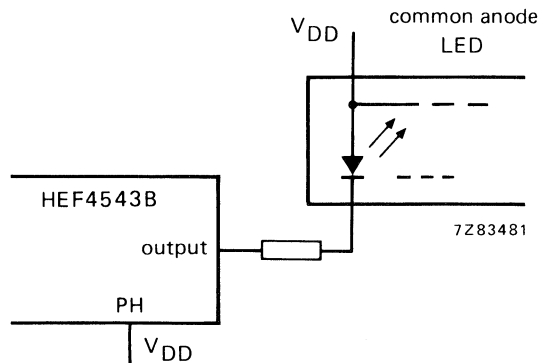

Fig. 7 Connection to common anode LED display readout.

Note to Figs 6 and 7: bipolar transistors may be added for gain where $V_{DD} \leq 10 \text{ V}$ or $I_{out} \geq 10 \text{ mA}$.

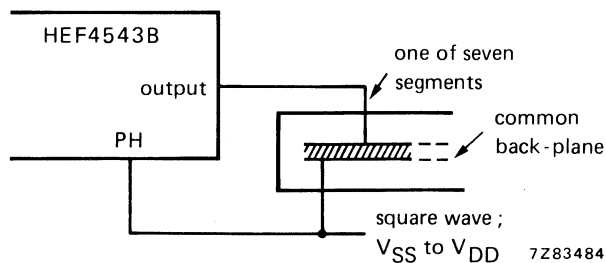

Fig. 8 Connection to liquid crystal (LCD) display readout.

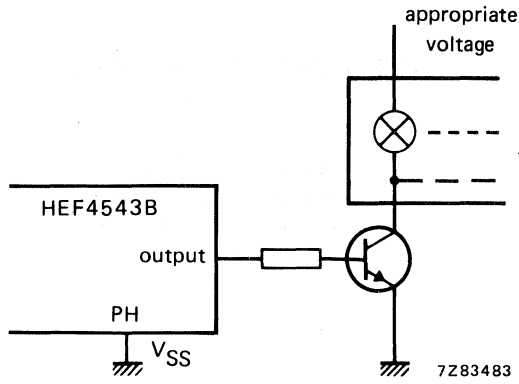

Fig. 9 Connection to incandescent display readout.

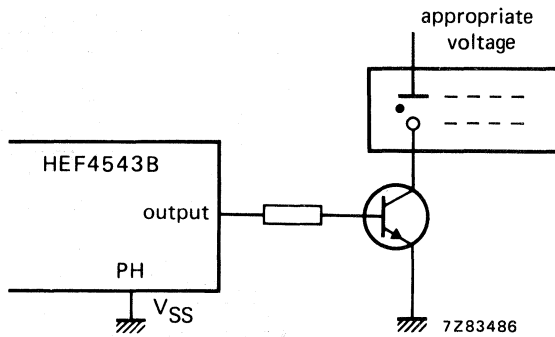

Fig. 10 Connection to gas discharge display readout.

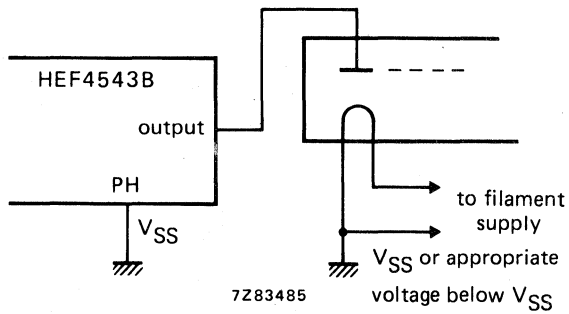

Fig. 11 Connection to fluorescent display readout.

DUAL 1-OF-4 DECODER/DEMULTIPLEXER



The HEF4555B is a dual 1-of-4 decoder/demultiplexer. Each has two address inputs (A_0 and A_1), an active LOW enable input (\bar{E}) and four mutually exclusive outputs which are active HIGH (O_0 to O_3). When used as a decoder, \bar{E} when HIGH, forces O_0 to O_3 LOW. When used as a demultiplexer, the appropriate output is selected by the information on A_0 and A_1 with \bar{E} as data input. All unselected outputs are LOW.

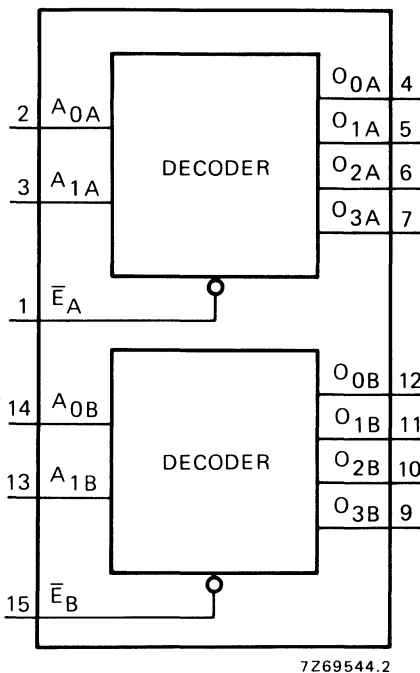

Fig. 1 Functional diagram.

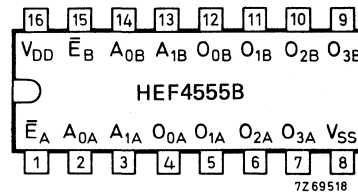

Fig. 2 Pinning diagram.

HEF4555BP : 16-lead DIL; plastic (SOT-38Z).
 HEF4555BD : 16-lead DIL; ceramic (cerdip) (SOT-74).
 HEF4555BT : 16-lead mini-pack; plastic
 (SO-16; SOT-109A).

PINNING

\bar{E} enable inputs (active LOW)
 A_0 and A_1 address inputs
 O_0 to O_3 outputs (active HIGH)

FAMILY DATA

} see Family Specifications

I_{DD} LIMITS category MSI

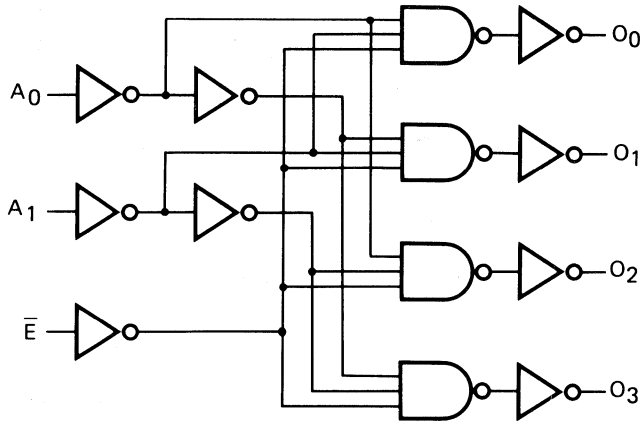

7Z69728.1

Fig. 3 Logic diagram (one decoder/multiplexer).

TRUTH TABLE

| inputs | | | outputs | | | |
|-----------|----------------|----------------|----------------|----------------|----------------|----------------|
| \bar{E} | A ₀ | A ₁ | O ₀ | O ₁ | O ₂ | O ₃ |
| L | L | L | H | L | L | L |
| L | H | L | L | H | L | L |
| L | L | H | L | L | H | L |
| L | H | H | L | L | L | H |
| H | X | X | L | L | L | L |

H = HIGH state (the more positive voltage)

L = LOW state (the less positive voltage)

X = state is immaterial

A.C. CHARACTERISTICS

 $V_{SS} = 0 \text{ V}$; $T_{amb} = 25 \text{ }^\circ\text{C}$; $C_L = 50 \text{ pF}$; input transition times $\leq 20 \text{ ns}$

| | V_{DD} V | symbol | min. | typ. | max. | typical extrapolation formula | | |
|--|---------------|------------------|------------------|------|------|----------------------------------|----------------------------|-----------------------------|
| Propagation delays $A_n \rightarrow O_n$ HIGH to LOW | 5 | t _{PHL} | | 115 | 230 | ns | 88 ns + (0,55 ns/pF) C_L | |
| | 10 | | 45 | 90 | ns | 34 ns + (0,23 ns/pF) C_L | | |
| | 15 | | 30 | 65 | ns | 22 ns + (0,16 ns/pF) C_L | | |
| | LOW to HIGH | 5 | t _{PLH} | | 140 | 280 | ns | 113 ns + (0,55 ns/pF) C_L |
| | | 10 | | 55 | 105 | ns | 44 ns + (0,23 ns/pF) C_L | |
| | | 15 | | 40 | 75 | ns | 32 ns + (0,16 ns/pF) C_L | |
| $\bar{E}_n \rightarrow O_n$ HIGH to LOW | 5 | t _{PHL} | | 125 | 250 | ns | 98 ns + (0,55 ns/pF) C_L | |
| | 10 | | 50 | 95 | ns | 39 ns + (0,23 ns/pF) C_L | | |
| | 15 | | 30 | 65 | ns | 22 ns + (0,16 ns/pF) C_L | | |
| | LOW to HIGH | 5 | t _{PLH} | | 150 | 295 | ns | 123 ns + (0,55 ns/pF) C_L |
| | | 10 | | 55 | 110 | ns | 44 ns + (0,23 ns/pF) C_L | |
| | | 15 | | 40 | 75 | ns | 32 ns + (0,16 ns/pF) C_L | |
| Output transition times HIGH to LOW | 5 | t _{THL} | | 60 | 120 | ns | 10 ns + (1,0 ns/pF) C_L | |
| | 10 | | 30 | 60 | ns | 9 ns + (0,42 ns/pF) C_L | | |
| | 15 | | 20 | 40 | ns | 6 ns + (0,28 ns/pF) C_L | | |
| | LOW to HIGH | 5 | t _{TLH} | | 60 | 120 | ns | 10 ns + (1,0 ns/pF) C_L |
| | | 10 | | 30 | 60 | ns | 9 ns + (0,42 ns/pF) C_L | |
| | | 15 | | 20 | 40 | ns | 6 ns + (0,28 ns/pF) C_L | |

| | V_{DD} V | typical formula for P (μW) | where f_i = input freq. (MHz) f_o = output freq. (MHz) C_L = load capacitance (pF) $\Sigma(f_o C_L)$ = sum of outputs V_{DD} = supply voltage (V) |
|---|---------------|---|--|
| Dynamic power dissipation per package (P) | 5 | $4500 f_i + \Sigma(f_o C_L) \times V_{DD}^2$ | |
| | 10 | $18\,800 f_i + \Sigma(f_o C_L) \times V_{DD}^2$ | |
| | 15 | $45\,700 f_i + \Sigma(f_o C_L) \times V_{DD}^2$ | |

APPLICATION INFORMATION

Some examples of applications for the HEF4555B are:

- Code conversion.
- Address decoding.
- Demultiplexing: when using the enable input as data input.

DUAL 1-OF-4 DECODER/DEMULTIPLEXER



The HEF4556B is a dual 1-of-4 decoder/demultiplexer. Each has two address inputs (A_0 and A_1), an active LOW enable input (\bar{E}) and four mutually exclusive outputs which are active LOW (\bar{O}_0 to \bar{O}_3). When used as a decoder, \bar{E} when HIGH, forces \bar{O}_0 to \bar{O}_3 HIGH. When used as a demultiplexer, the appropriate output is selected by the information on A_0 and A_1 with \bar{E} as data input. All unselected outputs are HIGH.

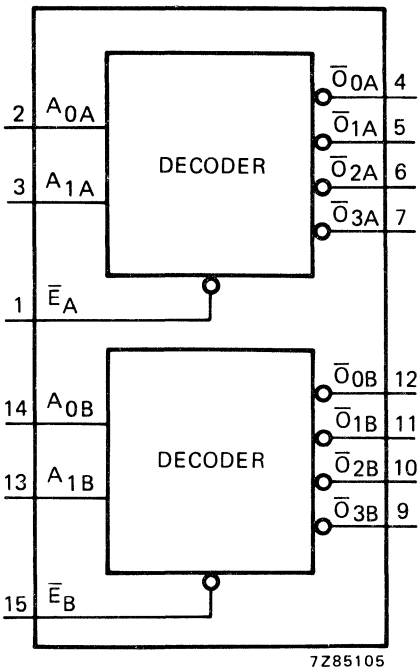

Fig. 1 Functional diagram.



Fig. 2 Pinning diagram.

- HEF4556BP : 16-lead DIL; plastic (SOT-38Z).
- HEF4556BD : 16-lead DIL; ceramic (cerdip) (SOT-74).
- HEF4556BT : 16-lead mini-pack; plastic (SO-16; SOT-109A).

PINNING

- \bar{E} enable inputs (active LOW)
- A_0 and A_1 address inputs
- \bar{O}_0 to \bar{O}_3 outputs (active LOW)

FAMILY DATA

I_{DD} LIMITS category MSI

} see Family Specifications

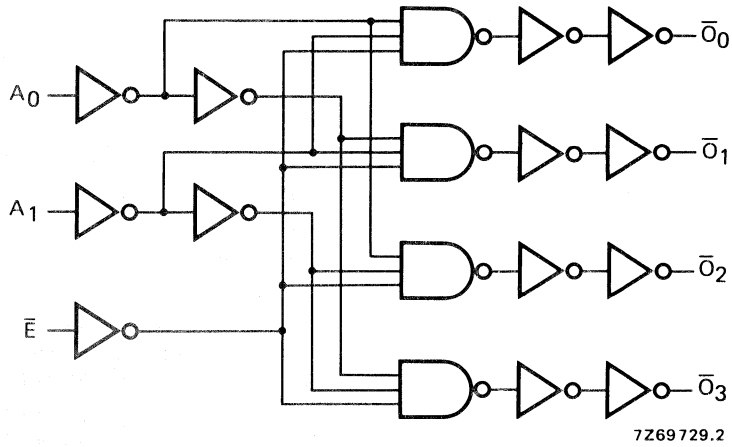

Fig. 3 Logic diagram (one decoder/multiplexer).

TRUTH TABLE

| inputs | | | outputs | | | |
|-----------|-------|-------|-------------|-------------|-------------|-------------|
| \bar{E} | A_0 | A_1 | \bar{O}_0 | \bar{O}_1 | \bar{O}_2 | \bar{O}_3 |
| L | L | L | L | H | H | H |
| L | H | L | H | L | H | H |
| L | L | H | H | H | L | H |
| L | H | H | H | H | H | L |
| H | X | X | H | H | H | H |

H = HIGH state (the more positive voltage)
L = LOW state (the less positive voltage)
X = state is immaterial

A.C. CHARACTERISTICS

$V_{SS} = 0\text{ V}$; $T_{amb} = 25\text{ }^{\circ}\text{C}$; $C_L = 50\text{ pF}$; input transition times $\leq 20\text{ ns}$

| | V_{DD} V | symbol | min. | typ. | max. | typical extrapolation formula | |
|--|---------------|-----------|------|------|------|--|---|
| Propagation delays $A_n \rightarrow \bar{O}_n$ HIGH to LOW | 5 | t_{PHL} | | 130 | 255 | ns | $103\text{ ns} + (0,55\text{ ns/pF}) C_L$ |
| | 10 | | 50 | 100 | ns | $39\text{ ns} + (0,23\text{ ns/pF}) C_L$ | |
| | 15 | | 35 | 65 | ns | $27\text{ ns} + (0,16\text{ ns/pF}) C_L$ | |
| LOW to HIGH | 5 | t_{PLH} | | 105 | 210 | ns | $78\text{ ns} + (0,55\text{ ns/pF}) C_L$ |
| | 10 | | 40 | 85 | ns | $29\text{ ns} + (0,23\text{ ns/pF}) C_L$ | |
| | 15 | | 30 | 60 | ns | $22\text{ ns} + (0,16\text{ ns/pF}) C_L$ | |
| $\bar{E}_n \rightarrow \bar{O}_n$ HIGH to LOW | 5 | t_{PHL} | | 120 | 240 | ns | $93\text{ ns} + (0,55\text{ ns/pF}) C_L$ |
| | 10 | | 45 | 90 | ns | $34\text{ ns} + (0,23\text{ ns/pF}) C_L$ | |
| | 15 | | 30 | 60 | ns | $22\text{ ns} + (0,16\text{ ns/pF}) C_L$ | |
| LOW to HIGH | 5 | t_{PLH} | | 105 | 205 | ns | $78\text{ ns} + (0,55\text{ ns/pF}) C_L$ |
| | 10 | | 40 | 80 | ns | $29\text{ ns} + (0,23\text{ ns/pF}) C_L$ | |
| | 15 | | 30 | 60 | ns | $22\text{ ns} + (0,16\text{ ns/pF}) C_L$ | |
| Output transition times HIGH to LOW | 5 | t_{THL} | | 60 | 120 | ns | $10\text{ ns} + (1,0\text{ ns/pF}) C_L$ |
| | 10 | | 30 | 60 | ns | $9\text{ ns} + (0,42\text{ ns/pF}) C_L$ | |
| | 15 | | 20 | 40 | ns | $6\text{ ns} + (0,28\text{ ns/pF}) C_L$ | |
| LOW to HIGH | 5 | t_{TLH} | | 60 | 120 | ns | $10\text{ ns} + (1,0\text{ ns/pF}) C_L$ |
| | 10 | | 30 | 60 | ns | $9\text{ ns} + (0,42\text{ ns/pF}) C_L$ | |
| | 15 | | 20 | 40 | ns | $6\text{ ns} + (0,28\text{ ns/pF}) C_L$ | |

| | V_{DD} V | typical formula for P (μW) | where f_i = input freq. (MHz) f_o = output freq. (MHz) C_L = load capacitance (pF) $\Sigma(f_o C_L)$ = sum of outputs V_{DD} = supply voltage (V) |
|---|---------------|---|--|
| Dynamic power dissipation per package (P) | 5 | $4400 f_i + \Sigma(f_o C_L) \times V_{DD}^2$ | |
| | 10 | $18\ 000 f_i + \Sigma(f_o C_L) \times V_{DD}^2$ | |
| | 15 | $43\ 300 f_i + \Sigma(f_o C_L) \times V_{DD}^2$ | |

APPLICATION INFORMATION

Some examples of applications for the HEF4556B are:

- Code conversion.
- Address decoding.
- Demultiplexing: when using the enable input as data input.

1-to-64 BIT VARIABLE LENGTH SHIFT REGISTER



The HEF4557B is a static clocked serial shift register whose length may be programmed to be any number of bits between 1 and 64. The number of bits selected is equal to the sum of the subscripts of the enabled length control inputs (L_1 , L_2 , L_4 , L_8 , L_{16} and L_{32}) plus one. Serial data may be selected from the D_A or D_B data inputs with the A/\bar{B} select input. This feature is useful for recirculation purposes. Information on D_A or D_B is shifted into the first register position and all the data in the register is shifted one position to the right on the LOW to HIGH transition of CP_0 while $\overline{CP_1}$ is LOW or on the HIGH to LOW transition of $\overline{CP_1}$ while CP_0 is HIGH. A HIGH on master reset (MR) resets the register and forces O to LOW and \bar{O} to HIGH, independent of the other inputs.

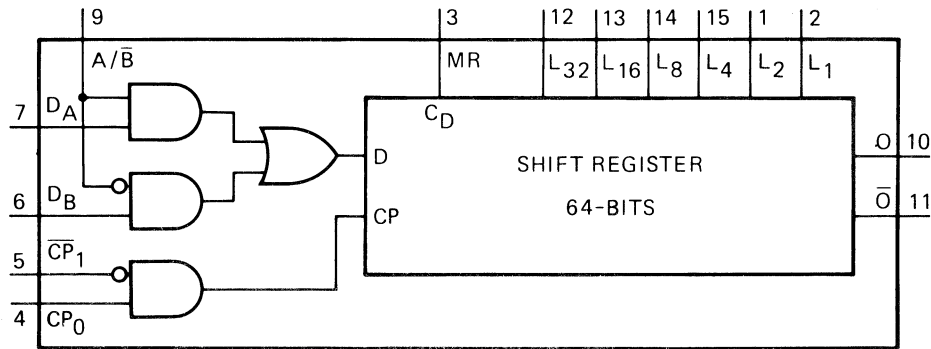

Fig. 1 Functional diagram.

PINNING

- D_A, D_B data inputs
- A/\bar{B} select data input
- CP_0 clock input
- $\overline{CP_1}$ clock enable input
- MR asynchronous master reset
- L_1 to L_{32} bit-length control inputs
- O, \bar{O} buffered outputs

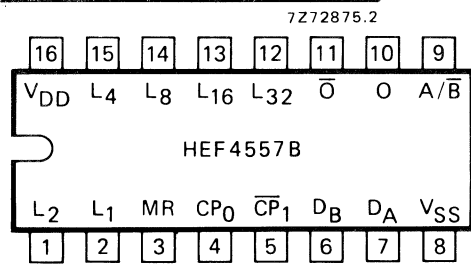

Fig. 2 Pinning diagram.

- HEF4557BP : 16-lead DIL; plastic (SOT-38Z).
- HEF4557BD : 16-lead DIL; ceramic (cerdip) (SOT-74).
- HEF4557BT : 16-lead mini-pack; plastic (SO-16; SOT-109A).

FAMILY DATA

I_{DD} LIMITS category LSI

see Family Specifications

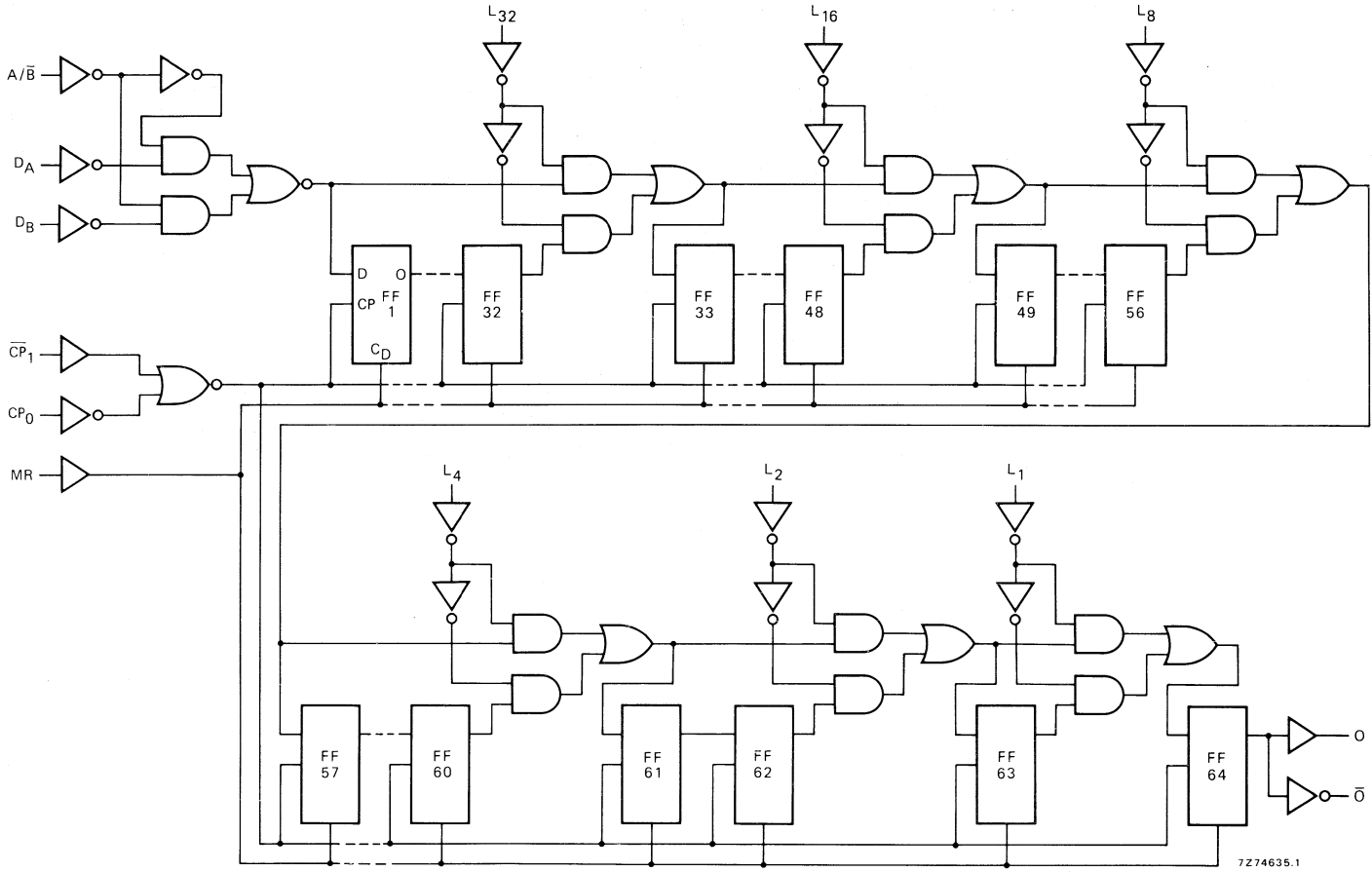

Fig. 3 Logic diagram.

FUNCTION TABLE

| inputs | | | | | | output |
|--------|--------------|----------------|----------------|-----------------|-------------------|----------------|
| MR | A/ \bar{B} | D _A | D _B | CP ₀ | $\overline{CP_1}$ | O * |
| L | L | D ₁ | D ₂ | / | L | D ₂ |
| L | H | D ₁ | D ₂ | / | L | D ₁ |
| L | L | D ₁ | D ₂ | H | \ | D ₂ |
| L | H | D ₁ | D ₂ | H | \ | D ₁ |
| H | X | X | X | X | X | L |

H = HIGH state (the more positive voltage)
 L = LOW state (the less positive voltage)
 X = state is immaterial
 / = positive-going transition
 \ = negative-going transition
 D_n = either HIGH or LOW

* The moment D_n appears at O depends on the bit-length shown in the table below.

BIT-LENGTH SELECT FUNCTION TABLE

| L32 | L16 | L8 | L4 | L2 | L1 | register length |
|-----|-----|----|----|----|----|-----------------|
| L | L | L | L | L | L | 1-bit |
| L | L | L | L | L | H | 2-bits |
| L | L | L | L | H | L | 3-bits |
| L | L | L | L | H | H | 4-bits |
| L | L | L | H | L | L | 5-bits |
| L | L | L | H | L | H | 6-bits |
| L | L | L | H | H | L | 7-bits |
| L | L | L | H | H | H | 8-bits |
| ↓ | ↓ | ↓ | ↓ | ↓ | ↓ | ↓ |
| L | H | H | H | H | H | 32-bits |
| H | L | L | L | L | L | 33-bits |
| H | L | L | L | L | H | 34-bits |
| ↓ | ↓ | ↓ | ↓ | ↓ | ↓ | ↓ |
| H | H | H | H | L | L | 61-bits |
| H | H | H | H | L | H | 62-bits |
| H | H | H | H | H | L | 63-bits |
| H | H | H | H | H | H | 64-bits |

A.C. CHARACTERISTICS

V_{SS} = 0 V; T_{amb} = 25 °C; input transition times ≤ 20 ns

| | V _{DD} V | typical formula for P (μW) | where f _i = input freq. (MHz) f _o = output freq. (MHz) C _L = load capacitance (pF) Σ(f _o C _L) = sum of outputs V _{DD} = supply voltage (V) |
|---|----------------------|--|--|
| Dynamic power dissipation per package (P) | 5 | 3 500 f _i + Σ(f _o C _L) × V _{DD} ² | |
| | 10 | 15 000 f _i + Σ(f _o C _L) × V _{DD} ² | |
| | 15 | 37 000 f _i + Σ(f _o C _L) × V _{DD} ² | |

A.C. CHARACTERISTICS

 $V_{SS} = 0\text{ V}$; $T_{amb} = 25\text{ }^{\circ}\text{C}$; $C_L = 50\text{ pF}$; input transition times $\leq 20\text{ ns}$

| | V_{DD} V | symbol | typ. | max. | | typical extrapolation formula | |
|--|-----------------------------------|------------------|-------------------|------|-----|---|---|
| Propagation delays $CP_0, CP_1 \rightarrow 0, \bar{0}$ HIGH to LOW | 5 | t _{PHL} | 240 | 480 | ns | $213\text{ ns} + (0,55\text{ ns/pF}) C_L$ | |
| | 10 | | 90 | 180 | ns | $79\text{ ns} + (0,23\text{ ns/pF}) C_L$ | |
| | 15 | | 65 | 130 | ns | $57\text{ ns} + (0,16\text{ ns/pF}) C_L$ | |
| | LOW to HIGH | 5 | t _{PLH} | 240 | 480 | ns | $213\text{ ns} + (0,55\text{ ns/pF}) C_L$ |
| | | 10 | | 90 | 180 | ns | $79\text{ ns} + (0,23\text{ ns/pF}) C_L$ |
| | | 15 | | 65 | 130 | ns | $57\text{ ns} + (0,16\text{ ns/pF}) C_L$ |
| | MR $\rightarrow 0$ HIGH to LOW | 5 | t _{PHL} | 170 | 340 | ns | $143\text{ ns} + (0,55\text{ ns/pF}) C_L$ |
| | | 10 | | 80 | 160 | ns | $69\text{ ns} + (0,23\text{ ns/pF}) C_L$ |
| | | 15 | | 60 | 120 | ns | $52\text{ ns} + (0,16\text{ ns/pF}) C_L$ |
| MR $\rightarrow \bar{0}$ LOW to HIGH | 5 | t _{PLH} | 140 | 280 | ns | $113\text{ ns} + (0,55\text{ ns/pF}) C_L$ | |
| | 10 | | 70 | 140 | ns | $59\text{ ns} + (0,23\text{ ns/pF}) C_L$ | |
| | 15 | | 55 | 110 | ns | $47\text{ ns} + (0,16\text{ ns/pF}) C_L$ | |
| Output transition times HIGH to LOW | 5 | t _{THL} | 60 | 120 | ns | $10\text{ ns} + (1,0\text{ ns/pF}) C_L$ | |
| | 10 | | 30 | 60 | ns | $9\text{ ns} + (0,42\text{ ns/pF}) C_L$ | |
| | 15 | | 20 | 40 | ns | $6\text{ ns} + (0,28\text{ ns/pF}) C_L$ | |
| | LOW to HIGH | 5 | t _{T LH} | 60 | 120 | ns | $10\text{ ns} + (1,0\text{ ns/pF}) C_L$ |
| | | 10 | | 30 | 60 | ns | $9\text{ ns} + (0,42\text{ ns/pF}) C_L$ |
| | | 15 | | 20 | 40 | ns | $6\text{ ns} + (0,28\text{ ns/pF}) C_L$ |

Interpolation table (see note next page)

| length control inputs | | | | | | minimum number of bits selected | set-up, hold, recovery times |
|-----------------------|----------------|----------------|----------------|-----------------|-----------------|---------------------------------------|------------------------------------|
| L ₁ | L ₂ | L ₄ | L ₈ | L ₁₆ | L ₃₂ | | |
| L | L | L | L | L | L | 1 | specified |
| H | L | L | L | L | L | 2 | |
| X | H | L | L | L | L | 3 | |
| X | X | H | L | L | L | 5 | six equal steps |
| X | X | X | H | L | L | 9 | |
| X | X | X | X | H | L | 17 | |
| X | X | X | X | X | H | 33 | specified |

H = HIGH state (the more positive voltage)

L = LOW state (the less positive voltage)

X = state is immaterial

A.C. CHARACTERISTICS

$V_{SS} = 0\text{ V}$; $T_{amb} = 25\text{ }^{\circ}\text{C}$; $C_L = 50\text{ pF}$; input transition times $\leq 20\text{ ns}$; see also waveforms Fig. 4

| | V_{DD} V | symbol | min. | typ. | | |
|---|------------------------|------------|------------|------|-----|----|
| Minimum clock pulse width; LOW for $\overline{CP_0}$ or HIGH for $\overline{CP_1}$ | 5 | t_{WCPL} | 180 | 90 | ns | |
| | 10 | or | 60 | 30 | ns | |
| | 15 | t_{WCPH} | 40 | 20 | ns | |
| Minimum reset pulse width; HIGH | 5 | t_{WMRH} | 150 | 75 | ns | |
| | 10 | | 70 | 35 | ns | |
| | 15 | | 50 | 25 | ns | |
| Set-up times $D_A, D_B, A/\overline{B} \rightarrow CP_0,$ $\overline{CP_1}$ L_1 to $L_{32} = \text{LOW}$ | 5 | t_{su} | 360 | 180 | ns | |
| | 10 | | 140 | 70 | ns | |
| | 15 | | 90 | 45 | ns | |
| | $L_{32} = \text{HIGH}$ | 5 | t_{su} | 40 | -20 | ns |
| | | 10 | | 35 | -10 | ns |
| | | 15 | | 30 | -5 | ns |
| Hold times $D_A, D_B, A/\overline{B} \rightarrow CP_0,$ $\overline{CP_1}$ L_1 to $L_{32} = \text{LOW}$ | 5 | t_{hold} | -40 | -110 | ns | |
| | 10 | | -10 | -45 | ns | |
| | 15 | | 0 | -30 | ns | |
| | $L_{32} = \text{HIGH}$ | 5 | t_{hold} | 90 | 30 | ns |
| | | 10 | | 60 | 20 | ns |
| | | 15 | | 50 | 15 | ns |
| Recovery times for MR L_1 to $L_{32} = \text{LOW}$ | 5 | t_{RMR} | 500 | 250 | ns | |
| | 10 | | 250 | 125 | ns | |
| | 15 | | 150 | 75 | ns | |
| | $L_{32} = \text{HIGH}$ | 5 | t_{RMR} | 110 | 50 | ns |
| | | 10 | | 70 | 30 | ns |
| | | 15 | | 60 | 25 | ns |
| Minimum clock pulse frequency | 5 | f_{max} | 2,5 | 5 | MHz | |
| | 10 | | 7 | 14 | MHz | |
| | 15 | | 10 | 20 | MHz | |

see note

Note

The set-up, hold and recovery times vary with the minimum number of bits selected. For other values as specified one may interpolate as shown in the table (see previous page).

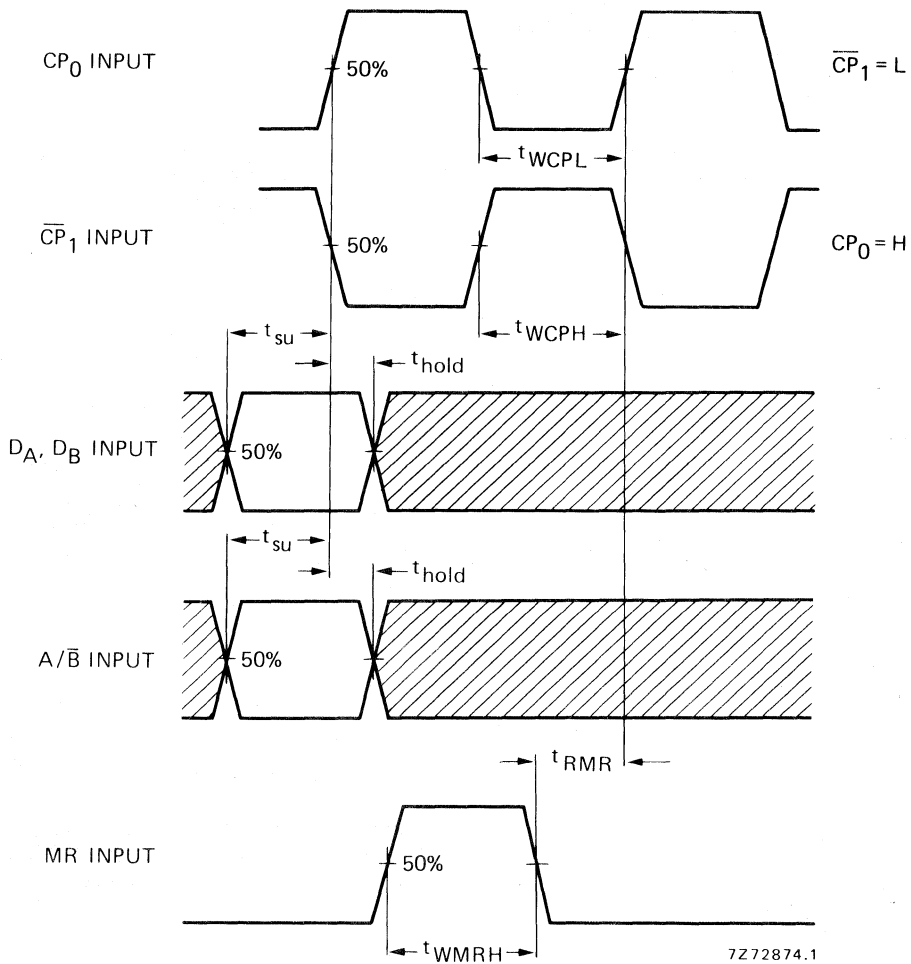

Fig. 4 Waveforms showing recovery time for MR and minimum CP_0 , \overline{CP}_1 and MR pulse widths, set-up and hold times for D_A , D_B and A/\overline{B} to CP_0 and \overline{CP}_1 . Set-up and hold times are shown as positive values but may be specified as negative values.



4-BIT MAGNITUDE COMPARATOR

The HEF4585B is a 4-bit magnitude comparator which compares two 4-bit words (A and B), whether they are 'less than', 'equal to', or 'greater than'. Each word has four parallel inputs (A_0 to A_3 and B_0 to B_3); A_3 and B_3 being the most significant inputs. Three outputs are provided; A greater than B ($O_{A > B}$), A less than B ($O_{A < B}$) and A equal to B ($O_{A = B}$). Three expander inputs ($I_{A > B}$, $I_{A < B}$ and $I_{A = B}$) allow cascading of the devices without external gates.

For proper compare operation the expander inputs to the least significant position must be connected as follows: $I_{A = B} = I_{A > B} = \text{HIGH}$, $I_{A < B} = \text{LOW}$. For words greater than 4-bits, units can be cascaded by connecting outputs $O_{A < B}$ and $O_{A = B}$ to the corresponding inputs of the next significant comparator (input $I_{A > B}$ is connected to a HIGH).

Operation is not restricted to binary codes, the devices will work with any monotonic code. The function table describes the operation of the device under all possible logic conditions.

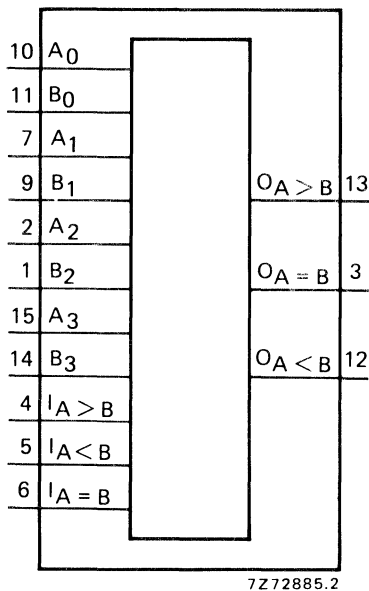

Fig. 1 Functional diagram.

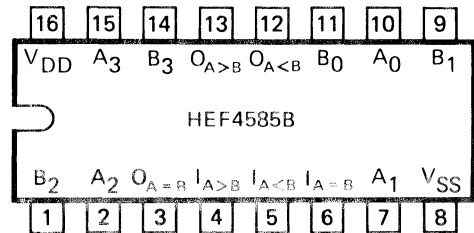

Fig. 2 Pinning diagram.

HEF4585BP: 16-lead DIL; plastic (SOT-38Z).
HEF4585BD: 16-lead DIL; ceramic (cerdip) (SOT-74).
HEF4585BT: 16-lead mini-pack; plastic (SO-16; SOT-109A).

PINNING

| | |
|---|-------------------------|
| A_0 to A_3 | word A parallel inputs |
| B_0 to B_3 | word B parallel inputs |
| $I_{A > B}$, $I_{A < B}$, $I_{A = B}$ | expander inputs |
| $O_{A > B}$ | A greater than B output |
| $O_{A < B}$ | A less than B output |
| $O_{A = B}$ | A equal to B output |

FAMILY DATA

I_{DD} LIMITS category MSI

} see Family Specifications

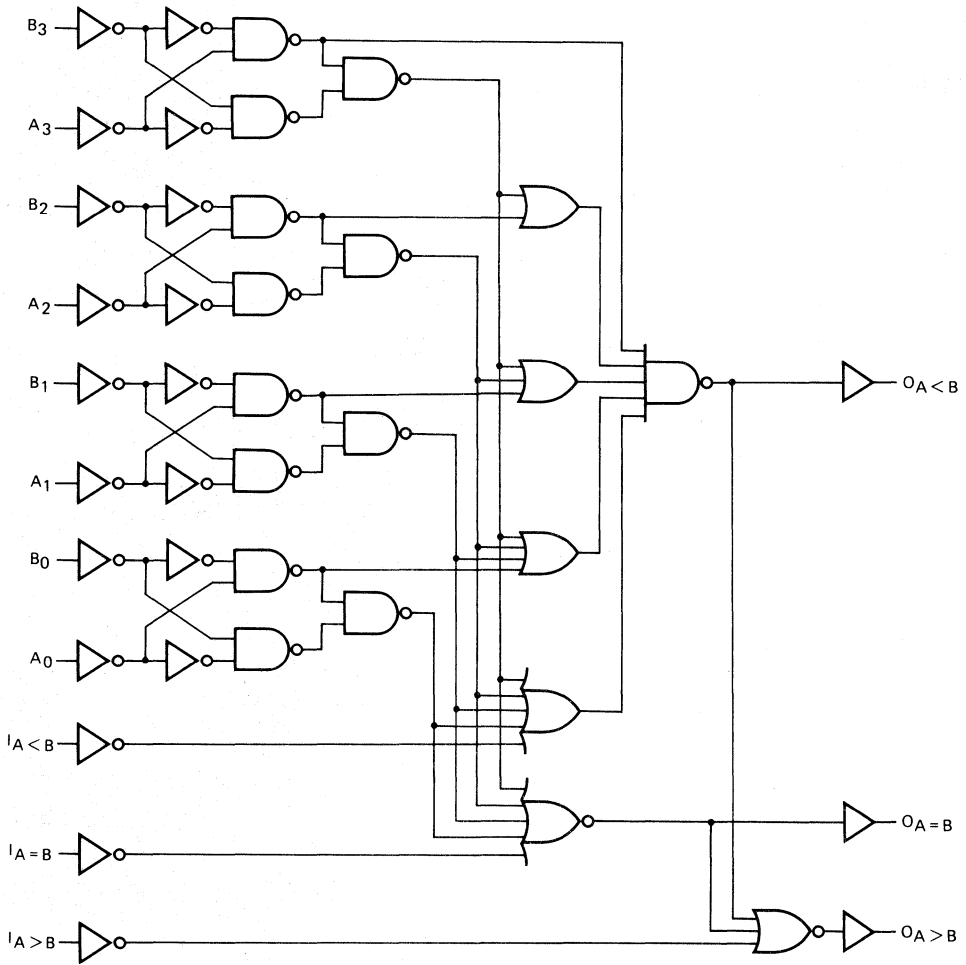

7274596.1

Fig. 3 Logic diagram.

FUNCTION TABLE

| comparing inputs | | | | cascading inputs | | | outputs | | |
|---------------------------------|---------------------------------|---------------------------------|---------------------------------|--------------------|--------------------|--------------------|--------------------|--------------------|--------------------|
| A ₃ , B ₃ | A ₂ , B ₂ | A ₁ , B ₁ | A ₀ , B ₀ | I _A > B | I _A < B | I _A = B | O _A > B | O _A < B | O _A = B |
| A ₃ > B ₃ | X | X | X | H | X | X | H | L | L |
| A ₃ < B ₃ | X | X | X | X | X | X | L | H | L |
| A ₃ = B ₃ | A ₂ > B ₂ | X | X | H | X | X | H | L | L |
| A ₃ = B ₃ | A ₂ < B ₂ | X | X | X | X | X | L | H | L |
| A ₃ = B ₃ | A ₂ = B ₂ | A ₁ > B ₁ | X | H | X | X | H | L | L |
| A ₃ = B ₃ | A ₂ = B ₂ | A ₁ < B ₁ | X | X | X | X | L | H | L |
| A ₃ = B ₃ | A ₂ = B ₂ | A ₁ = B ₁ | A ₀ > B ₀ | H | X | X | H | L | L |
| A ₃ = B ₃ | A ₂ = B ₂ | A ₁ = B ₁ | A ₀ < B ₀ | X | X | X | L | H | L |
| A ₃ = B ₃ | A ₂ = B ₂ | A ₁ = B ₁ | A ₀ = B ₀ | X | L | H | L | L | H |
| A ₃ = B ₃ | A ₂ = B ₂ | A ₁ = B ₁ | A ₀ = B ₀ | H | L | L | H | L | L |
| A ₃ = B ₃ | A ₂ = B ₂ | A ₁ = B ₁ | A ₀ = B ₀ | X | H | L | L | H | L |
| A ₃ = B ₃ | A ₂ = B ₂ | A ₁ = B ₁ | A ₀ = B ₀ | X | H | H | L | H | H |
| A ₃ = B ₃ | A ₂ = B ₂ | A ₁ = B ₁ | A ₀ = B ₀ | L | L | L | L | L | L |

H = HIGH state (the more positive voltage)

L = LOW state (the less positive voltage)

X = state is immaterial

The upper 11 lines describe the normal operation under all conditions that will occur in a single device or in a serial expansion scheme.

The lower 2 lines describe the operation under abnormal conditions on the cascading inputs. These conditions occur when the parallel expansion technique is used.

A.C. CHARACTERISTICS

$V_{SS} = 0\text{ V}$; $T_{amb} = 25\text{ }^{\circ}\text{C}$; $C_L = 50\text{ pF}$; input transition times $\leq 20\text{ ns}$

| | V_{DD} V | symbol | min. | typ. | max. | typical extrapolation formula |
|---|---------------|------------------|------|--------|--|---|
| Propagation delays $A_n, B_n \rightarrow O_n$ HIGH to LOW | 5 | t _{PHL} | | 160 | 320 ns | $133\text{ ns} + (0,55\text{ ns/pF}) C_L$ |
| | 10 | | 65 | 130 ns | $54\text{ ns} + (0,23\text{ ns/pF}) C_L$ | |
| | 15 | | 45 | 90 ns | $37\text{ ns} + (0,16\text{ ns/pF}) C_L$ | |
| LOW to HIGH | 5 | t _{PLH} | | 150 | 300 ns | $123\text{ ns} + (0,55\text{ ns/pF}) C_L$ |
| | 10 | | 60 | 120 ns | $49\text{ ns} + (0,23\text{ ns/pF}) C_L$ | |
| | 15 | | 45 | 90 ns | $37\text{ ns} + (0,16\text{ ns/pF}) C_L$ | |
| $I_n \rightarrow O_n$ HIGH to LOW | 5 | t _{PHL} | | 110 | 220 ns | $83\text{ ns} + (0,55\text{ ns/pF}) C_L$ |
| | 10 | | 45 | 90 ns | $34\text{ ns} + (0,23\text{ ns/pF}) C_L$ | |
| | 15 | | 30 | 60 ns | $22\text{ ns} + (0,16\text{ ns/pF}) C_L$ | |
| LOW to HIGH | 5 | t _{PLH} | | 120 | 240 ns | $93\text{ ns} + (0,55\text{ ns/pF}) C_L$ |
| | 10 | | 50 | 100 ns | $39\text{ ns} + (0,23\text{ ns/pF}) C_L$ | |
| | 15 | | 35 | 70 ns | $27\text{ ns} + (0,16\text{ ns/pF}) C_L$ | |
| Output transition times HIGH to LOW | 5 | t _{THL} | | 60 | 120 ns | $10\text{ ns} + (1,0\text{ ns/pF}) C_L$ |
| | 10 | | 30 | 60 ns | $9\text{ ns} + (0,42\text{ ns/pF}) C_L$ | |
| | 15 | | 20 | 40 ns | $6\text{ ns} + (0,28\text{ ns/pF}) C_L$ | |
| LOW to HIGH | 5 | t _{TLH} | | 60 | 120 ns | $10\text{ ns} + (1,0\text{ ns/pF}) C_L$ |
| | 10 | | 30 | 60 ns | $9\text{ ns} + (0,42\text{ ns/pF}) C_L$ | |
| | 15 | | 20 | 40 ns | $6\text{ ns} + (0,28\text{ ns/pF}) C_L$ | |

| | V_{DD} V | typical formula for P (μW) | where |
|---|---------------|--|------------------------------------|
| Dynamic power dissipation per package (P) | 5 | $1250 f_i + \Sigma(f_o C_L) \times V_{DD}^2$ | f_i = input freq. (MHz) |
| | 10 | | f_o = output freq. (MHz) |
| | 15 | | C_L = load capacitance (pF) |
| | | | $\Sigma(f_o C_L)$ = sum of outputs |
| | | | V_{DD} = supply voltage (V) |

APPLICATION INFORMATION

Some examples of applications for the HEF4585B are:

- Process controllers.
- Servo-motor control.

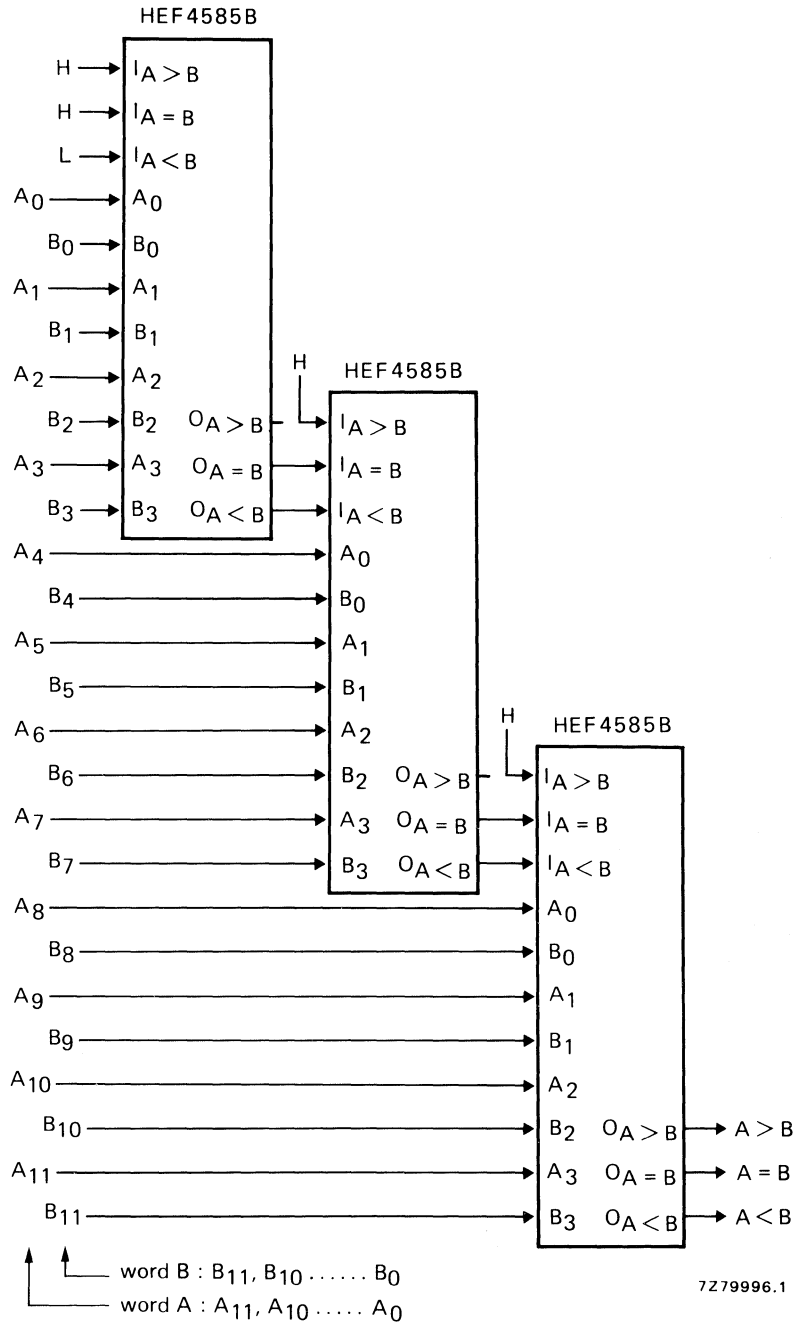

Fig. 4 Example of cascading comparators.

256-BIT, 1-BIT PER WORD RANDOM ACCESS MEMORIES

The HEF4720B and HEF4720V are 256-bit, 1-bit per word random access memories with 3-state outputs. The memories are fully decoded and completely static.

Recommended supply voltage range for HEF4720B is 3 to 15 V and for HEF4720V is 4,5 to 12,5 V; minimum stand-by voltage for both types is 3 V.

The use of LOC MOS gives the added advantage of very low stand-by power. The circuits can be directly interfaced with standard bipolar devices (TTL) without using special interface circuits. The memory operates from a single power supply. The separate chip select input (\overline{CS}) allows simple memory expansion when the outputs are wire-ORed. If \overline{CS} is HIGH, the outputs are floating and no new information can be written into the memory. The signal at \overline{O} has the same polarity as the data input D, while the signal at \overline{O} is the complement of the signal at O. The write control W must be HIGH for writing into the memory.

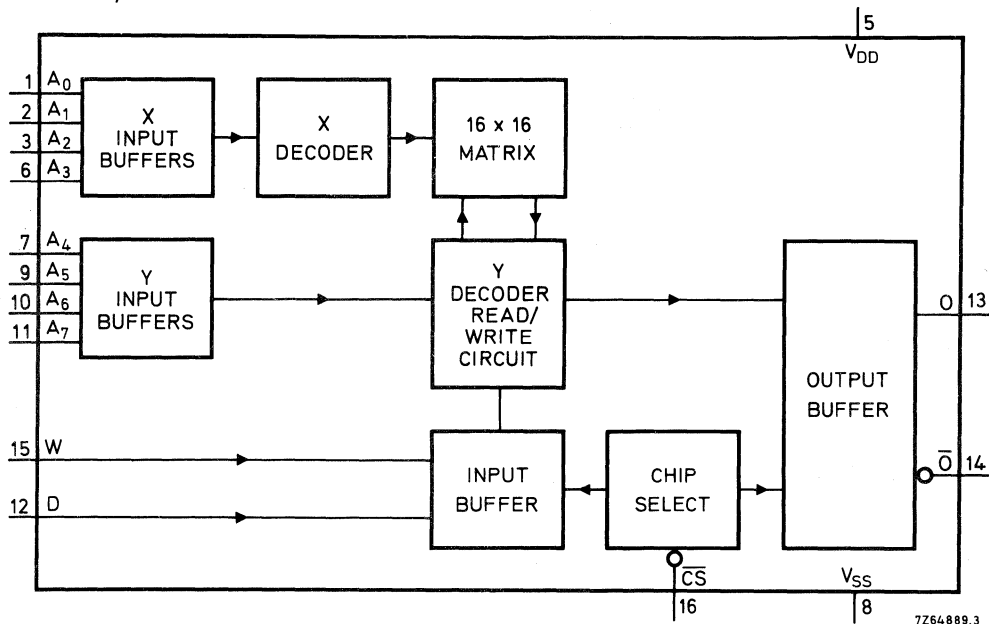

Fig. 1 Functional diagram.

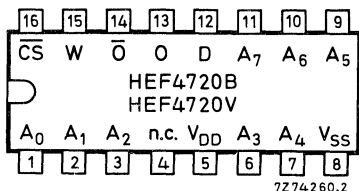

Fig. 2 Pinning diagram.

HEF4720BP; HEF4720VP: 16-lead DIL; plastic (SOT-38Z).

HEF4720BD; HEF4720VD: 16-lead DIL; ceramic (cerdip) (SOT-74).

HEF4720BT; HEF4720VT: 16-lead mini-pack; plastic (SO-16L; SOT-162A).

FAMILY DATA: see Family Specifications.

I_{DD} LIMITS: see next page.

HEF4720B
HEF4720V
LSI

FUNCTION TABLE

| \overline{CS} | W | O | \overline{O} | mode |
|-----------------|---|--------------------------|--|---------|
| L | H | data written into memory | complement of data written into memory | write |
| L | L | data written into memory | complement of data written into memory | read |
| H | X | Z | Z | inhibit |

H = HIGH state (the more positive voltage) X = state is immaterial
L = LOW state (the less positive voltage) Z = high impedance OFF-state

PINNING

\overline{CS} chip select input (active LOW)
W write enable input
D data input
A₀ to A₇ address inputs
O 3-state output (active HIGH)
 \overline{O} 3-state output (active LOW)

SUPPLY VOLTAGE

| | rating | recommended operating | stand-by min. |
|----------|------------|-----------------------|---------------|
| HEF4720B | -0,5 to 18 | 3,0 to 15,0 | 3 V |
| HEF4720V | -0,5 to 18 | 4,5 to 12,5 | 3 V |

The values given at $V_{DD} = 15$ V in the following d.c. and a.c. characteristics, are not applicable to the HEF4720V, because of its lower supply voltage range.

D.C. CHARACTERISTICS

$V_{SS} = 0$ V

| | V_{DD} V | V_{OL} V | symbol | T_{amb} (°C) | | | | | |
|---|---------------|---------------|--------------|----------------|------|------|------|------|-------------|
| | | | | -40 | | +25 | | +85 | |
| | | | | min. | max. | min. | max. | min. | max. |
| Output current LOW | 4,75 | 0,4 | I_{OL} | 2,4 | | 2 | | 1,6 | mA |
| | 10 | 0,5 | | 4,8 | | 4 | | 3,2 | mA |
| | 15 | 1,5 | | 10,0 | | 10 | | 7,5 | mA |
| Quiescent device current | 5 | | I_{DD} | | 25 | | 25 | | 200 μ A |
| | 10 | | | | 50 | | 50 | | 400 μ A |
| | 15 | | | | 100 | | 100 | | 800 μ A |
| Input leakage current HEF4720V HEF4720B | 10 | | $\pm I_{IN}$ | | 0,3 | | 0,3 | | 1 μ A |
| | 15 | | | | 0,3 | | 0,3 | | 1 μ A |

A.C. CHARACTERISTICS

| | V _{DD} V | symbol | min. | typ. | max. | |
|--------------------|----------------------|----------------|------|------|------|----|
| Output capacitance | 5 | C _O | | 5 | | pF |
| | 10 | | 5 | | pF | |
| | 15 | | 5 | | pF | |

A.C. CHARACTERISTICS

V_{SS} = 0 V; T_{amb} = 25 °C; C_L = 50 pF; input transition times ≤ 20 ns

| | V _{DD} V | symbol | min. | typ. | max. | typical extrapolation formula | |
|--|----------------------|-------------------|------|------|------|--------------------------------------|--------------------------------------|
| Read cycle | | | | | | | |
| Read access time | 5 | t _{ACC} | | 320 | 580 | ns | 292 ns + (0,55 ns/pF) C _L |
| | 10 | | 130 | 220 | ns | 118 ns + (0,23 ns/pF) C _L | |
| | 15 | | 100 | 160 | ns | 92 ns + (0,16 ns/pF) C _L | |
| Chip select to output time | 5 | t _{CO} | | | 180 | ns | |
| | 10 | | | | 70 | ns | |
| | 15 | | | | 50 | ns | |
| Address hold time | 5 | t _{OA} | 0 | | | ns | |
| | 10 | | 0 | | | ns | |
| | 15 | | 0 | | | ns | |
| Output hold time with respect to address input | 5 | t _{VAL1} | 60 | 170 | | ns | 142 ns + (0,55 ns/pF) C _L |
| | 10 | | 20 | 50 | | ns | 38 ns + (0,23 ns/pF) C _L |
| | 15 | | 15 | 40 | | ns | 32 ns + (0,16 ns/pF) C _L |
| Output hold time with respect to chip select input | 5 | t _{COH} | | | 130 | ns | |
| | 10 | | | | 70 | ns | |
| | 15 | | | | 60 | ns | |
| Output floating time with respect to chip select input | 5 | t _{COF} | 0 | | | ns | |
| | 10 | | 0 | | | ns | |
| | 15 | | 0 | | | ns | |
| Read cycle time | 5 | t _{RC} | 580 | | | ns | |
| | 10 | | 220 | | | ns | |
| | 15 | | 160 | | | ns | |
| Output transition times LOW to HIGH | 5 | t _{TLH} | | 60 | 120 | ns | 10 ns + (1,0 ns/pF) C _L |
| | 10 | | | 30 | 60 | ns | 9 ns + (0,42 ns/pF) C _L |
| | 15 | | | 20 | 40 | ns | 6 ns + (0,28 ns/pF) C _L |
| HIGH to LOW | 5 | t _{THL} | | 40 | 80 | ns | 14 ns + (0,52 ns/pF) C _L |
| | 10 | | | 22 | 40 | ns | 11 ns + (0,22 ns/pF) C _L |
| | 15 | | | 15 | 30 | ns | 7 ns + (0,16 ns/pF) C _L |

A.C. CHARACTERISTICS

 $V_{SS} = 0 \text{ V}$; $T_{amb} = 25 \text{ }^\circ\text{C}$; $C_L = 50 \text{ pF}$; input transition times $\leq 20 \text{ ns}$

| | V_{DD} V | symbol | min. | typ. | max. |
|---|---------------|------------|------|--------|------|
| Write cycle | | | | | |
| Write cycle time | 5 | t_{WC} | 580 | | ns |
| | 10 | | 220 | | ns |
| | 15 | | 160 | | ns |
| Address to write set-up time | 5 | t_{AW} | 110 | | ns |
| | 10 | | 50 | | ns |
| | 15 | | 50 | | ns |
| Write pulse width | 5 | t_{WP} | 370 | 10 000 | ns |
| | 10 | | 130 | 10 000 | ns |
| | 15 | | 80 | 10 000 | ns |
| Write recovery time | 5 | t_{WR} | 100 | | ns |
| | 10 | | 40 | | ns |
| | 15 | | 30 | | ns |
| Data set-up time | 5 | t_{DW} | 250 | | ns |
| | 10 | | 100 | | ns |
| | 15 | | 80 | | ns |
| Data hold time | 5 | t_{DH} | 100 | | ns |
| | 10 | | 30 | | ns |
| | 15 | | 20 | | ns |
| Chip select set-up time with respect to write pulse | 5 | t_{CSW} | 370 | | ns |
| | 10 | | 130 | | ns |
| | 15 | | 80 | | ns |
| Chip select hold time with respect to write pulse | 5 | t_{CSH} | 0 | | ns |
| | 10 | | 0 | | ns |
| | 15 | | 0 | | ns |
| Chip select lead time over write pulse to prevent writing | 5 | t_{CSL} | 0 | | ns |
| | 10 | | 0 | | ns |
| | 15 | | 0 | | ns |
| Read-modify-write cycle | | | | | |
| Read enable hold time | 5 | t_{RH} | 0 | | ns |
| | 10 | | 0 | | ns |
| | 15 | | 0 | | ns |
| Output hold time with respect to write pulse | 5 | t_{VAL2} | 60 | | ns |
| | 10 | | 20 | | ns |
| | 15 | | 15 | | ns |
| Read-modify-write cycle time | 5 | t_{RWC} | 1050 | | ns |
| | 10 | | 390 | | ns |
| | 15 | | 270 | | ns |

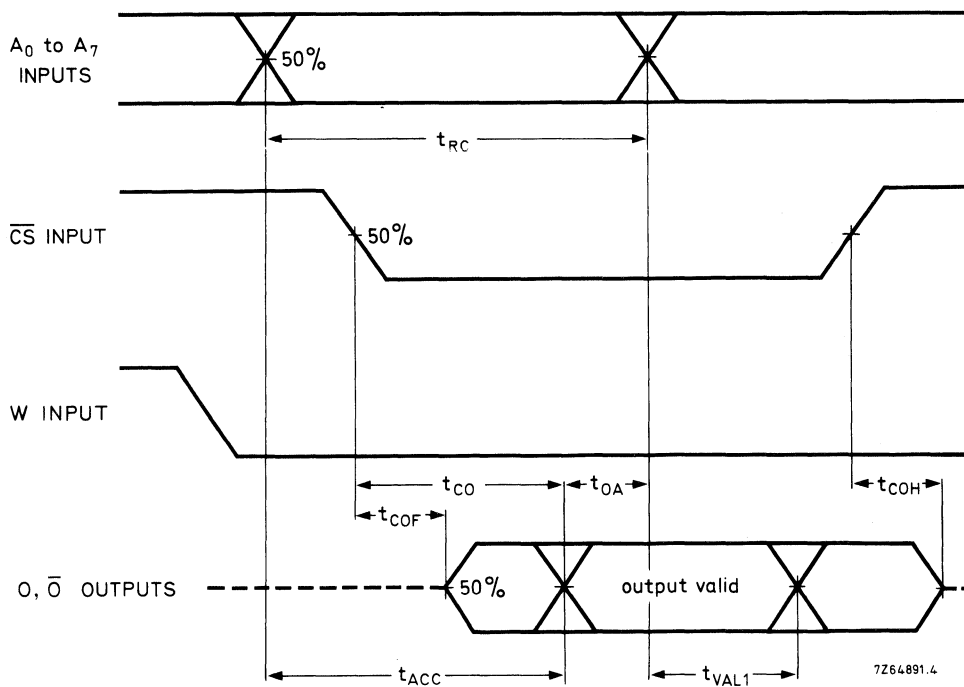

Fig. 3 Read cycle timing diagram.

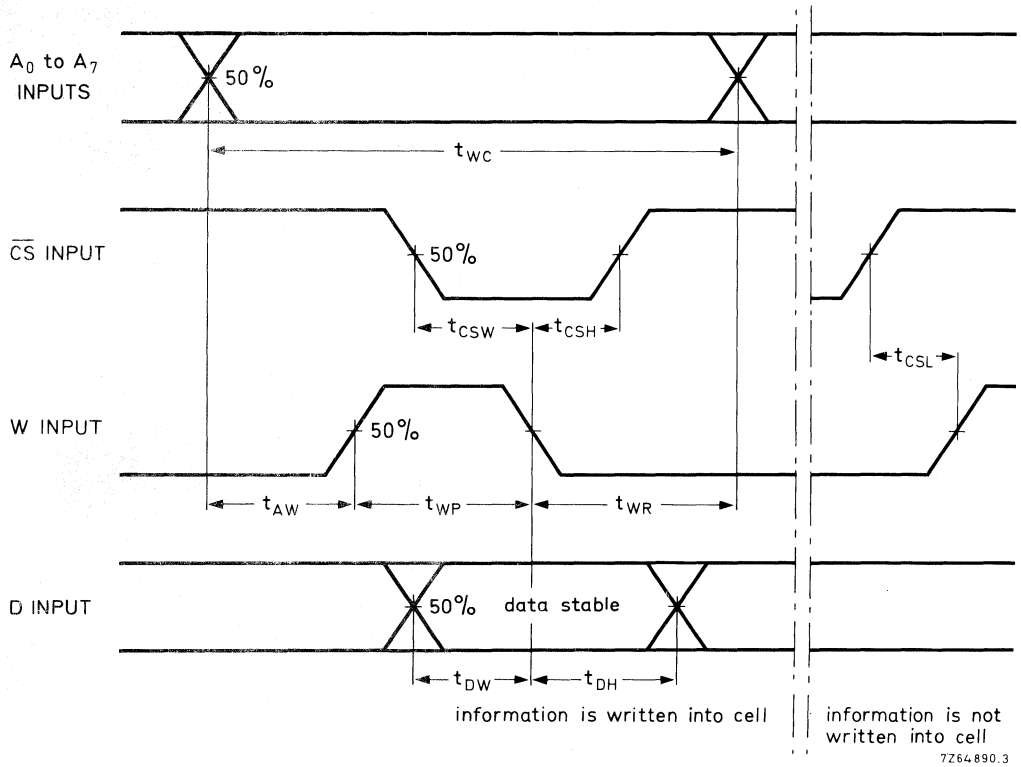
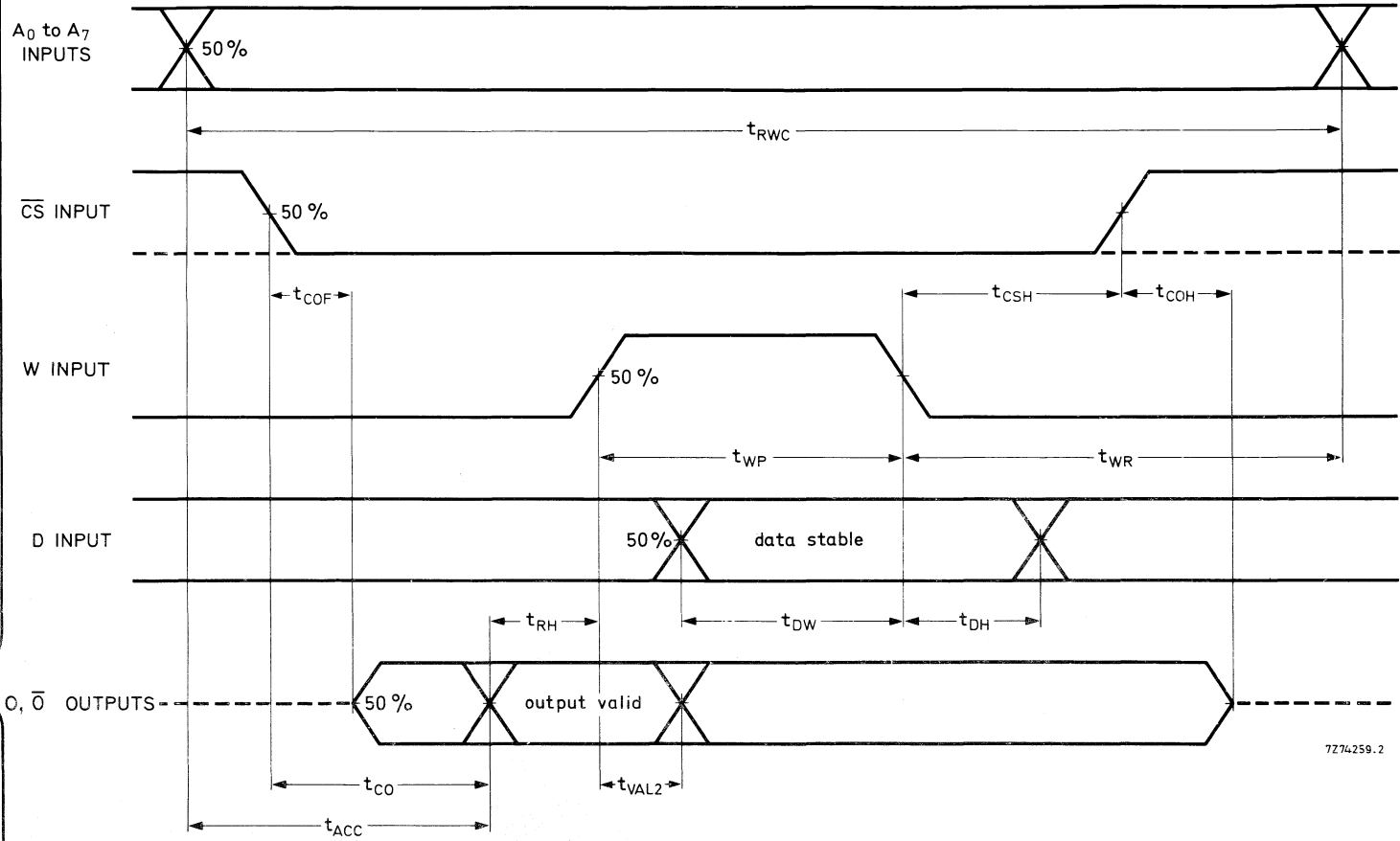

Fig. 4 Write cycle timing diagram.



7274259.2

Fig. 5 Read-modify-write cycle timing diagram.

HEF4720B
HEF4720V
LSI

APPLICATION INFORMATION

Extension of memory capacity

The memory capacity of the HEF4720B; V is 256 bits (or 256 words of 1 bit). The capacity of a system can be extended in various ways by the connection of further HEF4720B; V ICs.

Extending the word length

By connecting a number of HEF4720B; V ICs as shown in Fig. 6, the word length (i.e. bits per word) is multiplied by that number. That is, each device stores 1 bit per word but the total number of words remains 256. For example, if four devices are used in this way, 256 four-binary-bit words can be stored.

Extending the number of words

If a number of HEF4720B; V ICs are connected as shown in Fig. 7, the words available are multiplied by that number, but the word length remains 1 bit. Notice that in this case additional addresses are used in conjunction with the \overline{CS} input. In the case shown in Fig. 7 (4 x HEF4720B; V in parallel), the addresses and data inputs are loaded with four inputs (= 20 pF), the \overline{CS} inputs are loaded with one input each.

Extending both the word length and number of words

Figure 8 shows how a combination of the extensions described above can be used to obtain both greater word length and additional words. It is clear that the capacitive load of the driving circuits puts a limit to the free choice of the interface. In Fig. 8, each address is loaded with 16 inputs, i.e. $16 \times 5 = 80$ pF: each \overline{CS} inverter is loaded with 8 inputs, i.e. $8 \times 5 = 40$ pF. The data inverters in this case are loaded with only two inputs each.

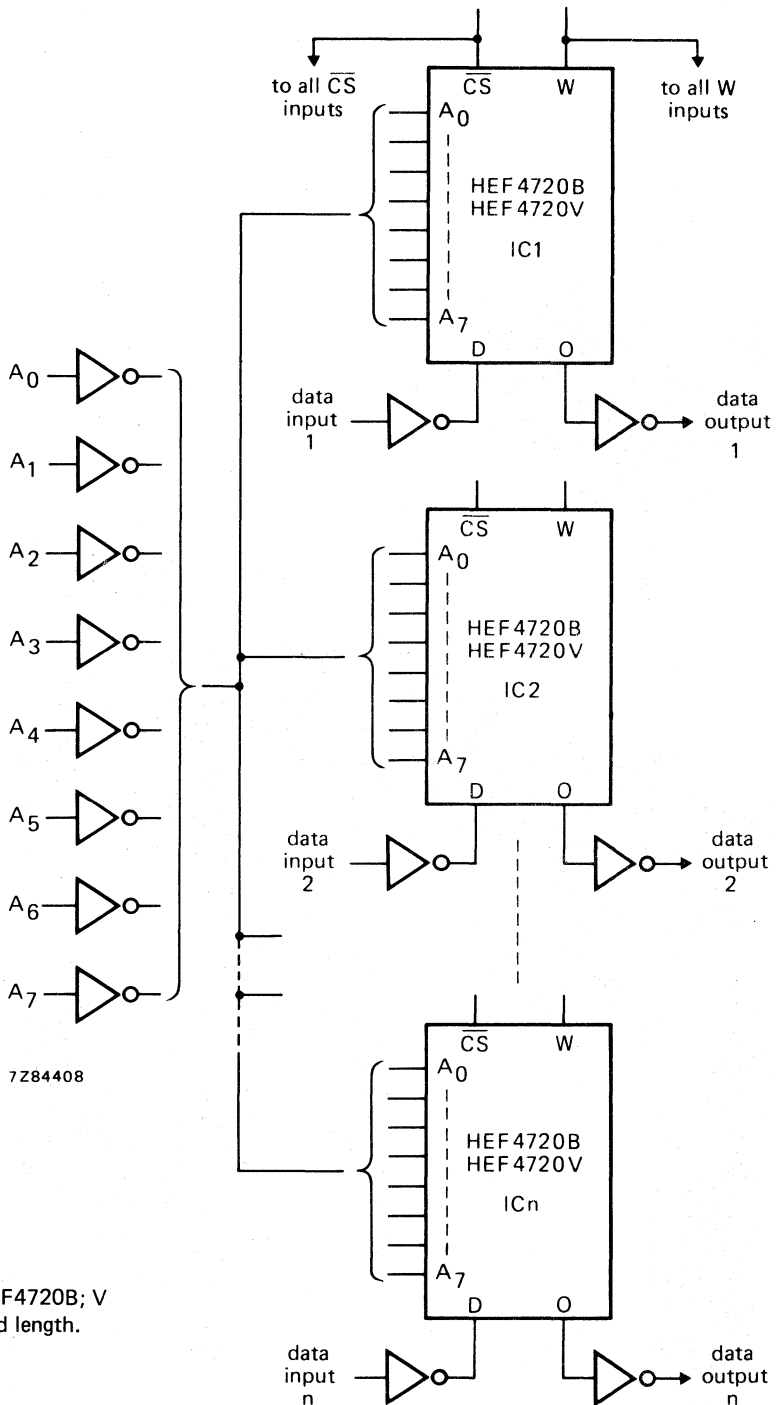

Fig. 6 Using extra HEF4720B; V ICs to extend the word length.

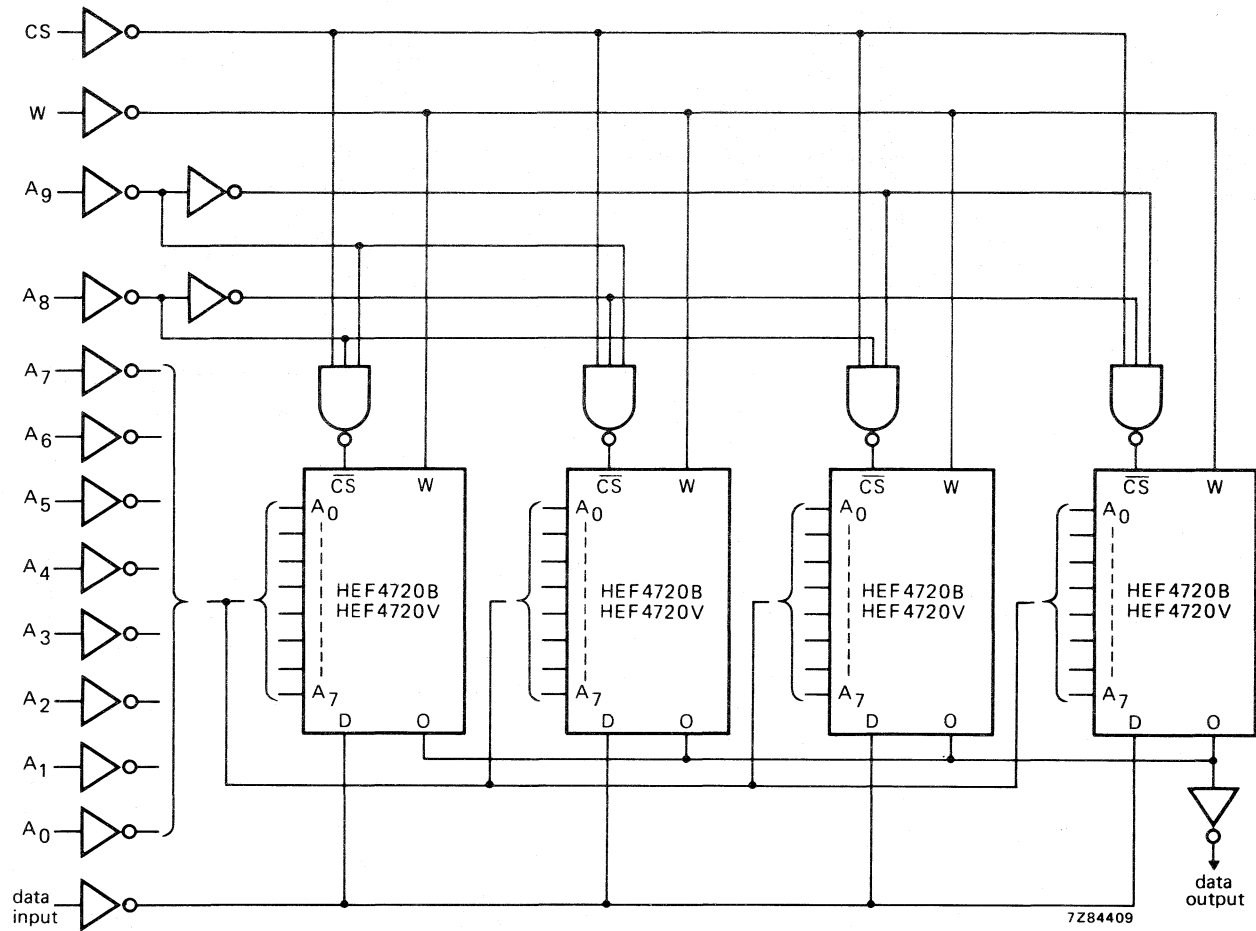
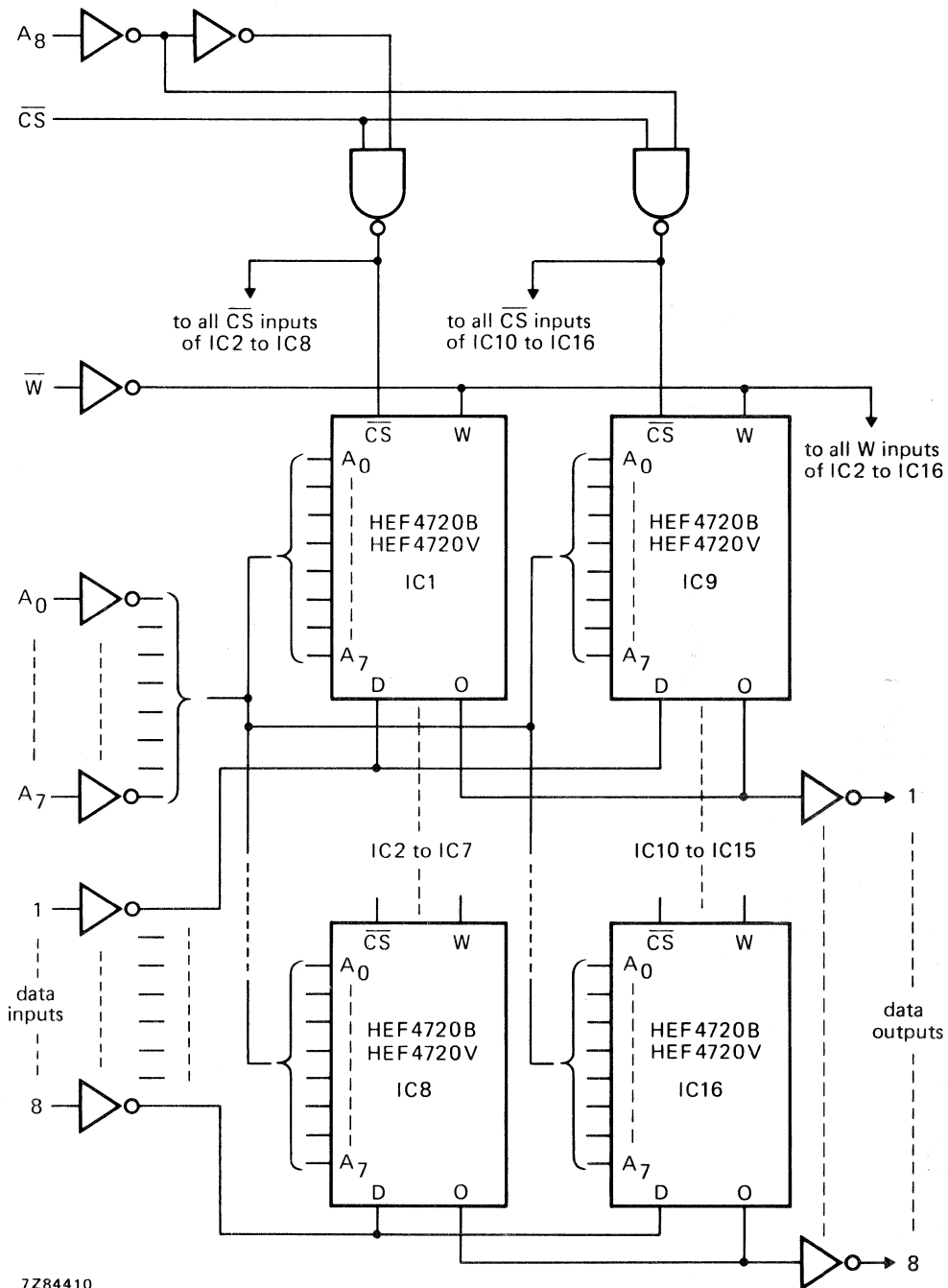

Fig. 7 Using extra HEF4720B; V ICs to obtain more words.



7284410

Fig. 8 Using extra HEF4720B; V ICs to obtain more words and greater word length.

APPLICATION INFORMATION (continued)

Memory retention

It is sometimes necessary to ensure that the information stored in the memory cannot be erased inadvertently. This can be arranged by adding detection circuits, by measures in the timing, and by the addition of a battery. With the HEF4720B; V, memory retention is very easily obtained because its current drain in the stand-by condition is almost zero. The wide supply voltage range makes it possible to keep the memory active by means of a simple battery, thereby preventing information loss.

In designing the memory retention circuits, two aspects should be kept in mind. The memory retention will not function in an optimum way if the battery voltage is low or if the voltage transitions at the address input are too slow. The first of these is usually the result of using too simple a battery back-up circuit, e.g. a battery charged via a diode from the TTL supply voltage. In this case, the LOCMOS supply voltage falls below the safe operating voltage. Special arrangements should be made to overcome this.

Slow address transitions (the second cause of memory loss) are due to a long RC-time in the power system. When the power is switched on or off, the 5 V line changes between 0 and 5 V in milliseconds to seconds so producing a correspondingly long transition time in the various logic outputs. This creates problems in the proper operation of the HEF4720B; V, with loss of memory as a possible result. This can be prevented by ensuring that input rise and fall times do not exceed 10 μ s.

Three possibilities for controlling the rise and fall times at the HEF4720B; V interface are given here:

1. LOCMOS gates can be connected between the address latch and the HEF4720B; V (Fig. 9). In the event of a low voltage, or mains supply failure, the gates can be blocked by a signal from the memory retention logic thus isolating the HEF4720B; V from the address and \overline{CS} inputs.
2. The interface power supply can be separated from the TTL power supply by means of a low-value resistor (Fig. 10); a thyristor is connected from the interface power supply to earth. The system is arranged so that, upon switching off or failure of the interface supply, the thyristor turns on thus ensuring a rapid fall of the supply voltage.
3. The best solution is to select the interface circuits from the LOCMOS family and to feed all these circuits from the battery (Fig. 11). These stages then remain active when the TTL 5 V supply fails. The interface circuits are mostly only active on a clock pulse, have the possibility of being inactive on a gate level, or can be forced into one position.

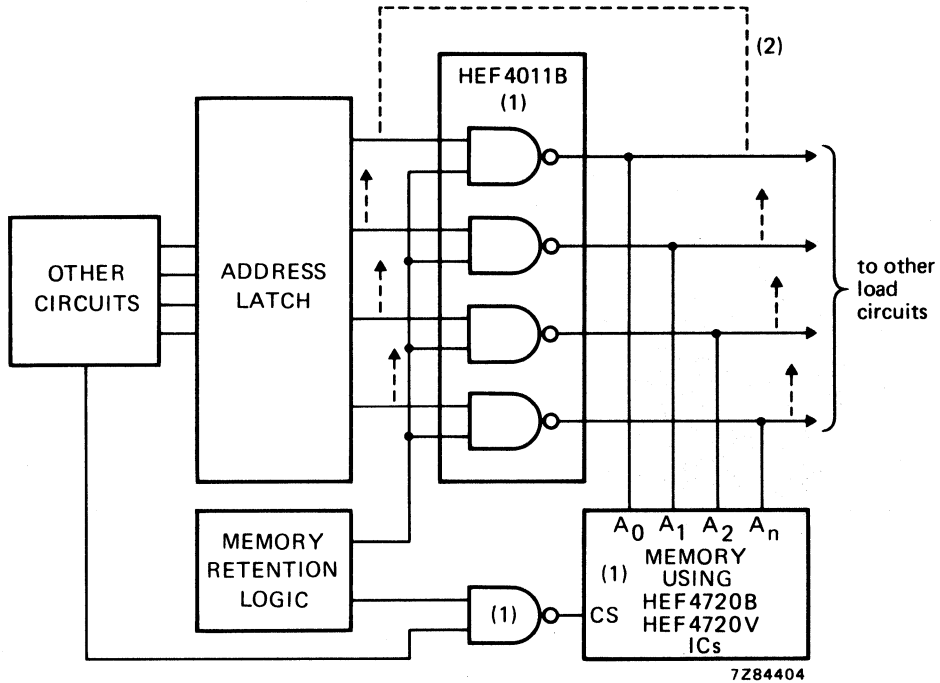

- (1) These devices have a battery supply.
- (2) Alternative connection.

Fig. 9 Use of battery-operated LOCMOS gates to isolate the memory in case of power supply failure. Devices marked (1) are connected to the battery. The HEF4011B can sink about 0,7 mA: if the load is greater than this, only the memory should be connected, other loads being connected to the address latch as shown by the dashed-line connections.

HEF4720B
HEF4720V
LSI

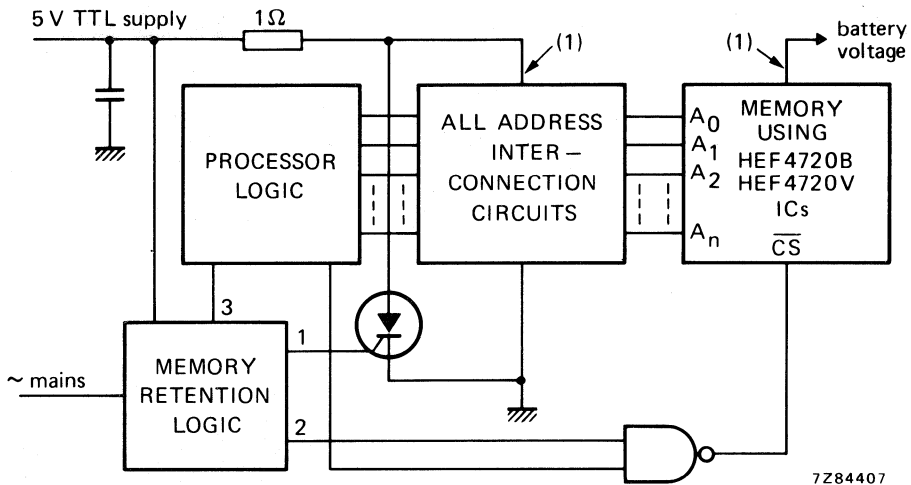

7284407

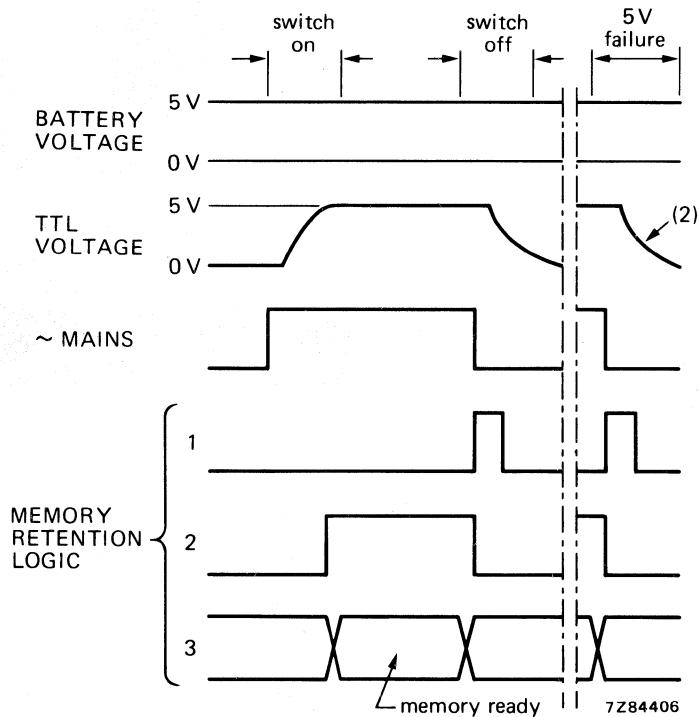

7284406

- (1) Leads should be so arranged to prevent cross-talk; thyristor connections must be short.
(2) Slope $> 500 \text{ mV}/\mu\text{s}$ in the vicinity of the threshold.

Fig. 10 Using a thyristor to ensure a rapid fall of interface supply at switch-off or supply failure.



8-BIT ADDRESSABLE LATCH

The HEF4724B is an 8-bit addressable latch with three address inputs (A_0 to A_2), a data input (D), an active LOW enable input (\bar{E}), an active HIGH clear input (CL), and eight parallel latch outputs (O_0 to O_7).

When \bar{E} and CL are HIGH, all outputs (O_0 to O_7) are LOW. Eight-channel demultiplexing or active HIGH 1-of-8 decoding with output enable operation occurs when CL is HIGH and \bar{E} is LOW. When CL and \bar{E} are LOW, the selected output (O_0 to O_7 ; determined by A_0 to A_2) follows D . When \bar{E} goes HIGH, the contents of the latch are stored. When operating in the addressable latch mode ($\bar{E} = CL = LOW$), changing more than one bit of A_0 to A_2 could impose a transient wrong address. Therefore, this should only be done while in the memory mode ($\bar{E} = HIGH, CL = LOW$).

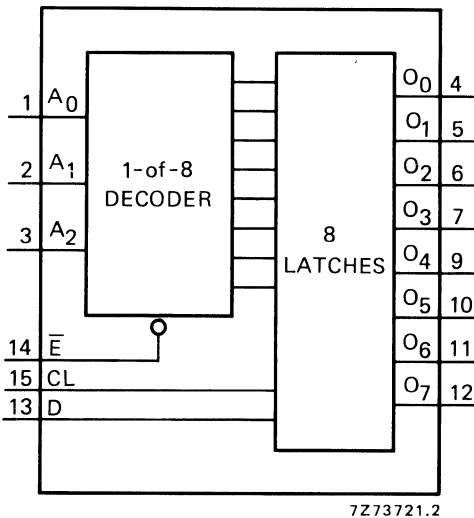

Fig. 1 Functional diagram.

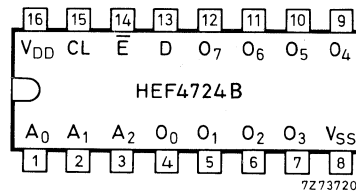

Fig. 2 Pinning diagram.

HEF4724BP : 16-lead DIL; plastic (SOT-38Z).

HEF4724BD : 16-lead DIL; ceramic (cerdip) (SOT-74).

HEF4724BT : 16-lead mini-pack; plastic (SO-16; SOT-109A).

PINNING

| | |
|----------------|---------------------------|
| A_0 to A_2 | address inputs |
| D | data input |
| \bar{E} | enable input (active LOW) |
| CL | clear input (active HIGH) |
| O_0 to O_7 | parallel latch outputs |

FAMILY DATA

} see Family Specifications

I_{DD} LIMITS category MSI

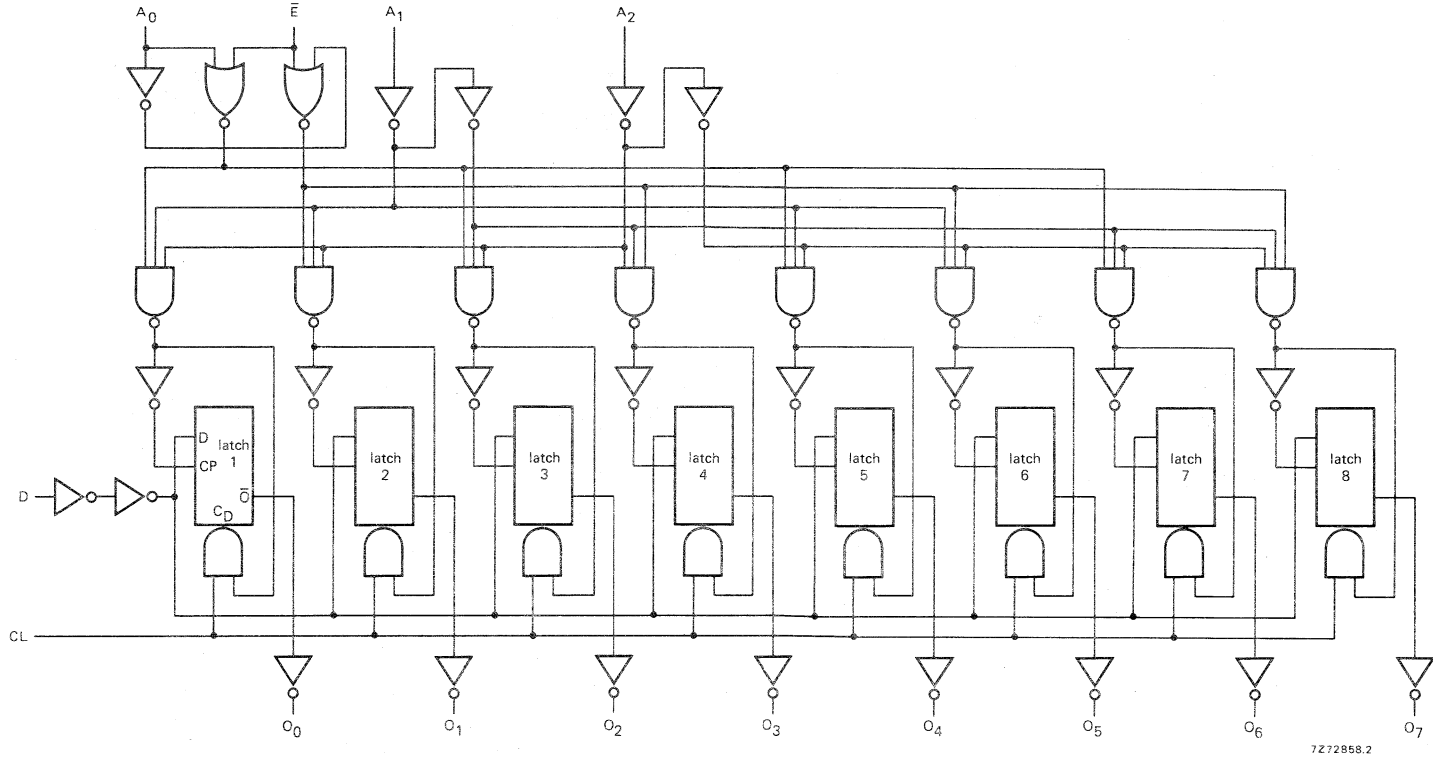

Fig. 3 Logic diagram.

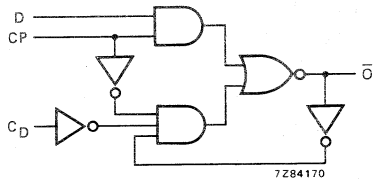

Fig. 4 Logic diagram (one latch).

MODE SELECTION

| \bar{E} | CL | mode |
|-----------|----|-------------------------------------|
| L | L | addressable latch |
| H | L | memory |
| L | H | active HIGH 8-channel demultiplexer |
| H | H | clear |

FUNCTION TABLE

| CL | \bar{E} | D | A ₀ | A ₁ | A ₂ | O ₀ | O ₁ | O ₂ | O ₃ | O ₄ | O ₅ | O ₆ | O ₇ | mode |
|----|-----------|----------------|----------------|----------------|----------------|------------------|------------------|------------------|------------------|------------------|------------------|------------------|------------------|--|
| H | H | X | X | X | X | L | L | L | L | L | L | L | L | clear |
| H | L | D ₁ | L | L | L | D ₁ | L | L | L | L | L | L | L | demultiplexer; unaddressed latch is cleared |
| H | L | D ₁ | H | L | L | L | D ₁ | L | L | L | L | L | L | |
| H | L | D ₁ | L | H | L | L | L | D ₁ | L | L | L | L | L | |
| H | L | D ₁ | H | H | L | L | L | L | D ₁ | L | L | L | L | |
| H | L | D ₁ | H | L | H | L | L | L | L | D ₁ | L | L | L | |
| H | L | D ₁ | L | H | H | L | L | L | L | L | D ₁ | L | L | |
| H | L | D ₁ | H | H | H | L | L | L | L | L | L | D ₁ | L | |
| H | L | D ₁ | H | H | H | L | L | L | L | L | L | L | D ₁ | |
| L | H | X | X | X | X | O _{n-1} | O _{n-1} | O _{n-1} | O _{n-1} | O _{n-1} | O _{n-1} | O _{n-1} | O _{n-1} | memory |
| L | L | D ₁ | L | L | L | D ₁ | O _{n-1} | O _{n-1} | O _{n-1} | O _{n-1} | O _{n-1} | O _{n-1} | O _{n-1} | addressable latch; unaddressed latch holds previous state |
| L | L | D ₁ | H | L | L | O _{n-1} | D ₁ | O _{n-1} | O _{n-1} | O _{n-1} | O _{n-1} | O _{n-1} | O _{n-1} | |
| L | L | D ₁ | L | H | L | O _{n-1} | O _{n-1} | D ₁ | O _{n-1} | O _{n-1} | O _{n-1} | O _{n-1} | O _{n-1} | |
| L | L | D ₁ | H | H | L | O _{n-1} | O _{n-1} | O _{n-1} | D ₁ | O _{n-1} | O _{n-1} | O _{n-1} | O _{n-1} | |
| L | L | D ₁ | L | L | H | O _{n-1} | O _{n-1} | O _{n-1} | O _{n-1} | D ₁ | O _{n-1} | O _{n-1} | O _{n-1} | |
| L | L | D ₁ | H | L | H | O _{n-1} | O _{n-1} | O _{n-1} | O _{n-1} | O _{n-1} | D ₁ | O _{n-1} | O _{n-1} | |
| L | L | D ₁ | L | H | H | O _{n-1} | O _{n-1} | O _{n-1} | O _{n-1} | O _{n-1} | O _{n-1} | D ₁ | O _{n-1} | |
| L | L | D ₁ | H | H | H | O _{n-1} | O _{n-1} | O _{n-1} | O _{n-1} | O _{n-1} | O _{n-1} | O _{n-1} | D ₁ | |

H = HIGH state (the more positive voltage)

L = LOW state (the less positive voltage)

X = state is immaterial

O_{n-1} = state before the positive transition of \bar{E}

D₁ = either HIGH or LOW

A.C. CHARACTERISTICS

V_{SS} = 0 V; T_{amb} = 25 °C; input transition times ≤ 20 ns

| | V _{DD} V | typical formula for P (μW) | where f _i = input freq. (MHz) f _o = output freq. (MHz) C _L = load capacitance (pF) Σ(f _o C _L) = sum of outputs V _{DD} = supply voltage (V) |
|---|----------------------|---|--|
| Dynamic power dissipation per package (P) | 5 10 15 | 700 f _i + Σ(f _o C _L) × V _{DD} ² 3700 f _i + Σ(f _o C _L) × V _{DD} ² 10 800 f _i + Σ(f _o C _L) × V _{DD} ² | |

A.C. CHARACTERISTICS

 $V_{SS} = 0\text{ V}$; $T_{amb} = 25\text{ }^{\circ}\text{C}$; $C_L = 50\text{ pF}$; input transition times $\leq 20\text{ ns}$

| | V_{DD} V | symbol | min. | typ. | max. | typical extrapolation formula | |
|--|---------------|------------|------|------|------|----------------------------------|--|
| Propagation delays $\bar{E} \rightarrow O_n$ HIGH to LOW | 5 | | | 115 | 230 | ns | $88\text{ ns} + (0,55\text{ ns/pF}) C_L$ |
| | 10 | t_{PHL} | | 50 | 95 | ns | $39\text{ ns} + (0,23\text{ ns/pF}) C_L$ |
| | 15 | | | 35 | 70 | ns | $27\text{ ns} + (0,16\text{ ns/pF}) C_L$ |
| LOW to HIGH | 5 | | | 95 | 195 | ns | $68\text{ ns} + (0,55\text{ ns/pF}) C_L$ |
| | 10 | t_{PLH} | | 40 | 80 | ns | $29\text{ ns} + (0,23\text{ ns/pF}) C_L$ |
| | 15 | | | 30 | 55 | ns | $22\text{ ns} + (0,16\text{ ns/pF}) C_L$ |
| $D \rightarrow O_n$ HIGH to LOW | 5 | | | 95 | 190 | ns | $68\text{ ns} + (0,55\text{ ns/pF}) C_L$ |
| | 10 | t_{PHL} | | 35 | 75 | ns | $24\text{ ns} + (0,23\text{ ns/pF}) C_L$ |
| | 15 | | | 25 | 55 | ns | $17\text{ ns} + (0,16\text{ ns/pF}) C_L$ |
| LOW to HIGH | 5 | | | 85 | 170 | ns | $58\text{ ns} + (0,55\text{ ns/pF}) C_L$ |
| | 10 | t_{PLH} | | 35 | 75 | ns | $24\text{ ns} + (0,23\text{ ns/pF}) C_L$ |
| | 15 | | | 25 | 55 | ns | $17\text{ ns} + (0,16\text{ ns/pF}) C_L$ |
| $A_n \rightarrow O_n$ HIGH to LOW | 5 | | | 110 | 225 | ns | $83\text{ ns} + (0,55\text{ ns/pF}) C_L$ |
| | 10 | t_{PHL} | | 45 | 95 | ns | $34\text{ ns} + (0,23\text{ ns/pF}) C_L$ |
| | 15 | | | 35 | 70 | ns | $27\text{ ns} + (0,16\text{ ns/pF}) C_L$ |
| LOW to HIGH | 5 | | | 95 | 190 | ns | $68\text{ ns} + (0,55\text{ ns/pF}) C_L$ |
| | 10 | t_{PLH} | | 40 | 80 | ns | $29\text{ ns} + (0,23\text{ ns/pF}) C_L$ |
| | 15 | | | 30 | 55 | ns | $22\text{ ns} + (0,16\text{ ns/pF}) C_L$ |
| $CL \rightarrow O_n$ HIGH to LOW | 5 | | | 85 | 165 | ns | $58\text{ ns} + (0,55\text{ ns/pF}) C_L$ |
| | 10 | t_{PHL} | | 35 | 70 | ns | $24\text{ ns} + (0,23\text{ ns/pF}) C_L$ |
| | 15 | | | 25 | 50 | ns | $17\text{ ns} + (0,16\text{ ns/pF}) C_L$ |
| Set-up times $D \rightarrow \bar{E}$ | 5 | | 40 | 20 | | ns | } see also waveforms Fig. 5 |
| | 10 | t_{su} | 15 | 5 | | ns | |
| | 15 | | 10 | 0 | | ns | |
| $A_n \rightarrow \bar{E}$ | 5 | | 40 | 20 | | ns | |
| | 10 | t_{su} | 20 | 10 | | ns | |
| | 15 | | 15 | 5 | | ns | |
| Hold times $D \rightarrow \bar{E}$ | 5 | | 20 | 0 | | ns | |
| | 10 | t_{hold} | 15 | 5 | | ns | |
| | 15 | | 15 | 5 | | ns | |
| $A_n \rightarrow \bar{E}$ | 5 | | 50 | 25 | | ns | |
| | 10 | t_{hold} | 20 | 10 | | ns | |
| | 15 | | 15 | 5 | | ns | |
| Minimum \bar{E} pulse width; LOW | 5 | | 75 | 35 | | ns | |
| | 10 | t_{WEL} | 30 | 15 | | ns | |
| | 15 | | 20 | 10 | | ns | |
| Minimum CL pulse width; HIGH | 5 | | 70 | 35 | | ns | |
| | 10 | t_{WCLH} | 30 | 15 | | ns | |
| | 15 | | 20 | 10 | | ns | |

A.C. CHARACTERISTICS

$V_{SS} = 0\text{ V}$; $T_{amb} = 25\text{ }^\circ\text{C}$; $C_L = 50\text{ pF}$; input transition times $\leq 20\text{ ns}$

| | V_{DD} V | symbol | min. | typ. | max. | typical extrapolation formula | |
|---|---------------|-----------|------|------|------|---|---|
| Output transition times HIGH to LOW | 5 | t_{THL} | | 60 | 120 | ns | $10\text{ ns} + (1,0\text{ ns/pF}) C_L$ |
| | 10 | | 30 | 60 | ns | $9\text{ ns} + (0,42\text{ ns/pF}) C_L$ | |
| | 15 | | 20 | 40 | ns | $6\text{ ns} + (0,28\text{ ns/pF}) C_L$ | |
| LOW to HIGH | 5 | t_{TLH} | | 60 | 120 | ns | $10\text{ ns} + (1,0\text{ ns/pF}) C_L$ |
| | 10 | | 30 | 60 | ns | $9\text{ ns} + (0,42\text{ ns/pF}) C_L$ | |
| | 15 | | 20 | 40 | ns | $6\text{ ns} + (0,28\text{ ns/pF}) C_L$ | |

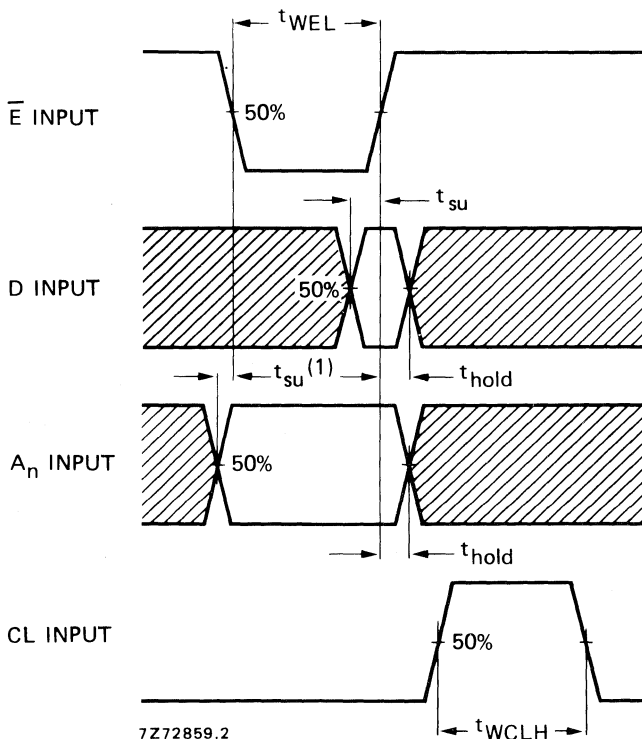

(1) The address to enable set-up time is the time before the HIGH to LOW enable transition that the address must be stable so that the correct latch is addressed and the other latches are not affected.

Fig. 5 Waveforms showing minimum \bar{E} and CL pulse widths, set-up times, hold times. Set-up and hold times are shown as positive values but may be specified as negative values.

QUADRUPLE 64-BIT STATIC SHIFT REGISTER

The HEF4731B and HEF4731V are quadruple 64-bit static shift registers each with separate serial data inputs (D_A to D_D), clock inputs (\overline{CP}_A to \overline{CP}_D) and data outputs (O_{63A} to O_{63D}) from the 64th register position.

Recommended supply voltage range for HEF4731B is 3 to 15 V and for HEF4731V is 4,5 to 12,5 V.

Data are shifted to the next stage on the negative-going transitions of the clock. Low impedance outputs are provided for direct interface to TTL.

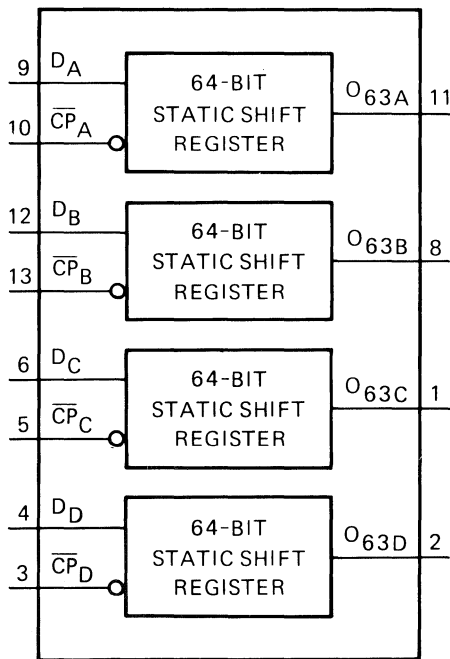

Fig. 1 Functional diagram. 7Z74633.1

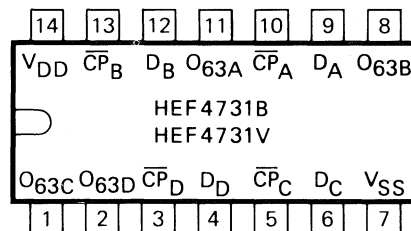

Fig. 2 Pinning diagram. 7Z74631

HEF4731BP; HEF4731VP : 14-lead DIL; plastic (SOT-27K, M, T).
HEF4731BD; HEF4731VD : 14-lead DIL; ceramic (cerdip) (SOT-73).

FAMILY DATA

I_{DD} LIMITS category LSI

} see Family Specifications

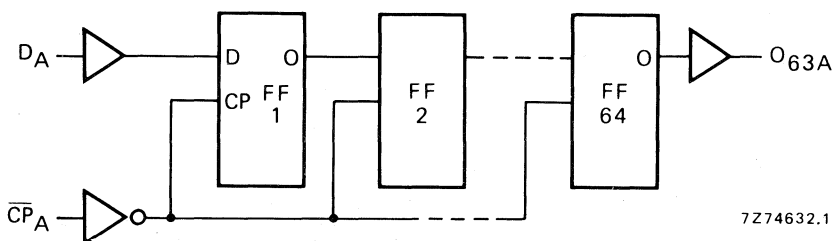

7274632.1

Fig. 3 Logic diagram (one of 64-bit shift register).

The values given at $V_{DD} = 15\text{ V}$ in the following d.c. and a.c. characteristics, are not applicable to the HEF4731V, because of its reduced supply voltage range.

D.C. CHARACTERISTICS

$V_{SS} = 0\text{ V}$; $V_I = V_{SS}$ or V_{DD}

| | V_{DD} V | V_{OL} V | V_{OH} V | symbol | T_{amb} (°C) | | | | | |
|------------------------------------|---------------|---------------|---------------|-----------|----------------|------|------|------|------|------|
| | | | | | -40 | | +25 | | +85 | |
| | | | | | min. | max. | min. | max. | min. | max. |
| Output (source) current HIGH | 5 | | 2,5 | $-I_{OH}$ | 3 | 2,5 | 2,0 | | | mA |
| | 5 | | 4,6 | | 1 | 0,85 | 0,65 | | | mA |
| | 10 | | 9,5 | | 3 | 2,5 | 2,0 | | | mA |
| | 15 | | 13,5 | | 10 | 8,5 | 6,5 | | | mA |
| Output (sink) current LOW | 4,75 | 0,4 | | I_{OL} | 2,3 | 2,0 | 1,6 | | | mA |
| | 10 | 0,5 | | | 6,0 | 5,0 | 4,0 | | | mA |
| | 15 | 1,5 | | | 20,0 | 18,0 | 14,0 | | | mA |

A.C. CHARACTERISTICS

$V_{SS} = 0\text{ V}$; $T_{amb} = 25\text{ °C}$; input transition times $\leq 20\text{ ns}$

| | V_{DD} V | typical formula for P (μW) | where |
|---|---------------|--|------------------------------------|
| Dynamic power dissipation per package (P) | 5 | $13\ 000 f_i + \Sigma(f_o C_L) \times V_{DD}^2$ | f_i = input freq. (MHz) |
| | 10 | $55\ 000 f_i + \Sigma(f_o C_L) \times V_{DD}^2$ | f_o = output freq. (MHz) |
| | 15 | $140\ 000 f_i + \Sigma(f_o C_L) \times V_{DD}^2$ | C_L = load capacitance (pF) |
| | | | $\Sigma(f_o C_L)$ = sum of outputs |
| | | | V_{DD} = supply voltage (V) |

A.C. CHARACTERISTICS

V_{SS} = 0 V; T_{amb} = 25 °C; C_L = 50 pF; input transition times ≤ 20 ns

| | V _{DD} V | symbol | min. | typ. | max. | typical extrapolation formula | |
|---|----------------------|-------------------|------|------|------|-------------------------------------|--------------------------------------|
| Propagation delays $\overline{CP} \rightarrow O_{63}$ HIGH to LOW | 5 | t _{PHL} | | 145 | 290 | ns | 132 ns + (0,26 ns/pF) C _L |
| | 10 | | 55 | 110 | ns | 47 ns + (0,16 ns/pF) C _L | |
| | 15 | | 40 | 80 | ns | 34 ns + (0,11 ns/pF) C _L | |
| LOW to HIGH | 5 | t _{PLH} | | 160 | 320 | ns | 138 ns + (0,45 ns/pF) C _L |
| | 10 | | 65 | 130 | ns | 56 ns + (0,19 ns/pF) C _L | |
| | 15 | | 45 | 90 | ns | 39 ns + (0,13 ns/pF) C _L | |
| Transition times O ₆₃ HIGH to LOW | 5 | t _{THL} | | 30 | 60 | ns | 10 ns + (0,40 ns/pF) C _L |
| | 10 | | 12 | 24 | ns | 3 ns + (0,18 ns/pF) C _L | |
| | 15 | | 10 | 20 | ns | 3 ns + (0,13 ns/pF) C _L | |
| LOW to HIGH | 5 | t _{TLH} | | 40 | 80 | ns | 8 ns + (0,65 ns/pF) C _L |
| | 10 | | 20 | 40 | ns | 5 ns + (0,30 ns/pF) C _L | |
| | 15 | | 15 | 30 | ns | 5 ns + (0,20 ns/pF) C _L | |
| Minimum clock pulse width; HIGH | 5 | t _{WCPH} | 160 | 80 | | ns | } see also waveforms Fig. 4 |
| | 10 | | 60 | 30 | | ns | |
| | 15 | | 40 | 20 | | ns | |
| Set-up time D → \overline{CP} | 5 | t _{su} | 25 | -5 | | ns | |
| | 10 | | 15 | -5 | | ns | |
| | 15 | | 15 | -5 | | ns | |
| Hold time D → \overline{CP} | 5 | t _{hold} | 50 | 20 | | ns | |
| | 10 | | 30 | 10 | | ns | |
| | 15 | | 20 | 5 | | ns | |
| Maximum clock pulse frequency | 5 | f _{max} | 3 | 6 | | MHz | |
| | 10 | | 8 | 16 | | MHz | |
| | 15 | | 12 | 25 | | MHz | |

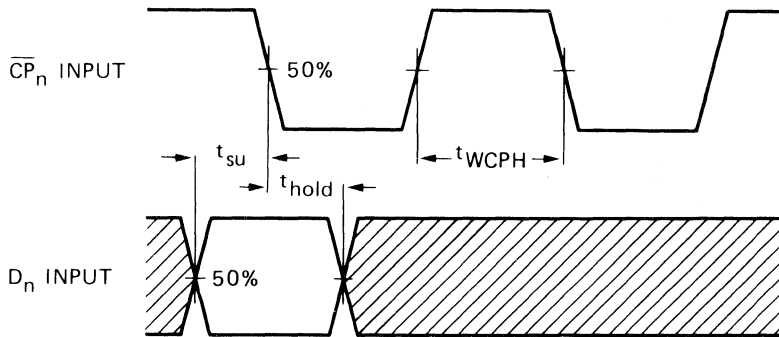

7274634

Fig. 4 Waveforms showing minimum clock pulse width, set-up and hold times for D to \overline{CP} . Set-up and hold times are shown as positive values but may be specified as negative values.

QUADRUPLE STATIC DECADE COUNTERS

The HEF4737B and HEF4737V are static quadruple decade counters for frequencies from 0 to 10 MHz. The counters are supplied with an extra overload flip-flop giving a total count capability of 19 999. The counter has the following inputs and outputs: a count input (CP), an asynchronous reset input (MR), an asynchronous preset input (PL), a transfer input (T), an output enable input (EO) (which controls the BCD outputs), the digit select inputs (S_A, S_B, S_C) (which perform selection of the contents of the latches to the 3-state BCD outputs (O_0 to O_3)), and the carry outputs (CO_2 to CO_5) (which give the carry signals of the decades except from the first decade).

The complementary MOS structure gives the devices very low stand-by and operating dissipation. Operating from a single supply voltage all outputs can drive one standard TTL input without interface circuitry under all specified operating conditions.

The BCD digit outputs are LOC MOS 3-state outputs. The high impedance off-state feature allows common bussing of the outputs. The counters are supplied with asynchronous reset and preset to 19 999 facilities making them suitable for counter and time base applications. All carry signals are available except from the first decade.

Schmitt-trigger action in the inputs makes the circuit highly tolerant to slower input rise and fall times.

Recommended supply voltage range for HEF4737B is 3 to 15 V and for HEF4737V is 4,5 to 12,5 V.

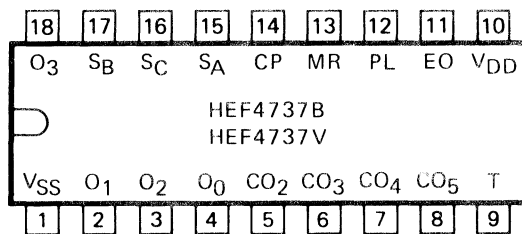

7269203.2

Fig. 1 Pinning diagram.

PINNING

| | |
|------------------|---------------------------|
| CP | count input |
| MR | asynchronous reset input |
| PL | asynchronous preset input |
| T | transfer input |
| S_A, S_B, S_C | digit select inputs |
| EO | output enable input |
| O_0 to O_3 | BCD outputs |
| CO_2 to CO_5 | carry outputs |

HEF4737BP; HEF4737VP: 18-lead DIL;
plastic (SOT-102).
HEF4737BD; HEF4737VD: 18-lead DIL;
ceramic (cerdip) (SOT-133).

SUPPLY VOLTAGE

| | rating | recommended operating |
|----------|------------|-----------------------|
| HEF4737B | -0,5 to 18 | 3,0 to 15,0 V |
| HEF4737V | -0,5 to 18 | 4,5 to 12,5 V |

FAMILY DATA

I_{DD} LIMITS category LSI

} see Family Specifications

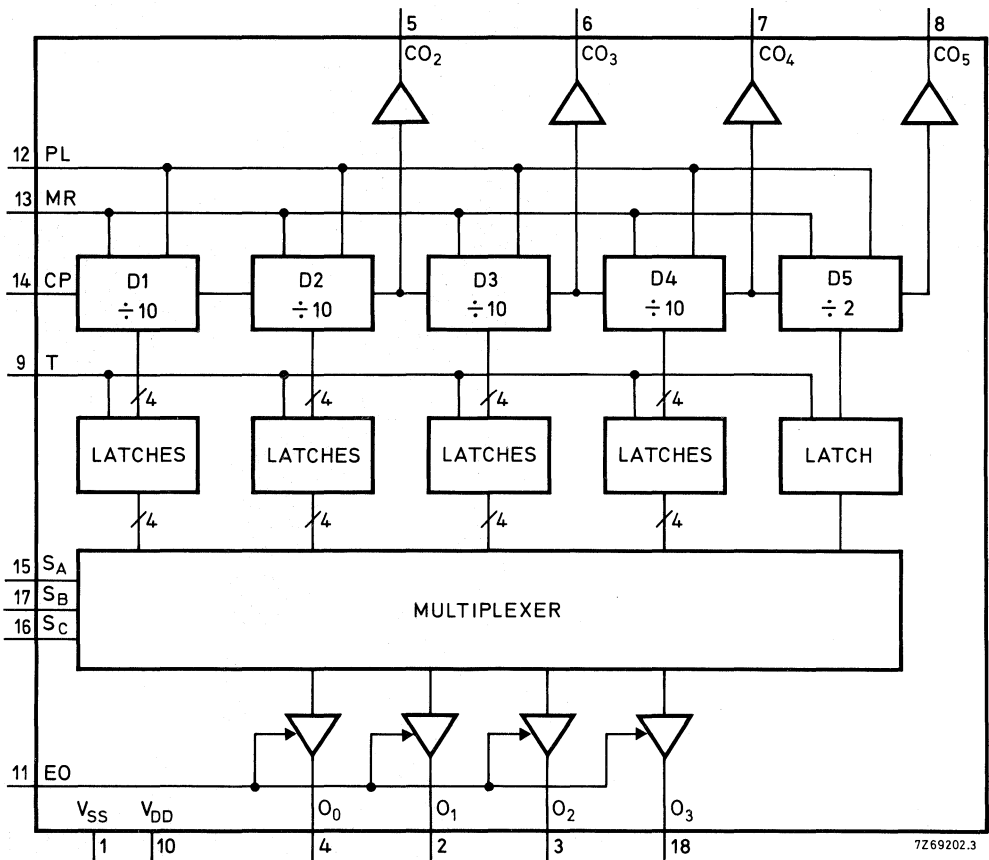

Fig. 2 Block diagram.

FUNCTIONAL DESCRIPTION

Input signals

Count input (CP)

The signal to be counted is applied to this input. When PL and MR are LOW the contents of the counter increments by one at a LOW to HIGH transition of CP.

Reset input (MR)

This is an asynchronous reset. A HIGH level applied to this input will reset the counter to zero independent of the level at the count input and preset input.

Preset input (PL)

This is an asynchronous preset. When MR is LOW a HIGH at the PL input will preset the counter to 19999 independent of the level at the count input.

Transfer input (T)

A HIGH level applied to this input allows the information held by the counter to pass to the latches.

Output enable input (EO)

A HIGH level at this input enables the BCD outputs and information can be read out of the latches using the multiplexer. A LOW level at this input disables the BCD outputs making them floating (high impedance off-state).

Digit select inputs (S_A, S_B, S_C)

| S _A | S _B | S _C | |
|----------------|----------------|----------------|------------------|
| L | L | L | selects D1 (LSD) |
| H | L | L | selects D2 |
| L | H | L | selects D3 |
| H | H | L | selects D4 |
| X | X | H | selects D5 (MSD) |

When D5 is selected, the contents of D5 is available at O₀ and O₁, O₂ and O₃ are LOW.

LSD = least significant divider

MSD = most significant divider

H = HIGH state (the more positive voltage)

L = LOW state (the less positive voltage)

X = state is immaterial

Output signals

The carry outputs are active LOW outputs.

Carry output CO₂

When the contents of the first two decades of the counter are both 9 then the CO₂ output becomes LOW. It remains LOW until the next LOW to HIGH transition of the count input, i.e. until the contents of the first two decades are zero. CO₂ is LOW when the contents of the counter are: 00 099, 00 199, 00 299 etc.

Carry output CO₃

When the contents of the first three decades of the counter are all 9 then the CO₃ output becomes LOW. It remains LOW until the next LOW to HIGH transition of the count input, i.e. until the contents of the first three decades are zero. CO₃ is LOW when the contents of the counter are 00 999, 01 999, 02 999 etc.

Carry output CO₄

When the contents of the first four decades of the counter are all 9 then the CO₄ output becomes LOW. It remains LOW until the next LOW to HIGH transition of the count input, i.e. until the contents of the first four decades are zero. CO₄ is LOW when the contents of the counter are 09 999 and 19 999.

The carry signals CO₂, CO₃ and CO₄ are suppressed while the preset is active. A HIGH to the preset input sets the counter to 19 999 but the carry signals remain HIGH until preset input returns to LOW, then the carry outputs will also become LOW.

Carry output CO₅

When the content of the counter is 10 000 the CO₅ output becomes LOW. It returns to HIGH when the content of the counter is zero.

Digit outputs (O₀ to O₃)

The digit outputs give the contents of the selected latch. The output is in the form of BCD, positive logic.

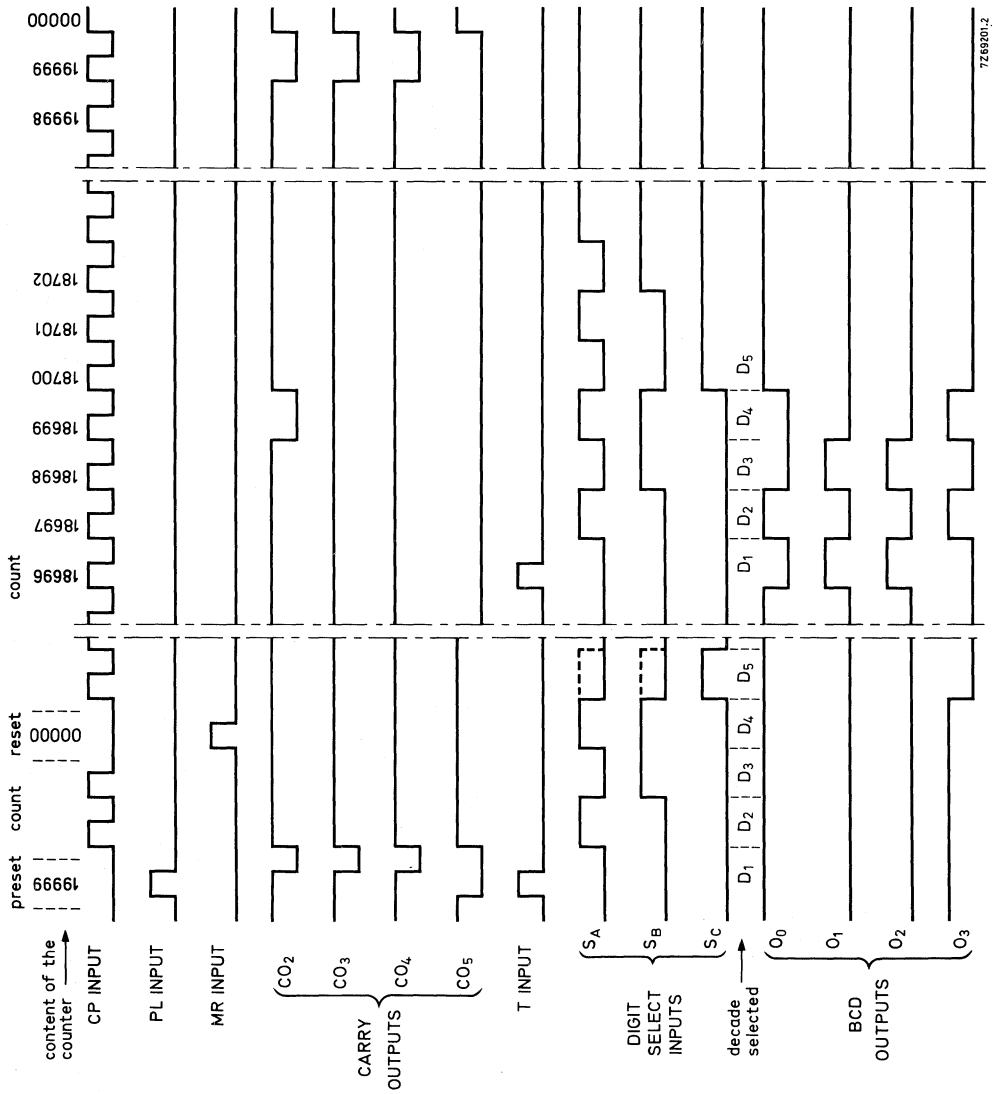

Fig. 3 Timing diagram.

The values given at $V_{DD} = 15\text{ V}$ in the following d.c. and a.c. characteristics, are not applicable to the HEF4737V, because of its reduced supply voltage range.

D.C. CHARACTERISTICS $V_{SS} = 0\text{ V}$

| | V_{DD} V | V_{OH} V | V_{OL} V | symbol | T_{amb} (°C) | | | | | | |
|--|---------------|---------------|---------------|--------------|----------------|------|------|------|------|------|---------------|
| | | | | | -40 | | +25 | | +85 | | |
| | | | | | min. | max. | min. | max. | min. | max. | |
| Input leakage current at $V_I = 0$ or V_{DD} | 10 | | | $\pm I_{IN}$ | - | - | - | 0,3 | - | 1 | μA |
| | 15 | | | | - | - | - | 0,3 | - | 1 | μA |
| Output (sink) current LOW | 4,75 | | 0,4 | I_{OL} | 1,6 | - | 1,6 | - | 1,4 | - | mA |
| | 10 | | 0,5 | | 2,5 | - | 2,3 | - | 1,7 | - | mA |
| | 15 | | 1,5 | | 7,0 | - | 6,0 | - | 4,0 | - | mA |
| Output (source) current HIGH | 5 | 4,6 | | $-I_{OH}$ | 0,96 | - | 0,80 | - | 0,65 | - | mA |
| | 10 | 9,5 | | | 2,4 | - | 2,0 | - | 1,6 | - | mA |
| | 15 | 13,5 | | | 7,0 | - | 6,0 | - | 4,5 | - | mA |
| Output (source) current HIGH | 5 | 2,5 | | $-I_{OH}$ | 3,0 | - | 2,5 | - | 2,0 | - | mA |
| 3-state output leakage current $V_O = 0$ or V_{DD} | 10 | | | $\pm I_{OZ}$ | - | 1,6 | - | 1,6 | - | 12 | μA |
| | 15 | | | | - | 1,6 | - | 1,6 | - | 12 | μA |

A.C. CHARACTERISTICS

$V_{SS} = 0\text{ V}$; $T_{amb} = 25\text{ }^\circ\text{C}$; $C_L = 15\text{ pF}$; input transition times $\leq 20\text{ ns}$

| | V_{DD} V | symbol | | | | typical extrapolation formula | |
|--|---------------|-----------|------|------|------|-------------------------------|---|
| | | | min. | typ. | max. | | |
| Propagation delays CP \rightarrow O_n (D1 selected) HIGH to LOW | 5 | t_{PHL} | | 320 | 640 | ns | $308\text{ ns} + (0,24\text{ ns/pF}) C_L$ |
| | 10 | | | 120 | 240 | ns | $125\text{ ns} + (0,10\text{ ns/pF}) C_L$ |
| | 15 | | | 90 | 180 | ns | $86\text{ ns} + (0,07\text{ ns/pF}) C_L$ |
| LOW to HIGH | 5 | t_{PLH} | | 320 | 640 | ns | $296\text{ ns} + (0,48\text{ ns/pF}) C_L$ |
| | 10 | | | 120 | 240 | ns | $110\text{ ns} + (0,20\text{ ns/pF}) C_L$ |
| | 15 | | | 90 | 180 | ns | $82\text{ ns} + (0,15\text{ ns/pF}) C_L$ |
| CP \rightarrow O_n (D5 selected) HIGH to LOW | 5 | t_{PHL} | | 620 | 1240 | ns | $608\text{ ns} + (0,24\text{ ns/pF}) C_L$ |
| | 10 | | | 330 | 660 | ns | $325\text{ ns} + (0,10\text{ ns/pF}) C_L$ |
| | 15 | | | 250 | 500 | ns | $246\text{ ns} + (0,07\text{ ns/pF}) C_L$ |
| LOW to HIGH | 5 | t_{PLH} | | 620 | 1240 | ns | $596\text{ ns} + (0,48\text{ ns/pF}) C_L$ |
| | 10 | | | 330 | 660 | ns | $320\text{ ns} + (0,20\text{ ns/pF}) C_L$ |
| | 15 | | | 250 | 500 | ns | $242\text{ ns} + (0,15\text{ ns/pF}) C_L$ |
| CP \rightarrow CO_2 HIGH to LOW | 5 | t_{PHL} | | 220 | 440 | ns | $208\text{ ns} + (0,24\text{ ns/pF}) C_L$ |
| | 10 | | | 110 | 220 | ns | $105\text{ ns} + (0,10\text{ ns/pF}) C_L$ |
| | 15 | | | 85 | 170 | ns | $81\text{ ns} + (0,07\text{ ns/pF}) C_L$ |
| LOW to HIGH | 5 | t_{PLH} | | 220 | 440 | ns | $196\text{ ns} + (0,48\text{ ns/pF}) C_L$ |
| | 10 | | | 110 | 220 | ns | $100\text{ ns} + (0,20\text{ ns/pF}) C_L$ |
| | 15 | | | 85 | 170 | ns | $77\text{ ns} + (0,15\text{ ns/pF}) C_L$ |

A.C. CHARACTERISTICS (continued)

 $V_{SS} = 0\text{ V}$; $T_{amb} = 25\text{ }^{\circ}\text{C}$; $C_L = 15\text{ pF}$; input transition times $\leq 20\text{ ns}$

| | V_{DD} V | symbol | min. | typ. | max. | typical extrapolation formula | |
|---|---------------|------------------|------|------|------|----------------------------------|--------------------------------------|
| Propagation delays | | | | | | | |
| CP \rightarrow CO ₅ | 5 | | | 350 | 700 | ns | 338 ns + (0,24 ns/pF) C _L |
| HIGH to LOW | 10 | t _{PHL} | | 160 | 320 | ns | 155 ns + (0,10 ns/pF) C _L |
| | 15 | | | 120 | 240 | ns | 116 ns + (0,07 ns/pF) C _L |
| LOW to HIGH | 5 | | | 350 | 700 | ns | 326 ns + (0,48 ns/pF) C _L |
| | 10 | t _{PLH} | | 160 | 320 | ns | 150 ns + (0,20 ns/pF) C _L |
| | 15 | | | 120 | 240 | ns | 112 ns + (0,15 ns/pF) C _L |
| S _n \rightarrow O _n | 5 | | | 200 | 400 | ns | 188 ns + (0,24 ns/pF) C _L |
| HIGH to LOW | 10 | t _{PHL} | | 80 | 160 | ns | 75 ns + (0,10 ns/pF) C _L |
| | 15 | | | 55 | 110 | ns | 51 ns + (0,07 ns/pF) C _L |
| LOW to HIGH | 5 | | | 200 | 400 | ns | 176 ns + (0,48 ns/pF) C _L |
| | 10 | t _{PLH} | | 80 | 160 | ns | 70 ns + (0,20 ns/pF) C _L |
| | 15 | | | 55 | 110 | ns | 47 ns + (0,15 ns/pF) C _L |
| T \rightarrow O _n | 5 | | | 220 | 440 | ns | 208 ns + (0,24 ns/pF) C _L |
| HIGH to LOW | 10 | t _{PHL} | | 90 | 180 | ns | 85 ns + (0,10 ns/pF) C _L |
| | 15 | | | 60 | 120 | ns | 56 ns + (0,07 ns/pF) C _L |
| LOW to HIGH | 5 | | | 220 | 440 | ns | 196 ns + (0,48 ns/pF) C _L |
| | 10 | t _{PLH} | | 90 | 180 | ns | 80 ns + (0,20 ns/pF) C _L |
| | 15 | | | 60 | 120 | ns | 52 ns + (0,15 ns/pF) C _L |
| MR \rightarrow O _n | 5 | | | 490 | 980 | ns | 478 ns + (0,24 ns/pF) C _L |
| HIGH to LOW | 10 | t _{PHL} | | 200 | 400 | ns | 195 ns + (0,10 ns/pF) C _L |
| | 15 | | | 60 | 120 | ns | 56 ns + (0,07 ns/pF) C _L |
| PL \rightarrow O _n | 5 | | | 260 | 520 | ns | 236 ns + (0,48 ns/pF) C _L |
| LOW to HIGH | 10 | t _{PLH} | | 110 | 220 | ns | 100 ns + (0,20 ns/pF) C _L |
| | 15 | | | 85 | 170 | ns | 77 ns + (0,15 ns/pF) C _L |
| MR \rightarrow CO _n | 5 | | | 350 | 700 | ns | 326 ns + (0,48 ns/pF) C _L |
| LOW to HIGH | 10 | t _{PLH} | | 160 | 320 | ns | 150 ns + (0,20 ns/pF) C _L |
| | 15 | | | 120 | 240 | ns | 112 ns + (0,15 ns/pF) C _L |
| PL \rightarrow CO _n | 5 | | | 350 | 700 | ns | 338 ns + (0,24 ns/pF) C _L |
| HIGH to LOW | 10 | t _{PHL} | | 160 | 320 | ns | 155 ns + (0,10 ns/pF) C _L |
| | 15 | | | 120 | 240 | ns | 116 ns + (0,07 ns/pF) C _L |
| Output transition times; any output | 5 | | | 35 | 70 | ns | 15 ns + (0,40 ns/pF) C _L |
| HIGH to LOW | 10 | t _{THL} | | 18 | 36 | ns | 9 ns + (0,18 ns/pF) C _L |
| | 15 | | | 15 | 30 | ns | 8 ns + (0,13 ns/pF) C _L |
| LOW to HIGH | 5 | | | 50 | 100 | ns | 15 ns + (0,70 ns/pF) C _L |
| | 10 | t _{TLH} | | 30 | 60 | ns | 13 ns + (0,33 ns/pF) C _L |
| | 15 | | | 25 | 50 | ns | 13 ns + (0,23 ns/pF) C _L |

| | V _{DD} V | symbol | min. | typ. | max. | |
|-------------------------------|----------------------|-------------------|------|------|------|-----|
| 3-state propagation delays | | | | | | |
| Output disable times | | | | | | |
| EO → O _n | 5 | t _{PHZ} | | 60 | 120 | ns |
| HIGH | 10 | | 35 | 70 | ns | |
| | 15 | | 25 | 50 | ns | |
| LOW | 5 | t _{PLZ} | | 60 | 120 | ns |
| | 10 | | 35 | 70 | ns | |
| | 15 | | 25 | 50 | ns | |
| Output enable times | | | | | | |
| EO → O _n | 5 | t _{PZH} | | 90 | 180 | ns |
| HIGH | 10 | | 40 | 80 | ns | |
| | 15 | | 30 | 60 | ns | |
| LOW | 5 | t _{PZL} | | 90 | 180 | ns |
| | 10 | | 40 | 80 | ns | |
| | 15 | | 30 | 60 | ns | |
| Minimum CP pulse width; LOW | | | | | | |
| | 5 | t _{WCPL} | 160 | 80 | | ns |
| | 10 | | 60 | 30 | | ns |
| | 15 | | 50 | 25 | | ns |
| Minimum MR pulse width; HIGH | | | | | | |
| | 5 | t _{WMRH} | 100 | 50 | | ns |
| | 10 | | 50 | 25 | | ns |
| | 15 | | 40 | 20 | | ns |
| Minimum PL pulse width; HIGH | | | | | | |
| | 5 | t _{WPLH} | 120 | 60 | | ns |
| | 10 | | 60 | 30 | | ns |
| | 15 | | 50 | 25 | | ns |
| Minimum T pulse width; HIGH | | | | | | |
| | 5 | t _{WTH} | 100 | 50 | | ns |
| | 10 | | 40 | 20 | | ns |
| | 15 | | 36 | 18 | | ns |
| Maximum clock pulse frequency | | | | | | |
| | 5 | f _{max} | 3 | 6 | | MHz |
| | 10 | | 8 | 16 | | MHz |
| | 15 | | 10 | 20 | | MHz |

| | V _{DD} V | typical formula for P (μW) | where |
|---|----------------------|---|--|
| Dynamic power dissipation per package (P) | 5 | 950 f _i + Σ(f _o C _L) × V _{DD} ² | f _i = input freq. (MHz) |
| | 10 | | f _o = output freq. (MHz) |
| | 15 | | C _L = load cap. (pF) |
| | | | Σ(f _o C _L) = sum of outputs |
| | | | V _{DD} = supply voltage (V) |

IEC/IEEE BUS INTERFACE

The HEF4738V is an implementation of the IEC-bus as described in IEC report 66 CO 22 (interface system for programmable measuring apparatus) as well as in IEEE standard 488-1975 (standard digital interface for programmable instrumentation).

Together with bus-drivers, level converters and multiplexers it is suitable for connecting electronic programmable and non-programmable equipment to an IEC/IEEE interface bus.

All inputs have standard HE4000B family levels.

In the circuit the following standard interface functions are incorporated:

- Complete source handshake (subset SH1)
- Complete acceptor handshake (subset AH1)
- Basic talker with serial poll and talk-only mode (when $I_t = \text{LOW}$, subset T1; $I_t = \text{HIGH}$, subset T5)
- Basic listener with listen-only mode (when $I_t = \text{LOW}$, subset L1; $I_t = \text{HIGH}$, subset L3)
- Complete service request (subset SR1)
- Complete remote local (subset RL1)
- Remote parallel poll configuration (subset PP1)
- Complete device clear (subset DC1)
- Complete device trigger (subset DT1)
- Some controller facilities

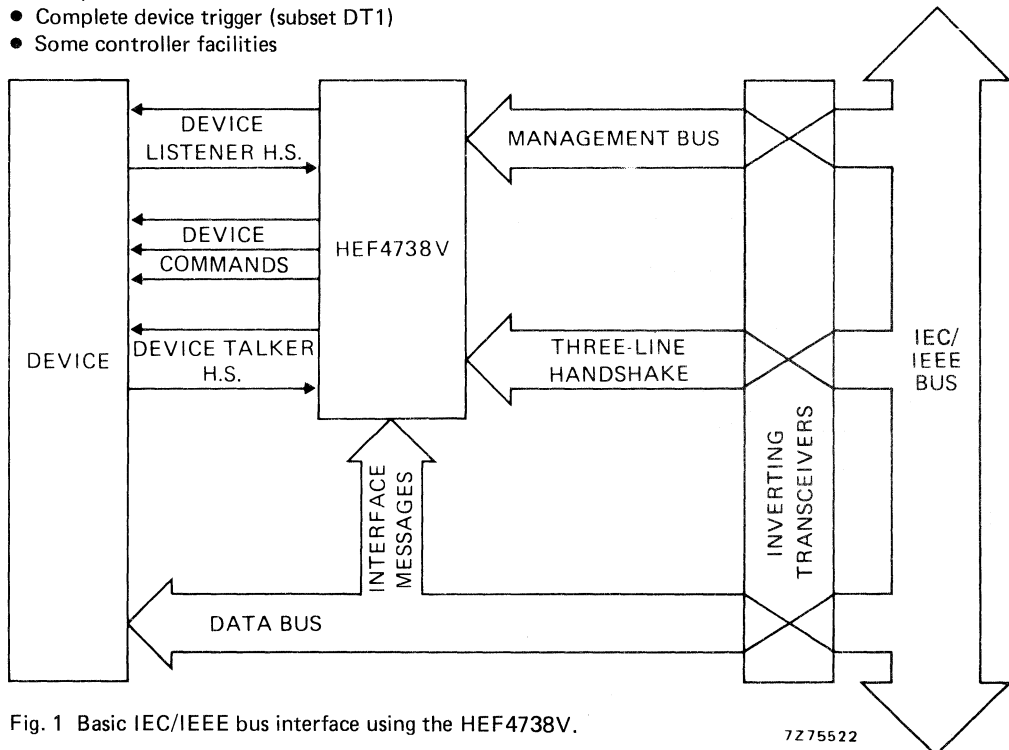

Fig. 1 Basic IEC/IEEE bus interface using the HEF4738V.

SUPPLY VOLTAGE

| rating | recommended operating |
|------------|-----------------------|
| -0,5 to 18 | 4,5 to 12,5 V |

FAMILY DATA

I_{DD} LIMITS category LSI

} see Family Specifications

GENERAL DESCRIPTION

The inputs IRFD, IDAC, $\overline{\text{IDAV}}$, $\overline{\text{IFC}}$, $\overline{\text{IREN}}$, $\overline{\text{IATN}}$, $\overline{\text{IDY}}$ and IDIO1 to IDIO7 must be connected via an inverting TTL to LOC MOS level converter to the respective bus lines: NRFD, NDAC, DAV, IFC, REN, ATN, IDY and DIO1 to DIO7.

The outputs ORFD, ODAC, $\overline{\text{ODAV}}$ and $\overline{\text{OSRQ}}$ can drive one standard TTL load and are suitable for driving NRFD, NDAC, DAV and SRQ via an inverting bus-driver circuit.

The parallel poll outputs OP1, OP2, OP3 and OPP can also drive one standard TTL load. Outputs OP1, OP2 and OP3 are connected to flip-flops, which store the attendant bits P1, P2 and P3 of the last PPE message. OP1, OP2 and OP3 have to be decoded externally and multiplexed to the DIO-lines when OPP is LOW.

All other output stages are standard HE4000B family.

Most of the functions in the IEC/IEEE interface IC are realized with synchronous sequential logic, which is driven from the clock input CP. HIGH to LOW transitions are used to synchronize input signals and LOW to HIGH transitions trigger the internal flip-flops. In order to meet the IEC/IEEE timing specifications, the maximum clock frequency is 2 MHz. The maximum data transfer is then 200 kbytes/second.

Input $\overline{\text{IrDY}}$ (not ready for next message) and output Odvd (data valid device) are intended for a two-wire handshake procedure between the acceptor function in the IC and the data input of the device (instrument to be connected to the interface system). The procedure is made so, that if the device reacts fast enough, the handshake procedure can be omitted by interconnecting Odvd and $\overline{\text{IrDY}}$. The conditions to be fulfilled by the device are:

- The device must be able to accept a data byte within one clock period after dvd goes HIGH under all conditions.
- The device must be ready to process a data byte within two clock periods plus the minimum settling time of the talker devices under all conditions.

Input $\overline{\text{InBa}}$ (not new byte available) and output Odcd (don't change data) are intended for a two-wire handshake procedure with the source function in the IC and the data output of the device (instrument). The procedure is so made that if the device reacts fast enough the handshake procedure can be omitted by interconnecting Odcd and $\overline{\text{InBa}}$. The conditions to be fulfilled by the device are:

- The device must be able to set a new data byte on the bus within one clock period after dcd goes LOW under all conditions.
- The device must be able to have the next data byte available within seven clock periods under all conditions.

Input Isr and output Ored should be connected to an external parallel-in/serial-out (when Ored is HIGH parallel-in, when LOW serial-out) shift register, which must be connected to the clock CP and must trigger on the LOW to HIGH transitions. The data on the parallel inputs of this external shift register are loaded in parallel and shifted-out via input Isr into an internal shift register. The eleven serial input signals are in the order of shifting: A5, A4, A3, A2, A1, ton, lon, lt, rsv, rtl and ist. Signals A5, A4, A3, A2 and A1 represent the device talker and listener address. When signal lt (either listener or talker) is HIGH, a listener addressing sets the talker to the idle state and a talker addressing sets the listener to the idle state (subset T5 and L3). With lt LOW, the device can be addressed to be a listener and a talker. Because of the serial input procedure, all these input signals arrive in the interface functions of the IC between 16 and 32 clock cycles.

The signals ton, lon, rsv, rtl and ist are standard IEC/IEEE inputs. When using ton or lon no controller action is possible.

The output Oclr or Otrg is HIGH for one clock pulse if DCAS (device clear active state) or DTAS (device trigger active state) respectively is active.

The output $Oloc$ is HIGH when $LOCS$ (local state) or $LWLS$ (local with lock-out state) is active. Output \overline{OSRQ} is HIGH when the rsv signal is read from the external shift register and the $SRQS$ (request service state) is active. After this request has been answered by a serial poll, \overline{ORQS} is HIGH in the $APRS$ (affirmative poll response state). The inverted signal on \overline{ORQS} must be multiplexed to bus-line $DIO7$, together with the status byte of the other DIO lines, when output Osp is HIGH in the $SPAS$ (serial poll active state).

When the device is in the $SPAS$ state the signal rsv may be removed (can be checked on \overline{ORQS}).

N.B.: When the interface has asked for service via rsv and is addressed as talker in the serial poll mode, a handshake must be initialized by the device via \overline{Inba} .

Input $Icats$ and output $Otct$ are intended for use of this IC in a controller. When $Icats$ is HIGH, the source handshake function will exit $SIDS$ and $SIWS$ and enter respectively $SGNS$ and $SWNS$. When the controller function is not used, the input $Icats$ must be connected to V_{SS} . Output $Otct$ is HIGH if the tct message is sent over the interface and the $ACDS$ state is active. A HIGH on input $Ipon$ sets each function to its initial state. This level can be set to LOW after the IC has received 32 clock pulses at stabilized supply voltage.

Note

After power-on the input $Ipon$ must stay LOW for at least 32 clock pulses, then HIGH for 32 clock pulses in order to force the function to its initial state. ←

After this, $Ipon$ must be set LOW.

HEF4738V

LSI

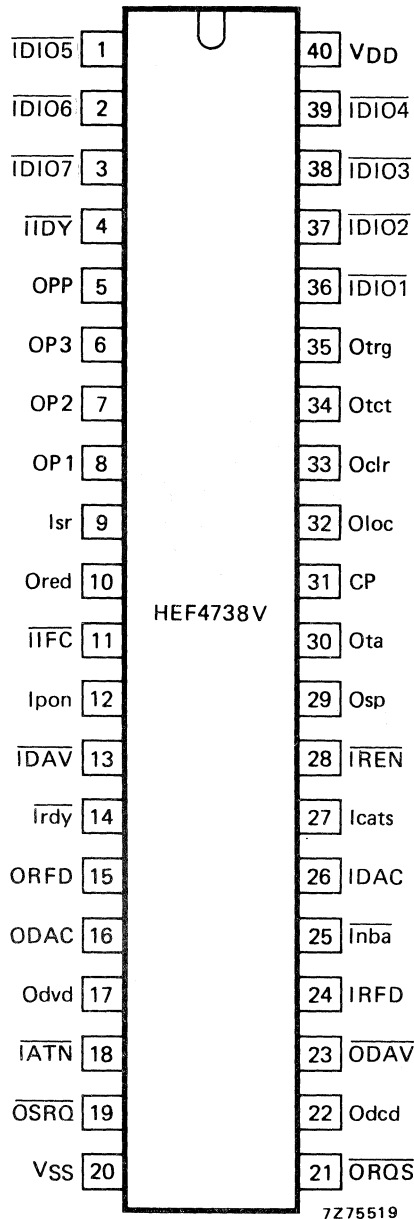

Fig. 2 Pinning diagram; for abbreviations see the following list.
HEF4738VP: 40-lead DIL; plastic (SOT-129).

Input pins

1,2,3,36,37,38,39 = IDIO1 to 7: input DIO
 4 = IIDY input IDY not
 *9 = Isr input shift register
 11 = IIFC input IFC not
 12 = Ipon input pon
 13 = IDAV input DAV not
 14 = Irdy input rdy not
 18 = IATN input ATN not
 24 = IRFD input RFD
 25 = Inba input nba not
 26 = IDAC input DAC
 27 = Icats input cats
 28 = IREN input REN not
 31 = CP clock pulse input

Output pins

5 = OPP output PP
 8,7,6, = OP1 to OP3 output P1 to P3
 10 = Ored output red
 15 = ORFD output RFD
 16 = ODAC output DAC
 17 = Odvd output dvd
 19 = OSRQ output SRQ not
 21 = ORQS output RQS not
 22 = Odcd output dcd
 23 = ODAV output DAV not
 29 = Osp output sp
 30 = Ota output ta
 32 = Oloc output loc
 33 = Oclr output clr
 34 = Otct output tct
 35 = Otrg output trg

Supply pins

20 = VSS: more negative supply line
 40 = VDD: more positive supply line

* Isr is serial input for signals A5, A4, A3, A2, A1, ton, lon, lt, rsv, rtl and ist.

Note

Because the circuit uses positive logic and the bus uses negative logic, all inputs and outputs to the bus must be inverted. For that reason, all terminals that are working with the bus have mnemonics which are the inverted ones of those on the bus.

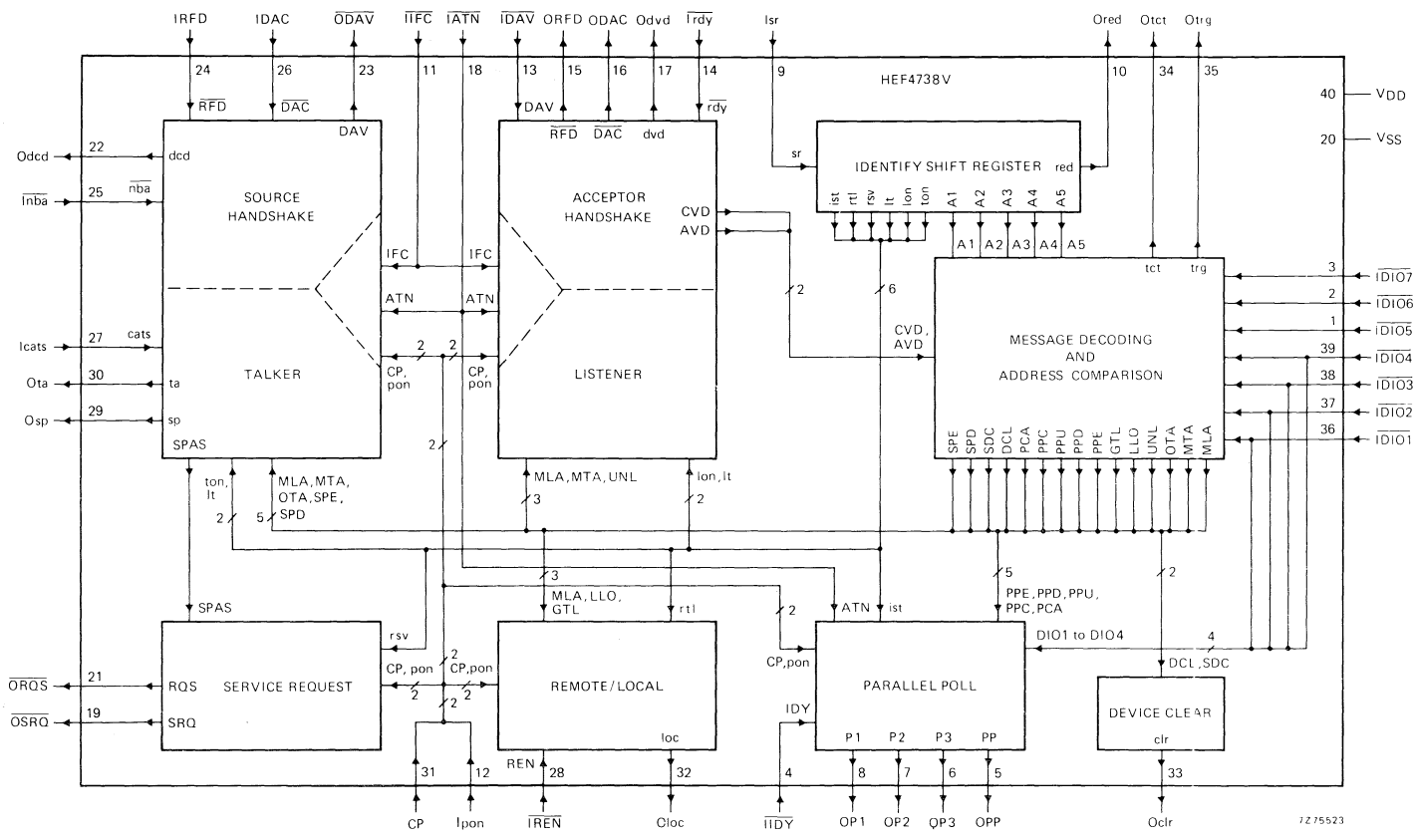

Fig. 3 Block diagram.

7275523

LIST OF USED ABBREVIATIONS

| | | | |
|----------|--|------|---------------------------------|
| A1 to A5 | address | SGNS | source generate state |
| ACDS | acceptor data state | SIDS | source idle state |
| APRS | affirmative poll response state | SIWS | source idle wait state |
| ATN | attention | sp | serial poll |
| AVD | address valid | SPAS | serial poll active state |
| cats | controller active or transfer state | SPD | serial poll disable |
| clr | device clear | SPE | serial poll enable |
| CVD | command valid | sr | shift register |
| DAC | data accepted | SRQ | service request |
| DAV | data valid | SRQS | request service state |
| DCAS | device clear active state | SWNS | source wait for new cycle state |
| dcd | don't change data | ta | talker active |
| DCL | device clear | tct | talk control |
| DIO | data input output | ton | talk only |
| DTAS | device trigger active state | trg | trigger |
| dvd | data valid device | UNL | unlisten |
| EOI | end of output/identify | | |
| GTL | go to local | | |
| IDY | identify | | |
| IFC | interface clear | | |
| ist | individual status | | |
| LLO | local lock-out | | |
| loc | local | | |
| LOCS | local state | | |
| lon | listen only | | |
| lt | decides whether the device can only be listener/talker or listener and talker simultaneously | | |
| LWLS | local with lock-out state | | |
| MLA | my listen address | | |
| MTA | my talk address | | |
| nba | new byte available | | |
| NRFD | not ready for data | | |
| NDAC | not data accepted | | |
| OTA | other talk address | | |
| P1 to P3 | parallel response messages | | |
| PCA | parallel poll configure accepted | | |
| pon | power on | | |
| PP | parallel poll message enable | | |
| PPC | parallel poll configure | | |
| PPD | parallel poll disable | | |
| PPE | parallel poll enable | | |
| PPU | parallel poll unconfigure | | |
| rdy | ready for next message | | |
| red | ready for next shift cycle | | |
| REN | remote enable | | |
| RFD | ready for data | | |
| RQS | requested service | | |
| rsv | request for service | | |
| rtl | return to local | | |
| SDC | selected device clear | | |

D.C. CHARACTERISTICS

 $V_{SS} = 0\text{ V}$

| | V_{DD} V | V_{OL} V | V_{OH} V | symbol | T_{amb} ($^{\circ}\text{C}$) | | | | | |
|----------------------------------|---------------|---------------|---------------|----------|----------------------------------|------|------|------|------|---------------|
| | | | | | -40 | | +25 | | +85 | |
| | | | | | min. | max. | min. | max. | min. | max. |
| Output current HIGH; see note | 5 | | 2,5 | I_{OH} | 3 | 2,5 | 2,0 | | | mA |
| | 5 | | 4,6 | | 1 | 0,85 | 0,65 | | | mA |
| | 10 | | 9,5 | | 3 | 2,5 | 2,0 | | | mA |
| Output current LOW; see note | 4,75 | 0,4 | | I_{OL} | 2,7 | 2,3 | 1,8 | | | mA |
| | 10 | 0,5 | | | 9,5 | 8,0 | 6,3 | | | mA |
| Quiescent device current | 5 | | | I_{DD} | 50 | 50 | | | 375 | μA |
| | 10 | | | | 100 | 100 | | | 750 | μA |

Note

Output currents for pins: 5 = OPP, 6 = OP3, 7 = OP2, 8 = OP1, 15 = ORFD, 16 = ODAC, 19 = $\overline{\text{OSRQ}}$, 23 = ODAV. These pins can drive one standard TTL load.

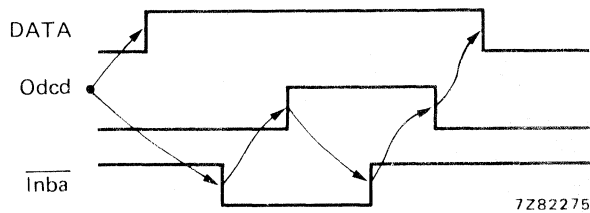

Fig. 4 Waveforms showing data exchange in talker function.

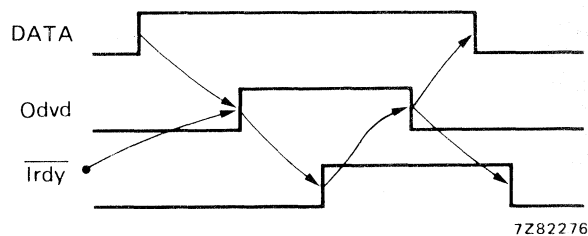

Fig. 5 Waveforms showing data exchange in listener function.

HEF4738V

LSI

APPLICATION INFORMATION

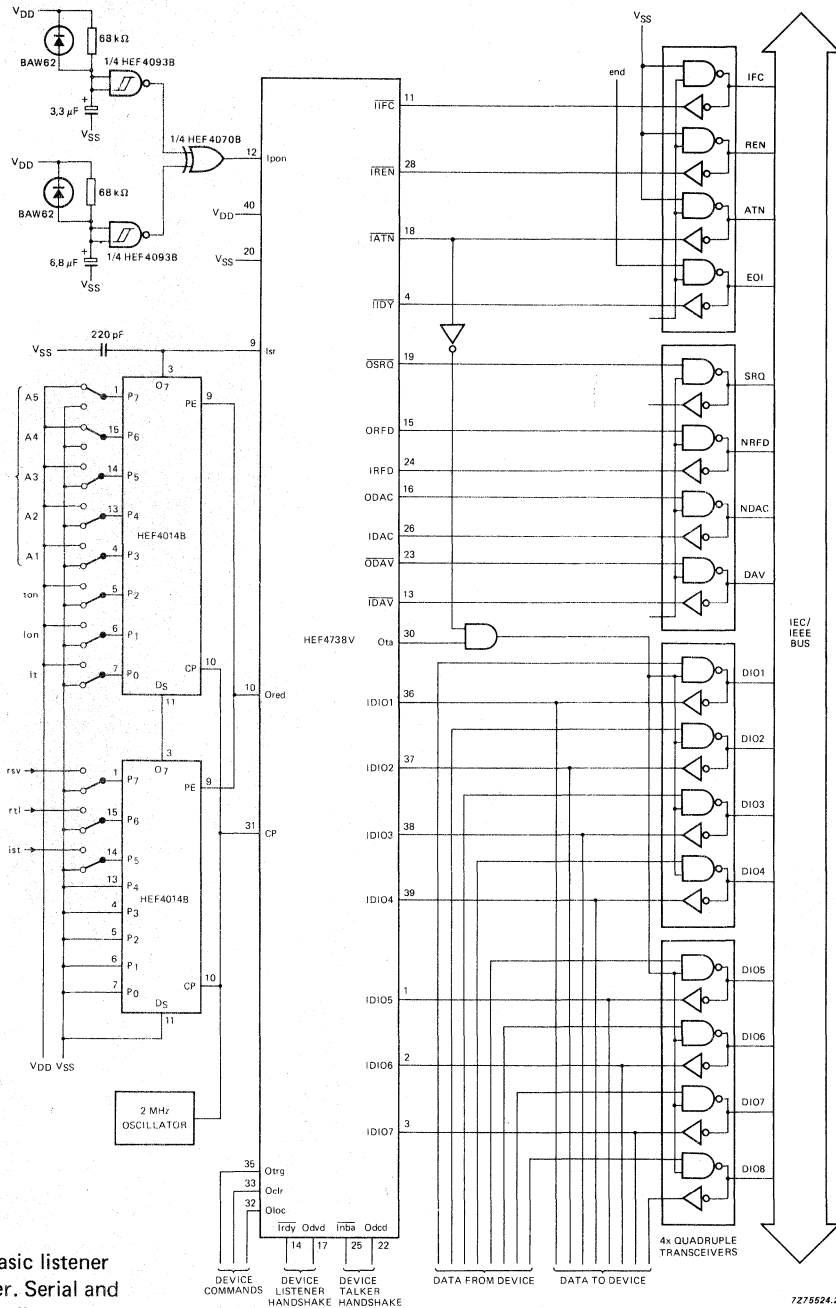

Fig. 6 Basic listener and talker. Serial and parallel poll are not implemented.

7275524.2

FREQUENCY SYNTHESIZER

The HEF4750V frequency synthesizer is one of a pair of LOCMOS devices, primarily intended for use in high-performance frequency synthesizers, e.g. in all communication, instrumentation, television and broadcast applications. A combination of analogue and digital techniques results in an integrated circuit that enables high performance. The complementary device is the universal divider type HEF4751V.

Together with a standard prescaler, the two LOCMOS integrated circuits offer low-cost single loop synthesizers with full professional performance. Salient features offered (in combination with HEF4751V) are:

- Wide choice of reference frequency using a single crystal.
- High-performance phase comparator — low phase noise — low spurious.
- System operation to > 1 GHz.
- Typical 15 MHz input at 10 V.
- Flexible programming:
 - frequency offsets
 - ROM compatible
 - fractional channel capability.
- Programme range $6\frac{1}{2}$ decades, including up to 3 decades of prescaler control.
- Division range extension by cascading.
- Built-in phase modulator.
- Fast lock feature.
- Out-of-lock indication.
- Low power dissipation and high noise immunity.

APPLICATION INFORMATION

Some examples of applications for the HEF4750V in combination with the HEF4751V are:

- VHF/UHF mobile radios.
- HF s.s.b. transceivers.
- Airborne and marine communications and nav aids.
- Broadcast transmitters.
- High quality radio and television receivers.
- High performance citizens band equipment.
- Signal generators.

SUPPLY VOLTAGE

| rating | recommended operating |
|--------------|--------------------------|
| -0,5 to + 15 | 9,5 to 10,5 V |

HEF4750V

LSI

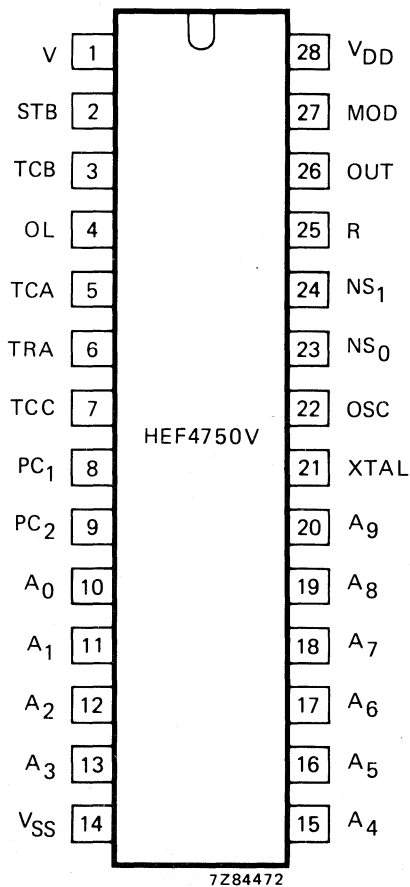

PINNING

| | |
|-----------------------------------|---|
| R | phase comparator input, reference |
| V | phase comparator input |
| STB | strobe input |
| TCA | timing capacitor C_A pin |
| TCB | timing capacitor C_B pin |
| TCC | timing capacitor C_C pin |
| TRA | biasing pin (resistor R_A) |
| PC ₁ | analogue phase comparator output |
| PC ₂ | digital phase comparator output |
| MOD | phase modulation input |
| OL | out-of-lock indication |
| OSC | reference oscillator/buffer input |
| XTAL | reference oscillator/buffer output |
| A ₀ to A ₉ | programming inputs/programmable divider |
| NS ₀ , NS ₁ | programming inputs, prescaler |
| OUT | reference divider output |

Fig. 1 Pinning diagram.

HEF4750VD: 28-lead DIL; ceramic (cerdip) (SOT-135A).

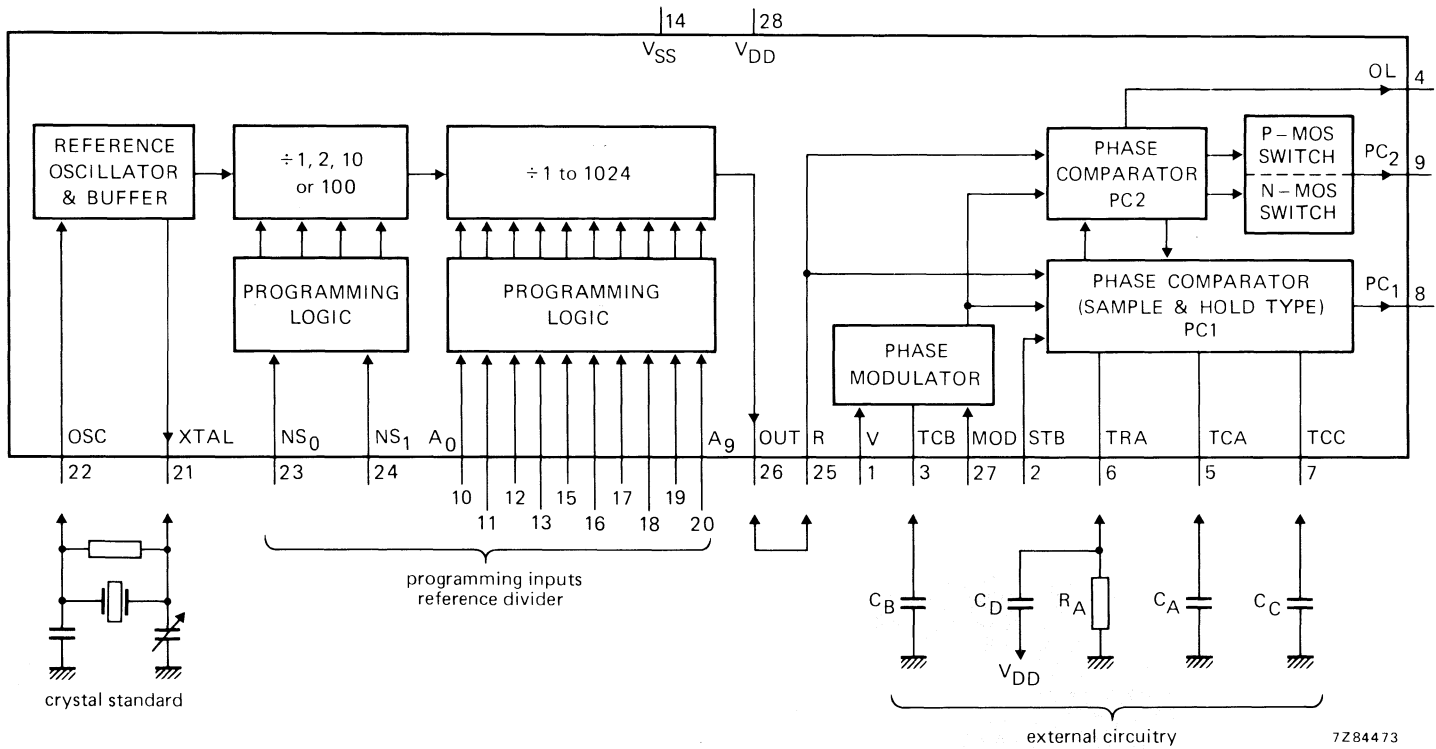

Fig. 2 Block diagram comprising five basic functions: phase comparator 1 (PC1), phase comparator 2 (PC2), phase modulator, reference oscillator and reference divider. These functions are described separately.

N.B. PC₁ = analogue output; PC₂ = 3-state output.

FUNCTIONAL DESCRIPTION

Phase comparator 1

Phase comparator 1 (PC1) is built around a SAMPLE and HOLD circuit. A negative-going transition at the V-input causes the hold capacitor (C_A) to be discharged and after a specified delay, caused by the Phase Modulator by means of an internal V' pulse, it produces a positive-going ramp. A negative-going transition at the R-input terminates the ramp. Capacitor C_A holds the voltage that the ramp has attained. Via an internal sampling switch this voltage is transferred to C_C and in turn buffered and made available at output PC₁.

If the ramp terminates before an R-input is present, an internal end of ramp (EOR) signal is produced. These actions are illustrated in Fig. 3.

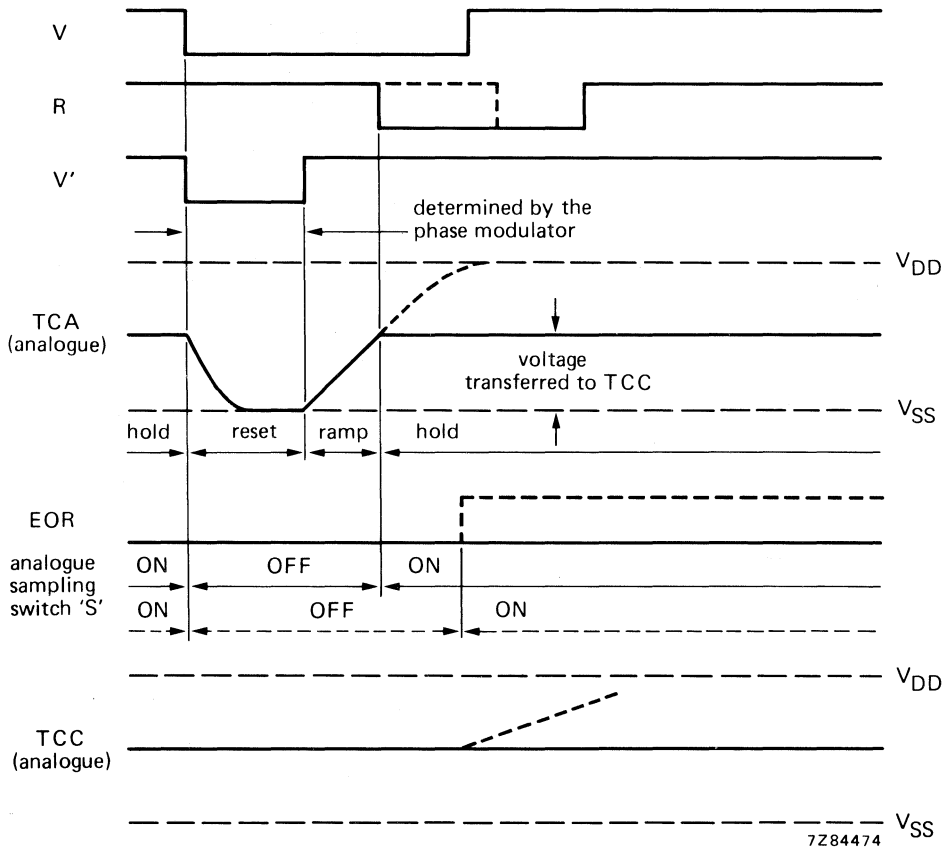

Fig. 3 Waveforms associated with PC1.

The resultant phase characteristic is shown in Fig. 4.

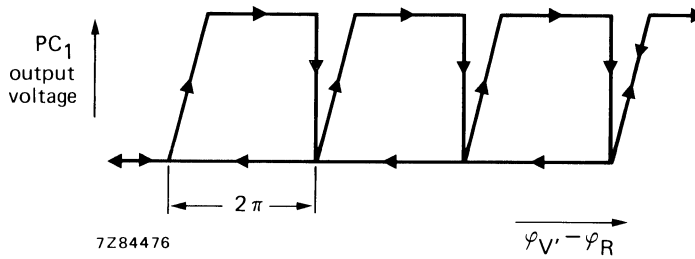

Fig. 4 Phase characteristic of PC1.

PC1 is designed to have a high gain, typically 3200 V/cycle (at 12,5 kHz). This enables a low noise performance.

Phase comparator 2

Phase comparator 2 (PC2) has a wide range, which enables faster lock times to be achieved than otherwise would be possible. It has a linear $\pm 360^\circ$ phase range, which corresponds to a gain of typically 5 V/cycle. This digital phase comparator has three stable states:

- reset state,
- V' leads R state,
- R leads V' state.

Conversion from one state to another takes place according to the state diagram of Fig. 5.

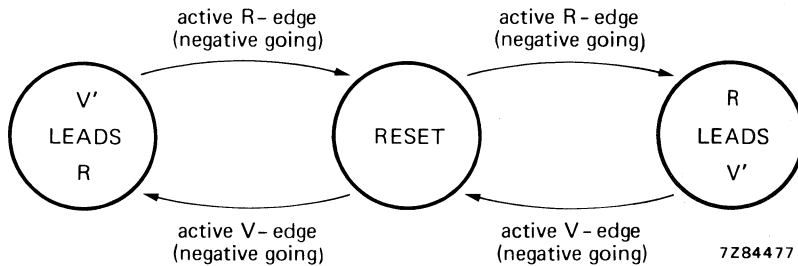

Fig. 5 State diagram of PC2.

Output PC2 produces positive or negative-going pulses with variable width; they depend on the phase relationship of R and V'. The average output voltage is a linear function of the phase difference. Output PC2 remains in the high impedance OFF-state in the region in which PC1 operates. The resultant phase characteristic is shown in Fig. 6.

FUNCTIONAL DESCRIPTION (continued)

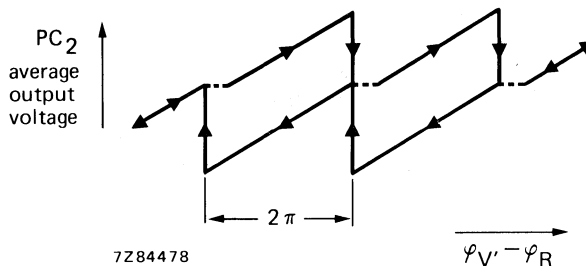

Fig. 6 Phase characteristic of PC₂.

Strobe function

The strobe function is intended for applications requiring extremely fast lock times. In normal operation the additional strobe input (STB) can be connected to the V-input and the circuit will function as described in the previous sections.

In single, phase-locked-loop type frequency synthesizers, the comparison frequency generally used is either the nominal channel spacing or a sub-multiple. PC₂ runs at the higher frequency (a higher reference frequency must also be used), whilst strobing takes place on the lower frequency, thereby obtaining a decrease in lock time. In a system using the Universal Divider HEF4751V, the output OFS cycles on the lower frequency, the output OFF cycles on the higher frequency.

Out-of-lock function

There are a number of situations in which the system goes from the locked to the out-of-lock state (OL goes HIGH):

1. When V' leads R, however out of the range of PC₁.
2. When R leads V'.
3. When an R-pulse is missing.
4. When a V-pulse is missing.
5. When two successive STB-commands occur, the first without corresponding V-signal.

Phase modulator

The phase modulator only uses one external capacitor, C_B at pin TCB. A negative-going transition at the V-input causes C_B to produce a positive-going linear ramp. When the ramp has reached a value almost equal to the modulation input voltage (at MOD), the ramp terminates, C_B discharges and a start signal to the C_A-ramp at TCA is produced. A linear phase modulation is reached in this way.

If no modulation is required, the MOD-input must be connected to a fixed voltage of a certain positive value up to V_{DD}. Care must be taken that the V' pulse is never smaller than the minimum value to ensure that the external capacitor of PC₁ (C_A) can be discharged during that time. Since the V' pulse width is directly related to the TCB ramp duration, there is a requirement for the minimum value of this ramp duration.

Reference oscillator

The reference oscillator normally operates with an external crystal as shown in Fig. 2. The internal circuitry can be used as a buffer amplifier in case an external reference should be required.

Reference divider

The reference divider consists of a binary divider with a programmable division ratio of 1 to 1024 and a prescaler with selectable division ratios of 1, 2, 10 and 100, according to the following tables:

• Binary divider

| N (A ₀ to A ₉) | division ratio |
|---------------------------------------|----------------|
| 0 | 1024 |
| 0 ≤ N ≤ 1023 | N |

• Prescaler

| programming word (NS ₀ , NS ₁) | division ratio |
|---|----------------|
| 0 | 1 |
| 1 | 2 |
| 2 | 10 |
| 3 | 100 |

In this way suitable comparison frequencies can be obtained from a range of crystal frequencies. The divider can also be used as a 'stand alone' programmable divider by connecting input TRA to V_{DD}, which causes all internal analogue currents to be switched off.

Biasing circuitry

The biasing circuitry uses an external current source or resistor, which has to be connected between the TRA and V_{SS} pins. This circuitry supplies all analogue parts of the circuit. Consequently the analogue properties of the device, such as gain, charge currents, speed, power dissipation, impedance levels etc., are mainly determined by the value of the input current at TRA. The TRA input must be decoupled to V_{DD}, as shown in Fig. 7. The value of C_D has to be chosen such that the TRA input is 'clean', e.g. 10 nF at R_A = 68 kΩ.

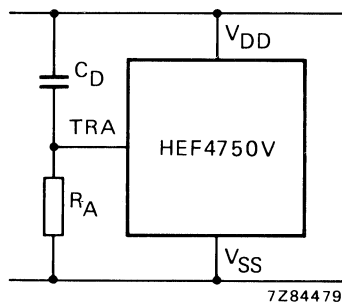

Fig. 7 Decoupling of input TRA.

HEF4750V

LSI

RATINGS

Limiting values in accordance with the Absolute Maximum System (IEC 134)

| | | |
|---|-----------|--------------------------|
| Supply voltage | V_{DD} | -0,5 to + 15 V |
| Voltage on any input | V_I | -0,5 to $V_{DD} + 0,5$ V |
| D.C. current into any input or output | $\pm I$ | max. 10 mA |
| Power dissipation per package for $T_{amb} = 0$ to + 85 °C | P_{tot} | max. 500 mW |
| Power dissipation per output for $T_{amb} = 0$ to 85 °C | P | max. 100 mW |
| Storage temperature | T_{stg} | -65 to + 150 °C |
| Operating ambient temperature | T_{amb} | -40 to + 85 °C |

D.C. CHARACTERISTICS at $V_{DD} = 10$ V \pm 5%; voltages are referenced to $V_{SS} = 0$ V, unless otherwise specified; for definitions see note 1.

| parameter | symbol | T_{amb} (°C) | | | | | | unit | notes | | | |
|--|--------------|-----------------------|------|------|------|------|------|------|-------|------|---------|------|
| | | -40 | | | + 25 | | | | | + 85 | | |
| | | min. | typ. | max. | min. | typ. | max. | min. | typ. | max. | | |
| Quiescent device current | I_{DD} | - | - | 100 | - | - | 100 | - | - | 750 | μ A | 2 |
| Input current; logic inputs, MOD | $\pm I_{IN}$ | - | - | 300 | - | - | 300 | - | - | 1000 | nA | 3 |
| Output leakage current at $\frac{1}{2} V_{DD}$ | | | | | | | | | | | | 3, 4 |
| TCA, hold-state | $\pm I_Z$ | - | - | 20 | - | 0,05 | 20 | - | - | 60 | nA | |
| TCC, analogue switch OFF | $\pm I_Z$ | - | - | 20 | - | 0,05 | 20 | - | - | 60 | nA | |
| PC ₂ , high impedance OFF-state | $\pm I_Z$ | - | - | 50 | - | - | 50 | - | - | 500 | nA | |
| Logic input voltage LOW | V_{IL} | max. 0,3 V_{DD} | | | | | | V | | | | |
| HIGH | V_{IH} | min. 0,7 V_{DD} | | | | | | V | | | | |
| Logic output voltage LOW; at $ I_O < 1 \mu A$ | V_{OL} | - | - | 50 | - | - | 50 | - | - | 50 | mV | 3 |
| HIGH | V_{OH} | min. $V_{DD} - 50$ mV | | | | | | mV | 3 | | | |
| Logic output current LOW; at $V_{OL} = 0,5$ V | | | | | | | | | | | | 3 |
| outputs OL, PC ₂ , OUT | I_{OL} | 5,5 | - | - | 4,6 | - | - | 3,6 | - | - | mA | |
| output XTAL | I_{OL} | 2,8 | - | - | 2,4 | - | - | 1,9 | - | - | mA | |

| parameter | symbol | T _{amb} (°C) | | | | | | unit | notes |
|---|------------------|-----------------------|-----------|------|-----------|---------|-----------|------|--------|
| | | -40 | | + 25 | | + 85 | | | |
| | | min. | typ. max. | min. | typ. max. | min. | typ. max. | | |
| Logic output current HIGH; at V _{OH} = V _{DD} - 0,5 V | | | | | | | | | 3 |
| outputs OL, PC ₂ , OUT | -I _{OH} | 1,5 | - - | 1,3 | - - | 1,0 | - - | mA | |
| output XTAL | -I _{OH} | 1,4 | - - | 1,2 | - - | 0,9 | - - | mA | |
| Output TCC sink current | I _O | - - - | - | 2,1 | - | - - - | - | mA | 3,4,5 |
| Output TCC source current | -I _O | - - - | - | 1,9 | - | - - - | - | mA | 3,4,6 |
| Internal resistance of TCC output swing ≤ 200 mV specified output range: 0,3 V _{DD} to 0,7 V _{DD} | R _i | - - - | - | 0,7 | - | - - - | - | kΩ | 3,4 |
| Output TCC voltage with respect to TCA input voltage | ΔV | - 0 - | - | 0 | - | - 0 - | - | V | 3,4,7 |
| Output PC ₁ sink current | I _O | - - - | - | 1,1 | - | - - - | - | mA | 3,4,8 |
| Output PC ₁ source current | -I _O | - - - | - | 1,0 | - | - - - | - | mA | 3,4,9 |
| Internal resistance of PC ₁ output swing ≤ 200 mV specified output range: 0,3 V _{DD} to 0,7 V _{DD} | R _i | - - - | - | 1,4 | - | - - - | - | kΩ | 3,4 |
| Output PC ₁ voltage with respect to TCC input voltage | ΔV | - 0 - | - | 0 | - | - 0 - | - | V | 3,4,10 |
| EOR generation V _{EOR} = V _{DD} - V _{TCA} | V _{EOR} | - 0,9 - | - | 0,7 | - | - 0,6 - | - | V | 3,4,11 |
| Source current; HIGH at V _{OUT} = ½ V _{DD} ; output in ramp mode | | | | | | | | | 3,4 |
| TCA | I _O | - - - | - | 13 | - | - - - | - | mA | |
| TCB | I _O | - - - | - | 2,5 | - | - - - | - | mA | |

A.C. CHARACTERISTICS

General note

The dynamic specifications are given for the circuit built-up with external components as given in Fig. 8, under the following conditions; for definitions see note 1; for definitions of times see Fig. 19; $V_{DD} = 10 \text{ V} \pm 5\%$; $T_{amb} = 25 \text{ }^\circ\text{C}$; input transition times $\leq 20 \text{ ns}$; $R_A = 68 \text{ k}\Omega \pm 30\%$ (see also note 4); $C_A = 270 \text{ pF}$; $C_B = 150 \text{ pF}$; $C_C = 1 \text{ nF}$; $C_D = 10 \text{ nF}$; unless otherwise specified.

| | symbol | min. | typ. | max. | unit | conditions | notes |
|------------------------------------|------------------|------|------|------|------------|-------------------------|-------|
| Slew rate | | | | | | | |
| TCA | STCA | — | 52 | — | V/ μ s | $R_A = \text{minimum}$ | 12 |
| TCA | STCA | — | 28 | — | V/ μ s | $R_A = \text{maximum}$ | 12 |
| TCB | STCB | — | 20 | — | V/ μ s | $R_A = \text{minimum}$ | 12 |
| TCB | STCB | — | 10 | — | V/ μ s | $R_A = \text{maximum}$ | 12 |
| Ramp linearity | | | | | | | |
| TCA | lTCA | — | 2 | — | % | | 13 |
| TCB | lTCB | — | 2 | — | % | | 13 |
| Start of TCA-ramp delay | tCBCA | — | 200 | — | ns | | |
| Delay of TCA-hold | tRCA | — | 40 | — | ns | | |
| Delay of TCA-discharge | tVCA | — | 60 | — | ns | | |
| Start of TCB-ramp delay | tVCB | — | 60 | — | ns | | |
| TCB-ramp duration | t _{rCB} | — | 250 | — | ns | $V_{MOD} = 4 \text{ V}$ | |
| | t _{rCB} | — | 350 | — | ns | $V_{MOD} = 6 \text{ V}$ | |
| | t _{rCB} | — | 450 | — | ns | $V_{MOD} = 8 \text{ V}$ | |
| Required TCB min. ramp duration | t _{rCB} | — | 150 | — | ns | | 14 |
| Pulse width | | | | | | | |
| V : LOW | tpWVL | — | 20 | — | ns | | |
| V : HIGH | tpWVH | — | 20 | — | ns | | |
| R : LOW | tpWRL | — | 20 | — | ns | | |
| R : HIGH | tpWRH | — | 20 | — | ns | | |
| STB : LOW | tpWSL | — | 20 | — | ns | | |
| STB : HIGH | tpWSH | — | 20 | — | ns | | |
| Fall time | | | | | | | |
| TCA | t _{fCA} | — | 50 | — | ns | | |
| TCB | t _{fCB} | — | 50 | — | ns | | |
| Prescaler input frequency | f _{PR} | — | 30 | — | MHz | all division ratios | |
| Binary divider frequency | f _{DIV} | — | 30 | — | MHz | all division ratios | |
| Crystal oscillator frequency | f _{OSC} | — | 10 | — | MHz | | |
| Average power supply current | | | | | | locked state | |
| with speed-up 1 : 10 | I _p | — | 3,6 | — | mA | | 15 |
| without speed-up | I _p | — | 3,2 | — | mA | | 16 |

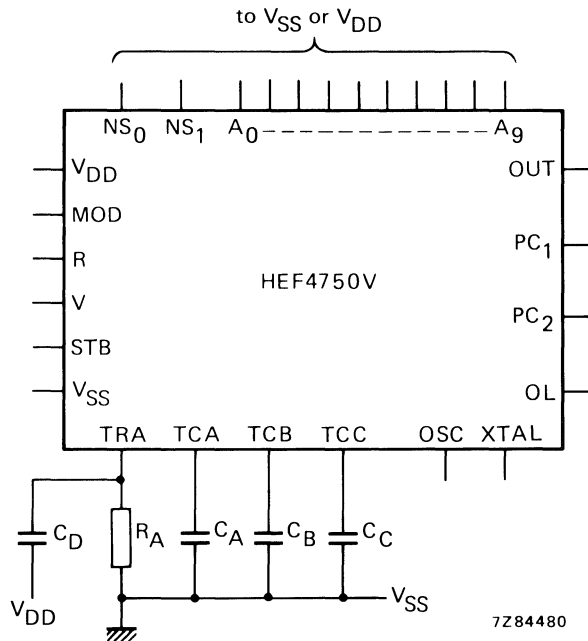

Fig. 8 Test circuit for measuring a.c. characteristics.

NOTES

1. Definitions:

- R_A = external biasing resistor between pins TRA and V_{SS} ; $68\text{ k}\Omega \pm 30\%$.
- C_A = external timing capacitor for time/voltage converter, between pins TCA and V_{SS} .
- C_B = external timing capacitor for phase modulator, between pins TCB and V_{SS} .
- C_C = external hold capacitor between pins TCC and V_{SS} .
- C_D = decoupling capacitor between pins TRA and V_{DD} .

Logic inputs: V, R, STB, A_0 to A_9 , NS_0 , NS_1 , OSC.

Logic outputs: OL, PC_2 , XTAL, OUT.

Analogue signals: TCA, TCB, TCC, TRA, PC_1 , MOD.

- 2. TRA at V_{DD} ; TCA, TCB, TCC and MOD at V_{SS} ; logic inputs at V_{SS} or V_{DD} .
- 3. All logic inputs at V_{SS} or V_{DD} .
- 4. R_A connected; its value chosen such that $I_{TRA} = 100\ \mu\text{A}$.
- 5. The analogue switch is in the ON position (see Fig. 9).

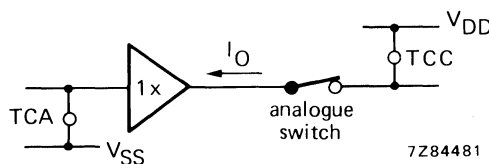

Fig. 9 Equivalent circuit for note 5.

NOTES (continued)

6. The analogue switch is in the ON position (see Fig. 10).

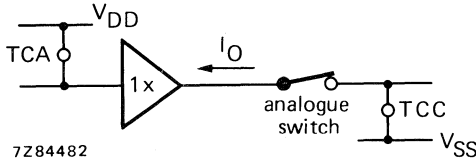

Fig. 10 Equivalent circuit for note 6.

7. This guarantees the d.c. voltage gain, combined with d.c.-offset.
Input condition: $0,3 V_{DD} \leq V_{TCA} \leq 0,7 V_{DD}$.
 $\Delta V = V_{TCC} - V_{TCA}$.

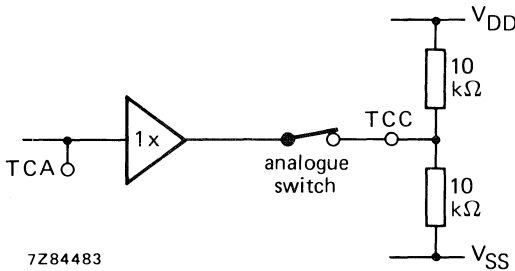

Fig. 11 Circuit for note 7.

- 8.

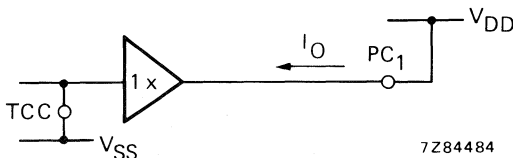

Fig. 12 Equivalent circuit for PC₁ sink current.

- 9.

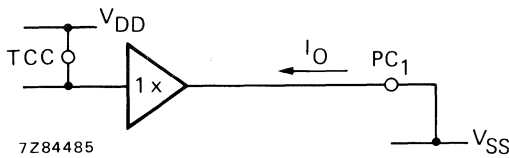

Fig. 13 Equivalent circuit for PC₁ source current.

10. This guarantees the d.c. voltage gain, combined with d.c.-offset.
Input condition: $0,3 V_{DD} \leq V_{TCC} \leq 0,7 V_{DD}$.
 $\Delta V = V_{PC1} - V_{TCC}$.

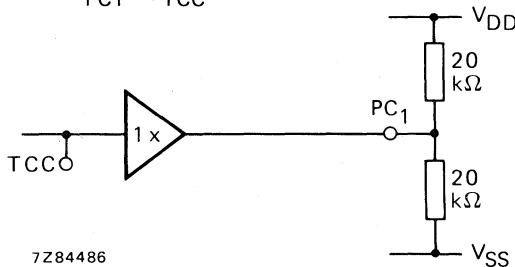

Fig. 14 Circuit for note 10.

- 11. Switching level at TCA, generating an EOR-signal, during increasing input voltage.
- 12.

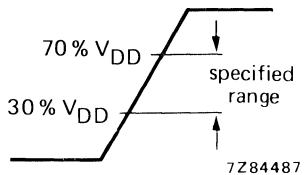

Fig. 15 Waveform at the output.

- 13. Definition of the ramp linearity at full swing.

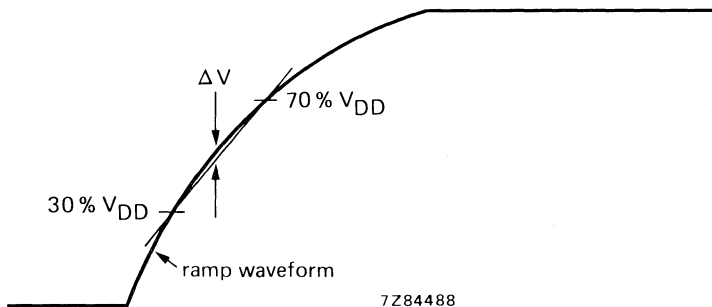

Fig. 16 ΔV is the maximum deviation of the ramp waveform to the straight line, which joins the 30% V_{DD} and 70% V_{DD} points.

$$\text{Linearity} = \frac{\Delta V}{\frac{1}{2} V_{DD}} \times 100\%.$$

- 14. The external components and modulation input voltage must be chosen such that this requirement will be fulfilled, to ensure that C_A is sufficiently discharged during that time.

HEF4750V

LSI

NOTES (continued)

15. Circuit connections for power supply current specification, with speed-up 1 : 10. V and R are in the range of PC₁, such that the output voltage at PC₁ is equal to 5 V.

$f_{OSC} = 5 \text{ MHz}$ (external clock)

$f_{STB} = 12,5 \text{ kHz}$

$f_V = 125 \text{ kHz}$

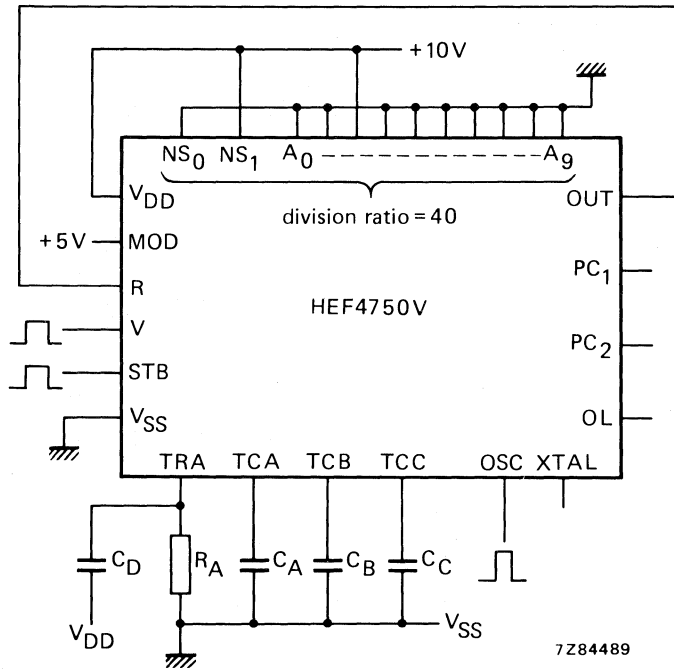

Fig. 17 Circuit for note 15.

16. Circuit connections for power supply current specification, without speed-up. V and R are in the range of PC1, such that the output voltage at PC1 is equal to 5 V.
 $f_{OSC} = 5 \text{ MHz}$ (external clock)
 $f_{STB} = 12,5 \text{ kHz}$
 $f_V = 12,5 \text{ kHz}$

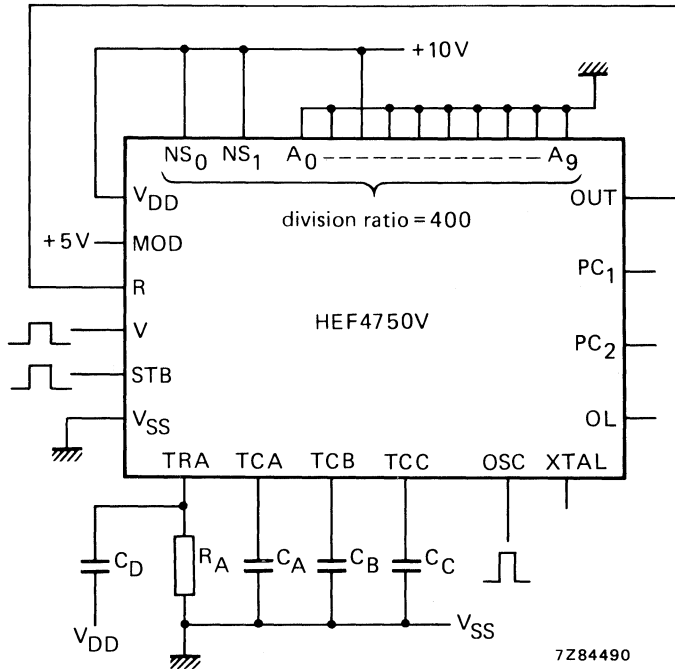
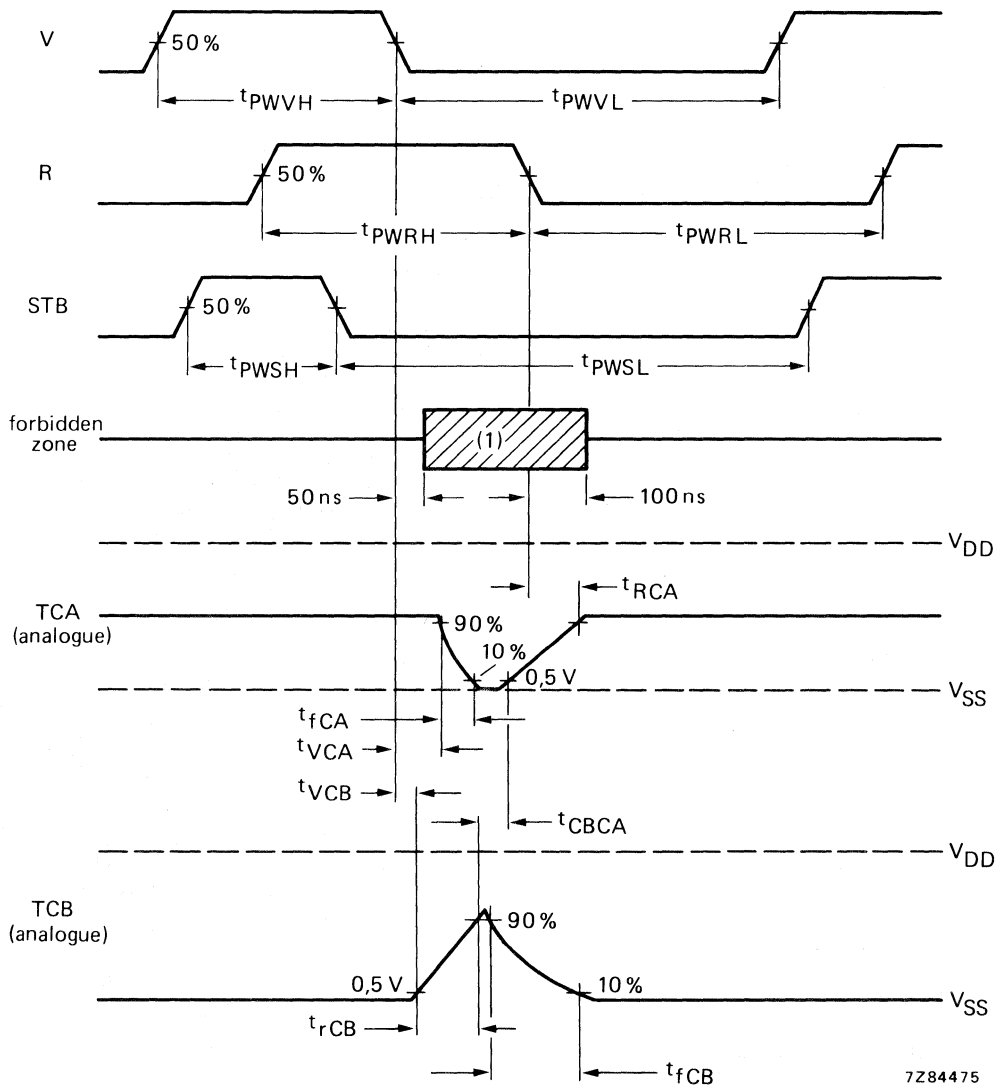

Fig. 18 Circuit for note 16.



7284475

(1) Forbidden zone in the *locked state* for the positive edge of V and R and both edges of STB.

Fig. 19 Waveforms showing times in the locked state.

UNIVERSAL DIVIDER

The HEF4751V is a universal divider (U.D.) intended for use in high performance phase lock loop frequency synthesizer systems. It consists of a chain of counters operating in a programmable feedback mode. Programmable feedback signals are generated for up to three external (fast) $\div 10/11$ prescaler.

The system comprising one HEF4751V U.D. together with prescalers is a fully programmable divider with a maximum configuration of: 5 decimal stages, a programmable mode M stage ($1 \leq M \leq 16$, non-decimal fraction channel selection), and a mode H stage ($H = 1$ or 2 , stage for half channel offset). Programming is performed in BCD code in a bit-parallel, digit-serial format.

To accommodate fixed or variable frequency offset, two numbers are applied in parallel, one being subtracted from the other to produce the internal programme.

The decade selection address is generated by an internal programme counter which may run continuously or on demand. Two or more universal dividers can be cascaded, each extra U.D. (in slave mode) adds two decades to the system. The combination retains the full programmability and features of a single U.D. The U.D. provides a fast output signal FF at output OFF, which can have a phase jitter of ± 1 system input period, to allow fast frequency locking. The slow output signal FS at output OFS, which is jitter-free, is used for fine phase control at a lower speed.

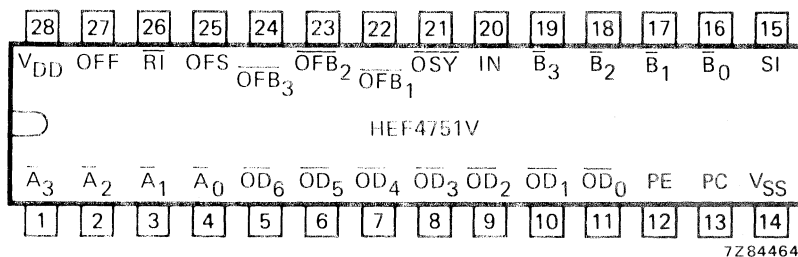

Fig. 1 Pinning diagram.

SUPPLY VOLTAGE

| rating | recommended operating |
|-------------|-----------------------|
| -0,5 to +18 | 4,5 to 12,5 V |

HEF4751VP : 28-lead DIL; plastic (SOT-117).

HEF4751VD : 28-lead DIL; ceramic (cerdip) (SOT-135A).

HEF4751VT : 28-lead mini-pack; plastic (SO-28; SOT-136A).

FAMILY DATA

I_{DD} LIMITS category LSI

} see Family Specifications

HEF4751V

LSI

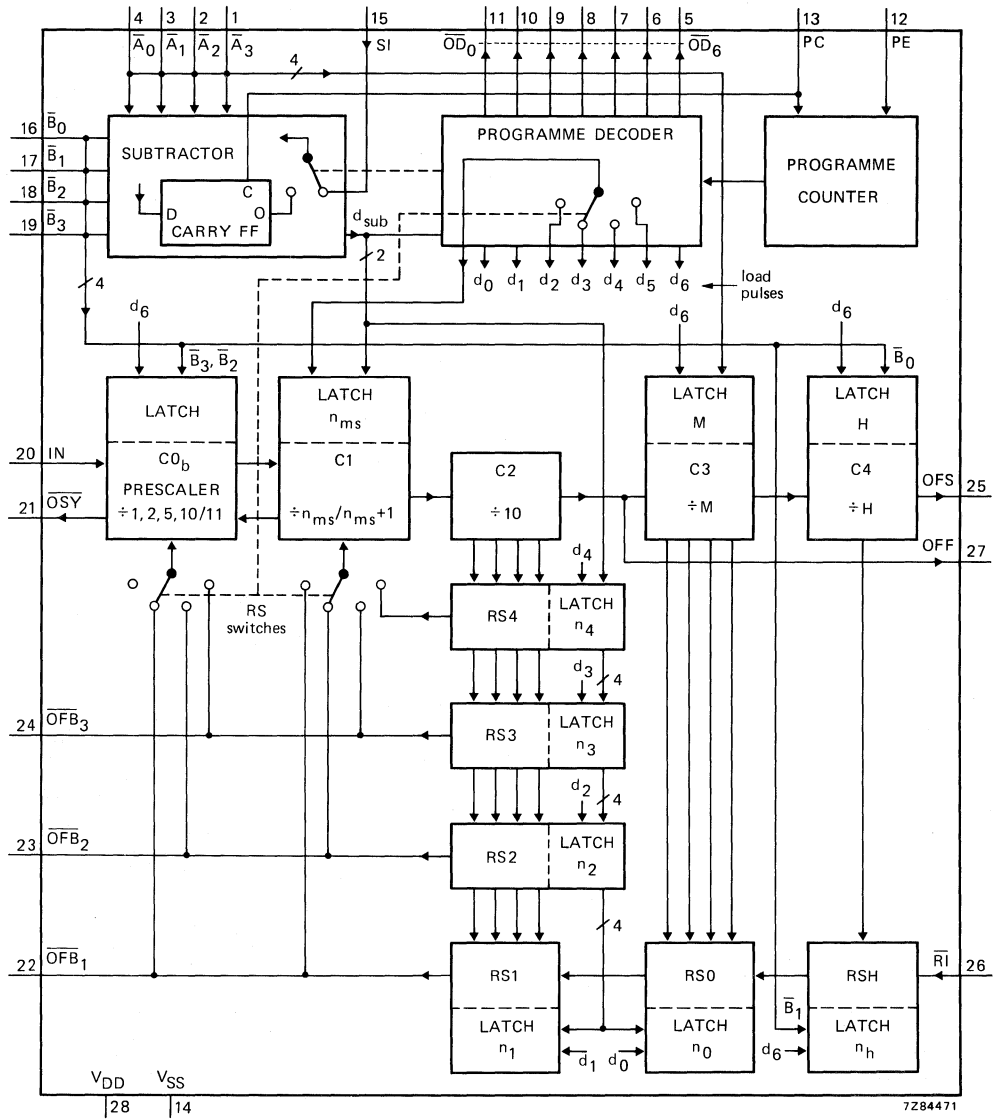

Fig. 2 Block diagram.

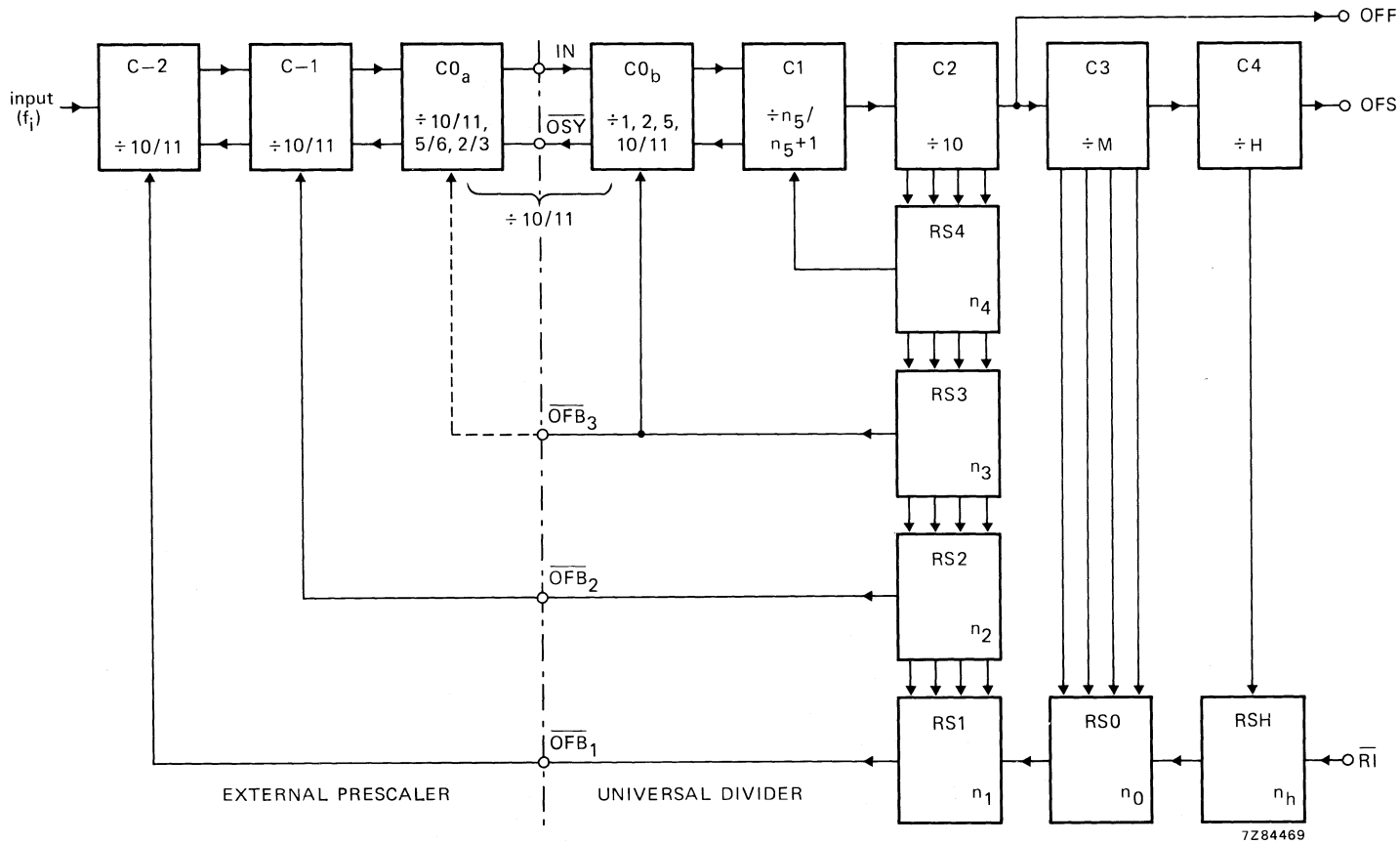
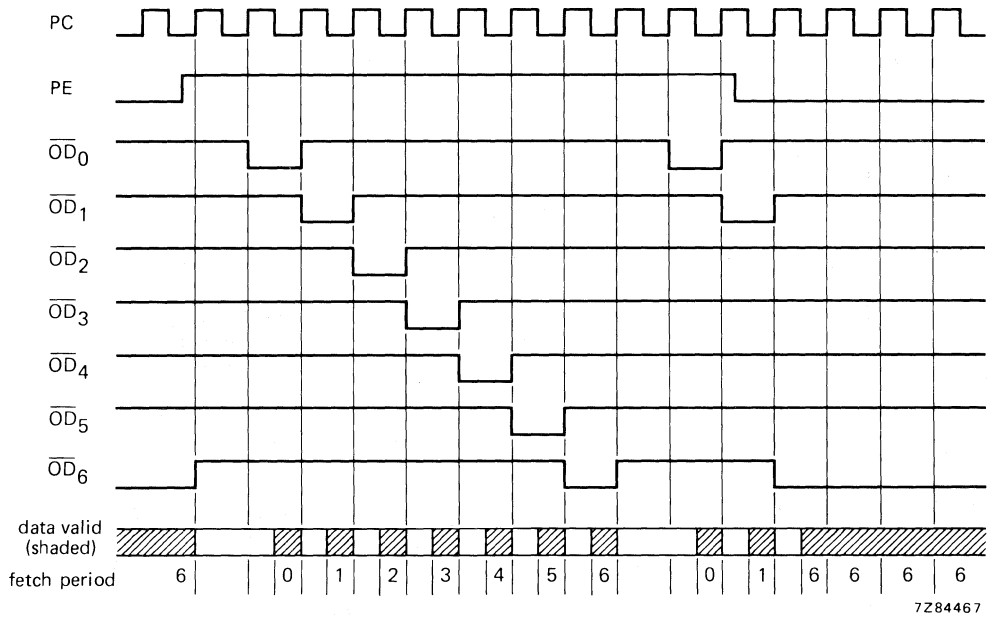

Fig. 3 The HEF4751V U.D. used in a system with 3 (fast) prescalers.

$$1 \leq M \leq 16; 1 \leq H \leq 2; n_5 > 0; f_i/f_{\text{OFS}} = \{(n_5 \cdot 10^4 + n_4 \cdot 10^3 + n_3 \cdot 10^2 + n_2 \cdot 10 + n_1) M + n_0\} H + n_h.$$

HEF4751V
LSI



7284467

Fig. 4 Timing diagram showing programme data inputs.

Allocation of data input

| fetch period | inputs | | | | | | | | |
|--------------|-------------|-------------|-------------|-------------|----------------|-------------|-------------------------------|-------------|----------|
| | \bar{A}_3 | \bar{A}_2 | \bar{A}_1 | \bar{A}_0 | \bar{B}_3 | \bar{B}_2 | \bar{B}_1 | \bar{B}_0 | SI |
| 0 | | n_{0A} | | | | n_{0B} | | | b_{in} |
| 1 | | n_{1A} | | | | n_{1B} | | | X |
| 2 | | n_{2A} | | | | n_{2B} | | | X |
| 3 | | n_{3A} | | | | n_{3B} | | | X |
| 4 | | n_{4A} | | | | n_{4B} | | | X |
| 5 | | n_{5A} | | | | n_{5B} | | | X |
| 6 | | M | | | $C0_b$ control | | $\frac{1}{2}$ channel control | | X |

Allocation of data input \bar{B}_3 to \bar{B}_0 during fetch period 6

| \bar{B}_3 | \bar{B}_2 | $C0_b$ division ratio | \bar{B}_1 | \bar{B}_0 | $\frac{1}{2}$ channel configuration |
|-------------|-------------|-----------------------|-------------|-------------|-------------------------------------|
| L | L | 1 | L | L | H = 1 |
| L | H | 2 | L | H | H = 2; $n_h = 0$ |
| H | L | 5 | H | H | H = 2; $n_h = 1$ |
| H | H | 10/11 | H | L | test state |

H = HIGH state (the more positive voltage)

L = LOW state (the less positive voltage)

X = state is immaterial

PROGRAMME DATA INPUT (see also Figs 3 and 4)

The programming process is timed and controlled by input PC and PE. When the programme enable (PE) input is HIGH, the positive edges of the programme clock (PC) signal step through the internal programme counter in a sequence of 8 states. Seven states define fetch periods, each indicated by a LOW signal at one of the corresponding data address outputs (\overline{OD}_0 to \overline{OD}_6). These data address signals may be used to address the external programme source. The data fetched from the programme source is applied to inputs \overline{A}_0 to \overline{A}_3 and \overline{B}_0 to \overline{B}_3 . When PC is LOW in a fetch period an internal load pulse is generated, the data is valid during this time and has to be stable. When PE is LOW, the programming cyclis is interrupted on the first positive edge of PC. On the next negative edge at input PC fetch period 6 is entered. Data may enter asynchronously in fetch period 6.

Ten blocks in the U.D. need programme input signals (see Fig. 2). Four of these (CO_b , C3, C4 and RSH) are concerned with the configuration of the U.D. and are programmed in fetch period 6. The remaining blocks (RS0 to RS4 and C1) are programmed with number P, consisting of six internal digits n_0 to n_5 .

$$P = (n_5 \cdot 10^4 + n_4 \cdot 10^3 + n_3 \cdot 10^2 + n_2 \cdot 10 + n_1) \cdot M + n_0$$

These digits are formed by a subtractor from two external numbers A and B and a borrow-in (b_{in}).

$$P = A - B - b_{in} \text{ or if this result is negative; } P = A - B - b_{in} + M \cdot 10^5.$$

The numbers A and B, each consisting of six four bit digits n_{0A} to n_{5A} and n_{0B} to n_{5B} , are applied in fetch period 0 to 5 to the inputs \overline{A}_0 to \overline{A}_3 (data A) and \overline{B}_0 to \overline{B}_3 (data B) in binary coded negative logic.

$$A = (n_{5A} \cdot 10^4 + n_{4A} \cdot 10^3 + n_{3A} \cdot 10^2 + n_{2A} \cdot 10 + n_{1A}) \cdot M + n_{0A}$$

$$B = (n_{5B} \cdot 10^4 + n_{4B} \cdot 10^3 + n_{3B} \cdot 10^2 + n_{2B} \cdot 10 + n_{1B}) \cdot M + n_{0B}$$

Borrow-in (b_{in}) is applied via input SI in fetch period 0 (SI = HIGH: borrow, SI = LOW: no borrow).

Counter C1 is automatically programmed with the most significant non-zero digit (n_{ms}) from the internal digits n_5 to n_2 of number P. The counter chain C - 2 to C1 (see Fig. 3) is fully programmable by the use of pulse rate feedback.

Rate feedback is generated by the rate selectors RS4 to RS0 and RSH, which are programmed with digits n_4 to n_0 and n_h respectively. In fetch period 6 the fractional counter C3, half channel counter C4 and CO_b are programmed and configured via data B inputs. Counter C3 is programmed in fetch period 6 via data A inputs in negative logic (except all HIGH is understood as: $M = 16$). The counter C0 is a side steppable 10/11 counter composed of an internal part CO_b and an external part CO_a . CO_b is configured via \overline{B}_3 and \overline{B}_2 to a division ratio of 1 or 2 or 5 or 10/11; CO_a must have the complementary ratio 10/11 or 5/6 or 2/3 or 1 respectively. In the latter case CO_b comprises the whole C0 counter with internal feedback, CO_a is then not required.

The half channel counter C4 is enabled with $\overline{B}_0 = \text{HIGH}$ and disabled with $\overline{B}_0 = \text{LOW}$. With C4 enabled, a half channel offset can be programmed with input $\overline{B}_1 = \text{HIGH}$, and no offset with $\overline{B}_1 = \text{LOW}$.

FEEDBACK TO PRESCALERS (see also Figs 5 and 6)

The counters C1, C0, C-1 and C-2 are side-steppable counters, i.e. its division ratio may be increased by one, by applying a pulse to a control terminal for the duration of one division cycle. Counter C2 has 10 states, which are accessible as timing signals for the rate selectors RS1 to RS4. A rate selector, programmed with n (n_1 to n_4 in the U.D.) generates n of 10 basic timing periods an active signal. Since $n \leq 9$, 1 of 10 periods is always non-active. In this period RS1 transfers the output of rate selector RS0, which is timed by counter C3 and programmed with n_0 . Similarly, RS0 transfers RSH output during one period of C3. Rate selector RSH is timed by C4 and programmed with n_h . In one of the two states of C4, if enabled, or always, if C4 is disabled, RSH transfers the LOW active signal at input \overline{RI} to RS0. If \overline{RI} is not used it must be connected to HIGH. The feedback output signals of RS1, RS2 and RS3 are externally available as active LOW signals at outputs \overline{OFB}_1 , \overline{OFB}_2 and \overline{OFB}_3 .

Output \overline{OFB}_1 is intended for the prescaler at the highest frequency (if present), \overline{OFB}_2 for the next (if present) and \overline{OFB}_3 for the lowest frequency prescaler (if present). A prescaler needs a feedback signal, which is timed on one of its own division cycles in a basic timing period. The timing signal at \overline{OSY} is LOW during the last U.D. input period of a basic timing period and is suitable for timing of the feedback for the last external prescaler. The synchronization signal for a preceding prescaler is the OR-function of the sync. input and sync. output of the following prescaler (all sync. signals active LOW).

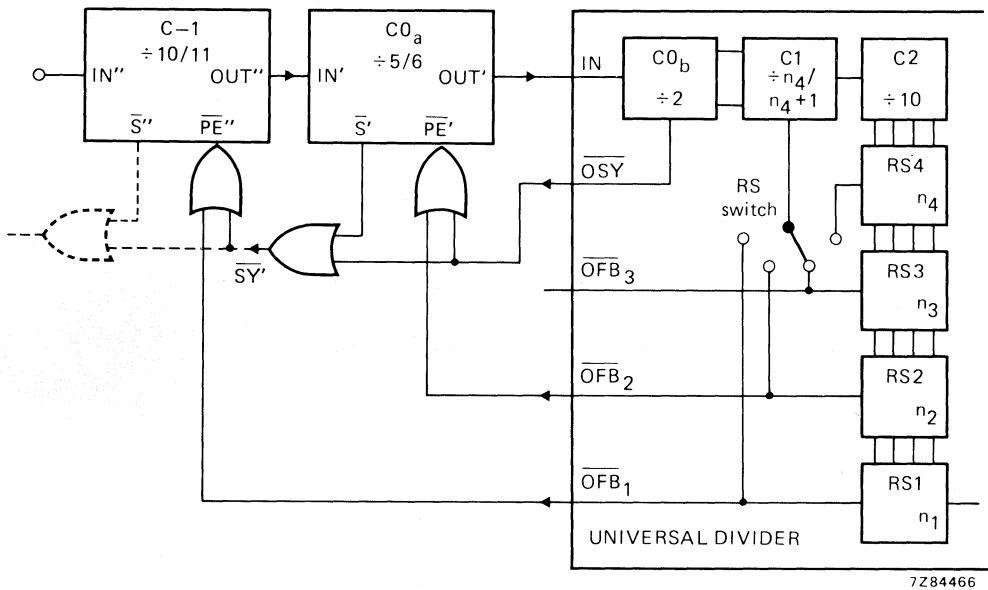

Fig. 5 Block diagram showing feedback to prescalers.

7284466

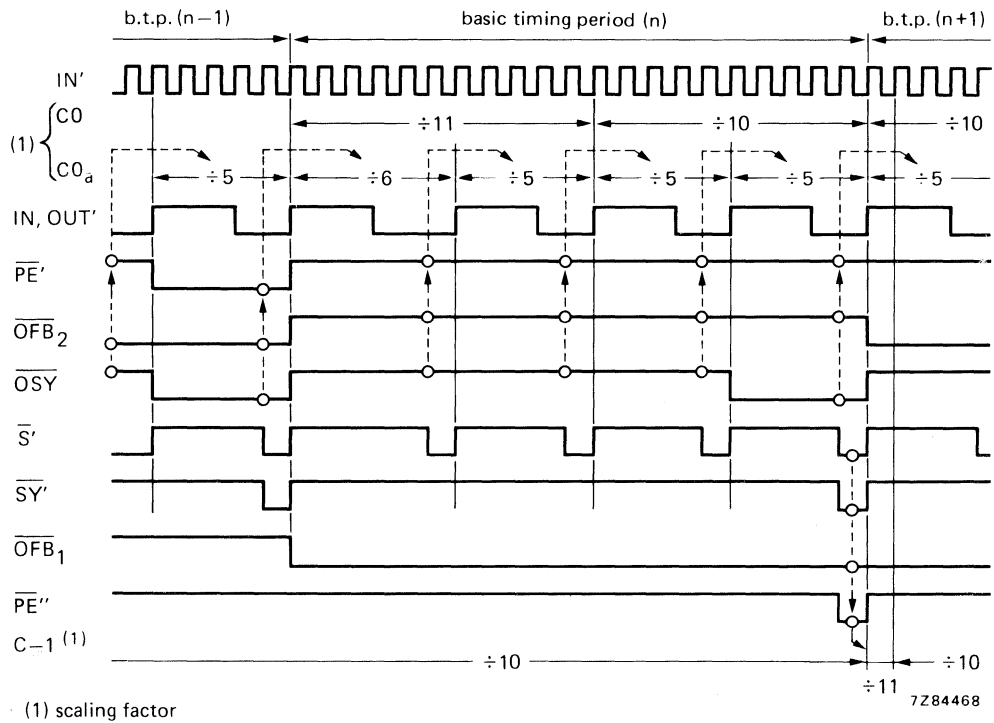

Fig. 6 Timing diagram showing signals occurring in Fig. 5.

CASCADING OF U.D.s (see also Fig. 8)

A U.D. is programmed into the 'slave' mode by the programme input data: $n_{2A} = 11$, $n_{2B} = 10$, $n_{3A} = n_{4A} = n_{3B} = n_{4B} = n_{5B} = 0$. A U.D. operating in the slave mode performs the function of two extra programmable stages C2' and C3' to a 'master' (not slave) mode operating U.D. More slave U.D.s may be used, every slave adding two lower significant digits to the system.

Output \overline{OFB}_3 is converted to the borrow output of the programme data subtractor, which is valid after fetch period 5. Input SI is the borrow input (both in master and in slave mode), which has to be valid in fetch period 0. Input SI has to be connected to output \overline{OFB}_3 of a following slave, if not present, to LOW. For proper transfer of the borrow from a lower to a higher significant U.D. subtractor, the U.D.s have to be programmed sequentially in order of significance or synchronously if the programme is repeated at least the number of U.D.s in the system.

Rate input \overline{RI} and output OFS must be connected to rate output \overline{OFB}_1 and the input IN of the next slave U.D. The combination thus formed retains the full programmability and features of one U.D.

OUTPUT (see also Fig. 7)

The normal output of the U.D. is the slow output OFS, which consists of evenly spaced LOW pulses. This output is intended for accurate phase comparison. If a better frequency acquisition time is required, the fast output OFF can be used. The output frequency on OFF is a factor $M \cdot H$ higher than the frequency on OFS. However, phase jitter of maximum ± 1 system input period occurs at OFF, since the division ratio of the counters preceding OFF are varied by slow feedback pulse trains from rate selectors following OFF.

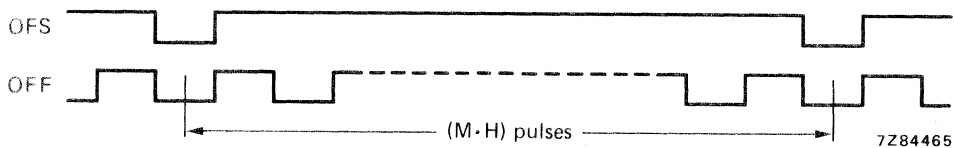

Fig. 7 Timing diagram showing output pulses.

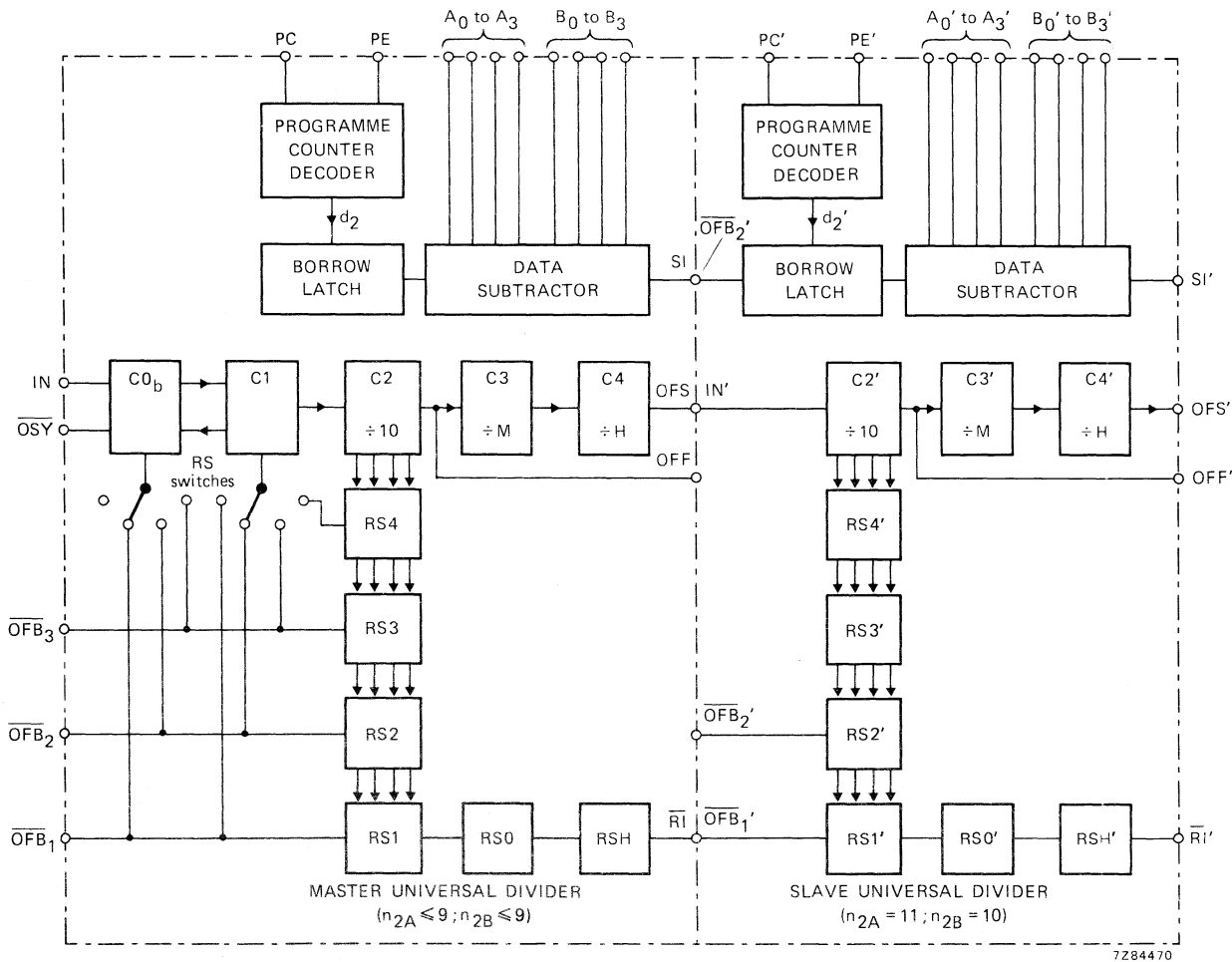

Fig. 8 Block diagram showing cascading of U.D.s.

HEF4751V

LSI

D.C. CHARACTERISTICS $V_{SS} = 0$ V

| | V_{DD} V | V_{OH} V | V_{OL} V | symbol | T_{amb} (°C) | | | | | |
|---------------------------------|---------------|---------------|---------------|-----------|----------------|------|-------------|------|-------------|------|
| | | | | | -40 min. | max. | +25 min. | max. | +85 min. | max. |
| Output (sink) current LOW | 4,75 | | 0,4 | I_{OL} | 1,6 | | 1,4 | | 1,1 | mA |
| | 5 | | 0,4 | | 1,7 | | 1,5 | | 1,2 | mA |
| | 10 | | 0,5 | | 2,9 | | 2,7 | | 2,2 | mA |
| Output (source) current HIGH | 5 | 4,6 | | $-I_{OH}$ | 1,0 | | 0,85 | | 0,55 | mA |
| | 5 | 2,5 | | | 3,0 | | 2,5 | | 1,7 | mA |
| | 10 | 9,5 | | | 3,0 | | 2,5 | | 1,7 | mA |

A.C. CHARACTERISTICS

$V_{SS} = 0$ V; $T_{amb} = 25$ °C; input transition times ≤ 20 ns

| parameter | V_{DD} V | symbol | min. | typ. | max. | unit | |
|---|---------------|-----------|------|------|------|------|---------------------------------------|
| Propagation delay IN \rightarrow \overline{OSY} HIGH to LOW | 5 | t_{PHL} | | 135 | 270 | ns | $C_L = 10$ pF |
| | 10 | | | 45 | 90 | ns | |
| Output transition times HIGH to LOW | 5 | t_{THL} | | 30 | 60 | ns | $C_L = 50$ pF |
| | 10 | | | 12 | 25 | ns | |
| LOW to HIGH | 5 | t_{TLH} | | 45 | 90 | ns | $C_L = 50$ pF |
| | 10 | | | 20 | 40 | ns | |
| Maximum input frequency; IN | 5 | f_{max} | 4 | 8 | | MHz | $\delta = 50\%$ CO_b ratio > 1 |
| | 10 | | 12 | 24 | | MHz | |
| Maximum input frequency; IN | 5 | f_{max} | 2 | 4 | | MHz | $\delta = 50\%$ CO_b ratio = 1 |
| | 10 | | 6 | 12 | | MHz | |
| Maximum input frequency; PC | 5 | f_{max} | 0,15 | 0,3 | | MHz | |
| | 10 | | 0,5 | 1,0 | | MHz | |

| | V_{DD} V | typical formula for P (μ W) | where |
|---|---------------|--|--|
| Dynamic power dissipation per package (P) | 5 | $1\,200 f_i + \Sigma(f_o C_L) \times V_{DD}^2$ | f_i = input freq. (MHz) |
| | 10 | $5\,400 f_i + \Sigma(f_o C_L) \times V_{DD}^2$ | f_o = output freq. (MHz) C_L = load capacitance (pF) $\Sigma(f_o C_L)$ = sum of outputs V_{DD} = supply voltage (V) |

A.C. MOTOR CONTROL CIRCUIT

The HEF4752V is a circuit for a.c. motor speed control utilizing LOCMOS technology. The circuit synthesizes three 120° out of phase signals, of which the average voltage varies sinusoidally with time in the frequency range 0 to 200 Hz. The method employed is based upon the pulse width modulation principle, in order to achieve a sufficient accuracy of the output voltages over the whole frequency range. A pure digital waveform generation is used.

All outputs are of the push-pull type. Inputs and outputs are protected against electrostatic effects in a wide variety of device-handling situations. However, to be totally safe, it is desirable to take handling precautions into account.

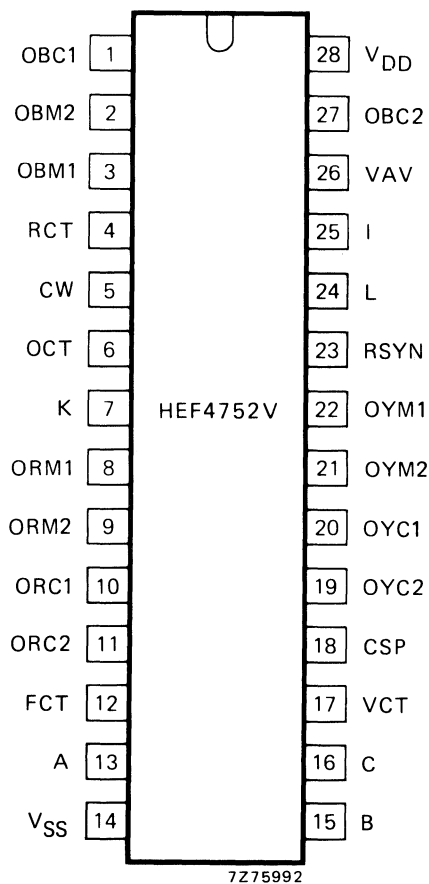

Fig. 1 Pinning diagram.

PINNING

Inputs; group I

24 = L data
 25 = I data
 7 = K data
 5 = CW data
 13 = A data
 15 = B data
 16 = C data

Inputs; group II

12 = FCT frequency clock
 17 = VCT voltage clock
 4 = RCT reference clock
 6 = OCT output delay clock

Outputs; group I

23 = RSYN R-phase synchronization
 26 = VAV average voltage
 18 = CSP current sampling pulses

Outputs; group II

8 = ORM1 R-phase main
 9 = ORM2 R-phase main
 10 = ORC1 R-phase commutation
 11 = ORC2 R-phase commutation
 22 = OYM1 Y-phase main
 21 = OYM2 Y-phase main
 20 = OYC1 Y-phase commutation
 19 = OYC2 Y-phase commutation
 3 = OBM1 B-phase main
 2 = OBM2 B-phase main
 1 = OBC1 B-phase commutation
 27 = OBC2 B-phase commutation

SUPPLY VOLTAGE

| | rating | recommended operating |
|----------|------------|-----------------------|
| HEF4752V | -0,5 to 18 | 4,5 to 12,5 V |

HEF4752VP : 28-lead DIL; plastic (SOT-117).

HEF4752VD : 28-lead DIL; ceramic (cerdip) (SOT-135A). FAMILY DATA see Family Specifications

D.C. CHARACTERISTICS $V_{SS} = 0\text{ V}$

| parameter | V_{DD} V | symbol | T_{amb} (°C) | | | | | | unit | conditions |
|---|---------------|--------------|----------------|------|--------|------|------|------|---------------|--|
| | | | -40 | | +25 | | +85 | | | |
| | | | min. | max. | min. | max. | min. | max. | | |
| Quiescent device current | 5 | I_{DD} | - | 50 | - | 50 | - | 375 | μA | } all valid input combinations; $V_I = V_{SS}$ or V_{DD} |
| | 10 | | - | 100 | - | 100 | - | 750 | | |
| Input leakage current | 10 | $\pm I_{IN}$ | - | - | - | 0,3 | - | 1 | μA | $V_I = 0$ or 10 V |
| Input voltage HIGH | 5 | V_{IH} | 3,5 | - | 3,5 | - | 3,5 | - | V | } inputs: group I |
| | 10 | | 7,0 | - | 7,0 | - | 7,0 | - | V | |
| Input voltage LOW | 5 | V_{IL} | - | 1,5 | - | 1,5 | - | 1,5 | V | } inputs: group I |
| | 10 | | - | 3,0 | - | 3,0 | - | 3,0 | V | |
| Output voltage HIGH | 5 | V_{OH} | 4,95 | - | 4,95 | - | 4,95 | - | V | } $V_I = V_{SS}$ or V_{DD} ; $ I_O \leq 1\ \mu\text{A}$ |
| | 10 | | 9,95 | - | 9,95 | - | 9,95 | - | V | |
| Output voltage LOW | 5 | V_{OL} | - | 0,05 | - | 0,05 | - | 0,05 | V | } $V_I = V_{SS}$ or V_{DD} ; $ I_O < 1\ \mu\text{A}$ |
| | 10 | | - | 0,05 | - | 0,05 | - | 0,05 | V | |
| Input tripping level; input voltage increasing | 5 | V_{ti} | 1,5 | 4,0 | 1,5 | 4,0 | 1,5 | 4,0 | V | } inputs: group II |
| | 10 | | 3,0 | 8,0 | 3,0 | 8,0 | 3,0 | 8,0 | V | |
| Input tripping level; input voltage decreasing | 5 | V_{td} | 1,0 | 3,5 | 1,0 | 3,5 | 1,0 | 3,5 | V | } inputs: group II |
| | 10 | | 2,0 | 7,0 | 2,0 | 7,0 | 2,0 | 7,0 | V | |
| Output current LOW | 5 | I_{OL} | 0,45 | - | 0,38 | - | 0,3 | - | mA | } $V_{OL} = 0,4\text{ V}$ } outputs: groups I $V_{OL} = 0,5\text{ V}$ } and II |
| | 10 | | 1,4 | - | 1,17 | - | 0,9 | - | mA | |
| Output current HIGH | 5 | $-I_{OH}$ | 0,3 | - | 0,25 | - | 0,2 | - | mA | } $V_{OH} = 4,6\text{ V}$ } outputs: group I $V_{OH} = 9,5\text{ V}$ } |
| | 10 | | 0,9 | - | 0,75 | - | 0,6 | - | mA | |
| Output current HIGH | 5 | $-I_{OH}$ | 0,9 | - | 0,75 | - | 0,6 | - | mA | $V_{OH} = 2,5\text{ V}$; outputs: group I |
| Output current HIGH | 5 | $-I_{OH}$ | 0,6 | - | 0,5 | - | 0,4 | - | mA | } $V_{OH} = 4,6\text{ V}$ } outputs: group II $V_{OH} = 9,5\text{ V}$ } |
| | 10 | | 1,8 | - | 1,5 | - | 1,2 | - | mA | |
| Output current HIGH | 5 | $-I_{OH}$ | 1,8 | - | 1,5 | - | 1,2 | - | mA | $V_{OH} = 2,5\text{ V}$; outputs: group II |
| Total supply current | 10 | I_{tot} | - | - | typ. 2 | - | - | - | mA | } $I_{OL} = I_{OH} = 0$; frequency applied to inputs; $F_{CT} = 700\text{ kHz}$; $V_{CT} = 400\text{ kHz}$; $R_{CT} = 400\text{ kHz}$ |

APPLICATION INFORMATION

Figure 2 shows the functional block diagram of a 3-phase a.c. motor speed control system using a thyristorized inverter with variable frequency output. The inverter control signals are generated by the HEF4752V (PWM-IC). A special feature of the PWM (Pulse-Width Modulation) - IC is here, that the motor is supplied by sinoidally modulated pulses, hence the resulting motor current will approach a sine-wave with a minimum on higher harmonics. In this way, an optimum speed drive with high performance is obtained.

Furthermore, the HEF4752V contains all logic circuitry required for this special waveform generation, so that the amount of control circuit components is reduced considerable. The speed drive system in Fig. 2 is controlled by the analogue control section.

The FCT and VCT clock pulse oscillators are driven in such a way, that a fast response speed control of the a.c. motor is obtained, depending on: the reference values for speed; motor voltage; motor current (Limited by the measured motor current via DCCT - d.c. current transformer -); the increasing value of V_{Cb} during braking action.

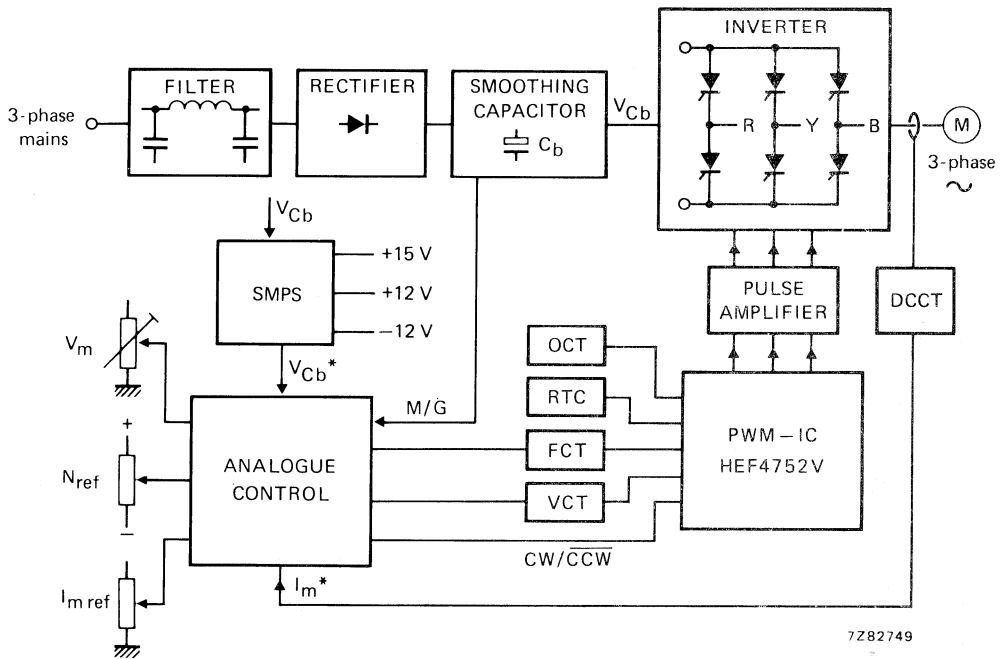

7Z82749

Fig. 2 PWM motor speed control system using HEF4752V.

MORE APPLICATION INFORMATION SUPPLIED ON REQUEST

UNIVERSAL TIMER MODULE

The HEF4753B is a universal timer module for counting and dividing as well as for event-recognition and manipulation of input sequences.

The following functions are included: synchronization and edge-detection of the input signal, programmable counter, clock divider with different lengths, operating mode decoder, control logic and output multiplexer.

Depending on the operating mode and the application, the circuit works as a presetable 8-bit counter with transient-pulse suppression, pulse duration selector divider, counter, positive or negative edge delaying module or low-frequency control circuit.

All manipulation possibilities depend on a time scaling, which is adjustable by the 8-bit programmable counter and the system clock. The system clock can be divided internally by 1, 16, 256 or 4096 as input clock for the counter. In all cases the manipulated input sequence appears at the only output OUT.

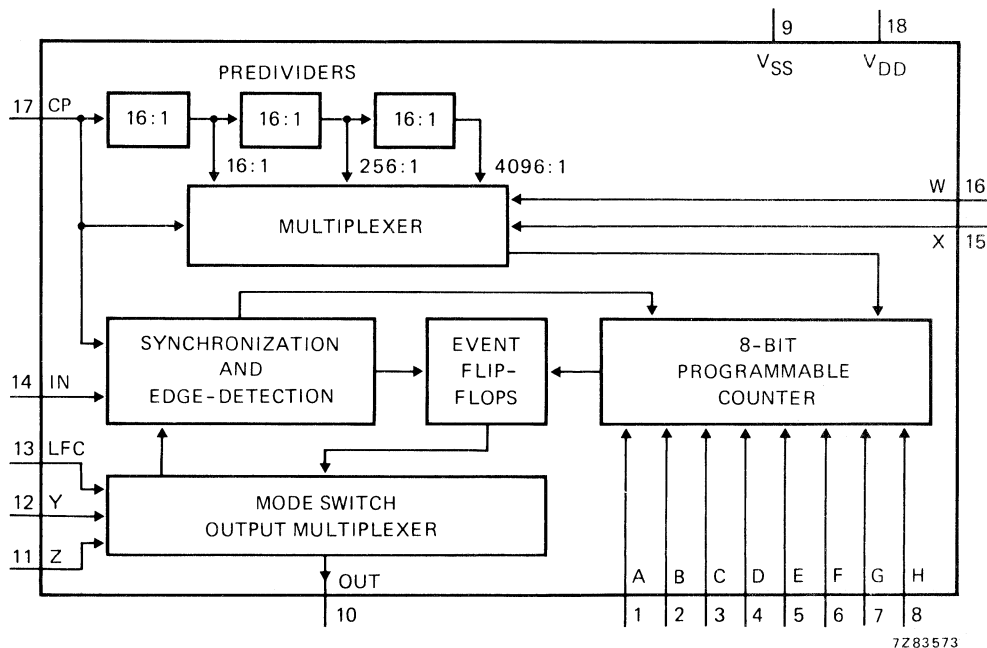

Fig. 1 Functional diagram.

FAMILY DATA

I_{DD} LIMITS category LSI

} see Family Specifications

HEF4753B

LSI

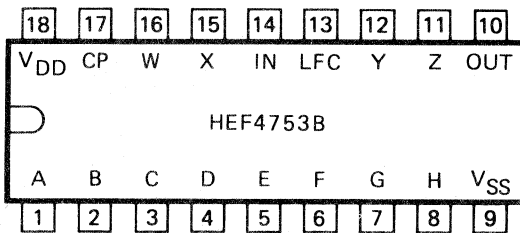

7Z83563

HEF4753BP: 18-lead DIL; plastic (SOT-102).

HEF4753BD: 18-lead DIL; ceramic (cerdip) (SOT-133).

Fig. 2 Pinning diagram.

FUNCTION TABLES

| inputs | | | operating mode |
|--------|---|---|---------------------------------|
| LFC | Y | Z | |
| L | L | H | counter |
| L | H | L | divider |
| H | H | L | delayed LOW to HIGH edge |
| H | L | H | delayed HIGH to LOW edge |
| H | H | H | transient pulse suppression |
| L | H | H | frequency recognition |
| LFC | L | L | digital pulse duration selector |

H = HIGH state (the more positive voltage).

L = LOW state (the less positive voltage).

Programmable 8-bit counter *

| inputs active LOW | value |
|-------------------|-------|
| A | 1 |
| B | 2 |
| C | 4 |
| D | 8 |
| E | 16 |
| F | 32 |
| G | 64 |
| H | 128 |

12-bit predivider

| W | X | clock for programmable counter CP/X |
|---|---|-------------------------------------|
| L | L | X = 1 |
| L | H | X = 16 |
| H | L | X = 256 |
| H | H | X = 4096 |

* All inputs A to H HIGH is not allowed.

FUNCTIONAL DESCRIPTION

Clock divider and decoder

The clock signal at input CP is, at its original frequency, the system clock, but it also drives the programmable counter. The counter input frequency can be predivided by the factors 1/16, 1/256 and 1/4096, depending on the logic state of inputs W and X (according to the function tables above).

8-bit programmable counter

The 8 inputs A to H are the set inputs of the 8 counter flip-flops. The setting is triggered by an edge of the input signal (at input IN) depending on of the chosen mode.

Event flip-flops, synchronization and edge-detection

The event flip-flops are used to recognize the positive and/or negative edge of the input signal at IN. Parts of the flip-flops are used together with the programmable 8-bit counter as a retriggerable mono-flop, which defines the time scaling for event recognition. The input IN is synchronized by the clock signal CP.

Mode switch and output multiplexer

This function switches the chosen output to the output (OUT) and gives the mode of which the edge at input IN has to be detected. The inputs Z, Y and LFC give 7 modes +1, that means in mode 'Digital Filter' the input LFC can be HIGH or LOW.

OPERATING MODES

The circuit has 6 operating modes which are activated by the logic state of inputs LFC, Y and Z. An extra mode is possible by using two circuits which are connected such so they function as a digital band-filter.

1. Counter mode (LFC = LOW; Y = LOW; Z = HIGH)

In this mode the output OUT should be connected to input IN. If not, only one counter cycle starts after a transition at input IN (see Fig. 3 and note 1).

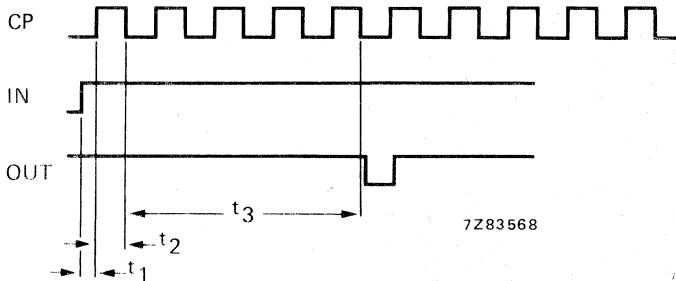
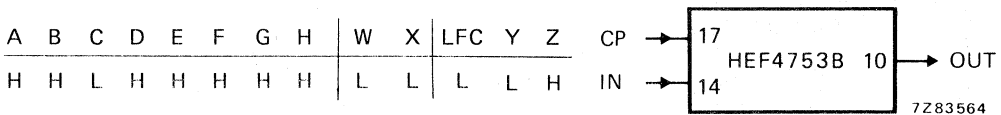

Fig. 3 Timing diagram for counter mode; t_1 = delay until set of 8-bit counter; t_2 = delay to set 8-bit counter; t_3 = predefined delay by programming.

OPERATING MODES (continued)

2. Divider mode (LFC = LOW; Y = HIGH; Z = LOW)

In this mode the output OUT should be connected to input IN. If not, only one counter cycle starts after a transition at input IN (see Fig. 4 and note 1).

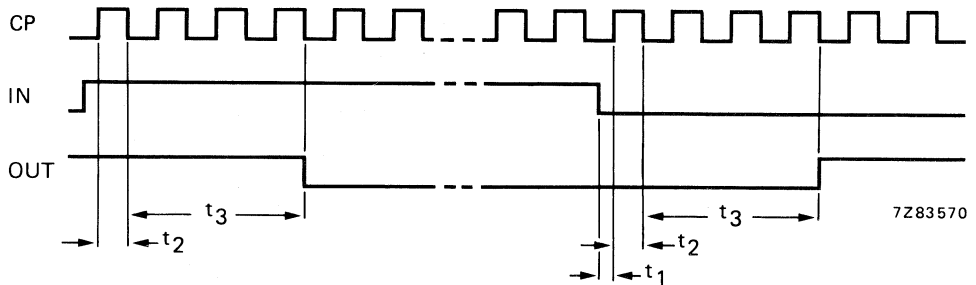
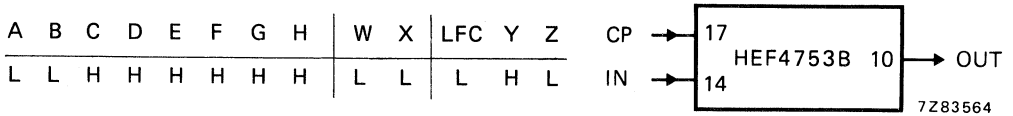

Fig. 4 Timing diagram for divider mode; t_1 = delay until set of 8-bit counter; t_2 , t_3 see Fig. 3.

3. Delayed LOW to HIGH edge mode; see note 2 (LFC = HIGH; Y = HIGH; Z = LOW)

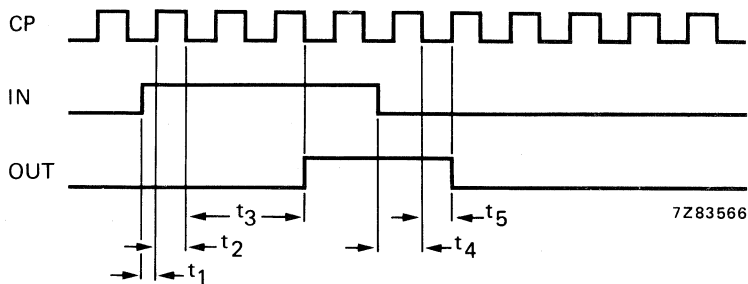
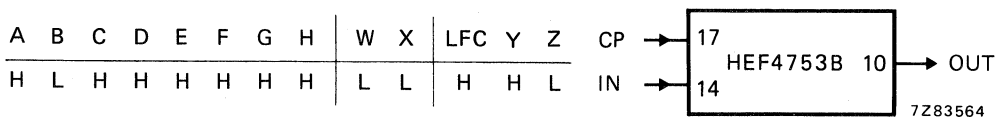

Fig. 5 Timing diagram for delayed LOW to HIGH edge mode; t_1 = delay until set of 8-bit counter; t_2 = delay to set 8-bit counter; t_3 = predefined delay by programming; t_4 = delay until next negative clock edge; t_5 = delay until next positive clock edge.

4. Delayed HIGH to LOW edge mode; see note 2 (LFC = HIGH; Y = LOW; Z = HIGH)

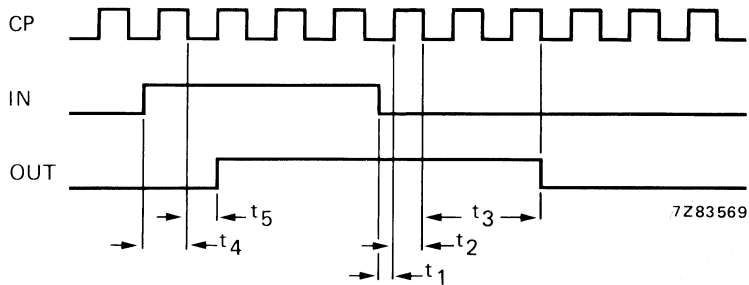
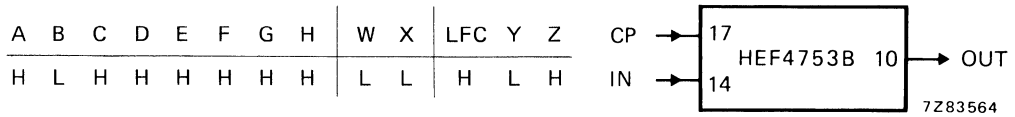

Fig. 6 Timing diagram for delayed HIGH to LOW edge mode; for t_1 to t_5 see Fig. 5.

5. Transient pulse suppression and pulse delaying mode; see note 2 (LFC = Y = Z = HIGH)

In this mode the circuit is working as a digital low-pass filter. An undisturbed pulse will only be delayed (see Fig. 7).

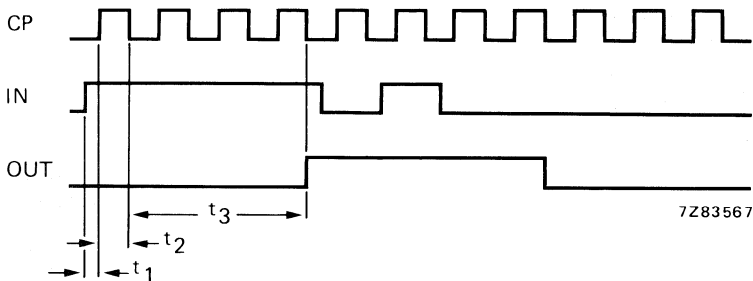
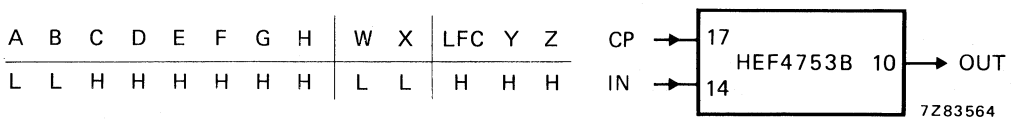
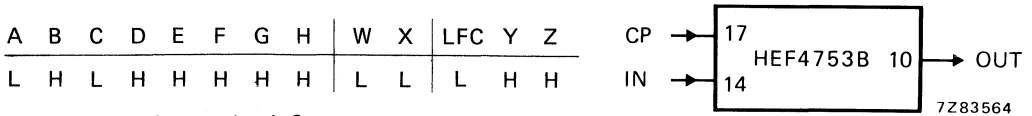

Fig. 7 Timing diagram for transient pulse suppression and pulse delaying mode; for t_1 , t_2 and t_3 see Fig. 5.

OPERATING MODES (continued)

6. Frequency recognition mode (LFC = LOW; Y = HIGH; Z = HIGH)

The incoming signal must be symmetrical within the limits as given by the specified delay time in note 2, to achieve lower or higher frequency detection (see Fig. 8).



Minimum dividing number is 3.

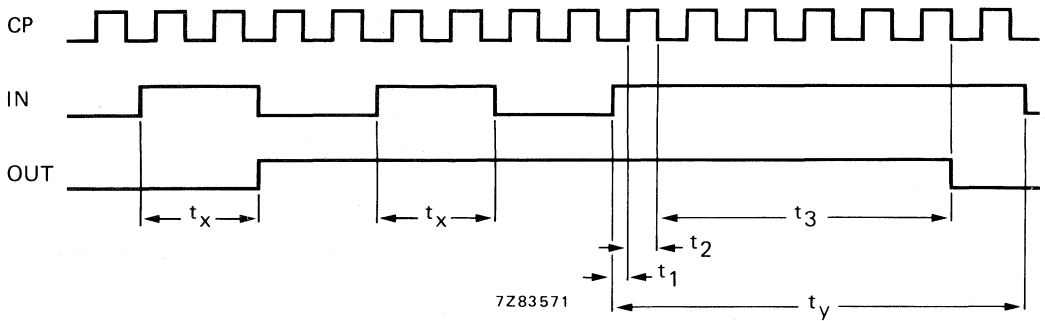

Fig. 8 Timing diagram for frequency recognition mode; t_x = time shorter than t_3 (OUT = H); t_y = time greater than t_3 (OUT = L); for t_1 , t_2 and t_3 see Fig. 5.

7. Digital pulse duration selector mode (Y = Z = LOW)

This mode is a combination of two circuits, both used for frequency recognition. Both circuits are driven by the same clock and same input signal, but programmed for different frequencies. The LFC input of the low-frequency circuit is set to logic LOW, the output is connected to the LFC input of the high-frequency circuit, whose output (OUT) is the 'filter' output. The delay time depends on the same facts as given in note 2. For timing diagram see Fig. 9.

| | | | | | | | | | | | | | |
|---|---|---|---|---|---|---|---|---|---|-----------|---|---|-----|
| A | B | C | D | E | F | G | H | W | X | LFC | Y | Z | |
| L | L | L | H | H | H | H | H | L | L | L | H | H | IC1 |
| L | L | H | H | H | H | H | H | L | L | OUT (IC1) | L | L | IC2 |

Minimum dividing number is 3.

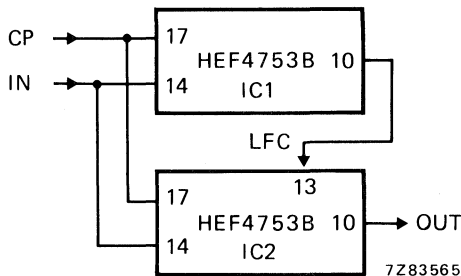

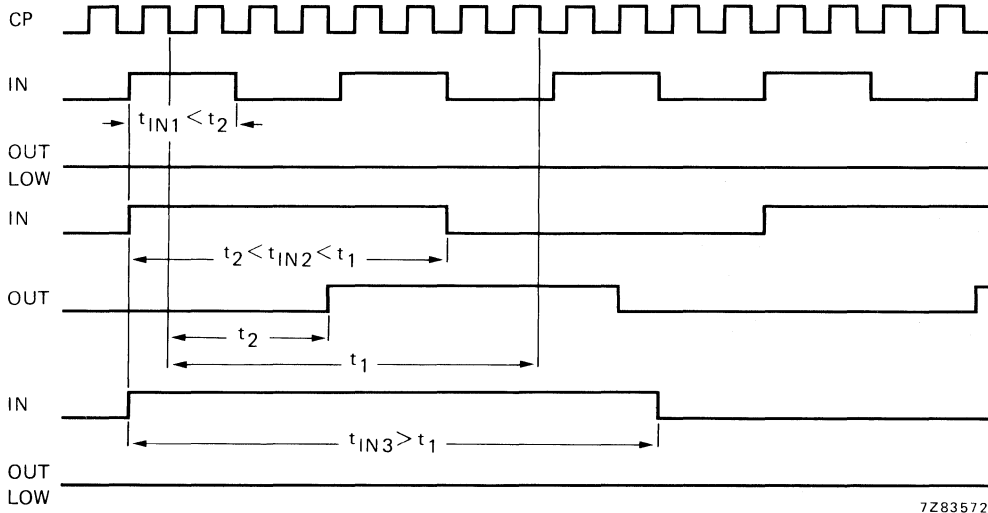

7Z83572

Fig. 9 Timing diagram for digital pulse duration selector mode; t_{IN1} , t_{IN2} and t_{IN3} are the IN input pulse durations; t_1 = predefined delay by programming IC1; t_2 = predefined delay by programming IC2.

Notes to operating modes

1. The number of clocks for one cycle in the counter and divider mode is:
 - a. Contents of programmable counter plus one if X = W = LOW.
 - b. Contents of programmable counter multiplied by 16, 256 or 4096 if X and/or W = HIGH.
2. The delay in the modes 3, 4, 6 and 7, and the delay which is identical to the maximum duration of the transient pulse in mode 5 depend on the optional divided clock frequency, the input conditions of the 8-bit presetable counter and in addition, different times of propagation delays, jitter and maximum one half of a clock frequency period.

HEF4753B

LSI

D.C. CHARACTERISTICS

$V_{SS} = 0\text{ V}$

| | V_{DD} V | V_{OH} V | V_{OL} V | symbol | T_{amb} (°C) | | | |
|---|---------------|---------------|---------------|-----------|------------------|------------------|------------------|----|
| | | | | | -40 min. max. | +25 min. max. | +85 min. max. | |
| Output (sink) current LOW (pin 10) | 4,75 | | 0,4 | I_{OL} | 2,7 | 2,3 | 1,8 | mA |
| | 10 | | 0,5 | | 9,5 | 8,0 | 6,3 | |
| | 15 | | 1,5 | | 24,0 | 20,0 | 16,0 | |
| Output (source) current HIGH (pin 10) | 5 | 4,6 | | $-I_{OH}$ | 0,6 | 0,5 | 0,4 | mA |
| | 10 | 9,5 | | | 1,8 | 1,5 | 1,2 | |
| | 15 | 13,5 | | | 6,0 | 5,0 | 4,0 | |

A.C. CHARACTERISTICS

$V_{SS} = 0\text{ V}$; $T_{amb} = 25\text{ °C}$; $C_L = 50\text{ pF}$; input transition times $\leq 20\text{ ns}$

| | V_{DD} V | symbol | min. | typ. | max. | typical extrapolation formula |
|---|---------------|------------|------|----------|------|----------------------------------|
| Propagation delays CP \rightarrow OUT HIGH to LOW | 5 | t_{PHL} | | 420 | 850 | ns |
| | 10 | | | 180 | 360 | ns |
| | 15 | | | 120 | 250 | ns |
| LOW to HIGH | 5 | t_{PLH} | | 450 | 900 | ns |
| | 10 | | | 200 | 400 | ns |
| | 15 | | | 140 | 280 | ns |
| Output transition times HIGH to LOW | 5 | t_{THL} | | 30 | 60 | ns |
| | 10 | | | 15 | 30 | ns |
| | 15 | | | 10 | 20 | ns |
| LOW to HIGH | 5 | t_{TLH} | | 60 | 120 | ns |
| | 10 | | | 30 | 60 | ns |
| | 15 | | | 20 | 40 | ns |
| Input rise and fall times pins 13, 14, 17 | 5 | t_r, t_f | } | no limit | | |
| | 10 | | | | | |
| | 15 | | | | | |
| Maximum clock pulse frequency pin 17; $\delta = 50\%$ | 5 | f_{max} | 3 | 6 | | MHz |
| | 10 | | 7 | 14 | | MHz |
| | 15 | | 8 | 17 | | MHz |

| | V_{DD} V | typical formula for P (μ W) | where |
|---|---------------|--|-------------------------------------|
| Dynamic power dissipation per package (P) | 5 | $1\,800 f_i + \Sigma (f_o C_L) \times V_{DD}^2$ | f_i = input freq. (MHz) |
| | 10 | $8\,000 f_i + \Sigma (f_o C_L) \times V_{DD}^2$ | f_o = output freq. (MHz) |
| | 15 | $19\,000 f_i + \Sigma (f_o C_L) \times V_{DD}^2$ | C_L = load capacitance (pF) |
| | | | $\Sigma (f_o C_L)$ = sum of outputs |
| | | | V_{DD} = supply voltage (V) |

18-ELEMENT BAR GRAPH LCD DRIVER

The HEF4754V drives an 18-element bar graph LCD in linear relation to the control voltage (V_c) in a pointer or thermometer mode.

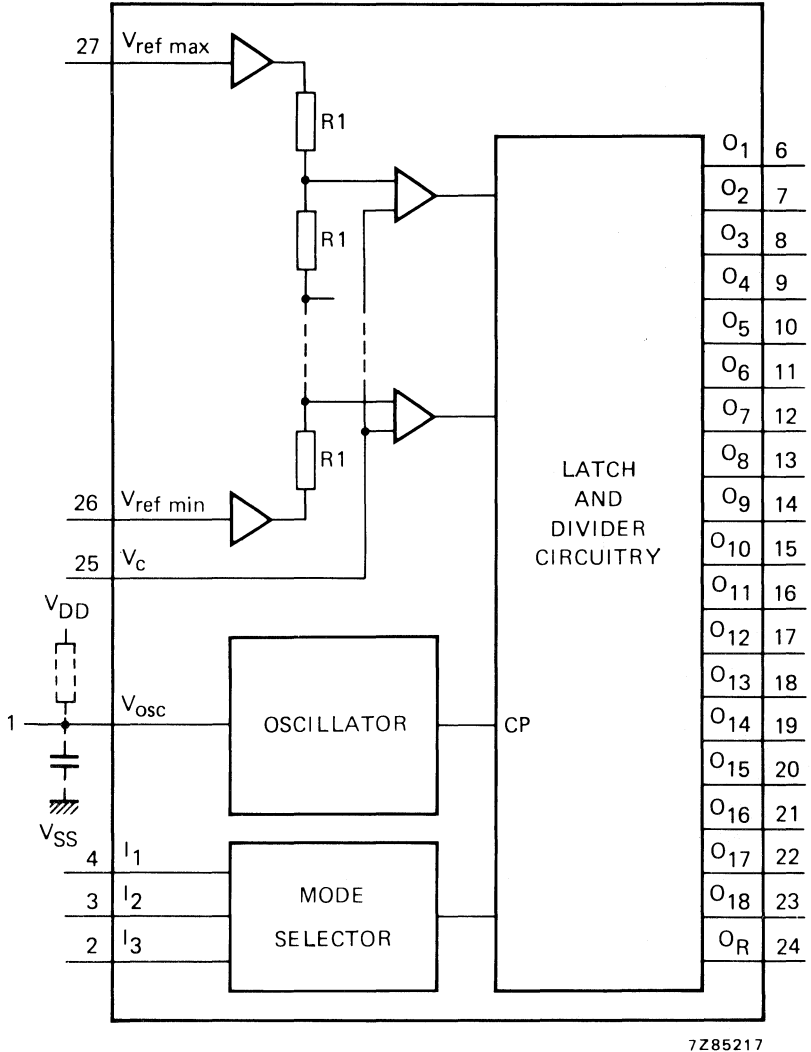

7Z85217

Fig. 1 Functional diagram.

FAMILY DATA see Family Specifications

HEF4754V

LSI

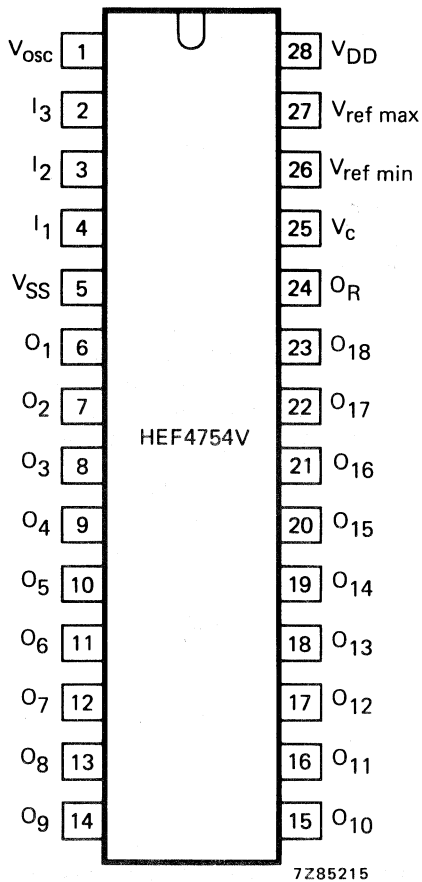

PINNING

- V_{osc} oscillator terminal
- V_c control voltage input
- $V_{ref\ min}$ } reference voltage inputs
- $V_{ref\ max}$ }
- I_1 thermometer/pointer (choice select input)
- I_2 peak value; reset/9 or 18 bars (choice select input)
- I_3 reset; repetitively reset (choice select input)
- O_1 to O_{18} bar outputs
- O_R back plate output

HEF4754VP : 28-lead DIL; plastic (SOT-117).
 HEF4754VD: 28-lead DIL; ceramic (cerdip) SOT-135A).
 HEF4754VT: 28-lead mini-pack; plastic (SO-28; SOT-136A).

Fig. 2 Pinning diagram.

FUNCTION TABLE

| I_1 | I_2 | I_3 | mode |
|-------|-------|-------|---|
| L | L | X | pointer; 18 bars |
| L | H | X | pointer; 9 bars |
| H | L | X | thermometer; no peak value |
| H | H | L | thermometer; peak value, repetitively reset |
| H | H | H | thermometer; peak value, manually reset |

H = HIGH state (the more positive voltage)

L = LOW state (the less positive voltage)

X = state is immaterial

GENERAL DESCRIPTION

The HEF4754V drives an 18-element bar graph LCD in linear relation to the control voltage (V_C) in a pointer or thermometer mode. The first bar lights up when V_C is smaller than $V_{T(\text{bar})2}$ (see equation [3] below).

In the pointer mode, the circuit can drive 9 or 18 bars; in the thermometer mode, the circuit also drives the peak value indication. This can be reset or repetitively reset, after 1,5 to 2 seconds.

The circuit has analogue and digital parts. The analogue part consists of 17 comparators, with their non-inverting inputs connected together and coupled to the control input V_C . The inverting inputs of the comparators are connected in succession to the nodes of an 18-part resistor divider. The distance between the switching levels of the comparators is defined by the voltage difference across this divider. The extremities of the resistor divider are coupled via high-input amplifiers to the maximum reference voltage input and the minimum reference voltage input.

The digital part has one reference output (O_R) to drive the back plate, and 18 outputs (O_1 to O_{18}) to drive each bar. Three latches and some gates are incorporated for each bar output. An on-chip oscillator (1024 Hz) with external R and C drives the circuit. The outputs are driven at 64 Hz. The select inputs I_1 to I_3 are provided with an on-chip pull-up element, and they may therefore be left floating (equals HIGH state).

LINEARITY

$V_{DD} = 10 \text{ V}$; $V_{\text{ref max}} = 9,5 \text{ V}$; $V_{\text{ref min}} = 0,5 \text{ V}$; $T_{\text{amb}} = 25 \text{ }^\circ\text{C}$

$\Delta V_1 = 250 \text{ mV}$ (this is the tolerance of the step voltage).

$$V_{\text{step}} = V_{\text{step}'} + \Delta V_1 \quad [1]$$

$V_{\text{step}'}$ is the (internal) voltage drop across the resistor-ladder network.

$$V_{\text{step}'} = \frac{(V_{\text{ref max}} \pm \Delta V_2) - (V_{\text{ref min}} \pm \Delta V_2)}{18} \quad [2]$$

ΔV_2 is the maximum offset voltage spread of the on-chip voltage follower.

$\Delta V_2 = 250 \text{ mV}$.

The linearity is guaranteed for $V_{DD} > 10 \text{ V}$.

The monotony between $V_{DD} = 5 \text{ V}$ and 10 V is guaranteed. During ramping-up of the input voltage a maximum of two bars might be activated simultaneously.

ABSOLUTE VOLTAGE TRIGGER LEVEL

The absolute voltage trigger level at the V_C pin is $V_{T(\text{bar})n}$;

$$V_{T(\text{bar})n} = (V_{\text{ref min}} \pm \Delta V_2^*) + \{ (n-1) V_{\text{step}'} \pm \Delta V_1 \}, \text{ in which} \quad [3]$$

$n = \text{number of bars}; 2 \leq n \leq 18$.

For $n = 1$ (first bar) see text above.

* For ΔV_2 the same sign (+ or -) should be used as in equation [2].

HEF4754V

LSI

RATINGS

Limiting values in accordance with the Absolute Maximum System (IEC 134)

| | | |
|---------------------------------------|-----------|--------------------------|
| Supply voltage | V_{DD} | -0,5 to + 18 V |
| Voltage on any input | V_I | -0,5 to $V_{DD} + 0,5$ V |
| D.C. current into any input or output | $\pm I_I$ | max. 10 mA |
| Storage temperature | T_{stg} | -25 to + 125 °C |
| Operating ambient temperature | T_{amb} | -20 to + 85 °C |

NOTES (to D.C. CHARACTERISTICS)

- $V_{ref\ min} = 0,5$ V; $V_{ref\ max} = 9,5$ V; $V_{osc} = V_c = 0$ V; I_1 , I_2 and I_3 at V_{DD} .
- Pin under test at V_{SS} or V_{DD} , all other inputs simultaneously at V_{SS} or V_{DD} .
- $I_O = 0$; all inputs at V_{SS} or V_{DD} .
- At $V_{DD} = 5$ V: $V_{OH} = 4,5$ V.
At $V_{DD} = 10$ V: $V_{OH} = 9,5$ V.
At $V_{DD} = 15$ V: $V_{OH} = 13,5$ V.
- At $V_{DD} = 5$ V: $V_{OL} = 0,4$ V; inputs at V_{SS} or V_{DD} .
At $V_{DD} = 10$ V: $V_{OL} = 0,5$ V; inputs at V_{SS} or V_{DD} .
At $V_{DD} = 15$ V: $V_{OL} = 1,5$ V; inputs at V_{SS} or V_{DD} .
- $V_{ref\ min} + 4$ V < $V_{ref\ max}$.

D.C. CHARACTERISTICS

 $V_{SS} = 0\text{ V}$

| | V_{DD} V | symbol | T_{amb} (°C) | | | | | | notes | | |
|--|---------------|--------------|----------------|------|-------|------|------|------|---------------|--------|---------------|
| | | | -40 | | + 25 | | + 85 | | | | |
| | | | min. | max. | min. | typ. | max. | min. | | max. | |
| Quiescent device current | 5 | I_{DD} | - | - | - | - | - | - | μA | 1 | |
| | 10 | | - | - | - | - | 1000 | - | - | | μA |
| | 15 | | - | - | - | - | 1600 | - | - | | μA |
| Input leakage current (except select inputs) | 5 | $\pm I_{IN}$ | - | - | - | - | 100 | - | - | 2 | |
| | 10 | | - | - | - | - | 100 | - | - | | nA |
| | 15 | | - | - | - | - | 100 | - | - | | nA |
| Input voltage HIGH select inputs | 5 | V_{IH} | 3,5 | - | 3,5 | - | - | 3,5 | - | V | |
| | 10 | | 7,0 | - | 7,0 | - | - | 7,0 | - | | V |
| | 15 | | 11,0 | - | 11,0 | - | - | 11,0 | - | | V |
| Input voltage LOW select inputs | 5 | V_{IL} | - | 1,5 | - | - | 1,5 | - | 1,5 | V | |
| | 10 | | - | 3,0 | - | - | 3,0 | - | 3,0 | | V |
| | 15 | | - | 4,0 | - | - | 4,0 | - | 4,0 | | V |
| Output voltage HIGH | 5 | V_{OH} | 4,99 | - | 4,99 | - | - | 4,95 | - | V | |
| | 10 | | 9,99 | - | 9,99 | - | - | 9,95 | - | | V |
| | 15 | | - | - | 14,99 | - | - | - | - | | V |
| Output voltage LOW | 5 | V_{OL} | - | 0,01 | - | - | 0,01 | - | 0,05 | V | |
| | 10 | | - | 0,01 | - | - | 0,01 | - | 0,05 | | V |
| | 15 | | - | 0,01 | - | - | 0,01 | - | 0,05 | | V |
| Output current HIGH | 5 | $-I_{OH}$ | 0,36 | - | 0,3 | - | - | 0,24 | - | mA | |
| | 10 | | 0,80 | - | 0,7 | - | - | 0,56 | - | | mA |
| | 15 | | 3,0 | - | 2,8 | - | - | 2,60 | - | | mA |
| Output current LOW | 5 | I_{OL} | 0,34 | - | 0,3 | - | - | 0,24 | - | mA | |
| | 10 | | 1,00 | - | 0,9 | - | - | 0,72 | - | | mA |
| | 15 | | 4,40 | - | 4,0 | - | - | 3,20 | - | | mA |
| Input voltage control input V_C | 5 | V_{IC} | - | - | 0 | - | 5 | - | - | V | |
| | 10 | | - | - | 0 | - | 10 | - | - | | V |
| | 15 | | - | - | 0 | - | 15 | - | - | | V |
| Max. input voltage $V_{ref\ max}$ input | 5 | V_{IRmax} | - | - | 4,5 | - | 4,5 | - | - | V | |
| | 10 | | - | - | 4,5 | - | 9,5 | - | - | | V |
| | 15 | | - | - | 4,5 | - | 14,5 | - | - | | V |
| Min. input voltage $V_{ref\ min}$ input | 5 | V_{IRmin} | - | - | 0,5 | - | 0,5 | - | - | V | |
| | 10 | | - | - | 0,5 | - | 5,5 | - | - | | V |
| | 15 | | - | - | 0,5 | - | 10,5 | - | - | | V |
| Operating supply current | 10 | I_{DD} | - | - | - | 750 | - | - | μA | Fig. 3 | |

For notes see opposite page.

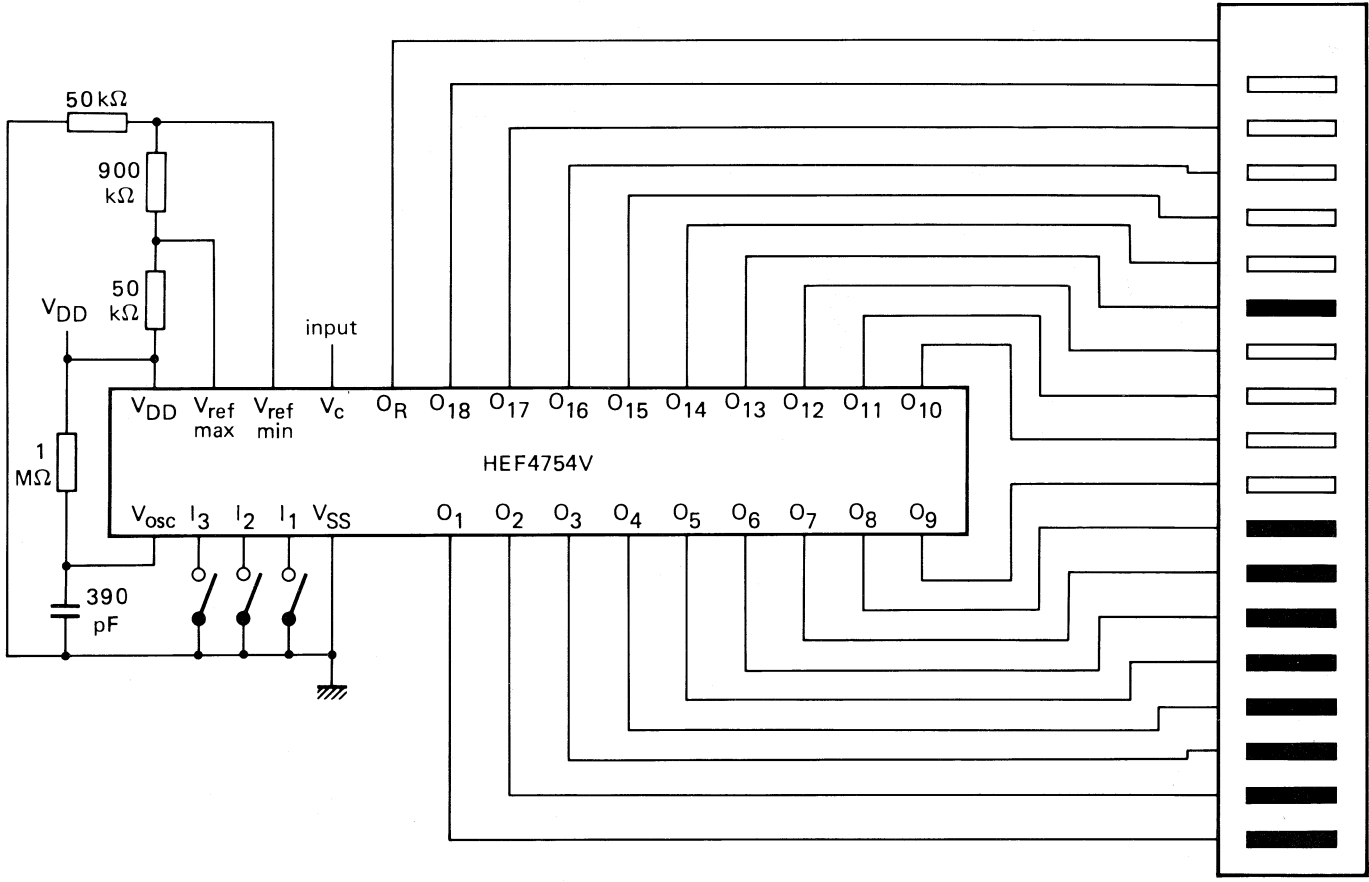

Fig. 3 Typical operating set-up.

7285216

DEVELOPMENT SAMPLE DATA

This information is derived from development samples made available for evaluation. It does not necessarily imply that the device will go into regular production.

HEF4755V
LSI

TRANSCEIVER FOR SERIAL DATA COMMUNICATION

The HEF4755V transceiver is a circuit for serial data communication. It provides maximum transmission security and effectiveness. Therefore, in addition to the normal precautions, it contains a programmable digital bit-check, a programmable CRC (Cyclic Redundancy Check; Hamming distance 4 or 6) and format protection.

The circuit has 8 possible operating modes:

- synchronous
 - error checking only
 - receiving
 - transmitting
 - receiving with data out and transmitting the same message
- asynchronous
 - error checking only
 - receiving
 - transmitting
 - receiving with data out and transmitting of a regenerated message.

FEATURES

| | | | |
|----------------------|----------|-------------|--------------|
| ● Transmission rate: | V_{DD} | synchronous | asynchronous |
| | 5 V | 0,8 Mbaud | 31 kbaud |
| | 7 V | 1,6 Mbaud | 62 kbaud |
| | 10 V | 3,2 Mbaud | 125 kbaud |

- Inputs: standard LOC MOS
- Outputs: TTL compatible (1 TTL load)
- Operating ambient temperature range: -40 to $+85$ °C
- Transmit or receive a serial binary data stream
- Start bit generation and recognition
- Format protection and checking
- Redundancy byte generation and checking
- Digital bit check
- Error recognition and error distinguishing
- 8-bit parallel input/output transfer

SUPPLY VOLTAGE/CURRENT

| | | |
|----------|-----------------|--------------------------|
| | rating | recommended operating |
| V_{DD} | $-0,5$ to $+15$ | $4,75$ to $12,6$ V |
| I_{SS} | 30 | – mA |

FAMILY DATA

I_{DD} LIMITS category LSI

} see Family Specification

HEF4755V

LSI

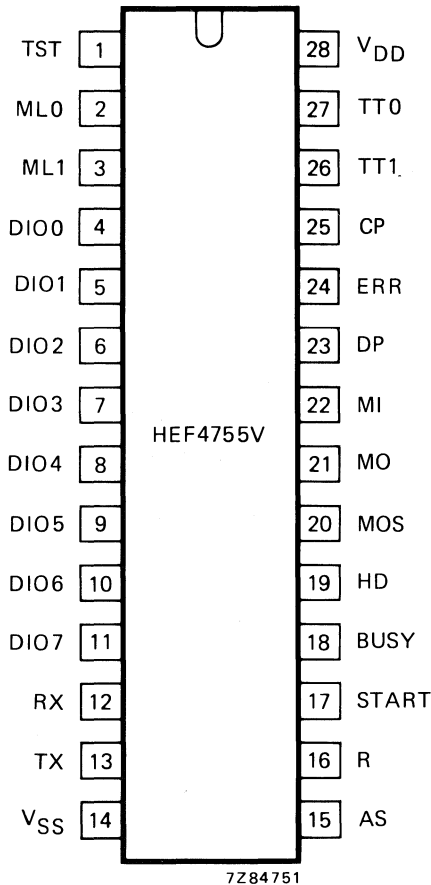

PINNING

| | | |
|----|-----------------|--|
| 1 | TST | Test pin; during normal use connected to V _{SS} . When TST is HIGH (V _{DD}), internal check points are connected to the data bus. |
| 2 | ML0 | Input code for message length (see Table 1). |
| 3 | ML1 | |
| 4 | DIO0 | Bidirectional data bus. |
| to | to | |
| 11 | DIO7 | |
| 12 | RX | |
| 13 | TX | Mode input: transmit |
| 15 | AS | Mode input: asynchronous |
| 16 | R | Reset; a positive signal resets all internal registers. |
| 17 | START | Input start in transmitting mode; synchronization input (from MOS) in synchronous receiving mode. |
| 18 | BUSY | Output busy; active during receiving or transmitting a message. |
| 19 | HD | Hamming distance; determines the length of the redundancy byte: LOW = 7 bit (HD = 4) HIGH = 15 bit (HD = 6) |
| 20 | MOS | Output message synchronization used in synchronous mode. |
| 21 | MO | Message output. |
| 22 | MI | Message input. |
| 23 | DP | Output data pulse; take-over pulse for data on the data bus. |
| 24 | ERR | Output error; an active output means that at least 1 transmission error is recognized. |
| 25 | CP | Clock input; in synchronous mode equal to the transmission bit rate. |
| 26 | TT1 | Programming of the permissible time tolerance in bit distortion (see Table 3). |
| 27 | TT0 | |
| 28 | V _{DD} | Positive supply voltage; 4,5 V to 12,5 V (is the logic HIGH level). |
| 14 | V _{SS} | Ground (is the logic LOW level). |

Fig. 1 Pinning diagram.

- HEF4755VP: 28-lead DIL; plastic (SOT-117).
- HEF4755VD: 28-lead DIL; ceramic (cerdip) (SOT-135).
- HEF4755VT: 28-lead mini-pack; plastic (SO-28; SOT-136A).

Table 1 Input code for message length

| ML0 | ML1 | message length |
|-----|-----|--|
| H | H | 6 data bytes |
| L | H | 4 data bytes |
| H | L | 2 data bytes |
| L | L | variable length depends on format byte |

Table 2 Input code for input mode

| RX | TX | AS | |
|----|----|----|--|
| L | L | L | status register connected to the data bus for error recognition |
| H | L | L | receiving in synchronous mode |
| L | H | L | transmitting in synchronous mode |
| H | H | L | receiving messages (without redundancy bit); data parallel out; calculating of redundancy byte; transmitting data with redundancy byte in synchronous mode |
| L | L | H | only bit check in asynchronous mode; no data output on data bus |
| H | L | H | receiving in asynchronous mode |
| L | H | H | transmitting in asynchronous mode |
| H | H | H | receiving and transmitting of a regenerated message in the asynchronous mode |

Table 3 Permissible time tolerance in bit distortion

| TT1 | TT0 | permitted distortion (dt/T) |
|-----|-----|-----------------------------|
| L | L | $6/32 \approx 19\%$ |
| L | H | $8/32 = 25\%$ |
| H | L | $10/32 \approx 31\%$ |
| H | H | $12/32 \approx 37\%$ |

H = HIGH state (the most positive voltage)

L = LOW state (the least positive voltage)

HEF4755V

LSI

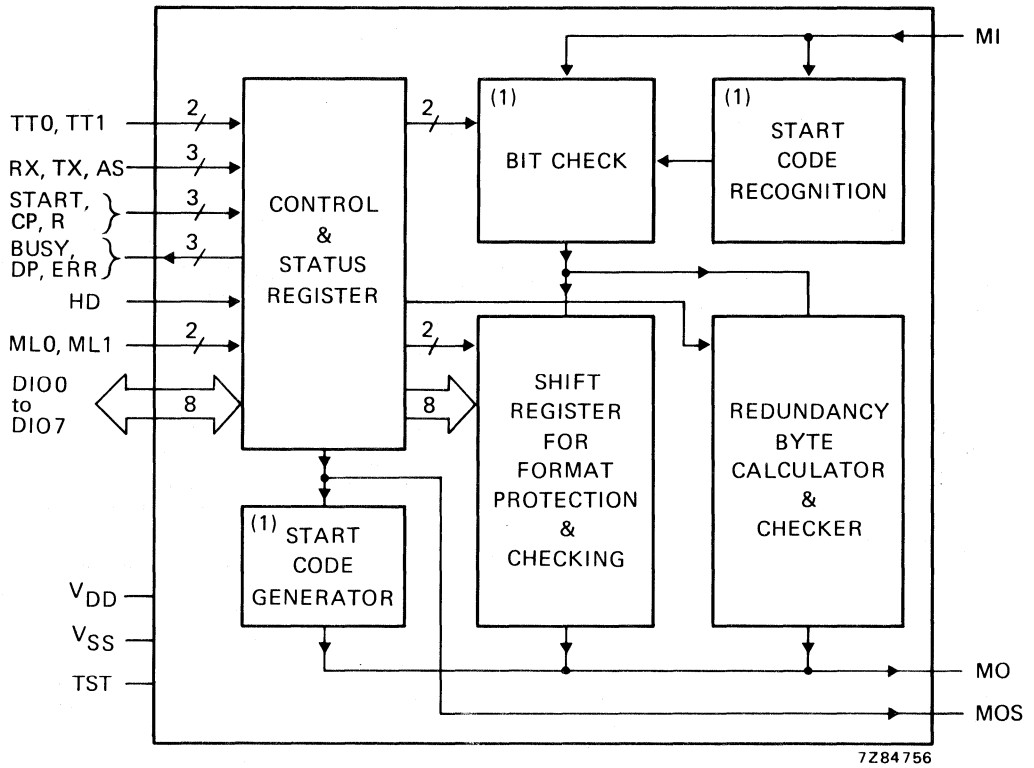

(1) Only used in the asynchronous mode.

Fig. 2 Block diagram.

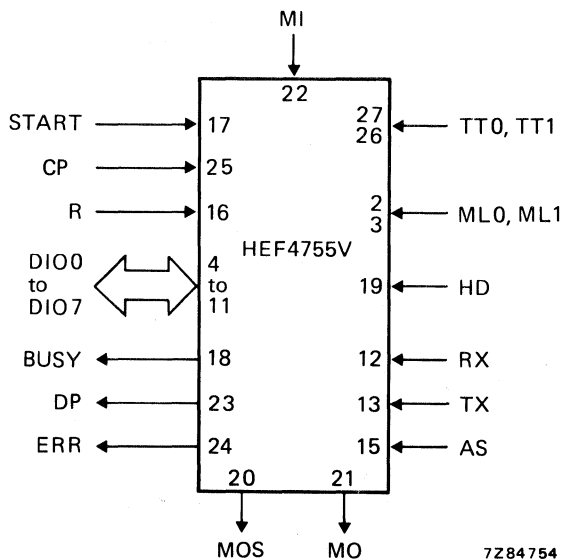

Fig. 3 Functional diagram.

7284754

FUNCTIONAL DESCRIPTION

General

The HEF4755V is used for protected-bit serial data communication. This protection makes it necessary to subdivide the serial data stream into data blocks called messages.

Messages

In the synchronous mode the HEF4755V will transmit or receive a message as follows:

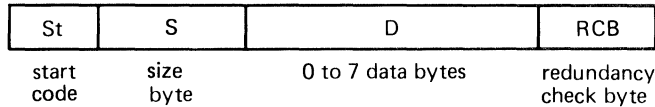

7Z84753

The first bit of a transmitted message is the start-bit which cannot be mis interpreted. It instructs the receiver, that information transfer has started and it defines the time-window for the following bits. The start-bit is only necessary in the asynchronous mode and it is omitted in the synchronous mode. The first byte contains the number of data bytes that will follow. This byte is checked by the receiver and if a discrepancy is found, the receiver reports a code-error. This first byte is called 'size'. The number of data bytes can also be fixed by wiring of the transmitter as well as the receiver. In this case the size byte is omitted. There is no protocol on the information of the data bytes, so the maximum number of informations per message is $2^{56} \approx 10^{17}$. The redundancy check byte secures the data bytes against transmission errors. This byte is calculated in parallel to the data stream and it is send as last byte by the transmitter. The receiver calculates its own redundancy byte and compares it with the received one. If there is a discrepancy, the receiver reports a code error.

Code protection

Size

The coding of the size byte is as follows:

$$\begin{aligned}
 \left. \begin{aligned}
 \text{DIO0} &= C \\
 \text{DIO1} &= B \\
 \text{DIO2} &= A \\
 \text{DIO3} &= P
 \end{aligned} \right\} n = C \cdot 2^2 + B \cdot 2^1 + A \cdot 2^0 \\
 &= \overline{C \oplus B \oplus A}
 \end{aligned}$$

The information is transmitted as follows:

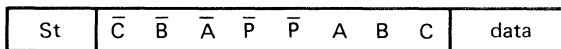

7Z84752

With this, a hamming distance of 4 is obtained.

DEVELOPMENT SAMPLE DATA

FUNCTIONAL DESCRIPTION (continued)*Redundancy byte*

The redundancy byte completes the data bytes with 15 (7) bits as a code word. If only one bit in the information has changed during the transmission, the two code words will differ by at least 6 (4) bit positions. So a change of up to 5 (3) bits will always be observed, even every odd number of false bits will be recognized. The HEF4755V has a programmable redundancy bit calculator which carries out this protection (the numbers given in parentheses are valid for the alternative possibility).

If the transmission line carries extreme noise, this kind of message protection is less effective. In this case, the message is protected by checking bit-per-bit in a smaller time scale (see 'bit protection' below).

Bit protection

The HEF4755V checks every received bit within the time window defined by the start-bit. The programmed time tolerance (19%, 25%, 31% and 37%) determines that the bit protection circuit decides after 32 samples which bit is a true logic HIGH or LOW level, or an error. In the latter case, there are too many samples HIGH to obtain a LOW and, too many samples LOW to obtain a HIGH.

Transmitting

In the transmitting mode the HEF4755V uses the data pulse signal (DP, pin 23) to take 8 bits from the data bus. These parallel bits are shifted serially to the message output (MO).

Receiving

In the receiving mode the HEF4755V receives serial bits at the message input (MI). The circuit checks the message for transmission errors and, with every data pulse, 8 bits are transferred in parallel to the data bus. Every recognized error is stored and the error output is activated. The kind of error can be recognized by reading the status register over the data bus.

Asynchronous and synchronous mode

If only one transmission line is available, then the receiver waits for the start-bit, synchronizes itself on the start bit and receives all the data bits of one message. This is called the *asynchronous mode*. By using 3 transmission lines, the circuit can go to the *synchronous mode*. In this case it is possible to transmit also the clock signal (CP) and message synchronization signal (MOS) in parallel with the data bits. The start bit and the bit check are omitted. In the synchronous mode the maximum transmission speed is 32 times the maximum speed in the asynchronous mode.

In asynchronous receive mode a reset pulse is necessary between two messages. It is possible to derive this reset pulse from the busy signal by using hardware. The duration of the START-pulse at the transmitter must always be shorter than the message to be transferred. A good procedure for achieving this is to use the BUSY-signal to end the START-pulse. The recovery time between two messages must be at least two bit periods. During this time, the line must remain stable to prevent generation of an error. This must be ensured with external hardware/software.

In the synchronous receive mode, the duration of the START-pulse at the transmitter must always be shorter than the message to be transferred. A good procedure for achieving this is to use the BUSY-signal to end the START-pulse. A continuous START-signal will cause malfunction. The recovery time between two messages must be at least one bit period. During this time, the message line must remain stable. A good way to achieve this is to use the trailing-edge of the BUSY-signal to generate a START-signal. In practice, if data is delivered to the transmitter fast enough, START can be BUSY. If the lines have different delays, the message line should have the longest delay. If it is not certain which line has the longest delay it is possible to phase-shift the clock signal of the receiver by inverting it. This is only possible with point-to-point lines.

D.C. CHARACTERISTICS

 $V_{SS} = 0 \text{ V}$; $T_{amb} = -40 \text{ to } +85 \text{ }^\circ\text{C}$; unless otherwise specified

DEVELOPMENT SAMPLE DATA

| parameter | V_{DD} V | symbol | min. | typ. | max. | unit | conditions |
|--------------------------------|-----------------|------------|--------------|------|--------------|---------------|---|
| Outputs | | | | | | | |
| Output voltage LOW | 4,75 to 12,6 | V_{OL} | — | — | 0,4 | V | $I_{OL} = 1,8 \text{ mA}$ |
| | 4,75 | V_{OL} | — | — | 0,4 | V | $I_{OL} = 2,3 \text{ mA}$ $T_{amb} = 25 \text{ }^\circ\text{C}$ |
| Output voltage HIGH | 4,75 to 12,6 | V_{OH} | $V_{DD}-1$ | — | — | V | $-I_{OH} = 1,1 \text{ mA}$ |
| | 4,75 | V_{OH} | $V_{DD}-1$ | — | — | V | $-I_{OH} = 1,4 \text{ mA}$ $T_{amb} = 25 \text{ }^\circ\text{C}$ |
| Inputs/outputs | | | | | | | |
| <i>As outputs</i> | | | | | | | |
| Output voltage LOW | 4,75 to 12,6 | V_{OL} | — | — | 0,4 | V | $I_{OL} = 1,8 \text{ mA}$ |
| | 4,75 | V_{OL} | — | — | 0,4 | V | $I_{OL} = 2,3 \text{ mA}$ $T_{amb} = 25 \text{ }^\circ\text{C}$ |
| Output voltage HIGH | 4,75 to 12,6 | V_{OH} | $V_{DD}-1$ | — | — | V | $-I_{OH} = 1,1 \text{ mA}$ |
| | 4,75 | V_{OH} | $V_{DD}-1$ | — | — | V | $-I_{OH} = 1,4 \text{ mA}$ $T_{amb} = 25 \text{ }^\circ\text{C}$ |
| Output leakage current HIGH | 12,6 | I_{OZH} | — | — | 20 | μA | $V_{OH} = 12,6 \text{ V}$ |
| | 12,6 | I_{OZH} | — | — | 5 | μA | $V_{OH} = 12,6 \text{ V}$ $T_{amb} = 25 \text{ }^\circ\text{C}$ |
| LOW | | $-I_{OZL}$ | — | — | 20 | μA | $V_{OL} = 0 \text{ V}$ |
| | | $-I_{OZL}$ | — | — | 5 | μA | $V_{OL} = 0 \text{ V}$ $T_{amb} = 25 \text{ }^\circ\text{C}$ |
| <i>As inputs</i> | | | | | | | |
| Input voltage LOW | 4,75 to 12,6 | V_{IL} | 0 | — | $0,3 V_{DD}$ | V | |
| Input voltage HIGH | 4,75 to 12,6 | V_{IH} | $0,7 V_{DD}$ | — | V_{DD} | V | |

A.C. CHARACTERISTICS

 $V_{SS} = 0\text{ V}$; $T_{amb} = -40\text{ to }+85\text{ }^{\circ}\text{C}$; unless otherwise specified

| parameter | V_{DD} V | symbol | min. | typ. | max. | unit | conditions |
|---------------------------------------|---------------|------------|------|------|------|---------------|----------------|
| Asynchronous mode | | | | | | | AS at V_{DD} |
| Clock pulse width LOW | 5 | t_{WCPL} | 500 | | | ns | |
| | 10 | | 125 | | | ns | |
| HIGH | 5 | t_{WCPH} | 500 | | | ns | |
| | 10 | | 125 | | | ns | |
| START pulse width HIGH | 5 | t_{WSH} | 0,9 | | | μs | |
| | 10 | | 0,22 | | | μs | |
| Set-up time $D_n \rightarrow CP$ | 5 | t_{su} | 1,4 | | | μs | |
| | 10 | | 0,35 | | | μs | |
| Hold time $CP \rightarrow D_n$ | 5 | t_{hold} | 0 | | | μs | |
| | 10 | | 0 | | | μs | |
| Reset (R) pulse width HIGH | 5 | t_{WRH} | 1 | | | μs | |
| | 10 | | 0,25 | | | μs | |
| Synchronous mode | | | | | | | |
| Clock pulse width LOW | 5 | t_{WCPL} | 625 | | | ns | |
| | 10 | | 150 | | | ns | |
| HIGH | 5 | t_{WCPH} | 625 | | | ns | |
| | 10 | | 150 | | | ns | |
| Set-up time START $\rightarrow CP$ | 5 | t_{su} | 0,6 | | | μs | |
| | 10 | | 0,15 | | | μs | |
| Hold time $CP \rightarrow START$ | 5 | t_{hold} | 300 | | | ns | |
| | 10 | | 75 | | | ns | |
| Set-up time $D_n \rightarrow CP$ | 5 | t_{su} | 600 | | | ns | |
| | 10 | | 150 | | | ns | |
| Hold time $CP \rightarrow D_n$ | 5 | t_{hold} | 0 | | | ns | |
| | 10 | | 0 | | | ns | |
| Reset (R) pulse width HIGH | 5 | t_{WRH} | 1 | | | μs | |
| | 10 | | 0,25 | | | μs | |

Note

Measured between output voltage levels of 0,8 V and 2 V.

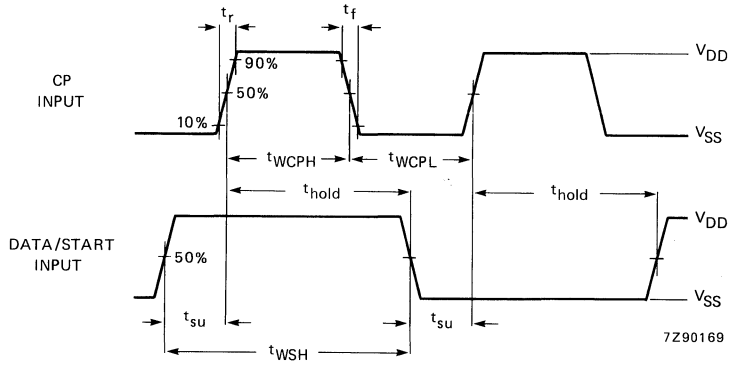

Fig. 4 Waveforms showing the clock, data and start timing.

DEVELOPMENT SAMPLE DATA

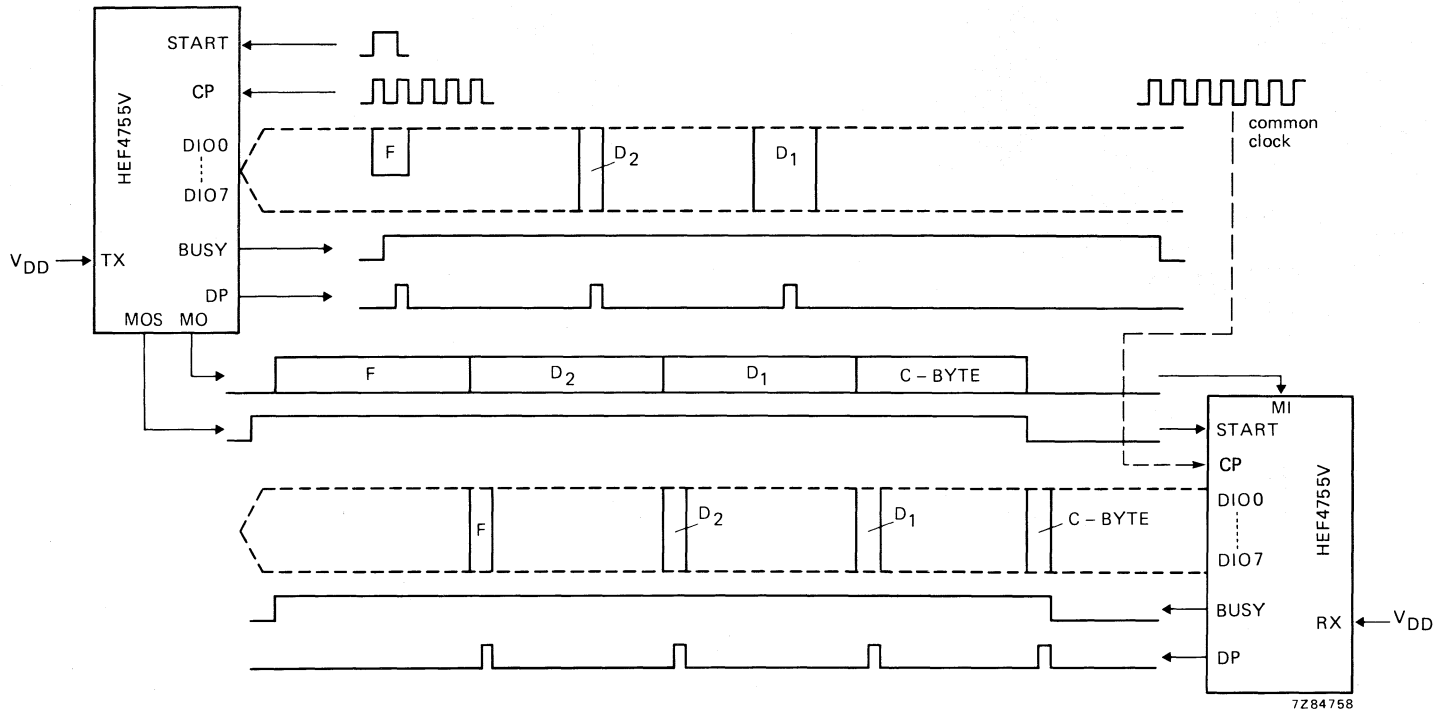

Fig. 5 Function/timing diagram when using the HEF4755V in the asynchronous mode where the byte number per message is variable and the hamming distance is 4.

DEVELOPMENT SAMPLE DATA

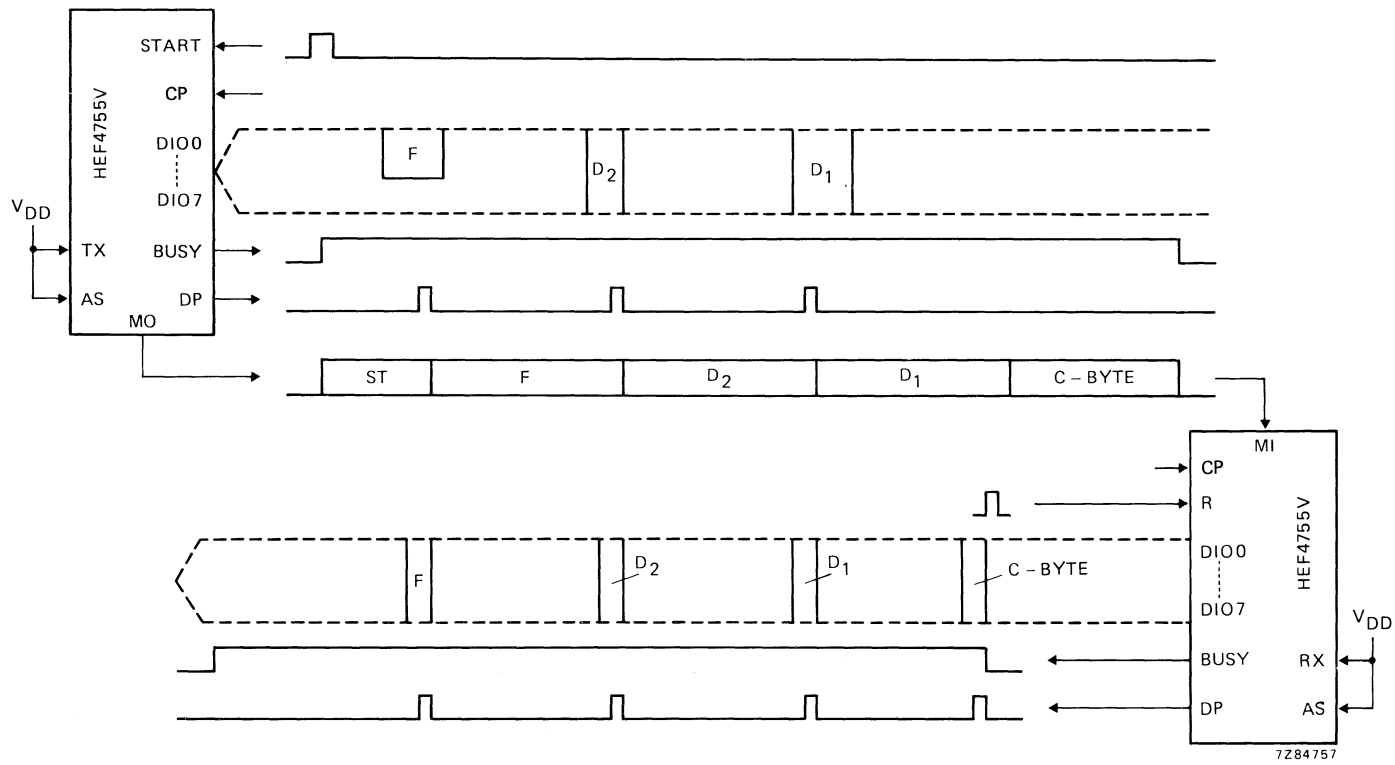

Fig. 6 Function/timing diagram when using the HEF4755V in the asynchronous mode where the byte number per message is variable and the hamming distance is 4.

3-STATE HEX NON-INVERTING BUFFER



The HEF40097B is a hex non-inverting buffer with 3-state outputs. The 3-state outputs are controlled by two enable inputs (\overline{EO}_4 and \overline{EO}_2). A HIGH on \overline{EO}_4 causes four of the six buffer elements to assume a high impedance or OFF-state, regardless of the other input conditions and a HIGH on \overline{EO}_2 causes the outputs of the remaining two buffer elements to assume a high impedance or OFF-state, regardless of the other input conditions.

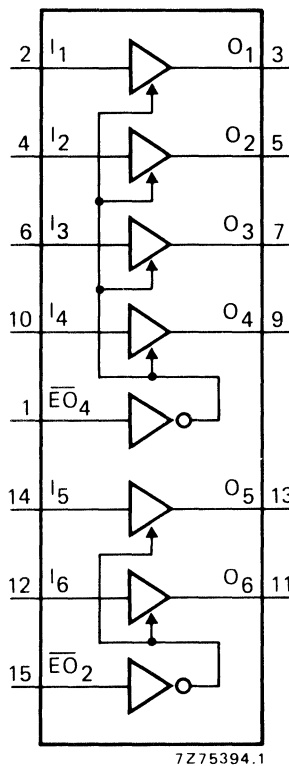
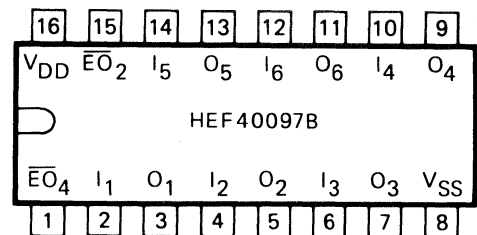

Fig. 1 Functional diagram.



7Z69520.2

Fig. 2 Pinning diagram.

HEF40097BP : 16-lead DIL; plastic (SOT-38Z).
 HEF40097BD: 16-lead DIL; ceramic (cerdip) (SOT-74).
 HEF40097BT: 16-lead mini-pack; plastic
 (SO-16; SOT-109A).

PINNING

I_1 to I_6 buffer inputs
 \overline{EO}_4 , \overline{EO}_2 enable inputs (active LOW)
 O_1 to O_6 buffer outputs (active HIGH)

FAMILY DATA

I_{DD} LIMITS category BUFFERS

} see Family Specifications

HEF40097B

buffers

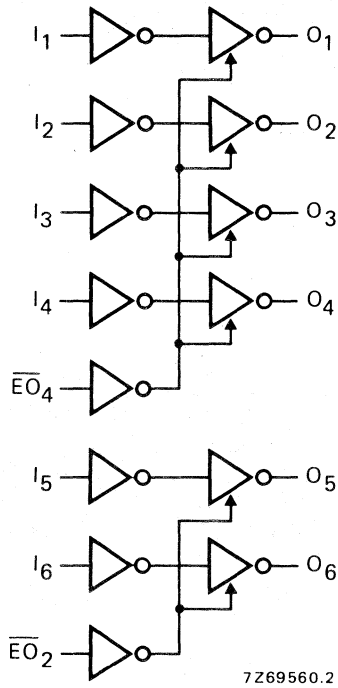

Fig. 3 Logic diagram.

D.C. CHARACTERISTICS

$V_{SS} = 0\text{ V}$

| | V_{DD} V | V_{OH} V | V_{OL} V | symbol | $T_{amb} (^{\circ}\text{C})$ | | | | | | |
|------------------------|---------------|---------------|---------------|-----------|------------------------------|------|------|------|------|------|----|
| | | | | | -40 | | +25 | | +85 | | mA |
| | | | | | min. | max. | min. | max. | min. | max. | |
| Output current HIGH | 5 | 4,6 | | $-I_{OH}$ | 1,2 | | 1,0 | | 0,8 | | |
| | 10 | 9,5 | | | 3,8 | | 3,2 | | 2,5 | | |
| | 15 | 13,5 | | | 12,0 | | 10,0 | | 8,0 | | |
| Output current LOW | 5 | 2,5 | 0,4 | I_{OL} | 3,8 | | 3,2 | | 2,5 | | |
| | 10 | | 0,5 | | 3,5 | | 2,9 | | 2,3 | | |
| | 15 | | 1,5 | | 12,0 | | 10,0 | | 8,0 | | |
| | | | | | 24,0 | | 20,0 | | 16,0 | | |

A.C. CHARACTERISTICS

 $V_{SS} = 0 \text{ V}$; $T_{amb} = 25 \text{ }^\circ\text{C}$; $C_L = 50 \text{ pF}$; input transition times $\leq 20 \text{ ns}$

| | V_{DD} V | symbol | typ. | max. | | typical extrapolation formula |
|--|---------------|------------------|------|------|----|-------------------------------------|
| Propagation delays $I_n \rightarrow O_n$ HIGH to LOW | 5 | t _{PHL} | 70 | 140 | ns | 60 ns + (0,20 ns/pF) C _L |
| | 10 | | 30 | 60 | ns | 26 ns + (0,08 ns/pF) C _L |
| | 15 | | 25 | 50 | ns | 22 ns + (0,06 ns/pF) C _L |
| LOW to HIGH | 5 | t _{PLH} | 60 | 120 | ns | 45 ns + (0,30 ns/pF) C _L |
| | 10 | | 25 | 50 | ns | 19 ns + (0,13 ns/pF) C _L |
| | 15 | | 20 | 40 | ns | 16 ns + (0,09 ns/pF) C _L |
| Output transition times HIGH to LOW | 5 | t _{THL} | 30 | 60 | ns | 15 ns + (0,30 ns/pF) C _L |
| | 10 | | 15 | 30 | ns | 10 ns + (0,11 ns/pF) C _L |
| | 15 | | 10 | 20 | ns | 7 ns + (0,07 ns/pF) C _L |
| LOW to HIGH | 5 | t _{TLH} | 35 | 70 | ns | 10 ns + (0,50 ns/pF) C _L |
| | 10 | | 20 | 40 | ns | 8 ns + (0,24 ns/pF) C _L |
| | 15 | | 15 | 30 | ns | 6 ns + (0,18 ns/pF) C _L |
| 3-state propagation delays | | | | | | |
| Output disable times $\overline{EO}_2, \overline{EO}_4 \rightarrow O_n$ HIGH | 5 | t _{PHZ} | 45 | 95 | ns | |
| | 10 | | 35 | 70 | ns | |
| | 15 | | 30 | 60 | ns | |
| LOW | 5 | t _{PLZ} | 60 | 120 | ns | |
| | 10 | | 35 | 70 | ns | |
| | 15 | | 25 | 55 | ns | |
| Output enable times $\overline{EO}_2, \overline{EO}_4 \rightarrow O_n$ HIGH | 5 | t _{PZH} | 75 | 150 | ns | |
| | 10 | | 35 | 70 | ns | |
| | 15 | | 30 | 60 | ns | |
| LOW | 5 | t _{PZL} | 95 | 190 | ns | |
| | 10 | | 40 | 80 | ns | |
| | 15 | | 30 | 65 | ns | |

| | V_{DD} V | typical formula for P (μW) | where f _i = input freq. (MHz) f _o = output freq. (MHz) C _L = load cap. (pF) $\Sigma(f_o C_L)$ = sum of outputs V _{DD} = supply voltage (V) |
|---|---------------|---|---|
| Dynamic power dissipation per package (P) | 5 | $5\,400 f_i + \Sigma(f_o C_L) \times V_{DD}^2$ | |
| | 10 | $25\,200 f_i + \Sigma(f_o C_L) \times V_{DD}^2$ | |
| | 15 | $96\,500 f_i + \Sigma(f_o C_L) \times V_{DD}^2$ | |

3-STATE HEX INVERTING BUFFER



The HEF40098B is a hex inverting buffer with 3-state outputs. The 3-state outputs are controlled by two enable inputs (\overline{EO}_4 and \overline{EO}_2). A HIGH on \overline{EO}_4 causes four of the six buffer elements to assume a high impedance or OFF-state regardless of the other input conditions and a HIGH on \overline{EO}_2 causes the outputs of the remaining two buffer elements to assume a high impedance or OFF-state regardless of the other input conditions.

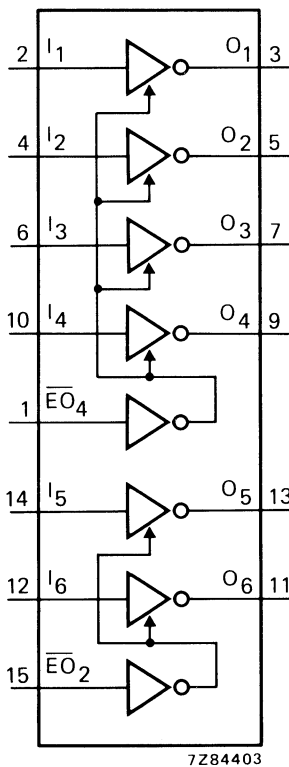

Fig. 1 Functional diagram.

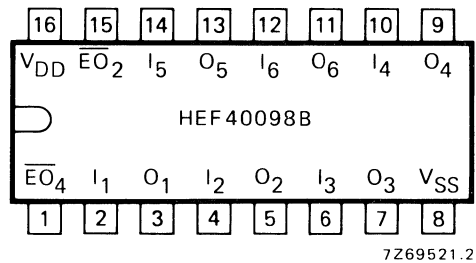

Fig. 2 Pinning diagram.

HEF40098BP: 16-lead DIL; plastic (SOT-38Z).
 HEF40098BD: 16-lead DIL; ceramic (cerdip) (SOT-74).
 HEF40098BT: 16-lead mini-pack; plastic (SO-16; SOT-109A).

PINNING

I_1 to I_6 buffer inputs
 \overline{EO}_4 , \overline{EO}_2 enable inputs (active LOW)
 O_1 to O_6 buffer outputs (active LOW)

FAMILY DATA

I_{DD} LIMITS category BUFFERS

} see Family Specifications

HEF40098B

buffers

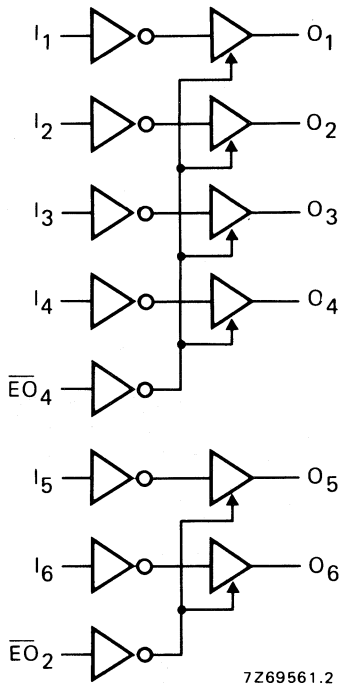

Fig. 3 Logic diagram.

D.C. CHARACTERISTICS

$V_{SS} = 0\text{ V}$

| | V_{DD} V | V_{OH} V | V_{OL} V | symbol | T_{amb} (°C) | | | | | |
|------------------------|---------------|---------------|---------------|-----------|----------------|------|------|------|------|------|
| | | | | | -40 | | +25 | | +85 | |
| | | | | | min. | max. | min. | max. | min. | max. |
| Output current HIGH | 5 | 4,6 | | $-I_{OH}$ | 1,2 | 1,0 | 0,8 | | | mA |
| | 10 | 9,5 | | | 3,8 | 3,2 | 2,5 | | | mA |
| | 15 | 13,5 | | | 12,0 | 10,0 | 8,0 | | | mA |
| Output current LOW | 5 | 2,5 | 0,4 | I_{OL} | 3,8 | 3,2 | 2,5 | | | mA |
| | 10 | | 0,5 | | 3,5 | 2,9 | 2,3 | | | mA |
| | 15 | | 1,5 | | 12,0 | 10,0 | 8,0 | | | mA |
| | | | | | 24,0 | 20,0 | 16,0 | | | mA |

A.C. CHARACTERISTICS

$V_{SS} = 0\text{ V}$; $T_{amb} = 25\text{ }^{\circ}\text{C}$; $C_L = 50\text{ pF}$; input transition times $\leq 20\text{ ns}$

| | V_{DD} V | symbol | typ. | max. | | typical extrapolation formula | |
|--|---------------|------------------|------------------|------|-----|--|--|
| Propagation delays $I_n \rightarrow O_n$ HIGH to LOW | 5 | t _{PHL} | 80 | 160 | ns | $70\text{ ns} + (0,20\text{ ns/pF}) C_L$ | |
| | 10 | | 35 | 70 | ns | $31\text{ ns} + (0,08\text{ ns/pF}) C_L$ | |
| | 15 | | 25 | 50 | ns | $22\text{ ns} + (0,06\text{ ns/pF}) C_L$ | |
| | LOW to HIGH | 5 | t _{PLH} | 65 | 130 | ns | $50\text{ ns} + (0,30\text{ ns/pF}) C_L$ |
| | | 10 | | 30 | 60 | ns | $24\text{ ns} + (0,13\text{ ns/pF}) C_L$ |
| | | 15 | | 25 | 50 | ns | $23\text{ ns} + (0,05\text{ ns/pF}) C_L$ |
| Output transition times HIGH to LOW | 5 | t _{THL} | 30 | 60 | ns | $15\text{ ns} + (0,30\text{ ns/pF}) C_L$ | |
| | 10 | | 15 | 30 | ns | $10\text{ ns} + (0,11\text{ ns/pF}) C_L$ | |
| | 15 | | 10 | 20 | ns | $7\text{ ns} + (0,07\text{ ns/pF}) C_L$ | |
| | LOW to HIGH | 5 | t _{TLH} | 35 | 70 | ns | $10\text{ ns} + (0,50\text{ ns/pF}) C_L$ |
| | | 10 | | 20 | 40 | ns | $8\text{ ns} + (0,24\text{ ns/pF}) C_L$ |
| | | 15 | | 15 | 30 | ns | $6\text{ ns} + (0,18\text{ ns/pF}) C_L$ |
| 3-state propagation delays | | | | | | | |
| Output disable times $\overline{EO}_2, \overline{EO}_4 \rightarrow O_n$ HIGH | 5 | t _{PHZ} | 45 | 85 | ns | | |
| | 10 | | 35 | 65 | ns | | |
| | 15 | | 30 | 60 | ns | | |
| | LOW | 5 | t _{PLZ} | 65 | 135 | ns | |
| | | 10 | | 40 | 80 | ns | |
| | | 15 | | 35 | 70 | ns | |
| Output enable times $\overline{EO}_2, \overline{EO}_4 \rightarrow O_n$ HIGH | 5 | t _{PZH} | 70 | 140 | ns | | |
| | 10 | | 35 | 75 | ns | | |
| | 15 | | 30 | 65 | ns | | |
| | LOW | 5 | t _{PZL} | 90 | 185 | ns | |
| | | 10 | | 40 | 85 | ns | |
| | | 15 | | 35 | 70 | ns | |

| | V_{DD} V | typical formula for P (μW) | where f_i = input freq. (MHz) f_o = output freq. (MHz) C_L = load cap. (pF) $\Sigma(f_o C_L)$ = sum of outputs V_{DD} = supply voltage (V) |
|---|---------------|---|---|
| Dynamic power dissipation per package (P) | 5 | $5\,000 f_i + \Sigma(f_o C_L) \times V_{DD}^2$ | |
| | 10 | $22\,800 f_i + \Sigma(f_o C_L) \times V_{DD}^2$ | |
| | 15 | $81\,000 f_i + \Sigma(f_o C_L) \times V_{DD}^2$ | |

HEX INVERTING SCHMITT TRIGGER



Each circuit of the HEF40106B functions as an inverter with Schmitt-trigger action. The Schmitt-trigger switches at different points for the positive and negative-going input signals. The difference between the positive-going voltage (V_P) and the negative-going voltage (V_N) is defined as hysteresis voltage (V_H).

This device may be used for enhanced noise immunity or to "square up" slowly changing waveforms.

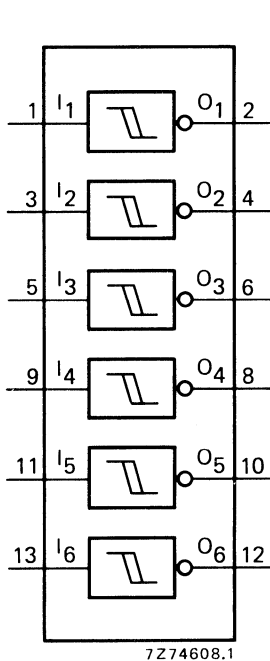

Fig. 1 Functional diagram.

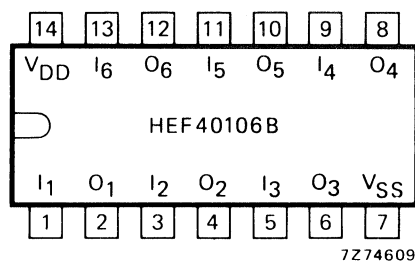

Fig. 2 Pinning diagram.

HEF40106BP : 14-lead DIL; plastic (SOT-27K, M, T).
 HEF40106BD : 14-lead DIL; ceramic (cerdip) (SOT-73).
 HEF40106BT : 14-lead mini-pack; plastic (SO-14; SOT-108A).

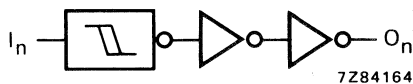

Fig. 3 Logic diagram (one inverter).

FAMILY DATA

I_{DD} LIMITS category GATES

see Family Specifications

D.C. CHARACTERISTICS

$V_{SS} = 0\text{ V}$; $T_{amb} = 25\text{ }^{\circ}\text{C}$

| | V_{DD} V | symbol | min. | typ. | max. | |
|---|---------------|--------|------|------|------|---|
| Hysteresis voltage | 5 | V_H | 0,5 | 0,8 | | V |
| | 10 | | 0,7 | 1,3 | | V |
| | 15 | | 0,9 | 1,8 | | V |
| Switching levels positive-going input voltage | 5 | V_P | 2 | 3,0 | 3,5 | V |
| | 10 | | 3,7 | 5,8 | 7 | V |
| | 15 | | 4,9 | 8,3 | 11 | V |
| negative-going input voltage | 5 | V_N | 1,5 | 2,2 | 3 | V |
| | 10 | | 3 | 4,5 | 6,3 | V |
| | 15 | | 4 | 6,5 | 10,1 | V |

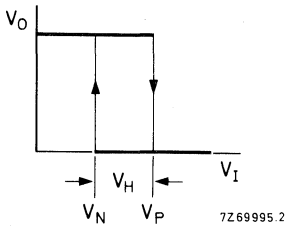

Fig. 4 Transfer characteristic.

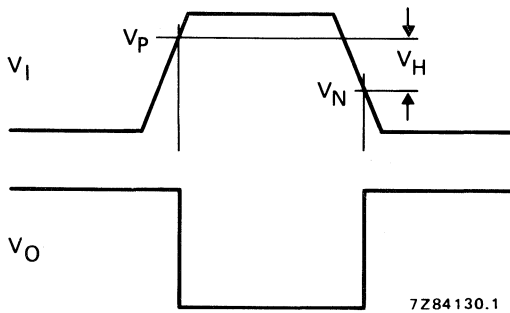

Fig. 5 Waveforms showing definition of V_P , V_N and V_H , where V_N and V_P are between limits of 30% and 70%.

A.C. CHARACTERISTICS

$V_{SS} = 0\text{ V}$; $T_{amb} = 25\text{ }^{\circ}\text{C}$; $C_L = 50\text{ pF}$; input transition times $\leq 20\text{ ns}$

| | V_{DD} V | symbol | typ. | max. | | typical extrapolation formula |
|--|---------------|-----------|------|------|----|--|
| Propagation delays $I_n \rightarrow O_n$ HIGH to LOW | 5 | t_{PHL} | 90 | 180 | ns | $63\text{ ns} + (0,55\text{ ns/pF}) C_L$ |
| | 10 | | 35 | 70 | ns | $24\text{ ns} + (0,23\text{ ns/pF}) C_L$ |
| | 15 | | 30 | 60 | ns | $22\text{ ns} + (0,16\text{ ns/pF}) C_L$ |
| LOW to HIGH | 5 | t_{PLH} | 75 | 150 | ns | $48\text{ ns} + (0,55\text{ ns/pF}) C_L$ |
| | 10 | | 35 | 70 | ns | $24\text{ ns} + (0,23\text{ ns/pF}) C_L$ |
| | 15 | | 30 | 60 | ns | $22\text{ ns} + (0,16\text{ ns/pF}) C_L$ |
| Output transition times HIGH to LOW | 5 | t_{THL} | 60 | 120 | ns | $10\text{ ns} + (1,0\text{ ns/pF}) C_L$ |
| | 10 | | 30 | 60 | ns | $9\text{ ns} + (0,42\text{ ns/pF}) C_L$ |
| | 15 | | 20 | 40 | ns | $6\text{ ns} + (0,28\text{ ns/pF}) C_L$ |
| LOW to HIGH | 5 | t_{TLH} | 60 | 120 | ns | $10\text{ ns} + (1,0\text{ ns/pF}) C_L$ |
| | 10 | | 30 | 60 | ns | $9\text{ ns} + (0,42\text{ ns/pF}) C_L$ |
| | 15 | | 20 | 40 | ns | $6\text{ ns} + (0,28\text{ ns/pF}) C_L$ |

| | V_{DD} V | typical formula for P (μW) | where f_i = input freq. (MHz) f_o = output freq. (MHz) C_L = load capacitance (pF) $\Sigma(f_o C_L)$ = sum of outputs V_{DD} = supply voltage (V) |
|---|---------------|---|--|
| Dynamic power dissipation per package (P) | 5 | $2\,300 f_i + \Sigma(f_o C_L) \times V_{DD}^2$ | |
| | 10 | $9\,000 f_i + \Sigma(f_o C_L) \times V_{DD}^2$ | |
| | 15 | $20\,000 f_i + \Sigma(f_o C_L) \times V_{DD}^2$ | |

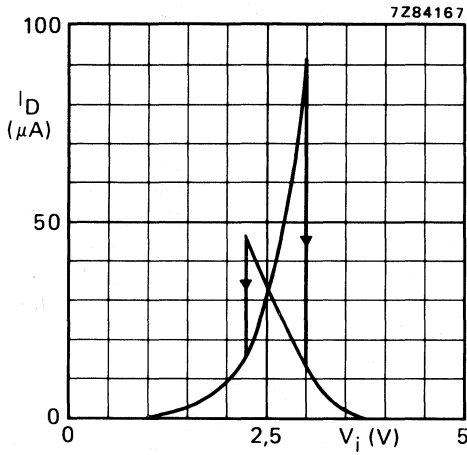

Fig. 6 Typical drain current as a function of input voltage; $V_{DD} = 5 V$; $T_{amb} = 25 ^\circ C$.

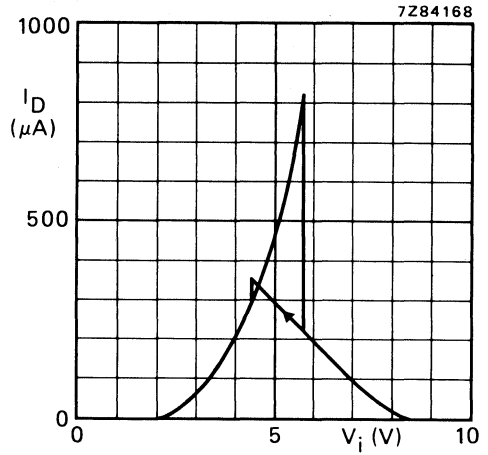

Fig. 7 Typical drain current as a function of input voltage; $V_{DD} = 10 V$; $T_{amb} = 25 ^\circ C$.

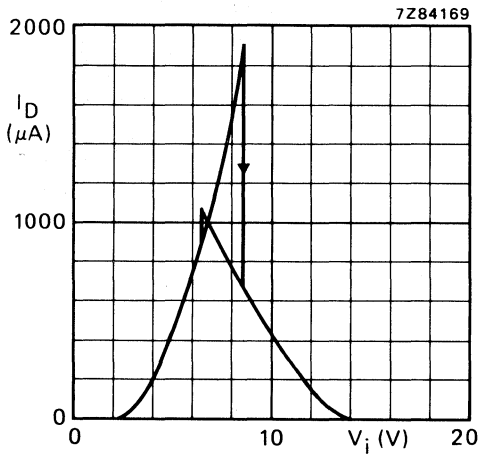

Fig. 8 Typical drain current as a function of input voltage; $V_{DD} = 15 V$; $T_{amb} = 25 ^\circ C$.

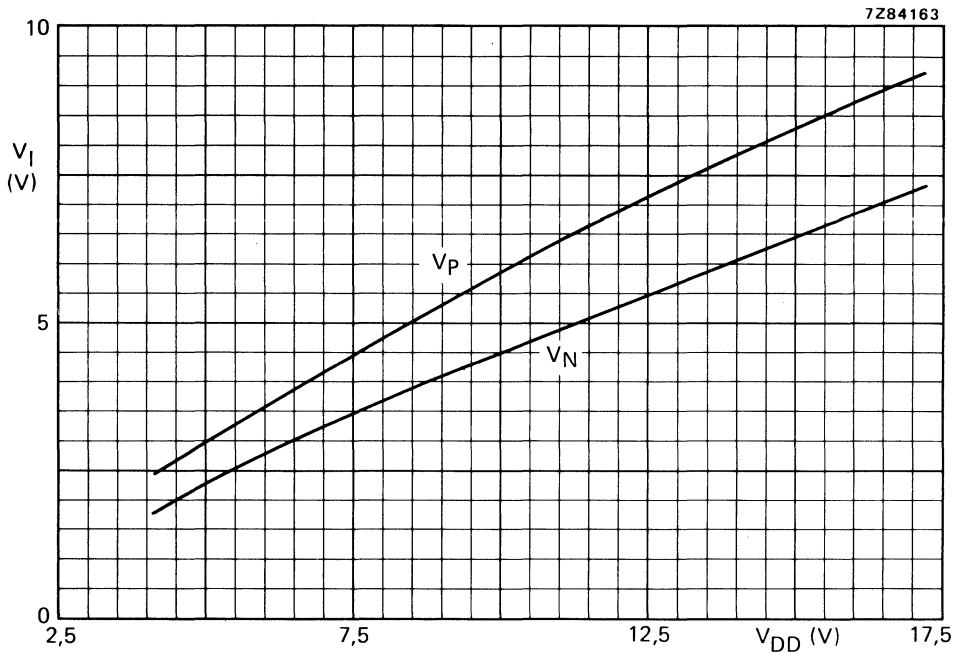

Fig. 9 Typical switching levels as a function of supply voltage V_{DD} ; $T_{amb} = 25^\circ C$.

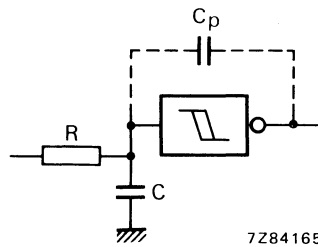

Fig. 10 Schmitt trigger driven via a high impedance ($R > 1\text{ k}\Omega$).

If a Schmitt trigger is driven via a high impedance ($R > 1\text{ k}\Omega$) then it is necessary to incorporate a capacitor C of such value that: $\frac{C}{C_p} > \frac{V_{DD}-V_{SS}}{V_H}$, otherwise oscillation can occur on the edges of a pulse.

C_p is the external parasitic capacitance between input and output; the value depends on the circuit board layout.

APPLICATION INFORMATION

Some examples of applications for the HEF40106B are:

- Wave and pulse shapers
- Astable multivibrators
- Monostable multivibrators.

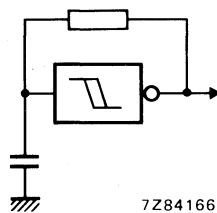

Fig. 11 The HEF40106B used as an astable multivibrator.

4-BIT SYNCHRONOUS DECADE COUNTER WITH ASYNCHRONOUS RESET



The HEF40160B is a fully synchronous edge-triggered 4-bit decade counter with a clock input (CP), an overriding asynchronous master reset (\overline{MR}), four parallel data inputs (P_0 to P_3), three synchronous mode control inputs (parallel enable (\overline{PE}), count enable parallel (CEP) and count enable trickle (CET)), buffered outputs from all four bit positions (O_0 to O_3) and a terminal count output (TC).

Operation is fully synchronous (except for the \overline{MR} input) and occurs on the LOW to HIGH transition of CP. When \overline{PE} is LOW, the next LOW to HIGH transition of CP loads data into the counter from P_0 to P_3 regardless of the levels of CEP and CET inputs.

When \overline{PE} is HIGH, the next LOW to HIGH transition of CP advances the counter to its next state only if both CEP and CET are HIGH; otherwise, no change occurs in the state of the counter. TC is HIGH when the state of the counter is 9 ($O_0 = O_3 = \text{HIGH}$, $O_1 = O_2 = \text{LOW}$) and when CET is HIGH. A LOW on \overline{MR} sets all outputs (O_0 to O_3 and TC) LOW, independent of the state of all other inputs. Multistage synchronous counting is possible without additional components by using a carry look-ahead counting technique; in this case, TC is used to enable successive cascaded stages. CEP, CET and \overline{PE} must be stable only during the set-up time before the LOW to HIGH transition of CP.

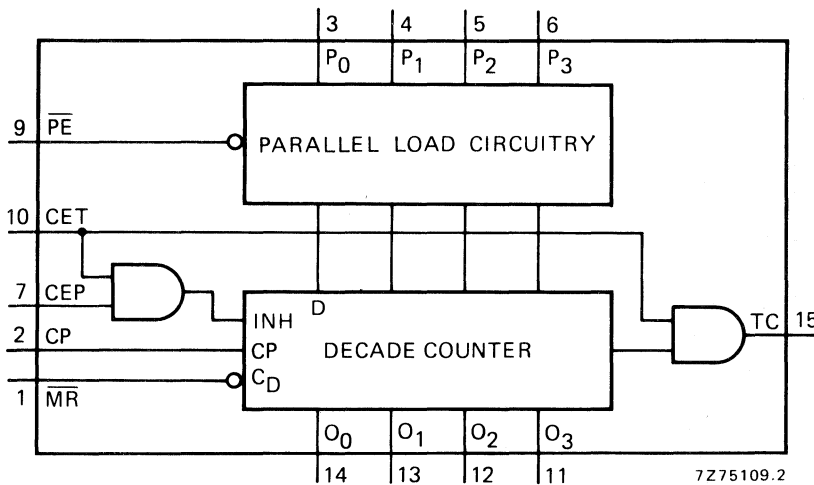

Fig. 1 Functional diagram.

FAMILY DATA

I_{DD} LIMITS category MSI

see Family Specifications

HEF40160B
MSI

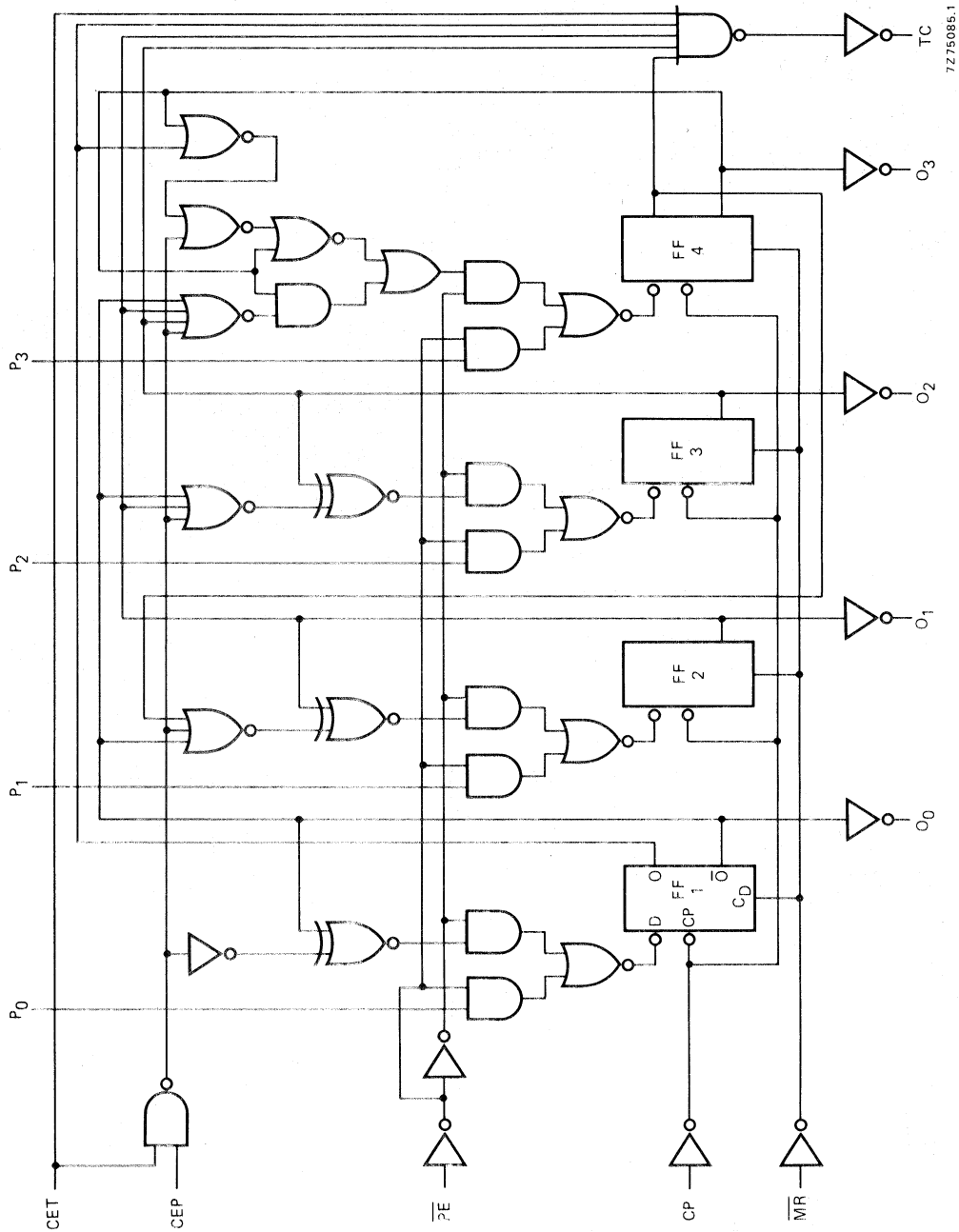

7275086.1

Fig. 2 Logic diagram.

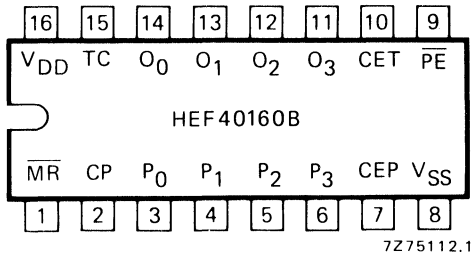

PINNING

- \overline{PE} parallel enable input
- P_0 to P_3 parallel data inputs
- CET count enable parallel input
- CET count enable trickle input
- CP clock input (LOW to HIGH, edge-triggered)
- \overline{MR} master reset input (active LOW)
- O_0 to O_3 parallel outputs
- TC terminal count output

Fig. 3 Pinning diagram.

HEF40160BP : 16-lead DIL; plastic (SOT-38Z).
 HEF40160BD : 16-lead DIL; ceramic (cerdip) (SOT-74).
 HEF40160BT : 16-lead mini-pack; plastic (SO-16; SOT-109A).

SYNCHRONOUS MODE SELECTION

| \overline{PE} | CEP | CET | mode |
|-----------------|-----|-----|-----------|
| L | X | X | preset |
| H | L | X | no change |
| H | X | L | no change |
| H | H | H | count |

\overline{MR} = HIGH

H = HIGH state (the more positive voltage)

L = LOW state (the less positive voltage)

X = state is immaterial

TERMINAL COUNT GENERATION

| CET | $(O_0 \cdot \overline{O}_1 \cdot \overline{O}_2 \cdot O_3)$ | TC |
|-----|---|----|
| L | L | L |
| L | H | L |
| H | L | L |
| H | H | H |

$$TC = CET \cdot O_0 \cdot \overline{O}_1 \cdot \overline{O}_2 \cdot O_3$$

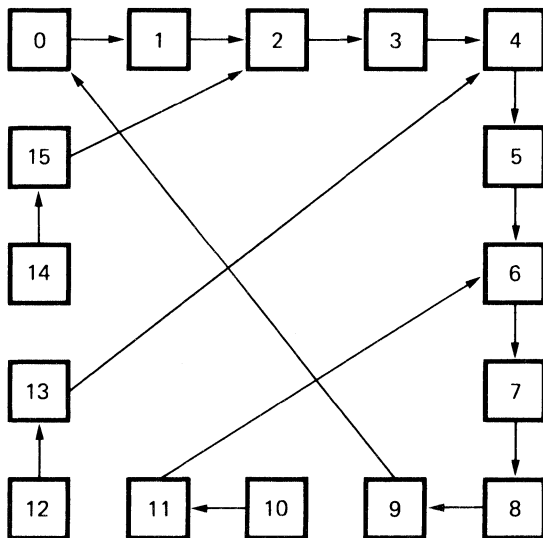

Fig. 4 State diagram.

7275086

HEF40160B

MSI

A.C. CHARACTERISTICS

$V_{SS} = 0\text{ V}$; $T_{amb} = 25\text{ }^{\circ}\text{C}$; input transition times $\leq 20\text{ ns}$

| | V_{DD} V | typical formula for P (μW) | where f_i = input freq. (MHz) f_o = output freq. (MHz) C_L = load capacitance (pF) $\Sigma(f_o C_L)$ = sum of outputs V_{DD} = supply voltage (V) |
|---|---------------|---|--|
| Dynamic power dissipation per package (P) | 5 | $1\,200 f_i + \Sigma(f_o C_L) \times V_{DD}^2$ | |
| | 10 | $5\,600 f_i + \Sigma(f_o C_L) \times V_{DD}^2$ | |
| | 15 | $16\,000 f_i + \Sigma(f_o C_L) \times V_{DD}^2$ | |

A.C. CHARACTERISTICS

$V_{SS} = 0\text{ V}$; $T_{amb} = 25\text{ }^{\circ}\text{C}$; $C_L = 50\text{ pF}$; input transition times $\leq 20\text{ ns}$

| | V_{DD} V | symbol | min. | typ. | max. | typical extrapolation formula | | |
|---|---------------|-----------|-----------|------|------|--|---|---|
| Propagation delays CP \rightarrow O_n HIGH to LOW | 5 | t_{PHL} | | 110 | 220 | ns | $83\text{ ns} + (0,55\text{ ns/pF}) C_L$ | |
| | 10 | | 45 | 90 | ns | $34\text{ ns} + (0,23\text{ ns/pF}) C_L$ | | |
| | 15 | | 30 | 60 | ns | $22\text{ ns} + (0,16\text{ ns/pF}) C_L$ | | |
| | LOW to HIGH | 5 | t_{PLH} | | 115 | 230 | ns | $88\text{ ns} + (0,55\text{ ns/pF}) C_L$ |
| | | 10 | | 45 | 95 | ns | $34\text{ ns} + (0,23\text{ ns/pF}) C_L$ | |
| | | 15 | | 35 | 65 | ns | $27\text{ ns} + (0,16\text{ ns/pF}) C_L$ | |
| CP \rightarrow TC HIGH to LOW | 5 | t_{PHL} | | 130 | 260 | ns | $103\text{ ns} + (0,55\text{ ns/pF}) C_L$ | |
| | 10 | | 55 | 105 | ns | $44\text{ ns} + (0,23\text{ ns/pF}) C_L$ | | |
| | 15 | | 35 | 75 | ns | $27\text{ ns} + (0,16\text{ ns/pF}) C_L$ | | |
| | LOW to HIGH | 5 | t_{PLH} | | 140 | 280 | ns | $113\text{ ns} + (0,55\text{ ns/pF}) C_L$ |
| | | 10 | | 55 | 115 | ns | $44\text{ ns} + (0,23\text{ ns/pF}) C_L$ | |
| | | 15 | | 40 | 80 | ns | $32\text{ ns} + (0,16\text{ ns/pF}) C_L$ | |
| CET \rightarrow TC HIGH to LOW | 5 | t_{PHL} | | 105 | 210 | ns | $78\text{ ns} + (0,55\text{ ns/pF}) C_L$ | |
| | 10 | | 50 | 100 | ns | $39\text{ ns} + (0,23\text{ ns/pF}) C_L$ | | |
| | 15 | | 35 | 75 | ns | $27\text{ ns} + (0,16\text{ ns/pF}) C_L$ | | |
| | LOW to HIGH | 5 | t_{PLH} | | 90 | 185 | ns | $63\text{ ns} + (0,55\text{ ns/pF}) C_L$ |
| | | 10 | | 35 | 70 | ns | $24\text{ ns} + (0,23\text{ ns/pF}) C_L$ | |
| | | 15 | | 25 | 50 | ns | $17\text{ ns} + (0,16\text{ ns/pF}) C_L$ | |
| $\overline{\text{MR}} \rightarrow O_n$ HIGH to LOW | 5 | t_{PHL} | | 120 | 245 | ns | $93\text{ ns} + (0,55\text{ ns/pF}) C_L$ | |
| | 10 | | 50 | 100 | ns | $39\text{ ns} + (0,23\text{ ns/pF}) C_L$ | | |
| | 15 | | 35 | 70 | ns | $27\text{ ns} + (0,16\text{ ns/pF}) C_L$ | | |
| | HIGH to LOW | 5 | t_{PHL} | | 145 | 295 | ns | $118\text{ ns} + (0,55\text{ ns/pF}) C_L$ |
| | | 10 | | 60 | 120 | ns | $49\text{ ns} + (0,23\text{ ns/pF}) C_L$ | |
| | | 15 | | 45 | 85 | ns | $37\text{ ns} + (0,16\text{ ns/pF}) C_L$ | |
| Output transition times HIGH to LOW | 5 | t_{THL} | | 60 | 120 | ns | $10\text{ ns} + (1,0\text{ ns/pF}) C_L$ | |
| | 10 | | 30 | 60 | ns | $9\text{ ns} + (0,42\text{ ns/pF}) C_L$ | | |
| | 15 | | 20 | 40 | ns | $6\text{ ns} + (0,28\text{ ns/pF}) C_L$ | | |
| | LOW to HIGH | 5 | t_{TLH} | | 60 | 120 | ns | $10\text{ ns} + (1,0\text{ ns/pF}) C_L$ |
| | | 10 | | 30 | 60 | ns | $9\text{ ns} + (0,42\text{ ns/pF}) C_L$ | |
| | | 15 | | 20 | 40 | ns | $6\text{ ns} + (0,28\text{ ns/pF}) C_L$ | |

A.C. CHARACTERISTICS

 $V_{SS} = 0 \text{ V}$; $T_{amb} = 25 \text{ }^\circ\text{C}$; $C_L = 50 \text{ pF}$; input transition times $\leq 20 \text{ ns}$

| | V_{DD} V | symbol | min. | typ. | max. | |
|--|---------------|------------|------|------|------|--|
| Minimum clock pulse width; LOW | 5 | t_{WCPL} | 100 | 50 | ns | see also waveforms Figs 5, 6, 7 and 8 |
| | 10 | | 40 | 20 | ns | |
| | 15 | | 30 | 15 | ns | |
| Minimum \overline{MR} pulse width; LOW | 5 | t_{WMRL} | 100 | 50 | ns | |
| | 10 | | 40 | 20 | ns | |
| | 15 | | 30 | 15 | ns | |
| Recovery time for \overline{MR} | 5 | t_{RMR} | 25 | 0 | ns | |
| | 10 | | 15 | 0 | ns | |
| | 15 | | 10 | 0 | ns | |
| Set-up times $P_n \rightarrow CP$ | 5 | t_{su} | 110 | 55 | ns | |
| | 10 | | 40 | 20 | ns | |
| | 15 | | 30 | 15 | ns | |
| $\overline{PE} \rightarrow CP$ | 5 | t_{su} | 120 | 60 | ns | |
| | 10 | | 40 | 20 | ns | |
| | 15 | | 25 | 10 | ns | |
| CEP, CET $\rightarrow CP$ | 5 | t_{su} | 260 | 130 | ns | |
| | 10 | | 100 | 50 | ns | |
| | 15 | | 70 | 35 | ns | |
| Hold times $P_n \rightarrow CP$ | 5 | t_{hold} | 20 | -35 | ns | |
| | 10 | | 10 | -10 | ns | |
| | 15 | | 5 | -10 | ns | |
| $\overline{PE} \rightarrow CP$ | 5 | t_{hold} | 15 | -45 | ns | |
| | 10 | | 5 | -15 | ns | |
| | 15 | | 5 | -10 | ns | |
| CEP, CET $\rightarrow CP$ | 5 | t_{hold} | 25 | -105 | ns | |
| | 10 | | 15 | -35 | ns | |
| | 15 | | 10 | -25 | ns | |
| Maximum clock pulse frequency | 5 | f_{max} | 2,5 | 5 | MHz | |
| | 10 | | 7 | 14 | MHz | |
| | 15 | | 9 | 18 | MHz | |

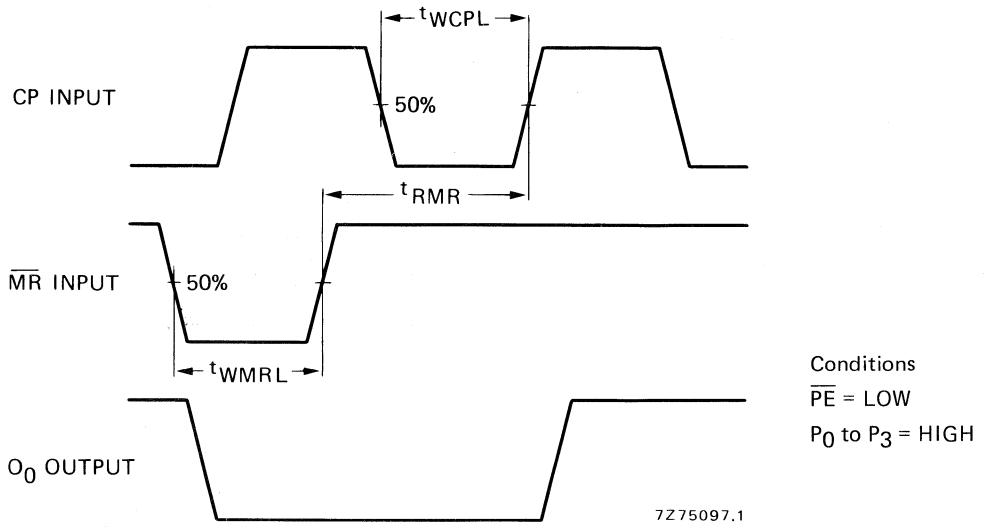

Fig. 5 Waveforms showing minimum CP and \overline{MR} pulse widths and \overline{MR} to CP recovery time.

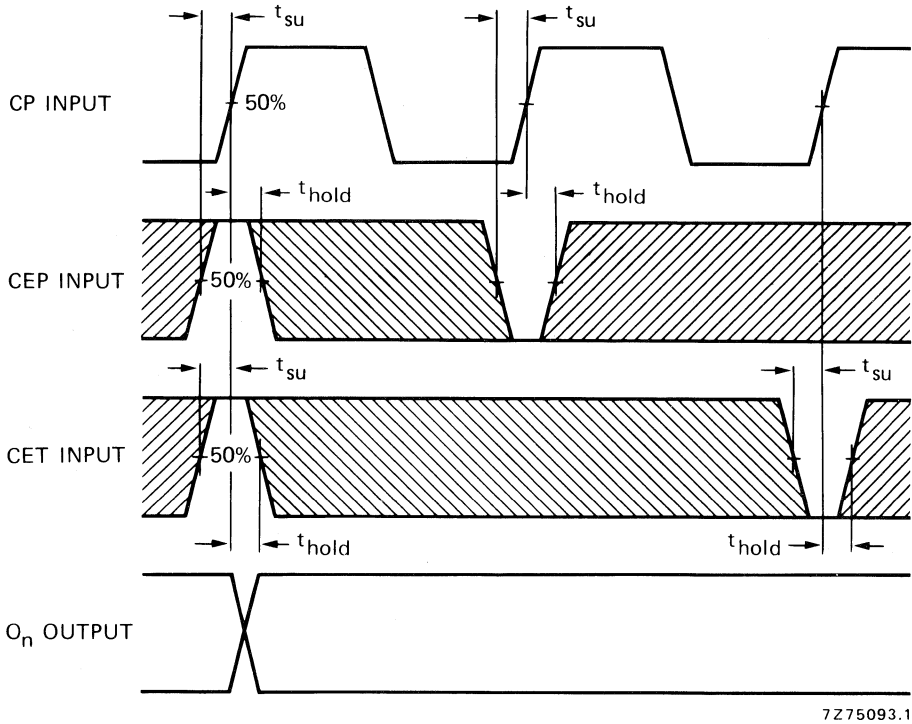
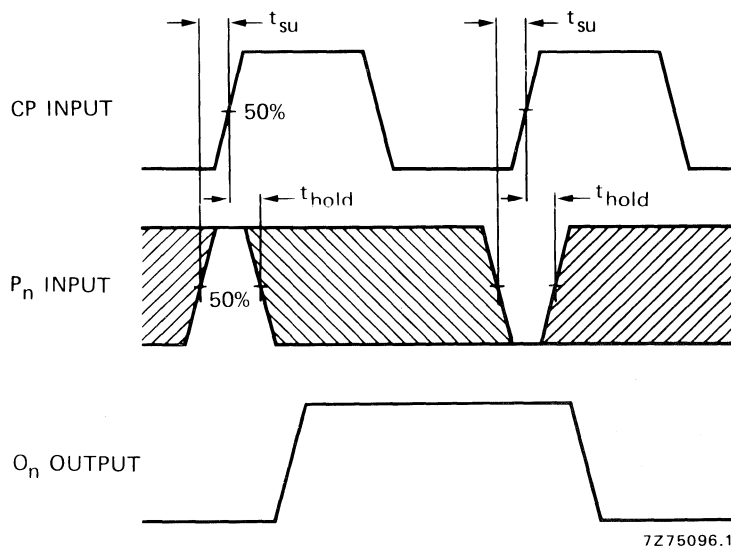

Fig. 6 Waveforms showing set-up times and hold times for CEP and CET inputs.

Conditions: $\overline{PE} = \overline{MR} = \text{HIGH}$.



Conditions
 $\overline{PE} = \text{LOW}$
 $\overline{MR} = \text{HIGH}$

Fig. 7 Waveforms showing set-up times and hold times for P_n inputs.

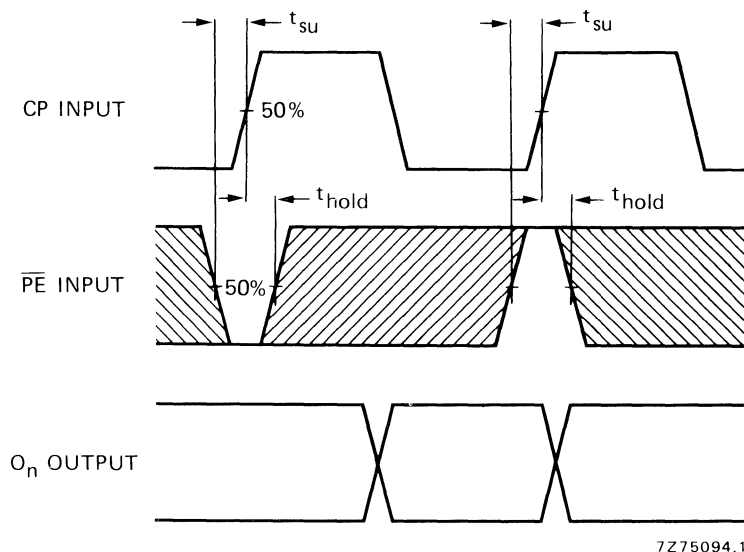

Condition
 $\overline{MR} = \text{HIGH}$

Fig. 8 Waveforms showing set-up times and hold times for \overline{PE} inputs.

Note

Set-up and hold times are shown as positive values but may be specified as negative values.

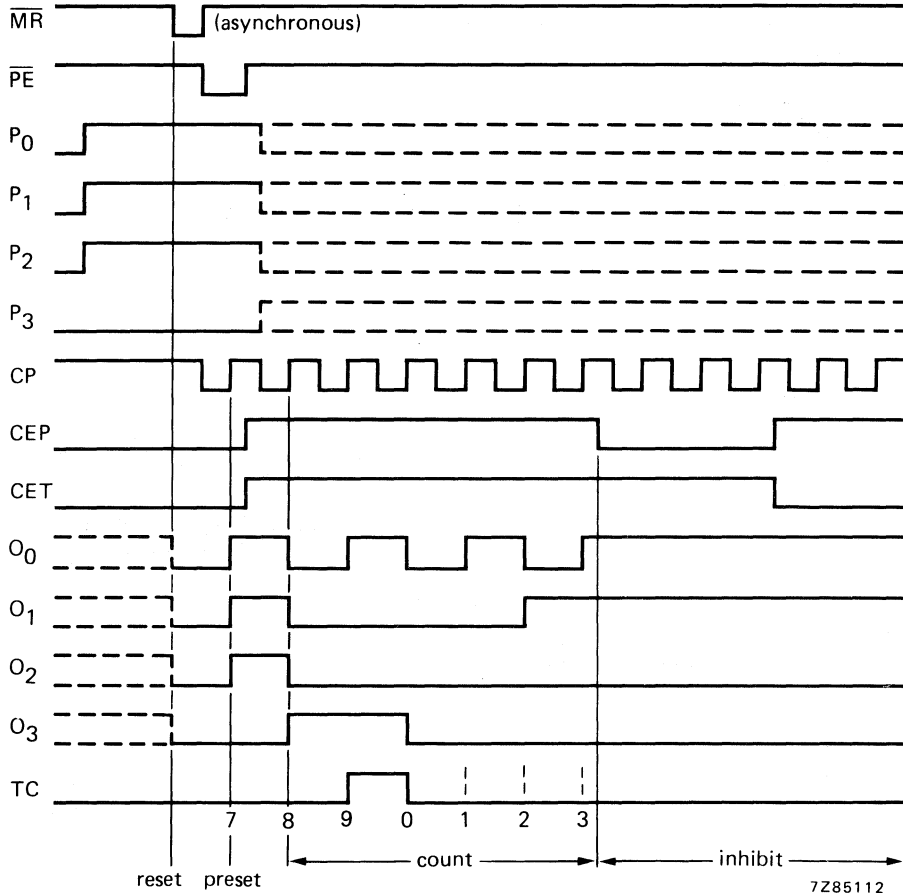

Fig. 9 Timing diagram.

APPLICATION INFORMATION

An example of an application for the HEF40160B is:

- Programmable decade counter.

clock

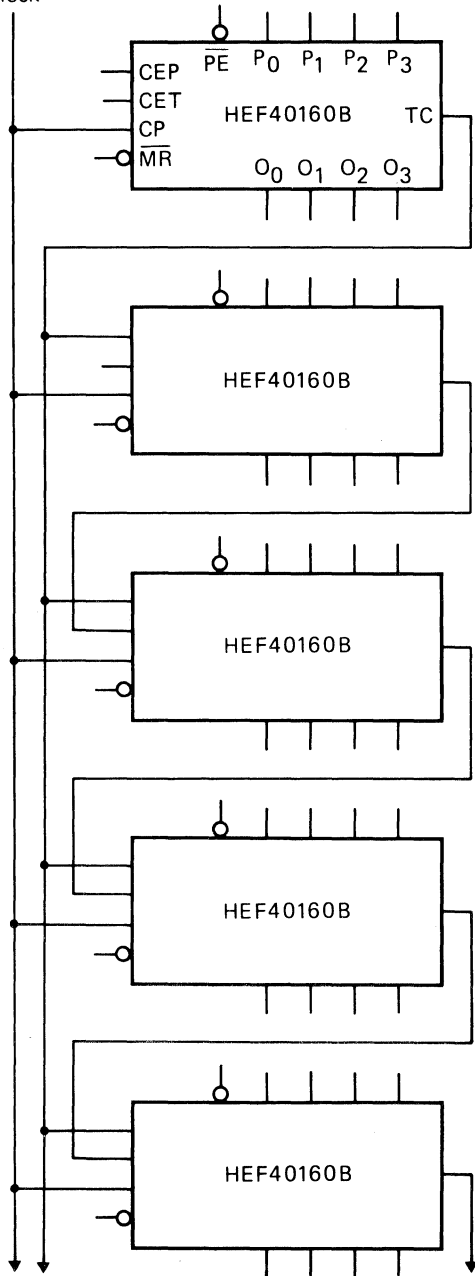

NOTE

On the TC outputs, glitches can occur during counting. In totally synchronous mode they will not have any adverse affect. However the TC output in asynchronous mode can cause problems.

Fig. 10 Synchronous multi-stage counting scheme.

7Z85114

4-BIT SYNCHRONOUS BINARY COUNTER WITH ASYNCHRONOUS RESET



The HEF40161B is a fully synchronous edge-triggered 4-bit binary counter with a clock input (CP), an overriding asynchronous master reset (\overline{MR}), four parallel data inputs (P_0 to P_3), three synchronous mode control inputs (parallel enable (\overline{PE}), count enable parallel (CEP) and count enable trickle (CET)), buffered outputs from all four bit positions (O_0 to O_3) and a terminal count output (TC).

Operation is fully synchronous (except for the \overline{MR} input) and occurs on the LOW to HIGH transition of CP. When \overline{PE} is LOW, the next LOW to HIGH transition of CP loads data into the counter from P_0 to P_3 regardless of the levels of CEP and CET inputs.

When \overline{PE} is HIGH, the next LOW to HIGH transition of CP advances the counter to its next state only if both CEP and CET are HIGH; otherwise, no change occurs in the state of the counter. TC is HIGH when the state of the counter is 15 (O_1 to O_3 - HIGH) and when CET is HIGH. A LOW on \overline{MR} sets all outputs (O_0 to O_3 and TC) LOW, independent of the state of all other inputs. Multistage synchronous counting is possible without additional components by using a carry look-ahead counting technique; in this case, TC is used to enable successive cascaded stages. CEP, CET and \overline{PE} must be stable only during the set-up time before the LOW to HIGH transition of CP.

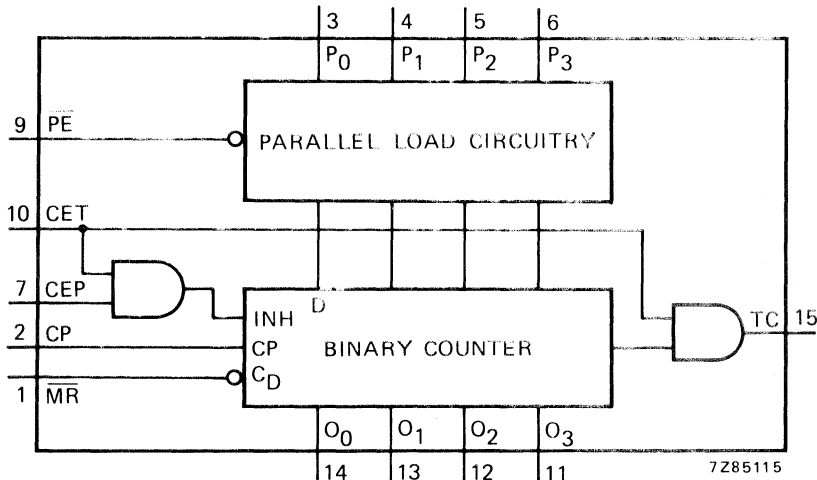
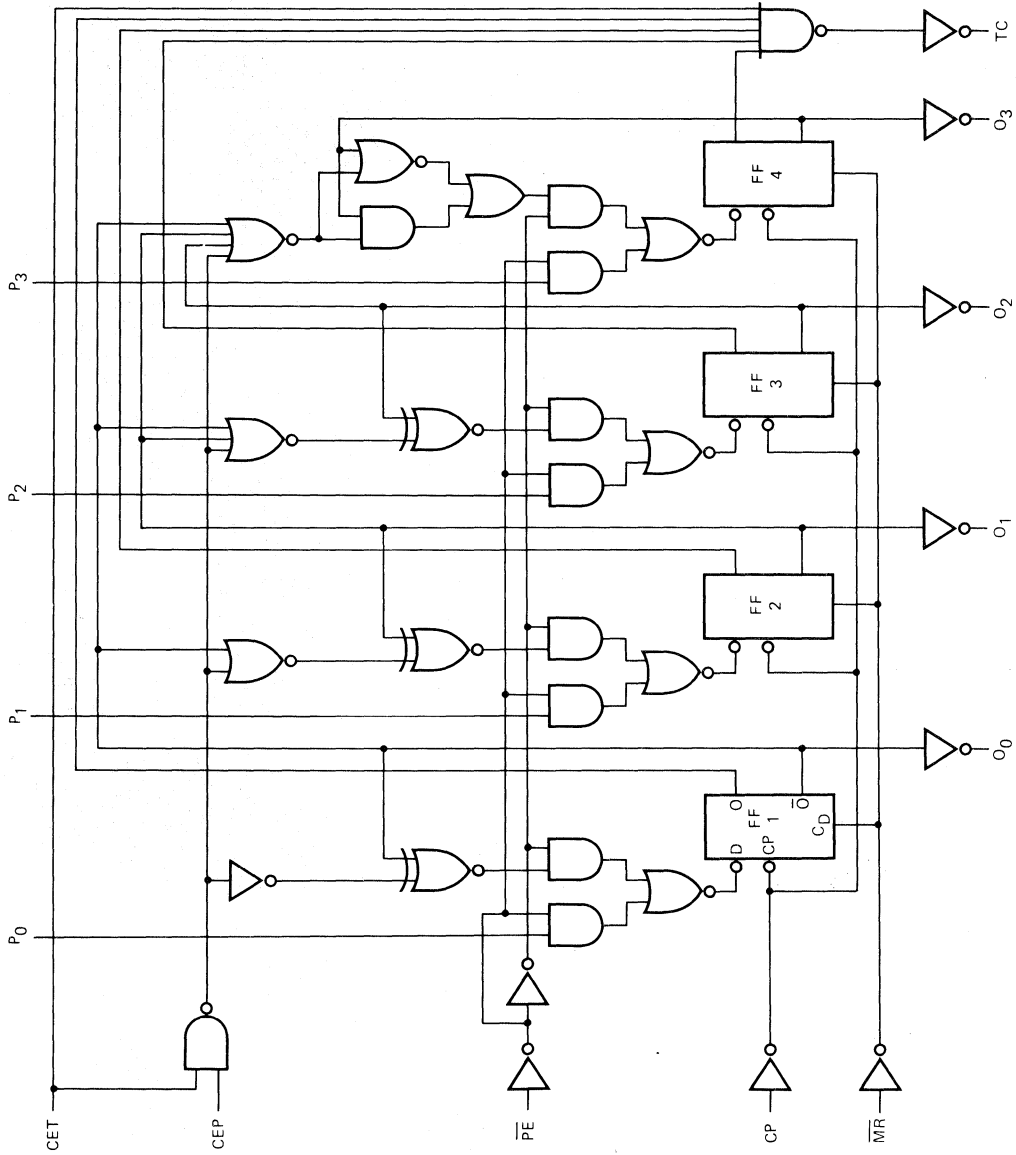

Fig. 1 Functional diagram.

FAMILY DATA

I_{DD} LIMITS category MSI

see Family Specifications



7275084.1

Fig. 2 Logic diagram.

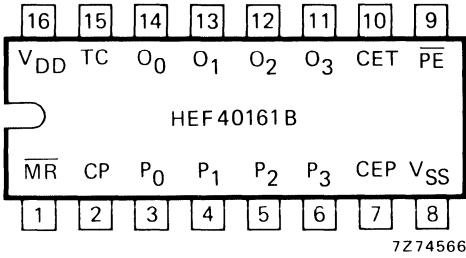

PINNING

- PE parallel enable input
- P₀ to P₃ parallel data inputs
- CEP count enable parallel input
- CET count enable trickle input
- CP clock input (LOW to HIGH, edge-triggered)
- \overline{MR} master reset input (active LOW)
- O₀ to O₃ parallel outputs
- TC terminal count output

Fig. 3. Pinning diagram.

HEF40161BP : 16-lead DIL; plastic (SOT-38Z).
 HEF40161BD: 16-lead DIL; ceramic (cerdip) (SOT-74).
 HEF40161BT : 16-lead mini-pack; plastic (SO-16; SOT-109A).

SYNCHRONOUS MODE SELECTION

| \overline{PE} | CEP | CET | mode |
|-----------------|-----|-----|-----------|
| L | X | X | preset |
| H | L | X | no change |
| H | X | L | no change |
| H | H | H | count |

\overline{MR} = HIGH

H = HIGH state (the more positive voltage)
 L = LOW state (the less positive voltage)
 X = state is immaterial

TERMINAL COUNT GENERATION

| CET | (O ₀ ·O ₁ ·O ₂ ·O ₃) | TC |
|-----|---|----|
| L | L | L |
| L | H | L |
| H | L | L |
| H | H | H |

$$TC = CET \cdot O_0 \cdot O_1 \cdot O_2 \cdot O_3$$

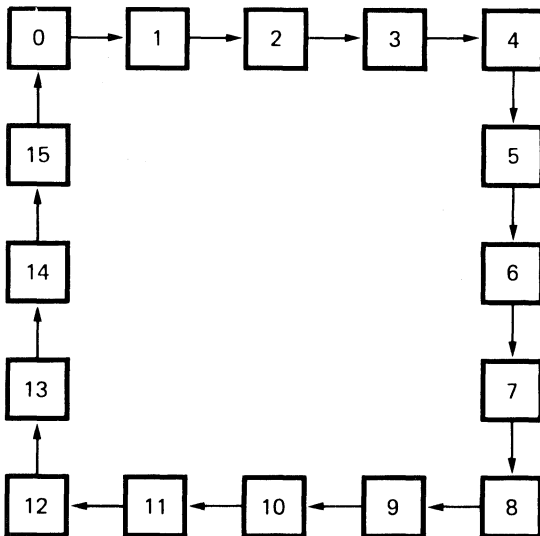

Fig. 4 State diagram.

7Z75087

A.C. CHARACTERISTICS

 $V_{SS} = 0\text{ V}$; $T_{amb} = 25\text{ }^{\circ}\text{C}$; input transition times $\leq 20\text{ ns}$

| | V_{DD} V | typical formula for P (μW) | where f_i = input freq. (MHz) f_o = output freq. (MHz) C_L = load capacitance (pF) $\Sigma(f_o C_L)$ = sum of outputs V_{DD} = supply voltage (V) |
|---|---------------|---|--|
| Dynamic power dissipation per package (P) | 5 | $1\,200 f_i + \Sigma(f_o C_L) \times V_{DD}^2$ | |
| | 10 | $5\,600 f_i + \Sigma(f_o C_L) \times V_{DD}^2$ | |
| | 15 | $16\,000 f_i + \Sigma(f_o C_L) \times V_{DD}^2$ | |

A.C. CHARACTERISTICS

 $V_{SS} = 0\text{ V}$; $T_{amb} = 25\text{ }^{\circ}\text{C}$; $C_L = 50\text{ pF}$; input transition times $\leq 20\text{ ns}$

| | V_{DD} V | symbol | min. | typ. | max. | typical extrapolation formula | |
|---|---------------|-----------|------|------|------|----------------------------------|---|
| Propagation delays $CP \rightarrow O_n$ HIGH to LOW | 5 | t_{PHL} | | 110 | 220 | ns | $83\text{ ns} + (0,55\text{ ns/pF}) C_L$ |
| | 10 | | | 45 | 90 | ns | $34\text{ ns} + (0,23\text{ ns/pF}) C_L$ |
| | 15 | | | 30 | 60 | ns | $22\text{ ns} + (0,16\text{ ns/pF}) C_L$ |
| LOW to HIGH | 5 | t_{PLH} | | 115 | 230 | ns | $88\text{ ns} + (0,55\text{ ns/pF}) C_L$ |
| | 10 | | | 45 | 95 | ns | $34\text{ ns} + (0,23\text{ ns/pF}) C_L$ |
| | 15 | | | 35 | 65 | ns | $27\text{ ns} + (0,16\text{ ns/pF}) C_L$ |
| $CP \rightarrow TC$ HIGH to LOW | 5 | t_{PHL} | | 130 | 260 | ns | $103\text{ ns} + (0,55\text{ ns/pF}) C_L$ |
| | 10 | | | 55 | 105 | ns | $44\text{ ns} + (0,23\text{ ns/pF}) C_L$ |
| | 15 | | | 35 | 75 | ns | $27\text{ ns} + (0,16\text{ ns/pF}) C_L$ |
| LOW to HIGH | 5 | t_{PLH} | | 140 | 280 | ns | $113\text{ ns} + (0,55\text{ ns/pF}) C_L$ |
| | 10 | | | 55 | 115 | ns | $44\text{ ns} + (0,23\text{ ns/pF}) C_L$ |
| | 15 | | | 40 | 80 | ns | $32\text{ ns} + (0,16\text{ ns/pF}) C_L$ |
| $CET \rightarrow TC$ HIGH to LOW | 5 | t_{PHL} | | 105 | 210 | ns | $78\text{ ns} + (0,55\text{ ns/pF}) C_L$ |
| | 10 | | | 50 | 100 | ns | $39\text{ ns} + (0,23\text{ ns/pF}) C_L$ |
| | 15 | | | 35 | 75 | ns | $27\text{ ns} + (0,16\text{ ns/pF}) C_L$ |
| LOW to HIGH | 5 | t_{PLH} | | 90 | 185 | ns | $63\text{ ns} + (0,55\text{ ns/pF}) C_L$ |
| | 10 | | | 35 | 70 | ns | $24\text{ ns} + (0,23\text{ ns/pF}) C_L$ |
| | 15 | | | 25 | 50 | ns | $17\text{ ns} + (0,16\text{ ns/pF}) C_L$ |
| $\overline{MR} \rightarrow O_n$ HIGH to LOW | 5 | t_{PHL} | | 120 | 245 | ns | $93\text{ ns} + (0,55\text{ ns/pF}) C_L$ |
| | 10 | | | 50 | 100 | ns | $39\text{ ns} + (0,23\text{ ns/pF}) C_L$ |
| | 15 | | | 35 | 70 | ns | $27\text{ ns} + (0,16\text{ ns/pF}) C_L$ |
| $\overline{MR} \rightarrow TC$ HIGH to LOW | 5 | t_{PHL} | | 145 | 295 | ns | $118\text{ ns} + (0,55\text{ ns/pF}) C_L$ |
| | 10 | | | 60 | 120 | ns | $49\text{ ns} + (0,23\text{ ns/pF}) C_L$ |
| | 15 | | | 45 | 85 | ns | $37\text{ ns} + (0,16\text{ ns/pF}) C_L$ |
| Output transition times HIGH to LOW | 5 | t_{THL} | | 60 | 120 | ns | $10\text{ ns} + (1,0\text{ ns/pF}) C_L$ |
| | 10 | | | 30 | 60 | ns | $9\text{ ns} + (0,42\text{ ns/pF}) C_L$ |
| | 15 | | | 20 | 40 | ns | $6\text{ ns} + (0,28\text{ ns/pF}) C_L$ |
| LOW to HIGH | 5 | t_{TLH} | | 60 | 120 | ns | $10\text{ ns} + (1,0\text{ ns/pF}) C_L$ |
| | 10 | | | 30 | 60 | ns | $9\text{ ns} + (0,42\text{ ns/pF}) C_L$ |
| | 15 | | | 20 | 40 | ns | $6\text{ ns} + (0,28\text{ ns/pF}) C_L$ |

A.C. CHARACTERISTICS

$V_{SS} = 0\text{ V}$; $T_{amb} = 25\text{ }^{\circ}\text{C}$; $C_L = 50\text{ pF}$; input transition times $\leq 20\text{ ns}$

| | V_{DD} V | symbol | min. | typ. | max. | |
|--|---------------|------------|------|------|------|--|
| Minimum clock pulse width; LOW | 5 | t_{WCPL} | 100 | 50 | ns | see also waveforms Figs 5, 6, 7 and 8 |
| | 10 | | 40 | 20 | ns | |
| | 15 | | 30 | 15 | ns | |
| Minimum \overline{MR} pulse width; LOW | 5 | t_{WMRL} | 100 | 50 | ns | |
| | 10 | | 40 | 20 | ns | |
| | 15 | | 30 | 15 | ns | |
| Recovery time for \overline{MR} | 5 | t_{RMR} | 25 | 0 | ns | |
| | 10 | | 15 | 0 | ns | |
| | 15 | | 10 | 0 | ns | |
| Set-up times $P_n \rightarrow CP$ | 5 | t_{su} | 110 | 55 | ns | |
| | 10 | | 40 | 20 | ns | |
| | 15 | | 30 | 15 | ns | |
| $\overline{PE} \rightarrow CP$ | 5 | t_{su} | 120 | 60 | ns | |
| | 10 | | 40 | 20 | ns | |
| | 15 | | 25 | 10 | ns | |
| $CEP, CET \rightarrow CP$ | 5 | t_{su} | 260 | 130 | ns | |
| | 10 | | 100 | 50 | ns | |
| | 15 | | 70 | 35 | ns | |
| Hold times $P_n \rightarrow CP$ | 5 | t_{hold} | 20 | -35 | ns | |
| | 10 | | 10 | -10 | ns | |
| | 15 | | 5 | -10 | ns | |
| $\overline{PE} \rightarrow CP$ | 5 | t_{hold} | 15 | -45 | ns | |
| | 10 | | 5 | -15 | ns | |
| | 15 | | 5 | -10 | ns | |
| $CEP, CET \rightarrow CP$ | 5 | t_{hold} | 25 | -105 | ns | |
| | 10 | | 15 | -35 | ns | |
| | 15 | | 10 | -25 | ns | |
| Maximum clock pulse frequency | 5 | f_{max} | 2,5 | 5 | MHz | |
| | 10 | | 7 | 14 | MHz | |
| | 15 | | 9 | 18 | MHz | |

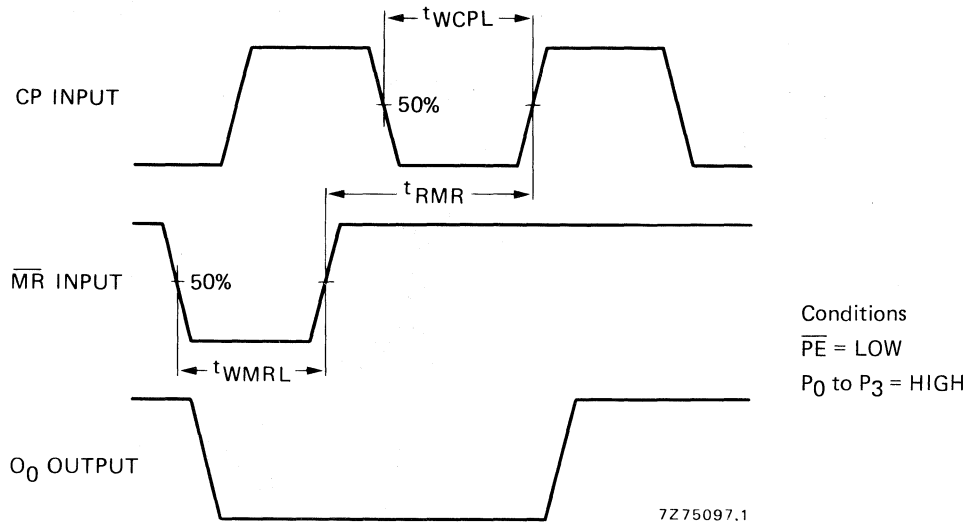

Fig. 5 Waveforms showing minimum CP and \overline{MR} pulse widths and \overline{MR} to CP recovery time.

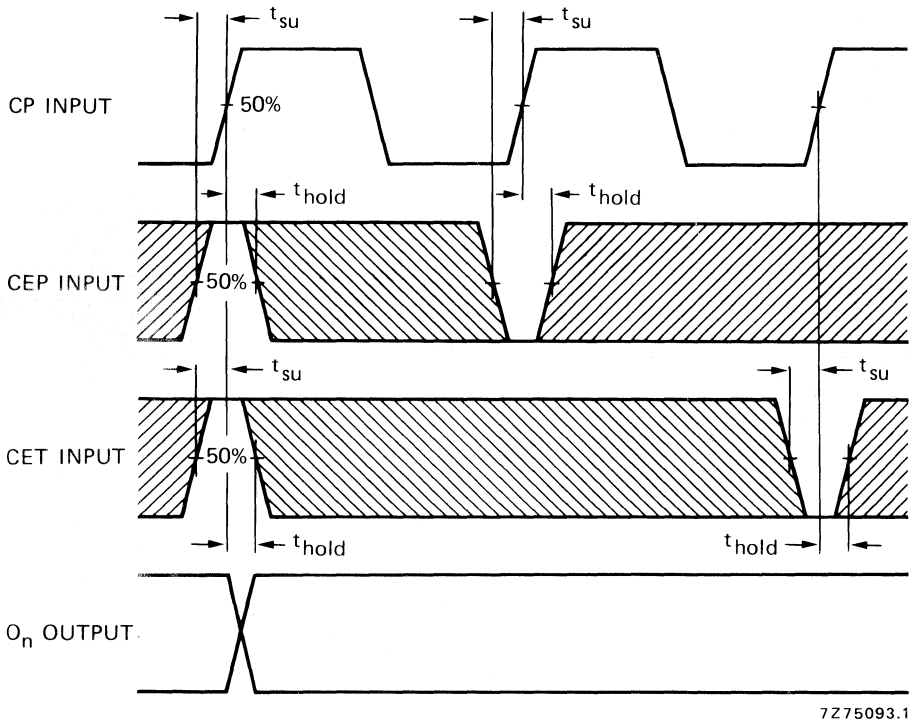

Fig. 6 Waveforms showing set-up times and hold times for CEP and CET inputs.
 Condition: $\overline{PE} = \overline{MR} = \text{HIGH}$.

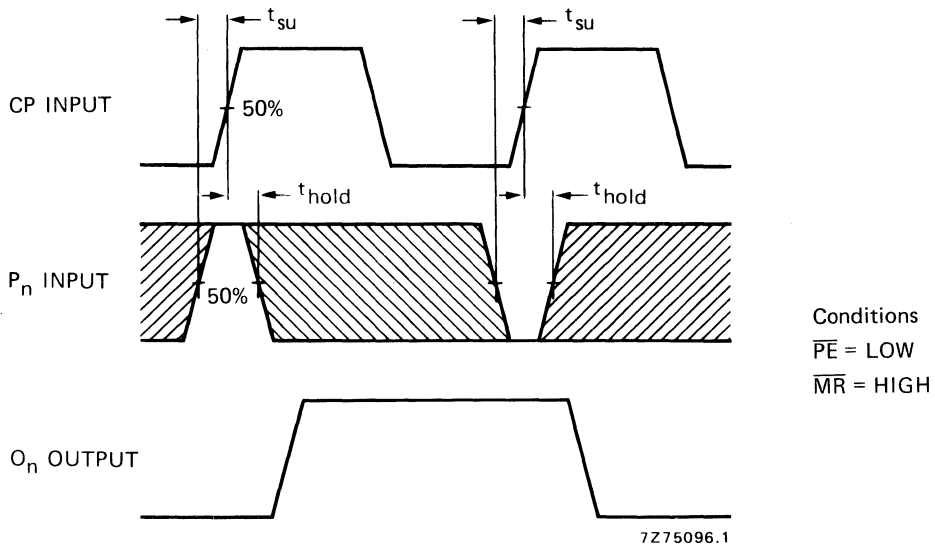

Fig. 7 Waveforms showing set-up times and hold times for P_n inputs.

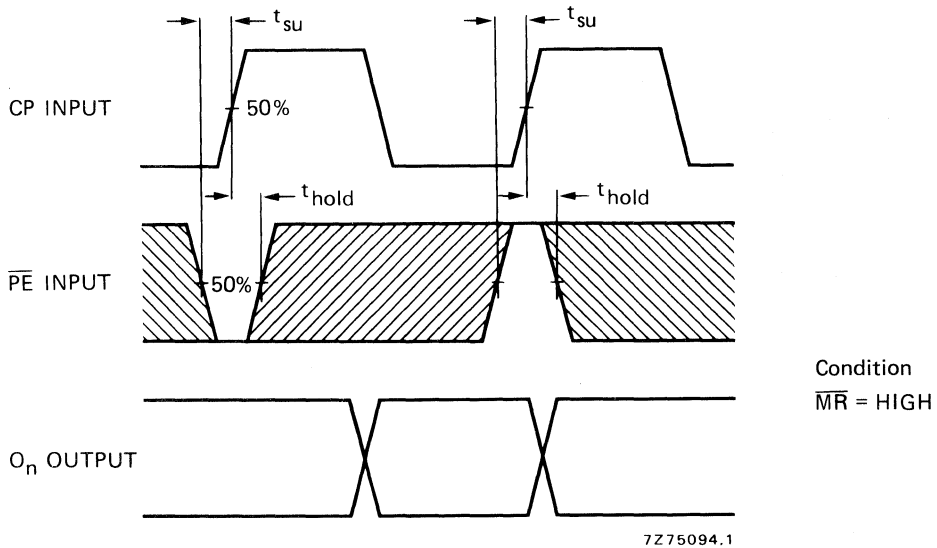

Fig. 8 Waveforms showing set-up times and hold times for \overline{PE} input.

Note

Set-up and hold times are shown as positive values but may be specified as negative values.

HEF40161B
MSI

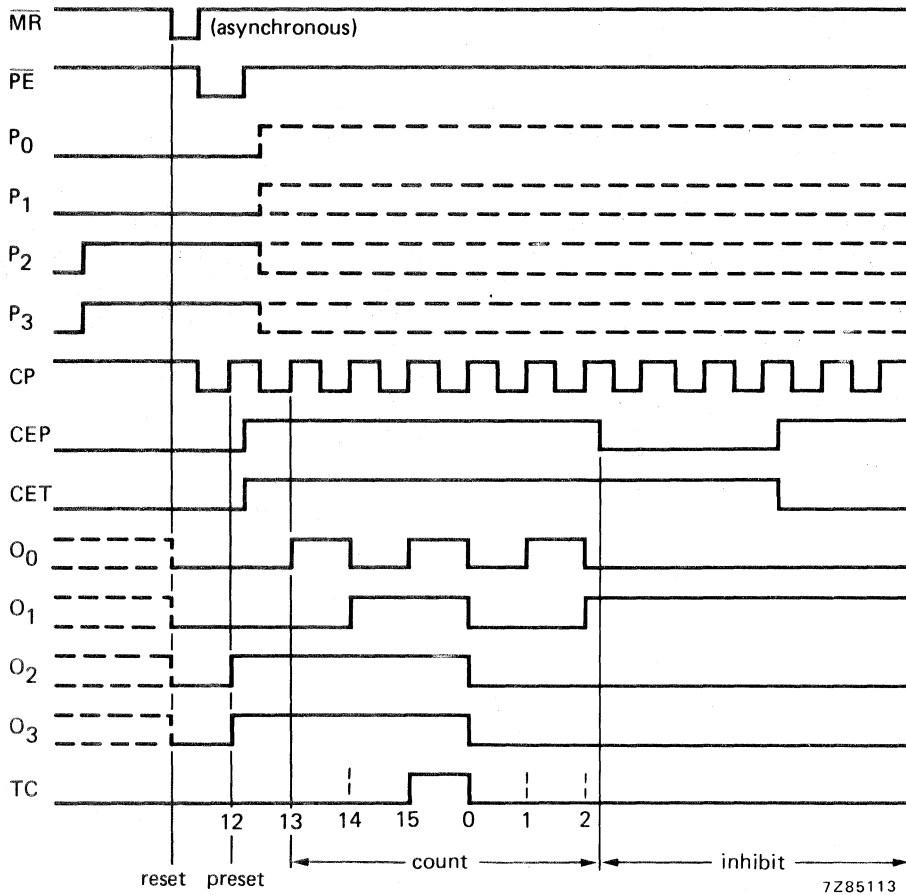
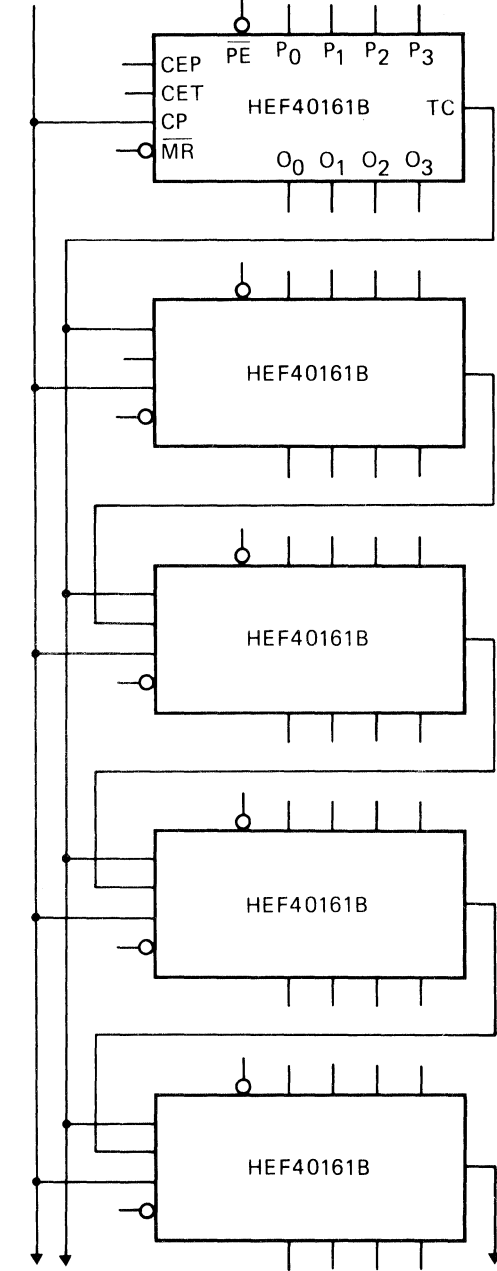

Fig. 9 Timing diagram.

APPLICATION INFORMATION

An example of an application for the HEF40161B is:

- Programmable binary counter.



NOTE

On the TC outputs, glitches can occur during counting. In totally synchronous mode they will not have any adverse affect. However the TC output in asynchronous mode can cause problems.

Fig. 10 Synchronous multi-stage counting scheme.

4-BIT SYNCHRONOUS DECADE COUNTER WITH SYNCHRONOUS RESET



The HEF40162B is a fully synchronous edge-triggered 4-bit decade counter with a clock input (CP), four synchronous parallel data inputs (P_0 to P_3), four synchronous mode control inputs (parallel enable (\overline{PE}), count enable parallel (CEP), count enable trickle (CET) and synchronous reset (\overline{SR})), buffered outputs from all four bit positions (O_0 to O_3) and a terminal count output (TC).

Operation is synchronous and occurs on the LOW to HIGH transition of CP. When \overline{PE} is LOW, the next LOW to HIGH transition of CP loads data into the counter from P_0 to P_3 . When \overline{PE} is HIGH, the next LOW to HIGH transition of CP advances the counter to its next state only if both CEP and CET are HIGH; otherwise no change occurs in the state of the counter. TC is HIGH when the state of the counter is 9 ($O_0 = O_3 = \text{HIGH}$, $O_1 = O_2 = \text{LOW}$) and when CET is HIGH. A LOW on \overline{SR} sets all outputs (O_0 to O_3 and TC) LOW on the next LOW to HIGH transition of CP, independent of the state of all other synchronous mode control inputs (CEP, CET and \overline{PE}). Multistage synchronous counting is possible without additional components by using a carry look-ahead counting technique; in this case, TC is used to enable successive cascaded stages. CEP, CET, \overline{PE} and \overline{SR} must be stable only during the set-up time before the LOW to HIGH transition of CP.

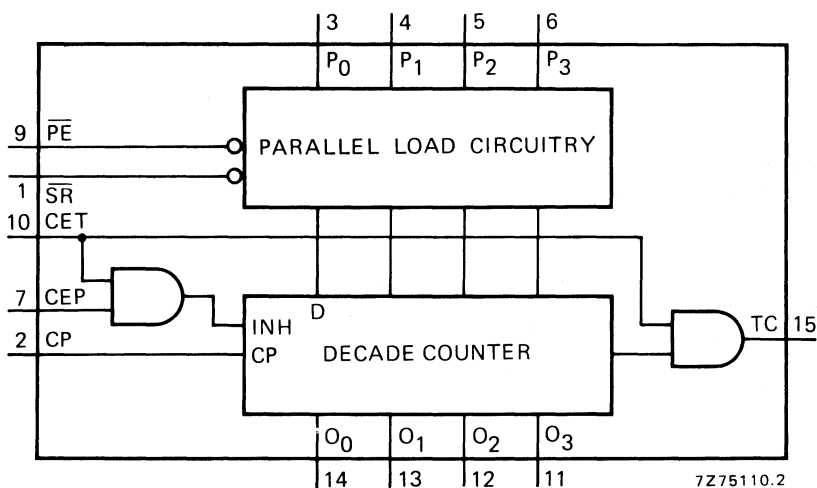
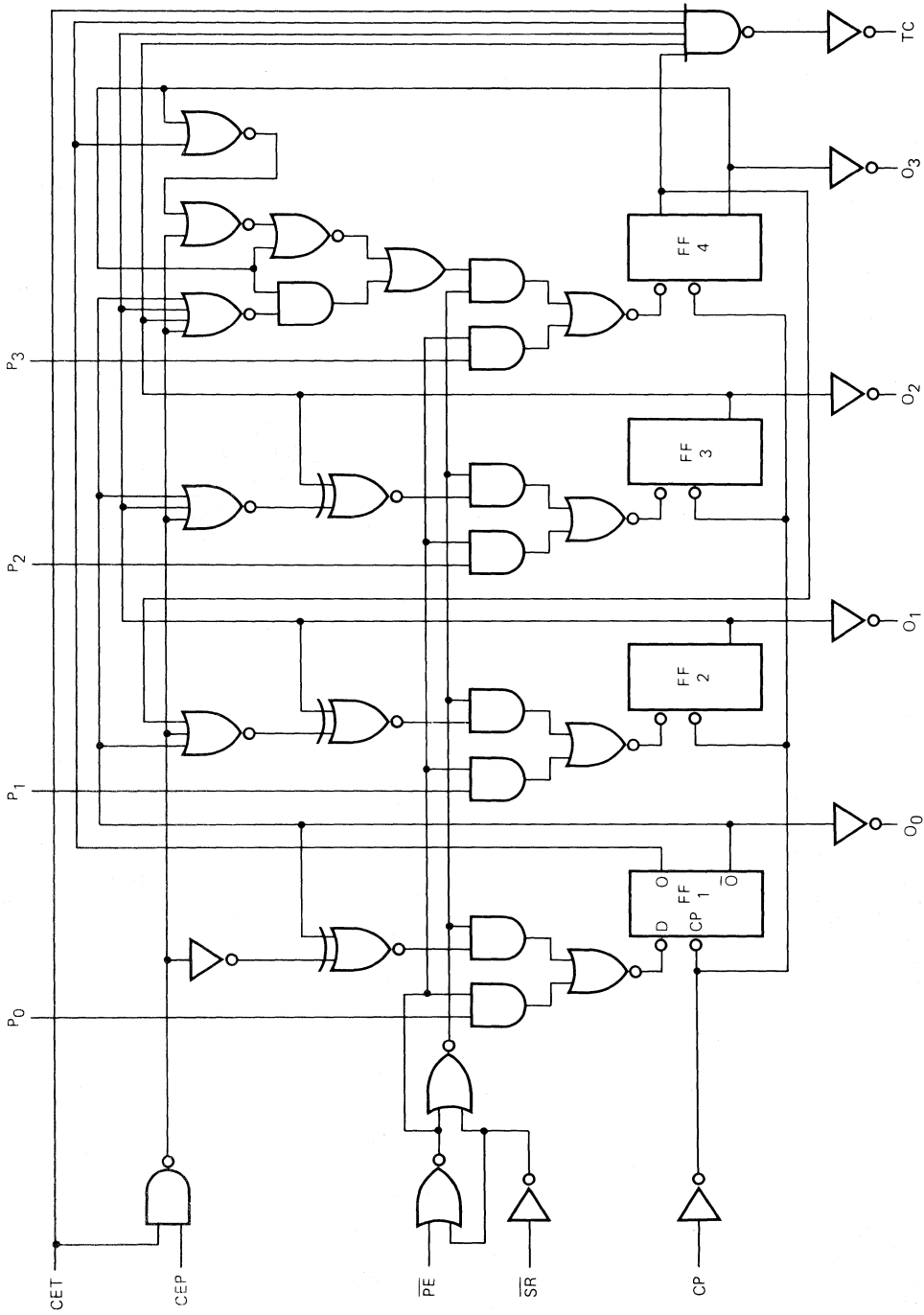

Fig. 1 Functional diagram.

FAMILY DATA

I_{DD} LIMITS category MSI

see Family Specifications



7274573

Fig. 2 Logic diagram.

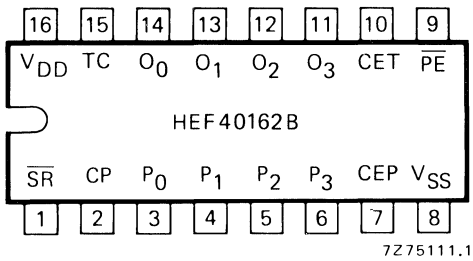

Fig. 3 Pinning diagram.

PINNING

- \overline{PE} parallel enable input
- P₀ to P₃ parallel data inputs
- CEP count enable parallel input
- CET count enable trickle input
- CP clock input (LOW to HIGH, edge-triggered)
- \overline{SR} synchronous reset input (active LOW)
- O₀ to O₃ parallel outputs
- TC terminal count output

- HEF40162BP : 16-lead DIL; plastic (SOT-38Z).
- HEF40162BD: 16-lead DIL; ceramic (cerdip) (SOT-74).
- HEF40162BT : 16-lead mini-pack; plastic (SO-16; SOT-109A).

SYNCHRONOUS MODE SELECTION

| \overline{SR} | \overline{PE} | CEP | CET | mode |
|-----------------|-----------------|-----|-----|-----------|
| H | L | X | X | preset |
| H | H | L | X | no change |
| H | H | X | L | no change |
| H | H | H | H | count |
| L | X | X | X | reset |

H = HIGH state (the more positive voltage)
 L = LOW state (the less positive voltage)
 X = state is immaterial

TERMINAL COUNT GENERATION

| CET | (O ₀ · $\overline{O_1}$ · $\overline{O_2}$ · O ₃) | TC |
|-----|--|----|
| L | L | L |
| L | H | L |
| H | L | L |
| H | H | H |

$$TC = CET \cdot O_0 \cdot \overline{O_1} \cdot \overline{O_2} \cdot O_3$$

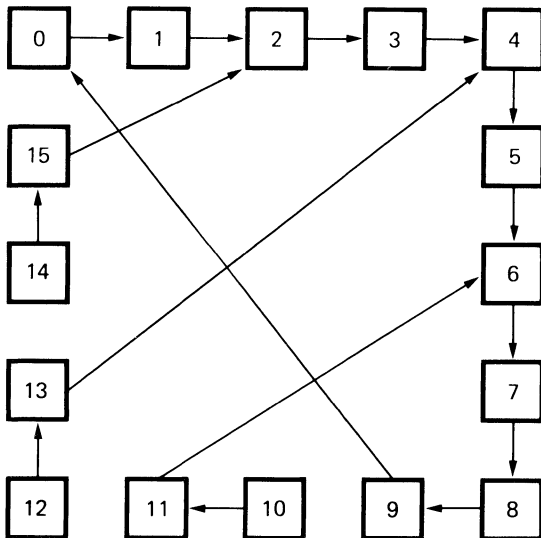

Fig. 4 State diagram.

7275086

A.C. CHARACTERISTICS

 $V_{SS} = 0 \text{ V}$; $T_{amb} = 25 \text{ }^\circ\text{C}$; input transition times $\leq 20 \text{ ns}$

| | V_{DD} V | typical formula for P (μW) | where f_i = input freq. (MHz) f_o = output freq. (MHz) C_L = load capacitance (pF) $\Sigma(f_o C_L)$ = sum of outputs V_{DD} = supply voltage (V) |
|---|---------------|---|--|
| Dynamic power dissipation per package (P) | 5 | $1\,200 f_i + \Sigma(f_o C_L) \times V_{DD}^2$ | |
| | 10 | $5\,600 f_i + \Sigma(f_o C_L) \times V_{DD}^2$ | |
| | 15 | $16\,000 f_i + \Sigma(f_o C_L) \times V_{DD}^2$ | |

A.C. CHARACTERISTICS

 $V_{SS} = 0 \text{ V}$; $T_{amb} = 25 \text{ }^\circ\text{C}$; $C_L = 50 \text{ pF}$; input transition times $\leq 20 \text{ ns}$

| | V_{DD} V | symbol | min. | typ. | max. | typical extrapolation formula | |
|-------------------------|---------------|-----------|------|------|------|-------------------------------|---|
| Propagation delays | | | | | | | |
| CP \rightarrow O_n | 5 | | | 110 | 220 | ns | $83 \text{ ns} + (0,55 \text{ ns/pF}) C_L$ |
| HIGH to LOW | 10 | t_{PHL} | | 45 | 90 | ns | $34 \text{ ns} + (0,23 \text{ ns/pF}) C_L$ |
| | 15 | | | 30 | 60 | ns | $22 \text{ ns} + (0,16 \text{ ns/pF}) C_L$ |
| LOW to HIGH | 5 | | | 115 | 230 | ns | $88 \text{ ns} + (0,55 \text{ ns/pF}) C_L$ |
| | 10 | t_{PLH} | | 45 | 95 | ns | $34 \text{ ns} + (0,23 \text{ ns/pF}) C_L$ |
| | 15 | | | 35 | 65 | ns | $27 \text{ ns} + (0,16 \text{ ns/pF}) C_L$ |
| CP \rightarrow TC | 5 | | | 130 | 260 | ns | $103 \text{ ns} + (0,55 \text{ ns/pF}) C_L$ |
| HIGH to LOW | 10 | t_{PHL} | | 55 | 105 | ns | $44 \text{ ns} + (0,23 \text{ ns/pF}) C_L$ |
| | 15 | | | 35 | 75 | ns | $27 \text{ ns} + (0,16 \text{ ns/pF}) C_L$ |
| LOW to HIGH | 5 | | | 140 | 280 | ns | $113 \text{ ns} + (0,55 \text{ ns/pF}) C_L$ |
| | 10 | t_{PLH} | | 55 | 115 | ns | $44 \text{ ns} + (0,23 \text{ ns/pF}) C_L$ |
| | 15 | | | 40 | 80 | ns | $32 \text{ ns} + (0,16 \text{ ns/pF}) C_L$ |
| CET \rightarrow TC | 5 | | | 105 | 210 | ns | $78 \text{ ns} + (0,55 \text{ ns/pF}) C_L$ |
| HIGH to LOW | 10 | t_{PHL} | | 50 | 100 | ns | $39 \text{ ns} + (0,23 \text{ ns/pF}) C_L$ |
| | 15 | | | 35 | 75 | ns | $27 \text{ ns} + (0,16 \text{ ns/pF}) C_L$ |
| LOW to HIGH | 5 | | | 90 | 185 | ns | $63 \text{ ns} + (0,55 \text{ ns/pF}) C_L$ |
| | 10 | t_{PLH} | | 35 | 70 | ns | $24 \text{ ns} + (0,23 \text{ ns/pF}) C_L$ |
| | 15 | | | 25 | 50 | ns | $17 \text{ ns} + (0,16 \text{ ns/pF}) C_L$ |
| Output transition times | | | | | | | |
| HIGH to LOW | 5 | | | 60 | 120 | ns | $10 \text{ ns} + (1,0 \text{ ns/pF}) C_L$ |
| | 10 | t_{THL} | | 30 | 60 | ns | $9 \text{ ns} + (0,42 \text{ ns/pF}) C_L$ |
| | 15 | | | 20 | 40 | ns | $6 \text{ ns} + (0,28 \text{ ns/pF}) C_L$ |
| LOW to HIGH | 5 | | | 60 | 120 | ns | $10 \text{ ns} + (1,0 \text{ ns/pF}) C_L$ |
| | 10 | t_{TLH} | | 30 | 60 | ns | $9 \text{ ns} + (0,42 \text{ ns/pF}) C_L$ |
| | 15 | | | 20 | 40 | ns | $6 \text{ ns} + (0,28 \text{ ns/pF}) C_L$ |

A.C. CHARACTERISTICS

 $V_{SS} = 0\text{ V}$; $T_{amb} = 25\text{ }^{\circ}\text{C}$; $C_L = 50\text{ pF}$; input transition times $\leq 20\text{ ns}$

| | V_{DD} V | symbol | min. | typ. | max. | |
|--------------------------------------|---------------|------------|------|------|------|--|
| Minimum clock pulse width; LOW | 5 | | 100 | 50 | ns | see also waveforms Figs 5, 6, 7 and 8 |
| | 10 | t_{WCPL} | 40 | 20 | ns | |
| | 15 | | 30 | 15 | ns | |
| Set-up times $P_n \rightarrow CP$ | 5 | | 110 | 55 | ns | |
| | 10 | t_{su} | 40 | 20 | ns | |
| | 15 | | 30 | 15 | ns | |
| $\overline{PE} \rightarrow CP$ | 5 | | 120 | 60 | ns | |
| | 10 | t_{su} | 40 | 20 | ns | |
| | 15 | | 25 | 10 | ns | |
| CEP, CET $\rightarrow CP$ | 5 | | 260 | 130 | ns | |
| | 10 | t_{su} | 100 | 50 | ns | |
| | 15 | | 70 | 35 | ns | |
| $\overline{SR} \rightarrow CP$ | 5 | | 50 | 25 | ns | |
| | 10 | t_{su} | 20 | 10 | ns | |
| | 15 | | 15 | 10 | ns | |
| Hold times $P_n \rightarrow CP$ | 5 | | 20 | -35 | ns | |
| | 10 | t_{hold} | 10 | -10 | ns | |
| | 15 | | 5 | -10 | ns | |
| $\overline{PE} \rightarrow CP$ | 5 | | 15 | -45 | ns | |
| | 10 | t_{hold} | 5 | -15 | ns | |
| | 15 | | 5 | -10 | ns | |
| CEP, CET $\rightarrow CP$ | 5 | | 25 | -105 | ns | |
| | 10 | t_{hold} | 15 | -35 | ns | |
| | 15 | | 10 | -25 | ns | |
| $\overline{SR} \rightarrow CP$ | 5 | | 15 | -10 | ns | |
| | 10 | t_{hold} | 5 | -5 | ns | |
| | 15 | | 5 | 0 | ns | |
| Maximum clock pulse frequency | 5 | | 2,5 | 5 | MHz | |
| | 10 | f_{max} | 7 | 14 | MHz | |
| | 15 | | 9 | 18 | MHz | |

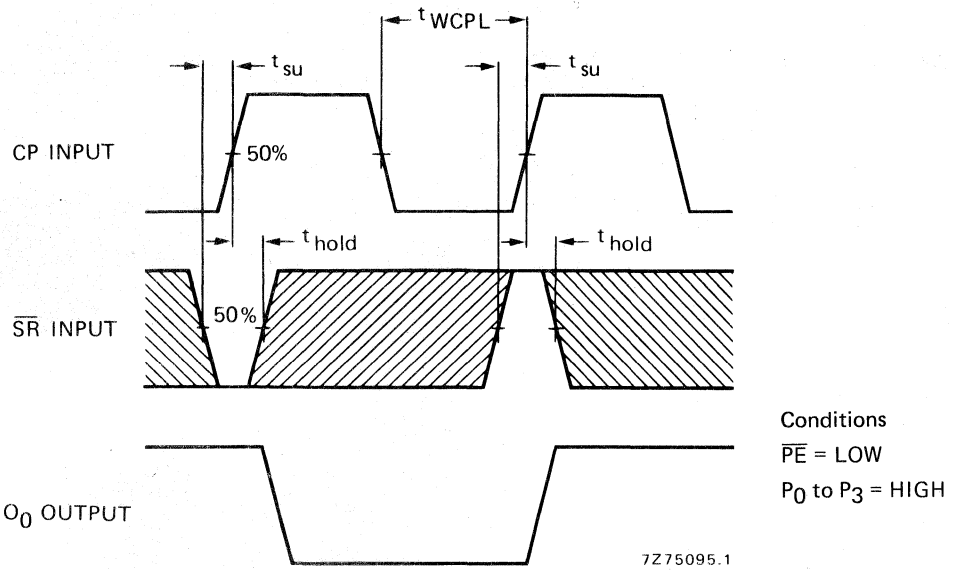

Fig. 5 Waveforms showing set-up times and hold times for \overline{SR} input and minimum CP pulse width.

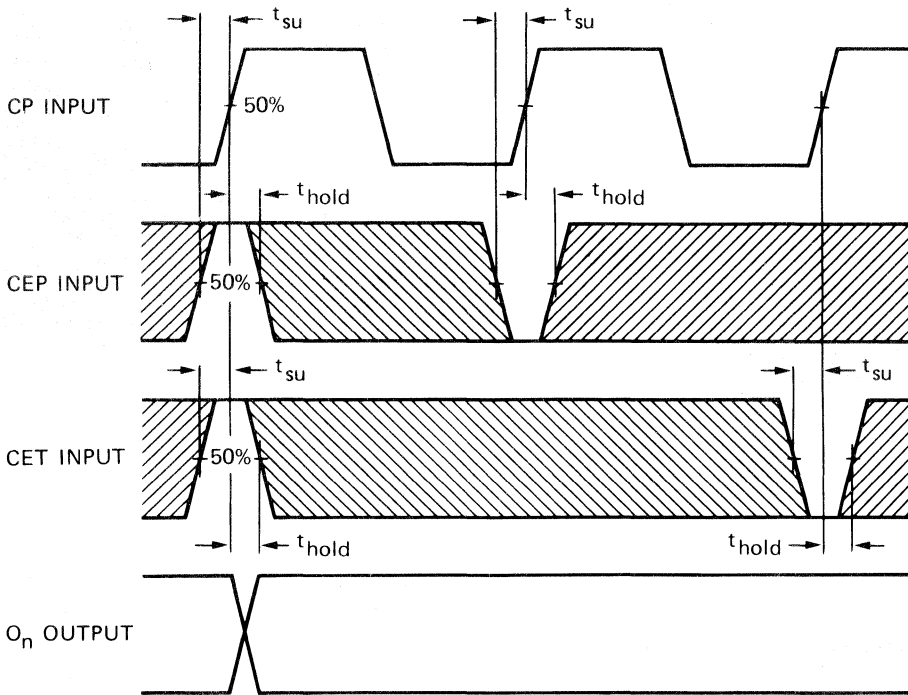
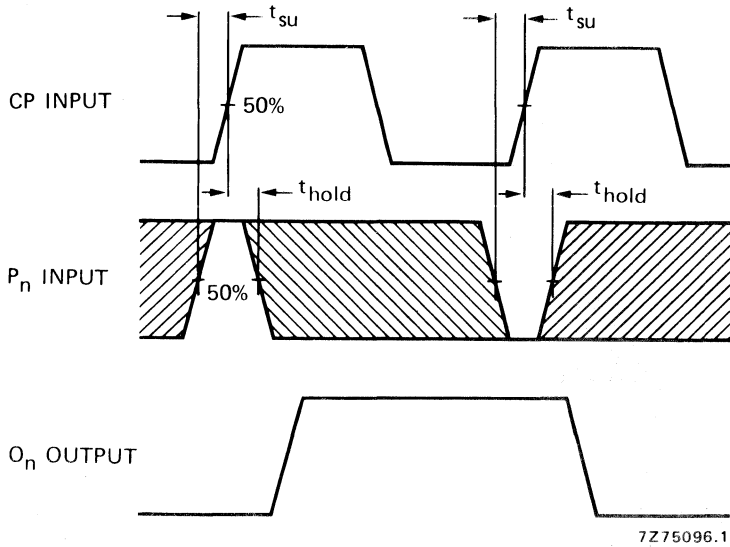

Fig. 6 Waveforms showing set-up times and hold times for CEP and CET inputs.

Condition: $\overline{PE} = \overline{SR} = \text{HIGH}$.



Conditions
 \overline{PE} = LOW
 \overline{SR} = HIGH

Fig. 7 Waveforms showing set-up times and hold times for P_n inputs.

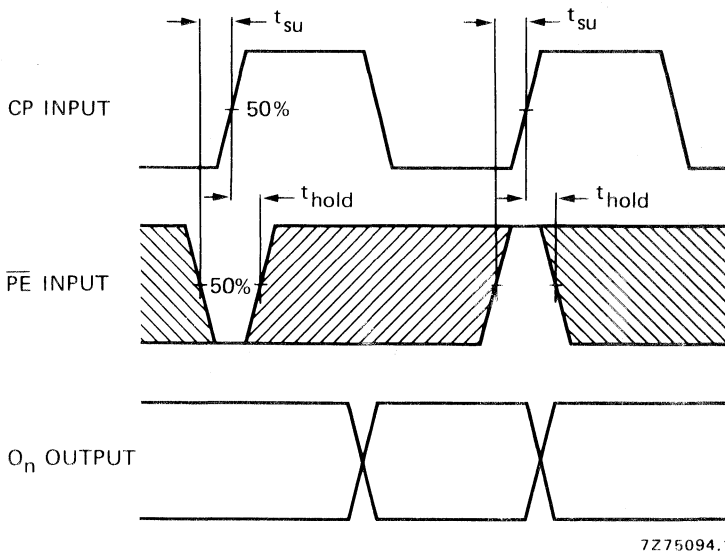

Condition
 \overline{SR} = HIGH

Fig. 8 Waveforms showing set-up times and hold times for \overline{PE} input.

Note

Set-up and hold times are shown as positive values but may be specified as negative values.

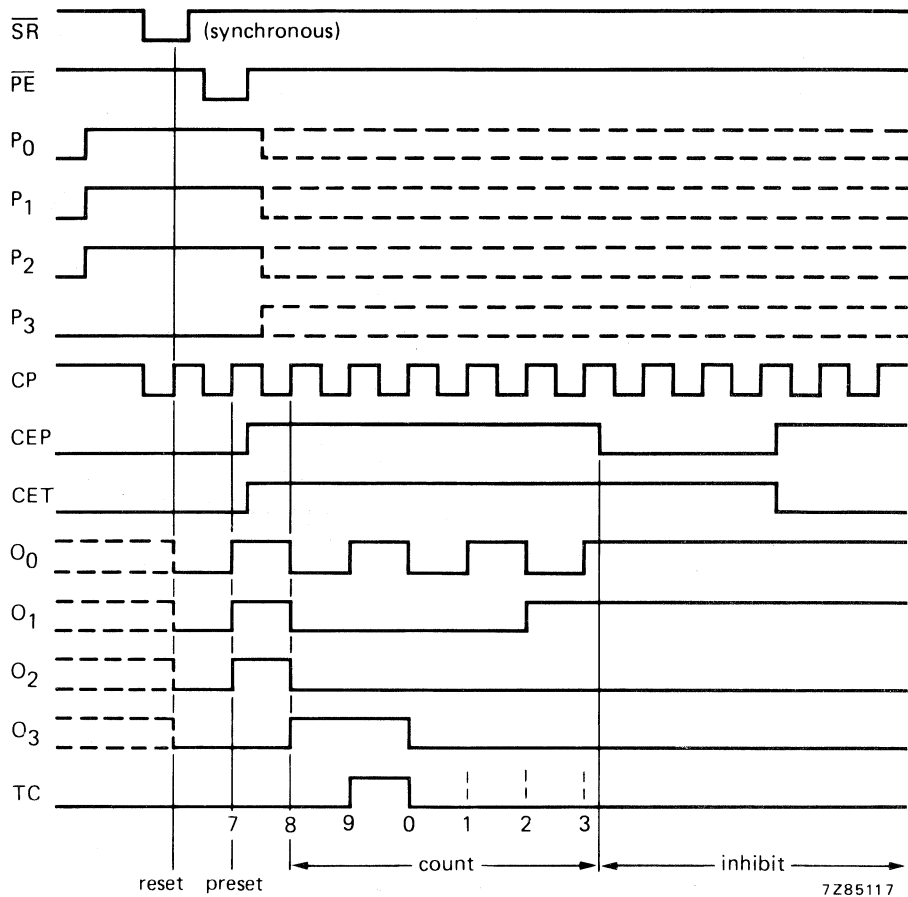

Fig. 9 Timing diagram.

APPLICATION INFORMATION

An example of an application for the HEF40162B is:

- Programmable decade counter.

clock

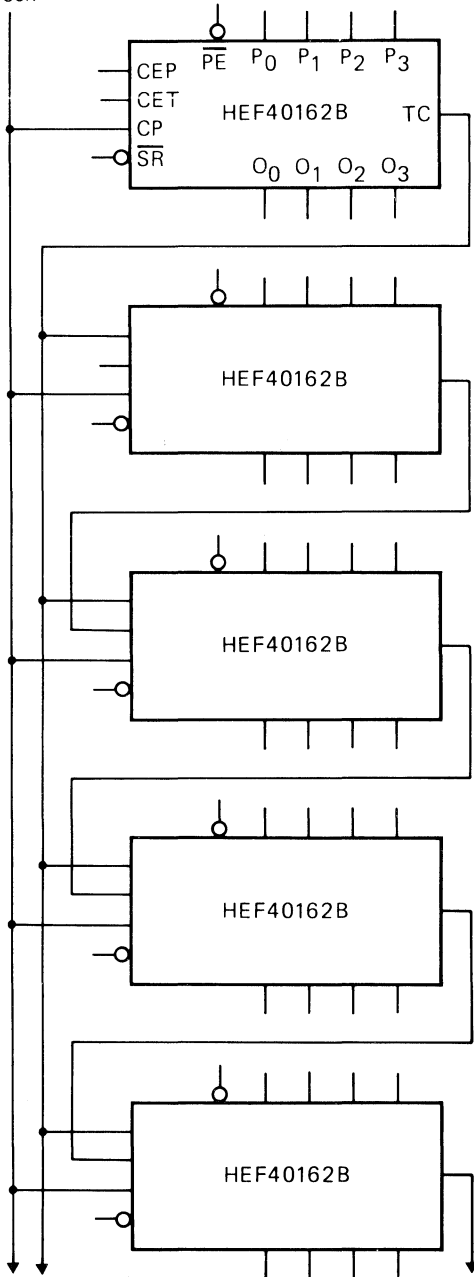

NOTE

On the TC outputs, glitches can occur during counting. In totally synchronous mode they will not have any adverse affect. However the TC output in asynchronous mode can cause problems.

Fig. 10 Synchronous multi-stage counting scheme.

4-BIT SYNCHRONOUS BINARY COUNTER WITH SYNCHRONOUS RESET



The HEF40163B is a fully synchronous edge-triggered 4-bit binary counter with a clock input (CP), four synchronous parallel data inputs (P_0 to P_3), four synchronous mode control inputs (parallel enable (\overline{PE}), count enable parallel (CEP), count enable trickle (CET) and synchronous reset (\overline{SR})), buffered outputs from all four bit positions (O_0 to O_3) and a terminal count output (TC).

Operation is fully synchronous and occurs on the LOW to HIGH transition of CP. When \overline{PE} is LOW, the next LOW to HIGH transition of CP loads data into the counter from P_0 to P_3 . When \overline{PE} is HIGH, the next LOW to HIGH transition of CP advances the counter to its next state only if both CEP and CET are HIGH; otherwise no change occurs in the state of the counter. TC is HIGH when the state of the counter is 15 (O_0 to $O_3 = \text{HIGH}$) and when CET is HIGH. A LOW on \overline{SR} sets all outputs (O_0 to O_3 and TC) LOW on the next LOW to HIGH transition of CP, independent of the state of all other synchronous mode control inputs (CEP, CET and \overline{PE}). Multistage synchronous counting is possible without additional components by using a carry look-ahead counting technique; in this case, TC is used to enable successive cascaded stages. CEP, CET, \overline{PE} and \overline{SR} must be stable only during the set-up time before the LOW to HIGH transition of CP.

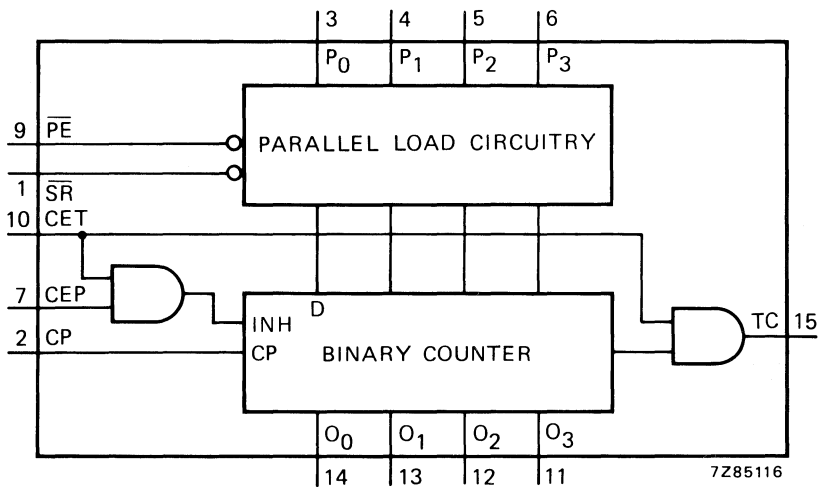

Fig. 1 Functional diagram.

FAMILY DATA

I_{DD} LIMITS category MSI

see Family Specifications

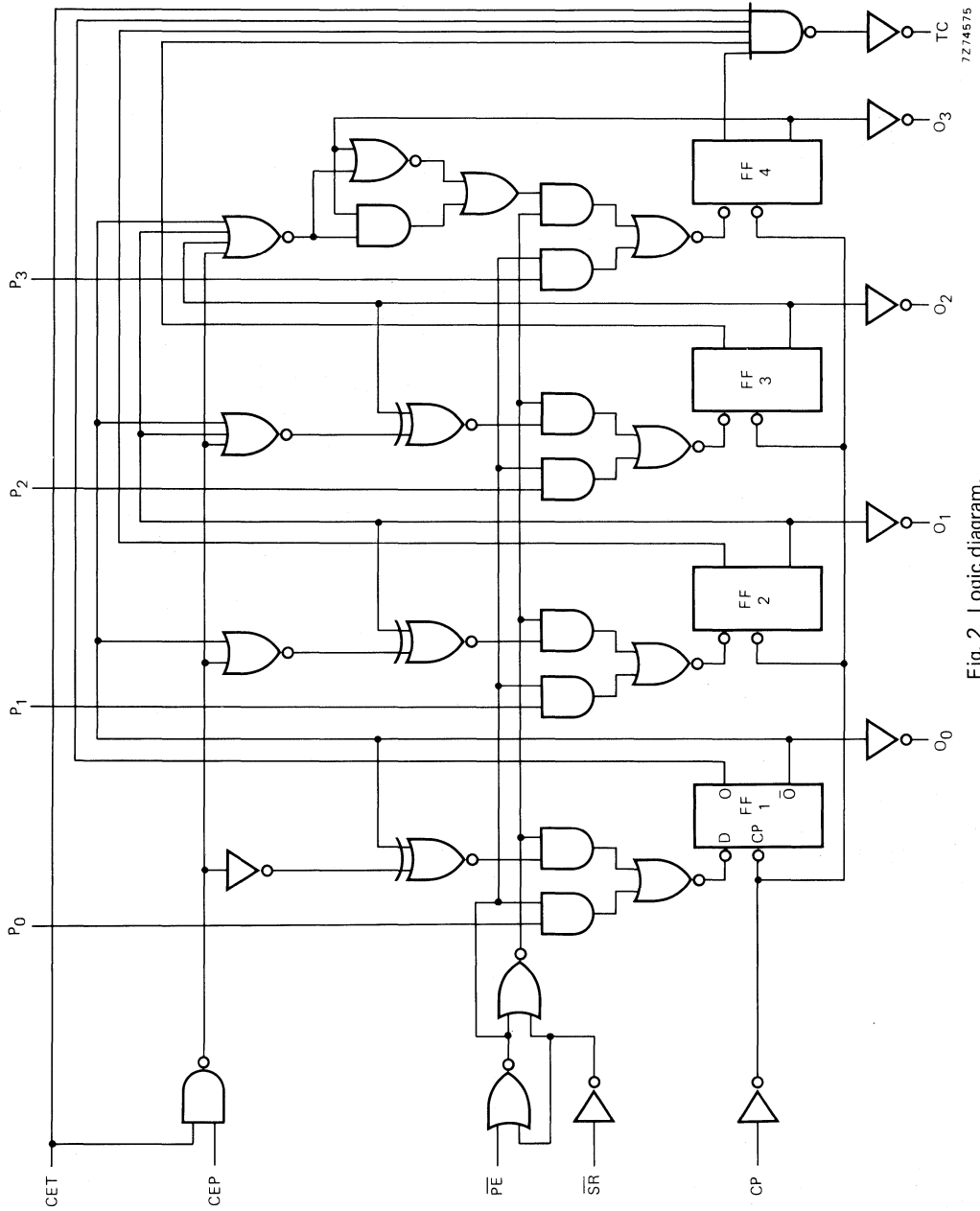

Fig. 2 Logic diagram.

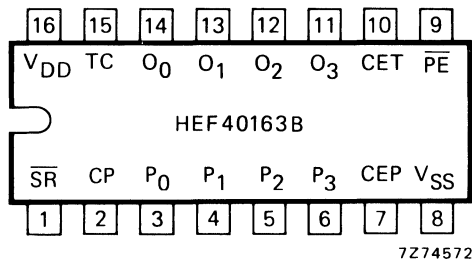

Fig. 3 Pinning diagram.

PINNING

- \overline{PE} parallel enable input
- P₀ to P₃ parallel data inputs
- CEP count enable parallel input
- CET count enable trickle input
- CP clock input (LOW to HIGH, edge-triggered)
- \overline{SR} synchronous reset input (active LOW)
- O₀ to O₃ parallel outputs
- TC terminal count output

HEF40163BP : 16-lead DIL; plastic (SOT-38Z).
 HEF40163BD: 16-lead DIL; ceramic (cerdip) (SOT-74).
 HEF40163BT : 16-lead mini-pack; plastic (SO-16; SOT-109A).

SYNCHRONOUS MODE SELECTION

| \overline{SR} | \overline{PE} | CEP | CET | mode |
|-----------------|-----------------|-----|-----|-----------|
| H | L | X | X | preset |
| H | H | L | X | no change |
| H | H | X | L | no change |
| H | H | H | H | count |
| L | X | X | X | reset |

H = HIGH state (the more positive voltage)
 L = LOW state (the less positive voltage)
 X = state is immaterial

TERMINAL COUNT GENERATION

| CET | (O ₀ · O ₁ · O ₂ · O ₃) | TC |
|-----|--|----|
| L | L | L |
| L | H | L |
| H | L | L |
| H | H | H |

$$TC = CET \cdot O_0 \cdot O_1 \cdot O_2 \cdot O_3$$

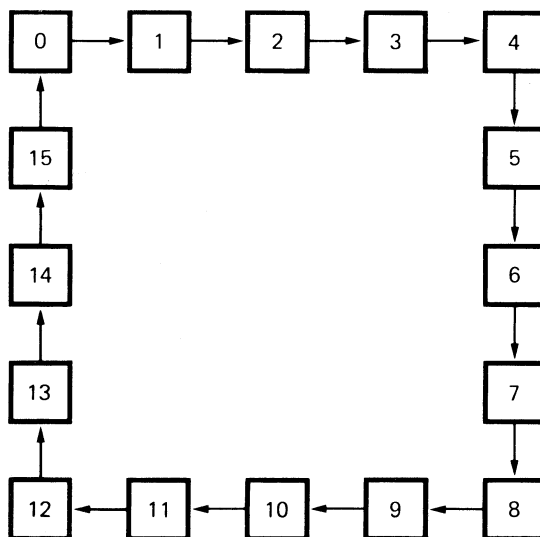

Fig. 4 State diagram.

7275087

A.C. CHARACTERISTICS

 $V_{SS} = 0\text{ V}$; $T_{amb} = 25\text{ }^{\circ}\text{C}$; input transition times $\leq 20\text{ ns}$

| | V_{DD} V | typical formula for P (μW) | where f_i = input freq. (MHz) f_o = output freq. (MHz) C_L = load capacitance (pF) $\Sigma(f_o C_L)$ = sum of outputs V_{DD} = supply voltage (V) |
|---|---------------|---|--|
| Dynamic power dissipation per package (P) | 5 | $1\,200 f_i + \Sigma(f_o C_L) \times V_{DD}^2$ | |
| | 10 | $5\,600 f_i + \Sigma(f_o C_L) \times V_{DD}^2$ | |
| | 15 | $16\,000 f_i + \Sigma(f_o C_L) \times V_{DD}^2$ | |

A.C. CHARACTERISTICS

 $V_{SS} = 0\text{ V}$; $T_{amb} = 25\text{ }^{\circ}\text{C}$; $C_L = 50\text{ pF}$; input transition times $\leq 20\text{ ns}$

| | V_{DD} V | symbol | min. | typ. | max. | typical extrapolation formula | |
|---|---------------|-----------|------|------|------|--|---|
| Propagation delays $CP \rightarrow O_n$ HIGH to LOW | 5 | t_{PHL} | | 110 | 220 | ns | $83\text{ ns} + (0,55\text{ ns/pF}) C_L$ |
| | 10 | | 45 | 90 | ns | $34\text{ ns} + (0,23\text{ ns/pF}) C_L$ | |
| | 15 | | 30 | 60 | ns | $22\text{ ns} + (0,16\text{ ns/pF}) C_L$ | |
| LOW to HIGH | 5 | t_{PLH} | | 115 | 230 | ns | $88\text{ ns} + (0,55\text{ ns/pF}) C_L$ |
| | 10 | | 45 | 95 | ns | $34\text{ ns} + (0,23\text{ ns/pF}) C_L$ | |
| | 15 | | 35 | 65 | ns | $27\text{ ns} + (0,16\text{ ns/pF}) C_L$ | |
| $CP \rightarrow TC$ HIGH to LOW | 5 | t_{PHL} | | 130 | 260 | ns | $103\text{ ns} + (0,55\text{ ns/pF}) C_L$ |
| | 10 | | 55 | 105 | ns | $44\text{ ns} + (0,23\text{ ns/pF}) C_L$ | |
| | 15 | | 35 | 75 | ns | $27\text{ ns} + (0,16\text{ ns/pF}) C_L$ | |
| LOW to HIGH | 5 | t_{PLH} | | 140 | 280 | ns | $113\text{ ns} + (0,55\text{ ns/pF}) C_L$ |
| | 10 | | 55 | 115 | ns | $44\text{ ns} + (0,23\text{ ns/pF}) C_L$ | |
| | 15 | | 40 | 80 | ns | $32\text{ ns} + (0,16\text{ ns/pF}) C_L$ | |
| $CET \rightarrow TC$ HIGH to LOW | 5 | t_{PHL} | | 105 | 210 | ns | $78\text{ ns} + (0,55\text{ ns/pF}) C_L$ |
| | 10 | | 50 | 100 | ns | $39\text{ ns} + (0,23\text{ ns/pF}) C_L$ | |
| | 15 | | 35 | 75 | ns | $27\text{ ns} + (0,16\text{ ns/pF}) C_L$ | |
| LOW to HIGH | 5 | t_{PLH} | | 90 | 185 | ns | $63\text{ ns} + (0,55\text{ ns/pF}) C_L$ |
| | 10 | | 35 | 70 | ns | $24\text{ ns} + (0,23\text{ ns/pF}) C_L$ | |
| | 15 | | 25 | 50 | ns | $17\text{ ns} + (0,16\text{ ns/pF}) C_L$ | |
| Output transition times HIGH to LOW | 5 | t_{THL} | | 60 | 120 | ns | $10\text{ ns} + (1,0\text{ ns/pF}) C_L$ |
| | 10 | | 30 | 60 | ns | $9\text{ ns} + (0,42\text{ ns/pF}) C_L$ | |
| | 15 | | 20 | 40 | ns | $6\text{ ns} + (0,28\text{ ns/pF}) C_L$ | |
| LOW to HIGH | 5 | t_{TLH} | | 60 | 120 | ns | $10\text{ ns} + (1,0\text{ ns/pF}) C_L$ |
| | 10 | | 30 | 60 | ns | $9\text{ ns} + (0,42\text{ ns/pF}) C_L$ | |
| | 15 | | 20 | 40 | ns | $6\text{ ns} + (0,28\text{ ns/pF}) C_L$ | |

A.C. CHARACTERISTICS

$V_{SS} = 0\text{ V}$; $T_{amb} = 25\text{ }^{\circ}\text{C}$; $C_L = 50\text{ pF}$; input transition times $\leq 20\text{ ns}$

| | V_{DD} V | symbol | min. | typ. | max. |
|--------------------------------------|---------------|------------|------|------|------|
| Minimum clock pulse width, LOW | 5 | | 100 | 50 | ns |
| | 10 | t_{WCPL} | 40 | 20 | ns |
| | 15 | | 30 | 15 | ns |
| Set-up times $P_n \rightarrow CP$ | 5 | | 110 | 55 | ns |
| | 10 | t_{su} | 40 | 20 | ns |
| | 15 | | 30 | 15 | ns |
| $\overline{PE} \rightarrow CP$ | 5 | | 120 | 60 | ns |
| | 10 | t_{su} | 40 | 20 | ns |
| | 15 | | 25 | 10 | ns |
| $CEP, CET \rightarrow CP$ | 5 | | 260 | 130 | ns |
| | 10 | t_{su} | 100 | 50 | ns |
| | 15 | | 70 | 35 | ns |
| $\overline{SR} \rightarrow CP$ | 5 | | 50 | 25 | ns |
| | 10 | t_{su} | 20 | 10 | ns |
| | 15 | | 15 | 10 | ns |
| Hold times $P_n \rightarrow CP$ | 5 | | 20 | -35 | ns |
| | 10 | t_{hold} | 10 | -10 | ns |
| | 15 | | 5 | -10 | ns |
| $\overline{PE} \rightarrow CP$ | 5 | | 15 | -45 | ns |
| | 10 | t_{hold} | 5 | -15 | ns |
| | 15 | | 5 | -10 | ns |
| $CEP, CET \rightarrow CP$ | 5 | | 25 | -105 | ns |
| | 10 | t_{hold} | 15 | -35 | ns |
| | 15 | | 10 | -25 | ns |
| $\overline{SR} \rightarrow CP$ | 5 | | 15 | -10 | ns |
| | 10 | t_{hold} | 5 | -5 | ns |
| | 15 | | 5 | 0 | ns |
| Maximum clock pulse frequency | 5 | | 2,5 | 5 | MHz |
| | 10 | f_{max} | 7 | 14 | MHz |
| | 15 | | 9 | 18 | MHz |

see also waveforms
Figs 5, 6, 7 and 8

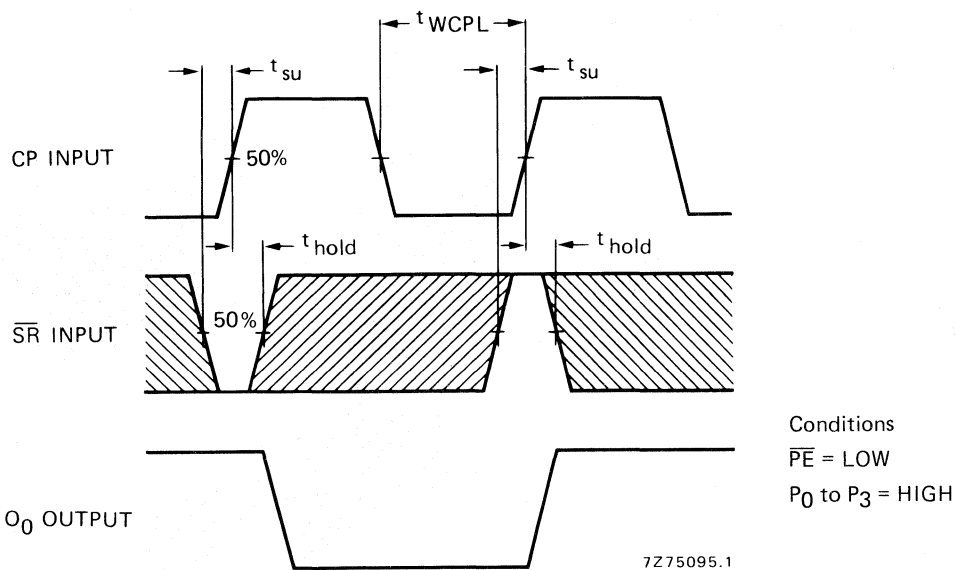

Fig. 5 Waveforms showing set-up and hold times for \overline{SR} input and minimum CP pulse width.

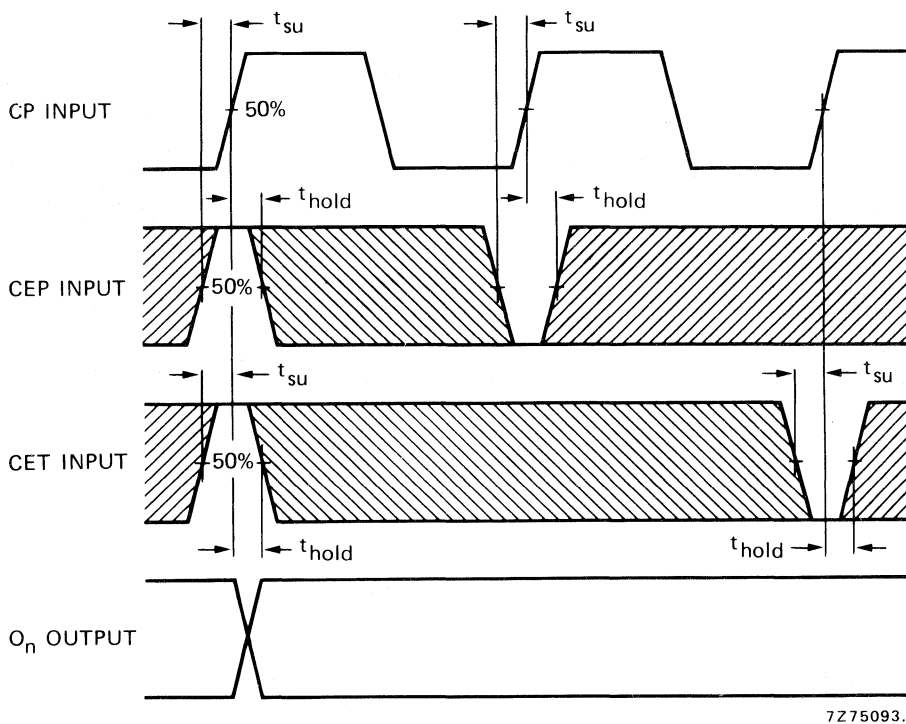
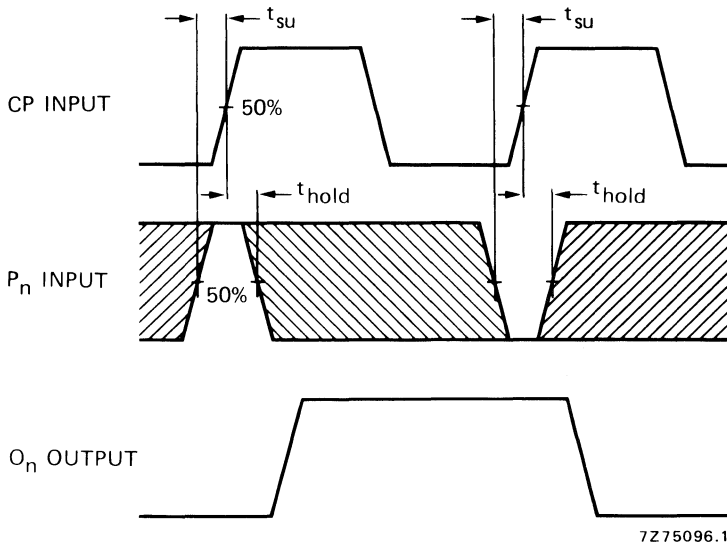
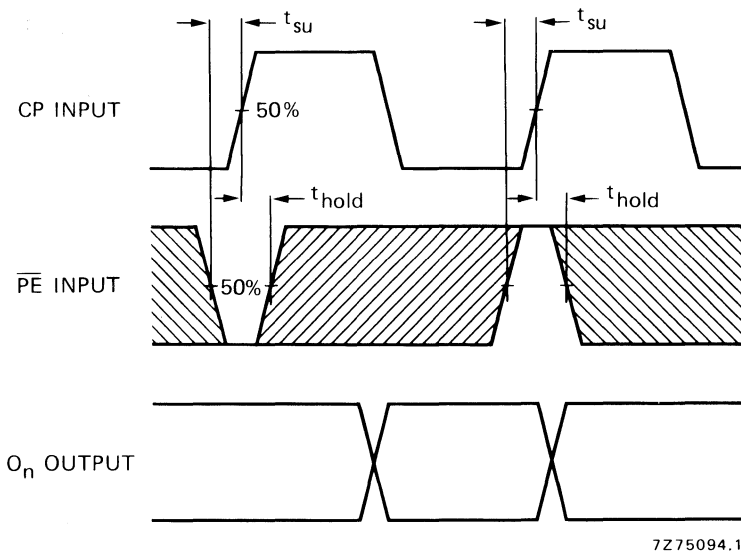

Fig. 6 Waveforms showing set-up times and hold times for CEP and CET inputs.
 Condition: $\overline{PE} = \overline{SR} = \text{HIGH}$.



Conditions
 \overline{PE} = LOW
 \overline{SR} = HIGH

Fig. 7 Waveforms showing set-up times and hold times for P_n inputs.



Condition
 \overline{SR} = HIGH

Fig. 8 Waveforms showing set-up times and hold times for \overline{PE} input.

Note

Set-up and hold times are shown as positive values but may be specified as negative values.

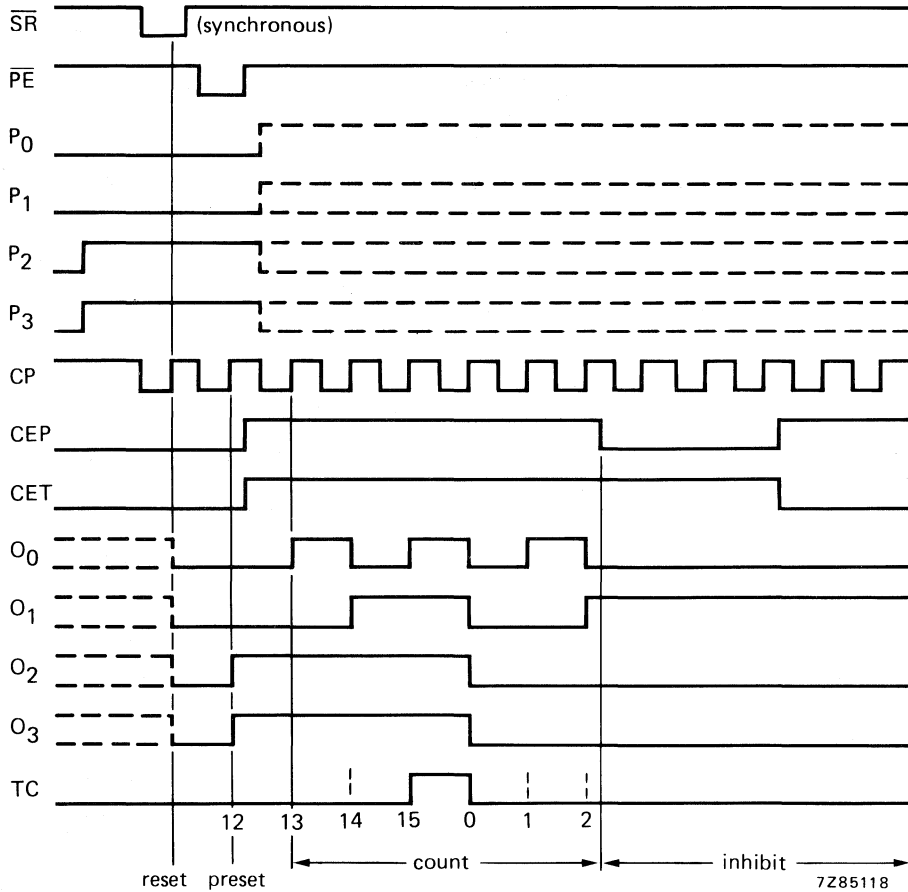
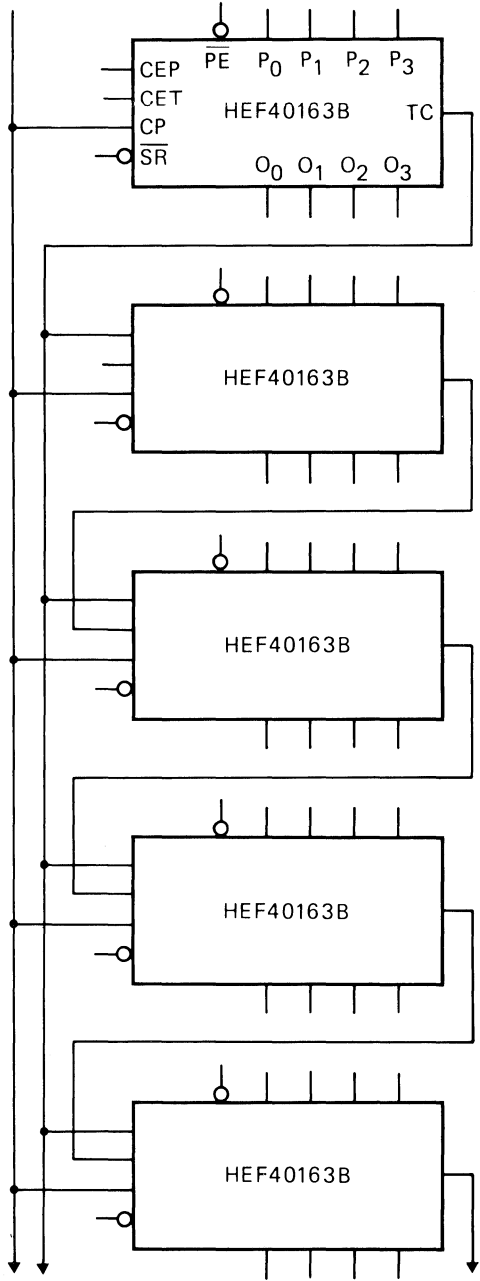

Fig. 9 Timing diagram.

APPLICATION INFORMATION

An example of an application for the HEF40163B is:

- Programmable binary counter.



NOTE

On the TC outputs, glitches can occur during counting. In totally synchronous mode they will not have any adverse affect. However the TC output in asynchronous mode can cause problems.

Fig. 10 Synchronous multi-stage counting scheme.

HEX D-TYPE FLIP-FLOP



The HEF40174B is a hex edge-triggered D-type flip-flop with six data inputs (D_0 to D_5), a clock input (CP), an overriding asynchronous master reset input (\overline{MR}), and six buffered outputs (O_0 to O_5). Information on D_0 to D_5 is transferred to O_0 to O_5 on the LOW to HIGH transition of CP if \overline{MR} is HIGH. When LOW, \overline{MR} resets all flip-flops (O_0 to $O_5 = \text{LOW}$) independent of CP and D_0 to D_5 .

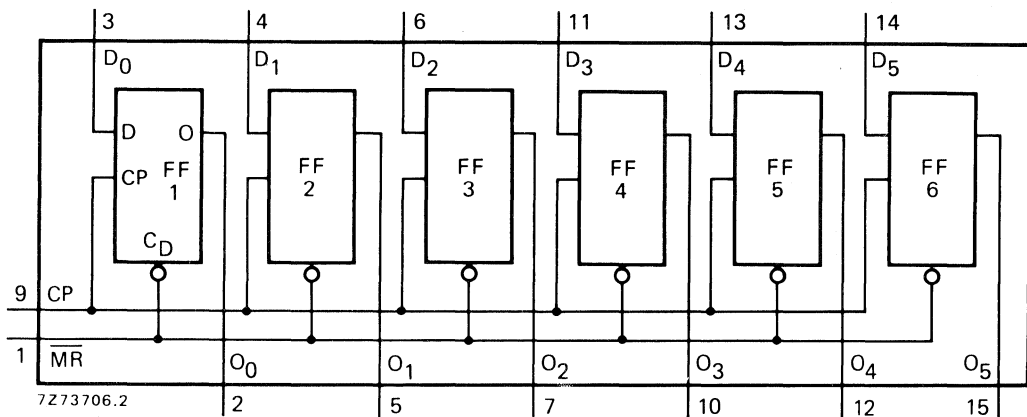

Fig. 1 Functional diagram.

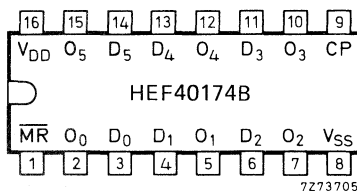

Fig. 2 Pinning diagram.

HEF40174BP: 16-lead DIL; plastic (SOT-38Z).
 HEF40174BD: 16-lead DIL; ceramic (cerdip) (SOT-74).
 HEF40174BT: 16-lead mini-pack; plastic (SO-16; SOT-109A).

FAMILY DATA

I_{DD} LIMITS category MSI

see Family Specifications

PINNING

D_0 to D_5 data inputs
 CP clock input (LOW to HIGH; edge-triggered)
 \overline{MR} master reset input (active LOW)
 O_0 to O_5 buffered outputs

FUNCTION TABLE

| | inputs | | | output O |
|------------|--------|---|-----------------|-------------|
| | CP | D | \overline{MR} | |
| \nearrow | H | H | H | H |
| \searrow | L | H | H | L |
| \sim | X | H | H | no change |
| X | X | L | L | L |

H = HIGH state (the more positive voltage)

L = LOW state (the less positive voltage)

X = state is immaterial

\nearrow = positive-going transition

\searrow = negative-going transition

A.C. CHARACTERISTICS

 $V_{SS} = 0\text{ V}$; $T_{amb} = 25\text{ }^{\circ}\text{C}$; $C_L = 50\text{ pF}$; input transition times $\leq 20\text{ ns}$

| | V_{DD} V | symbol | min. | typ. | max. | typical extrapolation formula |
|---|---------------|-------------------|------------------|-------|-------------------------------------|-------------------------------------|
| Propagation delays CP \rightarrow O_n HIGH to LOW | 5 | t _{PHL} | | 75 | 155 ns | 48 ns + (0,55 ns/pF) C _L |
| | 10 | | 30 | 65 ns | 19 ns + (0,23 ns/pF) C _L | |
| | 15 | | 20 | 45 ns | 12 ns + (0,16 ns/pF) C _L | |
| | 5 | | | 75 | 155 ns | 48 ns + (0,55 ns/pF) C _L |
| | 10 | | t _{PLH} | 30 | 65 ns | 19 ns + (0,23 ns/pF) C _L |
| | 15 | | 20 | 45 ns | 12 ns + (0,16 ns/pF) C _L | |
| $\overline{\text{MR}}$ \rightarrow O_n HIGH to LOW | 5 | t _{PHL} | | 85 | 175 ns | 58 ns + (0,55 ns/pF) C _L |
| | 10 | | 35 | 70 ns | 24 ns + (0,23 ns/pF) C _L | |
| | 15 | | 25 | 50 ns | 17 ns + (0,16 ns/pF) C _L | |
| | 5 | | | 60 | 120 ns | 10 ns + (1,0 ns/pF) C _L |
| | 10 | | t _{THL} | 30 | 60 ns | 9 ns + (0,42 ns/pF) C _L |
| | 15 | | 20 | 40 ns | 6 ns + (0,28 ns/pF) C _L | |
| Output transition times HIGH to LOW | 5 | t _{TLH} | | 60 | 120 ns | 10 ns + (1,0 ns/pF) C _L |
| | 10 | | 30 | 60 ns | 9 ns + (0,42 ns/pF) C _L | |
| | 15 | | 20 | 40 ns | 6 ns + (0,28 ns/pF) C _L | |
| | 5 | | | 60 | 120 ns | 10 ns + (1,0 ns/pF) C _L |
| | 10 | | t _{TLH} | 30 | 60 ns | 9 ns + (0,42 ns/pF) C _L |
| | 15 | | 20 | 40 ns | 6 ns + (0,28 ns/pF) C _L | |
| Set-up time $D_n \rightarrow$ CP | 5 | t _{su} | 20 | 10 | ns | see also waveforms Fig. 4 |
| | 10 | | 10 | 5 | ns | |
| | 15 | | 10 | 5 | ns | |
| Hold time $D_n \rightarrow$ CP | 5 | t _{hold} | 10 | 0 | ns | |
| | 10 | | 5 | 0 | ns | |
| | 15 | | 5 | 0 | ns | |
| Minimum clock pulse width; LOW | 5 | t _{WCPL} | 70 | 35 | ns | |
| | 10 | | 30 | 15 | ns | |
| | 15 | | 20 | 10 | ns | |
| Minimum $\overline{\text{MR}}$ pulse width; LOW | 5 | t _{WMRL} | 70 | 35 | ns | |
| | 10 | | 35 | 15 | ns | |
| | 15 | | 25 | 10 | ns | |
| Recovery time for $\overline{\text{MR}}$ | 5 | t _{RMR} | 45 | 25 | ns | |
| | 10 | | 20 | 10 | ns | |
| | 15 | | 15 | 5 | ns | |
| Maximum clock pulse frequency | 5 | f _{max} | 5 | 11 | MHz | |
| | 10 | | 15 | 30 | MHz | |
| | 15 | | 20 | 45 | MHz | |

| | V_{DD} V | typical formula for P (μW) | where f _i = input freq. (MHz) f _o = output freq. (MHz) C _L = load capacitance (pF) $\Sigma(f_o C_L)$ = sum of outputs V _{DD} = supply voltage (V) |
|---|---------------|---|--|
| Dynamic power dissipation per package (P) | 5 | $3500 f_i + \Sigma(f_o C_L) \times V_{DD}^2$ | |
| | 10 | $16\ 000 f_i + \Sigma(f_o C_L) \times V_{DD}^2$ | |
| | 15 | $42\ 000 f_i + \Sigma(f_o C_L) \times V_{DD}^2$ | |

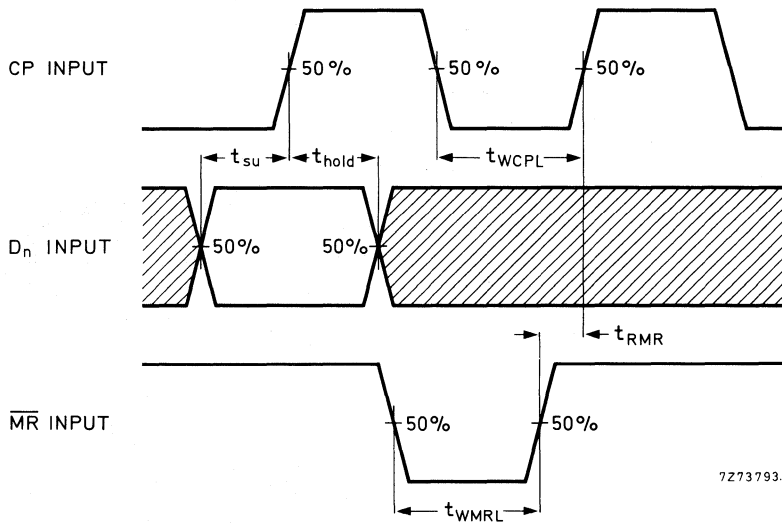

7273793.1

Fig. 4 Waveforms showing minimum pulse widths for CP and \overline{MR} , \overline{MR} to CP recovery time, and set-up time and hold time for D_n to CP. Set-up and hold times are shown as positive values but may be specified as negative values.

APPLICATION INFORMATION

Some examples of applications for the HEF40174B are:

- Shift registers
- Buffer/storage register
- Pattern generator

QUADRUPLE D-TYPE FLIP-FLOP



The HEF40175B is a quadruple edge-triggered D-type flip-flop with four data inputs (D_0 to D_3), a clock input (CP), an overriding asynchronous master reset input (\overline{MR}), four buffered outputs (O_0 to O_3), and four complementary buffered outputs (\overline{O}_0 to \overline{O}_3). Information on D_0 to D_3 is transferred to O_0 to O_3 on the LOW to HIGH transition of CP if \overline{MR} is HIGH. When LOW, \overline{MR} resets all flip-flops (O_0 to O_3 = LOW, \overline{O}_0 to \overline{O}_3 = HIGH), independent of CP and D_0 to D_3 .

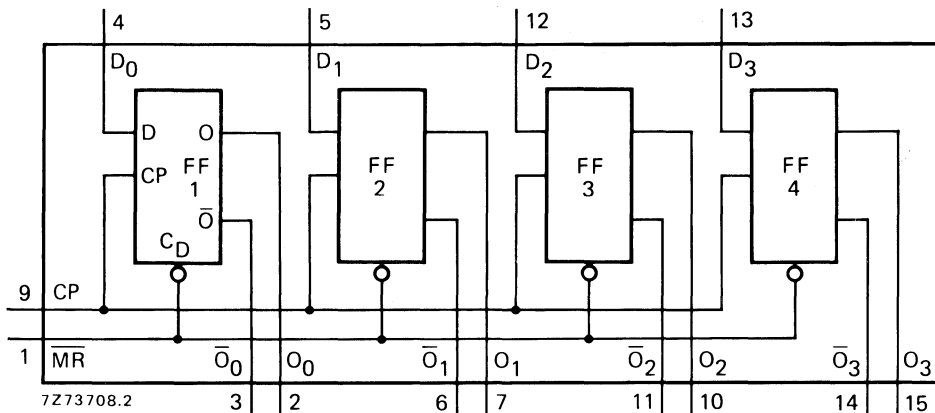

Fig. 1 Functional diagram.

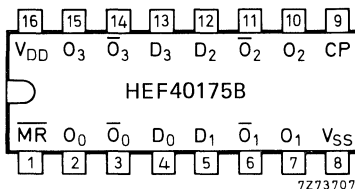

Fig. 2 Pinning diagram.

HEF40175BP: 16-lead DIL; plastic (SOT-38Z).

HEF40175BD: 16-lead DIL; ceramic (cerdip) (SOT-74).

HEF40175BT: 16-lead mini-pack; plastic (SO-16; SOT-109A).

FAMILY DATA

I_{DD} LIMITS category MSI } see Family Specifications

PINNING

D_0 to D_3 data inputs
 CP clock input (LOW to HIGH; edge-triggered)
 \overline{MR} master reset input (active LOW)
 O_0 to O_3 buffered outputs
 \overline{O}_0 to \overline{O}_3 complementary buffered outputs

FUNCTION TABLE

| inputs | | | outputs | |
|-------------|---|-----------------|-----------|----------------|
| CP | D | \overline{MR} | O | \overline{O} |
| \nearrow | H | H | H | L |
| \searrow | L | H | L | H |
| \setminus | X | H | no change | no change |
| X | X | L | L | H |

H = HIGH state (the more positive voltage)

L = LOW state (the less positive voltage)

X = state is immaterial

\nearrow = positive-going transition

\setminus = negative-going transition

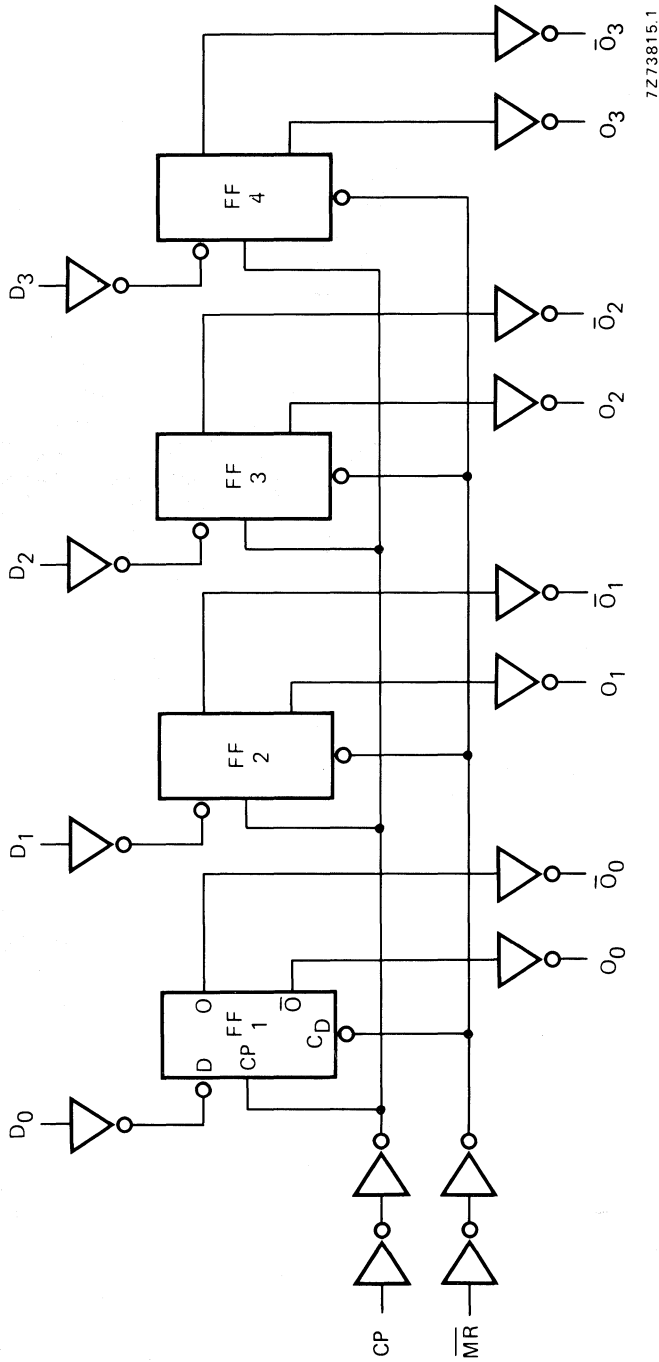

Fig. 3 Logic diagram.

A.C. CHARACTERISTICS

$V_{SS} = 0\text{ V}$; $T_{amb} = 25\text{ }^{\circ}\text{C}$; $C_L = 50\text{ pF}$; input transition times $\leq 20\text{ ns}$

| | V_{DD} V | symbol | min. | typ. | max. | typical extrapolation formula |
|--|---------------|------------|------|------|------|----------------------------------|
| Propagation delays $CP \rightarrow O_n, \bar{O}_n$ HIGH to LOW | 5 | t_{PHL} | | 80 | 160 | 53 ns + (0,55 ns/pF) C_L |
| | 10 | | | 35 | 70 | 24 ns + (0,23 ns/pF) C_L |
| | 15 | | | 25 | 50 | 17 ns + (0,16 ns/pF) C_L |
| LOW to HIGH | 5 | t_{PLH} | | 70 | 140 | 43 ns + (0,55 ns/pF) C_L |
| | 10 | | | 30 | 65 | 19 ns + (0,23 ns/pF) C_L |
| | 15 | | | 25 | 45 | 17 ns + (0,16 ns/pF) C_L |
| $\overline{MR} \rightarrow O_n$ HIGH to LOW | 5 | t_{PHL} | | 75 | 155 | 48 ns + (0,55 ns/pF) C_L |
| | 10 | | | 30 | 65 | 19 ns + (0,23 ns/pF) C_L |
| | 15 | | | 25 | 50 | 17 ns + (0,16 ns/pF) C_L |
| $\overline{MR} \rightarrow \bar{O}_n$ LOW to HIGH | 5 | t_{PLH} | | 70 | 140 | 43 ns + (0,55 ns/pF) C_L |
| | 10 | | | 30 | 65 | 19 ns + (0,23 ns/pF) C_L |
| | 15 | | | 25 | 50 | 17 ns + (0,16 ns/pF) C_L |
| Output transition times HIGH to LOW | 5 | t_{THL} | | 60 | 120 | 10 ns + (1,0 ns/pF) C_L |
| | 10 | | | 30 | 60 | 9 ns + (0,42 ns/pF) C_L |
| | 15 | | | 20 | 40 | 6 ns + (0,28 ns/pF) C_L |
| LOW to HIGH | 5 | t_{TLH} | | 60 | 120 | 10 ns + (1,0 ns/pF) C_L |
| | 10 | | | 30 | 60 | 9 ns + (0,42 ns/pF) C_L |
| | 15 | | | 20 | 40 | 6 ns + (0,28 ns/pF) C_L |
| Set-up time $D_n \rightarrow CP$ | 5 | t_{su} | 60 | 30 | ns | } see also waveforms Fig. 4 |
| | 10 | | 20 | 10 | ns | |
| | 15 | | 15 | 5 | ns | |
| Hold time $D_n \rightarrow CP$ | 5 | t_{hold} | 25 | -5 | ns | |
| | 10 | | 10 | 0 | ns | |
| | 15 | | 10 | 0 | ns | |
| Minimum clock pulse width; LOW | 5 | t_{WCPL} | 90 | 45 | ns | |
| | 10 | | 35 | 15 | ns | |
| | 15 | | 25 | 10 | ns | |
| Minimum \overline{MR} pulse width; LOW | 5 | t_{WMRL} | 80 | 40 | ns | |
| | 10 | | 30 | 15 | ns | |
| | 15 | | 20 | 10 | ns | |
| Recovery time for \overline{MR} | 5 | t_{RMR} | 0 | -30 | ns | |
| | 10 | | 0 | -20 | ns | |
| | 15 | | 0 | -15 | ns | |
| Maximum clock pulse frequency | 5 | f_{max} | 5 | 11 | MHz | |
| | 10 | | 15 | 30 | MHz | |
| | 15 | | 20 | 45 | MHz | |

A.C. CHARACTERISTICS

$V_{SS} = 0\text{ V}$; $T_{amb} = 25\text{ }^{\circ}\text{C}$; input transition times $\leq 20\text{ ns}$

| | V_{DD} V | typical formula for P (μW) | where f_i = input freq. (MHz) f_o = output freq. (MHz) C_L = load capacitance (pF) $\Sigma(f_o C_L)$ = sum of outputs V_{DD} = supply voltage (V) |
|---|---------------|---|--|
| Dynamic power dissipation per package (P) | 5 | $2000 f_i + \Sigma(f_o C_L) \times V_{DD}^2$ | |
| | 10 | $8400 f_i + \Sigma(f_o C_L) \times V_{DD}^2$ | |
| | 15 | $22\,500 f_i + \Sigma(f_o C_L) \times V_{DD}^2$ | |

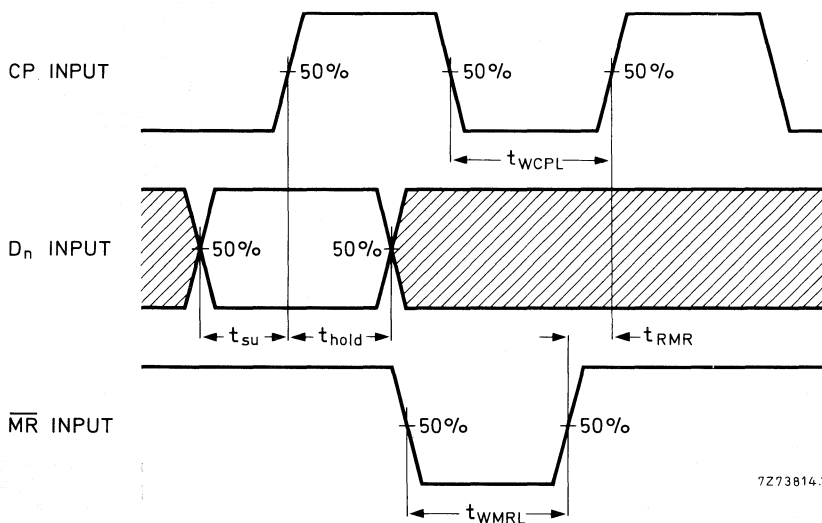

Fig. 4 Waveforms showing minimum pulse widths for CP and $\overline{\text{MR}}$, $\overline{\text{MR}}$ to CP recovery time, and set-up time and hold time for D_n to CP. Set-up and hold times are shown as positive values but may be specified as negative values.

APPLICATION INFORMATION

Some examples of applications for the HEF40175B are:

- Shift registers
- Buffer/storage register
- Pattern generator

4-BIT UP/DOWN DECADE COUNTER



The HEF40192B is a 4-bit synchronous up/down decade counter. The counter has a count-up clock input (CP_U), a count-down clock input (CP_D), an asynchronous parallel load input (\overline{PL}), four parallel data inputs (P_0 to P_3), an asynchronous master reset input (MR), four counter outputs (O_0 to O_3), an active LOW terminal count-up (carry) output (\overline{TC}_U) and an active LOW terminal count-down (borrow) output (\overline{TC}_D).

The counter outputs change state on the LOW to HIGH transition of either clock input. However, for correct counting, both clock inputs cannot be LOW simultaneously. The outputs \overline{TC}_U and \overline{TC}_D are normally HIGH. When the circuit has reached the maximum count state of '9', the next HIGH to LOW transition of CP_U will cause \overline{TC}_U to go LOW. \overline{TC}_U will stay LOW until CP_U goes HIGH again. Likewise, output \overline{TC}_D will go LOW when the circuit is in the zero state and CP_D goes LOW. When \overline{PL} is LOW, the information on P_0 to P_3 is asynchronously loaded into the counter. A HIGH on MR resets the counter independent of all other input conditions. The counter stages are of a static toggle type flip-flop.

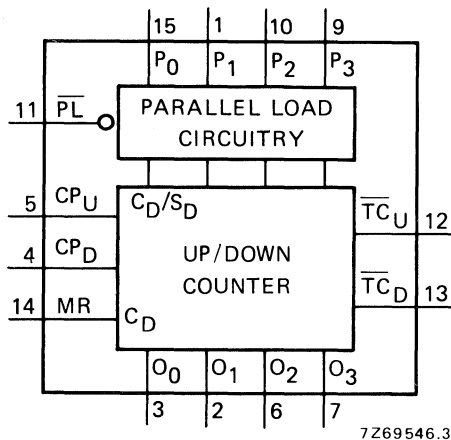

Fig. 1 Functional diagram.

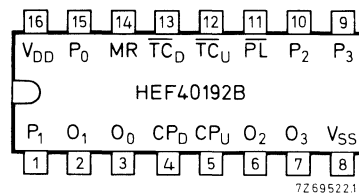

Fig. 2 Pinning diagram.

HEF40192BP : 16-lead DIL; plastic (SOT-38Z).
 HEF40192BD : 16-lead DIL; ceramic (cerdip) (SOT-74).
 HEF40192BT : 16-lead mini-pack; plastic (SO-16; SOT-109A).

PINNING

| | |
|-------------------|--|
| \overline{PL} | parallel load input (active LOW) |
| P_0 to P_3 | parallel data inputs |
| CP_U | count-up clock pulse input (LOW to HIGH, edge-triggered) |
| CP_D | count-down clock pulse input (LOW to HIGH, edge-triggered) |
| MR | master reset input (asynchronous) |
| \overline{TC}_U | buffered terminal count-up (carry) output (active LOW) |
| \overline{TC}_D | buffered terminal count-down (borrow) output (active LOW) |
| O_0 to O_3 | buffered counter outputs |

FAMILY DATA

I_{DD} LIMITS category MSI

see Family Specifications

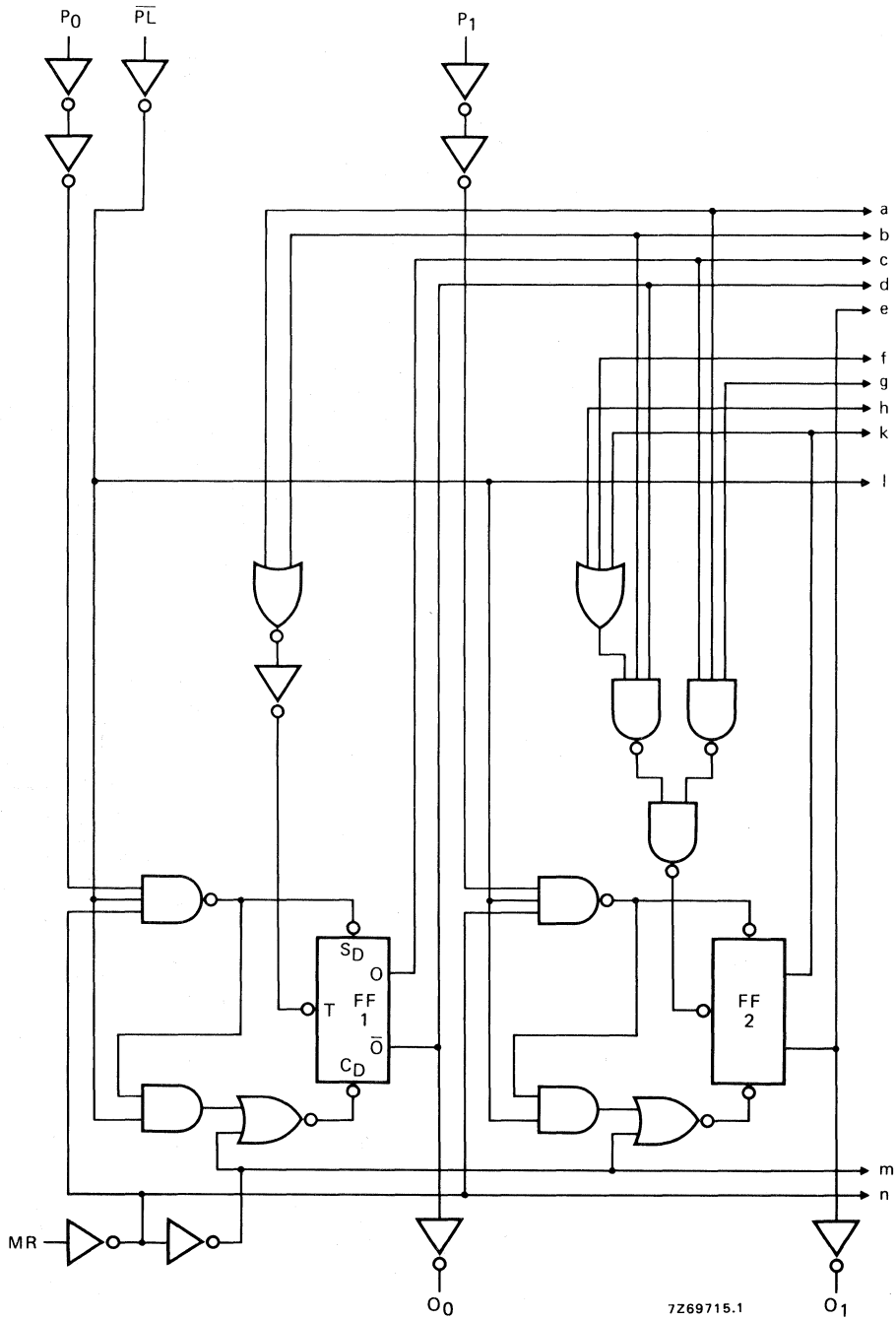

7269715.1

Fig. 3 Logic diagram (continued on next page).

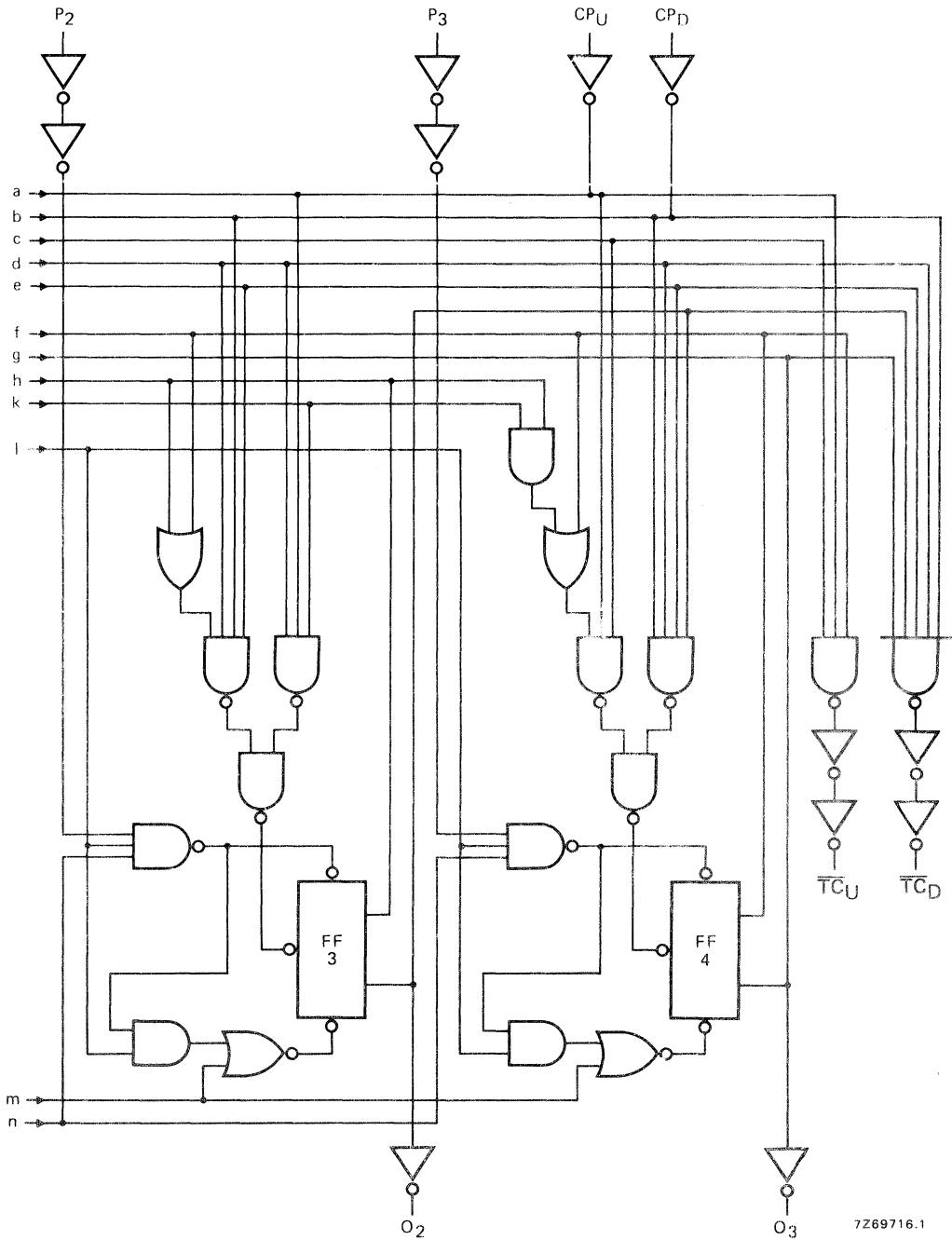

7269716.1

Fig. 3 Logic diagram (continued).

FUNCTION TABLE

| MR | \overline{PL} | CP _U | CP _D | mode |
|----|-----------------|-----------------|-----------------|---------------|
| H | X | X | X | reset (asyn.) |
| L | L | X | X | parallel load |
| L | H | \nearrow | H | count-up |
| L | H | H | \searrow | count-down |

H = HIGH state (the more positive voltage)
 L = LOW state (the less positive voltage)
 X = state is immaterial
 \nearrow = positive-going transition

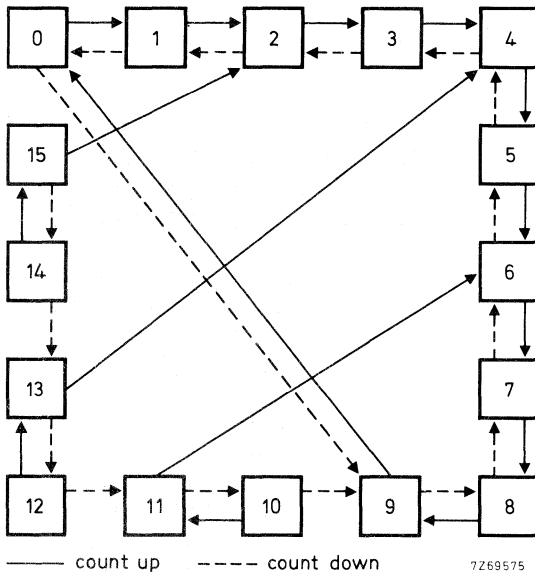

Logic equations for terminal count:

$$\overline{TC}_U = \overline{O_0} \cdot \overline{O_3} \cdot \overline{CP}_U$$

$$\overline{TC}_D = \overline{O_0} \cdot \overline{O_1} \cdot \overline{O_2} \cdot \overline{O_3} \cdot \overline{CP}_D$$

Fig. 4 State diagram.

A.C. CHARACTERISTICS

V_{SS} = 0 V; T_{amb} = 25 °C; input transition times ≤ 20 ns

| | V _{DD} V | typical formula for P (μW) | where |
|---|----------------------|--|--|
| Dynamic power dissipation per package (P) | 5 | 550 f _i + Σ(f _o C _L) × V _{DD} ² | f _i = input freq. (MHz) |
| | 10 | 2400 f _i + Σ(f _o C _L) × V _{DD} ² | f _o = output freq. (MHz) |
| | 15 | 6500 f _i + Σ(f _o C _L) × V _{DD} ² | C _L = load capacitance (pF) |
| | | | Σ(f _o C _L) = sum of outputs |
| | | | V _{DD} = supply voltage (V) |

A.C. CHARACTERISTICS

 $V_{SS} = 0 \text{ V}$; $T_{amb} = 25 \text{ }^\circ\text{C}$; $C_L = 50 \text{ pF}$; input transition times $\leq 20 \text{ ns}$

| | V_{DD} V | symbol | min. | typ. | max. | typical extrapolation formula | |
|------------------------------------|---------------|-----------|------|------|------|----------------------------------|---|
| Propagation delays | | | | | | | |
| $CP_U \rightarrow O_n$ | 5 | | | 210 | 415 | ns | $183 \text{ ns} + (0,55 \text{ ns/pF}) C_L$ |
| HIGH to LOW | 10 | t_{PHL} | | 85 | 165 | ns | $74 \text{ ns} + (0,23 \text{ ns/pF}) C_L$ |
| | 15 | | | 60 | 120 | ns | $52 \text{ ns} + (0,16 \text{ ns/pF}) C_L$ |
| LOW to HIGH | 5 | | | 170 | 340 | ns | $143 \text{ ns} + (0,55 \text{ ns/pF}) C_L$ |
| | 10 | t_{PLH} | | 70 | 140 | ns | $59 \text{ ns} + (0,23 \text{ ns/pF}) C_L$ |
| | 15 | | | 50 | 100 | ns | $42 \text{ ns} + (0,16 \text{ ns/pF}) C_L$ |
| $CP_D \rightarrow O_n$ | 5 | | | 210 | 420 | ns | $183 \text{ ns} + (0,55 \text{ ns/pF}) C_L$ |
| HIGH to LOW | 10 | t_{PHL} | | 85 | 170 | ns | $74 \text{ ns} + (0,23 \text{ ns/pF}) C_L$ |
| | 15 | | | 65 | 125 | ns | $57 \text{ ns} + (0,16 \text{ ns/pF}) C_L$ |
| LOW to HIGH | 5 | | | 170 | 340 | ns | $143 \text{ ns} + (0,55 \text{ ns/pF}) C_L$ |
| | 10 | t_{PLH} | | 70 | 140 | ns | $59 \text{ ns} + (0,23 \text{ ns/pF}) C_L$ |
| | 15 | | | 50 | 100 | ns | $42 \text{ ns} + (0,16 \text{ ns/pF}) C_L$ |
| $CP_U \rightarrow \overline{TC}_U$ | 5 | | | 125 | 250 | ns | $98 \text{ ns} + (0,55 \text{ ns/pF}) C_L$ |
| HIGH to LOW | 10 | t_{PHL} | | 50 | 100 | ns | $39 \text{ ns} + (0,23 \text{ ns/pF}) C_L$ |
| | 15 | | | 35 | 70 | ns | $27 \text{ ns} + (0,16 \text{ ns/pF}) C_L$ |
| LOW to HIGH | 5 | | | 95 | 185 | ns | $68 \text{ ns} + (0,55 \text{ ns/pF}) C_L$ |
| | 10 | t_{PLH} | | 40 | 80 | ns | $29 \text{ ns} + (0,23 \text{ ns/pF}) C_L$ |
| | 15 | | | 30 | 60 | ns | $22 \text{ ns} + (0,16 \text{ ns/pF}) C_L$ |
| $CP_D \rightarrow \overline{TC}_D$ | 5 | | | 140 | 280 | ns | $113 \text{ ns} + (0,55 \text{ ns/pF}) C_L$ |
| HIGH to LOW | 10 | t_{PHL} | | 55 | 110 | ns | $44 \text{ ns} + (0,23 \text{ ns/pF}) C_L$ |
| | 15 | | | 40 | 80 | ns | $32 \text{ ns} + (0,16 \text{ ns/pF}) C_L$ |
| LOW to HIGH | 5 | | | 100 | 195 | ns | $73 \text{ ns} + (0,55 \text{ ns/pF}) C_L$ |
| | 10 | t_{PLH} | | 40 | 85 | ns | $29 \text{ ns} + (0,23 \text{ ns/pF}) C_L$ |
| | 15 | | | 30 | 65 | ns | $22 \text{ ns} + (0,16 \text{ ns/pF}) C_L$ |
| $MR \rightarrow O_n$ | 5 | | | 195 | 390 | ns | $168 \text{ ns} + (0,55 \text{ ns/pF}) C_L$ |
| HIGH to LOW | 10 | t_{PHL} | | 80 | 160 | ns | $69 \text{ ns} + (0,23 \text{ ns/pF}) C_L$ |
| | 15 | | | 60 | 120 | ns | $52 \text{ ns} + (0,16 \text{ ns/pF}) C_L$ |
| $MR \rightarrow \overline{TC}_U$ | 5 | | | 145 | 285 | ns | $118 \text{ ns} + (0,55 \text{ ns/pF}) C_L$ |
| LOW to HIGH | 10 | t_{PLH} | | 60 | 115 | ns | $49 \text{ ns} + (0,23 \text{ ns/pF}) C_L$ |
| | 15 | | | 45 | 90 | ns | $37 \text{ ns} + (0,16 \text{ ns/pF}) C_L$ |
| $MR \rightarrow \overline{TC}_D$ | 5 | | | 365 | 730 | ns | $338 \text{ ns} + (0,55 \text{ ns/pF}) C_L$ |
| HIGH to LOW | 10 | t_{PHL} | | 130 | 265 | ns | $119 \text{ ns} + (0,23 \text{ ns/pF}) C_L$ |
| | 15 | | | 100 | 205 | ns | $92 \text{ ns} + (0,16 \text{ ns/pF}) C_L$ |
| $\overline{PL} \rightarrow O_n$ | 5 | | | 185 | 360 | ns | $158 \text{ ns} + (0,55 \text{ ns/pF}) C_L$ |
| HIGH to LOW | 10 | t_{PHL} | | 75 | 150 | ns | $64 \text{ ns} + (0,23 \text{ ns/pF}) C_L$ |
| | 15 | | | 55 | 110 | ns | $47 \text{ ns} + (0,16 \text{ ns/pF}) C_L$ |
| LOW to HIGH | 5 | | | 145 | 290 | ns | $118 \text{ ns} + (0,55 \text{ ns/pF}) C_L$ |
| | 10 | t_{PLH} | | 60 | 120 | ns | $49 \text{ ns} + (0,23 \text{ ns/pF}) C_L$ |
| | 15 | | | 45 | 90 | ns | $37 \text{ ns} + (0,16 \text{ ns/pF}) C_L$ |

A.C. CHARACTERISTICS

 $V_{SS} = 0 \text{ V}$; $T_{amb} = 25 \text{ }^\circ\text{C}$; $C_L = 50 \text{ pF}$; input transition times $\leq 20 \text{ ns}$

| | V_{DD} V | symbol | min. | typ. | max. | typical extrapolation formula | |
|--|---------------|------------|------|------|------|----------------------------------|---|
| Output transition times HIGH to LOW | 5 | t_{THL} | | 60 | 120 | ns | $10 \text{ ns} + (1,0 \text{ ns/pF}) C_L$ $9 \text{ ns} + (0,42 \text{ ns/pF}) C_L$ $6 \text{ ns} + (0,28 \text{ ns/pF}) C_L$ |
| | 10 | | | 30 | 60 | ns | |
| | 15 | | | 20 | 40 | ns | |
| LOW to HIGH | 5 | t_{TLH} | | 60 | 120 | ns | $10 \text{ ns} + (1,0 \text{ ns/pF}) C_L$ $9 \text{ ns} + (0,42 \text{ ns/pF}) C_L$ $6 \text{ ns} + (0,28 \text{ ns/pF}) C_L$ |
| | 10 | | | 30 | 60 | ns | |
| | 15 | | | 20 | 40 | ns | |
| Set-up time $P_n \rightarrow \overline{PL}$ | 5 | t_{su} | 160 | 80 | | ns | see also waveforms Fig. 5 |
| | 10 | | 60 | 30 | | ns | |
| | 15 | | 50 | 25 | | ns | |
| Hold time $P_n \rightarrow \overline{PL}$ | 5 | t_{hold} | 10 | -70 | | ns | |
| | 10 | | 5 | -25 | | ns | |
| | 15 | | 5 | -20 | | ns | |
| Minimum CP_U or CP_D pulse width; LOW | 5 | t_{WCPL} | 150 | 75 | | ns | |
| | 10 | | 50 | 25 | | ns | |
| | 15 | | 35 | 20 | | ns | |
| Minimum MR pulse width; HIGH | 5 | t_{WMRH} | 180 | 90 | | ns | |
| | 10 | | 70 | 35 | | ns | |
| | 15 | | 60 | 30 | | ns | |
| Minimum \overline{PL} pulse width; LOW | 5 | t_{WPLL} | 120 | 60 | | ns | |
| | 10 | | 45 | 20 | | ns | |
| | 15 | | 30 | 15 | | ns | |
| Recovery time for MR | 5 | t_{RMR} | 125 | 65 | | ns | |
| | 10 | | 70 | 35 | | ns | |
| | 15 | | 50 | 25 | | ns | |
| Recovery time for PL | 5 | t_{RPL} | 90 | 45 | | ns | |
| | 10 | | 35 | 15 | | ns | |
| | 15 | | 25 | 10 | | ns | |
| Maximum clock pulse frequency | 5 | f_{max} | 2,5 | 5 | | MHz | |
| | 10 | | 7 | 14 | | MHz | |
| | 15 | | 9 | 18 | | MHz | |

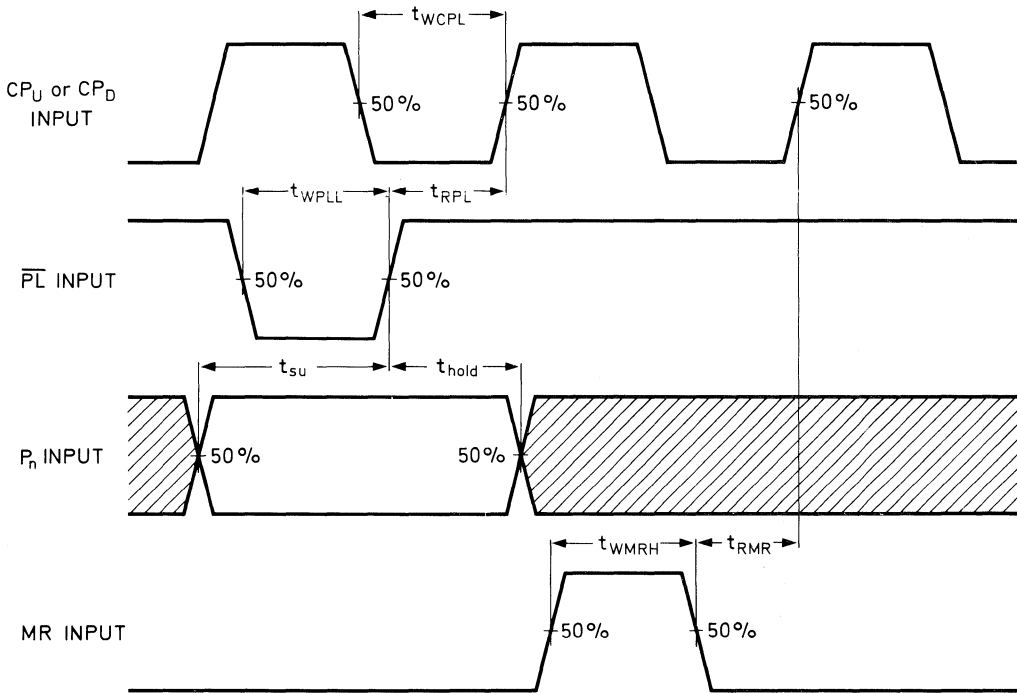

7269717.1

Fig. 5 Waveforms showing recovery times for \overline{PL} and MR, minimum pulse widths for CP_U , CP_D , \overline{PL} and MR, and set-up and hold times for P to \overline{PL} . Set-up times and hold times are shown as positive values but may be specified as negative values.

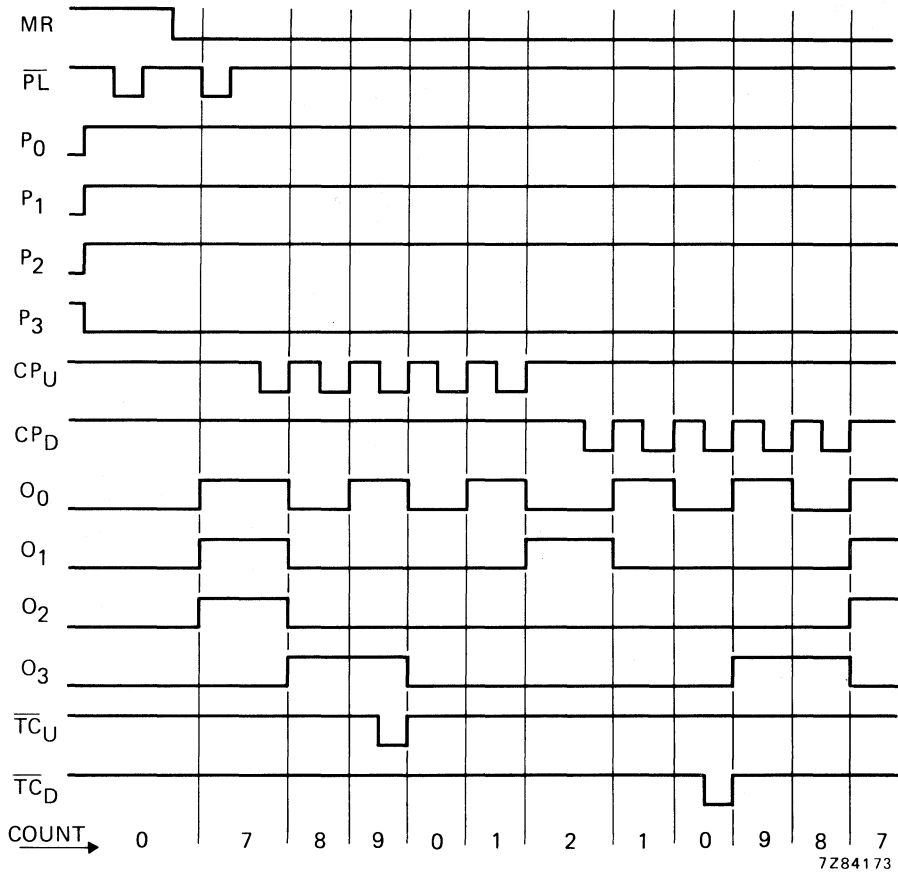

Fig. 6 Timing diagram.

APPLICATION INFORMATION

Some examples of applications for the HEF40192B are:

- Up/down difference counting
- Multistage ripple counting
- Multistage synchronous counting.

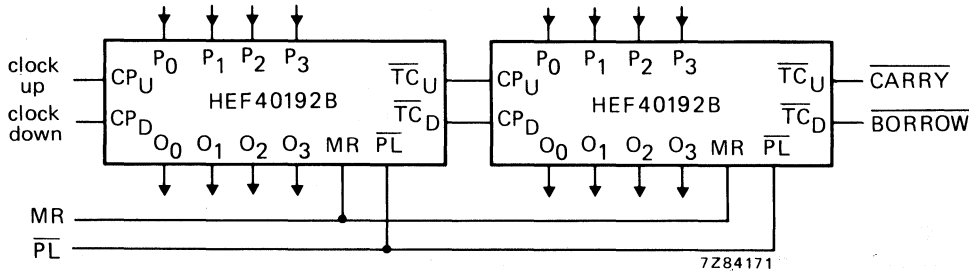

Fig. 7 Example of cascaded HEF40192B ICs.



4-BIT UP/DOWN BINARY COUNTER

The HEF40193B is a 4-bit synchronous up/down binary counter. The counter has a count-up clock input (CP_U), a count-down clock input (CP_D), an asynchronous parallel load input (\overline{PL}), four parallel data inputs (P_0 to P_3), an asynchronous master reset input (MR), four counter outputs (O_0 to O_3), an active LOW terminal count-up (carry) output (\overline{TC}_U) and an active LOW terminal count-down (borrow) output (\overline{TC}_D).

The counter outputs change state on the LOW to HIGH transition of either clock input. However, for correct counting, both clock inputs cannot be LOW simultaneously. The outputs \overline{TC}_U and \overline{TC}_D are normally HIGH. When the circuit has reached the maximum count state of '15', the next HIGH to LOW transition of CP_U will cause \overline{TC}_U to go LOW. \overline{TC}_U will stay LOW until CP_U goes HIGH again. Likewise, output \overline{TC}_D will go LOW when the circuit is in the zero state and CP_D goes LOW. When \overline{PL} is LOW, the information on P_0 to P_3 is asynchronously loaded into the counter. A HIGH on MR resets the counter independent of all other input conditions. The counter stages are of a static toggle type flip-flop.

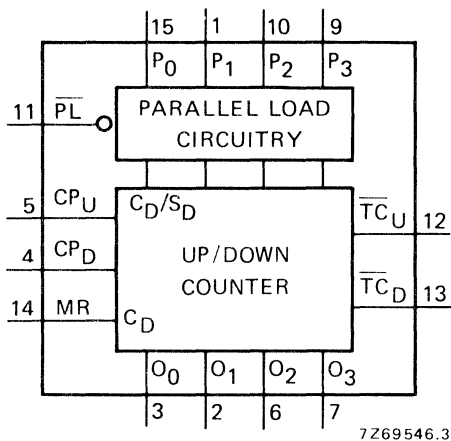

Fig. 1 Functional diagram.

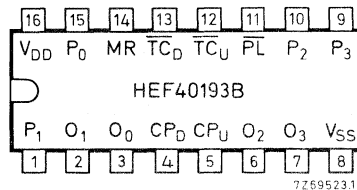

Fig. 2 Pinning diagram.

HEF40193BP : 16-lead DIL; plastic (SOT-38Z).
 HEF40193BD : 16-lead DIL; ceramic (cerdip) (SOT-74).
 HEF40193BT : 16-lead mini-pack; plastic (SO-16; SOT-109A).

PINNING

| | |
|-------------------|--|
| \overline{PL} | parallel load input (active LOW) |
| P_0 to P_3 | parallel data inputs |
| CP_U | count-up clock pulse input (LOW to HIGH, edge-triggered) |
| CP_D | count-down clock pulse input (LOW to HIGH, edge-triggered) |
| MR | master reset input (asynchronous) |
| \overline{TC}_U | buffered terminal count-up (carry) output (active LOW) |
| \overline{TC}_D | buffered terminal count-down (borrow) output (active LOW) |
| O_0 to O_3 | buffered counter outputs |

FAMILY DATA

 I_{DD} LIMITS category MSI

} see Family Specifications

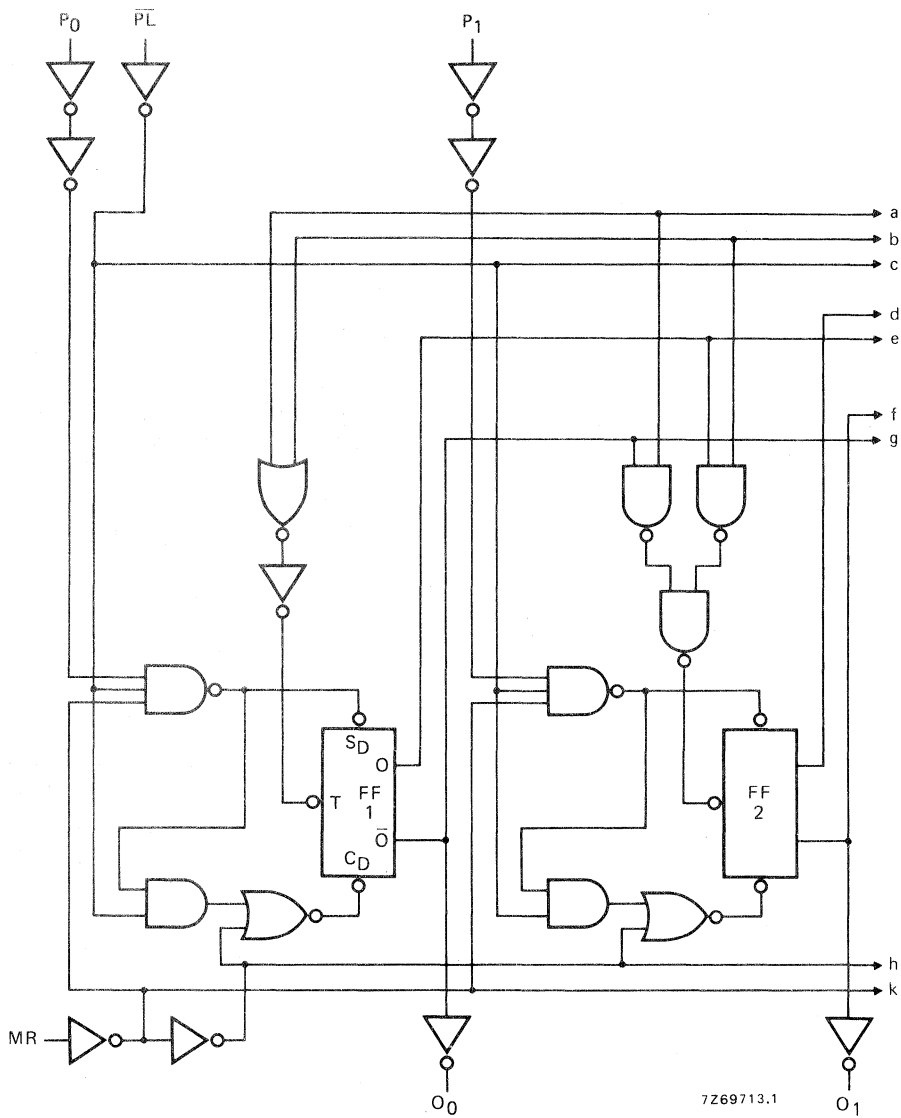

Fig. 3 Logic diagram (continued on next page).

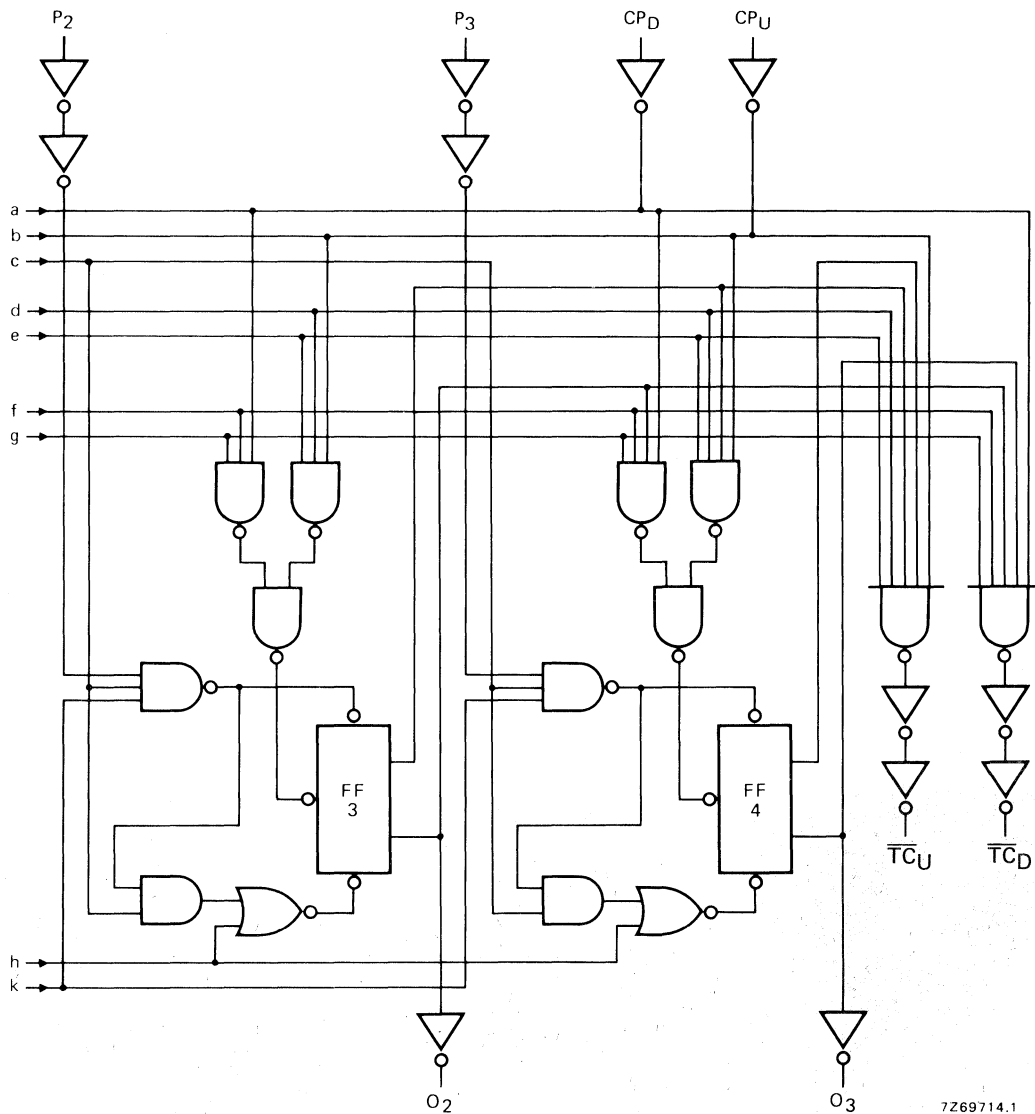
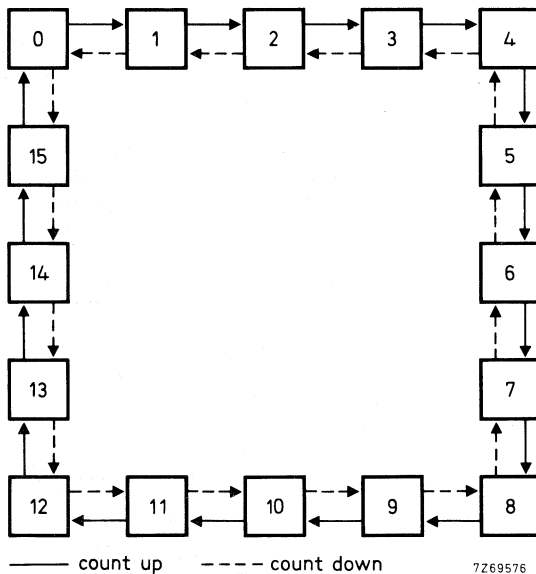

Fig. 3 Logic diagram (continued).

FUNCTION TABLE

| MR | \overline{PL} | CP_U | CP_D | mode |
|----|-----------------|------------|------------|---------------|
| H | X | X | X | reset (asyn.) |
| L | L | X | X | parallel load |
| L | H | \nearrow | H | count-up |
| L | H | H | \searrow | count-down |

H = HIGH state (the more positive voltage)
 L = LOW state (the less positive voltage)
 X = state is immaterial
 \nearrow = positive-going transition



Logic equations for terminal count:

$$\overline{TC}_U = \overline{O_0 \cdot O_1 \cdot O_2 \cdot O_3 \cdot CP_U}$$

$$\overline{TC}_D = \overline{\overline{O_0} \cdot \overline{O_1} \cdot \overline{O_2} \cdot \overline{O_3} \cdot CP_D}$$

Fig. 4 State diagram.

A.C. CHARACTERISTICS

$V_{SS} = 0\text{ V}$; $T_{amb} = 25\text{ }^\circ\text{C}$; input transition times $\leq 20\text{ ns}$

| | V_{DD} V | typical formula for P (μW) | where f_i = input freq. (MHz) f_o = output freq. (MHz) C_L = load capacitance (pF) $\Sigma(f_o C_L)$ = sum of outputs V_{DD} = supply voltage (V) |
|---|---------------|--|--|
| Dynamic power dissipation per package (P) | 5 | $600 f_i + \Sigma(f_o C_L) \times V_{DD}^2$ | |
| | 10 | $2700 f_i + \Sigma(f_o C_L) \times V_{DD}^2$ | |
| | 15 | $7500 f_i + \Sigma(f_o C_L) \times V_{DD}^2$ | |

A.C. CHARACTERISTICS

 $V_{SS} = 0 \text{ V}$; $T_{amb} = 25 \text{ }^\circ\text{C}$; $C_L = 50 \text{ pF}$; input transition times $\leq 20 \text{ ns}$

| | V_{DD} V | symbol | min. | typ. | max. | typical extrapolation formula |
|---|---------------|------------------|------|--------|-----------------------------|----------------------------------|
| Propagation delays $CP_U \rightarrow O_n$ HIGH to LOW | 5 | t _{PHL} | | 210 | 415 ns | 183 ns + (0,55 ns/pF) C_L |
| | 10 | | 85 | 165 ns | 74 ns + (0,23 ns/pF) C_L | |
| | 15 | | 60 | 120 ns | 52 ns + (0,16 ns/pF) C_L | |
| LOW to HIGH | 5 | t _{PLH} | | 170 | 340 ns | 143 ns + (0,55 ns/pF) C_L |
| | 10 | | 70 | 140 ns | 59 ns + (0,23 ns/pF) C_L | |
| | 15 | | 50 | 100 ns | 42 ns + (0,16 ns/pF) C_L | |
| $CP_D \rightarrow O_n$ HIGH to LOW | 5 | t _{PHL} | | 210 | 425 ns | 183 ns + (0,55 ns/pF) C_L |
| | 10 | | 85 | 170 ns | 74 ns + (0,23 ns/pF) C_L | |
| | 15 | | 60 | 125 ns | 57 ns + (0,16 ns/pF) C_L | |
| LOW to HIGH | 5 | t _{PLH} | | 170 | 340 ns | 143 ns + (0,55 ns/pF) C_L |
| | 10 | | 70 | 140 ns | 59 ns + (0,23 ns/pF) C_L | |
| | 15 | | 50 | 100 ns | 42 ns + (0,16 ns/pF) C_L | |
| $CP_U \rightarrow \overline{TC}_U$ HIGH to LOW | 5 | t _{PHL} | | 125 | 250 ns | 98 ns + (0,55 ns/pF) C_L |
| | 10 | | 50 | 100 ns | 39 ns + (0,23 ns/pF) C_L | |
| | 15 | | 35 | 70 ns | 27 ns + (0,16 ns/pF) C_L | |
| LOW to HIGH | 5 | t _{PLH} | | 95 | 185 ns | 68 ns + (0,55 ns/pF) C_L |
| | 10 | | 40 | 80 ns | 29 ns + (0,23 ns/pF) C_L | |
| | 15 | | 30 | 60 ns | 22 ns + (0,16 ns/pF) C_L | |
| $CP_D \rightarrow \overline{TC}_D$ HIGH to LOW | 5 | t _{PHL} | | 140 | 280 ns | 113 ns + (0,55 ns/pF) C_L |
| | 10 | | 55 | 110 ns | 44 ns + (0,23 ns/pF) C_L | |
| | 15 | | 40 | 80 ns | 32 ns + (0,16 ns/pF) C_L | |
| LOW to HIGH | 5 | t _{PLH} | | 100 | 195 ns | 73 ns + (0,55 ns/pF) C_L |
| | 10 | | 40 | 85 ns | 29 ns + (0,23 ns/pF) C_L | |
| | 15 | | 30 | 65 ns | 22 ns + (0,16 ns/pF) C_L | |
| MR $\rightarrow O_n$ HIGH to LOW | 5 | t _{PHL} | | 195 | 390 ns | 168 ns + (0,55 ns/pF) C_L |
| | 10 | | 80 | 160 ns | 69 ns + (0,23 ns/pF) C_L | |
| | 15 | | 60 | 120 ns | 52 ns + (0,16 ns/pF) C_L | |
| MR $\rightarrow \overline{TC}_U$ LOW to HIGH | 5 | t _{PLH} | | 145 | 285 ns | 118 ns + (0,55 ns/pF) C_L |
| | 10 | | 60 | 115 ns | 49 ns + (0,23 ns/pF) C_L | |
| | 15 | | 45 | 90 ns | 37 ns + (0,16 ns/pF) C_L | |
| MR $\rightarrow \overline{TC}_D$ HIGH to LOW | 5 | t _{PHL} | | 365 | 730 ns | 338 ns + (0,55 ns/pF) C_L |
| | 10 | | 130 | 265 ns | 119 ns + (0,23 ns/pF) C_L | |
| | 15 | | 100 | 205 ns | 92 ns + (0,16 ns/pF) C_L | |
| $\overline{PL} \rightarrow O_n$ HIGH to LOW | 5 | t _{PHL} | | 185 | 360 ns | 158 ns + (0,55 ns/pF) C_L |
| | 10 | | 75 | 150 ns | 64 ns + (0,23 ns/pF) C_L | |
| | 15 | | 55 | 110 ns | 47 ns + (0,16 ns/pF) C_L | |
| LOW to HIGH | 5 | t _{PLH} | | 145 | 290 ns | 118 ns + (0,55 ns/pF) C_L |
| | 10 | | 60 | 120 ns | 49 ns + (0,23 ns/pF) C_L | |
| | 15 | | 45 | 90 ns | 37 ns + (0,16 ns/pF) C_L | |

A.C. CHARACTERISTICS

 $V_{SS} = 0\text{ V}$; $T_{amb} = 25\text{ }^{\circ}\text{C}$; $C_L = 50\text{ pF}$; input transition times $\leq 20\text{ ns}$

| | V_{DD} V | symbol | min. | typ. | max. | typical extrapolation formula | |
|--|---------------|------------|------|------|------|---|---|
| Output transition times HIGH to LOW | 5 | t_{THL} | | 60 | 120 | ns | $10\text{ ns} + (1,0\text{ ns/pF}) C_L$ |
| | 10 | | 30 | 60 | ns | $9\text{ ns} + (0,42\text{ ns/pF}) C_L$ | |
| | 15 | | 20 | 40 | ns | $6\text{ ns} + (0,28\text{ ns/pF}) C_L$ | |
| LOW to HIGH | 5 | t_{TLH} | | 60 | 120 | ns | $10\text{ ns} + (1,0\text{ ns/pF}) C_L$ |
| | 10 | | 30 | 60 | ns | $9\text{ ns} + (0,42\text{ ns/pF}) C_L$ | |
| | 15 | | 20 | 40 | ns | $6\text{ ns} + (0,28\text{ ns/pF}) C_L$ | |
| Set-up time $P_n \rightarrow \overline{PL}$ | 5 | t_{su} | 160 | 80 | | ns | |
| | 10 | | 60 | 30 | | ns | |
| | 15 | | 50 | 25 | | ns | |
| Hold time $P_n \rightarrow \overline{PL}$ | 5 | t_{hold} | 10 | -70 | | ns | |
| | 10 | | 5 | -25 | | ns | |
| | 15 | | 5 | -20 | | ns | |
| Minimum CP_U or CP_D pulse width; LOW | 5 | t_{WCPL} | 150 | 75 | | ns | |
| | 10 | | 50 | 25 | | ns | |
| | 15 | | 35 | 20 | | ns | |
| Minimum MR pulse width; HIGH | 5 | t_{WMRH} | 180 | 90 | | ns | |
| | 10 | | 70 | 35 | | ns | |
| | 15 | | 60 | 30 | | ns | |
| Minimum \overline{PL} pulse width; LOW | 5 | t_{WPLL} | 120 | 60 | | ns | |
| | 10 | | 45 | 20 | | ns | |
| | 15 | | 30 | 15 | | ns | |
| Recovery time for MR | 5 | t_{RMR} | 125 | 65 | | ns | |
| | 10 | | 70 | 35 | | ns | |
| | 15 | | 50 | 25 | | ns | |
| Recovery time for \overline{PL} | 5 | t_{RPL} | 90 | 45 | | ns | |
| | 10 | | 35 | 15 | | ns | |
| | 15 | | 25 | 10 | | ns | |
| Maximum clock pulse frequency | 5 | f_{max} | 2,5 | 5 | | MHz | |
| | 10 | | 7 | 14 | | MHz | |
| | 15 | | 9 | 18 | | MHz | |

see also waveforms
Fig. 5

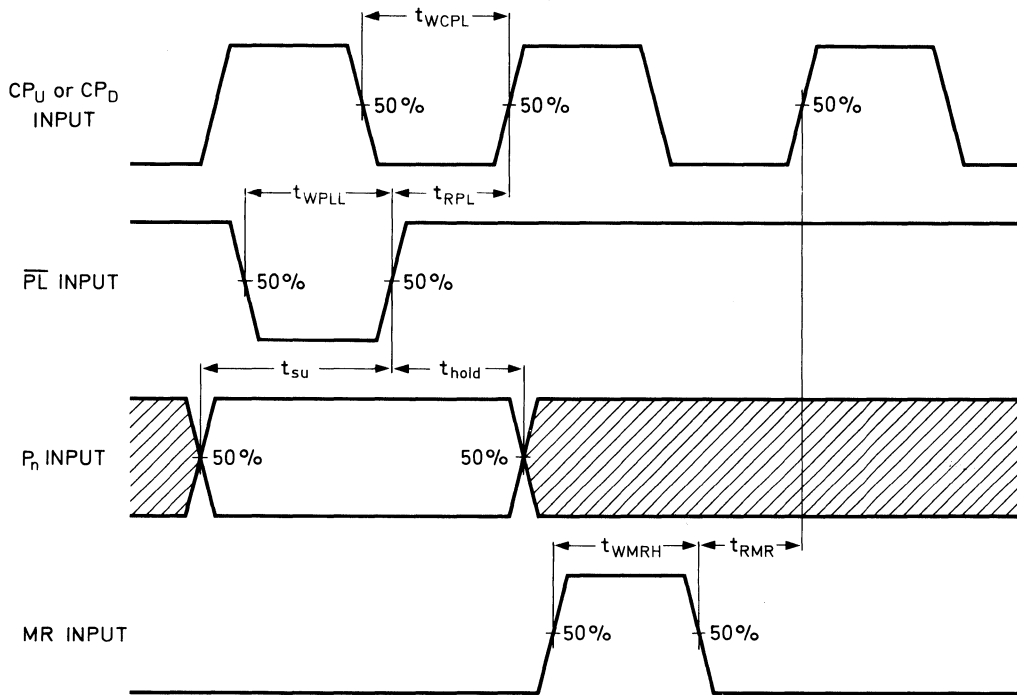

7Z69717.1

Fig. 5 Waveforms showing recovery times for $\overline{P_L}$ and MR, minimum pulse widths for CP_U, CP_D, $\overline{P_L}$ and MR, and set-up and hold times for P to $\overline{P_L}$. Set-up times and hold times are shown as positive values but may be specified as negative values.

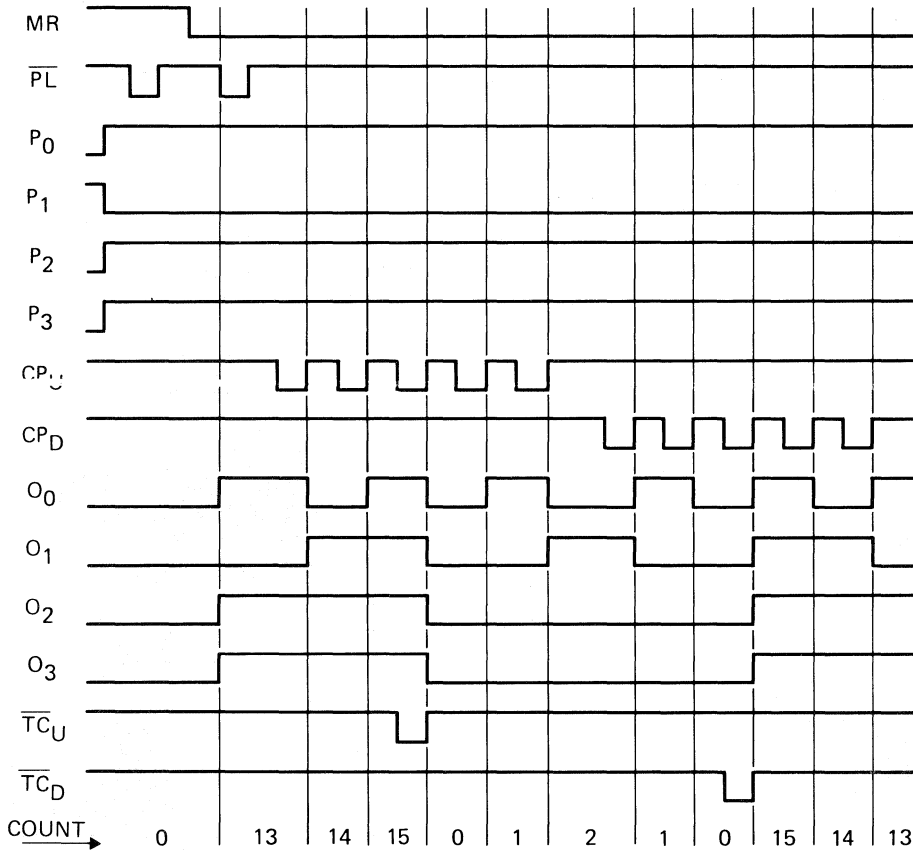

7Z84174

Fig. 6 Timing diagram.

APPLICATION INFORMATION

Some examples of applications for the HEF40193B are:

- Up/down difference counting
- Multistage ripple counting
- Multistage synchronous counting

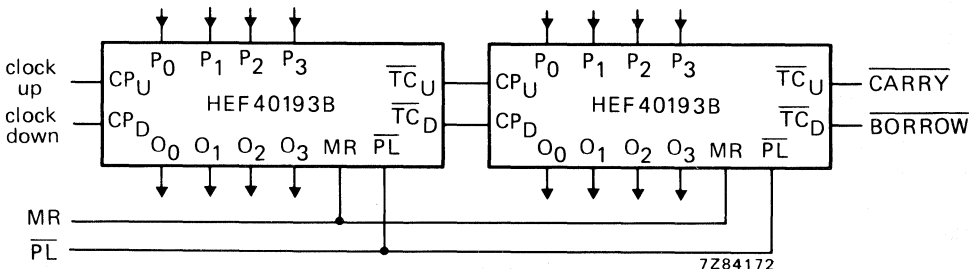

7Z84172

Fig. 7 Example of cascaded HEF40193B ICs.

4-BIT BIDIRECTIONAL UNIVERSAL SHIFT REGISTER



The HEF40194B is a 4-bit bidirectional shift register with two mode control inputs (S_0 and S_1), a clock input (CP), a serial data shift left input (D_{SL}), a serial data shift right input (D_{SR}), four parallel data inputs (P_0 to P_3), an overriding asynchronous master reset input (\overline{MR}), and four buffered parallel outputs (O_0 to O_3). When LOW, \overline{MR} resets all stages and forces O_0 to O_3 LOW, overriding all other input conditions. When \overline{MR} is HIGH, the operation mode is controlled by S_0 and S_1 as shown in the function table.

Serial and parallel operation are edge-triggered on the LOW to HIGH transition of CP. The inputs at which the data are to be entered and S_0 , S_1 must be stable for a set-up time before the LOW to HIGH transition of CP.

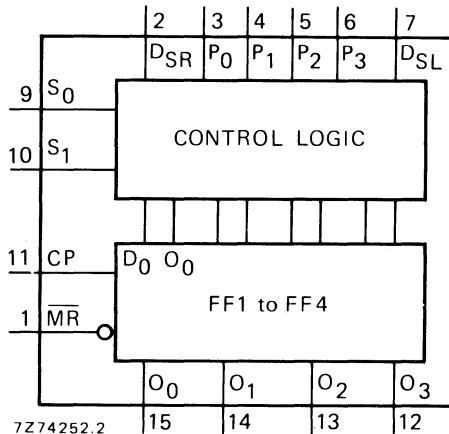

Fig. 1 Functional diagram.

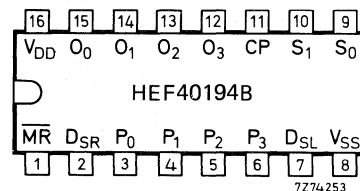

Fig. 2 Pinning diagram.

HEF40194BP : 16-lead DIL; plastic (SOT-38Z).
 HEF40194BD : 16-lead DIL; ceramic (cerdip) (SOT-74).
 HEF40194BT : 16-lead mini-pack; plastic (SO-16; SOT-109A).

PINNING

| | |
|-----------------|--|
| S_0 , S_1 | mode control inputs |
| P_0 to P_3 | parallel data inputs |
| D_{SR} | serial data shift right input |
| D_{SL} | serial data shift left input |
| CP | clock input (LOW to HIGH edge-triggered) |
| \overline{MR} | master reset input (active LOW) |
| O_0 to O_3 | buffered parallel outputs |

FAMILY DATA

I_{DD} LIMITS category MSI

see Family Specifications

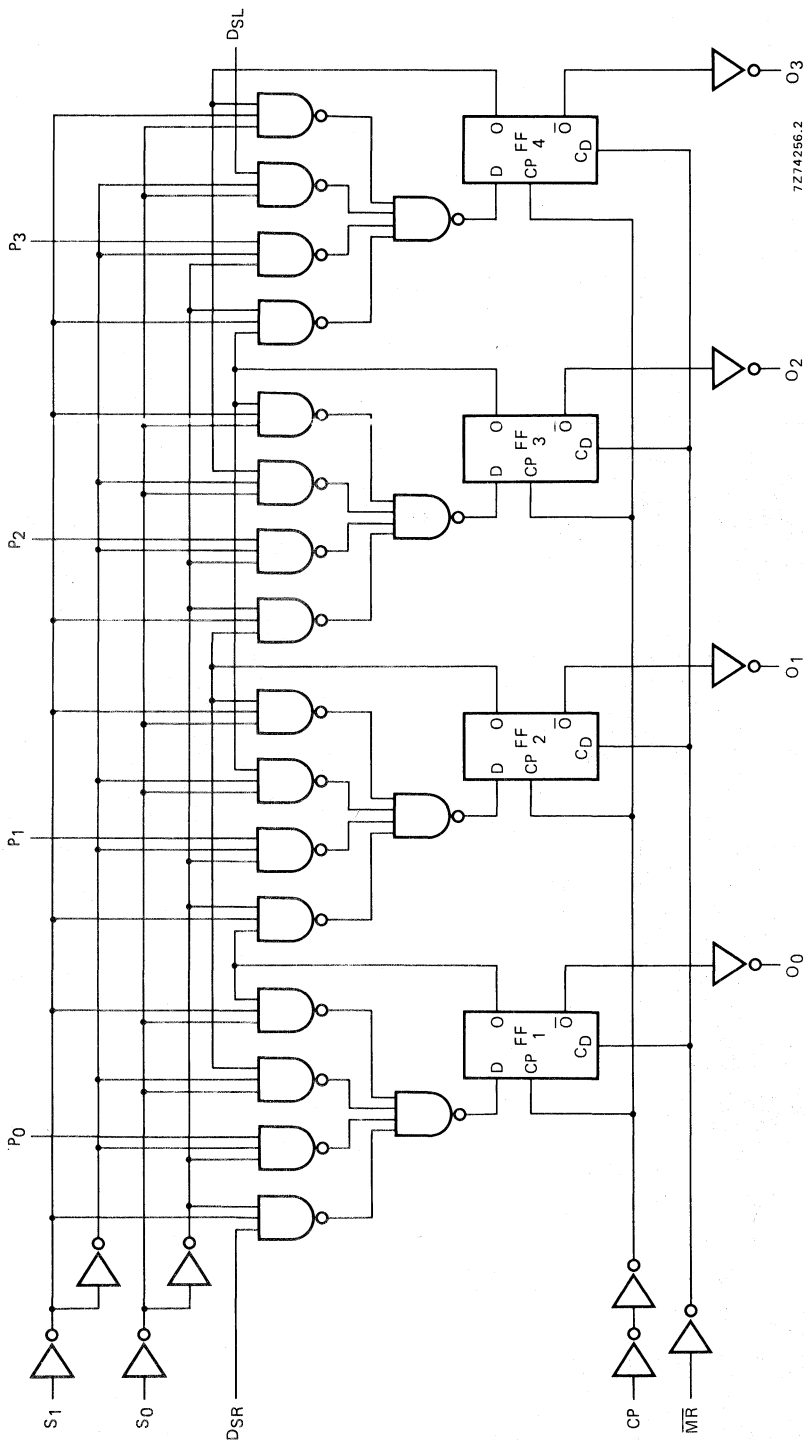

Fig. 3 Logic diagram.

FUNCTION TABLE

| operating mode | inputs ($\overline{MR} = \text{HIGH}$) | | | | | outputs at t_{n+1} | | | |
|----------------|--|----------------|-----------------|-----------------|----------------------------------|----------------------|----------------|----------------|----------------|
| | S ₁ | S ₀ | D _{SR} | D _{SL} | P ₀ to P ₃ | O ₀ | O ₁ | O ₂ | O ₃ |
| hold | L | L | X | X | X | O ₀ | O ₁ | O ₂ | O ₃ |
| shift left | H | L | X | L | X | O ₁ | O ₂ | O ₃ | L |
| | H | L | X | H | X | O ₁ | O ₂ | O ₃ | H |
| shift right | L | H | L | X | X | L | O ₀ | O ₁ | O ₂ |
| | L | H | H | X | X | H | O ₀ | O ₁ | O ₂ |
| parallel load | H | H | X | X | L | L | L | L | L |
| | H | H | X | X | H | H | H | H | H |

H = HIGH state (the more positive voltage)

L = LOW state (the less positive voltage)

X = state is immaterial

 t_{n+1} = state after next LOW to HIGH transition of CP**A.C. CHARACTERISTICS**V_{SS} = 0 V; T_{amb} = 25 °C; input transition times ≤ 20 ns

| | V _{DD} V | typical formula for P (μW) | where f _i = input freq. (MHz) f _o = output freq. (MHz) C _L = load cap. (pF) Σ(f _o C _L) = sum of outputs V _{DD} = supply voltage (V) |
|---|----------------------|---|---|
| Dynamic power dissipation per package (P) | 5 | $1\,500 f_i + \Sigma(f_o C_L) \times V_{DD}^2$ | |
| | 10 | $6\,900 f_i + \Sigma(f_o C_L) \times V_{DD}^2$ | |
| | 15 | $18\,900 f_i + \Sigma(f_o C_L) \times V_{DD}^2$ | |

A.C. CHARACTERISTICS

 $V_{SS} = 0 \text{ V}$; $T_{amb} = 25 \text{ }^\circ\text{C}$; $C_L = 50 \text{ pF}$; input transition times $\leq 20 \text{ ns}$

| | V_{DD} V | symbol | min. | typ. | max. | typical extrapolation formula |
|--|---------------|------------|------|------|------|--|
| Propagation delays | | | | | | |
| CP \rightarrow O_n | 5 | | 100 | 205 | ns | $73 \text{ ns} + (0,55 \text{ ns/pF}) C_L$ |
| HIGH to LOW | 10 | t_{PHL} | 40 | 85 | ns | $29 \text{ ns} + (0,23 \text{ ns/pF}) C_L$ |
| | 15 | | 30 | 60 | ns | $22 \text{ ns} + (0,16 \text{ ns/pF}) C_L$ |
| | 5 | | 80 | 165 | ns | $53 \text{ ns} + (0,55 \text{ ns/pF}) C_L$ |
| LOW to HIGH | 10 | t_{PLH} | 35 | 70 | ns | $24 \text{ ns} + (0,23 \text{ ns/pF}) C_L$ |
| | 15 | | 25 | 55 | ns | $17 \text{ ns} + (0,16 \text{ ns/pF}) C_L$ |
| $\overline{MR} \rightarrow O_r$ | 5 | | 85 | 175 | ns | $58 \text{ ns} + (0,55 \text{ ns/pF}) C_L$ |
| HIGH to LOW | 10 | t_{PHL} | 40 | 80 | ns | $29 \text{ ns} + (0,23 \text{ ns/pF}) C_L$ |
| | 15 | | 30 | 60 | ns | $22 \text{ ns} + (0,16 \text{ ns/pF}) C_L$ |
| Output transition times | | | | | | |
| HIGH to LOW | 5 | | 60 | 120 | ns | $10 \text{ ns} + (1,0 \text{ ns/pF}) C_L$ |
| | 10 | t_{THL} | 30 | 60 | ns | $9 \text{ ns} + (0,42 \text{ ns/pF}) C_L$ |
| | 15 | | 20 | 40 | ns | $6 \text{ ns} + (0,28 \text{ ns/pF}) C_L$ |
| | 5 | | 60 | 120 | ns | $10 \text{ ns} + (1,0 \text{ ns/pF}) C_L$ |
| LOW to HIGH | 10 | t_{TLH} | 30 | 60 | ns | $9 \text{ ns} + (0,42 \text{ ns/pF}) C_L$ |
| | 15 | | 20 | 40 | ns | $6 \text{ ns} + (0,28 \text{ ns/pF}) C_L$ |
| Set-up times | | | | | | |
| $P_n, D_{SR}, D_{SL} \rightarrow CP$ | 5 | | 80 | 40 | ns | |
| | 10 | t_{su} | 30 | 15 | ns | |
| | 15 | | 20 | 10 | ns | |
| | 5 | | 140 | 70 | ns | |
| $S_n \rightarrow CP$ | 10 | t_{su} | 60 | 30 | ns | |
| | 15 | | 40 | 20 | ns | |
| Hold times | | | | | | |
| $P_n, D_{SR}, D_{SL} \rightarrow CP$ | 5 | | 10 | -30 | ns | |
| | 10 | t_{hold} | 5 | -10 | ns | |
| | 15 | | 5 | -5 | ns | |
| | 5 | | 25 | -45 | ns | |
| $S_n \rightarrow CP$ | 10 | t_{hold} | 15 | -15 | ns | |
| | 15 | | 10 | -10 | ns | |
| Minimum clock pulse width; LOW | 5 | | 50 | 25 | ns | |
| | 10 | t_{WCPL} | 20 | 10 | ns | |
| | 15 | | 20 | 10 | ns | |
| Minimum \overline{MR} pulse width; LOW | 5 | | 80 | 40 | ns | |
| | 10 | t_{WMRL} | 40 | 20 | ns | |
| | 15 | | 30 | 15 | ns | |
| Recovery time for \overline{MR} | 5 | | 30 | 10 | ns | |
| | 10 | t_{RMR} | 15 | 5 | ns | |
| | 15 | | 15 | 5 | ns | |
| Maximum clock pulse frequency | 5 | | 6 | 12 | MHz | |
| | 10 | f_{max} | 15 | 30 | MHz | |
| | 15 | | 20 | 40 | MHz | |

see also waveforms
Figs 4 and 5

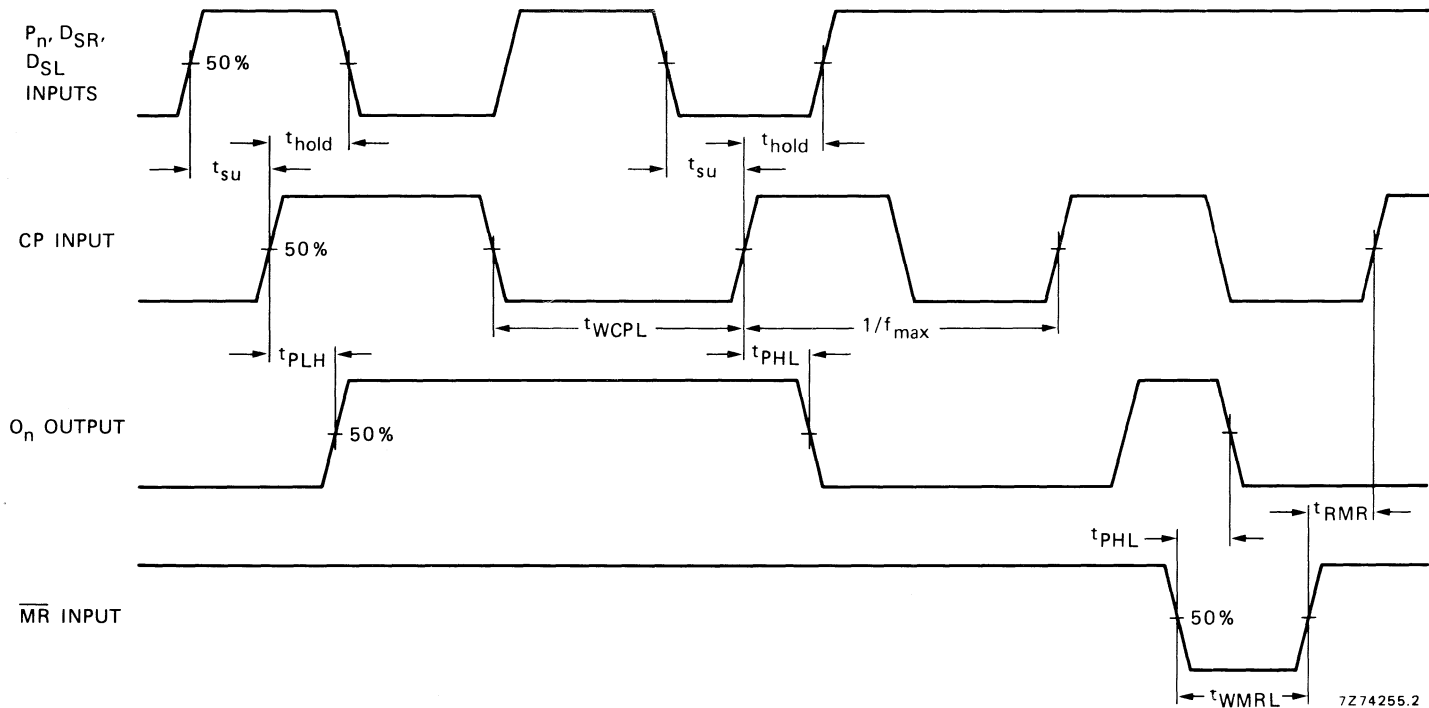

Fig. 4 Waveforms showing set-up times, hold times for D_{SR} , D_{SL} and P_n inputs; minimum \overline{MR} pulse width, \overline{MR} to output delays and \overline{MR} to CP recovery time; minimum CP pulse width and CP to output delays. Set-up and hold times are shown as positive values but may be specified as negative values.

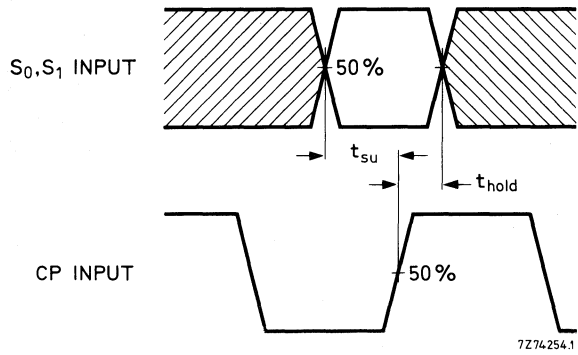

Fig. 5 Waveforms showing set-up times and hold times for S₀ and S₁ inputs. Set-up and hold times are shown as positive values but may be specified as negative values.

APPLICATION INFORMATION

Some examples of applications for the HEF40194B are:

- Arithmetic unit register
- Serial/parallel converter.



4-BIT UNIVERSAL SHIFT REGISTER

The HEF40195B is a fully synchronous edge-triggered 4-bit shift register with a clock input (CP), four synchronous parallel data inputs (P_0 to P_3), two synchronous serial data inputs (J , \bar{K}), a synchronous parallel enable input (\overline{PE}), buffered parallel outputs from all 4-bit positions (O_0 to O_3), a buffered inverted output from the last bit position (\bar{O}_3) and an overriding asynchronous master reset input (\overline{MR}). Each register stage is of a D-type master-slave flip-flop.

Operation is synchronous (except for \overline{MR}) and is edge-triggered on the LOW to HIGH transition of the CP input. When \overline{PE} is LOW, data are loaded into the register from P_0 to P_3 on the LOW to HIGH transition of CP. When \overline{PE} is HIGH, data are shifted into the first register position from J and \bar{K} and all the data in the register are shifted one position to the right on the LOW to HIGH transition of CP.

D-type entry is obtained by interconnecting J and K .

When J is HIGH and \bar{K} is LOW, the first stage is in the toggle mode. When J is LOW and \bar{K} is HIGH, the first stage is in the hold mode.

A LOW on \overline{MR} resets all four bit positions (O_0 to $O_3 = \text{LOW}$, $\bar{O}_3 = \text{HIGH}$) independent of all other input conditions.

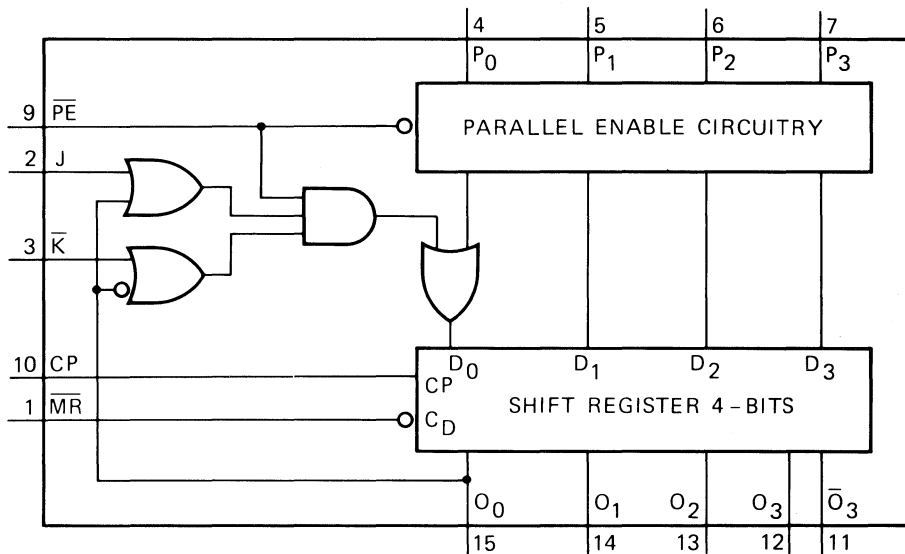

7Z69826.3

Fig. 1 Functional diagram.

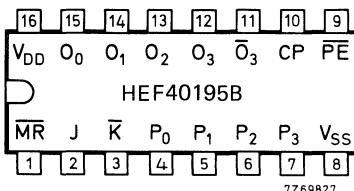

Fig. 2 Pinning diagram.

HEF40195BP : 16-lead DIL; plastic (SOT-38Z).
 HEF40195BD : 16-lead DIL; ceramic (cerdip) (SOT-74).
 HEF40195BT : 16-lead mini-pack; plastic
 (SO-16; SOT-109A).

FAMILY DATA

IDD LIMITS category MSI

} see Family Specifications



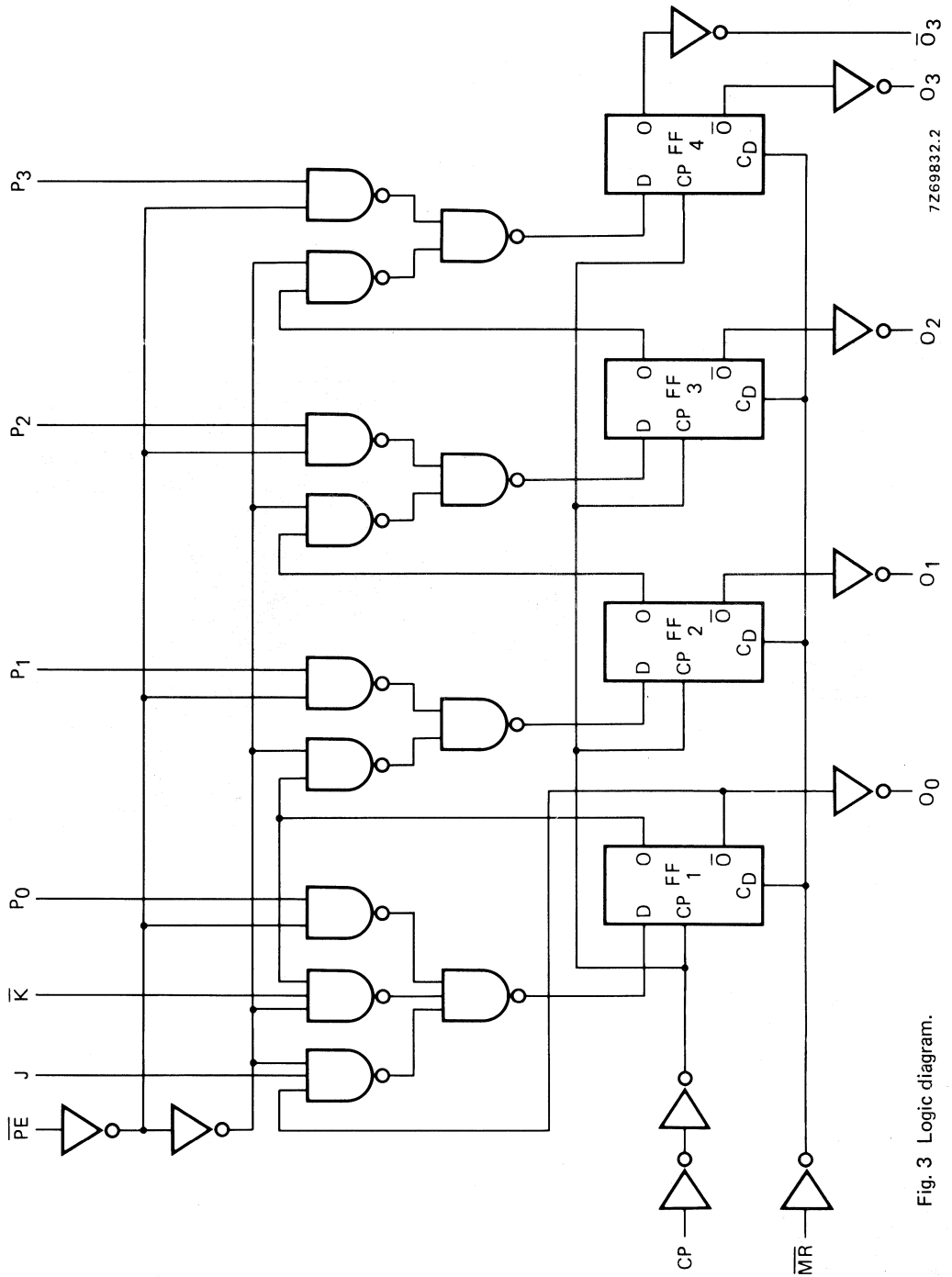

Fig. 3 Logic diagram.

7269832.2

PINNING

| | |
|------------------|--|
| \overline{PE} | parallel enable input (active LOW) |
| P_0 to P_3 | parallel data inputs |
| J | first stage J-input (active HIGH) |
| \overline{K} | first stage K-input (active LOW) |
| CP | clock input (LOW to HIGH edge triggered) |
| \overline{MR} | master reset input (active LOW) |
| O_0 to O_3 | buffered parallel outputs |
| \overline{O}_3 | buffered inverted output from last stage |

FUNCTION TABLE

| operating mode | inputs ($\overline{MR} = \text{HIGH}$) | | | | | | | outputs at $t_n + 1$ | | | | |
|---------------------|--|---|----------------|-------|-------|-------|-------|----------------------|-------|-------|-------|------------------|
| | \overline{PE} | J | \overline{K} | P_0 | P_1 | P_2 | P_3 | O_0 | O_1 | O_2 | O_3 | \overline{O}_3 |
| shift mode | H | L | L | X | X | X | X | L | O_0 | O_1 | O_2 | \overline{O}_2 |
| | H | L | H | X | X | X | X | \overline{O}_0 | O_0 | O_1 | O_2 | \overline{O}_2 |
| | H | H | L | X | X | X | X | \overline{O}_0 | O_0 | O_1 | O_2 | \overline{O}_2 |
| | H | H | H | X | X | X | X | H | O_0 | O_1 | O_2 | \overline{O}_2 |
| parallel entry mode | L | X | X | L | L | L | L | L | L | L | L | H |
| | L | X | X | H | H | H | H | H | H | H | H | L |

H = HIGH state (the more positive voltage)

L = LOW state (the less positive voltage)

X = state is immaterial

$t_n + 1$ = state after next LOW to HIGH transition of CP

A.C. CHARACTERISTICS

 $V_{SS} = 0\text{ V}$; $T_{amb} = 25\text{ }^{\circ}\text{C}$; $C_L = 50\text{ pF}$; input transition times $\leq 20\text{ ns}$

| | V_{DD} V | symbol | min. | typ. | max. | typical extrapolation formula | |
|------------------------------|---------------|--------|------|------|------|----------------------------------|--|
| Propagation delays | | | | | | | |
| CP \rightarrow O_n | 5 | | | 105 | 215 | ns | $78\text{ ns} + (0,55\text{ ns/pF}) C_L$ |
| HIGH to LOW | 10 | tPHL | | 50 | 95 | ns | $39\text{ ns} + (0,23\text{ ns/pF}) C_L$ |
| | 15 | | | 35 | 65 | ns | $27\text{ ns} + (0,16\text{ ns/pF}) C_L$ |
| | 5 | | | 90 | 180 | ns | $63\text{ ns} + (0,55\text{ ns/pF}) C_L$ |
| LOW to HIGH | 10 | tPLH | | 45 | 85 | ns | $34\text{ ns} + (0,23\text{ ns/pF}) C_L$ |
| | 15 | | | 30 | 60 | ns | $22\text{ ns} + (0,16\text{ ns/pF}) C_L$ |
| | 5 | | | 125 | 255 | ns | $98\text{ ns} + (0,55\text{ ns/pF}) C_L$ |
| CP \rightarrow \bar{O}_3 | 5 | | | 125 | 255 | ns | $98\text{ ns} + (0,55\text{ ns/pF}) C_L$ |
| HIGH to LOW | 10 | tPHL | | 50 | 100 | ns | $39\text{ ns} + (0,23\text{ ns/pF}) C_L$ |
| | 15 | | | 35 | 70 | ns | $27\text{ ns} + (0,16\text{ ns/pF}) C_L$ |
| | 5 | | | 120 | 240 | ns | $93\text{ ns} + (0,55\text{ ns/pF}) C_L$ |
| LOW to HIGH | 10 | tPLH | | 50 | 105 | ns | $39\text{ ns} + (0,23\text{ ns/pF}) C_L$ |
| | 15 | | | 35 | 75 | ns | $27\text{ ns} + (0,16\text{ ns/pF}) C_L$ |
| | 5 | | | 100 | 205 | ns | $73\text{ ns} + (0,55\text{ ns/pF}) C_L$ |
| $\bar{M}R \rightarrow O_n$ | 5 | | | 100 | 205 | ns | $73\text{ ns} + (0,55\text{ ns/pF}) C_L$ |
| HIGH to LOW | 10 | tPHL | | 45 | 90 | ns | $34\text{ ns} + (0,23\text{ ns/pF}) C_L$ |
| | 15 | | | 30 | 65 | ns | $22\text{ ns} + (0,16\text{ ns/pF}) C_L$ |
| | 5 | | | 125 | 235 | ns | $98\text{ ns} + (0,55\text{ ns/pF}) C_L$ |
| LOW to HIGH | 10 | tPLH | | 55 | 115 | ns | $44\text{ ns} + (0,23\text{ ns/pF}) C_L$ |
| | 15 | | | 40 | 85 | ns | $32\text{ ns} + (0,16\text{ ns/pF}) C_L$ |
| | 5 | | | 60 | 120 | ns | $10\text{ ns} + (1,0\text{ ns/pF}) C_L$ |
| Output transition times | 5 | | | 60 | 120 | ns | $10\text{ ns} + (1,0\text{ ns/pF}) C_L$ |
| HIGH to LOW | 10 | tTHL | | 30 | 60 | ns | $9\text{ ns} + (0,42\text{ ns/pF}) C_L$ |
| | 15 | | | 20 | 40 | ns | $6\text{ ns} + (0,28\text{ ns/pF}) C_L$ |
| | 5 | | | 60 | 120 | ns | $10\text{ ns} + (1,0\text{ ns/pF}) C_L$ |
| LOW to HIGH | 10 | tTLH | | 30 | 60 | ns | $9\text{ ns} + (0,42\text{ ns/pF}) C_L$ |
| | 15 | | | 20 | 40 | ns | $6\text{ ns} + (0,28\text{ ns/pF}) C_L$ |
| | 5 | | | 60 | 120 | ns | $10\text{ ns} + (1,0\text{ ns/pF}) C_L$ |

A.C. CHARACTERISTICS

 $V_{SS} = 0 \text{ V}$; $T_{amb} = 25 \text{ }^\circ\text{C}$; $C_L = 50 \text{ pF}$; input transition times $\leq 20 \text{ ns}$

| | V_{DD} V | symbol | min. | typ. | max. | |
|---|---------------|------------|------|------|------|------------------------------------|
| Set-up times J, $\bar{K} \rightarrow$ CP | 5 | t_{su} | 70 | 35 | ns | see also waveforms Figs 4 and 5 |
| | 10 | | 20 | 10 | ns | |
| | 15 | | 10 | 5 | ns | |
| $P_n \rightarrow$ CP | 5 | t_{su} | 85 | 40 | ns | |
| | 10 | | 25 | 10 | ns | |
| | 15 | | 10 | 5 | ns | |
| $\bar{P}\bar{E} \rightarrow$ CP | 5 | t_{su} | 115 | 55 | ns | |
| | 10 | | 45 | 20 | ns | |
| | 15 | | 30 | 15 | ns | |
| Hold times J, $\bar{K} \rightarrow$ CP | 5 | t_{hold} | 15 | -20 | ns | |
| | 10 | | 5 | -5 | ns | |
| | 15 | | 0 | -5 | ns | |
| $P_n \rightarrow$ CP | 5 | t_{hold} | 20 | -25 | ns | |
| | 10 | | 10 | -5 | ns | |
| | 15 | | 0 | -5 | ns | |
| $\bar{P}\bar{E} \rightarrow$ CP | 5 | t_{hold} | 10 | -50 | ns | |
| | 10 | | 5 | -20 | ns | |
| | 15 | | 5 | -10 | ns | |
| Minimum clock pulse width; LOW | 5 | t_{WCPL} | 60 | 30 | ns | |
| | 10 | | 25 | 10 | ns | |
| | 15 | | 20 | 10 | ns | |
| Minimum $\bar{M}\bar{R}$ pulse width; HIGH | 5 | t_{WMRL} | 100 | 50 | ns | |
| | 10 | | 40 | 20 | ns | |
| | 15 | | 30 | 15 | ns | |
| Recovery time for $\bar{M}\bar{R}$ | 5 | t_{RMR} | 30 | 10 | ns | |
| | 10 | | 15 | 5 | ns | |
| | 15 | | 15 | 5 | ns | |
| Maximum clock pulse frequency | 5 | f_{max} | 5 | 10 | MHz | |
| | 10 | | 14 | 28 | MHz | |
| | 15 | | 19 | 39 | MHz | |

| | V_{DD} V | typical formula for P (μW) | where f_i = input freq. (MHz) f_o = output freq. (MHz) C_L = load capacitance (pF) $\Sigma(f_o C_L)$ = sum of outputs V_{DD} = supply voltage (V) | |
|---|---------------|--|--|---|
| Dynamic power dissipation per package (P) | 5 | $1900 f_i + \Sigma(f_o C_L) \times V_{DD}^2$ | | |
| | 10 | | | $8300 f_i + \Sigma(f_o C_L) \times V_{DD}^2$ |
| | 15 | | | $22800 f_i + \Sigma(f_o C_L) \times V_{DD}^2$ |

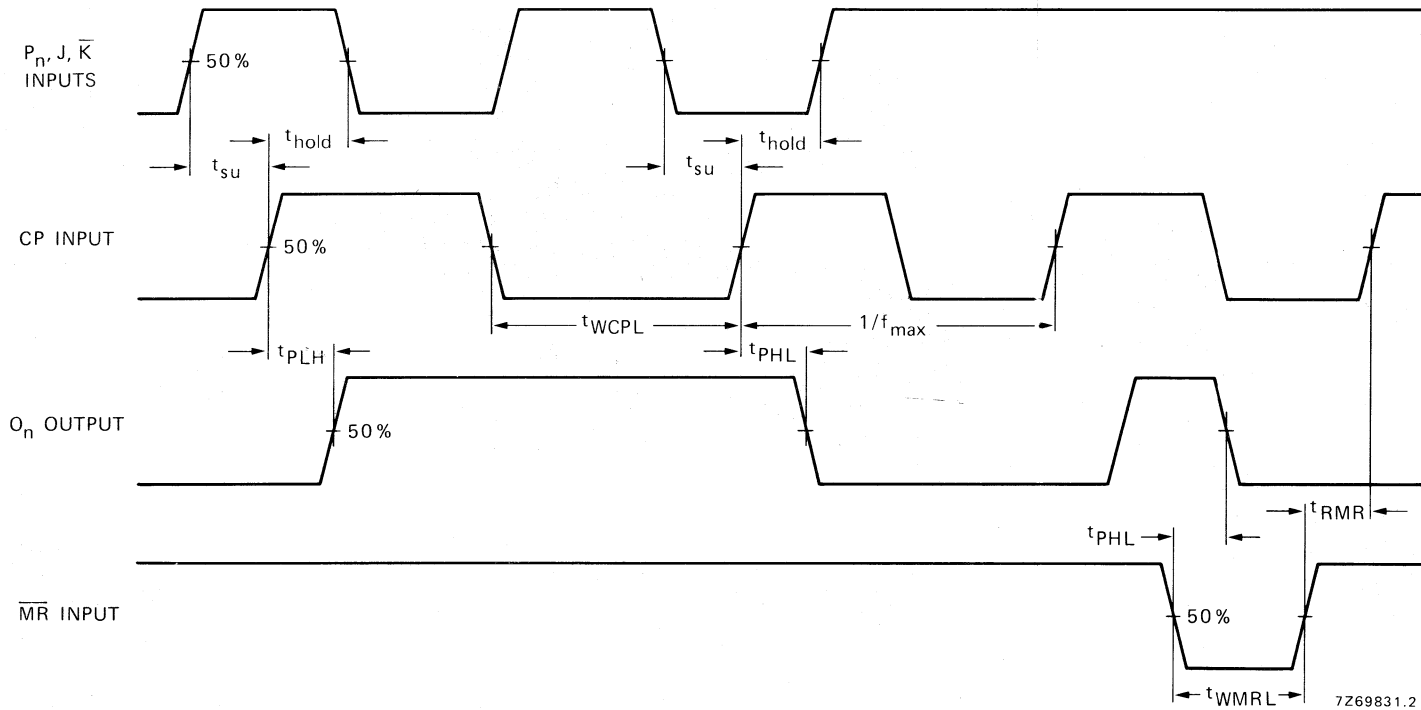

Fig. 4 Waveforms showing set-up times, hold times for J , \bar{K} and P_n inputs; minimum \bar{MR} pulse width, \bar{MR} to output delays and \bar{MR} to CP recovery time; minimum CP pulse width and CP to output delays. Set-up and hold times are shown as positive values but may be specified as negative values.

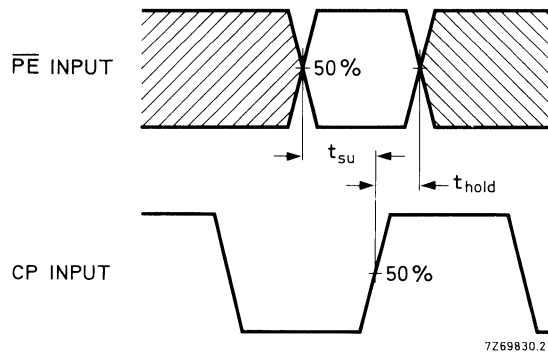

Fig. 5 Waveforms showing set-up and hold times for \overline{PE} input. Set-up and hold times are shown as positive values but may be specified as negative values.

APPLICATION INFORMATION

Some examples of applications for the HEF40195B are:

- Serial data transfer
- Parallel data transfer
- Serial to parallel data transfer
- Parallel to serial data transfer

OCTAL BUFFERS WITH 3-STATE OUTPUTS

The HEF40240B is an octal inverting buffer with 3-state outputs. It features output stages with high current output capability suitable for driving highly capacitive loads.

The 3-state outputs are controlled by the output enable inputs \overline{EO}_A and \overline{EO}_B . A HIGH on \overline{EO} causes the outputs to assume a high impedance OFF-state. The device also features hysteresis on all inputs to improve noise immunity.

Schmitt-trigger action in the inputs makes the circuit highly tolerant to slower input rise and fall times.

The HEF40240B is pin and functionally compatible with the TTL '240' device.

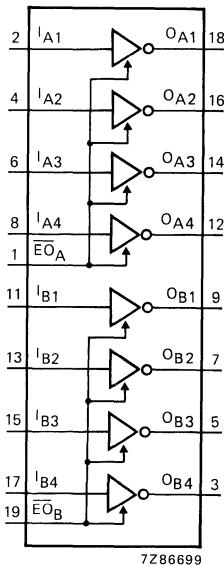

Fig. 1 Functional diagram.

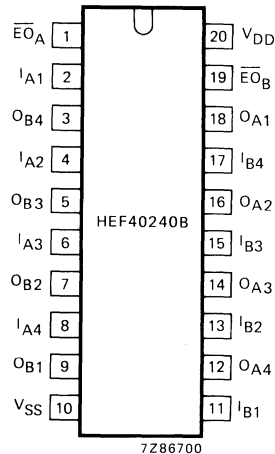

Fig. 2 Pinning diagram.

HEF40240BP : 20-lead DIL; plastic (SOT-146).

HEF40240BT : 20-lead mini-pack; plastic (SO-20; SOT-163A).

PINNING

I_{A1} to I_{A4} } inputs
 I_{B1} to I_{B4} }
 O_{A1} to O_{A4} } bus outputs
 O_{B1} to O_{B4} }
 \overline{EO}_A , \overline{EO}_B output enable inputs (active LOW)

FAMILY DATA

I_{DD} LIMITS category buffers

} see Family Specifications

HEF40240B

buffers

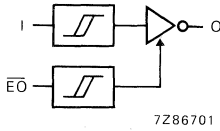

Fig. 3 Logic diagram (one buffer).

TRUTH TABLE

| inputs | | output |
|--------|-----------------|--------|
| I_n | \overline{EO} | O_n |
| H | L | L |
| L | L | H |
| X | H | Z |

H = HIGH state (the more positive voltage)
 L = LOW state (the less positive voltage)
 X = state is immaterial
 Z = high impedance off state

RATINGS

Limiting values in accordance with the Absolute Maximum System (IEC 134)

See Family Specifications except for:

| | | | |
|---|-----------|------|--------|
| D.C. current into any input | $\pm I_I$ | max. | 10 mA |
| D.C. source or sink current into any output | $\pm I_O$ | max. | 25 mA |
| D.C. current into the supply terminals | $\pm I$ | max. | 100 mA |

D.C. CHARACTERISTICS

$V_{SS} = 0\text{ V}$

| parameter | V_{DD} V | V_{OH} V | V_{OL} V | symbol | T_{amb} (°C) | | | | | | unit |
|--------------------------------------|---------------|---------------|---------------|-----------|----------------|------|------|-------|------|------|------|
| | | | | | -40 | | +25 | | +85 | | |
| | | | | | min. | typ. | min. | typ. | min. | typ. | |
| Output current HIGH | 5 | 3,6 | — | $-I_{OH}$ | 9,3 | — | 10,0 | 24,0 | 10,7 | — | mA |
| | 10 | 8,4 | — | $-I_{OH}$ | 14,4 | — | 15,0 | 46,0 | 15,0 | — | mA |
| | 15 | 13,2 | — | $-I_{OH}$ | 19,5 | — | 20,0 | 62,0 | 19,8 | — | mA |
| Output current HIGH | 5 | 4,6 | — | $-I_{OH}$ | 0,75 | — | 0,6 | 1,2 | 0,45 | — | mA |
| | 10 | 9,5 | — | $-I_{OH}$ | 1,85 | — | 1,5 | 3,0 | 1,1 | — | mA |
| | 15 | 13,5 | — | $-I_{OH}$ | 14,5 | — | 15,0 | 50,0 | 15,5 | — | mA |
| Output current LOW | 5 | — | 0,4 | I_{OL} | 2,9 | — | 2,3 | 5,4 | 1,75 | — | mA |
| | 10 | — | 0,5 | I_{OL} | 9,5 | — | 7,6 | 17,0 | 5,50 | — | mA |
| | 15 | — | 1,5 | I_{OL} | 30,0 | — | 25,0 | 45,0 | 19,0 | — | mA |
| Hysteresis voltage (any input) | 5 | — | — | V_H | — | — | — | 220,0 | — | — | mV |
| | 10 | — | — | V_H | — | — | — | 250,0 | — | — | mV |
| | 15 | — | — | V_H | — | — | — | 320,0 | — | — | mV |

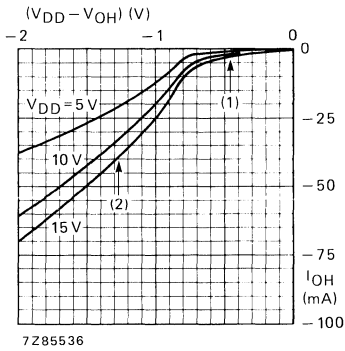

- (1) P-channel MOS transistor conducting.
- (2) P-channel MOS transistor and bipolar n-p-n transistor conducting.

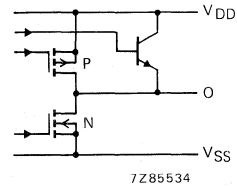

Fig. 4 Typical output source current characteristic.

Fig. 5 Schematic diagram of output stage.

A.C. CHARACTERISTICS

$V_{SS} = 0\text{ V}$; $T_{amb} = 25\text{ }^\circ\text{C}$; input transition times $\leq 20\text{ ns}$

| all buffers switching | V_{DD} V | typical formula for P (μW) | where |
|---|---------------|---|-------------------------------------|
| Dynamic power dissipation per package (P) | 5 | $4\ 250\ f_i + \Sigma (f_o C_L) \times V_{DD}^2$ | f_i = input freq. (MHz) |
| | 10 | $17\ 000\ f_i + \Sigma (f_o C_L) \times V_{DD}^2$ | f_o = output freq. (MHz) |
| | 15 | $46\ 000\ f_i + \Sigma (f_o C_L) \times V_{DD}^2$ | C_L = load capacitance (pF) |
| | | | $\Sigma (f_o C_L)$ = sum of outputs |
| | | | V_{DD} = supply voltage (V) |

HEF40240B

buffers

A.C. CHARACTERISTICS

$V_{SS} = 0\text{ V}$; $T_{amb} = 25\text{ }^{\circ}\text{C}$; $C_L = 50\text{ pF}$; input transition times $\leq 20\text{ ns}$

| parameter | V_{DD} V | symbol | min. | typ. | max. | unit | typical extrapolation formula |
|--|---------------|-----------|------|------|------|------|--|
| Propagation delays $A_n \rightarrow B_n$ HIGH to LOW | 5 | t_{PHL} | | 95 | 190 | ns | $83\text{ ns} + (0,24\text{ ns/pF}) C_L$ $35\text{ ns} + (0,10\text{ ns/pF}) C_L$ $26\text{ ns} + (0,07\text{ ns/pF}) C_L$ |
| | 10 | | 40 | 80 | ns | | |
| | 15 | | 30 | 60 | ns | | |
| $A_n \rightarrow B_n$ LOW to HIGH | 5 | t_{PLH} | | 85 | 170 | ns | $82\text{ ns} + (0,06\text{ ns/pF}) C_L$ $38\text{ ns} + (0,03\text{ ns/pF}) C_L$ $29\text{ ns} + (0,02\text{ ns/pF}) C_L$ |
| | 10 | | 40 | 80 | ns | | |
| | 15 | | 30 | 60 | ns | | |
| Output transition times HIGH to LOW | 5 | t_{THL} | | 40 | 80 | ns | see Fig. 6 |
| | 10 | | 20 | 40 | ns | | |
| | 15 | | 15 | 30 | ns | | |
| LOW to HIGH | 5 | t_{TLH} | | 30 | 60 | ns | |
| | 10 | | 20 | 40 | ns | | |
| | 15 | | 15 | 30 | ns | | |
| 3-state propagation delays | | | | | | | |
| Output disable times $\overline{E}O \rightarrow A_n, B_n$ HIGH | 5 | t_{PHZ} | | 70 | 140 | ns | |
| | 10 | | 35 | 70 | ns | | |
| | 15 | | 30 | 60 | ns | | |
| LOW | 5 | t_{PLZ} | | 75 | 150 | ns | |
| | 10 | | 40 | 80 | ns | | |
| | 15 | | 30 | 60 | ns | | |
| Output enable times $\overline{E}O \rightarrow A_n, B_n$ HIGH | 5 | t_{PZH} | | 80 | 160 | ns | |
| | 10 | | 35 | 70 | ns | | |
| | 15 | | 30 | 60 | ns | | |
| LOW | 5 | t_{PZL} | | 90 | 180 | ns | |
| | 10 | | 40 | 80 | ns | | |
| | 15 | | 30 | 60 | ns | | |

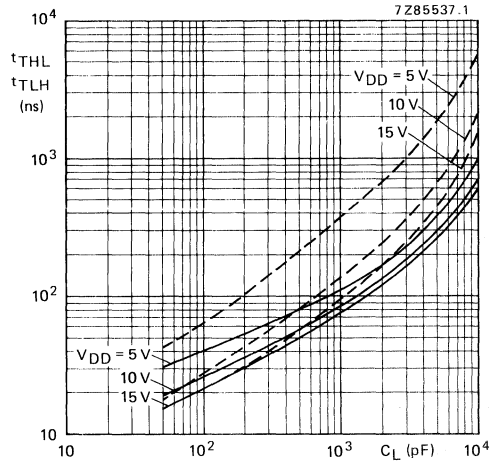

Fig. 6 Output transition times as a function of the load capacitance.
 ——— t_{TLH} ; - - - - t_{TLH} .



OCTAL BUFFERS WITH 3-STATE OUTPUTS

The HEF40244B is an octal non-inverting buffer with 3-state outputs. It features output stages with high current output capability suitable for driving highly capacitive loads.

The 3-state outputs are controlled by the output enable inputs \overline{EO}_A and \overline{EO}_B . A HIGH on \overline{EO} causes the outputs to assume a high impedance OFF-state. The device also features hysteresis on all inputs to improve noise immunity.

Schmitt-trigger action in the inputs makes the circuit highly tolerant to slower input rise and fall times.

The HEF40244B is pin and functionally compatible with the TTL '244' device.

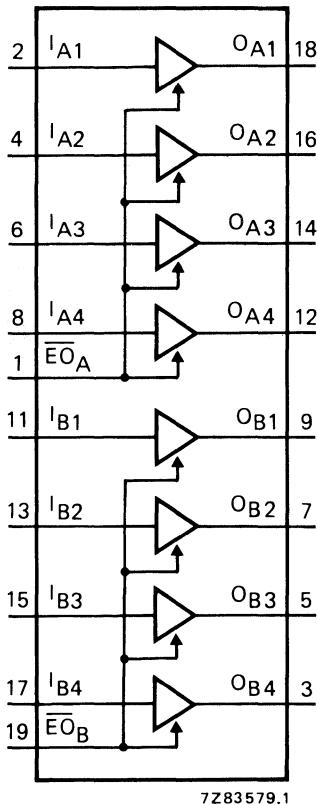

Fig. 1 Functional diagram.

FAMILY DATA

I_{DD} LIMITS category buffers

see Family Specifications

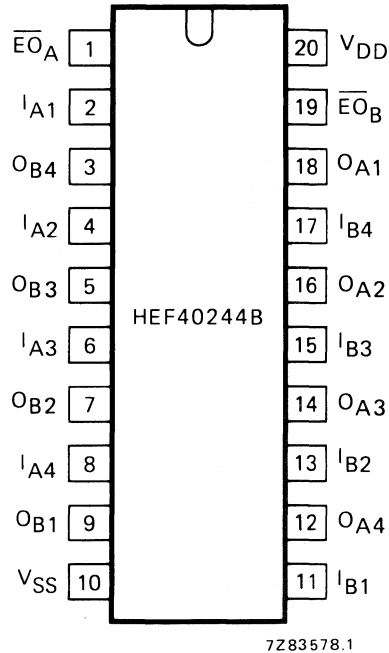

Fig. 2 Pinning diagram.

HEF40244BP : 20-lead DIL ; plastic (SOT-146).

HEF40244BT : 20 lead mini-pack ; plastic (SO-20; SOT-163A).

PINNING

I_{A1} to I_{A4} } inputs
 I_{B1} to I_{B4} }

O_{A1} to O_{A4} } bus outputs
 O_{B1} to O_{B4} }

$\overline{EO}_A, \overline{EO}_B$ output enable inputs (active LOW)

HEF40244B

buffers

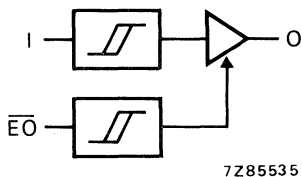

Fig. 3 Logic diagram (one buffer).

TRUTH TABLE

| inputs | | output |
|--------|-----------------|--------|
| I_n | \overline{EO} | O_n |
| H | L | H |
| L | L | L |
| X | H | Z |

H = HIGH state (the more positive voltage)

L = LOW state (the less positive voltage)

X = state is immaterial

Z = high impedance off state

RATINGS

Limiting values in accordance with the Absolute Maximum System (IEC 134).

See Family Specifications, except for:

| | | | |
|---|-----------|------|--------|
| D.C. current into any input | $\pm I_I$ | max. | 10 mA |
| D.C. source or sink current into any output | $\pm I_O$ | max. | 25 mA |
| D.C. current into the supply terminals | $\pm I$ | max. | 100 mA |

D.C. CHARACTERISTICS

$V_{SS} = 0$ V

| | V_{DD} V | V_{OH} V | V_{OL} V | symbol | T_{amb} (°C) | | | | | |
|--------------------------------------|---------------|---------------|---------------|-----------|----------------|------|------|------|------|------|
| | | | | | -40 | | +25 | | +85 | |
| | | | | | min. | typ. | min. | typ. | min. | typ. |
| Output current HIGH | 5 | 4,6 | | $-I_{OH}$ | 0,75 | | 0,6 | 1,2 | 0,45 | mA |
| | 10 | 9,5 | | | 1,85 | | 1,5 | 3,0 | 1,1 | mA |
| | 15 | 13,5 | | | 14,5 | | 15 | 50 | 15,5 | mA |
| Output current HIGH | 5 | 3,6 | | $-I_{OH}$ | 9,3 | | 10 | 24 | 10,7 | mA |
| | 10 | 8,4 | | | 14,4 | | 15 | 46 | 15,0 | mA |
| | 15 | 13,2 | | | 19,5 | | 20 | 62 | 19,8 | mA |
| Output current LOW | 5 | | 0,4 | I_{OL} | 2,9 | | 2,3 | 5,4 | 1,75 | mA |
| | 10 | | 0,5 | | 9,5 | | 7,6 | 17 | 5,50 | mA |
| | 15 | | 1,5 | | 30,0 | | 25 | 45 | 19,0 | mA |
| Hysteresis voltage (any input) | 5 | | | V_H | | | 220 | | | mV |
| | 10 | | | | | | 250 | | | mV |
| | 15 | | | | | | 320 | | | mV |

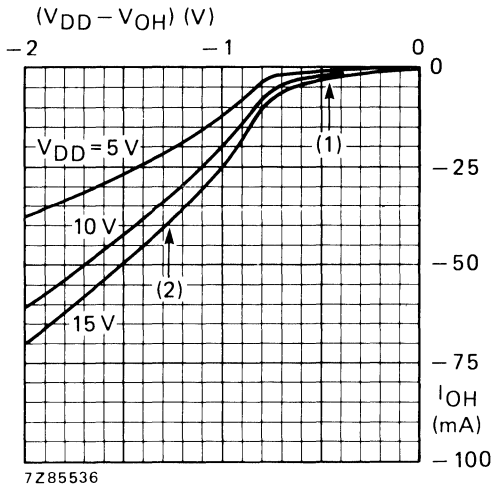

Fig. 4 Typical output source current characteristic.

- (1) P-channel MOS transistor conducting.
- (2) P-channel MOS transistor and bipolar n-p-n transistor conducting.

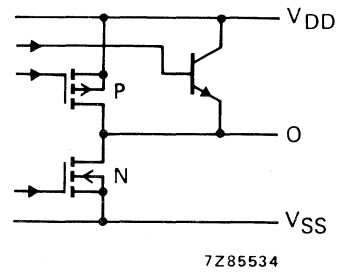

Fig. 5 Schematic diagram of output stage.

A.C. CHARACTERISTICS

$V_{SS} = 0\text{ V}$; $T_{amb} = 25\text{ }^\circ\text{C}$; input transition times $\leq 20\text{ ns}$

| all buffers switching | V_{DD} V | typical formula for P (μW) | where f_i = input freq. (MHz) f_o = output freq. (MHz) C_L = load capacitance (pF) $\Sigma(f_o C_L)$ = sum of outputs V_{DD} = supply voltage (V) |
|---|---------------|---|--|
| Dynamic power dissipation per package (P) | 5 | $4\ 250 f_i + \Sigma(f_o C_L) \times V_{DD}^2$ | |
| | 10 | $17\ 000 f_i + \Sigma(f_o C_L) \times V_{DD}^2$ | |
| | 15 | $46\ 000 f_i + \Sigma(f_o C_L) \times V_{DD}^2$ | |

HEF40244B

buffers

A.C. CHARACTERISTICS

$V_{SS} = 0\text{ V}$; $T_{amb} = 25\text{ }^\circ\text{C}$; $C_L = 50\text{ pF}$; input transition times $\leq 20\text{ ns}$

| | V_{DD} V | symbol | min. | typ. | max. | typical extrapolation formula | |
|--|---------------|--------|------|------|------|--|--|
| Propagation delays | | | | | | | |
| $A_n \rightarrow B_n$ HIGH to LOW | 5 | tPHL | | 95 | 190 | ns | $83\text{ ns} + (0,24\text{ ns/pF}) C_L$ |
| | 10 | | 40 | 80 | ns | $35\text{ ns} + (0,10\text{ ns/pF}) C_L$ | |
| | 15 | | 30 | 60 | ns | $26\text{ ns} + (0,07\text{ ns/pF}) C_L$ | |
| $A_n \rightarrow B_n$ LOW to HIGH | 5 | tPLH | | 85 | 170 | ns | $82\text{ ns} + (0,06\text{ ns/pF}) C_L$ |
| | 10 | | 40 | 80 | ns | $38\text{ ns} + (0,03\text{ ns/pF}) C_L$ | |
| | 15 | | 30 | 60 | ns | $29\text{ ns} + (0,02\text{ ns/pF}) C_L$ | |
| Output transition times | | | | | | | |
| HIGH to LOW | 5 | tTHL | | 40 | 80 | ns | } see Fig. 6 |
| | 10 | | 20 | 40 | ns | | |
| | 15 | | 15 | 30 | ns | | |
| LOW to HIGH | 5 | tTLH | | 30 | 60 | ns | |
| | 10 | | 20 | 40 | ns | | |
| | 15 | | 15 | 30 | ns | | |
| 3-state propagation delays | | | | | | | |
| Output disable times | | | | | | | |
| $\overline{EO} \rightarrow A_n, B_n$ HIGH | 5 | tPHZ | | 70 | 140 | ns | |
| | 10 | | 35 | 70 | ns | | |
| | 15 | | 30 | 60 | ns | | |
| LOW | 5 | tPLZ | | 75 | 150 | ns | |
| | 10 | | 40 | 80 | ns | | |
| | 15 | | 30 | 60 | ns | | |
| Output enable times | | | | | | | |
| $\overline{EO} \rightarrow A_n, B_n$ HIGH | 5 | tpZH | | 80 | 160 | ns | |
| | 10 | | 35 | 70 | ns | | |
| | 15 | | 30 | 60 | ns | | |
| LOW | 5 | tpZL | | 90 | 180 | ns | |
| | 10 | | 40 | 80 | ns | | |
| | 15 | | 30 | 60 | ns | | |

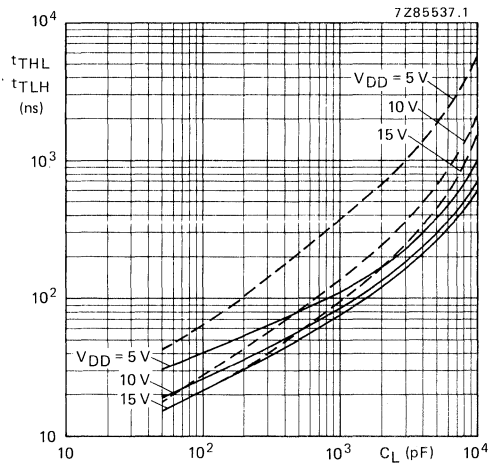

Fig. 6 Output transition times as a function of the load capacitance.

— t_{TLH} ; - - - t_{THL} .

OCTAL BUS TRANSCEIVER WITH 3-STATE OUTPUTS

The HEF40245B is an octal bus transmitter/receiver designed for 8-line asynchronous, 2-way data communication between data buses. It features output stages with high current output capability suitable for driving highly capacitive loads.

The direction input (DR) controls transmission of data from bus A to bus B, or bus B to bus A, depending on its logic level. The 3-state outputs are controlled by the enable input \overline{EO} . A HIGH on \overline{EO} causes the outputs to assume a high impedance OFF-state. The device also features hysteresis on all inputs to improve noise immunity.

Schmitt-trigger action in the inputs makes the circuit highly tolerant to slower input rise and fall times.

The HEF40245B is pin and functionally compatible with the TTL '245' device.

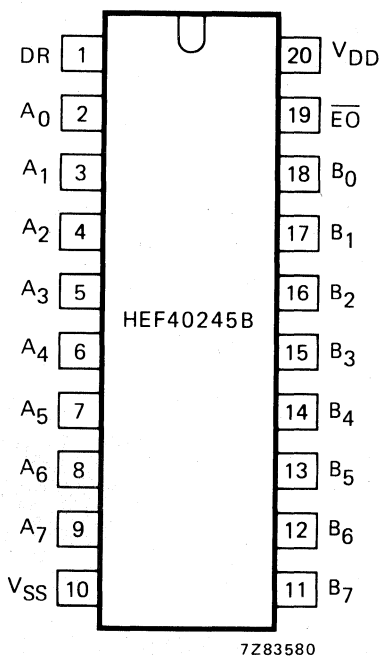

Fig. 1 Pinning diagram.

PINNING

| | |
|-----------------|----------------------------------|
| A_0 to A_7 | data input/output |
| B_0 to B_7 | data input/output |
| DR | direction input |
| \overline{EO} | output enable input (active LOW) |

HEF40245BP : 20-lead DIL; plastic (SOT-146).

HEF40245BT : 20-lead mini-pack; plastic (SO-20; SOT-163A).

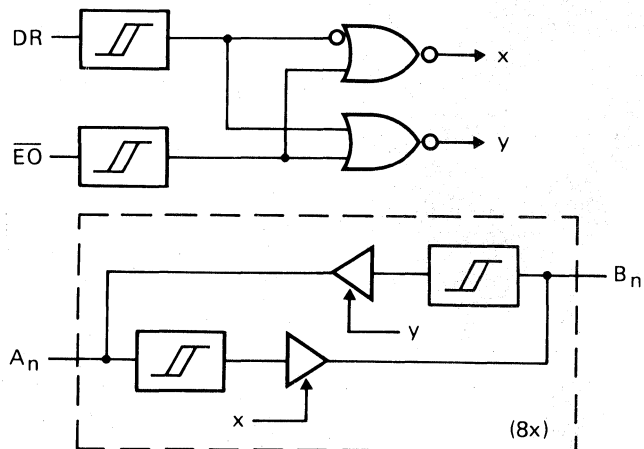

7Z85532

Fig. 2 Logic diagram; for functional diagram see Fig. 3.

FAMILY DATA

I_{DD} LIMITS category buffers

see Family Specifications.

HEF40245B

buffers

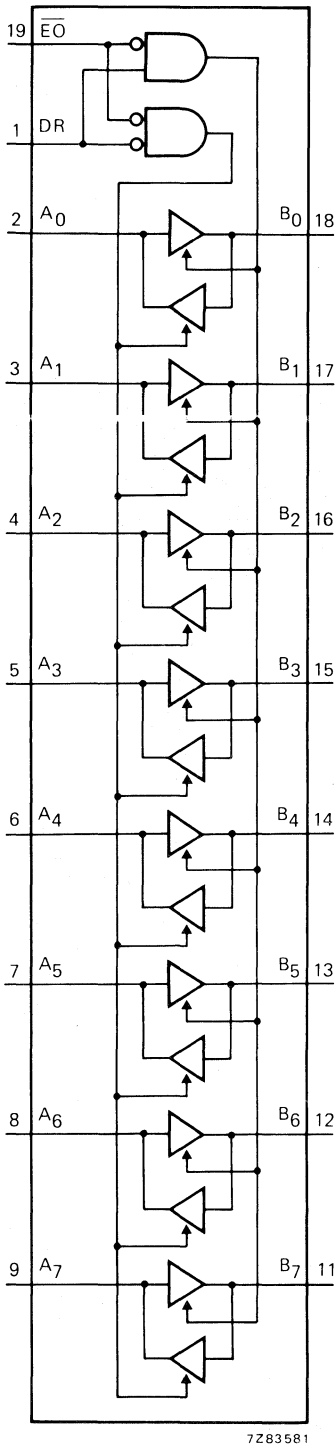

7283581

FUNCTION TABLE

| inputs | | inputs/outputs | |
|-----------------|----|----------------|-------|
| $\overline{E0}$ | DR | A_n | B_n |
| L | L | A = B | input |
| L | H | input | B = A |
| H | X | Z | Z |

H = HIGH state (the more positive voltage)

L = LOW state (the less positive voltage)

X = state is immaterial

Z = high impedance OFF-state

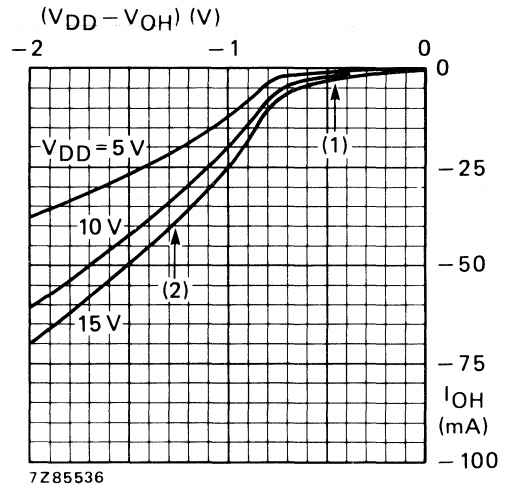

7Z85536

(1) P-channel MOS transistor conducting.

(2) P-channel MOS transistor and bipolar n-p-n transistor conducting.

Fig. 4 Typical output source current characteristic.

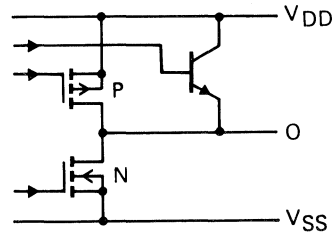

7Z85534

Fig. 5 Schematic diagram of output stage.

Fig. 3 Functional diagram.

RATINGS

Limiting values in accordance with the Absolute Maximum System (IEC 134)

See Family Specifications, except for:

| | | |
|---|----------------|--------|
| D.C. current into any input | $\pm I_I$ max. | 10 mA |
| D.C. source or sink current into any output | $\pm I_O$ max. | 25 mA |
| D.C. current into the supply terminals | $\pm I$ max. | 100 mA |

D.C. CHARACTERISTICS

 $V_{SS} = 0$ V

| | V_{DD} V | V_{OH} V | V_{OL} V | symbol | T_{amb} (°C) | | | | | | |
|---|---------------|---------------|---------------|------------|----------------|------|------|------|------|------|------------|
| | | | | | -40 | | +25 | | +85 | | |
| | | | | | min. | max. | min. | typ. | max. | min. | max. |
| Output current HIGH | 5 | 4,6 | | $-I_{OH}$ | 0,75 | | 0,6 | 1,2 | | 0,45 | mA |
| | 10 | 9,5 | | | 1,85 | | 1,5 | 3,0 | | 1,1 | mA |
| | 15 | 13,5 | | | 14,5 | | 15 | 50 | | 15,5 | mA |
| Output current HIGH | 5 | 3,6 | | $-I_{OH}$ | 9,3 | | 10 | 24 | | 10,7 | mA |
| | 10 | 8,4 | | | 14,4 | | 15 | 46 | | 15,0 | mA |
| | 15 | 13,2 | | | 19,5 | | 20 | 62 | | 19,8 | mA |
| Output current LOW | 5 | | 0,4 | I_{OL} | 2,9 | | 2,3 | 5,4 | | 1,75 | mA |
| | 10 | | 0,5 | | 9,5 | | 7,6 | 17 | | 5,50 | mA |
| | 15 | | 1,5 | | 30,0 | | 25 | 45 | | 19,0 | mA |
| Hysteresis voltage (any input) | 5 | | | V_H | | | | 220 | | | mV |
| | 10 | | | | | | | 250 | | | mV |
| | 15 | | | | | | | 320 | | | mV |
| 3-state input/output leakage current pins A_n or B_n | 15 | | | I_{OZ}^* | — | 1,6 | — | — | 1,6 | — | 12 μ A |

* Relevant output in OFF-state; A_n at V_{SS} or V_{DD} ; B_n at V_{SS} or V_{DD} .

HEF40245B

buffers

A.C. CHARACTERISTICS

$V_{SS} = 0 \text{ V}$; $T_{amb} = 25 \text{ }^\circ\text{C}$; $C_L = 50 \text{ pF}$; input transition times $\leq 20 \text{ ns}$

| | V_{DD} V | symbol | min. | typ. | max. | typical extrapolation formula | |
|---|---------------|--------|------|------|------|--|--|
| Propagation delays | | | | | | | |
| $A_n \rightarrow B_n$ HIGH to LOW | 5 | tPHL | | 95 | 190 | ns | $83 \text{ ns} + (0,24 \text{ ns/pF}) C_L$ |
| | 10 | | 40 | 80 | ns | $35 \text{ ns} + (0,10 \text{ ns/pF}) C_L$ | |
| | 15 | | 30 | 60 | ns | $26 \text{ ns} + (0,07 \text{ ns/pF}) C_L$ | |
| $A_n \rightarrow B_n$ LOW to HIGH | 5 | tPLH | | 85 | 170 | ns | $82 \text{ ns} + (0,06 \text{ ns/pF}) C_L$ |
| | 10 | | 40 | 80 | ns | $38 \text{ ns} + (0,03 \text{ ns/pF}) C_L$ | |
| | 15 | | 30 | 60 | ns | $29 \text{ ns} + (0,02 \text{ ns/pF}) C_L$ | |
| Output transition times | 5 | tTHL | | 40 | 80 | ns | } see Fig. 6 |
| HIGH to LOW | 10 | | 20 | 40 | ns | | |
| | 15 | | 15 | 30 | ns | | |
| LOW to HIGH | 5 | tTLH | | 30 | 60 | ns | |
| | 10 | | 20 | 40 | ns | | |
| | 15 | | 15 | 30 | ns | | |
| 3-state propagation delays | | | | | | | |
| Output disable times | | | | | | | |
| $\overline{E_O} \rightarrow A_n, B_n$ HIGH | 5 | tPHZ | | 100 | 200 | ns | |
| | 10 | | 50 | 100 | ns | | |
| | 15 | | 40 | 80 | ns | | |
| LOW | 5 | tPLZ | | 100 | 200 | ns | |
| | 10 | | 60 | 120 | ns | | |
| | 15 | | 50 | 100 | ns | | |
| Output enable times | | | | | | | |
| $\overline{E_O} \rightarrow A_n, B_n$ HIGH | 5 | tPZH | | 100 | 200 | ns | |
| | 10 | | 45 | 90 | ns | | |
| | 15 | | 35 | 70 | ns | | |
| LOW | 5 | tPZL | | 115 | 230 | ns | |
| | 10 | | 55 | 110 | ns | | |
| | 15 | | 45 | 90 | ns | | |

| all buffers switching | V_{DD} V | typical formula for P (μW) | where f_i = input freq. (MHz) f_o = output freq. (MHz) C_L = load capacitance (pF) $\Sigma(f_o C_L)$ = sum of outputs V_{DD} = supply voltage (V) |
|---|---------------|---|--|
| Dynamic power dissipation per package (P) | 5 | $4\,250 f_i + \Sigma(f_o C_L) \times V_{DD}^2$ | |
| | 10 | $17\,000 f_i + \Sigma(f_o C_L) \times V_{DD}^2$ | |
| | 15 | $46\,000 f_i + \Sigma(f_o C_L) \times V_{DD}^2$ | |

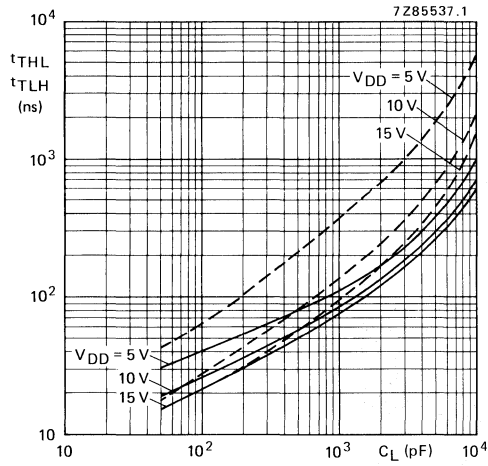

Fig. 6 Output transition times as a function of the load capacitance.
— t_{TLH} ; - - - t_{THL} .

OCTAL TRANSPARENT LATCH WITH 3-STATE OUTPUTS

The HEF40373B is an 8-bit transparent latch with 3-state buffered outputs. The output stages have high current output capability suitable for driving highly capacitive loads. The latch outputs follow the data inputs when the latch enable (E) is HIGH. When E is LOW, the data that meets the set-up times is latched. The 3-state outputs are controlled by the output enable input \overline{EO} . A HIGH on \overline{EO} causes the outputs to assume a high impedance OFF-state. The device features hysteresis on the E input to improve noise rejection.

Schmitt-trigger action in the E input makes the circuit highly tolerant to slower input rise and fall times.

The HEF40373B is pin and functionally compatible with the TTL '373' device.

Supply voltage range: 3 to 15 V.

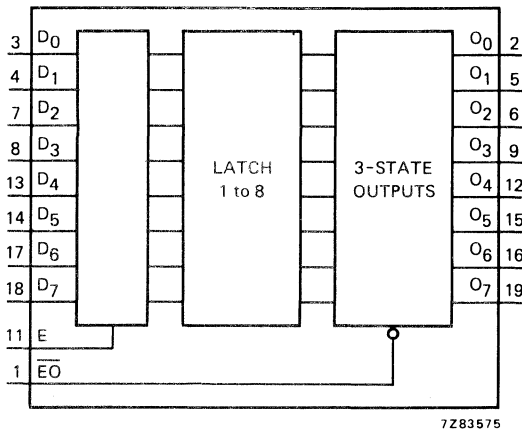

Fig. 1 Functional diagram.

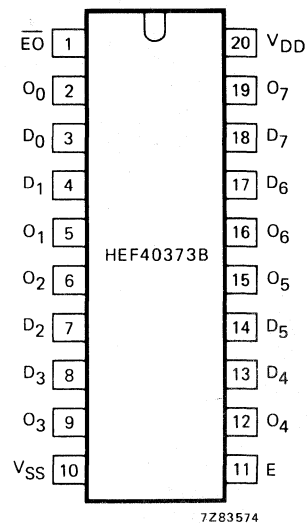

Fig. 2 Pinning diagram.

HEF40373BP : 20-lead DIL; plastic (SOT-146).

HEF40373BT : 20-lead mini-pack; plastic
(SO-20; SOT-163A).

PINNING

D₀ to D₇ data inputs
E latch enable input
 \overline{EO} output enable input (active LOW)
O₀ to O₇ 3-state buffered outputs

FAMILY DATA

I_{DD} LIMITS category MSI

see Family Specifications

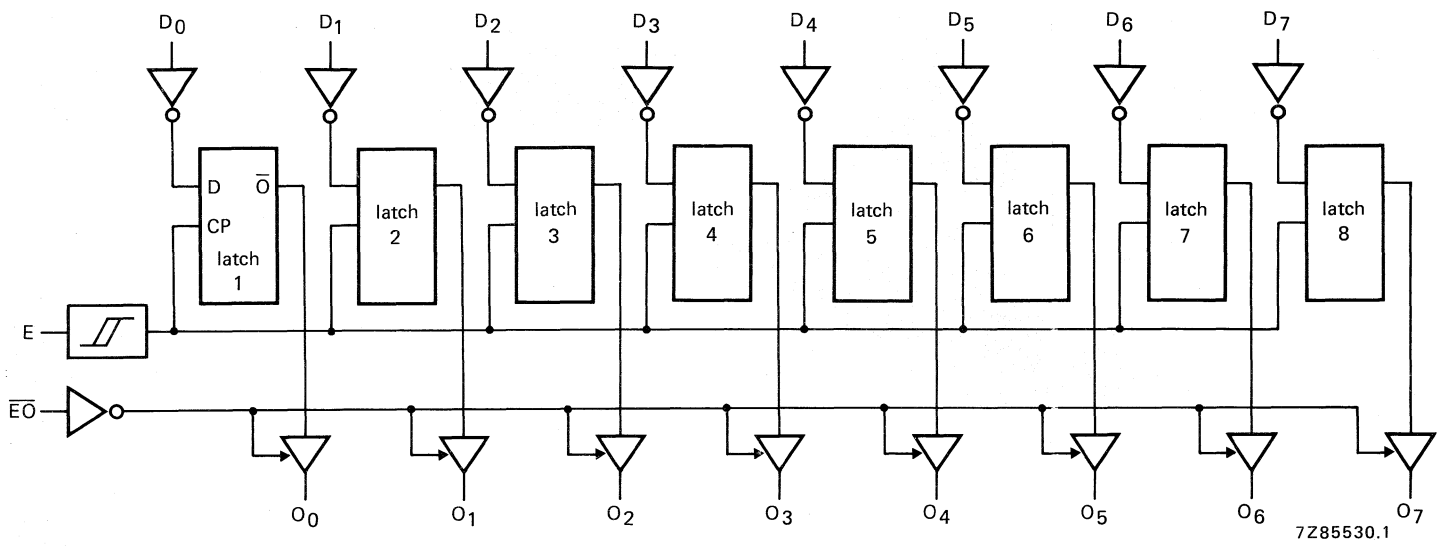

Fig. 3 Logic diagram.

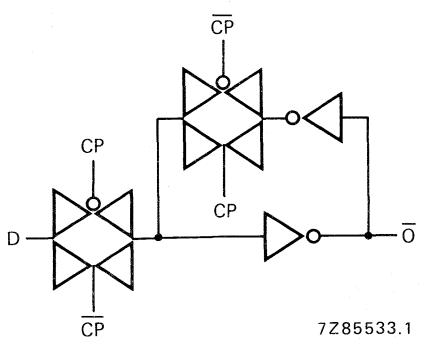

Fig. 4 Logic diagram (one latch).

FUNCTION TABLE

| operating modes | inputs | | | internal register | outputs O ₀ to O ₇ |
|-------------------------------------|-----------------|---|----------------|-------------------|---|
| | \overline{EO} | E | D _n | | |
| enable & read register | L | H | L | L | L |
| | L | H | H | H | H |
| latch & read register | L | L | l | L | L |
| | L | L | h | H | H |
| latch register & disable outputs | H | L | l | L | Z |
| | H | L | h | H | Z |

H = HIGH state (the more positive voltage)

h = HIGH state (one set-up time prior to the HIGH-to-LOW enable transition)

L = LOW state (the less positive voltage)

l = LOW state (one set-up time prior to the HIGH-to-LOW enable transition)

Z = high impedance OFF-state

RATINGS

Limiting values in accordance with the Absolute Maximum System (IEC 134)

See Family Specifications, except for:

| | | | |
|---|-----------|------|--------|
| D.C. current into any input | $\pm I_I$ | max. | 10 mA |
| D.C. source or sink current into any output | $\pm I_O$ | max. | 25 mA |
| D.C. current into the supply terminals | $\pm I$ | max. | 100 mA |

D.C. CHARACTERISTICS

$V_{SS} = 0\text{ V}$

| | V_{DD} V | V_{OH} V | V_{OL} V | symbol | T_{amb} (°C) | | | | | | |
|--|---------------|---------------|---------------|-----------|----------------|------|------|------|------|------|--|
| | | | | | -40 | | +25 | | +85 | | |
| | | | | | min. | typ. | min. | typ. | min. | typ. | |
| Output current HIGH | 5 | 4,6 | | $-I_{OH}$ | 0,75 | 0,6 | 1,2 | 0,45 | mA | | |
| | 10 | 9,5 | | | 1,85 | 1,5 | 3,0 | 1,1 | mA | | |
| | 15 | 13,5 | | | 14,5 | 15 | 50 | 15,5 | mA | | |
| Output current HIGH | 5 | 3,6 | | $-I_{OH}$ | 9,3 | 10 | 24 | 10,7 | mA | | |
| | 10 | 8,4 | | | 14,4 | 15 | 46 | 15,0 | mA | | |
| | 15 | 13,2 | | | 19,5 | 20 | 62 | 19,8 | mA | | |
| Output current LOW | 5 | | 0,4 | I_{OL} | 2,9 | 2,3 | 5,4 | 1,75 | mA | | |
| | 10 | | 0,5 | | 9,5 | 7,6 | 17 | 5,50 | mA | | |
| | 15 | | 1,5 | | 30,0 | 25 | 45 | 19,0 | mA | | |
| Hysteresis voltage at enable input (E) | 5 | | | V_H | | | 220 | | mV | | |
| | 10 | | | | | | 250 | | mV | | |
| | 15 | | | | | | 320 | | mV | | |

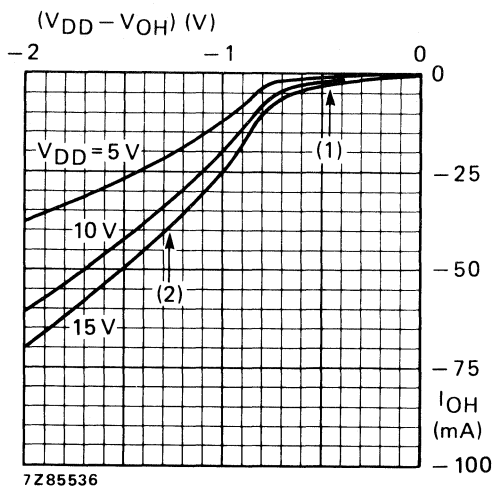

Fig. 5 Typical output source current characteristic.

- (1) P-channel MOS transistor conducting.
- (2) P-channel MOS transistor and bipolar n-p-n transistor conducting.

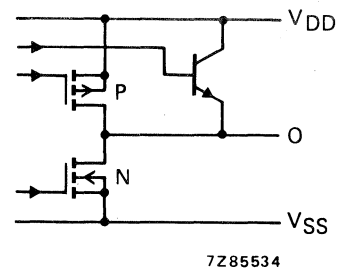

Fig. 6 Schematic diagram of output stage.

A.C. CHARACTERISTICS

 $V_{SS} = 0 \text{ V}$; $T_{amb} = 25 \text{ }^\circ\text{C}$; $C_L = 50 \text{ pF}$; input transition times $\leq 20 \text{ ns}$

| | V_{DD} V | symbol | min. | typ. | max. | typical extrapolation formula | |
|--------------------------------------|---------------|------------|------|------|------|----------------------------------|---|
| Propagation delays | | | | | | | |
| E \rightarrow O_n | 5 | | | 150 | 300 | ns | $138 \text{ ns} + (0,24 \text{ ns/pF}) C_L$ |
| HIGH to LOW | 10 | t_{PHL} | | 60 | 120 | ns | $59 \text{ ns} + (0,01 \text{ ns/pF}) C_L$ |
| | 15 | | | 40 | 80 | ns | $36 \text{ ns} + (0,07 \text{ ns/pF}) C_L$ |
| E \rightarrow O_n | 5 | | | 125 | 250 | ns | $122 \text{ ns} + (0,06 \text{ ns/pF}) C_L$ |
| LOW to HIGH | 10 | t_{PLH} | | 50 | 100 | ns | $48 \text{ ns} + (0,03 \text{ ns/pF}) C_L$ |
| | 15 | | | 40 | 80 | ns | $39 \text{ ns} + (0,02 \text{ ns/pF}) C_L$ |
| Output transition times | 5 | | | 40 | 80 | ns | } see Fig. 7. |
| HIGH to LOW | 10 | t_{THL} | | 20 | 40 | ns | |
| | 15 | | | 15 | 30 | ns | |
| LOW to HIGH | 5 | | | 30 | 60 | ns | |
| | 10 | t_{TLH} | | 20 | 40 | ns | |
| | 15 | | | 15 | 30 | ns | |
| 3-state propagation delays | | | | | | | |
| Output disable times | | | | | | | |
| $\overline{E}O \rightarrow O_n$ | 5 | | | 65 | 130 | ns | |
| HIGH | 10 | t_{PHZ} | | 30 | 60 | ns | |
| | 15 | | | 25 | 50 | ns | |
| LOW | 5 | | | 75 | 150 | ns | |
| | 10 | t_{PLZ} | | 40 | 80 | ns | |
| | 15 | | | 30 | 60 | ns | |
| Output enable times | | | | | | | |
| $\overline{E}O \rightarrow O_n$ | 5 | | | 65 | 130 | ns | |
| HIGH | 10 | t_{PZH} | | 30 | 60 | ns | |
| | 15 | | | 25 | 50 | ns | |
| LOW | 5 | | | 85 | 170 | ns | |
| | 10 | t_{PZL} | | 35 | 70 | ns | |
| | 15 | | | 25 | 50 | ns | |
| Set-up time | 5 | | 15 | 7 | | ns | |
| $D_n \rightarrow E$ | 10 | t_{su} | 10 | 5 | | ns | |
| | 15 | | 10 | 5 | | ns | |
| Hold time | 5 | | 25 | 15 | | ns | |
| $D_n \rightarrow E$ | 10 | t_{hold} | 15 | 4 | | ns | |
| | 15 | | 10 | 3 | | ns | |
| Minimum latch enable pulse width LOW | 5 | | 60 | 30 | | ns | |
| | 10 | t_{WEL} | 30 | 15 | | ns | |
| | 15 | | 20 | 10 | | ns | |

A.C. CHARACTERISTICS

$V_{SS} = 0\text{ V}$; $T_{amb} = 25\text{ }^{\circ}\text{C}$; input transition times $\leq 20\text{ ns}$

| | V_{DD} V | typical formula for P (μW) | where f_i = input freq. (MHz) f_o = output freq. (MHz) C_L = load capacitance (pF) $\Sigma(f_o C_L)$ = sum of outputs V_{DD} = supply voltage (V) |
|---|---------------|--|--|
| Dynamic power dissipation per package (P) | 5 | $3\ 325\ f_i + \Sigma(f_o C_L) \times V_{DD}^2$ | |
| | 10 | $14\ 200\ f_i + \Sigma(f_o C_L) \times V_{DD}^2$ | |
| | 15 | $37\ 425\ f_i + \Sigma(f_o C_L) \times V_{DD}^2$ | |

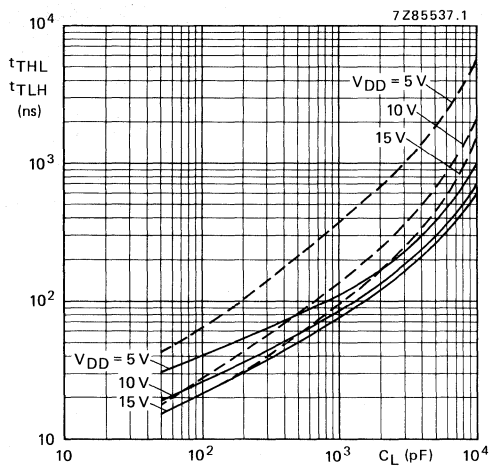

Fig. 7 Output transition times as a function of the load capacitance.

—— t_{TLH} ; - - - t_{TLH} .

OCTAL D-TYPE FLIP-FLOP WITH 3-STATE OUTPUTS

The HEF40374B is an octal D-type flip-flop with 3-state buffered outputs with a common clock input (CP). The device is used primarily as an 8-bit positive edge-triggered storage register for interfacing with a 3-state bus. Data on the D-inputs is transferred to storage during the LOW-to-HIGH transition of the clock (CP) input. The 3-state output buffers are controlled by an active LOW output enable input (\overline{EO}). A HIGH on \overline{EO} forces the eight outputs to a high impedance OFF-state. When \overline{EO} is LOW, the data in the register appears at the outputs.

The output stages have high current output capability suitable for driving highly capacitive loads.

The device features hysteresis on the CP input to improve noise rejection.

Schmitt-trigger action in the E input makes the circuit highly tolerant to slower input rise and fall times.

The HEF40373B is pin and functionally compatible with the TTL '374' device.

Supply voltage range: 3 to 15 V.

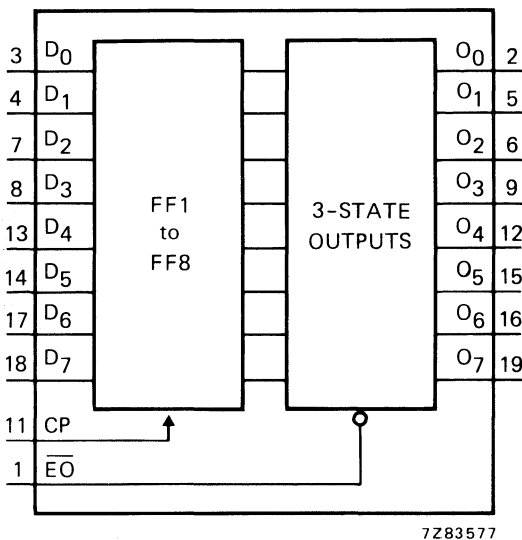

Fig. 1 Functional diagram.

PINNING

| | |
|-----------------|----------------------------------|
| D_0 to D_7 | data inputs |
| CP | clock input |
| \overline{EO} | output enable input (active LOW) |
| O_0 to O_7 | 3-state buffered outputs |

FAMILY DATA

see Family Specifications

I_{DD} LIMITS category MSI

Fig. 2 Pinning diagram.

HEF40374BP: 20-lead DIL; plastic (SOT-146).

HEF40374BT: 20-lead mini-pack; plastic (SO-20; SOT-163A).

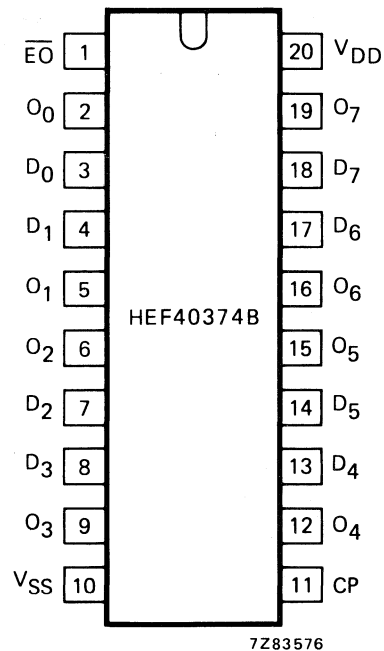
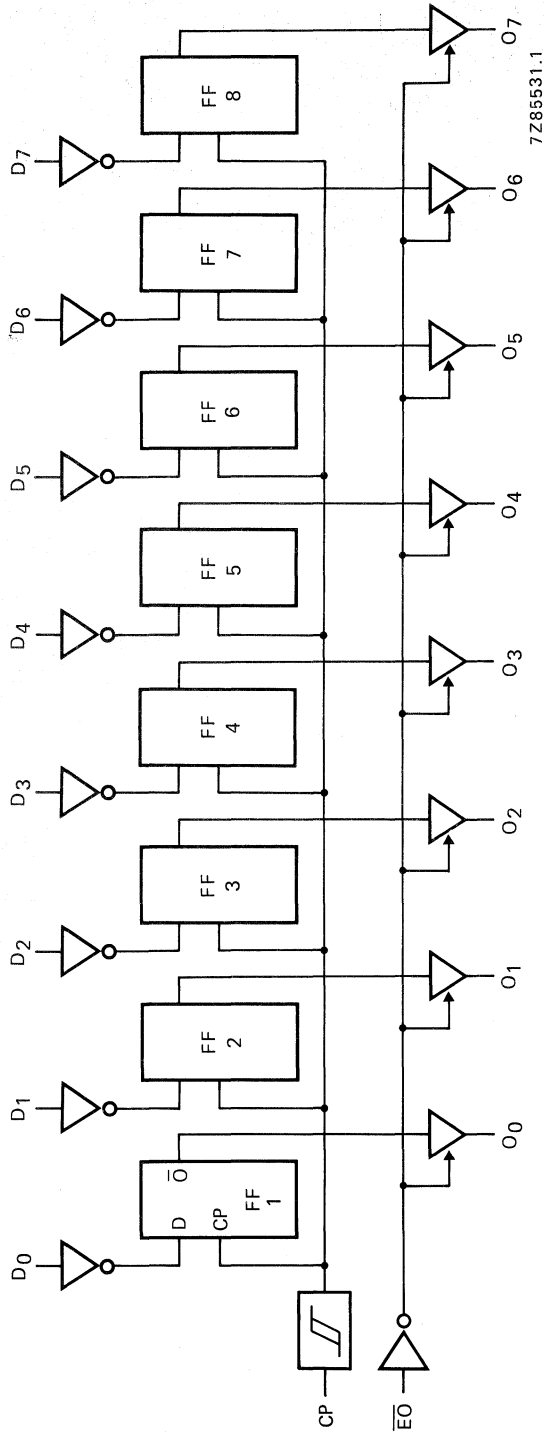

Fig. 3 Logic diagram.

FUNCTION TABLE

| operating modes | inputs | | | internal register | outputs O ₀ to O ₇ |
|------------------------------------|-----------------|----|----------------|-------------------|---|
| | \overline{EO} | CP | D _n | | |
| load & read register | L | / | l | L | L |
| | L | / | h | H | H |
| load register & disable outputs | H | / | l | L | Z |
| | H | / | h | H | Z |

H = HIGH state (the more positive voltage)

h = HIGH state (one set-up time prior to the
LOW-to-HIGH clock transition)

L = LOW state (the less positive voltage)

l = LOW state (one set-up time prior to the
LOW-to-HIGH clock transition)

Z = high impedance OFF-state

/ = LOW-to-HIGH clock transition

RATINGS

Limiting values in accordance with the Absolute Maximum System (IEC 134)

See Family Specifications, except for:

| | | | |
|---|-----------|------|--------|
| D.C. current into any input | $\pm I_I$ | max. | 10 mA |
| D.C. source or sink current into any output | $\pm I_O$ | max. | 25 mA |
| D.C. current into the supply terminals | $\pm I$ | max. | 100 mA |

D.C. CHARACTERISTICS

$V_{SS} = 0$ V

| | V_{DD} V | V_{OH} V | V_{OL} V | symbol | T_{amb} (°C) | | | | | | |
|--|---------------|---------------|---------------|-----------|----------------|------|------|------|------|------|----|
| | | | | | -40 | | +25 | | +85 | | mA |
| | | | | | min. | typ. | min. | typ. | min. | typ. | |
| Output current HIGH | 5 | 4,6 | | $-I_{OH}$ | 0,75 | 0,6 | 1,2 | 0,45 | | | |
| | 10 | 9,5 | | | 1,85 | 1,5 | 3,0 | 1,1 | | | |
| | 15 | 13,5 | | | 14,5 | 15 | 50 | 15,5 | | | |
| Output current HIGH | 5 | 3,6 | | $-I_{OH}$ | 9,3 | 10 | 24 | 10,7 | | | |
| | 10 | 8,4 | | | 14,4 | 15 | 46 | 15,0 | | | |
| | 15 | 13,2 | | | 19,5 | 20 | 62 | 19,8 | | | |
| Output current LOW | 5 | | 0,4 | I_{OL} | 2,9 | 2,3 | 5,4 | 1,75 | | | |
| | 10 | | 0,5 | | 9,5 | 7,6 | 17 | 5,50 | | | |
| | 15 | | 1,5 | | 30,0 | 25 | 45 | 19,0 | | | |
| Hysteresis voltage at clock input (CP) | 5 | | | V_H | | | 220 | | mV | | |
| | 10 | | | | | | 250 | | mV | | |
| | 15 | | | | | | 320 | | mV | | |

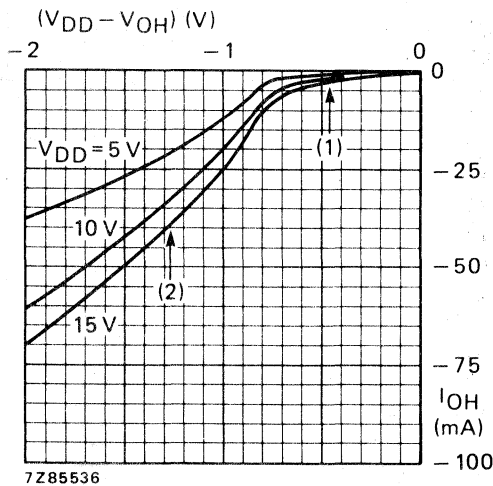

Fig. 4 Typical output source current characteristic.

- (1) P-channel MOS transistor conducting.
- (2) P-channel MOS transistor and bipolar n-p-n transistor conducting.

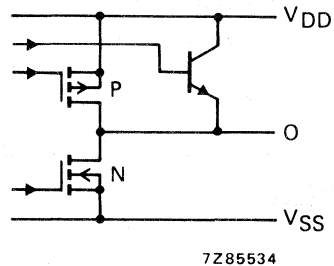

Fig. 5 Schematic diagram of output stage.

A.C. CHARACTERISTICS

 $V_{SS} = 0\text{ V}$; $T_{amb} = 25\text{ }^{\circ}\text{C}$; $C_L = 50\text{ pF}$; input transition times $\leq 20\text{ ns}$

| | V_{DD} V | symbol | min. | typ. | max. | typical extrapolation formula | | |
|---------------------------------|---------------|--------|------|------|------|----------------------------------|-----------------------------|-----------------------------|
| Propagation delays | | | | | | | | |
| CP \rightarrow O_n | 5 | | | 125 | 250 | ns | 113 ns + (0,24 ns/pF) C_L | |
| HIGH to LOW | 10 | tPHL | | 55 | 110 | ns | | 54 ns + (0,01 ns/pF) C_L |
| | 15 | | | 40 | 80 | ns | | 36 ns + (0,07 ns/pF) C_L |
| CP \rightarrow O_n | 5 | | | | 125 | 250 | ns | 122 ns + (0,06 ns/pF) C_L |
| LOW to HIGH | 10 | tPLH | | 55 | 110 | ns | 53 ns + (0,03 ns/pF) C_L | |
| | 15 | | | 40 | 80 | ns | 39 ns + (0,02 ns/pF) C_L | |
| Output transition times | 5 | | | | 40 | 80 | ns | } see Fig. 6 |
| HIGH to LOW | 10 | tTHL | | 20 | 40 | ns | | |
| | 15 | | | 15 | 30 | ns | | |
| LOW to HIGH | 5 | | | | 30 | 60 | ns | |
| | 10 | tTLH | | 20 | 40 | ns | | |
| | 15 | | | 15 | 30 | ns | | |
| 3-state propagation delays | | | | | | | | |
| Output disable times | | | | | | | | |
| $\overline{E}O \rightarrow O_n$ | 5 | | | 60 | 120 | ns | tPHZ | |
| HIGH | 10 | | | 30 | 60 | ns | | |
| | 15 | | | 24 | 48 | ns | | |
| LOW | 5 | | | 70 | 140 | ns | tPLZ | |
| | 10 | | | 35 | 70 | ns | | |
| | 15 | | | 30 | 60 | ns | | |
| Output enable times | | | | | | | | |
| $\overline{E}O \rightarrow O_n$ | 5 | | | 65 | 130 | ns | tPZH | |
| HIGH | 10 | | | 30 | 60 | ns | | |
| | 15 | | | 24 | 48 | ns | | |
| LOW | 5 | | | 85 | 170 | ns | tPZL | |
| | 10 | | | 35 | 70 | ns | | |
| | 15 | | | 25 | 50 | ns | | |
| Set-up time | 5 | | 20 | 0 | | ns | t _{su} | |
| $D_n \rightarrow CP$ | 10 | | 20 | 2 | | ns | | |
| | 15 | | 20 | 5 | | ns | | |
| Hold time | 5 | | 20 | 10 | | ns | t _{hold} | |
| $D_n \rightarrow CP$ | 10 | | 15 | 2 | | ns | | |
| | 15 | | 10 | 0 | | ns | | |
| Minimum clock pulse width; LOW | 5 | | 50 | 25 | | ns | tWCPL | |
| | 10 | | 25 | 12 | | ns | | |
| | 15 | | 20 | 10 | | ns | | |
| Maximum clock pulse frequency | 5 | | 25 | 5 | | MHz | f _{max} | |
| | 10 | | 6 | 12 | | MHz | | |
| | 15 | | 8 | 17 | | MHz | | |

A.C. CHARACTERISTICS

$V_{SS} = 0\text{ V}$; $T_{amb} = 25\text{ }^{\circ}\text{C}$; input transition times $\leq 20\text{ ns}$

| | V_{DD} V | typical formula for P (μW) | where f_i = input freq. (MHz) f_o = output freq. (MHz) C_L = load capacitance (pF) $\Sigma(f_o C_L)$ = sum of outputs V_{DD} = supply voltage (V) |
|---|---------------|---|--|
| Dynamic power dissipation per package (P) | 5 | $3\,775 f_i + \Sigma(f_o C_L) \times V_{DD}^2$ | |
| | 10 | $15\,700 f_i + \Sigma(f_o C_L) \times V_{DD}^2$ | |
| | 15 | $40\,575 f_i + \Sigma(f_o C_L) \times V_{DD}^2$ | |

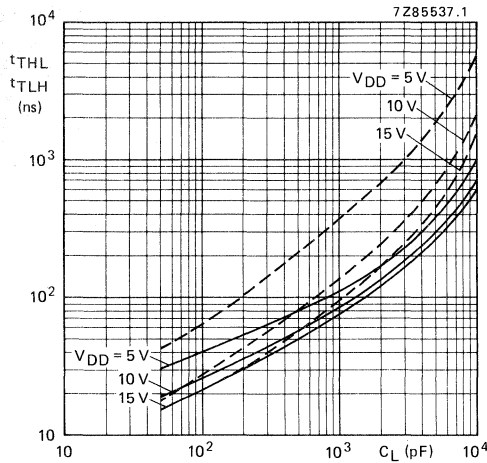

Fig. 6 Output transition times as a function of the load capacitance.

— t_{TLH} ; - - - t_{THL} .

Electronic components and materials for professional, industrial and consumer uses from the world-wide Philips Group of Companies

Argentina: PHILIPS ARGENTINA S.A., Div. Elcoma, Vedia 3892, 1430 BUENOS AIRES, Tel. 541-7141/7242/7343/7444/7545.
Australia: PHILIPS INDUSTRIES HOLDINGS LTD., Elcoma Division, 11 Waltham Street, ARTARMON, N.S.W. 2064, Tel. (02) 439 3322.
Austria: ÖSTERREICHISCHE PHILIPS BAUELEMENTE INDUSTRIE G.m.b.H., Triester Str. 64, A-1101 WIEN, Tel. 6291 11-10.
Belgium: N.V. PHILIPS & MBLE ASSOCIATED, 9 rue du Pavillon, B-1030 BRUXELLES, Tel. (02) 242 74 00.
Brazil: IBRAPE, Caixa Postal 7383, Av. Brigadeiro Faria Lima, 1735 SAO PAULO, SP, Tel. (011) 211-2600.
Canada: PHILIPS ELECTRONICS LTD., Elcoma Division, 601 Milner Ave., SCARBOROUGH, Ontario, M1B 1M8, Tel. 292-5161.
Chile: PHILIPS CHILENA S.A., Av. Santa Maria 0760, SANTIAGO, Tel. 39-4001.
Colombia: IND. PHILIPS DE COLOMBIA S.A., c/o IPRELENTO LTD., Cra. 21, No. 56-17, BOGOTA, D.E., Tel. 2497624.
Denmark: MINIWATT A/S, Strandlodsvej 2, P.O. Box 1919, DK 2300 COPENHAGEN S, Tel. (01) 54 11 03.
Finland: OY PHILIPS AB, Elcoma Division, Kaivokatu 8, SF-00100 HELSINKI 10, Tel. 17271.
France: RTC-COMPELEC, 130 Avenue Ledru Rollin, F-75540 PARIS 11, Tel. 43 38 80 00.
Germany (Fed. Republic): VALVO, UB Bauelemente der Philips G.m.b.H., Valvo Haus, Burchardstrasse 19, D-2 HAMBURG 1, Tel. (040) 3296-0.
Greece: PHILIPS HELLENIQUE S.A., Elcoma Division, 54, Syngrou Av., ATHENS 11742, Tel. 9215311/319.
Hong Kong: PHILIPS HONG KONG LTD., Elcoma Div., 15/F Philips Ind. Bldg., 24-28 Kung Yip St., KWAI CHUNG, Tel. (0)-2451 21.
India: PEICO ELECTRONICS & ELECTRICALS LTD., Elcoma Dept., Band Box Building, 254-D Dr. Annie Besant Rd., BOMBAY - 400 025, Tel. 4930311/4930590.
Indonesia: P.T. PHILIPS-RALIN ELECTRONICS, Elcoma Div., Setiabudi II Building, 6th Fl., Jalan H.R. Rasuna Said (P.O. Box 223/KBY) Kuningan, JAKARTA - Selatan, Tel. 512 572.
Ireland: PHILIPS ELECTRICAL (IRELAND) LTD., Newstead, Clonskeagh, DUBLIN 14, Tel. 693355.
Italy: PHILIPS S.p.A., Sezione Elcoma, Piazza IV Novembre 3, I-20124 MILANO, Tel. 2-6752.1.
Japan: NIHON PHILIPS CORP., Shuwa Shinagawa Bldg., 26-33 Takanawa 3-chome, Minato-ku, TOKYO (108), Tel. 448-5611.
(IC Products) SIGNETICS JAPAN LTD., 8-7 Sanbancho Chiyoda-ku, TOKYO 102, Tel. (03) 230-1521.
Korea (Republic of): PHILIPS ELECTRONICS (KOREA) LTD., Elcoma Div., Philips House, 260-199 Itaewon-dong, Yongsan-ku, SEOUL, Tel. 794-5011.
Malaysia: PHILIPS MALAYSIA SDN. BERHAD, No. 4 Persiaran Barat, Petaling Jaya, P.O.B. 2163, KUALA LUMPUR, Selangor, Tel. 77 44 11.
Mexico: ELECTRONICA, S.A. de C.V., Carr. México-Toluca km. 62.5, TOLUCA, Edo. de México 50140, Tel. Toluca 91 (721) 613-00.
Netherlands: PHILIPS NEDERLAND, Marktgroep Elconco, Postbus 90050, 5600 PB EINDHOVEN, Tel. (040) 793333.
New Zealand: PHILIPS NEW ZEALAND LTD., Elcoma Division, 110 Mt. Eden Road, C.P.O. Box 1041, AUCKLAND, Tel. 605-914.
Norway: NORSK A/S PHILIPS, Electronica Dept., Sandstuveien 70, OSLO 6, Tel. 68 02 00.
Peru: CADESA, Av. Alfonso Ugarte 1268, LIMA 5, Tel. 326070.
Philippines: PHILIPS INDUSTRIAL DEV. INC., 2246 Pasong Tamo, P.O. Box 911, Makati Comm. Centre, MAKATI-RIZAL 3116, Tel. 86-89-51 to 59.
Portugal: PHILIPS PORTUGUESA S.A.R.L., Av. Eng. Duarte Pacheco 6, 1009 LISBOA Codex, Tel. 6831 21.
Singapore: PHILIPS PROJECT DEV. (Singapore) PTE LTD., Elcoma Div., Lorong 1, Toa Payoh, SINGAPORE 1231, Tel. 35 02 000.
South Africa: EDAC (PTY.) LTD., 3rd Floor Rainer House, Upper Railway Rd. & Ove St., New Doornfontein, JOHANNESBURG 2001, Tel. 614-2362/9.
Spain: MINIWATT S.A., Balmes 22, BARCELONA 7, Tel. 301 63 12.
Sweden: PHILIPS KOMPONENTER A.B., Lidingsvägen 50, S-11584 STOCKHOLM 27, Tel. 08/7821000.
Switzerland: PHILIPS A.G., Elcoma Dept., Allmendstrasse 140-142, CH-8027 ZÜRICH, Tel. 01-48822 11.
Taiwan: PHILIPS TAIWAN LTD., 150 Tun Hua North Road, P.O. Box 22978, TAIPEI, Taiwan, Tel. 7120500.
Thailand: PHILIPS ELECTRICAL CO. OF THAILAND LTD., 283 Silom Road, P.O. Box 961, BANGKOK, Tel. 233-6330-9.
Turkey: TÜRK PHILIPS TICARET A.S., Elcoma Department, İnönü Cad, No. 78-80, P.K.504, 80074 ISTANBUL, Tel. 43 59 10.
United Kingdom: MULLARD LTD., Mullard House, Torrington Place, LONDON WC1E 7HD, Tel. 01-580 6633.
United States: (Active Devices & Materials) AMPEREX SALES CORP., Providence Pike, SLATERSVILLE, R.I. 02876, Tel. (401) 762-9000.
(Passive Devices) MEPCO/ELECTRA INC., Columbia Rd., MORRISTOWN, N.J. 07960, Tel. (201) 539-2000.
(Passive Devices & Electromechanical Devices) CENTRALAB INC., 5855 N. Glen Park Rd., MILWAUKEE, WI 53201, Tel. (414) 228-7380.
(IC Products) SIGNETICS CORPORATION, 811 East Arques Avenue, SUNNYVALE, California 94086, Tel. (408) 991-2000.
Uruguay: LUZILECTRON S.A., Avda Uruguay 1287, P.O. Box 907, MONTEVIDEO, Tel. 91 43 21.
Venezuela: IND. VENEZOLANAS PHILIPS S.A., c/o MAGNETICA S.A., Calle 6, Ed. Las Tres Jotas, App. Post. 78117, CARACAS, Tel. (02) 2393931.

For all other countries apply to: Philips Electronic Components and Materials Division, International Business Relations, P.O. Box 218, 5600 MD EINDHOVEN, The Netherlands, Telex 35000 phtcni

AB52

© Philips Export B.V. 1986

This information is furnished for guidance, and with no guarantee as to its accuracy or completeness; its publication conveys no licence under any patent or other right, nor does the publisher assume liability for any consequence of its use; specifications and availability of goods mentioned in it are subject to change without notice; it is not to be reproduced in any way, in whole or in part, without the written consent of the publisher.