

20 YEARS  
in the industry



Also: small business systems survey, on-line banking in Japan, computing in Korea, and a data base story . . .



# Series 9000...

## Still the hottest series around.

When you're hot, you're hot, and the thousands of Series 9000 Digital Tape Transports in use around the world prove we're doing something right. Part of the reason is the many unique features of Series 9000 — features such as:

- A position arm anticipatory sensing system. An exclusive Kennedy feature, the linear, non-contact (Mag Pot) position sensor requires no lamp source and assures performance for the life of the machine.
- Interchangeable electronics on all Series 9000 transports, reduce stocking costs and down time.
- Front-accessible off-line test panel, marginal skew check, threshold scanning which automatically compensates for drop-ins or drop-outs, Read-After-Write shortened skew gate, simplified tape path and quick-release hubs.

- All models are available with either 7 or 9 track, 800 NRZI, 1600 PE or 800/1600 NRZI/PE.
  - 7 and 9 track NRZI and PE format/control units to simplify customer electronics. Also, a variety of popular mini-computer mag tape controllers are available.
- Series 9000's performance is as impressive as its features, with data transfer rates to 72KHz, and tape speeds from 15 to 60 ips. Series 9000 is the most popular digital tape transport series around, and we continue to go that way, with constant improvements, tight quality control and greater service capabilities. That should give you a warm feeling if you have a requirement for digital tape transports.

### KENNEDY CO.

300 W. WOODBURY RD. AUSTIN, TEXAS 78701  
CIRCLE 1 ON READER CARD (214) 798-1958



**KENNEDY-QUALITY-COUNT ON**



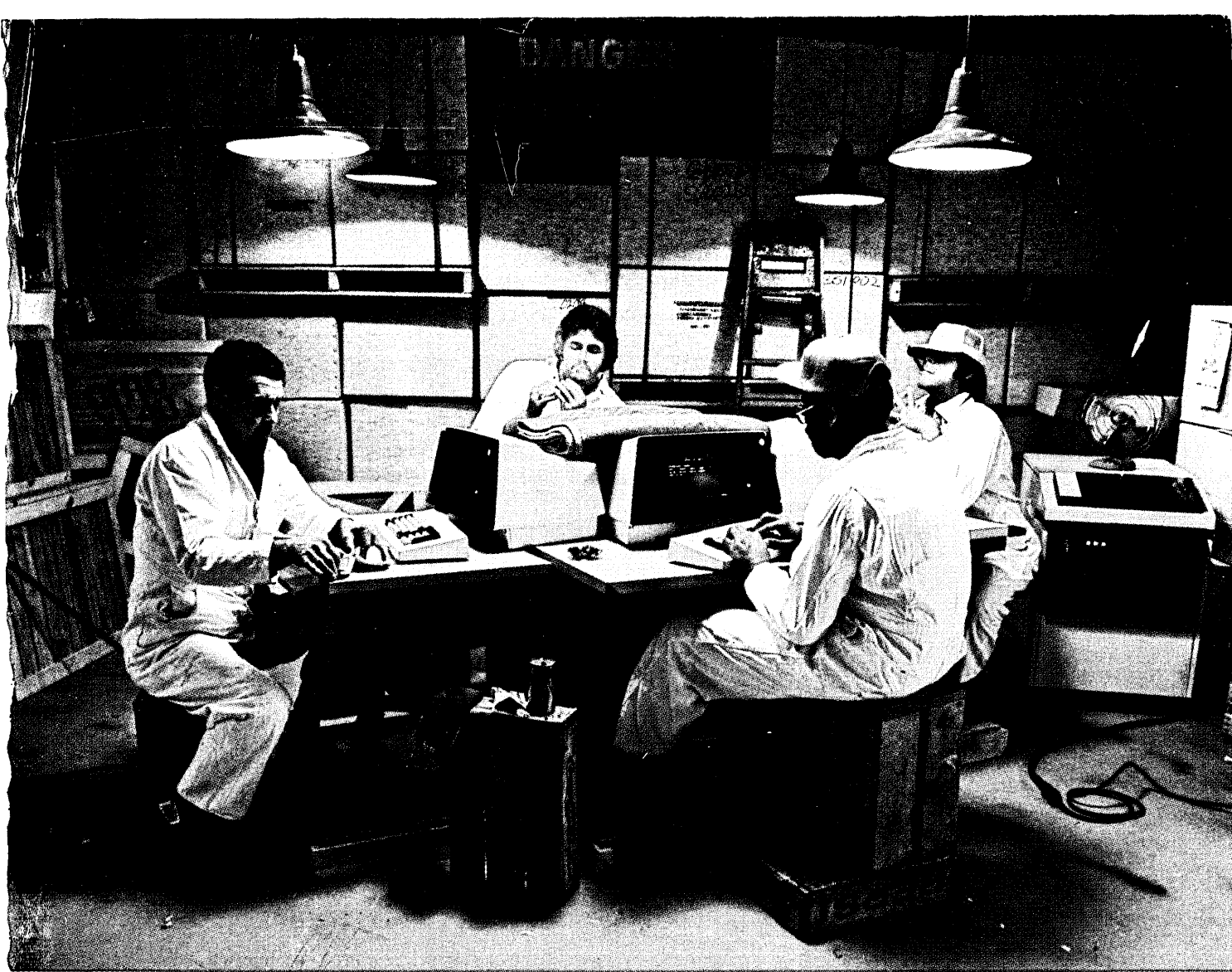

You'd be surprised how well the XL40 performs... even in your most demanding applications.

**The XL40 and you – a winning combination**

The XL40 Distributed KeyProcessing® System is the solution you've dreamed about for your organization's distributed processing requirements. That's why we call it The DREAM Machine for Data Retrieval, Entry And Management—the vital components of effective distributed processing.

**Distributed – for responsiveness at the source**

Data quality improves—and costs are reduced—when information is managed by the people who know it best. The XL40 was designed to be operated by source department personnel, not highly specialized operators. And PCC's professional education program will smooth the transition even more. In fact, you may be **very** surprised at some of the converts to your XL40.

**Turnkey – for instant productivity**

It doesn't take magical machinations to get the XL40 up and running fast. Designed for simplicity, the XL40 combines modular hardware and flexible, COBOL-based software to enable your staff to go right to work when the system is installed.

**Concurrent – for timesaving operations**

In addition to putting processing muscle at the source, the XL40 operates concurrently. While operators are entering data, the XL40 can generate a report and communicate with your central computer at the same time. Files can be retrieved, accessed and updated from source departments, creating a real-time data base and providing up-to-the-minute information.

**Reliable – Pertec Computer Corporation**

The XL40 is manufactured, marketed and serviced by Pertec Computer Corporation, the world's leading independent manufacturer of computer peripheral equipment and producer of distributed processing and data entry systems, with over \$100 million in revenues. And a reputation to boot.

Write to us today for more information about the XL40 Distributed KeyProcessing System—it's your ace in the hole.



**PERTEC  
COMPUTER  
CORPORATION**

**CMC Division**

12910 Culver Boulevard, P.O. Box 5000  
Los Angeles, California 90009  
(213) 822-9914 TWX (910) 343-64



**Ask  
CONTROL DATA  
about the breakthrough  
that can cut your data  
storage and handling  
costs in half.**

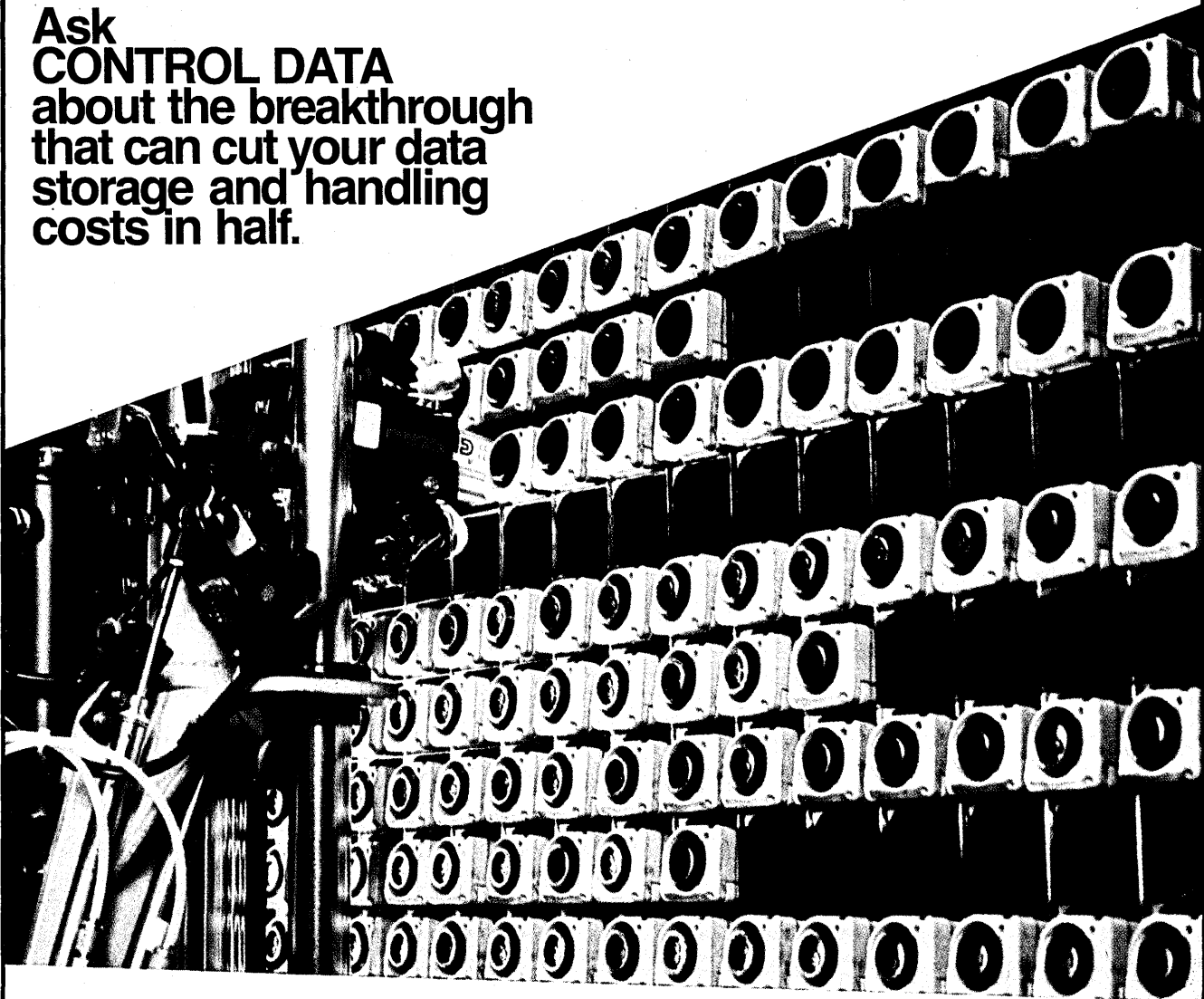

**MSS:**

**We have it.**

Join the insurance, manufacturing, and retail organizations, universities and steel companies that have made the better business decision of turning to Control Data Mass Storage.

For these data processors, speed is not the only benefit. The entry cost is low. The conversion to Mass Storage is simple and quick...the effort is negligible. Control Data's service back-up is in place. The compatibility is outstanding because Control Data's MSS uses standard IBM program ac-

counting entrances and exits; needs no modification of host computer, JCL, user programs, or operating system software. It features 100% cartridge accessibility and modular construction for simple future add-on expansion; and it either stages data to any disk or transfers directly to the mainframe.

Call (612) 553-4745 or return coupon to: John C. Magill, Product Sales Manager, Peripheral Products Sales, Control Data Corporation, P.O. Box 1980, Twin Cities Airport, St. Paul, MN 55111. Dept. D-97.

Please have a Representative call.  Please send additional literature.

Name \_\_\_\_\_ Title \_\_\_\_\_  
 Company \_\_\_\_\_ Area Code \_\_\_\_\_ Phone \_\_\_\_\_  
 Address \_\_\_\_\_  
 City \_\_\_\_\_ State \_\_\_\_\_ Zip \_\_\_\_\_

**The better business decision**





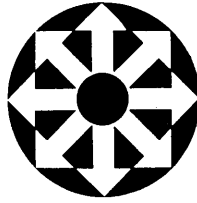

# DATAMATION<sup>®</sup>

1957  
77  
1977

VOLUME 23 NUMBER 9

This issue 146,805

SEPTEMBER 1977

## FEATURES

64 TWENTY YEARS OF DATA PROCESSING

Where have we been; where are we going? Here's a look at the industry's past, present, and future from a variety of viewpoints.

69 THE ROUGH ROAD TO TODAY'S TECHNOLOGY

Dan M. Bowers. A light and irreverent look at how we got to wherever we are.

75 THE WAY IT WAS: 1957

H.R.J. Grosch. For Herb and for the fledgling industry it was a vintage year, full of ferment and promise.

80 GEORGE STIBITZ AND THE BELL LABS RELAY COMPUTER

Evelyn Loveday. How a weekend play project helped usher in the computer age.

89 A JAPANESE ON-LINE BANKING SYSTEM

Yuzuru Abe. Handling 5,000 transactions a day with eight maxis, 700 minis, and 4,000 terminals at the bank with a heart.

101 COMPUTING UNDER THE GUN IN THE HERMIT KINGDOM

Bill Orr. An "economic miracle" and a technological revolution may be at hand in Korea.

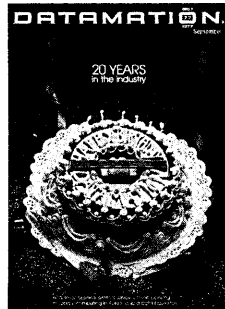

115 IMPROVING SYSTEM TESTING TECHNIQUES

Laura L. Sharer. The quality of systems test procedures, themselves, cannot be ignored.

139 A DATA BASE STORY

J.J. Sobczak. Data base is a systems philosophy, not a technology . . . a people problem, not a software tool.

159 TERMINAL DISTRIBUTORS: "OUR MOST IMPORTANT ASSET"

Vin McLellan. These middlemen draw mixed reviews from vendors and users alike, but their impact is undeniable.

189 SURVEY OF SMALL BUSINESS COMPUTERS

Alyn J. Gorman, Edmund J. Armon, and Kathleen M. Fernbach. Still a wide-open and growing market.

248 INFO '76

Back to the big apple this year.

283 THE DANGERS OF EGALITARIANISM

Arthur M. Lesk (aka Aaron J. Brenner). Just in time—a remedy for the insidious danger of treating everyone equally.

315 THE FORUM

A.G. Grace, Jr. One can achieve high productivity using small groups of very competent people, but what about the real world?

## NEWS IN PERSPECTIVE

251 COMMUNICATIONS

NCR readies terminals to interface with new DNA protocol.

252 SOFTWARE

Copyrights for software?

253 GOVERNMENT

Computer age legislators.

256 SOFTWARE

Is software valuable?

258 CONFERENCES

IFIP congress comes out of an ivory tower. Ford's Mayford Roark on managing change.

262 SERVICES

Bradford National: keeping the records straight.

263 GOVERNMENT PROCUREMENT

Fenaughty's fight for a fair shot.

266 SECURITY

Blackout aftermath: no data, no computer. FBI fugitive found dead.

268 PRODUCTS

The entrepreneurial urge.

269 HISTORY

Was computing more fun then?

272 OBITUARY

Edward Kleinschmidt, Teletype inventor.

273 INTERNATIONAL

British software consortium setting up shop in the U.S.

276 BENCHMARKS

A new twist; Microdata in Europe; Mohawk in preliminary talks; Flexible Xerox; High speed printer; He guessed the price; For self-assessment; Word processing.

## DEPARTMENTS

6 LOOKING BACK

15 LOOK AHEAD

21 LETTERS

9,453,600 papers to shuffle; more on thinking cool.

29 PEOPLE

Edward D. Orenstein: been there before; Herb Bright: for educated paranoia; Grace Householder: enthusiasm is contagious.

42 CALENDAR

47 SOURCE DATA

We review "Data Dictionary Systems" by Lefkovits; reports and references, and new vendor literature.

63 EDITOR'S READOUT

238 MARKETPLACE

288 HARDWARE

Color plotting, 370 emulator, off-line printing, a portable crt, and FCC certified DAA's.

298 BACK TO OUR ROOTS

1957 "new products" revisited; cryogenic memory, mag tape, computers, and an "intelligent" terminal.

300 SOFTWARE AND SERVICES

Software development cost estimating, Series/1 communications, and a PDP-8 simulator.

309 ADVERTISERS' INDEX

### About the Cover

Many people contributed to this small celebration of ourselves this month: Designer Barbara Benson; Photographer Bob Joan Lesser/Etcetera; Pastry Decorator Dino Sarno, Pastry Shop, Inc.; and CalComp, which loaned us the "c



# MEGADATA's Model 700/UETS Universal Emulating Terminal System

THE  
MEGADATA  
WAY

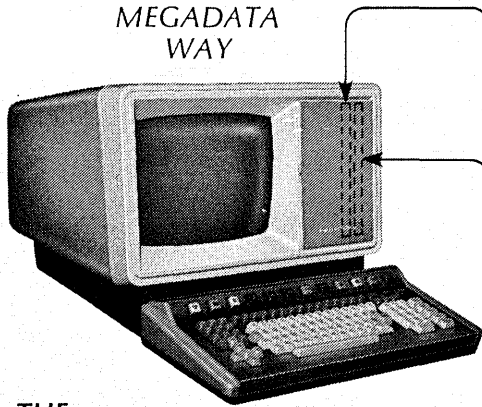

- Floppy Disk
  - Printer
  - Other Peripherals
- CAN EMULATE
- Incoterm
  - Four Phase
  - Datapoint
  - Sycor
  - VIP 7700
  - Your Terminals

THE  
OLD WAY

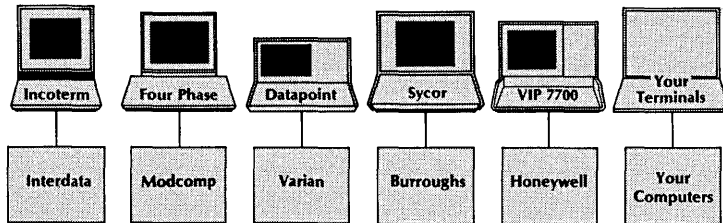

If you are a *multiple* computer user and your network includes many *different* types of terminals, the new and powerful MEGADATA UETS system is your key to vastly improved system utilization and operations.... A *SINGLE* UETS terminal can interface with a multitude of host computers, and it emulates any number of different terminal devices. It thus provides very significant advantages to the user.

- *APPLICATIONS ORIENTED*—readily configured for your specific application
- *VAST REDUCTION IN EQUIPMENT*—a *SINGLE* UETS can replace any number of different types of terminals
- *UNIFORM OPERATING PROCEDURE*—*ONE* basic operating procedure on *ONE* machine; no changing from unit-to-unit and procedure-to-procedure
- *REDUCED MAINTENANCE COMPLEXITY*—*ONE* serviceman from *ONE* company, with all spares supplied by *ONE* source

To provide all the required interfaces and emulations, the UETS has been developed as a most powerful piece of hardware. It contains a 12-bit MPU, a 15-inch diagonal display, a memory up to 73 K, and a 126-station keyboard with up to 71 function keys.

To find out more about our *UNIVERSAL EMULATING* system and the many other applications oriented MEGADATA terminals, call or write *TODAY!*

**MEGADATA CORPORATION**

35 Orville Drive • Bohemia, New York 11716  
Tel. 516-589-6800 • Telex 14-4659



Central Regional Office

2 N. Riverside Plaza • Chicago, Illinois 60606 • Tel. 312-648-1505

Western Regional Office

15910 Ventura Boulevard • Suite 800 • Encino, California 91316 • Tel. 213-990-9777

CIRCLE 171 ON READER CARD

**EDITORIAL STAFF**

**Editor**  
**Articles Editor**  
**Technology Editor**  
**International Editor**  
**European Editor**  
**Products Editor**  
**Departments Editor**  
**Reprint Editor**  
**News Editor**  
**Bureau Managers**  
**San Francisco**  
**Los Angeles**  
**Greenwich**  
**New York**  
**Washington, D.C.**  
**Boston**

John L. Kirkley  
Richard A. McLaughlin  
Michael Cashman  
Angeline Pantages  
Ralph Emmett  
Bill Musgrave  
Laura Semonian  
Pat Minford  
Tom McCusker

Edward K. Yasaki  
Edith D. Myers  
Angeline Pantages  
Laton McCartney  
Linda J. Fiato  
Vin McLellan

**Correspondents**  
**Minneapolis**  
**Southwest**  
**Australia**  
**Editorial Advisor**  
**Technical Advisor**  
**Contributing Editors**

James K. Johnson  
Robert F. Alexander  
Ken McGregor  
Robert L. Patrick  
Lowell Amdahl  
Paul Armer, Ralph G. Berglund, Howard Bromberg, Phillip H. Dorn, John M. Eger, William Helgason, Louis B. Marienthal, Carl Reynolds, F. G. Wittington

**EDITORIAL OFFICES**

**Headquarters:** 1801 S. La Cienega Blvd., Los Angeles, CA 90035. Phone (213) 559-5111. **Eastern:** 35 Mason St., Greenwich, CT 06830, (203) 661-5400. 420 Lexington Ave., New York, N. Y. 10017, (212) 682-7760. 134 Mt. Auburn St., Cambridge, Mass. 02138, (617) 354-2125. 6605 Burlington Pl., Springfield, VA 22152. (703) 569-3383. **Southwestern:** 2711 Cedar Springs, Dallas, TX 75201. (214) 744-0161. **Western:** 2680 Bayshore Frontage Rd., Suite 401, Mountain View, CA 94043, (415) 965-8222. **Foreign:** 15 A St. Ann's Terrace, St. John's Wood, London, NW8, England; (01) 439-8466; 24 Stafford Road, Artarmon, Sydney, NSW 2064, Australia, 41-5748.

**GRAPHIC DESIGN & PRODUCTION**

**Art & Production Director** Cleve Marie Boutell

**Advertising Production Manager** Marilee Pitman  
**Production Assistant** Alberta R. Martin

**CIRCULATION**  
35 Mason Street, Greenwich, CT 06830  
**Circulation Manager** Suzanne A. Ryan

**Marketing Research Manager** Deborah Dwellley  
**Publisher** James M. Morris  
**Assistant Publisher** F. Douglas De Carlo

Circulation audited by Business Publications Audit



Member  American Business Press, Inc.



**DATAMATION** is published monthly on or about the first day of every month by Technical Publishing Company, 1301 South Grove Ave., Barrington, Illinois 60010; Arthur L. Rice, Jr., Chairman of the Board; James B. Tafel, President; Gardner F. Landon, Executive Vice President. Executive and Advertising offices, 35 Mason Street, Greenwich, CT 06830, (203) 661-5400. Editorial offices, 1801 S. La Cienega Blvd., Los Angeles, CA 90035. Published at Chicago, Ill.

**DATAMATION** is circulated without charge by name and title to certain qualified individuals in the United States and Canada who are employed by companies involved with automatic information handling equipment. Available to others by subscription at the rate of \$24. Reduced rate for qualified students, \$14. Foreign subscriptions \$42.50, or £25.00; for airmail, additional charge \$40, or £23.75. Japan and Australia \$60, or £34.50 (air shipped). Sole agent for all subscriptions outside the U.S.A. and Canada is J. B. Tratsart, Ltd. 154 A Greenford Road, Harrow, Middlesex HA13QT, England. No subscription agency is authorized by us to solicit or take orders for subscriptions. Controlled circulations paid at Columbus, OH. © Copyright 1977 Technical Publishing Company. ® "Datamation" registered trademark of Technical Publishing Company. Microfilm copies of **DATAMATION** may be obtained from University Microfilms, A Xerox Company, 300 No. Zeeb Road, Ann Arbor, Michigan 48106. Printed by Beslow Associates, Inc. Circulation Office: 34 East Putnam Avenue, Greenwich, CT 06830. POSTMASTER: Form 3579 to be sent to Technical Publishing Company, P.O. Box 2000, Greenwich, CT 06830.

Publication Number: 148800. Single copy \$3.00 in U.S.A.

**DATAMATION**

# ADR's ROSCOE Improves Productivity And Reduces Manual Tasks At Hibernia National Bank

**ROSCOE Gave Our Programmers Their Own Computer** "Our 30 programmers and analysts are very high priced people to be spending time keypunching and running around trying to find

program decks. To cut that time and get out of the card business, we needed the ability to interact directly with our computer. The logical solution was ROSCOE," said Don Clark, DP Division Vice President. "Within a week

after ROSCOE was installed we could see the change.

The individual who had

been in a laborious, archaic card environment had his own online terminal. In effect, he had his own computer.

He can submit entries, verify them and have them in the system within seconds. "Everybody wants to use ROSCOE

now. For online maintenance.

Updating. Development programming.

Batch submission of testing.

Every programming function."

**One Big Difference Between ROSCOE and TSO**

"Many of our key people who had come from TSO shops thought ROSCOE would require



learning many new procedures. It didn't. They all found ROSCOE easy to use with almost no additional training," added Systems and Programming Manager Reg Campbell.

"We did, however, find one big difference between ROSCOE and TSO. ROSCOE requires much less overhead. Nearly 70% less, I'm told. It doesn't interfere with batch jobs and operations functions the way TSO did."

Each ADR product is not just a program but a complete package with full documentation and on-site support. ADR is the only software company with 50 branch offices and representatives in over 30 countries—each staffed with ADR-trained technicians.

For more information on what ADR software can do for you, call or write

 **APPLIED DATA RESEARCH** THE ONLINE SOFTWARE BUILDERS™

Route 206 Center, Princeton, N.J. 08540, Phone: 609-924-9100

ADR software products: in use at over 6000 installations worldwide. U.S. offices in Boston (617) 245-9540, Chicago (312) 694-2244, Cleveland (216) 228-0880, Houston (713) 526-3188, Los Angeles (213) 826-5527, New York (212) 986-4050, Princeton (609) 924-9100, San Francisco (415) 391-0690, Washington, D.C. (703) 281-2011. Foreign offices in Australia, Austria, Belgium, Brazil, Canada, Denmark, England, Finland, France, Germany, Holland, Hong Kong, Israel, Italy, Japan, Korea, Malaysia, Mexico, New Zealand, Norway, Philippines, Portugal, Puerto Rico, Republic of South Africa, Singapore, Spain, Sweden, Switzerland, Taiwan, Thailand, Venezuela.

Member SIA  Software Industry Association



# Looking Back in DATAMATION.

On our 20th anniversary

## The First Twenty Years

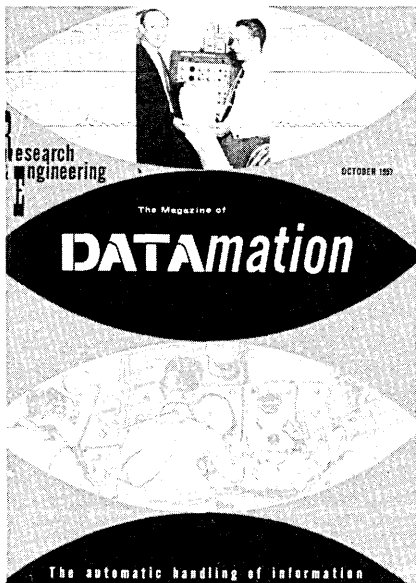

Twenty years ago publisher Frank Thompson decided to take a gamble on a new industry called information processing. On Oct. 1, 1957, an existing Thompson property, *Research and Engineering*, sprouted the subtitle, "The magazine of DATAMATION."

Advertising in this first issue reflected DATAMATION's rather confused embryonic state. An ad for Tektronics' scopes fit the new format fairly comfortably, but on the next page Narta Ultrasonics Corp. was into beer foaming, hull barnacle inhibition, and boiler descaling. Syntronic Instruments sold yokes, Amphenol pushed connectors, and Oster offered servos. But a DATAMATION house ad on page 12 indicated that Thompson knew where he was going. "Are you in step with progress?" he asked. "Get your profit where the money is," he urged manufacturers of computer components and subassemblies . . . "Be the first."

Editorially this issue also was an interesting hodgepodge with articles on data processing joining the regular R&E editorial package. On the cover, Caltech's Dr. H. L. Richter handed Dr. W. H. Pickering, director of Caltech's Jet Propulsion Laboratory, a printout of data from a Sputnik pass. Richter also wrote the lead article which described an amateur tracking receiver for satellite communications.

But the first editor, Charles R. Kluge (no connection to the "kludge" later coined by Jackson Granholm in a

DATAMATION article), was tentatively backing his way into data processing. Below the satellite story a little filler answered the question, "What is an analog computer?"

Back to aerospace with an article about a Ryan AN/APN-67 navigation system, and then, once again, a pertinent filler—this time 10 inches on a system for data communications called Kineplex from Collins Radio.

By this time Kluge had established a pattern. A rather turgid article on the use of choppers in d.c. amplification fell five inches short of filling its allotted space. The filler announced Nicholas Metropolis' intention to build a new supercomputer at the Univ. of Chicago—a follow-on to his Maniac I and Maniac II developed at Los Alamos.

Now the magazine was getting into it. Excerpts from a speech by David Sarnoff predicted computerized medical diagnosis and voice response systems. Program highlights from the Eastern Joint Computer Conference were followed by several interesting hardware announcements.

IBM's Data Processing Div. announced the 750M, "one of the most powerful electronic systems on the market for the processing of business data." From IBM's Time Equipment Div. came the introduction of the 610 Auto-Point Computer ("about the size of a spinet piano") and the 8200 Time Punch, an early source data entry device. The 610 was capable of 214 additions or subtractions or 52 divisions or multiplications a minute.

At the Stanford Univ.-SRI Computation Center, an ElectroData 205 was chugging away at various research tasks (those that would fit into 4K of memory). And down in Los Angeles, Ramo Wooldridge had announced their great white hope for the process control field—the rw-300, a "stored program" digital computer curiously enough about the size of a spinet piano.

### September, 1967

Well, 10 years later IBM's Time Equipment Div. was gone, ElectroData had been absorbed into Burroughs, R.W.'s process control effort had been sold off to G.E., scattering Dan McGurk and his colleagues all over southern California . . . and *Research and*

*Engineering* had disappeared from the DATAMATION logo.

DATAMATION and the industry had changed radically over the decade. Kluge had disappeared after two issues. Sandy Lanzarotta became DATAMATION's first real editor, followed by Hal Bergstein, and then Bob Forest who held the job for 10 years until 1973.

The 10th anniversary issue sported a pretty silver cover. Inside, five of DATAMATION's editorial advisors fearlessly held forth about the industry, past, present, and future.

Said Robert L. Patrick, after a broad and somewhat caustic look at the previous decade, "We have yet to learn how to manage our affairs really well so that we can produce a computer program on schedule and within a budget. We have allowed our applications to become more complex without developing the tools necessary for

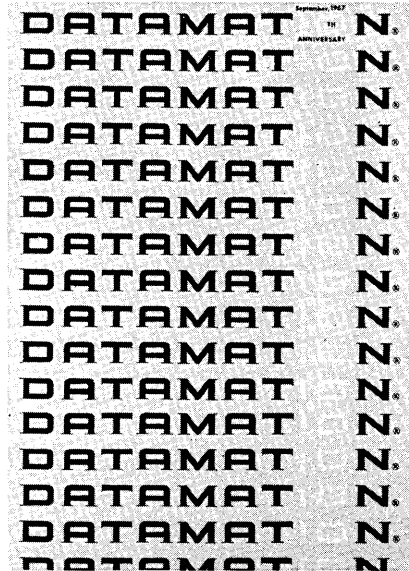

checking out on-line systems and those involving huge data files. We have made little progress toward measuring our own performance or consciously adjusting our own behavior so that the customer gets all the computing he pays for." Plus ça change, plus c'est la même chose.

Lowell Amdahl, writing about "the DATAMATION decade," noted an interesting anomaly in 1960 when 10 computers were announced, among them such notables as the General Mills Customized Computer, the IBM 7080,

# Documation Computer Subsystems... with a built-in reputation for value



## **Documation's new Printer and Card Input/Output Subsystem.**

It's another result of our innovative engineering and state-of-the-art manufacturing combination (we make over 95% of our precision mechanical parts) designed to give you greater function and value.

Our new subsystem appears to a 360 or 370 exactly as an IBM subsystem. That's where the similarity ends. We build in a lot more efficiency for a lot less money. The DOC 2250 Line Printer is 12½% faster than a 3211. Over twice as fast as a 1403. With an integrated controller you need less space and can perform off-line diagnostics. The DOC 6520 Punch comes with an optional interpret feature. Our buffered DOC 6501 Reader, featuring the patented pick mechanism, virtually eliminates systems halt due to channel overruns. And, we think you'll especially like the price/performance we built in. Our reputation depends on it.

Call (305) 724-1111 or write Documation Incorporated, P.O. Box 1240A, Melbourne, FL 32901.

**DOCUMATION**  
INCORPORATED

Call the Documation Representative nearest you. Atlanta, GA (404) 955-0309; Boston, MA (617) 890-2650; Chicago, IL (312) 782-0551; Dallas, TX (214) 661-9902; Detroit, MI (313) 353-8181; Greenwich, CT (203) 869-4123; Hartford, CT (203) 678-9313; Los Angeles, CA (714) 752-8782; Miami, FL (305) 592-9655; New York, NY (212) 695-4195; Oakbrook, IL (312) 920-0551; Philadelphia, PA (215) 574-0950; San Francisco, CA (415) 574-4060; Washington, DC (703) 356-2050. **International Offices:** London—Staines 61124; Paris 686 8207; Germany 06 11/728 128; Spain 416 B7 60.

CIRCLE 45 ON READER CARD



## LOOKING BACK

### The First Twenty Years . . .

the Ramo-Wooldrige 400 "polymorphic" machine, and the GE-225.

Bob Head predicted the rise of industry associations which would develop industry-tailored software; user groups concurrently would dwindle in significance. And, with the manufacturers no longer firmly in control, the independent software houses would flourish.

Howard Bromberg chronicled the rise of the computer consultant and wished fervently for the profession's continued good fortune. Ascher Opler urged a slowing down of the "breathless years"—the ballyhooing of cryton memories, predictions of the imminent supremacy of ocr, the claims of the machine language translation buffs and the time-sharing mavins—and a move toward experience and stability in the industry.

Wrapping up the 10th anniversary section was an interoffice memo from the Kludge Komputer Corp.'s marketing headquarters to their sales representatives of the Kludge Model 97. It began, "Shortly after the announcement of the Kludge Model 97 Super Time-Sharing System, research was begun into its feasibility."

It was a great year, 1967. Companies were hiring, venture capitalists were venturing, the industry was booming. In three years it would be 1970.

*The birthday "cake" on our cover is a Trident P-50 disc pack from CalComp; Don Wanless of Hughes Aircraft Co., and Hewlett-Packard Co. were the suppliers of the chad confetti and paper tape streamers.*

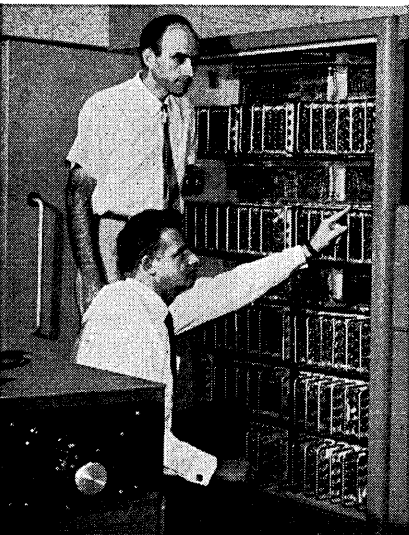

SRI's S. L. Perry and Arthur Briner, ElectroData resident engineer with the 205.

PATRICK  
AMDAHL

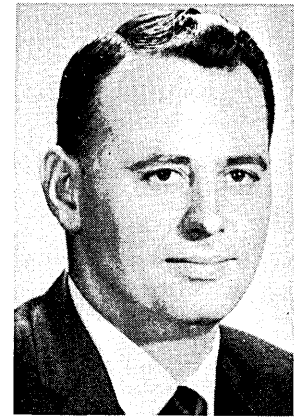

HEAD

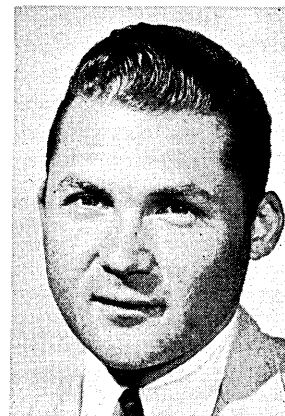

BROMBERG



OPLER

## The Early Years

Two former Datamation editors reminisce about the industry's formative years.

"It was the end of the beginning," recalled Santo A. Lanzarotta of the late '50s when DATAMATION was started.

Lanzarotta, today manager of corporate affairs, Western Operations for Xerox Corp., was the magazine's first editor under its current logo. "DATAMATION was started at exactly the right time," he said. "Computers were starting to multiply and it wasn't just IBM. There were a lot of other companies jumping in like Bendix, Royal McBee, Packard Bell, and a lot of little companies. Business computing had arrived."

He said the computer industry at that time was characterized by "the high priest syndrome. There was lots of talk about magic brains that buzzed and

blinked. Programming was a black art. The anointed few who understood revelled in talking of such things as memory and programming in machine language. It was like the early days of aviation. The barn-stormers were the consultants who really understood the business, who cruised around a lot."

Self-characterized as a "journalism generalist" at the time, Lanzarotta joined Thompson Publications (which merged with Technical Publishing Co. in April 1970) not to edit DATAMATION, but to be associate editor of a regional electronics publication, *Western Electronic News*, in October 1957. In the same month, Thompson acquired *Research & Engineering*, a magazine for research and develop-

# Don't let static kiss your computer's memory good-bye!

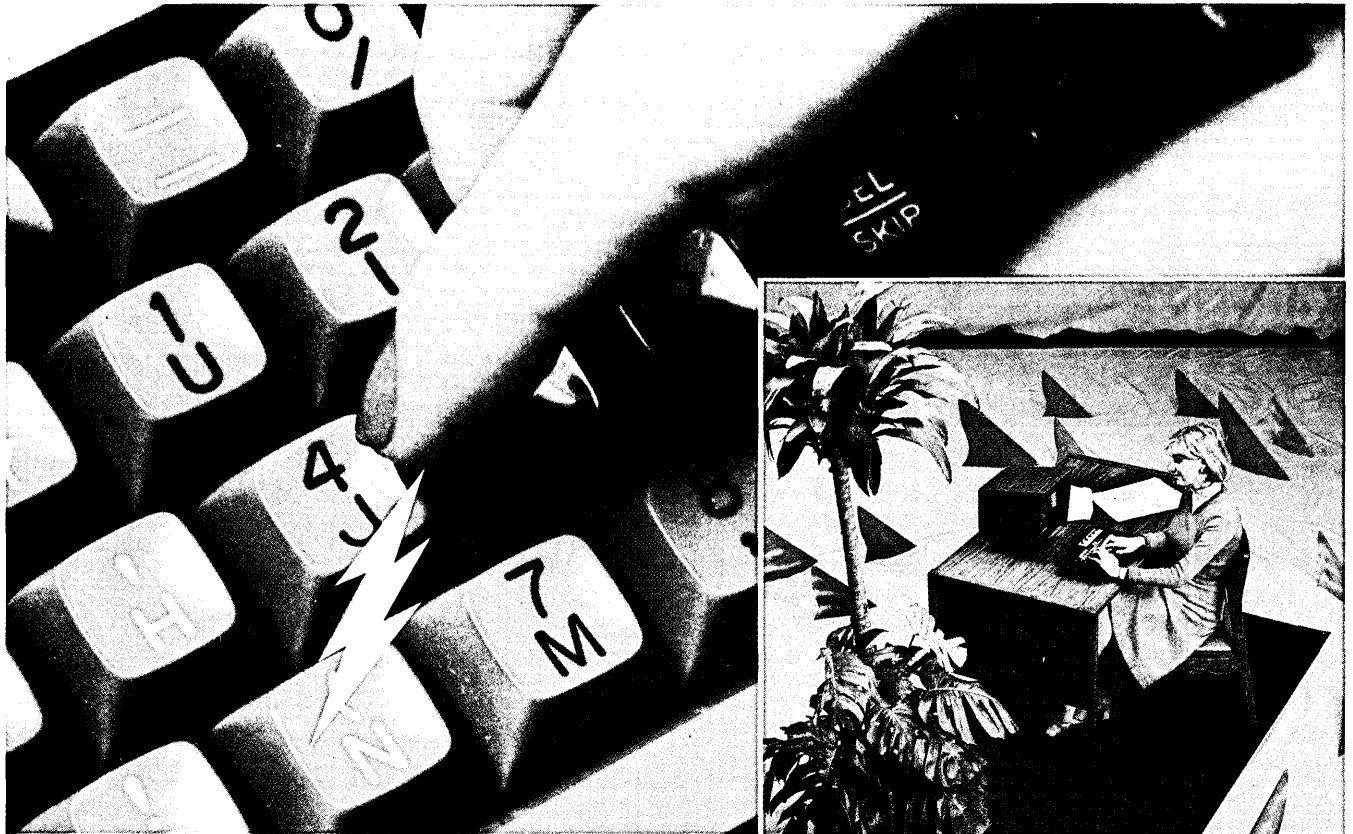

## Set up islands of protection with 3M Velostat Brand electrically conductive floor mats!

Static on personnel, discharged into a terminal, can upset the logic of your terminal, mini, or CPU . . . can send erroneous data . . . permanently damage circuits causing costly downtime and repair. No equipment is 100% immune. Some computer equipment makers report that as little as 200 volts of static can cause serious problems!

VELOSTAT Mats create positive paths to ground . . . drain static away from terminal operators . . . keep them static free. Simply place the mat where the operator must step on it to reach the keyboard, and the VELOSTAT Mats provide passive protection in such key areas as these:

- Around Data Entry, POS and Bank Terminals
- At Minicomputer and Word Processing Stations
- As a floor runner in Computer Room Entrances
- In front of Computer Printers and Disc Drives

**TO: Static Control Systems**  
 Dept. BZF-97  
 3M Company, St. Paul, MN 55101



YES, I'm interested in keeping static away from my terminal with VELOSTAT conductive floor mats.

- Please have a 3M Static Analyst call.  
 Send more information.

Name \_\_\_\_\_

Title \_\_\_\_\_

Company \_\_\_\_\_

Area Code \_\_\_\_\_ Phone \_\_\_\_\_

Address \_\_\_\_\_

City \_\_\_\_\_ State \_\_\_\_\_ Zip \_\_\_\_\_



## LOOKING BACK

### The Early Years . . .



SANTO A. LANZAROTTA  
"Like the early days of aviation . . ."

ment management. The company wanted to shift the magazine's emphasis to computers and to change its name to *DATAMATION*, but law required retention of the R & E name for a year. So the early issues were called *Research & Engineering*, the magazine of *DATAMATION*. Two issues were published in 1957 in the East. One was distributed at the Eastern Joint Computer Conference held that year in Washington, D.C.

When the magazine was moved west, the first editor, Charles R. Kluge, decided he didn't like the West Coast and left. Lanzarotta took over, and the present logo was adopted with the January 1958 issue. "I did everything," he recalled, "wrote all the copy, made up all pages, and made up the magazine."

He was the whole editorial show through '58 and '59. He got his first editorial help in mid-1960 when he hired the late Harold Bergstein, who was to become editor in 1961 when Lanzarotta left to join IBM.

Of himself and his two immediate successors, Bergstein and Bob Forest, Lanzarotta said: "DATAMATION had the right guys at the right time. As a journalism generalist, I functioned well as a one man gang. Hal, with his aggressive reporting techniques, was an attention getter. Bob Forest was by far the best writer among the three of us. He had a natural writing style and could present complicated subjects with clarity and entertainingly."

## AT THE BEGINNING OF THE CURVE

Robert Burns Forest, the man who became *DATAMATION*'s editor in 1963, in many ways exemplified the industry's inmates at the time. Everyone came into computing from "somewhere else," and Forest's particular route was via the English department of a California college.

He was in marketing and public relations at ElectroData (now part of Burroughs) and a computer industry free lance writer before joining *DATAMATION*.

"My official arrival was April 1," recalls Forest. "I don't know who the joke was on. I inherited an editorial staff consisting of wonderworker, Ed Yasaki, and a secretary who liked to take long lunch hours. I lucked out, getting into the magazine when the industry was beginning its big growth curve. It was very young, unstructured, although IBM already had a predominant role. Many new companies were coming in and exciting things were happening. Money was becoming easier and easier to raise. We began to see the first of the true software companies and firms making disc drives, memory devices, and other peripherals.

"Many new trends were evident. About then, RCA came up with a brand of magnetic auxiliary memory—the RACE system. A year later, NCR came up with one that was startlingly similar, followed by Magnavox and then someone else. I found out later that the same engineer was wandering from company to company, improving his design at every stage.

"People didn't stay in jobs very long, especially programmers. A programmer who had been around for three years was a manager and, a year later, he was an entrepreneur, having started his own software company."

In user establishments, said Forest, "programmers commanded big salaries for a minimum of expertise and practically no loyalty. They were like fruit tramps who followed the newest machine or newest program language from job to job and piled up experience of dubious value."

Elaborate and complicated systems were developed, he said, that no one could use. "That's not to say that there

wasn't a lot of good work being done, but users started to catch on to what an expensive proposition software development was."

Forest arrived in the industry in time to see the likes of Bendix and Packard Bell phase out of the business "sensibly, probably," while GE, RCA, and others were "still dreaming the big dream." New companies, like Control Data and Scientific Data Systems, were "gathering steam, trying to attract stockholders, investors, and cus-

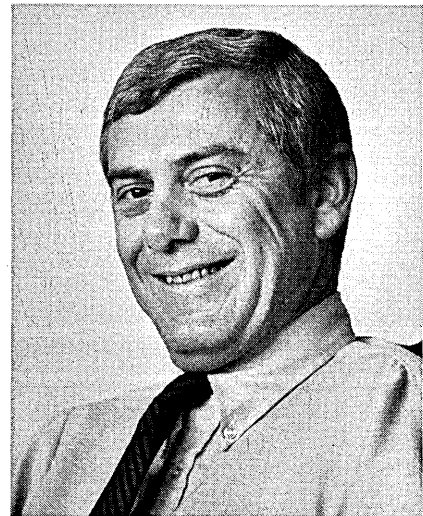

ROBERT BURNS FOREST  
"Dreaming the big dream . . ."

tomers." CDC's leader, William Norris, was out giving speeches saying that only companies whose main business was computers—not ovens, not thermometers—would survive. "It turned out he was right."

Forest described the industry of the '60s as being "full of people who didn't limit their vision and played it like a game in which the rules were made up as they went along . . . Many daring, energetic people who had an infinite number of ideas worked long, hard hours. . . . You had music majors, German majors, math majors, psychology majors, and English literature majors who'd somehow been sucked into this vast vacuum machine. Suddenly they were programmers or technical managers or marketing people. To my mind that was very healthy. I think now the trend is toward a more narrow approach to education and training and a more homogenized product . . . a little more discipline . . . a little dull." \*

# ATHANA

The research and depth of ATHANA product and manufacturing capability will astonish you — especially in an industry which is dominated by only a few very "large" magnetic media manufacturers and many companies who buy parts (including magnetic media material) for assembly into the finished disk or diskette product.

ARBER INDUSTRIES manufactures, processes, tests, assembles, and TESTS again every item offered for sale. Our ATHANA product line keeps the performance promise.

We totally process and produce coated disc substrates for the OEM market and alignment (CE) packs for engineering use in disk drive test in addition to a full line of ATHANA brand magnetic media disk and diskette products.

Distributor inquiries invited.

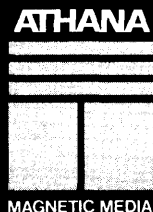

**ATHANA**  
AN ARBER INDUSTRIES COMPANY

1815 Mullin Ave. □ Torrance, CA 90510 □ (213) 775-3741 □ Telex 69-1502

CIRCLE 27 ON READER CARD



**990 Software.**

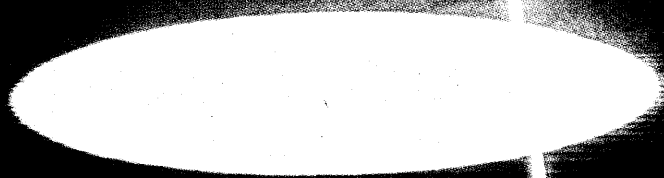

# Star performer in a supporting role.



## TEXAS INSTRUMENTS.

Most people see us as a hardware company. And that's good. But look again.

We offer in our 990 software the same experience and versatility found in our 990 hardware. And that's got to tell you something about our software capabilities.

### Software to fit your application.

The software we've designed for the 990 Computer Family serves a wide range of applications. You can get software for small standalone multitask applications requiring only a few hundred words of memory. Or software for medium-capacity floppy-based applications.

Or a choice of COBOL, FORTRAN IV, and *both* standard and Business BASIC for large, disc-based applications. You can even get a SORT/MERGE utility on all our higher level languages.

### It grows with your needs.

All 990 family software is completely upward compatible from the smallest to the largest member of our 990 Computer Family — from the TMS 9900

Microprocessor and 990/4 Microcomputer to the 990/10 Minicomputer. So as your needs grow, your system can grow — without scrapping the valuable software you've already developed.

You can increase the effectiveness of your programmers, too. Now they can use the faster, more powerful software of our larger family members to develop software for smaller systems.

### Depend on it.

You'll also like our after-the-sale support for 990 software. It includes field analyst support and our direct customer

telephone support line. You get it with all 990 operating systems, development utilities, assemblers and language packages. We even include a software update subscription service for *one full year* with every 990 software license.

At TI we know you need more than our proven 990 hardware. You need our software, too.

To find out all the latest 990 software enhancements, mail this coupon, contact your nearest TI sales office, or call Computer Systems Marketing at (512) 258-7111.



Yes! Fill me in on all the latest talents of 990 Computer Family Software. 10-9-DM

Send me the information.

Have your representative call.

Name \_\_\_\_\_

Title \_\_\_\_\_

Company \_\_\_\_\_

Address \_\_\_\_\_

City \_\_\_\_\_ State \_\_\_\_\_ Zip \_\_\_\_\_

Phone \_\_\_\_\_

Mail to: Texas Instruments Incorporated

P.O. Box 1444, M/S 784

Houston, Texas 77001

Copyright © 1977, Texas Instruments

TEXAS INSTRUMENTS  
INCORPORATED

# At last. The small business systems nobody's waiting for.



Data General's new Commercial Systems CS/40 models. They don't keep you waiting because they work the way business works. Interactively.

**Multiterminals, no waiting.** CS/40 puts data processing power right where your people need it, when they need it. In a distributed network or as a stand-alone system handling multiterminal applications or multiple single terminal applications or both. So some users could be updating inventory, while others enter orders, check payables, and process the payroll. All at the same time. And managers can still access the system any time.

**It speaks your language.** Interactive ANSI '74 COBOL, the standard business computer language and the language of large computers. With its COBOL, CS/40 has interactive debugging and workstation management, which makes it easier to use from the start.

**Small doesn't mean limited.** Three compatible models assure that as your company grows, CS/40 can grow along with you. And CS/40 can communicate with other popular commercial systems including our own. With features like up to 40 million bytes of online disc storage. And enough memory for

large applications. Plus utility software you wouldn't expect on a small system. And a smart spooler that frees up terminals so your system can do more work.

**And everything else you'd expect from Data General.** Like innovation, because we put a larger share of our revenues into R & D than any other major computer manufacturer. Like reliability, because we make virtually everything we sell. Add attractive quantity discounts, solid systems engineering, field service and our superior price/performance and you'll understand why there are already over 39,000 systems installed worldwide.

---

## Why wait any longer?

Mail to: Data General, Westboro, MA 01581

- Send me your Commercial Systems CS/40 series brochure.
- Send me your brochure and have your sales representative call.
- Quick, I'm getting ready to purchase. Call me pronto.

---

Name \_\_\_\_\_

---

Title \_\_\_\_\_

---

Company \_\_\_\_\_

---

Address \_\_\_\_\_ Tel. \_\_\_\_\_

---

City \_\_\_\_\_ State \_\_\_\_\_ Zip \_\_\_\_\_

---

© Data General Corporation, 1977 DM9

---

 **Data General**  
It's smart business.

Data General, Westboro, MA 01581, (617) 366-8911. Data General (Canada) Ltd., Ontario.  
Data General Europe, 15 Rue Le Sueur, Paris 75116, France. Data General Australia, Melbourne (03) 82-1361.



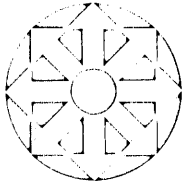

# LOOK AHEAD

## 3033 DELAYS: NOT EVERYONE'S IN A HURRY

Rumors that the unveiling of the 3031 and 3032 is imminent are "all wet" says a source close to IBM. With all the demands of the 3033-- and the long lead times being quoted on delivery--IBM probably won't get to those machines until early 1978. IBM is planning to accelerate production, but right now the 3033, 158, and 168 are straining the resources at the Poughkeepsie plant.

Regardless of what IBM does, it probably won't deliver more than 300 to 400 3033s in 1978, with a big spurt coming in 1979. Says one user, "Most of those companies buying them couldn't have handled the cutover logistically, anyway. Neither could IBM. It takes a lot of teams to make the cutover. Firms have big solid applications and data bases now that take enormous planning to convert. The ones who are hurt by the long lead times are those that planned to cut their budgets (due to the price decreases of the 3033) and those running out of capacity."

While problems with logic circuitry are said to be the culprit in the lead times, some feel IBM knew this on announcement and intended to stretch out deliveries. They accomplished several things: one is that the 3033 is a fighting machine against the PCM's almost like the 360/90 was against CDC, putting the onus on competitors to keep up with IBM's pricing or bail out. Another is that the lead times make it economical for users to buy more 158s and 168s, keeping IBM revenues up in a transition period.

## TWO AGENCIES EYE MERRILL LYNCH PLAN

A Cash Management Account program which Merrill Lynch will test this fall has yet to run into regulatory stumbling blocks though it is being closely monitored by both the Federal Reserve Board and the Justice Dept. The Fed told Merrill Lynch in a letter that the plan could "reduce effective monetary control over the growth of transactions balances in the economy," and that it was studying this and the issue of "unregulated banking" to determine if legislative and regulatory actions are needed.

Justice is reviewing the program, which would, among other things, provide Merrill Lynch customers with VISA cards and bank checks issued by the City National Bank and Trust Co., Columbus, Ohio, to see if it violates Sec. 21 of the Glass-Steagall Act, a law which seeks to separate functions of banking and securities. Merrill Lynch plans to test the program in Atlanta, Denver, and Columbus. Card and bank check transactions would be paid by cash funds maintained in a CMA. If cash is exhausted, a loan would be generated through the customer's margin account.

## MORE COMPETITION IN PACKET SWITCHING

Packet switched communication carriers like Telenet and Tymnet may be facing additional competition soon. National CSS, the Norwalk, Conn., computer services company, has added packet capabilities to its 60,000 leased data communications line network. And though National claims it doesn't intend to sell the capabilities directly, several industry sources suspect the firm eventually will file a 214 application with the Federal Communications Commission in order to enter the market as a full-fledged carrier. Also waiting in the wings is GE, which is considering the packet route for its Information Services Network. And in the Netherlands, Logica, Inc., has a packet

# LOOK AHEAD

switched network in the works.

## COMINGS AND GOINGS IN WASHINGTON

Some interesting comings and goings are expected this month out of Washington. Coming to fill the now empty slot of chairman of the Federal Communications Commission, is 43 year old lawyer Charles Ferris, a Capitol Hill veteran who formerly was general counsel to House Speaker Thomas (Tip) O'Neill. The Ferris nomination, expected to be announced by the White House early this month when Congress reconvenes, has the backing of such political powerhouses as O'Neill, Sen. Edward Kennedy, and Senate Majority Leader Robert Byrd.

Another top post also will be empty this month as Philip Verveer leaves the Justice Dept. where he honchoed the antitrusters' agonizingly slow AT&T suit. Verveer, who handed in his resignation letter in July, reportedly had differences of opinion with top trust-busters over how the sticky suit should be handled. "He wanted to run it his way," relates one Justice source, "and other people didn't want it run that way." There was also a question of how hard Verveer was pushing his staff--particularly the slew of outside economic experts Justice had rounded up for the case. "His leaving," points out the Justice source, "doesn't indicate a softening of our position. If anything, it indicates a greater resolution," he argues.

## NETS SOLVES A PROBLEM

The Nebraska Electronic Transfer System (NETS) has gotten around anti-trust objections to its operation expressed by the Justice Dept. by giving operating control of the network to Micor Inc., a Phoenix, Ariz., data processing subsidiary of Ramada Inns. Micor designed and installed the network for NETS. The new plan will permit NETS member banks and non-members to deal directly with Micor and will reduce NETS activities as the system's middleman.

## SYCOR'S FIRST 3270-COMPATIBLE PRODUCT

Its very first IBM 3270-compatible terminal also is Sycor Corp.'s answer to IBM's recent price cuts and enhancements to its 3270 terminal line. To be called the model 290, two versions of it will support eight and 16 devices, and communicate under both bisynch and IBM's Synchronous Data Link Control (SDLC) protocol at 1200 and 9600 bps. Its 15-inch crt screen has a capacity of 1,920 characters. The Ann Arbor, Mich., firm will offer the 290 at 20% below IBM's new prices, even lower for quantity buys.

It will be announced Sept. 21 at the same time that Italy's Olivetti--the overseas distributor for Sycor's intelligent terminals--announces its Sycor-made version, the model 280.

## ANOTHER BULK CORE OFFERING

Minneapolis memory manufacturer Fabri-Tek, Inc., is about to join Dataram and Ampex in offering a bulk core device that is aimed at replacing the function of fixed head discs in minicomputer systems and some large special application computers. Its BCM-750, a 512KB device, and the BCM-750 with 128K, are priced at around two-tenths of a cent per bit when purchased in large oem quantities. The 1.5 microsecond cycle time is about the same as Dataram's, but its access time is 500 nanoseconds, compared with 625 for the Dataram device. Fabri-Tek also will offer 16 and 20 bit word lengths, giving it the flexibility to offer odd-ball word sizes for various makes of computers.

(Continued on p. 278)

If you've reached that certain level of equipment and professional sophistication in the 'DP game', you are probably looking beyond IBM for your more specialized software needs.

And if one of those needs is for a teleprocessing monitor, you should look to Informatics.

Not only are we the largest independent software vendor in the world, we're also the Number One independent supplier of TP monitors. And as the recognized leader, we offer MONITOR IV,™ a product line of super-efficient, cost-effective teleprocessing systems oriented toward different user needs and requirements.

For smaller DOS and DOS/VS users who want to get on-line fast, we have MINICOMM — a powerful, flexible system that installs easily, takes minimal main storage, and doesn't require hardware upgrades.

For DOS and DOS/VS users who want the ultimate in flexibility, there's BETACOMM — a fully queued, multithreaded system that provides multitasking for application programs as well as the monitor. A

comprehensive file handler supports all standard access modes and popular data base systems.

INTERCOMM, for OS and OS/VS users, is the most sophisticated teleprocessing system available anywhere. Its many advanced features include device-independent support for over 30 terminal types, comprehensive error recovery with integrated checkpoint, message, queue, file, and data base recovery, plus a unique program-isolating feature.

Naturally, all of our MONITOR IV™ products have the full technical and educational support of the over 1,800-person Informatics team around the country and around the world. Our reputation among our more than 300 TP monitor customers is the envy of the software industry and we intend to keep it that way!

So remember . . . when you spell out your TP monitor needs, don't settle for the three-letter word. Think Informatics . . . the *last word*.

# When it comes to TP Monitors, Informatics is the last word.

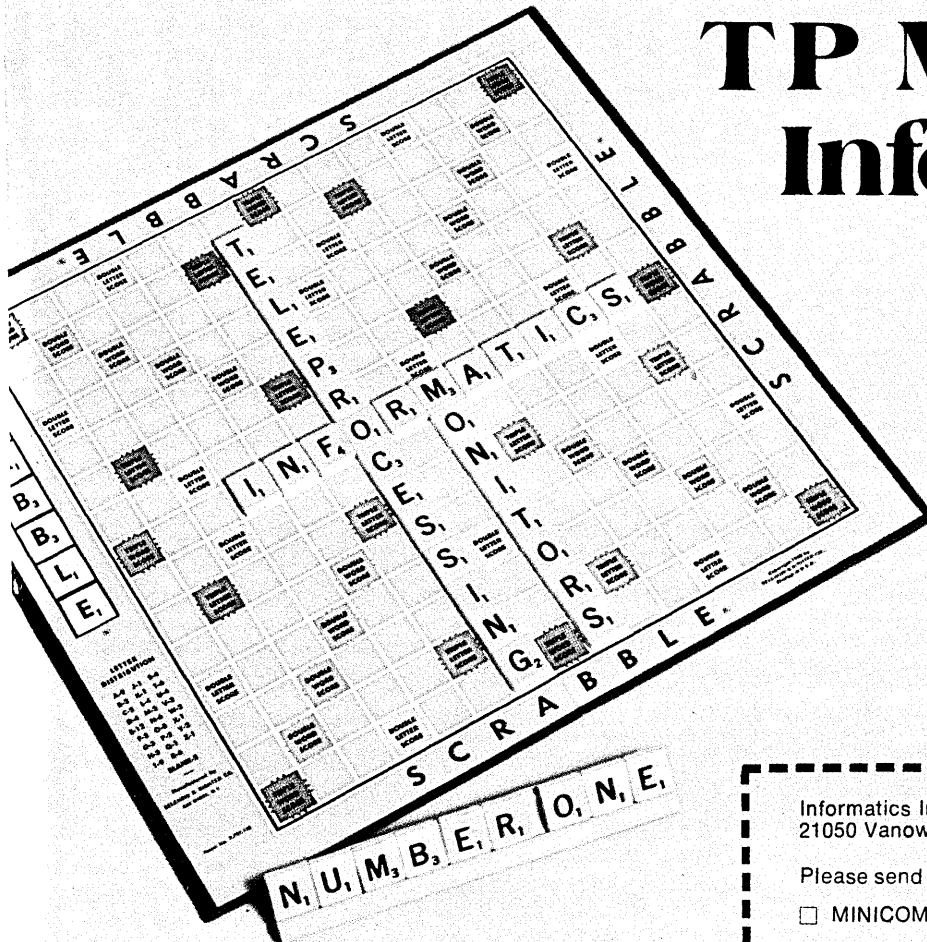

**informatics inc**  **Software Products**

World's Leading Independent Supplier of Software Products

CIRCLE 74 ON READER CARD

Informatics Inc., Software Products, Dept. D977  
21050 Vanowen St., Canoga Park, California 91304

Please send information on:

MINICOMM     BETACOMM     INTERCOMM

Name \_\_\_\_\_

Title \_\_\_\_\_

Company \_\_\_\_\_

Address \_\_\_\_\_ Tel \_\_\_\_\_

City \_\_\_\_\_ State \_\_\_\_\_ Zip \_\_\_\_\_

Computer \_\_\_\_\_ Operating System \_\_\_\_\_

SCRABBLE is the registered trademark of Selchow & Righter Company for its line of word games and entertainment services.

# Finally. A full-power that doesn't tax a Or an operat

We call it the CalComp IGT-100.

It's an acronym with the emphasis on action. Short for Interactive Graphics Terminal. A unique, new CalComp graphics tool that effectively combines built-in intelligence with advanced refresh technology.

The first in a new family of Interactive Graphic products from CalComp. All specifically designed to make things easier for both the host computer and the terminal operator.

For starters, we made the IGT-100 interactive. And truly intelligent. So it's fully capable of sharing the graphics workload with its host computer.

Then, we gave it a longer-lasting raster scan (TV) type display. To produce faster, brighter, flicker-free images. To give you sharper, black-and-white graphics. And to totally eliminate time-consuming image redrawing.

By contrast, most graphics terminals in the field today (with storage tubes) are about as far from interactive and intelligent as you can get.

Dependent is more like it. Because, typically, every graphic image — and every graphic manipulation — has to be carefully calculated, then transmitted, by the host computer to the waiting graphics terminal.

This whole routine not only puts a tremendous burden on the host computer (which usually has other jobs to do) but routinely requires lots of special software.

With storage tube type terminals, even routine manipulations like panning, zooming, selective erasing and message changing aren't very fast. In fact, the terminal operator is required to wait — up to several minutes — for a previous image to be completely erased and the second image to be tediously redrawn.

You get the picture, all right. But you'll get it faster with the new CalComp IGT-100. Because the IGT-100 is the quickest solution to these traditional problems. And easily, one of the most affordable.

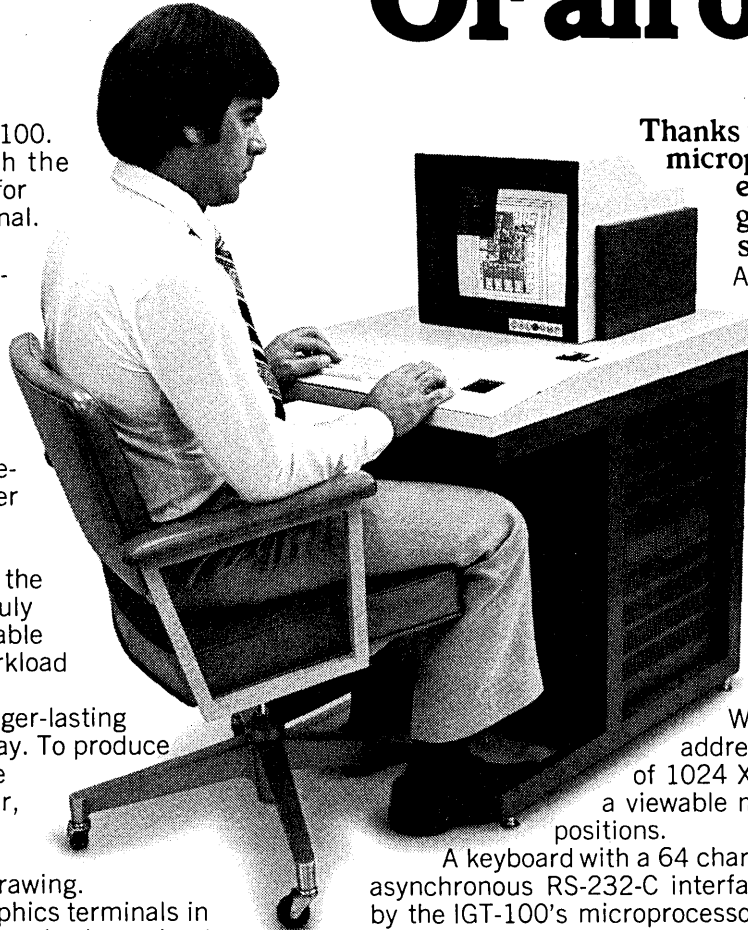

Thanks to our built-in microprocessor, efficiency doesn't get lost in the shuffle.

A built-in microprocessor helps make the new IGT-100 one of the smartest graphics terminals you can buy. And one of the most efficient.

Coupled with 12K bytes of RAM memory, the IGT-100's microprocessor permits local storage, manipulation and completion of display functions.

While providing an addressable memory matrix of 1024 X 680 bit positions. And a viewable matrix of 416 X 312 positions.

A keyboard with a 64 character ASCII set and an asynchronous RS-232-C interface are also supported by the IGT-100's microprocessor. Full or half duplex modes are switch-selectable. Along with asynchronous communication transmission rates from 300 to 9600 baud.

**Give your new IGT-100 the whole picture and you'll never redraw it again.**

Unlike most other graphics terminals, the new IGT-100 can store and manipulate images on a totally local level.

That means once an image is transmitted, you've got complete, autonomous control. All planning, selective erasing and message changing is instantaneously handled by the IGT-100's built-in microprocessor.

Even write-thru's, grids and zooms (2x, 4x, 6x and 8x) are displayed on the screen within 1/10th of a second.

And all without tying up your host computer. Or waiting several minutes for the image to be redrawn on a storage tube.

In fact, working with its built-in microprocessor, the IGT-100's longer-lasting raster scan screen will beat a conventional storage tube every time. Delivering a faster, brighter image at a flicker-free rate of 60 frames per second.

And that's a mighty pretty picture — any way you look at it.



# ed graphics terminal computer's power. or's patience.

## Six images that warrant some serious comparison shopping.

A quick look at basic viewing capabilities and you'll soon discover there's not a more versatile graphics terminal around than the CalComp IGT-100.

100's introductory price is super-competitive. Especially compared to storage tube devices. (And there's an equally attractive leasing plan, too.) But we didn't stop with just a great terminal at a great price. We added an entire year's worth of

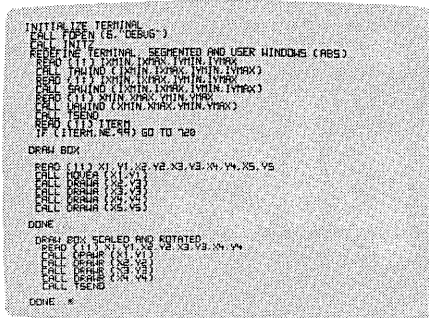

1. All alpha-numerics.

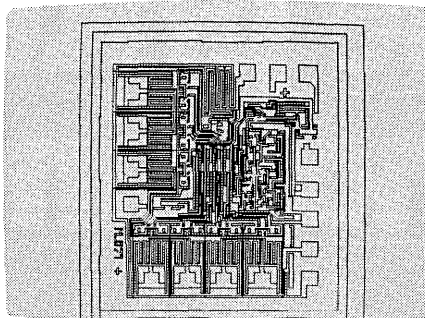

2. All graphics.

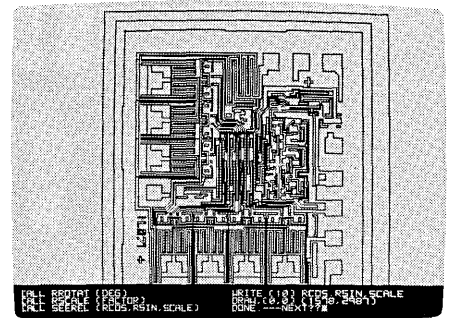

3. Alpha-numerics & graphics.

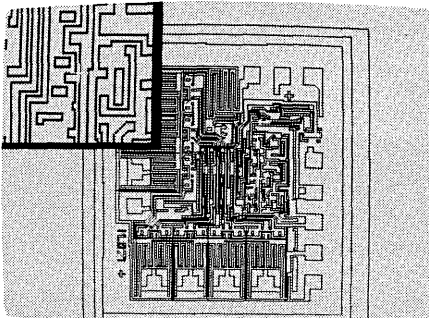

4. Graphics & View-window.

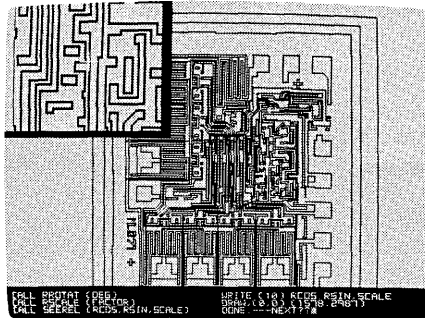

5. Alpha-numerics, graphics & View-window.

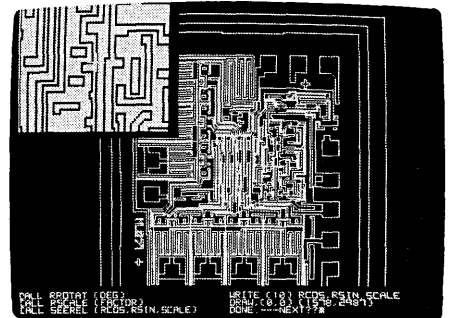

6. Alpha-numerics, Graphics & View-window (with reversed-out section).

To begin with, the IGT-100's special three-way, split-screen design provides you with separate alpha-numeric, graphics and view-window sections.

Plus the ability to independently view and control (i.e. panning, zooming, etc.) one or a combination of these sections simultaneously.

Images can even be reversed (white on black) in the graphics and view-window sections.

The IGT-100's basic screen design maximizes the amount of data that can be displayed while providing you with six basic screen arrangements. Annoying superimposed messages have been totally eliminated.

It's about time someone came up with a screen that you can tailor to fit the job — instead of the other way around. And that's exactly what we did.

### Did we mention the competitive price?

Price shouldn't be the primary consideration when you're looking for a full-powered graphics terminal.

But it's usually close to the top of everyone's list. That's why you'll be glad to know that the IGT-

service — labor, parts, everything — to the deal. Right along with the finest graphics terminal support software. (It's even compatible with standard CalComp plotting software and Plot 10.)

And then we backed it all up with CalComp's worldwide network of field engineers.

So if you're looking for a great deal on a graphics terminal, take a hard look at the new CalComp IGT-100.

And don't let a little thing like a low price scare you.

**CalComp's New IGT-100.**  
The time you save may be your own.

**CALCOMP**

Dept 100-DNS 2411 W. La Palma, Anaheim CA 92801  
Tel (714) 821-2011 TWX 910-591-1154

# You won't find a more versatile teleprinter for the price. It's that simple.

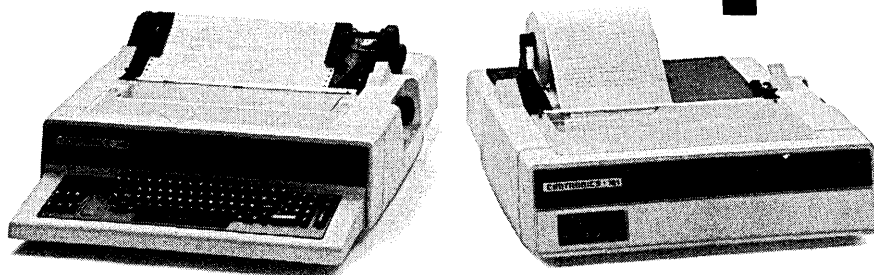

## The New Centronics Model 761.

No other teleprinter offers you more operating features — or a lower price. Because the 761 gives you micro-processor-control for maximum flexibility *and* lower-priced options.

Plus, the 761 gives you easier, more versatile operation . . . with maximum printout visibility . . . typewriter-style electronic keyboard that anyone can use without special training . . . table-top or free-standing installation . . . pinch roll, pin-feed platen or tractor paper handling systems . . . and a wide choice of 300 baud serial interfaces . . . in KSR and RO models.

And when you need fast, dependable service, remember the 761 is backed by one of the industry's best service programs. More than 100 professionally staffed service offices worldwide . . . a unique on-line diagnostic test center . . . central dispatch with toll-free phone access . . . and maintenance contracts as attractively priced as the 761.

More versatility, better service and reliability proven by more than 80,000 Centronics printers installed, make the 761 teleprinter simply a better choice. The *only* choice. Call today for details. Centronics Data Computer Corp., Hudson, N.H., 03051, Tel. (603) 883-0111 or Centronics Offices in Canada and throughout the world.

**CENTRONICS® PRINTERS**  
**Simply Better**

# letters

## 9,453,600 papers to shuffle

I am beginning to be appalled at what is going on in the whole field of automated information handling. My experience in the area of paperwork started before the first computer came on-line, and I have lived through the entire development of this information era in which we now live. I am convinced that we are in a state of overkill on information. There simply aren't enough people to pay attention to all the information we have and are developing. Let's look at examples:

Take the IBM 3800, which with the laser beam and electrostatic reproduction, processes paper at the rate of 31 feet per second. That's 1,860 feet per minute; 111,600 feet per hour.

If the paper is cut off at 8½-inch intervals to produce forms 8½ x 11-inches, that's 13,130 forms per hour filled in with information.

Let's assume a seven hour day (few computers or high speed printers are run only one shift) with six productive hours of work; that's 78,780 filled in forms per day, or 393,900 sheets of information per week. In 48 working weeks per year, that's 18,907,200 forms per year, and that's a lot of information. But maybe we're getting a mite ridiculous, so let's arbitrarily cut that in half (but why are the other half printed?). That leaves 9,453,600 sheets of information from only one IBM 3800.

Now let's assume again that each of those sheets consumes only two minutes of time for all the things that are done in paper handling and use. That's 18,907,200 minutes or 315,120 hours per year. Again assuming that there are 1,500 productive hours per year, that's 210 people, or the equivalent, working on the output of only one machine.

If those people are paid an average of only \$20,000 per year (clerks and mailroom personnel don't read computer printout), that's a whopping \$4,201,600 payroll per year. One machine, one shift, and that cut in half! Who's going crazy here?

But someone may say, "He's taken an extreme example." Okay! Let's go to the other extreme, the in-house print shop which produces the majority of the average company's forms which are used in average quantities of 500 or fewer per year. Most of these forms aren't subject to any management control worth speaking of.

In the lower and middle ranges of office work we will assume (seems I'm doing a lot of assuming, but if anyone has better figures, I'd like to see them) that there are 1,715 available hours or 1,286 productive hours, at 75%, per year.

If each of the 500 copies of that little form requires only 10 minutes of clerical time at \$8,000 (\$10,400 with fringe), and two minutes of supervisory time at \$12,000 (\$15,600 with fringe), that's \$877 worth of payroll for each one of those little forms which cost only \$6 to \$8 to produce.

So, whether the information comes from the little form or the big automated form, I'm of the opinion that there aren't enough people or hours or dollars to justify what is being done.

What's the answer? Certainly not the philosophy of "bigger is better." That is being proved fallacious throughout our entire society today. Whether the information comes out of government or private business; whether it's manual or automated; whether it's on paper or film; the only answer that I can see is that management simply is not managing paperwork and information. And that's an abdication of responsibility.

Paperwork expands according to the means available for its production. And it will continue to expand until management takes hold and restrains it within reasonable bounds.

FRANK M. KNOX

*New York, New York*

## SSA's reel-y busy

I have just finished reading with great interest your article, "SSA's Huge Systems Scheme" (July, p. 140). There is an error in the article that bothers me somewhat. Our tape library now has close to 400,000 reels, not 400 as stated in the article. Would that we had only 400 reels!

There is also a minor discrepancy in the number of "service sites" referred to in the article. The "3,400 nationwide service sites" should refer to our secondary facilities. (Secondary facilities are locations where we provide service on less than a full-time basis, e.g., county court houses and post offices in smaller cities.) In addition, we have 1,300 primary field facilities which provide service on a full-time basis in the larger cities of the United States. We thus provide service to the public from over 4,700 locations nationwide.

My thanks for a well-written and objective article.

E. R. LANNON

*Director, Office of Advanced Systems  
Department of Health, Education,  
and Welfare  
Social Security Administration  
Baltimore, Maryland*

## Accentuate the positive

I was disappointed when I read the write-up on our new product, IAM, in the "Software and Services" section (July, p. 176). Though it is not widely held, it is too often a strongly held misconception that software from other than IBM is a mishmash of "special purpose and one of a kind odd jobs," or worse, a place to go for replacement of non-supported products for those who make the mistake of not keeping up with IBM's latest hardware.

Your headline, "ISAM Replacement," and your oversight or omission of just what benefits IAM offers over VSAM was short-sighted and almost an accusation. IAM is an alternative or replacement for all non-operating system uses of VSAM and ISAM. To survive, the software industry traditionally has had to provide products superior to IBM's. Those products often have been the stimulus for IBM to improve the performance of its own software, or incorporate facilities demanded by users of the IBM products who threatened to switch to similar non-IBM software. Innovation hasn't ignored VSAM.

IAM has been shown by its users to reduce EXCP counts by 50% from comparative VSAM runs. IAM uses less memory and 20% to 40% less CPU time. There is a 10% to 30% savings in peripheral storage. Job elapse time is significantly reduced.

Comparison to any competitor's offerings should be made to the best they offer, not the worst.

THOMAS J. MEEHAN

*Vice-president*

*Innovation Data Processing*

*Clijton, New Jersey*

## First ask the typist

In "What's Happening in Word Processing" (April, p. 65), it is said that the dp manager should be in charge of the word processing facility because of his vast experience and knowledge of all aspects of computerized activity. Then we are given a long list of the novel requirements of word processing systems which the dp manager will need to learn about if he is to venture into this unfamiliar field.

Let's face it, the average dp manager is machine-oriented, wedded whether he likes it or not to one particular manufacturer, concerned with achieving an acceptable general throughput for customers who are more likely to be departments than individuals. The word processing manager, on the other hand, must be people-oriented, concerned with the individual jobs of personal customers who know what they want and don't

# letters

take kindly to attempts to tell them otherwise, particularly by a technician from another field.

I suggest that the right way to set up a word processing system is first to ask the office and typing staff what they want the system to do for them, and then get advice from an independent consultant on the best hardware and software to buy in order to carry out the tasks so defined. This way the system will start off with user support and won't be distorted in order to cover up past mistakes in hardware acquisition by the dp department.

E. W. WATSON  
*Watford, Herts., England*

## Pioneers are still plowing

Okay, let's hear it for the 1440 programmer—a nearly extinct but crusty bunch of old men and women. You say you never heard of one? (A 1440 programmer, that is?) Well son, there's still a few of us hardy souls left, out here in the old folks' home. While the rest of you ran away to fool around with some 370/155s we had to keep the homefires burning with our DCW's and MLC's. Someone had to stay home and keep the 1440 fed with autocoderisms. So it became our lot. We're still plowing the fields with gear from the second generation. Still, you kids don't know what a thrill it is to hold hands with a 16K and a 240 1pm.

I read in DATAMATION where they had a computer conference in Dallas. Be nice if they could have displayed our 1440 and some of us gray-heads fiddling around. Also, saw some employment ads in the same issue, but none wanting a 1440 programmer. Well, that's the way it is, but don't you kids forget us pioneers. Good luck.

AL KEPHART  
*USA Madigan Army Medical Center  
Tacoma, Washington*

## Think cool

Mr. Ecklin's reverse logic amazes me. After reading "Keeping Cool" (July, p. 24), I called and confronted him with  $E=mc^2$ . This equation kept the law for the conservation of energy intact. His response—the law already had to be changed once as Einstein found mass could be changed to energy, so why not change it again, and convert cold to energy?

He brought out another important point—since a superconductor has zero resistance, there is no voltage drop across it and as much current

flows from a wire or coil (electromagnet or motor winding) as we originally put into it.

THELMA S. BAUER  
*Silver Spring, Maryland*

The basic logic your readers should use about "Keeping Cool" is the law for the conservation of energy or the first law of thermodynamics. This law says energy cannot be created as Mr. Ecklin proposes. Further, we have not even been able to build a perpetual motion machine let alone some device that will output energy.

W. J. CATES  
*Arlington, Virginia*

Mr. Ecklin has written us: "From the responses so far, many people apparently read your "Letters" department without reading the headlines. Scientists, and some of your subscribers, really get hot under the collar when someone dares to question the law that energy can neither be created nor destroyed. They conveniently forget Einstein has already corrected and modified this law once (as Ms. Bauer noted above).

A large superconducting ring, anchored in bedrock, can store billions of watts of energy. If the temperature of this ring should rise less than a degree, all this energy suddenly vanishes. All the stresses from it's magnetic field disappear at the same time. If energy can so easily and completely be destroyed, there should be other ways, besides rearranging mass to get energy which we can surely use. Don't forget, cryodynamics is limited to a minus 459 degrees Fahrenheit, but there is no known limit to heat.

## PERFORM-ing

I agree with the suggestion by Mr. Parkes (July, p. 21) that a PERFORM DEPENDING ON feature in COBOL would be useful, but the example he gave would be much better handled by simply defining a table of counters and using the record type as a subscript to increment the proper entry:

ADD 1 TO RT-COUNT (RECORD-TYPE)  
Assuming, of course, that RECORD-TYPE is a numeric item and a check has been made to ensure the value is within the allowable range.

WILLIAM E. WEEMS, JR.  
*McDonnell Douglas Automation  
Company  
St. Louis, Missouri*

After reading Roderick Parkes' letter concerning the counting of record types using the DEPENDING ON option, I feel it would be much simpler and quicker to count using direct subscripting.

Since the DEPENDING ON option requires the value of interger-2 to a value from 1 to n, the direct subscripting could be employed with only one statement.

ADD 1 TO TABLE-CT (RECORD-TYPE).  
In addition to less procedure coding, working storage accumulators would not have to be individually defined.

JIM FLOWERS  
*Blue Cross Hospital Service, Inc.  
St. Louis, Missouri*

## Dump validation

In "Integrity in Data Base Systems," (May, p. 64), Mr. Curtice provides us with an excellent article. The techniques he describes are valid ones, however, most of them will work only if the log and/or dump tapes are valid. Many problems can occur when creating a tape and can be caused by software or hardware. For example, hardware can produce duplicate or short blocks.

Usually dump and log tapes are not used immediately after creation, but are retained for future use in case of a failure.

A bad log/dump tape at recovery time can have disastrous results. Retreating to a previous backup (if available) requires longer recovery time. A bad log tape however, is not so easily bypassed. All batch runs to cover the time period represented by the bad log tape must be reprocessed, or in the case of an updating on-line system, the remote users would be required to resubmit all their transactions. Clearly, these solutions seem unacceptable.

Our solution has been to write an extensive dump/log tape validation program for each of our file handlers. The success of our approach has prevented many headaches and saved many rerun hours. Whenever we discover an invalid tape, we are immediately aware of the problem and can take appropriate action, which in most instances is a dump (or redump) of the data base.

LAURENCE B. LEGORE  
*Data Base Administration  
Commonwealth of Pennsylvania  
Middletown, Pennsylvania*

## First teta, now peta

The June "Look Ahead" (p. 16), is in error when speaking of "First Terabit, now Tetabit." The prefix for  $10^{15}$  is "peta," not "teta." Just in case technology develops too fast, "exa" stands for  $10^{18}$ .

HANS J. OSER  
*U.S. Department of Commerce  
National Bureau of Standards  
Washington, D.C.*

Thyn cayme a programmyr  
To Louis Fried ("The Programmyr's Tale," June, p. 161):

(continued on p. 26)





## Does your Honeywell VIP take a big bite per byte? Our Harris 8770 doesn't.

Our new Harris\*8770 can do everything your Honeywell 7700 or 775\*\* can do—yet ours costs 10% to 30% less.

That's not all.

When you call us, we respond. For example, our average response time for maintenance is less than three hours. And you can understand why. Terminals are the only things we design, make, install and service. They're our entire line, not just a small piece of it. Stands to reason we give terminals all our attention.

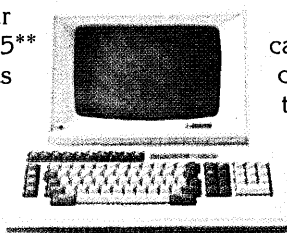

And that's not all. We build communications monitoring capabilities and self-test programs into our terminals. This not only lets you detect system failures and debug new applications. It also

helps isolate any problems in your front end, communications lines, modems, terminals or printer's basic operations.

Result? A lot less downtime. But even that's not all.

Harris terminals run without glare, heat, noise. They're

lightweight, compact, trimly designed. Easier to work with, look at, move around.

Harris terminals. They help you fight the big-cost bite. Why not phone or write for details and a demonstration? Harris Corporation, Data Communications Division, Daniel Webster Highway South, Nashua, NH 03060. 603-885-6685.

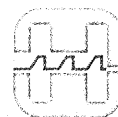

**HARRIS**  
COMMUNICATIONS AND  
INFORMATION HANDLING

\*Formerly Sanders Data Systems \*\*Trademark of Honeywell Corporation

CIRCLE 81 ON READER CARD

# Kodak announces 3 dry, convenient, laser COM's, on-line & off-line.

**One step** produces completely finished jobs.

**Dry**—absolutely no solutions, no wet processing.

**Laser imaging**—advanced technology gives outstanding image sharpness on a new Kodak film.

**Control software**—automates job setup and operation, simplifies operator tasks and training, greatly reduces error potential.

**Total convenience**—utmost ease of operation, a demonstration will prove it.

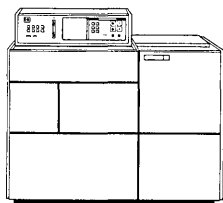

**Komstar 100 microimage processor**—on-line to IBM S360/370 computers, for distributed processing.

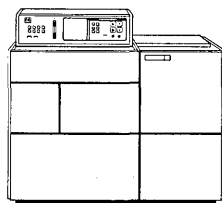

**Komstar 200 microimage processor**—intelligent, on-line to IBM S360/370 computers, saves CPU formatting time.

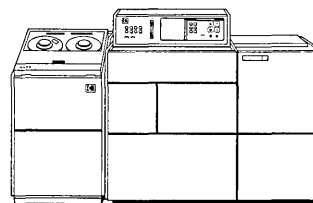

**Komstar 300 microimage processor**—intelligent, off-line COM, formats print tapes from most major mainframes.

For the detailed story, write Eastman Kodak Company, Business Systems Markets Division, DP-7933, Rochester, N.Y. 14650.

**KODAK KOMSTAR Microimage Processors**





# letters

(Continued from page 22)

Whan that ensconced oncet in limou-  
syne  
That carries to and fro the aeroport, e,  
I had twa bagges o' wynde both  
mayking paem  
Whilst seated juste behinde me for their  
sporte.

For respite I recyted the *Prologue*  
Commencing from the toppe: "Whan  
that Aprile . . ."  
Whyche proved to be a moste effectif  
drogue  
Agaynst a rising gorge fair'ld mayke me  
ille.

But lo! Whence came this bogus Pro-  
grammyr  
(A tale that has the metre and the  
lilte  
't would mayke a true addichy-on, no  
fear,  
Excepte for argot whyche keeps  
lyghtinge "TILT?").

But alle in alle, I'll mayke to ye no  
bonyes  
It reade ryghte fairly welle for the  
nones.

A. J. CRAWFORD  
*Manager, Corporate Management  
Information Services  
Colgate-Palmolive Company  
New York, New York*

Mr. Fried replies:  
Whan at firste that foolish tale was  
ywrit,  
Of any publick ken I trulie feared.  
How gladde am I to see swyche piece  
of wytte . . .  
'Sblude, a kyndred spyryte has ap-  
peared.

**The joke's on who?**  
The May issue (p. 266) reported a  
high school senior prank—report cards  
with mysteriously obtained "straight  
A's" were received by students at Los  
Altos High School while their rivals at  
a cross-town high school, Awalt High,  
received the "authentic" computerized  
forms reading "straight F's." Prank-  
sters rather anxiously observed the ef-  
fect that their hoax had upon the star-  
tled community. What it boiled down  
to was that our parents and classmates  
were instantly unveiled as people  
whose lives, however temporarily, are  
alterable by the grade point average  
assigned to them by a computer.

We began to see our prank as a  
social experiment, and at first thought  
were dismayed at the sight of computer  
control of society. If high school stu-  
dents with training given a twelfth-  
grade computer course were able to  
abuse the machine, how much more

destructive will the prank in store for  
America be when those more quali-  
fied turn to reprogramming computer  
banks?

Despite our wrongdoing, we came to  
the conclusion that the pranksters were  
not as corrupt as the community af-  
fected. Corruption lies in placing hu-  
man value on evaluations reportable by  
something as impersonal as a machine.  
Rational people used totally insuffi-  
cient input—high school grades—to  
reprogram their lives. We, as a nation  
or as a community, are prone to ma-  
chine terrorism or to subtle mockery so  
long as we overemphasize the impor-  
tance of artificial classifications and  
place no value on reality.

HIGH SCHOOL STUDENTS RESPONSIBLE  
*Los Altos High School  
Los Altos, California*

## Personality vs. preparation

. . . Mr. Patrick (April, p. 45) speaks of  
the *personality* of a good keyboarder  
who "for reasons best known to herself  
*chooses* a routine job." He is obviously  
unaware of the basics of the job market  
—economics of educational emphases,  
competition, and simple bias—which  
are far more involved than personality  
in job choices of this sort. Women go  
into routine jobs for the same reason  
that men do—they sometimes pay a bit  
better than any other job for which  
they are prepared. They sometimes are  
all there is to be had. The difference is  
in pay scales and society's respect.  
What keypuncher is paid the wages of

an auto assembler? What secretary  
wouldn't like her manager's words to  
the effect that the office depends on her  
translated into better pay and more  
responsibility?

It is inexcusable that a dp profes-  
sional be so unaware of basic attitudes  
among other professionals and among  
users. Whether or not managers set out  
to create sweatshops, the fact is that  
the data entry person is the least re-  
spected of dp workers, usually the least  
well-paid, and surely the least often  
consulted on her/his working condi-  
tions.

ROBIN KOWALCHUK BURK  
*Consultant  
Information Systems Consultants, Inc.  
McLean, Virginia*

\*

We welcome correspondence from  
our readers about the computer in-  
dustry and its effect on society, as  
well as comments on the contents  
of this magazine. Please double-  
space your letter when you write to  
DATAMATION, 1801 S. La Cienega  
Blvd., Los Angeles, CA 90035. We  
reserve the right to edit letters sub-  
mitted to us.

Said a mellow old robot named  
Newman,  
"When a man does not act with  
acumen,  
but is clumsy and coarse,  
I consider the source  
and remember that he's only human."  
—Gloria Maxson



"This wasn't my idea. Tell it to the school print-out."

© DATAMATION ©



# How to manage and control your DP Documentation with **DOCU-MATE™**

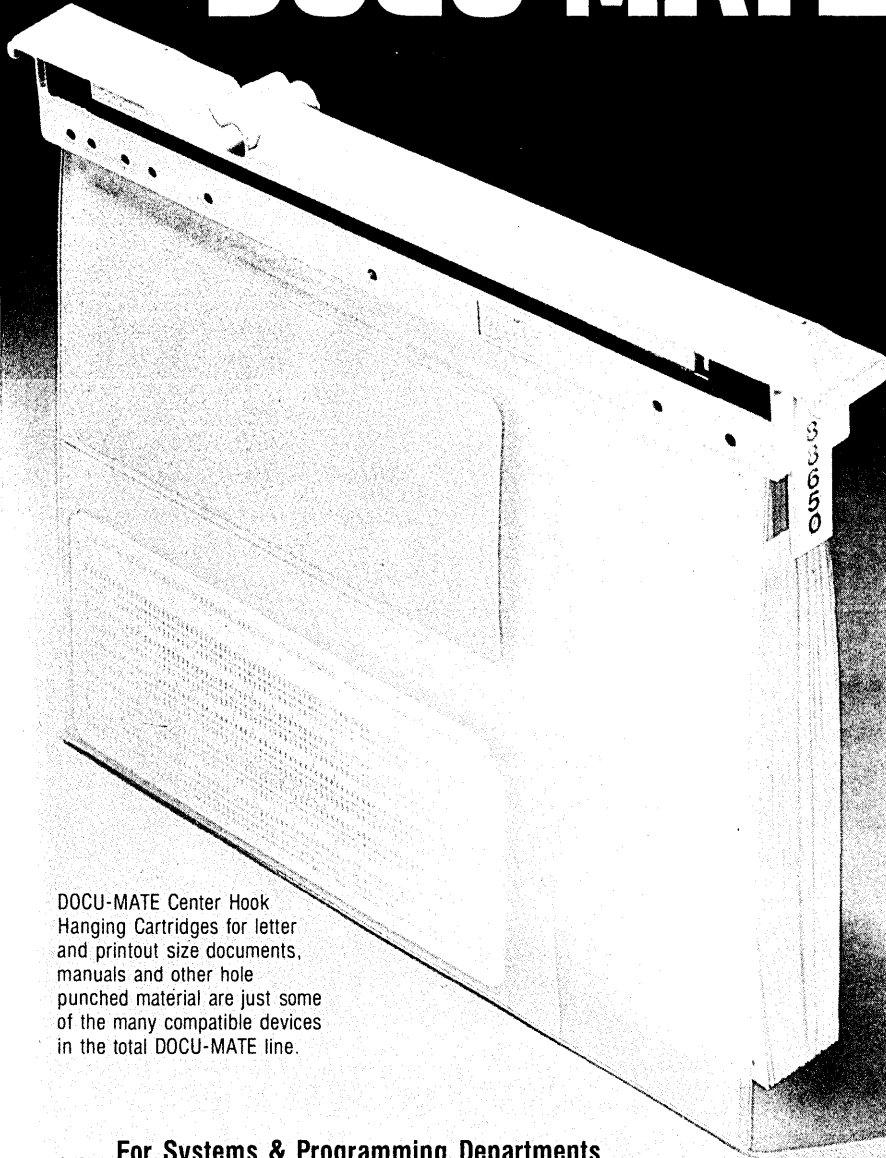

DOCU-MATE Center Hook Hanging Cartridges for letter and printout size documents, manuals and other hole punched material are just some of the many compatible devices in the total DOCU-MATE line.

## ... For Systems & Programming Departments

- Improve Project Control
- Increase Programming Productivity
- Improve Inter-Department Communication
- Reduce Documentation Filing Cost

In the U.S.A.: WRIGHT LINE INC., 160 Gold Star Boulevard, Worcester, Massachusetts 01606, 617-852-4300, TELEX 920-452, Cable Address: WRIGHTLINE, WORCESTERMASS. Area Offices: Boston 617-879-4160, Metropolitan New York 201-263-5300, Hartford 203-677-8581, Philadelphia 215-563-8666, District of Columbia 301-468-2100, Atlanta 404-455-1146, Columbus Ohio 614-864-2096, Chicago 312-593-0600, Los Angeles 213-788-2343, Dallas 214-241-8761, Denver 303-770-7550, San Francisco 415-692-1741 and sales offices in all principal cities. In Canada: THE WRIGHT LINE OF CANADA, LTD., 51 Esna Park Drive, P.O. Box 600, Agincourt (Toronto) Ontario (MIS9Z9) 416-495-6303 Area Offices: Toronto 416-495-6303, Montreal 514-737-1188, Ottawa 613-233-7624, Quebec 418-527-6845, Vancouver 604-685-2812 and sales offices in all principal cities. In Europe: WRIGHT LINE GmbH, Orber Strasse 24, 6000 Frankfurt am Main, West Germany, 41 03 62, TELEX (841) 417361 Area Offices: Switzerland 01/820 9075 TELEX 54177, Sweden and Denmark 02/965366 TELEX 33468, Netherlands (02520) 21077, United Kingdom 01/644 4355, West Germany 41 03 62 TELEX 417361, Italy 2566849. For all other countries throughout the world, contact: WRIGHT LINE INC., International Division, Worcester, Mass., U.S.A.



The DOCU-MATE System includes hanging cartridges, binders, folders and documentation holders for every size and shape of documentation including manuals, letter size documents, printout, cards and flow charting forms.



The DOCU-MATE System provides complete filing compatibility. Each DOCU-MATE device fits interchangeably in all equipment. You don't have to collect documentation packages from a number of conventional single purpose files and then explode them again for refiling.

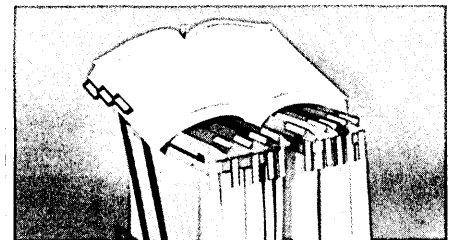

The DOCU-MATE System recognizes both a filing and a reference mode. The same devices used for filing fit into an ingenious array of desk racks, desk sides, mobile units, reference stands and roll-out reference files that allow you to reference documents without removing them from the file.



The DOCU-MATE System provides equipment for every need as documentation flows through the information system including lockable filing cabinets, open library filing, units and work station configurations for programmers, systems analysts, computer operators and even user department personnel.

For complete information circle readers' service number or call today for new 32 page color brochure.



A Subsidiary of Barry Wright Corporation

CIRCLE 117 ON READER CARD

In 49 years we've made a lot of connections

Happy 20th  
DATAMATION

# BUNKER RAMO

...the  
Information  
people

ON-LINE  
DATA TERMINAL SYSTEMS

## Used by:

Banks

Utilities

Airlines

Factories

Brokerages

Credit Companies

Saving Institutions

Car Rental Agencies

Insurance Companies

Government Agencies

## Applications:

Networking

News Retrieval

Credit Checking

Teller Operations

Word Processing

Data Base Access

Market Quotation

Message Switching

YOU'VE GOT A LOT OF EXPENSIVE DATA STORED IN YOUR COMPUTER.  
MAKE IT INSTANTANEOUSLY AVAILABLE TO YOUR PEOPLE  
— AT DESKS, COUNTERS AND WORK STATIONS — SO THEY CAN USE IT PROFITABLY  
FOR YOUR ORGANIZATION. MAKE THE RIGHT CONNECTIONS FOR THEM  
WITH A BUNKER RAMO ON-LINE DATA TERMINAL SYSTEM.

Bunker Ramo Corporation, Information Systems Division Trumbull, CT 06609 Tel. 203-377-4141

International Sales/Service: Austria • Canada • Dominican Republic • Haiti • Holland • Hong Kong • Indonesia • Malaysia • Netherlands Antilles •  
Philippines • Puerto Rico • Singapore • Switzerland • Thailand • Trinidad and Tobago • Venezuela • Virgin Islands • West Germany

CIRCLE 31 ON READER CARD

# people

## Time For A Change In Style

In its eight years of selling in IBM's shadow, Data 100 of Minneapolis has encountered a lot of problems financing its lease base. But the shocker hit early last year when it found it had overextended its revolving bank credit. And just prior to that, an ambitious oem plan had blown up in its face, when it decided not to market a micro-programmable minicomputer that emulated the DEC PDP-11 line because it didn't want the expense of litigation with Digital Equipment Corp. Further, foreign currency losses of nearly \$1.5 million were being suffered in 1976.

Edward D. Orenstein, the company's 45 year old president and chairman, had been through it all before, and had no doubts that the company

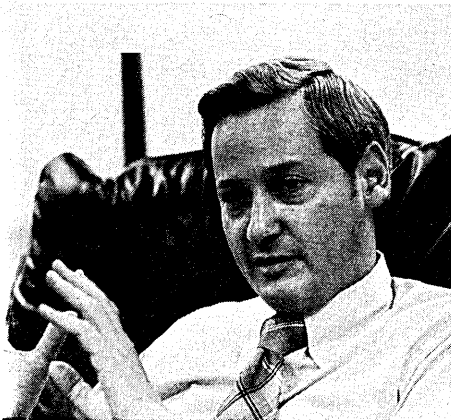

EDWARD D. ORENSTEIN  
He'll wait to become rich

would weather this latest setback. "But, I knew it was time to change our management style," said the tall, slender, former Air Force physicist. "When we opened our doors in 1969 we had seven v.p.'s and a secretary. All but two are still with us. We knew what we wanted and we did it. We wanted to go to \$100 million in revenues. In six years we had reached \$100 million. We had our own management style. Everyone used to report to me in an informal way. We didn't want outsiders."

Now the v.p.'s report to Bruce Bam-brough, the company's chief operating officer and a founder. It has built a computer modeling program that tracks 40 to 50 key indicators of the

company's business and projects results several years into the future. The company, now spread throughout 28 nations, has installed a distributed processing network, to help with dispatching and spares management and to expedite order handling. "Whether we're right or wrong, we'll at least be consistent," quips Ken Tiede, another company founder, who built the model.

And the company has restructured its financing by convincing banks of the long revenue earning life of its equipment, which consists of batch terminals, key-to-disc data entry systems and remote processing equipment. For instance, serial number 2 of its Model 70 has been used by six different customers in the last seven years, at 214% of cost.

When the company started in 1969 with its hard-wired Model 70 remote batch terminal, it estimated a market where 70% of what it made would be leased and the rest would be cash-generating outright purchases. It turned out, though, that 96% of what it made went on lease. Lease financing became a problem right away. So much so that Orenstein observed in 1973 when the company arranged for an \$11.5 million financing deal with a private source, "For the first time, we've got enough money to last more than two weeks."

At first, the cash hungry company thought it would be in the clear in three years as revenue from residuals poured in. Then it changed this forecast to seven years. "It's now more like eight to ten years," says Orenstein. Says one staffer, "Ed wants us to make him rich, but he's going to have to wait."

He will.

Last summer when the company again had gone to the money trough for cash—this time a \$15 million debenture offering—it was approached by an unidentified company with a tender offer for Data 100 shares, provided it withdrew the debenture offering. Data 100 turned it down flat.

Orenstein has always wanted to run his own shop—although he's reluctant to be interviewed for a profile, "which makes it seem like one guy has built a successful company from nothing. We're a team at Data 100. The right people are on board and working together."

Orenstein began working as an instructor in nuclear weapons with the Air Force at Lowry Field in Denver. He later went to Univac in Minneapolis, his home town, but left 15 months later when he was 27 to form Data Display, which made crt's. Control Data, which gave the company its first commercial contract for a crt to be used on the console of that company's 6600 computer, acquired the company seven years later when it was up to 200

employees and was doing \$2 million a year. Orenstein went to CDC along with the company as general manager of CDC's terminals operation. Three years later he set off again on his own to make and sell remote batch terminals. "It was a market that IBM had pioneered, but to such an extent that there was a three to nine month waiting period for the IBM equipment."

Private investors put \$2 million into the company and Data 100 raised an additional \$4 million through a stock sale. It displayed its first product the following spring at the Joint Computer Conference. Its success—"selling at 15% below IBM's price and delivering fast"—has been phenomenal. More than 6,600 terminals are installed throughout the world; it operates seven manufacturing plants, has 64 sales offices and 340 maintenance centers, and it employs 3,063 persons.

Its software power constantly is being beefed up as Data 100 offers "multi-function" systems—its buzzword for distributed processing systems. And price isn't all that matters any more. "We sell at about 10% below IBM when the competition is direct, but sometimes the price is higher when we have an edge on performance."

Orenstein, the engineer and physicist who "hasn't had a soldering iron in my hand since 1963," said the recent reorganization in management at Data 100 allows him to devote most of his time to "knowing where we want to be in the future . . . what will be the effect in three to five years of what we do today." It's a unique market "that allows us to grow as fast as we want to." The challenge is being able to manage the growth. Data 100 and Orenstein seem now to have that part under control.

## "They Should Be Paranoid"

He seems like the last person in the world who would ever talk about being paranoid. Sitting serenely behind his well-organized desk, Herb Bright, in the current vernacular, is a "laid back" man. But behind all this coolness and calmness lurks an irrepressible need—a need to incite what he calls "educated paranoia" among computer users.

They're slowly beginning to recognize," he says, "that they should be paranoid—that they should be scared." And what they should be scared about, according to the Computation Planning Inc. president, is the vulnerability of their dp systems which, in many cases, are easy rip-off targets.

"I don't think there's going to be anything," he avows, "that's perfect from a security standpoint. You can

## people

always find some gimmick to get around a system solution—whether it's bribing the customer engineer or chairman of the board." But what you can do, he claims, is "make it economically infeasible" for any would-be system scuttler to launch a direct attack.

One way to do this is through computational cryptographic techniques. A crypto convert, Bright believes these techniques can help in one of the

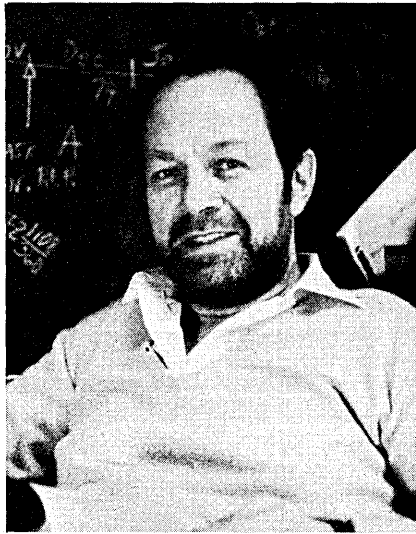

HERB BRIGHT

"You can always find some gimmick."

toughest security areas, program protection. It's in this program security area that the 57 year old Complan chief sees one of the most "serious hazards" to system security. But he doesn't overlook data security either. Ever since the Bethesda, Md., firm was established in 1966, founder Bright has plotted its course, originally in the direction of offering multidimensional computer consulting services. More recently, three years ago to be exact, the company decided to change course by plunging into the near-desolate computer security marketplace. Today, its crypto software/hardware products make up the bulk of its business. Comments Bright: "We've made a very heavy commitment (in the crypto area) and we're hoping that this part of our business will grow."

One thing that may brighten Bright's business prospects is the data encryption algorithm which earlier this year became a federal standard with the National Bureau of Standards' blessing. "The DES (Data Encryption Standard)," affirms Bright, "has been a big help because it's made people take the whole concept seriously." The IBM-developed formula also has been a boon, he admits, since the company

has found it can sell its own algorithm products against DES. Complan peddles a DES emulator and other proprietary algorithms with 128-bit key lengths. (DES uses a 64-bit key, but its effective length is 55 bits.)

While there's been some criticism that this key length is too short, Bright feels it's "quite adequate since it would be economically unrealistic to consider a brute-force attack" (trying every possible key) on a system using DES. All things considered, he believes both IBM and NBS should be commended for their work on the encryption standard.

But he still thinks much more progress in computer age cryptography can be made. And it would have been made years ago, he argues, if the military community hadn't used "cloak and dagger" methods to keep these techniques so secret. Instead, Bright urges the

crypto military mavins to open up more and adopt NBS' sensible approach, which is that "competent cryptographic applications should be capable of being completely in the open, aside from one thing, the cryptographic key."

Bright knocks the "traditional 1940-style" systems security methods used today as "a bunch of one-bit controls." But he's heartened by the fact that some more savvy system users are becoming more aware of their security loopholes. And those people who are turning out to be more security-conscious, he claims, are not the computer specialists, but the system users—"the people who are going to be most embarrassed if they get in trouble." However, even with the most advanced system safeguarding schemes, he cautions with characteristic coolness, "our best is still none too good."

## "Enthusiasm is Contagious"

Grace Householder is living proof of the power of enthusiasm.

The diminutive director of data processing for Weirton General Hospital, Weirton, W. Va., is enthusiastic in just about everything she undertakes.

"Gracie's enthusiasm is contagious," said a fellow member of CHUG, the Co-operative Health Care Users' Group of the National Federation of NCR Users. Householder is past president of CHUG, and is credited with having boosted the organization's membership and scope of activities. She currently is vice chairman of the federation in which she has been active since its inception in 1970.

She is firm in the belief that the future of health care is closely intertwined with the development of computer applications for the medical community, and her enthusiastic espousing of this belief has converted many a resistant medical professional. Twenty-two years ago, when she joined Weirton General Hospital, Grace didn't know much about health care or data processing. Today she can discuss both fields knowledgeably and with ease. Armed with a degree in accounting from West Virginia Northern Community College, she joined the hospital as a night switchboard operator and admitting clerk. One year later, she moved into the business office as a compensation clerk; was cashier a year after that; and within four years was office supervisor.

"The data processing department," she recalls, "was started by me as a one man show in 1966." The hospital purchased an NCR 500 first, and shortly thereafter some Addressograph-Multi-graph bar coding equipment. "I did all the programs for the 500," said Householder. Her only training was one week spent at NCR headquarters in Dayton, of which four days were devoted to

class work and the fifth to a tour of the facilities.

She was the data processing department for the first year, at the end of which she got some help—one person, part-time. "I taught the clerks in the payroll office to do their own input which was kind of distributed processing for those days."

Designing programs for new applications is Grace's special delight though she admits her ideas are not always enthusiastically received initially. "But they (the medical staff) usually come around," she said smilingly.

During a tour of St. Louis' Deaconess Hospital conducted during an NCR users' meeting last spring, Grace viewed demonstrations of a pilot installation of the NCR Medics on-line interactive system like a child looking into the window of a candy shop. She wasn't only impressed with the technology. "They must have had fantastic support from management."

She is quick to say that she gets support in some instances too. In talking of a computerized system for maintaining inventory control in the hospital's dietary department, implemented recently, she said implementation was expedited by "total cooperation and excellent communication between the two departments (dietary and data processing)."

Householder's staff now numbers 15. Equipment includes an NCR Century 101 and an IBM System/32 in the pharmacy. "I surprised a lot of people when I got the 32. They thought I wouldn't look at anything that wasn't NCR." As an avid user groupie, she's considering joining an IBM user group. And, as a believer in on-line systems

(Continued on page 34)

# “There’s no plotter like it. My terminal easily commands any graphics.”

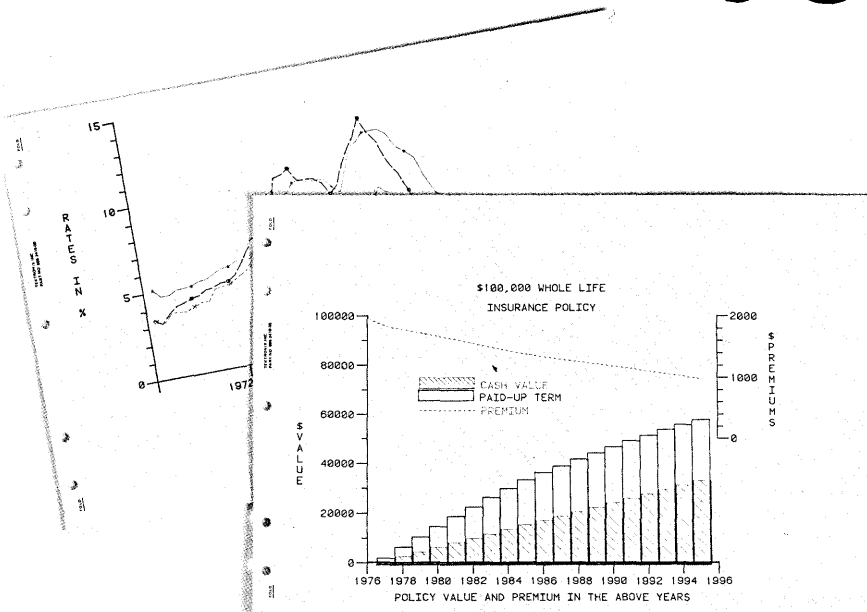

**Problem: You’d like computer graphics, but not at the price of adding more terminals.**

So you continue to use paid personnel to hand-plot charts, graphs and diagrams.

**Solution: Tektronix 4662 Interactive Digital Plotter. Plugs into most terminals for precise, multi-colored graphics.**

The 4662 plugs into almost all RS232-C or GPIB-compatible terminals. Use the 4662 to prepare graphics on paper or Mylar® polyester film for sales meetings, program presentations.

With computer accuracy and unexpected economy. Plus multiple colors from felt tip or wet ink pens.

**Easy interface to timeshare environments.**

Thanks to its built-in micro-processor, Tektronix modems, and Plot 10 software, operation is simple, accurate, and faster than any other plotter at the 4662’s low price.

**Don’t ask your people to do a plotter’s job.** Get a graphics specialist that pays for itself. Because the 4662 is from Tektronix, the worldwide graphics leader, you’re assured of exceptional reliability and fast service wherever you are. Talk to your local Tektronix Sales Engineer now, or call toll free, (800) 547-1880.

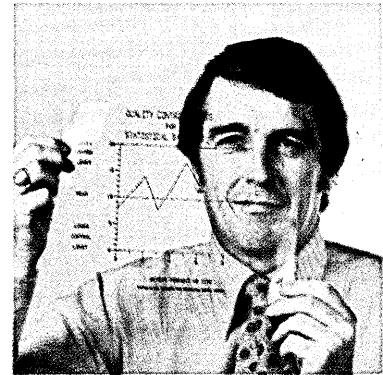

The 4662 can draw precise plots on Mylar® polyester film or acetate, offering an especially valuable graphic assist to overhead projectors.

**Tektronix, Inc.**  
Information Display Group  
P.O. Box 500  
Beaverton, Oregon 97077  
Tektronix Datatek NV  
P.O. Box 159  
Badhoevedorp, The Netherlands

## Get the 4662. Teach your old terminal new graphics.

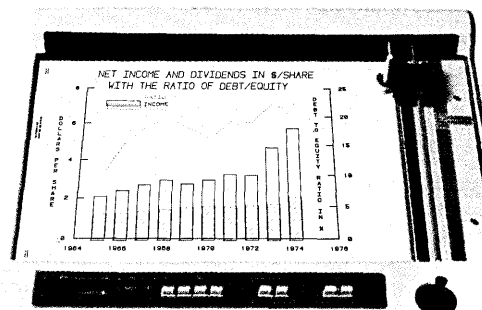

Copyright © 1977, Tektronix, Inc.  
All rights reserved. OEM prices available.



# HOW THE FENWAL FIRE SUPPRESSION SYSTEM IN THIS AUTOMOTIVE COMPANY PAID FOR ITSELF IN ONLY 2 WEEKS.

At 9:03 on a Wednesday night, an electrical malfunction caused overheating, and smoke began rising in the west end of this company's computer room.

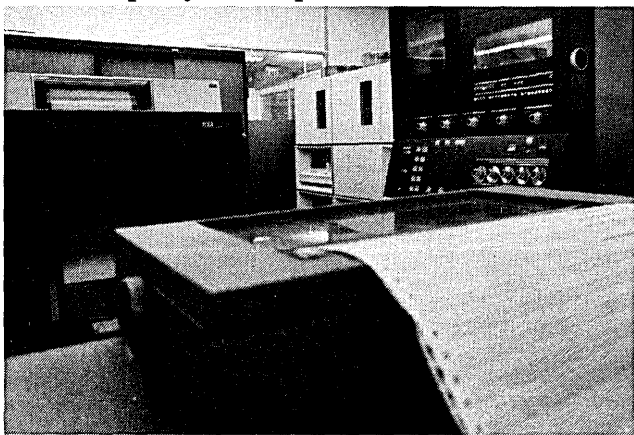

At 9:06, while the fire was still in the smoldering stage, the Fenwal Fire Suppression System automatically sensed this smoke and discharged its extinguishing agent (Halon 1301).

By 9:30 that same night, the smoke had cleared, employees had arrived and with the appropriate Fire Department clearance entered the computer room. Traces of Halon were present but there was no discomfort.

Close examination of the problem area revealed scorched and discolored internal wiring. Some relays would have to be replaced. But no other damage had occurred.

Even though the fire was inside the consoles, at the farthest point from the Fenwal discharge nozzles, the flames were snuffed out *dry*

and major damage or personnel injury was completely averted.

At 10:45 P.M. the Fenwal distributor who had installed the modular suppression system was called. By 5:30 A.M. it was re-charged and back in service.

This protection system had been installed just two weeks prior to the true incident described above.

It actually made the difference between a few hours of downtime and several weeks of expensive business interruption. The kind of interruption from which some businesses never really recover.

Fenwal has designed and installed more of these Fire Suppression Systems than any other manufacturer. And we make a full line of thermal, smoke and ultraviolet Detection Devices and Control Panels.

We have visual proof our Systems work in a variety of environments. Send for our film, "The Fireaters."

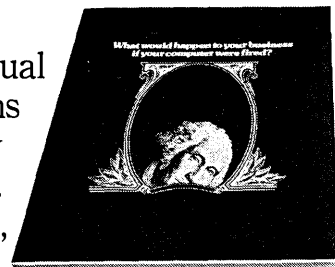

Or for a copy of our booklet on fire suppression. Write Fenwal Incorporated, Ashland, Mass. 01721. A division of Walter Kidde & Co., Inc., or call (617) 881-2000.

For installation and around-the-clock service, see our local distributors listed in the Yellow Pages under "Fire Protection."

# FENWAL®

Nobody in the world has more experience in fire and explosion protection systems.

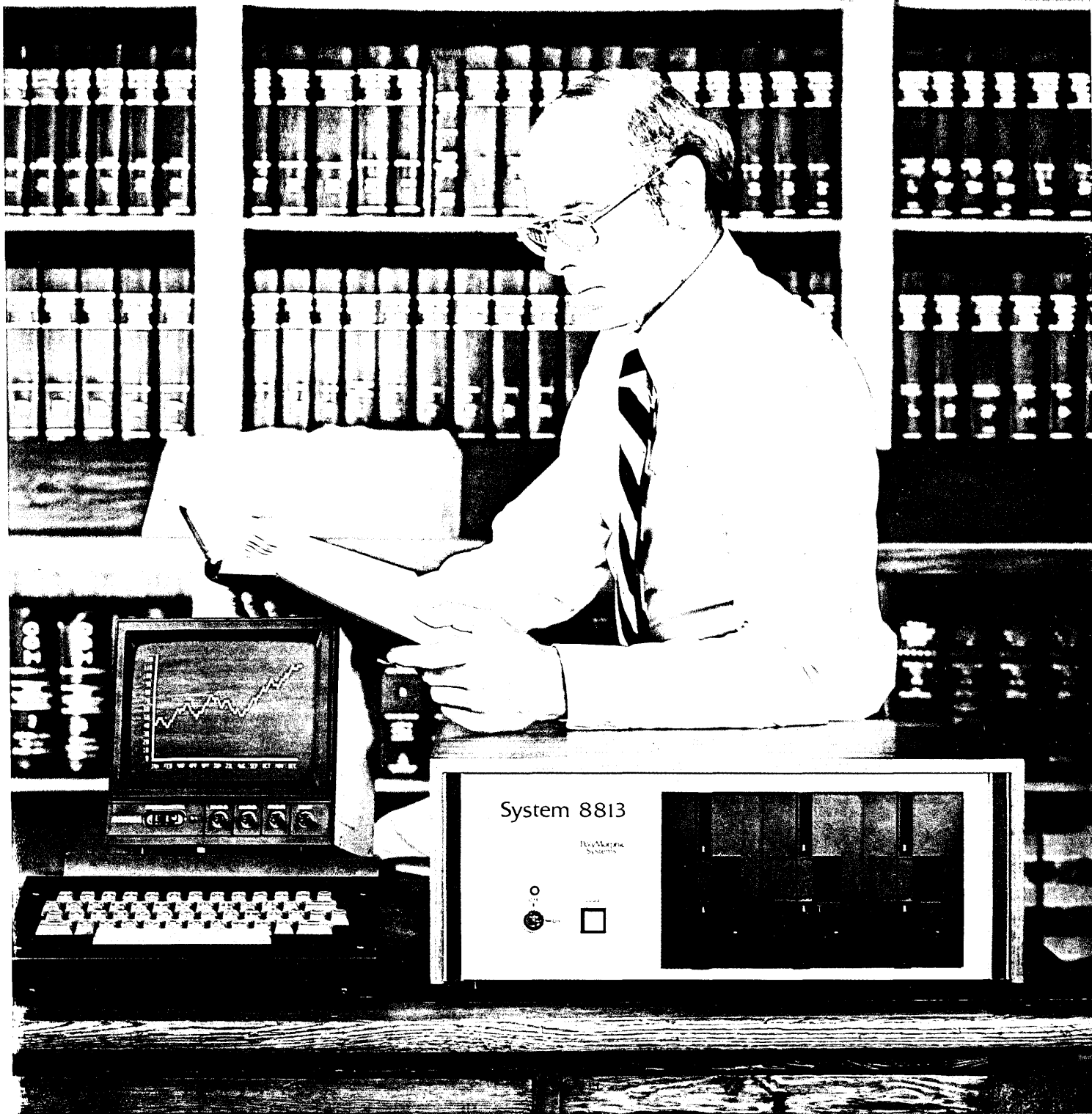

## The Computer for the Professional

Whether you are a manager, scientist, educator, lawyer, accountant or medical professional, the System 8813 will make you more productive in your profession. It can keep track of your receivables, project future sales, evaluate investment opportunities, or collect data in the laboratory.

Use the System 8813 to develop reports, analyze and store lists and schedules, or to teach others about computers.

It is easily used by novices and experts alike.

Reliable hardware and sophisticated software make this system a useful tool. Several software packages are included with the machine: an advanced disk operating system supporting a powerful BASIC language interpreter, easy to use text editor, assembler and other system utilities. Prices for complete systems start at \$3250.

See it at your local computer store or contact us at 460 Ward Dr., Santa Barbara, CA 93111, (805) 967-0468.

Polychrome  
Systems

# Summagraphics Digitizer.

## It does more than capture X's and Y's.

Summagraphics has built microprocessor controls into its data tablets and digitizers, giving them a higher level of accuracy and an unequaled range of performance. Now the Summagraphics ID (Intelligent Digitizer) can do its own scaling, skew correction, area calculation, distance measurement and other user defined functions. You don't have to program your computer to do board level operations, or tie up system memory.

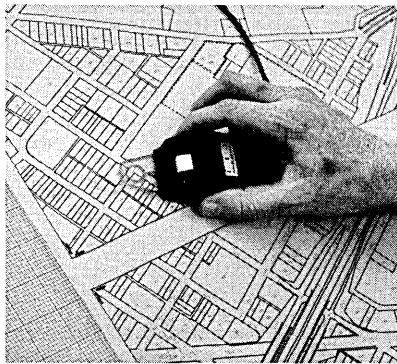

The built-in microprocessor has other advantages. It makes relocatable origin, binary/BCD conversion, metric output and incremental operation all standard, switch-selectable functions. And it makes the Summagraphics ID easier to interface, easier to operate and more efficient to use.

Any digitizer can give you the X's and the Y's. The Summagraphics ID gives you the answers.

**Application Notes:** Call or write Summagraphics for application notes describing use of digitizers in circuit design, drafting, geophysics, land management, even orthodontic research.

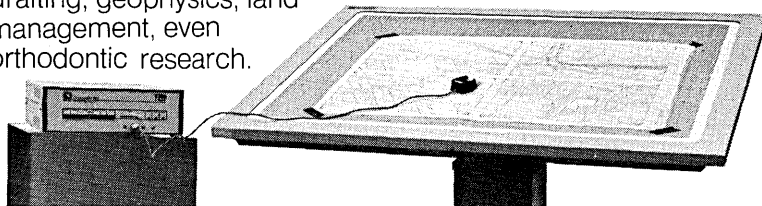

**Summagraphics**  
corporation

35 Brentwood Ave., Box 781, Fairfield, CT 06430  
Phone 203/384-1344. TELEX 96-4348

CIRCLE 184 ON READER CARD

## people

(Continued from page 30)

for hospitals, she's eagerly awaiting delivery of an NCR 8250 which will do on-line patient registration at Weirton General.

A source of pride to Grace is a Microbial Sensitivity Reporting System she began developing three and one-half years ago. It compares patient sensitivity to a wide variety of antibiotics when used in treatment of diseases caused by a variety of organisms. "The Center for Disease Control in Atlanta was interested in it and excited about it. A representative come to see it and



GRACE N. HOUSEHOLDER  
Health care and computers

helped me refine it."

The system also has been picked up by other hospitals which are members of CHUG who can get it free under a CHUG sharing policy.

A native of Mingo Junction, Ohio, Grace attended secondary schools there. She is married and the mother of two grown daughters and has been living in Weirton since 1948. She describes Weirton as "located in the panhandle of West Virginia." The hospital serves patients from three states: West Virginia, Ohio, and Pennsylvania.

## In New Posts

JAMES B. ALDRICH was named vice president—Airlines Operations for Sperry Univac Americas National Operations Div. . . . DONALD P. MOFFET joined Sycor, Inc. as chief operating officer and executive vice president . . . Harris Corp. appointed JACK C. DAVIS a corporate vice president—group executive . . . ARNOLD L. FELBERBAUM was named assistant vice president—operations for Mutual Institutions National Transfer System (MINTS) . . . HERBERT W. WHITE-MAN, JR., joined the Federal Reserve Bank of New York as vice president in data processing . . . JOHN F. WATTERS was appointed president of Pharm-Assist, a wholly owned subsidiary of Synergen Corp. \*

IDMS

Cullinane Corporation

# "IDMS has the best documentation."\*

\*say users in Datapro study

In the fourth annual Datapro Research survey of software users, Cullinane's IDMS was rated #1 among all Database Management Systems. #1 in Overall Satisfaction. #1 in Ease of Use. #1 in Ease of Installation. #1 in Training. #1 in Vendor Support. And #1 in Documentation.

Being tops in documentation isn't easy. It takes serious commitment. It also took a big investment, and outstanding technical writers, editors and production specialists to create the best DBMS documentation in the industry. Through the dedication, enthusiasm and leadership of William Casey, a vice president of

Cullinane Corporation, our documentation team has a long list of important developments to its credit.

This past year alone they've introduced: 1. Quick-Reference Cards for programmers and DBA's. 2. IDMS Database Design & Definition Guide. 3. IDMS Installation & Operations Guide. 4. IDMS Concepts & Facilities Guide. 5. Regular Technical Bulletins, including hints on system use, etc. 6. IDMS Programmers Reference Guide. And that's just part of it.

For the complete story — including technical literature on IDMS and a schedule of seminars for your area — complete this coupon or phone us at (617) 237-6600.

**Think twice. You'll pick the database system users rate #1.**

1976  
datapro  
HONOR  
ROLL

Name/Title \_\_\_\_\_

Organization/Department \_\_\_\_\_

City \_\_\_\_\_ State \_\_\_\_\_ Zip \_\_\_\_\_

Title \_\_\_\_\_

My computer is \_\_\_\_\_

Cullinane Corporation

# Cullinane Corporation

Wellesley Office Park 20 William St. Wellesley, Mass. 02181 (617) 237-6600





# Exceptional versatility makes the TermiNet® 30 printer King of the Mountain

General Electric's TermiNet® 30 printer has all the cost-saving flexibility you need in a true communications teleprinter.

Over 85 strappable functions, a wide range of options and your choice of interfaces make this 30 CPS teleprinter adaptable to almost any application.

In fact, there are dozens of things you'll like about TermiNet 30 printers. Like clear character legibility, internal and external modems, parity error detection, unattended operation, international configurations, numeric cluster and vertical formatting. And the list goes on.

What's more, it's loaded with human engineered features like the convenient and exceptionally long-lasting ribbon cartridge and the compact 132 column printout.

Options? Consider four of our newest, shown at the right: 1. A Multi-Form Selector produces crisp, clean, readable copies even with thick 10-part forms (up to .028 inches), 2. This single or dual cassette accessory adds more versatility, high speed data transfer and off-line processing, 3. A Paper Tape Accessory for those applications where paper tape inputs and outputs are required, 4. TWX/DDD Selectable—one machine for TWX plus dial-up, private line, timesharing and general purpose use.

For more information about the incredibly versatile TermiNet 30 printer, write General Electric Company, Section 794-16B Data Communication Products Department, Waynesboro, VA 22980.

For your special kind of needs—  
a special kind of printer

**GENERAL  ELECTRIC**

CIRCLE 37 ON READER CARD

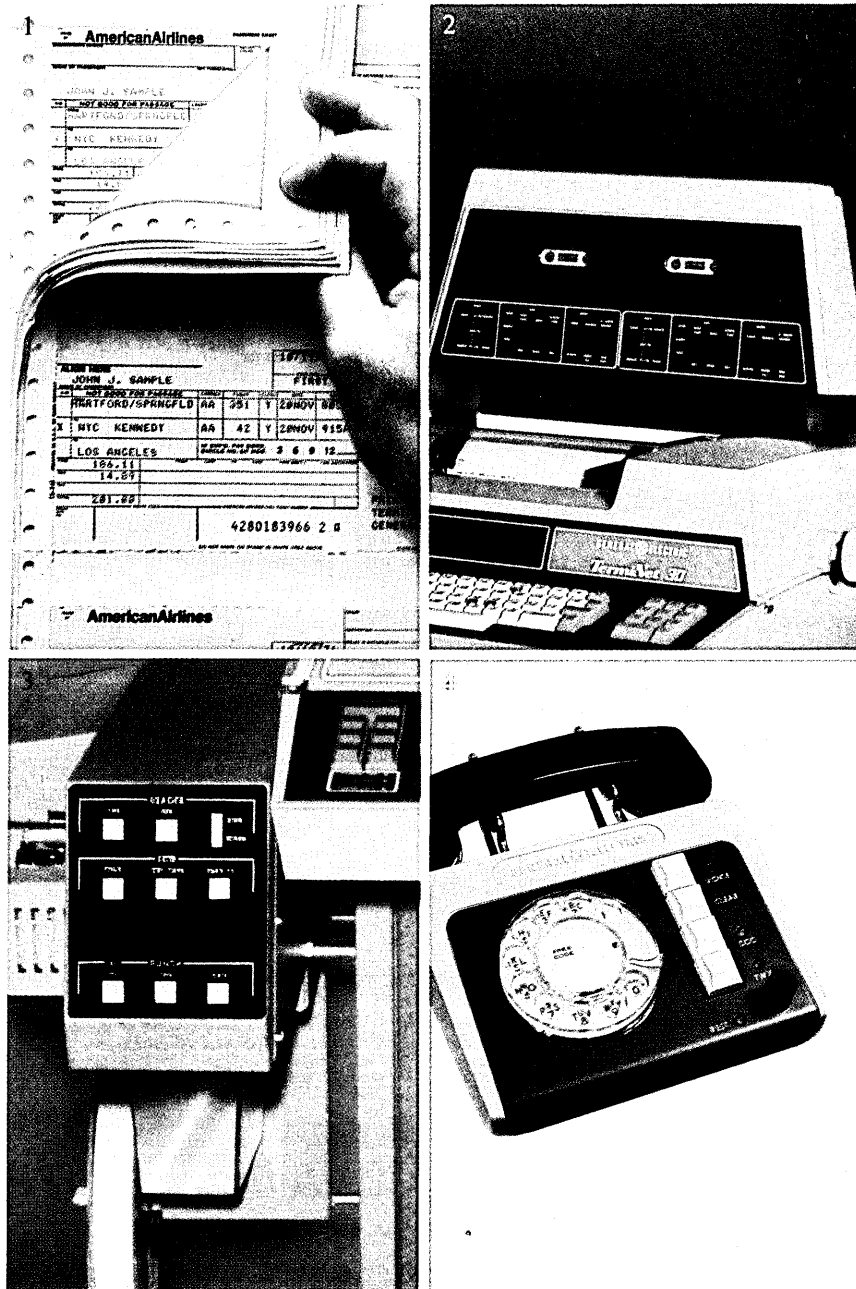

# Got a tough graphics problem?



## "Let me draw you a picture..."

I'm Dave Evans, President of Evans & Sutherland. Our ingenuity has helped progressive organizations world-wide solve their most difficult graphics problems. Bring us your problem, we would like to help! Here are a few of the things we've done."

- Boeing Commercial Airplane Company—Our PICTURE SYSTEM 2's are involved in solving complex engineering problems at Boeing's Aerodynamics Labs.
- Lufthansa—In conjunction with Redifon, we recently delivered the first Day/Night Computer Generated Image (CGI) System to be used by a commercial airline for pilot training.
- NOVOVIEW—In conjunction with Redifon, we have provided night/dusk CGI visual systems to more than 25 airlines throughout the world. This represents more than half of all such systems in existence.
- NASA-Ames Research Center—A number of Evans & Sutherland graphics systems play a role in the challenging research projects undertaken at NASA-Ames.
- National Institutes of Health—their installation and many others around the world are committed to molecular research through modeling and simulation using PICTURE SYSTEM 2.
- Central Institute for Industrial Research—this Oslo, Norway based firm is using our PICTURE SYSTEM 2 for ship design.

Whether engineering a machine tool or making a tooled part, designing a building or building a design, studying the universe or looking into a molecule, nearly every task imaginable can be done more effectively with help from Evans & Sutherland.

PICTURE SYSTEM 2 is our newest advancement in 3-D line drawing systems technology. It provides real-time interactive graphics capabilities with high precision digital hardware, powerful software and thorough maintenance and documentation.

For additional information call Dave Evans or Vel Casler at (801) 582-5847  
Evans & Sutherland Computer Corporation  
580 Arapeen Drive—Salt Lake City, Utah 84108  
Telex: 389492

## EVANS & SUTHERLAND

# Datagraphix® AutoCOM goes on-line.

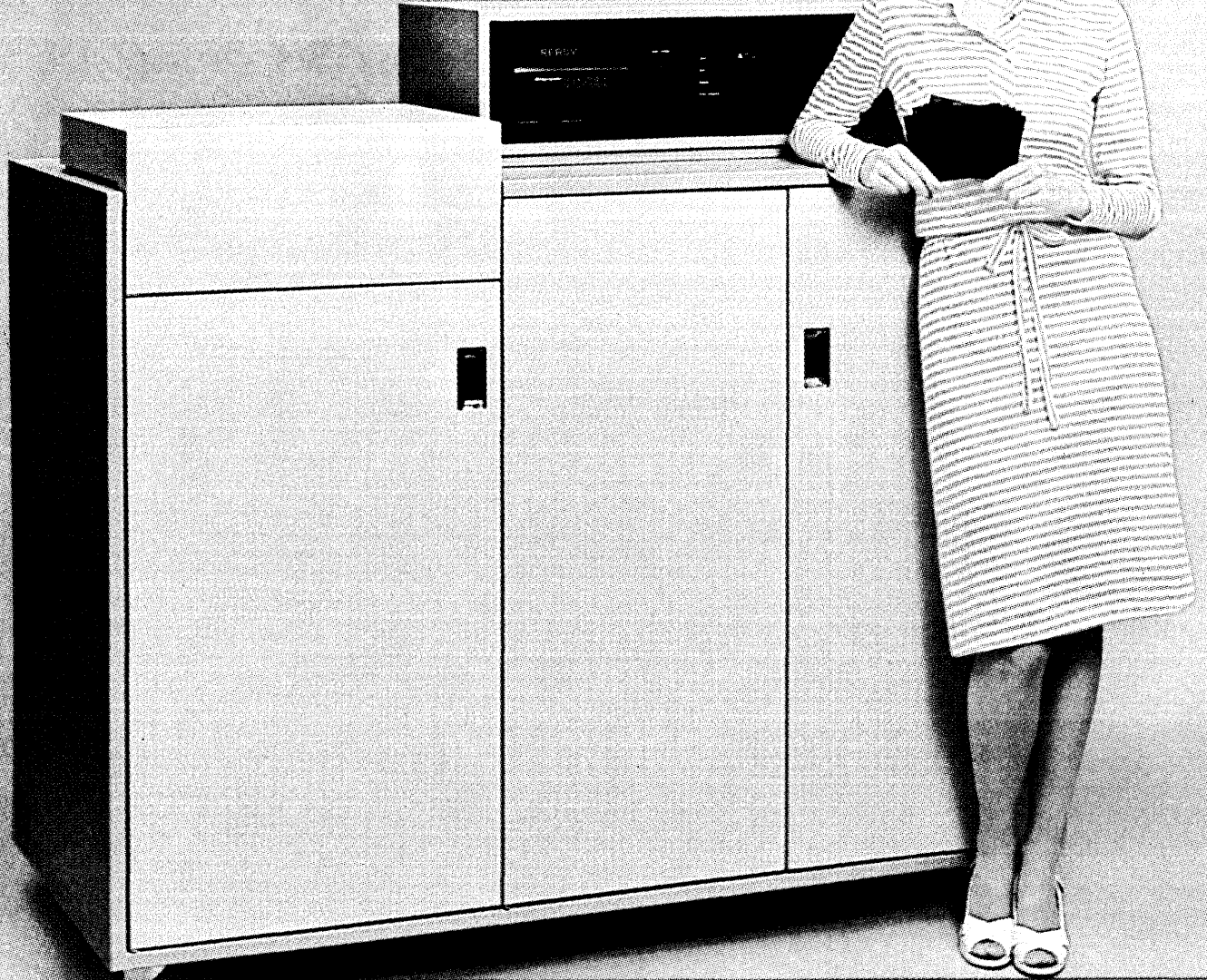

## Now you can wind up with microfiche and never unwind a reel of tape.

The simplicity and convenience of AutoCOM™ made on-line recording a natural. So we developed an on-line version to interface directly to the central processing unit of virtually any IBM 360/370 computer. That means you never have to bother with tape loading or rewind time.

Right on queue, on-line AutoCOM delivers cut, dry microfiche ready for immediate viewing. That means computer output

can be checked without waiting.

You get better efficiency because there is a full-page 16,000 - byte buffer system. This decreases channel connect and contention time.

A built-in test simulator contains its own diagnostics so there's no need to interrupt the CPU for maintenance. And on-line

AutoCOM is simple enough to be delivered, installed and operational in one day.

The AutoCOM product line includes models for every COM application.

Standard off-line AutoCOM. MiniAutoCOM™. And now on-line

AutoCOM, the system that lets you wind up with microfiche without ever unwinding a reel of tape.

The new on-line AutoCOM

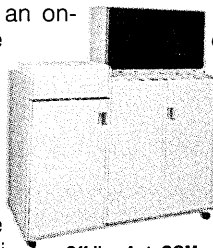

Off-line AutoCOM

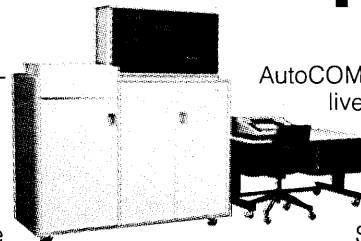

MiniAutoCOM

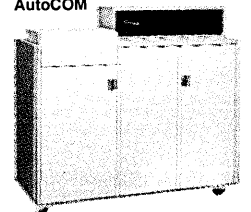

*Datagraphix*

a General Dynamics subsidiary

# Zilog introduces the first Z80 disk based microcomputer system.

The Z-80 MCS Microcomputer—designed to be the most advanced general purpose microcomputer available today. You get massive computing power at a price so low you'll find it most difficult to believe.

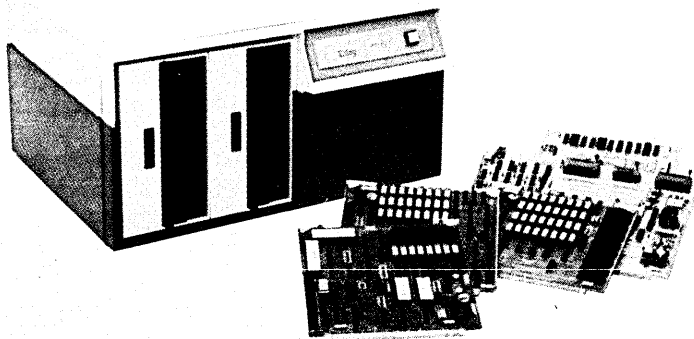

# A bold new weapon is Zilog's breakthrough Microcomputer System.

It's a general purpose unit that gives users high performance at remarkably low cost—and it features all the reliability and low maintenance you have come to expect—and get—from Zilog.

## Just for starters consider these Z-80 MCS system features.

- Full use of the powerful Z-80 CPU with its 158 instruction set, considered to be the most advanced in the industry.
- Main memory storage capacity of up to 64K bytes of RAM, PROM or EPROM. The standard basic system comes with 3K bytes PROM and 16K bytes of dynamic memory.
- Dual floppy disks with 600,000 bytes of storage.
- RS-232 or current loop serial interface for communication with a CRT or TTY. And room is available to add more.
- Two parallel I/O ports for simple interface to other peripherals, and more ports are available.

And a nine slot card cage, housed along with everything else in a heavy duty metal chassis, allows the Z-80 MCS the expansion capability and flexibility you need for design options. And you get a full complement of expansion cards. Read on.

## Standard software ready for development.

With the MCS you get a PROM Based Monitor. A Macro Assembler, File Maintenance, Editor, Debug and Utility Routines are also part of the standard package.

Available options: BASIC, MCS/RIO with relocating assembler and linking loader. And coming soon a powerful repertoire of programs including MCS-COBOL and PLZ.

Needless to say complete documentation and system support comes along as part of the package.

## Get unprecedented power thanks to the Z-80 MCS internal architecture.

Not only does it include all of the instructions of the preceding processors, but goes far beyond.

**Memory Block moves.** Up to 65K bytes can be moved at the rate of 8.4 microseconds per byte.

**Memory Block searches.** The entire memory of the system can be searched with a single instruction.

**Block I/O operations.** I/O transfers at rates of up to 125 kilobytes/second can be accomplished under software control.

**Bit Handling.** Any bit in any register or memory location can be set, tested or cleared with a single instruction.

**Relative Jumps.** Short, two-byte relative control transfers reduce program sizes. Three-byte absolute jumps provide access to any memory location.

**Eight and sixteen bit arithmetic operations** provide fast data and address calculations. BCD arithmetic and shifting is also supported.

## Plug in these cards to further expand the Z-80 MCS's capabilities.

- RMB: contains 16K bytes of RAM consisting of 4K dynamic RAM devices.
- IOB: allows you to expand the system by four I/O ports per board.
- SIB: allows you to add 4 Serial RS-232 ports per card.
- PMB: contains 16 sockets for additional PROM Memory per board.

## Configure the MCS the way you want it.

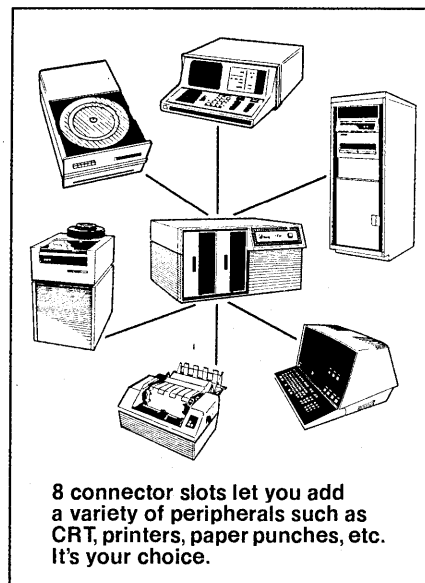

## This is all a part of our pledge.

That pledge, to stay a generation ahead is further demonstrated by the new Zilog MCS. We urge you to learn more and a suitable brochure has been prepared. It can be yours, just write or call.



10460 Bubb Road, Cupertino, California 95014  
(408) 446-4666/TWX 910-338-7621  
EASTERN REGION: (617) 890-0640  
MIDWESTERN REGION: (312) 885-8080  
WESTERN REGION: (213) 540-7749  
EUROPE (ENGLAND): (0628) 36131/2/3

AN AFFILIATE OF EXXON ENTERPRISES, INC.

CIRCLE 118 ON READER CARD

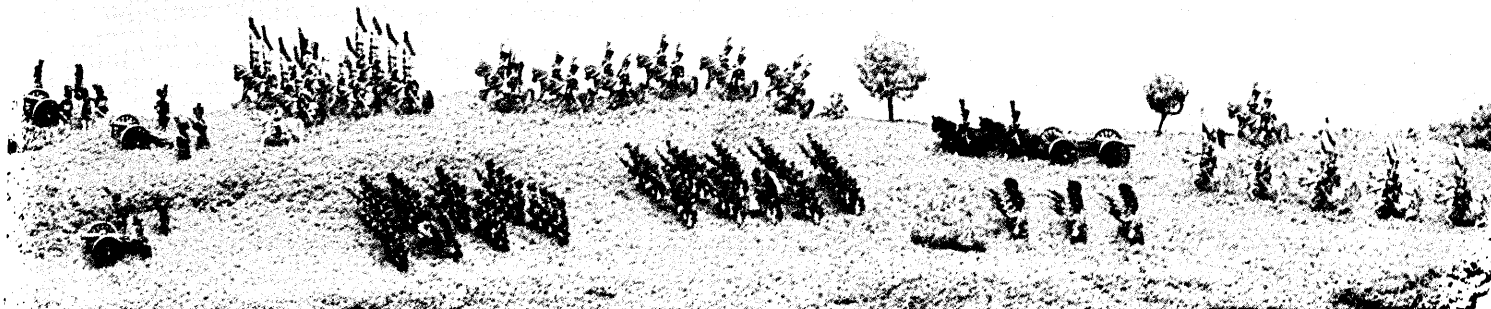



---

---

# calendar

---

---

## OCTOBER

**Northwest Systems Conference, Sept. 15-16**, Edmonton, Alberta, Canada. "Making Systems Effective" is the theme of this two-day conference sponsored by the Assn. for Systems Management. Sessions will feature lectures on such topics as applications techniques, staff development and retention, microfilm, computer auditing, mini-computers, and data base management. Fee: \$70, ASM member; \$80, non-member. Contact: Assn. for Systems Management, c/o K.I. Stuparek, 10040 104 St., Edmonton, Alberta, Canada T5J 2V6.

**9th Annual SMIS Conference, Sept. 26-28**, Los Angeles. MIS productivity as related to the issues of efficiency and effectiveness is the theme of this three-day conference. The conference will focus on the contributions of planning, measuring, technological innovations, new management approaches, and decision support systems to MIS productivity. Two days of workshops on how to apply the newest techniques in MIS will follow the conference. Contact: SMIS, 10 W. 31 St., Chicago, Ill. 60616.

**22nd Conference of the Assn. of Records Managers and Administrators, Oct. 2-5**, Houston, Texas. The emphasis of "A Forward Look in Record Management" will be on education for the records manager. All-day introductory sessions on the basics of records management will be presented on Monday and repeated on Tuesday. For the beginner, two of these sessions will provide a thorough grounding in the requirements necessary to begin a complete program of records management. Special interest groups will meet to discuss needs peculiar to groups such as the financial industry, manufacturing or processing industry, insurance, public utilities, law enforcement, and transportation. Half-day sessions aimed at the more advanced manager will be presented on Monday and repeated on Tuesday. Fee: \$150, complete member registration; \$180, complete non-member registration. The difference in the fee for the non-member may be applied towards the first year's membership dues in the ARMA. Contact: ARMA National Office, P.O. Box 281, Bradford, R. I. 02808.

**Euromicro Symposium, Oct. 3-6**, Amsterdam, The Netherlands. Euromicro provides a European forum on micro-processor systems and microprogramming. The technical program will cover subjects such as microprocessors, bit slices, microcomputers and their software, microprogramming, multi-microprocessor systems, design aids, debugging tools, and applications for microprocessors. An industrial exhibition and seminar will accompany the symposium. Contact: Ted Holtwijk, Philips Elcoma, Bldg BAE2, NL Eindhoven, The Netherlands.

**Conference on Very Large Data Bases, Oct. 6-8**, Tokyo. Tutorials intended to promote an understanding of very large data bases in terms of complexity of structure and physical size will highlight this conference. Topics covered will include: data base design, machine architecture, system analysis and evaluation, machines, systems, and performance evaluation, as well as applications, integrity and recovery, user interface, and data base languages. Contact:

James Gabbert, Room E53-330, MIT Sloan School, 50 Memorial Dr., Cambridge, Mass. 02139.

**INFO/EXPO'77, Oct. 9-12**, Washington, D.C. Nearly 60 seminars and panel presentations plus an exhibit of the latest in computer equipment, supplies, and services have been arranged for this annual gathering of the DPMA. The keynote speaker will be C. W. Spangle, Honeywell Information Systems president. The educational base of the conference has been organized along four tracks: management functions, management skills, technological forces and trends, and business and industry applications. Fees: total conference \$175, member; \$225, non-member; total education: \$115, member; \$165, non-member. One day, student, and guest registrations also are available. Contact: DPMA-Info/Expo, 505 Busse Hwy., Park Ridge, Ill. 60068.

**Micro/Minicomputer Exhibition and Seminar, Oct. 10-12**, Stockholm, and **SYSTEMS '77, Oct. 17-21**, Munich. The first event is an exhibition of microcomputers and minicomputers at the U.S. Trade Center in Stockholm, to be held in tandem with the second event, the Systems '77 seminar and exhibition. Systems '77 is a biennial computer show which is expected to attract a large audience of industry, government, and military users to the U.S. pavilion at the Munich Fairgrounds. Contact: Dwight L. Umstead, DIBA/OIM Room 1015C, U.S. Dept. of Commerce, Washington, D.C. 20230.

**INFO '77, Oct. 17-20**, New York, N.Y. Discussions on topics related to a particular business or industry will be concentrated into a single day so that a short visit to this annual conference and exposition will provide an overview of information problems and solutions in specialized fields. Those fields will include: hospitals, insurance, banks, manufacturing, office automation, financial management, marketing, and retailing. The sessions are geared to corporate managers who need information for planning and decision-making, and to dp managers who operate information systems, and towards showing those two groups how to work together to meet management needs. Contact: Clapp and Poliak, Inc., 245 Park Ave., New York, N.Y. 10017.

## ON THE AGENDA

**IFAC Symposium on Discontinuous Computer Control Systems, Sept. 19-23**, Prague, Czechoslovakia. Organizing Committee, Suchbatarova 4, 160 00 Prague 6, Dejvice.

**International Electrical Electronics Conference, Sept. 26-28**, Toronto, Canada. IEEE, 1450 Don Mills Rd., Don Mills, Ontario M3B 2X7.

**Data Communications Symposium, Sept. 27-29**, Snowbird, Utah. IEEE Computer Society (301) 439-7007.

**International Conference on Computers in Cardiology, Sept. 29-Oct. 1**, Rotterdam, The Netherlands. Dr. Jerome Cox, Dept. of Computer Science, Box 1045, Washington Univ., St. Louis, Mo. 63130.

**Western Systems Conference of the Assn. for Systems Management, Oct. 4**, Los Angeles, Calif. Larry Muich, Price, Waterhouse, and Co. (213) 623-2131.

**Annual Conference of the Canadian Micrographic Society, Oct. 5-7**, Ottawa, Canada. R. Desrosiers (613) 741-2007.

**10th Annual Workshop in Microprogramming, Oct. 5-7**, Niagara Falls, N.Y. Peter H. Lutz, Dept. of Computer Science, SUNY—Buffalo, 4226 Ridge Lea Rd., Amherst, N.Y. 14226.

**Symposium on Information Theory, Oct. 10-14**, Ithaca, N.Y. Dr. Richard Blahut, IBM Corp., Owego, N.Y. 13827.

**13th Meeting of CPEUG, Oct. 11-14**, New Orleans. Dennis M. Conti, A265/Technology Bldg, National Bureau of Standards, Washington, D.C. 20234. \*

# Wheel.

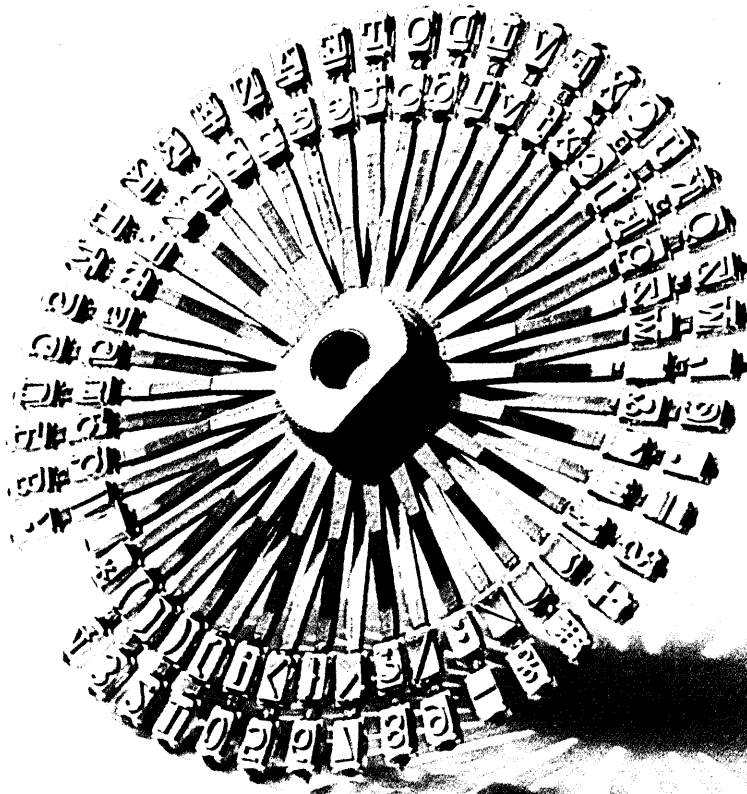

The petals are interlocking, of optimum hard plastic, with two characters to the type bar. This makes for a smaller wheel with less inertia and vibration...better printing quality. This is the action part of Ricoh Printer RP-40 and no one else makes anything like it.

RP-40 prints 33 perfectly aligned characters a second, bi-directional for tabulation,

136 characters to the line, space feed 1/120 inch. Wheels are available in 94 (or 125 characters). Special fonts made to order.

RP-40 is controlled by a micro CPU, with Ricoh-made servo-motors for character selection and printing positioning, pulse-motor operated platen and ribbon feed: a minimum mechanical parts.

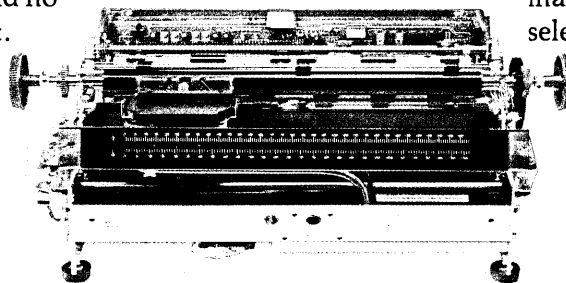

RICOH PRINTER RP-40

## OEM

**RICOH OF AMERICA, INC.**

389 Passaic Ave., Fairfield, New Jersey 07006  
Phone: (201) 575-9550 Telex: 235715

RICOH COMPANY, LTD. D.P.S. Division 15-5, Minami-Aoyama 1-chome, Minato-ku, Tokyo, Japan Phone: 03 (479) 3111 Telex: 2425415  
RICOH NEDERLAND B.V. Alpen Rondweg 102, P.O. Box 114, Amstelveen, Holland Phone: (020) 458651 Telex: 11384

CIRCLE 8 ON READER CARD

# THE DATAPOINT 6600--



*Datapoint 6600 Computer  
with 20-megabyte disk drive*

## For Network Planners It's a Disturbing System



think about "small" computer systems.

True, the 6600 is small physically, like the Datapoint computers that have come before it. But it is equipped with the latest technology, including features like 120K user memory, and can support up to 24 independently-functioning video display terminals in a true timesharing mode. In fact, the Datapoint 6600 packs the processing wallop of many of today's large-scale computers, at a fraction of their cost.

When combined with Datapoint's wide range of peripheral equipment, such as the new 20-megabyte disk drive, the 6600 can be used to produce a variety of disturbingly capable

systems. It will free network designers from many of the constraints that previously bound them. With the 6600, regional centers can remove a major processing burden from the central mainframe computer while boosting the efficiency of local operations. In fact, a well-planned dispersed processing network can in many cases eliminate "mainframe inflation" altogether.

Like other Datapoint dispersed processors, the 6600 functions well in a stand-alone mode. It has the speed and power to handle 24 different user programs simultaneously, or to run batch jobs in COBOL, BASIC and RPG II. And with communications capabilities always available, a stand-alone 6600 can be converted almost instantly into a functioning node in a dispersed processing network.

In truth, the 6600 is a disturbing system because it will challenge your present assumptions about what a

small computer can do for your operation.

Accept the challenge. Study the Datapoint 6600 in detail. Compare it with the competition. Look at the carefully planned sequence of compatible Datapoint hardware and software products which have preceded it. We think you'll come to the conclusion that the 6600 has more to offer than any comparable system now on the market.

For more information on the 6600, contact the Datapoint sales office nearest you, or write Datapoint Corporation, attention: Product Marketing, 9725 Datapoint Drive, San Antonio, Texas 78284 (512) 699-7151.

**DATAPPOINT CORPORATION**



The leader in dispersed data processing™  
Sales and service offices in principal cities

# NOW, LEAR SIEGLER AND BURROUGHS ARE ON SPEAKING TERMS.

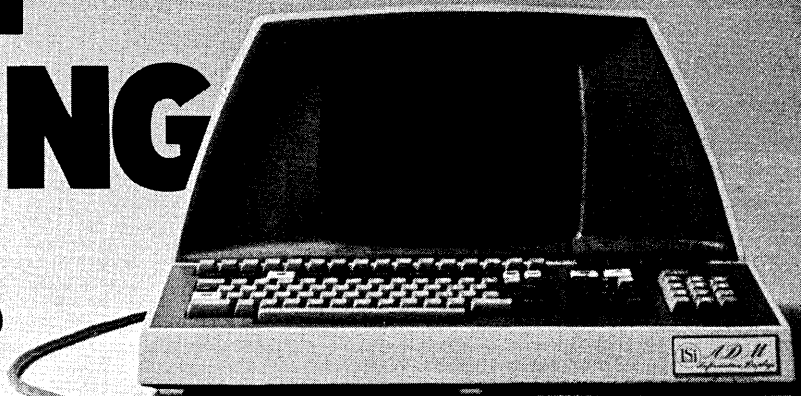

You're probably very happy with your Burroughs mainframe.

But you'd undoubtedly like to have the versatility and dependability of Lear Siegler terminals. If only they were compatible with your present system.

Now they are. Complete with standard Burroughs polling and address line disciplines.

What's more, the ADM-2B's forms mode capability is compatible with the TD-820.

The ADM-2B gives you full text editing capabilities. Including erase to end of line/field/page. Insert and delete character and line. Blinking and blanking fields. And tabbing.

Just flick a switch and you can convert the ADM-2B to a standard ADM-2 with Burroughs line discipline.

Line diagnostic mode is switch selectable — which makes it extremely valuable for troubleshooting.

Of course, there's all the support that Lear Siegler is famous for. Throughout the United States and in many foreign countries.

\$2485.

That's the full price. Including serial printer port. Numeric keypad. 24x80 character screen. 16 function keys. 110-9600 baud. RS232 interface. Burroughs two-wire direct connect is available as an option.

The fact is, Lear Siegler's new ADM-2B terminal gives you the best of both terminals. So you can use it right alongside your present Burroughs terminals and mainframe.

So rest easy, Burroughs users. Because now Lear Siegler speaks your language.

For more information contact: Lear Siegler, Inc., E.I.D./Data Products, 714 N. Brookhurst St., Anaheim, CA 92803; (800) 854-3805. In California (714) 774-1010.



**THE ADM-2B.  
SMART TERMINAL.  
SMARTER BUY.**



# MODEL 70

The new standard for the CRT terminal industry from the first independent commercial CRT manufacturer.

- Microprocessor controlled
  - 80 characters X 25 lines
  - Upper/Lower case
  - Eight function keys
  - Tilt/Swivel screen
- AND MUCH MORE

*Stability  
Age  
Beauty*

**TEC, Incorporated**

2727 N. FAIRVIEW AVENUE • TUCSON, ARIZONA USA 85705 • (602) 792-2230 • TWX 910-952-1377

AN EQUAL OPPORTUNITY EMPLOYER M/F, COMMITTED TO AFFIRMATIVE ACTION — A TEC INCORPORATED CORPORATE POLICY



# source data

SOURCE DATA provides information on books, courses, references, reports, periodicals, and vendor publications.



## Data Dictionary Systems

by Henry C. Lefkovits  
Q.E.D. Information Sciences,  
141 Linden St., Wellesley,  
Mass. 02181  
1977  
(500 pp, \$75.00, prepaid;  
\$85.00, invoiced)

The subject of data dictionaries is becoming more important to managers of data processing installations (see "The Role of the Data Dictionary," June, p. 129). A data dictionary can give the data processing department tools with which to create and enforce good data management.

For the interested person who would like to know what a dictionary is and how it can be useful, this book (actually more a soft-cover monograph report) is an overkill. However, for the serious prospective purchaser who is in the process of evaluating competitive packages to make a decision on purchase, this report is a must.

To the reviewers' knowledge, this report is the only available in-depth evaluation and comparison of the major data dictionary systems available on the market. The systems analyzed are: Arthur Anderson's Lexicon, Cincom Systems' Data Dictionary, IBM's DB/DC Data Dictionary, MSP's DATAMANAGER, Synergetics' Data Catalog, and UCC's UCC TEN. Unfortunately, two of the principal new competitors are not covered—MRI Systems' Control 2000, and Cullinane Corp.'s IDMS Data Dictionary. PRIDE Logik also is not covered.

The first two chapters in the book do a good job of defining the functions and uses of data dictionary systems in general. In chapter two, the author covers the full spectrum of the various features currently provided by data dictionary systems in general. Notable items covered are: security, the role of the data administrator, reports, and a fine explanation of the "bridges" facility which provides for the passage of data between the data

dictionary and the DBMS. Also provided are clear explanations of processing and usage entities, and a detailed look at the attributes of various data structures.

In chapters three through eight, Mr. Lefkovits has done a masterful job of providing enough "nitty-gritty" high level technical information to enable the reader to make well-documented comparisons in choosing the system best suited to the organization's needs. For nontechnical people, this material will be too in-depth to assimilate. However, study groups and committees that are evaluating packages will appreciate the level of detail provided. In chapter nine, Mr. Lefkovits compares all six data dictionary systems in several key areas: security features, supportive documentation, bridges, and other facilities. You don't have to rely on the author's evaluation, however, when he makes comparisons across the different systems. The detail supplied in chapters three through eight enables the reader to make his own analyses.

---

For the serious purchaser,  
this book is a must.

---

Chapter 10 is a look at the future, and speculates on such areas as: integrated data dictionary systems, centralized data dictionary systems in conjunction with computer networks and distributed data bases, end user facilities, and the storage of security attributes in the dictionary data base.

The report also includes a glossary, a favorite feature of the reviewers'.

The book's weak points include the fact that some of it is pompously written, and the fact that typographical errors occur at about the rate of one every other page.

Because the report's subject matter is a comparison of "current" products, its obsolescence rate will be extremely fast. For example, the information on the on-line facilities of Data Catalog is already largely obsolete. The half-life, in general, for information contained in this report is probably no greater than 12 months.

Nevertheless, it would be hard to justify the \$10,000 to \$20,000 that one would normally spend on pur-

chasing a license for a data dictionary without having first read a copy of this report.

—George Schussel and  
Richard Fitzpatrick

Mr. Schussel is vice-president of Information Systems for the American Mutual Insurance Companies in Wakefield, Mass., and also is a lecturer and author on data base-related materials.

Mr. Fitzpatrick is documentation services manager for American Mutual.



## New from Datapro

There are several new reports from Datapro Research.

The 36-page *All About Microcomputers* provides detailed specifications of 144 current models of microcomputers. The report is \$12.

The new *Directory of Suppliers* is 179 pages of profiles of 870 companies supplying products and services to computer users. Designed to help dp managers choose qualified vendors, the directory is \$15.

Twenty-three Datapro Honor Roll members address questions such as: where does the software industry stand today? where is it going in the future? and, how will the trends affect the end users of proprietary software? in the 16-page report, *Leading Software Vendors Analyze Industry Trends*. The report is available for \$12.

*Computer Performance Evaluation Tools: How to Select What's Right for You* describes the basic types of computer performance evaluation tools and identifies the major products available in categories such as job accounting systems, hardware and software monitors, simulation models, and data management utilities. Charts provide information on each type of tool, including product name, price, number of users, and names and addresses of each of the vendors. This report is \$12.

The 73-page updated report *All About Minicomputer Printers*, details 315 models of minicomputer printers from 96 vendors—all for \$12.

Users of optical readers will be interested in the 30-page report, *All About Optical Readers*. The report combines the ratings assigned by 85



# Matrix Horsepower

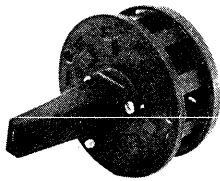

## A 100% Duty Cycle Makes Ours The Workhorse of Matrix Printers!

Inherent Diablo ruggedness and reliability and our unique ballistic head design give our Matrix printer a 100% duty cycle. Add to that, bidirectional printing, high speed tabbing, skip-over spacing and vertical forms control and the result is greater throughput. Our wide-gap ballistic head means paper clearances are never a problem and field head change requires only an allen wrench — no alignment! (All this plus incremental printing capability make our printer an ideal component for a workhorse terminal.) For a complete product demonstration, Diablo Systems, Inc., 24500 Industrial Blvd., Hayward, California 94545, Diablo Systems, S.A., Avenue de Fre 263, 1180 Brussels, Belgium, or Mitsui & Company, Ltd., 2-1 Otemachi 1-Chome, Chiyoda-ku, Tokyo.

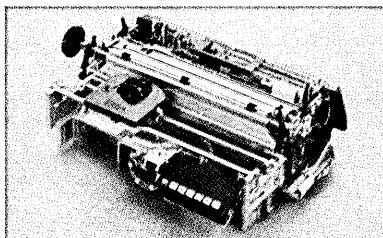

**Diablo Systems, Incorporated**  
A Xerox Company

Diablo and XEROX® are trademarks  
of XEROX CORPORATION

# source data

responding users to 112 optical character and mark code readers, and reaches the conclusion that users of the readers are reasonably well pleased with the performance of the devices. This report is \$12 per copy. DATAPRO RESEARCH CORP., 1805 Underwood Blvd., Delran, N.J. 08075.

## SWAP Proceedings

The 725-page *Proceedings of the 4th Annual Society for Wang Applications and Programs* is now available from the users' society. The publication contains over 50 papers on a large array of applications including general, business/commercial, education,

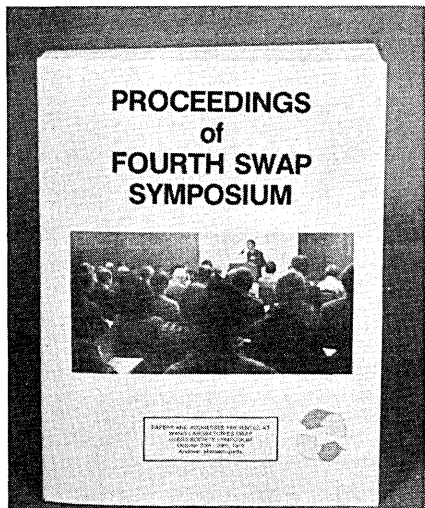

science, engineering, statistics, on-line, and medical applications. Also included are the transcribed questions and answers from the sessions. Copies are available for \$17.50 (prepaid—make check payable to Wang Laboratories) from SWAP USERS' SOCIETY, 1 Industrial Ave., Lowell, Mass. 01851.

## Financial Systems

*An Introduction to Financial Reporting and Modeling Systems* is designed to help users compare and select the most effective service for their individual needs. The 100-page report includes detailed information on vendor name, address and contacts, primary package offered, computer utilized, consulting availability, graphics capability, key selling points, guidelines for selecting a system, cpu costs for six runs, connect charges per hour, monthly storage cost per 1,000 characters, and the actual coding used by each system. The 14 financial packages evaluated include FML, CUFFS, FCS, IFPS, EPS, FAL II, SIMPLAN, FISCAL, PROPBIT II, XSIM,

OLSFMS, FPS, BBL, and FORESIGHT. The report is \$85. REAL DECISIONS CORP., 870 High Ridge Rd., Stamford, Conn. 06905.

## Book of MUMPS

A summary of current MUMPS activities is given in the 48-page *Book of MUMPS*. The center of the booklet is a cross-reference of the 197 major institutions using MUMPS worldwide, and the 230 applications they have made. Also included are articles on the MUMPS language, the users' group and its application library, computers on which MUMPS is implemented, publications, and MUMPS vendors. The summary is \$2; a pocket guide to standard MUMPS is also available for \$1. MUMPS USERS' GROUP, 700 S. Euclid Ave., St. Louis, Mo. 63110.

## Intro to Micros

Volume two of the *Introduction to Microcomputers—Some Real Products* is now being updated twice each year to keep pace with the rapidly developing LSI chip market. The new edition describes in detail all microprocessor LSI devices available today, and some devices that will enter the market in the coming months. The book includes product descriptions and part descriptions, and describes how to mix and match various manufacturers' devices for best results. The 1200-page book is \$15, and may be ordered from OSBORNE AND ASSOCIATES, 630 Bancroft Way, Berkeley, Calif. 94710.

## Evaluating Minis

The importance of application software, the requirements of day-to-day operation, how to analyze proposals and contracts, and how to figure the true cost of installing and operating a mini are discussed in the new publication, *Points to Consider Before Selecting a Computer*. The 24-page primer lists both pros and cons of acquiring and operating a mini, and points out the pitfalls that can result from uninformed decisions. It is designed to be particularly helpful to those companies without prior computer experience. The guide is available free of charge from KEYDATA CORP., 20 William St., Wellesley, Mass. 02181.

## English/French Glossary

A comprehensive glossary of computer communications and telecommunications terminology has been prepared by the Computer Communications Group of the TransCanada Telephone System. It contains universally accepted definitions for terms used in

some of the latest technologies such as packet switching and fiber optics technology. The glossary is available in English or French; the French version contains a complete English to French and French to English lexicon. For ordering information, contact Joanne P. Stanley, THE COMPUTER COMMUNICATIONS GROUP, 12-160 Elgin St., Ottawa, Ontario, Canada K17 3J4.

## CICS Guide

The new CICS *Applications Design Guide* has been designed to help the CICS programmer analyst in developing applications with less difficulty, the vendor says. There are nine basic sections to the publication: systems specification guidelines, system design concepts, CICS programming concepts, recommended naming convention, testing procedures, source module turnover procedures, documentation requirements, IBM and TelTech productivity aids, and TelTech utility transactions/programs. The appendix includes a sample CICS/vs turnover sheet and CICS turnover log. The guide is offered at \$15 per copy plus a \$2 postage and handling charge. Yearly updates will be available for \$7.50. TELECOMMUNICATIONS TECHNOLOGY CORP., 200 Park Ave., New York, N.Y. 10017.

## Micrographics Index

The 408-page key to the National Micrographics Assn.'s collection of books, journal articles, manuscripts, and other material concerning micrographics is now available from the association. The *1977 Micrographics Index* is divided into five major sections: main entry, journal, author, key word-in-context, and subject indexes. There is coverage of publications of historical interest dating from 1952, some classic works, and current material through March 1977, with 2,227 entries in all. Included are case histories of applications, user evaluations, research and project reports, descriptions and "how to" of technical processes, directories, state of the art reports, and standards. Price: \$12, members; \$18, nonmembers. All orders must be prepaid. NATIONAL MICROGRAPHICS ASSN., 8728 Colesville Rd., Silver Spring, Md. 20910.

## Computer Services Survey

*The Eleventh Annual Computer Services Industry Survey*, commissioned annually by ADAPSO, is designed to provide management with information concerning financial performance, markets served, and many other aspects of the computer services industry. Analyzed in detail are financial performance industry indicators, services rev-



## Here's the General Ledger System that the guys in Accounting have been dreaming about.

It's the General Ledger/Financial Control System from UCC. It can solve Accounting's financial information problems... without creating new ones for EDP.

UCC-FCS is the most advanced and complete system of its type. It offers full general ledger accounting. Plus budgeting, cost allocation and profit center reporting. Optionally, it generates over 100 standard reports. And UCC-FCS has an easy-to-use report writer that Accounting can use — with a minimum of EDP assistance.

Call us at 1(800) 527-3250 (in Texas, call 214-688-7313) or Circle 93

Our operating software will solve a lot of EDP problems, too:

A Tape Management System that insures

against loss or destruction of data (UCC-1). Circle 94

A DOS Under OS System that lets you use DOS programs, without reprogramming, while you convert to OS (UCC-2). Circle 95

A Disk Management System you should look into before you buy another disk drive (UCC-3). Circle 96

A PDS Space Management System that eliminates PDS compression (UCC-6). Circle 97

A Data Dictionary/Manager that will really get IMS under control (UCC-10). Circle 98

A Restart/Recovery Management System that makes restarting in a matter of seconds... a matter of fact (UCC-15). Circle 99

Software packages like these. One more way —

## We're helping the computer to do more of the work.

**UCC**

101 Duncan Mill Road — Don Mills, Ontario M3B 1Z3  
USA: P. O. Box 47911 — Dallas, Texas 75247 Europe: 1258 London Road — London, U.K. SW16 4EG

Member SIA  Software Industry Association

# Will your drive perform better with our disk pack?

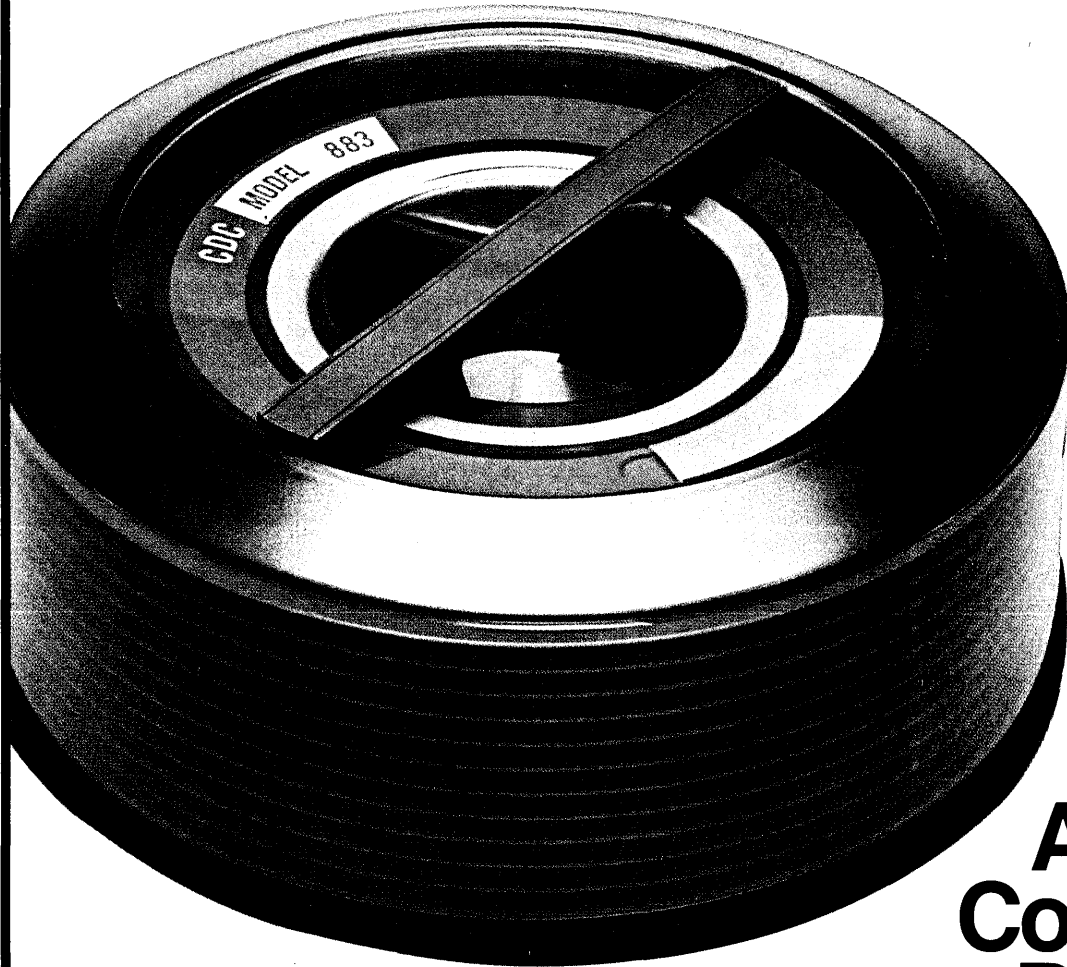

## Ask Control Data

We make disk packs that are compatible with virtually any maker's drive. And we make them very reliable indeed (we use them on our own computers). They're tested to tighter specifications than industry standards to help you prevent data loss, and each pack and cartridge

carries a lifetime warranty. For compatibility and reliability in disk packs, call one of these Control Data Business Products District Offices, or check the phone book for the local CDC Sales Office near you. Or write P.O. Box 1980, Twin Cities Airport, St. Paul, MN 55111.



Data modules



Flexible disks



Disk cartridges



Precision printed business forms

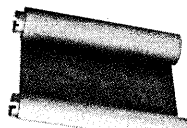

Printer ribbons

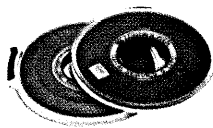

Half-inch magnetic tape

Get all these high quality EDP supplies from one convenient source.

**GD** CONTROL DATA CORPORATION



## Control Data Business Products Sales Offices

### UNITED STATES

California	
Los Angeles	(213) 642-2311
Oakland	(415) 834-7116
San Diego	(714) 291-7570
San Francisco	(415) 393-6858
Santa Ana	(714) 754-4081
Colorado, Denver	(303) 831-7440
Connecticut	
Greenwich	(203) 622-2420
Manchester	(203) 646-6200
Illinois	
Chicago	(312) 454-6750
Oakbrook	(312) 986-7000
Kansas, Kansas City	(913) 831-3600
Maryland	
Baltimore	(301) 727-0210
Rockville	(301) 468-8313
Massachusetts, Waltham	(617) 890-4600
Michigan, Detroit	(313) 353-3600
Minnesota, Minneapolis	(612) 830-6419
Nebraska, Omaha	(402) 333-0850
New Jersey, Union	(201) 687-5600
New York, New York	(212) 239-9570
North Carolina	
Greensboro	(919) 375-4804
Pennsylvania	
Philadelphia	(215) 854-1000
Texas	
Dallas	(214) 688-5927
Houston	(713) 965-5585
Washington, D.C.	(202) 637-6439

### CANADA

Alberta	
Calgary	(403) 287-1359
Edmonton	(403) 423-5030
B.C., Vancouver	(604) 255-8401
Ontario	
Ottawa	(613) 238-2325
Toronto	(416) 291-7151
Willowdale	(416) 492-4200
Manitoba, Winnipeg	(204) 774-3493
Quebec, Montreal	(514) 337-4040

### EUROPE

Austria, Vienna	52.5616
Belgium, Bruxelles	242.1080
Denmark, Copenhagen	31.0022
England, Letchworth	04/626.4211
France, Rungis Cedex	687.2218/2327
Germany, Frankfurt	0611/63051
Greece, Athens	951.0811
Holland, Rijswijk	070/94.9344
Israel, Tel Aviv	3+418146
Italy, Milano	255.0441 to 5
Norway, Oslo	026/86560
Spain, Madrid	207.1540
Sweden, Stockholm	08/84.0200
Switzerland, Zurich	01/39.14.34

### REST OF WORLD

Australia, Melbourne, Victoria	510351
Japan, Tokyo	5857811
Korea, Seoul	72-7801
Mexico, Mexico City	550-3455
New Zealand, Wellington	739505
South Africa, Sandton,	
Transvaal	33-6884
Taiwan, Taipei	7812131-5
Thailand, Bangkok	2338850

## source data

enue analysis, customer analysis, new product development, and future plans. The information provided presents a profile of what methods and products have caused companies to become profitable in today's market, and also provides an overview of what to expect from those competitors in the near future. There also are quantitative forecasts for the industry developed from IDC's marketing research sources. Price: \$395; quantity discounts are available. INTERNATIONAL DATA CORP., 214 Third Ave., Waltham, Mass. 02154.

### IBM Product Guide

All popular IBM teleprocessing products, current and past, including terminals, satellite processors, software packages, and communications controllers are included in this index of information sources for IBM communication products. Also included are references to 800 IBM technical manuals, and books, reports, and articles that deal with all aspects of IBM teleprocessing. The 144-page report lists sources for IBM's SNA/Advanced Communications Function, and a glossary of IBM communications terms, acronyms, and abbreviations. There also is a description of how IBM's technical document order and supply system provides suppliers and users with up-to-date information, and a description of their Service to Consultants. Price: \$45. Discounts for quantity orders are available. CONTEMPORARY COMMUNICATIONS, INC., P.O. Box 3075, Culver City, Calif. 90230.

### Intelligent Terminals

The Auerbach Guide to Intelligent Terminals has been updated to include the genuinely intelligent terminals—those that meet the criteria for intelligent terminals as opposed to programmable terminals. The 292-page report presents information on four levels of detail. The Product Class Report provides insight into the entire intelligent terminal market. The Search Chart gives the reader a quick glance at the functionality of the intelligent terminals on the market, and the Specification Chart offers a closer look at the terminals, listing detailed technical specifications for each. The individual Product Reports are narrative close-ups of each intelligent terminal. Also included is price information and a directory of suppliers. Price: \$24.95. AUERBACH PUBLISHERS INC., 6560 N. Park Dr., Pennsauken, N.J. 08109.

### Southwest Facilities

The 300-page *Directory of Computer Facilities in the Southwest* has recently been updated by Texas A & M Univ.

More than 900 organizations with a total of 1,340 computers in Texas, Louisiana, Arkansas, Oklahoma, and New Mexico are listed in four different ways: alphabetically, geographically, by application, and by manufacturer and model. Included is information on the type of computer, memory size, peripheral equipment, operating system used, whether rental use or programming assistance is available, application areas, and programming language. Price: \$20. TEXAS A & M UNIV., Industrial Economics Research Div., College Station, Texas 77843.

### Pioneers of Computing

It is only 25 years since the first practical working computers came into the market, and science is in the position of having the pioneers of the industry directly available for comment. The Science Museum of London, with the National Physical Laboratory, has commissioned a series of 30 taped interviews with some of the most distinguished scientists involved in the early years of computing. The resulting cassettes, each about one hour long, and said to be of excellent audio quality, are now becoming available, with the full set to be available by the end of 1977. Among those already recorded are: A.D. Booth, D.W. Davies, J.P. Eckert, J.W. Forrester, G. Hopper, T. Kilburn, J. Mauchly, J. Pinkerton, F.C. Williams, J.A. Wilkinson, and K. Zuse. Price: £2.50 each, plus postage and handling. SCIENCE MUSEUM, South Kensington, London SW7 2DD.

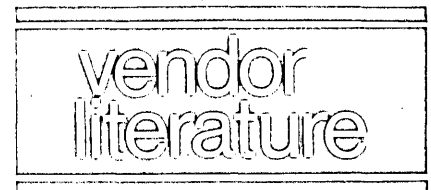

### Source Data Processing

Aimed at an audience of data processing managers and corporate executives, the 22-page illustrated booklet, "A Pocket Guide to Source Data Processing," tackles the problem of distinguishing the source data processing (SDP) concept from similar terms in the field, such as decentralized, dispersed, distributed, and distributive processing. The brochure includes critical elements to be considered by users in system selection—autonomous central control, data base management software, interactive and batch communications, and data capture at the source or point of data entry. It concludes with an overview that outlines how this vendor's family of source data processing systems—the 600 Series of minicomputers—are

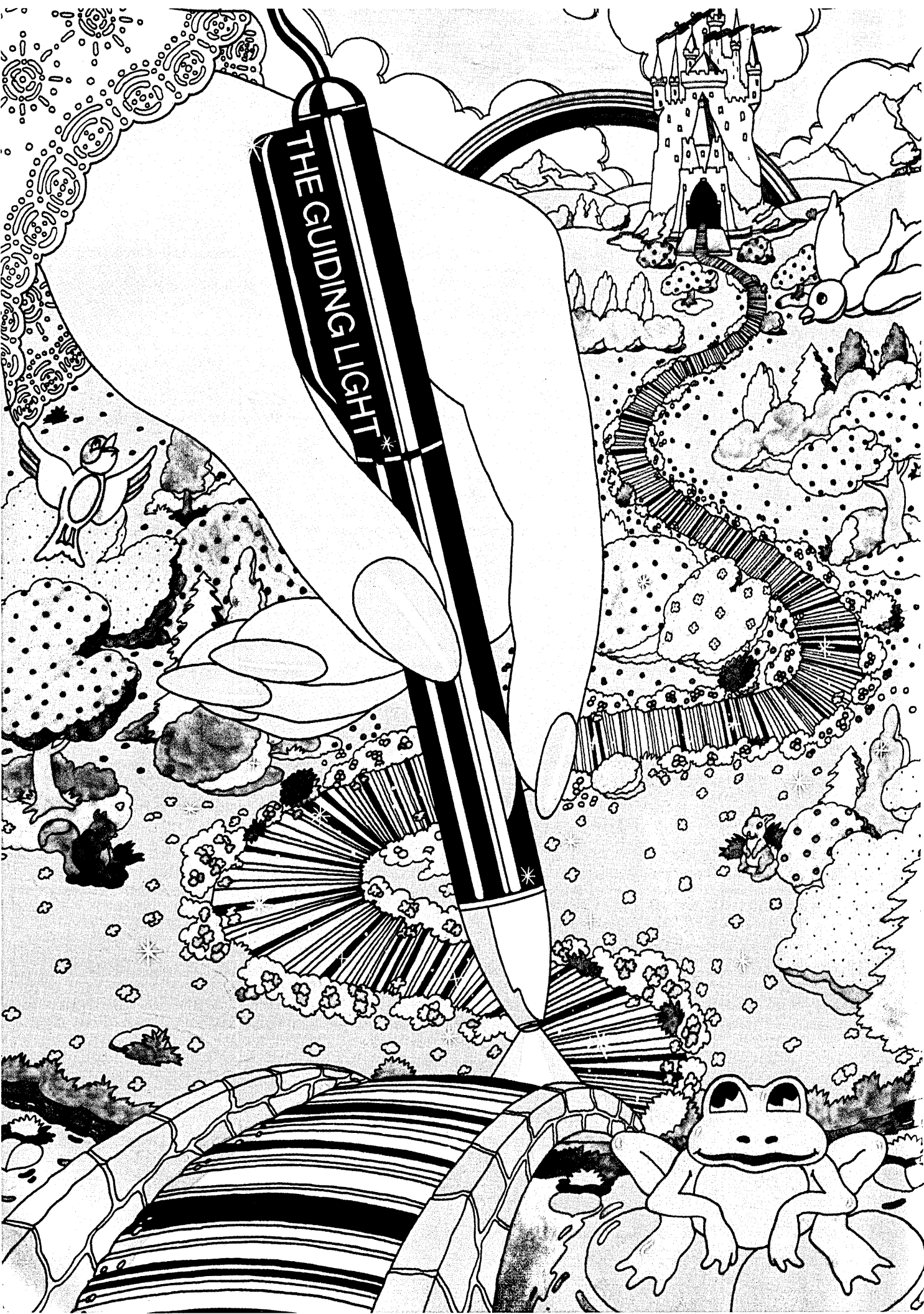

THE GUIDING LIGHT



# And then, with a wave of her magic wand, the wicked evils of keypunching disappeared forever.

With the possible exception of Prince or Princess Charming, a better data entry system has been the most frequently recurring dream since key punching came on the scene.

With the appearance of the new Guiding Light Data Entry System by Ames, the dream's come true.

You can hardly call it work, yet waving a wand across bar codes is more efficient than



12-38-76

work ever was. Data just gets picked up and swept off to the computer, leaving no room for error. And it's ten times faster than keypunching.

Happier day still when we

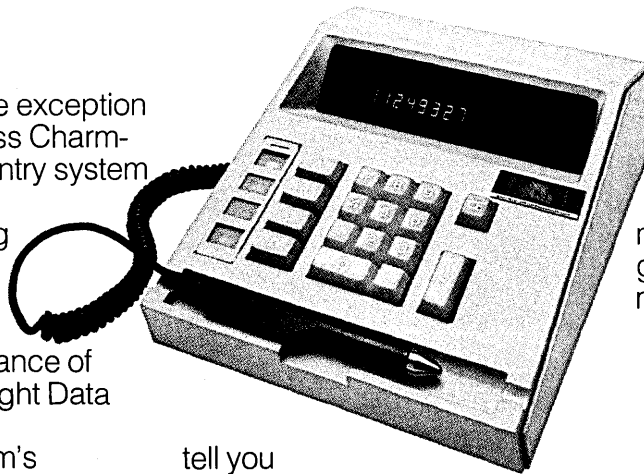

tell you our system's plug compatible with most computers. The Guiding Light can read most code formats, including, AMES CODE, CODABAR™, UPC versions A, E, and Extended Distribution Code. It also traces out-of-file records, controls quality, production and inventory, posts charges, verifies credit, communicates two-ways, and boasts four function keys and sixteen different tones.

And if you think all that's compatibility, wait till you see what happens when keypunch-

ing turns into wandwaving. Then anybody can enter data directly into the computer.

Oh all right, it's not a coachman and six horses. But it'll get you home before midnight, pumpkin.



**Ames Information Systems**  
12 Park Street, Somerville, Mass. 02143  
(617) 776-1142

Please send me information on Ames Guiding Light System.

Name \_\_\_\_\_

Firm \_\_\_\_\_

Street \_\_\_\_\_

City \_\_\_\_\_

State \_\_\_\_\_ Zip \_\_\_\_\_

Phone \_\_\_\_\_



## We've found one or two companies that couldn't use the new Xerox 1700 terminal.

It happens. But not very often. Because, of all the 1700's we sell or lease, over 98% find permanent homes. And for plenty of good reasons.

Most companies who do interactive work want very high print quality and that's exactly what they get with the 1700. The quiet, reliable HyType II prints sharp, crisp characters even at 45 cps.

Full ASCII character set, forward and backward printing and 1/120" horizontal and 1/48" vertical resolution lets you print charts, curves, formulas, or musical scores with the touch of a key.

And you know that if something goes wrong, Xerox is going to be there to make it right.

If you think your company could use the new Xerox 1700, call 213/679-4511, Ext. 2231. Or write Xerox, Dept. A1-15, 701 Aviation Blvd., El Segundo, CA 90245.

Then all you have to do is find a desk to put it on.

**Xerox Computer Printing**

**XEROX**

## source data

designed to free centralized processing power, reduce communications costs, and provide operational flexibility. ENTREX, INC., Burlington, Mass. FOR COPY CIRCLE 303 ON READER CARD

### Dp Job Bulletin

A new nationwide private employment agency owned by Control Data Corp. is providing computer-assisted recruiting by periodically listing openings with companies coast to coast. The service is said to combine individualized personal service with the Cybernet system. Individual resumes are

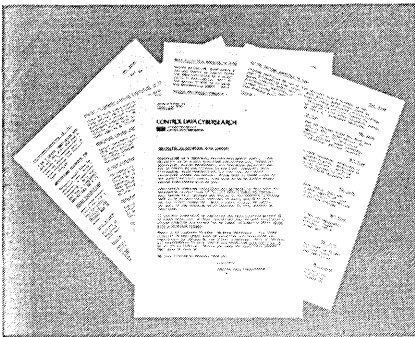

programmed and stored in the computer's memory to be automatically included in every search made for client companies. When a match occurs, Cybersearch notifies the qualified individual and arranges an interview. CONTROL DATA CYBERSEARCH, Chicago, Ill.

FOR COPY CIRCLE 302 ON READER CARD

### Patient Information System

A new eight-page, four-color brochure describes a patient information system from this vendor. A data base of more than 9,000 hospital-related computer programs integrates and automates patient data processing and communications into an on-line, real-time system that may be installed in all departments and used by the doctors, nurses, and other staff people responsible for patient care. Subsystems applicable to admissions/discharges/transfers, pharmacy services, diagnostic and treatment services, surgery, medical records, and dietary and housekeeping departments are described. Also detailed are the vendor's technology and customer support services. NATIONAL DATA COMMUNICATIONS, INC., Dallas, Texas.

FOR COPY CIRCLE 304 ON READER CARD

### Heathkit Computer Lit

Two new "total design" computer systems are described in this new 16-page, four-color catalog. The two

mainframes are based on the 8080A and LSI-11 MP modules. Vendor-designed software, crt terminal, paper tape reader/punch, serial, and parallel interfaces are said to make total system setup easy and fast. Easy self-service and trouble-shooting are also said to be benefits of the kits. The computers are to have full expansion potential. Mass storage capability is available in both audio cassette and paper tape format on the H8 and in paper tape format on the H11 for added convenience. Memory expansion boards can be added to either unit, along with an expanding number of I/O devices. HEATH CO., Benton Harbor, Mich.

FOR COPY CIRCLE 305 ON READER CARD

### Interconnector

This company's solution to the multi-computer interconnect problem is described in a new eight-page brochure. The HYPERchannel is said to provide an effective method of handling voluminous data traffic between the computer, storage, and access elements of large-scale computer systems. Features detailed include: dynamic switching for cpu access to all other systems elements; resource sharing between facilities up to one mile apart; data transfer up to 59 megabits over coaxial trunk; multiple, simultaneous data paths; and up to 64 devices on a single trunk. The brochure also details user benefits and contains typical application examples. NETWORK SYSTEMS CORP., Brooklyn Center, Minn.

FOR COPY CIRCLE 307 ON READER CARD

### Care and Feeding of Floppies

A new brochure, "An Operator's Guide to Care," is geared to the operator/user of floppy discs. The release outlines the storage and handling of floppies with practical information on the do's and don'ts of disc care. The brochure provides an overview of some of the problems encountered in disc use, with some positive and helpful suggestions on how to prevent the loss of data. ADVANCE ACCESS GROUP, Westchester, Ill.

FOR COPY CIRCLE 308 ON READER CARD

### Mini Accessories

An enlarged summer catalog of this vendor's full line of accessories and supplies is now available to minicomputer users. The 40-page catalog includes an expanded crt accessory line, and new tape and diskette mailers. There are also unique and hard-to-find items for end users and oem's. The

FOR AYDIN CIRCLE 149 ON READER CARD →

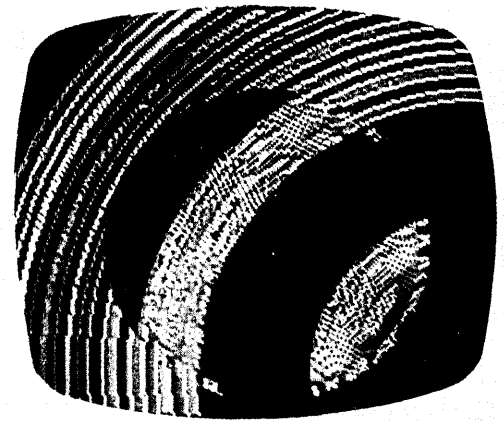

## Leave the World of FLICKER Behind

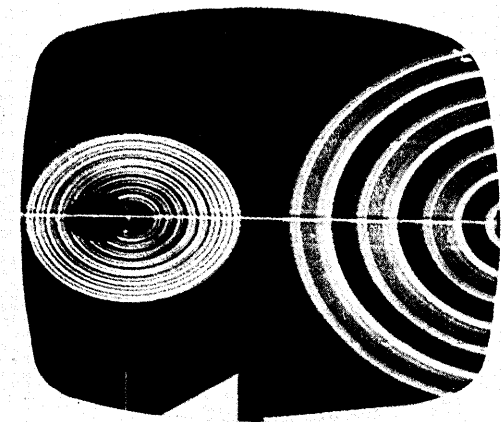

### NOW AVAILABLE FROM AYDIN CONTROLS . . .

A color display system with 512 x 512 resolution at a 60 Hz repeat field refresh rate. For the first time 512 flicker free lines in full color can be resolved. The Aydin Model 5214FS Display Generator eliminates flicker by outputting data at twice the conventional rate to the Aydin Model 8023 Ultra High Resolution 19 inch color CRT Monitor. A flicker free display is provided while still maintaining full image and graphic generation capability. The Model 5214FS provides vector, circle and character generation in addition to color look-up tables.

If you are ready to leave the world of flicker behind call or write us today.

## AYDIN X CONTROLS

One source for all your CRT  
display requirements

414 Commerce Drive  
Fort Washington, Pa. 19034

PHONE (215) 542-7800

TWX (510) 661-0518



# For the 1st time in history!

## In the latest DATAPRO survey, users gave the highest rating to a DB and a DC from the same vendor.

### Insyte Datacom is that vendor!

Package & Vendor	Weighted Average User Ratings*						
	Satisfaction	Throughput Efficiency	Ease of Installation	Ease of Use	Documentation	Vendor Tech. Support	Training
<b>DATACOM/DB</b>	<b>3.7</b>	<b>3.8</b>	<b>3.6</b>	<b>3.8</b>	<b>3.1</b>	<b>3.8</b>	<b>3.5</b>
ADABAS	3.6	3.4	3.7	3.7	2.3	3.2	2.4
IMS	2.9	2.4	2.2	2.5	2.8	2.8	2.9
DL-1	2.6	2.4	2.3	2.4	2.4	2.5	2.6
IDMS	3.8	3.3	3.4	3.6	3.0	3.6	3.5
SYSTEM 2000	3.0	2.6	3.0	3.0	2.5	3.0	3.0
TOTAL	3.5	3.1	3.4	3.4	2.8	3.0	2.8

All figures based on latest available Datapro survey.  
 \*All weighted averages are based on a scale of 4.0 for excellent.  
 Courtesy of Datapro Research Corporation, Delran, N.J. 08075

### DATACOM/DB rates highest!

Here's why users rate DATACOM/DB the leader: Easiest-to-use in design, implementation and maintenance of application systems  Best on-line performance for inquiry and/or update transactions under DATACOM/DC (our superior telecommunications monitor), CICS or other monitors  Unequaled sequential processing capabilities  Minimum use of 360/370 hardware resources including CPU cycles, memory, I/O events and DASD space  Exceptionally readable and usable documentation  Continual, innovative, cost-effective enhancements.

**DATACOM DB and DC.  
 Great by themselves.  
 Even better together.  
 Call or write today!**

Package & Vendor	Weighted Average User Ratings*						
	Satisfaction	Throughput Efficiency	Ease of Installation	Ease of Use	Documentation	Vendor Tech. Support	Training
<b>DATACOM/DC</b>	<b>3.4</b>	<b>3.4</b>	<b>2.8</b>	<b>3.7</b>	<b>2.3</b>	<b>3.6</b>	<b>3.0</b>
TASK/MASTER	3.3	3.2	2.8	3.3	2.5	2.7	2.7
ENVIRON 1	3.1	3.1	3.2	3.1	2.3	2.5	2.5
CICS	3.1	2.8	2.4	2.8	2.8	2.9	2.8
INTERCOM	2.7	2.8	2.2	2.5	2.1	2.1	2.5
IMS/DC	2.8	2.5	2.4	2.5	3.0	2.9	2.8

\*All weighted averages are based on a scale of 4.0 for excellent.  
 Courtesy of Datapro Research Corporation, Delran, N.J. 08075

All figures based on latest available Datapro survey.

### DATACOM/DC rates highest!

Here's why our users rate DATACOM/DC so high:

"In terms of total satisfaction, DATACOM/DC measured up completely to what we wanted and gave us more than we expected"

—David Hughes, Manager of Systems and Programming, Mass. State Lottery.

"When we installed DATACOM/DC, we experienced a 30% increase in throughput; more important, we eliminated downtime"

—Gary Dyer, Data Processing Director, Blue Cross of Idaho.

"DATACOM/DC was extremely easy to install and we had no TP experience"

—David Harp, Director of Data Processing, New Castle County, Del.

"My programmers say DATACOM/DC is very easy to use; as simple as writing a COBOL program. The documentation also is very good. Technical enough for the technical people yet simple enough for management people to understand"

—Harvey Kennedy, Vice President and Director of Management Systems, Southern Baptist Annuity Board (Dallas).

"Vendor technical support is Insyte's largest shining star. The support people are unparalleled in the industry."

—Ben Driver, Data Base/Data Communications Software Manager, Brockman On-Line Systems (Houston).

I want you to prove  DATACOM/DB  DATACOM/DC  DATACOM DB/DC superiority on 360/370 systems.

Name \_\_\_\_\_ Title \_\_\_\_\_  
 Firm \_\_\_\_\_ Phone \_\_\_\_\_  
 Address \_\_\_\_\_  
 City \_\_\_\_\_ State \_\_\_\_\_ Zip \_\_\_\_\_

DATACOM/DB and DC are made for each other... and you.

**insyte datacom**  
 corporation

214/526-4280  
 3707 Rawlins St. Dallas, TX 75219  
 Boston/Chicago/Denver/San Francisco/Mexico City/Frankfurt, W. Germany  
 Sydney, Australia



## source data

vendor states that they have new lower prices for media products, such as tapes and disc cartridges. MINICOMPUTER ACCESSORIES, Palo Alto, Calif. FOR COPY CIRCLE 309 ON READER CARD



### Mini Matters

The member news publication of the Minicomputer Industry National Interchange recently has been inaugurated. Volume one, number one of *Mini Matters* included articles such as "Preparing for Your First Computer," "IN-VU—System of the Future," and new product announcements on minicomputers from NCR and Sharp, a small scale system from Burroughs, and a small business computer from Sperry Univac. The columns "Current Reading" and "Worth Reading" are expected to be regular features in each issue. For more information on the organization and its publication, contact the MINICOMPUTER INDUSTRY NATIONAL INTER-



### Humanized Technology

*Humanized Technology for Edp Management* is a seminar intended for all dp managers and their technical staff. The seminar is designed to provide participants with information on methods which can contribute to increased technologist and system user productivity. Day one of the two-day seminar will have as its theme "Software Metrics: Specification and Measurement of System Quality." The second day's theme will be "Humanized Input and Data Engineering." The course instructor will be Tom Gilb, author of *Humanized Input* (April, p. 45). The seminar will be held Oct. 6-7 in Washington, D.C.; Oct. 10-11 in Chicago; Oct. 13-14 in Toronto; Oct. 20-21 in Seattle; Oct. 24-25 in San Francisco; and Oct. 27-28 in Houston. Price: \$450, includes all course materials and lunches. TSI SALES AND MARKETING, INC., 19 W. 44 St., New York, N.Y. 10036.

CHANGE, 4902 Tollview Dr., Rolling Meadows, Ill. 60008.

### People's Computers

The five year old publication *People's Computer Company*, has changed its name and format. Now called the *People's Computer*, the magazine is bimonthly and is aimed at those hobbyists, programmers, students, and educators who want to learn more about computers—how they work and how to use them. Planned articles include an introduction to computer networking, a continuation of a series on 6502 assembly programming, and information on how microcomputers are used in biofeedback applications. Each issue also will contain programming tips, book reviews, and computer games. Subscription: \$8/year, U.S.; \$12/year, Canada. PEOPLE'S COMPUTERS, 1263 El Camino Real, Menlo Park, Calif. 94025.

### WP Information Service

The Word Processing Industry Service will provide continuously updated information covering markets, products, technology, and companies. In addition to the updated notebooks, there will be newsletters, unlimited inquiry privileges, and an annual two day conference. The service is directed at industry participants, suppliers, equipment users, and financial analysts. DATAQUEST, INC., 3000 Sand Hill Rd., Menlo Park, Calif. 94025.

### The People Side of Dp

The aim of the five-day workshop, *How to Assess, Supervise, and Administer Computer People* is to provide a comprehensive review of the key factors bearing on the management and supervision of computer people. The workshop will dissect job components, consider selection of talents to match job characteristics, describe the variables affecting performance, and will stress the long-term retention of effective employees. The impact of systems controls and use of organizational dynamics also are emphasized as major factors in people performance. The workshop will be conducted in Washington, D.C., Sept. 19-23 and Nov. 7-11; and in San Francisco, Dec. 12-16. KESTON ASSOCIATES, 11317 Old Club Rd., Rockville, Md. 20852. \*

A studious robot in wrath  
abandoned the flower-strewn path  
of music and lit,  
for he had to admit  
he was a lot better at math.

—Gloria Maxson

CIRCLE 150 ON READER CARD →

a new  
generation of  
advanced  
color graphics

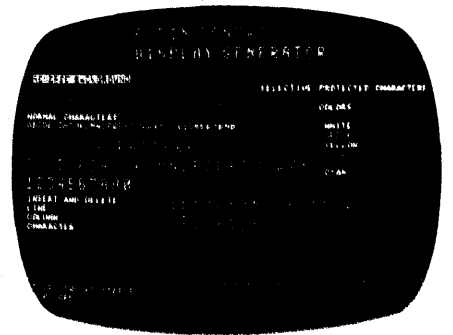

meets  
tomorrow's  
performance  
today

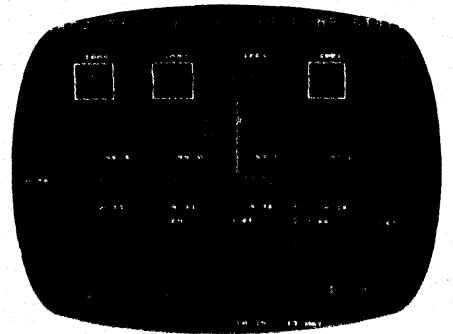

Seeing is believing . . . so take a good look at what Aydin Controls new raster scan, multi-channel, RGB display generator can give you at a reasonable cost:

Eight colors  256 alphanumerics and special symbols  Two character sizes  Upper and lower case block/and graphics  Subscript and superscript  Up to 80 characters per line with 48 lines per page  Two intensity levels  Reverse backgrounds  MOS random access refresh memory  Full edit from keyboard or computer  Dual 1/0 option.

To find out what our applications-oriented model 5215 can do for you, call or write us today.

AYDIN  CONTROLS

One source for all your CRT display requirements

414 COMMERCE DRIVE  
FORT WASHINGTON, PA. 19034  
PHONE (215) 542-7800  
TWX (510) 661-0518

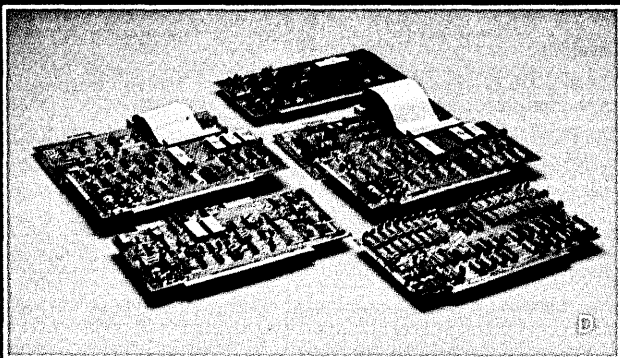
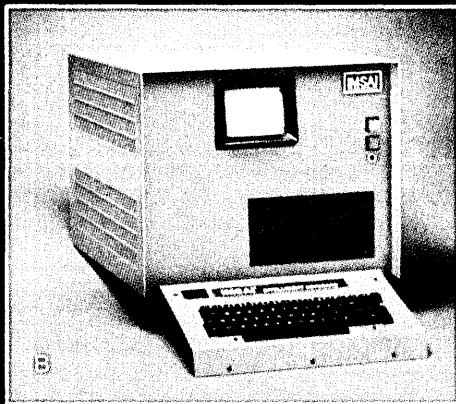

- A. VDP-80 Computer with 300 lpm printer.
- B. PCS-80 with CRT, dual floppy disk & Intelligent Keyboard options.
- C. Peripherals—(clockwise from left) 45 cps daisy-wheel printer /terminal, 24x80 CRT terminal, 45 cps daisy-wheel printer, Intelligent Breadboard, 44 col. alphanumeric line printer.
- D. Processor, Memory & Interface boards—shown MPU-A, 65K RAM, and floppy disk, line printer and serial I/O's.
- E. PCS-80 System—sample component configurations.

# Microcomputers: Just Ask IMSAI.

If you wonder who leads the way in technology, look into IMSAI's list of industry firsts—IMSAI 8048, first complete control computer on a board; IMSAI 65K RAM Board, first to offer four times the memory capacity previously available on one board; IMSAI printers, first with high-speed direct memory access.

If you wonder why IMSAI products have gained the reputation for the standard of excellence in microcomputer systems, check with any one of the more than 10,000 IMSAI owners.

If you wonder who offers the broadest line of hardware, software, and peripherals, visit any one of the more than 275 IMSAI dealers around the world.

If you wonder how microcomputing can fit your specific needs, ask IMSAI. Because when it comes to microcomputers, we have the answers.

## An IMSAI Product to Answer Every Microcomputing Need:

Let's start with our product line. In all, IMSAI offers more than 120 high quality, completely integrated systems, components, peripherals and software. Here's just a sampling:

### Single Board Central Processors:

- MPU-A (8080 based)—Industry standard.
- MPU-B (8085 based)—50% faster 8080.
- 8048—Programmable control computer.

### Interfaces:

- Video I/O—24x80 CRT. Edit & data entry.
- Serial I/O—2 port I/O, all std. protocols.
- Parallel I/O—4 & 6 port TTL level I/O.
- Multiple I/O—2 cassette, 2 parallel, 1 serial & 1 control I/O.
- DMA—For floppies & line printers.

### Peripherals:

- Printers—44/80/132 col. 30 cps-300 lpm.
- Video displays—Large assortment.
- Tape Drive—9 track. 800 bpi. 25 ips.
- Floppy Disks—Single/double density.

### Memory Expansion Boards:

- 4K RAM—Programmable memory protect.
- 16/32/65K RAM—16K paging option for virtual memory addressing.
- Intelligent Memory Mng. —Handles up to 1 megabyte.

### Self-Contained Systems:

- VDP-80—Computer/terminal/mass storage unit. Assembled & tested.
- PCS-80—Integrated component system.

### Software:

- DOS—Enhanced CP/M.
- BASIC—Interactive or compiler with scientific and/or commercial features.

- FORTRAN IV—Level 2 ANSI compiler.
- Self-contained Systems:
  - SCS 1 & 2/TCOS—Assembler/line editor/debugger.
  - 4 & 8K BASIC—Optional cassette support.

Compare IMSAI. You'll realize that ours is the most complete product line available. Whatever your needs, you can get them from one source. IMSAI.

A wide selection of components is only the beginning. IMSAI offers much more. Just ask.

## Answers For Businessmen:

Announcing IMSAI's VDP-80. This totally self-contained unit includes a megabyte of disk memory via floppy disk, 32K computer memory (expandable to 256K), 12" CRT and 62 pad main keyboard with 10 pad numeric keyboard. Several printer options available.

If you want speed and accuracy in high volume work such as word processing, or business data collection and analysis, the VDP-80 is your cost effective answer.

## Answers For The Personal User & Educators:

Introducing IMSAI's new PCS-80 System, the fully integrated microcomputer component system, configurable to your exact needs. The basic system consists of our Intelligent Keyboard and the PCS-80 which houses an 8085 based CPU, 16K of RAM, intelligent ROM monitor, serial I/O port, 24x80 CRT, with an extra 7 slots in the chassis for expansion.

System component options include single or dual mini and standard floppy disks. The choice is yours, configure the system as you like.

IMSAI has answers for the educator, too. Take the basic PCS-80, add 8K of PROM, 4K of RAM and our self-contained 8K BASIC software, and you have a complete operating system your entire department can use to teach anything from elementary programming to advanced computer science.

Require a bit less sophistication? Use our Intelligent Breadboard system for learning, designing and building microcomputer assemblies.

Rather do it from scratch? Start with our single board MPU-B central processor, the heart of the PCS-80 System. It has a 1K ROM monitor, 256 bytes of RAM and serial and parallel I/O.

Since the MPU-B is 8085 based, you can run all programs previously developed for the 8080. 50% faster. Without requiring faster memory.

## Answers For Industry:

IMSAI products provide the expandability and flexibility manufacturers demand for microcomputing applications.

We offer rack mountable components for the standard 19" RETMA racks, powerful MPU boards, I/O and memory boards for easy system expansion and configuration, and a broad line of peripherals and subsystems fully integrated and ready to go to work.

IMSAI has what you need to make tomorrow's design today's reality.

## Answers For Current IMSAI Users:

There are over 10,000 of you. And, we haven't forgotten. You might say that we thought of you before you even thought of us.

That's why every new product is designed to accommodate expansion, rather than outdate equipment.

For example, our new PCS-80 retrofit kit comes complete with MPU-B, replacement front panel photomask and additional hardware bracketing. So you can enjoy a single cabinet PCS-80 computer, with your choice of integrated component configurations.

## The Answer For Everyone:

Dial (415) 483-2093, Ext. ACT. That's IMSAI's action hotline. Designed to answer the thousands of questions we didn't have a chance to answer in the space of this ad.

Call us. We'll assist you in putting together a system, direct you to your nearest IMSAI dealer, and send you our new catalog with all the details.

In short, if you have any questions at all regarding microcomputers, put us to the test.

Just ask IMSAI.

# IMSAI®

**The Standard of Excellence in  
Microcomputer Systems.**

IMSAI Manufacturing Corporation  
14860 Wicks Blvd., Dept. D-9  
San Leandro, CA 94577  
(415) 483-2093 TWX 910-366-7287

Features and specifications subject to change without notice.

# The more significant the innovation, the more the corporation comes to depend on it.

## Distributed Processing.

Distributed data processing represents a significant advance in an organization's ability to monitor and control its own operations. So significant, in fact, that a large decentralized corporation quickly comes to depend on its distributed processing network in the same way that a biological organism depends on its nervous system. For this reason, it is vitally important that such a network be supported by a fast and efficient field engineering team.

**Field Engineering.** Four-Phase Systems provides 24-hour-a-day maintenance support to distributed processing sites from more than seventy field engineering offices nationwide. The Four-Phase field engineering organization is structured to support network operations, and combines such unique features as a national alert center, remote diagnostics, and local-regional-national spare parts inventory to insure the highest reliability in the corporate nervous systems we build and support.

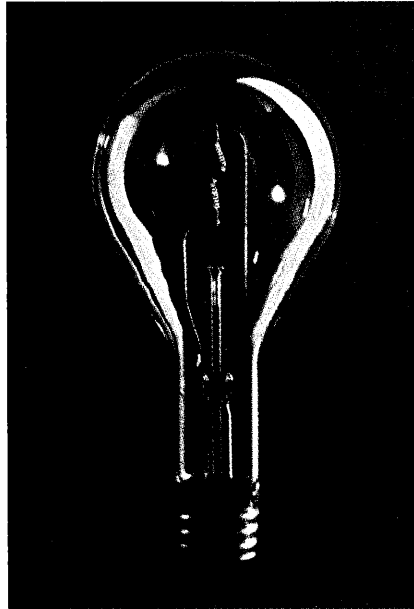

This team of field engineering professionals helps Four-Phase distributed processing systems achieve better than 99% uptime nationwide in typical multi-shift use. And every service incident which does occur is analyzed by the Four-Phase field engineering support group to determine whether maintenance response was timely and efficient and to supply statistical data to guide our product engineers toward even higher equipment reliability.

## Four-Phase Systems.

Who uses Four-Phase equipment today? Over 500 major organizations. Including ten airlines. Thirty insurance companies. Forty banks. Fifty government agencies. And more than a hundred of America's leading manufacturing corporations.

Why has Four-Phase succeeded in the hotly competitive world of business data processing? A primary reason is the fact that the Four-Phase product line was designed from scratch for its intended application... not "assembled" from commercially available electronic logic components. Of all the business computer manufacturers in America, only two have always designed and produced the integrated circuits which are the brains of their products... Four-Phase and IBM.

For further information, contact Four-Phase Systems  
19333 Vallco Parkway  
Cupertino, California 95014  
408-255-0900.

## Four-Phase Systems®

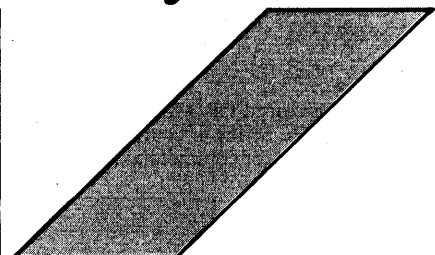
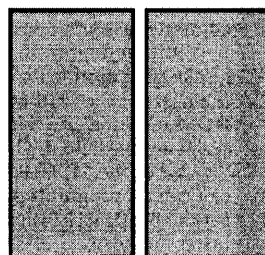



# Editor's Readout

John L. Kirkley, Editor



## The First Twenty Years

As you may have gathered from this month's cover, it's our birthday.

Twenty years in the computer industry. Long enough for the industry to grow and change dramatically, and long enough for what was *Research and Engineering* (the magazine of DATAMATION) to evolve into the publication it is today.

Because DATAMATION is an integral part of the industry, our editorial coverage and our fortunes have taken the same wild roller coaster ride.

In the fifties we were small but growing steadily, moving from the oscilloscope and hot solder world of scientific and engineering computing into commercial data processing. In the sixties the magazine grew fatter and fatter until the November 1969, Fall Joint Computer Conference issue resembled a Sear's catalog. Following some sort of Malthusian logic, the industry promptly collapsed. The burned out husks of companies were strewn around the landscape like bodies in a Sam Peckinpah movie. And DATAMATION was so thin you could practically see through it.

But the industry recovered and so did the magazine; we were both basically healthy.

Even though many undercapitalized and undermanaged firms bit the dust, the industry survived because it was firmly based on a technology whose time had come. DATAMATION was able to regroup and once more flourish because it was rooted in a solid editorial foundation, a framework clearly spelled out 20 years ago by the magazine's first publisher, Frank D. Thompson, in DATAMATION's second issue.

Thompson said, "All of automation is young . . . and the field of handling information automatically even younger. Because this field of endeavor is presently pioneering, it needs a voice—a voice which is responsible, intelligent, and which will assist its people by reporting and interpreting the industry's developments. DATAMATION intends to be that voice."

He stressed that DATAMATION was not to be a news magazine, but rather a "news report magazine," concerned with in-depth interpretive reporting. "DATAMATION will publish thoughtful articles by leading men in the data processing field," he continued. With admirable foresight, Thompson directed the magazine to cover international as well as domestic computing, recognizing data processing's potential as a worldwide activity.

As we go into our third decade, the industry is changing again. Low cost logic, personal computing, distributed systems, data communications, Japan, IBM and AT&T's strategic maneuvering, increased government intervention and regulation — these are just some of the forces that are reshaping the industry into forms that were inconceivable in 1957.

And as the industry changes, DATAMATION will inevitably change as well. But the basic editorial approach will remain—quality technical articles and leading edge reports by industry practitioners, interpretation and analysis of industry news, an international orientation, and a perspective that sees computers and data processing within a social and economic context.

Right now times are good for both the magazine and the industry, and we expect this condition to continue for some time to come. But we'll keep our seat belts fastened. After all, we're still on a roller coaster and we're only a little way into the ride.

✱

# Twenty Years of Data Processing

Brickbats and bouquets, commentary and observation, hindsight, foresight, fact and fancy . . . a view of the industry by some of its more vocal insiders.

Over the years DATAMATION has been fortunate to have some of the brightest, most capable, and experienced people in the computer industry associated with the magazine as contributing editors, advisors, and friends. In the next few pages some of them take a look at our industry, past, present and future. From the irasci-

ble Bob Patrick's view of our continuing foibles to Portia Isaacson's enthusiastic welcome to personal computing, there's a wide divergence of opinions and perspective which reflects the fact that after twenty years, the computer industry is still alive, changing, and growing. We wouldn't have it any other way.

Does this mean the business is grinding to a halt? Certainly not in terms of revenue and profit growth, judging from industry performance in 1976 and the first half of 1977. Probably not in new areas, either, such as distributed minisystems for responsive support of local activities and the aforementioned word, image, and voice processing.

But in terms of production data processing applications, once the general transition to interactive transaction processing with data bases has been completed (and it will be for most users well within the next 20 years) a period of maturity may follow. During the next 20 years, then, the companies may consolidate the conquests that have occupied them for the last 20 and send their armies increasingly into new territory.

In no case is progress likely to stop — but I'll bet some 1401 emulation will still be going on 20 years from now! \*

Ted Withington, a senior staff member of A. D. Little, Inc., is one of the most often quoted and influential members of the computer industry. He is a Datamation advisor and contributing editor of long-standing.

## The Data Processing Business — 20 Years Backward and Forward

by Frederic G. Withington

I dug out a 1956 report on the computer industry. It seems that in 1956, about 500 computers were installed in the U.S. worth about \$200 million. In 1976, maybe 300,000 computers were installed (depending on your definition of a mini) worth close to \$50 billion—pretty fair growth!

But not everything has changed so much. The 1956 report discussed 15 companies that made computers. The top five were IBM, Sperry Rand, Burroughs, Honeywell, and NCR. In the June 1977, DATAMATION feature "The Top 50 U.S. Companies in the DP Industry," guess which companies occupied five out of six top positions? (Control Data was the other one.)

And on a more sobering note, all ten of the remaining companies discussed in the 1956 report have left the general-purpose computer business. Twenty years from now, will the same pattern apply—the rich getting richer, and few others need apply? Perhaps not: there are numerous semi-rich now (the next ten or so in the top 50) that will be hard to kill. Also, as words, images, and voices get increasingly entangled with data during the next 20 years, other big names like Xerox, Siemens, 3M, Nippon Electric, and Eastman Kodak may join the list—not to mention AT&T.

The 1956 report bubbled happily about the rapid state of hardware evolution. New techniques and devices for logic, memory and peripherals

were appearing almost daily and being implemented rapidly in new products. New hardware technology still appears, but its implementation has become depressingly slow. Also, it seems that by the time new technology reaches the field any promised bottom line benefit has been frittered away in increased overhead. The reason is that the business is dominated by software (the 1956 report said nothing at all about software). The manufacturers' systems programs dominate and constrain their product lines, and user investments in program libraries constrain freedom of choice.

## The Curmudgeon's Corner

by Robert L. Patrick

Bah, humbug! We're ten years older and we have the same old problems! In the last ten years we've seen explosive growth and we've learned to speak of persons and be blind to the fact that men and women exist. That's not much progress for ten years' time.

Ten years ago we had training problems, we lacked a viable standards mechanism, and the computer societies were faulty. Today we have more partially trained personnel than ever before; our foremost standards authority says we must reorganize; and the computer societies are charging more and doing less than ever

before.

We hit a new low just the other day when I received an announcement for a local computer meeting with a hand-written label on it.

I guess a little progress has been made in some fronts. The auditors finally decided they couldn't audit around the computer and are now trying to find out what goes on inside the computer center. Prices have come down so you pay less for your computation. Computers come in smaller boxes and the little ones seem to operate satisfactorily in an office atmosphere, so we have stopped building hospital wards to house them in.

But there is no indication that we've reached the age of reason.

Several months ago a fellow at the National Archives put forth a proposal for a Taj Mahal which would house a few million magnetic tape reels in air-conditioned splendor for the scholars of the next century. Now that will take a heap of doing considering we sometimes have trouble reading last quarter's tape due to program updates and density changes. Since our files aren't self-defining, documentation is seldom current and practitioners have difficulty in determining the exact meaning of the data elements and codes today, I suspect a Taj Mahal containing a few million tape-reels would be the biggest boondoggle since typing tests for Washington secretaries.

Ten years ago the academic community predicted time-sharing was going to revolutionize the world. Well, I guess it did revolutionize the academic world. But to the commercial and industrial users it is just another tool, and while there is quite a bit of time-sharing going on, remote job entry stations seem to be very popular too.

On the way to massive integrated management information systems predicted ten years ago, we went hard aground on a reef called complexity. The hardware was pretty good, data management extensions appeared on most operating systems, and programmers managed to get their transaction processing codes checked out (more or less). But the beasts were hard to administer and unless you took extraordinary precautions, they occasionally suffered a catastrophic failure. The successful systems are highly tuned monuments to the diligence of the data base administrators.

Distributed systems have a certain appeal since they'll relieve the political pressure on the central site and put the responsibility and the authority back in the user's hands. However, without a strong dose of data administration (and some systems features to render all this possible), distributed data is likely to go the way of its predecessors.

Our biggest problem is people. The average age of the staff in most of the established shops is 35 creeping towards 40. Some shops have a few older people and we are beginning to see an occasional retirement party. I still don't see any career planning. Most of the troops are so interested in living the good life they don't perform the elementary arithmetic to discover that 65 minus 35 gives them 30 years yet to work.

The younger folks coming out of

college and entering the work force can code fairly well. We need to re-tread a large portion of our existing work force so they can pursue new jobs and leave their old jobs to the younger folks. The current crop of after-hours courses, books, magazines, and newspapers aren't filling the job. In the face of this need, one of the computer societies is turning itself into a guild while the other two seem to be dying on the vine. The biggest problem of the next ten years will be how to keep people productive in their middle years.

I guess we'll bumble through somehow. We used to have an opportunity

## On a Fast Track To . . . ?

by Phil Dorn

What progress in 20 years? The command languages are harder to use, the core dumps fatter and less readable, printing a file is a major project. Progress?

The hardware works; that wasn't true when DATAMATION was born. Most commercial shops still don't stretch their processors but the atom-busters and weather-watchers smile a bit more broadly every year. Hurray for Cray! Programmers still can't get at the hardware, "layers and layers of bug-ridden software" (a Maury Laver phrase) still intervene.

The hardware-happies led by T.I.'s Mark Shepherd think all software will be loaded into ROM's at the plant. Great! Where is the evidence engineers will be better at writing error-free programs than today's programmers?

Help is coming, at least for those not brainwashed into total centralization, dumb terminals, and massive data bases. Even inside IBM one hears muted protests against rote centralization.

The communications alphabet soup can be replaced. Minis can handle functionally discrete applications. Word processing, order entry, inven-

to bury our mistakes since each new computer was incompatible with its predecessors. Now, since most manufacturers are building lines of compatible equipment, the only time you get to throw it all out and start over again is when a vendor dies and you're forced to change.

Some of our past decisions will be around to haunt us for a long time. \*

The word curmudgeon is an interesting archaism meaning "a cantankerous fellow." The equally archaic Bob Patrick is Datamation's oldest and most venerated editorial advisor, known for his incisive and sometimes splenetic views of our industry and its shortcomings.

tory control, energy management, customer inquiry, distribution management, all have been sliced off the central blob. Unfortunately, too few MIS managers are able to understand that this is revolution, not a minor change.

Immediately ahead? Central management, remote processing. Not decentralization — a 1401 in every office isn't the answer. If Gene Amdahl thinks distributive processing is a fad, he will hear a lot of arguments in the next few years. The feasible route seems to be locally held operational data used locally to directly support local business transactions.

The next five years? Most will plug along trying to disintegrate oversized applications. The goal? Reliable, low cost, managerially effective computing that supports corporate goals and objectives. How? The many forms of intelligent remote processing.

Call me back in 1982! \*

Phil Dorn has earned his ribbons. He's been a battle-scarred user (dp manager at Union Carbide) and vox populi (past president of SHARE) to name just two milestones in his long and checkered computer industry career. He's long since parlayed this experience into a good living as a consultant, and serves Datamation as a contributing editor and industry advisor.

## The Challenges are Changing

by Lowell Amdahl

Twenty years are significant. This period constitutes most of the history of electronic computing, and even covers a tenth of the lifetime of our nation.

Looking through the slim early issues of DATAMATION, one is quickly reminded that much of today's technology was being discussed even then in embryonic form. With new appreciation, the reader is drawn to articles

that testify to the inventiveness of the time. Designers, with expensive and recalcitrant components, managed to develop products and systems that were grand achievements. The programmers of that period realized a sophistication in software with (from today's perspective) exceedingly limited storage and modest peripherals.

Where have we made the most

## TWENTY YEARS

gains in 20 years? First and foremost in device technology. Semiconductors for arithmetic and control, in combination with magnetic cores, tapes, and discs, were just then ushering in an era of computer stability and performance/price improvement that has had no parallel in other industries. Today's integrated circuits for memories, microprocessors, and general logic, are creating yet another revolution.

Through the efforts of the machine architect, the network designer, and the ubiquitous software designer, old computer applications have been steadily improved and new applica-

tions conquered. More and more, the user of a system perceives the computer as a tool that need not be understood.

As always, there is an abundance of problems to match these successes. As a large and growing industry we more frequently encounter the environments of government and other industries. The foibles of the communication industry now, in large measure, are our problem.

Banking regulations loom as a major obstacle to electronic funds transfer. Standards, security, and privacy are issues of the first magnitude. The solutions to these problems are vastly more difficult to implement than solutions to purely technical problems that the computer industry has addressed so well in the past.

DATAMATION has recognized its leadership publication role in reporting to its readers not only the technical side of computing, but also these broader issues that we are confronting. It has been a great satisfaction to me to have been a small part of this activity for quite a number of years. My congratulations on this 20th anniversary go to the DATAMATION management and staff, past and present, for a job done well and with considerable foresight. \*

Lowell Amdahl has been a Datamation advisor and contributing editor for well over a decade. His article here is an update of his thoughtful look at the industry that was part of the magazine's silver anniversary celebration back in September 1967. Lowell is the director of advanced engineering for the Infonet Division of Computer Science Corp.

### "... an age of government regulation gone wild."

by Ray W. Sanders

There is little doubt that the technology of data communications will be able to provide on-line computer capability on a massive scale in the next 20 years. Certainly in the last 20 years we have seen data communications progress from a small number of teleprinters being remotely connected to computers to the implementation of large-scale computer networks. With these dramatic changes we have witnessed so far, it should be clear that the future will produce additional changes of great impact, right?

Not necessarily!

We have, in the last 20 years, witnessed not only rapid changes in technology but, as well, we have seen great changes occur in the market environment. If present trends continue, we will most assuredly see the future of data communications controlled by political considerations and *not* by free markets and technology.

It takes only a short list of events of the recent past to vividly make the point that we could well be entering an age of government regulation gone wild. For example, the rapidity with which private line, TELPAK, and WATS tariffs are being changed under the direction of the Federal Communication Commission lead one to believe that Future Shock has finally arrived on the regulatory scene.

This is only the latest of a series of events which began in the United States several years ago when in the name of "competition," we have seen the emergence of additional regulated common carriers whose existence depends almost entirely on regulatory policy and political considerations. Unfortunately, the concept of "regu-

lated competition" has about as much semantic validity as attempting to define the "new" color "flourescent black." There is no more a way one can expect free market forces to operate overtime in an environment of regulatory tinkering than one could expect a black object to spontaneously emit light. In our modern world it appears that where politics and free market forces both are attempting to influence a particular marketplace, politics will prevail every time to the detriment of the ultimate user. This is particularly evident in the data network market outside the U.S. It is clear that the governments of some countries with state-owned communication facilities are attempting to institute pricing and technology policies which will provide direct government control of local data communications markets and indirect control of computer and terminal markets.

So what about the next 20 years? What we can expect is going to depend on the vigor with which the ultimate user can influence the political processes around the world. There is little evidence to suggest that regulated or government controlled entities can meet the challenges of a rapidly changing market such as the value-added data network market. There is much evidence to suggest that the best one can expect over time from the regulatory process is politically controlled market-sharing with innovation occurring at a slow pace.

The users are bound to lose in the end, and it appears that there is little time left for them to influence a seemingly inexorable chain of events. There are solutions which will clear-

ly define regulated monopoly transmission services and leave the remaining value-added market open to free market forces for all participants. We must insist on a reversal of the current trend or suffer the consequences 20 years from now. \*

A Datamation advisor for several years, Ray Sanders continues to contribute an occasional lucid article or express his candid views about the state of the computer/communications industry. However, he spends most of his time as the globe-trotting president of Computer Transmission Corp., the El Segundo, Calif., based data communications firm.

### Not the Mème Chose

by Howard Bromberg

Twenty years may not seem like a long time when measured against the spectrum of the totality of Western civilization, but it can feel like a millennium when one has lived through it recently. Twenty years of effort may not have produced 20 years of results although I most certainly believe that we've gotten more out of these past two decades than just 20 years older. My feeling is that we've become smarter. Maybe not as effective as we would like, but still smarter. Perhaps not as efficient or arrogant or productive, but wiser.

Now I don't intend to get involved in a dialectic regarding the nuances among the terms smarter, wiser, knowledgeable, and so forth. I am certain that you understand the point that I am making without that kind of exercise. And it is that from our experience of the past 20 years we know

more about what we are doing. This is not to say that we know how to do anything, but rather that we know more about what we are doing.

Let me illustrate with an example. About 20 years ago I overheard a telephone call being taken by the late Werner Von Braun at the Army Ballistic Missile Agency's computer center in Alabama. The Congress had recently taken away the responsibility



of building long-range missiles from the Army and given it instead to the other services. Von Braun was called to the phone to respond to a design question from the Navy. He answered that he had the same problem in 1939. The difference is between knowing the problem and encountering the problem. The former makes us smarter.

Twenty years ago, most of us would be hard-pressed to handle a new payroll system, much less on a fixed-price basis. Yet today, there are enough hard core data processors who would accept the name "Payroll" as the extent of the specification from which they could produce a system 80% effective. And look at the COBOL compilers today. Not that putting them on minis is such a great accomplishment. Years ago the first compilers were implemented for machines smaller than many of today's so-called minis. What is an accomplishment, however, are the techniques we have learned that allow fast compilation and development. COBOL compilers are built today in six months and for substantially less than \$100K. We are even building a compiler right now that will generate code for any machine, regardless of whether it has a COBOL. Now that is a pretty fair extension of the "OBJECT COMPUTER IS" clause.

Most problems have moved from the insurmountable to the unaffordable. Differences in measuring machine costs between cpu hours and wall time wane in the face of the ris-

ing labor costs. Programmers with one year's experience are looking to be paid \$10/hour while IMS experts are approaching \$50/hour. So the tab for rewrites is astronomical while the cost for merely hanging in there is foolishly labor intensive as well.

On the systems software side, we've made great strides in operating systems, data bases, and communications. Did you ever wonder what happened to all the OS jokes? And even the hardware side looks smarter. Big is no longer by definition better. False pride has given way to true economics. DEC, for example, could care less whose name appears on their case work and Intel is totally indifferent to whose software they execute. Systems houses negotiate deals with mini manufacturers (or vice versa) so they can disguise software costs in hardware discounts.

We've become so smart that we are now entering an age of new first-time users. Not the Fortune 500 types of 20 years ago, but the small business of today that cannot afford the entrance fees paid by their big brothers. So a new type of challenge is upon us. And one that undoubtedly will be met successfully by the NCR, Burroughs, and Univac types who have

## The Localized Machines Are Coming

by Fred Gruenberger

In case you hadn't noticed it, there is a lot of action going on among the do-it-yourself computer group. As one indicator, there are already seven journals catering to this group, all offering much the same material and competing for the same advertisers. They publish lists of things (clubs, meetings, stores, manufacturers); endless programs in BASIC (programs liberally sprinkled with GO TO's and usually reproduced in six-point type); BASIC interpreters in ever-smaller versions; and a great deal of material that is misleading, badly documented, and sometimes downright wrong.

Not much harm is being done, but not an awful lot of good, either. When the smoke clears (and at least four of those seven journals die) and the computer-as-big-toy craze subsides, there will still be left a distinct trend: hobby → home → personal → small business applications, and that will be followed (if, indeed, it is not already taking place) by the use of desktop computers for distributed computing in large businesses.

When you can have at your fingertips, all to yourself, something like:

- 64KB of random access storage
- endless auxiliary storage on cas-

settes or floppy discs

encountered the problem before while DEC, DG, HP, and the like, along with their OEMs will spin a lot of wheels before they really know the problem.

One of the major accomplishments of these past two decades is that we have become much more aware of what we do poorly. For example, it is pretty clear that we must concentrate on improving the way we design systems, how we measure their workability, individual productivity, testing procedures, automating maintenance and modification, and so on. And some of these are changing already because we have, over these past 20 years, become knowledgeable about the problem. Programmer communication is a case in point. Our staff of trained C3PO's is already able to interpret user requirements. Within the next 20 years we will have thousands of R2D2 robots available to reduce human labor intensity and apply the force of automation to the new found skill of on-time program production. \*

Howard Bromberg has been a Data-mation contributing editor for longer than anyone can remember. To support a rather florid life style, he founded and is president of International Computer Technology Corp. in San Francisco. His French is impeccable.

- microsecond cycle times
- keyboard, cathode ray tube display, and hardcopy
- packaged software to run all of the above

then, with some knowledge of what computing is all about, you can declare your independence from the tyranny of the big machine, its endless red tape and long turnaround time, and the inevitable interference factor caused by sharing the resources with others.

There are drawbacks to this scenario. The squirrel factor will be high (just who owns company-produced data?); the opportunities for bad or even worthless computing; an efficiency level that will almost certainly be low; opposition to the point of internecine war from the centralized high priests—but it's coming, and fast.

There is going to be a tremendous need for quality software; not just languages and miniature operating systems, but statistical packages, scientific problem solutions, and tiny management systems (a mini MARK IV?). We should be busy transliterating the best systems and software now available for large machines into quality



## TWENTY YEARS

products for the 8080 crowd.

If the movement I've described is inevitable, then it should be guided and planned by older and wiser hands at the trade. There is a huge education and training problem. The people who will use the localized machines (the distinction between mini and micro will soon be academic) will not want to be computer experts, nor should they be, but they will have to know some of the basics of the art. You won't want them writing programs to search their files linearly for each transaction. They ought to know about looping and subrouting and the use of library programs and, of course, how to document what they do. All these things have been worked out over the years—usually painfully and at great cost—and the whole process can now be shortcut for the coming masses of users. An article on looping that fails to tell about initializing the loops (as in one recent journal article) can do immeasurable harm.

We know that quality software is frightfully expensive, so the question is, who is going to pay for it in this new area? It seems to me that as small machines proliferate in business applications, the companies involved may find that *not* arranging to pay for it will be far costlier in the long run. It will not arrive "free," although there might be significant aid from the government, since government agencies will be one of the biggest groups involved. \*

Fred Gruenberger is a professor of Computer Science at California State Univ., Northridge, and is the publisher of Popular Computing. He is the most widely published author in the field, with 26 books to his credit, and over 100 journal articles in the past 25 years.

Besides being just awfully good at pointing out all the mistakes that have ever been made in the field, he can point with pride to having predicted the rise of the minicomputer, in a 1967 Datamation article.

## A Little Less Method in Our Madness

by Louis B. Marienthal

So far, during the short, turbulent life of the computer industry, changes in hardware have been more dramatic than the changes in software. But software suffers only by comparison.

Money and intellectual effort have been spent lavishly on programming. There are libraries of books about programming languages and compil-

ers, operating systems, programming techniques, and project management. And there are libraries of, by, and for the programmer.

Most of the investment has focused on the methodology of programming. But, unhappily the functions to be programmed have received comparatively little attention. We have made *how-to-program* into a science while largely ignoring the *what-to-program*.

Problem definition traditionally has been an *ad hoc* process whereby a system analyst converts the user's desires into problem statements for the programmer. Exceptionally, there are three problem/function areas that have received some general attention: sorting, report writing, and data entry.

Sorting was recognized as a bottleneck in the first Univac installations, and so intensive theoretical study resulted in several different methods of sorting. Because the problem is limited, most of these methods present the user with similar sets of parameters to use in defining the file to be sorted.

The functional analysis of report writing resulted in RPG, which is a

statement of a report in its own terms, but with a grammar familiar only to programmers. There are the beginnings of procedures whereby non-programmer users can define reports interactively with computer assistance. We could use more study of a theory of report writing — the options that a user may want, the terms that a user might employ to express his options, the logical constraints imposed by various data structures, and the physical constraints imposed by various output devices.

I believe that other functions can be defined in user-oriented or problem-oriented terms. Candidate functions include record selection (e.g., for a report), record purging, record transformation (i.e., input plus old record yields new record).

Over the next 20 years some measure of intellect and money should be diverted to the analysis of the tasks to be programmed as opposed to programming methodology. \*

Lou Marienthal, a consultant in the small business systems end of the industry, has been a Datamation author and small systems advisor for many years.

## The Computer as Household Appliance

by Portia Isaacson

The age of the personal computer is clearly foretold by recent happenings. The triggering factor was the decline in the cost of a computer system to about \$1,500. Tens of thousands of these low cost computers have been purchased by individuals during the past two years. A new hobby was born complete with clubs, posters, t-shirts, bumper stickers, and conventions.

The enthusiasm displayed by computer hobbyists is derived from the very general nature of the computer itself. The personal computer is the solution of a different problem for each individual and its uses are as varied as the individuals that apply them. Applications include entertainment via computer games, control of systems such as model trains, word processing, experimental music synthesis, financial analysis and planning, and speech synthesis for the mute to name only a few.

The computer is a mind-amplifying tool. As muscle-amplifying tools have enabled us to make physical achievements far beyond our unaided abilities, the abundant computer will allow us to make intellectual achievements far beyond what we can now imagine.

The computer hobbyist's activities are the leading edge of computers' movement into the home. By the very early 1980s, most American house-

holds will own personal computers. What family wouldn't be willing to spend a few hundred dollars for a device that would tutor their children in every conceivable subject from early childhood through college? Or, if the family is only casually interested in the educational value of the personal computer, perhaps its nearly unlimited entertainment value will be the convincing factor. Of course, the personal computer is hardly limited to education and entertainment since it will be capable of a seemingly endless variety of other tasks. The personal computer, with its large library of program cartridges, will soon be an essential appliance in the American home.

We live at a marvelous time—we are at the threshold of a change in our society as fundamental as the changes that came with the printing press, the assembly line, or the automobile. The change will begin when information processing power becomes available to the individual. The change has started. \*

Dr. Portia Isaacson is Datamation's newest contributing editor and our specialist on personal computers. She comes by it naturally, being the proprietor of The Micro Store in Dallas and the chairperson of this year's highly successful NCC in Dallas where her addition of a personal computing show almost upstaged the main conference.

# The Rough Road to Today's Technology

by Dan M. Bowers

People may come and go, but some products continue to haunt their designers. A look at some of them over the last quarter century provides clues to future technologies that have real-world possibilities.

The quarter-century history of the computer industry has left us with many significant milestones to look back upon. The serial processor. Von Neumann's machine. The magnetic core memory. The magnetic drum and disc, and the removable disc. The crt terminal. The digital modem. Solid state memory. The microprocessor.

In addition to the milestones on our road, there are also many headstones in our graveyards and even skeletons in our closets. These represent developments of exotic techniques and devices that, in their time, were as highly touted and as enthusiastically received at that great crap table on Wall Street as the truly significant and lasting breakthroughs. Holographic and laser memories. Fluid logic. The optical disc memory. Array processors. The digital unit-record microfilm chip. Cryogenic memories. Ternary logic. Viatron.

What was it that separated the developments worthy of a Hall of Fame (and which not incidentally reaped untold millions for those who bet on them early enough) from those that exhibited equal initial brilliance but turned out to have the lifetime of a meteorite (and sent venture capitalists to driving taxicabs in Altoona)? Was it luck, timing, science, engineering? Or promotion, soothsaying, statistical extrapolation, the Monte Carlo method? Or devotion, dedication, hard work? Fraud and deception?

Many of these breakthroughs died because the results of early experiments could not be consistently manufactured, because the early experimental results were too optimistically interpreted, because costs of production units could not be made attractive, because the development effort took so long that other techniques overtook them, and in some cases because the early announcements were more stock promotion puffery than technical fact.

Many others survived, but on a much more limited scale than earlier hoped; they exist today within or on the fringe of the computer industry, still alive but not setting the world afire. A few may yet prosper and even become cornerstones of the industry.

Let us call from memory some of

these possibly (and in many cases, best-) forgotten breakthroughs, study their origin and the state of technology at that time, recount their history and ultimate destiny, and derive lessons that might profitably be kept in mind as we read the publicity for the "breakthroughs" of today and tomorrow.

## Search for bulk memory

Computer-man has sought after the high speed, low cost, random access bulk memory almost from the dawn of computer-time, from the day he began to envision being freed from the shackles of serial delay-line memories and oxide-on-metal magnetic tape (at seven pounds per reel, with structural reinforcements to the building under the tape cabinet).

Bulk memory highly depends on the point of view. The first wondrous bulk memories, circa 1960, contained on the order of 50 megabits (which, for those of you who were not around when bits were the standard unit of measure, is just over 6MB), took up as much room as a grand piano, and looked variously like a stack of records on Goliath's changer (IBM's 305 RAMAC), a miniature steel rolling mill (Univac's Randex), two dozen Chinese laundry lists hung out to dry (NCR's CRAM), or a wheel lost from Casey Jones' locomotive (Bryant's 320 and 4000). With access times on the order of one-third second, at a cost of 0.1¢/bit, these bulk memories opened whole new applications and methods of data processing. Between them and the high speed (8.3 msec.), low capacity (100 kilobits), medium price (10¢/bit) head-per-track drums, plus the new core memories (1 usec., up to 8K characters. \$1/bit), computers had the capability to solve any problem.

Still we continued to yearn for the bulk memory which could be roughly defined as an order of magnitude more storage per device than we already had at any given time. For two decades we have been presented, on roughly a yearly basis, with the answer to the bulk storage problem. Let's analyze some of the answers we have seen over the past decade and a half, most of which are equally as well-remembered as Whistler's Father, M. LeFarge, or

Queen Kong.

What is a magnetic drum but a thin, virtually massless layer of ferrous oxide whirling in circular fashion, tangentially proximate to magnetic heads, and supported by a sinfully massive metal cylinder. What could be more logical than to eliminate the metal mass, float a layer of oxide-on-mylar, in the form of magnetic tape, on a layer of air, thereby simultaneously improving cost, speed, and operation in rugged environments (discs and drums, because of their mass, tend to act like gyroscopes and tear up their bearings under G forces such as those encountered in airplanes and ships).

Thus, in 1962 when the 50 megabit devices were the largest available, the tape-loop RAM emerged: 16 30-inch loops of two-inch-wide magnetic tape whirling at 360 rpm, each continually floating past its own head-positioning mechanism which positioned a set of read-write heads to any of 112 channels. Fifty megabits of removable-module storage with access time of 87.5 msec. at a mere \$15,000—a bargain price in 1962.

What happened? The tape-loop RAM was laboratory-proven using one-inch tape on hand-built models. Unwise extrapolations were made ("if it works on one-inch tape it must surely work at least twice as well on two-inch tape"), and the product was announced to the public before further tests or any production engineering was done. It ultimately proved impossible to produce units that would work for more than a few hours of continuous whirling (and consequent flexing of every part of the tape and oxide and the bonding between them) before chewing up the outer channels and then the inner channels on the tape.

Several years were spent trying to solve the problems. They never were solved, and even if they had been time had marched on and the world no longer cared about 50 megabit storage at 87.5 msec., even for \$15,000. Other simpler forms of tape loop memory were introduced during the mid and late '60s, but aside from a brief vogue as speed-shifting buffers in rather mundane telecommunications systems, they

## ROUGH ROAD

achieved no success.

The tape-loop RAM would have been a resounding success had it fulfilled its 1962 press releases in 1962 or even 1963. It was 1965 before "production" units were delivered, and even they could not fulfill reliability specs without extensive and frequent hand-engineering. By that time the world had gone on to greater things; the notion of a "mass memory" had moved up an order of magnitude. The RAM had missed its time.

What killed the RAM? It was announced and touted to the world before being completely engineered. It could not be mass-produced to meet both advertised specifications and price. The concept was timely but the execution took so long that nobody cared.

### Magnetic cards, strips, and chips

Numerous attempts were made to provide bulk memory—as many as a trillion bits—using magnetic media in nonrotating form. Some even were used at a few installations for a few years. The most successful of this class of device was NCR's CRAM; 384 foot-long sheets of four-inch wide mag tape were hung from five binary coded rods. One sheet was selected, dropped down a chute, and wrapped around a drum for reading. CRAM was, in effect, a magnetic drum with a replaceable surface. It was widely used for a decade and was an important contender for half of that period, until the dramatic increases in density (and capacity) of the magnetic discs and reductions in their access time through significant mechanical sophistications left it behind.

The other card, strip, and chip systems utilized equally bizarre mechan-

ical-magnetic systems. None achieved the success of CRAM. In fact, none of them ever worked very well at all, ever. For two decades, our father who art in Armonk expended tens of millions of dollars developing a magnetic-strip tub-file memory under names like Walnut and Cypress. The basic concept had magnetic strips hung radially in a tub that rotated eccentrically, thus providing access to all strips by a fixed-in-place plucking mechanism. The plucker extracted a chip, passed it by a read/write head, and returned it to its correct place—usually.

What went wrong? The storage capacity of these strip memories was tremendous, and the mechanical complexity does not seem beyond that of the finely positioned access mechanisms of today's disc files. However, it has been the case in our business that devices requiring two dimensions of controlled motion have been at least four times as difficult to make work reliably and repeatedly, and the two-dimensional systems have never endured. The 305 RAMC—the first disc file concept—gave way to comb-arm one-dimensional devices. The successful CRAM was one-dimensional and endured long after the 305 had disappeared. The masses, momentums, inertias, and shifting reference points of two-dimensional systems have kept their inventors busy trying to reproduce their laboratory concepts on the production line. Meanwhile, disc file engineers again double both the track and bit densities, the price of heads and electronics again drops by half, the disc access mechanisms again become 25% faster, and the established world has passed by the inventor.

### Memories

Another breakthrough of the early 1960s was the optical disc memory,

with 2,000 bits per inch and 2,000 tracks per inch density, read by a servo self-tracking light spot, providing throughput of 2.7 MHz and 65 megabits on a single disc. Granted it was a read-only memory, but many library-class problems can use read-only storage.

Our father in Armonk was the second company in a series of four (spanning a decade) to sponsor the concept and attempt to put it to useful work, as the dictionary in a machine language translation system. Like the RAM, however, the Photostore looked good as a laboratory concept but never worked satisfactorily in the real world of useful work and bottom lines. A mote of dust in the production process (using a laser in an evacuated chamber) was enough to obscure hundreds of words, making a perfect disc impossible, and all the errors were different from disc to disc. This meant that each disc had a different errata file in core (or magnetic disc), a programmed skip to it, etc. All this hassle was simply not worth the bother for a read-only mass memory that was not cheap in the first place.

Another laser-produced read-only memory used holes burned in a mylar tape. It had similar technical problems, balanced by no shining virtues as to reliability, cost, or performance, and the world pretty much ignored it. Read-only memories were not very exciting when the magnetic disc densities had just doubled again and gone down in cost.

During the mid-'60s, Ma Bell's prestigious research laboratory announced another breakthrough in mass memory, again of the read-only (or, in their words, "semipermanent") class. Information was stored as an array of holograms, and reading was performed with a laser and an array of  $10^4$  photo-

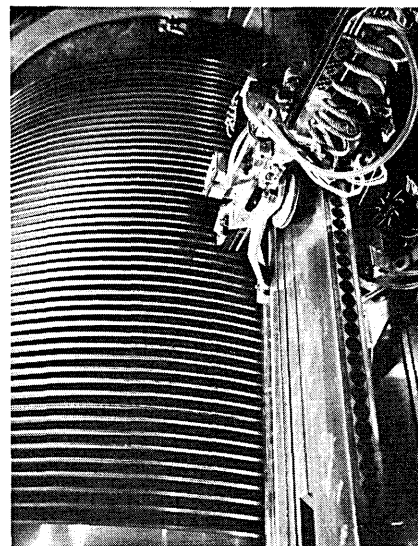
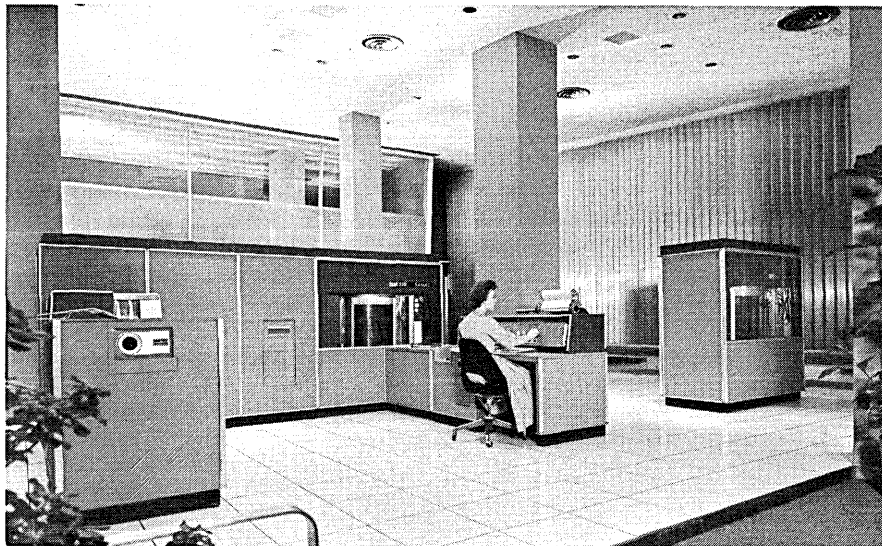

The IBM 305 RAMAC system and IBM's answer at the time to bulk memory—the RAMAC's discs stacked like a giant juke box.

detectors. Any of 256 holograms, each containing  $10^4$  bits, could be positioned and projected upon the same array of photodetectors.

For such a device to function, significant advances in a number of technologies were required: mechanical positioning, deposition of photodetectors, photographic preparation, laser beam deflection, etc. This was not easily done even in the environment of the world's most advanced laboratory, and to make such a device mass-producible and make it function in the usual working environment, at a price the ordinary user was willing to pay for a read-only memory, was beyond even Ma Bell.

Since so many of our wonderful and now extinct breakthroughs in storage were read-only, a word is appropriate regarding a significant shortcoming common to most of the programs discussed. Laboratory engineers created devices, and announced them to a world that, in most cases, was properly impressed. However, the inventors by and large left it to the users to imagine how these wonderful inventions could be put to useful work. The users, faced on the one hand with working systems marketed at a firm price with well-defined performance characteristics, and on the other hand with an unknown device having apparently marvelous performance by requiring an unknown amount of time and effort to put into use, chose (rightly) the known quantity.

It is still the case today that the computer industry has all the devices needed to perform any kind of processing; the challenge is to create cost-effective systems from existing devices. Had the purveyors of some of the read-only memory devices marketed them within useful systems, they might be important factors today. It is unfortunate that engineering expertise and applications know-how seldom reside in the same individual, much less in the same company.

Almost annually during the 1970s, a major company has announced the answer to the bulk storage problem in the form of a room-size bank of tape cartridges or small tape reels that can be plucked and read or written by a single read/write head and mechanism. In some devices the mechanism is transported, in some the tape containers are transported, and in others they both move. These devices are clever combinations of some of the least attractive features of earlier inventions. They have at least two dimensions of motion. They transport objects of considerable mass. They have a large number of moving and wearing parts to fail. They are expensive and slow. They must be combined with an information retrieval indexing and directory system

of considerable complexity to find the desired information. And they automate a function that has historically been done inexpensively and effectively by manual methods. Although they have not been with us long enough to completely write their epitaphs, we would not be wrong to begin chiseling the headstones.

### Core memory

Since memory is such a vital element of any data system (and, in fact, widespread use of data processing systems began only after memory devices of some capacity and convenience had been developed), the attentions of inventors have been devoted to other forms of memory, not just bulk memory. Principal among these has been the development of replacements for core memory, the demise of which has been widely predicted for a decade.

Originally internal memory consisted of mercury delay lines, which were slow, touchy, and bulky, but far more economical than the relay and vacuum-tube flip-flop alternatives. A generation of machines that followed were based upon acoustic delay lines using quartz or magnetostrictive wire, and several of these remained successful even after the introduction of the much faster core. But the cost of core systems fell, they achieved a dominance that only now, a decade-and-a-half later, is being lost.

### And the challengers

The thin film memory was one challenger to the core system. They utilize deposited spots of ferrite material for storage of bits, rather than the ferrite donuts used in core. Because the deposited two-dimensional film has different storage characteristics from core, a thin film memory is inherently faster than core, but requires more costly driving and sensing electronics. Since it is a basic tenet of computing equipment that in many cases higher speed is worth more money, a bright future was seen in the mid-1960s for thin film memories in scratchpads and in machines requiring very high speeds. The technology was well-developed, and several popular computers were marketed using thin film. Predictions were made that the ability to batch fabricate thin film memories would result in considerable price reductions and the displacement of cores.

A funny thing happened on the way to conquering the world. Integrated circuit memories began to eat into thin film's advantage at the high-speed, low-capacity end. And magnetic core technology, pushed by several strong vendors with massive self-interest in seeing cores remain dominant, continued to improve in performance and price.

Caught between two strong technologies, one old and one new, thin film smothered and quietly expired.

Several varieties of cylindrical film memories—variously called plated wire, rod, rope, or woven wire—were developed in the mid-60s. In cylindrical film memories the thin film was variously wrapped around one of the sense wires, or woven among them, or wrapped in rod or whisker form. It was slower than thin film but faster than core, and designers claimed it would ultimately be the cheapest of all magnetic memories for a given capacity. Such memories were used in some lines of commercial machines, but the predicted manufacturing efficiencies were slow in coming, and the squeeze between advances in solid-state memories and improvements in core memories snuffed out whatever promise might otherwise have existed in cylindrical film.

One of the seven dwarfs developed and announced in the late '60s was the laser-film memory using a thin ferromagnetic film combined with a laser. Writing was accomplished by heating a spot of the film with the laser to the Curie temperature ( $360^{\circ}\text{C}$ ), at which the original polarization is destroyed and a new polarization can be induced by a weak magnetic field as the material cools. Reading was performed by sensing the rotation of plane polarized laser light as it passed through the magnetized film (the Faraday effect), the rotation being proportional to the direction of magnetization (among several other things).

Such a device would constitute an interesting laboratory experiment for a graduate student in physics, but one could hardly imagine a more complex and impossible-to-mass-produce conglomeration of technologies. Despite its forecasts as the answer to the mass memory problem, this Rube Goldberg machine quickly and mercifully died.

Cryogenic, cryoelectric, and superconductive memories are based on the ability of certain metals to sustain electrical currents indefinitely, without outside power, until disturbed by an outside power source such as a magnetic field. These metals thus exhibit zero resistance; unfortunately, this phenomenon occurs only at a temperature in the range of  $3^{\circ}\text{K}$  ( $-270^{\circ}\text{C}$ ,  $-454^{\circ}\text{F}$ ), which is not found in your ordinary computer room.

The physical arrangement of the cryoelectric memories should make them easy to mass produce. When combined with the refrigeration units required, however, cryoelectric memories have not been proven feasible on any useful scale or in any useful environment, despite extensive efforts on the part of the largest and most capable laboratories. Their ultimate (and

## ROUGH ROAD

perhaps only) usefulness may come in the space environment, where absolute zero temperature comes for free.

### The big busts

Once upon a time, in the wild and woolly days of the mid-1960s, any two engineers and/or programmers working in a garage with an oscilloscope and a mimeograph machine, and capable of making exponentially ascending curves on a sales and P & L forecast could get at least a half million dollars from some "knowledgeable," high-technology venture capital outfit. Rumpled-suited, tieless, long-haired, with the gleam of the inspired but distracted scientist in the eyes behind horn-rimmed glasses, these entrepreneurs dispensed, in reserved tones, obfuscatory descriptions of breakthroughs that would merely revolutionize the data processing world. Immaculate in silk suits with wide silk ties, well-barbered and mustachioed, with the gleam of greed behind their gold-rimmed glasses, the gunslinger venture capitalists soaked up every word, understood not a one, and eagerly handed over their money (or, more properly, the money entrusted to them by equally greedy investors) to (ad-)ventures with names like Viatron, Energy Conversion Devices (Ovonics), Computing Efficiency, BIT, and Foto-Mem.

Many of these enterprises had no viable business plan or direction and no demonstrated product. Some, like Viatron, bet upon wildly optimistic extrapolations of the rate of technology advancement. Some, like Ovonics, were based on supposedly new, but unproven, basic physical principles.

Their histories were similar. Gather a technical staff. Announce the breakthrough. Get the money and spend it. Go public. Announce the breakthrough in even more glowing terms. Watch the stock skyrocket to ten times the opening price, while spending the money raised at the public offering. Take orders. Announce logical reasons why equipment is not being delivered. Deliver some hand-built models. Take them back when they can't be made to work. Borrow money, leaning on your now fearful investors to come up with guaranteed loans, debentures or preferred stock to "protect" their investment. Abandon the originally touted breakthrough and frantically seek other products or workable business plans to salvage the company using this new money. Go into Chapter XI as quietly as possible. Exit wiser than before and seek new adventures. Leave behind on Wall Street a fear of new computer-field ventures that will endure for a decade.

### Retrieval systems

Several of the memories discussed above utilized (or died in the attempt to use) optical techniques to accomplish digital data storage. The generalized problem of information retrieval—the "library" problem—requires rapid random access to a combination of digital data (names, numbers, etc.) and graphic data (maps, signatures, original invoices, catalog pages, parts drawings).

During the 1950s and '60s, a number of major attempts were made to develop the true unit record retrieval system, in which one search process would retrieve one record containing both the digital data and graphic

images. The early efforts—Minicard, Magnecard—utilized microfilm chips as the storage medium. Each postage stamp-sized chip contained a half-dozen or so 8½" x 11" pages of images, plus a few thousand associated bits. Retrieval of information required the handling and scanning of thousands of chips and the reading of digital information to find the right ones. In order to reduce the number of chips handled during a particular search, chips were massively duplicated and cross-filed into subcategories selected by human analysts. A complete system required input equipment, processors for code generation, cameras, film processors, film duplicators, clean rooms to keep the dust off the high-reduction photochips, chip sorters and selectors, chip copy-maker, viewers, and enlargers. All of these devices pushed the then state of the art in optics, electronics, mechanics, hydraulics, and chemistry. A complete system was in the \$3M range, in 1960 dollars. Some were sold to the Defense Dept., where cost is no problem, but attempts to commercially market the systems failed.

Similar in concept but vastly simpler was the aperture card, which also combined digital and graphic information on a single element, the common 80-column punched card. Digital data was punched as usual into the card, and a microfilm chip was glued into a square hole in the card. The digital capacity was much less than that of the microfilm chips, and the density of the microfilm was also less, but this made dust less of a problem. The aperture card could be handled by conventional punched card equipment, and the preparation equipment was mundane and



A random access memory from Potter Instruments used loops of mag tape in cartridges, each storing 3 to 40 million characters. Average access time was 168 milliseconds.

Back when discs were not considered a removable medium, General Precision offered them in this size.

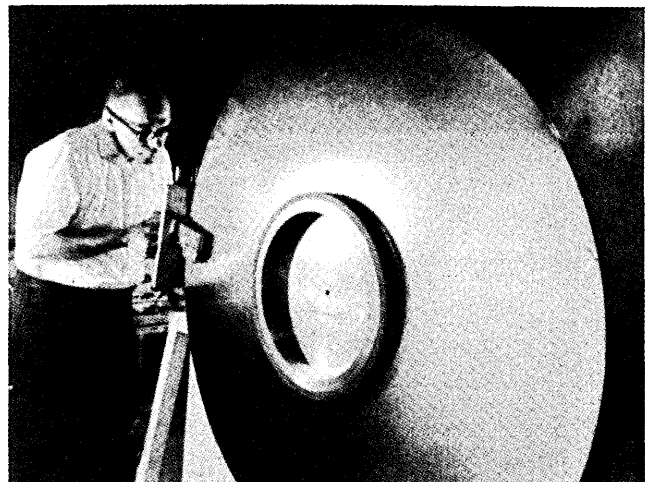



inexpensive. The microfilm chips became scratched after many passes through readers and sorters, but since they were inexpensive this presented little problem. The system was slow but worked reliably. Aperture card systems were the backbone of most of the useful unit record image-digital retrieval systems, and are still in use today.

Another attempt at the storage and retrieval of combined digital and graphic information was made in the early '60s by the major manufacturer of videotape equipment. Using conventional videotape for image storage, and recording digital information on the audio track, 250,000 pages could be stored on one reel of tape. Little interest was shown in this concept, and no known working commercial installations were made.

Roll microfilm devices with digital encoding, such as Miracode, have been a popular answer to the image retrieval problem. These are semimanual (or semiautomatic, depending upon your point of view). Probably the most sensible solution was introduced by 3M in the late 1960s. Recognizing that digital information is most simply and effectively stored by magnetic means and graphic information by microfilm, the Microdisc I combined a minicomputer retrieval system with disc memory for indexing and content searching, controlling a roll-microfilm viewer for display. Fiche versions of this also were available, and these are still today the most natural, effective and reliable "library" information retrieval systems.

### Processing and I/O technology

Although many of our "break-throughs" have been in storage devices, the remainder of the technology has not been ignored. The answers to "whatever happened to . . ." many formerly prominent items are rather simple. Digital modules, once a \$20M industry, were quickly obsoleted by integrated circuits, despite the efforts of manufacturers to peddle module cards containing IC's. Incremental magnetic tape recorders had an extended heyday in the '60s because they eliminated the need for an expensive core buffer to create tape records; once the cost of the buffer was drastically reduced, the awkwardness and slow speed of the incremental method was no longer justifiable.

Punched tape and cards, which many expected to be on the "whatever happened to . . ." list by now, are thriving despite competition from tape cassettes, cartridges, floppy discs, and key-to-tape and key-to-disc equipment. Equipment and techniques have improved, costs have decreased, and paper tape and cards are now more widely used than ever before. They are still convenient, reliable, well-known

and accepted, and they have the massive support of two of our most influential companies, IBM and Teletype.

In the mid-1960s came the announcement of a complete set of fluid logic elements and a working fluid computer. The fluid in this case was air, and the complete system needed only a small air compressor as the power source, a handful of cheap (a few cents) injection-molded gates, flip-flops, and some plastic tubing to "wire" it up. No noise problems, no radiation-proofing, no heat and humidity restrictions.

A decade earlier, fluid computing doubtless would have achieved some market penetration against \$150 electronic flip-flops and \$50 gates. But in 1965, the integrated circuit had already given us the \$10 flip-flop and would ultimately give us the 10¢ flip-flop. The computing industry, totally invested in electronic technology, ignored the slowly operating fluid logic, despite the fact that in many control applications it might have made good sense. The fluid gates and flip-flops were incorporated into simple pneumatic control systems, which are now frequently driven by the integrated-circuit computers that excluded them from the computer business.

Fluid logic was foreign to the electronic-based computer industry. It was also slow and quite obviously would never solve more than a very small part of the industry's needs. But in the early 1970s, optical digital circuitry—and therefore the possibility of an optical computer—was announced. Faster even than electronics, optical processing would seem to be the ultimate answer to a technology that has always announced new speed improvements in banner headlines.

The results are not yet in, but the high cost of optical elements has limited their use to critical and low-volume applications, such as noise isolation between devices. These self-contained devices are TTL-in and TTL-out; we have not yet seen computers or computing elements with logic connections made by mirrors, lenses, or fiber optics. Thus far the declining cost of electronic elements and their speed have been satisfactory, so there is no clamor for the optical computer. Nor has anyone satisfactorily answered the question of how to store and retrieve data optically, thus avoiding the need for a hybrid optical-electronic-magnetic system. And there has not been a massive R & D effort in the development of optical devices on a production basis.

It will come, probably in another decade; not with a bang but with a whisper. Self-contained chips such as the present opto-isolators will appear, perhaps first containing a complete

opto-processor, with electronic in/out. Momentum will build, such problems as storage will be attacked and solved, and we will have the optical computer—but not within the working lifetimes of most of us. The advance of technology is inherently irresistible.

### Fiber optics

For more than a decade fiber optics (FO) has been an accomplished solution, one in search of a problem. Medical fiberscopes, image guides, light pens, FO magnifiers and faceplates for crt's were developed early, and the advent of flexible plastic FO to replace glass reduced the cost and increased the potential range of applications. Scanners, sensors, movement detectors, the man-machine interface—all were suggested as ripe for adapting FO to data processing.

Aside from a few minor applications such as illuminating all the holes in a paper tape reader from one light bulb, FO has failed to penetrate the dp business. In fact, its impact on the world at large seems to have been limited to feed-back from automobile turn-signal indicators and cute "trees" on chrome coffee tables.

But the solution is about to find its rewarding problem in communications. Equally with the dp business, the communications industry perpetually needs more bits-per-second (they call it bandwidth) and transmission using an optical rather than electrical carrier can provide it. Over the next decade FO manufacturers may be kept so busy building optical telephone lines that they will not miss the business they never got from dp. And a well-developed optical communications technology cannot help but speed the advent of our optical processing units.

### Ternary logic

A digit in the binary system can describe either of two quantities, two digits describe any of four quantities, three digits eight quantities, etc. A single ternary (three-valued) digit can describe any of three quantities, two digits can describe any of nine quantities, three digits 27 quantities, etc. Why not, then, develop three-valued devices and vastly improve our processing efficiency per number of devices? Working on this premise, a number of logicians, mathematicians, researchers, and others who have no better use for their time than to toy with mathematical games, have developed a complete set of rules and theory for ternary machines, all of which is published exhaustively in such unread journals as the *IEEE Transactions on Electronic Computers*.

The problem is that the physical devices used to build machines are inherently binary—or, more accurately,



## ROUGH ROAD

are easier and cheaper to build as binary devices. The difference between writing and sensing one or zero in a punched card, magnetic spot, relay, or flip-flop, and being able to write and sense three states (how, for example does one detect half-a-hole in a punched card?) is tremendous in terms of reliability, operating margins, and producibility.

Some ternary devices have been produced, but their cost is sufficiently greater than binary devices that it is always more cost-effective to stay in binary. Further, a full range of ternary devices—most notably including storage—is by no means available. Further, the computer world has always been binary and will not change in the absence of compelling economic reasons to do so.

Ternary logic cannot be counted out since there is always the possibility that someone will discover a naturally three-state material or device. Nature does not seem particularly inclined to do so, however, so we might as well reserve the cemetery plot.

### Analog and hybrid computing

As computing technology developed through the 1940s and '50s, there was nearly an equal split between those who believed that analog computing was the most effective processing technology and those who advocated digital techniques. At that time, both kinds of circuits were horribly expensive, there was no important storage of either kind to influence the decision, and analog processing was much faster for a given amount of data.

This status changed with the development of binary devices and the headlong rush through the 1960s to make them cheaper and faster; the influence of the Hollerith card and its principal exponent were no small factor. Seeing the world rushing toward the digital bandwagon, the analog people countered with the hybrid machine, which was made up of both an analog and digital computer and divided problems into two parts, solving each part on the machine for which it was better suited. This system was effective for large simulation problems, such as space vehicle and nuclear power plant design, but never achieved any acceptance against fast, effective, inexpensive digital computing in the ordinary working world.

The analog people are still playing their old tune, but their market is now largely limited to educational toys, such as college laboratory demonstrators. Even complex simulation problems are now best solved on fast digital machines. There are segments of

everyday processing where analog and hybrid computing might be effective, such as data acquisition and business forecasting, but those who understand the problems do not understand analog/hybrid, and those who understand analog/hybrid do not understand the real world. If the gap can be bridged, perhaps we can avoid digging another grave.

Like analog and hybrid computers array/associative processors and their kin, content-addressable memories (CAM), are not well understood by the general population of computer people. These devices perform many operations in parallel. In a CAM, for example, the entire memory is searched in one memory cycle. They have been used principally for pattern recognition, signal processing, scheduling and routing, and mass information retrieval problems.

Despite the fact that solid state technology is now capable of cheaply producing the complex elements of an array processor, there is no great push in this direction because the mass-market applications are so effectively handled by conventional machines. These techniques seem to be relegated to the restricted applications they have always served; perhaps until some complete revolution, such as the conversion to optical computing, occurs.

### What's been learned

The list of "whatever happened to . . ." items is more endless than the pages of this magazine. Graphic computing and terminals and computer output microfilm both had a brief publicity vogue and then settled down to their own corner of the market. Flat-panel displays have been heralded for a dozen years but are just now beginning to appear and to challenge the uncounted millions of crt's. Color crt's are finally available (though a luxury). Optical character recognition and optical mark reading are still with us, but they have yet to surpass the widespread usefulness of their brother, magnetic-ink character reading.

Data entry is the facet of computer systems most ripe for new technology; ocr/omr/micr will play a part in the reconstitution of data entry that must come. Just as it is no longer possible to handle all telephone calls through human-operated switchboards, it will not always be possible to input all data through a human-operated keyboard.

Some of the "dead" breakthroughs may live on as appropriate portions of them are adapted for use in new ways or other systems—fluid logic elements, analog/hybrid, laser-based memories. Some may yet see the promised land of milk, honey, and an 18-month order backlog—bubbles and CCD's, cryogenic memories, optical circuitry, array pro-

cessors. The others are gone forever, in most cases deservedly so.

What can we learn from the past to help us as we evaluate new advancements? First, do not underestimate the power and momentum of entrenched technology and invested dollars. The mature computing industry has well-established conventions of software practices, hardware design, etc., and these habits are protected by massive investments in products, plants, production equipment, and training. A breakthrough, even though technologically sound and promising, is unlikely to succeed if it requires abandonment of current directions.

Second, the strongest underpinnings of our business, over a long period of time, have been semiconductor technology and magnetic storage. Do not bet against either of these. When they challenge each other, hedge.

Third, the real "breakthroughs" have natural scientific bases, such as the hysteresis property of magnetic material, or the holes in semiconductors. Rube Goldberg contraptions are usually trying to circumvent some natural law (or someone else's patent), and usually fail of their own weight.

Fourth, beware the entrepreneur with his sincere scientific demeanor, his abstracted gaze on your wallet, and an incomprehensible explanation of his wonderful new device. If it cannot be made comprehensible and sensible. It probably isn't.

Fifth, technology will improve. We will have faster, cheaper, better, and bigger, and not at the expense of the environment, minority groups, or endangered species. Our natural-law breakthroughs will provide more benefits while consuming less power and occupying less space. There is still room in the cemetery for the others. \*

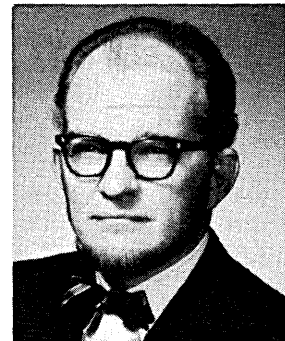

Mr. Bowers has been active in the industry for more than 20 years, dating back to the Univac 1 days. He has been a design engineer, research scientist, and engineering manager, and has been heading his own consulting company in Fairfield, Conn., for the last 11 years. He has served with the National Security Agency, Computer Control Co., IBM, and Potter Instrument.

# The Way It Was 1957

A vintage year.



by H. R. J. Grosch

*Here's some vintage Grosch, complete and unexpurgated—a free-flowing romp through the early days of computing by the industry's unchallenged l'enfant terrible. Not all the names may be familiar, but the flavor of the fervent fifties comes through with a clarity mellowed only slightly by time.*

A vintage year, it was; one of the great ones. The big companies were jumping into the bear pit. The first three user groups were off and running. Books—good books—were be-

ginning to appear. The professional societies were taking firm shape; ACM was ten years old! And yet, the sugar in the grape was still there: the feeling of unity, the ability to know most of the people, most of the installations, most of the problems. It had not fermented to the heady optimism of the early sixties, or the vinegar of Viet Nam.

Let me take you on a tour of the times. It will have to be a short one, and certainly many old-timers will be offended at the places where we stop, and at the guide's prejudices. Let's

Dr. Herbert R. J. Grosch may be best known for three laws that have come to bear his name: in computing, economy is as the square root of the speed; no one gets a foreign assignment who wants it; things can get worse without limit.

Or it may be for the fact he is the only man hired and fired by IBM twice. Then it could be because he was the first and only person with a beard hired by IBM in Thomas Watson, Sr.'s, lifetime.

He has been referred to as "the dp industry's most persistent gadfly," and as "the unsinkable computer consumer advocate." He himself is quick to agree with those who describe him as "outspoken."

Dr. Grosch listed computer history as one of his professional interests in his successful campaign late last year for the presidency of the ACM. And he knows his history and most of the people who made it.

He began his computing career in 1936 when he published his first orbit calculations while still an undergraduate in astronomy at the Univ. of Michigan. Since that time, in addition to IBM, he has been with General Electric, MIT, and the National Bureau of Standards. He did

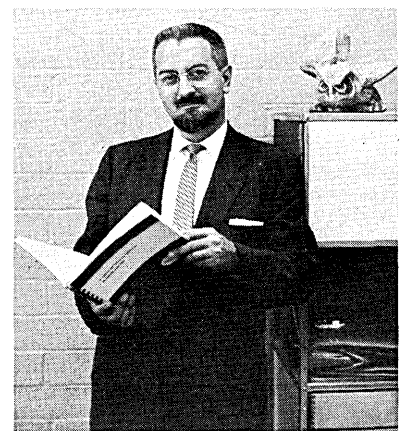

Herb Grosch, circa 1957  
During his tour in the desert with GE,  
Phoenix.

a stint as editorial director of Computerworld and for one issue, September/October 1959, was listed as an editorial advisor to Datamation.

It's a rare computer conference that doesn't have Herb Grosch among its attendees and, even when he's not on the program, he always has something to say.



## WAY IT WAS 1957

see: in 1957 I had gotten over floating point and the open shop, and hadn't yet generated a full head of steam about Magic Languages. Guess I was doing my grumping within General Electric, of which more later.

How big were we? Well, when SHARE started in August 1955, there were 17 founding members. Two years later there were less than a hundred, but there were 705s being delivered, and GUIDE had crept out of IBM's pouch. The 1103A had generated another dozen centers. A hundred major installations? Probably not too far out; the Office of Naval Research and the Ballistic Research Laboratory at Aberdeen, where primitive EDVAC had just been endowed

You would walk around inside a STRETCH . . . but inside SAGE you could get lost!

with a box of floating point, put out a newsletter and a biennial census.

There really wasn't any way to be an installation without a big computer, although change was coming fast. The Bendix G-15 and the IBM 650 were spreading, and on the data processing side there was that jolly jukebox, the IBM RAMAC. In two more years, when DATAMATION began to really flower, there would be hundreds of medium-sized shops—but their time had not *quite* come. Can I titillate you with a few specifications? Well, big core was 8K words (36KB), and RAMAC was five megabytes—but Poughkeepsie hadn't coined "byte" yet, not by half a decade. The Philco TRANSAC announced an upgrade, the S-2000, with an all-transistor ALU. We call 'em cpu's now, and they fit in a briefcase. Average multiply time on the 2000 was a startlingly fast 60,000 nanoseconds. Tubes in NORC (which was running) and SAGE (which had been shipped to McGuire) were a good deal faster, but the solid state handwriting was clear: "Mene, mene, LSI, upharsin!" IBM was STRETCHING their best transistors and architecture.

Do you realize the golf-ball typewriter was three years away? Now, *that's* primitive: "Grandma, how did you type? Well, you reached up and untangled those funny little arms, and rolled the paper up, and scrubbed at your mistake with a gritty eraser . . . Oh, come on!" But it was an adventurous time; I had my secretary's

machine painted to match her lovely hair. Eheu, fugaces!

DATATRON from ElectroData had begun deliveries from Pasadena—most machines, whatever the size, were made Back East—and nice people like Sybil Rock and Paul Brock were helping. There were even minicom-

---

I had my secretary's machine painted to match her lovely hair.

---

puters. Autonetics, the electronics branch of North American, was pushing one called RECOMP, and at the very bottom of the spectrum was the Burroughs E-101, which was a sort of electronic cribbage board. I

tons behind in Ohio, and a beautiful bowling-alley floor that we cut holes in for cabling (they had invented flexible flooring, but no one was buying it yet).

Networking was beginning. I had put in a four-node transceiver net a year or two before, the Signal Corps (remember the Signal Corps?) was sending data from Pennsylvania to France, and Sylvania had just announced an 18,000-mile private telephone net centering on a Univac I in Camillus, New York. We talked glibly about real-time, but only SAGE, still in its earliest months, and the first primitive airline reservation system (Eastern), were really very close. But the ideas were familiar, and the pitfalls—notably, huge wedges of unworkable programming—were already

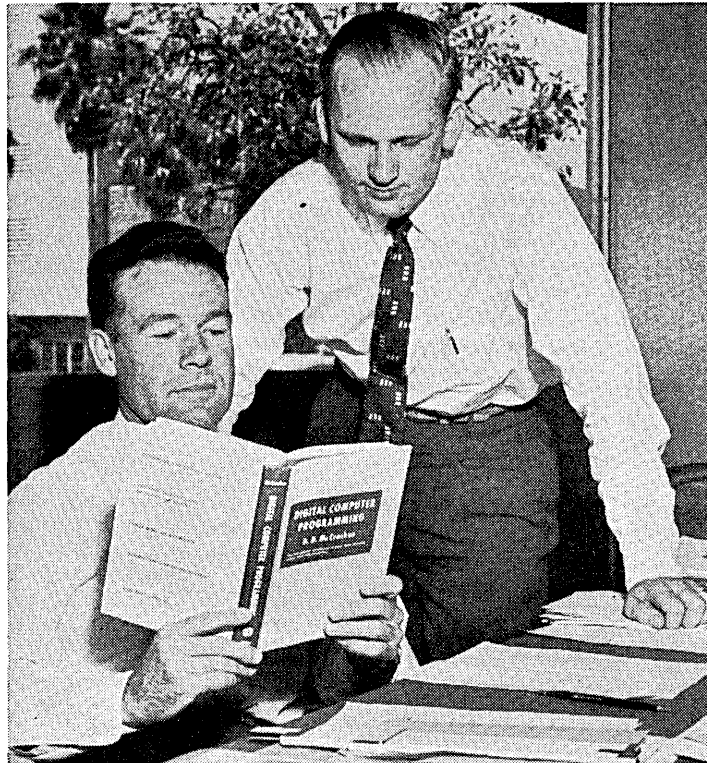

The June 1957 issue of the *General Electric News*, ran this picture of Dan McCracken (standing) smiling an author's proud smile as Dr. Lee Thompson of Arizona State College leafs through the author's copy of McCracken's book, the first ever published on digital computer programming.

remember RECOMP as all transistors, and that RADC or its 1957 predecessor, was the first victim.

Before I leave machinery—the 701s and 702s and 705s, the Univac I's and the 1103s, the ALWAC's and the BIZMAC's, I ought to talk about the physical shops themselves. We had lots of variety in those days. United Aircraft remodeled a hangar, and GE Lynn, a pre-Edison dark satanic mill. Other sponsors hired fancy designers and put in show places. Air conditioning was rife; I had left 220

listed.

Oh, and we didn't call it software—Freddie Gruenberger or Old Leopard Bowtie, or whoever, hadn't popularized the word. Let alone uglies like "firmware" and horrors like "peopleware!"

We had, if not the world's greatest hardware, at least the world's greatest people. Some of them, like Big John Lowe of Douglas, Santa Monica, have disappeared; some, like Bill Bell, founder of the first American technical computing bureau almost a de-

cade earlier, have died; many are still vigorously active, if a little grizzled around the edges. The West Coast ones appear at the annual DCA bash; the Digital Computing Assn. was still semi-serious in 1957, but the chowder-and-marching flavor was obvious. Gene Jacobs was president (SDC had just split off from Rand, but he had not yet converted).

On the East Coast, ACM was being run by John Carr. Other officers, all very straight, were Dick Hamming,

---

We had, if not the world's greatest hardware, at least the world's greatest people.

---

Charlie Concordia, and Jack Moshman. Two not quite so straight council members were Cuthbert Hurd, very big in IBM in those years, and Grace Hopper of Remington Rand Univac. The Eastern Joint was in Washington, so naturally it had been

ACM was about to bring out its *Communications*. Al Perlis was editor-in-chief, and department editors included Walt Bauer, not yet working on his first million; Bob Bemer, still at IBM as I remember it; and Ubiquitous Grace. The *Journal* was already several years old; in 1957 it had a microprogramming article (!), an article on real-time by Dave Israel, and a description by Tom Steel of the long-forgotten but seminal cooperative project called PACT (Project for the Advancement of Coding Techniques). Sounds more practical than today? Well, most of our efforts were.

It wasn't that we were pinched for money. And Heaven knows, our bosses knew even less of what we were about than in 1977. But there were still so few of us—and so many great projects begging to be worked on. The IRE (Institute of Radio Engineers, now part of IEEE) reported in March that its members, pretty much hardware types, in the Professional

ience; I didn't break the \$20K barrier until I went back to IBM in 1958.

And where was I in 1957? In Phoenix, of all places. "It was the best of times, it was the worst of times," said Dickens. General Electric had decided, just a year before, to enter the arena. They had watched the Remington Rand thrust, the powerful IBM riposte, the fumbling RCA entry—that was BIZMAC, the size of a house but with dog-kennel performance—the Honeywell buy-out of Sylvania. They had seen the proliferation of big ma-

---

BIZMAC, the size of a house but with dog-kennel performance . . .

---

chines in-house. They were dimly aware of Burroughs, of National Cash, of English Electric, and Bull. Bull! If they had known . . . ah, me!

Anyhow, I'd transferred from my beautiful shop in Ohio to the new site, and was trying with the help of some true believers like Dan McCracken and Charlie Asmus, and nearly a hundred new-hires, to explain programming and applications work to a dull bunch of Syracuse transplants. Off in Palo Alto, Bob Johnson and Joe Weizenbaum were struggling with ERMA, the check-cruncher GE was building for the Bank of America.

The exact moment of DATAMATION's birth? Well, I was probably on a plane between Phoenix and Huntsville. Some time in the early fall I had won a pioneering facilities management contract to operate von Braun's technical computing shop at what was still the Army Ballistic Missile Agency (yes, NASA came next year).

I had not yet decided to go back to IBM and the muggy East; the desert was wonderful, I had a charming new wife. But already the clumsiness of GE's entry was obvious. McCracken, who had finished his first book in Ohio, was at work on a thick second one with Arizona collaborators, but nevertheless pulled up his stakes. Soon I would reluctantly do the same.

I think of 1957, and the year or so before, and the year or two after, as the time when IBM began to do its tremendous thing *on purpose*. Look at what was going on. Manny Piore was putting them heavily into real research; the Old Man had given the concept terrific support, but never really understood it; now, Tom Junior and Al Williams and Vigorous Vin Learson were pouring on the coal. The *IBM Journal of Research and Development* started, with a foreword

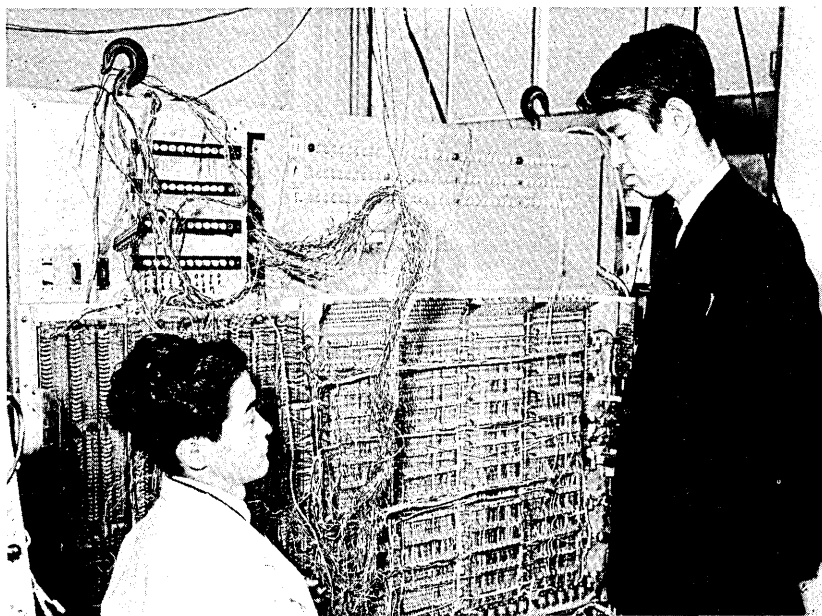

The parametron computer used no transistors, diodes, or vacuum tubes in its arithmetic and control units. Instead it used 3800 parametrons, a discovery of a 27-year-old Tokyo research assistant, Eiichi Goto, shown here on the left with Dr. Hidetoshi Takahashi, the computer's designer. A commercial prototype model was to be built according to the story in the May/June 1958, issue of *Datamation*.

chaired by Sam Alexander; the Western was to be in L.A., and was the first to be reported by DATAMATION. The Western featured "the" paper on FORTRAN by John Backus and (count 'em) twelve co-authors. They reported 18 man-years of programming to produce 24,000 instructions. They called it an "automatic coding system"—the jargon was much, much simpler 20 years ago. Tony Ralston, a youngster at Bell Labs, talked about error detecting and correcting codes for real-time computing.

Group on Electronic Computers, ran to about 2,500: 1,500 Eastern, 400 Middle Western, 600 Western. And believe it or not, still many more analog people than digital. In 1957! They went to the EJCC, the WJCC, but also to their own national meeting and to the early Wescon.

Salaries? The average engineer in the survey leveled off at \$12K and stayed there; the 90th percentile finally got up to \$19K. And the Ph.D. was only worth about \$2K extra, to 1957 engineers. Fits my own exper-

## WAY IT WAS 1957

about sharing new advances with others "throughout the world." Good show!

STRETCH and SAGE were walloping along. There were preliminary photos in IBM papers, along with a lot of stuff about cryotrons and superconductivity. (Even IBM doesn't win 'em all.) And don't forget, down in the bowels of Endicott or worse, they were still making timeclocks!

SAGE had had a big part of the early 1957 Eastern Joint. Bob Everett, then at Lincoln Labs, gave the basic story; there were photos, and models, and some of the real-time philosophy which would expand so overwhelmingly in the next two decades. There were 60,000 tubes in each center; two coupled machines. And lots of simple but powerful graphic displays; a fantasy! You could walk around inside a STRETCH; there is still one at Brigham Young to saunter through, if you don't believe me. But inside SAGE, you could get lost! And all this was pouring relentlessly out of steadily expanding, sophisticated, rich IBM.

Even on the international front, IBM had some special victories. Just as I had put a 704 into Phoenix to help General Electric, so did the engineering department of AEG in Germany put in a 650. And World Trade Europe was enlarging the Place Vendome scientific bureau, planning for a 709 in a year or two. This was in response to the Univac I which Carl Hammer was running for Battelle in Frankfurt. I was to ask, a few months later, for a World Trade assignment. The boys and girls overseas were awake! Alas, I was shackled in Pallid Flats instead.

IFIP was not yet dreamed of, nor had Ike Auerbach proposed the 1959 UNESCO preliminary session. But the control people had just put together IFAC (International Federation of Automatic Control) under Harold Chestnut; the pattern was coming clear. Japan was still asleep; Goto was known here, but the first government support, to set up JEIDA, the electronic industry development operation, came only in 1958.

The British were in full cry, and in Canada Kelly Gottlieb and Pat Hume published their first book. There had been a big early Ferranti machine in Toronto for three years, and I had seen the companion installation in Picone's institute in Rome in 1956.

Perhaps the areas most different from 1977 were the human, the educational, the hobby ones. The latter did not exist at all, of course; the

relics of the forties and the very early fifties were so lugubrious, so slow, so battered, that the thought of operating any of them in one's basement or garage had not dawned. And the kind of familiarity that led to high school clubs and The Resistors, years later, was present only in special localities. Harley Tillett, one of the dozen SHARE founders, worked in such a place; he and his wife put a bunch

---

Perhaps they knew the  
golf ball was lurking in the  
IBM rough!

---

of Navy kids (junior high level, mostly) onto the China Lake 701, using SPEEDCO, an antediluvian BASIC. And used the 704 and some SHARE software later, I recall. He reported it was "feasible to introduce computer programming instruction below the college level." Don't we know!

The big university push had begun, as had the transfer of funding from ONR, and almost entirely for hardware and hardware development, to mul-



tiple agencies and for more general purposes. The MANIAC III sort of thing, at Illinois, was passé before it started; industry had already forged out of sight. But instruction, and software research, were in full flower. One sad note for the socially conscious: the Army began funding the Mathematics Research Center at Madison in 1957, little dreaming of the bang and the whimper to come so sadly a decade later.

The cybernetics cult was still alive, and the term "artificial intelligence" was not abroad in the land, although Newell (still at Rand), Simon, and John McCarthy, were cranking up. At the other end of the spectrum, professorial attention to data processing was beginning; people like Tony Oettinger were interested, and *Fortune* had an article about it, instead of the usual "Gee Whiz, Williams tubes!" of

the previous quadrennium. Even word processing (the term itself still fifteen years in the future) had its tiny notices; Remington Rand announced a paper-tape office typewriter. Perhaps they knew the golf ball was lurking in the IBM rough!

The 705 III marched on the scene, and Howard Aiken's monstrous MARK II relay calculator at Dahlgren was retired. MONROBOT, a sub-mini, and Honeywell's giant DATAMATIC 1000, were unveiled, to the mini and giant yawns of the IBM/Univac enthusiasts. Perhaps the flavor is best recalled by the BRL report, which listed 103—yes, 103!—different computer systems, from DEUCE to Zuse, around our sprightly universe.

In that universe many of today's greats already flourished. Two year old SHARE had, of seven senior officers, Frank Wagner, Herb Bright, Paul Armer, and Frank Engel. But the others were Ben Ferber of Convair, Lee Amaya of Lockheed, and Walt Ramshaw of Pratt & Whitney: "*Où sont les neiges d'antan?*" said Villon five centuries before. Mel Grosz was at GUIDE; Cecil Hastings, the Compleat Approximator, not yet the first honorary member of the Polynesian Information Processing Society ("They're PIPS!"), was visiting from Hawaii. And can you believe it? The 1957 DCA meeting featured a Pioneer Session!! History, yet! Gruenberger was program chairman.

Yes, it was an eager time; the technical papers, the meetings, the books—from "Automata Studies" through Dick Canning to the last of the Bureau of Standards math tables—the new publications which DATAMATION was to complement, all were eagerly absorbed. Even the first book in English on the abacus!

There were great things happening in the outside world. At precisely the moment DATAMATION crawled from its R&E cocoon, the Sputnik signal went up, and with it not only NASA, and the space component of aerospace, but the long string of adventures that led to Armstrong's "giant step for mankind." Here the computer was to shine, to share with heroic but fallible human beings a voyage unequalled in our short and largely brutish history. It was the beginning of a new era.

And it was the end of an earlier one. John von Neumann, great Johnnie, had died earlier in the year. The first steps had been taken, by Babbage and Hollerith and Comrie and Aiken. And by von Neumann. Now development would proceed; IBM would swell and burgeon; a great trade would make its contribution across the whole world.

It was, indeed, a vintage year. ✱



# Get Smart.

ADDS Regent • Smart for the price of Dumb.

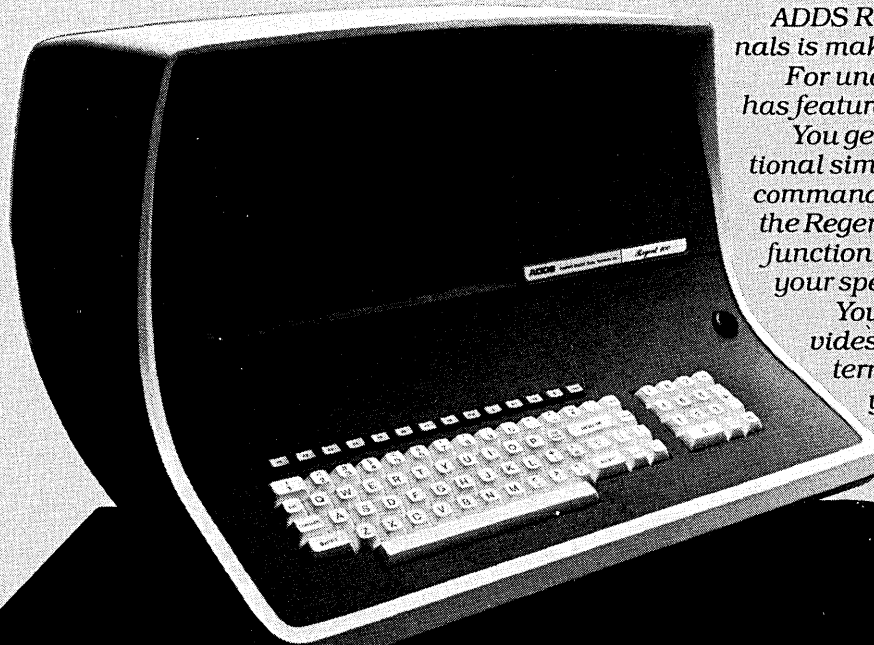

Time was, if a man bought a Dumb terminal, he was considered pretty smart. Times change.

ADDS Regent family of Smart terminals is making Dumb look dumb.

For under \$1000\* our Regent 100 has features no smart man can resist.

You get cursor controls for operational simplicity and extensive remote commands that make it easy to control the Regent from the computer. Optional function keys customize Regent to your specific application.

You get a Status Line that provides current information on the terminal's operating status. And, you get visual highlights such as blinking, zero intensity, half intensity, underline and reverse video.

You also get self diagnostics.

In other words, you get Smart. Or Smarter: Our Regent 200 has everything our 100 has plus buffered transmission, auxiliary port and editing options.

You can't get a whole lot more.

Get Smart. Get ADDS.

**Quality, Reliability and Integrity. It all adds up to ADDS.**

\*In moderate quantity.

**ADDS** Applied Digital  
Data Systems Inc.  
100 Marcus Blvd., Hauppauge,  
New York 11787 516-231-5400

Name \_\_\_\_\_

Firm \_\_\_\_\_

Title \_\_\_\_\_

Address \_\_\_\_\_

City \_\_\_\_\_ State \_\_\_\_\_

Phone \_\_\_\_\_

CIRCLE 11 ON READER CARD



# George Stibitz and the Bell Labs Relay Computers

by Evelyn Loveday

---

It all began with a dry cell, some flashlight bulbs, and pieces of a tobacco can.

---

On September 7, 1977, at its Washington, D.C., meeting, the prestigious Institute of Electrical and Electronic Engineers presented its first Emanuel R. Piore award and citation to George Robert Stibitz, Ph.D., Sc.D. The Piore award is given for outstanding achievement in the field of information processing, and is sponsored by the International Business Machines Corp.

Dr. Stibitz' citation read, "For pioneering contributions to the development of computers, utilizing binary and floating-point arithmetic, memory indexing, operation from a remote console, and program-controlled computations."

Many people today find it hard to believe that less than 40 years ago no one had a computer. In fact, only a handful of people dared dream that mathematical computations could be done more swiftly than with a gear-operated desk calculator.

Who is Dr. Stibitz? When did he make his pioneering contributions to information processing? How do those contributions relate to today's complex and incredibly rapid computers? Where is Dr. Stibitz now, and what is he doing?

In 1937, Stibitz was a Bell Labs research mathematician. He couldn't stop thinking of new ways of doing things. (He still can't.) Laborious mathematical calculations by hand or desk calculator were not rapid enough to suit him. In his work he had observed the circuit paths through relays and the similarity to binary notation for numbers, and had an idea he wanted to work out.

He liberated some relays from a scrap pile and, as a play project at home one weekend, he made a little model of a binary adder with relays, a dry cell,

flashlight bulbs, and strips of a tobacco can.

The relays were wired to give the binary digits of the sum of two one-digit binary numbers, which were en-

---

No lightning flashed to signal the computer age had begun.

---

tered into the arithmetic unit by pressing switches made of metal strips. The two flashlight-bulb output lighted up to



Dr. George Stibitz has earned belated recognition for his Model 1 Complex Computer, the earliest form of the digital computer, but his favorite invention is a bouncing ball device.

indicate a binary 1 and remained dark for a binary 0. (The table on which this model was built is still in use in the Stibitz home.)

When Stibitz took the model to the Labs to show it to some of his colleagues, no bells rang and no lightning flashed to signal that the computer age had just begun.

He began to wonder what could be done with a large number of such adders. More time was spent at home in sketching circuits for addition, multiplication, and even division. Next came the idea of setting up decimal digit adders in binary form, with each decimal digit expressed in binary form by multiple contacts on keys.

To avoid use of complicated "carry" circuits, the range of decimal digits was shifted to the middle of the list of four-bit binary numbers. This shift was equivalent to adding three to the decimal digit so that the decimal 0 was represented by binary 3 (0011), and so on. If two digits were added, the binary sum was shifted six units, and nine became binary 1111, while 10 (carry one), became 10,000 with an extra digit: a simple indication that a carry was to be made.

It is difficult to tell how many modern computers use this excess-three code today, but a glance at the specifications of commercially available integrated circuits shows that both binary coded decimal (BCD), and excess-three codes are embodied in chips such as excess-3-to-10 to wire code, and reverse.

All of this was still a Stibitz leisure time activity until his section chief asked if his calculator could do complex arithmetic. It could, and because of a need at Bell Labs, the weekend

play project became daily work. Dr. Stibitz always emphasizes that, while his was the mathematical concept, the project could not have been completed without the help of a skilled switching engineer, Sam Williams. He was thoroughly grounded in all the properties of relays and yet had to assimilate from Stibitz mathematics and number theory in order to complete the detail design.

Before the end of 1939, the Complex Calculator (later to be known as Bell Labs relay computer Model 1), was debugged. It was set up for the mathematics department's calculations people in January 1940, and had a Teletype machine as an input device.

It is believed that this relay computer was the first (at least in this country), to employ binary components and to use the excess-three code.

Another group at BTL, outside of the mathematics department, was doing a large number of calculations with complex numbers. Soon a second Teletype was installed in another part of the building for that group's use. A third

---

Stibitz used random walks to calculate the diffusion of drug and nutrient molecules through the walls of capillary blood vessels.

---

was added later in still another location. Thus this relay computer scored another "first." In a crude way it was the nucleus of a time-sharing system with lock-out facilities. Any one of the three Teletypes could be used on a first-come, first-served basis. Not for

several years after that, well into the computer age, would time-sharing be in common use.

In September 1940, the American Mathematical Society met at McNutt Hall at Dartmouth College in Hanover, N.H. At first, Dr. Stibitz had been asked to read a paper on the BTL relay computer. He did that and something more. Transceiving panels were installed in McNutt Hall, and a direct telegraph circuit to the computer at

BTL in New York City was arranged.

After the paper was read, the audience was invited to submit problems for the computer to solve. These were transmitted to the computer, and the teletypewriter in Hanover printed out answers in less than a minute. This was the first public demonstration of the remote operation of a computer, and foreshadowed the tremendously rapid growth of today's data transmission services.

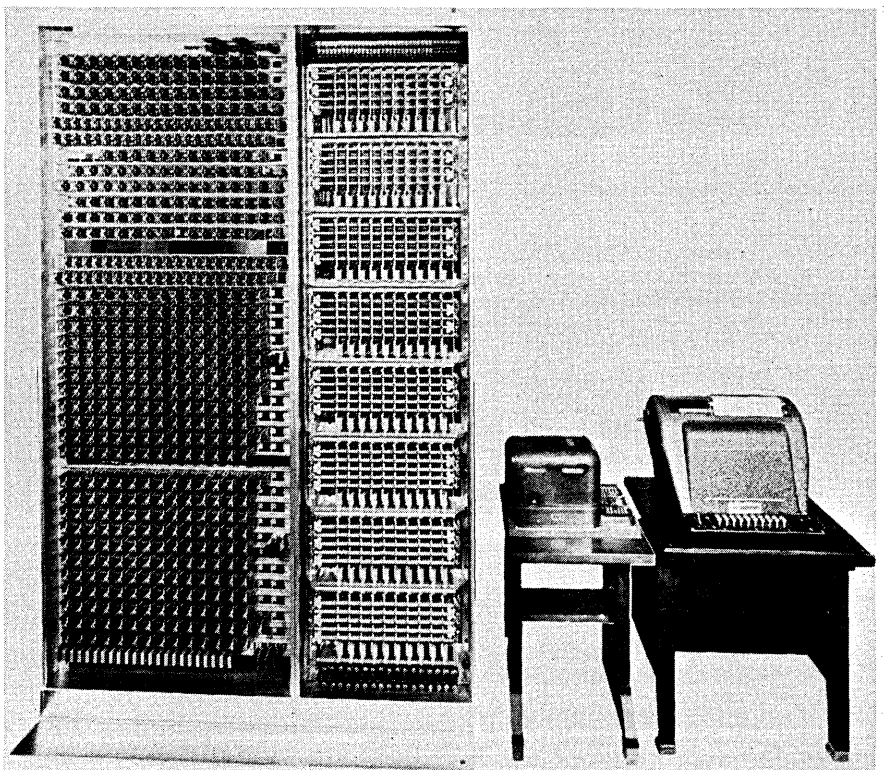

This 1939 photo shows the laboratory equipment used in George Stibitz' early Computing System for Complex Numbers, including a relay and switch frame, a Type 14 distributor, and a modified Type 26 printer.

All photos courtesy of Bell Laboratories



# Count on GA for big COBOL performance in multi-terminal applications.

And count on the lowest cost per terminal. Available now, General Automation's new 440 Data Series, starting below \$45,000, recognized for the best price/performance package in the computer field: "...It always works...far superior to any other full systems less than \$80,000. Any comparable system will cost over \$175,000!"

- 1. The most powerful ANSI COBOL**—years ahead of any other tested. Compiles 3-to-10 times faster than a 370/145.
- 2. Store 160 megabytes; 1 second response.** Support 16 terminals with less than 1 sec response; 128 KB main memory. Store up to 160 megabytes on disk, with the 720ns GA 440 minicomputer.
- 3. Concurrent batch and on-line processing.** With shared database protection: maximum multi-terminal access with minimum user-contention, all operating in our field-proven File Management System.
- 4. GA 440: fully field-proven and GA-serviced,** in more than 500 installations around the world to date.
- 5. Exhaustive system-testing:** over 400 different combinations rigorously tested for response time.

Count on GA for all your distributed processing systems—from a basic 2-terminal system to a 10,000-terminal network; from factory and business data collection to corporate networking systems—through our advanced line of high-technology mini and microcomputers. You'll be joining the world's largest corporations who now count on GA for the most productive system solutions: in financial, industrial and telecommunications applications.

**GENERAL**   
**AUTOMATION**

Please rush full information on GA's big COBOL 440 Data Series for multi-terminal applications.

Contact us for consultation without delay.  
Tel: ( ) \_\_\_\_\_ Ext. \_\_\_\_\_

Name \_\_\_\_\_

Title \_\_\_\_\_

Clip coupon to company letterhead and return to: General Automation, 1055 South East Street, Anaheim, CA 92805. Or call (714) 778-4800. General Automation Europe: 51 Aachen, Postfach 465, West Germany. Tel: 02405-641. Telex: 841-832-9500.

\*(Published quote of an independent computer expert. Name on request.)

## GEORGE STIBITZ

During the years 1938 to 1941, Stibitz made several written proposals to extend the relay computer's original design to new areas. These included the evaluation of polynomials and programmed calculation. However, Bell Labs had decided not to build any more computers because the first one had been so costly. One proposal concerned what Stibitz called the "floating decimal." Today this is sometimes called "scientific notation," and nearly every computer manufactured currently provides this option.

The need for this feature was noted by Stibitz when he saw that as the programs became longer, the user found it difficult to predict how large his results would be.

Why not have the computer itself be made to introduce factors that would keep the results within reasonable bounds? Thus, if the computer saw that the numbers in the run of the program were becoming too large for the capacity of the machine, it would divide by 10, or 100, etc., and remember that fact to be accounted for later. This accounting would be neatly done at every step.

This proposal was to lie dormant for some years. Bell Labs resumed building relay computers during World War II, and only one, the Model 5, reduced all numbers to the form called the floating decimal.

While the first relay computer (Complex Calculator), was extraordinary in its time, it had a very limited range of operations: addition, subtraction, multiplication, and division of complex numbers. Dr. Stibitz' mind was running ahead before construction of that first computer was completed. In 1939, he was thinking about a computer that could at least evaluate polynomials or other algebraic expressions according to instructions entered on a keyboard, or punched on tape: in short, a program.

Early in 1942, after the entry of the United States into World War II, Dr. Stibitz was loaned to the National Defense Research Council which functioned under the brilliant leadership of Dr. Warren Weaver. Stibitz brought to the council his knowledge of, and experience with, the capabilities of computers. It soon became obvious that with the masses of computations to be done for military fire control, more computers would be useful. So BTL built four more computers, planned by Stibitz (ably assisted by engineer Earnest Andrews), between 1942 and 1945. Model 2 used a taped program such as Stibitz had proposed in 1940. The program tapes were punched in

machine language which included five-hole codes for "transfer from register B to adder," "read data," "punch," and so on. The tape was then looped, with ends glued together, and added to the program library.

Model 2 was put into service in September 1943. It was designed to handle thousands of problems having identical programs, and ran for days at a time with only housekeeping attention by an operator. Thus, it was probably the first fully programmed computer.

In BTL's Model 4, the number of distinct programs increased greatly and programming became an art in itself.

---

Today a programmer who found no jump capabilities would not know what to do.

---

These programs were written in modified algebraic language.

It is interesting to note that the combination of key-controlled and stored programs has reappeared after 35 years in the small, hand-held programmable computers on the market today.

In the larger computers, many programs are stored on magnetic or paper tape as a cheap, long-time storage means. With the decreasing cost of more rapid and accessible forms of storage, the tape becomes less important and is used far less frequently.

In the relay computers, with programs limited to punched paper tapes, the use of jump instructions was lim-

ited by the delays in finding indicated instructions. With two-way drives injected into the Teletype tape readers, it was possible to tell the computer (Models 3 and 4) to jump to a specific address on tape. In Model 5, subprograms were placed on separate tapes and called in by jump instructions on the main program tape.

Today a programmer who found no jump capabilities would not know what to do. But in the early 1940s they didn't know what they were missing, and somehow wrote programs anyway. If a jump was absolutely unavoidable, two programs were created and one or the other was run according to requirements.

Finally, when Model 5 was used to solve differential equations, two subprograms were customarily used. These respectively expanded and contracted the time increments in the solution and were called in by the computer under control of a computed numerical text in the main program.

Both the conditional and unconditional jump instructions are found today even in the hand-held programmable computers.

At the end of World War II, there appeared to be no support for further work in computers, and, primarily a mathematician, Dr. Stibitz left BTL for a slightly different career as an independent consultant in applied mathematics. He moved with his family to Vermont, and for the next 19 years worked as a consultant to various business firms.

New ideas and new ways of doing



This is the keyboard of George Stibitz' first relay computer which was put into operation on January 8, 1940, at Bell Telephone Laboratories' West St. facility in New York City.

things have always crowded Dr. Stibitz' mind. Of course, many of his computer inventions were assigned to BTL, but he has patented many of his inventions for himself. His 35 patents range from computer elements to a stereophonic organ, a V-belt equalizer and a reversible lifting device.

Dr. Stibitz, when asked which one of his many inventions pleases him most, had difficulty in naming just one. Finally, he did so—the bouncing ball counter. He said, "It is ingenious, but vastly unimportant. However, every mathematician enjoys finding something simple and satisfying." He went on to describe the device on which he assigned two patents to BTL in 1942 and 1943.

"An instance of combining two disparate ideas is the bouncing ball counter of 1942. Like most school children I had been fascinated by the device for demonstrating the conservation of momentum found in every classical physics lecture room. A series of large wooden balls hung on cords from the ceiling, and normally all were in light contact. When the instructor swung the last ball in the series so that it struck the next ball, the intermediate balls remained quiet, but the ball on the other end swung out. This fact was the first of the ingredients in my counter.

"The telephone company has frequent occasion to count rapid pulses, as for instance, your dial sends pulses to the exchange. Expensive relays were and are used as counters. This is the second ingredient in my counter.

"A few months later I added a third



This photo of H. L. Marvin at a keyboard communicating with George Stibitz' Complex Computer, appeared in the *Bell Labs Record* of October 1940.

now-familiar ingredient, namely binary notation. By a tricky combination of balls in a two-dimensional array, I persuaded the balls to count in binary notation.

"A simple two-ball counter was also good. The 'row' of balls was reduced to an equivalent of five, two of them actually being fixed magnets, but acting like balls. The middle ball is movable and the end ones are driven together. When an electrical signal arrives it claps the two-balled driver together. If the movable ball is at the right end it

---

"Like most school children, I had been fascinated by the device for demonstrating the conservation of momentum . . ."

---

is driven left and vice versa, so its motions are (count of pulses), Modulus 2, or the representation of the last binary digit of the count. A contact on the mid ball can drive another two-ball set and give the next binary digit, and so on."

Not only has Dr. Stibitz been inventing and designing hardware, since 1930 he has been publishing many of his findings. To date he has been published 46 times on topics ranging from work in the computer field to mathematical models of biomedical problems. Two of his published works are books.\* The Smithsonian Institution has indexed all of the Stibitz papers which have been given to the archives of the Baker Library at Dartmouth College.

In 1964, Dr. Stibitz had a challenging offer from Dartmouth's Medical School. He was asked to become a research associate in physiology, using his tested techniques of applying mathematics and computers to biomedical areas. He had already done some work in this field with researchers at the Univ. of Vermont Medical School. He enjoyed it. He accepted the offer at Dartmouth and became a professor in physiology in 1966. Today he is a professor emeritus.

At age 73, Stibitz today theoretically is on half-time at work. He seldom spends more than eight hours a day at the Medical School! And he is proud of the fact that last fall he cut and split three cords of wood for his fireplace.

It seems peculiarly fitting that from 1964 to the present his work has involved the use of computers. Dartmouth has a large one with time-sharing capability, and there are eight

Teletype stations in the Medical School alone.

He could be called a resource person at the school and the associated Mary Hitchcock Hospital. His skills have been called upon by a pharmacologist, a neurophysiologist, a pathologist, and a radiologist, to name but a few.

Some of the problems he has dealt with by mathematical and computer methods are the motion of oxygen in the lungs, the diffusion of drugs and nutrient molecules in capillary blood vessels, the exchange and secretion of substances in the kidneys, the mechanical work of breathing, the dosage of radiation and the anatomy of brain cells.

The laws of physics are expressed in firmly established mathematics, but in the biological environment the details of application are often multitudinous and complicated. Therefore, the help of the computer is essential.

As an example: it was necessary to write a program to find the rate at which oxygen moves in the airways of the lungs, letting the computer trace imaginary molecules in random walks. With a pharmacologist, Stibitz used random walks to calculate the diffusion of drug and nutrient molecules through the walls of capillary blood vessels with over 100 million random steps, in various sizes and shapes of slits in the wall. The electron microscope shows the slits fairly well, but there are other problems in which there is no such firm information. Hence, it is necessary to construct tentative mathematical models which are defined by sets of equations that determine the response of the system under given conditions. Then the computer must try out many variations in the model in order to find the one that predicts responses which best agree with laboratory tests of the biological systems.

It requires little imagination to see how tedious and time-consuming such an effort would be without the use of the computer which, because of the complexity of most biological systems, has become absolutely indispensable in much research work.

Computers are equally involved in many other fields. The crowning irony for Dr. Stibitz was an incorrect computer billing from a nationwide company. It took him months to have the matter straightened out.

With a strained expression on his face, Stibitz quoted the phrase known in all computer centers: GI-GO—"Garbage in, garbage out."

Not all inventors live long enough to see their ideas expressed in practical and useful hardware, and to make professional use of the result. Certainly George Robert Stibitz was the right person in the right place at the right time. \*

\*Stibitz, G.R. and Larivee, J. A., *Mathematics and Computers* (New York: McGraw-Hill, 1957).

Stibitz, G.R., *Mathematics in the Life Sciences* (Chicago: Year Book Publishers, 1966).



# Hewlett-Packard brings a bright new look to low-cost graphics.

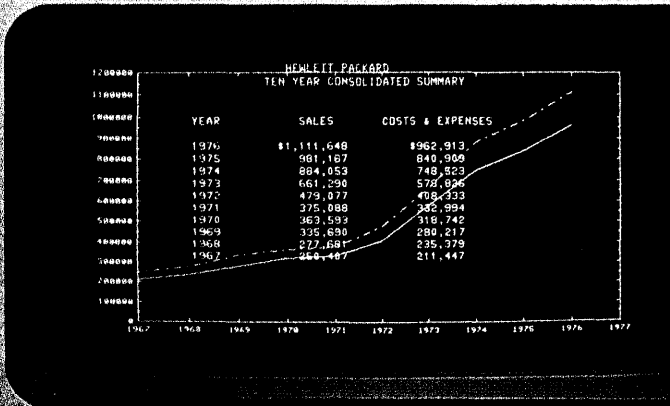

*Auto-Plot*

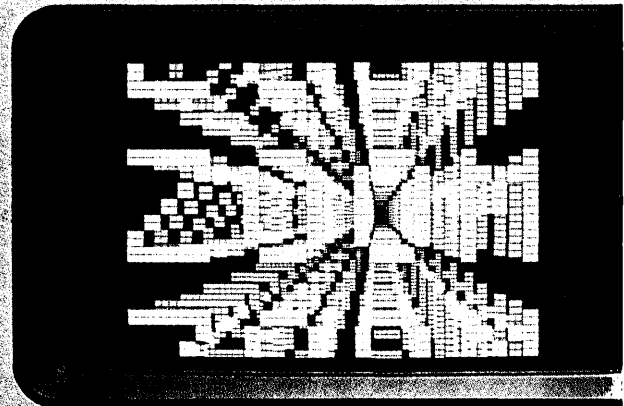

*Zoom*

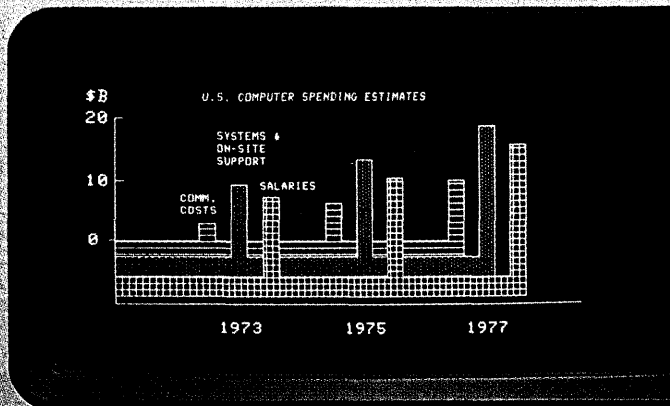

*Area shading*

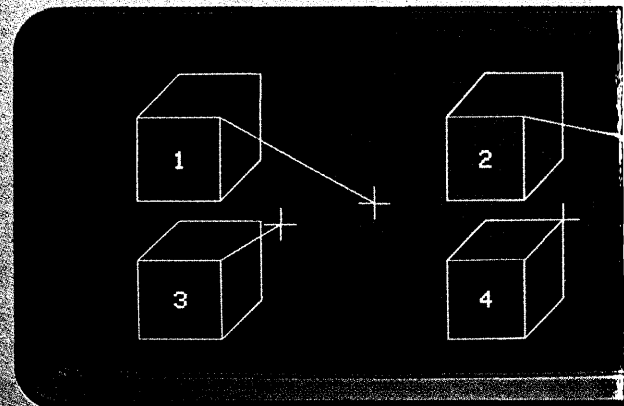

*Rubber band line*

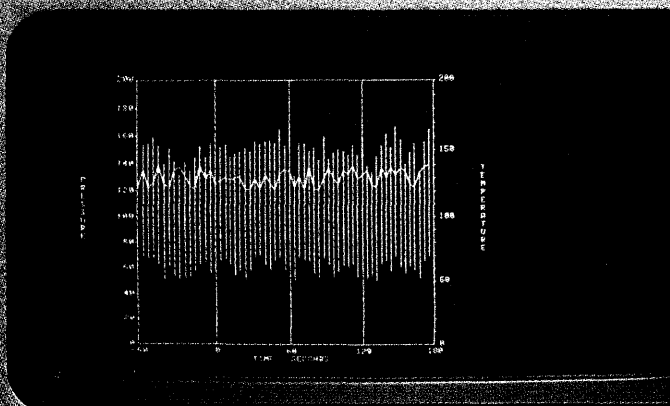

*Typical application: scientific plotting*

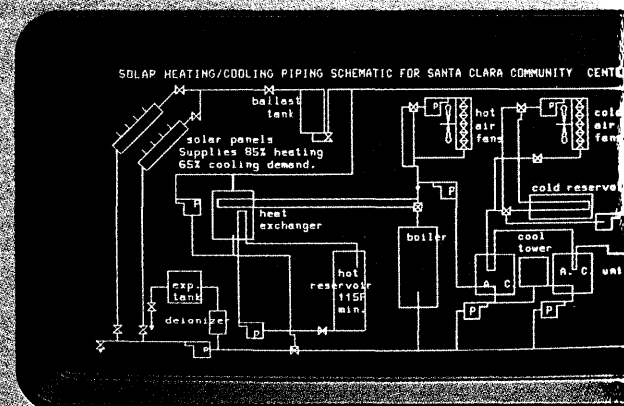

*Typical application: process flow diagram*

## The new Hewlett-Packard Graphics Terminal uses a microprocessor and raster scan technology to combine high performance with low cost.

The HP 2648A introduces a whole range of bright ideas to graphics. There's so much power built into the terminal itself that you can perform everything from auto-plots to zoom without any CPU help at all.

**Auto-Plot.** You don't need to know programming or invest in costly software. Once you've entered your facts and figures from the alphanumeric keyboard, press a few keys and your tabular data is plotted instantly.

**Raster Scan.** No more pulling down the blind to make your plots visible. Our display is clear and easy to read even in bright light. And the raster scan technology permits selective erase, cutting down the time it takes to modify your picture also.

**Zoom and Pan.** This lets you magnify any area of the display up to 16 times. And you can pan in any direction for closeup investigation of complex designs, without having to reinitialize the data.

**Area Shading and Pattern Definition.** This makes it easy to distinguish areas with similar shapes, such as bar charts, mechanical parts and architectural drawings.

**Rubber-band Line.** You can draw trial sketches, such as architectural floor plans, with or without CPU connection. Think of the time and money you'll save by cutting down mistakes.

**Independent Display Memories.** Both alphanumeric and graphic data can be shown independently or at the same time. And you can carry on a dialogue with the CPU without disturbing the picture.

The HP 2648A also has all the advantages of our popular HP 2645A alphanumeric terminal. Specifically: mass-storage on 110K byte cartridges (you can store graphics as well as data); 'soft keys' to speed up repetitive jobs; one-button self-test; plug-in PC boards for easy maintenance; extensive data communication and off-line capabilities.

This bright new look in graphic terminals is designed for such applications as electrical, mechanical and architectural design. For process and control. For scientific plots. And for business planning.

We'd like to give you a graphic demonstration of everything the HP 2648A can do. Send us the coupon and we'll set it up.

Or contact the nearest Hewlett-Packard sales office listed in the White Pages. We're sure you'll get the picture.

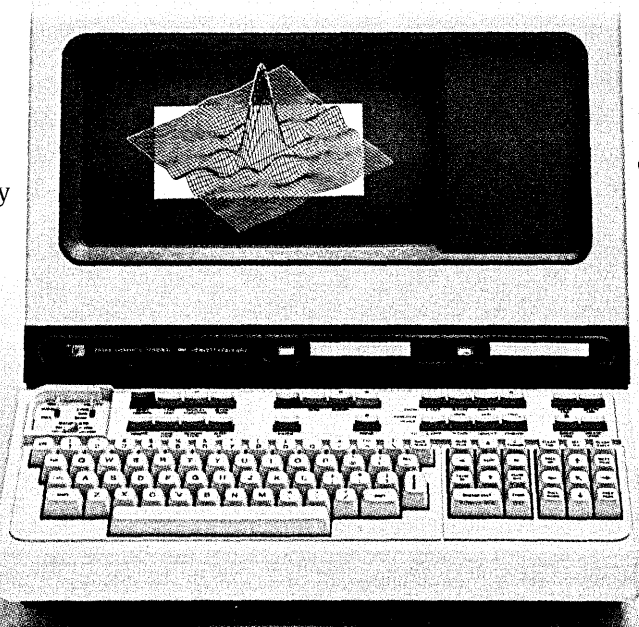

Yes, I'd like to take a closer look at your low-cost HP 2648A Graphics Terminal.

Contact me to arrange a demonstration.

Send me complete information.

Name \_\_\_\_\_

Company \_\_\_\_\_

Phone \_\_\_\_\_

Address \_\_\_\_\_

City/State/Zip \_\_\_\_\_

Mail to: Ed Hayes, Marketing Manager, Hewlett-Packard Data Terminals Division, 19400 Homestead Road, Dept. 407, Cupertino CA 95014.

**HEWLETT**  **PACKARD**

Make  
the  
right  
choice

Intelligent  
terminals

or OCR

Intelligent terminals are reducing data entry costs every day. And so are our Laser OCR-ONE optical character recognition systems!

If you're considering intelligent terminals, we believe you ought to be considering OCR too. We make a loud, clear claim that for many, many applications, OCR can top intelligent terminals hands down in efficiency and cost effectiveness. And we'd welcome the opportunity to prove it.

Something else to think about. OCR and intelligent terminals can be a money-saving natural at working together in a multi-media system. They complement each other very effectively in a multitude of applications.

You owe it to yourself to find out about our cost reducing Laser OCR-ONE optical character recognition system. Contact me today. Our systems applications staff will help you make the right choice.

Billy Graham  
Vice President/Marketing

**Optical Business Machines, Inc.**  
804 West New Haven Avenue  
Melbourne, FL 32901  
(305) 727-1774



**OBM**



# A Japanese On-Line Banking System

by Yuzuru Abe

Eight large-scale mainframes, 700 minis, and 4,000 terminals have been handling an average of 5,000 on-line transactions a day at Japan's largest bank, "the bank with a heart."



This February, our new on-line system centered around three super-scale computers went into operation. The new on-line system was named "HOPS," an acronym derived from "Heart On-line Processing System." The heart is the trademark and symbol of the Dai-Ichi Kangyo Bank and it represents our motto "the bank with a heart."

It took three years and 3,200 man-months to develop the HOPS system. Currently our terminal system consists of 700 minicomputers and 4,000 terminals, all up and running.

At the time of this writing, we were in our 150th day of continuous service without downtime, although we had a few I/O failures. These did not affect the on-line service of the system because of the built-in fail-safe functions.

Table 1 shows the extent of DKB's banking business as well as the number of on-line transactions on a peak day. Table 2 gives the background for the DKB on-line system and how it evolved.

The on-line system prior to HOPS consisted of three dual-processor 256K word FACOM 230-60 systems

connected in a triangular configuration, where the load was shared among the three systems. Its processing capability was on the order of 300,000 transactions/hour. However, our needs required that we design a computer center capable of handling twice that number of transactions and at the same time allow us to expand the system's processing power as much as three to four times. However, if we were to follow the same configuration principle each time we added one more system, our configurations would have looked like the illustrations in Fig. 1. We found out

# BANKING

that if this were the case, the hardware as well as the software would become excessively complicated and the development work extremely difficult. Further, since in the previous center system data files were *not* being shared, if one of the systems crashed, it would cause a 10 minute break in the on-line service offered to all of the branches connected to that computer. We also realized that our needs would entail the use of higher speed transmission lines than we were using at that time (600 1200 bps lines and 170 200 bps lines).

## Japanese banking habits

In order to understand why Japanese banks have to handle a voluminous number of transactions, one must look at the characteristic banking habits of the Japanese people. In comparison with the U.S., very few Japanese write checks, as this is not a Japanese custom. They prefer to use cash for settling accounts, and so a large number of people personally

go to the cash withdrawal and deposit counters of the banks. In addition, all money remittances and transfers to the payees' accounts are carried out by the clients who appear in person at the banks' counters. This naturally brings about a dire need for rapid on-line transaction processing at the banks' counters. It also results in a tremendous volume of transactions that must be processed between the particular branch and other banks through the data communica-

tions network. The increased use and preference for cash dispensers have caused their proliferation, and today there are roughly 10,000 units in operation all over Japan. Almost all of these cash dispensers are connected to the computer centers and the transactions are processed in an on-line basis. Also, many large enterprises and firms recently have started bringing to their banks magnetic tapes containing payroll data, and the employees' salaries are automatically

Capital	\$346 million
Deposits	\$31,045 million
Employees	25,000
Industry ranking	
Domestic (Japan)	1st
International	5th*
Number of branches/offices	
Domestic	316 (312 branches & 4 sub-branches)
International	18 (7 branches & 11 representative offices)
Number of accounts	16 million
Number of on-line transactions on a peak day	3 million

\*Source — Fortune, August 1976 issue.

Table 1.

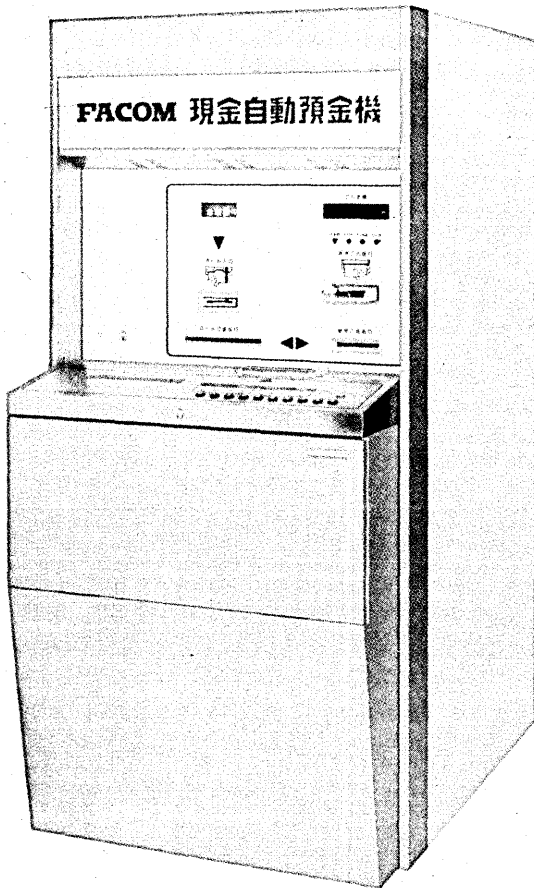

Japanese banking habits make an automatic cash depositing terminal like this an important component in an on-line system. There also are some 10,000 cash dispensers in operation throughout the country.

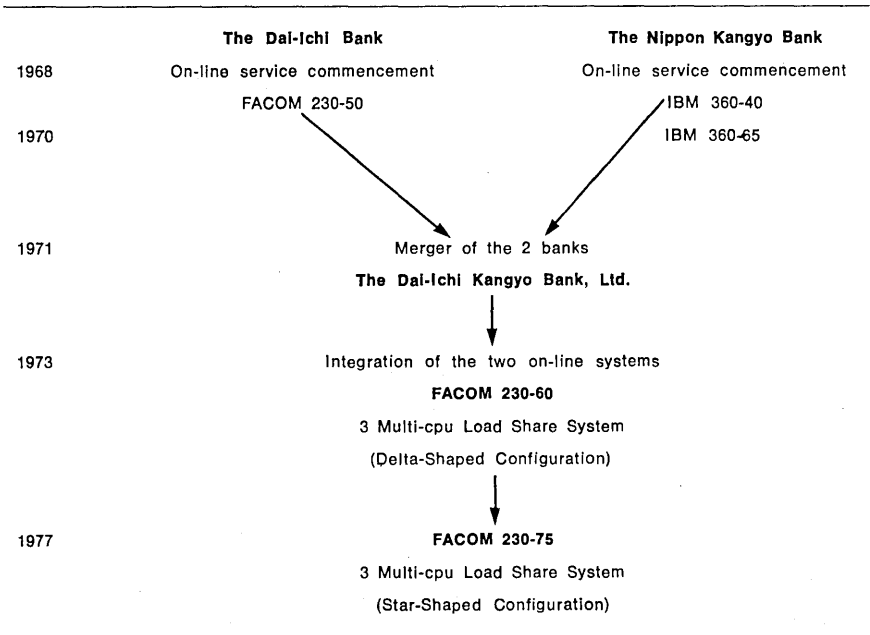

Table 2.

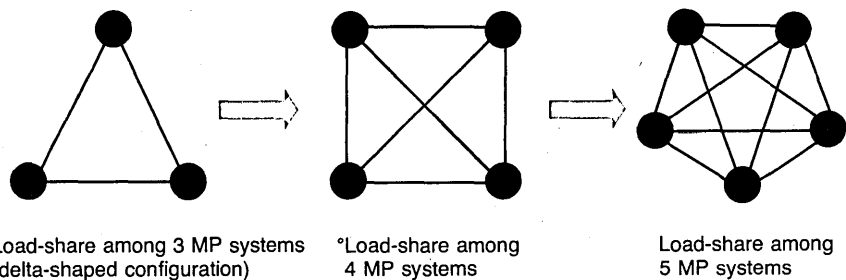

Fig. 1.

transferred to their personal accounts at the various banks. This causes a rush of employees and their dependents who come to withdraw cash on or immediately after payday. Again, all of these are on-line, and one can imagine the colossal number of transactions that have to be processed. For reference purposes, there are 45,000 registered accounts and 5,000 daily on-line transactions for an average of 1,300 clients per day at a DKB branch.

Bottlenecks in the previous system, and demands from the changing social situation formed the background leading to the development and installation of the HOPS on-line system by DKB. A few of the problems needed to be overcome were:

1. Need to remove the limits on processing capability to allow handling an increased volume of transactions.

2. Need for high speed mass storage files to handle the increasing burden of customer accounts and improve customer services.

3. Need for improved terminals with advanced functions.

4. Need to change emphasis from clerical to customer management-type processing with improved client service.

5. Creation of customer information files.

6. Need for a fail-safe or crash-free system.

7. Diversification of banking services and customer needs.

New technology was needed to realize the HOPS system, which could solve these problems. That technology included: high performance cpu and stable software, reliable load share system and shared-file technologies, high performance i/o equipment, high performance i/o equipment, high speed lines (48K bps), and improved terminal equipment with high intelligence.

From the numerous problems we faced, five significant problems drew a lot of our attention during the design phase, and these are briefly described below.

1. Even if a system were to go down, it should not under any circumstances cause all the terminals of any one branch to stop functioning even for a short time. That is, we were intent on achieving a fail-safe design.

2. The system would have to have enough processing power to handle 500,000 transactions/hour at the time of implementation and still allow for future expansion to handle as many as 1,100,000 transactions/hour without having to change any fundamental system concepts and/or design.

3. Another problem was alternating



Foreground unit labeled D10 is the cross-call adaptor devised to assure fail-safe operation of peripherals.

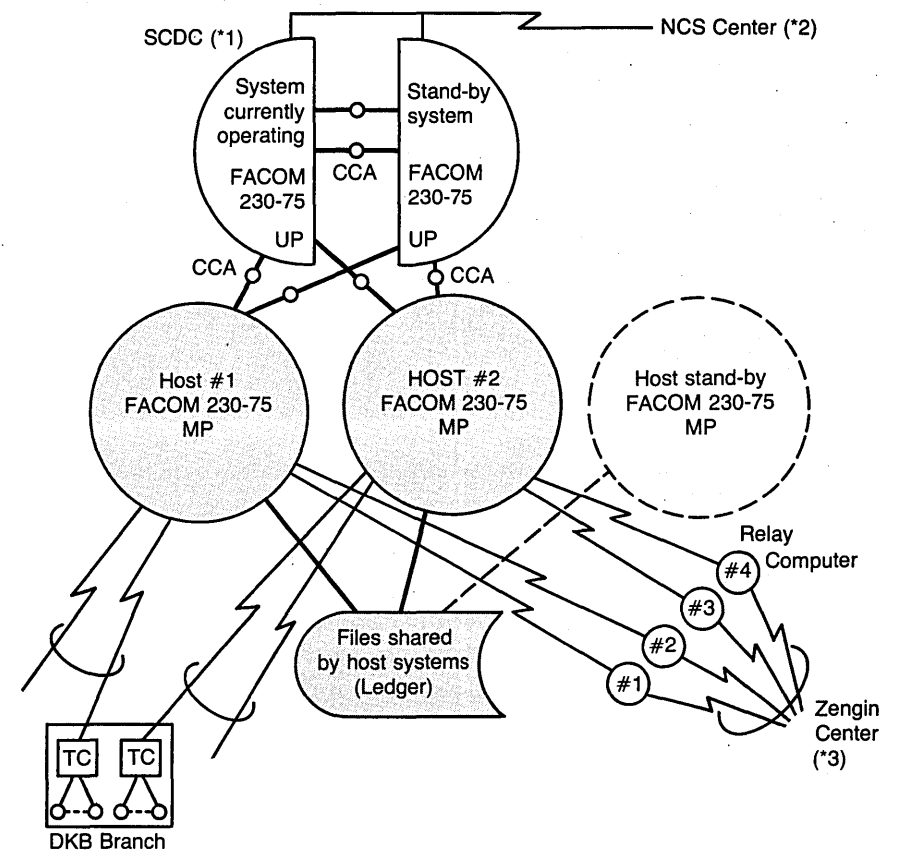

Fig 2. HOPS center configuration.

NOTE:

UP = Unit Processor

MP = Multiple Processor

TC = Terminal Controller

(\*1) scdc = System Control and Distribution Computer

(\*2) NCS = Nippon Cash Service; 200 cash dispensers installed at geo-

graphically dispersed public places allow depositors to withdraw cash from any of the 54 subscribing banks.

(\*3) ZENGIN = The on-line exchange system of all banks in Japan. This is a common network shared by 7,500 branches of 90 banks throughout Japan.



## BANKING

the data files, consisting of records arranged by item sequence and account sequence, to a structure that would permit better management and control of individual customer account data, thus improving the bank's service to individual clients. This file would have to serve as a customer information file for all the bank's customers.

4. The communications network would have to be planned to realize significant economies of scale in line utilization.

5. We would have to adopt the use of minicomputers and much more intelligence in the terminal system to allow the connection of various types of terminals in the future as well as to achieve a 50% improvement in the overall terminal performance (including factors such as ease of terminal operation, etc.).

### Center system configuration

A schematic diagram of the center system configuration is given in Fig. 2. Table 3 gives additional details regarding the system configuration.

Various reliability considerations were implemented in the system configuration such as load sharing among the host systems, and the shared access and use of the customer ledger files. The computer center is linked to each of the branches by two communications lines so that the entire terminal system of that branch would not become inoperative even in case of a central computer failure. In other words, the fail-safe concept was adopted in the system configuration as well. To ensure fail-safe operation of the peripheral devices such as the discs and tape drives, all of them are linked in a cross-call configuration. In addition, redundancy of all important files, such as the resident system file, assures added safety and protection.

Each host system is connected to the front-end System Control and Distribution Computers through channel-to-channel adaptors (CCA's) in a star-shaped configuration. The SCDC serves to monitor and control all of the host systems, as well as to relay data transferred from one host system to another. This method of linkage, as shown in Fig. 3, also has the added advantage of allowing future additions of host computers to cope with the need for increased processing power.

The SCDC monitors the operation of all of the host systems and issues commands to the host(s) or to the operator when the need arises, thereby making possible centralized control

	Host	SCDC	Remarks
Cpu	6 units	2 units	
Memory	1MW x 3	384KW x 2	
MTU (FACOM 611A)	68 units	16 units	Recording density = 6250 RPI Used as transaction detail files
DPU (FACOM 479B)	174 spindles	16 spindles	Storage capacity: 200MB/spindle Used to store customer ledgers and system resident files.

Table 3. Additional details of the HOPS system configuration.

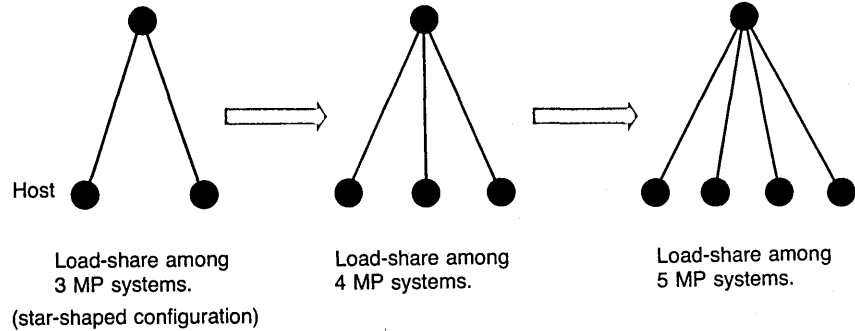

Fig. 3. The method of linkage.

of the entire system.

Device failures and/or system resource utilization status can be displayed on color display units whenever desired. The system is provided with a System Supervisor control unit that permits instantaneous switching to a different hardware configuration, or to an alternate linkage with the communications control unit by simply pressing a button. The entire system, which covers a floor space of 4,000 square meters on two floors of the building, is controlled centrally by two persons in a small room. In an on-line system of such a large scale, the crucial importance of this centralized control cannot be over-emphasized.

### The network

A schematic diagram of the communications network linking the computer center to the bank's branches all over Japan is shown in Fig. 4.

Table 4 shows the types and numbers of different communication lines and how they are used in the on-line network.

Each line linking the terminal system of the branches in the HOPS network is capable of carrying all types

of texts/messages for deposits, loans, and other business transactions. No line is dedicated to specialized transmissions.

The geographically remote branches of DKB are linked to time-division multiplexers installed in each geographical area which relay the data to the center over high speed lines, making substantial line cost reductions possible.

### The terminal system

A typical terminal system of an average DKB branch is shown in Fig. 5.

Each terminal controller consists of a mini with a maximum memory of 256KB. The mini's software makes the terminal system highly intelligent and allows multiprocessing of concurrent jobs entered from the various terminal units, each of which handles a different type of job. In addition, the use of the mini provides flexibility for connecting different types of terminal devices in the future.

The specialized terminals tailored to perform specific jobs were jointly developed with the manufacturer.

The fail-safe concept was also ap-

Line Speed	Number of Lines	Usage
48Kbps	10	Relay lines linking geographically remote concentrator installations with the center.
4,800bps	4	Lines linking the DKB center with the Zengin (The on-line exchange system network of all banks in Japan) system.
2,400bps	700	Lines connecting the terminal systems of the branches to the HOPS network.
	1	Links the HOPS system to NCS (Nippon Cash Service) computer center.

Table 4.

TDM: Time Division Multiplexor  
 BPS: Bits Per Second

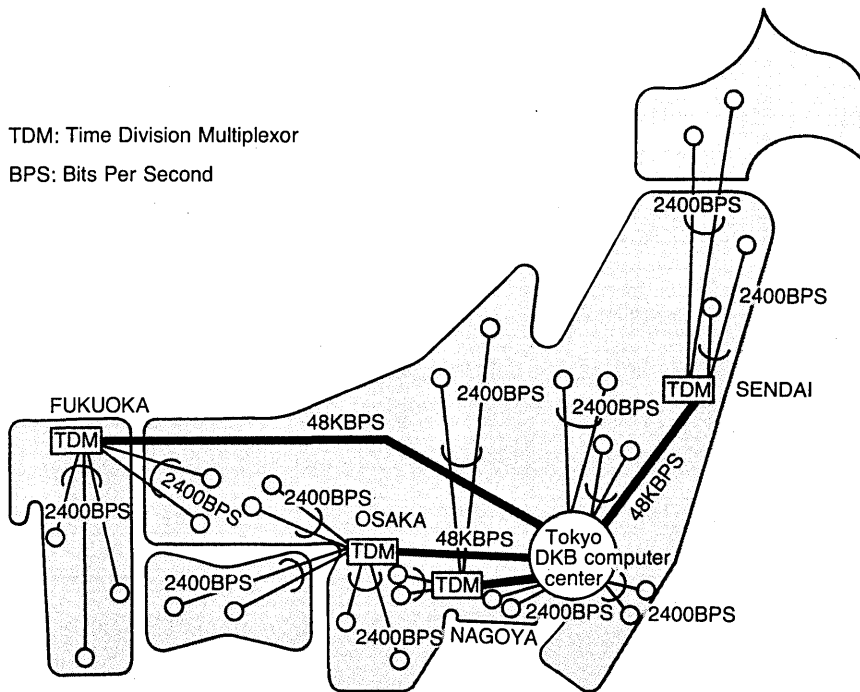

Fig. 4. Network of the new DKB on-line system (HOPS).

Description of Terminal Equipment	Number Installed
F1531M Terminal control units (minicomputer)	700 units
F1532N Terminals for handling deposits	2,500 units
F1533K/N Terminals for handling exchange & loans	800 units
F1538 Automatic cash dispensing terminals Automatic cash depositing terminals	700 units
F1552B Cassette-based data transmission/ receiving terminals	100 units
Total	4,100 terminals excluding the terminal control units.

Table 5. The number and type of terminal devices that make up the HOPS terminal system.

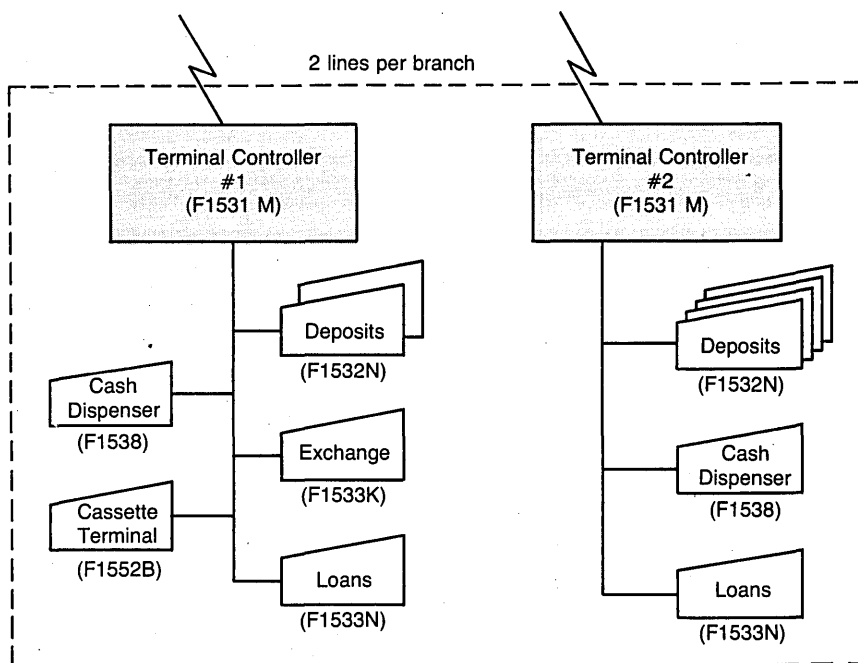

Fig. 5. A typical DKB branch terminal system.

plied to all of the terminal systems by having two lines connect the two independent terminal controllers of each terminal system to the network. Since the computer center itself shares the load among three host systems, continuous normal operations are ensured even if failures occur in the center computer, in the communications lines, or in the terminal control units.

Customer files are shared and allow cross-calling in the HOPS system. This feature too was implemented as part of the no-down concept. Although in principle it is not different from the conventional sharing of files as a common resource among a number of systems or jobs, we found that with conventional methods we would have certain problems in access control. (In the conventional method of controlling the right of file access, access rights normally are given to the system after the RESERVE/RELEASE declaration has been made, to prevent possible conflicts.) Some of the problems are as follows:

1. Difficulty in implementing recovery measures if a device crashes or a whole system goes down.
2. Increased access times (which would in turn cause a deterioration in the processing performance).
3. Increased path and file loads which would in turn cause an increase in overhead.
4. Complicated operational procedures.

These problems were solved in the HOPS system by implementing an improved control technique and developing some new utility programs.

Control of the commonly shared files is taken care of by microprogrammable hardware in the file control units. When a file access service request from a system is received by the file control unit, it complies with the request by permitting the access of the specified files in units of devices. The access right given to the requesting system is recorded in the stable reserve matrix of the file control unit and the cross-call adaptor. By using such a stable reserve matrix, simplified and therefore speedier accessing was made possible, in addition to allowing the commonly shared files to be handled as if they were dedicated (not-shared) files.

Several utility programs were developed to solve problems relating to failure recovery measures and ease of operation. One of these was the emergency recovery program. If a system were to go down while a portion of the customer ledger file, say, was in the reserved status, that file could not be accessed by another system. However, a solution to this

# BANKING

problem was found by developing a utility program that is activated by an alternate and operational system, instructed to do so by the SCDC after the crash occurs. The reserve status of the system that went down is first determined from the contents of the reserve matrix of the file control unit and is then automatically transferred to the alternate system. The particular record that was being processed when the system went down is retrieved from the checkpoint file by the operational system; it is then flagged to prevent any transactions from being made to this record. In this way the file is quickly released and normal operation is restored.

Thus we were able to solve the problems concerning file sharing and apply the solution to all customer ledgers. Some of the direct benefits of this are:

1. Realization of a fail-safe system.
2. Tremendous savings derived from making the file devices a shared resource.
3. Ease of future expansions in the applications or in customer files.

This resulted in noticeable improvements in customer service. Fig. 6 shows the shared file access control technique used in the HOPS system.

## Fujitsu software

The basic software MONITOR VII and the on-line software COP (Common On-line Package) used in the HOPS system was supplied by the hardware manufacturer Fujitsu Ltd.

All of the on-line application programs written by us are activated or deactivated under the control of COP. In addition, COP supports the intersystem shared file access control functions previously mentioned, plus communications between different system functions including the cca control functions, queue control, buffer control, etc.

Writing the on-line application programs was not very different from writing off-line batch programs as we did not have to worry about interlacing with COP; this was easily done by using macro instructions in that package. In fact, we did not have to write any on-line control programs.

## System evaluation

To ensure the quality of computer services to each of our branches and to ascertain the expected lifespan of the system, a lot of our attention went into system evaluation. Innumerable tests were carried out jointly in cooperation with Fujitsu.

The Generator/Logger (G/L) function of COP was utilized as a means of evaluating system performance. There are two types of Generator/Loggers;

one is used to test hardware aging of each individual system, and the other to test the performance capability of the actual systems in operation in the entire HOPS system by using the two individual system components as shown in Fig. 7 (p. 96).

In the latter performance evaluation test, the terminal simulator generates and logs message texts and measures the traffic and response times. On the other hand, the central system carries out the actual processing, and cpu loads are measured by a program package called PANSY (Performance Analyzing System) which is also supplied by Fujitsu.

The center and the terminal simulator both have multi-cpu's and the memory is interleaved 16 ways.

## On-line Processing Performance:

Response Time—this is defined as the time taken from the point a request to send is made by the terminal simulator to the central center system until the processed results are received by the terminal simulator. The results are recorded together with the original text on mag tape.

Fig. 8 (p. 96) shows the mean response time curve determined from the results of the measurements. It shows that response time does not increase until a 90% average cpu load is reached. (The logical mean response time value of 950 msec, predicted by the curve for an average cpu load of

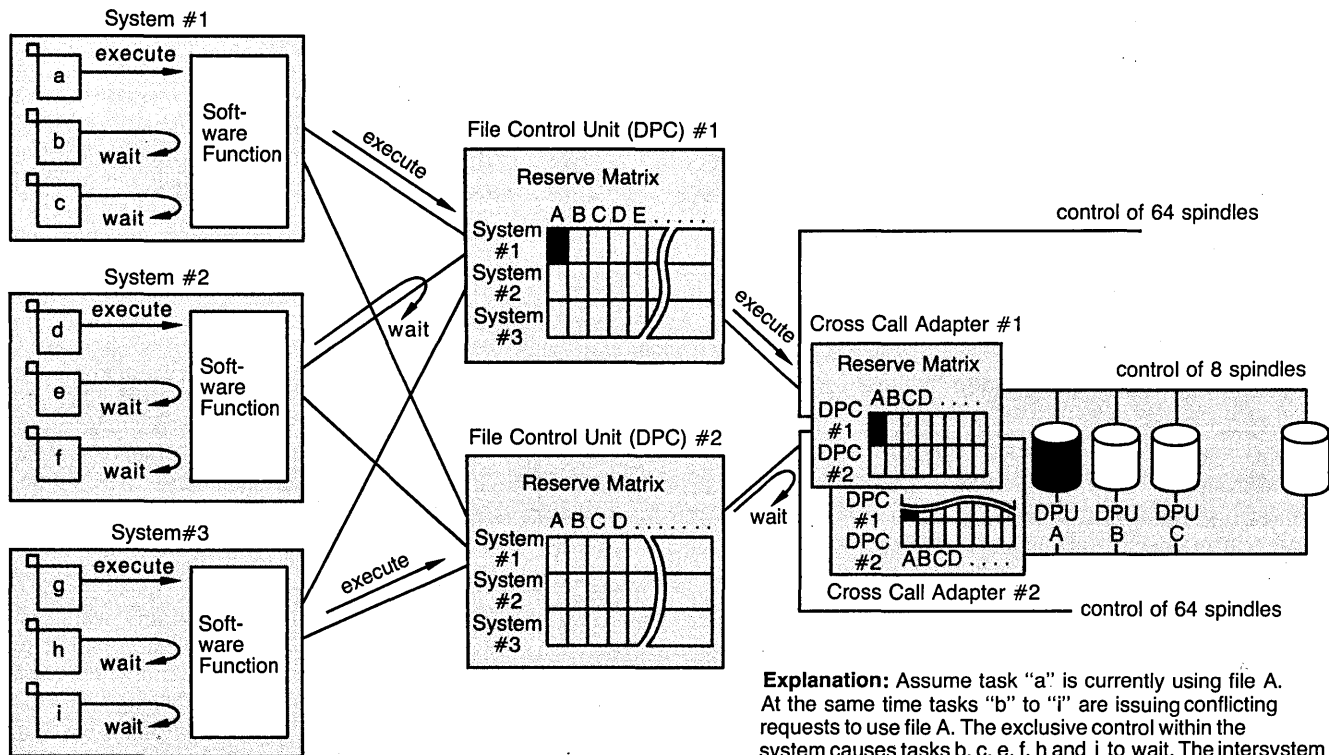
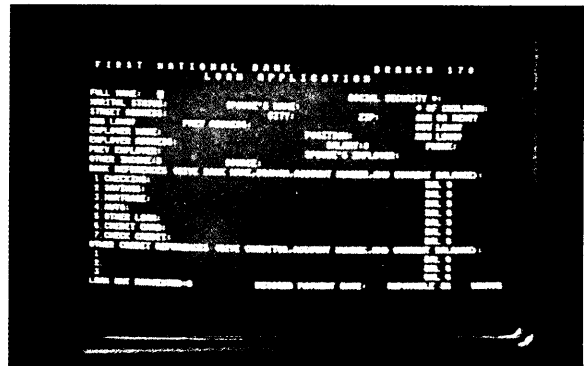
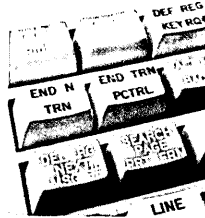

Fig. 6. The shared file access control techniques.

# Faster, more accurate data entry with powerful terminal software:



Data Entry Level II Software  
for Incoterm Series 30 and Series 40  
Intelligent Terminal Systems



## IDES II.

IDES II is an advanced, application-oriented Level II Data Entry software package. It helps an Intelligent Terminal make maximum use of your data gathering network. Helps make your people more productive.

Now you can greatly streamline entry procedures; provide extensive editing and validation.

Operators key in only new data to the form and depend upon program control for instant data editing and interactive validation routines.

Arithmetic functions are supported, as are batch controls, page subtotals, form totals, batch balance checks, conditional branching forward or back throughout up to 255 form pages.

Operators can reference the central data bank during data entry; to see if an insurance policy is active or cancelled before processing a claim, or if a freight station is served before creating a waybill.

Entered data is stored locally, ready for a polled request from the computer or for later batch transmission. Your entire data entry staff can continue to process data even when the computer or communication lines are down.

If your business generates data at remote action centers, why not learn more about IDES II from INCOTERM? Write or call for complete details.

More power  
to your  
terminal.

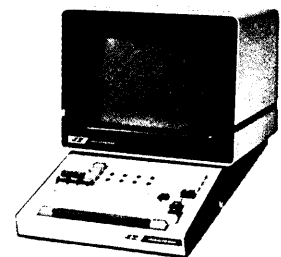

**INCOTERM**  
CORPORATION

65 Walnut Street, Wellesley Hills, Massachusetts 02181 Telephone: (617) 237-2100.  
Sales and customer service offices in major cities throughout the United States and abroad.

# BANKING

72% came very close to the actual measured value of 910 msec.)

Number of Transactions Processed Hourly by Each System—The relationship between the average cpu load and the number of transactions processed hourly per system is almost linear, as can be seen from the graph shown in Fig. 9. Therefore we can say that the processing capability is cpu-limited.

In a dual cpu system, normally, because of the effects of memory conflicts and system resource lock-outs, the multi-cpu coefficient  $M$  is not equal in value to two. The equation commonly used to determine the multi-cpu coefficient within a fixed time duration is as follows:

$$M = \frac{\text{number of transactions processed by multi cpu's}}{\text{number of transactions processed by single cpu}}$$

But with an on-line system we must also include time considerations (see Fig. 10). Along the x axis is the number of transactions processed in one hour, and along the y axis ( $P$ ) the percentage of these transactions processed within the 1.5-second response time.

For example, the curve shows that 97% of 150,000 transactions processed by a single cpu have a response time within 1.5 seconds, but with a multi-cpu system that figure is 90%. Thus with an increase in the number of transactions the cpu load factor also increases and the value of  $P$  decreases until it reaches a limit. If the multi-cpu coefficient is computed when the value of  $P$  is 80% for both the single- and multi-cpu, we get the value  $B/A = M = 1.8$ .

MONITOR VII software allows concurrent processing of on-line and batch jobs. The batch jobs concurrently processed consist of a data conversion program and a sort program.

In the MONITOR VII system, on-line task execution has a higher priority than any of the batch tasks. As the average cpu load goes up, the change does not affect the on-line task, but the batch tasks are affected considerably. The increase in turnaround time is gradual until an average cpu load factor of 60% is reached. After this point the rate of increase becomes very steep. When the load factor reaches a value in the region of 80% to 90%, the turnaround time for batch jobs deteriorates to the following values:

- a) Convert program—1.8 to 2.0 times as long to process

- b) Sort program—1.3 times as long
- c) Convert + sort program (2 concurrent jobs)—3 times as long

## The problems

When we commenced the operation of the HOPS system, we had in effect started a comprehensive on-line banking service consisting of numerous activities such as: ordinary deposits, current accounts, deposits at notice, time deposits, loans, business exchange, customer information file service, etc. These services were implemented simultaneously, along with new equipment such as terminals and minicomputers that make up the terminal system. We started with 150 terminals.

With regard to the implementation of the new system, our objectives were

to achieve a degree of reliability from the start, exceeding that of the previous system which had been operating satisfactorily.

For this purpose, we planned and implemented additional tests apart from the application program tests. However, we experienced more difficulties than we had anticipated in:

- hardware failure tests
- special tests for the complex system configuration—that is, reliability tests to confirm that load sharing control functions and shared file control functions, etc., were working properly
- overload tests using the G/L system.

In order to implement these tests, over 5,000 combinations of failures were simulated. It took 3,000 hours of machine time and 600 man-months

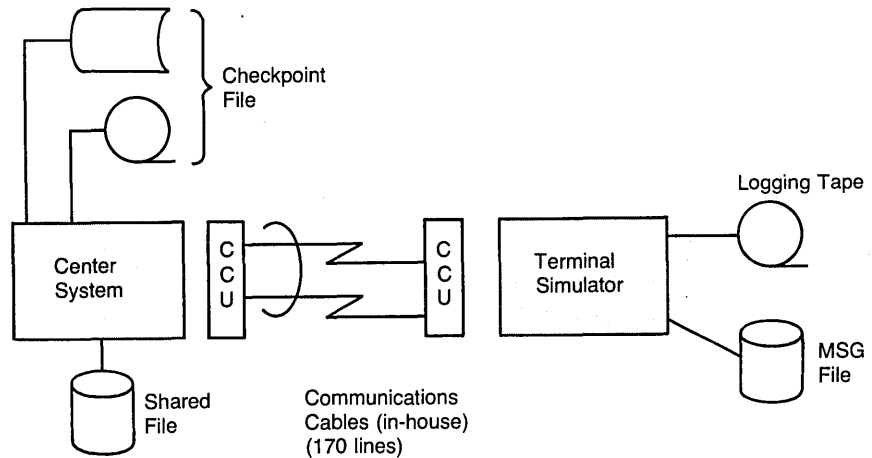

Fig. 7. The G/L concept.

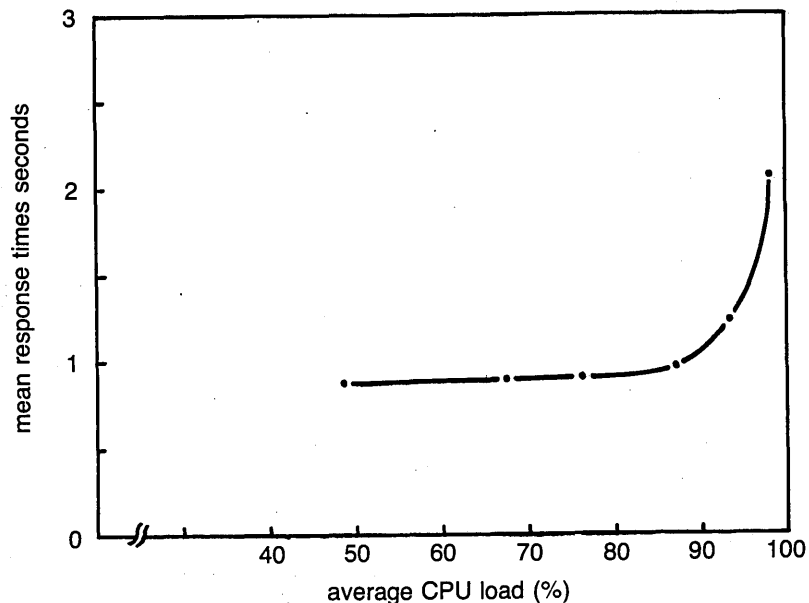

Fig. 8. Mean response time.

to complete the tests (which were conducted jointly with the manufacturer).

Some of the test combinations included double or triple hardware failures. Mainframe and I/O failures were intentionally caused during the testing, and software reliability was checked for each failure combination. From these tests we learned the hard way how difficult it is and how much

manpower it takes even to produce a good operator's manual.

We were unable to achieve a completely automated hot standby SDC system. From the outset we planned to use a dual-processor system, hoping to have one processor take over instantaneously when the other went down. As the system design work progressed, however, we found that soft-

ware development was a lot more difficult and complex than anticipated. Therefore we lowered our objectives to a more realistic level, whereby recovery could be achieved by operator intervention within two to three minutes after a system went down.

Now as we look back, we can feel a sense of satisfaction and pride at the techniques we had developed such as: the shared file access control method, load share technology, the system evaluation methods, etc. In fact, we can confidently say that the on-line banking system we developed was a state of the art system of the highest level in Japan. \*

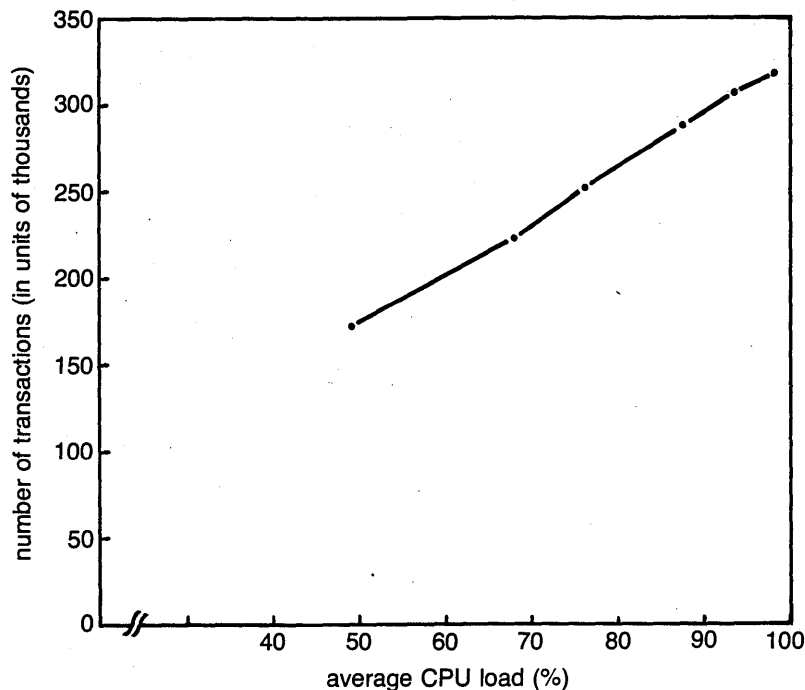
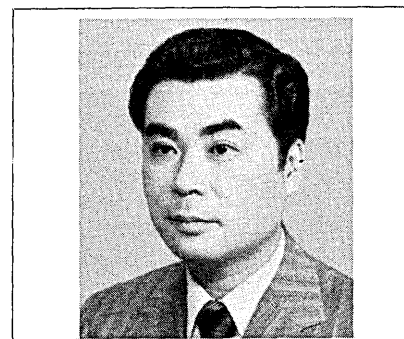

Fig. 9. Number of transactions processed hourly per system.



Mr. Abe joined the dp division of the Dai-ichi Bank in 1960. Five years later he was given responsibility for the design and development of an on-line system based on the Facom 230-50 computer. In 1973 a merger produced the Dai-ichi Kangyo, and two different systems were integrated into one. Since '76 he has been manager of the DKB's On-Line System Development Dept.

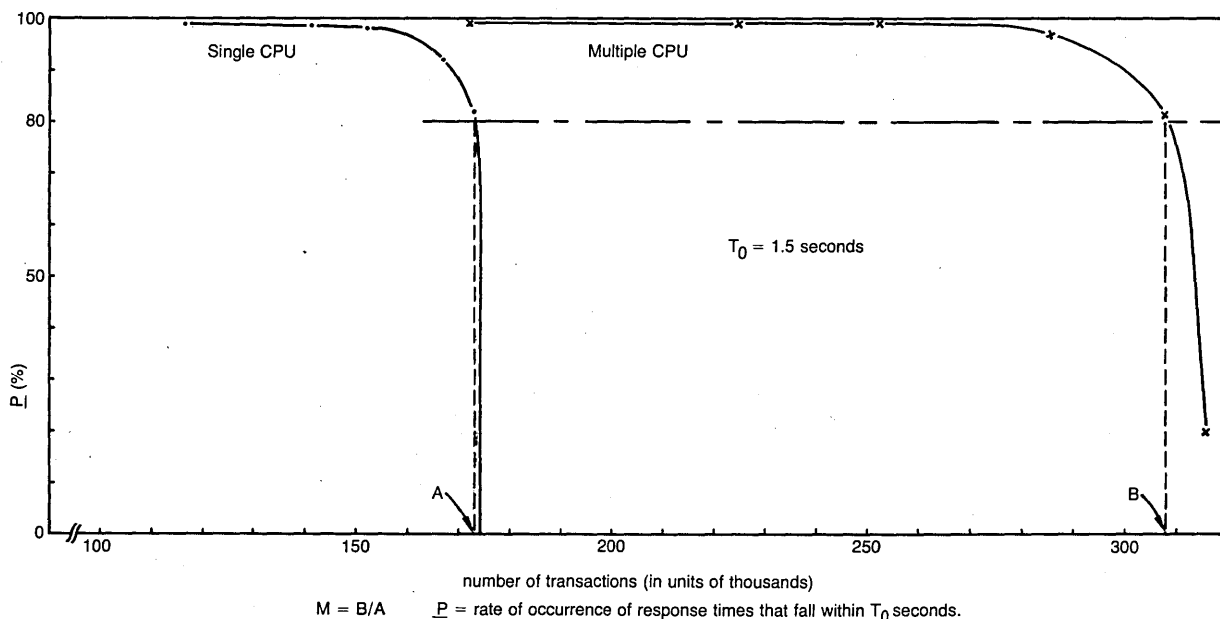
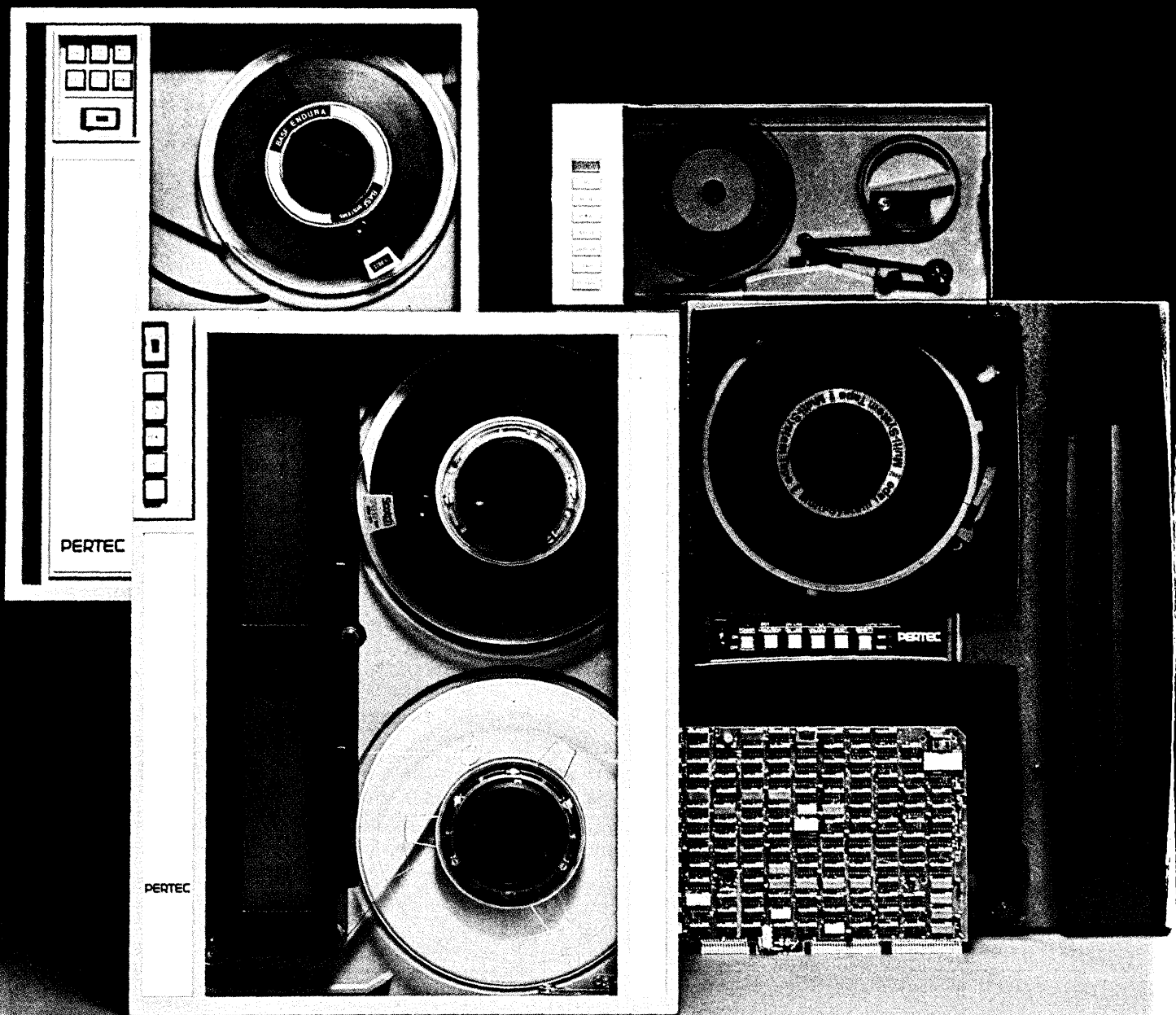

Fig. 10. Multi-cpu coefficient.



# CENTRAL INTELLIGENCE:



# The data formatter that came in out of the cold.

Tape drive intelligence has crossed the iron walls. And taken up residence *inside* a broad series of transports—through a special Microformatter™ that Pertec installs internally.

A real technology breakthrough for sure. But it's the hot savings potential that intrigues OEMs most.

Eliminates the need for any external formatter to control the reading and writing of data. Makes interface chores much easier.

Now add in the convenience and cost-efficiencies you'll realize with just one system to handle (and ship), instead of two separate devices.

**Saves integration time.** With the Microformatter built-in, a single interface can be used for 800 cpi NRZI, 1600 cpi PE, or dual formats.

**Saves redesign.** Formatted Tape Transports use the same Pertec industry-standard formatter interface. And the same Microformatter, to maintain parts commonality.

**Saves daisy-chain hassles.** Every master Formatted Transport can daisy-chain up to 3 more tape drives—either Pertec standards or our new Formatted models.

**Saves rack costs.** You free up former external-mount slots. And the single-board LSI

Microformatter is so compact it fits into each drive without restructuring standard rack mounts.

**Internal Formatting.** Deep down inside, you know it's right! And it's available in a flexible configuration range.

Formatted tension-arm: *FT7000*—compact 7" reel, NRZI or PE, 12.5 to 25 ips. *FT8000*—10½" reel; NRZI, PE, or dual NRZI/PE to 45 ips.

Formatted vacuum-column: *FT9000*—10½" reel, 37.5 to 75 ips NRZI, PE or dual. And *FT1000*—10½" reel, our vacuum column 125 ips high speed auto-thread, auto-load series, dual NRZI/PE.

**Fully proven product.** All are microformatted extensions of field-proven drives, produced by the world's largest independent manufacturer of peripheral equipment.

And backed by international sales/service facilities, with a long-term commitment to responsiveness. Making emergency assistance available on a 24-hour, 7-day basis, accessed through our toll-free 800 line.

At every level—product, sales, maintenance—Pertec intelligence has always recognized that cost-effectiveness is the central issue with OEMs.

- Please send full details on the Pertec Formatted Tape Transport Series.  
 Send pricing information as indicated on the RFQ below (no obligation or cost).

#### Request for Quote

Formatted Series #	Reel Size	Tape Velocity (ips)	Recording Mode	Quantity Required	Date Wanted	Send Specs
FT7000	7"	12.5-25	PE or NRZI			
FT8000	10½"	12.5-45	PE, NRZI, Dual			
FT9000 Vacuum Column	10½"	37.5-75	PE, NRZI, Dual			
FT1000 Vacuum Column	10½"	75-125	Dual NRZI/PE			

Name \_\_\_\_\_

Title \_\_\_\_\_ Phone \_\_\_\_\_ Ext \_\_\_\_\_

Please attach coupon/RFQ to company letterhead and return to Pertec, 9600 Irondale Avenue, Chatsworth, CA 91311.

For immediate requirements, call your nearest Pertec regional sales office: Los Angeles (213) 996-1333. Ann Arbor, Michigan (313) 668-7980. Hudson, New Hampshire (603) 883-2100. England (Reading) 582115.

## PCG PERTEC

a division of Pertec Computer Corporation

# What we did for branch banking in Denmark, we could do for you: Provide 99.9% on-line communications availability.

**And that's not all Rockwell-Collins On-Line Teller System can do for you.**

Improving on-line communications and system capacity was the primary objective of a group of savings banks in Denmark. They have more than 2,400 teller terminals generating as many as 1.2 million transactions per day. All the terminals are on-line to a computer facility operated by SDC\*, a service bureau in Copenhagen owned by the bank group.

After SDC installed a communications front-end, based on the Rockwell-Collins On-Line Teller System, this is what happened:

1. On-line availability rose from an unacceptable level to 99.9%, translating into an average downtime of less than 10 minutes per month. The reason: the Rockwell-Collins system controls the entire network and can capture data on disc even if the host computer goes down.

2. Communications throughput

\*Spærkassernes Data Centraler

capability tripled. The Rockwell-Collins system can handle up to 150 transactions per second.

3. The host computer got a new lease on life. Freed of most of its communications-related activities, the capacity of the host computer was increased by 25%, expanding its growth potential. Costly host computer upgrading can now be deferred much longer.

**A Rockwell-Collins system could do the same for you.** Let us tell you about all the advantages of a Rockwell-Collins On-Line Teller System: its ability to handle virtually any terminal type, for instance; the way it handles administrative communications from branch to branch, or from the central EDP system to branches. And many more.

To find out how to increase your on-line communications availability, contact: Communication Switching Systems Marketing, Collins Commercial Telecommunications Group, Rockwell International, Dallas, TX 75207. Phone (214) 783-3434.

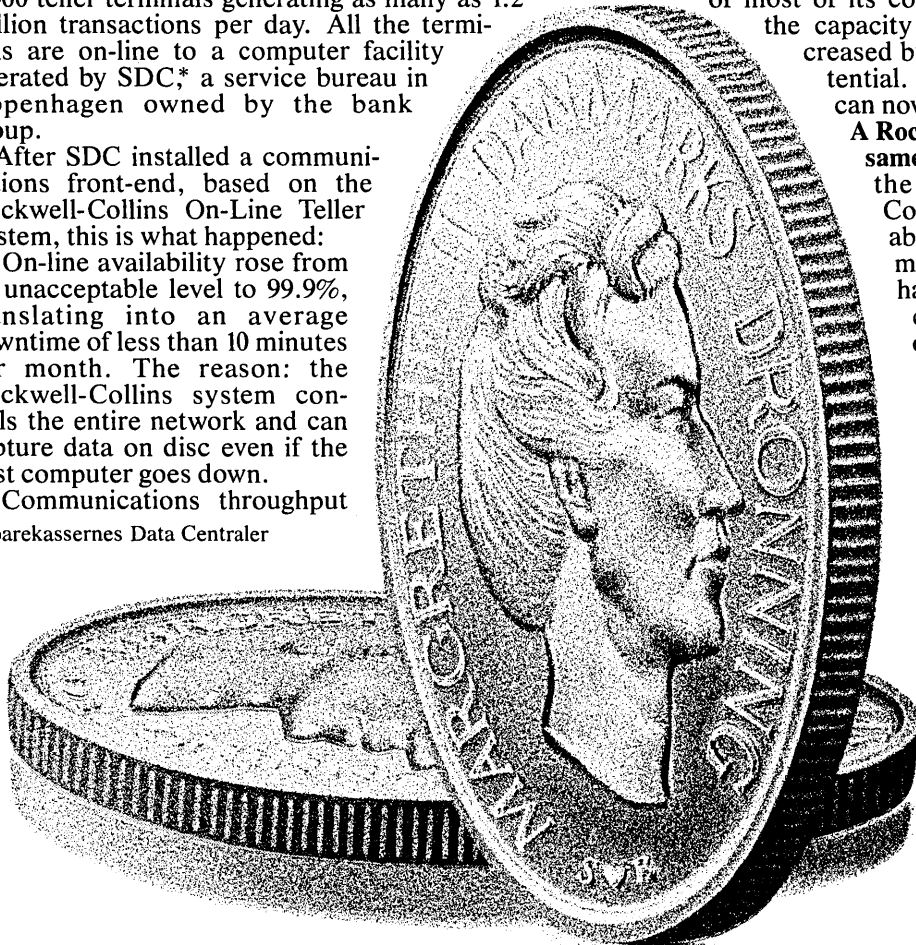

SEE US AT  
**INTEL  
COM 7**  
INTERNATIONAL  
TELECOMMUNICATION  
EXPOSITION  
ATLANTA, GEORGIA, USA  
9-15 OCTOBER 1977



**Rockwell  
International**

...where science gets down to business

Cairo 801525 • Frankfurt (Rodgau 6 Weiskirchen) (0) 6106-4093 • Hong Kong 5-274-321 • Johannesburg 211-521  
Kuala Lumpur 27283 • London 01-759 9911 • Mexico City (905) 533-1846 • Melbourne (Lilydale) (03) 726-0766 • Paris (Rungis Principal) 687-31-02  
Rio de Janeiro (021) 246-3276 • Riyadh 62284 • Rome (0) 6-862-415 • Tehran 685-180 • Toronto (416) 757-1101

# Computing Under the Gun in the Hermit Kingdom

by Bill Orr

---

A genuine economic miracle in the making.

---

Suddenly everybody seems to be talking about Korea. Will the peninsula explode into war again? Is South Korea replaying the Japanese "economic miracle?" If so, will a technology-smart South Korea be customer or competitor in the world market-place? From a broader perspective, there is a growing interest in the dynamics of "nation building." What kind of society is most likely to make it into the charmed circle of modern industrialized nations? How long does it take?

After hundreds of years of quiet agrarian obscurity, the "Hermit Kingdom" is suddenly ready to move into the limelight of the international economic stage as an industrialized world trader.

Projecting from a 15-year track record, South Korea will match Japan's present level of national affluence before the end of the century. In the next 5 to 10 years, South Korea will become a major world trader in such key industrial areas as

shipbuilding, steel, and automobiles. In the process, this intelligent, intensely competitive people will have made their unique mark on the world economy, just as postwar Japan & Germany have done.

Or will the bubble burst in fratricid-

al war before it's full blown?

A top ranking U.S. military officer in South Korea said that war is inevitable if American troops are withdrawn from their front-line positions on the invasion route from the north.

Well, the troops are going—over a five-year period on a schedule yet to be detailed. The North Koreans have a two-to-one advantage in aircraft and a heavy superiority in tanks. Their crushing perpetual war budget is widely regarded as an index of their military intent.

Still, it's hard to imagine the North Koreans overrunning their brothers and cousins to the south, who are determined, well armed, superbly trained, and thoroughly psyched-up for cold or hot war conflict. It's even harder to imagine military support coming from either of North Korea's quarreling superpower sponsors.

The celebrated hassle over withdrawal of U.S. troops goes beyond the arithmetic of tanks and



# Perkin-Elmer: System Integration by Design



Our design engineers spend a lot of time talking to each other. In fact, we insist on it.

Thanks to all the talk at the drawing boards, we can offer you systems that perform. At peak efficiency.

We realize that the more fully you can utilize the power of your system, the happier you'll be.

That's why we design every single product to suit the system. And every system to optimize its parts.

Perkin-Elmer Data Systems designs and builds a complete line of minicomputers from our Interdata

division; mass storage devices from our Wangco division; and I/O terminals from our Terminals division. They're all designed for system integration.

Excellent price/performance. Complete software. Field-proven hardware. Integrated sales and service. Worldwide customer support. Perkin-Elmer Data Systems supplies the tools and support you need.

Give us a call at our toll-free number: (800) 631-2154. We have a lot to talk about.

## PERKIN-ELMER DATA SYSTEMS

106 Apple Street, Tinton Falls, New Jersey 07724 Telephone: (201) 747-7900/TWX: 710-7226532

## HERMIT KINGDOM

aircraft. The whole subject is wrapped in emotional doubts that, after Vietnam, the U.S. will really live up to its commitments unless its own troops stay on as cold-war hostages. And South Korea has a big stake in whether the troops go sooner or go later, what equipment they leave behind, and other details of the inevitable withdrawal. It will cost two to four percentage points of GNP. Total self-defense will mean stretching out the country's growth plan.

### Economic evolution in a hurry

Korea's swift evolution from an impoverished agrarian society to a middle-income industrialized one began in 1962. The devastating war had ended, or at least moved to the political battlefields. The dust of internal political turmoil had more or less settled. Firm-handed former general President Park Chung Hee had launched the first Five-Year Plan.

In 1962, per capita GNP was \$87. In 1976, a year of 15% GNP growth, the per capita share was \$698. During the fourth Five-Year Plan (1977-81), South Korea expects to push it to over \$1,500 (at the current market price). One government researcher's projection, based on conservative growth rates, forecasts a per capita GNP of over \$3,000 in the 1990s. At that point, South Korea will have achieved a level of general affluence about equal to that of 1973 Japan. Most Korea-watchers will be surprised if those goals aren't reached years earlier, especially if the ongoing exploration for offshore oil pays off.

South Korea's economic credibility got a big boost during the oil crisis years of 1973 and '74. Thanks to some daredevil financial tactics, real GNP actually rose by respectable percentage points—while every other country in the world (excepting oil producers, of course) posted declines.

An affluent modern country must be a strong exporter. Korea's exports grew at an average annual rate of 40% between 1962 and 1976. This year, South Korea's exports will hit \$10 billion, comparable to Japan's in the mid-sixties. Exports are expected to double by 1981. And the mix will have made a "textbook" transformation from raw materials, to fabricated products exploiting cheap labor, to the current and future export superstars—250,000-ton tankers, cement plants, oil refineries, and automobiles. In 1976, over two-thirds of the GNP was derived from foreign trade, compared with about one-tenth in 1965. By 1981, heavy industry will contribute nearly half of the export total.

	Population (Millions)	Per-Capita GNP (In 1975 \$US)
World	4,078.8	\$1,531
Developed Countries	1,112.9	4,445
Less Developed Countries	2,966.0	437
United Arab Emirates	0.2	33,182
Qatar	0.1	21,111
Kuwait	1.0	13,900
Sweden	8.2	7,428
United States	213.6	7,098
Switzerland	6.4	6,975
Canada	22.8	6,362
West Germany	61.8	6,144
Japan	111.0	4,358
East Germany	16.9	3,574
USSR	254.5	3,088
Puerto Rico	3.5	2,474
Singapore	2.3	2,516
Venezuela	1.2	2,277
Spain	35.5	2,080
Argentina	29.4	1,569
Iran	33.0	1,514
Portugal	8.8	1,333
Brazil	107.1	913
Taiwan	16.0	900
South Korea	34.0	551
North Korea	16.5	545

Table 1. Selected per capita GNP's in 1975. (Source: U.S. Dept. of State, Special Report 33, May 1977.)

### Hermit Kingdom: front and center

Oriental scholars and Western Korea-watchers have good reason to marvel at the sudden transformation of the one-time "hermit kingdom" into a free-wheeling world trader.

In race and language, through the centuries the Korean society has been one of the world's most reclusive and inbred. But in this case, "inbred" doesn't imply "backward." Korea has a long tradition of religious and scientific scholarship.

Universal public education has been pushed hard for the past 15 years. The result is a literacy rate already well over 90%, on the verge of matching the levels of the most advanced Western societies and Japan. Most observers give Koreans high marks as quick-learning, resourceful technicians, and innovative theoreticians. This kind of educated populace is clearly a necessary foundation for the rapid development of a high-technology society.

### Computers and GNP

Two centuries ago, what we now call the industrial "revolution" began in England. It's still continuing, building on itself and enriching the nations lucky enough to have gotten in on the ground floor. Computers have become the intelligent prime mover of 20th Century industrialization.

Today, the world's highest per capita GNP's were reported by the familiar list of advanced industrialized nations. (See Table 1.) At this year's

National Computer Conference, attendees heard the keynoter give computers credit for about 15% of the U.S. growth in per capita GNP over the past 30 years. Other United Nations studies have found a close correlation, in industrial nations, between GNP and the population of computers.

One of the more interesting questions for developing nations is whether the correlation applies to them, too.

South Korean planners seem to have staked much of their growth expectations on the use of computers to increase national productivity. So the optimistic projections of GNP growth indicate a bright future for computer suppliers.

Let's look at what's happening in computers, and what's projected for the future.

South Korea's first computer, an IBM 1401, was installed in 1967 for econometric calculations. In the ensuing eight years, to the end of 1975, the computer population grew to 140 units valued at \$44.2 million. As Table 2 shows, U.S. manufacturers, led by IBM, dominate the market. Facom Korea, a unit of Fujitsu, is pushing hard for a larger share and seems sure to get it. The "9 others" furnished minis. At present, there is no local manufacture of computers.

Table 3 (p. 104), projects the computer population and total value through 1986.

The average compound annual growth rate is more than 20%, and the numbers get more interesting as the

Supplier	No. of Units	Value \$(Mil)	Share %
IBM	33	19.0	43.0
UNIVAC	19	10.6	24.0
CDC	9	6.3	14.3
FACOM (Fujitsu)	11	3.0	6.8
9 OTHERS	68	5.3	11.9
TOTAL	140	\$44.2	100.0%

Table 2. Computer manufacturer market shares as of Dec. 31, 1975. IBM is number one, but Fujitsu is pushing hard.



## HERMIT KINGDOM

	Units	Total Value	Avg. Value
1975	140	\$44.2M	\$316,000
1986	6300	340.0	54,000
Increase*	5160	295.0	262,000

\*Avg. annual growth rate: 20.4%

Table 3. The projected computer population and its total value through 1986.

process rolls along.

It's also interesting to see—although it shouldn't come as a surprise—that the average value of each unit drops from about \$316,000 to \$54,000. This rapid swing to minis clearly suggests that the South Korean computer market is getting to be a whole new ballgame with plenty of opportunities for new players.

As this article goes to press, it wasn't clear how much of this potential market will be available for foreign suppliers. The answer may be determined by an intense "make or buy" debate now going on at the highest levels of government which is considering these options:

1. Continue to purchase complete systems from mainframe manufacturers.
2. Develop a Korean minicomputer industry to serve local needs and offer exports in the world marketplace.
3. Function as a national "systems house," purchasing most components from foreign oem's and assembling complete systems in Korea.

Obviously, the final decision, expected this year, will have a deep impact on the character of the computer marketplace.

Officials in the government who are responsible for technology development are said to favor the "systems house" course of hardware procurement. They argue that developing an indigenous industry could actually slow the pace of computerization by diverting such scarce resources as materials, plant facilities, and trained specialists.

These officials also advocate an all-out effort to develop a South Korean software industry that will speed up the application of computer methods and at the same time provide software systems for export. These systems may be part of small- and medium-size process control plants designed and built for developing nations.

Whatever course is adopted, computerization throughout the South Korean economy will continue at top speed.

And the pace-setter in developing and applying computer methods will continue to be the Korea Institute of Science and Technology (KIST).

KIST was formed in 1967 as a non-profit center of excellence in applied research with the mission of reversing

the "brain drain" and helping to improve business methods.

Within KIST, computer applications are supported by a staff of about 200, half of whom are programmers and analysts. This year, KIST formed a Software Development Center, reflecting the new emphasis in development strategy.

The institute has a CDC CYBER 73/18. As of mid-year 1977, KIST's nationwide data communications network linked 16 batch and 25 interactive terminals to the computer center in Seoul. The system has hundreds of users, ranging from "drop-in" businessmen to the country's largest private enterprises, the telephone company, banking institutions, and government units at all levels. All customers are charged for services, and KIST plows back any surplus revenues into personnel or equipment. The amount of resources allocated to specific groups and projects is directly related to revenue from users. When revenues fall off, staff and budget do too, all the way to the vanishing point. Growth is brisk under this formula.

KIST presently is in the middle of a major upgrade of its computer installation. Among the goals are a three-to-one improvement in cost/performance and the ability to support thousands of users.

For the evaluation, KIST has prepared a comprehensive set of benchmarks, which are being run through summer and probably into fall. Competition is keen, befitting the size of the purchase and the prestige of the buyer. The field includes CDC, IBM, Univac, Burroughs, DEC, and Facom. The Facom entry may be the big M-190, equivalent to a 3033 or Amdahl 470-V6.

### Upgrading installations

Because of the acceleration of computer applications throughout South Korea, many other large users will be upgrading their installations in the next year or two. Among them are the huge Samsung conglomerate, Korea's largest business establishment, and Korea Electric. The trend appears to be toward a centralized data processing facility linked to branch offices via remote batch and interactive terminals. Distributed data processing (i.e. serious local computing) does not seem to be in the mainstream of currently

planned applications, at least for big users.

### So what?

Most of us in the computer industry have been bombarded with "gee whiz" hyperbole so long that we may miss some of the implications of the South Korea experience. "Economic miracle" is a term that rolls easily off the promoter's pen. But what does it really mean? It is a miracle when a country joins the select circle of advanced industrial economies? In the late 20th Century?

Since World War II, only Japan among the major nations has made the full transition from agrarian to advanced industrial status. And we can identify only a handful of candidates for the rest of the century: Spain, Argentina, Brazil, Yugoslavia, South Korea, and some special situations like Singapore, Hong Kong, Taiwan, and Puerto Rico. The oil-exporting countries may post some spectacular per capita GNP numbers, but they have a very long way to go to achieve the balance of economic activity and the distribution of wealth that are part of the definition of an advanced economy.

There is a growing consensus that computers can play a major role in transferring technology and finding innovative, environmentally "clean" approaches to nation building.

If the world dp industry can avoid being mesmerized by its own "hype," it has a chance to upset the rather dismal trend and make an historic contribution to the quality of human lives around the world. ❁

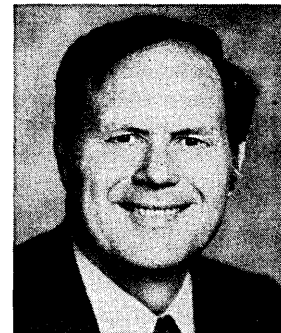

Mr. Orr reported on the first Southeast Asian Regional Computer Conference (December 1976, p. 99), and the material for this article came from personal interviews, including some at "Blue House" (Korean White House) level, augmented by research in periodicals and statistical publications.

Over the past 15 years, he has been active in AFIPS affairs, chairing sessions on the social implications of computers.

Mr. Orr is a marketing consultant based in Santa Monica, Calif.

Hewlett-Packard

# Computer Advances

Vol. 2 No. 3 September 1977

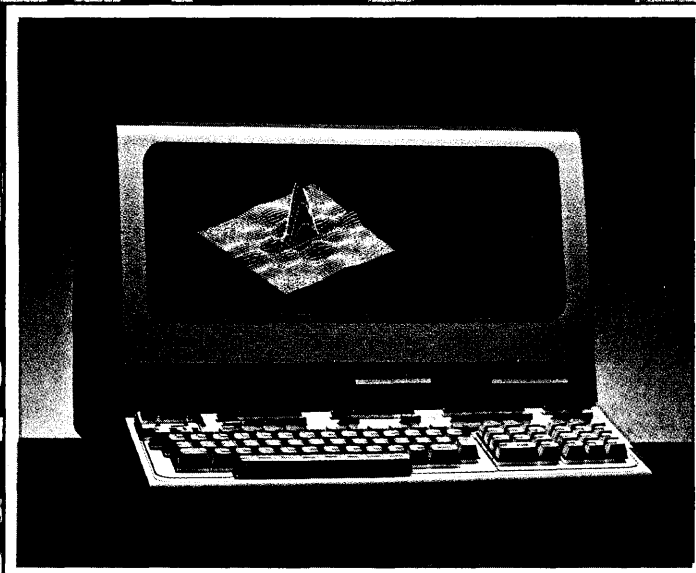

HP 2648—a bright idea  
in graphics terminals

The controllers

The HP 2026 keeps  
the data flowing

# A bright idea for a graphics display

The world of graphics is expanding to serve more and more people. High-performance graphics, previously found only with more expensive systems, are now available on the new HP 2648 which has micro-processor control and uses raster scan technology.

The advantages of refreshed raster scan technology are a continually bright display and selective erase—the ability to make changes without having to redraw the entire image. Raster scan graphics require a bit of memory for each displayable point. Low-cost, high-density semiconductor memory now makes this technology economical.

## Ready to plot

The HP 2648 is usable the minute you turn it on. The terminal was designed to be system and software independent, to solve real world problems right away without additional investment in software. All the graphics capabilities are hardware and firmware implemented and executable as simple keystroke functions. Off-line, the HP 2648 can record locally-generated drawing commands on optional tape cartridges, play them back, and support graphics program development. With a CPU complement, the user can interactively create more sophisticated graphics.

### ◀ Cover

*The design on the screen of the HP 2648 was zoomed to a 10 times magnification. The pattern used emerged from that enlargement.*

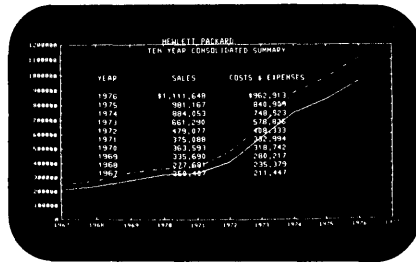

## Auto plot

User-generated tabular data can be automatically plotted with X & Y axes. The data can originate from a computer program, from the mini-cartridge, or from the CRT screen. A simple set of questions, in the form of a "menu," is displayed for the user. After first answering these questions—thus defining the data parameters—the user starts the plotting with a single keystroke. Within seconds, and independent of any system or software, the data is plotted. Sophisticated graphic representation of data is now available to more people in business, education, science, and management.

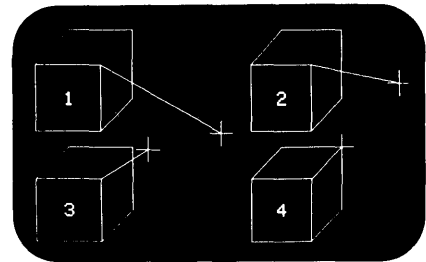

## Try it first

There are times when you want to change your drawing without disturbing the data points stored in the CPU's memory. The rubber band line offers a snappy solution to such trial sketches. Line drawings, such as architectural floor plans, can be made and modified quickly. They can even be recorded off-line on the optional mini-cartridge tapes for later batch transmission.

## Choices galore

As a user of an HP 2648, you can choose characters of varying shape, size, and orientation, and can right/left justify.

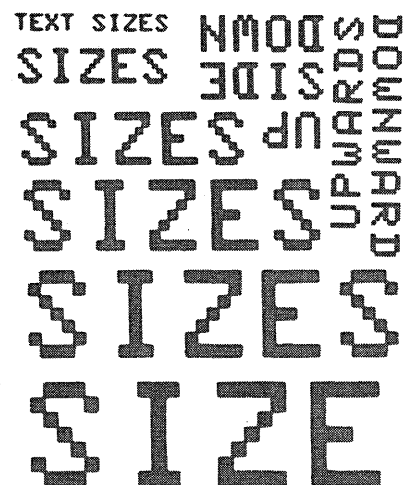

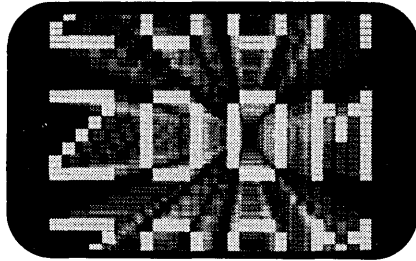

### Zoom and pan

Select an area of your display; move right in and magnify it. Zoom one step at a time, or with the touch of a key, zoom automatically to sixteen times the size. Then, pan in any direction through this enlarged display for closer investigation of complex designs. You do not need to re-initialize the data, since the graphics memory has not been disturbed. As zoom and pan are under microprocessor control, they are system and software independent. Without any special software packages or user programming, you can zoom and pan on or off-line.

### Now you see it, now you don't

The independent alphanumeric and graphics displays each have their own separate random access memory (RAM). So you can view the displays independently or both at the same time. Either memory can be suppressed without disturbing the other. Interact with the CPU/program in one memory and view the resultant picture in the other. This feature makes the HP 2648 perfect both for program development and trial-and-error graphics generation.

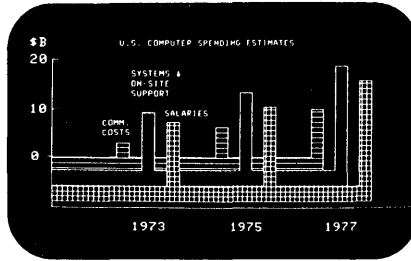

### Shade your drawings

Rectangular area shading helps distinguish similar shapes. The user can specify different portions of the drawing to be shaded with any of eight available patterns or with his or her own design.

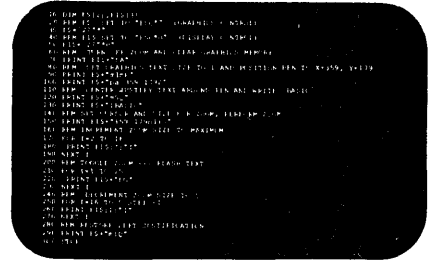
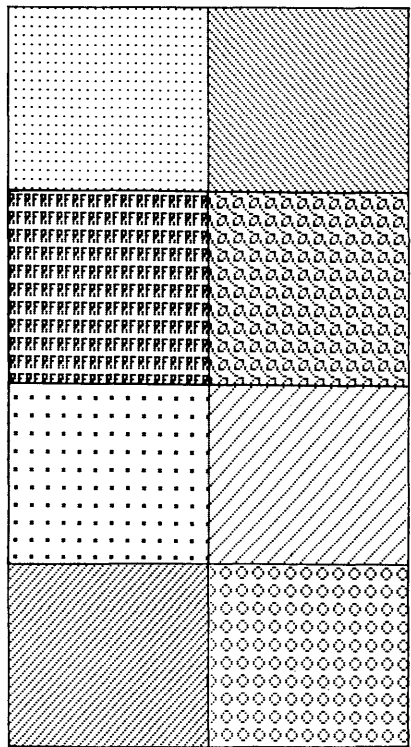

### Two terminals in one

The HP 2648 is a dual-capability terminal. Not only can it do sophisticated graphics; it also has those characteristics of HP's 2645 data entry and communications terminal that make programming so easy. These include flexible communications protocols, eight user-programmable keys, full editing, block or character transmission, and off-line data preparation with the dual mini-cartridges. This graphics and alphanumeric combination results in an especially versatile tool.

In the U.S., the HP 2648 costs \$5500; when equipped with cartridge tape drives, the price is \$7100. Quantity discounts are available.

It is difficult to describe on paper what happens on the display of an HP 2648. Check A on the reply card for a live demonstration or for more information.

# There's more than one way to weigh a mouse

There's more than one way to weigh a mouse because there's more than one Hewlett-Packard controller that can automate and control processes such as the weighing of medical research animals. Mettler Instrument Corporation of Princeton, N.J., for example, selected HP 9815 desk-top controllers for electronic balance systems that quickly weigh animals that don't want to be weighed. Hazeltine Corporation, of Green Lawn, N.J., on the other hand, plans to weigh fidgety animals using HP 2649 terminal/controllers. One of these products may be the way to solve your controller needs

## Terminal controllers

Hewlett-Packard's 2649 is a versatile, microprocessor-based terminal/controller for which technically-oriented users can design their own firmware or hardware. With the help of a Technical Information Package, custom designing application firmware is a three-step process.

Application programs are first

assembled on any system capable of producing 8080 object code, such as an HP 1000. Object code is transferred from the program development system to mini-cartridges using an HP 13290 development terminal.

The second step is to test and debug the application firmware by loading and executing these mini-cartridges into the RAM of the development terminal.

Then, application firmware object code is transferred to programmable-read-only-memory (PROM) chips for installation in multiple HP 2649 terminal/controllers. For high-volume applications, read-only-memory (ROM) chips are available from specified vendors.

There are two ways a designer can interface the HP 2649 to external devices. With HP's standard interface cards that provide for serial or parallel data transfer, the user need only fabricate a cable to complete the interface. If the application requires a nonstandard interface, users can design and build interface cards that plug into the back plane. The HP 2649 has eleven optional hardware slots available for I/O, display

enhancements, or memory.

Inherent networking capability of the HP 2649 makes it an ideal tool for interfacing specialized devices to various mainframes. Devices controlled by the HP 2649 vary widely. Among them are laboratory scales, cash registers, typesetting equipment, and analog sensors.

Because of the software and hardware development needed to customize an HP 2649, it is most economical when a quantity of systems are needed for dedicated applications. In a business or industrial environment, where untrained people are using the terminal, the customized HP 2649, with its display screen and modifiable keyboard, becomes an especially friendly interface. The HP 2649 costs \$2150\*.

## Buy a board, build a system

For the OEM designer who needs the power and flexibility of a microprogrammable minicomputer, HP offers the K-series processor, a component version of the 21MX computer family.

Designed to fill the need for high-power processing in a low-cost form that integrates easily into OEM systems, K-Series components offer flexibility in configuring inexpensive products with the full power of a minicomputer. The K-Series can be a full minicomputer that is hardware and software compatible with HP's entire 21MX line. Or, systems engineers can gain direct access to an extraordinarily fast control processor with 325 nano-second cycle time and 210 powerful microinstructions.

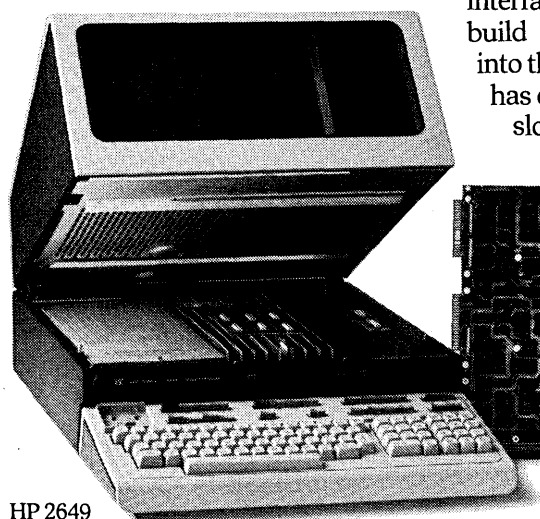

HP 2649

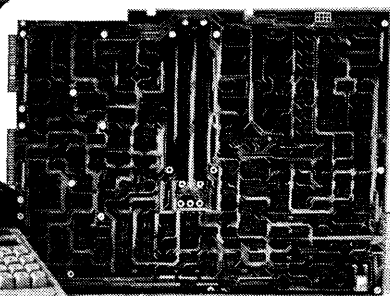

HP 21MX-K

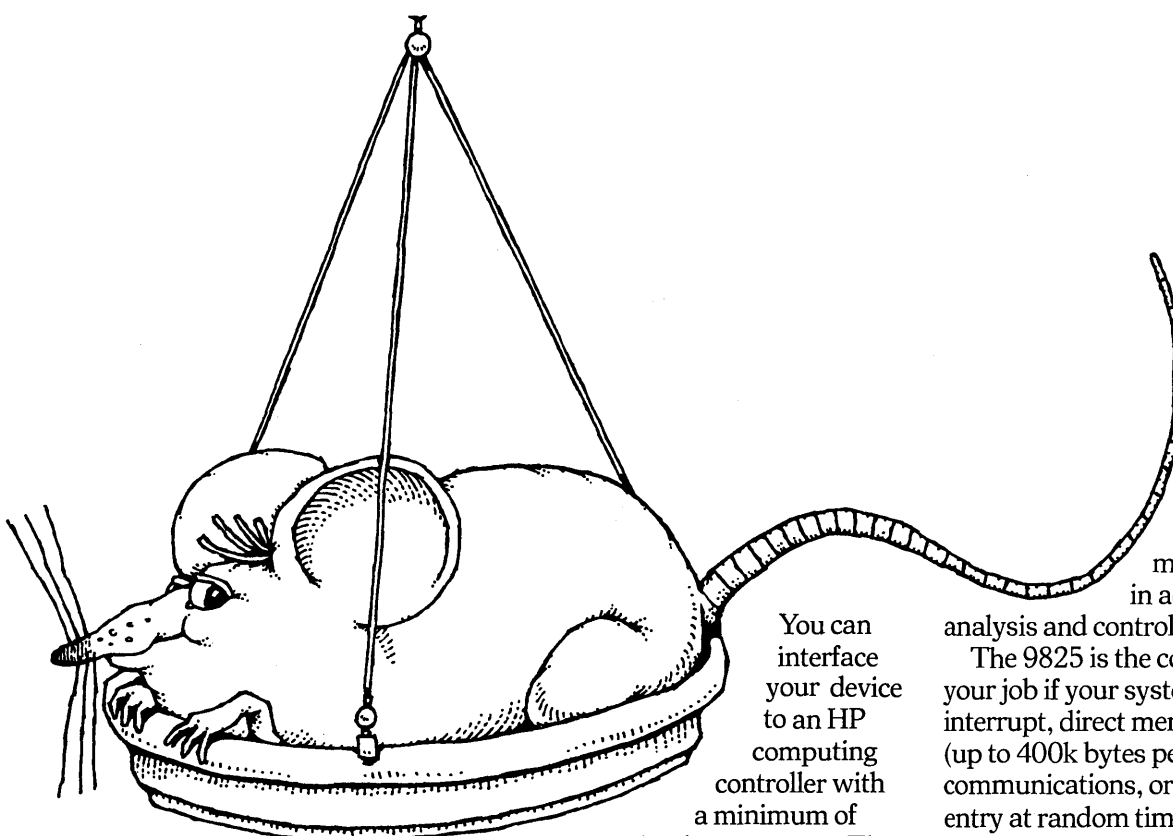

Among the many systems applications which can use the speed and power of K-Series components are spectrophotometers, numerical control units, smart data-entry terminals, word processing equipment, graphic display systems, medical diagnostic systems, and many kinds of test equipment. Because the K-Series uses the same I/O scheme as the 21MX family, a wide selection of subsystems is available. These include interface cards for data communications, measurement and control, HP-IB\*\*; and all of HP's broad range of computer peripherals. Prices for the processor board (OEM quantity 100) are \$975\*.

**Just plug them in and program** HP computing controllers, the 9815 and 9825, make system automation easy and direct. Unlike microprocessors and minicomputers, these controllers are integrated in a small, self-contained package that includes printer, tape storage, display, and keyboard. And, you get an operating system and high-level language (pre-programmed in ROM) so you do not need to learn machine language.

You can interface your device to an HP computing controller with a minimum of development time. The physical connection is an off-the-shelf interfacing card with a pre-programmed I/O driver in its read-only memory. You choose from four different interface options — BCD, bit parallel, bit serial (RS-232-C), or HP-IB\*\*. Just insert the card into the controller, and connect the cable to your product. The controller is ready to be programmed for your application using a powerful but simple-to-learn, high-level programming language. HP 9825's HPL provides the ease of BASIC with much of the power of FORTRAN. The HP 9815 uses reverse polish notation, RPN.

Computing controllers manage your instruments, gather data, and process the data to present it in an understandable form. For selected medical and analytical instrumentation applications, and for many measuring systems, HP's computing controllers deliver performance paralleling that of many

minicomputers in acquisition analysis and control functions.

The 9825 is the controller for your job if your system requires interrupt, direct memory access (up to 400k bytes per second), data communications, or automatic data entry at random times; or if you will be working with data bases of more than 100,000 bytes. If these capabilities are not essential, consider the HP 9815. It is the perfect cost effective controller for systems of one or two input or output devices.

The HP 9825 is the first small desk-top computer with interrupt capability. Interrupt gives the controller flexibility to respond to several independent devices that require service at unpredictable times. "Live keyboard" capability enables you to interrupt the 9825's processing to calculate or to interrogate — for example, to monitor a program, or to alter a variable while a program is running.

The HP 9815 is available for \$3100\*; the HP 9825 for \$5900\*. **For more information on HP's controllers, the 2649, 21MX-K, 9815, and 9825 indicate B, C, D, and E respectively on the reply card.**

\*U.S. domestic prices only.

\*\*HP-IB is Hewlett-Packard's implementation of IEEE Standard 488-1975, "Digital Interface for Programmable Instrumentation."





# The HP 2026— and how it keeps the data flowing at Hewlett-Packard

Hewlett-Packard's 2026 data entry and communications system takes a dramatic step beyond traditional data entry. Besides source data entry, it also supports local data storage and retrieval, data communications, and remote job entry — all in a single proven package that costs \$38,500\*.

The terminal-intensive HP 2026 system is suited to large companies with geographically-dispersed locations. It satisfies their need to enter, store, and retrieve data locally, yet process it elsewhere.

## Source data entry

The powerful Data Entry Application Language (DEAL) makes the development of data entry applications quick and easy. With development of screen formats at a central location, DEAL ensures that the same set of screen formats and edit specifications are used throughout the HP 2026-based network. Source data entry, then, is complete, accurate, and consistent.

## Local storage and retrieval

File management capability gives users the ability to quickly scan and retrieve information locally. It eliminates the need to enter repetitive data, and allows sophisticated source data editing.

## Point-to-point communications

Any HP 2026 system can act as a central data collection point within the network or transmit information directly to any other HP 2026. Use of innovative software technology results in significant reduction of data communications costs.

## Remote job entry

An RJE capability allows any HP 2026 system to communicate directly with large computers, such as HP 3000's or IBM 370's.

The basic HP 2026 system consists of an HP 21MX E-Series processor and disc drive in a desk-style cabinet, and an HP 2645A console terminal. Each HP 2026 can support a total of sixteen additional page-mode multidrop, 9600 baud 2645A CRT terminals. If your applications require more than just data entry and retrieval, and you need sophisticated data management, data processing, or program development using traditional programming languages, Hewlett-Packard offers the multi-purpose HP 3000 computer system.

The HP 2026 was originally developed to meet Hewlett-Packard's needs. Today, after six years of intensive use, it affects virtually everyone at HP...

**“Over 10 million words funnel through my data center every single day”**

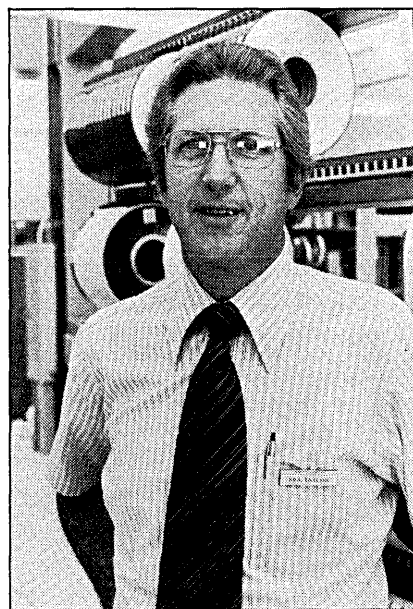

Bill Taylor, HP 2026 manager at HP headquarters, comments; “It’s a flexible, all-purpose network that transmits any digital information. Our central system receives data several times a day from other 2026 locations around the world.

“Sixty percent of the data is marketing-related,” Bill states, “such as customer orders and acknowledgements. Fifteen percent is accounting data, 10% is employee personnel/payroll data, another 10% is general message traffic, and 5% special files.

“An RJE capability also allows HP 2026 sites to directly communicate with larger host computers. Communication is possible via

\*U.S. domestic price (currently available in North America and Europe only)

2780 emulation and multileaving HASP workstation protocols. All data communications and RJE programs can be executed concurrently with data entry."

---

**"With just 20¢ and four hours I can send a message to any HP office in the world"**

---

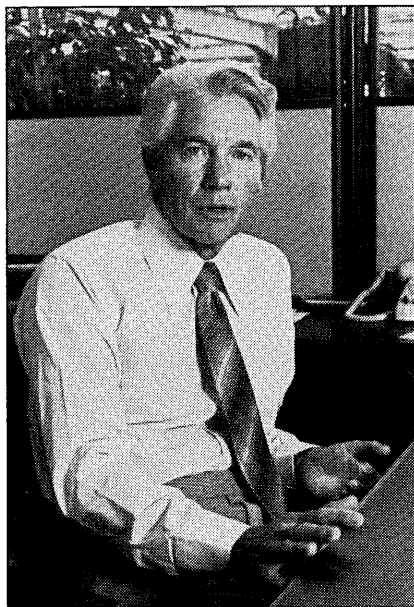

"It wasn't that way six years ago; our commercial TWX service costs were skyrocketing," reflects Bob Boniface, Hewlett-Packard's executive vice president of administration. "Now, with the 2026 network, 117 systems at any of 94 network sites can communicate with each other. And...the costs are descending, not spiraling upward."

---

**"If I ever again had to enter orders the way we used to, I'd quit"**

---



"I transmit over 3700 sales and service orders monthly," begins Carol Larsen, HP order entry clerk. "As I input an order, the HP 2026's CRT terminal prompts me through all the screens I need. And, it blinks to alert me if I make a mistake. Most errors are corrected at the terminal, so only valid data is transmitted to the system."

"We received the system 1:30 one afternoon," Carol relates, "and, by the time I went home, I felt comfortable using it. I didn't even pick up a user's manual — the terminal taught me with a 'how to' tape cartridge."

"Besides entering new orders, I can store and retrieve order status here, where we need it, to assure quick response to customer

inquiries. If a customer calls me about an order, I simply key in that order name and number, and provide a timely status report over the phone.

"Plus, I don't have to type repetitive data. Our sales office assigns a number to each customer. By entering that number alone, I can retrieve and automatically include customer name, address, phone number, shipping destination, and other pertinent information — all stored on local files."

---

**"We paid off all our capital equipment costs in nine months"**

---



"The HP 2026 gave us a significant, easily-measured return-on-investment," says Hank Taylor, HP corporate marketing services manager.

## The HP 2026 (cont.)

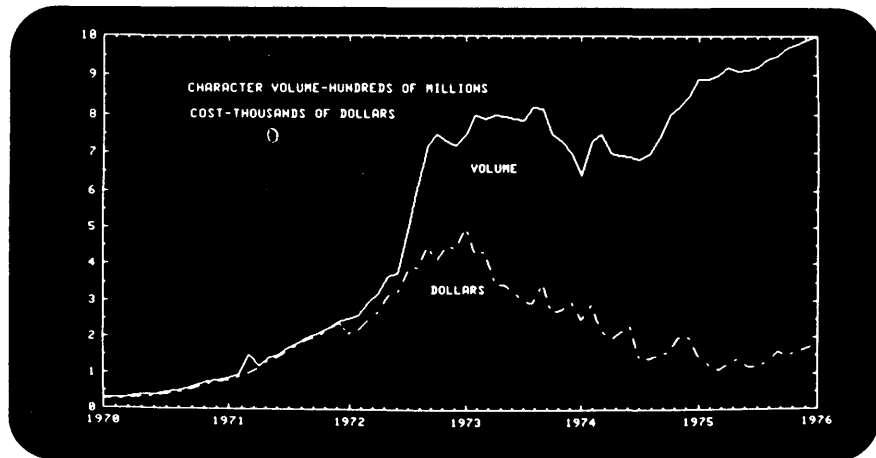

*In the last four years, the domestic volume of data transmitted by the HP 2026 has more than doubled. But, during that same time, costs have decreased by 60%.*

*This graph was generated by "auto plot" on the new HP 2648 graphics terminal. (See page 3)*

"Comparing data communications costs before and after installing the system revealed that, in less than a year, our line charge savings paid for the system.

"I also recall another significant measure. HP's data entry error rate decreased by 60% using HP 2026 system CRT's rather than former methods. This reduction in errors is also a result of the use of the HP 2026 Data Entry Application Language (DEAL). This powerful software simplifies and shortens the source data entry program development process.

"You see, our central data processing staff develops all data entry screens so that consistent formats and edits can be transmitted to each HP 2026 site. In this way, we maintain central control and ensure that everyone in the network is using the same set of data entry screens. All the development is done by one central data processing staff. Remote sites, of course, still have the capability through DEAL to quickly tailor our screen formats without data processing experts."

### **"HP'S 2026 is one of the most efficient point-to-point communication systems available"**

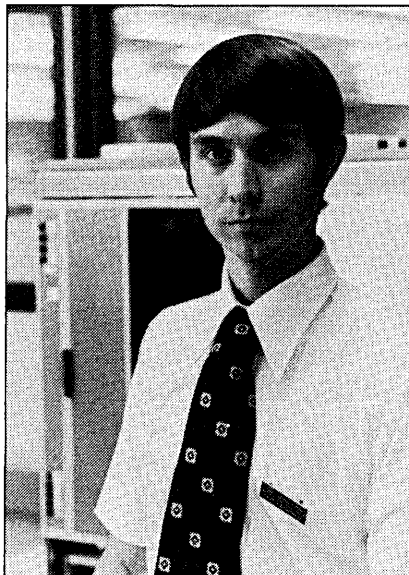

"We use voice grade common carrier facilities and two HP 2026 data transmission innovations which make the system unusually

efficient," explains Terry Eastham, lab engineer.

"A data compression/expansion technique used between HP 2026's typically compresses our data to 50% of its original volume," continues Terry. "Blanks, numeric strings, alpha strings, and redundant data are compressed and expanded by this feature. In addition, we use a reverse channel line protocol which can yield up to another 40% throughput improvement over normal bisynchronous techniques.

"The combination results in reduced data transmission time and, therefore, significant line cost savings."

For further information on the HP 2026 and HP 3000, check F on your reply card.

HEWLETT  PACKARD

# Improving System Testing Techniques

by Laura L. Scharer

---

Systems testing is a quality assurance function, yet it often bumbles along without standards or formal procedures to insure its own quality.

---

The system test is data processing's attempt to control the quality of the computer-based systems which it produces. Yet this quality control procedure itself often suffers from lack of thoroughness and organization. This needn't be the case, as we can show.

To begin with, a system test must be a joint effort of the data processing staff and the affected user group. Each party must contribute its specialized knowledge to the testing task. Basically, the data processing practitioners are responsible for technical assistance to the users in developing and executing the test plan. The users, on the other hand, lend their functional expertise to the project and are eventually responsible for creation of test data and evaluation of test results.

The management of each of these groups will direct the testing effort and will bear responsibility for the quality and acceptance of the software product. A team of programmers, analysts, computer operations personnel, supervisors, and clerks will join management in establishing system "correctness" relative to original system specifications.

Ideally, planning for the system test will commence as soon as detailed design and program specifications have been approved. The test plan will be devised by much the same group of users and technicians as contributed to the system definition and design stages. And the time and manpower required to produce and execute a thorough test plan should not be underestimated. (It is likely that understaffing and short time projections for the testing phase of the system life cycle are major contributors to overruns.)

## Who's who in testing

Specifically, the responsibilities of each of the members of the system test

team can be described as follows:

The *data processing manager* or project manager is ultimately responsible for the quality of the applications software produced by his staff. Although he cannot personally execute or evaluate every test of every system produced in his department, he can and should develop a testing standard and require that all tests meet its requirements. He can demand that all tests be documented and reproducible. In addition, the manager can periodically spot-check testing procedures using his standards as a guideline.

The *systems analyst* coordinates the system testing effort. The analyst must understand how to construct a test plan according to shop standards and must guide both users and programmers toward meeting testing requirements. He is responsible for educating the users in the use of the new system. Transaction types, input formats, editing criteria, and use of data entry forms should be explained in detail so that the users may create test data with the analyst's assistance.

The *programmer* is responsible for unit-testing all modules before turning them over for system testing. This means minimum unit testing standards must also be established and enforced. During system testing, the programmer remains responsible for additional debugging or reprogramming found necessary.

*Computer operations personnel* must provide machine time and manpower support for data entry, test file creation, and test execution.

The *user department manager* bears responsibility for final acceptance or rejection of the product delivered by data processing. He will assign and coordinate the tasks of the supervisors and clerks who participate in the system test. He will review the test plan

proposed by the systems analyst in terms of completeness and appropriateness. Thus, the manager becomes a participant in setting the conditions for acceptance of the computer system, and in so doing accepts some of the responsibility for seeing that these conditions are met.

A user of *supervisory* level should work closely with the systems analyst in learning the new system, understanding the testing standards, and developing a detailed test plan. Together, the supervisor and analyst will document the test plan, isolate classes of test cases to be generated, and instruct clerical workers in the creation of test transactions and prediction of test results.

*Clerical* workers will often actually produce the test transactions and predict the results which should be generated by the computer system. After test execution, they will compare actual results with predicted results and note discrepancies.

Such an arrangement of responsibilities within the system testing group assures several critical factors:

1. System testing does not occur in the vacuum of the data processing department. User participation is not only solicited, but required.
2. A test plan is developed in parallel with the programming phases of the project. Ideally, a system test plan will be ready and waiting as soon as all modules pass the unit testing stage.
3. Management must become involved with system testing. For one thing, quality control standards for software products must be developed by the data processing manager. For another, acceptance is the responsibility

DEC® RC-11 and RF-11 fixed-head disc...and  
Data General Novadisc® users:

# Replace Fixed-Head Disc with Dataram

# BULK CORE

See us in the  
U.S. Section at  
Systems 77

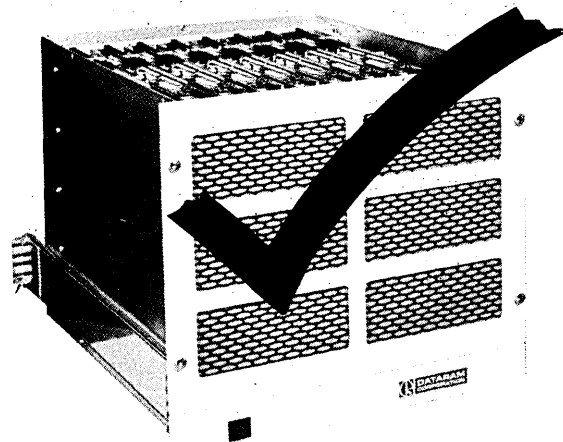
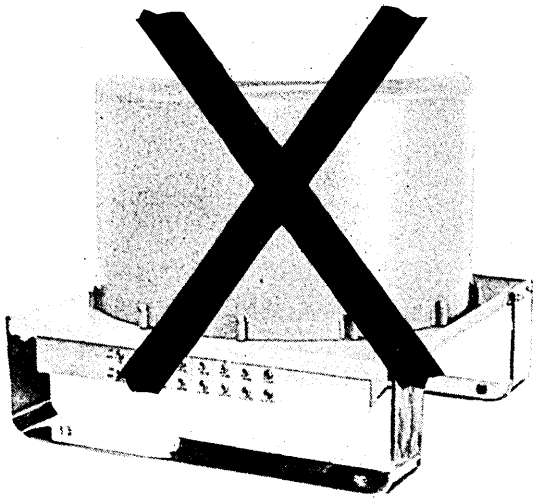

Now, all the remarkable features of Dataram's BULK CORE memory system are available to you in a unique storage peripheral with complete interfaces to emulate DEC and Data General fixed-head discs.

Basic building block of this dramatic, new peripheral is Dataram's BULK CORE module, which provides 256 kilobytes of storage on a single board. Eight of these modules can be packaged in a standard 19" chassis to provide two megabytes of storage.

To give you more of what you can't get from fixed-head discs. BULK CORE gives you microsecond-range access time, high reliability, and greatly improved maintainability. And at a price unheard of for core or semiconductor memory. Until now.

Until Dataram made its BULK CORE memory system plug-compatible with PDP-11 and Nova® minicomputers. To provide:

- ▣ Access time 1/10,000 of FHD
- ▣ High Throughput
- ▣ Zero Error Rate
- ▣ Self-Test for Fault Isolation
- ▣ Hardware & Software Transparent
- ▣ LED-spotlighted Fault Isolation
- ▣ 256 KB Modularity
- ▣ Non-Volatile
- ▣ Non-Mechanical
- ▣ High MTBF/Low MTTR
- ▣ Low Power
- ▣ Parity Check

Reasons enough to find out more about BULK CORE. If you use a DEC or Data General mini-computer—or any kind—and want to move ahead in performance, move a BULK CORE into your system.



PRINCETON-HIGHTSTOWN ROAD  
CRANBURY, NEW JERSEY 08512  
TEL:609-799-0071 TWX:510-685-2542

I'd like to learn more about BULK CORE for my

- PDP-11    Nova    \_\_\_\_\_  
 Please send information.  
 Please have a salesman contact me.

Name \_\_\_\_\_

Title \_\_\_\_\_ Phone \_\_\_\_\_

Company \_\_\_\_\_

Address \_\_\_\_\_

City \_\_\_\_\_ State \_\_\_\_\_ Zip \_\_\_\_\_

- Please send me information about Dataram's  
ADD-ON/ADD-IN memory for minicomputers.

DEC and PDP are registered trademarks of Digital Equipment Corporation.  
Nova and Novadisc are registered trademarks of Data General.

Canada: Tracan Electronics Corporation, Ontario/Quebec/British Columbia • Belgium/Luxembourg/Netherlands: Synelec Information Systems, (02) 647-67-12 • France: YREL, 950-2224 • Italy: Telcom, s.r.l. 422-8646 • Sweden/Finland/Norway: Teleinstrument AB, 08-380370 • Spain: Aupoca, (01) 457-53-12 • Switzerland: Interrest AG, 031-224481 • United Kingdom: Sintrom Ellinor Ltd., (0734) 85464 • West Germany/Austria: O.E.M. Elektronik GmbH, 0711-798047 • India: Industrial Electronic Instruments, 79281 • Israel: K.D.M. Electronics Ltd., (03) 58232 • Japan: Matsushita Electric Trading Co. Ltd., (03) 435-4552 • Australia/New Zealand: Anderson Digital Electronics, (03) 543-2077.

## TESTING

ty of the manager of the user group. The manager of the user group can demand evidence of a successful system test before he allows a new system to be installed.

4. User education about the new system begins early and continues throughout the system development process. The user group is an important contributor to the establishment of the correctness of the new system and, as such, is more interested in making the new system work.

### The operating environment

As we know from experience, a system which performs well in an artificial testing environment may fail when executed within its own specific operating ("live") environment. To keep this from happening, the elements of the operating environment must be defined, and these elements must be duplicated at some point during system testing.

The elements of a computer system's test or production environment include, for example:

1. the hardware upon which the system will execute
2. the operating system
3. the assembler or compiler producing the object code
4. the author of the test data (programmer vs. user)
5. data entry procedures
6. transaction volume
7. file size and content (test records vs. live records)
8. computer operations procedures
9. recipient and interpreter of output (programmer vs. user)
10. time frame imposed

A pure testing environment will minimize user participation and will often utilize hardware and systems software which is different than that upon which the system will be run in production mode. Thus, an artificial testing environment may be comprised of:

1. off-site hardware (same or different manufacturer or model)
2. different copy or type of operating system
3. different copy or version of the compiler or assembler
4. programmer-constructed test data
5. programmer-keyed test data
6. small number of transactions
7. small test files
8. system execution by the programmer in the computer room
9. programmer interpretation of results

10. expanded or unlimited time frame

In contrast, a "live" testing environment will be hardware-specific, will simulate real volume and timing characteristics, and will effectively test procedures and documentation as well as simple computer output.

Testing in a live environment may, then, include:

1. in-house (target) hardware, operating system, compiler
2. user-constructed test data
3. normal data entry procedures (data entry staff using standard instructions, or users from a terminal)
4. realistic transaction volume
5. live, full-sized files
6. execution by the operations staff using a standard run book
7. user examination of results
8. realistic time frame

A complete test plan will usually require more than one iteration of the testing procedure, each iteration assuming a different, and gradually more

---

The complete definition of test cases is often viewed as impossible, so no attempt at completeness is made.

---

live, testing environment. Testing standards should require that the production environment be defined in detail and that a successful test be demonstrated in that environment before the system may be delivered for installation. This is particularly important when installing systems which have been developed off-site or which have been purchased as a package from a software house.

### Calling the shots

The premise underlying system testing is that a prediction of correctness can be made and that the validity of a computer system can be ascertained by comparing predicted results to results obtained using the computer.

Prediction may proceed in one of two ways: by manually computing the expected results, or by using parallel techniques. Either way, it requires the following steps:

1. documenting the conditions which are to be tested
2. preparing transactions and test files to demonstrate each activity
3. documenting the exact expected results given these transactions and test files
4. comparing computer output to this standard

Parallel testing (involving the use of two systems) still requires completion of step one, the enumeration of test cases, and step two, the creation of test

data. However, in parallel testing an equivalent program or system is used as the standard of correctness. Identical test data and test files are run through the new and the existing system and results are compared. And this comparison may in fact be automated.

The key to constructing a minimal yet logically complete set of test data is the accurate and explicit enumeration of all cases or conditions handled by the program or system. Ideally, all conditions can be discovered from existing documentation of error messages, condition codes, parameter settings, transaction types, updating rules, etc. But the task is painstaking, slow, and relies heavily upon the quality of the available documentation and specifications.

The quality of the systems test often breaks down precisely at this starting point. The complete definition of test cases is viewed as an impossible task, so no attempt at an orderly enumeration of conditions to be tested is made at all.

In suggestion: begin by eliminating the obvious test cases. *Do* force all error conditions; *do* test all program terminations before normal end-of-job; *do* examine all aspects of the updating logic; etc. There is no excuse for failure to test the immediately obvious conditions.

After a list of test cases is complete, test files should be constructed to establish the set of valid identifying codes (customer numbers, product numbers, etc.) which will be used when building groups of transactions. Give special care to several aspects of test file creation, such as the time period for which the files are created, starting values in amount fields, inclusion of all record types, and inclusion of sufficient numbers of records so that control groupings and page breaks on reports can be demonstrated.

Test transactions can now be created. Each transaction should have a single specific purpose, either to force an error condition or to demonstrate some normal system function. As each transaction is coded, the test case which it is illustrating and the exact expected result of processing the transaction (such as an error message or an adjustment to an amount field) should be written down. The prediction process can be extended even further by recording the actual column entries and subtotals which will be generated on reports.

With the predicted results documented in such an orderly manner, the determination of system correctness becomes almost trivial. File dumps and edit and update reports can be compared directly to the manual predictions. The exact cases causing prob-



# What's a fast, low-cost way to

You recognize the problem: People representing you all over the country are in constant need of quick answers to questions from their customers or clients. Life insurance agents, for instance, require direct access to policy information stored in the home office computer.

The Bell System also recognizes the problem. We've gone even further and come up with advanced data communications systems, terminals, printers, modems. Like our new 43 teleprinter, the attractive



# answer queries from 110 offices?

and attractively-priced desk top unit that is compatible (without system conversion) with virtually all in-house and time-sharing systems. And our new Dataphone® 300/1200 data set which, when used at both the CPU location and at each terminal, allows them to operate at 0-300 or 1200 bps with a single group of computer ports by automatically adjusting the speed of incoming signals.

Solving problems in data communications is an all-out commitment of the Bell System. If you haven't talked systems with your local Bell Account Representative lately, you're missing something.

**The system is the solution.**



**Bell System**



# SYSTEM TESTING CHECKLIST

	Yes	Comment		Yes	Comment
<p><b>I. TEST PREPARATION.</b></p> <ol style="list-style-type: none"> <li>1. Test team members given assignments.</li> <li>2. Final operating environment defined.</li> <li>3. All conditions to be tested identified and documented.</li> <li>4. Test files created for execution of all system functions.               <ol style="list-style-type: none"> <li>a. file sequences correct</li> <li>b. meaningful starting values established</li> <li>c. all record types included</li> <li>d. file volume large enough to demonstrate control groups, totals, page breaks on reports</li> <li>e. meaningful time period established</li> </ol> </li> <li>5. Test transactions developed to demonstrate all test cases.               <ol style="list-style-type: none"> <li>a. unit testing criteria satisfied</li> <li>b. system testing criteria satisfied</li> <li>c. transactions created for at least two cycles of system execution</li> <li>d. end-of-period (month, year) system options demonstrated</li> </ol> </li> <li>6. Test results predicted and documented for later comparison with computer output.</li> <li>7. Parallel system output identified for standard of correctness.</li> <li>8. Acceptability and accuracy standards established and documented for later assessment of results.               <ol style="list-style-type: none"> <li>a. core availability in production mode.</li> <li>b. timing constraints in production mode</li> <li>c. if 100% accuracy not required—justify</li> </ol> </li> </ol>			<ol style="list-style-type: none"> <li>3. Execute time acceptable according to preestablished standards.</li> <li>4. Sufficient core available for execution and moderate expansion of program size.</li> <li>5. Input data accepted as formatted without data exception.</li> <li>6. All logical paths executed correctly.               <ol style="list-style-type: none"> <li>a. all invalid data trapped                   <ul style="list-style-type: none"> <li>• troublesome transaction combinations discovered</li> <li>• edit messages all forced</li> <li>• no-match or invalid-key conditions forced</li> </ul> </li> <li>b. program-controlled terminations before normal EOJ tested</li> <li>c. no-file case executing</li> <li>d. empty-file case (file exists, but has no member records) executing</li> <li>e. file updating accurate, complete, according to specifications                   <ul style="list-style-type: none"> <li>• first-record processing accurate</li> <li>• addition of a record prior to the first record executes correctly</li> <li>• multiple-file match logic working</li> <li>• last-record EOF processing accurate</li> <li>• addition of a record after the last record executes correctly</li> <li>• fields updated as specified: quantity replacement, quantity addition, etc.</li> <li>• record deletion, addition executes correctly</li> <li>• multiple transactions per master record all execute correctly</li> <li>• changes to keys handled accurately</li> </ul> </li> <li>f. all report breaks demonstrated                   <ul style="list-style-type: none"> <li>• page overflow</li> <li>• detail, minor and major control breaks, final control break</li> </ul> </li> </ol> </li> <li>7. Created files conform to design specifications.</li> <li>8. Field sizes in files adequate: no unexpected truncation, loss of significant digits.</li> <li>9. Mathematical accuracy, rounding</li> <li>10. Reports conform to designed layout.</li> <li>11. Report information contents agrees with titles, headers.</li> <li>12. Report page numbering accurate.</li> <li>13. Spelling correct on report titles, headers.</li> <li>14. Field sizes on reports adequate.</li> <li>15. Audit trails (control totals) accurate.</li> </ol>		
<p><b>II. TEST OPERATIONS.</b></p> <ol style="list-style-type: none"> <li>1. Test transactions entered by data entry department using standard procedures.</li> <li>2. Tests executed by operations personnel without programmer supervision.</li> <li>3. Transaction listing obtained before text execution.</li> <li>4. File dumps obtained prior to program execution.</li> <li>5. System executed to demonstrate all test cases. (May require multiple executions of the system or of individual modules.)</li> <li>6. All hardcopy (reports, control totals) obtained.</li> <li>7. Transcription of console messages (and timing information) obtained.</li> <li>8. File dumps taken after test execution.</li> <li>9. Output from parallel run available.</li> </ol>			<p><b>IV. SYSTEM TEST EVALUATION.</b></p> <ol style="list-style-type: none"> <li>1. JCL executes system without errors or unnecessary operator intervention, and file labels are correct.</li> <li>2. JCL-defined file capacities adequate, assuming moderate expansion.</li> <li>3. Execute time acceptable according to preestablished standards.</li> </ol>		
<p><b>III. UNIT-TEST EVALUATION.</b></p> <ol style="list-style-type: none"> <li>1. JCL executes program without errors or unnecessary operator intervention, and file labels are correct.</li> <li>2. JCL-defined file capacities adequate, assuming moderate expansion.</li> </ol>					

**DIGI-LOG MICROTERM II**  
**DESK TOP TERMINAL POWERHOUSE**



## **INTRODUCING MICROTERM® II**

### **A uniquely integrated microsystem for OEMs and Large Users**

Microterm II is a unique, multifunction, terminal system that takes the value-added vendor/user one step beyond competition. An entire random access system including dual Z80 processors, printer, CRT, and dual mini diskettes are successfully integrated into a single desk top unit that rests handsomely on a standard typing table. The power of Microterm II is released when your unique applications are added.

Microterm II has a powerful software development system that lets you convert

your applications knowledge into valuable working software. Your programs can be totally developed from the Microterm II keyboard in either BASIC or Z80 Assembly Language.

At \$6950 each, and \$4865 OEM quantity of 100, the reliable Microterm II represents a business opportunity well worth your consideration. For additional details, call or write today.

DIGI-LOG SYSTEMS, INC. Babylon Road,  
Horsham, Pa 19044 (215) 672-0800.

**DIGI-LOG**  
**SYSTEMS, INC.**

**micro systems for computer networks and data communications**





# DATAPRODUCTS' NEW ERA T-80 THERMAL PRINTER: 80 CPS FOR THE PRICE OF 30.

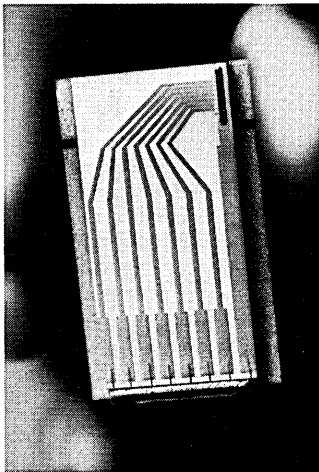

Dataproducts' New Era T-80 thermal printer is nearly three times faster than other thermal printers.

Yet it costs about the same.

What's more, the T-80 offers you Dataproducts dependability,

assured by a smartly conservative design, a unique solid-state print head, and a minimum of moving parts.

Noise, too, has been minimized.

The quiet T-80 hums at 80 cps, so it can be seen but barely heard.

And head changing is a snap.

Any operator can put in one of our incredibly small, self-cooling heads in a snappy 10 seconds.

Our New Era T-80 thermal printer, with its parallel or optional RS-232-C interface, is ready to tie into your CRT, your terminal, or your processor.

The T-80: fast, inexpensive, quiet, and reliable.

Altogether, an unbeatable combination.

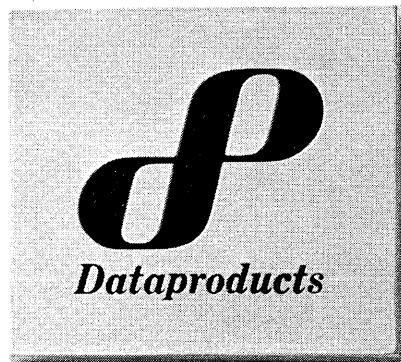

THE PRINTER COMPANY

NORTH AMERICAN SALES HQ: 6219 De Soto Avenue, Woodland Hills, CA 91365, (213) 887-8001; Telex 69-8492.  
EUROPEAN SALES HQ: Darmstaedter Landstrasse 199, Frankfurt, W. Germany, Phone 681034; Telex 841-416344.



# TESTING

	Yes	Comment		Yes	Comment
4. File sequences (sort specs) accurate throughout system execution.			work.		
5. No-file case executing throughout all system steps.			13. System restart procedures satisfactory.		
6. Empty-file case executing throughout all system steps.			14. File recovery procedures satisfactory.		
7. Available means for cross-checking system results exhausted.			15. Files and reports conform to output from parallel test, if applicable.		
a. different reports with same or derivative information			16. Output accurate after more than one execution cycle.		
b. file contents vs. report values			17. End-of-period output accurate, and period-totals reset to zero.		
c. control break totals vs. final totals					
8. Interfaces working accurately.			<b>V. ACCEPTABILITY TEST</b>		
a. between programs			1. User review of output.		
b. between subsystems			2. Judgment of acceptability according to predetermined standards.		
c. between other computer systems			3. Services provided by the system conform to originally stated user requirements.		
d. with existing manual systems			4. Changes in user requirements since original statement.		
9. Files closed at EOF (normal or due to error).			5. System testing judged complete.		
10. Execution sequence (system flow) accurate and workable.			6. User sign-off on output.		
11. Audit trails (control totals) accurate.					
12. Error-correction procedure loops					

lems can be readily determined, and distinct blocks of code can be examined for debugging purposes.

A stepwise prediction process as described above assures that several attributes of a good test are achieved:

1. All test cases are included in the testing procedure.
2. The test is reproducible.
3. Test results are easily demonstrated and reported.
4. Predictions (such as calculation of expected values) are carried out before system execution, thus counteracting the tendency to accept computer-generated results because they "look right."

## Use the proper tools

Automation can be applied quite effectively to system testing. In all but the most trivial instances, creative use of available testing tools can reduce the costs and increase the thoroughness and accuracy of the testing procedure.

The classes of computerized testing aids are:

1. program execution monitors
2. test data generators
3. terminal input simulators
4. file conversion programs
5. redundant programs
6. file comparison programs

A *program execution monitor* creates a record of the program statements which are executed during a run. Reports produced by the monitor summarize execution characteristics at the section, paragraph, or statement level. Additionally, the reports may display the activity of statements of a certain type (such as all IF state-

ments).

An execution monitor can provide the typical debugging advantages offered by the TRACE feature found in some programming languages. For example, infinite loops, or code which is mistakenly fallen into, are easily identifiable. On a higher level, and one more important to system testing, the program execution monitor can be used to evaluate the "logical completeness" of a given set of test data. Unexercised code is easily isolated so that additional test cases can be provided to complete the data set.

Conversely, a series of reports from the monitor may be examined when attempting to reduce the size yet retain the logical completeness of a test data set. Such a procedure may be undertaken to establish a minimal set of test transactions for maintenance testing.

Some language preprocessors allow the programmer to include the execution monitor capability on a permanent but inactive basis within the body of the program. The associated statements may be activated for testing by selecting compile-time or run-time options.

A *test data generator* is basically a sophisticated file-generation program. The test data generator translates a generalized description of the data base, file, record, and field characteristics into files meeting the desired specifications. The test data generator can be employed to create the test data base, the set of test transactions, or files containing predicted results of system execution. In any case, an explicit definition of the characteristics of the data

must be supplied to the generator, including:

1. the overall interrelated data base structure (Some test data generators can build specific proprietary data bases, including IMS and TOTAL structures.)
2. sequence in which records are to appear
3. record characteristics: blocking, length (fixed or variable), record types
4. number of each kind of record to be created
5. field characteristics: length, data type, repeating structures (arrays)
6. special field formats: date, time
7. value or range of values possible
8. distribution of values within the stated range
9. dependency of one field value upon the value of another field in the same or in a different record

A test data generator may be used to incrementally develop a set of test transactions as additional functions are added to the system. After all normal functions have been tested, invalid transactions may be added to the data set for exception testing. When all logical conditions have been exercised using a minimal set of transactions, a much larger test data set may be generated from the same definition of file characteristics, usually simply by changing the volume parameter. High-volume testing may then proceed.

After testing is complete, a fully developed test data set may be stored in the form of its parameters rather than

# One for All & All for One

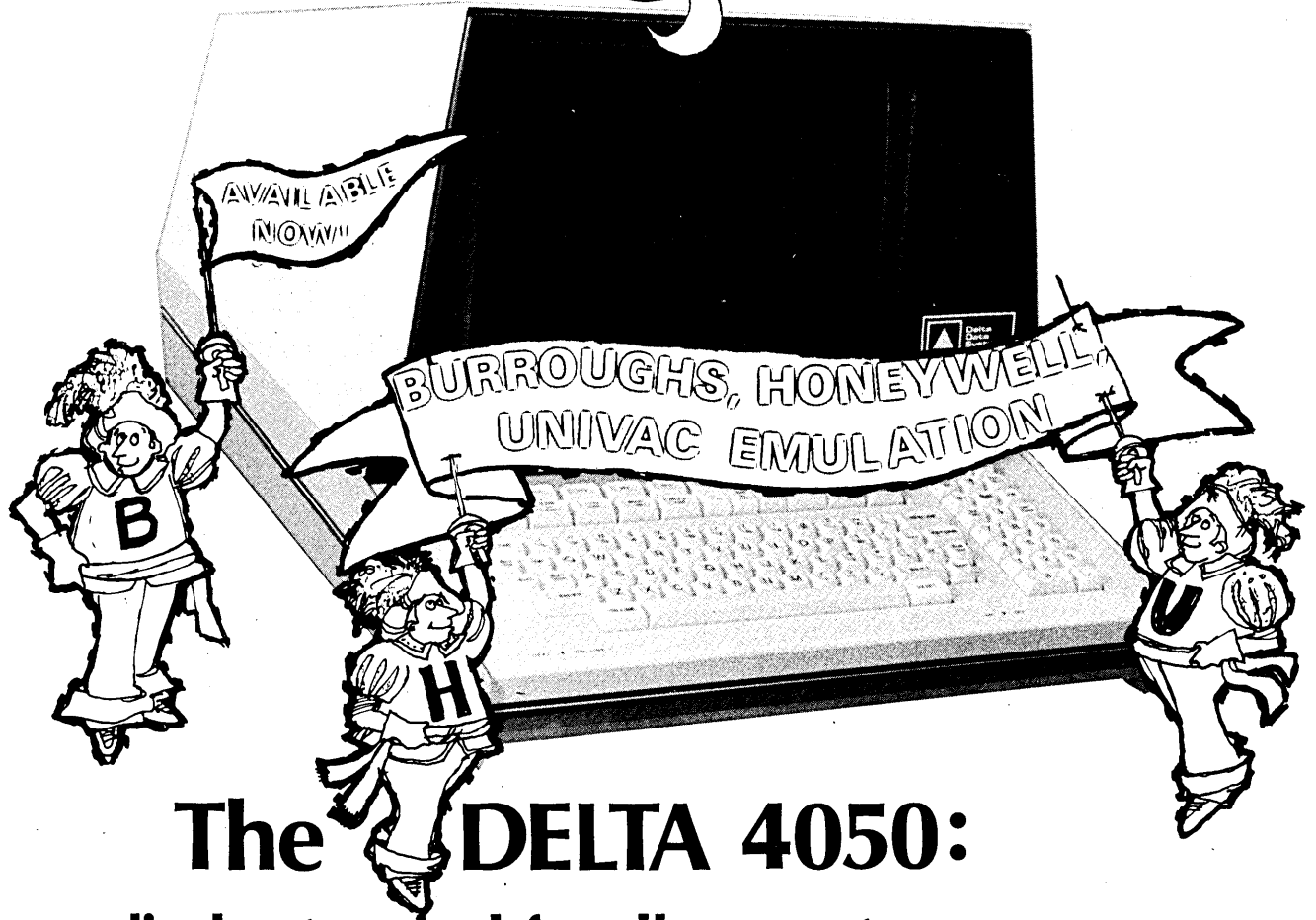

## The DELTA 4050:

one display terminal for all computers...

### all computers for one display terminal

Presenting the DELTA 4050, the microprogrammed video display terminal with "emulation PLUS" capability for BURROUGHS, HONEYWELL, UNIVAC, and other computers and display terminals. If you're looking to expand or enhance your system and lower your costs at the same time, look into the DELTA 4050 now.

- o Complete emulation for BURROUGHS TD820, HONEYWELL VIP7700, UNIVAC Uniscope 100/200, and others—to meet your present and future application requirements
- o Microprogrammed—up to 16K memory available
- o Full text editing capabilities
- o Optional full duplex communications monitoring
- o Ideal for data communications systems on single modem, daisy chained, single line configurations, multidrop or direct connect systems
- o Prompt delivery, nationwide service in over 150 locations
- o Reliable, around-the-clock performance
- o For user programmability ask about the DELTA 4550 with computer-loaded protocols

Our new DELTA 4050: the one for all & all for one video display terminal that's all you need to get your job going, and keep it going. Contact us today for more details or on-line demonstration.



DELTA DATA SYSTEMS Corporation  
Woodhaven Industrial Park  
Cornwells Heights, PA 19020  
Phone: (215) 639-9400

U.K. Subsidiary:  
DELTA DATA SYSTEMS LTD.  
Welwyn Garden 33833

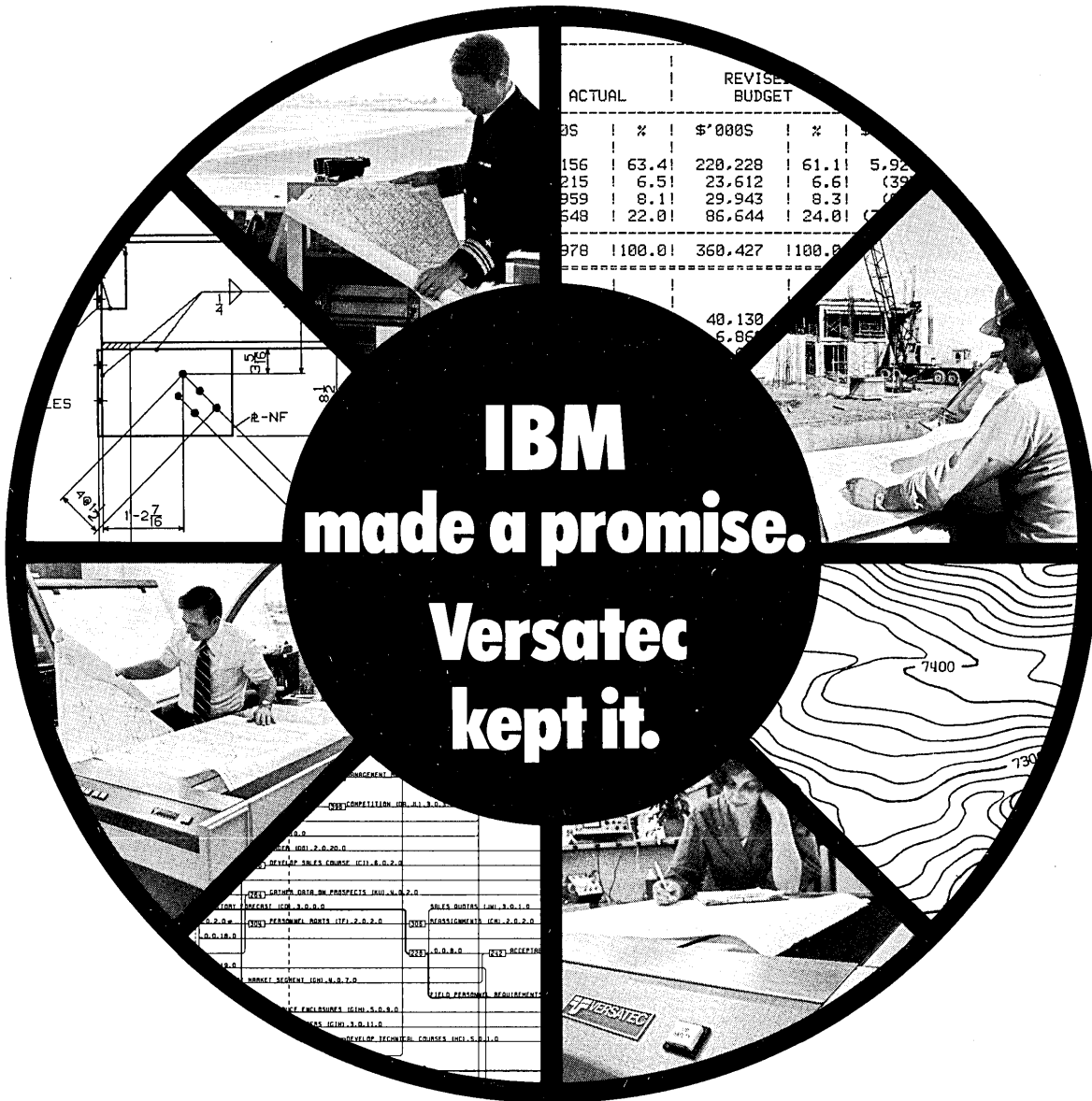

ACTUAL		REVISED BUDGET		
PS	%	\$'000S	%	
156	63.4	220,228	61.1	5.92
215	6.5	23,612	6.6	(39)
959	8.1	29,943	8.3	(6)
548	22.0	86,644	24.0	(7)
978	100.0	360,427	100.0	
		48,130		
		5,86		

**IBM  
made a promise.  
Versatec  
kept it.**

With the designation "360," IBM promised to satisfy the "full circle" of applications—business and scientific. One output system, designed specifically for IBM 360 and 370 computers, has kept that promise.

The Versatec 360/370 output system is plotting E-size drawings in sixty seconds. It is producing operating statistics, maps, financial data and management reports, complete with graphics. It is drawing six-foot wide IC plots and 200-foot long PERT charts.

Fast. Versatile. And thousands of hours more reliable than the pen plotters, line printers and CRT hard copy devices it replaces. Yet the total package costs less than a flatbed plotter.

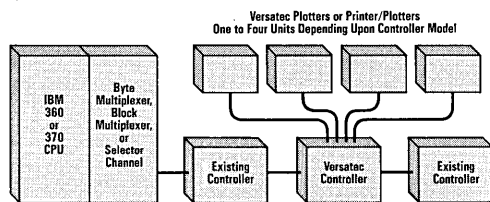

No changes are required in IBM hardware, operating system or application software. Emulating a standard IBM printer/controller, the Versatec programmable controller can adapt to changes in computer models, channel protocols or new applications.

Operating at a comparable I/O transfer rate, the controller accepts data in any form—print, vector, raster or simultaneous print/plot information. Output is delivered on up to four plotters or printer/plotters, up to 1000 feet away.

IBM gave you the total computer. Versatec gives you total output.



2805 Bowers Avenue  
Santa Clara, California 95051  
(408) 988-2800

- Please send literature:
- The 360/370 output system
  - Plotters, printers and printer/plotters
  - Plot widths: 8 1/2", 11", 20", 22", 24", 36", 42", 72"
  - Hard copy direct from CRT
  - Hard copy direct from video sources

- Please send samples
- Computer aided design
  - Business graphics
  - Scientific applications
  - Production drawings
  - Mapping

computer model and operating system

name telephone

organization

address

city, state and zip

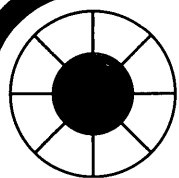

## **360/370 users report:**

"We use our Versatec for straight line printing, program listing, 370-directed plotting and for hard copies from Tektronix display. You can't get better utilization than that."

"We're doing salary administration reports and engineering plots on one machine (Versatec). Either application would have justified purchase."

"A CalComp drum plotter needed 175 24-hour days to plot the 9000 drawings. Versatec did the job in less than 15 hours."

"Sure, we're saving \$50,000 a year in direct cost, but the economic value of timely graphics is incalculable."

"Our first Versatec system is performing beautifully. I've recommended purchase of Versatec systems for our 370's in every operating division."

"The turnaround is fantastic. Not days, not hours, but seconds."

"The programmer couldn't believe it. Before he could order a second plot, the first one was done."

"Resolution is great, even on long curves. We can use Versatec for final drawings."

"Our 36-inch wide Versatec plotter is in an engineering building half a mile away from our 370, but we're operating on-line without a hitch."

"CPU time is no problem. Total I/O and CPU time for 33,000 vectors is less than ten seconds."

"This is the first plotter that gives us interactive graphics with E-size and J-size drawings."

"Our engineers call it a super design tool. We have ordered another Versatec 36-inch plotter."

"It took us longer to make tapes for our off-line Gerber than for total turnaround on Versatec."

"This is the best thing that ever happened to CADAM. Fast turnaround has significantly improved engineering efficiency."

"We are plotting PERT charts almost 200 feet long in less than ten minutes."

"I don't think Versatec realizes the enormous economic advantages of this system. Immediate turnaround of drawings is improving our procedures, engineering productivity and design quality."

## TESTING

in its extended form in order to save secondary storage. The file may be easily regenerated from its definition when it is needed for maintenance testing.

Automated test data generation is not a cure-all, however. The quality of the test data sets remains a function of the completeness and accuracy with which the test cases are defined. The analysis of what must be tested, and of how testing ought to proceed, is still a manual procedure. Only the mechanics of the file creation can be automated.

Also consider the fact that the values assigned to fields are usually generated in random nature within the designated range. This is often satisfactory; however, there are times when a specific mix of transaction types or field values is desired rather than random output. Moreover, it may be desirable to vary these combinations over several iterations in a specifically defined manner. This is often difficult if not impossible to define to the generating program.

Finally, using a test data generator does not directly relieve the analyst of the burden of predicting the results of each transaction. The anticipated effect of each generated transaction must still be individually documented for later comparison with the system's results.

Some features of the test data generator may be helpful to the prediction process, however. For example, record counts are maintained as test files are created. Also, the analyst may request that a grand total of all values generated in a specific field be provided. These amounts may be compared to similar totals which are derived by the system being tested.

The test data generator may be a standalone package, or it may be in the form of special statements which are incorporated into a higher-level language program. In the latter case, the test data generator draws in part upon the file, record, and field descriptions which are already present in the application program.

A *terminal input simulator* becomes important when testing on-line systems. The job of the input simulator is to present test transactions to the processing program in such a manner as to imitate the anticipated multiple-terminal environment in which the system will eventually operate. A user profile, containing information about the volumes and types of transactions which will enter the system relative to the time of day or the day of the year, should be incorporated into the simulator.

The use of a terminal input simulator makes it possible to begin testing an on-line system before terminals have been installed or users fully trained. In association with a test data generator, the terminal simulator can be used for stress testing by loading the system with excessive numbers of transactions in a limited period.

*File conversion programs* also can be used to advantage when creating test files or files of anticipated results. Especially if parallel testing techniques are being used, files can be converted from the old system, which has presumably been checked out and operating correctly for some time. Some test data generators may, in fact, incorporate file conversion into the building of records by allowing the specification of fields in external files as the source for the values in newly generated records.

*Redundant programming* is an infrequently used technique for ascertaining the accuracy of new software. The technique works on the same principle as parallel testing: the results obtained while using two different computer systems programmed to accomplish the same task are compared. A discrepancy in results indicates an error in one of the systems.

The problem with redundant programming is that both of the systems are usually newly written during the system development period, and thus each remains subject to a thorough system test before either one can be called the standard for correctness. Thus, an equal result does not necessarily mean that both programs are correct (both could be wrong in the same way); similarly, an unequal result does not necessarily isolate which program is in error.

In some complex systems, however, where no parallel system is available for comparison, redundant programming may be the only realistic method for evaluating system results. In this case, the testers must assume that there is a high probability that equal results imply correctness of system execution.

A *file comparison program* runs a field-by-field or a character-by-character comparison of the contents of two files in the same sequence and format. Automated file comparison greatly facilitates the comparison of system-generated results to the predicted correct results. Even if no parallel system exists and all results were predicted manually, it is often advantageous to enter the predictions onto a computer-readable file so that file comparison programs may be used. Depending on the capabilities of the available file comparison utility, even hardcopy reports may be directed to disc or tape and compared.

Exception reporting isolates only the discrepancies between files, so that er-

roneous procedures may be easily isolated. Automation of the file checking task not only speeds the assessment of test results, but also assures that entire files are examined to the letter, and that further errors are not introduced into the system during manual check-out.

An important point about all of these tools is that a front-end investment in the purchase or development of automated testing aids will benefit

---

### Continued testing is the best preventative medicine for premature system degeneration.

---

the system testing process not only during original system development, but also throughout the lifetime of the system as it is maintained.

If it is true, as sometimes claimed, that a programmer making even a minor modification to a program has less than a 50% chance of making that modification without generating a new error in the program, then it becomes obvious that a complete test should be executed and carefully evaluated every time a change is made to a program or a system function. Maintenance programming and maintenance testing should go hand-in-hand. Therefore, to facilitate maintenance testing, system documentation should include a copy of the system test plan, test data files, and files of predicted results.

Careful attention to continued system testing is the best preventative medicine against premature system degeneration. In fact, it is perhaps during maintenance testing that automated testing aids are of *most* value. For each system module, parameters for the generation of test data can be retrieved from a system testing library. Testing of new functions can be added by modifying the existing test file definitions.

It becomes necessary, then, to predict only the results of the newly added transactions. A file comparison program can be used to isolate the differences in the results obtained using the modified version of the program and the results obtained using the previously checked-out version. The differences can then be justified as being due to the introduction of new functions, or due to error.

### Sharing the recipe

The concepts presented here are also in the boxed set of guidelines. They are offered for use as a system testing standard. The standard is expressed as a list of tasks or quality checks which should be completed during a system test. The checklist can be used as a framework for constructing a test plan, or as a

Infoton has always produced a special breed of terminals.

Reliability is what has made seven generations of Infoton winners stand out from the field. And, like their predecessors, it's their reliability that makes the new Infoton 200 and 400 so very special.

They are just built better than other terminals in their class.

Take the 200, for example. A detachable keyboard of solid state construction guarantees 100 million operations . . . ten times the performance of most mechanical keyboards. And the keyboard comes in various configurations to suit users' unique requirements.

Other outstanding features include 9 x 9 dot matrix, addressable cursor, EIA and current loop interfaces and non-destructive forward and back spacing.

The 400 has everything the 200 has . . . and more. Designed around the Z-80 microprocessor, it performs a multitude of functions. Capabilities include complete formatting and editing with block mode transmission. Also character mode for normal log-in procedures or straight character operation.

Last but not least. Both the 200 and 400 have prices among the lowest in the industry. No wonder they are such favorites.

Write or call for full details.



# Two new *Low price.* thoroughbred winners

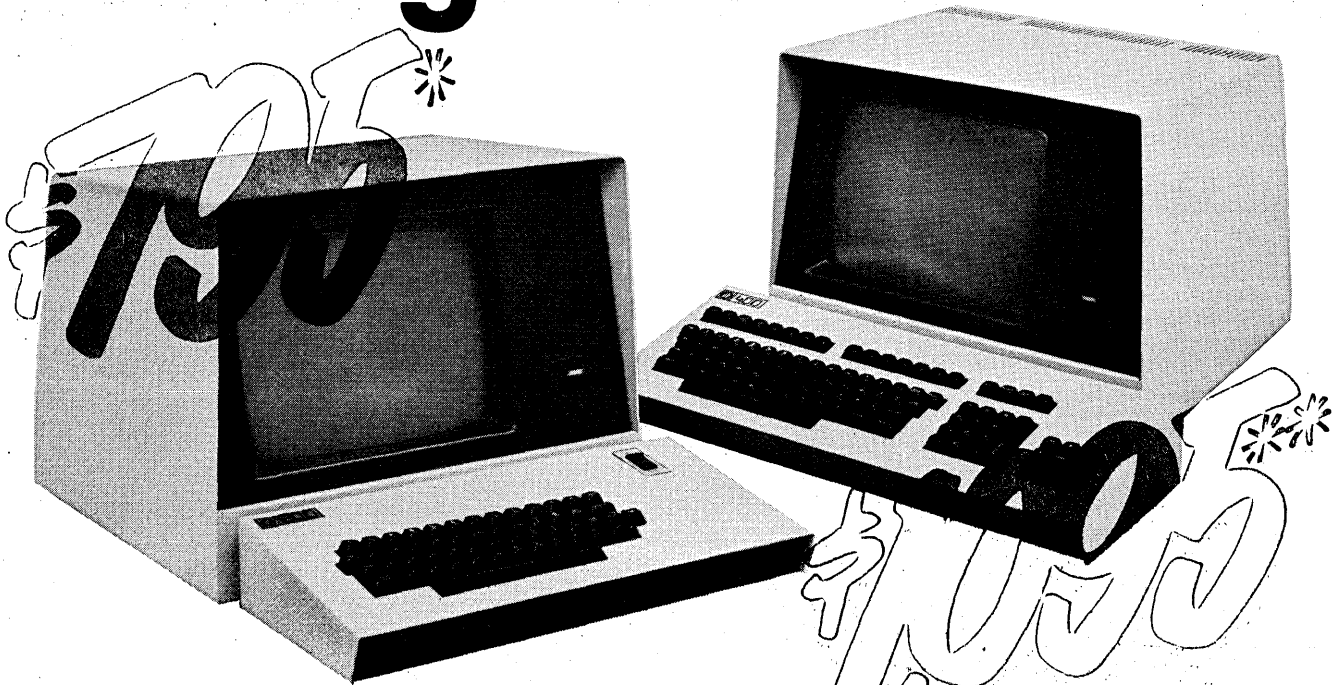

*\*Model 200/1 100 qty. price*  
*\*Model 400/4 100 qty. price*

 **Infoton**

Second Avenue, Burlington, MA 01803  
(617) 272-6660



# Price, Performance

That's an uncommon advantage  
covering a full family of  
field-proven Mag Tape Drives.

**Family resemblance goes deep.** The Cipher Series X was designed from the ground up for maximum commonality of electronics, accessories and hardware. Full family parts-in-common include the head, tape guides, EOT/BOT, File Protect, a single universal Read/Write Board for NRZI, PE or NRZI/PE, plus mechanical, electrical and electronic parts and sub-assemblies. All of which means lower stock requirements for spares, less cost, and far greater flexibility in system design for the OEM. The savings are truly remarkable.

**All in the family.** Every popular size and speed. From 7 inch to 10½ inch reels at standard speeds from 12.5 ips to 75 ips. NRZI, Phase Encoded, or both—on our exclusive single PC Board. Densities of 200, 556 or 800 bpi NRZI—7 track; or 800 bpi NRZI or 1600 bpi PE—9 track. On all models. High performance. High reliability. Low cost. With options in formatters, controllers, D.C. power, and alternative speeds and densities. And don't forget—the lowest cost "spares support" in the industry.

**Simplicity of design and ease of access.** Those PC Boards are not only elegant solutions to design requirements, they're easy to get at for service and



# & Common Spares

maintenance. All Cipher Boards are hinged for ease of access to all components. No extender boards required. No blind spots. No nonsense. These are simply the easiest machines to service in the industry. Bar none.

**Reliability is built-in — and demonstrable.** With full documentation. A calculated MTBF of 7912 hours — RADC standards. And a significant history — more than 10,000 units shipped to date. With all components pre-tested and burned-in to ensure reliability. Precision castings to ensure ruggedness. And large, powerful reel motors with a highly efficient servo system for less power consumption, lower operating temperatures and longer life. Cipher Mag Tape Drives are reliable by design, by manufacture and by testing. And we stand behind them with a no-nonsense, no-quibble Warranty. What more could you ask?

**Service when and where you need it.** With more than 100 field service locations in the U.S. and Europe, we're ready and responsive. And our factory service group maintains a 24-hour, 7-days a week phone contact for problems which exceed local capabilities. We don't let our customers down.

**Call collect for immediate requirements.** Or write or TWX for the full story. We can deliver to your

needs, at highly competitive prices, and our spares program is pacing the industry. For full particulars, contact your nearest Cipher Representative or Cipher Data Products, Inc., 5630 Kearny Mesa Road, San Diego, California 92111. (714) 279-6550. TWX: (910) 335-1251.

## Cipher Data Products

CIRCLE 40 ON READER CARD



## TESTING

standard against which current testing efforts can be evaluated.

Before undertaking a system test, evidence of a complete and successful unit test for each constituent program or module should be available. Criteria for evaluating the completeness of unit testing are included in this checklist in order to emphasize the importance of this phase to overall system testing.

System testing, as such, usually progresses through two iterations, each time with a more "real" environment. This too is reflected in the guidelines.

The first execution uses the minimal, logically complete set of test data which is created using the prediction process described above. Each condition and each transaction type were checked in turn by the analyst and supervisor who are coordinating the testing.

The second iteration uses a much larger set of test data and much larger test files (or copies of "live" files). This test data is usually generated by the users in a random or unstructured manner, or by a test data generator. Here, operating conditions should approach live as much as possible. All logical cases will probably not be in-

cluded (they rarely are in a single live run), but the volume and mix of transactions will reflect the expected values under normal operating conditions.

Due to the larger volumes and the more random nature of this iteration, less formalized checking procedures, such as tracking selected transactions through the system, may be used. Also during this iteration, subtle combination-of-input errors may be uncovered. In addition, the larger volumes may push the system toward its limits, allowing a check on factors such as file space allocation and time limits.

The testing standard divides the testing process into four phases which must necessarily occur in order. The first phase is preparation for testing. During this phase, test cases are enumerated, test files and test transactions are developed, correct output is predicted, and acceptability standards are established.

The second phase occurs in the computer room and is the actual execution of the test: running the programs, listing input and output files, and collecting reports.

The third phase is the evaluation of test results using criteria specific to the type of testing being done, such as looking for certain logical errors during unit testing and interface errors during system testing.

The last phase is the acceptability test, during which users review and sign-off on generated output according to the predetermined acceptability standards.

In all cases, a testing standard such as this must be applied with care. Some factors may not be at all applicable to the problem at hand. As with any generalization, this checklist should be applied when relevant, but ignored when it would become immaterial or superfluous. ❁

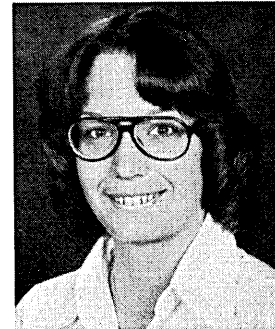

A systems analyst at the Ohio Wesleyan Univ. in Delaware, Mrs. Scherer also consults privately in the Central Ohio area. Her past experience includes work as a programmer and analyst for a national consulting firm, and the teaching of several business dp courses.

# SPLICE

## The Affordable COBOL Precompiler

(IT'S ONLY 5K)

### HIGHLIGHTS:

- SPLICE is a COBOL precompiler which drastically reduces the initial coding of all COBOL programs 50-70%. With "quick and dirty" programs 80% reductions are possible. Your programmers codes in SPLICE and SPLICE then generates the COBOL program. SPLICE removes the drudgery of COBOL coding without sacrificing the extensive documentation which makes COBOL so popular
- Mastering SPLICE is quick and easy. SPLICE is not a new language. If you can code COBOL, you can code SPLICE. SPLICE is 100% compatible with COBOL. Its logic parallels COBOL logic, SPLICE coding forms are identical, and all COBOL statements are acceptable by SPLICE.
- Responding to the increased interest in structured programming, SPLICE includes IF/ELSE alignment as part of its basic function. With this enhancement SPLICE will realign COBOL programs so the ELSE appears under the relevant IF according to compiler rather than programmer interpretation. In addition nested IF'S are successfully indented by four columns from the appropriate IF or ELSE.

### Additional Selectable Units: CHIP \$1K

### HIGHLIGHTS:

This selectable unit promotes installation standards on both new and existing programs by accepting English language free form commands.

#### specific capabilities

- Record prefixing of data division • Paragraph sequencing in procedure division • Conversion to standard forms and columns for usage, picture, and value clauses • Alphabetic listing of working storage entries • Replacement of non-descriptive data names with user defined expanded name • Insertion of EJECTS, SKIPS, and blank lines as desired • Ending or beginning lines upon encountering specified COBOL reserved word or punctuation.

#### additional standards capabilities

- SPLICE is applicable to maintenance as well as development programs. It has complete interface with PANVALET, LIBRARIAN and other systems.
- Identifying of AT END under READ, VARYING or UNTIL under PERFORM, etc. • Flagging undesirable COBOL verbs, e.g. ALTER • Stacking verbs, e.g. CALL, OPEN, etc. • Renumbering level numbers.
- SPLICE is available for all IBM 360's, 370's, Univac Spectra series, and Univac 9000 series.

#### user comments

1. *Jewel Foods — Tom McLain, Application Programming Manager*  
"I looked at every Cobol preprocessor on the market and chose Splice because it offers the best price performance ratio and my programming staff enjoys using it."
2. *Olin Corp. — Keith Sullivan, Manager/Systems Development*  
"We have experienced a noticeable increase in programmer productivity since we began using Splice."

For an on-site evaluation or detail documentation please call or write



IN EUROPE

## SOFTWARE MODULE MARKETING

THE SUPERMARKET OF SOFTWARE

CROCKER BANK BUILDING/PENTHOUSE  
1007 7th STREET • SACRAMENTO, CA 95814 (916) 441-7234

Telex SMMSAC 377-314

CALIFORNIA MODULE MARKETING, Ltd.  
%COUNTRY FORMATIONS, Ltd.  
27 KELSO PLACE • LONDON W.8

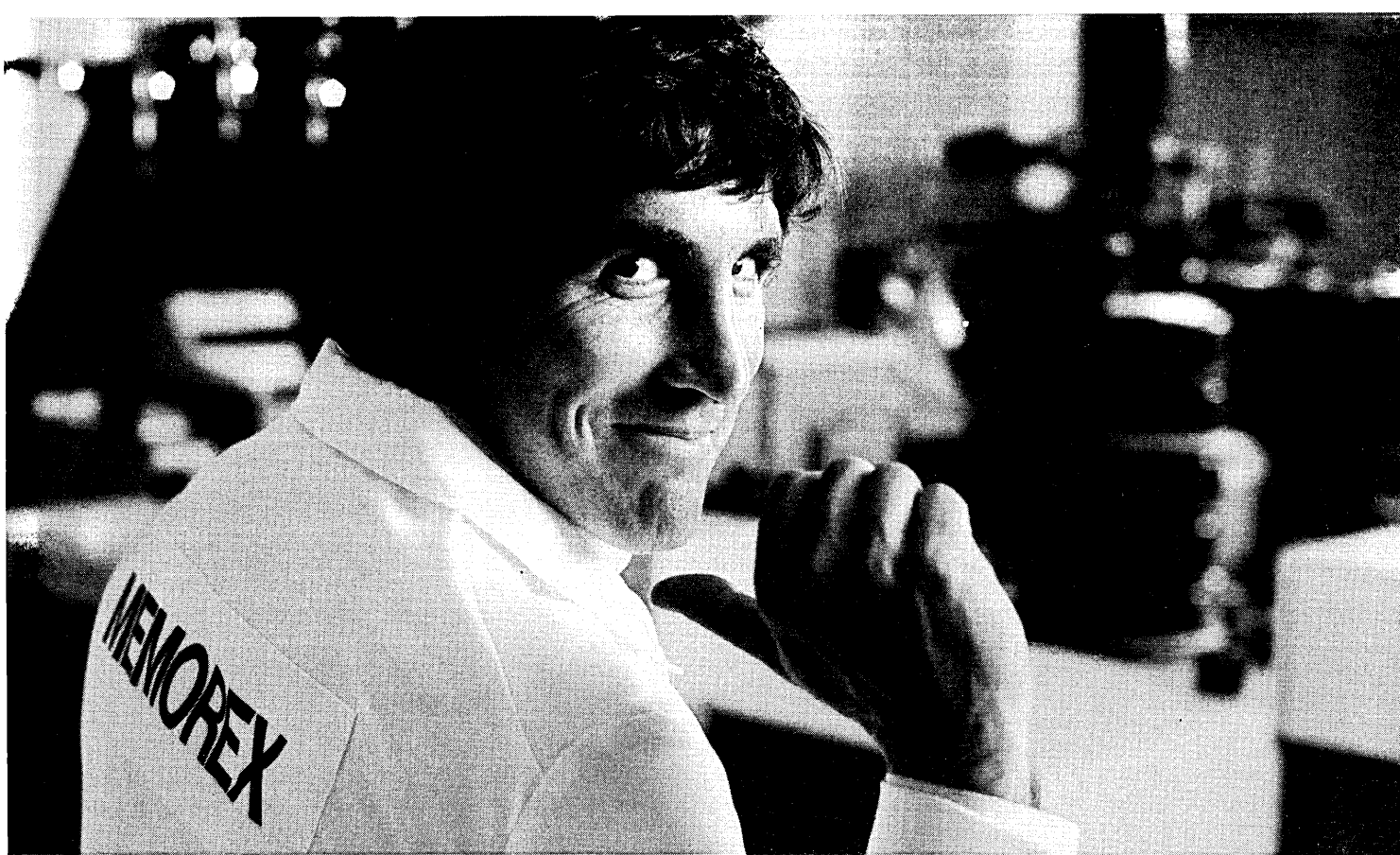

## Leader of the Packs.

We're the world's leading independent maker of disc packs. And we provide the largest service organization of all the independents for supporting them.

Disc packs and disc pack service for our drives. And for IBM, CDC, Honeywell, NCR, Calcomp and Ampex drives, too.

A leadership position made possible by our people—because it's their commitment to uncompromising standards in design and manufacturing that has led to making Memorex disc packs the Standard of Value.

We make 12 different models of disc packs. And every single one we make is made not just to meet industry specifications; rather, to exceed customer expectations.

Our customers expect unequalled performance from Memorex packs, and so can you. Because our concern for Memory Excellence has no equal.

Call your Memorex Representative, locations in principal cities worldwide. Or contact us at 1500 Memorex Drive, MS-0060, Santa Clara, CA 95052. Call collect (408) 987-1043.

**MEMOREX**CELLENCE

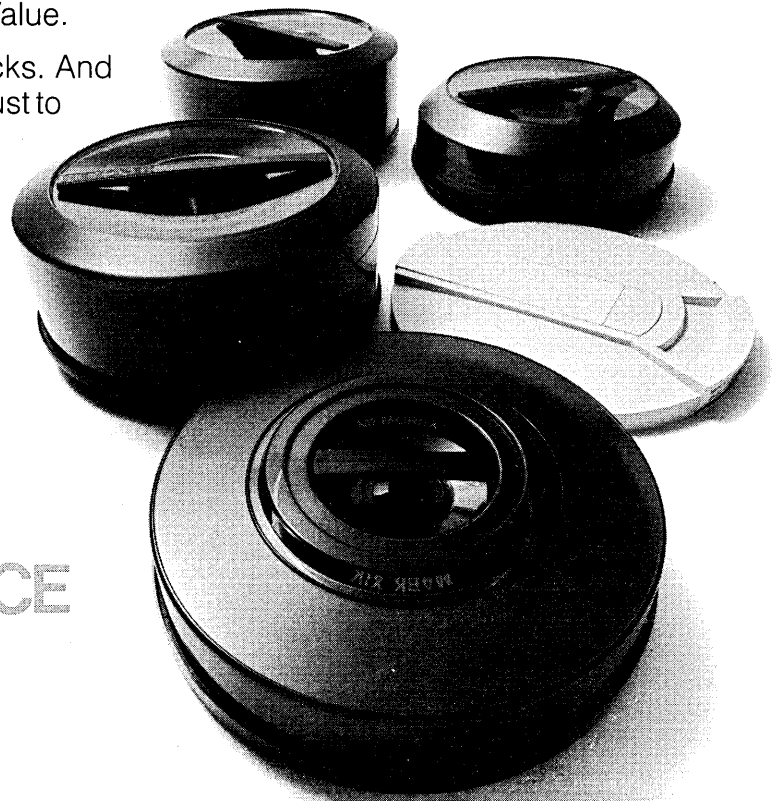

This is an ad  
for Xerox computers.  
(But not from Xerox.)

It's from Telefile Computer Products. And we've taken this space for two reasons:

First, we're a Xerox computer user and like the others, we *believe* in the mainframe. Price/performance is second to none.

Secondly, we're selfish. We manufacture and market fully compatible disk systems, main memory and other peripherals for Xerox computer users. So every new Xerox system sold represents an opportunity for us.

If you don't have a Xerox computer now, look into one. System architecture is remarkably advanced and in such tune with the software that users claim the computers deliver up to 95 percent of capacity. Unheard-of efficiency.

Tying the package together are two state-of-the-art operating systems: Control Program-Five (CP-V) and Control Program-R, for Real-time (CP-R). CP-V provides simultaneous access five ways: real-time, time-sharing, multi-programmed batch, remote batch, and transaction processing in any combination. CP-R is ideal for more dedicated engineering, scientific or real-time applications.

If you *do* have a Xerox computer now, look at the advantages you can have with Telefile's new generation of peripherals: Total hardware compatibility. Software transparency. Fast delivery. Lower cost. Better features. Strong back-up support.

Take it from Telefile, buy a Xerox computer. Then save by outfitting it with Telefile peripherals. Who knows, maybe next time they'll run an ad for us.

Telefile Computer Products, Inc., 6111 Dainler St., Irvine, CA 92705.

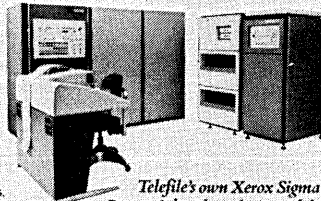

*Telefile's own Xerox Sigma 5.  
Our peripherals make it work better  
and last longer.*

## Compliments of a friend.

# What we've done for Xerox users, will now be done for Univac.

Xerox computers aren't getting older. They're getting *better*.

And that's all the more remarkable since Xerox *hasn't built one in years*.

Computer Enhancement is the reason.

It's a new industry being pioneered by Telefile. Applying latest technology, we revitalize computers so they can do more work faster. It may mean faster memory or peripherals. Or simply "black boxes" that extend a computer's capability beyond previous design limits.

Take Xerox. Since early 1975, when our ad appeared, Telefile has announced over 24 new Xerox-compatible products.

Compact main memory, high speed printers, communication processors, solid state RAD's, array processors, and on and on.

Most have powerful performance, reliability, and cost advantages over the Xerox units they replace. More important, they're available.

Recently, we announced a new mass store facility that brings "Winchester" disk drive technology to Xerox users—something previously available only to IBM users.

Telefile has even taken over complete system maintenance at some sites. Our service network now stretches to over 20 cities and it's growing monthly.

And now to give Xerox users room to grow, Telefile is embarking on the development of *two new micro-programmed Sigma mainframes* for introduction in 1978. One will run four times faster than Xerox' biggest machine, yet cost only about half as much.

That's computer enhancement. To Xerox users it means a way to take their computer investment and superior software into the 1980's in style.

Univac users, you're next.

## Telefile

Enhancing computers is our business.



# This is an ad for Univac computers.

(But not from Univac.)

It's an unsolicited testimonial from Telefile Computer Products. And we've taken space again for two reasons:

First, for sheer number crunching and handling of large data bases, Univac computers are in a class by themselves (how else could they thrive under a quarter century of IBM competition?).

Secondly, there are hundreds of *older* Univac installations that could benefit significantly from Telefile's computer enhancement capabilities.

Key to Univac's success has been its evolutionary approach to systems design. The new 1100 Series machines are direct descendants of the Univac 1108, first installed in 1964 and still running strong.

But as 1108's and other models have grown older, remarkable evolutionary advancements in memory, peripheral and mass storage facilities have grown up around them. One way users could upgrade was to change out the mainframe into a gleaming new model. Univac makes it easy by keeping the software compatible.

Think of Telefile as being *counter-evolutionary*. We reverse the tides of time by applying new memory and accessory design to computers hobbled by the past.

Take our new fully compatible add-on memory for Univac computers. By taking advantage of latest technology, it runs faster, takes up less floor space, and runs on only one-third the power of the Univac memory it replaces. No software changes are required. And costs *are cut about 70 percent*.

We currently offer unitized memory for 1110, 1100/40 and 1106 processors; and multi-modular memory for Univac 494, 1106, 1108, and 1110 processors.

Both memory types are currently up and running on Univac computers. On one, overall system throughput has been boosted by a remarkable *30 percent!*

But this is just the start. Coming down the line are a solid state drum replacement and disk systems that leapfrog 3330 technology. Not to mention some other exciting developments we'd rather not mention right now.

We don't expect Univac to run an ad for Telefile, but someday the users might.

Write: Telefile Computer Products, Inc.,  
17131 Daimler St., Irvine, CA 92714.  
Phone: (714) 557-6660.

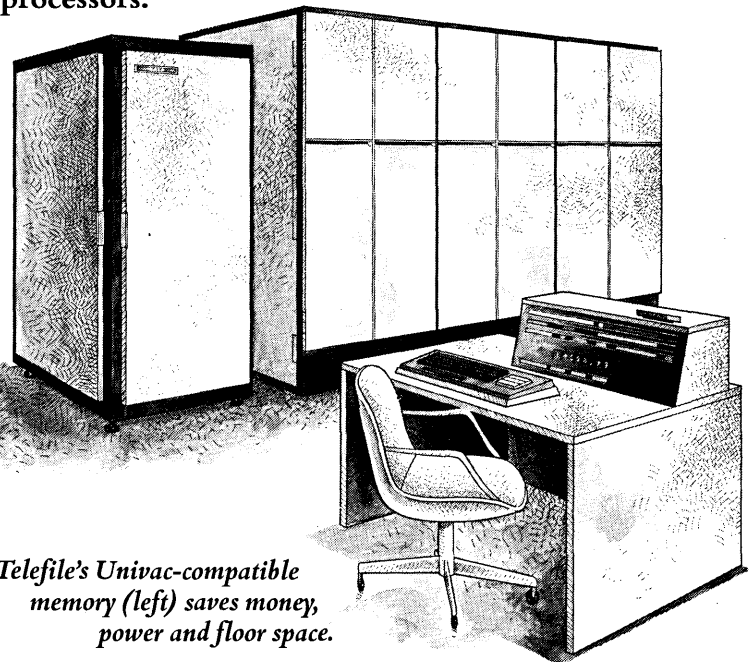

*Telefile's Univac-compatible  
memory (left) saves money,  
power and floor space.*

## Compliments of Telefile.



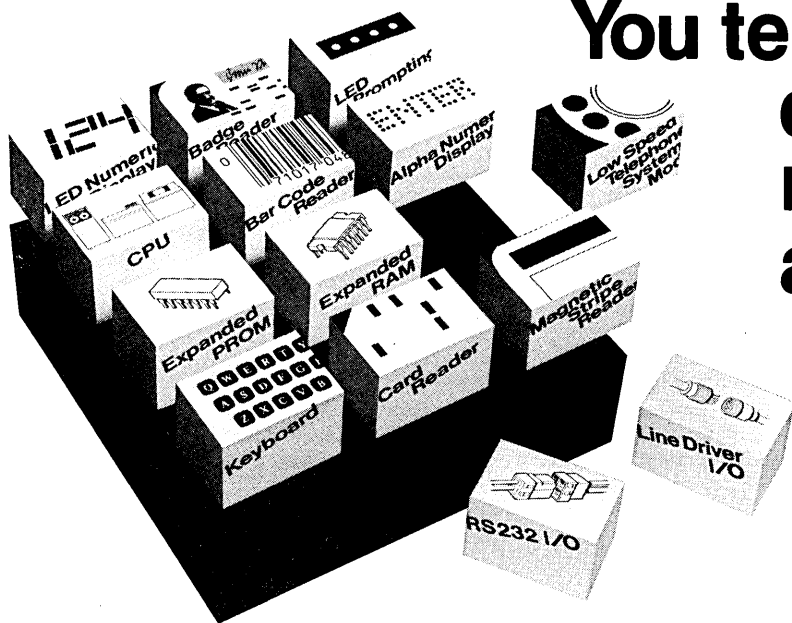

You tell us what your data collection requirements are.

We'll supply the parts.

With EPIC DATA'S new Model 1647 data collection terminals and Model 1648 system control units (SCUs), you can configure exactly the data collection system you need. These "building blocks," based on microprocessor architecture and modularity, allow you to provide your customers with simple, practical and flexible terminals or systems for virtually any combination of requirements they may have.

**simple.** EPIC DATA terminals with RS232C interface (ASCII), or optional alternative interfaces, are simple to use and deploy. No computer knowledge is required. Data collection building blocks can be combined to enable collection of information from a wide variety of pre-prepared and variable data. Maximum use of pre-prepared data reduces entry errors.

All models include an 8080 microprocessor; the user can program terminals to provide customized input, output and processing of data. In addition, programmability aids in prompting the user through entry steps, validating data and enables off-line or on-line operation.

EPIC DATA terminals weigh only 8½ pounds. They can hang on a wall, be placed on a desk, and are easily exchanged during maintenance.

**practical.** EPIC DATA terminals are designed with permanence in mind. Environmental tests conducted in conformity with MIL-STD-810 plus in-depth, on-site testing assure reliable operation over a broad spectrum of hostile, industrial environments. Simple design and rigorous testing have resulted in a demonstrated MTBF of over 19,000 hours. MTTR is only 30 minutes.

**flexible.** Choose the terminal and options which best meet your application. EPIC DATA terminals can optically read punched badges and 80-column ANSI cards. User-defined keys are available for inputting variable data. Key entry data or time of day is displayed and LEDs are available for prompting.

Terminals can be configured to scan bar codes and magnetic stripes or accommodate other peripherals through RS232 ports. Display options include additional numeric displays, up to 15 LEDs for prompting and a 32-character alpha/numeric display. A low-speed modem and serial asynchronous or synchronous communications ports with either RS232 or line driver I/O may be added. Both PROM and RAM memories are expandable.



**SCUs.** Model 1648 SCUs can be configured to poll up to 100 terminals, assemble transactions, format data, append time and date, and store or forward collected data to the host.

Let EPIC DATA show you how microprocessor-based architecture and building block modularity will provide you with simple, practical and flexible data collection terminals and SCUs.

OEM quantity (100) prices start at approximately \$1000. Contact your Epic Data representative today or write:

**epic data corporation**  
6350 LBJ Freeway/Dallas, TX 75240  
Phone (214) 387-3121/TWX910-860-5676

**Sales Offices:** 6350 LBJ Freeway, Suite 127, Dallas, TX 75240, (214) 387-3121 • 17 Amfer Court, Bayshore, NY 11706, (516) 666-0797  
Representatives: ARIZONA BFA Corporation (602) 994-5400 • CALIFORNIA Moxon Electronics (714) 635-7600 • FLORIDA COL-INS-CO (305) 423-7615 • ILLINOIS Systems Marketing Corp. (312) 593-6220 • MARYLAND Electronic Marketing Associates (301) 881-5300 • MASSACHUSETTS J & J Associates (617) 272-2606 • NEW YORK Cane Technical Sales (914) 698-4411 • NEW YORK Ossmann Instruments (315) 437-6666 • PENNSYLVANIA WKM Associates (412) 892-2953 • TEXAS DMA (713) 780-2511 • WASHINGTON DPM Associates (206) 453-9082 • MEXICO Electronica Hemisferica, S.A. Mexico City (905) 2-50-60-11 • UNITED KINGDOM Sintrom Elnor Ltd. Reading (0734) 85464

# they're here!

**H10**  
16-Bit  
Computer  
\$1295

## THE NEW HEATHKIT® PERSONAL COMPUTING SYSTEMS

The new VALUE-STANDARD in personal computing systems! Heathkit computers give you the power and performance to go wherever your imagination and programming prowess take you. They're designed to get you up and running fast, interface with I/O devices easily and quickly, accept additional memory and I/O devices, store and retrieve data with speed and accuracy, respond to your requests with lightning speed. They offer complete mass storage capabilities, power and reliability for any programming application, and they're priced to give you outstanding VALUE for your computer dollar!

These Heathkit computer products are "total system" designs with powerful system software already included in the purchase price. They're the ones you need to get up and running fast. And they're backed by superior documentation and service support from the Heath Company, the world's largest manufacturer of electronic kits.

**NEW H8 8-Bit Digital Computer.** This 8-bit computer based on the famous 8080A microprocessor features a Heathkit exclusive "intelligent" front panel with octal data entry and control, 9-digit readout, a built-in bootstrap for one-button program loading, and a heavy-duty power supply with power enough for plenty of memory and interface expansion capability. It's easier and faster to use than other personal computers and it's priced low enough for any budget. With assembler, editor, BASIC and debug software.

# FREE!

**Heathkit Catalog**  
Read all about our exciting computer systems and nearly 400 other fun-to-build, money-saving electronic products in kit form.

Prices are mail-order FOB, Benton Harbor, Michigan.  
Prices and specifications subject to change without notice.

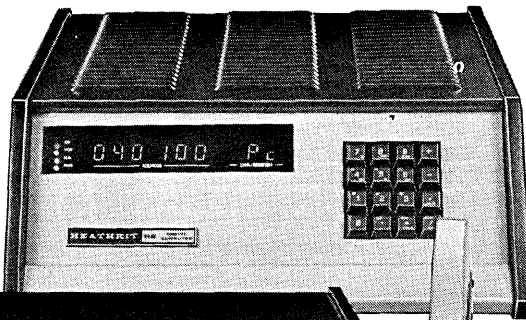

**H8**  
8-Bit  
Computer  
\$375

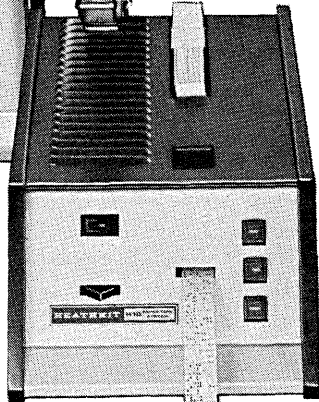
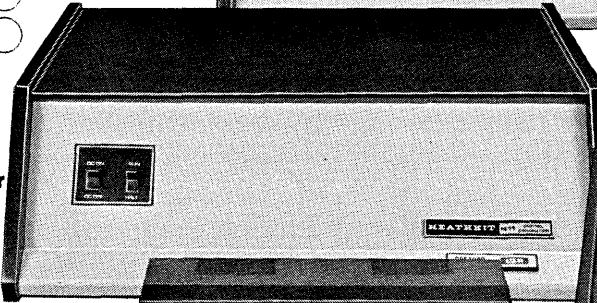

**H9**  
Video  
Terminal  
\$530

**H10**  
Paper Tape  
Reader/Punch  
\$350

**NEW H11 16-bit Digital Computer.** The most sophisticated and versatile personal computer available today — brought to you by Heath Company and Digital Equipment Corporation, the world leader in minicomputer systems. Powerful features include DEC's 16-bit LSI-11 CPU, 4096 x 16 read/write MOS memory expandable to 20K, priority interrupt, DMA operation and more. DEC PDP-11 software is included.

**NEW H9 Video Terminal.** A full ASCII terminal featuring a bright 12" CRT, long and short-form display, full 80-character lines, all standard serial interfacing, plus a fully wired and tested control board. Has auto-scrolling, cursor with full positioning controls, full-page or line-erase modes, a transmit page function and a plot mode for simple curves and graphs.

**NEW H10 Paper Tape Reader/Punch.** Complete mass storage peripheral uses low-cost paper tape. Features solid-state reader with stepper motor drive, totally independent punch and reader modes and a copy mode for fast, easy tape duplication. Reads up to 50 characters per second, punches up to 10 characters per second.

Other Heathkit computer products include a cassette recorder/player and tape for mass storage, the LA36 DEC writer II, serial and parallel interfaces, software, memory expansion and I/O cards, and a complete library of the latest computer books — everything you need to make Heath your personal computing headquarters!

HEATH  
Schlumberger

Heath Company, Dept. 360-330  
Benton Harbor, Michigan 49022

Please send me my FREE Heathkit Catalog.  
I am not on your mailing list.

Name \_\_\_\_\_

Address \_\_\_\_\_

City \_\_\_\_\_ State \_\_\_\_\_

CP-127 \_\_\_\_\_ Zip \_\_\_\_\_

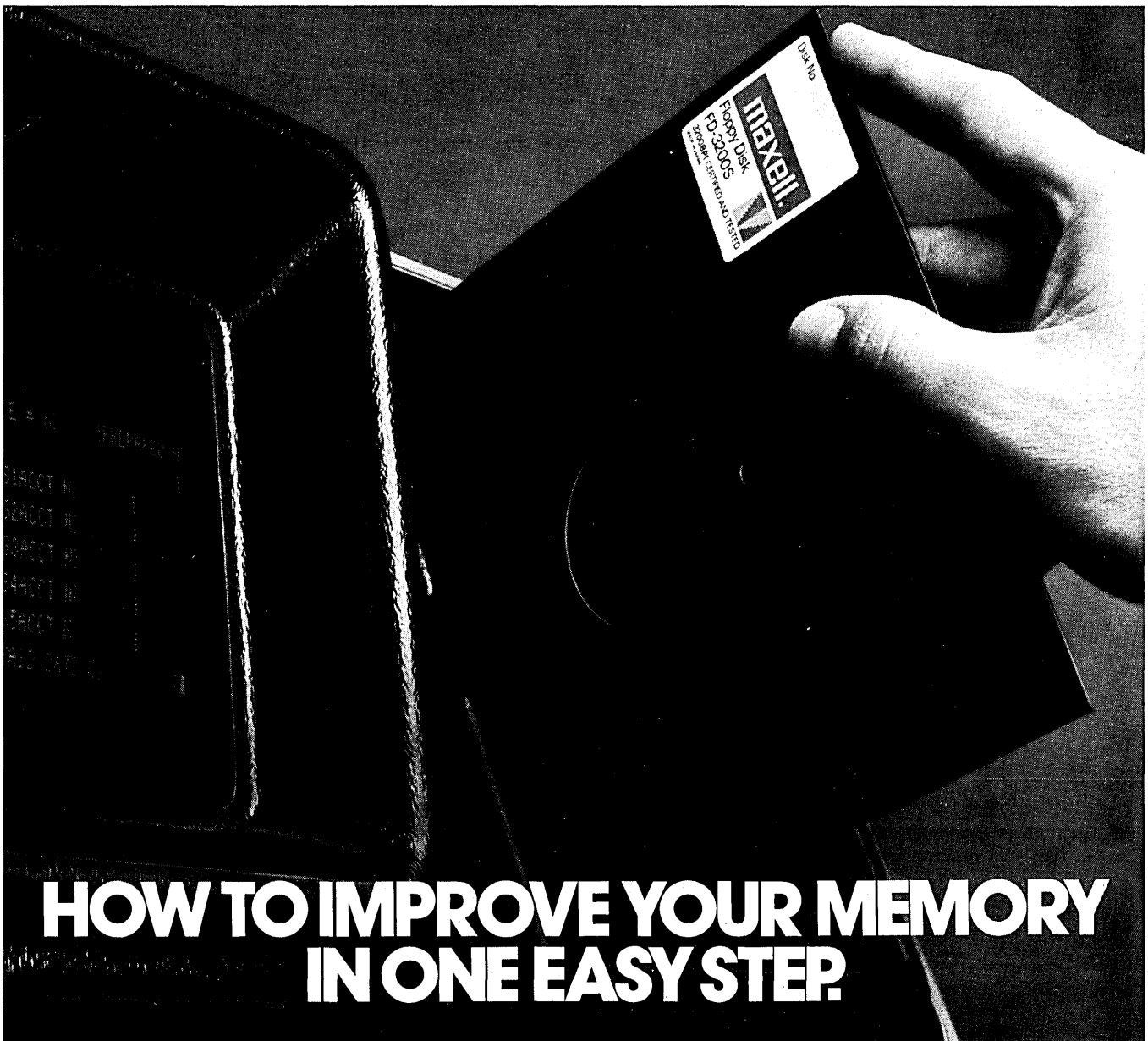

## HOW TO IMPROVE YOUR MEMORY IN ONE EASY STEP.

If your computer ever suffers from a lapse of memory, here's what you can do to help:

Always remember to use Maxell magnetic products. Because we put a lot of things into them to ensure that nothing ever drops out.

Our digital cassette tape, for example, is so good some of the biggest OEM's in the business use it.

And we firmly believe that our new floppys are every bit as good.

They're made to the strictest ISO and IBM Diskette specifications.

They're made of computer grade, super-fine magnetic materials for high density recording at 3200 BPI.

And they have a specially developed binder for improved particle dispersion and an incredibly smooth coating surface.

So if your computer has a problem remembering things, contact a Maxell sales representative and ask about the data products with the good memories.

But you better do it soon. Before you forget.

Maxell Corporation of America, 130 West Commercial Ave., Moonachie, N.J. 07074



# A Data Base Story

by J. J. Sobczak

Proving once again that what goes around comes around.

One day several years ago, in the data processing department of a large eastern manufacturing firm, the v.p. of dp decided that many of his people had been in the same job for too long. He and his managers decided to have a number of employees make nonpromotional moves to broaden their experience.

Included in these job assignment transfers were two senior systems analyst/project leader types we'll call Charlie and Joe. Both Charlie and Joe had similar backgrounds. Though neither was rated as exceptional, both were quite competent and had distinguished themselves through the years. Charlie had been associated with the accounts payable system for seven years, including the last three as project leader. He fully understood the system and there was not a question about accounts payable that Charlie could not answer. Joe had had similar experience with the inventory control system, and was recognized in the department as the only one who really understood the entire system. They approached their new assignments with great apprehension. Each was being asked to leave a world where he had full control and complete job knowledge, and enter a world where he knew very little.

A month or so after the transfers, Charlie and Joe were having a cup of coffee together.

"You know Charlie," Joe said, "the other day I spent some time going through the accounts payable master file and I was amazed how many fields the two systems have in common. It's not always obvious because the terminology is different, but I found that not only were many fields the same, many come from the same source document. Fields such as part number, vendor, vendor address, the three digit vendor code, plants shipped from, plants shipped to, price, and at least twenty others."

Charlie said, "I've noticed the same thing. In fact, I was wondering whether we should write a little program to compare the common data between the two systems to make sure there aren't any discrepancies. I've got a programmer I can spare for a few days, and if you can have one of your

guys create an input file for him, I'll have him write a comparison program. What do you think?"

"Well," Joe said, "I think that's a good idea. If there are discrepancies it's better we find out before someone else does. I'll have an input file in a few days. Have your guy call Sam and tell him the data he wants and the format he wants it in."

About two weeks later Charlie and Joe met again to discuss the results of the comparison program. Murphy had struck again, and there were countless discrepancies.

"Boy," Joe said, "this is worse than I

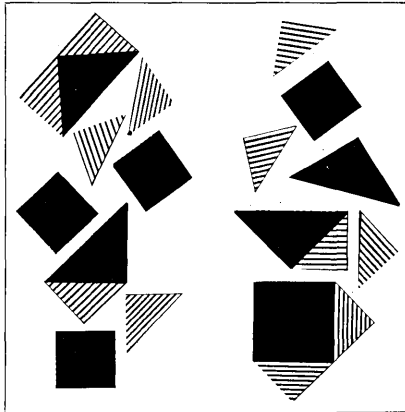

thought possible. We better find out why the files don't match." Within a few days a number of problems were discovered. In many cases field sizes and edit standards were different. Often, when errors with noncritical data were detected, the using department didn't bother entering the correction. Many times discrepancies existed only because of the timing differences in update cycles. The corrections were made and Charlie and Joe slept easier.

Then one day, three months later, Charlie and Joe decided to run the comparison program again. A few days later Joe stopped into Charlie's office to review the program results.

"How does it look?" Joe asked.

"Well," Charlie replied, "it's not as bad as last time, but there are still a number of discrepancies."

"What should we do?"

"I don't know," said Charlie, "but we better do something. Let's take the same type of corrective action we did

last time, but at the same time I think you and I should think about a more lasting solution. Let's sleep on it for a few days and meet again Friday to discuss it."

Friday came along and Charlie was anxious to discuss some of his ideas with Joe. He had been doing quite a bit of thinking and had arrived at what seemed to him an ideal solution.

As Joe walked in his office Charlie blurted out, "Sit down Joe, I think I have an answer but I want to bounce it off you."

"Great, go ahead," said Joe, somewhat relieved because to him the problem was still as perplexing as it had been three days before.

"Well," Charlie said, "my idea is to combine the accounts payable master file and the inventory control master file into a single master file. Then there will be only one entry for each field, and discrepancies will be impossible. If the vendor's address is wrong at least it will be consistently wrong wherever it appears."

Joe interrupted, "That doesn't really seem like much of a solution. It would make our lives more comfortable because our bosses are less likely to find out about our current problem. But the basic problem as far as the company is concerned would still be there—we'd still have bad data."

"Wait a minute Joe, you're jumping the gun. There's more," retorted Charlie. "I think we could improve our data accuracy by having the department most interested in an element of data be responsible for updating it. For example, the accounts payable department would be responsible for updating the price field. If you remember, that was one of the fields where our investigation of discrepancies showed that the inventory control file was usually the one that was wrong."

"Right," Joe inserted, "that's because the material people use that field more as a memo item." Joe began to show more interest.

Charlie went on. "There is another advantage that I think will help sell the idea to management. Think of all the duplication of effort that will be eliminated. For each duplicated field, the using departments have to mark up the input documents, submit data for key-

# Introd boggle-free From

There's nothing hard about Sycor software. Our step-by-step approach guides your operator through the maze of data processing procedures. Simply. And virtually without errors.

Even untrained clerical help can become comfortable with it—and productive—after a day or two of familiarization.

The reasons are simple. Sycor terminals and software are operator-oriented. They simplify data entry tasks by greatly reducing the number of keystrokes.

Our step-by-step approach has built-in checks to insure completeness and correctness of data. Since the system assures accuracy, your operators can concentrate on speed.

**COBOL, BASIC and TAL II.** Sycor speaks your programmers' language. We now offer multi-terminal COBOL, so your programmers can use one industry-standard language for both data entry and distributed data processing tasks.

We also offer BASIC and TAL II. All three languages can be easily programmed to perform index file look-ups, range checks, calculations and edits of numerical information.

This kind of versatility gives your programmers the software capability they need to customize data entry programs. The result is software that answers your needs for fast, accurate performance.

**You can communicate with Sycor.** You can operate in your own communications environment using Sycor software. We have BRJE, remote job entry software that operates in a Burroughs communications environment, and IRJE, for interactive remote, job entry needs in an IBM environment.

For your multi-leaving applications, Sycor has software that can handle your HASP work station requirements. We also offer spooling, powerful systems utilities and command chaining to help get your jobs done as quickly as possible.

# Using the software. Sycor.

And Sycor software is configurable, so it works in a broad range of environments. Your systems analysts can adapt the communications protocols of one program to talk to a variety of host computers.



The Sycor 440 gives you concurrent processing. While communicating with the CPU in a variety of environments, it still has the processing power to do up to eight other jobs.

Sycor is a pioneer in the distributed data processing industry. Our experience over the years has helped us develop hardware and software that can get your job done better. At less cost.

## Get the hard facts about Sycor software.

If you've been looking for a distributed processing system that won't boggle your workers or your budget, take a hard look at Sycor software.

Write Sycor, Inc., Corporate Offices, Ann Arbor, MI 48104.

Better yet, contact one of our nearby sales offices. We're in the Yellow Pages under "Data Processing Equipment."

**Sycor puts computer power where the work is.**

# SYCOR





**You know now that  
western peripherals  
is NUMBER ONE  
in Magnetic Tape  
Controllers for  
DATA GENERAL  
NOVA and  
DIGITAL EQUIPMENT CORPORATION  
PDP-11 minicomputers.**

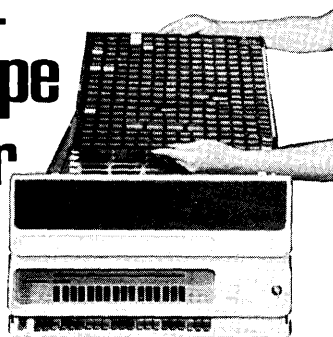

**You should also know  
we make the best  
Disc Controllers for  
these minicomputers too.**

For all NOVA's, NOVA-emulators and PDP-11's—Like our Tape Controllers, the Western Peripherals Disc Controllers are fully embedded. Engineered to take advantage of the latest in solid state technology, they offer the best combination of performance, reliability and cost. Features that make them preferred include: Total DG and DEC software compatibility, media compatibility, and accommodation of virtually any cartridge drive including front load, top load, or 10-high up to 100 megabytes.

WRITE FOR COMPLETE INFORMATION



(714) 991-8700 • TWX: 910-591-1687 • Cable: WESPER  
1100 Claudina Place, Anaheim, CA 92805

**DATA BASE**

punching, and process the error corrections. The data must be keypunched and the cards handled. Computer resources are used to edit and update the data, and storage resources store it. That's a lot of extra work. Well, what do you think?"

"Great," Joe said, "and I just thought of another advantage. The accounts payable department manager asked just last week for some special reports that included information we don't have, but I know is in the inventory file. For example, he wants the company part classification code on his reports. If we had a consolidated master file, I could easily give him reports like that."

"Hmmm, I never thought of that," said Charlie, "this is sounding better all the time. What do you think our next step should be?"

"Well," Joe said. "I think we should run this by Gardner. He's in systems programming now, but he's still the sharpest guy around here. If there are any holes in it, he'll find them."

"Good idea, Joe" agreed Charlie. "I'll give him a call and ask him to meet with us as soon as possible."

Gardner was the most respected member of the data processing department. He had been a programming hotshot and then an outstanding systems analyst. He eventually was transferred to head up the systems programming department because he knew more about systems programming than anyone else, even though his career had been mainly in the applications area. The next day Gardner agreed to sit down with Charlie and Joe to discuss their problem and proposed solution.

They explained the history of the discrepancies and the concept of eliminating them by having only one master file. They described their theory on why they believed accuracy would be improved, how duplication of people and machine resources would be eliminated, and the advantages to each department of being able to receive special reports containing data from the other's master file.

When they finished, Gardner, who was not the type who jumped to conclusions, said, "You guys have an intriguing idea. There may be a few implementation problems, but let me spend a few days analyzing your idea. I'll get back to you in about a week."

"Fine," said Charlie. "Let's set up a meeting now for a week from Monday. We can all benefit from spending a little more time thinking about this."

When the time for the meeting came around, Charlie and Joe were anxiously awaiting Gardner's opinion.

# Every time she sneezes, you'll wish you had let Moore preprint your weighted Mod 10 self-check consecutive numbers.

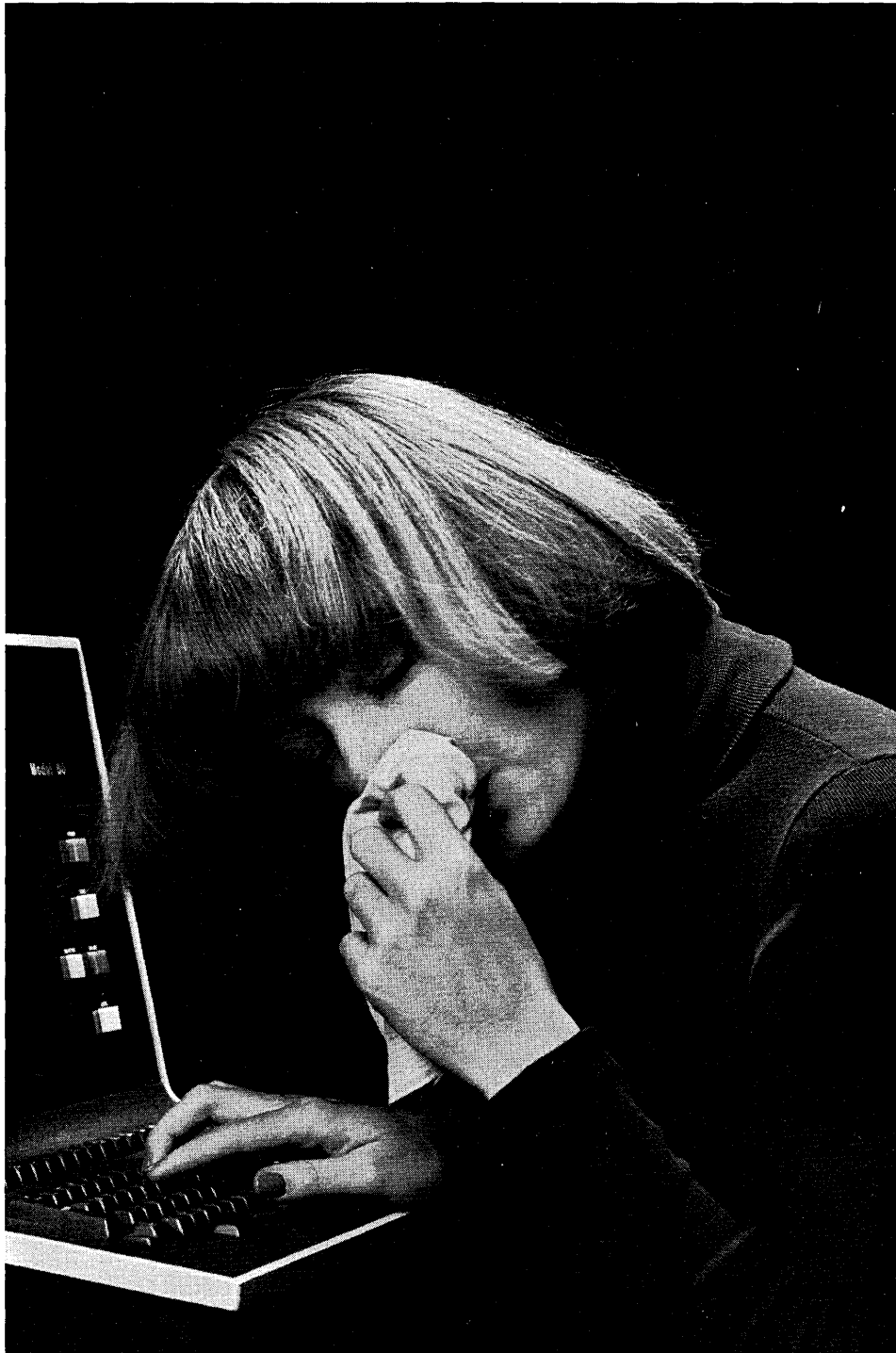

No matter how good your key operators are, they're human. And when they look away from their work, no matter what the distraction, they could enter a wrong number.

It need never happen again.

Because Moore, the world's largest designer of business forms, introduces Digi-Chek® computer-controlled numbering.

Preprinted Mod 10 forms. They're yours for the asking. Complete with weighted Mod 10 self-check digits already entered.

Moore will design you a Digi-Chek system on a form with consecutive numbers for error-free entries, guaranteed by the weighted Mod 10 system.

**26548 8**

Consecutive Numbering with  
Mod 10 Check Digit

Your new Moore forms with Digi-Chek can save costly errors in billing, accounts payable, payroll accounts, in a variety of industries such as banking, insurance, health care, brokerage, department stores and construction firms.

So put the world's largest forms company to work for you. Call your local Moore representative, or write us direct. We'll save you time, money and errors, which is nothing to sneeze at.

**Moore Business Forms, Inc.,**

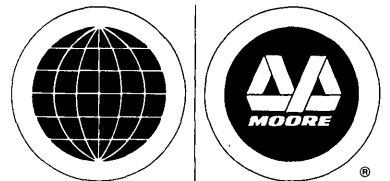

Toronto, Canada/Niagara Falls, N.Y.  
Denton, Texas/Oakland, Calif./Glenview, Ill.

**To the data processing  
executive who wants to  
work smart, not hard:**

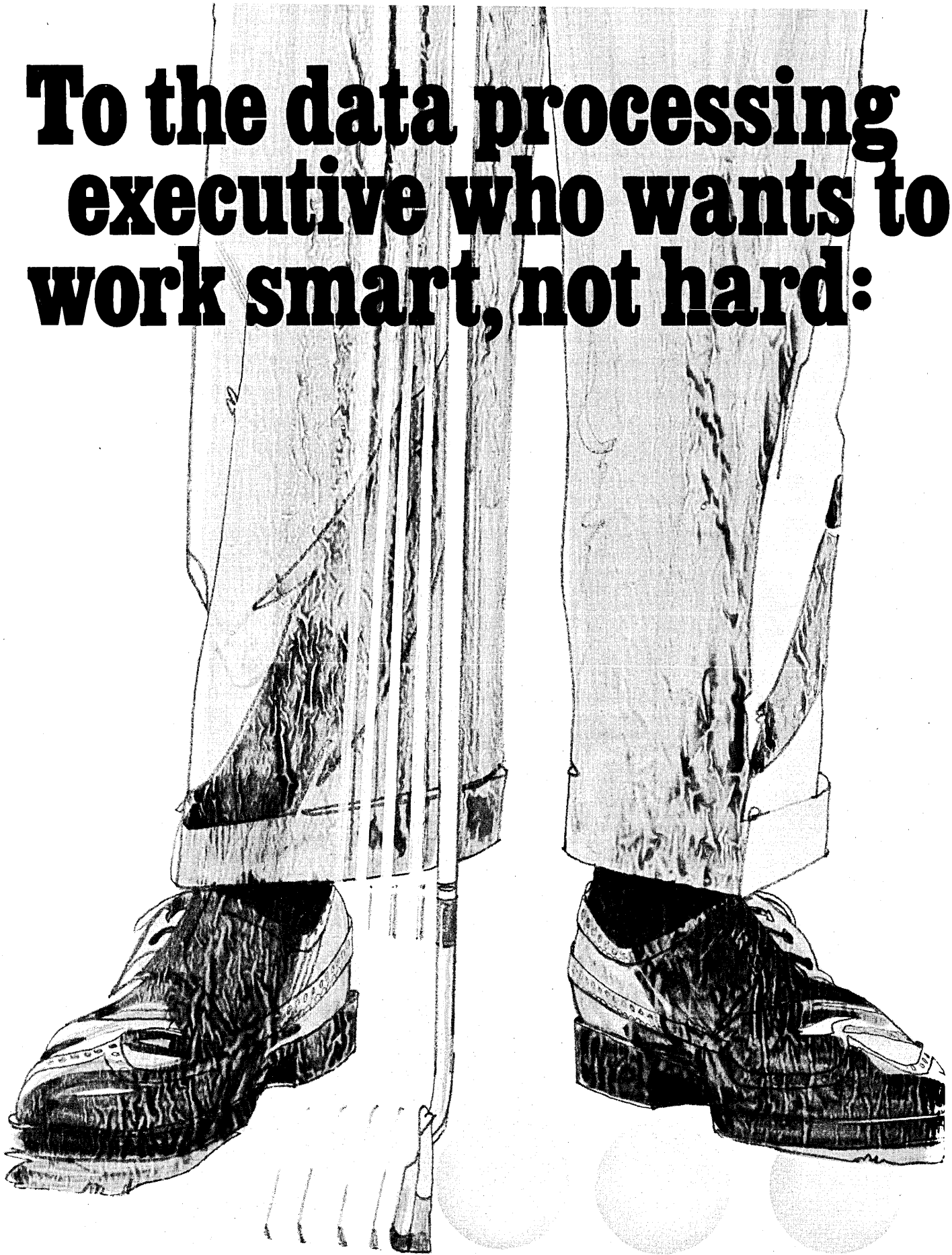

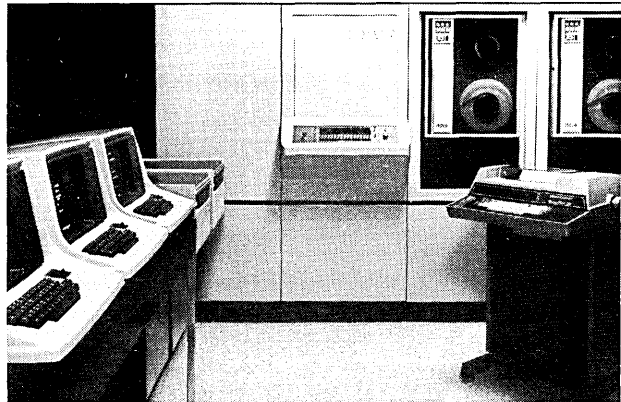

If you want to work smart, you need a computer that does the same. One that's flexible enough to do things your way.

Which means being able to run current applications written in standard languages like ANSI '74 COBOL and RPG II without a major conversion effort. And being able to develop new interactive applications with a CODASYL-compliant Database Management System.

This is the kind of computer Prime offers. A whole family of them in fact, designed to make the development and day-to-day running of interactive data processing applications easier and less costly than ever before.

They are no-risk systems that adapt easily to your established data processing standards and procedures. They can communicate directly with a wide variety of edp mainframes. They are programmed with the same languages your staff is already familiar with. And you can expand and upgrade them with incredible ease.

Typical systems for database management applications range from \$100,000 to \$350,000, or about \$2,170 to \$7,600 per month if you lease them directly from Prime. In other words, edp mainframe functionality at less than one-tenth the price.

For more information about our smart alternative to working hard, contact Joe D'Angelo, Marketing Manager, Prime Computer, Inc., 40 Walnut Street, Wellesley Hills, MA 02181, (617) 237-6990.

**PRIME**

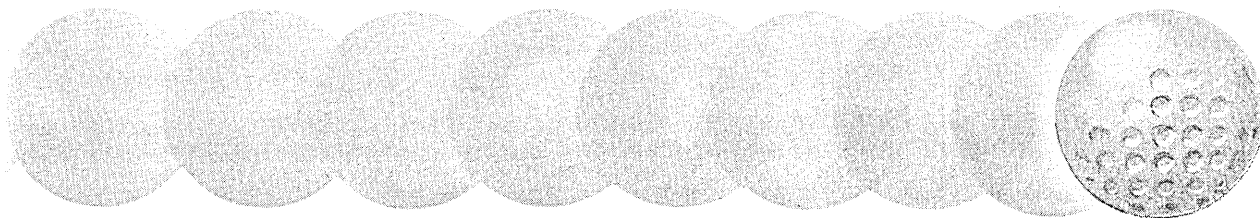

**Prime can help**

# How to distribute your data processing and decrease software & data transmission costs.

Putting a user's data base in the user's location is a great idea. But it can get expensive.

Image Systems has a new direction for Distributed Data Processing—the isi 5000, a multi-media mass storage peripheral that interfaces with your CPU or intelligent terminal network.

Up to a billion characters of data can be accessed with an 8 character code at on-line speed. Expensive core and disc storage requirements are reduced. Software is minimal. Data transmission loads are significantly less.

If you're looking at Distributed Data Processing (who isn't these days), take a good look at Image Systems' isi 5000. Call, or mail the coupon today—we'll show you how to distribute your data processing at less cost.

**Image Systems, Inc.**  
P.O. Box 2488  
11244 Playa Court  
Culver City, California 90230  
(213) 390-3378



Please send me more information:

Name \_\_\_\_\_

Title \_\_\_\_\_

Company \_\_\_\_\_

Address \_\_\_\_\_  
Street

City \_\_\_\_\_ State \_\_\_\_\_ Zip \_\_\_\_\_

Have representative call

\_\_\_\_\_ area code - phone \_\_\_\_\_

systems image systems image systems image systems image systems i  
systems image systems image systems **image systems** image system  
age systems image systems image systems image systems image syst  
image systems image systems image systems image systems image s

## DATA BASE

"Well Gardner, what do you think?" blurted Joe.

"First of all," Gardner started, "I think implementation of your idea is more complicated than you imagined. In fact, I've concluded that special software would have to be written to manage the data." A look of dejection came over Joe's face. "Don't look so forlorn," Gardner continued. "I know that sounds like bad news but on the other side of the coin, I think it may be worthwhile to develop that software. In fact, I've discussed it with some of my people and they're raring to go. All we need is management approval. You see, I think you have an idea that could actually revolutionize systems in our company.

"One of my people found that many of the data fields your two systems have in common can also be found in the customer service files and the engineering master files. And the same problem you found exists with other systems, too. You've uncovered the tip of the iceberg, so to speak.

"For example, the employee skill file and the payroll file have all kinds of duplicated information, not to mention the redundancy in many of the manually maintained files departments need because our data processing systems don't serve their needs. "You really started me thinking when you mentioned the accounts payable department manager requested a special report that required information from the inventory master file. I suddenly realized that many others in the company might be able to use information contained in somebody else's master file. That information itself could be considered valuable. Our problem is that we think of data as belonging to a using department and computer application. Instead, we should think of information as a corporate resource."

"That sounds great," said Charlie, not really understanding, or caring to understand what Gardner meant when he said information should be a corporate resource, "but tell us about the special software that has to be developed."

"Okay," Gardner continued. "You see, if you just combined the data into one large master file with the idea of sorting it into the appropriate sequence, you're going to run into a number of problems. First of all, you both are planning to eventually change your systems to an on-line operation, right?" Charlie and Joe both nodded. "Well the first thing a software package must do is store the data so both of your systems can access it at the same time and obtain the information it needs in the proper form. Even if you

didn't go on-line, you would have a problem organizing your master file, because although duplication exists, a one-to-one record correspondence between the files does not exist.

"You will have another problem preventing changes in one system from affecting the other. For example, you don't want to have to change all the programs in one system just because the size of the other's master file has increased.

"Security will be another problem. The accounts payable department won't be happy about having its data so readily accessible to other people. What I would propose to do is have my people write a software package for handling these problems and others I foresee. It would allow for storing information in what I'll call a data bank." Charlie and Joe didn't fully ap-

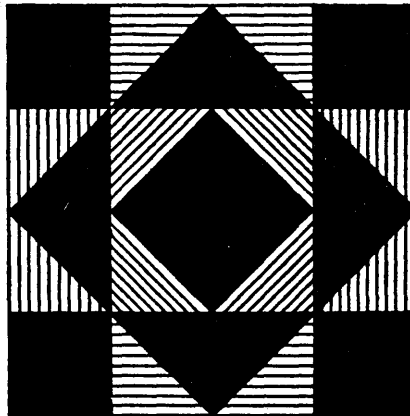

preciate all the points Gardner was making, but now they understood that the problem was more complicated than merely creating a single consolidated master file.

"Well, what's our next step?", asked Joe.

Gardner replied, "I think we should present this to Morley. He has the authority to let us proceed and will have some ideas on how to sell it to management. He's pretty forward thinking, and I'm sure he'll support us." Morley was the department manager with responsibility for both applications development and systems programming. Gardner enjoyed working for him and considered Morley the only really competent data processing manager in the firm. Though Charlie and Joe had difficulty grasping the concept of centralized data banks, Gardner was confident Morley would understand the potential.

They met with Morley the following day. Charlie and Joe explained the background carefully, omitting the data discrepancy part of the story. Gardner then explained his ideas, the potential he saw for revolutionizing systems in the company, the need for a software system to manage the data, and his manpower estimates for developing the software.

Gardner was right. Morley's eyes lit up and he understood what Gardner was getting at almost immediately. One of his major concerns was that top management viewed data processing as simply a method for reducing "general and administrative" expenses. Computers did not help them make the critical decisions that are vital to the company's success. Top management's general view was that if the computers weren't here, the only real effect on the company would be that there would be a lot more clerks with eyeshades running around. One of Morley's concerns was that before long, there wouldn't be any more clerks with eye-shades to replace. If that happened, the status of dp in the organization could drop even further.

Now Gardner, with Charlie and Joe, was proposing a whole new way of looking at data processing. If the vital information in the company somehow could be stored in centralized data banks, all kinds of possibilities opened up for inserting data processing into the firm's decision-making process.

Morley recalled his own ill-fated attempt to develop a corporate financial model that suffered from the inability to obtain accurate and timely data. The one thing that experience did teach him was that management was amenable to such applications. If someone could develop a better way of helping them run the business, they would be willing to spend the money required to develop that capability, even though the benefits could not be quantified in dollars and cents.

Morley gave Gardner, Charlie, and Joe the go-ahead. He proceeded to sell his management and the using departments that initially would be affected. An early decision was to concentrate first on the original idea of combining the accounts payable and inventory control systems. Gardner and his people, however, set out to develop a generalized software package that could be used for combining other applications.

Shortly thereafter, Gardner received a promotion to a position outside data processing. A few years later he was transferred to the company's European subsidiary for a two-year tour of duty. During that time he wasn't able to stay abreast of the corporate data bank project, but he did read the various articles that could be found in management-oriented publications on what was being called data base instead of data bank. These articles made him proud that he had been instrumental in what appeared to be a significant advancement in data processing. Occasionally, he received miscellaneous reports and letters from his old dp department that made it clear that the



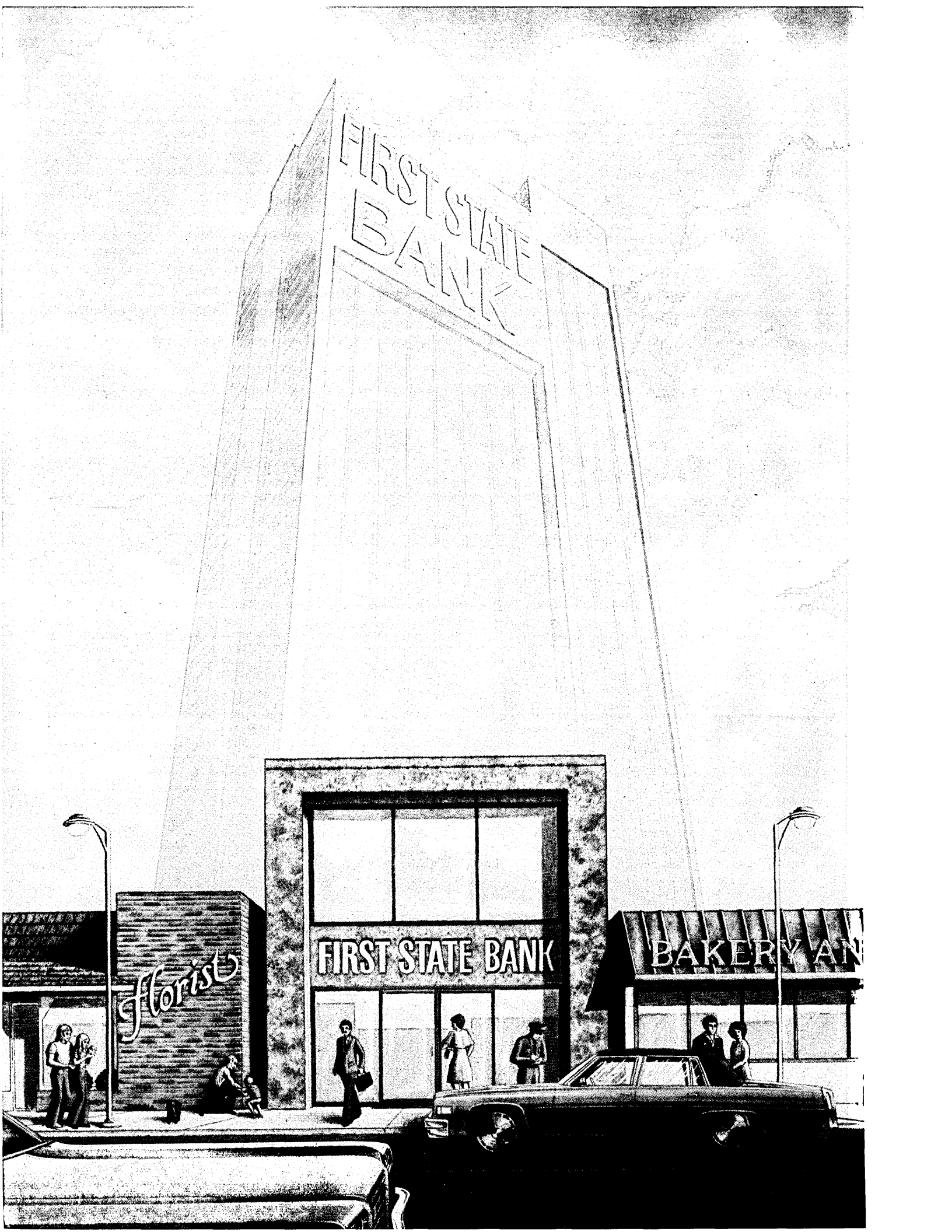

FIRST STATE  
BANK

FIRST STATE BANK

Florist

BAKERY AND

# Banking software that will go with you into the future.

That's because all UCC banking software packages are programmed for growth. And in the banking business, if you're not growing, somebody else is. Probably at your expense.

UCC banking software packages are as complete, as flexible, and as advanced as any on the market today. That will be just as true tomorrow, too; because UCC backs all its software with continuing in-depth support and regular enhancements.

For more information, call us toll-free at 1 (800) 527-3250 (in Texas, call 214-688-7313). We've already helped over 700 financial institutions prepare for the future with packages like:

*Central Information File (UCC/CIF).*

Provides a complete picture of each individual customer's activity and, thus, the total profitability of each total customer relationship. Can be integrated with UCC's Asset Card Management and Customer Transaction System to control multiple card classes and support on-line, unmanned teller devices. Circle 130.

*MICR capture/reporting system (UCC/MICR).*

The most complete, flexible and efficient MICR system in the industry. Supports 1419, 2956, 3890 sorters and the TRACE® system under DOS and OS. Circle 131.

*Financial Control System (UCC/FCS).*

Complete general ledger, responsibility reporting, cost accounting and funds evaluation

capability. Over 600 institutions are already using this important financial management tool. Circle 132.

*Commercial Loan System (UCC/CLS).*

A flexible, end-user oriented system that produces accurate, up-to-date information on the bank's commercial loan portfolio — including daily accrual, prime rate revisions and effective date posting. Circle 133.

*Instalment Loan System (UCC/ILS).*

The only single system that processes all six different types of consumer loans. And it only takes one system to set-up the loan, accept and apply payments, calculate additional charges (late, extensions, insurance), and produce both operating and management reports. Circle 134.

*"The Bill System™"*. A complete pay-by-phone package that allows the bank's customers to pay their bills by telephone. The software runs on the host computer and provides fully automatic handling of transactions from both Touch Tone and rotary telephones. Circle 135.

*Operating Software.* A broad line of systems software for Tape Management, DOS under OS operation, Disk Management, PDS Space Management, IMS Data/Dictionary Management, and Job/Recovery Management. Circle 136.

In over 2,500 installations around the world...

## We're helping people get more out of computers.

**UCC**

USA: P. O. Box 47911 • Dallas, Texas 75247

Canada: 101 Duncan Mill Road • Don Mills, Ontario M3B 1Z3

TRACE® is a Registered Trademark of Recognition Equipment Incorporated.

Member SIA  Software Industry Association

## DATA BASE

data base philosophy had taken over.

When his European assignment was over and Gardner was transferred back to corporate headquarters, he made it a point to visit the data processing department. He wanted to discover first hand the progress they were making toward developing a corporate data base.

As he walked into the department he first ran into Joe.

"Hi Joe," Gardner greeted him. "How are things going?"

"Fine Gardner, it's nice to see you," replied Joe.

"How is your data base coming along?"

"Well overall pretty well, except for a few software problems we've had converting to a new version of our data base management package. About three years ago we found it was too costly to maintain the software package your department developed because equivalent packages were commercially available at a reasonable price. The only mistake we made, I think, was that we haven't standardized on one package. For example, Charlie, who is now the data base administrator for the inventory control data base, uses different software than we do with the accounts payable data base."

Gardner was startled. "Are you saying that the inventory control data base and the accounts payable data base are separate?" he asked. Joe nodded affirmatively. "How can that be? The whole idea in the first place was to combine them into a single data base. If they're separate you're right back to where you were years ago. What happened?"

"Oh, we gave up on that idea years ago," Joe replied. "We had too much trouble with the users. Soon after we launched the system the accounts payable department wanted to expand the vendor classification code to include a credit rating. There were a lot of good reasons for doing it, but the material control people wouldn't agree. Their people were used to the old code, and they'd have to change their forms. They just weren't going to go along with it. I was the data base administrator but I didn't have the power to control either user. We ended up putting in two codes, one for each department. We continually had similar problems until we just gave up. Well, I'd like to talk to you longer but I have a meeting to attend." With that Joe rushed off leaving Gardner visibly shaken. Gardner headed for Morley's office.

He found Morley in his office and after exchanging greetings mentioned the conversation he had had with Joe.

"What happened, Morley?" It sounds like you're right back where you were years ago except that you're using more exotic and expensive software to access the data."

"Well Gardner, that's not quite true," replied Morley. "The new data base software packages have on-line query facilities that give us a capability we didn't have before, but other than that, you're right. We haven't progressed much. In fact when you consider the added machine overhead and cost of the data base software, we may have regressed."

"Joe described a problem you had with the vendor classification code. Was that typical?" asked Gardner.

"Gardner, that was just one of many, many problems. We had cases where the accounts payable department was pressured by their management for reports that required data that was controlled by the material control department. The material control manager refused to work the extra overtime required because they were already over their overtime budget and had their own priorities to worry about. Well, you can imagine the frustration that created in the accounts payable department. Instances like that forced us to split the data bases."

"Where did we go wrong?" Gardner asked, though he almost knew the answer.

Morley replied. "We completely underestimated the people problems involved in establishing a data base. Users think of the data associated with their application as their data. You don't just appoint a data base administrator and eliminate those feelings. The psychological ties are too strong. Instead of being concerned with these problems, we got all wrapped up in the technical detail associated with setting up a data base. We concentrated on things like network vs. hierarchical structure, inverted lists, and audit trails. We should have concentrated on the organizational aspect of the problem."

"What about all the other data bases you have around? Did they have the same problem?" queried Gardner.

"No," answered Morley, because none of them are integrated data bases in the way you and I think. You have to understand that data base has become the "in thing." People are using data base management software where they used to use sequential or direct access methods. Otherwise the applications are no different than they used to be. In fact, some of the so-called data bases we have don't even use data base software. They just started calling their old files data bases. One of the other managers here takes pride in the fact that he has installed thirty-seven different data bases. Sometimes it gets

quite humorous to watch. I've sat in meetings where they argue about data base administrator job responsibilities. Because they don't have a true data base they don't need one. Yet they read that they do need one. They end up defining a job that sounds suspiciously like a systems programmer."

"What about other companies?" Gardner asked. "Do they have the same situation?"

"I've been attending manufacturer user group meetings for the past few years," replied Morley, "and I've made it a point to find out what others are doing. Surprisingly, many are just like us. Occasionally I run into someone who is developing an integrated data base system. Almost always they are the ones who talk about the data administration problems rather than the technical software problems. But we are definitely not alone."

"Have you given up hope?" Gardner asked.

"No, the potential of what we are trying to accomplish is too great. I still have dreams that data processing can become an essential part of the company's decision-making process. That true company-wide information systems can be developed using the data base approach. But we are going to have to stop devoting 95% of our resources to the technical data base software details because that's only 10% of the problem. We have to think of data base as a systems philosophy, not a technology."

As Gardner left, he wondered whether he was part of the biggest hoax ever perpetrated on data processing, and whether there were enough Morleys in the world to turn the situation around. \*

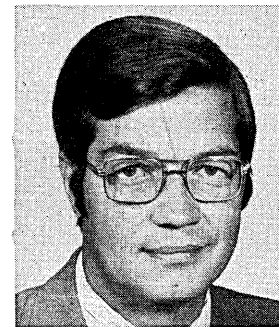

Mr. Sobczak is a member of Ford Motor Co.'s corporate systems staff where his responsibilities include advising company systems activities on data base matters. Previously, he managed the development of several data base applications, and also worked as an internal management consultant. His experience includes a variety of data processing assignments with emphasis on hardware and software planning and systems performance evaluation.

# DP Dialogue

Notes and observations from IBM that may prove of interest to data processing professionals.

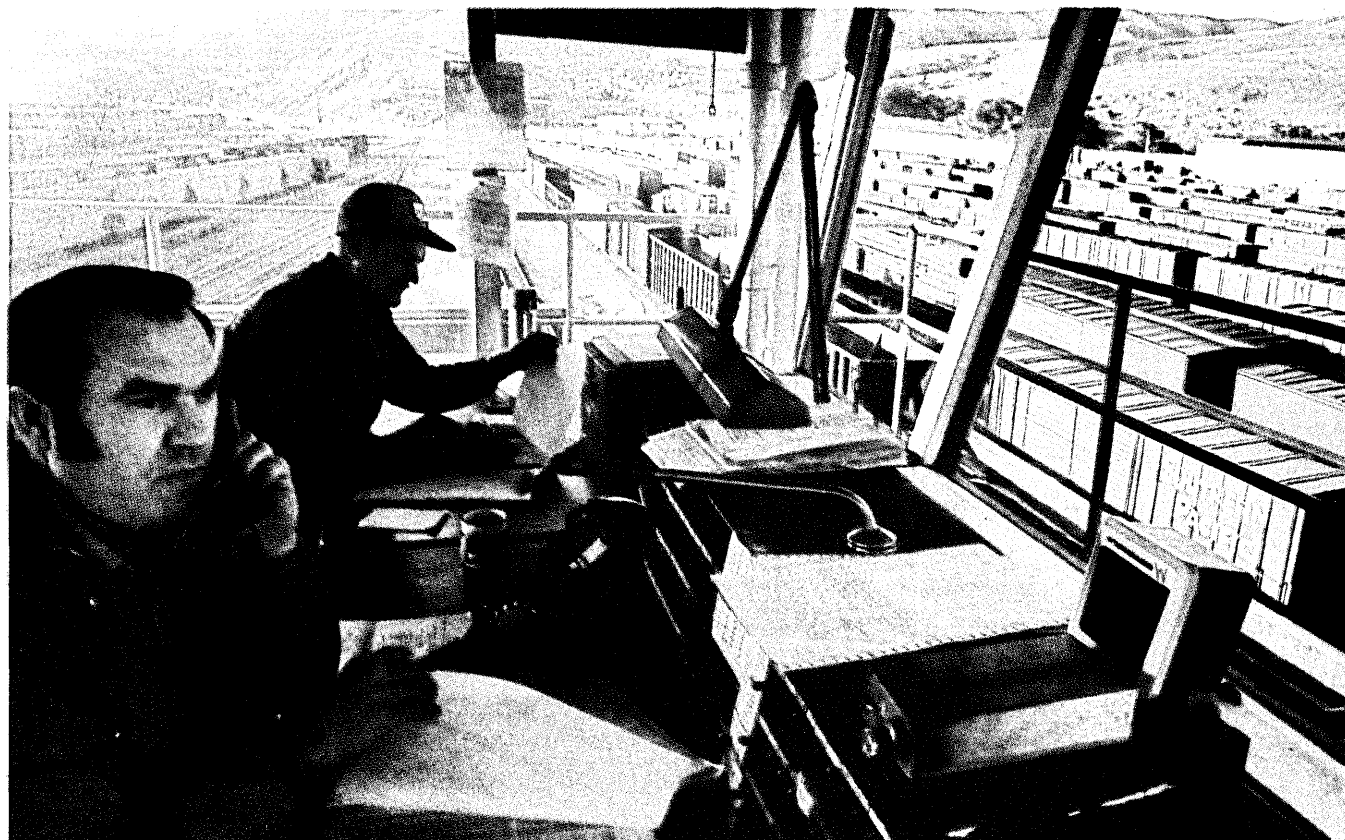

*TOPS supports freight car classification at Southern Pacific's Bayshore Yard, just south of San Francisco. Data on car movement is supplied by 545 terminals linked by telephone and microwave to dual IBM computers.*

## TOPS Saves Southern Pacific \$6 Million Yearly

The Total Operations Processing System (TOPS) of the Southern Pacific Transportation Company keeps track of the 100,000 freight cars that roll over 13,445 miles of railroad. According to railroad president Denman K. McNear: "TOPS is producing tangible recurring savings of \$6 million annually."

Terminals in switchyards throughout the vast rail system supply data on car movement to TOPS' dual System/370 Model 168's in Southern Pacific's San Francisco headquarters. From there, TOPS assigns cars to shippers, directs their movements and stores each car's current location. As a train approaches a switchyard, TOPS transmits the "consist": a listing of all cars, their contents, destination and special handling instructions. From this, yard men create a track

list which directs switching operations. When a departing train has been assembled, its new consist is transmitted to TOPS.

"We've been installing programmable units of the IBM 3770 Data Communication System at our terminal locations," says J.W. Germany, vice president of management services. "We can perform local switchyard data processing functions as well as computer input-output on the 3770. This integration has speeded up operations in the yards and cut down on errors."

"Overall, there has been no increase in our hardware costs, and TOPS data is more current. The higher data rates of the 3770 make better use of our communication links, resulting in further direct savings.

"The 3770 has opened the way for continuing enhancement of TOPS. We are currently running a pilot project in which we eliminate the paper waybills which accompany all freight cars. Instead, TOPS supplies required waybill data through the 3770 system."

"This is a substantial change in how we operate, and it holds a lot of promise. We're projecting important gains in personnel productivity, customer satisfaction, cash flow, error control, and shortened time from completion of movement to rendering of the bill."

Adds railroad president McNear: "The TOPS data base has made possible online inquiry of car location for shippers. And it permits better planning and better reporting on all levels of management."

# Networking Extends the Reach of Computers

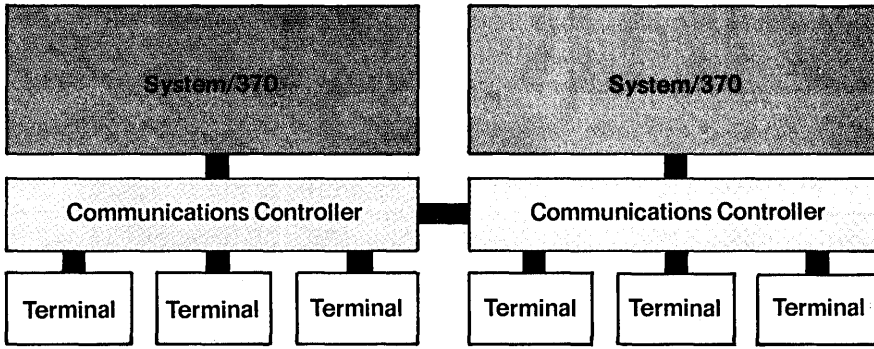

The engineer, visiting corporate headquarters, has a sudden requirement for a mathematical routine resident in a plant computer many miles away. He sits down at a terminal in headquarters—one which normally accesses business applications in the corporate computer—and logs on just as if he were at the plant. The local system senses that he is requesting a program available only at the plant, and routes his request to the computer there.

Similarly, a headquarters visitor to any company location with a terminal can as easily establish a link with an application in the corporate computer.

This mode of computer use is a feature of *networking*, and now a new form of networking is available from IBM under Systems Network Architecture (SNA). Called Advanced Communication Function (ACF), it includes enhancements to both the Virtual Storage operating systems for System/370 and the Network Control Program for the 3705 Communications Controller.

The 3705 can automatically switch a service request at any terminal to an application in any computer in the network. This action is “transparent” to the user, who sees a “single system image” and is not aware of or concerned with the

computer to which his work is routed.

ACF provides an architecture which lets the user specify recovery procedures, switching rules, the Initial Program Load (IPL) sequence, emergency reduced-service operation, and communication to and from operators. This structure is provided by the Network Operation Support Program (NOSP)—a programming mechanism by which the user enters his own decision rules and priorities.

Networking with ACF offers great advances in reliability, availability, and cost/performance. Idle capacity can be put to use quickly since a new application can be installed wherever there is room for it. And ACF can greatly improve the economics of such general applications as text processing and interactive training systems, by making them widely available through existing terminals. Similarly, more terminal sites become economical, since each can access more applications.

Tying computers together in a network makes their power more accessible, reliable and economical. It extends their reach to more users and into new application areas.

## Computer Model Throws Light on Solar Energy

Converting the sun's radiant energy directly into electricity could contribute significantly to the world's supply of energy. But the associated technical problems are complicated enormously by the fact that the sun's direct radiation is not the only important energy source.

A very significant portion of the energy of the sun is reduced in strength before it can reach the surface of the earth. This visible and invisible light is absorbed and scattered by the atmosphere—its water droplets, dust particles and gases—and the scattered radiation arrives at a solar cell along a nearly infinite number of indirect paths.

At the surface of the earth, explains Dr. J. V. Dave of the IBM Scientific Center in Palo Alto, California, such indirect radiation can range as high as 40 percent of the total energy on sunny days, and 100 percent on mildly overcast days. A system utilizing all available radiation, he points out, can lead to a more efficient harvesting of solar energy under average conditions as encountered at various feasible locations.

Using the computer, Dr. Dave is experimenting with a solar energy model to get a better picture of the total radiation energy arriving at the earth's surface.

“We live at the bottom of a very complex atmospheric soup,” he notes,

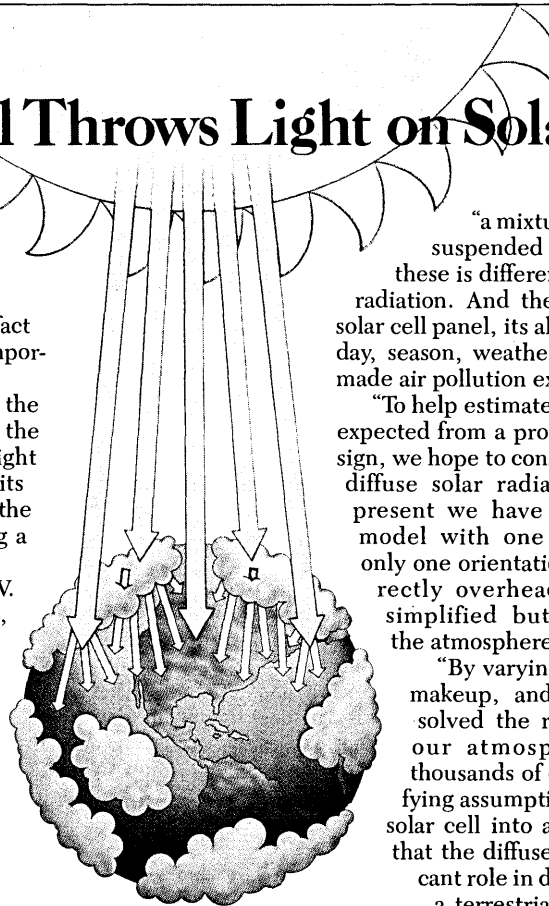

*Important amounts of solar energy reach the earth's surface indirectly, after dispersion in the atmosphere.*

“a mixture of gases, water droplets and suspended particles. The effect of each of these is different for each wavelength of solar radiation. And the geographical location of the solar cell panel, its altitude and orientation, time of day, season, weather and natural as well as man-made air pollution exert an influence.

“To help estimate the energy output that can be expected from a proposed solar energy system design, we hope to construct a computer model of the diffuse solar radiation in the atmosphere. At present we have completed an experimental model with one simplification: it considers only one orientation of the solar cell—aimed directly overhead, at the zenith. It uses a simplified but realistic representation of the atmosphere.

“By varying the time of day, atmospheric makeup, and other parameters, we have solved the radiative transfer equation for our atmospheric models for several thousands of data points. Taking our simplifying assumption about the orientation of the solar cell into account, these results indicate that the diffuse radiation plays a very significant role in determining the performance of a terrestrial solar cell. We are now planning for the radiation modeling for an arbitrarily oriented solar cell which requires several million data points.”



# OLIS: A Powerful New Tool for Legislators

In the Oregon State Capitol Building, in Salem, a Senator or Representative can step up to an IBM 3277 Display Station and learn the detailed status of any of thousands of bills pending before the state legislature: what committees have held or will hold hearings on it and when; what recommendations they made; how and when the bill was amended or otherwise acted on in each chamber; and when it will be called up for action again.

This information, referred to as Measure Status, is stored in one of two data bases included in the Oregon Legislative Information System (OLIS), an on-line computer system.

The Measure Status subsystem helps schedule and manage the business of the legislature. It is used to generate daily and weekly Legislative Calendars with details of past and future activity on every pending bill, in committee and on the floors of the two houses.

"Without Measure Status," says Jason D. Boe, president of the Senate, "we would be hard pressed to keep track of the workload, to organize proper consideration of all the important legislation that comes before us. The computer is the ultimate legislative tool."

Adds William Stow, director of OLIS: "During the 1975 meeting of the legislature, the Measure Status subsystem was one of the factors that enabled the presiding officers to shorten the session to 153 days, compared to 180 in the previous session, despite a rise in the number of submitted bills from 2303 to 2449."

The other OLIS data base contains the complete text of the body of state law, known as the Oregon Revised Statutes (ORS), and the complete text of all measures pending before the legislature.

By means of this data base, members of the legislature's staff can edit and proofread statutory language, working directly at 3277 Display Stations, entering all amendments to each bill as they are proposed.

To maintain this data base in the IBM



*Prior to a session of the Oregon State Senate, staff aides Marcella D. Green and Gladys Johnson can check the status of pending bills, accessing the OLIS data base at an IBM 3277 Display Station in the Senate chamber.*

System/370 Model 158, OLIS uses IBM's Advanced Text Management System (ATMS). Each new bill is entered via the keyboard of a 3277 Display Station or by means of an IBM Communicating Magnetic Card (CMC) Selectric Typewriter which can operate online, entering text directly, or off line, accumulating text on magnetic cards for later entry.

Some executive branch agencies have begun submitting bills already recorded on magnetic cards, which also serve as backup to the online data base.

ATMS permits material to be in-

serted, altered or deleted without rekeying of surrounding material, and with automatic renumbering of paragraphs and sections. For the 70 percent of all bills which revise existing statutes, ATMS serves to incorporate the unaffected language into the bill, avoiding manual entry and proofreading of this material.

A Text Retrieval subsystem of OLIS, based on IBM's Storage and Information Retrieval System (STAIRS/VS), is used for retrieving statutory material from the data base. It displays the desired portion of any statute, selected by subject matter or by key words in any combination.

At the end of each legislative session, the ORS must be set in type in its new form and printed. In recent years, as the legislature accomplished more work in each session, manual methods of typesetting and proofreading had begun to prove inadequate; the time required to prepare the ORS for printing had stretched into months, and the cost had mounted steeply.

Now, at the end of a session, ATMS is used to incorporate the new and amended laws into the ORS, to generate a new ORS index, and to prepare for the required biennial printing of the ORS.

OLIS uses TERMTEXT/Format, an IBM program, to prepare material for the phototypesetter. Non-printing format-control characters in the text indicate to TERMTEXT/Format the required column width, type size and font, page and in-text numbering systems, page top and bottom matter and similar format details of the printed document.

"ATMS and TERMTEXT/Format work beautifully together," Stow says. "They were simple to incorporate into OLIS and they produce complex finished documents, remarkably free of errors, with very little wasted effort at the keyboard."

"After the session," he notes, "the ORS was printed earlier than ever before. And the cost was \$300,000 less than our best proposal from a private company using phototypesetting."

## Software Products from IBM

Three products available from IBM extend the power of data processing systems:

1. **Teleprocessing Network Simulator (TPNS)** enables test and load measurement of terminal-oriented programs prior to installation of terminals.

2. **Conversational Monitor System (CMS)** provides the full spectrum

of IBM interactive computing capabilities under Virtual Machine Facility/370 (VM/370). Supports both program development and personal computing.

3. **Advanced Text Management System II (ATMS II)** is a conversational system that permits a terminal user to enter, edit, store, format, proofread and display textual material.

*DP Dialogue is designed to provide you with useful information about data processing applications, concepts and techniques. For more information about IBM products or services, contact your local IBM branch office, or write Editor, DP Dialogue, IBM Data Processing Division, White Plains, N.Y. 10604.*

# IBM®

Data Processing Division



# Easy Access ... Fail-Safe Indexing Plus Data Protection.

The Flex 80A... the flexible storage module for all floppy systems. Available at your data processing dealer or office supply. Capacity: 50 disks with envelopes.

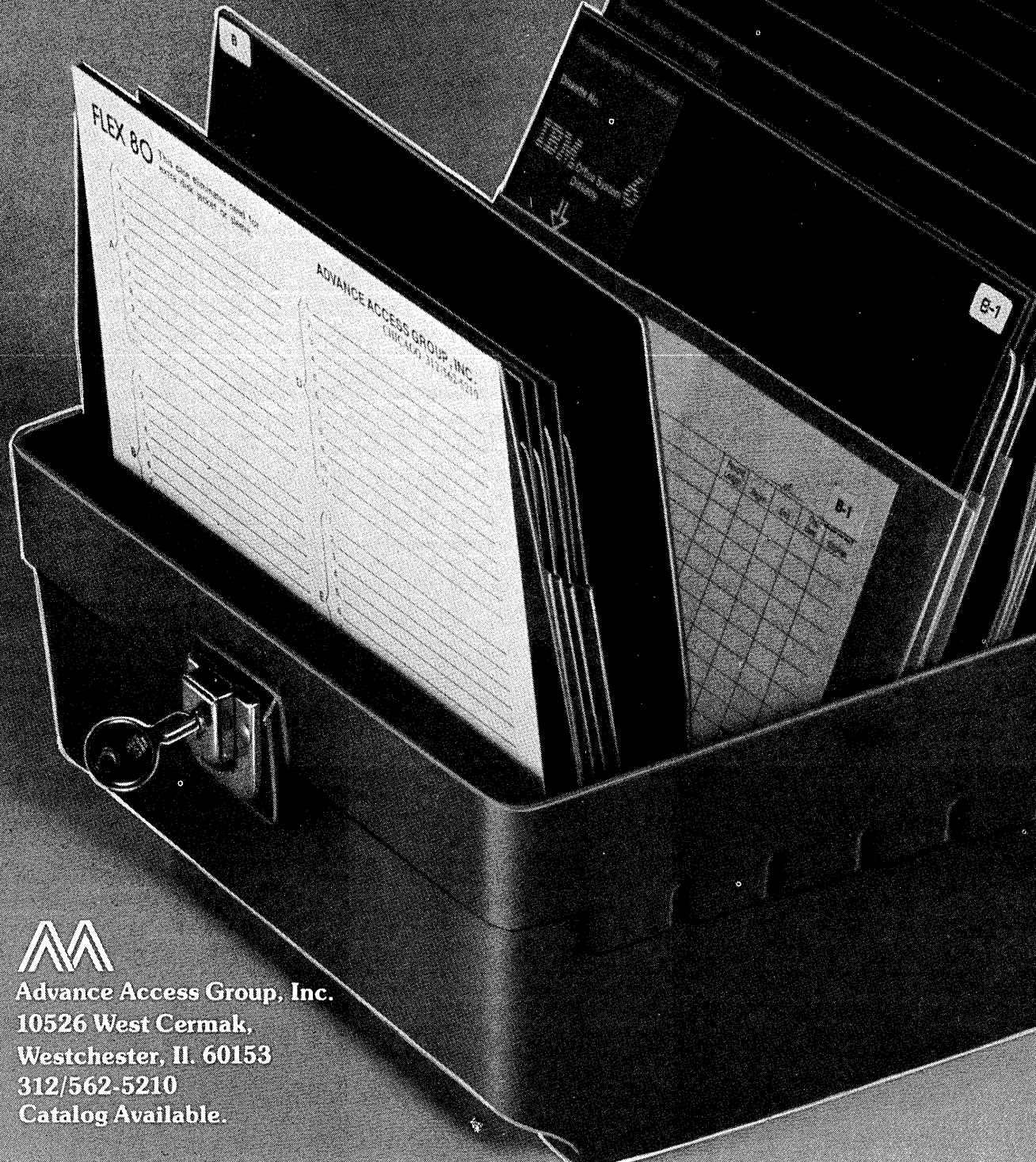

Advance Access Group, Inc.  
10526 West Cermak,  
Westchester, Il. 60153  
312/562-5210  
Catalog Available.

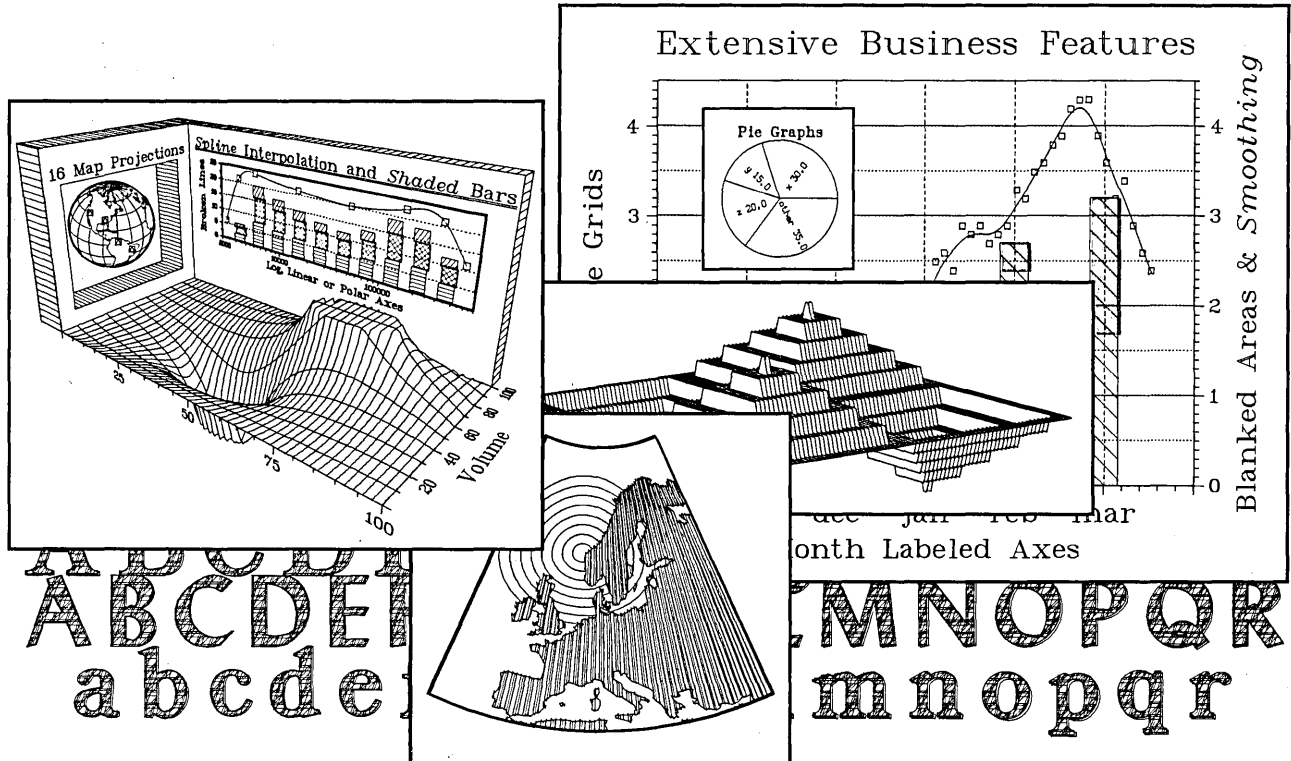

# DISPLA Speaks For Itself.\*

## MACHINE INDEPENDENT

DISPLA is now working on : IBM 360/370 ; CDC 6000, 7000 and Cyber 70 series ; UNIVAC 1100 series ; PDP 10 and 20 ; XDS Sigma 9 ; Honeywell 6000 series ; and Burroughs 6700.

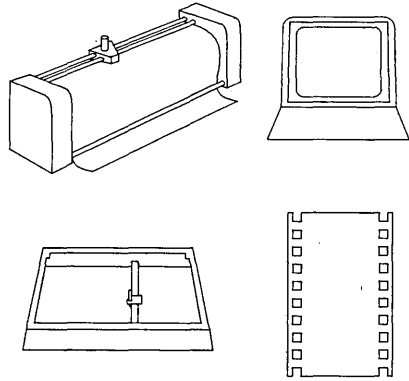

## DEVICE INDEPENDENT

DISPLA plots on Calcomp, Gerber, Houston Instruments, Hewlett Packard, Broomall, Xynetics and Zeta plotters ; BETACOM, SC4020 and SC4060, FR80, and Singer microfilm recorders ; Computek, Vector General, & Tektronix CRTs ; and others.

## EASY TO USE

DISPLA is a powerful system of FORTRAN routines called from the user's application program. DISPLA is to the basic plotter software what FORTRAN and COBOL are to Assembly Language.

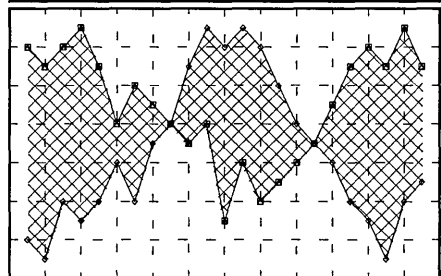
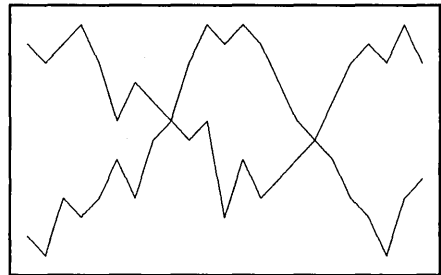

DISPLA transforms boring plots into exciting textbook masterpieces.

## WIDE USAGE

DISPLA has been in use more than seven years, and now in more than 100 installations in the U.S. and Europe. Ask us about our users.

## DISPLA

Display Integrated Software System and Plotting Language

For more information call : Sunny Harris (714) 452-0170 or (714) 565-8098 or write :

## ISICO

Integrated Software System Corp. 4186 Sorrento Valley Blvd., Suite G San Diego, California 92121

In Europe contact Repko van Blankenburgstraat 58 The Hague, Holland Telephone 070-608425

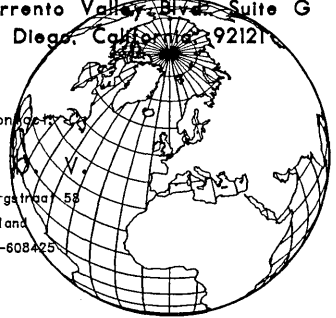

\*This entire ad is a plot produced by DISPLA on a 3-pen plotter.



# United Brands had an idea for delivering financial reports as fresh as their foods...

Foods and financial data have at least one thing in common.

Both are highly perishable. So unless they're delivered quickly to the customer, they soon lose their appeal and their usefulness.

As a leading international producer, processor and distributor of foods, including Chiquita\* Bananas, John Morrell\* Meats and A&W\* Root Beer, United Brands Company, and its subsidiary companies, depend on the freshness of its food products.

And, as the world's leading supplier of commercially available computer services, General Electric Information Services' reputation depends

on the freshness and immediacy of the data it provides to more than 5,000 companies around the world.

## **GE and Falcon replace manual system**

So when United Brands wanted reports faster, and more easily produced than those delivered by the existing manual methods, their idea was to upgrade to a proven automated system.

General Electric computing services and FALCON, an automated management reporting system, proved to be the best solution.

Developed by a major international accounting firm and

available exclusively on General Electric MARK III® Service, FALCON consolidates reams of financial and operating data from United Brands' 145 worldwide subsidiaries.

## **Complex reports easier to produce**

FALCON then automatically accumulates data, balances it, and delivers a wide variety of reports to United Brands management. These include financial statements, as well as information needed for tax returns, SEC and other government reports.

The combination of FALCON and General Electric computing services

\*Registered Trademarks of United Brands Company



## General Electric computing services helped bring it to reality.

has performed so successfully that United Brands is adding a companion system called FORECAST, which provides pro forma financial statements using the FALCON database to attempt to predict future financial positions.

### Computing services... think of the possibilities

Thousands of major companies in practically all industries have discovered that General Electric computing services can provide a good business solution to many of their information/data processing needs. Whether they use one of the hundreds of our standard programs, or have GE completely design

a customized system, they can rely on the computer power of GE MARK III Service for such tasks as economic analysis and planning, order service, cash management, budgeting, profit planning—and much more.

To see how other managers have harnessed the power of MARK III Service to their ideas, drop us a note on your company letterhead. We'll add your name to our award-winning executive magazine, "LEADER", and forward you a current issue. Write to: Roger Hobbs,

General Manager, Sales Department, General Electric Information Services Division, 401 N. Washington Street, Rockville, Maryland 20850.

And, the next time you have an idea that you'd like to bring into sharper focus, give our local GE Information Services Branch Manager a call. He can marshal all the people, programs, network, and computer power you need to help you make things happen. 291-17A



GENERAL  ELECTRIC

# New disk drive packs 10 Megabytes in unit one-third the size of conventional drives.

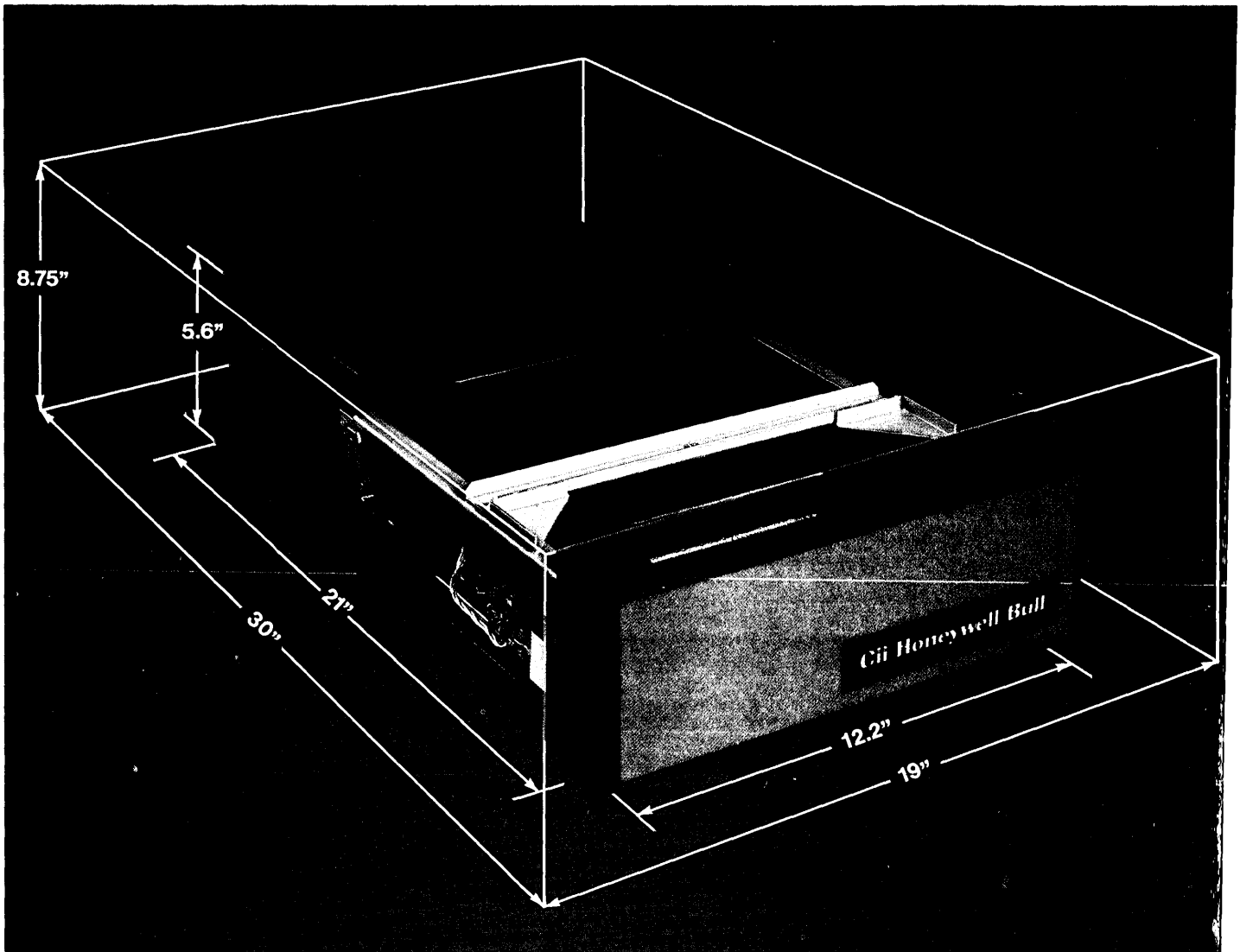

OEMs and systems builders will want to take a hard look at this new D120 MidiDisk drive (the first of a family) that combines large disk state-of-the-art technology in an unusually compact package.

Its performance advances include:

**Operating Versatility.** Three D120 units can be mounted vertically in a 19-inch rack. A table-top version is available also.

**New Midi-Cartridge.** The D120 uses a flat, ultra-thin midi cartridge which measures only 11" square, is less than one inch thick, and weighs only 2.8 pounds.

**Speed.** A fast 920 kilobytes per

second. (Densities of 4,750 B.P.I., and 500 T.P.I.)

**Accuracy.** Data-imbedded, servo-tracking techniques for head positioning eliminate the need for a transducer, thermal compensation, or head alignment techniques. This simplified mechanism rules out any need for preventive maintenance.

**Power Savings.** The midi cartridge is self-ventilated (operates at 3600 rpm). No air blower is required. (After startup, total power consumption is only 100 watts.)

**Reliability.** The spindle is an integral part of the brushless dc motor. There are no belts or pulleys, no

electronic/mechanical adjustments to make. And head loading is controlled automatically to prevent damage in the event of a failure.

**Available:** Controllers for industry-standard microprocessors.

For price and delivery information, contact: **In North America**—Jean-Paul Garodel, Honeywell Information Systems, 200 Smith St. (MS 464), Waltham, Mass. 02154. 617/890-8400, x 2019.

**In Europe**—Alain Kiffer, Cii Honeywell Bull, 6 Avenue des Usines, 90001 Belfort, France. (84) 228200.

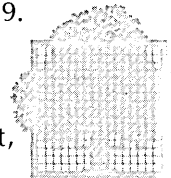

**Cii Honeywell Bull**

# Terminal Distributors: "Our Most Important Asset."

by Vin McLellan, Boston Bureau Manager

There are plenty of deals to be made as they slash prices to achieve big vendor discounts.

Wall Street doesn't like them because they don't manufacture anything; users describe them as slick, aggressive, but helpful with both pricing and the choice of the mix-and-match terminal systems; manufacturers find them sometimes insolent, often awkwardly independent, and occasionally brazen enough to sell a terminal system head-to-head against the manufacturer's own end user salesmen—and skilled enough in the arcane arithmetic of averaged discounts and lease accounting to do so successfully.

They call themselves terminal system dealers or distributors, and manufacturers call them independent "retailers" or "resellers." Their lineage goes back to the Teletype leasing warehouse speculators of the early '60s. They've been the major actors in the fierce price cutting that has reshaped the market for teleprinters—and as the spoor of a price war in CRT's becomes overwhelming, there's little doubt that they'll be in the front of the fray. They've evolved into an increasingly important middleman in the terminal industry as the cost of establishing nationwide sales and support organizations rises enormously, particularly for the growing number of smaller manufacturers who need but can't afford such expensive services.

These firms lease, rent, and sell (and the spectrum of them is perhaps best represented by the nearly 100 resellers who market Digital Equipment Corp.'s DECwriter line). All prefer to lease, of course, because that gives the compounded yield, the big payout over time. But financing is tight and lease capital requirements high, so throughout the industry it's common practice to finance the leases you can afford—and then sell for whatever you can clear on a tight price-cutters margin, or simply to turn over volume to make a pledged sales goal: to "wholesale" or sell cheaply at or above cost, preferably outside the seller's chosen market area.

## Price-cutting is rampant

The economics of lease financing

and manufacturers' volume-based step-discount schedules have made wholesaling inevitable, and while virtually everyone involved curses the price-cutting rampant in the market, it's not without a certain degree of hypocrisy, since virtually all parties aid and abet. The math is simple: with volume discounts, price-per-unit drops as resellers take more units, and any



**WILLIAM CHALMERS:** DEC's terminal product manager says resellers are very important and "I have to learn to live with them."

reduction of price that can be factored into terminal leases has a multiplied or leveraged effect on lease payout. Terminal lessor-resellers are constantly striving for volume to reach the higher discount level. As a caution to resellers, though, the manufacturer retains a "billback option." If the reseller doesn't turn over promised volume, he is charged retroactively for the difference between the volume-discount price he claimed and the higher price his volume deserved. It's a sure-fire formula for a high volume, bitterly price-competitive market.

## Perfected the system

The company that perfected this system and evolved the most sophisticated techniques to exploit it has been Digital Equipment Corp., the Massachusetts-based minicomputer giant that has moved into terminals with phenomenal success. DEC jumped into the medium-range teleprinter market a mere three years ago; now it has a \$100 million sales operation, and the DECwriter II, a 30 characters per second serial impact teleprinter, is the standard of challenge in the industry. This year DEC begins shipping its third generation machine, the programmable DECwriter III. Wall Street sources close to the company gleefully report that Digital expects to have no difficulty selling 100,000 terminals in fiscal 1978.

The first DECwriters were introduced in 1974 into a virtually moribund market that had been locked into Teletype's 10 cps, 110 baud format. By January 1975, when it introduced the DECwriter II, it had redesigned the unit to tailor it for the reseller-leasor market, using a modular, option-upgradable architecture. By early 1976, DEC had completed a crash program to develop data communications options, and sales soared. The redesign of the machine had complemented the marketing strategy, which focused on catalyzing a vigorous independent reseller network: DEC offered the highest reseller discounts in the industry, and still does, but it also promised not to lease or rent against the resellers, and never to sell to anyone in less than 50 unit volume.

## It's the only game in town

"People had been out there with the old Teletype KSR 33s whacking away at 10 characters per second, and all of a sudden along comes the DECwriter at 30 cps. Cheap, reliable—it became the only game in town," ruefully acknowledged Centronics product manager Fred Graham. Centronics' new model 761 will join new units from Teletype and Texas Instruments in a direct attack on the DECwriter market this year. But, ad-



# Remex launches a PDP-11 floppy disk system with above DEC performance

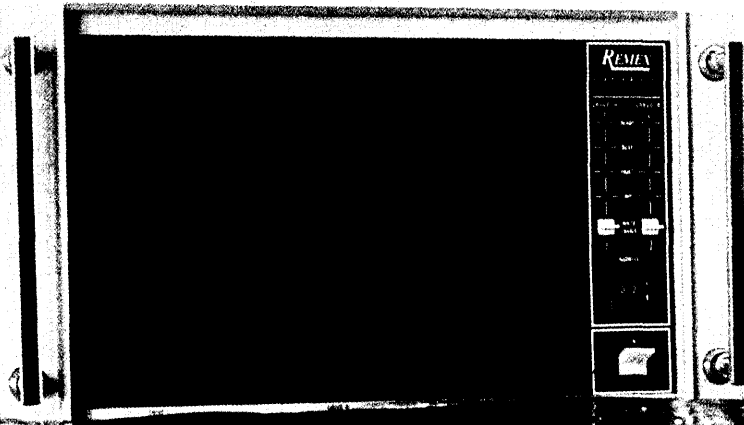

It's an integrated hardware/software system so compatible with DEC's RT-11 operating system that we named it Remex-11.

It connects directly to the PDP-11 or LSI-11 bus, offers about 25 percent greater storage capacity than Digital's RX11 disk system, and it costs less.

In addition, the Remex-11

provides faster throughput than standard DEC configurations with more efficient sectoring, by far. A single command transfers up to 65K words.

A full array of switches and indicators makes operation easy.

If you're a PDP-11 user, set sail for Remex. High quality peripherals and their

service are our only business. If you've bought any of our more than 100,000 punched tape and flexible disk units, you know what we mean.

Contact your nearest Remex Sales Office or the factory direct: P.O. Box C-19533, 1733 Alton St., Irvine, CA 92713. Phone: (714) 557-6860

Ex-Cell-O Corporation

**REMEX DIVISION**

CIRCLE 49 ON READER CARD

## DISTRIBUTORS

mitted Graham, "right now the DECwriter is king of the mountain!"

"I really think Digital really woke everybody up to the size of that (low end) market," he added, "just by pushing so many terminals out into the field. I mean, this year they will have sold 70,000 terminals, and the feeling is that if they had produced any more they could sell them. 70,000 terminals! From one manufacturer! That's incredible!"

Impressive anyway. Last fall, less than two years after they introduced the DECwriter II, the DEC components group, which markets DEC terminals and small business systems in volume, announced the shipment of the 50,000th LA 36, the keyboard/send-receive model (KSR) of the DECwriter II. Competitors estimate DEC sold 20,000 DECwriters in 1975, 32,000 in 1976, and 70,000 this year.

In a sense, the DEC components group is a reincarnation of its parent. The DECwriter is a device that can be sold stripped and handled in volume, and DEC laid the foundation for its astonishing growth in minis with a volume manufacturing operation and a marketing plan that concentrated on pushing raw iron into the hands of oem's. Today, with most of DEC evolving into market-oriented groups increasingly involved in end user system development, the digital components group (DCG) remains product-oriented, a lean organization dedicated to moving iron.

### The mimics

DEC's success with volume-only sales and their innovative use of the resellers has inspired mimicry within the industry, but there also is considerable caution on the part of other manufacturers. All the major terminal and datacomm peripheral manufacturers have sought links with the independent resellers. Teletype Corp. has jumped its volume reseller discount from a standard 20% to 30% to ensure their interest in its model 43; and Centronics, pitching its model 761, and Data General, trying to broaden the market base for its own minisystem terminal, the Dasher, have both been wooing the resellers. But everyone is moving much more cautiously than DEC did, more than a little hesitant to risk the sort of rampant price-cutting that has characterized the DECwriter market. They want to give volume discounts and all the rest, but they want a tamer, more stable price environment. Ironically, it is Texas Instruments —

the firm that first followed DEC into the reseller channel, then reconsidered and tried to back out, that now has flipped again and seems to be offering an open door policy for the smaller resellers—while DEC, having created and gotten the best of the energies in the reseller's surge, begins to force consolidation in its retail network.

### Resellers' troubled cash flow

Despite their increasing market importance, all is not rosy among the resellers. The leasors' need for capital and the increasingly complex finance requirements of the business (reflecting new Financial Accounting Standards Board rules on lease accounting and the trend toward shorter lease terms), on top of the tight margins in the sales end of the business and the debt risks common in any bargain hunter's price-cutting market, have generated severe cash flow problems among almost all the resellers. And it's a highly leveraged business: machines are bought on credit from the manufacturer and leased units are wholly or largely bank financed. The industry has a long cash tunnel, with several tight corners. And as the average volume of the resellers has grown,

Digital, the dominant supplier in the reseller market, has brought up tighter credit requirements. (DEC's resellers on the average took 100 units in 1975, 200 in 1976, and 350 in 1977, according to the offhand estimate of a DEC executive.) This year, particularly, Digital has begun to demand solid equity (roughly 10% of two monthly shipments). With their cash flow problems, this is a crisis for many smaller resellers. Many of these firms evolved from the Teletype repair firms of the 1960s, they're small single-proprietor companies or incorporated individuals, managers who keep a minimum of equity in the business to avoid double taxes on personal and corporate income.

Digital, while it's tightening the screws on credit, this year offered a new discount schedule that gives their largest volume retailers an even larger discount advantage over the smaller firms.

### Managing tier sales

This new volume pricing, together with DEC's tighter credit requirements, seems likely to accelerate — and at least temporarily, institutionalize—the growing practice of tiering, in which

## Market Size is Underestimated

Actual size of the teleprinter market is subject to some dispute, but it's accepted wisdom in the terminal industry that it's a market deeper and more elastic than any of the standard industry research profiles acknowledge.

Datapro, for instance, recently estimated that there were now more than 1.5 million terminals installed, with teleprinters and printer-only terminals accounting for 47% or 700,000 units. Yet Datapro estimated 1977 teleprinter shipments from all manufacturers at only 70,000—an estimate apparently to be dwarfed by actual total sales.

Teletype Corp., the grandfather of the industry, has shipped over 700,000 Model 33 and 35 terminals since 1962, placing about 75% of these in data communication applications (many in the Bell and Western Union systems, and the huge time-sharing market) and 25% as minicomputer terminals. Teletype now estimates that 40% of their present sales go on minis, and 60% into data communications.

Fred Graham, product manager at Centronics (a former reseller himself), believes that 76% of low and medium-speed teleprinter terminals are now attached to time-sharing

systems—"That's where the big market is!"—and he and virtually the whole industry agree that despite all the hoopla about terminal sales, 70% of the market is a lease business.

With not only the gigantic Teletype base, but with both GE and Texas Instruments, among others, well ensconced in the market, Digital's terminal product manager Bill Chalmers estimates the actual installed base of conversational teleprinters to be "in the millions"—and growing at 250,000 annually. "I've seen them all, and I believe that figures normally used are woefully understated," said the gruff, amiable RCA veteran. "I have to believe that after what we've done!"

He pointed out that the price for a used Teletype has risen from \$800 to \$900 or \$1,000 since DEC entered the business three years ago. "So they're not being thrown away, and we haven't put anybody out of business. I think the market is just much bigger than anyone realized. And with new technologies and quieter machines, I think it's more elastic and growing faster than people realized. So DEC, the new guy on the block, can dump this many machines and *still* not screw up anybody else!"

✱

## DISTRIBUTORS

smaller resellers buy through larger resellers. Anachronistically, the politics of the industry today have led many of the larger resellers to set up separate and ostensibly independent telephone booth sales operations to broker high volume turnover and manage tier sales. Atlantus, in Germantown, Md., has Data Communications International in Dallas; International Computing Equipment has National Terminal Corp., both in Oakland, Calif. and the same relationship is likely to be established between Data Access Systems (DAS) in Mountain Lake, N.J., and Transnet, a brokering operation in which DAS recently purchased a 25% interest. Other firms, preeminently Management Response in Chicago and Data Dimensions (DDI) in Greenwich, Conn., have let it all hang out and broker and tier through their normal sales operation.

The politics behind the subterfuge reflect the bitter divisions among the resellers, where there is a hierarchy of "respectability" according to lease-to-sale ratio and, more importantly, the full-service and maintenance program offered. Brokering or "wholesaling" is roundly cursed by everyone, sometimes loudest by those most active in it. The practice reflects the economic reality of the lease business and the volume discount schedules, but sales with little or no margin leave little reserve to finance maintenance and support service. Uncautious buyers sometimes get hurt, but although the industry gossip is full of damage reports and horror stories, few can be tracked down. In a handful of cases, DEC has moved in voluntarily to help a stranded end user, but —perhaps due to the extremely high reliability of the machine — "there have only been very, very few," said William Chalmers, DEC terminal manager, "less than we expected, really." There are a number of firms that have been, by reputation, predominantly "marketing companies" (large national firms like DDI, regional companies like Management Response, and local firms like Consolidated Data Terminals in Oakland, selling with DEC and third party maintenance) — but here again, the blustery volume sales image of each belies the internal effort to squirrel cash away for the lease-base development.

"Everybody leases and wants to lease more," remarked Chalmers. "If you ask me what I think is out there, I'd say there are companies that lease 70% and sell 30% and companies that sell 70% and lease 30% . . .

there's a natural lid on all this called finances."

### Off the record

Chalmers has a bulky earnestness that's impressive, particularly face-to-face, and he spent nearly 40% of his time on the road in his first two years managing DEC terminals, getting to know his market and his resellers. He has a habit, he concedes, of listening to everything and somehow giving the unjustified impression that he agrees when he doesn't contradict, or that he accepts a recommendation when he agrees to merely consider it. His habit and his earnestness have stood him in good stead. While there are a number of resellers who bitterly and furiously accuse him of duplicity (refusing to go on the record, like virtually all the reseller executives interviewed). Most come away from talking with him believing that DEC is biased toward them, or will at least give them a fairer shake than they had expected.

### Opportunity for newcomers

Chalmers believes the reseller scheme still offers a rare opportunity for newcomers to cut into the computer industry; a mere \$50,000 can be the entrance fee, he argues, but it takes financial management—perhaps more of a finance mind than is now prevalent among resellers. "If you and I start a business and we're careful and have a good cash-management program, we'd quickly find we could only put so many dollars a month away into a lease/rental program that is going to pay us big bucks in 18 months. But there are individual companies today who have not been careful figuring out what those bucks are. And so a salesman can't turn down an order—so they put a few extra terminals out on rent this month and around 12 months later those termi-

nals bite them in the rear end, because they haven't begun to pay off yet and its still a drain on them." They still have to pay the bank on the purchase loan, against which rental payments come up short, leaving a compounding debt that hits cash flow, even if the paper equity of the machine polishes up the balance sheet.

Currently a sizable number of maintenance-supporting resellers are being sustained through the price wars by the communications market, the Western Union Telex and rwx services. Western Union decided in 1973 not to invest further in terminals, reserving capital and opening their customer base to outside suppliers. It's a perfect market for resellers, who provide used but refurbished Teletype 33s and turn over a clean 20% margin; many in the industry say this is the crutch that will support the maintenance companies until the market stabilizes with the programmable terminals.

### Shake-out coming

It's an industry consensus that there is a shake-out coming. Already cash flow problems plague the whole industry. Even the largest companies are not exempt, and among the smaller firms it's an epidemic. The largest national companies are heavily lease-based, Atlantus (formerly Leasco), DDI, and Carterfone Communications — all DEC-oriented — and the GE and Teletype-based RCA Service Co. and Western Union Data Services. But even size and experience are no guarantee against poor financial planning. Carterfone of Dallas is a major data communications firm, but this year it has had major financial difficulties and current cash-crunch problems have all but removed them from the market. (Earlier this year, explained Carterfone marketing director Pat Houston, the company "put itself on

DEC'S DISCOUNTS ON SCHEDULE TO RESELLERS/LEASORS			
Qty.	1976 Discount		1977 Discount
5,000 plus	NA		56%
3,000-4,999	NA		50%
1,000-2,999	44%		49%
500-999	42%		48%
350-499	40%		45%
200-349	38%		44%
100-199	34%		42%
50-99	29%		40%
TEXAS INSTRUMENTS DISCOUNT SCHEDULE			
Qty.	Intelligent programmable terminal, except Model 742 discount	Model 742	Programmable teleprinter — Mod. LS-120
1,000 plus	30%	NA	NA
500-999	29%	NA	48%
200-499	28%	NA	NA
100-199	25%	NA	NA
50-99	22%	22%	41%
25-49	18%	18%	NA
10-24	14%	14%	NA
1-9	10%	10%	NA

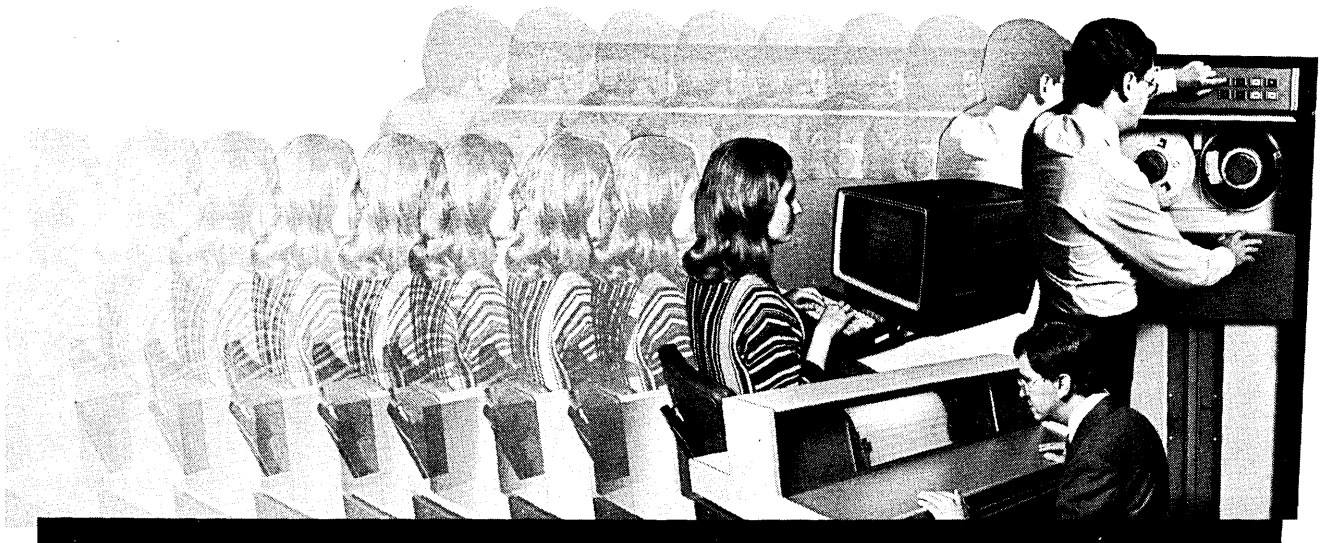

# IN THE FAST CHANGING WORLD OF INFORMATION MANAGEMENT, WHERE CAN YOU FIND ALL THE LATEST PRODUCTS AND APPLICATIONS UNDER ONE ROOF?

INFO 77 is the Exposition and Conference that shows you how to shape information systems to management's needs.

It brings together thousands of the latest products and applications in one great "showcase," the New York Coliseum, so you can quickly and easily find the newest and best solution to your specific problem.

The Conference explores a new concept that combines data processing, office systems, records management and telecommunications into a single function that is becoming increasingly important in the corporate structure: information management. It keeps you abreast of advances in technology, new applications that help you deliver the right information to management at the right time.

## SEE AND EXAMINE ALL THE LATEST TOOLS OF INFORMATION MANAGEMENT:

Computers... Data Communications... Distributed Data Processing... Dictating Systems... Duplication/Copying Systems... Information Retrieval Systems... Microfilm Systems... Software & Data Services... Word Processing Systems.

## PLUS THOUSANDS OF APPLICATIONS FOR:

Banking Systems... Office Systems... Financial Systems... Sales & Marketing... Insurance Systems... Hospital Systems... Small Business Systems... and more.

## ATTEND THE CONFERENCE THAT HELPS EDP MANAGERS BECOME BETTER INFORMATION MANAGERS:

More than 60 sessions in ten industrial and commercial areas. Nearly 200 experts share their experiences with you—case histories, state-of-the-art reviews on current practice. Cost effective applications for small business computers. Cost savings in office automation. And much more!

For information on the show and Conference call toll free, 800-221-0222 (in New York State only, call 212-786-7504) or write Clapp & Poliak, Inc., 245 Park Avenue, New York, N.Y. 10017.

49

# FOURTH INTERNATIONAL INFORMATION MANAGEMENT EXPOSITION & CONFERENCE

NEW YORK COLISEUM, OCTOBER 17-20



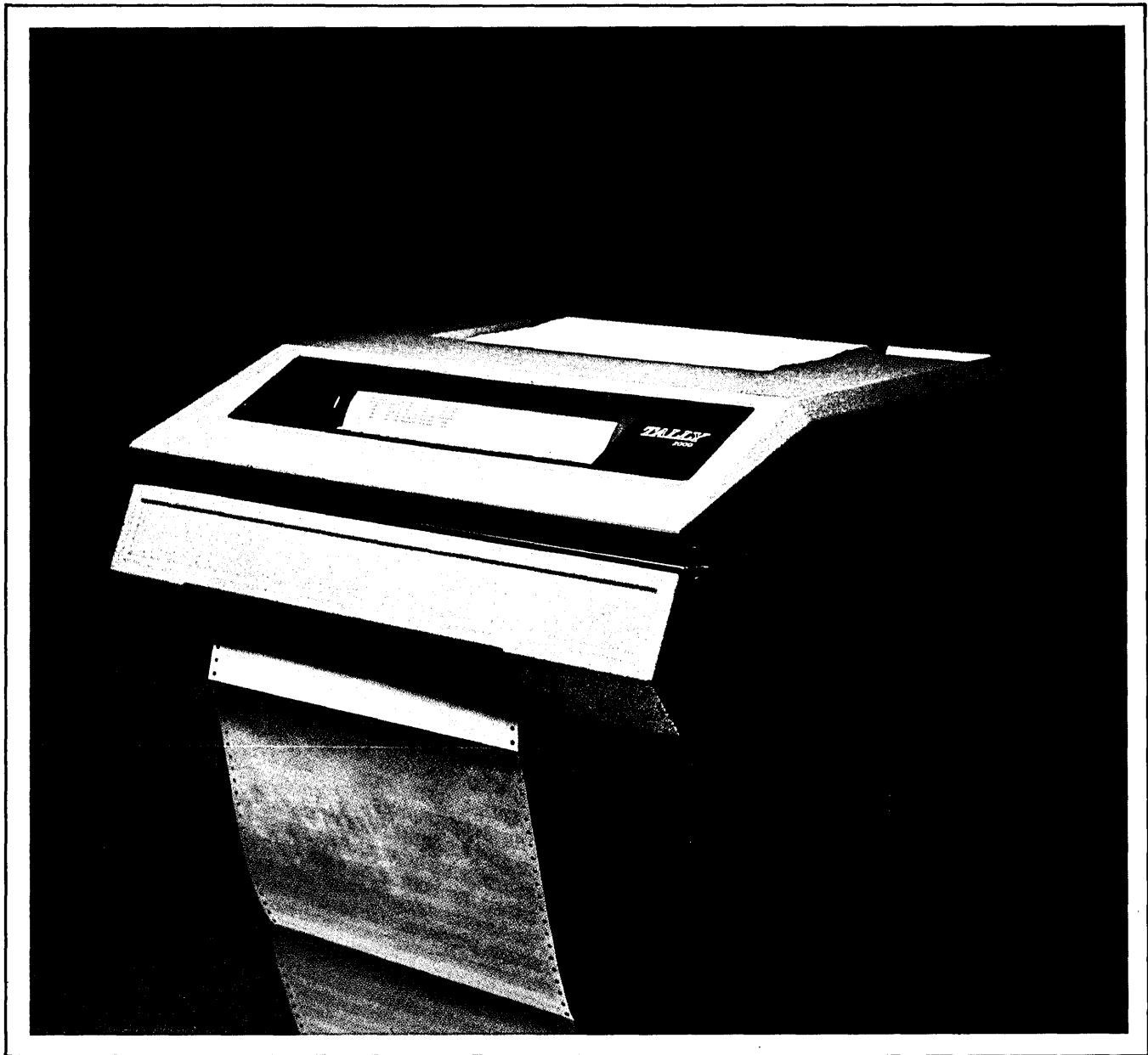

## Tally reliability. As good as gold.

Tally reliability is unmatched in the printer industry. The value to you is a 100% duty cycle, 200 line per minute printer that costs far less to own. Less than any other printer around.

You can run the T-2000 as long and as hard as you want without the frustration of downtime and costly repairs. Plus, preventive maintenance is unnecessary. Sliding bearings, pivots and lubrication points are eliminated. There are no electronic timing or hammer flight time adjustments. In short, there's nothing to adjust.

The reason behind this unparalleled reliability is the patented Tally print comb mechanism. It uses a unique flexure technology that's impervious to wear and designed for unlimited life. While other printers like to talk about calculated MTBF, Tally points to

field proven MTBF. Most of the Tally printers that have been in the field, including those in operation for over four years, have never required adjustment or repair to the print mechanism. In fact, many have experienced no malfunction at all! No one else can safely make that statement. And Tally backs every T-2000 with a full year print mechanism warranty.

The gold printer above is Tally's commemorative unit marking 10,000 machines delivered. The noteworthy statistic is that 99 per cent plus have never had a mechanism failure.

Find out all the facts on this proven performer and call your nearest Tally sales office, or write or call Tally Corporation, 8301 S. 180th Street, Kent, WA 98031. Phone (206) 251-5524.

# TALLY

OEM Sales Offices: Los Angeles (213) 378-0805 • San Antonio (512) 733-8153 • New York (516) 694-8444  
Boston (617) 272-8070 • Chicago (312) 325-9788 • Miami (305) 665-5751  
Washington, D.C. (703) 471-1145 • Seattle (206) 251-6730 • Business Systems (415) 254-8350

## DISTRIBUTORS

credit hold" with DEC when they had difficulty completing biannual refinancing arrangements with their lender, Westinghouse Credit. Apparently even after that was settled in April, the 45-day marketing freeze had so disrupted its cash flow that the company had to drop into low-gear to wait it out.)

Carterfone executives echo many other service-based resellers in complaining that DEC's resale program generated this fierce price market simply because DEC didn't understand that the low-priced DECwriter would inevitably become a commodity — "traded like wheat or pork bellies." One repercussion from the price war that DEC apparently did not foresee, however, was having its own volume resellers bid against DEC's own salesmen. DEC has a tough beat competition policy that allows them to outbid whoever, and they used it several times to put uppity resellers in their place. But volume resellers, with their ability to mix and match and juggle average discounts in package deals, can put together attractive bids. When, in July 1975, Data Dimensions (DDI), by repute the most aggressive of the large resellers, actually beat out DEC for a major time-share network sale, DEC took it very seriously. "It really shook up the entire industry," recalled Chalmers. The next time the two went head-to-head, bidding Dartmouth College in August 1975, the DEC salesmen came in with an "adjusted bid" with terms that would, according to DDI, be the envy of many institutional users. By the spring of 1976, after several clashes, DDI was preparing to sue DEC for restraint of trade under antitrust laws. The suit was never filed, but the threat was apparently enough to shake up DEC; making them more careful who they "put in their place" and how.

### Wading into the fray

DDI, the largest reseller for Texas Instrument terminals, led others into the fray bidding against TI salesmen too. Resellers with long experience with TI explain that TI wanted its dealers to go for the "onesy-twosey business" leaving the big business for TI's own end user salesmen. When the resellers turned against them, TI's salesmen were getting "creamed," claimed a salesman for one reseller. "I didn't have the slightest sympathy for TI," growled the sales manager for another. "They introduced a portable tabletop thermal printer several years ago; they took it around to resellers and promised them the world. Now

the guys who bought the con are using those things for boat anchors, because TI turned around and went into the rental business in direct competition several months later."

TI, unlike DEC, both leases and rents against its resellers; and whereas DEC has a single discount schedule, TI offered different schedules for end users, dealers, and oem's. Apparently — TI executives refuse to discuss the situation — the resellers' rebellion came just as TI was moving to strengthen its own end user sales force. TI declared war on the resellers. Last summer they froze the dealer network, accepting no new resellers (or effec-

tively forcing new resellers to buy as end users). Then they had their salesmen try to close on small accounts normally left for the resellers. Then in January 1977, TI decisively shuffled the deck: they readjusted the discount schedules, sweetening the oem discounts, but cutting the dealer volume discount, dropping it from a 1,000-unit maximum to a 200-unit maximum.

The jinx in the plan was the practice of TI salesmen using the oem pricing in sales pitches to a variety of clients — banks, service bureaus, time-sharing firms — that would be difficult to define as oem's in any

# RENT IT. TODAY.

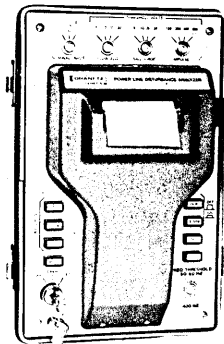

## DRANETZ MODEL 606 POWER LINE DISTURBANCE ANALYZER

Announcing the immediate availability of the Dranetz Model 606 — which analyzes, monitors, classifies and records line disturbances WHEN THEY HAPPEN. The 606 is ideal for pinpointing effects of line disturbances on digital communication equipment.

And you don't need to own one to use it!

Now you can rent the Model 606 whenever you need it — for only as long as you need it — with just one call to Leasametric.

Our diverse inventory includes the very latest state-of-the-art data communications test instruments from top manufacturers like Spectron, Digi-tech, Atlantic Research and Digi-Log

to name just a few.

All instruments are calibrated to the manufacturer's specs. Come with complete documentation. And ready for immediate shipment from one of our 17 fully-stocked Inventory Centers across the U.S. and Canada.

Remember, renting gets you what you need — when you need it — for only as long as you need it. Call for your FREE Telecommunications Test Equipment Rentals Brochure outlining our many services.

 **Leasametric**

Division of Metric Resources Corporation  
822 Airport Blvd., Burlingame, CA 94010

INVENTORY CENTERS: San Francisco, CA (415) 342-7111; Los Angeles, CA (213) 768-4200; Anaheim, CA (714) 634-9525; San Diego, CA (714) 565-7475; Houston, TX (713) 477-9911; Chicago, IL (312) 595-2700; Boston, MA (617) 244-9400; Midland Park, NJ (201) 444-0662; Long Island, NY (516) 293-5881; Washington, D.C. (301) 881-6700; Orlando, FL (305) 857-3500; Dayton, OH (513) 898-1707; Philadelphia, PA (215) 583-2000; Denver, CO (303) 429-7900; Minneapolis, MN (612) 854-3426; Dallas, TX (214) 661-9193; Toronto, Ontario (416) 676-1897.  
TOLL FREE NUMBERS: Outside California 800-227-0280; Outside New Jersey 800-631-7030; Outside Maryland 800-638-0838; Outside Illinois 800-323-2513.

CIRCLE 72 ON READER CARD



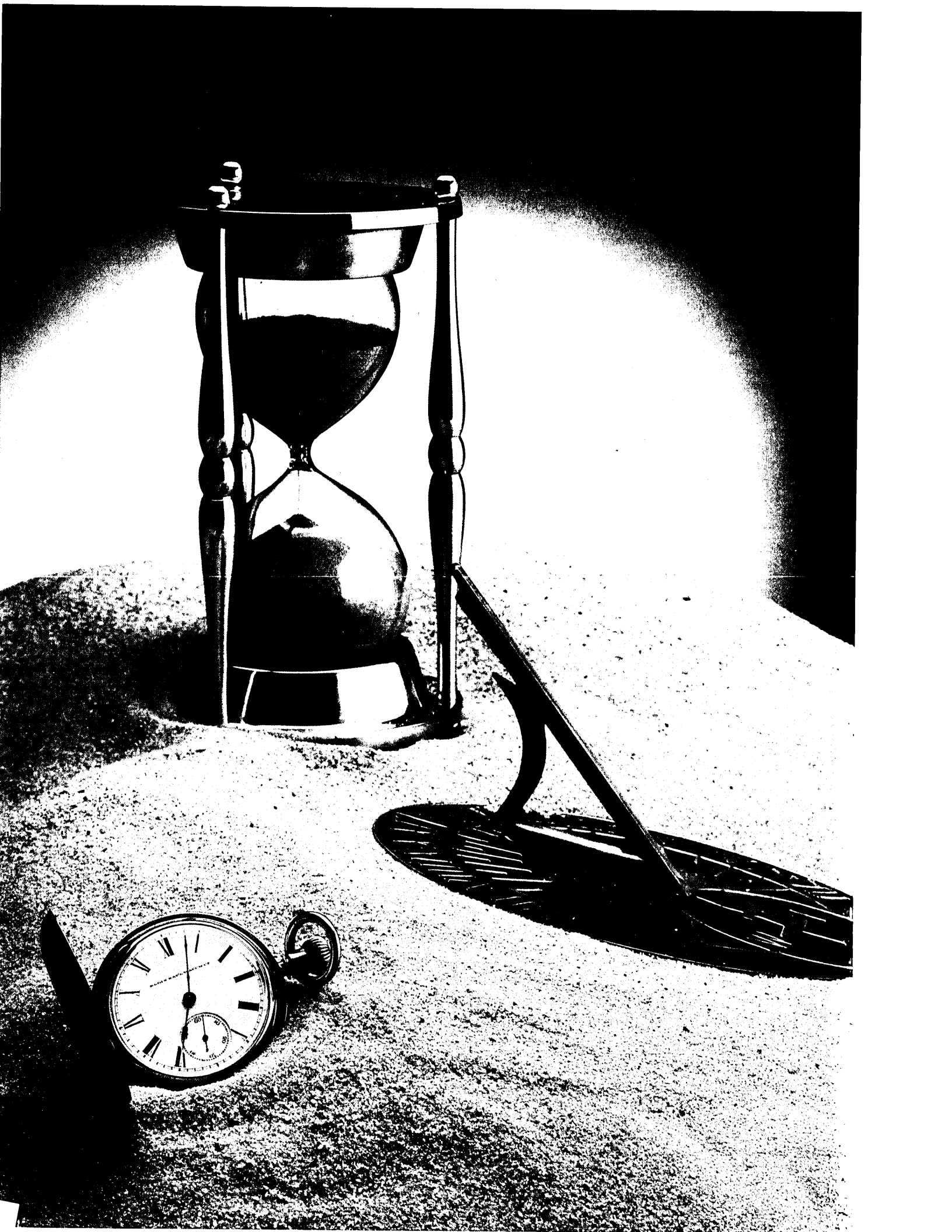

# Real-time problems? Systems has timely solutions.

Systems Engineering Laboratories has dedicated its 16 year corporate life to solving challenging real-time problems. The experience gained in solving these problems is what led us to pioneer the development of true 32-bit computer systems.

Look into the operating systems, the languages, the data base system, the real-time device handlers and terminal systems, and you will see that we build for the real-time environment. That's our business.

Choose from a well-bred family of computing systems: The SEL 32/35, the SEL 32/55, or the SEL 32/75. Unlike other so-called "32-bit minis" that are only bridge-the-gap systems developed from essentially 16-bit architecture, all SEL 32 systems are true 32-bit machines. This results in richer instruction sets, more precision in data representation and larger, directly-addressable memory. All are available with throughput rates in excess of 26 million bytes/second.

Systems computers fit the term "minicomputer" in price alone. If your application is performance-sensitive, we'll save you money. If you're budget-sensitive, we'll give you more performance for your dollar.

The SEL 32/35 can be configured from 64K bytes to 512K bytes of 900 nsec memory. Resembling its more powerful brothers, the SEL 32/35 is a complete package, including control processor with floating-point arithmetic, memory, chassis, power supplies and cabinet.

The SEL 32/55 is offered in a variety

of both single and multiple CPU configurations, with from 32K bytes to 1 million bytes of 600 nsec memory.

The SEL 32/75, with up to 16 million bytes of main memory, has a concept so new, we had to coin a special term to describe one of its main features: Regional Processing Units. Working independently, these RPU's contain sufficient control and buffer storage areas to process an I/O region and transfer the resultant data directly to main memory. Computer system throughput is further enhanced by High-Speed Floating-Point Hardware and Writeable Control Storage.

Just circle our number on the Reader Service Card, or call us today. We'll send you the powerful story of the SEL 32 family.

## SYSTEMS

ENGINEERING LABORATORIES

- CALL ME
- SEND ME MORE INFORMATION
- I HAVE PRESENT NEED FOR SYSTEM

NAME \_\_\_\_\_

COMPANY \_\_\_\_\_

PHONE \_\_\_\_\_

ADDRESS \_\_\_\_\_

CITY \_\_\_\_\_

STATE \_\_\_\_\_ ZIP \_\_\_\_\_

SYSTEMS Engineering Laboratories  
6901 West Sunrise Boulevard, Fort Lauderdale, Florida 33313  
(305) 587 2900

## DISTRIBUTORS

classical sense. By the spring of this year, TI faced at least two imminent lawsuits: one from a small Oakland reseller, Herb Williams of Consolidated Data Terminals; and a second, apparently seen by TI as a major threat, from an as-yet-unidentified end user who claimed as much right to the oem discount as Tymshare, a California time-sharing company that had received oem status.

### All contracts cancelled

Williams said he was approached through a third party to be an expert witness in the other suit regarding TI's oem policy, but he planned his own suit against TI's general effort to clamp down on the resellers. He was charging discrimination because TI sold to him as an end user, refusing to give him the dealer discount, although they knew he was reselling. TI, caught in a pincer, capitulated. On June 1, TI informed all their customers that they were cancelling all contracts and again redesigning their discount program. Oem's and "dealers" are now called "resellers" and given a single discount schedule; only end users get separate rates. A number of

resellers who had been refused TI dealer discounts during the little war received telephone calls inviting them to apply for "reseller" discounts. Herb Williams had a TI sales manager drop by to deliver the new contract by hand.

TI's new reseller discount schedule is interesting in that it is not biased toward high volume retailers, like the DECwriter II's new schedule—but like DEC, TI also separated their intelligent programmable terminal in a much more limited discount program. TI's discount schedule for all but the programmable Model 742 offers up to a 1,000-unit volume discount, but the schedule tightens at the high end.

### Major market changes

The next 12 months are likely to see major changes in this teleprinter market: AT&T, locked out of the industry for five years by the terms of their 1971 sale of TWX to Western Union, is reentering the market; FASB rules now require payout leases to be recorded as purchases; the beginnings of a crt price war have led some industry veterans to predict a \$500 crt in 1977. And most importantly, this year will see strong direct competitors to the DECwriter II enter the market with volume: Teletype 43s will be

available, significantly undercutting DEC's standard LA 36 pricing; Centronics will push its Model 762, and TI is expected soon to introduce a keyboard send-receive model of its impact printer, the 150 cps model 810. The monthly rentals from the Bell companies and the FASB accounting rule probably will accelerate the shift toward shorter contract lease terms—which will only increase the difficulties of those resellers currently having cash flow and finance problems. And some resellers are already worried at having to deal with a used DECwriter market that is expected to develop over the next six months, now that the three-year term of the 1975 leases is up.

(For firms which cannot legally or practically accept any possibility of retroactive price hikes—ie. bill-backs—DEC now offers a volume terminal purchase contract which offers a lesser discount, but a discount none the less, without a billback clause. It's a deal that only the manufacturer can offer, with terms that only those firms with specific limitations on their purchasing will find attractive. DEC qualifies only purchasers with solid credit and a three-year history of major terminal buying, and limits the no-bill-back purchaser's discount by dividing the purchaser's volume commitment in half and using that figure to determine price on DEC's standard volume/discount schedule. Thus, a purchaser planning to buy 1,000 DECwriters on a no-bill-back contract gets the discount normally given to 500-unit buyers.)

The rich discount benefits of the ultra-high volume levels have already led two of DEC's largest resellers into 5,000-unit commitments. It also may lure non-DEC independents like WU Data Services and RCA Service Corp. into the DEC sphere. Chalmers at DEC acknowledges that he hopes it will lead to refinancing among "a fair number" of DEC's present resellers. It certainly will lead the large resellers into extraordinary efforts to shuffle iron giving DEC maximum market penetration now, while their new direct competitors still are gearing up for the attack.

Perhaps revealingly, the 3,000-unit discount price for the DECwriter just about meets the resale discount price of Teletype's new Model 43, a major challenger—and the 5,000-unit price undercuts it.

Some of the underfinanced small firms that were relying on flat-cost volume turnover for their discount rate—and the few firms who were trying to make money on \$50 over cost mail order sales—are in trouble. With

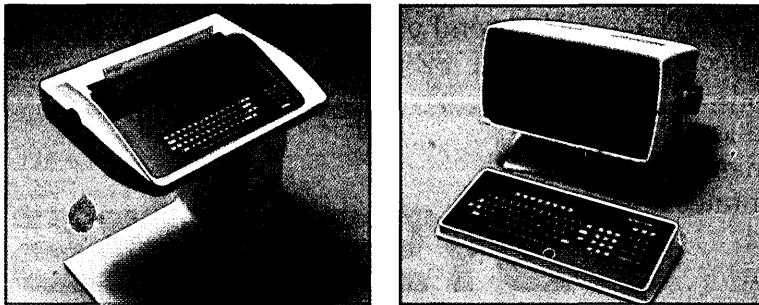

## Data General. A la Carte.

Now, you can order our DASHER™ terminals, even if you don't own a Data General computer system. Both our fast impact printer and our user-oriented video display are interface-compatible with any standard computer system.

60 or 30 cps versions of the DASHER printer, with a standard typewriter keyboard, u/l case, 132 columns.

DASHER display features a 1920 character screen, u/l case, detached keyboard, programmable function keys, and a monitor that tilts and swivels.

For more details call your Data General sales office or nearest independent supplier of Data General terminals. Or write. Even a bit of Data General in your computer system is better than none.

DASHER is a trademark of Data General Corporation  
© Data General Corporation, 1977

**Data General**  
It's smart business.

Data General, Westboro, MA 01581, (617) 366-8911. Data General (Canada) Ltd., Ontario.  
Data General Europe, 15 Rue Le Sueur, Paris 75116, France. Data General Australia, Melbourne (03) 82-1361.

The concept and design of the Printronix 300 Impact Matrix Line Printer/Plotter offers you several remarkable cost/performance advantages.

## Like plotting capability ... at no extra cost.

It would seem enough to find a 132 column, 300 lpm printer with print quality others can't match, with an elegantly simple mechanism that assures a greater MTBF, and a modular design that dramatically cuts MTTR. The Printronix 300 offers all of these advantages. But it also offers plotting capability. At no extra cost.

Because of its unique mechanism, it can put a single dot anywhere on paper. It forms characters a dot row at a time when printing. In the plot mode, it can form any pattern a dot at a time upon command. Drawings. Graphs. Bar codes. Large character labels. You name it and you can do it on a Printronix 300.

It's a handy capability to have around, and it comes to you with our compliments... at no extra charge... along with the other remarkable advantages that make the Printronix 300 your best buy. Send for our brochure. You'll discover why the Printronix 300 prints better, will last longer, and require far less maintenance. That's why it's been sold with a one-year warranty from the beginning.

Printronix Inc., 17421 Derian Ave., Irvine,  
California 92714. (714) 549-8272.



# PRINTRONIX 300

It's your best buy!

# IF YOU DIDN'T HAVE TO COMPARE PRICE,

IBM

370/58



Of course, when making a large investment, you would compare price—and find that Intel offers you substantial savings over IBM. But if you didn't have to compare cost, you'd compare features—and choose Intel's Advanced System.<sup>™</sup> Because we took IBM's best concepts and

improved them.

Dramatic advances in the semiconductor industry have allowed us to build a more compact, more reliable and more powerful CPU using about half the components IBM uses. Which means Intel's Advanced System takes up much less space than the comparable IBM system. In addition, the Advanced System runs approximately 9 degrees



# WHAT WOULD YOU COMPARE?

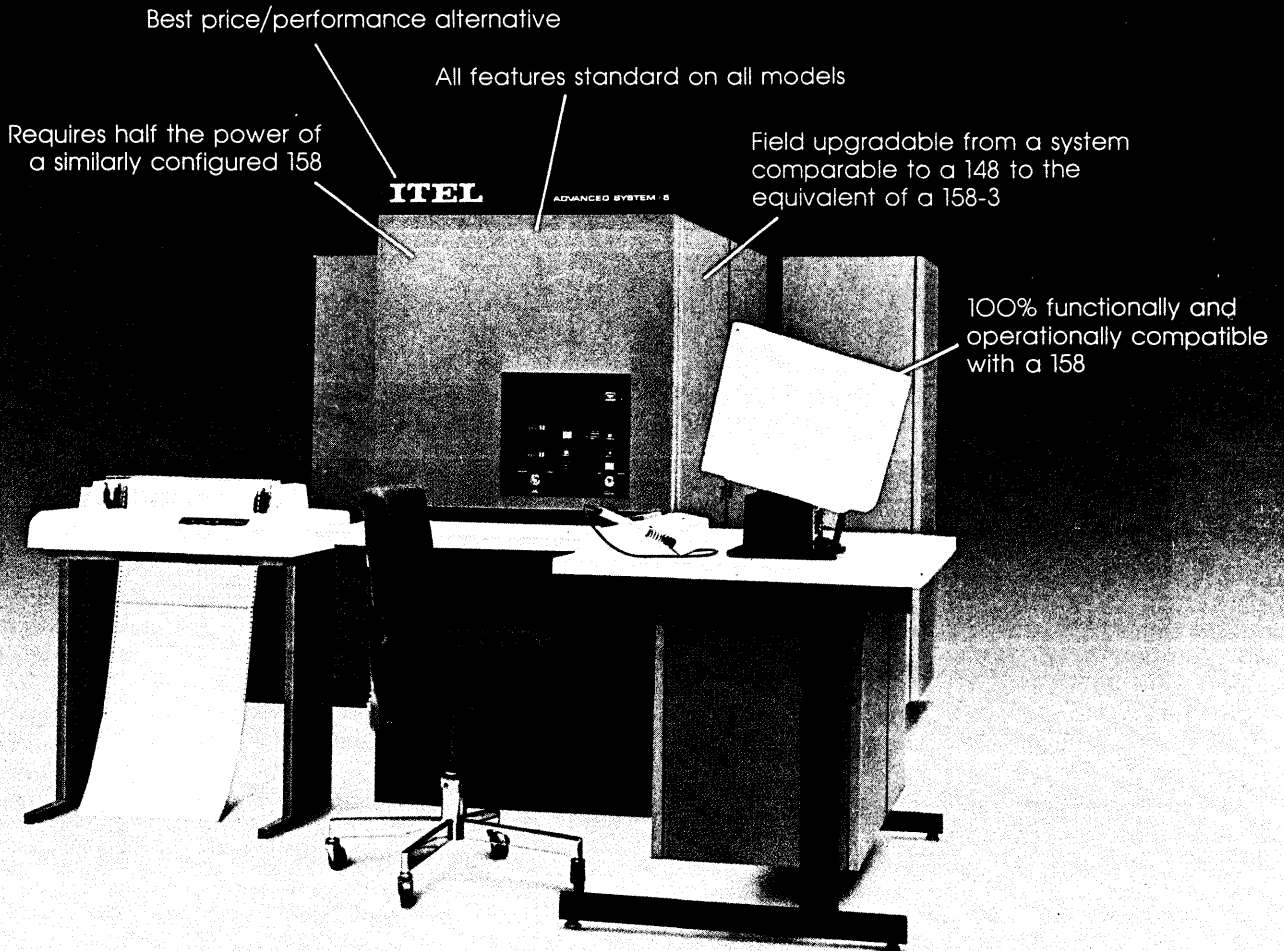

cooler, increasing the reliability of its integrated circuits.

And it comes complete, including a 180 cps printer. No optional "special features" that often end up costing you almost as much as the system itself.

What's more, the Advanced System's flexibility helps prevent obsolescence and protect your investment—all six of our models can be either upgraded or downgraded, as the situation

demands.

Itel's Advanced System gives you everything its IBM counterpart does, and in some cases, more. But, even with all our features, the Advanced System will cost you less than the comparable IBM system.

When it comes to price, features and performance, Itel is the only sensible alternative to IBM. Not only in total computer capability, but in systems and

software, in computer peripherals, in field engineering, in financial packaging.

Itel. The sensible alternative.

**ITEL**  
CORPORATION  
Data Products Group

One Embarcadero Center  
San Francisco, California 94111  
Telephone: (415) 955-0000



## DISTRIBUTORS

the big companies desperate to move machines and holding super-discount prices, the bottom line sale prices in the market will be offered by some price stability to the terminal sales end of the industry—without having undue impact on the lease base structure, which as always reflects the financing and support capabilities of the individual resellers.

### The third generation

To survey the ramifications of DEC's pricing and credit policies is to quickly

sketch a model forum for the introduction of DEC's third generation terminal, the programmable DECwriter III, just beginning volume shipments. Antitrust law makes it very difficult for DEC to refuse to do business with any of their established resellers, but DEC probably won't be unhappy to lose some of the firms most threatened by the new developments in the DECwriter II market. One worry at DEC has been that dumping the DECwriter III—with its much higher service and support requirements—into the present price-cutting, fast-shuffling market could cause an embarrassing backlash from end users sold this complex

piece of equipment by resellers who don't have the resources or inclination to properly support it.

Predictably, maintenance is another area in which DEC has been moving quietly to change the rules of the game. Last January, DEC surprised and angered many of their maintenance-based resellers by dropping the monthly price of DEC's own maintenance and service from \$25 (a price that had been supported by many independents) to \$19 a month. Said the marketing director of one of the larger reseller/lessors: "They just went around the country leaving six bucks on the table. It was crazy!"

The price cut was widely seen as a sacrifice move by DEC, cutting service margin to expand DEC's maintenance market share, estimated by resellers at a mere 6% or 7% of the installed DECwriters. What has not been clear until recently, however, is that the price drop was only part of a major reorganization of the company's terminal maintenance program. DEC until recently used its expensive computer maintenance staff to handle terminals, but as of last December they began to set up a separate organization of terminal repairmen. The price cut only reflected DEC's projected savings with the new maintenance organization, explained Jay Atlas, DEC's terminal service manager for North America, a projection of real savings they had already realized in a New York City test program. The new service organization now is operating in about 36 of DEC's 360 field service offices, said Atlas, and by the end of the year terminal specialists will be in well over 100 field offices.

The ramifications of the new DEC service program are as yet unclear, but obviously DEC will be offering a much stronger challenge to the independent reseller/lessors in the service end of the business. Certainly too, DEC will be reinforcing the service base for the DECwriter III, which with its microprocessor offers possibilities of a new world of centralized, on-line diagnostics and faster, cheaper terminal support. But in the current "old world," there may be some interesting complications. Some resellers report that they have been recently approached by DEC service salesmen and told that the new organization will enable DEC to offer service frills like on-site service during warranty and guaranteed fail-to-repair time with temporary unit replacement as backups, all of which would imply major changes in the contract terms and conditions the DEC component group currently offers. Top DEC repairman Atlas says he is studying the possibili-

# More than a simple sonic digitizer...

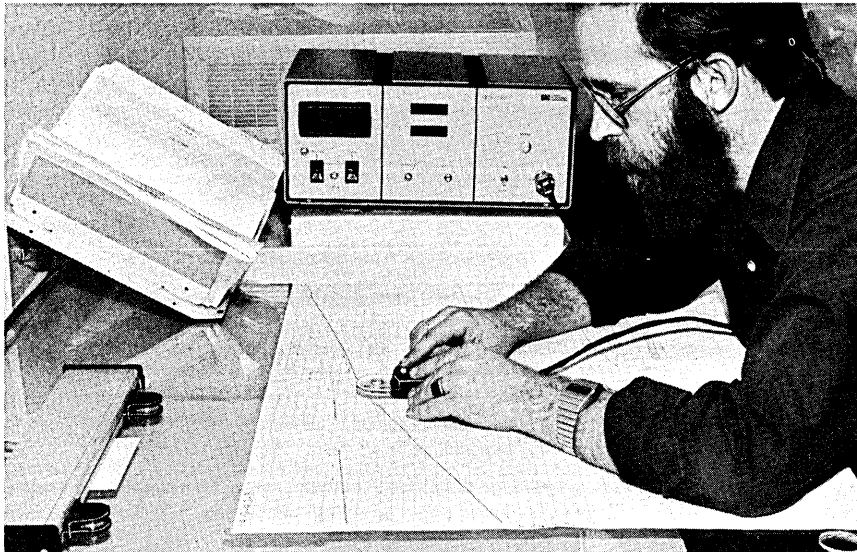

## our programmable $\mu$ P-based graphic-to-digital converter.

For those special applications where you want your sonic digitizer to automatically calculate line lengths, areas, volumes, position origins, map coordinate transformations, and other two- or three-dimensional data, we have an exciting new Graf/Pen™ model for you: The NT-501. Our exclusive microprocessor-based programmable sonic digitizer requires only two point sensors above the work area, allowing inter-action with a variety of graphic inputs, such as CRT or plasma displays, projected images, maps, and engineering drawings. And the unencumbered work

area provided by the movable point sensors accommodates the use of T-squares, triangles, and other drafting instruments, further facilitating digitization.

We could go on and on about the revolutionary NT-501. Our new technical literature tells the whole story. Ask for it.

**SAC**® SCIENCE  
ACCESSORIES  
CORPORATION

970 Kings Highway West, Southport, Connecticut 06490  
(203) 255-1526 Telex 964300

CIRCLE 182 ON READER CARD

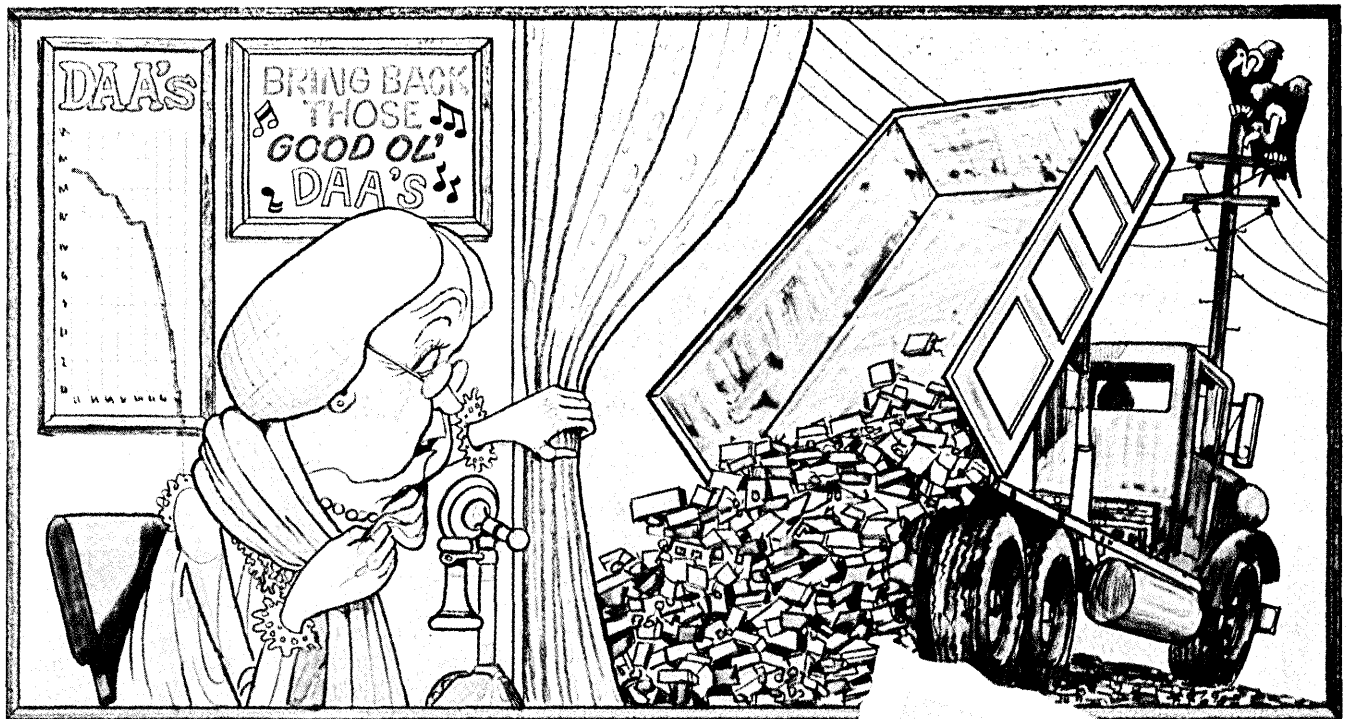

**Dear Ma:**

**You may be getting back some DAA's now that Vadic modems no longer need them.**

A lot of folks will be moving out of your high rent district, Ma, now that Vadic is delivering direct connect 300 bps modems, the first to be registered under Part 68 of the new FCC rules.

It's an historic occasion, because modem users happily will no longer have to spend from \$4 to \$8 each month renting your Data Access Arrangements (DAA). Instead, the new Vadic 317S connects directly to the telephone network, using the FCC approved data jack.

For end-users, the VA317S is available, with Vadic's powerful displays and diagnostics, either in a stand-alone cabinet, or in the Multiple Data Set System where 16 modems (including built-in DAA's) take up just 7 inches of vertical rack space. OEM's can buy the VA317S packaged on a single PC board.

The VA317S is only the beginning, Ma. Before long, all Vadic dial-up modems will have built-in DAA's. Also, Vadic has designed a complete line of stand-alone, rack mount, and card form DAA's.

You can get the whole story, Ma, by phoning, or writing, to Vadic today.

Your independent thinking son,

*Alexander Graham Jr.*

PS: Vadic has shipped over 140,000 modems to date.



Member of IDCMA

THE VADIC CORPORATION  
505 E. Middlefield Rd., Mountain View, CA 94043  
Tel: (415) 965-1620 TWX: 910-379-6567

See Vadic at NCC - Booths 1835 - 1837

Inquire about our new Ma Bell T-Shirts.  
See Vadic at Info 77 NYC and Intelcom 77, Atlanta, GA.



# You don't have to think big

One of the biggest names in big computers just became one of the biggest names in small computers.

Because Sperry Univac just acquired Varian Data Machines. Lock, stock, and slide rule.

From now on, Varian's complete line of mini's will be brought to you by the mini-computer operations of Sperry Univac.

The whole family—from the world's first mainframe on a board to the top of the line—will carry the Sperry Univac label.

Of course, these machines were always a good buy. But now they're assured of all the service and support that Sperry Univac can command. All the former VDM employees, all the dollars, all the dedication.

What's more, we're totally committed to



# to think Sperry Univac.

supporting and enhancing Varian's current product line.

Write to us at Sperry Univac Mini-computer Operations, 2722 Michelson Drive, Irvine, California 92713. Or call (714) 833-2400.

The fact is, Sperry Univac is going to be a big success in small computers.

Sperry Univac. Mini's that think like mainframes.

**SPERRY**  **UNIVAC**  
SPERRY UNIVAC IS A DIVISION OF  
SPERRY RAND CORPORATION

# Tbar

## wideband switching to 240Kb

Reconfigure systems using  
3270 style video terminals

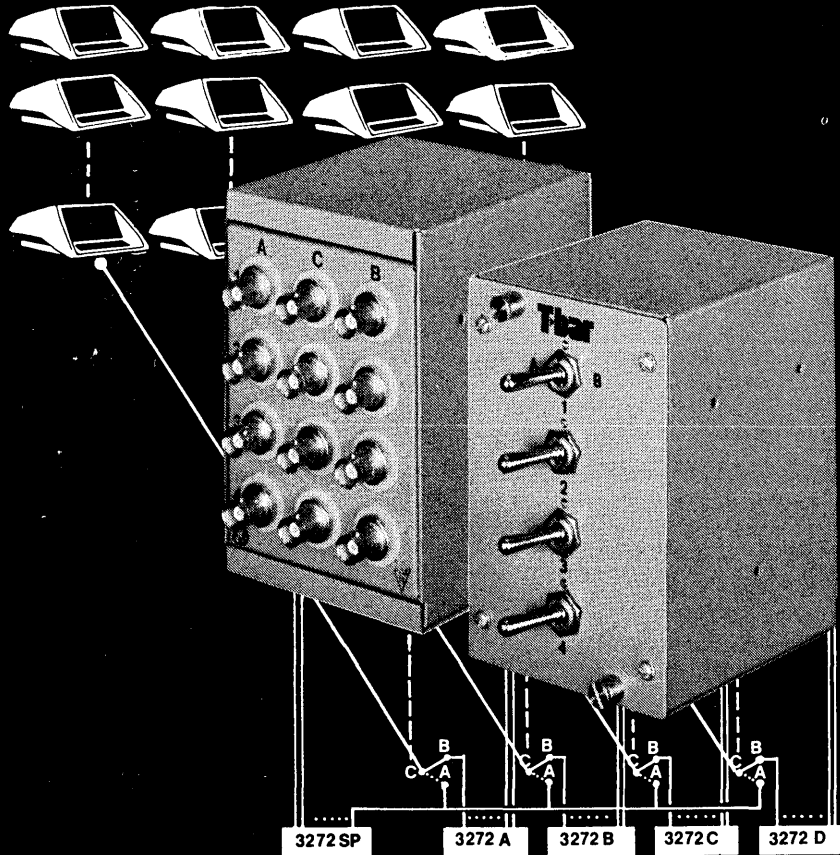

Reconfigure in seconds. Save set-up time. Save money too, by reducing cable routing with flexible T-BAR wide band switching. Transfer intelligent type video terminals between controllers or any front end coax interface, singly or in groups of 8, 16 or more.

Other T-BAR wide band switches available . . .

Want more facts?  
Write or phone today . . .

**Tbar** INCORPORATED

DATA COMMUNICATION SWITCHING EQUIPMENT 141 Danbury Road, Wilton, CT 06897  
Telephone: 203/762-8351 • TWX: 710/479-3216

Bell 303  
Interface

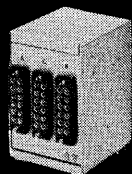

V35/Bell DDS  
Interface

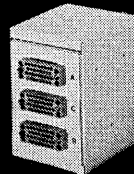

See us at TCA Show, San Diego, CA  
See us at Booth No. 318, INFO 77, New York City, October 17-20

CIRCLE 109 ON READER CARD

## DISTRIBUTORS

ties of the fail-to-repair guarantee and replacement units, but notes cryptically that the warranty terms (which currently require that damaged sections of the machine be returned to DEC through the reseller who originally purchased the unit) have been integral factors in determining prices. As much as the volume-only sales policy, the contract T&C's which shift the cost of depot support and warranty follow-up onto the resellers have been cornerstones of DEC's component group market strategy and pricing. With the independent distributors already realigning themselves to adjust to DEC's ultra-high-volume discounts, the impact of DEC's new muscle in maintenance puts another wild card in the deck.

### Syndicates locked out

There have been some attempts among smaller resellers to form syndicates or consortiums and buy collectively to get high-volume discounts, but DEC has refused to accept purchase orders from syndicates. Other companies have talked merger: Selecterm Inc. of Wakefield, Mass., and Data Access Systems Inc., two of DEC's most substantive regional resellers, met with Teltex of Dallas to discuss merger possibilities in a secret Virgin Islands conference after the Dallas NCC in June, but the talks apparently have broken down. Other groups have met around the country, but, as Chalmers at DEC remarked, "The individuals who are now running the businesses in this industry are rugged individualists. And when they get together to talk about who should take whose orders, it's probably the guy who has the least assets who thinks he should run the other guy's business."

Chalmers, the DEC point man whose personal pledge that DEC wouldn't lease, rent, or sell less than 50 units has been one of the few solid touchstones in this volatile and distrustful industry, has a list of complaints about resellers, yet remains firmly committed to the concept. "Doing business with this group of people may cause me more trouble or ulcers than it's worth," he grumped recently. "But right or wrong, I have a sense that they are very important and that I have to learn to live with them. . . . We kind of played right into their marketplace. By choice. And as I sit here talking to you, I still believe that this distribution channel is the most important asset that we have—beyond the good name of Digital and the quality of the product." \*

# Hazeltine puts performance into economy terminals

The Hazeltine 1500 Series—our third generation of microprocessor-based terminals—puts performance up front! Every feature you need to speed and streamline your data communication operation is available in one of three levels of performance. No extra cost options! Features include:

- Integral numeric keypad.
- Switchable upper/lower case.
- Ultra high-resolution video display—designed and built by Hazeltine, the Company that has pioneered video displays for over three decades.

Best of all, you get all this "Hazeltine Performance" at an economy price, with a nationwide network of trained Hazeltine specialists available for on-site service. Call for a convenient demonstration.

## Hazeltine 1500

*A new definition in conversational terminals that includes most features usually found only in higher priced terminals.*

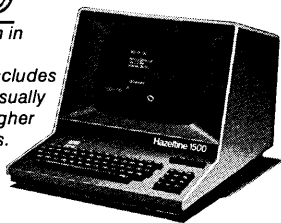

## Hazeltine 1510

*A buffered editing terminal with a unique concept in function keys.*



## Hazeltine 1520

*A multi-processor terminal system, with programmable peripheral controller and interface.*

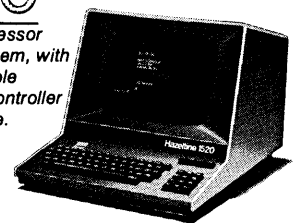

Hazeltine Corporation, Computer Terminal Equipment, Greenlawn, New York 11740 (516) 549-8800 Telex 96-1435  
EAST: N.Y. (212) 586-1970 □ Conn. (203) 875-6429 □ Boston (617) 261-5867 □ Pittsburgh (412) 343-4449 □ Phila. (215) 676-4348 □ Wash., D.C. (703) 979-5500 □ Rochester (716) 254-2479.  
MIDWEST: Chicago (312) 986-1414 □ Columbus (614) 488-5913 □ Detroit (313) 559-8223 □ Indianapolis (317) 299-5332. SOUTH: Atlanta (404) 434-8444 □ Dallas (214) 233-7776 Houston (713) 783-1760 □ Miami (305) 940-3113 □ Orlando (305) 628-0132. WEST: San Mateo (S.F.) (415) 574-4800 □ L.A. (213) 553-1811 □ Denver (303) 770-6330 □ Seattle (206) 242-0505.  
CANADA: MISCOE Data Communications Equipment Services, Ltd.  
Toronto (416) 678-7354 □ Montreal (514) 631-4381 □ Vancouver, B.C. (604) 731-0714 □ Calgary (403) 264-8237 □ Winnipeg (204) 944-0256  
ENGLAND: Hazeltine Ltd. 01-948-3111 Telex (851)-928572. GERMANY: Hazeltine GmbH 0611-590748 Telex (841)-416924. FOR WORLDWIDE SALES INFORMATION CALL: (516) 549-8800.

CIRCLE 63 ON READER CARD





# There's a very thin line between making it or breaking it.

## That's important to remember with high-density drives.

The advantages to 6250 CPI recording — like higher data transfer rates and a reduction in library size requirements — are numerous.

But there are also some disadvantages. One of them is the masking by the GCR format. Because of it the only way to get an accurate error listing is through sense byte interrogation. Ask your Graham product technology man why.

Because of unnoticed errors serious degradation in read/write reliability can occur. This is compounded by debris from bargain-priced computer tapes, which don't have the modulus of toughness and durability of Epoch 4.

Get certified error-free Epoch 4. It makes all the difference. Now — and for the future.

 **GRAHAM  
MAGNETICS**

Graham, Texas 76046

CIRCLE 57 ON READER CARD

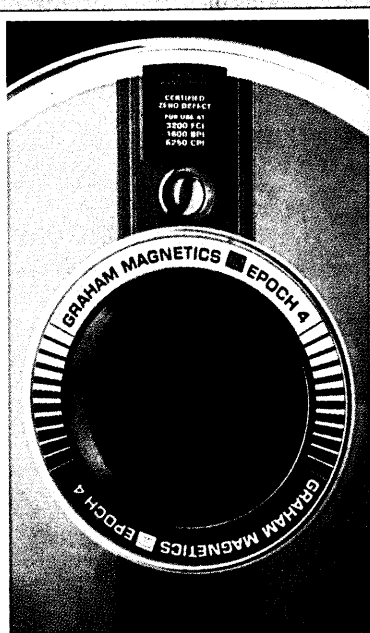

**Membership means many things to the more than 1000 member units that belong to the Association of Data Processing Service Organizations.**

**Membership means an opportunity to learn new management skills, to help form industry policy, and to fully understand the business challenges facing the computer services industry.**

# WHY ADAPSO IS NUMBER ONE

Toward these ends, ADAPSO offers a wide-range of services:

- Semi-annual management conferences to explore the opportunities motivating this \$5.5 billion industry.
- Management seminars on such timely subjects as turnkey minicomputer systems, advertising, international marketing and data communications.
- Development of positions on such governmental topics as privacy and security and electronic funds transfer.
- Commitment to forming policy on state taxation of computer and software products and services.
- Industry economic reports to use as a planning tool.
- Identification with the only association that represents software, data center and timesharing companies.

On October 19-21, ADAPSO will hold its 17th annual membership meeting and 47th management conference at the Hyatt House on Union Square in San Francisco. The conference provides a chance to learn about the major issues confronting the computer services industry. It will also furnish an opportunity to visit Computer Services Exposition—1, the first exposition held in conjunction with an ADAPSO management conference. Exhibitors can directly market their products and services to several hundred industry decision makers, executives who are responsible for buying such products as computer hardware and terminals, maintenance contracts, security systems, and software products.

ADAPSO 210 Summit Avenue, Montvale, N.J. 07645 (201) 391/0870



I see why ADAPSO is number one. Send me more information on:

- ADAPSO membership       The San Francisco Management Conference  
 Computer Services Exposition—1

name \_\_\_\_\_

address \_\_\_\_\_

city

state

zip

ADAPSO 210 Summit Avenue, Montvale, N.J. 07645 (201) 391/0870

# TI's new portable means remote



Until now, remote order entry meant expensive on-line operation with a computer via a telephone line.

But TI has changed all that.

The new *Silent 700\** Model 765 Portable Memory Terminal has built-in bubble memory. So it can remember, even when the power is off, while it waits to talk to your computer.

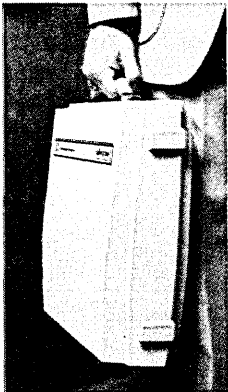

With the 765 you can enter sales and order information all day long using the typewriter-like keyboard.

Then you can edit when you have time.

The 765's powerful, yet easy-to-use text-editing functions let you add, delete, locate, and correct data on the spot. So you can transmit more accurate data when the phone rates are lower. At a fast 30 characters per second.

## **Traveling companion.**

Lightweight portability is the key to convenient field use. And at 17 pounds, the 765 is really compact.

But it's no lightweight when it



comes to features. With its built-in numeric cluster, keyboard with upper and lower case characters, quiet 30-cps printer, and

acoustic coupler for telephone connection, the 765 is a heavy-duty operator.

And the 765 gives you plenty of storage space. The basic terminal comes with 20K bytes of memory. And it can be expanded to 80K bytes—the equivalent of up to 20 fully typed pages.

# memory terminal order entry.



## Office companion.

Many people want a terminal with the features of the 765 for applications where portability is not required. So we designed the Model 763. A table-top version of the 765, the 763 has the same performance capabilities in a compact unit, and comes standard with either a TTY current loop or EIA interface instead of the acoustic coupler.

## Small price for remembering.

TI's new Model 765 Portable Memory Terminal is priced at only \$2,995.† Additional 20K increments of bubble memory are \$500† each.



And, the table-top Model 763 at \$2,695† is another price/performance leader. Of course, quantity discounts and a complete range of lease programs are available.

## TI terminals mean business.

Ask TI how the new *Silent 700* Memory Terminals can help your business. Return this coupon today for more information. Or call Terminal Equipment Marketing at (713) 494-5115, extension 3286.



## TEXAS INSTRUMENTS INCORPORATED

Yes! I am interested in the 765/763.

Please have your representative call.

Please send me more information.  765  763

**silent 700**  
electronic data terminals

13-9-DM

Name \_\_\_\_\_

Title \_\_\_\_\_

Company \_\_\_\_\_

Phone \_\_\_\_\_

Address \_\_\_\_\_

City \_\_\_\_\_ State \_\_\_\_\_ Zip \_\_\_\_\_

Mail to: Texas Instruments Incorporated, P.O. Box 1444,  
M/S 784, Houston, Texas 77001

\*Trademark of Texas Instruments Incorporated

†Qty. 1, U.S. Domestic Price

Copyright © 1977, Texas Instruments

# TEXAS INSTRUMENTS.

# The pioneer of small business computers now makes small business computers.

Actually, Basic/Four Corporation has been making its own central processing units since August, 1976. We now make our own terminals, too.

We wanted tighter rein on manufacturing and testing, choice of the latest components, total control of quality, production and delivery. So we could offer even more reliable, better products.

Now we do.

The Basic/Four® CPU's new semiconductor memory means 40% faster cycle time, down from 1 microsecond to 600 nanoseconds. New models make expansion even easier, accommodating one to 16 terminals. There are other improvements, too, with more to come.

And the Basic/Four systems we make have been running, bug-free. Just like before—only better. The best small business computers available.



## Look to the pioneer



Ever since we pioneered the field, our operating system has been acknowledged as the best of any small business computer. It had to be—because our systems were always interactive, even when others were batch.

Nowadays, everyone in the field

is talking "transaction processing"—following our lead, some six years later!

## All-around simplicity

We also made sure our system would be the easiest to install. And operate.

The software uses BUSINESS BASIC. And we have applications modules that are pre-planned and packaged, including such eminently usable programs as CBS (Comprehensive Business System) and EASY, an exception analysis system. Plus a multitude of specialty packages. For

hospitals, insurance, travel agencies, bond brokers, banking, the apparel industry, trucking, publishing—literally dozens, and more on the way.

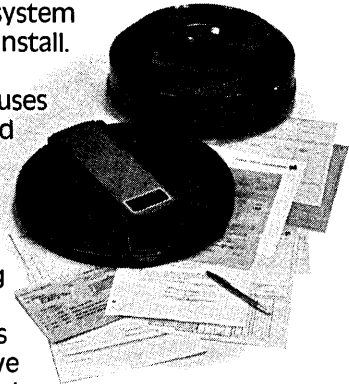

## Full time commitment

Our specialty is small business computers; it engages our full attention, dedication and effort. And, of course, as the pioneer, we've been at it longer.

Long enough to have established through SORBUS INC., our sister MAI company, a national network of support and service, 24-hours a day, if needed.

All this leadtime and concentration keeps us ahead.

And now we make our own. So we know we're offering the best.

If you'd like to know more, call or write: Basic/Four Corporation, 18552 MacArthur Blvd., Irvine, CA 92714



**basic / four corporation**  
an MAI company



Albuquerque • Atlanta • Baltimore/Washington • Birmingham • Boston • Buffalo • Chattanooga • Chicago • Cincinnati • Clark, N.J. • Cleveland • Dallas • Denver • Detroit • Fresno • Grand Rapids • Hartford • Houston • Indianapolis • Kansas City • Las Vegas • Los Angeles • Lubbock • Madison • Memphis • Miami • Milwaukee • Minneapolis/St. Paul • Nashville • New Orleans • New York • Orange County, CA • Philadelphia • Phoenix/Tucson • Pittsburgh • Portland • Richmond • Sacramento • Salt Lake City • San Antonio • San Diego • San Francisco • Seattle/Tacoma • St. Louis • Syracuse  
Basic/Four Systems are also marketed in more than 30 foreign countries.

# They work for Shugart.

**That's why  
Shugart works  
for you.**

**Commitment.** Founded in 1973, Shugart is committed to being the leading independent supplier of low cost disk storage. To be a leader in this complex product area, we believe you must understand the basic technology and concentrate company resources on applying this technology to provide cost-effective products.

**Technology.** Our engineers invented floppy technology. This has allowed us to make industry breakthroughs like the first independently developed IBM compatible floppy disk drive, the first double density drive, the first minifloppy® and the first double-sided, double density drive. These product developments are at work in more than 100,000 drives.

**Experience.** Our engineering staff holds more than 40 patents in disk and related technology. They developed the first floppy and all subsequent generations. At Shugart alone in the past four years, our engineers have 17 patents applied for or granted.

**Leadership.** More commitment, more technology, more experience. That's why more OEM's choose Shugart drives.

**Shugart. The leader in low cost disk storage.**

 **Shugart Associates**

415 Oakmead Parkway, Sunnyvale, California 94086  
Telephone: (408) 733-0100  
Europe Sales/Service: 3, Place Gustave Eiffel, Silic 311  
94588 Rungis, France Telephone: (1) 686-00-85

CIRCLE 7 ON READER CARD

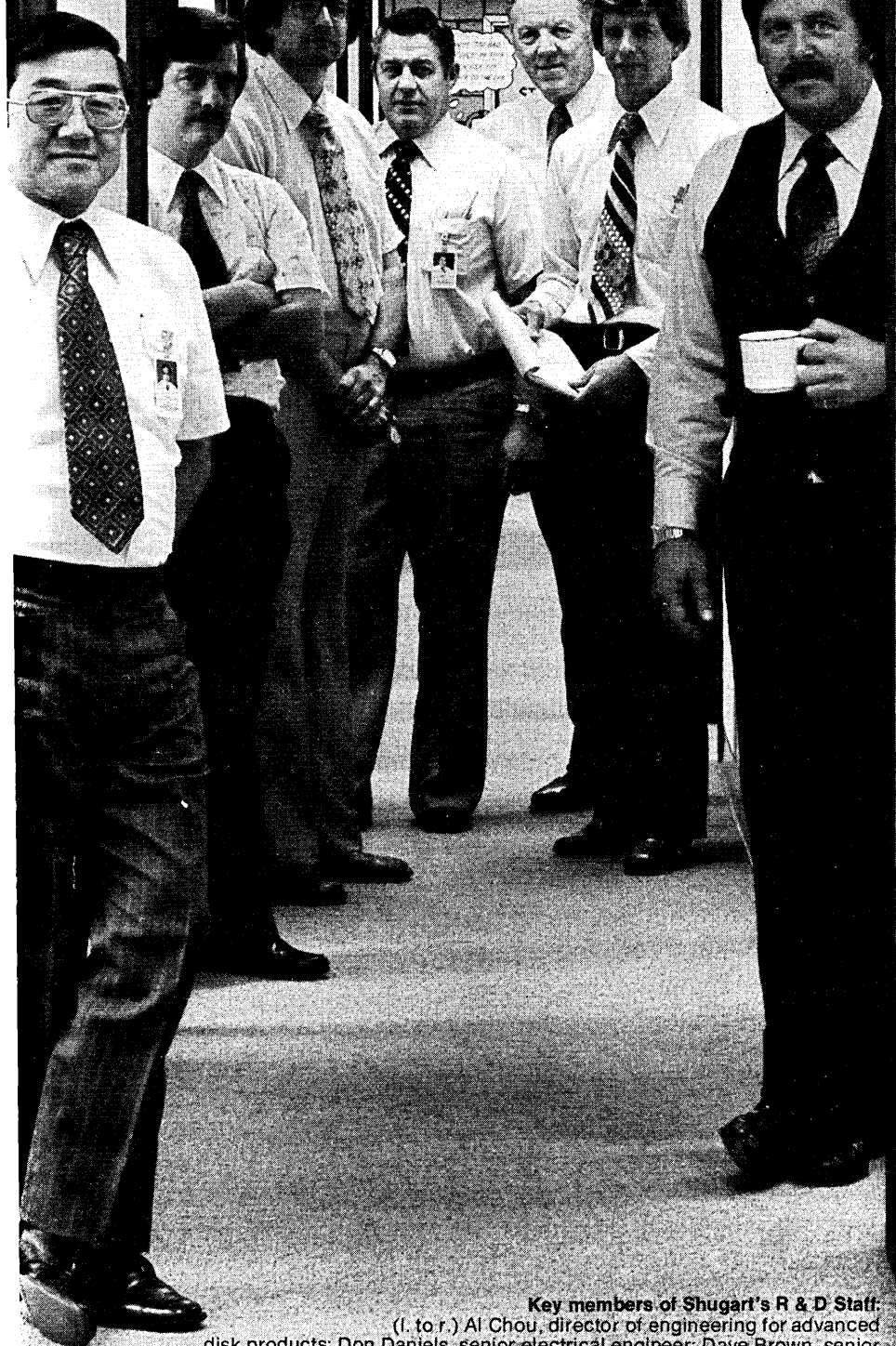

**Key members of Shugart's R & D Staff:**  
(l. to r.) Al Chou, director of engineering for advanced disk products; Don Daniels, senior electrical engineer; Dave Brown, senior mechanical engineer; Bob Franchini—manager, applications & support; Herb Thompson, director of recording technology; Warren Dalziel, senior mechanical engineer; Don Wartner, director of engineering for flexible disk products.



# Can your computer system pass this test?

Recent independent studies show that the HP 1000 real-time computer system, with its new 21MX E-Series high-speed processor, ranks head and shoulders above other small computers. Test your favorite against Hewlett-Packard's price/performance leader:

Feature	The HP 1000	Your old favorite
CPU	2M bytes memory capacity. Standard I/O rates of 2M bytes per second; burst rates up to 11.4M bytes per second.	
Micro-programming	Full software for developing and running 8.5K 24-bit words. 175 ns instruction execution time.	
Memory Speed	Cache speed 350 ns cycle time for all 2M bytes; just \$2100* per 32K bytes. 595 ns cycle time: \$1600 per 32K bytes (just 5¢ per byte!).	
Operating Systems	One upward-compatible family of Real-Time Executives: memory-based or disc-based RTE up to 2M bytes. BASIC, FORTRAN and Assembly languages. Pick what you need for today's job—expand when you're ready.	
Data Base Management	IMAGE, HP's complete DBM capability, plus QUERY language for easy access to related data, costs just \$2500.	
Networking	Over 150 RTE networks installed and running. Modems or high-speed hardwired communications. Also RJE/1000 2780 emulator at 9600 baud.	
IEEE-488 Interface	HP-Interface Bus (HP-IB). HP's implementation of IEEE-488, allows simple link to instruments. Complete software including driver, formatters, message subroutines.	
Cost (Every HP 1000 includes 21MX E-Series CPU: CRT with dual mini-cartridges and soft keys; and RTE operating system.)	Model 20, 64K-byte memory-based system: \$21,000. 500K-byte flexible discs optional.	
	Model 30, 64K-byte disc-based system, 15M-byte disc storage: \$36,500. 5M- and 50M-byte discs available.	
	Model 80, 128K-byte data base management system with 15M-byte disc storage, IMAGE, mag tape, and line printer: \$61,700. 50M-byte discs available.	
Delivery	12 weeks ARO.	

*\*All prices shown are U.S. Domestic List.*

I'd like to take a closer look at:

HP 1000 system Model 20\_\_\_\_, 30\_\_\_\_, 80\_\_\_\_, 21MX CPUs\_\_\_\_.

Please send literature.

Call me to arrange a demonstration.

Send me support information for OEMs\_\_\_\_, software houses\_\_\_\_.

Name \_\_\_\_\_ Phone \_\_\_\_\_

Company \_\_\_\_\_

Address \_\_\_\_\_

City/State/Zip \_\_\_\_\_

Any more questions about the price/performance winner? Then call your nearest Hewlett-Packard office listed in the White Pages and ask an HP Computer Systems Representative. We'll be glad to arrange a demonstration of the HP 1000. Or send us the coupon and we'll get in touch with you. You'll find that our computers are even better in action than they are on paper.

Mail to: Robert Puette, Hewlett-Packard, 11000 Wolfe Road, Dept. 406, Cupertino, CA 95014.

2270HPDS3

*Performance comes in three sizes:  
the HP 1000 Models 20, 30, and 80.*



HEWLETT  PACKARD

You can't solve today's access control problems  
with yesterday's concepts...

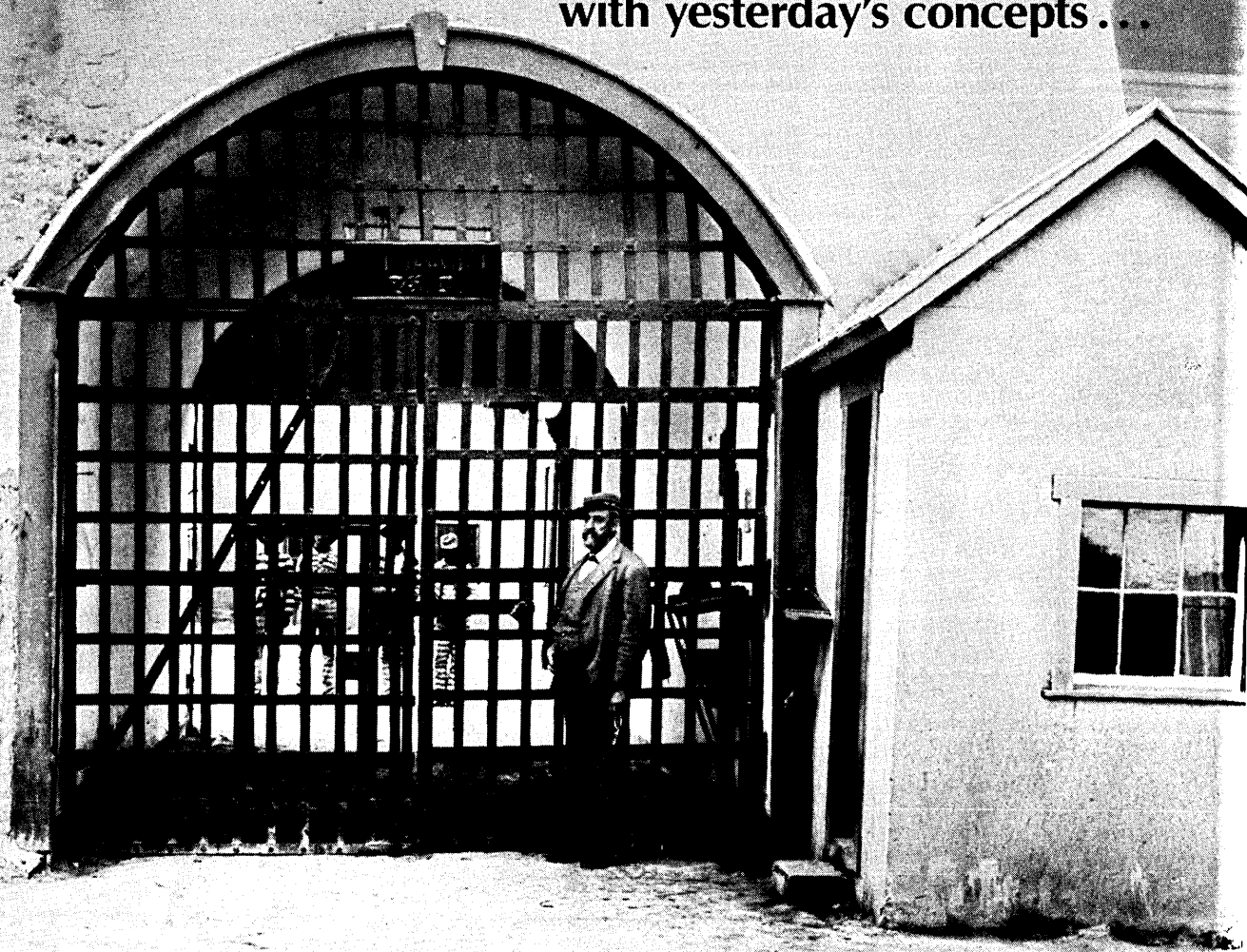

## Consider the hidden alternative — Schlage Electronics Access Control System

Schlage Electronics introduces an access control system that not only eliminates the need for guards and conventional keys, but for card slots or pushbuttons as well. It's the "hidden alternative," the first practical application of electronics technology to control access for business, industry, even residential complexes. Easy to use and install. Regulates and records access by door, time and individual. The Schlage system operates by proximity. A hidden sensor scans a credit card-size command card and transmits signals to a control unit, which regulates access, and to a printer, which records access and attempts. You program the system to suit your needs. Planning and installation is as close as your nearest Schlage Electronics dealer, backed by over 50 years of security service. You can start solving today's access control problems by calling toll-free, (800) 538-1755. In California call (408) 736-8430.



When a valid command card passes within 4 to 6 inches of a concealed sensor, the door is activated immediately. Command cards may double as employee ID cards and can be used to activate the Schlage system while remaining in a pocket or purse.

### **SCHLAGE ELECTRONICS**

A Schlage Lock Company  
1135 E. Arques Avenue  
Sunnyvale, California 94086  
(408) 736-8430



# Survey of Small Business Computers

by Alyn J. Gorman, Edmund J. Armon, and Kathleen M. Fehrenbach

A net loss of nine vendors since last year's survey suggests a maturing and highly competitive marketplace for these 88 suppliers to serve.

It's not yet as ubiquitous as the office copier, but the small business computer is getting there.

Shipments have grown from \$794 million in 1972 to \$1.4 billion in 1975 and are expected to continue to grow to \$2.2 billion by 1980. It is estimated that there are more than 100 participants in this lucrative market if systems houses are included. This update of a small business computer survey published by DATAMATION in October 1976, details characteristics of 249 systems currently available.

Generally, each system consists of a keyboard crt for data entry (cards, floppy discs, or cassettes also may be used), a processor with some 8KB of memory, a disc for file storage, and a 30 cps serial printer.

Increasing costs and complexities of doing business are forcing small businessmen to find ways to cut labor costs and gain tighter control over operations, and more and more of them are turning to the small business computers. But, small business computers (SBC's) are not only attractive to small business. Contributing to the growth of SBC's is the rapid increase in demand for distributed processing computer systems and word processing systems. This is attracting large companies to the market.

Major competitors in the market are IBM, Burroughs, NCR, Digital Equipment, Hewlett-Packard, and smaller firms like Basic/Four, Microdata, Nixdorf, and Wang.

In price and performance, SBC's span a wide range that fills the gap between conventional accounting machines and medium-scale computer systems. Purchase prices generally fall between \$5,000 and \$100,000. Microcomputer companies such as Applied Data Communications, Applied Systems Corp., Cado Systems Corp., and Wintex Computer Corp. are offering

SBC's that sell for \$20,000 and under.

## Wide open market

It's a wide open market, still at a stage where eventual domination by the larger firms is uncertain.

And, as with all data processing markets, caveat emptor is the watchword, particularly for the first time users. These frequently have little or no understanding of data processing principles and are in danger of buying the wares of the salesman who arrives first or sells hardest.

No company should ever buy a computer from the first salesman who comes through the door. It's always wiser to check out the offerings of at least a few of the other major suppliers. And a buyer shouldn't hesitate to play one vendor against another in an effort to get the most for his money. All promises of extra software, technical support, or other concessions should be spelled out in the contract.

Before seriously considering the acquisition of any SBC, a buyer should demand:

- detailed specifications of all pertinent hardware and software;

This article and the accompanying comparison tables are condensed from material published in *Datapro Reports on Minicomputers*, a looseleaf information service that includes detailed technical reports on most of the computers listed here.

The 62-page report, "Small Business Computer Specifications," on which this article is based, can be obtained separately from: Datapro Research Corp., 1805 Underwood Blvd., Delran, N.J. 08075. The price is \$12; postage and handling are free if a check accompanies the order.

- a full scale demonstration of the equipment on at least one of his own principal applications or, if that's not practical, on a demonstration program whose functions are similar enough to his own needs so that realistic conclusions can be drawn about the system's processing speed and ease of programming and operation;

- a detailed proposal that spells out exactly what equipment, software, and technical support will be supplied, estimated processing times for each of his applications, all responsibilities of both the vendor and the buyer, and the total purchase price;

- a list of users in his geographical area who are using the system for similar applications.

These users should be contacted and asked about their experiences. They can provide good leads as to what pitfalls to watch out for in installing and using the system.

## Software is critical

Software is a critical area to be evaluated. Availability of software should be carefully investigated and the investigation should include the programming languages, preprogrammed utility packages, and application packages. Vendors' claims and promises concerning the availability and capability of software should be carefully checked. This is particularly true of software that has been announced but not yet released. Vendors have been known to fail to live up to their marketing publicity.

The small business SBC user typically starts with no programming staff. In such a case it is important that appropriate program packages be available to fit specific requirements. If they're not, the buyer should require the vendor to take on full responsibility for writing and testing the initial programs he'll need. The alterna-

## SURVEY

tives are recruiting and training a programming staff or paying an outside software firm. Both are costly. If not kept under strictest control, software costs can accumulate until they equal, or even exceed, hardware costs. Potential dollar savings can quickly be devoured by software costs.

Availability of reliable and qualified vendor support for both equipment maintenance and software aid is another vitally important factor in the business minicomputer environment. The limited resources generally available to small computer users make them heavily dependent on their vendors for such assistance. In many cases the vendor will even design the initial system and make required changes to his program packages. The ability of the vendor to render competent and continuing service is a vital concern.

Some vendors do not offer equipment maintenance and/or software to complement their hardware offerings. In such cases, the user must deal with independent firms in order to complete the packages. In one respect, this is good, because overall costs may be lower. However, when a problem occurs, the finger-pointing game can begin; one vendor blaming another for the system's malfunction. Fortunately, this doesn't happen often. The multi-vendor approach can work well. If it didn't, the independent equipment maintenance and software firms would disappear, and that just isn't happening.

### Purchase vs. lease

And then there is the question of purchase versus lease. The single most important consideration here is the length of time that the particular system is likely to be able to handle the data processing requirements of the buyer's company. Is there room for system expansion, with regard to both the processor and the peripherals, or is this the top of the line? In most cases, it is not a wise decision to make a first system the most powerful system offered by a particular vendor. If a company's operations expand, how can the system be expanded? Will it be necessary to acquire a new and more expensive processor? Worse yet, will it be necessary to change vendors? Generally, if a buyer feels confident that a particular system can handle his data processing needs for five years or more, purchasing the system will be advantageous. But, if he's selected the top of the line or if there are fewer than five years of potential life in the system, it would

probably be better to lease.

From a basic configuration — data entry unit, cpu, storage unit, and printer — there is only one way to go, up, to more memory, additional peripherals, faster printers. The one limit should be what the buyer's wallet will allow.

A prime appeal of turnkey vendors such as Basic/Four, Mini-Computer Systems, Qantel, and STC systems is that all software is written by the vendor and there generally is a clear migration path. Most of these vendors also sell small business computers and services exclusively and, in many cases, are themselves small businesses.

As such they understand the small business user, and what they lack in size and resources is often compensated for by their quick reaction time to problems, general expertise, and eagerness to satisfy.

All this also is true of the growing number of companies now offering microprocessor-based small business systems. This group, still in its infancy, seems destined to be a major force in the SBC marketplace in the near future.

### Equipment from Europe

European-made equipment is making a much greater impact upon the

## Minicomputer Use Up and Increasing

A 21% increase in unit volume purchase of minicomputers in 1977 over 1976 is projected by a study conducted by DATAMATION and G. S. Grumman/Cowen Institutional Services.

A 41% increase in minicomputer purchase dollars is projected reflecting a foreseen step-up in average system price.

These conclusions are based on a survey of DATAMATION readers who indicated an interest as a user or buyer of minicomputers and/or microprocessors when qualifying for their DATAMATION subscriptions. User responses totaled 4,639.

Not surprisingly, the survey indicates Digital Equipment Corp. will dominate among vendors selling minicomputers in 1977. Survey results gave DEC 39.6% in terms of units and 37.3% in dollar volume. Other vendors got: Computer Automation, 4.4% units and 2.9% dollars; Data General, 17.3% units and 15.2% dollars; Digital Computer Controls, 1.6% units and 0.4% dollars; General Automation, 2.4% units and 1.4% dollars; Hewlett Packard, 5% units and 9.1% dollars; Honeywell, 2.5% units and 1.9% dollars; IBM, 2.9% units and 2.5% dollars; Interdata, 3% units and 3.7% dollars; Microdata, 2.6% units and 2.4% dollars; Modular Computer, 2.4% units and 4.7% dollars; Texas Instruments, 2.7% units and 1.7% dollars; Varian, 1.8% units and 2.1% dollars and others, 10.8% units and 14.7% dollars.

The survey showed that add-on purchases are an important component of respondent spending, especially in the case of end users. Respondents indicated 17.1% of their 1977 minicomputer spending was slated for add-on purchases for memory and peripherals.

Respondents also indicated that

some 2,300 of the minicomputers being purchased in 1977 would be for applications otherwise considered for, or previously performed on large mainframe systems.

The survey showed that applications areas with above average functional substitution of minicomputers for large mainframes included business data processing, scientific/engineering computation, time-sharing, and education.

By Standard Industrial Code (SIC) category those which apparently will be above average in substituting minis for big mainframes are food and kindred products, printing and publishing, rubber and plastics, banking, executive, legislative and general government, and administration of economic programs.

As for standalone use of minis as opposed to their use in a multi-cpu network, the survey indicated that Honeywell, Modcomp, and Prime equipment appear to be most heavily involved in multi-cpu configurations.

By vendor, respondents indicated standalone versus part-of-network use as: Computer Automation—standalone, 74%, part of network, 26%; Data General—standalone, 72%, part of network, 28%; DEC—standalone, 67%, part of network, 33%; General Automation—standalone, 76%, part of network, 24%; Hewlett-Packard—standalone, 76%, part of network, 24%; Honeywell—standalone, 51%, part of network, 49%; IBM—standalone, 73%, part of network, 27%; Interdata—standalone, 58%, part of network, 42%; Microdata—standalone, 79%, part of network, 21%; Modcomp—standalone, 51%, part of network, 49%; Prime—standalone, 53%, part of network, 47%; Texas Instruments—standalone, 70%, part of network, 30%; Varian—standalone, 67%, part of network, 33%. \*

small business computer market than in any other segment of the U. S. computer market. Honeywell, International Computers Ltd., Olivetti, Philips, and Nixdorf are marketing equipment manufactured in France, Great Britain, Italy, the Netherlands, and Germany.

The range of equipment from which to choose is wide and growing. Marketing methods differ too. A buyer can buy directly from a manufacturer or a systems house, or he can deal with a dealer. While we're a long way from the point where computer systems are sold like automobiles—off the show room floor—a growing number of SBC vendors have what they describe as auto company-like arrangements with a network of dealers. These include Microdata, Basic/Four, and such smaller companies as Randal Data Systems and Business Systems Products.

And there are alternatives to SBC's for the small business user which should be considered before a decision for an SBC is made. Many small companies (fewer than 200 employees and sales of less than \$5 million) have elected programmable calculators, computer service bureaus, or time-sharing companies to provide the same or comparable services.

Each user must decide which alternative provides the most cost-effective solution to his problem. Beyond that, decisions must be made regarding expandability, flexibility, ease of operation, reliability, turnaround time, compatibility with present operations, and the desirability of keeping all operations in-house. After careful consideration is given to these aspects and any other factors peculiar to a given buyer's operations, an informed decision can be made as to which approach will work best.

No report on today's small business computers could be totally complete. The field of suppliers is just too large and growing too fast. However, in this survey, every reasonable effort has been made to include all of the major suppliers and a high proportion of the smaller ones. The absence of any company from these comparison charts means either that the company was unknown to us or that it failed to respond to our repeated requests for information.

#### Reading the tables

The chart entries require only the following minor explanation:

*Model highlights* and *No. of models*: Space considerations made it necessary to combine many manufacturers' various models into a single column. This was only done when the various models were based on a com-

mon processor or compatible processors. The series name was retained in description, but specific model numbers are not present in every case. The number of compatible models combined is listed. (It should be pointed out that this "shrinking process" was not done by Datapro in its report; model attributes are listed for each model in the manufacturers' line-up.)

*Communications*: As an example of how complete the small business vendors' offerings have become, it wasn't always possible to list every communications protocol offered. Prospective users should either obtain the Datapro survey or rely on information supplied by the vendor through the reader service card mechanism.

*Word size/add time*: Add time was originally intended to be the time required to develop the arithmetic sum of two operands of at least five digits each. Most of the add times actually supplied, however, are for adding two words; some vendors didn't say how many digits were being added, and most of them obviously supplied register-register add times, not including fetch time from memory. Still, the figures can be thought of as a sort of *relative* (and somewhat subjective) power rating for the machines.

*Peripherals*: Not listed in the section of each column is "alphanumeric keyboard," but all of the computers included may be assumed to have one — though sometimes as an option.

*Pricing*: Base system purchase prices and lease or rental figures are approximate. They are included only as pointers.

*Notation*: Some abbreviations used might not be immediately recognizable, including "seq" and "indexed

seq" for sequential and indexed sequential access methods; "cart," "pack," and "fixed" for cartridge, disc pack, and fixed-head disc; "10-key" for numeric keypad; and "ppt" for punched paper tape.

Two other features of the tables require explanation. First, the notation "n/g" sometimes appears; it means "not given" rather than something derogatory. Second, "support" means different things to different people, and the true story as to what each vendor means by support should be obtained directly from them. (*Tables start on p. 194, vendor index, p. 222.*) Good hunting!

\*



Alyn J. Gorman is managing editor of Datapro Reports on Minicomputers, a looseleaf information service published by Datapro Research Corp. Previously, he served as both computers editor and peripherals editor of Datapro 70. Prior to joining Datapro, he was manager of software documentation for RCA Corp. and a senior programmer/analyst in product evaluation for Sperry Univac. His 17 years of dp experience also includes service as a programmer/analyst for Curtis Publishing Co. and the U.S. Government. He graduated from the Univ. of Pennsylvania with a B.A. in Journalism.



Edmund J. Armon is associate editor of Datapro Reports on Minicomputers. Prior to joining Datapro Research Corp., he was assistant director of the Institute of Computer Sciences in Philadelphia, where he developed the school's curriculum and supervised its in-house computer operation. He has more than 10 years of experience, and holds an M.A. in Mathematics from Temple Univ.



Kathleen M. Fehrenbach is assistant editor of Datapro Reports on Minicomputers. Previously, she was assistant editor of the Datapro Directory of Software. Before joining Datapro Research Corp., she was a research assistant for the College Placement Council. An honors graduate of College Misericordia with a B.A. in English, she also has done graduate work at Lehigh Univ.



# There isn't a single single- that can touch Tandem in

To begin with, we're twice as good. With multiple processors. It's as simple as this. On-line means on-demand, and one processor won't do. Because any processor, even one of ours, can fail. And if that failure occurs during a peak period of transactions, you're out of business while it's down. And out of luck if you miss your re-start point or clobber your data base. And out of control if you lose or duplicate the transactions in process when the failure occurs.

## **You need a NonStop™ System.**

Tandem has built the world's first multiple processor system, designed from scratch in both hardware and software, to provide non-stop processing—even during a failure—with no penalties in the speed, capacity, throughput or memory utilization of the system.

And it can grow without penalty. Starting with a basic two processor system, users can add processors, memory or terminals incrementally all the way to a fully expanded system of sixteen processors supporting 2048 data communications lines, with individual files of up to four billion bytes fully supported by a comprehensive data base management system. But the best part is that you never have to reprogram. Ever. Your Tandem NonStop System just gets bigger and better. At remarkably low cost.

## **Why the big ones fail.**

The big mainframes are expensive to begin with. And even they can fail. Which can leave you high and dry in the on-line environment. But there are other difficulties with the big numbers, too. Of prime consideration in the on-line world, they offer very limited throughput for their price. And by the time you've hung a lot of communications lines on them, they suffer a derating which makes their performance even less attractive.

And whereas you may eventually need that kind of horsepower in your

on-line system, chances are it's an expensive overkill at the outset. What you need is a system which will do the job efficiently on the way in, and grow as your needs grow, in modest price increments. It makes the big systems people wish they were more flexible.

## **One mini just won't make it.**

Minis have made a name for themselves, justifiably. But in the world of on-line, where needs keep growing, the one mini system just can't cut it. With the architectural limitations inherent to a single mini system, growth can build system overhead so fast you'll grind to a halt before you know it.

## **And strap-ups will kill you.**

The answer might seem to be to strap two processors together. One goes down, and the other takes over. Right? Wrong. It's not that simple. System software for a single processor system won't run on the strap-ups. And the fate of any transactions-in-process at the time of a failure is unknown. As is the state of any records being updated. And growth beyond the original system capacity is well nigh impossible.

*The Tandem 16 NonStop System is composed of multiple, independent processors with dual redundant communications paths. The unique interaction between Tandem hardware and software assures not only continuous operation, and the integrity of your data base, but also throughput unmatched by any other computing system of comparable cost.*

What you really need is the one multiple processor system designed for multiple processor operation. Tandem's NonStop System.

## **The four major "on-line" considerations.**

When anyone is considering an on-line system, regardless of size, there are four primary points to consider. Throughput. Availability. Data Integrity. Transaction Protection. The system must be able to handle the job. It must be there when you need it. You must be sure of the integrity of your data base. And you must be sure you don't lose or duplicate a transaction. Even during a failure. No single processor system anywhere can provide that assurance. It takes a multiple processor system designed for the on-line environment, and Tandem is it.

## **For better throughput, spread the files.**

We built the Tandem NonStop System with geographic independence of programs and files. They're handled automatically under Enscribe, our Data Base Record Manager. And instead of having one processor with one bottlenecking channel and a

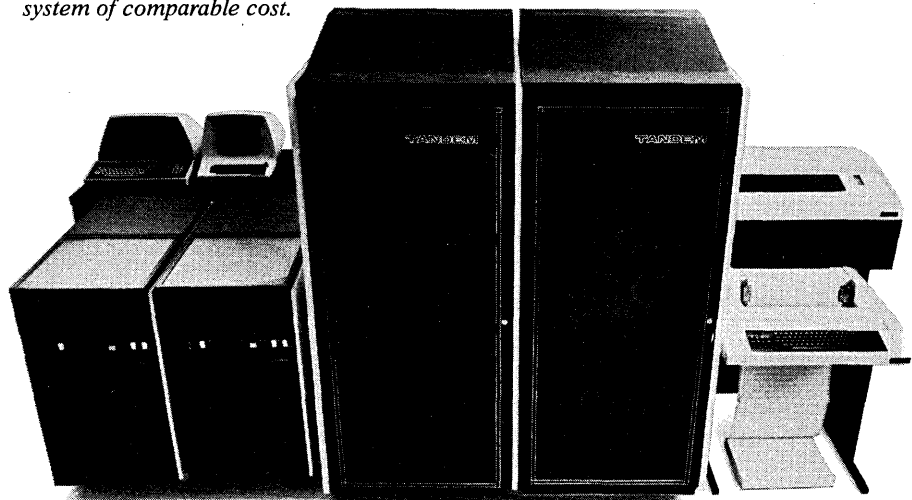

# processor system anywhere an "on line" environment.

fixed priority system, Tandem's NonStop System distributes the work and the files across multiple processors, multiple discs, and multiple channels. Enscribe controls the pattern and the flow for maximum efficiency. Because of simultaneous disc accesses, there's a dramatic improvement in response time. It's one of the performance benefits about a multiple processor system which you can't get on a single processor system.

## **Ease of programming, by design.**

Historically, multiple processor systems have been a bear to program. Not with Tandem. Guardian, Tandem's operating system, lets you write your programs as usual. You can add more processors, or memory, or terminals as you need them. No need to rewrite programs. Ever.

And we make it easy to write the programs in the first place, with COBOL or with TAL, a powerful language designed for fast, flexible programming. The software development tools of this mini-based system rival those of far more expensive systems, and include NonStop operation, data communications, mirror volume capability, full file protection, screen formatting programs, and a host of housekeeping utilities.

## **When you're thinking "on-line," think in Tandem.**

Which means think in multiples. Few, if any, "on-line" systems can be installed and forgotten. The number of transactions, the number of terminals on-line, or the number of applications programs to be run on the system keep growing. Most likely, all three will multiply.

Which is traumatic unless you've started with the one system on the market which can grow with you—even if the growth occurs during the initial configuration phase—without having to start all over again.

## **NonStop growth and NonStop protection, too.**

Because the Tandem System was designed for NonStop operation in both hardware and software, it offers an extraordinary measure of protection against a failure in any processor, I/O channel, disc drive, or in the software. No other system offers this measure of assurance.

When a failure does occur in any segment of the system, its back-up counterpart completes the task, without a hitch. Since all programs are geographically independent, and the operating system both distributes and monitors all work-in-process, recovery from a failure is instantaneous. There is no restart; no backing up to a hopefully safe point.

The system monitors its own operations, performing all tasks in a distributed fashion across the multiple processors. Even when a CPU goes down, another CPU is immediately aware of the failure and picks up the task in process and completes it. No data and no transaction need ever be lost or duplicated. The integrity of the data base can be fully protected. It is truly unusual, but it's one reason why we say no single processor system anywhere can touch us in the "on-line" environment.

## **NonStop software.**

### **Guardian: Operating System.**

NonStop operation.

Automatic re-entrant, recursive and shareable code.

Virtual memory system.

Geographic independence of programs and peripherals.

### **Enscribe: Data Base Record Manager.**

Provides relative, entry-sequenced and key-sequenced files.

Each file may be up to four BILLION bytes.

Up to 255 alternate keys per file.

Optional mirror copy by disc volume.

### **Envoy: Data Communications Manager.**

Languages: COBOL, TAL.

# TANDEM

Tandem Computers, Inc.,  
20605 Valley Green Drive, Cupertino,  
California 95014 or Tandem Computers GmbH, Bernerstrasse 50,  
Frankfurt 56, West Germany.

**Toll Free 800-538-9360 or 408-255-4800 in California.**

*Photo and schematic show three processor modules with space for fourth module, interconnected to disc controllers, tape controllers and communications controllers.*

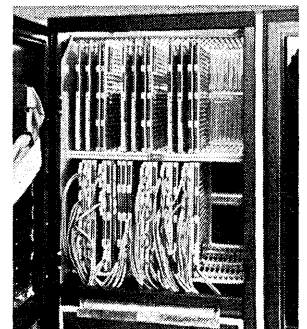
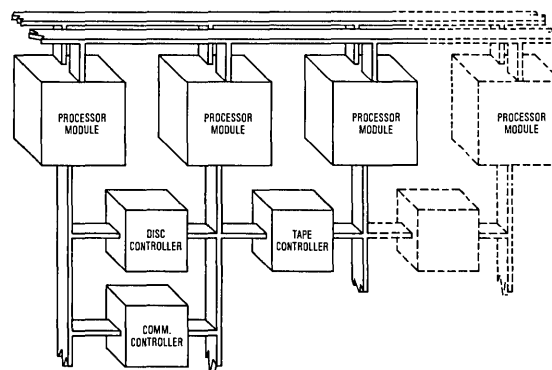

Manufacturer	Advanced Information	Advanced Information	A. K. Industries	A. K. Industries	Anderson-Jacobson
<b>System Highlights</b> No. of models No. installed/date Multiprogramming Communications Applications	System 3000 3 60 since Mar 75 5 partitions 15 lines (2780, 3780, SDLC) insurance, inventory, word proc., order entry, distrib.	System 4000 1 since Oct. '76 12 partitions Unknown limit of lines ins, inven, word proc., order entry, dist.	AKI-90 1 10 since Nov. 1974 no 1 line; synch/asynch/2780 inventory	AKI-91 1 1 since Aug. 1976 2 partitions 8 lines; asynch/synch/2780 inventory	1500 1 since April 1977 8 partitions 9 lines (own protocol); opt asynch CPAs, public accountants
<b>Processor</b> Internal storage Word size/add time	Interdata 7/16 32-64K core (1usec) 16bits, 1.5usec	Interdata 7/32 or 8/32 128K-1M core (750-300 nsec) 32bits, 600nsec	Datapoint 16K MOS 8bits/not given	8080A 32K-64K MOS 8bits/not given	AJ 1500 32K-64K MOS core (1.2 usec cycle) 8bits/4usec
<b>Mass Storage</b> Discs Access methods Mag tapes	floppy, cart, pack random, seq, indexed seq. reel-reel, cart, cassette	floppy, cart, pack random, seq, indexed seq. reel-reel, cassette, cart.	floppy random, seq, indexed seq no	pack random, seq, indexed seq no	floppy, cart sequential, direct no
<b>Peripherals</b>	10-key acct keyboard, ppt, card, serial print (165cps), line print (to 600lpm), mag card, crt	10-key, acct keyboard, ppt, card, serial print (165 cps), line print (to 1000 lpm), mag card, crt	serial print (165cps), line print (to 600lpm), crt, 10-key	10-key, serial print (165 cps), line print (to 600 lpm), crt	10-key, line printer 300lpm serial print (45, 120cps) crt
<b>Software</b>	COBOL, RPG, FORTRAN, macro assemb, PL/1, acct pkg, dbms, BASIC	COBOL, FORTRAN, BASIC, macro assemb, PL/1, acct pkg, dbms	BASIC, assembler, Databus, Dataform, acct pack	BASIC, assembler	BASIC, assembly, ESP acct package
<b>Base Prices</b> Software/support	\$18,528 (\$426/month) soft extra, support incl	\$66,750 (\$1,535/month) soft extra, support incl	\$25,000 (\$550) included	\$30,000 (\$660) included	\$19,990 soft and supp extra
<b>Comments</b>			turnkey system; does not require dp professional for operation	turnkey system; does not require dp professional for operation	Two diskette system; also avail w/four diskettes; up to 10MB

Manufacturer	Applied Data Comm.	Applied Data Processing	Applied Digital Comm.	Applied Digital Comm.	Applied Digital Comm.
<b>System Highlights</b> No. of models No. installed/date Multiprogramming Communications Applications	Series 70 1 100+ since May 1975 yes 2 lines (asynch/synch/bisynch) n/g	Resource/100 1 n/g June 1976 yes 7 lines; asynch to 1,200 bps, IBM 2780 not given	101 1 since 1977 yes no medicine, mfg.	201 1 since 1976 yes no process control	301 1 since 1977 yes no mfg. mgmnt., acctng., data logging
<b>Processor</b> Internal storage Word size/add time	Intel 8080 16K-64K MOS (2usec) 8bits/2usec	Data General Nova 64K-212K core (1usec) 16bits/1.35usec	Wang 2200 8K-32K MOS 8bits/800usec (13 digits)	Varian V77 8K-32K MOS/660nsec 16bits/2.31usec	HP 2100 6K-32K MOS/0.65usec 16bits/1.96usec
<b>Mass Storage</b> Discs Access methods Mag tapes	floppy, cart, fixed head random, seq, indexed seq. reel-reel; cart, cassette	pack random, seq, indexed seq reel-reel	floppy, cart random, indexed seq, seq reel-reel	floppy random, indexed seq reel-reel	floppy random, index seq reel-reel
<b>Peripherals</b>	10-key, acct keybd, ppt, ser. print (to 165cps), line printer (to 1,400 lpm), crt	10-key, ppt, card, serial print (to 330cps), line print (to 600lpm), crt	10-key, ppt, card, serial print, crt	10-key, ppt, card, crt	10-key, ppt, card, crt
<b>Software</b>	BASIC, assembler, acct package	BASIC (extended) assembler, DBMS, acct package	BASIC, acct pack	RPG, FORTRAN, BASIC, assembler	RPG, BASIC, ALGOL, FORTRAN, assembler DBMS
<b>Base Prices</b> Software/support	\$8,285 soft and support extra	\$39,300 (\$865/mo) soft and supp extra	\$30,000 soft and supp extra	\$40,000 soft and supp extra	\$40,000 soft and supp extra
<b>Comments</b>	expands to 8 double-density floppies or 4 10MB discs; time-sharing multi-user OS for 4 terminals		Drug inventory control, patient profile, payroll, text editing	Computer generated image systems, process control systems	

Manufacturer	Applied Digital Technology	Applied Systems Corp.	Applied Systems Corp.	J. Baker & Associates	Basic Four
<b>System Highlights</b> No. of models No. installed/date Multiprogramming Communications Applications	2 10 since Jan. 1972 yes 4 lines; async/sync property management, accounting	ASC 80 1 since 1975 optional 16, 32 lines/synch/asynch/ bisynch/DECnet comm., graphics, dp	ASC 1800 1 since 1974 no 16 lines/asynch/synch/bisynch communications	Distribution Systems 3 30 since Sept. 1975 yes 3-64 lines/2780 manufacturing distribution	350, 400, 600, 700 4 4,000 since 1971 8-16 partitions 8-lines/9600/2780 medical, insurance general business
<b>Processor</b> Internal storage Word size/add time	General Automation SPC-16745, 765 4K-64K core/1.4usec 16bits/1.4usec	Intel 8080/85; Opt. 780 4K-64K+MOS/0.5usec 8, 16bits/2usec,digit	Intel 8080 4K-64K MOS/0.5usec 8bits/2usec/byte	DEC PDP-11 models 32K-4MB MOS or core 16bits/1.8-7.7usec/word	RFC 1320 24-128K MOS (600nsec) 8bits/7.4usec
<b>Mass Storage</b> Discs Access methods Mag tapes	floppy, cart, pack, fixed head direct, seq, indexed seq reel-reel	floppy, cart, pack, fixed head seq, random reel-reel, cassette, cartridge	floppy, cart, pack, fixed head seq, random reel-reel, cassette, cart	floppy, cart, pack, fixed random, seq, indexed seq reel-reel, cassette	cart, pack random, sequential reel-reel
<b>Peripherals</b>	10-key, ppt, card, serial print (165cps), line print (to 600lpm), crt	10-key, acct-keybd, ppt, card, serial print (to 30 cps), line print (to 300 lpm), crt	10-key, acct keybd, ppt, card, serial print (30 cps), line print (to 600lpm), mag ledger card, crt	10-key, ppt, card, serial ptr up to 180cps, line ptrs to 900lpm, crt	10-key, ppt, card, 165 cps serial ptr, line ptrs to 600lpm, crt
<b>Software</b>	COBOL, RPG, FORTRAN, assembler, acct pack	FORTRAN, BASIC, PL/M, assembler, acct. pack	BASIC, assembler, PL/M, acct pack	COBOL, RPG, FORTRAN, BASIC, assembler, DIBOL, acctng pkg, dbms	BASIC, acctng pkg
<b>Base Prices</b> Software/support	\$50,000-\$100,000 soft and supp extra	\$1,500 (\$75/mo) soft and supp extra	\$5,000 (\$250) soft and supp extra	\$34,995 software and support extra	\$34,400 (\$757 month) soft and support extra
<b>Comments</b>	marketed in Chicago area only, purchase only	basic computer system for business and data comm, with modular expansion and peripheral options	oriented towards local and satellite processing w/comm support, or custom apps	distribution application pgms for a variety of vertical industries	available as packaged systems only

# 32-BIT PROFITABILITY



**Profit from  
our 32-bit  
experience.**

Scores of customers are taking advantage of our lead in 32-bit design right now, because we were there first . . . with the first mini with true 32-bit architecture. Hundreds of Interdata Megamini® computers have been working throughout the world since 1973.

Interdata's 8/32 computer processes data at one-half the speed of the IBM 370/158, for about one-tenth the cost. And the Model 7/32 offers even greater economies. With our Multiport Memory System, up to 14 processors can share a single memory bank, increasing throughput and processor-to-processor operation even further.

And, although they cost as little as the 16-bit DEC 11/70 or DG Eclipse, Interdata's Megaminis are the only low-priced computers with no constraint on program size. That's just one benefit of 32-bit architecture.

You also get 219 IBM-like standard instructions, and can create even more of your own with up to 512 words of Interdata Writable Control Store, raising throughput by a factor of five. And for still greater throughput, Interdata's exclusive Hardware Floating Point option improves the speed of scientific calculations ten times faster than software-bound minis.

Send me 1977 specs on your 7/32 and 8/32 Processors and field proven software.

NAME \_\_\_\_\_ TITLE \_\_\_\_\_

COMPANY \_\_\_\_\_

ADDRESS \_\_\_\_\_

CITY \_\_\_\_\_ STATE \_\_\_\_\_ ZIP \_\_\_\_\_

**INTERDATA®**

A UNIT OF  
**PERKIN ELMER DATA SYSTEMS**  
OCEANPORT, N.J. 07757 (201) 229-4040.

D-9

# When it comes to IBM Add-On Memories, we know them INSIDE...AND OUT

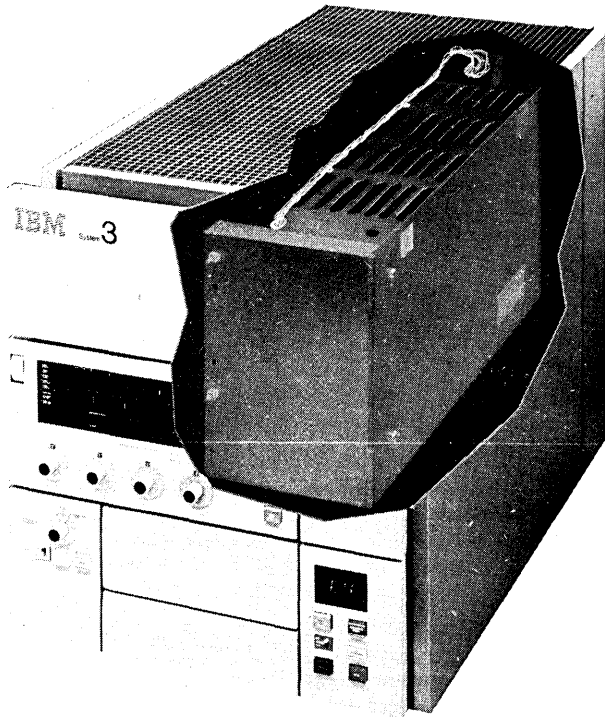

## ECOM<sup>®</sup>-3 FOR IBM SYSTEM/3

The ECOM-3 fits inside the CPU, eliminating site preparation and extra power requirements. Simple. Economical. The best way to upgrade your 5410 CPU to a full 64K Byte system in 8K increments. 5415 Models AB & CD may be expanded to 128KB and 256KB respectively. Plus both ECOM-3 Memory Systems feature automatic fault isolation and an on-line/off-line switch to run diagnostics on IBM memory exclusively. Our memory attachments are acceptable for IBM maintenance. Save money and space on the outside by putting your memory inside the CPU where it belongs.

All IBM Add-on's are newly manufactured and qualify for Investment Tax Credit.

IBM and their Model designations are registered trademarks of International Business Machines.

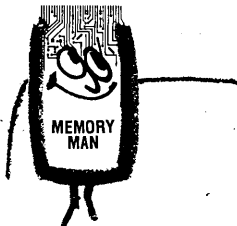

For an instant quotation call The Memory Man toll free: (800) 854-3792, (in California) (800) 432-7271.

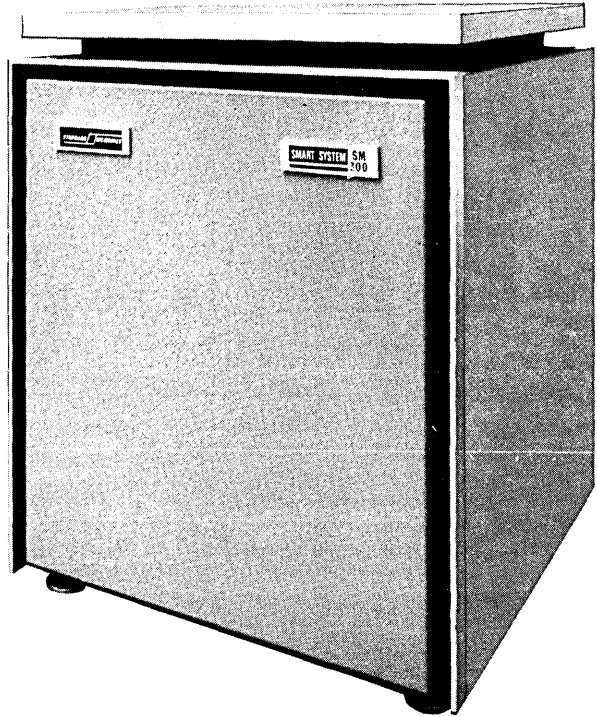

## SMART<sup>®</sup> SYSTEM FOR THE IBM 360

A new outlook on life expectancy for the IBM 360. With our SMART System you can replace your present 360 core memory or expand capacity to as much as 2.0 Meg-A-Bytes... which more than doubles the memory capacity offered by IBM. These expansive increases in memory come in a compact unit that's completely compatible with your host computer and requires a minimal downtime for installation. Buy or lease prices are far below IBM list as well as other manufacturers. All the more reason to get SMART (Standard Memories Add-on and Replacement Technology).

For information, write Standard Memories, 3400 West Segerstrom Ave., Santa Ana, CA 92704 or call (714) 540-3605. TWX 910-595-1596.

**STANDARD MEMORIES**  
*has grown into a new name*



# 10 REASONS WHY YOU SHOULD CONSIDER THE MODEL 40 OEM PRINTER FOR UNDER \$2000 INSTEAD OF SOMEONE ELSE'S FOR MORE.

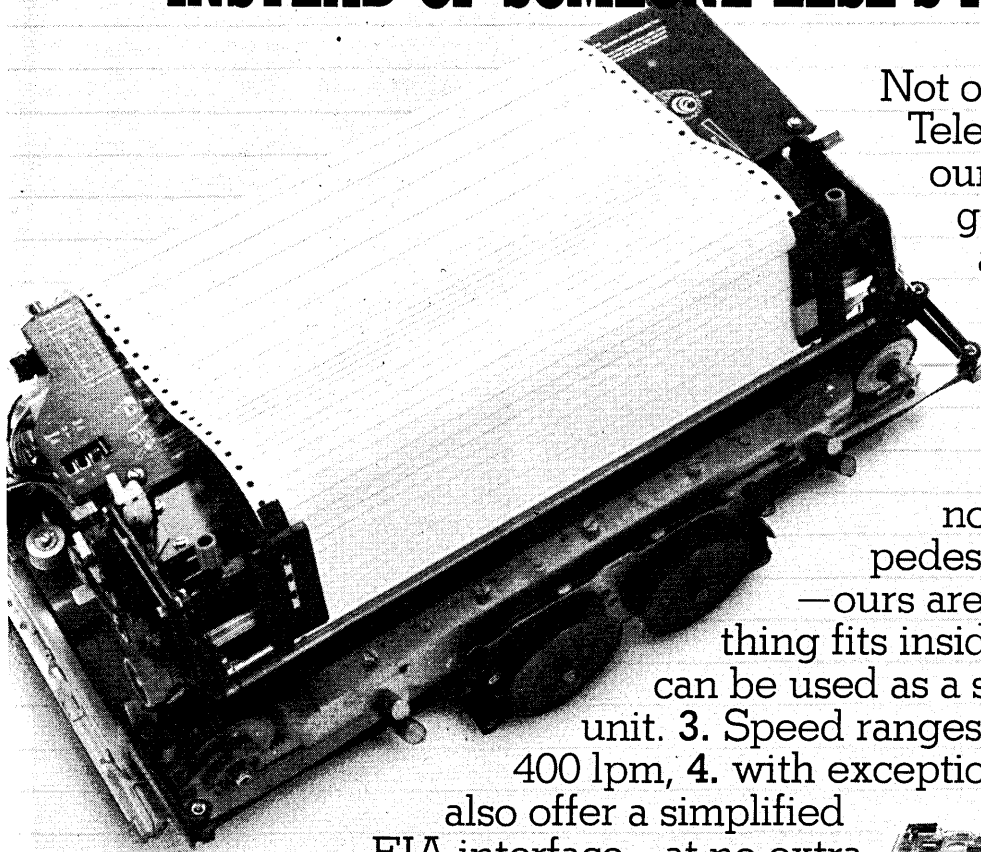

Not only do we at Teletype charge less for our printers, we also give you more quality and features for your money. 1. Like a modular, compact design with 2. state-of-the-art CMOS/LSI technology. Don't look for a pedestal full of electronics

—ours are so advanced everything fits inside the printer so it can be used as a stand-alone table-top unit. 3. Speed ranges from 200 to over 400 lpm, 4. with exceptional reliability. 5. We

also offer a simplified EIA interface—at no extra cost. 6. Field maintenance is simple, too. Service intervals are 2000 hours, and built-in diagnostics

cut trouble-shooting time. 7. There's nationwide service back-up, plus an exchange repair service on everything from printed circuit cards to major assemblies. 8. Print quality from our fully-formed characters is sharp and crisp—from the original to the sixth copy. And we're now offering an optional block-style character font. 9. Parts

commonality between all three printer models is 80%, for fewer logistical problems. 10. Last but not least, the model 40 printers are backed by a company people have depended on for nearly 70 years. Teletype.

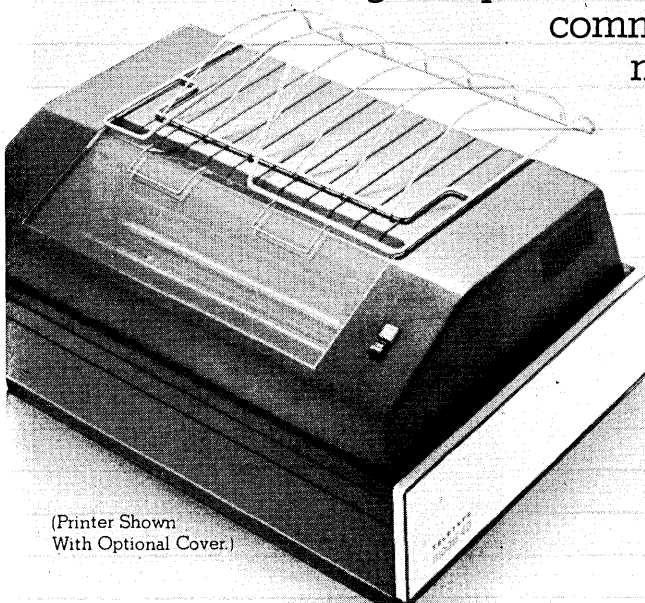
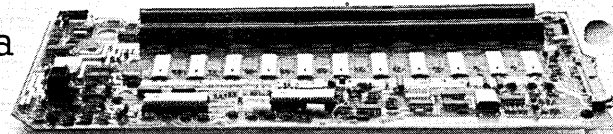

(Printer Shown With Optional Cover.)



**THE TELETYPE® MODEL 40 OEM PRINTER. NOTHING EVEN COMES CLOSE.**

Teletype is a trademark and service mark registered in the United States Patent and Trademark Office.

CIRCLE 113 ON READER CARD



Manufacturer	Basic Timesharing	Binary Data Systems	Burroughs	Burroughs	Burroughs
<b>System Highlights</b> No. of models No. installed/date Multiprogramming Communications Applications	4000 Series 2 n/g, since Jan. 1976 no up to 4 asynch 2500 bps lines school administration	UCOM 3 n/g, since July 1973 up to 64 partitions 256 lines, 2780, SDLC acctg, whsl, dist, real estate, med	B 80 3 n/g, since April 1976 3 programs 4 lines/asynch/synch/ bisynch/BDLC whsl, dist, med, financial	B 730/B 720 2 since May 1973 yes 1 line/asynch/synch/ bisynch/3780/BDLC business	B 801/B 810 2 n/g, since April 1977 yes up to 4 9600bps lines all business acctg applications
<b>Processor</b> Internal storage Word size/add time	BTI 4020 64K MOS (650nsec) 16bits/20usec (5 digits)	Nova 3, 3D, or Eclipse 64-512K (800nsec) 16bits, 10usec (word)	B 80/30, /40, /50 32K-124K MOS/1usec variable/not given	Burroughs B 731 32K-80K MOS/1usec 64bits/430usec	B 800 32-128K MOS (1usec) 64bits/add time not given
<b>Mass Storage</b> Discs Access methods Mag tapes	cart, pack random, seq, indexed seq reel-reel, cart	floppy, cart, pack, fixed random, seq, indexed seq reel-reel, cassette	floppy, cart random, seq, index seq cassette	floppy, cart sequential reel-reel, cassette	floppy, cart, pack random, seq indexed seq reel-reel, cassette, cart
<b>Peripherals</b>	line printer to 900lpm	10-key, ppt, card, serial print (165cps), line print (to 1500lpm), crt	10-key, serial print (to 180cps), line print (to 250 lpm), crt	10-key, ppt, card, serial print (60cps), line print (to 400lpm), crt	10-key, card rdr, serial ptrs (120cps), line ptrs to 750lpm, crt
<b>Software</b>	BASIC, acctg pkg, dbms	COBOL, FORTRAN, BASIC, assembler, dbms, acct pkg	COBOL, RPG, DSC, MPL, NDL, acctg pack	COBOL, RPG, AEL, acctg pack	COBOL, RPG, AEL, MPL, NDL, acctg pkg
<b>Base Prices</b> Software/support	\$35,950 soft extra, support incl	\$45,000 soft incl, support extra	\$22,010 (\$720/mo) w/MCP soft and supp extra	\$30,400 (\$968) soft and supp extra	\$32,400 (\$880/month) soft and support extra
<b>Comments</b>	Up to 32 user terminals concurrently, or 24 plus 4 comm lines	6usec (5 digit) add time for Eclipse-based models, dual processor redundancy		AEL programs can execute concurrently w/RPG or COBOL	

Manufacturer	Burroughs	Business Controls System	Business Controls System	Business Systems Prod.	Cado Systems Corp.
<b>System Highlights</b> No. of models No. installed/date Multiprogramming Communications Applications	B 18XX series 3 since 2nd qtr 1977 yes up to 32/bisynch, BDLC all business acctg applications	System 80 2 100 since 1971 15 partitions 16 lines/asynch/synch/ 2780 retail, mfg., dist., whsl., list maint.	System 80/11 2 since 1976 63 partitions 64 lines/asynch/synch/ SDLL retail, mfg, dist, whsl, list maint	Adviser II, Adviser III 2 n/g, since July 1976 24 partitions up to 24 lines/3780, SDLC distribution	System 40 200 since April 1976 no 1 line/asynch/synch/ 2780/3780 distributed processing, text editing
<b>Processor</b> Internal storage Word size/add time	B 1830, 1860, 1870 48-512K MOS 1220-333nsec 16bits/add time not given	DEC PDP-8/A, E 32K-256K core/1.2usec 12bits/2.6usec-3.0usec	DEC PDP-11/34, /70 64K-204K MOS, core bipolar/.98usec 16bits/2.7usec-7.3usec	Computer Auto. LSI-2/60 64-304K core (980nsec) 16bits/8.24msec (8 digits)	Intel 8080A 5K-9K MOS/1.1usec 8bits/200usec (9 digits)
<b>Mass Storage</b> Discs Access methods Mag tapes	floppy, cart, pack, random, seq, indexed seq reel-reel, cassette	floppy, cart random, seq, index seq reel-reel, cassette	floppy, cart, pack, fixed head random, seq, indexed seq reel-reel, cassette	cart, pack random, seq, indexed seq reel-reel	floppy, cart random, indexed seq reel-reel
<b>Peripherals</b>	card, serial ptrs to 300 cps, line printers (400-500lpm)	10-key, ppt, card, serial print (180cps), line print (to 600lpm), crt	10 key, ppt, card, serial print (180cps), line print (to 1,200lpm), crt	10-key, ppt, card, 120cps serial ptr, line ptrs to 600lpm, crt	10 key, ppt, serial print, line print (300lpm), crt
<b>Software</b>	COBOL, RPG, FORTRAN, BASIC, NDL, UPL, AEL, acctg pkg, dbms	FORTRAN, BASIC, assembler, DIBOL, COM, acctg pack	COBOL, RPG, FORTRAN, BASIC, assembler, DIBOL, DECform, acctg pack, dbms	FORTRAN, ABOL, acctg pkg, dbms	CADOL, assembler, dbms
<b>Base Prices</b> Software/support	\$115,590 (\$3,058 5-year) soft and support extra	\$29,990 (\$600) included	\$40,000 (\$800)	\$38,700 (\$850 month) soft and support extra	\$19,900 software extra
<b>Comments</b>	fixed disc optional on B 1870		supports all DEC operating systems, sorts, etc.	vendor responsible for software incl applications package library	

Manufacturer	Cascade Data	Cascade Data, Inc.	CDA	Century Computer	Century Computer
<b>System Highlights</b> No. of models No. installed/date Multiprogramming Communications Applications	Concept II, III 2 200 since January 1970 2, 4 partitions 8 lines, 2780/bisynch Actg, banking, medical, dist, networks Cascade Data	Concept IV 2 deliveries begin April 1978 2 partitions 8 lines/asynch/synch/ 2780 business acctg	INVOMATS 20, 40, 60, 200 4 68 since Nov. 1974 no 4-8 lines/2780 dist, inventory, acctg	Century 300 600+ since Feb. 1971 10 partitions 256 lines (asynch, synch, CCS) business acctg, dist	models 400-1000 4 186 since March 1975 10/20 partitions 256 lines acctg, dist, finance, hotel
<b>Processor</b> Internal storage Word size/add time	16-64K core (1-1.2usec/ byte) 16bits/8.8-7.5usec/word	Cascade Data 16K-64K MOS/1usec 8bits/2usec/byte	DG Nova 1200/DCC-116 32-64K core (1.35usec) 16 bits/1.35usec	Century 200 32K-60K MOS (600nsec) 8 bits, 2.6usec (5 digits)	Century 400 32-512K MOS/600nsec 16bits/2.6usec (5 digits)
<b>Mass Storage</b> Discs Access methods Mag tapes	floppy, cart n/g reel-reel	floppy random, seq, indexed seq no	floppy seq, indexed sequential reel-reel	floppy, cart, pack random, seq, indexed seq reel-reel, cassette	floppy, cart, pack random, seq, indexed seq reel-reel, cassette
<b>Peripherals</b>	10-key, ppt, card rdr, serial ptr (55cps), line ptrs to 600lpm, crt	10 key, serial print (60cps), line print (to 400lpm), crt	10-key, ppt, card, serial ptrs to 165cps, ptrs to 300lpm, crt	10 key, acctg keybd, ppt, card, serial print (165 cps), line print (to 600 lpm), crt	10-key, ppt, card rdr, serial ptr to 165cps, line ptrs to 1200lpm, crt
<b>Software</b>	RPG, assembler, acting pkg	BASIC, assembler, acctg pack	COBOL, FORTRAN, BASIC, assembler, and acctg pkgs, some separately priced	BASIC, CPL, assembler, acctg pack, dbms	BASIC, assembler, CPL, non-standard FORTRAN, ALGOL, acctg pkg, dbm:
<b>Base Prices</b> Software/support	\$22,200 (\$666/month) soft and support extra	\$14,000 (\$420) soft and supp extra	\$16,800 (\$355 month) includes support	\$30,000 soft and supp extra	\$34,000 software and support extra
<b>Comments</b>	Concept III to be delivered in Nov.		Turnkey systems include specific applications	turnkey system; software sold separately	expandable turnkey systems for handling small to large applications

Manufacturer	Complete Computer	Compucorp	Compucorp	Computata	Computata Systems
<b>System Highlights</b> No. of models No. installed/date Multiprogramming Communications Applications	models 2820-3955 5 n/g since March 1974 yes up to 18 lines/2780 mfg, costing, printing, mortgage banking, acctng	400 series 5 119 since Jan. 1976 no 4-7 lines, asynch only general business, agriculture	625  since July 1977 no 4 lines/asynch	DEC 300/DEC 500 Series 2 125 since 1975 yes up to 24 lines/2780, 3780 mfg, dist, services, retailing	IBM Series/1  1 since 1977 yes 256 lines/asynch/synch dist, services, retail, manuf
<b>Processor</b> Internal storage Word size/add time	Nova 2/10/Nova 3/12 64-256K core/MOS 16bits/1000-700nsec	Compucorp 3000 8-16K MOS (speed n/g) 64bits/80usec (13 digits)	Zilog Z-80 24K-64K MOS/1.6usec 48bits/50usec	DEC LSI-11 to PDP-11/70 42-512K MOS to 725msec 16+2 parity/ (300-2030nsec)	IBM 4953/4955 (Series/1) 64K-128K MOS/660nsec 16bits/4.2usec
<b>Mass Storage</b> Discs Access methods Mag tapes	floppy, cart random, seq, indexed seq reel-reel, cassette	floppy random, seq, indexed seq reel-reel	floppy, cart random, keyed, hashed reel-reel, cart	floppy, cart, pack, fixed random, seq, indexed seq reel-reel	floppy, cart random, seq, indexed seq no
<b>Peripherals</b>	10-key, ppt, card rdr, serial ptrs to 660cps, line ptrs to 300lpm, crt	10-key, 30cps serial ptr, crt, mag card rdr (1 model)	10 key, serial print (80 cps), line print, crt	10-key, ppt, card rdr, 180cps serial ptr, 300lpm line ptr	10 key, serial print (120cps), line print (155lpm), crt
<b>Software</b>	COBOL, RPG, FORTRAN, BASIC, assembler, actng pkg, dbms	assembler, actng pkg (1 model), dbms	BASIC, assembler, actng pack, dbms	FORTRAN, BASIC, DIBOL, actng pkg, dbms	COBOL, FORTRAN, assembler, actng pack
<b>Base Prices</b> Software/support	\$35,675 (\$744/month) soft and support extra	\$11,490 support extra	\$7,000 soft and support extra	\$17,000 (\$350 month) soft and support extra	\$26,000 (\$540) soft and support extra
<b>Comments</b>	floating-point hardware and 100 MB disc storage optional	most models include software in price		core memory on 500 Series machine (980 nsec).	

Manufacturer	Computer Automation	Computer Covenant	Computer Hardware	Computer Hardware	Computer Horizons
<b>System Highlights</b> No. of models No. installed/date Multiprogramming Communications Applications	SyFA  n/g since 1976 43 partitions up to 25 lines/2780/ distributed processing	CPBS 3 5 since June 1976 yes up to 60 lines, 2780, SDLC manufacturing, wholesale, distribution	2130, 3230 2 n/g since 1974 32 partitions 36 lines/2780, 3780, 3741 general actng	4210  since 1977 8 partitions 8 asynch, 1 synch general accounting	CHC Distribution System n/g 32 partitions 64 lines/asynch/SDLC inv, order proc, bus actng
<b>Processor</b> Internal storage Word size/add time	CALSI-2/60 64-304K core (1.2usec) 16bits/76usec (5 digits)	DEC PDP-11 56K-2MB MOS or core/ 16bits/as fast as 400nsec	2130/3231 16K-4MB MOS/ (800nsec) 16bits/2.7usec	CHI 4210 8K-4MB MOS/1.2usec 16bits/50usec	DEC PDP-11/34 16K-248K MOS, core/ 16bits/2usec
<b>Mass Storage</b> Discs Access methods Mag tapes	cart, pack random, seq, indexed seq no	floppy, cart, pack random, seq, indexed seq no	cart, pack, fixed random, seq, indexed seq reel-reel, cassette	floppy, cart seq, random cassette	pack seq, indexed seq reel-reel
<b>Peripherals</b>	10-key, serial ptrs to 165cps, line ptrs to 600lpm, crt	10-key, 300cpm rdr, up to 180cps serial ptr, up to 1200lpm ptr, crt	10-key, ppt, card, 60cps serial ptr, 600lpm ptr, crt	10-key, actng keybd, card, serial print (180cps), line print (300lpm), crt	serial print (180cps), line print (1,200lpm), crt
<b>Software</b>	FORTRAN, BASIC, SYBOL	COBOL, FORTRAN, BASIC, assembler, DIBOL, acct pkg, dbms	COBOL, RPG, FORTRAN, BASIC, assembler, ALGOL, SNOBOL, actng pkg, dbms	FORTRAN, assembler, actng pack	COBOL, BASIC, actng pack
<b>Base Prices</b> Software/support	\$45,000 support incl, software extra	\$24,000 (\$530 month five year) software and support extra	n/g support incl, some soft extra	n/g soft extra	\$30,000 supp extra
<b>Comments</b>	Supports up to 24 terminals and 35 peripherals BASIC and FORTRAN are unbundled	Price is based on 180cps ptr. Various models of PDP-11 used.	hardware floating point available		PDP-11/70 cpu may be substituted for 11/34

Manufacturer	Computer Interactions	Control Data	Corstar	Corstar	Data Communications
<b>System Highlights</b> No. of models No. installed/date Multiprogramming Communications Applications	Compo-II  77 since 1972 4 partitions 32 lines/synch/asynch whsle dist, pharm, med	Cyber 18-10, 18-20 2 n/g since May 1976 18-20 16 partitions n/g # lines, to 19.2 kbps manufacturing distribution	Corstar 310  10 since 1972 no 1 line to 2200bps, 2780 manufacturing, distribution	models 350, 534, 570 3 22 since November 1973 4, 32, 63 partitions 4, 32, 63 lines/2780 mfg, dist, financial publishing	TPS, DPS, DCS 3 n/g since Sept. 1976 DPS only 256 lines, many protocols marketing, mortgage banking, broadcasting
<b>Processor</b> Internal storage Word size/add time	DEC PDP-8/E, /F 16K-64K core, MOS/ 1.2usec 12bits/15usec (5 digits)	Cyber 18-10, 18-20 32-256K/core, MOS 750nsec 16 bits/1.76usec (word)	DEC Data-systems 310 16-64K core/MOS (1.4usec) 12bits/2.8usec	DEC Datasystems 32K-1MB MOS/core (980-720nsec) 16bits/7-1usec dep. on model	DG Nova, S/200, S/300 8-256K core (800nsec) 16bits/600-800nsec/word
<b>Mass Storage</b> Discs Access methods Mag tapes	floppy, cart, pack random, seq, indexed seq reel-reel, cart	floppy, pack n/g reel-reel	floppy, cart random, seq, indexed seq no	cart, pack random, seq, indexed seq no	floppy, cart, pack, fixed random, seq, indexed seq cassette
<b>Peripherals</b>	10-key, ppt, serial print (to 300cps), line print (300lpm), crt	10-key, card rdrs to 600cpm, line ptrs to 600lpm, crt	10-key, ppt, card rdr, 180cps serial ptr, 300lpm line ptr, crt	10-key, ppt, card rdr, 180cps serial ptr, 300lpm line ptr, crt	10-key, ppt, card rdr, 165cps serial ptr, line ptrs to 1200lpm, crt
<b>Software</b>	FORTRAN, BASIC, assembler, actng pack	FORTRAN, BASIC, assembler, macro assembler	DIBOL, actng pkg	COBOL, RPG II, FORTRAN, BASIC Plus, DIBOL, actng pkg	COBOL, RPG, RPG II, FORT IV, FORT V, BASIC, ALGOL, assembler, actng pkg, dbms
<b>Base Prices</b> Software/support	\$50,000 (\$1,200) supp extra	\$27,840 (\$982/month 3-yr) soft and support extra	\$13,000 soft and support extra	\$36,000 support and software extra	\$5,000 soft and support extra
<b>Comments</b>				larger versions exceed \$100,000	transactional, distributed, and data collection systems

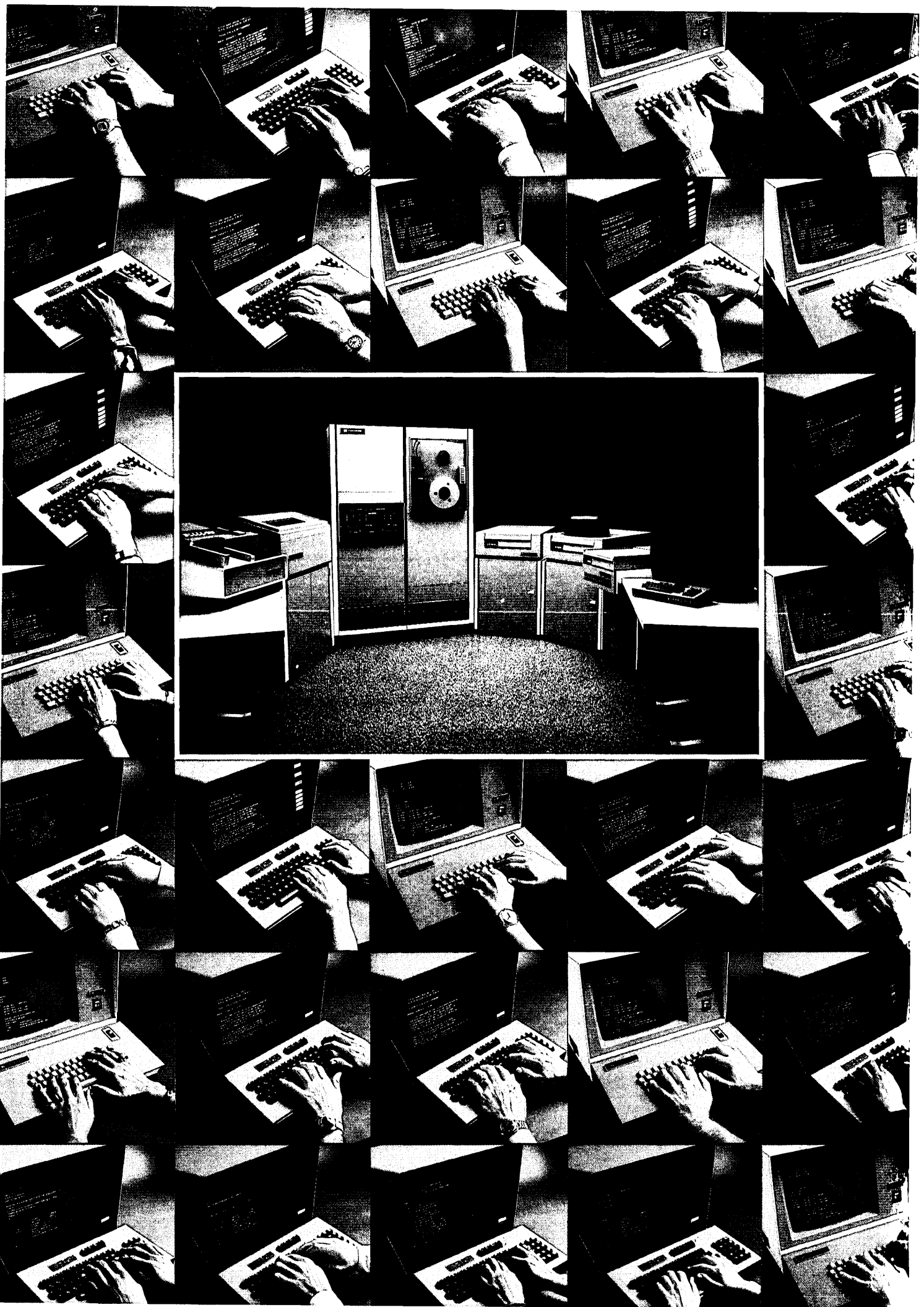

# All at once, it's Harris.

Harris now delivers the most cost/performance effective multi-use computer system in the industry.

Our new family of high performance systems—S115, S125 and S135—together with our powerful VULCAN Virtual Memory Operating System supports more than 50 terminals. Simultaneously.

This is a whole new line of medium-scale, multi-use systems with increased reliability and new state-of-the-art technology. You get greater I/O throughput. MOS memory with error correction. Powerful micro processor based CPU. Broad selection of highly reliable peripherals. And all operate with ANSI 74 COBOL, FORTRAN, RPG II, FORGO, SNOBOL, and extended BASIC.

The Harris S100 systems take on many different jobs all at the same time. Multi-stream batch processing. Multiple concurrent RJE's, both host and remote. Multiple interactive time sharing. Real-time processing. And this new generation of high performance computer systems from Harris delivers these all to you, *concurrently*.

If your need is distributed processing, time sharing, data base management, or any type of concurrent multi-use application, *benchmark our new computer system against any other system in the industry.*

**Harris Computer Systems, 1200 Gateway Drive, Fort Lauderdale, Florida 33309. Telephone (305) 974-1700. Europe: Harris Intertype, Ltd., 145 Farnham Road, Slough, SL1 4XD, England.**

**All at once, it's Harris.**

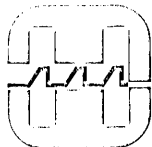

**HARRIS**  
COMMUNICATIONS AND  
INFORMATION HANDLING

Manufacturer	Data General	Datapoint	Decision Data Computer	Design Data	Digital Computer Controls
<b>System Highlights</b> No. of models No. installed/date Multiprogramming Communications Applications	CS/40 3 n/g since Sept. 1977 yes 1 line, 2780/3780 n/g	Cassette 1100-6600 7 15,500 since April 1972 5500, 6600 1-25 lines/most protocols banking, insurance, government, accounting	System/4 yes, 2 partitions 15 since July 1975 2 lines/asynch/synch/ 3780 distribution	ECS40/EC330 2 20 since Nov. 1975 2 partitions up to 256 lines/ HASP, 2780 manufacturing, order entry	Synergist 1500, 3700 3 60 since Dec. 1976 no up to 16 lines, 2780, 3780 manufacturing, wholesale, distribution
<b>Processor</b> Internal storage Word size/add time	Nova 3/12, Nova 3/D 64-192K MOS (700nsec) 16bits/700nsec (word)	equals model number 4-120K MOS (600-1600nsec) 8bits/1.15-4.8usec)	System/4 32K-64K MOS/1usec 8bits/not given	DG Eclipse C/300 96-256K core (800nsec) 16bits/2.4usec	DG Micro Nova, Nova 3/12, Nova 3/D 48-256K core/MOS (1.usec) 16bits/2.4-1usec
<b>Mass Storage</b> Discs Access methods Mag tapes	floppy, cart random, seq, indexed seq reel-reel	floppy, cart, pack random, seq, indexed seq reel-reel, cassette	floppy, cart direct, seq, indexed seq no	floppy, cart, pack random, seq, indexed seq reel-reel, cassette	floppy, cart, pack random, seq, indexed seq reel-reel
<b>Peripherals</b>	10-key, 165cps serial ptr, 300lpm ptr, crt	10-key, 300cpm rdr, serial ptrs, line ptrs to 600lpm, crt	10 key, acctg keybd, card, serial print (120cps), line print (to 600lpm), crt	ppt, 165cps serial ptr, 1200lpm line ptr, crt	10-key, ppt, card, serial ptrs to 275cps, line ptrs to 1200lpm, crt
<b>Software</b>	COBOL	COBOL, RPG, BASIC, assembler, Databus, Datashare, acctng pkg, RPG II	RPG, Ideal, acctng pack	COBOL, RPG, FORTRAN, BASIC, assembler, ALGOL, acctng pkg	BASIC, assembler, acctng pkg
<b>Base Prices</b> Software/support	\$32,915 (\$741/month) bundled	\$7,200 (\$165 month 2-yr) support incl, soft extra	\$20,000 some soft and supp extra	\$40,000 soft and support extra	\$8,000 support incl, soft extra
<b>Comments</b>	interactive COBOL from up to 9 terminals			ECS 40 is 32-96K core (1usec or 700nsec) 950-700nsec add time	executive inquiry systems

Manufacturer	Digital Equipment	Digital Equipment	Digital Scientific	Digital Systems	Dimis Inc.
<b>System Highlights</b> No. of models No. installed/date Multiprogramming Communications Applications	DataSystem 310 n/g since May 1975 no 1 line, to 4800bps, 2780 bus accounting	DataSystems 322-570 6 1,200 + since July 1975 two largest models 4-63, 2780/3780/SDLC business accounting	Meta 4/1130, UM2-TSO, 3 430 + since 1970 largest two models up to 32 lines/2780, bisynch marketing, medical, engineering	Galaxy/5 130, 140, 150 3 11 + since Dec. 1975 yes 120-480 lines acctng	Total 100 3 since June 1974 yes 32 lines/asynch/synch distribution
<b>Processor</b> Internal storage Word size/add time	DEC PDP-8/A 16-64K core (1.4usec) 12bits/1msec (15 digits)	DEC LSI-11 to PDP-11/70 32K-2MB core/MOS 16bits/10-1.07usec (word)	DSC 4030, 4031, 4040 16-256K core/900nsec 16bits/2.9usec (5 digits)	Galaxy/5 64K-1MB MOS (750nsec) 8bits/5usec (5 digits)	Modcomp II 128K core/800nsec 16bits/800nsec
<b>Mass Storage</b> Discs Access methods Mag tapes	floppy, cart random, seq, indexed seq no	floppy, cart, pack, fixed random, seq, indexed seq no	cart, pack random, seq, indexed seq no	pack, fixed random, seq, indexed seq reel-reel	floppy, cart, pack random, seq, indexed seq reel-reel
<b>Peripherals</b>	10-key, serial ptrs to 165cps, 30 crt	10-key, 300cpm rdr, serial ptrs to 180cps, line ptrs to 1,200lpm, crt	ppt, card	card, line ptrs to 900lpm, crt	10 key, acctng keybd, ppt, card, serial print, line print, crt
<b>Software</b>	DIBOL	COBOL, RPG, FORTRAN, BASIC, assembler, APL, DIBOL, dbms	COBOL, RPG, FORTRAN, BASIC, assembler, macro-assembler, APL, dbms	RPG, FORTRAN, BASIC, assembler, acctng pkg dbms	FORTRAN, assembler, acctng pack, dbms
<b>Base Prices</b> Software/support	\$14,095 soft incl, support extra	\$19,315 most software bundled	\$60,000 (\$1,500 month) soft incl, support extra	\$32,700 (cpu only) soft and support extra	\$135,000 supp extra
<b>Comments</b>		support extra	can run most IBM 1130/1800 pgms; digital-analog I/O, real-time, batch, t-s	additional peripherals can be attached through commo port	3 crts standard; price includes training and conversion support

Manufacturer	Display Data Corp.	Distribution Mgmt Sys	Distribution Mgmt Sys	Educomp-Quodata	Educomp-Quodata
<b>System Highlights</b> No. of models No. installed/date Multiprogramming Communications Applications	In*Sight 180 since Jan. 1974 20 partitions 16 lines/asynch auto dealers, contrctrs, whslrs	DMS-1000-8 43 since 1970 10 partitions 10 lines (asynch, synch, HASP) distribution	DMS-1000-11 n/g 30 partitions 32 lines (synch, asynch, SDLC, etc) distribution	E-1000, E-500 2 100 + since 1971 yes, up to 63 partitions 16-32 lines (synch, asynch, SDLC) educ, muni govt, general	E-600, E-700, E-940 3 100 + since 1972 63 partitions 32-63 lines/2780/3780 education and government
<b>Processor</b> Internal storage Word size/add time	Microdata 1600/30 32K-64K core/1usec 8bits/4.6usec	DEC PDP-8 32K (6bit) core (1.2usec) 12bits, 3usec	DEC PDP-11 64K-2048K, MOS (980nsec) 16bits, 300nsec-3.7usec	DEC PDP-8/A 64K-256K (6bit byte) core/MOS 12bits, 2.6usec-3usec	DEC PDP-11/34, PDP-11/70 32K-2MB core MOS (775 nsec) 16bits/3-2.16usec)
<b>Mass Storage</b> Discs Access methods Mag tapes	cart random, seq, indexed seq reel-reel	cart random, seq, indexed seq reel-reel	floppy, cart, pack, fixed head random, seq, indexed seq reel-reel	floppy, cart, pack, fixed random, seq, indexed seq reel-reel, cassette	floppy, cart, pack, fixed random, seq, indexed seq reel-reel, cassette, cart
<b>Peripherals</b>	10 key, serial print (120cps), line print (to 600lpm), crt	10 key, serial print (180 cps), line print (300lpm), crt	10-key, serial print (180 cps), line print (to 1,200 lpm), crt	10 key, ppt, card, serial print (180cps), line print (to 900lpm), crt	10-key, ppt, card, serial ptr 180cps, line ptrs to 900lpm, crt
<b>Software</b>	assembler, acctng pack	assembler, DEAL, ORACLE, acctng pack, dbms	COBOL, FORTRAN, BASIC, assembler, DEAL, ORACLE, acctng pack, dbms	COBOL, FORTRAN, BASIC, assembler, FOCAL, DIBOL	COBOL, RPG, FORTRAN, BASIC, assembler, APL, PASCAL, DIBOL, acting pkg, dbms
<b>Base Prices</b> Software/support	\$37,700	\$54,000 soft and supp extra	\$65,000 soft and supp extra	\$6,000 soft and supp extra	\$45,000 soft and support extra
<b>Comments</b>	Specialists in complete turnkey systems, support forms, and maintenance for selected businesses			systems built to customer's specs	turnkey systems designed to customer's specs

Manufacturer	Financial Computer	Four-Phase Systems, Inc.	General Automation	General Information	GRI Computer Corp.
<b>System Highlights</b> No. of models No. installed/date Multiprogramming Communications Applications	Fedder System 111/10, /6 2 170 since Jan. 1975 32 partitions 64 lines (synch, asynch) dist, mfg, const, acctng	System IV/40, /50, /70 3 2300 since Feb. 1971 no (synch, asynch, 3270, bisynch) mfg, insurance, educ	440 Data Series, DM-130 4 since Jan. 1974 up to 4 partitions 5-25 lines (synch, asynch, HASP) mfg, ins, dist, med	ABLE Series 3 4+ since December 1975 16-24 partitions 16 lines to 4800bps, 2780 acctng, mfg, dist, legal, medical, acctng, CPA	System 99 since 1975 yes, 4 partitions 3 lines (synch, asynch) mfg, retail, dist, constr, banking
<b>Processor</b> Internal storage Word size/add time	Fedder S 111 32K-256K MOS (not given) 8bits, n/g	Four-Phase 24-96K MOS (2usec) 24bits, 16usec	GA-16/440, SPC-16 series 64K-128K core (720-1440 nsec) 16bits, 780-1440nsec	DEC PDP-11/03, PDP-11/34 24-256K MOS (980-720 nsec) 16bits/3.1usec (6 digits)	GRI 99/50 32K-64K MOS (1.7usec) 16bits, add time n/g
<b>Mass Storage</b> Discs Access methods Mag tapes	floppy, cart random, seq, indexed seq reel-reel, cassette	floppy, cart, pack random, seq, indexed seq reel-reel (on IV/70)	cart, pack, fixed head relative, seq, indexed seq reel-reel	floppy, cart, pack, fixed random, sequential reel-reel, cassette, cart	cart random, seq, indexed seq reel-reel
<b>Peripherals</b>	10 key, ppt, card, serial print (to 200 cps), line print (to 1250ipm), crt	10 key, card, ppt, serial print (30cps), line print (to 700ipm), crt	10 key, card, serial print (165cps), line print (to 600ipm), crt	10-key, full acctng kbdr, card, serial ptrs, line ptrs	10-key, ppt, card, serial print (165cps), line print (600ipm), crt
<b>Software</b>	BASIC, assembler, CPL, PL/X, acctng pack, dbms	COBOL, RPG, assembler	COBOL, FORTRAN, assembler, acctng packs	COBOL, DPG, FORTRAN BASIC, assembler, DIBOL, acctng pkg, dbms	RPG, assembler, acctng pack
<b>Base Prices</b> Software/support	\$22,950 (\$460) soft and supp extra	\$30,315 (\$604) soft included	\$35,000 supp extra	\$24,000 (\$500 month) soft and support extra	\$33,333 apps and supp extra
<b>Comments</b>	can run interactive or batch in any partitions; Fedder Data systems is a division of Financial Computer Corp.	no COBOL or RPG on IV/40, but the IV/40 can run object code from /50, /70		some models use core memory a turnkey financial control system	sold through distributor network
Manufacturer	Harris Computer	Hewlett-Packard	Hewlett-Packard	Hewlett-Packard Co. Calculator Products Div.	Hewlett-Packard Co. Calculator Products Div.
<b>System Highlights</b> No. of models No. installed/date Multiprogramming Communications Applications	S Series 8 n/g since 1975 256 partitions all models 128 lines/2780/HASP many/plus time-sharing	1000 Series 3 n/g since December 1976 yes 16 lines, 2780, bisynch manufacturing	System 3000/1, /11 3 850 since March 1977 yes 16-63 lines (synch, asynch) mfg, educ	9830A, B 2 n/g since Nov. 1972 no 1 line (synch, asynch) real estate, med, engineering	9896A since March 1977 no no mfg, dist
<b>Processor</b> Internal storage Word size/add time	Harris 100 Series 96-768K core/MOS 450- 750nsec 24bits/600-750nsec (word)	HP 21MX E 64-608K (560nsec) 16bits/1.12usec	HP 3000 128K-512K core/MOS 16 bits, 1.225-1.05 usec	HP 9830A, B 3520-15,808 MOS (13usec) 8bits, 1msec (approx)	HP 9831A 7, 162-31, 738 MOS (1.83 usec) 16bits, 470usec (12 digits)
<b>Mass Storage</b> Discs Access methods Mag tapes	floppy, cart, pack, fixed random, seq, indexed seq reel-reel, cassette	floppy, cart, pack random, sequential reel-reel, cart	pack direct, seq, keyed seq reel-reel, cassette, cart	cart none cassette	floppy, cart direct cart
<b>Peripherals</b>	ppt, card, serial & line printers	ppt, card, serial ptrs, line ptrs	10-key, ppt, card, serial print (to 120cps), line print (to 1250ipm), crt	10-key, ppt, card, line print (to 300ipm), crt	10-key, ppt, card, serial print (30cps), line print (to 300ipm), crt
<b>Software</b>	COBOL, RPG, FORTRAN, BASIC, assembler, SNOBOL, FORGO, dbms	FORTRAN, BASIC, assembler, ALGOL, dbms	COBOL, RPG, FORTRAN BASIC, SPL, APL, dbms	acctng pack	BASIC, acctng pack
<b>Base Prices</b> Software/support	\$85,000 (3rd ptly lease) some soft extra, support incl.	\$21,000 soft and support extra	\$75,000 (\$1,566) soft and supp extra	\$4,900 soft and supp extra	\$18,700 (\$500)
<b>Comments</b>		a maximum of four active terminals is recommended on commo lines	3000 Series II is upgrade from previous 3000 CX Series	Software assigns portions of read and write memory to serve as registers	soft and supp extra
Manufacturer	Honeywell	Honeywell	IBM	IBM	IBM
<b>System Highlights</b> No. of models No. installed/date Multiprogramming Communications Applications	Series 60 Model 6 4 since Jan. 1976 yes 8-128 (asynch, bisynch) hospital, mfg, Inv, educ, office automation	Series 60/Level 62 1 since Aug. 1974 yes 9 lines/asynch/synch distribution, mfg	System/3 30,000+ since Dec. 1970 3 partitions 8 lines/asynch/SDLC dist, mfg, med, educ	System/32 10,000+ since Feb. 1975 no 1 line, asynch/bisynch/ SDLC dist, mfg, med, word proc	System/34 delivers begin Jan. 1978 8 partitions 8 lines, asynch/bisynch/ SDLC dist, med, mfg
<b>Processor</b> Internal storage Word size/add time	Honeywell CPS-series 8K-1024K NMOS (650- 1200nsec) 16bits, 1.9-2usec	Honeywell 62 48K-224K MOS/1usec 8bits/not given	IBM System/3 8K-256K core, MOS/ 1.52usec 8bits/24usec (5 digits)	IBM System/32 16K-32K MOS/0.6usec 8bits/150usec (5 digits)	IBM System/34 32K-64K MOS/0.6usec 8bits/68.5usec (5 digits)
<b>Mass Storage</b> Discs Access methods Mag tapes	floppy, cart, pack, fixed head random, seq, indexed seq reel-reel, cassette	floppy, cart, pack seq, indexed, relative reel-reel, cassette	floppy (via 3741), cart, pack random, seq, indexed seq reel-reel	floppy, fixed disc random, seq, indexed seq no	floppy, fixed disc random, seq, index seq no
<b>Peripherals</b>	10-key, ppt, card, serial print (165cps), line print (to 1100ipm), crt	10-key, card, serial print (30cps), line print (to 1,600ipm), crt	10-key, card, serial print (85cps), line print (to 1,100ipm), crt	10-key, card, serial print (to 80cps), line print (to 155ipm), crt	10-key, serial print (to 120cps), line print (to 300ipm), crt
<b>Software</b>	COBOL, RPG, BASIC, FORTRAN, assembler, acctng pack	COBOL, RPG, FORTRAN, acctng pack, dbms	COBOL, RPG II, BASIC, FORTRAN	RPG II, assembler, acctng pack	RPG II, assembler, acctng pack
<b>Base Prices</b> Software/support	\$3,700 (processor only)	\$36,879 (\$885) soft and support extra	\$22,430 (\$674) soft and support extra	\$33,560 (\$748) soft and support extra	\$34,700 (\$1,062) soft and support extra
<b>Comments</b>					





# Sound & Vision

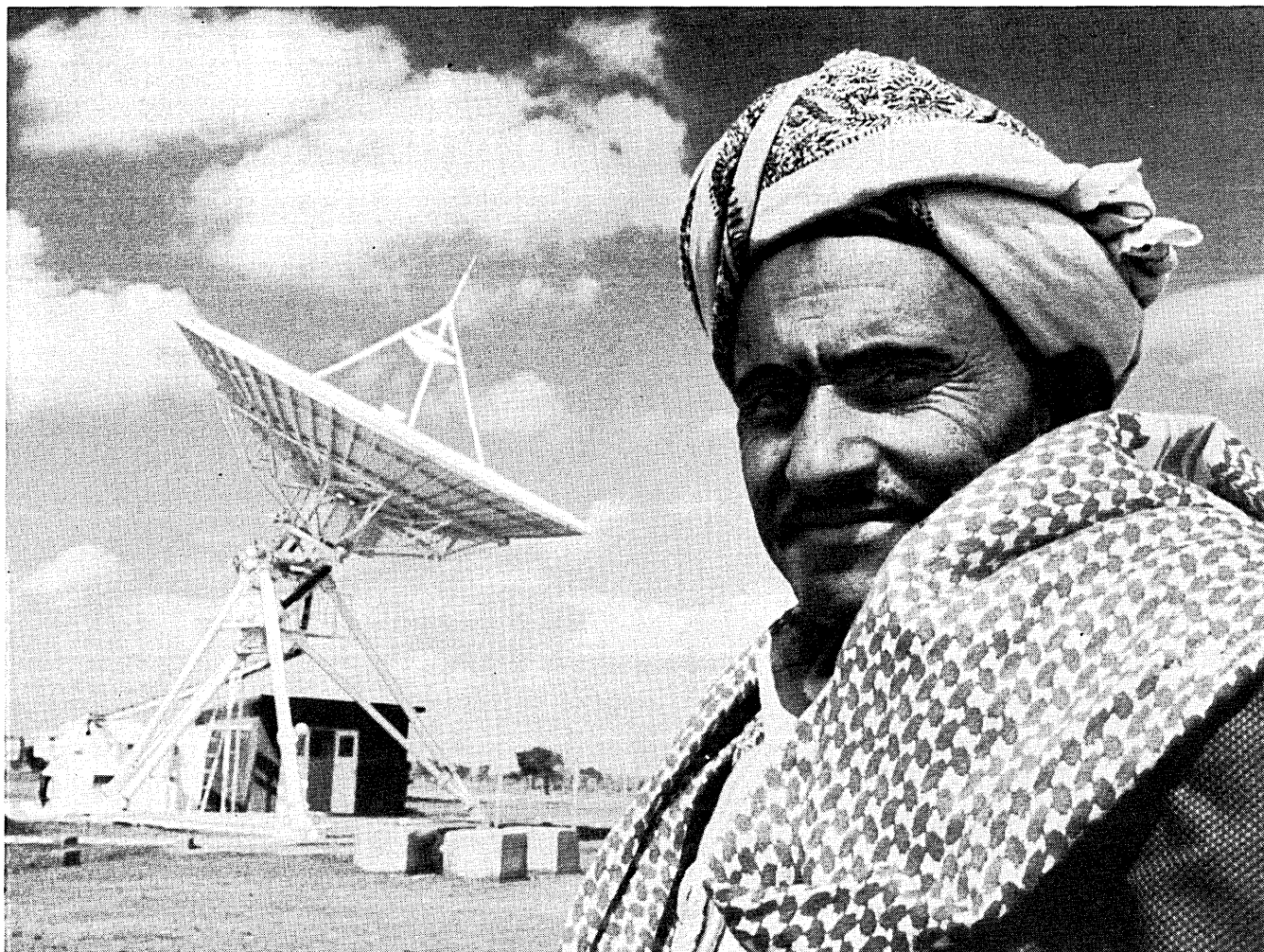

There's no quicker way to get TV, phone calls or data round the world than by the 45,000-mile satellite space route.

Earth stations send and receive messages to and from 'space stations'... the satellites. In recent months we've brought earth stations into service in the United Arab Emirates, Mauritius, Fiji, Seychelles and —shown above—the Yemen Arab Republic. The YAR earth station took just three months to complete from order to operation.

The 21 earth stations of Cable & Wireless and its associates are just part of our global network.

We provide public services for 37 nations. Our

private services in over 70 countries range from consultancy and planning to engineering, operation, maintenance and training... including nationwide telex systems in Iraq and Swaziland... telephone consultancy in Cameroon and Oman... airport services in Sudan and South America.

We are currently working on defence networks, submarine cable systems, specialised radio, computer and telephone networks for governments and international groups.

Whatever the problem—global or national—Cable & Wireless has the solution in its worldwide experience.

 **Cable & Wireless**  
**Communication Systems & Services**

U.S. Office: Cable & Wireless (NYK) Inc., Graybar Building, Suite 2020, 420 Lexington Av., New York 10017. Tel: 212-490-0610. Telex: 12094.  
Head Office: Mercury House, Theobalds Road, London, WC1X 8RX. Tel: 01-242 4433. Telex: 23181.

Manufacturer	IBM	IBM	IBM	ICL	Jacquard Systems
<b>System Highlights</b> No. of models No. installed/date Multiprogramming Communications Applications	1130 4,000 (approx) since 1965 no 16 lines/synch/bisynch engineering, mfg, med, dist.	System/360 Model 20 10,000 since Nov. 1964 no 1 line (asynch, bisynch) mfg, dist, govt, educ	5100 since Sept. 1975 no 1 line (asynch, 2741) financial analysis, statistics	2903/2904 2 n/g since 1974 4 partitions to 6 lines/2780, 4800bps manufacturing, retailing, distribution	J100-J50 Videocomputer 2 650 since Aug. 1975 256 partitions 10 lines (asynch, synch, 3780) dist proc, word proc, med, business
<b>Processor</b> Internal storage Word size/add time	IBM 1130 8K-64K core/2.2usec; 3.6usec 16bits/4.9usec; 8usec	IBM 360/20 4K-32K core (varles) 8bits, 209usec (5 digits)	IBM 5100 16K-64K MOS (530nsec) 8bits, 1nsec (approx)	2903, 2904 64-384K MOS (1.14usec) 24bits/17.7-11.8usec	Jacquard J100-J50 32K-256K core/MOS (1.5usec) 16bits, 7usec
<b>Mass Storage</b> Discs Access methods Mag tapes	cart, pack random, seq, index seq reel-reel	pack random, seq, indexed seq reel-reel	no  cart	cart, pack random, seq, indexed seq reel-reel	floppy, cart, pack random, seq, indexed seq reel-reel
<b>Peripherals</b>	ppt, card, serial print (15cps), line print (to 1,100lpm), crt	card, serial print (15.5cps), line print (to 1,100lpm)	10-key, serial print (80cps), crt	10-key, ppt, card, line ptrs to 1500lpm, crt	10-key, card, serial print (to 166cps), line print (to 900lpm), crt
<b>Software</b>	RPG, FORTRAN, assembler, acctng pack	RPG, assembler, PL/1, acctng pack	BASIC, APL	COBOL, RPG, FORTRAN, BASIC, acctng pkg, dbms	BASIC, assembler, acctng pack
<b>Base Prices</b> Software/support	\$19,840 (\$136) soft and support extra	\$13,470 (\$638) soft support extra	\$8,975 (\$450) some soft extra; supp extra	\$85,000 (\$2,200 month) soft and support extra	\$17,960 (\$550) app soft and supp extra
<b>Comments</b>		low end of 360 series, cycle times vary with processor model	portable (50 lbs) desk- top computer	full simultaneity; direct data entry through 8 crts RJT, batch, spooling	

Manufacturer	Litton/Sweda International	Logical Machine Corp.	Medical Computer Sciences	Microdata	Mini-Computer Systems
<b>System Highlights</b> No. of models No. installed/date Multiprogramming Communications Applications	Litton 1600 Series not given yes 8 lines (not given) whsle dist, client acctng	ADAM 250-300 since April 1975 no no acctng	System 2000 15 since Oct. 1973 no 64 lines (synch, asynch) hospital	Reality 500+ since Nov. 1973 yes 32 lines (asynch, synch, 2780) engin, educ, time share, acctng	Micos Systems 4 600+ since March 1973 yes 1 line (synch, HASP, 200UT) muni govt, fuel, educ, apparel, etc
<b>Processor</b> Internal storage Word size/add time	Data General Nova 1220 64K core (1.2usec) 16bits, 950nsec	LOMAC ALP 32K-64K MOS (800nsec) 16bits, not given	HP 2108 4K-384K MOS (650nsec) 16bits, 1.94usec (5 digits)	Microdata 1600 16K-128K core (1usec) 16bits, 5usec	Data General Nova 3/12 64K-256K core (800nsec) 16bits, 800nsec
<b>Mass Storage</b> Discs Access methods Mag tapes	cart seq, index seq no	floppy, cart indexed seq no	floppy, cart, pack seq, indexed seq reel-reel, cart, cassette	cart, pack, fixed-head random, seq reel-reel, cart	cart, pack random, seq, indexed seq reel-reel
<b>Peripherals</b>	10-key, serial print (16cps), crt	10-key, acctng keybd, serial print (to 300cps), crt	10-key, line print (to 1,200lpm), crt	10-key, card, serial print (165cps), line print (to 600lpm), crt	10-key, ppt, card, serial print (to 330cps), line print (to 600lpm), crt
<b>Software</b>	BASIC, acctng pack	ADAM	FORTRAN, BASIC, ALGOL, assembler, acctng pack, dbms	RPG, BASIC, assembler, English, acctng pack, dbms	BASIC, acctng pack
<b>Base Prices</b> Software/support	\$40,140	\$34,995 (\$720)	\$150,000 (\$2,500) soft extra	\$33,950 included	\$49,900 app soft and supp extra
<b>Comments</b>		ADAM is designed for use by non-dp professionals	separate systems for on-line adm and charge collection also avail	mktd through dealer network	

Manufacturer	Minuteman Computer Corp.	Modular Computer Sys	Modular Computer Sys	Mylee Digital Sciences	NCR
<b>System Highlights</b> No. of models No. installed/date Multiprogramming Communications Applications	1774, 1775, 1776 3 80 since 1973 no 1 line (asynch, synch) dist, mfg, liquor whslrs	Modcomp II since 1973 yes, 256 tasks 32 lines (asynch, synch, SDLC) dist, mfg	Modcomp IV since 1976 256 tasks 128 lines (asynch, synch, SDLC) dist, mfg	3056/3088 2 62 since May 1976 12 partitions 16 lines to 1200bps acctng, dist, inventory	8200-8250 2 300-400 since Sept. 197 7 partitions 7 lines (synch, asynch, 2780) hosp acctng, govt, dist, whsle, educ, mfg
<b>Processor</b> Internal storage Word size/add time	Data General Nova 3 16K-64K core (800-1000 nsec) 16bits, 2.7usec	Modcomp 11/26 64K-128K core (800nsec) 16bits, 2.4usec	Modcomp IV/35 128K-1M core (500nsec) 16bits, 1.6usec	Mylee 3000 56-152K MOS (800nsec) 16bits/125usec (5 digits)	NCR 605-NCR 6080 32K-128K core/MOS (1200-800nsec) 16bits, 2.4usec (8 digits)
<b>Mass Storage</b> Discs Access methods Mag tapes	cart, pack random, seq, indexed seq reel-reel, cassette, cart	floppy, cart, pack, fixed head random, seq, indexed seq reel-reel	floppy, cart, pack, fixed head random, seq, indexed seq reel-reel	cart indexed seq no	floppy, cart, pack random, seq, indexed seq reel-reel, cassette
<b>Peripherals</b>	10-key, ppt, card, serial print (165cps), line print (to 900lpm), crt	10-key, ppt, card, serial print (165cps), line print (to 1,000lpm), crt	10-key, ppt, card, serial print (165cps), line print (to 1,000lpm), crt	10-key, card, serial ptr, 300lpm line ptr, crt	10-key, card, serial print (175cps), line print (to 600lpm), crt
<b>Software</b>	COBOL, BASIC, FORTRAN, assembler, acctng pack, dbms	COBOL (next month), RPG, FORTRAN, assembler, acctng pack, dbms	COBOL (next month), RPG, FORTRAN, assembler, acctng pack, dbms	ACE, acctng pkg	COBOL, assembler, NEAT/3, acctng pack
<b>Base Prices</b> Software/support	\$34,995 soft and support extra	\$45,000 soft and support extra	\$75,000 soft and support extra	\$37,500 support incl	\$33,420 (\$945) soft and support extra
<b>Comments</b>		full turnkey system and support offered	full turnkey system and support offered	some soft separately priced; 8 inventory mgmt pkgs to choose from, 1 incl	

The Datum Model 4901 Storage Module Disk Controller provides an interface between a Data General computer and the CDC storage module series or equivalent disk drive. The controller can accommodate from 1 to 2 drives in a single or dual processor environment. The controller contains a microprocessor that executes commands received from the Nova computer. It also generates and checks CRC characters and monitors for the detection of bad tracks. When one is encountered, it seeks automatically to an alternate track that was programmed during the format operation, without intervention from the operating software. With Datum-supplied RDOS-compatible software drivers, the Disk subsystem becomes an operational component of any Data General computer system.

# New! DATUM Storage Module Controller

## SYSTEM FEATURES

- Two sector Buffer eliminates a variety of I/O timing problems during computer-to-disk-to-computer operations
- Two sector numbering sequences permit variable data rate to the computer
- Automatic bad track detection and alternate track selection without operational software intervention
- Microprocessor for monitor and control of events
- Detached header complete with track status and a 16-bit CRC character
- Basic software compatibility with Data General's 4231 disk controller
- Programmable Error Recovery

## Peripheral Products Division

1363 S. State College Blvd., Anaheim, CA 92806  
714/533-6333, TWX 910-592-1289,  
Telex 68-5579 • EUROPE: Datum House,  
Cranford Lane, Harlington, Middlesex,  
UK • 01-897-0456, Telex 935-398.

CIRCLE 32 ON READER CARD

**datum inc**

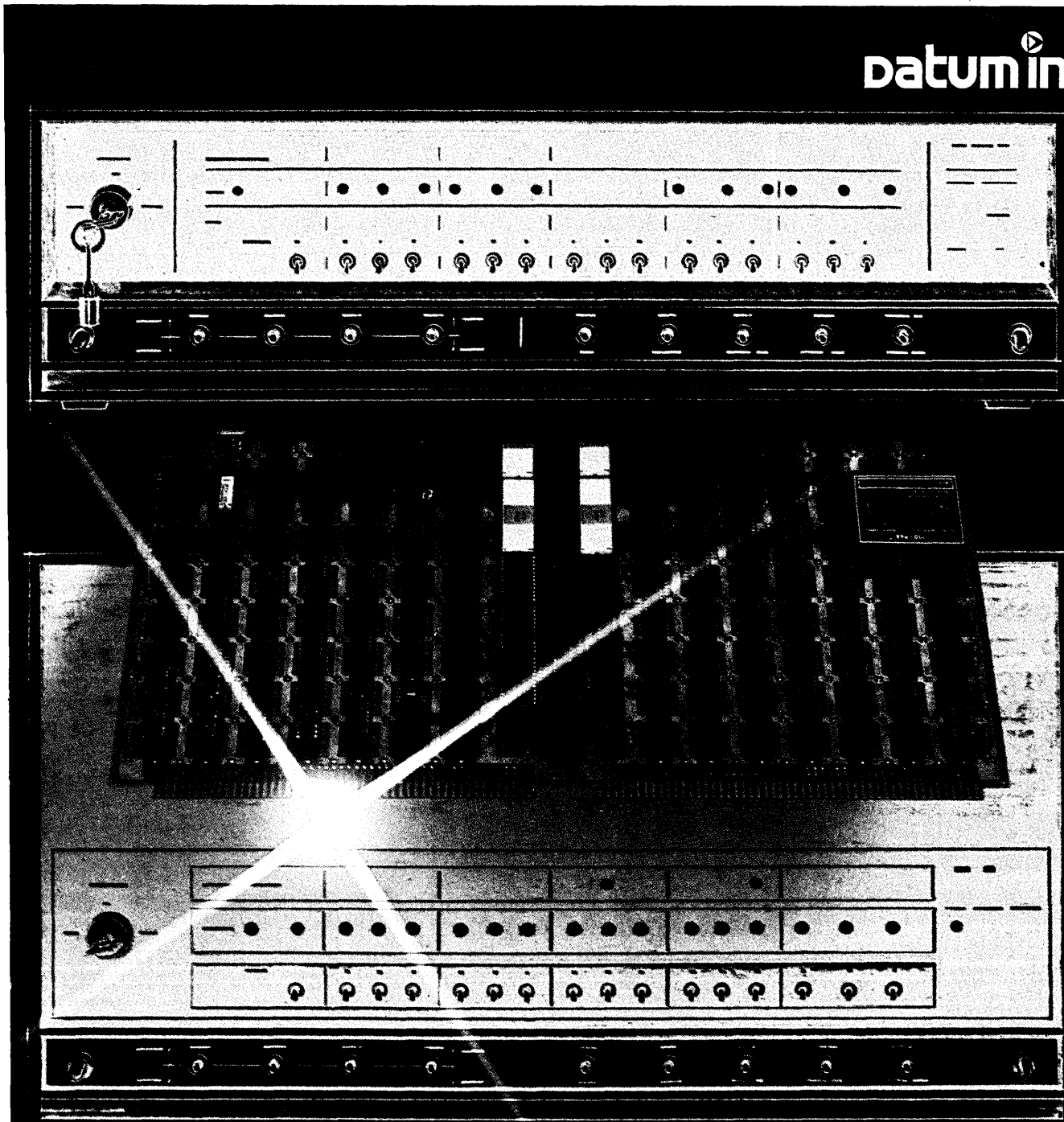



# THE JAMES MARTIN WORLD SEMINAR

on the design, management and  
future of distributed processing, data base,  
teleprocessing and network systems

26	- 30 SEPT	LONDON	EUROPA HOTEL
10	- 14 OCT	PARIS	NIKKO HOTEL
31 OCT -	4 NOV	CHICAGO	ARLINGTON PARK HILTON
7	- 11 NOV	BOSTON	PARKER HOUSE
14	- 18 NOV	LOS ANGELES	MIRAMAR, SANTA MONICA

## ACCLAIMED THROUGHOUT THE WORLD . . .

"THE SEMINAR CONTENT WILL HAVE A PROFOUND IMPACT ON THE OVERALL DIRECTION OF MY COMPANY IN NETWORK AND DATA-BASE PLANNING" . . . SAN FRANCISCO

"THIS COURSE IS BEAUTIFULLY DONE AND I CONSIDER IT A PRIVILEGE TO HAVE HAD AN OPPORTUNITY TO ATTEND" . . . HOUSTON

"A COURSE OF EXCEPTIONAL HIGH QUALITY AND EFFECTIVENESS" . . . AMSTERDAM

"MY PERSPECTIVES ARE FAR CLEARER AND THE WORK PRODUCTS OF MY DIVISION WILL BENEFIT DIRECTLY FROM THIS COURSE" . . . TORONTO

非常に有益なセミナーであった。

特に DB/DC についての新しい考え方を教えられる

様であり、今後、会社に帰って再整理して

実務に生かして行きます。

. . . TOKYO

"TWO WORDS SUMMARIZE THE SEMINAR, EXCELLENT AND THOROUGH" . . . MELBOURNE

"MR MARTIN'S FLAIR FOR EXPRESSING EXTREMELY COMPLEX SUBJECTS IN THE SIMPLEST MANNER IS SUPERB" . . . SINGAPORE

For full details telex: 65288 (U.K.) or telephone:  
415-525-7430 or 312-686-0400 in the U.S.A.,  
(0253) 21662 in the U.K., or 661.02.24 in France.

or complete the following coupon or write AIRMAIL to:—  
ABAQUEST, 221 St. Annes Road, Blackpool FY4 2BL, U.K.  
or 1719, Rose Street, Berkeley, Calif. 94703

Please send me full details of the James Martin Seminar in.....

Name..... Organisation.....

Address.....

**Quality is known by the company it keeps**



**Quality is known by the company it keeps and here are eight reasons why *CØMPLØT*<sup>®</sup> is outstanding in the field:**

- |       |   |              |  |
|-------|---|--------------|--|
| P-101 | All-new microprocessor-controlled plotter—\$3495                            | PTC-5A       | The new Remote Time Share Plotter Controller—two models—\$1945 & \$2595                        |
| P-1   | Classic 11" wide plotter—\$3550   | BTC-7 Series | Adds inexpensive graphic output to the CDC 734 and Cyber 18-5 and other Batch Terminals—\$2595 |
| P-11  | Our newest 11" wide plotter at speeds up to 4000 steps/sec.—\$3995          | MTR-4        | Magnetic Tape Reader/Controller \$15,500<br>1600 CPI Phase Encoded Model—\$19,950              |
| P-3   | Plotting on a 22" wide surface at 400 steps—\$5150                          |              |  |
| P-8   | One pen or three, 36" wide, super quiet, three models from—\$7600 to \$9500 |              |  |

**houston  
instrument**

**THE  
RECORDER  
COMPANY**

DIVISION OF BAUSCH & LOMB

ONE HOUSTON SQUARE (at 8500 Cameron Road) AUSTIN, TEXAS 78753  
(512) 837-2820 TWX 910-874-2022 cable HOINCO

TELECOPIER EUROPEAN OFFICE Rochesterlaan 6 8240 Gistel Belgium  
Phone 059/277445 Telex Bausch 1399

<sup>®</sup> A registered trademark of Houston Instrument  
US DOMESTIC PRICES ONLY

Plotters can be driven on-line, offline, time share or remote batch

CIRCLE 70 ON READER CARD



Manufacturer	NCR	NCR	NCR	Nixdorf	Norfield Datasystems
<b>System Highlights</b> No. of models No. installed/date Multiprogramming Communications Applications	Century Series 5: 50, 75, 100, 101, 151 1200 + since 1970 9 partitions on large mods 16-255 lines/2780/bisynch all business	299-100/200 no 1500 + since Jan. 1974 no 1 line (asynch) retail, whsle, mfg, financial	499 no 300 + since Feb. 1976 no 2 lines (asynch, synch, bisynch) business acctng	8870 n/g, since 1975 yes 9 lines (synch, asynch, etc) dist, med, garment	Nova-, Eclipse-based systs 2 20 + since June 1973 2 partitions 32-128 lines (synch, asynch) automated reporting, order entry
<b>Processor</b> Internal storage Word size/add time	615-910, -950, -955 16-128K core, film, MOS 8bits/15.8-59usec (5 digits)	NCR 299 4K-16K bits Core (7usec/bit) 64bits, 220msec	NCR 605 12K-32K core (1.2usec) 16bits, 1.7msec (5 digits)	DCC 116-H 64K-128K core (960nsec) 16bits, 1usec	Nova or Eclipse C/300 32K-256K core (800nsec) 16bits, 600-800nsec
<b>Mass Storage</b> Discs Access methods Mag tapes	cart, pack random, seq, indexed seq reel-reel, cassette	no n/g cassette	cart random, seq cassette	cart random, seq, indexed seq reel-reel	cart, pack random, seq, indexed seq reel-reel, cassette
<b>Peripherals</b>	10-key, card, line ptr, crt	10-key, ppt, serial print (15cps), mag ledger card	10-key, ppt, card, serial print (to 130cps), line print (to 300lpm), mag ledger card, crt	10-key, ppt, card, serial print (165cps), line print (to 600lpm), crt	10-key, ppt, card, serial print (to 420cps), line print (to 600lpm), crt
<b>Software</b>	COBOL, RPG, FORTRAN, BASIC, assembler, NEAT/3, acctng pkg, dbms	assembler, acctng pack	NEAT/AM, acctng pack	BASIC, assembler, acctng pack	COBOL, RPG, BASIC, FORTRAN, assembler, dbms
<b>Base Prices</b> Software/support	\$32,000 (\$1,075 month) soft and support extra	\$7,250 (\$310) soft and support extra	\$17,900 soft and support extra	\$37,990 (\$851) soft and support extra	\$35,000 (\$1,250) soft and support extra
<b>Comments</b>	cycle times on all systems range between 750nsec and 1.2usec	rental price for 299-200; 299-100 is purchase only		turnkey system that includes NIDAS dist acctng system	automatic reporting syst for orgs w/multiple dispersed operations
Manufacturer	Northrop Data Systems	Olivetti	Olivetti	Olivetti	Pako Corp.
<b>System Highlights</b> No. of models No. installed/date Multiprogramming Communications Applications	BDS 700, 1000 2 20 since June 1972 3 partitions 4 lines (asynch) hospital, med, furniture mfg	A4 2,000 + since Nov, 1975 no no credit union, fuel oil, financial	A5, A6 4 no 1 line (synch, asynch, 2780) credit union, educ, dist	A7 2 n/g, since March 1975 2 partitions 1 line (asynch, bisynch, synch) whsle dist, contractors	Pricing/Invoicing systems: 2 since June 1975 10 and 15 partitions 1 line (synch, 2780) photofinishing
<b>Processor</b> Internal storage Word size/add time	Microdata 1600 16K-64K core (1usec) var. 8-32, 9.68usec (7 digits)	Olivetti 4000 224 MOS (5msec) 8bits, 150msec	Olivetto 5010, 20, 30, 40 512K-4K MOS (1.5usec) 64bits, 10usec)	Olivetti 7072, 7074 16K-48K MOS (900nsec) 8bits, 6.1usec	CAI LSI-2/20 16K-64K core (1.2usec) 16bits, 25usec (8 digits)
<b>Mass Storage</b> Discs Access methods Mag tapes	cart random, seq, indexed seq reel-reel	no cassette	floppy random, seq, indexed seq cassette	floppy, cart random, seq, indexed seq cassette	floppy, cart random, seq, indexed seq reel-reel
<b>Peripherals</b>	10-key, card, serial print (to 120cps), line print (200lpm), crt	10-key, ppt, serial print (16cps)	10-key, ppt, serial print (16cps), line print (to 130lpm), mag ledger card	10-key, ppt, card, serial print (40 cps), line print (to 600lpm), mag ledger card, crt	10-key, ppt, card, line print (to 300lpm), crt
<b>Software</b>	BASIC, assembler, acctng pack, dbms	assembler, acctng pack	assembler, APLO, acctng pack	RPG, PL/1, assembler, acctng pack, dbms	dbms
<b>Base Prices</b> Software/support	\$38,900 soft and support extra	\$2,395 (\$86.45) soft and support extra	\$4,900 (\$177) soft and support extra	\$12,935 (\$455) soft and support extra	\$29,505 soft and support extra
<b>Comments</b>			floppy only on A6		Includes pricing term. w/bar code reader
Manufacturer	Philips	Philips	Prime	Programmed Control Corp.	Q1 Corp.
<b>System Highlights</b> No. of models No. installed/date Multiprogramming Communications Applications	P310, P320 2 750 since June 1975 no 1 line (synch, asynch, 2780) bank, insur, med, util	P350 2,300 since June 1970 no 1 line (asynch, synch, 2780) banking, insurance, utilities, med	300, 400, 500 3 660 since Feb. 1973 31 and 63 partitions 64 (asynch, synch, HASP) graphics, statistics	Prophet 21 2 20 since 1972 22, 128 partitions (asynch) industrial dists and wholesalers	Q1/LMC 200 since 1975 yes 8 lines (3741, synch, acctng, credit union, word proc
<b>Processor</b> Internal storage Word size/add time	Philips 310,320 8K-16K core (1.5usec) 8bits, n/g	Philips 350 12.8K-19.2K core (1.5usec) 64bits, n/g	Prime 300, 400, 500 64K-8MB MOS, 760nsec 16bits, 560-1560nsec	T1 960B, 990/10 32K-2MB MOS (700nsec) 16bits, 2.8-3.6usec	Intel 8080 8K-64K MOS (500nsec) 8bits, 2usec
<b>Mass Storage</b> Discs Access methods Mag tapes	floppy random, seq, indexed seq cassette	cart random, seq, indexed seq cassette	floppy, cart, pack, fixed random, seq, indexed seq reel-reel	cart, pack random, seq, indexed seq no	floppy, cart random, seq no
<b>Peripherals</b>	10-key, ppt, card, serial print (50cps), line print (70lpm), mag ledger card	10-key, ppt, card, serial print (40cps), line print (to 600lpm), mag ledger card	10-key, ppt, card, serial print (165cps), line print (1220lpm), crt	10-key, serial print (to 165cps), line print (250lpm), crt	10-key, serial print (to 200cps), line print (300lpm), crt
<b>Software</b>	assembler, acctng pack	assembler, acctng pack	COBOL, RPG, BASIC, FORTRAN, assembler, Forms, dbms	Prophet 21, acctng pack, dbms	assembler, PL/1, acctng pack, dbms
<b>Base Prices</b> Software/support	\$7,500 (\$170) soft and support extra	\$15,500 (\$350) soft and support extra	\$21,500 (\$473) soft and support extra	\$42,500 n/g	\$17,950 included
<b>Comments</b>			each user has virtual memory ranging from 128K to 512MB		

# In the small-computer business guess who's going head to head?

When it comes to managing information, Honeywell's Level 62 comes head-on. With more multiprogramming. More data communications. Data base management. Virtually unlimited growth potential.

Series 60 Level 62 lets you run lots of jobs concurrently. You can build a communications network, collect and distribute data to and from remote sites. All while running multiple batch.

And there's more. On-site system growth without hardware swapouts. Data management techniques. CP to CP communi-

cations. A range of power, performance, and peripherals not available with most comparable small systems. And our Remote Maintenance System that lets us diagnose problems, even correct software difficulties, from a remote terminal.

For Systems/3 users, Level 62

offers our Liberator/3 with automatic translation of your current System/3 programs. There are conversion aids for other systems, too.

Industry-oriented and financial management application systems are available for specific industries like manufacturing, and distribution.

For more information, call your local Honeywell representative. Or write us.

## Honeywell

Honeywell Information Systems  
200 Smith Street (MS 487)  
Waltham, Massachusetts 02154

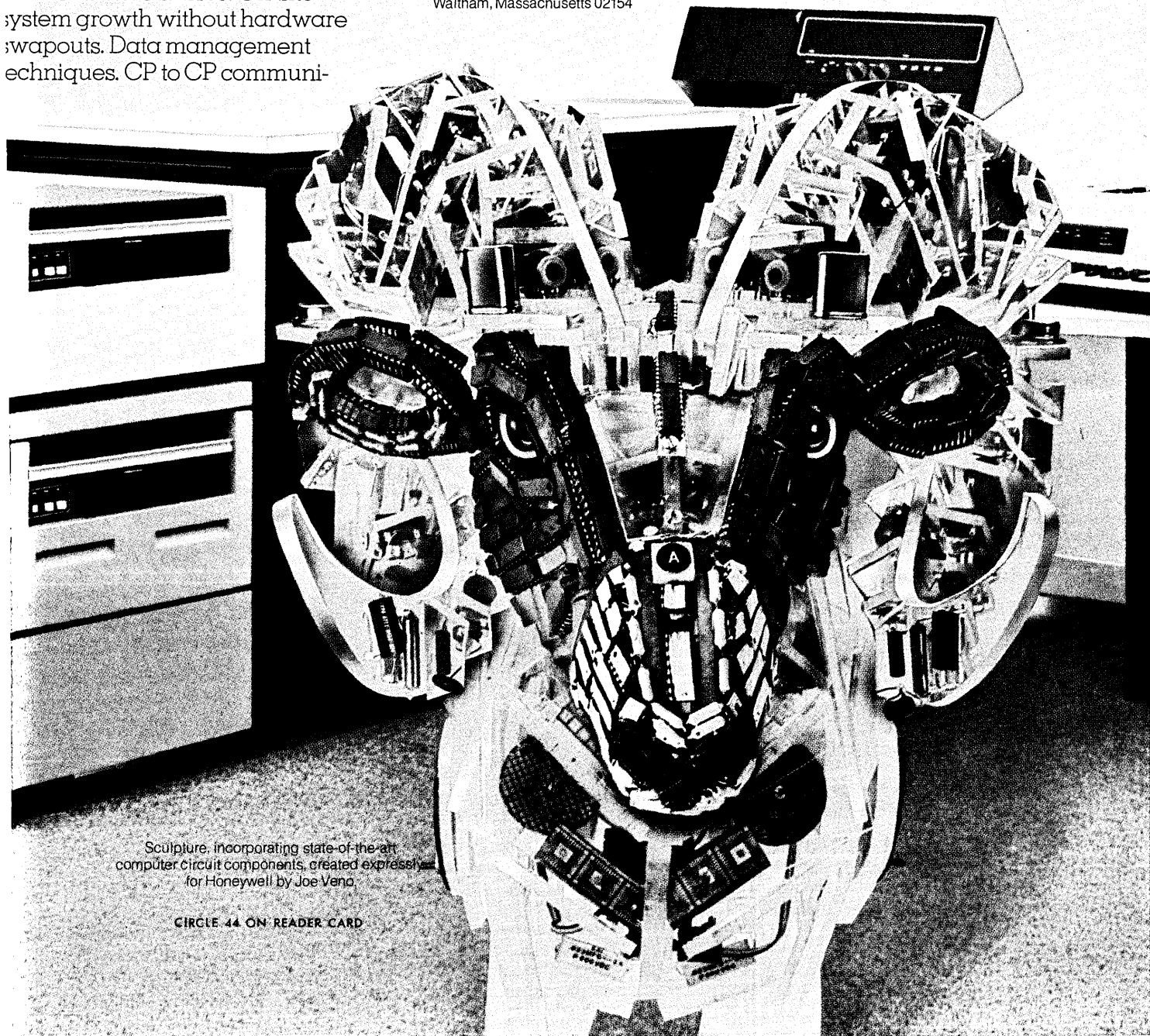

Sculpture, incorporating state-of-the-art computer circuit components, created expressly for Honeywell by Joe Veno

CIRCLE 44 ON READER CARD

# The Grandmaster.

Codex's new world champion for winning performance in data communications, the 6000 Series Intelligent Network Processor.

A master strategist that can move data through a network with efficiencies and economies previously impossible. Using statistical loading, the 6000 dynamically allocates available trunk bandwidth in response to terminal usage. Combine this with the 6000's data compression capability and the result... the 6000 outperforms traditional TDM's by factors as high as four to one.

And, like a true master, it never makes a mistake because the 6000 has a full duplex internal ARQ protocol to assure error-free node to node transmission.

The 6000 studies the board very carefully and gives you the facts to make intelligent moves. It surveys your network from the central site showing your trunk and terminal error rates, trunk and node performance, data compression efficiency, line utilization and much more. And it also lets you know when pre-set performance thresholds are exceeded.

Let the Grandmaster help you put your network problems in checkmate.

The clock is running...

The next move is yours.

member of  
**IDCMA**

Codex Corporation, 15 Riverdale Avenue, Newton, Massachusetts 02195 Tel: (617) 969-0600 Telex: 92-2443 Codex Europe S.A., Bte 7/Av. de Tervuren 412, B-1150 Brussels, Belgium Tel: 762.23.51/762.24.21 Telex: 26542. Offices and distributors in major cities throughout the world.

CIRCLE 17 ON READER CARD

**codex**  
We'll get you through

\*Patent Pending

# NOW--CA-SORT 77!

## Installs in ten minutes-- start saving with first run!

Your FREE 15-day trial will prove everything you have read about CA-SORT 77, the amazing sort software system more than 1700 DP Managers have chosen to use in their own daily routine and environment!

### START SAVING WITH THE VERY FIRST SORT RUN

Experience results like these:

- Save up to 50% on I/O activity!
- Save up to 50% on Disk Work Space!
- Save up to 25% on CPU time!

And ... you'll save turn around time, precious core space and find CA-SORT 77 easy to tune for maximum optimization

Overall - - you must improve throughput even during the 15-day FREE trial, or return the system and owe nothing!

### CA-SORT 77 IS THE NUMBER ONE DATA-PRO SORT SYSTEM!

Not only is CA-SORT Number One on the Datapro survey - - it is the **only** sort software system to earn a position on the "super honor roll" ... the exclusive upper 1% of all sort systems!

### CA-SORT USERS HAVE RECEIVED MORE THAN 50 ENHANCEMENTS SINCE 1974 - - ALL ABSOLUTELY FREE OF CHARGE!

Continuous world-wide research results in more effective use in typical CA-SORT installations! If you had installed CA-SORT in 1974, by now you would have received more than 50 improvements!

CA-SORT 77 incorporates every enhancement ... and is 15% more efficient than the previous release.

So - - try CA-SORT 77 free of cost. Just write or telephone **today**. The complete information kit will be rushed to you along with all the details of the trouble-free 15-day trial! Here's a coupon to start you on the road to savings!



## COMPUTER ASSOCIATES

U.S. OFFICES: California, Connecticut, District of Columbia, Georgia, Illinois, New York, Ohio, Texas.

WORLDWIDE OFFICES: Argentina, Australia, Austria, Belgium, Brazil, Denmark, France, Germany, Holland, Italy, Japan, Switzerland, United Kingdom.

### ----- FILL-IN AND MAIL TODAY -----

Computer Associates

655 Madison Avenue, New York, N.Y. 10021

CW-7/11

**YES!** Please rush me the complete CA-SORT 77 information kit. There's no charge or obligation. After examining the kit, I may if I wish install CA-SORT for 15-days FREE!

Name \_\_\_\_\_  
(Please print)

Address \_\_\_\_\_

Title \_\_\_\_\_

Company \_\_\_\_\_

City \_\_\_\_\_ State \_\_\_\_\_ Zip \_\_\_\_\_

Telephone \_\_\_\_\_  
(Area code, please)

Computer Model \_\_\_\_\_ System \_\_\_\_\_

**FOR FASTER ACTION: TELEPHONE RIGHT NOW . . .  
(212) 355-3333**

Call anytime, day or night, seven days a week.

© 1977 Trans-American Computer Associates, Inc. CA-SORT is a registered trademark of Computer Associates International, Ltd.

Manufacturer	Q1 Corp.	Qantel	Randal Data Systems	Raytheon	Shasta General Systems
<b>System Highlights</b> No. of models No. installed/date Multiprogramming Communications Applications	Q1/LITE since July 1977 yes 16 lines (asynch, synch, bisynch) credit union, banks, word proc, gen'l bus	900, 950, 1400, 1400-2 3 since 1975 5 or 30 partitions 1 or 4 lines asynch, synch, HASP whsl dist, med clinics	Link 100, 200, 500 3 200 since Oct. 1975 2-16 partitions 2-16 lines (asynch, synch, 2780) lumber industry, dental, med.	PTS/1200 1 100 since Nov. 1974 yes; 20 partitions 1 line; asynch/synch/ 2780/3780 transport, insurance, finance	Diablo 3200 1 50 since Dec. 1976 yes 9 lines/asynch/synch/ 2780 whsl, dist, med, financial, gen acctg
<b>Processor</b> Internal storage Word size/add time	Q1-LITE 16K-64K MOS (350nsec) 8bits, not given	Qantel std and high perf 32K-128K MOS (1.1-1.5 usec) 8bits, not given	Randal 100,200,500 32K-128K MOS (300nsec) 16bits, 1.2usec	PTS/1200 48K-128K MOS; 1.28usec 16bits; 2.8usec	Diablo 3200 16K-64K MOS/0.488usec 8bits/23.9usec (6 digits)
<b>Mass Storage</b> Discs Access methods Mag tapes	floppy, pack, ISAM, KSAM no	cart, pack random, seq, indexed seq reel-reel	floppy, cart, pack formatted, text, indexed seq reel-reel	cart random, seq, indexed seq reel-reel, cassette	floppy, cart random, seq, indexed seq no
<b>Peripherals</b>	10-key, acctg keybd, card, serial print (45cps), line print (300ipm), plasma display	10-key, card, serial print (165cps), line print (to 600ipm), crt	10-key, card, serial print (to 180cps), line print (300ipm), crt	10-key, card read, serial print (to 165 cps), line print (300ipm), crt	10-key, serial print (to 200cps), crt
<b>Software</b>	assembler, PL/1, acctg pack	assembler, QICBASIC, acctg pack	BASIC, assembler, acctg pack	MACROL, dbms	assembler, DACL
<b>Base Prices</b> Software/support	\$21,000 soft extra	\$27,900 some soft and supp extra	\$12,750 (\$280) soft and support extra	\$30,580 (830/mo, 3 yr lease) included	\$18,950 technical help extra
<b>Comments</b>	uses 6K ROM	program and report generation packages offered	marketed through distributorships	display-oriented distributed system. Apps also in RJE, data entry, 3270 emulation	DACL is an English-like compiler language

Manufacturer	A. O. Smith	Span Management Systems	Sperry Univac	STC Systems	Sycor
<b>System Highlights</b> No. of models No. installed/date Multiprogramming Communications Applications	Mesa Two 7000 Series 1 5 since May 1977 2 partitions 16 lines/asynch/synch/ 3780/HASP distribution, mfg	Series/1 2 since June 1977 yes synch/asynch/bisynch/ SDLC many	BC/7 1 since March 1977 2 partitions 2 lines/synch distribution, mfg	Ultimacc series 4 128 since 1973 8-50 partitions no limit (asynch, synch, 2780) mfg, banking, dist, govt, dist proc	410, 440 2 1200 since May 1976 no 2 lines (asynch, synch, HASP) used in many industries
<b>Processor</b> Internal storage Word size/add time	Data General Nova 3 64K-256K core/1usec 16bits/not given	IBM Series/1 16K-128K MOS/0.66usec 16bits/not given	Univac T3038 32K-64K MOS/1usec 8bits/106usec (5 digits)	Data General Nova 3 32K-256K core (1-1.35usec) 16bit, 1usec	Sycor 410, 440 24K-64K MOS (500nsec) 8bits, n/g
<b>Mass Storage</b> Discs Access methods Mag tapes	pack random, seq, indexed seq reel-reel	floppy, pack, fixed head IAM no	floppy, cart random, seq, indexed seq reel-reel, cassette	floppy, cart, pack random, seq, indexed seq reel-reel	floppy, cart random, seq, indexed seq reel-reel, cassette
<b>Peripherals</b>	10-key, serial print (165cps), crt	10-key, acctg keybd, serial print (120cps), line print (414ipm), crt	10-key, card, serial print (200cps), line print (to 250ipm), crt	10-key, ppt, card, serial print (165cps), line print (to 900ipm), crt	10-key, card, serial print (to 180cps), line print (300ipm), crt
<b>Software</b>	RPG, Mesa RPG II, FPG, acctg pack, dbms	assembler, acctg pack, dbms	RPG, ESCORT, acctg pack	COBOL, FORTRAN, BASIC, English 210, acctg pack, dbms	COBOL, BASIC, TAL-2, acctg pack
<b>Base Prices</b> Software/support	\$56,700 included	\$35,000 (\$1,167) soft and support extra	\$17,283 (\$385 month) some soft and supp extra	\$41,000	\$25,230 (\$553) included
<b>Comments</b>	system designed for data base mgmt w/RJE	offers time-sharing system and turnkey systems	Interactive applications; ESCORT is high-level lang		designed for transaction proc; available thru distributors

Manufacturer	Tal-Star	Tealtronic	Terak	Vanguard	Wang
<b>System Highlights</b> No. of models No. installed/date Multiprogramming Communications Applications	TDMS System since 1972 2 partitions 15 lines (synch, asynch) graphic arts, newspapers	2500 since 2nd qtr. 1977 no 1 line (asynch, 2780) not given	8510, 8510A 2 since June 1976 yes 4 lines (asynch) small business, educ, graphics	V500, V400 2 6 since March 1976 yes, variable up to 32 lines, 9600bps customized inventory billing only	WCS-20-WCS-40/2200T 5 n/g since January 1975 no up to 5 9600bps lines mfg, dist, medical, insurance, banking
<b>Processor</b> Internal storage Word size/add time	General Automation 18/30 32K-64K core (1.2usec) 16bits, 2.4usec	Tealtronic 2500 20K-64K MOS (600nsec) 8bits, n/g	DEC LSI-11 24K-56K MOS (1.2usec) 16bits, 3.5usec	Raytheon RDS-500 64-128K core (700- 900nsec) 16bits/400usec (18 digits)	Wang 2200T or 2200 MVP 8-64K MOS (1.6usec) 8bits/800usec (13 digits)
<b>Mass Storage</b> Discs Access methods Mag tapes	floppy, pack random, seq, indexed seq reel-reel	floppy sequential no	floppy random, seq, indexed seq no	floppy, cart, pack seq linked, indexed seq reel-reel	floppy, cart random, seq, indexed seq reel-reel, cassette
<b>Peripherals</b>	10-key, ppt, card, serial print (10cps), line print (240ipm), crt	10-key, serial print (to 165cps), line print (300ipm), crt	10-key, serial print (100cps), line print (300ipm), crt	10-key, card, serial ptr, line ptr, crt	10-key, ppt, card, serial ptrs, line ptrs to 600ipm, crt
<b>Software</b>	COBOL, RPG, FORTRAN, assembler, acctg pack, dbms	assembler, ACL, acctg pack	FORTRAN, BASIC, APL, AG/1, assembler, acctg pack, dbms	COBOL, SPL, dbms	BASIC, acctg pkg, dbm
<b>Base Prices</b> Software/support	\$73,600 soft and supp extra	\$9,900 soft free, supp extra	\$6,615 soft and supp extra	\$46,000 soft extra, some supp bundled	\$6,400 soft incl, support extra
<b>Comments</b>	on-line db support; direct entr circulation system for publications	ACL is compatible with the IBM 3741	compatible w/DEC RT-11 and DEC languages; 8510A has graphics	terminal-oriented system designed for development and application: to 5cpus	2780/3780/2741/3741 protocols supported *110usec on WCS-40





**The 50 Million Dollar Award . . .**  
 ICP's highest volume recognition . . .  
 awarded exclusively to  
 Cincom's TOTAL DBMS.

**The Software Honor Roll . . .**  
 Datapro's certification of quality . . .  
 user surveys made TOTAL the  
 only DBMS 3-time recipient.

## Quantity. Quality. More evidence of TOTAL acceptance.

So often in life, one must choose between quantity and quality. User success with the *TOTAL Data Base Management System* proves that *both* benefits accrue to the organization who selects TOTAL as the foundation for its information system requirements.

Nearly *2000 installations worldwide . . .* from efficient minis to the largest maxis . . . have demonstrated that the capabilities, ease of use, and power of the TOTAL DBMS can be applied successfully to nearly any operating environment. Inputs, feedback, and suggestions from this large and diverse user base insure an *exceptionally stable product . . .* so important in the world of data base processing . . . and a continuous *emphasis on product enhancements*. This is what makes quantity and volume as represented by the ICP 50 Million Dollar Award meaningful.

With nearly *four times* the number of user reports submitted than the next leading DBMS product, TOTAL received high marks for *overall satisfaction*

. . . recording a rating of 3.5 on a scale of 4.0 . . . in the Datapro Research survey. Other major factors in this independent survey include throughput/efficiency, ease of installation/use, documentation, and vendor training/technical support. Such user recognition brought TOTAL its *third Honor Roll award . . . unique* among DBMS. Quality and consistency are what makes this tribute meaningful.

If you are planning your organization's move into data base, and, if quantity acceptance coupled with consistent quality are most important to you, why not contact your local Cincom Systems representative today?

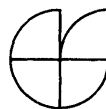

**Cincom Systems, Inc.**  
**We Create Efficiency.**

34 offices in major U.S. cities & worldwide  
 2300 Montana Avenue, Cincinnati, Ohio 45211  
 513/662-2300



**Why do we  
sign our name  
with these  
words?**

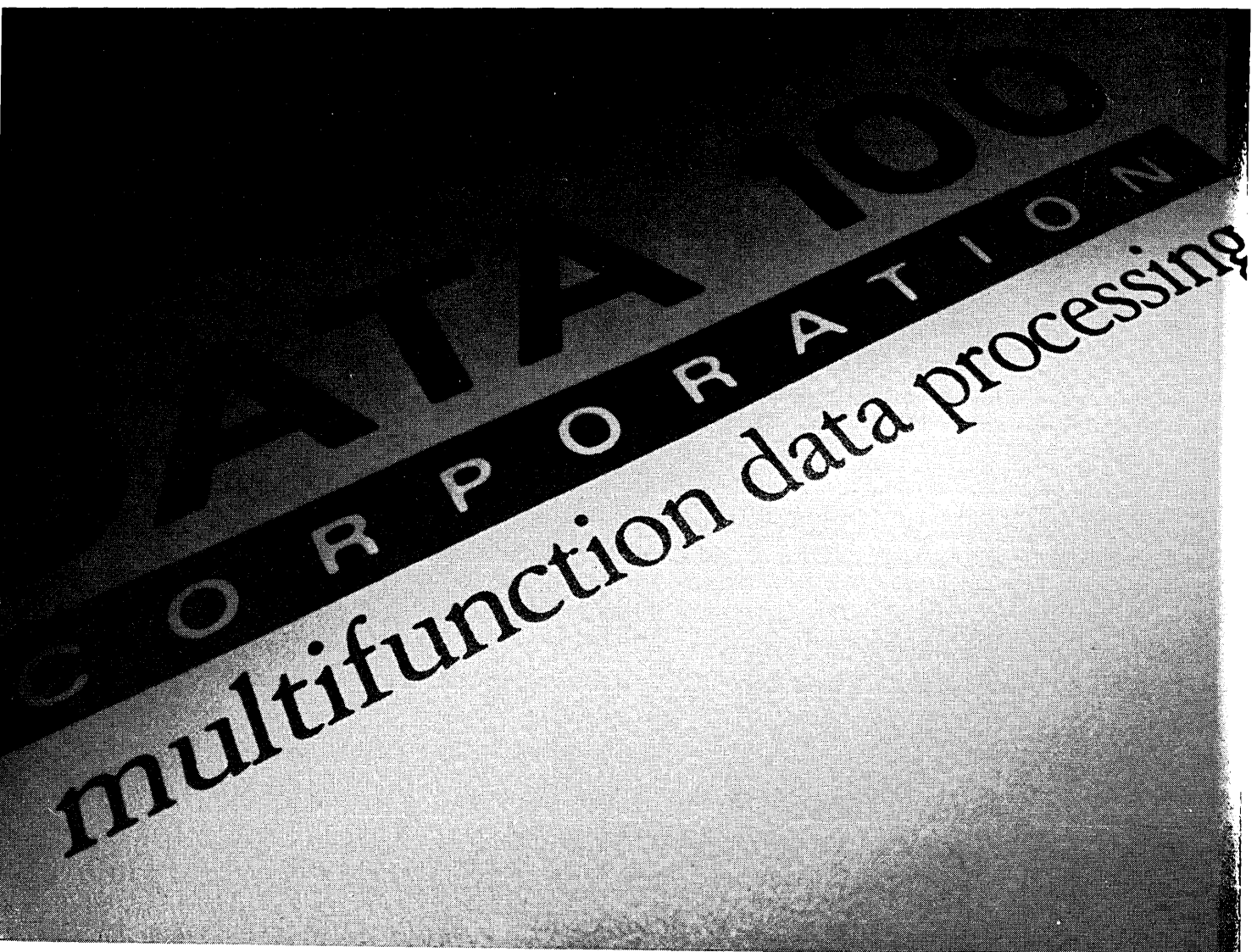

Because they sum up the basic concept behind our products.

Products that offer the user up to four functions in one system. Remote job entry. Key-to-disk data entry. On-line file management. And stand-alone processing. All configured to meet application requirements.

It's a concept that offers our customers a unique blend of stability, growth and economy. A concept we also offer to you.

## **We protect your past and present.**

Multifunction data processing developed from a major commitment we made when Data 100 came into being.

To protect the user's time and resource investment in system procedures and software, by providing continuity between every product in the Data 100 line.

Our first product was a remote batch terminal with remote job entry.

Today, we offer remote job entry, remote data entry, on-line file management and stand-alone processing.

In the meantime, we have protected the time and resource investments of our customers.

Software and system procedures used in early Data 100 products still operate with today's expanded multifunction systems.

## **We provide for your future.**

Data 100 products are designed for multiple tasks.

That's the beauty of multifunction data processing.

For example, you can buy a remote job entry product now, then add key-to-disk data entry later.

As your needs grow, you can add on-line file management; and still later, stand-alone processing.

And you don't obsolete your system as you grow.

## **We help you save money.**

Multifunction data processing systems can do four jobs, at nowhere near the cost of four systems.

That's economy. Real dollar savings.

Whether you buy a single function system now and add functions later, or buy a single system to do four functions, Data 100 can help you save money.

Multifunction data processing.

We sign our name with these words, because they tell you what Data 100 is all about.

# DATA 100

C O N F I D E N T I A L

multifunction data processing

FOR MORE INFORMATION, CALL ONE OF THE NUMBERS LISTED BELOW OR YOUR NEAREST DATA 100 SALES OFFICE.  
LOS ANGELES 213/645-4300 • SAN FRANCISCO 415/546-6000 • CHICAGO 312/992-0850 • BOSTON 617/848-6100 • DETROIT 313/358-5065 •  
MINNEAPOLIS 612/941-6500 • NEW YORK 212/867-6200 • PITTSBURGH 412/391-5425 • HOUSTON 713/777-4413 • WASHINGTON D.C. 703/790-5560 •  
WOODBRIIDGE N.J. 201/634-7800 • ATLANTA 404/455-3895 • ST. LOUIS 314/878-4911 • TORONTO 416/494-0434 • MONTREAL 514/761-5894 •  
LONDON ENGLAND (0442) 69161 • MELBOURNE AUSTRALIA 267-3544 • FRANKFURT GERMANY 72-04-71 • PARIS FRANCE 630-2144

Manufacturer	Warrex Computer	Warrex Computer	Warrex Computer	Wintex Computer
<b>System Highlights</b> No. of models No. installed/date Multiprogramming Communications Applications	Centurlan Series 3: I-A, II-A, III n/g since 1974 yes 4, 12 route acctg, Invtry ctl, oil/gas, medical, banking	Centurlan Series 2: II, IV n/g since 1975 yes 1-3 lines oil/gas, medical, dist, acctng	Centurlon VI n/g since 1978 yes 4, 64 lines acctng, dist, oil/gas, banking, medical	200 NS Bus. System n/g since January 1975 yes 1 line to 9600 bps dist, professional services
<b>Processor</b> Internal storage Word size/add time	CC-201, 202, 203 16-60K MOS (800nsec) 8bits/3.6usec (word)	CC-202, 204 16-60K MOS (800nsec) 16bits/8usec	CC-206 32-252K MOS (600nsec) 8bits/16usec	Wintex Microprocessor 8-64K MOS (650nsec) 8bits/1.5msec (5 digits)
<b>Mass Storage</b> Discs Access methods Mag tapes	floppy, cart, pack random, sequential no	cart random, sequential reel-reel, cassette	floppy, cart, pack random, sequential no	floppy, cart, packs random, seq, indexed seq no
<b>Peripherals</b>	10-key, ppt, card, crt	10-key, card, serial ptr, line printers to 600lpm	10-key, card, serial ptr, line ptr, crt	10-key, line ptr, crt
<b>Software</b>	assembler, CPL I, acctng pkg software bundled	FORTRAN, BASIC, assembler, CPL I, acctng pkg software bundled	assembler, CPL I, CPL II, acctng pkg software bundled	BASIC, assembler, acctng pkg
<b>Base Prices</b> Software/support	\$20,000 support extra	\$26,950 support extra	n/g support extra	\$12,000 soft extra, some support incl
<b>Comments</b>				Two 300K floppy drives standard

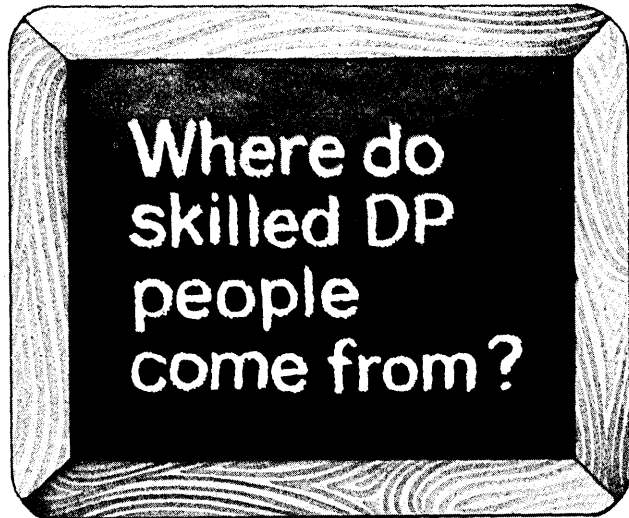

They're taught. And BCS trains a great number of them. As a major supplier and user of data processing services, we're big on training. Over the past 15 years we've trained more than 100,000 students, at BCS training centers and customer sites. We offer a complete range of data processing courses for programmers, analysts, managers and users. The courses,

developed by computer professionals, combine lecture, workshop, and hands-on training, allowing students to put their newly learned skills to work immediately. Get full details about BCS Education and Training. Contact your nearest BCS sales office today or mail the coupon.

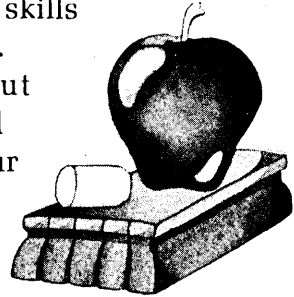

**The best reason to go outside.**



Education and Training Division  
P.O. Box 24346, Seattle, Washington 98124

Please send me more Education and Training information.

Name \_\_\_\_\_

Title \_\_\_\_\_ Phone \_\_\_\_\_

Company \_\_\_\_\_

Address \_\_\_\_\_

City/State/Zip \_\_\_\_\_

# Smartest Move Yet!

## Miniterm 1205 Portable ASR

for newspaper reporters



for field diagnostics

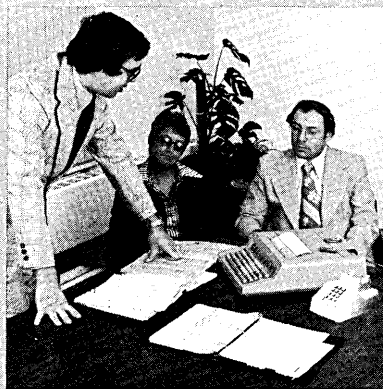
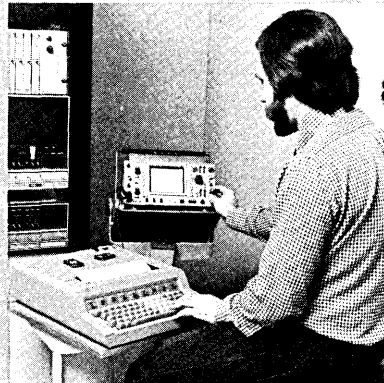

for sales representatives



for programmers

CDI has conceived the smartest move yet for terminal users . . . the Miniterm 1205 *Portable ASR*!

Incredibly, in one compact package the 1205 offers a portable, micro-processor-based terminal with removable storage media and off-line editing capabilities that rival some of the most sophisticated word-processing systems.

Users can now rely on a small, rugged terminal that packs a quiet printer with *both* an integral 8K Random Access Memory and a built-in Mini-Cassette tape unit with up to 68,000 characters of removable storage.

And when it comes to great moves . . . a salesman, programmer, field technician or journalist can go anywhere, plug the Miniterm 1205 ASR into an ordinary wall outlet, and communicate with any popular CPU via the built-in acoustic coupler.

Because you can prepare, edit and format data off-line where it is generated, and you no longer must store programs in an expensive time-sharing medium, you can substantially reduce both telephone line charges and program storage costs. In fact, in some cases, Miniterm 1205 ASR's can pay for themselves with savings better than three-to-four times the monthly rental charge.\*

Get the flexibility — plus real savings — that only CDI offers. The Miniterm 1205 Portable ASR. Make it your smartest move yet.

### The most versatile portable ever offered!

- Built-in Mini-Cassette tape transport with removable storage of 68,000 characters per Mini-Cassette
- Integral 8K Random Access Memory, expandable to 32K, with powerful high-speed editing capability
- Quiet, buffered, 35 CPS thermal printer
- Unique, three-mode keyboard (APL optional)
- Built-in Acoustic Coupler
- Portable Carrying case



**COMPUTER  
DEVICES INC.**

25 North Avenue  
Burlington, MA 01803  
(617)273-1550  
Telex: 94-9398

SALES AND MAINTENANCE OFFICES THROUGHOUT THE U.S. AND CANADA

# HP9830A/B and Infotek...



**WE DID IT! THE 256 ARRAY  
SUBSCRIPT LIMIT IS GONE! \***

**made for each other.**

**If you use the HP9830A/B, you know that it has great potential.**

Now you can extract the full measure of 9830 capabilities with Infotek's Memory, ROMs and Peripherals.

**Memory.** The EM-30, 32,192 byte memory for the '30, pioneered by Infotek, is one of the most significant contributions to increasing the '30's power.

EM-30B, in conjunction with Infotek's Mass Memory II ROM multiplies the speed of the 9880B Mass Memory System by avoiding redundant disc operations. A must for the 9880B user!

**Fast Basic ROMs.** The Fast Basic ROM series provides 54 statements, functions and commands. With these ROMs your '30 acquires versatility and speed superior to any other desk top computer. Here's just a few examples of Fast Basic Power.

**\* Dimension arrays any size you like. Sort or search any array that will fit in your memory!**

- Move information in or out at 10K bytes per second . . . fabulous for instrumentation and control applications.
- Interrogate and amend variables without halting the program, just like a live keyboard.

- Suspend any program including mass memory operations to cassette or floppy for future completion.
- Interrupt capability — a peripheral can now demand service, branch or initiate program execution.
- Edit program test and super-secure both program and data files.

If this is the kind of added capability that you can use in your '30 then read on, there's more!

**The FD-30 Series Floppy Discs.** Each of the FD-30s stores 305K bytes. Organize this information any way you like up to 2387 files. Best of all, you can talk to the FD-30s without any software changes because the FD-30 series obeys *every* 9830 cassette instruction.

The series consists of the FD-30A single disc unit, FD-30S slave drive, FD-30M multiple disc drive which contains a master and up to three slave drives, and the FD-30SR slave drive system which will accommodate one to four drives.

 **Infotek  
Systems**

A single master will support up to seven slaves and only one I/O slot is used.

**Peripherals.** Infotek has applied the same level of ingenuity reflected in the ROMs and floppys to the development of extremely high quality and reliable peripherals tailored to the needs of the 9830A/B. Now available are:

- LP-30, a 200 line per minute matrix printer
- CP-30, a 45 character per second character printer/plotter
- PS-30, a paper tape punch/reader
- TC-30 and RT-30 time clocks
- RS-30, a 9600 BAUD RS 232-C interface with 7 quartz reference rates.
- FI-30, a 10K byte/sec TTL I/O

**Contact us now for the name of your local Infotek representative. Discover why more than a thousand 9830 users working with Infotek enhancements believe that the 9830 and Infotek are made for each other.**

World-wide service and distribution centers back up Infotek's liberal warranty and service commitment.

*At Infotek we're dedicated to making good computers better.*

1400 NORTH BAXTER STREET • ANAHEIM, CALIFORNIA 92806 • (714) 956-9300 • TWX 910-591-2711

The 9830A/B is a product of Hewlett-Packard Company.



# New! \$1155 Fire Safe for small systems media

Now small systems users can have fire protection for valuable disks and tapes with Tab's DataGard™ fire safe. U. L.-rated to maintain a maximum internal temperature of 150° for one hour (85% maximum humidity), DataGard is designed in scale with small systems requirements. Outside dimensions are: height—39½", width—32⅝", depth—39".

The compact DataGard comes with casters and a textured off-white finish. Options include second door colors and a functional formica work top. The DataGard fire safe will economically store two 3348 Data Modules, ten 2315 Disk Cartridges or numerous other combinations of magnetic media including floppy disks, computer tape, microfilm, and cassettes.

For complete information, call your local Tab representative or write Tab Products Company, 2690 Hanover Street, Palo Alto, California 94304.

**TAB**  
PRODUCTS CO

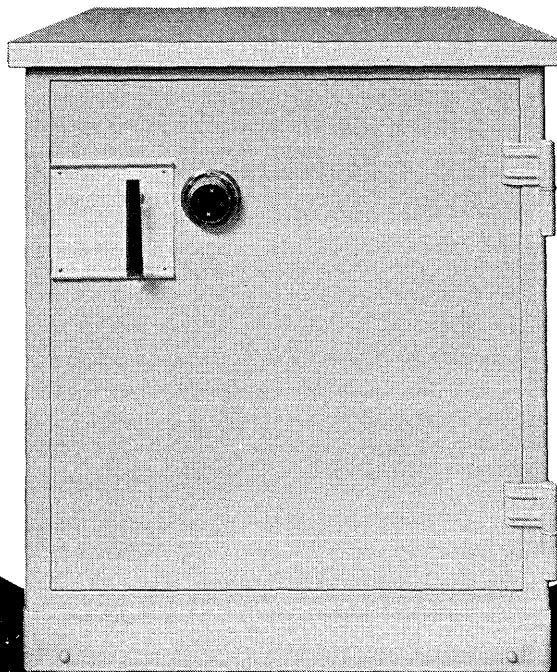



## Vendor Index

For additional information regarding the products in this survey please contact the vendors directly, either at the addresses listed below or by circling the appropriate number on the reader service card bound into this issue.

**Advanced Information Design**  
745 Distel Drive  
Los Altos, CA 94022  
(415) 961-0500  
CIRCLE 351 ON READER CARD

**A. K. Industries**  
P.O. Box 286  
Skippack PA 19474  
(215) 584-1776  
CIRCLE 352 ON READER CARD

**Anderson-Jacobson, Inc.**  
1065 Morse Avenue  
Sunnyvale, CA 94086  
(408) 734-4030  
CIRCLE 353 ON READER CARD

**Applied Data Communications**  
1509 East McFadden  
Santa Ana, CA 92705  
(714) 547-6954  
CIRCLE 354 ON READER CARD

**Applied Data Processing, Inc.**  
33 Bernhard Road  
North Haven, CT 06473  
(203) 787-4107  
CIRCLE 355 ON READER CARD

**Applied Digital Communications**  
214 W. Main St.  
Moorestown, NJ 08057  
(609) 234-3666  
CIRCLE 365 ON READER CSARD

**Applied Digital Technology, Inc.**  
8550 West Bryn Mawr Ave.  
Chicago, IL 60631  
(312) 694-4190  
CIRCLE 356 ON READER CARD

**Applied Systems Corp.**  
26401 Harper Ave.  
St. Clair Shores, MI 48081  
(313) 779-8700  
CIRCLE 357 ON READER CARD

**J. Baker & Associates**  
5135 W. Golf Road  
Skokie, IL 60076  
(312) 677-9760  
CIRCLE 358 ON READER CARD

**Basic/Four Corp.**  
18552 MacArthur Blvd.  
Santa Ana, CA 92707  
(714) 833-9530  
CIRCLE 359 ON READER CARD

**Basic Timesharing Inc.**  
650 North Mary Ave.  
Sunnyvale, CA 94086  
(408) 733-1122  
CIRCLE 360 ON READER CARD

**Binary Data Systems, Inc.**  
88 Sunnyside Blvd.  
Plainview, NY 18803  
(516) 822-1585  
CIRCLE 361 ON READER CARD

**Burroughs Corp.**  
Burroughs Place  
Detroit, MI 48232  
(313) 972-7000  
CIRCLE 362 ON READER CARD

**Business Controls Corp.**  
507 Boulevard  
Elmwood Park, NJ 07407  
(201) 791-7661  
CIRCLE 363 ON READER CARD

**Business Systems Products Inc.**  
2121 Campus Drive  
Irvine, CA 92715  
(714) 752-1799  
CIRCLE 364 ON READER CARD

**Cado Systems Corp.**  
2730 Monterey St.  
Torrance, CA 90503  
(213) 320-9660  
CIRCLE 366 ON READER CARD

**Cascade Data, Inc.**  
300 Kraft Ave., S.E.  
Grand Rapids, MI 49508  
(616) 942-1420  
CIRCLE 367 ON READER CARD

**CDA, Inc.**  
470 Commercial Ave.  
Palisades Park, NJ 07650  
(201) 944-2500  
CIRCLE 368 ON READER CARD

**Century Computer Corp.**  
1601 North Main St.  
Walnut Creek, CA 94596  
(415) 933-6736  
CIRCLE 369 ON READER CARD

**Complete Computer Systems**  
1 Fairway Plaza  
Huntingdon Valley, PA 19006  
(215) 947-7900  
CIRCLE 370 ON READER CARD

**Compucorp**  
12312 W. Olympic Blvd.  
Los Angeles, CA 90064  
(213) 820-5611  
CIRCLE 371 ON READER CARD

**Computata Systems, Inc.**  
772 Post Road East  
Westport, CT 06880  
(203) 226-4791  
CIRCLE 372 ON READER CARD

# Don't Let Packaged Software Box You In.

Check them all out — MSA, Software International, UCC — and when you're through check us,

AMS, American Management Systems. You'll know the difference. We're doing things differently so you don't have to. After seven years of management consulting, custom program development and researching the needs of today's management, AMS has introduced GFS, General Financial System. GFS handles all your financial applications. With GFS you define the parameters. You don't need to compromise your existing accounting procedures or reprogram interface files into predefined formats. GFS — tailored to today's needs and tomorrow's growth.

**AMS** ..Accounts Payable ..General Ledger  
..Accounts Receivable ..Standard Cost

1515 Wilson Boulevard, Arlington, VA 22209, (703) 841-6000 • New York (212) 233-1500 • San Mateo (415) 573-9481 • Chicago (312) 648-5555



# See things your way

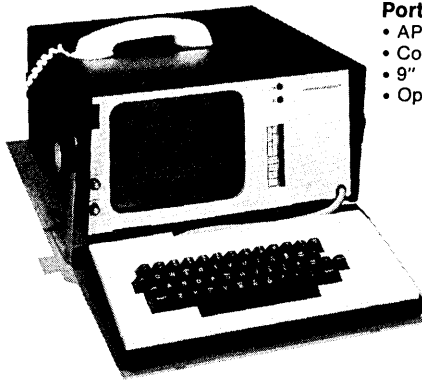

- Portable Elite 1520A**
- APL/ASCII (optional)
  - Compact, rugged construction
  - 9" display
  - Optional acoustic coupler

Circle 137 on Reader Card



- Elite 1520A**
- Conversational
  - X-Y addressable cursor
  - 64/128 character ASCII
  - Display 80 x 24

Circle 138 on Reader Card

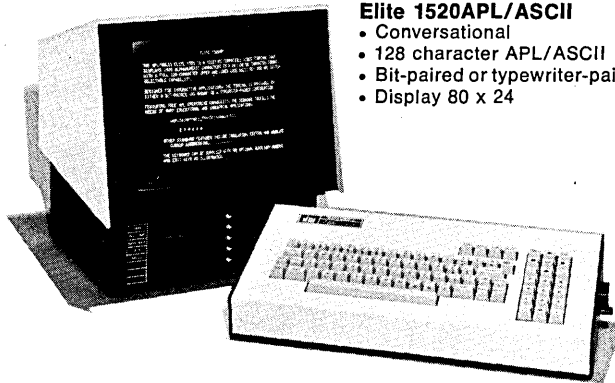

- Elite 1520APL/ASCII**
- Conversational
  - 128 character APL/ASCII
  - Bit-paired or typewriter-paired
  - Display 80 x 24

Circle 139 on Reader Card

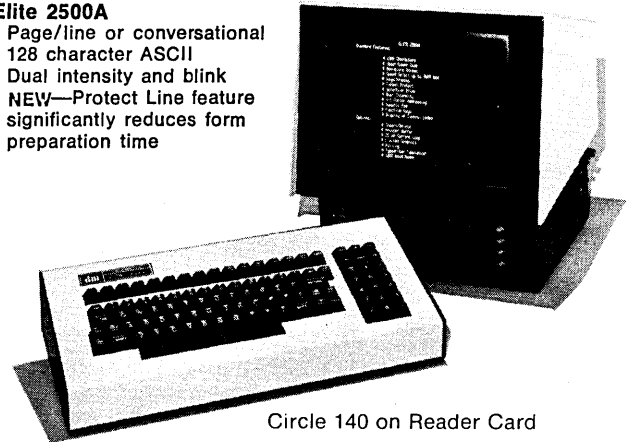

- Elite 2500A**
- Page/line or conversational
  - 128 character ASCII
  - Dual intensity and blink
  - NEW—Protect Line feature significantly reduces form preparation time

Circle 140 on Reader Card

## with Datamedia Elite Video Terminals

**A family of video terminals that offers a wide range of features to perform an even wider range of data entry and display tasks.**

If you're with an OEM firm or a system house, and look at peripherals with one eye on cost and the other on performance, you'll want to take a long look at these proven products from Datamedia.

Their modular design makes troubleshooting a breeze, and facilitates conformance to your system needs, and their quality workmanship assures that those needs will be met longer than you thought possible.

And if you believe in service after the sale the way Datamedia does, you'll appreciate the new dimension we've given to the word "responsive."

Datamedia. We've been seeing things the right way for users in industry, business services, government, education, medicine and research around the world.

Why don't you see what we can do for you.

**Datamedia Corporation**

**7300 N. Crescent Boulevard • Pennsauken, NJ 08110 • TEL: 609-665-2382 • TWX: 710-892-1693**

18311 Lost Knife Circle • Gaithersburg, MD 20760 • 301-948-1670

6520 Powers Ferry Road • Suite 200 • Atlanta, GA 30339 • 404-955-2859

5456 McConnell Avenue • Suite 180 • Los Angeles, CA 90066 • 213-397-3556

**Canada:** Datamex, Ltd., Ontario/Quebec • **Belgium:** Inex, (02) 512 4037 • **Finland:** Suma, (90) 440391 • **Italy:** Eltron s.r.l., (030) 55-26-41554 • **Sweden:** Teleinstruments ab, 08-38 03 70 • **Switzerland:** Teledynamics, 01-56 3300 • **United Kingdom:** Mellor Data, 020629-8181 • **West Germany:** Video Data Systems GmbH, (0 61 81) 7 39 51 • **Australia:** Inteltec Data Systems, (03) 232-3118 • **Japan:** Protech, Inc., (03) 384-0225.



**Elite 4000A Programmable Terminal System**

- Microprocessor based
- Direct memory access
- Expandable display memory
- 8-level video

Circle 141 on Reader Card

## Index

**Computer Automation, Inc.**  
18651 Von Karman Ave.  
Irvine, CA 92664  
(714) 833-8830  
CIRCLE 373 ON READER CARD

**Computer Covenant Corp.**  
136 Old Farms Road  
West Simsbury, CT 06092  
(203) 658-6697  
CIRCLE 374 ON READER CARD

**Computer Hardware, Inc.**  
4111 North Freeway Blvd.  
Sacramento, CA 95825  
(916) 929-2020  
CIRCLE 375 ON READER CARD

**Computer Horizons Corp.**  
747 Third Ave.  
New York, NY 10017  
(212) 371-9600  
CIRCLE 376 ON READER CARD

**Computer Interactions, Inc.**  
P.O. Box 1354  
Roslyn Heights, NY 11577  
(516) 487-9810  
CIRCLE 377 ON READER CARD

**Control Data Corp.**  
P.O. Box 0  
Minneapolis, MN 55440  
(616) 853-4656  
CIRCLE 378 ON READER CARD

**Corstar Business Computing Co., Inc.**  
One Aqueduct Road  
White Plains, NY 10606  
(914) 428-5550  
CIRCLE 379 ON READER CARD

**Data Communications Corp. Minicomputer Division**  
3000 Directors Row  
Memphis, TN 38131  
(901) 332-3544  
CIRCLE 380 ON READER CARD

**Data General Corp.**  
Route 9  
Southboro, MA 01772  
(617) 485-9100  
CIRCLE 381 ON READER CARD

**Datapoint Corp.**  
9725 Datapoint Drive  
San Antonio, TX  
(512) 690-7000  
CIRCLE 382 ON READER CARD

**Decision Data Computer Corp.**  
100 Witmer Road  
Horsham, PA 19044  
(215) 674-3300  
CIRCLE 383 ON READER CARD

**Design Data, Inc.**  
238 Main St.  
Cambridge, MA 02142  
(617) 661-7710  
CIRCLE 384 ON READER CARD

**Digital Computer Controls, Inc.**  
12 Industrial Road  
Fairfield, NJ 07006  
(201) 227-4702  
CIRCLE 385 ON READER CARD

**Digital Equipment Corp.**  
Parker St. PK 3-2  
Maynard, MA 01754  
(617) 897-5111  
CIRCLE 386 ON READER CARD

**Digital Scientific Corp.**  
11455 Sorrento Valley Road  
San Diego, CA 92121  
(714) 453-6050  
CIRCLE 387 ON READER CARD

**Digital Systems Corp.**  
P.O. Box 396  
Walkersville, MD 21793  
(301) 845-4141  
CIRCLE 388 ON READER CARD

**Dimis, Inc.**  
1060 Highway 35 South  
Middletown, NJ 07748  
(201) 671-1011  
CIRCLE 389 ON READER CARD

**Display Data Corp.**  
Executive Plaza IV  
Hunt Valley, MD 21031  
(301) 667-9211  
CIRCLE 390 ON READER CARD

**Distribution Management Systems Inc.**  
11 DeAngelo Drive  
Bedford, MA 01730  
(617) 275-2000  
CIRCLE 391 ON READER CARD

**Educomp-Quodata Corp.**  
196 Trumbull St.  
Hartford, CT 06103  
(203) 768-6777  
CIRCLE 392 ON READER CARD

**Financial Computer Corp.**  
412 W. Redwood St.  
Baltimore, MD 21201  
(301) 837-9510  
CIRCLE 393 ON READER CARD

**Four-Phase Systems, Inc.**  
19333 Vallco Parkway  
Cupertino, CA 95014  
(408) 255-0900  
CIRCLE 394 ON READER CARD

**General Automation, Inc.**  
1055 S. East St.  
Anaheim, CA 92805  
(714) 778-4800  
CIRCLE 395 ON READER CARD

## DATAMATION®

# 1977 MINI/MICROCOMPUTER SURVEY AVAILABLE NOW.

The most comprehensive analysis ever of the Mini/Microcomputer market has been compiled in a 200-page report . . . essential reading for industry analysts, market planners, sales executives and users themselves.

In this up-to-the-minute report, nearly 5,000 OEM, Systems House, and end-user sites in North America and Overseas answered questions about their plans to buy over 20,000 minicomputers, 15,000 microcomputers and 625,000 microprocessors this year.

Topics of the survey include: High Growth Application Markets • User Spending outlook for 1978 and beyond • User Assessment of IBM Series/1 and 32 Bit Computers • Future Hardware & Software Needs • 1977 Purchase Intentions • Most Important Factors in Choosing A Vendor • Miniperipheral Purchase Plans • The International Market.

**CHARTER OFFER . . . SAVE \$35.** This first in a series of annual DATAMATION Mini/Microcomputer survey reports is being offered at a \$35 saving off the regular price of \$365 in North America and \$395 elsewhere.

Return to:  
Ms. Deborah Dwelley  
DATAMATION Magazine  
35 Mason Street  
Greenwich, Conn. 06830  
Tel. 203-661-5400

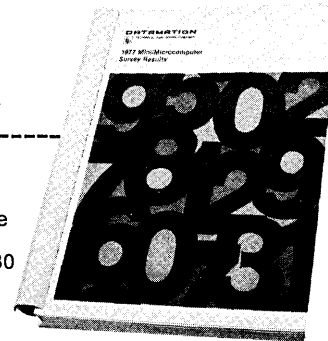

Please send me \_\_\_\_\_ copies of the 1977 DATAMATION Mini/Microcomputer Survey Report at the charter rate of \$\_\_\_\_\_ (\$330 in North America and \$360 elsewhere). Offer expires October 15, 1977.

Check enclosed       Bill me

Name \_\_\_\_\_  
Title \_\_\_\_\_ Telephone \_\_\_\_\_  
Company \_\_\_\_\_  
Address \_\_\_\_\_  
City \_\_\_\_\_ Country \_\_\_\_\_ State \_\_\_\_\_ Zip \_\_\_\_\_

# Verbatim™

## The whole message is quality.

You want to record your message verbatim—word for word—whether it's bits, bytes or "Dear Folks" translated into word processor language.

Our objective in manufacturing recording media for the electronics industry—digital tape cassettes, floppy disks, mag cards, computer cartridges—is to give you the finest, the best, the most dependable, the most cost-effective.

That means rugged, long-lived, abrasion-resistant recording media with superior magnetic qualities. If we made tires, they'd be steel-belted radials.

We delivered our first digital grade certified tape cassettes back in the beginning, 1969. We made the first commercial 3740-compatible floppy disks that didn't bear IBM's name. And the first Flippy® reversible flexible disks with *anyone's* name on them. The first mini data cassette is ours. And we've got the newest miniature flexible disk, the MD 525.

Now, Verbatim media. It's a new formulation of ferric oxides, an advanced macromolecular binder system to adhere it to the tough polyester film, and a process control system that demands over 200 separate quality checks before the material is cut, packaged, and certified to be 100% error-free.

The final quality check? "Make it pretty!" Our production people tell us that magnetic recording media is one of the rare instances in manufacturing where aesthetic appearance translates directly into final product quality. It has to look beautiful to work beautifully.

We have the formulas, the machines, the technology to make high quality recording media. But it takes the best people in the industry to deliver Verbatim disks, cards, cartridges and cassettes. You'll find them here. Write or call for our new monograph, "Data and Word Storage Media." Phone (408) 245-4400. TWX 910-339-9381. 323 Soquel Way, Sunnyvale, CA 94086.

**In Europe:** Information Terminals SA  
Case Postale 296  
1215 Genève  
Switzerland  
Tel: (022) 32-32-39  
Telex: 22647 ITGE CH



Information Terminals Corp. 

## Index

### General Information Systems

2024 N. Broadway  
Santa Ana, CA 92706  
(714) 834-0220  
CIRCLE 396 ON READER CARD

### GRI Computer Corp.

320 Needham St.  
Newton, MA 02164  
(617) 969-0800  
CIRCLE 397 ON READER CARD

### Harris Corp., Computer Systems Division

1200 Gateway Drive.  
Fort Lauderdale, FL 33309  
(305) 974-1700  
CIRCLE 398 ON READER CARD

### Hewlett-Packard, Calculator Products Division

P.O. Box 301  
Loveland, CO 80537  
(303) 667-5000  
CIRCLE 399 ON READER CARD

### Hewlett-Packard, Data Systems Division

11000 Wolfe Road  
Cupertino, CA 95014  
(408) 257-7000  
CIRCLE 400 ON READER CARD

### Hewlett-Packard, GSD Division

5303 Stevens Creek Road

Santa Clara, CA 95050  
(408) 249-7020  
CIRCLE 401 ON READER CARD

### Honeywell Information Systems Inc.

200 Smith St.  
Waltham, MA 02154  
(617) 890-8400  
CIRCLE 402 ON READER CARD

### IBM Corp., General Systems Division

P.O. Box 2150  
Atlanta, GA 30301  
(404) 256-7000  
CIRCLE 403 ON READER CARD

### International Computers (USA) Limited

555 Madison Ave.  
New York, NY 10022  
(212) 486-7400  
CIRCLE 404 ON READER CARD

### Jacquard Systems

2502 Broadway  
Santa Monica, CA 90404  
(213) 829-3493  
CIRCLE 405 ON READER CARD

### Litton Industries, Inc., Sweda International Division

34 Maple Ave.  
Pine Brook, NJ 07058  
(201) 575-8100  
CIRCLE 406 ON READER CARD

### Logical Machine Corp.

887A Mitten Road  
Burlingame, CA 94010  
(415) 692-4970  
CIRCLE 407 ON READER CARD

### Medical Computer Sciences, Inc.

2400 West Bay Drive  
Largo, FL 33540  
(813) 581-8721  
CIRCLE 408 ON READER CARD

### Mini-Computer Systems, Inc.

525 Executive Blvd.  
Elmsford, NY 10523  
(914) 592-8812  
CIRCLE 409 ON READER CARD

### Minuteman Computer Corp.

230 Second Ave.  
Waltham, MA 02154  
(617) 890-4070  
CIRCLE 410 ON READER CARD

### Mylee Digital Sciences, Inc.

155 Weldon Parkway  
Maryland Heights, MO 63043  
(314) 567-3420  
CIRCLE 411 ON READER CARD

### NCR Corp.

Main & K Streets  
Dayton, OH 45409  
(513) 449-2000  
CIRCLE 412 ON READER CARD

### Nixdorf Computer Inc.

O'Hare Plaza  
5725 East River Road  
Chicago, IL 60631  
(312) 693-6600  
CIRCLE 413 ON READER CARD

### Norfield Datasystems, Inc.

3 Depot Place  
Norwalk, CT 06855  
(203) 853-2777  
CIRCLE 414 ON READER CARD

### Northrop Data Systems

19000 South Vermont Ave.  
Torrance, CA 90502  
(213) 532-1510  
CIRCLE 415 ON READER CARD

### Olivetti Corp. of America

500 Park Ave.  
New York, NY 10022  
(212) 371-5500  
CIRCLE 416 ON READER CARD

### Pako Corp.

6300 Olson Memorial Hwy.  
Minneapolis, MN 55440  
(612) 571-6466  
CIRCLE 417 ON READER CARD

### Philips Business Systems, Inc.

175 Froelich Farm Blvd.  
Woodbury, NY 11797  
(516) 921-9310  
CIRCLE 418 ON READER CARD

# Informer mini-terminals are small enough to fit your pharmacy systems applications.

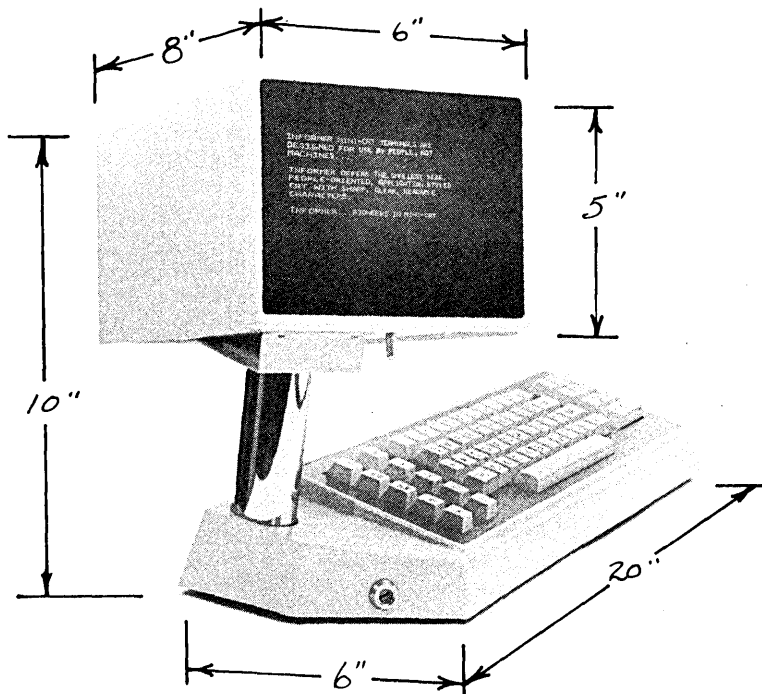

CIRCLE 165 ON READER CARD

When your big need is something small, INFORMER's line of mini-CRT terminals offers simple solutions to complex problems.

Imagine! Only 10 pounds, with a 5 1/2" display screen, pedestal mounted on a data entry keyboard that's only 6" x 20". No waste with 512 characters on 16 lines. Data rates from 110 to 9600 baud.

And INFORMER, Inc. is small enough to give you the modular design flexibility you need to serve your specialized customers. Your choice of electronics — character-by-character transmission or pollable block transfer. Your choice of keyboards — for the high-speed typist or the hunt-and-peck factory worker.

When the big need is something small, call INFORMER, the pioneer in mini-CRT terminals, at 213/649-2030.

# **informer**

8332 Osage Ave. • Los Angeles, Ca 90045

# SOFTWARE ADS ARE THE PITS.

Most software ads read like the Declaration of Independence engraved on the head of a pin. Besides, you have to see software in action. Give us a call and we'll show you a real software work out. You'll see a proven productivity product. It's called MENTEXT, the OS & OS/VS system enhancement package from:

## **MENTEL, INC.**

San Francisco: 459 Hamilton Avenue  
Palo Alto, CA 94302  
(415) 321-2787

New York: 160 Broadway  
New York, NY 10038  
(212) 227-3335

Chicago: 6033 N Sheridan Rd  
Chicago, IL 60600  
(312) 334-7899

Dallas: 3068 Forest Ln.  
Dallas, TX 75234  
(214) 241-9174

Member SIA  Software Industry Association



Good things keep coming from Kodak.

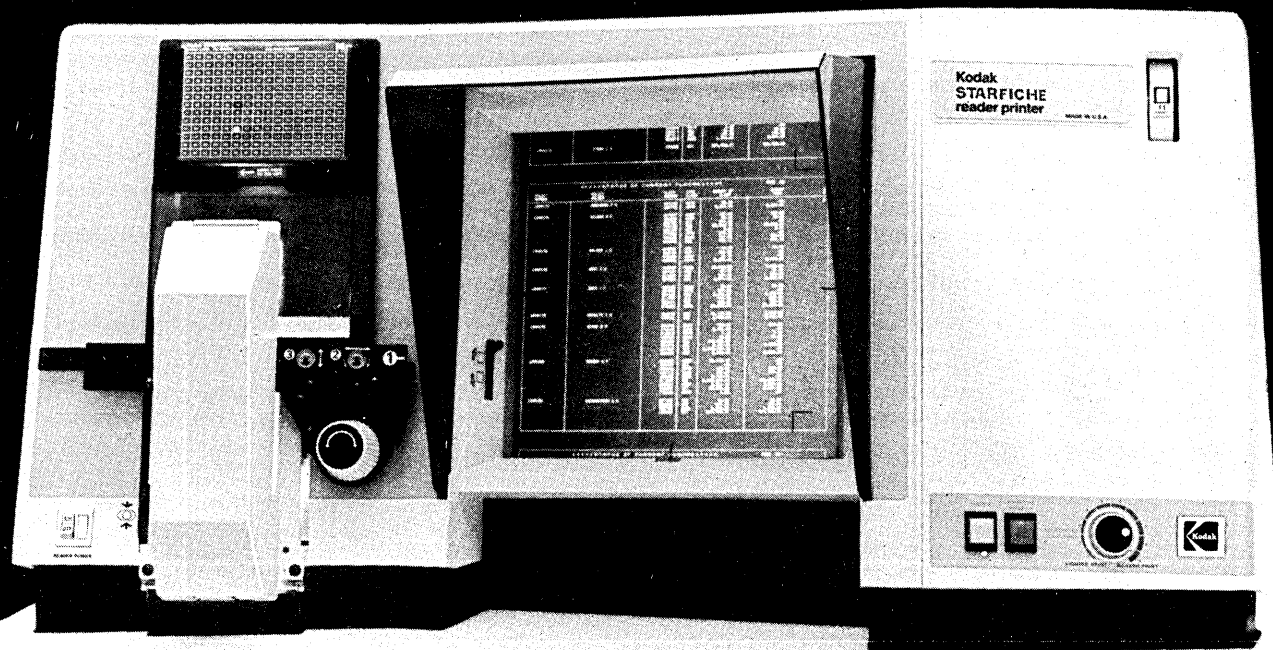

# Introducing the microfiche control center.

## Make the Kodak Starfiche reader-printer the center of your microfiche retrieval operation.

The attractive Starfiche reader-printer is a reliable piece of equipment that can provide rapid retrieval and high-quality prints in your microfiche program.

We call it the "control center" because it can be the heart of microfiche retrieval operations. It can speed workflow, maximize operator efficiency, and provide an excellent print on the first try... up to hundreds of prints a day.

This dependable piece of equipment—with push-button ease of operation and modern good looks—can now become your control center, too. Just fill out the coupon for more information.



Eastman Kodak Company  
Business Systems Markets Division,  
Dept. DP7780, Rochester, NY 14650

### Ask us

Please send me more information about the new Kodak Starfiche reader-printer.

Please have a Kodak representative contact me.

Name \_\_\_\_\_ Title \_\_\_\_\_

Company \_\_\_\_\_

Address \_\_\_\_\_

City \_\_\_\_\_ State \_\_\_\_\_ Zip \_\_\_\_\_

## Index

**Prime Computer, Inc.**  
40 Walnut St.  
Wellesley Hills, MA 02181  
(617) 237-6990  
CIRCLE 419 ON READER CARD

**Programmed Control Corp.**  
2 East Broad St.  
Hopewell, NJ 08525  
(609) 466-2100  
CIRCLE 420 ON READER CARD

**Qantel Corporation**  
3525 Breakwater Ave.  
Hayward, CA 94545  
(415) 783-3410  
CIRCLE 421 ON READER CARD

**Q1 Corp.**  
6 Dubon Court  
Farmingdale, NY 11735  
(516) 293-0700  
CIRCLE 422 ON READER CARD

**Randal Data Systems, Inc.**  
365 Maple Ave.  
Torrance, CA 90503  
(213) 320-8550  
CIRCLE 423 ON READER CARD

**Raytheon Data Systems Co.**  
1415 Boston-Providence  
Turnpike  
Norwood, MA 02062  
(617) 762-6700  
CIRCLE 424 ON READER CARD

**Shasta General Systems**  
895 Stanton Road  
Burlingame, CA 94010  
(415) 692-0722  
CIRCLE 425 ON READER CARD

**A. O. Smith Corp.**  
Data Systems Division  
P.O. Box 584  
Milwaukee, WI 53201  
(414) 447-4472  
CIRCLE 426 ON READER CARD

**Span Management Systems**  
Westminster Industrial Park  
East Providence, RI 02914  
(401) 438-2200  
CIRCLE 427 ON READER CARD

**Sperry Univac Division**  
**Sperry Rand Corp.**  
P.O. Box 500  
Blue Bell, PA 19422  
(215) 542-4011  
CIRCLE 428 ON READER CARD

**Sycor, Inc.**  
100 Phoenix Drive  
Ann Arbor, MI 48104  
(313) 995-1264  
CIRCLE 429 ON READER CARD

**STC Systems, Inc.**  
E-210 Route 4  
Paramus, NJ 07652  
(201) 843-0560  
CIRCLE 430 ON READER CARD

**Tal-Star Computer Systems, Inc.**  
P.O. Box T-1000  
Princeton Junction, NJ 08550  
(609) 799-1111  
CIRCLE 431 ON READER CARD

**Tealtronic of America Inc.**  
14 Commerce Drive.  
Cranford, NJ 07016  
(201) 272-2922  
CIRCLE 432 ON READER CARD

**Terak Corp.**  
14425 N. Scottsdale Rd.  
Suite 100  
Scottsdale, AZ 85260  
(602) 991-1580  
CIRCLE 433 ON READER CARD

**Tri-Star Computer Systems**  
304 Harper Drive  
Mt. Laurel, NJ 08051  
(609) 234-6661  
CIRCLE 434 ON READER CARD

**Vanguard Computer Systems, Inc.**  
7417 Van Nuys Blvd.  
Van Nuys, CA 91405  
(213) 994-7343  
CIRCLE 435 ON READER CARD

**Wang Laboratories, Inc.**  
836 North St.  
Tewksbury, MA 08176  
(617) 851-4111  
CIRCLE 436 ON READER CARD

**Warrex Computer Corp.**  
P.O. Box 943  
Richardson, TX 75080  
(214) 238-7238  
CIRCLE 437 ON READER CARD

**Wintex Computer Corp.**  
544 Lunt Ave.  
Schaumburg, IL 60172  
(312) 529-2080  
CIRCLE 438 ON READER CARD \*

### DECwriter II

**LA36 PRINTER TERMINAL**  
10-15-30 CHARACTERS SECOND  
REMOTE OR CONSOLE USE  
132 PRINT POSITIONS

**\$1,645 each**

### DECscope

**VIDEO DISPLAY TERMINAL**  
MODEL VT52 24 LINES 80 CHARACTERS  
NUMERIC PAD • HOLD SCREEN MODE  
SPECIAL FEATURES

**\$1,795 each**

### DECwriter III

**LS120 TELEPRINTER**  
PRINTS 180 CHARACTERS SECOND  
300, 1200 AND UP TO 9600 BAUD  
INCLUDES KEYBOARD, EIA INTERFACE,  
SELF-TEST MODE AND OTHER FEATURES

**\$3,295 each**

### DECprinter I

**LA180 HIGH-SPEED PRINTER**  
180 CHARACTERS SECOND  
132 PRINT POSITIONS  
INTERFACES AVAILABLE

**\$2,695 each**

#### 100% EQUITY RENTAL PLAN

	12 MONTHS	24 MONTHS
DECwriter II	\$150 month	\$ 83 month
DECwriter III	300 month	165 month
VT52 DECscope	165 month	90 month
DECprinter I	250 month	135 month

**FULL OWNERSHIP AFTER 12 OR 24 MONTHS**

**OPTIONAL FEATURES INSTALLED WITHOUT CHARGE  
QUANTITY DISCOUNTS, LEASE AND RENTAL PLANS  
WE ALSO MARKET MODEMS, ACOUSTIC COUPLERS  
AND DIGITAL CASSETTE UNITS**



**TRANSNET CORPORATION**  
2005 ROUTE 22, UNION, N.J. 07083  
201-688-7800

CIRCLE 189 ON READER CARD

## THE RMP-116 INTRODUCES A NEW DIMENSION TO SOLID STATE SOFTWARE FOR THE PDP-11

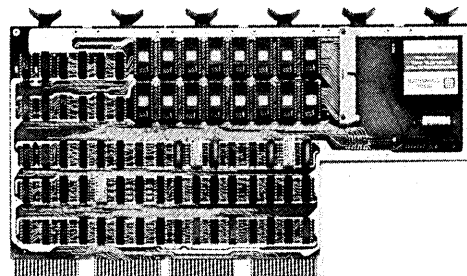

*For the first time you can have*

- Up to 16384 words of Intel 2716 EPROM or equivalent ROM on one small peripheral board.
- Complete on-board programming of the Intel 2716's under computer control.
- Unique and powerful hardware/software system for address space allocation permitting unlimited system expansion.
- Remote station available for added convenience in programming.

Price

RMP-116 \$895\* in quantities 1-9  
Remote Unit \$250

\*Does not include EPROMs



**DIGITAL PATHWAYS INC.**  
4151 MIDDLEFIELD ROAD  
PALO ALTO, CALIFORNIA 94306  
(415) 493-5544

CIRCLE 159 ON READER CARD

We've gone about our major training investment in a manner that's typical of Raytheon. Soon our program will reach 900 student days a quarter and grow from there. Our service engineers participate in comprehensive learning experiences involving most IBM central processing units and input/output devices which includes total 360 and 370 training. In short, Raytheon has gone after the best training program in the country with a single purpose in mind: to enhance further the background skills of our service engineers.

It's more of Raytheon's commitment not only to our customers but importantly to Raytheon

Service Company people who want their service product to be the best in the business. And to continue being the fastest growing service company in the computer business. I'd be pleased to tell you more about our training facilities, teaching staff and what it means to you and your installation. Call our Marketing Department in Burlington, MA. Our number is 617-272-9300 ext. 475.

Raytheon Service Company, Two Wayside Road, Burlington, Massachusetts 01803.

**RAYTHEON** Raytheon Service Company

CIRCLE 14 ON READER CARD

# "Raytheon's new training investment. A commitment to our customers and a statement to our staff."

Walt Schletter  
Manager of Training

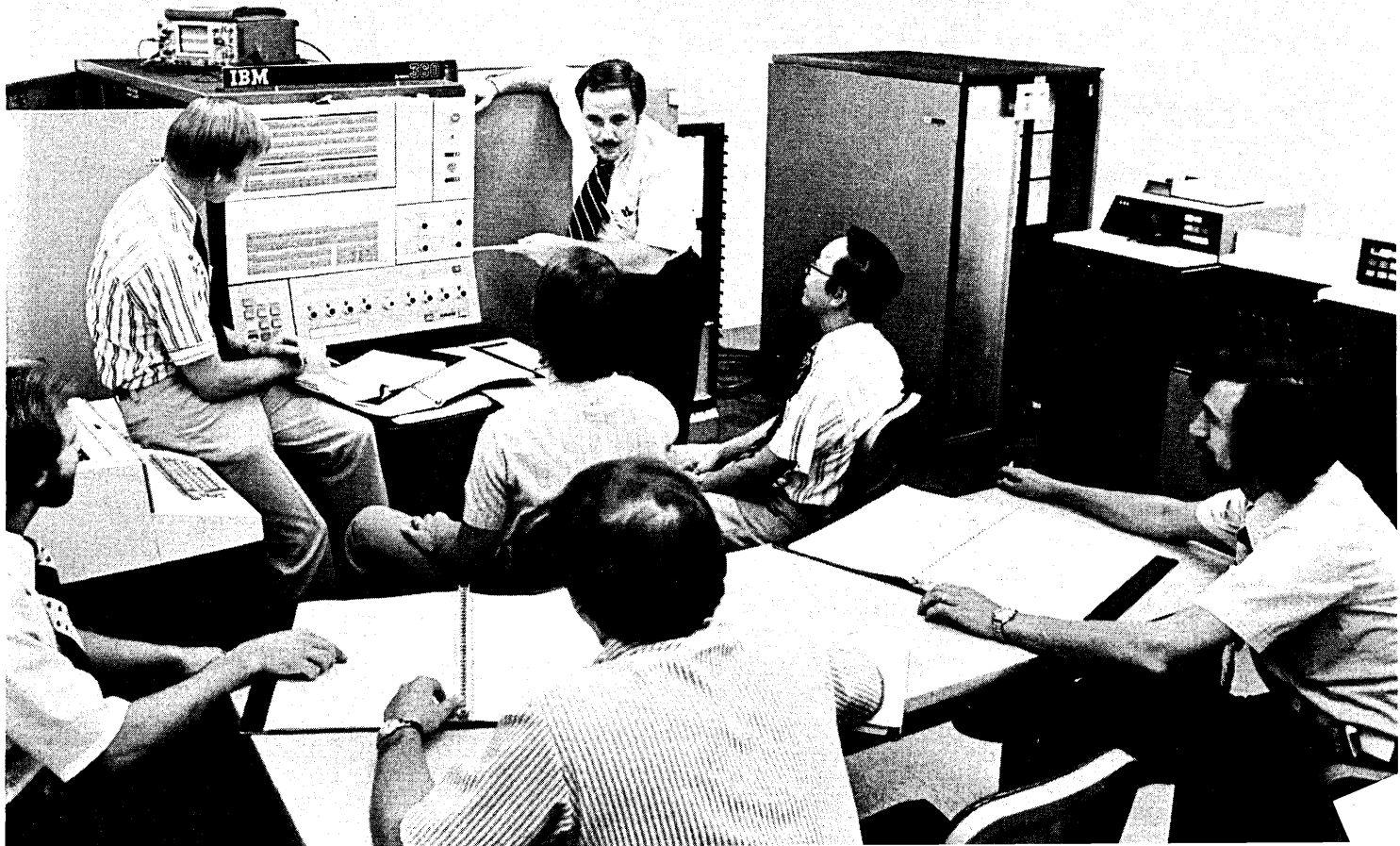

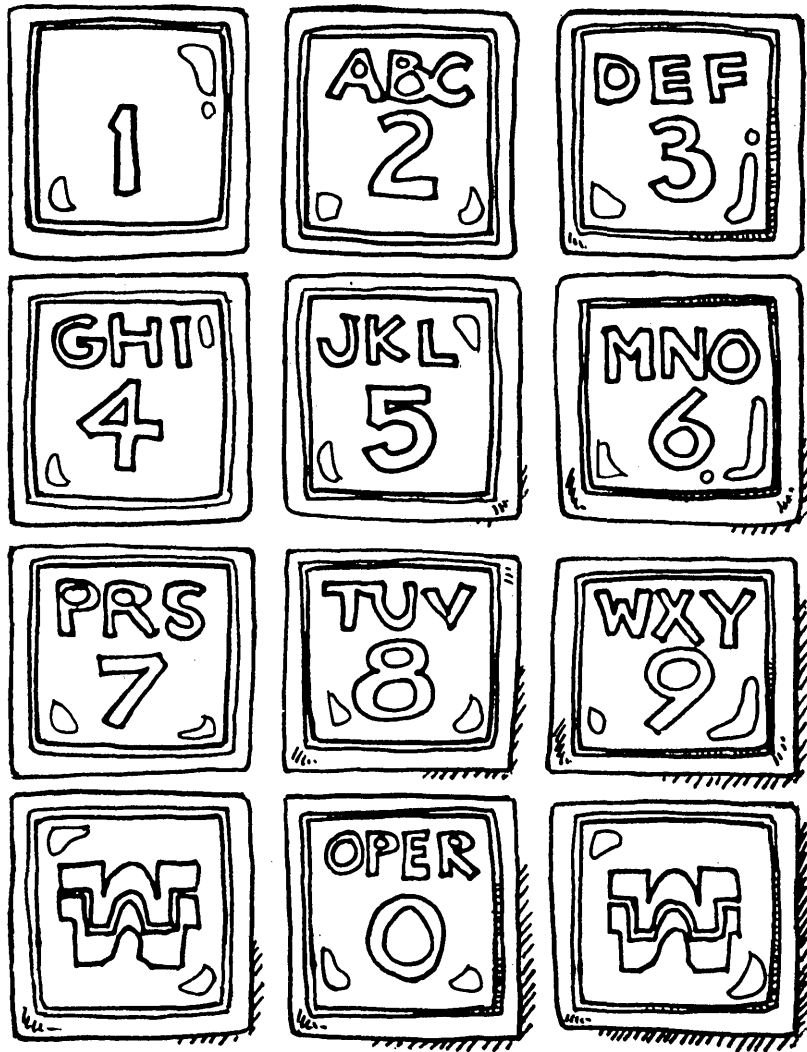

INTERFACE WEST  
IS TAKING  
RESERVATIONS!

800-225-4620

Data communications, data processing and communications professionals, call in your reservations today! Three days of conference sessions on the latest datacomm advances plus an exposition of all the hot, new products and services is drawing attendees in large numbers. Register by phone to reserve your place at INTERFACE WEST, Nov. 1-3, at the Los Angeles Convention Center.

INTERFACE WEST, co-sponsored by DATAMATION magazine and supported by leading industry publications, will bring together decision makers to enjoy a three-day conference program solidifying around a theme of "Productivity through Computing and Communications Alternatives."

### Pros Provide Direction

Your learning experience will be optimized by datacomm professionals such as Dr. Dixon Doll, Ralph Berglund, Richard Deal, Richard Kuehn, Einar Stefferud, David Farber, James Carlisle, and many others. More than 150 speakers in over 50 sessions offer a rich mix of tutorial and applications information on subjects such as networking, distributed computing, front ends, terminals, EFT/POS, time-sharing, electronic mail and much more. And beginners can attend our widely acclaimed Datacomm School. Thousands of attendees will find a broad selection of topics to improve their datacomm decision making.

To round out your information needs, INTERFACE WEST also offers complete programs in telecommunications management, computing alternatives for small business and micros for integration into computer and communication systems.

### Exhibits Galore

Picture a huge hall filled with hundreds of datacomm products and services. That's the exhibit floor of INTERFACE WEST. We're building a datacomm supermarket for your shopping convenience. Here's your chance to learn first-hand what solutions are best for your organization.

Exhibits will retain the familiar INTERFACE datacomm perspective for front ends, communications processors, datacomm/database software, data transmission services, test and diagnostic centers, timeshared systems and services, modems and multiplexers, remote batch and interactive terminals, and network design and implementation tools.

### How to Register

Pick up the nearest phone and punch 800-225-4620 (toll free), if in Massachusetts, call 617-879-4502. Our staff will register you immediately and send all the exciting details. It's that easy!

Registration Fee - Special "team rate" discounts are applicable **where 3 or more people from the same location of your organization pre-register at the same time.**

#### 3 Full Days Single Day

1st and 2nd attendees, each	\$75.	\$40.
3rd and more attendees, each	40.	20.

Accommodations - A group of excellent hotels, including our Conference Hotel, the Biltmore, will offer reduced rates. Simply make your reservations thru INTERFACE WEST.

**November 1, 2, 3, 1977**  
**Los Angeles Convention Center**  
**Los Angeles, California**



Co-Sponsored by  
**DATAMATION**  
 Magazine



We knew it from the beginning. And, so did our customers. We were convinced from the start that static RAM technology was the way to go on our 370 add-on memories. Static is faster. More reliable. And, totally compatible with IBM.

Now, we see an interesting thing happening. Our competitors, long-time proponents of dynamic technology, have suddenly changed their tunes. They're now planning to jump on the static bandwagon. But, they have a long way to go. We spent two years to develop our static technology before we started delivering it in 1975. We were the first with an NMOS static chip. The first with a 4K chip. And, our new 4K chip is the fastest, static or dynamic. All from EMM's own semiconductor facility in Phoenix.

Evidently, recent IBM enhancements have left some of our competitors holding the bag. We knew from the beginning that complete IBM compatibility requires static technology. We've kept right up with IBM. And that's how our customers are always going to be up-to-date with future IBM enhancements.

When you need add-on memories, check with EMM. We've got the best total all-around add-on-memory package going. We'll see to it that your memory stays IBM compatible.

# EMM: STATIC FROM THE BEGINNING



**COMMITTED TO  
MEMORY ALL THE WAY**

**EMM**

COMPUTER PRODUCTS

A division of Electronic Memories & Magnetics Corporation  
3216 West El Segundo Boulevard, Hawthorne, CA 90250

For more information, call your regional EMM sales office. Eastern (201) 845-0450. Central (321) 297-3110. Western (213) 477-3911. Europe: Bad Homburg, West Germany 06172/6094

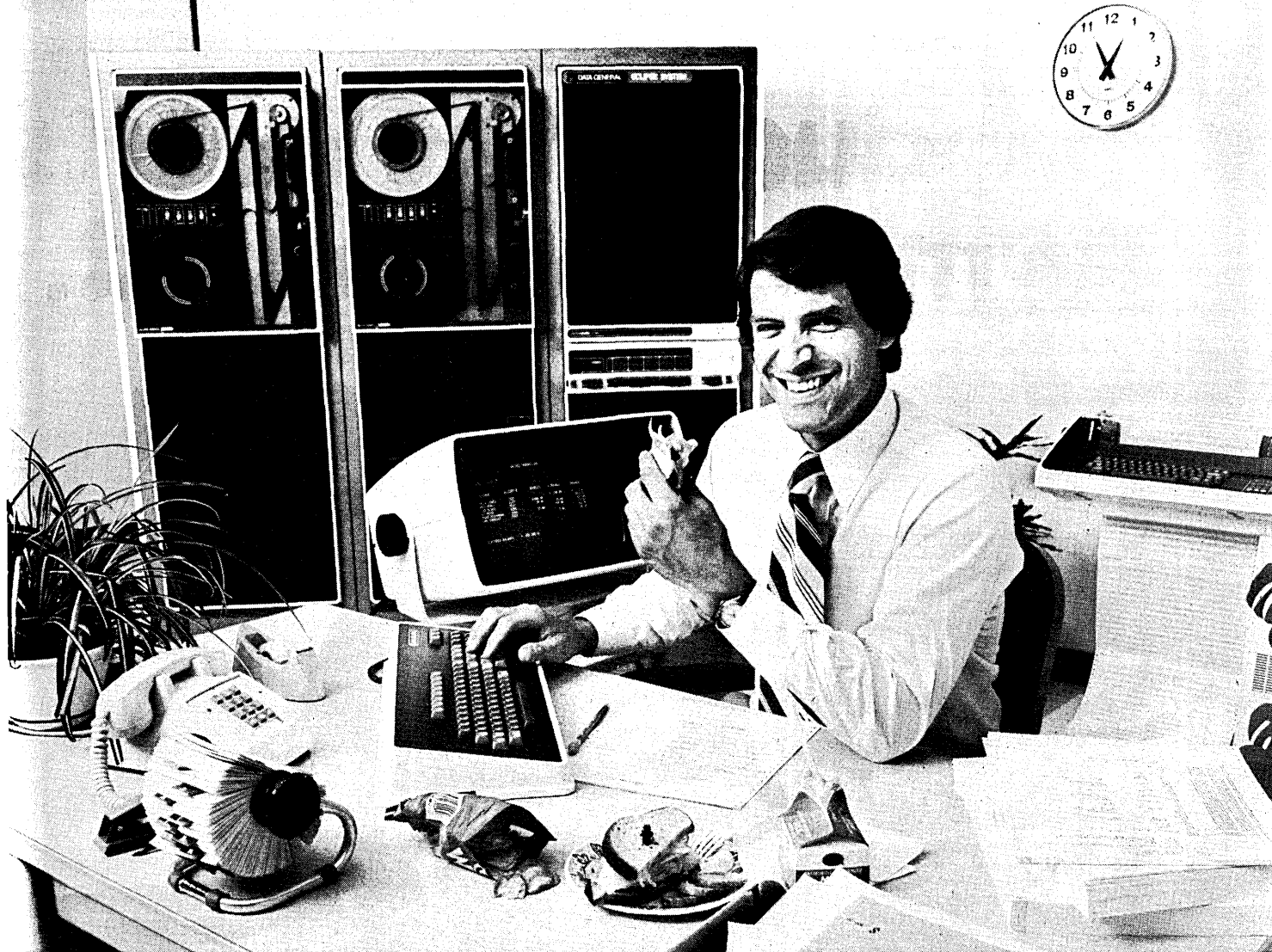

# Presenting lunch hour programming.

Programming on other computers can eat up a lot of valuable time. But on Data General commercial ECLIPSE systems you can develop workable screen formats in as little time as an hour. So instead of having to wait for a break in your computer's schedule, you could do a small data entry program on your lunch break. And wrap up entire applications in days rather than months.

A Data General commercial ECLIPSE data processing system can do it because it's a real-time data management system. It uses Idea, our interactive data entry/access software for online screen formatting. Idea also has an online multiterminal monitor and powerful English-like language resulting in faster screen-related programming. Plus applications developed under Idea can automatically access and maintain files built by a highly sophisticated data management system, our INFOS software.

Our commercial ECLIPSE data processing systems also use ANSI '74 COBOL implemented at the highest levels. For fast batch program execution with minimal

programmer retraining. Upgrading our system is no big deal either. It can grow right along with your expanding processing appetite.

Commercial ECLIPSE systems. The computer systems that digest programming easily and quickly. Send for our booklet today. Time is nibbling away.

Mail to: Data General, Westboro, MA 01581 DM9

- Send me your commercial ECLIPSE brochure.
- Send me your ECLIPSE brochure and have sales representative call.

Name \_\_\_\_\_

Title \_\_\_\_\_

Company \_\_\_\_\_

Address \_\_\_\_\_ Tel. \_\_\_\_\_

City \_\_\_\_\_ State \_\_\_\_\_ Zip \_\_\_\_\_

ECLIPSE is a registered trademark of Data General Corporation ©Data General Corporation, 1977.

Data General, Westboro, MA 01581, (617) 366-8911. Data General (Canada) Ltd., Ontario. Data General, Europe, 15 Rue Le Sueur, Paris 75116, France, 50-006-06. Data General Australia, Melbourne (03) 82-1361.

# Data General

It's smart business.

# Introducing the Smarts terminal control unit.



# It makes a terminal system work.

We designed our Smarts™ terminal controller with multiple microprocessors and floppy disk storage to perform concurrent operations and provide flexible editing capability.

All at a surprisingly low price.

With our Smarts controller, you can mix and match any terminals in our product line to tailor a system that meets your requirements.

Operating at speeds up to 1200 baud, a Smarts-controlled system is ideal for handling your data and message communication needs.

With a Smarts controller, operators can keyboard information, edit data, pre-store formats for operator prompting and can print out data in hard copy form. In addition, your computer can poll your Smarts-controlled system at any desired frequency.

## Concurrent operations.

As the chart shows, our Smarts controller can perform several operations concurrently.

For example, it can print data to a local printer, while data is either being transmitted to, or from, your computer—all while your operator is inputting data.

This concurrent capability enables your operators to work without interruption, making maximum use of their time and the Smarts-controlled system.

## Editing capability.

The Smarts controller also features a powerful 26-command text editor, providing

## Concurrent operations:

1. Keyboard → Smarts.

2. Smarts → Printer.

3. Smarts ↔ Computer.

Multi-micro based Smarts-controlled terminal system can perform three levels of concurrent operation.

word processing functions. Entire data strings can be substituted with unlimited character insert/delete capability.

A single disk storage unit has the capacity to store over 270,000 characters in up to 60 files which operators can access by name. Operators can segregate and link files for sending or receiving, and they can selectively print one or more of them. Disk files are dynamically allocated so your operator never has to specify file length in advance.

## Termicare too.

Like all terminals in our product line, our Smarts-controlled system is backed by our nationwide Termicare® service.

For more information, call Bob Roth toll-free 800-631-7050, (In New Jersey, 201-529-1170.)

Or write: Western Union Data Services, 70 McKee Drive, Mahwah, N.J. 07430.



**western union data services**



# The Marketplace...

## advertisers' index

### SOFTWARE MARKETPLACE

Allen Services Corporation .....	238
Bancroft Computer Systems .....	239
DATAMATION .....	238, 240
Dataware, Inc. ....	239
Interactive Information Systems .....	239
International Systems Inc. ....	238
Mathematica Products Group .....	238
Management Science America, Inc. ....	238
McCormack & Dodge Corporation .....	239
National Technical Information Service .....	240
SPSS Inc. ....	241
Software AG of North America, Inc. ....	240
Telcon Industries, Inc. ....	239
Triplex Computer Services Incorporated ..	241
Universal Computing Systems, Inc. ....	241
Virtual Systems, Inc. ....	240
Westinghouse Electric Corporation .....	240

### DP MARKETPLACE

American Used Computer Corporation .....	241
Foxboro .....	241
Freireich Systems, Inc. ....	241
RSVP Services .....	241

### SOFTWARE MARKETPLACE

## How do you get Project information to the top?



Project plans and status often have a difficult time getting from front line management up through the chain of command in a timely, consistent manner. Now there is a way not to leave that information hanging in mid-air.

## PAC II

PAC II is an automated project management system for planning, budgeting, and monitoring virtually any work effort.

Easily installed and used, PAC II is equally applicable in research, engineering, construction, marketing, financial and data processing departments.

International System's project management systems are serving hundreds of clients world-wide.

For more details about PAC II contact:

**International Systems Inc.**



890 Valley Forge Plaza, King of Prussia, Pa. 19406 (215) 265-1550

CIRCLE 225 ON READER CARD

## EXECUTOR

The EXECUTOR, high speed job processor, is designed to supplement OS and OS/VS job management. The EXECUTOR performs all initiation, termination, and resource allocation with techniques and algorithms specifically designed to effectively utilize all available system resources. EXECUTOR users are experiencing thru-put increases from 15% to 40% as well as experiencing a 5% to 20% return of their total CPU cycles. This thru-put increase provides such benefits as: alle late scheduling problems, improve data center service to users, increase programmer productivity, and extend hardware life. Because there is no conversion or JCL modifications required, the EXECUTOR can be easily and quickly installed. The EXECUTOR, which is an "overnight" solution to known problems, has proven itself successful in more than 100 large corporations, service bureaus, State/Federal Government Agencies, and Universities in over 4,000,000 hours of operation. Complete technical memo available upon request.

### ALLEN SERVICES CORPORATION

212 West National Road  
Vandalia, Ohio 45377  
(513) 890-1200  
Mr. Art Allen

CIRCLE 220 ON READER CARD

### Financial Software

## MSA'S Software systems\* helped our clients manage well over three trillion dollars in assets last year alone.

If you'd like to find out how our full line of financial software systems (as well as the people we have in the field supporting them) can help you manage every aspect of your business, call Marge Kimbrough at (404) 262-2376 or send us this coupon.



### THE FINANCIAL SOFTWARE COMPANY

Management Science America, Inc.  
3445 Peachtree Road, N.E.  
Dept. J-13  
Atlanta, Georgia 30326  
(404) 262-2376

Chicago 312-986-2450;  
Los Angeles 213-822-9766;  
New York 201-871-4700

\*I am interested in: General Ledger / Personnel Management and Reporting / Payroll Accounting / ALLTAX™ / Supplies Inventory Control and Purchasing / Accounts Receivable / Accounts Payable / Financial Information and Control / Fixed Asset / Property Accounting.

CIRCLE 227 ON READER CARD

SELL YOUR SOFTWARE  
IN THE  
**DATAMATION\***  
MARKETPLACE

CALL GINGER  
203-661-5400

## How to get at the heart of the information puzzle

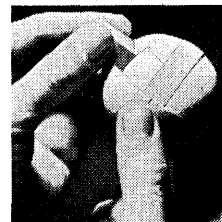

One of the problems facing decision-makers is the glut of data. How to get it, move it around—how to change it into information—can be a real puzzle.

RAMIS provides all the facilities needed for the economical design and operation of information systems in batch, remote job entry and time-sharing environments.

- Complete and automatic data base management technology
- An English-like language for report preparation

- A nonprocedural language for processing and validating transactions
- A data base interface for procedural languages
- An executive to control complex sequences of RAMIS routines

RAMIS lets DP professionals build complex systems in one-fifth the time while permitting management staff to tap corporate data bases without putting unnecessary pressure on the DP department.

**ramis** Mathematica Products Group P.O. Box 2392 Princeton, N.J. 08540 (609) 799-2600

CIRCLE 238 ON READER CARD

## SYSTEM CONFIGURATION COMPUTER FIRMS

Major datacommunication computer manufacturer requires capable system configuration companies in each major market area to system implement our computer for end users. Estimated monthly income \$20,000.00 per each major area. Each major area will have only one exclusive system house.

Inquire—

Telcon Industries, Inc.  
5701 N. W. 31st Ave.  
Ft. Lauderdale, Fl. 33309  
Area Code—(305) 971-2250  
Contact Sydney S. Simon

CIRCLE 231 ON READER CARD

## RPG TO COBOL

Dataware's software translator converts RPG and RPG II programs to the industry standard ANS COBOL (DOS or OS). The translator achieves an extremely high percentage of automatic conversion (approaching 100%) of the source code.

For information on our other translators, please check the appropriate box below and send direct to Dataware.

- RPG/RPGII-To-PL/1
- PL/1-To-COBOL
- EasyCoder/Tran-to-COBOL
- BAL/ALC-to-COBOL
- 7070/7074 Autocoder-to-COBOL
- COBOL-to-COBOL



**Dataware, Inc.**  
495 Delaware Street  
Tonawanda, New York 14150  
(716) 695-1412

CIRCLE 224 ON READER CARD

## AUTOCODER TO COBOL

Dataware's software translator automatically converts a high percentage of Autocoder source code to ANS COBOL (DOS or OS).

The translator converts from:

- IBM 1401
  - IBM 1401 SPS
  - IBM 1440
  - IBM 1410
  - IBM 7010
- } can be mixed in a single source program.



**Dataware, Inc.**  
495 Delaware Street  
Tonawanda, New York 14150  
(716) 695-1412

CIRCLE 223 ON READER CARD

## RPG II SYSTEMS

- ACCOUNTS RECEIVABLE B/F AND O/I
- GENERAL LEDGER
- PAYROLL
- INVENTORY
- UTILITY BILLING
- ACCOUNTS PAYABLE
- LINE GRAPH, LETTERS, MAILING LIST, CREDIT UNION, OTHER

Multicompany Systems With Both User and Systems Documentation Comprehensive Systems at Modest Prices

Bancroft Computer Systems  
P.O. Box 1533, Dept. D  
West Monroe, La. 71291  
(318) 388-2236

## PL/1 TO COBOL

Dataware's software translator automatically converts from IBM PL/1 to ANS COBOL (DOS or OS). The Translator is capable of handling IBM OS or DOS (48 or 60 character set) source programs as input.

For information on our other translators, please check the appropriate box below and send direct to Dataware.

- EasyCoder/Tran-to-COBOL
- BAL/ALC-to-COBOL
- 7070/7074 Autocoder-to-COBOL
- COBOL-to-COBOL



**Dataware, Inc.**  
495 Delaware Street  
Tonawanda, New York 14150  
(716) 695-1412

CIRCLE 222 ON READER CARD

## RPG TO PL/1

Dataware's software translator converts RPG and RPG II programs to an optimized PL/1 (DOS or OS). The translator achieves an extremely high percentage of automatic conversion (approaching 100%) of the source code.

The Translator converts RPG and RPG II from:

- IBM SYSTEM/3
- IBM MOD 20
- IBM 360/370 DOS/OS
- UNIVAC 9200 and 9300



**Dataware, Inc.**  
495 Delaware Street  
Tonawanda, New York 14150  
(716) 695-1412

CIRCLE 221 ON READER CARD

## RSTS/E ON-LINE APPLICATIONS SPECIALISTS

- Manufacturing Control
- Distribution Management
- Accounting
- Powerful System Tools
  - Data Base Manager
  - High Level Programming Language
  - CRT Text Editor
  - Utility Programs

Don't "reinvent the wheel." Contact IIS concerning any of these specialty areas.



**INTERACTIVE  
INFORMATION  
SYSTEMS**  
P. O. Box 37403  
Cincinnati, Ohio 45222  
(513) 761-0132

CIRCLE 226 ON READER CARD

## At McCORMACK & DODGE you know who you're dealing with.

*Software Professionals you can depend on.*

### Accounts Payable Information System\*

- Complete cash management reporting
- Multi company/bank processing
- G/L and inventory interfaces
- Check sorting

### Fixed Asset Analysis & Accounting System\*

- Seven depreciation methods
- ADR/guideline reporting
- Recapture and ITC
- Continuous CPA review

### G/L Plus - General Ledger/Financial Reporting System

- Soon to be released



\*Rated No. 1 in 1976  
Datamation/Datapro poll.



**MCCORMACK & DODGE CORPORATION**  
381 Elliot St., Newton, MA 02164 (617) 964-6610  
Atlanta (404) 477-1020 Chicago (312) 298-3666 San Francisco (415) 383-1443

CIRCLE 228 ON READER CARD



**SOFTWARE MARKETPLACE**

**JOB ACCOUNTING**

A low cost accounting system designed to inform you how your computer is being used and how to make better use of system resources.

The Westinghouse Job Monitor provides Job Accounting information for DOS, DOS/VS and/or POWER/VS installations. Captured information is put into comprehensive reports which provide systems, operations and management personnel with the following:

- Daily Job Stream and Partition Activity
- CPU Hourly Activity
- Graphic Analyses of Overload Conditions and Machine and Device Availability
- Start I/O and Paging Summaries
- 30 Day Statistical Summaries
- POWER/VS Statistics By Day and Job
- New Charge Back Capabilities for Cost or Profit Centers
- Free Trial Available

The complete package is provided requiring no special education or programming costs and no dedication of hardware units. One time charge for purchase.

Operating Software Packages  
Westinghouse Electric Corporation  
2040 Ardmore Blvd.  
Pittsburgh, Pa. 15221  
(412) 256-5583

CIRCLE 237 ON READER CARD

**DISK SPACE MANAGER**

**20% AVERAGE DISK SPACE SAVINGS**

This automatic disk space managing system uses low system overhead techniques to allocate and keep up with permanent and/or temporary (work) files for disk devices.

**FREE YOURSELF FROM NEEDLESS DOS/VS SPACE MANAGEMENT HASSLES AND WASTE**

- Automatic disk file space allocation
- No modifications to standard DOS/VS JCL software
- Automatic or user controlled release of space
- Any or all portions of disk area managed
- Free trial available

JOIN THE MORE THAN 3000 USERS OF WESTINGHOUSE SOFTWARE THROUGHOUT THE WORLD

Operating Software Packages  
Westinghouse Electric Corporation  
2040 Ardmore Blvd.  
Pittsburgh, Pa. 15221  
(412) 256-5583

CIRCLE 235 ON READER CARD

**WESTI**

**THE ONLY TP-INTERFACE THAT MADE IT**

The Westinghouse Teleprocessing Interface System is the first and only teleprocessing monitor to be selected by its users since 1975 for the DATAPRO Software Honor Roll.

WESTI provides a low cost, low overhead, easy-to-interface for 3270, 2260 and teletype (33/35) display terminals or equivalents operating in a DOS or DOS/VS environment.

- Complete Management of Terminals and Application Programs
- Cobol, Assembler, and PL/1 Application Programming
- Over 225 Users
- Extended and Improved Data Entry Capability
- Data Base Independence (DL/I, Total, DBOMP, Etc.)
- Logging, Journaling, Enqueueing for Advanced On-Line Applications
- Sophisticated Error Recovery
- Subtask Communication and Operations
- Supportive Utilities At No Extra Cost
- Training, Installation and Trial Period Available

Operating Software Packages  
Westinghouse Electric Corporation  
2040 Ardmore Boulevard  
Pittsburgh, Pa. 15221  
(412) 256-5583

CIRCLE 234 ON READER CARD

**DISK UTILITY SYSTEM**

Referred to by DATAPRO as "among the best liked software products in the EDP Industry," the success and satisfaction of this product is clearly evidenced by more than 2,800 installations to date. The product provides users with a fast, reliable and easy to use means of backing up or copying disk files (including libraries and data bases, either to tape or disk and time savings in general, the programs can dump multiple disk volumes and/or files of different organizational structure to tape, can selectively restore any file or volume dumped to tape and can copy complete volumes and/or files from disk to disk.

Features of the product include full verification of data, self relocation for running in any or all partitions, ISAM reorganization and reblocking VSAM support, device independence among all IBM supported disk devices and equivalents, self adaptation to core and channel configurations, simple format parameter card input and library backup, condense and reorganize capabilities including selective bookmark restore offer considerable operation convenience and time savings.

Operating Software Packages  
Westinghouse Electric Corporation  
2040 Ardmore Boulevard  
Pittsburgh, Pa. 15221  
(412) 256-5583

CIRCLE 236 ON READER CARD

The VS1 and MVT\* formula for TP success

**COM-LETE=**  
**TSO+CICS-OVERHEAD**

Com-lete provides the interactive program development functions of TSO and the conversational transaction processing functions of CICS. All this with less overhead than either one.

For example: over 30 terminals in 130K and over 250 terminals in 300K...which includes user program areas.

And there's much more. Call or write for details.

\*SVS and MVS in the near future.

**software ag**  
OF NORTH AMERICA, INC.

Reston International Center, 11800 Sunrise Valley Drive,  
Reston, Virginia 22091. Phone: (703) 860-5050

**AVAILABLE WORLDWIDE**

CIRCLE 230 ON READER CARD

**Cartographic Automatic Mapping Program**

CAM makes:

- variable map and scale locations
- up to 16 basic map projections

PLUS CAM draws:

- Coastlines
- Grid lines
- Range rings
- Circles
- Ellipses
- Rectangles
- Azimuths
- Elevation rings and symbols

Order CAM today—PB-238 357/CPM \$200 (Outside North American Continent, prices on request) from:

NTIS National Technical Information Service  
U.S. DEPARTMENT OF COMMERCE  
5285 Port Royal Road  
Springfield, Va. 22161

For more information on this and other computer products contact Computer Products Manager at (703) 557-4763 or write at the address above.

CIRCLE 229 ON READER CARD

**COGENT Compiler Writing System**

COGENT is a software tool used to reduce the costs and lead times normally associated with developing and implementing compilers for

- Systems languages
- Applications-oriented languages
- Industry standard languages

COGENT is operational on most computer systems which support FORTRAN IV.

**VIRTUAL SYSTEMS, INC.**

1500 Newell Avenue, Suite 406  
Walnut Creek, California 94596  
Phone: (415) 935-4944

CIRCLE 233 ON READER CARD

**MINI/MICRO-COMPUTER USERS SPEAK OUT.**

The most comprehensive analysis ever of the Mini/Microcomputer market has been compiled by DATAMATION Magazine in a 200-page report that is essential reading for industry analysts, market planners, sales executives as well as users themselves.

CHARTER OFFER SAVES \$35. This first in a series of annual DATAMATION Mini/Microcomputer survey reports is offered at a \$35 saving off the regular price of \$365 until October 15, 1977.

**DATAMATION**  
TECHNICAL PUBLISHING COMPANY

35 Mason St., Greenwich, Conn. 06830  
(203) 661-5400

## COBOL

for  
DATA GENERAL'S MINI-COMPUTERS  
OPERATING WITH RDOS

Sequential, Random, and ISAM disk files.  
Up to 32 million bytes per disk file.  
Three levels of subscribing.  
Full editing capability.  
Up to 30 characters in data and paragraph names.  
PERFORM statements may be nested to any level.  
Conditional statements may be nested to ten levels.  
Automatic decimal place alignment.  
Automatic sign control.  
14 digit numeric accuracy for display data.  
48 bit accuracy for binary data.  
Assembler subroutines.  
5 key stand alone SORT.

Supports moving and fixed head disks, magnetic tape, cassette tape, paper tape, card readers, line printers, and consoles.

UNIVERSAL COMPUTING SYSTEMS, INC.  
P.O. Box 3597  
Evansville, IN 47734  
(812) 423-1841

CIRCLE 232 ON READER CARD

## TRI-LIBE

The Triplex Library System provides easy maintenance and complete security for any 80-column image in highly-compressed form on disk. Freeform commands can be used to make permanent or temporary changes to any data set in the library. User-selected options and defaults make it very easy to learn and use. SCAN for any number of character strings and list or replace hits. COPY within or between data sets. INCLUDE standard layouts, data-names or routines. ADD, DEL, or REP by keyword or sequence number. TRI-LIBE also provides PASSWORD protection, level number verification, BACKUP/RESTORE and multi-level audit trails. The library never requires condensing. Free trial available.



TRIPLEX COMPUTER  
SERVICES INCORPORATED  
616 Canal Street  
San Rafael, CA 94901  
(415) 457-6400

CIRCLE 240 ON READER CARD

## SENIOR SOFTWARE MANAGEMENT

Very attractive positions for those having experience in DESIGN, DEVELOPMENT & APPLICATION of real-time software systems.

Must also have experience in directing major software development projects and supervising design personnel. A technical degree and ability to work effectively with non-software managers necessary.

Pleasant medium sized midwest city. Send your resume or letter of interest in complete confidence to Datamation, DM-9-77, 35 Mason St., Greenwich Ct. 06830.

equal opportunity employer

## DP MARKETPLACE

### NO MAILING LIST PROBLEM IS TOO SMALL FOR FREIREICH SYSTEMS, INC.

Why tie up an expensive processor with time-consuming menial tasks. Let our small-list specialists handle these jobs for you:

- Maximum name selection flexibility
- Complete file maintenance
- On-line updating
- 1-2-3-4-5 Across labels
- Clear status reporting

FSI—Leaders in small list maintenance

Freireich Systems Inc.  
535 Fifth Avenue  
New York, N.Y. 10017  
(212) 687-2441

CIRCLE 242 ON READER CARD

## PROGRAMMERS AND ANALYSTS

Free Employment Service  
Northeast, Southeast & Midwest U.S.

Scientific and commercial applications • Software development and systems programming • Telecommunications • Control systems • Computer engineering • Computer marketing and support

Call or send resume or rough notes of objectives, salary, location restrictions, education and experience (including computers, models, operating systems and languages) to either one of our locations. Our client companies pay all of our fees.

RSVP SERVICES, Dept. D  
Suite 700, One Cherry Hill Mall  
Cherry Hill, New Jersey 08002  
(609) 667-4488

RSVP SERVICES, Dept. D  
Suite 300, Dublin Hall  
1777 Walton Road  
Blue Bell, Penna. 19422  
(215) 629-0595

RSVP SERVICES  
Employment Agency for  
Computer Professionals

CIRCLE 245 ON READER CARD

YOU'RE INVITED . . .

TO A FREE HALF-DAY PRESENTATION  
OF

## SCSS\*

SPSS\* Conversational  
Statistical System

From SPSS inc.

- FULLY CONVERSATIONAL  
runs on 360/370 TSO (and soon, CMS) installations. CDC CYBER and DECsystem 10 and 20 versions are underway.
- SELF-INSTRUCTIONAL  
three prompting modes for new users. Or, you can direct the system without waiting for prompts.
- EFFICIENT AND INEXPENSIVE  
a transposed file structure minimizes memory size, I/O operations and general CPU usage.
- FROM THE AUTHORS OF SPSS  
the standard in statistical software — see ad on previous page.
- FILE COMMUNICATION WITH SPSS  
system data files created by SPSS can be analyzed by SCSS, and vice versa.

The following free presentations have been scheduled for the mornings of . . .

Oct. 18 — CHICAGO	Jan. 17 — COLUMBUS
Nov. 15 — ST. LOUIS	Feb. 14 — SAN FRANCISCO
Dec. 13 — ATLANTA	Feb. 17 — LOS ANGELES

TO REGISTER — indicate your city choice on a business card or letterhead and send to:

Wylie Crawford  
Director of Customer  
Services

or call us at

SPSS, Inc.  
Suite 1234  
111 East Wacker Drive  
Chicago, Illinois 60601  
312/861-0933

\*SCSS and SPSS are trademarks of SPSS, Inc.

CIRCLE 243 ON READER CARD

## Data Base Design

We are seeking an experienced Senior Systems Programmer who will work with our Systems and Programming groups in developing, designing and implementing the physical and logical IMS data bases including backup/recovery/reorganization of such data bases.

Qualified candidates will have a minimum of 2 years' experience in designing and installing physical and logical IMS data bases and an appropriate Bachelor Degree of the equivalent.

Interested candidates should send a resume or detailed letter with salary history to Judith B. Godsill, Dept. 977-D, The Foxboro Company, 38 Neponset Ave., Foxboro, MA 02035. Foxboro is an equal opportunity employer, M/F.

CIRCLE 244 ON READER CARD

# CENTRONICS

**101A.... \$1500**  
165 CHAR/ SEC. 32 COL, 60 LPM

**102A.... \$2000**  
330 CHAR/SEC. 132 COL. 125 LPM

**103 .... \$2000**  
165 CHAR/SEC. 132 COL, LSI  
BIDIRECTIONAL PRINTING, 70 LPM

**1 DAY SHIPMENT**

AMERICAN USED COMPUTER  
CORPORATION  
**617-261-1100**  
P.O. Box 68, Kenmore Station, Boston, MA 02215

CIRCLE 241 ON READER CARD

# Intelligent Terminals

# and Common Sense

# Ontel

The Ontel OP-1 series...  
User programmable...  
Flexible, Versatile,  
Reliable...Modular  
structure...Up to 64K of  
memory...Designed  
for field upgrade of  
features...Cluster or  
stand-alone configura-  
tions...Up to three

microprocessors...  
Easily programmed...  
Full range of communica-  
tions controllers and  
peripheral interfaces...

Ontel terminals...your  
best hardware buy for  
the money.

**That's intelligent**

Ontel software  
packages...  
Comprehensive...  
Designed for today's  
needs...  
Includes  
an extensive set  
of utilities...  
Word processing...  
Text editing...  
Forms generation...

Two high level lan-  
guages...  
Communication  
emulators...  
Diagnostics...  
And more.

Ontel terminals...your  
best software buy for  
the money.

**That's common  
sense**

Ontel terminals...tops  
in reliability and  
software...Priced to be  
competitive and  
affordable.

**And that's the  
right price**

Edward J. Heinze  
National Sales Manager  
Ontel Corporation  
250 Crossways Park Drive  
Woodbury, NY 11797

(516) 364-2121



# The Fourth Dimension of Data.

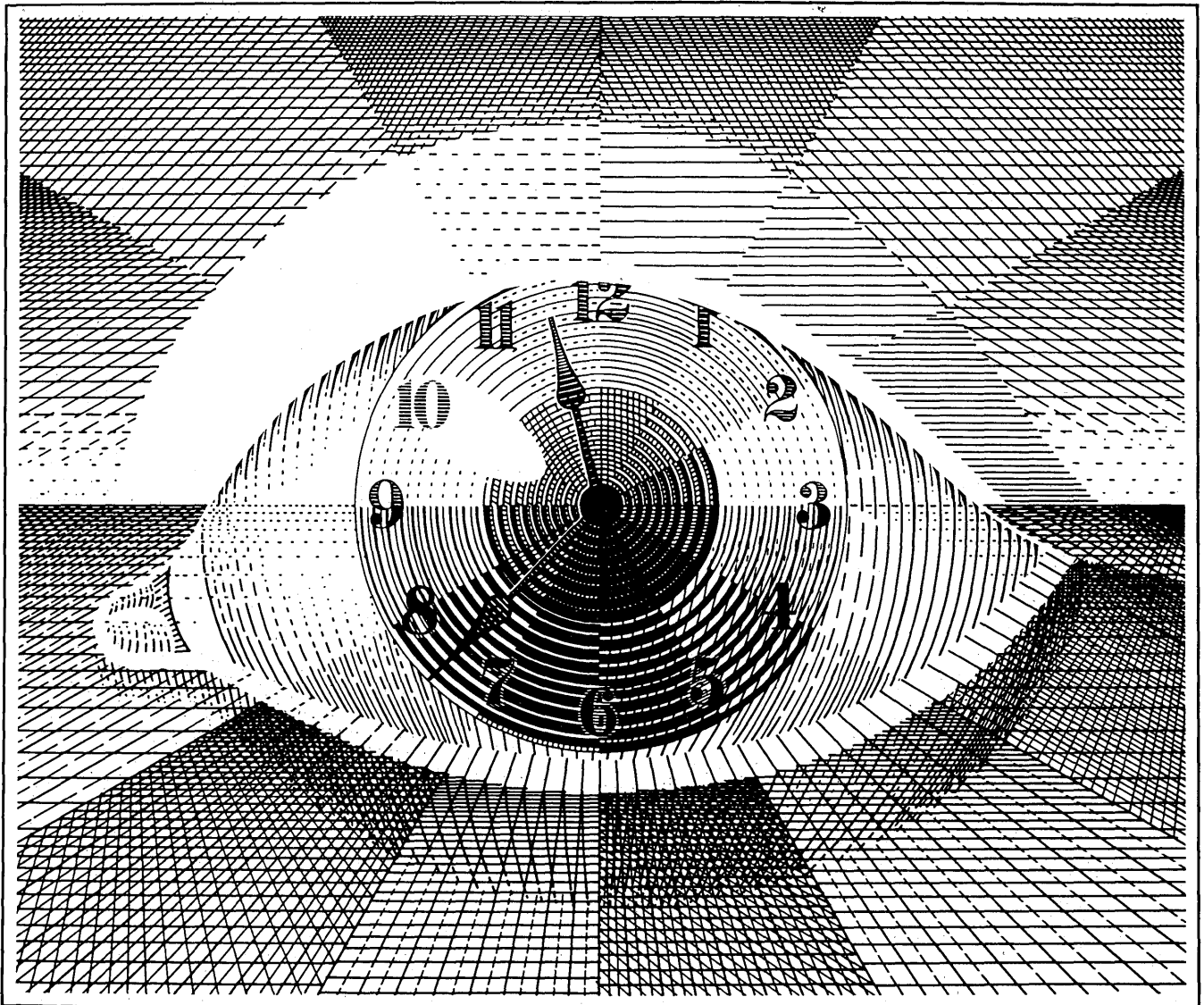

Response on the time-line determines the value of a system.

You have collected the data; processed it; neatly stored it away. But can you get the answers you need? Is your DBMS an obstacle or a resource?

One system was designed to confront the temporal as well as the physical aspects of data. From problem conception to data base design, INQUIRE® slices the time it takes to respond. (And with answers in seconds, managers know immediately whether they've asked the right questions!)

INQUIRE lets problem solvers see solutions before the future becomes the past.

One DBMS can meet your challenge. INQUIRE... The problem solver.

While there's still time, telephone (703) 578-3430 or write INQUIRE, Infodata Systems Inc., 5205 Leesburg Pike, Falls Church, Virginia 22041.

**INQUIRE**<sup>®</sup>  
Infodata Systems

©COPYRIGHT 1977 \*INQUIRE REGISTERED U.S. PATENT OFFICE TO INFODATA SYSTEMS INC., ROCHESTER, NEW YORK, U.S.A. COVERED BY U.S. PATENT NUMBER 3670310



THE UNITED KINGDOM  
A One-Way Trip For Your

# Computers and Peripheral Equipment

You are Invited to Take Part in This  
**U.S. DEPARTMENT OF COMMERCE**  
Sponsored Exhibition at the—

U.S. Trade Center  
London, England  
January 16-20, 1978

### The Market:

1978—\$825 Million  
1979—\$950 Million  
1980—\$1.2 Billion

U.S. Share: Over 60%

Come exhibit your products at this exhibition  
and take part in this rapidly expanding market.

### Background:

The North Sea oil drilling program is beginning  
to pay off with big dividends for all segments of  
industry and society. Government, banking and  
finance, insurance, communications, education  
and research, transportation, retailing,  
publishing, utilities, hospitals, and EDP Service  
Centers are all making plans to up-date and  
modernize their operations, using the latest  
available systems.

**For More Information and Details,  
Please Fill Out The Attached Form and Return To:**

JOHN L. WOLF  
PROJECT OFFICER  
Room 4217  
U.S. Dept. of Commerce  
Washington, D.C. 20230

Tel: (202) 377-3459

**TO: Bureau of International Commerce**

Date \_\_\_\_\_

**SUBJECT: COMPUTERS and PERIPHERAL EQUIPMENT  
U.S. TRADE CENTER, LONDON, ENGLAND  
January 16-20, 1978**

- We wish to participate. Please send necessary material.
- We would appreciate further information without obligation.
- We are  are not represented in country of exhibit.

Our Exhibition-related products are: \_\_\_\_\_

Name of Company \_\_\_\_\_

Address \_\_\_\_\_

Zip \_\_\_\_\_

Name of Company Official \_\_\_\_\_

Title \_\_\_\_\_ Telephone( \_\_\_\_\_ ) \_\_\_\_\_

# HOW

to keep up with what's new in  
computer techniques and management  
easily—and inexpensively

## The Library of Computer and Information Sciences

and start with  
a whale of a value—

### Take any 3 books for only \$1 each

(values to \$60.00)

if you will join now for a trial period  
and take three more books—at member  
discount prices—within the next 12 months.

(Publishers' Prices shown)

**62620. MICROCOMPUTER HANDBOOK.** Charles J. Sippl. Detailed reference to the technology and applications of microprocessors. Covers software to the effect of micro technology on mainframe users. \$19.95

**54450. THE IBM 5100 PORTABLE COMPUTER: A Comprehensive Guide for Users and Programmers.** Harry Katzan Jr. Includes sample BASIC and APL programs for payroll and inventory control applications. \$19.95

**35450. AUTOMATIC DATA PROCESSING HANDBOOK.** The Diebold Group. Line practitioners report on the latest technology: auxiliary memory, peripherals, systems design, consultant services, software packages. Counts as 2 of your 3 books. \$29.50

**84385. TOP-DOWN STRUCTURED PROGRAMMING TECHNIQUES.** Clement McGowan and John R. Kelly. Practical solutions in actual code serve to introduce the revolutionary new concept of structured programming. \$14.95

**73191. QUEUEING SYSTEMS. Volume II, Computer Applications.** Leonard Kleinrock. Takes informational processing theories and demonstrates how they can be used to solve real-world problems. Counts as 2 of your 3 books. \$25.00

**41665. DATA PROCESSING PROJECT MANAGEMENT.** Thomas R. Gildersleeve. A step-by-step guide to the development of a data processing system. \$14.95

**83400. THEORY AND DESIGN OF SWITCHING CIRCUITS.** Arthur D. Friedman and Premachandran R. Menon. Covers practical solutions to optimization problems for large-scale systems, plus flip-flop memory elements, mathematical models. \$19.95

**66010. OPERATING SYSTEMS: A Systematic View.** William S. Davis. Covers everything from cpu's to number systems, with specifics on multiprogramming, job control, and specialized systems for particular applications. \$15.95

**58085. LEARNING TO PROGRAM IN STRUCTURED COBOL.** Edward Yourdon. Treats COBOL as a foreign language, and offers several dramatic, easy techniques to help you learn the basics of structured programming—process, decision, loop, CASE. \$17.95

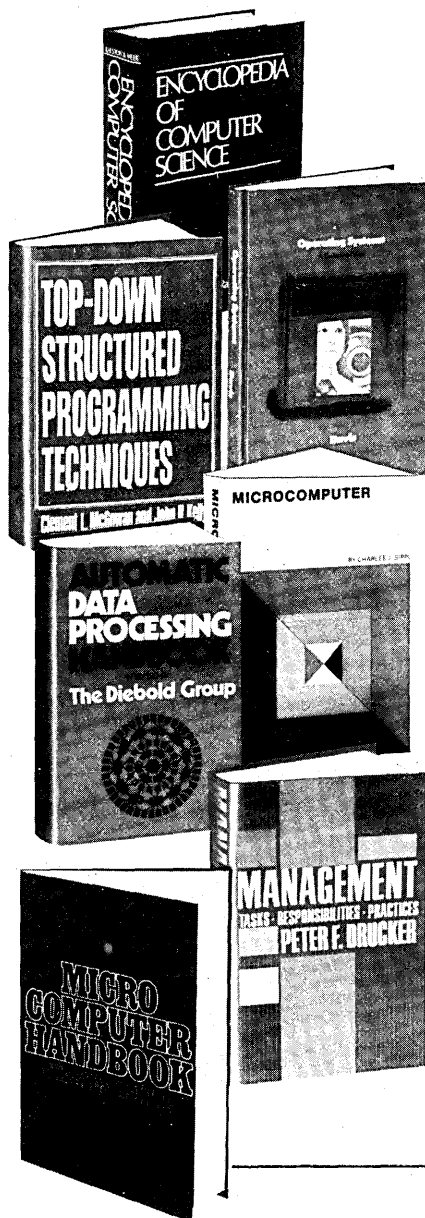

**82560. TECHNIQUES OF PROGRAM STRUCTURE AND DESIGN.** Edward Yourdon. Over 300 illustrative problems, 90 valuable references, and four demonstration projects. \$16.95

**37580. CHESS AND COMPUTERS.** David Levy. Excellent, fascinating look at the fundamentals of chess gamesmanship via computer. Softbound. \$7.95

**58805. LOGICAL DESIGN OF DIGITAL SYSTEMS.** Arthur D. Friedman. Basic reference to gate level logic design, combinational circuits, sequential circuits, register transfer languages, more. \$16.95

**34150. APPLIED DATA MANAGEMENT.** Charles T. Meadow. A practical approach to data bases. Covers data structures, communication, organization, design and management, and more. \$17.95

**55415. INFORMATION AND DATA IN SYSTEMS.** Borje Langefors and Kjell Samuelson. Covers basic retrieval functions, processing techniques, design methodology, more. \$14.95

**30820. ABEND DEBUGGING FOR COBOL PROGRAMMERS.** Bernard H. Boar. Examines three major abends: problem programs, data management, and supervisor. \$12.95

**62635. MICROCOMPUTER DICTIONARY AND GUIDE.** Charles J. Sippl. Encyclopedic reference to microcomputer technology. More than 5,000 separate entries. Appendixes covering math notation, languages, number systems. \$17.95

**82180. SYSTEMS PROGRAMMING: Concepts of Operating and Data Base Systems.** David K. Hsiao. Covers assembly systems, input/output operations, batch processing operating systems, data base managers, more. \$16.95

**70110. PRINCIPLES OF DATA-BASE MANAGEMENT.** James Martin. Covers data structures, security, file storage, real-time vs. non-real time, more. \$18.50

**39970. COMPUTER ARCHITECTURE.** Caxton C. Foster. Covers micro-programming, switching circuitry, memory speed increases in main-frames, tessellated computers, much more. \$16.95

**62640. MICROPROCESSORS AND MICROCOMPUTERS.** Branko Soucek. Offers a thorough account of the general programming and interfacing techniques common to all microcomputers and a complete rundown of all major microprocessor families. Counts as 2 of your 3 books. \$23.00

**59920. MANAGEMENT: Tasks, Responsibilities, Practices.** Peter F. Drucker. A brilliant task-focused handbook of the skills, techniques and tools a good executive needs to stay effective in modern management. \$17.50

**44900. ENCYCLOPEDIA OF COMPUTER SCIENCE.** Edited by Anthony Ralston and Chester L. Meek. Contains 470 articles, 1550 pages of the latest accurate information on hardware, software, systems, theory, economic, social, and professional issues, by 208 leading experts. Counts as 3 of your 3 books. \$60.00

If the reply card has been removed, please write to:  
The Library of Computer  
and Information Sciences  
Dept. 7-4AK, Riverside, N.J. 08075  
to obtain membership information and an application.



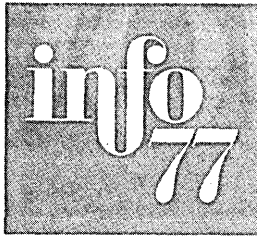

## Back to the Big Apple

Fourth conference has more exhibitors and a streamlined program for people involved in information management systems. And it's all under one roof.

"I think we've finally arrived," says Ed Greif, a public relations spokesman for Info '77, the fledgling Information Management Exposition and Conference which opens Oct. 17 at New York's Coliseum.

Greif's assessment seems correct: there are more exhibitors than ever before in Info's four-year history. The conference of 225 speakers at 70 sessions has been streamlined to meet the needs of a more accurately defined audience. And both the exposition and conference are under the same roof.

When Info was established in 1974, reputedly to fill a gap left when the National Computer Conference emerged as a once a year event instead of the twice yearly Spring and Fall Joint Computer Conferences, it occupied the Coliseum for the exhibit and Lincoln Center and the Americana Hotel for the conferences. When the NCC returned to New York last year, Info '76 moved to Chicago's huge McCormick Place where ev-

erything was under one roof.

That led the sponsoring organization, Clapp & Poliak, to decide to hold everything under one roof in the Coliseum, even though it will require huge expenditures in building temporary sound-proof walls to house up to eight sessions running at the same time. The decision was made after it was found that one out of four Info visitors spent the \$150 Info charges to attend all four days of the conference which runs through Oct. 20.

Dr. I. Edward Block, managing director of the Society for Applied Mathematics, who has organized the conferences for Info, said this year's session will be grouped into 13 "conferences within a conference" on the following subjects: information management; distributed data processing and data base management; electronic data processing management; office automation; data processing for small business; recent advances in technology; manufacturing

systems; financial management; physical distribution management; electronic funds transfer; bank information systems; insurance information systems; and hospital and health care information systems.

### The keynoter

Harvey Poppel, senior v.p., Booz, Allen and Hamilton, Inc., a New York management consulting firm, will deliver the keynote address, "Strategic Planning for Information Resources—a View from the Top." The keynote session, at 10 a.m. on opening day, will be chaired by David W. Benjamin, v.p., data processing, with Blue Cross/Blue Shield of Greater New York.

That Info '77 is coming into its own is evidenced by the growing number of exhibiting firms. Some 155 companies will occupy 42,050 sq. ft. on the second floor of the New York Coliseum. That compares with 123 who took 29,276 sq. ft. of exhibit space in Chicago last year, and 104 exhibitors in 21,035 sq. ft. at the Coliseum in 1975. Attendance has ranged just under the 10,000 mark, but this year the sponsors won't argue with a projected turnout of 12,000 to 13,000.

### Promotion budget

Its promotion budget has been increased by a third to \$300,000 over last year's figure, and includes the purchase of 32 pages in technical and general business publications; four advertising inserts in the *Wall Street Journal* and the *New York Times*; the mailing of 600,000 invitations to secure an advance program for Info, and the mailing of some 200,000 programs. In addition, some 750,000 tickets have been distributed through magazines and exhibitors.

A charge of \$5 is made to people attending the exhibits only (or \$1 if they already have a complimentary ticket). Conference fees are as follows: \$150 for four days; \$90 for two days; \$50 for one day; \$30 for a half day.

The exhibit is dominated by software companies—at least 25 of them. Seventeen publishing firms also will exhibit,



NEW YORK COLISEUM: For first time in three years, Info '77 will be held under one roof.

along with 15 manufacturers of terminals, 13 companies who make word processing devices, 10 firms offering communications devices, and seven mini-computer manufacturers. Six manufacturers of small business systems will exhibit, and five each in the data entry and microfilm business. There will be four time-sharing exhibitors and four selling printers. Most exhibitors are among the top in their fields.

### Retrieval system

They'll be supported at the conference by an on-line retrieval system supplied by Service Bureau Corp. that links an attendee's buying interest with products or services supplied by the exhibitors.

Block said the make-up of the conference matches the interests of persons who come to Info, "primarily users with all sorts of titles involved in the management of information systems." Block said, however, that very few are of the type that attend technical conferences on computers. For instance, fewer than 10% of the persons surveyed at Chicago last year went to the NCC. Block said the survey found that 41% of the Chicago turnout do not go to other trade shows.

Block quotes other statistics that show a profile of persons attending: 64% have an information management department in their company; 56% of them work in that department; and 87% of them believe the information management function will become more important to their company over the next five years. "As the price of hardware continues to go down, the prime importance in the information management department will be in managing the far-flung dp functions, the data bases, the people, and to what use the company is putting its information," Block says.

Block said the program tries to reflect these needs. Here is a rundown of highlights:

**Distributed Data Processing and Data Base Management:** Eight sessions are to be devoted to this revolutionary subject, beginning Monday afternoon with a session, "From Mainframes to Minis," with Allan Proske of Manufacturers Hanover Trust Co. and Roger Taylor of Martin Marietta Data Systems. They'll discuss such subjects as the availability of cheaper and more capable minicomputers, demand by local management for control over their dp operations, and for the first time, the ability of management to map the structure of its data processing equipment and data communications network onto an organization chart.

A full day will be devoted to "Data Base Administration in a Decentralized Environment." The morning will be given over to systems and personnel management, with John Turner, of Columbia Univ.; Melvin Blitz, Corporate Technical Planning, Waltham, Mass.; and Eugene Altschuler, consultant, speaking. In the afternoon, data base administration through collateral management will be discussed by Mobil Oil's G. T. Gunnell and Equitable Life's F. H. Miller, followed by a comparison of the experiences of Grumman and Mobil in this area.

Four speakers will explain conversion to distributed data processing. They are Illario Simonette and John Nuxall of Peat, Marwick, Mitchell and Co.; Dr. J. A. Rockart of the Sloan School of Management; and J. L. Hughes of Citibank.

Another all-day session will present case histories of companies which are implementing distributed data processing. The participants are: Peter Augusta, regional director of financial market-

ing with NCR Corp. in New York; Larry D. Woods, manager of distributed processing with Deere and Co., Moline, Ill.; Tony Harris, director of data processing with Finning Tractor Co., Vancouver, Wa.; Harry Vickers, v.p. of Entrex; and Dr. Norman Morrison, director of MIS with the Knight-Ridder Newspapers, Inc., Miami.

**Data Processing Management:** "Disaster Recovery in a Large Scale Data Processing Environment" is the first topic in this session, and it assesses the backup plans for dp departments to get back on-line after disaster strikes. Morton B. Comer, v.p. of Provident National Bank of Philadelphia will discuss how Philadelphia area firms have formed a cooperative data center to serve as a backup in the event of a huge fire or other disaster. The other speakers in this session are: John Konvalinka, Arthur Anderson and Co., Philadelphia; and Oliver J. DeSofi of the National Bank of North America.

A related session, "Cost Effectiveness in Protecting the Data Base," includes a talk on cryptographic security for file systems by Dr. S. M. Matyas of IBM, and security by software design by M. F. Smith of Norda Chemical Corp., East Hanover, N. J.

David M. Harris, a CPA with the firm of Lilly and Harris, Cleveland, will lead a session on "Planning for the EDP Audit," a course on getting ready for an audit and what you should expect from the auditor. Charles D. LaBelle, v.p. of human resources with Manufacturers Hanover Trust Co., New York, will lead a session on "Putting a 'Heart' in Your Dp Organization," devoted to a case study of a structured system to improve the people environment and increase the productivity of a dp organization. A related session, "Motivation and Management Styles—Essential Consider-

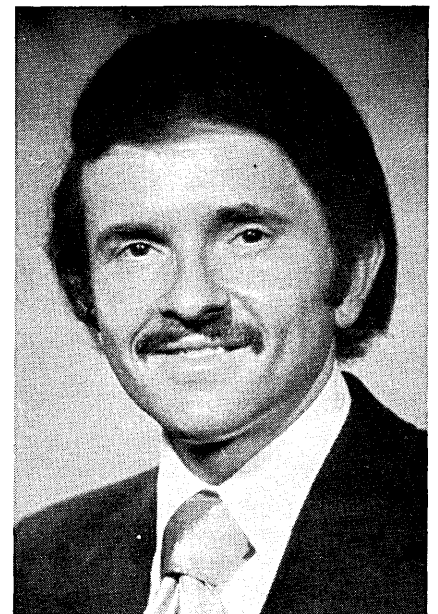
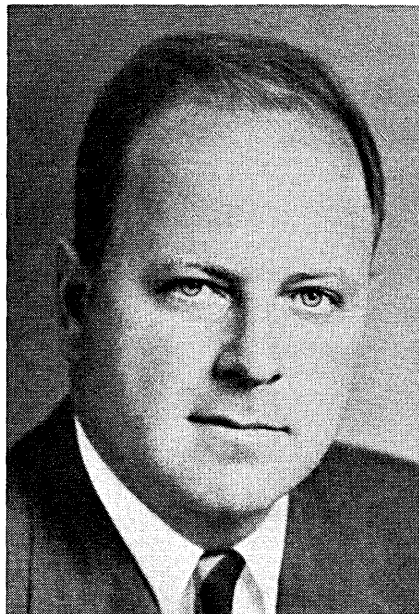

FEATURED AT INFO '77: Richard S. Wolcott, of Clapp & Poliak runs Info '77. Dr. I. Edward Block stages the conference program, and Harvey L. Poppel, of Booz, Allen and Hamilton, Inc., is the conference keynoter.

ations for Successful EDP Projects," will be headed by Nate A. Newkirk, a Mt. Kisco, N. Y., consultant. The final session in dp management is "The Corporate EDP Manager in a Decentralized Environment," a session examining the inevitability of decentralized computing because of the emergence of minicomputer and communications technology. Chaired by Edward J. Farrell, of AMAX, Greenwich, Conn., it will hear talks by Howard Frank, of Network Analysis; W. R. McCartin, of Nexell Corp; and Charles Siegel, of U. S. Fidelity & Guaranty.

**Advances in Technology:** Top dp managers must make strategic hardware and software investment choices for data communications today which they'll need to live with for the next decade. A session, "Data Communications Planning for the 1980s" will explore this subject from several points of view, including that of the session chairman, Dr. David N. Freeman, of Ketron, Inc., with a paper on "Buying Today for the '80s." Murray H. Robinson, of Murray H. Robinson and Associates, Ltd., will discuss circuits, messages, or packets, and consultant Ralph Berglund will talk on wire, microwave, or satellite. Finally, Dr. Carl H. Mayer, of IBM, will explore cryptographic protection of data communications.

Another session, "Using Minis to Replace Mainframes—What's Required and the Cost Effectiveness," pits two speakers with contrasting views: C. A. Conover, v.p. of systems planning and programs with Honeywell, Inc., Minneapolis, will suggest that the tasks of the general purpose computer be made modular, but kept centralized; and Jon S. Gould, of Citibank, N. Y., will propose that total computing power be distributed to small groups of users. The debate will be chaired by Dr. Jean-Michel Gabet, staff associate with Gnostic Concepts, Inc., Menlo Park, Calif.

Other sessions discuss new mainframes, micrographic systems for information storage and retrieval, smart terminals and clusters, and front-end systems that relieve the data entry bottleneck.

**Data Processing for Small Business:** Guidelines and pitfalls of installing your own small computer will be discussed in one of the four sessions on small business computers. Chairman Alan C. Verbit, a consultant with Haskins and Sells, Philadelphia, will talk about what to do if you don't like what you've acquired. Did the vendor fulfill his commitment: did you fulfill yours? Can the system do what you require? Should you expand it, change it, or change the vendor?

Another session, "Minicomputer Small Business Systems—Use and Effectiveness in the Business Community,"

will examine applications, and how users rate their installed small computer systems, this latter being based on a Data Pro 70 research project.

**Information Management:** Highlight of the information management sessions include "The New Management Function Combining Computer, Office, and Telecommunications Systems," by David S. O'Dwyer, of AT&T's strategy group. Some companies are now merging these three systems into an integrated information management function, and O'Dwyer will offer some guidelines to determine when a single information management function is appropriate and offer several approaches for implementing such a function. Robert J. Cymbala, of Booz, Allen and Hamilton, New York, will chair the session.

Other sessions deal with long range planning for information systems managers and how to increase the productivity of the information system. Cymbala, who will chair one of these sessions, discusses new ways for corporate management to assess capital investment, project the cost benefits and trade-offs between longer-term investments and short term savings, and offer a framework to set realistic goals for increased productivity.

**Financial Management:** Five sessions on financial management address financial data bases, "what if" planning models, and economic and business forecasting. Joel W. Darrow, Morgan Guaranty Trust Co., New York, chairs a session on "Financial Data Bases—What's Available and How They're Used." The participants are Richard B. Karram, Standard and Poors Corp.; Samuel A. Wolpert, Predicasts, Inc.; Dr. Dennis O'Brien, Data Resources; and Bruce E. Beene, Business International Corp. One of the speakers on what-if

planning is Geoffrey R. Cross, managing director for International Computers Ltd., London.

**Office Automation:** Fourteen sessions are devoted to many aspects of the office of the future. For example, in a session, "The Merger of Computers and Micrographics in the Storage and Dissemination of Information," IBM's L. Patrick Briody will talk of the day when incoming paper won't be seen in offices. Documents will be stored on microfilm or digital media in the mailing room, and the paper coming in will be thrown away after it is stored for recovery on crt's or other imaging devices.

Paul G. Truax, president of Truax-Smith and Associates, will report on a survey of the needs of the user in a session, "User Needs and Trends in Office Automation." Truax will base his discussion on more than 400 independent surveys in 20 major industry segments. He'll examine what office system needs exist and what the major suppliers are doing to meet these needs, based on the current state of equipment technology. Trends in product offerings during the next five years will be considered.

Philip Hayes, director of telecommunications with Minnesota Mining and Manufacturing Co., will head a session, "Telecommunications Planning for the Office of the Future," in which the marriage of word processing, office systems, data processing, telecommunications, and electronic mail will be examined from the point of view of how it will effect the office work station in 1980. Daniel Lavery, a senior staff consultant with Quantum Sciences, will talk of "The Office of the Future—What It Will Look Like and How It Will Work." Charles S. Pedlar, of Tele/Resources, will discuss communications needed for the decentralized office. \*



INFO '77 sponsors think this year's conference will exceed considerably past turnouts of under 10,000. Some forecast up to 15,000 at the New York affair.

## Communications

# NCR Ready to Interface Terminals That Interface with DNA Protocol

Software enhanced version of 721 communications processor is first of products that tie large systems to DNA

Several terminals in NCR's present product line will become interfaceable during the coming year with the company's newly announced Distributed Network Architecture (DNA) packet communications protocol. Interface software for the 280 and 2151 retail terminals, 279 teller machine, Financial Modular Terminal System, 1770 in-lobby self-service banking terminal, and 796 crt terminal is now being written or planned, according to NCR sources.

This month, the company plans to announce a software-enhanced version of its Model 721 communications processor which will tie NCR dp systems to DNA and also will act as an interface for clusters of remote terminals. The computers that will be interfaceable to DNA through the enhanced 721 include the Century and 8000 series. Included in this latter group are the Criterion computers (models 8550 and 8570) NCR introduced last year. Two new Criteria, which will extend the line upward and downward, are scheduled for announcement next month.

Montgomery Ward is reported to be one of the first users of the enhanced 721 communications processor. The retailing giant has a nationwide, multipurpose data communications network already in operation that uses numerous 721s to interconnect some 18,000 terminals. Most of these are NCR point-of-sale machines, but there also are other makes, including IBM System/3s.

### New cash registers

Next November, NCR plans to announce a new family of electronic cash registers, designed "from the ground up" to operate with DNA. Based on an Intel 8080 microprocessor and featuring a resident memory of up to 128KB, the series is designed for supermarket, drug store, hotel/motel, and bar/restaurant applications. The new series reportedly will be significantly lower

priced than the NCR 255, the company's most widely used checkout machine. Mainly, this is because the 255 needs a backroom minicomputer, costing about \$120K, to provide additional processing and storage capability. The new ECR machine won't need the mini, at least in most installations, because it will have substantially more built-in logic and memory than the 255.

### Delivery next year

Delivery dates for DNA network software modules will be announced "early next year," said an NCR spokesman. He anticipates that the modules needed to provide both link control and end-to-end control will be ready for delivery before the end of 1978. A number of enhancements to this initial release are planned—including a capability to combine packets from different terminals into a single message frame and thus improve network utilization.

Key to the DNA architecture is the

separation of communications processing from application processing, explained the NCR spokesman. He said this arrangement insulates the application programmer from procedural aspects of communications. This architecture also provides the means for interconnecting multiple computer systems in a distributed processing environment.

### Proprietary protocol

Main elements of NCR/DNA include a proprietary, bit-oriented, link protocol—NCR Data Link Control—which is to be made compatible with ISO/HDLC, ANSI/ADCCP, and IBM/SDLC so that the network can be interfaced with non-NCR terminals, computers, and communications processors.

Another major component of the new communications system is the NCR/Telecommunications Access Method (NCR/TAM). It encompasses several operating system services—for example,

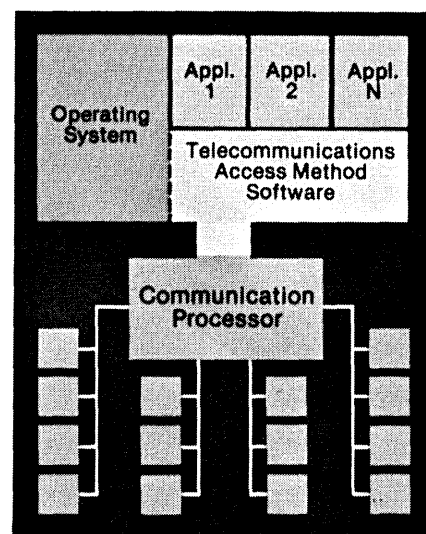
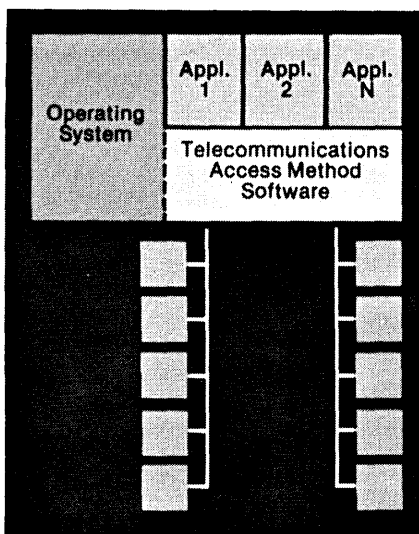

NCR'S DNA: Key to the architecture is the separation of communications processing from applications processing. It also provides the means for interconnecting multiple computer systems in a distributed processing environment.

an ANSI COBOL 74 message control system that provides standardized access to applications programs. Other TAM functions include system and link control, queue management, resource scheduling, addition and deletion of packet headers, error recovery and reporting, and provision for in-service diagnostic capabilities.

The final major element of NCR/DNA is a data transporting network (DTN) module, which routes and controls the movement of messages over multiple paths between node processors. The first of these processors will be the newly enhanced 721, scheduled for announcement this month.

A special feature of the node-to-node control scheme, said NCR, is that the user's application processes address each other by unique logical names without regard to physical locations. Routing tables in each node processor then convert the logical addresses to physical addresses. "This technique permits an application process, such as a data base, to be moved to a new location without changing every application that communicates with it," NCR said, adding that "only the tables in the node processors must be altered."

DTN also provides rerouting in case a

system element or an internodal link fails.

Other DNA components include a set of user tools designed to assist the user in defining the topology of a network, assigning and naming the processes attached to each node, and specifying the rules governing process-to-process access.

These user tools execute on appropriate processors as part of total system generation. They also allow terminals to be added, or assigned to different node processors, enabling the user to reconfigure a network dynamically.

The in-service diagnostic feature of DNA is said to aid in the isolation of faults to a particular location in the network or to a communication link between locations. Diagnoses can be performed on any part of the network without shutting down the rest of it, NCR said.

R. L. Phelan, NCR's vp for research and development, said, "NCR/DNA has been developed for use with distributed processing systems, message-switching systems, and large-scale retail and financial systems, including those providing electronic funds transfer. It provides a foundation for all telecommunications systems, large or small." \*

nizations. Their views, the report says, "may be interpreted as follows: 11 favored copyright; 3, patent protection; 3, trade secrecy; 8 had no preference; and 2 perceived no need for protection."

## Hersey's "mechanical device"

Hersey, whose "additional views" amended to the report exceeded the report itself in length, essentially argued that copyright protection is inappropriate for computer programs because a program is a "mechanical device, which is engaged in the computer."

His suggestion for new legislation which could be named the "Computer Software Protection Act" and could involve the creation within the Department Commerce of "The Registry of Computer Software" which would receive and register computer software products, and in which rights would be asserted under the provisions of the Act.

"Every (computer) program has but one purpose and use," Hersey argued, "one object: to control the electrical impulses of a computer in such a particular way as to carry out a prescribed task or operation. In its object form it does not describe or give directions for mechanical work. It does the work." The Software Subcommittee report calls a program "a writing which sets forth instructions or sets of instruction." Hersey doesn't believe this analogy will hold up. "Description and printed instructions tell human beings how to use materials or machinery to produce desired results. In the case of computer programs, the instructions themselves become an essential part of the machinery that produces the results," he says.

A true writing, he infers, doesn't 'do' anything, "no matter how fervently many an author" may have wished his words could.

He allows as how the computer "in rare instances may serve as a storage and transmission medium for writings in their original and entire text—in such cases these writings can be adequately secured at both ends by the present copyright law; but in the overwhelming majority of cases, its purposes are precisely to use programs to transform, to manipulate, to select, to edit, to search and find, to compile, to control and operate computers and a vast array of other machines and systems—with a result that the original writing of the computer programmer is nowhere to be found in recognizable form, because it has been converted into a mechanical device that does these sorts of work."

## "It utters work"

He argues that a computer program, "once it enters a computer in its object phase, does not communicate information of its own, intelligible to a human

## Copyrights

# Copyrights for Software?

## Are discs, tapes, and punched cards literary works?

"It boggles the mind to think of the magnetized discs and tapes, the punched cards, and the silicon chips of programs in their object phase as 'literary works.'"

Such is the feeling of author John Hersey as expressed in a dissenting opinion amended to a report by the Software Subcommittee of the National Commission on New Technological Uses of Copyrighted Works (CONTU). The basic report essentially recommends that the commission advocate copyright protection of software and specific provision in law for the protection of programs.

CONTU was created by the Copyright Act of 1976 to recommend to Congress periodic revisions of the new law, which goes into effect Jan. 1, 1978. Its next meeting was scheduled to be held Sept. 15 and 16 in Chicago, and one day of the meeting was slated for testimony

from people wanting to be heard on the software report and on one by CONTU's data base subcommittee.

Michael S. Keplinger, senior attorney for the commission, said in late August that some 20 people had requested appearances before the commission on one or the other report, and that an equal number of written comments had been received. Deadline for both written comment and requests to appear was Sept. 1.

## Response to software report

He said most of the response was to the software report rather than to the data base report. The latter said essentially that the introduction of a work into a computer memory would, consistent with the new law, be a reproduction of the work which is one of the exclusive rights of a copyright proprietor.

The more controversial software report notes that in 1976 the commission received oral and written testimony from 20 witnesses representing 18 orga-



being. It utters work. In its object phase its direct product is not communication but electrical work. It is purely and simply a mechanical substitute for human labor."

CONTU, Hersey said, "has a duty to consider the impact of its recommendations, not only on proprietors and users of information systems, but also on the public. Specifically, considering the long history of copyright's bond to the written word (in both works of literature and practical works), and its bond to musical composition, to painting and sculpture, to the theater, to dance, to film, we must weigh the impact of what we recommend upon the national culture. For copyright has always been a mainstay and a guarantee of the creative wellsprings of the culture."

Hersey, who is a member of the commission, often has said in commission discussions that the dual purposes of copyright are the encouragement of creative work and the wide scattering of its fruits. "The sanctioning of copyright protection for this new thing, which is both a writing and a mechanical device, would, in this view, tend to dampen the first purpose. Its impact on the creative community would be bound to be discouraging. Furthermore, its indirect impact on consumers of all forms of creative work would, in this view, be unfortunate," he says in his dissenting opinion.

"This pollution of copyrighted 'writings' with units of mechanical work would affect not only the creators but also the consumers of the culture. Placed beside such traditional end products as books, plays, dance, film, and music, under the aegis of copyright, what end products of computer programs would we find?" he questions.

"A definite danger to the quality of life comes with a blurring and merging of human and mechanical communication," he warns.

### Fear of the future

Hersey has another fear. He notes that IBM's Ralph Gommerly, in testimony before the commission, suggested that, "If the automobile industry had progressed on the same curve as computers in the last 15 years, we would now have been able to buy for \$20 a self-steering car that would attain speeds up to 500 mph and be able to drive the length of California on one gallon of gasoline."

He noted that Peter Weiner of Rand "gave us the vision of a 'computer-based' society a quarter of a century hence, with terminals in every home for all sorts of mechanical and communications aids."

Says Hersey: "Loading all this expanding technology onto the field of copyright would be bound to bring a progressive change in emphasis, and

the great new dominant interests would all be corporate. The Constitutional aim of encouraging individual 'authors' would have relatively less and less weight."

Hersey was expected to be as eloquent at the September hearings as he was in his dissenting opinion.

At writing it was unclear who would be called to appear at the hearings. Susan Nycum, an attorney with Chickering and Gregory, San Francisco, and chairman of the ACM's standing committee on legal issues, said she would be

appearing at one or more hearings and would bring with her opinions expressed by members of her committee which would be varied.

Although the number of requests to appear and of written responses was hardly overwhelming, Keplinger said that while more than 600 copies of each subcommittee report were sent out, requests for additional copies continued to come in throughout the summer, indicating a latent interest which perhaps hasn't progressed into opinion.

—Edith Myers

## Government

# Computer Age Legislators

## Senate doles out terminals while House members must pay

In the beginning there was a computer. First in the House and then in the Senate. Then there were more computers, more software and more applications, and the Congressional computer shops set up in the early '70s began to grow. And they're still growing, independently but cooperatively.

Bound together by a common service bond, the Congressional computer crews each cater to the administrative and legislative needs of the information-hungry Congress. But while the dp services they provide are usually the same or similar, the catering approaches taken to meet those needs are often markedly different.

Explains John Swearingen, head honcho of the Senate's Computer Services Staff: "The Senate and House are not carbon copies of each other and neither are their staffs. We work on many simi-

lar projects, but we're different in other ways." This difference between the two computer camps is directly reflected by twists in philosophies, dictated mainly by the size of the organizations they're serving.

Says Swearingen: "When you have four and one-third times as many people to deal with (as the House does), you look at the economics much differently." While the Senate dpers must try to satisfy the computer needs of 100 Senate members, the House Information Systems squad has to contend with the computer demands of 439 House members. So instead of just doling out terminals or other dp wares to each individual member, as the Senate has done, the House has opted for a laissez-faire approach, allowing representatives to siphon money from their "clerk hire" fund to buy or rent computer gear or services.

### Waste of money

If the House had taken the Senate route, speculates House Information Systems head Boyd Alexander, it probably would have resulted in a waste of money. Not only would it be very expensive to supply 439 terminals, but he also questions whether the equipment would even be used by all the members. "Suppose," he contends, "only half the members used the terminals and the rest pushed them in closets or used them to set plants on. I don't think the American taxpayers would be very happy to know that we wasted their money."

In the Senate, Swearingen explains that ever since the computer operation's inception in the early '70s, the idea has been to provide direct dp services to Senate and committee offices. Following this policy, Hazeltine Model 2000 terminals were set up in all member offices (most committee offices also have their own Hazeltine 2000s). Through



SENATE'S JOHN SWEARINGEN  
He envisions Senate putting terminals outside Washington



# news in perspective

this terminal network, Senators and their staffs, as well as committee personnel, have access to the Library of Congress' legislative and other data bases.

The House has comparable services available through terminals in 209 member offices, providing access to the library data bases as well as special data bases furnished by its Member Information Network (MIN). These terminals, all individually procured by the members themselves, come from 16 different vendors—the most favored suppliers being Diablo, Anderson Jacobson, Trendata, AT&T (Dataspeed 40), and Hazeltine. The word processing equipment stash also includes a wide variety of different types of gear which the House Information Systems office expects will be computer linked in the near future. Several IBM System 6s and System/32s also are being used in a few member offices, mainly for word processing chores.

To get this computer power, House members can take up to \$1,000/month out of the kitty they use to hire staffers. But sometimes these computer-age congressmen are less than anxious to dip into this fund for dp devices. "Substituting machines for people," points out Alexander, "is a hard decision for any member to make."

## On board the caravan

However, it's obvious the legislators—almost half of them anyway—have overcome their reluctance to make the trade-off. According to Alexander, this hands-off approach of letting members decide if and when to use dp technology reflects HIS' original philosophy of "letting the marketplace initially determine (computer) use." But that "initial" period may be coming to end as more and more members and committees jump on board the computer caravan.

As a result, Alexander explains, the House dp planners will have to rethink their game plan, possibly bringing it more into line with the Senate's bulk buying approach. However, that's just one of many alternatives being considered. "We don't know if we'll go exactly the way the Senate has," declares the



**HOUSE'S BOYD ALEXANDER**  
A full-blown distributed processing network around minicomputers

HIS chief, "but whichever way we go, we want members and committees to know exactly how much this computer resource costs." To do this, he says, HIS would set up a special accounting and billing system to tally user dp costs.

Such a system would run off one of the two IBM 370/158s the House computer group is using. Both Houses now have two identical mainframes (the Senate's second 370/158 went on-line early last month). In addition to the IBM cpu's, the House also uses dual CDC 1700s and associated crt's in the electronic voting

system which has been operational since 1973. Having a slight hardware edge over the Senate, the House has implemented two new systems which run off minicomputers. One is an electronic publishing system powered by a Digital Equipment Corp. PDP-11, and the other is an experimental word processing system using two Harris Corp. minis.

Both dp shops also use Comten front end communications processors for their terminal net link-ups. That solved one major compatibility problem, and also allowed better communication with the Library of Congress, which also uses the Comten.

## Compatibility and back-up

Compatibility and back-up muscle are two primary concerns of the House and Senate computer cadres. While both groups like to maintain their autonomy, they also realize that it's to their benefit to cooperate in certain areas. To formalize this cooperation, a joint Policy Coordination Group (PCG) was set up earlier this summer.

Made up of dp staffers from the House, Senate, and Library of Congress' Research Service, the panel will be looking at ways to step up efficiency and to avoid unnecessary duplication and redundancy between the three Congressional dp divisions. Task forces, most of which haven't been activated yet, will probe priority projects in such areas as word processing, computer output microfilm, and video/audio technology.

Work in these key areas has, of course, already been done by both Houses, but under the new cooperation pact, dp planners hope to come up with some shared solutions to their common problems. One prime example of this is the Legislative Information and Status System (Legis) which both system squads have been working on jointly for three years. A PCG task force currently is reviewing this work effort, trying to pull it together so the sophisticated sys-

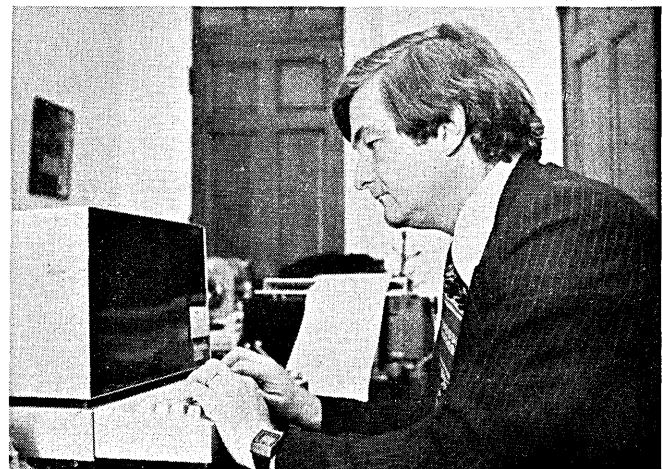
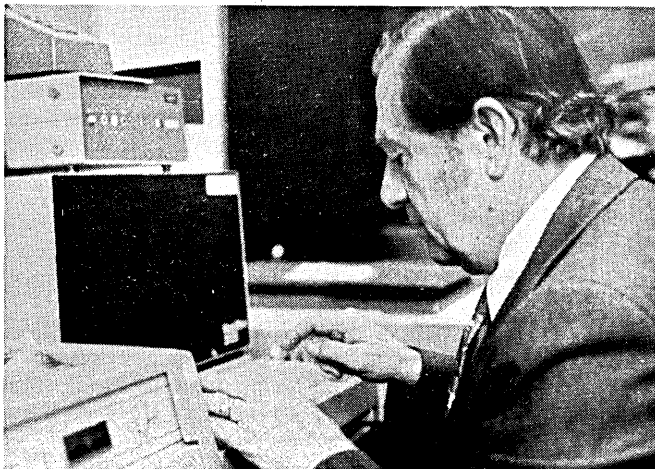

**HANDS ON:** Sen. Howard W. Cannon of Nevada, chairman of Senate rules committee, left, and Rep. Charles Rose of North Carolina, of policy group on information and computers, pluck information from files through terminals installed in their offices. Senate uses Hazeltine model 2000 crt's, while House has a variety, including Diablo, Anderson Jacobson, Trendata, AT&T, and Hazeltine.

tem can run effectively in all three Congressional branches.

### Tracking legislation

An upgraded version of the House-developed bill status system, Legis, which became operational in the House in late July, is a legislative information tracking system, providing status, content, summary, and cross-reference information on all official Congressional activities. To keep the system current, the House and Senate swap data bases every day. The Senate, trying to play catch-up with the House, just finished building its file and getting it up to date, and will be ready to offer limited Legis service next month. Top Senate dper Swearingen hopes the system will be fully operational in the Senate by the first of the year. As in the House, the system will be available over the terminal network.

The terminals in both the House and Senate currently operate over dial-up phone lines to the Comten front end switchers. Both Swearingen and Alexander would rather move to cable transmission facilities. The feasibility of such a move will be studied by the PCG's video/audio task group.

But in the meantime the House is exploring the possibility of using cables for audio, video, and digital transmission. Right now, it's running a video test in one of the House office buildings to provide coverage of floor action. Engineering studies also are being done to check out the costs of using a cable to pipe in audio, video, and digital signals—the digital transmission segment being used for the Houses' internal terminal communications network.

### Less elaborate

The Senate's current data communications plans appear to be less elaborate. However, Swearingen backs the cable concept, and believes the Senate eventually will tie into the House through such a system. His other data communications schemes seem to mesh with his distributed processing goals. Distributed processing, he affirms, "is the next stage in our development of the communications system. We'll soon have enough terminals so that we'll have to start dealing with them in a different way than having the computer driving all of them. We may even," he notes, "put some of the terminals outside Washington."

His Alexander envisions the possibility of having a full-blown distributed processing network centered around minicomputers in member offices. Under this decentralized plan, various offices would be clustered around a mini which would handle the dp chores of those offices. Alexander also sees distributed processing as an important element in word processing development

in the House.

He cites the experimental wp system currently being operated in eight members' offices as an application of this technology. (Approximately 141 members have also set up wp systems through time-sharing companies like Digital Management and Dialcom Inc.) Word processing for committees is being provided by MITS, a version of IBM's Administrative Text Management System (ATMS) which interfaces with electronic composition gear at the Government Printing Office.

While his planners feel it's important to build committee word processing strength, their first concern is in getting this technology down to the member level. To do this, the planners started pilot testing a system called the Member Office Support System (MOSS) last year in eight member offices. It is designed to provide services such as constituent correspondence tracking, letter writing, and management reporting. Offices currently on the system are equipped with crt and hardcopy terminals linked to a Harris mini. Future plans call for MOSS to be expanded to more offices, with the possibility of setting up access terminals in members' district offices.

### Senate, too

The Senate also is getting wise to the ways of word processing. The committees, according to Swearingen, are using IBM's ATMS system to produce calendars and reports. But it's at the member level, he notes, where the most sophisticated wp scheme is underway. That scheme is the highly publicized Correspondence Management System (CMS), which has been pilot tested for two years.

Thirteen Senators' offices are now using CMS under the pilot project to turn out letters and keep track of correspondence. System input is through the Hazeltine 2000 terminals which are linked to On-Line Systems' time-sharing service. Slated to be fully implemented in approximately one year, CMS will go on-line in four to five offices a month. Swearingen estimates that around 80 offices eventually will have CMS hookups, with each office having three terminals dedicated to CMS.

The Senate also is looking into getting a text processing system similar to one that was installed last April in the House. Swearingen admits this system "looks very good." The HIsers think so too, mainly because they claim it's sliced \$2 million off their printing bill. They also insist it's more efficient since it provides speedy computerized capture, edit, and printing of hearings and bills. Procured from ATEX Inc., the new publishing system, based on a Digital Equipment Corp. PDP-11 mini, supports up to 96 users at a time.

This printing power could put some

real pizzazz into the Senate's publishing operation. Swearingen realizes this and probably so do some of his more savvy system users. He knows this too. "When people in the Senate want some (dp tool) we don't have and they find the House has it, we hear about it very quickly," he acknowledges.

The Senate computer team constantly hear about new projects it should launch. "The demand," contends the soft-spoken Swearingen, "exceeds our ability to supply it. We're still catching up."

Operating under the Senate Rules and Administration Committee, the Computer Services Staff includes eight full-time project managers. The Senate computer center itself is supported by a staff of 110, mostly programmers and operators. Swearingen would like to keep this work force from growing too large. "We don't want a huge computer center," he insists. His philosophy is that he and his staff will work with what they've got, "and if we have to go out and get special software or whatever, we'll go out and get it. We're not embarrassed about that."

Nor is HIS, which has adopted about the same stand on utilizing outside services and equipment. Dp requirements, explains his head Alexander, "can be met through HIS or other sources such as outside consultants, time-sharing services, or even other government agencies."

### Seven divisions

Alexander's staff, totaling 204, is broken down into seven divisions, which include a mix of system personnel. The computer group operates under the House Administration Committee and gets additional scrutiny from the new Policy Group on Information and Computers, headed by North Carolina computer enthusiast Charles Rose.

Rose, along with House Administration Committee chairman Frank Thompson of New Jersey, has hammered home the need to view computerized information as a resource with intrinsic value. His leader Alexander strongly supports this concept and believes it should be applied throughout Congress.

This new mind-set about machines also seems to be reflected in the goals of the fledgling coordination project which is aimed at helping the three Congressional computer camps share some of their valuable information resources and know-how. Alexander is particularly pleased about this, and about the whole cooperative effort in general. He says it's "very important" to future Congressional computer operations.

Swearingen, who's been on the job for more than three years, is much more reserved in his enthusiasm over the

project. While he agrees with newcomer Alexander that the project is worthwhile, he also adds that "we've done it before." But not wanting to put a damper on the whole thing, he quickly points out, "I guess it's an evolution from where we were before."

And Alexander couldn't agree more. "All of Congress," he reflects, "is finally starting to look at itself as a whole in the area of information and computers. And that's where I think the future lies."

—Linda Flato

### Software

## Is Software Valuable?

"The software industry was asleep at the switch," said James R. Porter, v.p., Industry Applications Group, Informatics, Inc.

He was talking about the industry's reaction when the Financial Accounting Standards Board in late 1974 issued Statement No. 2 dealing with treatment

of research and development expenses and later, Interpretation No. 6, relating computer software to the Statement.

With the Statement, the standards board ruled that outlays on research and development should be charged off as incurred, rather than deferred and charged off only as income materialized from selling the resulting products. The interpretation detailed when software costs are deemed part of R&D.

"At first the industry didn't seem to think the ruling really applied to them," said Porter. "Some even thought it was a blessing because there had been abuses in the deferring of expenses. It wasn't until the auditors started coming around saying 'take this off the books and take that off the books' that we began to sit up and take notice. Do we want to be an assetless industry? No. We have assets and they are of value."

Porter is chairman of a subcommittee of ADAPSO's Software Industry Assn.'s Accounting Committee, formed 18 months ago specifically to deal with problems created by the FASB ruling. Serving with him are John Imlay, Management Science America; Larry Welke, International Computer Programs, Inc.; and Martin Goetz, Applied Data Research.

### Told to go home

"I first became concerned two years ago when our auditors began telling us to take things off our books. It was as if the FASB was saying software has no value," said Porter. When he first presented the problem to ADAPSO, he said, "I was told to go home and shut up. Since that time, the subject has been on the program of just about every ADAPSO meeting."

Porter believes there is a problem in terminology. The software industry always has used the term software development. "The word development is inherently associated with risk, developing a form of prototype which may or may not ever be marketed." He would prefer the term software construction.

In a paper submitted to the FASB by Porter and Informatics' controller, Thomas F. Harincar, the development and production of software is likened to the production of motion picture films or recorded music. "In each instance, costs are incurred to produce an intangible asset which, if successful, will be licensed or otherwise marketed. All authoritative pronouncements containing accounting principles applicable to the entertainment industry require the deferral of production costs and the subsequent amortization in relation to projected future benefits."

### Discernible future benefits

In its argument for expensing software, the paper points out, "The board refers to the general lack of discernible

# The best terminal printer made isn't worth owning.

Not when you can lease it from RCA.

An RCA lease and service price, for example, means maintenance by data communications specialists in 175 cities.

It means you're never at a loss for service. It means RCA expertise is always at your fingertips.

What's more, RCA has eight warehouse locations coast to coast. And that means prompt delivery, and reliable installation and maintenance.

You might say, leasing from RCA makes owning obsolete. So, whatever your terminal needs are, GE TermiNet\* 30 printers, Extel\*\* equipment or a complete line of Teletype\*\*\* terminals, look to RCA before you lease.

RCA wants you to know that while leasing is more advantageous than owning, not all leases are created equal.

For full details and rates, call or write: RCA Service Company, A Division of RCA Data Services, Bldg. 204-2, Cherry Hill Offices, Camden, N.J. 08101, Phone: (609) 779-4129

\* Registered trademark of General Electric Company.  
\*\* Registered trademark of Extel Corp. \*\*\* Registered trademark of Teletype Corp.

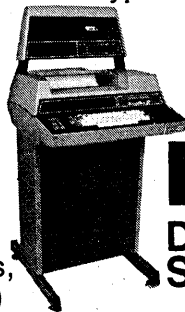

**RCA**  
Data Services

future benefits at the time such costs are incurred. Since the accounting treatment required for film and music production is the exact opposite of that prescribed for software production, one can only assume that the FASB, in its wisdom, feels that judgments and predictions concerning discernible future benefits are somehow more precise in the entertainment industry."

The board's response to this argument, said Harincar, was to point out that it had not issued the pronouncements on the film and recorded music industries, that these were a holdover from its predecessor, the Accounting Principles Board (APB) of the American Institute of Certified Public Accountants (AICPA). "They (the FASB) copped out on that one," said Harincar.

FASB pronouncements have the force and effect of law on public companies, Harincar explained, "because the SEC (Securities and Exchange Commission) enforces them." The FASB is an arm of the Financial Accounting Standards Foundation, formed and financed by private industry in the early 1970s to assure that accounting rule-making would be kept in the private sector.

#### High risk activity

In their paper, Porter and Harincar say the board, in ruling that costs incurred in the development of computer software systems must be charged to income as a current period expense, "reached its conclusion primarily on the premise that research and development is a high risk activity, and that future benefits are uncertain. The board, in its statement, did not properly consider the nature of software design and development, nor did it properly evaluate the historical risk associated with software products. The result is certain to be a significant distortion in reported financial results, perhaps even a negative influence on what otherwise might be a sound business decision."

"We're facing a depressed stock market making public funds for additional development out of the question," said Porter. "Institutional financing is going to be a fact, and institutional loans generally are made on assets."

He said his subcommittee informally surveyed 400 software companies and received some 35 to 40 responses. All generally agreed that "yes, we should be able to capitalize our software."

Porter said development in the software industry tends to come in cycles. "Generally there hasn't been a replacement cycle for original products as yet. We don't know what the financial problems are going to be. There are those in the software industry who are too entranced with technology to think in a businesslike way about the future."

Purchased software is deemed an asset by the FASB. "The rationale here,"

say Harincar and Porter in their paper, "is that purchase lends credibility to the asset's value. The result is a conflicting presentation of purchased assets on the balance sheet and constructed assets expensed as the costs are incurred. It is also conceivable that a businessman, faced with a make or buy decision, might decide on the basis of prescribed accounting treatment rather than the relative economics. Can anyone really argue convincingly that a purchased asset has more value than a constructed asset?"

#### Request for a hearing

Porter's subcommittee presented a position paper to the FASB last De-

ember. The board, via a letter to ADAPSO's Thomas Farewell from J. T. Ball, its director of the Emerging Problems Div., responded with a request for additional information. Additional information, including the fact that there have been incorrect applications of the pronouncements, was provided last May, and a request was made for an in-person hearing. As yet that request has not been granted.

"In my last discussion with them (the board), I was told there wasn't enough flack," said Harincar.

The paper he and Porter submitted to the board concludes: "Statement No. 2 was adopted with little or no opposition from the software industry as it did



## Two New Refreshing Alternatives MEGRAPHIC 5000 & 7000 SERIES

### Dollar For Dollar, The Best Performing, Most Powerful, Intelligent Graphics Systems

#### DYNAMIC REFRESH

All MEGAPHIC Systems feature 100% vector refresh. Sharp, bright lines with 12 bits of screen resolution. Individual vectors or symbols can be erased, translated, rotated or scaled in real-time. No need to blank the entire screen to change one, one hundred, one thousand, ten thousand, or more points!

Local minicomputer power eliminates the host or minimizes its support requirements.

#### TEKTRONIX®\* COMPATIBLE

Our 5014 emulates all Tektronix® 4010/4014™ Series storage terminals. MEGATEK's EDS™ adds powerful local edit capabilities, not available on a storage tube.

Easy to use, easy to pay for. Flexible cost effective systems, backed by MEGATEK engineering and software support. PDP-11, DATA GENERAL, and OEM interfaces available. We listen to your problems and solve them with quality products.

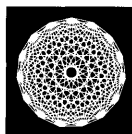

**MEGATEK CORPORATION**

**The Refreshing Alternative**

1055 Shafter Street, San Diego, California 92106 Telephone: (714) 224-2721

\*TEKTRONIX is a registered trademark of Tektronix, Inc., use of which in no way constitutes endorsement.

# news in perspective

not appear to be applicable to software development when circulated as an exposure draft. Even after it was issued, there were misunderstandings as evidenced by the subsequent issuance of the interpretation dealing with computer software. The 'due process' procedures prescribed by the board's charter were, therefore, circumvented because

the board did not have the opportunity to consider responses from representatives of the software industry prior to issuance of the pronouncement. No matter how distasteful, the FASB must reopen the issue to avoid additional loss of credibility."

—Edith Myers

## Conferences

# IFIP Congress: Out Of an Ivory Tower

The "wings of man" sometimes can let you down. And that's exactly what happened last month to weary travelers trekking to Toronto for the sixth triennial meeting of the International Federation of Information Processing. Trapped in the middle of a disruptive air traffic controllers' strike which broke out on the eve of IFIP Congress 77, the disgruntled conference goers were sent shuffling off to Buffalo and other close-in points to the air-locked Canadian con-

vention capital.

"People," gushed one enthusiastic IFIP official, "made extraordinary efforts to get here." Some of those "extraordinary efforts" required tedious travel over circuitous routes which took up to 20 and 30 hours. One more enterprising group of IFIP-bound journeymen reportedly solved their transportation problems by chartering a private boat to take them across Lake Ontario. But most IFIP travelers had to resort to

more mundane and time-consuming modes of transport such as trains, cars, and buses—many of which got hung up in customs for hours.

"The great airline shuffle," as it has since come to be called, cut into Congress 77 attendance, but not as much as conference planners had expected. Total turnout for the five-day meeting, held Aug. 8 to 12, was 3,540—over 500 short of the minimum 4,100 draw IFIP organizers had counted on. This lower turnout was in part reflected by a smaller U.S. contingent than was anticipated. The U.S. press, charged a chagrined conference spokesman, "let us down."

But despite the travel turmoil, the IFIP organizing crew managed to pull the conference together with what appeared to be a minimum of difficulty. Only one session had to be cancelled later in the week, although quite a few panels, especially on opening day, had to be reconfigured with stand-ins for the panelists who couldn't make it. In all, the conference's technical program included 90 sessions, 30 mini symposia and panel discussions, as well as 100 papers.

## Employment troubles

Kicking off Congress 77, which drew delegates from 50 countries, Canadian Minister of State for Science and Technology J. Hugh Faulkner zeroed in on

# All major mainframe manufacturers use Kybe tape cleaners and testers.

The reason is simple. Kybe cleaners and testers have set the industry standards for years. They're first with the highest throughput speeds. First with the most effective cleaning and testing techniques. First in precision re-tensioning and restacking. And first in ease of operation. That's why all major mainframe manufacturers use Kybe equipment. It's also why

more tape manufacturers and more tape libraries install Kybe equipment than all others combined. Find out for yourself. Kybe makes a complete family of cleaners, testers, bulk erasers and supplies to keep your tapes and tape drives at peak operating levels. The best equipment, competitively priced . . . from Kybe. Write for complete details.

Kybe's TMS-70 tester (right photo) gives you a hard copy record charting the exact condition of your tapes. The E-24 Mod VI (left) cleans, retensions and restacks a 2400' reel of tape in 3 minutes. There's nothing faster . . . or easier.

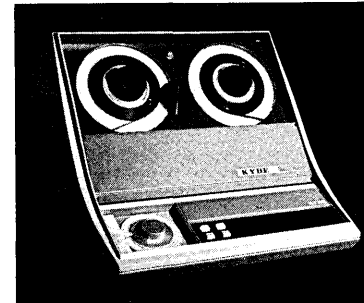
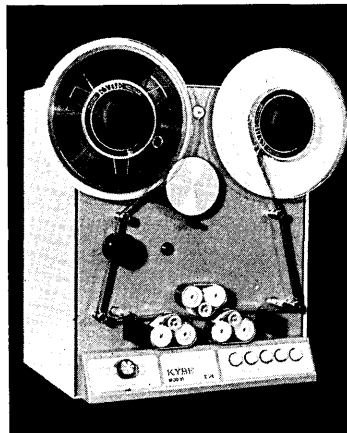

**KYBE**

**KYBE CORPORATION**  
132 Calvary Street, Waltham, Mass. 02154  
Tel. (617) 899-0012; Telex 94-0179

Sales Offices  
Boston — (617) 899-0012  
Chicago — (312) 644-5650  
Houston — (713) 524-3111  
Los Angeles — (213) 980-8365  
New York — (212) 594-9272  
Wash., D.C. — (703) 527-2292





IFIP PROGRAM CHAIRMAN W. M. Turski talks at opening ceremony.

some of Canada's problems in the new "information era." According to Faulkner, rapid advances in telecommunications and computer technologies "have combined to accentuate the problem of national control over national destinies." This is particularly true in Canada, he pointed out, where the "technological drain" has created balance of payments and employment troubles. Another "worrisome implication" spawned by this dp drain, he maintained, is "the danger that industrial and social development will largely be governed by the decisions of interest groups residing in another country."

To keep this from happening, conference keynoter Josef Kates, head of the Science Council of Canada, recommended that middle powers like Canada take advantage of opportunities "to improve their international position in terms of technological interdependence." One way to do this, he explained, is through software developments which he said "will lead to employment of a kind that challenges the intellectual abilities of a large number of Canada's population. The reduced dependence on capital investment that this area involves, together with microprocessor technology and large-scale integrated circuitry," he noted, "poses an exciting challenge to the large multinational companies that have so far dominated the computer industry."

#### Communicate all implications

Calling science and technology, "the engines of social, economic, and industrial change," Kates stressed the need for scientists and technologists "to take more seriously the responsibility to understand themselves and to communicate to others not only the technical, but also the social, economic, and even philosophical implications of their discoveries."

IFIP conference coordinators seemed to take this message to heart, structuring five panel sessions around the social im-



OPENING DAY AT EXHIBITS: Dignitaries at exhibit include Paul V. Godfrey, chairman of Metropolitan Toronto Council; W. Hutchison, chairman of IFIP exhibition committee; Hugh Faulkner, Canada's Minister of State for Science and Technology (seated at terminal); and Surander P. Jain, systems engineer with Honeywell, Ltd.

pact of computers and information processing. Another welcome addition to the conference program was the plethora of sessions devoted to business applications and administration. The IFIP program committee carefully targeted these discussions at dp managers, bringing together the big names in international computing to talk on such topics as data base management, distributed processing, microprocessors, telecommunications, and programming.

#### Out of an ivory tower

This represented a marked departure from IFIP's normal emphasis on the theoretical foundations of dp. "This Con-

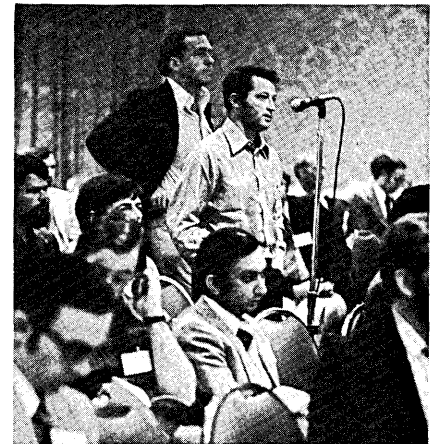

CONFERENCE ACTIVITY: Only one session had to be cancelled because of air traffic controllers' strike, but a few panels had to be reconfigured with stand-ins.



# news in perspective

gress has finally come out of an ivory tower," quipped Paul Dixon, director of information systems for Massey-Ferguson in Toronto. Dixon, who was responsible for putting many of these business-oriented sessions together, is chairman of the IAG, IFIP's business arm. He claims conference organizers got "good feedback" on these "more practical" sessions.

They also got good attendance. And so did the Congress 77 exhibition which drew 9,780. Touting their dp wares and services, 116 companies had booths in the three-section exhibit area in the Sheraton Hotel which was four blocks away from the main conference hotel, the Royal York. Prominently located at the main door of one of these exhibit sites was IBM and its Canadian counterpart, IBM Canada Ltd. A clear standout however was the obtrusive NCR booth with its blazing red decor. Conspicuous by their absence, particularly since the conference is an international forum, were Siemens, ICL, Burroughs, and Control Data.

## French showed packet network

Many companies offered live on-the-floor demonstrations of their gear. Par-

ticularly impressive was the French packet switching demo using the Canadian Datapac net via satellite to its own RCP (Transpac prototype) net in France. CII Honeywell Bull also put on a hands-on demonstration of its Cyclades teleprocessing set-up which serves the French government as well as scientific and academic users.

All exhibitors agreed that the first day of the conference was slow, but things picked up considerably by the end of the week. Toronto press coverage, stepped up due to the air strike situation, helped attract locals who wouldn't normally have bothered to attend, claimed one IFIP spokesman.

This made the hustling exhibitors happy, but what made them even happier was the solid lead prospects that many of them claimed to have picked up at the show. Considerably less enthusiasm, however, was expressed over the next Congress 80 conference which will be split between Tokyo, Japan, and Melbourne, Australia. Already worried about potential problems, miffed exhibitors, such as NCR, were trying to decide whether to show their wares in one or both conference locations.

The split site set-up for Congress 80

also seemed to bother other travelworn IFIPers who, along with the exhibitors, grumbled that there had to be a better way to structure the meeting than dividing it across 6,000 miles of water. But the final word on the Congress 80 controversy comes from irrepressible IFIPer Paul Dixon who optimistically declared: "Solomon, too, was a great king, and he, too, succeeded in sawing a baby in half."

—L.F.

## Ford's Roark on Managing Change

The manager in the systems profession who can't cope with change can't be effective, Mayford Roark, Ford Motor information systems executive, said during a management program at the IFIP Congress in Toronto.

Roark set the tone for the sessions in a speech entitled, "Some Approaches to the Management of Change."

"In the systems profession," he said, "change is the essence of our work as we strive for continuing productivity improvement. The manager who cannot cope with change, plan for change, who cannot produce continuing change, will not be effective. This role... is something I believe to be new and different from the traditional roles of management."

# The Interconnect Answer



## It's HYPERchannel™!

Eliminate data traffic congestion between the COMPUTE, STORAGE, and ACCESS elements of your installation with HYPERchannel. Filling the void in today's system architecture, HYPERchannel enables efficient, cost-effective data movement at rates up to 50 mbits per second.

HYPERchannel can save CPU time, channel time, and money, whatever your need:

- CPU to CPU interconnection
- Improved I/O performance
- Peripheral pooling
- Efficient storage management

Get tomorrow's technology — today! Call or write for details.



**Network Systems Corporation**

6820 Shingle Creek Parkway  
Brooklyn Center, MN 55430 (612) 566-5050

SALES OFFICES: San Francisco, CA 415/344-6331  
Huntsville, AL 205/539-7929 Washington, D.C. 703/938-4215  
Philadelphia, PA 215/542-8039 Detroit, MI 313/569-1801

Management of change is, in fact, a virgin area of study in the dp industry, and Roark's 12 propositions, based on Ford's own experiences, establish a framework for it. Among them was first, the warning that "the attempt to build Utopian-like total systems... invariably fails" due to their complexity, inevitable cost, and time overruns, and the enormous adaptation required of the user organization. "A series of achievable projects" in a long-range plan is the key.

The manager must recognize, too, that technological achievement is no longer an individual thing, but a product of highly skilled groups with considerable resources. In computers this is "even desirable," since it reduces vulnerability to abuse and fraud and "one man's fancies."

#### Maintain flexibility

Roark advocated the use of: techniques to maintain flexibility—matrix organization, specialized task forces, chief programmer teams, and structured walkthroughs; new development tools, especially top-down design and structured programming; and planning that allows for gradual revision and modification as the organization evolves.

Productivity within the system should be sought, he said, noting that Ford has increased system workload nearly 20% annually, but total dp expense has de-

clined by more than 25% in ten years. In the last of his propositions, Roark told managers to conserve themselves as a "key resource." "For most of us the opportunity to grow, to develop new skills, and to explore new interests may be the most important elements of our jobs."

#### Not like the old days

Interestingly, during IFIP, a person who had attended a meeting of senior information executives said that persons nearing retirement age were not unhappy about it; they expected their roles to change so dramatically due to the distribution of systems that they would "lose their power" and "it wouldn't be like the old days." Roark's contention seemed to be that the manager's influence would increase as long as he himself changed.

"After experiencing the creative satisfaction of applying technologies to the solution of tough problems, could any of us settle for the static way of life of our ancestors?"

Robert I. Tricker picked up from Roark and delved into "The Impact of Information Systems Management on Organizational Thinking." Tricker's paper was based on the work done at the Oxford Center for Management Studies in the U.K. For the last four years, the center, with IFIP/IAG, has held discussion groups, or "Top Level Brief-

ings," for executives in major international organizations.

Again the word "power" came up. "There are emerging pressures which identify information with power," he said, and the manager now has to cope with numerous forces fighting for their share of its control. This was exemplified in a recent briefing, he noted, when information systems executives were asked to identify the most critical issues affecting future system development. No mention was made of technology or methodology. Instead, they focused on internal organizational problems, third party involvement (labor, consumer groups, governments, etc.), and external factors.

Some of these "third parties" getting involved in the control of information and systems were represented in the social implications sessions of IFIP Congress 77. In a panel asking "Is the Erosion of Privacy an Unavoidable Consequence of Computer Applications?" experts from the U.S., Europe, and Australia described various developments in their countries. The Council of Europe, which is developing an international convention to rationalize privacy laws, was represented by a chief architect of that convention, Frits Hondius. Hondius noted that both a second draft of that general convention and a first pass at one for medical data are due out this month.

—A.P.

## HAVE YOU WEIGHED THE ALTERNATIVES? WE HAVE! CALL INFONATIONAL

A Division of Foresight Systems, Inc. — First Choice In Finance

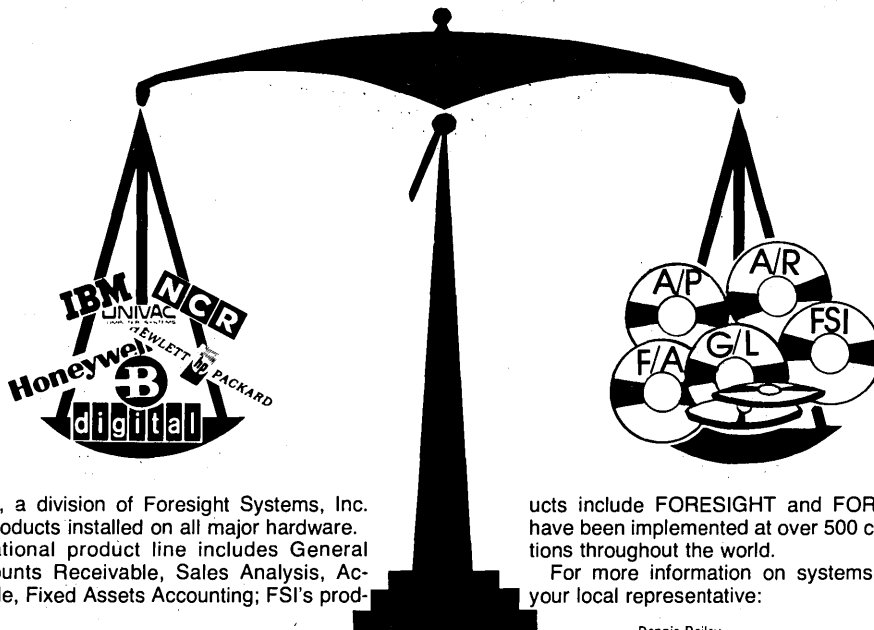

Infonational, a division of Foresight Systems, Inc. has proven products installed on all major hardware.

The Infonational product line includes General Ledger, Accounts Receivable, Sales Analysis, Accounts Payable, Fixed Assets Accounting; FSI's prod-

ucts include FORESIGHT and FORETAX — which have been implemented at over 500 computer installations throughout the world.

For more information on systems availability, call your local representative:

Kim Lombard  
INFONATIONAL  
6626 Convoy Court  
San Diego, California 92111  
714/560-7070

Steve Fredrickson  
INFONATIONAL  
4544 Post Oak Place  
Houston, Texas 77027  
713/622-4490

Ray Clayton  
INFONATIONAL  
150 North Wacker Drive  
Chicago, Illinois 60606  
312/782-2375

Dennis Dailey  
Tom Curran  
INFONATIONAL  
Two Penn Plaza  
New York, New York 10001  
212/736-4225

Art Pearlman  
FORESIGHT SYSTEMS, INC.  
1901 Avenue of the Stars  
Los Angeles, California 90067  
213/277-2722

# news in perspective

## Services

### Bradford Natl: Keeping The Records Straight

In case no one's noticed, competition in the computer service industry is heating up these days. Firms like Automatic Data Processing have been making acquisitions right and left, while other concerns—National css, for example—have significantly bolstered their list of capabilities.

In short, the big boys are getting bigger, and more aggressive. And one of the firms that's emerging as a winner in this increasingly competitive environment, Bradford National Corp., is something of a surprise because the New York City-based company is not exactly a household word in much of the dp industry.

Even so, the nine year old company, which traditionally has functioned behind the scenes providing financial record keeping and computer/clerical processing services for banks, mutual funds, and the like, has been popping up more and more in the newspapers recently. Earlier this year, Bradford beat out EDS and Citibank for a highly lucrative (\$100 million plus) contract to set up and operate a Medicaid watchdog system for New York State. In an ensuing donnybrook, Citibank subcontractors reportedly tried to pressure N.Y. State Social Services Commissioner Philip Toia into dropping Bradford, claiming the firm's performance capabilities were questionable. Toia stuck to his guns, and Bradford kept the contract that overnight made it a major factor in the health services field.

#### Now the SEC

Now Bradford is engaged in another fight, this time taking on none other than the Securities Exchange Commission. At issue: the market for processing thousands and thousands of stock transactions.

These controversies—and the headlines that have accompanied them—point up the fact that Bradford has entered the big league. Indeed, annual revenues now exceed \$65 million, a 15% increase over last year. And they've been growing at a compounded annual rate of more than 21%. Perhaps more importantly, the revenue base has become increasingly strong and diversified, growing at a projected annual rate of 30%. Today Bradford boasts a customer list that includes:

- 400 banks including 10 of the 20 largest banks in the country;
- some 2,000, or so, corporations for

which Bradford provides stock shareholder services, processing stock sales and purchases for about nine million shareholders;

- more than 75 mutual funds and 15 major fund groups.

In addition, the company has become the country's largest municipal bond clearing agent. It was a major contractor for New York City's Integrated Management and Financial Control System (February, p. 146), and currently is involved with a host of other projects that range from the design and implementation of an off-shore water pollution control and abatement system for the U.S. Navy and Coast Guard to providing portfolio record keeping for the Ford Foundation's \$2 billion investment portfolio.

#### Mountain of data

Systems design, facilities management, consulting—Bradford offers a full range of services while processing a mountain of data for its various customers. "Each business day we process more than 100,000 separate transactions with a combined value in excess of \$100 million," says the firm's chairman and chief executive officer, Peter Del Col.

At the heart of Bradford's processing business is its computer and data communications network. "To move these mountains of securities and cash from point to point across the nation (the company has facilities in 33 cities), we employ our own innovative and proprietary systems of electronic value transfer," Del Col explains. "We maintain six fully equipped data centers in major money markets, staffed by 400 transaction processing specialists whose work is coordinated through our national computer services center in Teaneck, N.J."

Because of the geographical diversity of its business and the tremendous amount of data it must handle, Bradford either had to have extensive dp capabilities on-site regionally or develop a high speed distributed system that divorced the central location from the regional clerical location. The company chose the latter approach, developing a network with two 370/158s (one of which is an advanced processor) at Teaneck as its nucleus; high speed printers as front-end devices; AT&T's DDS system as its communications lifeline, and terminals and minis in its regional offices for on-site processing.

#### Innovative thresholds

"We've crossed a number of innovative technological thresholds," says Ron Smith, president of Bradford National Computer Services, Inc., Bradford's service arm. "For example, the Pix 11

mini-driven printers we've gotten from Paradyne give us such high speed printing capabilities that we can transmit up to 56kb."

Smith says Bradford is considering a number of satellite carriers to further expedite transmission, and notes that IBM dropped its traditionally centralized posture and helped implement Bradford's distributed approach when it saw the handwriting on the wall.

Bradford's specialized processing requirements—and the need for distributed capabilities—are pointed up by its stock transfer application. For example, if an investor buys, say, 100 shares in



RON SMITH OF BRADFORD  
Considering satellite carriers to expedite transmission

one of the 2,000 corporations Bradford services, the buy order and the corresponding sell order must be matched up. Bradford's Manhattan personnel print up the order and capture it on ocr. These orders are subsequently batched to Teaneck where they're filed. Subsequently Teaneck sends a message back to Manhattan for a new certificate to be printed from the inventory of thousands of blank stock certificates stored in the Bradford vault. The inventory itself is under extremely close security and is continually updated and monitored through an on-site program utilizing historical records of past stock sales. Print order in hand, Bradford's Manhattan personnel print up the certificate for 100 shares in the new owner's name.

#### Business jeopardized

The securities transaction business, however, or a major segment of it, is now jeopardized by a recent move the Securities Exchange Commission has made to create a government-controlled securities clearance and settlement organization called the National Securities Clearance Corp. (NSCC). The SEC authorized NSCC to process all transactions for the New York and American stock exchanges as well as the National Assn. of Security Dealers, but Bradford, which has a multi-million dollar contract to provide these

same services to the National Assn. of Security Dealers, as well as the Pacific Security Exchange, has asked the U.S. Court of Appeals to set aside the SEC-established service organization; it claims that a competitive national securities market can't be based upon a noncompetitive (the SEC created the organization without taking any bidding), monopolistic, government-regulated securities clearance and settlement agency empowered to fix rates for the national market and—in Bradford's view—engage in predatory pricing and stifle regional competition.

Bradford, and some of the leading figures in the regional stock markets, view the SEC move as a means by which the big New York brokerage firms—with the SEC's help—can capture the national market by controlling its underlying transaction process. In effect, Bradford is saying whoever controls the computer controls the game.

Whatever the outcome of its SEC suit, Bradford remains manifestly positive about its future. And ironically, it's a future that's increasingly dependent for Bradford and other service firms on the government's growing involvement in the private sector's affairs. "We believe Bradford is riding the crest of a groundswell in which government will require ever more detailed financial record keeping while industry, to keep

pace, will require increasingly sophisticated reporting, record keeping, and accounting services," Del Col told Bradford stockholders at a recent annual meeting.

—Laton McCartney

## Government Procurement

### Fenaughty's Fight for a Fair Shot

It's not easy to woo the Social Security Administration. One company in particular that found this out the hard way is Information International Inc. which has been diligently courting the mammoth Social Security agency for six years. And now at last all their dogged persistence may pay off—and pay off big if the indefatigable company can capture an SSA contract claimed to represent "the largest government ocr procurement in history."

Trying to wean the stubborn SSAers away from the paper scanning gear they've been using for the past eight years, triple-I zealously has been touting its GRAFIX I, a sophisticated computer output microfilm system, as a more efficient alternative to SSA's paper scanner

set-up. The Culver City, Calif., company has sold two of these multimillion dollar systems to date, one to the Navy's Air Rework Facility in Jacksonville, Fla., and one to the British government's Dept. of Health and Social Security in Newcastle-On-Tyne, England.

The UKers report that their GRAFIX system, in operation since last year, is performing well. So well that they've tried to tip off SSA on the advantages of setting up the same system. The biggest advantage of the system, according to the company, is its ability to read a mixture of hand-printed letters and numbers.

The substitution error rate also is impressive. The company claims the British system automatically reads over 99.2% of hand print and over 98% of machine line print. Unrecognized characters are stored in memory for later call up on a crt manned by an operator who then keystrokes the rejected characters back in.

SSA, which originally started out in the '60s with IBM ocr gear, began to build up its ocr muscle by renting a Recognition Equipment Inc. Input 80 paper-scanning system in 1974. That system was then bought two years later and another Input 80 was put on lease earlier this year. The systems are being used to process Form 941s, the quarterly earnings reports that each U.S. employ-

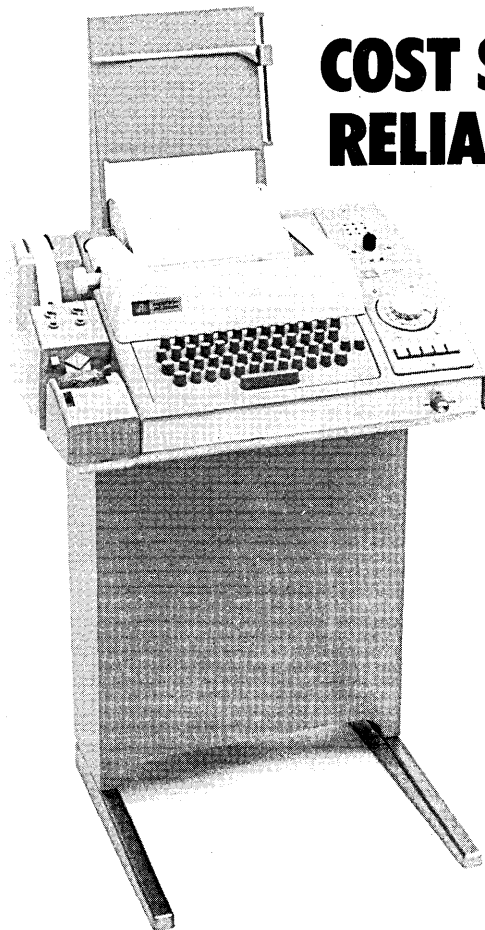

## **COST SAVINGS, PERFORMANCE, AND RELIABILITY...TWX 33, FROM AJ.**

For the cost-conscious communication user, Anderson Jacobson offers the TWX 33 featuring the reliability of the industry proven ASR 33 together with solid state electronics. AJ combines options in financing, service, and equipment configuration to meet the most demanding customer requirements.

With the TWX 33 installed on a lease basis, the user can realize significant annual savings. Additionally, every lease payment accrues real dollars toward the equipment purchase.

AJ also knows that a lost call in business can mean lost dollars, and our service policy reflects this. AJ offers nationwide service by factory trained personnel committed to providing prompt response to any problem!

Upgrade your TWX network with the TWX 33 from AJ and get performance, reliability, and real cost savings. For more information, write or call.



**ANDERSON  
JACOBSON**

Anderson Jacobson, Inc., 521 Charcot Avenue  
San Jose, California 95131, (408) 263-8520



Inforex 1300 and 1301 offer highly cost effective data entry capability for smaller installations (4 to 8 keystations) or remote locations where you can take advantage of our communications capabilities.



The 1303 provides medium range data entry capacity, with about triple the disc capacity of the 1301. It supports up to 16 keystations and the addition of edits, table look-ups, range checks and cross-footing. The 1303 also offers communications capabilities such as *spooling*, *HASP* and *RJE*.

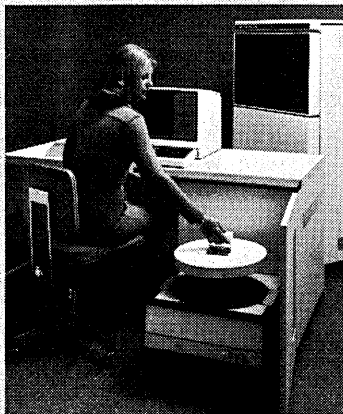

With the 1330, you can consolidate remote job entry and batch data entry applications without compromising either function. The system features expandable disc storage (up to four - 10 Mb. drives) foreground and background editing and bisync communications.

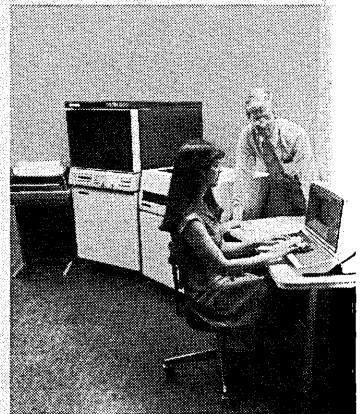

The Inforex 3300 is a powerful pre-processing system that allows you to edit data at the point of entry, enabling you to offload your mainframe. Its sophisticated editing capabilities can also handle many of those applications which you haven't had time to put on your present mainframe.



## INFOREX: THE SIMPLEST SOLUTION TO ALL YOUR DATA ENTRY PROBLEMS.

The simplest and best solution to all your data entry problems is right here: the Inforex data entry family.

Simplest because we design them for ease of use and speed of throughput.

Best because we've been a leader in the innovation and development of key-to-disc data entry products and capabilities right from the start.

Which is why our family's got it all. From the basic keypunch replacement System 1300 to the tremendously powerful maxi-editing System 3300.

So whatever your needs—modest, middling, or immense—the growing Inforex data entry family will meet them.

You don't have to settle for a compromise system. You don't have to sweat out an unsatisfactory price/performance choice. All you have to do is choose the system that's best for you.

And that's where an Inforex Support Team comes in. They'll help you select just what you need. They'll provide expert installation. And they'll give you the benefit of their years of experience in other installations.

But even after all that, you won't be left high and dry. Whenever and wherever you need help, an Inforex Support Team will be available with the support you need.

The Inforex data entry family. You shouldn't settle for anything less.

I would like more information on the following:

- Key-to-disc data entry
- Distributed processing
- Computerized records management
- I would like to talk with an Inforex Sales Representative

Name \_\_\_\_\_

Title \_\_\_\_\_

Organization \_\_\_\_\_

Address \_\_\_\_\_

City \_\_\_\_\_

State \_\_\_\_\_ Zip \_\_\_\_\_

Telephone \_\_\_\_\_

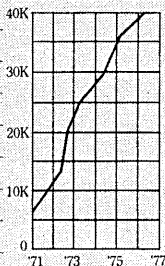

DM-9

Offices in major cities throughout the United States, Canada and Europe. Distributors worldwide.

# INFOREX

Inforex, Inc., Dept. 321, 21 North Avenue, Burlington, Mass. 01803

er must file with SSA. Listed sequentially on these forms are all employees, their Social Security numbers, and the amount of Social Security tax paid.

### Dramatic increase

These ocr processing requirements, while already steep, will increase dramatically by the beginning of 1979 when the agency moves to annual reporting of wages. Under this new set-up, employers, instead of sending in the 941 forms, will turn over to SSA a modified version of the W-2, W-2P (pension), and W-3 (summary) forms. After reading and processing the data from these forms, SSA will then hand over its mag tapes to the Internal Revenue Service.

To handle this heavier workload, SSA will have to get some new optical scanning devices. According to conservative estimates, the agency will be processing 32 billion characters in 1979. That's a lot of processing, and it will require a lot of ocr power. So to prepare for the ocr onslaught, SSA released a request for proposals (RFP) for bids on multifont optical scanning gear in late July.

There was one major problem, however—the equipment specifications spelled out in the RFP were totally tailored for a paper feed scanner-type system virtually identical to the REI Input 80. With such a restrictive spec, other alternative technological approaches, namely COM, were completely ruled out. Thus, it looked suspiciously like SSA was setting itself up for a sweet-heart deal with REI.

### Trip to California

That's apparently exactly what the discouraged Information International thought too. After five years of pleading with the intransigent agency to at least take a look at their GRAFIX I system, the firm had finally convinced SSA in June to make a trip to California to check out the system's capabilities. After an exhaustive demonstration, the SSAers "were really shocked to see how well the (GRAFIX gear) worked," claims triple-I's tenacious president Alfred Fenaughty.

But while they claimed to be impressed, he notes, they still had their minds set on Input-80-type hardware, and had already decided to write the system spec that would eliminate the company from bidding its GRAFIX wares.

Undaunted by this setback, the company launched a counter-attack to get SSA to reconsider its options. As part of this counterattack, spearheaded by fearless Fenaughty, the company began bombarding top SSA dp policymakers (including the contracting officer) with

requests to amend the ill-conceived RFP. They also took their case to key Congressional leaders and the Dept. of Health, Education and Welfare. As a last resort, they also were prepared to file a formal protest with the ultimate arbitrator in procurement disputes, the General Accounting Office.

### "Take them to the mat"

The usually soft-spoken, low-key Fenaughty was adamant. "We have to take them to the mat on this," he declared emphatically. "All we want is a fair shot at (bidding on the contract). I don't believe the procurement at the technical level is dishonest," he explained. "I just think it's narrow-minded. SSA seems to be treating REI the same way the rest of the dp world treats IBM. It's comfortable for them."

But that "comfort" began to dissolve rapidly last month. Folding under pressure from the heavies on the Hill and HEW, SSA announced that it would amend the troublesome RFP. An initial amendment, expected out last month, will extend the due date for proposals. Another amendment will take care of the stickier technical changes—changes that will allow triple-I and other COMers to bid on the highly coveted contract. The technical amendment also is expected to include stringent requirements for benchmarking and total cost benefit evaluation.

This total cost benefit evaluation was not considered in the original RFP, which took into account only the procurement price of the scanning devices themselves, and not the costs associated with entering rejected copy and correcting errors.

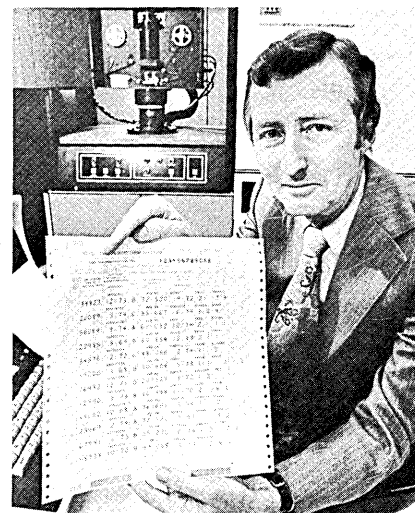

**ALFRED L. FENAUGHTY**  
With British Social Security form with mixed computer lineprint and human handprint



# news in perspective

Information International's Fenaughty feels this was a serious oversight since the major system costs, he argues, would be incurred through these last two steps if Input 80-type equipment was used. These expenses would mainly be attributed to increased personnel needs. SSA estimates it will take 7,300 people to process the rejects and make corrections. (A staff of 1,000 currently is being used to process the 941s on the two REI systems.)

## People saving

Information International claims that its COM system, with a substantially lower reject and substitution rate than Input 80, would require "no more than 635 people," saving SSA "between \$200 million and \$250 million a year in labor costs alone." The feisty firm makes a point of touting these purported cost advantages, since REI hardware costs are much lower than the \$2.5 million price tag of the GRAFIX I system. That's why

triple-I has been pushing SSA to look into the total cost aspect. But this approach also makes sense to one top SSA ADPer who seems to feel that the agency could well afford to shell out \$15 million for six GRAFIX I's if labor costs could be trimmed.

Other SSA officials, although willing to give triple-I a fair shot at the contract, feel the tenacious firm overplayed its hand. They seem resentful of the pressure tactics, especially the political string pulling, the company used to cinch the RFP overhaul.

But triple-I boss Fenaughty believes his overkill methods were justified. Without the Capitol Hill clout, he contends, SSA never would have budged. And now that it has, he seems confident about the company's chances of clinching the contract. He sees the RFP modifications as the company's first step on the road to victory. But, he's also cautious in his optimism. "We've won the first battle," he declares, "but there are other battles to be fought. We're a long way from having won."

—Linda Flato

## TIRED OF WAITING FOR REPORTS?

With EASYTRIEVE, there is no need to wait for reports. In a matter of moments a program can be coded in English and run to provide exactly the information you require in a report you can read. EASYTRIEVE does the formatting, the figuring, the selection of just the data you need. Automatically. Quickly.

You don't have to be a wizard to learn to use EASYTRIEVE. Auditors, financial directors, secretaries, and other non-DP people use it every day. Yet, EASYTRIEVE is powerful enough to do systems housekeeping, create test data, do job accounting and forecasting. The system does multifile processing, print jobs, mailing labels, bar graphs and more. EASYTRIEVE accesses most DBMS files as well. And all without coding forms, extensive training or high overhead.

EASYTRIEVE is one of several valuable software solutions for the IBM 360/370 environment provided by Pansophic, the leading software company dedicated to solving your software problems. Call or write today for further information on our complete line of proven software products.

## PANSOPHIC

709 Enterprise Drive • Oak Brook, IL 60521

East (703) 821-8370  
Central (312) 986-6070  
West (214) 233-0486

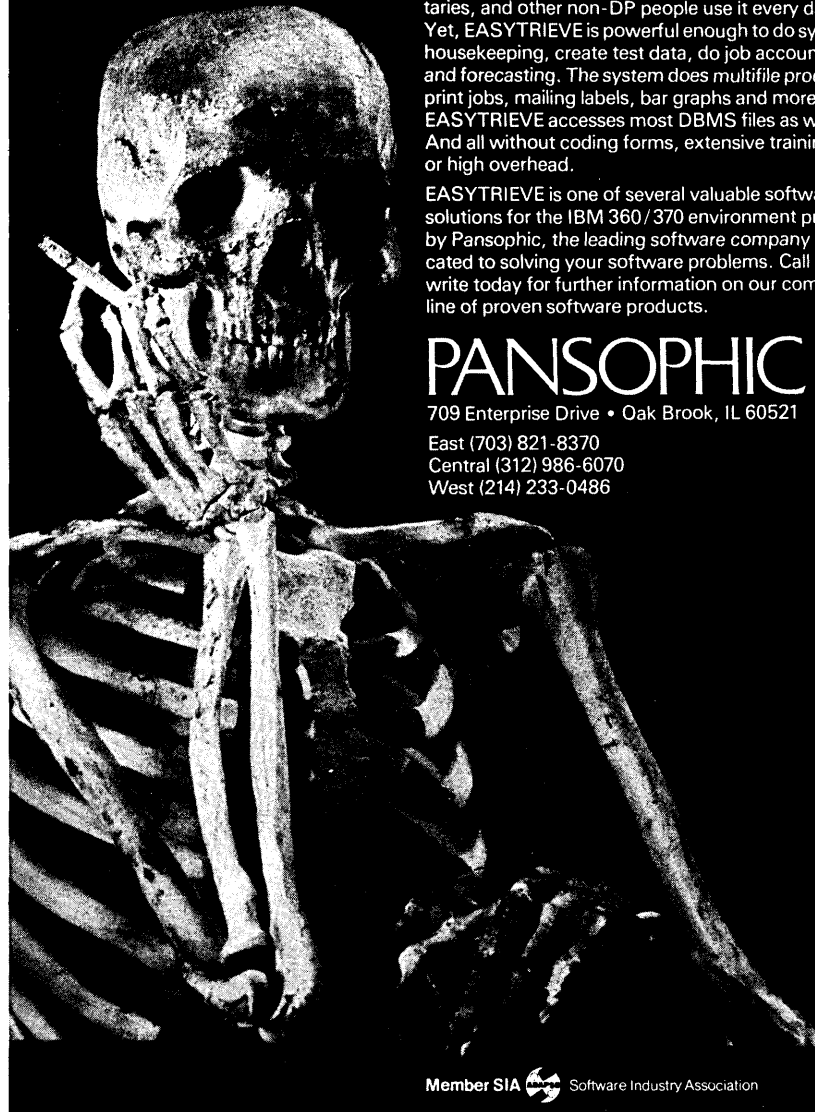

Member SIA  Software Industry Association

## Security

### Blackout Aftermath: No Data, No Computer

When J. Bruce Llewellyn, the 50 year old president of Fedco Food Corp., walked into his combined warehouse and office following New York City's July blackout and looting, he was in for a double-barreled shock.

Not only had the warehouse—along with half the supermarket chain's 16 stores—been ransacked by looters, but the company's Wang minicomputer also had been destroyed, and with it all Fedco's inventory and financial data for the quarter beginning May 1.

"It was completely ruined," Llewellyn says of the system he purchased from Wang three years ago for about \$40,000, "and the duplicate discs we kept were destroyed too."

The discs had been kept in a big concrete safe in the warehouse. The looters who broke into the safe found no money and scattered the discs on the floor where they were ruined by heat and water resulting from a fire arsonists subsequently set. Also destroyed were Fedco's printouts of the records.

#### It was insured

Fortunately Llewellyn had the system insured. He also has a business associate who let him use one of his own backup systems until Fedco received a new computer on order from Wang.

"The Wang people also have been very helpful and have lent me pieces of equipment," Llewellyn adds. "I just wish

that new computer would hurry up and get here."

Then, too, Llewellyn was lucky in that his printouts and discs from other fiscal quarters were stored elsewhere, as were his software programs. Consequently all escaped damage. "It would have been a total disaster if we'd lost the programs," Llewellyn says.

Llewellyn, who had to turn down a federal appointment as head of the

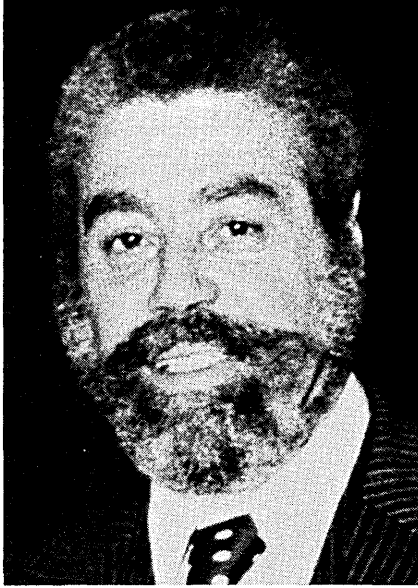

J. BRUCE LLEWELLYN  
Turned down federal appointment  
to settle fire-damaged affairs

Overseas Private Investment Corp. so he could put his own business—the largest black-owned food chain in the country—back together after the looting damage, estimates it will be months before Fedco can reconstruct the lost data and tool up the new system. The price tag? At least \$100,000, Llewellyn says.

As someone who's been through a computer disaster, Llewellyn has this advice for other users. "Secure the damn computer as best you can," he says. "And store data separately and by quarter, and keep your software locked up away from the computer site if possible." Those measures saved the Fedco system from being wiped out altogether. \*

## FBI Fugitive Found Dead

James Francis Collins returned a year ago last May to Denver, Colo., where he was born 40 years ago under the name Henry Joseph Manning, III. Thirteen months later he was found dead in a suburban hotel in Thornton, Colo., an apparent suicide victim.

The tall, friendly programmer/analyst was described by associates at the Davis Brothers Co., a large wholesale drug

company in Denver, as being "friendly and competent in his work." He had worked there as a programmer/analyst for more than a year, after leaving a similar job with Cubic Data Systems in San Diego (August, p. 124).

Collins, or Manning, also was the object of a long search by the FBI after a federal warrant was issued in Kansas City in 1974, where he allegedly gave false statements concerning his net worth in connection with his application for a bank loan under the name of David L. Robinson. And there were arrests and convictions in Sioux Falls, S.D., and in California, where he had escaped from San Quentin Prison in June of 1973,

during the second year of a 10-year sentence for grand theft of \$14,000.

### Bad checks in San Diego

When he suddenly left Cubic Data Systems in May 1976, leaving behind a wife and a trail of bad checks, company officials came to the realization that there was more to Kenneth Allen (the name he used in San Diego) than a competent COBOL programmer with experience on Honeywell equipment.

Last July, the FBI furnished the weekly newspaper *Computerworld* with a wanted notice on Manning and his many aliases. When the July 25 issue of the newspaper arrived at Davis

# WYLBUR<sup>TM</sup> is ten-times more cost-effective than TSO!

...And WYLBUR can prove it to you  
in your own office through our unique  
Dial-A-Demo<sup>TM</sup> service.

- ◇ WYLBUR, the conversational, on-line program development system, has great text editing and RJE/O features which will make your staff more productive; will help you reduce system development and maintenance time.
- ◇ WYLBUR minimizes CPU overhead associated with telecommunications and user management. This means you can have the benefits of a program development system on-line without hampering through-put received by existing systems.
- ◇ English-like commands, which are easy to learn and to use, allow your personnel to become effective WYLBUR users in less than one day.
- ◇ Developed by Stanford University, WYLBUR, by agreement with Stanford, now is available with full support, including installation. No modifications to host operating systems are required.

Want proof? Enjoy a lively two-way conversation with WYLBUR. Call today for a Dial-A-Demo time reservation. If you're considering systems like TSO, ROSCOE, VSPC, CMS or CRJE, call us. Even if you already are using TSO, WYLBUR is complementary and will save you time and dollars. Telephone (415) 391-9555.

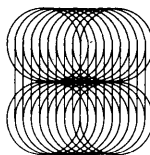

## On-Line Business Systems, Inc.

115 Sansome Street, San Francisco, CA 94104 • Telephone: (415) 391-9555

# news in perspective

Brothers, Manning (or Collins) was confronted by fellow employees, but told them it was impossible that he and Manning were the same person. But he apparently knew the end of his career as a fugitive was near.

The next day he checked into the Capri Hotel in nearby Thornton. And late in the afternoon of July 28, police discovered his body. There was an open bottle of sleeping pills and Manning had been drinking heavily, but death was attributed by police to asphyxiation—a plastic bag was wrapped around his head. Police said there was no evidence that he had met foul play and that a fingerprint check had determined his identity as Manning.

Dick Jensen, head of data processing at Davis Brothers, said he was shocked. "We all considered him a friend. He got married only six weeks before it happened." (It turned out that it was Manning's sixth marriage.)

Jensen said, though, that when Manning applied for work at Davis Brothers, he gave as a reference a Denver contract programming house that had since gone out of business. And he told Jensen that before then, he had been in the Air

Force for 20 years. "He was an excellent programmer." (The company operates an IBM 370/138.) "So good, in fact, that he'd just been named project manager for a huge inventory control program we were starting on." \*

## Products

### The Entrepreneurial Urge . . .

"We'll have color by early November," said Bill Glover of Recreational Computer Systems of Atlanta.

He was referring to his firm's PDP-8 based systems (April, p. 168) which produce high quality pictures of people and can transfer them to t-shirts, tote bags, and/or wall plaques.

Glover's firm places the systems in such places as hotels and amusement parks either as its own operation or through sales to outsiders who want to buy an absentee business for from \$29,000 to \$46,000. To date the pictures have been black and white, although

Glover has been working with color since early this year.

He believes his firm will be the first to offer color among the "dozen or so" competitors who have sprung up since he started his business two and one-half years ago. He also believes his is the only firm which buys equipment used in its systems outright.

Recreational Computer Systems in mid-August had 25 systems installed and was beginning to ship at the rate of three systems per month. Installations included one in Hong Kong, two in Taiwan, two in Canada, and one each in Brazil and France.

### Doesn't have to promote

Glover said he does not have to promote. "We have trouble keeping up with the people who come to us on their own."

One of his competitors which apparently feels it does need to promote is Computers Ventures Inc., whose distributors, The House of Troy, Dallas, had a crowd-pleasing booth at a "Start Your Own Business" show last month in Los Angeles. "Our computer is an artist," proclaimed this company's literature to constant crowds who not only listened but asked some fairly penetrating questions about such things as service and support. Some even took notes.

A lonelier booth at the same show

## Over 1000 DP Managers now use the Johnson Job Accounting Report System.

- Accurate Job Accounting
- Continuous Performance Measurement
- Equitable Cost Distribution
- Optimized Software Performance
- Accurate Customer Billing
- Realistic Thruput Analysis
- Optimum Resource Utilization

### Supports:

MFT-MVT-VS1-VS2-HASP- DOS-DOS/VS-POWER/VS CICS/VS-IMS/V

Send for FREE

30 Page System Characteristics Manual

Name \_\_\_\_\_

Title \_\_\_\_\_

Company \_\_\_\_\_

Address \_\_\_\_\_

City \_\_\_\_\_ State \_\_\_\_\_

Zip \_\_\_\_\_ Phone \_\_\_\_\_

Computer \_\_\_\_\_ Operating System \_\_\_\_\_

Johnson Systems Inc.  
8400 Westpark Drive, McLean Virginia 22101 D977

BLIS/COBOL GETS IT ALL TOGETHER

## BLIS/COBOL OEM's MULTIUSER OPERATING SYSTEM HARDWARE supported by BLIS/COBOL

BLIS/COBOL Supports the Mini's and Peripherals of over 40 Manufacturers (listed below). "You plug them together, BLIS/COBOL does the rest."

<p>ADDS CRT's AED Disks AMPEX Disks, MEGASTORE Bulk Core AT&amp;T CRT's, DATASPEED Printers BALL Minicomputers, Disks, Mag Tapes, CRT's, Printers, Card Readers, Controllers BEEHIVE CRT's CALCOMP TRIDENT Disks CENTRONICS Printers CENTURY Disks CDC Disks CIPHER Mag Tapes CUSTOM SYSTEMS I-O Controllers DATA 100 CRT's, Printers DATA GENERAL GS/40, NOVA, ECLIPSE, Disks, Mag Tapes, CRT's, Printers, Card Readers, Controllers DATA PRODUCTS Printers DATARAM Bulk Core DATUM Disk Controllers DECISION Disk Controllers DIABLO Disks, Printers DIGI-DATA Mag Tapes DCC Minicomputers, Disks, Mag Tapes, CRT's, Printers, Card Readers, Controllers</p>	<p>DEC CRT's, DECWRITER DOCUMENTATION Card Readers G.E. TERMINET, Teleprinters, Printers HAZELTINE CRT's, Printers INFOREX SYSTEM 7000 (BLIS/COBOL, the System 7000's Operating System) INFOTON VISTAR &amp; VISTA CRT's LEAR SIEGLER CRT's MEDIA III Disk Controllers MINICOMPUTER TECHNOLOGY Disk Controllers NEWBURY LABS (England) CRT's PERTEC Disks PRINTEC Printers SYSTEM INDUSTRIES Disks, Controllers TALLY Printers TEKTRONIX CRT's TELETYPE Teletypes, Printers TEXAS INSTRUMENTS Printers WANGCO Disks, Mag Tapes WESTERN PERIPHERALS Disk Controllers XYLOGICS Disk Controllers</p>
--	---

BLIS/COBOL with features like up to 30 users, ANS '74 COBOL compiling, on-line debugging of COBOL programs, data entry masks via COBOL, virtual memory (multiple simultaneous execution of 200K COBOL programs in 32K bytes of memory), simultaneous communications via COBOL, 16 million record 500 MB INDEXED files with ALTERNATE KEYS, databases covering up to eight 300 MB disks; all interactive and multiuser.

BLIS/COBOL, the successful OEM's minicomputer OS/VS with over 100 installations operational worldwide.

For more information in a hurry call . . .

(305) 647-2200 • TWX (Telex) 810 853-5033 U.S.A.  
1850 LEE ROAD, WINTER PARK (ORLANDO), FLORIDA 32789



CIRCLE 164 ON READER CARD

DATAMATION

was that of Tel-A-Computer, a division of Southwestern Alliance Corp., Shawnee Mission, Kansas, which has a micro-computer-based telephone calling and answering device. From them a prospective entrepreneur could, for \$12,200, receive three, three unit systems, a choice of five programs, and complete training in running an office and sales program.

REL Industries, Van Nuys, Calif., was offering custom minicomputer-based systems which prospective investors could peddle to a variety of businesses.

And then there was Computer Capital Corp. which, for a fee of \$9,000, would set up the right person as something of an investment counselor. What Computer Capital would provide is access to a data base of some 2,000 worldwide sources of capital. The new entrepreneur would interview people needing investment capital and then would have these people's needs matched against the requirements of investors in the data base.

#### A nice meal

There were games galore, most microprocessor-based, but by far the most interesting game was based on a plain old barnyard chicken. Money Making Opportunities, a Northern Calif. firm, has conditioned chickens to respond to a series of lights to play tic-tac-toe. The

firm claims their chickens have never been beaten. When a human player inserts a coin in the game machine, a light goes on telling the chicken to make the first move. Then the human player makes a move and another light goes on telling the chicken what that move was. And so the game goes on and when the chicken has won or played to a tie, he gets a reward, a kernel of corn. Any human player beating a chicken gets \$5, but it hasn't happened yet.

And if the chicken malfunctions, it could make a nice meal— something that can't be said of a microprocessor. \*

### History

## Was Computing More Fun Then?

In 1943, the world was at war. D-Day, when Allied forces would storm the beaches at Normandy, was still a year away. Hitler held the upper hand in Europe and a battle of sea power was not going well against Japan.

The United States, under President Franklin D. Roosevelt, decided to produce a superior weapon under a project which was code-named "Manhattan District." For the highly technical work

involved in the project, a group of the country's best nuclear physicists was assembled at Los Alamos, New Mexico. The work they did there led not only to the development of the atomic bomb two years later, but also to very valuable contributions to the field of computing. And, since those early years, the Los Alamos Scientific Laboratories have continued to be known almost as much for work in computing as for work in physics. Thus, for its contributions to data processing, LASL was awarded the National Computer Conference's Pioneer Award this year, and made the subject of a Pioneer Day Session.

The pioneering work done in nuclear physics was supported at Los Alamos at first by armies of GI's working with calculators. But the list of computers used at the Labs through the years reads very much like a history of computing. The Labs acquired, for example, the very first models of the IBM 701 "Defense Calculator" in 1953; the IBM "Stretch" or 7030, in 1961; and even the first Cray 1 in 1975. When available machines couldn't handle the size of problems being attempted, the Labs constructed some of its own—the MANIAC I, finished by Nick Metropolis and Jack Jackson around 1951, and the MANIAC II around 1957.

Participants in the Pioneer Day session at the 1977 National Computer

## THIS COUPON WILL BRING YOU THE FULL STORY ON DAY-FLO® PRE-INKED ROLLERS

Name \_\_\_\_\_  
Firm \_\_\_\_\_  
Address \_\_\_\_\_  
City \_\_\_\_\_ State \_\_\_\_\_ Zip \_\_\_\_\_  
Phone \_\_\_\_\_

Consider Dayco's line of microporous rollers. Ink-impregnated rollers designed for precision ink transfer, even at high speeds. *Custom* designed to fit your system or application.

Pre-inked rollers for credit card im-  
printers, check encoders, character printers,  
print-outs, ribbon re-inking, high-speed  
character printers, on-line marking and a

number of other printing and marking  
applications.

For the full story on the finest and most  
complete line of pre-inked rollers made,  
phone 513/226-5866. Or complete and  
mail this coupon to: Dayco Corporation,  
Printing Products Division, P.O. Box 1004,  
Dayton, Ohio 45401.

**DAYCO**  
CORPORATION



PRINTING PRODUCTS DIVISION

DAYTON, OHIO 45401

© 1977 Dayco

# news in perspective

Conference in Dallas recounted some of the more interesting parts of the early days of computing, and did their best to field the question, "Why was computing more fun then?" Their answers suggest that there have been nearly as many losses as gains in the "progress" made in the industry.

Session chairman Jack Worlton of Southern Methodist Univ. reminded the several hundred people in his audience that day in mid-June that the ENIAC, finished just after World War II was over, was not a serial machine.

A sense of *deja vu* about structured programming was felt when Ed Voorhees (still with LASL) told of a 1956 paper he'd found suggesting that the GO TO was probably undesirable in machine languages. (The subject of the paper was the ALGAE language for the IBM 704.)

## "Personal" computing

The idea of personal computing, a strong theme for this year's NCC, has no big claim to newness either, Voorhees suggested, since early computer users

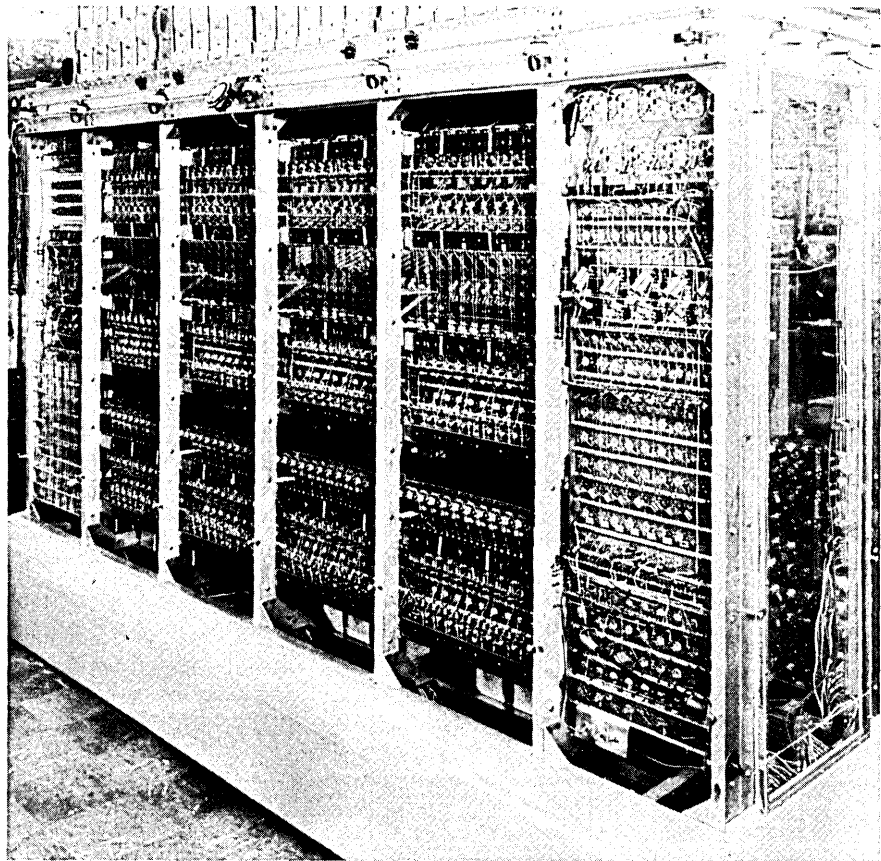

MANIAC: In the early days at Los Alamos, it wasn't unusual to find one of the world's foremost scientists scrambling about on hands and knees on the floor picking up output from MANIAC's Annelex printer.

## RS-232 micro disc!



### TOTALLY OPERATOR ORIENTED

No confusion — simple, easy

- String Search
- Local and remote data access
- Powerful editing
  - 110 thru 9600 Baud
  - Much, much more

#### Call or Write Today!

Techtran Industries, Inc.

200 Commerce Drive

Rochester, N.Y. 14623

Phone (716) 334-9640 TWX 510-253-3246

**TECHTRAN**  
INDUSTRIES, INC.

CIRCLE 186 ON READER CARD

# FREE

## The New Minicomputer Accessories 1977 CATALOG

40 pages loaded with hundreds of standard (but hard to find) products needed to support your minicomputer installation — Disk Cartridges, Mag Tape, Floppy Disks, Carrying Cases, Binders, I/O Connectors and Cables, Racks and a great deal more.

**IMPROVE ORGANIZATION AND EFFICIENCY** with ideas found on every page . . . money and time-saving products and ideas that help you beat the high cost of repetitive tasks and misplaced data.

**A FULL, NO-NONSENSE GUARANTEE** on all MCA products assures your satisfaction or we'll take it back. And every MCA product is field-proven before we offer it in our catalog. Only by providing products of the highest quality are we able to offer a no-strings guarantee.

**SAME DAY SHIPMENT** of many of our products gets them to you within 24 hours. Last year MCA met a New York customer's need for custom cables with delivery and installation by 7 a.m. the next morning.

Write or call for your free catalog (415) 969-5678. Please advise minicomputer make and model.

#### New 1977 Catalog

For the professional minicomputer user, a reference guide to accessories, supplies, connectors and cables.



Call (415) 969-5678 or write for MCA Catalog.

**MCA** MINICOMPUTER  
ACCESSORIES

1015 Corporation Way, P.O. Box 10056-M, Palo Alto, CA 94303

CIRCLE 128 ON READER CARD

**DATAMATION**

were most often scientists, programmers, and operators all at once. His claim was backed up by Mark Wells, also of LASL, who described how even Nobel Prize winner Enrico Fermi was a do-it-yourselfer where computing was involved, even doing his own key-to-paper tape input preparation for the MANIAC. Those who were at Los Alamos in the early days say it wasn't unusual to find one of the world's foremost scientists scrambling about on hands and knees on the floor near the MANIAC's Annelex printer, picking up output.

#### Intimacy lost

It isn't only the intimacy with the machines which has been lost, said Max Goldstein who now is with the Courant Institute in New York. There also was a greater intimacy between the programmer (then called a coder) and the problem being worked. The users, he said, knew the relations of their numbers. In this thought, he seconded the remarks of Roger Lazarus of LASL who said that early users did more initial analysis, estimating rather than calculating."

Other things have been lost. Voorhees noted that, "There was much pride in coding then. And now conventions, standards, regulations, and procedures have stifled that." Mark Wells added,

"It's a shame that FORTRAN was frozen and became a standard so early in the game," as now its widespread use means it cannot be changed and improved.

#### Not missed

Some things gone are not missed including the radio amplifier used on the MANIAC and other machines so that users could listen to the performance of their programs—and even "hear" mistakes in code.

"Remember though," author Dan McCracken interjected, that "all the *bad* things were invented in the '50s too. And we're making them (the mistakes) all over again with micros. We're finding there is an infinite supply of new users who don't know the cost of software development."

And, it seems the artifacts of dp history are being discarded. McCracken said the last working Vannevar Bush analyzer, a room-filling pre-computer, very likely will be sold to the scrap dealer who bid \$100 for the UCLA-owned "fossil"—because the university needs the space for vending machines.

Is there a way to rekindle interest in computer history? Herb Grosch, president of the Assn. for Computer Machinery (ACM) offered one. "Encourage computer companies like IBM to ask their own retired employees for their file material." Another suggestion was to have ACM trade life memberships for the files held by old-timers.

And there will continue to be the NCC Pioneer Day sessions.

—R.A.M.

**Perform a  
death-defying act.  
Eat less saturated fat.**

Give Heart Fund  
American Heart Association



**Hewlett-  
Packard  
9830 Users**

You can now dimension, sort and search any array that will fit in your memory.

With Infotek's Fast Basic III ROM the 256 row-column limit no longer exists!!!!

**Infotek Systems**

1400 N. BAXTER STREET • ANAHEIM, CALIF. 92806  
(714) 956-9300 • TWX 910-591-2711

**Plug In  
High Performance  
\$950<sup>00</sup>**

single quantity



Techtran 815 DATACASSETTE \*

**Now For The First Time Anywhere...  
A super low cost, plug compatible,  
DIGITAL CASSETTE RECORDER!**

Featuring:

- 145,000 character storage
- Terminal & Modem/CPU Interfaces
- Automatic send/receive

\*Now available in a battery-powered model.

Call or Write Today!

**TECHTRAN**  
INDUSTRIES, INC.

Techtran Industries, Inc.  
200 Commerce Drive Rochester, N.Y. 14623  
Phone (716) 334-9640 TWX 510-253-3246



## History

### Edward Kleinschmidt: Teletype Inventor

Edward E. Kleinschmidt, an inventor who was a founder of the Teletype Corp. of Chicago, died last month at the age of 101 in a convalescent home in Canaan, Conn.

Kleinschmidt, a German-born tinkerer who built his first workshop in the basement of his brother's drugstore in New York when he was 16, had 118 patents and invented or helped to devel-

op the high-speed stock ticker, an automatic fishing reel, and a railroad signaling device. His last invention was completed when he was 92. It was a miniature teletype for use in police cars so messages didn't have to be sent by radio.

He told an interviewer when he was 91: "I got the habit of working quite young, and I can't seem to drop it."

**"I got in the habit of working quite young, and can't seem to drop it."**

Kleinschmidt's miniature Teletype was developed in 1966 for the SCM Kleinschmidt Div. in Deerfield, Ill., nearly a decade after he went into "retirement" when SCM acquired his Kleinschmidt Laboratories, Inc., which he had formed in 1931. He had been president of Kleinschmidt Electric Co. in New York, which developed telegraph printers in competition with Morkrum Co. of Chicago. The two companies merged in 1924 to form Morkrum-Kleinschmidt where, as v.p. for development and patents, he gener-



# EPITAPE HOLDS THE RECORD FOR DATACOMM DIAGNOSTICS

EPITAPE holds the record — the record that greatly expands your ability to analyze data communications traffic.

EPITAPE is an effective datacomm analysis tool because it literally "duplicates the line." It captures full-duplex data dialog, in real time, at a switch selectable rate from 50 to 19,200 BPS. The data can be held for as long as you wish and then reconstructed — either at system speed or at a slower rate for detailed analysis. In either case, you have precise data, control status and regenerated clock to reconstruct events as they actually occurred on the communications line.

The unit is independent of modem clocks and line disci-

plines, including async, bisync, SDLC and any others. Full-duplex data, along with six RS-232 control signals can be captured and replayed. External and manual event markers simplify subsequent location and retrieval of specific transactions which may be vital to solving your problem.

EPITAPE'S portability simplifies its application in widely dispersed systems; it weighs just 26 pounds and fits into a compact 5" x 20" x 17 1/2" package.

Be a record holder — use EPITAPE to reconstruct the line transmissions in your data communications network. For details, contact Epicom, Inc., 592 North Douglas Ave., Altamonte Springs, Fl. 32701. Telephone 305/869-5000.



EPICOM, INC.

Created by Hall & McKenzie, Inc., Winter Park & St. Petersburg, Fl.



EDWARD E. KLEINSCHMIDT in picture taken in 1968 when he was 93. Kleinschmidt is shown with a multiplex printer model 3B (left) which was manufactured by what was then known as Kleinschmidt Electric Co. in 1914, and the teletype printer Model 22 made in 1919.

ally is credited with guiding to completion the now historic Morkrum-Kleinschmidt tape printer. The company later became the Teletype Corp., and in 1930 was bought out by AT&T in a stock deal estimated at \$31.5 million. He recalled recently that his cut from the deal was only about \$150,000. "I never seemed able to make money," Kleinschmidt said.

His Teletype machine, a communications breakthrough that linked the world, still is used by news wire services, which began installing them in 1914.

The inventor was born in Bremen, Germany, Sept. 9, 1875, and came to the United States at the age of 8. In addition to his wife, Kleinschmidt leaves a daughter, Mrs. Doris Knight of Cazenovia, N. Y., seven grandchildren, and six great-grandchildren.

---

## International

---

### U.K. Software Group Aims at U.S. Market

A strong new consortium of British service companies moved into the U.S. this month with an ambitious plan to acquire U.S. software firms, form joint ventures, and establish a U.S. sales force. It has \$52 million with which to operate during the next five years. And there may be more coming.

Called INSAC Data Services—but better known simply as INSAC since its establishment in February—its purpose is to match software skills in the U.K. with world demand. Its first target in the U.S., which, according to the consortium's architect, John Pearce, provides about half of a world computer services marketplace believed to be worth \$13 billion and growing at a rate of 19% a year.

Says Pearce of the U.K.'s software skills: "An American looking at his market 10 years ago noticed that it was a larger market with an abundance of venture capital. So he went into hardware. The Briton, on the other hand, looked at his market and noticed that it was small and lacking in venture capital. He went into software."

The result, said Pearce, is that there now are more than 500 software/service firms in Britain, probably as many as in the rest of Europe put together. But they are small firms. Only 5% do more than \$4 million.

#### Seek world markets

Their main problem—squashed as many of them are in a \$625 million U.K. market that no longer is large enough to contain them—lies between them and the world market. Many just do not have the resources to break out and tackle the attractive U.S., Middle East, and Japanese markets.

Pearce, who worked with IBM in New York in the 1960s and later in the early '70s when he formed the U.S. subsidiary for the British computer services concern, Hoskyns, which he cofounded with John Hoskyns, believes INSAC could be the catalyst to put U.K. supply in touch with world demand.

Fledgling U.S. operations are being run in New York by Seymour (Sy) Joffe, who will head INSAC Data Services's U.S. subsidiary. Joffe, a former Univac and Datran officer, will follow a three-point plan devised by Pearce: acquire market share; ship work back to the U.K.; ship product development back to the U.S.

#### Acquisitions provide a market

Pearce says the quickest way to gain market share is to acquire companies in the U.S. This gets you eyes and ears as well as a marketplace. It also has the added effect of giving you immediate credibility in the U.K. Once you get going, your acquisitions can be persuad-

ed to ship work back to INSAC member companies in the U.K.

He notes that this is the kind of thing the British computer manufacturer, ICL, is doing with its Singer and Cogar acquisitions. Some spin-off high level software developments for a new 1500 terminal, under development at the Utica, N.Y., manufacturing plant, have been providing jobs for ICL programmers in Bracknell, England.

Later, says Pearce, the consortium must develop product specs. He estimates that the first class of work that INSAC will undertake in the U.K. will be "one-off" (one of a kind) turnkey jobs, or specials. For example, one of the Wall Street banks or finance houses

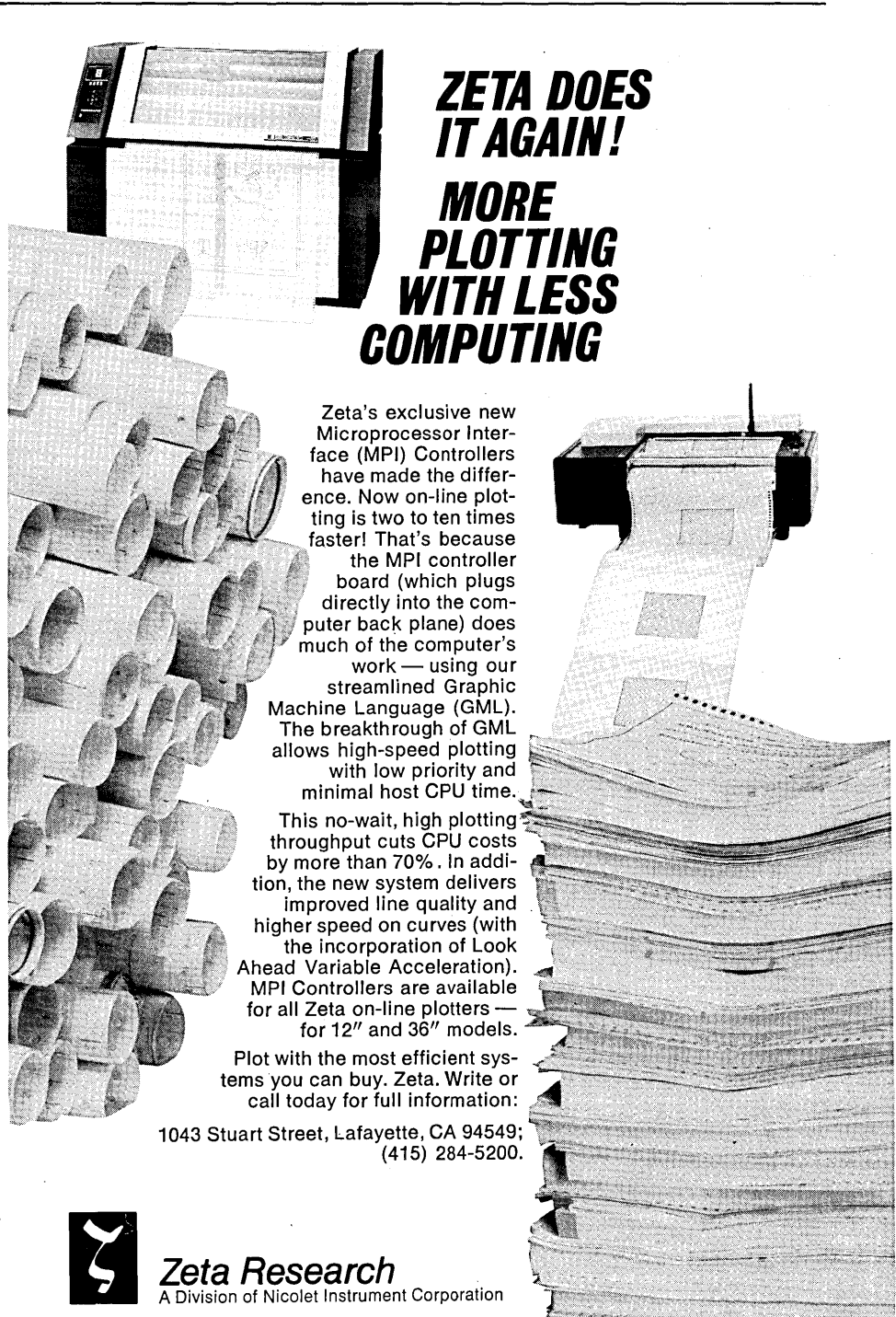

**ZETA DOES IT AGAIN!  
MORE PLOTTING WITH LESS COMPUTING**

Zeta's exclusive new Microprocessor Interface (MPI) Controllers have made the difference. Now on-line plotting is two to ten times faster! That's because the MPI controller board (which plugs directly into the computer back plane) does much of the computer's work — using our streamlined Graphic Machine Language (GML). The breakthrough of GML allows high-speed plotting with low priority and minimal host CPU time.

This no-wait, high plotting throughput cuts CPU costs by more than 70%. In addition, the new system delivers improved line quality and higher speed on curves (with the incorporation of Look Ahead Variable Acceleration). MPI Controllers are available for all Zeta on-line plotters — for 12" and 36" models.

Plot with the most efficient systems you can buy. Zeta. Write or call today for full information:

1043 Stuart Street, Lafayette, CA 94549;  
(415) 284-5200.



**Zeta Research**  
A Division of Nicolet Instrument Corporation

## news in perspective

may come to INSAC in the U.S. with a spec for a medium sized hardware/software system tailored to his needs. The specs then would be sent to the U.K. for programming.

The second class of work will be the development of packages. On occasion, Pearce said, INSAC will pay its U.K. members to develop packages it feels will fulfill a U.S. need even when there is no immediate user in sight. He said in such cases the product will be owned by INSAC, and its members will be given

the right to sell the product in the U.K., where INSAC will not operate, or elsewhere outside the U.S.

### Wide portfolio

"We intend to give our U.S. sales force a wide portfolio of software products to sell," says Pearce, exuding quiet confidence. "We have not assumed that all these products exist in Britain. That would be foolish. They must be built over time. But where good products do exist, whether in the hands of INSAC or

non-INSAC members in the U.K. or U.S. firms, we would hope to persuade their owners to sell them via INSAC."

Pearce says that ever since news of the new software/services "power block"—as he likes to call it—first leaked out before it was announced in February, he's been approached by "potential clients both in the U.S. and the Middle East." He says this is just a "taste" of what will happen from now on as persons recognize the nature of the U.K. software industry, where for every New York programmer earning \$22,000, there's an equivalent in London earning \$10,000. Pearce said a U.K. firm is bidding to write a compiler for a Washington customer at one-third the cost and in 66% of the time offered by U.S. bidders.

### National Enterprise Board

Pearce, who left Hoskyns in 1975 after it was sold to Martin Marietta, took his idea for INSAC to the U.K. National Enterprise Board in 1976, and in August that year joined the NEB's computers and electronics division to set up the consortium.

The NEB is a public corporation formed in 1975 to provide funds for industrial investment and to breathe new life into various sectors of U.K. industry. It has sunk \$52 million into INSAC to cover its first five years. Pearce sees his initial membership consisting of about 10 firms doing some \$70 million.

Membership is by invitation, and the NEB acquires a 26% interest in the firms. Some \$18 million of the \$52 million has been set aside to acquire the stock.

# Advance and be recognized.

You can do both at Data General.

Because here is where advancements are measured in months, not years. And recognition of a job well done is immediate.

We began less than 9 years ago with an idea. Since then we've redefined the computer industry with phenomenally successful systems like NOVA,<sup>®</sup> ECLIPSE<sup>®</sup> and microNOVA.

Today our sales exceed \$177 million annually. And we don't plan to slow down.

So if you're eager to move ahead, move to Data General.

Immediate opportunities exist for the following:

- Production Engineers (PCB)**
- Production Control Section Manager**
- Production Control Planners**
- Manufacturing Test Engineers (PCB)**
- QC Test Engineers (PCB)**
- New Product Planners**
- Manufacturing Engineers (Analog and Digital)**
- Manufacturing Engineers-New Products**
- Systems Test Supervisors**
- Material Control Supervisors**

To arrange for an interview appointment with one of our technical managers—in person or by telephone—mail your resume or a detailed letter outlining your education and experience to Tom Aldrich, Dept. D9, Data General Corporation, Route 9, Southboro, MA 01772. Data General is an equal opportunity employer M/F.

 **Data General**



**JOHN PEARCE**  
Putting U.K. software supply in touch with world demand

Pearce's plan was to get three or four firms by the end of this year, and to have boosted it to the 10 by the end of 1978. Nearly \$2 million already has been spent getting 30% of the shares of two leading firms, and another deal was being finalized in late August. The two are CAP U.K., one of Britain's top software houses, and Systime, one of the

leading houses specializing in turnkey applications. SPL International is another candidate. SPL and CAP do more than \$18 million in business between them. Other firms, such as Logica and Arbat that already are working successfully in New York, are likely to be approached.

—Ralph Emmett

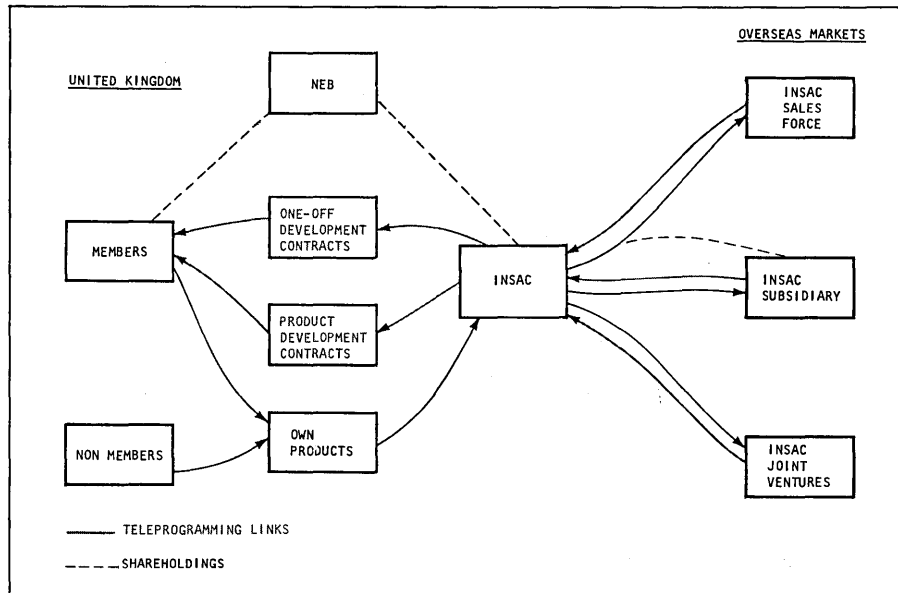

**HOW INSAC WORKS:** Britain's National Electronics Board would have an interest in U.K. software firms belonging to INSAC. These firms would get business from overseas INSAC sales force, joint ventures, and subsidiaries.



**"I CAN HELP CHANGE YOUR LIFE. BUT I CAN'T HELP CHANGE YOUR SPARK PLUGS!"**

If you want to find inner peace, come see me. But to fix a car, you must seek knowledge somewhere else.

The Consumer Information Catalog is put out by the Federal Government and lists over 200 consumer booklets that one can send away for. Most are free. And they can help you in many areas, from raising tomatoes to lowering your fuel costs.

So send for the free catalog. Write: Consumer Information Center, Dept. A, Pueblo, Colorado 81009. That way you won't have to climb a mountain to gain knowledge. You can merely go to your mailbox.

**THE CONSUMER INFORMATION CATALOG**

A catalog of over 200 helpful publications.

 General Services Administration • Consumer Information Center

### PDP-11 USERS

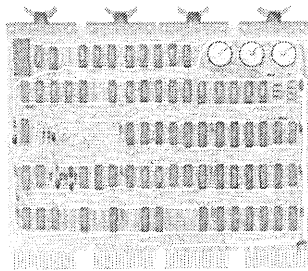

*put a calendar clock in your computer!*

The TCU-100 Timing Control Unit puts an end to the inconvenience and possibility for error when operators are required to enter the correct date and time.

*here are some of the TCU-100's main features!*

- A simple read instruction gives the user the date (month and day) and the time (hours and minutes) and seconds.
- The rechargeable battery-powered TCU-100 keeps on working even when the computer is off, for as long as three months.
- The TCU-100 makes it possible for you to keep track of system downtime, even during power failures.
- The unit can be set to interrupt at preset times, or at regular intervals as short as 1/2048 seconds.

### LSI-11 USERS

The TCU-50 incorporates all of the features of the TCU-100, without the interrupt capability. Resetting the date and time is performed by a simple software routine.

*price in quantities 1-9*

TCU-100 - \$495    TCU-50 - \$325



**DIGITAL PATHWAYS INC.**  
4151 MIDDLEFIELD ROAD  
PALO ALTO, CALIFORNIA 94306  
(415) 493-5544

for TCU-100 CIRCLE 192 ON READER CARD

for TCU-50 CIRCLE 158 ON READER CARD

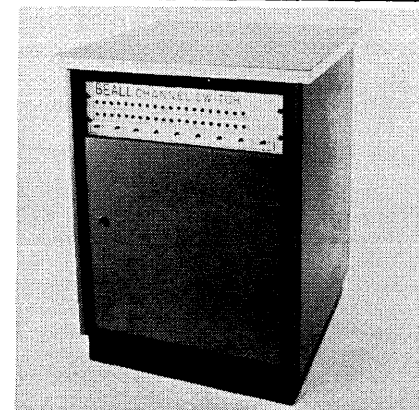

## BEALL CHANNEL SWITCH Model III

- Configurations available: 2 x 2, 2 x 4, 2 x 6, 2 x 8, dual 2 x 1, dual 2 x 2, dual 2 x 3, dual 2 x 4
- Special features (optional): Remote control capability External interrupt switching
- Reasonable prices
- Quick delivery
- Satisfaction guaranteed

**JOHN BEALL & COMPANY, INC.**

447 Gorge Road  
Cliffside Park, N.J. 07010  
(201) 945-1188

CIRCLE 151 ON READER CARD

## News in Perspective **BENCHMARKS . . .**

**A New Twist:** Greyhound Computer Corp.'s antitrust trial against IBM, cut off in 1972 in Phoenix when Judge Walter E. Craig issued a directed verdict in favor of IBM before the case could go to the jury, has been ordered retried by a U.S. Court of Appeals in San Francisco. While the court agreed with the judge that IBM hadn't breached a contract with Greyhound, it did agree there was sufficient evidence in the Greyhound case for a jury to determine if IBM had violated the Sherman Antitrust Act. "There was evidence from which the jury could reasonably infer that IBM possessed monopoly power in the leasing of general purpose commercial computers," the court ruled. A new trial is expected to be held in Phoenix. Meanwhile, California Computer Products, whose \$102 million antitrust suit against IBM earlier this year ended also in a directed verdict, filed its brief in late August asking for a new trial. Calcomp's trial lawyer, Maxwell M. Blecher, said the ruling "changes the whole perspective," and that Calcomp will get a new trial also. In late August, IBM said it was "confident that given the opportunity to present our case, we will prevail on the merits."

**Mohawk in Preliminary Talks:** Mohawk Data Sciences Corp., the data entry firm, said in early August it was discussing an acquisition or merger with unidentified major shareholders of Keuffel and Esser Co., which makes a broad line of instruments for the engineering profession and certain other specialized fields. Mohawk's chairman Ralph H. O'Brien said the talks were "informal" and another spokesman for Mohawk said he felt "various aspects of their business . . . may be complementary to Mohawk." Keuffel, headquartered in Morristown, N.J., had sales of \$82.8 million in 1976, and Mohawk, of Parsippany, N.J., had total revenues of \$146 million.

**Flexible Xerox:** After its Diablo Systems subsidiary ran into trouble making a flexible disc drive for its Ranger small business system, Xerox turned around and signed a letter of intent to acquire the king of the floppy market, Shugart Associates, the privately owned Sunnyvale, Calif., firm. Shugart, formed in 1973 by former IBM and Memorex engineers, headed by Al Shugart, last June shipped its 70,000th diskette drive, and is estimated to be turning out about 6,000 drives a month. Diablo's Series 10 diskette drive was withdrawn from marketing more than a year ago and the Xerox subsidiary is buying Shugart floppy drives for its small business sys-

tem, marketed by Shasta General Systems, Burlingame, as the Shasta 3200. The two companies said they expected a final agreement by mid-October and for the transaction to be completed by the end of the year.

**Microdata in Europe:** Microdata Corp., the Irvine, Calif., manufacturer of small business computers and peripheral equipment, said it will offer \$11 million in cash, debentures, and stock to acquire Computer Machinery Co., a group that operates in nine European companies. Microdata said it will sell its Reality and still-to-be-completed Express computer systems and its peripherals through the CMC companies, and also launch manufacturing operations in CMC's U.K. and French plants. The companies formerly were owned by Computer Machinery Corp., the data entry firm, which sold them before being acquired by Pertec Corp. Sycor Corp. of Ann Arbor, Mich., recently signed a distribution agreement with CMC for the companies to market its model 400 clustered intelligent terminal systems, along with an agreement of understanding to acquire part of the companies. But it later withdrew the acquisition agreement. Sycor officials said in early August that CMC's price was too high, but declined to disclose it. If the Microdata deal goes through, it will be a distributor for Sycor equipment—a situation that does not disturb Sycor's v.p. of marketing Paul LaVoie because Sycor has never competed against Microdata in the U.S.

**High Speed Printer:** Itel Corp., San Francisco, which has been selling IBM-compatible peripherals and cpu's, now will begin marketing a high speed non-impact laser printer subsystem that also is compatible with IBM's 3800 printer announced two years ago. Itel has entered into an agreement with the West German firm, Siemens A. G., to jointly develop the system in which Itel will use the ND-2 laser printer, a product made by Siemens. Itel said it will install the printer at its technical support center in Palo Alto for demonstrations and benchmarks by year end.

**He Guessed The Price:** Thomas W. Cook (right), an engineer with Mobil Oil Co. in Dallas, receives congratulations from Al Vaughn, a Hazeltine Corp. sales representative on his winning of a Hazeltine-sponsored "Guess the Price" contest at the June National Computer Conference. Cook's prize was a Hazeltine Modular One terminal. In late August he still hadn't received it, but a Hazeltine spokesman assured it "will be shipped momentarily." Cook said he'll probably run it for awhile at Mobil, then put it up for sale. In the contest, participants were asked to guess

correct oem and end user prices for two new terminals shown by Hazeltine at the NCC, the 1510 and the 1520. One or more correct guesses qualified an entry



THOMAS W. COOK  
"Those turkeys haven't sent me anything yet!"

for a drawing held in early August at Hazeltine headquarters. Fifty contestants qualified and Cook was the lucky winner, or so he was hoping in late August.

**For Self Assessment:** The Data Processing Management Assn. (DPMA) has formed a self-assessment project task group with William A. Paling, director, Information Services, Transco Companies, Inc., Houston, as chairman. The group will be part of DPMA's Education Foundation, founded in 1975 as an independent not-for-profit organization whose primary purpose is to expand educational opportunities for data processing professionals. The self-assessment project, DPMA said, "seeks to develop a program for the evaluation of management skills for managers in the data processing field." The organization said the project will be performed in two phases: a pilot to culminate in a sample test to be administered at DPMA's international conference and business exposition next month, and a development project to formulate and administer the broad scope of a self-assessment program.

**Word Processing:** There will be 792,000 automatic text editing typewriters installed in the U.S. by 1981, compared with the 327,500 that had been installed last year, and the 114,000 units at the end of 1973. Creative Strategies, Inc., a San Jose market research firm, said the most dynamic market segment will be in display-based word processing typewriters: 73,000 of them to be shipped by 1981, valued at \$234 million. The company's study, *The Word Processing Typewriter Industry*, also reports that IBM will remain the dominant force in the industry; a market shakeout is underway; rapid growth will peak in 1980 when saturation is reached in large businesses; and card storage will lose ground to tape and disc media. (The study is sold for \$595 by the company, 4340 Stevens Creek Blvd., San Jose, Calif. 95129.) \*

# We'll cut your shipping costs in half.

## Ship during the day.

To get our "Daylight Savings" rate, just load up one of our big lower deck containers. Then, get your shipment to us between 4 a.m. and 4 p.m.—our least busy time. We'll reward you with our big discount.

## Ship 3,000 lbs. for the cost of 1,500 lbs.

You can save 50% or more on high-density shipments because we figure the rates point-to-point, per container. The more weight you load in each container, the less you pay per hundredweight.

## Get more widebody lift to more destinations.

United has the largest widebody fleet (55 jets) and the largest schedule. For you it means more lift, more reliability to 110 cities.

## Example: United's "Daylight Savings" rates from New York City.

Weight of LD-3 contents (lbs.)	1500	2100	2700	3000	(Max.) 3160	
Density (lbs. per cubic foot)	10	14	18	20	21	
New York City to:	flat charge*	Cost per 100 pounds				
Chicago	\$152	\$10.13	\$ 7.24	\$ 5.63	\$ 5.07	\$ 4.81
San Francisco	\$443	29.53	21.10	16.41	14.77	14.02
Los Angeles	\$424	28.27	20.19	15.70	14.13	13.42

Ask us about our door-to-door service and rates.

\*Based on airport-to-airport Time of Tender "Daylight Savings" rates. These rates were effective October 23, 1976, and are subject to change.



See why United's No. 1 in the cargo sky.

**UNITED AIRLINES CARGO**



# LOOK AHEAD

(Continued from p. 16)

It's understood the company has had the device for some time, and that it has been shown to prospects. But it's delayed announcement pending market studies that may confirm the company's feeling that the BCM's, which are expandable in 32KB units to 8MB, can see many other uses besides as fixed disc replacements. Shipments, it's understood, will begin in the first quarter of '78.

## GETTING THE LAST BUG OUT

The audience laughed at a personal computing session at the recent NCC when speaker Bruce Venetta of IMSAI, which sells personal computers, said, "I don't know if the general user is aware of it, but it costs money to get the last bug out of a piece of hardware and there are a couple of interesting ways you can get (it done)--you can ship it at some point in the design cycle." Then, he added, the money starts flowing in and you have hundreds of technicians out there working on your board. "You go through your morning mail and do your engineering that way." Venetta said all the companies in the personal computer market have done this, although the five or six largest don't do it anymore.

The principals of CCW Data Systems, Oakland, Calif., had they been there, probably wouldn't have joined in the laughter. CCW last March filed suit against IMSAI and Kentucky Fried Computers, a Berkeley computer store. They charged breach of warranty and fraud, arising from Kentucky Fried Computers selling CCW an IMSAI floppy disc drive that was "not capable of performing the mass storage and retrieval functions it was intended for." It asks for damages from both and \$5,000 in punitive damages from IMSAI for fraud. The suit states that the plaintiffs were justified in believing IMSAI's claims due to the company's "superior knowledge" and "because plaintiff had previously purchased some products made by IMS Associates, Inc. (IMSAI's former name), which were not defective in design or manufacture." The various causes for action took place during 1976. CCW said it suspects the case may not go to trial for at least a year.

## DISTRIBUTION MANAGEMENT SYSTEM FOR SERIES/1

A distribution management system built around the IBM Series/1 mini-computer and incorporating a DMS operating system may be announced soon by Distribution Management Systems, Inc., Bedford, Mass. The company, which specializes in systems for controlling distribution functions, is headed by Pete Peterson who left the presidency of SofTech last fall to take over the company when it was known as Codon, a distributed processing pioneer. The tall, thin, energetic ex-crewman brought in new financial, marketing, and technical management, and then hit the sales trail.

First new product, we hear, is a random locator system for warehouse inventory control, to be followed by a distribution management system that can incorporate any of the newer DEC machines (Condon's system was built around the PDP-8). Then the Series/1 product. Peterson feels there's no viable IBM distribution management system in his price/performance range, and happily plans to fill the vacuum for that sizable crowd of people who hanker for IBM gear.

## RUMORS AND RAW RANDOM DATA

IBM is quarreling with the British Post Office over who will maintain the 3750 PABX on the telephone network -- IBM wants to maintain its own system, but the BPO insists on handling the task. The two already have clashed openly, notably at the London Transport, and the quarrel is scaring away other buyers.

# Turning a profit in turnkey systems:

If your business is selling turnkey computer systems, using the right computer can be the key to making more sales—profitably.

You need a computer that's easy to use—and adaptable to many uses so you can get more customers. And you want a computer that's priced to sell, at a margin that's profitable.

You want a computer that can really protect your proprietary software—keep it safe, and saleable, sale after sale. And you need a better way of supporting your software than having to visit sites.

You need a computer with proven reliability, so there'll be fewer service problems. And you want a fast, dependable service network when there are.

## Needs and wants met here

For all this, the one computer you want is the one we make:

The BTI 4000 Interactive Timesharing System.

It's a ready-to-go system with 10 megabytes of storage, magnetic tape drive, and 8 ports—just add terminals. And it's easily expandable—add disk storage to 400 megabytes, increase user capacity to 32 ports, add peripherals like industry-compatible magnetic tape and a line printer.

The BTI 4000 is designed, manufactured and supported by Basic Timesharing Inc. We're the manufacturer with timeshare experience. Which has helped us produce a computer uniquely right for multi-user applications.

## A dedicated performer

The BTI 4000 has been proven in all kinds of applica-

tions—general accounting, dealer inventory control, entertainment ticketing, text publishing, school administration, and more.

What's more, the BTI 4000 is proving its reliability at locations in 39 states, in 5 provinces of Canada, and in Europe, too.

## Things you'll like

The BTI 4000 uses BASIC-X, an unusually powerful extension of BASIC. With the features you need to get your software up—quickly, efficiently. So you

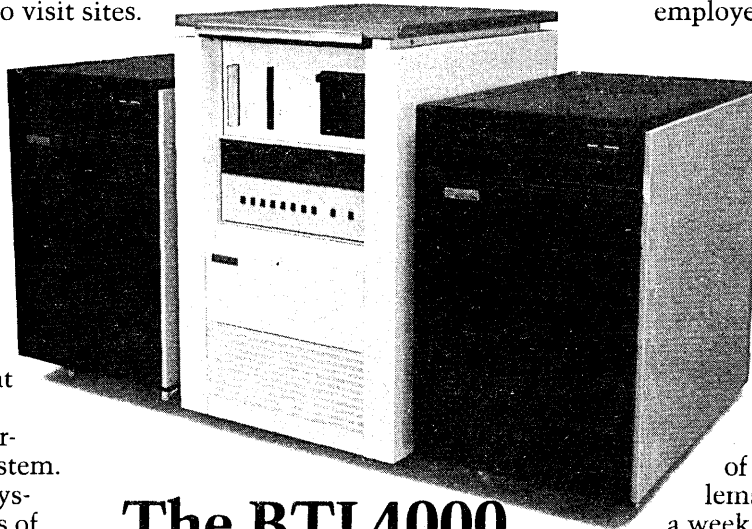

## The BTI 4000 Means Business.

can start selling sooner.

Especially important to you, the BTI 4000 protects your proprietary software. So you can count on selling it again, and again. Without losing control of it. And with the convenience of dialup access, so you can support it without the cost of site visits.

## Things your customers will like

The BTI 4000 is a true timesharing system. It allows doing any mix of tasks, all at the same time, from any number of locations.

Your customers will enjoy faster response, because the BTI 4000 implements many of your application program operations in firmware.

The system also offers continuous availability, because software backups, updates, and other housekeeping activities can be performed locally, remotely or programmatically, with users on the system.

And the BTI 4000 is so easy to manage, your customer won't have to add a specially-trained employee just to run it.

## Service—good and fast

In the packaged systems business, service can have a real impact on your success.

That's why service is such an important part of our business.

The BTI 4000 is designed for over-the-phone, on-line diagnosis of actual and potential problems. 24 hours a day, 7 days a week, we're ready to help. If a BTI 4000 ever needs on-site service, we have a network of field specialists to provide just that.

## Priced to please

A single BTI 4000 costs \$35,950. There are attractive quantity discounts—like \$28,760 each for a quantity of 10.

For that price you get all the features and support benefits mentioned above, not a scaled-down version.

You can get complete information at your BTI regional office, listed below.

The BTI 4000. It could be your key to turning more profit in your turnkey installations.

# An Editing Pet That

The perfect editing terminal for transaction processing must be more than a little bit smart. It has to be wise like our OWL-1200. With features that assure high accuracy source data entry, fast data editing, simplified host computer programming, and reduced host computer loading.

Our OWL gives you all the human engineering features you get with our FOX-1100, plus a lot more. And the price is right. Just \$1496 in quantities of 25.

Check the comparison chart of editing terminals to see all the reasons why the OWL-1200 is simply "incomparable."

## USER REQUIREMENT FEATURES

High Operator Data Entry Accuracy	Protected fields Low-intensity fields Numeric only fields Inverse video fields Blink fields Line drawing capability
Simple, Fast Editing of Data	Insert/delete character Insert/delete line
Minimized Loading on Host Computer	Host programmable send keys: send all data, send only unprotected data, send only data modified by operator, send only a "request to send" header.
Simplified Programming	Ability of host CPU to read device status
	Ability of host CPU to read device mode key settings and communication option straps
	Program override on mode key settings
Simplified Program Debugging	Transparent mode permits all characters to be displayed
Cost Effectiveness	OEM price in quantities of 25*

PERKIN-ELMER	HAZEL-TINE	LEAR SIEGLER		ADDS
OWL-1200	MOD. 1 EDITING	ADM-1A	ADM-2	980
Yes	Yes	Yes	Yes	Yes
Yes	Yes	Partial	Partial	Partial
Yes	Yes	No	No	No
Yes	Yes	No	No	No
Yes	Yes	No	Yes	Yes
Yes	No	No	No	Yes
Yes	Yes	Partial <sup>1</sup>	Yes	Yes
Yes	Yes	Partial <sup>1</sup>	Yes	Yes
Yes	No	No	No	No
Yes	No	No	No	No
Yes	No	No	No	No
Yes	No	No	Yes	No
Yes	No	No	No	No
\$1496	\$1670	<del>\$1795</del> * \$1595	<del>\$2395</del> * \$2095	\$1995

\*When unit includes editing capabilities, 24 x 80 display, numeric pad, and upper/lower case characters.

<sup>1</sup>No Key. Requires Two Key Code.

\* Just announced price changes

## PERKIN-ELMER | TERMINALS DATA SYSTEMS | DIVISION

Randolph Park West, Route 10 & Emery Avenue  
Randolph, N.J. 07801 (201) 366-5550 TWX: 710-987-7913

Domestic, call:

(617) 890-0557 Boston, MA  
(312) 437-3547 Chicago, IL  
(214) 234-8880 Dallas, TX  
(714) 544-9093 Los Angeles, CA  
(201) 229-4040 Oceanport, NJ  
(408) 249-5540 San Francisco, CA

Overseas, call:

887-1000 New South Wales, Australia  
416-677-8990 Mississauga, Ontario, Canada  
539-2260 Paris, France  
753-34511 Slough, Berkshire, UK  
089-753081 Germany  
2200949 Singapore  
031/450/160 Frolunda, Sweden

**A  
T**

**'s Wise as an Owl**



**OWLS  
AVAILABLE FOR  
LIVERY NOW!**

Please send me more  
information on the OWL 1200.  
Attach your business card here.

CIRCLE 198 ON READER CARD

# Nobody turns COM data into sound business decisions the way 3M can.

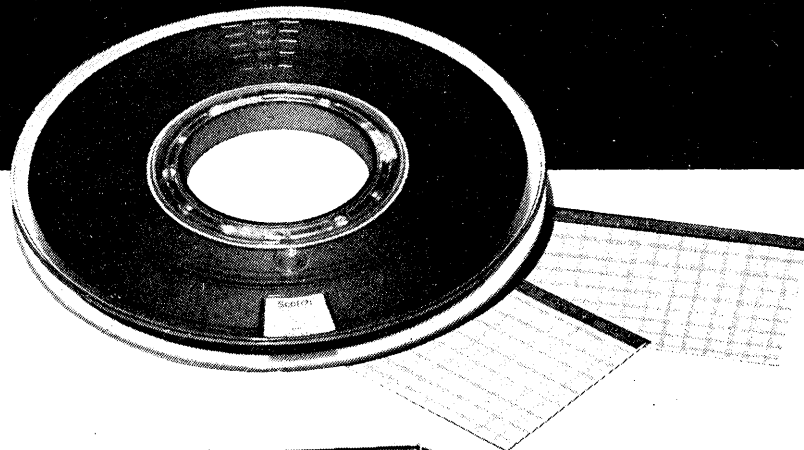

Only 3M Beta System offers programmable COM with the big plus of business graphics—to make your COM output more useful to your company's decision makers!

With 3M Beta COM, you make data easier to interpret, decisions easier to make in either of two ways:

**Highlight the data.** The 3M Beta System gives you underlines, italics, bold face, 8 different character sizes through simple operator-entered instructions. No host computer modification needed!

**Graph the data.** Reduce complicated numbers to easy-to-scan pie charts, graphs, tables. The 3M Beta System includes the software needed for graphic presentation of data.

But making business decisions

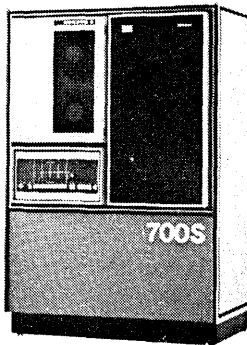

## BETA Systems

easier is only the first step. Beta System makes your job easier, too. From software innovations to installation and operator training programs to field and home base service nobody offers you the unique total system support approach 3M can.

So whether you're interested in business graphics or want to move up to programmable COM, move COM in-house or expand your operation, let 3M show you the way. Call your local 3M Business Products Center or write Microfilm Products Division, 3M Company, St. Paul, MN 55101.

For entry-level COM, let 3M show you "LBR"—the only **totally dry COM** and the most convenient way to record computer data on 105mm microfiche.

## Better microfilm systems start here...

# 3M COMPANY

# The Dangers of Egalitarianism

by Aaron J. Brenner

---

Is the computer undermining management? Can we avoid disaster?  
Who was Vic Prynne?

---

*We are indeed fortunate that this seminal speech has been brought to our attention by Dr. Arthur M. Lesk so that we may publish it here. In addition to sitting through after-dinner speeches, Dr. Lesk is now with the MRC Laboratories of Molecular Biology in Cambridge, England.*

It is a great pleasure to have the opportunity to address you tonight on a subject that has claimed my professional interest for almost three years—an interest that is just beginning to bear fruit. I am deeply honored by this award, of course, and can only hope that I can continue to be worthy of it. As Vic himself was fond of saying: "It is not the title that does honor to the man, but the man who does honor to the title."

My subject tonight is "The Dangers of Egalitarianism." My object is to alert those of you who have not yet recognized it to the threat which modern computer technology poses to all that we managers and advisors to managers hold dear; and to describe, in a humble way, some of the weapons that we are developing in defense of our own profession.

I am sure there is consensus in this room that egalitarianism—treating everyone alike—is anathema to modern American industry. As Vic used to say: "It takes motivation to wind up tight the rubber band of productivity."

Where exactly lies the threat? Here: compare the world of two programmers—one a novice, the second a se-

nior member of the staff. Suppose that each of them submits a FORTRAN program containing a statement with three left parentheses and two right parentheses, and compare the response of a typical compiler to each: the first slide (Fig. 1) shows the response to the novice:

```
IGI 0131 SYNTAX ERROR: UN-  
MATCHED PARENTHESES
```

Fig. 1

The next slide (Fig. 2) shows the response to the senior member of the staff:

```
IGI 1031 SYNTAX ERROR: UN-  
MATCHED PARENTHESES
```

Fig. 2

These are, as you will have noticed, the same.

The same!

This, gentlemen, is our problem. If everyone is treated the same, how can anyone be motivated to better himself?

Now you will perhaps say that there are already ample distinctions, that the ordinary perquisites of rank—higher salary, larger offices, private secretary—are sufficient. But this comment fails for two reasons. First of all, I can bring you a sheaf of statistics that *prove* that giving people raises costs money. Second, and nearly as important, the standard perquisites of rank do absolutely nothing to defend against

the creeping egalitarianism of the monitor system itself.

You will say that you could give senior people higher priority on the system—a larger time slice—or allot to them more storage space on the disc. All these things are certainly being tried. And I do not say that they should not be tried. But they are in the province of the technicians, and irrelevant to yours and mine. A man's ego is not stroked by giving him an extra cylinder or two. As long as we must employ human labor, we must reward it in the coin of the human realm. (Of course I speak metaphorically.)

Well, this is the problem I faced: how can we modify current practice in managing data processors, at minimal cost, to improve productivity. Tonight I shall report to you on three of our lines of attack.

To illustrate each of these ideas, let us consider three basic "types": the novice trainee, the junior-level career staff man, and the senior executive. Our first project involved the shocking uniformity of discourse by monitor systems, of which I gave you an example earlier. (See Figs. 1 and 2).

*There is no reason why messages from the monitor system need to be the same for all classes of user.*

Our staff is going through the Message and Code book line by line to create appropriate versions of each message for each user class. Let me cite examples. Consider again the case of the FORTRAN program containing a statement bearing an unmatched pa-



## DANGERS

renthesis. There are three versions of the diagnostic message. For the lowest rank:

"Sorry sonny, your program finished out of the money. This time, mismatched parentheses." As you see, no sense of respect is communicated.

For an intermediate rank:

"This program contains serious errors: viz., mismatched parentheses. Correct and resubmit." A sincere, but unflattering, statement of fact.

But for the executive we propose the following, appropriate to his position:

"Sir, the compiler is unable to decide precisely what you had in mind in line

begs for additional data. Please supply!"

Our second project deals with the type fonts appearing on different employees' terminals. Currently, the physical appearance of the actual letters is the same for all; but with modern graphics terminals this need not continue. We have designed a character set for the lowest rank of programmer that resembles the handwriting of a second grade child who has just learned to print. The intermediate level man will read a perfectly serviceable, standard, sans serif text; but senior personnel will receive their output at terminal displayed by elegant fonts described by lengthy stroke and arc tables.

The third suggestion, perhaps the

most far-reaching of all, was developed jointly with a firm of architects in connection with planning a large corporate research center. The specific problem was that it was impossible to provide everyone with a window. But there is a growing body of evidence that factors in the working environment—including light and monotony—have important psychological and physiological effects on productivity.

Our resolution of this dilemma makes use of the new technologies of computer graphics. Each office will be equipped with one wall containing a 3 x 5-foot display screen connected to a computer capable of generating and animating three-dimensional, full color, lifelike images. Each employee will believe he is looking out a window at the world outside.

Now, this was as far as the technical people had gotten when the plans reached our hands. We sensed immediately, of course, that the architects had missed a golden opportunity. They had suggested the creation of software to display ordinary street scenes: people walking their dogs, women pushing baby carriages, etc.—an electronic Norman Rockwell—to create a sense of satisfaction for everyone. Again, you notice, the theme of egalitarianism. And a particularly intolerable example of it, too.

My suggestion will come as no surprise to anyone in this room: *we have designed a software package with the option of displaying many different socioeconomic environments.*

In terms of our three types, the novice will look out—and up—at an alley. Prominent garbage cans, fire escapes, sleeping winos, a fire hydrant—intermittent dogs. For the intermediate rank: here the street scene as originally suggested, or perhaps a country road. Nothing unpleasant, but definitely nothing that anyone would go out of his way to visit. But for the executive: a view of formal gardens, à la Versailles.

From this, the next step was to real-

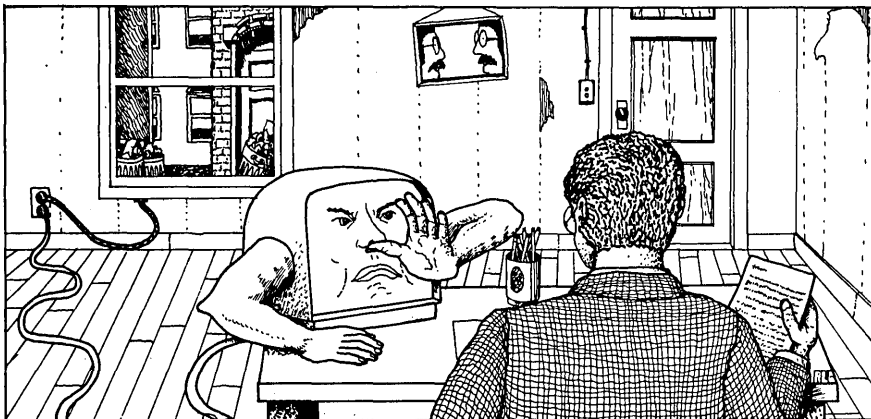

"Again you had to go and ruin it . . ."

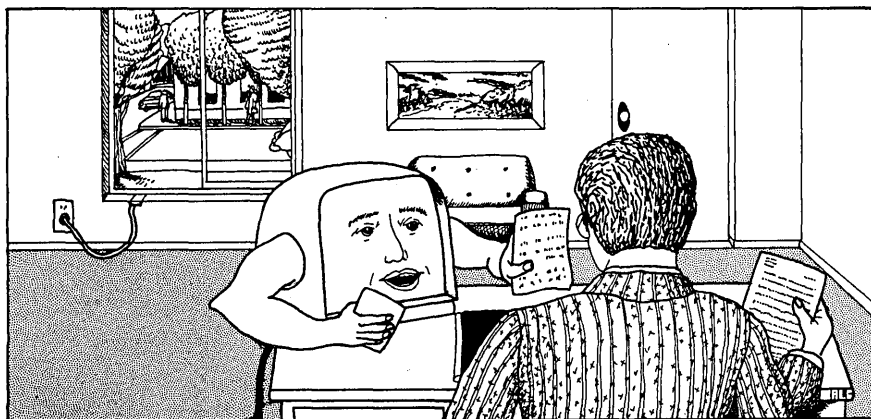

"Program encountered EOF on unit . . ."

14. There does seem to be an imbalance in the number of right and left parentheses. Would you kindly enlighten us?"

Now suppose, on the other hand, that a program attempting to read data encounters an end-of-file. Our suggested messages:

For the novice:

"Again you had to go and ruin it. We ran off the end of input unit: . . . (unit number)"

For the intermediate rank:

"Program encountered EOF on unit. . ."

And for the executive:

"Sir, a project as ambitious as yours

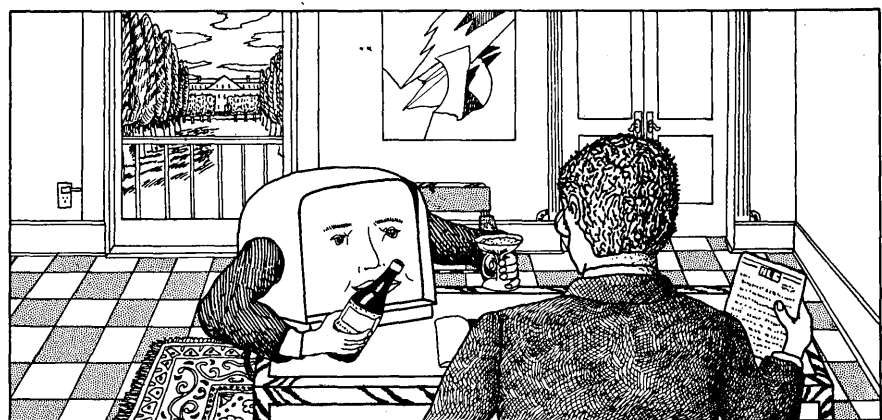

"Sir, a project as ambitious as yours . . ."

# On-Line Job Status Throughout Your Entire Data Center.

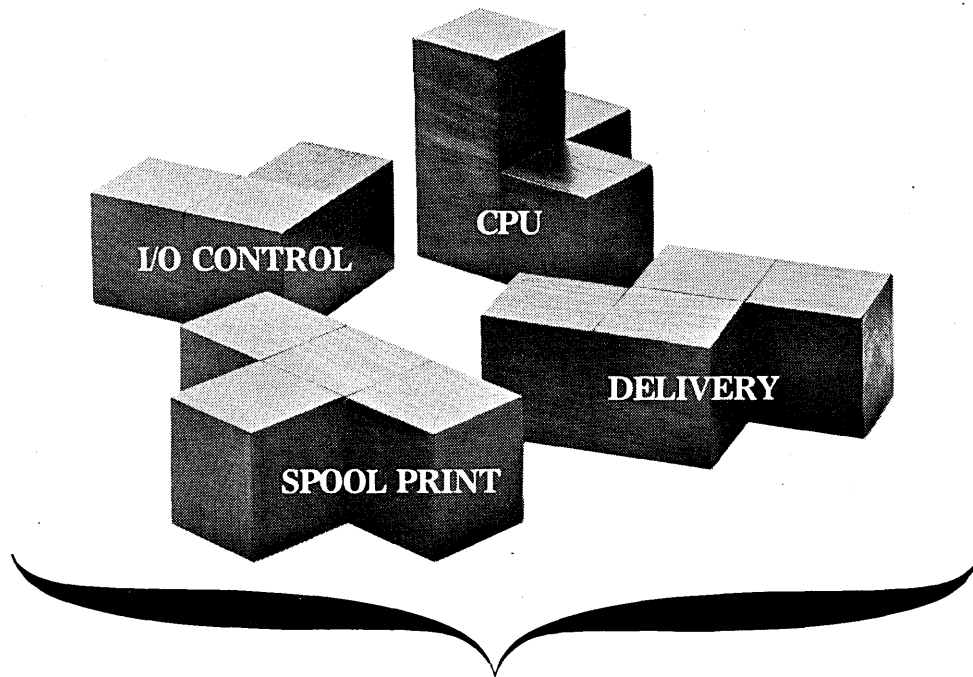

## INQUIRY

- Job Status
- Abended Jobs
- Entire Network Status
- Overall Production Status

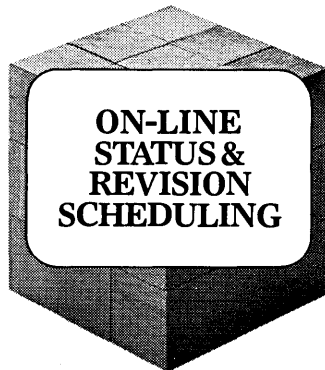

## PROMPTING

- Job Starting Late
- Predecessor Job Abended
- Job on CPU started before I/O work completed
- Production schedule behind One Hour-Revision Required

**The Industry's First On-Line Data Center  
Scheduling & Status System From  
The Computer Operations Company.**

# Value Computing Inc.

Please send me more information about  
ON-LINE SCHEDULING & PRODUCTION CONTROL

NAME \_\_\_\_\_  
 COMPANY \_\_\_\_\_  
 TITLE \_\_\_\_\_  
 PHONE \_\_\_\_\_  
 ADDRESS \_\_\_\_\_

CITY \_\_\_\_\_  
 STATE \_\_\_\_\_  
 ZIP \_\_\_\_\_  
 CPU \_\_\_\_\_  
 OPERATING SYSTEM \_\_\_\_\_

Mail to: VALUE COMPUTING INC.  
 300 VCI Building, W. Marlton Pike  
 Cherry Hill, New Jersey 08002  
 Or phone 800-257-8242

VCI-5103

# DELTA IS READY WHEN YOU ARE.<sup>®</sup>

**WITH DELTA AIR FREIGHT THAT OFFERS YOU MORE PRIME TIME FLIGHTS TO MORE PRIME MARKETS.** Delta covers 90 prime markets throughout the Western Hemisphere. Few shipments are too large, none are too small. Pick-up, delivery available.

**WITH DELTA AIR EXPRESS THAT GUARANTEES SHIPMENT ON THE FLIGHT YOU CHOOSE.** Airport-to-airport or door-to-door. Local pickup, delivery available. Shipments accepted up to 90 minutes before flight departure time.

**WITH 3D™ AIR FREIGHT (DELTA DENSITY DISCOUNT)™ THAT GIVES YOU 40% OFF REGULAR FREIGHT RATES.** Shipments with a density of 25 lbs. or more per cubic foot get 40% discount. Applies to non-containerized shipments of 250 lbs. or more.

**WITH DASH (DELTA AIRLINES SPECIAL HANDLING) THAT GETS YOUR SMALL PACKAGE THERE IN A BIG HURRY.** Up to 90 inches, width + length + height is acceptable, at airport ticket counters up to 30 minutes before flight time, 60 minutes freight terminals.

Ship prepaid or collect, cash or approved credit. COD, RFC, Signature Service, advanced charges and excess valuation on request. DASH shipments prepaid.



CIRCLE 157 ON READER CARD

## DANGERS

ize that this design allows us to push the Hawthorne effect—that productivity increases in response to *any* change in working conditions (for better or for worse)—to its limit. Our current recommendation is that employees who have earned it be rewarded during the summer with a trip to "The Resort." That is, for a week the ordinary display sequences in their offices would be replaced by a view of a lake or a beach—without the employee's having to leave so much as his desk. These employees would be encouraged to change into suitable clothing upon arrival at work.

Pilot tests of this idea show that not only does productivity of an employee so treated increase to an unusual and unanticipated extent during this time period, but personnel will even tolerate uncomfortably hot ambient temperatures, leading to savings on air conditioning bills. An extension to the winter is under development; here we may confidently anticipate savings on heating bills.

Our current estimate is that this design will recoup its extra initial costs many times over in a very short time.

In conclusion, let us recall the original problem: how can we divert the dangerous tendency towards egali-

tarianism inherent in modern technology. I like to think that Vic Prynne would have been pleased by the fact that not only have we met the enemy and made him ours, but that we have licked him with the weapons raided from his own arsenal. I thank you. \*



Aaron J. Brenner is a native of New York City. In 1966, he left his position as personnel development manager at the Katz Pajama Company of Brookfield, Conn., to form his own management consulting firm, specializing in data processing. He was the recipient this year of an honorary D.H.B.A. degree from Chelm Univ.

The token of his present award, a lapel pin, is inscribed on the reverse: "1977 Victor I. Prynne award for creative Achievement in human-software management: Aaron J. Brenner."

### Computer/Semi-Conductor Specialists

## Explore and advance the latest in computer/electronics technology... at Bendix Research Laboratories

Three positions at our Corporate R & D facility in suburban Southfield, Michigan are ideal for creative professionals seeking both recognition and career growth on the scientific and/or managerial ladder. All candidates must have a strong academic record and proven accomplishment in their speciality. Openings are in the following areas:

#### Operating Systems

Will be key technical contributor to our Software Technology Laboratory—with major emphasis on task scheduling and communication for control systems using microprocessors. Requirements include participation in the implementation of at least one operating system for mini/micro or large-scale machines... and experience in systems architecture, computer communication/networks, data base management, and software engineering. MS or PhD in Computer Science or EE desired.

#### Microelectronics

Requires broad LSI experience within the semi-conductor industry—including exposure to MOS/bipolar process technologies, LSI circuit design, and advanced

manufacturing and test techniques. Ideal candidate will have management talent and the ability to interface effectively with top engineering and manufacturing personnel. PhD in EE desired.

#### Computer Graphics

Requires at least 10 years experience in three-dimensional computer graphics research as well as background in managing business aspects of research projects. Must also have in-depth knowledge of picture processing algorithms—including clipping techniques, hidden-line surface algorithms, and related dynamic perspective picture processing methods—as well as hardware implementation experience. Advanced degree desired.

All positions offer fully commensurate salary and excellent benefits. Send resume, indicating position of interest and salary progress, to: K.M. Sachs, Bendix Research Laboratories, Bendix Center, Southfield, Michigan 48076.



An equal opportunity employer, m/f

CIRCLE 197 ON READER CARD

# WANG'S PCS-II

## THE END OF THE LINE FOR INTELLIGENT TERMINALS.

Wang's PCS-II. The small business computer that makes intelligent terminals obsolete. And introduces a whole new world of Distributed Data Processing.

Endowed with commercial BASIC and exclusive Wang minidiskette storage, the PCS-II delivers direct access data processing capabilities no ordinary terminal can. And with Wang's programmerless "EASYFORM" forms building and data-entry language, the PCS-II is a hands-on winner in any data-entry or forms-processing environment.

Wang modularity lets you expand memory, communications or peripherals as your needs grow. Or new technologies as they develop. Directly at the operator site.

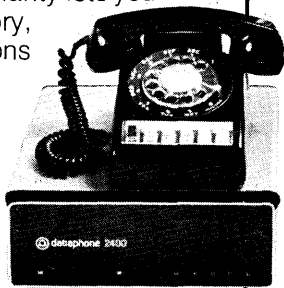

The PCS-II even gives you a price tag no intelligent terminal can match—just \$6,200. With 50K memory, dual minidiskette drives and bisynchronous 2780/3780 communications it's still only \$9,200.



Hungry for more intelligence? Call your local Wang office or mail this coupon to PCS-II Product Sales, Dept. DDP, Wang Laboratories, Inc., One Industrial Ave., Lowell, Massachusetts 01851.

I'm hungry. Send me information on Wang's PCS-II.

Name \_\_\_\_\_

Title \_\_\_\_\_ Phone \_\_\_\_\_

Company \_\_\_\_\_

Address \_\_\_\_\_

City \_\_\_\_\_ State \_\_\_\_\_ Zip \_\_\_\_\_

DP72/D97

# hardware

## Off-line

A message processing center developed by the Air Force System Command's Electronic Systems Div. was used for the first time during a joint services operational effectiveness demonstration at Shaw Air Force Base, S.C. Part of a joint service program called TACS/TADS (Tactical Air Control Systems/Tactical Air Defense Systems Interface), the equipment allows five tactical data systems used by the Air Force, Army, Navy, and Marine Corps to "talk" directly to each other. "By tying these systems together with a message processing center, surveillance information can be immediately exchanged among the military services," explains Patrick M. Shanley, TACS/TADS project engineer. This means that a display console operator at any site has access to aircraft tracks maintained within any other system's tactical data base. Hughes Aircraft is under contract to build the message processing centers. System Development Corp. performed system testing, and the MITRE Corp. provided system engineering support.

Training for the first of three Multi-Access Airline Agent Reservation System (MAARS) pilot projects has begun at the New York City world headquarters of the American Society of Travel Agents, Inc. (ASTA). The pilot project is "the initial step in creating an unbiased computerized reservations system that will maintain freedom of choice both for the travel agent and for the traveler," according to Ray N. Smith, ASTA v.p. Inco-term/Videcom supplies the computer equipment.

Electronic Memories and Magnetics announced that Digital Equipment Corp. recently filed a patent infringement suit in an attempt to block sales of EM&M's SECS-11/1 minicomputer. EM&M maintains that although the SECS-11/1 can emulate PDP-11/34 and 11/35 minis, its hardware is the product of independent original design work and differs radically from the DEC machine. EM&M further states that its customers will be protected under its patent indemnity clause.

## 370 Emulator

Taking advantage of the similarities between Interdata's 7/32 processor and the IBM 370, this vendor has implemented in firmware the additional functions that will let the processor execute the 370's BAL instruction set. Additional firmware for the scientific and commercial instruction sets is anticipated.

Installation of the 370 firmware does not preclude executing Interdata object code. A bit in the program status word tells the processor which instruction set is in use. Interdata's operating system is used to control the system. Since the 370's privileged instructions haven't been coded, IBM operating systems aren't available on the Duo 70.

For existing 7/32 installations, the firmware for Duo 70 sells for \$15,000. The vendor will also sell the 7/32 and firmware as a package. Maintenance is available through Interdata. THE KARDIOS SYSTEMS CORP., Randallstown, Md.

FOR DATA CIRCLE 458 ON READER CARD

## Intelligent Terminal

The 8080 microprocessor-based 8035 Intelligent Terminal System comprises a crt terminal, IBM 3740-compatible dual flexible disc subsystem, operating system software, and an RS232C interface. The first in this vendor's Designer Series, the 8035 is totally user-programmable; all functions of the system are under software control. The terminal can support from 20K to 64K of RAM for storing operating software. FDOS, the operating system, includes an editor, assembler, and debugger. FDOS also includes file management routines to handle file creation, deletion, and modification. The diskette subsystem can store half a megabyte of data and programs. A 120 cps printer optionally may be connected to the 8035. Transmission rates range up to 9600 bps. Single unit prices start at \$7,200, depending on configuration. Delivery is quoted at 60 days. OMRON ELECTRONICS, INC., Information Products Div., Sunnyvale, Calif.

FOR DATA CIRCLE 460 ON READER CARD

## Micro Development System

Combining a special assembler and a memory emulation module, this Z80-based development system can help users prepare applications for many different microprocessors, including

the 8080, 6800, and 6502. The user can load the assembler's symbol table with the information appropriate to his target microprocessor and generate code into the emulator memory space where it can be executed by the target processor. Multibyte instructions, such as those used with the Z80, are supported. A buffered connector plugs into the target micro's 2708 EPROM socket; any target machine that runs off standard 2708s can be programmed and debugged using breakpoints. Up to 4KB of 2708 control store can be emulated.

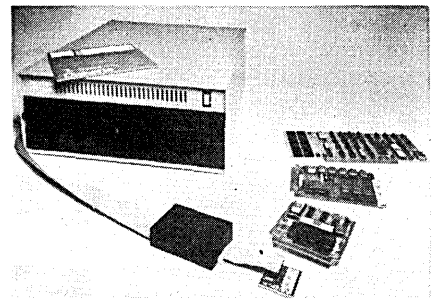

An advantage of the system especially attractive to users developing systems for several different micros is that only one editor, one operating system, one assembler, and one set of utilities need be learned. The development/emulator system, including Z80 cpu, 32KB of RAM, 4KB of emulator RAM, and dual single-density diskette drive, sells for \$5,995. Deliveries take 30 to 60 days. Digital Systems will handle manufacturing and marketing for the product's developers. M & E ASSOCIATES, Cupertino, Calif.

FOR DATA CIRCLE 450 ON READER CARD

## Portable Crt

Small enough to fit under an airplane seat, the P-1881 contains a seven inch crt, ASCII keyboard with upper and lower case, editing features, and a 8,000 character buffer memory. The buffer memory can retain data for as long as 24 hours after removing line power. The P-1881 sells for \$3,995; deliveries take 10 to 12 weeks. TELE-RAM COMMUNICATIONS CORP., Mamaroneck, N.Y.

FOR DATA CIRCLE 461 ON READER CARD

## Series/1 System

Packaging hardware and software, this vendor offers a Series/1 turnkey system. The basic Series/1 offered consists of a 64KB processor, 9.3 MB fixed disc, 512K diskette, 120 cps printer, and a crt with a 1,920-character screen for input and inquiry.

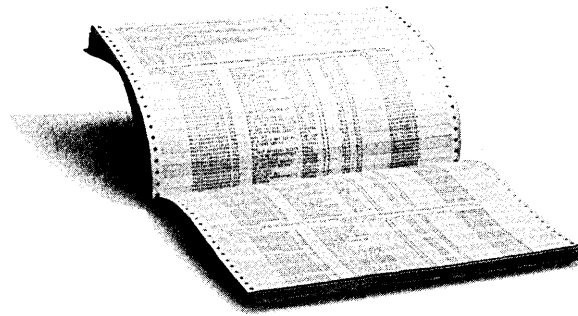

# The word's out... the picture's in.

## Graphics give you complete project control.

Words can't express what graphs can do for total project planning, scheduling, monitoring, and most importantly, control.

Unlike stacks of unwieldy tabular reports, graphs give you the total picture at a glance.

And if they're made by an EZPERT® system, they can be revised and updated in a wink.

## EZPERT gives you complete graphics.

No matter what kind of scheduling program you're running, EZPERT helps your computer equipment draw every kind of project control graph or chart you need.

Automatically!

And with each project update, EZPERT quickly updates the individual graphs.

Automatically!

You save time. And you keep tight rein on the budget and schedule.

As with the computer itself, you may wonder how you got along without EZPERT before.

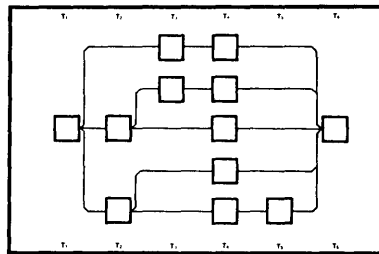

Time Scale Networks

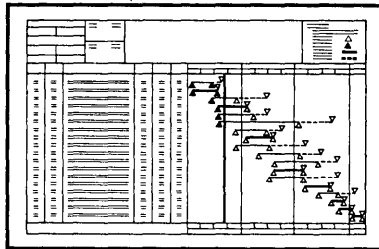

Gantt Barcharts

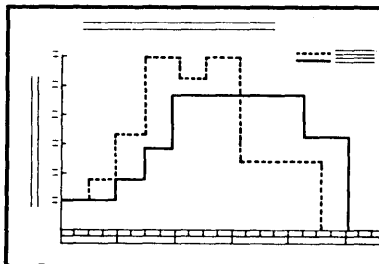

Cost & Manpower Graphs

## You're closer to having an EZPERT system than you think.

If you're already using a computer and plotter, you're 95 percent there.

What you get for a relatively small additional investment is a lot of additional capability.

EZPERT puts your computer equipment to work drawing invaluable project graphics.

## You're already doing virtually all the work, too.

The same computer output that's used to print your tabular reports is also used to plot EZPERT graphics.

So, when you enter data for one, you're actually entering data for both.

It's almost like getting something free.

## The rest is E•Z.

It's easy to join the rapidly growing list of EZPERT users, which includes many leading manufacturing companies, government agencies and engineering/construction contractors.

Just contact us, and we'll send the additional information you need right away.



**SYSTONETICS, INC.**

600 NORTH EUCLID STREET • ANAHEIM, CALIFORNIA 92801 • (714) 778-1600



# hardware

The initial library of applications programs will duplicate some of the vendor's turnkey products based on DEC hardware. An enhanced operating system running COBOL programs will complement the packaged application programs. Generalized applications include: order processing, billing, inventory control, accounts receivable, accounts payable, payroll, and general ledger. Specialized packages will be offered for accountants, fuel oil dealers, food distributors, and others. A basic Series/1 computer with applications programs for accounting systems and on-premises training start at \$41,000 or \$870/month lease. Software also will be offered for purchase separately. Maintenance of the Series/1 is provided directly by IBM through its nearest local service office. COMPUTATA SYSTEMS, INC., Westport, Conn.

FOR DATA CIRCLE 459 ON READER CARD

## Off-Line Printing

The DOC-TPS tape-to-print system uses up to four of this vendor's high-speed line printers to provide print speeds ranging from 1,250 lpm to 9,000 lpm on a single system. The system operates with one to four industry-compatible tape drives connected to a single central controller. Compatible with tapes prepared on IBM, Burroughs, and Honeywell mainframes, the system has top of forms restart and forms and line counting for job accounting records. Deliveries are said to take between 30 and 45 days. Twelve different configurations are available with lease rates ranging from about \$2,600 to \$9,573 per month. DOCUMENTATION INC., Melbourne, Fla.

FOR DATA CIRCLE 457 ON READER CARD

## Instrument Interface

Users of the popular PDP-11 can interface to IEEE Standard 488-1975 General Purpose Interface Bus-compatible devices using this vendor's GPIB11-1 interface. The GPIB11-1 (a single quad-height card) plugs into a small peripheral controller (SPC) slot, allowing as many as 14 GPIB-compatible instruments to be connected to the PDP-11's UNIBUS. Utility and driver programs are furnished as macro source files which may be assembled as FORTRAN, BASIC, or macro-callable subroutines. A single GPIB11-1, including a two-meter cable with a standard bus connector, sells for \$1,495. Quantity discounts are offered. NATIONAL INSTRUMENTS, Austin, Texas.

FOR DATA CIRCLE 455 ON READER CARD

## Terminal

The QT-P55 uses a Qume daisywheel print mechanism to produce "letter quality" output at 55 cps. Transmission rates include 600 bps and 1200 bps to take full advantage of the 55 cps print speed. The keyboard-printer model QT-P55 sells for \$4,450; a re-



ceive-only model, the QT-R55 sells for \$4,200. Options include a roll-around stand (\$180), and floppy disc systems for off-line editing and buffering high-speed communications. A single floppy editing unit adds \$3,560 to the terminal's price; a dual diskette intelligent

drive, including BASIC language programming capability adds \$6,940 to the terminal's price. Other options include IBM code conversion and a crt display. Delivery takes two to four weeks. QUALTERM TERMINALS, Mountain View, Calif.

FOR DATA CIRCLE 447 ON READER CARD

## Computers

The System 88 consists of three separate series of computer systems, all based on Interdata's 7/32 32-bit processor. The main differences between the Series 1, Series 2, and Series 3 are the disc, communications, and printer subsystems.

The System 88 Series 1 consists of a cpu with 131,072 bytes of main memory, 20MB of on-line disc storage (two drives), two crt terminals, and a 300 lpm printer. Series 1 sells for \$58,900.

Series 2 has 196,608 bytes of main memory, 134 MB of disc storage on two drives, two 9-track tape drives,

## product spotlight



## Color Plotting

A 15,625-color plotting system? That's the number of different shades users can get using this three-color ink-spitting color plotter system. Just as a color television produces its wide range of colors by combining the three primary colors—red, yellow, and blue—this plotter uses three ink supplies to generate colors.

The color plotting system operates off-line, and is capable of generating a full-color 22 x 34-inch image on paper, overhead transparency film, or other media. A full-sized plot takes at least 8½ minutes. The resolution is five points per millimeter (127 points per inch) produced by constant sized spots from each of the three ink jets.

Input tapes to the plotting system

are generated with a set of FORTRAN-callable subroutines for making maps and charts as well as handling direct input from raster-scan devices. Written in ANSI FORTRAN IV, the software is designed to run on most mini and mainframe computers. There are two levels to the software system: Basic Software and Application Software. Basic Software handles fundamental graphics, such as plotting points, lines, circles, polygons, text, and backgrounds. Application Software handles charting, mapping, and three-dimensional projections.

First deliveries of the color plotting system are slated for next month. The system, including plotter and tape unit, sells for \$45,000. APPLICON INC., Burlington, Mass.

FOR DATA CIRCLE 442 ON READER CARD

# Unlock the secrets of MVS.

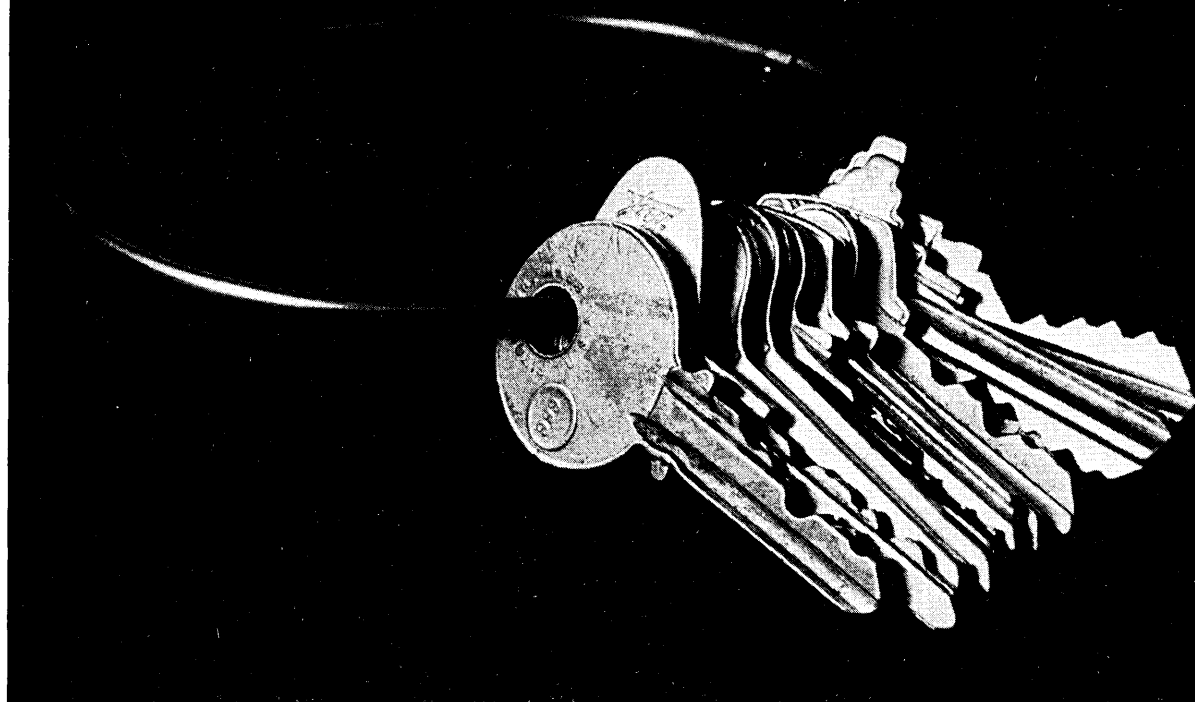

Every day, day-in, day-out, your MVS operating system is doing things you know nothing about and have no control over.

MVS is making decisions and taking actions without asking you for advice or assistance. It locks its secrets away and never lets you see them.

Resolve is the *only* product that helps you unlock MVS's secrets. It lets you see what's going on so you can make corrections before problems cause sluggish performance and lost productivity.

It helps you allocate resources to critical work areas to improve operational efficiency.

Resolve gives you the means to solve problems unique to your installation. It automatically provides early warnings when problems are developing so you can solve them before they become critical.

In addition, Resolve offers you complete password protection of your services as well as tracking and logging capabilities.

If you're tired of your MVS operational system not letting you know what's going on so you can correct problems before they start, find out more about Resolve for MVS.

It's your key to a better MVS

operating system.

Call or write us today.

**In California: 408/735-9550**  
**Outside California dial toll free: 800/538-1872**

In Europe contact: CGS Products, 366 Sir Winston Churchillaan, Rijswijk (ZH), The Netherlands, Tel. 070-94.93.25, telex 33646.



**Boole &  
Babbage**

Operations Division  
Boole & Babbage Inc.  
850 Stewart Drive  
Sunnyvale, California 94086

Member SIA  Software Industry Association



**INTERNATIONAL TELECOMMUNICATION EXPOSITION**

ATLANTA, GEORGIA, USA  
9-15 OCTOBER 1977

# Everyone's Going To Georgia, U.S.A.

**USERS**

- Applications Sessions such as:
- Defense Communications
- Electronic Copy Processing Systems
- Publishing
- Banking
- Transportation
- Retailing
- Reports of Worldwide User Groups
- Domestic and International Policies
- Mini University Course: International Telecommunications Management
- Mini University Course: How To Get The Most Out Of Your Telecommunications Dollars
- Exhibits and Demonstrations

**DATA COMMUNICATIONS**

- Technical Sessions such as
- Public Data Networks
- International Packet Switched Networks
- International Services, Tariffs & Policies
- Digital & Hybrid Transmission Systems
- Digital Video Systems
- Application Sessions
- Marketing Sessions
- Mini University Course: Computer Network Tutorial
- Mini University Course: Communications Terminals
- Mini University Course: Distributed Processing
- Exhibits and Demonstrations

**MANUFACTURERS/SALES**

- Marketing Opportunities For Telecommunications
- International Standards
- Telecommunications Needs in Developing Countries
- Financial Seminar
- Mini University Course: How To Market Telecommunications Products
- Mini University Course: The Businessman's Saudi Arabia
- Exhibits and Demonstrations

**GOVERNMENT OFFICIALS**

- Financial Seminar
- Technical Sessions such as:
- Economics & Social Considerations
- Domestic Land International Policies
- Informations Society
- International Services, Tariffs Regulatory and Policy
- Impact of Rewrite of Communications Act of 1934 on International Telecommunications
- Future Telecommunications Social Impact
- Mini University Course: Telecommunications Planning In The Developing Countries
- Exhibits and Demonstrations

**TELEPHONE ENGINEERING AND MANAGEMENT**

- Technical Sessions such as
- System Development Policies & Patterns
- Local Telephone Network Sessions
- International Services, Tariffs & Policy
- Impact of Rewrite of Communications Act of 1934
- Mini University Course: Transition From Analog to Digital Switching for Developing Countries
- Mini University Course: Teletraffic Engineering
- Exhibits & Demonstrations
- Financial Seminar

**FINANCIAL EXPERTS**

- Financial Seminar
- Telecommunications Marketing Sessions
- Telecommunications Business in Middle East
- Telecommunications in Developing Countries
- Domestic and International Telecommunications Policies
- Plenary Session
- Mini University Course: How To Market Telecommunications Products
- Mini University Course: Telecommunications Planning In Developing Countries

**PLANNERS**

- Telecommunications Economics
- Problems & Opportunities For Doing Business In The Developing Countries
- Financial Seminars
- Mini University Course: Telecommunications Planning In The Developing Countries
- Exhibits and Demonstrations
- Marketing Sessions

**CONSULTANTS**

- Financial Seminar
- Technical Sessions
- Broadband & Narrowband Services
- Economics of Telecommunications
- Mobile Communications
- International Telecommunications
- Exhibits and Demonstrations

**TELECOMMUNICATIONS PUBLISHERS & WRITERS**

- Financial Seminar
- Technical Sessions such as:
- Telecommunications Writers Forum I & II
- Future Telecommunications Social Impact
- Electronic Copy Processing Systems For Newspaper & Wire Services
- Publishing by Facsimile
- Exhibits and Demonstrations

**AGENTS/DISTRIBUTORS**

- Marketing Opportunities for Telecommunications
- Financial Seminars
- Satellite Communications
- Data Communications
- Telephone Networks
- Exhibits and Demonstrations

**POLICY MAKERS**

- Domestic and International Telecommunications
- Economics of Telecommunications
- Telecommunication Needs In Developing Countries
- Social Impact of Telecommunications
- Mini University Course: Telecommunications Planning In Developing Countries
- Exhibits and Demonstrations

**EDUCATORS**

- Social Impact of Telecommunications
- Applications Sessions
- Engineering & Training For Local Distribution Networks
- Future Development And Plans For Teleconferencing
- Mini University Courses
- Exhibits and Demonstrations

**BROADCASTING**

- Financial Seminar
- Broadcast Systems Applications
- Technical Program
- Broadband & Narrow Services
- Mini University Course: Teleconferencing
- Exhibits and Demonstrations

Everyone that's interested in Telecommunications is headed for Georgia October 9th to 15th. Why are they going to Georgia? To attend the first International Telecommunications Exposition to be held in the United States. INTELCOM 77 will be held October 9th to 15th and will include Technical Programs, Financial Seminars, Applications, "Mini Telecommunications University" Courses and 250 of the world's largest exhibitors that will show the most up-to-date equipment in the world today. . . along with live demonstrations to show you how it works. All segments of the Telecommunications Industry worldwide will be there. You'll hear Experts Analyze Today's and Tomorrow's Trends in Computers and Telecommunications technology, and you'll See What's Available today and What's Coming Tomorrow . . . all in one short week in Atlanta, Georgia, October 9th to 15th.

Simply run your eye down the column pertinent to your telecommunications function. If at least two areas of Intelcom 77 apply to your work, attendance at Intelcom 77 will more than pay for itself in short order.

If you've checked off more than two boxes, then send the coupon below for complete information on INTELCOM 77. . . or call our Toll Free number 1-800-225-9977.

Horizon House International  
610 Washington St., Dedham, Mass. 02026

Yes, I'm interested in going to Atlanta, Georgia October 9th - 15th. Please Send me all the details.

Name \_\_\_\_\_ Title \_\_\_\_\_

Company \_\_\_\_\_ Tel. No. \_\_\_\_\_

Address \_\_\_\_\_ City \_\_\_\_\_

State/Country \_\_\_\_\_ Zip \_\_\_\_\_

## hardware

four crt's, and a 600 lpm printer, with a price of \$110,000.

The \$192,600 Series 3 has 262,144 bytes of main memory, two disc drives providing 512MB of on-line storage, two 800/1600 bpi selectable tape drives, eight crt's, and a 1,000 lpm printer.

Planned for growth, System 88 is intended to expand as the user's requirements grow. The vendor says it is committed to the concept of modular expansion of the original system rather than replacing it with a larger model. System 88 is aimed at the low to medium 360/370 market, as well as the System/3 Model 15 market. Firmware to emulate the 370 instruction set is available, as is the TOTAL data base management system. The vendor also offers application software support. COMPUTER SYSTEMS AND SERVICES, INC., Springfield, Ohio. FOR DATA CIRCLE 449 ON READER CARD

### Auto-Load Diskette Drive

The Automatic Floppy Disc Unit is billed as an enhancement to this vendor's line of systems products. Beside its on-line uses, the unit is expected to appeal to the media conversion market. IBM 3740-compatible, the unit consists of an automatic loader, dual floppy disc units, and a power supply. Holding a maximum of 20 dis-

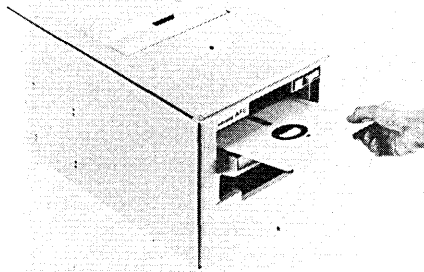

ettes, the unit performs its automatic loading cycle in roughly 5½ seconds. In a conversion application, data from various diskette recording stations can be pooled on the unit and converted to mag tape for processing by a mainframe. Pricing starts at \$4,560. OLIVETTI CORP. OF AMERICA, New York, N.Y.

FOR DATA CIRCLE 448 ON READER CARD

### Printer/Plotter

The EX-810 is a graphics plotter that can print 8,192 dots per second with as many as 512 dots per row. Functioning as an 80-column alphanumeric printer, it can print at 160 cps. A TTL-compatible controller takes care of all timing functions needed to drive the printhead and advance the paper. The EX-810 prints on five-inch wide elec-

# BUYING SOFTWARE?

## GO TO THE **DATAMATION** MARKETPLACE PAGE 238

## MAGNETICALLY SHIELDED TAPE DATA PRESERVERS

Protect your magnetic tapes from degradation and physical damage. Designed for storage, shipment and hand carrying. A wide choice of models and capacities available for standard reels, discs, disk packs, flexible disks and standard cassettes. Immediate shipment from stock.



### MAGNETIC SHIELD DIV.



PERFECTION MICA CO.  
740 North Thomas Drive  
Bensenville, Ill. 60106, USA  
Phone 312 / 766-7800  
TWX 910-256-4815

SEND FOR NEW  
TP-5 CATALOG

CIRCLE 178 ON READER CARD

# APL

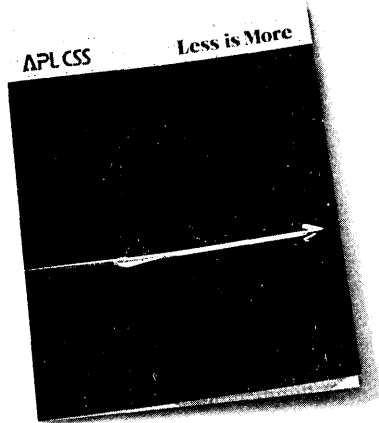

## From the National CSS 10 million dollar language library.

The simplicity of APL/CSS makes it the ideal language for both the non-DP professional and the DP expert.

APL/CSS gives you all the latest APL developments, but goes even further with features like:

A sophisticated report-formatter that allows you to easily structure your output in any form you want.

And a workspace you can adjust up to 8 megabytes according to your needs.

APL/CSS is only one of the many languages we have developed through an investment of over 10 million dollars and 250,000 man-hours.

For your free brochure on APL/CSS, just fill out the coupon and drop it in the mail. We'll also send you our complete library list.

.....  
 Name \_\_\_\_\_  
 Title \_\_\_\_\_  
 Company \_\_\_\_\_  
 Address \_\_\_\_\_  
 City \_\_\_\_\_ State \_\_\_\_\_ Zip \_\_\_\_\_  
 Telephone \_\_\_\_\_

## National CSS

542 Westport Avenue, Norwalk, Connecticut 06851(203) 853-7200.

CIRCLE 196 ON READER CARD

## hardware

tro-sensitive paper. Single unit price is \$795, with oem discounts available.

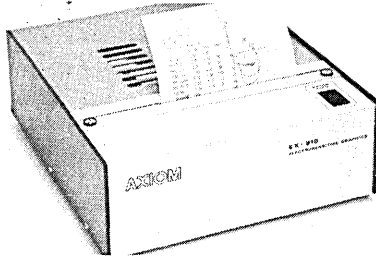

Delivery is 30 days. AXIOM CORP., Glendale, Calif.  
 FOR DATA CIRCLE 453 ON READER CARD

### Terminal Interface

The QuadrAsync/c gives PDP-11 users four asynchronous 20ma current loop communications channels, but presents only one load on the processor's UNIBUS. Each channel is said to be equivalent to the channel provided by DEC's DL-11c. The QuadrAsync/c comprises one quad board and four DEC-compatible Berg Connectors. Both full and half-duplex operation is supported. There are seven independently selectable transmission rates per channel, ranging from 110 bps to 9600 bps; each channel's transmitter and receiver operate at the same rate. A single QuadrAsync/c sells for \$1,600; quantity discounts are offered. Delivery takes 30 days. ABLE COMPUTER TECHNOLOGY, Santa Ana, Calif.  
 FOR DATA CIRCLE 452 ON READER CARD

### Synchronous Modem

The 2400 LSI is a 2400/1200 bps synchronous modem designed for operation over two or four-wire dedicated or dial networks. Conforming to CCITT Type A or B four-phase modulating techniques, the 2400 LSI is compatible with Bell System 201B or C data sets, most other phase shift keying modems and Bell's 801 Automatic Calling Unit. The modem has an equalizer that is strappable in either the transmit or receive sections. Strap options can select transmitter output levels, carrier detect level, internal or external clock, carrier detector response time, RTS/CTS delays, and equalization. When operating over the DDD network, automatic answer circuits allow unattended call answering when connected via a Type CBS or CBT data coupler. Integral local digital and analog loopback circuitry reduces the time required to localize system malfunctions. A built-in test pattern generator and receiver pattern detector assist in both on- and off-line testing and trouble-shooting. In single quantities, a dedicated-line version of the

## Now - a

# DATA COMMUNICATIONS TEST SYSTEM YOU CAN GROW WITH

## INTERSHAKE II<sup>®</sup> INTERVIEW<sup>™</sup> (CRT)

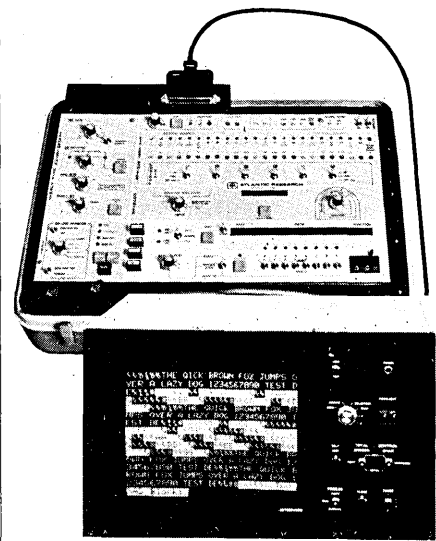

Designed for today and tomorrow

Monitoring — Simulation — Data Acquisition

The most powerful portable or rack-mounted data communications test system available today—Intershake II/Interview will monitor full duplex transmission at speeds up to 256 Kbps, display all or selected transmissions, trap and record protocol or messages, make timing measurements and record status of all EIA/V.24 leads at any time in the test. Powerful new jump and branch instructions permit on-line test subroutines for fully defining anomalies.

As a simulator, Intershake II will duplicate any modem, front end, terminal—even a cluster of terminals. And with a program of 1024 steps with nonvolatile memory, Intershake is ready to go when you are.

Most importantly, Intershake II/Interview will run tests, measure results and retransmit the results to your printer or CRT. Used as a full-time performance evaluation system, Intershake II/Interview will pay for itself by identifying and eliminating excessive turn-around times, downtimes, extra sync and pad characters and system degradation (excessive NAK's) before the system washes.

Intershake II/Interview—another quality product from



ATLANTIC RESEARCH CORPORATION  
 5390 CHEROKEE AVENUE • ALEXANDRIA, VIRGINIA 22314 703 354 3400

CIRCLE 148 ON READER CARD

DATAMATION

2400 LSI sells for \$789. PENRIL CORP., Rockville, Md.  
FOR DATA CIRCLE 441 ON READER CARD

#### Terminal

Consisting of a single-line, 32-character gas discharge display and a 53-key tty-style keyboard, the Transactor I Data Terminal can connect to most computers via an RS232 or 20 ma current loop interface. Switches let the user select operating modes including 110 bps to 9600 bps data rates, full or half duplex, even/odd/no parity, and one or two stop bits. The Transactor comes in an aluminum case measuring 6 x 15 x 11-inches. A stylized molded case also is available.

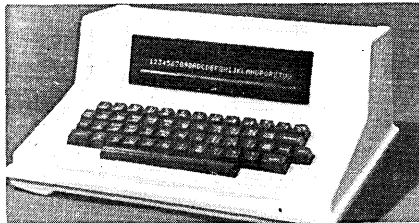

The standard Transactor I sells for \$595 in quantities of 100, the single unit price is \$750. Deliveries take 60 to 90 days. COMPUTERWISE, INC., Grandview, Mo.  
FOR DATA CIRCLE 462 ON READER CARD

#### Fiber Optic Data Set

Users seeking to exploit the advantages of fiber optics — resistance to interference, overload safety, elimination of ground loops, signal emission security, and so on—can use the model FD-10K data set. The unit interfaces RS 232C or CCITT-compatible devices to the fiber optic communications link. Using plastic fibers from DuPont, the

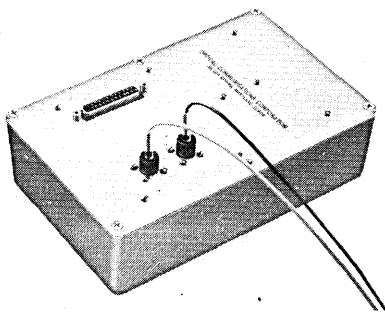

data link may be 150 feet long; 1,200 foot links are possible when using toughened silica fibers. The maximum data rate is 9600 bps for the standard unit, with optional speeds of up to 50K bps. A pair of FD-10Ks sells for \$675 in quantities of 250 pairs. Optical fibers are priced separately. OPTICAL COMMUNICATIONS CORP., Silver Spring, Md.  
FOR DATA CIRCLE 440 ON READER CARD

#### Communications tester

The Model 80 CCITT v.35 Interface Breakout Panel is a battery-powered, hand-held instrument designed to

# SELLING SOFTWARE?

## GO TO THE DATAMATION MARKETPLACE

PAGE 238

# ROYTRON™

Readers, Punches and Combination Reader/Punches are offered in over 20 standard configurations.

Paper Tape/Edge Punch Card Punch (50-60 cps)

Paper Tape/Edge Punch Card Readers (50 cps)

Combination Paper Tape Reader/Punch Reader (50/150/250 cps) Punch (60 cps)

All made in U.S.A.  
Parts Availability, Interface Documentation, Servicing Documentation, In-Plant Service, High Reliability and Cost/Performance assured.

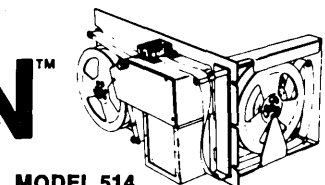

**MODEL 514**  
**RACK MOUNTED**  
12" x 19" x 10 1/2"

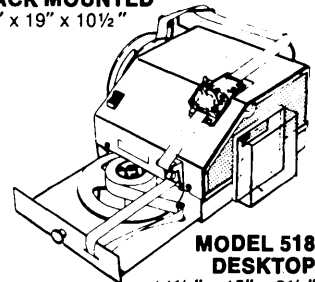

**MODEL 518**  
**DESKTOP**  
14 1/2" x 15" x 9 1/2"

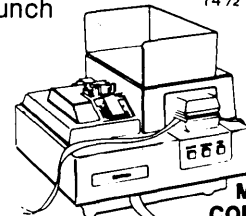

**MODEL 1560**  
**COMBINATION**  
**READER/PUNCH**  
16" x 16" x 10 1/2"



for full details, write or call

**SWEDA INTERNATIONAL**  
Litton OEM Products

34 Maple Avenue, Pine Brook, N.J. 07058/(201) 575-8100

IN U.K. — ADLER BUS. SYSTEMS/OEM PRODS., Airport House, Purley Way, Croyden, Surrey, England

IN FRANCE — SWEDA INTERNATIONAL/OEM, 103-107 Rue de Tocqueville, 75017 Paris, France

CIRCLE 180 ON READER CARD



# datamax 6

the first **UNIVERSAL DATA COMMUNICATION PROCESSOR**

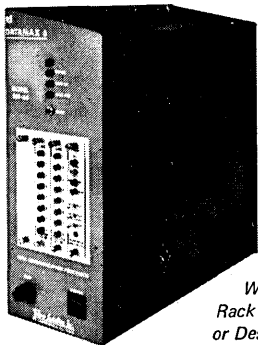

Wall,  
Rack Mount  
or Desk Top

### APPLICATIONS

- TDM
- CODE CONVERTER
- TELEX SWITCH
- 32K BUFFER MEMORY
- SELECTIVE CALLING
- POLLING
- SPEED CONVERTER
- TECH CONTROL
- MUX
- CONCENTRATOR
- ALARM SYSTEM
- INTELLIGENT TERMINAL

### BOARD COMPLIMENT

- CPU WITH PORTS
- 1200 / 1800 / 2400 MODEM
- 4, 8, 16 K MEMORY CARDS
- 2, 8, 64 PORT BOARDS
- 2 CHANNEL FDM
- TTY UTILITY WITH EPROM PROGRAMMER
- 6800 SYSTEM ANALYZER
- VIDEO CRT CARD
- FLOPPY DISC

**ti** *Telcon Industries, Inc.*  
TELEPHONE and DATA EQUIPMENT

5701 N.W. 31st Avenue  
Fort Lauderdale, Florida 33309  
(305) 971-2250

CIRCLE 188 ON READER CARD

## hardware

monitor and break out a standard CCITT v.35 interface between a modem and a terminal. The user plugs the Model 80 into the circuit between the modem and the terminal to gain access to all 17 signal conductors specified by the V.35 or Bell 306 interfacing specifications. The on or off

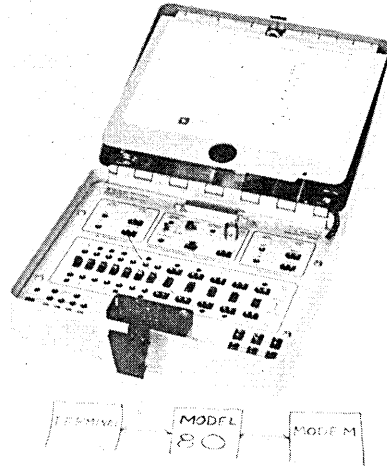

state of each conductor is indicated by an LED. Switches allow interruption of interface signals for testing and monitoring. A pulse trap senses any spurious transition on the signal lines. The Model 80 sells for \$990. Delivery is 30 days. INTERNATIONAL DATA SCIENCES, INC., Providence, R.I.  
FOR DATA CIRCLE 444 ON READER CARD

### Terminal Interfaces

The 2031 series of asynchronous line interfaces allows users to interface their PDP-11s to terminals operating at any popular transmission rate. Data rates, address selection, and operating mode are all DIP switch-selectable. An appropriate cable connector selects EIA voltage level or current loop operation. The 2031 series is said to be hardware and software compatible with the DEC processor, capable of replacing DEC's DL-11 series of interfaces. The 2031-01 replaces DEC's DL-11A and C 20ma current loop interfaces. Model 2031-02 offers full data set control and EIA voltage level or current loop operation to replace DEC's DL-11-A, B, C, D, and E. Standard transmission rates range from 75bps to 9600bps (or any externally supplied rate); special rates can be accommodated. The 2031-01 sells for \$525; the 2031-02 sells for \$575. Shipment is from stock. GEN/COMP INC., Canton, Mass.  
FOR DATA CIRCLE 451 ON READER CARD

### Data Access Arrangements

Instead of renting Data Access Arrangements (DAA's) from the phone

company, modem users can purchase them from this vendor. Users will still have to pay Ma Bell for a data jack, but that's only a one-time charge of roughly \$20, the vendor notes. A single channel VA851 DAA sells for \$135; the dual unit VA852 is \$215. The phone company is said to charge from \$4 to \$8 per month for its DAA's. VADIC, Mountain View, Calif.  
FOR DATA CIRCLE 445 ON READER CARD

### Printer

The 4100sc is plug-compatible with IBM's 328X printers for use with 3270 systems. It can print characters from a tenth of an inch to seven-tenths of

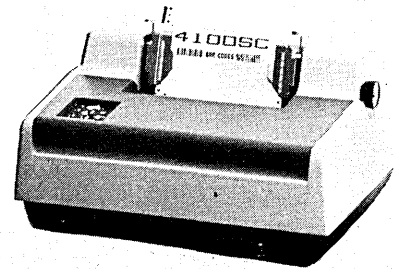

an inch high, as well as printing bar codes. For normal sized characters, the 4100sc prints 120 cps. The 4100sc sells for \$6,400, with quantity discounts available. Delivery is 90 days. INTERFACE SYSTEMS, INC., Ann Arbor, Mich.

FOR DATA CIRCLE 454 ON READER CARD

### Communications Processor

The 20 Series Communications Processor, built around the Z80 microprocessor, is suited to the implementation of concentrators or contention units with four or eight channels and single channel converter systems between different communications protocols. The unit consists of a Z80 processor, up to 19K of RAM buffer storage, up to 8K of PROM control storage, up to nine communications

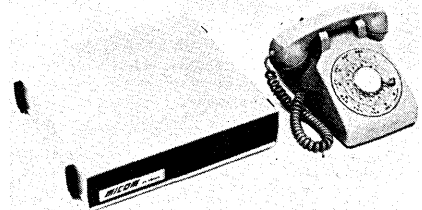

interfaces, and an integral operator's console. Normally supplied in a turn-key fashion, tailored to the user's requirements, the unit is also available with a program development system for oem's. Prices for the unit start at \$880 for a two-channel unit. Quantity discounts are offered. Delivery takes 45 days. MICOM SYSTEMS, INC., Chatsworth, Calif.  
FOR DATA CIRCLE 443 ON READER CARD

### Add-on Memory

DEC System 10 users in need of more memory may find the 512K word ARM-10L of interest. The ARM-10L is said to be compatible with the System 10's hardware and software. The add-on memory will lower expansion costs for users of the KI and KL models of the System 10, according to the manufacturer. The core memory is equipped with two- or four-way internal interleaving, and can be fitted with up to eight ports (in two port increments). Typical access time is 500 nsec with a maximum of 520 nsec. Cycle time is typically 750 nsec with a maximum of 770 nsec. Available 30 days ARO, the 512K word ARM-10L sells for \$175,000. AMPEX CORP., El Segundo, Calif.  
FOR DATA CIRCLE 456 ON READER CARD

### Audio Alarm

The Hawkeye Sentry attaches to IBM's System/32, sounding an audible alarm when the computer needs its operator's attention. The Sentry summons the operator when the computer is in an Interactive Data Entry Mode and no one has entered data in a significant amount of time, when a system detected "blinking" error occurs, or when the System/32 is in a READY state. The alarm repeats every fifteen seconds until the operator acknowledges that he is correcting the situation. Pressing STOP on the system control panel tells the alarm that the system is to be validly idle for a time. Two month deliveries are quoted for the \$285 Hawkeye Sentry. The unit is user-installable. IOTA COMPUTER SERVICES, INC., Provo, Utah.  
FOR DATA CIRCLE 463 ON READER CARD

### Basic Extension

The Fast BASIC III ROM lets HP 9830 users avoid the 256-per-side array dimension limit. With this ROM, users can dimension, sort, and search any size array that will fit in available memory. Other capabilities in the ROM



provide 10KB/sec. I/O transfer rates for control and instrumentation, quasi-live keyboard, and more. Fast BASIC III sells for \$525; price breaks are offered when the ROM is purchased with other ROM's in the product line. INFOTEK SYSTEMS, Anaheim, Calif.  
FOR DATA CIRCLE 446 ON READER CARD

# PROJECT SYSTEMS ENGINEERS.

Aramco needs five Project Systems Engineers who are the very best available in their field. Your permanent assignment would be in Saudi Arabia where Aramco has projects under way whose size and scope are unequalled in the world today.

### The job.

You would be working on the world's largest computer automated system for controlling the movement of crude oil, NGL, and natural gas. This system will control the world's largest crude oil pipeline network and marine terminal and one of the world's largest refineries with the software system coordinating Aramco's entire production. It is to be the ultimate in computerized systems for moving petroleum products and presents to those Systems Engineers who can qualify, the greatest challenge of their careers.

### The requirements.

We are looking for engineers who have B.S.E.E. or M.S.E.E. degrees, the latter being preferred. You must be project-oriented and have a minimum of 5 years' experience in real time computer systems for the pipeline or process control industries.

Your first assignment will be in Houston for approximately 18 months working as Aramco's representative with a major contractor who is developing the engineering design proposal. Here you will overview the design and installation of all hardware and software for the entire project, making sure it meets Aramco's specifications. At the end of the design phase you will then be permanently transferred to Saudi Arabia, where you will oversee the installation, acceptance testing, and continued operations.

### Why work for Aramco?

Besides the challenge and career opportunities of your job, working for Aramco overseas offers several excellent advantages. You'll receive a good salary and savings plan, plus a generous tax-protected expatriate premium.

And you can travel the world if you wish, because on the average of every 12½ months you receive 40 fully paid vacation days, as well as round trip vacation travel fare to the U.S. Add to this an average of 12 paid holidays each year. In addition, Aramco offers a comprehensive medical program and a generous retirement plan, plus excellent recreational facilities.

### Interested?

If so, and you're qualified, please write for an application. We'll be back in touch with you as soon as possible.

# ARAMCO

SERVICES COMPANY

WRITE DEPT. D0900A, 1100 MILAM BUILDING, HOUSTON, TEXAS 77002

## Back to Our Roots

For the past several years, "getting back to one's roots" has been a fashionable undertaking. A number of popular musicians have done it, some with critical acclaim. Alex Haley did it and wound up with a best-selling book and a fantastically popular television special. And now, on our twen-

tieth anniversary, DATAMATION gets back to its roots with these product announcements from our October, November, and December 1957, issues. Some have been shortened by deleting whole sentences and paragraphs, but aside from that, not a word has been changed. \*

## Digital data system

**BJ Electronics, Borg-Warner Corp.**, 3300 Newport Blvd., Santa Ana, Calif., has introduced a new digital data processing and recording system, known as the S-100, that is capable

of sampling inputs from one to 100 vibroton digital transducers at rates of up to 100 per second. Measurement input is delivered as directly-digital information, either sequentially or upon demand.

Etched circuitry is employed

throughout the component groups with plug-in type fabrication used to facilitate system maintenance with minimum operating interruptions. Pressure variations are measured by vibroton pressure transducers. Temperature data and inputs from other measurement instrumentation are also accepted by the system.

Measurement data received are transferred to the storage register until

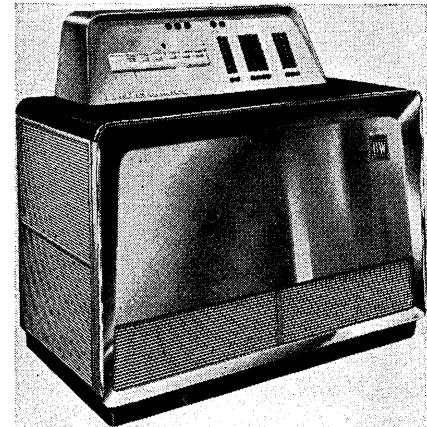

demand by a data recording system. Information from the buffer storage register may be programmed by the system operator and routed to the appropriate output equipment.

System outputs include visual read-out, tabulations, punched cards, tape, and other output media. Output provisions for process monitoring and control may also be incorporated. Power requirements: 115v, 60 cycle.

## Minute memory cell

**International Business Machines Corp.**, 590 Madison Ave., New York 22, has announced the development of a super-high-speed "memory" device that responds in a hundred-mil-

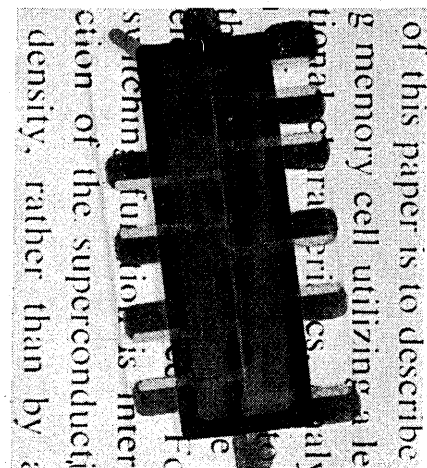

lionth of a second. The device, which utilizes a miniature printed circuit of metallic lead at temperatures close to absolute zero ( $-459.7^{\circ}$  F.), is believed to hold great promise for use in high-speed, high-capacity electronic computers of the future.

DATA PROCESSING

# A WORLD OF OPPORTUNITY IN

- COMPUTER AIDED DESIGN
- ENGINEERING APPLICATIONS
- OPERATIONS RESEARCH
- SOFTWARE & SYSTEMS ANALYSIS

is available at Fluor Corporation. Because Fluor recognizes the needs of professionals, we translate words like opportunity and progress into a language that engineers as well as computer specialists understand as challenge and growth.

Our projects cover the spectrum of business and scientific computer applications. As a member of our staff, you will be working with other professionals at our new, innovatively designed facility in the Newport Beach area.

Your background should include a BS in ME, ChE, EE, Systems Engineering, Physics, or Computer Science; and/or experience in one or more of the following:

## BUSINESS SYSTEMS

- Broad experience/knowledge of estimating, accounting, material control, cost, scheduling, and/or payroll.

## COMPUTER AIDED DESIGN SYSTEMS

- Interactive graphic application design, programming and documentation.
- Engineering interactive graphic data base management systems.
- Engineering interactive archival data base management systems.
- Interactive graphic hardware and software systems design.

## SCIENTIFIC SYSTEMS

- Power systems
- Pressure vessels
- Process heat transfer
- Maintenance of NOS-BE product sets.

No matter which of the above areas is included in your experience, you will be involved in creative thinking. Creative employees are the reason for our success.

Complete benefits package and a salary commensurate with experience will be discussed during an interview. If you've read this far, let's keep communication going. Send resume to:

Nellie Bedford, Dept: DTM

# FLUOR CORPORATION

P.O. Box 11977  
Santa Ana, CA 92711

An Equal Opportunity Employer M/F



CIRCLE 204 ON READER CARD

### Machine tool control system

**Wang Laboratories, Inc.**, 37 Hurley St., Cambridge 41, Mass., has announced the design, development, and completion of the first Weditrol, a numerically controlled machine tool control system. The Weditrol gets its command from a punched paper tape and develops the control. All the programmings are generated internally, and require no special computers to generate the pulses.

### Long-wear magnetic tapes

**Minnesota Mining & Mfg. Co.**, 900 Bush St., St. Paul 6, Minn., has introduced two new long-wearing magnetic tapes for instrumentation use that outwear conventional "Scotch" brand instrumentation tapes by an average of 6 to 1, yet increase short wave length response by 3.5 db.

Key to the superior wear characteristics of the new tapes is a new, more durable binder construction which minimizes problems of oxide rub-off and deposit on the machine heads. The tapes contain no more than one drop-out per 2,500' roll.

Both tapes are available in standard widths of 1/4, 1/2, 3/8, 3/4, and 1", and are hermetically sealed in plastic bags to protect the tape from contamination by dust or moisture during shipment or storage.

### Miniature computer

**Codetypewriter Laboratories**, 1027 Casa Vista Dr., Pomona, Calif., has announced a new, low-cost Model EBC3 Codetypewriter that will automatically key a radio transmitter as any of the keys

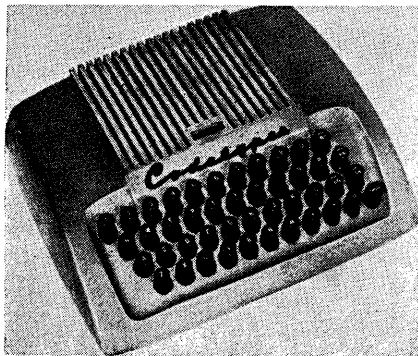

on the typewriter-like keyboard are touched. No trained operator is needed in an emergency. Speed is continually adjustable from 10 to 75 wpm. Containing only 12 miniature tubes, the unit is smaller and lighter than a portable typewriter.

### New IBM System

**Data Processing Div. of IBM** has announced the 705-III, one of the most powerful electronic systems on the market for the processing of business data. It is the latest addition to the

IBM 700-series of large-scale electronic data processing systems now at work in scores of business, scientific, and government installations.

One of the features of the new system is a completely-transistorized magnetic tape unit with an input-output rate fast enough to read or write the equivalent of a full-length novel once every 15 seconds. This ultra-high speed tape unit, the IBM 729 Model 3, can read or write business information at the rate of 60,000 characters per second, automatically checking the information for validity and readability at the same time.

The system also utilizes the new

767 Data Synchronizer which controls magnetic tape input and output so that the 705-III can read problem data, compute, and write answers simultaneously.

### Magnetic tape transport

**ElectroData Div. of Burroughs Corp.**, 460 Sierra Madre Villa, Pasadena, Calif., has announced a 10-speed magnetic tape transport for electronic data processing systems known as Model 546-53368 Digital Magnetic Tape Transport. A speed ratio of 60:1 is available with this transport. Three-quarter-inch tape is used, wound on two 10 1/2" reels. \*

## LARGE-SCALE OPPORTUNITIES IN ADVANCED-TECHNOLOGY EDP SYSTEMS DEVELOPMENT

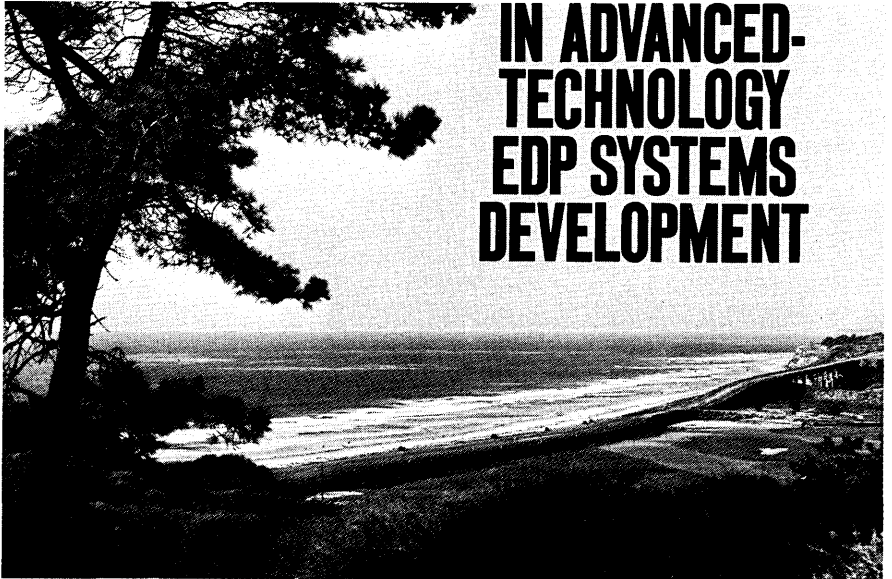

in the part of San Diego  
that even San Diegans dream about

### Distributive Processing System Development

Even though we're in the "country" — about halfway between La Jolla and Torrey Pines—we're still just minutes from downtown San Diego. Our mission is broad: development of advanced, high-technology EDP systems for customers worldwide. You'll be creating for the long term, drawing from the full spectrum of NCR technical resources. You'll enjoy an excellent salary, generous benefits and the advancement potential that accompanies NCR's policy of merit reviews. If one of these new positions describes you, get set to make your last move.

Positions are available in the development of a very large distributive processing system, advancing the state-of-the-art technology utilizing the spectrum of EDP equipment—minis to large mainframe with assorted peripherals and terminal devices. Experience in telecommunications, networks, file processing or operating systems plus expertise in COBOL and assembly languages preferred.

### Communications Software Development

These positions entail the system design and development of software for large communications networks. Experience in assembly languages, telecommunications and a minicomputer background; related BS degree preferred.

Please submit your resume including salary history to Thom W. Harris, Employment Specialist

# NCR

## Special Systems Division

4043 Sorrento Valley Blvd., San Diego, Calif. 92121 ☐ (714) 452-1020  
An Equal Opportunity Employer M/F

# software & services

## Updates

The ACM's Special Interest Group on Documentation (SIGDOC) has begun a review of the ANS X3.5-1970 flowchart standard. It's been more than five years since the last review, and existing standards may need updating to reflect such changes in the industry as the growing use of COM and intelligent terminals, says Ned Chapin, flowchart committee chairman. The committee solicits written comments and suggestions for the improvement, modification, or change of the current standard. Or, if the existing standard is adequate, please say so. Direct your comments to Ned Chapin, Flowchart Committee Chairman, InfoSci Inc., Box 7117, Menlo Park, Calif. 94025.

Designed to locate chemical compounds on the basis of their structural characteristics, the NIH/EPA Substructure Search System (SSS) is being offered jointly by Tymshare and Fein-Marquart Associates. The on-line, interactive SSS uses structural characteristics as keys to search through a number of data bases. Some data bases are derived from regulatory and governmental operations on certain classes of chemicals, such as pesticides or industrial chemicals. Other data bases are collections of compounds having some common attribute, such as the set of compounds in the Merck index.

Several training courses have recently come to our attention. The Edutronics Group, Kansas City, Mo., has added a multimedia "Report Writer" module to its COBOL Efficiencies curriculum. The firm also introduced "POWER/VS," an addition to its Disc Operating System curriculum.

Hewlett-Packard released a completely revised "Digital Troubleshooting" video tape program, said to cover as much as a two-day live seminar.

Informatics announced an audio cassette course covering the capabilities of the MARK IV Extended Segment Processing special feature. The firm also said it has graduated its 20,000th student in its Basic MARK IV course.

And Dylakor Software Systems created a Test Run for DYL-260 software programmer training. The package, available to 360/370 shops on a 30-day free trial basis, comes with a test program and three problems.

## Series/1 Commo

The IBM Series/1 is about the best thing to happen to software houses in years. The machine may some day become the most popular mini, and there's precious little software available for it, considering all it can do. The 3270 BSC System should help matters. It basically allows a Series/1 mini to replace an IBM 3271 mod 2 controller and 3277 mod 2 display terminals and provide distributed processing capabilities. The package enables the mini to communicate in bi-synch, and supports both point-to-point and multipoint communications. Up to 16 display terminals in a 3270-compatible system are supported; 64 terminals if modifications are acceptable. (The feeling is that most sales will involve customization, and a "certain amount" of it is included in the price. And the price is: \$5K for the operating system and another \$5K for the bisynch. The packages are coded in assembler. CONVERSATIONAL SYSTEMS CORP., New York, N.Y. FOR DATA CIRCLE 475 ON READER CARD

## PDP-8 Simulator

Requiring at least 12K of memory and a terminal, the Simul8tor PDP-8 simulator will run on any 8080- or Z80-based microcomputer. Simul8tor provides exact simulation of the PDP-8, (with the exception of timing), a virtual "software front panel," dynamic display of PDP-8 data on the micro's console lights, support for console-less micro's (such as PolyMorphic Systems) with a simple patch, and the ability to run existing PDP-8 programs. A loader for use with DEC's "BIN" format paper tapes, documentation, and information on DEC's user group and its library of programs are included in the Simul8tor Package. The vendor is quite candid in pointing out two possible limitations of the Simul8tor: execution speed is degraded due to simulation so programs such as CINET BASIC and FOCAL may be annoyingly slow; and most PDP-8 software comes on paper tape which may inconvenience some users. On the other hand, Simul8tor opens the door on the vast library of software for the PDP-8, which includes FORTRAN II, ALGOL, LISP, editors, assemblers, and floating point packages (available from DEC or its user group at modest prices). The Simul8tor, supplied on Tarbell Cassette or paper tape, sells for \$20 plus

\$3 for each cassette. Quantity discounts are offered. THE AMIDE CORP., Sag Harbor, N. Y. FOR DATA CIRCLE 474 ON READER CARD

## Queue Sharing

At \$7,500, the price for a perpetual license to o\*SHARE might seem like a lot of money. But consider what the modification to IBM's POWER/VS spooler enables users to *not* do: dedicate unit record devices for each memory-resident copy of POWER/VS—the same cpu can control all unit record and I/O devices. The immediate benefits are fairly obvious, being greater flexibility in scheduling, increased throughput, and cost reductions. It's claimed that o\*SHARE installs in minutes, and that the operation of POWER/VS will appear to function just as it did before installation of the new package. (No JCL changes are required.) Lease and rental arrangements also are available. LABYRINTH SYSTEMS LTD., Great Neck, N.Y. FOR DATA CIRCLE 472 ON READER CARD

## 8080 Programming Aid

The 8080 Hex Code Card is a slide rule-like aid for programming and debugging 8080 assembler programs. It contains all mnemonics (color coded to indicate which flags are affected) and their corresponding hexa-

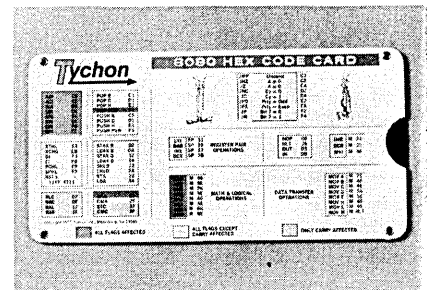

decimal codes. The back of the card has a table of ASCII codes plus the 8080 status word and register pair codes. The card sells for \$2.95 post-paid. Quantity discounts start at 10 units, and custom printing is offered. TYCHON, INC., Blacksburg, Va. FOR DATA CIRCLE 468 ON READER CARD

## BMDP Statistics Package

Retaining most of the FORTRAN code from the original BMDP Statistical Package (developed by the Health Sciences Computing Facility at UCLA for 360s and 370s), this version of BMDP for DEC PDP-11s consists of all 26 programs and features described in

# asi/inquiry

## The IMS DB/DC QUERY LANGUAGE

USED BY MORE IMS INSTALLATIONS THAN  
ANY COMPETING PRODUCT



ASI/INQUIRY is an IMS DB/DC query language that operates completely as an interactive Message Processing Program. The design of ASI/INQUIRY is such that the *structure of the data base is transparent to the user*. Moreover, one need not have familiarity with DL/1 segment logic or the complexities of multipathing. Extremely rapid response time is assured.

### MAJOR HIGHLIGHTS

- End-user oriented
  - Easy-to-use language
  - Requires no knowledge of IMS
  - Comprehensive diagnostic messages
- Rapid response time for even the most complex queries
- Dynamic priority scheduling to maximize system performance
- Availability of default as well as user-defined screen formatting

Recently delivered, Release 2 of ASI/INQUIRY contained a number of major enhancements, including:

- Development of a TSO-supported version
- Full support of IMS/VS secondary indexing
- Open-ended computational facilities
- Ability to SORT display output

In summary, ASI/INQUIRY represents the state-of-the-art product in an IMS DB/DC or TSO-supported IMS environment. It is the only system combining an easy to use language, complete user flexibility, and rapid response time in a single package. If you want to start answering "What if . . . ." immediately, call or write today for further information.



The Software Manufacturer

Applications Software, Inc.  
Corporate Offices  
21515 Hawthorne Boulevard  
Torrance, California 90503  
(213) 542-4381



## Using rented modems in audio/response? Save costs, save space, with Audioport.

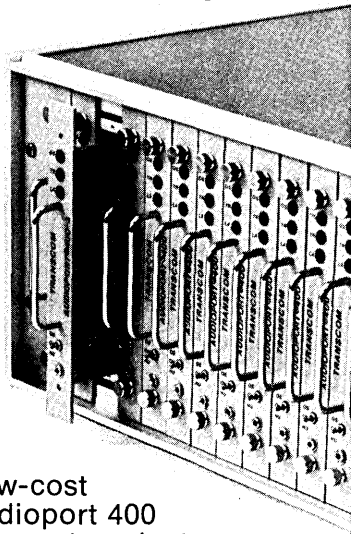

Low-cost Audioport 400 pays out against telephone company rental in as little as 12 to 18 months! And the space savings are just as spectacular: this multiple modem pack holds up to 12 in the space of a single 403E or two 401J modems.

And Audioport 400 is available. You are never on the waiting list—whether you order one or one hundred.

Audioport 400 is the answer in audio/response modems—the interface for Transcom terminals, push button phones and other portable terminals.

Many installations. Names on request. Customers will tell you our product support measures up right to the products. Write or call Transcom, a Subsidiary of Hi-G Incorporated, 580 Spring Street, Windsor Locks, CT 06096. (203) 623-2481

**TRANSCOM**  
A Subsidiary of Hi-G, Inc.



## software & services

the BMDP Manual. Several coding changes were made to improve efficiency and ease of use on the mini, but no significant modifications have been made to the statistical algorithms themselves.

The conversion was made under RSTS/E, and the package is completely compatible with both the RSX and IAS operating systems. Minimum systems requirements are 28K of user space and a 132-column output device. If all programs in the package are to be on-line at one time, at least 5,000 blocks of disc are required. Although floating point hardware is strongly recommended, it is not required.

The only limitation of the package stems from address space limitations on the PDP-11. The internal array space has been reduced to about one-third of the default size of the orig-

## software spotlight

### Cost Estimating

Once there was a programming project manager who was handed his own head on a silver platter when his \$20,000 project came in slightly over budget at \$75,000. Our manager friend might still be in one piece if he had used the PRICE S model for estimating the budget for software development projects.

PRICE S can help managers prepare budgets and schedules. A parametric model using regression techniques, PRICE S operates in interactive mode, requiring the user to input less than a coding sheet of project descriptors, and returning results in a matter of minutes (on a lightly used time-sharing system at about 6:30 p.m., we saw PRICE S gave nearly instantaneous results). The user inputs the data and the system calculates the missing values; for instance, if the user knows how much money is available, the model can tell him how complex a system he can expect to implement and still remain within budget. The model has internal checks on its input, and will print warnings when it detects possible inconsistencies. One such warning said we may have underestimated the complexity of the project by a factor of nearly four. PRICE S was warning that the number and mix of peripherals were inconsistent with

the level of complexity specified. An informal survey of users taken by UCLA indicates that more than 75% of the problems being solved with BMDP are small enough to run on the PDP-11.

Distributed on a 9-track, 800 bpi tape the BMDP package has a one-time license fee of \$500, discounted to \$150 for educational institutions. SOFTWARE DEVELOPMENT INC., Middlebury College, Middlebury, Vt. FOR DATA CIRCLE 467 ON READER CARD

### Mailing Lists

The Micro-Label system is a general purpose mailing label program designed to run on 8080-based microcomputers. The package handles creation and maintenance of mailing lists and similar label applications. Additions, changes, and deletions are applied to the master file via crt. Micro-Label prints labels on a 132-column, pin or tractor feed printer. File storage must be on dual North Star-compatible minifloppy discs. Options include custom record formats, custom sorts, and custom label height.

the level of complexity specified.

PRICE S produces cost break-outs for five categories in each of three overlapping development phases—engineering, design, implementation, and test and integration. The five cost categories comprise systems engineering, programming, configuration control, documentation, and program management. Possible variances also are calculated. PRICE S operates in three modes: normal operation, for projecting budgets and schedules; ECIRP (PRICE spelled backward) which runs the model in “reverse,” calculating PRICE empirical factors from known project costs (useful in tuning the model for each specific user); and GEOSYN, which uses specified costs to compute typical program sizes and project schedules. The system also includes escalation factors (back to 1946) to account for inflationary variations in the economy (useful in long-term projects and when running in ECIRP mode).

PRICE S can be assessed on several time-sharing services. The vendor charges \$30,000 per year for access by one terminal (\$20,000 each for two through five, \$15,000 each for six to ten, and \$10,000 for each additional terminal). Additionally, users must pay time-sharing charges, estimated to be \$2,500 to \$5,000 per 1,000 PRICE S runs. A three-day training program goes for \$600 per trainee. RCA GOVERNMENT SYSTEMS DIV., PRICE Systems, Morristown, N. J. FOR DATA CIRCLE 470 ON READER CARD

# ASM2.

## ANNOUNCING RELEASE 2.3

**RELEASE INDEPENDENT FROM MVT 21.6 THROUGH  
MVS 3.7 AND VS 1. SUPPORTS ALL TYPES OF DASD/SUPERDISK/MSS.  
SUPPORTS BDAM, PDS, SEQUENTIAL, ISAM, AND VSAM DATA SPACES.**

### ARCHIVAL/RETRIEVAL.

Online space reduction through the offloading of infrequently-used data sets to less-expensive storage media. Easy, high performance retrieval under user or Data Center control.

Commands and functions operative in batch and from online facilities such as TSO, provide users with powerful, yet simple to use, space management control without JCL.

### BACKUP.

The incremental dump. Non-redundant offloading of only the most recently modified data sets, substantially reduces the duration and size of the normal daily backup operation.

### COMPRESS/DASD CONVERSION.

Highly efficient compression features assure complete reclamation of unused space and offer a powerful assist in DASD conversions. ASM2 will automatically adjust allocations for differing source and receiving DASD types and data set organizations.

### ACTIVITY REPORTING.

Complete management and user reporting. Concise, yet comprehensible at any level.

### DYNAMIC ALLOCATION.

Even on pre-MVS and ASP systems, ASM2 will, under user-specified conditions, dynamically allocate both tape and disk.

### USER EXITS.

Powerful (SMF-like) exits provide the capability for users to tailor system results to specific, installation-determined purposes. Space management flexibility found only in ASM2.

### SUPERSCRATCH.

Based upon predetermined global criteria, ASM2's superscratch facility provides yet another dimension in space conservation.

**AND IN ADDITION TO PROVIDING PROVEN, RELIABLE  
SOLUTIONS TO YOUR SPACE MANAGEMENT PROBLEMS,  
ASM2 OFFERS MORE:**

### EXTENDED SPACE REPORTING AND BILLING.

Billing and utilization reporting at the track/day level. User exits permit the transfer of custom formatted billing data to the installation's job accounting or chargeback system.

### EXTENDED PDS.

High performance, PDS data set and member-specific dump/restore Data Movers feature dynamic reblocking of load-modules moved to a disk device with insufficient track capacity.

### DISK TO DISK.

Added flexibility through the provision or intermediate storage of archived files on disk. A multi-tiered archival structure results which manages data on-line, archived to disk/MSS, or archived to tape while permitting complete archive, scratch, and restore capability throughout.

### GDG CONTROL.

Guarantees a specified ratio of online vs. offline members of generation data groups enabling users to standardize GDG usage.

### VOLUME RECONFIGURATION/DEFRAGMENTATION.

Device independent reconstruction of entire volumes. High-speed dump/restore facilities intelligently restructure volumes and dynamically re-block data to like or different target volumes based on user criteria.

### TAPE CONSERVATION.

ASM2 archive tapes containing partially useful data are consolidated via a forward-merge process incorporating multi-volume data set capabilities allowing large data sets to optionally span archive/backup tapes.

### INTEGRITY.

Complete system integrity is assured. All files and catalogs are easily reconstructible from transaction journals even under the most drastic circumstances.

**IN OVER 150 LARGE-SCALE INSTALLATIONS,  
OFFERING SUPPORT IN CANADA AND EUROPE AS WELL AS  
IN THE DOMESTIC U.S., AN IMPECCABLE REPUTATION  
FOR QUALITY, INTEGRITY, AND RELIABILITY.**

**DELIVERING THE UNDISPUTED LEADER IN SPACE  
MANAGEMENT SOFTWARE SINCE FEBRUARY OF 1974!**

**The Cambridge Systems Group**

**19857 Beekman Place, Cupertino, California 95014 (408) 255/5727**

## software & services

The Micro-Label System, which can print labels one inch high and up to 132 columns wide, sells for \$500 on a North Star-compatible diskette. Options are \$40 each. TYLOG SYSTEMS INC., Miami, Fla.  
FOR DATA CIRCLE 469 ON READER CARD

### Cross Assembler

This vendor's cross-assembler lets the user define the assembly language syntax and target machine code forms, effectively providing as many assemblers as the user has definitions. Macro and conditional assembly features may be included in the assembler definition. Additionally, since it runs on 360s and 370s under OS or DOS, the user can take advantage of the host's editor and utility programs. The package features an unlimited number of operation codes, relocatable symbols and expressions, free form input, decimal, octal, and hexadecimal constant forms, choice of hex or octal assembly listing, and generalized expressions with 12 operations and seven levels of hierarchy. The package

also produces a cross-reference listing. The cross-assembler has a price of \$6,000. PACIFIC PROGRAMMING SERVICES, Los Angeles, Calif.  
FOR DATA CIRCLE 476 ON READER CARD

### Programming Aid

The BOPA (basic operational programming aid) comes with 32 removable slats on which a programmer can write his assembly language code. Users can move code around, insert instructions or delete lines easily. The frame which holds the slats has mem-

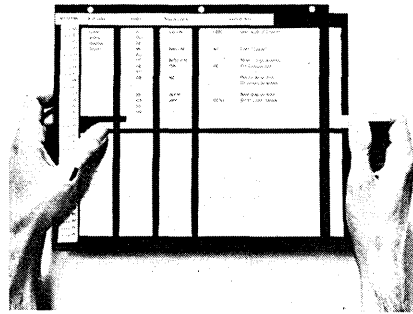

ory addresses, in hex, running down its left side and column headings across the top. When the programmer is satisfied with his work, he can Xerox it for documentation or input. A single-card BOPA with space for 32 entries sells for \$11.95, an eight-card set sells for \$74.95 and has room for

256 lines of code. The manufacturer intends to market the BOPA through computer stores and through the mail. VAMP INC., Los Angeles, Calif.  
FOR DATA CIRCLE 465 ON READER CARD

### Assembler to COBOL

IBM 360/370 users with applications written in assembler may wish to use this firm's assembler to ANS COBOL translator to make their programs more readable and easier to maintain. Capable of handling 360/370 (DOS or OS) assembler and Mod 20 BAL assembler, the translator generates COBOL source statements and standard DOS and OS macro calls. The translator is said to perform a 90%+ conversion. Original data and procedure names are used when possible and a side-by-side listing is produced. The translator also generates a cross reference listing. "Conversion aid" notations assist the programmer in completing an accurate translation. The translator is written in ANS COBOL for 360s and 370s and takes about 100K of memory. Lease and purchase "rights of use" go for \$4,000 per month (six month minimum) and \$40,000, respectively. The vendor will also perform conversions on a service basis. DATAWARE INC., Tonawanda, N. Y.

FOR DATA CIRCLE 466 ON READER CARD

## MMS GENERAL LEDGER gives you extra muscle for wrestling with budgets

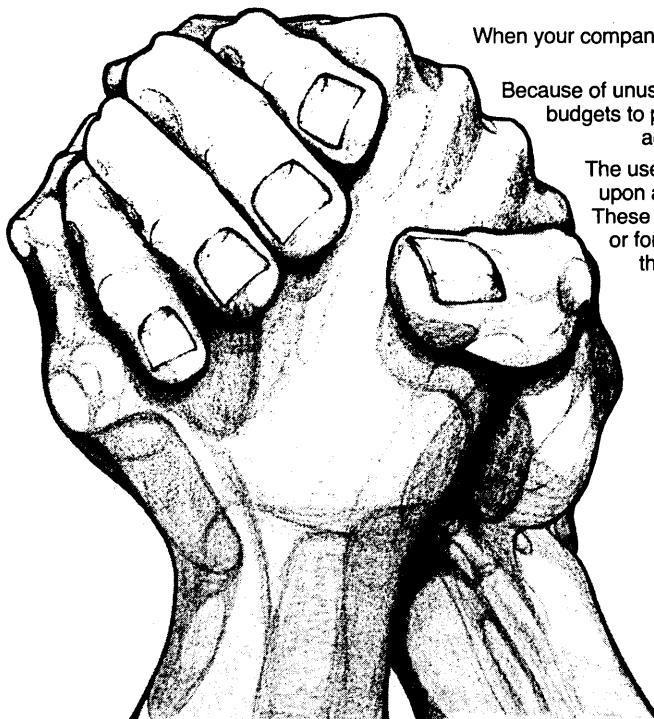

When your company's accountants wrestle with operating budgets, give them some extra muscle with the MMS GENERAL LEDGER.

Because of unusually flexible design, the MMS General Ledger allows loading of budgets to particular accounting periods or the spreading of budgets across accounting periods based on guidelines established by the user.

The user can also automatically create budget input transactions based upon actual performance and/or original budget, plus a desired factor. These transactions can be subsequently applied to next year's budget, or for revision of the current budget. Finally, the allocation routines of the powerful MMS GENERAL LEDGER can easily revise budgets based on current productivity.

Best of all, Financial Reporting Systems from Software International operate under DOS, O/S, IMS, DL/1 and TOTAL. More than 500 corporations around the world have installed our packages on IBM 360/370, System/3, Honeywell, and other computer systems.

Get your hands on the MMS GENERAL LEDGER. You'll see that those budgeting problems are pushovers.

**SOFTWARE<sup>®</sup>  
INTERNATIONAL**

Elm Square, Andover, Mass. 01810 (617) 475-5040

New York (914) 332-0040 Washington, D.C. (301) 770-6460  
Philadelphia (302) 995-7101 Chicago (312) 729-7410

San Diego (714) 292-9833 Toronto (416) 862-0521 Dallas (214) 233-5856  
Columbus, OH (614) 773-2167 San Francisco (415) 433-5797

\*Registered Trademark of Software International Corporation of America

CIRCLE 183 ON READER CARD

### Hardware Basic

It's too bad this manufacturer had to temper the announcement of a hardware BASIC interpreter chip for the ubiquitous Intel 8080 microprocessor with claims that it's the first "solid-state" software. But that might be all that's wrong with the development—the price is certainly attractive. For \$95, the user gets the two EA3200 ROM's containing 4K eight-bit words each, assembler listing, and user's guide in quantities of 1 to 24. The BASIC interpreter takes up 6K on the two chips and is complete with floating point arithmetic, tty I/O, memory check, and monitor routines. ELECTRONIC ARRAYS, INC., Mountain View, Calif.

FOR DATA CIRCLE 473 ON READER CARD

### Plotting

This vendor has developed an integrated software and hardware off-line plotting system for use with Control Data's 6000 and Cyber series of large scale number-crunchers. Running under SCOPE 3.4 or NOS/BE, either of two software packages will prepare tapes for off-line plotting. The programs are written in FORTRAN-extended and Compass assembly language.

The first of the two Versaplot-07 software packages is known as the Pen Plotter Emulation Program (PPEP).

PPEP offers a set of optimized subroutines call-compatible with basic pen plotter programs. The second package, Electrostatic Plotter Software, is an extension of PPEP which uses special electrostatic plotting capabilities through GRID and TONE subroutines. With GRID, users can plot horizontal and vertical grid patterns simultaneously with data. Any specific polygonal region may be shaded with any tone pattern—dots, lines, symbols, screens, or solid blacks—with a call to TONE.

The hardware part of the system consists of one of 34 of the vendor's electrostatic plotters and a raster processor unit with read-only tape drive. Complete plotting systems, including software, raster processor, and plotter are priced from \$20,550. The software, available in object code or complete source code, carries prices ranging from \$3,500 to \$5,500. VERSATEC, Santa Clara, Calif.

FOR DATA CIRCLE 480 ON READER CARD

### Micro Conversion

One of the Z80 microprocessor's selling points is that it can execute Intel 8080 object code. However, this compatibility isn't present at the assembly language level, so this vendor has prepared a program that translates 8080 assembler source code into Z80 assembler source code. That means an 8080 user can switch over to a Z80, translate

his programs at the assembler level, and perform modifications taking advantage of the Z80's larger instruction set. The translator is written in ANSI FORTRAN and will run on any computer, regardless of word length. Purchased by itself, the translator is \$300; when purchased with the vendor's Z80 assembler, the translator is \$50. MICROTEC, Sunnyvale, Calif.

FOR DATA CIRCLE 481 ON READER CARD

### 3790 Communications

The VTAM Batch Communications Program sends and receives data between IBM 370 computers using DOS/VS, OS/VS1, OS/VS2, and 3790 Communications Systems. With the program it is possible to communicate with an unlimited number of 3790 systems over switched or dedicated lines. Users can take advantage of the enhanced communications facilities available under IBM's Systems Network Architecture (SNA) and Synchronous Data Link Control (SDLC) protocol. The program provides a 3790 building block for VTAM communications. By using VTAM to control all telecommunications activity, TP users can increase throughput and receive the advantages of IBM's SNA and Network Control Program, according to the vendor. A perpetual license is \$7,000. COMPUTER DYNAMICS, INC., New York, N.Y. \*

FOR DATA CIRCLE 482 ON READER CARD

# UNIX

## SUPPORTED

at last

UNIX for time sharing  
UNIX for programming  
UNIX for text processing  
UNIX for typesetting

complete  
UNIX systems and services

by

### Interactive Systems Corporation

Peter G. Weiner, pres.  
1526 Cloverfield Blvd., Santa Monica, CA., 90404 (213)829-7741  
\*UNIX is a trademark of the Bell System

CIRCLE 168 ON READER CARD

September, 1977

# FREE!

with your business card or send \$1.00 (refundable on 1st order)



**LARGEST CATALOG IN ITS FIELD**

**Catalog Includes:**

- Manufacturer's catalogs
- News about amazing breakthroughs in the Mini-micro computer field
- \$2.00 Discount Certificate
- Discounts up to 90% on Used Equipment

**Complete Computer System Just \$289**

- Fully Assembled
- Fully tested
- Fully Warranted

Money-Back Guarantee

- KIM-1 — MOS Technology Computer Module 1K-RAM audio cassette interface 15 bidirectional I/O lines 24-key keyboard and six-digit LED display
- System Power Supply (5V at 1.2A 12V at 0.1A) with power line and switch
- Software — System Executive Sample application programs
- Documentation — User hardware & programming manuals wall size System Schematic Programmer's Reference Card

Visa & Master Charge accepted

## NEWMAN COMPUTER EXCHANGE

1250 N. Main St. Ann Arbor, Mi. 48104  
(313) 994-3200 Dept. DA

CIRCLE 174 ON READER CARD

# Software System Engineers P.O.S. Terminal Systems

To design, modularize and code major vocational software modules for fast food and bar restaurant P.O.S. Terminal Systems. Systems involve real-time on-line processing.

Candidates should bring a degree and possess a strong background in on-line systems and experience in multi-tasking operating systems. Some systems design will be a 'plus' in order to better evaluate hardware/software tradeoffs and memory requirements.

*The positions are in a highly visible environment in NCR's P.O.S. facility in rural, east central Ohio. We invite your response as soon as practical.*

**Mr. Robert W. Donovan**  
Terminal Systems Division  
NCR Corporation  
P.O. Box 728  
Cambridge, Ohio 43725



An Equal Opportunity Employer

# CUSTOMER ENGINEERS

TANDEM COMPUTERS is actively seeking experienced customer engineers for New York, Washington, D.C., Miami/Tampa, Atlanta, Chicago, St. Louis, Omaha, Dallas, Denver, Phoenix, Los Angeles, and Toronto, Canada locations.

Successful candidates will be mature, self-motivating individuals who have a software background and at least five years of demonstrable experience in identifying, isolating, and repairing system malfunctions.

Daily work involves the total responsibility for and travel to customer installations for preventive and corrective maintenance procedures on all aspects of the entire system and associated peripherals. This responsibility includes the installation and testing of both upgraded and new software and hardware products.

TANDEM is a young, growing company specializing in multi-processor systems which run non-stop in a wide variety of critical applications where continued operation and data integrity is of utmost importance.

If you believe you meet our qualifications, submit your resume and salary history in complete confidence to

**Mr. Jerry Everett**  
Customer Engineering Manager  
Tandem Computers Inc.  
20605 Valley Green Drive  
Cupertino, Ca. 95014



An Equal Opportunity Employer

CIRCLE 214 ON READER CARD

# SYSTEMS PROGRAMMER OS/MVS/CPE

Looking for maximum career opportunity? Come maximize our computer utilization.

If you're an experienced specialist with a background in Computer Performance Evaluation (CPE), come grow with the Computer Planning Section of R. J. Reynolds Industries in Winston-Salem, N.C.

Our large-scale computer facility is undergoing conversion from DOS/VS to OS/MVS. You can play a key role in this changeover and make the most of your knowledge of OS and hardware and software monitoring of IBM 370s.

You'll be using hardware and software monitors, evaluating results, providing management with summary reports of utilization, and writing recommendations for improvements. You should have monitoring experience with IBM 370s and MVT, SVS, or better, MVS skills. Degree desirable.

We offer opportunity for rapid and sustained career growth, commensurate salary, and paid relocation to one of the most attractive living areas of the East Coast. Send resume and salary history to Mr. Denis G. Simon, Manager of Employment, R. J. Reynolds Industries, Inc., 401 North Main St., Winston-Salem, N.C. 27102.



RJReynolds Industries, Inc.

Tobacco Products  
Foods & Beverages  
Oil & Gas  
Packaging  
Transportation  
Aluminum

An equal opportunity employer m/f

# EDP SEARCH

WHY IS FOX-MORRIS THE FIRST CHOICE  
OF EDP PROFESSIONALS?

A recognized staff of professional experts offering LOCAL, REGIONAL & NATIONAL COVERAGE through our direct branches as well as coast to coast coverage through our 75 member firms of National Personnel Consultants, Inc.

Completely confidential service geared to your career objectives.

Unparalleled contacts with industry based on years of successful results.

Professional resume evaluation and career guidance.

Client companies assume all employment costs—including interview expense, relocation (if necessary) and search fee.

SEND RESUME DIRECT, OR CIRCLE NUMBER BELOW ON READER CARD.

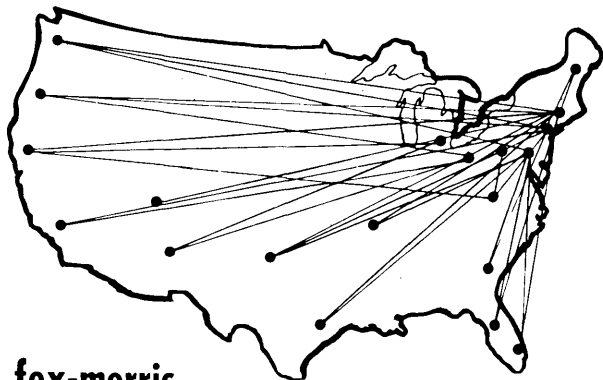

**fox-morris**  
personnel consultants

Philadelphia: (215)561-6300, 1500 Chestnut St., Philadelphia, Pa. 19102  
New York: (212) 697-1820, 605 Third Ave., New York, N. Y. 10016  
Fort Lee: (201) 947-6920, 2125 Center Ave., Fort Lee, NJ 07024  
Pittsburgh: (412) 232-0410, 4 Gateway Center, Pittsburgh, Pa. 15222  
Wilmington: (302) 654-4465, 2005 Concord Pike, Wilm., Del. 19803  
Princeton: (609) 452-8135, 3490 U.S. Rt. 1, Princeton, N. J. 08540  
Baltimore: (301) 296-4500, 409 Washington Ave., Baltimore, Md. 21204  
Charlotte: (704) 527-4980, 4000 Park Road, Charlotte, N.C. 28209  
Atlanta: (404) 393-0933, 47 Perimeter Ctr., East, N.E., Atlanta, Ga. 30346

CIRCLE 205 ON READER CARD



IN CONGR

The unanimous Declaration

# How powerful is the printed word?

Technical Publishing Company believes the printed word is the strongest communication influence in the country. It moves information. It moves minds. It helps make our enterprise system work. But the hard part is to shorten the time between reception and understanding.

Understanding is one of the primary goals in our eight national business/professional magazines. *Datamation*, with its graphic, concise reporting helps business leaders solve practical problems, keep up on market trends and new technologies. It also enables advertisers to pinpoint their selling message to a specialized audience.

Training and entertainment are equally important in communicating understanding. Our TPC Training Systems, through self-instructional programs, help train needed maintenance craftsmen for industry, utilities, hospitals, and vocational/technical schools. And our DBI Books subsidiary (formerly Digest Books) fulfills a growing leisure-time market as people are intent on keeping well informed about their avocations. DBI Books has over 60 titles devoted to sports, hobbies, crafts, and nostalgia.

The power of the printed word is strong . . . and keeps growing every year, as does our success in communication. Technical Publishing showed a 25% revenue gain with earnings up 88% in 1976, and for 23 consecutive quarters, our sales and earnings have bettered those of the previous year.

For information on any of our properties or the company, which is publicly owned with stock traded over-the-counter, write James B. Tafel, President and Chief Executive Officer.



**Technical Publishing Company**  
1301 South Grove Avenue  
Barrington, Illinois 60010

# Yours Free!

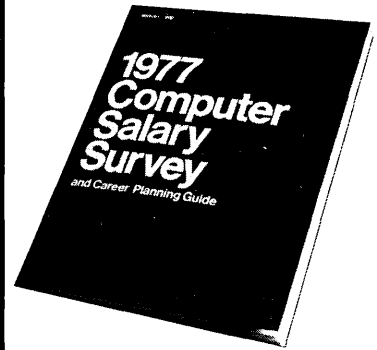

Call for your FREE copy today!

Source Edp's 1977 Computer Salary Survey is now available. This authoritative and up-to-the-minute report will allow you to compare your compensation directly with professionals across the country performing the same duties you perform. It also examines in detail the strategies and techniques thousands of successful computer professionals have used to enhance their careers. After fifteen years of recruiting experience, Source Edp knows how you can gain broader professional exposure, maximize your compensation and break into management. It's all in Source Edp's 1977 Computer Salary Survey and career planning guide.

For your FREE copy, call the Source Edp office nearest you.

- |                        |              |
|------------------------|--------------|
| <b>East</b>            |              |
| Boston                 | 617/482-7613 |
| Greenwich              | 203/869-5977 |
| Hartford               | 203/522-6590 |
| New York               | 212/736-7445 |
| Philadelphia           | 215/665-1717 |
| Union, NJ              | 201/687-8700 |
| Washington, D.C.       | 703/790-5610 |
| Wellesley, Ma.         | 617/237-3120 |
| <b>Midwest</b>         |              |
| Chicago                | 312/782-0857 |
| Oak Brook, Ill.        | 312/986-0422 |
| Cleveland              | 216/771-2070 |
| Detroit                | 313/352-6520 |
| Kansas City, Mo.       | 816/474-3393 |
| Minneapolis            | 612/544-3600 |
| St. Louis              | 314/862-3800 |
| St. Paul               | 612/771-0544 |
| <b>South/Southwest</b> |              |
| Atlanta                | 404/325-8370 |
| Dallas                 | 214/387-1600 |
| Denver                 | 303/773-3700 |
| Fort Worth             | 817/338-9300 |
| Houston                | 713/626-8705 |
| New Orleans            | 504/561-6000 |
| <b>West Coast</b>      |              |
| Encino, Ca.            | 213/995-8866 |
| Irvine, Ca.            | 714/833-1730 |
| Los Angeles            | 213/386-5500 |
| Oakland                | 415/444-5955 |
| Palo Alto              | 415/328-7155 |
| San Francisco          | 415/434-2410 |
| Torrance, Ca.          | 213/540-7500 |



If unable to call, write:  
Source Edp  
Department D-9  
721 Enterprise  
Oak Brook, Illinois 60521

(When writing, please be sure to indicate home address and current position title.)



# PROGRAM MANAGER (Software Leader)

Join our Corporate Retail Program Management team and apply your expertise in program management.

You will be a generalist who is knowledgeable in basic and applied software, including OS usage, compilers, peripherals, communications, and industry standards.

You will be involved with product planning, business strategies and design reviews.

If you have the above experience plus a BS in CS/Business or equivalent educational qualifications, send your resume to:

**Mr. Vernon L. Mirre**  
Corporate Executive &  
Professional Recruitment  
NCR Corporation  
Dayton, Ohio 45479



An Equal Opportunity Employer

## Even Webster's Knows About QUEST

**QUEST** (kwest). v. 1. To make a search; to go on a quest.

**QUEST SYSTEMS, INC.** n. 1. A corporation founded in 1968. 2. The largest professional recruitment firm in the U.S. functioning solely in the computer sciences; its client companies pay all employment fees, interviewing and relocation expenses. Quest is known for its deep personal commitment to relate to each candidate as an individual with individual goals. 3. Its professional staff averages over 6 years of experience in EDP recruiting (additionally, staff members have direct hands-on experience in programming, systems, hardware sales, etc.) 4. Quest is presently searching for programmers and analysts (commercial, scientific, systems software) for over 3,500 client companies in the U.S. *Quest has openings in over 700 U.S. towns and cities.* 5. Methodology — see Questsystem.

**QUESTSYSTEM** (kwest sis'tem). n. 1. Discussing with an individual what he would like to be doing in light of what he has been doing. 2. Analyzing the realities of his objectives as they relate to the current job marketplace. 3. Contacting client companies and other Quest staff personnel to identify positions of possible interest. 4. Introducing the job candidate to his prospective employers by providing complete details to each about the other, ensuring the efficacious use of everyone's time. 5. Arranging interviews. 6. If employment offers are extended, Quest assists in evaluating the responsibilities, compensation and opportunities (and relates those to the initially stated objectives). The Questsystem has been working for thousands of professionals at no expense, whatsoever. Ask your friends of their past dealings with Quest. Then, put the Questsystem to work for you. For additional information on this subject, please inquire directly to Quest Systems, Inc. (All inquiries/resumes received will be responded to immediately and in confidence.)



**QUEST SYSTEMS INC.**

6400 Goldsboro Road  
Washington, D. C. 20034 (301) 229-4200

Baltimore: (301) 265-1177 • Philadelphia: (215) 667-3322

CIRCLE 210 ON READER CARD

## CORPORATE STAFF MANAGEMENT INFORMATION SYSTEMS

### Florida Location

Harris, a Fortune 500 Corporation, has established a new facility in Melbourne, Florida, for corporate MIS operations. This provides an outstanding opportunity for career growth and recognition for creative, proven, results oriented professionals.

We are looking for qualified individuals who will be key participants in integrating the MIS function with the long range plans of the Corporation. Broad knowledge of business operations, hardware, software, communications networks, and operations analysis is required. Candidates must be able to work with all levels of management and have potential for advancement to an executive position in MIS or Operating Management. Background with electronic or related industries is desirable.

### MANAGER-MARKETING/CUSTOMER SUPPORT SYSTEMS

Requires expertise in design and implementation of computerized business systems in support of Market Forecasting, Sales Leads and Inquiries, Field Service Failure Reporting, Service Inventories, and Order Administration. Ten years combined business and systems experience.

### DATA COMMUNICATIONS SPECIALIST

Plans, designs, and develops systems and networks for computer communications. Responsible for consulting with internal users as to requirements, selection of equipment and communications services, configuring networks, specifying components, and implementation. Will coordinate installation and select services to meet immediate needs as well as define data portions of a long-range corporate telecommunications network.

### CUSTOMER SERVICES COORDINATOR

User oriented individual required to assist decentralized divisions in effective use of the Corporate Information Processing Facilities. Specific responsibilities include resolution of customer problems, analyzing job stream requirements, work flow scheduling, and general assistance to customers with design and analysis of data base systems. Position requires at least three years of experience in business systems analysis and programming (COBOL, expertise in O/S JCL, strong communicative skills).

### SYSTEMS PROGRAMMER

Experienced Systems Programmer with extensive assembly language experience to provide Systems Software support for on-line data base systems. Must be experienced with BTAM and 3270 (or equivalent) devices and possess familiarity with OS 360/370 internals.

Please send resume with salary history in confidence to: R.W. Underhill, Harris Corporation, P.O. Box 430, Melbourne, Florida 32901.



**HARRIS**  
COMMUNICATIONS AND  
INFORMATION HANDLING

An Equal Opportunity Employer—M/F and Handicapped

CIRCLE 206 ON READER CARD

**DATAMATION**

# advertisers' index

ABAQUEST .....	208
ADAPSO .....	181
Advance Access Group, Inc. ....	154
American Management Systems Division .....	222
American Telephone and Telegraph Company .....	118, 119
Ames Information Systems .....	54, 55
Anderson Jacobson, Inc. ....	263
Applications Software, Inc. ....	301
Applied Data Research .....	5
Applied Digital Data Systems Inc. ....	79
ARAMCO Services Company .....	297
Athana Corporation .....	11
Atlantic Research Corporation .....	294
Aydin Controls .....	57, 59
Basic/Four Corporation .....	184
Basic Timesharing Inc. ....	279
John Beall & Company, Inc. ....	275
The Bendix Corporation, Industrial Controls Division .....	286
†Benson .....	244-E
†Binder Magnete GmbH .....	244-N
Boeing Computer Services, Inc. ....	218, 310, 316
Boole & Babbage .....	291
Bruning Division of Addressograph Multigraph .....	318
Bunker Ramo Corporation, Information Systems Division .....	28
Bureau of International Commerce .....	244
†Bureau of International Commerce .....	244-NN
Cable & Wireless .....	205
California Computer Products, Inc. ....	18, 19
Cambridge Systems .....	303
Centronics Data Computer Corp. ....	20
†CGS Products .....	244-MM
Cii Honeywell Bull .....	158
Cincom Systems, Inc. ....	215
Cipher Data Products, Inc. ....	130, 131
Clapp & Poliak, Inc. ....	163, 164, 165
Codex Corporation .....	212
Computer Associates, Inc. ....	213
Computer Devices .....	219
Control Data Corporation .....	2, 52, 53
Cullinane Corporation .....	35
Data General .....	14, 170, 235, 274
Data 100 Corporation .....	216, 217
†Data Recording Instrument Company Ltd. ....	244-I, 244-V
DatagraphiX .....	39
DATAMATION Marketplace .....	293, 295
DATAMATION Mini/Microcomputer Survey .....	224

From the "bottom line" people . . .

## Truly decentralized data entry just became practical, economical



**. . . and available!**

Now, without specialized training, regular office personnel can quickly capture data on pages or documents virtually at *the source* . . . at any workstation, in any office.

Two new Scan-Optics OCR systems, the 506 and 515 (8 models in all) give you performance ranging from 30 documents or 3 pages per minute up to 60 documents or 7½ pages per minute. All operate off-line. All handle a variety of OCR fonts and handprint. Designed for use in decentralized installations, each contains a mini-computer, scanner, CRT display/keyboard and data storage.

Optional features include communications capability, line printers and more.

For complete information, write Marketing Manager, or call toll-free 1 (800) 243-8791 • TWX: 710/425-6130

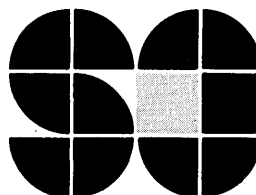

SCAN-OPTICS, INC.  
22 Prestige Park  
East Hartford, Ct. 06108  
203/289-6001

# advertisers' index

Datapoint Corporation	44
Dataproducts	122, 123
Datamedia Corporation	223
Dataram Corporation	116
Datum, Peripheral Products Division	207
Dayco Corporation, Printing Products Division	269
Delta Airlines	286

Delta Data Systems Corporation	125
Diablo Systems Incorporated, A Xerox Company	48
Digi-Log Systems, Inc.	121
Digital Equipment Corporation	313
Digital Pathways Inc.	230, 275
Documation Incorporated	7
Dylakor Software Systems, Inc.	319, 320
Eastman Kodak Company, Business Systems Markets Division	24, 25, 228, 229

Electronic Memories & Magnetics Corporation	234
EMI Technology	244-Y, 244-Z
Epic Data Corporation	136
Epicom, Inc.	272
Evans & Sutherland Computer Corporation	38
Ex-Cell-O Corporation, Remex Division	160
Fenwal Incorporated	32
Fluor Corporation	298
Four-Phase Systems	62
Fox-Morris Personnel Consultants	306

## CAO/CAM DATA BASE MANAGER

Boeing Computer Services, Inc., is seeking an experienced data base systems manager for integrated Computer Aided Design and Computer Aided Manufacturing data base systems.

The selected candidate will organize and direct data base systems to manage aircraft design data storage, retrieval, control and linkage to product design, tool design and manufacturing numerical control programming operations. U.S. citizenship is required.

We would like to hear from you if you:

- Have managed the development and operation of large scale data base systems.
- Understand current data base systems technology trends and options.
- Desire the challenge of managing critical technical advancements.

Attractive salary fringe benefits and moving allowances will be offered qualified candidates. And living is a pleasure in the unspoiled Northwest with its many recreational and sports activities and relaxed lifestyles.

Look into these outstanding opportunities.

Send your detailed résumé to The Boeing Company, P.O. Box 3707-JHT, Seattle, WA 98124.

An equal opportunity employer.

**BCS**

BOEING COMPUTER SERVICES, INC.

Gates	315
General Automation	82, 83
General Electric, Data Communication Products Department	36, 37
General Electric Information Service Business Division	156, 157
Gould Inc., Instrument Systems Division	Cover 3
Graham Magnetics	180
GTE Automatic Electric	314
Harris Computer Systems	200, 201
Harris Corporation, Communications and Information Handling	308
Harris Corporation, Data Communications Division	23
Hazeltine Corporation	179
Heath Company	137
Hewlett-Packard	86, 87, 105-114, 186, 187
Honeywell Information Systems	211
Houston Instrument, Division of Bausch & Lomb	209
IBM Data Processing Division	151, 152, 153
Image Systems, Inc.	146
IMSAI Manufacturing Corporation	60, 61
Incoterm Corporation	95
Infodata Systems Inc.	243
InfoNational	261
Inforex	264, 265
Informatics Inc., Software Products	17
Information Processing Incorporated	268
Information Terminals Corp.	225
Informer	226
Infotek Systems	220, 271
Infoton	129
Insyte Datacom Corporation	58
Integrated Software Systems Corp.	155

Intelcomm 77 .....	292
Interactive Systems Corporation ..	305
Interdata, A Unit of Perkin Elmer Data Systems .....	195
Interface West, Inc. ....	232, 233
Itel Corporation .....	172, 173
Johnson Systems Inc. ....	268
Kennedy Co. ....	Cover 2
Kybe Corporation .....	258
Lear Siegler, Inc./Electronic Instrumentation Division .....	45
Lesametric, Division of Metric Resources Corporation .....	167
The Library of Computer and Information Sciences ..	245, 246, 247
LRK Associates .....	311
Magnetic Shield Division, Perfection Mica Company .....	293
Maxell Corporation of America .....	138
Megadata Corporation .....	4
Megatek Corporation .....	257
Memorex .....	133
†Memorex Corporation ..	244-HH, 244-II
Mentel, Inc. ....	227
†Microtecnica .....	244-OO
Mini Computer Accessories .....	270
Moore Business Forms, Inc. ....	143
Motorola Government Electronics Division .....	312
National CSS .....	294
NCR Corporation .....	308
NCR Special Systems Division .....	299
NCR Terminal Systems Division ..	306
Network Systems Corporation .....	260
Newman Computer Exchange .....	305
†Norsk Data Electronics A.S. .....	244-EE, 244-KK
On-Line Business Systems, Inc. ....	267
Ontel Corporation .....	242
Optical Business Machines, Inc. ...	88
Pansophic .....	266
Perkin-Elmer Data Systems .....	102, 280, 281
Pertec Computer Corporation, CMC Division .....	1
Pertec Peripheral Equipment Division .....	98, 99

PolyMorphic Systems .....	33
Prime Computer, Inc. ....	144, 145
†Philips Industries .....	244-P
Printronix, Inc. ....	171
Quest Systems Inc. ....	308
†Racal-Milgo Limited .....	244-U
Raytheon Service Company .....	231
RCA Data Services .....	256
RJ Reynolds Industries, Inc. ....	306

Ricoh of America, Inc. ....	43
Rockwell International .....	100
†R 2 E .....	244-S
Rusco Electronic Systems .....	204
†Saab-Scania .....	244-BB, 244-CC
Scan-Optics, Inc. ....	309
Schlage Electronics, Inc. ....	188
Science Accessories Corporation ...	174
Shugart Associates .....	185
Software International .....	304
Software Module Marketing .....	132

# Tackle The Tough Ones

"TOP DOWN" definition and design concepts call for a high level of engineering skill. These positions are long term, continuing project assignments on the staff of a Top-10 Electronics Manufacturer. We're looking for in-depth experience in the following areas: COMMAND & DECISION SOFTWARE DEFINITION & DESIGN; SOFTWARE SYSTEMS DESIGN & DEVELOPMENT; INTELLIGENCE SYSTEMS SOFTWARE DESIGN; RADAR SOFTWARE SYSTEMS; NAVAL SYSTEMS; SHIP INTEGRATION (Mechanical/Electrical); COMBAT SYSTEMS; SIGNAL PROCESSING DESIGN; DIGITAL DESIGN; MICROWAVE DESIGN.

If you have been working at the state-of-the-art in one or more of these fields, we want to talk with you about an outstanding offer; excellent benefits; relocation to an attractive suburban area near ocean resorts, and significant opportunity for professional advancement. Please send your resume to LRK ASSOCIATES, 6845 Elm Street, (D-9), McLean, Virginia 22101.

U.S. CITIZENSHIP REQUIRED  
 Representing an Equal Opportunity Employer M/F/H

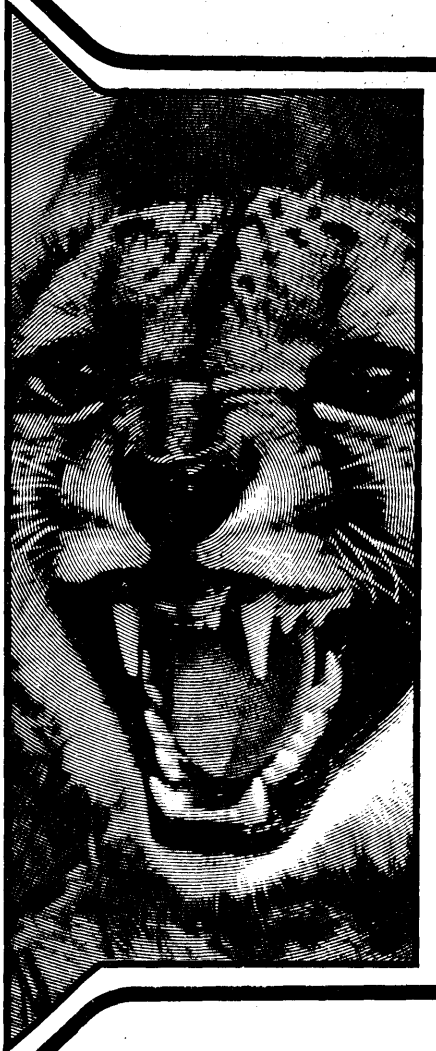

LRK

ASSOCIATES

CIRCLE 207 ON READER CARD

# Guard against data thieves.

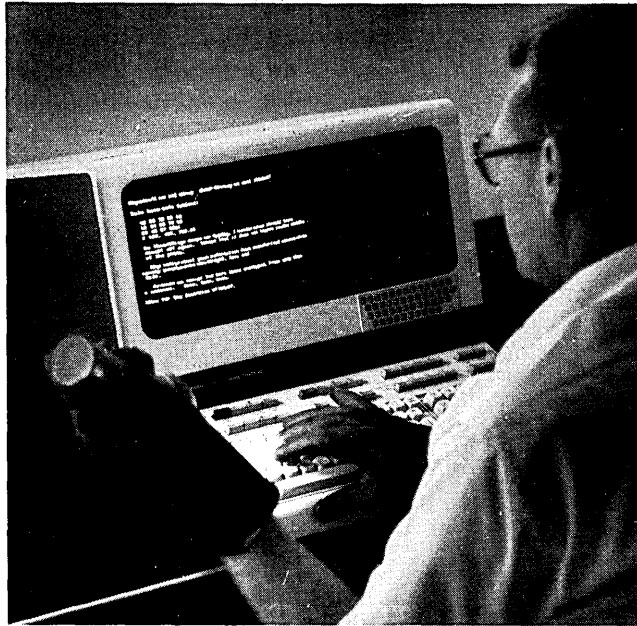

Computer-information thieves are among the most sophisticated of all white-collar criminals. Data transmission, processing, and storage are all open to the potential threat. Whether you are using small, medium, or large-scale computers or shared-resource networks.

## Motorola's Info-guard™ system protects data against unauthorized access.

All Info-guard systems provide hardware, not software, protection for your computer information using the National Bureau of Standard's algorithm . . . an encryption code adopted by the U.S. Government to make it virtually impossible for information thieves to electronically crack your system.

OEM compatible, or simply added on to interface with operating computer systems.

Info-guard's designed-in protection is based on decades of experience in building secure communications for national defense.

If you're interested in making your computer data electronically safe, you need copies of the free booklets, "Computer Threats" and "The Info-guard Security Kit." Then we can talk about hardware prices and delivery. Call James Booth, 602/949-4111 or write to him at Motorola Government Electronics Division, Dept. G-1, P.O. Box 2606, Scottsdale, AZ 85252.



# MOTOROLA

CIRCLE 172 ON READER CARD

## advertisers' index

Source EDP .....	307
Spectron Corporation .....	317
Sperry Univac, A Division of Sperry Rand Corporation .....	176, 177
Standard Memories, An Applied Magnetics Company .....	196
†Stansaab Elektronik AB .....	244-GG
†Summa Computer Services Corporation .....	244-LL
Summagraphics Corporation .....	34
Sweda International, OEM Products .....	295
Sycor .....	140, 141
†System Industries .....	244-M
Systems Engineering Laboratories .....	168, 169
†Systems 77 .....	244-NN
Systonetics, Inc. ....	289
Tab Products Company .....	221
Tally Corporation .....	166
Tandem Computers, Inc. ....	192, 193, 306
T-Bar Data Communications Switching Division .....	178
Technical Publishing Company .....	307
TEC Incorporated .....	46
Techtran Industries Inc. ....	270, 271
Tektronix, Inc., Information Display Group .....	31
Telcon Industries, Inc. ....	296
Telefile Computer Products, Inc. ....	134, 135
Teletype Corporation .....	197, Cover 4
Texas Instruments Incorporated .....	12, 13, 182, 183
3M Company, Microfilm Products Division .....	282
3M Company, Static Control Systems .....	9
TRANSCOM, A Subsidiary of Hi-G, Inc. ....	302
TransNet Corporation .....	230
†TRW Datacom International .....	244-F
†Turnkey Systems Inc. ....	244-J
United Airlines .....	277
University Computing Company .....	50, 51, 148, 149
The Vadic Corporation .....	175
Value Computing Inc. ....	285
Versatec, A Xerox Company .....	126, 127
Wang Laboratories, Inc. ....	287
Western Peripherals .....	142
Western Union Data Services .....	236, 237
Wright Line, A Division of Barry Wright Corporation .....	27
Xerox .....	56
Zeta Research .....	273
Zilog .....	40, 41

†European Insert Advertisers



## Technical Publishing Company

Arthur L. Rice, Jr., Chairman of the Board  
James B. Tafel, President & Chief Executive Officer

Gardner F. Landon, Exec. Vice President  
Robert L. Dickson, Exec. Vice President  
Calverd F. Jacobson, Financial Vice President and Treasurer

Thomas A. Reynolds, Jr., Secretary  
M. Jay Turner, Jr., Director of Publishing Services  
Paul C. Jarvis, Director of Information Services

### Advertising Offices

#### Eastern District Managers

A. Treat Walker,  
Warren A. Tibbetts: Greenwich, Ct. 06830  
35 Mason St. (203) 661-5400

New England District Manager & Vice President  
Warren A. Tibbetts: Manchester, N.H. 03104  
112 W. Haven Rd  
(603) 625-9498

#### Midwest District Manager

John M. Gleason: Chicago, Ill. 60611  
444 No. Michigan Ave.  
(312) 644-3970

#### Western District Managers

Alan Bolté, Jr.: Los Angeles, Calif. 90035  
1801 S. La Cienega Blvd.  
(213) 559-5111

James E. Filiatrault: Mountain View, CA 94043  
2680 Bayshore Frontage Rd.  
Suite 401  
(415) 965-8222

#### U.K., Scandinavia, Benelux

Intergroup Communications, Inc.  
Wallace K. Ponder, European Director  
Paul D. Dimmock, Regional Manager  
31 Lyncroft Avenue  
Pinner, Middx, HA5 1JU  
England  
Tel: (01) 868 9289  
Cables: PACOM, Pinner

#### Germany, Austria, Eastern Europe

Fritz Taeuber  
Soltauer Strasse 85  
D-314 Lueneburg  
Germany  
Tel: (0 41 31) 4 38 49

#### France, Switzerland, Italy, Spain

Gerard Lasfargues  
32 rue Desbordes Valmore  
75016 Paris  
France  
Tel: (1) 288 90 22

#### Japan

Shigeru Kobayashi  
Japan Advertising Communications, Inc.  
New Ginza Building  
3-13 Ginza 7-chome  
Chuo-ku, Tokyo 104, Japan  
Tel. (03) 571-8748

### Technical Publishing Company



Business Magazines  
Consumer Books  
Training Systems

Consulting Engineer  
Datamation  
Electric Light & Power  
Plant Engineering  
Plant Engineering Directory and Specifications Catalog  
Pollution Engineering  
Power Engineering  
Purchasing World  
Research/Development  
TPC Training Systems  
DBI Books, Inc.

# The Software Documentation people we're looking for probably aren't looking for a job.

We're the Digital Software Documentation Group, a proud collection of Writers and Editors. We like being part of this organization, not just because Digital is an important computer company, but because we're important to Digital.

We are on an equal footing with the Software Development organization, not a step below it. This is reflected in our salaries, our autonomy, our enthusiasm, and our corporate clout. We're not used to getting a lot of empty promises. What we do get is the necessary funding for our projects and enough freedom to produce the kind of documentation end-users can really sink their teeth into.

We have some of the best software documentation people in the business. And now we want the rest of the best because this group is determined to produce nothing but the highest quality work. We're looking for great Writers, Editors, and Programmers with a flair for writing; people doing fine where they are but who would thrive in an organization that provides a great challenge to grow.

## What Do We Offer You?

An opportunity to work for a company that recognizes the importance of software documentation; to be an integral part of the development team.

An opportunity to work with a highly autonomous, highly charged group, where quality, not volume, is the objective.

An opportunity to experience real freedom, to take what has to be done and put your personal stamp on it.

An opportunity to have real impact on the support group, Digital, and the industry as a whole.

An opportunity to be catapulted forward in your career and choose your own directions to move in. You can follow either the administrative or technical path of our dual career program. Either way there will be personal satisfaction and, of course, compensation.

If this is the kind of involvement you're looking for—or if you'd just like to learn more about us—let's talk.

Forward your resume to Theresa Buckley,  
Digital Equipment Corporation, Dept. 8,  
146 Main Street, Maynard, Massachusetts 01754.

We're the company looking for people.

**digital**  
digital equipment corporation

an equal opportunity employer m/f





# Advanced Software Design

## Applications/ Systems/Data Base Design

Telecommunications is one of the most rapidly growing segments of the software frontier. We have major projects underway now . . . forerunners of our long-term commitment to significantly advancing the state-of-the-art. We're working from definition and design through development and implementation in areas such as CAD, Data Base Systems, Simulation, Fault Recovery, Diagnostics and many areas of software design in an on-line, real-time environment.

## Software Design Engineers

We're looking for an indepth background in the development of systems software and a minimum of 3 years' experience in structured design, testing and documentation of programs running on large data base, multi-file systems in real-time. Familiarity with HIPO design documentation, TSO usage and software simulation techniques as well as PL1, Fortran and assembler languages for the 8080 and PDP 11 programming is also important.

## Data Base Design

You will need a minimum of 5 years' experience in the planning, development, design and implementation of data base software, including data base management systems administration. Your primary responsibilities will be the development of data base system for a large on-going project including the implementation, support and administration of systems.

## Computer Aided Design

We are looking for an extensive background in the design of CAD/CAM systems and the development of Interactive access by the users of CAD/CAM functions. Required is 5-10 years' experience in both hardware and software aspects; DA systems operations, and design, and systems engineering. Your initial responsibilities will include evaluation of existing systems, and working with a project team in the Architectural Planning of a major new system.

## Mini-Computer Programmers

We have specific assignments available on project development teams responsible for the design implementation of various telecommunication processing systems utilizing mini-computers as the processing element. Responsibilities will include the development of software programs for real-time operating systems as well as unique hardware elements incorporated into the systems.

If you have in-depth expertise in one or more of these areas, a BS, MS or PhD in Electrical Engineering, Computer Science, Math or other appropriate engineering discipline and have an interest in moving forward with one of the challenging new frontiers in computer technology, talk with us.

**CALL TOLL FREE**  
**(800) 323-1966** In Illinois (800) 942-0491

Monday thru Friday,  
from 8 am to 5 pm cst

If unable to call, please send your resume to:  
Paul Jensen or Doug Allen

**GTE** **AUTOMATIC  
ELECTRIC**

400 N. Wolf Road  
Northlake, IL 60164

An Equal Opportunity Employer M/F

This forum is offered for readers who want to express their opinion on any aspect of information processing. Your contributions are invited.

---

# the forum

---

## The Dimensions of Complexity

In his now classic paper, "Structured Programming" (Rome NATO Conference, October 1969), Edsger Dijkstra explained that his concern is with "intrinsically large programs" and that "the leading question [is whether it is] possible to increase our programming ability by an order of magnitude." He concludes that it is possible and implies that it is necessary to achieve such a gain.

But "intrinsically large programs," no matter how complex they may be, in Prof. Dijkstra's judgment never require more than a small number of people during the course of their construction. That is, he confines his domain of interest to the consideration of intellectual complexity. He does not deal with organizational complexity except to deny its necessary existence, at least with respect to programming.

Beginning with reports of the activities of Harlan Mills, various accounts of productivity gains have appeared in literature. Much credit is given to Dijkstra (perhaps more than he would like), but the proclaimed improvements are also ascribed to the Chief Programmer Team organization, which is Mills' concept.

It is my contention that, while Dijkstra has ignored it, Mills has not dealt meaningfully with organizational complexity. Fred Brooks, in his satirical treatment of the Chief Programmer Team concept, points out the same thing. The problem is to improve the productivity of somewhat larger organizations, composed of real people, operating in real environments. And it is important to agree that the gains also are "real." It is the need for agreement which makes it difficult to find suitable universal measures.

What has been demonstrated so far is that small groups of competent people can apply the ideas of Dijkstra (and others) to the construction of reasonably complex programs and produce them better and cheaper than, tradition has it, had been the case in the past. What has also been demonstrated is that the gains (which have been confined largely to new programs) usually are measured in terms of lines of code produced per mythical man-month.

Lines of code produced per unit of human energy is certainly a measure. In some cases it may be a good measure; in others a bad or even useless one. But what it

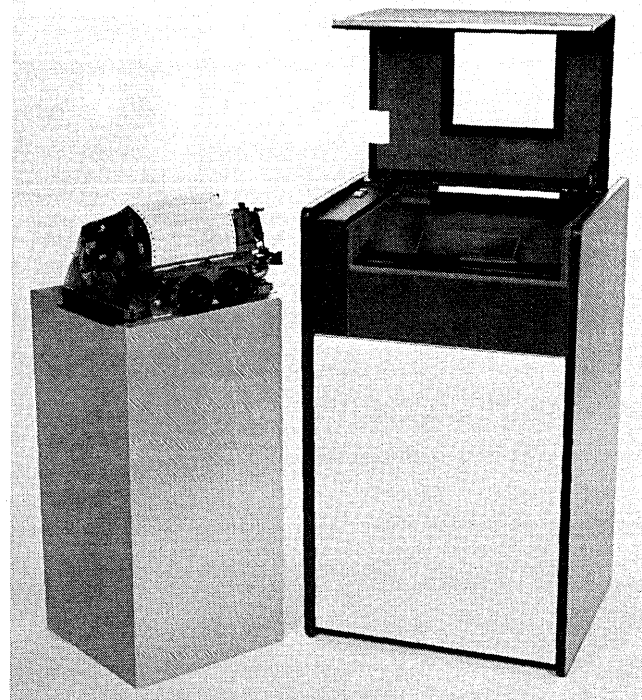

## HOW TO QUIETLY IMPROVE YOUR TELETYPE® MODEL 40 PRINTER. (Even if you haven't bought it yet.)

The Model 40 is an excellent printer. But it's even better when you enclose it in a Gates Sound Controller. It becomes so quiet that you can place it anywhere without distraction.

### DESIGNED FOR YOUR MACHINES

If you're getting a new printer, you can order a complete Gates Sound Controller instead of a regular teletype case. You'll actually save money. Or you can order Sound Controllers for the printers you already have. Every Sound Controller has a built-in cooling system and space for paper storage.

### DESIGNED FOR YOUR PEOPLE

All controls are easily accessible from outside the cabinet. So there's no problem with operation or servicing.

### DESIGNED FOR YOUR DECOR

Gates Sound Controllers look as good as they sound. The styling is attractive, and colors can be selected to harmonize with your own decor.

### COAST TO COAST SAVINGS

Only Gates has plants on both coasts so your order can be delivered promptly. With more than 35 years of experience, Gates is America's most trusted name in Sound Control. *We make superb Sound Controllers for more than 250 business machines, including all terminals and word processors.*

Call us toll free 800-358-8265. In California, call collect 707-544-2711.

# GATES

**WE'RE QUIETLY IMPROVING THE BUSINESS WORLD**

Gates Acoustinet, Inc., Box PP, Santa Rosa, California 95403

CIRCLE 193 ON READER CARD

# SOFTWARE SPECIALISTS

Boeing Computer Services, Inc., in Seattle, Washington is seeking experienced computer professionals for important assignments in the following areas:

## COMMAND AND CONTROL/REALTIME SYSTEMS

- Design, development and test of Realtime software for command and control weapons systems, communications systems and ground support.
- Development of simulation and training software for Realtime surveillance systems.

## COMPUTING METHODS AND TECHNOLOGY/SYSTEM DESIGN AND ANALYSIS

- Design, development, programming and formal documentation of the Realtime executive component of a large, complex command and control system.

## DATA ANALYSIS SYSTEMS

- Development of interactive graphics software using a TEKTRONIX 4051 interfacing with a CDC 6600.

## SOFTWARE TEST AND VERIFICATION

- Development, verification, qualification and formal documentation of software test requirements and procedures.

## MINI-COMPUTER SYSTEMS SPECIALISTS

- Mini-computer application analysis, system design and software analysis for data reduction/acquisition, data entry, data base management and output processing.
- Design DC mini-business and scientific systems. Experience with Realtime mini-computer simulation of missile flight dynamics and analysis of radar data and message switching.

- Development, maintenance and preparation of comparative analyses of mini-computer software and operating systems.

## OPERATING SYSTEM PROGRAMMERS

- Maintain NOS 1.0 or KRONOS 2.1 operating systems.
- Requires in-depth knowledge of CDC 6600, CYBER 70 and 170 hardware.

## COMPUTER AIDED DESIGN/ MANUFACTURING

- N/C Systems Analysts and Programmers to integrate the APT system with Process Control Computer Systems.
- Systems Analysts for design and maintenance of N/C distributed system software.
- CAD/CAM Software Designers to design and implement software to integrate CAD/CAM interactive mini-computer graphics systems with large scale computers.

## DATA BASE DESIGNERS/ANALYSTS

- To design, develop and implement physical and logical data base applications using IMS, IDMS, System 2000, CICS, or distributed processing.

## DATA PROCESSING INSTRUCTORS

- Requires experience in Structured Programming/Design or IMS.
- Instructor experience desired.

Attractive salary, fringe benefits and moving allowances will be offered qualified candidates. And living is a pleasure in the unspoiled Northwest with its many recreational and sports activities and relaxed life-styles.

Look into these outstanding opportunities.

Send your detailed résumé to The Boeing Company, P.O. Box 3707-JHV, Seattle, WA 98124.

An equal opportunity employer.

**BCS**

BOEING COMPUTER SERVICES, INC.

# the forum

can never be is a universal measure.

(Please note that this is not the same thing as saying that we should not know the number of lines of code in every system by component and module, along with whatever additional engineering data we find (locally) meaningful. Failure rates, cost histories, projected vs. actual sizes, error-days, schedule and delivery histories, by module, by component, by system, by team, by programmer, by department, etc.)

I question the wisdom of attempting to discover universal measures for problems which are, perhaps inherently and certainly practically, local in character. A universal measure is, by definition, a measure which is acceptable to the members of the concerned universe. Many people seeking improved productivity of systems and data processing organizations will not accept, nor should they accept, lines of code as a meaningful measure. But there must be measures and there must be agreement as to what they are. For those reasons, the productivity problem is a local one.

The productivity problem is also a systems problem. It is my opinion that for a sizable organization it is probably a more difficult systems problem than any of the other problems the organization is attacking. That is definitely not the case for small organizations. The reasons have to do with the dimensions of complexity, and a tendency on the part of many people not to take organizational complexity seriously enough.

Let's restate the productivity problem as follows:

**Problem:** To improve the productivity of a particular organization by a factor of, say, 10% per year, with the gain to be compounded annually for a period of several years.

**Constraint:** The gain must be expressed in terms which are understandable and acceptable to people beyond those whose productivity is being improved. For example, it is more important for senior management and the local using community to agree that the projected gains have been made than it is for people outside the local environment to concur with that judgment.

True, at the rate of 10% per year it will take us about seven years to double the productivity of a particular organization, and 25 years to reach the goal set forth by Dijkstra. But we have already spent 25 years wallowing in complexity . . . oceans of complexity . . . ever-expanding oceans with ever-higher tides. And despite our continuing technical achievements, the situation remains out of control. The problem transcends the work going on in software engineering which is largely confined to the intellectual dimension.

Dealing with organizational complexity is, in part, an intellectual problem which should be structured by someone I shall call an "architect." It is also a management problem. The idea that manager and architect are either interchangeable roles or simply two sides of a single person is a concept whose value is a decreasing function of the size of the organization. It stems from the heavy emphasis placed on individual excellence, particularly in higher education. The result is that by the time we have finished our formal education, we know little or nothing about organizational complexity, except that it is there. (We continue to concentrate on intellectual complexity in universities where, partly because of our failure to deal properly with organizational complexity, the student/teacher ratio and the student/administrator ratio are approximately equal!)

In any case, while the "manager is the architect" concept is valid for first line managers—professors, surgeons, leaders of small technical efforts, chief programmers, etc.—it

## Define your data communications problems

...with Spectron's modular switches and patches. Rapid "fault-isolation," system backup, and system reconfiguration is made possible with the ability to move your "data stream" to any front end, any port, any modem or any line—individually or in predetermined groups. Whether you are monitoring, switching, or patching, all 25 leads as defined in the EIA RS-232 specification are provided to protect against system obsolescence and let you benefit from technological advancements being offered by modem and front end manufacturers.

### Conserve capital

Your Spectron equipment expands with your data network—one circuit at a time, for the least cost in the least amount of space. Discrete data leads (SD, RD, CD, etc.) can be provided on each interface for rapid visual analysis of data traffic or automatic alarm intervention in the failure mode.

### All contacts are environmentally protected

The heart of our switches and patches utilize the most reliable form of switch ever devised—the magnetic reed. Each contact point is hermetically sealed in a glass envelope and operated by its own "uninterruptible power source" to allow system reconfiguration even during power outages.

Spectron switches and patches—the best answer you can find in data communications. We have become the industry leader by offering the best in cost/performance. From Spectron Corporation, the people who work with you to help you find the best answer to your data communications test and control requirements—from simple cables to the most sophisticated manual or automatically controlled tech control systems and diagnostic equipment.

**SPECTRON CORPORATION**

Specialists in Data Communications  
Church Road and Roland Avenue  
Mt. Laurel, N.J. 08057  
609/234/5700

# Doubles reading speed, instantly.



## Introducing the Bruning 97 pushbutton page/select viewer.

You can't read a page till you find it. And our new automated Model 97 viewer instantly locates the page you want, centered perfectly on the screen—with pushbutton ease and accuracy.

It works on the classic grid-map coordinate principle. Sounds simple, but only Bruning offers it in an automated microfiche viewer. And our pushbutton technique is faster and more efficient than tedious manual methods.

The Model 97 is ideal for multiple-frame searches on the same fiche, plus most sequential rapid-search applications.

Another aid to speed reading is its large 12" x 20" screen. It displays two full 8½" x 11" pages at 24X. Or single frames at 42X.

Contact your local Bruning office for a hands-on demo. Or write Bruning, 1834 Walden Office Square, Schaumburg, Illinois 60196.

**The bold force in micrographics.**



**BRUNING**

DIVISION OF  
ADDRESSOGRAPH MULTIGRAPH

CIRCLE 28 ON READER CARD

## the forum

has considerably less value if the problem is to design and implement a productivity improvement program for a sizable organization. There is no way that the top manager can be his own architect. He simply does not have the time to design a productivity improvement program which will have the required payoff.

Further, he may not have anyone in his department who has both the time and the capability to come up with the "architecture." Almost by definition, that person must have a deep insight into what is involved in managing a large organization. People with that sort of insight are likely to be managing departments and unavailable to serve as architects even if they could qualify.

I have used the term "architect" very loosely. To be more precise, there is really no such person as an architect. There are only architects with respect to certain problems, or classes of problems. If the problem is to improve the productivity of a particular organization, then an architect who can design an improvement program must be found. And both architect and architecture must be managed. In time I believe that we will come to depend upon architects of more traditional bents.

Defining, building, and installing a productivity improvement program for a reasonably large (100 to 1,000 people) organization is neither an intellectual exercise nor a seat of the pants management task. And it can not be waved away as a "team-of-teams" kind of thing, which is what some of those who have had success with small groups recommend. Neither is it a by-product of the installation of good technical practices, although that certainly is to be encouraged. It is a difficult systems problem and must be treated as such. Despite all of the talk about systems life cycle methodologies, most organizations simply do not deal with the productivity problem in a systematic way.

I conclude that:

1. Management must recognize that the productivity problem, for nontrivial organizations, is both intellectually and organizationally complex; to attack it on only one axis is a fatal mistake.

2. The productivity problem must be treated as a local problem with locally defined measures of success. Global measures have value only to the extent that they are acceptable locally.

3. It must be understood that an architecture is required, and that manager and architect have distinct responsibilities.

4. The training of productivity improvement architects is, itself, a nontrivial problem.

5. The problem of improving the productivity of a very large organization probably cannot be solved in a strictly top-down way. My feeling is that the way to attack such a problem is by systematically improving the components of the organization, subject to the constraint that a "component" can be no larger than, say, 1,000 people.

Finally, it seems that the invariant in building systems, whether we use the old or the new technology, is user unhappiness. (See "Data for Rent," May, p. 167 for another assessment of the famous *New York Times* project.) I think that this situation can be traced to our preoccupation with universal measures of productivity which, in turn, is a result of our failure to understand the nature of organizational complexity.

—Alonzo G. Grace, Jr.

Mr. Grace is president of his own company, A. G. Grace and Co., based in Glastonbury, Conn. His motto, as reflected in this Forum and appearing on his stationery, is "rational thought for all seasons."

# YOU'VE GOT THE REMOTE, WE'VE GOT YOUR GRAPHICS.

Gould's new Remote Graphics Processor gives you the speed, image clarity, ease of operation and cost effective graphics of an electrostatic plotter.

The RGP interfaces to most remote job entry and remote batch terminals, or can be operated stand-alone through a modem. With appropriate Gould host computer software, the RGP processes highly encoded character data which can be transmitted by your mainframe's standard spooling software.

Gould software is available for IBM 360/370, Univac 1100 Series and Control Data 6000, 7000 or Cyber 70 Series.

Paper speed is a function of the baud rate and the complexity of the plot, and can range from a rate of 0.04 to 1.0 in/sec — a substantial improvement

over pen plotters.

If you're already into remote graphics, you owe it to yourself to examine the RGP's potential. And if you're not now involved in graphics, let's talk anyway. Because you might be soon.

For more information on Gould's remote graphic capability, contact Gould Inc., Instrument Systems

Division, 3631 Perkins Avenue, Cleveland, Ohio 44114. Telephone: (216) 361-3315.

Or Gould Advance, Raynham Rd., Bishop Stortford, Hertz, Great Britain.

For brochure call toll-free (800) 325-6400 Ext. 77. In Missouri: (800) 342-6600.

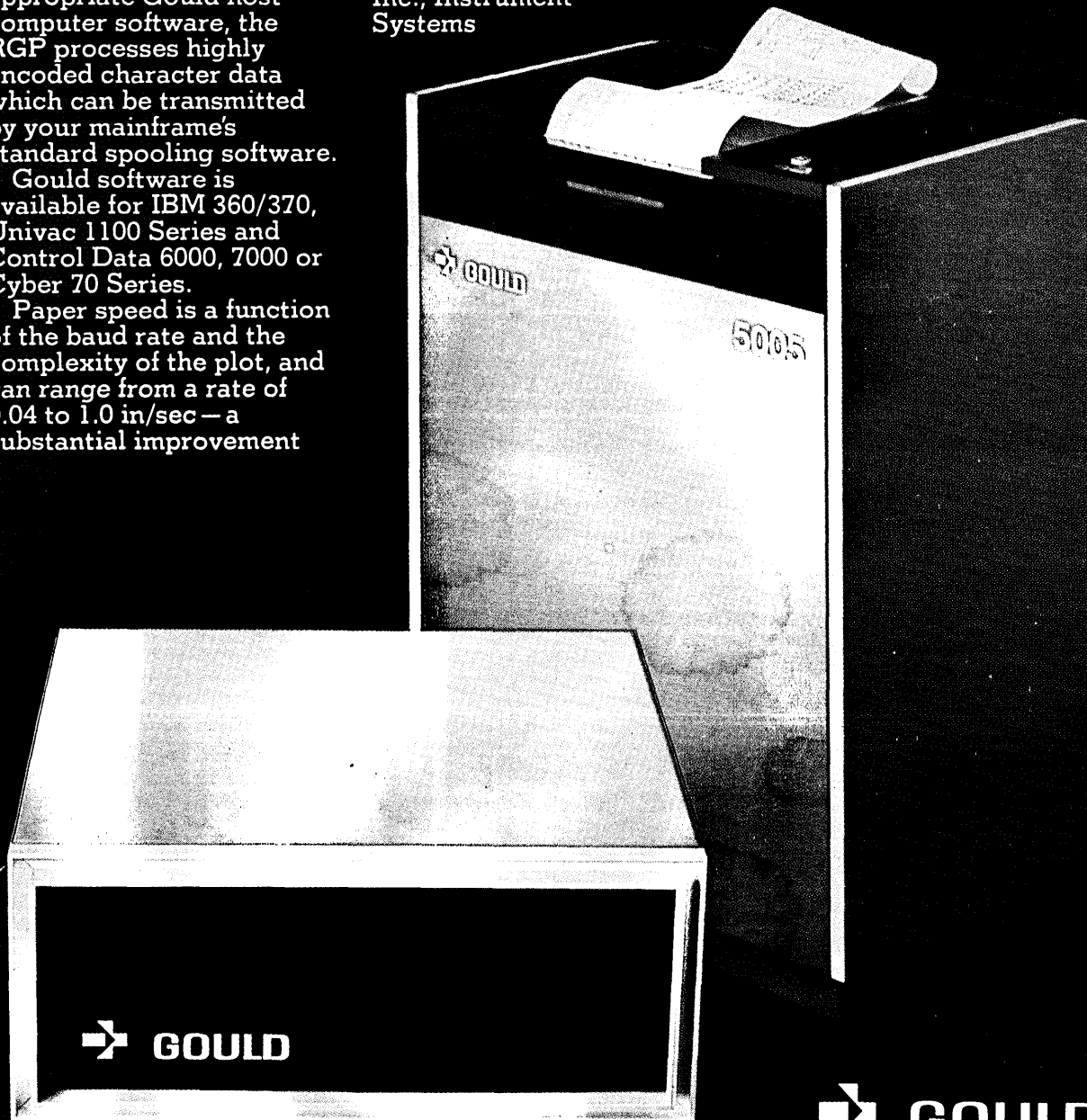

 **GOULD**

 **GOULD**  
The product development company



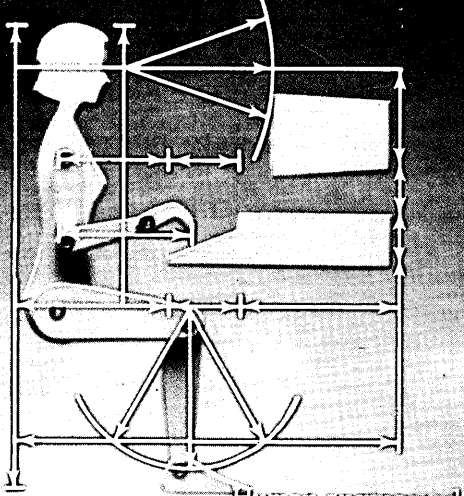

Human engineered for more throughput

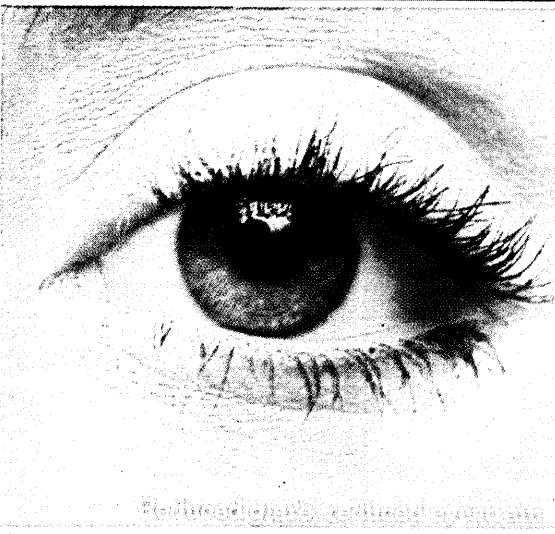

Redundant, redundant, redundant

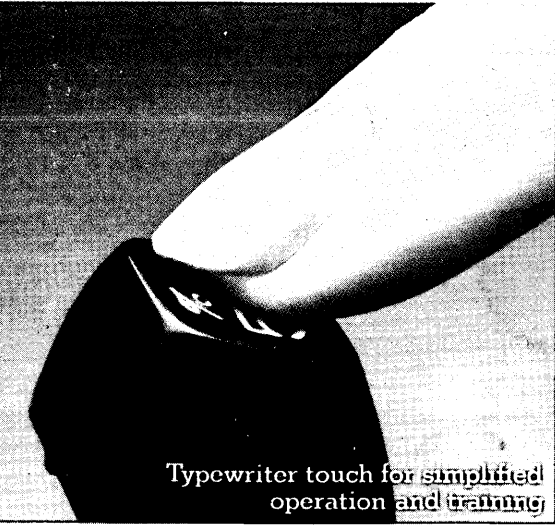

Typewriter touch for simplified operation and training

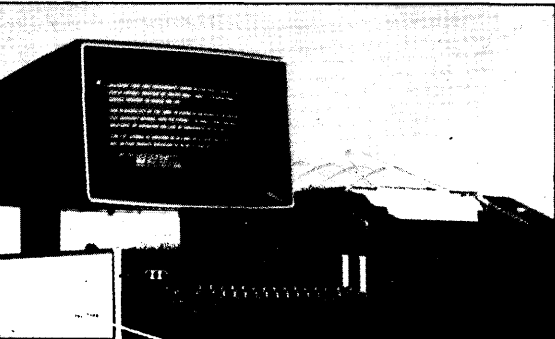

State of the art technology with a human touch.



**THE MOST SOPHISTICATED, COMPLICATED COMPONENT OF ANY DATA TERMINAL SYSTEM IS THE PERSON BEHIND THE CONSOLE.**

When we designed the Teletype<sup>®</sup> model 40 product line, we paid as much attention to human engineering as we did to electronic engineering. Simply because we don't think one makes much sense without the other.

After all, throughput is as much a function of operator performance as it is of advanced CMOS technology.

That's why we positioned the tube so it's a comfortable 19" to 21" from the operator. The tube isn't in a fixed position, either, but tilts through 20° to adjust for lighting conditions and individual viewing preferences.

To eliminate eyestrain, a specially darkened and etched glass is used on the screen to diffuse surface reflections and increase contrast by 100%. Even the large 7 x 9 display font is designed for legibility, with a flicker-free refresh rate of 60 times/second. Plus generous spacing between characters and lines increases readability even more.

Keyboard controls aren't just grouped by function so they look right, we made them "feel" right, too. Not only do they fit the fingers, they also duplicate the touch and feel of office typewriters.

As you can see, we think the best way to impress you with our model 40 product line is to make sure your operator is impressed. For more information, write: Teletype, 5555 Touhy Ave., Skokie, IL 60076. Or call: 312/982-2000.



Teletype is a trademark and service mark registered in the United States Patent and Trademark Office

CIRCLE 3 ON READER CARD