

AMPEX

**AMPEX 230/219
VIDEO DISPLAY TERMINALS
SERVICE MANUAL**

3515021-01

JUNE 1985

AMPEX MEMORY PRODUCTS DIVISION

**AMPEX 230/219
VIDEO DISPLAY TERMINALS
SERVICE MANUAL**

3515021-01

JUNE 1985

DISCLAIMER

Ampex Corporation makes no representation or warranties with respect to the contents of this manual and disclaims any implied warranties or fitness for any particular application. Ampex Corporation reserves the right to revise this manual without obligation of Ampex Corporation to notify any person or organization of such revision.

COPYRIGHT NOTICE

Copyright 1985 by Ampex Corporation. All rights reserved worldwide. No part of this publication may be reproduced without the express written permission of Ampex Corporation.

WARNING

This equipment generates, uses, and can radiate radio frequency energy and if not installed and used in accordance with the instructions in this book, may cause interference to radio communications. It has been tested and found to comply with the limits for a Class A computing device pursuant to Subpart J of Part 15 of FCC Rules, which are designed to provide reasonable protection against such interference when operated in a commercial environment. Operation of this equipment in a residential area is likely to cause interference in which case the user at his own expense will be required to take whatever measures may be required to correct the interference.

TABLE OF CONTENTS

Section	Paragraph	Page
I	OVERVIEW	
	1.1 Purpose and Scope	1-1
	1.2 References	1-1
	1.3 General Description.	1-1
	1.4 Ampex 230 Specifications	1-3
	1.5 Ampex 219 Specifications	1-5
II	INSTALLATION	
	2.1 Introduction	2-1
	2.2 Serial Port Interfaces	2-1
	2.2.1 Primary Port Interface	2-1
	2.2.2 Printer Port Interface	2-2
	2.3 User-Installable Options	2-3
	2.4 Installation Requirements.	2-3
	2.4.1 Space Allocation	2-4
	2.4.2 Input Power.	2-5
	2.4.3 AC Power Cord and Plug	2-7
	2.4.4 Interface Cable Connections.	2-7
	2.4.5 Keyboard Port Connection	2-7
	2.5 Power-On and Reset	2-9
	2.6 Self-Test.	2-9
III	THEORY OF OPERATION	
	3.1 Introduction	3-1
	3.2 General Description.	3-1
	3.3 Operation and Components of the Terminal Controller PWBA	3-1
	3.3.1 Input/Output Mapping and the CPU	3-4
	3.3.1.1 Display I/O	3-4
	3.3.1.2 Communication I/O	3-4
	3.3.1.3 Keyboard I/O.	3-4
	3.3.2 Central Processing Unit.	3-4
	3.3.2.1 Functions of the CPU.	3-4
	3.3.2.2 Buses Used for Interfacing.	3-5
	3.3.2.3 Memory Interfaces	3-6
	3.3.3 Operation of CPU Memory.	3-8
	3.3.3.1 Program ROM/PROM.	3-8
	3.3.3.2 Data RAM.	3-8
	3.4 Operation of Display Circuitry	3-8
	3.4.1 General Information.	3-10
	3.4.2 Operation of the PVTIC Chip	3-10
	3.4.3 Initialization Register Parameters	3-11
	3.4.4 Valid Address/Blanking and Sync Signals Relationship.	3-12
	3.4.4.1 Horizontal Sync	3-13
	3.4.4.2 Vertical Sync	3-15
	3.4.4.3 Cursor Signal	3-15
	3.5 Operation of the Display RAM	3-15
	3.6 Character Generation	3-15

TABLE OF CONTENTS (Continued)

Section	Paragraph	Page
III	3.7 Generation of Video Signals	3-16
	3.7.1 Basic Video	3-16
	3.7.2 Attribute Control Signals	3-16
	3.8 Operation of Serial Interface Circuitry	3-17
	3.9 Driver-Receiver Operation	3-17
	3.9.1 Primary Port - RS232C Interface	3-17
	3.9.2 Primary Port - Current Loop Interface (Option).	3-17
	3.9.3 Primary Port - RS422 (Option)	3-18
	3.9.4 Printer Port.	3-18
	3.10 Operation of Bus Interface Chip	3-18
IV	MAINTENANCE	
	4.1 Introduction.	4-1
	4.2 Test Equipment.	4-1
	4.3 Performance Testing	4-2
	4.3.1 Power On Self Test.	4-2
	4.3.2 Test Pattern.	4-2
	4.3.3 Keyboard Test	4-3
	4.4 Video Adjustments	4-3
	4.4.1 Brightness.	4-3
	4.4.2 Focus	4-5
	4.4.4 Horizontal Size	4-5
	4.4.5 Vertical Linearity.	4-6
	4.5 Troubleshooting	4-6
V	REMOVAL AND REPLACEMENT	
	5.1 Introduction.	5-1
	5.2 Subassembly/Parts Location.	5-1
	5.3 Preliminary Procedure	5-3
	5.3.1 Display (Bezel) Cover Removal and Replacement	5-3
	5.3.2 Pedestal Cover Removal and Replacement.	5-4
	5.3.3 Controller PWBA Removal and Replacement	5-5
	5.3.4 Power Supply PWBA Removal and Replacement	5-5
	5.3.5 Discharging the CRT	5-5
	5.3.6 Video PWBA Removal and Replacement.	5-7

Appendix A Instructions for Installing User-Installable Options
Appendix B Reference Drawings

LIST OF ILLUSTRATIONS

Figure	Title	Page
1-1	Ampex 230/219 Video Display Terminal.	1-2
2-1	Overall Dimensions.	2-4
2-2	Voltage Strapping Plug (Versions 1 and 2)	2-6
2-3	Ampex 230/219 Video Display Terminal.	2-8
2-4	Keyboard Port on Display Terminal	2-8
3-1	Terminal Basic Block Diagram.	3-2
3-2	Controller PWBA Block Diagram	3-3
3-3	Video PWBA Block Diagram.	3-9
3-4	PVTC Chip Timing Frame (80 Column x 26 Lines)	3-13
3-5	PVTC Chip Timing Frame (132 Columns x 26 Lines)	3-14
4-1	Video Adjustments	4-4
4-2	Dimensions of E Character	4-6
4-3	Interconnection Diagram	4-7
4-4	Video Waveform.	4-8
4-5	Vertical Sync Waveform.	4-8
4-6	Horizontal Sync Waveform	4-9
4-7	Vertical Deflection Waveform.	4-9
4-8	Horizontal Deflection Waveform.	4-10
5-1	Subassembly Location Diagram.	5-2
5-2	Removing the Display Cover.	5-3
5-3	Removing the Pedestal Cover	5-4
5-4	Discharging the CRT	5-6

LIST OF TABLES

Table	Title	Page
2-1	Primary Port Pin Signal Assignments	2-1
2-2	Printer Port Pin Signal Assignments	2-2
2-3	Input Power Requirements.	2-5
3-1	Program Instruction Memory Configurations	3-6
3-2	Attribute Delimiter Bits.	3-8
3-3	PVTC Chip Initialization Register Selection	3-10
3-4	RS232C Pin Signal Assignments	3-17
3-5	Current Loop Pin Signal Assignments	3-18
3-6	RS422 Pin Signal Assignments.	3-18
4-1	Test Equipment.	4-1
4-2	Bad Component Error Messages.	4-2
5-1	Subassembly and Parts List.	5-1

SECTION I OVERVIEW

1.1 PURPOSE AND SCOPE

This manual provides installation and maintenance information for the Ampex 230/219 Video Display Terminals. General information about the terminal, including specifications, is provided in this section. Installation procedures are explained in Section II. Section III is the general theory of operation. Maintenance information, including testing, definitions of error messages, adjustment procedures, and troubleshooting is included in Section IV. Section V provides removal and replacement procedures of the major components of the terminal. Appendix A gives installation instructions for user-installable options. Reference drawings and schematics are provided in Appendix B.

1.2 REFERENCES

Operation Manuals for the Ampex 230/219 terminals are available from Ampex. The part number for the Ampex 230 manual is 3515332-01, Rev B. The part number for the Ampex 219 manual is 3515453-01.

1.3 GENERAL DESCRIPTION

The Ampex 230/219 Video Display Terminals (henceforth referred to as the terminal) are a series of microprocessor-controlled, computer input/output peripherals. The terminals operate in either full-duplex or half-duplex; conversation, block, or line transmission modes, or local (non-transmission) mode.

Physically, the terminal is composed of three major subassemblies: display unit, keyboard, and pedestal unit (Figure 1-1). The display unit is a two-piece molded plastic case housing a cathode ray tube (CRT) and the electronic circuitry necessary to perform the display functions. The pedestal unit is also a two-piece plastic case. In it, are housed the circuitry necessary to perform the required interfacing and data communications functions of a video display terminal. The keyboard unit provides the interface between the terminal operator and the display/pedestal units. A single, coiled cable connects the keyboard to the pedestal unit.

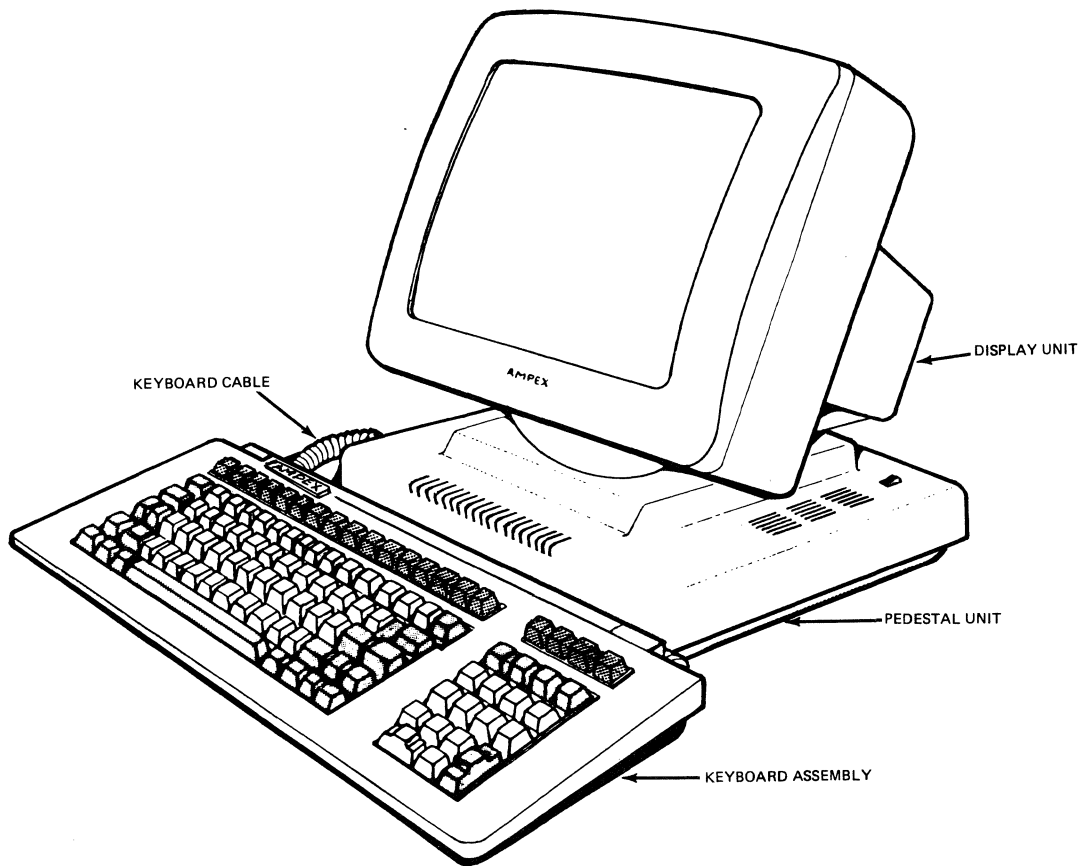

6350

Figure 1-1. Ampex 230/219 Video Display Terminal
(Major Subassemblies)

1.4 AMPEX 230 SPECIFICATIONS

The following is a list of operating characteristics and specifications for the Ampex 230 terminal.

Display Screen

14-inch nonglare screen
Green or amber phosphor
60 or 65 Hz refresh rate (operator-selectable)

Displayed Character Set

238 displayable characters
96 ASCII characters
32 control characters
15 line graphic characters
64 block graphic characters
31 national characters
24 data lines; 1 status line; 1 user-programmable line
2 display pages standard (optional 3rd and 4th pages)

Character Typestyle

7 x 10 dot matrix in a 9 x 12 dot field

National Character Sets

United States/United Kingdom
German
French
Swedish
Danish
Norwegian
Italian
Spanish

Video Attributes

Flash
Blank (security)
Reverse video
Underline
Half-intensity

Cursor

Block or underline
Flashing or Steady
No cursor
Readable and addressable

Cursor Control Keys

↑, ↓, ←, →, Home, Tab, Back Tab, Return,
Linefeed, Backspace

Keyboard

Low profile 30 mm DIN Standard
16 programmable function keys (32 shifted)
Audible keyclick (selectable on/off)
Adjustable slope of 7, 11, and 15 degrees
Detached, with coiled cable
Separate numeric keypad
Separate editing keys
Step-sculptured, selectric-type layout

Edit Keys

Line insert/delete
Character insert/delete
Erase to end of line
Erase to end of page

Emulations

Ampex 230, 210, D175, D150E, D150, D125, D80, D81, D30
TeleVideo 950, 925, 924/914
Wyse WY-50

Operating Modes

Full-duplex/half-duplex
Conversation, block, local
Protect, write protect
Programmable Function Key
Monitor
Set-up (operator-selectable operating parameters via status
line displays)
Split Screen
Extended Page
132-column
Double-size characters
Jump Scroll
Smooth Scroll (4 speeds)
Auto-Flip

**Primary Port and Printer Port Data Transmission Rates
(Independently-selectable)**

50, 75, 110, 150, 300, 600, 1200, 1800, 2400, 3600, 4800,
7200, 9600, 19,200, and 38,400 bits per second

Interfaces

Primary Port - RS232C (Standard) serial port
RS422 (customer-installable option)
Current Loop (customer-installable option)
Auxiliary Port - RS232C serial port

Regulatory Compliance

FCC Class A (United States)
UL (United States)
CSA (Canada)

Printer Functions

Local print (page print)
 Transparent print
 Extension (copy) print
 Unformatted print
 Bidirectional port on/off

Operating Environment

Temperature: 32°F to 104°F (0°C to 40°C)
 Humidity: 5% to 95%

Physical Dimensions

	Display Unit	Keyboard
Width:	13.5 in. (343 mm)	19.0 in. (483 mm)
Depth:	13.5 in. (343 mm)	7.5 in. (191 mm)
Height:	14.5 in. (369 mm)	1.5 in. (38 mm)
Weight:	19.4 lb (8.7 kg)	2.0 lb (0.9 kg)

Power Requirements

115 vac (+10%, -15%) at 0.5 amp, 60 Hz
 230 vac (+10%, -15%) at 0.25 amp, 50 Hz

Transmission Protocol

XON/XOFF
 DTR High/DTR Low

1.5 AMPEX 219 SPECIFICATIONS

The following is a list of operating characteristics and specifications for the Amplex 219 terminal.

Display Screen

14-inch nonglare screen
 Amber or green phosphor
 60 or 65 Hz refresh rate (operator-selectable)

Displayed Character Sets

174 displayable characters
 96 ASCII characters
 32 control characters
 32-special character and line graphic set
 24 data lines; 1 user line; 1 status line
 2 display pages standard (optional 3rd and 4th pages; user-installable)
 Double-high/double-wide characters

Character Typestyle

7 x 10 dot matrix in a 9 x 12 dot field

National Character Sets

United States
Denmark
France
Germany
Italy
Norway
Spain
Sweden
United Kingdom

Video Attributes

Blink, Reverse Video
Half-intensity, Underline (combination)

Cursor

Block or underline
Flashing or steady
Cursor On/Off
Readable and addressable

Keyboard

Low profile 30mm DIN Standard
16 programmable function keys
Audible keyclick (selectable on/off)
Adjustable slope of 7, 11, and 15 degrees
Detached, with coiled cable
Separate numeric keypad
Separate editing keys (VT-131 compatible)
Step-sculptured, selectric-type layout
4 PF keys (general purpose function keys)

Cursor Control Keys

↓, ↑, ←, →, Home, Tab, Back Tab, Return, Linefeed, Backspace, Enter

Edit Keys

Line Insert/Delete
Character Insert/Delete

Emulations

Ampex 219
DEC VT131, VT100/VT102, VT52
WY-75

Operating Modes

Full-duplex/half-duplex
Conversational, block (edit), local
Set-up, monitor

Display Format

80 or 132 column display
24-48 lines/page (96 lines/page optional)
Split screen
Auto-paging
Jump Scroll
Smooth Scroll (4 speeds)

**Primary Port and Printer Port Data Transmission Rates
(Independently-selectable)**

50, 75, 110, 134.5, 150, 300, 600, 1200, 1800, 2400, 3600, 4800,
7200, 9600, 19,200, 38,400 bits per second

Interfaces

Primary Port - RS232C (Standard) serial port
 RS422 port (customer-installable option)
 Current loop interface (customer-installable option)
Auxiliary Port - RS232C serial port

Printer Functions

Print screen
Auto print
Transparent print (Printer Controller)
Print cursor line

Operating Environment

Temperature: 32°F to 104°F (0°C to 40°C)
Humidity: 5% to 95%

SECTION II INSTALLATION

2.1 INTRODUCTION

The Ampex 230/219 Video Display Terminals may be operated in a wide variety of physical environments. The remainder of this section provides explanations and diagrams to assist the user during installation of these terminals.

2.2 SERIAL PORT INTERFACE

The Ampex 230/219 terminals use standard RS232C serial port interfaces for both the primary and printer ports.

2.2.1 Primary Port Interface

Table 2-1 provides interface pin signal assignments of the primary port.

Table 2-1. Primary Port Pin Signal Assignments

Pin No.	Signal Name	Signal Direction
1	Chassis ground	
2	Transmit Data Output	From Terminal
3	Receive Data Input	To Terminal
4	Request-to-Send Output	From Terminal
5	Clear-to-Send Input	To Terminal
6	Data-Set-Ready Input (optional)	To Terminal
7	Signal Ground	
8	Data Carrier Detect	To Terminal
20	Data-Terminal-Ready Output	From Terminal

Definitions Of The Primary Port Pins - The primary port conforms to the RS232C standard set forth by the EIA for a DTE.

Pin 20 - Data Terminal Ready - This pin is made active by the terminal when it is ready to receive or transmit data. If DTR handshaking protocol is selected via the Set-up menu, then Pin 20 can be used to control the flow of data from the host. Pin 20 becomes inactive when the input buffer is 50% full.

Pin 6 = Data Set Ready - The terminal expects this pin to be active before data can be either transmitted or received.

Pin 5 = Clear to Send - The terminal expects this pin to be active before data can be transmitted.

Pin 8 = Data Carrier Detect - The terminal expects this pin to be active before data can be received.

Pin 2 = Transmit Data Output - The terminal uses this pin to transmit data to the host.

Pin 3 = Receive Data Input - The terminal uses this pin to receive data transmitted by the host.

Pin 4 = Request to Send - The terminal makes this pin active prior to the transmission of data to the host in half-duplex mode. In full-duplex mode, this pin is kept active at all times.

Pin 7 = Signal Ground - The terminal uses this pin as a reference by where the other pins are judged active or inactive.

NOTE: If a pin is not connected it will be considered active.

2.2.2 Printer Port Interface

Table 2-2 provides pin signal assignments for the printer port.

Table 2-2. Printer Port Pin Signal Assignments

Pin No.	Signal Name	Signal Direction
1	Chassis ground	
2	Transmit Data Output	To Terminal
3	Receive Data Input	From Terminal
4	Request-to-Send Output	To Terminal
5	Clear-to-Send Input	From Terminal
6	Data-Set-Ready Input	From Terminal
7	Signal Ground	
8	Data Carrier Detect	From Terminal
20	Data Terminal Ready	To Terminal

Definitions of the Printer Port Pins - The printer port conforms to the RS232C standard set forth by the EIA for a DCE.

Pin 20 - Data Terminal Ready - The terminal will transmit/receive data to/from the printer port device when this pin is made active by the printer port device.

Pin 2 - Transmit Data Output - The terminal expects to receive data transmitted by the printer port device.

Pin 3 - Receive Data Input - The printer port device receives data transmitted by the terminal/host.

Pin 7 - Signal Ground - The terminal uses this pin as a reference by which the other pins are judged active or inactive.

2.3 USER-INSTALLABLE OPTIONS

The Ampex 230/219 allow alternatives to the standard RS232C interface at the primary port. These user-installable options are:

RS422 Interface
Current Loop Interface

These options are available in kits provided by Ampex and may be ordered through your Ampex Sales Representative. Part numbers for these kits are as follows:

RS422 Interface Kit - Ampex Part No. 3515412-02A
Current Loop Interface Kit - Ampex Part No. 3515413-02A

Refer to Appendix A for installation instructions on these user-installable options.

2.4 INSTALLATION REQUIREMENTS

The Ampex 230/219 terminals are designed to be placed on a flat, hard surface such as a desk or table top capable of supporting at least 22 pounds (10 kg). Ambient temperature of the operating environment must be within 32° F to 104° F (0° to 40° C) range.

CAUTION

Do not block any of the air vents on the unit. All air vents of the terminal case must be kept clear in order to provide proper cooling during operation.

2.4.1 Space Allocation

The detached keyboard permits considerable flexibility in positioning the unit for use. Figure 2-1 illustrates the terminal's overall dimensions as well as the minimum surface area required for installation.

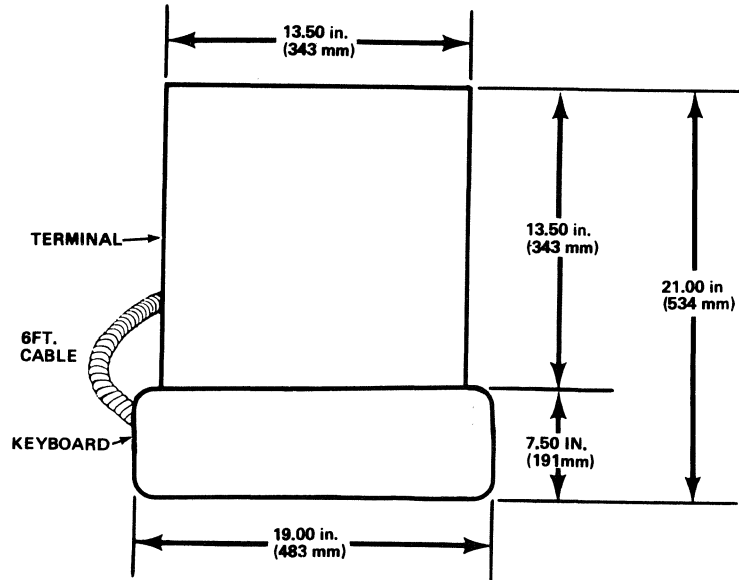

6151

Figure 2-1. Overall Dimensions

2.4.2 Input Power

The Ampex 230/219 are configured at the factory for either 115 or 230 volts alternating current (vac). Installation site power requirements for both versions are listed in Table 2-3.

Table 2-3. Input Power Requirements

Version	Phasing	Frequency	Current
115 vac +10% -15%	Single Phase	60 Hz $\pm 3\%$	0.50 A
230 vac +10% -15%	Single Phase	50 Hz $\pm 3\%$	0.25 A

WARNING

High voltage is present within the case when power is on. Remove the power cable from the ac receptacle before removing the top cover. Only authorized service personnel should open the case.

The Ampex 230/219 may be strapped for 115 or 230 volts. Figure 2-2 contains drawings showing the two versions of the strapping plug. Refer to these drawings when changing the voltage from 115 volts (applicable in the United States) to 230 volts (applicable outside the United States) or vice versa.

NOTE

The fuse, located in the fuseholder on back panel of the display unit (Figure 2-3), must be changed when the voltage is changed. For:

- 115 volts - Use a 2A fuse
- 230 volts - Use a 1A fuse

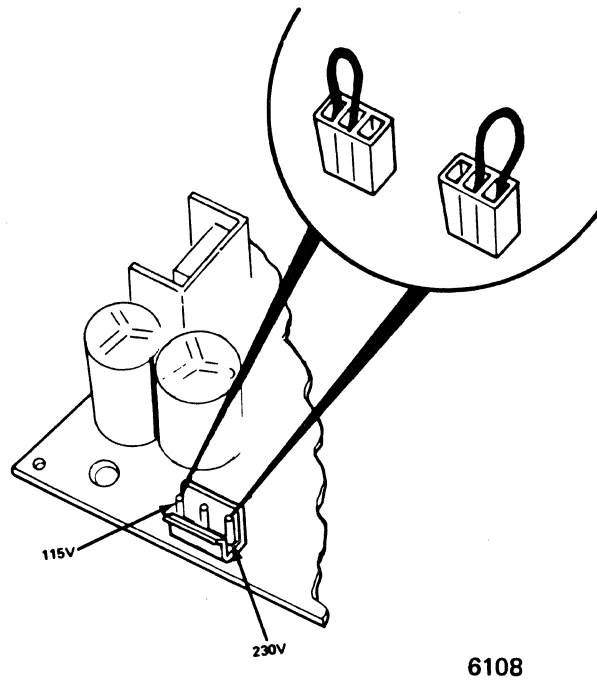

Version 1

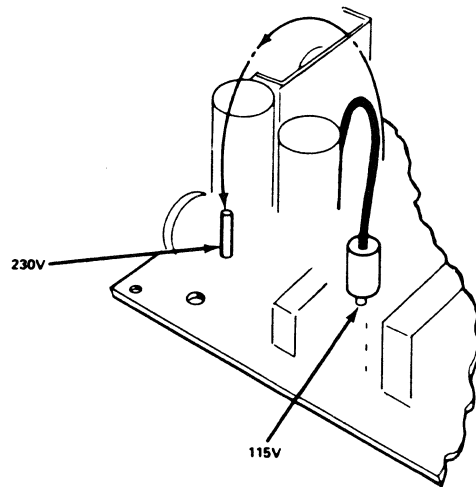

Version 2

Figure 2-2. Voltage Strapping Plug (Versions 1 and 2)

2.4.3 AC Power Cord and Plug

Each terminal is shipped with either a 115 vac/60 Hz power plug (for use in the United States) or a 230 vac/50 Hz power plug (for use outside the United States). Ampex 230/219 terminals in the United Kingdom and Australia may need customized power plugs to fit the receptacles in these countries.

WARNING

Electric shock may result if the power cord is connected to AC power when the plug is cut off for Be sure to disconnect the cord from AC power before customizing the power plug.

2.4.4 Interface Cable Connections

Figure 2-3 is a view of the back panel of the Ampex 230/219 Video Display Terminals. Refer to this figure when attaching the primary port (to computer) and the auxiliary port (to printer) interface cables.

2.4.5 Keyboard Port Connection

Figure 2-4 shows the location of the keyboard cable port. Refer to this figure when attaching the keyboard cable to the display terminal.

CAUTION

Do not connect or disconnect the keyboard to or from the display unit when the power is on. Erratic performance may result.

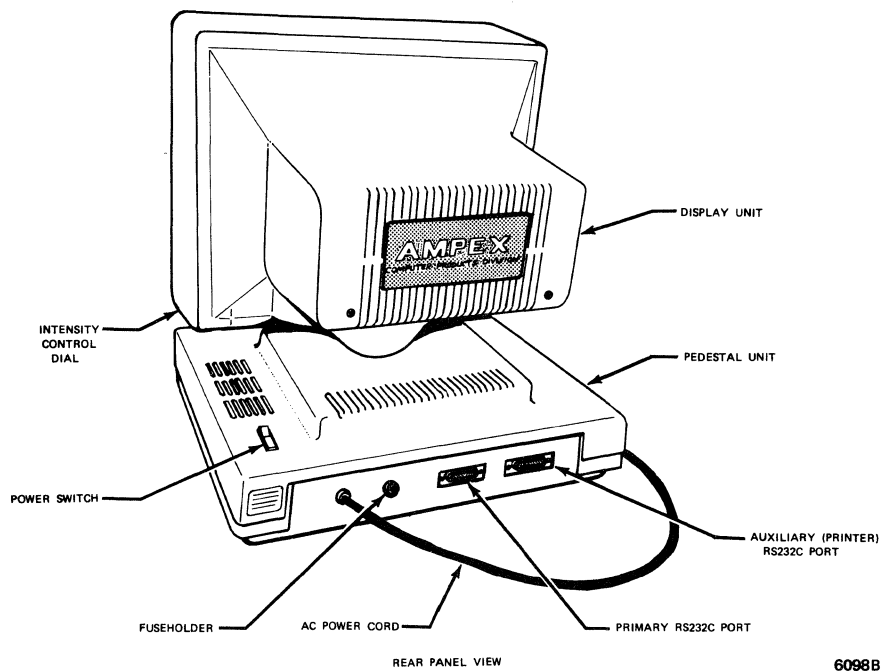

Figure 2-3. Ampex 230/219 Video Display Terminal (Back Panel View)

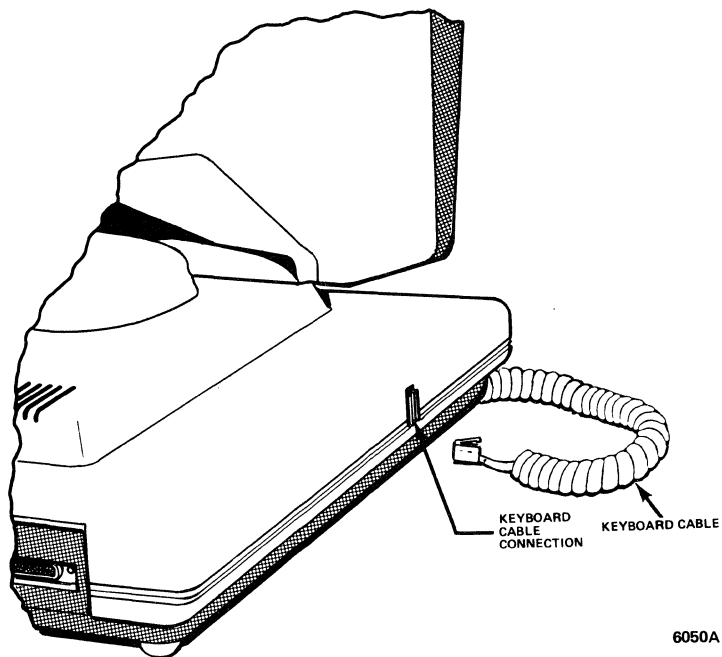

Figure 2-4. Keyboard Port on Display Terminal

2.5 POWER-ON AND RESET

To power on the terminal:

1. Make sure all interface cables are connected properly to their respective ports (refer to 2.4.4 Interface Cable Connections and 2.4.5 Keyboard Port Connection).
2. Make sure the power cable is plugged into the proper outlet (refer to 2.4.3 AC Power Cord and Plug).
3. Set the on/off switch to on.
4. Within seconds, the unit undergoes its self-test.
5. After the self-test is completed, a "beep" will sound and the cursor will appear in the top left-hand corner of the screen.
6. Adjust the intensity by rotating the intensity control dial, located underneath the right-hand portion of the display unit.
7. The terminal is now ready to begin performing the operations described in the remaining sections of this manual.

To reset the terminal while performing normal operations, press CTRL/SHIFT/RESET.

2.6 SELF-TEST

The self-test feature is activated each time the terminal is powered on. For the most part, the test pattern on the screen cannot be viewed at initial power-on. To view the test pattern, initiate a self-test while the terminal is already "on" by entering Set-up mode (refer to Section IV) and typing "1".

The self-test operation checks the following:

- CMOS RAM (a check sum of the terminal set-up information)
- DATA RAM
- DISPLAY RAM
- ROM
- VISUAL ATTRIBUTES (displays on the test pattern)

Result of Terminal Self-Test

A test pattern will display, showing all character sets, visual attributes, firmware version number, and copyright information. If any component errors are detected, a message will display in the lower portion of the screen.

NOTE

Some characters may display which are not accessible using the standard firmware.

Possible error messages are:

CMOS CHECKSUM ERROR
DATA RAM ERROR
DISPLAY RAM ERROR
ROM ERROR

If any of the above error messages display on the screen:

1. Press CTRL/SHIFT/RESET to reset the terminal.
2. Enter Set-up mode and set the parameters. Press SHIFT/S to save the parameters and exit Set-up mode.
3. Enter Set-up mode again. Type: 1
(System will undergo another self-test procedure.)
4. Verify any error messages:
 - a. If the error message no longer displays, the terminal is ready to operate.
 - b. If the error message still displays, contact an Ampex service location immediately. Do not attempt to correct the problem.
5. Press CTRL/SHIFT/RESET to reset the terminal and clear the screen.

NOTE: Ampex service locations are listed on the Warranty Information sheet included in the box with the terminal.

SECTION III THEORY OF OPERATION

3.1 INTRODUCTION

This section describes the theory of operation of the major subassemblies of the Ampex 230/219 terminals.

3.2 GENERAL DESCRIPTION

The basic block diagram in Figure 3-1 illustrates signal flow between the subassemblies of the terminal. The following paragraphs discuss the interfacing of subassemblies.

3.3 OPERATION AND COMPONENTS OF THE TERMINAL CONTROLLER PWBA

The hardware and circuitry of the controller PWBA is composed of the major functional blocks, input/output mapping, and interface buses shown in Figure 3-2.

Functional sections of the terminal are controlled by the Central Processing Unit (CPU) via a system data bus, an address bus, and control lines. Display and communications sections have some circuitry that run independently of the CPU. The display section, for example, refreshes video continuously and automatically once initiated by the CPU.

The host computer communicates with the terminal via an RS232C interface. The CPU receives serial data from the keyboard via a keyboard interface circuit resident in the Cathode Ray Tube (CRT) controller chip.

The CPU is a Z80A microprocessor with fully-enhanced 8080-like instruction set. The hardware, as designed, uses Input/Output (I/O) instructions to access the I/O ports.

There are two interrupt sources. The maskable interrupt is generated by a Z80A DART chip and the non-maskable interrupt is generated by a PVTC (Programmable Video Timing Controller) chip.

The data/address buses and control lines allow the CPU to access the program ROM, the scratch pad RAM, and all of the I/O ports. Depending on firmware requirements, 16K to 32K bytes of program P/ROM can be installed.

The CPU's scratch-pad and data memory consists of a 2K x 8 CMOS RAM and provides nonvolatile storage of all of the set-up parameters including optional modes, communication parameters, emulation parameters, etc., through the use of a 3V lithium battery.

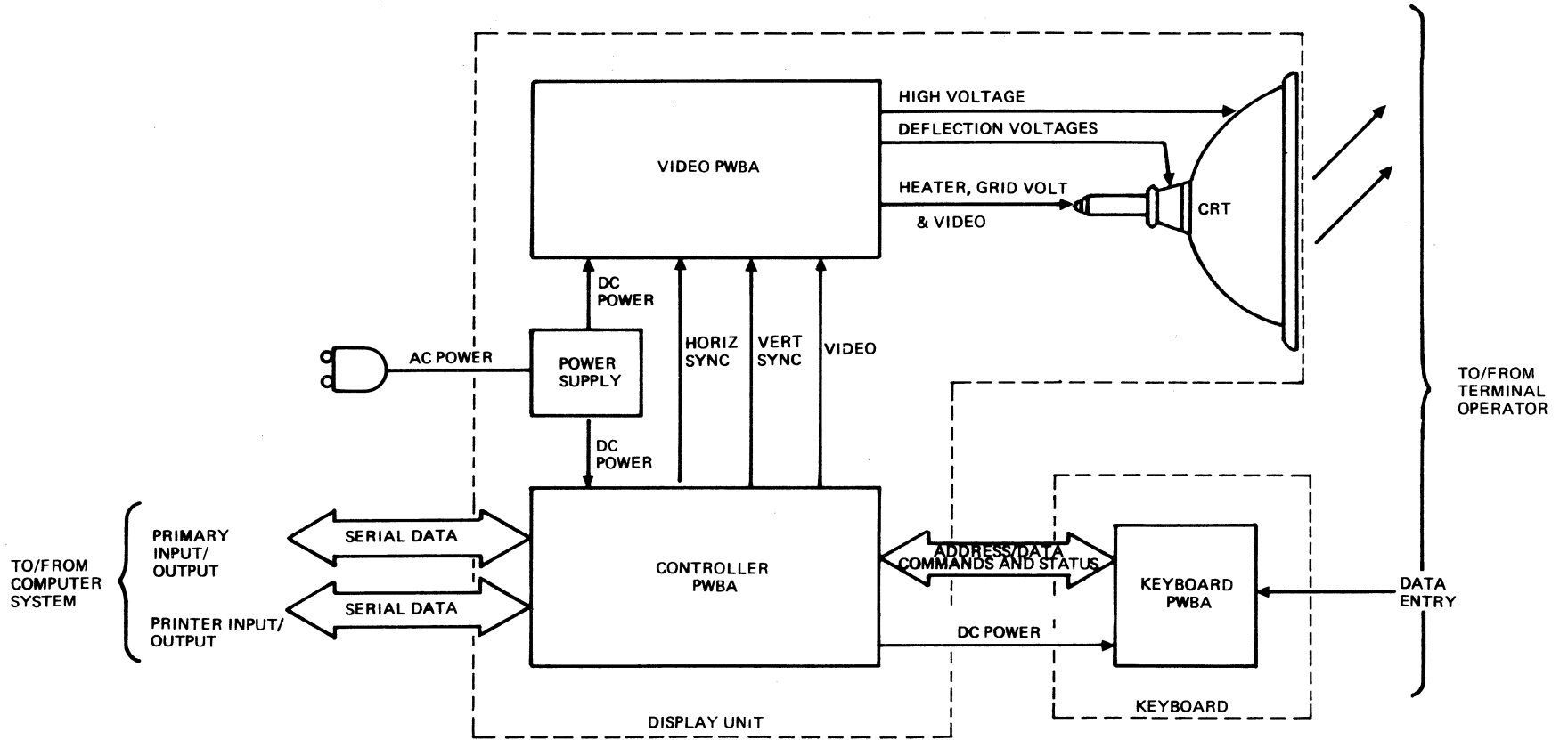

Figure 3-1. Terminal Basic Block Diagram

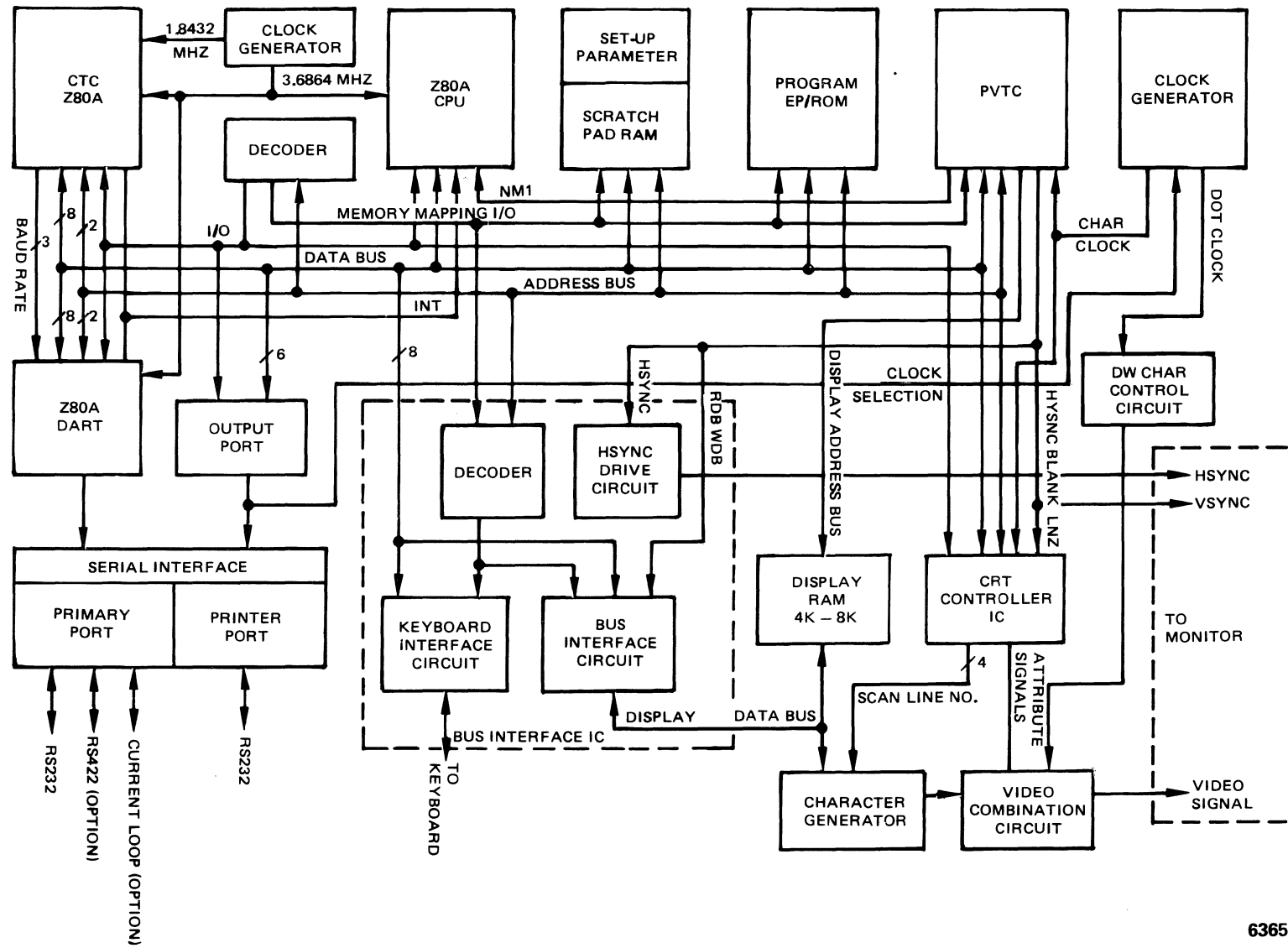

Figure 3-2. Controller PWBA Block Diagram

3.3.1 Input/Output Mapping and the CPU

Through I/O mapping, the CPU interfaces with:

- PVTC chip
- Z80A DART chip and other communications-related circuitry
- Keyboard (via bus interface chip)
- CRT controller chip
- Bus interface chip
- Z80A-CTC chip

3.3.1.1 Display I/O

Display I/O gives the CPU control over the PVTC chip (including initializing the PVTC chip, reading/writing cursor position, flashing clock, and scrolling).

Once initialized by the CPU, the PVTC chip subsequently performs the continuous refreshing required of the PVTC by generating the video, horizontal drive, and vertical sync signals required by the CRT monitor.

3.3.1.2 Communication I/O

The communication I/O gives the CPU control over the Z80A DART chip (including sending/receiving characters on the word level and checking Z80A DART status) and other communications circuitry (including primary/printer port selection and bidirectional/extension printer port selection).

Once initialized by the CPU, the Z80A DART chip and other communications circuitry subsequently perform the parallel-to-serial, serial-to-parallel, and signal level conversions required for serial port interfacing.

A Z80A-CTC chip is needed to generate the baud rate for the Z80A DART.

3.3.1.3 Keyboard I/O

The keyboard I/O allows the CPU via the bus interface chip to transmit and receive data to and from the keyboard.

3.3.2 Central Processing Unit

The CPU is the control center of the terminal controller. The following paragraphs describe the functions of the CPU, the buses, and memory interfaces used to control other parts of the system.

3.3.2.1 Functions of the CPU

As mentioned earlier, the CPU is a Z80A microprocessor. It contains circuitry for program execution as well as the program registers:

Clock - The CPU clock is a 3.6864 MHz generated from a 3.6864 MHz crystal. The clock input to the Z80A requires special high level generation by a 74LS04 driver (U32) and a 1K ohm resistor (R34).

Reset - The CPU is reset by the power-up reset circuit or power-down reset circuit.

Memory Request (MREQ) - At the beginning of each cycle, an MREQ is issued. The MREQ is used to enable the decoding circuitry (U46) to generate chip select signals.

Read/Write Signals - Following the MREQ for each memory-mapped I/O read/write cycle, a Bus read or write signal occurs when a byte is to be read from or written to memory or memory-mapped I/O.

Input/Output Request (IORQ) - The IORQ is used to enable the I/O port function.

Maskable Interrupt - Maskable interrupt of the CPU is generated by the Z80A DART chip. There are three types of maskable interrupts: Receive Data Register Full, Transmit Data Register Empty, or External/Status interrupt.

Non-maskable Interrupt - Non-maskable interrupt input of the CPU is generated by the PVTC chip. There are two possible causes of non-maskable interrupts: Vertical Blank or Line Zero.

3.3.2.2 Buses Used for Interfacing

During the CPU's read memory or write memory, the Data/Address bus signal lines carry address information to the other components and data information to or from those components.

Data Bus - The CPU's eight data lines, D7 through D0, carry the data between the CPU and all of the memories and I/O devices.

Address Bus - There are sixteen address lines, A0 through A15, used to address the memories and I/O ports. In general, the lower address lines are used to address specific bytes in the program P/ROM and the data RAM. The highest address bits select between the system entities.

3.3.2.3 Memory Interfaces

The following paragraphs contain descriptions of the various memory interfaces:

Program ROM/PROM - The program instruction memory can be configured out of various types of numbers of ROMs/PROMs. The total memory space is 32K. Table 3-1 shows the various jumper settings and IC (Integrated Circuit) locations for select memory capacity.

Table 3-1. Program Instruction Memory Configurations

Jumper Settings	Total Memory	Address Ranges for Access	IC Location	IC Type	Memory for each IC
W16-W17 W20-W21	16K	0 - 3FFF	U34	27128/23128	16K
W16-W17 W20-W21	20K	0 - 3FFF 4000 - 4FFF	U34 U35	27128/23128 2732/2332	16K 4K
W16-W17 W20-W21	24K	0 - 3FFF 4000 - 5FFF	U34 U35	27128/23128 2764/2364	16K 8K
W16-W17 W20-W21	32K	0 - 3FFF 4000 - 7FFF	U34 U35	27128/23128 27128/23128	16K 16K
W17-W18 W19-W20	32K	0 - 7FFF	U34	27256/23256	32K

Data RAM - Depending on terminal configuration, the data RAM can consist of 2K or 8K bytes static CMOS random-access memory.

Jumper Settings	Address Ranges for Access	IC Type	Memory for each IC
W11 - W12	C000 - C7FF	5517	2K
W10 - W11	C000 - DFFF	5565	8K

The data RAM is split into two different regions. The first region is used as memory for the programmable function keys and as software switches defining the terminal's default states. The second region is used as the CPU's scratch-pad RAM.

Display RAM - Depending on terminal configuration, there are either two or four pages of display memory. Jumper settings are as follows:

Total Pages	Jumper Settings	Address Ranges for Access	IC Location	IC Type	Memory for each IC
(For PCB 3515400)					
2	W7 - W9	0 - 07FF	U17, U23	2016	2K
	W2 - W3	800 - 0FFF	U18, U24	2016	2K
	W5 - W6				
4	W8 - W9	0 - 1FFF	U17, U23	5565	8K
	W1 - W2				
	W4 - W5				

(For PCB 3515455)

2	W7 - W8	0 - 7FF	U17, U23	2016	2K
	W1 - W2	800 - 0FFF	U18, U24	2016	2K
	W4 - W5				
4	W7 - W9	0 - 1FFF	U17, U23	5565	8K
	W2 - W3				
	W5 - W6				

Each character contains 16 bits:

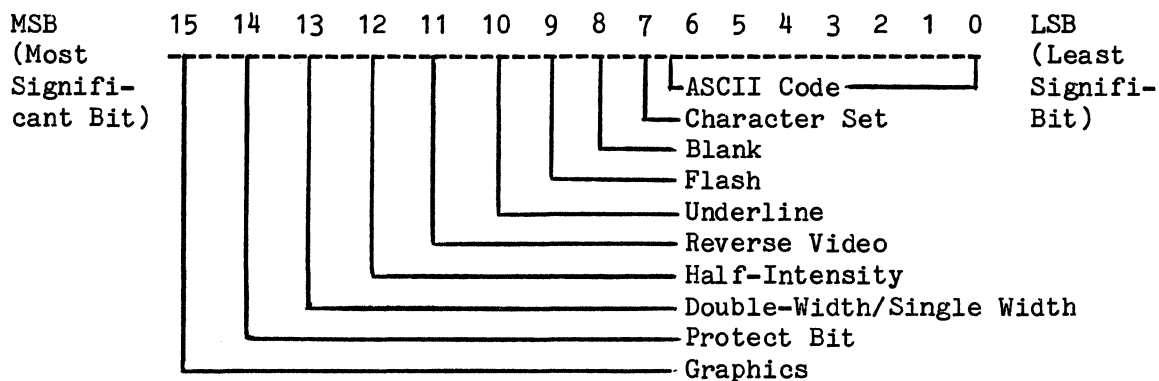

The seven least significant bits contain the ASCII character to be displayed in that character position. The other nine bits affect how that character is actually displayed: one bit selects the graphic character set, one bit represents protected data, one bit determines the character size, and five bits determine the visual attributes.

In field (or embedded) attribute emulation, bits 11 through 8 are not used. For the attribute delimiter, the pattern of bits 15, 14, 7, 6, and 5 should be 01000. When a TeleVideo terminal is being emulated, bit 4 should be 0. Visual attributes are activated when the corresponding bit; 4, 3, 2, 1, or 0 is set to "1." Table 3-2 defines each bit of an attribute delimiter.

Table 3-2. Attribute Delimiter Bits

Bit	Definition
4	Half-Intensity (Wyse WY-50 emulation)
3	Underline
2	Reverse Video
1	Flash
0	Blank

Transfer of data between the CPU and the display RAM is accomplished via the memory interface circuit resident in the bus interface chip and is controlled by the PVTC signals: Read Data Buffer and Write Data Buffer.

3.3.3 Operation of CPU Memory

The general theory of operation of the hardware for program memory is described in the following paragraphs.

3.3.3.1 Program ROM/PROM

The program ROM/PROMs are static and begin their access time as soon as the address lines are valid (i.e., they access continuously). The ROM/PROM drive the main data bus directly so that the access time from address valid to data out is 350 nsec, maximum. The upper memory address bits are used to select and enable the specific ROM/PROM's data outputs using pin 20 of the selected IC.

3.3.3.2 Data RAM

The CMOS RAM is used together with a long life (10 years minimum) 3.4V lithium battery for nonvolatile storage of modes of operation. The CMOS RAM write enable pin goes directly to the CPU's WR pin (U24-U22). When AC power is off, the CMOS RAM will draw standby current from the 3.4V battery. When AC power is on, the CMOS RAM will draw current from the +5V supply.

3.4 OPERATION OF DISPLAY CIRCUITRY

The following paragraphs discuss the operation of programmable video timing controller and display circuitry. Figure 3-3 is a block diagram of the Video PWBA.

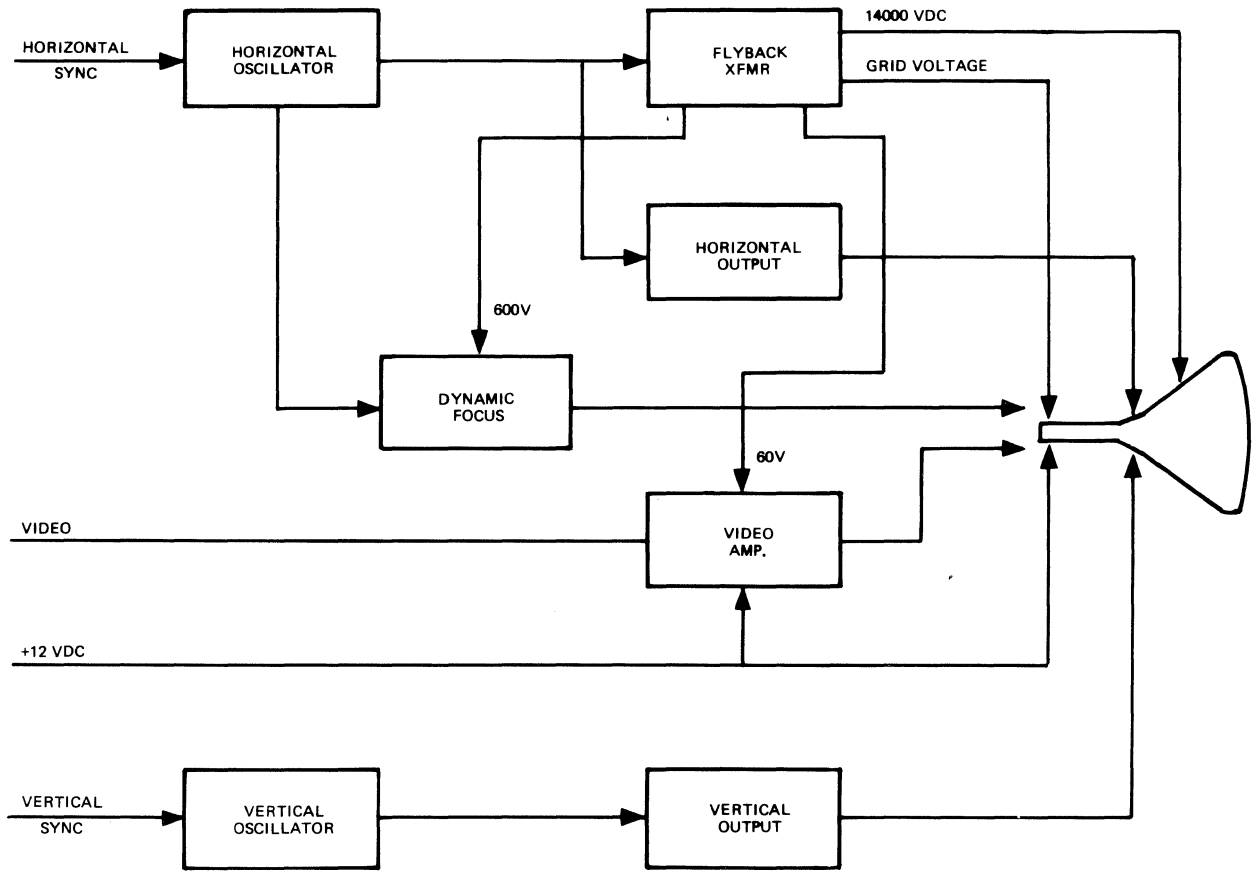

6163

Figure 3-3. Video PWBA Block Diagram

3.4.1 General Information

The characters displayed on the screen are accessed (read and written) by the CPU via the display RAM. Memory can be two or four pages of 1,920 sixteen-bit words each and separate status and user lines of 80 sixteen-bit words each. In the 16 bits of display RAM location, five bits determine the attribute (underline, flash, blank, reverse video, or half-intensity), one bit determines the character size, one bit represents the protect flag, and one bit selects the international character set for each corresponding character as defined in the remaining eight bits.

The display RAM requires that the Programmable Video Timing Controller (PVTC) be properly controlled by the CPU for transferring data to and from the display RAM.

3.4.2 Operation of the PVTC Chip

The Programmable Video Timing Controller (PVTC) chip is accessed by three control strobes: Chip enable, CPU read, and CPU write signals. The 8000H decode output of the upper address lines provide the chip select for the PVTC. The lower three address lines (A0-A2) and read/write signals go to the PVTC chip for initialization register selection.

In order to attain the 26 data lines at 60 or 65 Hz refresh rate, the initialization registers (IR0-IR10) are loaded by the firmware as shown in Table 3-3.

Table 3-3. PVTC Chip Initialization Register Selection

Initialization Registers	Value (In Hex)			
	60 Hz		65 Hz	
	80 Col	132 Col	80 Col	132 Col
IR0	58	58	58	58
IR1	1D	1D	1D	1D
IR2	21	60	21	60
IR3	8C	8C	26	26
IR4	19	19	19	19
IR5	4F	83	4F	83
IR6	0B	0B	0B	0B
IR7	2B	2B	2B	2B
IR8	00	00	00	00
IR9	40	40	40	40
IR10	99	99	99	99

Note that there are 11 initialization registers which are accessed sequentially via a single address (08000). The PVTC maintains an internal pointer to these registers which is incremental after each write at this address until the last register (IR10) is accessed. This internal pointer can also be preset to any register of the group by loading a value from 10H to 1AH to PVTC command register (08001).

3.4.3 Initialization Register Parameters

Parameters of the initialization register values indicated in Table 3-3 are:

Initialization Register 0 (IR0)

Bit 7, not used (=0)
 Bits 6 - 3 = N; Scan lines/character row (where scan lines/
 character row = N + 1)
 Bit 2 = 0; sync select (VSYNC)
 Bit 1 - 0 = 00; buffer mode select (independent mode)

Initialization Register 1 (IR1)

Bit 7 = 0; non-interlace
 Bits 6 - 0 = N; equalizing constant (where equalizing constant
 = N + 1)

Initialization Register 2 (IR2)

Bit 7 not used (=0)
 Bits 6 - 3 = N; horizontal sync width (where horizontal sync
 width = $2 * N + 2$)
 80 Col - horizontal sync width = $2 * 4 + 2 = 10$ CCLK
 132 Col - horizontal sync width = $2 * 12 + 2 = 26$ CCLK
 Bits 2 - 0 = T; horizontal back porch (where horizontal back
 porch = $4 * T + 1$)
 80 Col - horizontal back porch = $4 * 1 + 1 = 5$ CCLK
 132 Col - horizontal back porch = $4 * 0 + 1 = 1$ CCLK

Initialization Register 3 (IR3)

Bits 7 - 5 = N; vertical front porch (where vertical front porch
 = $4 * N + 4$)
 60 Hz: vertical front porch = $4 * 4 + 4 = 20$ (scan lines)
 65 Hz: vertical front porch = $4 * 1 + 4 = 8$ (scan lines)
 Bits 4 - 0 = T; vertical back porch (where vertical back porch
 = $2 * T + 4$)
 60 Hz: vertical back porch = $2 * 12 + 4 = 28$ (scan lines)
 65 Hz: vertical back porch = $2 * 6 + 4 = 16$ (scan lines)

Initialization Register 4 (IR4)

Bit 7 = 0; character blink rate = 1/16 VSYNC
 Bits 6 - 0 = N; character row/screen (where character row/screen
 = N + 1)

Initialization Register 5 (IR5)

Bits 7 - 0 = N; character/row (where character/row = N + 1)
 80 Col - character/row = 4F (H) + 1 = 50 (H) = 80
 132 Col - character/row = 83 (H) + 1 = 84 (H) = 132

Initialization Register 6 (IR6)

Bits 7 - 4 = N; first line of cursor (scan line 0)
 Bits 3 - 0 = T; last line of cursor (scan line 11)

Initialization Register 7 (IR7)

Bits 7 - 6; not used (=0)
 Bit 5 = 1; cursor blinking
 Bit 4 = 0; normal size character
 Bits 3 - 0 = N; underline position (scan line 11)

Initialization Register 8 (IR8)

Bits 7 - 0 = display buffer first address Least Significant Bits
 = 00H

Initialization Register 9 (IR9)

Bits 7 - 4 = N; display buffer last address (where display buffer
 last address = 1024 x N + 1023)
 Bits 3 - 0 = display buffer first address Most Significant Bits = 0

Initialization Register 10 (IR10)

Bit 7 = 1; cursor blink rate = 1/32 VSYNC
 Bits 6 - 0 = N; split screen interrupt row = 19 (H) = 25

3.4.4 Valid Address/Blanking and Sync Signals Relationship

Figures 3-4 and 3-5 illustrate the timing of a frame (80 columns and 132 columns respectively) showing the relationship between the valid character address and the blanking and sync signals. The left and right edges correspond to the start of the horizontal sync and the top and bottom edges (different for 60 and 65 Hz) correspond to the start of the vertical sync.

The inner solid-lined rectangle (26 character rows x 80/132 characters) represents the time during which the PVTIC chip outputs valid address on DADD0 - DADD12. The DADD0 - DADD12 lines range from 0 to 79/131 on each scan across the 80/132 character positions counting out the 26 character rows, covering rows 0 through 25 on each frame. The CRT controller IC presents the scan line number or LA0 - LA3, covering all rows 0 through 25 on each frame.

The positive-true blanking signal is emitted with no character time delays after the end of the last character to the beginning of the first character address, as well as continuously from the end of the last character row until the beginning of the first character row.

3.4.4.1 Horizontal Sync

The horizontal sync (HSYNC) is delayed by five characters (as blanking) and additionally has a "back porch" of five characters (for 80 columns) or one character (for 132 columns) after the HSYNC ending. The HSYNC signal width is ten characters long for 80-column display or 26 characters long for 132-column display.

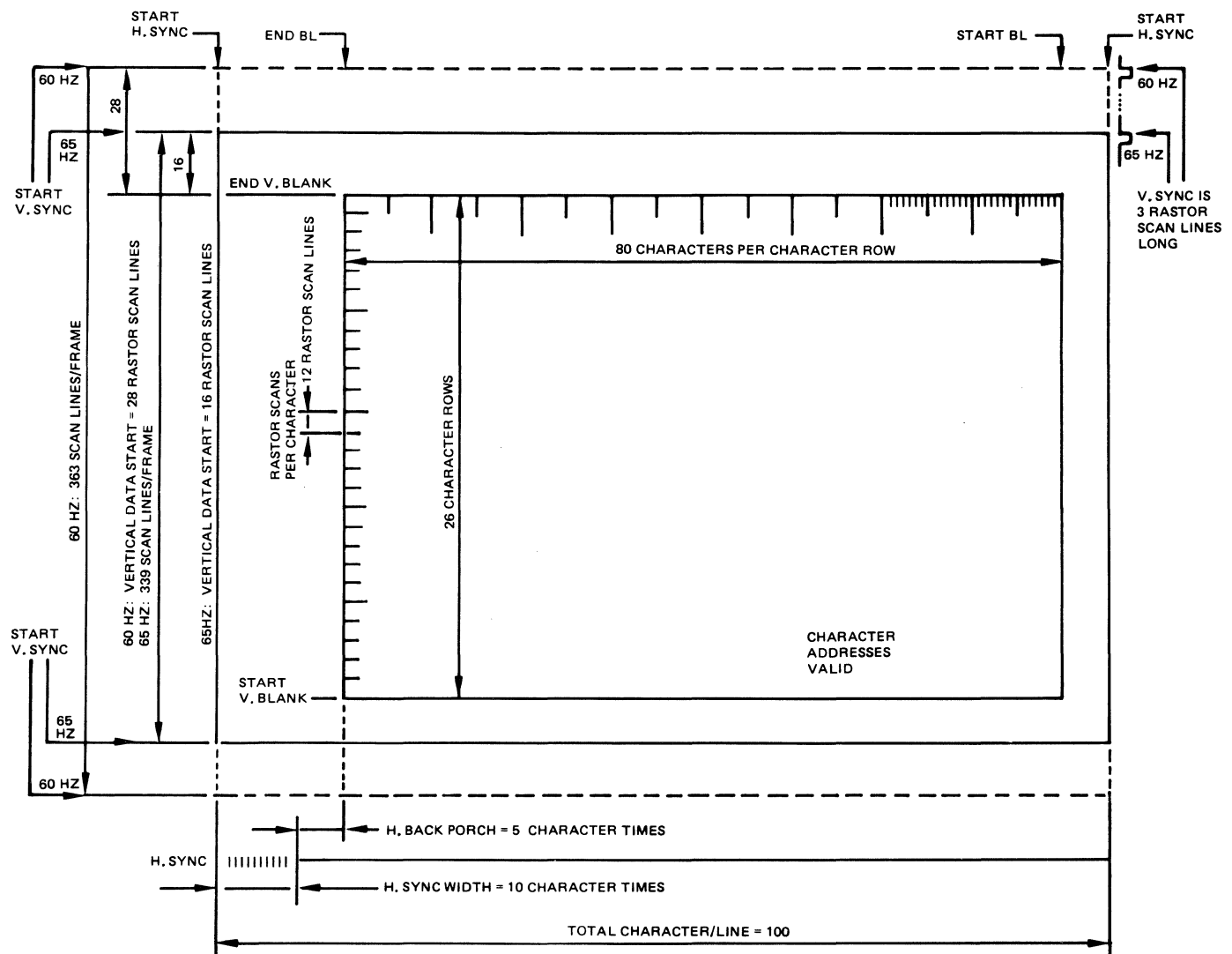

6363

Figure 3-4. PVTC Chip Timing Frame (80 Column x 26 Lines)

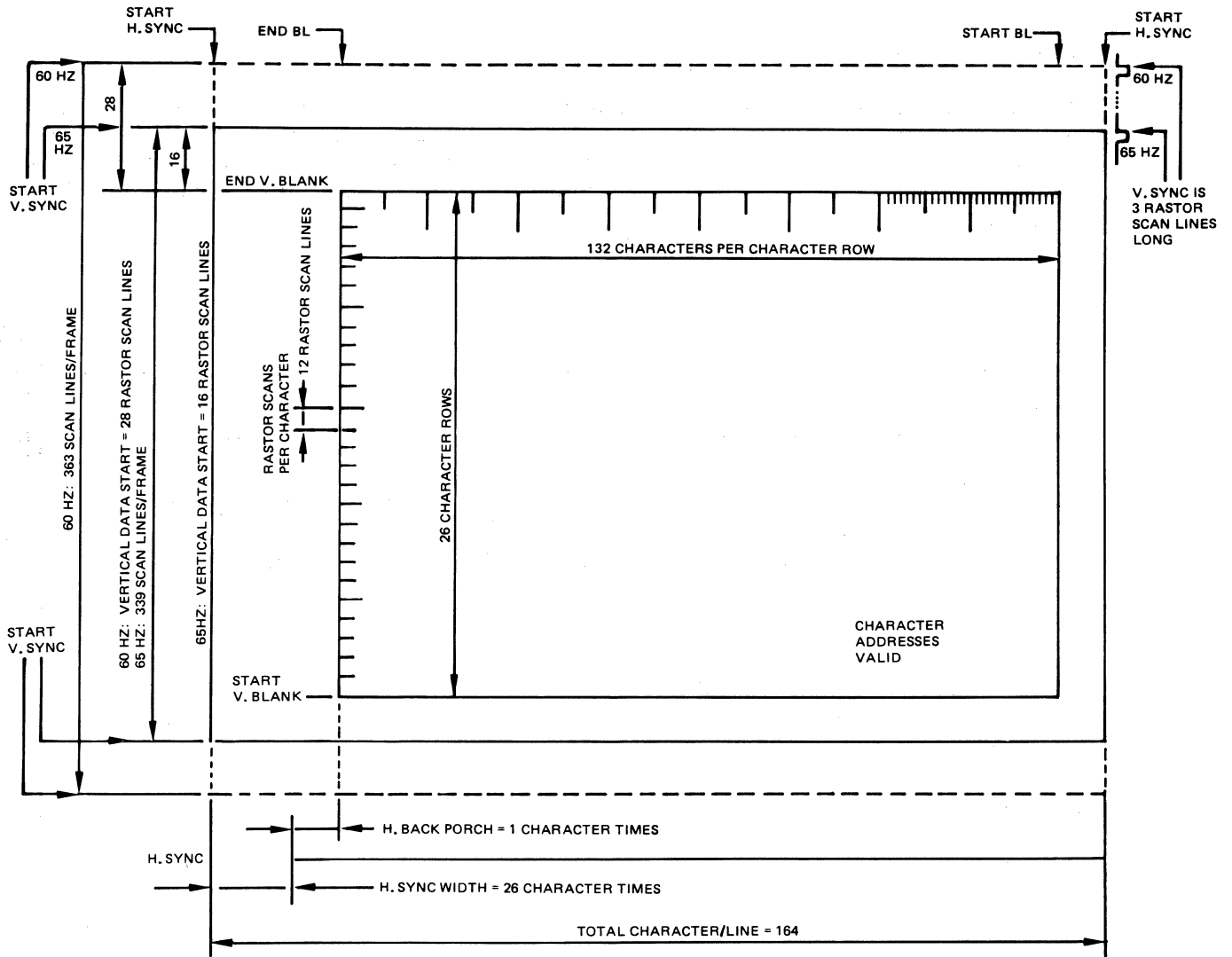

6364

Figure 3-5. PVTC Chip Timing Frame (132 Columns x 26 Lines)

3.4.4.2 Vertical Sync

The vertical sync (VSYNC) starts after the last scan line of the frame and continues for three horizontal scan lines. The programming of the total scan lines per frame determines whether there are 60 or 65 frames per second. Following the last scan line (at the same time the VSYNC starts), the vertical character row start is delayed by 28 scan lines for 60 Hz and 16 scan lines for 65 Hz. This variation provides for approximately the same vertical centering for both 60 Hz and 65 Hz.

3.4.4.3 Cursor Signal

The cursor signal is emitted during the time when the internal cursor address matches the screen address (DADD0 - DADD12).

3.5 OPERATION OF THE DISPLAY RAM

Displayed characters and attribute control characters are stored in and received from either 2K x 8 or 8K x 8 S/RAMs. The PVTIC chip generates three control signals: Buffer Chip Enable, Write Data Buffer, and Read Data Buffer. These signals provide the transfer of data between the CPU and the display RAM (via the interface circuits resident in the Bus Interface chip).

3.6 CHARACTER GENERATOR

The four least significant address bits of the character generator are derived from the scan line address bits of the CRT controller IC chip. During actual display, the seven ASCII bits address a "character generator ROM" which allows the specifications of a 7 x 10 dot matrix to be displayed within the 9 x 12 field as shown below. Thus, each 9-bit data word can select any one of 512 character-generated ROM patterns to fill in the 7 x 10 dot matrix.

The display character field has the following format:

ROW	COLUMN									
	0	1	2	3	4	5	6	7	8	
0	X	X	X	X	X	X	X	X	X	Blank*
1	X	A	A	A	A	A	A	A	X	Top Scan Row
2	X	A	A	A	A	A	A	A	X	Character Scan Row
3	X	A	A	A	A	A	A	A	X	"
4	X	A	A	A	A	A	A	A	X	"
5	X	A	A	A	A	A	A	A	X	"
6	X	A	A	A	A	A	A	A	X	"
7	X	A	A	A	A	A	A	A	X	"
8	X	A	A	A	A	A	A	A	X	"
9	X	A	A	A	A	A	A	A	X	"
10	X	A	A	A	A	A	A	A	X	Bottom Scan Row
11	-	-	-	-	-	-	-	-	-	Blank **

*Row 0 is always blank, except for graphics.

**Row 11 is always blank, except for graphics and underlines.

The bit maps for character scan line display matrices have this format:

For normal characters: B D7 D6 D5 D4 D3 D2 D1 B 0 (D0=0)
 For graphics characters: D7 D7 D6 D5 D4 D3 D2 D1 D1 1 (D0=1)

3.7 GENERATION OF VIDEO SIGNALS

At the end of each character generator access, the dot data are loaded into a shift register in order to begin displaying the scan line of the character. The basic video "dots" emanate from the shift register.

3.7.1 Basic Video

For normal (non-graphics) characters, the first and last dot positions are always blanked. For graphics characters, the first dot position has the same value as the next dot position. This allows the horizontal line graphics characters to extend all the way to the adjacent character fields for producing multicharacter solid horizontal lines.

If blank video is desired, the video "dots" will be blanked. If reverse video is desired, the video "dots" will be driven onto a two-level video point where there is a half or full intensity before being driven onto the monitor for display.

3.7.2 Attribute Control Signals

Attribute data become active as the shift register is loaded. They are loaded into the final pipeline register. The attribute bits are held constant throughout the display character's dots for the scan line in progress.

During field attribute emulation, the attributes are all loaded into the attribute hold register as the attribute delimiter is encountered. These attributes remain constant until another attribute delimiter is encountered.

The half-intensity bit, when enabled, causes the two-level video point to be loaded down, thereby lowering the video intensity level.

The inverse video bit complements video polarity. It effectively follows character and scan line blanking controls and reverses the background intensity level.

The blank attribute bit blanks the character's video level causing the character to recede into the background. The blinking bit causes the video to alternate between the normal and blanked-to-background states. The blinking rate is under program control.

3.8 OPERATION OF SERIAL INTERFACE CIRCUITRY

Operation of Z80A-CTC - The Z80A-CTC (Counter/Timer Circuit) is a programmable component with four independent channels that provide the transmitter and receiver clocks for the primary and printer ports. Channels 0 and 1 are primary port transmitter and receiver baud rates, respectively. Channel 3 is the printer port baud rate.

Operation of Z80A-DART - The Z80A-DART (Dual Asynchronous Receiver/Transmitter) provides a program-controlled interface between 8-bit micro-processor-based systems and serial communication data sets.

3.9 DRIVER-RECEIVER OPERATION

The primary port can transmit and receive data via RS232C, current loop, or RS422 lines. The printer port is a bidirectional RS232C serial port.

3.9.1 Primary Port - RS232C Interface

When the RS232C interface is used, data will be transmitted via RS232C circuit BA and data input via RS232C circuit BB. RS232C control lines are controlled or sensed by the CPU according to the EIA RS232C specification. The RS232C interface is configured such that the terminal controller becomes a Data Terminal Equipment (DTE).

Table 3-4 lists the RS232C pin signal assignments.

Table 3-4. RS232C Pin Signal Assignments

Pin No.	RS232C Circuit	Definition
1	AA	Protective Ground
2	BA	Transmit Data to Modem/Host
3	BB	Receive Data from Modem/Host
4	CA	Request-to-Send
5	CB	Clear-to-Send
6	CC	Data Set Ready
7	AB	Signal Ground
8		Data Carrier Detect
20	CD	Data Terminal Ready

3.9.2 Primary Port - Current Loop Interface (Option)

If the Current Loop interface option board is installed, the transmitter current loop is always active on the port connector pins, J4, 6-13 and J4, 6-25. The receiver current loop is always active on the port connector pins, J4, 6-4 and J4, 6-12. Table 3-5 lists current loop interface pin signal assignments.

Table 3-5. Current Loop Pin Signal Assignments

Pin No.	Definition
9	20 mA Source
12	Current Loop Receive (+)
13	Current Loop Transmit (-)
14	20 mA Source
24	Current Loop Receive (-)
25	Current Loop Transmit (+)

3.9.3 Primary Port - RS422 (Option)

If the RS422 interface option board is installed, data will be transmitted and received according to EIA RS422 specifications. Table 3-6 lists the RS422 pin signal assignments.

Table 3-6. RS422 Pin Signal Assignments

Pin No.	Definition
15	Receive Data (+)
17	Receive Data (-)
19	Transmit Data (+)
25	Transmit Data (-)

3.9.4 Printer Port

The printer port's data and control signals are directly connected to the primary port via a multiplex circuit. This allows the printer port to function as a bidirectional printer port.

3.10 OPERATION OF BUS INTERFACE CHIP

The bus interface IC includes:

- a. Bus interface circuit
- b. HSYNC drive circuit
- c. Keyboard interface circuit

a. The bus interface circuit provides the necessary circuitry for the CPU to access the display RAM data bus.

b. The HSYNC drive circuit extends the HSYNC pulse to fit the video board requirement.

c. The keyboard interface circuitry uses two shift registers to convert the serial data to parallel data. The clock of shift registers is derived from a sixteen-divided counter from HSYNC. The counter starts counting from VSYNC and stops when 12 data bits are received. Since the data stored in the shift register will clear as VSYNC occurs, the CPU should read the data before then and answer the keyboard by accessing the appropriate I/O port.

**SECTION IV
MAINTENANCE**

4.1 INTRODUCTION

This section contains maintenance information for the Ampex 230/219 Video Display Terminals. Corrective action for field repair of the terminal should be limited to removal and replacement of subassemblies (Section VI). Procedures involving maintenance adjustments and repairs should be performed by service personnel familiar with data terminal and video equipment.

WARNING

Exercise caution while working on the energized video or power supply sections. Avoid physical contact with high voltage leads and connections.

4.2 TEST EQUIPMENT

A list of test equipment (equivalent items may be substituted) for use during adjustment and troubleshooting is provided in Table 4-1. In addition to the items listed, hand tools commonly used in the repair of electronic equipment will be required.

Table 4-1. Test Equipment

Test Equipment	Manufacturer	Model or Part No.
AC Current Probe	Tektronix	P6021
Termination for AC Current Probe	Tektronix	011-0105-00
Oscilloscope	Tektronix	485B
Digital Voltmeter	Fluke	8020A

4.3 PERFORMANCE TESTING

The procedures described below can provide an evaluation of terminal performance.

4.3.1 Power On Self Test

1. Detach the interface cables connected to the primary port and printer port.
2. Apply power to the terminal. Verify the following:
 - a. Alarm (beep) sounds within 5 seconds.
 - b. User line and cursor appear within 15 seconds.
 - c. No bad component error messages are indicated on the status line. Bad component error messages are explained in Table 4-2.

Table 4-2. Bad Component Error Messages

Message	Explanation	Corrective Action
CMOS CK ERROR	CMOS CHECK SUM FAILURE	Replace Controller PWBA
DATA RAM ERROR	DATA MEMORY FAILURE	Replace Controller PWBA
DISPLAY RAM ERROR	DISPLAY MEMORY FAILURE	Replace Controller PWBA
ROM ERROR	PROGRAM MEMORY FAILURE	Replace Controller PWBA

NOTE: Clear bad component error indicators by resetting the terminal.

4.3.2 Test Pattern

1. Apply power to the terminal.
2. Enter Set-up mode.
3. Press the number, 1.

4. Verify the following:
 - a. The terminal's model number and firmware revision level are displayed on line 1.
 - b. Reverse video, half intensity, underlining, and flashing character visual attributes are displayed.
 - c. All alphanumeric characters, national characters and symbols, and monitor mode facsimile symbols are displayed.
 - d. Block and line graphics are displayed.

4.3.3 Keyboard Test

1. Apply power to the terminal or press CTRL/SHIFT/RESET to reset the terminal if power is already on.
2. Place the terminal in local mode (enter Set-up mode).
3. Starting at the upper left corner of the keyboard, press each symbol, number, and letter key (shifted and unshifted) in sequence.
4. Verify that:
 - a. Keys do not stick.
 - b. Characters appear on the screen as keys are pressed.
 - c. Appropriate character appears on screen for corresponding key (depends upon character set; selectable in Set-up mode).
 - d. Only one character appears on the screen when each key is pressed and released once.

4.4 VIDEO ADJUSTMENTS

Seven adjustments on the Video PWBA, as shown in Figure 4-1, permit adjustment of the brightness, focus, vertical size, vertical linearity, and horizontal size. Note that brightness (paragraph 4.4.1) should be adjusted prior to performing the other adjustments.

4.4.1 Brightness

1. Apply power to the terminal. Place the terminal in local mode (enter Set-up mode).
2. Select a reverse video background (Status Line 2 in Set-up mode).

3. Enter SHIFT/S to generate a reverse video display.
4. Turn the intensity control dial (under lower-right corner of display screen on exterior of case) to maximum intensity (refer to Figure 2-3).
5. Remove the top cover (see paragraph 6.3.1).
6. Adjust brightness (VR301 on Video PWBA: see Figure 4-1) so that CRT display is at maximum brightness but no raster is visible.
7. Using the intensity control dial, lower the CRT brightness to a comfortable viewing level.
8. Remove power from the terminal.
9. Replace the top cover.

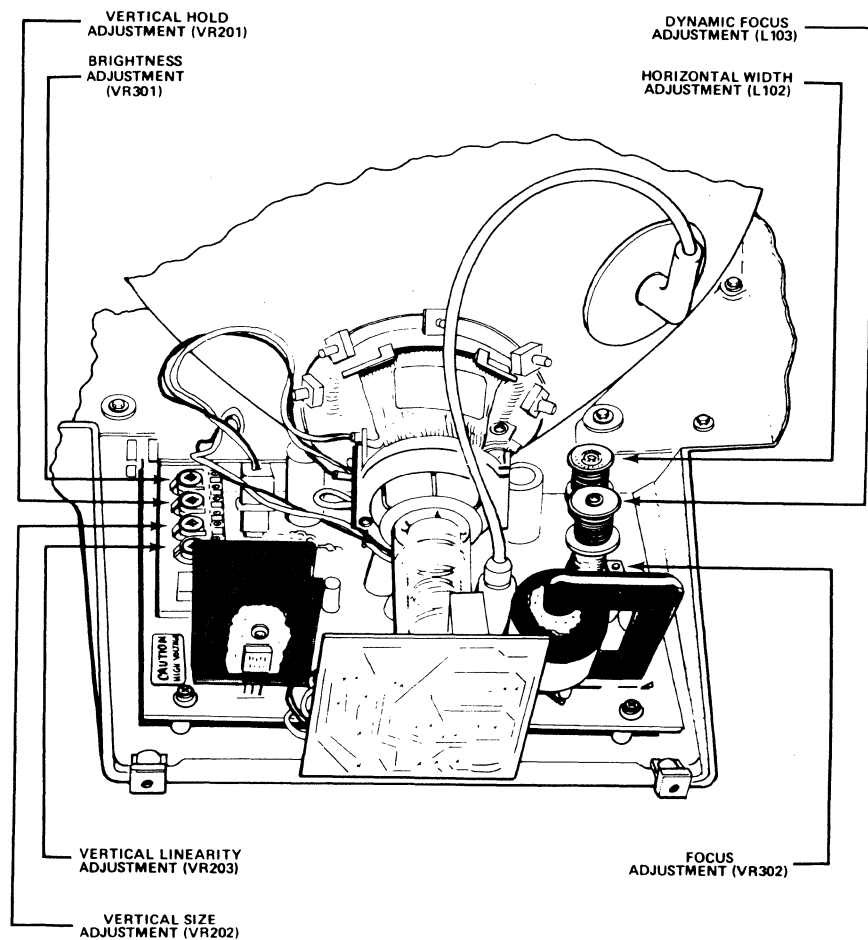

6154

Figure 4-1. Video Adjustments

4.4.2 Focus

1. Apply power to the terminal. Place the terminal in local mode (enter Set-up mode).
2. Fill the screen with exclamation marks (!).
3. Remove the top cover.
4. Adjust Focus (VR302 on Video PWBA for center focus; focus coil L103 for edge focus: see Figure 4-1) so that the dot of every exclamation mark (in both center and edge areas of the screen) is clearly separated.
5. Remove power from the terminal.
6. Replace the top cover.

4.4.3 Vertical Size

1. Apply power to the terminal.
2. Enter Set-up mode and place terminal in local mode.
3. While still in Set-up mode, type the number "0" to generate an alignment pattern.
4. Remove the top cover.
5. Adjust the vertical dimension of the video display (VR202 on Video PWBA: see Figure 4-1) to 172mm (± 3 mm).
6. Remove power from the terminal.
7. Replace the top cover.

4.4.4 Horizontal Size

1. Apply power to the terminal.
2. Enter Set-up mode and place the terminal in local mode.
3. While still in Set-up mode, type the number "0" to generate an alignment pattern.
4. Remove the top cover.
5. Adjust the horizontal dimension of the video display (L102 on Video PWBA: see Figure 4-1) to 239 mm (± 5 mm).
6. Remove power from the terminal.
7. Replace the top cover.

4.4.5 Vertical Linearity

1. Apply power to the terminal.
2. Enter Set-up mode and place the terminal in local mode.
3. While still in Set-up mode, type the number "0" to generate an alignment pattern.
4. Remove the top cover.
5. Adjust vertical linearity (VR203 on Video PWBA: see Figure 4-1) so that typical dimensions of any "E" character are within 15 percent of the dimensions illustrated in Figure 4-2.
6. Remove power from the terminal.
7. Replace the top cover.

4.5 TROUBLESHOOTING

Figure 4-3 is an interconnection diagram of the terminal. The waveforms provided in Figures 4-4 through 4-8 are representative of typical oscilloscope CRT displays.

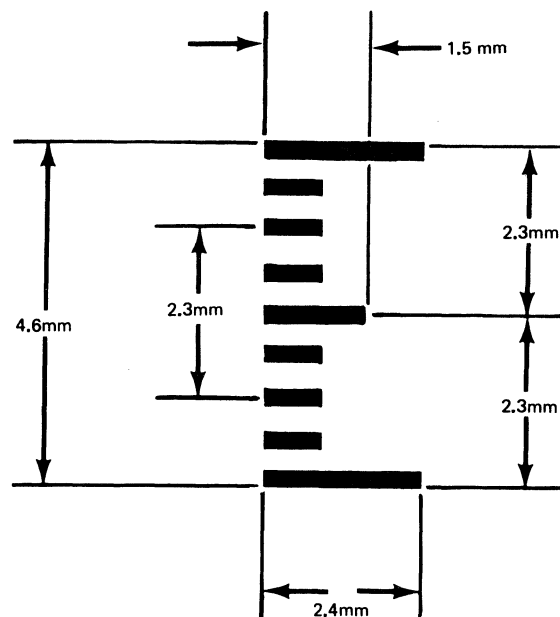

6189

Figure 4-2. Dimensions of E Character

4-7

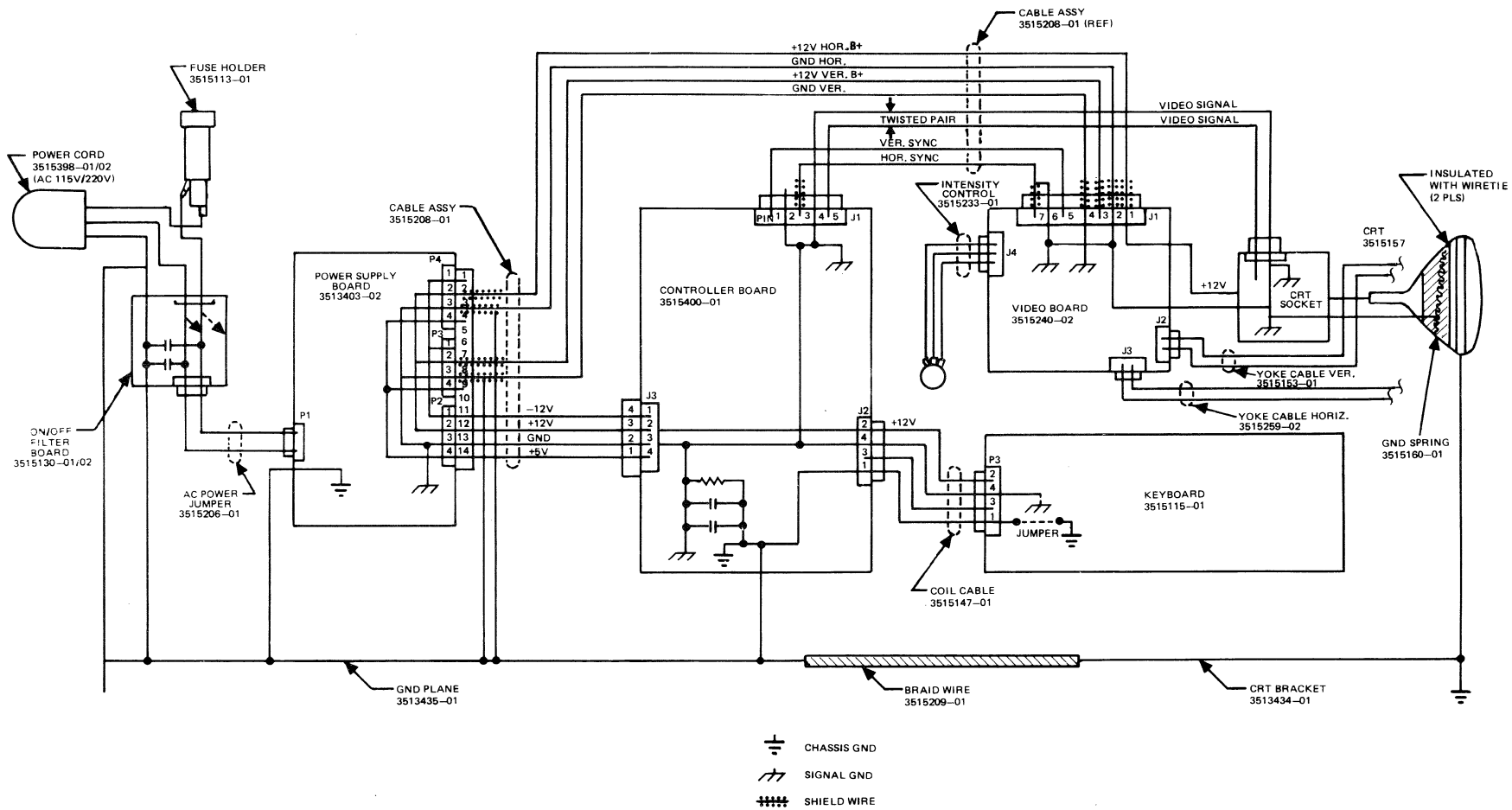

6369

3515021-01

Figure 4-3. Interconnection Diagram

1. Dot Rate is 19.6 MHz
in 80 Columns;
32.14 MHz in 132 Columns

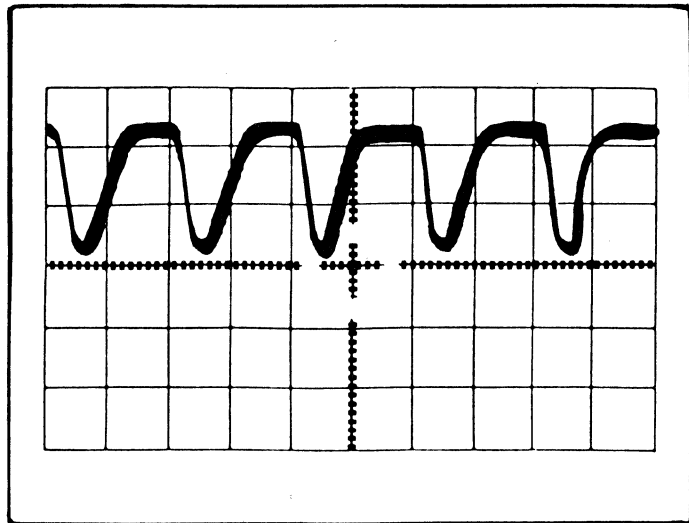

TEST POINT
E2-①

20V/DIV. ● .2 MICROSECONDS

6201

Figure 4-4. Video Waveform

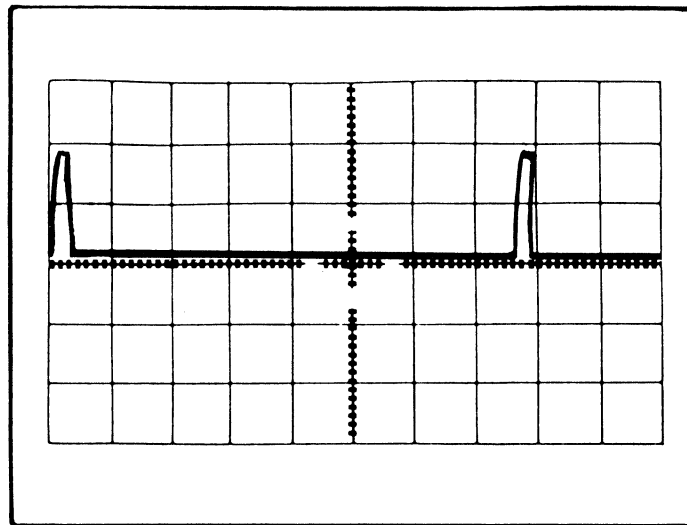

TEST POINT
J1-5-②

2V/DIV ● 2 MILLISECONDS

6202

Figure 4-5. Vertical Sync Waveform

- 1. HORIZONTAL RATE IS 21.778KHz
- 2. HORIZONTAL DRIVE PULSE WIDTH IS 12 Ms

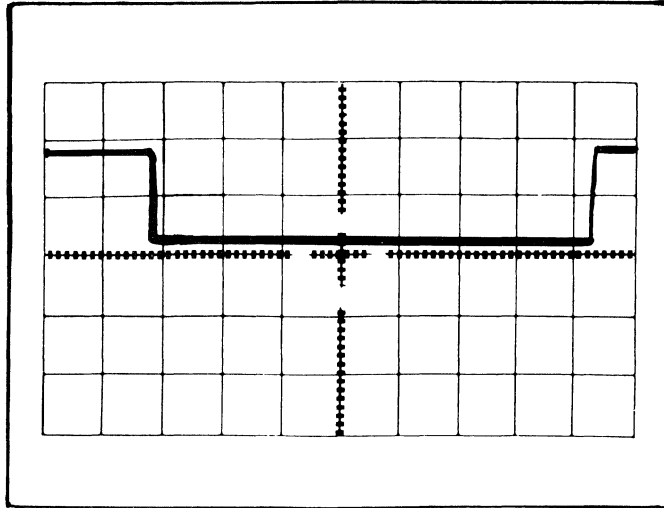

TEST POINT
J1-7-③

2V/DIV @ 5 MICROSECONDS

6203A

Figure 4-6. Horizontal Sync Waveform

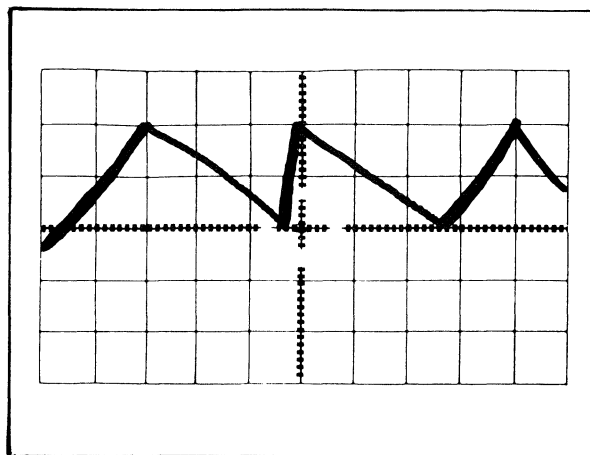

TEST POINT
J2-④

200 MA/DIV @ 5 MILLISECONDS

6204A

Figure 4-7. Vertical Deflection Waveform

1. Horizontal Deflection current is 21.78 KHz

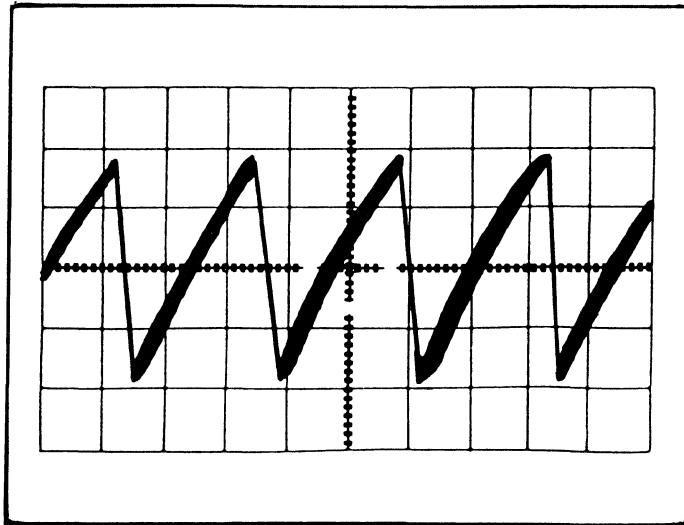

TEST POINT
J3-⑤

2A/DIV. @ 20 MICROSECONDS

6205

Figure 4-8. Horizontal Deflection Waveform

**SECTION V
REMOVAL AND REPLACEMENT**

5.1 INTRODUCTION

This section provides instructions for the removal and replacement of the terminal's major replaceable parts.

WARNING

There are hazardous voltages inside the pedestal and display units. Extremely high voltages are present on the CRT. The CRT may retain a charge for an indefinite period of time if not discharged. Always discharge the CRT before replacing it or working near it.

5.2 SUBASSEMBLY/PARTS LOCATION

Table 5-1 provides a list of removable parts and subassemblies for the Ampex 230/219 terminals. Figure 5-1 is an exploded view of the location of those parts and subassemblies.

Table 5-1. Subassembly and Parts List

Ref Fig. 5-1	Subassembly/Part	Part No.
A	Pedestal Assembly	3515333
B	CRT Housing, Bottom	3513426
	Ground Spring Assembly	3515160
C	Video, PWBA	3515240
D	CRT Housing, Top	3513427
E	Video, PWBA (hard-wired to major board)	3515240
F	Pedestal Unit, Top	3513425
G	CRT Amber	3515151
	CRT Green	3515151
	Intensity Control Assembly	3515233
H	Yoke/Cable Assembly	3515158
I	Controller, PWBA	3515400, 3515455
J	ON/OFF Switch/Filter	3515385
K	Power Supply, PWBA	3513403
	Choke Assembly	3515230
L	Keyboard Cable Connector to Keyboard Assembly	3515334
	Keyboard Cover	3513420
	Keyboard Base	3513421
	Coil, Cable 6-ft	3515147

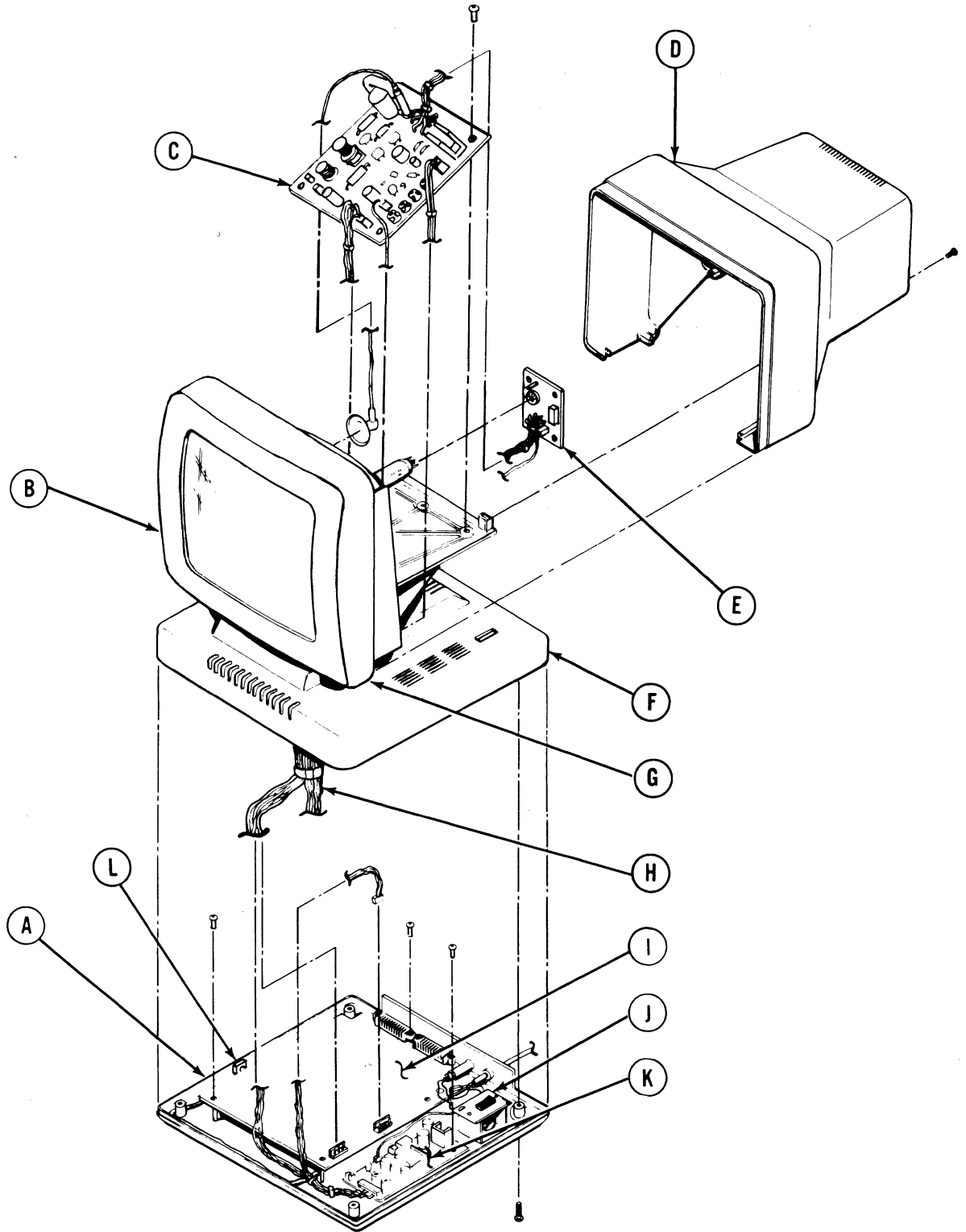

6229D

Figure 5-1. Subassembly Location Diagram

5.3 PRELIMINARY PROCEDURE

Before removing or replacing any of the parts of the terminal, turn the power off and unplug power cord. Disconnect the keyboard cable from the display unit. When removing parts with cable or wire connections, it is recommended that the cables or wires are tagged in order to ensure correct replacement.

5.3.1 Display (Bezel) Cover Removal And Replacement

Using a Phillips screwdriver, remove the two screws at the rear of the display unit. Carefully slide the cover away from the screen (Figure 5-2). When cover will slide no further, gently tilt cover up and lift off.

Replacement is the reverse of removal. Ensure that the sides of the cover slide into place before replacing the two screws at the rear of the cover.

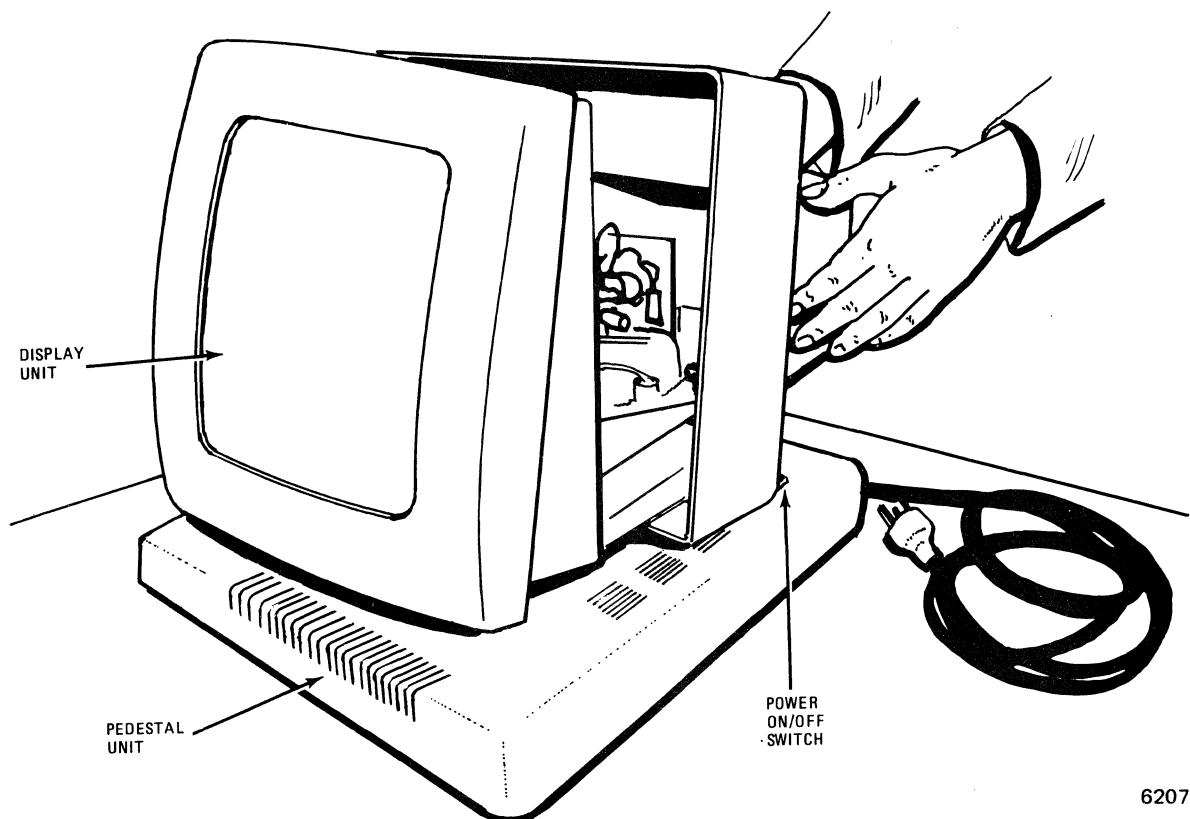

6207A

Figure 5-2. Removing the Display Cover

5.3.2 Pedestal Cover Removal And Replacement

Tilt the display assembly until the unit is resting on its side.

Using a Phillips screwdriver, remove the four screws on the underside of the pedestal unit. Gently force the bottom cover away from the display (Figure 5-3).

Replacement is the reversal of removal. Make sure that the bottom cover is in place before replacing the four screws.

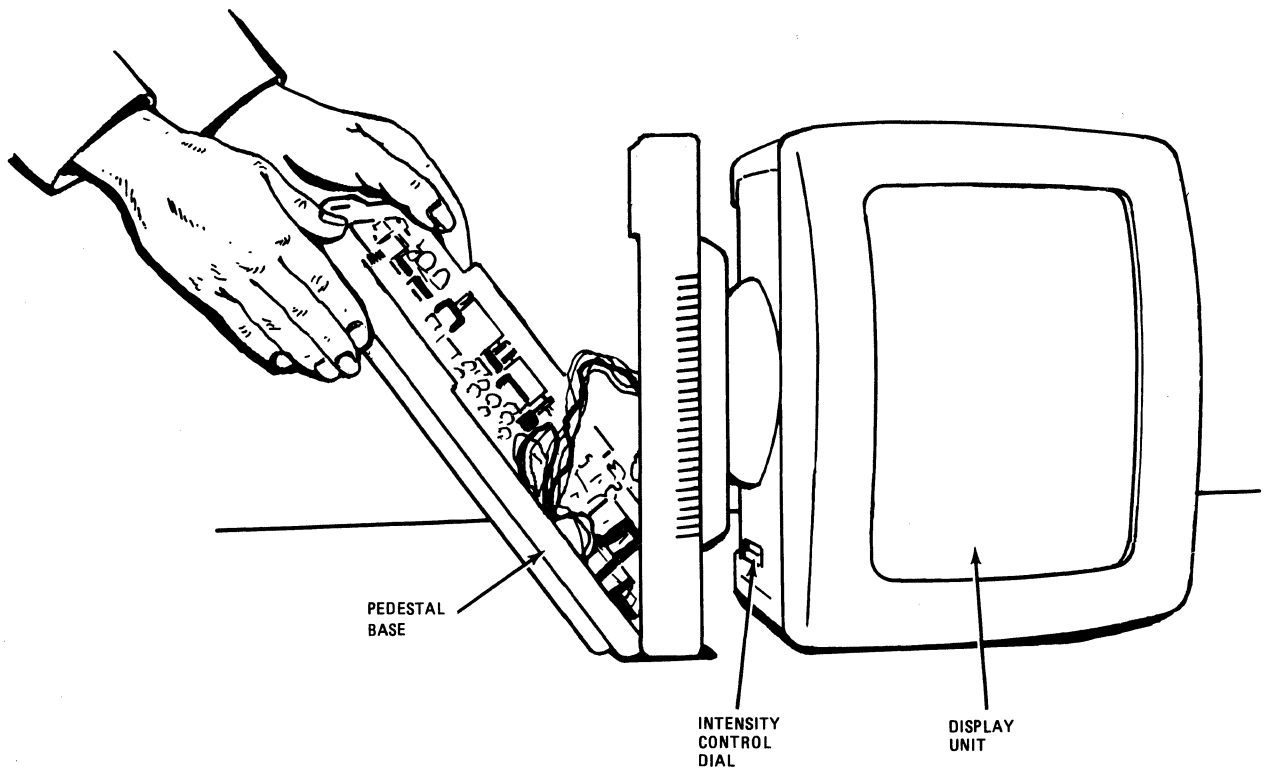

6208A

Figure 5-3. Removing the Pedestal Cover

5.3.3 Controller PWBA Removal And Replacement

The Controller printed wiring board assembly (PWBA) is located in the pedestal unit (refer Figure 5-1).

1. Using a Phillips screwdriver, remove the screws holding the board in place.
2. Tag and disconnect any cables connected to the board.
3. Slowly slide the board away from the two RS232C serial ports. When the serial connectors are free of their ports, lift the board up and out of the unit.

To replace the board, reverse the procedure. Make sure the board is firmly seated before replacing the screws.

5.3.4 Power Supply PWBA Removal And Replacement

The power supply PWBA is located in the pedestal unit (see Figure 5-1).

1. Using a Phillips screwdriver, remove the four screws holding the power supply board in place.
2. Tag and disconnect any cables connected to the board.
3. Slowly pull the board up and out of the pedestal unit.

To replace the power supply board, reverse the procedure. Make sure the board is firmly seated before replacing the screws.

5.3.5 Discharging The CRT

WARNING

The CRT Anode may stay charged at an extremely high voltage for a long time after the power is removed from the terminal. Be sure to follow the CRT discharging procedure carefully. Make sure that a good discharge path is made between the ground wire around the CRT and anode connector beneath rubber cover.

1. Make sure that power is off and that the power cord is disconnected from the ac power outlet.
2. Using a wire lead with an alligator clip on each end, connect one alligator clip to ground screw and the other clip to a flat-blade screwdriver with an insulated, rubber handle (Figure 5-4).

3. Hold the screwdriver by the insulated handle with one hand and move the other hand away from the unit.
4. Slip the screwdriver blade under the rubber anode cover and touch the end of the anode lead. This action should discharge the CRT through the ground wire.

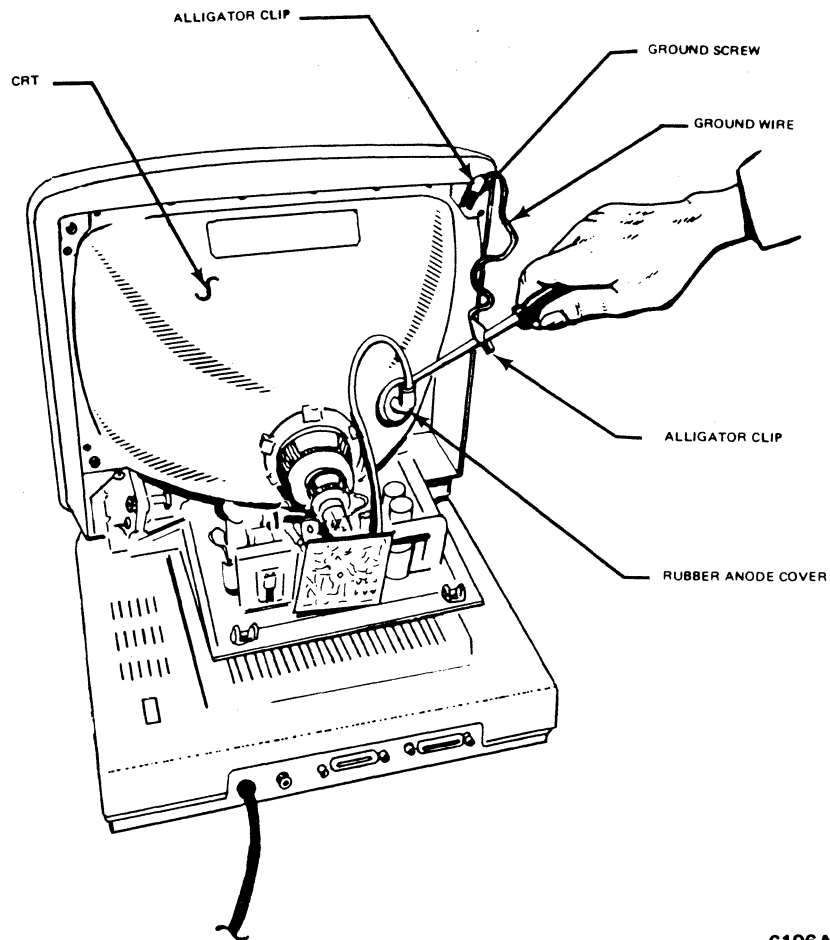

6196A

Figure 5-4. Discharging the CRT

5.3.6 Video PWBA Removal and Replacement

The video PWBA (board) is located in the display (bezel) unit (see Figure 5-1). Make sure the CRT has been discharged before removing the video board.

1. Pull up on the two black plugs in the corners of the video board until they pop out.
2. Tag and disconnect any cables attached to the board.
3. Gently slide board away from the screen. Then lift up and remove from the bottom of the unit.

To replace the board, reverse the procedure. Make sure the board is firmly seated before replacing the cover of the display unit.

APPENDIX A
INSTRUCTIONS FOR INSTALLING USER-INSTALLABLE OPTIONS

RS422 INTERFACE INSTALLATION PROCEDURE

1. Install four snap-on plastic mounting clips (P/N 283-339) into four mounting holes on Controller board (P/N 3515400) as shown in Figure 1. Make sure wings of each clip do not interfere with components of Controller board.
2. Install RS422 Interface board (P/N 3515435) to Controller board over the four newly installed snap-on clips with U1 on RS422 Interface board towards left side of Controller board as shown in Figures 1 and 2.
3. Install cable assembly (P/N 3515517 *) between U1 of Interface board and U40** of Controller board. Align pin 1 on both ends of cable to pin 1 of U1 and pin 1 of U40.
4. Make sure both ends of cable are seated into U1 and U40 properly.

*If alternate cable assembly is used (P/N 636-215), use wire tie (P/N 302-335) to secure excess cable to lower-left side mounting clip.

**If Controller board is a 4-layer board (P/N3515455), one end of the cable assembly should be installed into U46 position.

Part No. 3515412-02A

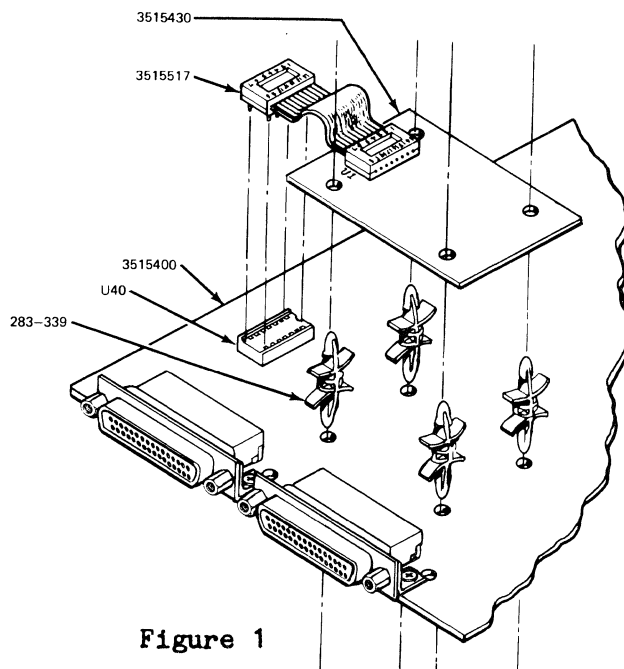

Figure 1

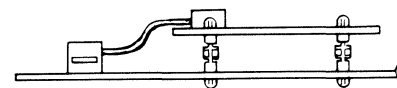

Figure 2

6904

5. Pin signal assignments for the RS422 port are:

15	REC Data (+)
17	REC Data (-)
19	XMIT Data (+)
25	XMIT Data (-)
7	Ground
1	Chassis Ground

CURRENT LOOP INSTALLATION PROCEDURE

1. Install four snap-on plastic mounting clips (P/N 283-339) into four mounting holes on Controller board (P/N 3515400) as shown in Figure 1. Make sure wings of each clip do not interfere with components of Controller board.
2. Install Current Loop board (P/N 3515430) to Controller board over the four newly installed snap-on clips with U1 on Current Loop board towards left side of Controller board as shown in Figures 1 and 2.
3. Install cable assembly (P/N 3515517 *) between U1 of Current board and U40** of Controller board. Align pin 1 on both ends of cable to pin 1 of U1 and pin 1 of U40.
4. Make sure both ends of cable are seated into U1 and U40 properly.

*If alternate cable assembly is used (P/N 636-215), use wire tie (P/N 302-335) to secure excess cable to lower-left side mounting clip.

**If Controller board is a 4-layer board (P/N3515455), one end of the cable assembly should be installed into U46 position.

Part No. 3515413-02A

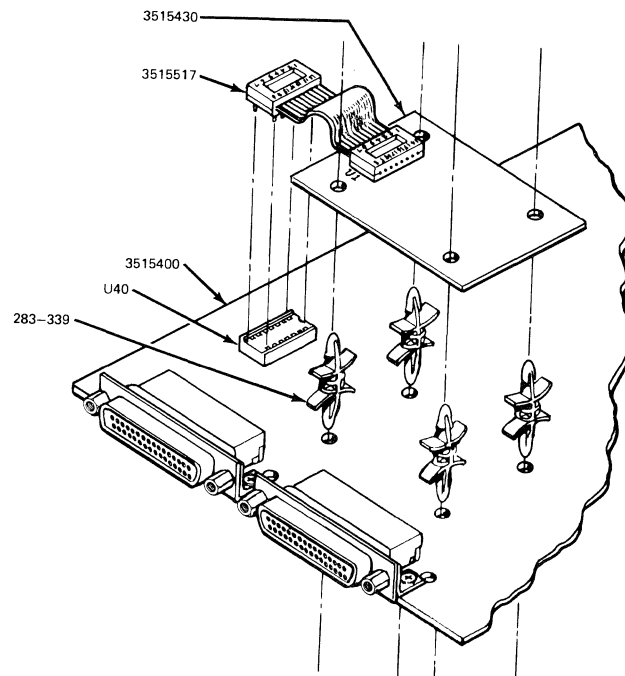

Figure 1

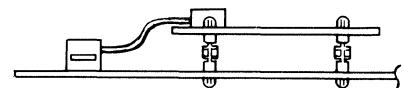

Figure 2

6904

5. Pin signal assignments for the current loop option are:

- 9 20 MA Source
- 14 20 MA Source
- 13 XMIT Current (-)
- 25 XMIT Current (+)
- 12 REC Current (+)
- 24 REC Current (-)
- 7 Ground
- 1 Chassis Ground

**APPENDIX B
REFERENCE DRAWINGS**

Drawing No.	Title
3513403	PWBA - Power Supply
3515113	Fuse Holder Assembly
3515115	PWBA - Keyboard
3515156	Yoke/Tube Assembly
3515158	Yoke/Cable Assembly
3515233	Intensity Control Assembly
3515240	PWBA - Video Board
3515319	Cable Assembly - AC Power Jumper
3515333	Pedestal Assembly
3515334	Keyboard Assembly
3515335	Key Assembly
3515385	PWBA On/Off Switch/Filter
3515398	PWBA - Power Supply
3515400	PWBA Terminal Controller
3515455	PWBA Terminal Controller

EODEISE

REVISIONS			SIGNATURE AND DATE		
LTR	ZONE	DESCRIPTION	DFTG	CHK	ENGRG
A		ERN 0300 (PROTO)	<i>[Signature]</i>	<i>[Signature]</i>	10-19-83
B		ERN 0305 (PROTO) ADDED -02	<i>[Signature]</i>	<i>[Signature]</i>	12-9-83
B		ERN 0307 EDNT	AL	AL	7-4-84 3-13-84

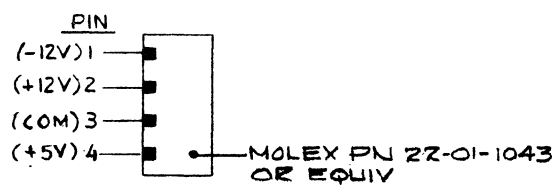
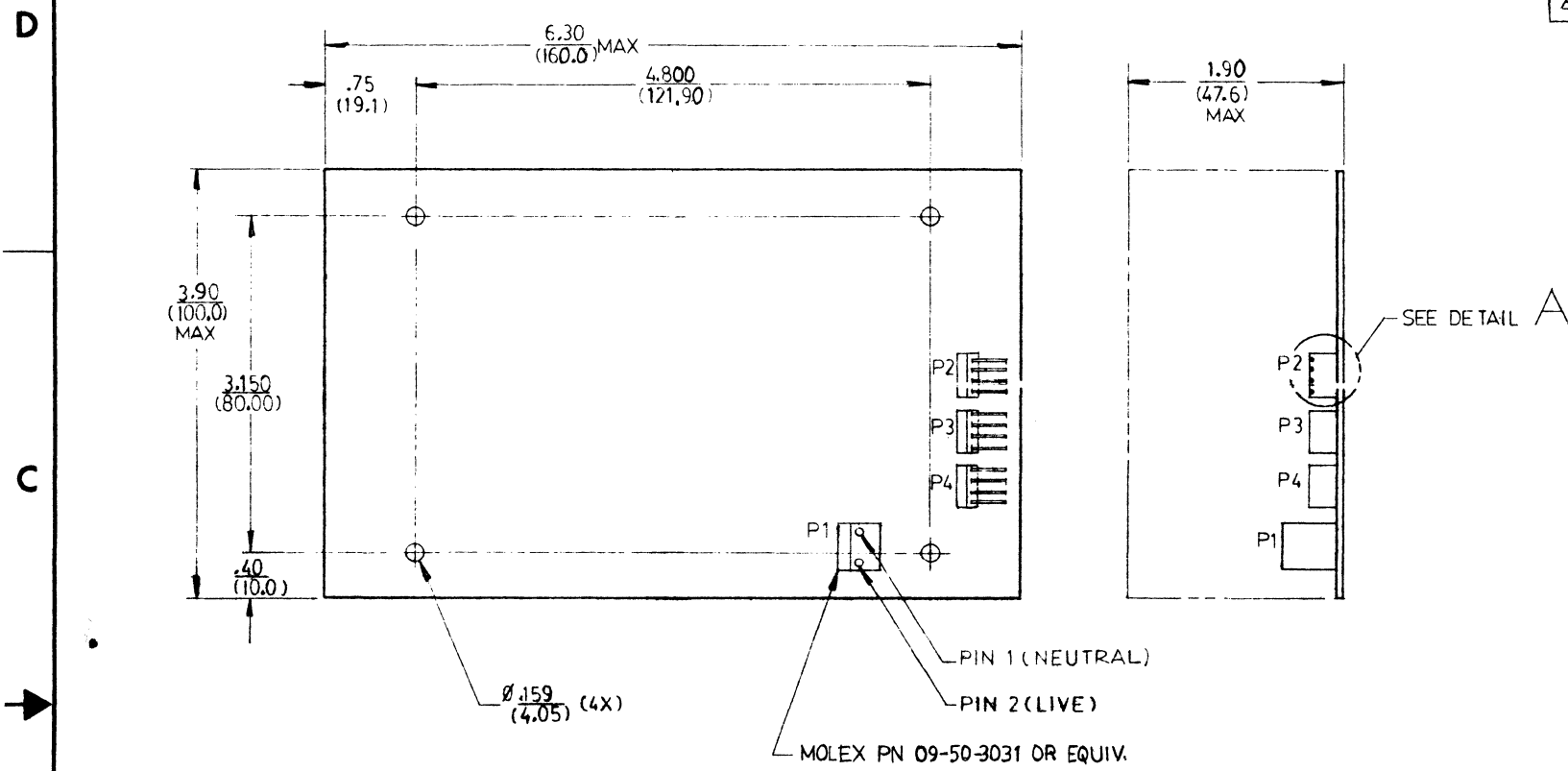

DETAIL A (DC OUTPUT)
 TYP P2, P3, P4

- 5 PART MAYBE PURCHASED FROM:
 A) ASTEC CO, HONG KONG
4. DIMENSIONS IN PARENTHESIS ARE MM.
 TOL: .X = .8MM, .XX = .25MM
3. FOR POWER SUPPLY SPECIFICATION SEE DRAWING 3513401.
2. MARK PART WITH PART NO. AND LATEST REV. LTR PER AMPEX SPEC 3124500, PARA 3.1. LOCATE PER VENDOR OPTION.
1. PART NO. TO BE PER VERSION TABLE.
- NOTES: UNLESS OTHERWISE SPECIFIED

VERSION TABLE		
PART NO	VENDOR P/N	REMARKS
3513403-01	AC8151	NON-VDE APPROVED
3513403-02	AC8151-01	VDE-APPROVED

SPECIFICATION CONTROL DRAWING

<p>NOTICE</p> <p>THIS DRAWING SHALL NOT BE DUPLICATED, USED FOR ANY PURPOSE OTHER THAN THAT FOR WHICH PROVIDED OR DISCLOSED, IN WHOLE OR IN PART, WITHOUT THE WRITTEN CONSENT OF AMPEX CORPORATION. PROVIDED, HOWEVER, THAT IF THIS DRAWING IS SPECIFIED TO BE DELIVERED TO THE GOVERNMENT, OR TO A GOVERNMENT CONTRACTOR, PURSUANT TO A GOVERNMENT PRIME OR SUBCONTRACT, THE GOVERNMENT MAY MAKE SUCH USE OF THIS DRAWING AS IS PERMITTED BY THE APPLICABLE "DATA" CLAUSE SET FORTH IN SUCH CONTRACT OR SUBCONTRACT.</p>	<p>UNLESS OTHERWISE SPECIFIED</p> <p>DIMENSIONS ARE IN INCHES AND INCLUDE CHEMICALLY APPLIED OR PLATED FINISHES.</p> <p>TOL: 2 PL 3 PL ANLR</p> <p>REMOVE BURRS AND SHARP EDGES DRILL TOL PER AND 10387</p> <p>INTERPRET DRAWING PER ANSI Y14.3</p>	<p>SIGNATURE</p> <p>DATE</p> <p>DRAWN BY <i>[Signature]</i> 10-19-83</p> <p>CHK BY <i>[Signature]</i> 10-20-83</p> <p>DFTG APVD <i>[Signature]</i> 10-20-83</p> <p>ENGRG APVD <i>[Signature]</i> 10-20-83</p> <p>AUTH BY <i>[Signature]</i> 10-21-83</p>	<p>AMPEX</p> <p>MEMORY PRODUCTS DIVISION 200 N. Nash Street El Segundo, California 90246</p>	
	<p>APPLICATION</p> <p>3515150 ORION</p> <p>NEXT ASSY USED ON</p>	<p>MATERIAL: 9</p> <p>FINISH:</p>	<p>POWER SUPPLY (ORION)</p>	<p>SIZE CODE IDENT NO.</p> <p>C 09150 3513403</p>
	<p>SCALE</p>	<p>DO NOT SCALE THIS PRINT.</p>	<p>SHEET 1 OF 1</p>	
	<p>UC-3882-08 (REV NOV 78) PRINTED IN U.S.A.</p>			

3513403

3515113

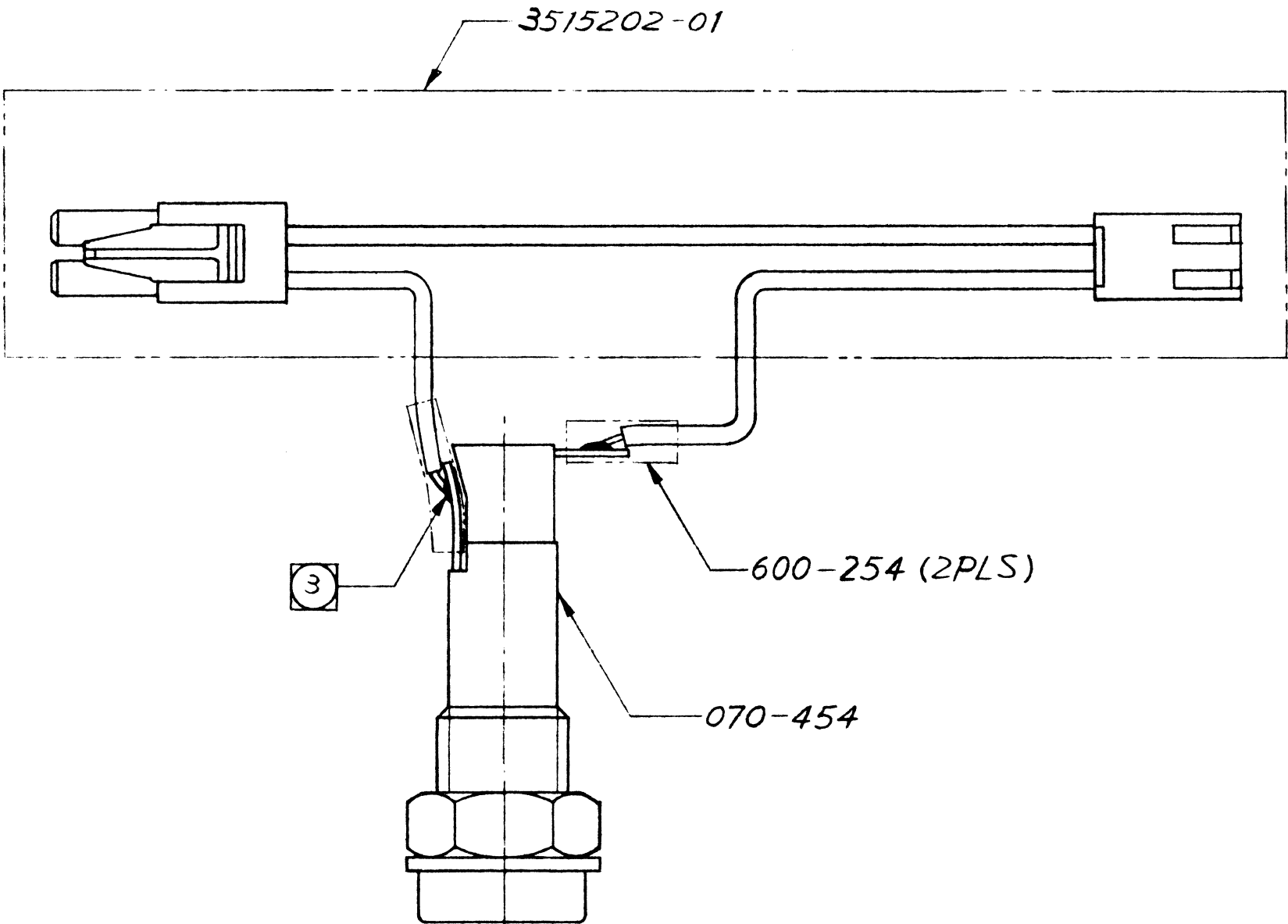

REVISIONS				
LTR	DESCRIPTION	SIGNATURE AND DATE		
		DFTG	CHK	ENGRG
A	NEVER REL			
B	ERN 0011	<i>J. M. M.</i> 11-8-83	<i>B. Hill</i> 11-8-83	<i>I. V.</i> 11-8-83
B	ERN 0024 (CONT.)	<i>J. M. M.</i> 2-24-84	<i>B. Hill</i> 3-2-84	<i>I. V.</i> 3-2-84

- 4 METRIC ENGRG & DFTG PRACTICES PER AMPEX STD MB-3.
- ③ ASSEMBLE PER AMPEX STANDARDS, HC2-5.
- 2 IDENTIFY PART NO. & ISSUE LTR. PER AMPEX SPEC 3124500, PARA 3.2 .
- 1 PART NO TO BE 3515113-01.

NOTES: UNLESS OTHERWISE SPECIFIED

PARTS LIST

<p>3515150 ORION</p> <p>NEXT ASSY USED ON</p> <p>APPLICATION</p>		<p>NOTICE</p> <p>THIS DRAWING SHALL NOT BE DUPLICATED, USED FOR ANY PURPOSE OTHER THAN THAT FOR WHICH PROVIDED OR DISCLOSED, IN WHOLE OR IN PART, WITHOUT THE WRITTEN CONSENT OF AMPEX CORPORATION. PROVIDED, HOWEVER, THAT IF THIS DRAWING IS SPECIFIED TO BE DELIVERED TO THE GOVERNMENT, OR TO A GOVERNMENT CONTRACTOR, PURSUANT TO A GOVERNMENT PRIME OR SUBCONTRACT, THE GOVERNMENT MAY MAKE SUCH USE OF THIS DRAWING AS IS PERMITTED BY THE APPLICABLE "DATA" CLAUSE SET FORTH IN SUCH CONTRACT OR SUBCONTRACT.</p>	<p>UNLESS OTHERWISE SPECIFIED</p> <p>DIMENSIONS ARE IN INCHES AND INCLUDE CHEMICALLY APPLIED OR PLATED FINISH.</p> <table border="1"> <tr> <th>TOL</th> <th>2 PL</th> <th>3 PL</th> <th>ANLR</th> </tr> <tr> <td>+</td> <td></td> <td></td> <td></td> </tr> </table> <p>REMOVE BURRS AND SHARP EDGES DRILL TOL PER AND 10387 INTERPRET DRAWING PER ANSI Y14.5</p>	TOL	2 PL	3 PL	ANLR	+				<table border="1"> <tr> <th colspan="2">SIGNATURE</th> <th>DATE</th> </tr> <tr> <td>DRAWN BY</td> <td><i>J. M. M.</i></td> <td>11-8-83</td> </tr> <tr> <td>CHK BY</td> <td><i>B. Hill</i></td> <td>11-8-83</td> </tr> <tr> <td>DFTG APVD</td> <td><i>B. Hill</i></td> <td>11-8-83</td> </tr> <tr> <td>ENGRG APVD</td> <td><i>I. V.</i></td> <td>11-8-83</td> </tr> <tr> <td>AUTH BY</td> <td><i>I. V.</i></td> <td>11-8-83</td> </tr> </table> <p>MATERIAL: _____</p> <p>FINISH: _____</p>	SIGNATURE		DATE	DRAWN BY	<i>J. M. M.</i>	11-8-83	CHK BY	<i>B. Hill</i>	11-8-83	DFTG APVD	<i>B. Hill</i>	11-8-83	ENGRG APVD	<i>I. V.</i>	11-8-83	AUTH BY	<i>I. V.</i>	11-8-83	<p>AMPEX</p> <p>COMPUTER PRODUCTS DIVISION Marina del Rey, California 90291</p> <p>FUSE HOLDER ASSY</p> <p>SIZE B CODE IDENT NO. 09150</p> <p>3515113</p> <p>SCALE _____ DO NOT SCALE THIS PRINT SHEET OF _____</p>
TOL	2 PL	3 PL	ANLR																												
+																															
SIGNATURE		DATE																													
DRAWN BY	<i>J. M. M.</i>	11-8-83																													
CHK BY	<i>B. Hill</i>	11-8-83																													
DFTG APVD	<i>B. Hill</i>	11-8-83																													
ENGRG APVD	<i>I. V.</i>	11-8-83																													
AUTH BY	<i>I. V.</i>	11-8-83																													

3515115

REVISIONS			
LTR	ZONE	DESCRIPTION	SIGNATURE AND DATE
G	2	ERN 0304 (PROT)	[Signature] 2-24-84
G	2	ERN 0024 (CONT.)	[Signature] 2-24-84
H	2	ECN 42031	[Signature] 2-27-84
J	2	ECN 42039	[Signature] 3-20-84
K	2	ECN 42147	[Signature] 5-24-84

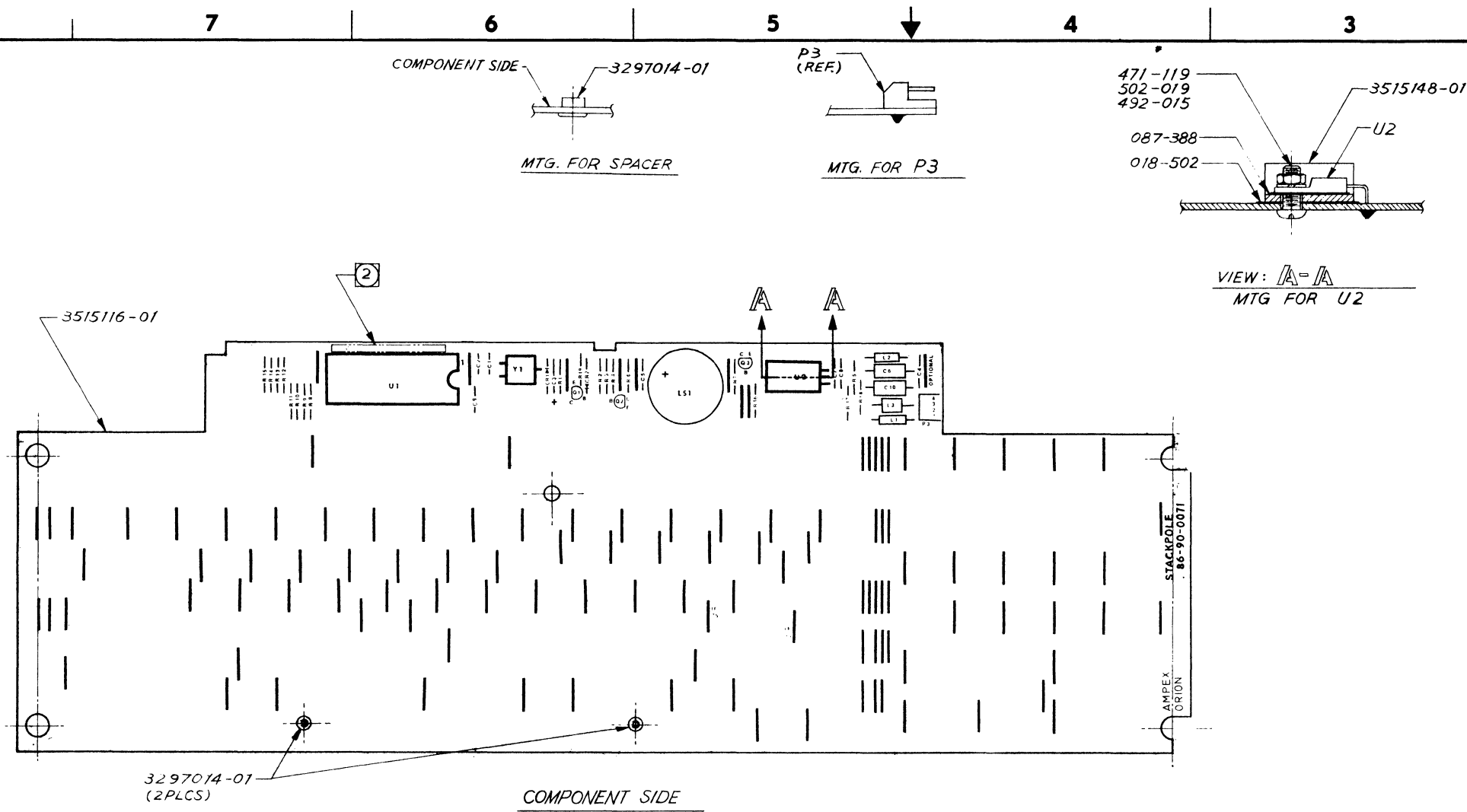

REFERENCE DESIGNATION TABLE

ITEM	PART. NO	DESCRIPTION	REMARK	ITEM	PART. NO	DESCRIPTION	REMARK
1	3515116-01	PWB KEYBOARD		21	068-303	L2 CHOKE	33uH, 200MA, ±10%
2	587-438	U2 VOLTAGE REGULATOR	IC 7805	22	068-304	L1 CHOKE	22uH, 190MA, ±10%
3	580-647	Q1, Q2 TRANSISTOR	2N 3904	23	068-305	L3 CHOKE	25mH, 200MA, ±10%
4	580-800	Q3 TRANSISTOR	2N 5550	24			
5	017-238	Y1 CRYSTAL	4.9152 MHz	25	615-012	WIRE, SOLID BARE	A.W.G. # 20
6	650-333	LS1 BUZZER	PIEZOELECTRIC	26	135-549	P3 RT. ANGLE HEADER	4 PIN
7	066-668	R1, R3, R6 RESISTOR	4.7KΩ, 1/4W, ±5%	27	164-168	DECOUPLING CAP, CERAMIC	0.1uF ALT: 164-169, 164-163
8	066-830	R2, R8-R17, R19	10KΩ, 1/4W, ±5%	28			
9	066-664	R4, R7	510Ω, 1/4W, ±5%	29			
10	066-677	R5	68Ω, 1/4W, ±5%	30	3515148-01	HEAT SINK	
11	066-839	R18	560Ω, 1/4W, ±5%	31	3297014-01	SPACER	
12				32			
13	063-460	C10 CAP. LYTIC	47u, 16V, +75%/-10%	33			
14	064-937	C1, C2 CAP. DISK ALTERNATE: 064-460	22P, 50V, ±5%	34			
15	3512886-01	C4, C5 CAP. MONO	330P, 50V, ±5%	35			
16	063-456	C3 CAP. LYTIC	1u, 50V, +75%/-10%	36			
17	063-458	C6 CAP. LYTIC	10u, 35V, +75%/-10%	37			
18	064-941	C7-C9 CAP. MONO ALTERNATE: 064-458	0.1u, 50V	38			
19				39			
20	581-105	CR1, CR2 DIODE, SWITCHING ALTERNATE: 581-403	1N4148	40			

- 7 MAX. LEAD PROTRUSION OF COMPONENTS ON SOLDER SIDE IS 1.6 MM.
- 6 COMPONENT DESIGNATIONS ARE FOR REF. ONLY.
- 5 COMPONENT MUST NOT EXTEND BEYOND OUTLINE OF BOARD.
- 4 ASSEMBLE PER AMPEX STD.
- 3 FOR LOGIC DIAGRAM SEE SH. 2.
- 2 MARK ISSUE LTR. AND SERIAL NO. PER AMPEX SPEC. 3124500 PARA 3.1.
- 1 PART NO. TO BE 3515115-01.

NOTES: UNLESS OTHERWISE SPECIFIED

NOTICE THIS DOCUMENT CONTAINS CONFIDENTIAL INFORMATION OF A PROPRIETARY NATURE TO AMPEX CORPORATION. REPRODUCTION, TRANSMISSION OR USE FOR ANY PURPOSE WITHOUT THE EXPRESS WRITTEN CONSENT OF AMPEX CORPORATION IS PROHIBITED. PROVIDED HOWEVER, THAT IF THIS DOCUMENT IS SPECIFIED TO BE DELIVERED TO THE GOVERNMENT PURSUANT TO A GOVERNMENT PRIME OR SUBCONTRACT, THE GOVERNMENT MAY MAKE SUCH USE OF THIS DOCUMENT AS IS PERMITTED BY THE APPLICABLE "DATA" CLAUSE SET FORTH IN SUCH CONTRACT OR SUBCONTRACT.	UNLESS OTHERWISE SPECIFIED DIMENSIONS ARE IN INCHES AND INCLUDE CHEMICALLY APPLIED OR PLATED FINISHES.	SIGNATURE DRAWN BY: [Signature] DATE: 11/12/83	AMPEX MEMORY PRODUCTS DIVISION 200 N. Nash Street El Segundo, California 90245
	TOL ± 2 PL 3 PL ANLR	CHECK BY: [Signature] DATE: 12/14/83	
	REMOVE BURRS AND SHARP EDGES DRILL TOL PER AND 10387	ENGRG APVD: [Signature] DATE: 12/14/83	
	INTERPRET DRAWING PER ANSI Y14.5	AUTH BY: [Signature] DATE: 12/14/83	
MATERIAL: _____ FINISH: _____	SIZE CODE IDENT NO. D 09150	3515115	SHEET / OF 2

3515115

REVISIONS			SIGNATURE AND DATE		
LTR	ZONE	DESCRIPTION	DFTG	CHK	ENGRG
K		SEE SH. 1			

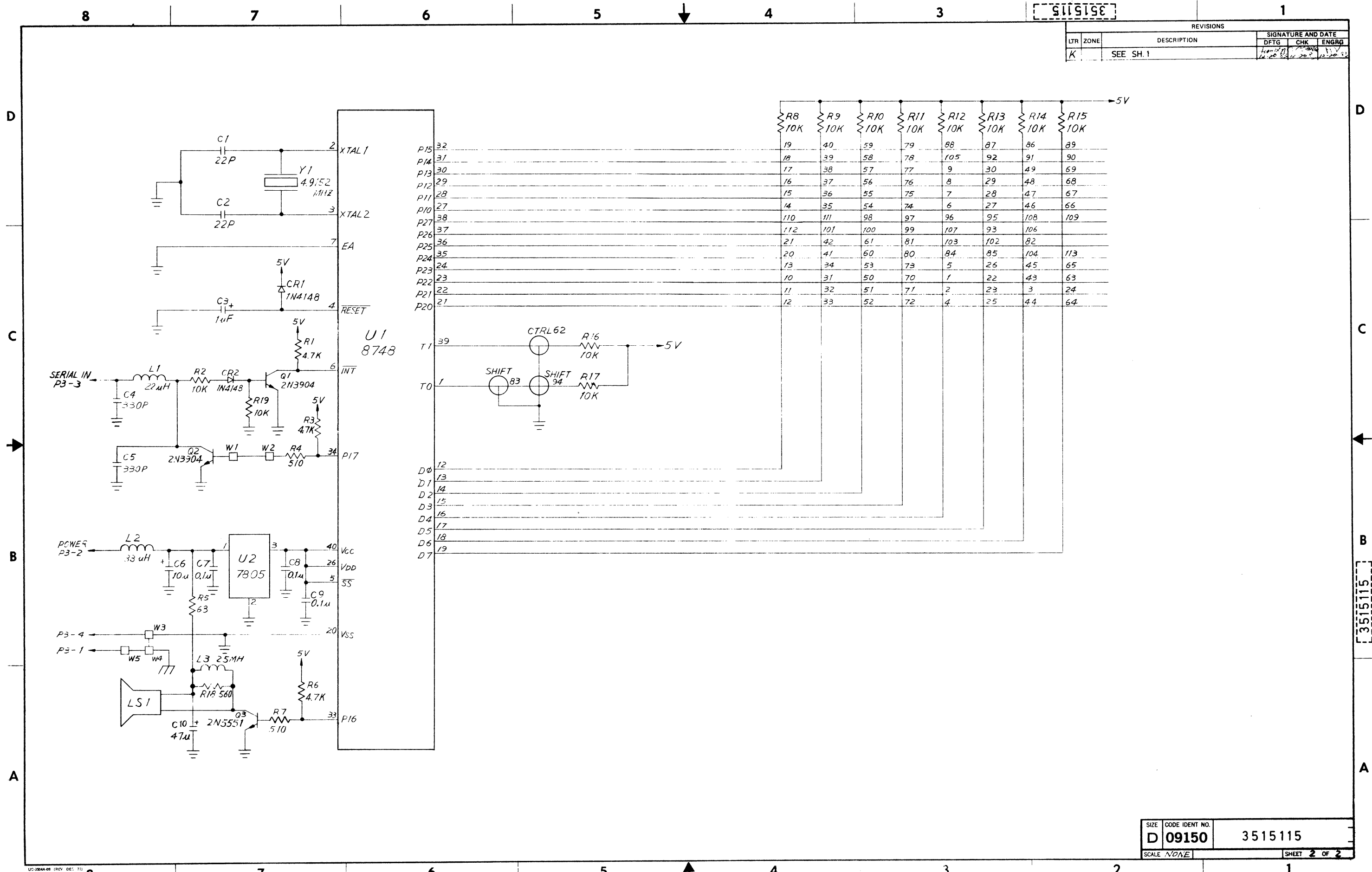

SIZE	CODE IDENT NO.	3515115
D	09150	
SCALE	NONE	SHEET 2 OF 2

3515156

REVISIONS					
LTR	ZONE	DESCRIPTION	SIGNATURE AND DATE		
			DFTG	CHK	ENGR
A		ERN 0009			
B		PCR 42010			
B		ERN 0024 (CONT.)			
C		ERN 0067 (ADD-03)			

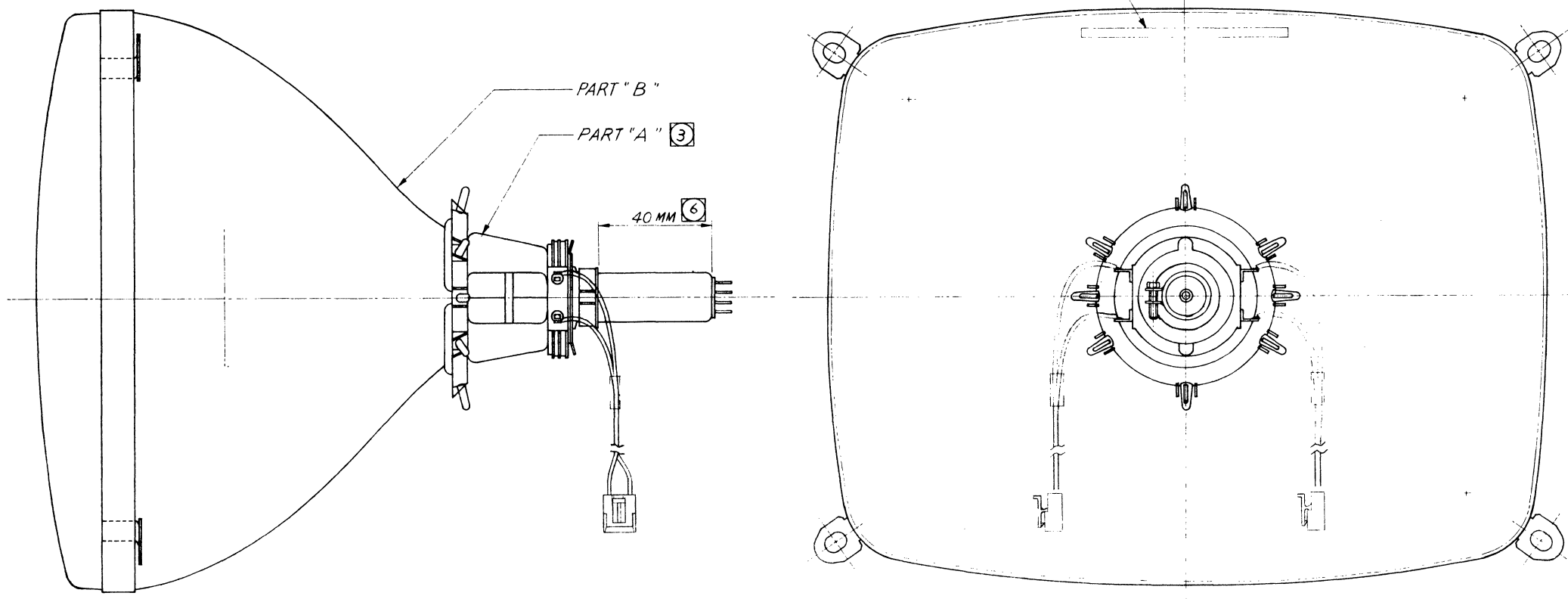

- ⑥ APPLY 225-527 TAPE TO NECK OF TUBE UNDER YOKE CLAMP. TAPE APPROX 3/4 TO 9/10 OF A COMPLETE TURN AROUND NECK LOCATE APPROX 40 MM FROM END OF TUBE.
 - 5 FOR ALIGNMENT PROCEDURE SEE DWG. 3515186.
 - ④ INSTALL WARNING LABEL ON THE TOP OF THE CRT.
 - ③ INSTALL 3515158 AS FAR AS POSSIBLE ON NECK OF CRT (PART "B"). FOR YOKES WITH RADIAL ROSTS, MAGNETS 029-025 AND 029-026 MAY BE USED TO FACILITATE ALIGNMENT.
 - 2 ASSEMBLE PER AMPEX STANDARDS.
 - 1 PART NO. TO BE PER VERSION TABLE.
- NOTES: UNLESS OTHERWISE SPECIFIED

PART NO	PART "A" (YOKE)	PART "B" (TUBE)	COLOR
3515156-03	3515158-01	3515157-06	GREEN
3515156-02	3515158-01	3515157-02 (ALTERNATE 3515157-04)	GREEN
3515156-01	3515158-01	3515157-03 (ALTERNATE 3515157-05)	AMBER

VERSION TABLE

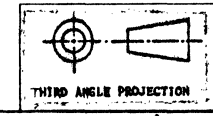

3515152	ORION
NEXT ASSY	USED ON
APPLICATION	

NOTICE		UNLESS OTHERWISE SPECIFIED		SIGNATURE		DATE	
THIS DRAWING SHALL NOT BE DUPLICATED, USED FOR ANY PURPOSE OTHER THAN THAT FOR WHICH PROVIDED OR DISCLOSED, IN WHOLE OR IN PART, WITHOUT THE WRITTEN CONSENT OF AMPEX CORPORATION. PROVIDED, HOWEVER, THAT IF THIS DRAWING IS SPECIFIED TO BE DELIVERED TO THE GOVERNMENT, OR TO A GOVERNMENT CONTRACTOR, PURSUANT TO A GOVERNMENT PRIME OR SUBCONTRACT, THE GOVERNMENT MAY MAKE SUCH USE OF THIS DRAWING AS IS PERMITTED BY THE APPLICABLE "DATA" CLAUSE SET FORTH IN SUCH CONTRACT OR SUBCONTRACT.		DIMENSIONS ARE IN INCHES AND INCLUDE CHEMICALLY APPLIED OR PLATED FINISHES.		DRAWN BY: <i>[Signature]</i>		9-9-83	
TOL		2 PL 3 PL ANLR		CHK BY: <i>[Signature]</i>		11-2-83	
±		-- -- --		DFTG APVD: <i>[Signature]</i>		11-2-83	
REMOVE BURRS AND SHARP EDGES		DRILL TOL PER AND 10387		ENGRG APVD: <i>[Signature]</i>		11-3-83	
INTERPRET DRAWING PER ANSI Y14.5		MATERIAL:		AUTH BY: <i>[Signature]</i>		11-3-83	
FINISH:		SCALE		DO NOT SCALE THIS PRINT		SHEET / OF /	

PARTS LIST <input type="checkbox"/>		MEMORY PRODUCTS DIVISION 200 N. Nash Street El Segundo, California 90245	
AMPEX		YOKE / TUBE ASSY	
SIZE	CODE IDENT NO.	3515156	
D	09150		

↓ 3515158

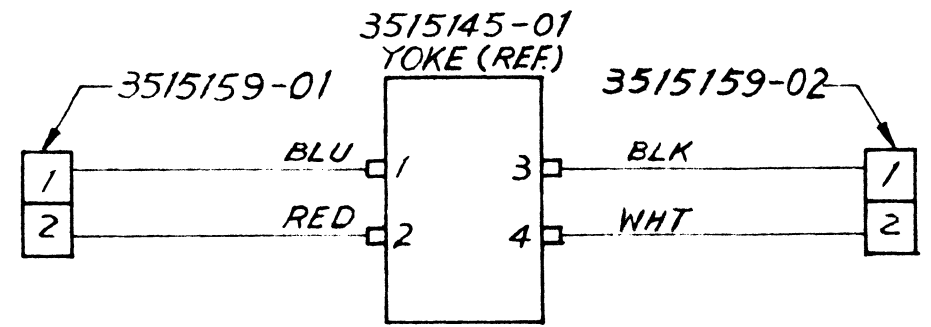
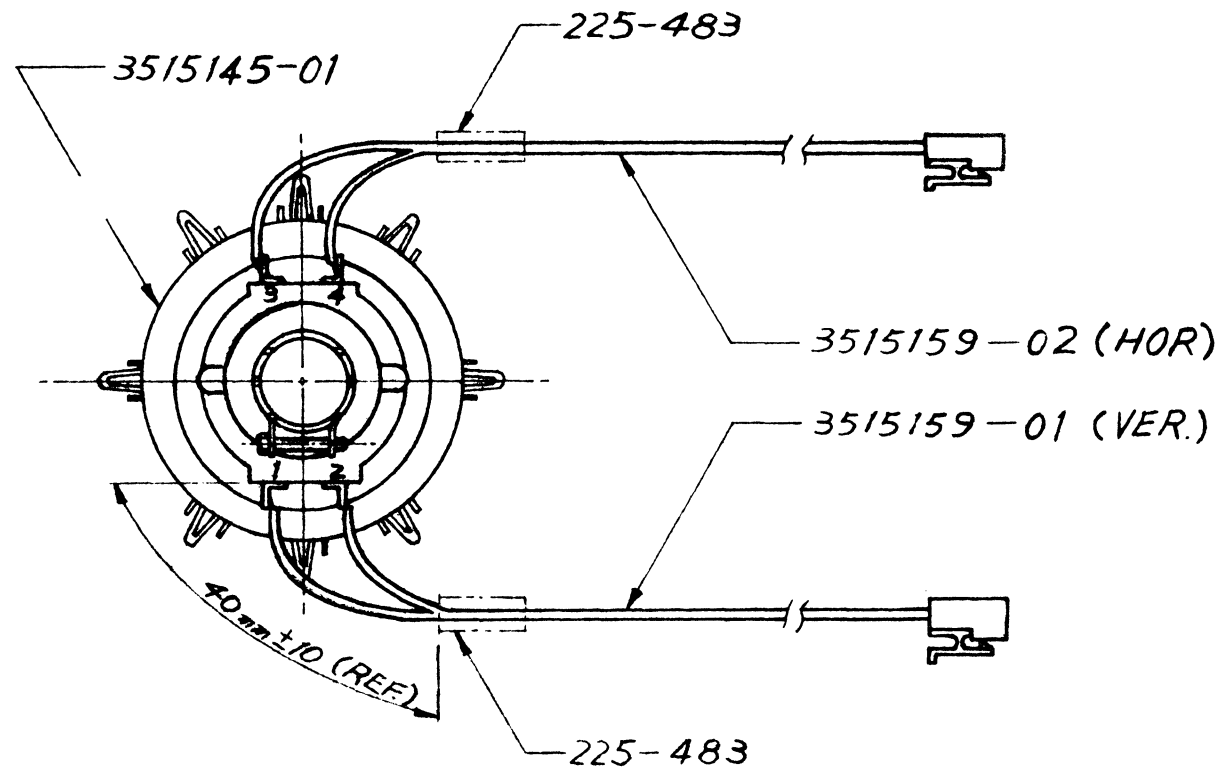

WIRING DIAGRAM

REVISIONS				
LTR	DESCRIPTION	SIGNATURE AND DATE		
		DFTG	CHK	ENGRG
A	ERN0011	<i>J. M. N.</i> 9-10-83	<i>B. Rich.</i> 11-8-83	<i>V.V.</i> 11-8-83
A	ERN0024 (CONT.)	<i>J. M. N.</i> 2-24-84	<i>B. Rich.</i> 3-2-84	<i>V.V.</i> 3-2-84

4. METRIC ENGRG AND DFTG PRACTICES PER AMPEX STD MB1-3.
3. IDENTIFY PART NO, ISSUE LTR PER AMPEX SPEC 3124500, PARA 3.2
2. ASSEMBLE PER AMPEX STANDARDS, HC2-5.
1. PART NO. TO BE 3515158-01.

NOTES UNLESS OTHERWISE SPECIFIED

PARTS LIST

	NOTICE	UNLESS OTHERWISE SPECIFIED	SIGNATURE	DATE	AMPEX	COMPUTER PRODUCTS DIVISION Merina del Rey, California 90291			
	THIS DRAWING SHALL NOT BE DUPLICATED, USED FOR ANY PURPOSE OTHER THAN THAT FOR WHICH PROVIDED OR DISCLOSED, IN WHOLE OR IN PART, WITHOUT THE WRITTEN CONSENT OF AMPEX CORPORATION. PROVIDED, HOWEVER, THAT IF THIS DRAWING IS SPECIFIED TO BE DELIVERED TO THE GOVERNMENT, OR TO A GOVERNMENT CONTRACTOR, PURSUANT TO A GOVERNMENT PRIME OR SUBCONTRACT, THE GOVERNMENT MAY MAKE SUCH USE OF THIS DRAWING AS IS PERMITTED BY THE APPLICABLE "DATA" CLAUSE SET FORTH IN SUCH CONTRACT OR SUBCONTRACT	DIMENSIONS ARE IN INCHES AND INCLUDE CHEMICALLY APPLIED OR PLATED FINISH.	DRAWN BY <i>J. M. N.</i>	<i>9-10-83</i>	YOKE / CABLE ASSY				
		TOL	2 PL	3 PL			ANLR	CHK BY <i>B. Rich.</i>	<i>11-8-83</i>
		+ - - - -	REMOVE BURRS AND SHARP EDGES DRILL TOL PER AND 10387				DFTG APVD <i>B. Rich.</i>	<i>11-8-83</i>	
		3515156	OR/ON	INTERPRET DRAWING PER ANSI Y14.5			ENGRG APVD <i>V.V.</i>	<i>11-8-83</i>	
	NEXT ASSY	USED ON	MATERIAL:		AUTH BY <i>V.V.</i>	<i>11-8-83</i>			
	APPLICATION		FINISH:		SIZE	CODE IDENT NO.			
					B	09150			
					SCALE	3515158			
						DO NOT SCALE THIS PRINT			
						SHEET / OF /			

3515240

REVISIONS				
LTR	ZONE	DESCRIPTION	SIGNATURE AND DATE	
			DFTG	ENGRG
X	A	ECN 42105		
Y		ECN 42109		
Z		ECN 42113		
A1		ECN 42122		
AB		ECN 42134		
AC		ECN 42149		

REVISIONS				
LTR	ZONE	DESCRIPTION	SIGNATURE AND DATE	
			DFTG	ENGRG
A		NEVER RELEASE		
B		NEVER RELEASE		
C		NEVER RELEASE		
D		NEVER RELEASE		
E		ERN 0016		
F		PCR 42010		
G		PCR 42014		
H		PCR 42015		
H		ERN 0024 (CONT.)		
J		ECN 42024		
K		ECN 42038		
L		ECN 42047		
M		ECN 42057		
N		ECN 42063		
P		ECN 42068		
R		ECN 42072		
S		ERN 0054 ACD-02)		
T		ECN 42083		
U		ECN 42085		
V		ECN 42090		
W		ECN 42102		

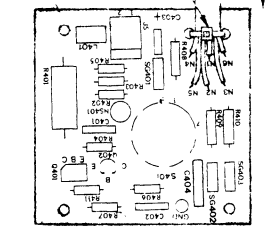
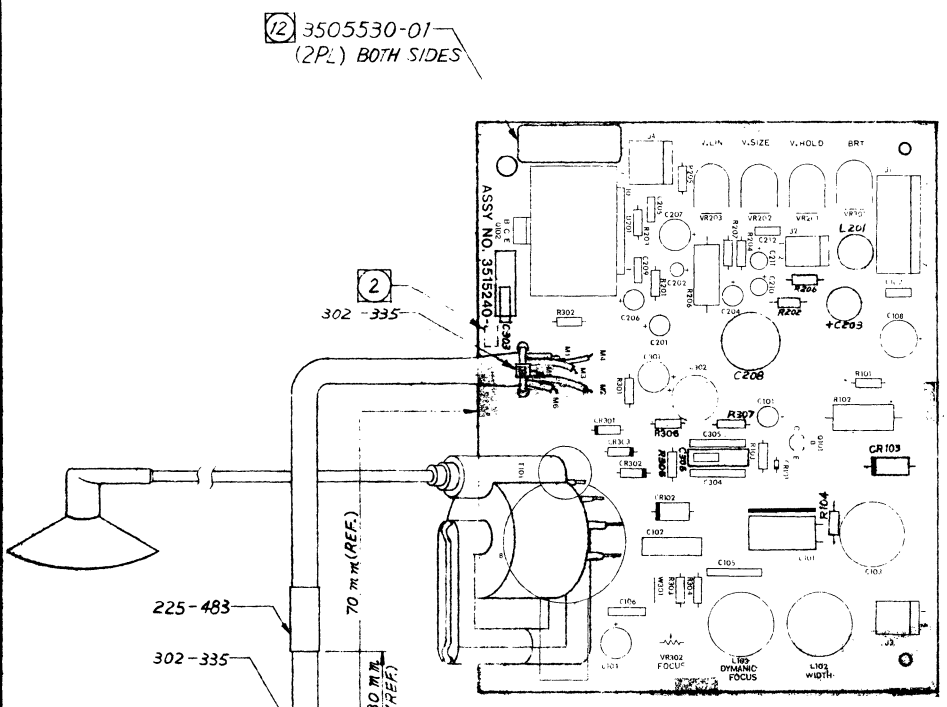

CRT SOCKET BOARD		MASTER BOARD	
N1	WHT. 619-266	M1	
N2	YEL. 619-340	M2	
N3	BLU. 619-342	M3	
N4	RED. 619-338	M4	
N5	ORN. 619-339	M5	
N6	BLK. 619-267	M6	

WIRING DIAGRAM FOR REF.

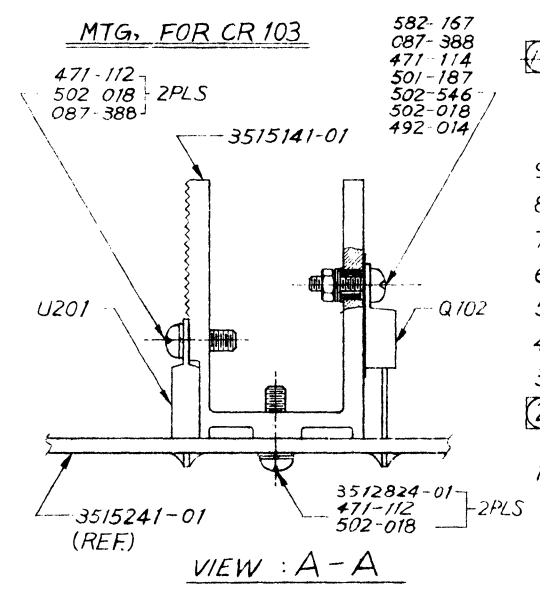
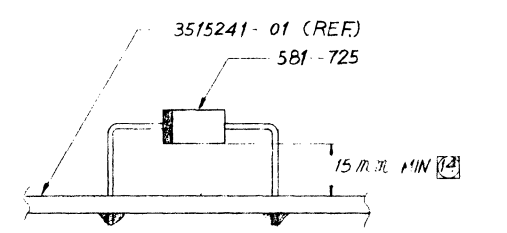
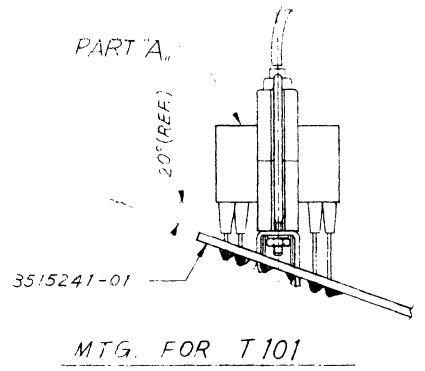

- 15 CUT TRACE BETWEEN LEADS OF L401. (FOR 3515240-02 ONLY)
- 14 CLEARANCE BETWEEN BOTTOM SIDE OF CR103 AND BOARD IS 15 mm MIN.
- 13 MAX. LEAD PROTRUSION ON SOLDER SIDE IS 3.2 mm.
- 12 ADHERE 3505530-01 APPROX AS SHOWN.
- 11 APPLY HOT MELT (018-531) TO HOLD PARTS Q401, C208, C302, C103, L101. TO FWBA RIGIDLY.
- 10 AFTER FLYBACK SEATING IN PROPER POSITION TWIST 4 TABS OF FLYBACK MOUNTING BRACKET TO CONSOLIDATE FLYBACK ON BOARD.
- 9 METRIC ENGRG & DFTG PRACTICES PER AMPEX STD. MBI-3
- 8 ADHERE 3505530-01 APPROX AS SHOWN.
- 7 HEAVY LINE ON DIODE DENOTES CATHODE END.
- 6 PLUS SIGN ON CAPACITORS DENOTES POSITIVE END.
- 5 FOR SCHEMATIC SEE SH 3.
- 4 COMPONENT REF. DESIGNATIONS ARE FOR REF ONLY.
- 3 ASSEMBLY PER AMPEX STANDARDS, HC 2-5.
- 2 MARK DASH NO., SERIAL NO. AND ISSUE LTR PER AMPEX SPEC 3124500, PARA 3.1.
- 1 PART NO. TO BE PER VERSION TABLE.

NOTES: UNLESS OTHERWISE SPECIFIED



<p>NOTICE</p> <p>THIS DRAWING SHALL NOT BE DUPLICATED, USED FOR ANY PURPOSE OTHER THAN THAT FOR WHICH PROVIDED OR DISCLOSED, IN WHOLE OR IN PART, WITHOUT THE WRITTEN CONSENT OF AMPEX CORPORATION. PROVIDED, HOWEVER, THAT IF THIS DRAWING IS SPECIFIED TO BE DELIVERED TO THE GOVERNMENT, OR TO A GOVERNMENT CONTRACTOR, PURSUANT TO A GOVERNMENT PRIME OR SUBCONTRACT, THE GOVERNMENT MAY MAKE SUCH USE OF THIS DRAWING AS IS PERMITTED BY THE APPLICABLE "DATA" CLAUSE SET FORTH IN SUCH CONTRACT OR SUBCONTRACT.</p>		<p>UNLESS OTHERWISE SPECIFIED</p> <p>DIMENSIONS ARE IN MILLIMETERS AND INCLUDE CHEMICALLY APPLIED OR PLATED FINISHES.</p> <p>TOL: 2 PL 3 PL ANLR</p> <p>REMOVE BURRS AND SHARP EDGES. DRILL TOL PER AND 10387.</p> <p>INTERPRET DRAWING PER ANSI Y14.6</p> <p>MATERIAL:</p> <p>FINISH:</p>		<p>SIGNATURE</p> <p>DATE</p> <p>DRAWN BY: Leo M. [Signature] 11-25-83</p> <p>CHK BY: B. [Signature] 11-28-83</p> <p>DFTG: [Signature] 11-28-83</p> <p>ENGRG: [Signature] 11-28-83</p> <p>APVD: [Signature] 11-28-83</p> <p>AUTH BY: C. N. [Signature] 11-28-83</p>		<p>PARTS LIST</p> <p>MEMORY PRODUCTS DIVISION</p> <p>200 N. Nash Street</p> <p>El Segundo, California 90245</p>	
<p>3515152 ORION</p> <p>NEXT ASSY USED ON</p> <p>APPLICATION</p>		<p>AMPEX</p> <p>PWBA - VIDEO BOARD</p>		<p>SIZE: D</p> <p>CODE IDENT NO.: 09150</p> <p>3515240</p>			
<p>THIRD ANGLE PROJECTION</p>		<p>SCALE: NONE</p> <p>DO NOT SCALE THIS PRINT</p>		<p>SHEET 1 OF 3</p>			

0729193

REVISIONS			SIGNATURE AND DATE		
LTR	ZONE	DESCRIPTION	DFTG	CHK	ENGRG
AC		SEE SH. 1			

REFERENCE DESIGNATION TABLE

ITEM	PART NO.	DESCRIPTION	REMARKS	Q'TY
1	3515141-01		HEATSINK HOR/VER.	1
2	PART "A"	T101	X'FORMER HOR. OUTPUT	1
3	3515143-01	L103	COIL FOCUS	1
4	3505211-01	L102	COIL HOR. WIDTH	1
5	3515248-C1	L101	COIL HOR. LINEARITY	1
6	PART "B"	L401 (FOR 02 ONLY)	COIL PEAKING	1
7	581-681	CR301	1N4003	1
8	013-871	CR302, CR303	1N4006	2
9	581-725	CR103	MR852/G1852	1
10	581-485	CR102	MR854/G1854	1
11	581-403	CR101	SWITCHING	1
12				
13	579-048	Q101	MPS9434J	1
14	580-647	Q402	2N3904	1
15	579-151	Q401	2N6553	1
16	579-154	Q102	8U806	1
17				
18	002-036	U201	4PC1031H2/LA1385	1
19				
20	075-364	VR203	2KΩ	1
21	075-365	VR202	20KΩ	1
22	075-366	VR201	50KΩ	1
23	075-367	VR301	500KΩ	1
24	075-376	VR302	2MΩ X-201-R5	1
25				
26	066-834	R407, R103	33Ω 5% 1/4W	2
27	066-938	R411	47Ω " "	1
28	PART "C"	R406	SEE VERSION TABLE	1
29	066-835	R207	82Ω " "	1
30	066-663	R402	220Ω " "	1
31	066-814	R301	270Ω " "	1
32	066-665	R101, R208, R403	1KΩ " "	3
33	066-675	R404	18KΩ " "	1
34	066-666	R203	2.7KΩ " "	1
35	066-829	R201, R204, R205	6.8KΩ " "	3
36	066-847	R202	33KΩ " "	1
37	066-913	R304, R305, R307	220KΩ " "	3
38	066-673	R303	1MΩ " "	1
39	062-182	R408	1KΩ " 1/2W	1
40	062-199	R410, R409	10KΩ " 1/2W	2
41	079-425	R206	1Ω " 1W	1
42	079-427	F102	100Ω " 2W	1
43	059-885	R401	820Ω " 4W	1
44	066-560	R306	56Ω " 1/4W	1
45	PART "D"	R405	SEE VERSION TABLE	1

ITEM	PART NO.	DESCRIPTION	REMARKS	Q'TY
46	064-993	C402	120PF 50V ±5%	1
47	064-975	C107, C401	0.1μF 50V ±20%	2
48	030-299	C106	0.001μF 1KV 20%	1
49	030-129	C105, C304, C305, C404	0.01μF 1KV 20%	4
50	064-410	C212, C209, C205	0.047μF 50V 20%	3
51	3515584-01	C303, C306	0.33μF 250V 20%	2
52	3512840-03	C102	0.022μF 400V 5%	1
53	037-493	C202	1μF 15V 20%	1
54	067-116	C210, C211	22μF 10V 10%	2
55	063-459	C101, C201, C204	10μF 16V 20%	3
56	063-552	C207	100μF 10V 10%	1
57	063-460	C206	47μF 16V 20%	1
58	063-461	C108, C203	220μF 16V 20%	2
59	063-462	C208	2200μF 16V 20%	1
60	063-553	C104	100μF 25V 20%	1
61	063-554	C302	100μF 80V 20%	1
62	063-551	C403	10μF 100V 20%	1
63	3515299-01	C103	6.8μF 25V 20%	1
64	063-564	C301	10μF 160V 20%	1
65				
66	064-984	SG402, SG403	SPARK GAP 1KV GAP-R75	2
67				
68	060-049	NS401 NS402	NEON LIGHT 105VAC 2mA	2
69	012-270	S401	SOCKET 7P CRT BASE	1
70				
71	135-534	J1	HEADER 7-P	1
72	135-530	J2, J3, J5	HEADER 2-P	3
73	135-531	J4	HEADER 3-P	1
74				
75	177-352	GND	PIN DISCONNECT	1
76	615-012	W301	WIRE SOLID BARE #20	1
77				
78	066-838	R104	330Ω 5% 1/4W	1
79	066-590	R302	68KΩ 5% 1/4W	1
80	3515538-01	L201 CHOKE		1
81				
82				
83				
84				
85				
86				
87				
88				
89				
90				

FWBA VERSION	PART "A"	PART "B"	PART "C"	PART "D"
3515240-02	3515142-02	3515296-01 (15)	066-855 1/4W 390HM	066-838 1/4W 330HM
3515240-01	3515142-01		066-938 1/4W 470HM	066-663 1/4W 220HM
VERSION TABLE				

SIZE	CODE IDENT NO.	3515240
D	09150	
SCALE	SHEET 2 OF 3	

8

7

6

5

4

3

072516

1

REVISIONS			SIGNATURE AND DATE		
LTR	ZONE	DESCRIPTION	DFTG	CHK	ENGRG
AC		SEE SH. 1			

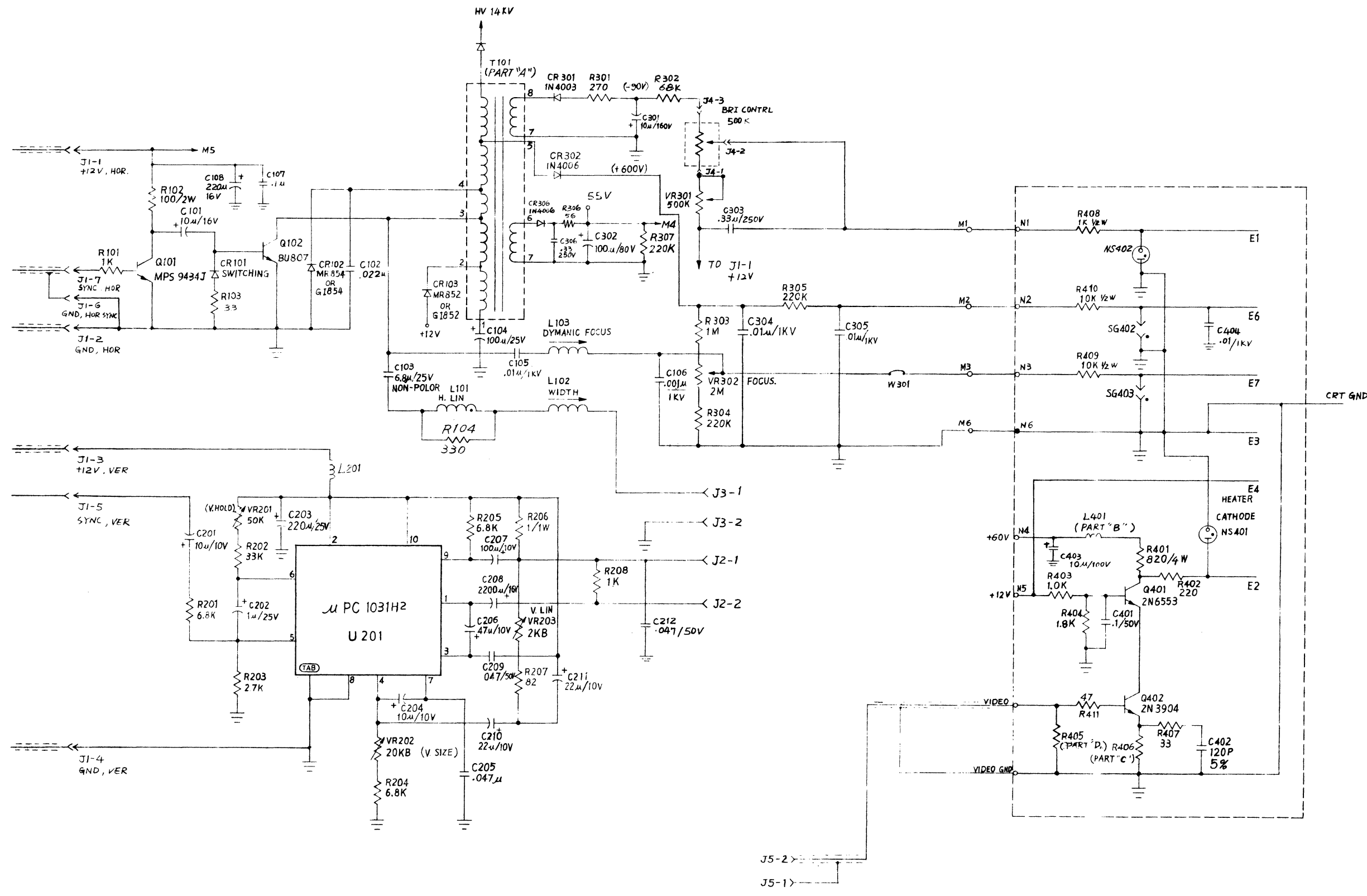

SIZE	CODE IDENT NO	3515240
D	09150	
SCALE	NONE	SHEET 3 OF 3

8

7

6

5

4

3

2

1

3515240

▼ [8]E[5]E[9]

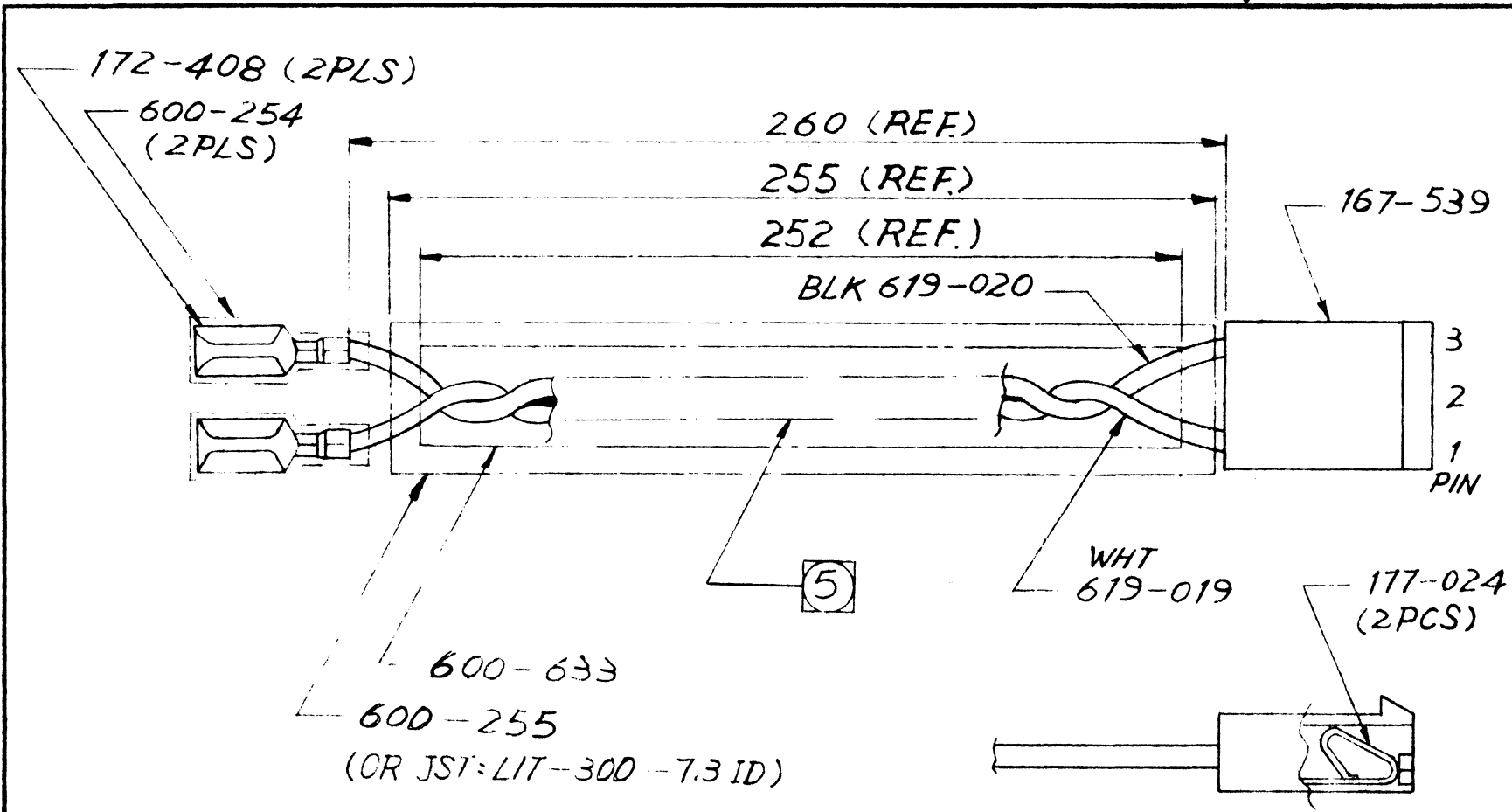

REVISIONS				
LTR	DESCRIPTION	SIGNATURE AND DATE		
		DFTG	CHK	ENGRG
A	ERN 0067 (CONT.)	SY [Signature] 10-30-84	B. [Signature] 10-30-84	CN [Signature] 10-30-84
B	ECN 42141	SY [Signature] 3-22-85	B. [Signature] 3-22-85	11 [Signature] 3-22-85

- 5 TWIST PAIR SHOULD BE 24 TURNS MIN. FOR ALLOVER LENGTH WIRES ARE 260 MM LG. AFTER TWISTING.
- 4 METRIC ENGRG & DFTG PRACTICES PER AMPEX STD. MB1-3.
- 3 ASSEMBLE PER AMPEX STANDARDS, HC2-5.
- 2 IDENTIFY PART NO. & ISSUE LTR PER AMPEX SPEC 3124500 PARA 3.2.
- 1 PART NO. TO BE 3515318-01.

NOTES: UNLESS OTHERWISE SPECIFIED

PARTS LIST

<p>NOTICE</p> <p>THIS DRAWING SHALL NOT BE DUPLICATED, USED FOR ANY PURPOSE OTHER THAN THAT FOR WHICH PROVIDED OR DISCLOSED, IN WHOLE OR IN PART, WITHOUT THE WRITTEN CONSENT OF AMPEX CORPORATION. PROVIDED, HOWEVER, THAT IF THIS DRAWING IS SPECIFIED TO BE DELIVERED TO THE GOVERNMENT, OR TO A GOVERNMENT CONTRACTOR, PURSUANT TO A GOVERNMENT PRIME OR SUBCONTRACT, THE GOVERNMENT MAY MAKE SUCH USE OF THIS DRAWING AS IS PERMITTED BY THE APPLICABLE "DATA" CLAUSE SET FORTH IN SUCH CONTRACT OR SUBCONTRACT.</p>		<p>UNLESS OTHERWISE SPECIFIED</p> <p>DIMENSIONS ARE IN INCHES AND INCLUDE CHEMICALLY APPLIED OR PLATED FINISH.</p>		<p>SIGNATURE</p>		<p>DATE</p>		<p>AMPEX</p> <p>COMPUTER PRODUCTS DIVISION Marina del Rey, California 90291</p>							
		<table border="1"> <tr> <th>TOL</th> <th>2 PL</th> <th>3 PL</th> <th>ANLR</th> </tr> <tr> <td>+</td> <td>---</td> <td>---</td> <td>---</td> </tr> </table>		TOL	2 PL	3 PL	ANLR			+	---	---	---	<p>DRAWN BY</p> <p>SY [Signature] 10-30-84</p>	
		TOL	2 PL	3 PL	ANLR										
		+	---	---	---										
<p>REMOVE BURRS AND SHARP EDGES</p> <p>DRILL TOL PER AND 10387</p> <p>INTERPRET DRAWING PER ANSI Y14.5</p>		<p>DFTG</p> <p>APVD [Signature] 10-30-84</p>		<p>ENGRG</p> <p>APVD [Signature] 10-30-84</p>		<p>CABLE ASSY —</p> <p>A.C POWER JUMPER</p>									
<p>MATERIAL:</p> <p>_____</p>		<p>FINISH:</p> <p>_____</p>		<p>AUTH BY</p> <p>CN [Signature] 10-30-84</p>		<p>SIZE</p> <p>B</p>		<p>CODE IDENT NO.</p> <p>09150</p>							

3515318	ORION
NEXT ASSY	USED ON
APPLICATION	

3515318

SCALE **NONE** DO NOT SCALE THIS PRINT SHEET 1 OF 1

↓ 3515233

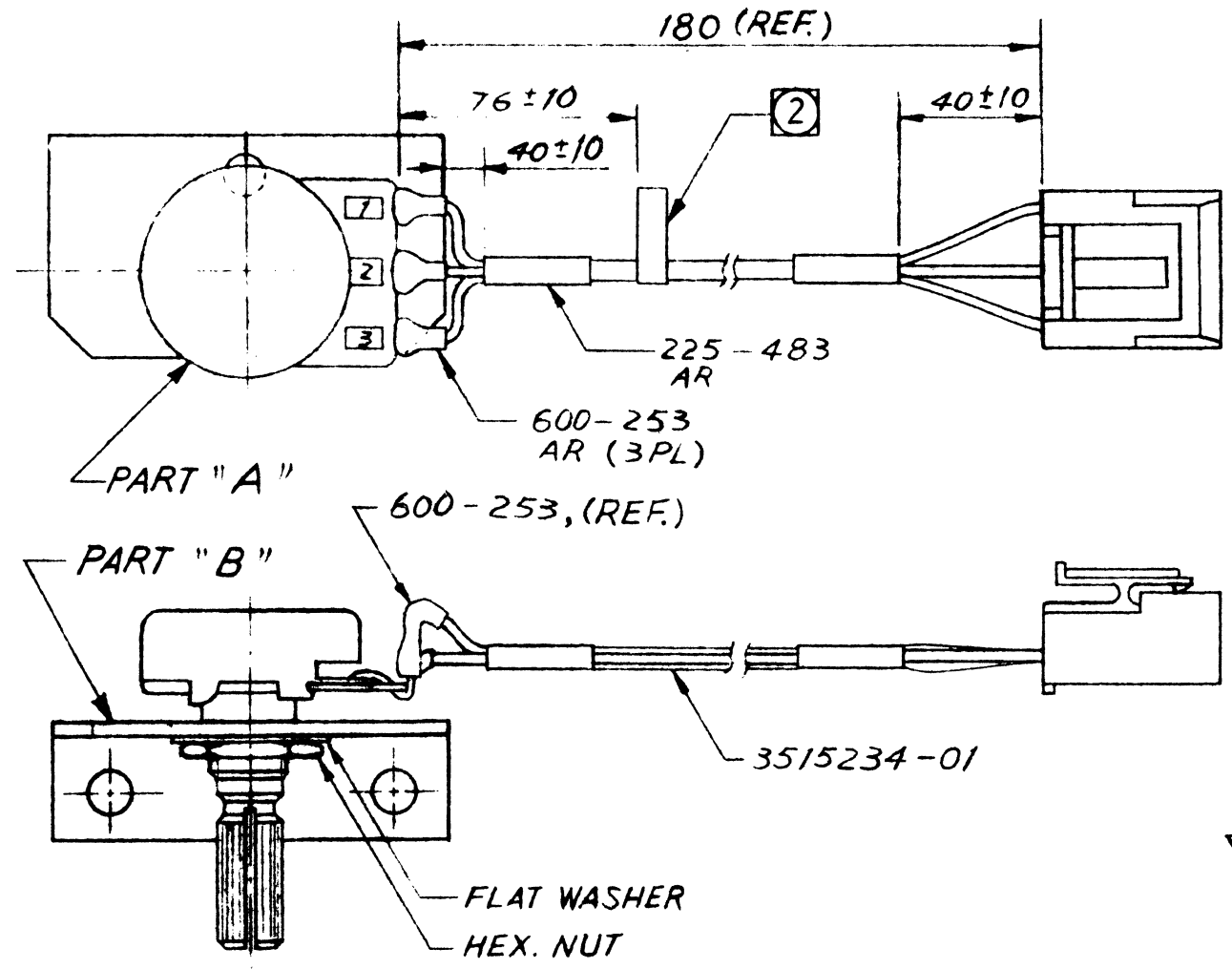

REVISIONS				
LTR	DESCRIPTION	SIGNATURE AND DATE		
		DFTG	CHK	ENGRG
A	NEVER REL			
B	ERN 0011	<i>[Signature]</i> 11-8-83	<i>[Signature]</i> 11-8-83	<i>[Signature]</i> 11-8-83
C	PCR 42010	<i>[Signature]</i> 12-20-83	<i>[Signature]</i> 12-20-83	<i>[Signature]</i> 12-20-83
C	ERN 0024 (CONT.)	<i>[Signature]</i> 3-24-84	<i>[Signature]</i> 3-2-84	<i>[Signature]</i> 3-2-84
D	ECN 42031	<i>[Signature]</i> 3-19-84	<i>[Signature]</i> 3-19-84	<i>[Signature]</i> 3-19-84
E	ERN 0069 (ADD-02)	<i>[Signature]</i> 11-20-84	<i>[Signature]</i> 11-20-84	<i>[Signature]</i> 11-20-84

- 4. METRIC ENGRG AND DFTG. PRACTICES PER AMPEX STD MBI-3
- 3. ASSEMBLE PER AMPEX STANDARDS, HC2-5.
- ② IDENTIFY PART NO. AND ISSUE LTR. PER AMPEX SPEC 3124500, PARA 3.1.
- 1. PART NO. TO BE PER VERSION TABLE.

NOTES. UNLESS OTHERWISE SPECIFIED

PART NO.	PART "A"	PART "B"	REMARKS
3515233-02	3515309-01	3515380-01	
3515233-01	075-316	3513439-01	

VERSION TABLE

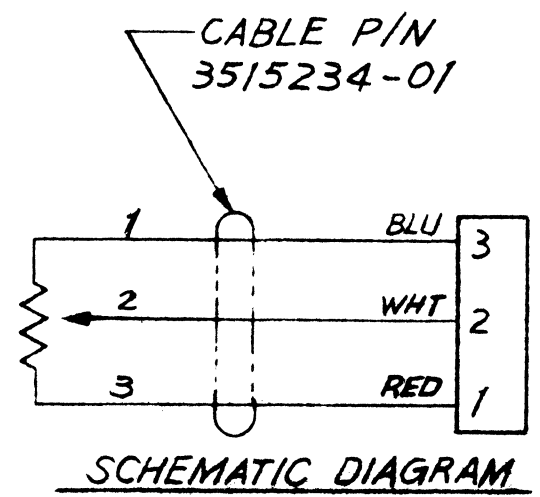

PARTS LIST

<p style="text-align: center;">NOTICE</p> <p>THIS DRAWING SHALL NOT BE DUPLICATED, USED FOR ANY PURPOSE OTHER THAN THAT FOR WHICH PROVIDED OR DISCLOSED, IN WHOLE OR IN PART, WITHOUT THE WRITTEN CONSENT OF AMPEX CORPORATION. PROVIDED: HOWEVER, THAT IF THIS DRAWING IS SPECIFIED TO BE DELIVERED TO THE GOVERNMENT, OR TO A GOVERNMENT CONTRACTOR, PURSUANT TO A GOVERNMENT PRIME OR SUBCONTRACT, THE GOVERNMENT MAY MAKE SUCH USE OF THIS DRAWING AS IS PERMITTED BY THE APPLICABLE "DATA" CLAUSE SET FORTH IN SUCH CONTRACT OR SUBCONTRACT</p>	<p>UNLESS OTHERWISE SPECIFIED</p> <p>DIMENSIONS ARE IN MM AND INCLUDE CHEMICALLY APPLIED OR PLATED FINISH.</p> <table border="1" style="font-size: small;"> <tr> <td>TOL</td> <td>2 PL</td> <td>3 PL</td> <td>ANLR</td> </tr> <tr> <td>+</td> <td>—</td> <td>—</td> <td>—</td> </tr> </table> <p>REMOVE BURRS AND SHARP EDGES</p> <p>DRILL TOL PER AND 10387</p> <p>INTERPRET DRAWING PER ANSI Y14.5</p>	TOL	2 PL	3 PL	ANLR	+	—	—	—	<table border="1" style="font-size: small;"> <tr> <th>SIGNATURE</th> <th>DATE</th> </tr> <tr> <td>DRAWN BY <i>[Signature]</i></td> <td>10-29-83</td> </tr> <tr> <td>CHK BY <i>[Signature]</i></td> <td>11-8-83</td> </tr> <tr> <td>DFTG APVD <i>[Signature]</i></td> <td>11-8-83</td> </tr> <tr> <td>ENGRG APVD <i>[Signature]</i></td> <td>11-8-83</td> </tr> <tr> <td>AUTH BY <i>[Signature]</i></td> <td>11-8-83</td> </tr> </table>	SIGNATURE	DATE	DRAWN BY <i>[Signature]</i>	10-29-83	CHK BY <i>[Signature]</i>	11-8-83	DFTG APVD <i>[Signature]</i>	11-8-83	ENGRG APVD <i>[Signature]</i>	11-8-83	AUTH BY <i>[Signature]</i>	11-8-83	<p style="text-align: center;">AMPEX</p> <p style="text-align: center;">COMPUTER PRODUCTS DIVISION Marina del Rey, California 90291</p> <p style="text-align: center; font-size: 2em;">INTENSITY CONTROL ASSY</p>
	TOL	2 PL	3 PL	ANLR																			
	+	—	—	—																			
	SIGNATURE	DATE																					
DRAWN BY <i>[Signature]</i>	10-29-83																						
CHK BY <i>[Signature]</i>	11-8-83																						
DFTG APVD <i>[Signature]</i>	11-8-83																						
ENGRG APVD <i>[Signature]</i>	11-8-83																						
AUTH BY <i>[Signature]</i>	11-8-83																						
<table border="1" style="font-size: small;"> <tr> <td>3515152</td> <td>ORIGN</td> </tr> <tr> <td>NEXT ASSY</td> <td>USED ON</td> </tr> <tr> <td colspan="2" style="text-align: center;">APPLICATION</td> </tr> </table>	3515152	ORIGN	NEXT ASSY	USED ON	APPLICATION		<p>MATERIAL: _____</p> <p>FINISH: _____</p>	<table border="1" style="font-size: small;"> <tr> <td>SIZE</td> <td>CODE IDENT NO.</td> <td rowspan="2" style="font-size: 2em; text-align: center;">3515233</td> </tr> <tr> <td>B</td> <td>09150</td> </tr> </table>	SIZE	CODE IDENT NO.	3515233	B	09150	<p style="text-align: center;">SCALE</p> <p style="text-align: center;">DO NOT SCALE THIS PRINT</p> <p style="text-align: center;">SHEET 1 OF 1</p>									
3515152	ORIGN																						
NEXT ASSY	USED ON																						
APPLICATION																							
SIZE	CODE IDENT NO.	3515233																					
B	09150																						

351533

REVISIONS		DATE	INITIALS
A	ERN 0052 (CONT.)		
B	ECN 42082		
C	ECN 42089		
D	ECN 42092		
E	ECN 42100		
F	ECN 42103		
G	ECN 42106		
H	ECN 42120		
J	ECN 42153		

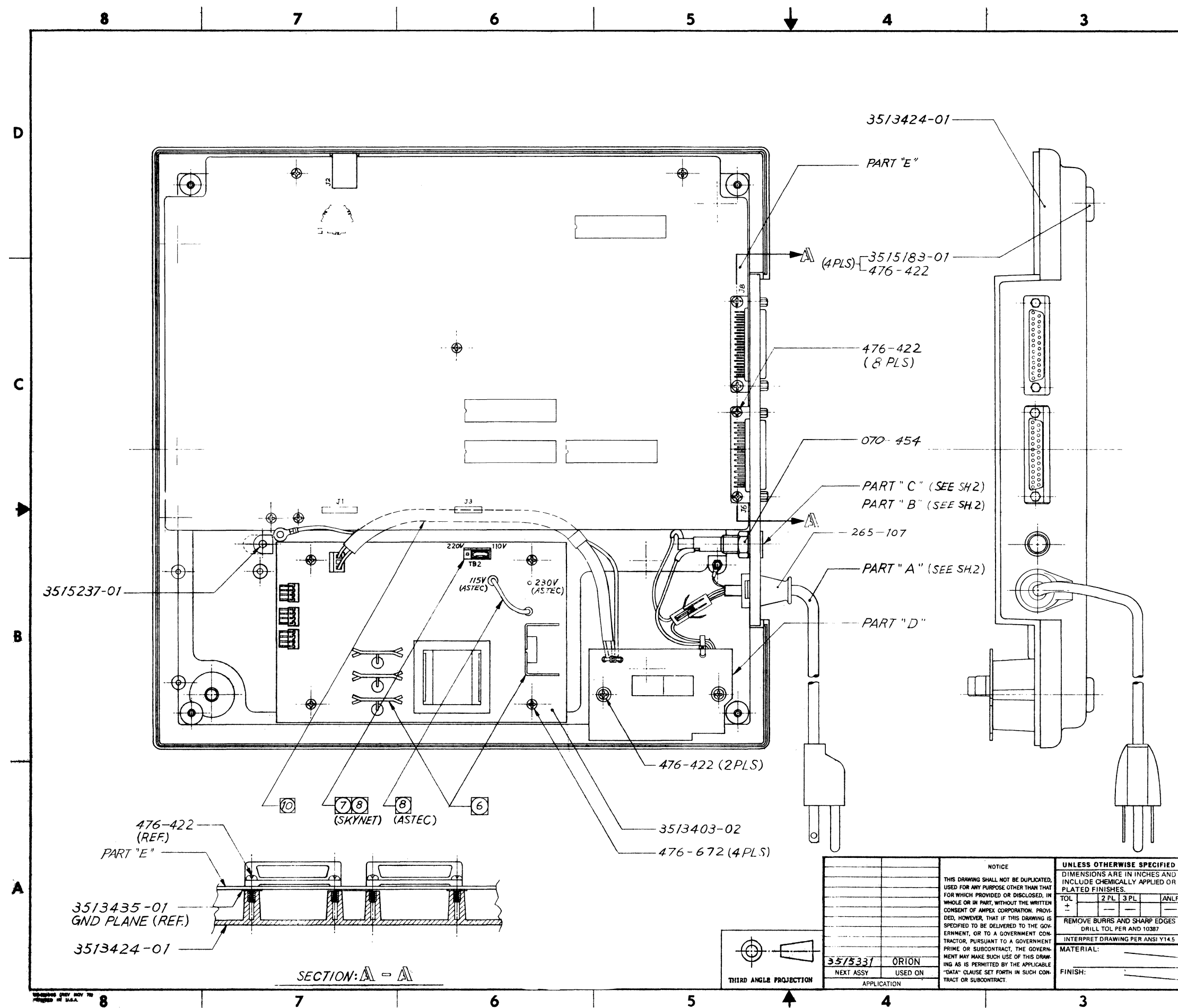

- 10 DRESS AC POWER JUMPER WIRES UNDER CONTROL BOARD & AS CLOSE TO GROUND PLANE AS POSSIBLE.
 - 9 AC POWER CONNECTION:
FOR 115V - SEE SH.1 ZONE B-5 & SH.2 AC WIRING DIAGRAM.
FOR 220V - SEE SH.2 ZONE D-2 VIEW E-E & AC WIRING DIAGRAM.
 - 8 FOR 220V APPLICATION, SHIFT 3P CONNECTOR OF TB2 TO LEFT SIDE 1 POSITION AS SHOWN IN SH.1 ZONE B-6 WHEN USE SKYNET P/S PWBA; PULL AND INSERT SINGLE PIN CONNECTOR FROM 115V PIN POSITION TO 230V PIN POSITION AS SHOWN IN SH.1 ZONE B-6 WHEN USE "ASTECC" P/S PWBA.
 - 7 DRESS AC POWER JUMPER WIRES THRU WIRE LOOP OF TB2 CONNECTOR OF SKYNET P/S PWBA TO KEEP WIRES AWAY FROM HEAT SINKS.
 - 6 DRESS ALL WIRES AWAY FROM HEAT SINKS OF P/S PWBA.
 - 5 ADHERE GROUND PLANE INSULATOR TO GROUND PLANE, PROPERLY AS SH.2 DOT LINES SHOWN WITH "3M" DOUBLE SIDE ADHESIVE TAPE "400 1/2" TO AVOID LIFT UP.
 - 4 METRIC ENGRG & DRAFTING PRACTICES PER AMPEX STD. MBM.
 - 3 MARK PART NO., ISSUE LTR, SERIAL NO PER AMPEX SPEC 3124500 PARA 3.1.
 - 2 ASSEMBLE PER AMPEX STD.
 - 1 PART NO. TO BE PER VERSION TABLE. (SEE SH.2)
- NOTES: UNLESS OTHERWISE SPECIFIED

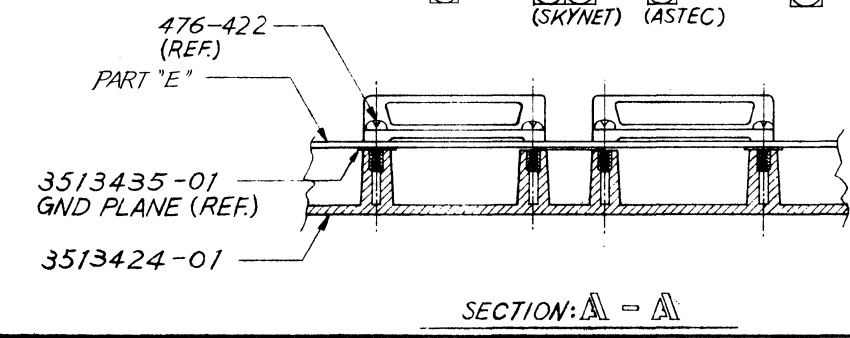

NOTICE THIS DRAWING SHALL NOT BE DUPLICATED, USED FOR ANY PURPOSE OTHER THAN THAT FOR WHICH PROVIDED OR DISCLOSED, IN WHOLE OR IN PART, WITHOUT THE WRITTEN CONSENT OF AMPEX CORPORATION. PROVIDED, HOWEVER, THAT IF THIS DRAWING IS SPECIFIED TO BE DELIVERED TO THE GOVERNMENT, OR TO A GOVERNMENT CONTRACTOR, PURSUANT TO A GOVERNMENT PRIME OR SUBCONTRACT, THE GOVERNMENT MAY MAKE SUCH USE OF THIS DRAWING AS IS PERMITTED BY THE APPLICABLE "DATA" CLAUSE SET FORTH IN SUCH CONTRACT OR SUBCONTRACT.	UNLESS OTHERWISE SPECIFIED DIMENSIONS ARE IN INCHES AND INCLUDE CHEMICALLY APPLIED OR PLATED FINISHES.	SIGNATURE DRAWN BY: <i>[Signature]</i> 7-31-84 CHK BY: <i>[Signature]</i> 7-31-84 DFTG APVD: <i>[Signature]</i> 7-31-84 ENGRG APVD: <i>[Signature]</i> 7-31-84 AUTH BY: <i>[Signature]</i> 7-31-84	DATE 7-31-84	PARTS LIST <input checked="" type="checkbox"/>	MEMORY PRODUCTS DIVISION 200 N. Nash Street El Segundo, California 90245
	TOL + 2 PL 3 PL ANLR - - - - - REMOVE BURRS AND SHARP EDGES DRILL TOL PER AND 10387 INTERPRET DRAWING PER ANSI Y14.5	MATERIAL: FINISH:	AMPEX PEDESTAL ASSY		SIZE CODE IDENT NO. D 09150
3515331 ORION NEXT ASSY USED ON APPLICATION	SCALE DO NOT SCALE THIS PRINT		SHEET 1 OF 2		

3515333

REVISIONS			SIGNATURE AND DATE		
LTR	ZONE	DESCRIPTION	DFTG	CHK	ENGR
H		SEE ST.1			

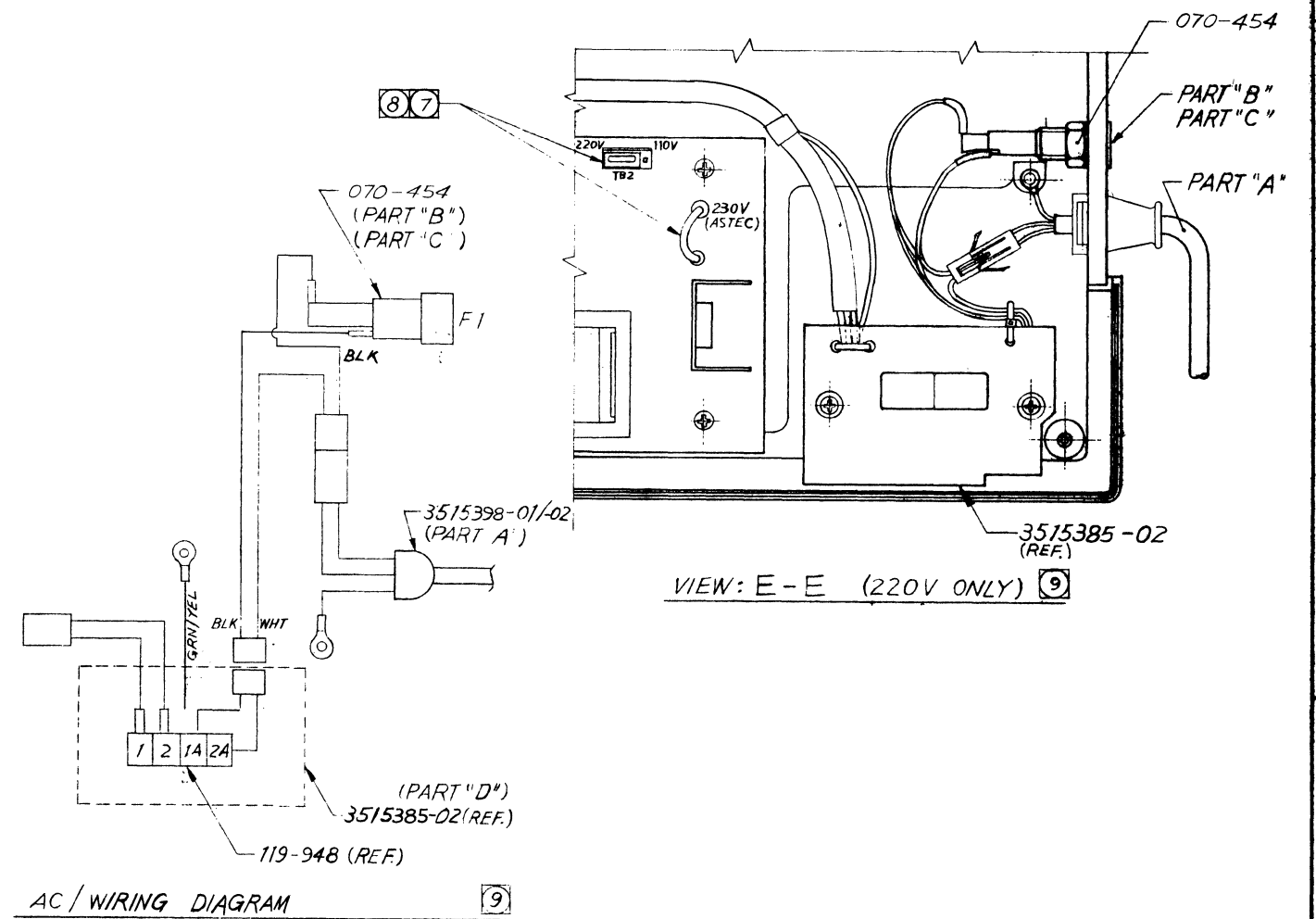
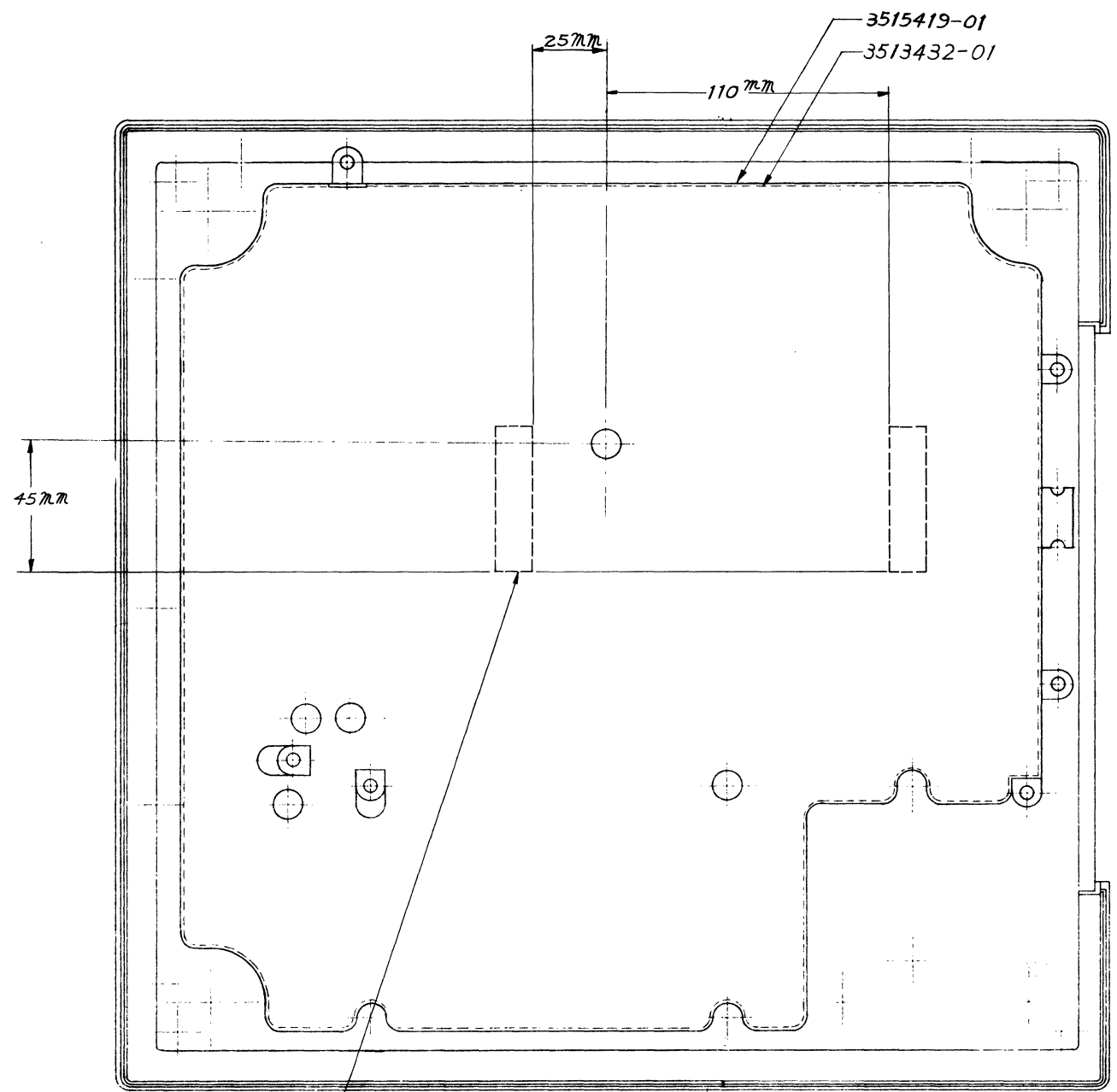

PART NO.	DESCRIPTION	REMARK
3515333 - 02	PART "A" AC POWER CORD	220V
3515333 - 01	PART "A" AC POWER CORD	115V
070-413	PART "B" FUSE PART CAP	
070-412	PART "B" FUSE PART CAP	
070-467 ALTERNATE 070-471	PART "C" FUSE	
070-312	PART "C" FUSE	
3515385-01	PART "D" PWBA - ON-OFF SWITCH / FILTER	
3515385-01	PART "D" PWBA - ON-OFF SWITCH / FILTER	
3515400-02	PART "E" CONT. PWBA	
3515400-05	PART "E" CONT. PWBA	

VERSION TABLE

REV	CODE IDENT NO	3515333
D	09150	
SHEET 2 OF 2		

3515333

7889198

REVISIONS			SIGNATURE AND DATE		
LTR	ZONE	DESCRIPTION	DFTG	CHK	ENGRG
A		ERN 0052 (CONT.)	[Signature]	[Signature]	[Signature]
B		ERN 0087 (ADD -02~-09)	[Signature]	[Signature]	[Signature]

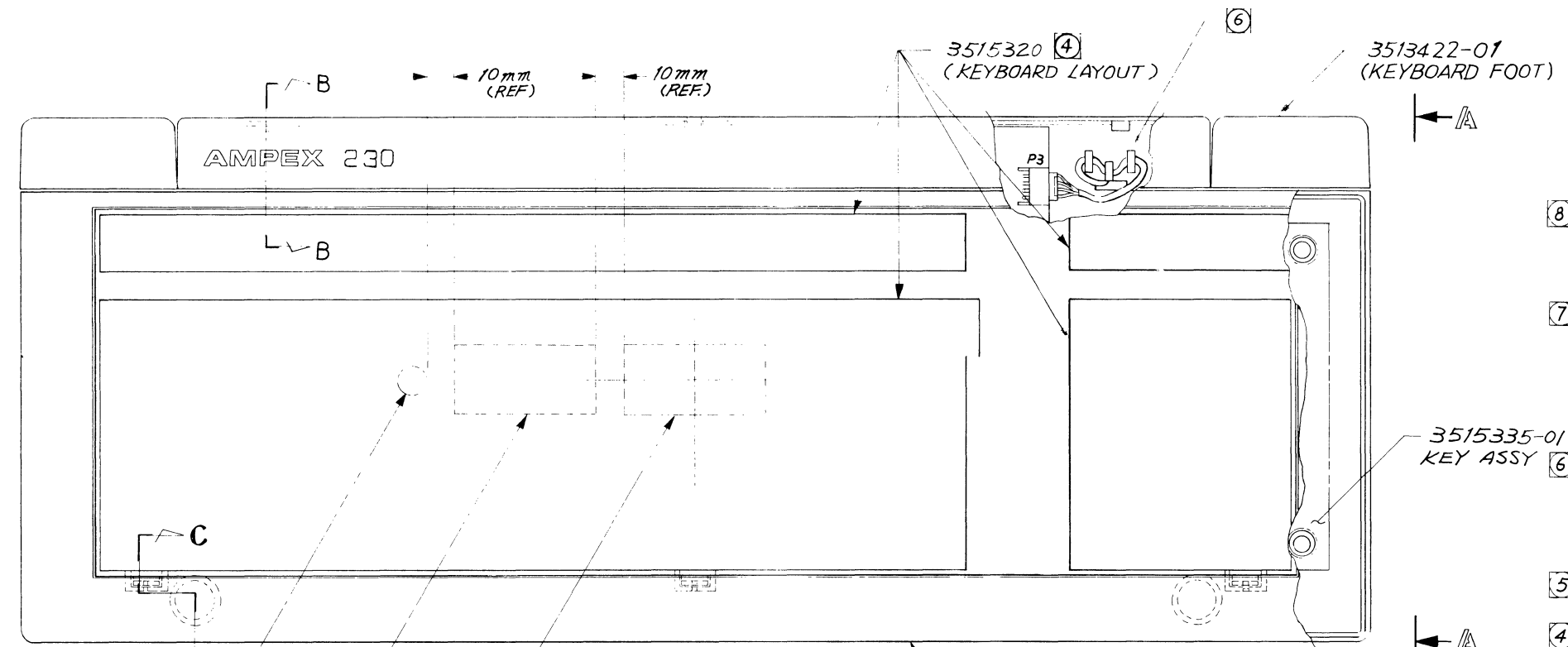
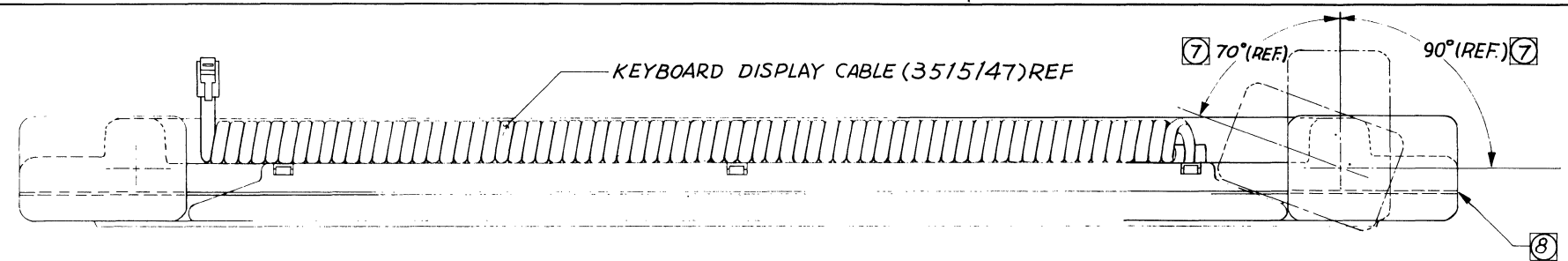

- 8 THE MECHANICAL ALIGNMENT MUST ALLOW THE KEYBD BASE TO FIT INTO COVER ASSEMBLY TO INSURE 1.02 mm MATE (ACCENT) LINE IS CONSISTANT ALL AROUND.
- 7 ROTATE BOTH KEYBOARD FEET 90° AND 70° AS SHOWN TO INSURE ROTATION & HEIGHT ARE CONSISTENT, THEN ROTATE THEM BACK TO HORIZONTAL POSITION.
- 6 DRESS KEYBOARD DISPLAY CABLE INTO 3 PLASTIC HOOKS OF INSIDE KEYBOARD BASE PROPERLY AND PULL CABLE FROM OUTSIDE TO INSURE NO LOOSEN CABLE.
- 5 MOUNT BUMPER FOOT (P/N.250-155) AS SHOWN
- 4 ALIGN KEY ASSEMBLY INTO TOP PLATE SO THAT ALL KEYS ARE FREE TO MOVE WITH .05 mm CLEARANCE MIN. AFTER ASSEMBLY.
- 3 ASSEMBLE PER AMPEX STANDARDS.
- 2 IDENTIFY PART NO, ISSUE LETTER AND SERIAL NO. PER AMPEX SPEC 3124500 LOCATE LABEL APPROX WHERE SHOWN.
- 1 PART NO. TO BE PER VERSION TABLE.

3286138-01 FAR SIDE
 3511043-01 FAR SIDE
 3502462-01 (2) FAR SIDE
 351514-03 (KEYBOARD CASE)
 TOP VIEW

NOTES: UNLESS OTHERWISE SPECIFIED

NOTICE		UNLESS OTHERWISE SPECIFIED DIMENSIONS ARE IN $\frac{1}{16}$ AND INCLUDE CHEMICALLY APPLIED OR PLATED FINISHES		SIGNATURE		DATE		PARTS LIST <input type="checkbox"/>		MEMORY PRODUCTS DIVISION 200 N Nash Street El Segundo California 90245	
FINAL ASSY A 230		TOL ±		DRAWN BY [Signature]		7-31-84		AMPEX		A	
NEXT ASSY USED ON		2 PL 3 PL ANLR		CHK BY [Signature]		7-31-84		CRT KEYBOARD ASSY (BASIC DWG.)			
APPLICATION		REMOVE BURRS AND SHARP EDGES DRILL TOL PER AND 10387		DFTG [Signature]		7-31-84		SIZE D		CODE IDENT NO 09150	
		INTERPRET DRAWING PER ANSI Y14.5		ENGRG [Signature]		7-31-84		SCALE		3515334	
				AUTH BY [Signature]		7-31-84				1 2	

3515334

3515334

REVISIONS			SIGNATURE AND DATE		
LTR	ZONE	DESCRIPTION	DFTG	CHK	ENGRG
B		SEE SH.1			

VERSION TABLE				
FINAL ASSY PART NO.	KEY ASSY		LANGUAGE	REMARKS
3515334-01	3515335-01		USA/UK	A230
3515334-02	3515335-02		USA/UK	A219
3515334-03	3515335-03		SWEDISH	A230
3515334-04	3515335-04		SPANISH	A230
3515334-05	3515335-05		ITALIAN	A230
3515334-06	3515335-06		NORWEGIAN	A230
3515334-07	3515335-07		GERMAN	A230
3515334-08	3515335-08		FRENCH	A230
3515334-09	3515335-09		DANISH	A230

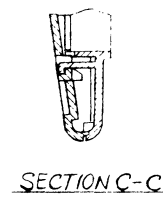
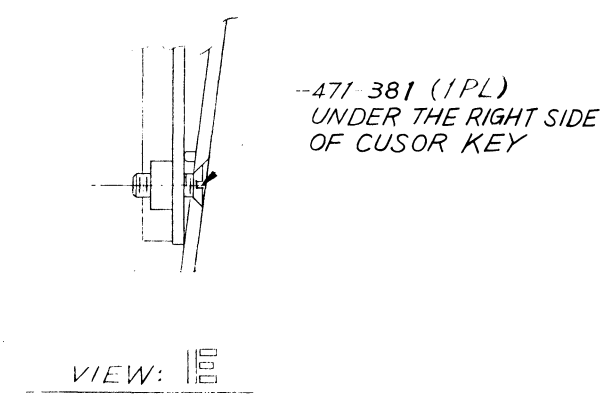
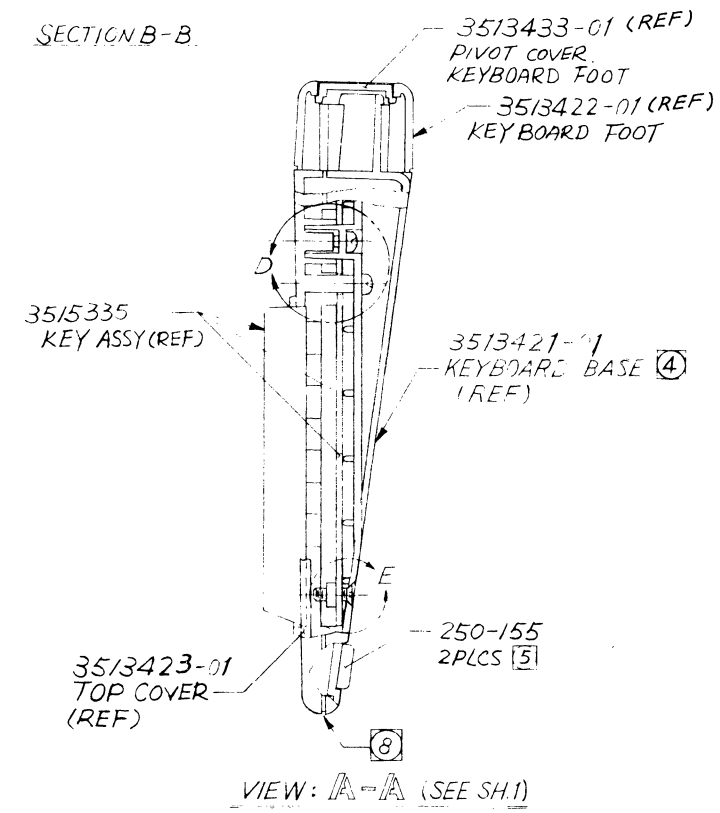
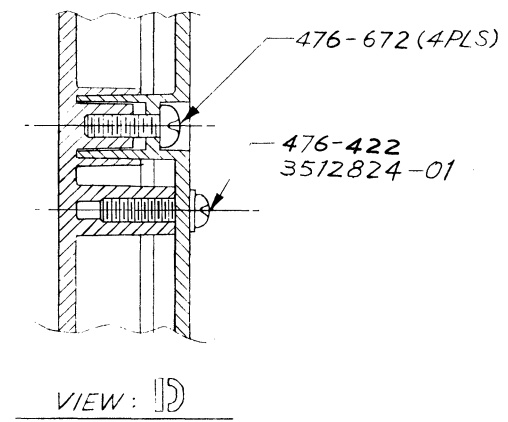
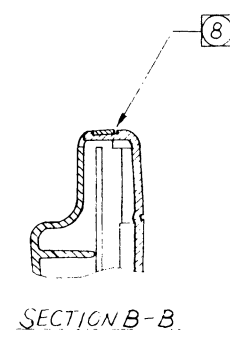

SIZE	CODE IDENT NO.	
D	09150	3515334
SCALE NONE	SHEET 2 OF 2	

8 7 6 5 4 3 2 1

SECRET

VERSION TABLE			
PART NO.	SWITCH ASSY	KEYTOP LEGEND	REMARK
3515335-01	3513458-01	3515320	
3515335-02	3513458-01	3515330	
3515335-03	3513458-01	3515321	
3515335-04	3513458-01	3515322	
3515335-05	3513458-01	3515323	
3515335-06	3513458-01	3515324	
3515335-07	3513458-01	3515325	
3515335-08	3513458-01	3515326	
3515335-09	3513458-01	3515327	

REVISIONS					
LTR	ZONE	DESCRIPTION	SIGNATURE AND DATE		
			DFTG	CHK	ENGRG
A		ERN 0049 (CONT.)			7-3-84
B		ECN42075			7-3-84
C		ERN 0087 (ADD-02~-09)			7-3-84

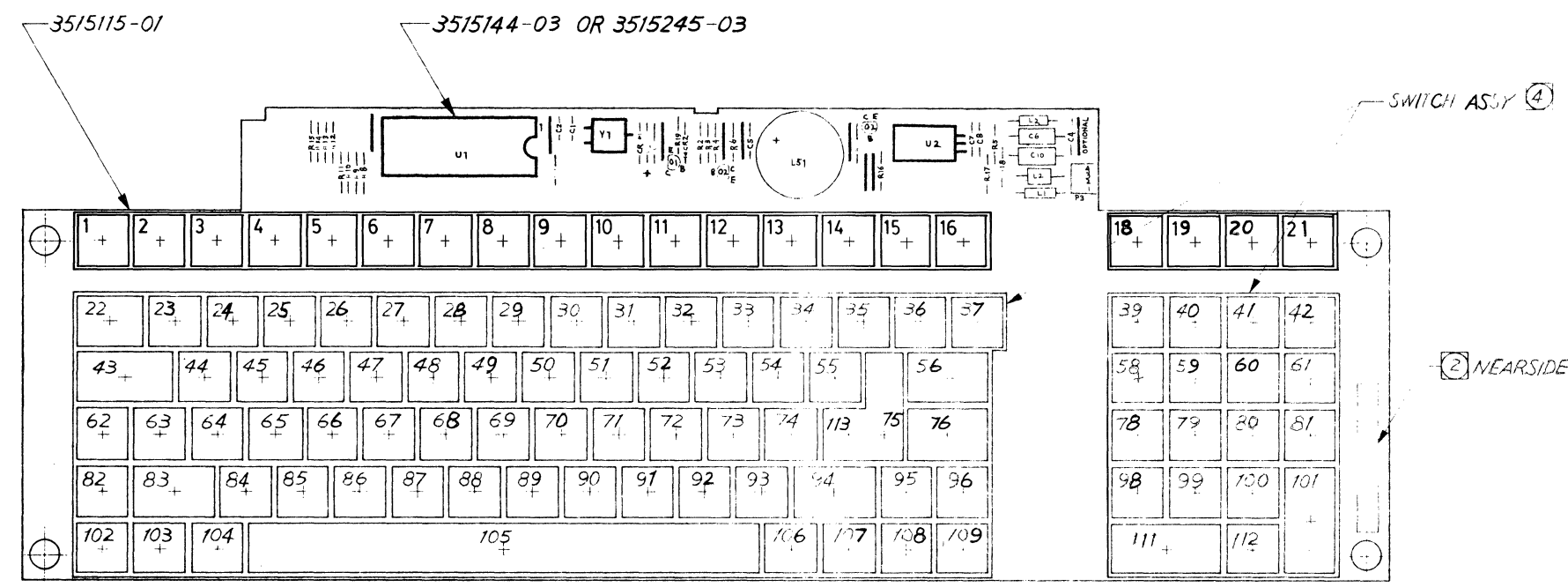

- 4 KEYTOP LEGEND PER VERSION TABLE.
- 3 PART NO. TO BE PER VERSION TABLE
- 2 MARK PART NO AND ISSUE LETTER PER AMPEX SPEC 3124500 PARA 3.1.
- 1 PLACEMENT OF COMPONENTS SHOWN FOR REF ONLY. ACTUAL PLACEMENT MAY VARY.

NOTES: UNLESS OTHERWISE SPECIFIED

NOTICE THIS DRAWING SHALL NOT BE DUPLICATED, USED FOR ANY PURPOSE OTHER THAN THAT FOR WHICH PROVIDED OR DISCLOSED, IN WHOLE OR IN PART, WITHOUT THE WRITTEN CONSENT OF AMPEX CORPORATION. PROVIDED, HOWEVER, THAT IF THIS DRAWING IS SPECIFIED TO BE DELIVERED TO THE GOVERNMENT, OR TO A GOVERNMENT CONTRACTOR, PURSUANT TO A GOVERNMENT PRIME OR SUBCONTRACT, THE GOVERNMENT MAY MAKE SUCH USE OF THIS DRAWING AS IS PERMITTED BY THE APPLICABLE "DATA" CLAUSE SET FORTH IN SUCH CONTRACT OR SUBCONTRACT.	UNLESS OTHERWISE SPECIFIED DIMENSIONS ARE IN INCHES AND INCLUDE CHEMICALLY APPLIED OR PLATED FINISHES.	SIGNATURE DRAWN BY: L. Huang 7-3-84 CHK BY: J. Hwang 7-3-84 DFTG: R. P. 7-3-84 ENGRG: 111 7-3-84 AUTH BY: 111 7-3-84	DATE 7-3-84	AMPEX MEMORY PRODUCTS DIVISION 36 N. Main Street San Jose, California 95128	
	TOL ± 2 PL 3 PL JANLR	REMOVE BURRS AND SHARP EDGES DRILL TOL PER AND 10397 INTERPRET DRAWING PER ANSY145	MATERIAL:		SIZE: D CODE IDENT NO.: 09150 PART IDENT NO.: 3: 15335
	APPLICATION: 3515334 Section II NEXT ASSY: USED ON	FINISH:	SCALE:		SHEET: OF 1
	APPLICATION:	FINISH:	SCALE:		SHEET: OF 1

8 7 6 5 4 3 2 1

3515385

REVISIONS			SIGNATURE AND DATE		
LTR	ZONE	DESCRIPTION	DFTG	CHK	ENGRG
A		ERN 0072 (CONT.)	SY Henry 12-7-84	B. Hill 12-7-84	V 12-7-84

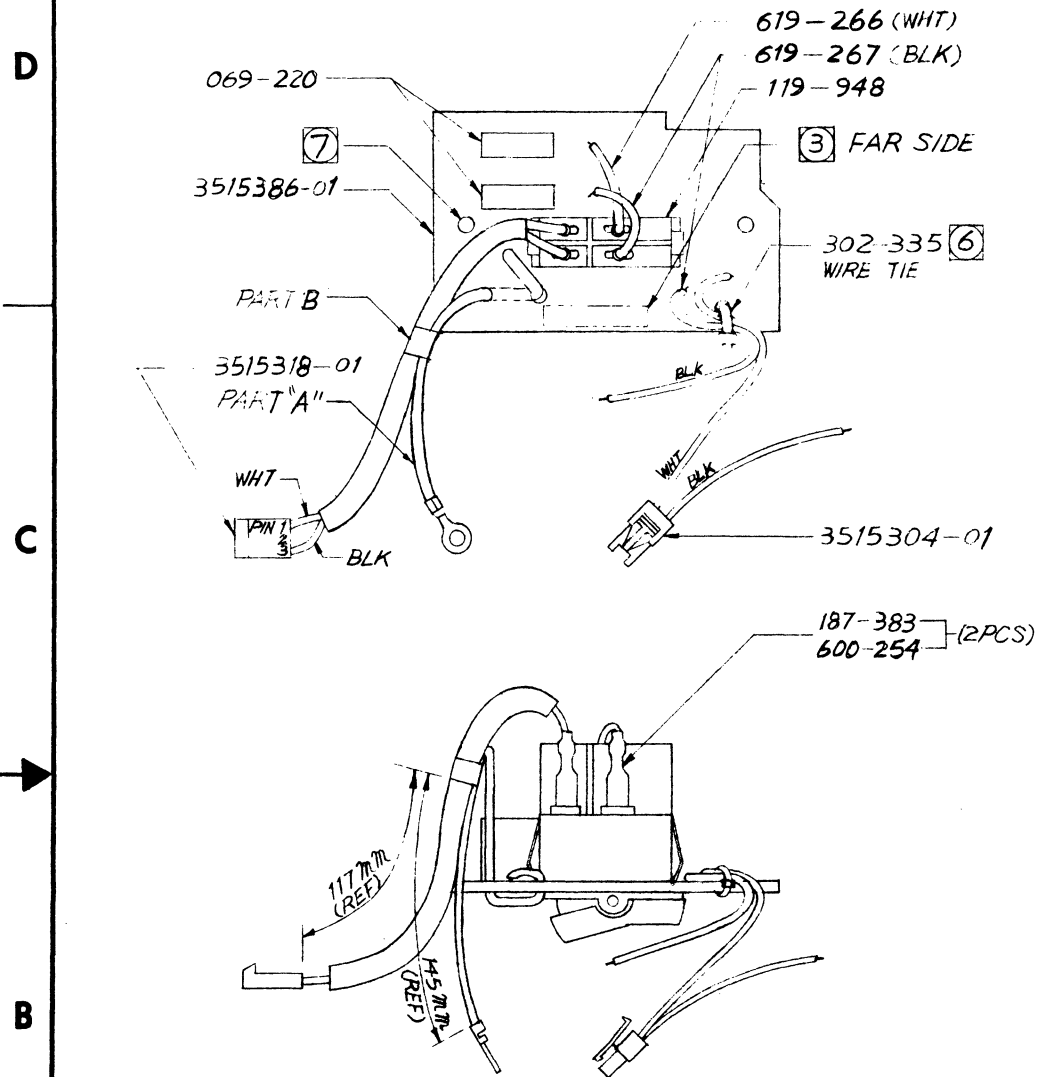

- ⑦ ADD SOLDER AROUND COPPER PAD OF MTG HOLE.
- ⑥ MAKE SURE BOTH BLACK & WHITE WIRES NOT TO TOUCH BOARD SHARP EDGE. WIRES SHOULD BE WRAPPED TO BOARD SURFACE TIGHTLY ENOUGH.
- 5 COMPONENT REF. DESIGNATIONS ARE FOR REF. ONLY.
- 4 METRIC ENGRG & DFTG PRACTICES PER AMPEX STD MB 1-3.
- ③ IDENTIFY P/N & ISSUE LTR. PER AMPEX SPEC 3124500 PARA 3.1.
- 2. ASSEMBLE PER AMPEX STD. HC 2-5
- 1. PART NO. SEE VERSION TABLE.

NOTES: UNLESS OTHERWISE SPECIFIED

3515385-02		
3515385-01	3515205-01	225-487
PART NO.	PART "A"	PART "B"

VERSION TABLE

NOTICE		UNLESS OTHERWISE SPECIFIED		SIGNATURE		DATE		AMPEX		MEMORY PRODUCTS DIVISION 200 N. Nash Street El Segundo, California 90245	
THIS DRAWING SHALL NOT BE DUPLICATED, USED FOR ANY PURPOSE OTHER THAN THAT FOR WHICH PROVIDED OR DISCLOSED, IN WHOLE OR IN PART, WITHOUT THE WRITTEN CONSENT OF AMPEX CORPORATION. PROVIDED, HOWEVER, THAT IF THIS DRAWING IS SPECIFIED TO BE DELIVERED TO THE GOVERNMENT, OR TO A GOVERNMENT CONTRACTOR, PURSUANT TO A GOVERNMENT PRIME OR SUBCONTRACT, THE GOVERNMENT MAY MAKE SUCH USE OF THIS DRAWING AS IS PERMITTED BY THE APPLICABLE "DATA" CLAUSE SET FORTH IN SUCH CONTRACT OR SUBCONTRACT.		DIMENSIONS ARE IN INCHES AND INCLUDE CHEMICALLY APPLIED OR PLATED FINISHES.		DRAWN BY SY Henry		12-6-84		PWBA-ON-OFF SWICH / FILTER		SIZE C CODE IDENT NO. 09150 3515385	
		TOL ± 2 PL 3 PL ANLR		CHK BY B. Hill		12-7-84					
		REMOVE BURRS AND SHARP EDGES DRILL TOL PER AND 10387		DFTG APVD B. Hill		12-7-84					
		INTERPRET DRAWING PER ANSI Y14.5		ENGRG APVD V		12-7-84					
NEXT ASSY USED ON APPLICATION		MATERIAL:		AUTH BY V		12-7-84		SCALE NONE		DO NOT SCALE THIS PRINT SHEET 1 OF 1	

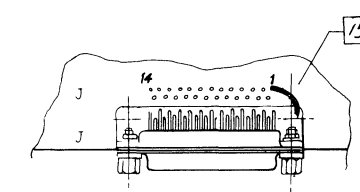
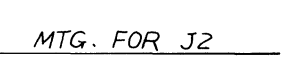
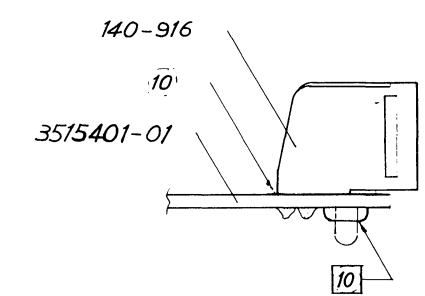
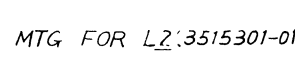
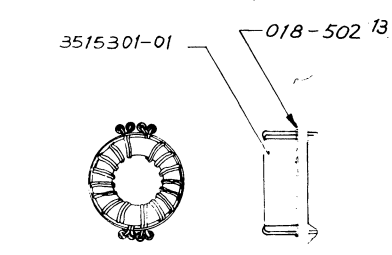
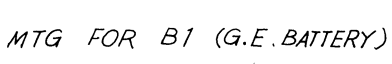
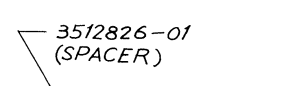
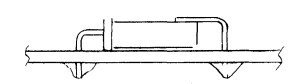
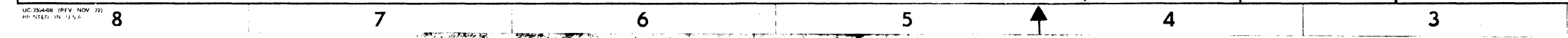
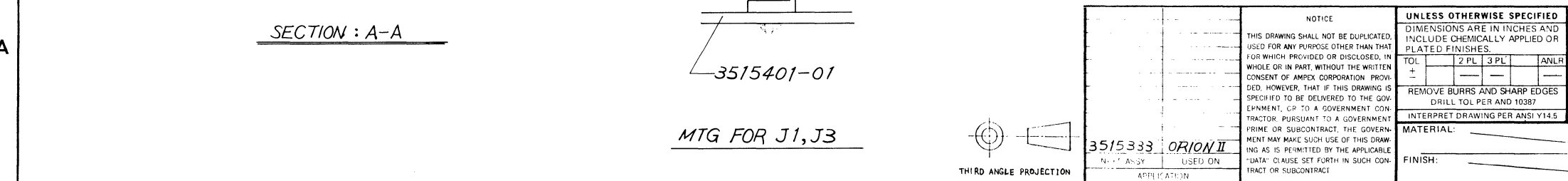
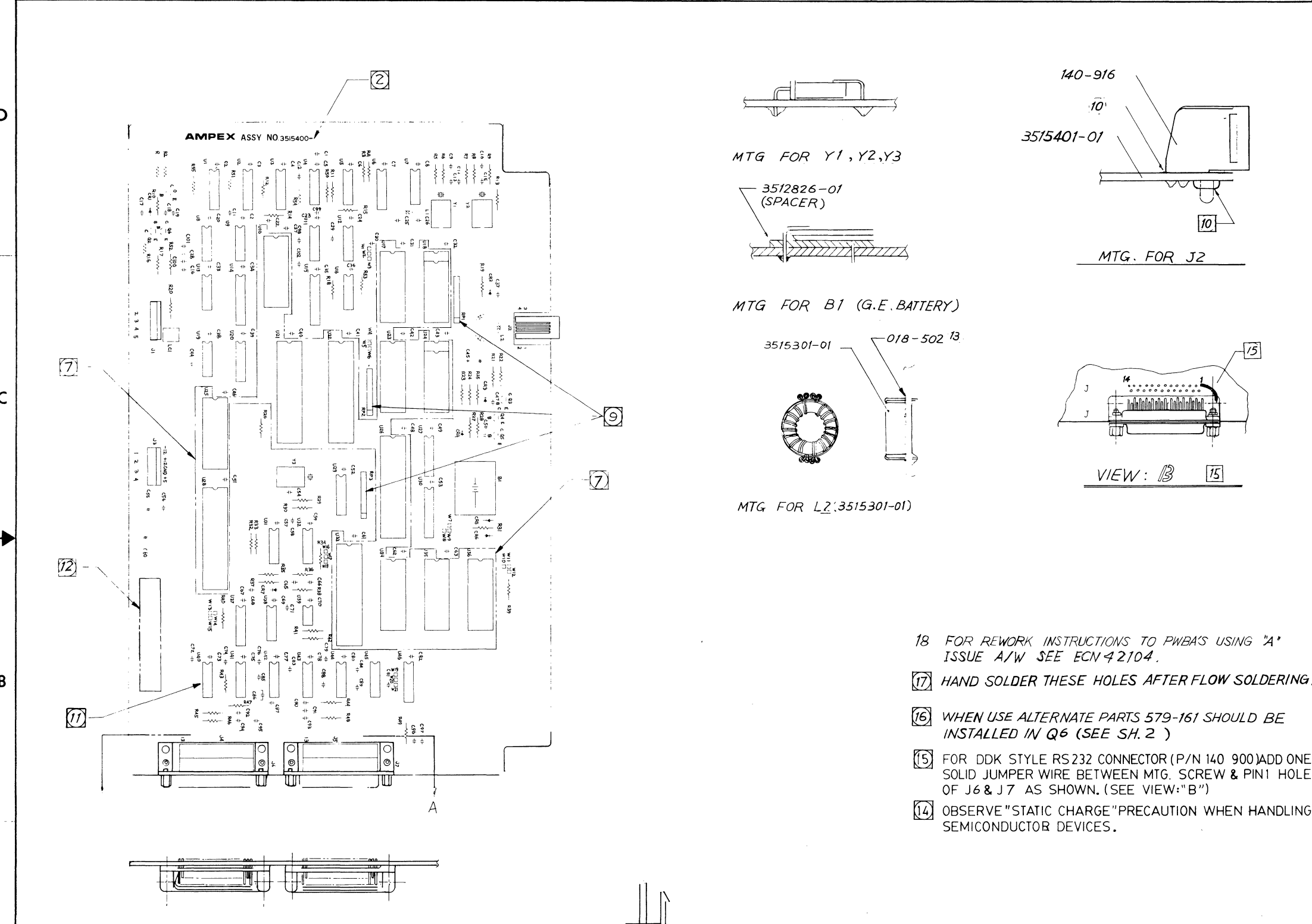

REVISIONS				
LTR	ZONE	DESCRIPTION	SIGNATURE AND DATE	
			DFTG	ENGRG
C		ERN 0063 (CONT.)	SYH	10-1-84
D		ECN 42104	SYH	10-1-84
E		ERN 0073 (ADD-02)(CONT.)	SYH	10-1-84
F		ECN 42114	SYH	10-1-84
G		ECN 42117	SYH	10-1-84
H		ECN 42119	SYH	10-1-84
J		ERN 0075 (ADD-03)	SYH	10-1-84
K		ECN 42131	SYH	10-1-84
L		ECN 42138	SYH	10-1-84
M		ECN 42150	SYH	10-1-84
N		ECN 42151	SYH	10-1-84
P	★	ERN 0095 (ADD-04,-05,-06)	SYH	10-1-84

- 13 ASSEMBLE PER AMPEX STANDARDS HC-2-17.
 - 12 ADHERE MASR LABEL TO THIS AREA AFTER MARKING PART NO & REV. LETTER.
 - 11 FOR CURRENT LOOP USE ONLY.
 - 10 HEAT SEAL 2 PLASTIC INTERLOCKER OF J2 TO CONSOLIDATE J2 TO BOARD. OR BOND IT TO BOARD WITH 018-502 ADHESIVE
 - 9 PIN 1 OF RESISTOR PACK SHOULD BE ORIENTED ON BOTTOM SIDE.
 - 8 UNUSED IC POSITIONS: ARE TO BE KEPT FREE OF SOLDER.
 - 7 FOR INSTALLATION OF EPROM OR ROMS AT: U10, U34, U35, SEE VERSION TABLE. (SH.2) SOCKETS ARE PROVIDED AT U10, U17, U23, U33 ~ U36, U40.
 - 6 MAX. LEAD PROTRUSION ON SOLDER SIDE IS 2.3 mm
 - 5 ASSEMBLE PER AMPEX STANDARDS.
 - 4 COMPONENT DESIGNATION ARE FOR REFERENCE ONLY.
 - 3 FOR SCHEMATIC DIAGRAM SEE SHEET 3 THRU 6.
 - 2 MARK DASH NO. SERIAL NO. AND ISSUE LETTER PER AMPEX SPEC 3124500 PARA, 3.1.
 - 1 PART NO. SEE VERSION TABLE.
- NOTES: UNLESS OTHERWISE SPECIFIED

NOTICE		UNLESS OTHERWISE SPECIFIED		SIGNATURE		DATE		AMPEX		MEMORY PRODUCTS DIVISION	
THIS DRAWING SHALL NOT BE DUPLICATED, USED FOR ANY PURPOSE OTHER THAN THAT FOR WHICH PROVIDED OR DISCLOSED, IN WHOLE OR IN PART, WITHOUT THE WRITTEN CONSENT OF AMPEX CORPORATION. PROVIDED, HOWEVER, THAT IF THIS DRAWING IS SPECIFIED TO BE DELIVERED TO THE GOVERNMENT, OR TO A GOVERNMENT CONTRACTOR, PURSUANT TO A GOVERNMENT PRIME OR SUBCONTRACT, THE GOVERNMENT MAY MAKE SUCH USE OF THIS DRAWING AS IS PERMITTED BY THE APPLICABLE "DATA" CLAUSE SET FORTH IN SUCH CONTRACT OR SUBCONTRACT.		DIMENSIONS ARE IN INCHES AND INCLUDE CHEMICALLY APPLIED OR PLATED FINISHES.		DRAWN BY: SYH		10-1-84		200 N. Nash Street El Segundo, California 90245		PWBA TERMINAL CONTROLLER	
		TOL ± 2 PL 3 PL ANLR		CHK BY: JAMES LIA		10-1-84				SIZE CODE IDENT NO.	
		REMOVE BURRS AND SHARP EDGES DRILL TOL PER AND 10387		DFTG APVD: JAMES LIA		10-1-84				D 09150	
		INTERPRET DRAWING PER ANSI Y14.5		ENGRG APVD: CNH		10-1-84				SCALE	
		MATERIAL:		AUTH BY: CNH		10-1-84				DO NOT SCALE THIS PRINT	
		FINISH:								SHEET 1 OF 6	
3515333 ORION II		APPLY TO:									

REVISIONS				SIGNATURE AND DATE		
LTR	ZONE	DESCRIPTION	DFTG	CHK	ENGRG	
P		SEE SH.1				

ITEM	PART NO.	DESCRIPTION	REMARK
1			
2			
3	590-244	U25	Z80A CTC
4	589-619	U33	Z80A CPU
5	003-206	U28	Z80A DART
6	001-908	U36	ALTERNATE: 003-200, 003-205, 003-168 CMOS SRAM
7	590-983	U17, U18, U23, U24	SRAM
8	PART "C"	U10	CHARGEN MROM
9	PART "A"	U34	SYSTEM ROM1
10	PART "B"	U35	" " 2
11	3515348-01	U22	BUS INTERFACE
12	3515495-01	U21	ALTERNATE: 3515349-01 CRT CONTROLLER
13	003-136	U26	SCN2672ACAN40
14	589-537	U14, U15, U30	74 LS 374
15	003-119	U6	ALTERNATE 003-203 74 AS163
16	587-410	U46	74 LS139
17	587-534	U13, U45	74 LS 08
18	587-523	U11, U19, U38, U47	74 LS 32
19	586-830	U7	ALTERNATE 590-935 74 S 00
20	586-831	U12	74 S04
21	587-533	U32	74 LS04
22	587-751	U4	74 S08
23	587-158	U1	ALTERNATE: 589-937 74 S174
24	590-108	U42, U44	75188
25	587-856	U41, U43	75189
26	587-291	U39	NE555 TIMER
27	586-752	U16	ALTERNATE 586-690 7416
28	587-746	U8	74 LS86
29	587-770	U20, U27	74 LS174
30	587-924	U2, U3	74 S194
31	589-362	U37	ALTERNATE 589-825 74 LS 257
32	587-510	U9	74 LS00
33	587-387	U31	74 LS 74
34	587-095	U5	ALTERNATE 003-111 74 S 74
35	587-279	U29	74 LS138
36			
37			
38			
39			
40			
41	066-661	R18	120 OHM, 1/4W, 5%
42	066-663	R5, R6	220 " " "
43	066-834	R33	33 " " "
44	066-668	R4, R11, R19, R32, R41~R48, R51	4.7K " " "
45	066-814	R14	270 " " "
46	066-849	R35, R37	100K " " "
47	066-838	R10, R16, R20	330 " " "
48	066-830	R31, R39, R49	10K " " "
49	066-665	R1, R7, R9, R15, R22, R23, R28, R34	1K " " "
50	066-689	R25, R36	2.2K " " "
51	066-675	R27	1.8K " " "
52	076-004	R2, R24	180 " " "
53	066-820	R21	750 " " "
54	066-673	R38	1M " " "
55	066-821	R17, R29, R30	820 " " "
56	066-824	R8, R13	1.5K " " "
57	066-720	R40	33K " " "
58			
59	3512803-01	RP1, RP2, RP3	NTWK SIP 8 RES 22K OHM, 1/4W, 5%
60			

ITEM	PART NO.	DESCRIPTION	REMARK	
61	064-997	C22, C29, C37, C74, C90~C95		
62	" "	ALTERNATE 064-983 CERAMIC DISC	330PF, 50V, ±20%	
63	064-939	C58	ALTERNATE 030-977 CERAMIC DISC	0.001UF, 50V, 20%
64	064-444	C56, C61	CERAMIC MONO	1UF, 50V, 20%
65	064-116	C9, C47, C50, C96	" DISC	.01UF, 50V, "
66	064-937	C13, C15, C16, C54, C44	" "	22PF, 50V 5%
67	063-391	C45, C55, C60	LYTIC	100UF, 16V
68	064-462	C10	CERAMIC MONO	47PF, 100V
69	064-998	C67	CERAMIC DISC	2000PF, 50V, 20%
70	064-464	C14, C26	" "	100PF, 100V
71	" "	ALTERNATE: 064-996 CERAMIC MONO		
72	164-004	C2~8, C20, C21, C23, C24, C27, C31~35		0.1UF, 25V
73	" "	C38~43, C46, C48, C49, C51~53, C57	" "	" "
74	" "	C62, C63, C65, C66, C71, C75, C78~80, C82	" "	" "
75	" "	C68	ALTERNATE: 064-465	" "
76				
77				
78	579-156	Q2	XSTR ALTERNATE 579-161	2SC1730
79	014-889	Q3, Q5	XSTR	2N3643
80	014-772	Q1, Q4	XSTR	2N3644
81				
82	013-599	CR1~CR7	ALTERNATE 581-403, 581-105	DIODE 1N4531
83				
84	080-060	B1	BATTERY	3V LITHIUM
85	3515498-01	FB1~FB16		FERRITE BEAD
86	582-203	XU33	ALTERNATE 582-387 IC SOCKET	40PIN
87				
88				
89	582-191	XU40	IC SOCKET	14PIN
90	582-202	XU10, XU17, XU23, XU34~XU36		28PIN
91	" "	IC SOCKET ALTERNATE 582-386		
92	3515139-01	Y3	CRYSTAL	3.6864 MHZ
93	3515382-01	Y2	"	19.6 MHZ
94	3515389-01	Y1	"	32.147 MHZ
95	135-533	J1	CONNECTOR	5PIN VIDEO
96	135-532	J3	"	4PIN POWER
97	140-900	J4, J5	"	25PIN RS232C
98	140-916	J2	"	4PIN KEYBD
99	3515301-01	L2		CHOKE ASSY
100	052-036	LC1		EMI FILTER

PART NO	COMPONENTS
3515400-01 3515400-03 3515400-04 3515400-06	INSTALL ALL COMPONENTS SHOWN IN REFERENCE DESIGNATION TABLE EXCEPT: C83~C89, C36, C25, C30, C98, C59, C69, C70 C72, C73, C76, C77, C81, R26, J6, J7 Q6, CR8, CR9, L1
3515400-02 3515400-05	C83~C89, C98, C25, C30, C16, C59, C69, C70, C72 C73, C76, C77, C81, C36, C97, R26, J6, J7 Q6 L1, CR8, CR9, XU35,

PART NO.	PART "A"	PART "B"	PART "C"	REMARK
3515400-06	3515510-01	3515511-01	3515512-01 ALT: 3515513-01	
3515400-05	3515414-01		3515339-01 ALT: 3515345-01	
3515400-04	3515346-02	3515347-02	3515339-01 ALT: 3515345-01	
3515400-03	3515510-01	3515511-01	3515512-01 ALT: 3515513-01	
3515400-02	3515414-01		3515339-01 ALT: 3515345-01	
3515400-01	3515346-02	3515347-02	3515339-01 ALT: 3515345-01	

---	W16 --- W17	W17 --- W18	---
---	W20 --- W21	W19 --- W20	---
COMP. SIDE	SOLDER SIDE	COMP. SIDE	SOLDER SIDE
CUT TRACE		ADD JUMPER (P/N 615-004)	
CUT TRACE AND JUMPER WIRE LIST (FOR-02, -05)			

007519E

REVISIONS			SIGNATURE AND DATE		
LTR	ZONE	DESCRIPTION	DFTG	CHK	ENGRG
N		SEE SH. 1			

REFERENCE DESIGNATION		
COMPONENT	LAST USED	NOT USED
I.C	U47	
CAPACITOR	C99	C64, C17, C18
RESISTOR	R53	
RESISTOR PACK	RP3	
DIODE	CR7	
TRANSISTOR	Q6	
CRYSTAL	Y3	
JUMPER HOLE	W21	
INDUCTOR	L2	
BATTERY	B1	
JACK CONNECTOR	J7	
EMI FILTER	LC1	
FERRITE BEAD	FB16	

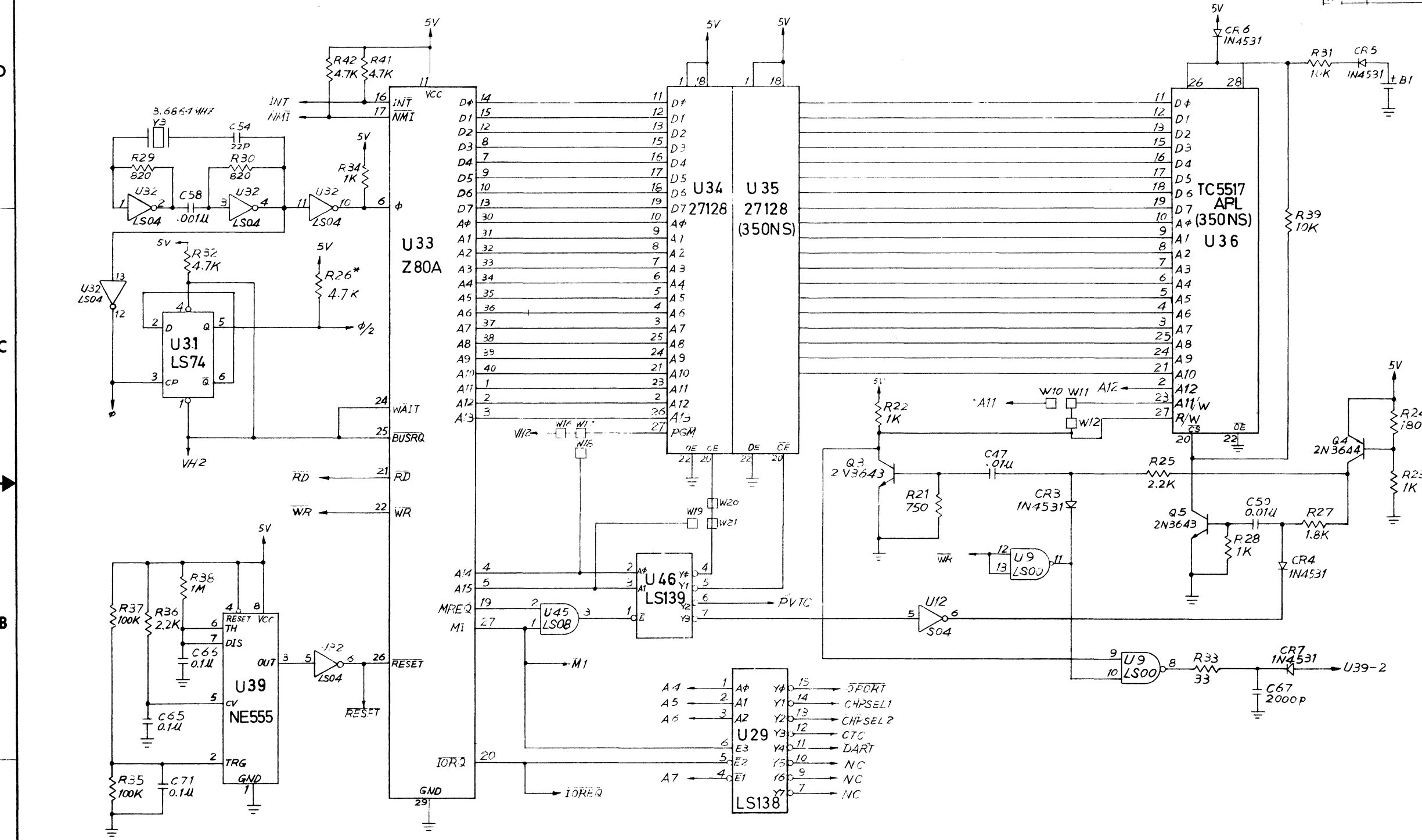

909198

REVISIONS			SIGNATURE AND DATE		
LTR	ZONE	DESCRIPTION	DFTG	CHK	ENGR
W		SEE SH.1			

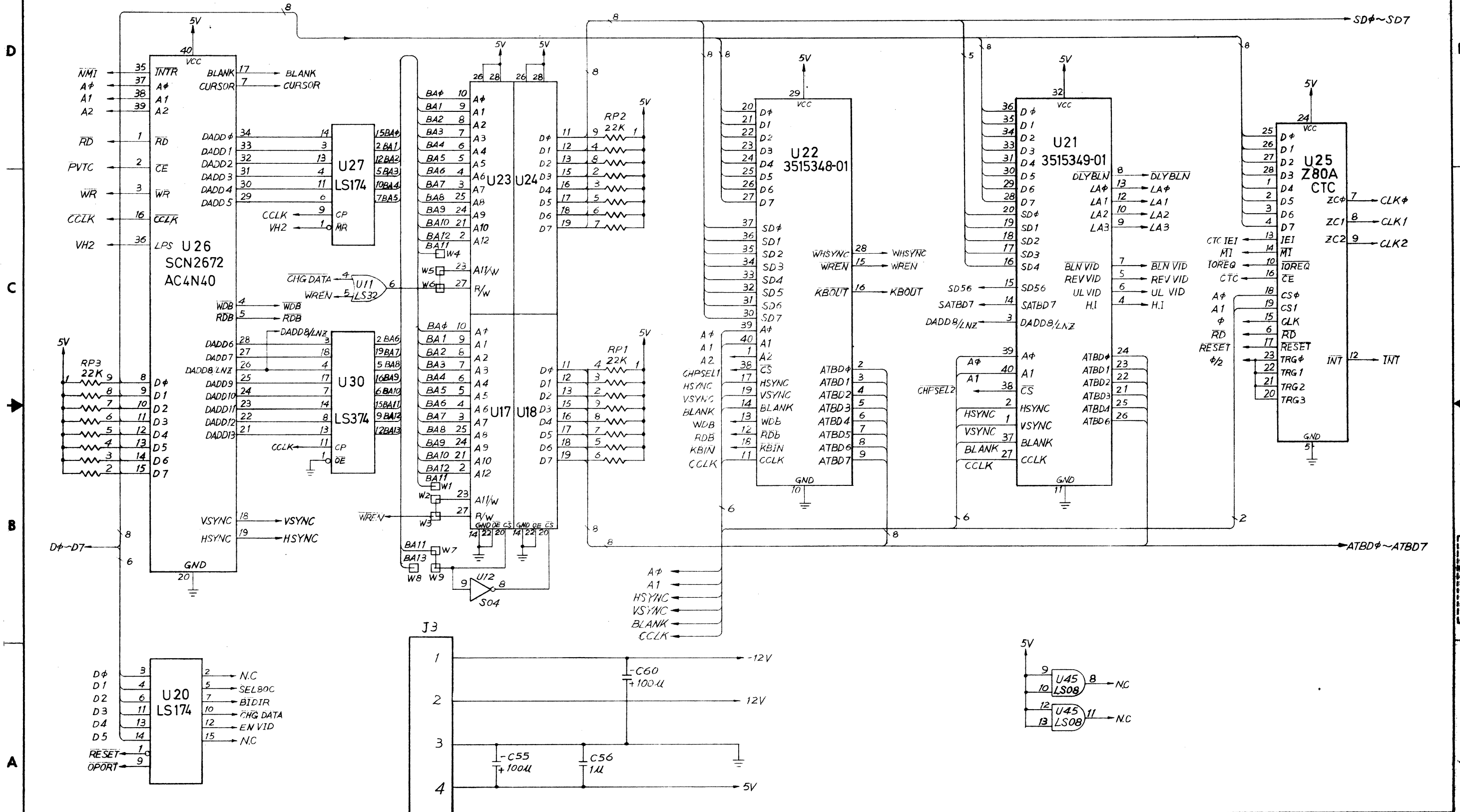

SIZE	CODE IDENT NO.	3515400
D	09150	
SCALE		SHEET 4 OF 6

REVISIONS	
LTZ	DESCRIPTION
P	SEE SH. 1

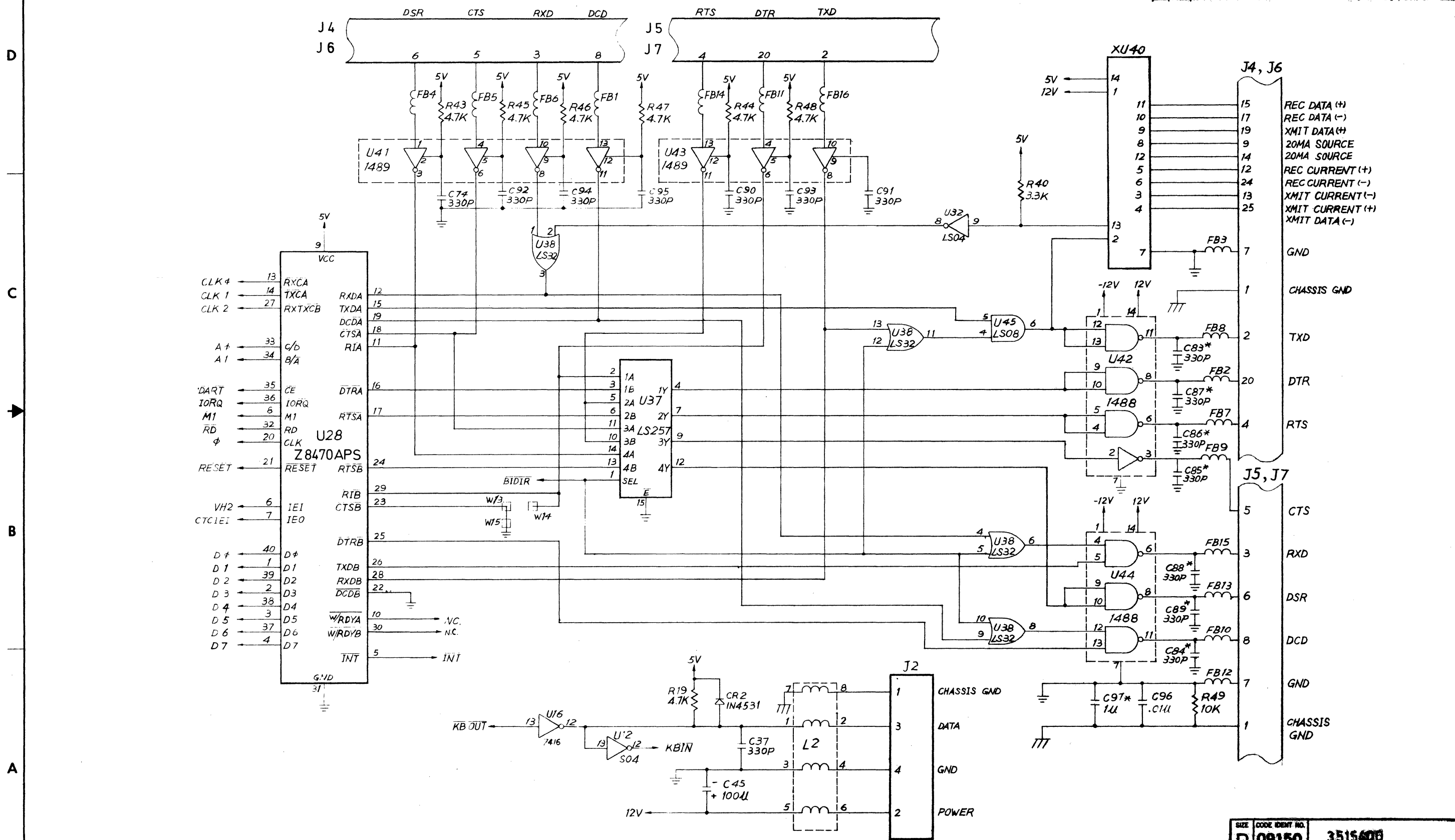

SIZE	CODE IDENT NO.	3515408
D	09150	

AMPEX ASSY NO.3515400-

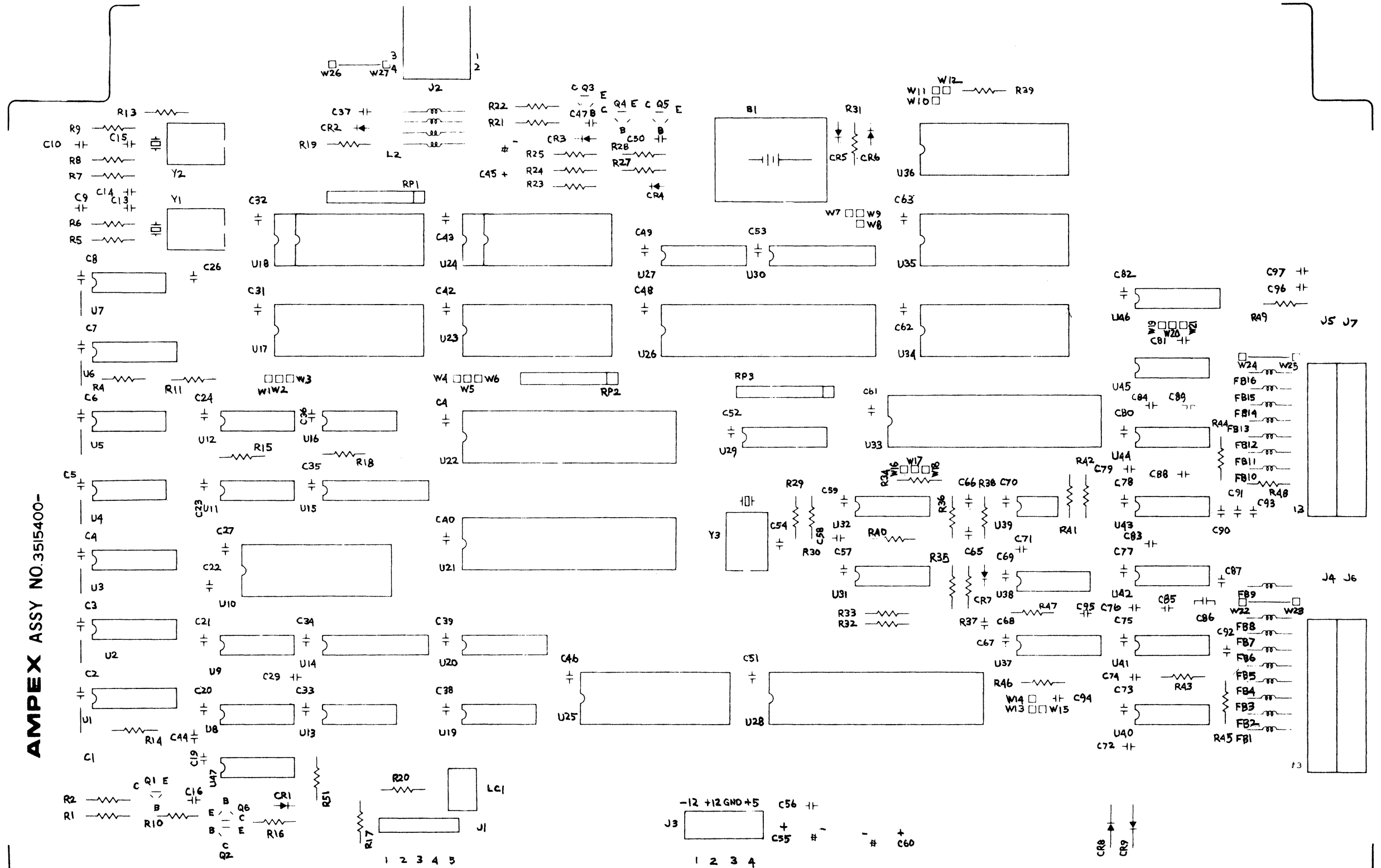

REVISIONS				
REV	DATE	DESCRIPTION	APPROVED	BY
A	11-3-82	ERT 0058 CONT		
B	12-1-82	ECN 42110		
C	1-2-85	ECN 42115		
D	1-2-85	ECN 42121		
E	1-2-85	ECN 42135		
F	1-2-85	ECN 42146		

3515-01 ORION II NEXT ASSY: ORION II APPLICATION:		DRAWN: A.C. Chang DATE: 1/2/85 CHECKED:	AMPEX SILKSCREEN -CONTROL BD. SIZE: C CODE IDENT NO: 09150 DRAWING NO: 3515403 SCALE: 1/1 SHEET: 1 OF 1
---	--	---	---

3515452

REVISIONS			SIGNATURE AND DATE		
LTR	ZONE	DESCRIPTION	DFTG	CHK	ENGRG
A		ERN 0089 (CONT.)	SYN	SYN	ENR
B		ECN 42153			

D
C
B
A

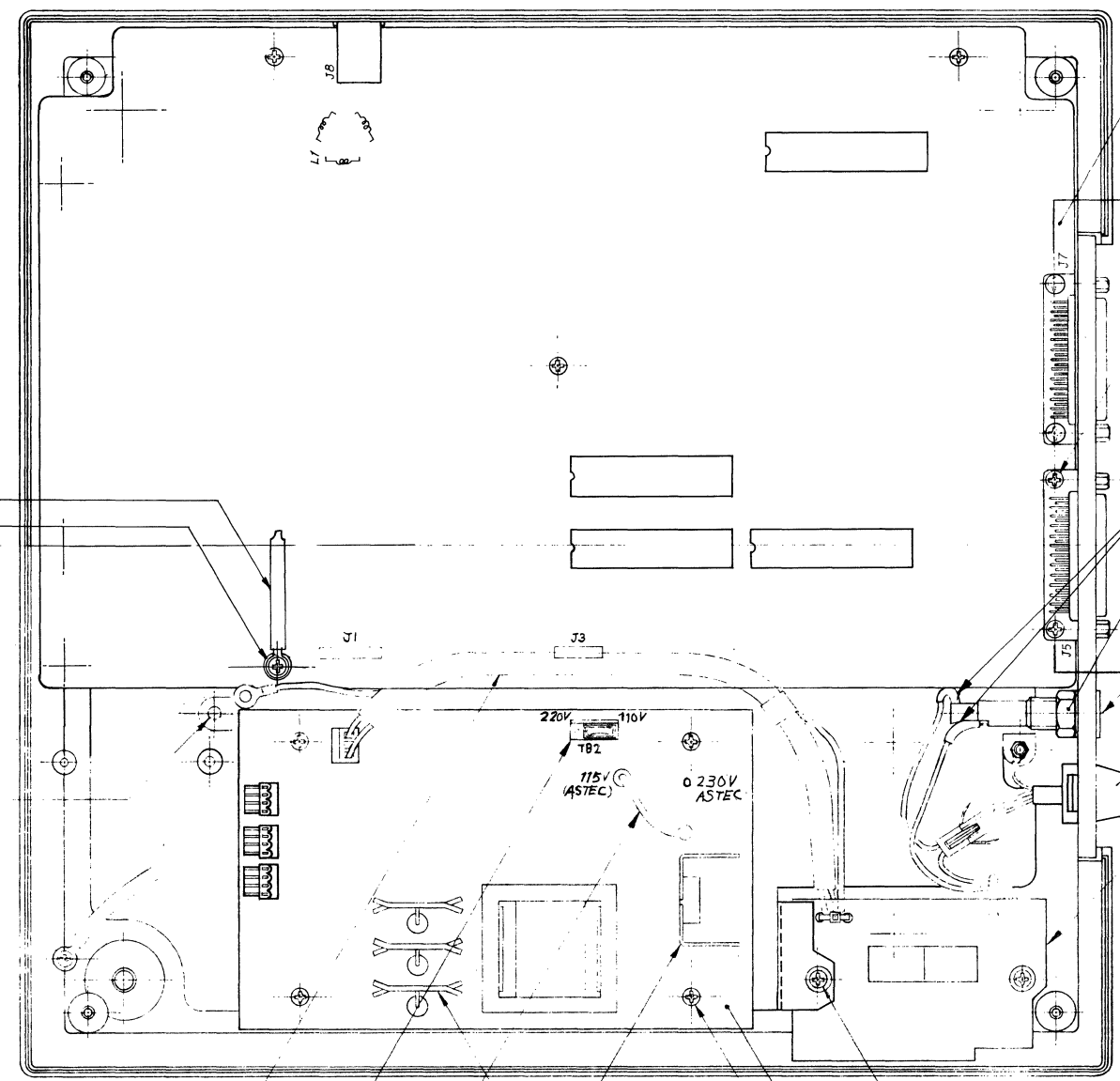

- 10 DRESS AC POWER JUMPER WIRES UNDER CONTROL BOARD AS CLOSE TO GROUND PLANE AS POSSIBLE.
- 9 AC POWER CONNECTION:
FOR 115V - SEE SH.1 ZONE B-5 & SH.2 AC WIRING DIAGRAM.
FOR 220V - SEE SH.2 ZONE D-2 VIEW E-E & AC WIRING DIAGRAM.
- 8 FOR 220V APPLICATION, SHIFT 3P CONNECTOR OF TB2 TO LEFT SIDE 1 POSITION AS SHOWN IN SH.1 ZONE B-6 WHEN USE SKYNET P/S PWBA; PULL AND INSERT SINGLE PIN CONNECTOR FROM 115V PIN POSITION TO 230V PIN POSITION AS SHOWN IN SH.1 ZONE B-6 WHEN USE "ASTECC" P/S PWBA.
- 7 DRESS AC POWER JUMPER WIRES THRU WIRE LOOP OF TB2 CONNECTOR OF SKYNET P/S PWBA TO KEEP WIRES AWAY FROM HEAT SINKS.
- 6 DRESS ALL WIRES AWAY FROM HEAT SINKS OF P/S PWBA.
- 5 ADHERE GROUND PLANE INSULATOR TO GROUND PLANE PROPERLY AS SH.2 DOT LINES SHOWN WITH "3M" DOUBLE SIDE ADHESIVE TAPE "400 1/2" TO AVOID LIFT UP.
- 4 METRIC ENGRG & DRAFTING PRACTICES PER AMPEX STD MBI-3
- 3 MARK PART NO., ISSUE LTR, SERIAL NO PER AMPEX SPEC 3124500 PARA 3.1.
- 2 ASSEMBLE PER AMPEX STD.
- 1 PART NO. TO BE PER VERSION TABLE. (SEE SH.2)

3512653-01
3515454-01

3515237-01
(2PLS)

476-422
(REF)
PART "D"

3515419-01
GND PLANE (REF)

3513424-01

7 8 8
(SKYNET) (ASTECC)

3513403-02
476-672 4PLS

3513424-01
PART "D"
(4PLS) 3515183-01
476-422

476-422
(8 PLS)

600-254 (2PLS)
070-454

PART "C" (SEE SH.2)
PART "B" (SEE SH.2)

265-107
(REF)

PART "A" (SEE SH.2)

3515385-02

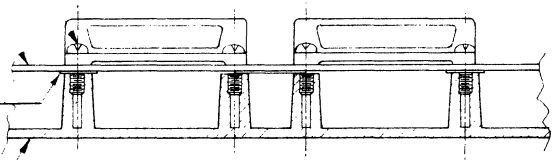

SECTION: A - A

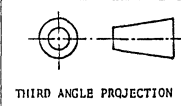

3515451	A219
NEXT ASSY	USED ON
APPLICATION	

NOTICE
THIS DRAWING SHALL NOT BE DUPLICATED, USED FOR ANY PURPOSE OTHER THAN THAT FOR WHICH PROVIDED OR DISCLOSED, IN WHOLE OR IN PART, WITHOUT THE WRITTEN CONSENT OF AMPEX CORPORATION. PROVIDED, HOWEVER, THAT IF THIS DRAWING IS SPECIFIED TO BE DELIVERED TO THE GOVERNMENT, OR TO A GOVERNMENT CONTRACTOR, PURSUANT TO A GOVERNMENT PRIME OR SUBCONTRACT, THE GOVERNMENT MAY MAKE SUCH USE OF THIS DRAWING AS IS PERMITTED BY THE APPLICABLE "DATA" CLAUSE SET FORTH IN SUCH CONTRACT OR SUBCONTRACT.

UNLESS OTHERWISE SPECIFIED		SIGNATURE		DATE	
DIMENSIONS ARE IN INCHES AND INCLUDE CHEMICALLY APPLIED OR PLATED FINISHES.		DRAWN BY <i>Leo K. R.</i>		3-4-85	
TOL	2 PL 3 PL ANLR	CHK BY			
REMOVE BURRS AND SHARP EDGES		DFTG			3-4-85
DRILL TOL PER AND 10387		ENGRG			3-4-85
INTERPRET DRAWING PER ANSI Y14.5		APVD			3-4-85
MATERIAL:		AUTH BY			
FINISH:					

PARTS LIST	
AMPEX	MEMORY PRODUCTS DIVISION 200 N. Nash Street El Segundo, California 90245
PEDESTAL ASSY	
SIZE	CODE IDENT NO.
D	09150
SCALE	DO NOT SCALE THIS PRINT
SHEET 1 OF 2	

AMPEX		MEMORY PRODUCTS DIVISION 200 N. Nash Street El Segundo, California 90245	
PEDESTAL ASSY			
SIZE	CODE IDENT NO.	3515452	
D	09150		
SCALE	DO NOT SCALE THIS PRINT	SHEET 1 OF 2	

C
B
A

3515452

8 7 6 5 4 3 1

8 7 6 5 4 3 2 1

3515452

REVISIONS			SIGNATURE AND DATE		
LTR	ZONE	DESCRIPTION	DFTG	CHK	ENG
B		SEE SH.1			

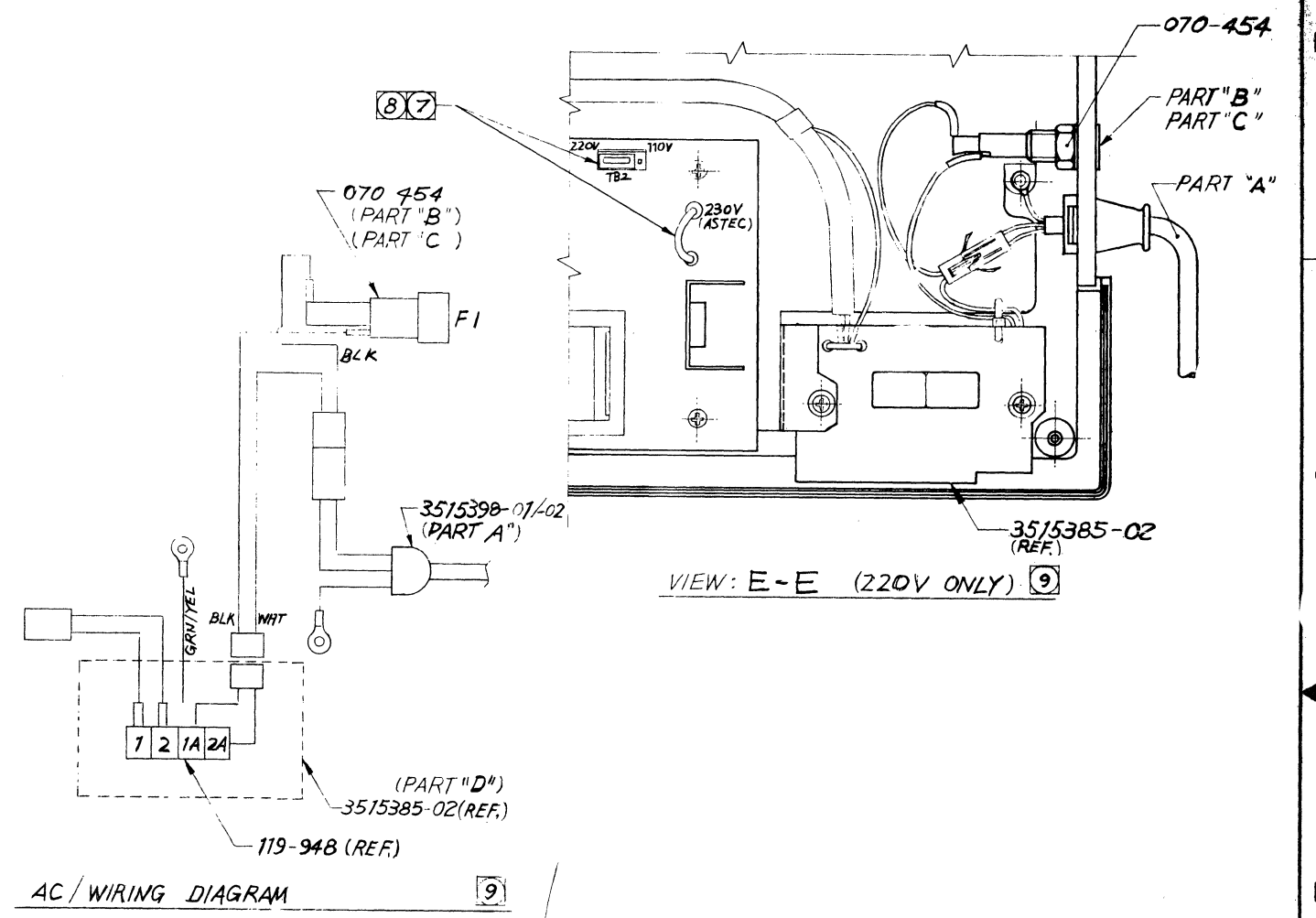
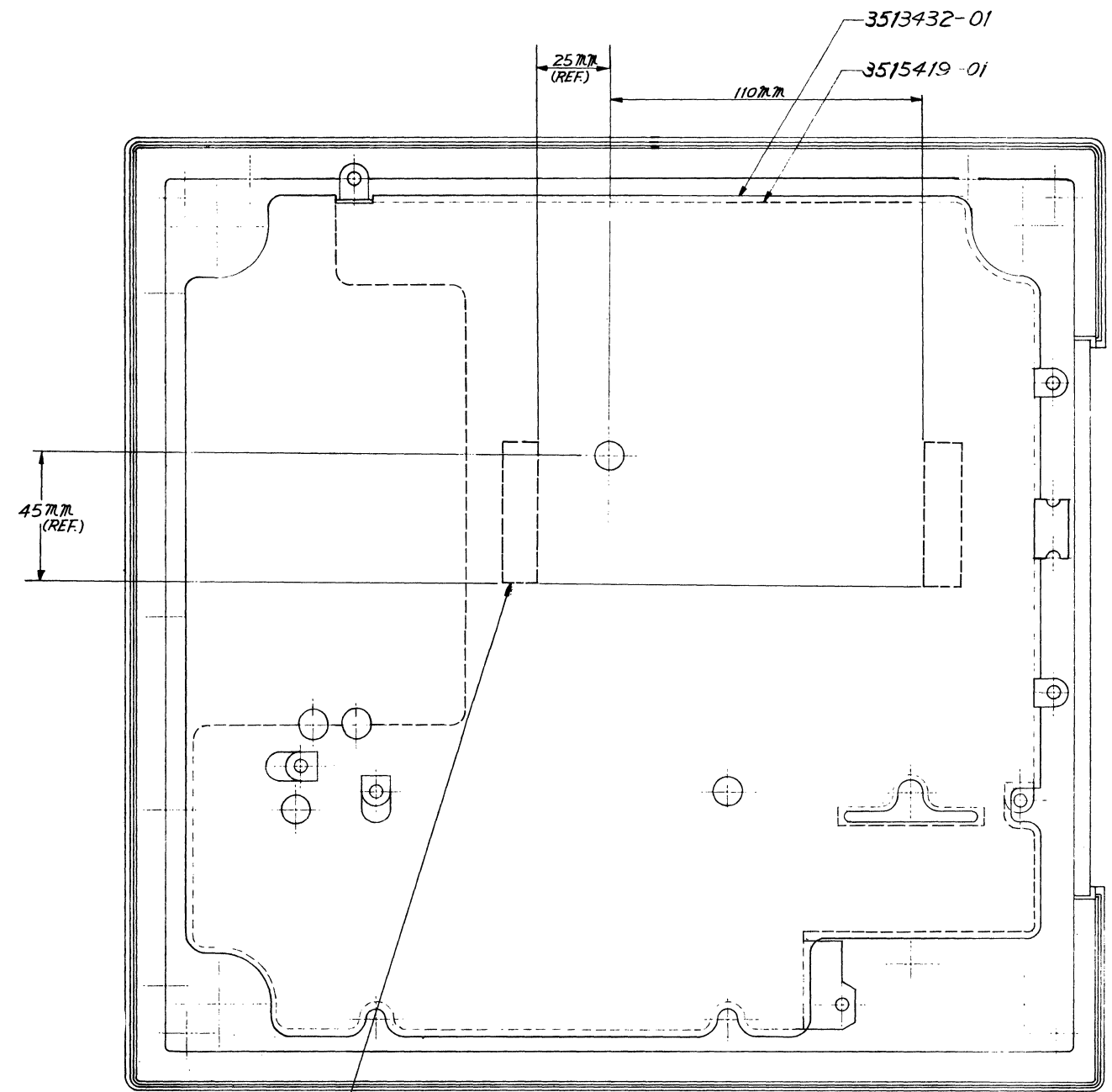

5 50mm x 12.5mm (REF.)
DOUBLE SIDE ADHESIVE TAPE
(TOTAL 2 PLS)

PART NO.	PART 'A' AC POWER CORD	PART 'B' FUSE PART CAP	PART 'C' FUSE	PART 'D' PANEL - CONT. BOARD	REMARKS
3515452-02	3515398-02	070-413	070-467 ALTERNATE 070-471	3515400-03	220V
3515452-01	3515398-01	070-412	070-312	3515400-06	115V

VERSION TABLE

SIZE	CODE IDENT NO.	3515452
D	09150	
SCALE	NONE	SHEET 2 OF 2

