

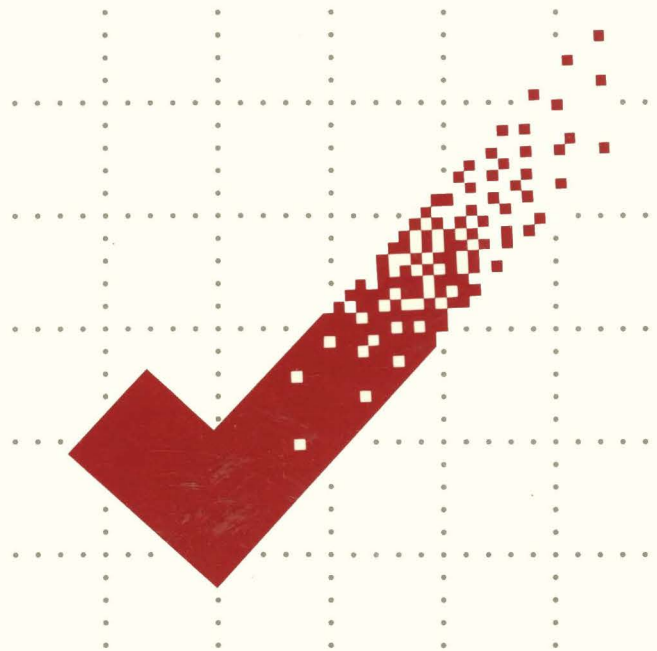

# Apple Support Training Library

Apple  
Support  
Training  
Library

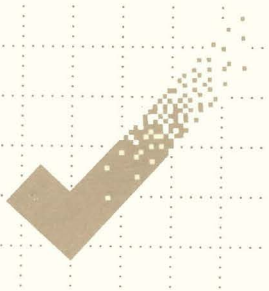

072-0186

.....  
MACINTOSH  
VOL. I

.....  
M A C I N T O S H  
VOL. I

# Welcome to the Apple Support Training Library

The Apple Support Training Library is an example of Apple's commitment to helping you provide better support to users of Apple® products. The Library's modules allow for both quick reference and customized training. The modules contained in this binder are part of three series: Macintosh, Apple II, and Peripherals.

**Training.** Because the library's modules are self-paced, individuals can learn and practice by themselves. Or the modules can be combined with other modules as a course. If given as a course, the self-paced modules allow students to progress at their own pace, freeing the instructor to answer questions and help students with problems. Each module lists any prerequisites and equipment required.

**Reference Catalog.** To facilitate your search for information on Apple products, we developed the Support Training Reference Catalog, available on AppleLink™. The catalog references manuals, publications, courses, and training modules that provide information and instruction on a wide range of computer skills. For each skill listed, the catalog identifies training resources and tells how to sign up for the training, how to acquire the materials, and what the prerequisites are.

**Update Subscription.** This binder contains the modules which have been released to date for this series. Along with this binder you receive a subscription to all additional modules produced for the series this year. (Modules are released quarterly.) At the end of the year, you will receive a renewal letter that you can use to order a subscription for the modules to be released the following year.

**Change of Address.** If you change your address, please notify your local Apple Support Center.

### Recommendations when using this Library:

- Read the modules thoroughly.
- Contact your Apple support representative if you have any questions or need additional information not covered in the modules.
- Back up your files as you follow the practice exercises to avoid losing important data.

### Copyright

©1986 Apple Computer, Inc. All rights reserved.  
Apple Computer, Inc.  
20525 Mariani Avenue  
Cupertino, CA 95014

Apple grants to its authorized dealers and other authorized customers the right to reproduce and distribute this material for use in training classes provided that there is no additional fee charged for the material distributed in such classes, and that it is distributed only to bona fide participants of such classes.

Apple does not endorse any of the third-party products mentioned in this module. They are included only to make you aware of their availability.

Apple, the Apple logo, and the Macintosh logo are registered trademarks of Apple Computer, Inc. AppleLink is a trademark of Apple Computer, Inc. Macintosh is a trademark of McIntosh Laboratory, Inc. and is being used with express permission of its owner.

These modules were produced using the Apple LaserWriter printer.

# Apple Support Training Library

## Macintosh Vol. I

---

### Table of Contents

- |                |          |   |
|----------------|----------|---|
| <b>Section</b> | <b>1</b> | <b>Macintosh Product Overview</b><br><i>Learn to identify the hardware components of the Macintosh, how to set up the system, and what accessory products are available.</i>  |
|                | <b>2</b> | <b>Learning to Use Macintosh</b><br><i>Learn to use Macintosh, including basic Macintosh techniques such as using the mouse and menus, and how to work with documents, folders, and disks.</i>  |
|                | <b>3</b> | <b>Supporting the Macintosh Finder</b><br><i>Learn to use and support the features of the Finder. Use the Finder utilities in different versions of the Finder to support Macintosh users.</i>  |
|                | <b>4</b> | <b>Supporting the Font/DA Mover</b><br><i>The Font/DA Mover is a utility that helps you move fonts and desk accessories. You use it to add room to a crowded disk, or to add fonts or desk accessories that allow you to be more productive. A section on the original Font Mover is included.</i>  |
|                | <b>5</b> | <b>Managing Macintosh Files</b><br><i>Macintosh uses a flat file structure with 400K disk drives and the Macintosh XL. Learn how to support this structure using folders and disks to organize your files, documents, and applications. Learn how to support the Document Directory dialog box (also called the "Standard File") by using it and the Save As command.</i> |
|                | <b>6</b> | <b>Fundamentals of the Macintosh Operating System</b><br><i>Learn how to explain some of the features and functions of the operating system and user interface. Learn how to respond to Macintosh users who have trouble starting up Macintosh, or who have lost a file or a document.</i>  |
|                | <b>7</b> | <b>Using MacDraw</b><br><i>Learn to use MacDraw by completing the Guided Tour of MacDraw and specially designed practice exercises.</i>   |

- 8 Supporting MacDraw**  
*Information that will help you support MacDraw users, including technical specifications and answers to commonly asked questions about using MacDraw.*
- 9 Supporting MacProject**  
*Information that will help you support MacProject users, including hints on how to create, display, and work with project schedules, answers to commonly asked questions, and troubleshooting techniques.*
- 10 Supporting MacWrite**  
*Information that will help you support MacWrite users, including integration with other applications such as graphics programs, useful techniques, answers to commonly asked questions, and technical specifications.*
- 11 Using MacTerminal**  
*Learn to use MacTerminal, including configuring it to communicate with other computers, transferring files, integration with other applications, and practice exercises for connecting to another Macintosh, an Apple II, and a public information service.*
- 12 Using MacTerminal with IBM Computers**  
*How to use MacTerminal to communicate with IBM computers, including a description of the products involved, and the appropriate MacTerminal settings for each, practice using the AppleLine, and answers to commonly asked questions.*
- 13 Supporting MacTerminal**  
*Information that will help you support MacTerminal users, including answers to commonly asked questions, technical specifications, and pinouts.*

# Apple Support Training Library

There are three binder series in the Apple Support Training Library: Macintosh, Apple II, and Peripherals. Here is a listing of the modules currently available for each series.

## **Macintosh, Vol. I & II** (Part No. 072-0186)

### **Macintosh Product Overview**

*Learn to identify the hardware components of the Macintosh, how to set up the system, and what accessory products are available.*

### **Learning to Use Macintosh**

*Learn how to use Macintosh, including basic Macintosh techniques such as using the mouse and menus, and how to work with documents, folders, and disks.*

### **Supporting the Macintosh Finder**

*Learn to use and support the features of the Finder. Use the Finder utilities in different versions of the Finder to support Macintosh users.*

### **Supporting the Font/DA Mover**

*The Font/DA Mover is a utility that helps you move fonts and desk accessories. You use it to add room to a crowded disk, or to add fonts or desk accessories that allow you to be more productive. A section on the original Font Mover is included.*

### **Managing Macintosh Files**

*Macintosh uses a flat file structure with 400K disk drives and the Macintosh XL. Learn how to support this structure using folders and disks to organize your files, documents, and applications. Learn how to support the Document Directory dialog box (also called the "Standard File") by using it and the Save As command.*

### **Fundamentals of the Macintosh Operating System**

*Learn how to explain some of the features and functions of the operating system and user interface. Learn how to respond to Macintosh users who have trouble starting up Macintosh, or who have lost a file or a document.*

### **Using MacDraw**

*Learn to use MacDraw by completing the Guided Tour of MacDraw and specially designed practice exercises.*

### **Supporting MacDraw**

*Information that will help you support MacDraw users, including technical specifications and answers to commonly asked questions about using MacDraw.*

### **Supporting MacProject**

*Information that will help you support MacProject users including hints on how to create, display, and work with project schedules, answers to commonly asked questions, and troubleshooting techniques.*

### **Supporting MacWrite**

*Information that will help you support MacWrite users, including integration with other applications such as graphics programs, useful techniques, answers to commonly asked questions, and technical specifications.*

### **Using MacTerminal**

*Learn how to use MacTerminal, including configuring it to communicate with other computers, transferring files, integration with other applications, and practice exercises for connecting to another Macintosh, an Apple II, and a public information service.*

### **Using MacTerminal with IBM Computers**

*How to use MacTerminal to communicate with IBM computers, including a description of the products involved, and the appropriate MacTerminal settings for each, practice using the AppleLine, and answers to commonly asked questions.*

### **Supporting MacTerminal**

*Information that will help you support MacTerminal users, including answers to commonly asked questions, technical specifications, and pinouts.*

### **Supporting the Macintosh Switcher**

*Information that will help you support Switcher users, including installing and configuring several applications in a Switcher set to establish a desired set of integrated software.*

### **The Inside Story**

*Learn the basic computer components and the flow of information through a computer.*

### **Using the Macintosh XL Migration Kit**

*Follow the step-by-step procedures to convert all of your Lisa 7/7 documents into Macintosh documents. Learn how to prepare your Lisa 7/7 documents, install the migration software, and perform the Lisa and Macintosh portions of the migration.*

## **Macintosh, Vol. I & II** (continued)

### **Using the Finder 5.3 Menus**

*Learn to use the various features of the latest versions of the Finder and System. This module is an update to Supporting the Macintosh Finder, located in Macintosh Volume I of the Apple Support Training Library. This module explains the new features and changes in the existing ones.*

### **Using the Installers**

*Learn how to update your Startup disk using the latest version of the System Installer disk. The module discusses the System Installer and the dragging method of updating, and explains how and when to use both. You will also learn to use the Printer Installation disk to update your printer drivers.*

## **Apple II, Vol. I** (Part No. 072-0187)

### **Apple II Product Overview, Rev 1**

*Learn about the capabilities of the Apple IIGS, Apple IIe, and Apple IIc, including information on enhancements and upgrades. Also learn about the various Apple Memory Expansion Cards.*

### **The Inside Story**

*Learn the basic computer components and the flow of information through a computer.*

### **Apple II System Utilities**

*Learn to use the Apple II System Utilities disk to perform basic operations, including its use with the Apple II Memory Expansion Card.*

### **Supporting ProDOS and DOS**

*Compare ProDOS with DOS, and learn the basics needed to support programmers, including where to go for more information.*

### **Using Subdirectories with AppleWorks**

*Learn about setting up subdirectories and using pathnames to identify and manage files.*

### **Color Printing with AppleWorks**

*Learn how to print color documents on the ImageWriter II using all three AppleWorks applications.*

### **Access II Basics**

*Learn why you'd use Access II, how to set up a system—both hardware and software—for Access II, and how to log on to an information service. Practice solving typical problems with Access II.*

### **Access II: Recording and Receiving Files**

*Learn how to save to disk information that you receive from an electronic service. Learn the difference between recording and receiving, and how to solve related customer problems.*

### **Access II: Overview of Transmitting Files**

*Learn the general principles for transmitting files by using an Apple II (with Access II) to send a file to another Apple II user (who has Access II).*

### **Access II: Preparing Files for Transmission**

*Before transmitting a file, you must know which type of file to send. Here, using quick reference guides, you learn how to determine this. You'll also learn to answer questions regarding different file types such as DIF, ASCII, and formatted text files.*

### **Using the Apple IIGS Control Panel**

*Learn how to use the Control Panel when setting up your Apple IIGS system to provide peripherals information and set personal preferences.*

# **Peripherals, Vol. I**

**(Part No. 072-0188)**

## **ImageWriter II Basics**

*Learn how to set up the ImageWriter II and the SheetFeeder, including how to set dip switches, how to run the printer self-test, and how to test the connection. Also learn the basic software settings for Macintosh applications and AppleWorks.*

## **Using the LaserWriter, Rev 1**

*Learn how to set up an AppleTalk network and use it to print a document on the LaserWriter; how to install LaserWriter software; and how to troubleshoot an AppleTalk network and the LaserWriter. Also learn about the added benefits of the LaserWriter Plus.*

## **Data Communications Terms**

*A brief introduction to terms that will help you support Apple data communications products. A glossary of terms is provided.*

## **Interfaces and Cabling**

*Introduces you to RS-232 communications. This module includes pin information, and brief exercises that help you speak knowledgeably with data communications professionals.*

## **Introduction to Supporting Desktop Communications**

*Learn the process of qualifying desktop communications customers and configuring solutions for them. Learn concepts and terms that are common to most desktop communications solutions.*

## **Supporting Desktop Communications**

*Learn how to qualify a customer for a specific desktop communications solution. Learn concepts and terms that are unique to information systems and electronic mail, local area networks, and large system communications.*

## **Apple II Peripherals Overview**

*Learn about the various Apple II monitors, disk drives, printers, modems, and accessories.*





# Macintosh Product Overview

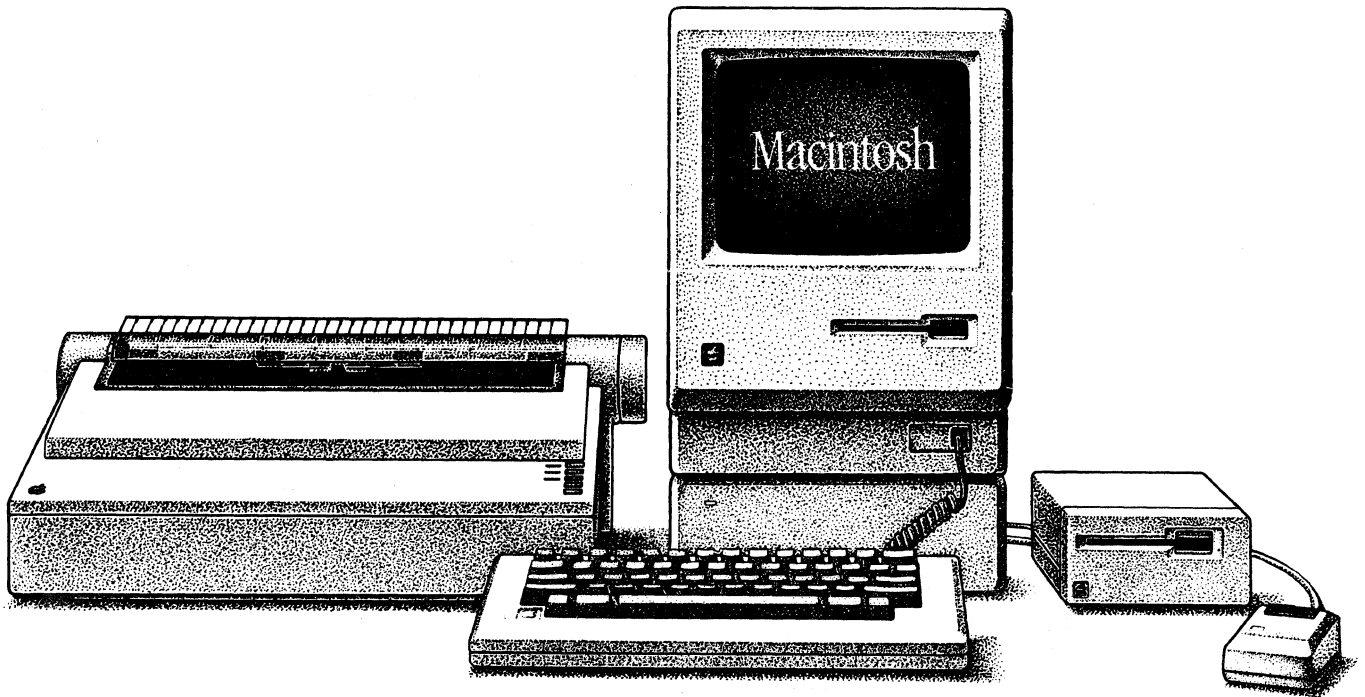

---

## Contents

- 2 Overview
- 3 Objectives, Materials
- 4 Hardware Overview and Setup  
*A look at the hardware components of Macintosh and how to set up the system.*
- 9 Accessory Products  
*Details all of the Apple Macintosh accessories, as well as various products available from third-party vendors for the Macintosh.*
- 16 Review
- 17 Resources

---

## Overview

This module identifies all the hardware features of the Macintosh™ computer and explains how to set up the system. Then there is a brief description of the accessory products available from Apple for the Macintosh and the key third-party accessory products.

This is only an overview of the products available for the Macintosh, not an in-depth analysis or description of each. If you want to know more about specific products that are mentioned, particularly Apple® products, read additional modules from the Apple Support Training Library or ask your Apple support representative for the manual for you to review.

If you aren't familiar with some of the terms used in this module ("byte," "baud," "128K," "modem," and so forth), or if you want to know more about how a computer works, read *The Inside Story* module.

This module is designed for first-time Macintosh users.

### Prerequisites

There are no prerequisites for this module.

---

## Objectives

- Identify the following Macintosh hardware components: accessory connectors, brightness control, clock battery compartment, On/Off switch, security kit connector, and sound jack.
- Set up the Macintosh, including connecting the mouse, keyboard, and power cord.
- Identify the accessory products currently available from Apple for the Macintosh, as well as certain key third-party products.

---

## Materials

### To complete this module, you will need:

- A Macintosh, keyboard, mouse, and power cord (All components should be disconnected, as if they were just taken out of the box.)
- *Apple Presents the Personal Computer: The Macintosh* videotape (available as part of the ASC Training Kit: Macintosh Products—p/n 076-8114-A)

---

## Hardware Overview and Setup

### Overview

**This section identifies all of the Macintosh hardware components.**

You'll begin this section by watching a videotape that introduces the Macintosh. Then you'll learn about all of the system's hardware features.

### Watch the Videotape

**It's called *Apple Presents the Personal Computer: The Macintosh*.**

The video will introduce the Macintosh, some of the accessory products you can use with it, and some basic concepts for its use. Continue with this module when you have finished viewing the video.

### Examine the Front of the Macintosh

**Here are the components you can see on the front of the Macintosh.**

As you read about each feature, be sure you can find it on your Macintosh. The features are the same for the Macintosh 128K and Macintosh 512K. The only difference between the two systems is the amount of memory.

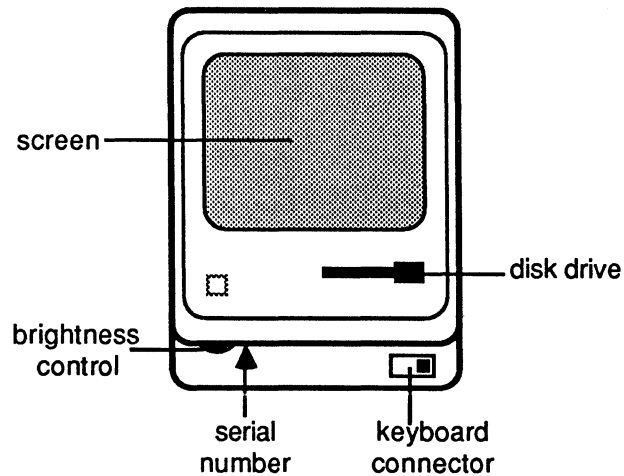

- **Screen.** The screen is a 9-inch video display, similar to a television set. This is where you will see everything you are working on.
- **Disk Drive.** The disk drive is just below the screen, on the right side. It handles disks that can store as much as 400K (a "K" is equivalent to 1,024 characters) of information.

The tiny, round hole to the right of the disk-drive slot enables you to eject a disk that can't be ejected in any other way. You simply insert a straightened paper clip into the hole and push.

**Warning:** This method should only be used as a last resort. If used inappropriately, it may cause the loss of information.

- **Keyboard connector.** The keyboard attaches to the connector below the disk drive. Notice that it uses the same type of connector as your phone.

**Warning:** While the keyboard plug and a phone plug may look the same, they are quite different. If you insert a phone cord into the keyboard connector of your Macintosh, you could cause serious damage.

- **Serial Number.** The serial number is under the screen, on the left side. (You'll have to tip the Macintosh back to see it.) It's important for warranty repairs and theft control.
- **Brightness Control.** The brightness control is under the screen, on the left side—next to the serial number.

## Examine the Back of the Macintosh

### These are the components that are on the back of the Macintosh.

- **On/Off Switch.** Face the front of the Macintosh, and run your left hand along its left side. Toward the back, you'll find a smooth spot in the texture of the plastic. Just around the corner, on the back of the Macintosh, is the On/Off switch.

Now turn the Macintosh around so its back faces you, and find each of the components as they are described.

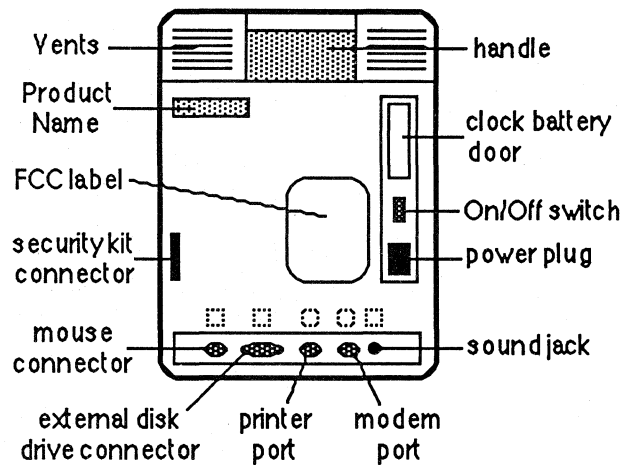

- **Power Plug.** The power cord connects to the socket just below the On/Off switch.
- **Clock Battery Door.** The Macintosh clock runs on battery power when the Macintosh is turned off. The battery will last about two years. As the battery is wearing out, the clock will lose time. When this happens, remove the clock battery door and replace the battery. Use a 4.5-volt battery (Eveready No. 523, or equivalent, which is available on the Apple price list, p/n 742-0003).
- **Accessory Connectors.** The connectors along the bottom of the back of the Macintosh are labeled with an "icon," or symbolic representation, of the device that can be attached to each. From left to right, there is the mouse connector, external disk drive connector, the Printer port, and the Modem port.

The Printer and Modem ports are RS-422 serial ports to which you can connect a variety of Apple and third-party products.

- **Sound Jack.** If you want to work (or play) without disturbing others around you, connect an earphone to this jack. You can also use it to connect to an amplifier.
- **Security Kit Connectors.** A Macintosh security kit attaches to the back of the Macintosh case (just above the mouse connector) and to the keyboard (on the edge that faces the Macintosh). Once installed, the two security kit connectors are locked in place. A cable wrapped around an immovable object and through the eyelets in the connectors will lock the Macintosh into place.
- **Programmer's Switch.** A programmer's switch (or interrupt/reset switch) is included for people who want to write their own applications programs. You'll find the switch in the plastic accessory kit that was in the top of your Macintosh box. To install the switch, snap it into place at the bottom of the left side, toward the back of the Macintosh.

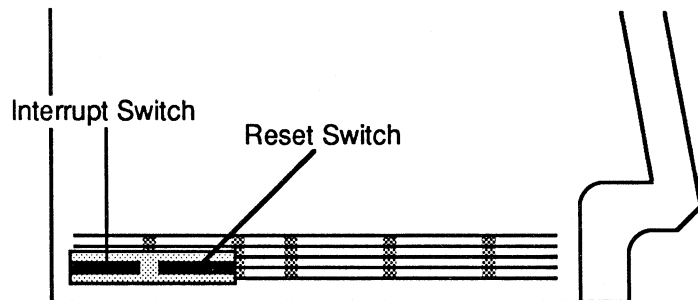

The back part is an interrupt switch, which is useful to developers. The front part is a reset switch. If you want to start up from a different disk, pressing the reset button is like turning your Macintosh off and then on again. *But care should be taken with the Programmer's Switch because using it in the wrong way could cause you to lose information.*

### Vents Around Top and Sides

**Avoid blocking the vents, or the Macintosh may overheat.**

Macintosh doesn't have an internal fan. The vents around its sides and on its top allow air to flow through the cabinet, keeping the components cool. If you block the vents, the Macintosh may overheat.



## Set Up the Macintosh



### Attach the mouse, keyboard, and power cord.

You don't need any tools to set up your Macintosh.

To begin, connect the mouse to the mouse connector on the back of the Macintosh. The icons above the ports tell you what to connect where. The icon above the mouse connector is shown at the left. The connector only fits on one way so it's impossible to attach it wrong. Use the thumbscrews to hold the connector in place.

Connect the keyboard to the Macintosh, just below the disk drive. The connector only fits in one way.

Make sure the system is turned off, and then connect the power cord to the Macintosh and plug it into a 110-volt, three-hole plug. Don't use an adapter, or your Macintosh will not be properly grounded.

Continue when you have connected the mouse, keyboard, and power cord to your Macintosh.

## What to Do Next

### After completing this module, learn how to use the Macintosh and available software.

After you read the remainder of this module to learn about the accessory products available for Macintosh, you'll probably want to learn how to use the system.

Complete the *Learning to Use Macintosh* module to learn basic Macintosh techniques, such as how to use the mouse and menus, and how to work with text. Then you'll be ready to begin one of the various applications training modules.

## Accessory Products

### Overview

**This section describes the accessory products available from Apple for the Macintosh.**

Key third-party accessory products are also mentioned. In addition, new products are constantly being introduced, both by Apple and by third-party developers. Check Macintosh publications such as *Macworld*, the *Macintosh Buyer's Guide*, *Macintosh Connection*, or *A+*, and AppleLink™ for ongoing information about new products.

(Note: AppleLink is a product developed by Apple to provide information and electronic mail capabilities to its Sales organization and dealers. If you don't have access to AppleLink, ask your Apple support representative for information referenced in this module that can be found there.)

### Find Technical Detail Elsewhere

**Check AppleLink or other references for technical information.**

This section doesn't go into technical detail on the products mentioned. If you want more information, check AppleLink or one of the references listed at the end of this module.

### Printers

**There are several printers you can use with Macintosh.**

This section includes a basic description of the various printers available for the Macintosh. If you want more information about the different printer technologies described and the trade-offs involved, read *The Inside Story* module from the Apple Support Training Library.

### ImageWriter II Printer

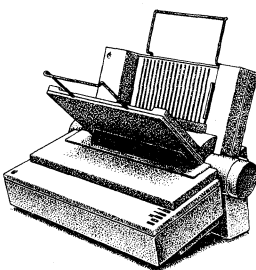

**The ImageWriter II is the printer most often purchased with a Macintosh.**

The ImageWriter™ II is a serial, dot matrix printer that can print high-resolution graphics and text. It was introduced in September 1985 to replace the original ImageWriter, which had been the most popular printer for use with Macintosh. The ImageWriter II is faster than the original ImageWriter, and can also print in color—with the right software. It's good for correspondence text and graphics, but the resolution is not high

enough for business correspondence that requires typewriter quality.

### Check the ImageWriter II switches.

Every printer has switches that must be set correctly in order for it to function properly. The ImageWriter II switches are inside the printer, on the left side, toward the front. On the original ImageWriter, the switches are located inside the printer, on the right, under the track that the print head moves on. Refer to the printer's user's manual for the appropriate switch settings for use with Macintosh and other computers.

### Connect the ImageWriter cable.



To connect the ImageWriter or the ImageWriter II to your Macintosh, plug the cable (which is included in the accessory kit) into the printer and into the Macintosh connector marked with a picture of a printer, like the one shown at the left. The cables can only be connected one way. Secure the connection with the thumbscrews.

## LaserWriter Printer

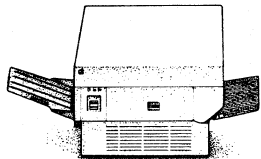

### The LaserWriter printer produces near-typeset-quality output.

The LaserWriter™ printer is at the top of Apple's printer line. It's a high-speed, high-resolution laser printer that can produce graphics and text output of such high quality that it looks typeset. For increased cost-effectiveness, the LaserWriter can be shared by as many as 31 Macintosh users over the AppleTalk™ Personal Network—Apple's networking solution for small workgroups. (More information about AppleTalk appears later in this module. You can also refer to the *Using the LaserWriter* module from the Apple Support Training Library for more information on AppleTalk and the LaserWriter.)

## Letter-Quality Printers

### Software is available that enables you to use a letter-quality printer with Macintosh.

Use a letter-quality printer (also known as a *daisy wheel* printer or *impact* printer) if you need typewriter-quality documents. However, such printers aren't good for printing graphics.

The Mac Daisywheel Connection is a program that provides letter-quality printer support for MacWrite™. It's not a *driver*, (special code needed to use a printer with any application), but

an application that prints MacWrite documents. The program supports character sizes of 10, 12, and 15 point, as well as proportional print wheels and various font styles. It also supports many different printers, including the Apple Daisy Wheel Printer. The Mac Daisywheel Connection is available from Assimilation, Inc. (AppleLink has additional information.)

### External Disk Drive

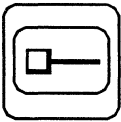
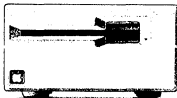

### An external disk drive is available.

Apple manufactures an external disk drive that's identical to the built-in drive. This drive can handle disks that store 400K of information.

Connect the disk drive to the external disk-drive port on the back of the Macintosh. This port is identified by a picture of a disk drive, as shown at the left. Secure the connection with the thumbscrews.

**Warning:** Place the external disk drive on the right side of the Macintosh to avoid potential ventilation and shielding problems.

### Apple Hard Disk

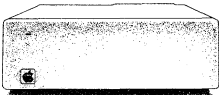

### Hard disks provide greater storage capacity and faster access time.

The Hard Disk 20 is Apple's 20-megabyte hard disk for the Macintosh. It attaches to the external disk-drive port and is designed to sit under the Macintosh, so it's out of the way and aesthetically pleasing. The Hard Disk 20 also allows you to daisy chain another hard disk, a floppy-disk drive, or a backup device such as a tape drive. (See the Third-Party Accessories section of this module for a list of hard disks available from third-party developers.)

### Modems

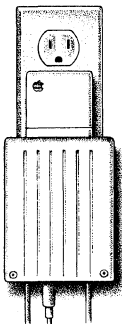

### Apple makes two modems.

A *modem* is a hardware device that enables you to communicate with another computer through a telephone line. The Apple Personal Modem (shown at left) and the Apple Modem 300 both work with the Macintosh. The Modem 300 operates at 300 *baud* (which is a measure of how fast information is transmitted), and the Personal Modem operates at 300 or 1200 baud. (Note: The Apple Personal Modem is functionally identical to the Hayes Smart Modem 1200.)

A higher baud rate means information can be sent more quickly between computers. (See the *Data Communications Terms* module from the Apple Support Training Library for additional information about the data communications vocabulary used in the previous paragraph. See the *Using MacTerminal* module for more information about modems and their use with Macintosh.)

### Connect the modem to Macintosh and to a phone line.

The modem accessory kit contains the cables, user's manual, and other documentation.

Both Apple modems have two connectors for phone cables (as shown below on the Apple Modem 300). Connect the phone line to one port and your telephone to the other. When the modem is not in use, you can use the phone normally.

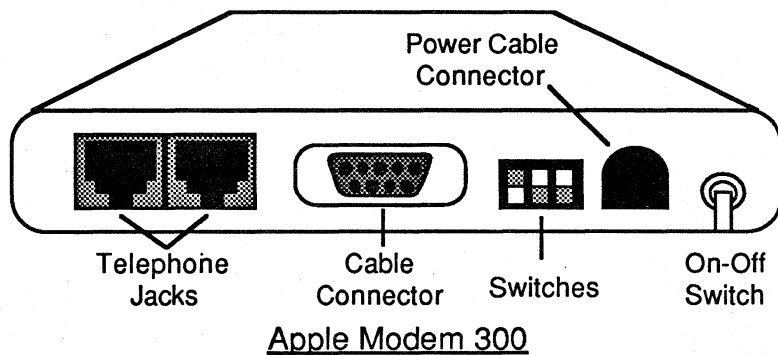

Connect one end of the serial cable that's provided in the accessory kit to the modem's cable connector and the other end to the modem socket on the back panel of the Macintosh, which is identified by the icon shown at the left. There is only one way to attach the cable. Secure the connection with the thumbscrews.

Check the owner's manual for the correct switch settings (the switch settings shown above are correct for use with Macintosh). Then connect the power cord, and you're ready to go.

There are no switches on the Personal Modem, and you plug it right into a power socket, so there isn't a power cord either. Just connect it to the phone line and to your Macintosh and it's ready for use.

## AppleTalk Personal Network

There are several accessories available to everyone connected to the AppleTalk network.

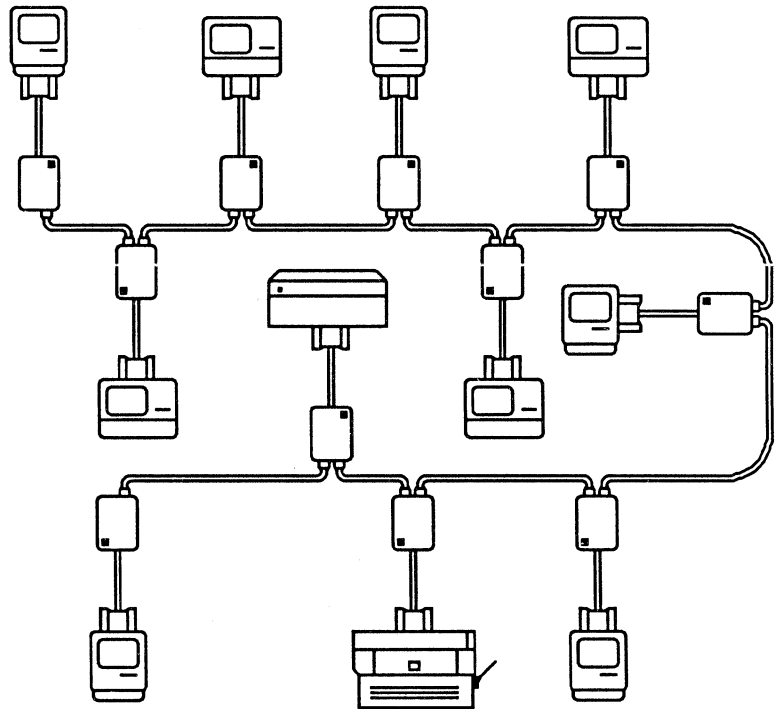

AppleTalk is Apple's local interconnect system. It was designed to be easy to install, easy to use, and very inexpensive compared to other networking solutions.

Macintoshes, LaserWriter printers, and third-party file servers can all be part of an AppleTalk network. Via AppleTalk, you can store and retrieve information using a file server, print your documents on the LaserWriter or other shared printers, and transfer documents to other workstations.

Read the *Using the LaserWriter* module from the Apple Support Training Library, the LaserWriter owner's manual, or the *AppleTalk Personal Network Installation Guide* for more information about AppleTalk and the LaserWriter printer.

## Other Macintosh Accessories

**Use the numeric keypad if you enter a lot of numbers.**

The numeric keypad is an optional addition to your Macintosh that enables you to enter numbers more quickly than using the numbers across the top of the standard keyboard. It also

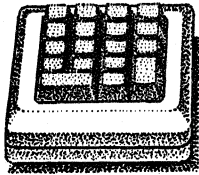

includes several keys for special functions. (You can enter numbers and invoke all of the special functions using the standard Macintosh keyboard, but the numeric keypad lets you do both faster.)

To connect the keypad:

1. Unplug the keyboard cable from the keyboard.
2. Insert it into the socket on the keypad marked with a picture representing the Macintosh.
3. Plug the cable that comes with the keypad into the remaining socket on the keypad.
4. Plug the other end of that cable into the socket on the keyboard.

When you finish, the numeric keypad and keyboard should be connected to your Macintosh as shown below.

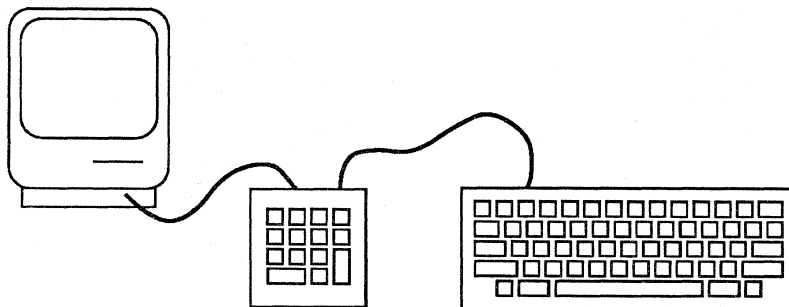

### The Security Kit.

If your Macintosh is used in a public place, you can secure the main unit and the keyboard using the security kit. See the Macintosh owner's manual for instructions on its use.

### Third-Party Accessories

**The following is a partial list of accessory products available from third-party developers.**

Check AppleLink and Macintosh publications for other products available for the Macintosh.

### Disks

#### HyperDrive by General Computer Company.

HyperDrive is a 10-megabyte hard disk that fits inside the Macintosh cabinet. It's convenient because it doesn't occupy any additional desktop space.

**Bernoulli Box by IOMEGA.**

The Bernoulli Box is a 5-megabyte *removable* hard-disk cartridge.

**OmniDrive by Corvus.**

OmniDrive is a line of hard disks that can be shared among several Macintosh computers connected via AppleTalk. Each user can have private storage space on disks which range in size from 5 to 126 megabytes.

**QC10 and QC20 by Quark.**

The QC10 and QC20 are 10- and 20-megabyte hard disks, respectively, that connect to the Macintosh external disk drive port. They can also be used with an Apple II.

**Digitizers and Graphic Enhancers****ThunderScan by Thunderware.**

This is an optical reader that attaches to the ImageWriter. ThunderScan will create a MacPaint™ document from any drawing or photograph you feed through your ImageWriter. It's very accurate, but not very fast.

**MacVision by Koala.**

MacVision enables you to connect a video camera to Macintosh and create MacPaint documents from drawings, photographs, or live video images. It's quite fast but not as accurate as ThunderScan.

**MacTablet by Summagraphics.**

MacTablet is a drawing tablet that replaces the mouse as a graphics input device. It's very good for detailed drawing or tracing.

**Other Products**

**Hayes has a 2400-baud modem available.**

**MacCharlie will make your Macintosh compatible with an IBM PC.**

MacCharlie consists of a disk drive and a keyboard extender that enable you to run MS-DOS software on your Macintosh.



---

## Review

### Hardware Overview

**The hardware components of a Macintosh are:**

- Screen
- Brightness control
- Keyboard connector
- Disk drive
- Security kit connector
- Mouse connector
- External disk drive, printer, and modem ports
- Sound jack
- Power plug
- On/Off switch
- Clock battery

If you're not sure where each of these components are, refer to the diagrams earlier in this module.

### Hardware Setup

**To set up your Macintosh, connect the mouse, keyboard, and power cord.**

### Accessory Products

**A large variety of accessory products are available for the Macintosh.**

Apple manufactures the following products that can be used with the Macintosh:

- ImageWriter II printer
- LaserWriter printer
- Daisy Wheel Printer
- External disk drive
- 20-megabyte hard disk
- Modem 300 and Personal Modem
- Numeric Keypad
- Security Kit

There are also many accessory products available from third-party developers including other disk drives, digitizers, modems, and optical scanners.

## Resources

- *Macintosh*, the owner's manual
- AppleLink (If you have access to AppleLink, use it to find information about all of Apple's products.)
- Accessory product owner's manual (For more information about any of the Apple accessory products mentioned in this module, refer to that product's owner's manual.)
- Macintosh periodicals (For more information about third-party accessory products, check Macintosh publications such as *Macworld*, *The Macintosh Buyer's Guide*, *MACazine*, and *A+*. They will have articles, reviews, or ads that will tell you who to contact for more information.)
- *Using the LaserWriter* module from the Apple Support Training Library (Read this module for more information about the AppleTalk Personal Network and the LaserWriter printer, and for a comprehensive list of additional materials.)

Apple does not endorse any of the third-party products mentioned in this module. They are included only to make you aware of their availability.

Apple and the Apple logo are registered trademarks of Apple Computer, Inc. AppleLink, AppleTalk, ImageWriter, LaserWriter, MacPaint, and MacWrite are trademarks of Apple Computer, Inc. Macintosh is a trademark of McIntosh Laboratory, Inc. and is being used with express permission of its owner. Bernoulli Box is a trademark of Iomega Corporation. HyperDrive is a trademark of General Computer Company. IBM is a registered trademark of International Business Machines Corporation. MacCharlie is a trademark of Dayna Communications. Mac Daisywheel Connection is a trademark of Assimilation, Inc. MacTablet is a trademark of Summagraphics Corporation. MacVision is a trademark of Koala Technologies Corporation. OmniDrive is a trademark of Corvus Systems, Inc. QC10 and QC20 are trademarks of Quark Peripherals, Inc. Smart Modem 1200 is a trademark of Hayes Microcomputer Products, Inc. ThunderScan is a trademark of Thunderware, Inc.



# Learning to Use Macintosh

---

## Contents

- 2 Overview
- 3 Objectives, Materials
- 4 How to Use This Module
- 5 Guided Tour of Macintosh  
*Use the computer-based training to learn the basic techniques for using Macintosh.*
- 33 Basic Macintosh Techniques  
*Mouse techniques and other skills that will make it easier to use Macintosh.*
- 42 Documents and Folders  
*How to work with documents and folders; covers how to move, copy, and save your work.*
- 52 Disks  
*How to work with disks on Macintosh; covers how to back up, erase, and care for them.*
- 71 Review
- 76 Resources

---

## Overview

The Macintosh™ computer is designed to be easy to learn and easy to use. The mouse and graphics-based interface enable even the most inexperienced person to do useful work in just a few hours. Macintosh even comes with its own self-paced training program called the Guided Tour of Macintosh.

In this module, you will go through the Guided Tour, which teaches you the basic techniques for using Macintosh. After each session of the Guided Tour, you are given an opportunity to practice what you have learned.

Even with a computer as easy to use as a Macintosh, there are specific techniques you should learn. After going through the Guided Tour, you will learn how to work with disks, documents, and folders on the Macintosh, including how to copy and move documents and folders, and how to back up disks.

These are basic techniques that everyone needs to know before learning how to use specific applications software. Investing a few hours now will save you many frustrating hours later.

This module is designed for anyone who is using a Macintosh for the first time.

### Prerequisites

You should already be familiar with the Macintosh hardware and how to set it up. If you can't identify the key hardware components of the Macintosh (disk drive, mouse, keyboard, On/Off switch, and accessory ports), complete the *Macintosh Product Overview* module from the Apple Support Training Library.

---

## Objectives

- Learn the basic techniques for using Macintosh, which include how to use the mouse, windows, menus, and icons.
- Move and copy documents and folders.
- Save your work on disks.
- Use the Trash to throw away documents and folders.
- Properly care for disks.
- Initialize, back up, repair, and erase disks.
- State the contents of, and create, a startup disk.

---

## Materials

### To complete this module, you will need:

- Macintosh 128K or Macintosh 512K
- Guided Tour of Macintosh disk and cassette
- Audiocassette player
- Macintosh system disk
- MacWrite™ disk
- Blank disk
- *Macintosh*, the owner's manual

### If available, the following is recommended:

- External disk drive

---

## How to Use This Module

### Follow the Instructions

### Complete the Guided Tour, read the review, then practice the techniques.

The first part of this module has you complete the Guided Tour of Macintosh and then practice what you have learned. During a Guided Tour session, you'll listen to a tape describing what's happening on your screen. But you won't actually *do* anything. After each session of the Guided Tour, there's a review of the techniques that were introduced (so don't feel you have to take notes on what you see during the Guided Tour). *Read the review, but don't try to practice the techniques yet.* Following each review, there is a practice exercise that will help you practice the skills you saw in the Guided Tour and read about in the review.

In this module, it's very important to read everything and to follow instructions. You'll have plenty of time to practice, so don't jump the gun and practice during the reviews.

If you want to complete this section more quickly, you can complete the entire Guided Tour without stopping. However, you will learn—and retain more—about using Macintosh by reading each of the reviews in this module and practicing each of the techniques taught.

The other two main sections of the module are Documents and Folders, and Disks. In these two sections there is a description of the various techniques you will use when working with these items, followed by clearly identified practice exercises. Read the descriptions, and then complete the practice exercises.

### Refer back to the reviews or descriptions during the practice exercises.

If, as you are going through a practice exercise, you forget how to do something, refer back to the description or review given earlier in the module.

After you complete this module, you can always refer back to its descriptions and reviews for quick reminders about specific techniques.

If, at any time, you would like a reminder of the definitions of basic Macintosh terms, check the glossary in Appendix B of *Macintosh*, the owner's manual.

## Guided Tour of Macintosh

### Overview

**Use materials included with your Macintosh to learn the basic techniques.**

The Guided Tour of Macintosh disk and cassette, and the Macintosh owner's manual, which are packaged with your Macintosh, provide an excellent starting point for learning how to use the system. In completing this module, you will use the Guided Tour disk and cassette, and then read key parts of the manual.

After each Guided Tour session, there's a review of the techniques covered in that session. Read the review but don't try the techniques yet. After each review, there's an exercise that will enable you to practice what you saw in the Guided Tour.

There are five Guided Tour sessions. To complete this section, do the following:

1. Read the module section titled Mousing Around (up to the Guided Tour heading).
2. Complete the mouse exercises (which are called Mousing Around).
3. **Complete the Guided Tour of Macintosh.** Follow the instructions in this module (under the Guided Tour heading) to complete the first Guided Tour session, "Show me my Electronic Desk!"
4. **Read the review of the Guided Tour in this module.** Read the review of the session starting with the Review of the Guided Tour heading.
5. **Practice what you saw in the Guided Tour.** Do each step as it's described, beginning at the Practice heading that follows the review.
6. Repeat Steps 3, 4, and 5 for the other four Guided Tour sessions.



## Mousing Around

### Complete the mouse exercises on the Guided Tour disk to learn how to use the mouse.

The first part of the Guided Tour is an exercise called Mousing Around. It's a series of exercises designed to teach you how to use the mouse.

To start the mouse exercises, do the following:

1. Insert the Guided Tour disk, metal end first with the label facing up, into the built-in disk drive. Push the disk all the way in, until it clicks into place.
2. Turn on the Macintosh. The On/Off switch is on the back, above where the power cord connects.

The first time a Guided Tour of Macintosh disk is used, it will automatically start with Mousing Around. Subsequently, when you start up the Guided Tour disk, it will present the Guided Tour screen, which is shown below.

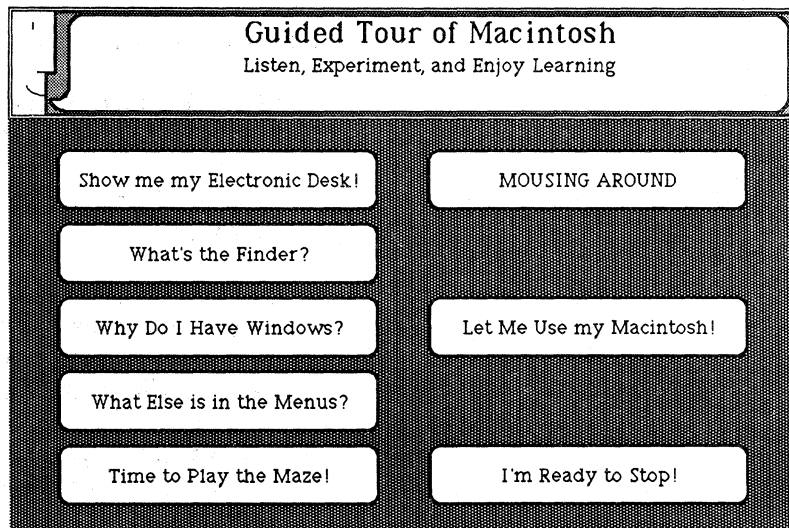

If you see this screen before you complete Mousing Around, roll the mouse on the table top to position the arrow on the screen on top of the words **Mousing Around**. Then press and release the mouse button to begin the mouse exercises.

Do the mouse exercises now. Continue when you have finished.

## Guided Tour

### Complete the first Guided Tour session, "Show Me My Electronic Desk!"

When you start the Guided Tour cassette, there will be a review of some of the material you just read. If you have not yet completed the mouse exercises (Mousing Around), follow the instructions on the tape to do so.

As soon as you see the Guided Tour screen (shown on the facing page) after completing the first session, stop the cassette and read the Review of the Guided Tour below.

Start the Guided Tour of Macintosh cassette now. It will tell you exactly what to do from here on. Continue with this module when you have finished the first session of the Guided Tour of Macintosh.

## Review of the Guided Tour

### Read this review of the first Guided Tour session, "Show Me My Electronic Desk!"

*Stop the cassette*, if you have not already done so.

*Read* the following review of what was covered in the Guided Tour before trying any of the techniques taught. Following the review, you will have an opportunity to practice what you have learned.

## The Macintosh Desktop

### The gray area on your screen is called the *desktop*.

Your Macintosh desktop is like your own desk—it's the area where you do your work, and it holds the objects and information that you work with. On the desktop are various icons, each of which can be opened so you can view the information it contains.

Some of the icons, such as disks and file folders, contain other icons. You can move icons anywhere on the desktop without affecting the information they contain.

## Icons

Each icon has a different function.

These are the most common icons you will see on your Macintosh. You may not see all of these icons your screen at one time, but at some point you will notice each of them.



Disk – To store information.



Trash – To throw documents away.



Application – To create new documents.



Document – Information you have already entered.



Folder – To group several documents together.



System Files – Information Macintosh needs to function.

## Menus

Menus contain all of the capabilities available to you on the Macintosh.

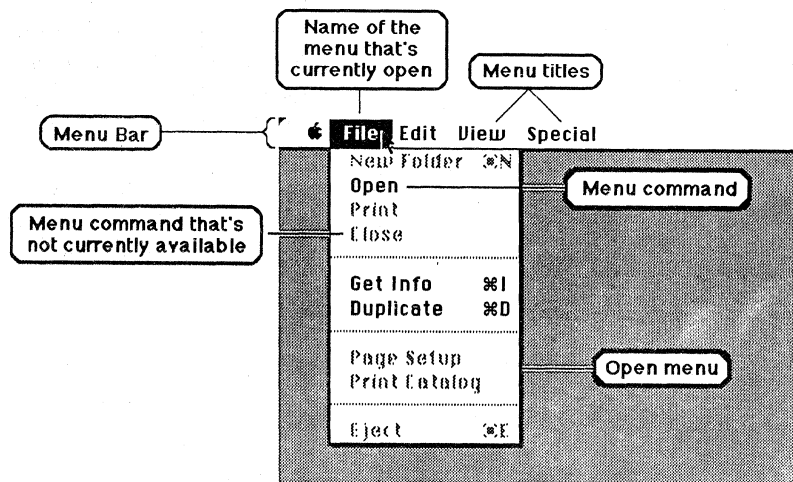

Each word in the menu bar across the top of the screen represents a different menu. Each menu contains several options, or *commands*, that are available to you.

**Some menu commands are black; others are gray.**

Menu commands that are in black type are currently available to you. If a particular command or menu title is gray, it's inappropriate for your current selection or for the environment you're in.

For example, if a window is not open, all of the **View** menu commands will be gray. They are inappropriate, because they only affect how information is displayed in an open window.

**There are four steps to choosing a menu command.**

To choose a command from a menu:

1. Point to the menu you want to open.
2. Hold down the mouse button. The menu name will become highlighted and the menu will open.
3. While holding down the mouse button, point to the command you want. It will become highlighted.
4. Release the mouse button. The command you chose will be implemented and the menu will disappear.

**"Select, then operate" is the normal pattern of operation.**

Use these two steps to perform most operations when using Macintosh.

1. Select what you want to work with (for example, some text or an icon).
2. Follow the four steps above to choose the appropriate command from a menu.

For example, to open an icon, you would first select the icon, and then, choose **Open** from the **File** menu.

If a menu command seems to have no effect, or is gray, you probably didn't remember to begin by selecting what you wanted to work with.

## Selecting Information

### This indicates what you want to work with.

To *select an object* means to indicate that you want to work with it. (For example, if you want to open an icon, first select it to indicate which icon you want to open.)

There are several ways to select what you want to work with. To select an icon, point to it and click the mouse button once. To select some text, hold down the mouse button and drag the pointer through it.

Everything you select will become highlighted in some way (so you can check to see that you selected it correctly, and as a reminder of what's selected. Most objects will become inverse images of themselves when selected (white dots turn black and black dots, white).



Icon that's not selected



Selected Icon

Regular Text

Selected Text

Selecting an object doesn't actually change anything. It only indicates what will be affected by the change you're about to choose. So, if you make an incorrect selection, no harm is done. Just start again, and select what you meant to select in the first place. The most important thing to remember about selecting is a point made earlier: Before you can work with something, you *must* select it.

## Opening and Closing Icons

### Open an icon to view its contents.

Open an icon any time you want to see the information it represents. If the icon is a file folder, for example, the documents stored in the file folder will be displayed. If the icon is the Trash, the objects you recently threw away will be displayed.

#### To open an icon, do the following:

1. Select the icon. It will become highlighted.
2. Choose **Open** from the **File** menu.

The icon will open and its contents will be displayed in a *window*. A window is a rectangle on your screen that has a title at the top and displays some information. There are many things you can do with windows, such as alter their size and move them around on the screen, which will be discussed in later Guided Tour sessions.

You can also open an icon by pointing to the icon and clicking the mouse button twice in rapid succession (double-clicking). If nothing seems to happen when you double-click on an icon, try doing it faster.

Close a window when you're finished working with the information it contains. You can have several windows open at once, but your desktop will get cluttered if you don't close unneeded windows.

To close a window, choose **Close** from the **File** menu. The window will disappear as it returns to its icon form.

## Moving Icons

### **You can organize your work better by grouping related icons.**

If you have several icons that are related—perhaps a report, the cover graphics, and the overhead transparencies you'll use when presenting the report—you may want to have those icons close to each other in the disk window, to remind you that they go together. Or you may want to organize your work still further, by moving the document icons into a file folder.

### **Here's how to move an icon on the screen:**

1. Point to the icon you want to move.
2. Hold down the mouse button.
3. While holding down the mouse button, move the mouse. The icon will move to the location of the pointer.
4. Release the mouse button when you get the icon where you want it.

### **You can move several icons at the same time.**

To move several icons, you must first select all of them. You do this with a *selection box*. To draw a selection box:

1. Imagine a rectangle completely enclosing the icons you want to select.
2. Point to one corner of that imaginary rectangle, but not to any icon in particular.

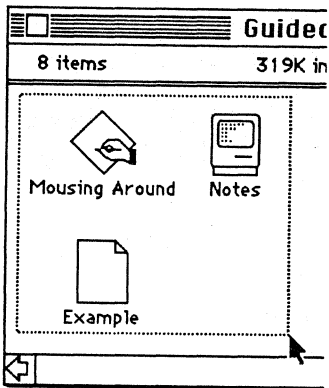

3. Hold down the mouse button and move to the corner diagonally opposite. The rectangle you imagined will be drawn.
4. When the rectangle completely encloses all of the icons you want to select, release the mouse button. *Anything that's either completely or partially in the rectangle will be selected.*

To move the group of icons, move any one of the selected icons the same way you move a single icon. All of the other icons that are selected will follow.

Another way to select several icons is to use the Shift-click technique.

1. Select the first icon.
2. Hold down the Shift key.
3. Point to the next icon you want to select and click the mouse button. Both icons will now be selected.
4. Continue Shift-clicking on icons until you have selected all of the icons you want to move.

This is a particularly useful technique if the icons you want to select are interspersed with other icons.

## Practice

### Practice Guided Tour Techniques

### Practice what you saw in the first Guided Tour session, "Show me my Electronic Desk."

Do each step as it's described.

From the Guided tour screen, click **Let Me Use my Macintosh!**

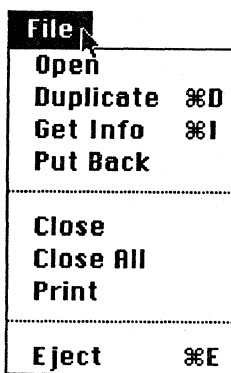

### Open menus.

1. Point to the word **File** at the top of the screen. This is the title of the **File** menu.
2. Press the mouse button and hold it down to open the menu.
3. Don't choose anything from the menu.
4. Release the mouse button to close the File menu.
5. Open the other menus (point to the title and hold down the mouse button) to see what's in each and to see which commands are gray and which are black.



## Open and close icons.

1. Select the Guided Tour disk icon by pointing to it and clicking the mouse button.
2. Choose **Open** from the **File** menu to open it.
3. Choose **Close** from the **File** menu to close it.
4. Select the Trash icon.
5. Choose **Open** from the **File** menu to open it.
6. Choose **Close** from the **File** menu to close it.

## Move individual icons.

1. Open the Guided Tour disk icon.
2. Point to one of the icons in the Guided Tour window.
3. Hold down the mouse button.
4. Move the mouse to move the icon to a different part of the window.
5. Release the mouse button to deposit the icon in its new location.
6. Practice moving other individual icons.

## Move a group of icons.

1. Imagine a rectangle completely surrounding all of the icons in the Guided Tour window.
2. Point to one corner of the rectangle with the mouse, but don't point to any icon in particular.
3. Hold the mouse button down.
4. Move the mouse to the diagonally opposite corner of the rectangle. Be sure all of the icons are at least partially in the rectangle.
5. Release the mouse button. All of the icons either partially or completely within the rectangle will be selected.
6. Move one of the selected icons onto the gray part of your screen, and all of the icons will follow (as shown below).

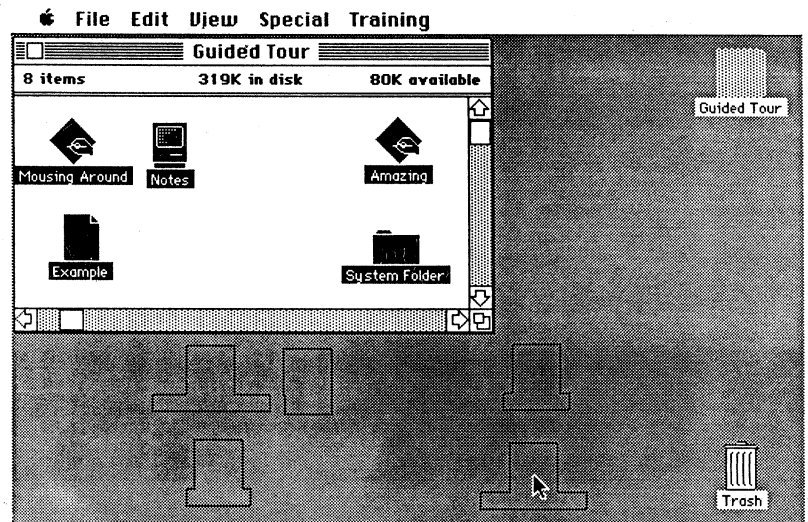



## Practice (cont'd)

7. While the icons are still selected, move all of them back inside the Guided Tour window.
8. Click anywhere within the window, but not on an icon, to *deselect* the icons. None of the icons will remain selected.

**Return to the Guided Tour screen.**

Choose **Quit** from the **Training** menu.

---

## Feedback

### Practice Guided Tour Techniques

**If you had trouble, do one of the following:**

- Replay the first session of the Guided Tour, "Show me my Electronic Desk!"
- Read the appropriate section of *Macintosh*, the owner's manual, which contains complete explanations of all of the techniques taught in this module.
- Ask a colleague, your course manager, or your Apple support representative for help.

---

## Guided Tour of Macintosh (cont'd)

### Guided Tour

**Complete the second Guided Tour session, "What's the Finder?"**

You are now ready to learn the techniques taught in the second session of the Guided Tour of Macintosh. Do the following:

1. Start the cassette again, and follow the instructions to listen to the second Guided Tour session.
2. As soon as you see the Guided Tour screen, stop the cassette.
3. Read the Review of the Guided Tour (on the next page).

4. Use the Practice exercise in this module practice the techniques you saw in the Guided Tour.

Continue with this module when you have finished the second session of the Guided Tour.

## Review of the Guided Tour

**Read this review of the second Guided Tour session, "What's the Finder?"**

*Stop the cassette*, if you haven't already done so.

*Read* the following review of what was covered in the Guided Tour. Following the review you'll have an opportunity to practice what you've learned.

## The Finder

**The Finder is a program that helps you organize other applications and documents.**

The Finder and the desktop are functionally identical. *The Finder is the application that controls the desktop.* Think of the Finder as a home base. It helps you keep track of what you have done and it's a starting point for running applications.

Three versions of the Finder have been released. The Guided Tour of Macintosh uses Version 1.0. Version 1.1 is the version that was released with the Macintosh applications. And in May 1985, Version 4.1 of the Finder was released. The differences between Version 1.1 and Version 4.1 are mentioned throughout this module. (See the *Supporting the Macintosh Finder* module from the Apple Support Training Library for more information.)

You can find out which version you have by choosing **About the Finder** from the **Apple** menu.

## Duplicate

**Create a duplicate if you want to keep more than one version of a document.**

If you want to keep the original version of a document, and the revised version, first make a duplicate of the document. Make your revisions to one copy, and keep the other unchanged.

You might also make duplicates of documents if you create templates of documents or forms that you use often. Creating a duplicate of a template is like tearing a sheet off of the top of a stack of forms.

**To duplicate a document (or any icon), do the following:**

1. Select the icon.
2. Choose **Duplicate** from the **File** menu. A new icon will appear titled "Copy of <icon name>."

**Rename**

**Rename your revised version so you won't confuse it with the original.**

If you're working with templates, rename the duplicate to reflect the true contents of that particular document.

**To rename a document (or any icon), do the following:**

1. Select the icon. The icon and its name will become highlighted.
2. Type a new name. Whatever you type will replace the existing name.

**File a Document In a Folder**

**Put several related documents into the same file folder.**

Just as you store related documents in the same file folder in your filing cabinet, you can store related Macintosh documents in the same file folder. This reduces the clutter in your windows, making it easier to find the document you're looking for.

**To put a document into a folder, do the following:**

1. Point to the document to be moved.
2. Hold down the mouse button.
3. Move the mouse to move the icon so that it's on top of the folder into which you want to put the documents. The folder should become highlighted (as the Opus Project folder is at the left).
4. Release the mouse button.

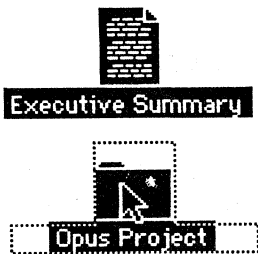

If the folder icon is not highlighted, the documents will not be deposited into the folder. Be sure the folder icon is highlighted before you release the mouse button.

## Throw away a Document

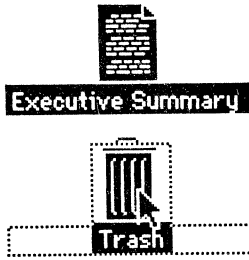

To throw a document away, move it onto the Trash icon.

To throw away a document, you use the technique you just learned for putting a document into a folder—except that this time you put the document icon onto the Trash icon. Again, be sure the Trash icon is highlighted before you release the mouse button. Highlighting is how Macintosh tells you that you're in the correct place. Use this same technique to throw away folders, or any other icon.

## Retrieve a Document From the Trash

If you accidentally throw something away, you can reach into the Trash and pull it out.

How many times have you thrown something in the wastebasket in your office, only to have to reach in and pull it out again. You can do the exact same thing on Macintosh, at least until the trash is emptied (just like in your office).

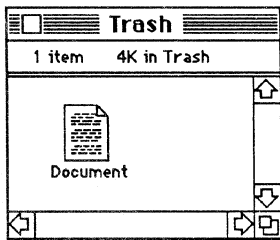

Open the Trash and move the document to another location.

1. Open the Trash the same way you would open any icon (select it and choose **Open**).
2. You'll get a window displaying its contents.
3. Move the document or folder you want to retrieve from the Trash to the desired location—a disk, file folder, or the desktop.

## Empty Trash

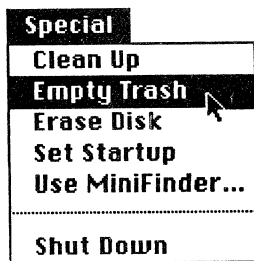

There are three ways to empty the trash.

- Choose **Empty Trash** from the **Special** menu.
- Start up an application.
- Eject the disk either by choosing **Eject** or by choosing **Shut Down** (Version 4.1 only).

If the **Empty Trash** command is gray and will not highlight when you try to choose it, it means the Trash is already empty (in which case, the command is irrelevant).

## Open the Information Window

Use the Information window to determine the latest revision of a document.

If you have several versions of the same document, and you aren't sure which is the latest, open the Information window

for each document. Check the Modified date to see which one is the most recently modified, and therefore the latest revision.

**Information about any icon on the desktop.**

To display the Information window for any icon on the desktop, do the following:

1. Select the icon.
2. Choose **Get Info** from the **File** menu. You'll get a screen similar to the one shown below.

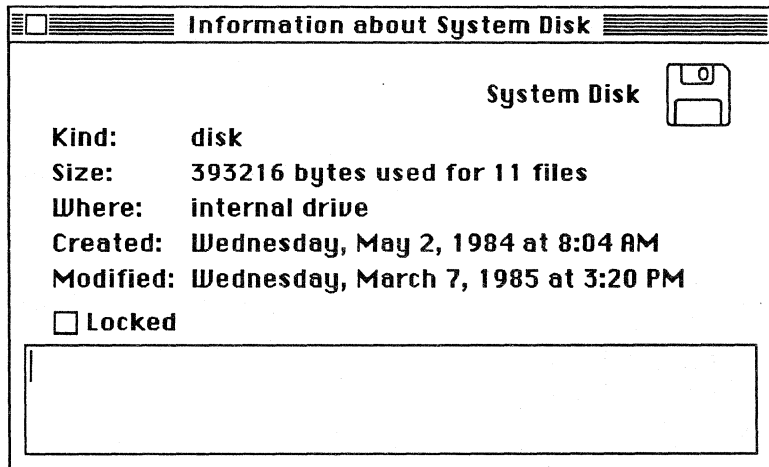

**Working with Text**

**The flashing vertical line is the insertion point.**

It indicates where anything you type will be added. To move the insertion point, do the following:

1. Use the mouse to position the pointer where you want the insertion point to be.
2. Click the mouse button.

Click the mouse button to move the insertion point here

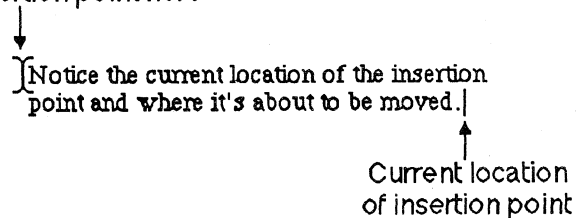

Most of the time you can't make the insertion point go away. You can only move it.

## Select text before you work with it.

To select text:

1. Position the pointer at one end of the word, phrase, or passage you want to select.
2. Hold the mouse button down.
3. Move the pointer to the other end of what you want to select.
4. Release the mouse button.

Everything between where you pressed the mouse button and where you released it will be selected. It doesn't matter if you start at the beginning or the end of the text you want to select.

## Moving Text

### Use Cut and Paste to move text.

To move text using the cut-and-paste technique:

1. Select the text you want to move.
2. Choose **Cut** from the **Edit** menu.
3. Use the mouse to place the text insertion point where you want to add the text.
4. Choose **Paste** to insert the text you previously cut.

The technique for cutting, or copying, and then pasting information is the same in all Macintosh applications, regardless of what is being moved.

## Close Box

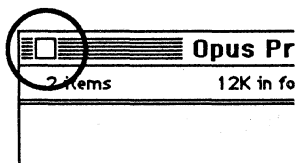

### Click in the close box to close a window.

The *close box* is the small box in the top left corner of an open window (as shown at the left).

Click in the close box to close an open window. This is exactly the same as choosing **Close** from the **File** menu.

## Practice

### Practice Guided Tour Techniques

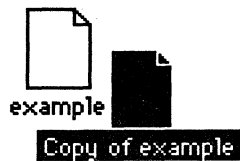

### Practice what you saw in the second Guided Tour session, "What's the Finder?"

Do each step as it's described.

Click **Let Me Use my Macintosh!** from the Guided Tour screen.

#### Duplicate a document.

1. Select the Example document.
2. Choose **Duplicate** from the **File** menu.
3. Move the duplicate to an open area in the window. The duplicate will be called "Copy of Example."

#### Rename the document.

1. Select the "Copy of Example" document. The document and its name will become highlighted.
2. Type a new name, such as **New Example**. Whatever you type will replace the existing name.

#### File the document in a folder.

1. If you're using Finder 1.1, make a duplicate of the empty folder. If you're using Finder 4.1, choose **New Folder** from the **File** menu.
2. Rename it (perhaps, New Folder).
3. Point to the New Example document you made earlier.
4. Hold down the mouse button.
5. Move the document so that it's on top of the New Folder you just created. The New Folder will become highlighted when you are in the right place.
6. Release the mouse button.

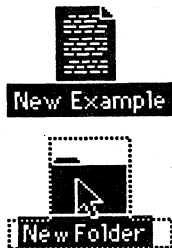

#### Throw the file folder away.

1. Point to the New Folder file folder.
2. Hold down the mouse button.
3. Move the folder so that it's on top of the Trash icon. Be sure the *pointer* is on top of the Trash icon and the Trash icon is highlighted.
4. Release the mouse button.

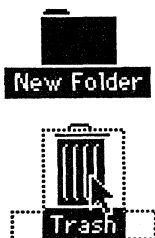

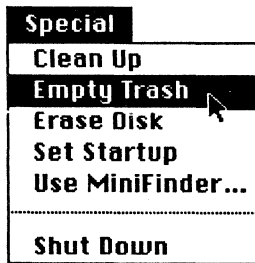
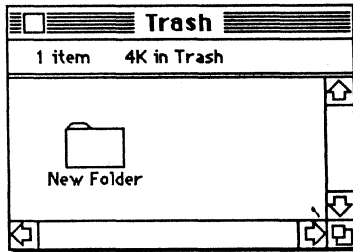

### Retrieve the file folder from the Trash.

1. Open the Trash.
2. Move the New Folder back into the disk window.
3. Close the Trash window.

### Empty the Trash.

(Note: In order to practice emptying the Trash, there must be something *in* the Trash. Hence the first step, even though it seems repetitive.)

1. Throw away the New Folder.
2. Open the Trash (so you'll be able to see what happens; this is not necessary to empty the Trash).
3. Choose **Empty Trash** from the **Special** menu.
4. Close the Trash window.

### Open the Information window.

1. Select the Example document icon.
2. Choose **Get Info** from the **File** menu. Leave the Information window open on your screen.

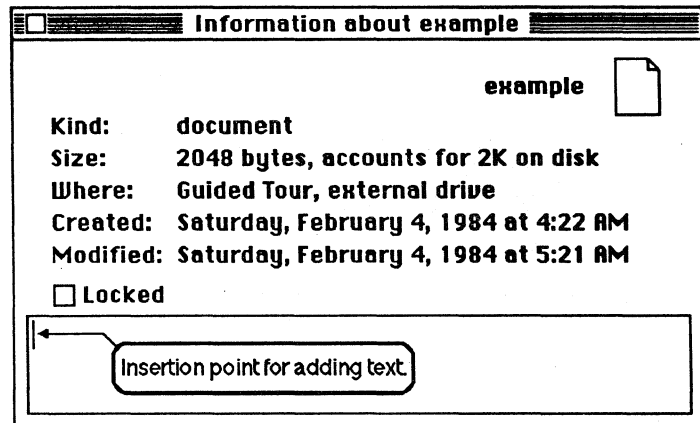

### Enter some text, then move it.

Notice the insertion point in the box in the bottom of the Information window. Anything you type will appear there.

1. Type something that you might enter into the Information window, such as the revision date, a deadline, or a reminder. Type at least several words.
2. Select the first half of the text you just entered. (Notice that the pointer on the screen has changed into a *text pointer* or *I-beam pointer*.)



3. Choose **Cut** from the **Edit** menu.
4. Move the insertion point to the end of the remaining text (position the pointer after the text, and click the mouse button).
5. Choose **Paste** from the **Edit** menu. The text you cut will be pasted into its new location within the box.

**Close the Information window and return to the Guided Tour screen.**

1. Click in the close box to close the Information window.
2. Choose **Quit** from the **Training** menu.

---

## **Feedback**

### **Practice Guided Tour Techniques**

**If you had trouble, do one of the following:**

- Replay the second session of the Guided Tour.
- Read the appropriate section of *Macintosh*, the owner's manual, which contains complete explanations of all of the techniques taught in this module.
- Ask a colleague, your course manager, or your Apple support representative for help.

---

## **Guided Tour of Macintosh (cont'd)**

### **Take a Break**

**You've been working hard. Relax for 10 to 15 minutes before continuing.**

### **Guided Tour**

**Complete the third Guided Tour session, "Why Do I Have Windows?"**

Start the cassette and follow the instructions to complete the next Guided Tour session. As soon as you return to the Guided Tour screen, stop the cassette and read the review below. After the review, practice the techniques you saw in the Guided Tour.

Continue with this module when you have finished the third session of the Guided Tour.

## Review of the Guided Tour

### Review of the third Guided Tour session, "Why Do I Have Windows?"

*Read* the following review of what was covered in the third session of the Guided Tour. Following the review you will have an opportunity to practice what you have learned.

## Active Window

### You can work in only one window at a time—the active window.

You can have several windows open on your desktop at the same time, but you can only work in the *active* window. If you want to work in a different window, you must first select that window.

To select a window, point to any visible part of it and click the mouse button. If the window was partially obscured by another window, it will now be "on top of the stack" and fully visible.

There are several ways to tell which window is the active window.

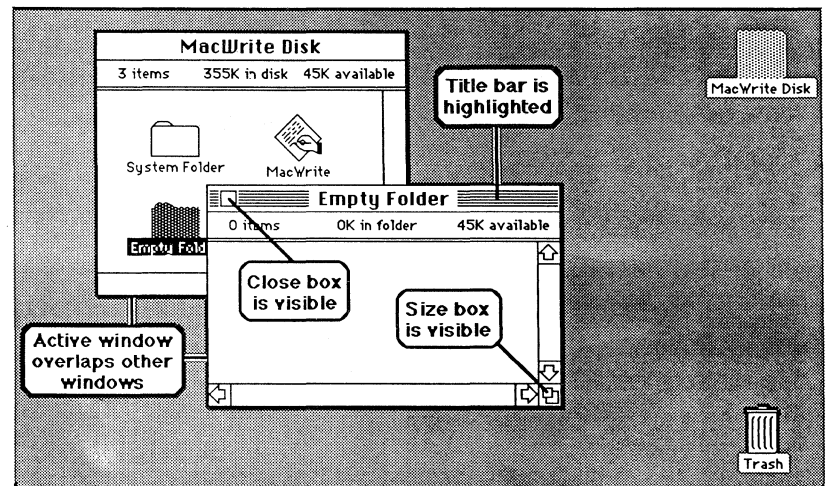

- The title bar (at the top of the window) is gray on both sides of the title. On other windows it will be white.
- The close box is visible.
- If the windows are overlapping, the active window will always be on top.

- The size box (the lower right corner of the window, which enables you to enlarge and shrink the window) is visible.

## Resizing Windows

### Resize windows to view the contents of more than one window at a time.

Most windows are initially only slightly smaller than the screen. If you want to view the contents of more than one window at a time, you must make the windows smaller. Then later, if you want to view more information in one particular window, enlarge it again.

### Use the size box to enlarge or shrink a window.

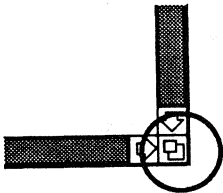

1. Point to the size box in the extreme lower right corner of the window (as shown at the left).
2. Hold the mouse button down.
3. Move the mouse to resize the window.
4. Release the mouse button when the window is the size you want.

## Moving Windows

### Move a window to view the contents of more than one window.

If you want to view the contents of more than one window, you'll have to resize *and move* at least one of the windows.

### To move a window, grab the title bar.

1. Point anywhere within the title bar (at the top of every window).
2. Hold the mouse button down.
3. Move the mouse to move the window.
4. Release the mouse button when the window is where you want it.

## Scroll Bars

### Use the scroll bars to view other parts of your document.

Most of the documents you'll create will be too large to fit entirely on the Macintosh screen. Spreadsheets, word-processing documents, and even graphics will usually be much wider and/or longer than the screen. Use the horizontal

and vertical scroll bars to view the portions of your documents that aren't initially visible.

**There are three components of the scroll bars:**

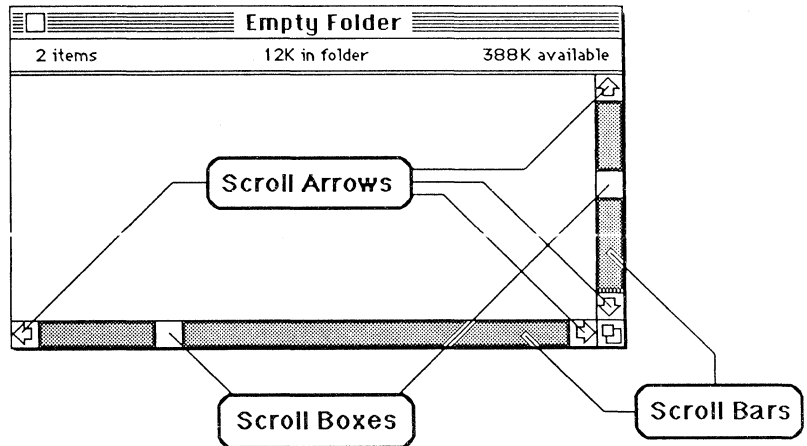

- **Scroll arrows.** These enable you to slowly scroll up, down, left, or right. Point to the appropriate arrow and click the mouse button to scroll once in that direction. Or hold the mouse button down to scroll continuously.
- **The scroll box.** This indicates your relative position in the window. To quickly jump to any part of the window, use the mouse to drag the scroll box (point to it, hold the mouse button down, and move it) to the desired location, and release the mouse button.
- **The gray area around the scroll box.** Click here to scroll through your document window by window. For example, what if you want to quickly scroll through a text document? Click in the gray area below the scroll box in the vertical scroll bar. The last line of text will become the first line of text and you will be able to see the next window of information below that line.

## Practice

### Practice Guided Tour Techniques

Practice what you saw in the Guided Tour and what you read about in the review.

Do each step as it's described.

1. Click **Let Me Use my Macintosh!** from the Guided Tour screen.
2. Open the Guided Tour disk.
3. Open the System Folder.

### Move a window on your screen.

Notice that you can't see the bottom of the System Folder window. To move the window up the screen, do the following:

1. Point to the title of the System Folder window.
2. Hold the mouse button down.
3. Move the mouse to move the System Folder window up the screen.
4. Release the mouse button when you get the window where you want it. (It's okay to overlap the Guided Tour window.)

### Identify the active window.

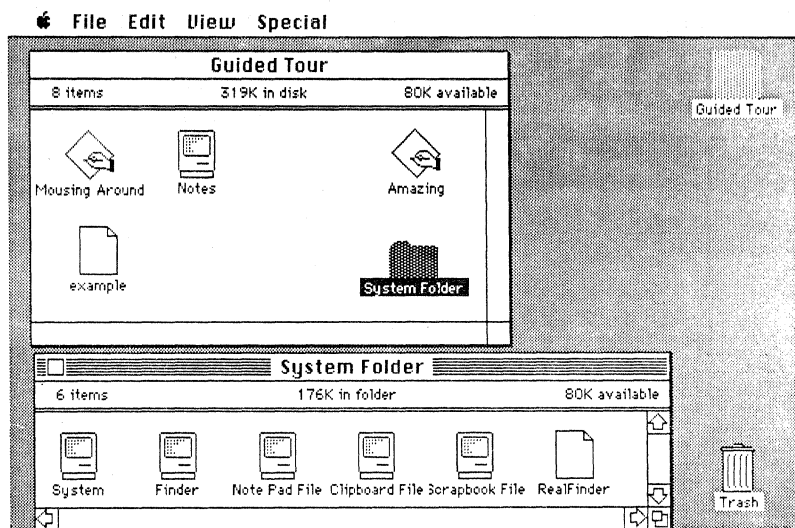

The System Folder window is now the active window. Notice that it differs from the Guided Tour window in the following ways:

- Its title bar is highlighted.
- It has a close box.
- It has a size box.
- If they originally overlapped, the active window now covers part of the other window.

1. Select the Guided Tour disk window to make it the active window. Notice how the window changes when it becomes the active window.
2. Select the System Folder window.
3. Close the System Folder window.

### Use the size box.

1. Point to the size box in the Guided Tour window.
2. Hold the mouse button down.
3. Move the mouse to shrink the Guided Tour window.
4. Release the mouse button.
5. Enlarge the Guided Tour window to its original size.

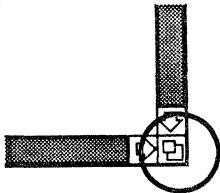

### Scroll through a window.

1. Shrink the Guided Tour window.
2. Click on the arrow that's pointing down, to scroll down through the window.
3. Continue scrolling down until you can't scroll anymore; you're at the bottom of the window.
4. Point to the up arrow.
5. Hold the mouse button down to scroll continuously back to the top of the window. Watch the scroll box.
6. Grab the scroll box in the horizontal scroll bar (across the bottom of the window).
7. Move it to the right edge of the window.

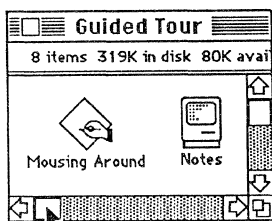
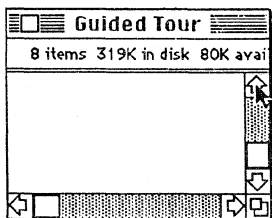
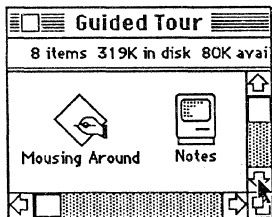

## Practice (cont'd)

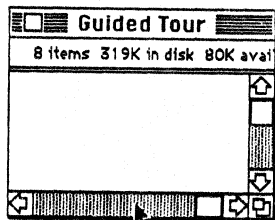

8. Point in the gray area to the left of the scroll box.
9. Click the mouse button to scroll in window-size increments.
10. Continue clicking in the gray area until you are back at the left side of the window.
11. Enlarge the Guided Tour window to its original size.

### Return to the Guided Tour screen.

1. Choose **Close** from the **File** menu or click in the close box to close the Guided Tour window.
2. Choose **Quit** from the **Training** menu.

---

## Feedback

### Practice Guided Tour Techniques

### If you had trouble, do one of the following:

- Replay the Guided Tour session.
- Read the appropriate section of *Macintosh*, the owner's manual, which contains complete explanations of all of the techniques taught in this module.
- Ask a colleague, your course manager, or your Apple support representative for help.

---

## Guided Tour of Macintosh (cont'd)

### Guided Tour

**Complete the fourth Guided Tour session, "What Else Is In The Menus?"**

Continue with this module when you have finished the fourth session of the Guided Tour.

### Review of the Guided Tour

**Read this review of the fourth Guided Tour session, "What Else Is In The Menus?"**

This session talked about the Finder menus. The **Apple** menu, the **File** menu, and the **Edit** menu are always available, even when you are running an application. The other two Finder menus, the **View** menu and the **Special** menu, are available only when you are using the Finder (when you're in the desktop environment and not running an application). The **Training** menu is available only on the Guided Tour disk.

**There is no practice exercise for this Guided Tour session.**

When you finish the entire Guided Tour of Macintosh, you'll read about the capabilities of each Finder menu in the Macintosh manual. So they won't be reviewed here, and there isn't a practice exercise.

Continue with the fifth, and final, session of the Guided Tour.

### Guided Tour

**Complete the final Guided Tour session, "Time To Play The Maze."**

Continue with this module when you have finished the final session of the Guided Tour of Macintosh.

### Review of the Guided Tour

**Read this review of the fifth Guided Tour session, "Time To Play The Maze."**

Following the review you'll have an opportunity to practice what you have learned.



## Dialog Boxes

**A dialog box is Macintosh's way of asking for information or telling you what's going on.**

Dialog boxes are windows that open on your screen to present or ask for additional information, or to inform you of the current situation. Sometimes they are the result of something you have done, such as choosing a menu option that ends with an ellipsis (...). Sometimes they are unsolicited, informative comments from the Macintosh, for example, that you are running low on space on the disk and should remove some documents to make more room.

If Macintosh is not responding, check for a dialog box and make the appropriate response—make a selection, click **OK**, press Return, or whatever is called for. The dialog box will not go away—nor will the Macintosh proceed—until you take some action.

## Running Applications

**To run an application, open an icon.**

There are two types of icons you can open to run an application.



Mousing Around



Amazing



The icon that looks like a hand writing on paper is the application itself. Open it to create a new document using that application. There are two applications on the Guided Tour disk: Mousing Around and Amazing (which are shown at the left).

If you save what you have already entered using an application, the information will be represented as a document on your screen (like the MacWrite document shown at the left). When you open the document, the application will be started automatically and the information you previously entered will be displayed on the screen. You're now ready to revise your document.

When you quit an application, you're returned to the Finder and your Macintosh desktop.

## Practice

### Practice Guided Tour Techniques

Practice what you saw in the Guided Tour and what you read about in the review.

Do each step as it's described.

Click **Let Me Use my Macintosh!** from the Guided Tour screen.

### Run an application.

If you haven't already tried to solve a maze for yourself, go ahead and try it now.



Amazing

1. Click on **Let Me Use my Macintosh!**
2. Open the **Amazing** icon.
3. Choose **Skill** from the **Maze** menu.

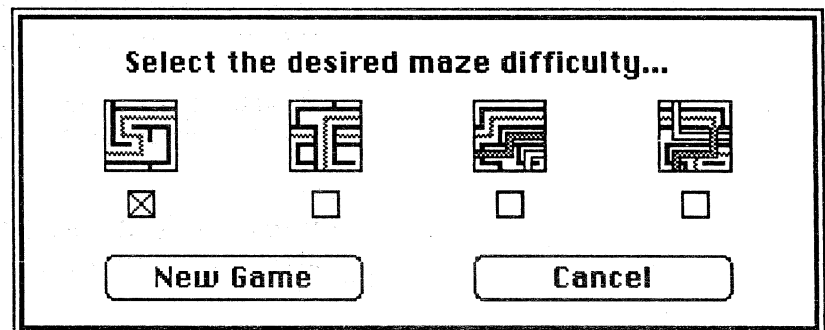

When you choose **Skill** from the **Maze** menu, you're presented with a dialog box of the different skill levels available. The first level isn't very difficult. Each level is harder than the previous one, and the fourth level is almost impossible.

4. Select the level you want from the **Skill** dialog box.

If you'd like to, take some time now to try to solve one or two of the mazes. Continue when you have finished running **Amazing**.

5. Choose **Quit** from the **Maze** menu.

Don't choose **Quit** from the **Training** menu, because there's one more practice exercise for which you'll need the Guided Tour disk.

---

## **Feedback**

### **Practice Guided Tour Techniques**

**If you had trouble, do one of the following:**

- Replay the Guided Tour session.
- Read the appropriate section of *Macintosh*, the owner's manual, which contains complete explanations of all of the techniques taught in this module.
- Ask a colleague, your course manager, or your Apple support representative for help.

---

## **Guided Tour of Macintosh (cont'd)**

### **Finder Menus**

**Read the manual to learn about all of the Finder menu commands.**

Read the Finder Menus section of Chapter 4 in *Macintosh*, the owner's manual to learn about each of the Finder menu commands.

Continue with this module when you have finished reading about the Finder menus.

## Basic Macintosh Techniques

### Overview

**This section explains skills that will make it easier to use the Macintosh.**

The Guided Tour of Macintosh taught you most of the skills needed to use Macintosh. There are a couple other subtle points, though, that are worth making because they will make it easier for you to use your Macintosh.

There are practice exercises interspersed throughout the remainder of the module that will give you a chance to try out these techniques.

### Mouse Techniques

**There are only four ways to use the mouse.**

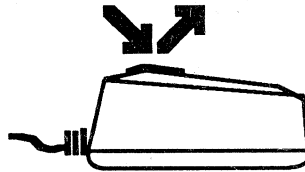

- **Click.** Press and immediately release the mouse button. Click to select an icon, close a window, or make a selection in a dialog box.

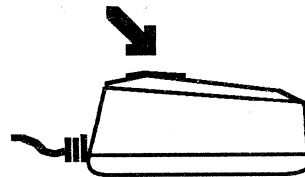

- **Press.** Press and hold down the mouse button. Press to use the scroll arrows or to view the contents of a menu.

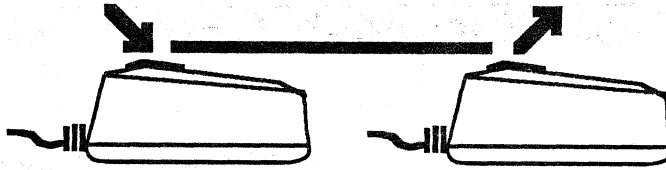

- **Drag.** Press and hold down the mouse button, move the mouse, and then release the mouse button. Drag to choose a menu command, move an icon, select some text, or draw a selection rectangle (to select several icons).

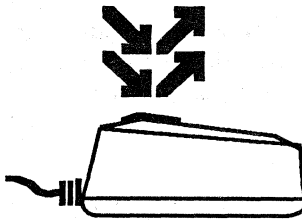

- **Double-click.** Click the mouse button twice in rapid succession. Double-click to open an icon or select a word.

### Variations on the theme.

There are a couple of variations on these basic techniques, but you will recognize that they are indeed variations, and not new techniques.

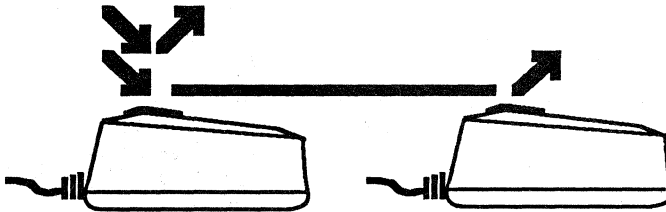

- **Double-click, drag.** Double-click, and hold down the mouse button on the second click. In other words, click the mouse button, and then immediately hold the mouse button down to start to drag. Use this technique to select multiple words of text. (If you just drag through text you will select individual letters. Double-click, drag will select only complete words.)

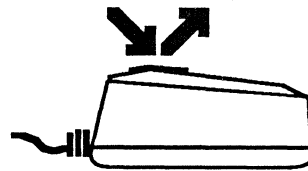

- **Shift-click.** Hold down the Shift key and click. Shift-click to select several icons or to deselect specific icons from a group of already-selected icons.

**These same techniques are used by all application programs.**

No matter which application you are using or what type of information you are working with, you'll always use the same mouse techniques. But each application uses the techniques to achieve results appropriate to that particular application. For example, in MacPaint™, double-clicking the eraser will erase the contents of the entire window.

## Finding Lost Windows

**Because you can have several icons open at once, you might lose windows on the desktop.**

Think of a stack of papers on your desk. It's very easy to temporarily lose a particular piece of paper when things get cluttered. The same thing can happen on Macintosh when you have several windows open at once.

There are three easy ways to find the window you are looking for:

**Double-click on the window's icon shadow.**

If you can see the window's icon shadow (see the next page for information about icon shadows), double-click on it, and that window will become the active window.

**Change the size of the top window, or move windows out of the way.**

It's possible that the top window is completely covering the one you are looking for. Use the size box to shrink the top window, revealing the window(s) under it. Or, move the top window to one side.

**Close everything, then open the one you want.**

A final alternative is to close all of the windows (choose **Close All** from the **File** menu) and then open the one that was "lost."

## Icon Shadows

**An icon shadow is a placeholder for a window.**

When you open an icon, an *icon shadow* is left behind to mark where the window will be filed when it is closed. If you see an icon shadow, it means that the icon has been moved onto the desktop, or that it's open.

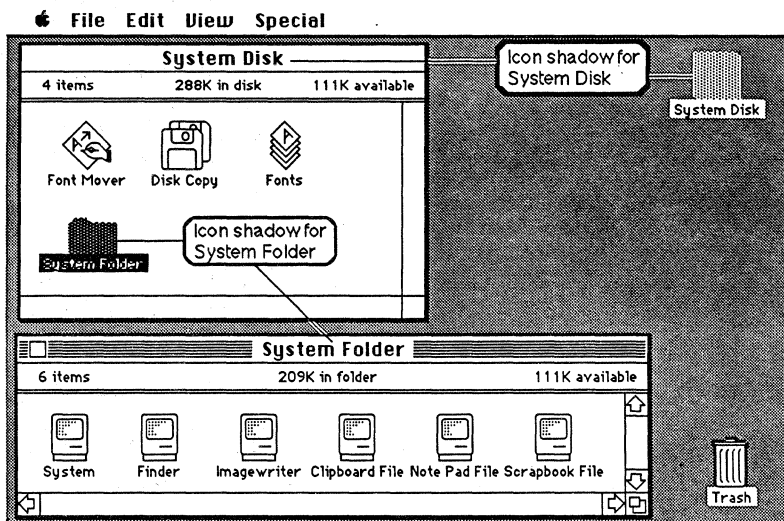

Select an icon shadow to change the name of the icon without closing the window. Double-click on an icon shadow to make an open window become the active window.

---

## Practice

### Mouse Techniques and Icon Shadows

**Practice the mouse techniques and using icon shadows to find lost windows.**

You've already had a chance to practice most of the mouse techniques many times. This exercise provides the opportunity to practice two of the techniques, double-clicking and Shift-clicking, which can save you time, and be very useful.

You'll also practice using icon shadows to locate a lost window.

### Practice mouse techniques.

The Guided Tour disk window should be open on your screen. If not, open it now.

What if you want to select only the Notes, Example, and System Folder icons? There are two ways to do it: (1) select each icon individually, and (2) select all the icons and then deselect the ones you don't want. Perform each step below, as it's described, to practice both of these techniques.

### Select each icon individually.

1. Select the Notes icon.
2. Hold down the Shift key and click on the Example icon. Both icons should now be selected.
3. Hold down the Shift key and click on the System Folder icon. All three icons should now be selected.

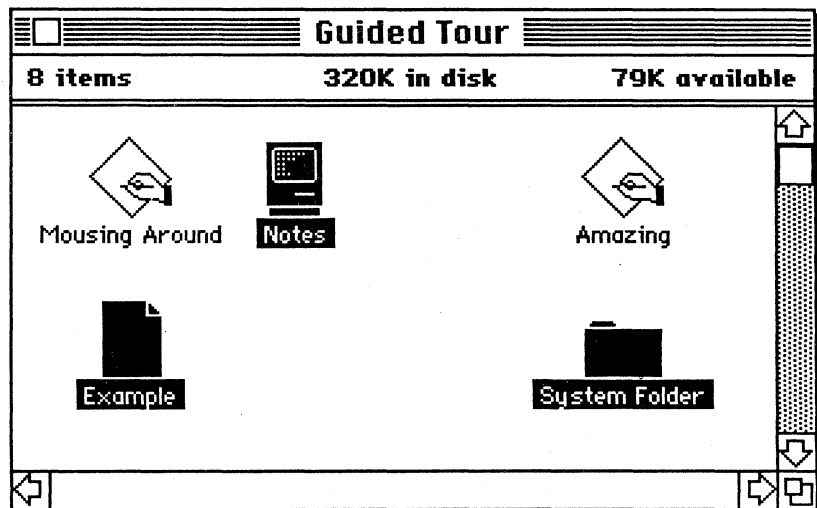

### Select all of the icons and then deselect the ones you don't want.

1. Position the pointer away from all of the icons and click the mouse button to cancel the current selection.
2. Draw a selection box around all of the icons in the Guided Tour window to select them.



## Practice (cont'd)

3. Press the Shift key and click on the Amazing icon. It should become deselected while the other icons remain selected.
4. Hold down the Shift key and click on the Mousing Around icon. It should become deselected while the other icons remain selected.

### Use the icon shadow to find a lost window.

1. Position the pointer away from all of the icons and click the mouse button to deselect everything.
2. Move the System Folder icon onto the desktop, just below the Guided Tour disk shadow.

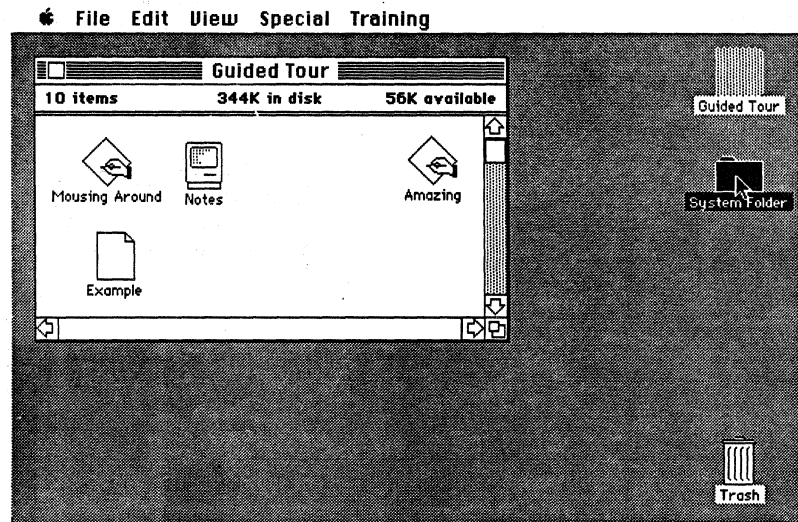

3. Double-click on the System Folder to open it. (If it doesn't open, double-click faster.)

4. Move the System Folder window up the screen so that it covers most of the Guided Tour window.

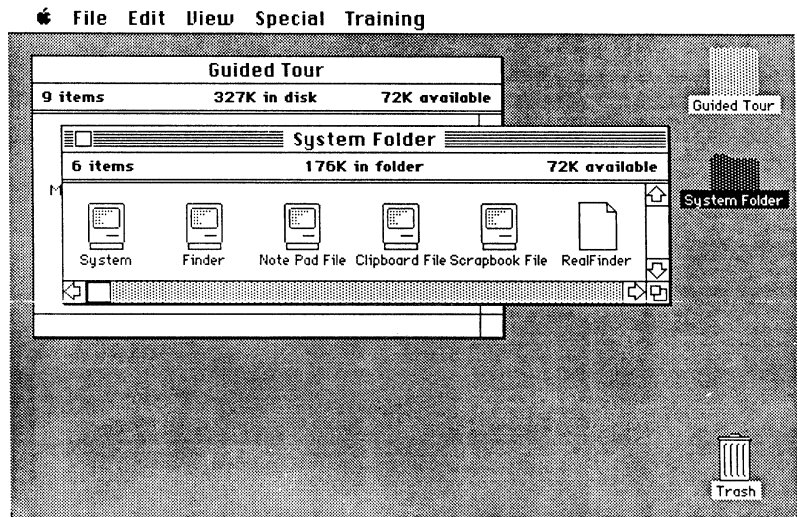

5. Shrink the System Folder so that it lies completely within the Guided Tour window.

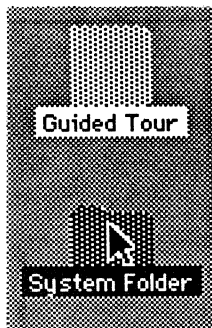
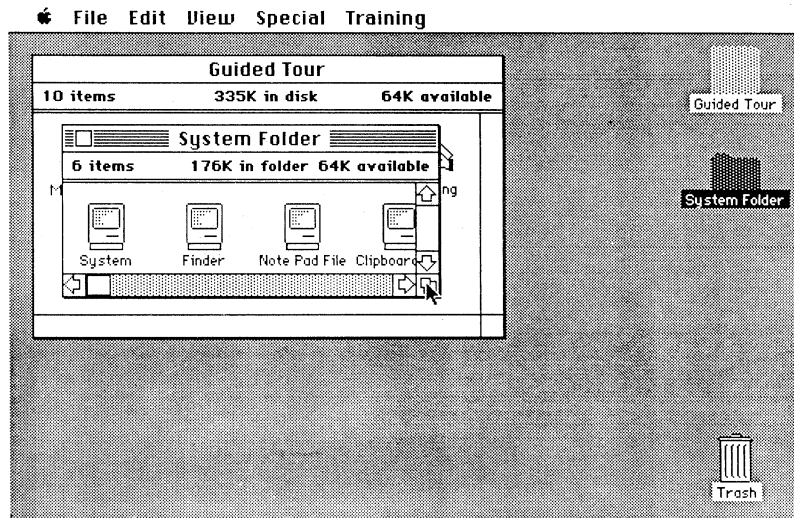

6. Click on any visible portion of the Guided Tour window to make it the active window. The System Folder window will be completely hidden behind the Guided Tour window.
7. Double-click on the System Folder shadow (shown at left) to make the System Folder window the active window. The window will now be back on top of the Guided Tour window.

## Practice (cont'd)

8. Return the System Folder window to its original size and location on the desktop.

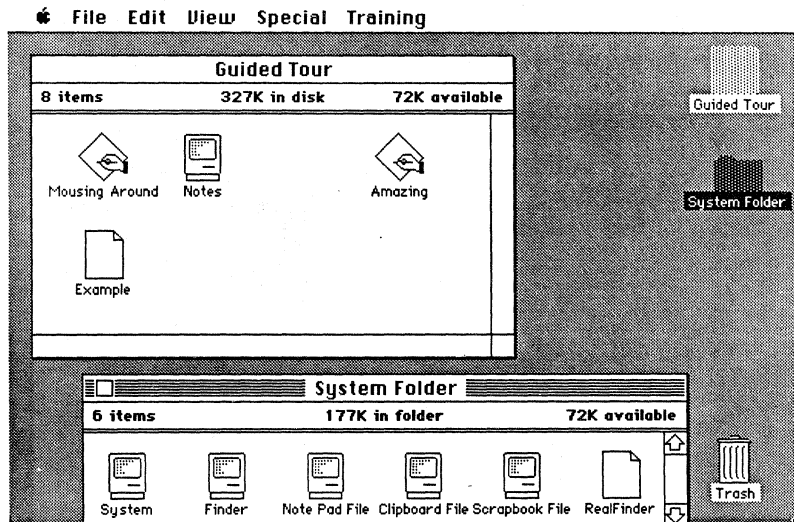

9. Close the System Folder and place the icon back inside the Guided Tour window.

### Return to the Guided Tour screen and stop.

1. Choose **Quit** from the **Training** menu.
2. From the Guided Tour screen click **I'm Ready to Stop!** The Guided Tour disk will be ejected.

---

## Feedback

### Mouse Techniques and Icon Shadows

#### If you had trouble, do one of the following:

- Reread this section to be sure you understand the techniques covered.
- Read the Summary of Mouse Techniques section of Chapter 3 in *Macintosh*, the owner's manual.
- Ask a colleague, your course manager, or your Apple support representative for help.

---

## Guided Tour of Macintosh (cont'd)

### Command Key

Use the Command key to choose menu commands from the keyboard.

Some people prefer to use the keyboard rather than the mouse. The commands that can be chosen either way are those which are listed in the menus followed by the Command-key symbol and a letter of the alphabet. To choose one of these commands, hold down the Command key (just to the left of the spacebar) and type the appropriate letter.

Here's a summary of the Finder menu commands that have keyboard equivalents.

File		Edit	
New Folder	⌘N	Undo	⌘Z
Get Info	⌘I	Cut	⌘H
Duplicate	⌘D	Copy	⌘C
Eject	⌘E	Paste	⌘V
		Select All	⌘A

### Take a Break

You've been working hard. Relax for 10 to 15 minutes before continuing.

---

## Documents and Folders

### Overview

**This section describes techniques for working with documents and folders.**

The Macintosh desktop environment is very different from the operating environments of traditional personal computers. You do many things on the Macintosh desktop using pictures of documents, file folders, and trash cans, the same way you do those same tasks at a real desk with real documents, file folders, and trash cans. Therefore, many users will find using Macintosh intuitive and very easy to learn.

However, despite its similarity to the real world, there *are* some differences, as well as some techniques unique to Macintosh that don't have a real-world analogy. For example, there's no task associated with a real desk that's comparable to viewing the contents of a folder by icon or by size.

This section describes how to do the obvious tasks, as well as the not-so-obvious. You will learn how to move documents and folders, copy them, save your work, and throw away what you don't want anymore.

Practice exercises are included to give you an opportunity to try each of the techniques. *Read* the description of each technique. *Then practice* each technique in the exercises provided. Have your Macintosh ready, along with the following:

- A Macintosh System Disk
- A MacWrite disk
- A blank disk

### Desktop Analogy

**The desktop analogy encompasses all phases of information management on your computer.**

Working on your Macintosh is, in many ways, like working at your desk. But it goes beyond pictures of documents and folders on the screen. It's worth spending some more time drawing some parallels to help you understand what's going on both inside the computer and on the screen.

So, let's go back to the precomputer office, and see how closely the two worlds correlate.

**Computer memory is like a chalkboard.**

Writing notes on a chalkboard is similar to working with information in a computer's memory, commonly called *RAM* (Random Access Memory). The information on the chalkboard and the information in memory is easily removed or lost. A colleague can come in and erase the board, and a power failure can make the information in the Macintosh RAM disappear.

**Transferring information to paper is analogous to saving it on a disk.**

Transferring the information from the chalkboard to a sheet of paper is analogous to saving the information to a disk. A version of the information is safely on disk and can easily be referred to in the future. Also, both forms of storage are easily transportable.

**Duplicating some paper is similar to backing up a disk.**

Duplicating the sheet of paper and filing it in a different place from the original is a safety precaution similar to backing up a Macintosh document or disk. The information resides in two separate places, ensuring that the destruction of one copy does not result in the total loss of the information.

**A filing cabinet is analogous to a hard disk.**

A filing cabinet is used to store large amounts of information and the information tends to stay there for a long time. A hard disk performs the same function when you are using a Macintosh. You can store your documents and file folders there and retrieve them at some time in the future. Also, both tend to be permanently located in one place.

A hard disk is basically the same as a smaller disk in its ability to store information. It's different from a smaller disk in that it can store much more information; it can access that information more quickly; and it's not as portable.

**The techniques for copying and moving documents are similar.**

The techniques for storing and duplicating paper also have correlates in the Macintosh working environment. On the Macintosh, you can copy documents and move them between file folders and the hard disk (filing cabinet) just as you would with pieces of paper.

### **Throwing away documents is very similar, too.**

Throwing away your papers and file folders when they aren't needed anymore is the same as putting Macintosh documents and folders into the Trash and erasing disks when the information they contain is no longer needed.

Throwing away a file folder throws away its contents, too. In Version 4.1 of the Finder, throwing away a disk actually ejects it and removes its shadow from the screen (you don't lose any information).

## **Moving Documents and Folders**

### **The technique is different depending on the source and destination.**

The Guided Tour of Macintosh introduced you to these concepts and procedures. This section will show you the techniques used to copy and move documents and folders, and will clarify the difference between copying and moving documents on the same disk and between disks.

### **Moving an icon from one place to another has different effects.**

Dragging an icon from one place to another moves that icon to a new location. The result of the move depends on where you move the icon.

- Dragging an icon onto the desktop has no effect.
- Dragging an icon from one place to another *on the same disk* (or to a folder on that disk) just moves the icon to a new location. No information is actually moved anywhere.
- Dragging an icon *to another disk* (or to a folder on another disk) puts a copy of the document on the disk and leaves the original where it is.

### **Choose Duplicate to place a copy on the same disk.**

Dragging an icon elsewhere on the same disk just moves the icon. Choosing **Duplicate** creates a copy of the document on the same disk as the original. The duplicate will be titled "Copy of <original name>."

### Move a document onto another disk.

Remember that if you drag an icon to another disk, a copy of that document or folder will be placed on the disk but the original will stay where it is. Moving a document, by definition, means that the document is in a new location, and that it no longer exists at the original location.

For example, to create some room on a disk, move several documents onto a separate data disk.

To move a document or folder to another disk:

1. Drag the document or folder to the destination disk.
2. Throw away the original.

Here is a table that summarizes the techniques just described. The technique is the same for folders as it is for individual documents.

	SAME DISK	DIFFERENT DISK
COPY	Select Duplicate Drag to new location	Select Drag to other disk
MOVE	Select Drag to new location	Select Drag to other disk Put original in Trash

### Saving Your Work

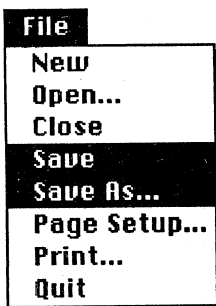

### There are two ways to save the information in your document.

To ensure that your work on the Macintosh will be around for modification in the future, save it on a disk. Use either of the two save commands in the File menu, **Save** and **Save as**, to preserve your work.

(Note: These commands are available only when a document is open. They are not available when you're in the Finder.)



### Choose Save to store the information under the same name.

If the document is new, you will be asked to enter a name for the document. When you choose Save, you'll get the following dialog box:

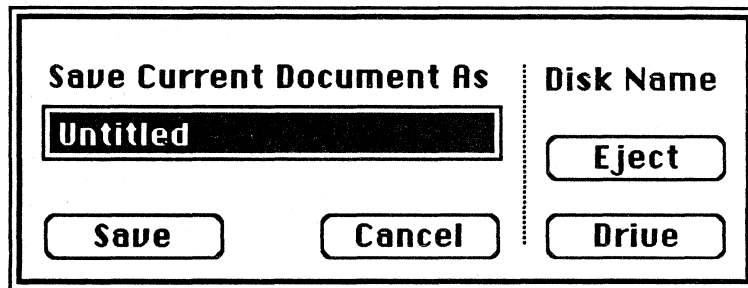

Enter a name and choose which disk you want to save it to by clicking **Drive**. If the disk on which you want to save the document is not available, click **Eject** to eject the disk whose name is displayed in the dialog box above the **Eject** button, and then insert the appropriate one. This dialog box may vary slightly from application to application, but the basic content is the same.

The **Save** command automatically stores the document you're currently working on under the same name it was stored under previously (no dialog box appears). It also leaves the document window open so you can continue entering information or making modifications.

### Choose Save As to store the information under a different name.

The **Save as** command is similar to **Save**, except that it gives you the opportunity to save your document under a different name or on a different disk. **Save as** also leaves the window open so you can continue making modifications.

Use **Save as** when you want to save a copy of a document to a different disk or when you want to keep the original in addition to the revised version.

When you choose **Save as**, you'll get the dialog box described above. The name defaults to the original name of the document. Changing the name is optional, but if you're saving two versions of the document on the same disk, you can't use

the same name. Choose which disk you want to save your work on, and click **Save**.

After you click **Save**, the document displayed on your screen is the one you just saved, not the original. For example, if you created your original on the internal disk and then used **Save As** to save a copy on a disk in the external disk drive, the document open on your screen is the one saved on the disk in the external drive. If you make changes and choose **Save**, the changes will be written to the disk in the external drive.

Click **Cancel** if you want to ignore the **Save** command, close the window, and continue editing the document.

## Closing a Window

### Choose **Close** to close the document window.

You have already used **Close** and the close box to close a disk or folder window while in the Finder. When you have a document open, you also choose **Close** to close the window.

The **Close** command closes the document window that's currently active, but leaves you in the application that was used to open the document. If you have made some changes to the document, the following dialog box will appear, asking you if you want to save your changes:

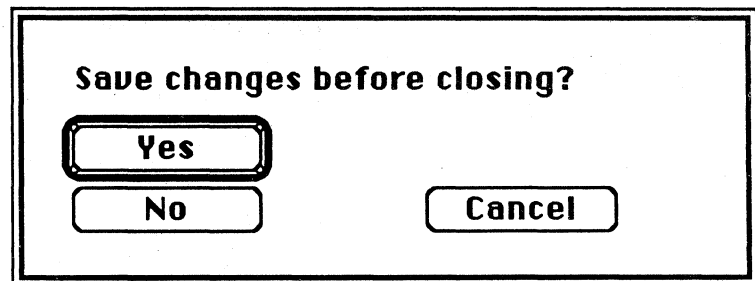

Click **Yes** to save your changes. Click **No** to throw away all of your changes. Click **Cancel** to ignore the **Close** command and leave the window open so you can continue working on the document. This dialog box will vary slightly from application to application, but the message is the same.

Choose **Close**, or click in the close box, when you want to close the document you're working on so you can open another document using the same application. This method is faster than quitting, returning to the Finder, and opening the next document. The technique for doing this is described in many of the applications modules.

**Quit****Quit closes the window and returns to the Finder.**

Choose **Quit** from the **File** menu when you are finished with the document you're working on and you want to stop using the application. If you choose **Quit** before saving your changes, the same dialog box that appears when you choose **Close** will appear. Click either **Yes**, **No**, or **Cancel**.

**Quit or Close?**

**Quit** and **Close** both close the active window and give you an opportunity to save your changes. The difference is that **Quit** returns you to the Finder, whereas **Close** keeps you in the application and allows you to quickly open another document.

---

**Practice**
**Practice Working with Documents and Folders****Do each step as it's described.**

This Practice provides a series of exercises to help you practice creating, saving, revising, and backing up documents.

**Create and save a document.**

1. Insert the MacWrite disk and turn on the Macintosh.
2. Open the disk icon.
3. Double-click on the MacWrite application icon (shown at the left) to create a new MacWrite document.
4. When the window is open and you see the insertion point, type something. (Anything but "The quick brown fox..." Be creative.)
5. Save what you have done so far by choosing **Save** from the **File** menu.
6. Enter a name for the document.
7. Click **Save**.

The work you've done so far has been saved. The window is still open on your desktop with the new name in its title bar.

**Modify the text, but don't save your changes.**

Sometimes you will be revising or experimenting with a document and will decide you liked the original better. Here's how to throw away all of your revisions and keep the original:



MacWrite

1. Enter some more text or change what you have already typed. (Remember how to move text? Select it, choose **Cut**, move your insertion point, and choose **Paste**.)
2. Choose **Close** (or click in the close box) to close your document.
3. When asked if you want to save your changes, click **No**.

The window will be closed without the changes being saved. But you are still in MacWrite—notice that the MacWrite menus are still visible and the desktop icons have not appeared.

### **Save your changes *and* keep the original.**

What if, as you are revising a document, you decide you want to keep both the original and the revised version? Here's how to do it.

To create two versions of the document:

1. Choose **Open** from the **File** menu. You will be presented with the Document Directory dialog box.
2. If you don't see the name of your document, scroll down through the list of names.
3. Point to the name of your document and click the mouse button to select it (it will become highlighted).
4. Click **Open**.
5. Add some text to what you already have.
6. Choose **Save as** from the **File** menu.
7. Enter a new name for the document.
8. Click **Save**.

The original won't be affected and your changes will be saved under the new name. The window will remain open on your screen but the title will change to the name you just entered. Further changes are made to the copy, not to the original. When you choose **Save**, all changes will be made to the document whose name appears at the top of the window.

### **Revise the original and keep the changes.**

This is probably the most common situation you'll encounter.

1. Click in the close box to close the revised version. Because you just saved it, you will not be asked if you want to save changes.
2. Choose **Open** to open the original document.
3. If you don't see the name of your document, scroll down through the list of names.
4. Double-click on the name of your document to open it. This is the same as selecting the name and clicking **Open**.
5. Revise your document (change the text or add to it).

## Practice (cont'd)

6. Choose **Quit** from the **File** menu. You will be asked if you want to save your changes.
7. Click **Yes**.

You have just edited a document, saved your changes, quit the application, and returned to the Finder.

### Make some backup copies of your documents.

Insert the blank disk into the external drive. If you are told the disk is not a Macintosh disk, click **Initialize** in the dialog box. This will take a couple of minutes. When the initialization is complete, enter a name for the disk, and click **OK** (see the **Disks** section of this module for more information about initializing disks).

For this part of the exercise, let's be sure you have the terms straight. The *MacWrite disk*, where you created your *original document* and saved your *revised document*, is in the internal disk drive. You just inserted the *backup disk* into the external disk drive—and possibly initialized it.

To practice moving and copying documents, do the following:

1. *Copy* the original document onto the backup disk:
  - Drag the icon on the original document onto the icon of the backup disk.
  - Be sure the backup-disk icon is highlighted when you release the mouse button.
2. *Make a duplicate* of the revised document on the MacWrite disk:
  - Select the revised document icon.
  - Choose **Duplicate**.
3. *Move* the duplicate you just made to the backup disk (remember that moving something, unlike copying, by definition means that it's no longer in its original location):
  - Drag the icon for the duplicate you just made onto the backup-disk icon to put a copy on the backup disk.
  - Throw away the duplicate you just made to complete the move.

4. The MacWrite disk should contain the original document and the revised document. Open the backup disk to confirm that it contains backup copies of each document.

Often after creating documents, you'll want to move them onto another disk, on which you'll revise them at some later date. This last part of the practice exercise has you create a file folder for the documents on the data disk, which will make them easier to find, and then has you remove the documents from the MacWrite disk.

1. The backup-disk icon should be open and it should be the active window.
2. Choose **New Folder** from the **File** menu to create an Empty Folder on the backup disk. (If you don't see the **New Folder** command, you have an old version of the software. Instead, make a duplicate of the Empty File Folder.)
3. Rename the folder (it's already selected, so just type a new name).
4. Put the documents that are on the backup disk into the file folder.
5. Make the MacWrite disk the active window (click on any visible portion of the window).
6. Throw away the original document and the revised document from the MacWrite disk.
7. Empty the Trash.
8. Choose **Shut Down** from the **Special** menu. (If **Shut Down** isn't in the **Special** menu, you have an old version of the software. Instead, select each icon and choose **Eject**.)
9. Turn off the Macintosh.

---

## Feedback

### Practice Working with Documents and Folders

#### If you had problems, try one of the following:

- Reread the section of this module that pertains to the area with which you had difficulty.
- Read the section of *Macintosh*, the owner's manual, that contains complete explanations of the techniques covered in this module.
- Ask a colleague, your course manager, or your Apple support representative for help.

---

## Disks

### Overview

**Learn what is on a disk, how to handle disks, and how to use them.**

Disks are one of the most important components of a computer. You run applications from disks and save all of your work on them. Because of the amount of handling involved, they're also the cause of most problems. Therefore, the more you know about disks, the fewer problems you'll have.

This section covers how to handle and care for disks, what's on a disk, the difference between startup disks and data disks, and how to initialize, back up, erase, and repair disks.

Exercises are included to help you practice the techniques described in this section. Read the descriptions of disk techniques in the first part of this section, and then complete the practice exercises when you get to them.

(See the *Supporting ProDOS and DOS* module from the Apple Support Training Library for a more technical description of how data is stored on a disk.)

### Disk Care

**Take care of your disks, and you'll have fewer problems with them.**

Inside the disk's plastic shell is a small flat disk, made of material similar to that used in audiocassettes. Like the audiocassette, the disk must be treated with care.

The cause of many personal-computer problems is lack of proper care for disks. If you adhere to these three rules, you will have very few problems.

**Keep disks away from extreme heat.**

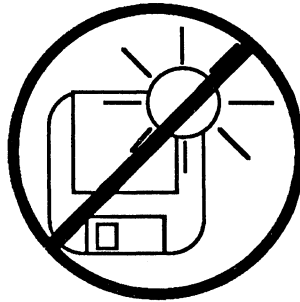

Just like record albums, disks can warp and become useless. Therefore, avoid leaving your disks in extreme heat or direct sunlight for an extended period of time. Don't leave them in a closed car on a hot day, or on top of something that gets very warm, such as your computer.

**Do not touch the surface of the disk.**

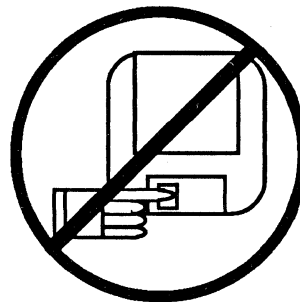

Oil from your fingers can attract dust, which will interfere with the computer's ability to read information from the disk. Fortunately, the Macintosh disks have a shutter that automatically closes over the disk surface to prevent you from accidentally touching it. Still, be careful when handling disks.

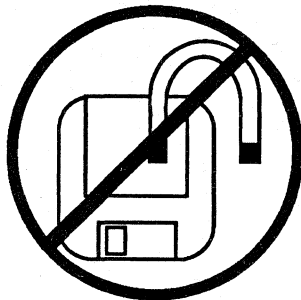

**Keep disks away from magnets.**

Information is stored on disks magnetically. If a disk gets too close to a magnet, the information stored on that disk could be lost.

This isn't as easy as you might think, because magnets are everywhere. Telephone bells have magnets. Televisions and video monitors have magnets that are used to align the picture. Fluorescent fixtures, stereo speakers, and headphones also have magnets. These magnets are usually quite small, but that doesn't mean they can't do some damage.

Often, the damage to the disks is not immediate. However, after storing disks near a magnetic source for a period of time, noticeable damage may occur.

**If your disk is damaged, you may get an error message.**

If your disk becomes damaged, the Macintosh may display a message stating: "Disk has been damaged," "Disk needs repairs," "Can't read this paragraph," or something similar.

This is one of the reasons for keeping backups of your disks. If you have a backup, you can copy the backup onto another disk and continue working. If you don't have a backup and your original disk becomes damaged, you may have just lost everything. (See the *Managing Macintosh Files* module from the Apple Support Training Library for techniques for salvaging documents and disks.)

## What's on a Disk?

**A disk contains a directory and the information you have saved.**

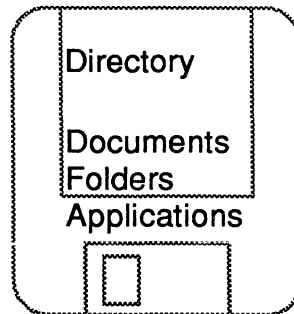

The directory is like a table of contents for the disk. It contains the name, location, and size of each piece of information, and the size and location of any available space on the disk.

The information consists of applications, documents, folders, operating systems, and so forth, that are stored on your disk.

Hard disks and disk have the same two basic components.

## Initializing a Disk

**You must initialize all disks before you can use them.**

Initializing prepares a disk so that information, such as startup information or documents, can be saved on it. A disk, before it's initialized, is like a newly paved parking lot—totally blank and without order. Initializing the disk is like painting the lines in the parking lot—it provides a framework for organization. Technically speaking, initializing a disk creates the directory.

Manufacturers don't sell disks already initialized because disks usually can be used on a variety of computers and each computer has its own way of storing information.

Initializing a disk erases all information previously stored on it. To prevent you from accidentally losing valuable information, initializing programs usually warn you just before they begin that you're about to erase information, so you can cancel the initialization if necessary.

When you insert a disk that has not been initialized on a Macintosh, you will get the following message:

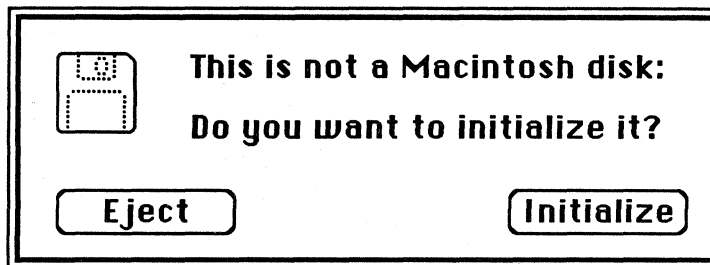

Click **Initialize** to go ahead and initialize the disk, or click **Eject** to eject the disk, unchanged.

After the disk has been initialized, you'll be asked to name it.

## Startup vs. Data Disks

**A disk is either a startup disk or a data disk, depending on the information it contains.**

(Note: A *startup* disk is often called a *boot* disk in other computer systems.)

*Startup disks* contain the information needed to start up your computer. When the Macintosh is first turned on, information is read from the startup disk that tells the computer what to do next. On the Macintosh, all of the startup information is in the System Folder. In addition to getting your Macintosh up and running, the System Folder also contains information that tells the computer how to print your documents and how to create the desktop screen display.

You can't do much with just the System Folder, though. So, for most purposes, you will add an application, such as MacWrite or MacDraw™, to your startup disk.

If a disk does not contain the startup information (the System Folder), it is a *data disk*. This means that it's only used to store data, and can't be used to start up your Macintosh. But because you don't have the startup information on the disk, there is much more room for data. To use a data disk, start up the Macintosh using a startup disk, and then store information or retrieve it from the data disk.

For example, the System Disk that comes with your Macintosh is a startup disk because it contains the necessary startup

information (in the System Folder). The blank disk that comes with your Macintosh is a data disk.

Any disk can be used as either a startup disk or a data disk.

**You can make a data disk into a startup disk by moving the startup information onto it.**

To make a data disk into a startup disk, copy the System Folder onto a data disk. To make a startup disk into a data disk, throw away the System Folder.

If you attempt to start up the Macintosh from a data disk, the Macintosh will eject the disk and display a disk icon with a flashing "X" to indicate that the disk is not a startup disk.

---

## ***Practice***

### **Create a Startup Disk**

#### **Practice different techniques for creating a startup disk.**

To use disk space most efficiently, some disks should be startup disks and others should be data disks. An application can reside on either a startup disk or a data disk. Most people find it more effective to have the application on the startup disk.

There are two ways to create a startup disk:

- Copy the System Folder onto a data disk.
- Duplicate a startup disk and throw away what you don't need.

Depending on which Macintosh configuration you are using, one way of creating a startup disk may be easier or faster than the other. The following Practice section will help you to identify the best procedure to use on each Macintosh configuration. There's an exercise for each that outlines the steps used.

## Practice (cont'd)

### Three Exercises

**Choose the exercise that's appropriate for the system you're using.**

There are three different practice exercises because the techniques are different for different Macintosh systems. The three exercises are for the following system configurations:

- Macintosh 128K or 512K with two disk drives.
- Macintosh 128K with one disk drive.
- Macintosh 512K with one disk drive, or Macintosh XL.

Do the exercise that is appropriate for your system, and read through the other two to become familiar with the alternative techniques.

### Create a Startup Disk: Two-Drive System

#### Copy the System Folder.

If you have either a Macintosh 128K or a Macintosh 512K with two drives, create a startup disk by copying the System Folder from a startup disk to the data disk.

Use the System Disk and a blank disk to practice this. The steps to create a startup disk are listed below. If you think you already know how to do it, try it without looking at the directions.

To create a startup disk on a two-drive system, do the following:

1. Start up from the System Disk.
2. Insert the blank disk into the external drive.
3. If you get a message saying the disk is not a Macintosh disk, click on **Initialize**. After initializing the disk, enter a name for it.
4. Open the System Disk icon.
5. Move the System Folder to the icon for the data disk.

When the copying process is finished, your data disk will be a startup disk.

Read through the other two exercises, and then follow the instructions to check your work.

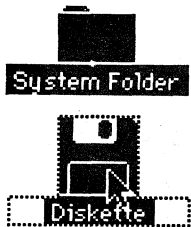

## Create a Startup Disk: One-Drive, 128K System



Disk Copy

### Copy the disk, and then throw away what you don't want.

(Note: It is possible to use the two-drive method for creating a startup disk on a one-drive system. But it takes longer than the method outlined below because you will have to swap disks.)

On a Macintosh 128K with one disk drive, the fastest way to create a startup disk is to use the Disk Copy program to copy the original startup disk, and then throw away what you don't need.

*Disk Copy is designed for the Macintosh 128K with a single disk drive. It does not take advantage of the external disk drive and won't work on a Macintosh 512K.*

Use the System Disk and a blank disk. If you think you already know how to complete the exercise, try it without looking at the directions.

To create a startup disk on a Macintosh 128K with one disk drive, do the following:

1. Start up from the System Disk.
2. Open the disk icon.
3. Select and open the Disk Copy icon. If you don't see Disk Copy, look in the System Folder.
4. Follow the instructions on your screen to use the Disk Copy program. It will involve swapping the original and backup disks several times.

When the Disk Copy program has finished, you will have an exact duplicate of the System Disk. The next step is to remove what you don't want on your new startup disk.

5. Change the name of the destination disk, which is now a startup disk identical to the System Disk, to ensure that all of your disks have unique names.
  - Start up from the copy of the System Disk. (If the new startup disk doesn't work, go to the Feedback section following this exercise.)
  - Select the disk icon.
  - Type a new name for the disk.
6. Open the disk and select all of the icons except the System Folder and put them in the Trash. (Either use the selection rectangle, or use the Shift-click technique to select the icons you want.)

## Practice (cont'd)

You have now created a startup disk from your System Disk.

Now read through the last exercise, or skip to the end of the practice exercises and continue with this module.

### Create a Startup Disk: One-Drive 512K, or XL

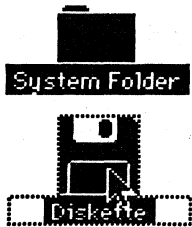

### Copy the System Folder.

If you have a Macintosh 512K with one disk drive or a Macintosh XL, there is enough memory to be able to copy the entire System Folder with only two disk swaps (one to read the information from the original, and the other to write the information to the destination disk).

Use the System Disk and a blank disk. If you think you already know how to complete the exercise, try it without looking at the directions.

To create a startup disk on a Macintosh 512K with one disk drive, or on a Macintosh XL, do the following:

1. Start up from the System Disk.
2. Choose **Eject** to eject the System Disk.
3. Insert the blank disk. Initialize it if you have not previously done so.
4. Open the System Disk icon shadow (the gray image left behind when you ejected the disk).
5. Move the System Folder to the blank disk.
6. Swap disks when you are asked to do so.

When the copy is finished, the System Folder will have been added to your blank disk. If you already had other information on the destination disk, it would still be there. The System Folder was added to the existing contents of the disk.

### Check Your Work

#### Start up from the newly created startup disk to be sure it works.

If you are using a Macintosh 128K with one disk drive, you've already checked your work, so you can move on to the Feedback section.

Otherwise, you should start up from the newly created startup disk to be sure you did everything correctly. Right now, your screen should be displaying the desktop.

To check your work, do the following:

1. Choose **Shut Down** from the **Special** menu. If the **Shut Down** command isn't there, you have an old version of the Finder. Instead, do the following:
  - Eject both disks by first selecting the icon and then choosing **Eject** from the **File** menu.
  - Press the Reset button or turn the Macintosh off and then on again.
2. Insert the newly created startup disk into the internal disk drive.

If everything works as it should, you will see the desktop. If the Macintosh doesn't start up, repeat the exercise.

3. Choose **Shut Down** again, or choose **Eject** to eject the disk.
4. Turn off the Macintosh.

---

## Feedback

### Create a Startup Disk

**You should now have two startup disks.**

You should have your original startup disk, and the one you just made and tested. If not, reread the exercise and complete the steps you missed.

If you have problems, refer to the section on Creating a Startup Disk in Chapter 3 of the Macintosh manual, or ask a colleague, your course manager, or your Apple support representative for help.

---

## Disks (cont'd)

### Add to the Startup Disk

**Add applications so you can do more than just start up the Macintosh.**

You can't do much with a disk that has only the System Folder on it (except start up Macintosh). Most of the time, you will want to add an application to the startup disk to make it more



useful. To add an application, you need to start up from your new startup disk, insert the application disk, and move the application icon to the disk icon.

## **Make an Existing Data Disk into a Startup Disk**

### **First check to be sure there's room.**

If you want to convert an existing data disk, one that already has information on it, into a startup disk, you must first check to be sure there's room.

To see how much room a System Folder takes, open the startup disk from which you're going to copy the System Folder and choose **by Size** from the **View** menu. The first item in the list should be the System Folder, and the first column tells you how much room it needs.

Then open the data disk that you want to make into a startup disk. The amount of free space is displayed at the right edge of the title bar.

### **Add the System Folder to information already on the data disk.**

To convert a data disk into a startup disk on a two-drive system, a Macintosh 512K, or a Macintosh XL, use the same procedure you used to create a startup disk. Copy the System Folder onto the data disk by moving the System Folder icon. The information in the System Folder will be added to information already on the disk.

What about a Macintosh 128K with one disk drive?

The technique for creating a startup disk on a Macintosh 128K starts by completely erasing the contents of the destination disk. What if there is data on that disk that you want to save?

If you want to add the startup information but don't want to lose existing documents on the disk, do the following:

1. Start up from the System Disk.
2. Eject the System Disk.
3. Insert the data disk.
4. Open the System disk's shadow.
5. Move the System Folder from the System Disk window to the data disk.

On a Macintosh 128K, you will be asked to swap disks many times, and you will end up with two startup disks: the System Disk and one containing the System Folder and all of your data.

Because this technique adds the startup information to existing documents on the disk, be sure there's enough room available. Otherwise, you'll get a message saying there is not enough room and you will have to start all over again. To create more room on a disk, transfer some documents to other disks or throw them away.

## Locking Disks

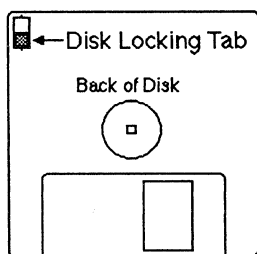

### Lock your disks to avoid accidentally erasing your information.

(Note: The term *locked* is the same as *write protected* on other computer systems.)

To be absolutely sure you won't accidentally write over information that you want to keep, lock the disk. To do this, slide the small red (or black) tab at the top right corner toward the top edge of the disk. This makes it impossible to write to the disk or erase existing information until you move the tab back into place.

Here is an easy way to remember what each position of the tab means: Most disks have red tabs, and red generally means danger. When you are looking at the front of the disk, if you see the red tab, watch out! You are in danger of losing information. The disk is *not* locked. If you don't see the red tab (you see right through the disk), there is no danger. The disk is locked.

Locking a disk doesn't interfere with reading information from it.

You can't lock the disk you use to start up your Macintosh. This is because information regarding the desktop display and other system information is constantly being written on the startup disk.

## Backing Up Disks

### Back up your disks in case you lose the information on your original disk.

In the original office analogy, disks corresponded to pieces of paper—a "somewhat" permanent, portable copy of your information. The reason it's only somewhat permanent is that it is always possible to lose a piece of paper, accidentally throw it away, or perhaps spill something on it that renders it unreadable. This is true for disks, too, except the consequences could be much worse. If you lose a disk or it becomes unreadable, you could lose not just a page or two, but hundreds of pages of work. That's why it's very important to keep backup copies of your disks.

A backup is an exact copy of your disk. If something happens to your original disk, just make a working copy of your backup, and in minutes, you're back on track.

Depending on how much work you are generating, you should make a backup at least once a week, and possibly once every day.

### **Back up either entire disks or individual documents.**

Creating a backup means saving a spare copy of the original in a separate place. The backup can be of an entire disk or of individual documents. The type of documents you're working with and the amount of information that's changed will determine which is appropriate.

If you are making changes to only one document on the disk, it's necessary to back up just that document. If you are working with a large document that takes most of the disk, it is quicker to back up the entire disk. If the disk you are working with is a startup disk, doing a full-disk backup will save all of the startup information (which you don't really need to back up). So, it might be more efficient to back up only individual documents.

### **When you back up a disk, the directory and all of the information is copied.**

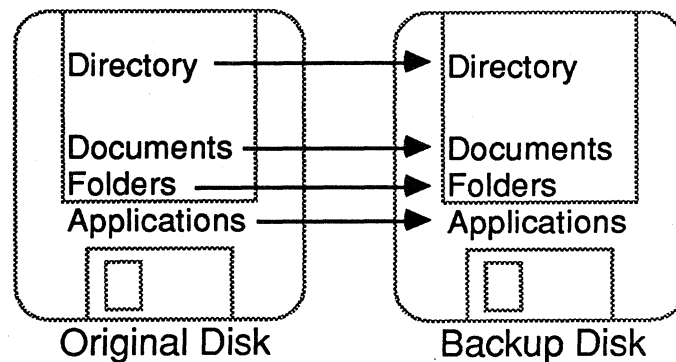

Remember what's on a disk: the directory and all of the information you have stored. When you do a disk backup, the directory and all the information is copied exactly as it appears on the original.

It's important to remember that when you finish backing up a disk, the contents of the destination (backup) disk will be

identical to the contents of the original disk. (The name of the destination disk stays the same, though.) It's not a situation of adding documents to a disk, but of replacing everything on a disk with what is on the original. Therefore, be sure your destination disk doesn't have any information you will need later.

## Backing Up an Entire Disk

### Don't do it yet.

*Read* this section. Then follow the instructions in the practice exercises to try these techniques.

### Macintosh 128K or 512K—two disk drives.

If you have a two-drive system, insert both disks and drag the icon for the original disk onto the icon for the destination disk. You will be asked if you want to erase everything on the destination disk. Click **Yes**.

### Macintosh 128K—one disk drive.

If you have a Macintosh 128K with one disk drive, use the Disk Copy program on your System Disk. To use the Disk Copy program, follow the instructions in the practice exercise at the end of this section. Or, follow the instructions that the program gives you (it tells you exactly what to do and is very easy to use). The Disk Copy program works only on a Macintosh 128K.

### Macintosh 512K with one disk drive, or a Macintosh XL.

If you have a Macintosh 512K with one disk drive, or a Macintosh XL, do the following:

1. Insert the original disk.
2. Choose **Eject** to eject the original disk.
3. Insert the backup disk.
4. Drag the icon of the original disk onto the icon of the backup disk.
5. When asked if you want to completely replace the contents of the disk, click **OK**.

You will only need to swap disks twice. The name of the backup disk will remain the same, so you may want to change it.

## Backing Up Individual Documents

Use the Finder or the Save As command.

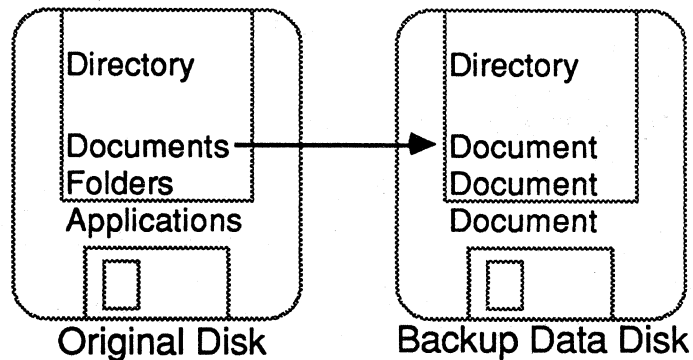

If you are going to back up individual documents, create a backup data disk. Don't put applications or startup information on it—you should already have copies of those, and they take up room you could otherwise use for backing up additional documents.

If you are in the Finder, insert your backup disk and copy the document from the original disk to the backup disk. The document will be added to those already on the disk.

If a document is open (you're running an application), you can make a backup copy by choosing **Save as** from the **File** menu. Keep the original name or enter a new one, such as "document—backup," and be sure you are saving it to your backup disk. (For detailed instructions, see the section earlier in this module about saving your work.)

## Erasing a Disk

**Erase disks containing unneeded information so you can reuse them.**

After you have had your Macintosh for a while, you will find yourself with quite a collection of disks. You may not even remember what is on many of them. Instead of letting those disks gather dust as you continue to open boxes of new disks, recycle any old ones that contain outdated information.

Erasing a disk removes all of the old information and creates a disk identical to a brand-new disk that has just been initialized.

## Here's the procedure for erasing a disk.

*Read* the procedure below. Then continue on to the exercise to practice this and other techniques covered in this section.

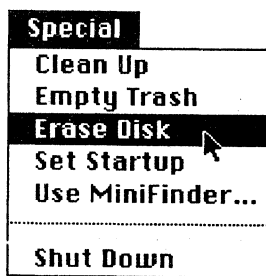

1. Start up from any startup disk.
2. Insert the disk to be erased into the second disk drive. If you are using a one-drive system, eject the startup disk and insert the disk to be erased into the built-in drive.
3. The disk you just inserted should already be selected (highlighted). If it isn't, select it (point to it and click the mouse button).
4. Choose **Erase Disk** from the **Special** menu.
5. When asked if you really want to erase the disk, click **OK**.

An alternative is to open the disk, select all of the contents, and throw everything in the Trash. Be sure to empty the Trash to recover all of the space taken up by what you threw away.

## Here's how to erase a startup disk.

You can't erase the disk from which you started up. If you want to erase a startup disk, start up from a different disk, and then insert the disk to be erased and erase it using either of the methods described above.

## Ejecting a Disk

### Eject a disk to be sure you don't accidentally lose some information.

You have already ejected a disk a couple of times, so you should know *how* to do it (select the disk icon and choose **Eject** from the **File** menu). But you may not know *why* it's important.

When you eject a disk, Macintosh does some straightening up of the information on that disk before the disk is actually ejected. The directory is updated, the Trash is emptied, the location of icons in the window is recorded, and so forth.

If you turn the Macintosh off without first ejecting the disk, you are preventing the Macintosh from doing this "house cleaning" and you may actually lose some information.

You should always eject all disks before turning off the Macintosh. Version 4.1 of the Finder added a new command to the **Special** menu—**Shut Down**. Choosing this command ejects all disks, and restarts the Macintosh. A fast and safe way to turn your Macintosh off is to first choose **Shut Down** and then turn the On/Off switch to off.

---

## Practice

### Back Up and Erase

#### Practice backing up and erasing disks.

Now that you have read about how to back up and erase disks, here's a chance for you to practice those techniques.

### Three Exercises

#### Choose the exercise that's appropriate for the system you're using.

There are three different practice exercises because the techniques for backing up disks are different for different Macintosh systems. The three exercises are for the following system configurations:

- Macintosh 128K or 512K with two disk drives.
- Macintosh 128K with one disk drive.
- Macintosh 512K with one disk drive, or Macintosh XL.

Do the backup exercise that is appropriate for your system, and read through the other two to become familiar with the alternative techniques.

Then do the **Erase** exercise (which is the same for all Macintosh systems).

### Create a Backup Disk: Two-Drive System

#### Move one icon on top of the other.

If you have a Macintosh 128K or Macintosh 512K with two disk drives, back up a disk by dragging one icon on top of the other. Use the System Disk and a blank disk to practice. The steps to back up a disk are listed below. If you think you already know how to complete the exercise, try it without looking at the directions.

To back up a disk on a two-drive system:

1. Start up from the System Disk.
2. Insert a blank disk into the external drive.
3. Move the System disk icon onto the icon for the blank disk. Be sure the icon is highlighted so you know you are in the right place.
4. When you are asked if you want to completely replace the contents of the disk, click **OK**.

5. Change the name of the backup disk so you can identify it later.

Read through the other two techniques, or skip ahead to practice erasing a disk.

### **Create a Backup Disk: 128K, One-Drive System**

#### **Use the Disk Copy program.**

If you have a Macintosh 128K with one disk drive, back up a disk using the Disk Copy program. Use the System Disk and a blank disk to practice. The steps to back up a disk are below. If you think you already know how to do it, try it without looking at the directions.

To back up a disk on a Macintosh 128K with one disk drive:

1. Start up from the System Disk.
2. Open the disk icon.
3. Open the Disk Copy icon.
4. Click **OK**. (Follow the instructions at the bottom of the screen.)
5. Reinsert the System Disk when requested to do so.
6. Swap the System Disk and the backup disk as instructed (about eight times).
7. Click **Quit** when the copy has finished.
8. Change the name of the backup disk so you can identify it later.

Now read through the third technique, or skip ahead to practice erasing a disk.

### **Create a Backup Disk: One-Drive 512K, or XL**

#### **Drag the original disk's icon onto the icon for the backup disk.**

If you have a Macintosh 512K with one disk drive, or a Macintosh XL, back up a disk by dragging the icon for the original disk onto the icon for the backup disk. Use the System disk and a blank disk to practice. The steps to back up a disk are below. If you think you already know how to do it, try it without looking at the directions.

To back up a disk on a Macintosh 512K with one disk drive or a Macintosh XL:

1. Start up from the System Disk.
2. Eject the disk and insert a blank disk (or a disk whose contents you don't mind erasing).



## ***Practice (cont'd)***

3. Drag the icon shadow of the original disk onto the icon for the backup disk. The icon will be highlighted.
4. Swap disks as directed.
5. Change the name of the backup disk so you can identify it later.

### **Erase a Disk**

#### **Practice erasing a disk by erasing the backup you just made.**

You can't erase the startup disk, so regardless of what system you are using, start up from the System Disk and then erase the backup disk.

To erase a disk:

1. Be sure the backup disk is in the disk drive and the icon is selected.
2. Choose **Erase Disk** from the **Special** menu.
3. When asked if you really want to erase this disk, click **OK**.

The disk is now just like a new disk that has just been initialized.

---

## ***Feedback***

### **Backup and Erase**

#### **You should end up with a System Disk and a blank disk.**

During the exercise you should have made a backup copy of the System Disk, and then erased it. If you didn't do that, reread the exercise and complete the parts you missed.

If you had problems, read the Copying an Entire Disk section in Chapter 3 of the Macintosh manual, or the explanation of the **Special** menu in the Menus section of Chapter 4. Or ask a colleague, your course manager, or your Apple support representative for help.

---

## Review

### Guided Tour of Macintosh

#### Learn the basic techniques for using Macintosh.

The Guided Tour of Macintosh is a computer-based training program that teaches you the basic skills you will need for using Macintosh. After viewing all five sessions of the Guided Tour and completing the practice exercises included in this module, you should have mastered many of these techniques. Here is a quick summary of the major areas covered by the Guided Tour.

#### The Macintosh desktop.

The Finder maintains the desktop and enables you to keep track of where your information is stored and what you want to do next.

Each icon on the desktop has a different function. The icons, in conjunction with the menu bar across the top of the screen, represent all of your information and capabilities on the Macintosh. To choose something from a menu, you just open the menu, point to what you want, and then release the mouse button.

There are two steps to doing most things on the Macintosh: (1) Select what you want to work with, and (2) Choose the appropriate menu command. For example, to open an icon you should first select it, and then choose **Open**.

The menu commands that are currently available and meaningful are shown in black type. The gray menu commands are inapplicable to your current selection.

#### Working with icons.

Select icons by pointing to them and clicking the mouse button. Select several icons by using either the selection rectangle or the Shift-click technique. Open and close icons by using the appropriate command from the **File** menu.

You can use the mouse to move icons. You can also duplicate icons to create copies, and rename them by selecting the icon and then typing a new name. Organize icons by depositing them in the appropriate place. For example, you can deposit a document into a file folder, a file folder onto a disk, or anything into the Trash.

You can open the Trash and retrieve anything you have thrown away, until you empty the Trash. There are three ways to empty the Trash: (1) Choose **Empty Trash**, (2) Start up an application, and (3) Eject the disk.

### **Windows, and how to use them.**

Windows are rectangles on the screen that display information associated with specific icons. You can have several windows open at once.

Across the top of a window is the title bar. Grab the title bar to move a window. In the top left corner is the close box. Click in the close box to close a window. In the bottom right corner is the size box. Grab the size box to resize a window.

Down the right side and across the bottom are the scroll bars. Use the scroll bars to view other parts of your document.

There are three ways to scroll through your documents:

- Click on the arrows to scroll a little at a time.
- Grab the scroll box to move anywhere within the document.
- Click in the gray area above or below the scroll box to scroll window by window.

To select a window, click in any visible portion. There are four ways to identify the active window:

- Its title bar is highlighted
- The close box is visible
- The size box is visible
- It's on top of all other windows.

### **Entering text.**

The insertion point indicates where anything you type will be added. To move the insertion point, position the pointer where you want the insertion point to be, and click the mouse button.

To select text, position the pointer at one end of the text to be selected, and hold down the mouse button. Then move the pointer to the other end of the text to be selected, and release the mouse button.

To edit text, select the text and type—whatever you type will replace what was selected. This also works for icon names.

To move text, select it, choose **Cut**, move the insertion point to the desired location, and choose **Paste**.

## Dialog boxes and applications.

Dialog boxes are windows that the Macintosh will periodically display on the screen. They inform you of the current situation, and enable you to enter some needed information or to make a choice between available options. Until you respond to them with the appropriate action, you can't do anything else.

To run an application, either open the application icon (a hand on paper) or open a document that was originally created with that application.

## Basic Macintosh Techniques

### Mouse techniques and other skills.

There are four techniques for using the mouse:

- click
- press
- drag
- double-click

There are two variations:

- double-click, drag
- Shift-click

To find a lost window, move the other windows that are covering it. Move the window, resize it, or close it. Or choose **Close All** to close all of the windows and then open the one you want.

An icon shadow is a placeholder for a window. It's an indication that that icon is open on your desktop. Double-click on it to make the window the active window.

The Command key enables you to perform many menu commands from the keyboard. Hold down the Command key and type the appropriate letter. The letters are indicated on the right side of open menus.

## Documents and Folders

### Working on a Macintosh is like working at your desk.

Many of the images you see and the techniques you use are similar to the same activity without a computer. This is part of what makes Macintosh so easy to learn and use. The Macintosh environment in which you work is even called the desktop.

### Copying and moving documents and folders.

- To make a copy of a document on the same disk, select the document and choose **Duplicate**.
- To place a copy of a document on another disk, move the document icon to the other disk's icon.
- To move a document elsewhere on the same disk, move the icon (this doesn't actually move any information).
- To move a document to another disk, copy the document and then throw away the original.

The techniques are the same for folders.

### Saving your work.

If the document has already been saved, choose **Save** to save your changes under the same name (without the Save dialog box).

Choose **Save as** to save your work under a different name.

If you're saving a document for the first time or using the **Save as** command, you can save the document to either disk drive. You can even choose to eject a disk to save the document on a disk that was not in either drive.

Choose **Close** to close a window but stay in the application. Use this option if you want to open another document from the same application. To open another document, choose **Open**. When you choose **Close**, you have the opportunity to either save or ignore your changes.

Choose **Quit** to quit an application and return to the Finder. Again, you have the option of either saving or ignoring your changes.

## Disks

### Take care of your disks.

- Keep disks away from extreme heat and direct sunlight.
- Never touch the surface of the disk.
- Keep disks away from magnets.

### A disk contains a directory and information.

The directory contains the name, location, and size of all of the information on the disk, and the size and location of all available space. The information includes all applications,

documents, startup information, and the operating system. The directory is first created when you initialize a disk. You can't use a disk until you initialize it.

### **Startup disks vs. data disks.**

Startup disks contain specific information needed to start the Macintosh. This takes up a lot of room. Keep some of your disks as strictly data disks, containing nothing but information you have created and want to keep. You can only start up your Macintosh from a startup disk.

To create a startup disk, move the System Folder to any data disk or new disk.

### **Locking, backing up, and erasing disks.**

Lock disks to prevent accidental loss of stored information. To lock a disk, slide the red (or sometimes black) tab in the top right corner of the disk so that you can't see it from the front side (move it toward the top edge of the disk).

Back up your disks as a precaution in case something happens to your original disk.

Backing up an entire disk copies the directory and all of the information. Backing up an individual document backs up only that document and updates the existing directory (instead of replacing it).

To back up an entire disk, use the Disk Copy program (Macintosh 128K with one disk drive) or drag one disk icon onto the other (Macintosh 512K, Macintosh XL, or Macintosh 128K with two disk drives).

Erase a disk to remove outdated information, so you can reuse the disk. To erase a disk, choose **Erase Disk**. Everything on the disk will be lost, so be sure there's nothing you want to save. The result is the same as initializing a disk.

## Resources

- *Macintosh*, the owner's manual, Apple Computer, Inc.
- Macintosh publications (The premier issue of *Macworld*, February 1984, has an entire section on the Macintosh desktop. Read *Macworld* and other Macintosh publications, such as *MACazine*, *A+*, Macintosh Buyer's Guide, and *Macintosh Connection*, for up-to-date information about Macintosh.)

### Books

There are dozens of books about the Macintosh. Many of them are basic product overviews that contain little more than the manual. But sometimes a new perspective and a different author can clarify an area that was previously unclear to you.

Here are a few of the product overview books that are particularly good:

*Macintosh! Complete*, by Doug Clapp, Softalk Publishing.

*The Apple Macintosh Book*, by Cary Lu, Microsoft.

*Macintosh: The Definitive User's Guide*, by John M. Allswang, Brady Communications, Inc.

*Tips & Techniques for the Macintosh Computer*, by Susan Sutphin, Price-Waterhouse.

*MacGuide: The Complete Handbook to the Macintosh*, by the Editors of Microtrend, Inc., New American Library.

*Apple Computer does not endorse any of the third-party products or publications mentioned in this module. They are included only to make you aware of their availability.*

*Apple and the Apple logo are registered trademarks of Apple Computer, Inc. MacDraw, MacPaint, and MacWrite are trademarks of Apple Computer, Inc. Macintosh is a trademark of McIntosh Laboratory, Inc. and is being used with express permission of its owner.*

# Supporting the Macintosh Finder

## Contents

- 2 Overview
- 3 Objectives
- 4 Materials
- 5 Using the Finder Menu  
*Finder menu commands are discussed, and exercises are provided for practice.*
- 14 Installing the MiniFinder  
*Learn the options and features of the MiniFinder and practice installing it.*
- 19 Using the MiniFinder Buttons  
*Use the MiniFinder buttons to help you open applications and manage your documents.*
- 22 Other Finder Features  
*Features and file-management techniques are discussed.*
- 25 Using Finder Version 1.1g  
*This optional section discusses the earliest release of the Finder and details its menu commands.*
- 35 More of the Finder 1.1g Menu  
*The File, Edit, View, and Special menus in Finder Version 1.1g are discussed and exercises are provided in this optional section.*
- 50 Summary Exercise  
*A short exercise to review some major points about the Finder.*
- 52 Questions and Answers
- 55 Finder Features Comparison Chart  
*This chart is provided to give you a thumbnail sketch of some of the features of Finder Version 4.1 vs. Version 1.1g.*
- 56 Review
- 57 Resources



---

## Overview

The information and exercises presented in this module are designed to acquaint you with the Macintosh™ Finder. Finder Version 4.1 is highlighted in the first sections, while Finder Version 1.1g is discussed in later sections. Many of the differences between the two released versions of the Finder are noted throughout the text. A chart is provided at the end of the module to summarize the differences between the two.

This module is intended for use by people who support the Macintosh computer and Macintosh software applications published by Apple Computer, Inc.

### Prerequisites

Basic knowledge of Macintosh and the Macintosh Finder. This can be achieved by completing the Apple Support Training Library module, *Learning to Use Macintosh*.

## Objectives

---

- Use the **About** command in the **Apple** menu to display the amount of memory in your system.
- Choose the commands in the **Choose Printer** desk accessory to print a document.
- Use the **New Folder** option in the **File** menu to add a new folder to an active window.
- Print a catalog of the files on a disk or in a folder using the **Print Catalog** and **Page Setup** commands.
- Choose the commands in the **View** menu to manipulate documents and folders.
- Install and remove the MiniFinder using the commands in the **Special** menu.
- **Shut Down Macintosh.**
- Use the MiniFinder commands to open applications, documents, and disks.
- Use other features of the Finder to name icons, drag icons, and eject disks.

---

## Materials

### To complete this module, you will need:

- A Macintosh 128K, Macintosh 512K, or Macintosh XL
- An external disk drive
- A startup disk that includes the Finder Version 4.1, **Choose Printer**, and the ImageWriter™ and/or ImageWriter 15, and/or Apple® LaserWriter™ printing resources with AppleTalk™
- A disk containing MacWrite™ Version 4.5, MacPaint™ Version 1.5, and the Font/DA Mover
- Two blank disks

### If available, the following are recommended:

- A startup disk that includes the Finder Version 1.1g
- *Macintosh Update* (May 15, 1985), a written update distributed with the Macintosh System Update disk (It discusses the Finder Version 4.1 and the Font/DA Mover; *Macintosh Update* can be obtained by contacting your Apple support representative, or by using AppleLink™. If you use AppleLink, search the "Technical Info Library" for "Macintosh and Update and July and 1985.")

## Using the Finder Menus

### The Five Finder Menus

Knowing these five menus is the key to using Macintosh.

The Finder menus offer a great deal of power and flexibility. Knowing how to use their commands will help you use Macintosh, and will help you to support other users. These menus are from Version 4.1 of the Finder. They are only slightly different from the menus in Version 1.1g.

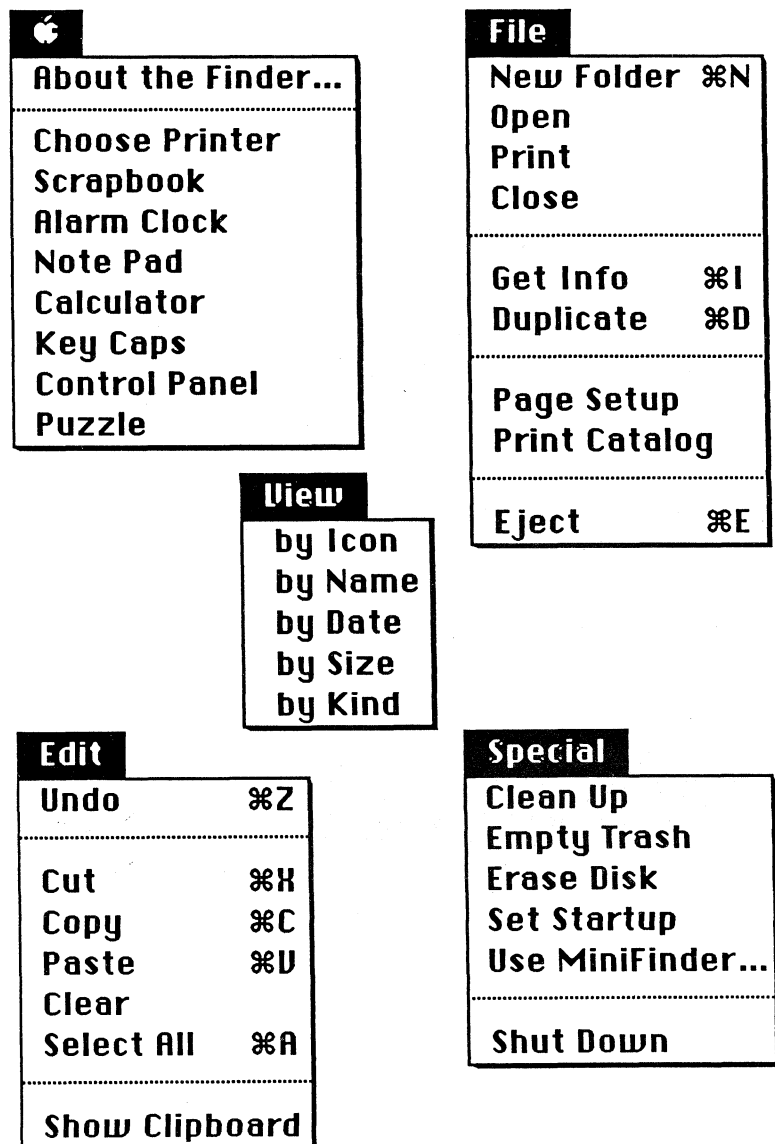

### **Read the *Macintosh Update*.**

Read the *Macintosh Update* that was released with the System Update disk (see the Materials section to locate this document). It discusses the updates to the Finder, and to the Font/DA Mover.

### **The Apple Menu**

#### **Choose "About the Finder."**

The Finder 4.1 version of the **About the Finder** dialog box has a different look from the Finder 1.1g dialog box—the Finder 4.1 dialog box is very simple in appearance. Its function is only slightly changed, however, in that it displays the memory size of your Macintosh: either 128K, 512K, or about 900K for the XL (the actual size of the XL memory depends on which version of MacWorks™ you're using).

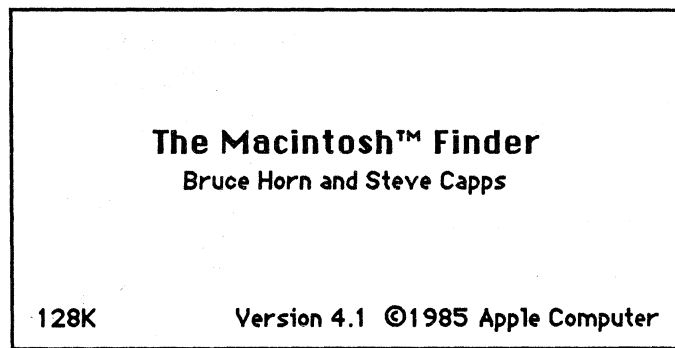

## The Choose Printer desk accessory expands your printing options.

The Apple menu has been expanded to contain the **Choose Printer** option.

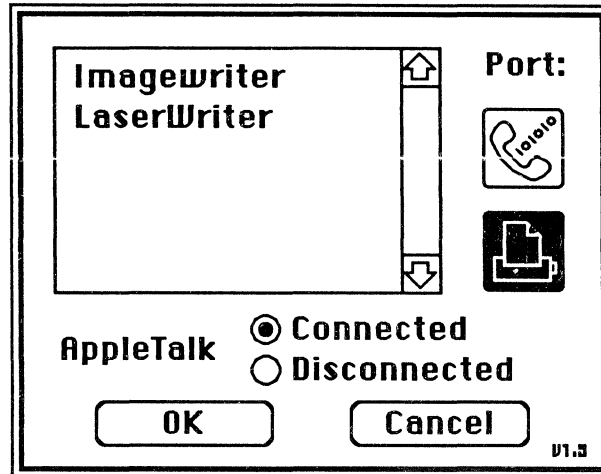

When you select this option, a dialog box appears. It allows you to choose the Printer port, or the Modem port to be used for printing, and to use any of the printing resources named on your system. In this example, you could choose the ImageWriter or the LaserWriter. You could also choose to connect or disconnect AppleTalk.

For additional information, see the Apple Support Training Library module, *Using the LaserWriter*, available from your Apple support representative.

## The File Menu

### New Folder, Page Setup, and Print Catalog are File menu commands.

The File menu contains these new commands: **New Folder**, **Page Setup**, and **Print Catalog**. **Close All** and **Put Back** are Finder 1.1g commands, but aren't included in Finder 4.1.

### Choose New Folder.

When you open a disk window, you may notice that there isn't a folder titled "Empty Folder." The folder function has been replaced by using the File menu command, **New Folder**.

This command can be chosen either from the **File** menu, or by pressing **Command-N** (see the illustration on page 5 for this and other Finder 4.1 commands and **Command-key** equivalents).

### Use the Get Info command to lock a file.

The ability to lock a file hasn't changed. The difference is that when you lock a file, the icon of a padlock appears in one of the following locations:

- In the upper left-hand corner of an open window, when viewing the contents by **Icon**.

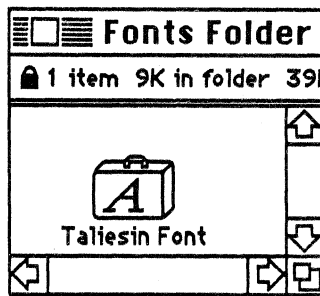

- Next to the date when viewing the contents in any function other than by **Icon**.

Update				
Name	Size	Kind	Last Modified	
Fonts Folder	9K	folder	Fri, Jun 21, 1985	
Font/DA Mover	25K	application	Tue, Apr 9, 1985	
MacPaint	60K	application	Thu, May 23, 1985	
PageSetMenu	11K	MacPaint document	Fri, Jun 21, 1985	
System Folder	145K	folder	Fri, Jun 21, 1985	
System Update	99K	application	Tue, Apr 9, 1985	

### Page Setup and Print Catalog are a pair.

Choose **Print Catalog** to print out the catalog of an active disk or folder window. The documents and folders are listed according to the **View** menu command chosen, and in the order of their appearance in the window.

**Print Catalog** uses the **Page Setup** dialog box to select various print options, as shown below:

<b>ImageWriter (Standard or Wide)</b>		<b>OK</b>
<b>Paper:</b>	<input checked="" type="radio"/> <b>US Letter</b> <input type="radio"/> <b>A4 Letter</b>	<b>Cancel</b>
	<input type="radio"/> <b>US Legal</b> <input type="radio"/> <b>International Fanfold</b>	
	<input type="radio"/> <b>Computer Paper</b>	
<b>Orientation:</b>	<input checked="" type="radio"/> <b>Tall</b> <input type="radio"/> <b>Tall Adjusted</b> <input type="radio"/> <b>Wide</b>	
<b>Pagination:</b>	<input checked="" type="radio"/> <b>Normal pages</b> <input type="radio"/> <b>No breaks between pages</b>	
<b>Reduction:</b>	<input checked="" type="radio"/> <b>None</b> <input type="radio"/> <b>50 percent</b>	

See the Apple Support Training Library module, *ImageWriter II Basics*, for specific details on how to use this dialog box for printing.

---

## Practice

### Print Catalog

**Practice printing the catalog using different View menu commands.**

1. Start up with your System Disk.
2. Open the disk icon and choose the **by Icon** command from the **View** menu.
3. Print a catalog of the disk by choosing the appropriate command from the **File** menu.
4. After you've used the **by Icon** command, choose the **by Name** command and print the same catalog. Notice that the print function is formatted to the currently selected **View** menu command.



---

## **Feedback**

### **Print Catalog**

### **Print Catalog is a useful command.**

If you have any questions about how to use this command, or about how it could be useful to you, ask a colleague, your Course Manager, or your Apple support representative.

---

## **Using the Finder Menus (cont'd)**

### **The Edit Menu**

### **The options in this menu haven't changed.**

The commands and the Command-key equivalents have remained the same. See the Finder 1.1g section at the end of this module, the Apple Support Training Library module, *Learning to Use Macintosh*, or Chapter 4 in *Macintosh*, the owner's manual, for more information about the **Edit** menu.

### **The View Menu**

### **The View menu is a file-management tool.**

Each **View** menu command has the same file-management capabilities as the **by Icon** command. You can create new folders, place documents in folders, and throw them away. You can also duplicate documents and folders in any **View** menu command.

The practice exercise will demonstrate some of these **View** menu functions.

---

## ***Practice***

### **Use the View Menu**

**Select different views at the same time, and perform the same function in each view.**

1. Start up from your System Disk ( use a backup disk, not your original copy).
2. Choose **by Name** from the **View** menu.
3. Choose **New Folder** from the **File** menu, or by pressing **Command-N**. Notice that an Empty Folder appears in the **by Name** list.
4. While still viewing **by Name**, drag a document or application into the Empty Folder.
5. Open the Empty Folder. Notice that the icon inside is displayed **by Icon** (the preset **View** menu command).
6. Drag the icon out of the folder, and place it back in the disk window.
7. Close the Empty Folder window, and throw away the Empty Folder from the **by Name** listing.
8. Change the view back to **by Icon**.

## Feedback

### View Menu Options

The results of this exercise demonstrate the flexibility of the View menu commands.

The System Disk window and the Empty Folder window should look similar to the windows shown below.

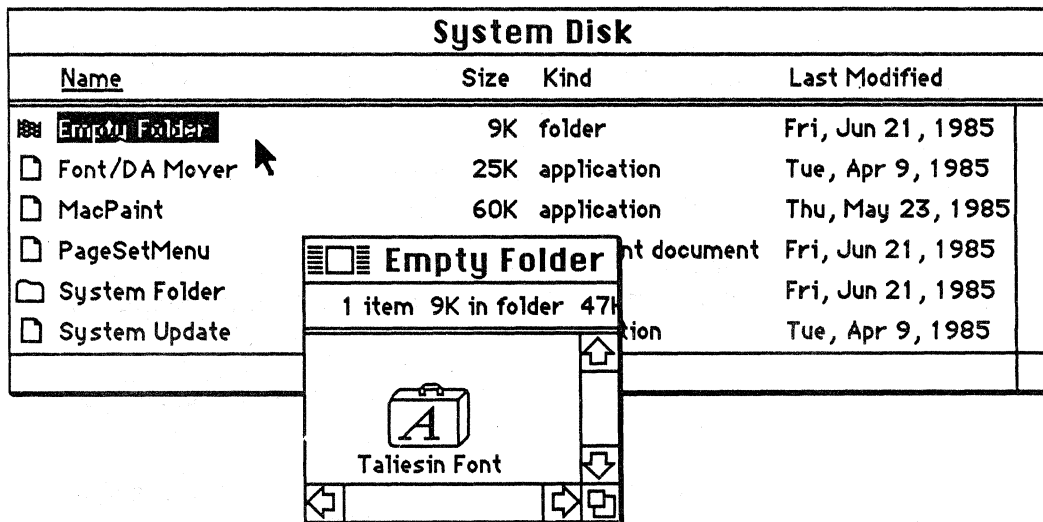

The windows you see might be a different size, and the name of your System Disk might be different. But, as long as you can use the Empty Folder and the different commands in the View menu, you're doing fine.

If you need some practice, or have some questions, another practice session is provided at the end of this module. Your Apple support representative is always available to answer any of your questions, so don't hesitate to ask. You can also check with a colleague, or with your course manager.

---

## Using the Finder Menus (cont'd)

### The Special Menu

**The Use MiniFinder and Shut Down commands are new to this menu.**

**Clean Up, Empty Trash, Erase Disk, and Set Startup** are the same in the Version 4.1 as in the Version 1.1g. **Use MiniFinder and Shut Down** are new. See the section "More of the Finder 1.1g Menus" at the end of this module for more about the **Special** menu.

**The Use MiniFinder command gives you a key to file management.**

The **Use MiniFinder** command allows you to establish another operating level on your Macintosh desktop. It is used to move quickly between applications without having to return to the Finder each time you quit an application. This command can be used on any disk that has an application on it, not just on startup disks. This command is explained in detail in the next section.

**Shut Down allows you to change startup disks quickly.**

The **Shut Down** command is a convenient way to eject the current startup disk and restart your Macintosh (128K or 512K). Just choose the **Shut Down** option. When the "?" icon appears, insert a new startup disk, and begin working again (see the Apple Support Training Library module, *Fundamentals of the Macintosh Operating System*, for more on the "?" icon).

If you're using a Macintosh XL, the **Shut Down** command will eject your disk and turn off the system.

## Installing the MiniFinder

### Overview

**Choose Use MiniFinder for faster response time when moving between applications.**

The MiniFinder's faster response time allows you to move into and out of applications quickly. When it's installed, it allows you to keep the documents and applications you use most often at your fingertips. This section provides some practice with the MiniFinder, and offers some suggestions for its use. The buttons you see in the screen shot below will be covered in the next section.

### Use MiniFinder

**The MiniFinder can be used with any disk, and acts as an application.**

The MiniFinder is an application that resides on your disks. It provides quick access between applications and specific documents, significantly increasing the response of the software. Part of the reason for the increased speed is that the Finder doesn't have to reconstruct the desktop each time you quit an application.

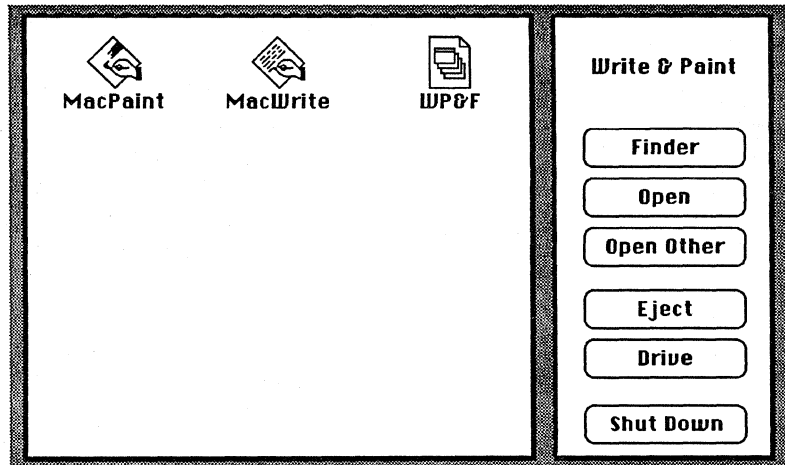

It can be used on any Macintosh, and can have from 1 to 12 documents or applications installed in it.

**To install the MiniFinder, open a window.**

First, open a disk or a folder window. Use it to group the application and document icons (folder icons don't work) you want to install in the MiniFinder for use on this disk.

Be sure that all of the documents and applications you want to install are selected. Your selection must include one application.

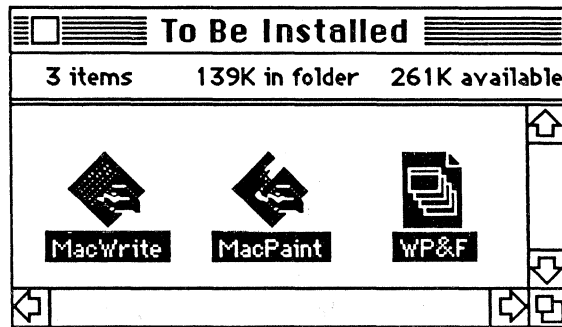

When you choose the option, **Use MiniFinder**, a dialog box appears that looks like this:

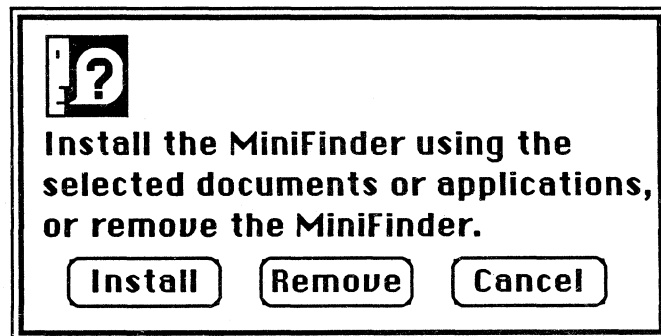

Click **Install**. Once the MiniFinder is installed, a Macintosh icon titled "MiniFinder" is displayed in the disk window. Open the icon. When you do, a screen that is similar to the MiniFinder screen shown on the previous page will appear.



The MiniFinder icon is like any other document icon. It can be opened, duplicated, moved, or thrown away.

## Other MiniFinder Commands

**You can change the icons in the MiniFinder, and you can remove it.**

The commands in the MiniFinder install dialog box allow you to change the icons in the MiniFinder (using **Install**), to remove the MiniFinder, or to cancel the **Use MiniFinder** command.

**Click Install to add an icon to, or remove an icon from, the MiniFinder.**

If you want to add an icon to, or remove one from, an installed MiniFinder, follow the procedure for installation that was discussed on the previous page:

1. Open a disk or folder window.
2. Select the icons you want to install (use a selection box or use the Shift-click method of icon selection).
3. Choose **Use MiniFinder** from the **Special** menu, and click **Install**.

This process will install a new MiniFinder and replace the last one you installed on that disk.

**Deleting a document or application from a disk doesn't automatically update the MiniFinder.**

The MiniFinder is a separate application from the Finder. So, when you delete a document or application from the Finder, you must also delete it from the MiniFinder.

If you do delete a document or application from the Finder, and then try to open it from the MiniFinder, the MiniFinder will notify you that the document or application you've chosen can't be found.

You would simply follow the installation process to reinstall the MiniFinder without the missing document or application.

## Two other ways to remove the MiniFinder.

In addition to reinstalling the MiniFinder (which removes one and replaces it with another), you can just throw the current MiniFinder icon into the Trash. Or you can choose **Use MiniFinder** from the **Special** menu, and click **Remove**.

## A MiniFinder startup disk can save room on a disk.

You can create a disk that has a MiniFinder, a System file, and the icons you want to use, but no Finder:

1. Start up Macintosh with a regular startup disk.
2. Insert the disk you want to use as your MiniFinder startup disk.
3. Copy the System file and the icon(s) you want to use onto the disk you just inserted.
4. Select the icon(s) you want to install.
5. Choose **Use MiniFinder**.
6. When the MiniFinder icon appears, click it, and choose **Set Startup** from the **Special** menu.
7. To use the new disk, choose **Shut Down** and insert the MiniFinder startup disk you just created.
8. Macintosh will start up from the MiniFinder screen.

By following this procedure, you will create a startup disk that has roughly an extra 45K of disk space because it doesn't have a Finder. You can open any application on the disk from this screen. If you click **Finder**, though, you'll get the message, "Application not found." Just select another application and continue working.

## Change the disk back to a nonstartup (data) disk.

If you decide you want to remove the MiniFinder, and use the disk as a nonstartup disk, eject the disk. Restart Macintosh from a regular startup disk (one that starts up from the Finder). Insert the MiniFinder startup disk, and throw away the System file and the MiniFinder icon from that disk. The disk is now a nonstartup, or data disk.



---

## **Practice**

### **Install the MiniFinder**

#### **Follow these steps to set up the MiniFinder:**

1. Open the disk you want to install the MiniFinder on.
2. Place all the icons you want to access from the MiniFinder into an active disk or folder window and select them.
3. Choose **Use MiniFinder** from the **Special** menu.
4. When the dialog box appears, click **Install**.
5. When the MiniFinder icon appears in the disk window, double-click on the MiniFinder icon to use the MiniFinder.

---

## **Feedback**

### **Install the MiniFinder**

#### **The MiniFinder screen should look like the one in this module.**

When you've completed the steps in the practice exercise, you should see a MiniFinder screen similar to the one described earlier.

More practice is provided at the end of this module. If you have any questions, discuss them with a colleague, your course manager, or your Apple support representative.

## Using the MiniFinder Buttons

### Overview

Use the MiniFinder buttons to help you manage your files.

These buttons offer a convenient, speedy way to access documents and applications on the current startup disk, or on any other Macintosh disk. This section discusses how to use them.

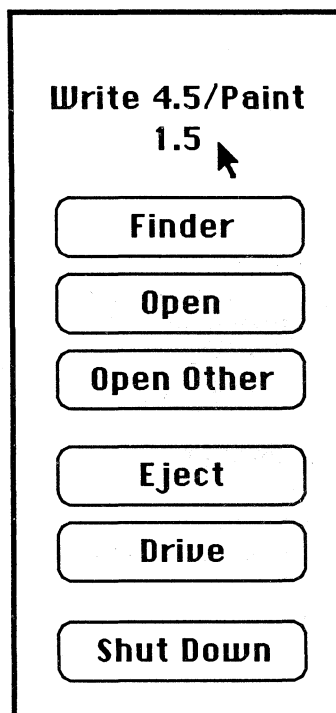

**Use the Finder button to access the desktop.**

Click **Finder**, or press the Enter key to go to the desktop.

**The Open button opens a selected document or application icon.**

This button works in the same way as the **Open** button in the Document Directory dialog box. Once you've selected the document or application you want to open, click **Open** to "launch" the application, or to open the document.

### **Open a file from the MiniFinder screen.**

Another way to open a document or file from the MiniFinder is to double-click the icon you want to open. If you've selected a document, the document will open within its correct application, whether or not that application is on the disk with the MiniFinder. If you open an application, it will open to an "Untitled" document, just as you would expect. You may begin working at that point, or you may close the document and open the document of your choice.

If the application that will open the icon you've selected can't be found on either the internal or external disk, the message "Application not found" will appear at the bottom of the MiniFinder screen.

### **The Open Other button opens a Document Directory dialog box.**

The **Open Other** button opens a Document Directory dialog box that lists all of the applications residing on the disk identified above the buttons. This includes the applications visible in the MiniFinder window. When you're working with a two-drive system, click **Drive** to view the application(s) available on your other disk.

### **Select an application from the dialog box.**

To select an application from the Document Directory dialog box, click the application. If you have a list of applications and would like to select an application that you can't see, scroll through the directory, or type the name of the application. The application will appear highlighted in the Document Directory window.

If you type the name of the application, type fast, or simply type the first few letters of the name of the application.

To open the application from the dialog box, double-click on the application name, or select the application and click **Open**.

### **Click Eject to eject a disk.**

Click the **Eject** button to eject the disk whose name appears above the buttons, without having to return to the Finder.

**Click Drive to select a disk.**

Click the **Drive** button to display the contents of the inactive drive (if there isn't a second drive, **Drive** will be dimmed).

If a MiniFinder has been installed on the other disk, that MiniFinder's screen will be displayed. You will be alerted if there is no MiniFinder installed on the other disk. In that case, you can still open an application on that disk by choosing **Open Other**.

Click **Drive** in conjunction with **Eject** to select files on other disks. When you click **Eject** (using a two-drive system), the disk in the active drive will eject. If there is a startup disk remaining in either drive, that disk will function as the current startup disk.

**The Shut Down button ejects your disks and resets your Macintosh.**

If you are using a Macintosh 128K or Macintosh 512K, choosing **Shut Down** ejects the disk(s), both internal and external, and resets Macintosh. A "?" icon should appear, indicating that the Macintosh is waiting for another startup disk. See the Apple Support Training Library module, *Fundamentals of the Macintosh Operating System*, for more on the "?" icon.

The **Shut Down** command, when used on a Macintosh XL, will eject the disk, and completely power down the Macintosh. To restart the system press the white On/Off button.

---

## Other Finder Features

### Overview

**The Finder has several features not included in the menus or in the MiniFinder.**

The Finder Version 4.1 has several features in addition to those provided by the menus and the MiniFinder.

### Other Finder Features

**The Finder has a hard-disk orientation that facilitates its overall operation.**

The Finder Version 4.1 is faster than its predecessor. That's one reason it's good for managing files on a hard disk. It races through file-management commands such as **Open**, **Copy**, and **Close**, and it opens and closes windows quickly. With this version, handling up to 500 files isn't a problem. Version 1.1g gets bogged down after about 100 files.

#### **Rename your icons.**

To rename a disk or folder icon, you must click the icon, even if it's highlighted. This makes it less likely that a disk or folder icon will be renamed accidentally. Other icons, such as those for a new folder, a document that has been moved, or a duplicated icon, can be renamed—while they're highlighted—without being clicked. Press Enter after you type the name, to ensure that you don't accidentally rename the icon.

#### **Some methods for ejecting disks have been enhanced.**

- You can eject unhighlighted disks from both drives by choosing the command **Eject** from the **File** menu, or by using its Command-key equivalent. This will eject disks one at a time, beginning with the startup disk.
- You can also eject disks (other than the startup disk) by moving them to the trash. This will eject the disk, and remove its icon from the screen.

For other methods of ejecting disks, see the section "More of the Finder 1.1g Menus."

#### **Drag icons to icon shadows to copy them.**

If you move the icon of a document, application, or folder to an icon shadow of a folder or disk, the Finder will copy the icon

to that folder or disk. The Finder will place the copied icon in the first available spot in the disk or folder window.

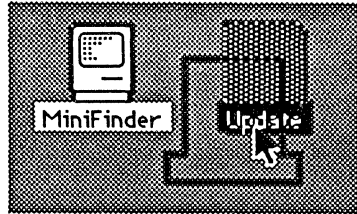

This method can also be used for copying the contents of one disk to another disk on a Macintosh 512K, or a Macintosh XL.

(Note: You can't use this to copy over the contents of the startup disk.)

## Disk Repair and Folders

### First level folders are kept during the repair function.

When you use the repair function (hold down the Option and Command keys while starting up Macintosh), you lose all of your folders except for those at the first level. In other words, you'll lose all of the folders except for the ones that have at least one document or application residing in them.

When a disk repair is done, the first level of folders will be renamed as Unnamed #1, Unnamed #2, and so on, as shown in the example below.

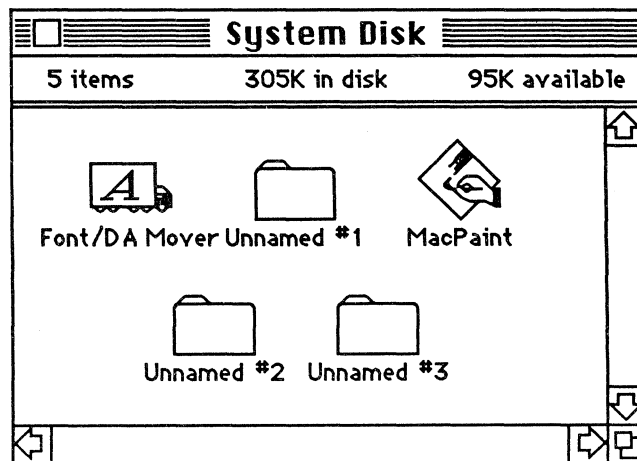

It's up to you to put the folders in their proper order and to give them their proper names—Macintosh won't do it for you.

### **Select a Document**

**Open a dialog box, and type the characters of the document you want to open.**

Earlier you typed the name of an application to select it from the Document Directory dialog box. You can do this inside an application to select a document. When using this feature, be sure to type the name in quickly and correctly. Macintosh uses the typing speed you've selected in the Control Panel in the Apple menu to help you select the desired file.

### **Now That You've Reached This Point**

**You can continue with the module, or skip to the Summary Exercise section.**

This completes the information on Finder Version 4.1. The information in the rest of the module was written to help support Finder Version 1.1g; some of it is a repeat of information you've already read. However, it provides exercises and information that apply to both versions. Reading it will help you provide support for these two versions of the Macintosh Finder.

---

## Using Finder Version 1.1g

### Overview

**This section of this support module is optional.**

This section provides information and exercises specific to the Finder Version 1.1g. It also discusses Finder menu commands that are employed in both of these versions of the Finder.

### The Finder

**The Finder manages your Macintosh documents and applications.**

The Finder is an application that's always available on the desktop; in fact, it is often synonymous with the desktop. You use it to manage documents and applications, and to access disks.

This application and its menus are your keys to working efficiently with Macintosh. Whether you're a Macintosh user, or you support other Macintosh users, you should be familiar with all of the functions of the Finder.

### The Apple Menu

**Use the About function and the desk accessories to help you support Macintosh.**

You can use the Apple menu to:

- Find out which version of the Finder you're using. (One of the first questions a support representative will ask is, "What version of the Finder (or software) are you using?")
- Find out which version of the software you're using. You must know this to be able to answer questions about its capabilities and limitations, such as the number of pages a particular version of MacWrite can accommodate.
- Use the desk accessories. Desk accessories contain information and resources such as a Clock, Note Pad, and Scrapbook that can help you become more productive with your Macintosh.



## "About the Finder..."

Information about the Finder is available by choosing the "About..." command.

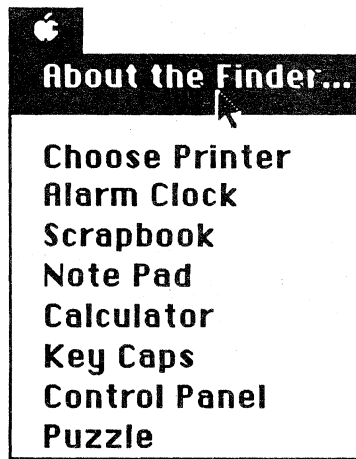

When you start up Macintosh, choose **About the Finder** from the **Apple** menu. It provides information about the version of the Finder that you're using. The example shown here is of Finder Version 1.1g, which was authored by Bruce Horn and Steve Capps.

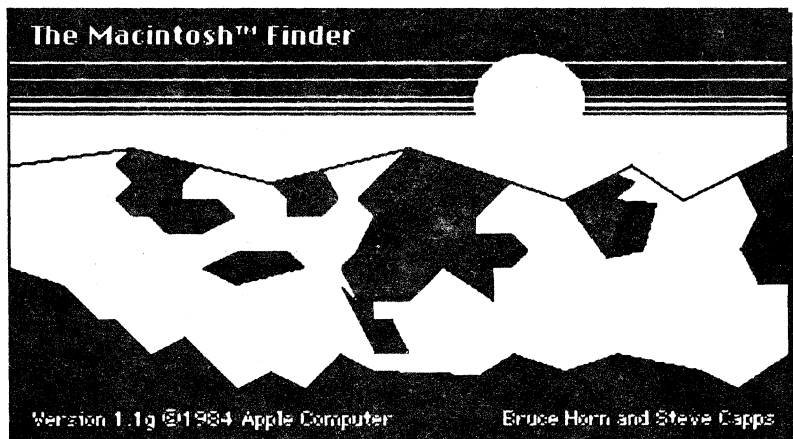

**Different versions of the Finder have been released.**

Different versions of the Finder are available. Check with your Apple support representative for the latest version, and update your files to that version.

## Other information "About..."

The Apple menu contains information about the application currently open on the desktop.

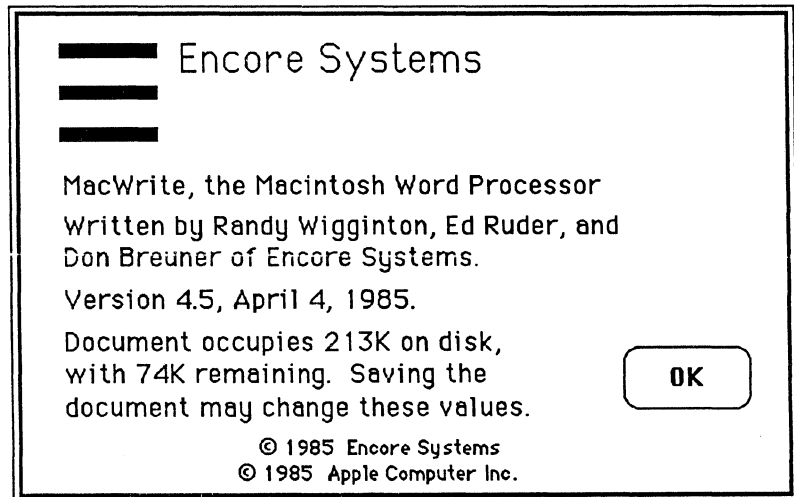

As shown above, choosing **About MacWrite** from the **Apple** menu while using MacWrite will produce a display of the following information:

- The version of MacWrite you are using.
- The amount of disk space occupied by the document currently on the desktop.
- The amount of space remaining on the disk.

(Remember, it's important to know the software version in use, particularly if a problem occurs.)

Other applications, such as MacProject™, use the "About..." command to supply you with introductory information or help notes regarding the use of that application.

All Macintosh applications from Apple use the **Apple** menu command, **About...** to display information about the version of software that's being used. This isn't necessarily done by other developers of Macintosh applications, so consult the documentation accompanying your software for the specific use of this command.

---

## **Practice**

### **Use "About..." the Finder**

#### **Choose "About..." to get information about the Finder.**

1. Start up from a MacWrite disk. When the desktop appears, choose **About the Finder** from the **Apple** menu.
2. Write down the version of the Finder you're using. Label your disk with this information after the exercise. It's useful to have this available if you have any questions regarding the Finder.
3. Click the mouse button at any point on the screen to close the dialog box and return to the desktop.

### **"About..." an Application**

#### **Choose "About..." to get information about an application.**

1. Open MacWrite and choose **About MacWrite** from the **Apple** menu.
2. Write down the version of MacWrite you're using. It will be useful to have this available if you have any questions regarding MacWrite. Be sure to label your disk with this information.
3. Close the dialog box and return to the desktop.

### **"About..." a Document**

#### **Choose "About..." to get information about a document.**

1. Start up from a MacProject disk. Open a MacProject document and choose **About MacProject** from the **Apple** menu.
2. Write down the version of MacProject you're using.
3. Read the other information contained in **About MacProject**.
4. Close the dialog box return to the desktop.

---

## Feedback

### Use "About..."

### Remember this about "About..."

Knowing the version of your software can be your key to answering many questions about it. When you call an Apple support representative, the first question you'll be asked is, "What software version are you using?"

Always note the software version on the disk label for quick reference. If you have any questions about this, talk to a colleague, ask your course manager, or call your Apple support representative.

---

## Using Finder 1.1g (cont'd)

### Desk Accessories

The desk accessories can save you time, and serve as a valuable resource.

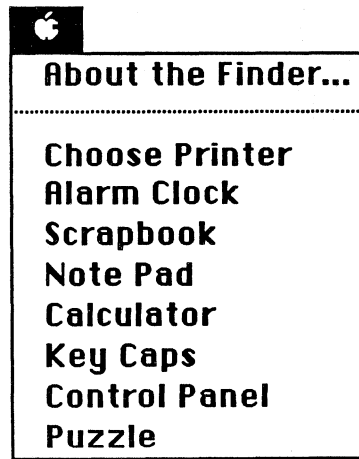

As you can see from the **Apple** menu shown above, the Macintosh desktop comes with many of the desk accessories that you'd find on your own actual desktop.

Several Apple desk accessories can be on the desktop at once.

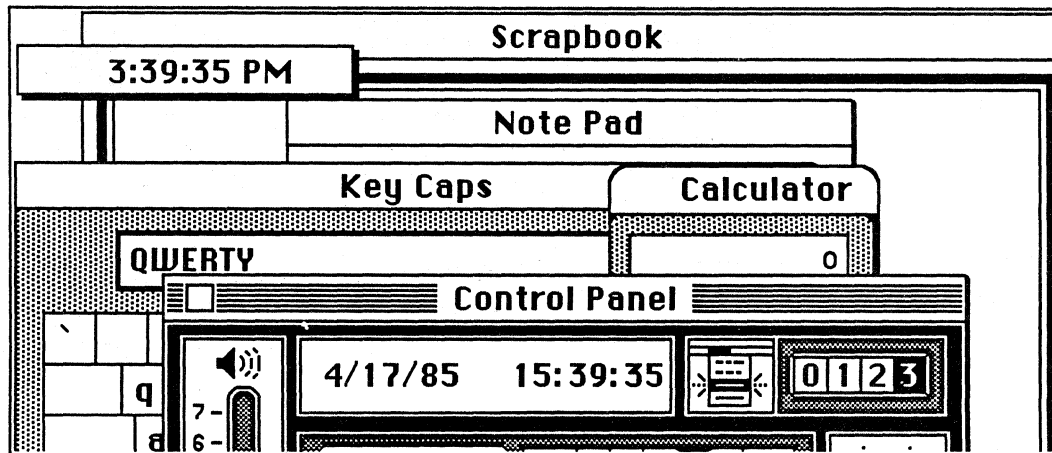

As you can see here, all of the desk accessories except **Choose Printer** are on the desktop. This makes them convenient to use while working in most applications. There are a few applications, such as MacPaint, that require you to close the desk accessories before you can work on any documents.

Try using some of these accessories. In particular, experiment with the elements on the **Control Panel**. These are explained in detail in Chapter 4 of *Macintosh*, the owner's manual.

You can cut and paste between Macintosh applications and three Apple desk accessories: the Scrapbook, Note Pad, and Calculator. For example, if you're editing a report in MacWrite and notice that a few of the accounting numbers don't seem to add up properly, you can open the Calculator, do the addition again, copy the correct sum from the Calculator, and insert it into your text—all without leaving the MacWrite document.

To practice using **Choose Printer**, see the *LaserWriter* owner's manual or the *Macintosh Office Quick Reference Guides*.

(Note: A Desk Accessory Mover is part of the system update released with the Finder Version 4.1. It can be used like the Font Mover to add or delete desk accessories.)

Also, software is available from third-party developers that will allow you to manipulate your desk accessories, adding to or subtracting from them. A calendar, desktop text editor, and data communications application are some of the options available. Check recent issues of *Macworld*, *The Macintosh Buyer's Guide*, and other major computer publications for more information about the latest software available.

### **A convenient application of the Note Pad and Calculator.**

For those who need to run and rerun the same calculations, the Calculator can be used as a programmable calculator. (You could try this now, but there's a practice exercise on the next page that covers this.)

1. Open the Note Pad and the Calculator.
2. Type a formula on the Note Pad (for example,  $9*8-12/24$ ) and choose **Copy**.
3. Open the Calculator and choose **Paste**.
4. The Calculator outputs the answer.
5. For successive calculations, just repaste the formula into the Calculator.

### **How to use multiple Note Pads.**

If you find that the Note Pad has too few pages, you can use the following procedure to create additional pads:

1. When the Note Pad's eight pages are filled up, rename its icon (stored in the System Folder) to something like Note1.
2. A new pad is created the next time you choose **Note Pad** from the **Apple** menu.
3. If you need to look at something in the original pad, change the name of the second Note Pad to "Note2", or "Other Note," and rename the first Note Pad icon with the original name, "Note Pad File."
4. You can continue to create storage files for notes until the disk is full.

As you have seen, the **Apple** menu provides excellent resources for saving notes and checking numbers you want to include in a document. Think of these **Apple** menu resources as you would the note pad and calculator you normally keep at your fingertips.

**Don't try to use the Puzzle for anything other than entertainment.**

If you try to use the Puzzle to cut or copy from, the results will be less than fruitful. The Puzzle is there to provide a break from your real work. Similarly, the Control Panel isn't a source of illustrations or text. It's there to help you get the most from your desktop environment. For more information on the Control Panel, see the Apple Support Training Library module, *Learning to Use Macintosh*.

**Use the Scrapbook and the Note Pad.**

You could fill an entire disk with illustrations and notes in the Scrapbook or the Note Pad. The only limit is the size of the disk. But remember, there are only 400K bytes of information available on a disk. So, if you need a lot of room on a disk for text or for data-base files, you might want to keep the Scrapbook and Note Pad clear of all but really important illustrations or truly brilliant ideas.

Print the Note Pad periodically, and back up the Scrapbook to an archive disk. Then you won't overload working disks with these files.

---

## Practice

### The Note Pad

#### Use a MacWrite document and the Note Pad.

1. Start up from a MacWrite disk, and open a MacWrite document.
2. Choose **Note Pad** from the **Apple** menu, and type a few lines of text.
3. Select the text you have just typed, and copy it.
4. Close the Note Pad.
5. Paste the text onto the MacWrite document.
6. Once you've completed steps 1 through 5, try the same procedure with other desk accessories, such as the Calculator.

### The Calculator

#### Use the Note Pad and the Calculator.

1. Start up from any startup disk that has the Calculator and Note Pad. From the desktop, or within any application, open the Note Pad.
2. Type the formula,  $9*8-12/24$ . Don't add any spaces or punctuation.
3. Select the formula, and choose **Copy**.
4. Open the Calculator.
5. Choose **Paste**, to paste the formula onto the Calculator (watch the Calculator keys when you do this).
6. Try this same exercise with another set of numbers such as,  $52384/6548*4*2+8*7/12$ . Type the numbers and the functions onto the Note Pad the same way you would enter them into the Calculator.



---

## ***Feedback***

### **The Calculator and Note Pad**

### **The Apple menu provides additional resources.**

The answer to the first practice calculation is **2.5**, and the answer to the final calculation is **42**. The operation can also be performed using MacWrite instead of the Note Pad.

If you have any questions, ask your course manager, a colleague who is familiar with the Macintosh, or your Apple support representative.

---

## More of the Finder 1.1g Menus

### Overview

**This section reviews the File, Edit, View, and Special menus.**

In this section, you'll read more about the options and commands in each menu. You'll learn to use the Command-key equivalents as an alternative to using the pull-down menus. The Enter key can also be used as a shortcut.

### Command-Key Equivalents

**These equivalents can be used as shortcuts in place of the pull-down menus and the mouse.**

You'll learn the Command-key equivalents for some of the Finder commands. As you practice, you'll find that there are times when the mouse is easier to use than the Command-key equivalents to choose commands, and times when the opposite is true. A combination of these is often best.

As you develop these techniques, you'll find the combinations that are fastest and most comfortable for you. During this part of the module, experiment with the different techniques available.

### The File Menu

The File menu has many useful commands.

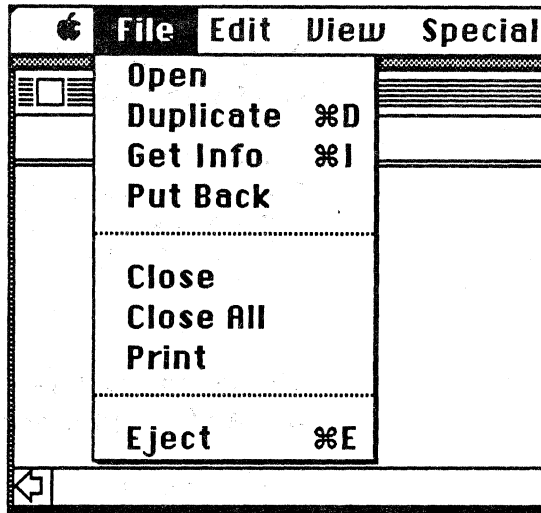

All of the commands in the File menu help you manage your documents, applications, and folders. For example, **Open** will open any selected icon.

For more information about the File menu, review the "Finder Menus" section in Chapter 4 of *Macintosh*, the owner's manual.

### The Command Key

Use the Command-key equivalents as shortcuts to the menu commands.

One way to access some of the commands in many menus is to hold down the Command key and type the letter that corresponds to that command ("Command-key equivalents"). This way, you can select these commands from the keyboard without having to open the menu.

**Duplicate**, **Get Info**, and **Eject** all have Command-key equivalents. To duplicate an icon, hold down the Command key and type **D** (often shown simply as, **Command-D**). To get information about a specific icon, select that icon and press **Command-I**. And, to eject a highlighted disk, press **Command-E**.

The Command key (also called the Apple key on the Macintosh XL, and the feature key or function key on the Macintosh) is the key just to the left of the space bar.

## The Enter Key

### The Enter key can be used to respond to dialog boxes.

The Enter key can be used as a shortcut to save a trip from the keyboard to the mouse. Most often, using the mouse to click command buttons is the quickest way to respond to a dialog box. However, there are times when pressing the Enter key is faster. For example, the Enter key will mean "OK" or "Yes" when a dialog box contains a "Do you want to continue" message. Also, if a specific button is highlighted, pressing Enter will initiate that action, as shown below:

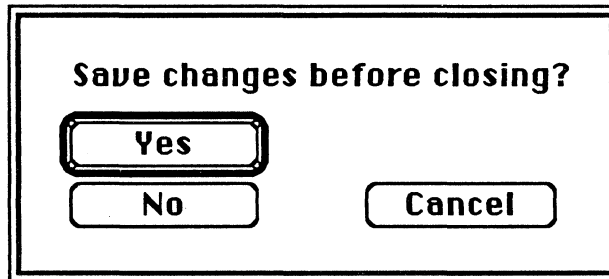

In this example, pressing Enter will save the document and then close it.

---

## Practice

### Use the Command Key

### Try using the Command-key equivalents, and the Enter key.

1. Start up from a MacWrite disk.
2. Open the disk icon and select the MacWrite icon (be careful not to open the application).
3. Press **Command-I (Get Info)**.
4. Note the information available in the information window.
5. Close the information window.
6. Select the MacWrite icon again.
7. Press **Command-D (Duplicate)**.
8. A duplicate file, called "Copy of MacWrite," will appear.
9. Press **Command-I to Get Info** on "Copy of MacWrite."
10. Choose **Close** from the **File** menu to close the "Copy of MacWrite" information window.
11. Throw away the "Copy of MacWrite" icon.
12. A dialog box will appear, asking you if you really want to throw away this application. Instead of clicking **OK**, press the **Enter** key to respond.

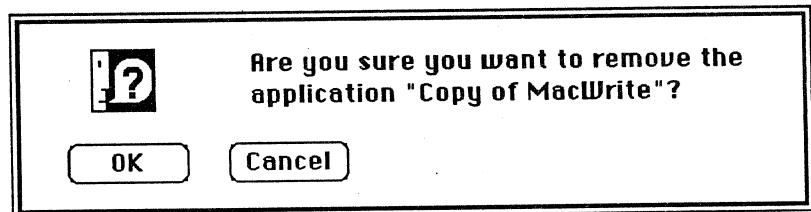

13. Choose **Close All** to close all of the open windows.
14. Select the MacWrite disk icon, and press **Command-E** to eject the MacWrite disk.

---

## ***Feedback***

### **Using the Command Keys**

**These keys are listed in the menus for your convenience.**

As you can see, using the Command-key equivalents and the Enter key can be useful and fast.

Don't worry about knowing all of these keys. They're all listed in the pull-down menus next to the command they initiate. You'll become more familiar with their use as you progress through the Macintosh modules.

If you have any questions, be sure to discuss them with a colleague, your course manager, or your Apple support representative.

---

## More of the Finder 1.1g Menus (cont'd)

### The Edit Menu

The Edit menu has several Command-key equivalents.

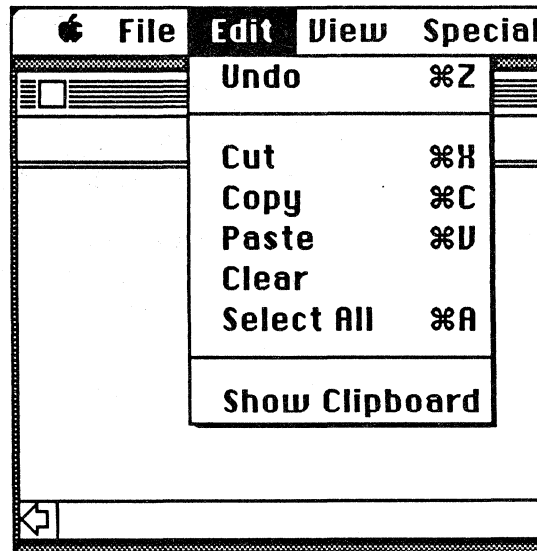

The **Edit** menu uses more Command-key equivalents than any of the other Finder menus. Practice these commands using both the mouse and the Command-key equivalents. This practice exercise will demonstrate how even basic processes for managing and naming documents can be done faster using the Command-key equivalents.

---

## Practice

### The Edit Menu

#### Use the Edit menu on the desktop.

1. Start up from a MacWrite disk.
2. Open the MacWrite disk icon.
3. Choose **Show Clipboard** from the **Edit** menu.
4. Be sure that you can see all of the icons in the MacWrite startup disk window.
5. Check the Clipboard window. Be sure it's open enough for you to see at least a few words of text, and that it isn't overlapping the MacWrite disk window (you'll want to watch all of your work as it appears on the screen).
6. Select the MacWrite application icon.
7. Press **Command-C (Copy)**. Notice that the title, "MacWrite," is all that appears in the Clipboard window. **Copy** copies only the name of the icon, not the entire file.
8. Try this again, but this time, select the System Folder.
9. Press **Command-X (Cut)**. The text "MacWrite" has been replaced with "System Folder," and the System Folder title has been removed from under its icon.
10. To replace the icon name, press **Command-V (Paste)**. "System Folder" becomes the icon name, and it ("System Folder") remains on the Clipboard.  

(Note: The text on the Clipboard can't be selected.)
11. Activate the MacWrite disk window. Press **Command-A (Select All)**. All of the icons are selected.
12. Click the mouse button once on the desktop or in the window to deselect the icons.
13. Close the MacWrite disk icon window and press **Command-E (Eject)**.



---

## Feedback

### The Edit Menu

Use the Command key to invoke Edit menu commands.

If you have any questions about this exercise, ask your course manager, consult a colleague, or ask your Apple support representative.

---

## More of the Finder 1.1g Menus (cont'd)

### The View Menu

This menu displays the ways you can view a catalog or directory of your files.

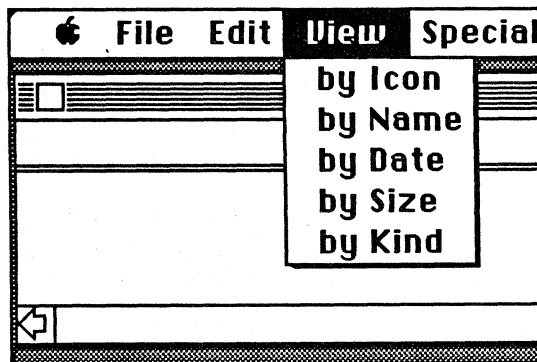

### Catalog or Directory

Use the View menu to display document and folder information by the categories listed.

By using the commands available in the View menu, it's easy to find the latest version of a document you've created. Or, if you've forgotten which document had all the latest information added to it, you can check the size of the documents, and select the largest.

The information is displayed in a format similar to those used by other operating systems.

In the View menu, the information displayed is similar to that which is provided when you type the "catalog" or "directory"

commands at the opening prompt in other operating systems such as ProDOS®, MS-DOS, PC DOS, or CP/M.

So, if you're acquainted with these other systems, and would like to see what you would consider a "typical" directory of files, you can select the option that most closely resembles that of the system you're familiar with.

### View commands display specific information.

You can read a lot about a file by using the commands in the **View** menu. For example, if you view the contents of a window using the **by Name** command (see example below), you'll see the size, name, and kind of document or folder, and the date it was last modified, displayed in alphabetical order by name. This same information is displayed when you use the other **View** menu commands (except **by Icon**), but it appears in a different order.

Special Write			
Size	Name	Kind	Last Modified
60K	MacPaint	application	Wed, Aug 22, 1984
55K	MacWrite	application	Mon, Sep 24, 1984
7K	Sample Memo	MacWrite document	Thu, Jan 10, 1985
223K	System Folder	folder	Fri, Mar 22, 1985
20K	Test Folder	folder	Fri, Mar 22, 1985

### Most Finder commands are available to you when using any viewing method.

In Finder Version 1.1g, when you're displaying the contents of a window by name, date, size, or kind, you have access to many of the same commands as when you're using the **by Icon** command.

In Version 4.1 of the Finder, all of the desktop operations are available in any view.

**Viewing by Icon**

**By Icon offers more Finder commands.**

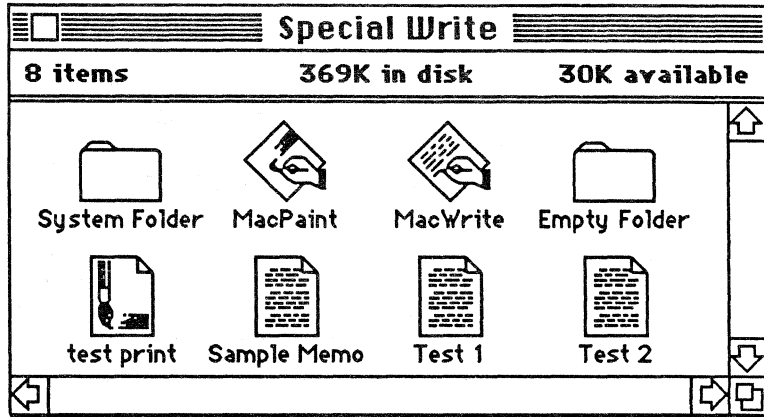

The **by Icon** command allows you to do more than the **View** menu commands just mentioned. You can move documents and folders, name them and rename them, throw them away, or arrange them in any order on your desktop.

**Viewing in Several Ways**

**You can view the contents of each disk or folder window using any of the methods.**

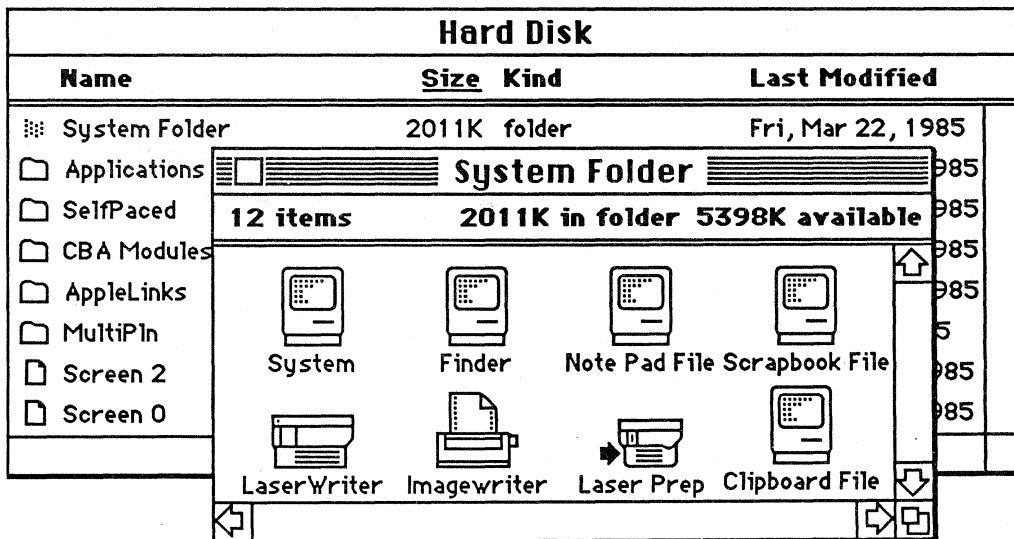

In the example shown above, the Hard Disk window is being viewed **by Size**, and the System Folder is being viewed **by Icon**.

## The Special Menu

The options in the Special menu provide tools for effective file management.

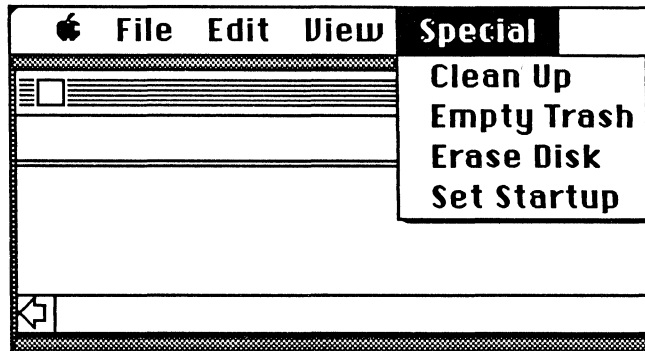

**Clean Up** lets you organize your desktop.

This command will move icons to the closest open space in a window. Even if the icons are already close to being in a straight line, the **Clean Up** command will make that row neater, as shown below.

**Step one: The icons are out of alignment.**

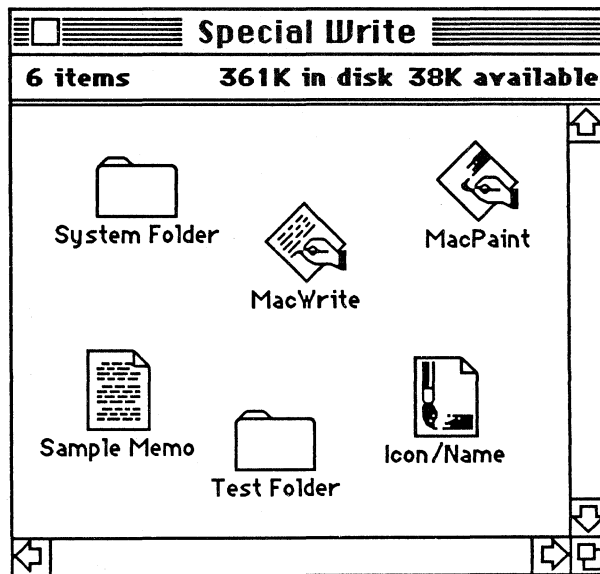

You may have a disk that is arranged like this. If you choose **Clean Up**, your desktop would change to look like the one shown under Step two.

**Step two: The icons are in a neat arrangement on your desktop.**

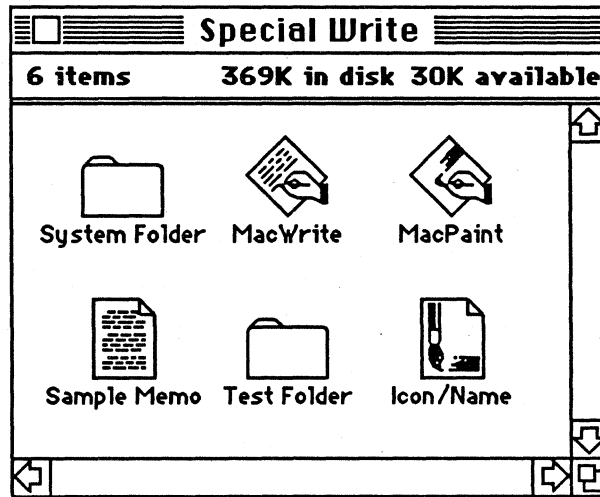

Now all of the icons are neatly arranged. If you keep your office desktop neat, it follows that you'd like to keep your Macintosh desktop neat. This is an easy way to do it.

Another benefit of this command is that it may help you find a "lost" file. The file may just be buried under one or two other icons, in which case **Clean Up** may reveal it. Or if you're moving a disk window from the larger XL screen to the smaller Macintosh screen, you may seem to have lost an icon or two. They're probably still there. By choosing **Clean Up**, you may be able to find them.

### **Set Startup lets you start up quickly.**

You can use **Set Startup** to start up Macintosh in a specific application, such as MacWrite. If you're a writer, you may use your Macintosh primarily for word processing. To save time, you can create a MacWrite disk that starts up from the MacWrite application, without bringing up the desktop.

To create the special startup disk, select the MacWrite icon that's on the desktop, and choose **Set Startup**. The next time you start up from that disk, it will start up in MacWrite.

**You can change the disk back, so it starts up from the Finder again.**

To start up from the Finder again, quit MacWrite. When you return to the Finder, select the Finder icon and choose **Set Startup**. Next time you use that startup disk, you'll start up from the Finder. To practice this, follow the instructions in the exercise that starts on the next page.

**Use this command to set up a disk that starts up from an application, and has no Finder.**

Can a startup disk have a System file only, and no Finder? Yes. See the Installing the MiniFinder section in this module. Using **Set Startup** works the same with an application as it does with the Finder, or the MiniFinder. When used without the Finder, it saves time and disk space, since the Finder consumes about 45K of disk space.

**Finder 4.1 Update****Additional options are available using the Finder Version 4.1.**

The first sections of this module were written about the Finder Version 4.1. You'll notice many similarities between it and Version 1.1g, and several differences. The reference chart at the end of this module summarizes some of the differences between the two versions.

If you have any questions about the Finder, talk to a colleague who is familiar with Macintosh, ask your course manager, or contact your Apple support representative.

---

## Practice

### Use the Special Menu

### Use each of the Finder 1.1g Special menu commands.

Choose **Clean Up** to arrange the documents and folders on your MacWrite disk.

Throw away any unnecessary documents, or your Empty Folder, by choosing **Empty Trash** (if you need another Empty Folder, use the Finder to create one).

Find a disk you don't need any more, and choose **Erase Disk** to erase it.

Choose **Set Startup**. Follow the steps below to set up a disk to start up from MacWrite. Then return the startup function to the Finder.

1. Insert your MacWrite startup disk, and open the MacWrite disk icon.
2. Select the MacWrite application icon, and choose **Set Startup** from the **Special** menu.
3. Press Enter when you see the dialog box that says, "Are you sure you want to make 'MacWrite' the startup application?"
4. Close the MacWrite disk window, eject the disk, and turn off Macintosh.
5. Turn on Macintosh. Macintosh will start up immediately in MacWrite with an "Untitled" document on the desktop.
6. To start up from the Finder again, choose **Quit** from the **File** menu.
7. Open the System Folder and select the Finder.
8. Choose **Set Startup** from the **Special** menu.
9. Press Enter when you see the dialog box that says, "Are you sure you want to make 'Finder' the startup application?"
10. Close the System Folder, eject the disk, and turn off Macintosh.
11. Turn Macintosh on again. The Finder and its menus will appear on the desktop.

---

## ***Feedback***

### **The Special Menu**

**In this exercise you used all of the Special menu commands.**

If you have any questions about any of the commands in this exercise, ask a colleague who is familiar with Macintosh, ask your course manager, or contact your Apple support representative.



## Summary Exercise

### Using Finder Commands

### Use most of the Finder Version 4.1 commands.

Refer to the module or use any resources you need to complete this exercise.

1. Use the disk that you set up in the first exercise of this module.
2. Install a MiniFinder. Use the MacWrite, MacPaint, and at least one document.
3. Open the MiniFinder, and open (launch) a MacWrite document. Make a few modifications to the document. Save the changes, and quit MacWrite.
4. Choose Finder and create a new folder. Place the MacWrite document you just modified into the empty folder, and name the folder.
5. Insert another disk into the external disk drive, and open it. Copy the folder onto the new disk by dragging the folder icon to the disk icon shadow.
6. Rename the folder that you just copied to the other disk.
7. Rename the disk in the external drive and eject it without using menu options or the Command key.
8. Reinsert the disk into the external disk drive, and **Shut Down Macintosh**.
10. When the "?" icon appears, insert the startup disk with the MiniFinder into the internal disk while holding down the Option and Command keys.
11. Rename the folder(s), and lock one of them.
12. Use **Choose Printer** to verify your printing resource, then use **Page Setup** and **Print Catalog** to print a catalog of your disk. Use a **View** menu option other than **Icon** when you print the catalog of your files.
13. Remove the MiniFinder.
14. Shut Down the Macintosh, and turn it off.

---

## ***Feedback***

### **Summary Review**

**This exercise covered most of the Finder 4.1 menu commands.**

If you have any questions about any of the functions presented in this exercise, consult a colleague, ask your course manager, or contact your Apple support representative.

---

## Questions and Answers

### Startup Disks

*What is a startup disk?*

It's a disk that you can use to start up Macintosh.

*What must be on a disk to make it a startup disk?*

A startup disk usually has a System Folder on it. However, it really only needs to have a System file and one application (for example, the Finder) that has been designated as a startup application. For an example and an exercise, see the Installing the MiniFinder section in this module.

### Startup-Disk Icons

*I started Macintosh with my MacWrite startup disk. I quit MacWrite, and opened MacPaint (it's also a startup disk) from the external disk drive. When I quit MacPaint, I noticed that the two icons had switched positions on the screen. The MacPaint icon was in the top right corner, and the MacWrite icon was underneath. What happened?*

Macintosh keeps track of the current startup disk by keeping it in the upper right corner of your screen. In this case, both disks are startup disks, so Macintosh assumes that MacPaint is the current one, since it was the last to be used. If you opened MacWrite again, you'd notice that the two icons would switch positions again.

*I understand that you can select your current startup disk by opening the Finder on the preferred disk. How is this done?*

Press and hold the Option and Command keys while you double-click on the icon of the Finder you want to start up from.

### Folders

*What files must be in a System Folder?*

None. Macintosh doesn't require a System Folder to operate properly. Typically, however, you *will* have a System Folder, containing a System file, Finder, Note Pad file, Clipboard file, Scrapbook file, and your printing resources, such as an ImageWriter file or a LaserWriter file or both.

*I've updated my startup disks with the Finder 4.1. How can I be sure they're all updated?*

First, check the menus to see if they contain any new commands, such as **Shut Down**. If they do you're in good shape. If an Empty Folder keeps appearing when you don't want it to, even when you keep throwing it away, it's a good indication that you need to update at least one more disk.

## **Restart Macintosh XL**

*How can I restart my Macintosh XL without turning it off?*

Using MacWorks 3.0, press the Command key and hold it while you press the white On/Off switch.

You can also start up from the internal disk. Press the Option key while you press the white On/Off switch.

## **Shut Down**

*Can I use **Shut Down** even if there aren't any disks in my disk drives?*

Yes. If you're using a Macintosh 128K or 512K, **Shut Down** will restart Macintosh and a "?" icon will appear. Of course, if you use **Shut Down** on a Macintosh XL, it will shut down and turn off.

## **Standard File**

*I've heard of a Standard file on Macintosh. What is it?*

It appears while you are in an application. If you close one window, and choose **Open** from the **File** menu, the dialog box that appears is called the Standard file. It's often just called a dialog box. In these modules, it's referred to as the Document Directory dialog box.

Features	Version 4.1	Version 1.1g
<b>Menu Options</b>		
<b>Apple Menu</b>		
Choose Printer	Yes	No
<b>File Menu</b>		
New Folder	Yes	No
Get Info	Yes (lock feature)	Yes
Put Back	No	Yes
Close All	No	Yes
Page Setup	Yes	No
Print Catalog	Yes	No
<b>Edit Menu</b>		
No Changes		
<b>View Menu</b>		
Available Options were expanded	Options expanded	
<b>Special Menu</b>		
Use MiniFinder	Yes	No
Shut Down	Yes	No
<b>Finder Features</b>		
Enhanced speed management	Yes	No
Increased file-management	About 500 files	About 100 files
MiniFinder to open applications and documents	Yes	No
Click on icons to name them	Yes	No
Duplicate names in Trash emptied	Yes	No
Move disk icon to Trash to eject	Yes	No
Eject unhighlighted disks	Yes	No
Drag icons to hollow icons to copy	Yes	No
Folders kept during "Repair" function	Yes (first-level folders kept and renamed)	No
Type file name to open document or application	Yes	No

---

## Finder Features Comparison Chart

**Each Feature Is Reviewed**

**The features listed on the opposite page compare the Finder Versions 4.1 and 1.1g.**

Use the chart on the opposite page to compare some of the features of the Finder 1.1g that have been enhanced or deleted in Version 4.1.

The list is a long one, and it will continue to grow as the Finder is enhanced. Be sure to ask your Apple support representative for the latest version of the Finder, and for a list of its enhancements.

---

## Review

### Using the Finder Menus

**Knowing the Finder menus is fundamental to using Macintosh.**

The Finder menus offer information about the software you are using, and help control the Macintosh processing environment. The menus are the keys to managing Macintosh files, documents, and applications.

### Installing the MiniFinder

**The MiniFinder commands provide quick access to documents and applications.**

### The MiniFinder Buttons

**Click these buttons to move quickly between disks, documents, and applications.**

### Other Finder Features

**Finder utility functions are provided on the desktop to facilitate file management.**

The Finder desktop utilities perform vital functions to handle disks, files, documents, and applications, such as Copy, Move, Duplicate, and Repair.

### Using Finder Version 1.1g

**This was the first Finder released with Macintosh, and is still widely used.**

The Apple menu provides you with many valuable commands. You can work with the Calculator, Scrapbook, or Note Pad, and control a lot of your Macintosh operating environment—or play with the Puzzle.

Many people still use Version 1.1g of the Finder. Users should be encouraged to upgrade to the most recent version that's appropriate for their needs, because it's more powerful and offers more commands.

### More of the Finder 1.1g Menus

**The Finder 1.1g File, Edit, View, and Special menus still provide powerful tools.**

Even though there are more recent versions of the Finder, many commands haven't changed at all. Much of the information remains the same from a support point of view.

## Resources

- Apple Support Training Library modules: *Fundamentals of the Macintosh Operating System*, *ImageWriter II Basics*, *Learning to Use Macintosh*, and *Using the LaserWriter*.
- AppleLink Technical Info Library (available to Apple support personnel)
- *LaserWriter*, the owner's manual
- *Macintosh*, the owner's manual
- *Macintosh 68000 Development System User's Manual* and *Inside Macintosh* (included with the Macintosh 68000 Development System), Apple Computer, Inc.
- *The Macintosh Buyer's Guide*, Redgate Publishing Company, Vero Beach, Florida 32963
- *Macintosh Update* (5/15/85), a written update distributed with the Macintosh System Update disk. Also available on AppleLink.
- *Macworld*, PC World Communications, Inc., San Francisco, CA 94107

*Apple, the Apple logo, and ProDOS are registered trademarks of Apple Computer, Inc. AppleLink, AppleTalk, ImageWriter, LaserWriter, MacPaint, MacProject, MacWorks, and MacWrite are trademarks of Apple Computer, Inc. Macintosh is a trademark of McIntosh Laboratory, Inc. and is being used with the express permission of its owner. CP/M is a registered trademark of Digital Research, Inc. MS-DOS is a trademark of Microsoft Corporation.*





# Supporting the Font/DA Mover

---

## Contents

2	Overview, Objectives
3	Materials
4	Overview of the Font/DA Mover <i>The features of this application allow you a great amount of flexibility in designing your system environment.</i>
8	The Font Mover <i>Use the Font Mover to copy, move, and remove fonts from the System file.</i>
17	The DA (Desk Accessory) Mover <i>Use the Desk Accessory Mover to copy, move, and remove desk accessories from the System file.</i>
22	Using the Original Font Mover <i>This section discusses the original Font Mover. Complete this section only if you actively support the product.</i>
31	Questions and Answers
33	Review
34	Resources

---

## Overview

This module is designed to acquaint you with the Font/DA Mover. The first section describes the Font/DA Mover and its features. The second section discusses how to use the Font/DA Mover to copy, move, and remove fonts from the System file. The third section details how to copy, move, and remove desk accessories from the System file.

Included in this module is a brief section on the original Font Mover. It's provided to help you support that product, and to demonstrate some of the differences between the original and current products. Completing the section is optional. Most of the information in it is also discussed in the first three sections.

This module is intended for use by people who support the Macintosh™ computer and the software applications for Macintosh published by Apple Computer, Inc.

### Prerequisites

- You should know how to use Macintosh and MacWrite™. This can be achieved by completing the Guided Tours of Macintosh and MacWrite, or by reading Chapter 3 in *Macintosh*, the owner's manual.

---

## Objectives

- Add a font or a desk accessory to the System file on a disk.
- Create more room on a disk by removing fonts and desk accessories from the System file.
- Create special font and desk accessory files, such as a "fonts only" or "desk accessory only" file to move and store groups of fonts and desk accessories.

---

## Materials

### To complete this module you will need:

- A Macintosh 512K (with external disk drive), or a Macintosh XL (A Macintosh 128K may be used. However, a font other than Taliesin 18 must be used during the practice exercise in the Font Mover section)
- A disk containing these applications:
  - Font/DA Mover (Version 1.2)
  - MacWrite (Version 4.5)
  - MacPaint™ (Version 1.5)
- A startup disk containing Finder (Version 4.1), ImageWriter™, ImageWriter 15, and/or Apple® LaserWriter™ printer resources
- A blank disk

---

## Overview of the Font/DA Mover

### Overview

**The Font/DA Mover application is a useful Macintosh utility.**

The Font/DA Mover can be one of your most useful applications. This section describes its purpose, and provides an overview of its functions.

### Managing with the Font/DA Mover

**Use the Font/DA Mover to manage the fonts and desk accessories in your System files.**

By using the Font/DA Mover, you can tailor your System files to meet your data-processing needs. The commands within this application allow you to move the fonts and desk accessories that you need into the System file on a startup disk. The Font/DA Mover also lets you move them off the disk to free up space, maximizing the disk space available for use with other applications, to create large documents, or to accommodate printing resources.

**Macintosh uses the fonts and desk accessories in your System file.**

- Macintosh uses the fonts in your System file to take the information that you're typing and put it on the screen, or to print that information on your ImageWriter or LaserWriter printer.
- Desk accessories, such as the Calculator, Note Pad, and Scrapbook, are handy desktop tools, as functional as their counterparts on your desk. You can use the Control Panel, another desk accessory, to control some of the Macintosh processing environment. Then, you can take a break and use the Puzzle for some recreation.

However, before you can use any fonts or desk accessories, they must already be in your System file, or else loaded into the System file using the Font/DA Mover.

(Note: There are some desk accessories that require special installation software, such as Choose Printer, and some third-party accessories. Still others have special backup files that must be copied to your startup disk before they can be used. Carefully read the instructions that come with these accessories before you install them.)





**The Font/DA Mover handles fonts and desk accessories in the same way.**

Operationally, fonts and desk accessories are handled in the same way. But because of some of the functional differences between font files and desk accessory files, this module is divided into three sections: the Overview (this section), the Font Mover, and the Desk Accessory Mover.

**Font Mover Update**

**The original version of Font Mover should be updated to the Font/DA Mover.**

You may be familiar with the icon of the Font Mover application (it's shown below on the left). That original Font Mover is no longer in use. If you find it, update it to the Font/DA Mover (the icon shown below on the right).

<b>Applications</b>	 Font Mover	 Font/DA Mover
<b>Corresponding File Icons</b>	 Fonts	  DA Fonts      DA Accessories

The original Font Mover could move fonts into a System file. It could be used to create storage files to archive fonts for future use, or to remove fonts to create more room on a disk. The Font/DA Mover can do all of these things with fonts, *and* with desk accessories. For more information on the original Font Mover, see the optional section near the end of this module.

### Font/DA Mover and Disk Space

### The Font/DA Mover helps manage disk space.

Fonts and desk accessories are necessary to the operation of Macintosh. They also take up disk space. One font in your system can consume from 4K to 14K of disk space. Desk accessories (such as the ones on your Macintosh system disk) need from 1K to 8K each. The fonts and the desk accessories supplied with Macintosh occupy about 160K. That's a lot of disk space on a startup disk.

#### The System File

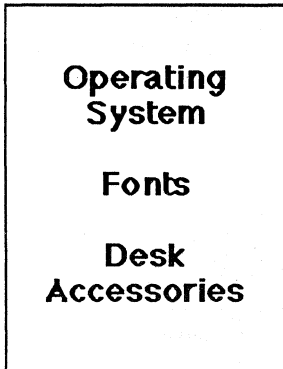

#### The Startup Disk

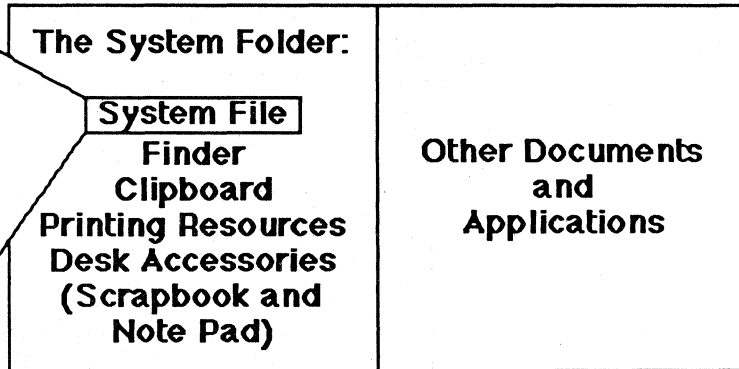

You can use the Font/DA Mover to add the fonts and desk accessories that you want to use right away, to remove the ones that you don't want, and to store the rest on another disk for use at another time. This helps you to maximize your available disk space.

## The disk-space management process begins with the Font/DA Mover window.

When you open the Font/DA Mover, you're opening a window into your System file. The window is preset to open to the Font Mover, and to display the fonts in your startup disk's System file.

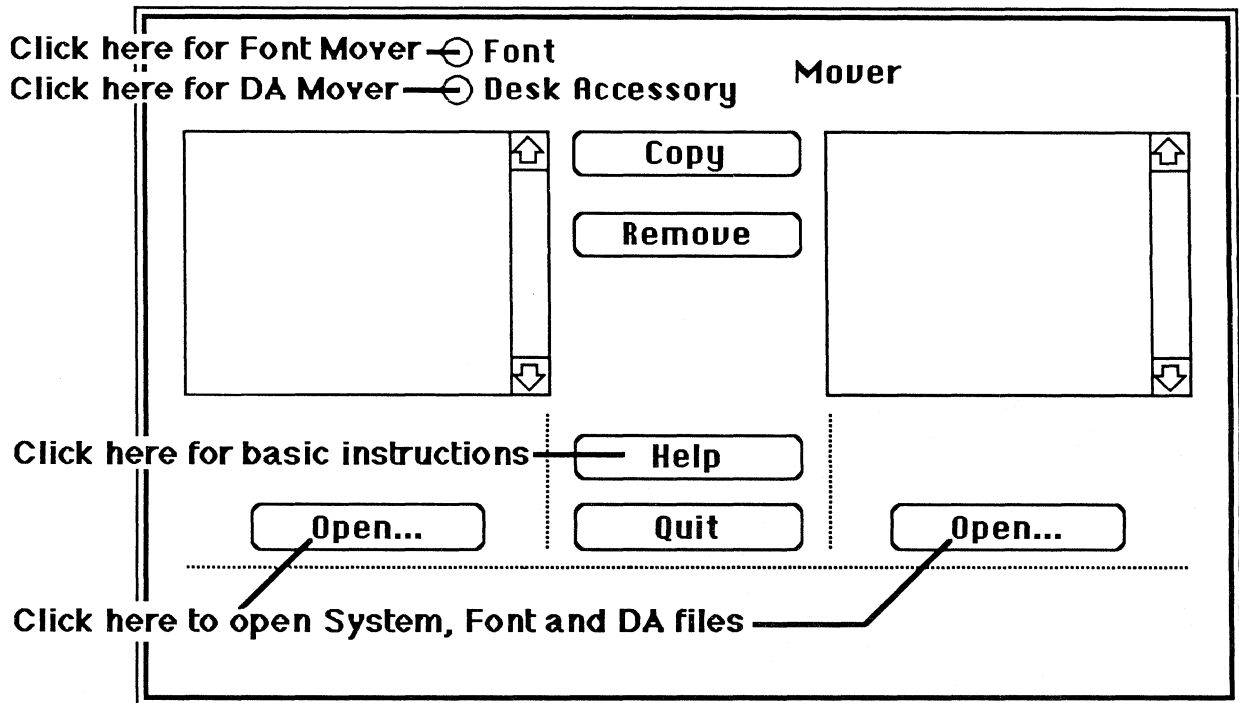

As the module continues, you'll look closely at each of the commands available in the application window, and see how these commands affect the use of fonts and desk accessories.

### The Operations are the Same

### The same operations are used by both the Font Mover and the DA Mover.

The Font Mover and DA Mover use the same operations to manipulate fonts and desk accessories, and to create storage files. Therefore, the practice exercises in the Font Mover section can apply to the DA Mover section. If you would like more practice with the DA Mover after you have completed the module, use the practice exercises in the Font Mover section substituting a desk accessory wherever a font is indicated. You'll see how similar the operations are.



## The Font Mover

### Overview

#### The Font Mover accesses the fonts in your System files and in special font files.

In this section, you'll learn how to use the Font Mover to add more working space to your disk, and how to store fonts for future use.

#### Choose the Font Mover section of the Font/DA Mover.

By selecting the Font Mover, you can move fonts between any combination of System and storage files.

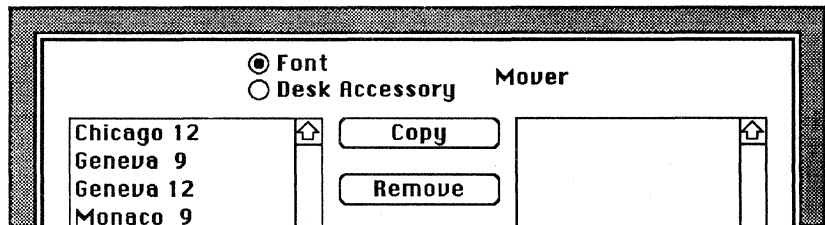

When you open the application, the fonts in the System file of your startup disk are displayed in the box on the left. Several fonts are displayed, including the four basic fonts that the System file requires: Chicago - 12, Geneva - 9, Geneva - 12, and Monaco - 9. The fonts are used on the screen in menus, in icon names, and in other places where system- or software-generated text appears on the screen. These fonts are also available for your use whenever you need them. Don't try to remove them, though—the system won't let you.

### Copy, Move, and Remove

#### Copy, move, and remove fonts to maximize disk space.

Since fonts take up space on a disk, you'll want to remove any you aren't using, and store them where they can be easily accessed. Fonts that you use for word processing aren't necessarily the same as fonts you might want to use for the overhead slides in a sales presentation. But you still want them to be accessible.

## Fonts-Only Disks

### Create a fonts-only disk.

One way to archive fonts is to create a fonts-only disk. Use the Font Mover to move as many fonts as you can to a specific disk. (It won't take long to fill a disk with fonts, unless you're using a hard disk, in which case you can have as many fonts as you like on your disk.) There are a few limitations: Some applications can use as many as 15 different fonts, while others are limited to only a few. To be sure you haven't added too many fonts, look at the **Font** menu. If you can see all of your fonts, great. If not, remove the fonts you don't need until you can see all of the fonts available in your **Font** menu.

### If you want to create a fonts-only disk, there is a practice exercise that can help.

There are two practice exercises in the section of this module, Using the Original Font Mover. Use the second exercise to create a fonts-only disk.

## Print Quality

### Standard-resolution print quality requires one font size; high-resolution output requires two.

If you're using an ImageWriter as your primary printer, you need to have only one font size for each font to be able to print in standard print mode. To print text in high-resolution mode requires a larger font size. For example, with text input using 12-point Geneva, you must have 24-point Geneva for high-resolution printing. The ImageWriter takes the 24-point Geneva and shrinks it to produce the higher-quality printed text.

## Use Your Old Font Files

### The Font/DA Mover can use any font file.

You can use the Font/DA Mover to open font files created with the Font Mover. However, font files created using the Font/DA Mover aren't compatible with the original Font Mover.

Though the Font/DA Mover can open original Font Mover files, it won't upgrade or "convert" them. This means that Font Mover files that are opened using Font/DA Mover can still be opened by the original Font Mover.

The best thing to do is to throw away any copies of the old Font Mover, and upgrade to the Font/DA Mover.

## File Names

**Font file names do not have to be changed to be used by the Font/DA Mover.**

The Font/DA Mover can use any font file on a disk, regardless of its name. This is unlike the situation with files created using the original Font Mover, in which the name of the file must be "fonts." If you want to create more than one font-storage file on the same disk (with the original Font Mover), you must change the name of the font file to something like "Fonts1". Only one file per disk can be called "Fonts" and be used by the Font Mover.

---

## Practice

### Use the Font Mover Portion

**Remove a font from the System file on one disk, and add it to the System file on another.**

1. Create a "Font Disk" that contains these files: a System file, Finder Version 4.1, and the Font/DA Mover.

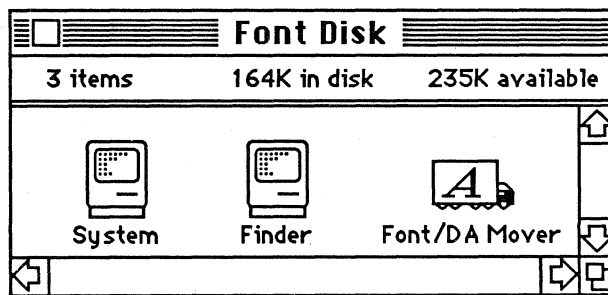

2. Open the Font/DA Mover on your new Font Disk. When the Font/DA Mover dialog box appears, it should look similar to the one on the next page.

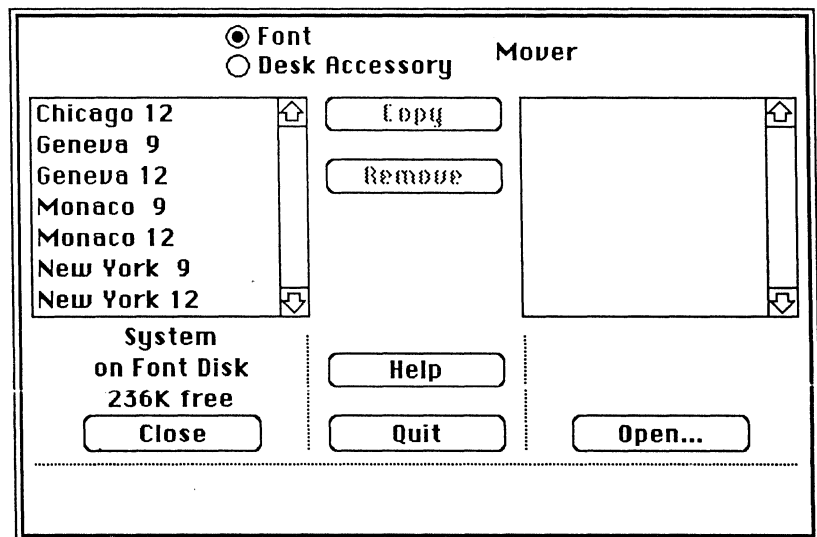

3. Click **Open** on the lower right side of the dialog box. This should open another dialog box that has a directory of the font files that includes the System file.

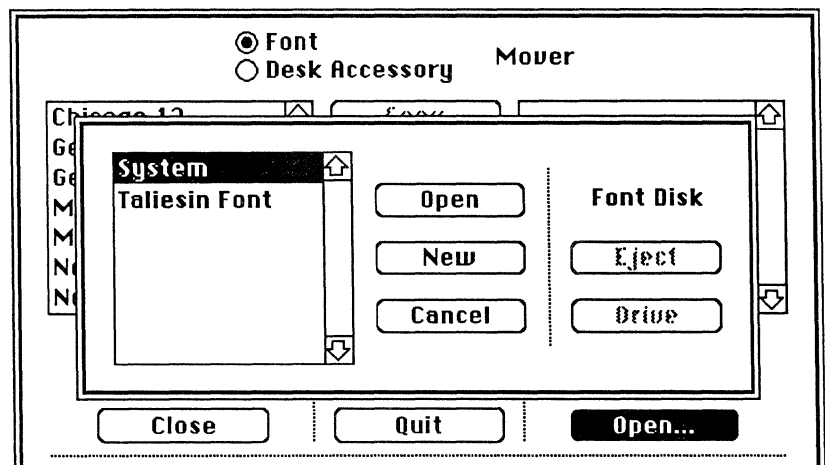

4. Open the Taliesin Font file (if you're using a Macintosh 128K, use a font other than the Taliesin 18).
5. When the document directory disappears, select the Taliesin 18 font (as you select a font, you'll notice that the Copy and Remove buttons are highlighted).

## Practice (cont'd)

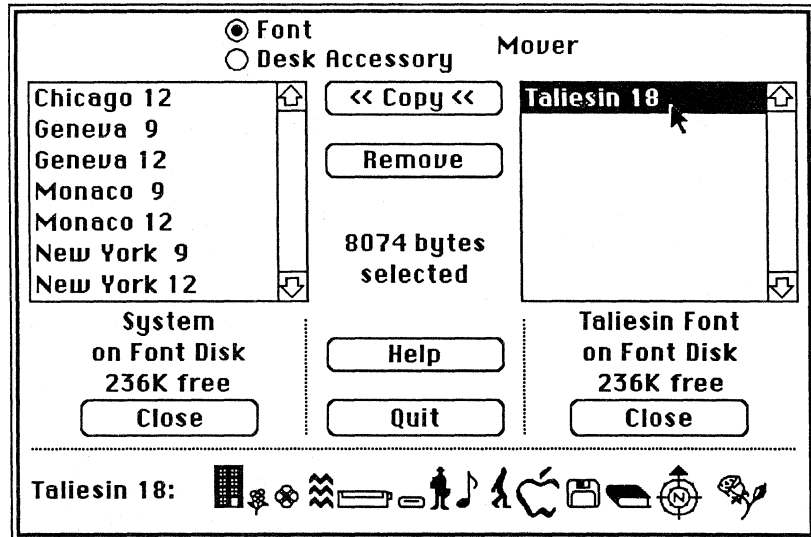

(Note: So far the operation of the software is very similar to that of the Font Mover. But the similarity ends quickly. Now, you can use either side of the dialog box for System files, or for storage files. The options aren't as limited as in the old Font Mover.)

6. Click **Close** at the bottom of the screen. The screen should look almost blank (compared with a moment ago).
7. Click **Open** on the lower left side of the screen. The document directory dialog box should appear.
8. When it does, open the Taliesin Font file. The Taliesin 18 font should now be showing in the upper left corner of the directory window on the left side of the dialog box.
9. Click **Open** on the lower right side of the screen. When the dialog box appears, open the System file. The directory window on the right side should display the fonts contained in the System file.

10. Copy the Taliesin 18 font to the System file on the Font Disk. Notice that two things happen:

- The elevator bar on the right side of the window should be highlighted. Scroll it down to view all of the fonts.

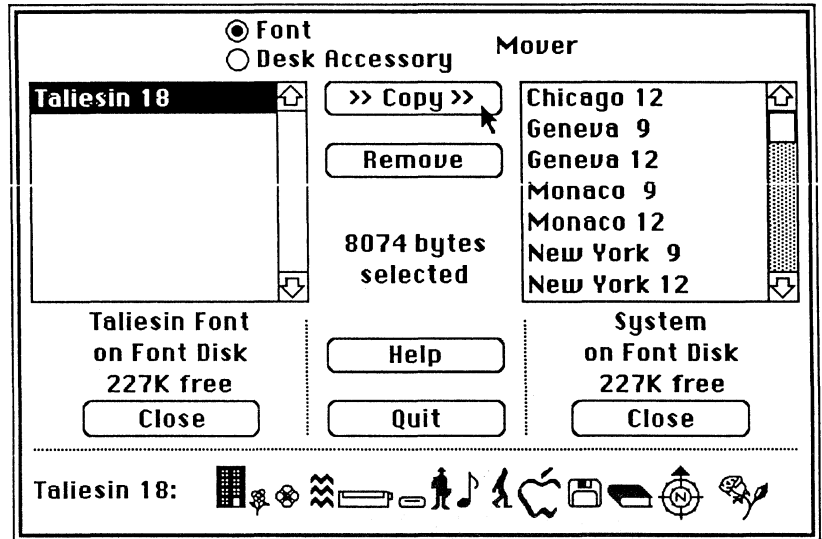

- The amount of free space on the disk is reduced by about 9K (as indicated by the number just above the **Close** button).

11. Scroll the System file down. You can see that the Taliesin 18 font has been copied to that file.
12. Click **Close** to close the Taliesin Font file.
13. Click **Open**.
14. Insert a startup disk in the external disk drive. Use the Font/DA Mover buttons to open the System file on the disk in the external drive.

## Practice (cont'd)

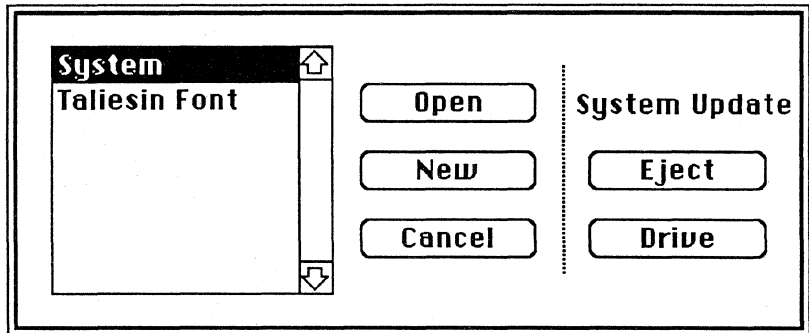

15. Now, copy the Taliesin 18 font from the System file on the internal drive to the System file on the external drive.

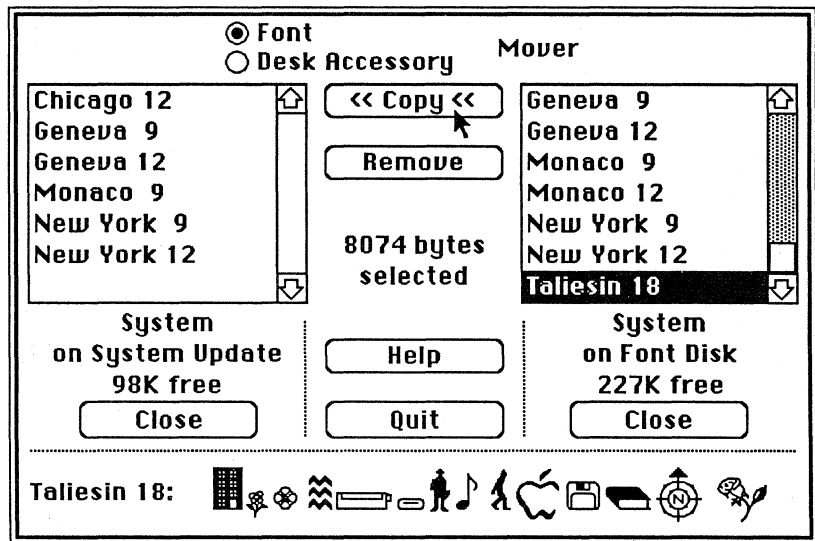

16. While the Taliesin 18 font is highlighted on the internal disk, click **Remove**.

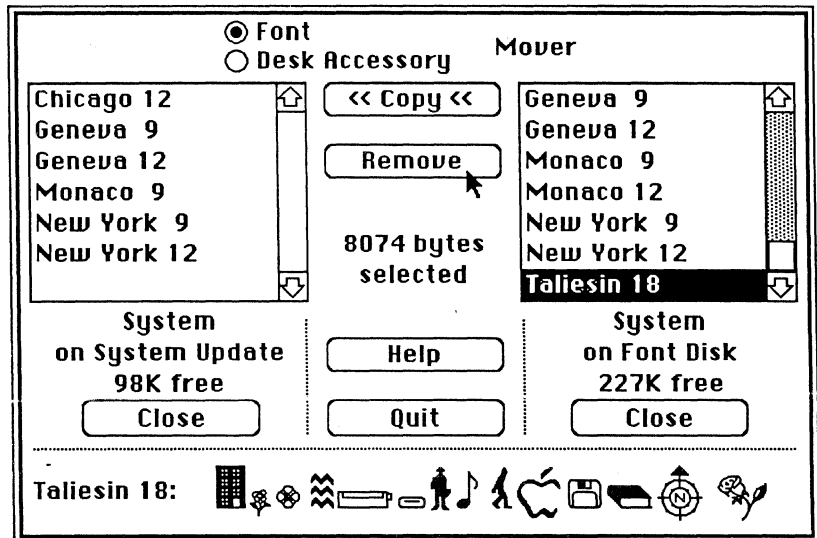

(Note: By removing the Taliesin 18 font from the System file, you have increased the amount of available space on the disk by about 9K.)

17. Your final Font/DA Mover screen should look like the one on the next page.



## Feedback

### Using Font Mover

Your final screen should resemble this one:

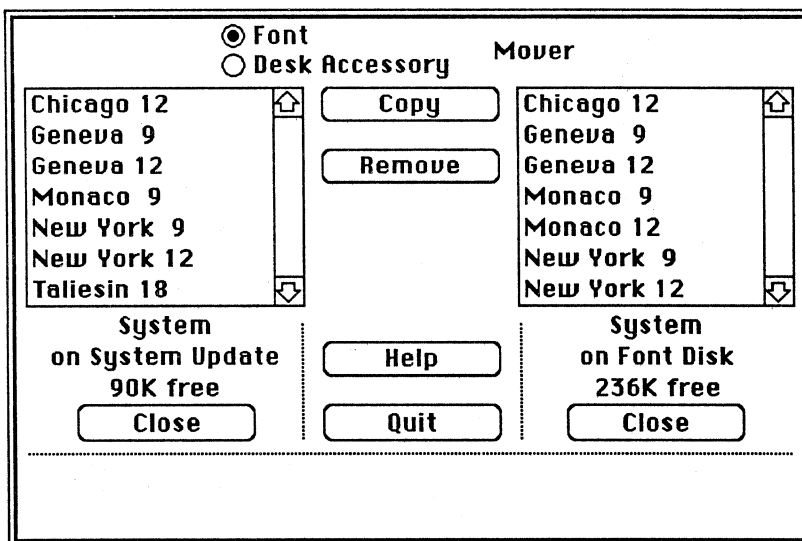

Both System files should be showing. You should have a copy of the Taliesin 18 font in the external disk, and copies of the seven fonts in the System file on the Font Disk that you started out with.

In this practice, you should have been able to move a font between two System files, remove a font from a System file, and use the Document Directories in the application dialog box to help maximize free disk space.

You also practiced moving font files between disks and using the buttons to manage files on two disks at once. It is also possible to use the buttons to help cycle a number of disks through the Font/DA Mover application.

If you need any help, or require further assistance, ask a colleague, check with your course manager, or contact your Apple support representative.

## The DA (Desk Accessory) Mover

### Overview

The Desk Accessory Mover is similar to the Font Mover in function.

The Desk Accessory Mover portion of the Font/DA Mover can be used to move desk accessory files into and out of System files.

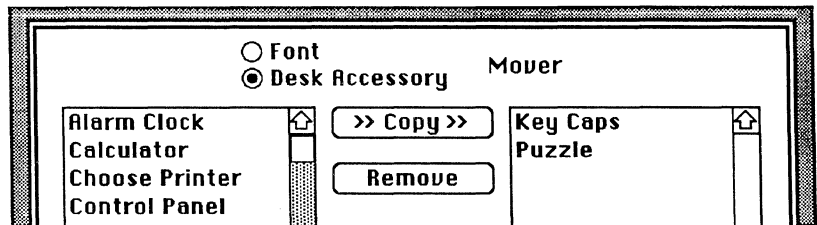

Desk accessories are accessed through the **Apple** menu. See Chapter 4 in *Macintosh*, the owner's manual, for more on the desk accessories.

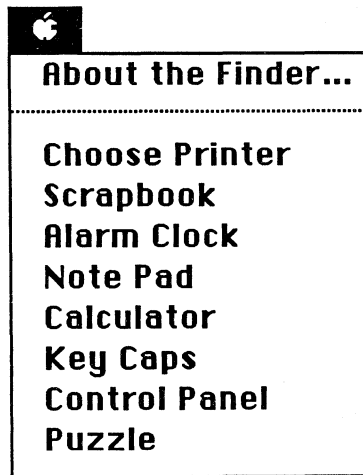

### Desk Accessories

You can have as many as 15 desk accessories on a disk.

Although the **Apple** menu can hold up to 15 desk accessories, you won't necessarily want to keep all of your desk accessories in your System file, where they can be accessed from the **Apple** menu. Desk accessories, like fonts, take up disk space.

That space can be used for other things, such as word-processing documents or high-resolution graphics.

The standard Apple-supported accessories are shown on the previous page, in the illustration of the **Apple** menu. These accessories are supplied with most Apple-supported Macintosh applications.

Not all of them are necessary to run applications. So, to create more disk space, you can remove some accessories, or move them to another disk for storage. Do *not*, however, remove *all* of the accessories from the System file. If you try to, you'll get a dialog box with the following message:

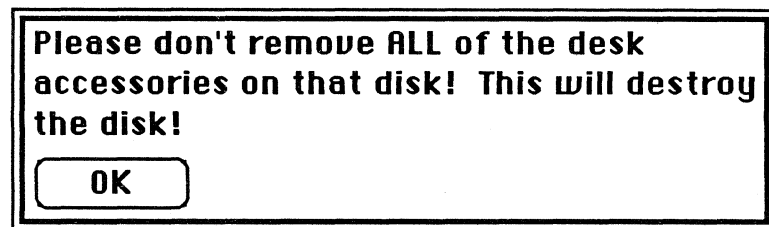

In addition, all of the standard Apple desk accessories, combined, require less than 30K of disk space. The Puzzle, for example, requires less than 1K, Choose Printer requires 6K, and the Control Panel, which helps control much of the Macintosh user environment, needs about 8K. You're not going to gain much space by removing them (but you may need that extra bit of room some time).

### **The Scrapbook, Note Pad, and Clipboard are unusual.**

You can throw away the icons for these files. As long as the Scrapbook and the Note Pad are in the System file, they can always be used, whether their icons appear or not. The icons will reappear when you choose them from the **Apple** menu. The same is true for the Clipboard icon. It can be thrown away, but it will reappear when you use **Cut** or **Copy**.

### **Third-party applications use the desk accessories, and add some of their own.**

Third-party vendors use the Apple-supported desk accessories, and have created many of their own. Some software is written to run exclusively as desk accessories, serving as "mini-applications." These mini-applications can provide very creative solutions to everyday processing needs. You can

customize your own desktop options by adding some of this third-party software using the Font/DA Mover.

### **There is an advantage to running small applications as desk accessories.**

A popular data communications package that's available as public-domain software is used on the desktop at the same time you're running an application such as MacWrite. It isn't as powerful as MacTerminal™, but you don't have to quit your application to use it.

Appointment calendars, telephone/address books, and spreadsheets are a few of the many desk accessory offerings that are currently available.

Apple supports only the desk accessories it supplies with its Macintosh system disks.

(Note: Some of these third-party accessories work very well. Others may not be completely compatible.)

---

## **Practice**

### **The DA Mover**

#### **Use the Desk Accessory Mover to remove a desk accessory from the System Folder.**

1. Use a backup of the System Update disk, or create a startup disk that contains the Font/DA Mover.
2. Check the startup disk to be sure that the **Apple** menu has all of the standard Apple-supported desk accessories (see page 14 for the list).
3. Open the System Folder on your backup disk. Throw away the Scrapbook and the Note Pad icons.

(Note: You're only throwing away the icons. If you open the **Apple** menu you'll see the Scrapbook and Note Pad still listed (even if you use **Empty Trash**). Don't worry, you'll have a chance to clear them out of the system.)

4. Close the System Folder, and open the **Apple** menu. Compare the list of accessories, and notice which accessories are still there.

## ***Practice (cont'd)***

5. Now, open the Font/DA Mover. Notice which part of the application opens first (Font or DA), and which file opens first (it should be the System file on the startup disk).
6. Click the Desk Accessory Mover button. Note the names of the files that are displayed in the Document Directory window of the System file, and write down the amount of space remaining on the disk.
7. Close the System file on the external disk, and click **Open**.
8. Create a new file called "For DAs Only."
9. Select the Scrapbook and the Note Pad.  

(Note: You threw away just the icons in Step 3; you didn't throw away the files held in the System file itself. The icons hold information not the actual Scrapbook and Note Pad files held by the System file.)
10. Copy the Scrapbook and Note Pad files into the "For DAs Only" file.
11. Remove the Scrapbook and Note Pad files from the System file on the internal disk. When that operation is complete, note how much space is free on the disk in the internal drive. It should be about 6K more than the amount you noted in Step 6.
12. Click **Quit**.
13. When you have returned to the Finder, select the **Apple** menu, and notice that the Scrapbook and Note Pad are no longer there.
14. Check the System Folder, and notice that the icons aren't there either. You have succeeded in throwing them away.

### **Try This**

#### **Throw away the icons.**

To experiment further, try this with another disk:

1. Throw away the icons of the Scrapbook and Note Pad, and empty the Trash.
2. Open the **Apple** menu, and choose the Scrapbook and then the Note Pad.

3. Check the disk window. The icons should appear.
4. Place them back in the System Folder, or else throw them away.

**Use the information in this exercise to back up your desk accessories.**

The other **Apple** menu desk accessories don't have icons on the desktop. The only way to access them is through Font/DA Mover.

Since they can't be copied using icons, use what you've learned in this practice exercise, and create a "DAs Only" disk that'll be a backup file for your accessories. Then they'll always be available when you need them.

---

## **Feedback**

### **The DA Mover**

#### **The Scrapbook and Note Pad don't act like the other desk accessories.**

When you threw away the Scrapbook and Note Pad icons, only the icons were deleted, and not the files. One of the ways to remove those files completely is to remove them using Font/DA Mover, as you just did.

#### **Creating a backup DA file.**

If you create a backup desk accessory file, you have some insurance against the unexpected.

### **More Practice**

#### **To get more practice using the Desk Accessory Mover, use the Font Mover practice.**

As you've seen, the Font Mover and Desk Accessory Mover are the same operationally. So if you would like more practice using the DA Mover, use the Font Mover practice exercise, just substitute desk accessories for the fonts.

If you have any questions, or need some help with this exercise, ask a colleague, your course manager, or contact your Apple support representative.

---

## Using the Original Font Mover

### Overview

**Review this section only if you support the original Font Mover.**

This section of the module was written prior to the release of the Font/DA Mover (Version 1.2). There are people who still use the original Font Mover, this section was included to help you support those people.

Much of the information in this section is repeated from the earlier part of the module. You don't need to complete this part of the module if you aren't supporting the original Font Mover.

When you're asked about the Font Mover, suggest that the user upgrade to the latest version of the application.

### The Original Font Mover

**The Font Mover can be an effective file-management tool.**

Review the section about the Font Mover in Chapter 3 of *Macintosh*, the owner's manual, and read the Font Mover "help notes" contained within the application. The notes are available when you open Font Mover and select "Help" from the Font Mover menu.

**Use the Font Mover to manage disk space.**

One of the advantages of word processing on the Macintosh is that you can use various fonts, font sizes, and type styles. The Font Mover and the Fonts file help keep track of the various fonts that are available, and can help to manage fonts efficiently on your disks.

**Don't use too much of a good thing.**

Fonts are maintained in files that average from 4K to 6K in size; 52 of the most commonly available fonts for the Macintosh require a total of about 230K of disk space. However, some fonts can require up to 14K. For example, the four basic fonts used by the system each require a total of 11K on a disk. Slightly less than 100 fonts can fill a disk. With all the various fonts available from Apple and third-party developers, it's tempting to load your disks with a multitude. Try to resist this temptation.

**Create a master font disk.**

To maximize the amount of space available on your disks for applications and documents, use Font Mover to create a master font disk. The fonts on this disk will be available to all of your other disks through Font Mover. By creating a separate disk to hold all of your fonts, you are assured of having all the fonts you need, when you need them.

**Fonts reside in the System file or Fonts file.**

The System file holds fonts and font sizes you can use with each application; each System file has its own set of fonts. You can customize your System files to hold the fonts you use the most. Fonts can be stored in a Fonts file when they are not being used by the System file.

**Fonts can't be used within an application until they are moved into the System file.**

The only time a font can be used by Macintosh is when that font has been moved into the System file by Font Mover. Each application can use a very wide variety of fonts. However, the actual number of fonts that can be used is limited by the size of the Font menu within each application.

**Font Mover is like a moving van.**

Disks are like houses that have rooms (files). The System file and the Fonts file are like rooms of furniture that store the fonts for current and future use. Font Mover is a vehicle used for moving and removing fonts.

The Fonts moving van is used to move furniture (fonts) from a fonts room in one house (disk) to a fonts room in another house (disk). The Fonts moving van is unique in that it can both move furniture from house to house, and also from room to room within a house.

The furniture can be either stored for future use, or moved into the System file for immediate use.

Font Mover is simply a vehicle to move fonts from one disk file to another, and from a Fonts file on a disk to the System file and back again.



**Some fonts are reserved for system use.**

Chicago-12, Geneva-9, Geneva-12, and Monaco-9 are the four fonts reserved for system use. You see them displayed on the screen in menus, icon names, and other places where system- or software-generated text appears on the screen. These fonts can't be removed from the System file.

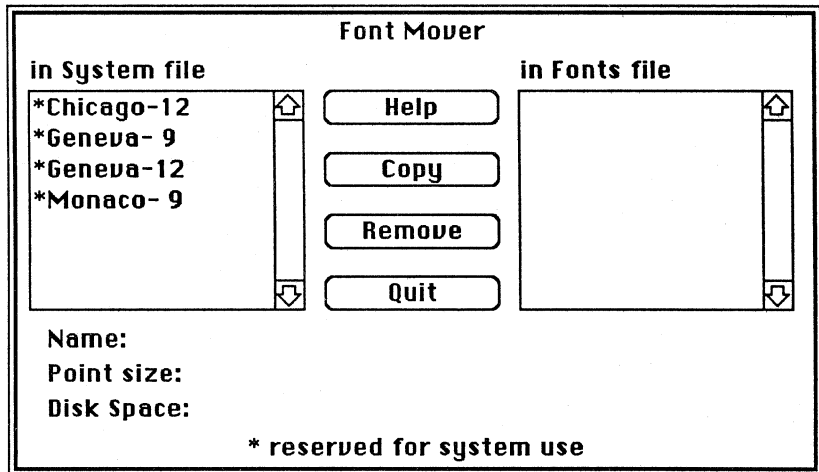

**Basic fonts, the System file, the Finder, and the Font Mover require about 130K.**

To create a master font startup disk, start with the basic file configuration shown below. You need to have the System file, Finder, and Font Mover on the disk. Those three files and the four basic fonts (shown above) take up about 130K.

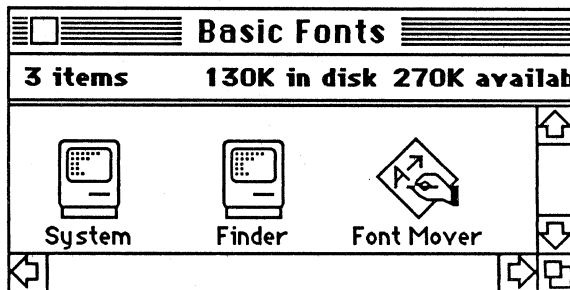

The disk used in the illustration below has 52 fonts and uses about 200K for fonts only. It has the 4 fonts needed by the system, and 48 other fonts from Apple and third-party developers.

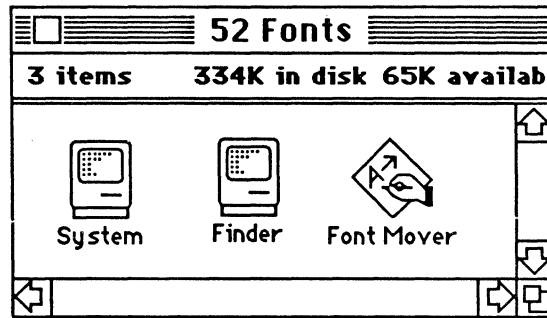

### Fonts can crowd a disk.

As you can see, 52 fonts plus the System file, the Font Mover, and the Finder, nearly fill a disk. Below is an example of a disk that has no System file or Finder, just 52 fonts and the Font Mover—yet more than half the disk is full.

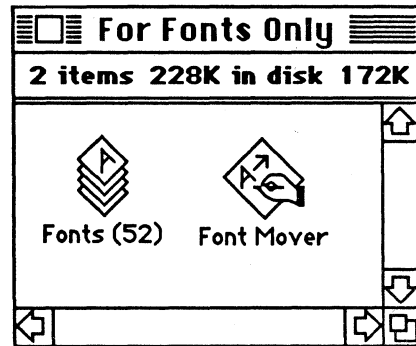

### Create a fonts-only disk.

To create a fonts-only disk, simply use Font Mover to copy as many fonts as you have into one Fonts file. After you have done this, move the Fonts file and Font Mover onto a disk that contains no other files. There is a practice exercise at the end of this section to help you do this.

(Note: If you are working on a Macintosh XL, you can load up the disk with all the fonts you think you will be using on a regular basis. Remember, though, the more files you have on your hard disk, the more the Finder has to work to keep track of them.)

### **How many fonts do you need on a disk?**

The best MacWrite startup disk is one that has the smallest number of fonts on it, thus providing the maximum available space for your documents. Using Font Mover, you can create a MacWrite disk that contains only those fonts and resources you will need for a particular document or set of documents.

To do this, you need to determine what font and font sizes you plan to use, and then decide on the type of printing: ImageWriter (standard or high-resolution), LaserWriter, or another printer such as a daisy wheel printer. Making these decisions and selecting your fonts ahead of time will help minimize the number of "Disk full" messages you'll get.

### **Print Quality**

#### **Standard resolution print quality requires one point size.**

Most of this document was created using Helvetica™ 12-point font. That font had to be available to the application from the startup disk's System file. No other font (except the required system fonts) was needed on this disk to create it or to print it in standard-resolution print on an ImageWriter.

## High-resolution print quality requires two point sizes.

High-resolution printing uses the point size that is twice the size you see on the screen, and compresses it to produce higher-quality printed letters. For example, to print high-resolution 12-point Geneva output, 24-point Geneva must be available.

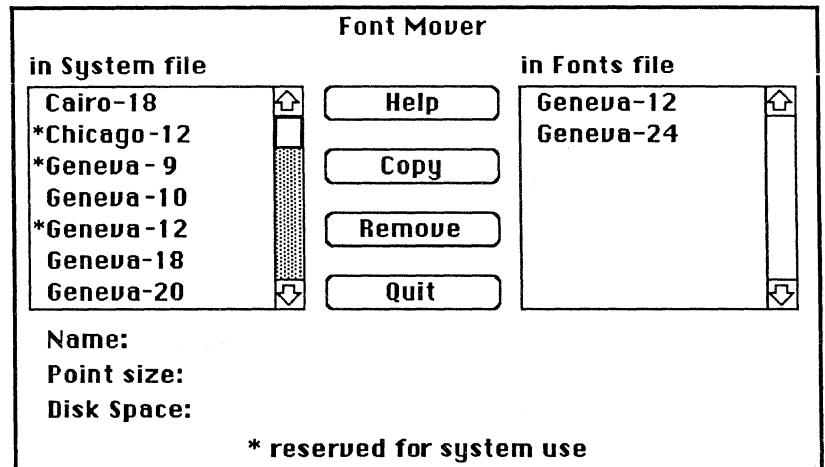

Once a font is no longer needed on a disk, remove it. Otherwise you'll be wasting disk space.

---

## Practice

### Disk Space

#### How much room do fonts consume?

1. Turn on your Macintosh and insert your MacWrite application disk.
2. *Do not use your original MacWrite disk for this exercise.* Back it up onto a "clean" disk (either initialize, erase, or copy over a disk). Label your new disk, and set aside your original MacWrite disk.

## ***Practice (cont'd)***

3. Be sure there's a Font Mover file on the MacWrite disk you've just created. If there isn't, find a disk that has Font Mover on it and move it to your new backup MacWrite disk.
4. You should now have a new startup disk with MacWrite and Font Mover on it.
5. Turn off your Macintosh and start it up from your new MacWrite startup disk.
6. Open the disk window.
7. Write down the amount of space on your disk.
8. Open the Font Mover.
9. Count the number of fonts in the System file. In the example on the previous page, there are about eight fonts available (only seven are showing).
10. Follow the directions in Chapter 3 of *Macintosh*, the owner's manual. Use Font Mover to remove all of the fonts except those required by the System file. Remove any fonts in the Fonts file, also.
11. Choose **Quit** from the Font Mover menu.
12. Once you're back to the desktop, write down the amount of space you now have on your disk. You should have more space now as a result of removing the fonts from your disk. You also now have a MacWrite disk that isn't cluttered with unnecessary fonts.

## Fonts-Only Disk

### Create a fonts-only disk using Font Mover.

(Note: This exercise is for use with the original version of Font Mover, not the Font/DA Mover.)

1. Get a recycled or erased disk (an initialized disk).
2. Insert the disk into your external drive and name it "Fonts Only."
3. Copy Font Mover onto the disk.
4. Open Font Mover, select all of the fonts in the System file and copy them to the Fonts file. If there isn't a Fonts file on your disk, Font Mover will create a new one.
5. Choose **Quit** from the Font Mover menu.
6. Since your new MacWrite startup disk has so few fonts (in the previous exercise we removed all of the fonts except the ones required by the System file), you'll need to get your Macintosh system disk. This will have several more fonts on it.
7. Eject the MacWrite disk. Turn off Macintosh. Insert the System disk and turn on Macintosh.
8. Open Font Mover on your fonts-only disk.
9. You'll see that there are more fonts available to you. Select all of the fonts you want to move.

(Note: If you try to copy fonts from the System file to the Fonts file, and they are already there, a dialog box will appear and state which fonts are already present. Click **OK**, or press Enter to continue.)

10. Continue the process of copying fonts from other System files until you either fill the disk or have as many fonts on the fonts-only disk as you feel you might use (be sure to save space for some of the exotic fonts such as Cairo and Symbol font—they're fun to use).
11. Eject the fonts-only disk and label it. Store it where it's safe and easily accessible.

---

## **Feedback**

### **Fonts-Only Disk**

#### **Using a fonts-only disk saves disk space and time.**

Now that you have a fonts-only disk, you don't need to worry about removing fonts from different disks to free up more space for documents. All of your fonts are on one disk. Since you don't have to hunt through several disks to find them, you'll save time.

Use the fonts-only Fonts file to supply the System file with the fonts you need for a particular document or application. To use it open the Font Mover on the fonts-only disk.

### **If You Have a Question**

#### **If you had any trouble with this exercise, ask questions.**

Your course manager, a colleague, or your Apple support representative will help you with any questions you might have about the Font Mover.

## Questions and Answers

### Font Mover

*I tried copying the Taliesin 18 font with my Macintosh 128K. All I got was a Finder error. How can I copy this font? It has a few characters on it I would like to use.*

Due to a system enhancement, you can't use the Font/DA Mover (Version 1.2) to copy the Taliesin 18 font on your Macintosh 128K.

### Select Multiple Fonts

*How do I select multiple fonts (to copy, or to remove)?*

There are two methods:

- If you're selecting multiple fonts that follow each other in succession in the directory window, click the first font, and drag to the last font you want to select.
- Shift-click, as if you were selecting documents or files.

(Note: These same methods apply to selecting desk accessories.)

### MacDraw Fonts

*I installed a few more fonts in my System file, but now when I open MacDraw™ I can't use some of the fonts. In fact they don't even appear in the Font menu. How can I correct this?*

To correct this, you must:

1. Copy the font(s) you want to use from the System file.
2. Remove the font(s) from the System file.
3. Then copy the font(s) back into the System file.

This will change their position in the **Font** menu and allow you to access them.

For example, you want to use the Taliesin font. Since you've just installed the LaserWriter fonts, the Taliesin font no longer appears in your MacDraw **Font** menu. To change its order in the **Font** menu, you must follow the steps shown above.

### Desk Accessories

*Are all desk accessories compatible all the time?*

All Apple desk accessories are compatible with all Apple applications. This isn't necessarily true for all third-party applications.



## New System File

*When I installed a new System file, I lost a lot of my desk accessories. What happened?*

When you replaced your System file with another System file, all of the desk accessories and fonts in the new file replaced the old ones. *Always* back up your files, including your System files so that you have copies of your desk accessories. If you have to replace a special System file, it's always easier to do from a backup file.

*I tried to install a desk accessory using the installation disk supplied with the application. All I got were errors, and now my System file doesn't work at all. What should I do?*

Start up Macintosh from another startup disk. Replace the damaged System file with the one on the current startup disk (use your backup System file in place of the damaged file).

The error you encountered could have been because there wasn't enough room on the disk for the new desk accessory. Some desk accessories can require up to 35K of disk space. Use the Font/DA Mover to free some space on the disk, and try the operation again. If you are still unsuccessful, call your support representative for that application.

## New Accessories

*I used the Font/DA Mover to install a desk accessory, but it doesn't work. Why?*

There could be several reasons. A common situation with third-party desk accessories is that they require backup files on the disk. For example, one popular calendar program uses a document in the System Folder to hold its text files. If that backup file isn't present, the desk accessory won't work properly.

Check the installation disk for a file or a document other than the desk accessory file. Copy that file or document onto the startup disk, and try the desk accessory again. If that doesn't work, read through the instructions again; if you still have a problem, call the support representative for that product.

---

## Review

### Overview of the Font/DA Mover

**The Font/Da Mover is one application that can manage two types of files.**

The features of this application allow you a great deal of flexibility. The functions of fonts and desk accessories are different, but this application handles both of them to create a specialized and personalized processing environment.

### Font Mover

**Font Mover moves, removes, and copies fonts for use and for storage.**

Font Mover has been enhanced to include the ability to move fonts between several files of different names, including the System file. You can create your own Font files, and name them anything you wish.

Font Mover is used primarily to save disk space; however, its use also saves a lot of time. You don't have to look far to find your favorite fonts, and since you are managing your disk space, you don't have as many "Disk full" messages.

### DA (Desk Accessory) Mover

**Operationally it's the same as the Font Mover.**

The greatest advantage of this application is its ability to move desk accessories into and out of the System file (the same way you can move Font files).

You can remove desk accessories from a disk to create more space for truly great documents, and fascinating illustrations. Any desk accessories that you remove can be stored for future use.

### Using the Original Font Mover

**This section is a review of the original Font Mover application.**

The original application is still used by many people. However, users should be encouraged to upgrade to the Font/DA Mover.

---

## Resources

- AppleLink™ Technical Info Library, (available to Apple support personnel from Apple Computer, Inc.)
- *Macintosh*, the owner's manual

*Apple and the Apple logo are registered trademarks of Apple Computer, Inc. AppleLink, ImageWriter, LaserWriter, MacDraw, MacPaint, MacTerminal, and MacWrite are trademarks of Apple Computer, Inc. Macintosh is a trademark of McIntosh Laboratory, Inc. and is being used with the express permission of its owner. Helvetica is a trademark of the Allied Corporation and is used by Apple under license.*

# Managing Macintosh Files

---

## Contents

2	Objectives, Materials
3	Folders and File Structure <i>Folders can define a file structure or file hierarchy.</i>
15	Lock an Icon <i>The Get Info information window can be used to lock an icon, and to make notes about the information in that icon.</i>
18	The Document Directory Dialog Box <i>Learn more of the uses of the Document Directory and the Save As dialog boxes.</i>
26	Review
27	Resources

---

## Overview

This module is an overview of techniques you can use to manage Macintosh™ computer documents, applications, and files. It discusses how to use dialog boxes and other Macintosh desktop features to organize your documents and folders.

This module is designed for everyone who uses Macintosh or who supports other users.

### Prerequisites.

- Before beginning this module you must know how to use Macintosh, the Macintosh Finder, Font/DA Mover, and MacWrite™. To achieve this level of knowledge, complete the Apple Support Training Library modules, *Supporting the Macintosh Finder*, *Supporting the Font/DA Mover*, and their prerequisites.

---

## Objectives

- Define what's meant by a Macintosh file, document, and application.
- Define the difference between a startup disk and a data (nonstartup) disk.
- Use folders, and describe why they help to define file structure.
- Use the Finder to effectively manage the system and minimize disk swapping.
- Lock an icon. Describe what that does, and use other information window features to help keep track of the information in your documents and files.
- Open, name, and save documents to the current startup disk, or to another disk, using the Document Directory dialog box.
- Use the Document Directory dialog box to cut and paste information within an application.

---

## Materials

### To complete this module, you will need:

- A Macintosh 128K, a Macintosh 512K, or a Macintosh XL
- An external disk drive
- *Macintosh*, the owner's manual
- A startup disk that includes the Finder Version 4.1, the Font/DA Mover, and MacWrite

## ■ Folders and File Structure

### Overview

#### **Macintosh uses folders to help you organize your files, documents, and applications.**

The Macintosh Finder uses a flat file structure with 400K disk drives and the Macintosh XL. It uses a hierarchical file structure with other Macintosh disk drives, such as the Hard Disk 20.

This section discusses how to use folders to organize your files, documents, and applications within a flat file structure. It tells how a flat file structure differs from a hierarchical file structure.

### Files, Documents, and Applications

#### **Organize files, documents, and applications in folders on disks.**

Macintosh has three designations for icons (files): System files, working documents, and applications.

- System files are normally found in the System Folder. They typically include the System file, Finder, printer resource files (such as the ImageWriter™), Scrapbook file, Note Pad file, and the Clipboard file.
- Working documents can be MacWrite word-processing documents, MacPaint™ graphics documents, or any other working file created by an application. Often they are referred to as data documents, or data files.
- Applications are the programs used to create documents. MacWrite and MacPaint are examples of applications.

During this module, the term "file," as in "file-management," will be used generically.

For more information on these designations, see the Disks, Documents, and Folders section in the Apple Support Training Library module, *Learning to Use Macintosh*.

## Macintosh and File Structure

### Macintosh uses a flat file structure rather than a hierarchical file structure.

All Macintosh disk files (except those using the HFS Finder) are maintained at one level on the disk directory in a flat file structure. That means that Macintosh looks at all of the files on the directory at one time.

Some operating systems, such as ProDOS<sup>®</sup>, MS-DOS, PC DOS, and CP/M, have a hierarchical filing system. The object of hierarchical file structure is to group files in a logical order within a directory and subdirectories on a disk.

### Directories and subdirectories are used to access files.

When a disk (or volume) is first formatted, it gets a name and a directory. Anything you save on that volume is accessed through its directory. The directory is a file that keeps track of where other files on the disk are stored. You could say that a directory file is like an address book.

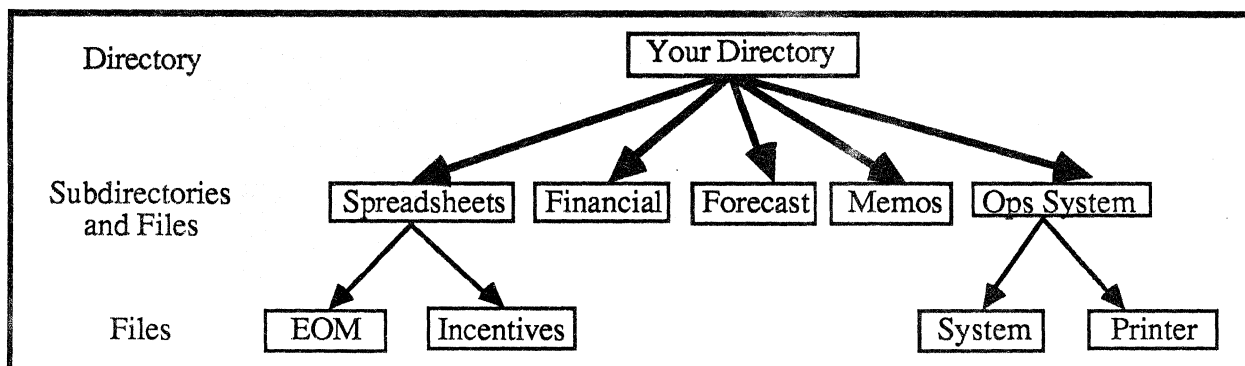

At some point, you'll want to organize your files (especially if you're using a hard disk) so you won't have to shuffle through your financial reports to get to your incentive plan. To do this, you'll need to establish a "hierarchical" file structure.

In the example shown above, the file structure starts with a directory file named "Your Directory." It has subdirectories titled "Spreadsheets" and "Ops System." The subdirectories contain the documents "EOM" and "Incentives," in addition to the System and Printer files. Financial, Forecast, and Memos are files (or documents), not subdirectories.

So, "Your Directory" knows the addresses for Spreadsheets, Financial, Forecast, Memos, and Ops System. "Spreadsheets" knows where to find the EOM and Incentives documents. "Ops System" knows the location of the System and Printer files. This kind of arrangement is called a hierarchical file structure because files are organized into successive levels.

### Folders and Flat File Structure

### Folders create the illusion of a hierarchy.

Folders were developed to allow Macintosh icons (files) to appear in a hierarchical display on the screen.

By placing one or more icons and/or folders into another folder, Macintosh icons can be grouped logically. The System Folder, shown below in a screen shot (from a Macintosh XL), is like the Ops System subdirectory in the previous example.

The files you see (System, Finder, Note Pad File, and so on), are organized in the System Folder (subdirectory), just as System and Printer were found in the Ops System subdirectory.

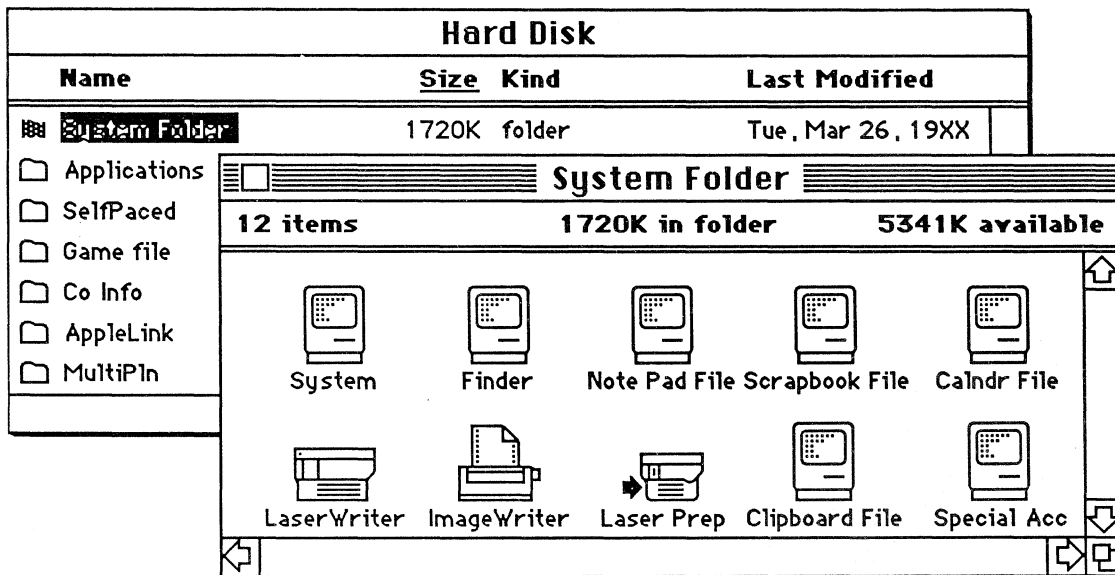

The directories, subdirectories, and files (folders and documents) are displayed as icons that can themselves be placed within icons of folders. You can create multiple levels of folders, similar to a hierarchical structure with directories and subdirectories, by putting folders within folders.





---

## ***Practice***

### **Create a Series of Folders**

### **Use folders to organize your files, documents and applications.**

1. Choose **New Folder**, and name it "The Directory."
2. Open The Directory and put all of the documents and folders on your MacWrite disk in it (don't include the applications).
3. Choose **New Folder** and name the empty folder "Applications."
4. Place all of your applications, such as MacWrite, in that folder, and place it inside The Directory.
5. Create another folder named "MacWrite Docs," and place all of your MacWrite documents in it. Place that folder in The Directory.
6. Stop here, or continue to add new folders until you've arranged all of your icons (files, documents, and applications) in folders.

# Feedback

## Folder Review

**Organize your files, documents, and applications by using folders.**

At the beginning of the exercise, your desktop may have shown icons of many files, documents, applications, and folders, similar to the screen shot below.

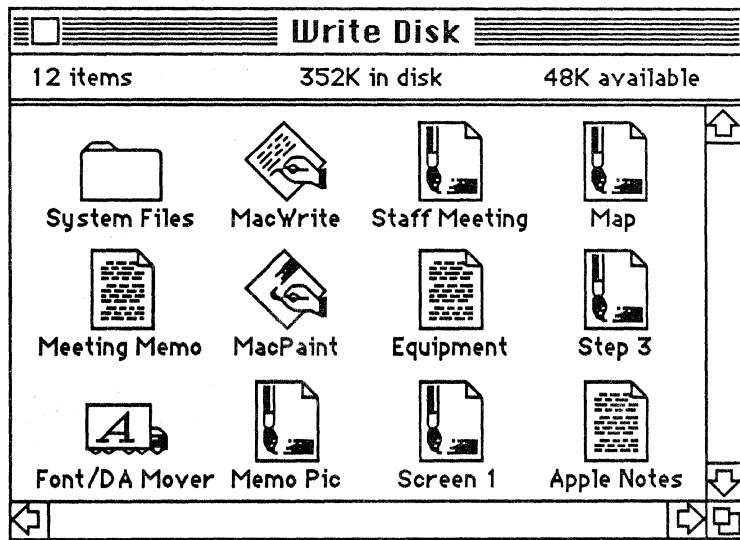

No matter how many icons you started with, your final screen should look similar to the screen shot below.

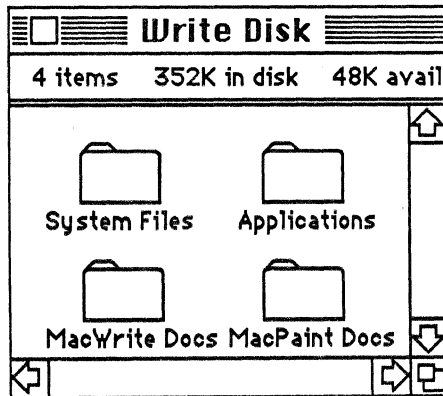

Open each folder. Your organization should look like this.

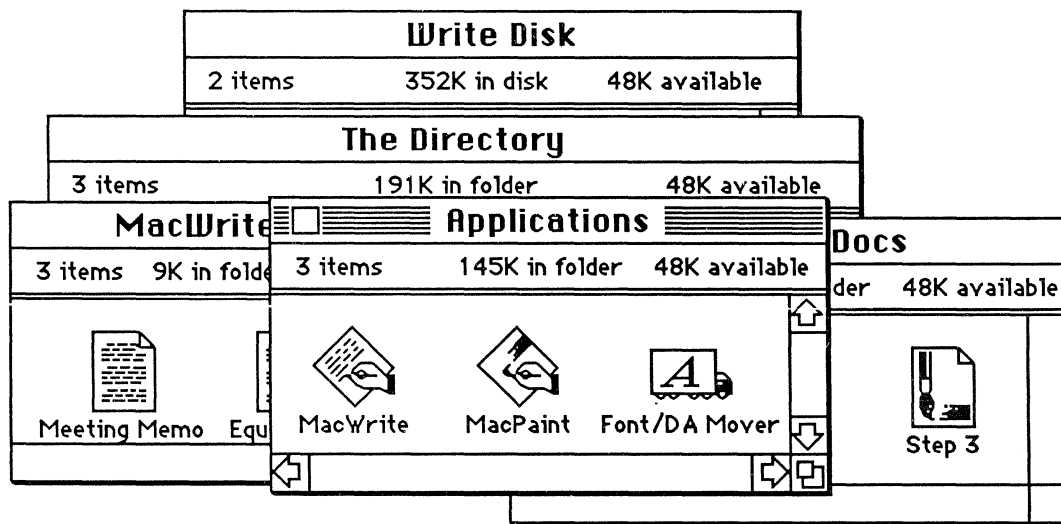

The folders on the Write Disk form a hierarchy.

The folders shown above, when illustrated as a hierarchy, have the structure shown below.

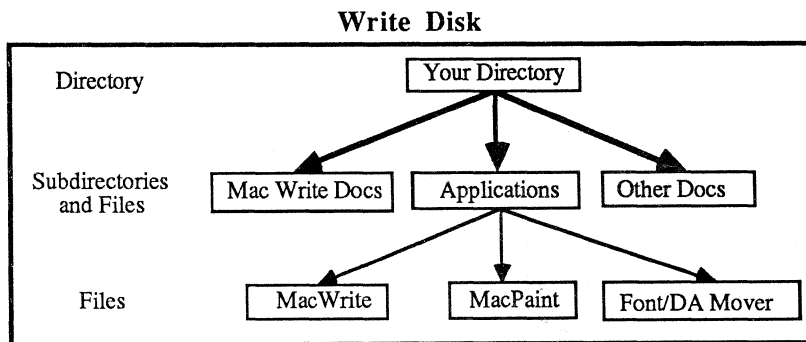

Discuss the use of folders with a colleague, your course manager, or your Apple support representative. Since everyone has a different method, ask these people how they use folders. Do they organize documents by date, by subject, or by project? Choose a method that works for you.

---

## Folders and File Structure (cont'd)

### Managing Files on a Disk

#### **Review your icons and their organization regularly.**

As you can see, the effective use of folders to organize your files, documents, and applications is very important. It is even more critical if you're using a hard disk for storage. You should monitor all of your icons regularly. Since documents on your disks can become outdated very quickly, it's helpful to review them once a month and remove any that are unneeded. The fewer icons the Finder has to manage, the faster it will perform its functions.

The Finder can, however, keep track of a large number of icons. Version 1.1g, for example, can keep track of over 100 files, documents, and applications. Newer versions of the Finder can manage increasingly larger numbers of icons quickly and efficiently. For example, Version 4.1 manages up to 500 icons.

### System Folders and Startup Disks

#### **Keep track of your startup disks.**

Most startup disks have a System Folder that contains a System file and a Finder. Nonstartup disks, or data disks, don't contain the System file or Finder. They therefore have more room for applications and documents. For more information on startup vs. nonstartup disks, see the Installing the MiniFinder section of the *Supporting the Macintosh Finder* module.

### Disk Swapping on a Two-Drive System

#### **Disk swapping might be necessary even with a multidrive system.**

A frequent complaint is as follows: "I tried to copy a document onto this disk, and the system keeps prompting me to swap disks. I thought that since I have a second disk drive I wouldn't have to swap disks again."

If you copy your internal startup disk to your external disk by moving the icon (disk copy on the 512K), you usually won't have to swap disks.

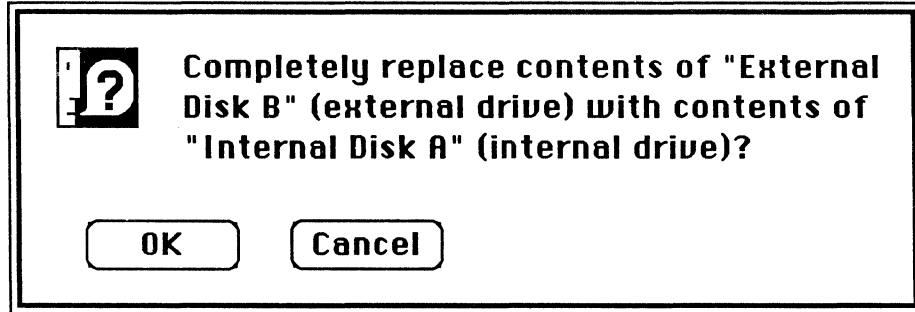
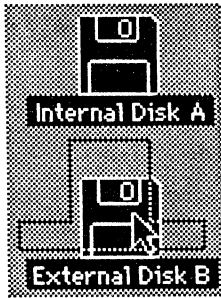

However, if you're copying a disk other than your startup disk to your external disk, the Finder will ask you to swap disks.

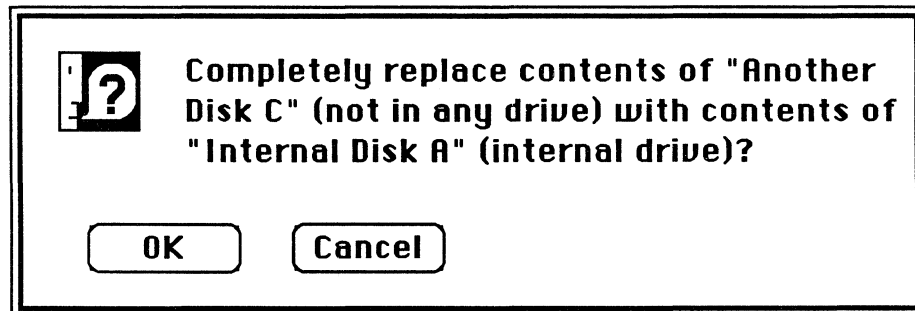
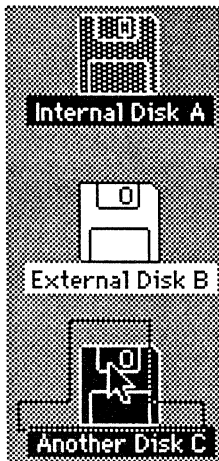

**The startup disk uses its Finder to keep track of your disks during the copy sequence.**

When you start up a disk, its Finder keeps track of your files. If you start up your two-drive Macintosh with a startup disk in each drive (insert them both before you turn it on), the Macintosh will use the Finder and System files in the internal drive to keep track of the files on both disks.

**A Startup Disk in Each Drive**

**Macintosh will default to the System file and Finder on the application disk.**

As soon as you start up from an application that's on the external disk drive, Macintosh will use the Finder and System file on that disk instead of those on the original startup disk. Until you change it, the startup disk is now the one located in the external drive.

### The Macintosh XL's icons reflect any changes.

One of the easiest ways to see this change in startup disks occur is by using a Macintosh XL. When the Macintosh is started up and the desktop appears, the icon in the upper right corner of the screen is usually the hard-disk icon.

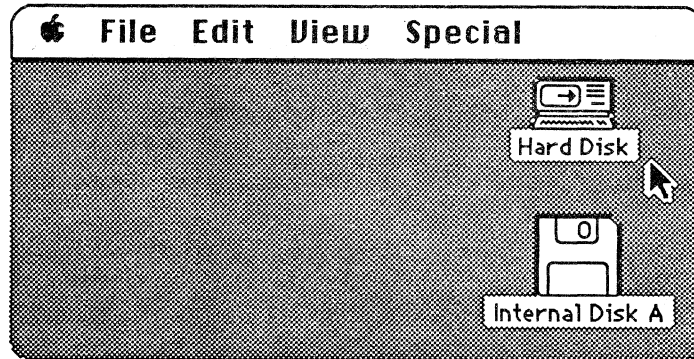

Insert a startup disk that has an application on it—for example, a MacWrite or MacPaint startup disk. Open the icon for that disk and double-click on an application icon in the disk window.

Once the application's "Untitled" document appears on the screen, quit the application. As you return to the desktop, the internal-disk icon will appear in the upper right corner.

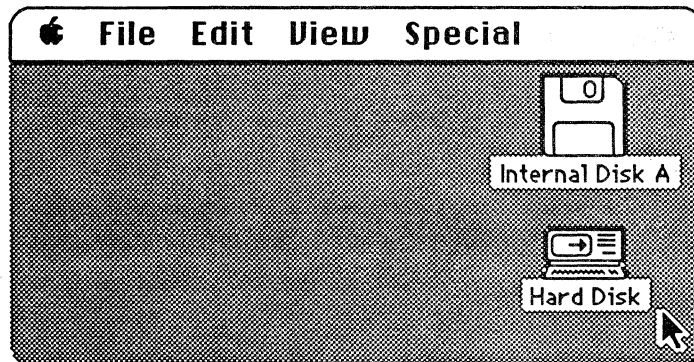

The hard-disk icon will appear below the internal-disk icon for the smaller disk. Sometimes (depending on the version of the System file you're using) the hard disk may have the 3.5-inch icon image.

## Documents use the startup disk applications.

If you open a document from the second disk, and that document's application is on the first disk, the first disk will remain the current startup disk (even if the application is also on the second disk)—see example, below.

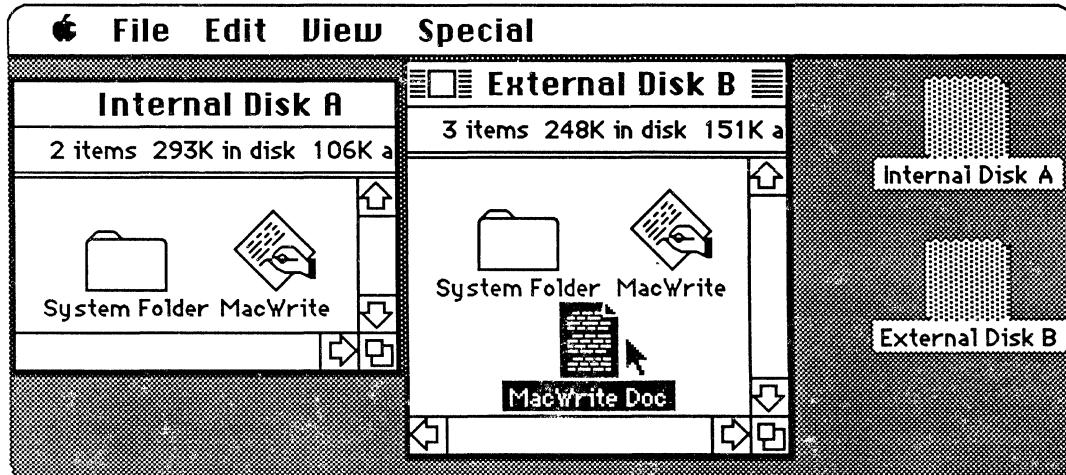

## Other File Management Hints

### Make the second disk in a two-drive system the startup disk.

Another way to change the startup disk in a two-drive system with two startup disks is to:

1. Open the System Folder on the disk that isn't the current startup disk.
2. Double-click on the Finder icon while holding down the Command and Option keys.

This is handy if you want to keep one disk as your startup disk, and change either disk quickly, without restarting Macintosh.

### Maximum number of windows open on the desktop.

Generally, you can have up to seven windows open on your desktop at one time. This allows for easy visual file management, and offers flexibility in moving files from one folder or disk to another.



But be careful: Trying to open more than seven windows at once will bring up a dialog box that will warn you not to open any more. You won't lose any files, however. Just click **OK** and close a few windows before you continue.

### **Restart a Macintosh XL without turning it off.**

Beginning with MacWorks™ Version 3.0, you can restart your Macintosh XL, or change your startup disk from the hard disk to the internal disk, without turning the system off.

- To restart the Macintosh XL, hold down the Command key while you press the white On/Off switch. You will restart the Macintosh XL from the hard disk, and return to the desktop.
- To restart the Macintosh XL from the internal disk drive, hold down the Option and Command keys while you press the white On/Off switch. You'll restart from the disk in the internal drive. If you have neglected to insert a startup disk in the internal drive, a "?" icon will appear until you do insert one.

### **Additional techniques are available.**

Other helpful techniques are available from resources such as *Macworld* and other Macintosh publications. Also, see the Apple Support Training Library modules that cover each application.

## Lock an Icon

### Overview

**Lock an icon to help you keep track of what's in it, and to protect information.**

People often assume that when a document, application, folder, or disk is locked, it's completely protected. This isn't always true. This section discusses locking, and describes the handy information box that helps you keep track of what's in a locked icon.

**Lock an icon to keep it from being renamed or thrown away.**

To lock an icon, choose **Get Info** from the **File** menu.

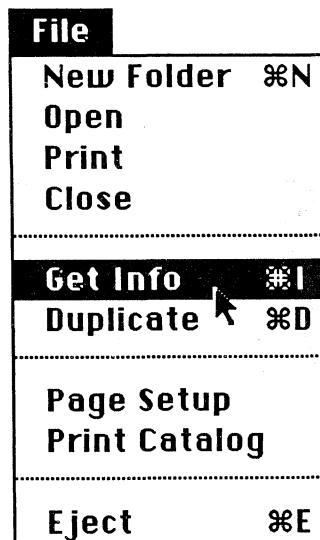

When you do, a window such as the one on the next page will appear. Read the note at the bottom of the window.

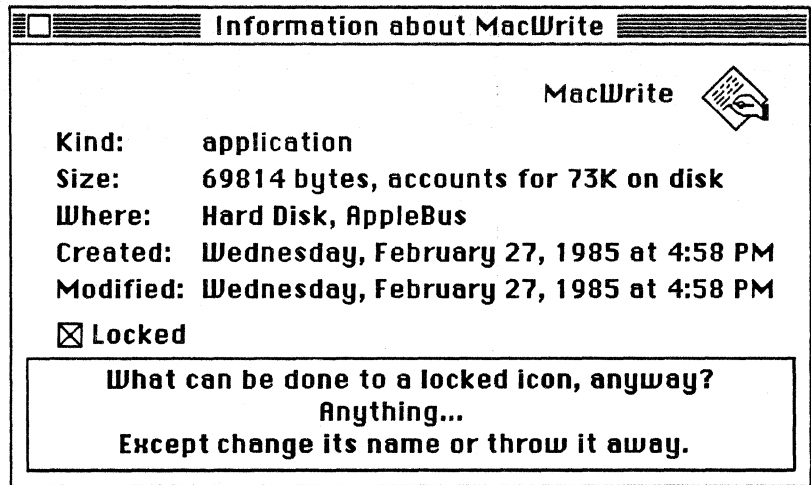

You can cut, copy, and paste to and from a locked icon, just as you would with any other file. Some operating systems have "write protect" or "read only" functions available that won't allow a specific file or document to be edited. A locked document, System file, application, or folder *isn't* a "write protect" or "read only" icon—it *can* be changed.

But you can't change the name of a locked icon, and you can't throw it away. You can remove an icon from a locked folder, but you can't put it back without unlocking the folder.

If you want to lock a document so that parts of it can't be removed or destroyed, you must lock (or "write protect") the disk that the document is on.

## Use the Get Info window for notes about icons.

When you lock an icon, be sure to use the box that's provided for notes. You can use it to record brief notes about the contents of the icon, or to explain why you've locked it. That way you never have to leave the Finder to know what you've put in a document. For example, see the notes on the Switcher™ document below.

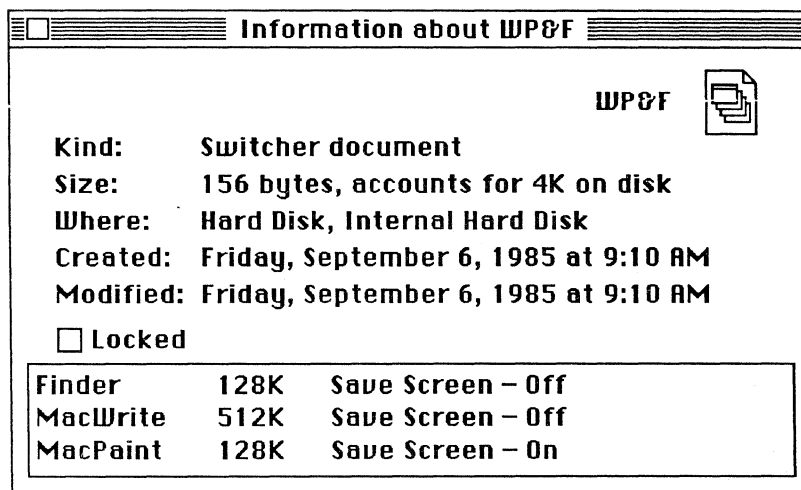

If you use the Switcher regularly and have several Switcher documents, the names of the documents can't tell you very much. But, you can use the box to record notes that tell you about the applications you've installed, the options you've selected, and the amount of space allocated for each. Otherwise, you must open the document and watch Switcher install it to find out what it contains.

For more information about how to use **Get Info**, see Chapters 1 and 4 in *Macintosh*, the owner's manual, or see the Apple Support Training Library module, *Learning to Use Macintosh*.

# The Document Directory Dialog Box

## Overview

The Document Directory dialog box resides inside each application.

A convenient way of managing documents within an application is by using the Document Directory dialog box.

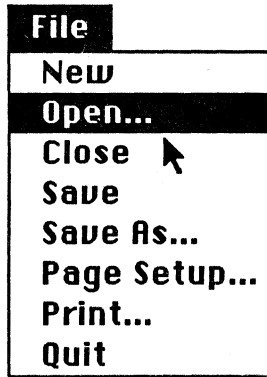

The Document Directory dialog box appears on the screen when you choose Open.

When a document is closed and you choose Open, a dialog box similar to the one shown below will appear. The documents shown on the left side of this dialog box are MacWrite documents that are available on the disk titled "Write."

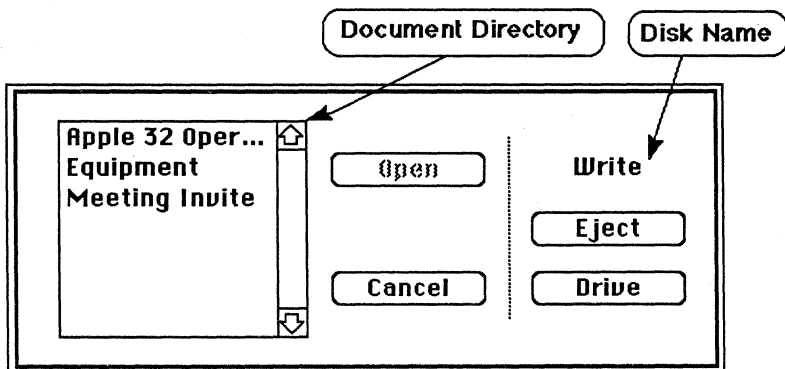

### Sometimes the Document Directory dialog box is referred to as the Standard File.

Occasionally you'll hear the term "Standard File." This is a technical reference to the Document Directory dialog box.

### The Document Directory and Save As dialog boxes are available in most applications.

Within most applications, there's a Save As dialog box that appears the first time you save an "Untitled" document, or when **Save As** is chosen from the **File** menu.

There are two ways to save an entire document or text from the Save As dialog box. The first way is to type in the name of the file and click **Save**. The document will be saved to the disk displayed in the upper right corner of the dialog box. If you want to display the documents that are on the other drive, click **Drive**, and you'll see the name of the other disk appear, along with the display of its documents.

### The colon in the document name box can be used to save files.

Another way to save a document to a specific disk is to type the name of the disk you want to save the document to, followed by a colon (:) and the name that you want to use for that document, as shown in the example below.

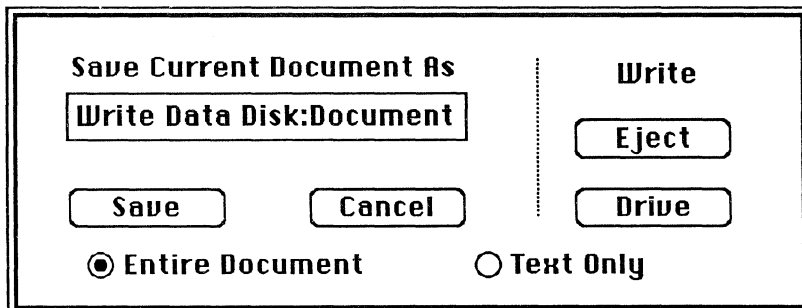

*Macintosh*, the owner's manual, states that you can use any character on the keyboard except the colon when naming a document. This is because the colon is used by the Macintosh to separate the name of the disk from the name of the individual documents on that disk. If you use this command, be sure the icon name appears exactly as it's spelled.

### Other buttons extend your Save As options.

In the example above, you can see the **Entire Document** and **Text Only** commands. These commands change with different applications. Also, some Save As dialog boxes have a different look. See the manual for each application for the specific meaning of each of the options available.

### Save Time When Saving Documents

#### Save files by choosing either Close or Quit.

An easy way to save time is to choose **Close** or **Quit** from the **File** menu before choosing **Save** from the **File** menu. This reduces the number of keystrokes it takes to **Save** and **Close** a document.

When you choose **Close** or **Quit** after making changes to a document, and before you choose **Save**, you'll get the following dialog box:

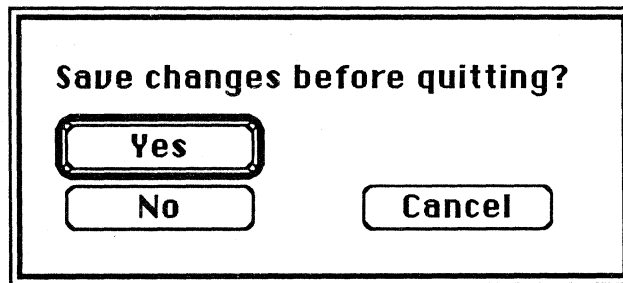

Click **Yes** to save your changes. Click **No** to close or quit without saving the changes (the document will revert to the previously saved version). Click **Cancel** to ignore the **Quit** or **Close** command you just issued, and to return to the current document.

Although this method isn't recommended, it can be used occasionally. It's also a "safety net" in case you forget to save your work.

---

## Practice

### Document Directory and Save As

### Use the Document Directory and Save As dialog boxes as file-management tools.

In this exercise, you'll use the functions of the Document Directory and Save As dialog boxes to:

- Open, name, and eject disks.
- Copy and paste within an application using multiple disks.
- Save documents to disks using a colon (:) in the document-name field.

#### Open a disk, name it, and eject it.

1. Start up your Macintosh from a MacWrite startup disk.
2. Insert a blank, initialized disk into your external disk drive.
3. Name the disk in the external drive "Write Data Disk."
4. Eject the disk in the external drive (remove its shadow, too).

#### Copy data from a document on one disk, and paste it into a document on another disk.

1. Insert a disk that has a MacWrite document on it into the external drive.
2. Open the disk icon and the icon of the MacWrite document.
3. Select a few lines of text, and copy them to your Clipboard.
4. Click on the close box, to close the document.
5. Choose **Open** from the **File** menu. Be sure the disk name displayed in the Document Directory dialog box corresponds to the disk that's in the external disk drive. If not, click **Drive** to change the disk.
6. Eject the disk in the external drive by choosing **Eject** from the Document Directory dialog box. Then insert the Write Data Disk.
7. Choose **Cancel** and open a new MacWrite document by choosing **New** from the **File** menu.



## ***Practice (cont'd)***

8. Paste the contents of the Clipboard into the new "Untitled" document, and choose **Save** from the **File** menu.
9. When the dialog box appears, type **Document 1** as the name of the document, and press Enter to continue.
10. When "Document 1" appears in the title bar on the screen, choose **Save As** from the **File** menu.
11. After the dialog box appears, click on **Drive**. The name of the disk in the internal drive will appear as your current disk.
12. Type **Write Data Disk:Document 2**.  

(Note: Part of the name will disappear from the screen, but once the new copy of the document is loaded, the name of the disk and the new document name will appear in the title bar.)
13. Save Write Data Disk:Document 2 by pressing Enter to continue.
14. Close the document you just saved, and choose **Open** from the **File** menu. When the Document Directory dialog box appears, you'll notice that the current disk is your MacWrite applications disk.

### **Verify that all the documents have been saved to the proper disks before you Quit.**

1. Click **Drive**. The current disk will change to the Write Data Disk where you saved the Document 1 and Document 2 files.
2. Double-click the Document 1 title to open it. Don't click **Open**.
3. Close Document 1 and return to the Document Directory dialog box by choosing **Open** from the **File** menu.
4. Choose **Eject** from the dialog box to eject the Write Data Disk.
5. Choose **Cancel** from the dialog box and **Quit** from the **File** menu to return to the desktop.

---

## Feedback

### Document Directory Dialog Box

### Using the Document Directory dialog box to manage files.

When you choose **Open** from the **File** menu, this dialog box appears on your screen:

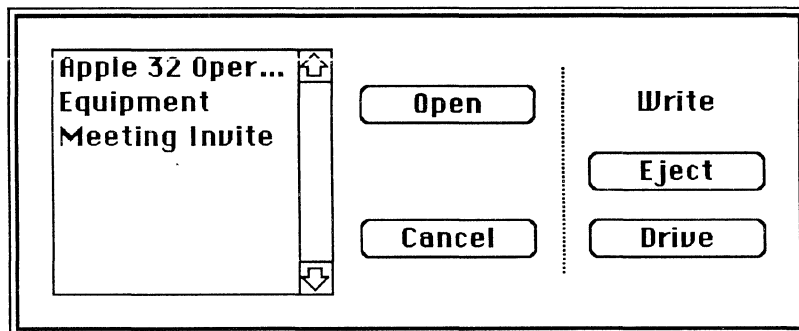

**You can double-click to open a document.**

To open files from this dialog box, you can highlight the document name and choose **Open** from the menu...

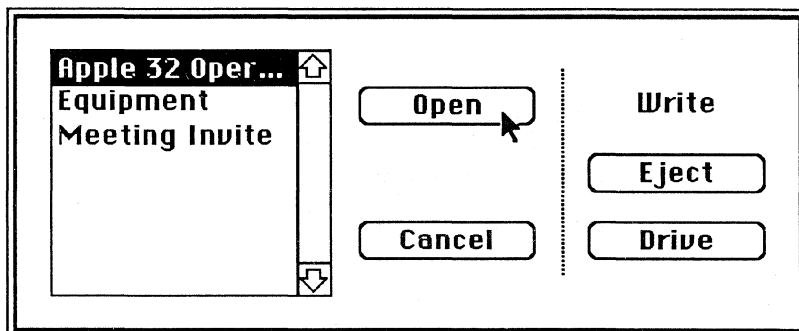

## Feedback (cont'd)

...or you can double-click on the document name.

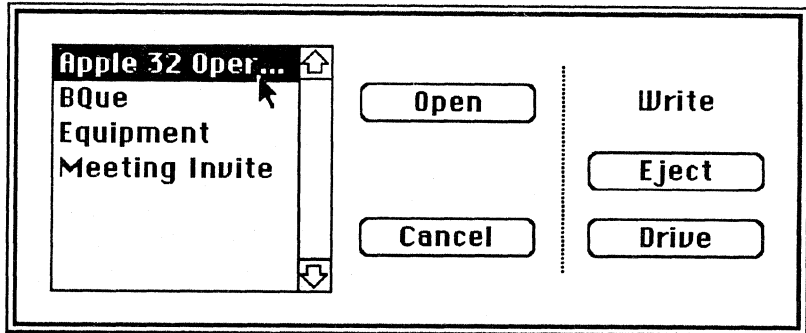

### You can eject disks using the Document Directory dialog box.

Use the Document Directory dialog box menu as you'd use the File menu. Eject is an example of a Finder command that works well within an application to help manage files on various disks. While in an application, you can look at the files on different disks and load the documents from each disk without continually returning to the Finder.

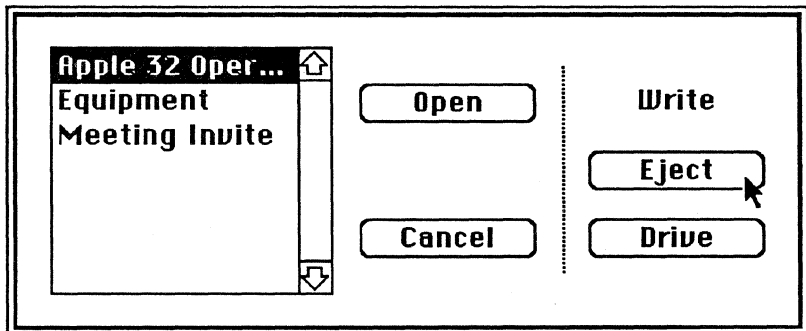

### Select the disk drive.

Selecting the drive and juggling disks from the Document Directory dialog box can be a shortcut to saving documents, copying files, and ejecting disks while remaining in an application. For some **Copy** and **Save** routines that involve more than one disk, some disk swapping may be involved.

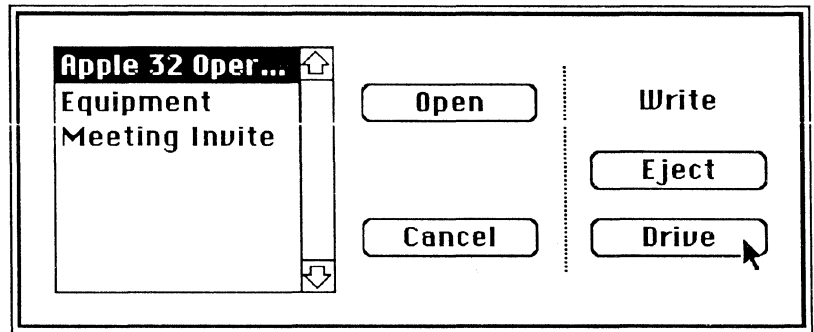

---

## **Review**

### **Folders and File Structure**

**Use folders to create your own hierarchical filing system.**

You can structure your Macintosh files, documents, and applications for easy access by using folders like you'd use folders in your desk to store documents.

### **Lock an Icon**

**Locking an icon keeps you from renaming it or throwing it away unintentionally.**

Use **Get Info** to lock an icon. When you do, be sure to record informational notes about that icon. That way, you won't have to open the document to find out what's in it.

### **The Document Directory Dialog Box**

**The Document Directory dialog box is used to manage documents.**

Use the Document Directory dialog box within an application to avoid going to the Finder when you want either to save, copy, or name documents, or to eject disks.

Use the **Save As** command to rename documents, or to name them and save them to the current startup disk or to another disk.

## Resources

- Apple Support Training Library modules: *Learning to Use Macintosh*, *Supporting the Font/DA Mover*, *Supporting the Macintosh Finder*.
- AppleLink™ Technical Info Library (available to Apple support personnel)
- *Macintosh*, the owner's manual
- *Macintosh 68000 Development System User's Manual* and *Inside Macintosh* (included with the Macintosh 68000 Development System), Apple Computer, Inc.
- *Macworld*, PC World Communications, Inc., San Francisco, CA 94107

*Apple, the Apple logo, and ProDOS are registered trademarks of Apple Computer, Inc. AppleLink, ImageWriter, MacPaint, MacWorks, MacWrite, and Switcher are trademarks of Apple Computer, Inc. Macintosh is a trademark of McIntosh Laboratory, Inc. and is being used with the express permission of its owner. CP/M is a registered trademark of Digital Research, Inc. MS-DOS is a trademark of Microsoft Corporation.*



# Fundamentals of the Macintosh Operating System

---

## Contents

- 2 Overview, Objectives
- 3 Materials
- 4 An Overview of Macintosh ROM
  - Explains the two levels of Macintosh ROM, the operating system and the user interface.*
- 13 Macintosh Drivers and the Elements of ROM
  - How Macintosh uses drivers in ROM and in the software to control peripheral devices and desk accessories.*
- 19 Macintosh Startup Icons
  - What the "Happy Macintosh," "Sad Macintosh," "Question icon," and "X icon" indicate.*
- 23 Reference Chart for Startup Icons
  - A handy aid that shows the message conveyed by each icon, and the correct response to the situation, if one is necessary.*
- 24 How to Handle "Disk Full" Messages
  - "Disk full" messages are a common occurrence. This section suggests some ways you can avoid them.*
- 28 How to Repair a Crashed Disk
  - Techniques that are commonly used to try to open a crashed disk, or document.*
- 33 Review
- 34 Resources



---

## Overview

Some of the support questions you'll frequently be asked require a knowledge of the Macintosh™ computer operating system, and its utilities. This module discusses the fundamentals of the operating system and the user interface contained in Macintosh ROM. It provides some solutions and suggestions on how to use the Macintosh system utilities to recover lost documents and to avoid many disk full messages.

Who should complete this module? Anyone who hasn't taken the Macintosh technical training course and who supports people who use Macintosh.

### Prerequisites

- The material presented in this module assumes that you have read *Macintosh* (the owner's manual), and have a working knowledge of Macintosh.

---

## Objectives

- Identify the elements of the Macintosh operating system and user interface. Explain how they work together to form the Macintosh operating environment.
- Describe how the elements of ROM work with the disk operating system to drive printers and other peripheral devices.
- Describe what a "Happy Macintosh" indicates.
- Describe what a "Sad Macintosh" indicates, and recommend a response.
- Identify the "Question" and "X" icons, state what they indicate, and state how to respond.
- Demonstrate how to handle a "Disk full" message or a message that indicates there's not enough room on the disk to print a document.
- Detail various ways to repair a crashed disk.

---

## Materials

**To complete this module, you will need:**

- A Macintosh 128K or a Macintosh 512K with an external disk drive, or a Macintosh XL
- A system disk that includes Finder Version 4.1

**If available, the following is recommended:**

- A crashed disk and/or a disk with a "lost" file

---

## **An Overview of Macintosh ROM**

### **Overview**

**Macintosh ROM contains the elements of the operating system and the user interface.**

Programmed into the Macintosh ROM (read-only memory) is the heart of what makes Macintosh work, the operating system and the user interface.

**The user interface forms a buffer between the operating system and the Macintosh user.**

Macintosh is dynamic and different because a buffer called the user interface has been placed over the operating system.

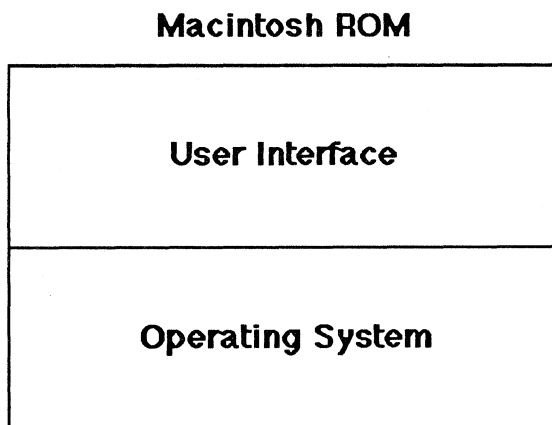

The user interface has been placed over the operating system to act as a "shell." This frees users from having to deal with the operating system directly allowing them to concentrate on productivity instead of on coping with the many different file commands (slashes, spaces, and colons) that are common to most other operating systems.

### **One Basic Similarity**

**The operating system is a traffic cop.**

Even though it includes the user interface, the Macintosh operating system is basically the same as other microcomputer operating systems. It's the traffic cop of the computer. It tells information that's being fed into it where to go, and tells the other parts of the computer what to do with it. The user interface masks almost all of these operations from the user.

## The Big Question

### How do you access the Macintosh operating system?

This question can be posed in several ways, such as, "I want to get into the operating system to write a simple program. How can I do this?" Other frequent questions are those regarding recovering lost data, or accessing system utilities. Many people are simply curious, or use operating systems that don't have a user interface similar to that of the Macintosh. A few others are interested in developing major applications for Macintosh.

Macintosh Pascal, and several other programming languages are available to write programs to run on Macintosh. To write major applications in the Macintosh development environment, there are two considerations about Macintosh and the Macintosh operating environment that must be understood.

### First Consideration

#### Macintosh is designed to be easy to learn and to use.

Macintosh was designed for people who want to set up their computers and begin working with a minimum of instruction.

### Second Consideration

#### The operating system is protected by the user interface.

To accomplish this desired ease of learning and use, the designers of Macintosh placed the shell called the user interface over the operating system. Nearly everything that happens between the Macintosh user and Macintosh goes through this shell.

#### The television is an example of a simplified user interface.

If it's working properly, a television will carry information into your home with very little effort on your part. You can use it with very little information about how it works, switching from program to program, without any effort. But despite this ease of use, the television, like Macintosh, is a very sophisticated machine.

There are few advanced television users (no matter how many hours they watch it). There aren't many advanced Macintosh users either, and that's just the point.

Alan Kay, Apple Fellow, once summed up the net effect of the user interface to a group from Apple Technical Support with the following words:

"...The Macintosh user interface is a very simple design. It was designed so that the average user could be familiar with how to use it within 20 minutes. To become an intermediate user doesn't take much longer.... This has some trade-offs in that there's no room for the advanced user...."

However, an applications developer may be considered one example of an advanced Macintosh user. One way to become an advanced Macintosh user is to learn to use the applications development tools.

Even if you don't plan to become a developer, there's a lot to be learned about Macintosh to help you support it. But the simplified user interface also simplifies the amount of information you need to know, and makes your job as a technical support person much easier.

## Consistent Commands

**Some commands are the same in almost all Macintosh software.**

Because of the user interface, many of the commands and basic techniques, such as **Cut** and **Paste**, are the same in every application. The same commands in different programs are invoked the same way: using a double-click of the mouse button to issue a command, pressing and dragging to move icons, or placing the insertion point to insert text. This consistency, along with the graphics and the mouse, makes the Macintosh easy to use, and simplifies the development process.

## Developing Macintosh Applications

**One way to learn to access the Macintosh operating system is to become a developer.**

An applications developer needs to become thoroughly knowledgeable about the Macintosh user interface. To do that, the developer must attend the "Macintosh Technical Training," (also known as "Macintosh High School") presented by Apple Support Programs, and/or attend "Macintosh College," presented by Apple Software Development.

***Macintosh 68000 Development System and Inside Macintosh* are the tools.**

The *Macintosh 68000 Development System* is a complete programmer's tool for developing Macintosh applications. This development system, when used with the Apple

publication *Inside Macintosh*, is all that the experienced applications programmer needs to begin creating programs for Macintosh.

## Macintosh ROM User Interface

### The user interface is the higher of the two levels of ROM.

The user interface, (or User Interface Toolbox), is provided to facilitate the use of Macintosh applications. It is the most visible and accessible part of Macintosh ROM.

This high-level user interface provides windows, menus, and the desktop, as well as text and utility functions. It also provides an element called "QuickDraw" that underlies all of the graphics.

Programmers should notice that the user interface is called "high level." This is because the interface is positioned a level above the operating system and is in constant use by the user (or user application). The user interface seldom works directly with the hardware. So don't confuse this use of the term "high level" with traditional high-level machine language.

### The operating system is the lower level.

The lower level of Macintosh ROM works directly with the Macintosh hardware. This part of the system supplies the elements of what is generally thought of as an operating system. Drivers, direct system managers, and memory-management and event-management routines are handled at this level.

### To summarize from *Inside Macintosh*...

"The User Interface Toolbox is a level above the operating system; it helps...implement the standard Macintosh user interface.... The Toolbox calls the operating system to do low-level operations.... The operating system is at the lowest level; it does basic tasks such as input and output, memory management, and interrupt handling."

## Elements of ROM

### The ROM is composed of a number of elements with specific functions.

The chart on the next page, and the definitions that follow, briefly illustrate the function or operation performed by each of the elements of Macintosh ROM. For complete definitions of these elements, read the sections that discuss each element in *Inside Macintosh*.

# Macintosh ROM Overview

## Macintosh User Application

### The User Interface Toolbox

Dialog Manager  
Control Manager    Menu Manager    TextEdit  
Window Manager  
Toolbox Utilities  
Toolbox Event Manager  
Disk Manager                      Scrap Manager  
QuickDraw  
Package Manager                      Font Manager  
Resource Manager

### The Operating System

Memory Manager  
Segment Loader  
Operating System Event Manager  
File Manager  
Device Manager  
Disk Driver  
Sound Driver                      Serial Driver  
Vertical Retrace Manager  
System Error Handler  
Operating System Utilities

### The Macintosh Hardware

## High-Level ROM

### The User Interface Toolbox contains the following elements:

**Resource Manager.** The part of the Toolbox that reads and writes resources, such as data used by an application, or the application code itself.

**QuickDraw.** Performs all graphics operations on Macintosh. QuickDraw is often called the "heart of the Macintosh User Interface Toolbox routines."

**Font Manager.** Supports the use of various character fonts for QuickDraw when it draws text.

**Toolbox Event Manager.** Allows an application to monitor the user's actions with the mouse, keyboard, and keypad.

**Window Manager.** Provides routines for creating and manipulating windows and menus.

**Control Manager.** Provides routines for creating and manipulating controls, such as buttons, check boxes, and scroll bars (see Operating System Utilities).

**Menu Manager.** Deals with setting up menus and letting the user choose from them.

**TextEdit.** Supports basic text entry and editing capabilities.

**Dialog Manager.** Provides routines for implementing dialog and alert boxes.

**Desk Manager.** Supports the use of desk accessories from an application.

**Scrap Manager.** Enables cutting and pasting between applications and desk accessories, or between windows.

**Toolbox Utilities.** Performs generally useful operations such as fixed-point arithmetic, string manipulation, and logical operations on bits.

**Package Manager.** Lets you access Macintosh RAM-based packages.



## Macintosh ROM Overview

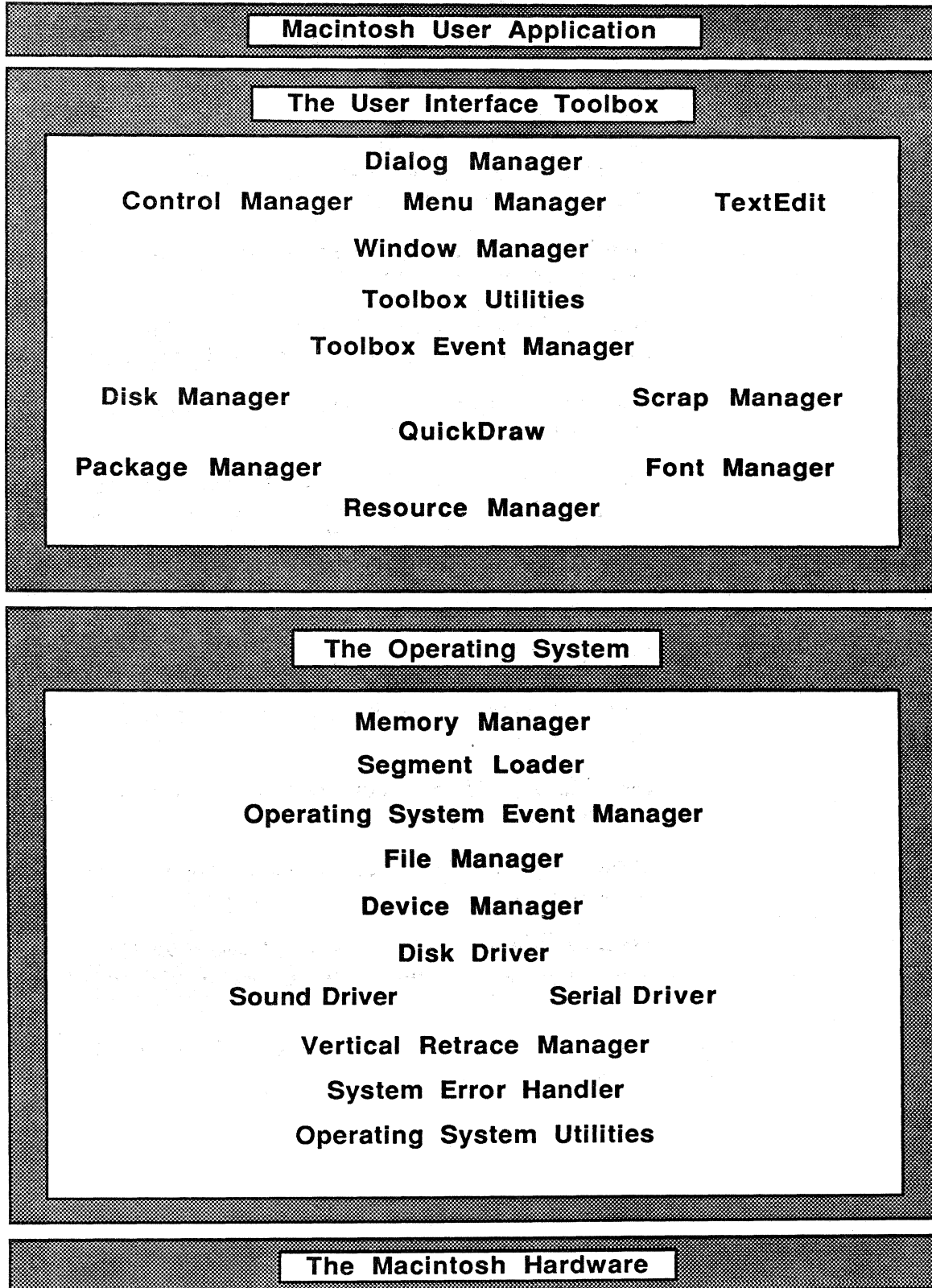

## Low-Level ROM

**The operating system is the lowest level of ROM, and interfaces with the hardware.**

**It contains the following elements:**

**Memory Manager.** The part of the operating system that dynamically allocates and releases memory space in the heap. The heap is an area of memory in which space can be allocated and released on demand.

**Segment Loader.** Loads the code of an application into memory, either as a single unit or divided into dynamically loaded segments.

**Operating System Event Manager.** Reports hardware-related events such as mouse-button presses and keystrokes.

**File Manager.** Supports file input and output (I/O).

**Device Manager.** Supports device I/O.

**Disk Driver.** The device driver that controls storage and retrieval on 3 1/2-inch disks.

**Sound Driver.** The device driver that controls sound generation in an application.

**Serial Driver.** The device driver that controls communication, via serial ports, between applications and serial peripheral devices.

**Vertical Retrace Interrupt.** An interrupt generated 60 times per second by the Macintosh video circuitry while the display tube beam returns from the bottom of the screen to the top. The **Vertical Retrace Manager** schedules and executes it.

**System Error Handler.** Assumes control when a fatal error (such as running out of memory) occurs.

**Operating System Utilities.** Operating-system routines that perform miscellaneous tasks such as getting the date and time, finding out the user's preferred speaker volume and other preferences, and doing simple string comparison.

## A Key Graphic Element

### **QuickDraw is key to Macintosh graphics.**

Macintosh depends on graphics. For example, the screen, printers, and software are all graphics oriented. MacPaint™ and MacDraw™ are examples of graphics applications that have been written specifically for Macintosh. They take advantage of most of the Macintosh graphics capabilities. Even MacWrite™, a word-processing software package, depends on graphics.

### **Briefly stated, QuickDraw does it all!**

Whenever an object is placed on the Macintosh screen, QuickDraw draws a rectangle. If a circle is being drawn, QuickDraw first draws a rectangle, and then fills it with a circle. When a letter is typed on the screen, QuickDraw draws a rectangle, and the Font Manager supplies the size, font style, and letter to be placed on the screen. QuickDraw gets the letter from the Font Manager and puts it in the rectangle.

## Managing Macintosh

### **Managers work together as a group to manage Macintosh.**

A "Manager" in the Macintosh user interface and operating system is a group of subroutines, a library, a convenient way to group routines that are used to manage the same type of data objects (text or graphics).

Managers such as Quickdraw, the Control Manager, the Toolbox Event Manager, and Resource Manager, don't perform any functions by themselves. They perform as a group to coordinate and complete related tasks, like putting letters on the screen, or responding to the click of the mouse.

### **The good news is that half of the programmer's work has been done.**

There are about 500 calls to the Macintosh user interface and operating system, as compared to 50 calls to ROM in ProDOS®, and 100 calls to MS-DOS. In other words, half of the programming has been done for the programmer. It's there in Macintosh ROM. That's the good news. The other news is that the programmer has to understand that half.

## Macintosh Drivers and the Elements of ROM

### Overview

**The elements of the operating system work to control various peripheral devices.**

Macintosh ROM contains a number of drivers. The Device Manager, Disk Driver, and the Serial Driver control the peripheral devices that are necessary to all Macintosh users. Disk drives, video output, sound from the Macintosh speaker, and output to all printers and modems are each controlled by their respective elements in ROM. Input via the mouse, keyboard, and serial ports (from a modem or digitizer), is also controlled from the programs resident in Macintosh ROM.

But the elements in ROM depend on information from the software to coordinate such tasks as receiving input from the mouse or printing on an ImageWriter™ printer.

### ROM Needs Software to Run I/O Devices

**The correct software must be used to drive the input and output devices used by Macintosh.**

The elements of Macintosh ROM need instructions to help them drive the input/output (I/O) devices that are used by Macintosh. These instructions come from the corresponding drivers in the information contained on the Macintosh startup, system, and application disks.

Open the System Folder on any Macintosh System Disk, or on most startup disks. The folder will contain at least a System file, and a Finder, and may also contain a printer driver file (for example, the ImageWriter) as shown in the following System folder window.

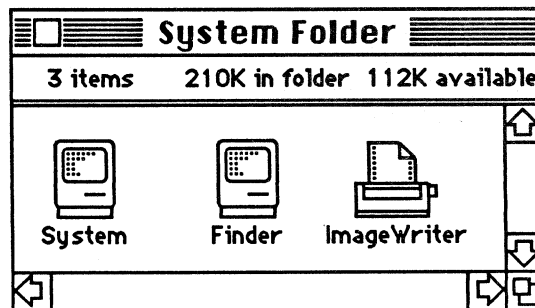

Chances are you'll have the icon of the ImageWriter in your System Folder. This icon represents the file that contains the printing instructions to drive this printer. This file works with the Device Manager and the Serial Driver to send your files to the ImageWriter.

**Macintosh needs the operating system and the software drivers to print files.**

To print a file, the Macintosh operating system and the System file on the Macintosh disk must talk to each other. When you start up Macintosh, the elements of the operating system and user interface get instructions from the disk (for example, from the ImageWriter Driver) and load those instructions into RAM.

Macintosh checks the printing resources on the disk and uses the resources you have chosen along with the resources in ROM. The document is printed, based on those instructions.

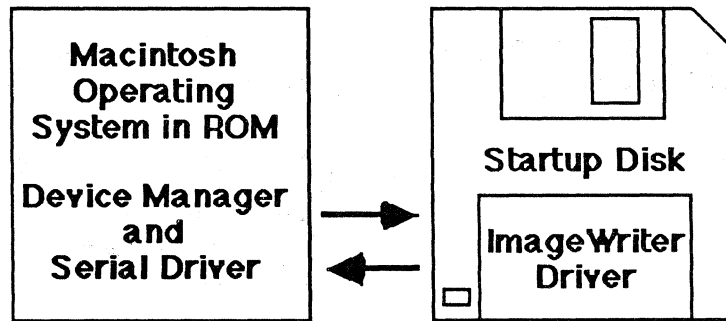

Some of these instructions come from the System file and the application, but without the specific information provided by the ImageWriter Driver, the selected document won't print.

## You may have a few printer drivers on your disk.

In addition to the ImageWriter Driver file, you may have software that allows you to use a variety of printers, for example the Apple® LaserWriter™. If so, you may have a group of files that look similar to the ones shown in the following picture.

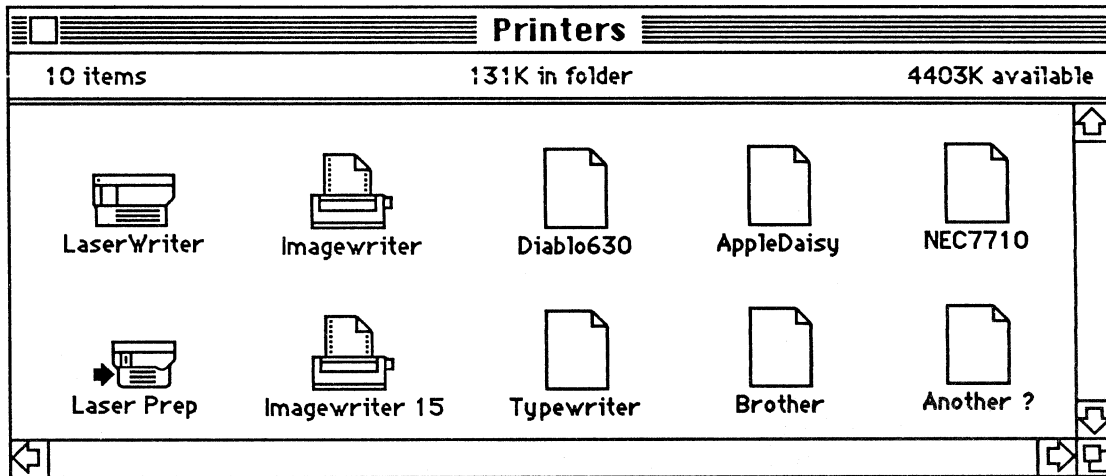

If the appropriate printer driver file for the printer you have chosen isn't on your disk, then you can't print your documents on that printer.

## Macintosh Serial Ports

### The Modem and Printer ports support the serial interface for Macintosh.

Macintosh has two RS-232/RS-422 serial ports. These are a Modem port and a Printer port. Macintosh assumes that you will use each port as it is labeled. Unless you have software that allows you to use the ports differently, always be sure that devices are plugged into the proper ports.

### Some Apple and third-party products have expanded connection capabilities.

Apple products such as the LaserWriter can use either port once the software is installed. The LaserWriter uses the AppleTalk™ Network Driver to make this possible. Third-party hardware and software manufactures use the two serial ports and the mouse port for many different input and output devices. For example, bar-code readers, digitizers, and optical scanners take advantage of the advanced graphics capabilities of Macintosh.

## AppleTalk Driver

### The AppleTalk Driver and software allow you to use both serial ports for printing.

If you have several serial devices available to you (such as an ImageWriter, AppleTalk, and a modem), you may need to use your serial ports differently from the way they originally were labeled. For example, you can use MacTerminal to connect a modem to either port. Also, if you choose **Choose Printer** from the **Apple** menu, you can connect your ImageWriter to either port.

When you select **Choose Printer**, a dialog box will appear:

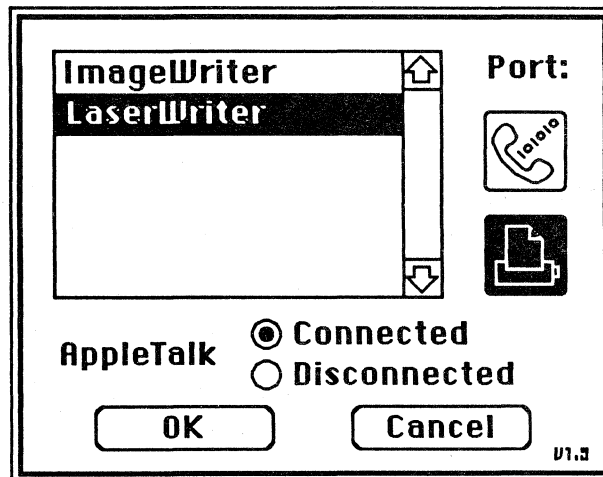

From **Choose Printer** you can opt to use either the Modem port or the Printer port for printing. In this illustration, the LaserWriter is using the Printer port, AppleTalk is connected, and the ImageWriter is available.

If you have other printer drivers available, the names of those printers appear in the dialog box. Without this special software, the standard ImageWriter printer file uses the Printer port for printing.

## Other Drivers

**Macintosh has several programs, such as the Desk Accessories, that are considered drivers.**

Each Apple Desk Accessory in the Macintosh system file is labeled as a driver. This includes the alarm clock, keyboard, control panel, and other devices. Some of them help run the Macintosh hardware, and are controlled by the user from the Control Panel, Font/DA Mover, or from **Choose Printer**.

The fact that these accessories are referred to as drivers, doesn't mean they're drivers. Some are called drivers for programming convenience. For example, the alarm clock and calculator aren't drivers, but have a DRVR (driver) application type. Applications developers and some users need to be aware of this designation.

## New Products

**Many new products become available for the Macintosh every day.**

*Macworld* and the *Macintosh Buyer's Guide*, as well as many other publications on the market announce new products in each issue. Consult these to discover the growing number of ways to use your Macintosh more effectively and productively.





## Macintosh Startup Icons

### Overview

**The Macintosh startup icons provide important support information.**

Often the opening Macintosh screen provides an important clue to a Macintosh support question. This section discusses the startup icons, and provides answers to the support questions involved.

### The "Happy Macintosh"

**What does a Happy Macintosh indicate? When does this icon appear?**

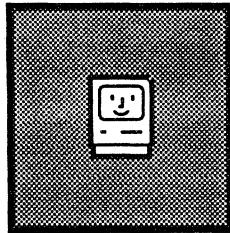

This icon appears on the Macintosh screen when Macintosh is turned on and a startup disk is inserted into in one of the disk drives.

### What message is conveyed?

The Happy Macintosh appears on the screen to let you know that:

- Macintosh is working and has completed the first part of its self-test.
- The disk that has been inserted has started to load part of the Macintosh operating-system software.

### Is a solution needed?

No. So far, so good. As long as the system continues to function, the portion of the operating system contained in the software will continue to be loaded into RAM. As the operating system is properly loaded, Macintosh will progress to the "Welcome to Macintosh" screen, and on to the desktop environment.

## "Question Icon"

**What does a Question icon indicate? When does this icon appear?**

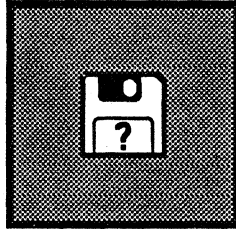

This icon appears on the Macintosh screen when Macintosh is turned on and is waiting for a working startup disk to be inserted into either of the disk drives.

### **What message is conveyed?**

The Question icon appears on the screen to let you know that:

- Macintosh is working and is waiting for a startup disk. This could be due to either of two reasons:
  - There wasn't a disk in Macintosh when it was turned on.
  - You've just used **Shut Down**.

### **Is a solution needed?**

Yes.

### **Possible solutions are:**

- Insert a working Macintosh startup disk, or simply turn off Macintosh.

## The "X Icon"

**What does the X icon indicate? When does this icon appear?**

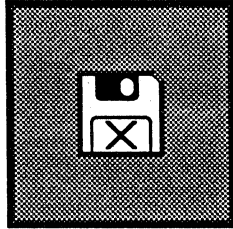

This icon appears on the Macintosh screen when Macintosh is turned on and the disk it tries to start up from is an uninitialized disk, or a non-Macintosh disk. Macintosh ejects the disk and displays this icon. This icon can also appear when a disk ejects from a working Macintosh as it's turned on (because the user is holding down the mouse button).

### **What message is conveyed?**

The X icon appears on the screen to let you know that:

- Macintosh is working.
- The disk that was in the disk drive when Macintosh was turned on isn't a startup disk (so, it's ejected).

### **Is a solution needed?**

Yes.

### **Possible solutions are:**

- Insert a working Macintosh startup disk, or simply turn off Macintosh.

## "Sad Macintosh"

### What does the Sad Macintosh indicate? When does this icon appear?

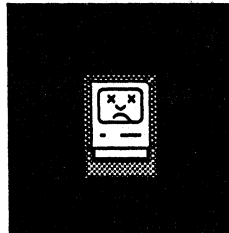

This icon appears on the Macintosh screen when Macintosh is turned on and isn't working (it can't read the disk, and won't start up). Sometimes when a startup disk is inserted, Happy Macintosh will appear on the screen, but before the "Welcome to Macintosh" screen can appear, a Sad Macintosh takes its place, and the disk will be ejected.

### What message is conveyed?

The Sad Macintosh appears on the screen to let you know that:

- The startup disk began to load the operating system and then a problem occurred, such as an address error, a bad System file, or no System file, and Macintosh was unable to continue (Macintosh probably also ejected the disk).
- Macintosh isn't working. It may be a hardware problem.

### Is a solution needed?





Yes.

### Possible solutions are:

- Turn off Macintosh, insert a working Macintosh startup disk, and turn on Macintosh again.
- Turn off Macintosh and follow the instructions in the "How to Repair a Crashed Disk" section.
- Call your service representative. It might be a hardware error.

## Reference Chart for Startup Icons

Keep this chart as a reference.

ICONS				
When does each icon appear?	When a Macintosh is started with a startup disk, or when a disk is inserted in response to a ? or X icon.	When a working Macintosh is turned on without a disk in the drive.	When a disk is ejected from the disk drive while starting up a Macintosh, either manually or by the system.	When Macintosh is turned on, or a Happy Macintosh appears, but the disk then ejects due to a software system error.
Message conveyed by each icon.	Macintosh is working and a good startup disk is in the disk drive.	Macintosh is working, no disk in drive, (X icon may have appeared), Macintosh is waiting for a good startup disk.	Macintosh is working, but the disk is ejected due to damaged software.	Macintosh is not working, it may be a hardware error or you didn't use a good startup disk.
Solution needed?	No	Yes	Yes	Yes
Possible solutions are:		Insert a good startup disk or turn off the Macintosh.	Insert a good startup disk or turn off the Macintosh.	Insert a good startup disk or turn off the Macintosh. If Macintosh does not work, call your service rep.

---

## How to Handle "Disk Full" Messages

### Overview

**This section explains how to handle "Disk full" messages.**

"Disk full" messages occur at various times while you're using Macintosh. But, all these occurrences have a very similar message: There isn't enough room on your disk or in memory to complete the operation just initiated. For example, if you want to copy a section of text, you might get a message that alerts you that the disk is out of space and you can't. Or, you might try to print a file, only to be interrupted by a dialog box that says that there isn't enough room on the disk.

### **What can you do about this?**

Good file-management habits can keep the number of occurrences to an acceptable level. However, even the most conscientious of file managers can't always avoid these messages. So, before looking at some of the ways to avoid "Disk full" messages, let's take a quick look at some of their causes.

### Some Causes

**Here are a few causes of "Disk full" messages:**

- The disk contains unnecessary documents.
- The System file has more fonts or desk accessories than necessary.
- The Scrapbook contains a lot of information.
- The disk has more than one application on it, and/or more than one printing source (both ImageWriter and LaserWriter).
- The disk has bad or damaged sectors that cause I/O messages (this may cause the entire disk or some of your documents to be unusable).

## Some Solutions

### **Archive unused but necessary files on disks in a safe place, and delete the others.**

Setting up a library of files is one solution. No matter how careful you may be, it's easy to begin collecting files that are no longer useful. If this seems to be an issue, create an archive file. Use a filing cabinet, or a series of disk holders or boxes that can be labeled and organized. This file could include copies of backup applications disks, old spreadsheets or data-base files that are important for payroll accounting, or last year's Christmas card cross-reference list.

Once you've archived your important documents, delete the originals and other unused files. Also, check their creation and modification dates. Delete the ones you know aren't going to be used. Keeping files current is important to efficient file maintenance, and reducing the number of "Disk full" messages.

## Fonts and Desk Accessories

### **Maintain a minimum number of fonts and desk accessories in your System file.**

Keep the number of fonts stored in the System file to a minimum. Use the Font/DA Mover to create a "For Fonts Only" disk (see the Support Programs Library module *Supporting the Font/DA Mover* for instructions). That way, you can move them into the system when you need them, and they can stay out of your way the rest of the time.

## Scrapbook and Note Pad

### **Limit the amount of information in your Scrapbook and Note Pad.**

Use the Scrapbook only for necessary or important illustrations; for example, a corporate logo that can be used in memos or letters. Remember to clear the Note Pad once you've used the notes, or transferred them into another document. These files take up a lot of disk space that could be used for word-processing documents or spreadsheets.

## Printing Resources

### **Limit the number of printing resources that share a disk with an application.**

Keep only one application per disk for applications that have a lot of files, or very large files. For example, spreadsheets and data-base files can consume disk space very quickly. When you limit the number of applications and printing resources on a disk, you'll have more room for data, and you can minimize disk swapping and "Disk full" messages.



When you use an ImageWriter as your primary printer, there is no need to have the LaserWriter print file on your application startup disk. When you want to use the LaserWriter, copy the document you want printed to an application disk that has the LaserWriter print file installed.

One way to limit your printing resources on a disk is to keep them on different disks. For example, keep the ImageWriter file on your primary application disks, and the LaserWriter files on your backup application disks. Be sure that the disks are clearly labeled.

## Other Causes

### **Damaged disks or disks with bad sectors can cause "Disk full" messages.**

To avoid some "Disk full" messages, all you have to do is to maintain your disks properly. There are many causes of damaged disks, such as heat, breakage, or just plain overuse. Keep your disks in disk carriers in cool, safe places. This will help prolong their life.

To protect yourself against bad disks, always back up your documents daily, and when you're working on a document, save your work every 10 minutes. If you back up your files, and you get a "Disk full" error -- or a disk error that's more serious -- you won't lose all that time or information. There are several ways of reclaiming files that you may think have been lost.

If you find that you continue to get "Disk full" messages, and you know that you don't have many files on that disk, you may have a bad disk. Often if you copy that disk to another disk, the error will be "fixed" on the new disk. Initialize the old disk, or erase it and try to use it again. This simple routine may save your file, and your disk (and your sanity!).

## Room to Print

### **"Not enough room to print" may appear even when you think there's enough room.**

If this message appears when you begin to print a document, and you know there's plenty of room on the data disk, it means there isn't enough room on the startup disk. Your application may need this room to create a print file.

One remedy is to move the application to your data disk. Your first disk will remain the startup disk and will contain the printing resources. It'll now have room for the print file. The second disk will be your data disk and will contain your application and the document you want to print.

Another way to do this is to always keep the application and the data on the same disk. Have two startup disks: one that contains the ImageWriter software, and another that has the LaserWriter software. This will free up more room on the application disk, and on the startup disk for large documents.

For more information on "Disk full" messages and document organization, see the *Managing Macintosh Files* module.

---

# How to Repair a Crashed Disk

## Overview

### **Some lost documents can be recovered.**

One of the most common crises faced by technical support people is recovering the information on a crashed disk. Here are a few methods that have been successful in many cases. Since there are many ways to blow up disk directories, though, these methods are not always 100 percent effective.

## Rule Number One

### **The first rule for every computer user is backup your work, and use Save often.**

Now that the primary means of disk (or document) recovery has been established, please continue reading.

## Repair a Disk

### **Method 1: Repairing a startup disk.**

1. If possible, make a backup copy of the bad disk.
2. With the Macintosh turned off, put the copy of the bad disk into the internal drive.
3. Before you turn on the Macintosh, hold down the Option and Command keys.
4. Turn on the Macintosh. Continue holding down the Option and Command keys until the disk icon appears.
5. If this works with the copy of your original disk, you may want to use it as your new disk. If not, follow the same procedure with your original disk.

This method sometimes requires several attempts. It recreates the desktop file and the disk directory. One of these files may have been the cause of the problem.

This process restores your documents, but your folders (except for the first level) are lost. This first level of folders is placed on your desktop. The system names them "Unnamed #1," "Unnamed #2," and so forth. You must re-create your folders, and put back the recovered documents and files manually.

This method is especially useful if your Macintosh ever displays a bomb and the message, "A serious system error has occurred."

**ERROR: ID = 02****Method 2: Recovering from Error: ID = 02.**

To repair a data disk (or if Method 1 doesn't work):

1. Start up with a disk that you know is good. Then eject the disk. Do *not* use **Shut Down**.
2. Hold down the Option and Command keys and insert the problem disk.
3. You'll lose your folders, so replace them as described above.

(Note: This method also works on a Macintosh XL. Start up from the MacWorks™ program. Hold down the Option and Command keys and insert the bad 3.5-inch disk.)

(Note: The repair function for the hard disk isn't available at the time of this printing.)

**Recover a Startup Disk****Method 3: Recovering the information on a bad startup disk by replacing the System file.**

This method has been known to work with disks that fail to start up, and exhibit a Sad Macintosh with the address 0F0028, or 0F0064.

1. Attempt Method 1.
2. If that doesn't work, start up Macintosh using a good startup disk and then insert the bad disk.
3. If the icon of the bad startup disk appears on the desktop, replace the System file with a working copy of the System file from the good disk.

(Note: This last method doesn't seem to work with disks that exhibit a Sad Macintosh with the address 2F0064.)

**Try this with a Macintosh XL.**

If you're using a Macintosh XL, start with Step 2 above. Start up with MacWorks from the internal disk drive. When the system is ready, insert a startup disk. After the startup disk icon and the hard-disk icon appear, replace the System file and/or the Finder on the hard disk with the System file and/or Finder on the internal disk.

## Back Up a Disk to Recover Lost Files

### Method 4: Backing up the disk to a clean disk.

A method that often helps to recover a "lost" disk is to use a backup utility to move the data, applications file(s) and the disk directory to another disk (there might be a bad sector or other problem with the disk that has rendered it unreadable). This method might take several tries to work.

If you can, try to open the disk on a different Macintosh, or use a different Macintosh to copy the disk. If you keep getting disk messages, it might be evidence of difficulties with the hardware.

## Recover a Document

### Method 5: Recovering documents that won't open.

1. Make a copy of the disk that contains the document(s) you want to recover.
2. Turn on Macintosh with a good copy of the application needed to read the document(s) you wish to recover.
3. Open the application.
4. Once the application is open, close the document called "Untitled."
5. Choose **Open** from the **File** menu.
6. If you're using a two-drive system, insert the bad disk. If you're using a one-drive system, click **Eject** and insert the bad disk.
7. Select the disk by clicking **Drive** (if the disk isn't already selected), and open the desired document(s) from the Document Directory dialog box.
8. If this works, save the document(s) to a good disk, back up your work, and continue.

---

## ***Practice***

### **Crashed Disk Practice**

**To practice any of these routines, you must have a crashed disk.**

Try each of the methods listed above. Use disks that you previously thought were lost. If you don't have any of these disks, ask a colleague, or just wait. The opportunity to practice these techniques is bound to occur. Refer to this module when you get a problem disk.

**Rule number one should always be practiced.**

You should be in the habit of backing up your documents regularly, at least once a day. You may even want to keep backups of your backups, and archive some of your work away from your work area.

**Method 1 can be practiced with any disk.**

To practice method 1, be sure to use a disk that has a few folders on it. You'll lose the folders, but you'll see what the operation looks like and how much time it takes.

---

## **Feedback**

### **Crashed Disks and Documents**

#### **There are other methods available via third party products.**

Your Apple support representative or authorized Apple dealer can help you with any of the methods that were addressed. Discuss other ideas you may have with your course manager, or a colleague.

In addition to the recovery systems that were mentioned, there are many third-party applications available through user's groups. Check with your Apple support representative for applications that might be available, or check the resources listed at the end of this module.

## Review

### **An Overview of Macintosh ROM**

**Macintosh ROM has two levels: the operating system and the user interface.**

### **Identify Macintosh Drivers**

**Device drivers are needed for each I/O device, such as the mouse, printers, and digitizers.**

Macintosh drivers work to support a wide variety of peripheral devices. These devices work in conjunction with the drivers contained in ROM, the drivers that are part of the software, and information provided by the System file and the application.

### **Macintosh Startup Icons**

**There are four icons that can appear when you start up Macintosh.**

The Happy Macintosh, Question icon, X icon and the Sad Macintosh.

### **How to Handle "Disk Full" Messages**

**Use good file-management techniques to avoid frequent "Disk full" messages.**

### **Some Causes and Some Solutions**

**There are a number of causes for these messages, and there is usually a solution.**

### **Repair a Crashed Disk**

**Back up your files. Then when messages such as Error = 02 appear, you have alternatives.**

Five methods of error recovery (such as recovering bad disk files by using the Option and Command key function) were discussed. Of course, the best method of avoiding a lost-file disaster, is to back up your files often, and save them to disk every 10 minutes.



---

## Resources

- *AppleLink*, Available to Apple support personnel, Apple Computer, Inc.
- *Inside Macintosh*, Apple Computer, Inc., Addison-Wesley Publishing Company, Inc., Reading, MA 01867, 1985
- *Macintosh* (the owner's manual), Apple Computer, Inc.
- *Macintosh 68000 Development System User's Manual*, and *Inside Macintosh*, Apple Computer, Inc.
- Macintosh Technical Training, available through Apple Support Training, Apple Computer, Inc.

*Apple, the Apple logo, and the Macintosh logo are registered trademarks of Apple Computer, Inc. AppleLink, AppleTalk, ImageWriter, LaserWriter, MacDraw, MacPaint, MacWorks, and MacWrite are trademarks of Apple Computer, Inc. Macintosh is a trademark of McIntosh Laboratory, Inc. and is being used with the express permission of its owner. MS-DOS is a trademark of Microsoft Corporation.*

# Using MacDraw

---

## Contents

- 2 Overview
- 3 Objectives, Materials
- 4 Overview of MacDraw
- 5 Learning How to Use MacDraw  
*Use the Guided Tour and read the manual to learn how to use MacDraw.*
- 33 Practice Using MacDraw  
*Practice the techniques you learned in the previous section.*
- 49 Integrating MacDraw with Other Applications  
*What information can you paste into MacDraw and what MacDraw information can you paste into other applications.*
- 52 Useful Techniques  
*Hints, tips, and techniques for using MacDraw most effectively.*
- 69 Review
- 70 Resources

---

## Overview

Read this module to learn how to use MacDraw™. The module includes basic product training, information about integrating MacDraw with other Macintosh™ computer applications, and a collection of tips and techniques to make MacDraw more useful and powerful.

If you have never used MacDraw, you should complete the entire module. If you already know how to use MacDraw, you may still benefit from the Useful Techniques, and Integrating MacDraw with Other Applications sections.

### Prerequisites

- The basic techniques for using Macintosh, including how to use the mouse and menus, how to open and close documents, and how to work with text. You can learn these by completing the *Learning to Use Macintosh* module or the Guided Tour of Macintosh, or by reading Chapters 1 and 2 of *Macintosh*, the owner's manual.

---

## Objectives

- Use all of the features of MacDraw as described in the Guided Tour of MacDraw.
- State the function of each of the menu commands.
- Describe the specific information that can be moved between MacDraw and other applications distributed by Apple<sup>®</sup> for the Macintosh. Also describe, in general, the information that can be moved between MacDraw and spreadsheets or data bases.

---

## Materials

**To complete this module, you will need:**

- Macintosh 128K or Macintosh 512K
- MacDraw disk
- *MacDraw*, the owner's manual
- Guided Tour of MacDraw disk and cassette
- Audiocassette player
- A blank disk

**If available, the following is recommended:**

- An external disk drive

---

## Overview of MacDraw

### What Is MacDraw?

**MacDraw is a professional graphics solution for presentations, drafting, and design.**

MacDraw is a structured graphics editor. Components of your drawings are stored as independent graphic elements, or "objects," which may be freely moved and changed. You create your drawing by combining many of these basic graphic elements, which include circles, rectangles, lines, curves, and text.

MacDraw is different from MacPaint™, which is a pixel-oriented graphics editor. MacPaint lets you manipulate dots on the screen, while MacDraw lets you manipulate fully formed graphics objects.

### MacDraw Benefits

**These are the key benefits of MacDraw.**

**More effective communication.** Graphically represent concepts that would be impossible to describe with words alone.

**Accurate.** Its a precision tool that can be used by architects, engineers, and others who draw to scale.

**Integrated with other applications.** Enhance other Macintosh documents through the addition of graphics, and use MacDraw to enhance graphics pasted in from other applications.

**High quality output.** Use MacDraw with the Apple LaserWriter™ printer to produce publication-quality graphics output.

**Easy to learn.** Eliminate time spent learning to use graphics-design tools.

**Economical.** Using MacDraw to produce high-quality graphics is much less expensive than hiring a professional graphics designer.

---

# Learning How to Use MacDraw

## Overview

### Use existing materials to get started using MacDraw.

The Guided Tour of MacDraw disk and cassette, and the MacDraw manual, which are packaged with MacDraw, are an excellent starting point for learning how to use the application. You'll start with the Guided Tour, and then read key parts of the manual.

(Note: Be sure you have a Macintosh 128K or a Macintosh 512K because the Guided Tour of MacDraw doesn't work on a Macintosh XL.)

After each Guided Tour session, complete the appropriate practice exercise in this module. In each exercise, you'll practice the techniques covered in the portion of the Guided Tour that you just completed.

If you have questions that are not answered in this module or in the Guided Tour, refer to *MacDraw*, the owner's manual, or ask a colleague, your course manager, or your Apple support representative.

## Practice Exercises

### Use the actual MacDraw disk (not the Guided Tour) to complete the practice exercises.

After each Guided Tour session, eject the Guided Tour disk and start up from the MacDraw application disk to complete the practice exercise. Don't use the Guided Tour disk for the exercise because you can't save your work onto it.

In several of the practice exercises that follow the four Guided Tour sessions, you'll work on the same drawing. Be sure to save your work when instructed to do so.

The exercises include screen shots that reflect what your screen should look like at various stages in the exercise. It's not necessary to match these screen shots exactly.

Following each practice exercise, there's a Feedback section you should read to confirm that you have completed the exercise correctly. The Feedback section will also suggest what to do if you have trouble.

If you want to finish the Learning How to Use MacDraw section more quickly, you could go through the entire Guided Tour without stopping and then complete the Practice Using MacDraw section. However, you will learn—and retain—more about MacDraw if you complete all of the practice exercises in this module.

## Guided Tour

### Complete the first session of the Guided Tour of MacDraw, "What Is MacDraw?"

Continue with the following practice exercise when you have finished the first session of the Guided Tour of MacDraw.

---

## Practice

### Fixing Mistakes

#### Use the Clear, Undo, or Revert commands.

As you work on this practice exercise, you'll probably make some mistakes. Correcting them is easy with the help of the **Clear**, **Undo**, and **Revert** commands.

Whenever you don't like the last thing you drew, just choose **Clear** from the **Edit** menu while the object is still selected. The object will be removed and you can try drawing it again. Or choose **Undo** from the **Edit** menu to undo the last addition or change to your drawing. For example, if you change the size of a rectangle, choose **Undo** to change it back to its original size. You can also choose **Revert** from the **File** menu to undo all of your changes *since you last saved the document*. (If you never saved your work, your document will revert to a blank document.)

All of these options are explained in more detail in the Guided Tour and the manual.

### Start Up MacDraw

#### Use the MacDraw disk to complete the practice exercise.

1. Click **I'm Ready to Stop** from the Guided Tour screen. The Guided Tour disk will be ejected automatically.
2. Insert the MacDraw disk.
3. Open the MacDraw disk icon.
4. Open the MacDraw application icon, either by selecting it and choosing **Open**, or by double-clicking on the icon.

## Draw a Macintosh

### Use the techniques introduced in the Guided Tour to draw a picture of a Macintosh.

This section contains step-by-step instructions to complete your drawing of a Macintosh, and screen shots showing approximately what your screen should look like. Complete each step as it is explained. It's not necessary to match the screen shots exactly.

As you create the various parts of your drawing, the tool you should use is identified on the screen shot with a hollow arrow (  ). This arrow will not appear on your screen.

### Draw the outline of the Macintosh.

1. Click on the rectangle tool in the palette.
2. Position the pointer where you want one corner of the outline of the Macintosh to be.
3. Hold down the mouse button and move the pointer to the opposite corner.

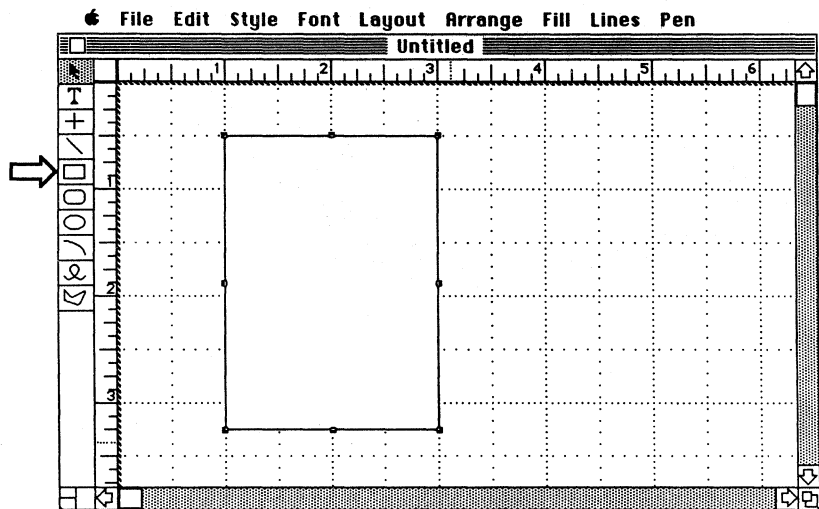

4. Release the mouse button. Notice that your rectangle now has handles and the selection pointer (the arrow at the top of the palette) is now selected. You'll always return to the selection pointer after drawing something.

### If necessary, move or resize the rectangle.

If you need to reposition the rectangle, point anywhere inside it, and while holding the mouse button down, move it to the desired location.



## Practice (cont'd)

If you need to resize the rectangle, position the tip of the pointer on one of the handles, and, while holding down the mouse button, move the mouse to change the rectangle to the desired size.

Or use the **Clear** command to remove the rectangle completely, and then redraw it.

### Draw the screen.

1. While the rectangle, which is the outline of your Macintosh, is still selected (the handles are showing), choose **Duplicate** from the **Edit** menu.
2. To resize the duplicate, first point to the lower right handle.

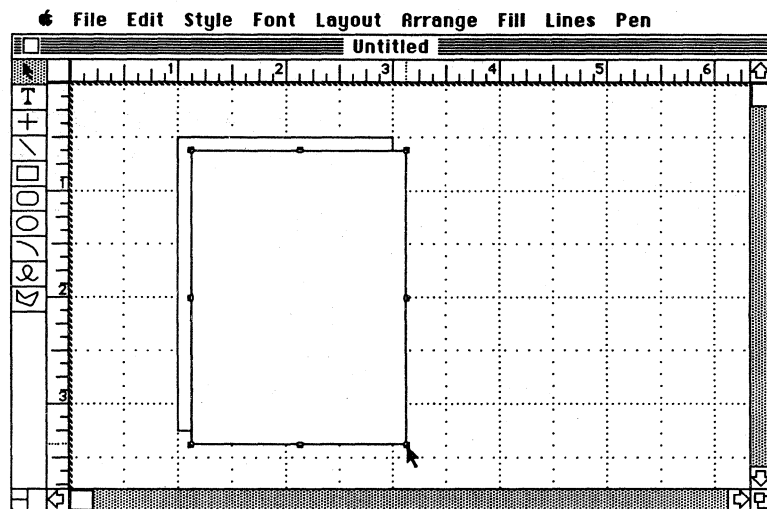

3. Hold the mouse button down. The handle should disappear. If it doesn't, release the mouse button and try again. If all of the handles disappear, reselect the rectangle by clicking anywhere within its borders.
4. Move the mouse to resize the rectangle. Make it smaller than the original rectangle, as shown in the next screen shot.
5. Release the mouse button when the rectangle is the desired size.
6. While the small rectangle (the screen) is still selected, choose an appropriate shading from the **Fill** menu.

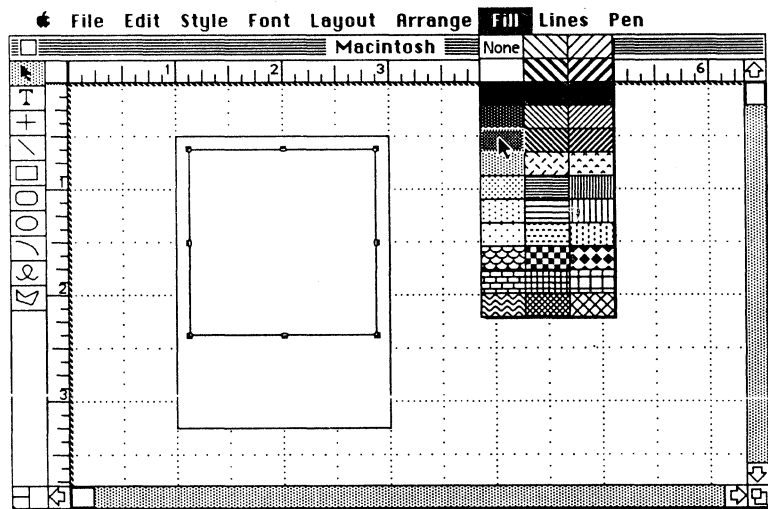

### Add the disk drive.

1. Choose the perpendicular lines tool from the palette. This enables you to draw horizontal and vertical lines.
2. Draw a line representing the disk drive.
3. While the line is still selected, choose a thicker line from the **Lines** menu.

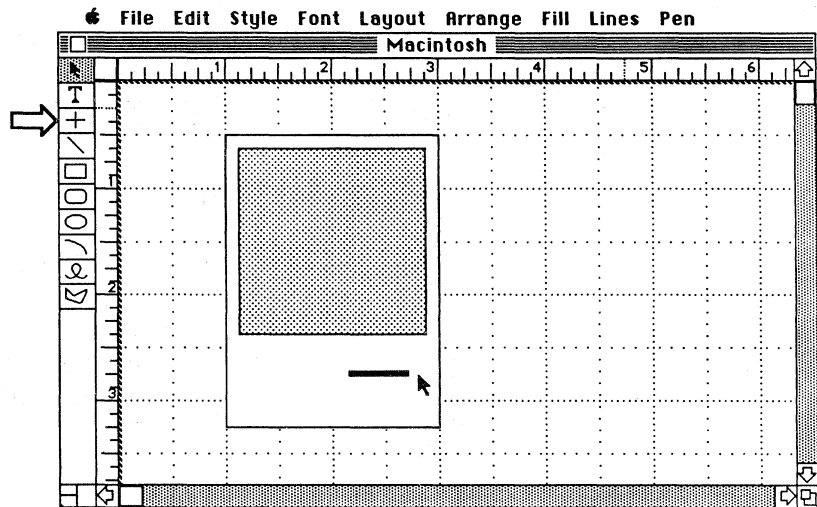

## Practice (cont'd)

### Round the corners of the cabinet and the screen.

1. Select the large rectangle (the outline of the Macintosh) by pointing to it and clicking the mouse button.
2. Choose **Round Corners** from the **Edit** menu.
3. Click on **1/8"** and click **OK**.
4. Use the same technique to round off the corners of the screen (the small rectangle).

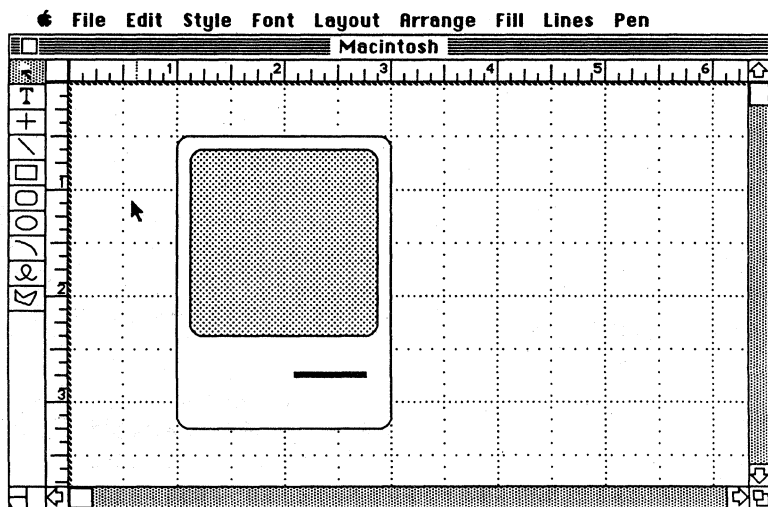

### Draw the mouse.

1. Choose the rectangle tool from the palette and draw the outline of the mouse.
2. Duplicate the outline to create the rectangle that will become the mouse button.
3. Grab the lower right handle and shrink the duplicate to the appropriate size.

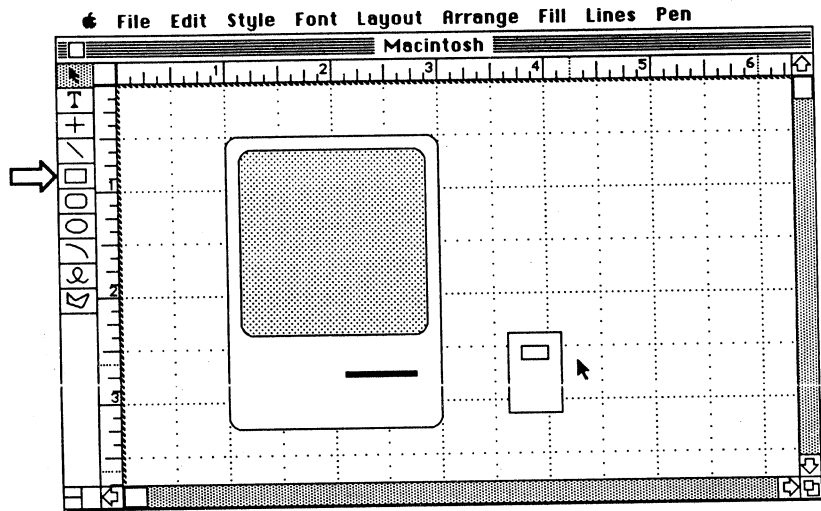

### Add the mouse cable.

1. Choose the freehand shape tool from the palette and draw a line connecting the mouse to the back of the Macintosh.
2. While the line is still selected (there are handles in the shape of a rectangle surrounding the line), choose a thicker line width from the **Lines** menu.

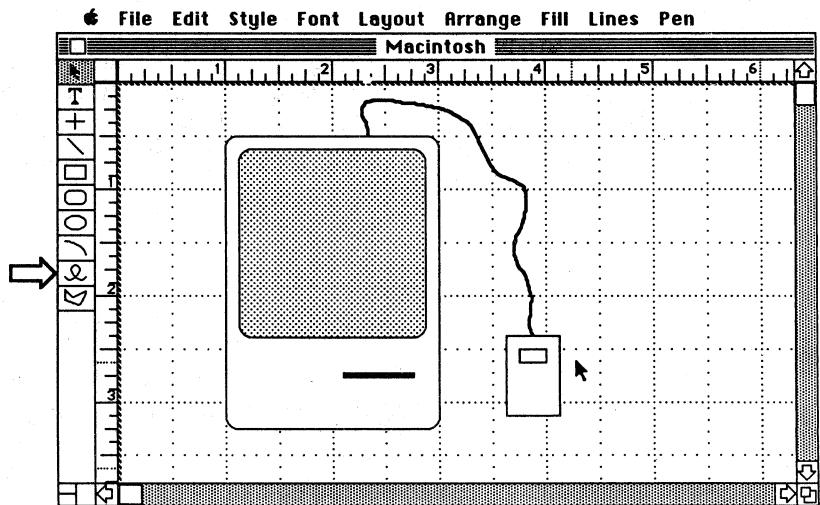

## Practice (cont'd)

### Quit MacDraw.

1. Choose **Quit** from the **File** menu to quit MacDraw and return to the Finder.
2. You won't be saving your changes, so click **No** when you're asked if you want to save changes before closing.
3. Choose **Shut Down** from the **Special** menu, which will eject the MacDraw disk and restart your Macintosh.
4. Insert the Guided Tour of MacDraw disk.

If, after inserting the Guided Tour disk, you get the Macintosh desktop with a disk icon instead of the Guided Tour screen, turn the Macintosh off, and then on again.

---

## Feedback

### Draw a Macintosh

**Be sure you understand the techniques covered in this section before continuing.**

When you have finished, your entire drawing should resemble the last screen shot, shown on page 11. If it doesn't, and you don't understand why, reread this section to be sure you understand all of the techniques taught.

If you don't understand a particular aspect of MacDraw, you have several options:

- Listen to the first Guided Tour session again.
- Refer to *MacDraw*, the owner's manual.
- Ask a colleague, your course manager, or your Apple support representative.

Continue when you are comfortable with all of the techniques taught so far.

---

## Learning How to Use MacDraw (cont'd)

### Guided Tour

**Complete the second session of the Guided Tour of MacDraw, "More Drawing!".**

Continue with the following practice exercise when you have finished the second session of the Guided Tour of MacDraw.

---

## Practice

### Fixing Mistakes

**Use Clear, Undo, or Revert.**

If at any time you don't like the last thing you drew, just choose **Clear** from the **Edit** menu while the object is still selected. Or choose **Undo** to undo any addition or change to your drawing (for example, move, resize, or fill). You can also choose **Revert** from the **File** menu to undo all of your changes since you last saved your document.

### Start Up MacDraw

**Use the MacDraw disk to complete the practice exercise.**

Be sure to use the MacDraw disk for this exercise. At the end of the exercise, save your drawing, because in the next exercise you'll add to it.

1. Click **I'm Ready to Stop** from the Guided Tour screen. The Guided Tour disk will be ejected automatically.
2. Insert the MacDraw disk.
3. Open the MacDraw disk icon.
4. Open the MacDraw application icon.

### Draw an Organization Chart

**Use the techniques introduced in the Guided Tour to draw an organization chart.**

This section contains step-by-step instructions to complete your drawing, and screen shots showing approximately what your screen should look like. Complete each step as it's described. It's not necessary to match the screen shots exactly.

## Practice (cont'd)

### Draw the first box of the organization chart.

Draw a rectangle, similar to the one shown below, in approximately the same location. If you aren't satisfied with it, either resize it, move it, or choose **Clear** and start again.

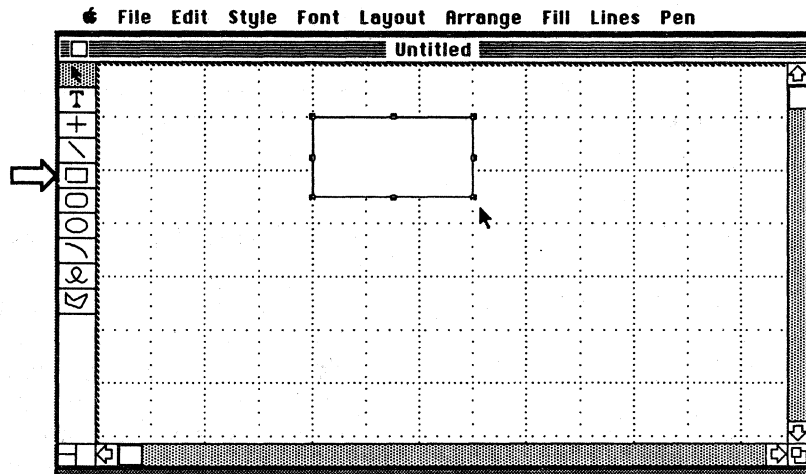

### Make it a round-corner rectangle.

1. While the box is still selected, choose **Round Corners** from the **Edit** menu.
2. Click on **1/8"** and click **OK**.

### Make three duplicates, which you'll use to make the rest of your organization chart.

1. Select the first box (if it's not already selected).
2. Hold down the Command key and press **D**. A duplicate of the rectangle will be made.
3. Press Command-D twice more to make two more duplicates.

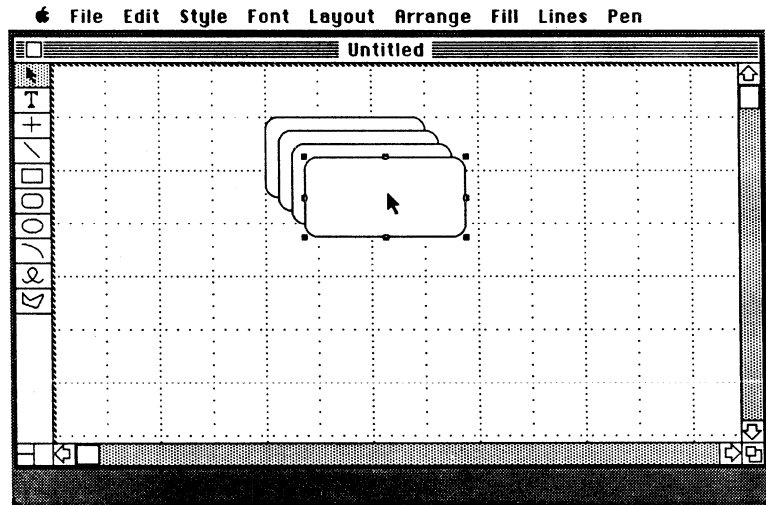

4. Move the boxes into the positions shown in the screen shot below.

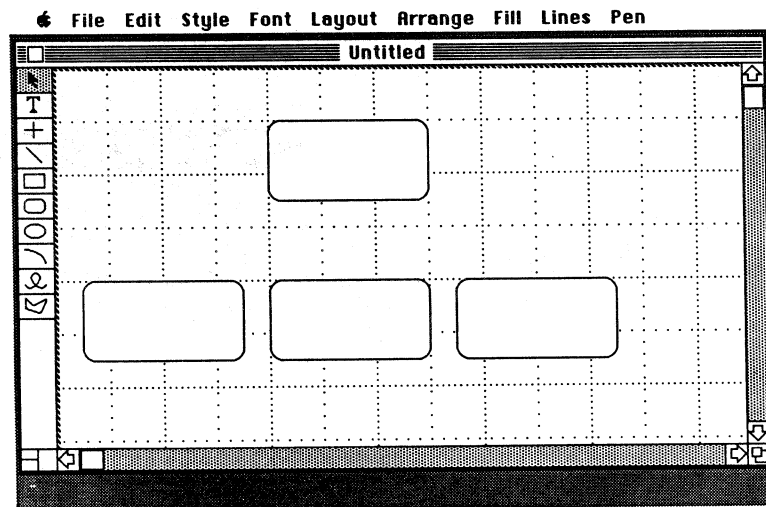

### Add text.

1. Choose the text tool from the palette.
2. Position the pointer in the top box and click the mouse button to set an insertion point.
3. Type **President**.



## Practice (cont'd)

4. In the next three boxes, starting with the one on the left, type **VP Sales**, **VP Distribution**, and **VP Manufacturing**.
5. Click on the selection pointer (the arrow).
6. Move the text to the center of the boxes.
7. Resize the boxes if the text doesn't fit.

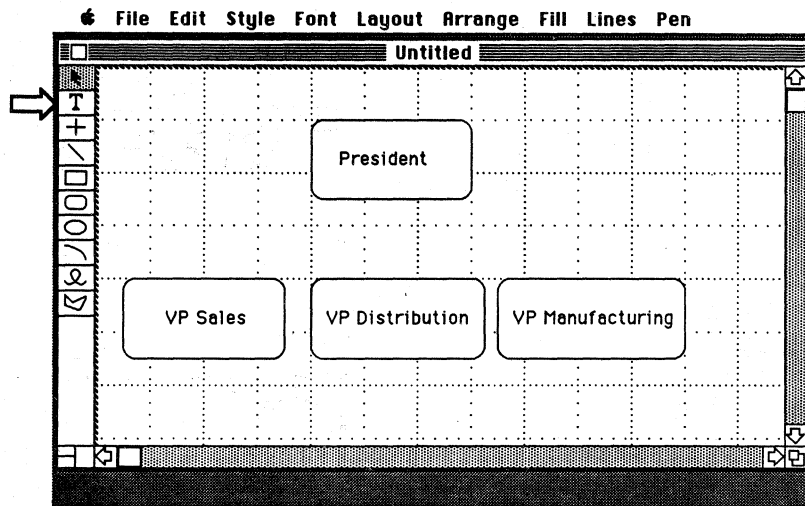

### Add lines to show the structure of the organization.

If you hold down the Command key, you can draw several of the same type of object without having to return to the palette. Use that technique, and follow the instructions below to draw the lines to connect the boxes together.

1. Choose the perpendicular lines tool from the palette.
2. Draw one of the lines shown in the screen shot below.
3. Hold down the Command key to draw another line.
4. Continue to hold down the Command key as you draw all of the lines shown below.

If you have trouble lining up the boxes and the lines, don't worry about it right now. Later, you'll learn about the grid and how to align objects.

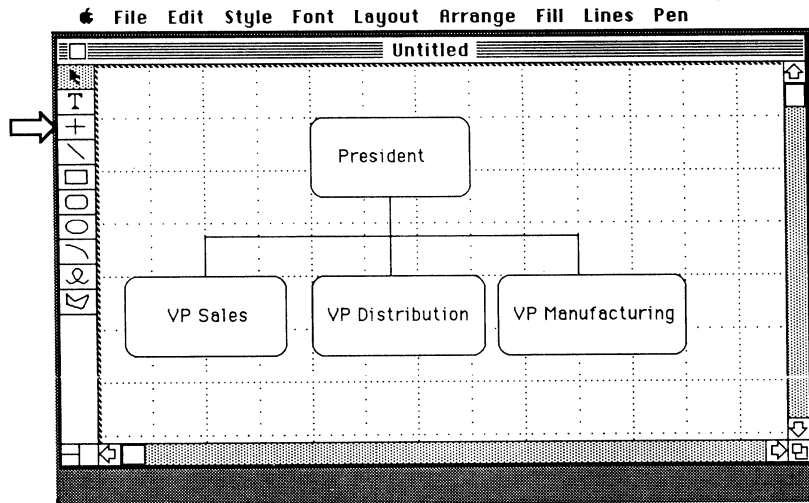

### Enhance your drawing

#### Change the type style of a word.

1. Choose the selection pointer and point to the word "President." Click the mouse button to select it.
2. Choose **18 point** from the **Font** menu.
3. Choose **Bold** from the **Style** menu.
4. Reposition the text to keep it in the center of the rectangle.

#### Make the boxes bolder.

1. Select one of the boxes.
2. Hold down the Shift key and click on the second box. Both boxes should now be selected.
3. Use the Shift-click technique to select all four boxes.
4. Choose a slightly bolder line from the **Lines** menu.

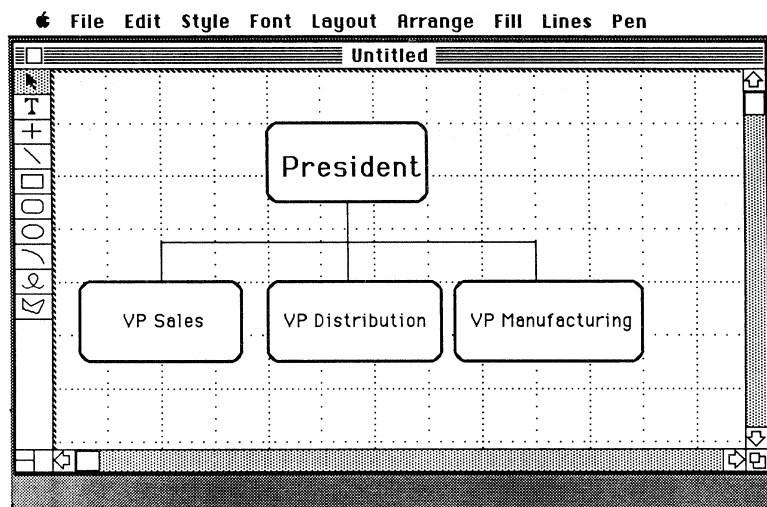

## Practice (cont'd)

### Make room for a title.

Before you can add a title, you must make some room at the top of your drawing.

1. Choose **Select All** from the **Edit** menu to select everything in your drawing. (**Select All** selects everything in the *entire document*. So when you use **Select All**, be careful not to move objects that you don't really want to move—for example, objects that aren't currently visible in the window.)
2. Move any part of the drawing down the screen. The rest will follow.

### Add a title.

1. At the top of the screen, type **Organization Chart**.
2. Use the **Font** and **Style** menus to change the type style of the title to **New York, 18 point, and Shadow**.

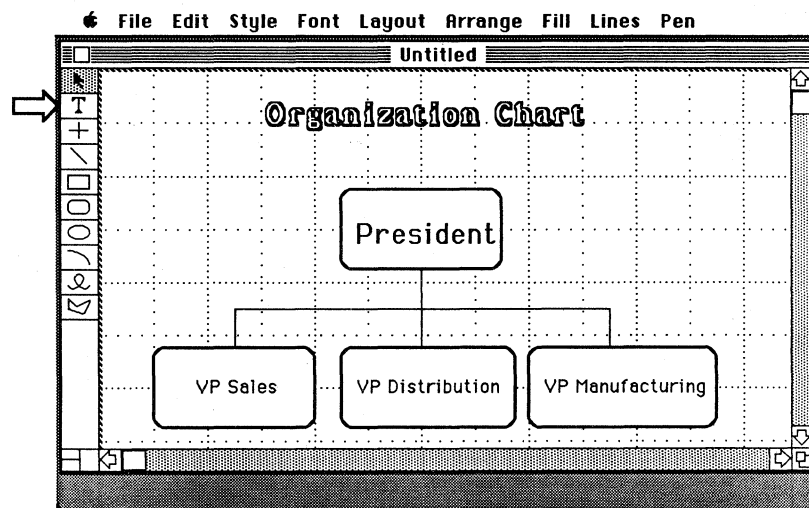

**Highlight the title by drawing two polygons around it, as shown below.**

1. Choose the polygon tool from the palette.
2. Click where you want to start the polygon.
3. Move the mouse to the second *vertex*, or corner, and click again. Each time you click the mouse button, you will establish a new vertex.
4. Continue clicking the mouse button to set each vertex until your polygon is finished.
5. Double-click on the last vertex of the polygon.
6. Either hold down the Command key or click on the polygon tool again to start the second polygon.

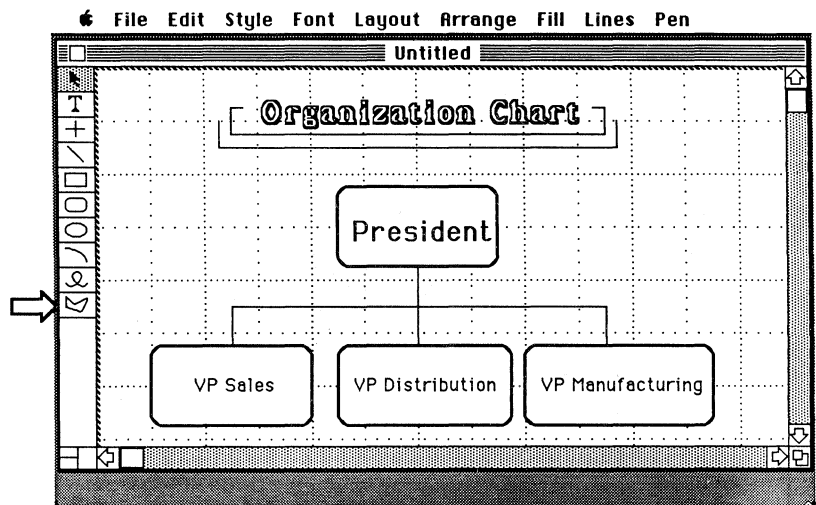

**Quit MacDraw and save your work.**

1. Choose **Quit** from the **File** menu. You will be asked if you want to save the changes.
2. Click **Yes**.
3. Type a name for your document, such as "Org Chart."  
(Henceforth, this document will be referred to as the Org Chart document.)
4. Click **Save**.
5. Choose **Shut Down** from the **Special** menu.
6. Insert the Guided Tour disk.

If you don't see the Guided Tour screen, turn the Macintosh off and then on again.

---

## **Feedback**

### **Draw an Organization Chart**

**Be sure you understand the techniques covered in this section before continuing.**

When you have finished, your drawing should resemble the last screen shot. If it doesn't, and you don't understand why, reread this section to be sure you understand all of the techniques taught.

If you don't understand a particular aspect of MacDraw, you have several options:

- Listen to the second Guided Tour session again.
- Refer to *MacDraw*, the owner's manual.
- Ask a colleague, your course manager, or your Apple support representative.

Continue with this module when you are comfortable with all of the techniques taught so far.

---

## **Learning How to Use MacDraw (cont'd)**

### **Guided Tour**

**Complete the third Guided Tour segment, "What Can I Do with MacDraw?".**

Continue with the following practice exercise when you have finished the third session of the Guided Tour of MacDraw.

---

## **Practice**

### **Fixing Mistakes Review**

**Use Clear, Undo, or Revert.**

Remember, if you don't like the last object you drew, you can use the **Clear** command to remove it. Or choose **Undo** to undo any addition or change to your drawing. You can also use the **Revert** command to undo all of your changes since you last saved your document.

## Start Up MacDraw

**Use the MacDraw disk to complete the practice exercise.**

1. Click **I'm Ready to Stop** from the Guided Tour screen.
2. Insert the MacDraw disk.
3. Open the Org Chart document.

## Enhance the Organization Chart

**Use the techniques introduced in the Guided Tour to enhance your chart.**

This section contains step-by-step instructions to complete your drawing, and screen shots showing approximately what your screen should look like. It's not necessary to match the screen shots exactly.

**Center the text in the boxes.**

Upon choosing the **Align Objects** command from the **Arrange** menu (don't do it yet), you will get several choices for how you want to line up the selected objects. The **Top**, **Bottom**, **Left**, and **Right** options are straightforward. The **L/R Centers** (Left/Right) option relocates the objects left and right until they are centered vertically. The **T/B Centers** (Top/Bottom) option moves the objects up and down until they are centered horizontally.

1. Use either the selection rectangle or the Shift-click technique to select the top box and the text it contains.
2. Choose **Align Objects** from the **Arrange** menu.
3. Click **L/R Centers** and **T/B Centers**, and then click **OK**. The text will now be centered in the box, both horizontally and vertically.
4. Deselect the box and text by clicking on an empty part of your drawing. The handles will all disappear.
5. Repeat the process for the other three boxes.

## Practice (cont'd)

### Add shadows to the boxes.

1. Use the Shift-click technique to select all four boxes, but not the text.
2. Choose **Duplicate** from the **Edit** menu.
3. Choose **Send To Back** from the **Arrange** menu.
4. Choose the black fill pattern from the **Fill** menu.

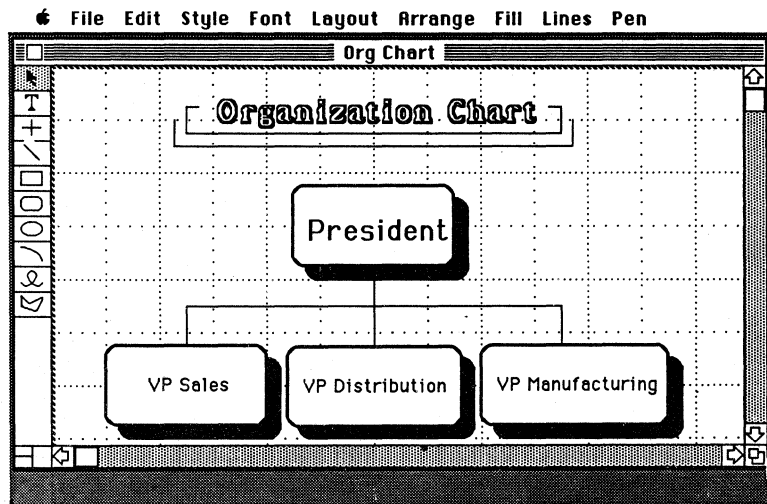

### Draw a round-corner rectangle of a specific size.

1. Choose **Show Rulers** from the **Layout** menu.
2. Choose the round-corner rectangle tool from the palette (#1 in the following screen shot).
3. Just below the title, on the right side of your chart, draw a rectangle 1 1/2 inches long and 1/2 inch high. (See the next screen shot.)

### Add text centered in the box.

1. Choose the text tool in the palette (#2 in the screen shot below).
2. Choose **Center** from the **Style** menu.
3. Position the text-insertion point in the middle of the box.
4. Type **Effective 1/86**.

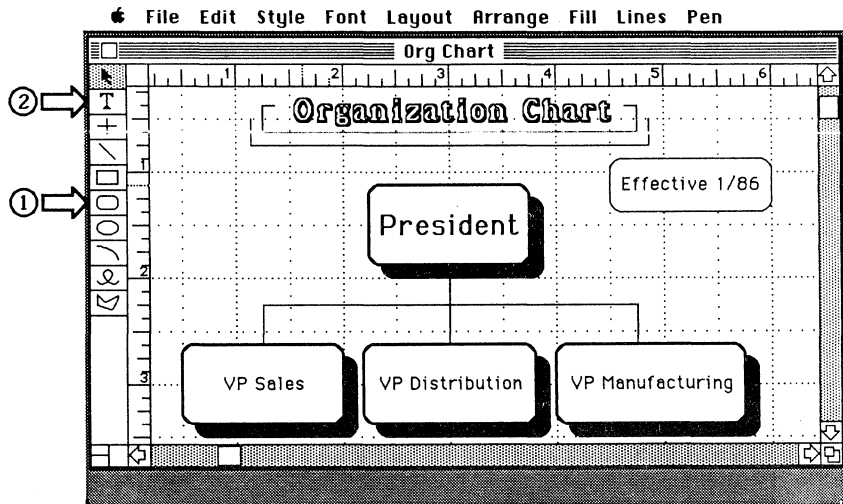

### Change the lines to arrows.

1. Select the three vertical lines that lead to the bottom boxes.
2. From the **Lines** menu, choose the first line that has a single arrowhead.
3. If the arrows in your drawing are pointing up instead of down, choose the other single-headed arrow from the **Lines** menu while the lines are still selected.

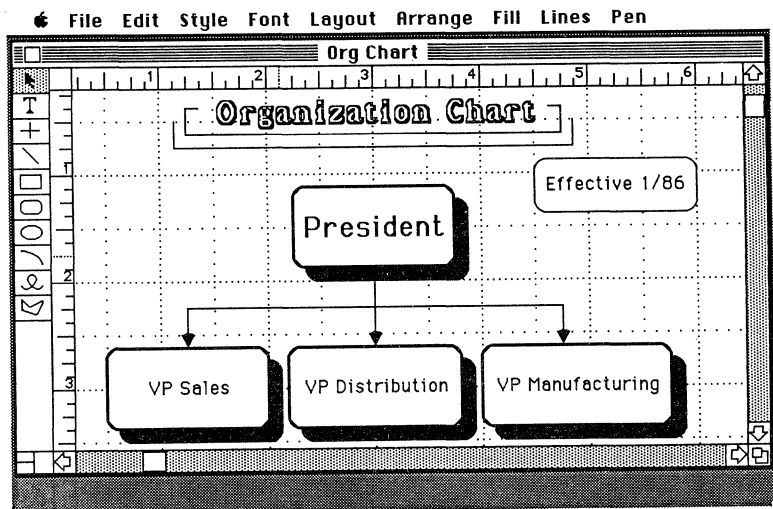



## ***Practice (cont'd)***

### **Quit MacDraw.**

1. Choose **Quit** from the **File** menu.
2. When asked if you want to save changes, click **Yes**.

MacDraw will automatically save your changes under the same name as you saved the document earlier, and on the same disk. If you had wanted to keep both versions of your document, you would have chosen **Save As** and then entered a new name for the current version of your drawing. This would have left the original untouched.

3. Choose **Shut Down**.

---

## ***Feedback***

### **Enhance Your Organization Chart**

### **Be sure you understand the techniques covered in this section before continuing.**

When you have finished, your entire drawing should resemble the last screen shot, shown on page 23. If it doesn't, and you don't understand why, reread this section to be sure you understand all of the techniques taught.

If you don't understand a particular aspect of MacDraw, you have several options:

- Listen to the third Guided Tour session again.
- Refer to *MacDraw*, the owner's manual.
- Ask a colleague, your course manager, or your Apple support representative.

Continue with this module when you are comfortable with all of the techniques taught so far.

---

## Learning How to Use MacDraw (cont'd)

### Guided Tour

**Complete the fourth Guided Tour session, "Big Drawing!".**

Continue with the following practice exercise when you have finished the fourth session of the MacDraw Guided Tour.

---

## *Practice*

### Start Up MacDraw

**Use the MacDraw disk to complete the practice exercise.**

1. Click **I'm Ready to Stop** from the Guided Tour screen.
2. Insert the MacDraw disk.
3. Open the "Org Chart" document.

### Add to the Organization Chart

**Use the techniques introduced in the Guided Tour to create a large chart.**

This section contains step-by-step instructions to complete your drawing and screen shots showing approximately what your screen should look like. Complete each step as it's described. It's not necessary to match the screen shots exactly.

## Practice (cont'd)

Give yourself more room to work.

1. Choose **Reduce to Fit** from the **Layout** menu. Notice how large your drawing is, where it is on the paper, and how many pages you have available (one).
2. Choose **Drawing Size** from the **Layout** menu.
3. Click in the box next to the black one to indicate that you want the size of your drawing increased to two pages.

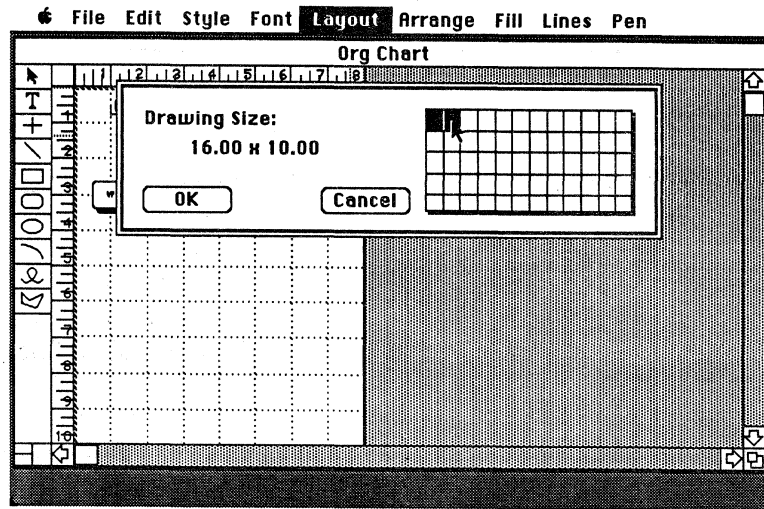

4. Click **OK**.

## Create a "building block" for making the chart larger.

*Read this paragraph,* and then follow the numbered step-by-step instructions to actually make the changes to your document. The next step is to select various parts of your chart and group them so they will be treated as a single object. You'll select only the boxes, their shadows, and the lines connecting them. Once these objects are grouped, you can easily copy, paste, and move entire sections of your organization chart.

1. Use the selection box or the Shift-click technique to select the boxes, their shadows, and the lines (*not* the text, heading, or the "Effective 1/86" box). If you use a selection box, use the Shift-click technique to deselect all of the text.

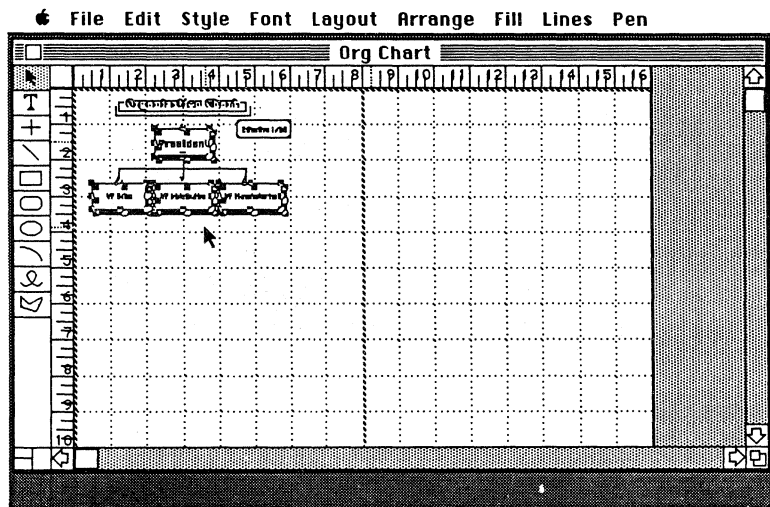

2. Choose **Group** from the **Arrange** menu to group all the boxes and lines.
3. If your text disappears, Choose **Send to Back** from the **Arrange** menu.
4. Choose **Copy**.

## Practice (cont'd)

### Add to the Organization Chart.

1. Move the pointer to the middle of the second page, and click the mouse button (notice that a hand briefly appears pointing to the spot where you just clicked).
2. Choose **Paste**. The "building block" will be pasted where you clicked the mouse button.
3. Move it so that the top box is level with the three boxes on the left page.

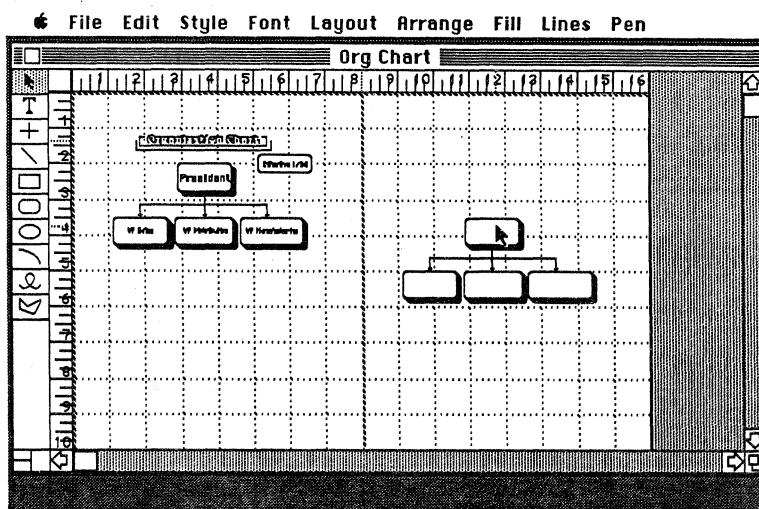

4. Draw the two lines indicated below to connect the new part of the chart to the existing part.

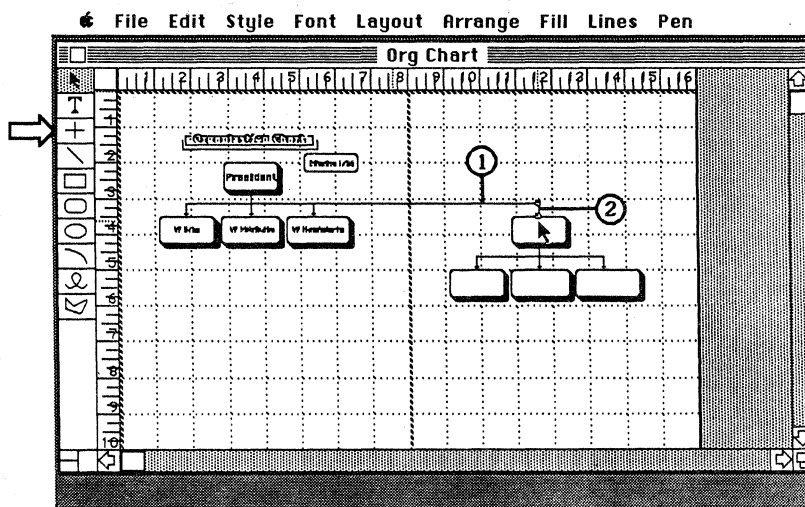

### Enlarge your chart some more.

1. Click the mouse button in the lower half of the first page.
2. Choose **Paste** to add another branch of your organization chart below the original part.
3. Move the new addition to the desired location, centered below the middle box.
4. Draw a straight line down from the "VP Distribution" box to connect the new branch to the rest of the chart.

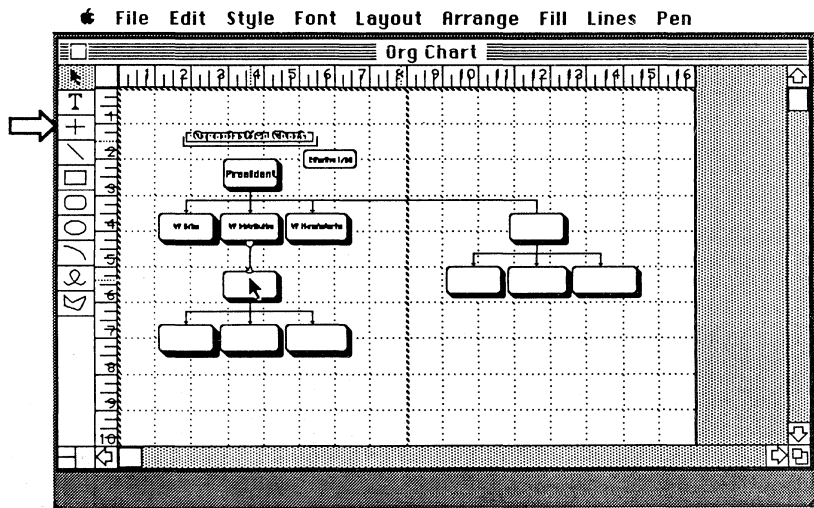

### See what the chart will look like when it's printed.

1. Choose **Hide Rulers** from the **Layout** menu.
2. Choose **Hide Ruler Lines** from the **Layout** menu (this removes the reference lines from your drawing).
3. Choose **Hide Page Breaks** from the **Layout** menu.

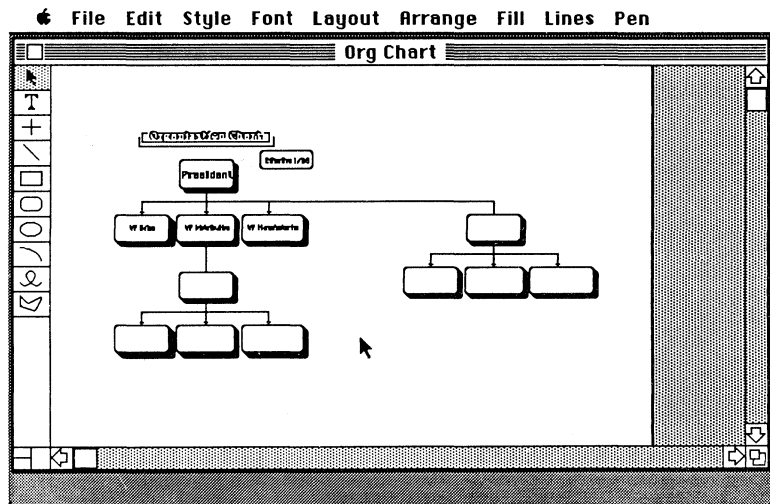

## Practice (cont'd)

**Get ready to add text to the new part of the chart.**

1. Select the right branch of the chart.
2. Choose **Normal Size** from the **Layout** menu. Notice that the part you selected is now centered on your screen.

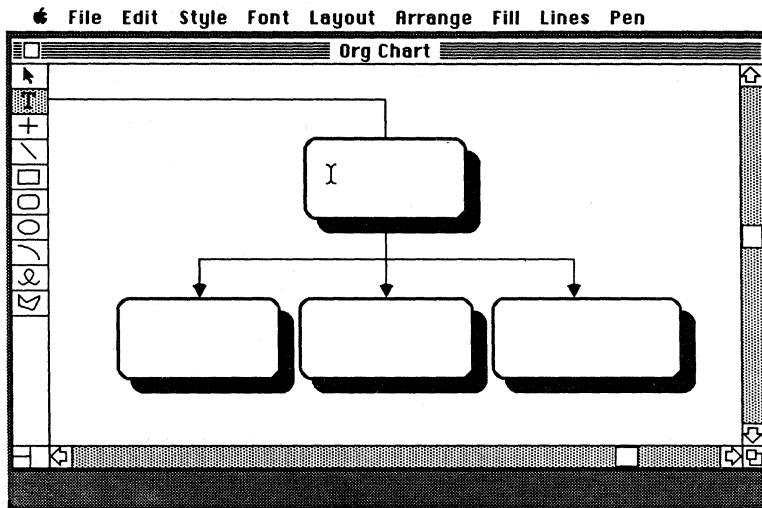

You are now ready to add text to complete your organization chart. Since you already know how to add text, this exercise won't guide you through it. If you want the practice, add some text on your own and center it in the boxes.

You may want to ungroup these objects so you can align text in a box or so you can enlarge or shrink an individual box to fit the text.

### Quit MacDraw.

1. Choose **Quit** from the **File** menu to return to the Guided Tour menu screen.
2. When asked if you want to save changes, click **No**.

---

## Feedback

**Add to the  
Organization Chart**

**Be sure you understand the techniques  
covered in this section before continuing.**

When you have finished, your entire drawing should resemble the next-to-last screen shot, shown at the top of page 30. And your screen should resemble the screen shot at the bottom of page 30. If either isn't true, and you don't understand why, reread this section to be sure you understand all of the techniques taught.

If you don't understand a particular aspect of MacDraw, you have several options:

- Listen to the fourth Guided Tour session again.
- Refer to *MacDraw*, the owner's manual.
- Ask a colleague, your course manager, or your Apple support representative.

Continue with this module when you are comfortable with all of the MacDraw techniques taught so far.

**Take a Break**

**You've been doing great! It's time for a break.  
Relax for 10 to 15 minutes before continuing.**

---

## Learning How to Use MacDraw (cont'd)

**Learn All of the  
Menu Commands**

**The function of each menu command is  
explained in the manual.**

Read the section of the manual that explains the function of each of the menu commands, not only to learn the information, but also to become familiar with the manual as a valuable reference tool. Read the MacDraw Menus section in Chapter 3 of *MacDraw*, the owner's manual.

Continue with this module when you have finished reading about the MacDraw menus.



## North American Distribution System

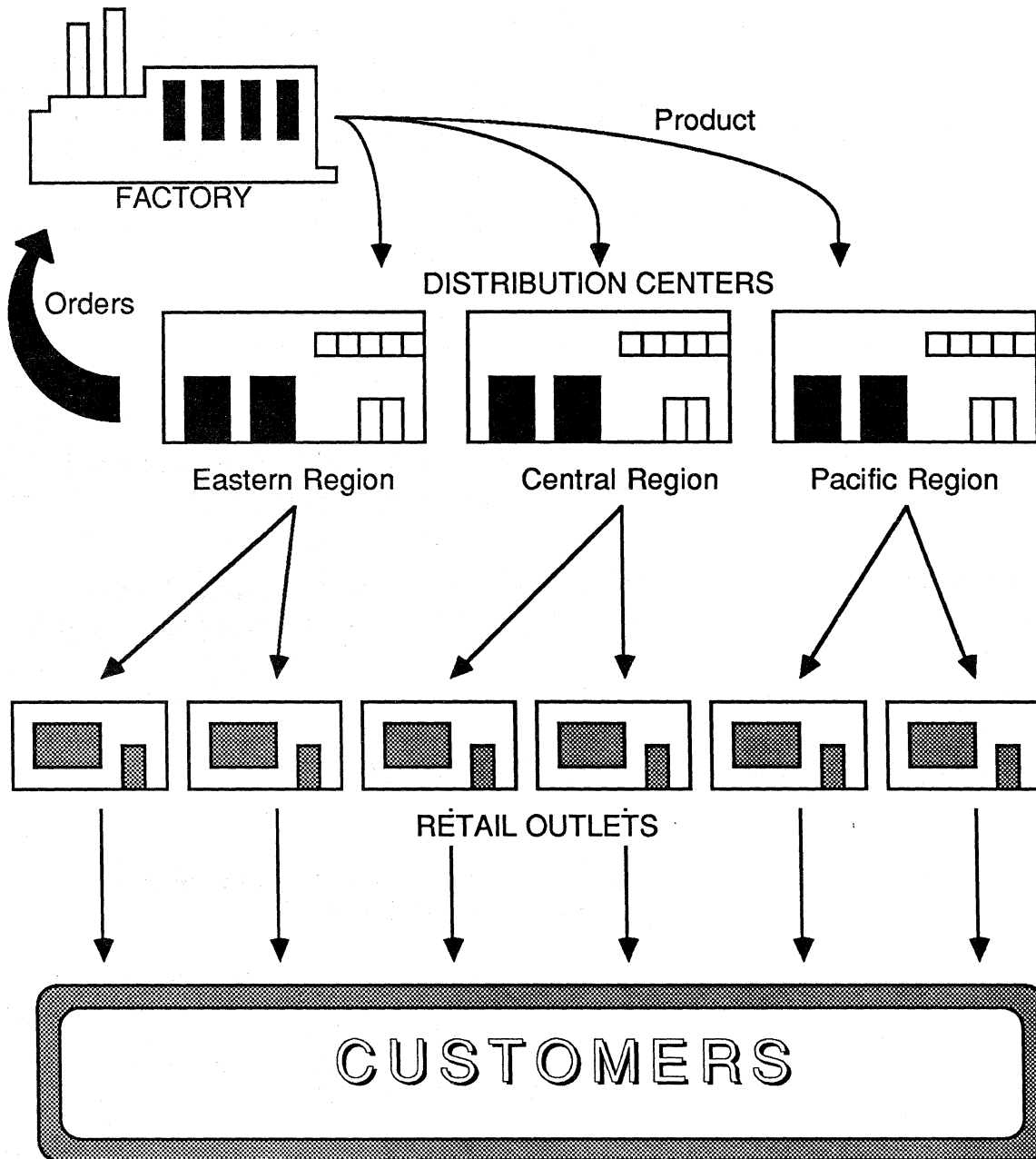

---

## Practice Using MacDraw

### Overview

**Practice what you learned in the Guided Tours, and learn a few more features.**

This exercise is designed to give you an opportunity to practice using many of the features you were introduced to in the Guided Tour. You will also learn how to use additional features that the Guided Tour didn't cover. You will *not*, however, learn everything there is to know about using MacDraw. The best way to learn everything is to thoroughly read the manual and then simply use the product.

### **Draw a distribution diagram.**

Let's say you've been asked to prepare a presentation explaining how your company distributes its products, from the factory all the way to the customer. A drawing showing the overall picture is a great way to start the presentation—and MacDraw is just the tool you need to create it.

In this final practice exercise, you'll draw the diagram shown on the facing page. The exercise includes step-by-step instructions and screen shots so you can check your work. Perform each step as it is described. It's not necessary to match the screen shots exactly. In this exercise, the screen shot showing the effect of a particular change to your drawing is placed before the instructions on how to make that change to provide an example of what you're about to draw.

As with earlier practices, the drawing tools you will use are identified in the screen shots by hollow arrows () , which won't appear on your screen.

Remember, if you make a mistake, or you don't like the last object you drew, use the **Undo**, **Clear**, and **Revert** commands.

If you forget how to use a particular feature, or you don't understand what to do, refer to *MacDraw*, the owner's manual, or ask a colleague, your course manager, or your Apple support representative.

## Practice

### Draw Your Company's Distribution System

#### Start up from the MacDraw disk.

Insert the actual MacDraw application disk (not the Guided Tour disk) and open the MacDraw icon to start up the application.

The open document covers most of the screen, but there's about half an inch of desktop all the way around it. Move the window to the top left corner of the screen and then expand it to fill the *entire* screen.

#### Draw a factory, like the one shown below.

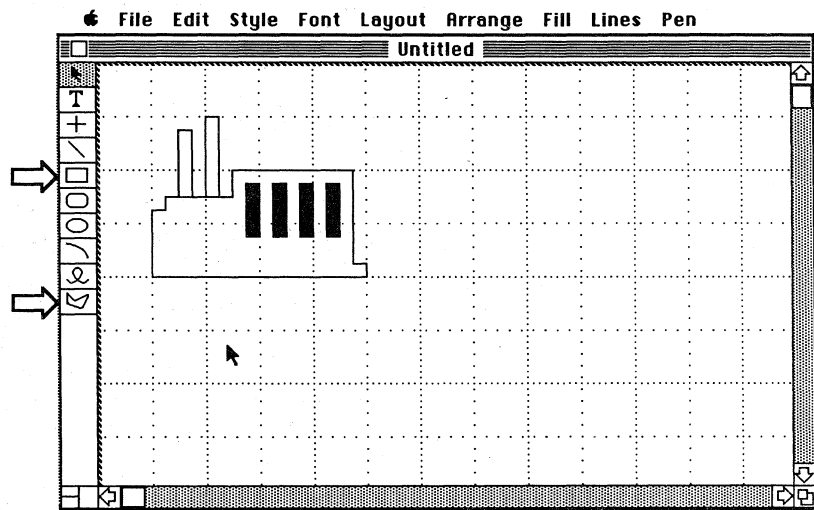

1. Choose the polygon tool from the palette and draw the outline of the factory.
2. Choose the rectangle and draw the first smokestack.
3. Hold down the Command key to draw the second smokestack without having to click in the palette again.
4. Draw the first window and fill it with black.
5. Press Command-D to duplicate the window.
6. Position the duplicate next to the original, as shown above.
7. Press Command-D two more times to add two more windows. The third and fourth windows will retain the spacing you established between the first two.

### Shrink the factory.

1. Choose **Select All** from the **Edit** menu.
2. Choose **Group** from the **Arrange** menu (or press Command-G).
3. Grab the lower right handle and shrink the factory (see the screen shot below for the approximate size).

### Draw the first distribution center, like the one shown below.

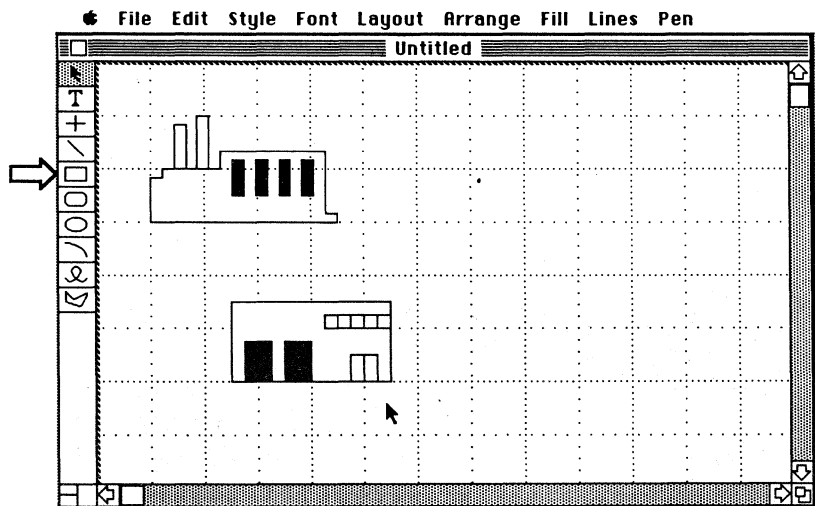

1. Draw a rectangle for the outline.
2. Draw a small square for the first window in the top right corner of the rectangle.
3. Press Command-D to duplicate the first window. Move it next to (and adjoining) the original, and then press Command-D three more times to line up five windows. (Remember, each time you press Command-D, a duplicate is created with the same spacing relative to the previous object as that established between the first and second objects.)
4. Draw a rectangle for the small door and then add a vertical line to make it look like a double door.
5. Draw a large rectangle for the first shipping door, and fill it with a pattern from the **Fill** menu.
6. Duplicate it to make the second shipping door.

## Practice (cont'd)

Add two more distribution centers.

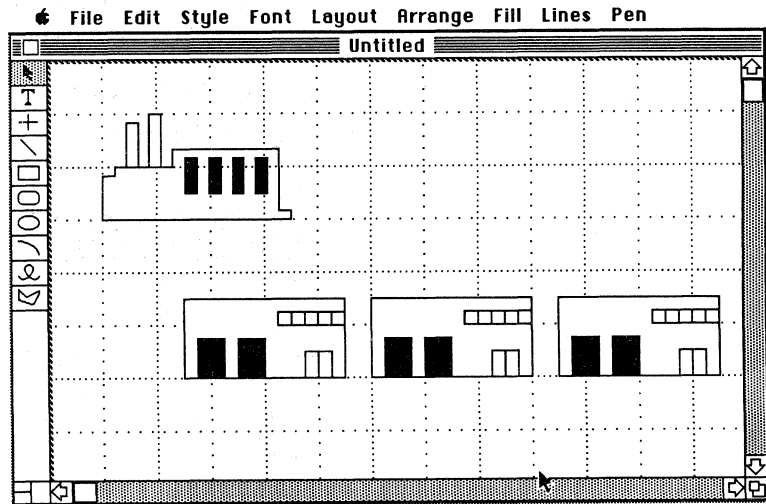

1. Use the selection box to select the distribution center.
2. Group the objects together.
3. Duplicate the grouped objects and place the duplicated distribution center next to the original.
4. Choose **Duplicate** again to create a third distribution center.

Add labels to your drawing.

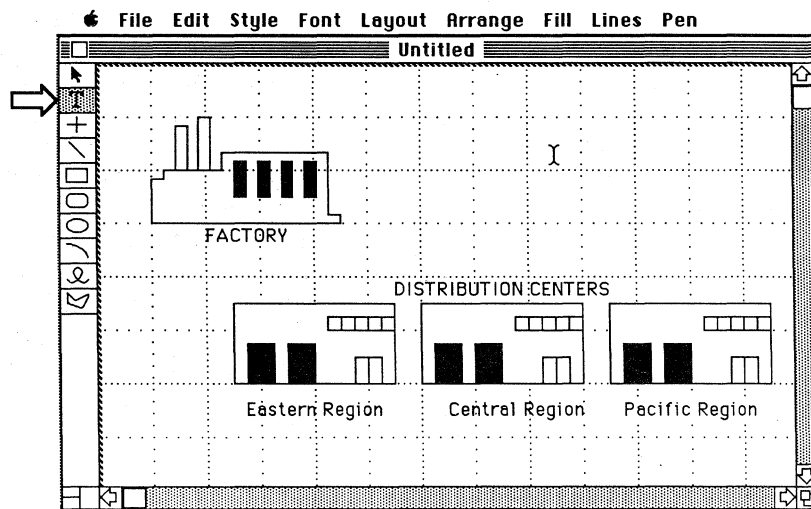

1. Type **FACTORY** below the factory and move the text so it's centered beneath the picture.
2. Type **DISTRIBUTION CENTERS**, and center it above the three distribution centers.
3. Type the following below the three distribution centers: **Eastern Region, Central Region, and Pacific Region.**

#### **Center the text below the distribution centers.**

1. Select the first distribution center.
2. Use Shift-click to select the text beneath it.
3. Choose **Align Objects** from the **Arrange** menu.
4. Click on **L/R Center** and then click **OK**.
5. Do the same for the other two distribution centers. For the **Central Region**, also select "**DISTRIBUTION CENTERS**" so that it will be centered above the middle drawing, and therefore above all three distribution centers.

#### **Save Your Work**

#### **Choose Save to save what you have done so far.**

You should save your work regularly, every 10 to 15 minutes, to minimize the loss of work should there be an accident, such as someone tripping over your power cord.

1. Choose **Save** from the **File** menu.
2. If you have an external disk drive, insert your blank data disk. If you don't have an external disk drive, click **Eject** to eject the MacDraw disk and then insert the blank data disk.
3. Enter a name for your document, such as **Distr System**.
4. Click **Save**.
5. If you don't have an external disk drive, you need to reinsert the MacDraw application disk. Press **Command-Shift-1** to eject the data disk. Then insert the MacDraw application disk.

## Practice (cont'd)

Continue with  
Your Drawing

Add arrows pointing to the distribution centers.

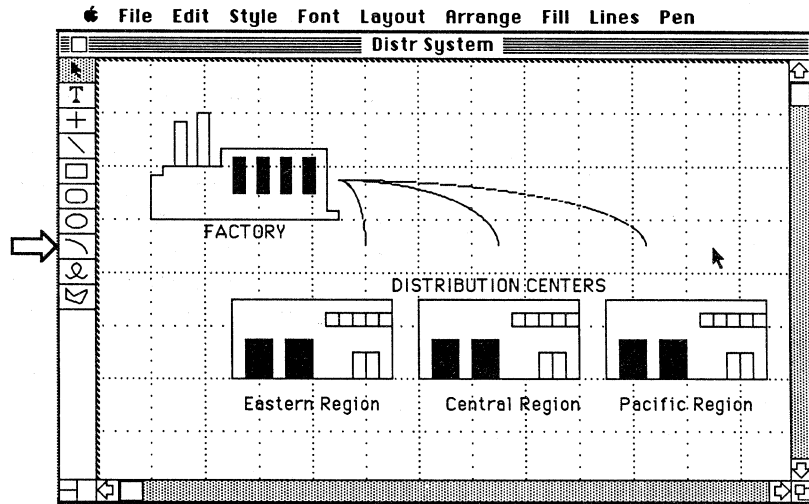

Choose the arc tool from the palette and draw three arcs as the first part of the arrows. Stop the arcs short of the distribution centers to save room for the arrowheads. You can't automatically make arcs into arrows, so you'll have to add short, straight-line arrows to each arc.

Add arrow heads.

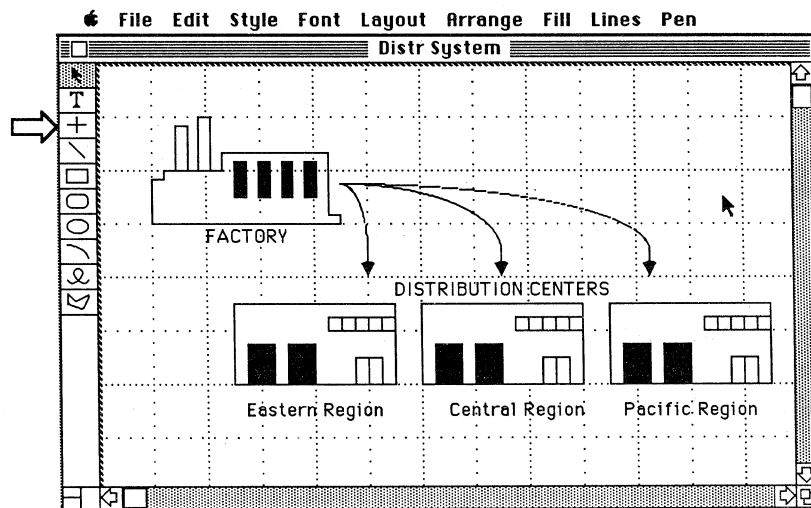

1. Choose the perpendicular lines tool and add a short line to the bottom of the first arc.
2. Choose the first line that has a single arrowhead from the **Lines** menu. If an arrow doesn't appear, the line is too short. The line must be at least 1/4 inch long for an arrow to appear.
3. Duplicate the arrow and add it to the other two arcs.

### Draw the large arrow pointing back to the factory.

The **Show Size** command helps you draw objects of exact sizes. When resizing arcs, it measures them in degrees. Use arcs and the **Show Size** feature to draw a large arrow pointing back to the factory. Screen shots are included to show you what the arrow should look like at interim stages.

1. Choose the arc tool.
2. Choose **Show Size** from the **Layout** menu.
3. Start the arc to the left of the Eastern Regions distribution center. Draw an arc whose size is 0.62 inches by 0.62 inches in the shape shown in the screen shot below.
4. While the arc is still selected, choose **Reshape Arc** from the **Edit** menu.
5. Grab the top handle and move it around the circle until the size reads **307** degrees.
6. Start another arc 1/4 inch above the first. Its size should be 0.50 inches by 0.50 inches.
7. Choose **Reshape Arc**.
8. Grab the top handle and move it around the circle until the size reads **296** degrees.

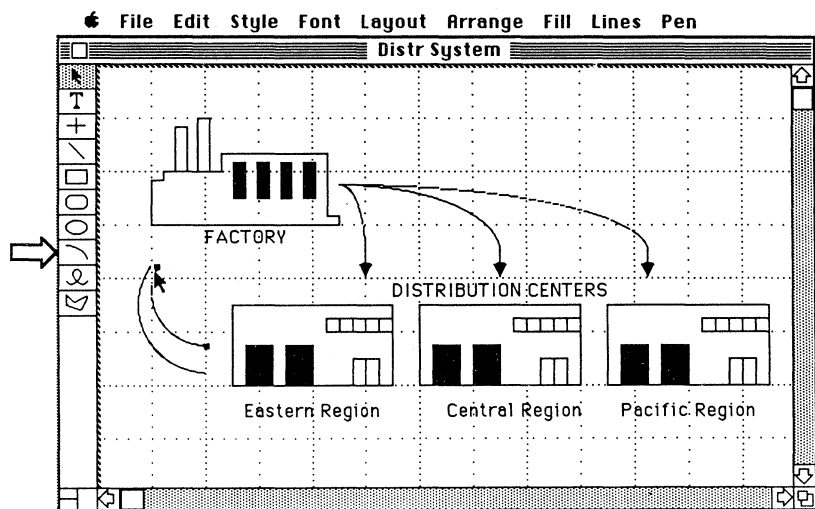



## Practice (cont'd)

9. While the smaller arc is still selected, choose the white fill pattern from the **Fill** menu.
10. Select the larger arc and choose the black fill pattern from the **Fill** menu.
11. Choose **Hide Size** from the **Layout** menu.

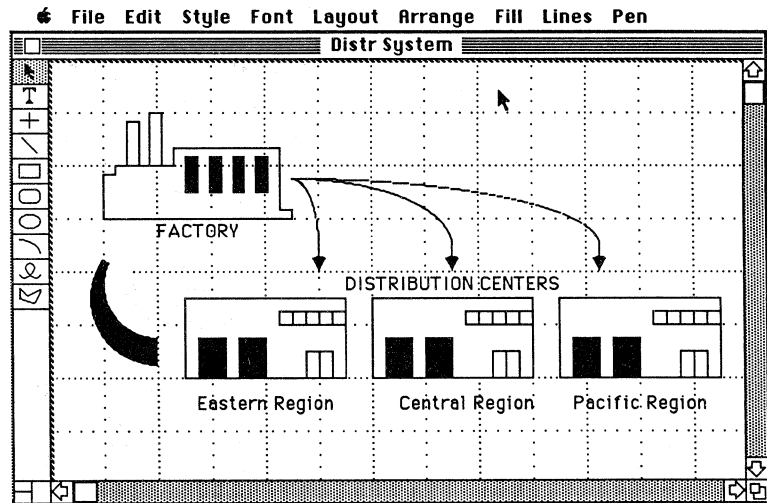

Add an arrowhead to the two arcs.

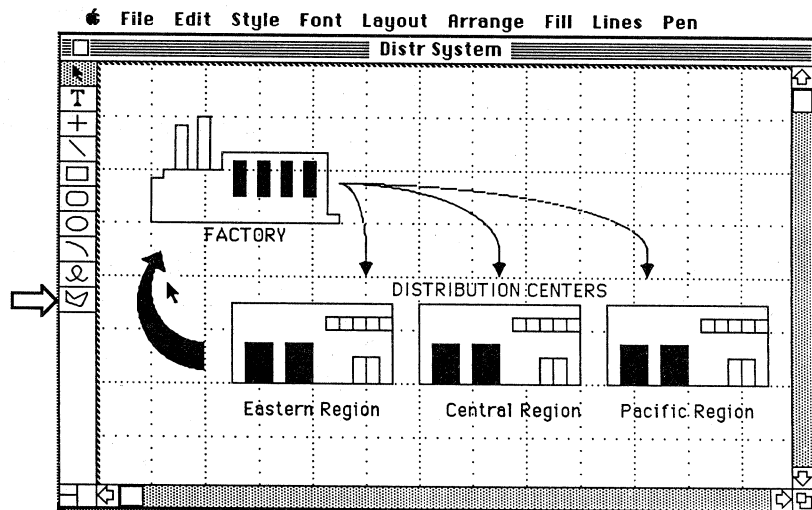

Try drawing an arrowhead as shown. It will be difficult to get it the right size and at the correct angle. This is because of the grid. The grid is an invisible gravitational force that limits mouse movements to the smallest increment of the ruler, regardless of whether you are creating something or moving an existing object. For example, if the smallest increment of the ruler is 1/8 inch (as it is now), you can only move or change the size of objects in 1/8-inch increments. (There is additional information about the grid in the Useful Techniques section of this module.)

1. Choose **Turn Grid Off** from the **Layout** menu.
2. Choose the polygon tool and draw a triangle for the arrowhead (see the previous screen shot or the one below).
3. Choose the black fill pattern.

**Add text to the arrows.**

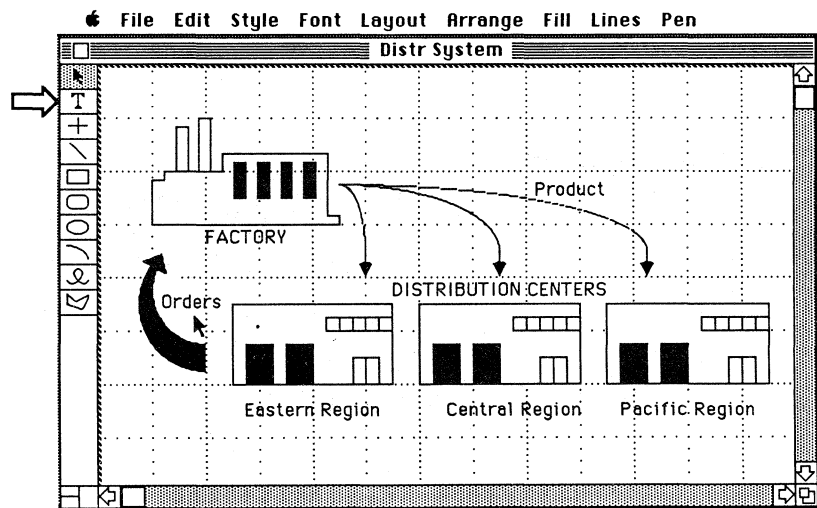

1. Turn the grid back on by choosing **Turn Grid On** from the **Layout** menu.
2. Next to the three arrows, type **Product**.
3. Next to the large arrow, type **Orders**.

## Save Your Work

**Get in the habit of saving your changes regularly.**

Choose **Save** from the **File** menu to save your changes. If you have an external disk drive, all of your changes will be saved to the data disk (which should still be in the drive).

## Practice (cont'd)

If you don't have an external disk drive, when you choose **Save**, you'll be asked to insert the data disk. When you've finished saving your work, press **Command-Shift-1** to eject the data disk, and then insert the MacDraw application disk.

Either way, notice how quick and easy it is to save your changes. It's strongly recommended that you do this often. A good habit to get into is to save your work every 10 to 15 minutes as well as whenever you're not working on the documents, for example, when you leave for lunch or when you're interrupted by a visitor or a phone call.

### Continue with Your Work

### Add six retail outlets.

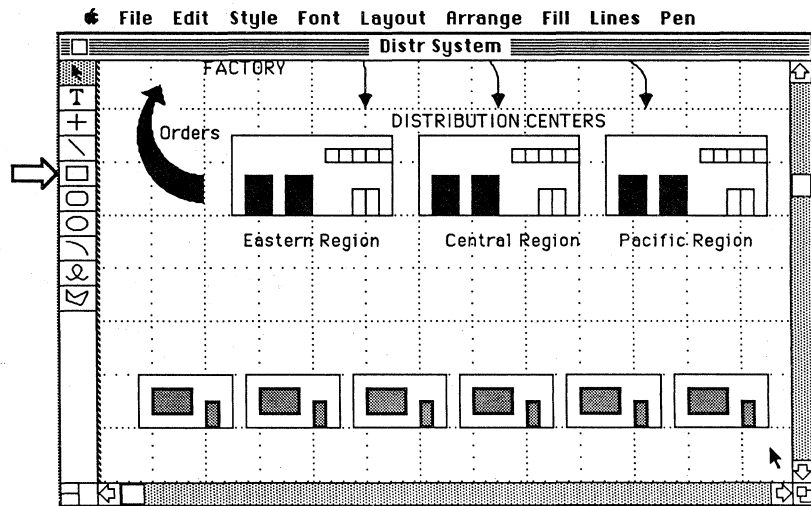

1. Scroll down the page.
2. Draw the outline of the first retail outlet.
3. Add a door and a picture window. Fill them.
4. Group the three objects together.
5. Press **Command-D** to duplicate the retail outlet.
6. Position the duplicate next to the original.
7. Press **Command-D** four more times to add four more outlets.

Add arrows from the distribution centers to the retail outlets.

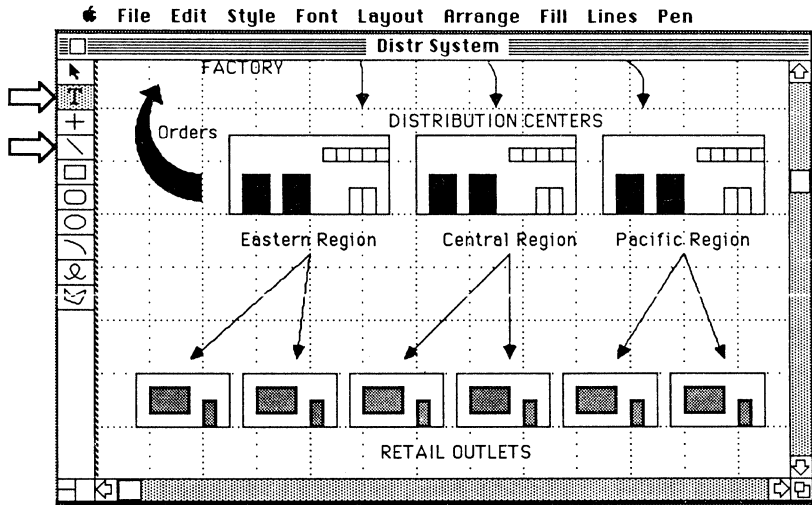

1. Choose the diagonal lines tool.
2. Choose the first line that has a single arrowhead from the **Lines** menu.
3. Draw all six arrows starting at the distribution centers. Hold down the Command key to draw the lines without having to reselect the tool. If the arrows are pointing the wrong way, choose the other line with a single arrowhead from the **Lines** menu.
4. Type **RETAIL OUTLETS** below the six outlets you just drew.
5. Position the text so it's centered under the retail outlets.

Draw the large rectangle representing the customers.

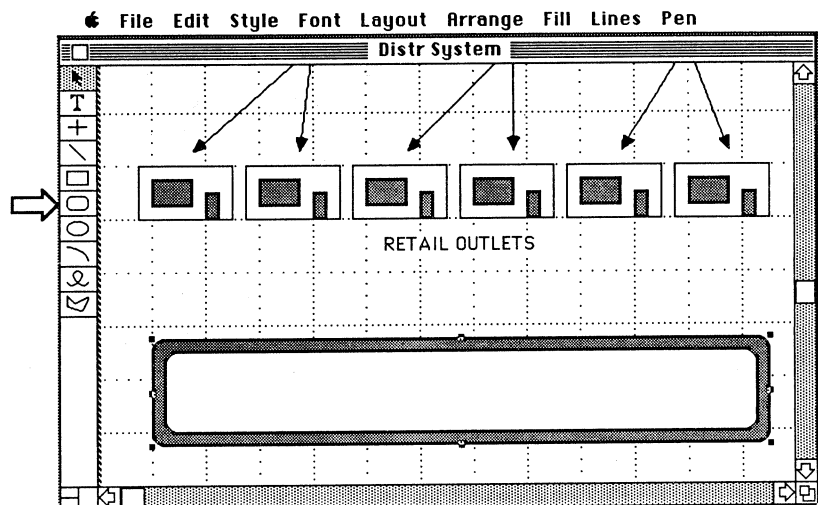

## Practice (cont'd)

1. Scroll down the page until there's enough room to draw the rectangle shown in the last screen shot.
2. Choose the round-corner rectangle tool from the palette.
3. Draw the white rectangle (shown above) below the retail outlets.
4. Choose **Round Corners** from the **Edit** menu.
5. Click on **1/8"** and click **OK**.
6. Duplicate the rectangle.
7. Grab the top left handle and stretch the rectangle until it's slightly larger than the original all the way around.
8. Choose **Send To Back** from the **Arrange** menu.
9. Choose a pattern from the **Fill** menu.

**Add text to the new rectangle.**

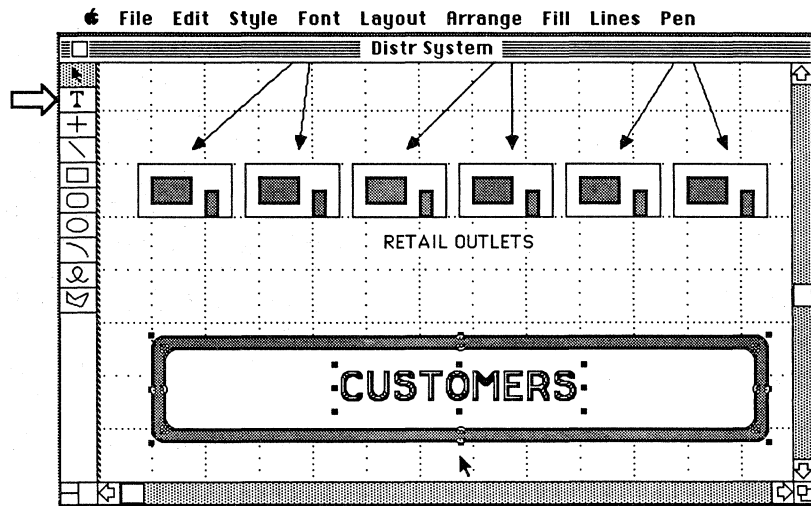

1. Type **CUSTOMERS** in the rectangle.
2. Change the type style to **24 Point** and **Shadow**.
3. To center the text in the rectangle, first select the text and the two boxes.
4. Choose **Align Objects** from the **Arrange** menu.
5. Click on **T/B Centers** and **L/R Centers** and click **OK**.

**Save Your Work**

**Choose Save from the File menu. Insert your data disk, if necessary.**

## Finish Your Drawing

Add arrows from the retail outlets to the customers.

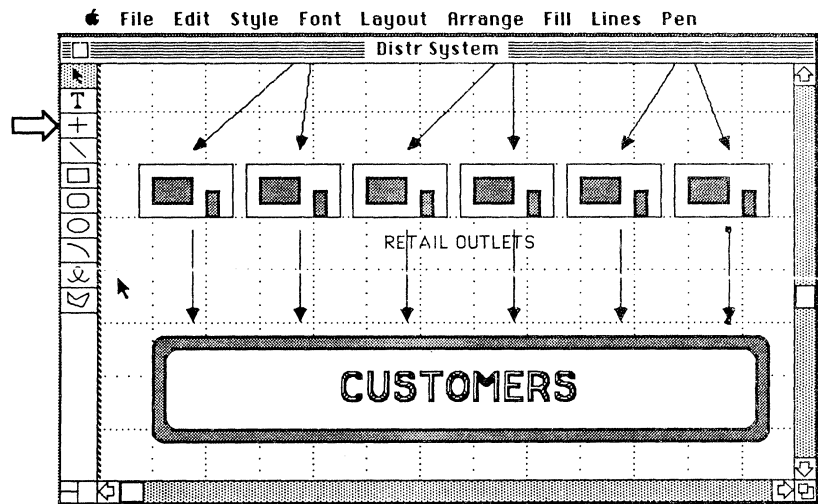

The last time you drew arrows, you changed the lines to arrows before drawing the first line. This changes the palette so all subsequent lines will also be arrows. Therefore, you don't have to use the **Lines** menu to indicate that you want arrows this time. Every straight line you draw will continue to be an arrow until you change the palette again.

1. Choose the perpendicular lines tool.
2. Draw an arrow from the first retail outlet to the customers.
3. Duplicate the arrow and move it so that it's correctly positioned under the second retail outlet.
4. Press Command-D four more times.

Notice that the middle two lines go right over "RETAIL OUTLETS." With MacDraw, objects are drawn on top of other objects, just as pieces of paper can overlap on your desk. You can rearrange the objects using **Bring to Front** and **Send to Back** commands in the **Arrange** menu. Follow the instructions on the next page to rearrange the text and lines in your drawing.

## Practice (cont'd)

5. Select the text, "RETAIL OUTLETS."
6. Choose the white fill pattern from the **Fill** menu.
7. Choose **Bring to Front** from the **Arrange** menu.

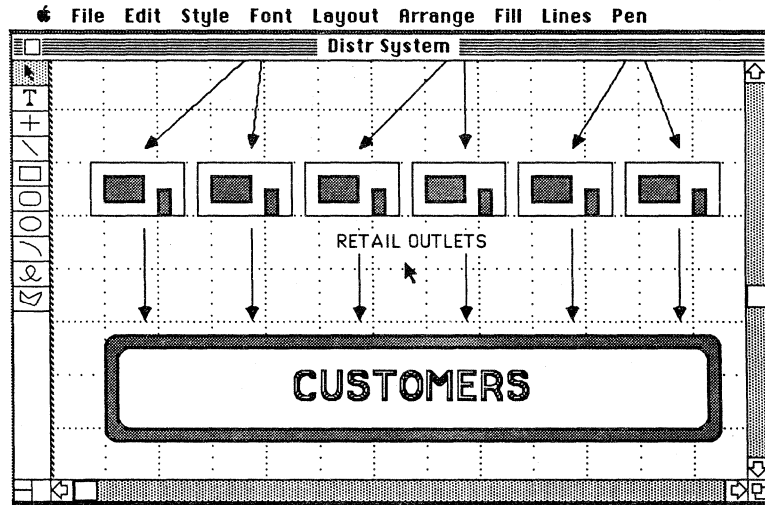

### Reposition the entire drawing on the page.

1. Choose **Reduce to Fit** from the **Layout** menu.
2. Choose **Select All** from the **Edit** menu (or press Command-A).
3. Grab any part of your drawing and move it so it's centered horizontally on the page and there's room at the top for a title. If you accidentally grab a handle, your drawing may change drastically. Just release the mouse button and choose **Undo**. Then try again. (See the screen shot below.)

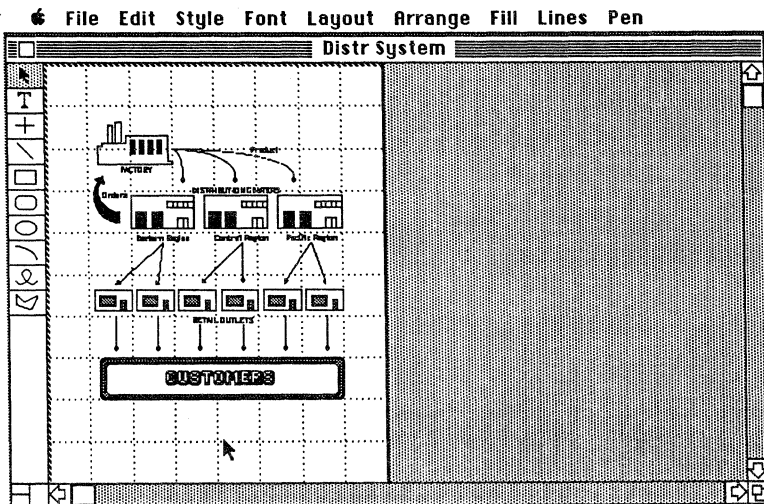

### Add a title.

1. Click at the top of the page. This does two things: (1) it deselects everything, and (2) it indicates where you want to work when you return your drawing to normal size.
2. Choose **Normal Size** from the **Layout** menu.
3. At the top of the drawing, type **North American Distribution System**.
4. Change the type style to **18 point, Bold, Underlined, and New York** font.
5. Move the title so that it's centered over your drawing.
6. To see what it will look like when printed, choose **Hide Ruler Lines** from the **Layout** menu.

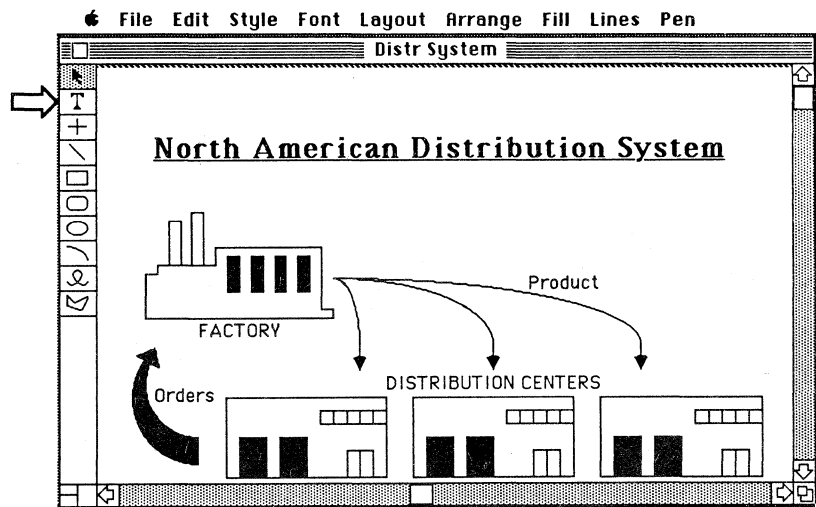



---

## ***Feedback***

### **Draw Your Company's Distribution System**

**Be sure you understand the techniques covered in this section before continuing.**

When you have finished, your entire drawing should resemble the drawing on page 28 and your screen should look like the screen shot above. If either isn't true, and you don't understand why, reread this section to be sure you understand all of the techniques taught.

If you don't understand a particular aspect of MacDraw, refer to the *MacDraw* manual, or ask a colleague, your course manager, or your Apple support representative for assistance.

Continue when you are comfortable with using all of the MacDraw features that were covered.

---

## Integrating MacDraw with Other Applications

### Overview

#### What is possible, and how is it done?

One of the key benefits of the Macintosh is being able to copy and paste information from one application to another. For example, you can make a MacWrite™ document more meaningful by including a drawing from MacDraw or MacPaint.

This section begins with a reminder of how to move information from one document to another. Then there is a description of what integration is possible between MacDraw and other Macintosh applications.

### How to ...

#### Use Copy and Paste.

To move information between any two documents, use the following technique:

1. Select what you want to move.
2. Copy it.
3. Open the second document.
4. Indicate where you want to add the information.
5. Choose **Paste**.

Your ability to do this will depend on what types of information each application is able to handle.

## Pasting into MacDraw

### Here's a brief summary of what can be pasted into MacDraw from other applications.

MacDraw can accept text and graphics from any application. However, there are limitations (explained below) on the amount of text that can be received. Here's some additional information regarding pasting information into MacDraw.

**MacDraw.** You can paste anything from one MacDraw document into another.

**MacPaint.** You can paste any MacPaint picture into MacDraw. But once the MacPaint picture is in MacDraw, all you can do with it is resize it (be careful not to distort the image) and move it around. You can't edit it in any way.

**MacProject.** You can paste the Schedule Chart or either of the time lines from MacProject™ into MacDraw. The components of the chart will be pasted in as individual graphics objects, each of which can be modified. You can't paste the tables, though. If the chart or time line is larger than the current size of your document, MacDraw will add pages as needed.

**MacTerminal.** You can paste any text from MacTerminal™ into MacDraw. It will be pasted in either as paragraph text or as caption text (see the "Useful Technique" about Putting Text into Objects which explains caption and paragraph text). MacDraw will add pages to the right as needed (up to 12). Caption text that still falls off the right side will be lost.

**MacWrite.** You can paste anything from MacWrite into MacDraw. Text can be pasted in either as paragraph text or as caption text (see MacTerminal paragraph above), and MacPaint pictures are pasted as if they were pasted directly from MacPaint. MacDraw graphics that were previously pasted into MacWrite are pasted back into MacDraw as *MacDraw graphics*. Therefore, you can edit them, just as you could the originals.

**Business Graphics.** You can paste charts from business graphics programs, such as Microsoft Chart, into MacDraw. The components of the graph are pasted in as individual graphic objects, each of which can be modified.

## Pasting MacDraw Data into Other Applications

### Here's a summary of what information can be pasted into other applications.

You can paste MacDraw information into any application that can handle graphics. Here's some specific information regarding each application.

**MacDraw.** You can paste anything from one MacDraw document into another.

**MacPaint.** You can paste anything from MacDraw into MacPaint, as long as it fits into the MacPaint window. The drawing will be pasted in as a bitmap, just as if you created it in MacPaint. If you paste something larger than the window into MacPaint, the center of the object will appear in the window and the edges will be cropped. Once the drawing is in MacPaint you can edit it with all of MacPaint's features.

**MacProject.** You can paste small amounts of text (a few words) from MacDraw into MacProject. You can't paste MacDraw graphics into MacProject.

**MacTerminal.** You can paste any text from MacDraw into MacTerminal, but all font and type style information is lost. You can't paste graphics into MacTerminal, but you can use MacTerminal to send an entire MacDraw document to another Macintosh (see the *Using MacTerminal* module).

**MacWrite.** You can paste anything from MacDraw into MacWrite, as long as it fits between MacWrite's margins. If the margins are too narrow, the drawing will be shrunk to fit. (See the Adding Graphics section of the *Supporting MacWrite* module.)

---

## Useful Techniques

### Overview

**This section explains techniques that will help you get the most out of MacDraw.**

Reading a manual and doing some practice exercises is only part of learning how to use an application. When you start using an application, you'll discover additional techniques to help you produce *higher-quality work*—and produce it *more efficiently*.

This section describes many of those techniques to help you become more productive on MacDraw more quickly. At the end of the module, there are some resources you should check regularly for more information on how to get the most out of your Macintosh and MacDraw.

### Have MacDraw Available

**Practice exercises are not included, but you are encouraged to try each technique.**

In this section, and for the remainder of the module, you are not directed to complete specific practice exercises. However, it would be valuable for you to have a Macintosh equipped with MacDraw available as you read this section, and to try the various techniques as you read about them.

### Moving Between MacDraw Documents

**Use the Document Directory.**

You can have up to four MacDraw documents open on your screen at the same time. To move from one document to the next, click on any visible portion of the document you want to work with.

If you already have four MacDraw documents open and you want to open a different MacDraw document, here's what to do:

1. Select the document to be closed.
2. Choose **Close** from the **File** menu or click in the close box.
3. Choose **Open** from the **File** menu. You will get a list of all the MacDraw documents on that disk in the Document Directory dialog box.

4. If you want to open a document on another disk, either click **Drive** to display the documents on the disk inserted in the other drive, or click **Eject** to eject the data disk, and then insert the disk containing the document you want.
5. Double-click on the name of the document you want to open.

## Command Key

Use it to invoke menu commands.

Use the Command key in combination with the appropriate letter to invoke many of the menu commands. For example, holding down the Command key and pressing N will open a new document. Here is a summary of the menu commands that have Command-key equivalents.

File		Edit	
New	⌘N	Undo	⌘Z
Open...	⌘O	Cut	⌘H
Save	⌘S	Copy	⌘C
Quit	⌘Q	Paste	⌘U
		Duplicate	⌘D
		Select All	⌘A
		Reshape	⌘R
Style		Arrange	
Plain Text	⌘P	Group	⌘G
Bold	⌘B		
Italic	⌘I		
Underline	⌘U		

## Option Key

Hold down the Option key to display objects as you move them.

If you're moving a group of objects, only the object you were pointing to when you started the move will be displayed (sometimes only the boundary of the entire group of objects is displayed).

Hold down the Option key to display all the objects as you move them. The same technique holds for text—holding down the option key as you move the text allows you to see every character.

This technique makes it much easier to position objects exactly where you want them.

## The Grid

### What is it and how do you affect it?

There are two grids—the visible lines, *ruler lines*, and the invisible gravitational force to which objects cling, the *grid*. Each can be turned on and off independently from the **Layout** menu.

The increment of the ruler lines and the grid is determined by the rulers. The ruler lines appear at every major division of the ruler and are only for reference. They don't affect any of the objects you draw and are not printed.

If the grid is on, any object you draw will change size in the smallest increment of the ruler. If you want to draw or edit in smaller increments, turn the grid off or increase the number of minor divisions on the ruler.

For example, if the grid is on and you're using the standard ruler, every object will change size and move in increments of 1/8 inch.

## Document Layout

### Choose Reduce to Fit to do your rough document layout.

Since you can draw, move, and edit objects while in reduce-to-fit mode, do your "rough cut" document design and layout while the document is reduced. Then return the drawing to normal size and do the detailed work.

Using MacDraw in reduced mode enables you to lay out entire documents, much as you can using some third-party desktop publishing applications. You can place boxes where you will later place text, enter headings, and place your graphics just where you want them. Then work with your document in normal size to add the actual text into the boxes (see the later comment on Putting Text into Objects) and fine-tune your drawings.

## Complex Drawings

### Use many overlapping objects.

New objects are always drawn on top of existing objects. Use **Bring to Front** and **Send to Back** to change the order of the overlapping objects you have created.

Once a component of your drawing is complete, group the independent objects so you don't inadvertently change them.

## Aligning Objects

Here are several techniques to keep in mind when aligning objects.

- When aligning text, watch for blank spaces before or after the text. Select the text with the selection pointer (not with the Text tool) to see its actual size.
- If you're aligning the left sides of a group of objects, all the objects will align to the leftmost object. Similarly, everything will be aligned to the topmost, rightmost, or bottommost object when you choose to align the top, right, or bottom of the objects, respectively.
- If you want to center one object exactly inside another, align on **L/R Centers** and **T/B Centers**.
- If you want to align objects that cover too large of an area to fit on the screen, select and align them while your drawing is reduced to fit in the window.

## Selecting Multiple Objects

There are three techniques for selecting more than one object.

### The Shift-click technique:

1. Select the first object.
2. Hold down the Shift key and click the mouse button to select additional objects.

### The Select All command:

1. Choose **Select All** from the **Edit** menu to select everything in your drawing.
2. Shift-click to deselect specific object (other selected objects will remain selected).

### The selection box technique:

1. Point to a blank part of your drawing.
2. Draw a selection box around several objects. (All the objects *completely within* the selection box will be selected. If there is no place to start the selection box, that is, if the drawing completely covers the screen, hold down the Shift key as you draw the selection box. Then only the objects in the selection box will be selected and the object the mouse was actually on when you clicked the mouse button will not be affected.)



3. Shift-click either to deselect specific objects or to select additional objects.

If you want to select more than what is visible on the screen (for example, you want to use **Align Objects** to line up all the text on the entire page), first choose **Reduce to Fit** and then select the objects you want to work with using any of the three selection techniques.

## Experiment with Duplicates

### Don't risk ruining your original.

If you're halfway through your drawing and you're not sure how to proceed, don't experiment with the original. Use one of the following techniques to protect the original as you experiment. And then, if the experiment works, keep the duplicate. If the experiment doesn't work, go back to the original.

- Create a duplicate of the object you're working with and then experiment with the duplicate.
- Copy the object, paste it into a new MacDraw document (remember that you can have four documents open at once), and then paste it back into the original document if the experiment works.
- Choose **Save**, and then if the experiment doesn't work, choose **Revert**.
- If you're in the Finder, duplicate the entire document.

## Drawing Dotted Lines

### Use an appropriate pen pattern to get a dotted or dashed line.

The dotted line in the **Lines** menu is not really a dotted line—it represents a line of zero width, or "no border." To get dotted lines, do the following:

1. Draw a line or object.
2. While the object is still selected, choose one of the pen styles that achieves the desired effect, such as one of the striped patterns.

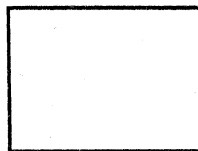

A rectangle ..... with this pen pattern ... produces this effect.

## Fill Around an Object

**Draw a new object as background and choose Send to Back.**

If you want to fill around an object, instead of the inside of an object, do the following:

1. Choose the dotted line from the **Lines** menu (no border).
2. Draw a circle or rectangle around the object, completely enclosing it.
3. Fill the new object with the desired background pattern.
4. Choose **Send to Back** from the **Layout** menu.

## Rotating Filled Objects

**If you want to rotate the fill pattern, paste the object into MacPaint first.**

In MacDraw, when you rotate a filled object, only the object rotates, not the fill pattern. In the example below, notice that the orientation of the fill pattern hasn't changed.

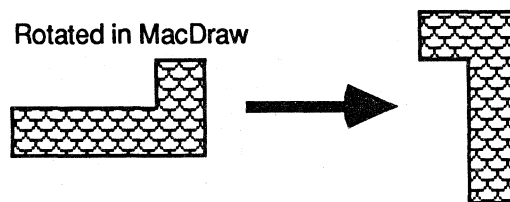

If you want to rotate the fill pattern, too, do the following:

1. Paste the object into MacPaint.
2. Rotate it.
3. Paste it back into MacDraw.

In this example, notice that the fill pattern rotated with the object.

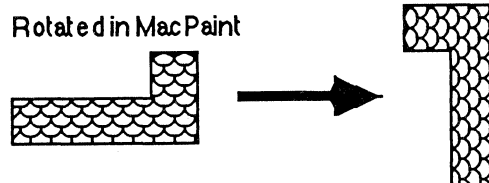

## Symmetric Objects

Here's an easy way to draw symmetrical objects.

1. Draw one half of the object.
2. Duplicate it.
3. Flip it horizontally (or vertically, as appropriate).
4. Put the two halves together.
5. Group the objects.

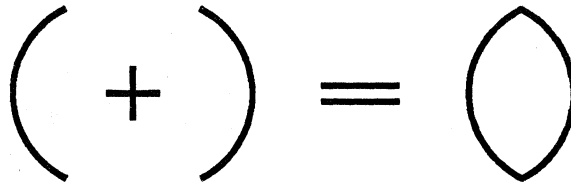

## Multiple, Equally Spaced, Objects

The Duplicate command preserves relative spacing between objects.

(Note: You have already used this technique several times in the practice exercises. It is included here for easy reference.)

1. Draw the original object.
2. Duplicate it.
3. Move the duplicate to the correct location relative to the original.
4. Choose **Duplicate** again—the third object will have the same location relative to the second that the second object had relative to the first.
5. Continue to choose **Duplicate** to create any number of objects all equally spaced.

## Use Drawing Aids

Draw temporary objects to make drawing, aligning, and spacing objects easier.

Draw temporary alignment aids to help you create your drawing. For example, draw a vertical line where you want several lines of text to begin to be sure they line up, or draw a small box as a spacer to check the spacing between objects.

If you want to enlarge an object and keep its exact proportions, use a small square as a drawing aid.

1. If you're enlarging several objects, group them together.
2. Turn the grid on, and draw a 1/2-inch square.
3. Place the square close to the object you want to enlarge.

4. Select both of them, and enlarge the square to 1 inch.  
The object will exactly double in size in both dimensions.

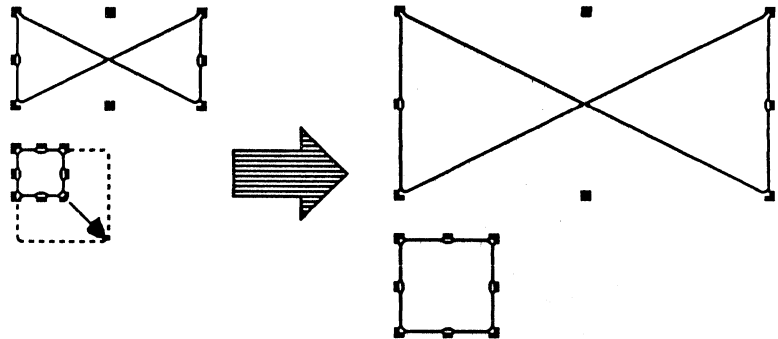

You can use the reverse technique for shrinking something without losing its proportions. If you only want to enlarge or shrink the object a small amount (less than the minimum increment of the ruler), turn off the grid and choose **Show Size** from the **Layout** menu. Then use the size to stretch or shrink the square the same amount in each direction.

When you enlarge objects, work in the middle of a page, or even in the middle of several pages, to avoid bumping into the edge of the document with the enlarged object.

### Create your own rulers.

Another drawing aid that may be helpful is custom rulers that you draw yourself. If you want to establish spacing within your drawing that is difficult with the built-in rulers, create your own rulers. Draw the outline of the ruler and then use the technique described earlier for creating many equally spaced objects to draw the tick marks. Be sure to group the components of the ruler.

Once you have drawn your ruler, you can move it to where it will be most helpful, or you can rotate it to establish the same spacing vertically. You can even shrink it to create another ruler with a similar, but smaller, scale.

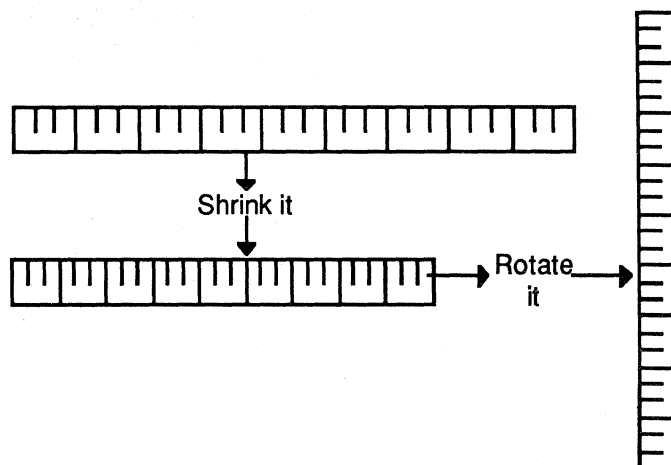

When you're finished using them, remove the drawing aids by selecting them and then choosing **Cut** or **Clear**, or by pressing the Backspace key.

## Concentric Circles

**Use a line as a drawing aid, or use the Align Objects capability.**

1. Draw a line at a 45-degree angle (hold down the Shift key as you draw the line to draw it at exactly 45 degrees).
2. Use the **Duplicate** command to draw a series of equally spaced lines along the 45-degree line.
3. Group the components of your drawing aid.
4. Set the fill pattern to **None**.
5. Start and end every circle on the 45-degree line where one of the short lines intersects. (The circles themselves will not intersect the line at that point—the boundaries will.)
6. When you're finished, remove the 45-degree line.

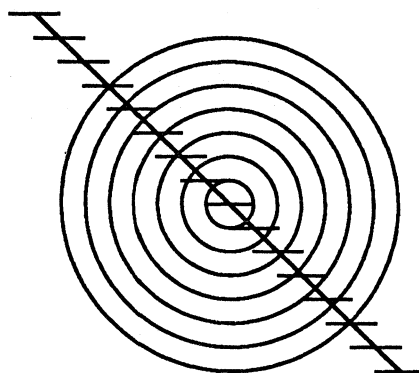

The following is another technique for drawing concentric circles:

1. Draw a series of circles with a fill pattern of None.
2. Select all of them.
3. Choose **Align Objects** from **Layout** menu.
4. Click on **L/R Centers** and **T/B Centers**, and click **OK**.

## Drawing to Scale

### Configure the custom ruler to draw to scale.

For example, if you want 1 inch to equal 3 feet, do the following:

1. Choose **Custom Rulers** from the **Layout** menu.
2. Click in the box next to **Custom**.
3. Leave **Major Division Spacing** at 1.
4. Set the **Number of Minor Divisions** to 3 to see minor divisions every 1 foot, to 6 for minor divisions every 1/2 foot, and so forth.
5. Set **Numbering Increments** to 3, so every major division will be the next multiple of 3 feet; that is, the 1-inch line will have a 3 next to it, the 2-inch line a 6, and so forth.

<b>Custom Rulers:</b>		<input type="button" value="OK"/>
<b>Ruler:</b>	<input checked="" type="radio"/> On	<input type="radio"/> Off
	<input checked="" type="radio"/> Inch	<input type="radio"/> Centimeter
	<input type="radio"/> Standard	<input checked="" type="radio"/> Custom
<b>Zero Point:</b>	<input type="radio"/> Locked	<input checked="" type="radio"/> Unlocked
<b>Major Division Spacing:</b>	<input type="radio"/> 1/2	<input checked="" type="radio"/> 1
	<input type="radio"/> 1 1/2	<input type="radio"/> 2
<b>Number of Minor Divisions:</b>	<input type="radio"/> 1	<input type="radio"/> 2
	<input type="radio"/> 3	<input type="radio"/> 4
	<input type="radio"/> 5	<input checked="" type="radio"/> 6
	<input type="radio"/> 8	<input type="radio"/> 10
	<input type="radio"/> 12	<input type="radio"/> 16
	<input type="radio"/> 24	<input type="radio"/> 32
<b>Numbering Increments:</b>	<input type="radio"/> 1	<input type="radio"/> 2
	<input checked="" type="radio"/> 3	<input type="radio"/> 4
	<input type="radio"/> 5	<input type="radio"/> 6
	<input type="radio"/> 8	<input type="radio"/> 10
	<input type="radio"/> 12	<input type="radio"/> 16
	<input type="radio"/> 24	<input type="radio"/> 32
		<input type="button" value="Cancel"/>

If you choose **Show Size**, the size will be shown in increments consistent with the ruler.

To measure a distance, choose **Show Size** and draw a line along the area you want to measure. The size will be the actual distance, for example, if the line is actually 2 1/2 inches long, the size will be shown on the screen as 7 1/2 (feet).

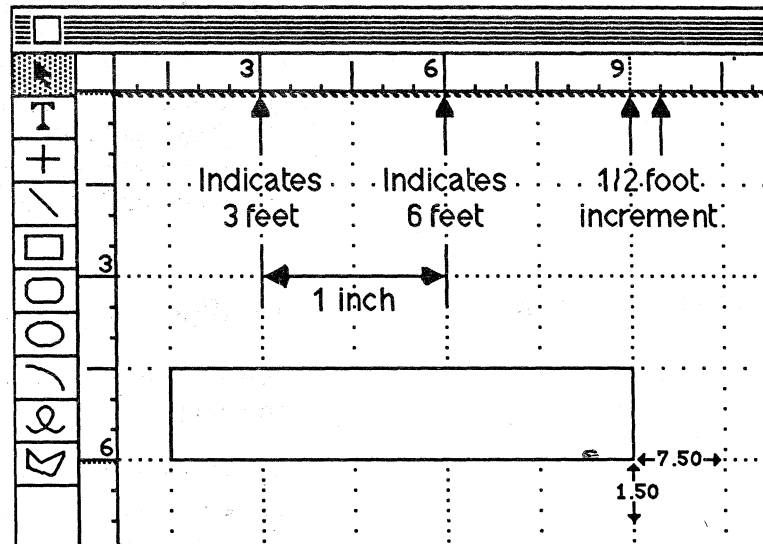

## Smoothing Polygons

**Approximate the shape of an object with a polygon, then smooth it.**

A very effective technique for drawing curved objects, especially if you want part of the object straight and part curved, is to approximate the object's shape with a polygon and then smooth the object (the alternative is a combination of arcs and lines).

Draw a polygon that approximates the shape of the object you're after. Then use **Smooth** and **Reshape** to fine-tune your drawing. (See the profile drawing on the next page for an example.)

To smooth a polygon, select the polygon and choose **Smooth** from the **Edit** menu. All vertices of the polygon will be smoothed (see comment on **Cusps** below for the exception). The degree of smoothing depends on the degree of the angle and the proximity of the next vertex. You can also choose **Unsmooth** to return the polygon to its original shape.

When you choose **Reshape**, you get one handle for each of the original vertices. You can also resize the smoothed polygon by grabbing one of the eight handles that normally surround a selected object.

The only drawback to this method is that smoothed polygons take a lot of memory, and they are slow to move.

## Cusps

**Cusps allow you to smooth part of a polygon and not smooth other parts.**

A cusp is a vertex of a polygon that will *not* be smoothed when you choose Smooth. To draw a polygon with cusps:

1. Hold down the Option key and double-click on each vertex that is to be a cusp (not smoothable).
2. Single click on each regular vertex (smoothable).
3. To finish the polygon, double-click without the Option key, or click on your starting point.

See the example below and read the MacDraw manual for more information about cusps and additional examples.

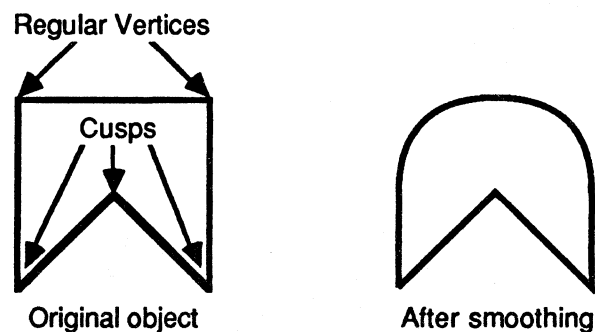

## Keeping Detail in Smoothed Objects

**Smoothing very large objects keeps more detail than smoothing small objects.**

As was just explained, good technique for drawing freehand objects is to approximate the object with a polygon or freehand curve and then smooth the object. When you do this, though, you lose much of the detail (see example below).





If you first enlarge the object, and then smooth it, more of the detail remains (the larger the object, the greater the detail).

Use a drawing aid to help you enlarge your object and then shrink it again after it has been smoothed (see earlier technique for using drawing aids). Here is the procedure:

1. Enlarge the size of your drawing (to 4-9 pages), and move the object to the middle of your drawing area to give yourself room to work.
2. Turn the grid on and draw a small square next to the object.
3. Select both objects.
4. Enlarge the square to two or three times its original size.
5. While both objects are still selected, choose **Smooth** from the **Edit** menu.
6. Shrink the square back to its original size.

Here is the result of using this technique on the example shown earlier.

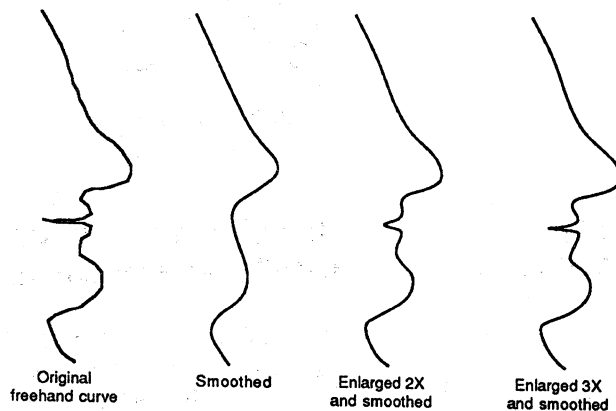

## Poster Fonts

### Here's how to create very large characters.

The numbers in the illustration that follows refer to the step in which that phase of the procedure is explained.

1. Type the character in MacPaint. Choose the largest fully formed size available (the size is shown in hollow type).
2. Copy it and paste it into MacDraw—it will be pasted in as a bit-mapped character, not as text.
3. Duplicate the letter and enlarge the duplicate to the desired size for use as a drawing guide (see the hint on using drawing aids to enlarge objects). Keep the original for reference. The enlarged duplicate will look very blocky because it is an enlarged bit map.

4. Turn the grid off and trace the enlarged letter with a polygon. Use cusps where you want to keep very sharp corners.
5. Remove the enlarged bit-mapped character.
6. Smooth and fill the polygon and add anything else that's needed, such as the vertical line in the example below.
7. Choose **Reshape Polygon** to fine-tune the letter.

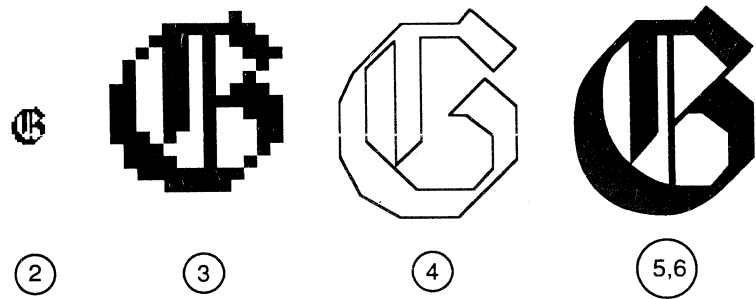

### Putting Text into Objects

**The text will conform to the shape of the object, even if you change the object's size.**

There are two kinds of text in MacDraw, "caption" text and "paragraph" text. Caption text is entered by choosing the text tool and typing. It will continue on one line, adding pages to the right if necessary, until you press Return. Most of the text you enter in MacDraw is caption text.

Paragraph text is formed by selecting an object—usually a rectangle—and typing. All the text will automatically stay within the left and right boundaries of the object. Paragraph text will insert its own Return characters to stay within the object. If you enter more text than will fit in the object, it will spill out the bottom, but it will always stay within the left and right boundaries. You can't enter paragraph text by choosing the text tool from the palette. You must first select an object, and then just type.

The handles that surround an object when it's selected form the "boundary." The boundary is always the smallest rectangle that can completely enclose an object.

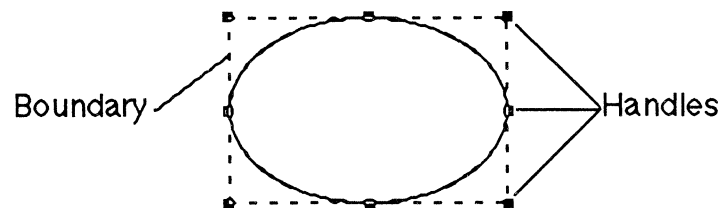

Paragraph text does not conform to the shape of the object itself, but to the shape of the boundary. Therefore, you can't automatically have paragraph text conform to the shape of a circle or polygon. It will always be in the shape of a rectangle.

If you select both the text and the object it's in, or group the text and the object together, and then reshape the object, the text will continue to conform to the shape of the object's shape.

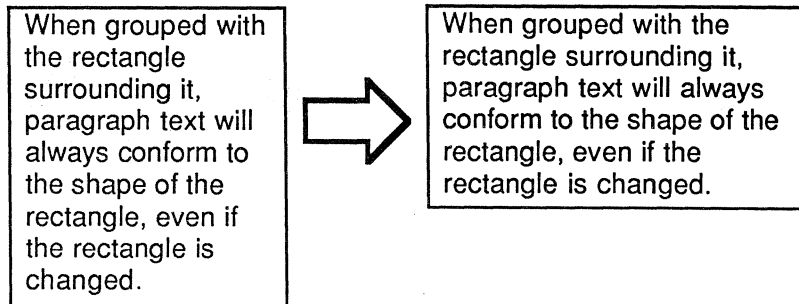

You can also change the shape of paragraph text by selecting just the text and then moving one of the handles, just as you reshape any object.

### Use paragraph text to create columns of text.

1. Draw a rectangle the width of the column.
2. Select the object and start typing to create paragraph text.
3. When you finish typing, cut the rectangle.
4. The text will keep its shape when you edit it, even after you remove the rectangle.

If you want to keep the rectangle (so you can later change the width of the column), but you don't want to see it, change the pen pattern to white. This will make the surrounding rectangle invisible.

### Converting caption text to paragraph text:

1. Choose the text tool and triple-click to select the entire caption you want to convert to paragraph text (don't use the selection arrow).
2. Choose **Copy**.
3. Create some paragraph text by drawing a rectangle the approximate width you want the paragraph to be. While the rectangle is selected, type two or more letters.
4. Select the text tool and triple-click on the paragraph text (the letters you just typed).
5. Choose **Paste** to replace the selected text with the caption you copied earlier. It will be pasted as a paragraph of text that will word wrap within the confines of the rectangle.

6. Remove the original caption text and the rectangle.

Changing caption text to paragraph text does not remove Return characters that were added to make a multi-line caption.

### Changing the Typestyle of a Single Word

#### Enter a highlighted word as a separate text object.

Text entered together is always treated the same. So after typing a line of text, if you choose **Bold**, all the text will become bold. If you're not sure which text was entered together, do one of the following:

- Select the text with the selection pointer. All of the text that's within the handles was probably entered at the same time, and therefore, will be affected by any type-style change.
- Select the text and change the type style to italic, shadow, or some other style that's particularly noticeable. Then, once you've identified the text that was entered together, choose **Undo** to change it back to its original type style.

To change the type style or size of only a single word, do the following:

1. Type that word separately.
2. Change it to the desired type style.
3. Leave space in the main body of text for the highlighted word.
4. Move the highlighted word into place in the middle of the main body of text.
5. Add or remove spaces in the main body of text so the highlighted word fits correctly.

### White Text on a Black Background

#### Use the Outline option to produce reverse type.

1. Type the text.
2. Change the type style to **Outline**.
3. You can also use **Bold** to make the text more noticeable.
4. Draw a rectangle (or any other shape) that completely encloses the text.
5. Choose **Send to Back**.
6. Choose the black fill pattern.

Use the outline type style for white text on a black background.

### Masks

**A mask is something you draw over something else to hide part of your drawing.**

Masks are the best alternative to erasing only part of an object, which is not possible with MacDraw. Instead of erasing, draw another object to hide part of your drawing. Here are some things to keep in mind when using a mask:

- Choose no border (dotted line in Lines menu) and choose a fill pattern to match the background (usually white).
- You can use any MacDraw object as a mask.
- Since masks are meant to be invisible, you may forget they are there, so group them with the object they are partially covering.

### Printing Large Drawings

**Here is the order in which the pages print.**

When you print a multipage document, the first *column* of pages is printed first, followed by the second column, and so forth. The order in which the pages are printed is shown below.

1	3
2	4

---

## Review

### Overview of MacDraw

**MacDraw is a structured graphics editor, unlike MacPaint.**

MacDraw graphics consist of independent graphic objects that can be moved, edited, and combined to create your drawing. The key benefits of MacDraw are as follows:

- It provides more effective communication.
- It's accurate.
- It's integrated with other applications.
- It produces very high-quality output on the LaserWriter.
- It's easy to learn.
- It's much less expensive than a graphic artist.

### Learn How to Use MacDraw

**Do the Guided Tour and complete the practice exercises.**

Refer back to the manual if you have questions on how to use specific menu commands.

### Practice Using MacDraw

**Do this exercise to practice many of the techniques you learned.**

### Integrating MacDraw with Other Applications

**Use the standard copy-and-paste technique to move information between documents.**

Basically, MacDraw can accept any text or graphics information from any application. It doesn't properly display tables copied from MacProject, spreadsheets, or data bases.

You can paste MacDraw graphics into any application that understands graphics, including MacWrite and MacPaint. You can paste MacDraw text into any application that deals with text, including MacWrite and MacTerminal.

### Useful Techniques

**These will help you become more productive with MacDraw more quickly.**

Refer back to them and distribute them to others so they, too, may become more efficient MacDraw users.

---

## Resources

- *MacDraw*, the owner's manual, Apple Computer, Inc.
- *Becoming a Mac Artist*, by Vahé Guzelimian, Compute! Publications, Inc.
- AppleLink™ (If you have access to AppleLink, check it regularly for additional information about MacDraw.)
- Macintosh publications, such as *Macworld*, *MACazine*, *Macintosh Connection*, and *A+* (Check these regularly for additional information and techniques for using MacDraw.)

*Apple and the Apple logo are registered trademarks of Apple Computer, Inc. AppleLink, LaserWriter, MacDraw, MacPaint, MacProject, MacTerminal, and MacWrite are trademarks of Apple Computer, Inc. Macintosh is a trademark of McIntosh Laboratory, Inc. and is being used with express permission of its owner. Microsoft Chart is a trademark of Microsoft Corporation.*

# Supporting MacDraw

---

## Contents

- 2 Objectives, Materials
- 3 Questions and Answers  
*Prepare yourself for the questions most commonly asked by MacDraw users.*
- 12 Using the Manual  
*Learn how to use the manual as a reference tool.*
- 15 MacDraw Specifications  
*Learn the capabilities and limitations of MacDraw.*
- 17 Review
- 18 Resources

---

## Overview

Read this module to gain knowledge that will help you to support users of MacDraw™ software. The module includes answers to commonly asked questions, an exercise to help you become more familiar with the manual, and product specifications.

Anyone who will supporting MacDraw users will benefit from this module.

### Prerequisites

- Basic techniques for using MacDraw including the use of all of the tools in the palette, and each of the menu commands. This can be acquired by completing the *Using MacDraw* module and its prerequisites, by completing the Guided Tour of MacDraw, or by reading Chapters 1 and 2 of *MacDraw*, the owner's manual.



---

## Objectives

- Answer questions about how to use MacDraw.
- State the product specifications for MacDraw.

---

## Materials

**To complete this module, you will need:**

- *MacDraw*, the owner's manual

## Questions and Answers

### Overview

**Here are the questions most commonly asked by MacDraw users, and the correct answers.**

As a support person, you'll be called upon to answer many questions about MacDraw. This next section is a summary of the questions most commonly asked by users about MacDraw.

This material does not go into technical detail about the product. It only covers what most users will need to know in order to use it.

### Disk Full

*When printing to an Apple® ImageWriter™ printer, I get a message saying that my disk is full. How do I print the document?*

The amount of room needed on your startup disk to print a document has changed with different versions of the software. If you're using Version 1.0 of the Finder and an early version of the ImageWriter resource file (see icons below), you should have space on the startup disk equal to two times the size of the document you want to print. If you're using Version 4.1 or later of the Finder and the ImageWriter II resource file, you only need space on the startup disk equal to the size of the document you want to print.

#### New ImageWriter Resource



#### Old ImageWriter Resources



The solution to this problem is to create more room on the startup disk. Here are some suggestions for creating additional room. (See the *Managing Macintosh Files* module from the Apple Support Training Library for more information about creating additional room on your disk.)

- Move the document onto a data disk and then remove it from the startup disk.
- If you're using a one-drive system, close the document and remove as much as possible from startup disk—all you need is System and Finder files, the ImageWriter resource,

and MacDraw itself. Remove documents, fonts, and desk accessories, if necessary.

- On a two-drive system, copy the application file to the data disk and remove it from the startup disk, to make more room for the print file on the startup disk.
- Copy part of the document and paste it into a new document. Print each document separately.
- Print the document from a hard disk.
- Print the document one page at a time.

### Run Out of Room for Your Drawing

*I seem to run out of room very quickly when running MacDraw on a Macintosh™ 128K. How can I conserve memory?*

The size (complexity) of your drawing is only limited by the amount of memory available. Here are some tips for limiting the amount of memory needed by your drawing.

- Simple objects (arcs, circles, boxes), take up very little room.
- Grouping objects takes up a lot of extra room, so don't group objects unless necessary.
- Freehand curves, text, and smoothed polygons also take up a lot of memory, so try to use these sparingly.

Appendix B of *MacDraw*, the owner's manual, details exactly how much memory each object takes.

### Cut but Can't Paste

*I want to consolidate two drawings (or at least move a part of my drawing) using **Cut and Paste**. When I cut the selected objects and then try to paste, I get a message saying there's not enough memory. What should I do?*

It's too late, you can't do anything. But you *can* prevent this problem in the future!

When you cut something and then paste it, two copies are created: one on the Clipboard, created when you cut the drawing, and one in your document, created when you pasted it. If your drawing takes up more than 50 percent of available memory, there's not enough room for two copies of it. When you cut it, there's still only one copy, the one on the Clipboard.

When you choose **Paste**, MacDraw tries to create a second copy, but there isn't enough room. Therefore, after you cut it, it can't be pasted.

If you try to copy the drawing before you cut it, there will also need to be the same two copies, the original in your document and the copy on the Clipboard. So, if you have a large or complex drawing you want to cut and paste, first try to copy it. If there's not enough memory to copy it, don't cut it or you won't be able to paste it back in.

## Invisible Handles

*I have an even number of identical objects exactly on top of each other (I selected the objects and then aligned L/R Middles and T/B Middles). If I select all of them, it looks like nothing is selected; I can't see the handles that are normally present when something is selected. How do I know whether anything is selected?*

Two handles exactly overlapping will cancel each other out, and you won't be able to see either. But, they *are* actually there. Work with the objects the same way you would with any other selected object. To reshape the objects, simply click where you would expect a handle to be.

## Round-Corner Rectangles vs. Square Rectangles

*What's the difference between a round-corner rectangle without any rounding, and a regular rectangle?*

You can create a round-corner rectangle and then take away the rounding to make it a regular rectangle. Or you can draw a square rectangle and then round the corners. Both are included in the palette for convenience.

The only difference between a round-corner rectangle that has been squared off, and a regular rectangle is that the corners of the former will print incorrectly (see the example below).

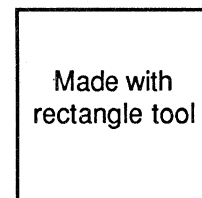
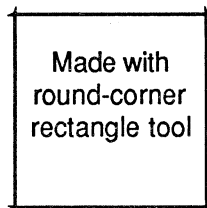

## Moving Grouped Objects

*When I move a group of objects, I can't see all of the objects as I move them. How can I tell if the objects are in the correct place?*

To solve this problem, try one of the following:

- Hold down the Option key as you move the object. Every object, including text, will be displayed as you move it.
- Point to a component of the group of objects that will enable you to determine whether everything is correctly placed. As you move the object, the outline of that component will remain visible.

## Object Lost Behind Another Object

*How can I select an object that I can't see because it's completely hidden behind a larger object?*

Try one of the following:

- Change the fill pattern of the larger object to **None** so you can "see through it" and therefore select the lost object.
- Select the larger object and choose **Send To Back**, which will send it behind the smaller object.
- Move or resize the larger object to reveal the smaller object.

## Superscript and Subscript

*How do I use superscript and subscript?*

MacDraw does not automatically support superscript and subscript. To achieve the same effect, type the superscript or subscript as a separate text object and leave space in the main body of text. Then move the superscript or subscript to the desired location. (See the technique titled "Changing the Typestyle of a Single Word" in the Useful Techniques section of the *Using MacDraw* module.)

## Text Doesn't Line Up

*My document contains several columns of text. The left edge of the second and subsequent columns never quite line up. It's either a little to the left or a little to the right of the previous line. Why can't I line them up?*

There are basically two kinds of fonts: "fixed pitch" and "proportionally spaced." Fixed pitch fonts allow exactly the same amount of space for every letter, punctuation, and space. So an "m" gets just as much space as an "i" or a space. Proportionally spaced fonts allow different amounts of space for each letter, as needed. So an "m" would get considerably more room than an "i" which gets more room than a space.

Proportionally spaced fonts look better because there is a more natural spacing between letters (see the following example ).

Among the Apple LaserWriter™ printer fonts, Helvetica and Times are proportionally spaced fonts, and Courier is a fixed pitch font.

Example of fixed pitch vs. proportionally spaced fonts.

Look at each letter and how much room it takes.

Fixed pitch vs. proportionally spaced. (Helvetica)

Fixed pitch vs. proportionally spaced.  
(Courier)

If you use a proportionally spaced font to create columns of text, each group of words will take up a different amount of space, depending upon the exact combination of letters used. So if you then space over to the next column, each line of that column will begin in a different place, because each line of the previous column ended in a different place.

There are two solutions to this problem:

- Use the Courier font, which is fixed pitch.
- Create your columns as separate text objects, and then place them appropriately on the page relative to each other.

## Wrong Font

*I created my drawing at home and then brought it into the office to print it on the LaserWriter. When I opened the document, the text was in the wrong font. What happened?*

If the font you actually used is not on startup disk from which you're printing, MacDraw will display your text in a different font. To avoid this, be sure the font you used to create the document is available when you print it.

## Tall vs Tall Adjusted

*What is the difference between Tall and Tall Adjusted in the Page Setup window, and when should I use each?*

When you print after choosing Tall from the Page Setup window, text in a MacDraw document prints the same as it looks on the screen. However, it may not be placed correctly in relation to graphic objects and the word wraparound of paragraphs may be different than it appears on the screen.

With Tall Adjusted, text is placed correctly in relation to objects, and the word wraparound is as it appears on

the screen. However, text looks more "squat" than when printed **Tall**.

When exact text placement and word wraparound of paragraphs are important, use **Tall Adjusted**. If a document is mostly text, or if the appearance of the text is important, use **Tall**.

## PICT Format

*What's the difference between saving a document in MacDraw format vs. PICT format?*

The file format of MacDraw documents is proprietary information. The PICT format is a public, graphics-oriented, data format that should be supported by any developer who wants open MacDraw documents. (For example, MacPlot uses the PICT format to print MacDraw documents on a variety of plotters.) If, as a Macintosh user, you want to be able to open a MacDraw document from a third-party application that supports the PICT format, you must save the MacDraw document in the PICT format. (Use the **Save as** command to save the document in *both* PICT format and MacDraw format.)

(**Note:** This does not affect the copying and pasting of MacDraw graphics between applications.)

## Width of Printed Page

*I opened a new MacDraw document, created a one-page drawing, and then printed it on the LaserWriter. Why was the right edge of my drawing printed on a second page?*

When using a LaserWriter, each page is actually 7 1/2 inches wide. But if the document was created using a disk that doesn't have a LaserWriter driver, or was created while the ImageWriter was the active printer, the window on your screen is 8 inches wide. So anything you draw between 7 1/2 and 8 inches will be printed on a second page. Once you print the document or choose **Page Setup**, the window on your screen will be the correct width.

## Plotter Support

*Does MacDraw support a plotter?*

Yes, with the help of third-party software. One program is called MacPlot by Microspot. Listed below are a few of the standard plotters it supports:

- Apple Plotter
- Calcomp81
- Epson H180

- Graphtec MP1000-01 and FP5301
- Hewlett Packard HP7470A, HP7475A, HP7550A, HP7220, and HP7221A

MacPlot also supports the following professional plotters (A0 or 'E' size):

- Calcomp 1040 Series
- Graphtec GP9101
- Hewlett Packard HP7580B, HP7585B, HP7586B
- Houston Instruments DMP42/DMP52

Another program that supports plotters on Macintosh is MacPlots II from Computer Shoppe in Greensboro, North Carolina. It supports a full range of Hewlett-Packard and Houston Instruments standard and professional plotters.

## Pasting into MacWrite

*My drawing is out of proportion when I paste it into MacWrite™. It looks like the sides have been squeezed in. What happened?*

If the document is wider than the space between the MacWrite margins, the document will shrink to fit. Sometimes text pasted into MacWrite, usually as part of an organization chart or flow chart, will look OK on the screen but the placement of the margins will cause the text to overlap when printed.

To avoid distortion, don't paste a drawing into MacWrite that is larger than the margins will accommodate. (For more information about pasting graphics into MacWrite, see the Adding Graphics section of the *Supporting MacWrite* module from the Apple Support Training Library.)

## Pasting Text from Other Applications

*When I paste a paragraph of text into MacDraw from another application, it appears as one long string instead of a paragraph. How can I make it into a paragraph?*

Text is pasted into MacDraw either as *caption text* or *paragraph text*. Caption text is text to be used as a caption under a drawing and is *always on a single line*. Paragraph text will word wrap into a paragraph.

If you first create some paragraph text in MacDraw, and select it with the text tool, then when you choose **Paste**, the text you're inserting will be added as paragraph text. If you just choose **Paste** without first creating and selecting some paragraph text, the text will be inserted as caption text. If the text is wider than the document, pages will be added to the right, as needed.



If text is pasted in as caption text, do one of the following:

**Choose the text tool and insert Return characters.**

This makes the text into a paragraph, although the text is really just multiple lines of caption text.

**Convert the caption text to paragraph text.** Here's how:

1. Choose the text tool and triple-click to select the entire caption you want to convert to paragraph text (don't use the selection arrow).
2. Copy the caption.
3. Create a paragraph
  - Draw a rectangle the approximate width you want the paragraph to be.
  - While the rectangle is selected, type two or more letters to create a paragraph within it.
4. Select the text tool from the palette and triple-click on the paragraph to select it.
5. Choose **Paste** to replace the selected text with the caption you copied earlier. It will be pasted as a paragraph of text that will word wrap within the confines of the rectangle.
6. Cut the original caption and the rectangle.

## Undocumented Features

*I've heard that there are features of MacDraw not documented in the manual. What are they?*

- There is a new graphics font called Taliesin (*Tally-ES-in*). The guide on the next page shows all the different characters that are available. Taliesin characters look best in 18-point type, which is the size shown on the next page.
- A 50 percent reduction option has been added to the **Page Setup** window when printing to the ImageWriter. You can reduce a document down to 25 percent and enlarge it up to 400 percent when printing to the LaserWriter.
- A new desk accessory in the **Apple** menu, **Choose Printer** (also known as the *Chooser*), has been added. **Choose Printer** allows you to use your ImageWriter from either serial port. If you are connected to a LaserWriter through an AppleTalk™ Personal Network and you have an ImageWriter, use the **Chooser** to identify the connections and the printer you want to use.

Taliesin - 18 pt.

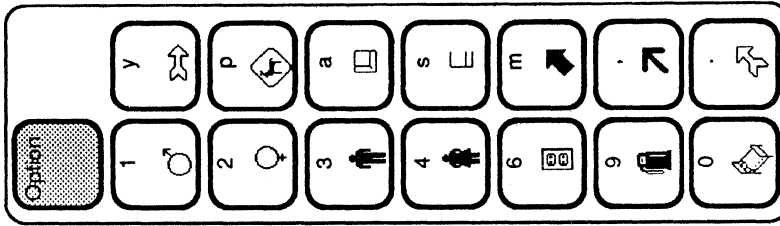
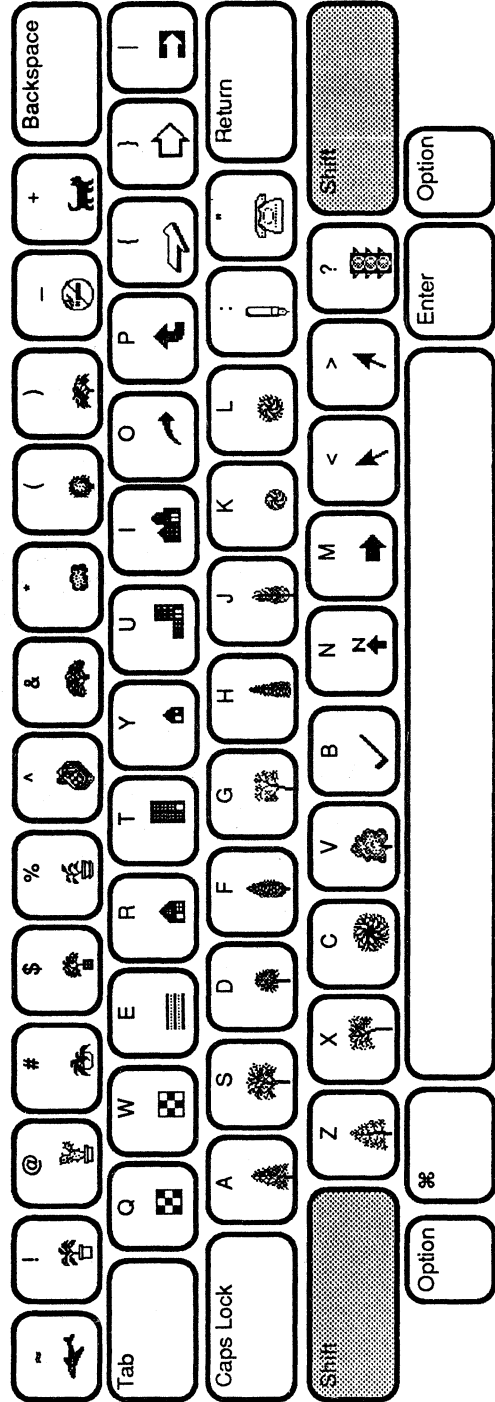
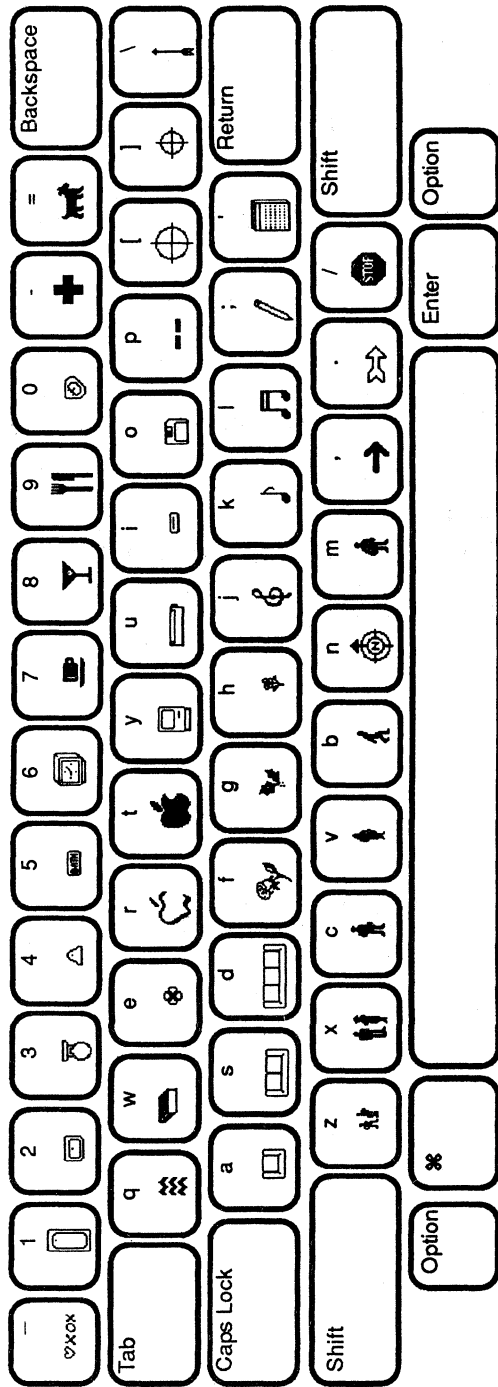

---

## Using the Manual

### Overview

**This section gives you practice finding specific information in the manual.**

Frequently you'll be asked a question that you won't be able to answer immediately. The next best thing is to know where to find the answer or how to find it quickly. In order to do this, you must be familiar with the various manuals (and other documentation) that contain the answers.

This section gives you a chance to familiarize yourself with the MacWrite manual by finding the answers to specific questions.

#### **Use the table of contents and the index.**

This section will ask questions similar to those you can expect to get from users. Use the table of contents and the index to locate the information, then write down the answer and where you found it.

When you're finished, check the Feedback section, which will give the answer and the chapter and section in which it was found. Specific page numbers won't be given because they might change with manual revisions.

---

## **Practice**

**Use the Manual to  
Answer These Questions**

**How can I easily draw a line that's at a  
45-degree angle?**

---

---

---

**I want the middle of the ruler to be zero with  
positive and negative numbers. How can I do  
this?**

---

---

---

---

**What can I do to a locked object?**

---

---

---

---

## Feedback

### Use the Manual to Answer These Questions

#### How can I easily draw a line that's at a 45-degree angle?

Select the diagonal lines tool and hold down the Shift key as you draw the line. This will constrain the line to only 45 or 90 degrees.

The answer is in the Drawing Lines, Polygons, Freehand Shapes, and Arcs section of Chapter 2.

#### I want the middle of the ruler to be zero with positive and negative numbers. How can I do this?

Move what is called the *zero point*. To do this, click on a ruler where you want the zero point to be. Or press the mouse button on a ruler and then drag it into the window. This will set both the horizontal and vertical zero points. (If nothing happens when you click on a ruler, choose **Custom Rulers** from the **Layout** menu and click on **Unlocked** for the zero point.)

The answer is in the Using Rulers section of Chapter 2.

#### What can I do to a locked object?

You can select it, copy it, and group it. If it's text, you can edit it.

You *can't* move, cut, clear, duplicate, rotate, or flip it; change its size, appearance, or stacking order; or align it to the grid. If the object is text, you *can't* resize or move it, or change its font or type style.

The answer is in the Arrange Menu section of Chapter 3.

## MacDraw Specifications

### Overview

**This section covers MacDraw's capabilities and limitations.**

In addition to the questions answered in the last section, you will receive many questions regarding the capabilities and limitations of MacDraw, or topics such as the maximum number of pages or objects. This section details the specifications for MacDraw that will enable you to answer these questions.

If you want to know the limit for a particular aspect of MacDraw and it's not identified below, then no limit has been set. See Appendix A of *MacDraw*, the owner's manual, for more information on specifications and preset options.

**Version.** The current version of MacDraw is 1.9. The only difference between Version 1.9 and the earlier release, Version 1.7, is that a critical problem was fixed. The functionality is exactly the same.

**Drawing Size.** The maximum drawing size is 96 inches by 48 inches (54 pages of 8 1/2 by 11 inch paper).

**Number of Active Documents.** The number of active documents depends on how much memory you have. On a Macintosh 512K or a Macintosh XL, you can have four documents open at one time. On a Macintosh 128K, you can only have one document open at a time (even if you're connected to a Hard Disk 20).

**Complexity of the Drawing.** The number of objects in a drawing is limited only by the amount of memory available. Some objects take more room than others. So the maximum number of objects is also determined by which objects you draw. Appendix B of *MacDraw*, the owner's manual, details exactly how many bytes certain objects take.

**Maximum Number of Fonts .** You can have up to 11 fonts per document. You can have any number of type styles and sizes of each font, but no more than 11 different fonts.

If you have more than 11 fonts in the System file, only 11 will be displayed in the **Fonts** menu. The fonts available are the ones most recently added.

**Complexity of a Polygon.** There is no limit on the number of points in a polygon.

**Paper Sizes.** MacDraw supports the following sizes of paper:

- US letter—8 1/2 inches wide, 11 inches tall
- US legal—8 1/2 inches wide, 14 inches tall
- A4 letter—210 mm wide, 11 2/3 inches tall
- International Fanfold—210 mm wide, 12 inches tall
- Computer paper —14 inches wide, 11 inches tall

You can also print horizontally on any of these sizes. And, with the help of third-party software, you can print on E-size and larger plotter paper (see the Questions and Answers section for information on plotter support for MacDraw).

**Space Taken per Object.** Appendix B of *MacDraw*, the owner's manual contains a table detailing exactly how much memory certain objects take.

---

## **Review**

### **Questions and Answers**

**These are the questions you can expect to get from users of MacDraw.**

Explanations and solutions are included so you can quickly help users with their problems. Refer back to this section for the answers to commonly asked questions.

### **MacDraw Specifications**

**This section covers the capabilities and limitations of MacDraw.**

This section contains the answers to questions you will get regarding the limits of MacDraw.



---

## Resources

- *MacDraw*, the owner's manual, Apple Computer, Inc.
- AppleLink™. If you have access to AppleLink, check it regularly for additional information about MacDraw.
- *Becoming a Mac Artist*, by Vahé Guzelimian, Compute! Publications, Inc.
- Macintosh publications, such as *Macworld*, *MACazine*, *Macintosh Connection*, and *A+* (Check these regularly for additional information and techniques for using MacDraw.)

*Apple does not endorse any of the third-party products mentioned in this module. There are included only to make the reader aware of their availability.*

*Apple and the Apple logo are registered trademarks of Apple Computer, Inc. AppleLink, AppleTalk, ImageWriter, LaserWriter, MacDraw, and MacWrite are trademarks of Apple Computer, Inc. Macintosh is a trademark of McIntosh Laboratory, Inc. and is being used with express permission of its owner. Helvetica and Times are trademarks of Allied Corporation, and are used by Apple Computer, Inc. under license. Apple does not endorse any of the third-party products*

# Supporting MacProject

---

## Contents

- 2 Overview
- 3 Objectives, Materials
- 4 Introduction
- 6 MacProject Benefits
- 7 MacProject Menus  
*Read the manual to learn about every MacProject menu command.*
- 8 Useful Techniques  
*An introduction to the next three sections.*
- 11 Creating Your Project Schedule  
*Hints on how to most efficiently start your project schedule.*
- 17 Viewing the Information You Have Entered  
*How to view the variety of information available to you.*
- 20 Working with Your Project Schedule  
*How to use your MacProject document as a project planning tool.*
- 24 Questions and Answers  
*Prepare yourself for the questions most commonly asked by users.*
- 32 Troubleshooting Techniques  
*General techniques to help you figure out what's wrong with a project schedule.*
- 34 Using the Manual  
*Learn how to use the manual as a reference tool.*
- 37 MacProject Specifications  
*Learn the capacity and limitations of MacProject.*
- 38 Review
- 39 Resources

---

## Overview

This module covers a variety of information and techniques for supporting MacProject™ software users. It includes a summary of the key benefits of MacProject, useful techniques for creating, viewing, and modifying your project schedule, the answers to commonly asked questions, and product specifications.

Anyone who is supporting users of MacProject should complete this module.

### Prerequisites

- Basic techniques for using the Macintosh™ computer, which include using the mouse and menus, opening and closing documents, and working with text. These techniques can be learned by completing the *Learning to Use Macintosh* module from the Apple Support Training Library, or the Guided Tour of Macintosh, or by reading Chapters 1 and 2 of *Macintosh*, the owner's manual.
- How to use MacProject. Check the Apple Support Training Reference Catalog (which is on AppleLink™) for resources you can use to learn MacProject.

---

## Objectives

- Use all the features of MacProject and state the function of each of the menu commands.
- Answer user-level questions about how to use MacProject.
- State the product specifications for MacProject.
- Troubleshoot erroneous project schedules.

---

## Materials

**To complete this module, you will need:**

- Macintosh 128K, Macintosh 512K, or Macintosh XL
- MacProject application disk
- *MacProject*, the owner's manual

---

## Introduction

### What is Project Management ?

**It's systematically keeping track of all aspects of a project.**

Many people are involved in project management today and don't even know it. Anyone who has ever built a house, or a hotel, or an oil rig, is a project manager. Anyone who has helped a company go public, or managed the development and release of a new product, is a project manager.

Project management is applicable to *any job that has a definite beginning and completion point, and involves a series of steps.*

MacProject is an application that helps a project manager plan a project, allocate resources, budget costs, track progress and the load on resources, plan cash flow, and, most importantly, quickly see the effect of a change on all of these things.

### PERT and CPM

**Here are brief descriptions of two very important project management techniques.**

Two tried and true project-management techniques are PERT (Project Evaluation and Review Technique) and CPM (Critical Path Method). PERT uses boxes to represent individual tasks, which combine to make up the entire project schedule. The boxes are connected by lines to indicate which tasks must be preceded by others and which tasks can be performed independently.

CPM identifies the individual tasks that must be finished on time if the entire project is to finish on time. These are called *critical tasks*, and all critical tasks throughout a PERT chart form the chart's *critical path* (hence Critical Path Method).

MacProject uses both of these techniques. However, it's not in the scope of this module to describe them in any more detail.

### Project Management Theories

**Read recommended books and articles to learn the theory of PERT and CPM.**

If you want to learn more about the theory of PERT charts and CPM, or about some actual examples of using these techniques in project management, there's a list of recommended reading in the Resources section on the last page of this module.

**Goal of This Module****Prepare yourself to answer questions about project management and MacProject.**

This module assumes you already know how to use MacProject. If this is not the case, use the materials referenced in the Support Training Reference Catalog.

Just knowing how to use the product is not enough if you're going to be supporting other users. The goal of this module is to make you a MacProject expert.

This module includes a discussion of the benefits of MacProject, so that you can help people decide if they need it. There's a section covering techniques for creating and modifying project schedules. There's also a question-and-answer section, and hints to help you troubleshoot project schedules.

---

## MacProject Benefits

### Overview

**These are the key benefits of MacProject.**

In addition to questions about how to use a product, you may also get requests for product recommendations. This section briefly lists the key benefits of MacProject to help you make appropriate recommendations and to help users decide whether MacProject is the program they need.

### MacProject Benefits

**Plan and Manage Projects Better.** Improve your planning, understanding, and control of entire projects and project elements.

**Choose the Best of Several Options.** Test different scenarios to see the impact of changes in resources and time schedules.

**Anticipate Problems.** Plan ahead and resolve potential problems before they arise.

**Manage Resources.** Schedule and allocate resources, in addition to scheduling tasks.

**Control Costs.** Estimate and control costs and cash flow.

**Identify and Manage Critical Tasks.** MacProject automatically calculates the critical path and slack time (float).

**Track Progress.** Track the project and easily update the chart to reflect unforeseen changes.

**Easy to Use.** MacProject is easy to learn and use because of its interactive nature and its graphical representation of information.

**Integrated With Other Applications.** Easily create powerful reports and perform cost analyses by integrating MacProject with other Macintosh applications. You can move tables of information from MacProject into spreadsheet, data-base, business graphics, and word-processing programs. MacProject also allows you to move all or part of the schedule chart or timelines into graphics or word-processing programs.

**Proven Techniques.** MacProject is based on PERT and CMP, which are proven project-management techniques (although, you don't have to know them to use MacProject).

---

## MacProject Menus

### Read the Manual

### Read about the MacProject menu commands.

If you're going to be able to help others use MacProject, you must know the function of every MacProject menu command. In learning to use MacProject, you used most of the menu commands, but probably not all.

Read the MacProject Menus section of Chapter 4 of *MacProject*, the owner's manual, to ensure you understand the function of *every* menu command. Continue with this module when you have finished reading the manual.



---

## Useful Techniques

### Overview

**The next three sections explain techniques to help you get the most out of MacProject.**

Reading a manual and doing some practice exercises is only part of learning to use an application. Beyond the basics, there are many techniques for producing *higher-quality* work—and doing it *more efficiently*. The next three sections describe many of the techniques that will help you become more productive on MacProject more quickly.

Creating Your Project Schedule will help you create your chart more quickly and will decrease the need for revising the layout of your project schedule.

Viewing the Information You Have Entered describes several ways to display all of the information you have entered into your chart.

Working with Your Project Schedule describes techniques that will help you use MacProject to make decisions and effectively manage your project.

At the end of the module, there are some resources you should check for information on how to get the most out of your Macintosh and MacProject. There is also a list of suggested reading in case you want to learn more about the background, theory, or application of PERT and Critical Path Management techniques.

### Have MacProject Available

**Practice exercises are not included, but you're encouraged to try each technique.**

In the next three sections, and for the remainder of the module, you are not directed to complete specific practice exercises. However, it would be valuable for you to have a Macintosh equipped with MacProject available as you read the module so you can try the various techniques as you read about them.

## Icons in the Margin

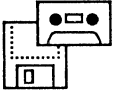

## Use the Manual

### Icons indicate techniques you may already know.

Some of the techniques covered in the remainder of this module were already covered in the Guided Tour of MacProject. These techniques are identified by an icon in the margin, like the one to the left. The techniques are repeated in this module because they're particularly useful or important enough to deserve another mention.

### If you have questions that are not answered here, check the manual.

*MacProject*, the owner's manual, is your most complete resource regarding MacProject. It explains the basic theory of project management, how to use all of the menu commands, how to get started, and many techniques to help you get the most out of MacProject. There is also a very good foldout at the end of the first chapter of the MacProject manual that reviews all of the components of a project schedule chart. Have the manual handy and refer to it if you have questions that are not addressed in this course.

The Using the Manual section later in this module has you look in the manual for answers to typical questions, to be sure you can use the manual as a reference tool.

**Command Key****Use it to invoke menu commands.**

Using the Command key is a technique you can use with all Macintosh applications and in all phases of creating, viewing, and working with your project schedule.

Use the Command key in combination with the appropriate letter to invoke many of the menu commands. Here's a summary of the the menu commands that have Command key equivalents.

<b>Edit</b>		<b>Style</b>	
Undo	⌘Z	Plain Text	⌘P
Cut	⌘H	<b>Bold</b>	⌘B
Copy	⌘C	<i>Italic</i>	⌘I
Paste	⌘V	<u>Underline</u>	⌘U
Duplicate	⌘D	<u>Outline</u>	⌘O
Select All	⌘A	<b>Shadow</b>	⌘S
<b>Task</b>			
Change to Milestone	⌘M		
Show Task Info	⌘T		

---

## ■ Creating Your Project Schedule

### Starting from Scratch

**Set up the basic structure of your project, then fill in the details.**

1. Estimate how many pages your schedule will take and choose **Set Chart Size** from the **Layout** menu to set the number of pages accordingly. Give yourself plenty of room to work—though, you can always add more pages later.
2. Start creating your schedule in the middle of the chart. You may end up having to add as many tasks to the left of where you start as you add to the right. If you later want to reposition your project schedule, it's easy to do while viewing the entire chart.
3. Draw one task box, and then duplicate it several times so you have a pool of task boxes to draw on. (This makes all of your task boxes the same size, so your document looks neater and more attractive.)

Or use the third technique under **Duplicating Task Boxes** (the next key point) to create additional task boxes *with* dependency lines.

4. Position the task boxes where you want them and enter the task name into each. Don't enter other task information or dependency lines (the lines connecting the task boxes) yet.
5. Once your task boxes are in place, draw the dependency lines and fill in the task information.

(**Note:** See the **Steps in Creating a Project** section of Chapter 2 of *MacProject*, the owner's manual, for some additional suggestions on creating your project schedule.)

## Duplicating Task Boxes

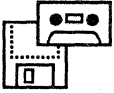

There are three ways to duplicate a task box:

### Copy and Paste.

1. Select a task box.
2. Choose **Copy** from the **Edit** menu.
3. Click where you want to put the new task box.
4. Choose **Paste** from the **Edit** menu.
5. A box identical to the one you copied will be added to your schedule chart.

### Use the Duplicate command.

1. Select a task box.
2. Choose **Duplicate**.
3. You'll get a box exactly the same size as the original, which you can then move anywhere on the schedule. The name of the original task, or any other information associated with it, is *not* included in the duplicate.

### Click and Drag technique.

1. Position the pointer inside a task box.
2. Hold the mouse button down and move the pointer out of the task box as if you were going to draw a dependency line.
3. Continue to hold the mouse button down and move the pointer to the desired location for the new task box.
4. Release the mouse button.
5. You'll get a task box exactly the same size as the original, and a dependency line will have been drawn to connect the two tasks.

## Grouping Tasks by Function and Time

This makes it easier to see the tasks to be completed by each group.

- If you have several major groups working on the same project (for example, Sales, Marketing, and Training) and they all have independent tasks, group all the tasks for each department together. For example, the top of your page could have all the tasks for which Sales is responsible, while the middle is for Marketing, and the bottom is for Training.
- Use page breaks as major time divisions; for example, have one page represent a month or a quarter.
- Add annotations to label the different groups or the different time segments.

- Combining these two techniques will help you see who is doing what at any given time.

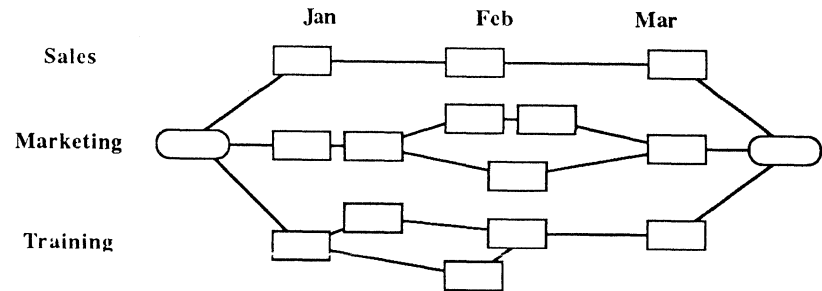

## Using Milestones

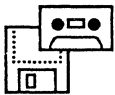

### What are milestones and where do you use them?

Here are several important facts to remember about milestones.

- Milestones are visual cues marking significant places or events in the project.
- Milestones are used to indicate the start and completion of the project.
- They can represent a key goal in the middle of a project, showing the completion of several tasks or aspects of the project.
- The names of milestones are normally be in the past tense (for example, "Materials Purchased" or "Plan Approved").
- Milestones can also function as comments, reminders, or alert indicators.
- Milestones don't usually have a duration, but they often have a cost or income.
- When dates are displayed, milestones include the year.
- In the schedule chart, milestones are rounded rectangles. In the timelines, milestones are indicated by diamonds.
- Milestones make a project schedule easier to read and understand. (See the example on the next page.)

A project schedule without milestones:

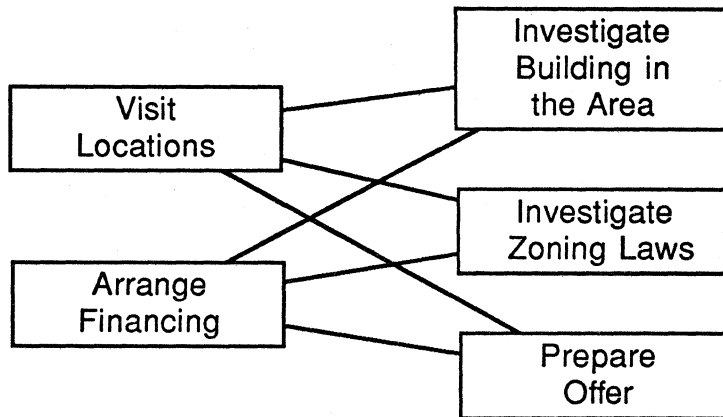

This chart is very confusing. The following chart shows the same tasks, but with a milestone in the middle. Notice how much easier it is to read.

The same project schedule *with* a milestone:

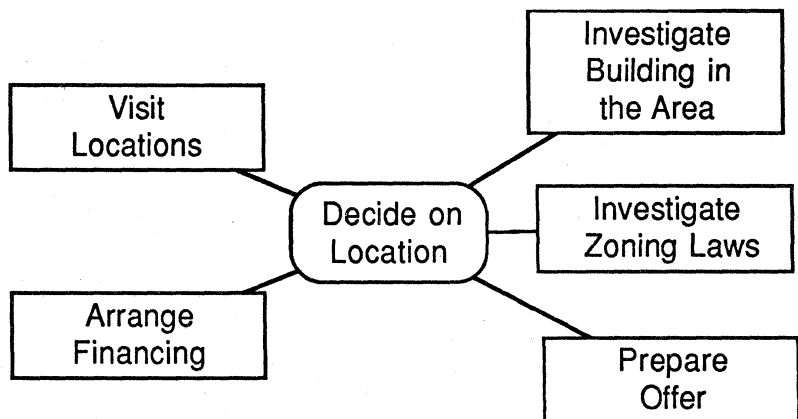

### Making Room for New Tasks

**In one step, you can move everything to the right of a particular task box.**

Move a task box or milestone far enough to the right to make room for the new tasks. Be sure it at least partly overlaps one of its dependent tasks to the right of its original position. All the tasks linked to, and to the right of, the task you moved will be moved the same distance.

### Choosing Single vs. Multiple Accrual Payments

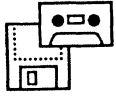

### Multiple payments can be much more expensive than single payments.

Use *single payment* if you want to pay a resource only once for all tasks worked on during a single unit of time. For example, a person may be scheduled to work on more than one task in a single day, but he's still going to be paid for only one day's work. Choose **Single Accrual Method** for that resource.

Use *multiple payments* to pay a single resource each time it's assigned to a task during a single unit of time. For example, if the resource is a trucking company, you'll have to pay for every truck that you hire, which is determined by how many tasks involve shipment of materials on that day. Choose **Multiple Accrual Method** for that resource.

### Annotating Your Chart

### Use text to annotate your chart.

Include in your project schedule any notes and reminders about important events that may affect your project. You can enter text anywhere on the schedule chart.

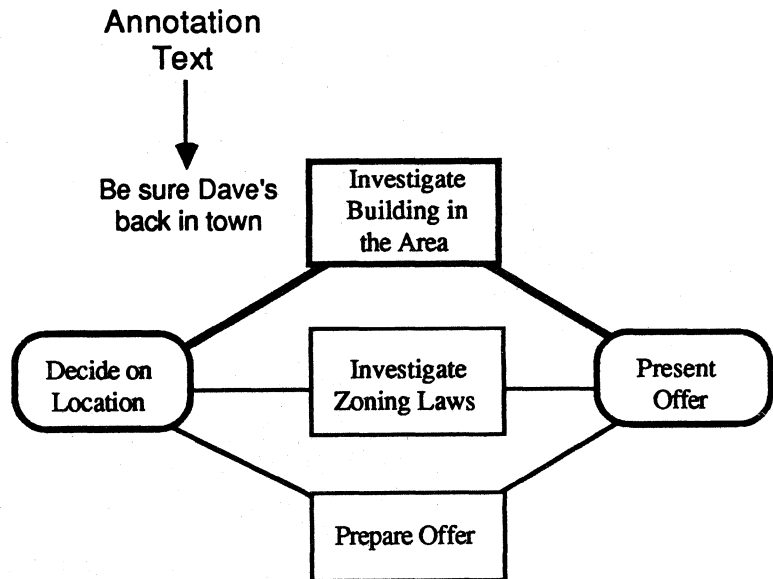



## Setting Dates

### Set the Earliest Start, Latest Finish, or other key dates in your project.

- Set the Earliest Start date of the start milestone (or leftmost task) to determine the project's earliest possible completion date (the Earliest Finish date on the final milestone or task).
- Set the Latest Finish date of the final milestone (or rightmost task) to see when you must start the project in order to finish it on time (the Latest Start date of the start milestone or task).
- Set the date of a key task or milestone that you know must be completed by, or that can't be started until, a certain date.

To set a date, select the task or milestone and then choose either **Set Earliest Start** or **Set Latest Finish** from the **Dates** menu. You'll get the dialog box shown below.

The dialog box is titled "Set Start Date:". It contains a date field with the text "06/02/86" and a time field with the text "09:00". The date field has small up and down arrow icons to its right, and a mouse cursor is pointing to the digit "6" in the date. Below the date and time fields are three buttons: "Set", "Clear", and "Cancel".

Click on the digit you want to change, and then either type the new number or click on the up or down arrow to increment or decrement the digit, respectively. (For the remainder of this module, the dates you specifically set are called "fixed dates.")

All fixed dates are underlined on the schedule chart and they override any dates MacProject calculates. Other dates are calculated on the basis of the dates you have set.

If you want to clear a date you set previously, to allow MacProject to calculate the date for you, select the milestone or task, choose **Set Earliest Start** or **Set Latest Finish**, and click **Clear**.

### Don't set too many dates.

Setting too many dates may cause confusing results. Set only the dates you know are fixed, and allow MacProject to calculate the other dates and determine the best possible schedule.

## Viewing the Information You Have Entered

### Moving Around in a Large Schedule

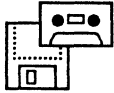

#### Indicate where on the chart you want to work:

1. Choose **Show Entire Chart** from **Layout** menu.
2. Move dotted rectangle to the area you want to work on.
3. Click outside the chart. Your document will now display the portion of the chart that was inside the dotted rectangle.

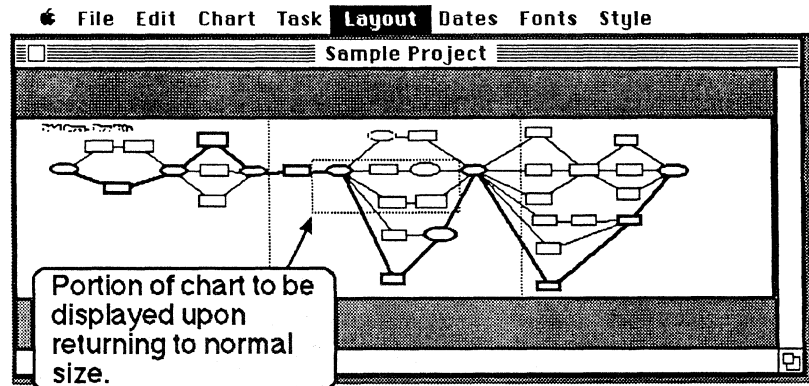

#### From this reduced view, you can also move the entire chart on the page.

Just press the mouse button while pointing to any part of the chart outside the dotted rectangle and move the chart where you want it. You might do this to create room near one part of the chart, or to prevent a task from crossing a page break (which makes it hard to read when printed).

### Using the Keyboard to Display Task Information

#### Use the Tab key and the Return key.

1. Select a task and press the Tab key to open the Task Information window.
2. Press Tab again to move to the next field in the Task Information window. When you get to the last field, press Tab again to go back to the first field.
3. Press Return to select the next task on the right of the task currently selected. The newly selected task does not have to be dependent upon the original task. The Task Information window doesn't have to be open in order to use the Return key to move between tasks.

4. The schedule will automatically scroll to bring newly selected tasks fully into view.
5. When you get to the last task or milestone in the schedule, press Return again to select the first task or milestone in the schedule.

### Viewing Task Information with Time-Line Charts.

You can view task information while any one of the time-line charts is displayed.

The Task Information window stays visible if you select one of the time-line charts, but you can't use Return to move between tasks. When you click on a task in a time-line chart to display its task information, the time-line window covers most of the Task Information window. You should move the time-line window down the screen so that both windows are visible at the same time. (See the previous comment about using the Tab and Return keys to display the task information from the Schedule chart.)

### Moving Between Two MacProject Documents

Use the Document Directory dialog box.

If you have a MacProject document open and you want to open a different MacProject document, you could choose **Quit** from the **File** menu and then open the other document from the Finder. But there is a faster way.

1. Choose **Close** from the **File** menu or click in the close box.
2. Choose **Open** from the **File** menu. A list of all the MacProject documents on that disk will be presented in the Document Directory dialog box, as shown below.

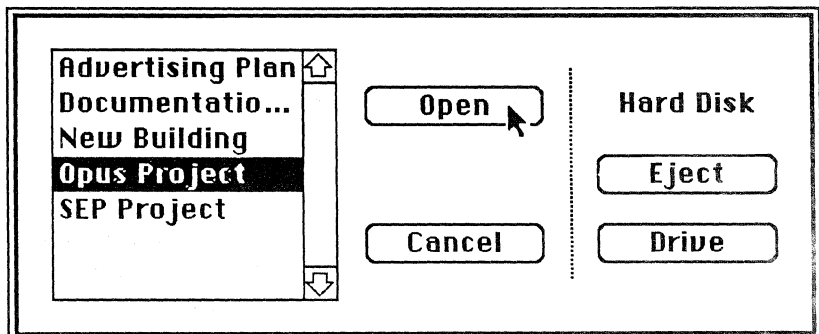

3. If you want to open a document on another disk, either click **Drive** to look at the documents on the disk inserted in the other drive, or click **Eject** and insert the disk containing the document you want.
4. Open the document. Click once on the name of the document to select it and then click **Open**, or double-click on the name of the document.

## Working with Your Project Schedule

### Calculating Dates Backwards

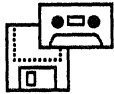

Use this technique if you are working toward a fixed deadline you must meet.

1. Select the last task or milestone.
2. Choose **Set Latest Finish** from the **Dates** menu.
3. Set the Latest Finish date to the date by which you must finish the project. All the Finish Dates will be calculated based on the date you entered.
4. The Latest Start date of the first task will be the date by which you must begin in order to finish on time.

To see the dates, choose **Show Dates** from the **Dates** menu and display the Latest Start date (in the lower left corner) and the Latest Finish date (in the top right corner).

### Tracking the History of a Project

Keep copies of each version of the project schedule.

- Add annotations when you make major changes.
- Freeze and date the schedule at key points during the project. Then duplicate the document before going on to make revisions and continuing to track the project.
- Accumulate schedules from each critical phase of the project.

### Tracking Your Progress

Tracking your progress manually works best.

1. Print your schedule chart.
2. If it's several pages long, tape the pages together.
3. As you complete each task, highlight the task box with a color pen. You'll be able to see your progress at a glance.

## Your Project Takes Too Long

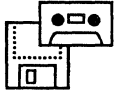

### Try "What if?" scenarios to see what must be done to finish the project on time.

If your project is taking too long and you want to see what it would take to finish earlier, choose **Calendar** from the **Dates** menu. You'll get the clock and calendar, shown below, which you can change to reflect how many hours per day and how many days per week are being spent on the project.

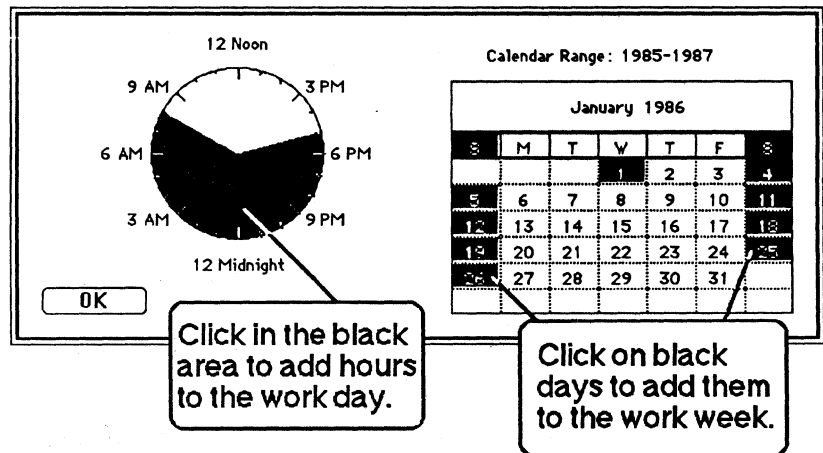

Do one of the following and see how much sooner you could finish the project:

- Increase the number of hours worked each day.
- Increase the number of days worked each week..

Be sure to adjust costs (for example, are extra hours per day, or days per week, paid as overtime?). MacProject doesn't automatically adjust for overtime, so you'll have to account for such changes manually.

## Changing the Calendar Halfway Through a Project

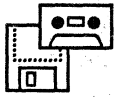

### How can you make a change that affects only part of the project?

What if halfway through a project you realize you need to speed things up to get the project done on time? If you change the calendar to see what would happen if everyone started working 10-hour days, it would change the calendar for the entire project, not just the part that's yet to be completed. So, you would pick up an unrealistically large amount of time. To change the calendar for only the unfinished part of the project:

1. Remove all of the dependency lines linking the part yet to be completed to the part that has already been completed (select the dependency line and choose **Cut**).
2. Add a new start milestone (or task) where you removed the dependency lines.
3. Connect the milestone to the first task(s) of the portion yet to be completed.
4. Set the starting date of the milestone (choose **Set Starting Date**).
5. Make the desired change to the calendar.
6. Ignore the dates for tasks that have already been completed (the part to the left of your new start milestone). Tasks to the right will show the effect of the calendar change and will show a new finish date.

## Splitting Someone's Time Between Tasks

### Enter the amount of time spent on each task.

If you have a person working on two tasks at once, MacProject will assume that the person can do two things at once, which may be impossible.

To ensure that you have truly accounted for all the time each person will need to complete his assigned tasks, do the following:

1. Be sure the time scale is set to the increment appropriate for how you're going to schedule each person's time. For example, if someone has three tasks to complete in two days, set the time scale to hours.
2. For each task the person is working on, enter the amount of time he will be working on that particular task.

## Setting More than One Time Scale

### What if most of your project is in days, but you want to schedule part of it in hours?

1. In the schedule chart, enter a single task for the entire portion of the project that will be scheduled in hours.
2. Create a new project schedule chart that divides the one task into its component parts, scheduled in hours.
3. Enter the total duration of the Hours chart as the duration, in days, of the single task in the Days chart (see the example below).

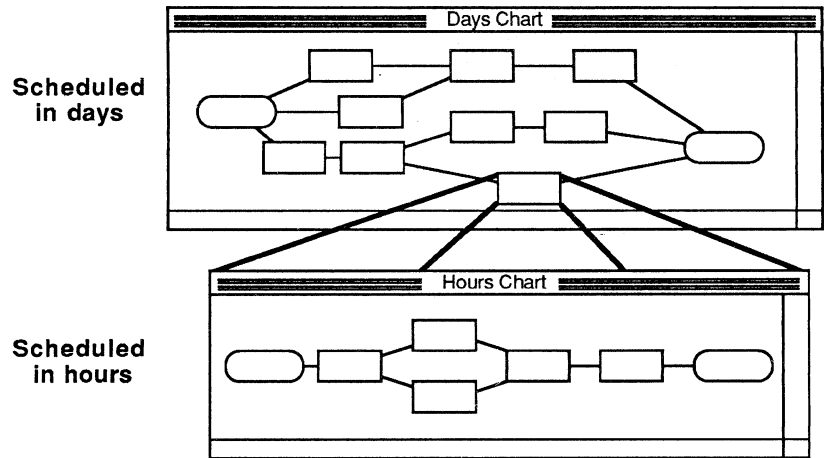

This technique works for any two units of time, not just days and hours. For example, if your main schedule chart is scheduled in months, you can create a subordinate chart in weeks or days.

**(Note:** You can't link two charts. If the Hours schedule changes, you must update the Days schedule manually.)



## Questions and Answers

### Overview

**These are the questions most commonly asked by MacProject users, and the correct answers.**

You should now know how to use MacProject, as well as many of the techniques that most users take months to discover. But as a support person, you'll also be called upon to answer other users' questions about the program. This section is a summary of the most commonly asked questions about using MacProject.

This material does not go into technical detail about the product. It only explains what most users will need to know in order to use it.

### Slack Time

*What's "slack time"?*

Slack time is the amount of extra time you have available to finish a particular task. In other words, it's how late that task can be without affecting the rest of the project. It's calculated by figuring the number of days between the Early Start date and the Late Finish date, and then subtracting the duration of the task. In other words, slack time is the difference between the Latest Finish and Earliest Finish dates.

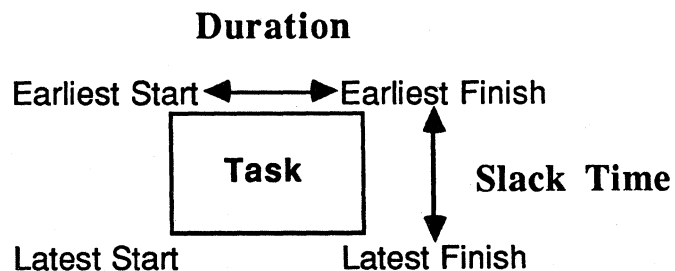

For example, if the dates are as shown below, and the task has a duration of 15 days, you'll have 5 days of slack time. (Remember that weekends don't count.)

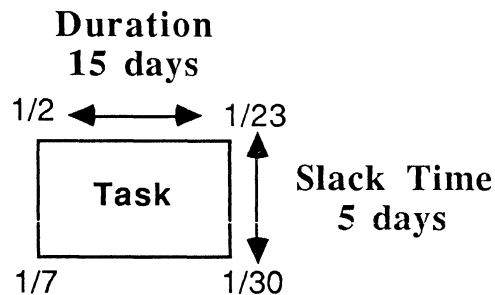

## Disk Full

*When printing to an ImageWriter™ printer, I get a message saying my disk is full. How do I print the document?*

You need free space on the startup disk equal to approximately twice the size of the document you want to print, so you will need to create more room on the startup disk.

Here are a few suggestions for creating more room on your disk and some work-arounds for this problem.

- Move the document you are trying to print onto a data disk and then remove it from the startup disk.
- If you are on a one-drive system, close the document and remove as much as possible from the startup disk—all you need is the System, Finder, and ImageWriter files, and MacProject itself. Remove documents, fonts, and desk accessories, if necessary.
- On a two-drive system, copy the application to the same disk you moved your document to and remove it from the startup disk. This will free up additional room on the startup disk for the print file.
- Print the document from a hard disk.
- Print the document one page at a time.

(See the *Managing Macintosh Files* module for more information about creating additional room on your disk.)

### Using Quarterly Time Lines

*When I display the time line by quarters, the time divisions are not every three months. Why not?*

This is a problem with MacProject. The time divisions are every twelve weeks, not every three months. So, by the end of four quarters you're four weeks short of a full year.

### Displaying Information Around Task Boxes

*How do I display the information I want around a task box?*

You can display only one item at each of the four corners of the task box. Choose **Show Dates** from the **Dates** menu to see what can be displayed at each corner of the task box (see the screen below). All of the information about a task can be displayed somewhere around the task. Choose **Resource** at more than one corner if you have more than one resource working on any particular task. A different resource, up to a total of four, will be displayed at each corner.

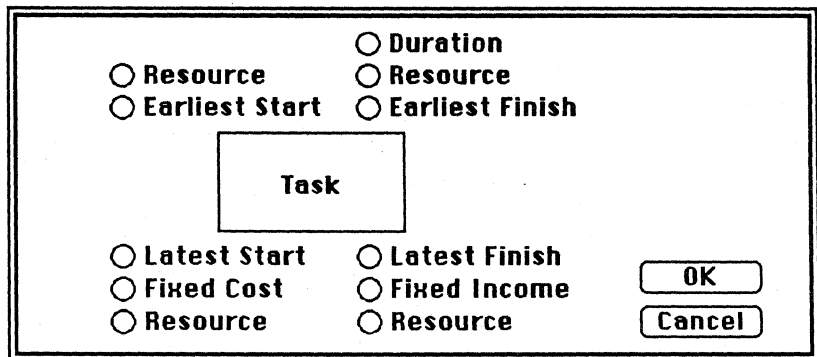

### Avoiding Overlapping Task Boxes

*How do I prevent information from different task boxes from overlapping?*

Try one of the following:

- Choose a smaller type size. This will change the type for all the tasks and milestones, but not for annotations.
- Make your entire document larger (choose **Show Chart Size** from the **Layout** menu) and spread out your task boxes.

**Bold Dates**

*What does it mean when an individual date is displayed in bold?*

**5/14**    **5/14**

Decide on Location
-----------------------

A bold date indicates that the date is theoretically impossible to meet. This is because you have more than one fixed date and the tasks between the fixed dates take longer to complete than you have allowed. Check all fixed dates in your schedule and make any necessary changes.

**Unrealistic Total Expense**

*My total expenses are higher than what I think they should be. What might cause this?*

Check the payment method for each resource. Resources that are people are usually set to **Single Accrual Method**. A multiple accrual means that if a person is scheduled for more than one task at a time, he is getting paid more than once for a single day's work. This could inflate your estimated costs. (See the comment titled "Single vs. Multiple Payment" in the Creating Your Project Schedule section of this module.)

**Critical Path**

*There are two different types of highlighting around task boxes. What does each mean?*

Critical Task
---------------

Unachievable Task
----------------------

The two types of highlighting around task boxes are for *critical* and *unachievable* tasks. These may be present when you have *negative slack time*. Remember, slack time is the amount of extra time you have available to finish a particular task. *Negative* slack time means that the tasks between two fixed dates take longer than you have allowed. Therefore, you can't possibly finish on time.

For example, let's say you set the Earliest Start date for one task to February 1, and the Earliest Start date for a subsequent task for March 1. If the intervening tasks take 25 days, you will have negative slack time. It's theoretically impossible to

finish 25 days work in the 20 days that are available. You need to revise your schedule to eliminate the negative slack time.

- **Critical Tasks.** These boxes are highlighted on all sides. Critical tasks are those that have the least amount of slack time in the entire project (usually equal to, but never greater than zero). These tasks need close attention to be sure they don't fall behind schedule.
- **Unachievable Tasks.** These boxes are highlighted on vertical sides only. These are tasks with slack time less than or equal to zero, but greater than the slack time of the tasks along the critical path. An unachievable task would have to be started before its earliest start date to keep the project on schedule.

You'll only get unachievable tasks if you have more than one fixed date in your project.

**Example of critical and unachievable tasks.**

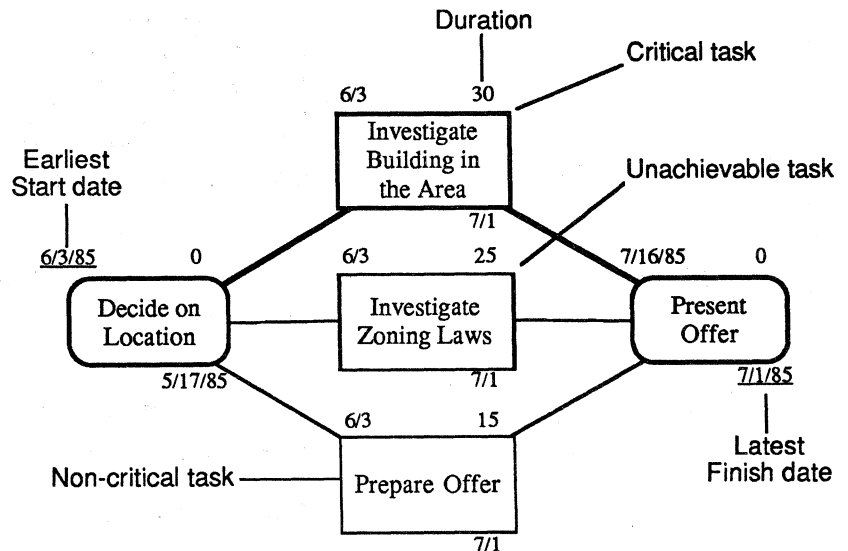

The "Investigate Building in the Area" task is critical because it has the longest duration. The "Investigate Zoning Laws" task is unachievable because it has a shorter duration than the critical task, but it would still have to start before its earliest start date if it's to be finished on time. Its slack time is negative because its duration is longer than the number of days between the Earliest Start date and the Latest Finish date, which have been specifically set.

To eliminate the unachievable task, change the fixed dates or change the duration of the task so that it's possible for it to be

completed on or before the Latest Finish date. You should use the same techniques to also eliminate the negative slack time in the critical task.

**Question Marks Where the Dates Should Be**

*What does it mean when there are question marks where the dates should be?*

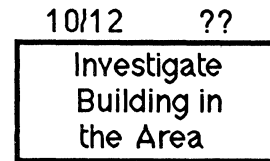

The dates of your project go beyond the calendar range set for the project. To correct this, do the following:

1. Choose **Calendar** from the **Dates** menu.
2. Widen the range for the project by increasing the **Calendar Range** (the range can be up to 10 years).

**Multiple Projects**

*How can I schedule more than one project on the same document?*

You can have more than one start milestone in the same project schedule and thereby have two independent schedule charts in one document. But your resources will be scheduled as if for one big project. To completely separate the projects, create separate documents or give your resources two different names, such as DAVID1 and DAVID2.

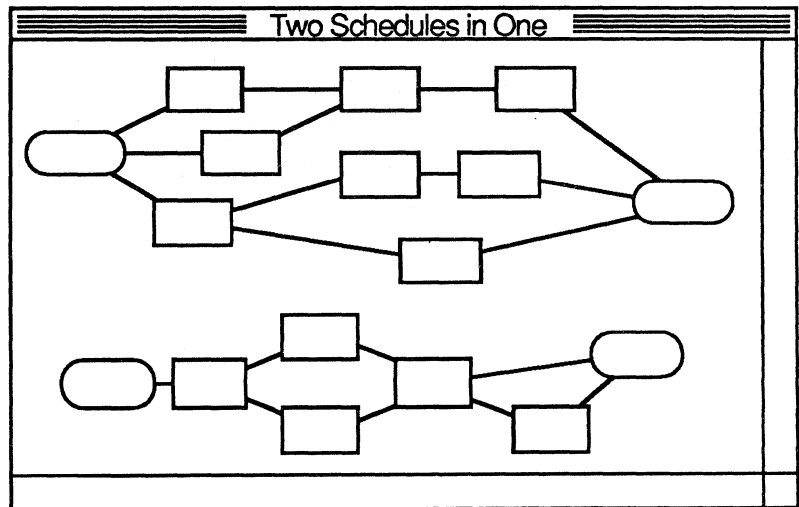

## Moving Information Into Other Applications

*How do I move something from MacProject into another application?*

To move something from your project schedule to another document, use the same technique you would use to move anything between any two documents:

1. Select what you want to move.
2. Copy it.
3. Open the second document (preferable using the Switcher).
4. Indicate where you want to add the information.
5. Choose **Paste**.

Use standard techniques to select all or part of any MacProject chart or table. (For specific selection techniques see the section on Selecting in Chapter 2 of the MacProject owner's manual.)

*What integration is possible?*

There are two types of information in MacProject:

- **Graphics:** Schedule Chart, Resource Timeline, and Task Timeline; and
- **Tables:** Task Cost Entry, Resource Cost Entry, Cash Flow Table, and Project Table.

Refer to the table below for what types of information can be moved *from* MacProject *into* other Macintosh applications.

<u>Pasted into</u> <u>This Application</u>	<u>Limits/Comments</u>
MacDraw™	No limits
Mac Paint™	Tables and graphics; limited to one screenful at a time
MacProject	Schedule Chart only; keeps task info and dates
MacTerminal™	Tables (columns separated by Tabs); complete files transferred using the XModem protocol
MacWrite™	Tables and graphics; limited to width of 1 vertical page; if moving a table, set Tabs in MacWrite to separate columns
Spreadsheets	Tables only
Data bases	Tables only if data base can accept a series of fields separated by Tabs and Returns

The only information you can paste into MacProject is:

- Small selections of text (a few words), which can be pasted into a task box, the Task Cost Entry table, or the Resource Cost Entry table.
- All or part of another Schedule Chart.
- ThinkTank outlines and headings (that can then be expanded into full project schedules.)

Refer to *MacProject*, the owner's manual, for more information about moving information between applications. (Look in the index under "Copying to another application.")

### **Can't Move Entire Chart Into Another Document**

*When I try to move my schedule chart into another MacProject document or into a MacDraw document, I get a message saying that my document is too big to move. How can I move it?*

Use the Shift-click or the selection box to move the chart piece by piece.

### **System Crashes When Copying Project Table**

*Why does my system crash when I copy the Project Table?*

MacProject will crash if a task name is longer than 63 characters and you copy the Project Table. You'll have to restart your Macintosh and you'll lose all changes since you last saved the document. There is no solution, so—*don't do it!*

### **Dates Printed in Wrong Typestyle**

*Why is it that when I print the Schedule Chart on the LaserWriter™ printer, the dates are printed in the wrong type style, usually hollow type?*

This is a bug in MacProject. To work around it, paste the entire project schedule into MacDraw and print it from there. Or, print the document on an ImageWriter.



## Troubleshooting Techniques

### Overview

Here are some techniques to help you solve complex problems.

This section provides some general techniques to help you figure out why a particular schedule doesn't work the way it should. Problems may manifest themselves as bold dates or unachievable tasks, which indicate theoretically impossible dates and negative slack time, or as unrealistic beginning dates, completion dates, or expenses.

### Show Entire Chart

#### Does the chart look "normal"?

The first step is to choose **Show Entire Chart** from the **Layout** menu. Does the chart look "normal"? In other words, does anything jump out at you as being obviously wrong or out of place? Here are some specific things to look for:

- Are there orphans (tasks with no predecessors or successors)? If so, connect them to the rest of the chart, or remove them.
- Are all the tasks connected? If not, add any necessary dependency lines.
- Are there any fixed (underlined) dates? Use fixed dates only when you know the date is fixed. If you include too many fixed dates, the schedule becomes confusing, and problems may arise.
- Are there any bold dates? If so, this date is theoretically impossible to meet and you should change it.

Only fixed dates, which are normally underlined, will appear in bold type. A bold date indicates a fixed date which is impossible to keep. Dates that aren't set are automatically calculated by MacProject, which won't calculate a date that's impossible to meet.

- Are there any unachievable tasks? If so, the schedule as it currently stands is theoretically impossible. Check fixed dates and durations and revise the schedule as necessary.

## Display All Dates

### **Dates help you understand what's really happening.**

You can get a much better idea of what is happening and where problems may lie by displaying all the dates. It helps you understand why a particular task is critical or unachievable. You can see which dates are set and where the negative slack time—which may be causing the problems—is occurring.

## Find Cause of Impossible Dates

### **Check all the fixed dates to find the one that's causing the problem.**

1. For all fixed dates, write the date as an annotation next to the task.
2. Clear all fixed dates to allow MacProject to calculate the dates on its own. If there are no fixed dates, there will not be any bold dates or unachievable tasks.
3. Reset the dates one by one. You will then be able to see the effect of each fixed date, and determine which one is causing the problem.

---

## Using the Manual

### Overview

**This section offers practice in finding specific information in the manual.**

Often you will be asked a question that you can't answer immediately. You should know where to find the answer and how to find it quickly. In order to do this, you must be familiar with the various manuals (and other documentation) that contain information about MacProject.

This section gives you a chance to familiarize yourself with the MacProject manual by finding the answers to specific questions.

### **Use the table of contents and the index.**

This section will ask questions similar to those you can expect to get from users. Use the manual's table of contents and index to locate the information, then write down the answer and where you found it.

When you're finished, check the Feedback section, which will give both the answer and the chapter and section in which it was found. (Specific page numbers won't be given because they might change with manual revisions.)

---

## **Practice**

**Use the Manual to  
Answer These Questions**

**How are the Fixed Dates identified on the  
Schedule Chart?**

---

---

---

---

**How do you set the size of your chart ?**

---

---

---

---

**What are the various time intervals available  
for time lines?**

---

---

---

---

---

## **Feedback**

### **Use the Manual to Answer These Questions**

#### **How are the Fixed Dates identified on the Schedule Chart?**

Fixed Dates are underlined. Dates calculated by MacProject are shown in plain type.

The answer can be found in the Setting Dates section of Chapter 2.

#### **How do you set the size of your chart ?**

Choose Set Chart Size from the Layout menu.

The answer can be found in two places (you only need to have identified one of them): It's in the Making a Chart a Larger Size section of Chapter 2 and in the Layout Menu section of Chapter 4.

#### **What are the various time intervals available for time lines?**

1 minute, 30 minutes, 1 hour, 1 day, 1 week, 2 weeks, 1 month, 1 quarter.

The answer is in the Dates Menu section of Chapter 4.

---

## MacProject Specifications

### Overview

**This section covers the capabilities and limitations of MacProject.**

In addition to the questions addressed in the last section, you'll be asked many questions regarding the capabilities or limitations of MacProject. (For example, How many pages? Total number of tasks? and so forth.) This section details the specifications for MacProject to enable you to answer these questions.

### Specifications

**Capacity.** 200 tasks on a Macintosh 128K; 2000 tasks on a Macintosh 512K or Macintosh XL.

**Number of Resources.** Maximum of 6 per task; 50 per project.

**Size of Document.** Maximum size: 94"x48" (up to 54 pages).

**Number of Holidays.** Unlimited.

**Time Span.** Project can span up to 10 years.

**Task Box Title.** Maximum of 255 characters (technically). Practically, the limit is 63 characters. (See the comment titled "System Crashes When Copying Project Table" in the Questions and Answers section of this module.)

**Fonts.** Each annotation limited to one font, size, and style. You can work around this by clicking the mouse button to start a new annotation.

**Number of Different Fonts.** There is no limit to the number of different fonts and type styles you can have in the annotation portions of a document (all of the task boxes are always in the same font). However, there is a limit to the number of fonts that will fit in the **Font** menu.

On a Macintosh 128K or Macintosh 512K, the names of only 20 fonts can be seen in the menu. If you have more fonts than that, some will run off the bottom of the screen and will not be selectable. On a Macintosh XL you can have up to 22 fonts in the **Font** menu. (See the *Supporting the Font/DA Mover* module from the Apple Support Training Library for more information about adding and removing fonts.)

---

## **Review**

### **How to Use MacProject**

**Use existing MacProject training materials to learn how to use the application.**

### **MacProject Benefits**

**Knowing the key benefits will make it easier to make appropriate recommendations.**

- Plan and manage projects better.
- Choose the best of several options.
- Anticipate problems.
- Manage resources.
- Control costs.
- Identify and manage critical tasks.
- Track progress.
- It's easy to learn and use.
- It's integrated with other Macintosh applications.
- It uses proven project management techniques (PERT and CPM).

### **Advanced Techniques**

**These will help you become more productive with MacProject more quickly.**

Refer back to them and distribute them to others so they, too, can become more efficient MacProject users.

### **Questions and Answers**

**These are the questions you can expect to get from users of MacProject.**

Explanations and the answers are included so you can quickly help users with their problems. Refer back to this section for the answers to commonly asked questions.

### **Troubleshooting Techniques**

**These will help you find the solution when something is wrong with a project schedule.**

### **MacProject Specifications**

**This section covers the capabilities and limitations of MacProject.**

A lot of user questions concern the capabilities of MacProject. This section contains the answers to this type of question.

## Resources

- *MacProject*, the owner's manual, Apple Computer, Inc.
- *Macintosh Software Selling Guide* (Distributed in May 1985)
- *Macworld* (Read the July/August 1984 issue for additional MacProject hints and techniques. Other publications such as *A+*, *Macintosh Connection*, and *MACazine* often contain helpful information about using Macintosh and MacProject.)
- AppleLink (If you have access to AppleLink, check it regularly for additional information about MacProject.)

The following resources are recommended if you want information on the theory of project management, PERT, and CPM.

### BOOKS:

- *PERT/CPM, As Easy As ABC*, by John Mulvaney (Published by Management Planning and Control Systems)
- *Managing High Technology Programs and Projects*, by Russell D. Archibald [Published by Wylie Interscience Books, (ISBN - 047103308-1)]

### MAGAZINE ARTICLES:

- "Hard-Hat Management: Two On-Site Tools," by Richard Parry, *Interface Age* magazine, February 1981 (This provides a basic definition of PERT and CPM.)
- "When the Objective Is Efficient Project Management," by Kevin Strehlo, *Personal Computing*, January 1984 (This article defines the key concepts, and discusses the limitations, of PERT and CPM.)
- "PERT For Monthly Financial Closing," by Alvert P. Ameiss and Warren A. Thompson, *Management Adviser*, January-February 1974 (Using PERT charts to prepare financial statements.)
- "Bringing Order to Project Jumble," by Elisabeth Horwitt, *Business Computer Systems*, December 1983 (This article describes how personal computers can be useful when scheduling projects. It briefly discusses the theories of PERT and CMP.)



*Apple and the Apple logo are registered trademarks of Apple Computer, Inc. AppleLink, ImageWriter, LaserWriter, MacDraw, MacPaint, MacProject, MacTerminal, and MacWrite are trademarks of Apple Computer, Inc. Macintosh is a trademark of McIntosh Laboratory, Inc. and is being used with express permission of its owner. ThinkTank is a trademark of Living Videotext.*

# Supporting MacWrite

---

## Contents

- 2 Overview
- 3 Objectives, Materials
- 4 MacWrite Benefits
- 5 Using the Manual
  - Learn how to use the manual as a reference tool.*
- 9 Integrating MacWrite with Other Applications
  - What information can you paste into MacWrite, and what MacWrite information can be pasted into other applications?*
- 12 Adding Graphics
  - How to add and work with graphics in your MacWrite document.*
- 15 Useful Techniques
  - Here are some tips on how to use MacWrite most effectively.*
- 28 Questions and Answers
  - Prepare yourself for the questions most commonly asked by users.*
- 36 MacWrite Specifications
  - Learn the capacity and limitations of MacWrite.*
- 40 Review
- 41 Resources

---

## Overview

Read this module to learn how to support the MacWrite™ software. The module includes key MacWrite benefits, how to work with graphics, information on advanced techniques, the solutions to commonly asked questions, and product specifications.

Anyone who is supporting people who use MacWrite should complete this module.

For information regarding using MacWrite with the Apple® LaserWriter™ printer, see the *Using the LaserWriter* module from the Apple Support Training Library.

### Prerequisites

- Basic techniques for using the Macintosh™ computer such as how to use the mouse and menus, how to open and close documents, and how to work with text. You can learn these by completing the *Learning to Use Macintosh* module or the Guided Tour of Macintosh, or by reading Chapters 1 and 2 of *Macintosh*, the owner's manual.
- Knowledge of how to use MacWrite, which can be acquired by completing the Guided Tour of MacWrite, or by reading Chapters 1 and 2 of *MacWrite*, the owner's manual.

---

## Objectives

- Use all the features of MacWrite, including the use of special keys; adding graphics; working with rulers, and headers and footers; and other useful techniques.
- State the function of each of the menu commands.
- State the product specifications for MacWrite.
- Answer user-level questions about how to use MacWrite.

---

## Materials

**To complete this module, you will need:**

- Macintosh 128K, Macintosh 512K, or Macintosh XL
- MacWrite disk
- *MacWrite*, the owner's manual

---

## MacWrite Benefits

### Overview

**These are the key benefits of MacWrite.**

In addition to getting questions about how to use a product, you may also get requests for product recommendations. This section briefly lists the key benefits of MacWrite. In other words, why should someone use MacWrite over any other word processor?

### MacWrite Benefits

**Enhance a document's impact.** Use the many typefaces and styles to produce a professional-quality document.

**Include information from other applications.** Easily incorporate graphics, spreadsheet data, and information obtained from other computers.

**View your document on the screen as it will appear on paper.** This eliminates the need to print drafts.

**Easily create and edit your work.** The consistent user interface of Macintosh applications makes it easy to create and edit your work, so you can concentrate on content.

**High-quality output.** Use MacWrite with the LaserWriter to produce publication-quality text.

---

## Using the Manual

### Overview

**This section offers practice in finding specific information in the manual.**

Often, you'll be asked a question that you can't answer immediately. If you don't know the answer, the next best thing is to know where to find it—and how to find it quickly. In order to be able to do this, you must be familiar with the various manuals (and other documentation) that contain the answers.

This section gives you a chance to familiarize yourself with the MacWrite manual by finding the answers to specific questions.

### **Use the table of contents and the index.**

This section will ask questions similar to those you can expect to get from users. Use the table of contents and the index to locate the information in the manual, then write down the answer and where you found it.

When you're finished, check the Feedback section, which will give both the answer and the chapter and section in which it was found. (Specific page numbers won't be given because they might change with manual revisions.)



---

## ***Practice***

**Use the Manual to  
Answer These Questions**

**How do I select a ruler so that I can remove it?**

---

---

---

**How do I begin a document with a page  
number other than 1?**

---

---

---

**What does the Title Page command in the  
Format menu do, and how do I turn it off?**

---

---

---



---

## **Feedback**

### **Use the Manual to Answer these Questions**

#### **How do I select a ruler so that I can remove it?**

Click anywhere on the inch scale of the ruler. To remove it, press Backspace or choose Cut from the Edit menu.

The answer is in the Editing Tasks section of Chapter 2.

#### **How do I begin a document with a page number other than 1?**

Choose Set Page # from the Format menu.

The answer is in the Changing the Format section of Chapter 2.

#### **What does the Title Page command in the Format menu do, and how do I turn it off?**

The Title Page command causes the header and footer not to appear on the first page of a document. When you choose this option, a check mark will appear next to it in the menu, indicating that it's in effect. To turn it off, choose it again.

The first half of the answer is in several places in the manual. But the second half only appears once. You can find the entire answer in the Menu Bar section of Chapter 3.

# Integrating MacWrite with Other Applications

## Overview

### What's possible, and how is it done?

One of the key benefits of the Macintosh is being able to copy and paste information from one application to another. For example, you can often make a MacWrite document more meaningful by including a drawing from MacPaint™ or MacDraw™.

This section begins with a reminder of how to move information from one document to another. A description of what integration is possible between MacWrite and other Macintosh applications follows.

## How To ...

### Use Copy and Paste.

To move information between any two documents, do the following:

1. Select what you want to move.
2. Copy it.
3. Open the second document.
4. Indicate where you want to add the information.
5. Choose Paste.

(Note: Your ability to do this will depend on what types of information each application is able to handle.)

## Pasting Into MacWrite

### Here's a brief summary of what can be pasted into MacWrite from other applications.

MacWrite can accept text, tables, and graphics as long as they fit within its margins. Here's some additional information you should know regarding pasting information into MacWrite.

**MacDraw.** You can paste any MacDraw drawing into MacWrite. If the graphic is larger than the margins, it shrinks to fit. If it's smaller than the margins, it appears left justified. (See the next section of this module for more information about pasting graphics into MacWrite.)

**MacPaint.** You can paste any MacPaint picture into MacWrite. If the graphic is larger than the margins, it shrinks to fit. If it's smaller than the margins, it appears left justified. Text is printed as bit-mapped graphics, not as text. (See the next section of this module for more information about pasting graphics into MacWrite.)

**MacProject™.** You can paste any of MacProject's tables into MacWrite. Columns are separated by tabs and each line ends with a Return character. Be sure you set one tab for each column. Once in MacWrite, the information is treated like any other text.

**MacTerminal™.** You can paste anything from MacTerminal into MacWrite. It's pasted as text and assumes the font and type style of the existing text into which it is pasted. If you copy a table of information from MacTerminal using the **Copy Table** command, columns within the table are separated by tabs when pasted into MacWrite.

**MacWrite.** Anything pasted into MacWrite from another MacWrite document appears just as it did in the original document. It keeps its font and type-style information, although it's subject to the margins set by the ruler in the receiving document unless you copy and paste a ruler with the text. You can also copy graphics that were previously pasted into MacWrite and paste them into another MacWrite document.

**Spreadsheets.** You can paste any information from a spreadsheet into MacWrite. But if the information doesn't fit within the MacWrite margins, each line will wrap around onto a second line (so it won't look like it did in the spreadsheet). Columns are separated by tabs, and there's a Return character at the end of every line.

**Data bases.** You can paste any data-base information into MacWrite, as long as the fields are separated by tabs and there is a Return character at the end of every record when you copy it to the Clipboard. The information will appear in MacWrite as a table, but, if it doesn't fit within the MacWrite margins, each line will wrap around onto a second line.

## Pasting MacWrite Data into Other Applications

### Here's a summary of the information that can be pasted into other applications.

You can paste MacWrite information into any application that can handle text. Here's some specific information regarding each application.

**MacDraw.** MacWrite text can be pasted into MacDraw either as "paragraph" text (will wordwrap at the end of the line) as "caption" text (will appear on one line and pages will be added to the right as needed to accommodate the text). (See the *Supporting MacDraw* module from the Apple Support Training Library for more information about working with paragraph and caption text.) You can also copy graphics (originally from any application) that were previously pasted into MacWrite and paste them into MacDraw. If the graphics originated in MacDraw, they will be pasted in as MacDraw graphics, and can be edited. You can't edit any other graphics.

**MacPaint.** By default, all text will be pasted into a rectangle in the middle of the screen that's approximately 4 inches wide and as long as necessary. If you draw a selection rectangle before choosing **Paste**, the text will word wrap within the rectangle until you get to the bottom of the selection rectangle. Any text that doesn't fit is lost, so be sure your rectangle is large enough. You can also copy any graphics that were previously pasted into MacWrite and paste them into MacPaint. You can then edit the drawing, just as you edit any MacPaint drawing.

**MacProject.** You can only paste very small amounts of text into MacProject—whatever will fit into one of the data-entry tables.

**MacTerminal.** You can paste any text from MacWrite into MacTerminal, but all font and type-style information is lost. Graphics that have been pasted into MacWrite can't be pasted into MacTerminal. If a MacWrite document is saved as Text Only, it can be opened directly from MacTerminal.

**MacWrite.** You can copy anything, including graphics, from a MacWrite document and paste it into another MacWrite document.

**Spreadsheets.** You can only copy small amounts of text from MacWrite and paste it into individual cells in a spreadsheet. You can't paste graphics from MacWrite into a spreadsheet.

**Data bases.** You can only copy small amounts of text from MacWrite and paste it into individual cells in a data base. You can't paste graphics from MacWrite into a data base.

## Adding Graphics

### Overview

**This section covers techniques for adding MacPaint and MacDraw graphics.**

Copying and pasting information is a consistent and easy feature of all Macintosh applications, and one you should already be familiar with. But, there are a few specifics about including graphics in a word-processing document that require further explanation.

This section covers how to move graphics, from either MacPaint or MacDraw into MacWrite, how to determine where the graphics appear, and how to move or resize your graphics once you've moved them.

### How to Add Graphics to Your Document

#### Use Copy and Paste.

To move a drawing from either MacDraw or MacPaint into MacWrite, use the standard copy-and-paste technique—copy it from one document and then paste it into another.

In MacDraw, use any standard selection technique. In MacPaint, the lasso is recommended, because it eliminates any white space around the drawing.

#### Set the margins before pasting.

When you paste a drawing into MacWrite, it will appear at the left margin (the black triangle), not at the left indent (the arrow). If the drawing doesn't fit within the margins, it will automatically shrink to fit. The effect is the same as when you shrink a drawing in MacPaint. In the example below, the first graphic is the original, and the second is what the graphic looks like when it has been pasted into a MacWrite document whose margins are too close together.

#### Original Graphic

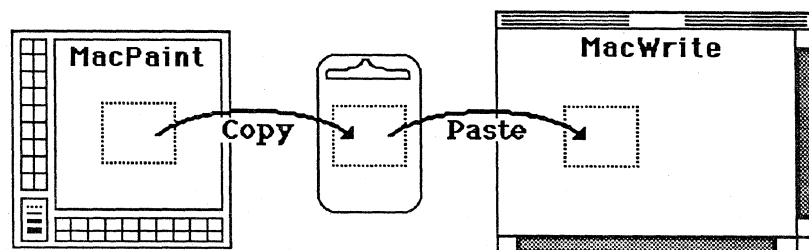

### The Same Graphic Pasted into a Document with Narrow Margins

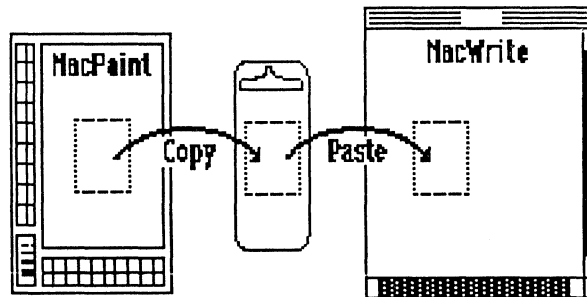

Another effect of margins that are too narrow is that text pasted in from MacDraw, usually as part of an organization chart or flow chart, will appear OK on the screen, but words will overlap when the document is printed.

If your margins are too confining, widen them and then repaste the graphic.

### Working with Graphics

**To move or resize a drawing, select it and use the handles.**

Once you've pasted the drawing into your MacWrite document, you can move it and resize it. First, select it by clicking on any part of the drawing. The drawing will be surrounded by a thin line with three handles across the bottom, as shown below.

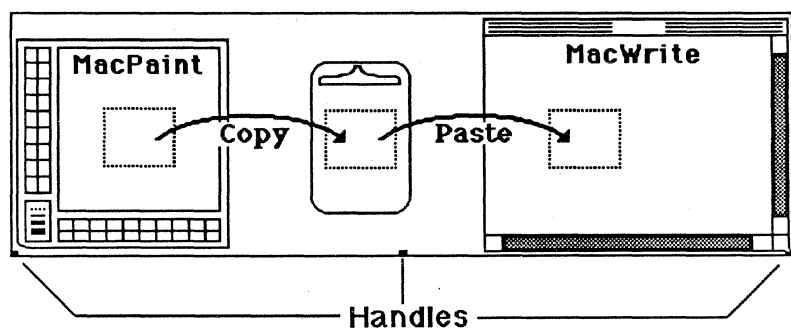

If the drawing is smaller than the space between the margins, you can move it horizontally by following these steps:

1. Point to any edge of the drawing.
2. Hold down the mouse button.
3. Move the drawing right or left to the desired location.
4. Release the mouse button.

You can resize the drawing vertically and horizontally at the same time by grabbing either of the outside handles. To resize the drawing vertically only, use the middle handle.

### **You can't add text next to a drawing.**

If you want text to the right or left of your drawing, add it while you are in MacDraw or MacPaint, and then copy and paste the text with the drawing. You can't add text next to a drawing once it has been pasted into MacWrite.

(Note: For a consistent look, use the same font in the drawing that you use in the remainder of your document.)

The only way to change a drawing, or text within a drawing, once it has been pasted into MacWrite, is to edit it in MacDraw or MacPaint and then repaste it into MacWrite.

### **To remove a drawing, select it and choose Cut.**

When you select the drawing, the border and handles will return. Then choose **Cut** or press Backspace. You can select and cut graphics at the same time you remove text.

## **Dealing with Distortion**

### **Your MacPaint image may appear distorted.**

Sometimes, when you paste a MacPaint drawing into MacWrite, it appears slightly distorted. It may still print normally, however. So, always start by trying to print the document.

If it doesn't print normally, choose **Tall Adjusted** from the **Page Layout** window. This should correct the distortion, but it will also slightly widen the text part of the document. The effect will vary with type styles, sizes, and fonts. Experiment to see what works best.

A drawing might also be distorted because it has been resized or shrunk to fit within narrow margins. Be sure your margins allow enough room, and use the handles to resize the document.

## Useful Techniques

### Overview

**This section covers techniques to help you get the most out of MacWrite.**

Reading a manual and doing practice exercises is only part of learning to use an application. Beyond these basics, there are many techniques for producing *higher quality* work—and doing it *more efficiently*.

This section describes many of those techniques, so you can become more productive on MacWrite more quickly. Also, at the end of the module, there is a list of resources you should check regularly for more information on how to get the most out of your Macintosh and MacWrite.

### Have MacWrite Available

**Practice exercises are not included, but you are encouraged to try each technique.**

Since specific practice exercises aren't included in this module, it may be useful to have a Macintosh equipped with MacWrite available as you read this section so you can try the various techniques as you read about them.

### Two Versions of MacWrite

**Most of the techniques described in this section apply to both versions of MacWrite.**

MacWrite is currently available in two versions, 2.2 and 4.5. Any differences in how these techniques are implemented are noted. If you aren't sure which version you have, start up MacWrite and choose **About MacWrite** from the **Apple** menu. (See the MacWrite Specifications section of this module for more information about the two versions of MacWrite.)

**If you're using Version 2.2, upgrade to the more powerful Version 4.5.**

MacWrite Version 4.5 has some distinct advantages over Version 2.2, which are listed in the Specifications section of this module. While you're at it, also update your Finder to the latest version, if you haven't already done so. (See the *Supporting the Macintosh Finder* module from the Apple Support Training Library for specific differences between Finder 1.0 and Finder 4.1. Ask your dealer or Apple support representative about upgrading your software.)



## Command Key Equivalents

### Use the Command key to invoke menu commands.

You can use the Command key in combination with the appropriate letter key to implement many of the menu commands. Many people find this is faster than reaching for the mouse, especially in an application like MacWrite, which is very keyboard oriented.

Here is a summary of the menu commands that have Command key equivalents.

Edit		Style	
Undo Typing	⌘Z	Plain Text	⌘P
Cut	⌘H	<b>Bold</b>	⌘B
Copy	⌘C	<i>Italic</i>	⌘I
Paste	⌘V	<u>Underline</u>	⌘U
		Outline	⌘O
		<b>Shadow</b>	⌘S
		Superscript	⌘H
		Subscript	⌘L
Format (Ver 4.5 only)		Search (Ver 4.5 only)	
Align Left	⌘N	Find Next	⌘F
Align Center	⌘M	Goto Page #	⌘G
Align Right	⌘R		
Justify	⌘J		
Use Ruler	⌘D		

## Enter and Return Keys

### Use Enter or Return to accept preset buttons in windows.

Many dialog boxes have a choice of buttons for you to push (OK, Cancel, Open, and so forth). One of them is usually highlighted with a bold border (for example, the Yes button in the Close window below).

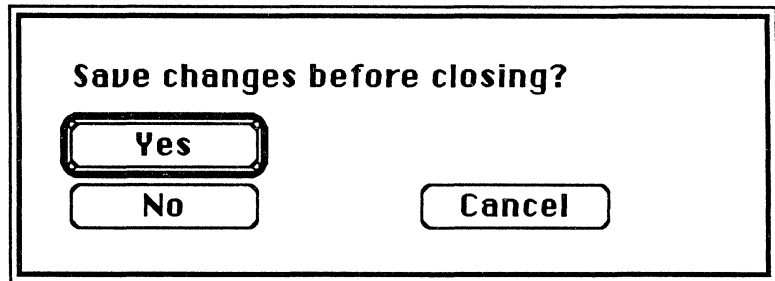

This is the preset button. You can save time by pressing the Enter or Return key to accept the preset, rather than using the mouse to click on Yes.

### Keeping Words Together

#### Use the Option key to prevent words from being separated by the end of a line.

Many times there are two words that you want to appear right next to each other, but they land at the end of a line and therefore get separated, for example, a date like March 15, 1986. (See!?! )

To keep two words together, hold down the Option key as you type the space. Instead of being separated by the end of the line, the words will both appear at the beginning of the next line.

### Moving Between Two MacWrite Documents

#### Use the Document Directory dialog box.

If you have a MacWrite document open, and you want to open a different MacWrite document, you could choose **Quit** from the **File** menu and then open the second document from the **Finder**. But the following way is faster:

1. Choose **Close** from the **File** menu or click the close box.
2. Choose **Open** from the **File** menu.

You'll get the Document Directory dialog box, which contains a list of all the MacWrite documents on that disk.

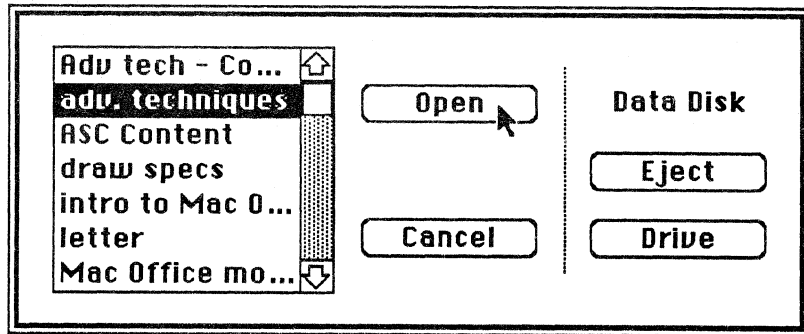

The name of the disk whose contents are displayed is in the top, right corner of the window. If you want to open a document on another disk, either click **Drive** to look at the documents stored on the disk inserted in the other drive, or click **Eject** to eject the disk whose name appears above the Eject button, and then insert the disk containing the document you want.

Double-click on the name of the document you want to open, or select it and click **Open** (as shown in the above screen shot). If the name of the document doesn't fit in the space provided, three dots will be added to the end of what does fit.

The documents are listed in alphabetical order. If you have a long list of documents, you can quickly jump to the part of the alphabet under which your document is listed by typing the first letter of the name of your document. For example, if you are looking for the document titled "Sales Meeting Notes," type the letter **S** and the first document beginning with the letter **S** will jump to the top of the list. Or you can scroll through the Document Directory the same way you scroll through any window.

## Screen Shots

**There are several options for printing the current contents of the screen.**

By typing the correct combination of keys, you can save the screen as a MacPaint document or print it on an ImageWriter™ printer connected to the Printer port. By saving or printing the contents of the screen, you're creating what is called a "screen shot." (You can't print the contents of the screen directly to the LaserWriter. You must save it as a MacPaint document and then print it by running MacPaint.)

Use the following keystrokes to create a screen shot:

<u>Keystrokes</u>	<u>Effect</u>
Command-Shift-3	Save screen as a MacPaint file.
Command-Shift-4	Print the active window.
Command-Shift-Caps Lock-4	Print the entire screen.

The commands are the same for the Macintosh XL. But, on the Macintosh XL, printing the entire screen is impractical because the right-hand 2 inches wrap around and overlap the left side of the screen shot, obscuring what was already there.

## Double-Clicking

### Double-click to open icons, and to select single words and groups of words.

- To open any icon, point to it and double-click the mouse button. This is the same as selecting the icon and choosing **Open** from the **File** menu.
- To select a single word, double-click anywhere on it.
- To select text in word increments (instead of letter increments), do the following:
  - Point anywhere in the middle of the first word you want to select.
  - Double-click and hold the mouse button down on the second click.
  - Move to the end of the group of words you want to select.

The resulting selection will consist of only complete words.

## Select Large Amounts of Text

### Use Shift-click to select large blocks of text.

1. Click mouse button at the beginning or the end of the text you want to select.
2. Scroll to the other end of the text you want to select.
3. Hold down the Shift key and click the mouse button again. Everything between the two mouse clicks will be selected.

## Quick Ways to Delete

### Use the Backspace key.

If you want to get rid of some text permanently, select it and press Backspace. You will *not* be able to paste the text, but you can recover it by choosing **Undo Typing** *before clicking the mouse button.*

### **Or hold down the Enter key as you select text.**

Another quick way to delete text is to hold down the Enter key as you select the text. As soon as you release the mouse button, the text will be deleted. You can also select the text first and then press the Enter key to delete it, just as you would press the Backspace key. You can recover the text by choosing **Undo Typing** *before clicking the mouse button*.

### **Use Command-Backspace to Recover Text**

### **Command-Backspace will replace text you backspaced over.**

If you use the Backspace key to delete text a letter at a time, you can replace the text by holding down the Command key and continuing to press Backspace. The letters you deleted will be replaced one at a time. However, this technique won't work if you select the text and then press the Backspace key to delete it.

### **Page Breaks**

### **How to delete a page break.**

1. Select it by clicking anywhere between where the text ends and the end of the page.
2. Choose Cut or press Backspace.

### **Undo/Redo**

### **These commands enable you to experiment and recover from mistakes.**

The **Undo** command enables you to easily recover from mistakes, and to experiment without the fear of permanently losing information. You can choose **Undo** to reverse the effect of your last action *as long as you haven't clicked the mouse button*. **Undo** is always the first command in the **Edit** menu, and it changes depending on the last action taken.

For example, if you had just cut some text, the command would be **Undo Cut**. If you had just typed something, the command would be **Undo Typing**.

Anytime you choose the **Undo** command, it immediately changes to **Redo**. **Redo** reverses the effect of the **Undo**, *as long as you have not pressed the mouse button again*. The second word of the command stays the same. For example, **Undo Cut** changes to **Redo Cut**.

## Undo Typing removes text you just typed.

Choose **Undo Typing** to remove everything you have typed *since you last clicked the mouse button*. If you first selected some text and then typed over it, the text that was removed will be replaced. Choose **Redo Typing** to put back the text that was removed when you chose **Undo Typing**.

## Rulers

### Here's a lot of information about rulers and how to use them.

In MacWrite, you use rulers to set up the format of your document: margins, line spacing, tabs, and justification. Anytime you want to change the format of part of your document, you insert another ruler. Each ruler affects all of the text until the next ruler.

The next several items concern different aspects of using rulers. (Refer to *MacWrite*, the owner's manual, for additional basic information about using rulers.)

### To add a ruler, choose **Insert Ruler** or use **Copy and Paste**.

To insert a ruler, position the insertion point where you want to add it and choose **Insert Ruler** from the **Format** menu. A ruler identical to the ruler currently affecting that part of your document will be added and all of the text affected by that ruler will be checked to be sure it conforms to the new ruler. If you're working with a long document, this checking process may take up to 30 seconds. When you make any change to the new ruler (for example, moving a margin or inserting a tab) the format of the affected text will be changed immediately.

You can also copy and paste rulers the same way you copy and paste anything else:

1. Select the ruler by clicking on the numbered portion of it.
2. Choose **Copy**.
3. Click where you want to add the ruler.
4. Choose **Paste**.

The affected text will be reformatted immediately. This is a good way to add a preformatted ruler that's different from the one that would be added if you chose **Insert Ruler**.

**Hint: If you're inserting two rulers, insert the second one first.**

Many times you'll write your document and then go back and adjust the format. If you want to change the format of one short section and then return to the original format, you will have to insert two rulers. Insert the second ruler first and be prepared to wait a bit while MacWrite checks the formatting down to the next ruler. Then when you insert the first one (the ruler you will use to change the format of the short section) the wait will be very short because there is not much text until the next ruler.

### Ruler Symbols

**Here's an explanation of the symbols on the ruler and how to use them.**

There are two left-margin indicators on every ruler.

- The one with the arrow is called the "left indent." It indicates the left margin for the first line of every paragraph.
- The black triangle is the "left margin," which indicates the margin for the subsequent lines of a paragraph.

Use the mouse to change either margin indicator.

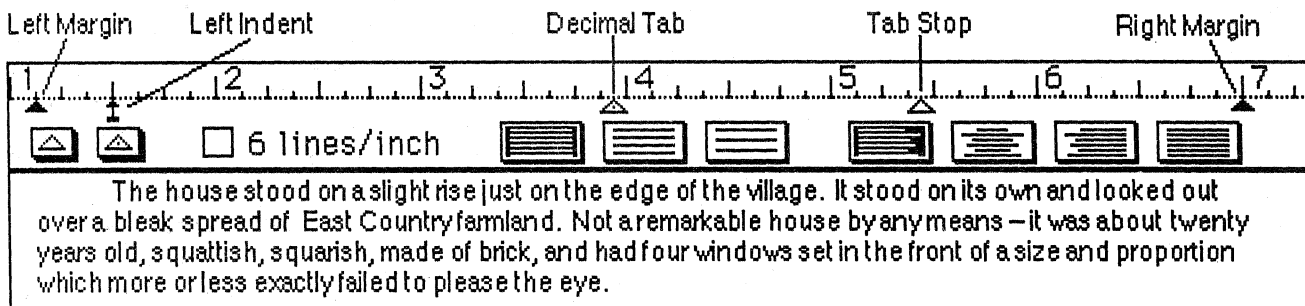

If you move the left margin to the right of the left indent, it also will be treated as a tab stop. Press the Tab key to start a new paragraph at the left margin of the remainder of the paragraph.

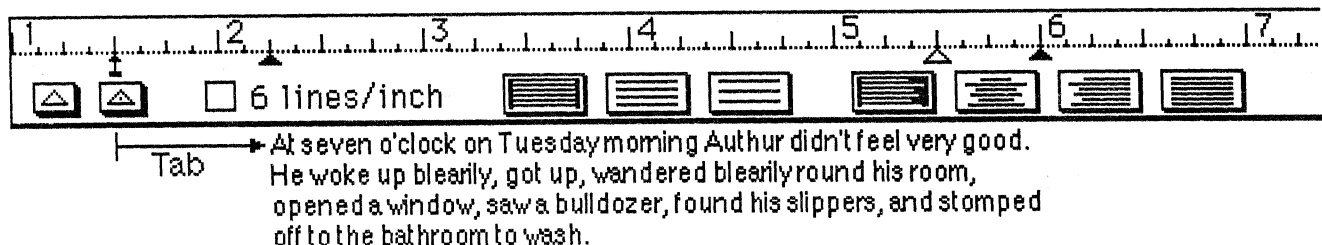

You can set a tab to the left of the left indent, but not to the left of the left margin. In other words, the left margin is always the first tab stop.

Tabs can be as close as 3/16 of an inch to the left margin, but no closer. Tabs can be as close 1/16 of an inch to the left indent.

## How to Move the Right Margin Beyond 7"

### Display the right end of the ruler.

When you open a MacWrite document, you can only see 6-1/8 inches of your document (from 1 inch to 7-1/8 inches). If you want to move your right margin beyond 7-1/8 inches, do the following:

1. Move the entire document to the left. Part of it will go off the screen.
2. Use the size box to enlarge the window to the right, which will expose more of the ruler.
3. Move the right margin to the desired location. The maximum right margin is 8 inches.
4. Shrink the document before you move it back to the right, or you won't be able to see the scroll bars.

## Hiding vs. Deleting Rulers

### What's the difference?

You cannot cut or delete the ruler at the beginning of a document. You can, however, insert additional rulers each time you want to change the format throughout your document.

If you want to see your document as it will print (without rulers) choose **Hide Rulers** from the **Format** menu. The rulers will no longer be visible, but the format of the text won't change.

If you want to get rid of one particular ruler, select it by clicking on the numbered portion, and choose **Cut** or press **Backspace**. The ruler will be removed from the document, and the text that was formatted according to that ruler will follow the format of the preceding ruler in the document.



## Centering Text

### Use the ruler or the Format menu.

There are two ways to center text automatically:

- Click the centered text icon on the ruler (shown below). All the text until the next ruler will be centered.

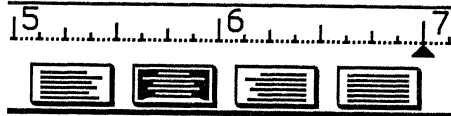

- Click anywhere in the paragraph to be centered and press Command-M or choose **Align Center** from the **Format** menu to center one paragraph—this works well for headings. (Note: This is new in Version 4.5.)

The other alignment options in the ruler shown above are, from left to right, flush-left, center, flush-right, and fully justified.

## Columns

### Use tabs to set up columns.

There's no automatic column capability in MacWrite. The best way to create columns of information is by using tabs. You can have either flush-left columns or columns that line up on decimals, both of which are shown below.

Here are my expenses for my recent trip, broken down by date and meal. If you have questions, please contact me.

<u>Date</u>	<u>Meal</u>	<u>Location</u>	<u>Amount</u>
7/17	Lunch	The J and L	25.67
	Dinner	Talbot's	63.50
7/18	B'fast	Hotel Coffee Shop	8.25
	Lunch	42nd Street	31.35

You can also use decimal tabs for flush-right columns, as long as the information doesn't contain decimals or periods.

In MacWrite, you can't select information by column. The text is basically a series of lines that are formatted the same way. (See *MacWrite*, the owner's manual, for more information about entering and editing columns.)

## Go to Specific Page

### Here's a quick way to go to a specific page.

MacWrite Version 4.5 offers a new command in the Search menu, **Goto Page #**. It enables you to go quickly to any page within your document without using the scroll bar. If you don't want to have to reach for the mouse, you can use the **Goto Page #** command entirely from the keyboard. The keystrokes are:



1. Command-G
2. <page number>
3. Enter or Return

The top of the page entered will be displayed in the MacWrite window. In Version 4.5, the page number is displayed in the scroll box, so you can easily scroll to a specific page.

## Headers and Footers

### Change the type style of the page number and other icons.

The following three icons are available in the header and footer windows:

-  **Page Number**
-  **Date**
-  **Time**

To include one of them in your header or footer, use the mouse to drag the icon to the desired location. The icons aren't affected by returns or spaces. If you want to move one of the icons within the header or footer, always use the mouse.

By default, the icons are printed in 12 point Geneva. If you try to change the font or type style, you may notice that you can't select the icons the way you would normally select text.

Here is how to change the font or type style of the page number, date, or time icon:

1. Open the footer or the header.
2. Select the entire header or footer, including blank lines.
3. Choose the desired font, size, and type style.

If you want to include text in a different font, type size, or style than the icons, first use this technique to change the entire header or footer to the type style you want for the page number, date, or time. Then make the desired changes to the text.

### **Using Version 4.5 on a One-Drive System**

#### **Keep your document and MacWrite on the same disk.**

With MacWrite Version 2.2, you can keep your documents on one disk and the MacWrite application on another disk, even when working on a one-drive system. When you want to edit a document, load it into memory, eject the data disk, and keep the MacWrite disk in the drive. As you edit your document, changes are stored in memory. When you're finished, you just reinsert the data disk and save your revised document.

But remember that MacWrite version 4.5 is *disk based*, which means that both the application and the disk file that holds your document are continually being accessed. If you have your documents on one disk and the MacWrite application on another disk, you'll be constantly swapping disks. Therefore, you should keep the document you're working on and the application on the same disk.

Also keep in mind that this will limit the potential size of your document. The actual amount of space available will depend on the number of fonts and desk accessories on your disk.

### **Helpful Hints**

#### **Here are several suggestions to make using MacWrite easier and more productive.**

##### **Copy and Paste; don't Cut and Paste.**

As you move text either between documents or within a document, always copy the text as the first step instead of cutting it. You can easily go back and delete the original text once the move has been completed, and you will greatly decrease the risk of losing the text completely.

##### **Mark your location with a special character to facilitate returning there.**

Frequently, when you work on a long document, you need to jump away from where you are currently working. An easy way to return to exactly where you left off is to use a rare or

unique character to mark the location (for example, @, ®, †, or &). When you want to return to that location, just use the **Find** command in the **Search** menu to find the unique character.

### **Confirm all Search and Replace commands.**

One of the options in the window that opens when you choose **Change** from the **Search** menu is **Change All**. This can be a dangerous command, especially if you are searching for partial words. For example, if you want to replace all instances of "man" with "person," the word "manipulate" will become "personipulate." To avoid this problem, confirm every successful search by choosing either **Change then Find** or **Find Next** from the Change window.

### **Split large documents into smaller ones.**

If you are working on a very large document (longer than 40 pages) MacWrite will start to slow down and it will become harder to write or edit your document. To keep MacWrite operating at its peak speed, break large documents into smaller documents.

When you finish, you can either use **Copy** and **Paste** to put the parts together again, or use the **Set Page #** command (Version 4.5 only) to start each section with the appropriate page number.

---

## Questions and Answers

### Overview

**Here are the questions most commonly asked by MacWrite users, and the correct answers.**

You should now know how to use MacWrite, as well as many of the techniques that most users take months to discover. But as a support person, you'll also be called upon to answer questions about the program. This section is a summary of the most commonly asked questions about using MacWrite.

This material does not go into great technical detail. It only explains what most users will need to know in order to use MacWrite.

### Large Documents on Macintosh XL

*I'm working on a very large document on the Macintosh XL (more than 50 pages) and MacWrite is functioning very slowly. It's easy to get ahead of the screen while I'm typing. How can I speed it up?*

- Create and edit the document on a disk and then save it or back it up onto the hard disk.
- Even when there's plenty of disk space, removing as many documents from the hard disk as possible seems to speed up MacWrite.
- Using a lot of rulers in MacWrite will slow it down. So, add the rulers after entering all of the text.
- Split the document into several smaller documents.

### Document Size

*How can I tell how large my document is?*

If you're in the Finder, use the View menu to display the contents of your disk by name or size. Included in the listing is the approximate size of your document.

If the document is open, choose About MacWrite from the Apple menu. The window that appears (shown on the next page) will include the size of your document (in this case, 11K). Notice that the version number (4.5) is also mentioned in this window.

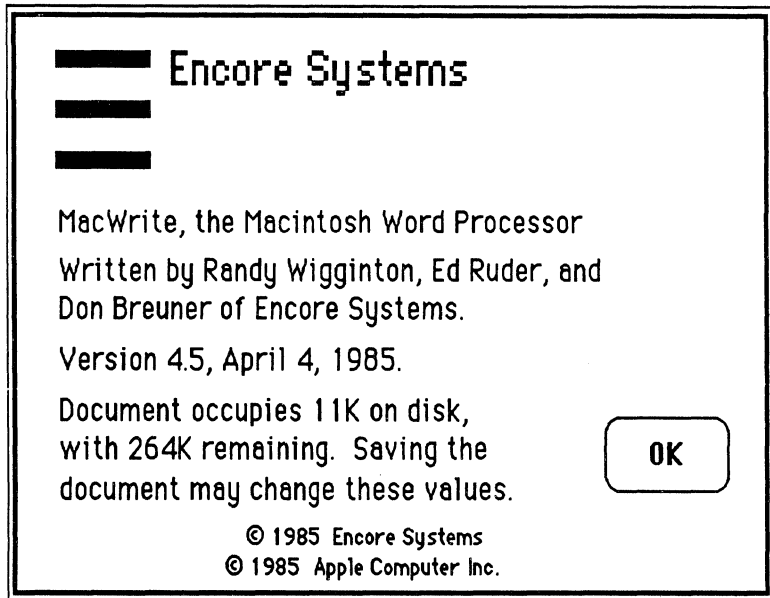

Note: This is not necessarily the same for all applications. It depends on what the software developers chose to put in the "About..." window.

There may be a small discrepancy between the size displayed in the Finder and in the "About..." window because of the way the Finder allocates space on the disk.

## Disk Full

*When I use an ImageWriter, especially when I'm printing a long document, I often get a message saying that my disk is full and my document can't be printed. How can I print my document?*

Here are several solutions. Try the one that seems most appropriate for your situation.

- Print only selected pages.
- Move the document onto a data disk and then remove it from the startup disk. Then print it from the data disk.
- Close the document and remove as much as possible from the startup disk—all you need are the System and Finder files, the ImageWriter driver, and MacWrite itself. Remove documents, fonts, and desk accessories, if necessary. You need free room on the startup disk greater than the size of the document that you are trying to print. (See the *Managing Macintosh Files* module for more information about creating additional room on your disk.)

- On a two-drive system, copy the application file to a data disk to allow more room for the print file on the startup disk.
- Copy part of the document and paste it into a new document. Print each new document, one at a time.
- Print the document from a hard disk.

### Can't Save Document

*When I try to save my document, I get a message telling me the disk is full. How can I save the document?*

MacWrite Version 2.2 is a memory-based application. That is, your document resides entirely in memory as you are working on it. Therefore, it's possible to create a document larger than what you have room to save on your disk. If you get a "Disk Full" message, there are too many other documents on the disk to which you are trying to save the document.

Save the document to a blank disk. To do this:

1. Choose **Save As**.
2. Click **Eject**.
3. Insert a blank disk.
4. Click **Save**.

This situation won't happen with MacWrite Version 4.5 because your data is constantly updated on the disk. If your document gets too large, you will get a message saying that there is no more room on the disk. You will *not* lose any information or get into the situation described above. (This is a good reason to upgrade to Version 4.5.)

### Can't Open Document

*I can't open the icon for a document I already created and saved. How can I recover the document?*

- Try a later version of MacWrite (a document created with Version 4.5 can't be opened with Version 2.2).
- Copy the document onto a blank data disk.
- See the *Fundamentals of the Macintosh Operating System* module for more information about recovering lost documents.

## Text-Only Documents



Text Only

*When I first save a document, one of the options in the Save window is **Text Only**. What is this option for?*

The **Text Only** option saves your document as an ASCII text file, without any of the normal MacWrite formatting information and without graphics. Use this command if you are going to send the document to another computer via MacTerminal (see the *Using MacTerminal* module) or if you want to move the document into another application that doesn't support the MacWrite format (for example, a programming language). Saving a document as a text-only file will not affect the original MacWrite document. You'll end up with two documents: the original and the text-only document.

Documents received via MacTerminal or AppleLink™ will initially be text-only documents. If you want to open a text-only document that was not originally created in MacWrite, open MacWrite, close the Untitled document, and choose **Open** from the **File** menu. All text-only documents will be included in the Document Directory. Upon opening a text-only file, a MacWrite document will be created and you will end up with two documents: a text-only document and a MacWrite document.

*When I open a text-only document, I get this message: "Should carriage returns signify a new paragraph or a line break?" How should I respond?*

MacWrite has word-wrap capability. So, if the application that originally created the document put carriage returns at the end of every line, you want to ignore them because MacWrite will take care of wrapping the text to the next line. Therefore, choose for a carriage return to signify **Line Breaks**. MacWrite will then ignore single carriage returns, and keep one if it sees two returns in a row, which signify the end of a paragraph.

If the application that originally created the document had automatic word wrapping (MacTerminal, MacWrite, AppleLink), carriage returns will only have been inserted at the end of paragraphs. Therefore, you want to keep all the carriage returns, so choose **Paragraphs**.



## Lost Formatting

*I have a blank line between two paragraphs that have different formats. When I select the blank line and delete it, I lose the formatting of the second paragraph. What happened?*

Rulers are stored with the return character at the end of the line preceding the first paragraph of the new format. (Remember that the first paragraph may be a blank line.) If you select the whole line and delete it (either by pressing Backspace or by choosing Cut), you are deleting the ruler, too.

However, you can't delete a ruler by backspacing over it. If you try to backspace over a ruler, the Backspace key will simply have no effect. So, to delete that blank line, backspace over it instead of selecting it and deleting it.

## Text Disappears

*Periodically, some text disappears while I'm editing my document. Why?*

When text is selected (highlighted), pressing any key replaces the selected text with what you type. When text disappears, it is probably because you selected some text and then accidentally touched the keyboard.

**Choose Undo Typing** from the **Edit** menu *before clicking the mouse button* to recover your lost text.

## Tall vs. Tall Adjusted

*What's the difference between choosing Tall and Tall Adjusted from the Page Setup window?*

Use the **Tall** option to print the majority of your MacWrite documents. The **Tall Adjusted** option is for printing graphics whose relative spacing and proportions are critical. The net result is that **Tall Adjusted** widens the graphics by about 12 percent. The graphics still look OK when using **Tall**. And text still looks OK when using **Tall Adjusted**, although it's a bit wide.

The **Tall** and **Tall Adjusted** options are only available when you're using a LaserWriter printer.

## Reduced Printing

*What is the **Reduction** option in the Page Setup window for?*

If you are printing to an ImageWriter, and you click on **50% Reduction**, the document will shrink by that amount *both* horizontally and vertically. Therefore, it will be printed at a quarter of its original size.

If you are printing to a LaserWriter, you can enter any percentage of reduction from 25 percent (document will be printed as 25 percent of its original size in each dimension) to 400 percent (four times the original size in each dimension).

With MacWrite, though, if you try to print a document larger than the original (greater than 100 percent) nothing to the right of the original page will print, because MacWrite can't print anything wider than one page. (See the *Using the LaserWriter* module from the Apple Support Training Library for more information regarding printing with the LaserWriter.)

## Wide Carriage ImageWriter

*Why do I get garbage when I print my MacWrite Version 2.2 document on a wide carriage ImageWriter?*

Be sure you have the correct printer resource on your startup disk. The file you need is called ImageWriter 15 and is usually in the System Folder. If you have the ImageWriter 15 resource, you can print to either ImageWriter. The original ImageWriter resource can only print to the standard ImageWriter.

You can find the ImageWriter 15 file on the MacWrite Version 4.5 and MacProject application disks. Also, when you use the LaserWriter Installation disk, it will put the ImageWriter 15 file on your startup disk. (See the *Using the LaserWriter* module for information about using the Installation disk.)

## Letter-Quality Printing

*How do I print to a daisy wheel printer?*

Use the Mac Daisywheel Connection program available from Assimilation Process. This is an application that reads Macintosh documents and converts them into the appropriate format for a large variety of letter-quality printers. Contact Assimilation, Inc. in Los Gatos, California.

## Spelling Checkers

*Does a spelling checker actually do anything to my document, and does it add size limitations?*

There are several spelling checkers available for the Macintosh, which are listed below. Contact the appropriate vendors for specific information about the characteristics of their programs.

<u>Product Name</u>	<u>Developer</u>
Hayden-Speller	Hayden Software Co., Lowell, Mass.
MacSpell+	Creighton Development, Irvine, Calif.
Mac Spell Right	Assimilation, Inc., Los Gatos, Calif.

## Outlined Type Sizes

*Why are some type sizes in the Style menu in outlined text and others in regular text?*

Type sizes that appear in outlined text have actual font files associated with them; they are the sizes that will look best on the screen and when printed. The sizes that are in regular type are interpolated from the existing font files; they don't look as good on the screen or when printed.

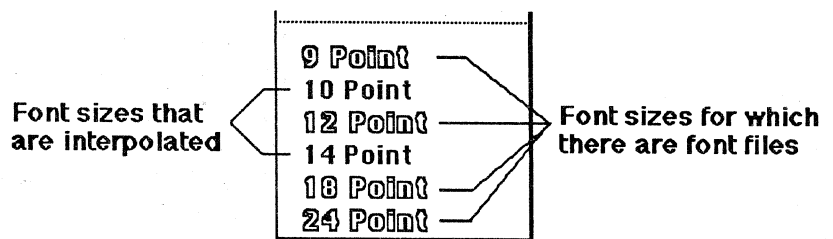

## Temporary Files when Using the Switcher

*I am running MacWrite and the Finder under the Switcher™. When I switch into the Finder, I notice three new files in the System folder: "Undo File," "New File," and "Scrap File." What are these files for?*

These are temporary files created by MacWrite. They will not be visible upon quitting the Switcher.

The Undo File enables you to use the Undo/Redo commands to reverse many of your actions. The New File is your working file and contains all of the changes you have made to your document. This makes it possible to not save your changes upon closing a document.

The Scrap File is used for copying and pasting information within the MacWrite document. It doesn't alter font and type style information, which is reformatted when the information is placed on the Clipboard, so pasting information back into MacWrite is faster.

If you suffer a system crash or if you abnormally exit the Switcher, you may also see these files upon restarting your Macintosh. Throw them away and empty the Trash before you run MacWrite again. You can't use the New File to recover your unsaved changes.

## Six Lines per Inch

*What is the effect of clicking 6 lines/inch on a MacWrite ruler? (This is a new feature in Version 4.5.)*

The **6 lines/inch** option is an alternative to the three line-spacing options in the ruler. Regardless of font or size, there will be six lines of text per inch, both on the screen and when you print it. (As a point of comparison, 12-point, single-spaced, Geneva has about 5 lines per inch.)

The **6 lines/inch** option is useful for printing on standard printed forms and labels, or for designing forms that are consistent with those proportions. You can still use single- (6 printed lines/inch), space-and-a-half (4 printed lines/inch), or double-spacing (3 printed lines/inch).

Some fonts may appear slightly chopped off, especially if you single-space large type sizes, superscripts, or subscripts. However, the problem often disappears when you print the document.

## Converting Documents

*How do I convert my MacWrite Version 2.2 documents to MacWrite 4.5, and what are the consequences?*

1. Make a backup of your disk, just in case something goes wrong.
2. If your documents are on a startup disk that includes MacWrite Version 2.2, throw away the System folder and MacWrite Version 2.2.
3. Start up from a MacWrite Version 4.5 disk.
4. Open the document to be converted. You'll get a message saying that the document is being converted, and that it will open as an Untitled document.
5. Save the document and give it a new name. You'll now have both the original Version 2.2 document, and the new, Version 4.5 document.
6. Throw away the old version (if you don't plan to use it ever again).

Once a document has been converted, you will not be able to open it again with MacWrite Version 2.2.

---

## MacWrite Specifications

### Overview

**This section covers MacWrite's capabilities and limitations.**

In addition to the questions addressed in the last section, you will receive many questions regarding the capabilities or limitations of MacWrite. For example, how many pages can it handle? and, how wide are the margins? This section will enable you to answer such questions.

**There are two versions of MacWrite.**

MacWrite Version 2.2 is memory based, which means that your entire document resides in memory while you are working on it. Therefore, the size of your document is limited by the amount of available memory.

MacWrite Version 4.5, released in Spring 1985, is disk based, which means that your document resides on the disk while you are working on it. Therefore, the size of your document is limited by the amount of space available on the disk and not by available memory.

Except where noted, the specifications shown here are the same for both versions of MacWrite.

### Maximum Document Size MacWrite Version 2.2

**On a Macintosh 128K, 20 double-spaced pages.**

With MacWrite Version 2.2, the maximum size of a document is based on how much information fits in memory. On a Macintosh 128K, it is greater than 27,000 characters, or approximately 5,000 words. That equals about 10 single-spaced pages, using a 12-point font.

**On Macintosh 512K, 80 double-spaced pages.**

With MacWrite Version 2.2, the maximum size of a document that can be created on a Macintosh 512K is approximately 20,000 words, or 40 single-spaced pages.

**Capacity depends on fonts and graphics.**

The more fonts, type styles, and graphics there are in your document, the fewer pages there are available.

## Maximum Document Size MacWrite Version 4.5

**The size of a document depends on the amount of disk space, not memory.**

The total size of a document is determined by three things:

- Total number of return characters. (You can have up to 500 carriage returns per document on a Macintosh 128K, and up to 2,047 carriage returns per document on a Macintosh 512K.)
- The amount of disk space available.
- Maximum of 250 pages per document.

## Page Sizes

**You can print in either landscape or portrait orientation on 8-1/2x11-inch or 8-1/2x14-inch.**

If you choose to print in landscape mode, the maximum right margin is still 8 inches.

### Number of lines of text per page.

All these figures are based on 12-point, single-spaced text, and they include space taken by headers and footers.

- ImageWriter fonts: 45 lines/page.
- Helvetica: 52 lines/page.
- Times: 60 lines/page.

## Margins

**Here are the limits for your margins.**

- Minimum left margin: 1 inch
- Maximum right margin: 8 inches (regardless of paper size or orientation)
- Margins cannot be within 2 inches of each other
- Margins cannot be within 3/16 of an inch of a tab

### Ruler Specifications.

- Minimum space between Tabs: 3/16 of an inch
- Smallest visible increment: 1/8 of an inch
- Smallest actual increment: 1/16 of an inch
- Maximum number of Tabs per ruler: 10

## Visible Area

### How much of a document can you see at a time?

- Macintosh 128K or Macintosh 512K: 6-1/8 inches
- Macintosh XL: 7-1/4 inches
- Minimum size of a window: 2-1/4 inches

## Headers and Footers

### Headers and footers can each have up to six paragraphs of text and graphics.

Headers and footers can have up to just over 3 inches of information in them, or about one third of a page. This is also the maximum size of the header and footer windows, and since you can't scroll through them, it's quite clear when your header or footer is too large.

If your header or footer becomes too large, you will get a message to that effect when you close the header or footer window or click in the main document window.

You can also have graphics in your header or footer. Each drawing counts as one paragraph and can be as large as the entire header or footer.

In MacWrite Version 2.2, if you use draft mode to print a document that has more than three lines of text in the header or footer, a dialog box appears after each header or footer of your document is printed. The dialog box states: "The printer is not responding—check the printer switches, cables, etc.,—click OK to continue or CANCEL to quit." The printer continues printing and the buttons in the dialog box have no effect.

## Number of Different Fonts

### There's no limit on the number of fonts and type styles you can have in a single document.

However, there is a limit to the number of fonts that will fit in the **Font** menu. On a Macintosh 128K or Macintosh 512K, the names of only 20 fonts can be seen in the menu. If you have more fonts than that, some will run off the bottom of the screen and will not be selectable. On a Macintosh XL, you can have up to 22 fonts in the **Font** menu. (See the *Supporting the Font/DA Mover* module from the Apple Support Training Library for more information about adding and removing fonts.)

## New Features in Version 4.5

### Here is a summary of the new features of MacWrite Version 4.5.

- Disk-based (Version 2.2 is memory-based)
- Can handle larger documents
- **Find Next** command in **Search** menu
- **Goto Page #** command in **Search** menu
- **Set Page #** command in **Format** menu
- Alignment commands in **Format** menu
- Page numbers displayed in scroll box
- 6 lines/inch option in rulers
- Reduced printing



---

## **Review**

### **MacWrite Benefits**

**Here are the key benefits of MacWrite to help with basic product comparisons.**

- Enhance a document's impact.
- Include information from other applications.
- View your document as it will print.
- Consistent user interface.
- High-quality output.

### **How to Use MacWrite**

**Use existing MacWrite training materials to learn how to use the application.**

### **Advanced Techniques**

**These will help you become more productive with MacWrite more quickly.**

Refer back to them and distribute them to others so they, too, can become more efficient MacWrite users.

### **Common Questions and Solutions**

**These are the questions you can expect to get from users of MacWrite.**

Explanations and solutions are included so you can quickly help users with their problems. Refer back to this section for the answers to commonly asked questions.

### **MacWrite Specifications**

**This section covers MacWrite's capabilities and limitations.**

A lot of questions are asked regarding the limits of MacWrite. This section contains the answers.

## Resources

---

- *MacWrite*, the owner's manual, Apple Computer, Inc.
- AppleLink (If you have access to AppleLink, check it regularly for additional information about MacWrite.)
- MacWrite application training course, Apple Computer, Inc.
- Macintosh publications (Read the July/August, 1984 issue of *Macworld* and other Macintosh publications such as *MACazine*, *Macintosh Connection*, and *A+* for additional MacWrite hints and techniques.)

*Apple and the Apple logo are registered trademarks of Apple Computer, Inc. AppleLink, ImageWriter, LaserWriter, MacDraw, MacPaint, MacProject, MacTerminal, MacWrite, and Switcher are trademarks of Apple Computer, Inc. Macintosh is a trademark of McIntosh Laboratory, Inc. and is being used with express permission of its owner. Mac Daisywheel Connection and MacSpell Right are trademarks of Assimilation, Inc. MacSpell+ is a trademark of Creighton Development, Inc. Hayden:Speller is a trademark of Hayden Software Company, Inc.*



# Using MacTerminal

---

## Contents

- 2 Overview
- 3 Objectives, Materials
- 4 About MacTerminal
  - A basic explanation of MacTerminal's capabilities.*
- 10 MacTerminal Menu Commands
  - Learn the function of every MacTerminal menu command.*
- 11 Terminal Settings
  - Terminal settings for communicating with other computers and public data bases.*
- 21 Connecting to Other Computers
  - Basic rules to follow when connecting to any computer.*
- 27 Transferring Files
  - How to send and receive fully formatted Macintosh files, and how they differ from text files.*
- 39 Connecting to Another Macintosh
  - Connect two Macintosh computers, and use MacTerminal to communicate between them.*
- 48 Integrating MacTerminal with Other Applications
  - How to move information between MacTerminal and other Macintosh applications.*
- 57 Connecting to an Apple II
  - Settings and considerations for communicating between a Macintosh and an Apple II.*
- 59 Connecting to a Public Information Service
  - Learn how to connect to the many public information services and data bases that are available.*
- 63 Review
- 66 Resources

---

## Overview

Data communications is one of the most popular personal computer applications today, especially in the office environment. MacTerminal™ is the data communications application available from Apple for the Macintosh™ computer and is a vital link in the data communications chain.

This module covers the capabilities of MacTerminal and how to use the application to communicate with other computers. You'll have an opportunity to connect two Macintosh computers and use MacTerminal to transfer information between them, including moving MacWrite™ and Microsoft Excel information. You will also learn how to connect a Macintosh to an Apple® II computer and to a public information service.

Anyone who will be using MacTerminal should complete everything up to and including the Connecting a Macintosh to an Apple II section. Anyone who is supporting other users of MacTerminal should complete the entire module.

### Prerequisites

- Ability to use a Macintosh, which includes using the mouse and menus, opening and closing documents, and entering text. This can be learned by completing the *Learn to Use Macintosh* module or the Guided Tour of Macintosh, or by reading Chapters 1 and 2 of *Macintosh*, the owner's manual.
- Knowledge of data communications terminology, which is covered in the *Data Communications Terms* module and in the *Data Communications Primer* in the *Apple Support Programs* binder.

Data communications terminology is also covered in John Stanley's Basic Data Communications course on Apple products, which is available from:

John Stanley Training Programs  
208 Charter Oaks Circle  
Los Gatos, CA 95030  
(408) 374-1235

---

## Objectives

- List the MacTerminal settings for communicating with the following:
  - Another Macintosh
  - An Apple II
  - A public information service
- Be able to describe the function of every MacTerminal menu command.
- Use the appropriate cable to connect two Macintosh computers, correctly configure MacTerminal, and transfer information—including a Macintosh disk file— between the two computers.
- Be able to answer commonly asked questions about MacTerminal.

---

## Materials

### To complete this module, you will need:

- Two Macintosh computers (128K, 512K, or XL)
- Macintosh-to-Macintosh cable or Macintosh-to-Macintosh XL cable
- *MacTerminal*, the owner's manual.
- Two MacTerminal application disks
- One MacWrite application disk

### If available, the following are recommended:

- External disk drives for both Macintosh computers
- Access to a public information service such as The Source or CompuServe
- Excel Program Disk

---

## About MacTerminal

### Overview

#### **MacTerminal is the data communications program for Macintosh.**

Every computer needs special software in order to communicate electronically with other computers. This special software is called data communications software, and MacTerminal is Apple's data communications program for the Macintosh.

This section describes the capabilities of MacTerminal and the main uses of data communications software. Later in the module, you'll learn how to use MacTerminal to actually implement each of the capabilities described.

### Data Communications and Networking

#### **Here are the definitions of terms used in this module.**

The terms *data communications* and *networking* are defined many different ways, depending on who you are talking to and the environment you're working in. These are the definitions that will be used for the duration of this module.

- *Data communications* is a *temporary* connection between two computers for the purpose of transferring information between them. Once the information has been transferred, the communications link is severed.
- *Networking* is a *permanent* wiring-together of many computers, partly for the purpose of exchanging information, and also to share high-performance (and expensive) accessory products such as high-speed printers and large-capacity disk drives.

If you want more information on Apple's networking solutions, read the *Using the LaserWriter* module from the Apple Support Training Library.

### MacTerminal's Capabilities

#### **MacTerminal enables communication between computers.**

MacTerminal enables the exchange of information between computers, either via a direct connection or through a modem.

## **MacTerminal can send complete Macintosh files.**

You can use MacTerminal to send any Macintosh file to another Macintosh, either directly or via a mainframe. A *file* is any Macintosh document or code file, such as a MacProject™ document, or the MacProject application itself.

## **MacTerminal runs on the desktop with other Macintosh applications.**

MacTerminal is fully integrated with other Macintosh applications, so you can copy information from other applications and paste it into MacTerminal—and vice versa.

## **Three Main Uses of Data Communications Software**

### **1. Communicate with mainframes.**

The mainframe with which you want to communicate can be your in-house business computer, or one located across the country—and it can be made by any of a variety of manufacturers. MacTerminal can emulate TTY, DEC VT100, and DEC VT52 terminals. It can also be used in conjunction with a protocol converter such as AppleLine™ or the Apple Cluster Controller to emulate an IBM 3278 Model 2 terminal. (Note: The Apple Cluster Controller is available only in the United States.)

Though MacTerminal can't emulate *every* specialized terminal, it *can* communicate with many different kinds of host computers by using asynchronous ASCII communications protocols.

### **2. Access information services and public data bases.**

MacTerminal can be used with a modem to access a large variety of information services and public data bases, including the Dow Jones News/Retrieval, The Source, and CompuServe.

### **3. Exchange information with other microcomputers.**

MacTerminal can be used to communicate, either directly or via a modem, with another microcomputer that's also running data communications software.



## What Are Some Actual Applications?

### MacTerminal can be used to:

- Download data from a mainframe and paste it into another Macintosh application.
- Access a mainframe-based electronic-mail network or bulletin board.
- Upload Macintosh text documents to a mainframe-based typesetter.
- Send Macintosh documents across the country in minutes (instead of the days it would take via the regular mail).
- Share information between different kinds of computers.

This module and the *Using MacTerminal with IBM Computers* module will describe the specific solutions for many of the applications described above.

## Two Versions of MacTerminal

### There's a new version of MacTerminal and an update to the manual.

MacTerminal Version 2.0 was released in fall 1985. The new version:

- Provides new file transfer options.
- Supports the 25th line (status line) on AppleLine.
- Unilaterally filters the file transfer character (Control-\) from text-file transfers and from keyboard actions when in IBM 3278/AppleLine mode.
- Optimizes use of memory in Macintosh 512K.
- Supports new products, including new ROMs and double-sided disk drives.
- Includes an option to scroll information off the screen, instead of erasing it, when a Clear Screen command is received.
- Provides an expanded international character set.
- Fixes several problems in Version 1.1, including not being able to use the **Wait for Call** command.

A new manual (p/n 030-1179-A) was released with MacTerminal Version 1.1 starting in June 1985. The main difference between it and the previous manual is new information on the addition of international character sets to the Character Set Settings.

The documentation for MacTerminal Version 2.0 consists of the new manual plus an update. In other words, there's no new manual specifically for Version 2.0. If you need the

update, contact your Apple support representative. The new features of Version 2.0 are also described in the Specifications section of the *Supporting MacTerminal* module from the Apple Support Training Library.

If you don't have the new manual and/or the new software, what you read in your manual and what you see on your screen may be slightly different from what you read in this module. You are encouraged to upgrade to Version 2.0 of the software, and to buy the new version of the manual. However, you *can* complete this module with the original manual and software.

## MacTerminal Window

### **Everything you type appears in the window.**

There are two ways to receive information using MacTerminal: (1) You can receive complete files, which will be represented as icons, and whose contents won't be entered into your MacTerminal document but *will* be saved on your disk (see the Transferring Files section of this module for more information); and (2), you can receive text right into your MacTerminal document.

Once information appears in the MacTerminal window, it's there to stay. Unlike other Macintosh applications, you can't cut anything out of a MacTerminal document—you can only copy information to be pasted elsewhere.

Everything you type or paste, and anything you receive into the MacTerminal window, appears at the end of the current contents of the document. You can't add text in the middle of what you already have, because the content of the MacTerminal window is actually a record of your communications session, and any additional data transfer would naturally occur *after* everything that has already transpired.

Like all Macintosh applications, if there's more information in your document than will fit on the screen, you can scroll through the entire contents of the document. Because of this, you can receive large amounts of information very quickly, and then later scroll through it to read it at a leisurely pace.

When you save the document, everything that has appeared in the window will be saved. The next time you open the document, it will be just as you left it, and information entered or received will be added to the end of what's already there.

### **Three ways to erase information.**

There are three ways to erase information that's been entered or received into a MacTerminal document:

- Close the document without saving the changes. Everything that has been added since the document was opened or last saved will be erased.
- Choose **Clear Lines Off Top** from the **Commands** menu. This will erase everything except the last 23 lines of information in the document (the capacity of one full-size window).
- Choose **Don't Record Lines Off Top** from the **Commands** menu. This will erase everything that scrolls off the top of the screen.

### **Erasing the entire contents of a document.**

If you want to erase the current contents of a document:

1. Choose **Clear Lines Off Top**.
2. Change the Line Width to **132 Characters**.
3. Change the Line Width back to **80 Characters**.

Another way to create an empty MacTerminal document is to open a new document (see below) and then configure it as you did the original.

## **MacTerminal Disk**

**The MacTerminal disk provides the application and several preconfigured documents.**

In addition to startup information, the MacTerminal disk contains the application plus six preconfigured documents. Each is an empty document that is set up to communicate with or through a particular system or device.



If you open the MacTerminal application icon, shown at left, you'll get an untitled document that you'll need to configure for the system with which you're going to establish a connection.

Use the preconfigured documents as *templates*. If you open one of them, you should either *not* save your changes when you close it, or else choose **Save as** to save the document under a different name. Or, you can make a duplicate of the template before you begin. Then, any time you want to use template, it won't be cluttered with remnants of previous data communications sessions. You can also create your own templates for other systems with which you regularly communicate.

In the MacTerminal Setting section of this module, always open the MacTerminal application icon instead of one of the templates. This will help to ensure that you understand each of the configurations taught in that section. Then, later on, you can use the templates to save time that would otherwise be spent configuring the document.

---

## MacTerminal Menu Commands

### Overview

**In this section, you will learn about all of the MacTerminal menu commands.**

MacTerminal has a wide range of features that you should learn about and be able to implement as needed. Learning the function of each of the menu commands will tell you a lot about MacTerminal's wide range of capabilities. It's also the first step toward actually learning how to use MacTerminal.

In the next section, you'll have a chance to put some of the commands to use.

### Menu Commands

**The function of each menu command is explained in the manual.**

This and other sections of this module refer you to *MacTerminal*, the owner's manual. Take the time to read the manual, not only to learn the information, but also to become familiar with it as a valuable reference tool.

Read Chapter 3 of the MacTerminal manual. It explains the function of every menu command, grouped by menu.

Continue with this module when you have finished reading Chapter 3.

---

## Terminal Settings

### Overview

**This section describes terminal settings for the most common uses of MacTerminal.**

MacTerminal has the flexibility to communicate with a wide range of computers, each of which expects to receive information in a particular format. Before you can correctly configure MacTerminal to communicate with a specific mainframe, microcomputer, or public information service, you need to know the correct terminal and compatibility settings.

This section describes the settings that are appropriate for the computers with which you'll be communicating most frequently. The configurations discussed will enable you to connect to:

- A Macintosh (128K, 512K, or XL)
- An Apple IIe or Apple IIc
- Most public information services

A practice exercise is provided at the end of the section to ensure that you know how to configure MacTerminal in each of these situations.

### Terminal Settings

**The various terminal settings are explained in the manual.**

The **Settings** menu contains the commands used for configuring MacTerminal to communicate with a particular computer.

A detailed explanation of each of the settings is included in *MacTerminal*, the owner's manual. It explains all of the options for configuring your Macintosh as a terminal and for sending and receiving information. (You should already have read about the **Settings** menu in Chapter 3 of the MacTerminal manual.)

**To Connect to Another Macintosh**

**The manual explains the terminal settings used for connecting to another Macintosh.**

When you want to connect two Macintosh computers, configure them identically. This will enable both systems to send and receive information. If you want to connect to a Macintosh XL that's running LisaTerminal™, configure MacTerminal in exactly the same way as you would to connect to another Macintosh running MacTerminal.

Read the Communicating With Another Macintosh section in Chapter 2 of *MacTerminal*, the owner's manual, to learn how to configure MacTerminal to communicate with another Macintosh. Continue with this module when you have finished reading the manual.

**To Connect to an Apple II**

**Configure MacTerminal as you would to communicate with another Macintosh.**



Access II (on either the Apple IIc or Apple IIe) and MacTerminal have very similar capabilities and features. Configure both programs in the same way as you configured MacTerminal to communicate with another Macintosh.

**To Connect to Public Data Bases**

**Use the asynchronous ASCII protocol to access a public information service.**

When you create a new MacTerminal document, it's preset to communicate with most public information services, though, depending on the modem you're using, you may have to change the baud rate. The next two screen shots show the terminal settings and compatibility settings of a MacTerminal document configured to communicate with a public information service through an Apple Modem 1200.

Terminal Settings			
Terminal	<input checked="" type="radio"/> UT100	<input type="radio"/> TTY	<input type="radio"/> IBM 3278
Mode	<input checked="" type="radio"/> ANSI		<input type="radio"/> VT52
Cursor Shape	<input checked="" type="radio"/> Underline		<input type="radio"/> Block
Character Set	<input checked="" type="radio"/> United States		<input type="radio"/> United Kingdom
Line Width	<input checked="" type="radio"/> 80 Columns		<input type="radio"/> 132 Columns
Protocol Conv	<input type="radio"/> AppleLine		<input type="radio"/> Cluster Ctrl
<input checked="" type="checkbox"/> On Line	<input type="checkbox"/> Local Echo		<input type="checkbox"/> Status Lights
<input checked="" type="checkbox"/> Auto Repeat	<input type="checkbox"/> Auto Wraparound		<input type="checkbox"/> New Line
<input type="checkbox"/> Repeat Ctrls	<input type="checkbox"/> Transparent	<input type="button" value="OK"/>	<input type="button" value="Cancel"/>

Compatibility Settings	
Baud Rate	<input type="radio"/> 50 <input type="radio"/> 75 <input type="radio"/> 110 <input type="radio"/> 134.5 <input type="radio"/> 150 <input type="radio"/> 200 <input type="radio"/> 300 <input type="radio"/> 600 <input checked="" type="radio"/> 1200 <input type="radio"/> 1800 <input type="radio"/> 2000 <input type="radio"/> 2400 <input type="radio"/> 3600 <input type="radio"/> 4800 <input type="radio"/> 9600 <input type="radio"/> 19200
Bits per Character	<input type="radio"/> 7 Bits <input checked="" type="radio"/> 8 Bits
Parity	<input type="radio"/> Even <input type="radio"/> Odd <input checked="" type="radio"/> None
Handshake	<input type="radio"/> HOn/HOff <input checked="" type="radio"/> None
Connection	<input checked="" type="radio"/> Modem <input type="radio"/> Another Computer
Connection Port	<input checked="" type="radio"/>  <input type="radio"/> 
<input type="button" value="OK"/> <input type="button" value="Cancel"/>	

### Why certain settings were chosen—and why others may be changed.

Why choose **VT100** rather than **TTY**? **TTY** (teletype) ignores many commands from the remote computer that **VT100** can respond to. **TTY** responds only to returns, tabs, backspaces, and line feeds; it ignores control characters and escape sequences.

Why choose **ANSI** (American National Standards Institute) rather than **VT52**? **VT52** provides a set of cursor-control functions that isn't normally available. Use **VT52** if the computer you are communicating with supports it; use **ANSI** whenever **VT52** isn't available.

The **Cursor Shape** and **Line Width** settings are a matter of personal preference.

Change the **Baud Rate** setting to **300** if you're using a 300-baud modem.

The **Handshake** setting is **None** because **XOn/XOff** isn't needed when the baud rate is 1200 or lower.



---

## ***Practice***

### **Mark Appropriate Settings**

### **Configure MacTerminal to communicate with the computer indicated.**



On the facing page are four pairs of screen shots, each consisting of a Terminal Settings window and a Compatibility Settings window. Mark the appropriate settings for each data communications situation. If it would be helpful, refer to the manual or to any portion of this module.

When you have finished, check your answer against the Feedback section that follows this exercise.

## Another Macintosh

Configure MacTerminal to connect directly to another Macintosh (not through a modem).



Terminal Settings	
Terminal	<input type="radio"/> UT100 <input type="radio"/> TTY <input type="radio"/> IBM 3278
Mode	<input type="radio"/> ANSI <input type="radio"/> VT52
Cursor Shape	<input type="radio"/> Underline <input type="radio"/> Block
Character Set	<input type="radio"/> United States <input type="radio"/> United Kingdom
Line Width	<input type="radio"/> 80 Columns <input type="radio"/> 132 Columns
Protocol Conv	<input type="radio"/> AppleLine <input type="radio"/> Cluster Ctr
<input type="checkbox"/> On Line	<input type="checkbox"/> Local Echo <input type="checkbox"/> Status Lights
<input type="checkbox"/> Auto Repeat	<input type="checkbox"/> Auto Wraparound <input type="checkbox"/> New Line
<input type="checkbox"/> Repeat Ctrls	<input type="checkbox"/> Transparent
<input type="button" value="OK"/> <input type="button" value="Cancel"/>	

Compatibility Settings	
Baud Rate	<input type="radio"/> 50 <input type="radio"/> 75 <input type="radio"/> 110 <input type="radio"/> 134.5 <input type="radio"/> 150 <input type="radio"/> 200 <input type="radio"/> 300 <input type="radio"/> 600 <input type="radio"/> 1200 <input type="radio"/> 1800 <input type="radio"/> 2000 <input type="radio"/> 2400 <input type="radio"/> 3600 <input type="radio"/> 4800 <input type="radio"/> 9600 <input type="radio"/> 19200
Bits per Character	<input type="radio"/> 7 Bits <input type="radio"/> 8 Bits
Parity	<input type="radio"/> Even <input type="radio"/> Odd <input type="radio"/> None
Handshake	<input type="radio"/> XOn/XOff <input type="radio"/> None
Connection	<input type="radio"/> Modem <input type="radio"/> Another Computer
Connection Port	<input type="radio"/>  <input type="radio"/> 
<input type="button" value="OK"/> <input type="button" value="Cancel"/>	

## Public Data Bases

Configure MacTerminal to communicate via a modem with a public data base or information service.

Terminal Settings	
Terminal	<input type="radio"/> UT100 <input type="radio"/> TTY <input type="radio"/> IBM 3278
Mode	<input type="radio"/> ANSI <input type="radio"/> VT52
Cursor Shape	<input type="radio"/> Underline <input type="radio"/> Block
Character Set	<input type="radio"/> United States <input type="radio"/> United Kingdom
Line Width	<input type="radio"/> 80 Columns <input type="radio"/> 132 Columns
Protocol Conv	<input type="radio"/> AppleLine <input type="radio"/> Cluster Ctr
<input type="checkbox"/> On Line	<input type="checkbox"/> Local Echo <input type="checkbox"/> Status Lights
<input type="checkbox"/> Auto Repeat	<input type="checkbox"/> Auto Wraparound <input type="checkbox"/> New Line
<input type="checkbox"/> Repeat Ctrls	<input type="checkbox"/> Transparent
<input type="button" value="OK"/> <input type="button" value="Cancel"/>	

Compatibility Settings	
Baud Rate	<input type="radio"/> 50 <input type="radio"/> 75 <input type="radio"/> 110 <input type="radio"/> 134.5 <input type="radio"/> 150 <input type="radio"/> 200 <input type="radio"/> 300 <input type="radio"/> 600 <input type="radio"/> 1200 <input type="radio"/> 1800 <input type="radio"/> 2000 <input type="radio"/> 2400 <input type="radio"/> 3600 <input type="radio"/> 4800 <input type="radio"/> 9600 <input type="radio"/> 19200
Bits per Character	<input type="radio"/> 7 Bits <input type="radio"/> 8 Bits
Parity	<input type="radio"/> Even <input type="radio"/> Odd <input type="radio"/> None
Handshake	<input type="radio"/> XOn/XOff <input type="radio"/> None
Connection	<input type="radio"/> Modem <input type="radio"/> Another Computer
Connection Port	<input type="radio"/>  <input type="radio"/> 
<input type="button" value="OK"/> <input type="button" value="Cancel"/>	

---

## ***Feedback***

### **Check Your Answers**

**Check your answers against those shown here.**



In the Terminal Settings, the Cursor Shape and Line Width options can be set either way. In the screen shots on the next two pages, they are set the way they are most often used. But their actual setting is left to your personal preference.

If there are discrepancies that you don't understand, reread the section of the manual that pertains to that feature. If you still have questions, check with a colleague, the course manager, your Apple support representative, or anyone else who is familiar with MacTerminal or data communications in general (such as your data-processing manager).

## Another Macintosh

### Configure MacTerminal to connect directly to another Macintosh (not through a modem).

Terminal Settings			
Terminal	<input checked="" type="radio"/> VT100	<input type="radio"/> TTY	<input type="radio"/> IBM 3278
Mode	<input checked="" type="radio"/> ANSI	<input type="radio"/> VT52	
Cursor Shape	<input checked="" type="radio"/> Underline	<input type="radio"/> Block	
Character Set	<input checked="" type="radio"/> United States	<input type="radio"/> United Kingdom	
Line Width	<input checked="" type="radio"/> 80 Columns	<input type="radio"/> 132 Columns	
Protocol Conv	<input type="radio"/> AppleLine	<input type="radio"/> Cluster Ctr	
<input checked="" type="checkbox"/> On Line	<input checked="" type="checkbox"/> Local Echo	<input type="checkbox"/> Status Lights	
<input checked="" type="checkbox"/> Auto Repeat	<input checked="" type="checkbox"/> Auto Wraparound	<input checked="" type="checkbox"/> New Line	
<input type="checkbox"/> Repeat Ctrls	<input type="checkbox"/> Transparent		
<input type="button" value="OK"/> <input type="button" value="Cancel"/>			

Compatibility Settings				
Baud Rate	<input type="radio"/> 50	<input type="radio"/> 75	<input type="radio"/> 110	<input type="radio"/> 134.5
	<input type="radio"/> 150	<input type="radio"/> 200	<input type="radio"/> 300	<input type="radio"/> 600
	<input type="radio"/> 1200	<input type="radio"/> 1800	<input type="radio"/> 2000	<input type="radio"/> 2400
	<input type="radio"/> 3600	<input type="radio"/> 4800	<input checked="" type="radio"/> 9600	<input type="radio"/> 19200
Bits per Character	<input type="radio"/> 7 Bits			<input checked="" type="radio"/> 8 Bits
Parity	<input type="radio"/> Even	<input type="radio"/> Odd	<input checked="" type="radio"/> None	
Handshake	<input type="radio"/> HOn/HOff			<input checked="" type="radio"/> None
Connection	<input type="radio"/> Modem			<input checked="" type="radio"/> Another Computer
Connection Port	<input checked="" type="radio"/> 	<input type="radio"/> 		
<input type="button" value="OK"/> <input type="button" value="Cancel"/>				

### Sometimes you'll use a different baud rate.

Since you are connected directly, you can use 9600 baud. If you were connected through a modem, you would set the baud rate to that of the modem (usually 300 or 1200 baud).

### You would normally use the XModem protocol.

When communicating with another Macintosh, you would normally use the XModem protocol. (XModem is available in the File Transfer Settings window, which isn't shown.) The XModem protocol performs error checking as the information is sent, therefore greatly decreasing the chance of erroneous data being received. (For more information on the XModem protocol, see the Transferring Files section of this module).

**XOn/XOff** controls the flow of information so that the receiving buffer doesn't overflow. This is one way of ensuring error-free data transmission. Since the XModem protocol also ensures error-free data, you don't need to use XOn/XOff flow control when using XModem.



The preceding screen shots assume XModem is on. Therefore, the Handshake setting is **None**. If you choose *not* to use the XModem protocol, change the setting to **XOn/XOff** if the baud rate is greater than 1200.

## Feedback (cont'd)

### Public Data Bases

Configure MacTerminal to communicate via a modem with a public data base or information service.

Terminal Settings		
Terminal	<input checked="" type="radio"/> UT100	<input type="radio"/> TTY <input type="radio"/> IBM 3278
Mode	<input checked="" type="radio"/> ANSI	<input type="radio"/> VT52
Cursor Shape	<input checked="" type="radio"/> Underline	<input type="radio"/> Block
Character Set	<input checked="" type="radio"/> United States	<input type="radio"/> United Kingdom
Line Width	<input checked="" type="radio"/> 80 Columns	<input type="radio"/> 132 Columns
Protocol Conv	<input type="radio"/> AppleLine	<input type="radio"/> Cluster Ctrl
<input checked="" type="checkbox"/> On Line	<input type="checkbox"/> Local Echo	<input type="checkbox"/> Status Lights
<input checked="" type="checkbox"/> Auto Repeat	<input type="checkbox"/> Auto Wraparound	<input type="checkbox"/> New Line
<input type="checkbox"/> Repeat Ctrls	<input type="checkbox"/> Transparent	
		<input type="button" value="OK"/> <input type="button" value="Cancel"/>

Compatibility Settings		
Baud Rate	<input type="radio"/> 50	<input type="radio"/> 75 <input type="radio"/> 110 <input type="radio"/> 134.5
	<input type="radio"/> 150	<input type="radio"/> 200 <input type="radio"/> 300 <input type="radio"/> 600
	<input checked="" type="radio"/> 1200	<input type="radio"/> 1800 <input type="radio"/> 2000 <input type="radio"/> 2400
	<input type="radio"/> 3600	<input type="radio"/> 4800 <input type="radio"/> 9600 <input type="radio"/> 19200
Bits per Character	<input type="radio"/> 7 Bits	<input checked="" type="radio"/> 8 Bits
Parity	<input type="radio"/> Even <input type="radio"/> Odd	<input checked="" type="radio"/> None
Handshake	<input type="radio"/> HOn/HOff	<input checked="" type="radio"/> None
Connection	<input checked="" type="radio"/> Modem	<input type="radio"/> Another Computer
Connection Port	<input checked="" type="radio"/> 	<input type="radio"/> 
		<input type="button" value="OK"/> <input type="button" value="Cancel"/>

Some settings may vary.

Parity and Handshake settings can vary from one information service to another. Check the user's manual for the service you're using to see which settings you should use.

### What if you use the wrong settings?

If the settings are wrong, a variety of things can happen. You may see nothing on your screen, or random characters, or a combination of the two. Check the Feedback section for the practice exercise in which you actually connect to an information service, (later in this module), and the Question and Answer section in the *Supporting MacTerminal* module, for solutions to specific problems.

(Note: You can use the same settings for protocol converters that you use for public data bases.)

---

## Practice

### Configure MacTerminal



MacTerminal

### Configure MacTerminal to communicate with another Macintosh.

You have read about the MacTerminal menu commands and you now know the correct terminal settings for communicating with another Macintosh. Now it's time to put this knowledge to work.

Do the following steps as they are described:

1. Start up your Macintosh using the MacTerminal disk.
2. Open the MacTerminal disk icon.
3. Open the MacTerminal application icon (shown at left) to create a new document.
4. Enter the correct terminal and compatibility settings for communicating with another Macintosh.
5. Leave the MacTerminal document open when you've finished.

When you have finished, check your work against the feedback on the next page.

## Feedback

### Configure MacTerminal

### Configure MacTerminal to communicate with another Macintosh.

After opening a new MacTerminal document, you should have chosen **Terminal** and **Compatibility** from the **Settings** menu, and entered the correct settings.

To check your work, do the following:

1. Choose **Terminal** from the **Settings** menu.
2. Check your settings against the Terminal Settings window shown below.
3. Click on **OK** to close the Terminal Settings window.
4. Choose **Compatibility** from the **Settings** menu.
5. Check your settings against the Compatibility Settings window shown below.

Terminal Settings			
Terminal	<input checked="" type="radio"/> UT100	<input type="radio"/> TTY	<input type="radio"/> IBM 3278
Mode	<input checked="" type="radio"/> ANSI	<input type="radio"/> VT52	
Cursor Shape	<input checked="" type="radio"/> Underline	<input type="radio"/> Block	
Character Set	<input checked="" type="radio"/> United States	<input type="radio"/> United Kingdom	
Line Width	<input checked="" type="radio"/> 80 Columns	<input type="radio"/> 132 Columns	
Protocol Conv	<input type="radio"/> RppletLine	<input type="radio"/> Cluster Ctlr	
<input checked="" type="checkbox"/> On Line	<input checked="" type="checkbox"/> Local Echo	<input type="checkbox"/> Status Lights	
<input checked="" type="checkbox"/> Auto Repeat	<input checked="" type="checkbox"/> Auto Wraparound	<input checked="" type="checkbox"/> New Line	
<input type="checkbox"/> Repeat Ctrls	<input type="checkbox"/> Transparent	<input type="button" value="OK"/>	<input type="button" value="Cancel"/>

Compatibility Settings				
Baud Rate	<input type="radio"/> 50	<input type="radio"/> 75	<input type="radio"/> 110	<input type="radio"/> 134.5
	<input type="radio"/> 150	<input type="radio"/> 200	<input type="radio"/> 300	<input type="radio"/> 600
	<input type="radio"/> 1200	<input type="radio"/> 1800	<input type="radio"/> 2000	<input type="radio"/> 2400
	<input type="radio"/> 3600	<input type="radio"/> 4800	<input checked="" type="radio"/> 9600	<input type="radio"/> 19200
Bits per Character	<input type="radio"/> 7 Bits			<input checked="" type="radio"/> 8 Bits
Parity	<input type="radio"/> Even	<input type="radio"/> Odd	<input checked="" type="radio"/> None	
Handshake	<input type="radio"/> HOn/HOff			<input checked="" type="radio"/> None
Connection	<input type="radio"/> Modem			<input checked="" type="radio"/> Another Computer
Connection Port	<input checked="" type="radio"/>	<input type="radio"/>	<input type="button" value="OK"/>	<input type="button" value="Cancel"/>

If your settings are different than those shown, do one of the following to be sure you understand the steps you should follow, and why each setting is appropriate:

- Reread the Terminal Settings section of this module.
- Read the section about menus in the MacTerminal manual.
- Check with a colleague, your course manager, or your Apple support representative.

## Connecting to Other Computers

### Overview

**Understanding some basic concepts will help make connecting to another computer easy.**

Regardless of which computer you are going to connect to, there are some basic concepts that always apply. This section discusses how to connect to another computer, which computers you can communicate with, and some basic rules that make the process easy.

### Two Options for Connection

**You can connect either directly or through a phone line.**

Most data communications functions are accomplished through the telephone system, using a modem. However, if the computer you want to communicate with is close to your computer, you can establish a direct connection between the two computers, using the appropriate cable. (The maximum distance over which this is possible depends on the cable vendor's specifications and the baud rate that you want to use.)

If you connect directly (as opposed to through a phone line), you can usually send and receive information faster and with fewer errors. You also eliminate the need for a modem at each end. The key benefit of a modem is that it allows you to communicate over very long distances through a system that is already in place and easily accessible—the phone system.

### Direct-Connect Cable

**Use a serial communications cable.**

Serial cables are used to connect a Macintosh to a large variety of devices—other computer, modems, printers, and so forth. However, each cable is different. The cable used for a direct connection must be configured such that one computer's transmit line connects with the other computer's receive line, and vice versa. (Modem cables are discussed later in this module.)

The pinouts for the Macintosh 9-pin serial ports are listed in the Pinouts section of the *Supporting MacTerminal* module. To build a custom cable, you also need to know the pinouts for the other computer.



### **Apple makes a Macintosh-to-Macintosh cable.**

If you want to temporarily connect a Macintosh to another Macintosh for data communications purposes, be sure to use the appropriate cable (p/n 590-0200). It's included with the Macintosh 68000 Development System (order from Macintosh Products price list, p/n M0534). You can also use a Macintosh modem cable (p/n 590-0197) if you cut off (*clip*) Pin 6 at each end. Once you do this, however, you will no longer be able to use the cable as a modem cable.

If you want to connect a Macintosh to a Macintosh XL or an Apple IIe, use the Macintosh ImageWriter™ cable (p/n 590-0169).

(Note: Part numbers are included here for identification purposes only. You may or may not be able to order each cable independently. Check Apple's service parts price list.)

If you need to build your own cable, see the table in the Pinouts section of the *Supporting MacTerminal* module for specifications.

## **Connect via a Modem**

### **Use a modem to connect two computers through the telephone system.**

If the computer you want to communicate with is not close enough to be directly connected by a cable, use a modem to connect the computers through telephone lines. A modem is a hardware device that connects to both your computer and the phone line, and enables your computer to use the existing phone system to exchange information with other computers.

A modem takes computer information and translates it into telephone signals. At the receiving end, the modem translates the telephone signals into digital information that can be understood by a computer. This translation process is called "MOdulation/DEMOdulation," hence the name modem.

### **There are three Apple modems.**

Apple currently manufactures the Apple Modem 300, which is a 300-baud modem that fits under a desktop telephone, and the Apple Personal Modem, which is a 300/1200-baud modem designed to plug directly into a wall outlet. Until October 1985, Apple also made the Apple Modem 1200, which is a 300/1200-baud "under the phone" modem—now replaced by the Apple Personal Modem. The modems can be used with any Apple computer, but be sure to get the appropriate modem

Accessory Kit, which includes the correct cable and manual, for the computer you're using. (There's a different Accessory Kit for each computer.)

On the back of the Apple Modem 300 and Apple Modem 1200, there are three switches. Check the table below for the correct settings when using the modem with MacTerminal. Refer to the owner's manual that came with the modem for more information about the switch settings.

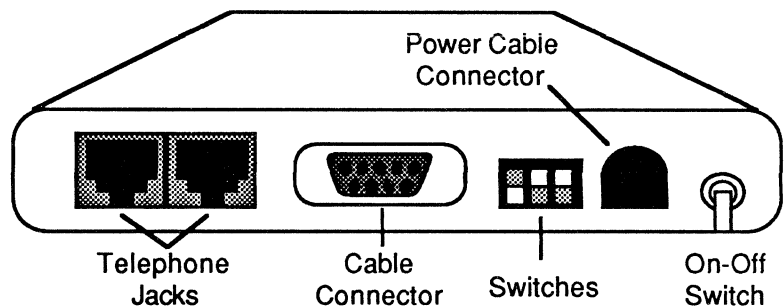

	<u>Switch 1</u>	<u>Switch 2</u>	<u>Switch 3</u>
Apple Modem 300	Down	Either	Up
Apple Modem 1200	Down	Up	Up

If you want to use the Apple Modem 1200 at 300 baud, just set the baud rate of your MacTerminal document to **300**. You don't need to change anything on the modem itself.

There aren't any switches on the Apple Personal Modem.

### You can also use third-party modems.

You can use any third-party modem with Macintosh as long as it's *212A-Type compatible* (for 1200-baud modems), or *Bell-103 compatible* (for 300-baud modems).

Be sure you have the appropriate cable: Use the pinouts in the *Supporting MacTerminal* module, along with similar information for the modem you are using to determine what kind of cable you should purchase or build.

Some modems are called *smart* modems because they can understand a variety of commands sent from the computer. (All three Apple modems are smart modems.) As you choose different MacTerminal menu options, specific commands are sent to the modem. For example, when you choose **Dial** from the **Phone** menu, the code "ATDT" followed by the phone number is sent to the modem (AT = Attention; DT = Dial,

Touch Tone). You could accomplish the same thing manually by typing the appropriate code—MacTerminal saves you that work.

The modem you are using may not use the same set of commands, in which case you won't be able to use the MacTerminal menus. But you can always communicate with a smart modem by typing the appropriate commands from the keyboard. Check the owner's manual for the modem you are using or just experiment to see whether the modem understands the MacTerminal commands.

## Modem Cable

**Apple manufactures modem cables, but you can also build your own.**

When connecting a Macintosh to an Apple Modem 300 or Apple Modem 1200, you can either use Apple's modem cable (p/n 590-0197) or build one according to the table in the Pinouts section of the *Supporting MacTerminal* module. The cable for connecting a Macintosh to an Apple modem is the same as the Macintosh-to-Macintosh cable, except that Pin 6 should be wired straight through.

When connecting to an Apple Personal Modem, always use the connector that comes in the modem Accessory Kit. The connector on the Apple Personal Modem is an 8-pin mini-circular jack. The cable has the corresponding circular connector on one end and either a DB-9 connector (for Macintosh 128K and Macintosh 512K) or a DB-25 connector (for Macintosh XL and Apple IIe) on the other.

## Which Computers Can You Communicate with?

**You can communicate with microcomputers, minicomputers, and mainframes.**

As stated earlier, MacTerminal can emulate DEC VT52 and VT100 terminals, as well as IBM 3278 Model 2 terminals (in conjunction with AppleLine or the Apple Cluster Controller). In addition, you can use MacTerminal with third-party protocol converters to communicate with many other mainframes. If a protocol converter isn't available for the particular mainframe you are connecting to, you can often still communicate as a dumb terminal, using asynchronous ASCII. This is usually the way MacTerminal connects to a public information service or data base.

To learn more about information services, read the Connecting to a Public Information Service section of this module. For more information regarding connecting to IBM computers, see the *Using MacTerminal with IBM Computers* module from the Apple Support Training Library.

For more information on which computers you can communicate with, and how to do it, see the data communications information in the References section of the *Apple Support Programs* binder. It includes a list of what's available and methods for connecting to a large variety of minicomputers and mainframes. Also, if you have access to AppleLink™, check the Tech Support news icon and the Technical Info library.

## Check Protocol and Terminal Settings

### **The key to communicating with another computer is to have identical terminal settings.**

The key to communicating with another computer is the same as it is when you are trying to talk to another person: *You must be speaking the same language.* Applying this to the data communications world, the two computers must be using the same baud rate, parity, and so forth.

This is a complete list of all the settings that must match in order for you to establish a working connection between two computers:

- Baud rate
- Terminal type (VT100, TTY, etc.)
- Bits per character
- Parity
- Handshake (XOn/XOff, None)

These are some other settings that affect how the information appears on your screen, but that don't prohibit you from making the connection:

- Cursor shape
- Line width (80 or 132 characters)
- Local echo (simplex, half duplex, full duplex)
- Auto wraparound
- Automatic line feed

If you are not sure how to configure MacTerminal, contact the technical support person for the computer you are trying to communicate with, and ask about these settings.

## Helpful Hint

### **Create a MacTerminal document for each of the different computers you communicate with.**

If you use MacTerminal to communicate with a variety of different computers, set up a MacTerminal document for each one. Then, when you want to connect to a particular computer, you can just open the appropriate document and you're all set to go. When you finish the session, either don't save the changes, or choose **Save As** to save the document under a different name. That way, your original document won't get filled up with old information, and will always be ready to go.

Your MacTerminal disk came with MacTerminal documents configured for communicating to another Macintosh, to public information services, via AppleLine, and to the Apple Cluster Controller. You may want to add documents for communicating with your in-house mainframe, or with specific information services such as Dow Jones News/Retrieval, The Source, or CompuServe.

## Transferring Files

### Overview

#### How and why would you use MacTerminal's file transfer capabilities?

Sending text through MacTerminal sends text, nothing more. What if you want to send someone a MacWrite document complete with formatting and type styles? Or a MacDraw™ document? You can't send either of these via MacTerminal as text, but you *can* send them as complete files.

This section begins with an explanation of the two ways to send information:

- *On-line communication*, in which text is entered and received into the MacTerminal window; and
- *File transfer*, in which entire files and documents are sent.

You will get a chance to try both ways of sending and receiving information in the Connecting to Another Macintosh section of this module. The remainder of this section details the file transfer capabilities of MacTerminal, and how to send and receive complete files.

### Two Ways to Send and Receive Information

#### 1. Enter and receive information directly in the MacTerminal window.

One way to send information to another computer is to establish the connection and then simply enter the information into the MacTerminal window, either by typing it or by pasting it in from another document. As soon as the information appears in the window, it is sent to the other computer.

In the same way, information sent by the other computer appears in your MacTerminal window, along with whatever you enter. This is the only place the information appears. So, if you want to save it, you must copy it and paste it into another document, or save the MacTerminal document itself.

This back-and-forth, interactive dialog is often called on-line communication.

#### 2. Send and receive complete files.

The alternative is to send or receive complete files, all at once, without any interaction or dialog. This is called file transfer

and is made possible by the XModem protocol, which will be described shortly.

There are two types of files you can send using the file-transfer capabilities of MacTerminal: *text files* and *disk files*. Text files are documents that contain only text—they don't have any format or type-style information associated with them. Text files include MacTerminal documents, AppleLink documents, and documents saved using **Text Only**. Disk files include everything on a disk—documents, systems files, code files, *and* text files.

If you are receiving text, it will always appear in the MacTerminal window—regardless of whether it's sent via on-line communication or file transfer. (In other words, ASCII text is always received in the window.) When you receive a disk file (for example, one sent using MacTerminal's file transfer capabilities), nothing will appear in the MacTerminal window, but a new icon will be added to your disk.

## XModem Protocol

**XModem is a protocol that enables you to send and receive Macintosh disk files.**

Choosing **File Transfer** from the **Settings** menu offers you a choice of five different file transfer options (as shown below for MacTerminal Version 2.0). The first option is for transferring text, and the other four options are variations of the XModem protocol, and are used for sending complete files. The only options in MacTerminal Version 1.1 are **XModem** and **Text**, and the window looks slightly different. Check the MacTerminal manual to see what it looks like.

(Note: If you don't know which version of MacTerminal you have, open any MacTerminal document and choose **About MacTerminal** from the **Apple** menu.)

File Transfer Settings	
<b>Settings for Pasting or Sending Text:</b>	<b>File Transfer Protocol</b>
Delay Between Chars <input type="text" value="0"/> 60ths Second	<input type="radio"/> Text
Delay Between Lines <input type="text" value="0"/> 60ths Second	<input type="radio"/> MacBinary
<input checked="" type="checkbox"/> Word Wrap Outgoing Text	<input type="radio"/> XModem Text
	<input type="radio"/> MacTerminal 1.1
<b>Settings for saving lines off top:</b>	<input type="radio"/> Straight XModem
<input checked="" type="checkbox"/> Retain Line Breaks	
<input type="checkbox"/> Save Screens Before Clearing	
	<input type="button" value="OK"/> <input type="button" value="Cancel"/>

The XModem protocol enables MacTerminal to send and receive data in an uninterpreted binary form, and to perform error checking on each block of characters it sends or receives. The XModem protocol sends 128-character blocks of data and calculates a "checksum" as the data is received. (A checksum is the sum of the numerical value of all of the characters in a block. It's used to verify that the information was sent correctly.) After the entire block has been received, the checksum is sent back to the sending system, which verifies that it's correct. If the checksum is correct, the block of data was sent without error, and the next block is sent. If the checksum is incorrect, the block is retransmitted.

(**Note:** The XModem protocol is equivalent to the "MODEM7" and the "Ward Christensen" protocols.)

Here's a brief description of each of the five options available in the File Transfer Settings window. Read the MacTerminal manual update for more information about these options.

- **Text.** For sending text files to any computer that doesn't support the XModem protocol. The Text option sends and receives files as ASCII characters. Most Macintosh applications give you the option of saving a document either with its formatting and graphics, or as text only (which saves only the text itself, but not the formatting or type-style information).
- **MacBinary.** For exchanging Macintosh files with another Macintosh or any other system that supports the XModem protocol, such as CompuServe.
- **XModem Text.** For exchanging *text files* with non-Macintosh systems that support the XModem protocol. Line feeds and returns are adjusted to achieve proper word wrapping at the end of each line.
- **MacTerminal 1.1.** For exchanging Macintosh files with another Macintosh that's running either MacTerminal Version 1.1 or another utility that's compatible with MacTerminal Version 1.1.
- **Straight XModem.** For sending (not receiving) Macintosh text files to a non-Macintosh system without translating the data in any way (as opposed to **XModem Text**).

MacTerminal isn't the only program that uses the XModem protocol. Other computers with other communications software can also send and receive data using this protocol. Use it whenever you can, since it allows MacTerminal to transfer entire documents (including fonts, type sizes and



styles, and graphics) and code files (such as applications) without error.

If the computer you're communicating with doesn't support the XModem protocol, you can only send text information from MacTerminal.

## Sending Files

### When and how to use XModem and Text.

As described above, you can use either the XModem protocol or the Text protocol to transfer files. But when should you use each, and what are the results in each case? This section describes the results of using the XModem and Text features of MacTerminal Version 2.0 when sending and receiving files. (If you're still using Version 1.1, the commands are very similar. Check the MacTerminal manual.)

### Sending a file using XModem.

Use this to send files to another Macintosh and to any other computer that supports the XModem protocol.

To send a file to any computer that supports XModem (including another Macintosh), do the following:

1. Choose the appropriate XModem option. (See the Four "Real World" Situations at the end of this section, or the Specifications section of the *Supporting MacTerminal* module for a description of what's available.)
2. Be sure the other system is running the appropriate data communications software and that it's correctly configured to communicate with your Macintosh. If you can't personally check the other system (for example, it's across the country), call the person who's waiting to receive the information and ask him to check it.
3. Choose **Send File** from the **File** menu. You'll get a list of *all* files on the startup disk, including documents, system files, and code files.
5. If there's a disk in the external drive, click **Drive** to display its contents.
6. Select the document you want to send.
7. Click **Send**.

You'll get a window indicating the progress of the file transfer, but *nothing will appear in your MacTerminal window.*

### **Sending a file using the Text option.**

Remember that with the **Text** option, you can only send *text documents*. You can't send graphics, and any formatting information will be lost. Use this option only when the receiving computer doesn't support the XModem protocol.

To send a text file to a computer that doesn't support XModem, do the following:

1. Select **Text** in the File Transfer Settings window.
2. Be sure that the other system is running the appropriate data communications software and that it's correctly configured to communicate with your Macintosh. If you can't personally check the other system (for example, it's across the country), ask the person who's waiting for the information to check.
3. Choose **Send File** from the **File** menu. You'll get a list of *all* text documents that are on the startup disk.
4. Click **Drive** to display the text documents that are stored on either the disk that's inserted into the external drive or on an available hard disk.
5. Select the document you want to send.
6. Click **Send**.

The entire document will now be sent. All of the text will appear in your MacTerminal window, just as if you had typed it or pasted it in from another document.

### **Receiving Files**

#### **There are four situations in which you will receive information using MacTerminal.**

You can receive:

- A Macintosh file from any computer system (including Macintosh) that supports XModem.
- A Text file from a computer other than a Macintosh that supports XModem.
- A code file from a computer other than a Macintosh that supports XModem.
- Text from a computer other than a Macintosh that doesn't support XModem.

This section describes how to use MacTerminal to receive information in each of these situations.

### Receiving a Macintosh file.

Use the XModem protocol to receive a Macintosh file from any other computer that supports the XModem protocol. Inherent in this statement is the fact that the other system must support Macintosh files.

To receive a Macintosh file from any other system, do the following:

1. Select **MacBinary** in the File Transfer Settings window.
2. Choose **Receive File**. Macintosh will wait 1 1/2 minutes for the file to be sent.
3. If you are connected via a modem, choose **Wait For Call** from the **Phone** menu.

You'll get a window indicating the progress of the file transfer, but *nothing will appear in your MacTerminal window*. When you quit MacTerminal, you'll see an icon identical to the original icon on the sending system. You can open it if you have the appropriate application.

### Receiving a text file.

To receive a *text* file from a computer other than a Macintosh that supports XModem, do the following:

1. Choose **XModem Text** in the File Transfer Settings window.
2. Choose **Receive File** from the **File** menu. You'll be asked to enter a name for the file that's about to be created. Your Macintosh will wait for the file for 1 1/2 minutes after you click **Receive**.
3. If you are connected via a modem, choose **Wait For Call** from the **Phone** menu.

You'll get a window indicating the progress of the file transfer, but *nothing will appear in your MacTerminal window*. When you quit MacTerminal, you'll see a Blank Page icon (shown at left) representing the file you just received. To open the file, open the MacWrite application icon, close the untitled document, and then use the **Open** command.



Blank Page Icon

### Receiving a non-Macintosh code file.

To receive a file that isn't a text file or a Macintosh file (for example, a code file or a data file containing non-text

information), from a computer other than a Macintosh that supports XModem, do the following:

1. Choose **Straight XModem** in the File Transfer Settings window.
2. Choose **Receive File** from the **File** menu. You'll be asked to enter a name for the file that's about to be created. Your Macintosh will wait for the file for 1 1/2 minutes after you click **Receive**.
3. If you are connected via a modem, choose **Wait For Call** from the **Phone** menu.



Blank Page Icon

You'll get a window indicating the progress of the file transfer, but *nothing will appear in your MacTerminal window*. When you quit MacTerminal, you'll see a Blank Page icon (shown at left) representing the file you just received. You can open it if you have the appropriate utility, or you can store it and later forward it using **Straight XModem** without ever opening it. If you can open the file using any Macintosh application, then you should have used the **MacBinary** option to transfer it.

### Receiving a file using the Text option.

If you indicate **Text** in the File Transfer Settings, the **Receive File** command in the **File** menu will be dimmed. You can use the Text option to send a file, or to receive text directly into your MacTerminal window during an on-line communication session, (which you can then copy and paste into another document). But you *can't* receive a text file directly to disk using the **Receive File** command.

**Summary**

**Refer to this chart for the effects of XModem and Text on sending and receiving files.**

		<b>Send a File</b>	<b>Receive a File</b>
<b>XModem</b>	<b>Who:</b>	To a Macintosh and any other system that supports XModem.	From a Macintosh and any other system that supports XModem.
	<b>How:</b>	Choose <b>Send File</b> . Select document and click <b>Send</b> .	From Macintosh, using <b>Receive File</b> .
	<b>Result:</b>	Nothing appears in window.	Nothing in window; icon appears in Finder.
<b>Text</b>	<b>Who:</b>	Any system that doesn't support XModem.	This option not available; you can receive only text, not a complete file, into MacTerminal window,
	<b>How:</b>	Choose <b>Send File</b> . Select document and click <b>Send</b> .	
	<b>Result:</b>	Text appears in MacTerminal window.	

## Four "Real World" Situations

### When should you use XModem, and when should you use Text?

If you're running MacTerminal, there are four possibilities for sending and receiving files. (See the diagram below; your Macintosh is the one in the middle.) This section will explain when you would use one of the XModem options and when you would use the Text option in each of the situations described.

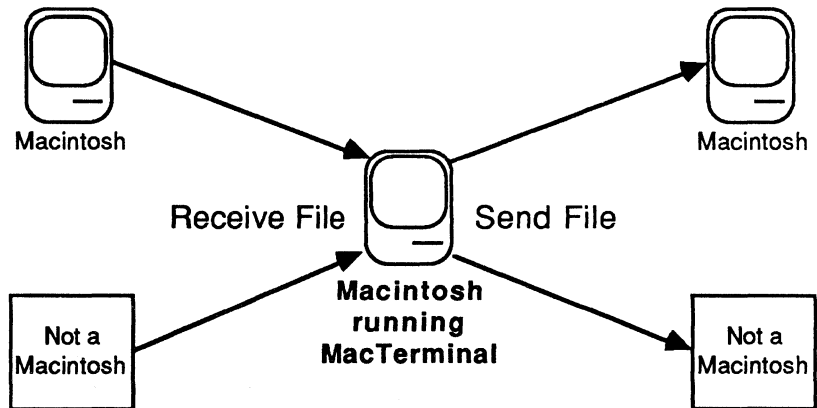

#### Receiving a file from another Macintosh.

Always use XModem. That way you'll preserve the formatting and type styles that are in the original, and you'll be able to receive graphics. In Version 1.1, the Macintosh sending the file will automatically arrange for your Macintosh to receive it as long as you have a MacTerminal document open. (You don't have to choose **Receive File**; all you have to do is be sure MacTerminal is correctly configured and then wait for the file to arrive.) When you're using MacTerminal Version 2.0, you must choose **Receive File**.

Based on which versions of MacTerminal are running on the sending and receiving systems, choose **XModem** and the appropriate file transfer setting from the table below. (Use this table when you are sending or receiving information.)

<u>Sender</u>	<u>Receiver</u>	<u>Choose This Option</u>
2.0	2.0	<b>MacTerminal for Remote System</b>
1.1	1.1	<b>MacBinary</b>
2.0	1.1	If you're using Ver 2.0, choose: <b>MacTerminal 1.1</b> .
1.1	2.0	
		If you're using Ver 1.1, choose <b>MacTerminal</b> .

### **Sending a file to another Macintosh.**

Always use XModem and be sure the receiving Macintosh is also using XModem. Choose **Send File** from the **File** menu, select the file you want to send, and click **Send**.

Based on which version of MacTerminal is running on each system, configure the systems the same way as described earlier for receiving a file from another Macintosh.

### **Receiving a file from a computer other than a Macintosh.**

Always use XModem if the other computer supports it. Depending on the situation, choose the appropriate settings in the File Transfer Settings window:

<u>Situation</u>	<u>Choose These Options</u>
MacTerminal 1.1	<b>XModem and Other</b>
MacTerminal 2.0; receiving a Macintosh file	<b>MacBinary</b>
MacTerminal 2.0; receiving a non-Macintosh <i>text file</i>	<b>XModemText</b>
MacTerminal 2.0; receiving a non-Macintosh <i>code file</i>	<b>Straight XModem</b>

Then choose **Receive File**. MacTerminal will wait for about 1 1/2 minutes to receive the file.

If the remote system does not support the XModem protocol, choose **Text** in the File Transfer Settings window. Remember that the **Receive File** command won't be available. The text will appear in the MacTerminal window just as if someone at the other end were typing it.

## Sending a file to a computer other than a Macintosh.

Always use XModem if the receiving computer supports it. Depending on the situation, choose the appropriate settings in the File Transfer Settings window:

<u>Version</u>	<u>Receiving System</u>	<u>Choose These Options</u>
1.1	Any non-Macintosh	<b>XModem and Other</b>
2.0	Supports Macintosh file system †	<b>MacBinary</b>
2.0	Doesn't support Macintosh file system	Text file: <b>XModem Text</b> Code file: <b>Straight XModem</b>

† For example, CompuServe can store Macintosh documents and applications that you can download to your Macintosh.

Then choose **Send File** from the **File** menu. Select the file you want to send, and click **Send**. You'll get a window indicating the progress of the file transfer, but nothing will appear in your MacTerminal window.

If you are sending a file to a computer that doesn't support the XModem protocol, you can send only text files. Remember, text files include MacTerminal documents, AppleLink documents, and documents saved using the **Text Only** option. Select **Text** and **Other** in the File Transfer Settings window and then choose **Send File** from the **File** menu. From the list of text files presented, select the file you want to send and click **Send**.

The file will be sent and the text will appear in the MacTerminal window just as if you had copied it and pasted it into MacTerminal.



## Summary

**Always use XModem if possible.**

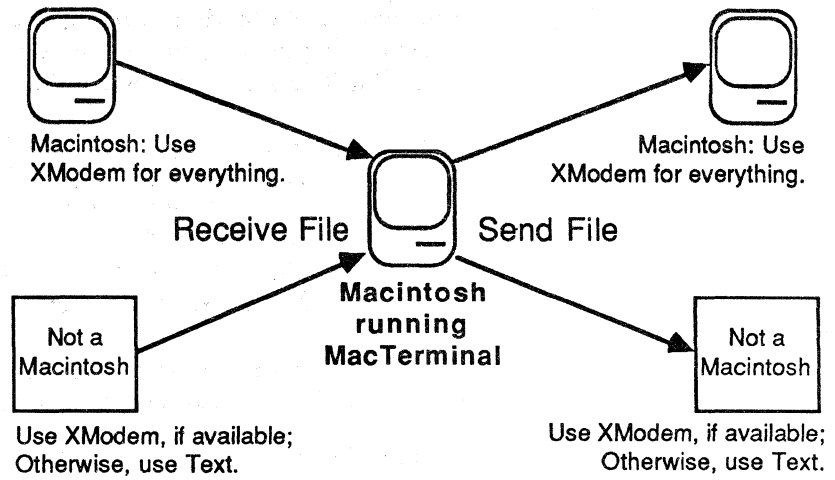

Because error checking is built into the XModem protocol, use it whenever possible to transfer entire files. In MacTerminal Version 2.0, be sure to use the appropriate XModem option. Use the **Text** option only if the XModem protocol isn't available.

## Connecting to Another Macintosh

### Overview

#### Practice what you have learned so far.

This section gives you a chance to practice using many of the MacTerminal features that you've learned. You'll connect two Macintoshes and use MacTerminal to send information between them.

(Note: The part numbers provided in this section are only to help you identify the correct parts. You can't necessarily order the parts from Apple except as part of another product. Check the service parts price list for availability of individual items.)

#### Why is this important?

You may be wondering, "Why should I connect two Macintoshes with cables and go through all the trouble of using MacTerminal when I could just carry my disk over to the other system, instead?"

The answer is that this is the best way to practice using MacTerminal, because you immediately see the results of what you're doing. You may never again need to connect two Macintosh computers directly, but you probably *will* need to transfer information to another Macintosh (or some other computer) over the phone line using a modem. Doing that, and *understanding what you are doing*, will be much easier after completing this exercise.

### Connecting the Cable

#### You need the right cable to connect the two Macintoshes.

To connect two Macintosh computers, you need a serial cable with a male DB-9 connector at each end. Apple manufactures a cable for just this purpose (p/n 590-0200). The Macintosh-to-Macintosh cable is included with the Macintosh 68000 Development System; you can also use the Macintosh modem cable if you clip Pin 6 at each end.

#### You need a different cable if you are connecting a Macintosh to a Macintosh XL.

You can also connect a Macintosh to a Macintosh XL. Information can be transferred between the two systems in either of two ways: by running MacTerminal on both, or by

running MacTerminal on the Macintosh and LisaTerminal on the Macintosh XL.

The Macintosh XL's serial ports have different connectors than the Macintosh's, so you need a different cable. The cable should be a serial cable with a male DB-9 connector at one end and a male DB-25 connector at the other. The cable that comes in the ImageWriter Accessory Kit for the Macintosh works perfectly (p/n 590-0169).

### **Attach the cable to either serial port.**

MacTerminal allows you to indicate which port (Printer or Modem ) you are communicating through. It doesn't matter which one you connect the cable to. In most cases, the Printer port will be used either for an ImageWriter or for AppleTalk™, in which case it will be easier to attach the cable to the Modem port.

If both ports already have cables attached, turn the Macintosh off, disconnect one of the cables, attach the serial cable, and then turn the Macintosh back on.

---

## **Practice**

### **Practice Using MacTerminal**

### **Connect two Macintoshes and send information between them.**

Perform each step as it's described. You can do this exercise with any two Macintosh computers. The instructions assume you're using MacTerminal Version 2.0. If you're using Version 1.1, the actual commands you use may be different from those mentioned in this exercise. If you use a Macintosh XL, use MacWorks™ to run MacTerminal (rather than using LisaTerminal).

In this exercise, you will connect two Macintosh computers, communicate on-line via MacTerminal, and then use the XModem protocol to send a Macintosh document from one system to the other.

If you have problems, check your MacTerminal settings and be sure you are using the correct cable. If you still have problems, check the Feedback section or ask a colleague, your course manager, or your Apple support representative for help.

### Set up the hardware and send some information.

1. Attach the correct cable to both Macintosh computers.
2. Earlier in this module, you learned the correct terminal and compatibility settings for communicating with another Macintosh. You also learned which menu commands you should use to correctly configure your Macintosh.

Now use both of these skills to start up your Macintosh, open a MacTerminal document, and set up the document to communicate with another Macintosh. (If it would help, refer to earlier parts of this module.) Continue when MacTerminal is running and correctly configured on the first Macintosh.

3. Start up MacTerminal on the second Macintosh, and set up your document in exactly the same way that you did on the first Macintosh. Continue when MacTerminal is running and correctly configured on the second Macintosh.
4. Check to be sure both MacTerminal documents are on line.
5. Now you are connected and ready to go. Anything you type in one MacTerminal document will automatically appear in the other.

Type something into one of the MacTerminal documents to see how it works. Everything is being transmitted—via the serial cable—to the other Macintosh, which is configured to receive the information.

Information can go both ways, but only one way at a time. Type something on the other Macintosh, too.

Continue when you are satisfied that everything is working as it should, and you've finished sending information between the two Macintosh computers. Leave the documents open for the next exercise.

### Use XModem to Send a Disk File

### Send any Macintosh file to another Macintosh.

You can send any document created by any Macintosh application; the document will retain all of its formatting and type-style information.

In this part of the exercise, you will send a MacWrite document to another Macintosh (the instructions assume you're using MacTerminal Version 2.0).

## ***Practice (cont'd)***

### **Indicate which file transfer method you're using.**

On the Macintosh you will be using to send the file, do the following:

1. Choose **File Transfer** from the **Settings** menu.
2. Click on **MacBinary**. Leave the other settings set to their defaults.

### **Prepare the receiving Macintosh.**

Now you're ready to send the file, so the receiving Macintosh must be prepared to receive it:

1. Open a **MacTerminal** document (if one isn't already open).
2. Set **MacBinary** in the **File Transfer Settings** window. The **MacTerminal** document on the receiving Macintosh doesn't have to be on line, that is, **On-Line** in the terminal settings doesn't need to be on, but the document *does* need to be open.
3. Choose **Receive File** from the **File** menu. **MacTerminal** will wait 1 1/2 minutes to receive a file.

### **Send a disk file.**

Be sure you have a **MacWrite** document to send, and the **MacWrite** application (so you'll be able to open the document to confirm that it was sent correctly).

1. Choose **Send File** from the **File** menu. All the documents available for you to send will be listed.
2. Select the name of the **MacWrite** document you want to send from the dialog box.
3. Click **Send**. Watch both screens to see what happens.

Continue when you have finished sending a disk file.

### **Check your work.**

Now, go to the receiving Macintosh and quit **MacTerminal**. Check to see how the document has been received: On the startup disk, there will be a **MacWrite** document icon identical to that of the original document; insert the **MacWrite** disk in the

external drive, and open the document to confirm that it has arrived intact.

### Get ready for the next exercise.

In the next exercise, you will send the same document, using the Text file transfer protocol instead of the XModem protocol. In order to do this, you must save the document you just transferred; it must be saved as a text-only document.

1. Choose **Save as** from the **File** menu.
2. Enter a different name for the document.
3. Click on **Text Only**.
4. Click **Save**.



Text Only

You will now have a text-only document, represented by the icon shown at the left, in addition to the original MacWrite document.

---

## Feedback

### Check Settings

**If you have trouble, check your settings against those listed earlier in this module.**

You should end up with a MacTerminal document, with information that you typed, on each system. You should also have a document that was sent via XModem on one of the Macintosh computers. If you don't have these three documents, reread the practice to see what you missed.

If MacTerminal didn't work as described, check your settings and the cable you used. The correct settings are shown in the Terminal Settings section of this module.

If you still have problems, check the cable part number (which is on one of the connectors) against the part numbers mentioned earlier in this section. Also, check the cable connections to be sure that they're secure.

You can also ask a colleague, the course manager, or your Apple support representative for assistance.

---

## Practice

### Send a Text File

#### Send a file using Text instead of XModem.

This exercise will give you an opportunity to see the difference between using XModem and Text when sending a file. You already used the XModem protocol to send a document, which arrived looking exactly like the original—complete with the correct type styles and formatting. This time, send a file using the Text option and notice what the information looks like when it arrives.

You can send text files only, such as documents saved using text only, MacTerminal documents, or Apple Link documents. The system that was previously the receiving system—the system on which you just saved the document as text only—will be the sender in this exercise. Do each step as it's described to send the document.

### Start Up MacTerminal and Send the File.

#### Set the file transfer method.

After starting up MacTerminal, you must indicate the file transfer method you are using. On both Macintosh computers, do the following:

1. Choose **File Transfer** from the **Settings** menu.
2. Click on **Text**.

Leave the other settings set to their defaults. The receiving Macintosh does not have to be on line.

#### Send the file.

To send a file, go to the sending Macintosh and do the following:

1. Choose **Send File** from the **File** menu. All text documents will be listed.
2. Select the name of the text-only document.
3. Click **Send**.

#### Check your work.

The text will be entered into the window of the sending Macintosh and will be sent at the same time to the other system, where it will also appear in the window. Notice the difference

between the appearance of this document and the appearance of the previous document that you sent using XModem. There is no specific type style, size, or font information associated with the text. You can, however, copy the information out of MacTerminal, paste it into a MacWrite document, and add formatting.

## Optional Exercise

### Do this exercise to see the results of incorrect terminal settings.

Be sure both systems are on line, then change various settings (shown below), one at a time, and type some information into one of the MacTerminal documents. Notice the results. *After each experiment, change the option being tested back to its original setting.* This practice could be very valuable if you ever need to help others figure out why their information is not being received correctly.

#### Do This

Turn off **Local Echo**

#### Watch for This

Nothing appears when you type. Text still appears on receiving system.

Turn off **New Line**

When you press Return, you start at the beginning of the same line instead of beginning on a new line. Text is OK on receiving system.

Turn off  
**Auto Wraparound**

Letters pile up at the end of the first line. Words don't wrap onto the next line. Text is OK on receiving system.

Change Line Width to  
**132 Columns**

Type size is the same, but 132 characters will fit on first line before text is wrapped onto next line. Use the scroll bar to view the rest of the window. Text still displayed in 80 columns on receiving system.

Change Sending Baud  
Rate to **4800**

Paste several paragraphs of text. Text is OK on sending system. Receiving system displays garbage.



## Practice (cont'd)

### Do This

Change Bits per Character to 7

Change Parity to **Odd** on sending system and to **Even** on receiving system

Change Handshake to **XOn/XOff**

### Watch for This

Text is OK when typed. When pasted, receiving system displays garbage.

Text is OK in sending system. Appears as gray blocks on receiving system.

Text is sent OK at low speeds. At 9600 or 19,200 baud, receiving system displays garbage.

**Change all the settings back and close both documents.**

Be sure all of the options are set back to the correct settings for connecting to another Macintosh. You'll be using both documents again, later in the module.

Here's a chance to practice clearing out the contents of a document. *On the sending system*, do the following:

1. Choose **Clear Lines Off Top** from the **Commands** menu.
2. Change the Line Width to **132 Columns**.
3. Change the Line Width back to **80 Columns**.
4. Choose **Quit** from the **File** menu.
5. When asked if you want to save this document, click **Yes**.
6. Enter a name and click **Save**.

*On the receiving system*, do the following:

1. Choose **Clear Lines Off Top**.
2. Change the Line Width to **132 Columns**.
3. Change the Line Width back to **80 Columns**.
4. Click in the close box to close the window.
5. When asked if you want to save this document, click **Yes**.
6. Enter a name and click **Save**.

---

## **Feedback**

### **Check Settings**

**If you have trouble, check your settings against those listed earlier in this module.**

Before you cleared out its contents, the MacTerminal document on your receiving Macintosh should have contained, in addition to whatever was previously there, the contents of the text-only document. If the text-only document never arrived, reread the section and check your work.

If you can't find anything wrong with your settings, cables, connections, or the procedure you followed, ask a colleague, your course manager, or your Apple support representative for help.

# Integrating MacTerminal with Other Applications

## Overview

### What information can be moved between applications and how is it done?

One of the key benefits of the Macintosh is being able to copy and paste information from one application to another. For example, you can make a MacWrite document more meaningful by including a table from a spreadsheet or data-base application.

If you want to send or receive entire Macintosh documents, use the XModem protocol. But, if you want to send just part of a document, copy it and paste it into the MacTerminal window.

This section explains what information can be moved between MacTerminal and other Macintosh applications, and describes the actual process of moving information from one document to another.

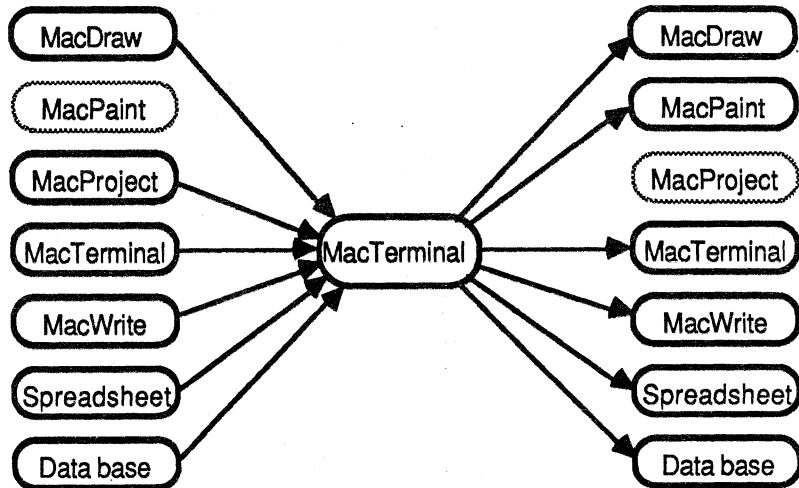

### Receive Text and Numbers From Anywhere

### MacTerminal can receive text copied from any application.

MacTerminal understands only numbers and text. Therefore, you can't paste graphics of any kind into a MacTerminal document. You can, however, paste text or numerical data from any application.

In addition to the Apple applications shown in the diagram, you can also copy information from data bases and spreadsheets

and paste it into MacTerminal. However, you'll lose all formatting, fonts, and type styles when you paste anything into MacTerminal.

## Paste Text and Numbers Anywhere

## Paste information from MacTerminal into any application that can handle text.

You can copy information from a MacTerminal document either as text or as a table of data. You can then paste the information into any document that can handle text, or you can paste numeric data into either a data base or a spreadsheet *as numeric data*, not just as plain text.

## How To Move Information

## Here is the procedure for moving information to or from a MacTerminal document.

The basic technique is the same for all Macintosh applications. The only variation for MacTerminal is its ability to copy information either as text or as a table of data.

1. Select the information you want to move.
2. Choose **Copy** from the **Edit** menu. If you want to copy a table of numeric information from MacTerminal, choose **Copy Table**. When you choose **Copy Table**, columns are separated by tabs, and a return is inserted at the end of each line.
3. Close the MacTerminal document and open the document into which you want to paste the information.
4. Select where in the document you want to put the information.
5. Choose **Paste**.

## You can't cut information from MacTerminal.

With other applications you can choose either **Copy** or **Cut** before you paste the information elsewhere. But with MacTerminal, only **Copy** is available. Once information is in a MacTerminal document, it's there to stay, unless you erase the lines off the top of the screen or choose not to save changes when you close the document.

## Specific Applications

### Each application has special considerations.

**MacDraw.** Though you can't paste graphics into MacTerminal, you *can* move the text portion of your MacDraw document into it, and you can move text from MacTerminal into MacDraw. (Remember, you can exchange entire MacDraw files with another Macintosh using MacTerminal's XModem protocol.)

**MacPaint™.** You can't paste text from MacPaint into MacTerminal because MacPaint is a bit-mapped application and there is no way to select the text and copy it as such. You can, however, paste text from MacTerminal *into* MacPaint.

**MacProject.** You can exchange information with any of MacProjects data tables, but you can't copy anything from the schedule chart or any of the time lines.

**MacTerminal.** Everything from one MacTerminal document can be copied and pasted into any other MacTerminal document.

**MacWrite.** Any text from MacWrite can be copied and pasted into MacTerminal. But graphics that have been pasted into a MacWrite document can't be moved into MacTerminal. Everything from MacTerminal can be pasted into MacWrite.

**Spreadsheets.** Any spreadsheet data can be copied and pasted into MacTerminal. Information from MacTerminal can be copied either as text or as a table of numeric data and pasted into a spreadsheet. If you're copying text, you can copy and paste only one line at a time. If you're copying a table of data, you can copy and paste any amount of information.

**Data bases.** Text information from data bases can be copied and pasted into MacTerminal. Information from MacTerminal can be copied and pasted into data bases, one field at a time. If you can move between fields of the data base using the Tab and Return keys, you can copy information from MacTerminal as a table of data and paste it into the data base.

---

## **Practice**

### **Move MacWrite Data via MacTerminal**

#### **Overview of the exercise.**

In this exercise, you'll copy information from a MacWrite document and paste it into MacTerminal to send it to the other Macintosh. Then you'll copy it from MacTerminal and paste it into another MacWrite document on the receiving Macintosh.

#### **Copy information from MacWrite and paste it into MacTerminal.**

1. On the receiving Macintosh, open the MacTerminal document you saved earlier.
2. On the sending Macintosh, insert a MacWrite disk into the internal drive. If you have an external drive, insert a MacTerminal disk into it.
3. Start up your Macintosh.
4. Open an existing MacWrite document or open a new MacWrite document and enter some text.
5. Copy some information from the MacWrite document.
6. Quit MacWrite. (If you have a one-drive system, eject the MacWrite disk and insert a MacTerminal disk.)
7. Open the MacTerminal document (for connecting to another Macintosh), that you saved earlier.
8. Choose **Paste**.

The information will be pasted into the first MacTerminal document and will immediately be sent to the other Macintosh. Continue when you have finished pasting MacWrite information into MacTerminal and the information has successfully been sent to the other Macintosh.

#### **Copy information from MacTerminal and paste it into MacWrite.**

Once the MacWrite information has been received, do the following to move the information from the MacTerminal window on the receiving Macintosh into a MacWrite document.

1. Copy the desired information.
2. Quit MacTerminal.
3. If you have a one-drive system, eject the MacTerminal disk and insert a MacWrite disk.
4. Create a new MacWrite document by opening the application icon.
5. Choose **Paste**.

## ***Practice (cont'd)***

When you have successfully copied information from MacTerminal and pasted it into MacWrite, do the following:

1. On the receiving system, quit MacWrite and eject the disk.
2. On the sending system, quit MacTerminal and eject the disk.

---

## ***Feedback***

### **Move MacWrite Data via MacTerminal**

#### **A review, and what to do if you have problems.**

You should have copied information from MacWrite, and pasted it into MacTerminal, which should have sent it to the other Macintosh. Then, you should have copied the information from MacTerminal and pasted it into another MacWrite document on the receiving Macintosh. If you didn't do each of these steps, reread the practice exercise and complete the step(s) you missed.

The text you received and then pasted into MacWrite may have lost its formatting (depending on how the rulers are set in the new MacWrite document), and will have lost type styles and sizes. But the basic information, the actual characters, should be the same.

If the MacTerminal-to-MacTerminal part of the exercise didn't work, check the settings, which should be the same as they were for the earlier practice exercise (when you typed information into MacTerminal).

If you don't see anything in the MacTerminal window after choosing **Paste**, check to be sure **Local Echo** is on.

If you still have problems or questions, ask a colleague, your course manager, or your Apple support representative for help.

## Practice

### Move Excel Information via MacTerminal

#### Overview of the exercise.

Excel is a combined spreadsheet, graphics, and data-base application available from Microsoft. In this practice exercise, you'll copy information from an Excel document and paste it into a MacTerminal document to send it to the other Macintosh. On the receiving end, you'll copy it from MacTerminal and paste it into another Excel document.

You need an external drive on both systems to complete this exercise.

#### Copy information from Excel and paste it into MacTerminal.

1. Be sure the receiving MacTerminal document is still open and on line.
2. Insert a MacTerminal disk into the internal drive and the Excel Program Disk into the external drive.
3. Start up your Macintosh.
4. Open an Excel spreadsheet document and enter some data (you can use the data shown below, or a subset of it, if you wish). Formulas are not transferred via MacTerminal, so there is no point in entering them during this exercise.

Worksheet1						
	A	B	C	D	E	F
1	Region A	20.49	22.95	53.3	13.22	99.56
2	Region B	78.37	74.18	39.77	70.95	67.81
3	Region C	68.23	99.12	80.6	91.53	23.72
4	Region D	18.59	97.96	20.14	40.78	61.04
5	Region E	99.08	45.11	78.89	67.53	94.19
6	Region G	58.82	15.14	1.43	8.34	61.16
7	Region H	5.86	84.72	55.51	70.6	23.97
8	Region I	8.44	34.83	33.01	84.58	10.41
9	Region J	1.25	13.78	71.4	4.43	83.36
10	Region K	61.12	15.06	48.85	44.57	27.8
11						
12						
13						
14						
15						
16						
17						
18						
19						

5. Copy all of the information you entered.
6. Quit Excel. Don't save your changes.



## Practice (cont'd)

7. If you get a "Disk is too full" message, you can ignore it. It means there is no room for the Resume Excel document on the Excel Program Disk. The Clipboard is still intact on the MacTerminal disk.
8. If you have only one copy of Excel, eject it now so you can use it on the receiving Macintosh.
9. Open the MacTerminal document you used earlier for communicating with another Macintosh.
10. Choose Paste.

The information will be pasted into the first MacTerminal document, as shown below, and will immediately be sent to the other Macintosh.

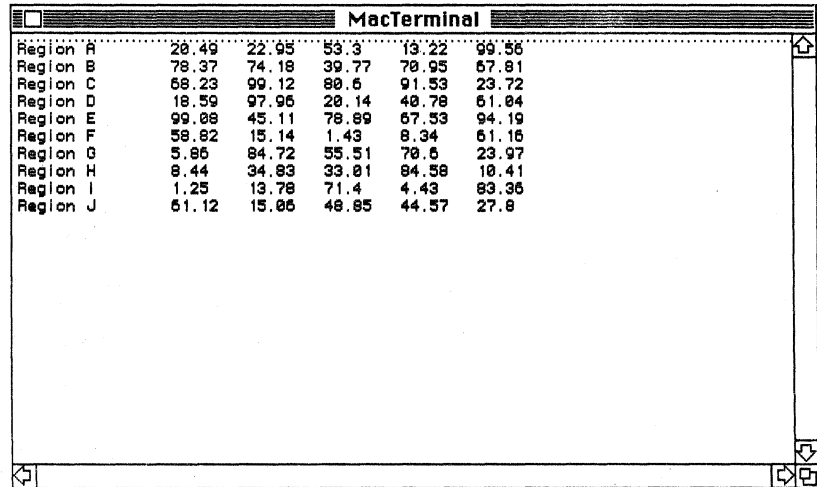

Region	A	B	C	D	E	F	G	H	I	J
Region A	20.49	22.95	53.3	13.22	99.56					
Region B	78.37	74.18	39.77	70.95	67.81					
Region C	68.23	99.12	80.6	91.53	23.72					
Region D	18.59	97.96	20.14	40.78	61.04					
Region E	99.08	45.11	78.89	67.53	94.19					
Region F	58.82	15.14	1.43	8.34	61.16					
Region G	5.86	84.72	55.51	70.6	23.97					
Region H	8.44	34.83	33.81	84.58	10.41					
Region I	1.25	13.78	71.4	4.43	83.36					
Region J	61.12	15.06	48.85	44.57	27.8					

When you have successfully pasted information from Excel into MacTerminal and watched it being sent to the other Macintosh, quit MacTerminal and continue with this exercise.

### Copy information from MacTerminal and paste it into Excel.

Once the information you pasted into the MacTerminal document has been received by the other Macintosh, do the following to move the information into an Excel document.

1. The information you pasted into MacTerminal should be visible in the MacTerminal window that's open on the receiving Macintosh. If it's not, repeat the sending process.
2. Select all of the information and choose **Copy Table**.

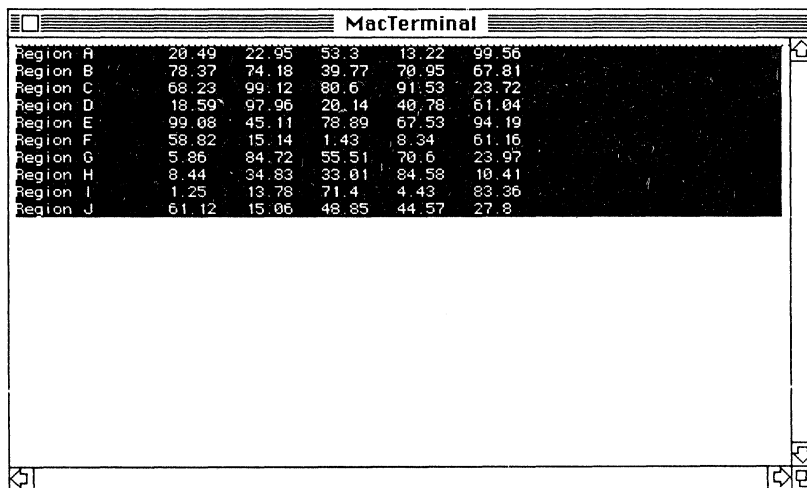

The image shows a MacTerminal window with a title bar labeled "MacTerminal". The window contains a table of data with 10 rows and 5 columns. The rows are labeled "Region A" through "Region J". The data is as follows:

Region A	20.49	22.95	53.3	13.22	99.56
Region B	78.37	74.18	39.77	70.95	67.81
Region C	68.23	99.12	80.6	91.53	23.72
Region D	18.59	97.96	20.14	40.78	61.04
Region E	99.08	45.11	78.89	67.53	94.19
Region F	58.82	15.14	1.43	8.34	61.16
Region G	5.86	84.72	55.51	70.6	23.97
Region H	8.44	34.83	33.01	84.58	10.41
Region I	1.25	13.78	71.4	4.43	83.36
Region J	61.12	15.06	48.85	44.57	27.8

3. Quit MacTerminal. Don't save changes.
4. Insert the Excel Program Disk into the external drive.
5. Open an Excel spreadsheet document.
6. Choose **Paste**. The new Excel document should look just like the original from which you copied the information.
7. Quit Excel.

Continue when you have successfully copied information from MacTerminal and pasted it into an Excel document.

---

## **Feedback**

### **Move Excel Information via MacTerminal**

#### **A Review and what to do if you have problems.**

You should have copied information from Excel and pasted it into MacTerminal, which should have sent it to the other Macintosh. On the receiving end, you should have copied it from MacTerminal and pasted it into another Excel document. If you didn't do each of these steps, reread the practice exercise and complete the step(s) you missed.

If the MacTerminal-to-MacTerminal part of the exercise didn't work, check the settings, which should be the same as they were for the earlier practice exercise (when you pasted MacWrite information into MacTerminal).

If you don't see anything in the MacTerminal window after choosing **Paste**, check to be sure **Local Echo** is on.

If you have a label that is part text and part number, separated by a space (for example, "Region 3"), the number portion of the label may be put in a separate cell in Excel. To avoid this problem, either use letters or omit the space. It's not worth redoing the exercise just to fix that problem, but be aware of it in the future.

If you still have problems or questions, ask a colleague, your course manager, or your Apple support representative for help.

## Connecting to an Apple II

### Overview

#### **Learn how to use MacTerminal to communicate with an Apple II.**

This section describes how to connect an Apple II Plus, Apple IIc, or Apple IIe to a Macintosh and then send information from one to the other.

Using MacTerminal to connect to an Apple II is basically the same as using it to connect to another Macintosh. You can communicate between the two systems either through a modem or via a direct connection. Just be sure you configure the two systems in the same way, and be sure to use the correct cable if you are connecting the two systems directly.

If, after reading this section, you want more information about using Access II on an Apple II, read the *Using Access II* module from the Apple Support Training Library.

#### **Configure the two systems.**

Set up MacTerminal in exactly the same way that you would if you were communicating with another Macintosh. Access II *does* support the XModem protocol, so you can use it for file transfer. Or, once you establish a connection, you can enter information into the MacTerminal window.

Access II is a data communications program for the Apple II. It provides the same functionality that MacTerminal does for Macintosh. It has the same terminal, compatibility, and file transfer options, but the way you specify the settings you want is slightly different. As with any system with which you want to communicate, make its configuration the same as that of MacTerminal.

If you are connecting through a modem, be sure to enter the phone number in addition to the terminal, compatibility, and file transfer settings.

#### **Make the hardware connection.**

The Apple II Plus and Apple IIe do not have built-in connectors. If you want to connect directly to a Macintosh, you need to insert a Super Serial Card into Slot 2. Be sure the jumper block on the Super Serial Card is pointing to TERMINAL. Then use the Macintosh ImageWriter cable (p/n 590-0169) to connect the Macintosh modem port to the Super Serial Card.

The Apple IIc has a modem (serial) port built in. Use the Apple IIc modem cable (p/n 590-0192) to connect the modem port on the Apple IIc to the Modem port on the Macintosh.

**Establish the communications connection.**

You're now set up and ready to go. Be sure both systems are on line and dial the phone number if you are using a modem. Once you've established the connection, you can enter information into either MacTerminal or Access II and it will immediately be communicated to the other system, just as it is when you have two Macintoshes connected. Or, you can transfer a file using the XModem protocol.

If you transfer a file, be sure the receiving system has a program or utility that will enable you to open that file. For example, you can send a MacPaint file using the XModem protocol, but it won't do you any good if you can't open the document on the Apple II.

## Connecting to a Public Information Service

### Overview

**This section describes the services available and how to access them.**

One area of the data communications world that is dramatically increasing in popularity is the use of personal computers to access what are commonly called "public information services" or "public data bases." This section will describe what these services are and how you can use Macintosh and MacTerminal to access them.

If you, or a colleague, have access to a public information service, this section will also give you an opportunity to practice using Macintosh and MacTerminal to gain access to the service.

### What Are They?

**Public data bases offer a wide range of information and services.**

A public information service, or public data base, is a mainframe containing information, tended by someone who's responsible for maintaining that information. Anyone who has a personal computer, a modem, data communications software, and an account with the service, can access the information. Generally, you're charged either by how long you're connected to the service, or by how much information you access. Many services will bill charges directly to your major credit card.

The information available varies almost as widely as the books available in your community library. Here's a short sample of what you can find in public information services:

- Stock quotes
- Historical and financial data on public companies
- Worldwide news
- Airline flight schedules
- Home banking
- Home shopping
- Results of current medical research
- Information on special interests and hobbies
- Demographic and sales-potential information
- Electronic mail
- Games
- Freeware (free computer software)

CompuServe, The Source, and Dow Jones News/Retrieval are a few of the largest and most popular services available. Hundreds of others are also available, many specializing in one particular field, such as aviation, psychology, world politics, or sports. Local computer users' groups often maintain their own data bases, or "bulletin boards," containing answers to common questions or hints and tips on using your computer.

Once you discover what's available, and how easy the services are to access, the amount of information at your fingertips is virtually unlimited.

### **How to access the information.**

The first step in accessing one of these services is getting an account, if one's necessary, and then finding out the service's local phone number and sign-on procedure (get this information from the people who maintain the service).

Now you're ready to sign on. At this point, just read through the procedure. If you have access to a service, or if you know someone else who does, you will have a chance in a moment to practice the procedure outlined here.

1. Start up and configure MacTerminal.
2. Dial the service's local phone number.
3. Follow the sign-on ("log-on") procedure.
4. You should now be in the system. Check the service's user's guide for the correct procedure for accessing the information that's available.
5. When you have finished, use the designated procedure to sign off ("log off").
6. At this point, you can scroll back through the MacTerminal document and copy any information you received.
7. Quit MacTerminal.

---

## Practice

### Access a Public Information Service

### Practice using MacTerminal to communicate with a public information service or data base.

If you (or a colleague) have access to one of these services, here is a chance for you to practice using MacTerminal to make the connection. Even if you can't practice now, you can refer back to this section when you need a reminder of the procedure.

1. Connect your modem to the phone line and your Macintosh.
2. Start up MacTerminal and configure it as described earlier. Set the baud rate to the speed of your modem, and check the service's user's guide for specific settings, such as parity, handshake, number of bits per character, and auto wraparound or line feed.
3. Use the **Phone** menu to enter the phone number. (The people who maintain the service will provide you with the phone number you should call. It's usually a local call.)
4. Use the **Phone** menu to dial the phone number. After the number is dialed, you should hear one or two rings and then a very high-pitched tone. This tone is provided by the modem answering the phone and is called the "carrier." You will next hear a number of high-pitched tones mixed together, followed by silence. This is your modem making the connection. (Some modems allow you to adjust the volume of what you hear.)
5. Follow the sign-on procedure as outlined by the people who maintain the service. (Sometimes, after you hear the phone answered, you will have to press Return or the space bar to get the first prompt.)
6. Follow the instructions in the service's user's guide to access the available information.
7. When you've finished, use the designated procedure to sign off. (Each service has its own procedure.)
8. At this point, you can scroll back through the entire communication session and copy any information that you want to paste into another document.
9. Quit MacTerminal.



---

## **Feedback**

### **Access a Public Information Service**

#### **Be sure all of your settings are correct.**

If you have trouble connecting to the information service, here are a few things to check:

- Is MacTerminal configured as the service's user's guide says it should be?
- Is the baud rate set to that of the modem? If it's 1200 baud, can the service handle 1200 baud?
- Is the modem connected correctly (using the correct cable, and connected to the correct port)? Is it connected to the phone line?
- Is the phone answered after you dial? If not, are you dialing the correct number? If you are in an office where you need to dial a digit to get an outside line, be sure to include that digit in the phone number that you set MacTerminal to dial. (Separate it from the rest of the phone number by a comma. This will cause MacTerminal to pause for a second while waiting for a dial tone.)

If what you see on the screen is garbage, check the various possible solutions in the Question and Answer section of the *Supporting MacTerminal* module.

If, after checking both the list above and the Questions and Answers section, you still can't connect to the information service, check with a colleague, the course manager, or your Apple support representative.

## Review

### MacTerminal's Capabilities

#### Use MacTerminal to...

- Communicate with other computers.
- Send any Macintosh file to another computer.
- Copy and paste information between MacTerminal and other applications.

### Three Main Uses

#### 1. To communicate with mainframes.

MacTerminal can emulate DEC VT100 and DEC VT52 terminals. MacTerminal can also communicate with IBM mainframes, using AppleLine or the Apple Cluster Controller, and with many other mainframes using asynchronous ASCII communications protocols.

#### 2. To access public information services.

MacTerminal can be used with a modem to tap into large amounts of information through services such as Dow Jones News/Retrieval, CompuServe, and The Source.

#### 3. To connect to other microcomputers.

MacTerminal can be used to communicate with other microcomputers, such as another Macintosh or an Apple II, either through a modem or via direct connection.

### MacTerminal Menus

**Chapter 3 of *MacTerminal*, the owner's manual contains a description of each menu command.**

### Terminal Settings

**The manual also contains explanations of terminal settings and compatibility settings.**

*MacTerminal*, the owner's manual, contains the correct settings for three of the most common uses of MacTerminal: connecting to an IBM mainframe through AppleLine or the Apple Cluster Controller, connecting to another Macintosh, and accessing a public data base.

Refer to the manual or to this module if you have questions about how to configure your MacTerminal document.

## Connecting to Other Computers

### **You can connect directly using an RS-232 cable.**

To directly connect your Macintosh to another computer, be sure to use the correct cable. (Apple makes a cable specifically for connecting one Macintosh to another.) Use standard RS-232 cables or build custom cables to connect to other computers.

### **You can also connect via a modem.**

You can use one of Apple's modems or third-party modems that are 212A-Type compatible (1200-baud modems) or Bell-103 compatible (300-baud modems).

### **As long as your settings are correct, you can connect to most other computers.**

Using the MacTerminal terminal-emulation capabilities or asynchronous ASCII mode, you can communicate with many other computers—microcomputers, minicomputers, and mainframes. The key is to be sure that the two computers are "talking the same language."

## Disk Files and Text Files

### **Two ways to send and receive information.**

You can either enter and receive information directly in the MacTerminal window, or you can send complete Macintosh disk files. If you send disk files, the information sent is not limited to text, and it doesn't appear in the MacTerminal window.

### **XModem is a protocol that enables you to send and receive disk files.**

Use XModem whenever possible to exchange information with other Macintosh computers or with other computers that support the XModem protocol. The alternative is to send and receive files as text files, which produces the same result as entering the information directly into the MacTerminal window. Use Text when you are exchanging files with a computer that doesn't support the XModem protocol.

## Connecting to Another Macintosh

### **Be sure you have the correct cable.**

You need an RS-232 serial cable, with a male DB-9 connector at each end, to connect two Macintoshes. Use the Macintosh-to-Macintosh cable that comes with the Macintosh 68000 Development System, or use a Macintosh modem cable that has Pin 6 clipped. You can attach the cable to either the Printer port or the Modem port, because MacTerminal allows you to indicate which port you are using.

### **Send information either way.**

Once each Macintosh is running MacTerminal and each is correctly configured, whatever you enter into one MacTerminal document will immediately appear in the second as well. Both systems can send and receive, but not at the same time.

### **Integration with other Macintosh applications.**

You can copy information from other Macintosh documents and paste it into the MacTerminal document to send it to another Macintosh. Then you can copy the information from the MacTerminal document and paste it into other Macintosh applications, either as text or as tables of numerical data.

## Connecting to an Apple II

### **Configure MacTerminal in the same way as if you were communicating with a Macintosh.**

To connect a Macintosh to an Apple II Plus, Apple IIe, or Apple IIc, use Access II on your Apple II and configure it in the same way as you did MacTerminal. Use a Macintosh ImageWriter cable to connect your Macintosh to an Apple II Plus or Apple IIe. Use the Apple IIc modem cable to connect Macintosh to an Apple IIc. You could also connect both systems to modems and communicate through a phone line.

## Connecting to a Public Information Service

### **You can easily access a large variety of information.**

Use MacTerminal to access hundreds of general or special-interest public information services, data bases, and bulletin boards. All you need is a Macintosh, MacTerminal, a modem, and an account with the people (or company) who maintain the service.

## Resources

- *MacTerminal*, the owner's manual, Apple Computer, Inc.
- *MacTerminal Update* (which has been included with *MacTerminal* since January 1986 and is available from your Apple support representative)
- *Apple Support Programs* binder
- *AppleLine User's Guide*, Apple Computer, Inc.
- *Apple Cluster Controller and AppleLine Sales Reference Guide*, Apple Computer, Inc.
- John Stanley Data Communications Workshop
- AppleLink (If you have access to AppleLink, check it regularly for additional data communications information, particularly the Technical Info library.)
- *Data Communication Terms* module from the Apple Support Training Library
- *Using MacTerminal With IBM Computers* module from the Apple Support Training Library
- *Supporting MacTerminal* module from the Apple Support Training Library

*Apple and the Apple logo are registered trademarks of Apple Computer, Inc. AppleLine, AppleLink, AppleTalk, ImageWriter, MacDraw, MacPaint, MacProject, MacTerminal, MacWorks, and MacWrite are trademarks of Apple Computer, Inc. Macintosh is a trademark of McIntosh Laboratory, Inc. and is being used with express permission of its owner. CompuServe is a registered trademark of CompuServe Corp., an H&R Block company. DEC, VT52, and VT100 are trademarks of Digital Equipment Corporation. Dow Jones News/Retrieval is a registered trademark of Dow Jones & Company, Inc. IBM is a registered trademark of International Business Machines Corporation. Microsoft is a registered trademark of Microsoft Corporation. The Source is a service mark of Source Telecomputing Corp., a subsidiary of the Reader's Digest Association, Inc.*

# Using MacTerminal with IBM Computers

---

## Contents

- 2 Overview
- 3 Objectives, Materials
- 5 The IBM World  
*An overview of the key components of an IBM computer system.*
- 7 Apple Products  
*A description of AppleLine and the Apple Cluster Controller (ACC).*
- 13 The IBM 3278 Keyboard  
*Learn how the Macintosh keyboard emulates all of the functions of the 3278 keyboard.*
- 15 Terminal Settings  
*Terminal settings for communicating with other computers and for accessing public data bases.*
- 21 AppleLine Supervisor  
*Learn about the Supervisor and its role in configuring AppleLine.*
- 23 Practice Using AppleLine  
*Use AppleLine to communicate with an IBM mainframe.*
- 31 Communicating with an IBM PC  
*Use third-party software on the IBM PC to communicate with MacTerminal.*
- 32 Questions and Answers  
*Prepare yourself for the most commonly asked questions.*
- 35 AppleLine and ACC Specifications  
*Learn the capacities and limitations of AppleLine and the Apple Cluster Controller.*
- 38 Review
- 40 Resources

---

## Overview

Approximately 65 percent of the mainframes in the United States are made by IBM. Between 30 percent and 40 percent of the personal computers sold in the U.S. through retail stores are made by IBM. This module describes many of the components of the IBM world and where Apple® products fit in. You will learn how to use the MacTerminal™ application in conjunction with other Apple products to emulate an IBM terminal, and how to communicate with an IBM PC.

Anyone who is using MacTerminal to communicate with IBM computers, or supporting such users, should complete this module.

### Prerequisites

- Knowledge of data communications terminology, which can be acquired by completing the *Data Communications Terms* module from the Apple Support Training Library or the *Data Communications Primer* (which is in the *Apple Support Programs* binder).
- Ability to use MacTerminal. This can be acquired by completing the *Using MacTerminal* module from the Apple Support Training Library, after completing its prerequisites.

---

## Objectives

- Identify the main components of an IBM installation.
- Describe the function of AppleLine™ and the Apple Cluster Controller.
- List the MacTerminal settings used for communicating with the following:

The AppleLine Supervisor

An IBM mainframe through AppleLine

An IBM mainframe through an Apple Cluster Controller

- Use MacTerminal to enable a Macintosh™ computer to emulate an IBM 3278-2 terminal.
- Answer questions about Macintosh-to-IBM communications.
- Learn the specifications and pinouts for AppleLine and the Apple Cluster Controller, which will enable you to answer user questions.

---

## Materials

### To complete this module, you will need:

- A Macintosh 128K, Macintosh 512K, or Macintosh XL
- *MacTerminal*, the owner's manual
- MacTerminal Version 2.0 application software
- An AppleLine with power cord, Loop-Back Connector, and Gender Changer Connector
- A serial cable to connect a Macintosh to the AppleLine
- *AppleLine User's Manual*.

### If available, the following are recommended:

- An external disk drive
- Access to an IBM mainframe



# IBM Computer Components

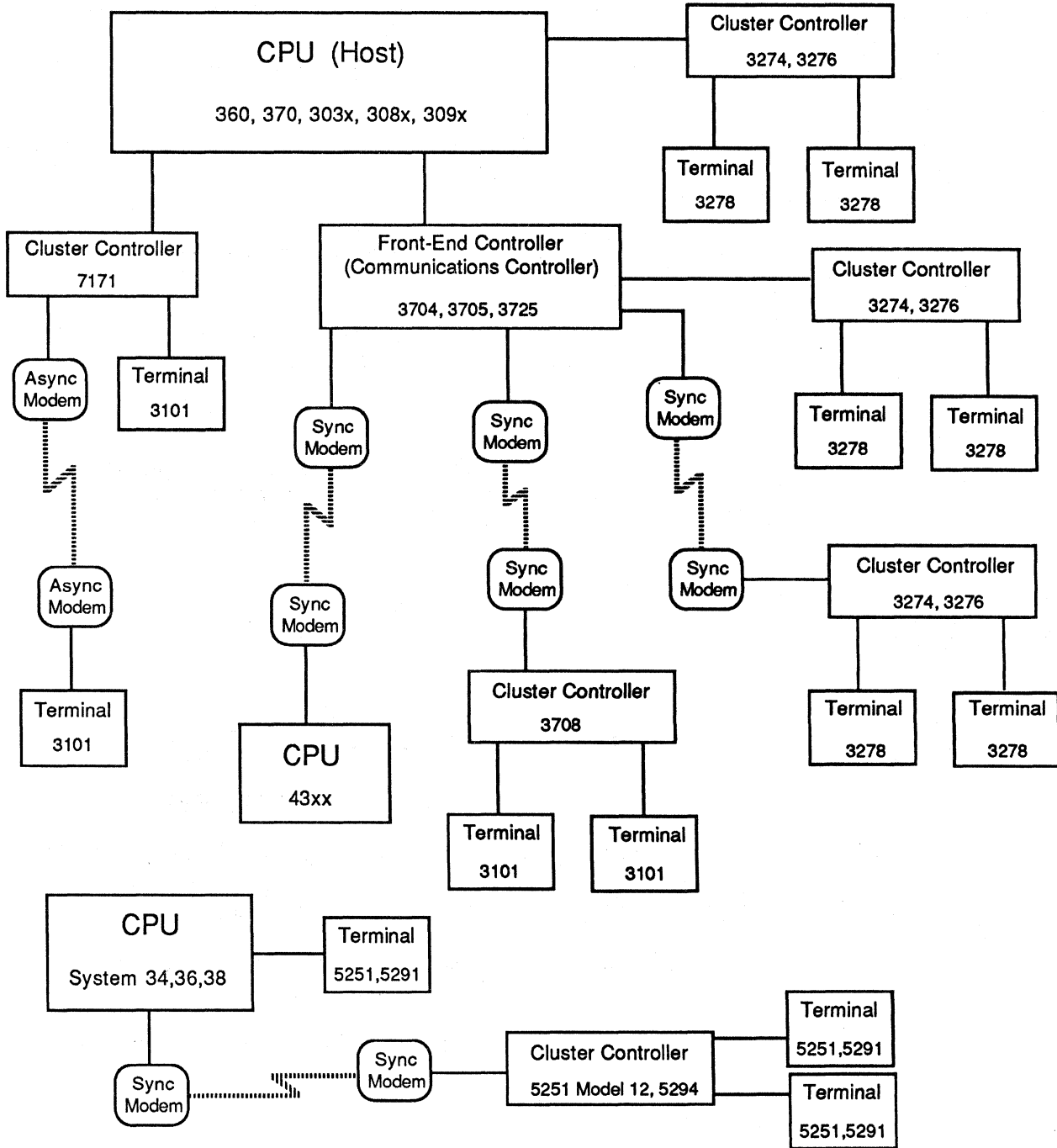

Only those IBM components that Apple products can emulate or communicate with are shown.

## The IBM World

### Overview

#### It's important to understand the components of an IBM installation.

On the facing page is a diagram showing the relationships among many of the most common IBM computer components. Before you can understand how Apple products fit into this structure, you should know something about each of these IBM components.

#### Mainframes

A mainframe (or *host* computer) is the central computer you ultimately want to connect to. It contains, or manages, the information you want to access.

You can use MacTerminal with AppleLine or an Apple Cluster Controller to talk to the following IBM mainframes:

- 360
- 370
- 43xx
- 303x
- 308x
- 309x

You can also communicate with System 34s, System 36s, and System 38s ("System 3x" in the diagram) using MacTerminal and a third-party protocol converter. Renex, PCI, Perle, and Wall Data, among others, have products that enable you to connect your Macintosh to one of the System 3x computers.

#### Terminals

A terminal is the device that enables a user to communicate with the mainframe via a video display and keyboard.

A Macintosh that's running MacTerminal, in conjunction with AppleLine, can emulate an IBM 3278 Model 2 terminal (3278-2). A Macintosh running MacTerminal can also emulate an IBM 3101 terminal.

## Cluster controllers

A cluster controller fits between the mainframe and the terminals to help the mainframe manage what information is sent to which terminal, and in what order. Several terminals can connect to a single cluster controller. Without the cluster controller, the mainframe would not be able to keep track of as many terminals without some performance degradation.

You can connect AppleLine to IBM 3274 and 3276 Cluster Controllers. Or you can connect your Macintosh directly to an Apple Cluster Controller, which acts like the following IBM cluster controllers:

3271  
3274  
3276

You can also use Macintosh running MacTerminal to connect directly to the following IBM cluster controllers:

3708  
7171

## Front-end processors

A front end processor, or communications controller, is another component that helps the mainframe manage terminals and information. Front-end processors poll terminals, allocate resources, and manage the communications channel to the mainframe. Without a front-end processor, you would not be able to access the host from a remote location, and the processing speed of the mainframe could decrease considerably.

You can connect AppleLine to the following IBM front-end processors:

3704  
3705  
3725

**For additional information, see the *Support Programs* binder.**

If you want to know more about IBM computer components, and how they interrelate, read the data communications information in the References Section of the *Support Programs* binder. The binder also includes a list of recommended reading.

## Apple Products

### Overview

#### **Apple has two products that enable you to communicate with IBM mainframes.**

In most IBM installations, you can't communicate with the mainframe using MacTerminal alone. You need something to translate the information from the format that Macintosh understands to a format that can be understood by the IBM system.

AppleLine and the Apple Cluster Controller enable a Macintosh to act as a terminal communicating with an IBM mainframe. This section briefly describes them.

### AppleLine

#### **AppleLine is an asynchronous ASCII-to-IBM 3278-2 protocol converter.**

A protocol converter is a piece of hardware that receives information in one format, converts it, and transmits it in the new format. Protocol converters are usually designed to emulate specific terminals that work with a specific mainframe or family of mainframes.

AppleLine is a protocol converter that receives asynchronous ASCII data from Macintosh and converts it into the format generated by an IBM 3278-2 terminal. AppleLine enables your Macintosh, running MacTerminal, to emulate an IBM 3278-2 terminal. Said another way, Macintosh plus MacTerminal plus AppleLine replaces an IBM 3278-2 terminal. Information appears on the Macintosh screen just as it would appear on a 3278 screen.

Macintosh connects to AppleLine either directly (via RS-232 cable), or through a modem. You need one AppleLine per Macintosh. AppleLine always connects directly to an IBM cluster controller or front-end processor

#### **Additional information about AppleLine is available.**

If you want to know more about AppleLine and its specifications and features, a good description, written by Adrian Mello, appeared in the July/August 1984 issue of *Macworld*. The article has also been entered into the AppleLink™ Technical Info library.

You can also check the data communications information in the References section of the Apple *Support Programs* binder, and read the appropriate section of the workbook that goes with the Apple segment of John Stanley's "Basic Telecommunications: Apple Video Workshop." The materials for the self-paced video training are available from John Stanley Training Programs in Los Gatos, California.

## Apple Cluster Controller

### **The ACC is functionally the same as an IBM 3274 Cluster Controller.**

A cluster controller is the link between terminals and the mainframe. The Apple Cluster Controller (ACC) performs the same function as an IBM 3274 Cluster Controller—it enables several terminal to access one mainframe.

There are four different Apple Cluster Controllers. The differences have to do with how many terminals the ACC supports and which protocol it uses.

- 3 ports, Bisync
- 7 ports, Bisync
- 3 ports, SNA/SDLC
- 7 ports, SNA/SDLC

*Bisync*, or *BSC* (Binary Synchronous Communication), is a character-oriented synchronous protocol. It can handle only a limited number of devices and cluster controllers (several thousand) and is generally used on older networks.

*SNA/SDLC* (System Network Architecture/Synchronous Data Link Control) is a bit-oriented synchronous protocol. It has a hierarchical structure and can handle millions of devices. It is the current standard for IBM networks.

With the ACC, you don't need to use AppleLine. You can connect your Macintosh to the Apple Cluster Controller either directly (via RS-232 cable), or through an asynchronous modem.

### **Additional information about the Apple Cluster Controller is available.**

If you want more information about the Apple Cluster Controller, check the data communications information in the References section of the Apple *Support Programs* binder.

Also read the appropriate section of the workbook that goes with the Apple segment of John Stanley's "Basic Telecommunications: Apple Video Workshop." The materials

for the self-paced video training are available from John Stanley Training Programs.

### **AppleLine or ACC?**

#### **When do you use AppleLine and when do you use an ACC ?**

Use AppleLine when you already have an IBM cluster controller in place (assuming that it has ports available). If there isn't an IBM cluster controller in place, or if all of its ports are already taken, use an Apple Cluster Controller.

Sales studies have shown that more people buy AppleLines and connect them to existing cluster controllers than buy ACCs.

### **Apple Products in an IBM World**

#### **How do AppleLine and the ACC fit into the IBM world described earlier?**

On the next page is a diagram similar to the IBM Computer Components diagram earlier in this module. In this diagram, however, Macintosh (running MacTerminal), Apple II (running Access II), AppleLine, and the Apple Cluster Controller, have been substituted for IBM products wherever possible.

Refer to this diagram to see how Apple products fit into an IBM world.



# Apple Products in an IBM World

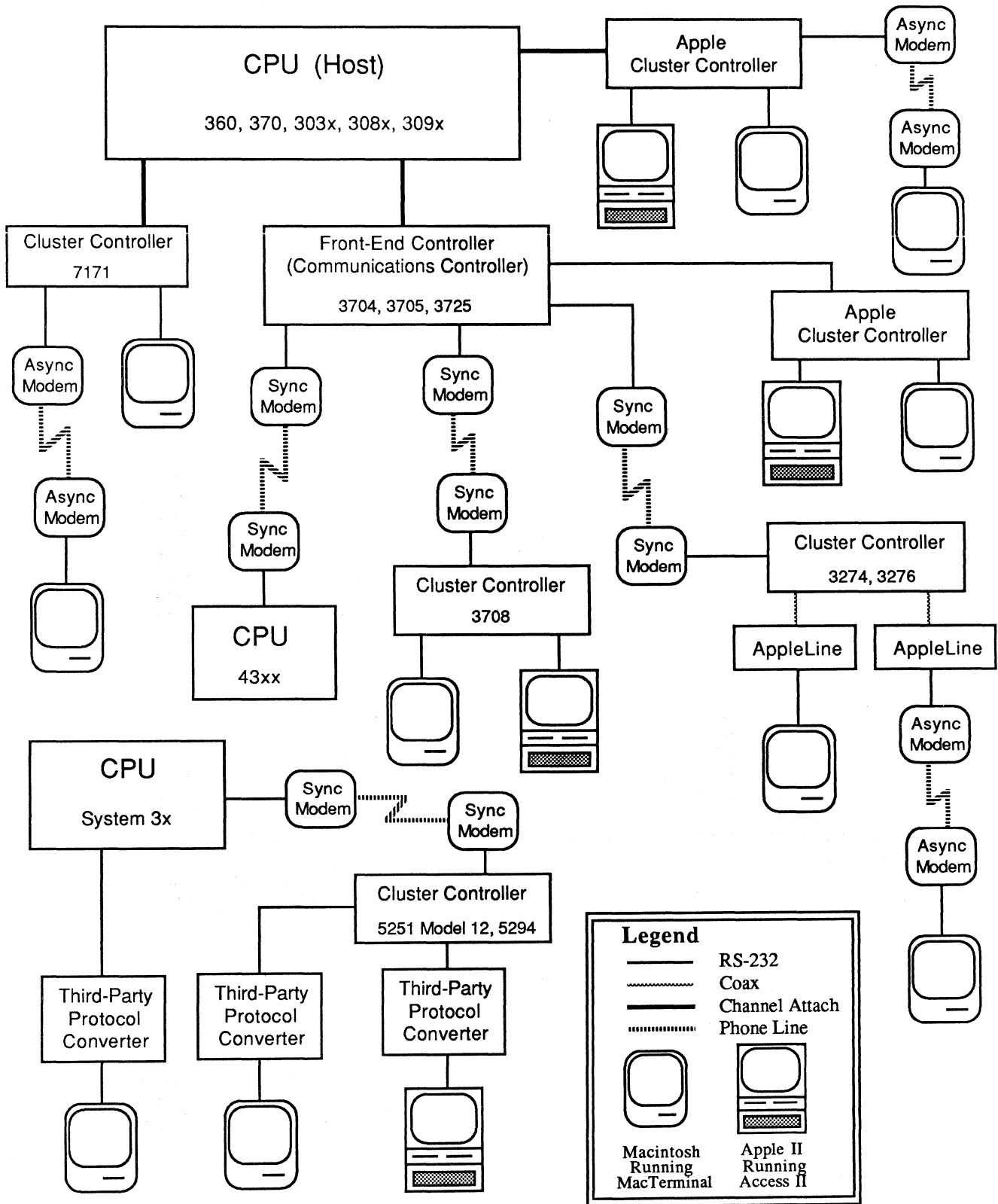



## MacTerminal Keyboard Equivalents for 3278 Terminal Emulation

<u>IBM Keys</u>	<u>AppleLine</u>	<u>Hex Equiv.</u>	<u>ACC</u>	<u>Hex Equiv.</u>
<b>Keypad Menu Options</b>				
PF1	Ec1	1B31	Ec1	1B31
PF2	Ec2	1B32	Ec2	1B32
PF3	Ec3	1B33	Ec3	1B33
PF4	Ec4	1B34	Ec4	1B34
PF5	Ec5	1B35	Ec5	1B35
PF6	Ec6	1B36	Ec6	1B36
PF7	Ec7	1B37	Ec7	1B37
PF8	Ec8	1B38	Ec8	1B38
PF9	Ec9	1B39	Ec9	1B39
PF10	Ec0	1B30	Ec0	1B30
PF11	Ec-	1B2D	Ec-	1B2D
PF12	Ec=	1B3D	Ec=	1B2D
PF13	Ec!	1B21	EcQ	1B51
PF14	Ec@	1B40	EcW	1B57
PF15	Ec#	1B23	EcE	1B45
PF16	Ec\$	1B24	EcR	1B52
PF17	Ec%	1B25	EcT	1B54
PF18	Ec^	1B5E	EcY	1B59
PF19	Ec&	1B26	EcU	1B55
PF20	Ec*	1B2A	Ed	1B49
PF21	Ec(	1B28	EcO	1B4F
PF22	Ec)	1B29	EcP	1B50
PF23	Ec_	1B5F	EcF	1B46
PF24	Ec+	1B2B	EcG	1B47
PA1	Ec]	1B5B	EcZ	1B5A
PA2	Ec]	1B5D	EcX	1B58
ATTN	©A	01	Shift-Enter	0000 *
PRINT	©P	10	EcV	1B56
HOME	©A	1C	©A	01
ERASE EOF	©F	06	©X	18
DELETE	©Backspace	7F	©T	14
ERASE INPUT	©L	0C	©R	12
INSERT	©]	1D	©Y	19
RESET	©R	12	Ec©A	1B01
SYS REQ	©B	02	Ec;	1B3B
CLEAR	©E	05	EcM	1B4D

### Other Keys on the 3278 Keyboard

CURSOR SEL	©D	04	n/a	n/a
IDENT	©V	16	n/a	n/a
TEST	©T	15	n/a	n/a
DEV CNCL	©X	18	n/a	n/a
TAB	Tab	09	Tab or ©I	09
BACK TAB	©K	0B	©O	0F
NEW LINE	Return †	0D	©J or Return	0A
ENTER	Enter	0D0A	Enter	0D
DUP	©U	15	©N	0E
FIELD MARK	©Y	19	©W	17
UP ARROW	EcOA	1B4F41	Ec[A	1B5B41
DOWN ARROW	EcOB	1B4F42	Ec[B or ©D	1B5B42
RIGHT ARROW	EcOC	1B4F43	Ec[C	1B5B43
LEFT ARROW	EcOD	1B4F44	Ec[D or ©H	1B5B44

**Note:** Ec = Escape Key (~); © = Control Key (Command)

\* A least half a second of zeros (Hex 00); this is also called a Break.

† Available in MacTerminal Version 2.0 only.

# The IBM 3278 Keyboard

## Overview

**MacTerminal provides the functions of all of the special keys on a 3278 keyboard.**

The IBM 3278-2 terminal has quite a variety of special-function keys, command keys, and arrow keys, in addition to the standard keyboard (as shown below). While emulating an IBM 3278-2 terminal through either AppleLine or an ACC, you have access to all of these special keys.

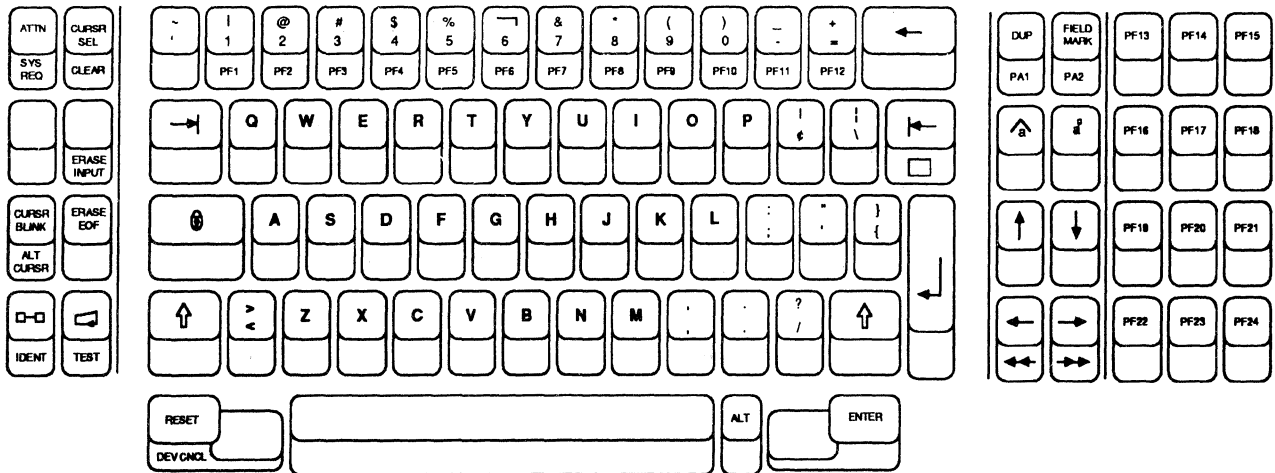

This section describes how Macintosh is able to emulate the function of all of the keys on the 3278 keyboard.

## Use Special Keys

**Macintosh uses the Escape and Control keys to provide the features of the 3278 keyboard.**

One way to emulate all of the 3278 keys is by combining the Escape and Control keys with other keys on the Macintosh keyboard. (The Tilde key—top left corner of the Macintosh keyboard—is the Escape key, and the Command key—next to the spacebar—is the Control key.) A chart that shows which Macintosh keys are used to emulate each of the 3278 keys is shown on the facing page. (This information is also listed on a quick reference card that's included in the back of the *AppleLine User's Manual*.)

## Use the Mouse

### Use the mouse and the Keypad menu instead of the Escape and Control keys.

When you open the **Keypad** menu, you'll have access to many of the special keys that are on the 3278 keyboard. Use the mouse to "press" the key you want.

#### Keypad

PF1	PF2	PF3	PF4	PF5	PF6	PF7	PF8	PF9	PF10	PF11	PF12
PF13	PF14	PF15	PF16	PF17	PF18	PF19	PF20	PF21	PF22	PF23	PF24
PA1	PA2	Attn	Print	Home	Erase EOF	Delete	Erase Input	Insert	Reset	Sys Req	Clear

### You can also use the mouse, instead of the arrow keys, to control the cursor.



The 3278 keyboard has arrow keys to control the cursor on the screen. On the Macintosh XL, there are cursor keys on the numeric keypad. On any of the Macintosh models, you can hold down the Option key and the mouse pointer will change into four arrows (as shown at the left). Use the mouse to indicate where you want the cursor, and then, while still holding down the Option key, click the mouse button to actually move the cursor to that position.

## Terminal Settings

### Overview

**This section describes terminal settings for the most common MacTerminal uses.**

MacTerminal has the flexibility needed to communicate with a wide range of computers, each of which expects to receive information in a particular format. Before you can correctly configure MacTerminal to communicate with a specific mainframe, you need to know the correct terminal and compatibility settings.

This section describes the settings that are appropriate for the computers with which you will be communicating most often. The configurations discussed in this section are for connecting a Macintosh to the following systems:

- The AppleLine Supervisor
- An IBM mainframe, through AppleLine
- An IBM mainframe, through an Apple Cluster Controller

At the end of the section is a practice exercise that will help to ensure that you know how to configure MacTerminal for each of these situations.

### Terminal Settings

**The various terminal settings are explained in the manual.**

When using AppleLine, there are two sets of communications settings to consider:

- The MacTerminal settings, which control how MacTerminal communicates with AppleLine. They are displayed by choosing the appropriate command from the **Settings** menu. If it would be helpful, review the section in Chapter 3 of the MacTerminal manual that describes the **Settings** menu.
- The AppleLine Supervisor settings, which control how the AppleLine communicates with MacTerminal. The Supervisor settings can be displayed by choosing the appropriate option from the Supervisor's main menu that's displayed in the MacTerminal window. (The Supervisor is described in more detail in the next section.)

When using an Apple Cluster Controller, you only need to be concerned with the MacTerminal settings.

## Terminal Settings for an IBM Mainframe

**Read the manual to learn the terminal settings for connecting to an IBM mainframe.**

Read all of Appendices C and D of *MacTerminal*, the owner's manual, to learn how to configure MacTerminal to communicate with an IBM mainframe through AppleLine and through the Apple Cluster Controller. Appendix C describes how to use MacTerminal to run the Supervisor program, which enables you to configure AppleLine, and how to connect to a mainframe through AppleLine. Appendix D explains how to use the Apple Cluster Controller. Just *read* the appendices—don't start up MacTerminal (even though the manual instructs you to do so). You'll have a chance later in this module to practice doing what the manual describes.

Continue with this module when you have finished reading Appendices C and D.

---

## ***Practice***

### **Check Appropriate Settings**

**Configure MacTerminal to communicate with the computer indicated.**

On the next page, there are two pairs of screen shots, each consisting of a Terminal Settings window and a Compatibility Settings window. Mark the appropriate settings for each data communications situation. If it would be helpful, refer to the manual.



When you've finished, check your answers by reading the feedback that follows this exercise.

## IBM with AppleLine

## Configure MacTerminal to communicate with an IBM mainframe through AppleLine.

(Note: You are *not* running the AppleLine Supervisor program. Mark the appropriate settings for using AppleLine to connect to an IBM mainframe.)

Terminal Settings			
Terminal	<input type="radio"/> UT100	<input type="radio"/> TTY	<input type="radio"/> IBM 3278
Mode	<input type="radio"/> ANSI		<input type="radio"/> UT52
Cursor Shape	<input type="radio"/> Underline		<input type="radio"/> Block
Character Set	<input type="radio"/> United States		<input type="radio"/> United Kingdom
Line Width	<input type="radio"/> 80 Columns		<input type="radio"/> 132 Columns
Protocol Conv	<input type="radio"/> AppleLine		<input type="radio"/> Cluster Ctlr
<input type="checkbox"/> On Line	<input type="checkbox"/> Local Echo		<input type="checkbox"/> Status Lights
<input type="checkbox"/> Auto Repeat	<input type="checkbox"/> Auto Wraparound		<input type="checkbox"/> New Line
<input type="checkbox"/> Repeat Ctrls	<input type="checkbox"/> Transparent		
			<input type="button" value="OK"/> <input type="button" value="Cancel"/>



Compatibility Settings				
Baud Rate	<input type="radio"/> 50	<input type="radio"/> 75	<input type="radio"/> 110	<input type="radio"/> 134.5
	<input type="radio"/> 150	<input type="radio"/> 200	<input type="radio"/> 300	<input type="radio"/> 600
	<input type="radio"/> 1200	<input type="radio"/> 1800	<input type="radio"/> 2000	<input type="radio"/> 2400
	<input type="radio"/> 3600	<input type="radio"/> 4800	<input type="radio"/> 9600	<input type="radio"/> 19200
Bits per Character	<input type="radio"/> 7 Bits		<input type="radio"/> 8 Bits	
Parity	<input type="radio"/> Even	<input type="radio"/> Odd	<input type="radio"/> None	
Handshake	<input type="radio"/> XOn/XOff		<input type="radio"/> None	
Connection	<input type="radio"/> Modem		<input type="radio"/> Another Computer	
Connection Port	<input type="radio"/> 	<input type="radio"/> 		
			<input type="button" value="OK"/> <input type="button" value="Cancel"/>	

## IBM with ACC

## Configure MacTerminal to communicate with an IBM mainframe via an Apple Cluster Controller.

Assume that your Macintosh is connected directly to the Apple Cluster Controller—not through a modem.

Terminal Settings			
Terminal	<input type="radio"/> UT100	<input type="radio"/> TTY	<input type="radio"/> IBM 3278
Mode	<input type="radio"/> ANSI		<input type="radio"/> UT52
Cursor Shape	<input type="radio"/> Underline		<input type="radio"/> Block
Character Set	<input type="radio"/> United States		<input type="radio"/> United Kingdom
Line Width	<input type="radio"/> 80 Columns		<input type="radio"/> 132 Columns
Protocol Conv	<input type="radio"/> AppleLine		<input type="radio"/> Cluster Ctlr
<input type="checkbox"/> On Line	<input type="checkbox"/> Local Echo		<input type="checkbox"/> Status Lights
<input type="checkbox"/> Auto Repeat	<input type="checkbox"/> Auto Wraparound		<input type="checkbox"/> New Line
<input type="checkbox"/> Repeat Ctrls	<input type="checkbox"/> Transparent		
			<input type="button" value="OK"/> <input type="button" value="Cancel"/>

Compatibility Settings				
Baud Rate	<input type="radio"/> 50	<input type="radio"/> 75	<input type="radio"/> 110	<input type="radio"/> 134.5
	<input type="radio"/> 150	<input type="radio"/> 200	<input type="radio"/> 300	<input type="radio"/> 600
	<input type="radio"/> 1200	<input type="radio"/> 1800	<input type="radio"/> 2000	<input type="radio"/> 2400
	<input type="radio"/> 3600	<input type="radio"/> 4800	<input type="radio"/> 9600	<input type="radio"/> 19200
Bits per Character	<input type="radio"/> 7 Bits		<input type="radio"/> 8 Bits	
Parity	<input type="radio"/> Even	<input type="radio"/> Odd	<input type="radio"/> None	
Handshake	<input type="radio"/> XOn/XOff		<input type="radio"/> None	
Connection	<input type="radio"/> Modem		<input type="radio"/> Another Computer	
Connection Port	<input type="radio"/> 	<input type="radio"/> 		
			<input type="button" value="OK"/> <input type="button" value="Cancel"/>	

---

## **Feedback**

### **Check Your Answers**

**Check your answers against those shown on the next two pages.**



In the Terminal Settings window, **Cursor Shape** can be set either way. In the screen shots on the next two pages, it's set the way it is most often used; the actual setting is left to your personal preference.

If there are discrepancies that you don't understand, reread the section of the manual that pertains to that feature of MacTerminal. If you still have questions, check with a colleague, the course manager, your Apple support representative, or anyone else who is familiar with MacTerminal or data communications in general (such as your data-processing manager).

## IBM with AppleLine

## Configure MacTerminal to communicate with an IBM mainframe through AppleLine.

Terminal Settings			
Terminal	<input type="radio"/> VT100	<input type="radio"/> TTY	<input checked="" type="radio"/> IBM 3278
Mode	<input checked="" type="radio"/> RNSI		<input type="radio"/> VT52
Cursor Shape	<input checked="" type="radio"/> Underline		<input type="radio"/> Block
Character Set	<input checked="" type="radio"/> United States		<input type="radio"/> United Kingdom
Line Width	<input checked="" type="radio"/> 80 Columns		<input type="radio"/> 132 Columns
Protocol Conv	<input checked="" type="radio"/> AppleLine		<input type="radio"/> Cluster Ctr
<input checked="" type="checkbox"/> On Line	<input type="checkbox"/> Local Echo		<input type="checkbox"/> Status Lights
<input checked="" type="checkbox"/> Auto Repeat	<input type="checkbox"/> Auto Wraparound		<input checked="" type="checkbox"/> New Line
<input type="checkbox"/> Repeat Ctrls	<input type="checkbox"/> Transparent		
<input type="button" value="OK"/> <input type="button" value="Cancel"/>			

Compatibility Settings				
Baud Rate	<input type="radio"/> 50	<input type="radio"/> 75	<input type="radio"/> 110	<input type="radio"/> 134.5
	<input type="radio"/> 150	<input type="radio"/> 200	<input type="radio"/> 300	<input type="radio"/> 600
	<input type="radio"/> 1200	<input type="radio"/> 1800	<input type="radio"/> 2000	<input type="radio"/> 2400
	<input type="radio"/> 3600	<input type="radio"/> 4800	<input checked="" type="radio"/> 9600	<input type="radio"/> 19200
Bits per Character	<input checked="" type="radio"/> 7 Bits		<input type="radio"/> 8 Bits	
Parity	<input checked="" type="radio"/> Even	<input type="radio"/> Odd	<input type="radio"/> None	
Handshake	<input checked="" type="radio"/> XOn/XOff	<input type="radio"/> None		
Connection	<input type="radio"/> Modem	<input checked="" type="radio"/> Another Computer		
Connection Port	<input checked="" type="radio"/> 	<input type="radio"/> 		
<input type="button" value="OK"/> <input type="button" value="Cancel"/>				

**Your choice of the Baud Rate setting may be different.**

If your Macintosh is connected directly to AppleLine, set the baud rate to **9600**. If you are communicating with AppleLine through a modem, set the baud rate to **1200**.

**There are different configurations for Supervisor mode and User mode.**

The main differences in how you configure your MacTerminal document when running the Supervisor program versus signing on as a user and communicating with an IBM mainframe, are as follows:

	<u>Terminal</u>	<u>New Line</u>
Supervisor	VT100	OFF
User	3278	ON





## Feedback (cont'd)

### IBM with ACC

Configure MacTerminal to communicate with an IBM mainframe via an Apple Cluster Controller.

Terminal Settings	
Terminal	<input type="radio"/> UT100 <input type="radio"/> ITTY <input checked="" type="radio"/> IBM 3278
Mode	<input checked="" type="radio"/> RNSI <input type="radio"/> UT52
Cursor Shape	<input checked="" type="radio"/> Underline <input type="radio"/> Block
Character Set	<input checked="" type="radio"/> United States <input type="radio"/> United Kingdom
Line Width	<input checked="" type="radio"/> 80 Columns <input type="radio"/> 132 Columns
Protocol Conv	<input type="radio"/> AppleLine <input checked="" type="radio"/> Cluster Ctr
<input checked="" type="checkbox"/> On Line	<input type="checkbox"/> Local Echo <input type="checkbox"/> Status Lights
<input checked="" type="checkbox"/> Auto Repeat	<input checked="" type="checkbox"/> Auto Wraparound <input type="checkbox"/> New Line
<input type="checkbox"/> Repeat Ctrls	<input type="checkbox"/> Transparent
<input type="button" value="OK"/> <input type="button" value="Cancel"/>	

Compatibility Settings	
Baud Rate	<input type="radio"/> 50 <input type="radio"/> 75 <input type="radio"/> 110 <input type="radio"/> 134.5 <input type="radio"/> 150 <input type="radio"/> 200 <input type="radio"/> 300 <input type="radio"/> 600 <input type="radio"/> 1200 <input type="radio"/> 1800 <input type="radio"/> 2000 <input type="radio"/> 2400 <input type="radio"/> 3600 <input type="radio"/> 4800 <input checked="" type="radio"/> 9600 <input type="radio"/> 19200
Bits per Character	<input checked="" type="radio"/> 7 Bits <input type="radio"/> 8 Bits
Parity	<input checked="" type="radio"/> Even <input type="radio"/> Odd <input type="radio"/> None
Handshake	<input checked="" type="radio"/> HOn/HOff <input type="radio"/> None
Connection	<input type="radio"/> Modem <input checked="" type="radio"/> Another Computer
Connection Port	<input checked="" type="radio"/>  <input type="radio"/> 
<input type="button" value="OK"/> <input type="button" value="Cancel"/>	

The Baud Rate setting may vary.

The baud rate is set to 9600 because Macintosh is directly connected to the Apple Cluster Controller. If Macintosh were connected via a modem, the baud rate would be set to that of the modem, usually 1200.

# AppleLine Supervisor

## Overview

**This section describes the Supervisor and other aspects of using AppleLine.**

Without the Supervisor, you wouldn't be able to use AppleLine to communicate with IBM mainframes. Therefore, it's very important that you understand what the Supervisor does and when to use it. This section describes the basic purpose of the Supervisor, the two steps to using AppleLine, and the difference between configuring MacTerminal as a VT100 to communicate with the Supervisor, and configuring MacTerminal as a 3278 terminal for communicating with an IBM mainframe through the AppleLine.

## Two Steps to Using AppleLine

### 1. Run the Supervisor to configure AppleLine.

Just as you can configure MacTerminal in a variety of ways, you can configure AppleLine to communicate with a variety of terminals, (for example, a Macintosh that's running MacTerminal). The Supervisor is a program that resides in AppleLine and enables you to configure it to communicate with the terminal you're using.

The first step in using AppleLine to connect a Macintosh to an IBM mainframe is to use the Supervisor to configure AppleLine for communicating *with the Macintosh*. (AppleLine already knows how to communicate with the mainframe.) Configure MacTerminal as a VT100 terminal to run the Supervisor. This means establishing a local connection between the Macintosh and the AppleLine. You don't need to be connected to a mainframe to use the Supervisor.

### 2. Use the AppleLine to communicate with a mainframe.

After running the Supervisor, the next step is to use AppleLine as a protocol converter to connect to an IBM mainframe.

Configure MacTerminal to emulate an IBM 3278 terminal. Information from Macintosh will be sent to AppleLine, which will translate it into a format that the mainframe can understand. Then AppleLine will send the information on to the 327x Cluster Controller that's connected to the mainframe (see the IBM Computer Components diagram, earlier in the module, for a reminder of how these components work together).

Cluster Controller that's connected to the mainframe (see the IBM Computer Components diagram, earlier in the module, for a reminder of how these components work together).

### **Why must MacTerminal be configured first as a VT100, then as a 3278?**

As you read earlier, when using the AppleLine Supervisor you should configure MacTerminal as a VT100 terminal. But when communicating with a mainframe through AppleLine, you should configure MacTerminal as a 3278 terminal. You may be wondering why you need to use the different settings and what the differences between them are.

AppleLine can be used with many types of terminals, so the Supervisor needs to be able to communicate with as many terminals as possible. Therefore, it supports a very basic protocol that most terminals can emulate, VT100.

You can also use the VT100 protocol when you want to communicate with a mainframe, but you won't have easy access to the 3278 terminal's various special keys. You'll have to use the Escape and Command keys to enter the appropriate codes. The MacTerminal 3278 terminal-emulation mode provides 3278 keyboard mapping, and changes the **Keypad** menu to conform to the various special keys available on a 3278 terminal. The actual communication between MacTerminal and the AppleLine is still basically in VT100 protocol. The 3278 terminal-emulation mode just makes it easier to access the various special keys that are on a 3278 keyboard.

For more information on the Supervisor, refer to the *AppleLine User's Guide*.

## Practice Using AppleLine

### Overview

**This section gives you an opportunity to use AppleLine.**

When you first use AppleLine to connect to an IBM mainframe, the normal series of events is the following:

1. Run the Supervisor program to configure AppleLine for communicating with a Macintosh.
2. Set the MacTerminal terminal type to **IBM 3278**.
3. Connect to the mainframe (through AppleLine).

Subsequently, you only need to do steps 2 and 3, unless you want to change the Supervisor's terminal settings or passwords.

In this exercise, you will:

1. Set up your AppleLine.
2. Run the Supervisor program and change the AppleLine terminal settings and passwords.
3. Use AppleLine to emulate a 3278-2 terminal. (If you don't have an IBM 3274 Cluster Controller, skip this part.)
4. Use the Loop-Back Connector to reset the AppleLine terminal settings and passwords to their default settings.

Complete each step as it's described. If you need help, refer to this module, the MacTerminal manual, or the *AppleLine User's Guide*. If you need help connecting to the IBM mainframe, check with your company's data processing manager, or another authorized person who is experienced using the system. If you need assistance with any of the Apple products, ask a colleague, your course manager, or your Apple support representative.

---

## **Practice**

### **Set Up and Use AppleLine**

### **In this exercise you will set up and use AppleLine.**

You'll begin this practice by connecting AppleLine to your Macintosh. Then you'll run the Supervisor program and adjust its communications settings. If you have access to an IBM 3274 Cluster Controller and an appropriate mainframe, you will also have a chance to use AppleLine to communicate with the mainframe. Finally, you will reset all of the Supervisor settings using the Loop-Back Connector.

If you have problems at any time during this exercise, check the Feedback section that immediately follows.

### **Set Up AppleLine**

### **Be sure you have all the equipment you need.**

(Note: You have already read about this procedure in the manual. Some of what you read is repeated here to guarantee that you understand the steps involved and are able to set up and use the AppleLine correctly.)

Included with AppleLine, you should have:

- Transformer/power cable
- Gender Changer Connector
- Loop-Back Connector

You'll also need a cable to connect AppleLine to your Macintosh, and the appropriate cable to connect the AppleLine to the IBM 3274. To connect to the Macintosh you need a standard RS-232 serial cable. The Macintosh ImageWriter™ cable (p/n 590-0169) is recommended. To connect to the 3274 you need a coaxial cable with a BNC connector on the AppleLine end.

(Note: See Appendix B in the *AppleLine User's Manual* for more information about cables.)

### **Connect the cables.**

1. Plug the power cord into the socket marked "24v AC" on the back of AppleLine. Don't turn it on yet.

2. Plug the transformer into a 110v socket. Use the screw that came with the transformer to ground and firmly attach the transformer to the socket.
3. Connect the serial cable to AppleLine and to the modem connector on the Macintosh.
4. Attach the cable that is connected to the IBM 3274 Cluster Controller (if you have one) to the BNC connector.

*Don't turn AppleLine on yet.*

### **Start Up MacTerminal**

### **Start up your Macintosh from your MacTerminal disk.**

*Be sure to use MacTerminal Version 2.0. Otherwise, the commands you should enter and the sequence of events may be different from those shown here.*

1. Open the AppleLine Supervisor document that's on the MacTerminal disk. (If you do not have the original MacTerminal disk, open the MacTerminal application icon to create a new MacTerminal document.)
2. Check the settings. The correct terminal and compatibility settings for communicating with the AppleLine Supervisor were shown earlier in this module. Open the Terminal Settings and Compatibility Settings windows to be sure they are correct, and make any necessary changes. Specifically, be sure the document is on line. If you think it would help, refer to the MacTerminal manual.

### **Run the AppleLine Supervisor Program**

### **Use the Supervisor to check the AppleLine settings and to change the passwords.**

The Supervisor is only for communicating between the Macintosh and AppleLine. It doesn't affect how Macintosh communicates with the mainframe.

1. Turn on AppleLine. (The switch is on the right side, near the front.) Wait for the yellow and green lights to flash alternately.
2. Press Return in response to the message on your screen. If you don't see anything on your screen, press Enter (or any letter key) on your keyboard.

## **Practice (cont'd)**

3. When asked for the password, type **Apples**. If the password is not "Apples," skip ahead to the Reset Terminal Settings section of this exercise and do what is necessary to reset the passwords. Then return to this exercise.
4. Type **A** to display the current AppleLine terminal settings.
5. The terminal settings are fine as they are, but if you want to see how to change them, type **B** from the AppleLine main menu. (These settings are for communicating with the Macintosh, so if you change them you must be sure that MacTerminal is configured the same way.)
6. AppleLine has five passwords—one to run the Supervisor and four user passwords. Type **C** from the AppleLine main menu to change any of the passwords.
7. Type **A** to change the first user password. Enter the password you want, and press Return to accept the default response (Yes) to the confirmation question.

**Warning:** Don't change the Supervisor password to make it the same as one of the user passwords, or you won't be able to run the Supervisor. Also, don't change one of the user passwords to *Apples*—which is currently the Supervisor password.

8. Type **F** to return to the main menu.
9. Type **D** to quit the Supervisor. You can to save any changes that you made, to either the settings or the passwords.
10. Quit MacTerminal. If you wait more than a couple of seconds before turning off the Macintosh, the initial log-on screen will be redisplayed. It's okay to quit MacTerminal at this time.

## Connect to the Mainframe

### Use AppleLine to connect to an IBM mainframe through an IBM 3274 Cluster Controller.

If you're not going to connect to a mainframe, just read through this part of the practice exercise, and then continue following the instructions beginning with the Reset Terminal Settings heading.

1. On the released MacTerminal disk, there is a document named *AppleLine* that's already configured to communicate through AppleLine to an IBM mainframe. If you do not have the actual MacTerminal release disk, open a new MacTerminal document.
2. Earlier in this module, you learned the correct terminal and compatibility settings for using AppleLine to connect to an IBM mainframe. Check the settings of the document you just opened to be sure they are correct. (If it would help, refer to this module or to the MacTerminal manual.)
3. Turn AppleLine off, then on again. This will configure it according to the settings entered via the Supervisor.
4. Turn on the IBM 3274 Cluster Controller.
5. Place your MacTerminal document on line, if you have not already done so.
6. Press Return in response to the message on the screen.
7. Enter the password. Use any one of the four user passwords, which are **Apple1**, **Apple2**, **Apple3**, and **Apple4** (unless you changed them when you were in the Supervisor).
8. The next thing you will see is the initial screen sent from the IBM mainframe, which is different for every system. It will appear exactly as it would appear on an IBM 3278-2 terminal. (Note: If you see "X()" on the screen, it means *wait*.)
9. Follow the appropriate procedure to log on to the mainframe.
10. You can now access the mainframe exactly as you would if you were using at a 3278-2 terminal.
11. After you finish your communications session, log off the mainframe.
12. Quit MacTerminal.



## Practice (cont'd)

### Reset Terminal Settings

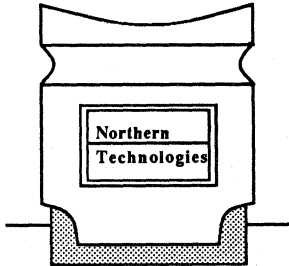

### Use the Loop-Back Connector to reset the terminal settings and passwords.

The AppleLine communication settings and passwords, as set by the Supervisor program, are stored in AppleLine. The Loop-Back Connector changes these settings and passwords back to their default settings, which are listed in Chapter 3 of the *AppleLine User's Manual*. The Loop-Back Connector is the small white plastic connector, similar to the one shown at the left.

There are two situations in which you might need to use the Loop-Back Connector.

- You change the terminal settings and then forget what they are. Remember that the settings are for communicating with MacTerminal, so if you forget the correct settings you won't be able to correctly configure MacTerminal to communicate with AppleLine.
- You forget your password or you change the Supervisor password so that it is the same as one of the user passwords, which prevents you from running the Supervisor.

Complete each step of the Loop-Back test as it's described.

### Perform the Loop-Back test.

1. Turn your AppleLine off.
2. Unplug (from the back of AppleLine), the serial cable that connects AppleLine to the Macintosh.
3. Connect the Loop-Back Connector to the DB-25 connector that's on the back of the AppleLine.
4. Turn AppleLine's power switch on. Wait until the yellow light starts blinking.
5. Remove the Loop-Back Connector (with the power on).
6. Wait five seconds.
7. **Don't turn the power off.**

You're now ready to reconnect the cable that runs to the Macintosh. All of the settings and passwords have been reset to their defaults.

### Check Supervisor settings.

1. Reconnect the cable leading to the Macintosh (while AppleLine is still on).
2. Follow the same procedure you used earlier to run the AppleLine Supervisor program. (Be sure to turn AppleLine back on.) If it would help, refer back to that part of the practice exercise.
3. Display the Supervisor terminal settings by typing A in response to the Supervisor main menu. The settings should have the default values listed in Chapter 3 of the *AppleLine User's Guide*.
4. Type D to quit the Supervisor.
5. Quit MacTerminal.

---

## Feedback

### Set Up and Use AppleLine

#### Summary of Practice exercise.

You should have done the following:

- Set up AppleLine and connected it to a Macintosh.
- Run the Supervisor program via MacTerminal, and displayed (and possibly changed) terminal settings and passwords.
- Connected to an IBM mainframe via MacTerminal and AppleLine (if you had access to a mainframe).
- Used the Loop-Back Connector to reset the AppleLine settings and passwords.
- Rerun the Supervisor to see the results of the Loop-Back test.

#### All AppleLine settings should be set to their defaults.

The last thing you did was to use the Loop-Back Connector to return the AppleLine settings to their default values. If you had some problems along the way, here are some possible solutions and where to look for help. If the suggestions below don't help, check with a colleague, your course manager, or your Apple support representative.

## **Feedback (cont'd)**

### **Set up AppleLine and run MacTerminal.**

If you had troubles setting up AppleLine, check the *AppleLine User's Manual*. If you had problems connecting AppleLine to the Macintosh, or if you're not sure you configured MacTerminal correctly, reread the Practice Using AppleLine section in this module, or Appendix C of the MacTerminal manual.

### **Run the Supervisor program.**

- Read Chapter 3 of the *AppleLine User's Manual* for more information on using the Supervisor.
- Be sure MacTerminal's terminal and compatibility settings are configured in the same way as the Supervisor's. If you couldn't get into the Supervisor because the settings were wrong, use the Loop-Back Connector to reset the Supervisor to its default terminal settings. Then be sure MacTerminal is configured the same way.

### **Connect to a mainframe.**

- Confirm that you're connected to the IBM 3274 correctly, and that you know the log-on procedure for getting into the mainframe.
- Check Appendix C of the MacTerminal manual to be sure that MacTerminal is configured correctly for connecting to an IBM through AppleLine.

### **Use the Loop-Back Connector.**

Review Chapter 4 of the *AppleLine User's Manual* if you would like more information about running the Loop-Back test.

## Communicating with an IBM PC

### Use MacTerminal in Async ASCII

### Communicate with a comparably configured program on an IBM PC.

You can use your Macintosh with MacTerminal to communicate with an IBM PC by using the same techniques you use to communicate with many other computers for which you don't have a terminal emulator. You need to configure MacTerminal to communicate in asynchronous ASCII, and be sure that MacTerminal and the program running on the PC are "talking the same language" (in other words, that they are using the same data communications settings). You can connect either directly (be sure that you have the appropriate serial cable) or through a modem.

You can use XModem if the software running on the PC also supports the XModem protocol and if you have the appropriate software to open the file you transfer.

Hayes SmartCom II is a data communications program that runs on the IBM PC and is compatible with the Hayes SmartModem. It has auto-dial and auto-answer capabilities and works well for communicating with MacTerminal.

The following are some other data communications programs that enable communications between a Macintosh and an IBM PC:

- Crosstalk XVI from Microstuf.
- MacLink from DataViz (file translation: Wordstar <—> MacWrite; 123 <—> Multiplan; Multimate <—> MacWrite).
- Mite from Microft Labs.
- PC to MAC and BACK from dilithium Software.
- SmartTerm from Persoft, Inc. (VT100 emulation).

## Questions and Answers

### Overview

**Here are the questions commonly asked by MacTerminal users, and the correct answers.**

You now know how to use MacTerminal with IBM computers. But as a support person, you will also be called upon to answer end users' questions about AppleLine, the Apple Cluster Controller, and using MacTerminal to communicate with IBM computers.

This section is a summary of the most commonly asked questions, and the correct answers. This material does not go into technical detail beyond what most users need to know in order to use the product.

### Check for Terminal Type

*How do I check for the terminal type when connected to the Apple Cluster Controller?*

There are two aspects to this question:

(1) When you connect to the Apple Cluster Controller, there is a banner across the top of the window that tells you the terminal type, among other information. The terminal type should be **VT100/ANSI**. If at any time you want to redisplay this banner, press **Escape Command-S**. (Remember, the Tilde key (~) is the Escape key.)

(2) A switch setting on the Apple Cluster Controller printed circuit board determines the base brand "family" of the terminal. To display the base brand, press **Escape Command-B**. The value displayed for a VT100-type terminal should be **0C**.

### AppleLine Passwords

*How can I get into the Supervisor if I forget my AppleLine password?*

Use the Loop-Back Connector to reset the AppleLine to its default passwords. It will reset the terminal settings to their defaults, too. (See the Practice exercise in the Connecting to an IBM Computer section of this module, or the *AppleLine User's Manual*, for detailed instructions on how to use the Loop-Back Connector.)

**AppleLine Wait Message**

*When I'm using the AppleLine, what does the message "X( )" mean?*

It means to wait, just as if you saw the wristwatch while running other Macintosh software.

**Different 3278 Models**

*Does AppleLine replace 3278 Model 4 and Model 5 terminals?*

No. AppleLine replaces 3278 Model 2 terminals. If you want to replace a 3278 Model 4 or Model 5 terminal with a Macintosh and AppleLine, you must reconfigure the host to recognize that node as a 3278 Model 2 terminal.

**MacTerminal and Switcher**

*I'm using the Switcher™ to run MacTerminal along with other applications, and I am currently using MacTerminal and AppleLine to connect to a host computer. What happens when I switch to another application?*

AppleLine keeps the session active even if the MacTerminal document is not active. It will continue to be active until it gets a signal from MacTerminal to end the session. If information is being downloaded from the host, AppleLine will hold the information in its buffer. If its buffer fills up, it will use the buffer in the 3274. When that fills up, it signals the host to stop transmitting information.

When you reactivate the MacTerminal document, all of the information stored in the AppleLine buffer and the 3274 buffer is downloaded into the MacTerminal document, and AppleLine signals the host to start transmitting again.

No information is lost while MacTerminal is inactive, that is, while you have switched to another application.

**Printing the Screen**

*MacTerminal Version 2.0 will scroll the screen contents off the top of the screen when a clear screen command is received (in Version 1.1, the contents of the screen are lost). Can the contents of the screen be printed automatically when a clear screen command is received, in addition to or instead of scrolling the information off the top of the screen?*

The basic ability is there, but the specific software to do it has not been written. In the meantime, everything is saved in your MacTerminal document, so print the document when you have finished the data communications session.

## AppleLine Passwords

*Why are there four user passwords when you can only use AppleLine with one Macintosh?*

Though only one user can use AppleLine at a time, up to four users can share access to one AppleLine via modems. Four passwords are available so that four different users can each have their own password for using the same AppleLine. Then, if one user loses the right to access the host, his password can be canceled or changed without affecting the other three users.

## AppleLine ROM Versions

*What is the current version of the AppleLine ROMs, and how do I find out what I have?*

There are two parts to the version number. The current version is *Version 2.2 with 3.30*. To check which ROMs you have, do the following:

1. Find the first part of the version number on the initial AppleLine screen (the one that asks you to press Return to continue). On the top line, you will see "Vx.x" next to the date. The "x.x" is the first part of the version number (currently it's "V2.2").
2. Once you're into AppleLine, press Escape Control-B to display the contents of all of the registers. In the third and fourth columns, near the bottom, you'll notice "REV.LOW" and "REV.HI." These two registers contain the other half of the version number, which consists of REV.HI followed by a decimal point followed by REV.LOW. For example, if REV.HI is "03" and REV.LOW is "30", the second part of the version number is "3.30."

---

## AppleLine and ACC Specifications

### Overview

This section lists the specifications for AppleLine and the Apple Cluster Controller.

This information is provided to help you answer users' questions.

### AppleLine

#### Terminal Types

Access 3270  
Access III (VT100 Emulation)  
LisaTerminal  
MacTerminal

#### Apple Interface Options

ASCII code  
7 or 8 data bits  
1 or 2 stop bits  
Odd, even, mark, space, or no parity

#### Apple Interface Data Rates

45.5 to 19200 baud

#### Buffer Capacities

Command: 15 characters  
Screen: 3840 characters



**Pinouts**

<u>Pin</u>	<u>Code</u>	<u>Function</u>
1	SNG	Shield ground
2	TXD	Transmitted data
3	RCD	Received data
4	RTS	Request to send
5	CTS	Clear to send
6	DSR	Data set ready
7	GND	Signal ground
8	DCD	Data carrier detect
9-11	NC	No connection
12	CH	Data signal rate selector
13-19	NC	No connection
20	DTR	Data terminal ready
21	NC	No connection
22	CE	Ring indicator
23-25	NC	No connection

Additional pinout information is given in the AppleLink Technical Info library.

**Apple Cluster Controller****Protocols**

- SNA/SDLC (System Network Architecture/Synchronous Data Link Control)
- BSC (Binary Synchronous Communication)

**Cluster Controllers Emulated**

- SNA/SDLC: IBM 3274, 3276 Model 12
- BSC: IBM 3276 Model 2

**Devices Emulated**

- Terminals:
  - SNA/SDLC: IBM 3278-2
  - BSC: IBM 3277
- Printer: 3287-1

**Transmission Speed**

Up to 9600 bps

**Interface**

- Asynchronous: 7-bit ASCII, Full duplex
- Synchronous: 8-bit EBCDIC

## Apple Systems Supported

- Macintosh 128K, Macintosh 512K, Macintosh XL
- Apple III
- Apple II, II Plus, IIe, or IIc (not recommended)

## Terminal Software Supported

- Macintosh: MacTerminal
- Macintosh XL: MacTerminal or LisaTerminal
- Apple III: Access III or Access 3270
- Apple II: Access II

## Pinouts

<u>Pin</u>	<u>Code</u>	<u>Function</u>
1	SNG	Shield ground
2	TX	Transmit data
3	RX	Receive data
4	RTS	Request to send
5	CTS	Clear to send
6	DSR	Data set ready
7	GND	Signal ground
8	DCD	Data carrier detect
9-19	NC	No connection
20	DTR	Data terminal ready
21-25	NC	No connection

Additional pinout information is given in the AppleLink Technical Info library.

## Use AppleLink to get more information.

You can find more information regarding the Apple Cluster Controller in the AppleLink *Technical Info* library. Search for "Cluster and Specifications."

## Review

### The IBM World

#### **First you must understand the IBM world.**

Refer to the diagram at the beginning of this module, or see the information in the *Apple Support Programs* binder, for an overview of the types of products you will find in a typical IBM computer installation. Once you are familiar with an IBM installation, you can see where Apple products fit in.

### Apple Products

#### **AppleLine and the Apple Cluster Controller allow access to IBM mainframes.**

AppleLine connects a single Macintosh to an IBM 3274/76 Cluster Controller either directly or through a modem. The Apple Cluster Controller is functionally identical to an IBM 3274/76 Cluster Controller. You can connect your Macintosh directly to the ACC, which then can be connected to the IBM mainframe either directly or through a synchronous modem.

### The IBM 3278 Keyboard

#### **MacTerminal can emulate all of the keys on the 3278 keyboard.**

The IBM 3278-2 terminal keyboard has many specialized and general-purpose function keys. MacTerminal uses the **Keypad** menu and the Command and Escape keys to emulate all of the functions of the 3278 keyboard. Refer to the table earlier in this module for the specific keyboard mapping and hexadecimal equivalents.

### Terminal Settings

#### **MacTerminal, the owner's manual, contains terminal settings and compatibility settings.**

The MacTerminal manual contains the correct settings for running the AppleLine Supervisor program and for connecting to an IBM mainframe through AppleLine or through the ACC. Refer to the manual or to this module if you have questions about how to configure your MacTerminal document.

**Practice Using AppleLine****Step-by-step instructions for using the Supervisor and connecting to a mainframe.**

This section provides a guided practice exercise for using the AppleLine Supervisor program and for connecting to an IBM mainframe through AppleLine.

**Communicating with an IBM PC****Use third-party software running on the PC to communicate with MacTerminal.**

Configure MacTerminal in the same way you would if you were communicating with any microcomputer. Connect either directly or through a modem, and be sure the two programs are configured identically.

**Questions and Answers****Refer to this section for answers to commonly asked questions about using MacTerminal.**

You should also check AppleLink periodically for new information regarding MacTerminal and communicating with IBM computers.

**AppleLine and ACC Specifications****This section lists the capabilities and limitations of AppleLine and the ACC.**

This information will help you answer questions you'll get regarding the capabilities of AppleLine and the Apple Cluster Controller.

## Resources

---

- *MacTerminal*, the owner's manual, Apple Computer, Inc.
- *Apple Support Programs* binder
- *AppleLine User's Guide*, Apple Computer, Inc.
- *Data Communications Technical Procedures* binder, Volume 1
- *Apple Cluster Controller and AppleLine Sales Reference Guide*, Apple Computer, Inc.
- *Apple Systems Fact Book*, Apple Computer, Inc.
- AppleLink (If you have access to AppleLink, check it regularly—particularly the Technical Info library—for additional data communications information.)
- *Supporting MacTerminal* module in the Apple Support Training Library.

*Apple Computer does not endorse the third-party products mentioned in this module. They're included here because Apple wants you to be aware of their availability. Contact the developer or a retail dealer for more information.*

*Apple, the Apple logo, and Lisa are registered trademarks of Apple Computer, Inc. AppleLine, AppleLink, ImageWriter, MacTerminal, and Switcher are trademarks of Apple Computer, Inc. Macintosh is a trademark of McIntosh Laboratory, Inc. and is being used with express permission of its owner. IBM is a registered trademark of International Business Machines Corporation. MacLink is a trademark of DataViz, Inc. MITE is a trademark of Microft Labs, Inc. PC to MAC and BACK is a trademark of dilithium Press. Smartcom II is a trademark of Hayes Microcomputer Products, Inc.*

# Supporting MacTerminal

---

## Contents

- 2 Overview
- 3 Objectives, Materials
- 4 Questions and Answers  
*Prepare yourself to answer commonly asked questions about using MacTerminal.*
- 12 Using the Manual  
*Learn how to use the manual as a reference tool.*
- 15 MacTerminal Specifications  
*Learn the capabilities and limitations of MacTerminal, and the differences between the two released versions.*
- 18 Pinouts  
*Hardware pinouts to help you build custom cables.*
- 22 Review
- 23 Resources

---

## Overview

This module includes a variety of information that will prepare you for supporting end users of MacTerminal™ software. There's an opportunity to familiarize yourself with the manual, which contains a broad spectrum of information about the program. Much of the module consists of answers to commonly asked questions and important facts and tips about using MacTerminal. There are also sections that contain MacTerminal specifications and hardware pinouts.

Anyone who will be supporting end users of MacTerminal should complete the entire module.

### Prerequisites

- Knowledge of data communications terminology. This can be acquired by completing the *Data Communications Terms* module from the Apple Support Training Library.
- Experience using MacTerminal and knowledge of its capabilities and features, which can be acquired by completing the *Using MacTerminal* module from the Apple Support Training Library.

---

## Objectives

- Answer common end-user questions about MacTerminal either from memory or by looking up the answer in any available resource, including this module and the manual.
- Learn MacTerminal specifications and Macintosh™ pinouts in order to be able to answer additional user questions or to build a custom cable.

---

## Materials

**To complete this module, you will need:**

- *MacTerminal*, the owner's manual



---

## Questions and Answers

### Overview

**Here are the answers to many of the questions you may get about using MacTerminal.**

This section contains the answers to questions you can expect to get about using MacTerminal. Additional information will periodically be made available, primarily through AppleLink™. Check AppleLink regularly, or if you don't have access to it, ask your Apple® support representative.

### Special Keys

*Which keys on the Macintosh keyboard are equivalent to the Escape key and the Control key?*

This was mentioned in the manual, but is worth repeating. The Command key on the Macintosh keyboard, immediately to the left of the space bar, is equivalent to the Control key on other keyboards. The Tilde (~) key, in the top left corner of the keyboard, is equivalent to the Escape key on other keyboards. (Type Command-Shift-~ to produce the Tilde character. Hold down just the Command key to produce the accent.)

### Line Feeds

*Why do I receive all the text on one line?*

When you are receiving information into MacTerminal or the LisaTerminal™ software, it's the job of the sending device to provide line feeds after carriage returns. For example, when you're using your Macintosh computer to send text to another Macintosh, you must select **New Line** on the sending system or the user on the other end will receive all the incoming text overwritten on one line.

If you are sending information from LisaTerminal to MacTerminal, set **Auto New Line** in LisaTerminal to **On** to send a line feed after a carriage return. If you are sending information to Access II on an Apple® II, set **LF after CR**.

If you are sending an entire disk file, line feeds will be provided when you open that document. You only need to be sure line feeds are provided by the sending machine when the information is going directly into an open MacTerminal window.

## Backspacing

*How do I backspace over a character in MacTerminal?*

The host you communicate with using MacTerminal may or may not support the methods of backspacing available to you on the Macintosh. Try typing Command-H to delete a character, or press Backspace to backspace the cursor so you can type over the last character. Or press Command-Backspace to backspace the cursor and remove the last character.

If these methods don't work, consult the host's operating manual or ask someone familiar with the host system.

## Send Graphics

*How do I send graphics via MacTerminal?*

MacTerminal supports *full* transfer of graphics from one Macintosh to another using the XModem protocol. Macintosh-to-mainframe-to-Macintosh also works, as long as the mainframe supports the XModem protocol and acts only as a passive storage medium (doesn't change the information). Sometimes this is called "store and forward."

(**Note:** For more information about XModem, check the MacTerminal manual, and the Disk Files and Text Files section of the *Using MacTerminal* module.)

MacTerminal also supports VT100 graphics.

## Answerback Message

*What is the Answerback Message, and how do I use it?*

The Answerback Message is any string of characters that can be transmitted to the computer to which you are connected. Traditionally, it's used to allow your terminal to identify itself to the host computer. There are two ways for the message to be sent:

- Upon receiving Command-E, MacTerminal will transmit the Answerback Message. Command-E is a standard VT100 convention for a host to request the Answerback Message.
- Type Command-Enter to request that MacTerminal send your Answerback Message to whomever you're connected to.

You may use the Answerback Message to respond to routine prompts, such as the log-on prompt. Enter the response into the Answerback Message dialog box (choose **Answerback Message** from **Settings** menu), and then when you receive the prompt from the host, type Command-Enter to send the reply.

To enter a carriage return in your message, type "^M" (CARET-M). For example "Hello^MAccess 3^MPassword" will be interpreted as:

```
Hello
Access 3
Password
```

## Auto Answer

*How do I get MacTerminal to answer the phone?*

Apple modems and MacTerminal will automatically answer any incoming call as long as your MacTerminal document is open. So to get MacTerminal to auto answer, *don't do anything!*

In MacTerminal Version 1.1, the **Wait for Call** command in the **Phone** menu doesn't work, so don't use it. Actually if you do use it, it *prevents* your Apple modem from answering. This has been fixed in MacTerminal Version 2.0.

The same software problem that prevents you from using **Wait for Call** in Version 1.1 also causes the **Number of Rings Before Answer** command in the **Phone Settings** dialog box to be ignored. This also has been fixed in MacTerminal Version 2.0.

When you're using Version 1.1 and you want to change the number of rings before your Apple or Hayes modem answers the phone, run MacTerminal and type ATSO=n, where n is the number of rings between 1 and 255 (don't set it to 0 or the modem won't answer).

If you're using a 1200-baud Hayes modem, be sure Switch 5 is in the up (open) position if you want the modem to answer automatically.

## Paragraphs or Line Breaks

*I received a text file via MacTerminal and now I want to open it as a MacWrite™ document. I get a message asking if carriage returns should signify paragraphs or line breaks. Which should I choose?*

There are a several ways you may end up with text documents that you want to open as MacWrite documents.

- Documents saved as text only.
- All MacTerminal documents, which includes those into which you have received text from other computers.
- Documents saved from AppleLink.
- Text documents that were sent to another Macintosh using MacTerminal's XModem protocol.

To open any of the text documents mentioned above as MacWrite documents, do the following:

1. Open the MacWrite application icon.
2. Close the Untitled document.
3. Choose **Open**, which lists all MacWrite and text documents.
4. Select the document you want to open.
5. Click **Open**.

You will see the following message:

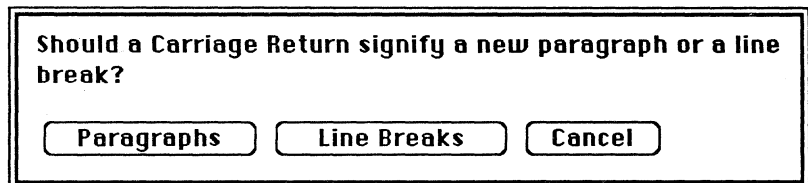

If the application that originally created the document put Return characters at the end of every line, you want to ignore them because MacWrite will take care of wrapping the text to the next line. Therefore, choose for Return characters to signify **Line Breaks**. MacWrite will then ignore single Return characters, only keeping one if it sees two Return characters in a row. For example, if you receive a document via XModem that was originally saved with a Return characters at the end of each line, choose **Line Breaks**.

If the application that originally created the document had automatic word wrapping, Return characters will only have been inserted at the ends of paragraphs. Therefore, you would want to keep all the Return characters, so you would choose **Paragraphs**. For example, all MacTerminal documents only

have Return characters at the end of paragraphs, so choose **Paragraphs**.

You will see a similar message when you send a text file. If the system to which you're sending the file has word wrapping, specify for carriage returns to signify **Paragraphs**. Otherwise, choose **Line Breaks**.

### **XModem Sends Duplicate Text**

*Why doesn't XModem work while XOn/XOff is set?*

The XModem protocol performs checksum error checking. It sends one block at a time, and if, upon receiving the block, the checksum matches, the block is declared OK, and the next block is sent.

**XOn/XOff** controls the flow of information between the two systems. It queries to be sure both systems are ready, and then tells each system when to start and stop sending information. If both are on and an **XOn/XOff** handshake occurs while a block is being sent, the XModem checksum received at the end of the block will be incorrect. This situation generates a request to resend the block, which causes the receiver to receive duplicate text.

### **Non-Apple Modems**

*Can I use MacTerminal with non-Apple modems?*

Yes. As long as 1200-baud modems are 212A Type compatible and 300-baud modems are Bell 103 compatible. (See the Connecting to Other Computers section of the *Using MacTerminal* module for more information on using non-Apple modems.)

### **Little Boxes**

*What does it mean when I see little rectangular boxes among the text?*

You have the parity set wrong. Check the parity of the system you are communicating with or just try other settings. Parity errors might also cause certain characters to be consistently wrong.

### **Wrong Characters**

*What should I do if the words look like they are the right lengths, but the letters are wrong?*

Check the number of bits per character (either 7 or 8) and switch it to the other setting.

**Some Good, Some Bad**

*Most of the screen looks OK, then I get garbage for a while. Why?*

Check to be sure your baud rate is the same as that of the other system. If the baud rate is OK and it's above 1200, turn on **XOn/XOff**.

**Losing Characters**

*Why are characters missing when I receive data?*

Information is being sent faster than you can receive it. Try any of the following solutions:

- Be sure the baud rate is the same on both systems.
- Turn on **XOn/XOff**.
- Slow down the baud rate on both systems.
- Choose **Don't Record Lines Off Top** to speed up the Macintosh's ability to process incoming information.

**Random Characters**

*Why does the last block transferred contain random character when using XModem?*

The XModem protocol sends 128-character blocks. If the last block is not full, it will be filled with random characters. Just delete them from your file.

**Noisy Phone Line**

*I'm getting garbage that seems like it's the result of a noisy phone line, but the phone connection is fine. What should I do?*

If you're using an Apple Modem 1200, check the middle switch. It's usually set in the UP position. Try switching it to DOWN. If this doesn't work, you may just have a bad line. So, hang up, wait a bit, and dial again.

If you're using an Apple Modem 300, the noise may be caused by improper shielding against radio transmissions. There really is no solution other than using an Apple Modem 1200 or the Apple Personal Modem.

**Back Brackets**

*Why do I get intermittent back brackets ( ] ) ?*

These are usually caused by a noisy phone line. Hang up the phone, wait a bit, and then dial again.

## Nothing On the Screen

*What should I do when the modem answers the phone, but nothing appears on my screen?*

First try pressing the Return key a couple of times. Some systems won't transmit until you do so. If that doesn't work, check the following:

- baud rate
- other terminal and compatibility settings
- cable (the cable leading from the modem to your Macintosh may be bad)
- cable connections.

*When I type, nothing appears on the screen. Why?*

There are two ways for a character to be displayed on your screen.

- Your Macintosh displays each character at the same time it sends it to the receiving system.
- When the system receives a character, it echoes the character back to your Macintosh to confirm that the character was correctly received. The character is displayed when it's received by your Macintosh.

If nothing appears on your screen when you type, then neither method is in effect. To get your Macintosh to display what you type, turn on **Local Echo**.

## Double Characters

*When I type, I get two of every character. Why?*

In this case, both methods for displaying characters on your screen are in effect (see previous answer)—the Macintosh is displaying every character on the screen, and the other system is echoing every character back to you. Turn off **Local Echo** to prevent your Macintosh from displaying what you type. You'll then only see the characters that are being echoed back from the receiving system.

## Not Enough Room on Disk

*I get a message saying there's not enough room on my disk to save my document. How can I save it?*

When you get this message, you've already lost some information, and there's no way to get it back except by having it retransmitted. To save what you *do* have, save the document

to a new, blank disk. However, it's best to be prepared for these situations ahead of time.

If you're planning to receive a large amount of information, put the MacTerminal document into which the information will be received on its own disk. All of your startup information and the MacTerminal application should be in one disk drive, and your data disk, with only one document on it, should be in the other drive.

*As I'm downloading a file, I get this message: "Insufficient disk space to read any more lines." Why do I get this and what should I do?*

This only happens in Version 1.1. A new document is able to save far fewer lines than a previously created document. To avoid this situation, do the following:

1. Open a new MacTerminal document.
2. Set the phone, terminal, and compatibility settings.
3. Close the document.
4. Open the document again when you are ready to download the file.

The document is no longer a new MacTerminal document, so it will be able to receive many more lines of information. To save time during subsequent data communications sessions, create a template of this document, and then duplicate it when needed.

This problem has been fixed in MacTerminal Version 2.0.

### First Line Bad

*When I connect to a public information service, the first line of text is garbage. What should I do?*

Type any letter or press Return. The mainframe will often use the character to detect your terminal speed and will conform to it. Typing a character accomplishes the same thing as sending the Autobaud message.

### Beeping Sound

*Why do I get a telephone carrier error (beeping sound) with the Apple Modem 300?*

This happens on some phone lines when using tone dial. Use the pulse dial and it works OK (click on **Pulse** after choosing **Phone Settings** from the **Phone** menu).



---

## Using the Manual

### Overview

**This section gives you practice finding specific information in the manual.**

Many times you'll be asked a question that you can't answer immediately. In these cases, the next best thing is to know where to find the answer and how to find it quickly. In order to quickly find the answers you seek, you should be familiar with the various manuals (and other documentation) that contain the answers.

This section gives you a chance to familiarize yourself with the MacTerminal manual by finding the answers to specific questions.

**Use the table of contents or the index.**

This section will ask questions similar to those you might be asked when supporting MacTerminal users. Use the table of contents or the index to locate the information, and then write down the answer and where you found it.

When you're finished, check the Feedback section, which will give the answer, and the chapter and section in which it was found. Specific page numbers won't be given because they might change with manual revisions.

The first question is a sample to be sure you know what's expected.

---

## Practice

### Sample

**When I choose Send File, which documents are listed when I've indicated Text, and when I've indicated one of the XModem transfer options?**

When you've indicated **Text**, only text files are listed; documents saved as text only, MacTerminal documents, and AppleLink documents. When you've indicated one of the four available XModem file transfer options, all files on a disk are listed; all documents, system files, code files, etc.

The answer is found in the Sending Data to Another Computer section of Chapter 1.

### Use the Manual to Answer These Questions

**What do "Delay Between Chars" and "Delay Between Lines" in File Transfer Settings mean?** \_\_\_\_\_

---

---

---

---

**What does EBCDIC stand for?**

---

---

**How long can the Answerback Message be?**

---

---

**How do you display and use cursor keys in VT100 terminal-emulation mode?**

---

---

---

---

## **Feedback**

### **Use the Manual to Answer These Questions**

#### **What do "Delay Between Chars" and "Delay Between Lines" in the File Transfer Settings mean?**

These commands enable you to slow down the transmission of information to be sure the receiving system gets it all. They're usually used with private systems (as opposed to public information systems) when you can't adjust the baud rate.

The answer is in the Settings Menu section of Chapter 3.

#### **What does EBCDIC stand for?**

Extended Binary Coded Decimal Information Code.

The answer is in the glossary.

#### **How long can the Answerback Message be?**

The Answerback Message can be 40 characters long.

The answer is in the Settings Menu section of Chapter 3.

#### **How do you display and use cursor keys in VT100 terminal-emulation mode?**

Hold down the Command key while you open the Keypad menu. The cursor keys are in the top right corner of the keypad. Open the Keypad menu without the Command key to display the normal function keys that are in the locations shared by the cursor keys.

The answer is in the Keypad Menu section of Chapter 3.

# MacTerminal Specifications

## Overview

**This section covers the capabilities and limitations of MacTerminal.**

In addition to the questions dealt with in the Questions and Answers section, you'll receive many questions regarding the capabilities and limitations of MacTerminal. For example, what baud rates are supported? or how many characters per line? This section details the specifications for MacTerminal that will enable you to answer these questions.

This section also includes the differences between the original release of MacTerminal, Version 1.1, and the other official release, Version 2.0.

## Specifications

**Maximum size of a document is dependent upon available storage space.**

**Maximum size of the Clipboard.**

32,000 characters, or approximately 16 pages of single-spaced text.

**Number of lines displayed in a window.**

- Version 1.1: 24 lines
- Version 2.0: 25 lines with the AppleLine™ protocol converter; 24 lines without

**Terminal Emulated.**

- VT100/VT52
- TTY
- ANSI
- IBM 3278 (when used with AppleLine or the Apple Cluster Controller)

**Protocol converters supported under IBM 3278.**

- AppleLine
- Apple Cluster Controller
- Wall Data Cluster Controller (System 3x)
- Irmaline

### Transmission Characteristics.

- Speed: 50 to 19200 baud (see Compatibility Settings)
- Asynchronous communications
- Full- or half-duplex

### Terminal Settings.

- Character sets: Graphics, US ASCII, UK ASCII, Norwegian, French, Spanish, German, Danish, French-Canadian, Italian, Swedish/Finnish E47, Swedish/Finnish D47
- Line width: 80 or 132 characters

### Compatibility Settings.

- Supports the Macintosh Modem port or Printer port
- Bits per character: 7 or 8
- Parity: Even, Odd, or None
- Supports XOn/XOff flow control

### Protocol Specifications.

The MacTerminal protocol specifications are in the *Mac-to-Mac File Transfer Protocol* document that was mailed in February 1985. If you want a copy, ask your Apple support representative.

## Version 1.1 vs 2.0

### Here are the new features of MacTerminal Version 2.0.

- When using Text file transfer mode, you can choose **Save Screens Before Clearing**. This is intended primarily for use in IBM 3278 emulation where no text is ever scrolled off the top, hence none is captured for later use. This option will save the screen in the "lines off the top" area before clearing the screen.
- There are now four XModem file transfer options: **MacBinary**, **XModem Text**, **MacTerminal 1.1**, and **Straight XModem**.

**MacBinary** is for transferring Macintosh disk files between two Macintoshes, or for uploading and downloading Macintosh files to and from information utilities, public bulletin boards, and timesharing systems that support the XModem protocol. **XModem Text** is for transmitting text files. **MacTerminal 1.1** is the same as

**XModem** in the earlier release of MacTerminal and is included only for compatibility with MacTerminal 1.1. **Straight XModem** is for sending a binary file to a non-Macintosh computer system.

- 25th-line support will be added for IBM 3278 terminal emulation using AppleLine.
- Additional LaserWriter™ printer support includes port arbitration protocols to prevent it from interfacing with the AppleTalk™ Personal Network, faster printing, the use of the fixed pitch Courier font, and better column alignment.
- There's a new mapping for the Macintosh Numeric Keypad when in IBM 3278 emulation mode (see the Using MacTerminal with IBM Computers module).
- The **Keyboard** command was added to the **Settings** menu.
- **Wait for Call** has been fixed.
- **Number of Rings Before Answering** has been fixed.
- International character sets have been added.
- The **Reset** and **Clear Lines Off Top** commands can be invoked without the "Are You Sure?" alert if you hold down the Option key as you choose the menu command.
- Takes better advantage of additional memory in Macintosh 512K and Macintosh XL.
- Supports new products including the new Macintosh ROMs and double-sided disks.

## Pinouts

### Overview

**This section contains pinouts for Macintosh cables and serial ports.**

This section details the pinouts for the Macintosh serial ports, a Macintosh-to-Macintosh cable, the Macintosh modem cable, and a Macintosh-to-DEC cable.

If you're going to build a custom cable, be sure you have the pin assignments for the device to which you are connecting, in addition to the pinouts for Macintosh.

Check AppleLink for any pinouts not included in this section.

### Macintosh Serial Ports

**Here are the pin assignments for the Macintosh serial ports.**

Pin	Name	Description/Notes
1	CGND	Chassis ground
2	+5V	*
3 †	CGND	Chassis ground
4	TxD+	Transmit Data line (RS-422 only)
5	TxD-	Transmit Data line
6	+12V	*
7	HSK	Handshake: CTS or TRxC **
8 †	RxD+	Receive Data line (RS-422 only)
9	RxD-	Receive Data line

\* See Macintosh hardware documentation for power limits.

† Pins 3 and 8 should be jumpered together.

\*\* HSK is an input-only line designed to accept an external device's DTR handshake signal or a high-speed data clock.

## Custom Cables

### Macintosh-to-Macintosh cable.

The table below shows the pin connections for connecting a Macintosh to another Macintosh. This cable is included in the 68000 Development System (Apple Finished Goods Price List, p/n M0524).

<u>Pin</u>		<u>Pin</u>
1	<----->	3
5	<----->	9
7	<----->	7
9	<----->	5

Jumper Pins 3 and 8 together on both ends of the cable. You can achieve the same results by clipping Pin 6 of a Macintosh modem cable (p/n 590-0197), but then you won't be able to use that cable with a modem again.

There are several variations on wiring Pins 1, 3, and 8, which are the ground wires. The configuration specified here is the one recommended by Apple technical support. But other configurations may also work.

### Standard Macintosh modem cable.

The table below shows the pin assignment for the Macintosh modem cable (p/n 590-0197).

<u>Macintosh</u>		<u>Modem</u>
1	<----->	3
5	<----->	9
6	<----->	6
7	<----->	7
9	<----->	5

Jumper Pins 3 and 8 together on both ends of the cable.

There are several variations on wiring Pins 1, 3, and 8, which are the ground wires. The configuration specified here is the one recommended by Apple technical support. But other configurations may also work.



### Apple Personal Modem.

The location of each Pin in the 8-Pin DIN connector are shown below:

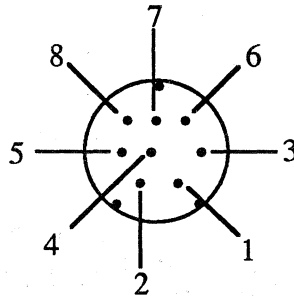

The Pin assignments for the 8-Pin DIN connector are:

<u>Pin</u>	<u>Name</u>	<u>Function</u>
1	DSR	Data Set Ready
2	DTR	Data Terminal Ready
3	RXD	Receive Data
4	SGND	Signal Ground
5	TXD	Transmit Data
6	SGND	Signal Ground
7	DCD	Data Carrier Detect
8	N.C.	Not Connected
Shield	Shield	Chassis Ground

Apple makes cable for connecting the Apple Personal Modem to each computer. The part numbers are:

- 590-0331: Apple II, Apple II+, Apple IIe, Apple III, Macintosh XL
- 590-0332: Apple IIc
- 590-0333: Macintosh 128K, Macintosh 512K

### Macintosh to non-Apple modem that has a DB-25 connector.

<u>Function</u>	<u>DB-9</u>		<u>DB-25</u>	<u>Function</u>
	1	<----->	1	Chassis ground
	3,8	<----->	7	Signal ground
Transmit	5	<----->	2	Transmit
Handshake	7	<----->	20	Data terminal ready
Receive	9	<----->	3	Receive

This configuration is for modems that identify themselves to the Macintosh as data communications equipment. If a modem identifies itself as a terminal, connect the Macintosh Pin 5 to the DB-25 Pin 3 and the Macintosh Pin 9 to the DB-25 Pin 2 (switch the Transmit and Receive lines at the modem end.)

These are the Pin assignments for a Macintosh ImageWriter™ printer cable plus a modem eliminator cable, and it works for most non-Apple modems that have a DB-25 connector. If it doesn't work, use the first table in this section (Macintosh serial port pinouts) plus a similar table for the modem connector to design a custom cable.

### Macintosh-to-DEC direct connection.

Use the table below to build a custom cable for directly connecting a Macintosh to a DEC, in the place of a VT100 terminal.

<u>Function</u>	<u>DB-9</u>		<u>DB-25</u>	<u>Function</u>
Ground	3	<----->	7	Ground
Transmit	5	<----->	2	Receive
12 V	6	<----->	20	Data terminal ready
Clr to Send	7	<----->	6	Data carrier detect
Receive	9	<----->	3	Transmit

### Pinouts for connecting to IBM computers.

The pinouts for connecting your Macintosh to an AppleLine, Apple Cluster Controller, and IBM PC are in the *Using MacTerminal with IBM Computers* module from the Apple Support Training Library.

---

## **Review**

### **Questions and Answers**

**Refer to the answers to commonly asked questions on MacTerminal as you need them.**

Refer to the information in the this section of the module as you need it. If you have access to AppleLink, look there for answers to specific questions, and check it periodically for new information regarding data communications and MacTerminal.

### **MacTerminal Specifications**

**This section covers MacTerminal capabilities and limitations.**

A lot of questions are regarding the limitations and capabilities of MacTerminal. Refer to this section for the answers to these questions.

### **Pinouts**

**Refer to this section for the pinouts for products used with MacTerminal.**

Additional pinout information can be found in other Apple Support Training Library modules and in the Technical Info library on AppleLink.

---

## Resources

- *MacTerminal*, the owner's manual, Apple Computer, Inc.
- *Apple Support Programs* binder
- John Stanley Data Communications Workshop †
- AppleLink (If you have access to AppleLink, check it regularly for additional data communications information, particularly the Technical Info library.)
- *Data Communications Terms* module from the Apple Support Training Library
- *Using MacTerminal* module from the Apple Support Training Library
- *Using MacTerminal with IBM Computers* module from the Apple Support Training Library
- *AppleLine User's Guide*, Apple Computer, Inc.
- *Apple Cluster Controller and AppleLine Sales Reference Guide*, Apple Computer, Inc.

† For more information, contact:  
John Stanley Training Programs  
208 Charter Oaks Circle  
Los Gatos, CA 95030  
(408) 374-1235

*Apple and the Apple logo are registered trademarks of Apple Computer, Inc. AppleLine, AppleLink, AppleTalk LaserWriter, LisaTerminal, MacTerminal, and MacWrite are trademarks of Apple Computer, Inc. Macintosh is a trademark of McIntosh Laboratory, Inc. and is being used with express permission of its owner. DEC, VT52, and VT100 are trademarks of Digital Equipment Corporation. IBM is a registered trademark of International Business Machines Corporation.*

