

GD CONTROL DATA

**CDC[®] CC63X
DISPLAY TERMINAL**

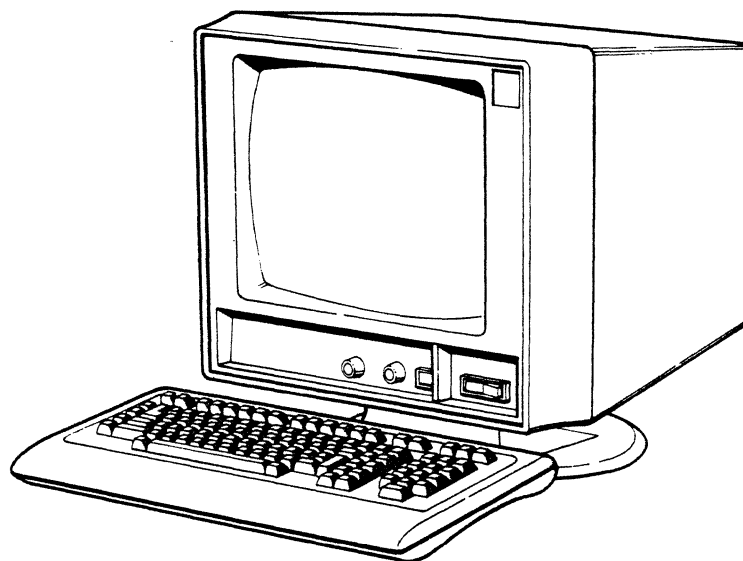

**HARDWARE MAINTENANCE MANUAL
(REPAIR-CENTER INFORMATION)**

REVISION RECORD

REVISION	DESCRIPTION
A (07-16-82)	Manual released. Includes ECOS 15132, 15134, 15137, and 15166.
B (09-01-82)	Manual revised to incorporate ECOS 15132, 15217, 15236, 15251, 15259, 15280, 15290, 15295, 15298, 15322, 15337, 15344, 15345, 15347, 15394 and 15422.
C (04-07-83)	Manual revised to incorporate ECOS 15408, 15428, 15435, 15457, 15493, 15523, 15553, 15555, 15589, 15613, 15623, 15625, 15642, 15655, 15656, 15659, 15675, 15679, 15681, 15705 and 15819. Adds diagrams and parts data for the new XA363-A Rigid-Disk Interface board. This printing obsoletes all previous editions.
D (09-12-83)	Manual revised to incorporate ECOS 15826, 15879, 15909, 15923, 15942, 15943, 15980, 15991, 15993, 16044, 16047 and 16097. Adds documentation for CC634-B and CC638-B terminals, which have 4.0 firmware and a new power-cord interlock.
E (11-22-83)	Manual revised to incorporate ECOS 16125, 16127, 16133, 16145, 16214, 16236, and 16237.
F (03-23-84)	Manual revised to incorporate ECOS 16168, 16273, 16376, 16419, 16443, 16454, 16480, 16488, 16541, 16564, 16575, and 16591.
G (10-02-84)	Manual revised to incorporate ECOS 16512, 16520, 16652, 16667, 16668, 16686, 16687, 16702, 16710, 16723, 16754, 16831, 16845 and 16884. Includes Service Bulletin 5899.
H (03-29-85)	Manual revised to incorporate ECOS 16868, 16896, 16956, 16972, 16984, 17023, and 17067.
J (06-15-85)	Manual revised to incorporate ECOS 17107 and 17120.
K (10-25-85)	Manual revised to incorporate ECOS 17177, 17183, and 17184.
L (10-24-86)	Manual revised to incorporate ECOS 17152, 17518, 17571, 17601, 17714, 17775, and 17794.
Publication No. 62940037	

REVISION LETTERS I, O, Q, S, X AND Z ARE NOT USED.

Address comments concerning this manual to:

Control Data Corporation
Technology and Publications Division
4201 North Lexington Avenue
St. Paul, Minnesota 55126-6198

©1982, 1983, 1984, 1985, 1986
by Control Data Corporation
All rights reserved
Printed in the United States of America

or use Comment Sheet in the back of this manual.

MANUAL TO EQUIPMENT LEVEL CORRELATION SHEET

This manual reflects the equipment configurations listed below.

EXPLANATION: Locate the equipment type and series number, as shown on the equipment FCO log, in the list below. Immediately to the right of the series number is an FCO number. If that number and all of the numbers underneath it match all of the numbers on the equipment FCO log, then this manual accurately reflects the equipment.

EQUIPMENT TYPE	SERIES	WITH FCO'S	COMMENTS
CC634-A	01		
	01	-	ECOs 15224 and 15236 (S/N 101)
	01	-	ECOs 15346 and 15259 (S/N 138)
	02	-	ECO 15337 (S/N 163)
	03	-	ECO 15553 (S/N 426)
	04		
CC634-B	01		
	01	-	ECO 16419 (S/N 1946)
	02		
CC638-A	01	-	
	01	-	ECOs 15224 and 15236 (S/N 101)
	01	-	ECO 15347 (S/N 207)
	02	-	ECOs 15346 and 15259 (S/N 226)
	03	-	ECO 15337 (S/N 232)
	04	-	ECO 15553 (S/N 1303)
	05		
CC638-B	01	-	
	01	-	ECO 16419 (S/N 6946)
	02		

MANUAL TO EQUIPMENT LEVEL CORRELATION SHEET (CONTD)

EQUIPMENT TYPE	SERIES	WITH FCO'S	COMMENTS
XA358-A	01 01 02	- - -	ECO 15347 (S/N 106)
XA360-A	01 01 01	- - -	16575 (S/N 101)
XA363-A	01		
XA368-A	01		
YA274-A	01 01 02	- - -	ECO 16145
YA274-B	01 01 02	- - -	ECO 16145
YA274-C	01 01 02	- - -	ECO 16145
YA274-D	01 01 02	- - -	ECO 16145

MANUAL TO EQUIPMENT LEVEL CORRELATION SHEET (CONTD)

EQUIPMENT TYPE	SERIES	WITH FCO'S	COMMENTS
YA274-E	01	-	ECO 16145
	01	-	
	02		
YA274-F	01	-	ECO 16145
	01	-	
	02		
YA275-A	01	-	ECO 16145
	01	-	
	02		
YR101-A	01	-	ECO 15322 only
	01	-	
	02		
YR102-A	01		
YR109-A	01		

LIST OF EFFECTIVE PAGES

New features, as well as changes, deletions, and additions to information in this manual, are indicated by bars in the margins or by a dot near the page number if the entire page is affected. A bar by the page number indicates pagination rather than content has changed.

PAGE	REV	PAGE	REV	PAGE	REV	PAGE	REV	PAGE	REV
Cover	-	1-44	H	2-8.1	H	2-46	B	2-90.1	D
Title Page	-	1-45	C	2-8.2	L	2-47	B	2-90.2	D
ii a	L	1-46	C	2-9	C	2-48	B	2-91	D
iii	G	1-47	C	2-10	F	2-49	B	2-92	H
iv/vi	F	1-48	H	2-10.1	L	2-50	B	2-92.1	H
vii/viii	L	1-49	C	2-10.2	L	2-51	B	2-92.2	H
ix/x	A	1-50	G	2-10.3	D	2-52	L	2-93	C
xi	D	1-51	A	2-10.4	D	2-53	L	2-94	C
xii	L	1-52	A	2.10.5	L	2-54	L	2-95	C
xiii	H	1-53	A	2.10.6	L	2-55	L	2-96	C
1-1	A	1-54	L	2-11	L	2-56	L	2-97	C
1-2	F	1-55	G	2-12	D	2-57	G	2-98	E
1-3	F	1-56	B	2-13	D	2-58	L	2-99	E
1-4	F	1-57	B	2-14	D	2-58.1	L	2-100	E
1-5	F	1-58	B	2-15	D	2-58.2	L	2-101	E
1-6	F	1-59	G	2-16	A	2-58.3	L	2-102	D
1-7	F	1-60	L	2-16.1	D	2-58.4	L	2-103	D
1-8	F	1-61	B	2-16.2	D	2-59	B	2-104	D
1-8.1	F	1-62	B	2-17	D	2-60	G	2-105	A
1-8.2	D	1-63	B	2-18	A	2-61	G	2-106	A
1-8.3	F	1-64	G	2-18.1	D	2-62	C	2-107	A
1-8.4	D	1-65	D	2-18.2	D	2-63	C	2-108	A
1-8.5	D	1-66	D	2-19	D	2-64	E	2-109	A
1-8.6	D	1-67	D	2-20	B	2-65	E	2-110	A
1-9	B	1-68	D	2-21.1	D	2-66	F	2-111	G
1-10	B	1-69	B	2-21.2	D	2-66.1	H	2-112	C
1-11	B	1-70	B	2-21	D	2-66.2	H	2-113	G
1-12	B	1-71	B	2-22	F	2-67	H	2-114	D
1-13	B	1-72	C	2-23	F	2-68	H	2-115	D
1-14	B	1-73	C	2-24	F	2-68.1	H	2-116	C
1-15	B	1-74	C	2-25	F	2-68.2	H	2-117	G
1-16	B	1-75	C	2-26	F	2-68.3	H	2-118	C
1-17	B	1-76	C	2-27	F	2-68.4	H	2-119	C
1-18	B	1-76.1	H	2-28	F	2-69	B	2-120	C
1-19	B	1-76.2	F	2-29	F	2-70	B	2-121	C
1-20	B	1-76.3	F	2-30	F	2-71	B	2-122	J
1-21	B	1-76.4	H	2-31	F	2-72	L	2-123	J
1-22	B	1-77	A	2-32	L	2-73	L	2-124	J
1-23	B	1-78	D	2-32.1	F	2-74	L	2-125	J
1-24	B	1-79	A	2-32.2	F	2-75	L	2-126	J
1-25	B	1-80	A	2-33	F	2-76	G	2-127	H
1-26	B	1-81	A	2-34	F	2-77	G	2-128	J
1-27	B	1-82	A	2-34.1	L	2-78	G	2-129	J
1-28	B	2-1	A	2-34.2	L	2-79	G	2-130	J
1-29	B	2-2	L	2-35	L	2-80	G	2-131	J
1-30	L	2-2.1	G	2-36	L	2-80.1	G	2-132	J
1-31	D	2-2.2	G	2-36.1	L	2-80.2	G	2-133	H
1-32	H	2-3	L	2-36.2	L	2-81	C	2-134	H
1-33	L	2-4	D	2-36.3	L	2-82	E	2-135	H
1-34	G	2-5	D	2-36.4	L	2-82.1	E	2-136	J
1-35	C	2-6	D	2-37	A	2-82.2	G	A-1	A
1-36	H	2-6.1	F	2-38	A	2-83	G	A-2	A
1-37	L	2-6.2	F	2-39	A	2-84	H	A-3	L
1-38	C	2-6.3	F	2-40	B	2-85	H	A-4	L
1-39	H	2-6.4	F	2-41	B	2-86	G	A-5	E
1-40	C	2-6.5	F	2-42	B	2-87	G	A-6	E
1-41	H	2-6.6	H	2-43	B	2-88	A	A-7	J
1-42	L	2-7	H	2-44	B	2-89	A	A-8	G
1-43	C	2-8	H	2-45	B	2-90	A	A-9	D

LIST OF EFFECTIVE PAGES

New features, as well as changes, deletions, and additions to information in this manual, are indicated by bars in the margins or by a dot near the page number if the entire page is affected. A bar by the page number indicates pagination rather than content has changed.

PAGE	REV	PAGE	REV	PAGE	REV	PAGE	REV	PAGE	REV
B-1	A								
B-2	A								
B-3	A								
B-4	A								
B-5	A								
B-6	A								
Comment Sheet	L								
Mailer	-								
Back Cover	-								

PREFACE

This manual contains repair-center information for the CDC® 63X series Display Terminals. This information consists of diagrams, parts data, drawings, and packing information.

The following publication is to be used in conjunction with this manual:

CC63X Display Terminal Hardware Maintenance Manual
(Service-Center and On-Site Information)
Publication Number 62940034

Copies of the above publication or additional copies of this manual may be ordered from:

Control Data Corporation
Literature & Distribution Services
308 North Dale Street
St. Paul, Minnesota 55103

CONTENTS

1. DIAGRAMS

Interconnection Diagram, Display Terminal 1-2
Schematic Diagram, 1AHD Power Supply Board 1-4
Schematic Diagram, 81AH-3 Power Supply 1-8.1
Schematic Diagram, 1AJD Main Logic Board 1-9
 Processor and Address Buffer 1-10
 Main Timing and Line Buffer Addressing 1-11
 Memory Control 1-12
 Memory Control and Wait Circuits 1-13
 Refresh Address Counter 1-14
 Pointer Address Mux and Dynamic RAM Address Mux 1-15
 Dynamic RAM and Control Signal Bus Drivers 1-16
 Line Buffer Address Mux and Foreign Character ROM 1-17
 Line Buffers and Data-Output Latches 1-18
 Character Generator and RAM Character Generator 1-19
 Video Shift Registers 1-20
 Data Bus Driver and Video Driver 1-21
 RAM, ROM, and I/O Address Decoding 1-22
 Keyboard UART and Timer 1-23
 Communication UART and CRT Controller 1-24
 Programmable I/O and LED Latch and Bank Selects 1-25
 Interrupt Circuits and Scan Counting 1-26
 RS-232 Drivers/Receivers and Loopback Switch 1-27
 ROM Memory 1-28
 CMOS RAM and Current Loop 1-29
Schematic Diagram, 1AJD-1 (Main Logic) 1-30
 Processor and Address Buffer 1-31
 Main Timing and Line Buffer Addressing 1-32
 Memory Control 1-33
 Memory Control and Wait Circuits 1-34
 Refresh Address Counter 1-35
 Printer Address MUX and Dynamic RAM Address MUX 1-36
 Dynamic RAM and Control Signal Bus Drivers 1-37
 Line Buffer Address MUX and Foreign Character ROM 1-38
 Line Buffers and Output Data Latches 1-39
 Character Generators and RAM Character Generator 1-40
 Video Shift Registers 1-41
 Data Bus Driver and Video Driver 1-42
 RAM, ROM and I/O Address Decoding 1-43
 Kybd UART and Timing 1-44
 Comm UART and CRT Controller 1-45
 Programmable I/O and LED Latch and Bank Selects 1-46
 Interrupt Circuits and Scan Counts 1-47
 RS 232 Drivers & Receivers and Loop-Back Switch 1-48
 ROM Memory 1-49
 C-MOS RAM, Current Loop 1-50
Schematic Diagram, 1AUD Mother Board 1-51
Schematic Diagram, 1ALD Graphics Logic Board 1-54
 Main Timing 1-55

Schmitt Address Buffer	1-56
Data In/Out and Graphics Video Shift Register	1-57
Graphics Video Control and Z80 Control-Signal Buffer	1-58
Z80 Access and Video Control	1-59
Memory Control and Bulk Write	1-60
RAM-Address Latch and Graphics Function Decoder	1-61
Graphics RAM and Z80 Data-Output Latch	1-62
Touchpanel Sequential Counter and Coordinate Trap	1-63
Touchpanel Decoder	1-64
Schematic Diagram, 1AWD Dual Asynchronous-Interface Board	1-65
Schematic Diagram, 1BLD Parallel Interface Board	1-69
Schematic Diagram, 1CCD Rigid Disk Adapter	1-72
Schematic Diagram, 82AMD Modem Interface	1-76.1
Schematic Diagram, Keyboard	1-77
Schematic Diagram, Display Assembly	1-78
Logic Support Document (Timing and Block Diagrams)	1-79

2. PARTS DATA

Genealogy Chart, Display Terminal	2-2
Display Terminal Assembly	2-4
Display Terminal (CC634-B)	2-6.2
1200/1200 Modem (TLA) (Inactive)	2-6.6
1200/1200 Modem (TLA)	2-8
Drawer Assembly	2-8.2
Drawer Assembly, Metric (CC634-B)	2-10.2
Display Adapter Assembly	2-12
Rear Panel Assembly	2-16
Panel Assembly, Metal, Metric (CC634-B)	2-16.2
Option-Board Cover Assembly	2-18
Cover/Snap Assembly (CC634-B)	2-18.2
Keyboard Assembly	2-20
Keyboard Assembly, Metric (CC634-B)	2-20.2
Power Supply Board Assembly, 1AHD	2-22
Power Supply Board Assembly, 1AHD-1	2-26
Power Supply Board Assembly, 1AHD-2	2-32
P.C. Card Assembly, 81AHD-3 Power Supply	2-34.2
P.C. Card Assembly, 81AHD-4 Power Supply	3-34.5
P.C. Card Assembly, 81AHD-4 Power Supply	2-36
Line Filter Assembly	2-36.4
Mother Board Assembly, 1AUD	2-38
Main Logic Board Assembly, 1AJD	2-40
Main Logic Board Assembly, 1AJD-1	2-46
Main Logic Board Assembly, 1AJD-2	2-52
P.C. Card Assembly, 1AJD-3 Logic Board (2 Layer)	2-55
P.C. Card Assembly, 1AJD-4 Logic Board (6 Layer)	2-58
Dual Asynchronous-Interface Board Assembly, 1AWD	2-58.4
Dual Asynchronous-Interface Board Assembly, 1AWD-1	2-60
Parallel Interface Board Assembly, 1BLD	2-62
Rigid Disk Interface Assembly, 1CCD	2-64
P.C. Card Assembly, 82AMD Modem Interface (Inactive)	2-66.1
P.C. Card Assembly, 82AMD-1 Modem Interface	2-68
Dot Graphics and Touchpanel Assembly	2-68.2
TLA Graphics Option	2-68.3

Graphics Logic Board Assembly, 1ALD	2-69
Graphics Logic Board Assembly, 1ALD-1	2-72
Monitor Cable Assembly	2-76
Ribbon Cable Assembly	2-79
Keyboard Cable Assembly	2-82
Wire Jumper Assembly	2-84
Power-Switch Wire Assembly	2-86
Power-Supply Connector Assembly	2-88
Power Cable Assembly	2-90
Firmware Option 4.0 (YR109-A)	2-90.3
TLA Graphics Viking X Display Terminal	2-91
TLA Touchpanel Option	2-92
Keyboard Conversion Kit, United Kingdom	2-92.1
Keyboard Conversion Kit, Spanish	2-93
Keyboard Conversion Kit, German	2-94
Keyboard Conversion Kit, French	2-96
Keyboard Conversion Kit, Swedish/Finnish	2-98
Keyboard Conversion Kit, Danish/Norwegian	2-100
Cross-Reference List, Keyboard	2-102
Cross-Reference List, Display Assembly	2-111
Cross-Reference List, Viking X Audiotronics Video Display Head	2-122
Source Control Drawing, CRT w/Magnet Compensated, 110° Yoke, 381mm (15-inch)	2-126

APPENDIXES

A. OPTION-BOARD INSTALLATION DRAWINGS

Installation Drawing, Small Option Boards	A-2
Installation Drawing, Large Option Boards	A-3
Installation Drawing, XA363-A	A-9

B. PACKING INFORMATION

Viking X Display, 721-10, CC634	B-2
General Packaging Specification	B-6

TABLES

2. PARTS DATA

2-1 Explanation of Column Headings of Computer- Generated Assembly Parts Lists	2-1
---	-----



This section contains interconnection and schematic diagrams covering the display terminals. Included are CDC diagrams plus vendor diagrams of the keyboard and display assemblies. The CDC diagrams have the following information on them.

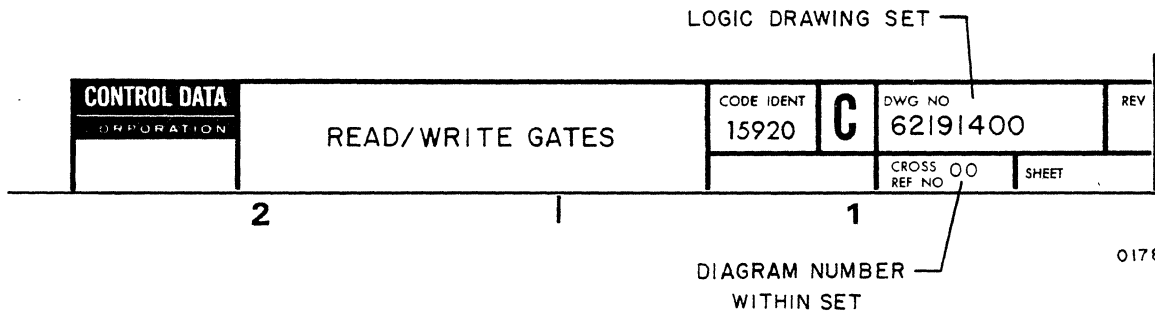

1
2
3
4

REVISION RECORD			
REV	CO	DESCRIPTION	DATE
1	00	RELEASED CLASS B	1/1/81
2	01	REVISED PER ECO	3/20/82
3	02	REVISED PER ECO	3/20/82
4	03	REVISED PER ECO	3/20/82
5	04	REVISED PER ECO	3/20/82
6	05	REVISED PER ECO	3/20/82
7	06	REVISED PER ECO	3/20/82
8	07	REVISED PER ECO	3/20/82
9	08	REVISED PER ECO	3/20/82
10	09	REVISED PER ECO	3/20/82
11	10	REVISED PER ECO	3/20/82
12	11	REVISED PER ECO	3/20/82
13	12	REVISED PER ECO	3/20/82
14	13	REVISED PER ECO	3/20/82
15	14	REVISED PER ECO	3/20/82
16	15	REVISED PER ECO	3/20/82
17	16	REVISED PER ECO	3/20/82
18	17	REVISED PER ECO	3/20/82
19	18	REVISED PER ECO	3/20/82
20	19	REVISED PER ECO	3/20/82
21	20	REVISED PER ECO	3/20/82
22	21	REVISED PER ECO	3/20/82
23	22	REVISED PER ECO	3/20/82
24	23	REVISED PER ECO	3/20/82
25	24	REVISED PER ECO	3/20/82
26	25	REVISED PER ECO	3/20/82
27	26	REVISED PER ECO	3/20/82
28	27	REVISED PER ECO	3/20/82
29	28	REVISED PER ECO	3/20/82
30	29	REVISED PER ECO	3/20/82
31	30	REVISED PER ECO	3/20/82
32	31	REVISED PER ECO	3/20/82
33	32	REVISED PER ECO	3/20/82
34	33	REVISED PER ECO	3/20/82
35	34	REVISED PER ECO	3/20/82
36	35	REVISED PER ECO	3/20/82
37	36	REVISED PER ECO	3/20/82
38	37	REVISED PER ECO	3/20/82
39	38	REVISED PER ECO	3/20/82
40	39	REVISED PER ECO	3/20/82
41	40	REVISED PER ECO	3/20/82
42	41	REVISED PER ECO	3/20/82
43	42	REVISED PER ECO	3/20/82
44	43	REVISED PER ECO	3/20/82
45	44	REVISED PER ECO	3/20/82
46	45	REVISED PER ECO	3/20/82
47	46	REVISED PER ECO	3/20/82
48	47	REVISED PER ECO	3/20/82
49	48	REVISED PER ECO	3/20/82
50	49	REVISED PER ECO	3/20/82
51	50	REVISED PER ECO	3/20/82
52	51	REVISED PER ECO	3/20/82
53	52	REVISED PER ECO	3/20/82
54	53	REVISED PER ECO	3/20/82
55	54	REVISED PER ECO	3/20/82
56	55	REVISED PER ECO	3/20/82
57	56	REVISED PER ECO	3/20/82
58	57	REVISED PER ECO	3/20/82
59	58	REVISED PER ECO	3/20/82
60	59	REVISED PER ECO	3/20/82
61	60	REVISED PER ECO	3/20/82
62	61	REVISED PER ECO	3/20/82
63	62	REVISED PER ECO	3/20/82
64	63	REVISED PER ECO	3/20/82
65	64	REVISED PER ECO	3/20/82
66	65	REVISED PER ECO	3/20/82
67	66	REVISED PER ECO	3/20/82
68	67	REVISED PER ECO	3/20/82
69	68	REVISED PER ECO	3/20/82
70	69	REVISED PER ECO	3/20/82
71	70	REVISED PER ECO	3/20/82
72	71	REVISED PER ECO	3/20/82
73	72	REVISED PER ECO	3/20/82
74	73	REVISED PER ECO	3/20/82
75	74	REVISED PER ECO	3/20/82
76	75	REVISED PER ECO	3/20/82
77	76	REVISED PER ECO	3/20/82
78	77	REVISED PER ECO	3/20/82
79	78	REVISED PER ECO	3/20/82
80	79	REVISED PER ECO	3/20/82
81	80	REVISED PER ECO	3/20/82
82	81	REVISED PER ECO	3/20/82
83	82	REVISED PER ECO	3/20/82
84	83	REVISED PER ECO	3/20/82
85	84	REVISED PER ECO	3/20/82
86	85	REVISED PER ECO	3/20/82
87	86	REVISED PER ECO	3/20/82
88	87	REVISED PER ECO	3/20/82
89	88	REVISED PER ECO	3/20/82
90	89	REVISED PER ECO	3/20/82
91	90	REVISED PER ECO	3/20/82
92	91	REVISED PER ECO	3/20/82
93	92	REVISED PER ECO	3/20/82
94	93	REVISED PER ECO	3/20/82
95	94	REVISED PER ECO	3/20/82
96	95	REVISED PER ECO	3/20/82
97	96	REVISED PER ECO	3/20/82
98	97	REVISED PER ECO	3/20/82
99	98	REVISED PER ECO	3/20/82
100	99	REVISED PER ECO	3/20/82

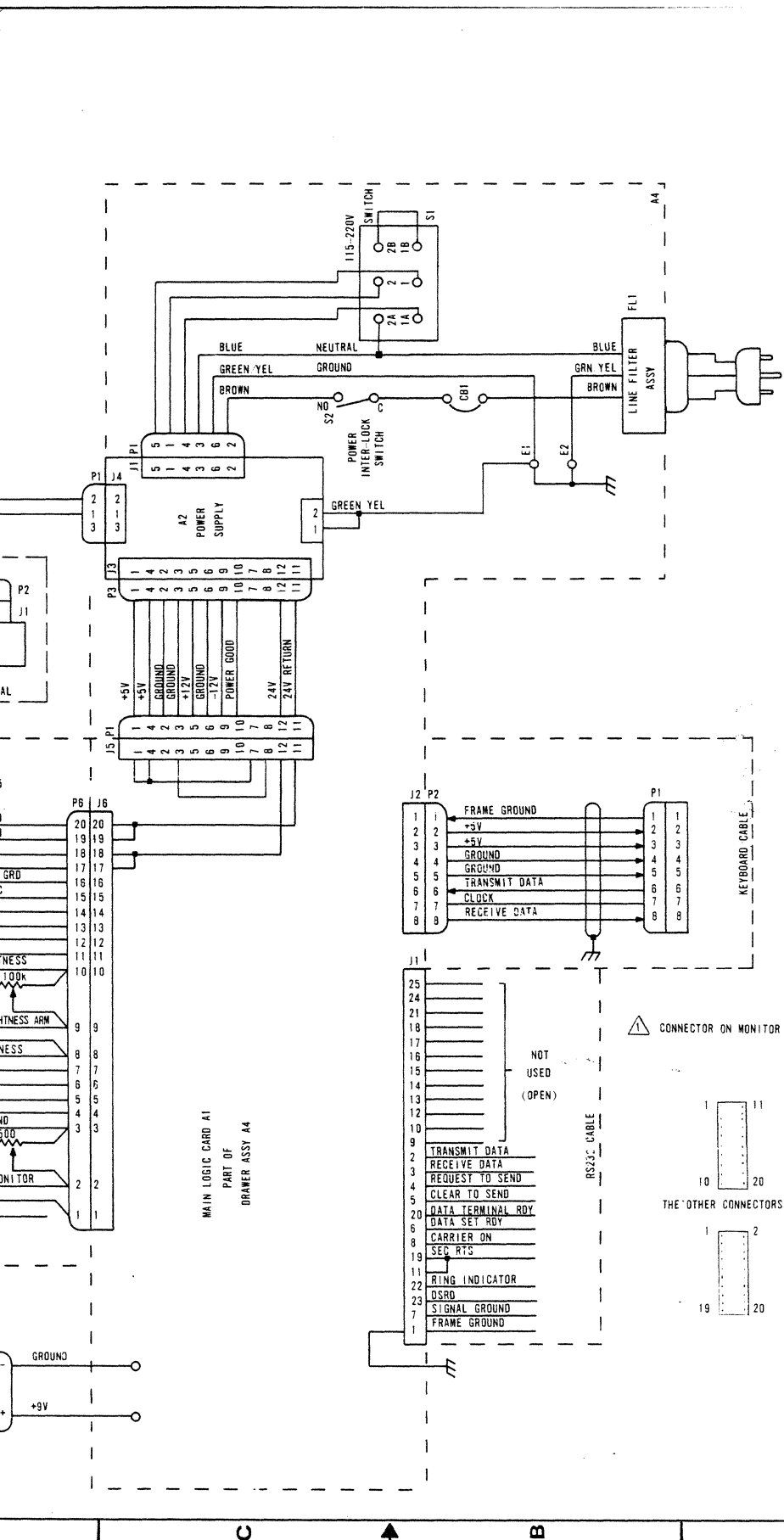

CONTROL DATA	
FIRST USED ON	DATE
CC634A	10-10-81
Maxy Diaz	11-4-81
ENGR	11-4-81
APP	11-4-81

REFERENCE DRAWING	SCALE

TITLE	CODE IDENT	DRAWING NO
INTERCONNECTION DIAGRAM, DISPLAY TERMINAL	15920	62201067

CROSS REF NO	SHEET	OF
	1	2

62940037 F

D

C

B

A

J1	P2		P1	J8
19	19	+5V		19
17	17	-BANK 10 OPT MEM		17
15	15	-BANK 8 OPT MEM		15
13	13	V+H BLANK A		13
11	11	-HORIZ SYNC		11
9	9	VIDEO A_N		9
7	7	GROUND		7
5	5	-DOT COUNTER CARRY		5
3	3	GRAPHICS VIDEO		3
1	1	POWER GROUND		1
20	20	+5V		20
18	18	-BANK 9 OPT MEM		18
16	16	-BANK 7 OPT MEM		16
14	14	+VERT SYNC		14
12	12	GROUND		12
10	10	-INTERRUPT 4		10
8	8	SCAN 20		8
6	6	-EXT CLOCK IN		6
4	4	-REFRESH CLK		4
2	2	POWER GROUND		2

	P1	J3
+5V	1	1
-WRITE	2	2
MEM MODULE BANK SELECT	3	3
ADDRESS BUS 213	4	4
ADDRESS BUS 212	5	5
ADDRESS BUS 27	6	6
ADDRESS BUS 26	7	7
ADDRESS BUS 25	8	8
ADDRESS BUS 24	9	9
ADDRESS BUS 23	10	10
ADDRESS BUS 22	11	11
ADDRESS BUS 21	12	12
ADDRESS BUS 20	13	13
DATA BUS 20	14	14
DATA BUS 21	15	15
DATA BUS 22	16	16
POWER GROUND	17	17
+5V	18	18
-MEMORY REQUEST	19	19
-MEMORY MODULE SELECT	20	20
ADDRESS BUS 215	21	21
ADDRESS BUS 28	22	22
ADDRESS BUS 29	23	23
ADDRESS BUS 211	24	24
-READ	25	25
ADDRESS BUS 210	26	26
ADDRESS BUS 214	27	27
DATA BUS 27	28	28
DATA BUS 26	29	29
DATA BUS 25	30	30
DATA BUS 24	31	31
DATA BUS 23	32	32
-MEM MOD OPTION PRESENT	33	33
POWER GROUND	34	34

MAIN LOGIC CARD

J4	P1		P3		P4		P2	J1	SMALL OPTION MOTHER BOARD	A8	J2	J3	J4
49	49	+5V		49		49		49					12
47	47	+12V		47		47		47					15
45	45	-12V		45		45		45					14
43	43	-MEMORY REQUEST		43		43		43					17
41	41	ADDRESS BUS 215		41		41		41					19
39	39	ADDRESS BUS 28		39		39		39					21
37	37	ADDRESS BUS 29		37		37		37					23
35	35	ADDRESS BUS 211		35		35		35					25
33	33	-READ		33		33		33					27
31	31	ADDRESS BUS 210		31		31		31					29
29	29	ADDRESS BUS 214		29		29		29					31
27	27	DATA BUS 27		27		27		27					33
25	25	DATA BUS 26		25		25		25					35
23	23	DATA BUS 25		23		23		23					37
21	21	DATA BUS 24		21		21		21					39
19	19	DATA BUS 23		19		19		19					41
17	17	-BUS REQUEST		17		17		17					43
15	15	-WAIT		15		15		15					45
13	13	-IORD		13		13		13					47
11	11	-BANK 12 OPT MEM		11		11		11					49
9	9	-REFRESH		9		9		9					51
7	7	-INTERRUPT 3		7		7		7					53
5	5	-INTERRUPT 1		5		5		5					55
3	3	+6MHZ OSC		3		3		3					57
1	1	POWER GROUND		1		1		1					60
50	50	+5V		50		50		50					11
48	48	+5V		48		48		48					13
46	46	-WRITE		46		46		46					16
44	44	ADDRESS BUS 213		44		44		44					18
42	42	ADDRESS BUS 212		42		42		42					20
40	40	ADDRESS BUS 27		40		40		40					22
38	38	ADDRESS BUS 26		38		38		38					24
36	36	ADDRESS BUS 25		36		36		36					26
34	34	ADDRESS BUS 24		34		34		34					28
32	32	ADDRESS BUS 23		32		32		32					30
30	30	ADDRESS BUS 22		30		30		30					32
28	28	ADDRESS BUS 21		28		28		28					34
26	26	ADDRESS BUS 20		26		26		26					36
24	24	DATA BUS 20		24		24		24					38
22	22	DATA BUS 21		22		22		22					40
20	20	DATA BUS 22		20		20		20					42
18	18	-BUS ACKNOWLEDGE		18		18		18					44
16	16	-MI		16		16		16					46
14	14	-POWER ON RESET		14		14		14					48
12	12	-BANK 11 OPT MEM		12		12		12					50
10	10	+6MHZ PRIME		10		10		10					52
8	8	-INTERRUPT 2		8		8		8					54
6	6	1.8432 MHZ OSC		6		6		6					56
4	4	POWER GROUND		4		4		4					58
2	2	POWER GROUND		2		2		2					59

RIBBON CABLE - MAIN BUS

LOC
GROSS REF NO

1-3

	DISPLAY TERMINAL	CODE IDENT 15920	C	DWG NO 62201067	REV A
				CROSS REF NO	SHEET 2

1-4

62940037 F

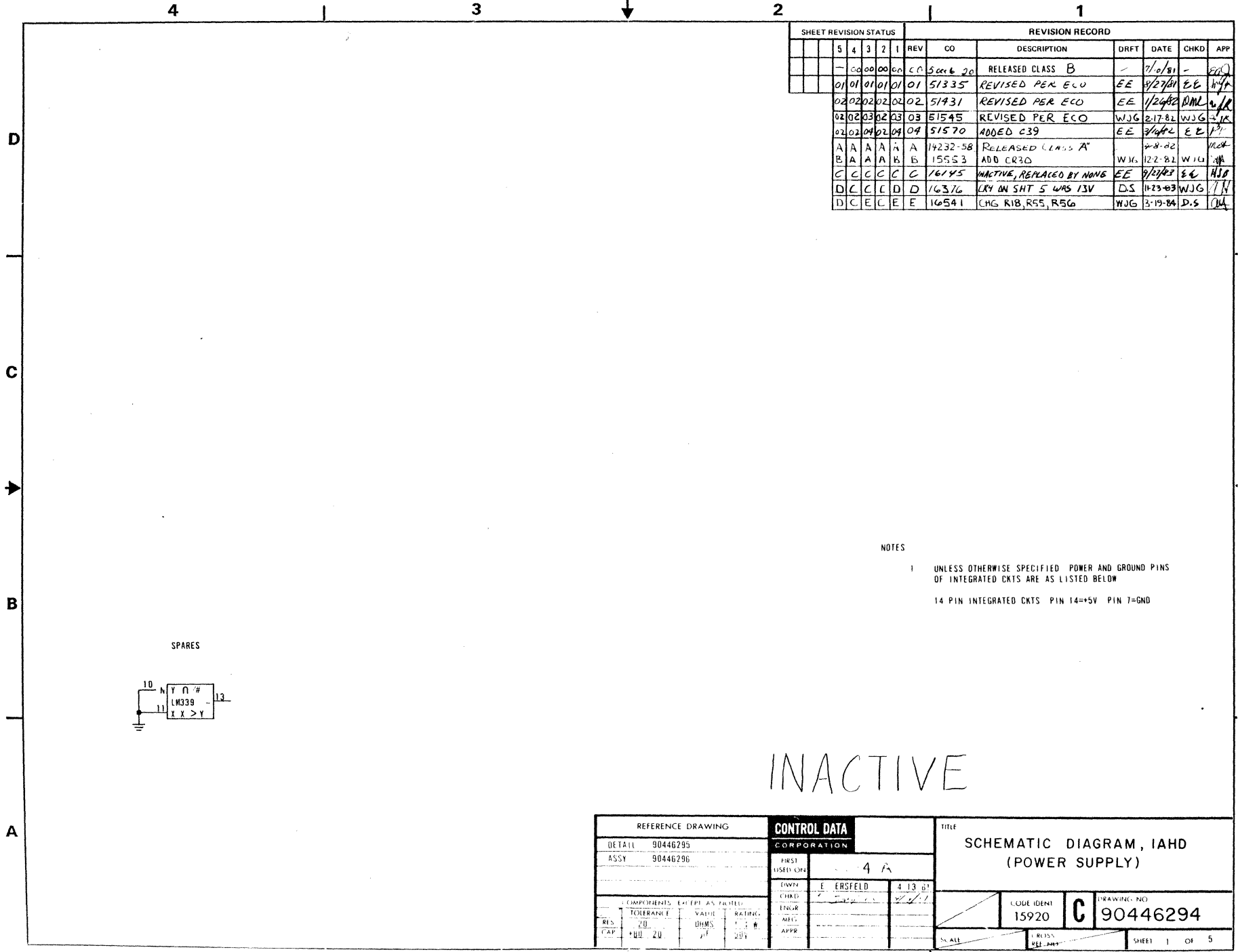

SHEET REVISION STATUS					REVISION RECORD							
	5	4	3	2	1	REV	CO	DESCRIPTION	DRFT	DATE	CHKD	APP
							5006 20	RELEASED CLASS B	-	7/0/81	-	GD
						01	51335	REVISED PER ECO	EE	8/27/81	EE	HFA
						02	51431	REVISED PER ECO	EE	1/24/82	DML	WJR
						02	51545	REVISED PER ECO	WJG	2-17-82	WJG	WJR
						02	51570	ADDED C39	EE	3/4/82	EE	WJR
						A	14232-58	RELEASED CLASS A	WJG	4-8-82	WJG	WJR
						B	15553	ADD CR30	WJG	12-2-82	WJG	WJR
						C	16145	INACTIVE, REPLACED BY NONE	EE	9/27/82	EE	HFA
						D	16376	CR4 ON SHT 5 WAS 13V	DS	11-23-83	WJG	WJR
						D	16541	CHG R18, R55, R56	WJG	3-19-84	DS	WJR

NOTES
 1 UNLESS OTHERWISE SPECIFIED POWER AND GROUND PINS OF INTEGRATED CKTS ARE AS LISTED BELOW
 14 PIN INTEGRATED CKTS PIN 14=+5V PIN 7=GND

INACTIVE

REFERENCE DRAWING		CONTROL DATA		TITLE	
DETAIL	90446295	CORPORATION		SCHEMATIC DIAGRAM, IAHD (POWER SUPPLY)	
ASSY	90446296	FIRST USED ON	4 A		
COMPONENTS, EXCEPT AS NOTED:		OWN	E. ERSFELD	4 13 81	
RES	20	CHKD			
CAP	20	ENGR			
		APP			
SCALE		DRESS		CODE IDENT	DRAWING NO
				C 15920	90446294
				SHEET 1 OF 5	

BUILD ARC 440

ASSEMBLY PARTS LIST

PRINT DATE	PAGE	FILE CHANGE NO.
00-01-83	1	1553-54

DIV.		ASSEMBLY NUMBER	CD	REV.	DWG.	DESCRIPTION	MC	STATUS	STATUS DATE	ENG. RESP.	FILE DATE		
0000		61409656	B	A	D	KEYBOARD ASSY	0	REL	07-29-83	CC034A/B	00-01-83		
ITEM NO	LT	PART NUMBER	CD	QTY	U/M	PART DESCRIPTION	MC	TLD	ECO. NO. IN	ECO. NO. OUT	S/N	WE IN	WE OUT
001	01	51941115	1	1		PC KYBD, 106-KEY ANSI SERIAL I/O	P						
002	01	71493277	9	1		PC COVER, KYBD TOP	P						
003	01	71493279	5	1		PC COVER, KYBD BOT (HLD OFF-WHT)	P						
004	01	71493238	1	2		PC RETAINER, KYBD LEG (PLSTC)	P						
005	01	71493241	5	1		PC LEG, KYBD (MOLDED OFF-WHITE)	P						
006	01	51805803	7	2		PC BUMPER, RUBBER .330H SLF-STKB	P						
007	01	61409530	5	1		PC CBL ASSY, VX SHLD KEYBOARD	A						
008	01	15164916	7	4		PC MSCR HEX/W-LK PLN M4X22MM STL	B						
009	01	94205715	9	2		PC SPG, COMP .50L 6.6LB/IN MW	P						
010	01	71493739	8	1		PC CLAMP, CABLE (VX KYBD-CRS/IF)	P						
011	01	18862901	8	2		PC SCR TP6 FLT PHL (4) 3/8L STL	B						
						0011 TOTAL LINES							

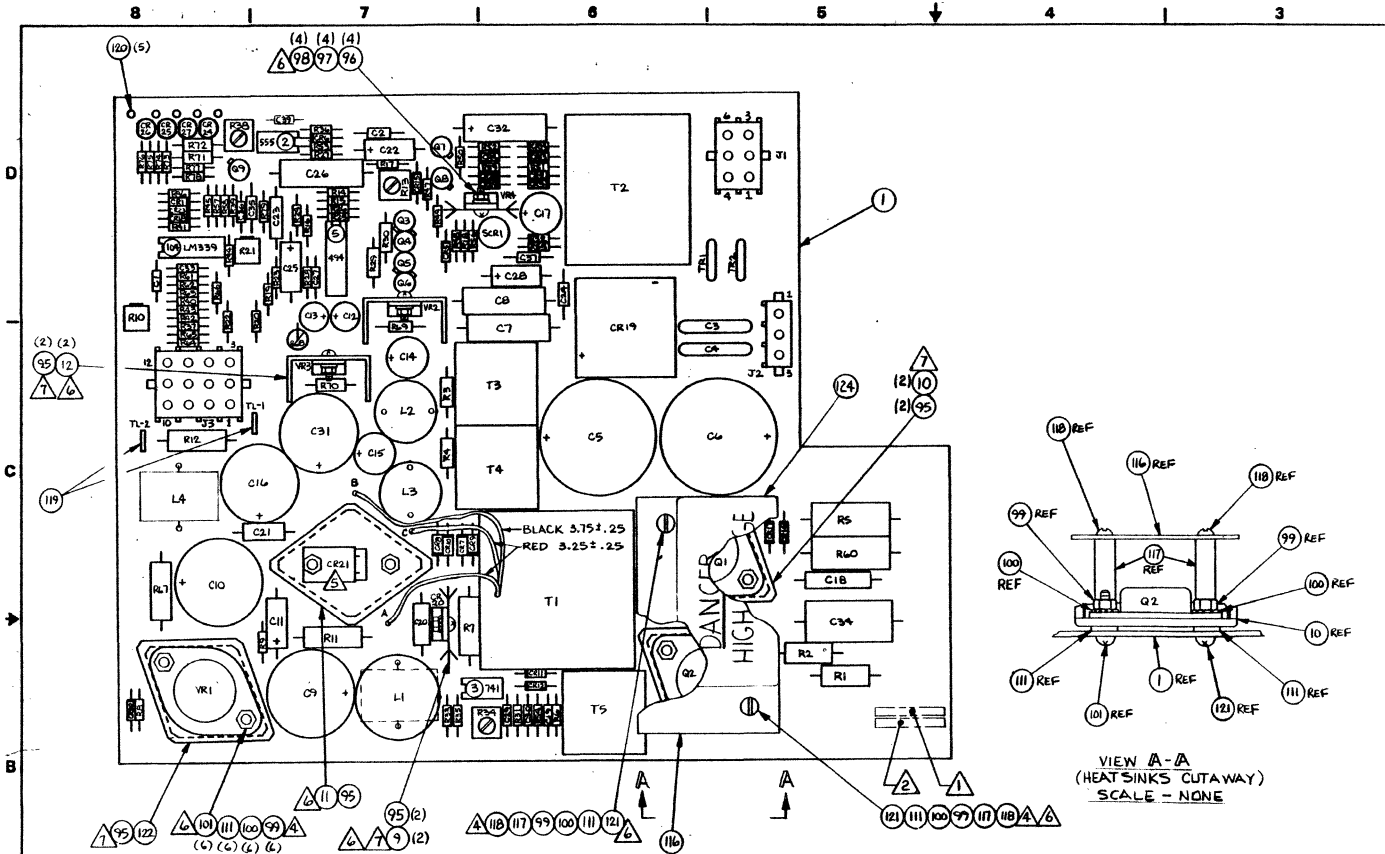

ROSS REFERENCE TABLE		ROSS REFERENCE TABLE		ROSS REFERENCE TABLE		ROSS REFERENCE TABLE	
IND	DESCRIPTION	IND	DESCRIPTION	IND	DESCRIPTION	IND	DESCRIPTION
1	VR4	27	Q3 Q6	48	R67	70	R26 R45 R64 R24
2	VR3	28	Q9	49	C2 C24 C39 C35 C37	71	R36
3	VR2	29	Q4 Q5 Q7 Q8	50	C23	72	R15 R71 R19
4	VR1	30	Q1 Q2	51	C7 C8 C26	73	R58
5	CR1	31	SCR1	52	C34	74	R8
6	CR2	32	CR21	53	C32	75	R77 R78
7	CR3	33	CR20	54	C32	76	R5 R60
8	CR4	34	CR19	55	C11 C25 C28	77	R6 R20 R22 R10 R37 R39 R54
9	CR5	35	CR1 CR6 CR18 CR23	56	C22	78	R52
10	CR6	36	CR7 CR8 CR9 CR18	57	C14 C15	79	R55
11	CR7	37	CR15	58	C5 C6	80	R31
12	CR8	38	CR5	59	C10	81	R14
13	CR9	39	CR4	60	C16 C31	82	R14
14	CR10	40	CR2 CR3 CR11 CR12 CR13 CR14 CR16 CR22 CR28 CR29	61	R15 R38	83	R23 R25 R27 R47
15	CR11	41	CR7	62	R65	84	R59
16	CR12	42	C1 C29 C39	63	R34	85	R9
17	CR13	43	C20	64	R11	86	R41
18	CR14	44	CR	65	R12	87	R57
19	CR15	45	C3 C4	66	R1	88	R40 R42
20	CR16	46	C19 C36	67	R1 R2	89	R28
21	CR17	47	CR1	68	R3 R4	90	R46 R48 R49 R50 R51 R61 R62
22	CR18			69	R29 R30	91	R79

SHEET REVISION STATUS		REVISION RECORD				
REV	ECO	DESCRIPTION	DEPT	DATE	CHKD	APP
00	5006L-20	RELEASED CLASS B		7/10/81		
01	51355	RETAPED & REDRAWN	DC	10/28/81		
02	51431	REVISED T&E ECO	DC	11/29/81		
03	51477	REVISED T&E ECO	DC	12/29/81		
04	51610	REVISED T&E ECO	DC	1/23/82		
05	51528	ADD F/N 124		2/11/82		
06	51543	REVISED PER CCO		2/23/82		
07	51570	ADDED C39	EE	3/2/82		
A	14537-38					
B	15228	INACTIVE REPLAZED BY 10446476	R.H.	2/6/82		
C	16541	ENG F/N 75,76,78,80,ADD F/N 100	R.S.	1/1/84		

- NOTES:
- MARK ASSY. NO., REV LEVEL, AND LOC CODE IN AREA SHOWN. MARK PER CDC SPEC 10121508, CHARACTER HEIGHT .12 (10 PT) COLOR WHITE.
 - MARK SERIAL NUMBER IN AREA SHOWN PER RVLOPS P&P NO. 80:20:34 AND PER MARKING REQUIREMENTS IN NOTE (1) ONE.
 - FIND NUMBERS, ELEMENT IDENTIFIERS, AND REFERENCE DESIGNATIONS ARE FOR REFERENCE ONLY AND DO NOT APPEAR ON PART.
 - TIGHTEN BOTH SCREWS EVENLY ON Q1, Q2 AND VR1.
 - REMOVE CENTER PIN (NUMBER 2) ON CR21.
 - TORQUE REQUIREMENTS PER CDC STANDARD 10120300.
 - COMPONENT MOUNTING SURFACE TO BE COMPLETELY COVERED WITH F/N 95. (TYPICAL - .005 SHOULD SHOWN ON SIDES OF COMPONENTS AFTER TIGHTING.

INACTIVE

UNLESS OTHERWISE SPECIFIED DIMENSIONS ARE IN INCHES		TOLERANCES		CONTROL DATA		TITLE	
PLACE	PLACE	ANGLE	FIRST CHG. ON	CCG34-A	P.C. CARD ASSEMBLY, 1AHD POWER SUPPLY		
DO NOT SCALE DRAWING	CHECKED BY	DATE	10-27-81	15920	D	90446296	
MATERIAL	ENGINEER	DATE	2/2/82				
APPROVED	MECH	DATE	4/1/82				

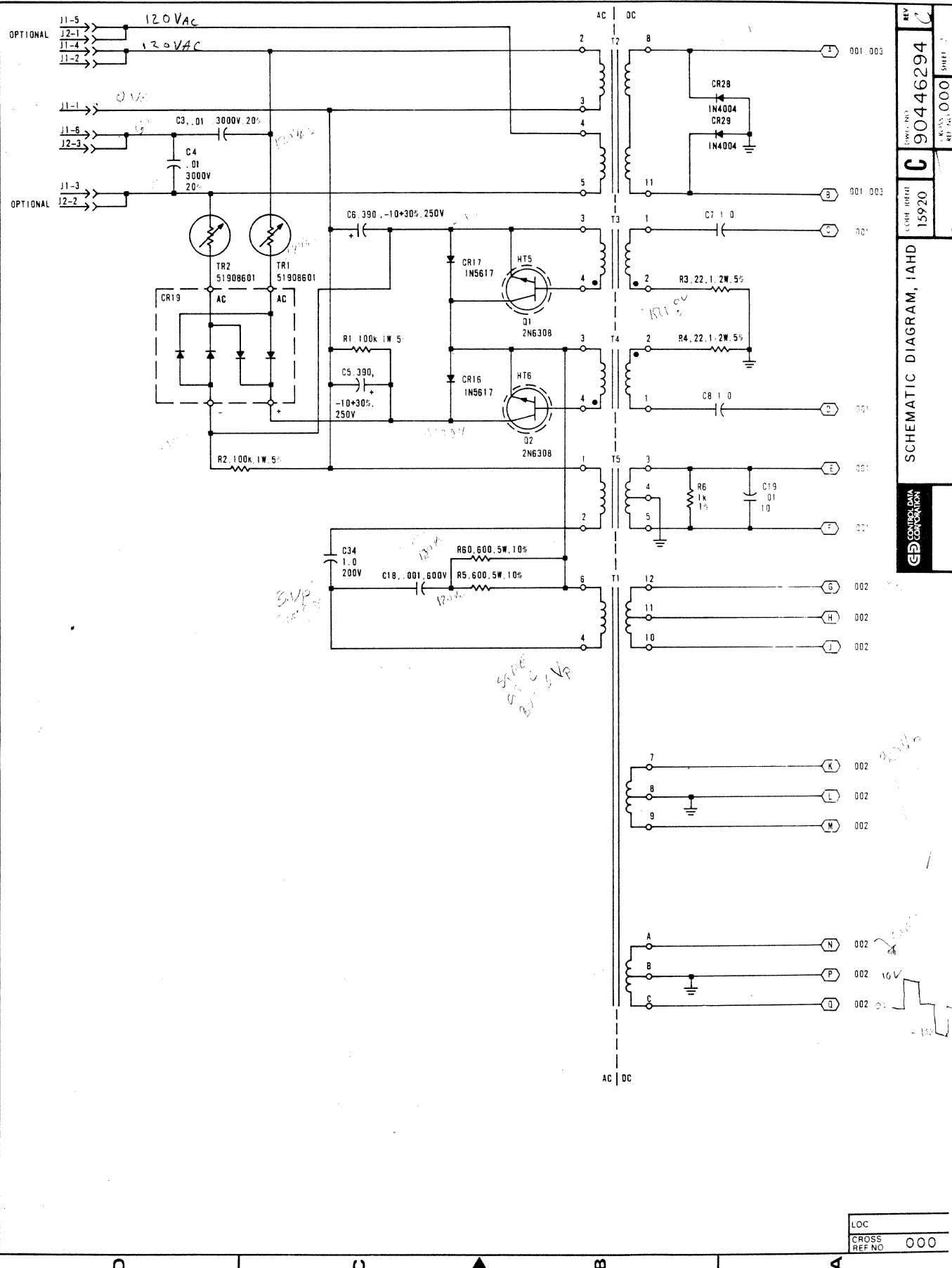

REV **C**
 LOW VOLT 90446294
 CROSS REF NO 000
 SHEET 1
 CORE IDENT 15920
 SCHEMATIC DIAGRAM, IAH4
 GENERAL ELECTRIC CORPORATION

LOC
 CROSS REF NO 000

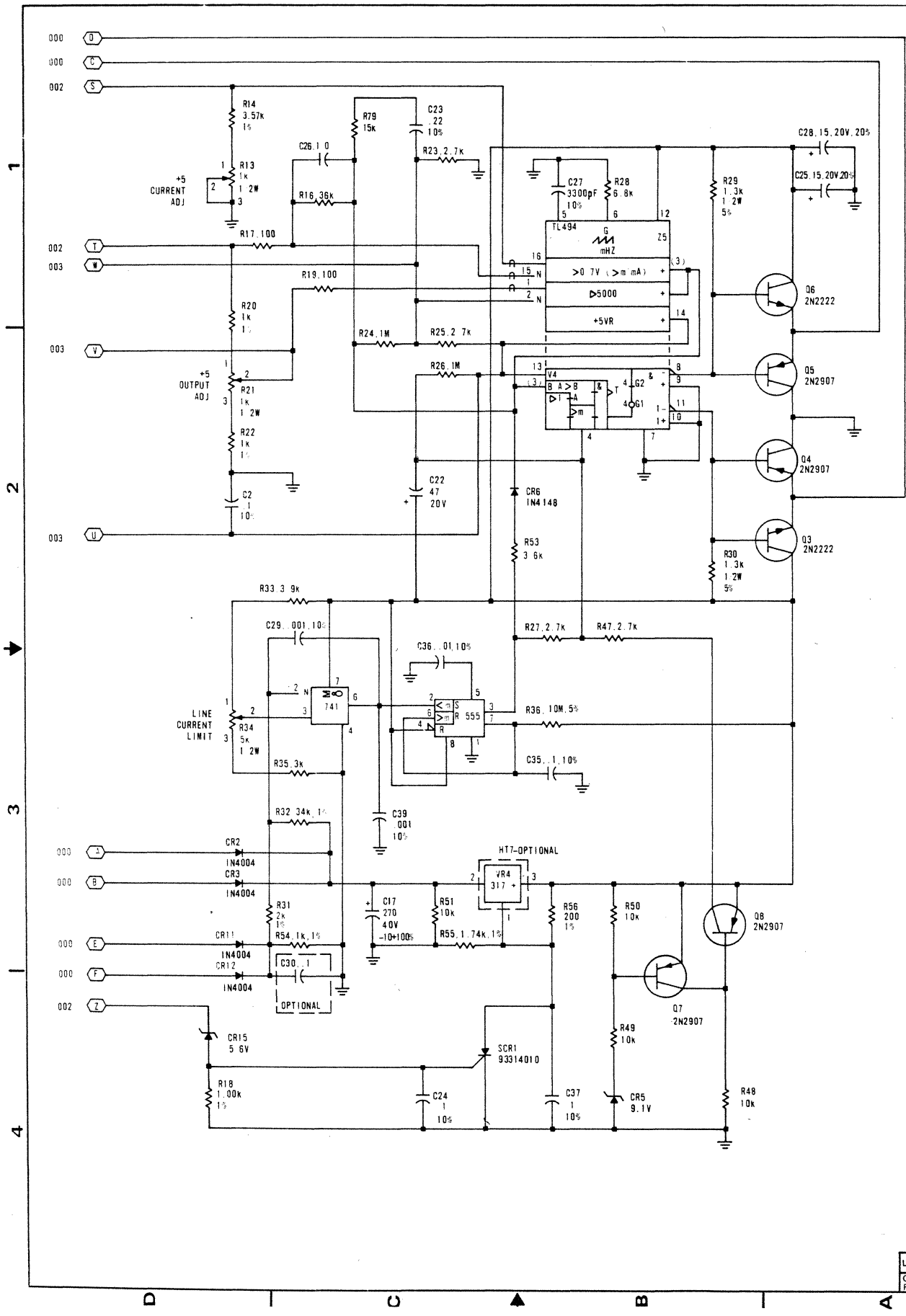

LOC
 CROSS REF NO 001

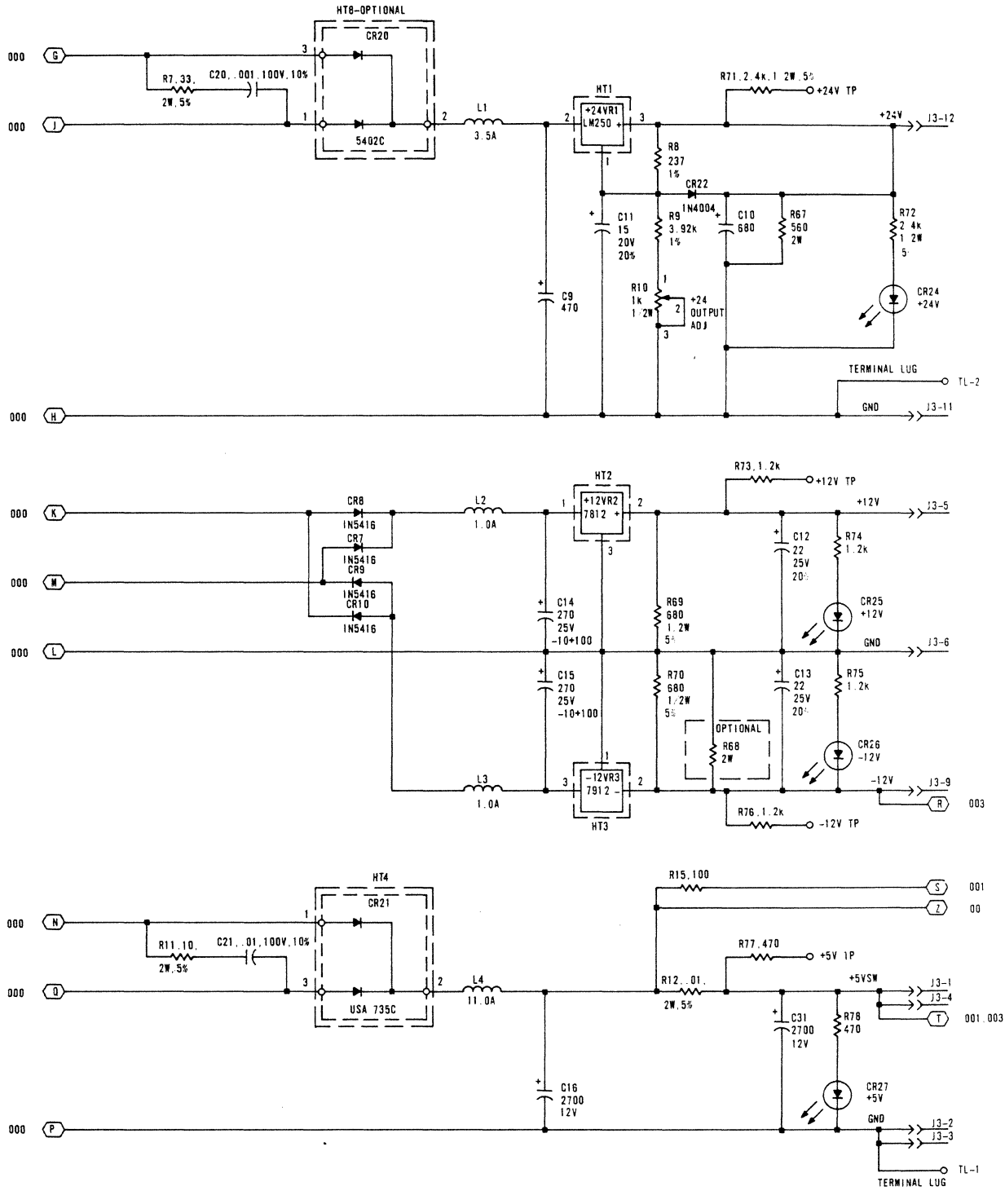

LOC
 CROSS REF NO 002

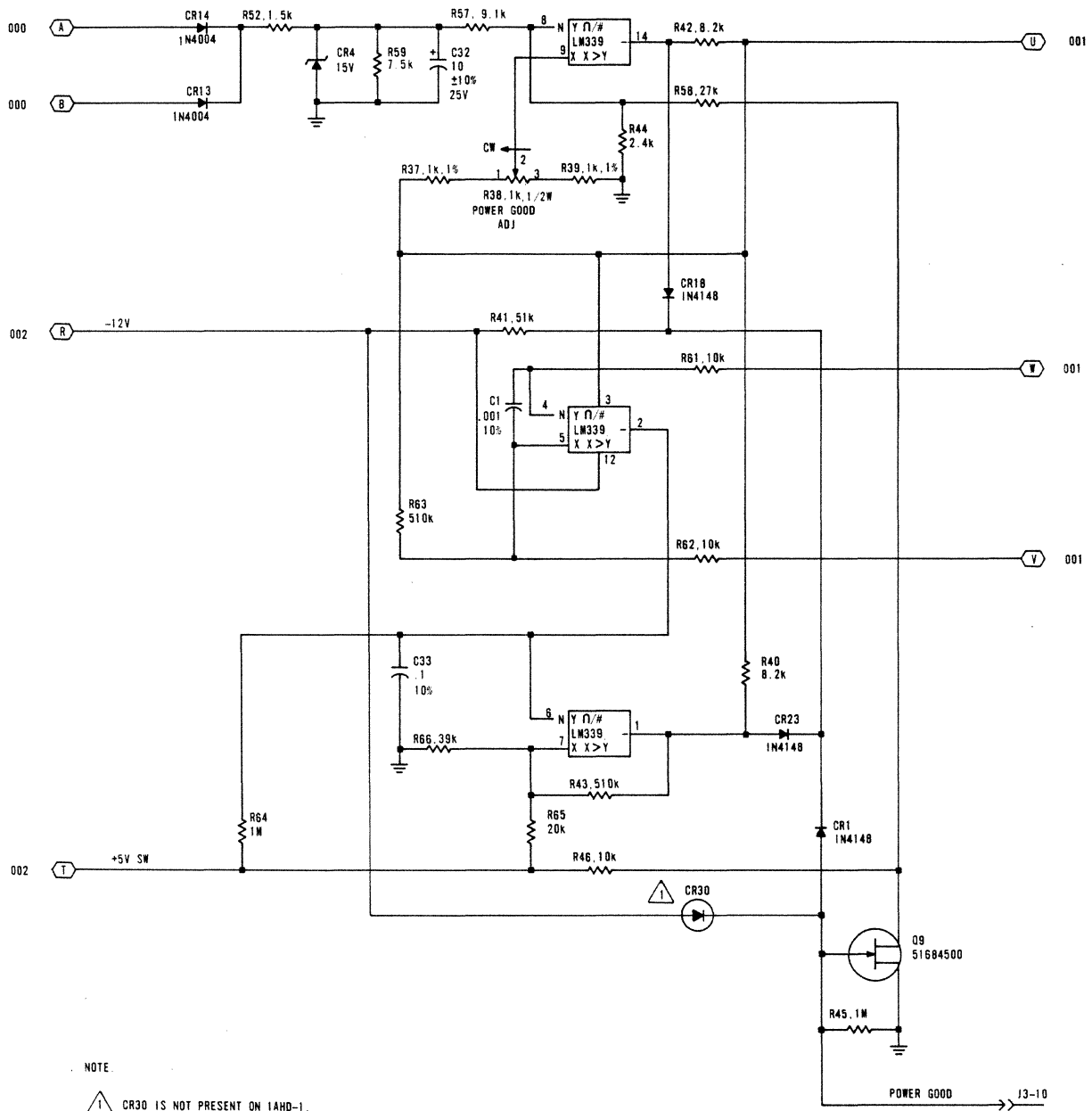

NOTE
 CR30 IS NOT PRESENT ON IAHD-1.

LOC	
CROSS REF NO	003

4

3

2

1

62940037 F

D

C

B

A

SHEET REVISION STATUS						REVISION RECORD						
	5	4	3	2	1	REV	CO	DESCRIPTION	DFT	DATE	CHKD	APP
							50	RELEASED CLASS B		1/2/53		
							Sec. 9-57					
						01	51991	REVISED PER ECO	EE	3/9/53	42	
						01	52091	REVISED PER ECO	EE			
						A	15153-58	RELEASED CLASS A		2-8-53		
						A	16541	REVISED PER ECO	WIC	3-11-53	DS	

NOTES

- 1 UNLESS OTHERWISE SPECIFIED POWER AND GROUND PINS OF INTEGRATED CKTS ARE AS LISTED BELOW
- 14 PIN INTEGRATED CKTS PIN 14=+5V PIN 7=GND

SPARES

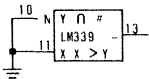

REFERENCE DRAWING			CONTROL DATA			TITLE		
DETAIL			CORPORATION			SCHEMATIC DIAGRAM, 81AHD-3		
ASSY			FIRST USED ON			(POWER SUPPLY)		
			CC634-A					
COMPONENTS EXCEPT AS NOTED			DWN			CODE IDENT		
TOLERANCE			CHKD			15920		
VALUE			ENGR			DRAWING NO.		
RATING			MFG			90446563		
RES 20 OHMS 1/4 W			APPR			SCALE		
CAP +80 20 UF 50V						SHEET 1 OF 5		

1-8.1

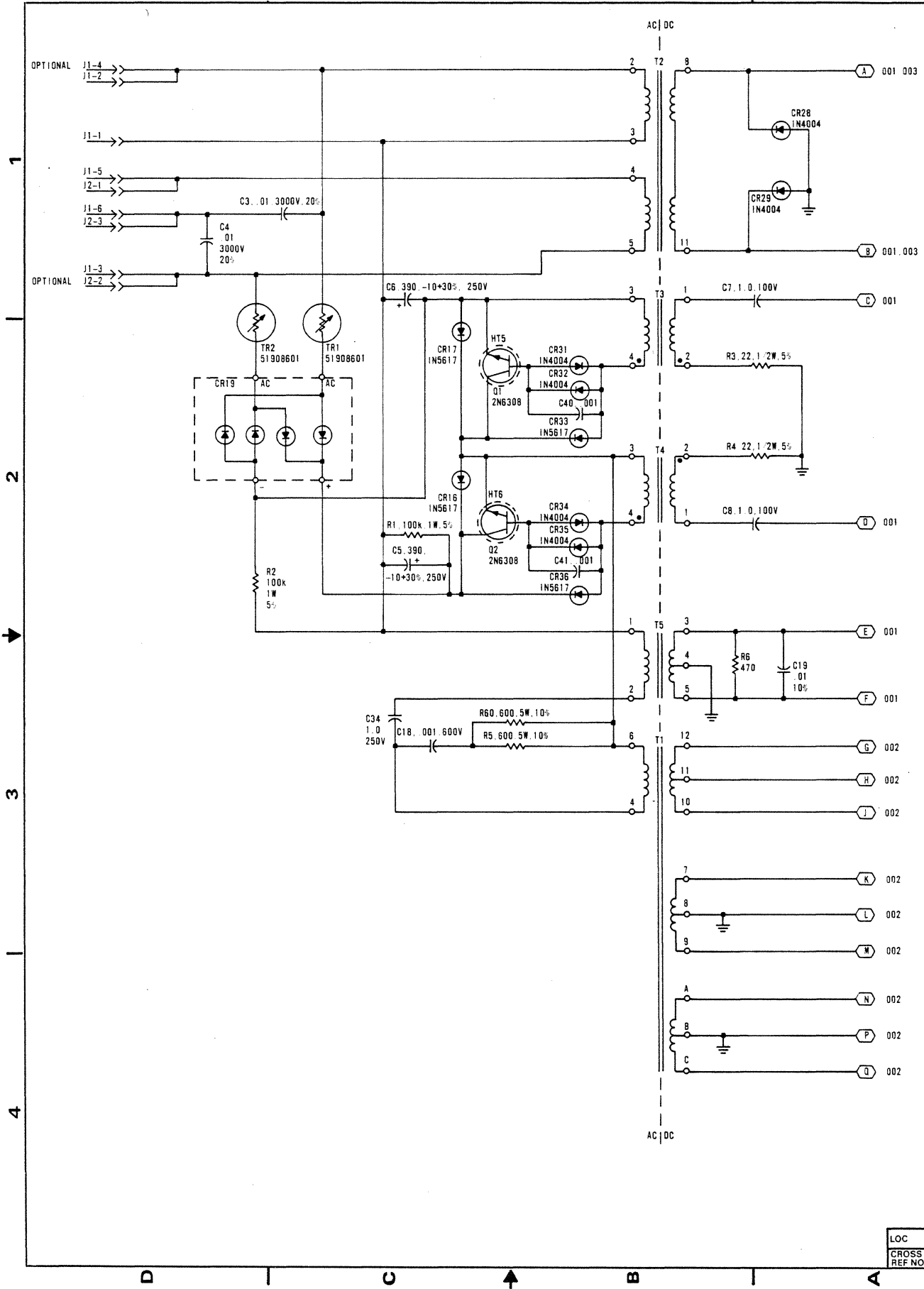

REV	A
DWG NO	90446563
CODE IDENT	15920
CROSS REF NO	000
SHEET	2

SCHEMATIC DIAGRAM, 81AHD-3
POWER SUPPLY

LOC
CROSS REF NO 000

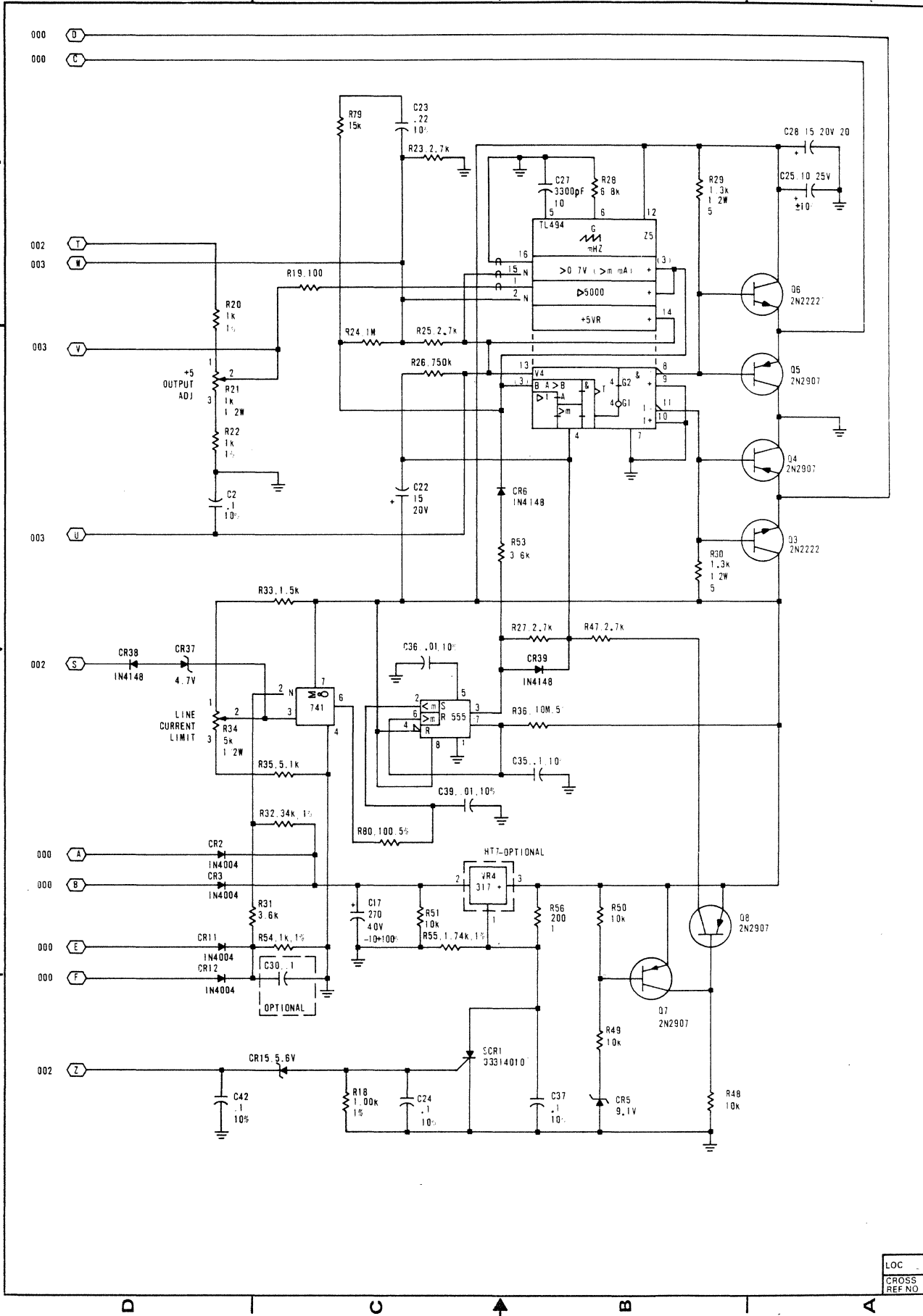

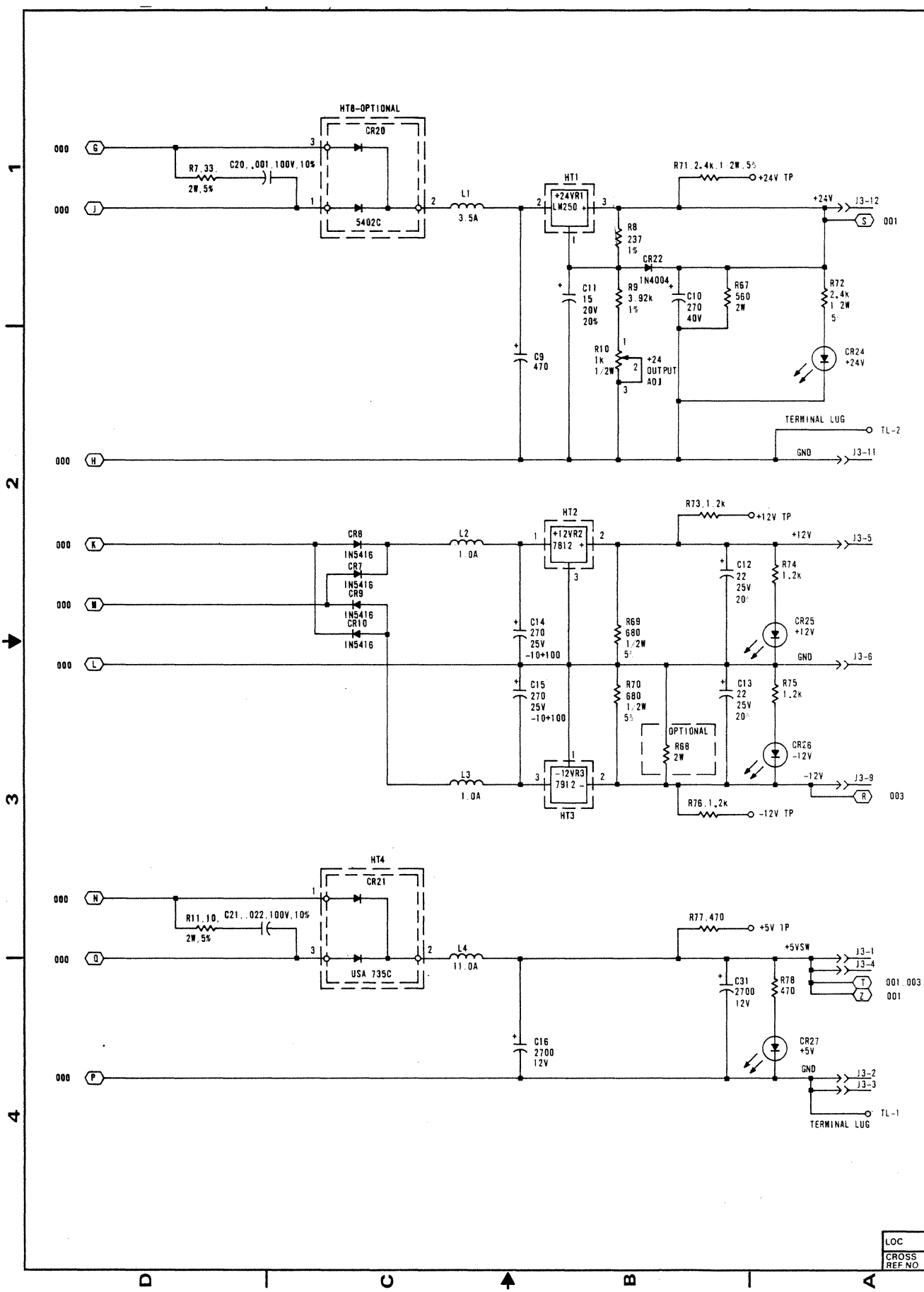

LOC	
CROSS REF NO	001

REV	A
DWG NO	90446563
CROSS REF NO	002
SHEET	4
CODE IDENT	15920
SCHEMATIC DIAGRAM, 8IAHD-3 POWER SUPPLY	
CONTRIBUTOR GENERAL ELECTRIC	

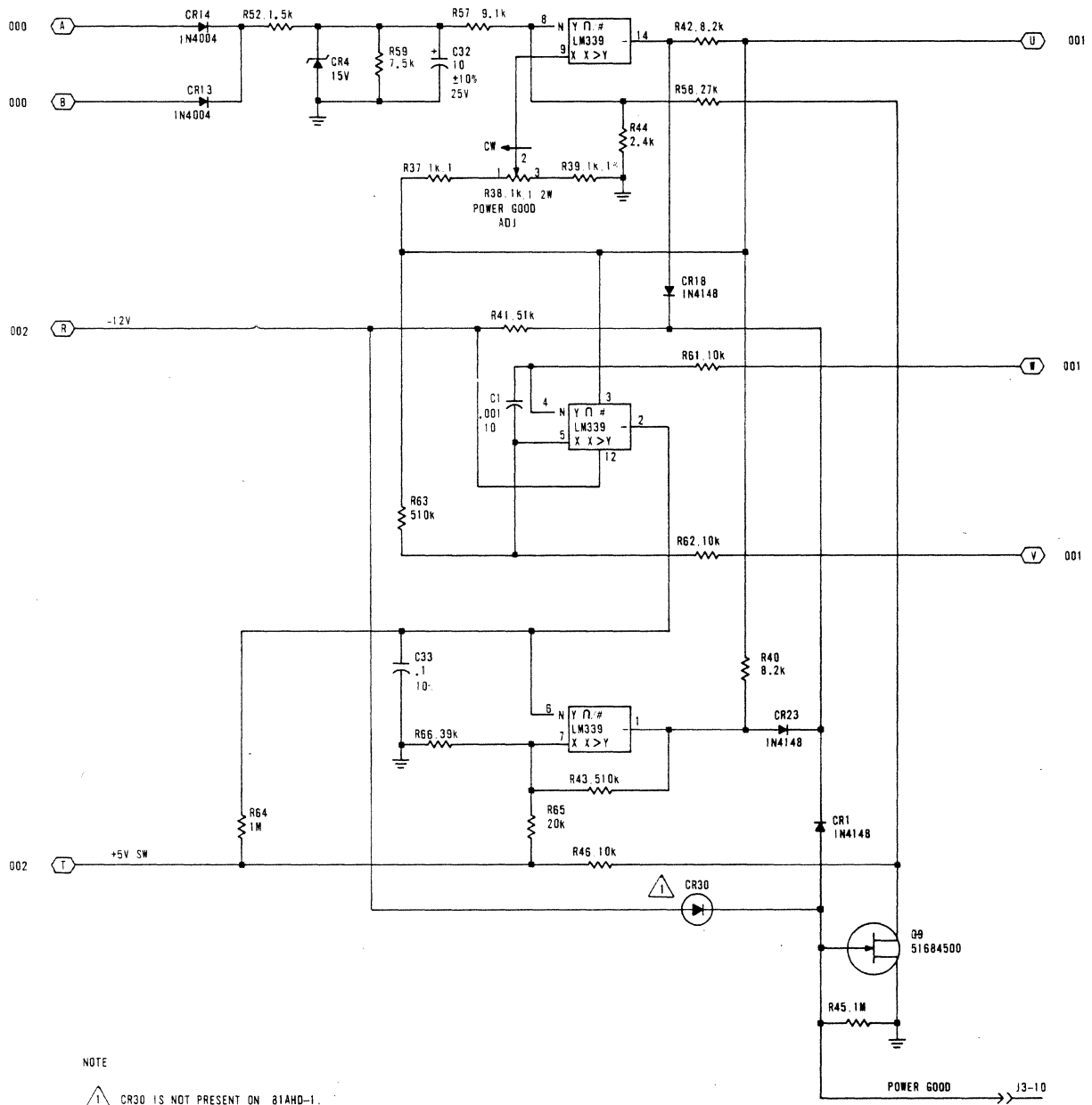

LOC
CROSS REF NO 002



NOTE
 CR30 IS NOT PRESENT ON 81AHD-1.

62940037 B

1-9

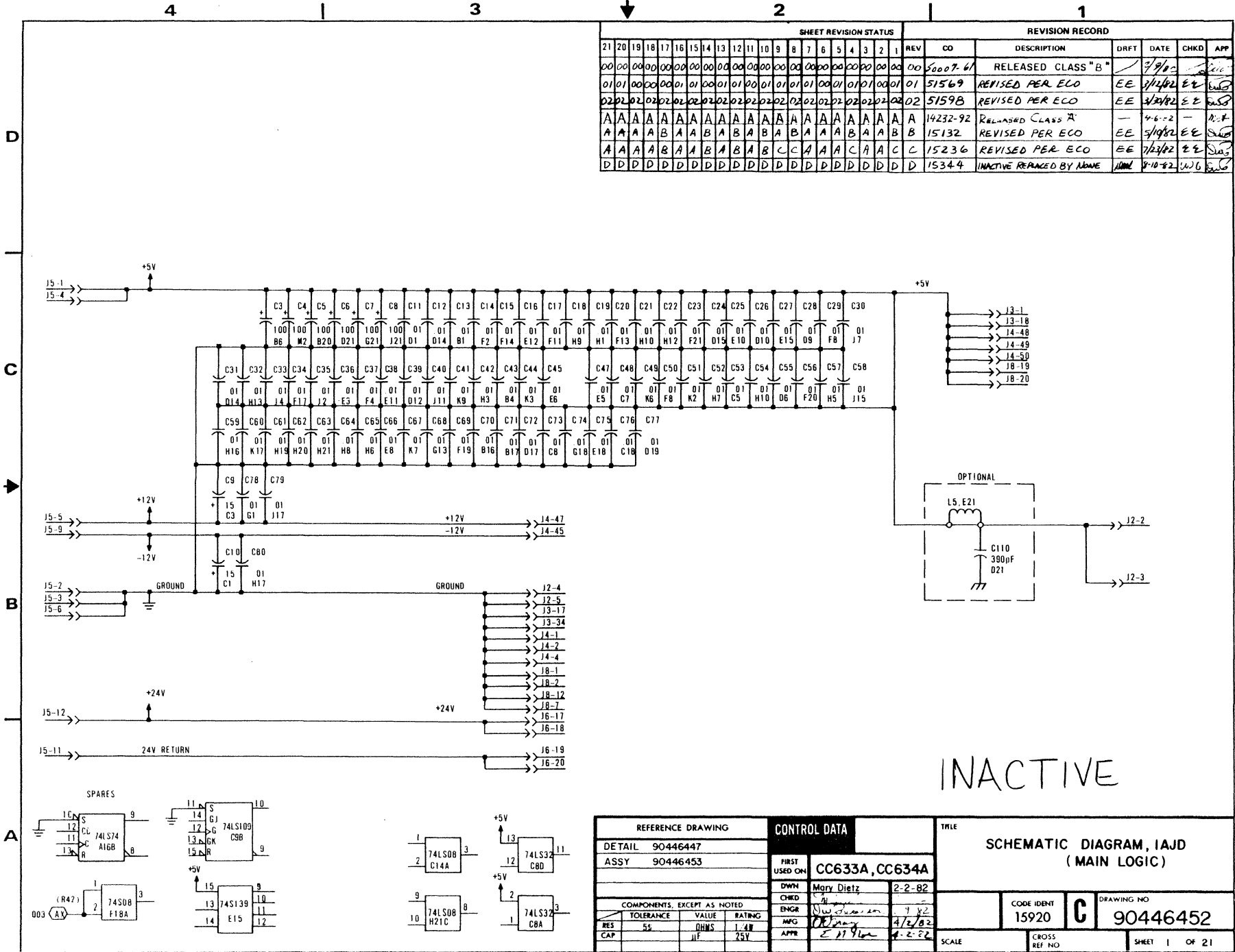

SHEET REVISION STATUS												REVISION RECORD															
21	20	19	18	17	16	15	14	13	12	11	10	9	8	7	6	5	4	3	2	1	REV	CO	DESCRIPTION	DRFT	DATE	CHKD	APP
00	00	00	00	00	00	00	00	00	00	00	00	00	00	00	00	00	00	00	00	00	00	50007-61	RELEASED CLASS "B"	EE	7/9/82	EE	WJG
01	01	00	00	00	01	00	01	01	00	01	01	01	01	00	01	01	01	00	01	01	01	51569	REVISED PER ECO	EE	7/14/82	EE	WJG
02	02	02	02	02	02	02	02	02	02	02	02	02	02	02	02	02	02	02	02	02	02	51598	REVISED PER ECO	EE	7/20/82	EE	WJG
A	A	A	A	A	A	A	A	A	A	A	A	A	A	A	A	A	A	A	A	A	A	14232-92	RELEASED CLASS "A"	EE	4-6-82	EE	WJG
A	A	A	A	A	A	A	A	A	A	A	A	A	A	A	A	A	A	A	A	A	B	15132	REVISED PER ECO	EE	5/10/82	EE	WJG
A	A	A	A	A	A	A	A	A	A	A	A	A	A	A	A	A	A	A	A	A	C	15236	REVISED PER ECO	EE	7/23/82	EE	WJG
D	D	D	D	D	D	D	D	D	D	D	D	D	D	D	D	D	D	D	D	D	D	15344	INACTIVE REPLACED BY NONE	WJG	8-10-82	WJG	WJG

INACTIVE

REFERENCE DRAWING		CONTROL DATA		TITLE	
DETAIL	90446447	FIRST USED ON	CC633A, CC634A	SCHEMATIC DIAGRAM, IAJD (MAIN LOGIC)	
ASSY	90446453	DWN	Mary Dietz	2-2-82	
		ENGR			
		MFG			
		APPR			
COMPONENTS, EXCEPT AS NOTED					
RES	TOLERANCE	VALUE	RATING		
CAP	5%	OHMS	1/4W		
		UF	25V		
SCALE		CROSS REF NO		SHEET 1 OF 21	

REV	D
SWG. NO	90446452
CODE IDENT	C
15920	
ISS. REF. NO.	000
SHEET	2

PROCESSOR AND ADDRESS BUFFER

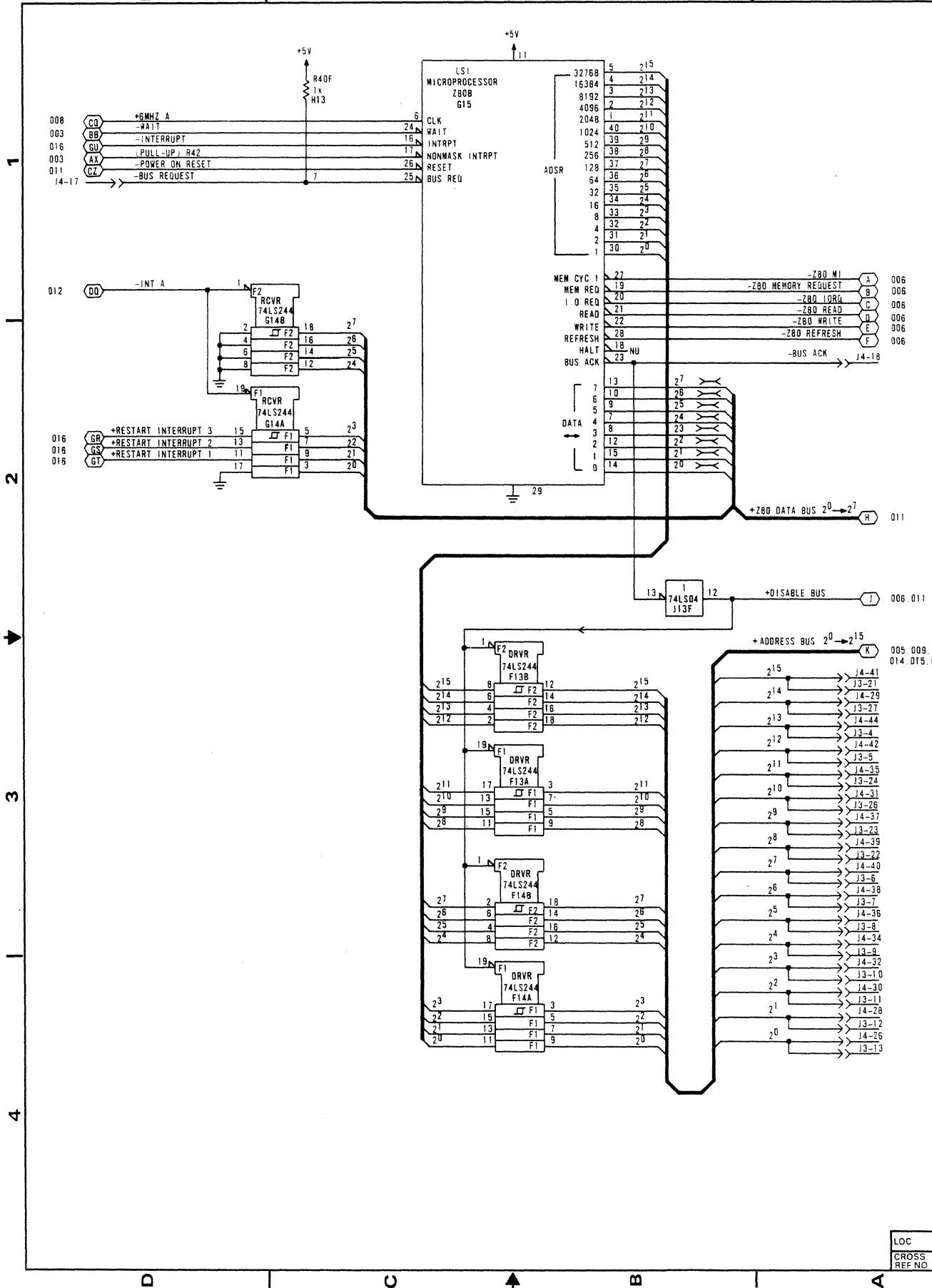

LOC
CROSS
REF. NO. 000

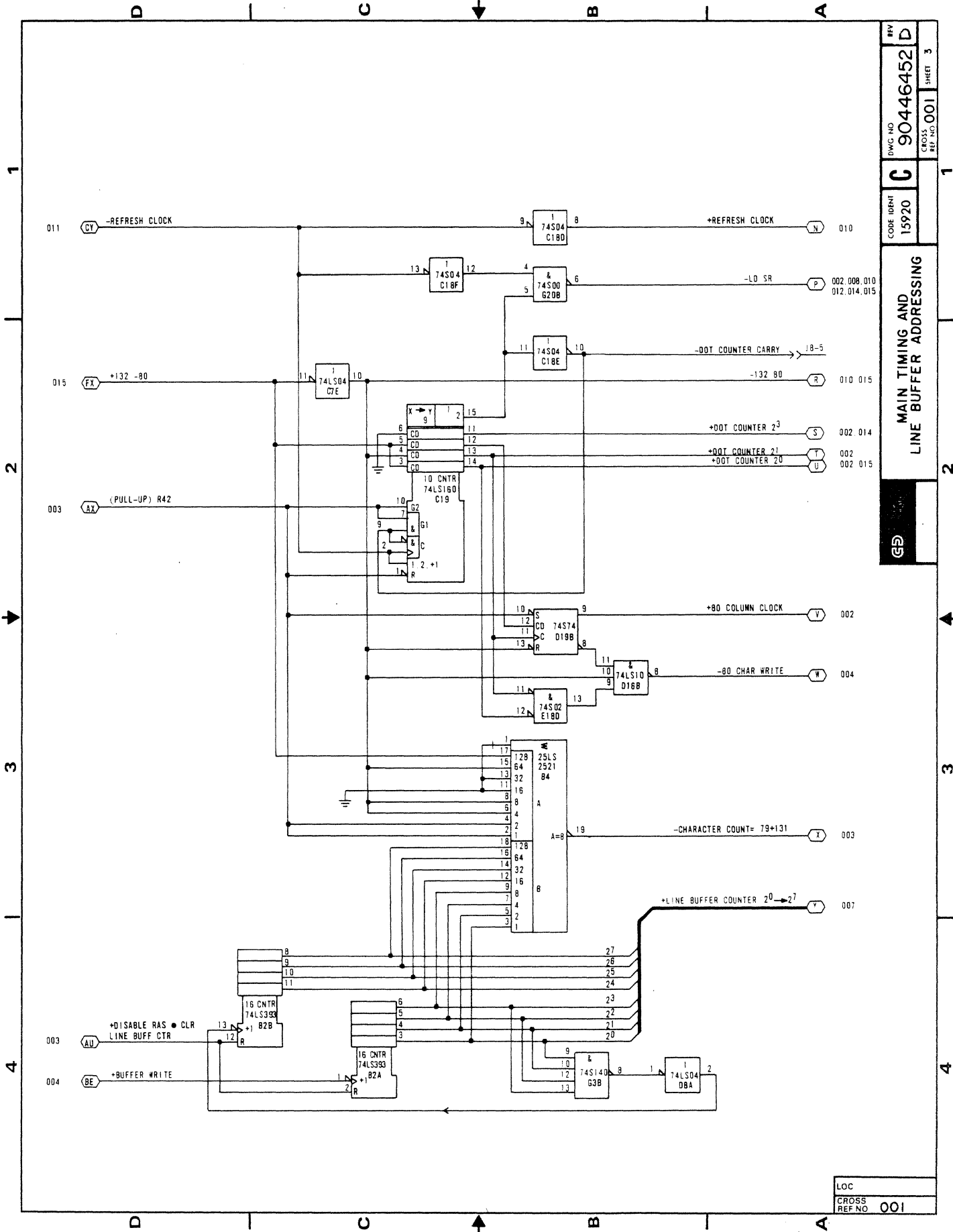

LOC
CROSS REF NO 001

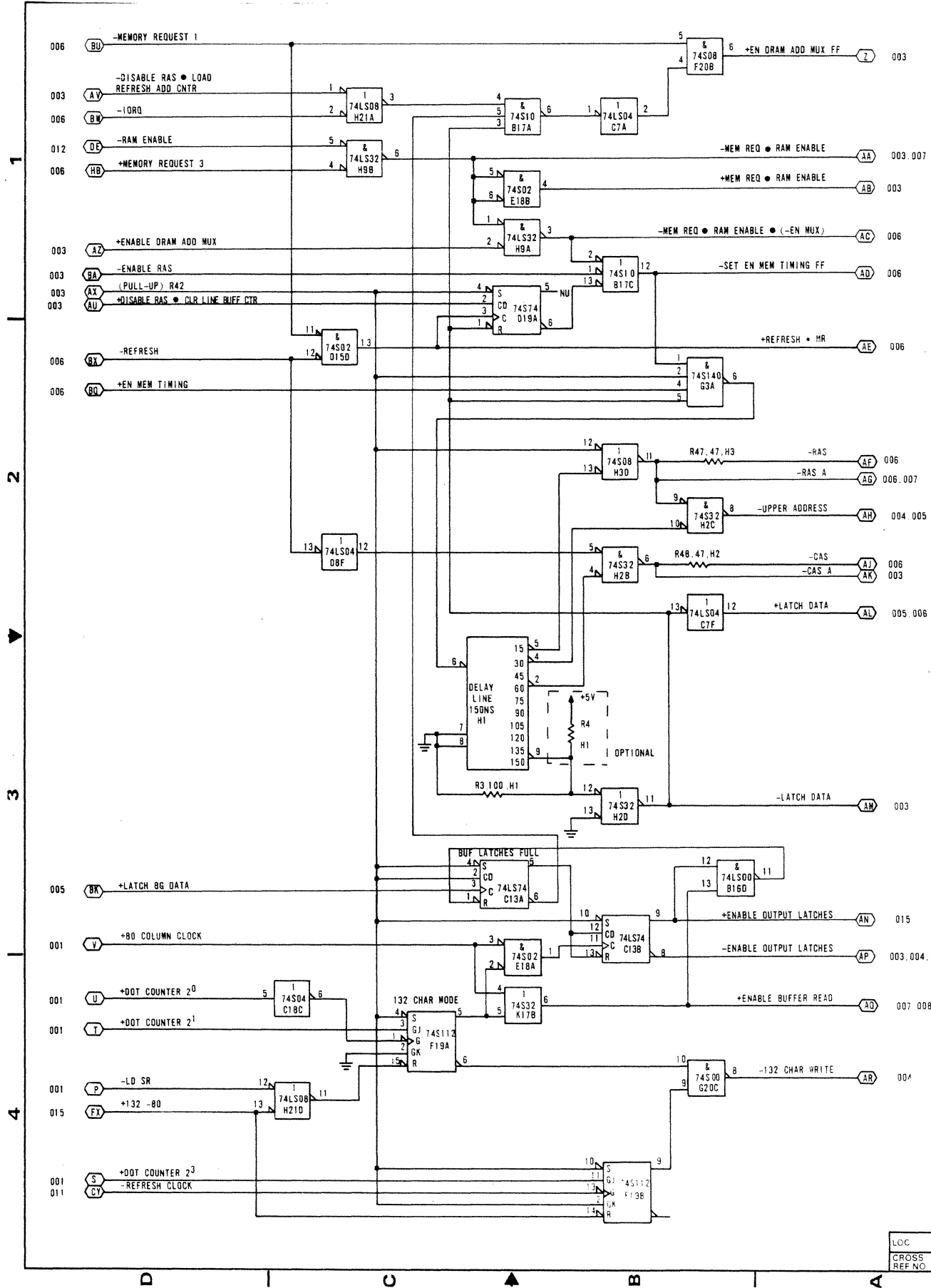

LOC	
CROSS REF NO	002

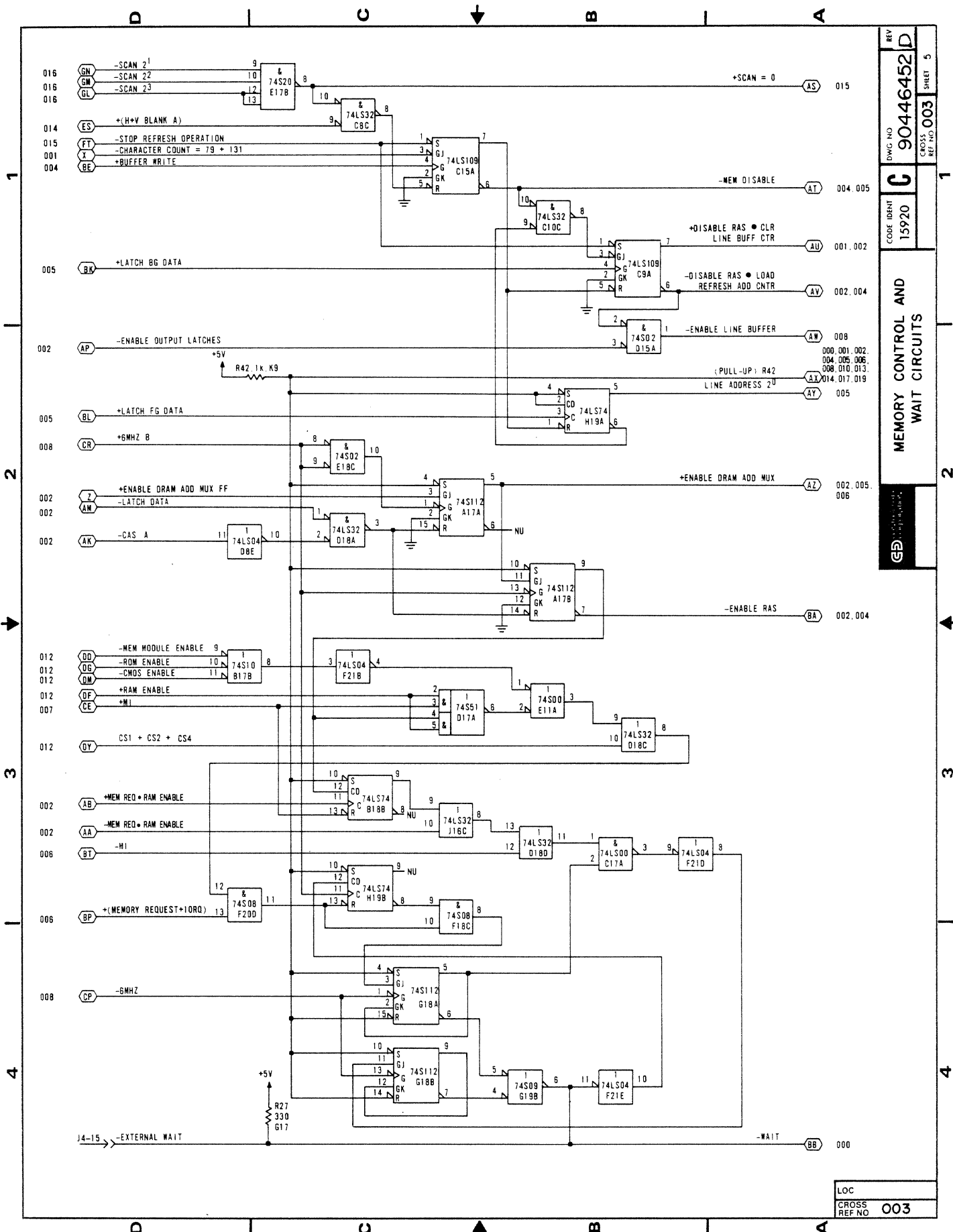

REV	D
DWG NO	90446452
CODE IDENT	C
15920	
MEMORY CONTROL AND WAIT CIRCUITS	
REV NO	003
SHEET	5

1
2
3
4

1
2
3
4

LOC	
CROSS REF NO	003

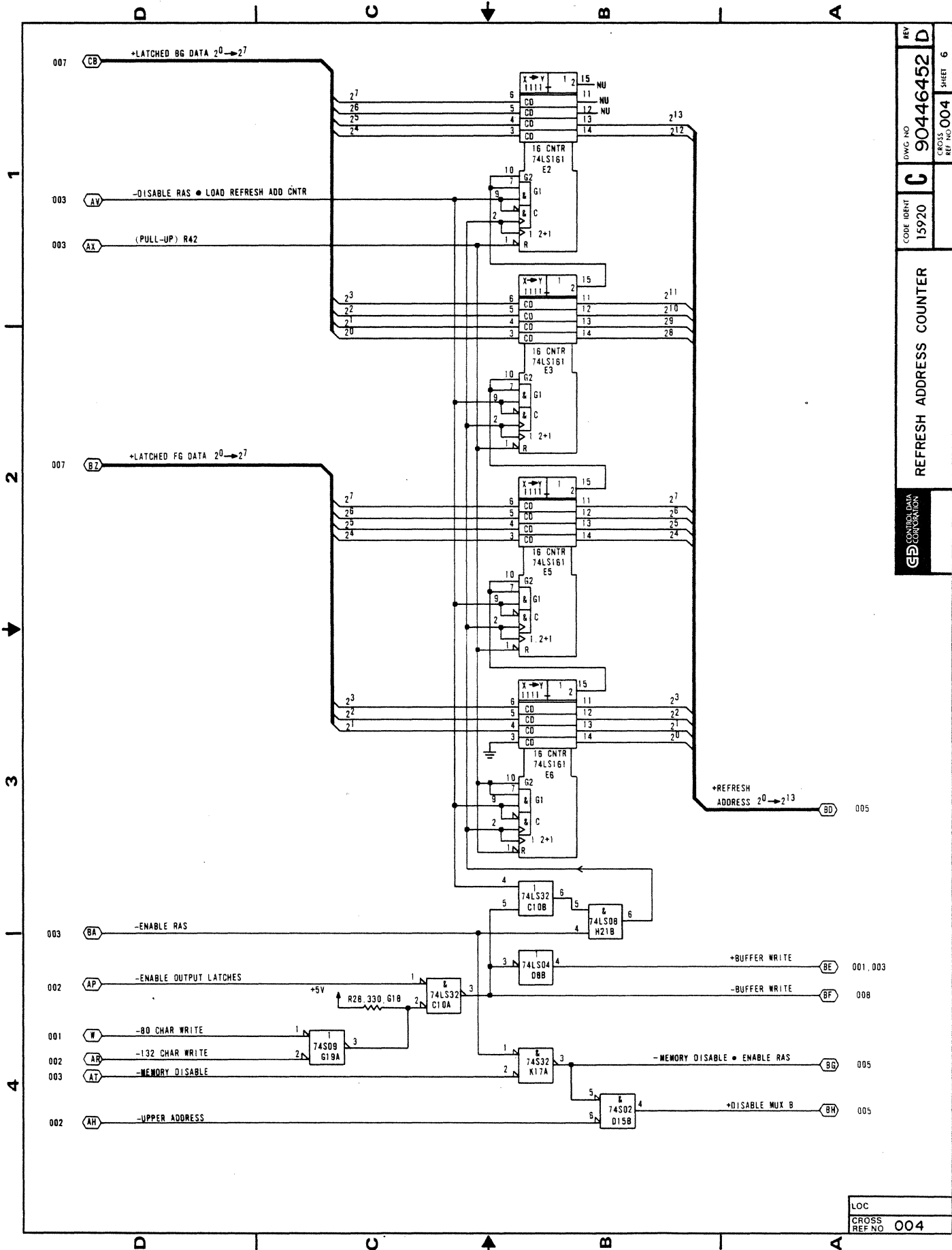

REV	D
DWG NO	90446452
CROSS REF NO	004
SHEET	6
CODE IDENT	C
15920	
REFRESH ADDRESS COUNTER	
CONTROL DATA COMPANION	

LOC
CROSS
REF NO 004

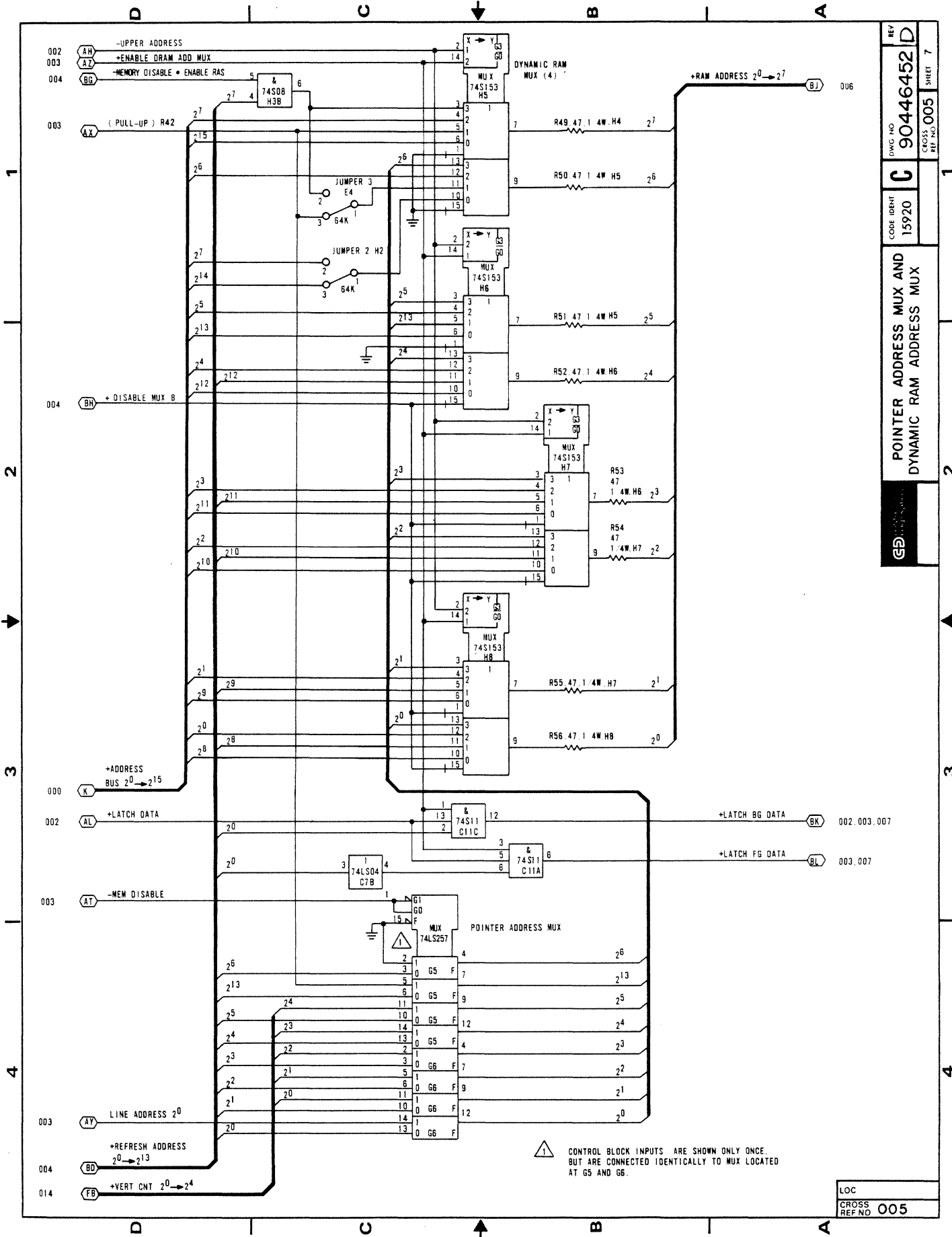

REV	D
DWG NO	90446452
CODE IDENT	C
CROSS REF NO	005
SHEET	7

POINTER ADDRESS MUX AND
DYNAMIC RAM ADDRESS MUX

⚠ CONTROL BLOCK INPUTS ARE SHOWN ONLY ONCE, BUT ARE CONNECTED IDENTICALLY TO MUX LOCATED AT G5 AND G6.

LOC
CROSS REF NO 005

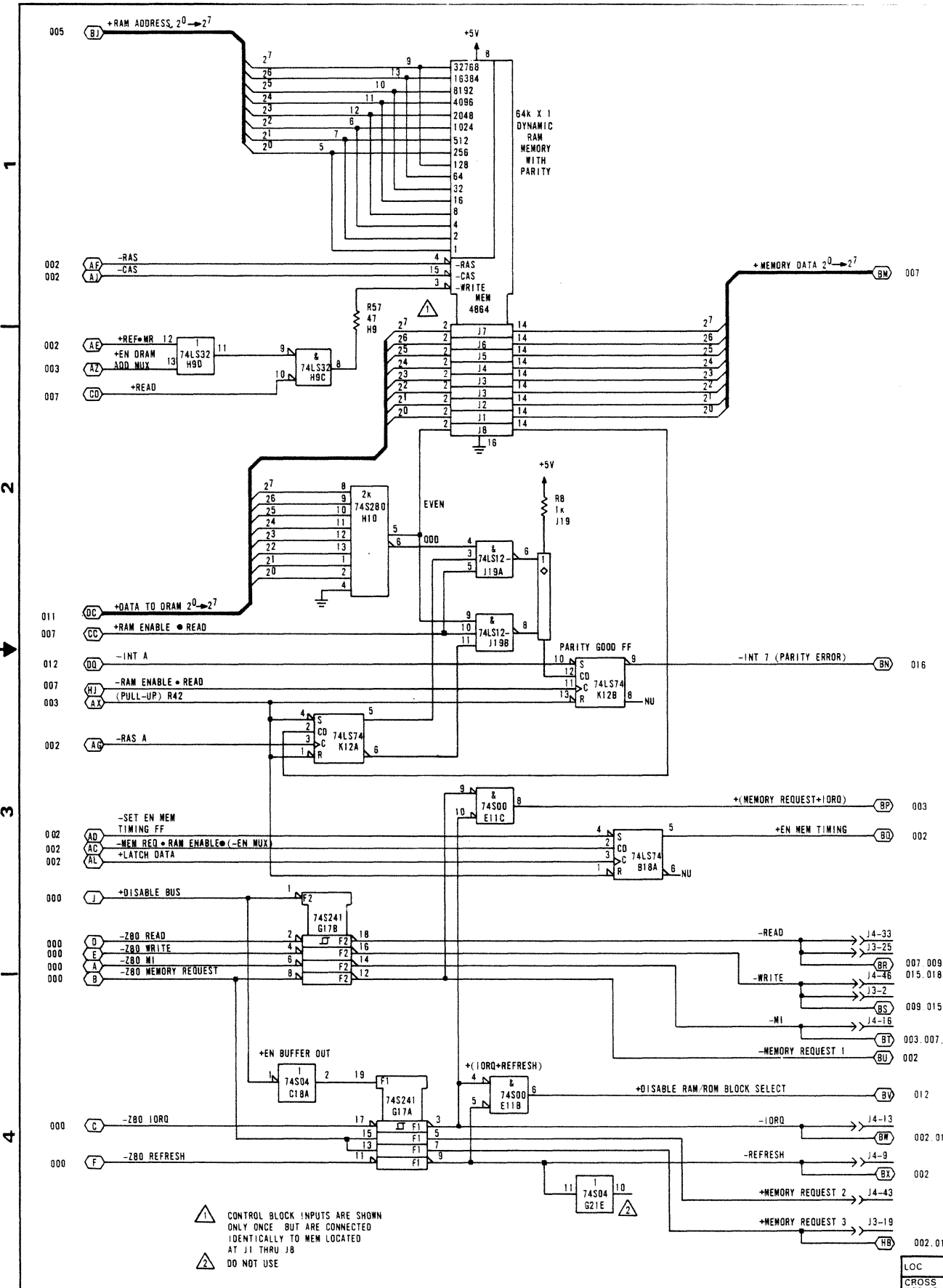

REV	D
DWG NO	90446452
CROSS REF NO	006
SHEET	8
CODE IDENT	C
15920	
DYNAMIC RAM AND CONTROL SIGNAL BUS DRIVERS	
GEO. UNIV. CONTROL	

⚠ CONTROL BLOCK INPUTS ARE SHOWN ONLY ONCE BUT ARE CONNECTED IDENTICALLY TO MEM LOCATED AT J1 THRU J8
 ⚠ DO NOT USE

LOC
 CROSS REF NO 006

1
2
3
4

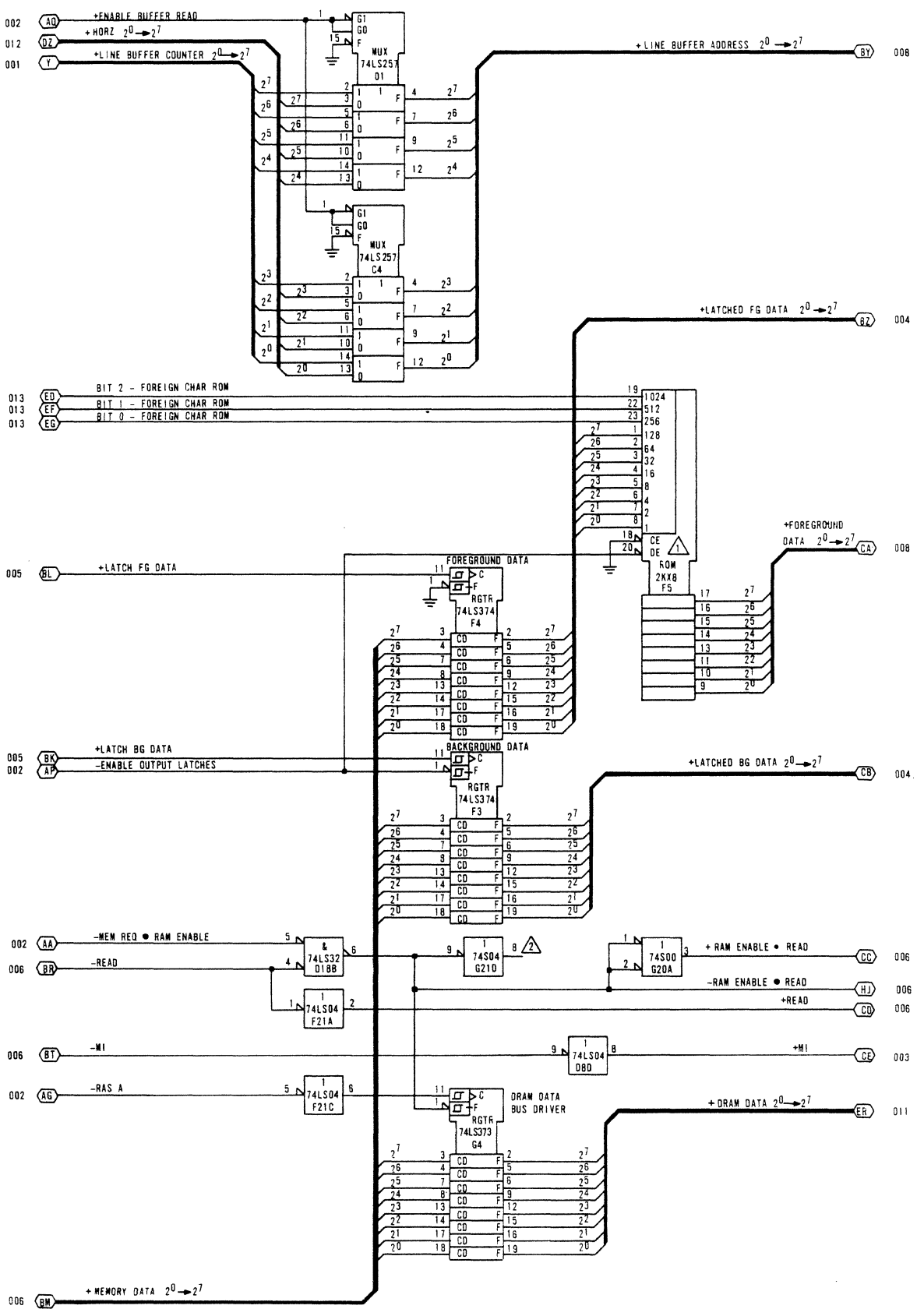

REV	9
UWG NO	90446452
CROSS REF NO	007
CODE IDENT	C
15920	
LINE BUFFER ADDRESS MUX AND FOREIGN CHARACTER ROM	

△ FOREIGN CHARACTER CODE CONVERSION ROM
 △ DO NOT USE

LOC
 CROSS REF NO 007

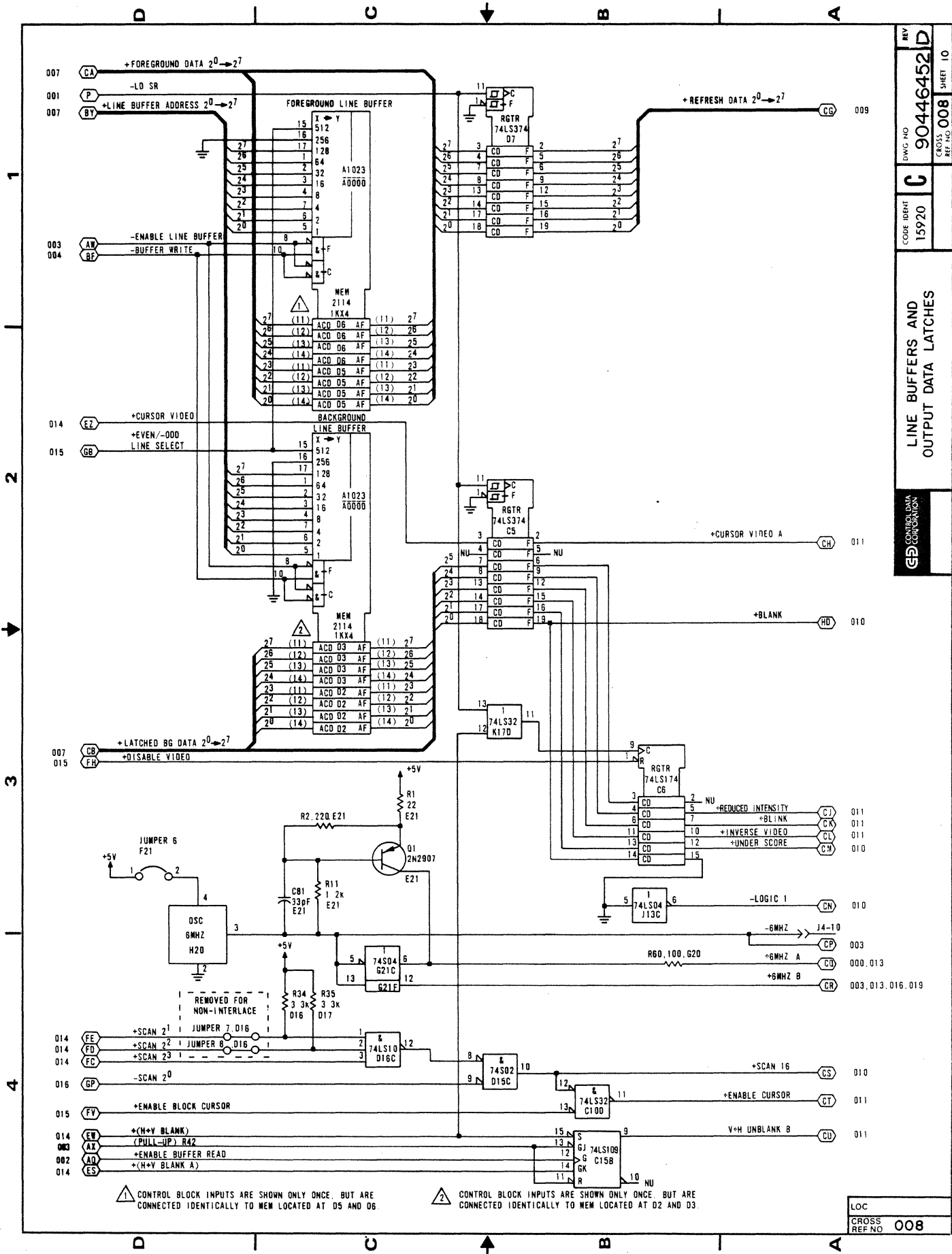

REV	90446452	D
DWG NO	C	008
CODE IDENT	15920	
CROSS REF NO		SHEET 10
LINE BUFFERS AND OUTPUT DATA LATCHES		
CONTROL DATA DATA SECTION		

△ CONTROL BLOCK INPUTS ARE SHOWN ONLY ONCE, BUT ARE CONNECTED IDENTICALLY TO MEM LOCATED AT D5 AND D6

△ CONTROL BLOCK INPUTS ARE SHOWN ONLY ONCE, BUT ARE CONNECTED IDENTICALLY TO MEM LOCATED AT D2 AND D3

LOC	
CROSS REF NO	008

CHARACTER GENERATOR AND
 RAM CHARACTER GENERATOR

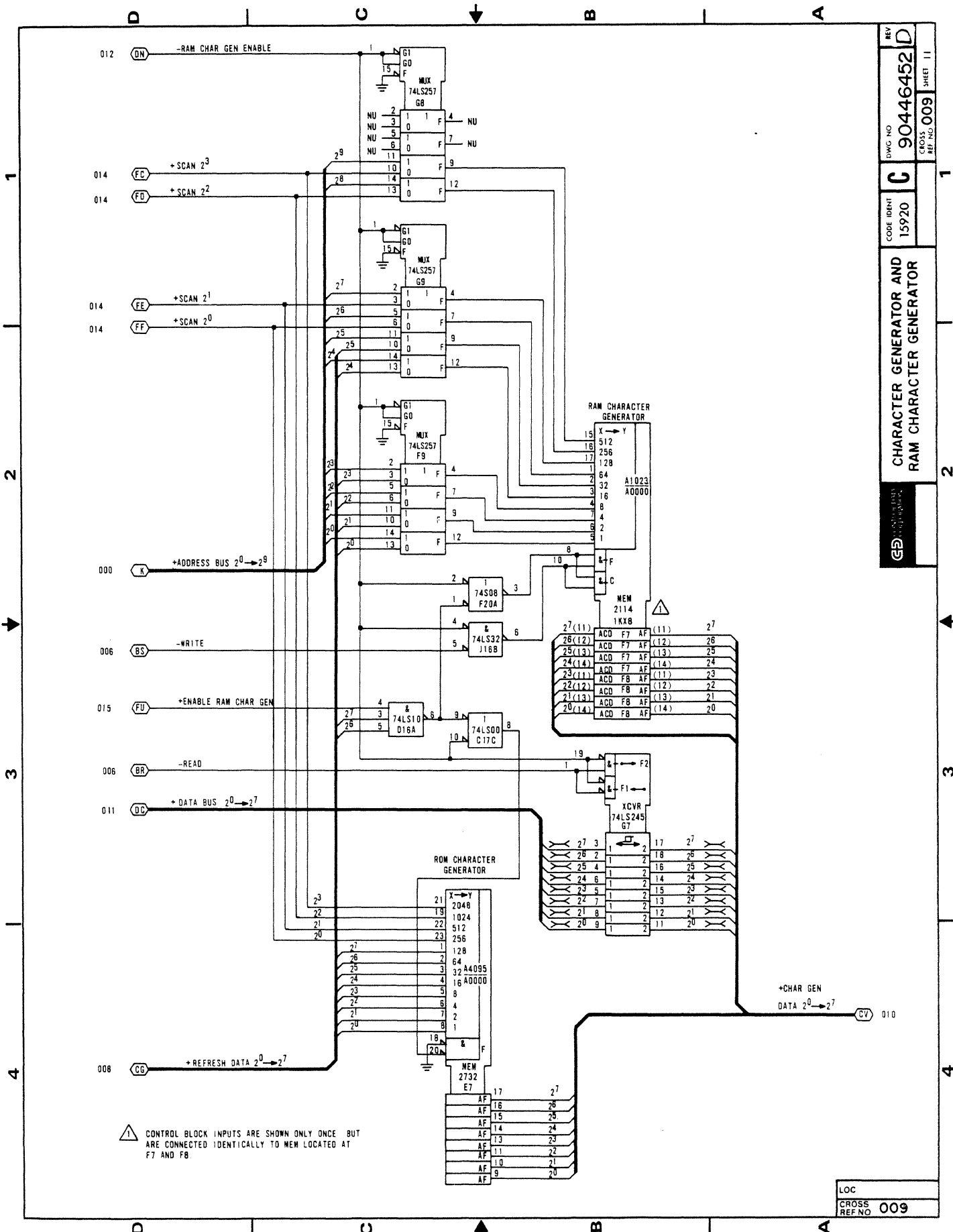

1
 2
 3
 4

1
 2
 3
 4

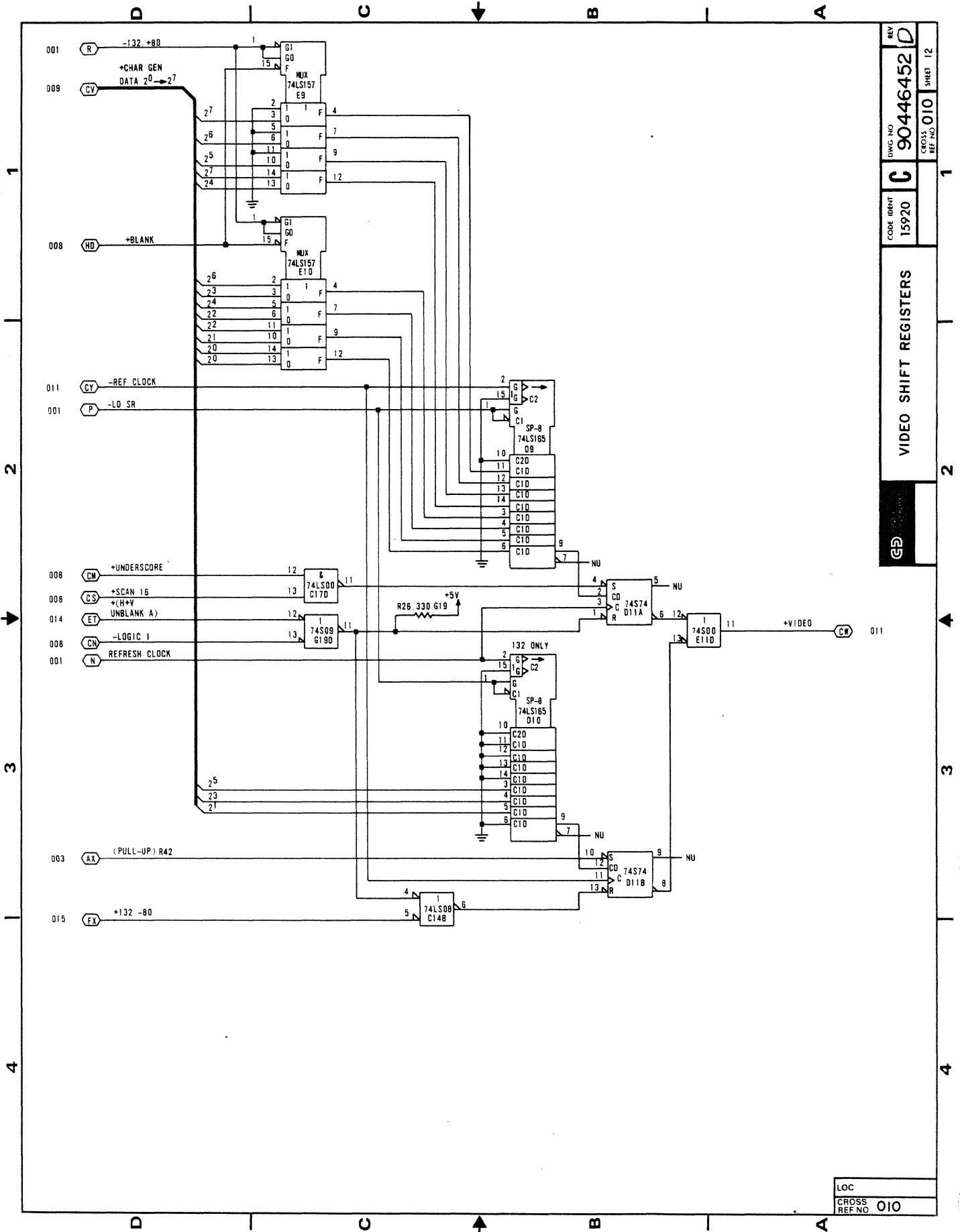

REV	D
DWG NO	90446452
CROSS REF NO	010
SHEET	12
CODE IDENT	C
15920	
VIDEO SHIFT REGISTERS	
(GD)	

LOC
CROSS REF NO 010

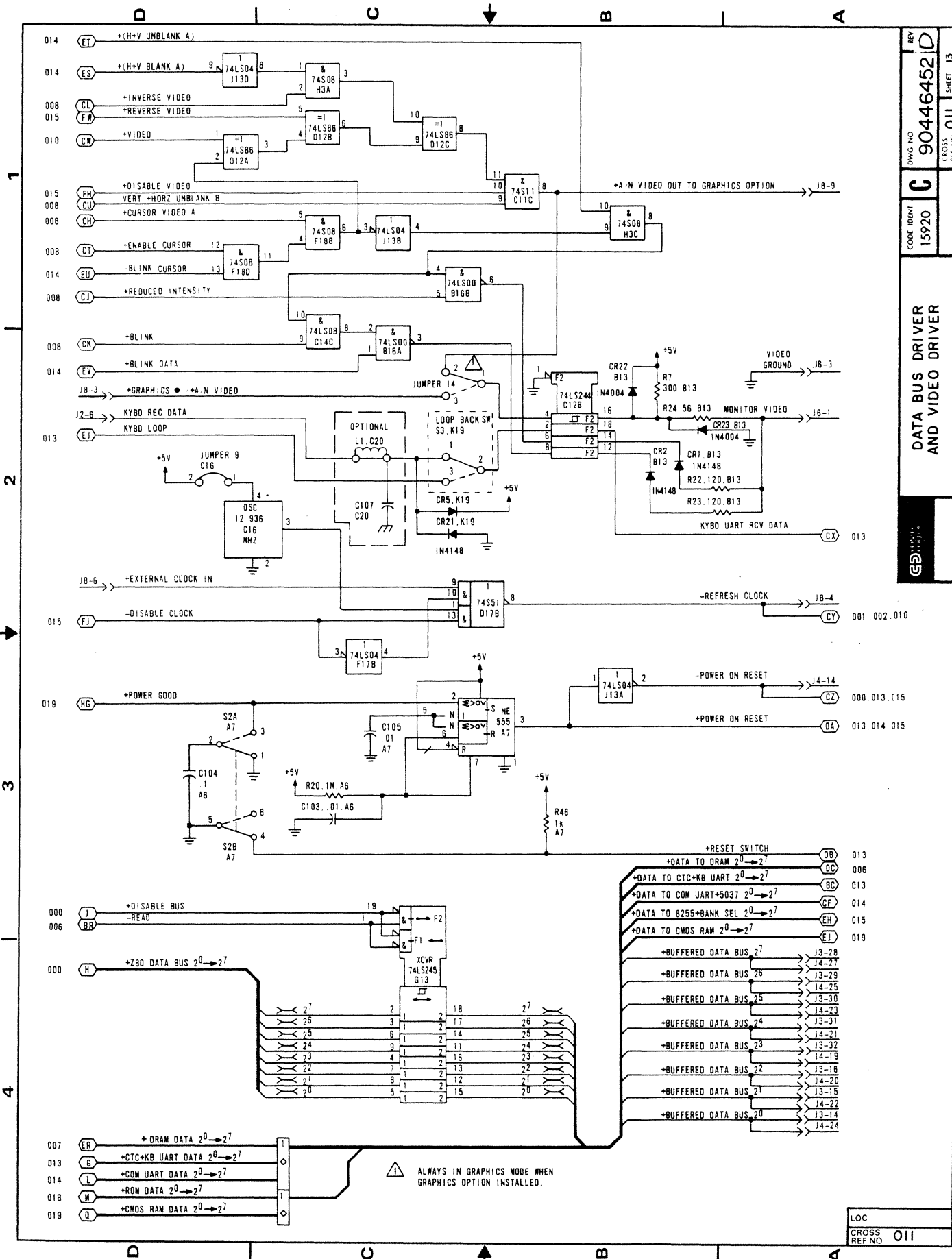

1
 2
 3
 4

1
 2
 3
 4

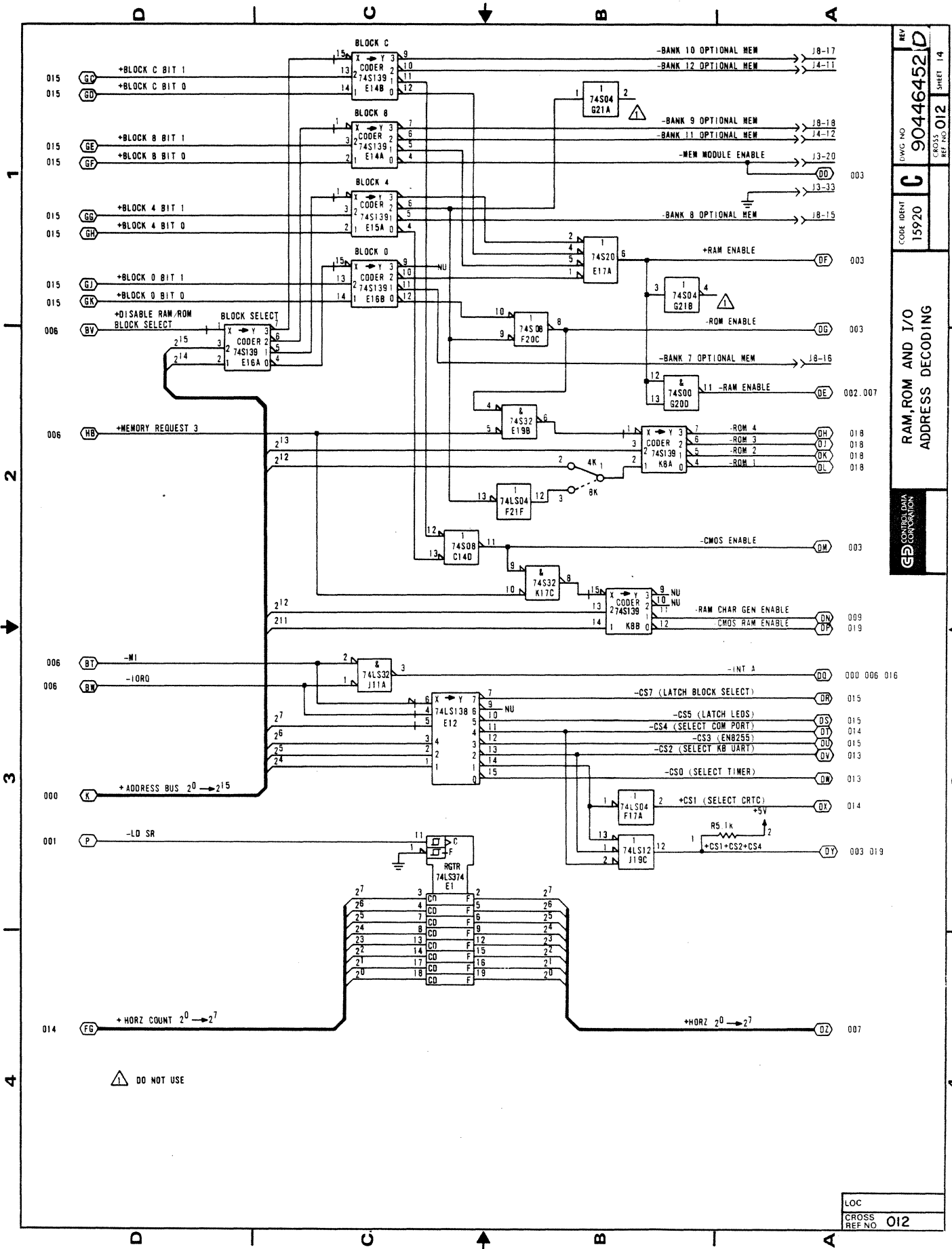

REV 90446452 D SHEET 14

DWG NO 15920

CODE IDENT C

RAM, ROM AND I/O ADDRESS DECODING

CONICAL DATA CORPORATION

CROSS REF NO 012

LOC	
CROSS REF NO	012

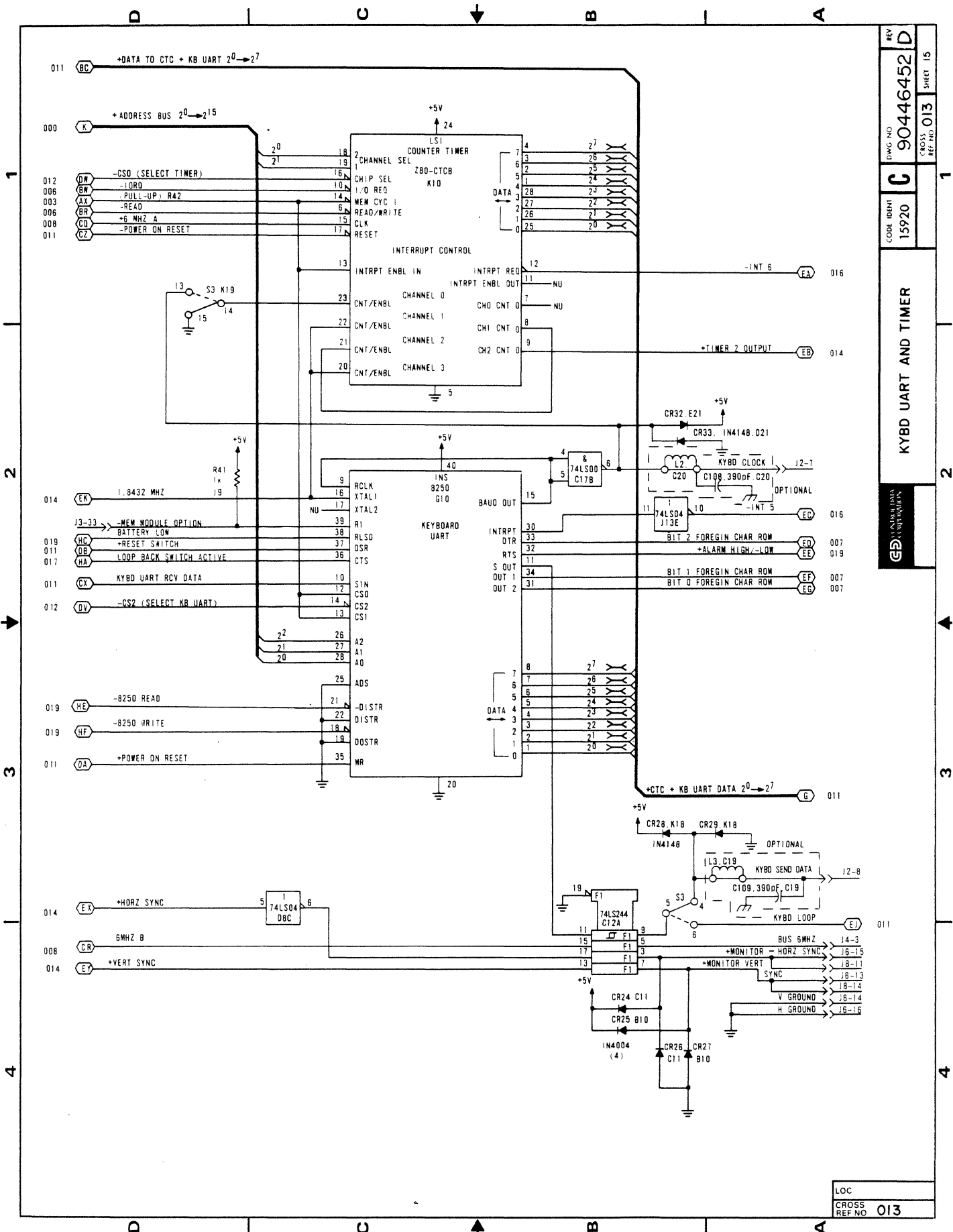

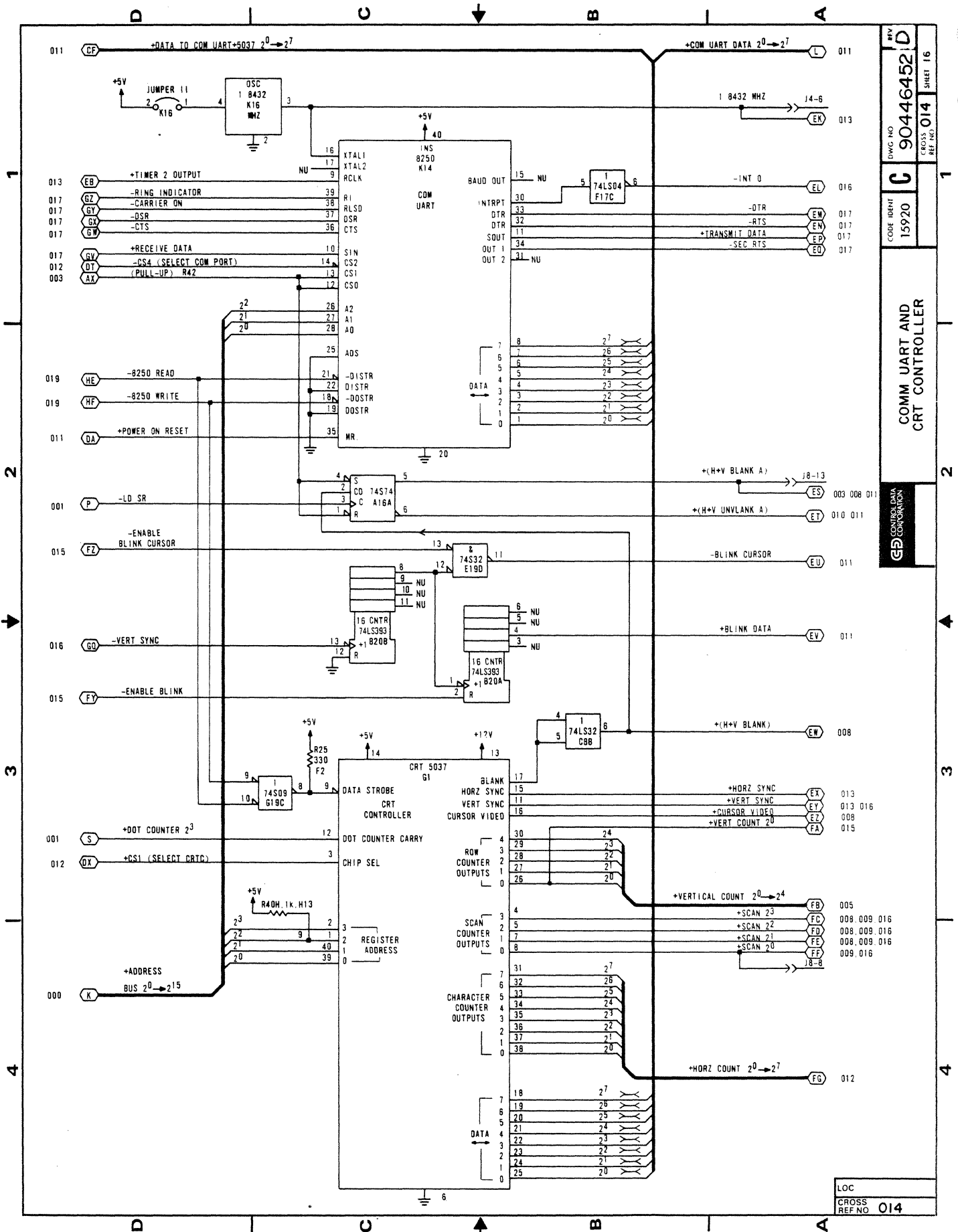

REV D
 DWG NO 90446452
 CROSS REF NO 014
 SHEET 16
 CODE IDENT 15920
 COMM UART AND CRT CONTROLLER
 CONTROL DATA CORPORATION

LOC
 CROSS REF NO 014

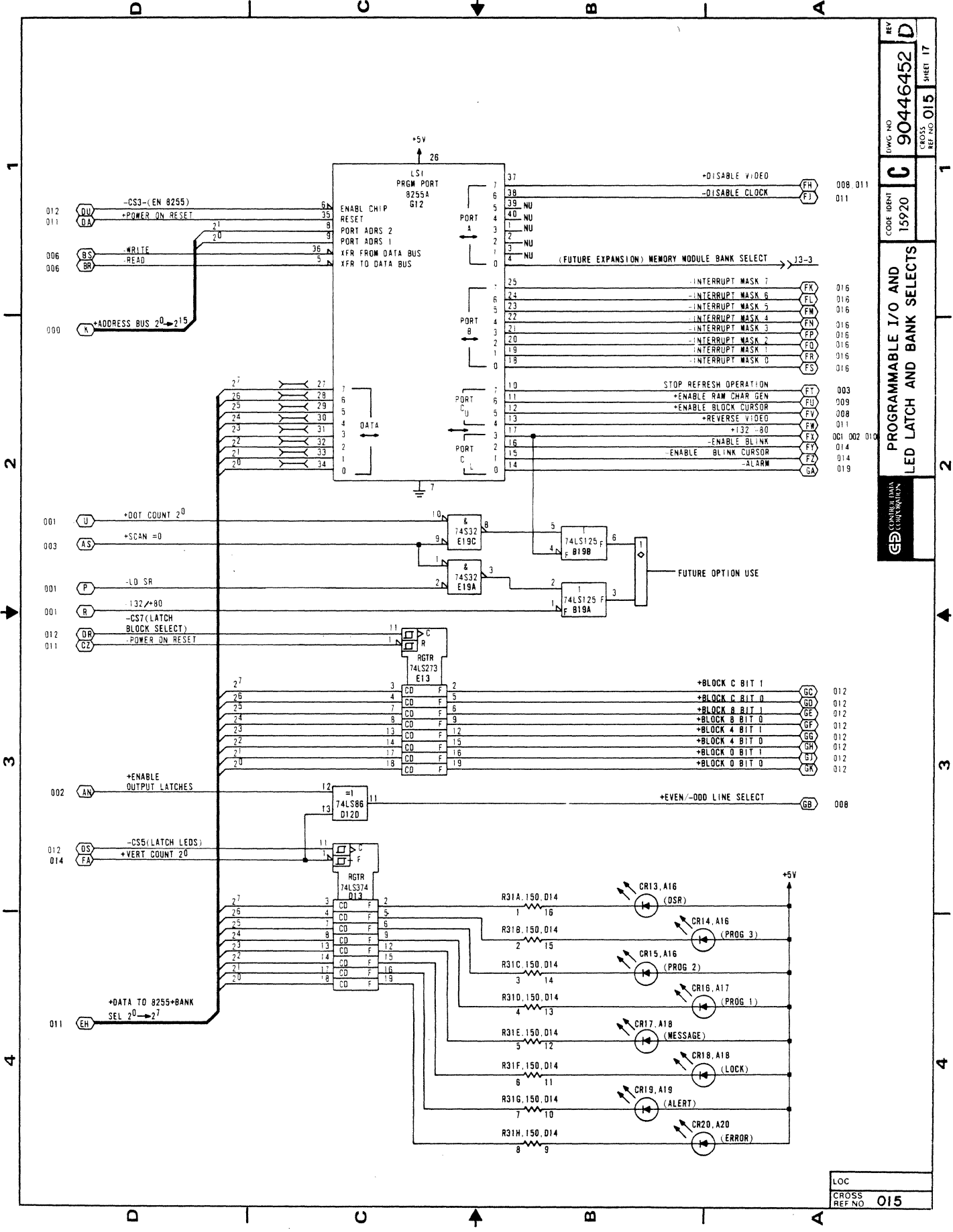

LOC
 CROSS REF NO 015

D C B A

1

2

3

4

REV 90446452 D
 DWG NO 90446452 D
 SHEET 18
 CODE IDENT 15920
 CROSS REF NO 016
 SHEET 18
INTERRUPT CIRCUITS AND SCAN COUNTS
 CONTROL DATA CORPORATION

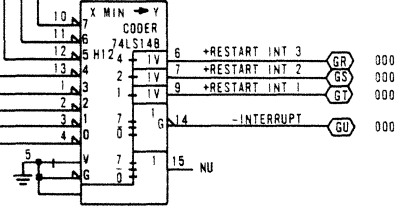
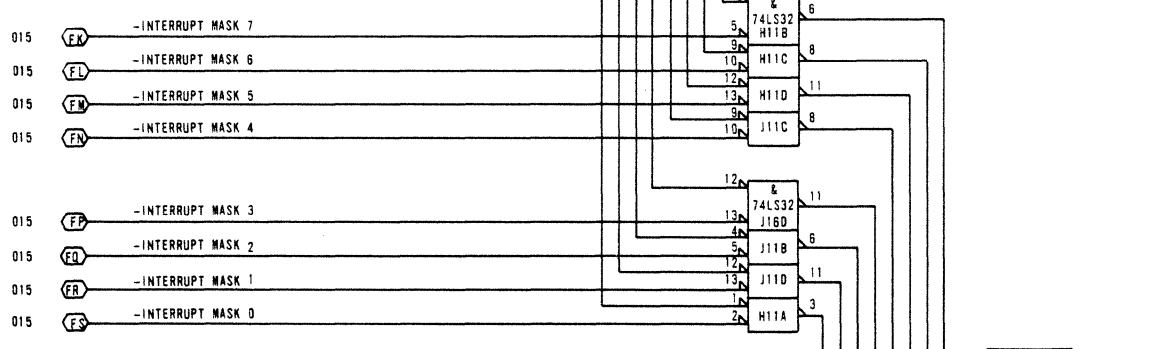
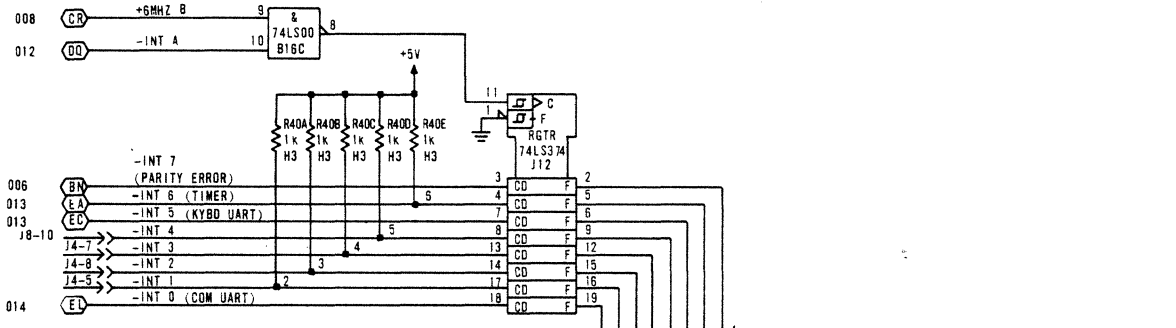
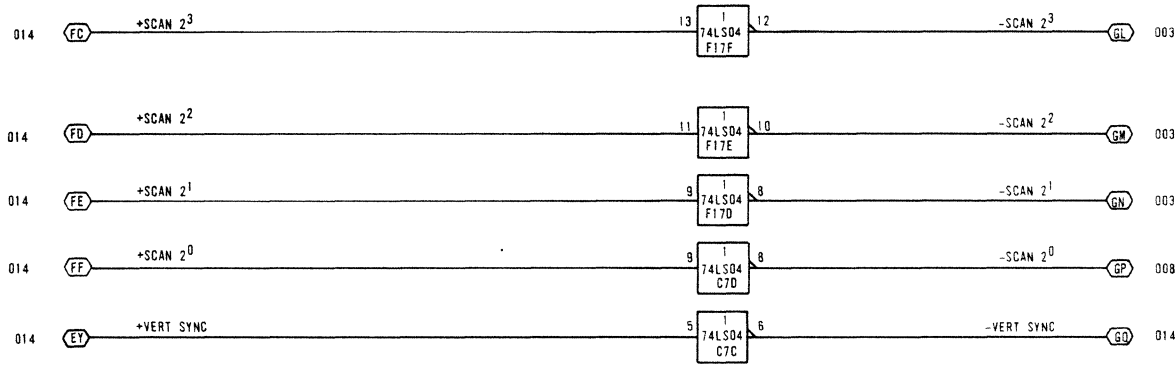

1

2

3

4

D C B A

LOC CROSS REF NO 016

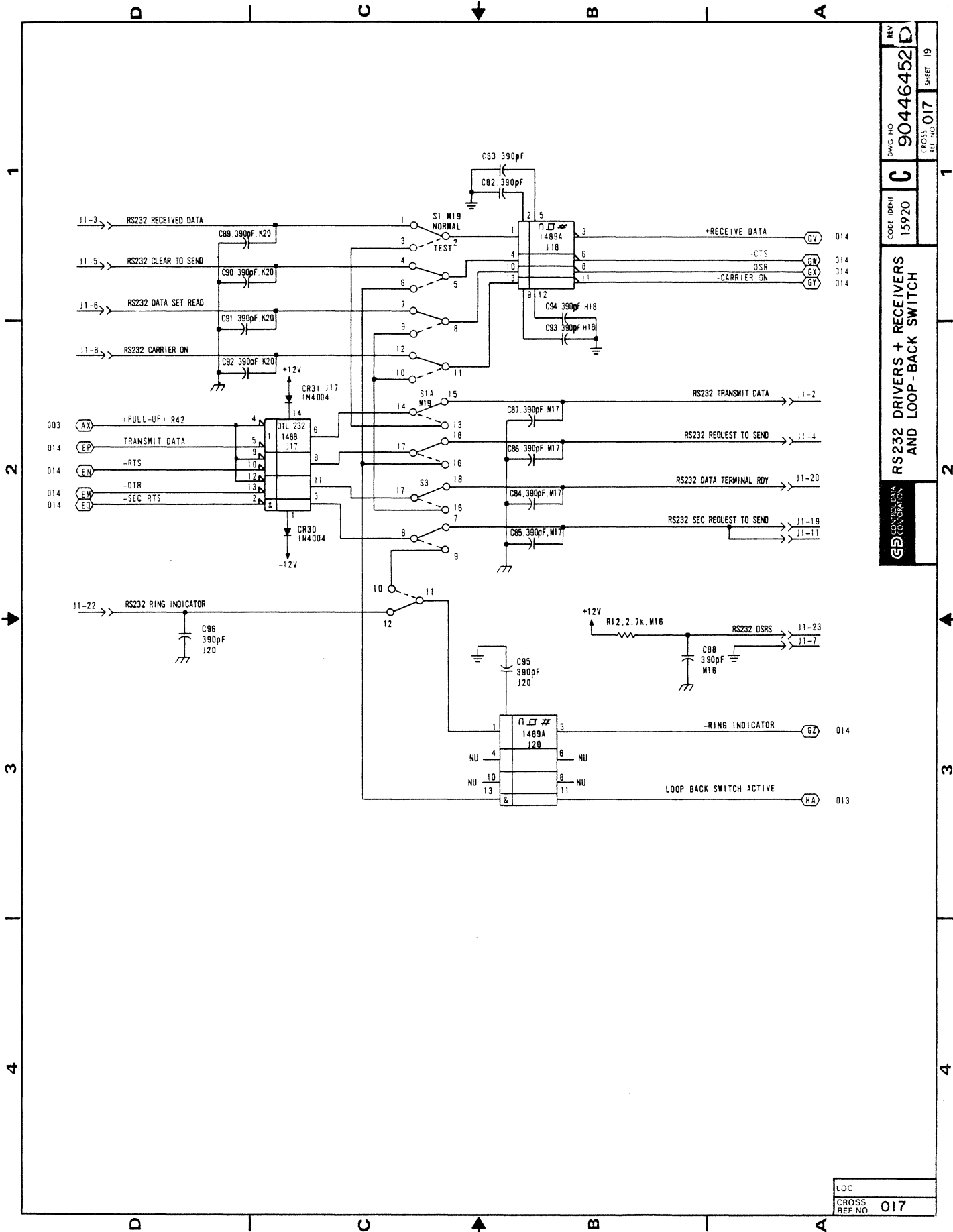

REV	D
DWG NO	90446452
CODE IDENT	C
CROSS REF. POS	017
SHEET	19
RS232 DRIVERS + RECEIVERS AND LOOP-BACK SWITCH	
CONTROL DATA CONCEPTS	

LOC
CROSS REF NO 017

REV	D
DWG. NO.	90446452
CODE IDENT	C
CROSS REF. NO.	018
SHEET	20
ROM MEMORY	
GE	

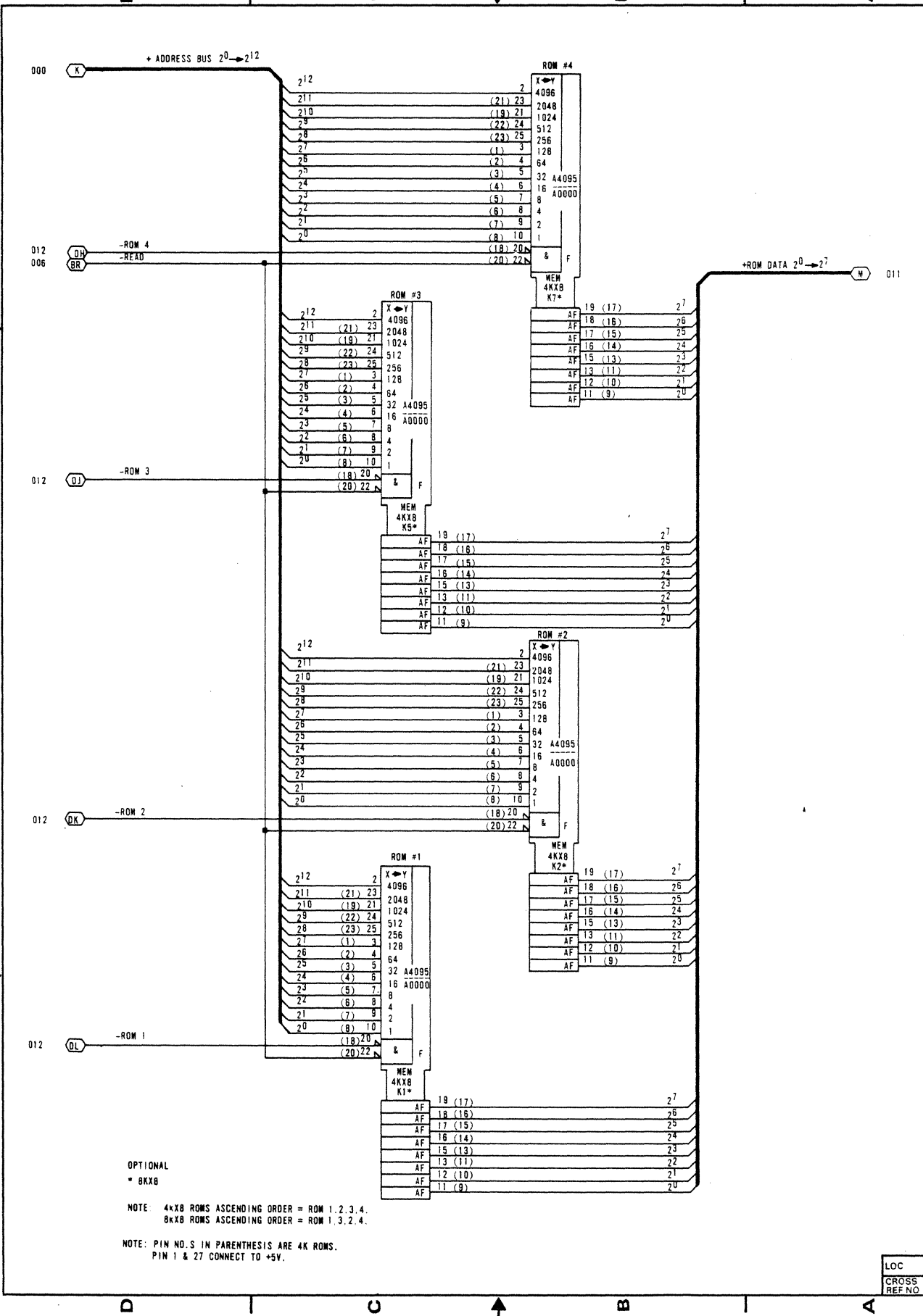

OPTIONAL
 * 8Kx8

NOTE: 4Kx8 ROMS ASCENDING ORDER = ROM 1, 2, 3, 4.
 8Kx8 ROMS ASCENDING ORDER = ROM 1, 3, 2, 4.

NOTE: PIN NO. S IN PARENTHESIS ARE 4K ROMS.
 PIN 1 & 27 CONNECT TO +5V.

LOC
 CROSS REF. NO. 018

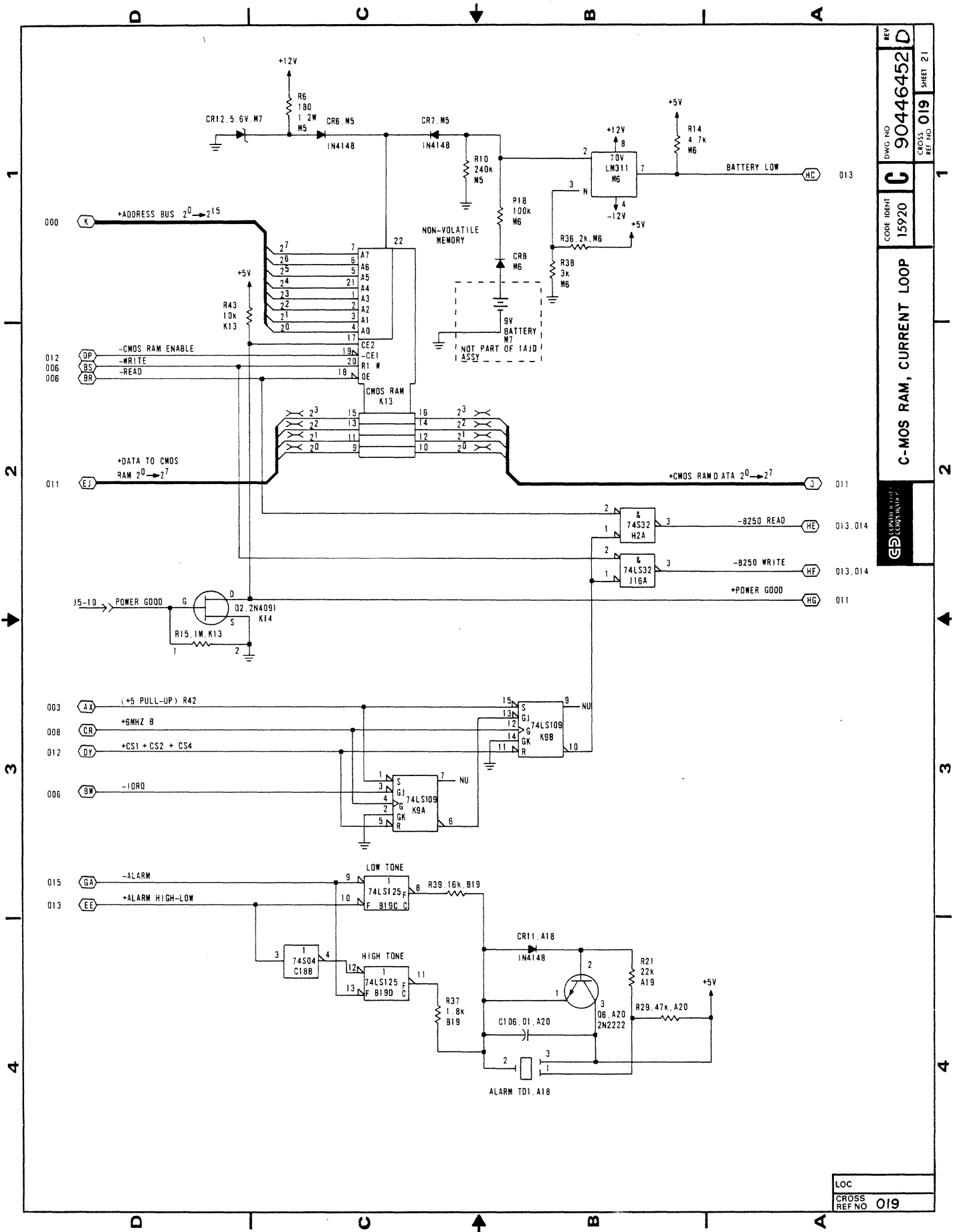

REV	D
DWG NO	90446452
CROSS REF NO	019
SHEET	21
CODE IDENT	C
15920	
C-MOS RAM, CURRENT LOOP	

LOC	
CROSS REF NO	019

SHEET REVISION STATUS													REVISION RECORD														
REV	CO	DESCRIPTION	DRFT	DATE	CHKD	APP	21	20	19	18	17	16	15	14	13	12	11	10	9	8	7	6	5	4	3	2	1
A	A	A	A	A	A	A	A	A	A	A	A	A	A	A	A	A	A	A	A	A	A	A	A	A	A	A	A
A	A	A	A	A	A	A	A	A	A	A	A	A	A	A	B	A	B	A	B	A	A	A	A	A	A	B	B
A	A	A	C	A	A	A	A	C	B	A	B	A	B	A	A	A	A	A	A	A	A	A	A	A	A	C	C
D	A	D	C	D	A	D	D	D	B	A	B	D	D	D	D	D	D	D	D	D	D	D	D	D	D	D	D
D	A	D	C	D	A	D	D	D	E	A	B	D	D	D	D	D	D	D	D	D	D	D	D	D	D	D	D
D	A	D	C	D	A	D	D	D	B	A	B	D	F	A	D	D	D	D	D	D	D	D	D	D	D	D	D
D	A	D	C	D	A	D	D	D	B	A	B	D	G	A	D	D	D	D	D	D	D	D	D	D	D	D	D
H	A	D	C	D	A	D	D	D	B	A	B	D	G	A	D	D	D	D	D	D	D	D	D	D	D	D	D
J	A	D	C	D	A	J	D	D	B	A	B	D	G	A	D	D	D	D	D	D	D	D	D	D	D	D	D
J	A	D	C	D	A	J	D	D	B	A	B	D	G	A	D	K	K	K	K	K	K	K	K	K	K	K	K
J	A	L	C	D	M	L	D	D	L	A	L	D	G	L	D	K	L	L	L	L	L	L	L	L	L	L	L
J	A	L	C	D	M	M	D	D	M	A	M	D	M	M	M	M	M	M	M	M	M	M	M	M	M	M	M
J	A	L	C	D	M	M	D	N	M	A	M	D	N	M	M	M	M	M	M	M	M	M	M	M	M	M	M
J	A	L	C	D	M	M	D	N	M	A	M	D	N	H	M	P	N	M	P	P	P	P	P	P	P	P	P

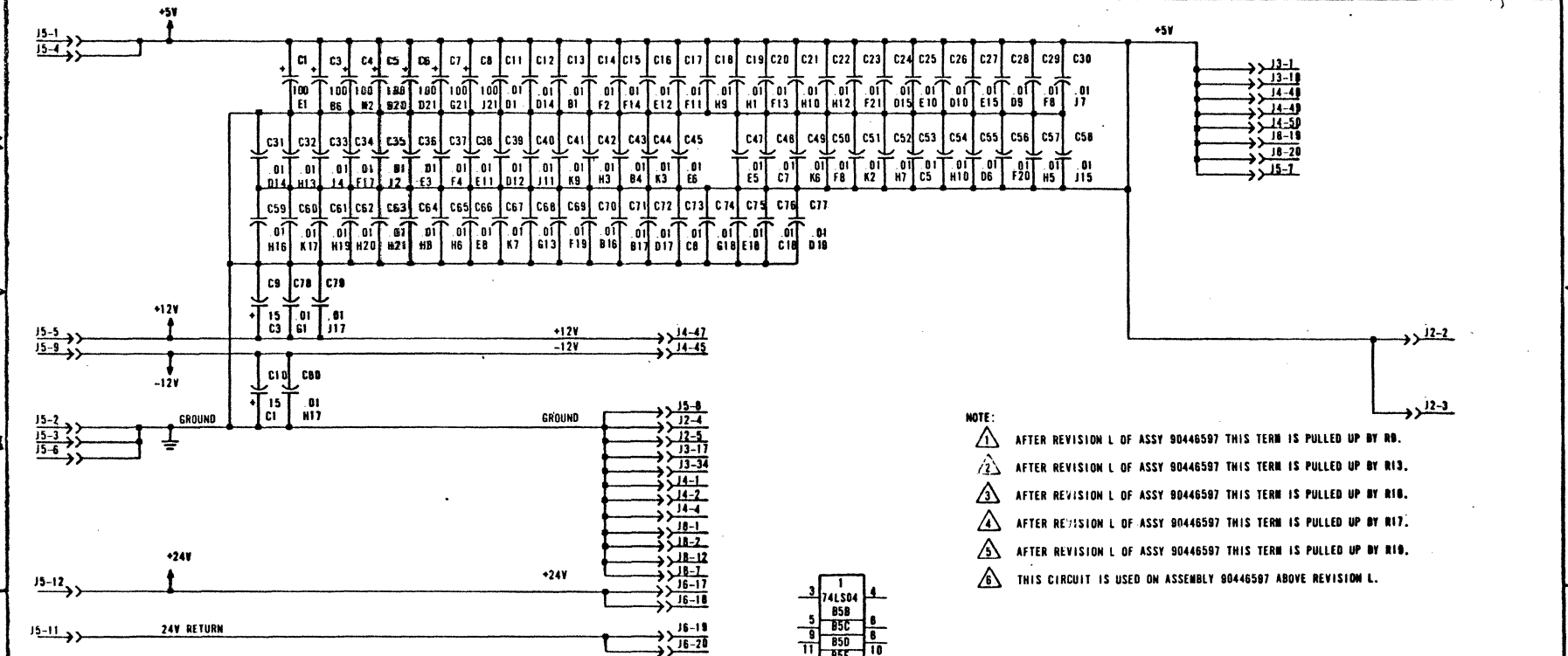

- NOTE:
- 1 AFTER REVISION L OF ASSY 90446597 THIS TERM IS PULLED UP BY R8.
 - 2 AFTER REVISION L OF ASSY 90446597 THIS TERM IS PULLED UP BY R13.
 - 3 AFTER REVISION L OF ASSY 90446597 THIS TERM IS PULLED UP BY R18.
 - 4 AFTER REVISION L OF ASSY 90446597 THIS TERM IS PULLED UP BY R17.
 - 5 AFTER REVISION L OF ASSY 90446597 THIS TERM IS PULLED UP BY R18.
 - 6 THIS CIRCUIT IS USED ON ASSEMBLY 90446597 ABOVE REVISION L.

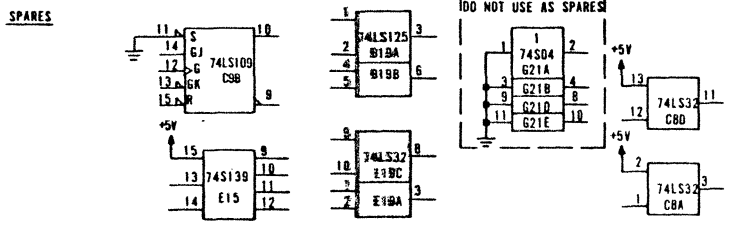
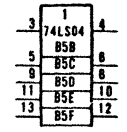

REFERENCE DRAWING		TITLE	
DETAIL 90446484	ASSY 90446485	SCHEMATIC DIAGRAM, 1AJD-1 (MAIN LOGIC)	
COMPONENTS, EXCEPT AS NOTED		FIRST USED ON	
TOLERANCE VALUE RATING		CC634A	
RES 5% 0.1MS 1.4W	CAP 10% 25V	DWN CHKD Mary Dietz 2-2-82	ENGR ENR J.C. Y2
MFG DATE		APPR	
SCALE		CROSS REF NO	
DRAWING NO 90446483		SHEET 1 OF 21	

REV M
 DWG NO 90446483
 CROSS REF NO 000 SHEET 2

CODE IDENT C
 15920

PROCESSOR AND ADDRESS BUFFER



005, 009, 012, 013, 014, 015, 018, 109

LOC
 CROSS REF NO 000

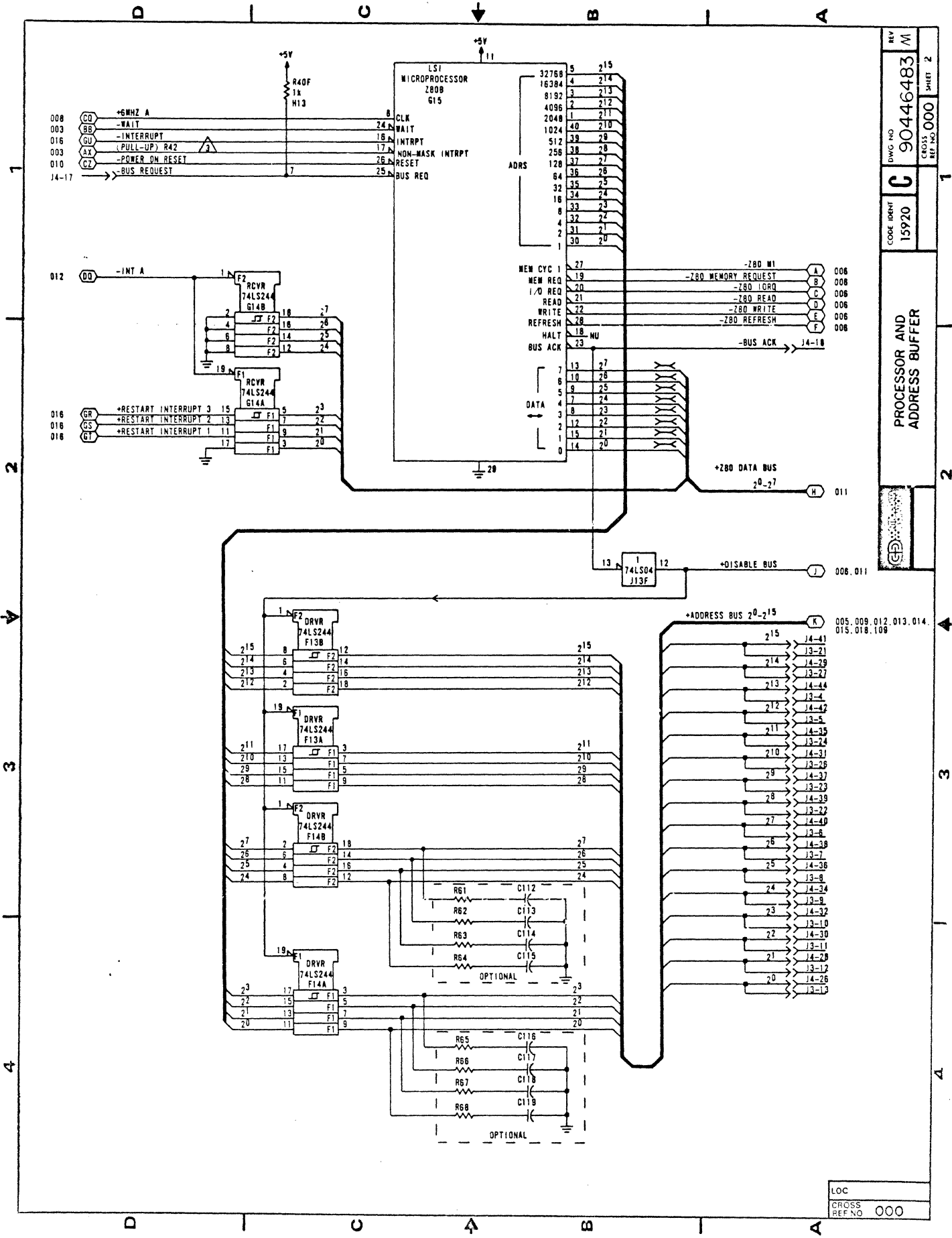

REV	90446483	SHEET 3
OWG. NO.	15920	CROSS REF. NO. 001
CODE INST	C	
MAIN TIMING AND LINE BUFFER ADDRESSING		

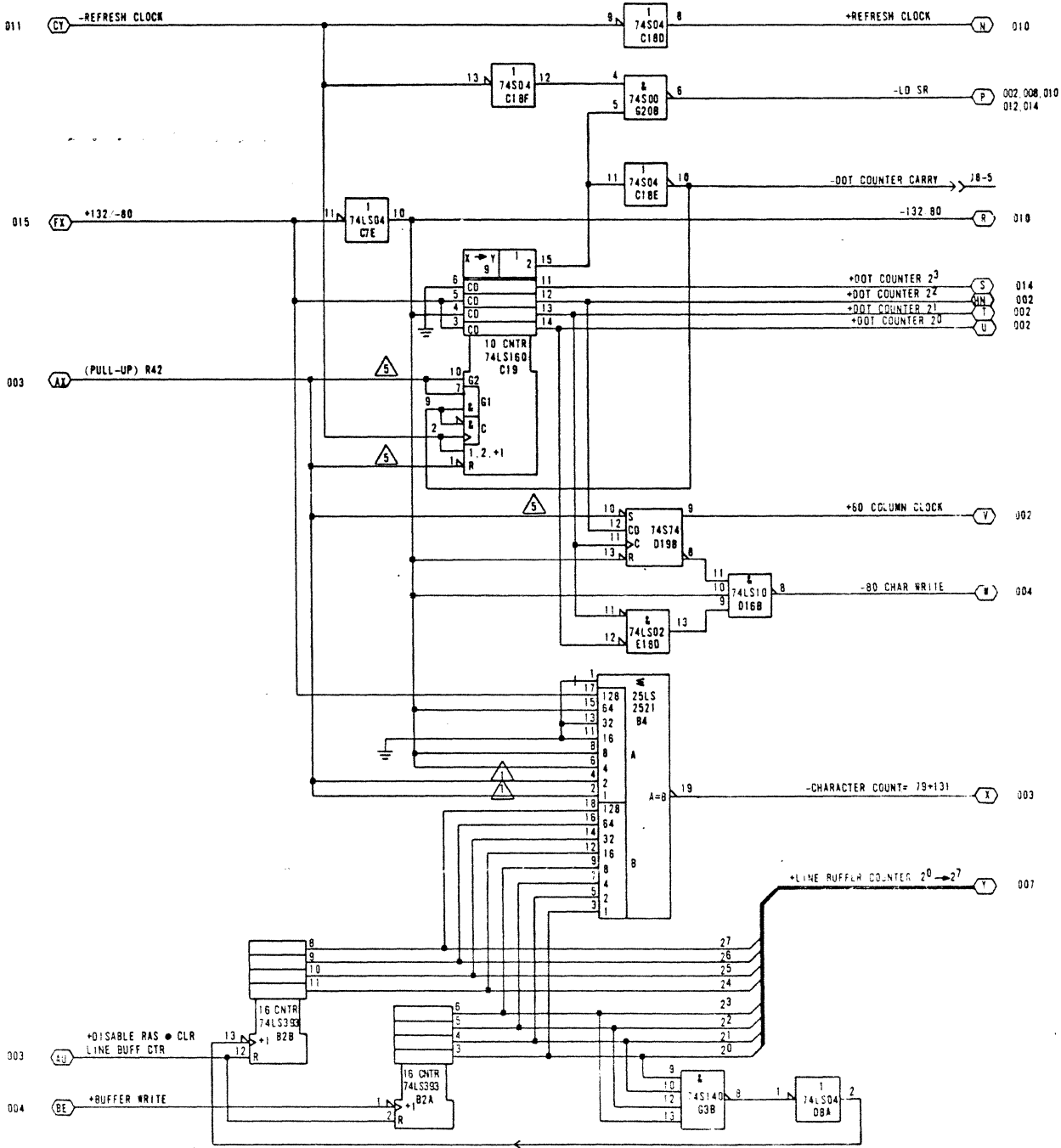

LOC
CROSS
REF NO 001

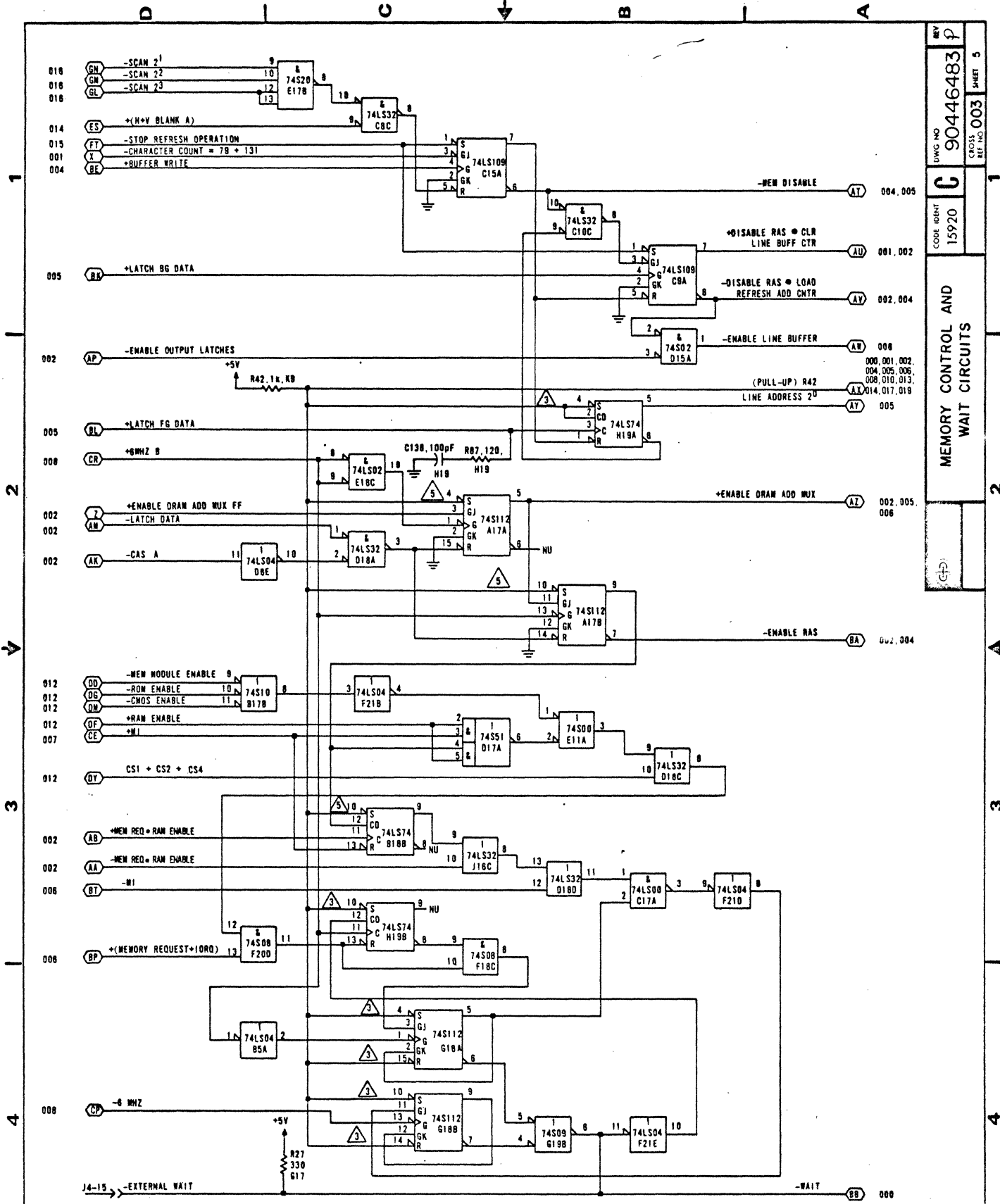

REV	90446483 P	SHEET 5
DWG NO	90446483 P	
CODE IDENT	15920	
CROSS REF NO	003	
MEMORY CONTROL AND WAIT CIRCUITS		

LOC
CROSS REF NO
003

REV	M
OWC NO	90446483
CODE IDENT	C
15920	
(CROSS REF. NO.)	004
UNIT	6
REFRESH ADDRESS COUNTER	

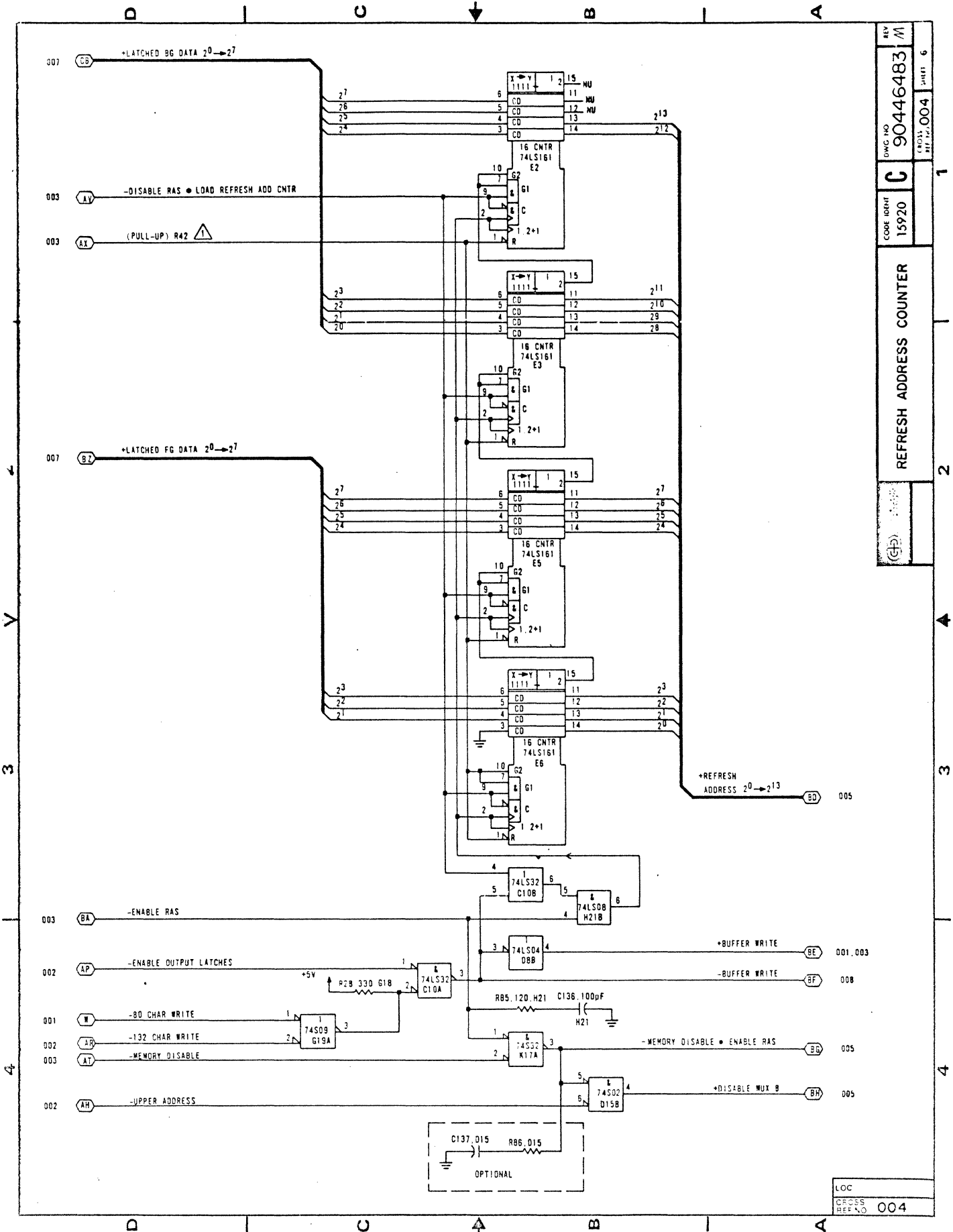

LOC
 CRCS
 REF NO 004

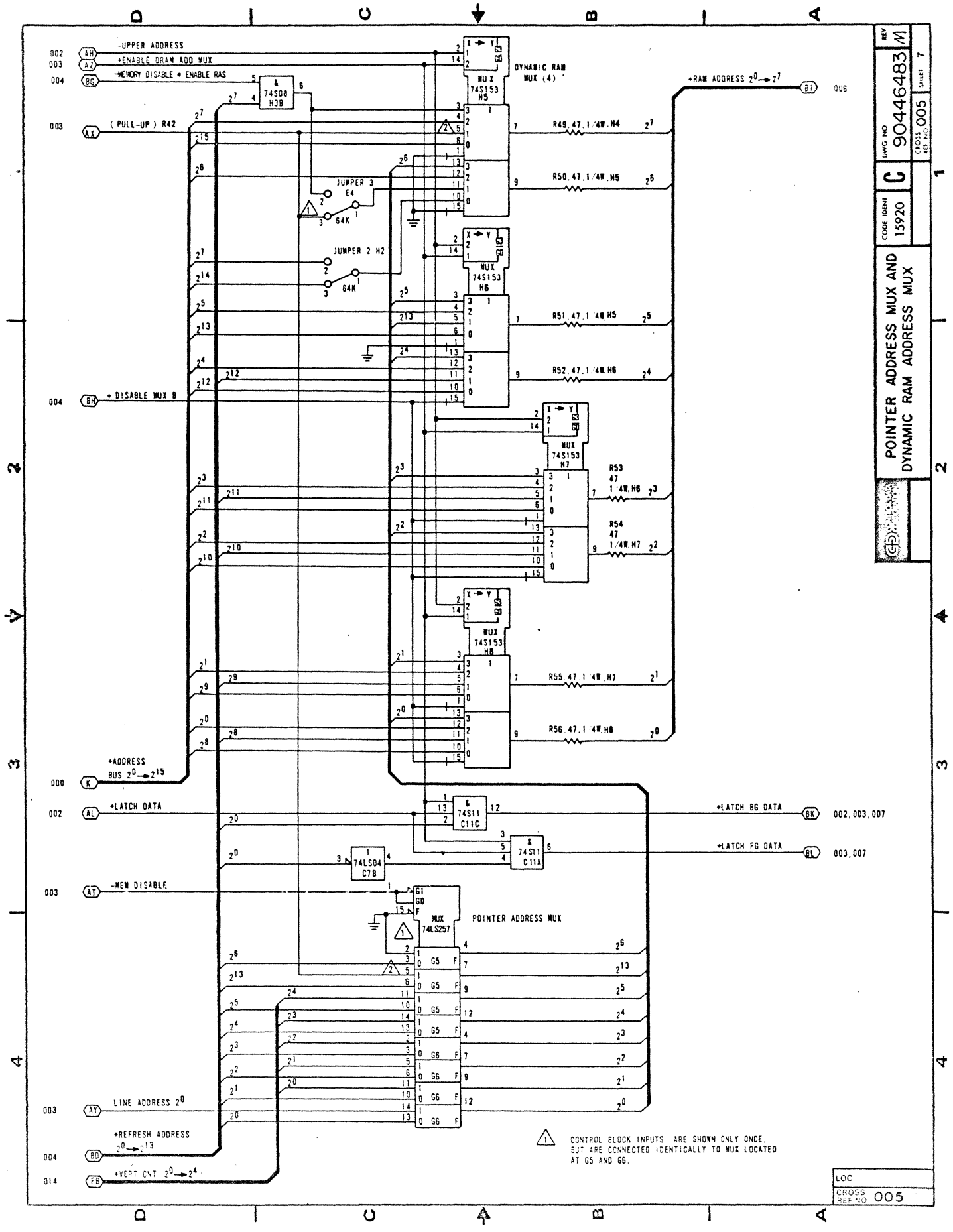

REV	M
DWG NO	90446483
CODE IDENT	C 15920
CROSS REF NO	005
SHEET	7
POINTER ADDRESS MUX AND DYNAMIC RAM ADDRESS MUX	

LOC
 CROSS REF NO 005

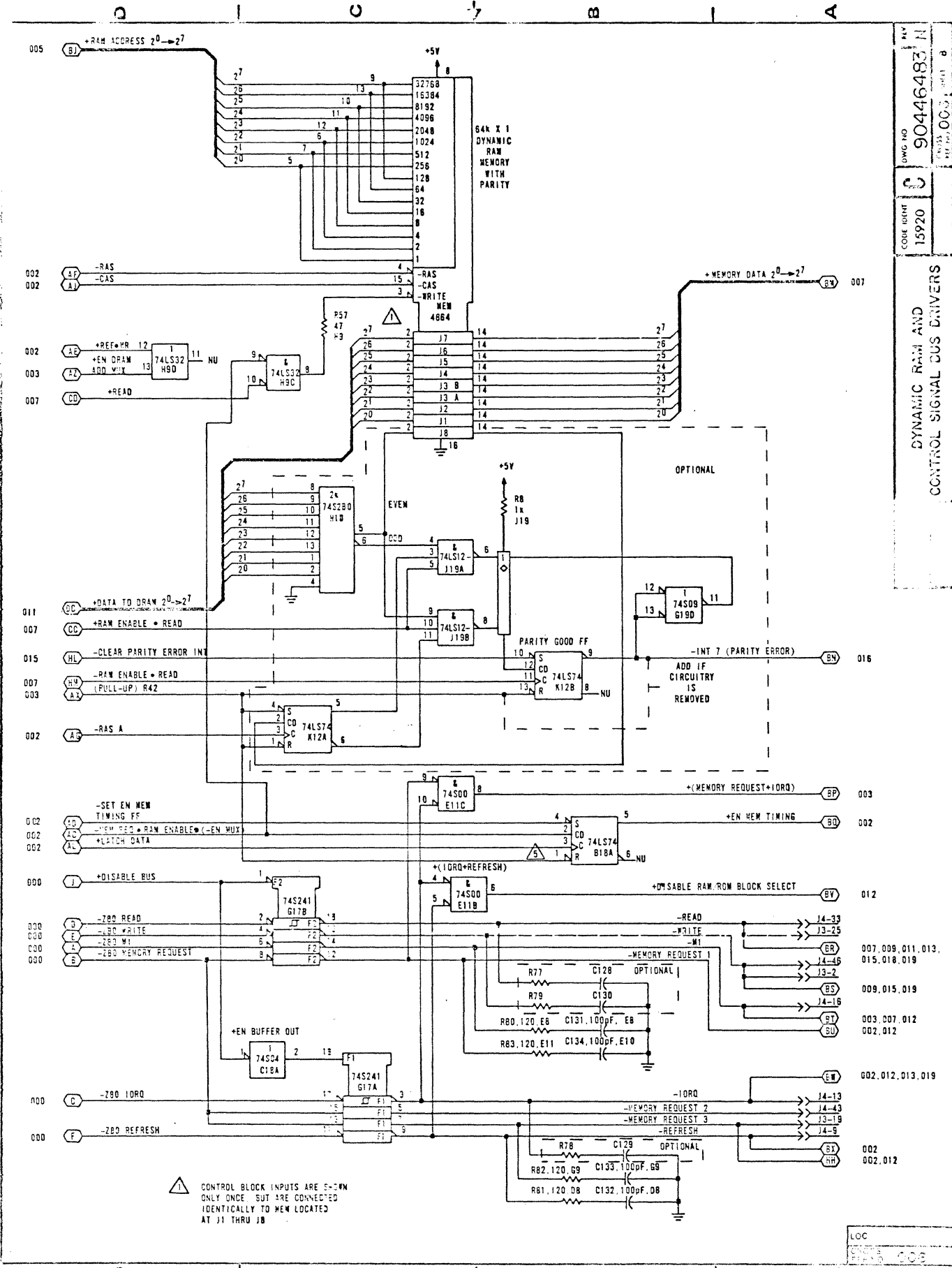

REV 90446483 N
 DWG NO 15920
 CODE IDENT C
 90446483 N
 15920 C
 DYNAMIC RAM AND CONTROL SIGNAL BUS DRIVERS

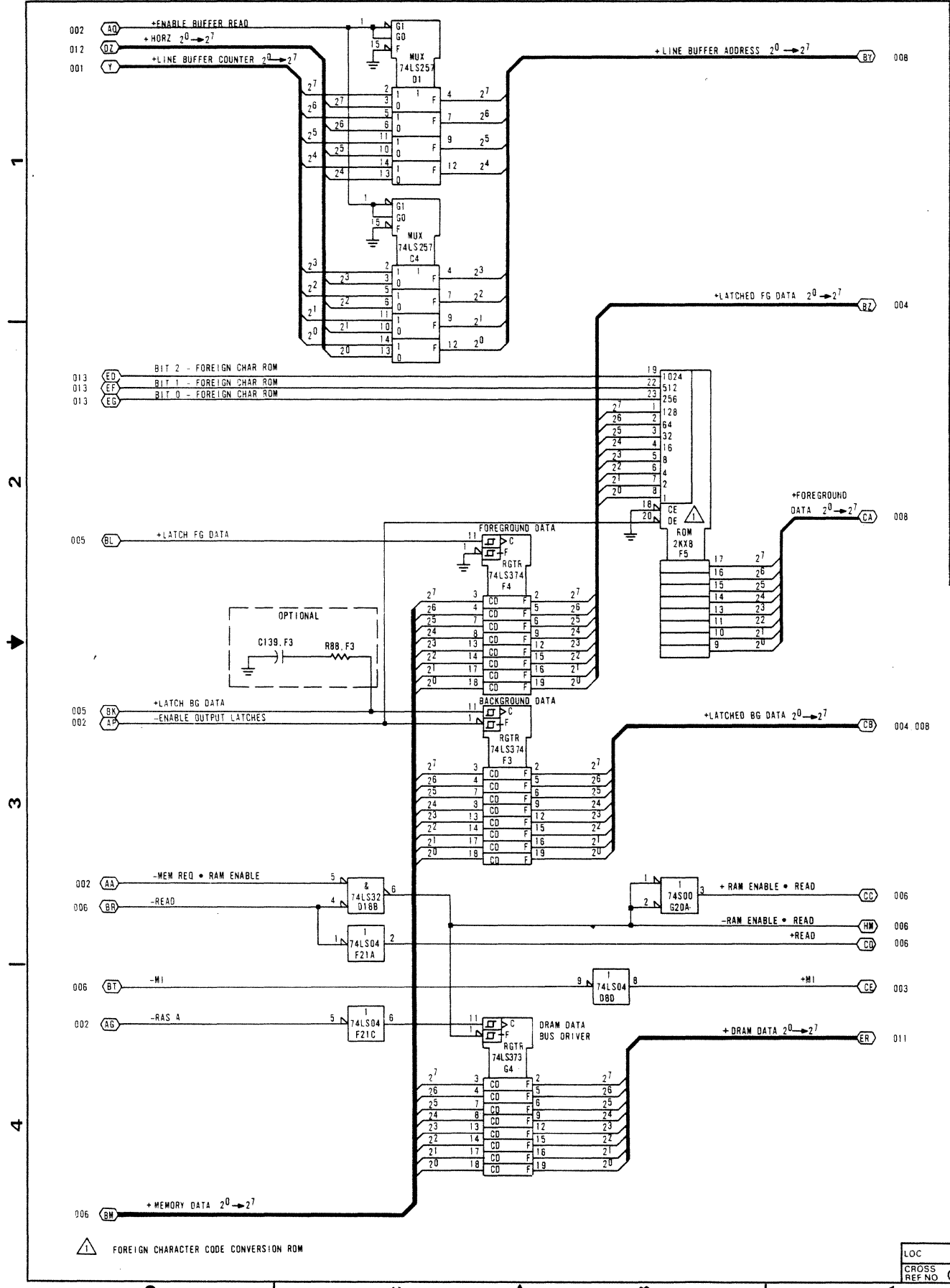

REV	D
DWG. NO.	90446483
CROSS. REF. NO.	007
SHEET	9
CODE IDENT.	15920
LINE BUFFER ADDRESS MUX AND FOREIGN CHARACTER ROM	
CONTROL DATA CORPORATION	

- 002 (A0) +ENABLE BUFFER READ
- 012 (BZ) +HORIZ 2⁰ → 2⁷
- 001 (Y) +LINE BUFFER COUNTER 2⁰ → 2⁷
- 008 (BY) +LINE BUFFER ADDRESS 2⁰ → 2⁷
- 004 (BZ) +LATCHED FG DATA 2⁰ → 2⁷
- 008 (CA) +FOREGROUND DATA 2⁰ → 2⁷
- 004 (CB) +LATCHED BG DATA 2⁰ → 2⁷
- 008 (ER) +DRAM DATA 2⁰ → 2⁷
- 006 (BM) +MEMORY DATA 2⁰ → 2⁷
- 013 (ED) BIT 2 - FOREIGN CHAR ROM
- 013 (EF) BIT 1 - FOREIGN CHAR ROM
- 013 (EG) BIT 0 - FOREIGN CHAR ROM
- 005 (BL) +LATCH FG DATA
- 005 (BX) +LATCH BG DATA
- 002 (AP) -ENABLE OUTPUT LATCHES
- 002 (AA) -MEM REQ • RAM ENABLE
- 006 (BR) -READ
- 006 (BT) -M1
- 002 (AB) -RAS A
- 006 (GC) +RAM ENABLE • READ
- 006 (HM) -RAM ENABLE • READ
- 006 (GD) +READ
- 003 (CE) +M1
- 011 (ER) +DRAM DATA 2⁰ → 2⁷

△ FOREIGN CHARACTER CODE CONVERSION ROM

LOC CROSS REF. NO. 007

LINE BUFFERS AND
 OUTPUT DATA LATCHES

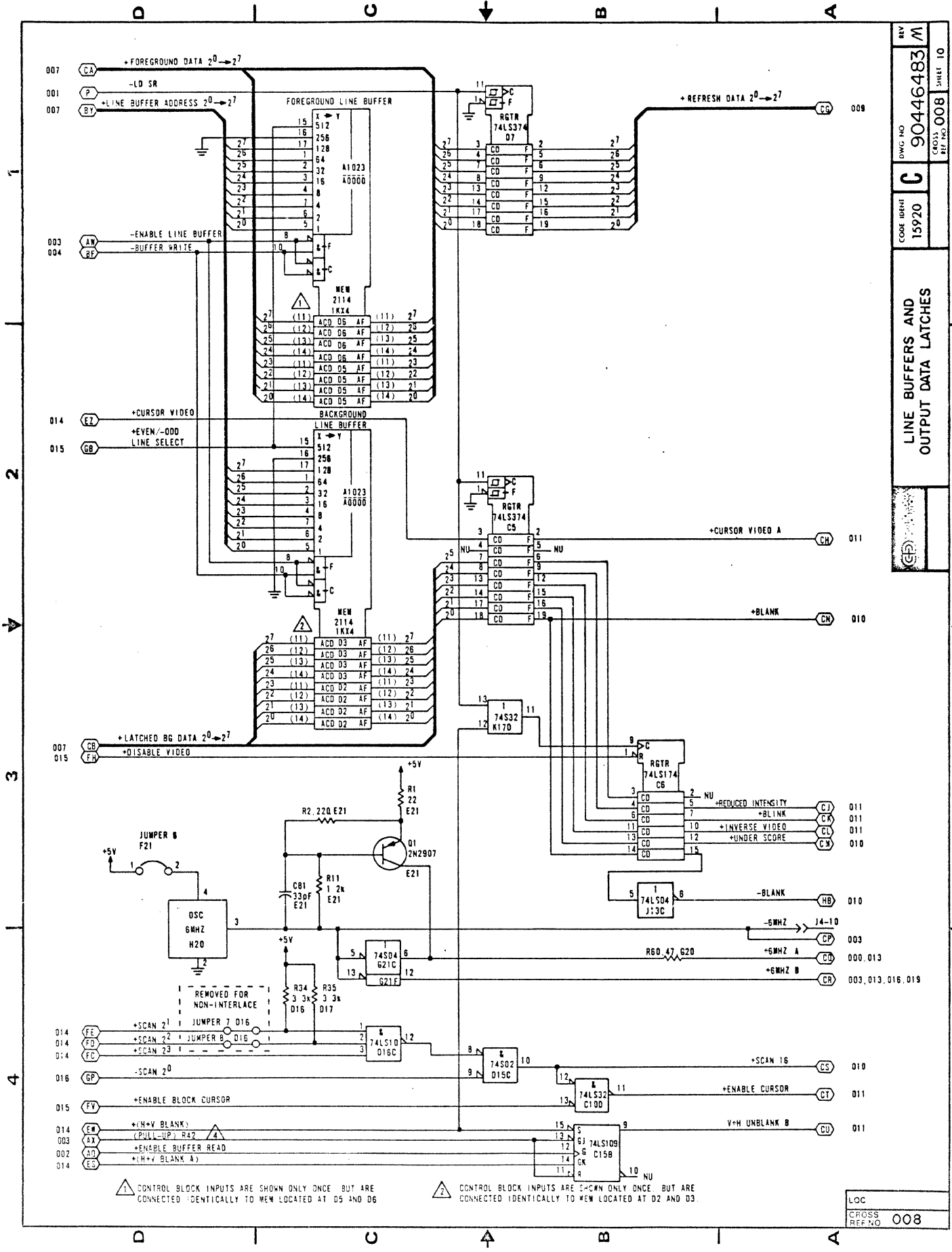

△ CONTROL BLOCK INPUTS ARE SHOWN ONLY ONCE BUT ARE CONNECTED IDENTICALLY TO MEM LOCATED AT D5 AND D6

△ CONTROL BLOCK INPUTS ARE SHOWN ONLY ONCE BUT ARE CONNECTED IDENTICALLY TO MEM LOCATED AT D2 AND D3

LOC
 CROSS REF NO 008

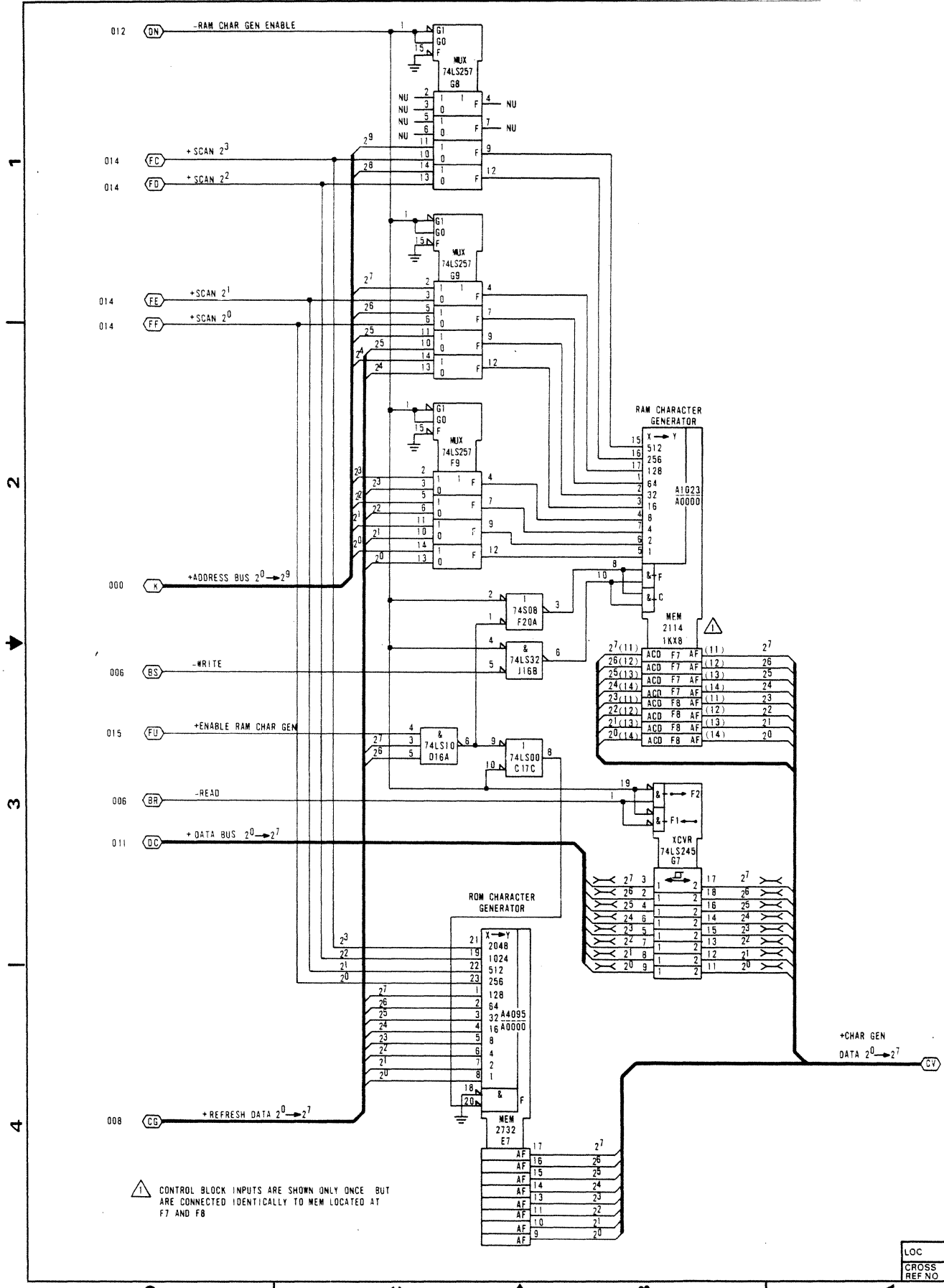

REV
 DWG NO 90446483 A
 CODE IDENT 15920 C
 CROSS REF NO 009 SHEET 11
 CHARACTER GENERATOR AND
 RAM CHARACTER GENERATOR
 CONTROL DATA CORPORATION

1
 2
 3
 4

REV	M
UWG NO	90446483
CODE IDENT	C
REV. NO.	010
SHEET	12
VIDEO SHIFT REGISTERS	

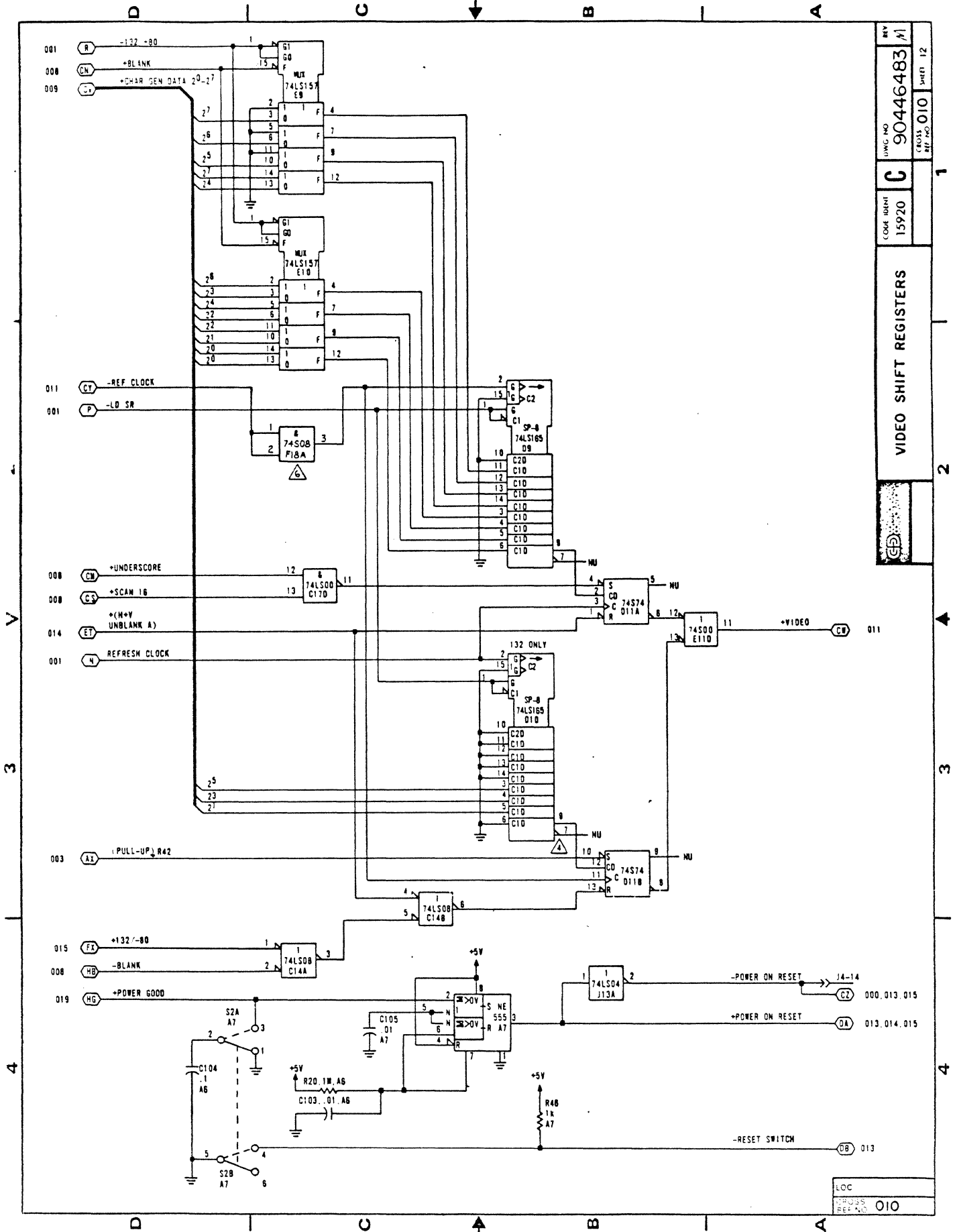

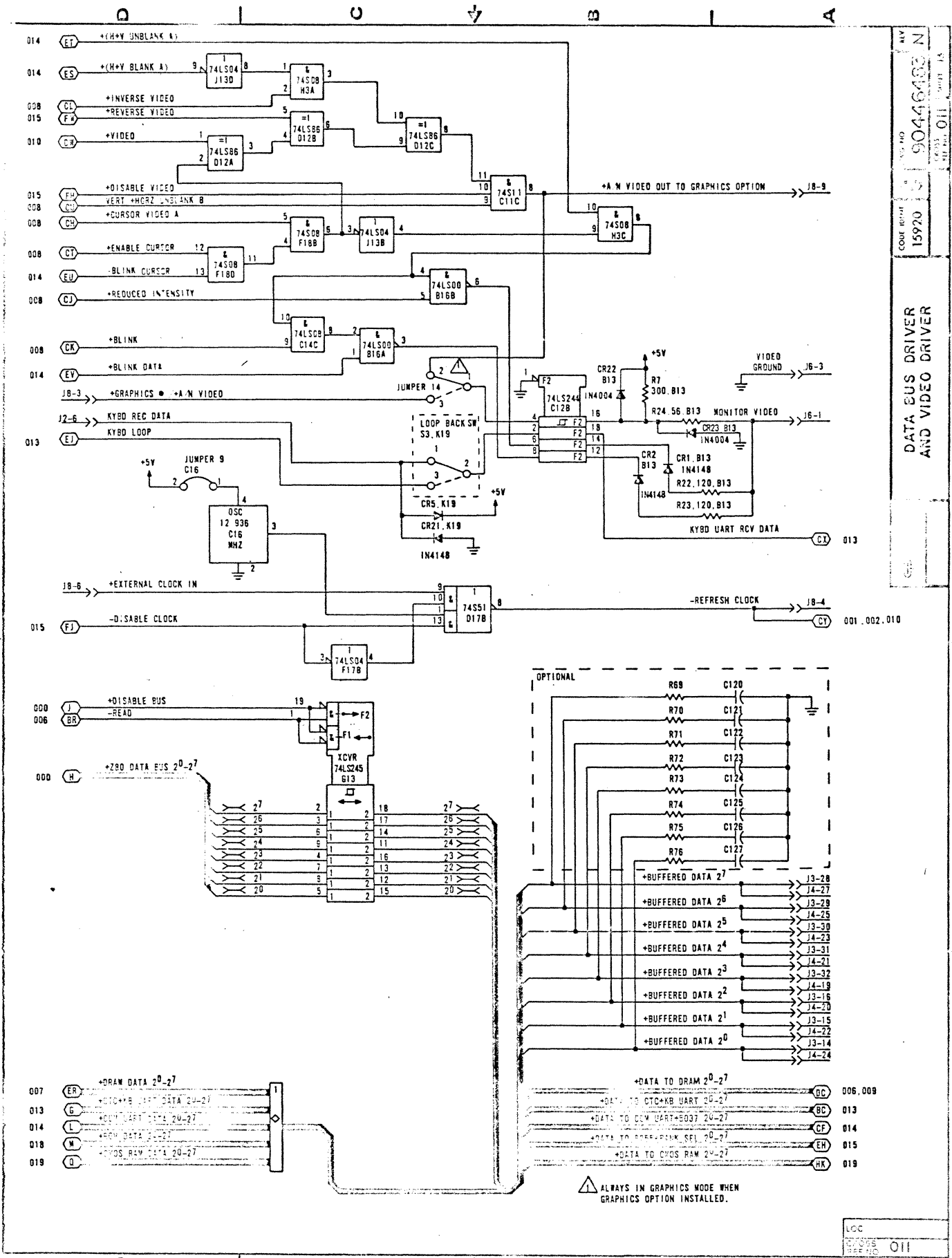

90446400 Z
 15920
 DATA BUS DRIVER
 AND VIDEO DRIVER

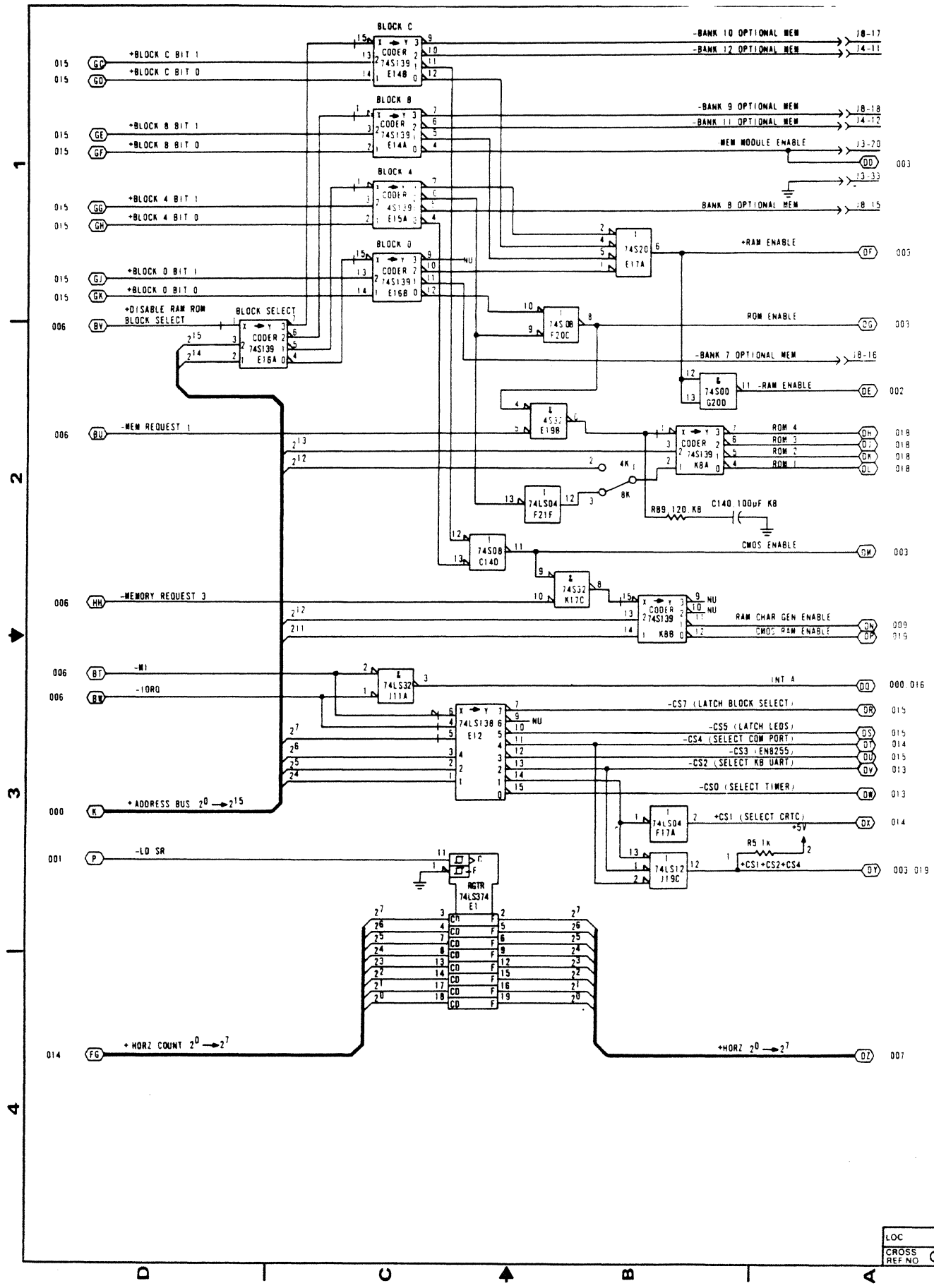

LOC	
CROSS REF NO	012

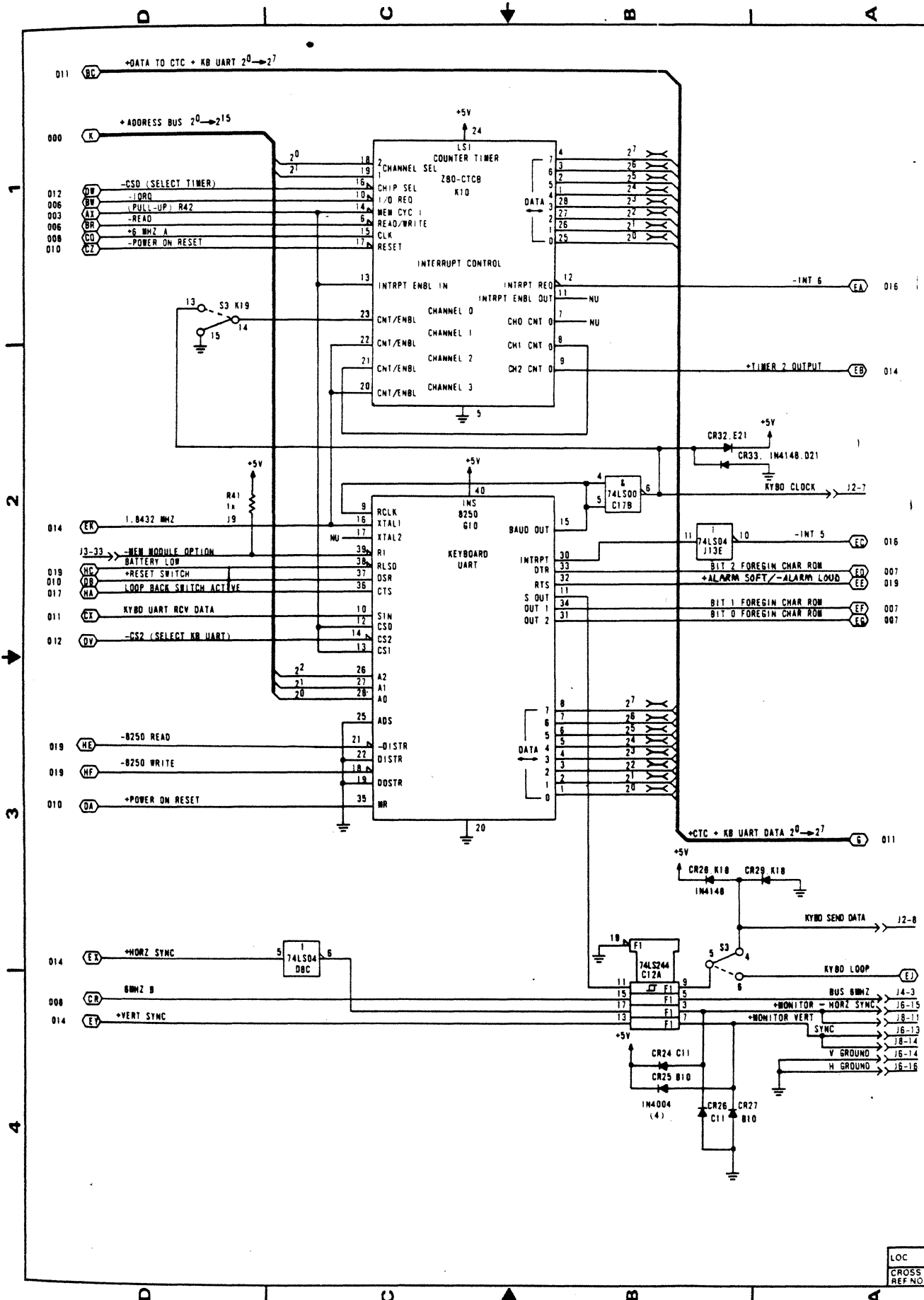

REV	J
ENGR. NO.	90446483
CODE IDENT	C
15920	
DESIGN REF. NO.	013
SHEET	15

KYBD UART AND TIMER	
GG	

LOC	
CROSS REF NO.	013

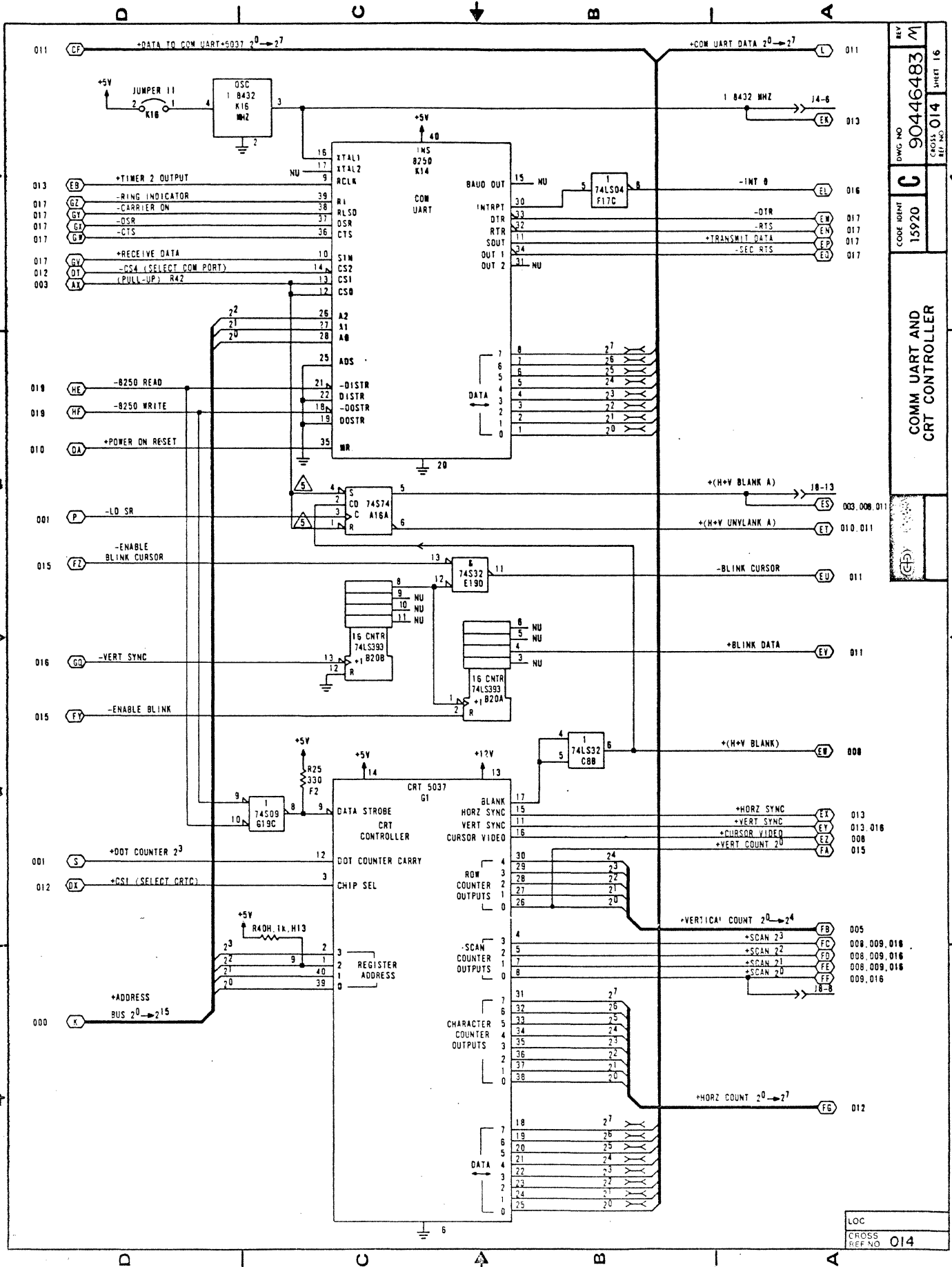

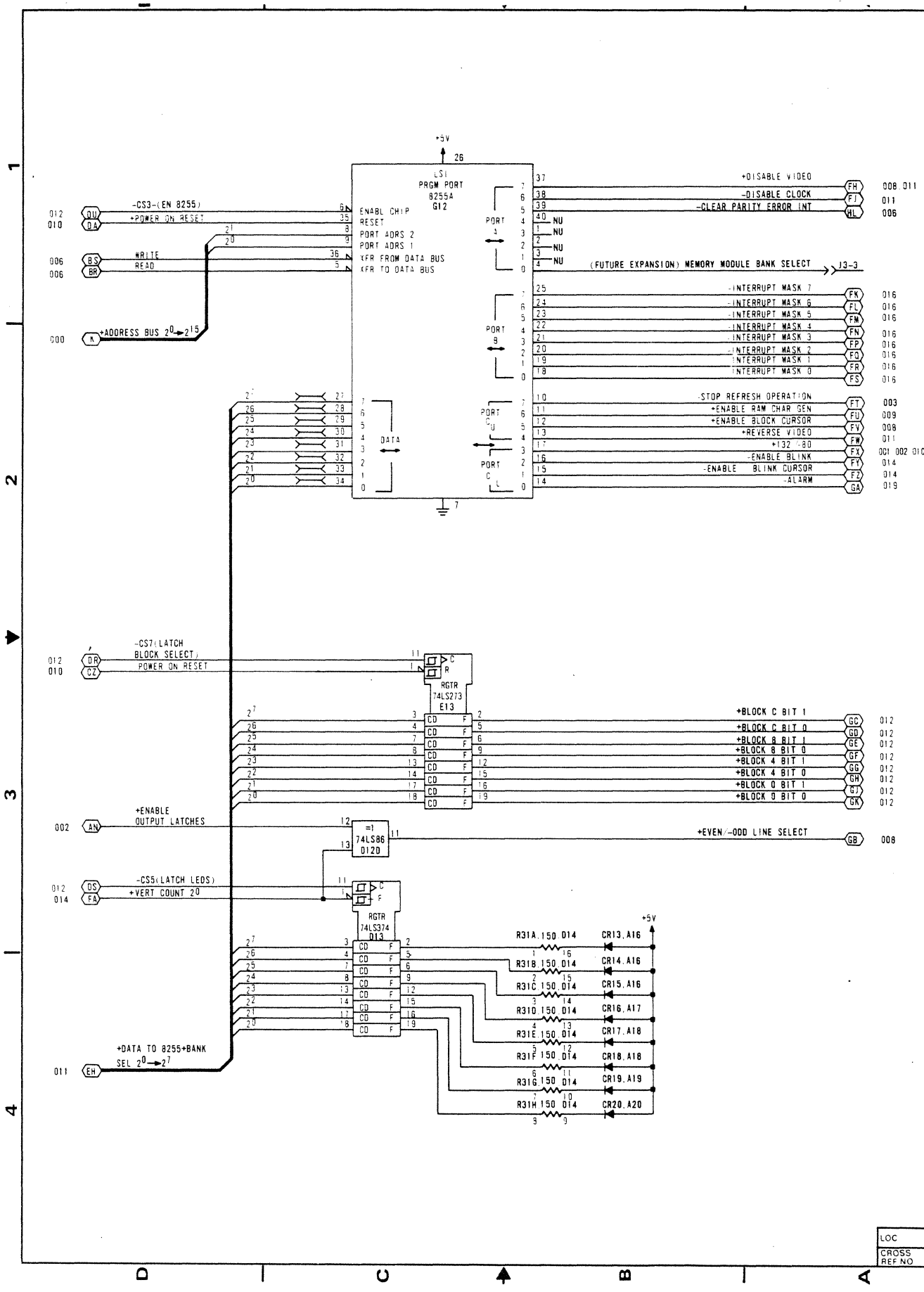

LOC
 CROSS REF NO 015

1
 2
 3
 4

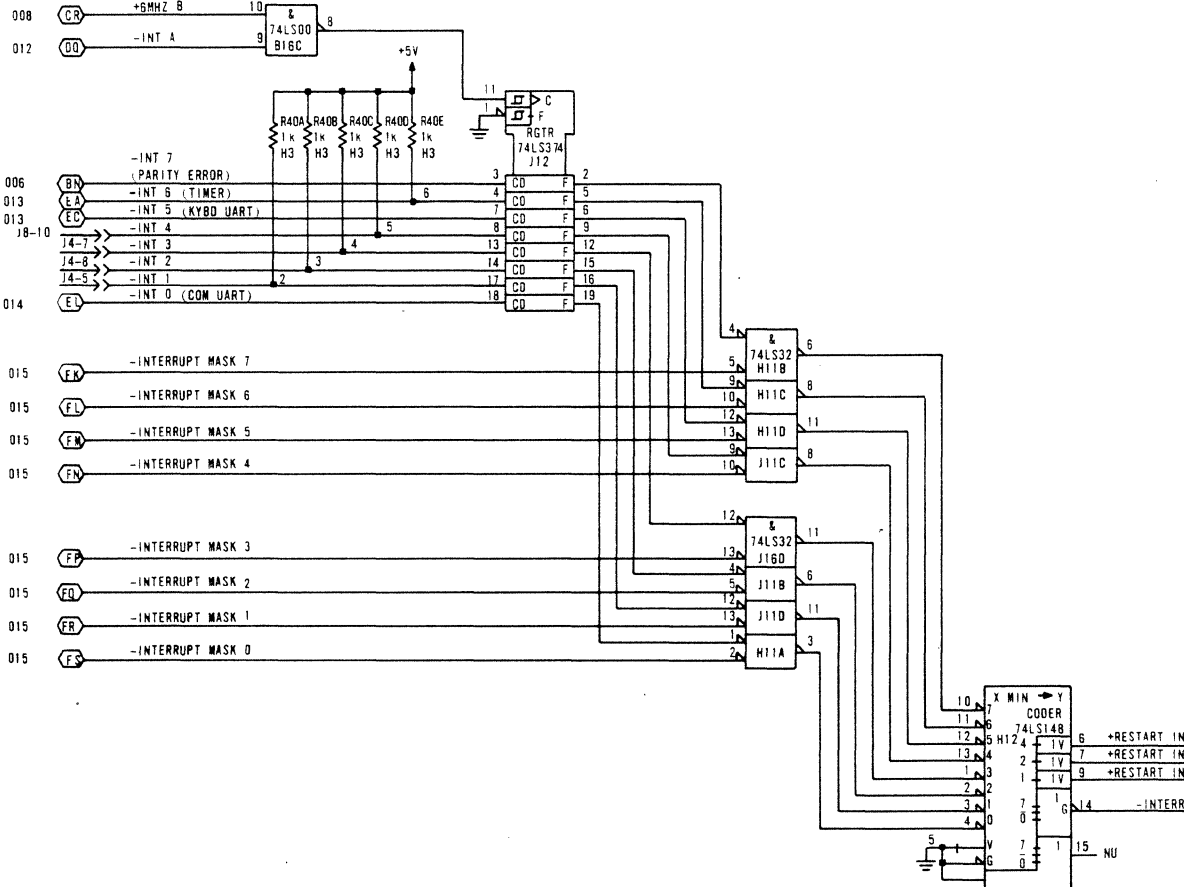
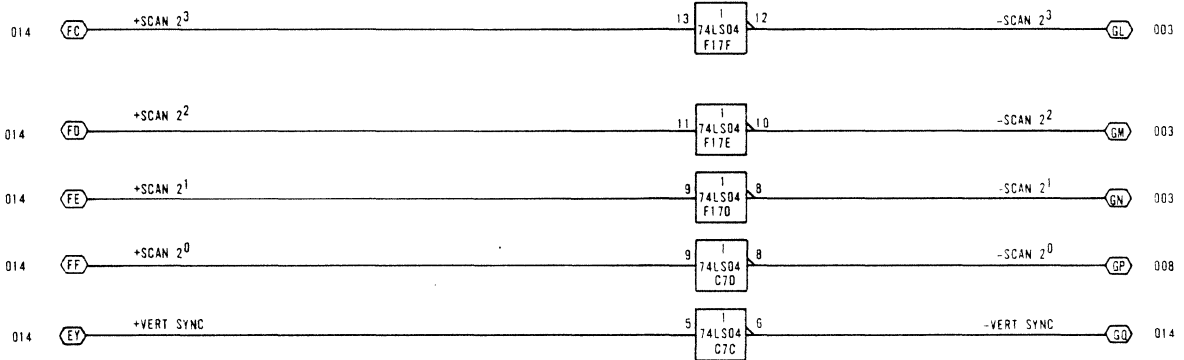

LOC
 CROSS REF NO 016

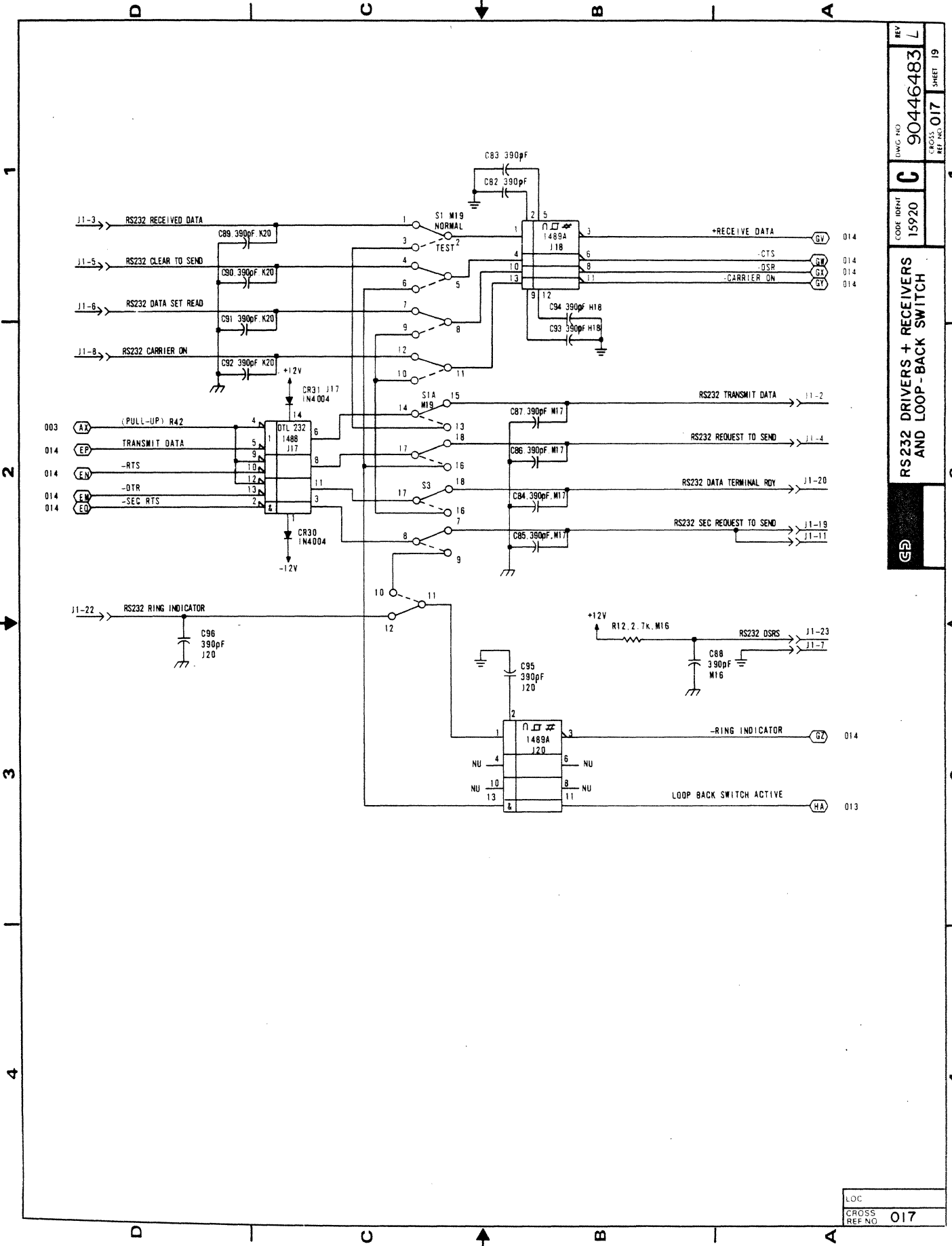

REV	L
DWG NO	90446483
CODE IDENT	C
CROSS REF NO	15920
SHEET	19
RS232 DRIVERS + RECEIVERS AND LOOP-BACK SWITCH	

LOC	
CROSS REF NO	017

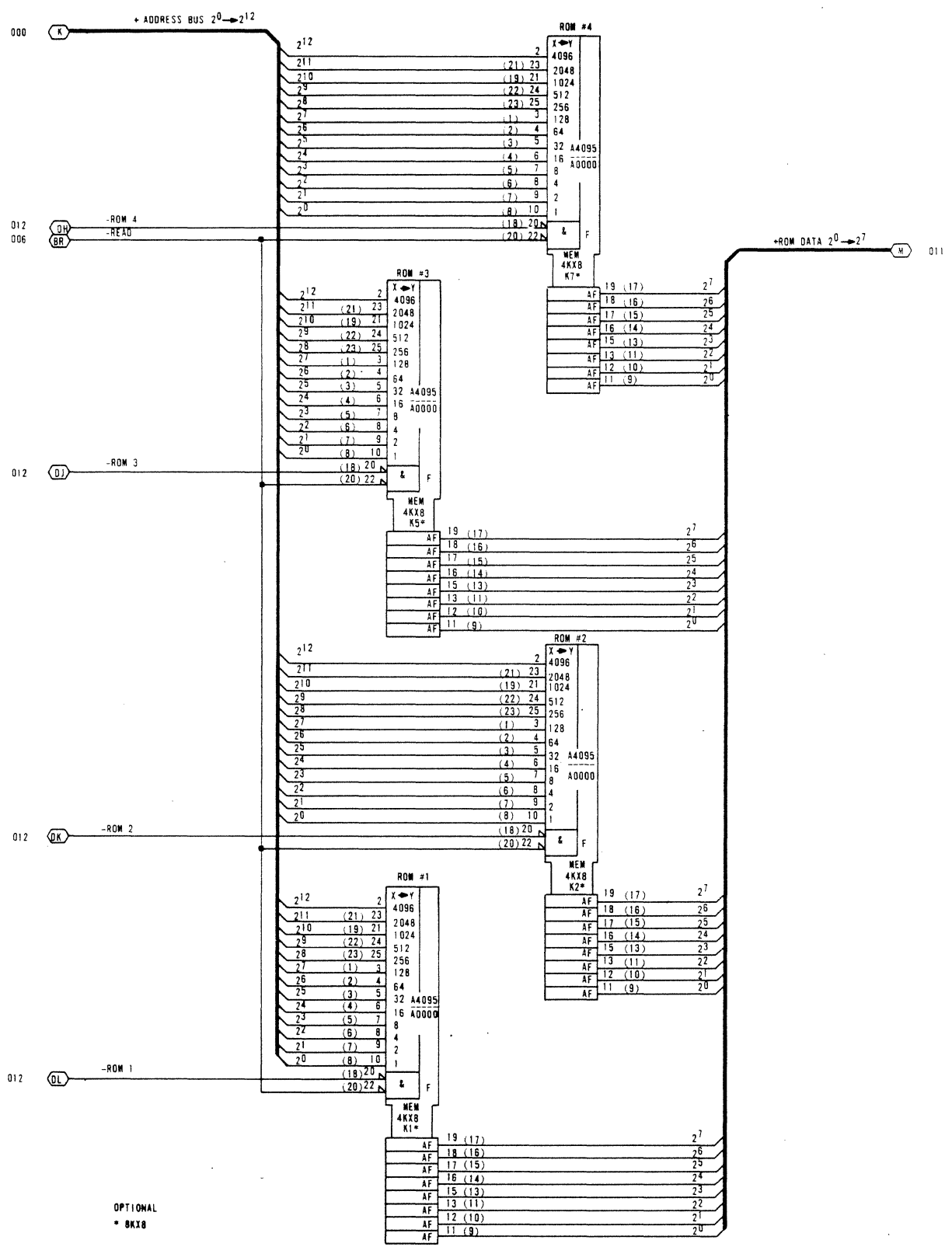

OPTIONAL
 = 8Kx8
 NOTE 4Kx8 ROMS ASCENDING ORDER = ROM 1.2.3.4.
 8Kx8 ROMS ASCENDING ORDER = ROM 1.3.2.4.
 NOTE: PIN NO.'S IN PARENTHESIS ARE 4K ROMS.
 PIN 1 & 27 CONNECT TO +5V.

LOC
 CROSS REF NO 018

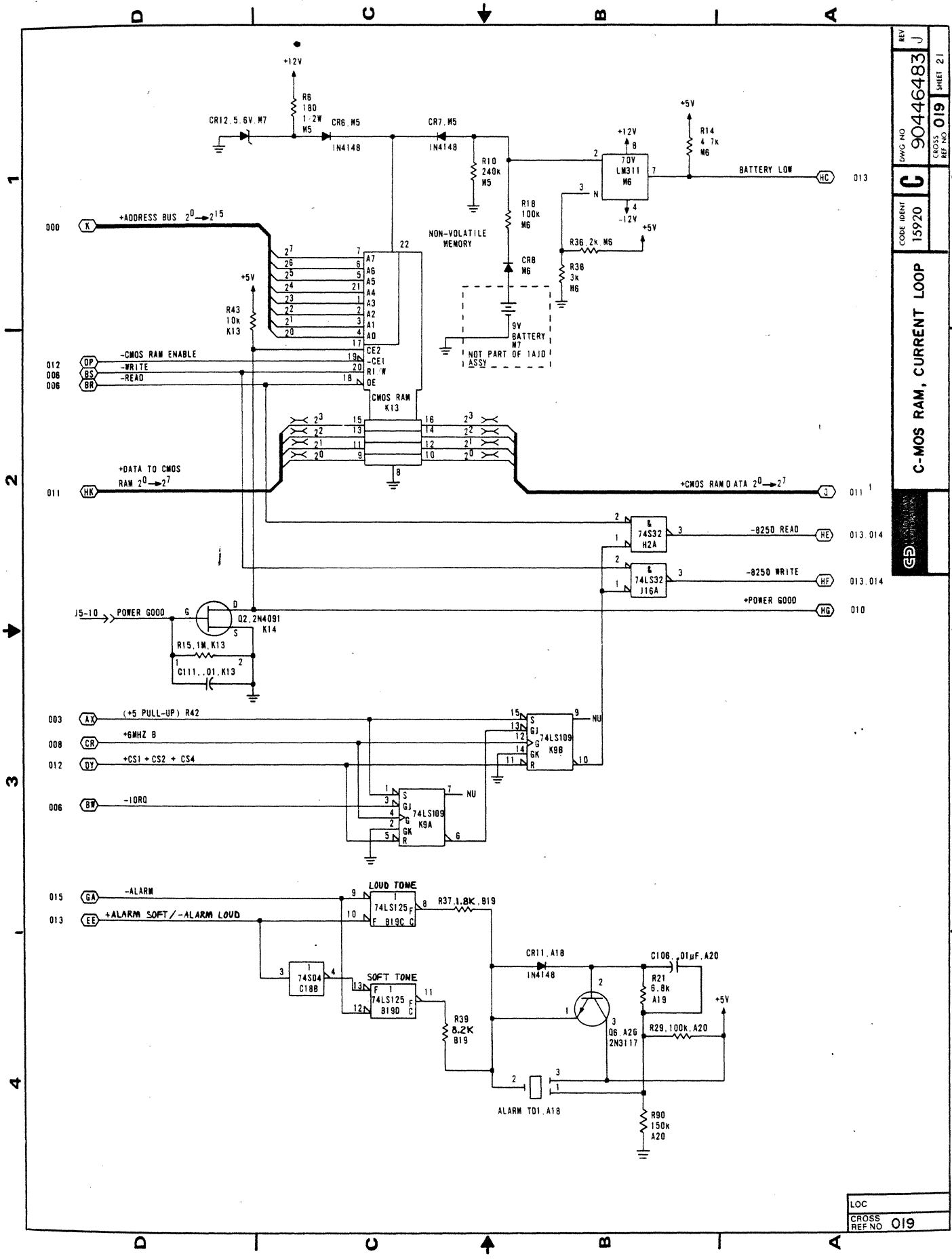

REV	J
DWG NO	90446483
CROSS REF NO	019
SHEET 21	21
CODE IDENT	C
15920	
C-MOS RAM, CURRENT LOOP	

LOC
CROSS REF NO 019

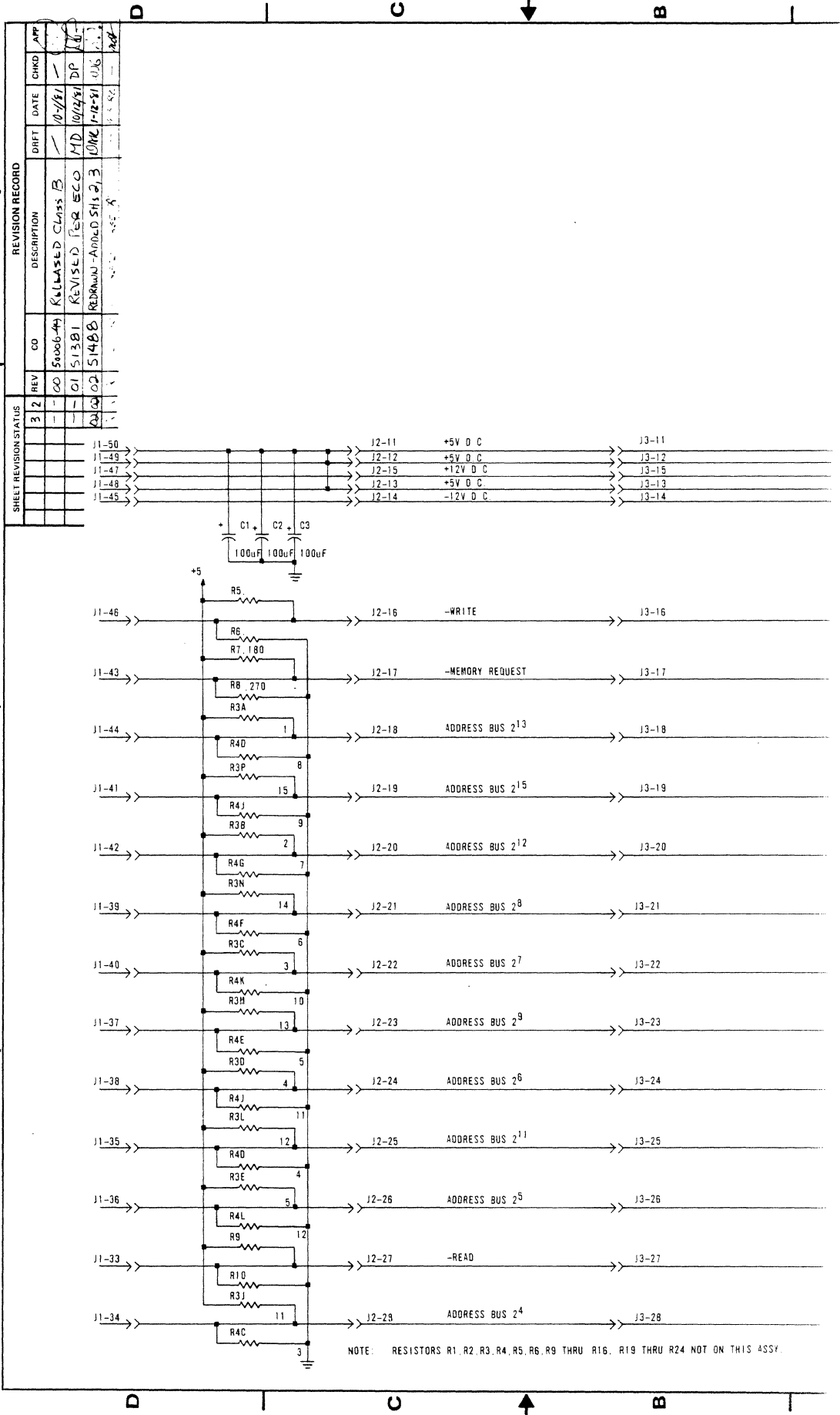

REVISION RECORD			
REV	CO	DESCRIPTION	DATE
00	50006-4	RELEASED CLASS B	10-7-81
01	51381	REVISED FOR EECO	10/24/81 DP
02	51488	REDRAWN - APPROVED SHS 2/3	10/26/81
03			
04			

SHEET REVISION STATUS			
SHEET	REV	DATE	APP
1	00		
2	00		
3	00		
4	00		

NOTE: RESISTORS R1, R2, R3, R4, R5, R6, R9 THRU R16, R19 THRU R24 NOT ON THIS ASSY.

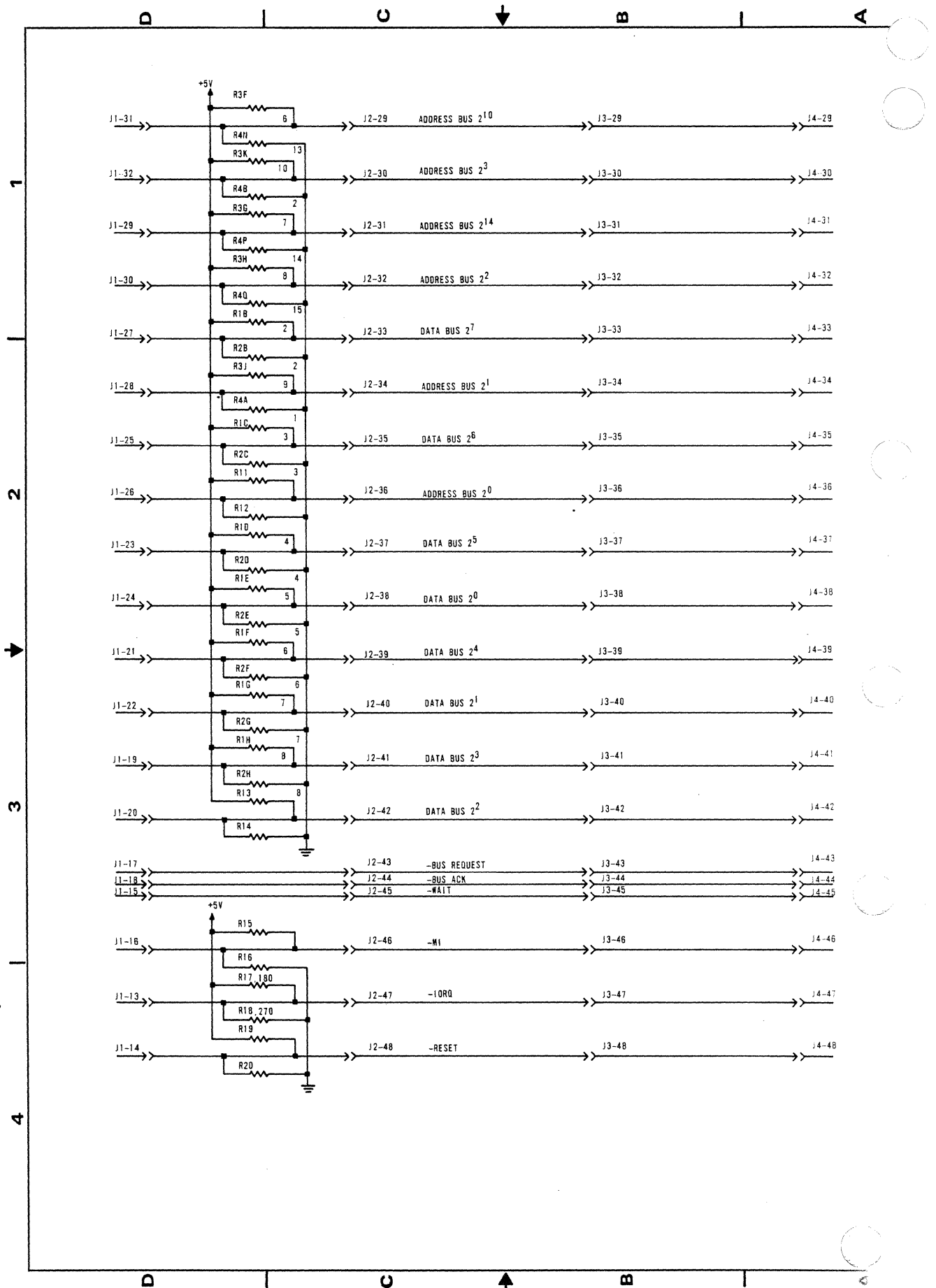

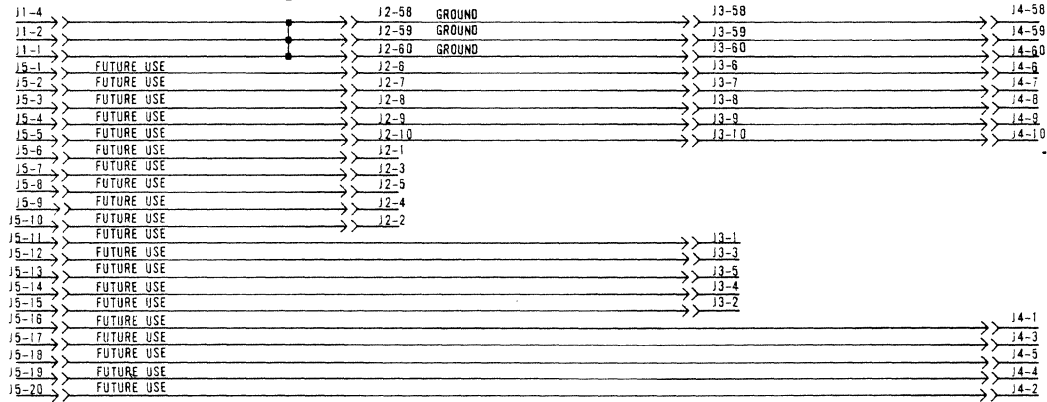
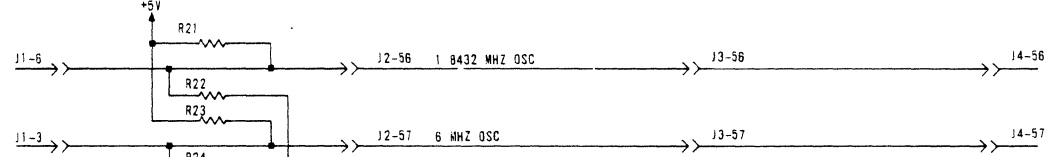
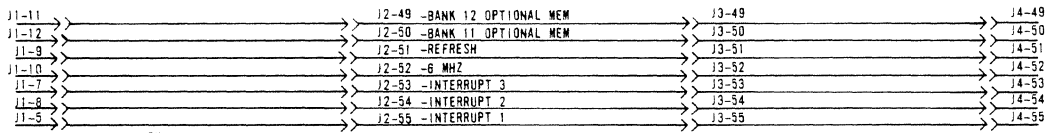

NOTE: J5 NOT ON THIS ASSY

REV	A
DWG NO	90446326
CROSS REF NO	3
CODE IDENT	15920
SCHEMATIC DIAGRAM, 1A UD	
LUMBER DATA CORPORATION	

LOC
CROSS REF NO

1-54

62940037 L

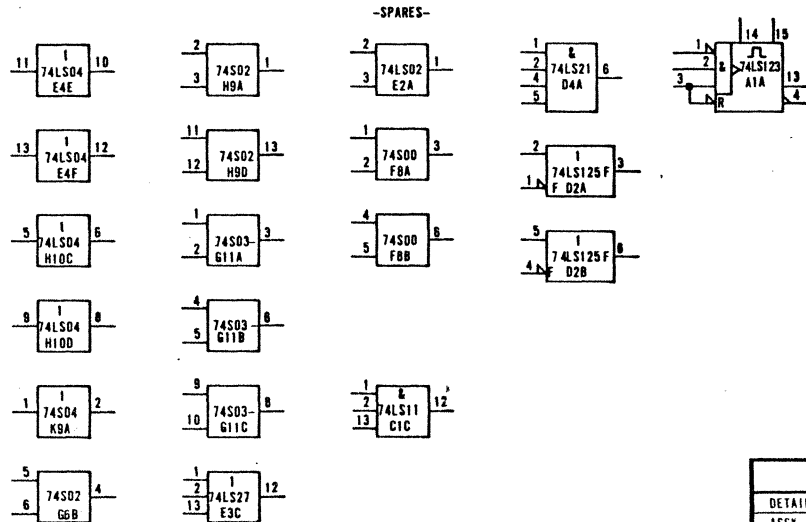
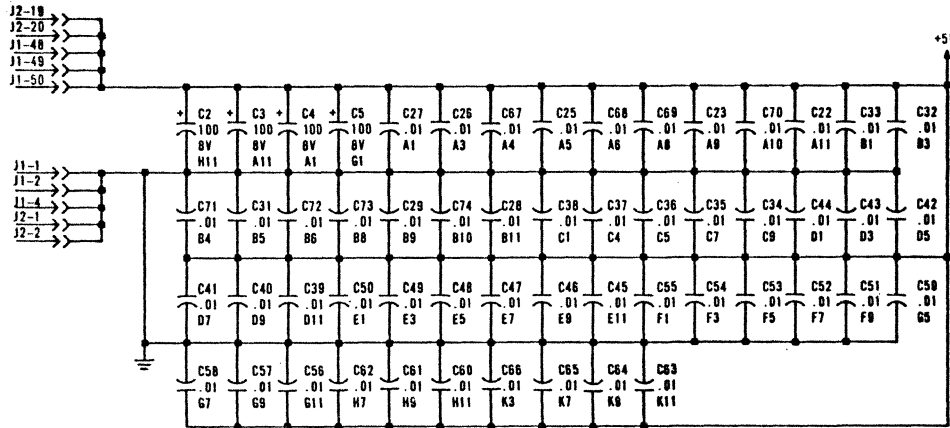

SHEET REVISION STATUS											REVISION RECORD						
11	10	9	8	7	6	5	4	3	2	1	REV	CO	DESCRIPTION	DRAFT	DATE	CHKD	APP
00	00	00	00	00	00	00	00	00	00	00	00	5000776	RELEASED CLASS B		2/1/76		
01	01	01	01	01	01	01	01	01	01	01	01	51629	REVISED PER ECO	EE	3/4/82	EE	EWG
A	A	A	A	A	A	A	A	A	A	A	A	19232-64	RELEASED CLASS A		4-5-82		
A	A	A	A	A	A	A	A	A	A	B	B	15134	REVISED PER ECO	IX	5-10-82	WJG	CAF
A	C	A	B	A	B	A	A	A	A	C	C	15347	F24F3 WERE 74LS156	MIC	8-6-82	WJG	CAF
D	C	A	B	A	D	A	A	D	D	D	D	16512	USED SPARES LOC H9B,C	EE	6/15/84	WJG	CAF
D	C	A	B	E	D	A	A	D	E	E	E	17714	DELETED R63,R65 & R66	EE	3/25/86	DS	R/SB

NOTES:
 1. UNLESS OTHERWISE SPECIFIED, POWER AND GROUND PINS OF INTEGRATED CKTS ARE AS LISTED BELOW:
 14 PIN INTEGRATED CKTS: PIN 14=+5V, PIN 7=GND.
 16 PIN INTEGRATED CKTS: PIN 16=+5V, PIN 8=GND.
 20 PIN INTEGRATED CKTS: PIN 20=+5V, PIN 10=GND.
 24 PIN INTEGRATED CKTS: PIN 24=+5V, PIN 12=GND.

REFERENCE DRAWING		CONTROL DATA		TITLE	
DETAIL	90446304	FIRST USED ON		SCHEMATIC DIAGRAM, IALD	
ASSY	90446305	XA358-A		(GRAPHICS LOGIC BOARD)	
COMPONENTS, EXCEPT AS NOTED		CHKN	E ERSFELD	7 31 81	
TOLENANCE	VALUE	RATING	ENGR	R. GAYLOR	2/23/77
RES	OHMS	1 4W	MFG	J. JEA. J.A.	2/23/77
CAP	UF	50V	APPR	W. J. J.	2/23/77
		SCALE	CROSS REF. MFG	DRAWING NO	90446303
				CODE IDENT	C
				SHEET 1 OF 11	

90446303

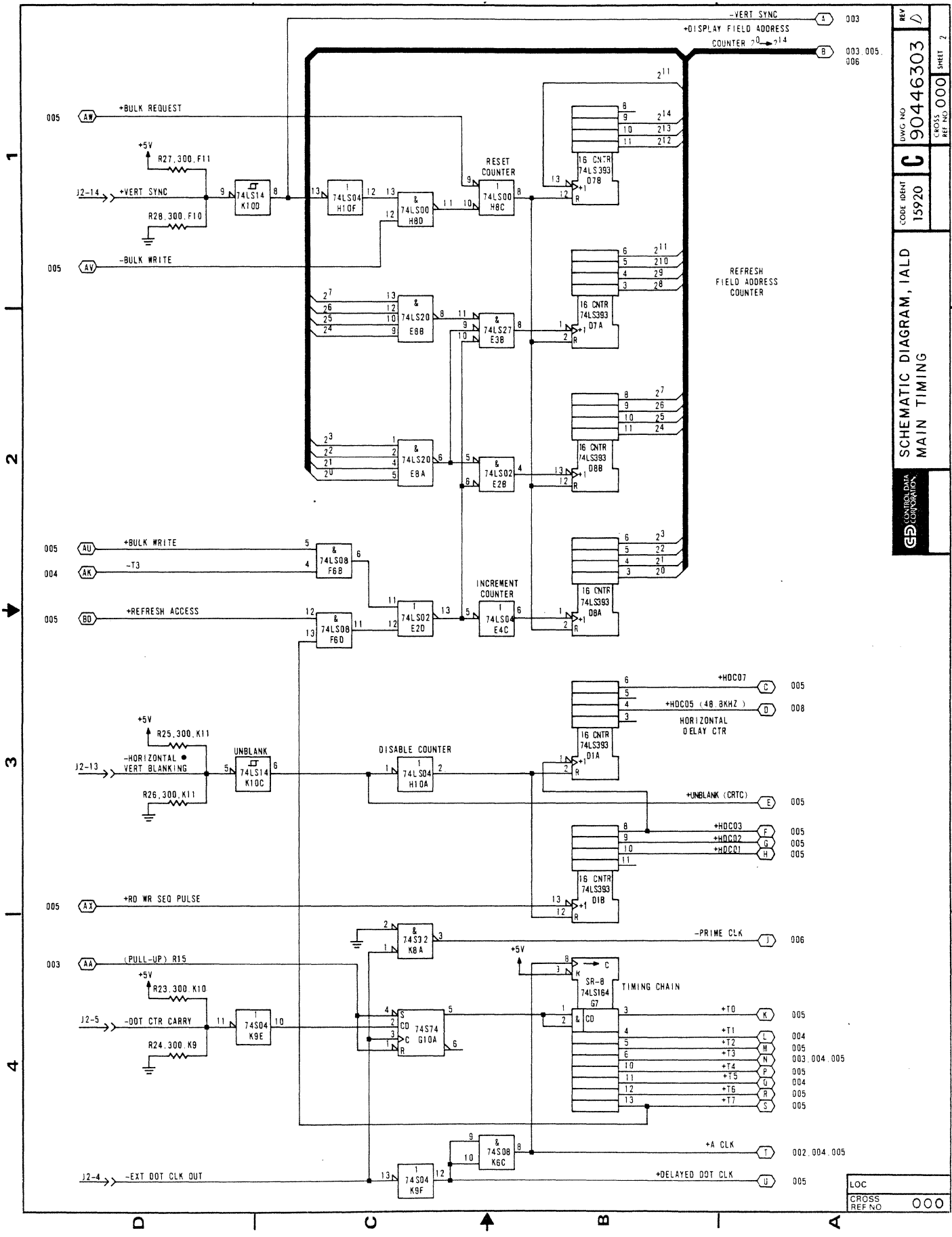

REV D
 DWG NO C 90446303
 CODE IDENT 15920
 SCHEMATIC DIAGRAM, IALD
 MAIN TIMING
 GEORGE B. BAKER CORPORATION
 CROSS REF NO 000
 SHEET 2

LOC
 CROSS REF NO 000

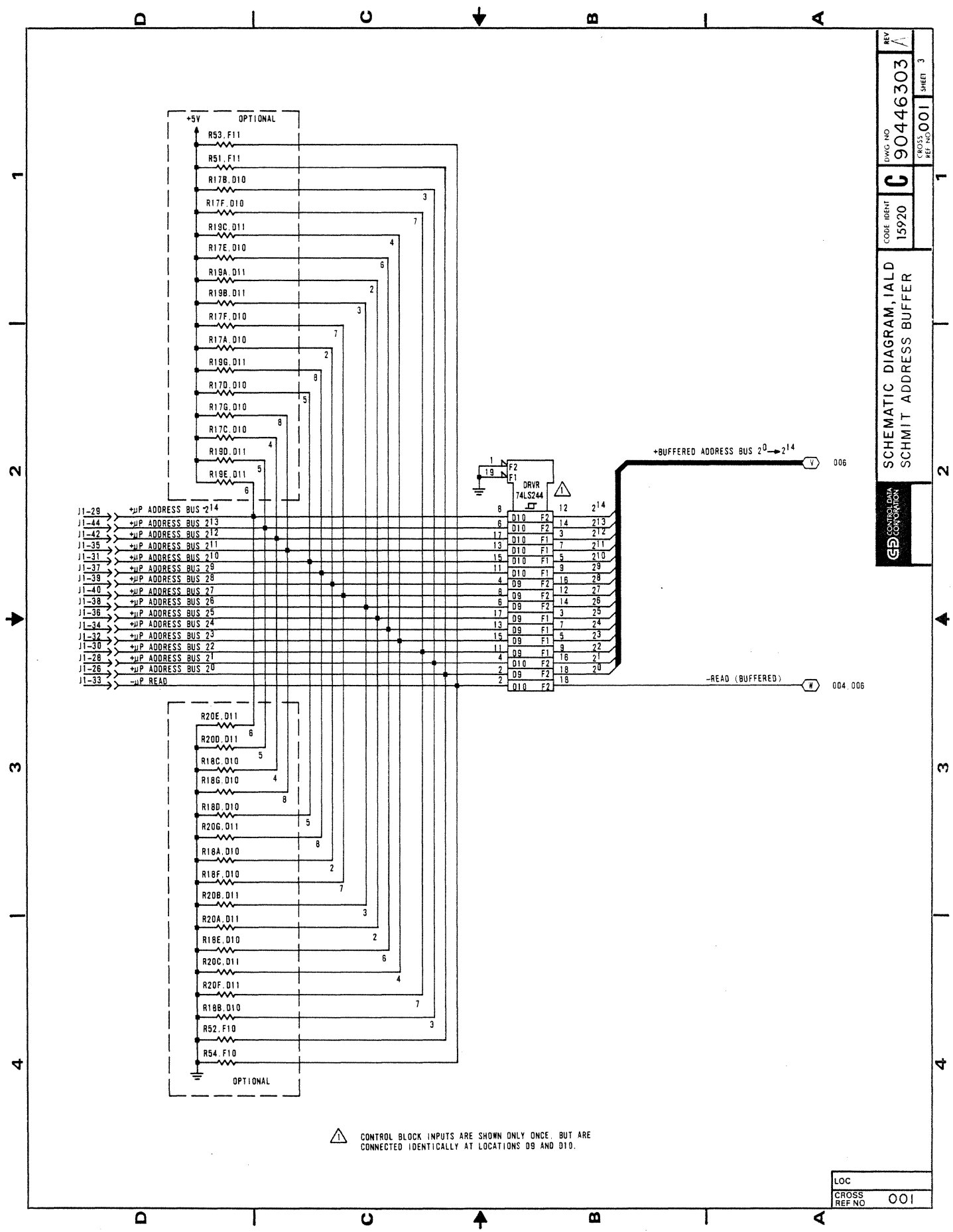

REV	A
DWG. NO.	90446303
CODE IDENT	C
CROSS REF. NO.	15920
REV. NO.	001
SHEET	3

SCHEMATIC DIAGRAM, IALD
SCHMITT ADDRESS BUFFER

CONTROL DATA
CONNECTION

LOC
CROSS
REF NO 001

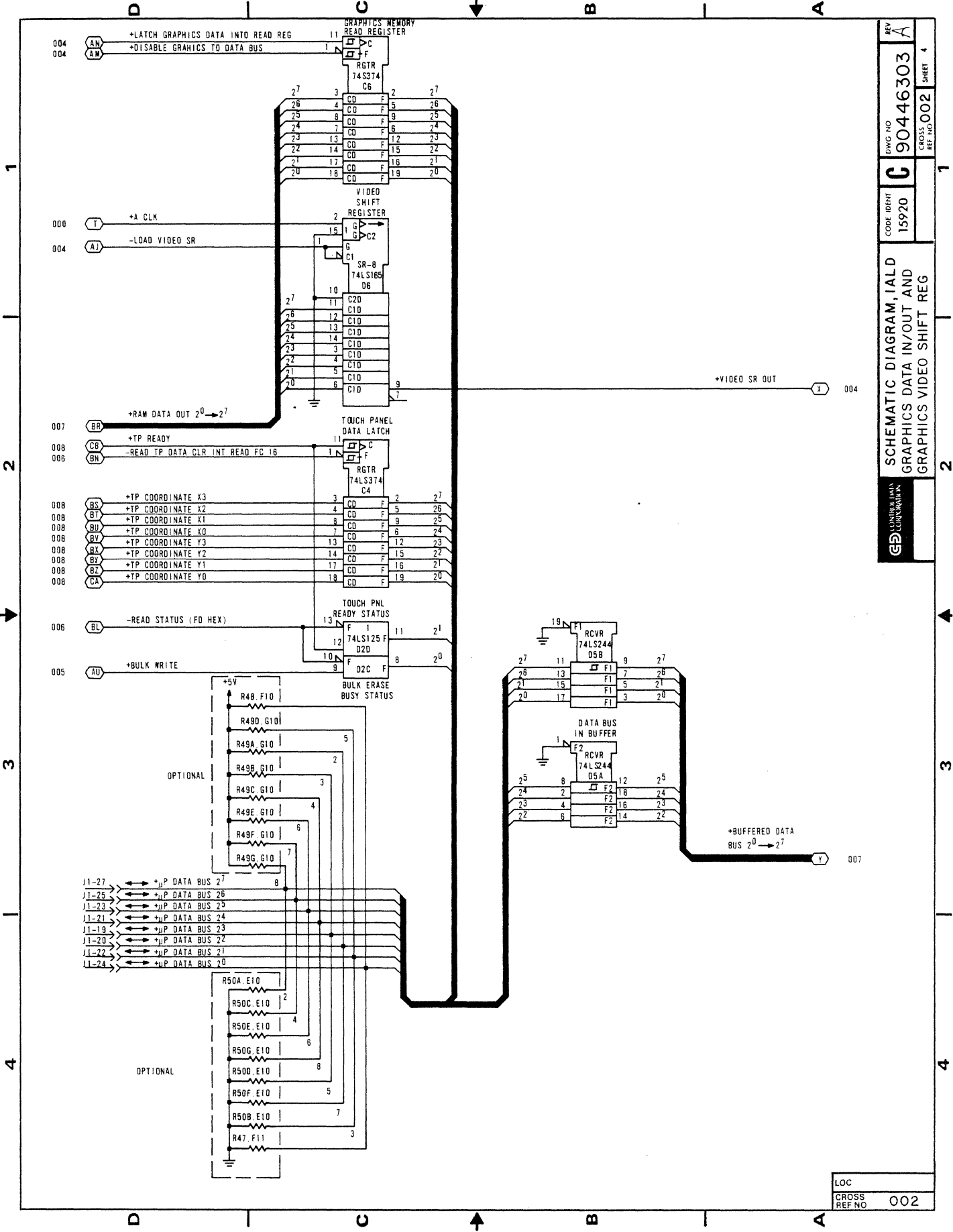

REV	A
DWG NO	90446303
CODE IDENT	C
CROSS REF NO	002
SHEET	4

SCHEMATIC DIAGRAM, IALD
 GRAPHICS DATA IN/OUT AND
 GRAPHICS VIDEO SHIFT REG

LOC
 CROSS REF NO 002

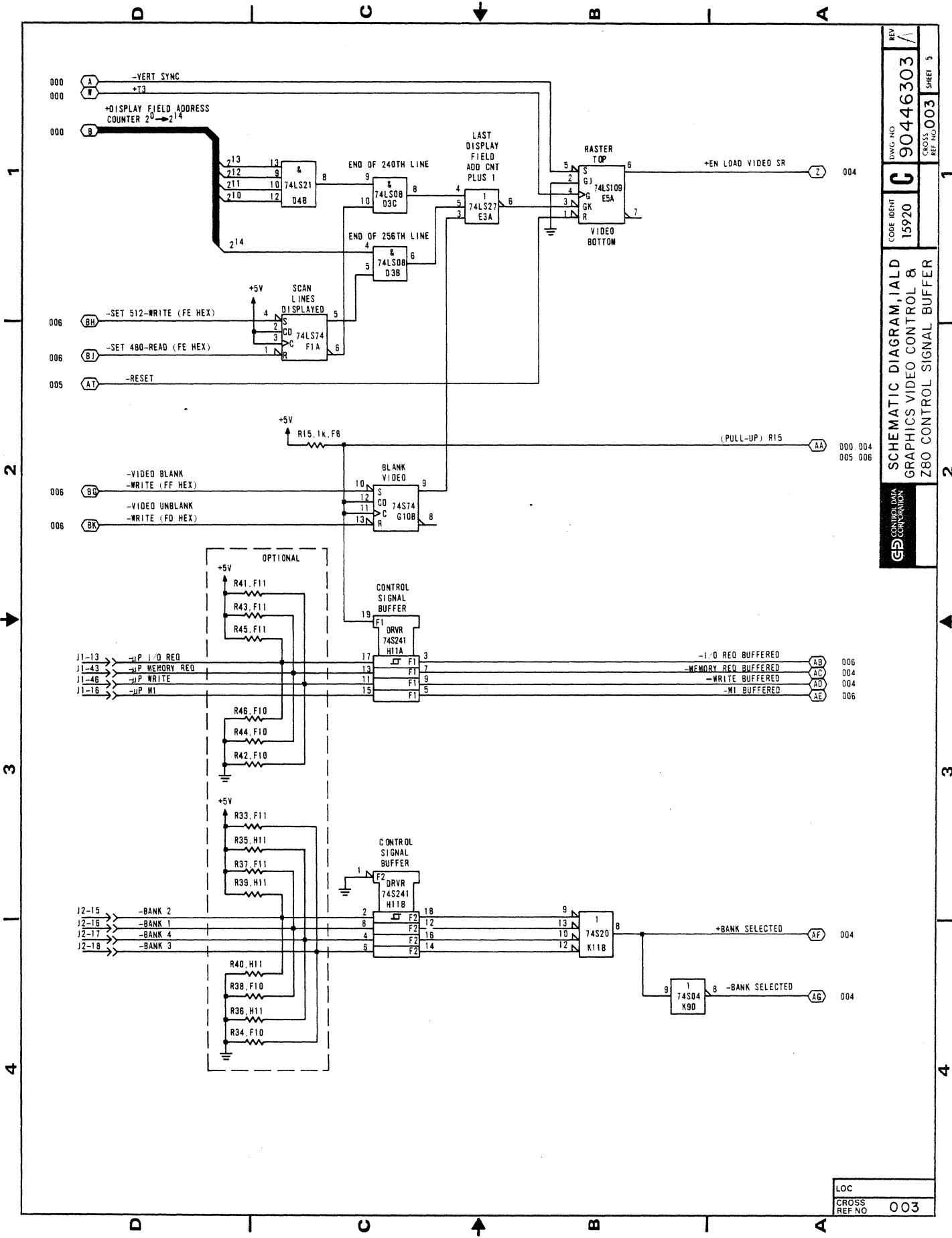

REV	90446303	SHEET 5
DWG NO	90446303	CROSS REF NO 003
CODE IDENT	15920	
SCHEMATIC DIAGRAM, IALD		
GRAPHICS VIDEO CONTROL &		
Z80 CONTROL SIGNAL BUFFER		
GDD CONTROL DATA CONNECTION		

LOC
CROSS REF NO 003

1
2
3
4

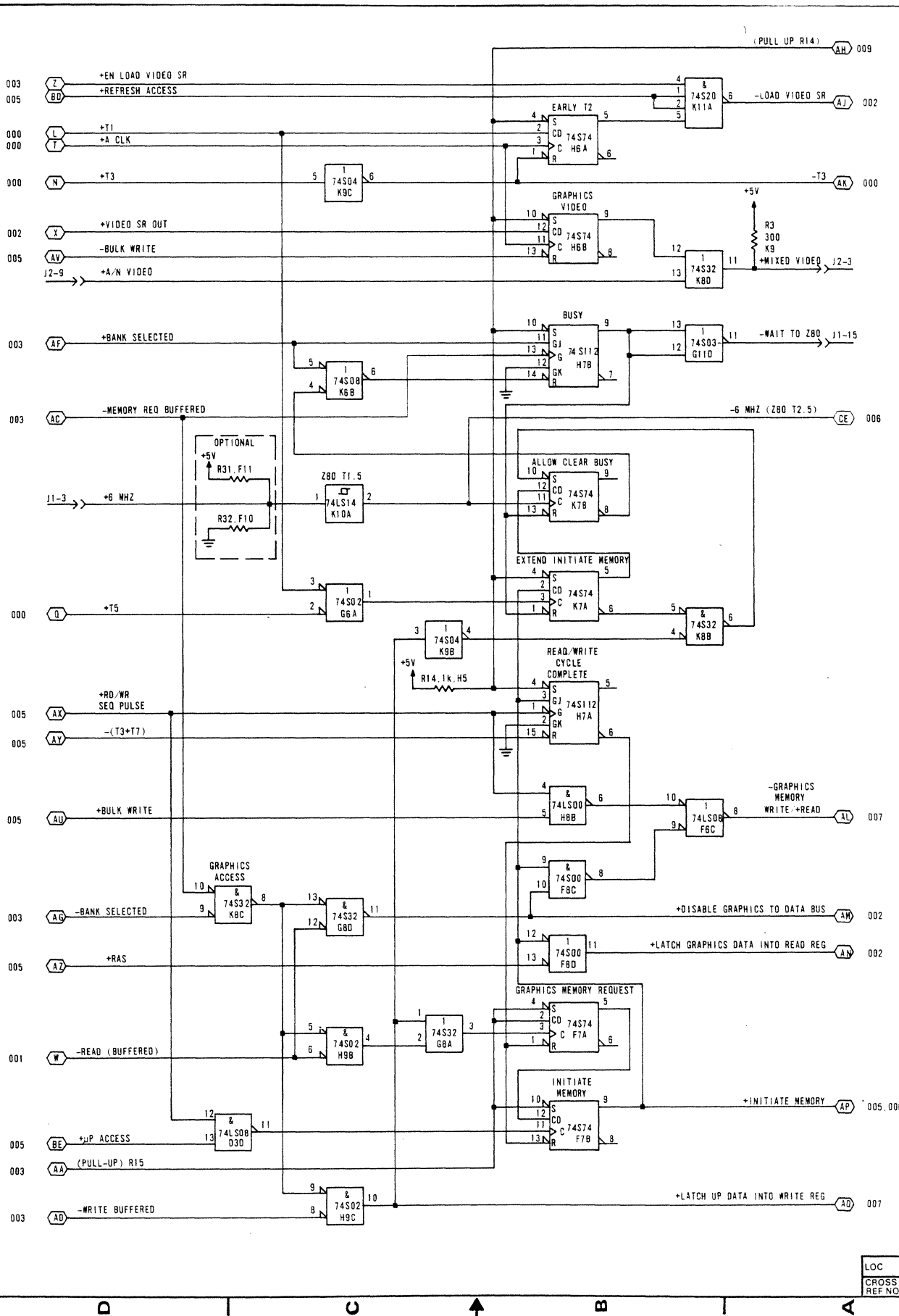

REV L
 DWG NO 90446303
 CODE IDENT C 15920
 CROSS REF NO 004
 SHEET 6
 SCHEMATIC DIAGRAM, IALD
 Z80 ACCESS AND VIDEO
 CONTROL

LOC	
CROSS REF NO	004

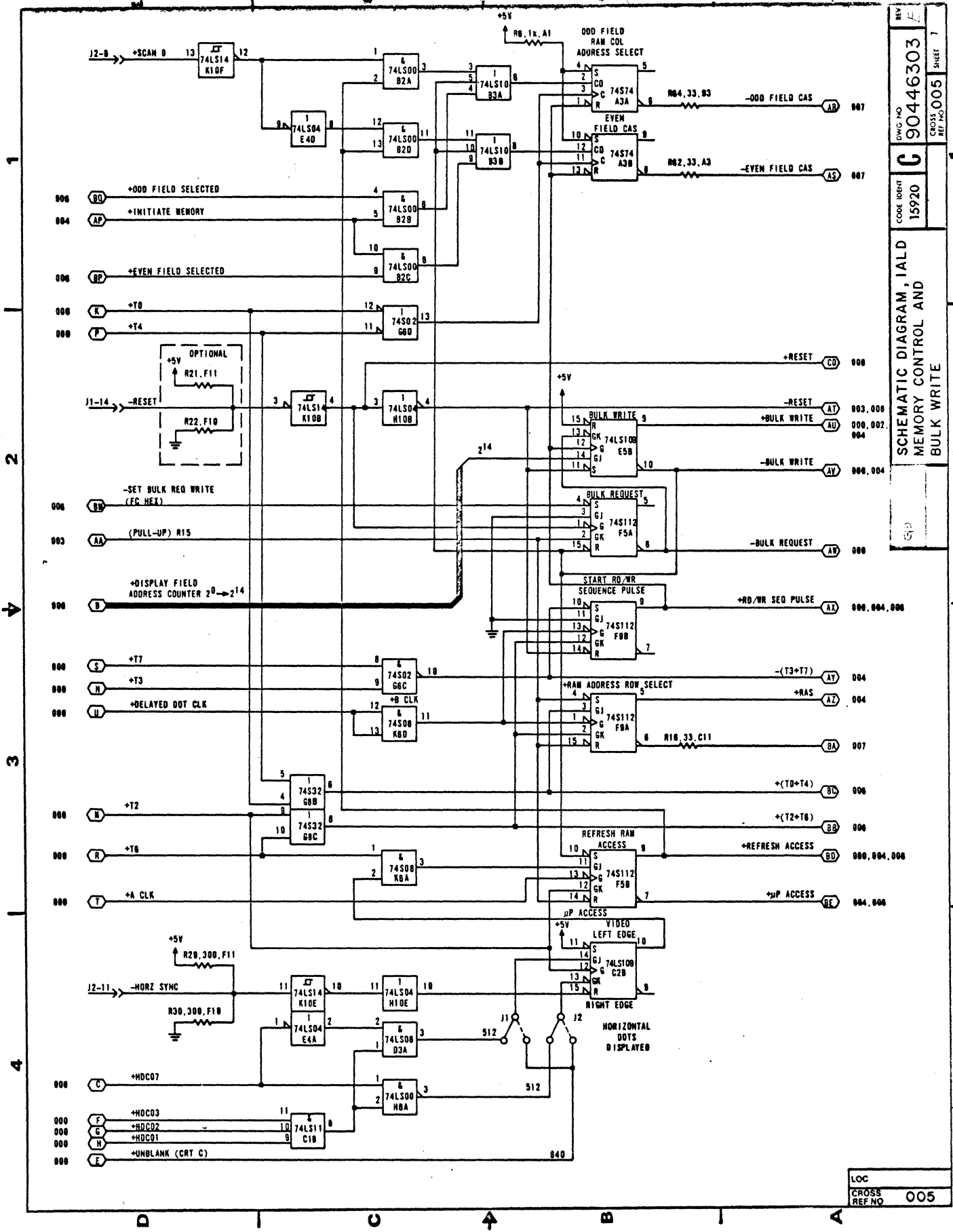

REV E
 DWG NO 90446303
 CODE IDENT 15920
 SCHEMATIC DIAGRAM, IALD
 MEMORY CONTROL AND
 BULK WRITE
 CROSS REF NO 005
 SHEET 1

LOC
 CROSS REF NO 005

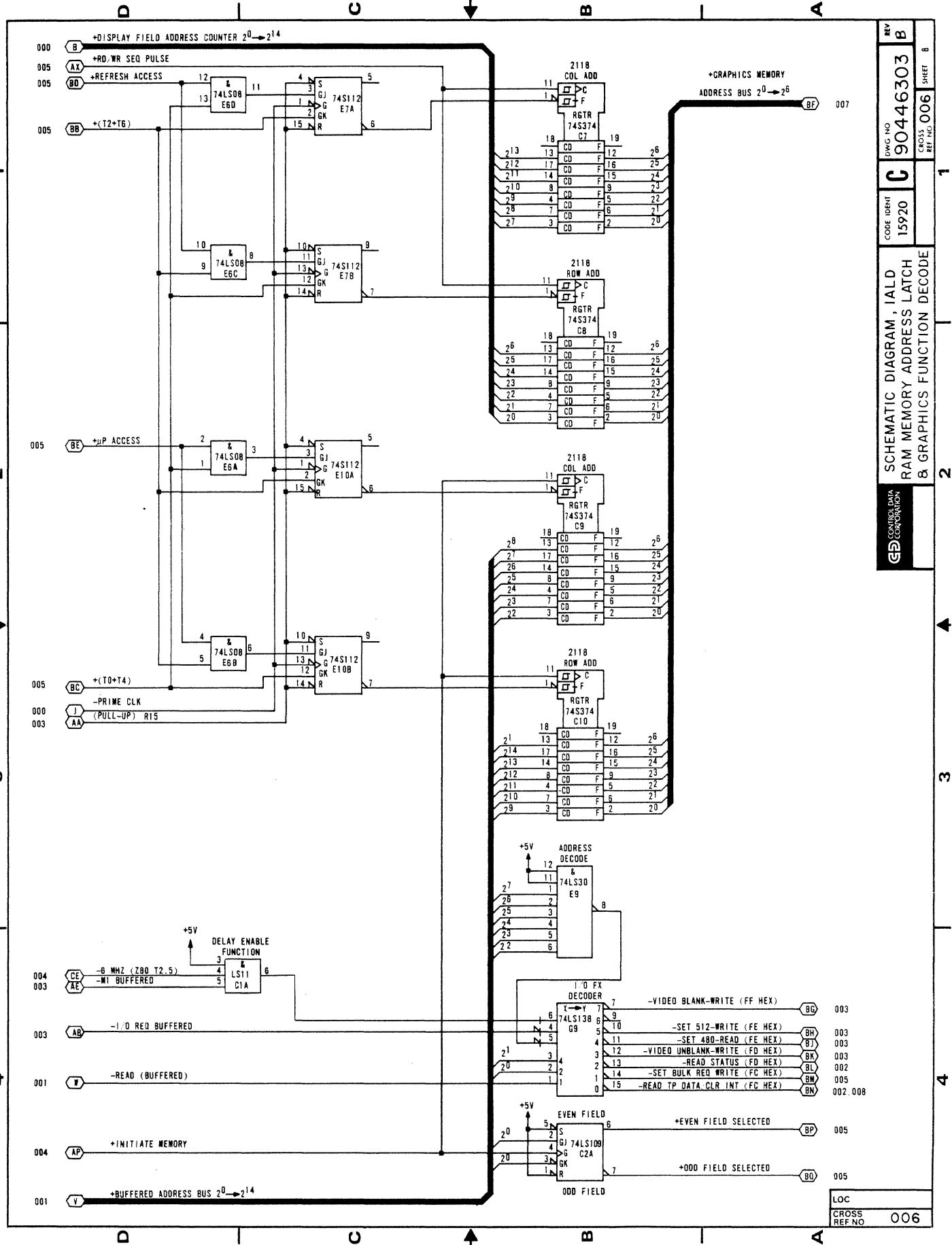

REV	B
DWG NO	90446303
CODE IDENT	15920
CROSS REF NO	006
SHEET	8

SCHEMATIC DIAGRAM, IALD
RAM MEMORY ADDRESS LATCH
& GRAPHICS FUNCTION DECODE

LOC
CROSS REF NO 006

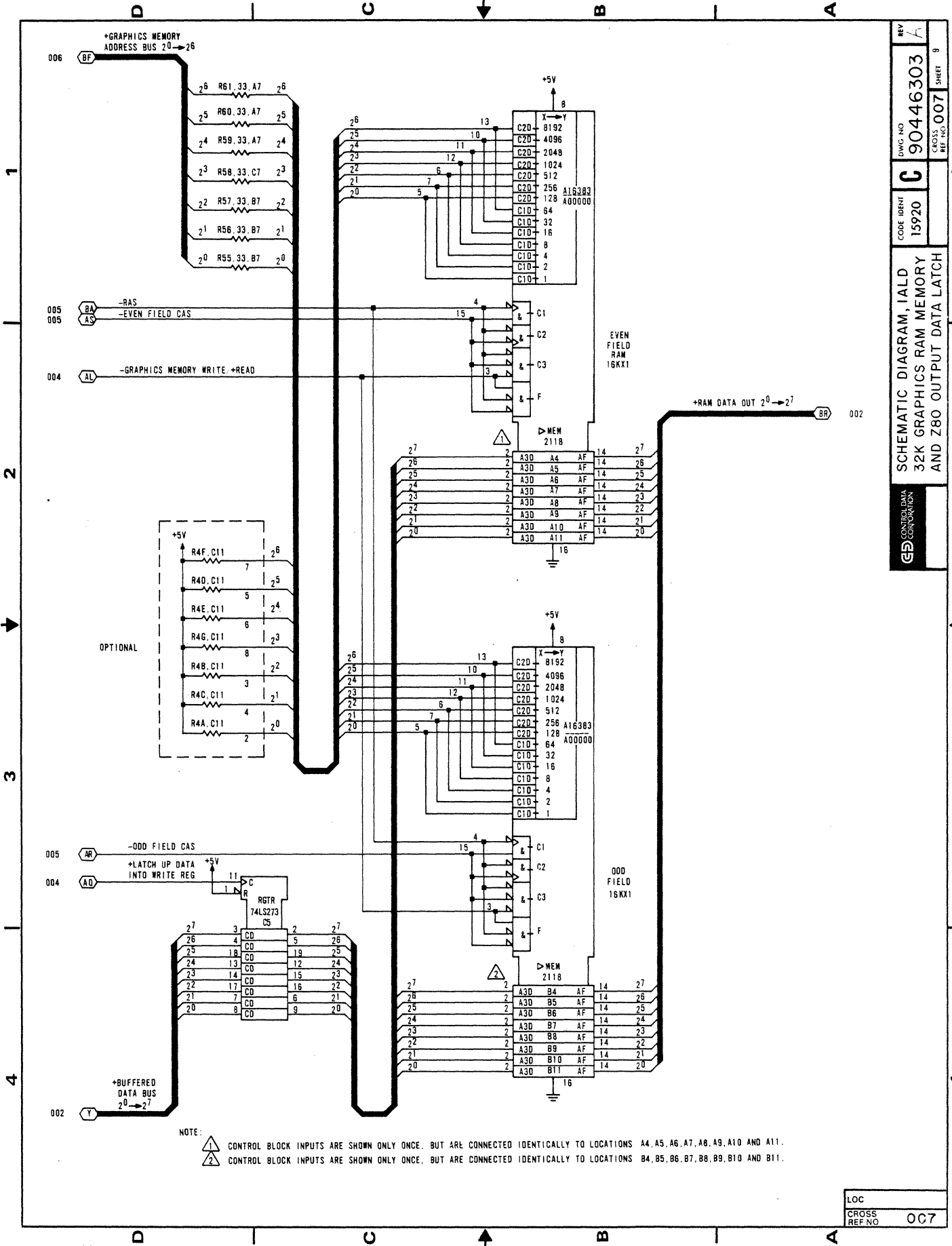

REV	A
DWG NO	90446303
CROSS REF NO	007
SHEET	9
CODE IDENT	15920
SCHEMATIC DIAGRAM, IALD 32K GRAPHICS RAM MEMORY AND Z80 OUTPUT DATA LATCH	
GE CONTROL DATA CORPORATION	

LOC
CROSS REF NO 007

1
2
3
4

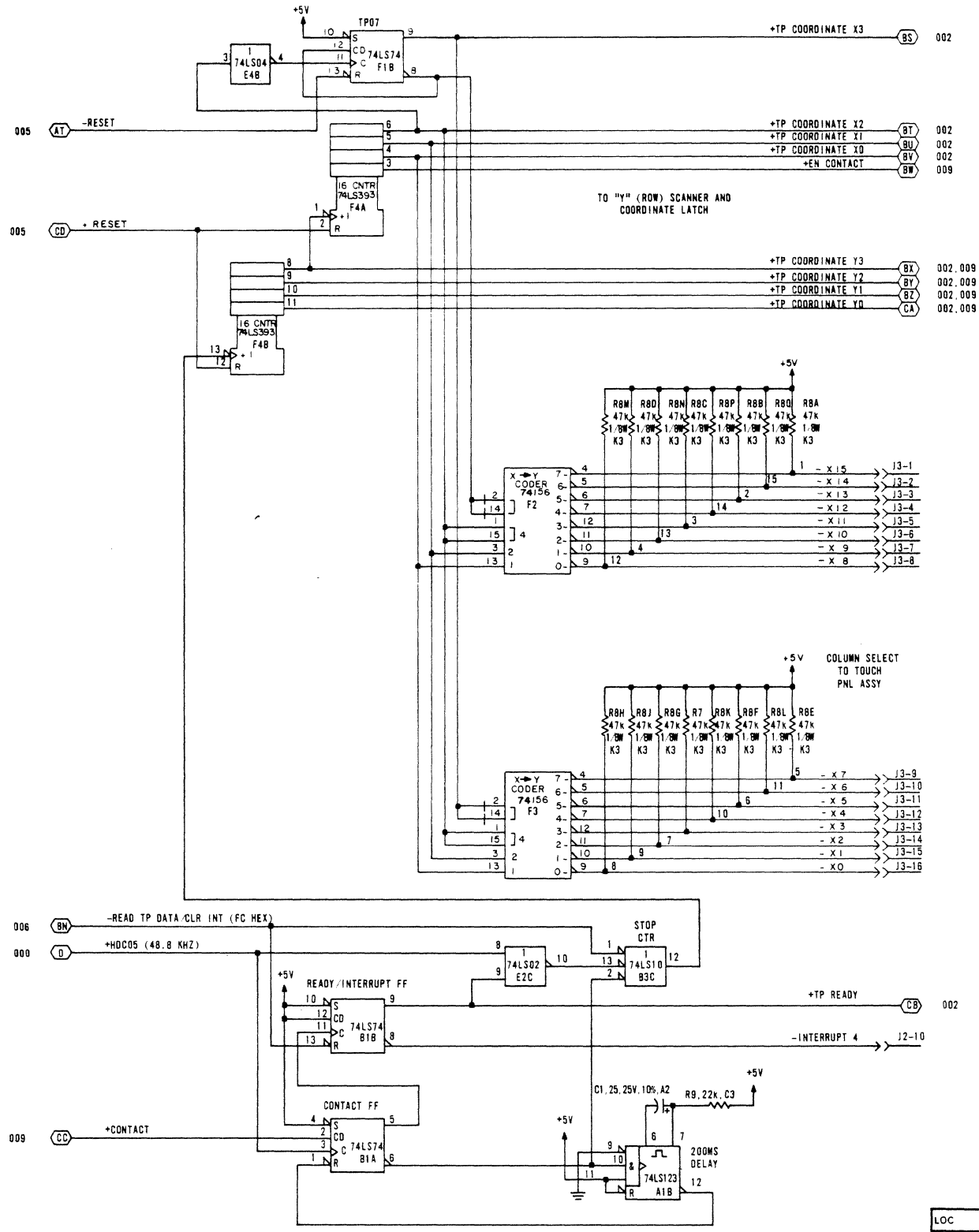

LOC
 CROSS REF NO 008

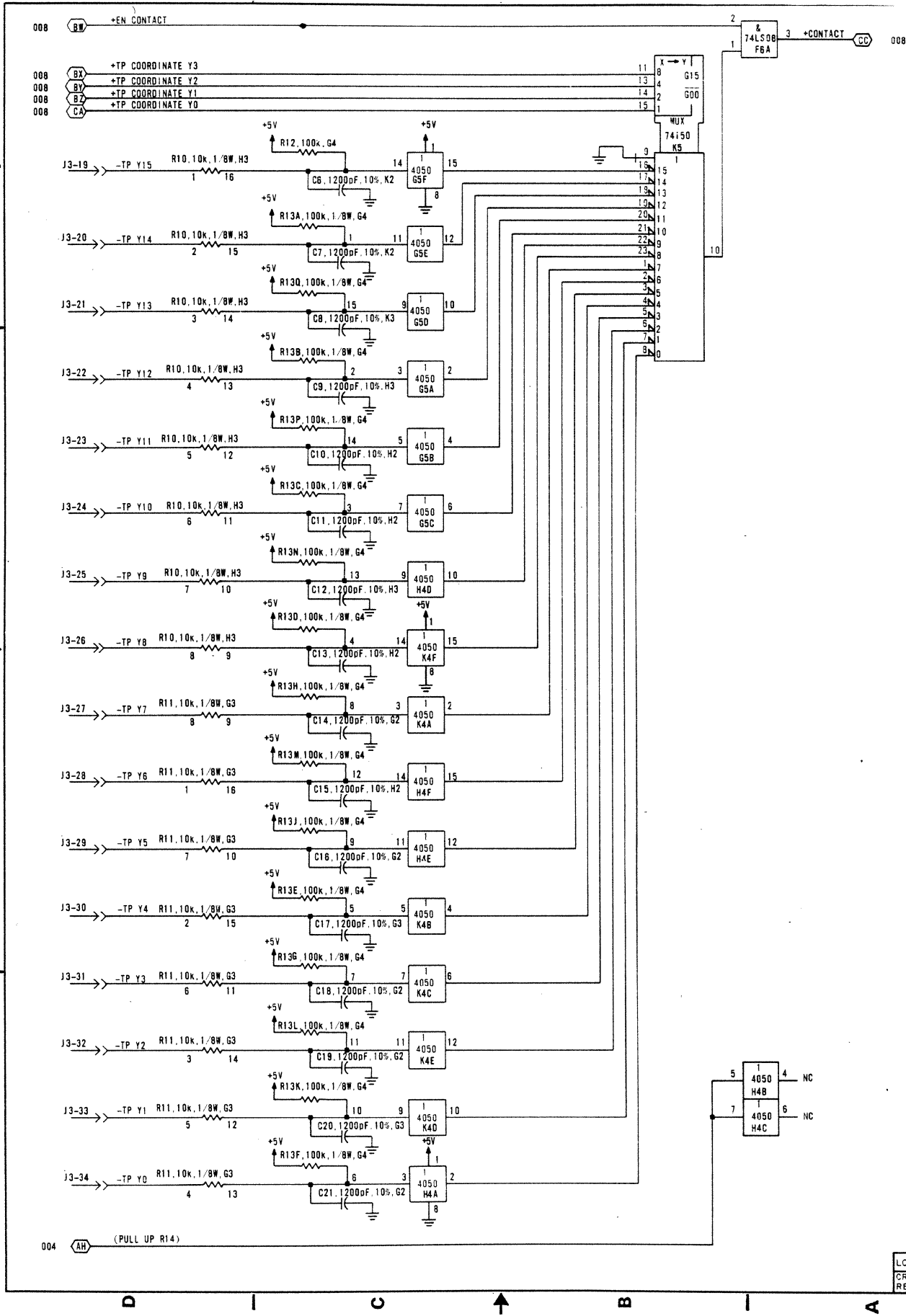

REV **D**
 DWG NO **90446303**
 CODE IDENT **C**
 15920
 CROSS REF NO **009**
 SHEET 11
 SCHEMATIC DIAGRAM, IALD
 TOUCH PANEL DECODER
 CONTROL DATA

LOC
 CROSS REF NO **009**

62940037 D

1-65

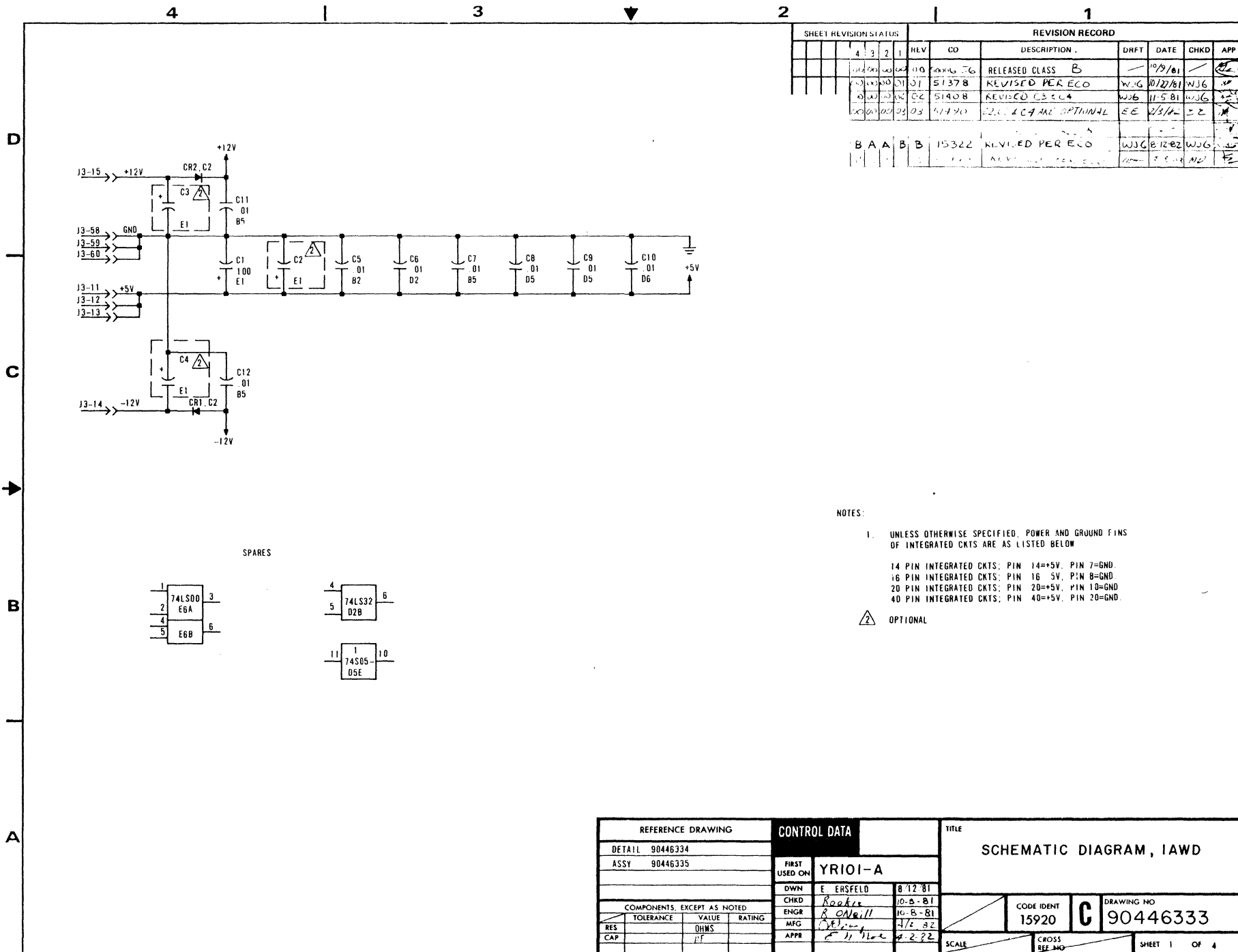

SHEET REVISION STATUS				REVISION RECORD					
REV	CO	DESCRIPTION	DRFT	DATE	CHKD	APP			
1	ERS	RELEASED CLASS B		10/9/81					
2	ERS	REVISED PER ECO		10/27/81	WJG				
3	ERS	REVISED PER ECO		11-5-81	WJG				
4	ERS	REVISIONS ARE OPTIONAL		2/3/82	EE				
5	ERS	REVISED PER ECO		12/2/82	WJG				

NOTES:

- UNLESS OTHERWISE SPECIFIED, POWER AND GROUND PINS OF INTEGRATED CKTS ARE AS LISTED BELOW
- 14 PIN INTEGRATED CKTS: PIN 14=+5V, PIN 7=GND
- 16 PIN INTEGRATED CKTS: PIN 16 5V, PIN 8=GND
- 20 PIN INTEGRATED CKTS: PIN 20=+5V, PIN 10=GND
- 40 PIN INTEGRATED CKTS: PIN 40=+5V, PIN 20=GND

OPTIONAL

REFERENCE DRAWING			CONTROL DATA		TITLE	
DETAIL	90446334		FIRST USED ON	YR101-A		SCHEMATIC DIAGRAM, IAWD
ASSY	90446335		DWN	E ERSFELD 8/12/81		
COMPONENTS, EXCEPT AS NOTED			CHKD	Rookie 10-8-81		CODE IDENT 15920
RES	TOLERANCE	VALUE	ENGR	R O'Neill 10-8-81		
CAP		RATING	MFG	2/2/82		DRAWING NO 90446333
			APPR	E H H... 2-2-82		
SCALE					CROSS REF NO	SHEET 1 OF 4

1
2
3
4

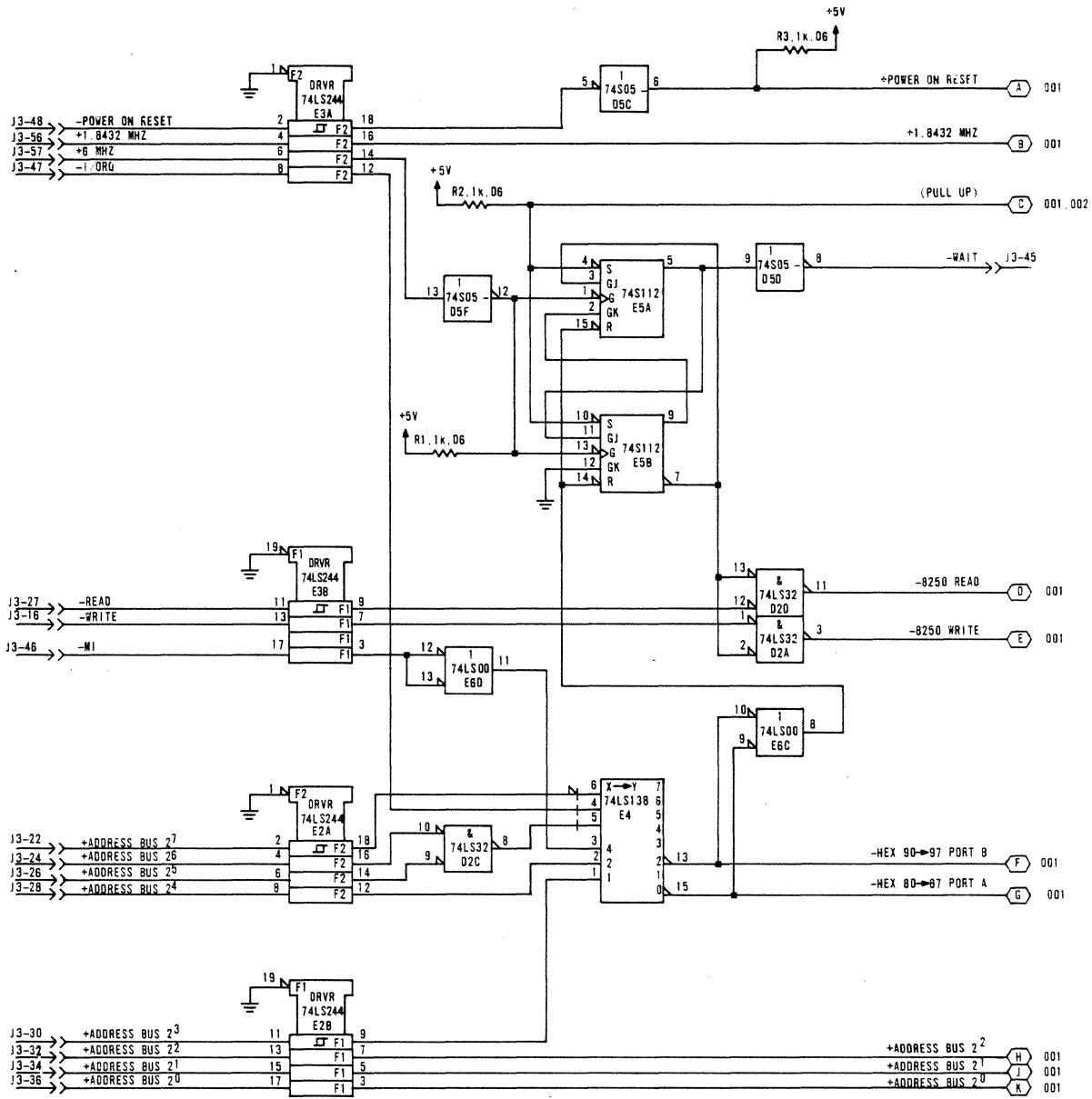

REV C
DWG NO 90446333
CODE IDENT 15920
PROCESS REF NO 000
SHEET 2

SCHEMATIC DIAGRAM, IAWD

CONDOR
CORPORATION

LOC	
CROSS REF NO	000

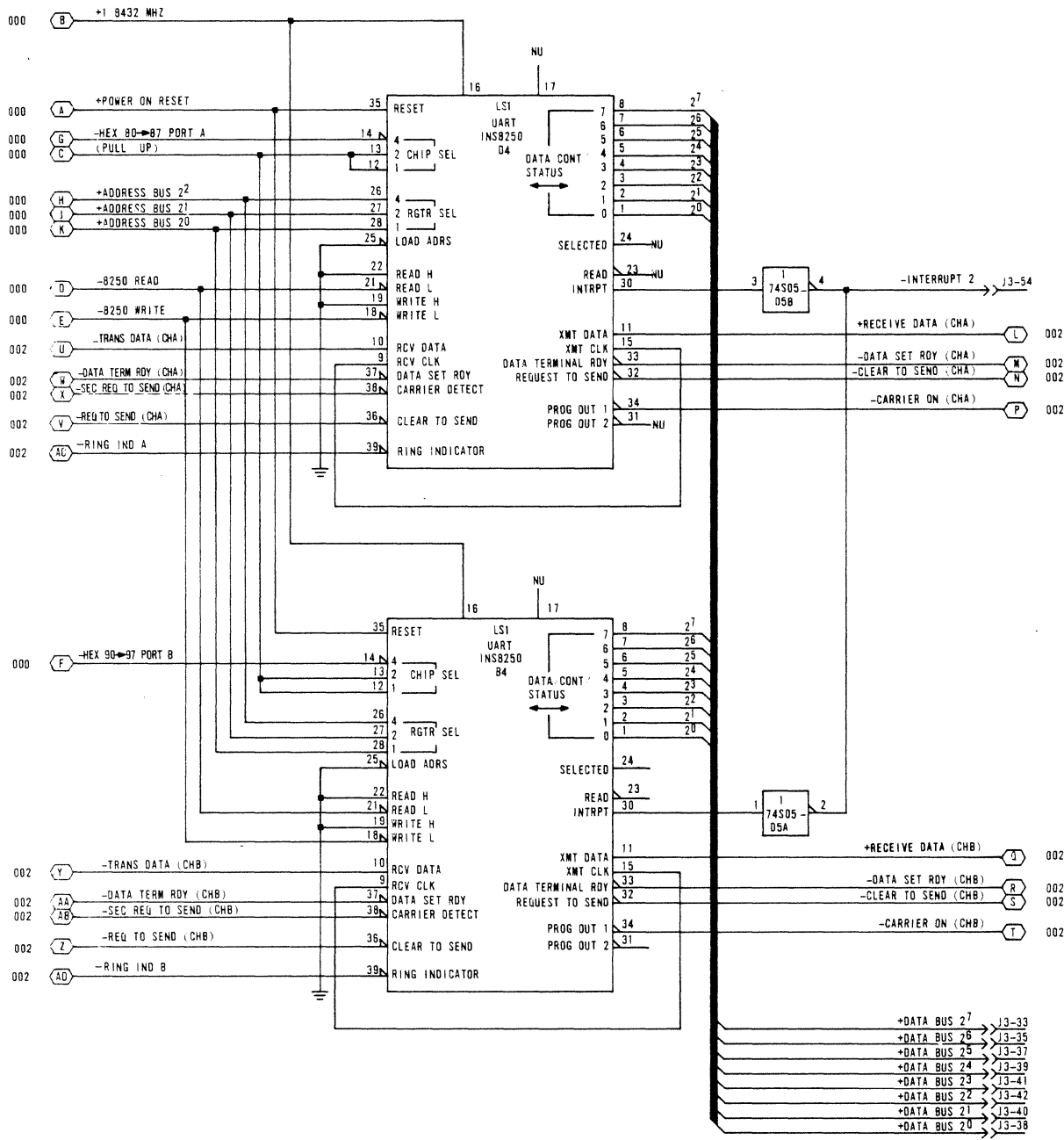

1
2
3
4

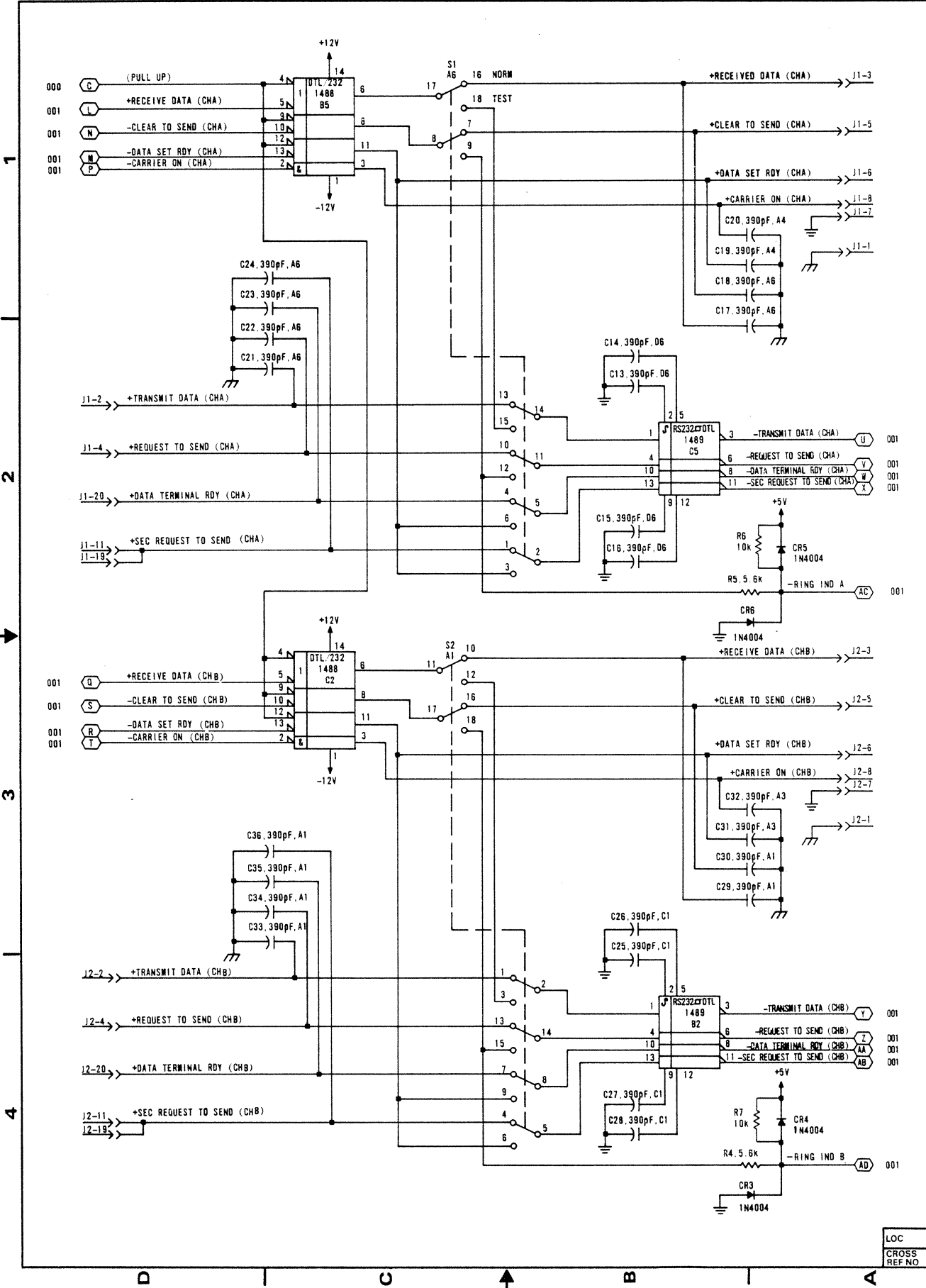

REV C
 DWG NO 90446333
 CODE IDENT 15920
 CROSS REF NO 002 SHEET 4
 SCHEMATIC DIAGRAM, IAW
 CONTROL DATA CORPORATION

LOC
 CROSS REF NO 002

62940037 B

1-69

4 3 2 1

SHEET REVISION STATUS				REVISION RECORD					
REV	CO	DESCRIPTION	DRFT	DATE	CHKD	APP			
3	2	1							
0000	04	00							
		5000 7-43							
0000	01	51990							
A	A	A							
A	A	A							
B	A	B							
		14232-66							
		15394							
		RELEASED CLASS B		1/5/82	EE				
		REVISED PER ECO		2/4/81	EE				
		RELEASED CLASS 'A'		4-5-82					
		CHP 74LS123 HAS 74123		1/2/82	EE				

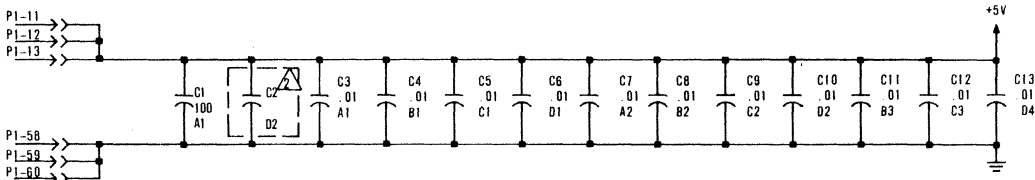

NOTE:
 1. UNLESS OTHERWISE SPECIFIED, POWER AND GROUND PINS OF INTEGRATED CKTS ARE AS LISTED BELOW.
 14 PIN INTEGRATED CKTS: PIN 14 = +5V, PIN 7 = GND
 16 PIN INTEGRATED CKTS: PIN 16 = +5V, PIN 8 = GND
 20 PIN INTEGRATED CKTS: PIN 20 = +5V, PIN 10 = GND
 2 OPTIONAL

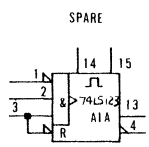

REFERENCE DRAWING		CONTROL DATA		TITLE	
DETAIL 90446383		FIRST USED ON YR 82-A		SCHEMATIC DIAGRAM, IBLD (PARALLEL INTERFACE)	
ASSY 90446384		DWN E. ERSEFELD 11/24/81		CODE IDENT 15920	
COMPONENTS, EXCEPT AS NOTED		CHKD [Signature] 11/2/82		DRAWING NO C 90446382	
RES TOLERANCE VALUE RATING		ENGR [Signature] 11/2/82		SCALE	
CAP 10% 100 pF 50V		MFG [Signature] 11/2/82		CROSS REF NO	
		APPR [Signature] 11/2/82		SHEET 1 OF 3	

1
2
3
4

REV A
DWG NO 90446382
CODE IDENT 15920
CROSS REF NO 000
SHEET 2

SCHEMATIC DIAGRAM, IBLD

GD

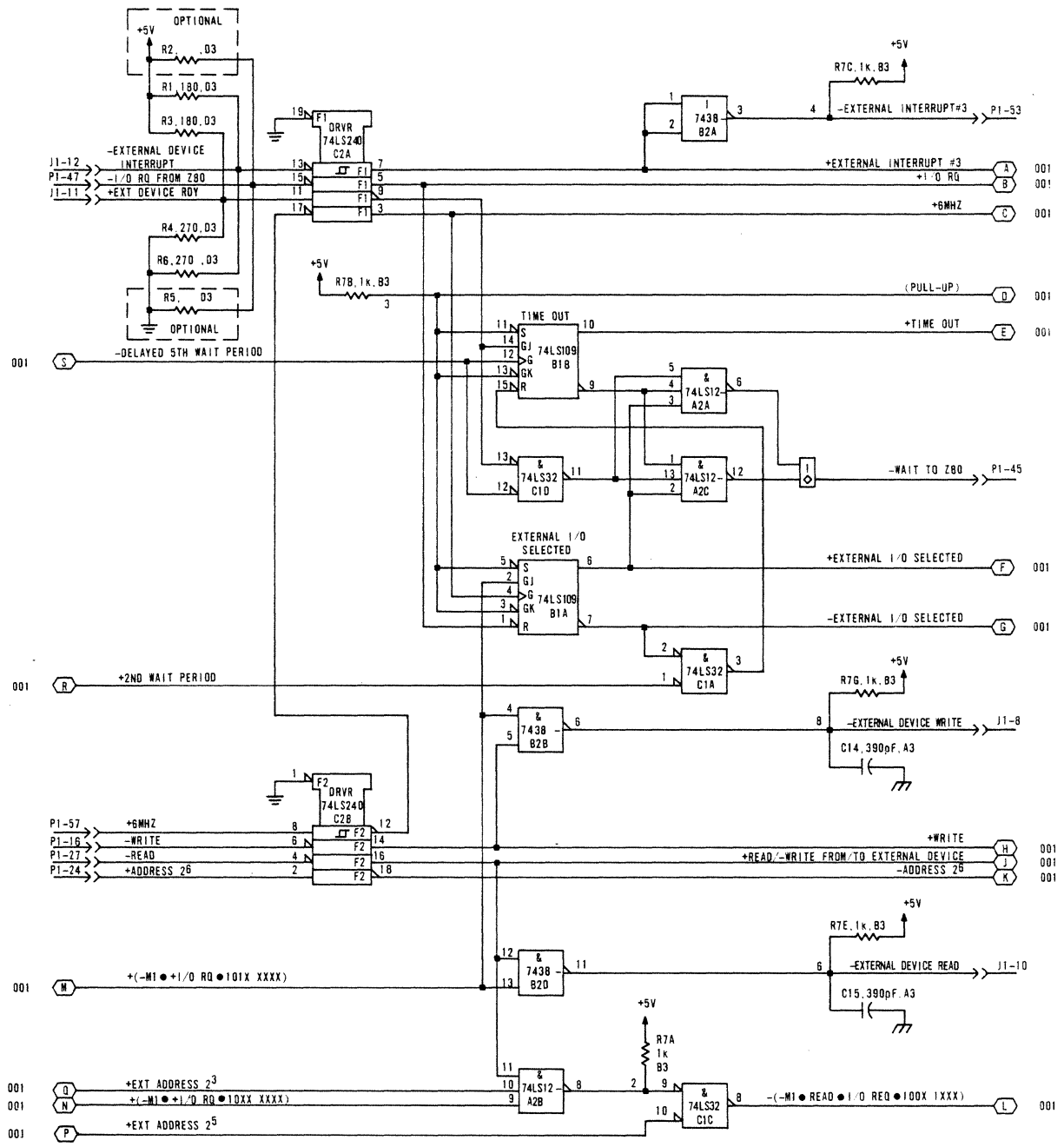

LOC	
CROSS REF NO	000

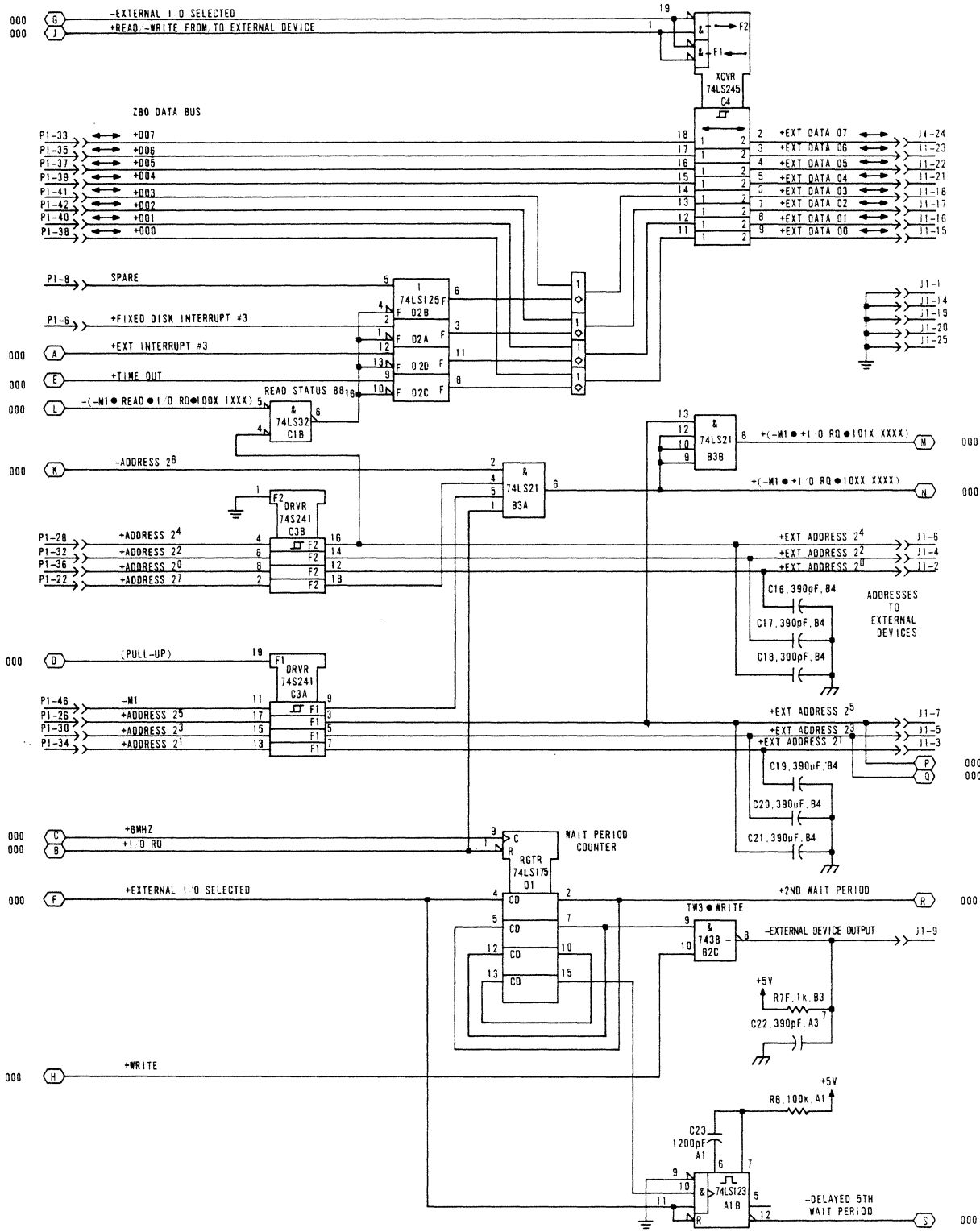

LOC	
CROSS REF NO	001

1-72

62940037 C

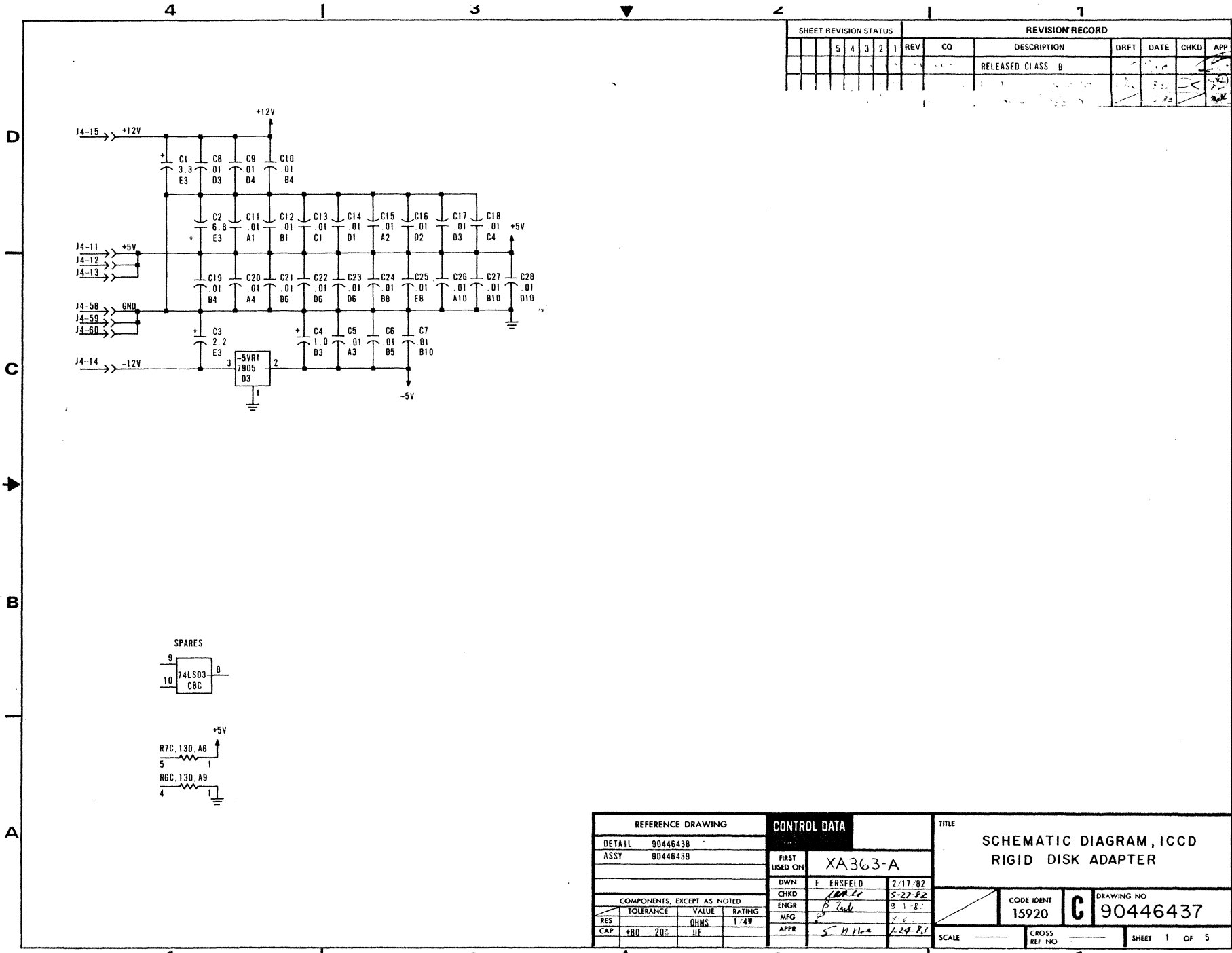

SHEET REVISION STATUS							REVISION RECORD				
REV	CO	DESCRIPTION	DRFT	DATE	CHKD	APP					
1		RELEASED CLASS B									

REFERENCE DRAWING		CONTROL DATA		TITLE	
DETAIL	90446438	FIRST USED ON		SCHEMATIC DIAGRAM, ICDD	
ASSY	90446439	XA363-A		RIGID DISK ADAPTER	
COMPONENTS, EXCEPT AS NOTED		DWN	E. ERSFELD	2/17/82	
TOLERANCE		CHKD	<i>MAE</i>	5-27-82	
RES	VALUE	ENGR	<i>B. Calk</i>	9-1-82	
CAP	RATING	MFG		P.E.	
		APPR	<i>S. H. Hwa</i>	1-24-82	
		SCALE		CROSS REF. NO.	
		SHEET 1 OF 5			

1
2
3
4

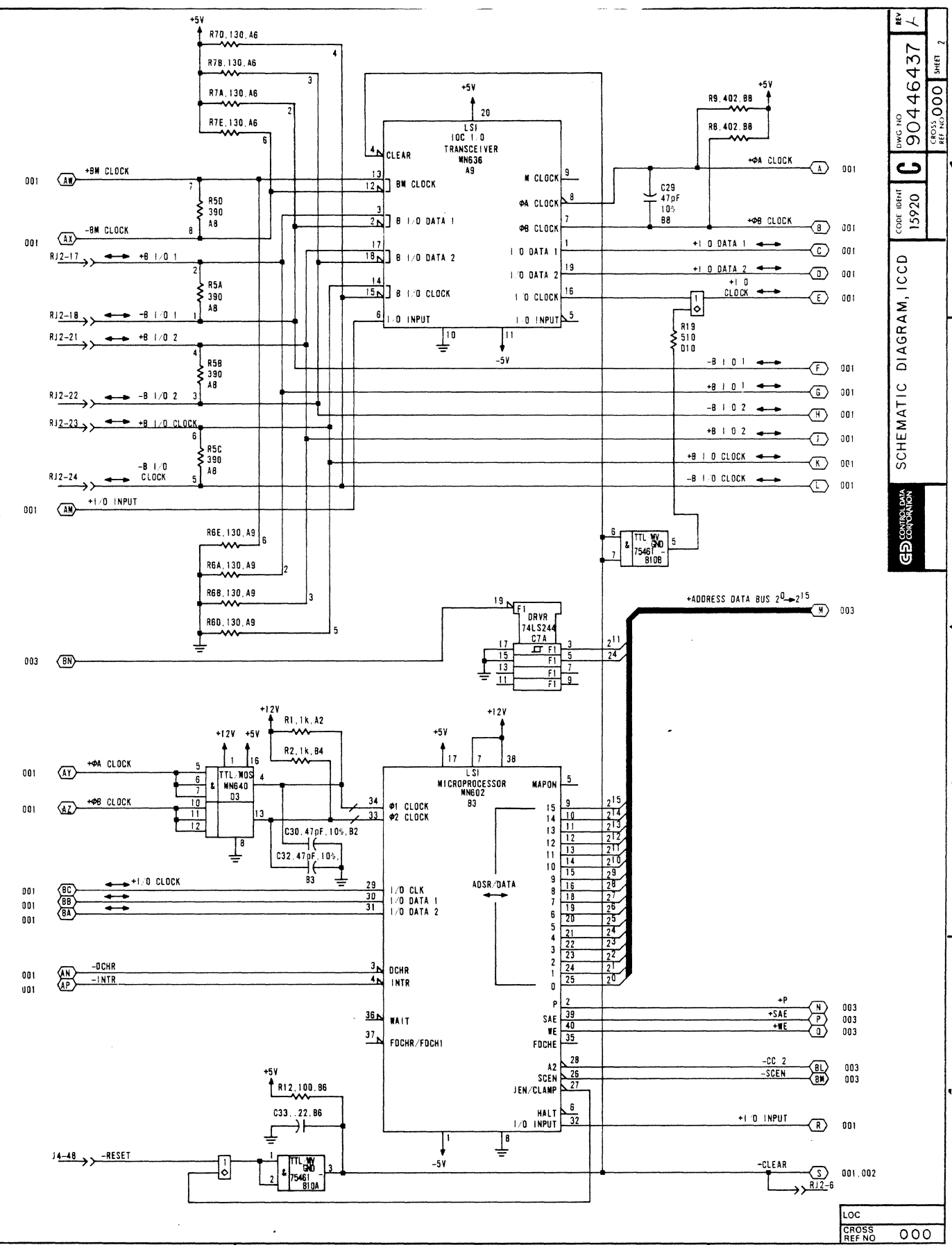

REV 1
DWG NO 90446437
CODE IDENT 15920
CROSS REF NO 000
SHEET 2
SCHEMATIC DIAGRAM, ICCD
CONTROL DATA CORPORATION

LOC
CROSS REF NO 000

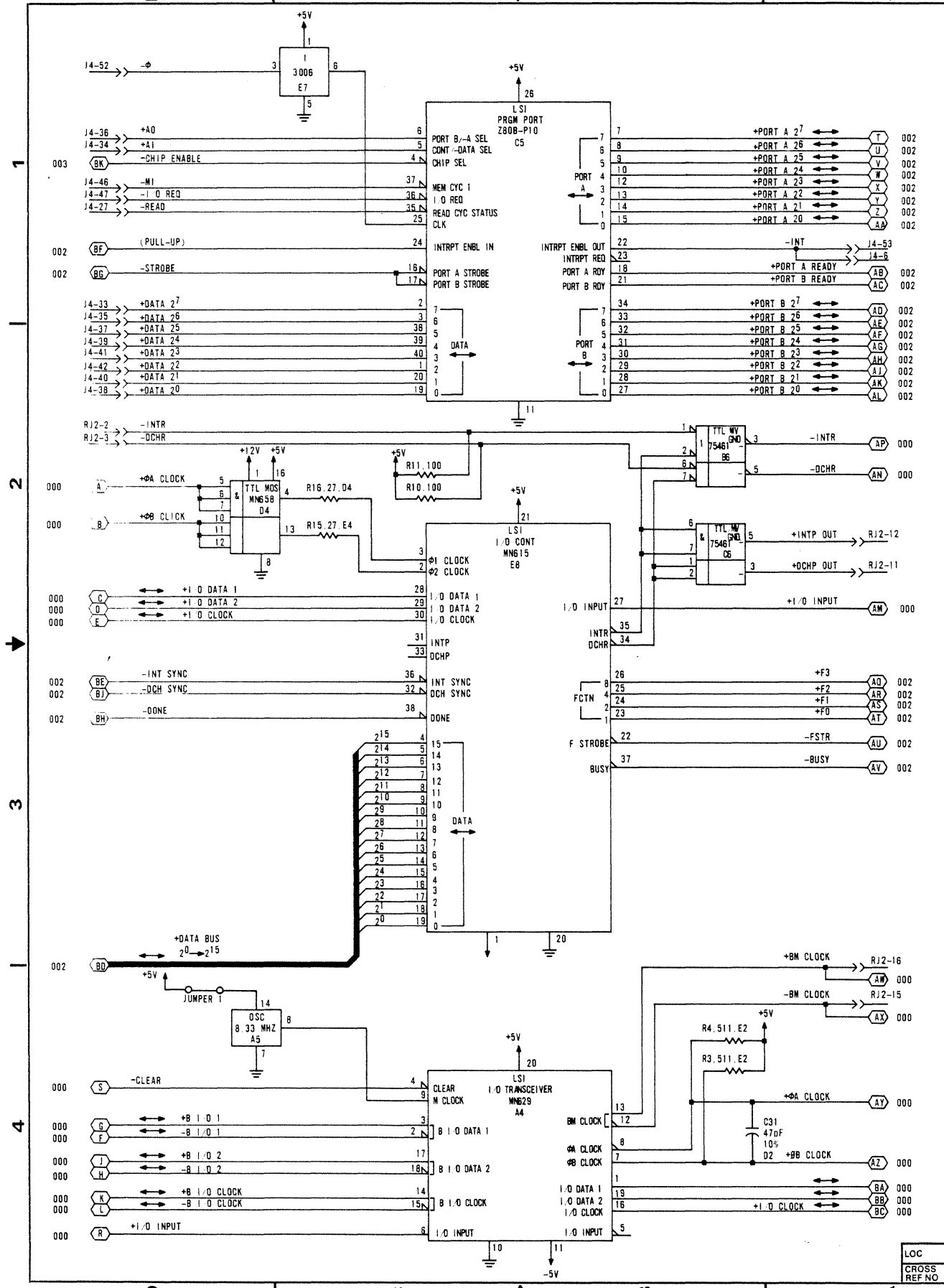

REV A
 HWG NO 90446437
 CODE IDENT 15920
 CROSS REF NO 001
 SHEET 3

CONTROL DATA CORPORATION
 SCHEMATIC DIAGRAM, ICCD

LOC
 CROSS REF NO 001

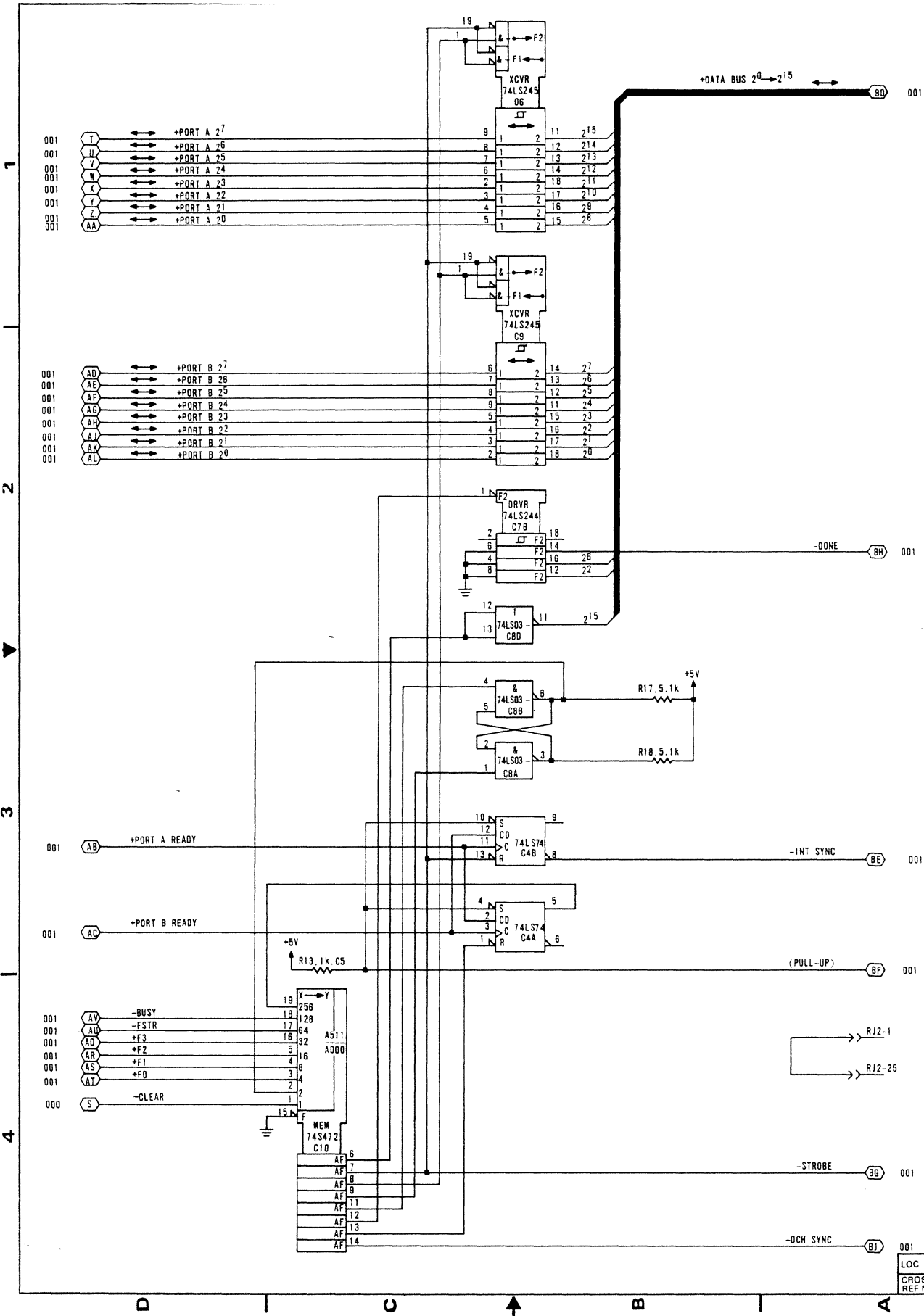

REV	1
DWG NO	90446437
CODE IDENT	C
15920	
CROSS REF NO	002
SHEET	4
SCHEMATIC DIAGRAM, IC CD	
CONTROL DATA CORPORATION	

LOC
CROSS REF NO 002

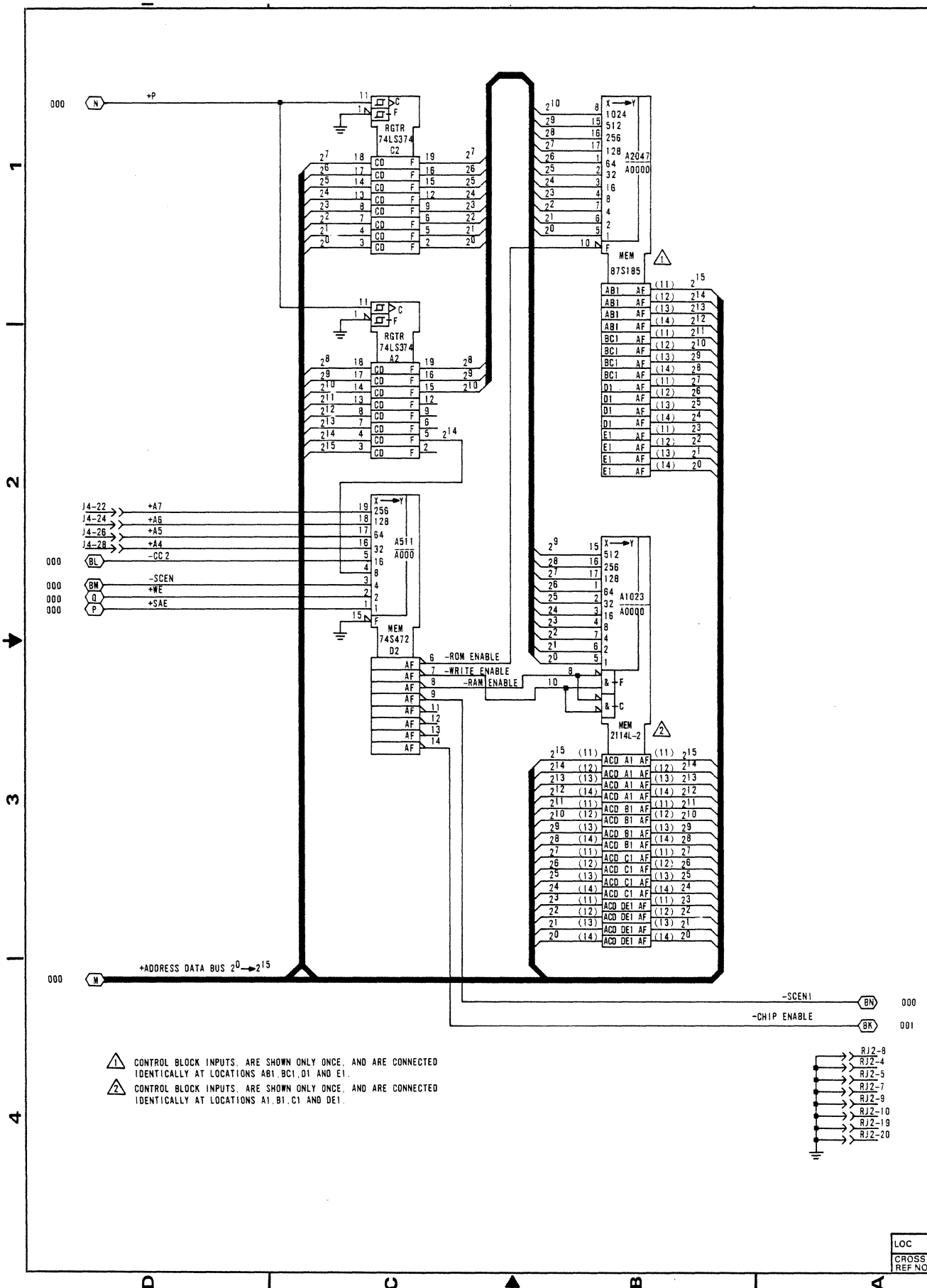

62940037 H

1-76.1

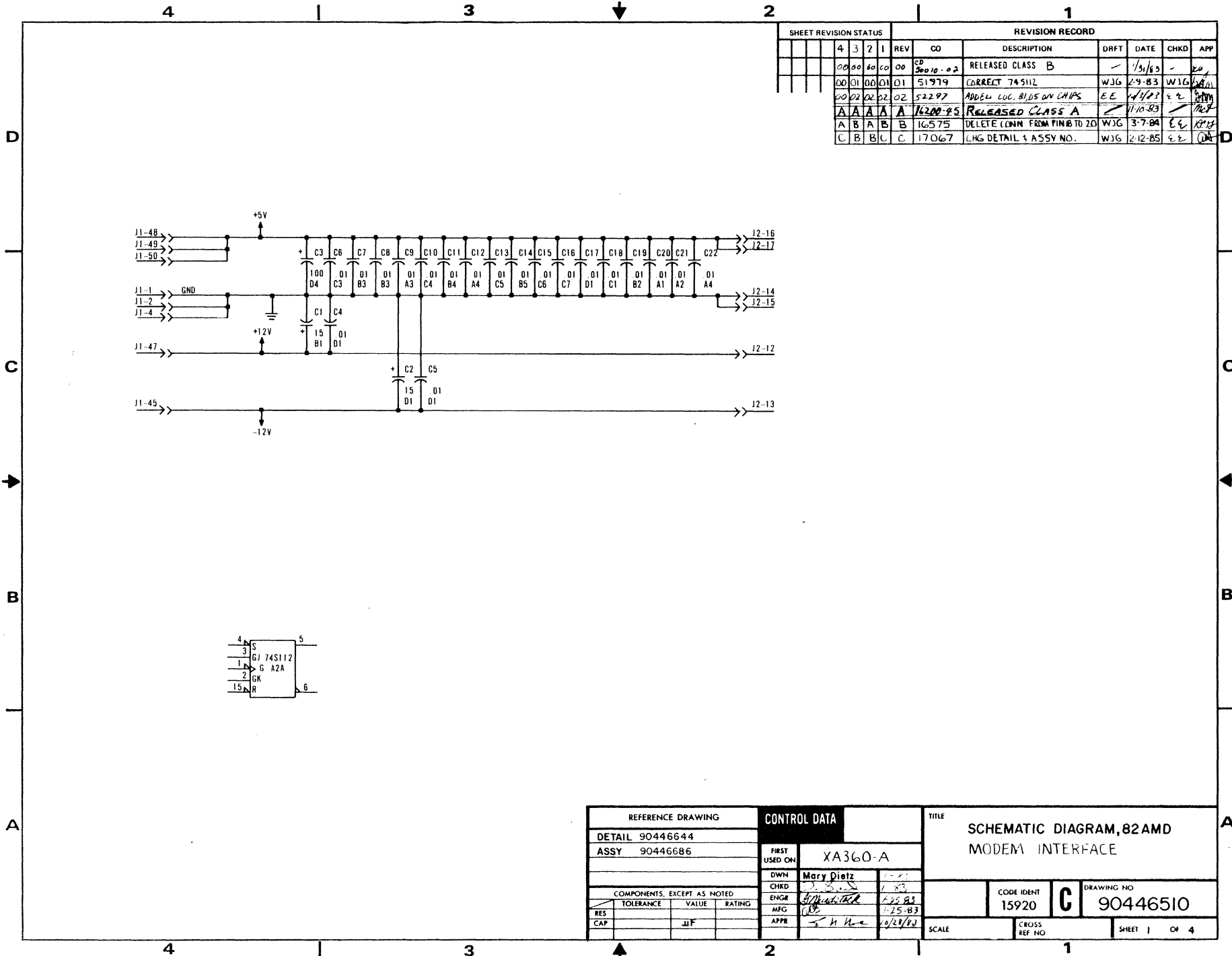

SHEET REVISION STATUS					REVISION RECORD				
REV	CO	DESCRIPTION	DRFT	DATE	CHKD	APP	REV	CO	DESCRIPTION
00	00	00	00	00	00	00	00	00	RELEASED CLASS B
00	01	00	01	01	51979	CORRECT 74S112	WJG	2-9-83	WJG
00	02	02	02	02	52297	ADDED LOC. B105 ON CHIPS	E.E.	11/10/83	E.E.
A	A	A	A	A	16200-95	RELEASED CLASS A			
A	B	A	B	B	16575	DELETE CONN FROM PIN 16 TO 20	WJG	3-7-84	E.E.
C	B	B	C	C	17067	CHG DETAIL & ASSY NO.	WJG	2-12-85	E.E.

REFERENCE DRAWING		CONTROL DATA		TITLE	
DETAIL 90446644		FIRST USED ON		SCHEMATIC DIAGRAM, 82AMD	
ASSY 90446686		XA360-A		MODEM INTERFACE	
COMPONENTS, EXCEPT AS NOTED		DWN		CODE IDENT	
TOLERANCE		CHKD		15920	
VALUE		MGR		DRAWING NO	
RATING		APPR		C 90446510	
RES		Mary Dietz		SCALE	
CAP	J1F	1-25-83		CROSS REF NO	
		1-25-83		SHEET 1 OF 4	
		10/27/82			

1

2

3

4

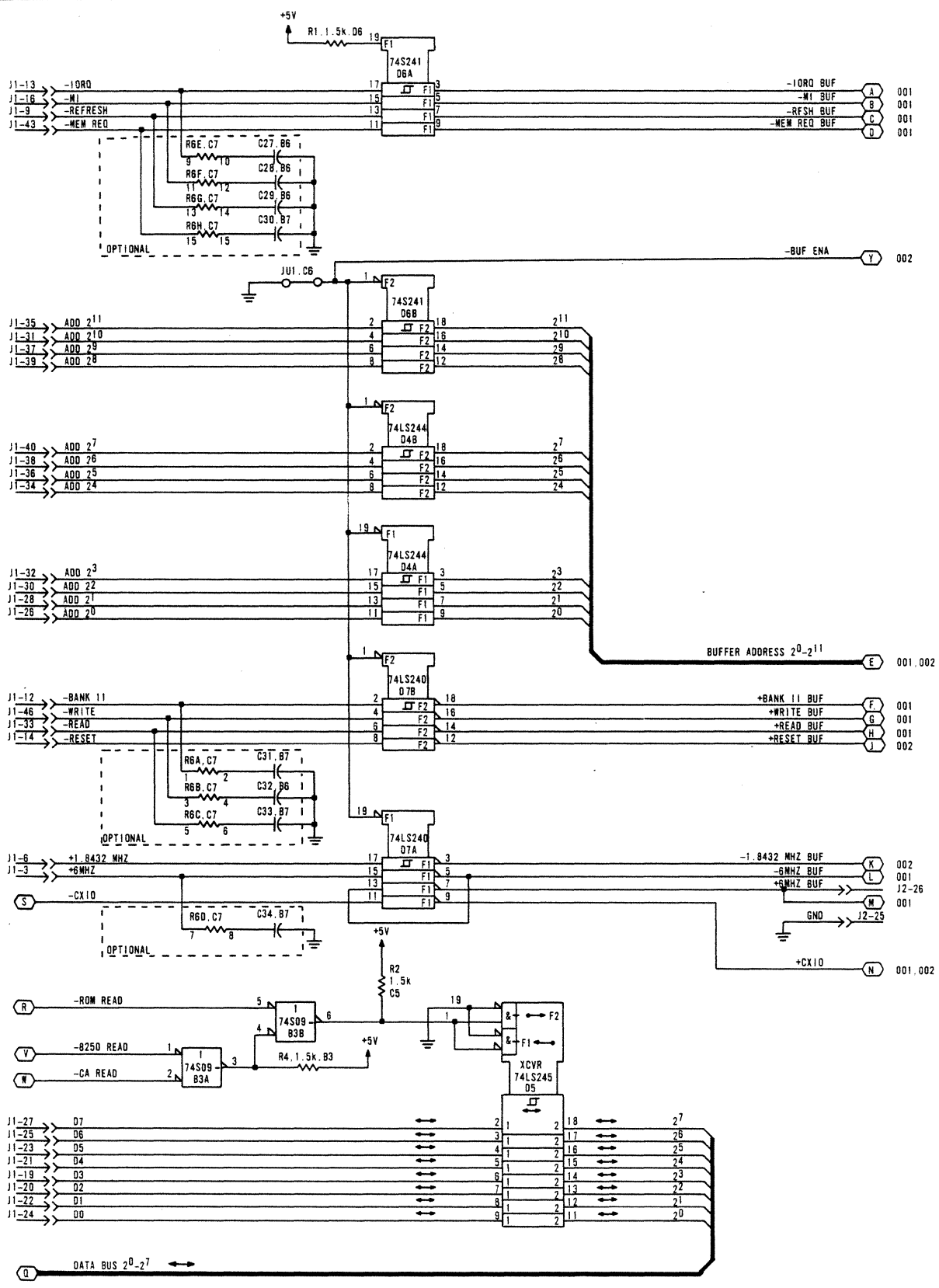

REV	A
DWG NO	90446510
CODE IDENT	C
	15920
CROSS REF NO	000
SHEET	2

SCHEMATIC DIAGRAM, 82AMD

GE CORPORATION

LOC	
CROSS REF NO	000

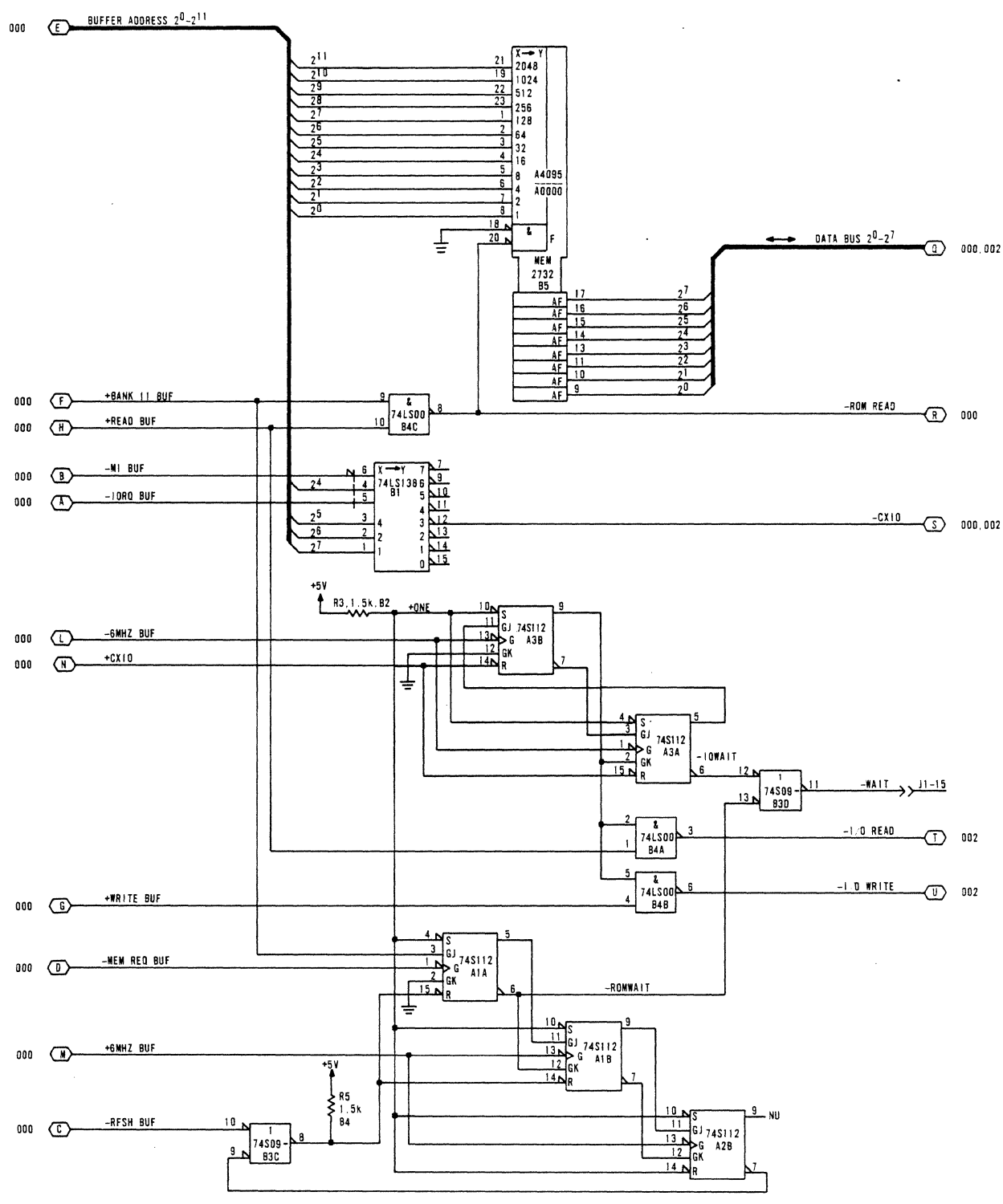

LOC
CROSS REF NO 001

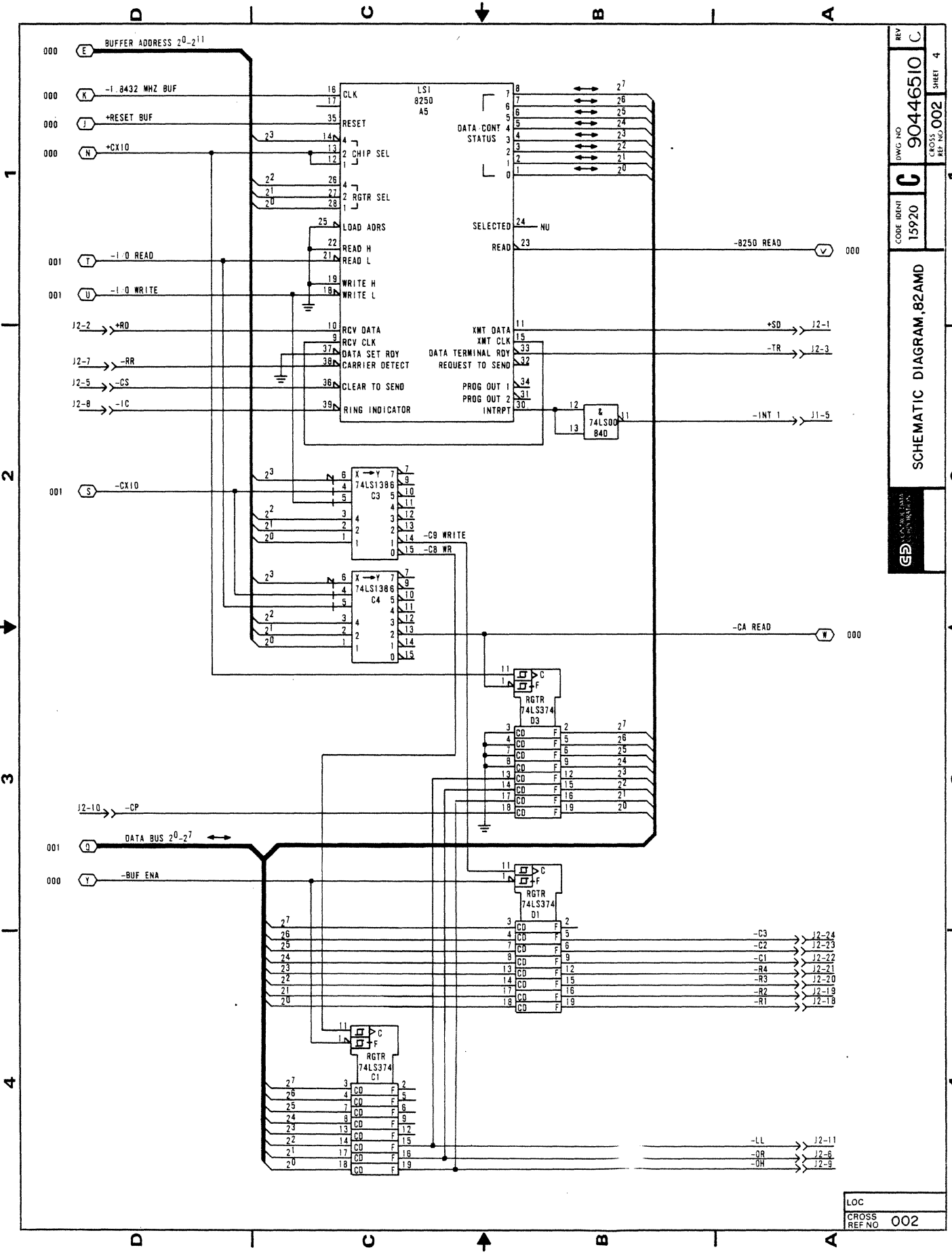

REV C
 DWG NO 90446510
 CODE IDENT 15920
 CROSS REF NO 002
 SHEET 4

SCHEMATIC DIAGRAM, 82AMD

LOC
 CROSS REF NO 002

62940037

1-77

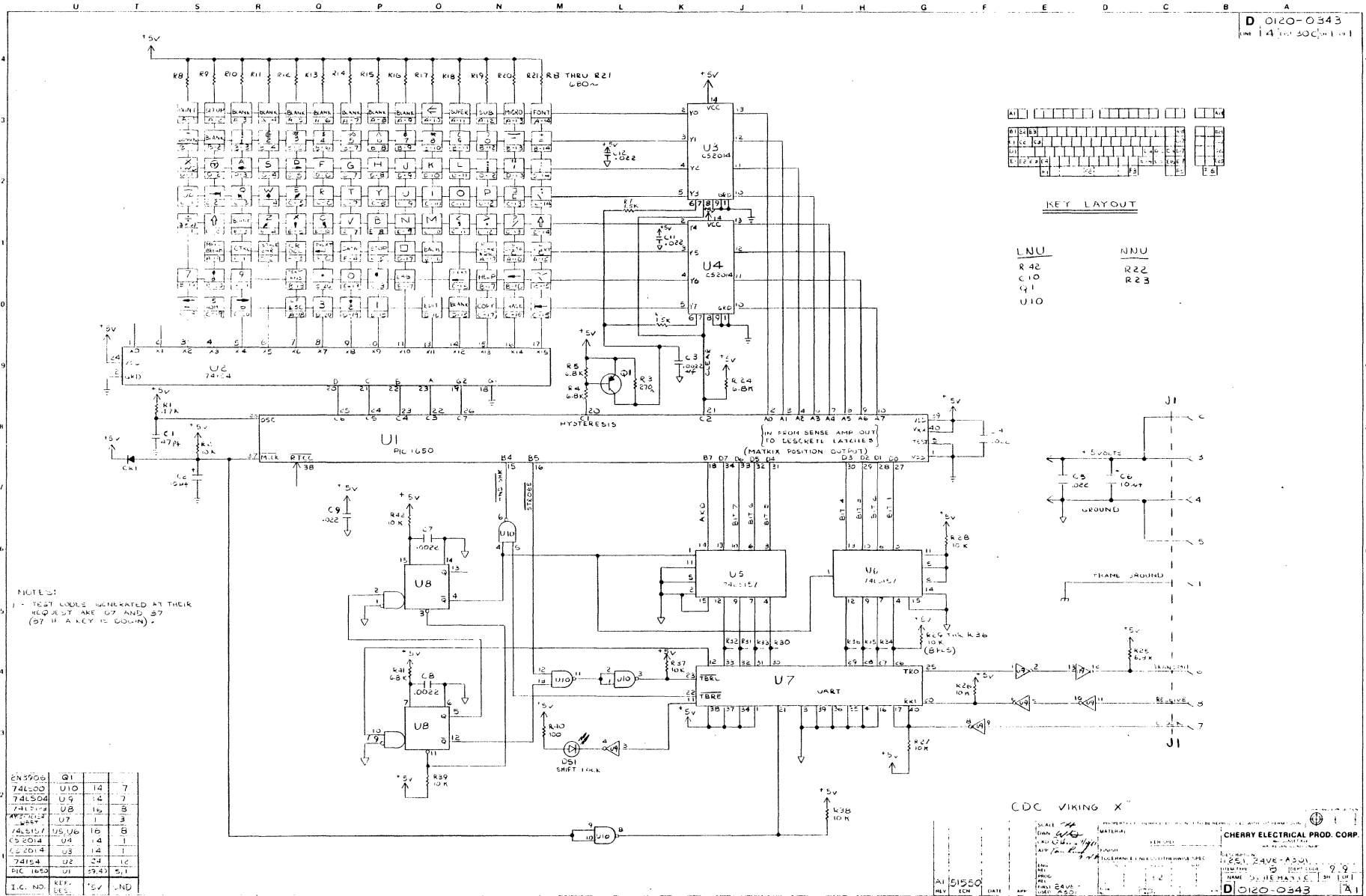

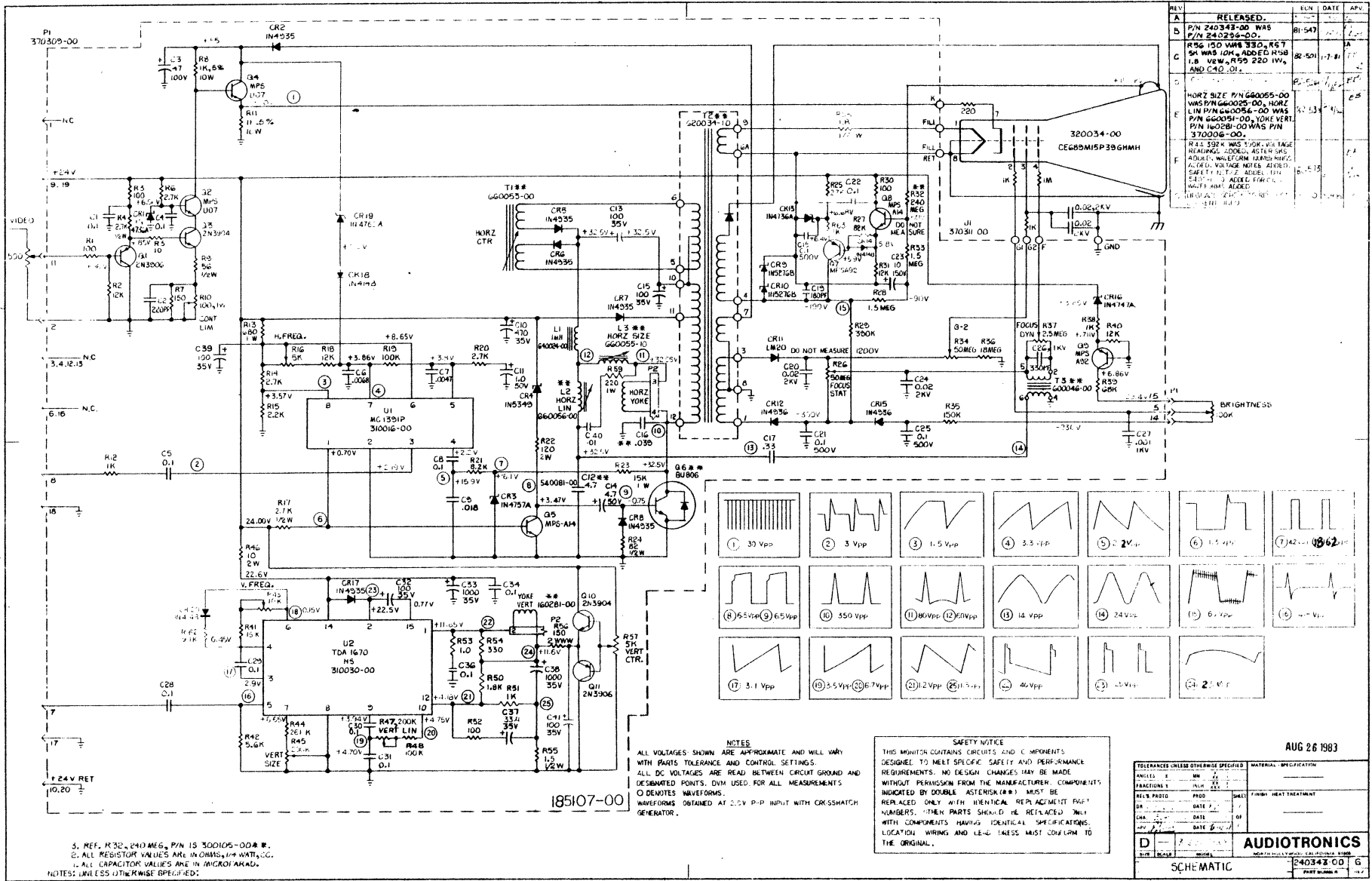

REV	RELEASED	REV	DATE	APP
A	P/N 240343-00 WAS P/N 240296-00.	81	5-77	JA
B	R56 150 OHMS 500V, R57 50 OHMS 10K, R58 220 OHMS 1/2W, R59 220 OHMS 1/2W AND C42, O.I.	82	10-77	JA
C	HORIZ SIZE P/N 660055-00 WAS P/N 660056-00, HORIZ LIN P/N 660056-00 WAS P/N 660054-00, VOLT VERT. P/N 100281-00 WAS P/N 370006-00.	82	10-77	JA
D	R44 39K WAS 500K, VOLTAGE REGULATOR CODES, 4510 WAS ADDED, WAVEFORM 18 AND 19 CHANGED, VOLTAGE NOISE ADDED, SAFETY H.T.P. 2, ADDED, P/N 370006-00 ADDED.	82	10-77	JA

AUG 26 1983

TOLERANCES UNLESS OTHERWISE SPECIFIED	MATERIAL SPECIFICATION
ANGLES 1/2	MM 20
FRACTIONS 1/2	INCH 20
REL'S PROJ	PROD
DATE	DATE
DR	DATE
CHKD	DATE
APP'D	DATE

AUDITRONICS
 MADE IN U.S.A.
 SCHEMATIC P/N 240343-00 G

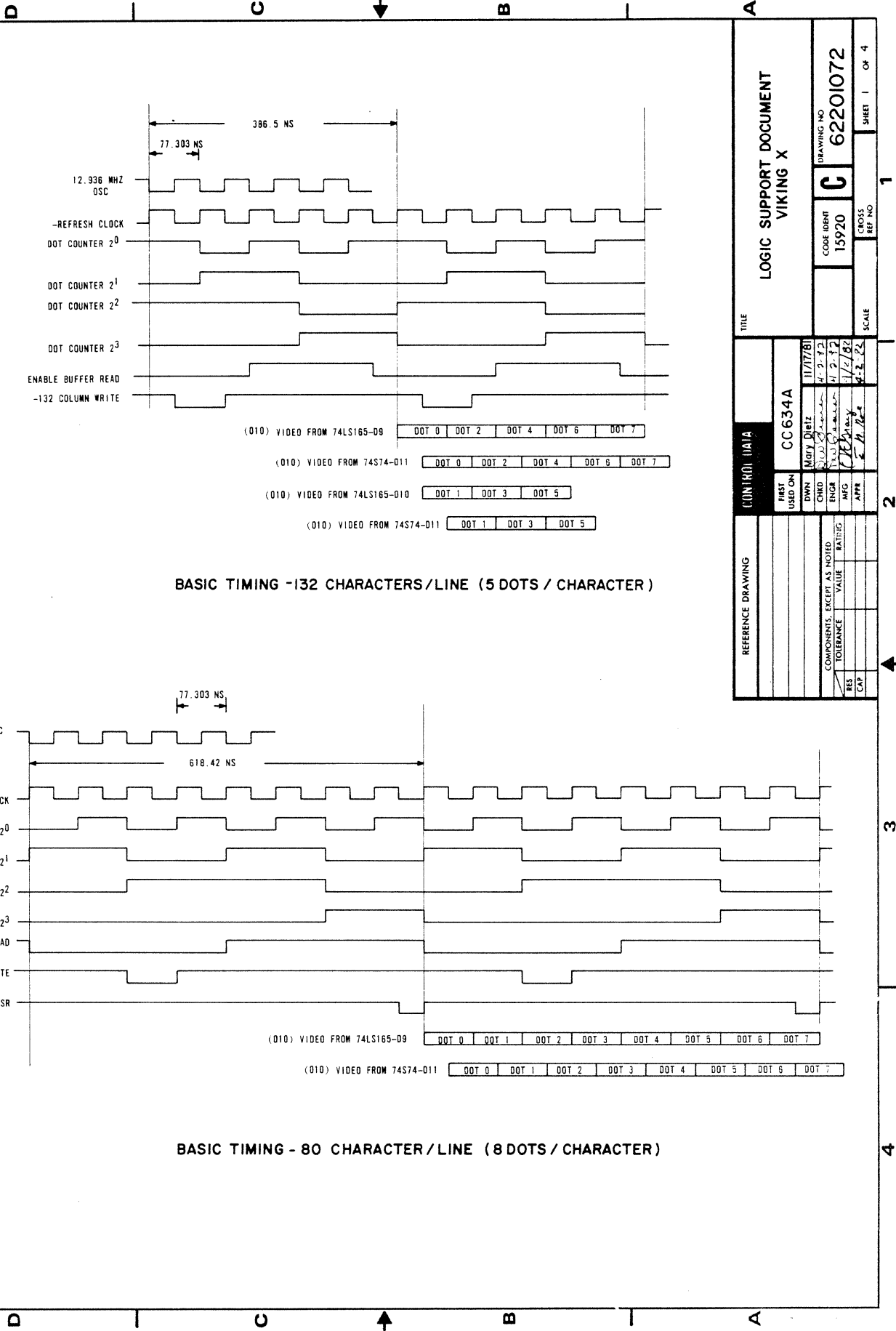

REVISION RECORD			
REV	CO	DATE	CHKD APP
1	1	4-2-82	
RELEASED CLASS X			

SHEET REVISION STATUS	
REV	DATE

REFERENCE DRAWING			
CONTR	DATE	REV	APP
CC 634A	11/17/81		
DRN	Marty Dietz	4-2-82	
CHKD	...	4-2-82	
ENGR	...	4-2-82	
WFO	...	4-2-82	
APP	...	4-2-82	

TITLE
LOGIC SUPPORT DOCUMENT
VIKING X

DRAWING NO 62201072	SHEET 1 OF 4
CODE INST 15920	CROSS REF NO
SCALE	

D C B A

REV	A
DWG NO	62201072
CROSS REF NO	SHEET 2
CODE INHIT	C
15920	
TIMING DIAGRAM	
CONTROL DATA CONVENTION	

1

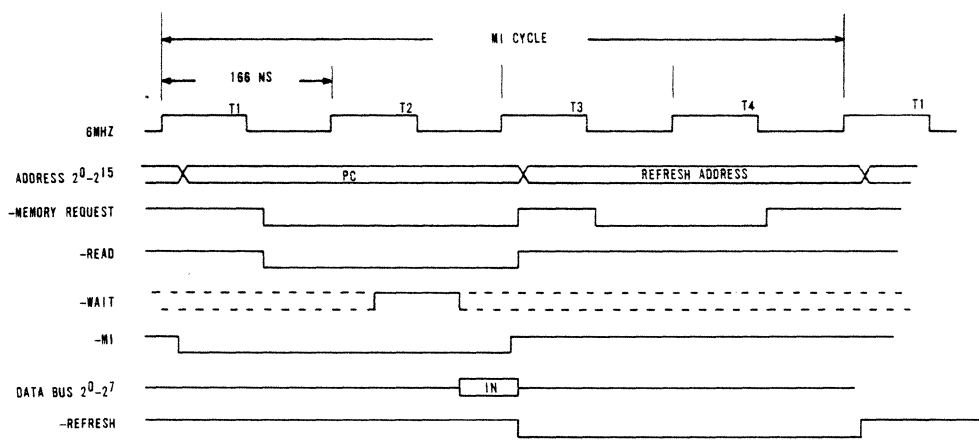

Z80B INSTRUCTION OP CODE FETCH TIMING -WITH NO WAIT STATES

2

3

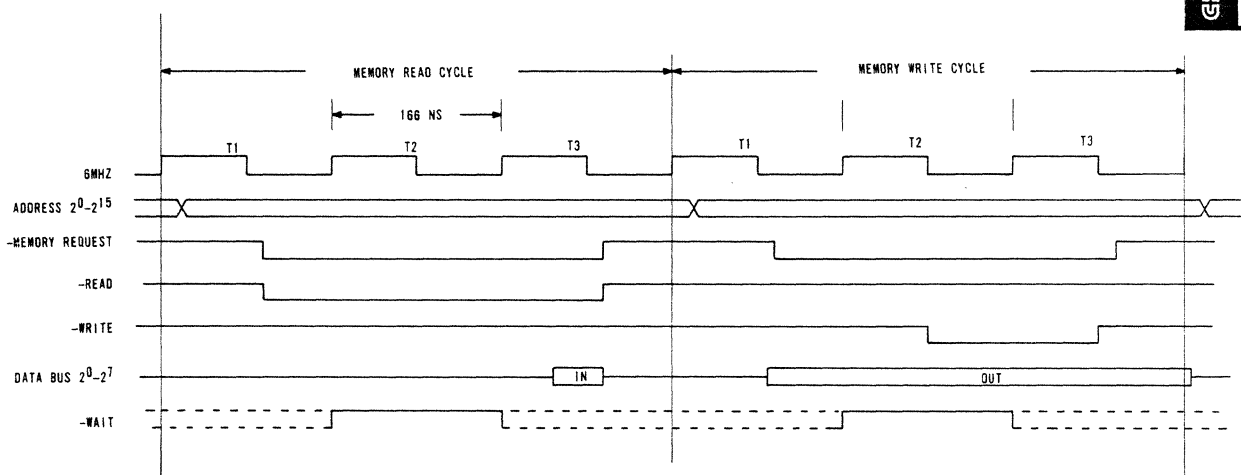

NOTE: IF WAIT STATE NEEDED, CPU SAMPLES WAIT LINE DURING T2. IF LOW, IT INSERTS A WAIT STATE BETWEEN T2 AND T3. DURING THAT WAIT STATE IT SAMPLES THE WAIT LINE AGAIN FOR ADDITIONAL WAIT STATUS.

Z80B MEMORY READ OR WRITE TIMING -WITH NO WAIT STATES

4

D C B A

LOC

CROSS REF NO

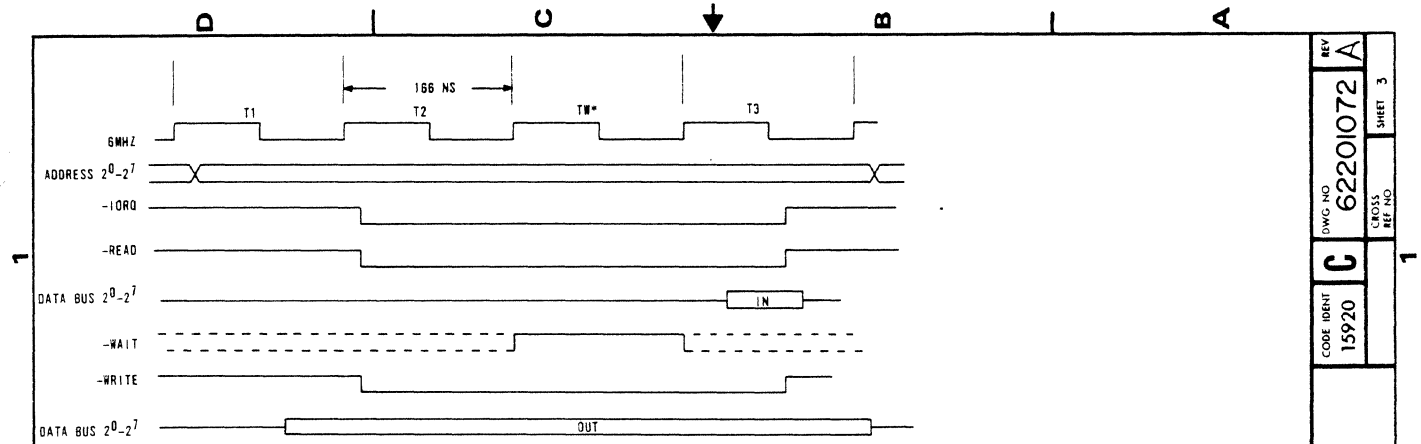

* SINGLE WAIT STATE INSERTED AUTOMATICALLY BY CPU
WAIT LINE IS SAMPLED DURING THE WAIT STATE FOR
ADDITIONAL WAIT STATES

Z80B INPUT OR OUTPUT TIMING

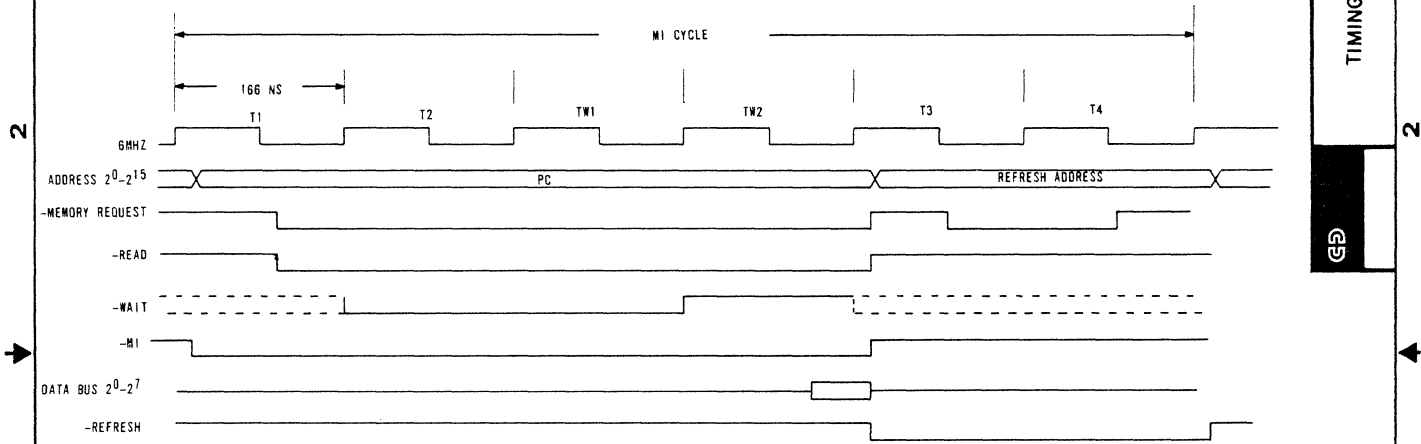

Z80B INSTRUCTION OR CODE FETCH TIMING - WITH 2 WAIT STATES

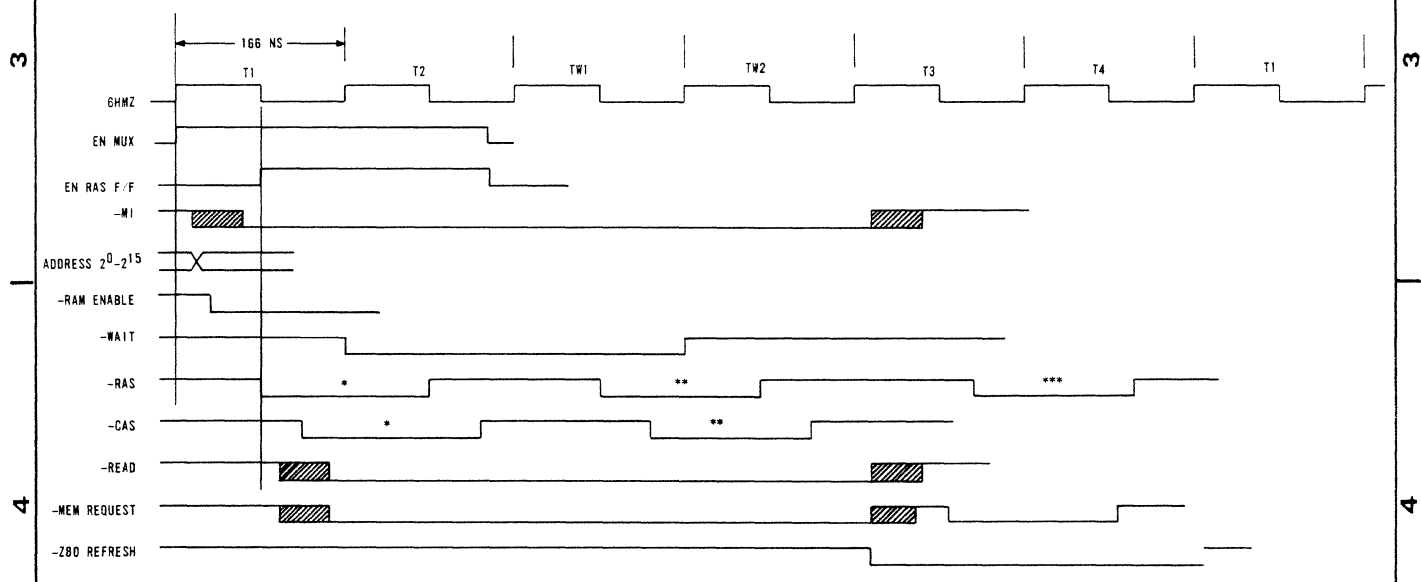

* MEMORY CYCLE TO READ CHARACTER FOR LINE BUFFER.
** INSTRUCTION FETCH MEMORY CYCLE FROM PROCESSOR.
*** Z80 RAS ONLY REFRESH CYCLE - ONLY OCCURS IF LINE BUFFERS ARE FULL.

DYNAMIC RAM MEMORY TIMING

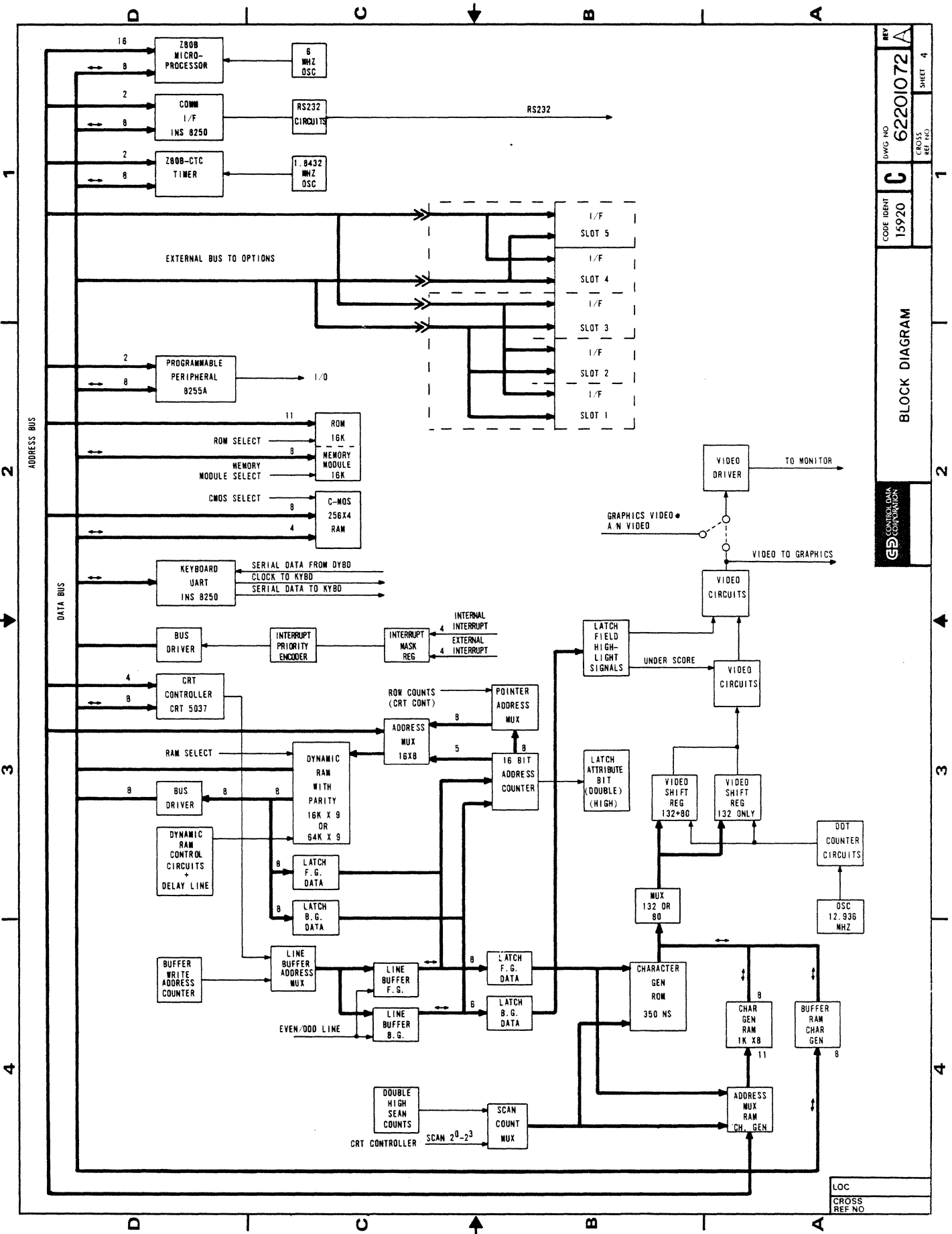

REV	62201072 A	SHEET	4
DWG NO	C	CROSS REF NO	
CODE IDENT	15920		
BLOCK DIAGRAM			
CONTROL DATA CORPORATION			

This section provides a parts breakdown of the display terminals. Included are genealogy charts, assembly drawings with associated parts lists, and cross-reference lists of vendor part numbers and CDC part numbers.

Table 2-1 explains the column headings for the computer-generated parts lists.

TABLE 2-1. EXPLANATION OF COLUMN HEADINGS OF COMPUTER-GENERATED ASSEMBLY PARTS LISTS

COLUMN HEADING	EXPLANATION
FIND NO.	Identifies an electrical or mechanical part on an assembly drawing. If more than one listing appears for a find number, refer to LI, WK IN, and WK OUT.
LI (Line Item)	Gives a chronological or historical record of the addition of a new part to a find number. For example, 01 indicates that the part was the first one used, and 02 indicates the second, etc. See also WK IN and WK OUT.
PART NUMBER	Gives the Control Data Corporation part identification. Use this number when ordering replacements.
CD (Check Digit)	Gives the information-control system a means of cross-checking the correctness of a part number.
QUANTITY	Lists the total number of a part required to complete an assembly. The vertical line near the center of the column acts as a decimal point. Numbers to the left of the line are whole numbers. Those to the right of the line are tenths, hundredths, and thousandths.
U/M (Unit of Measure)	Indicates how the information-control system counts or supplies a part.
PART DESCRIPTION	Describes the physical appearance, type, or name of a part.
MC (Material Code)	Supplies additional descriptive data to the information-control system.
YLD (Yield)	A 2-digit number that indicates the usable portion of any quantity of parts expressed as a percentage.
ECO NO. IN	Engineering Change Order that adds a new part to an assembly. See also WK IN.
ECO NO. OUT	Engineering Change Order that deletes a part from an assembly. See also WK OUT.
S/N (Serial Number)	Used to specify an ECO's effectivity by serial number.
WK IN (Week In)	Lists the date when manufacturing begins using a new part and when it is available for parts replacement. For example, 7222 means a part is available of the 22nd week of 1972.
WK OUT (Week Out)	Lists the date when manufacturing no longer uses a part in building an assembly. See also WK IN. Do not order a part after its week-out date.

0643-2A

2-2

62940037 L

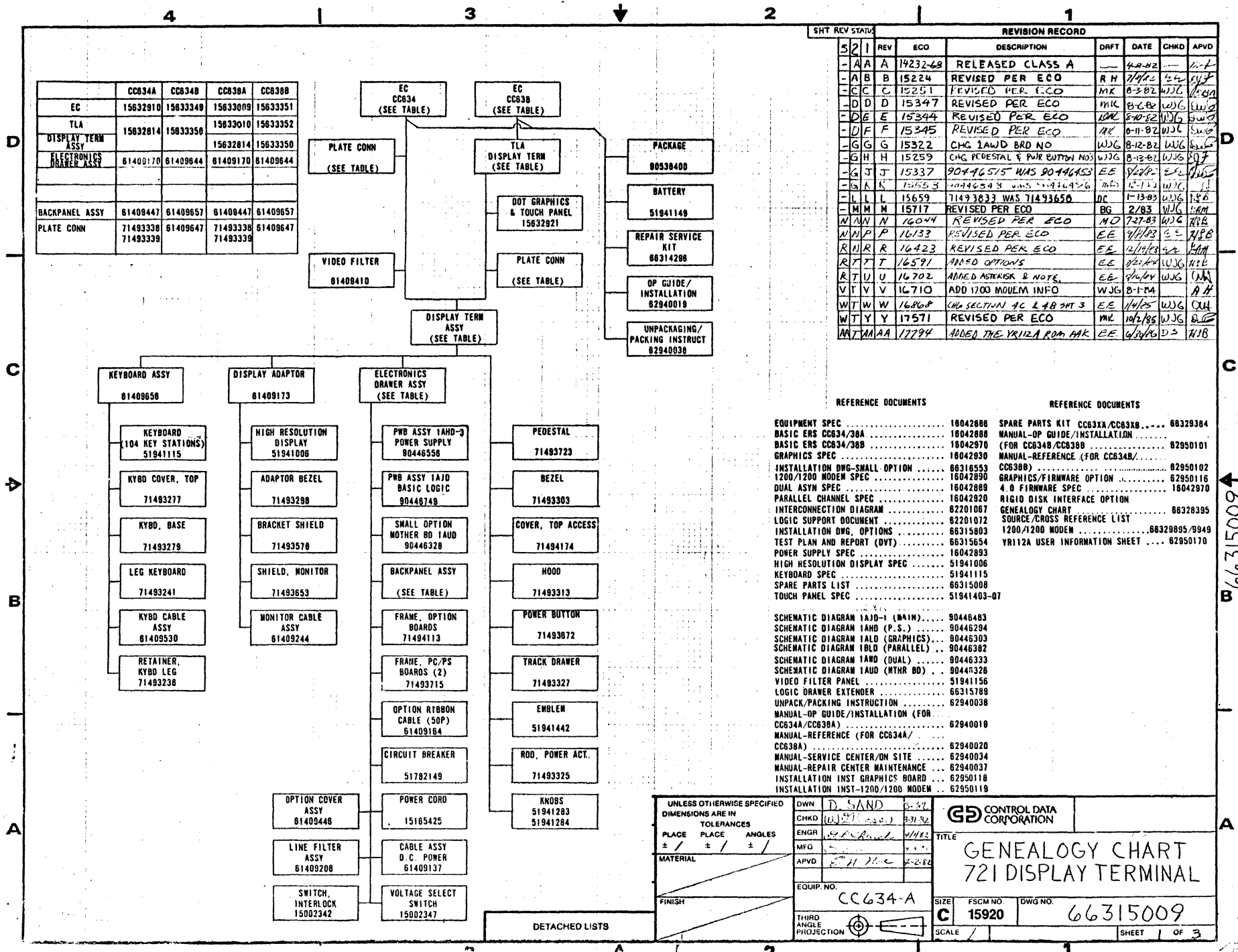

SHT REV STATUS		REVISION RECORD					
REV	ECO	DESCRIPTION	DRAFT	DATE	CHKD	APVD	
-AA	A	RELEASED CLASS A	RH	4-2-82			
-AB	B	REVISED PER ECO	RH	7/1/82			
-CC	C	REVISED PER ECO	MK	8-3-82			
-DD	D	REVISED PER ECO	MK	8-2-82			
-DE	E	REVISED PER ECO	MK	8-10-82			
-DF	F	REVISED PER ECO	MK	8-11-82			
-GG	G	CHG LAWD BRD NO	WJG	8-12-82			
-GH	H	CHG PEDESTAL & PKR BUTTON NOS	WJG	8-13-82			
-GJ	J	90446575 WAS 90446453	EE	8/22/82			
-GN	K	90446543 WAS 90446456	EE	12-13-82			
-LLL	L	71493833 WAS 71493650	DC	1-13-83			
-MM	M	REVISED PER ECO	BG	2-28-83			
-NN	N	REVISED PER ECO	MD	7-27-83			
-NNP	P	REVISED PER ECO	EE	9/10/83			
-NNR	R	REVISED PER ECO	EE	12/14/83			
-RTT	T	ADD OPTIONS	EE	2-2-84			
-RTU	U	ADDED ASTERISK & NOTE	EE	2/16/84			
-VTY	V	ADD 1200 MODEM INFO	WJG	8-1-84			
-WTW	W	CHG SECTION AC 2 & 3	EE	1/1/85			
-WTY	Y	REVISED PER ECO	MK	10/9/85			
-AAA	AAA	ADDED THE YRIZA ROM PK	EE	6/20/86			

REFERENCE DOCUMENTS

EQUIPMENT SPEC	18042888	SPARE PARTS KIT C634A/CC638B	66328384
BASIC ERS C634/38A	18042888	MANUAL-OP GUIDE/INSTALLATION	
BASIC ERS C634/38B	18042970	(FOR C634B/CC638B)	62950101
GRAPHICS SPEC	18042830	MANUAL-REFERENCE (FOR C634B/CC638B)	62950102
INSTALLATION DWG-SMALL OPTION	66316553	GRAPHICS/FIRMWARE OPTION	62950116
1200/1200 MODEM SPEC	16042890	4.0 FIRMWARE SPEC	16042970
DUAL ASYN SPEC	16042889	RIGID DISK INTERFACE OPTION	
PARALLEL CHANNEL SPEC	16042920	GENEALOGY CHART	66328395
INTERCONNECTION DIAGRAM	62201067	SOURCE/CROSS REFERENCE LIST	
LOGIC SUPPORT DOCUMENT	62201072	1200/1200 MODEM	66328895/9949
INSTALLATION DWG, OPTIONS	66315803	YR112A USER INFORMATION SHEET	62950170
TEST PLAN AND REPORT (DVT)	66315654		
POWER SUPPLY SPEC	16042893		
HIGH RESOLUTION DISPLAY SPEC	51941006		
KEYBOARD SPEC	51941115		
SPARE PARTS LIST	66315008		
TOUCH PANEL SPEC	51941403-07		
SCHMATIC DIAGRAM 1A1D-1 (MAIN)	90446483		
SCHMATIC DIAGRAM 1AHD (P.S.)	90446294		
SCHMATIC DIAGRAM 1ALD (GRAPHICS)	90446303		
SCHMATIC DIAGRAM 1BLD (PARALLEL)	90446382		
SCHMATIC DIAGRAM 1AWD (DUAL)	90446333		
SCHMATIC DIAGRAM 1AUD (MTHR BD)	90446326		
VIDEO FILTER PANEL	51941156		
LOGIC DRAWER EXTENDER	66315789		
UNPACK/PACKING INSTRUCTION	62940038		
MANUAL-OP GUIDE/INSTALLATION (FOR C634A/CC638A)	62940019		
MANUAL-REFERENCE (FOR C634A/CC638A)	62940020		
MANUAL-SERVICE CENTER/DM SITE	62940034		
MANUAL-REPAIR CENTER MAINTENANCE	62940037		
INSTALLATION INST GRAPHICS BOARD	62950118		
INSTALLATION INST-1200/1200 MODEM	62950119		

UNLESS OTHERWISE SPECIFIED DIMENSIONS ARE IN TOLERANCES	DWN D. SAND 6-87	CONTROL DATA CORPORATION
ENGR (U.S.T.) 3-31-82		
PLACE PLACE ANGLES	MFD (S.T. RICH) 4/1/82	TITLE GENEALOGY CHART 721 DISPLAY TERMINAL
MATERIAL	APVD (S.T. RICH) 4-2-82	
FINISH	EQUIP. NO. CC634-A	SIZE C
	THIRD ANGLE PROJECTION	FSCM NO. 15920
		DWG. NO. 66315009
		SHEET 1 of 3

DETACHED LISTS

66315009

4 3 2 1

OPTIONS INSTALLED BY SERVICE CENTER ONLY

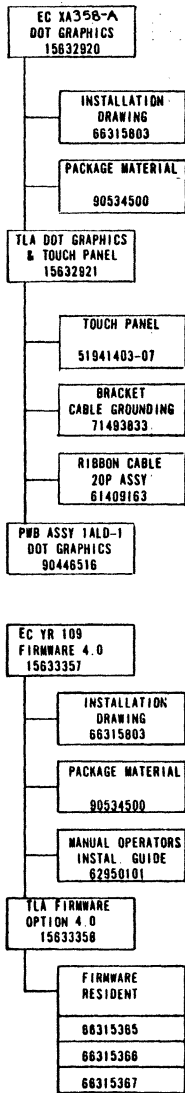

FACTORY INSTALLED
IN C66348/388

REVISION RECORD						
REV	ECO	DESCRIPTION	DRFT	DATE	CHKD	APVD

FIELD INSTALLED OPTIONS

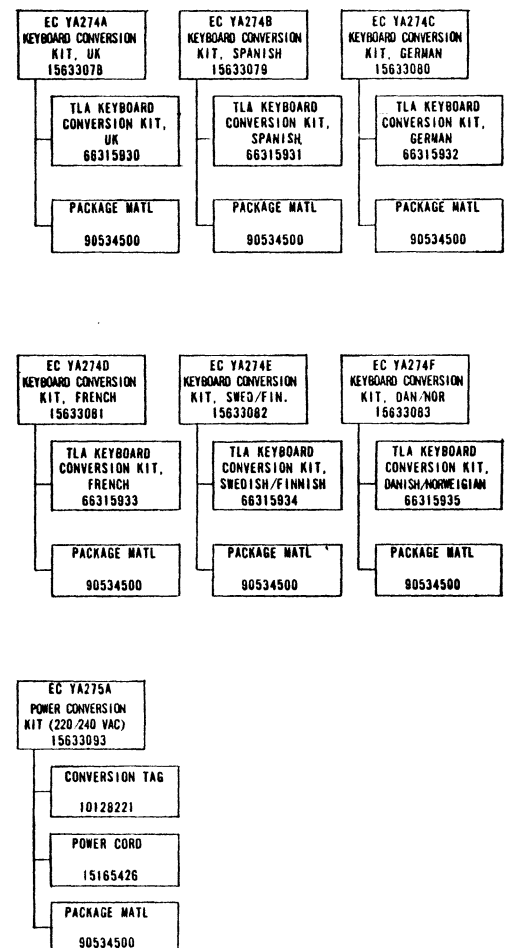

UNLESS OTHERWISE SPECIFIED DIMENSIONS ARE IN TOLERANCES		DWN	
PLACE	PLAC	CHKD	
PLAC	ANCLLS	FINISH	
MATERIAL		MT G	
		APVD	
		EQUIP. NO	
FINISH		THIRD ANGLE PROJECTION	
CONTROL DATA CORPORATION		TITLE	
GENEALOGY CHART		721 DISPLAY TERMINAL	
SIZE	FSCM NO.	DWG NO.	REV
C	15920	663150097	
SCALE	SHEET 2 OF 3		

DETACHED LISTS

62940037 G

2-2.1/2-2.2

OPTIONS INSTALLED BY CUSTOMER ONLY

REVISION RECORD						
REV	ECO	DESCRIPTION	DRFT	DATE	CHKD	APP

629940037 L

D

C

B

A

D

C

B

A

66315009

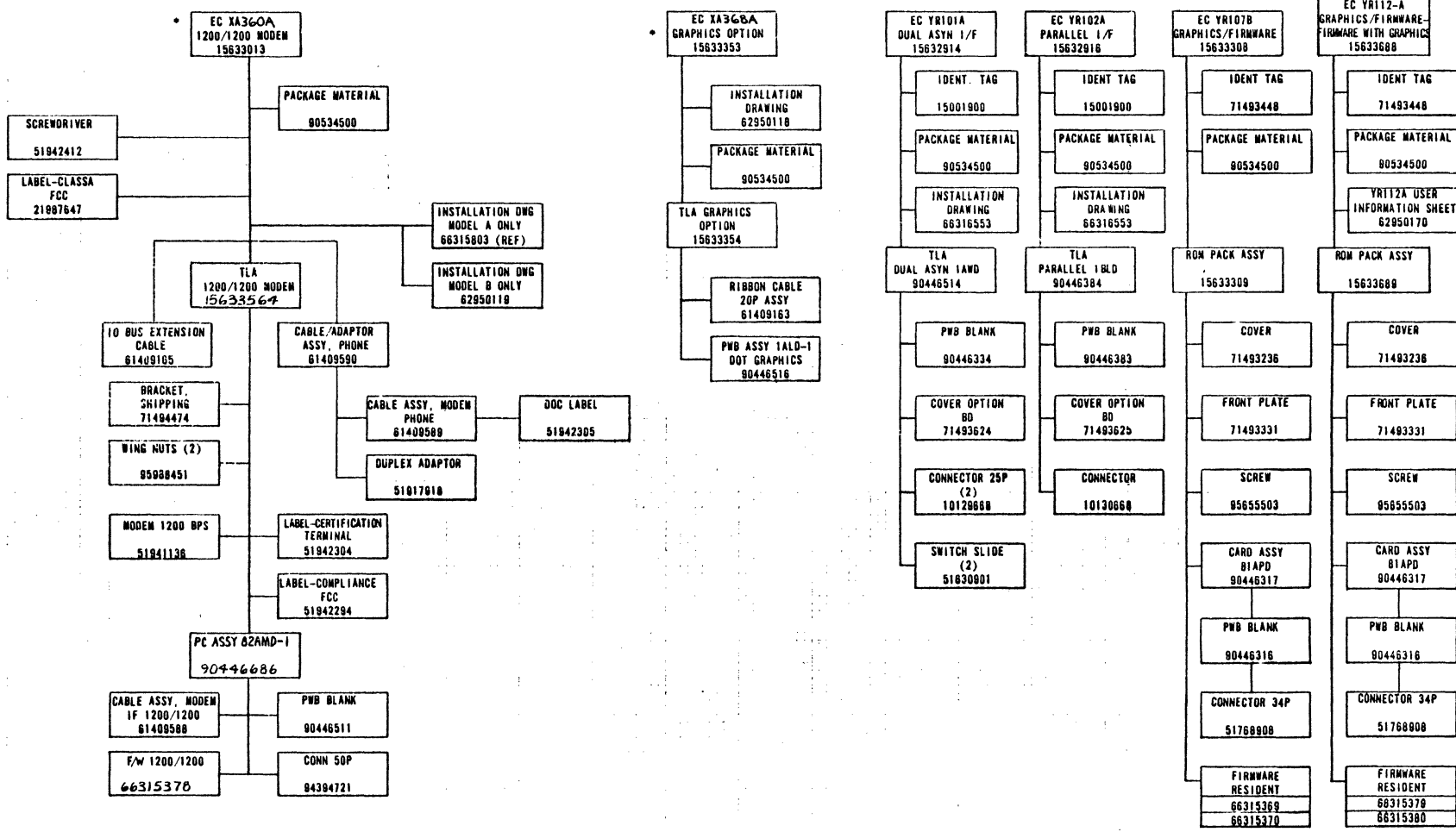

* EC XA360A AND EC XA360A WILL BE INSTALLED BY CUSTOMER ONLY IN THE CC634 AND CC638 B MODEL TERMINALS. THEY WILL BE INSTALLED BY THE SERVICE CENTER FOR THE A MODEL TERMINALS.

CONTROL DATA	GENEALOGY CHART			CODE IDENT	DWG NO	REV
	721 DISPLAY TERMINAL			15920	C 66315009	AA
				SHEET 3		

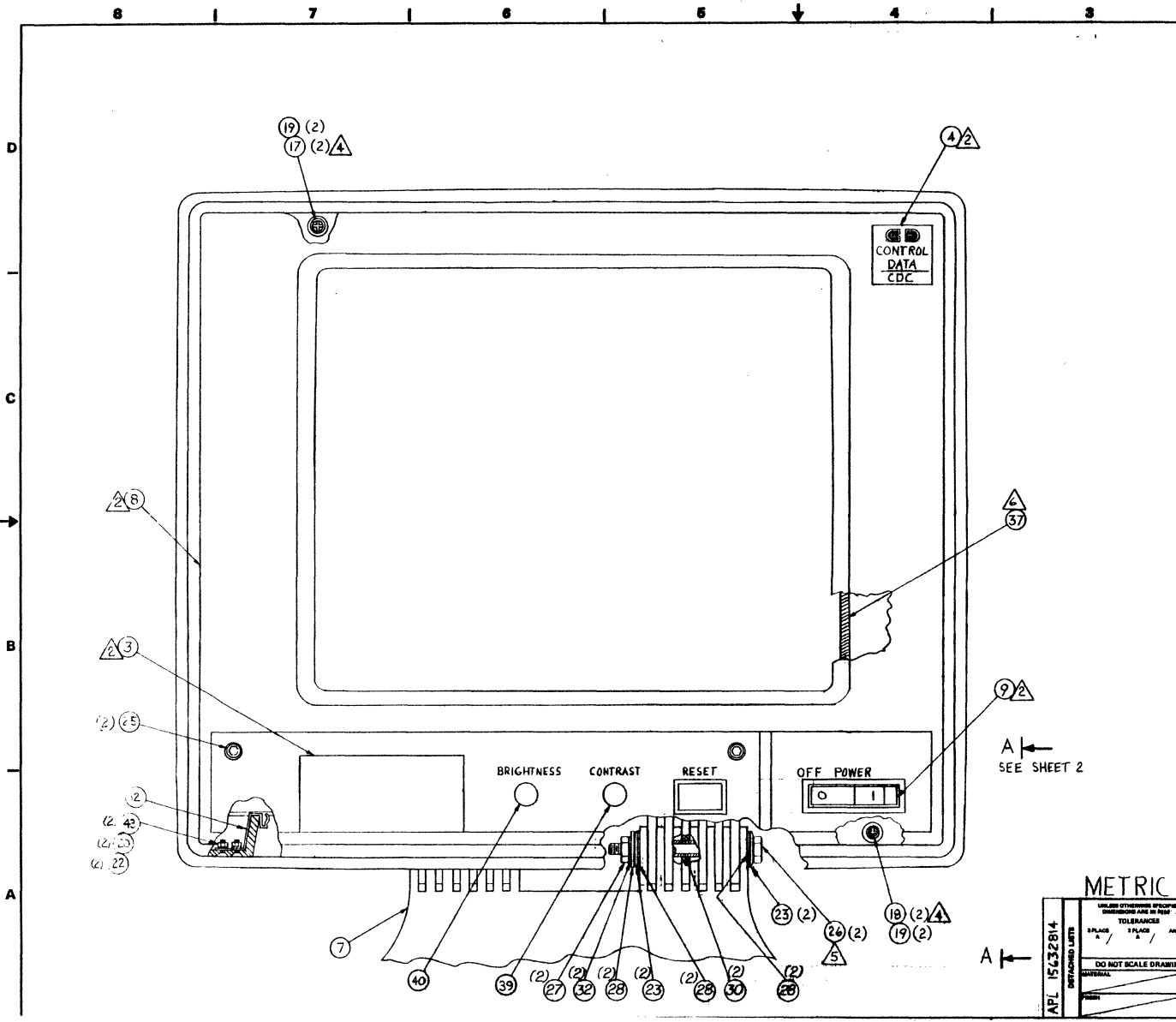

SHEET REVISION STATUS		REVISION RECORD				
REV	ECO	DESCRIPTION	DEPT	DATE	CHKD	APP
00	0000-77	RELEASED CLASS B		12/21/77		
01	51409	DELETE F/N 30 AND F/N 37 & 40	WJC	12-21-77	WJC	
02	51418	CHANGE F/N 12 TO 140	PS	12/21/77	WJC	
03	51459	DELETE F/N 35 ADD F/N 41 & 42	DS	12-21-77	WJC	
04	51807	ADD NOTES 3, 4, 5, CHG F/N 28 TO 31	WJC	12-28-77	WJC	
05	51813	CHG F/N 30	WJC	12-28-77	WJC	
06	51820	ADD NOTE 7 TO F/N 23 & 27 & 28	WJC	1-4-78	WJC	
07	51625	REVISED PER ECO	PM	1-25-78	WJC	
08	51625	CHG F/N 39 & 40	WJC	1-25-78	WJC	
09	51666	FIX NOTE 5	WJC	1-25-78	WJC	
A	15729-79	RELEASED CLASS A		1-25-78		
B	A 15746	MAILED REVISED F/N 39 & 40	DS	1-25-78	WJC	
C	C 15259	CHG F/N 30 AND F/N 36 & 41	WJC	1-25-78	WJC	
D	D 15263	CHG F/N 30 AND F/N 36	WJC	1-25-78	WJC	
E	E 15656	ADD NOTE B	DC	1-10-78	WJC	
F	F 15819	CHG F/N 37 & NOTE 6	MD	1-24-78	WJC	
G	G 15909	REVISED PER ECO	ND	6-27-78	WJC	

- NOTES:
- ▲ MARK "ASSY 15632814" ON BOTTOM OF F/N 7 PER CDC SPEC 10121508.
 - ▲ NOMENCLATURE SHOWN AS REF ONLY.
 - ▲ TORQUE TO 22-26 INCH-POUNDS.
 - ▲ APPLY A MINIMUM TORQUE OF 19 CM-KG, ADDITIONAL TORQUE MAY BE REQUIRED TO INSURE THAT THE DISPLAY REMAINS STABLE IN ANY SELECTED POSITION THROUGHOUT THE TILT RANGE. THE FINAL TORQUE VALUE SHOULD ENABLE TELETYPE YET RELATIVELY EFFORTLESS CHANGES IN DISPLAY POSITION.
 - ▲ ADHERE F/N 37 TO F/N 8, TAPE TO BE POSITIONED ON OUTER EDGE OF AREA SHOWN.
 - ▲ APPLY F/N 43 TO F/N 9 IN AREA INDICATED
 - B. F/N 33, KYBD ASSY, TO BE TERMINATED IN N.H.A.

A ← SEE SHEET 2

METRIC

APL 15632814 DEFINING LIMITS	UNLESS OTHERWISE SPECIFIED DIMENSIONS ARE IN INCHES		TOLERANCES		CONTROL DATA		TITLE	
	3 PLACES + / -	2 PLACES + / -	ANGLES ±		PRINT USED-ON	CC 634-A		DISPLAY TERMINAL
DO NOT SCALE DRAWING				DESIGNED BY	D. SAND		18-2787	
MATERIAL				ENGINEER	S. H. BELL		18-2787	
FINISH				APP'D	S. H. BELL		18-2787	
				APPROVED	E. H. H.		18-2787	
				SCALE	1/1		15632810	SHEET 1 OF 2

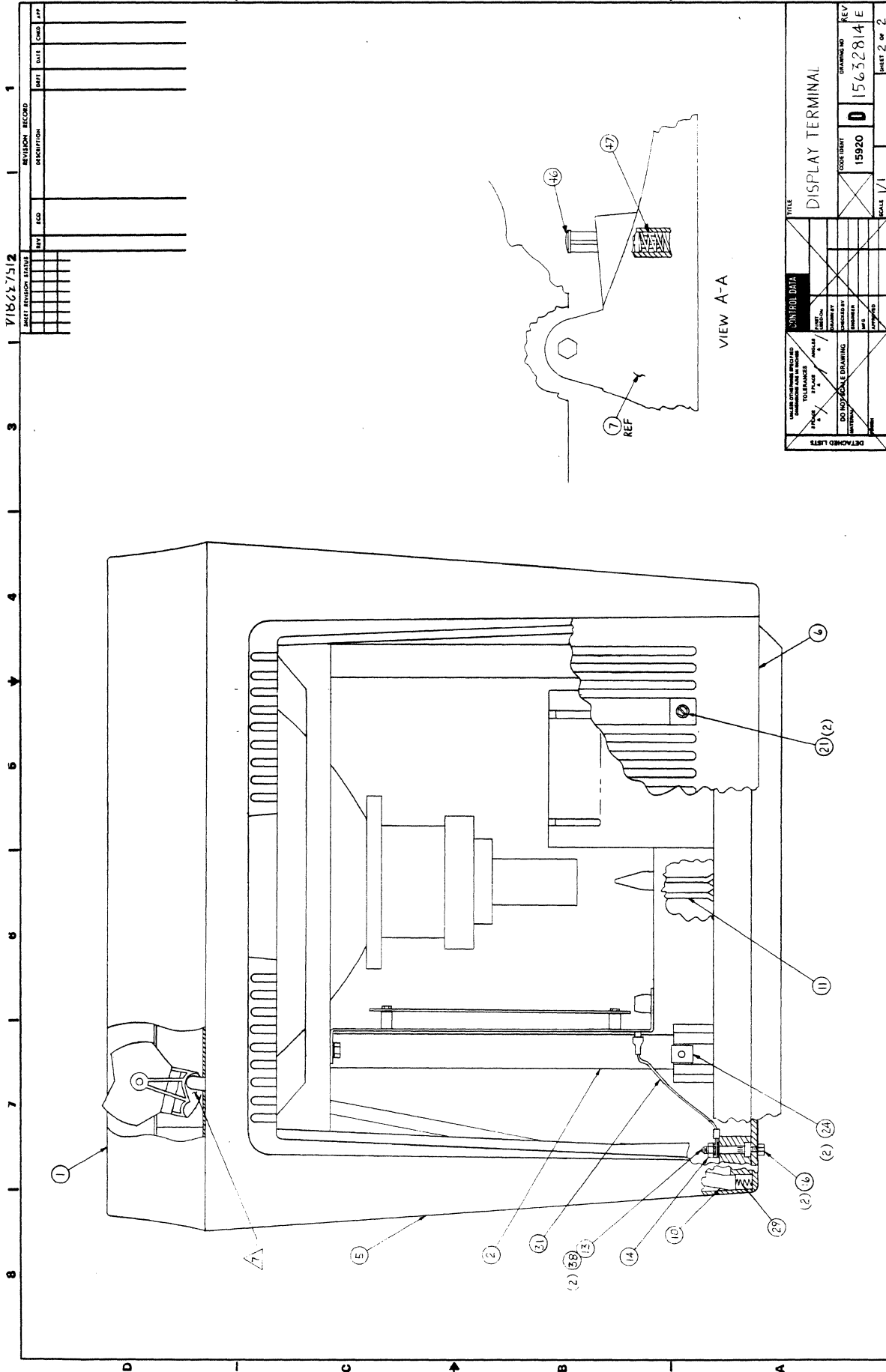

718627512

DATE	REVISION	RECORD	BY	DATE	BY	DATE	BY

CONTROL DATA		DRAWING NO		REV	
TITLE		15920		0	
DISPLAY TERMINAL		15632814		E	
SCALE 1/1		PART 2 OF 2			
DO NOT SCALE DRAWING		CHECKED BY		DATE	
TOLERANCES		DRAWN BY		DATE	
PARTS		DATE		DATE	

BUILD ARC 440

ASSEMBLY PARTS LIST

PRINT DATE 06-21-83 PAGE 1 FILE CHANGE NO. 00015909

DIV	ASSEMBLY NUMBER	CD	REV.	DWG.	DESCRIPTION	MC	STATUS	STATUS DATE	ENG. RESP.	FILE DATE			
0860	15632814	B	G	D	TERM, VX I/O DSPL 60HZ (TA)	G	REL	04-15-82	CC634A	06-21-83			
TFIND NO	LI	PART NUMBER	CD	QTY	U/M	PART DESCRIPTION	MC	YLD	ECO. NO. IN	ECO. NO. OUT	S/N	WR IN	WR OUT
001	01	61409173	4	1		PC ADPTR ASSY, VX DSPL/BEZEL	G						
002	01	61409170	0	1		PC DRAWER ASSY, VX MAIN	G						
003	01	71493332	2	1		PC LABEL, LED INDICATOR DECAL	P						
004	01	51941442	9	1		PC EMBLEM, CDC PROD ID RVS-C MED	P						
005	01	71493313	2	1		PC HOOD (MOLDED OFF-WHITE)	P						
006	01	71493308	2	1		PC COVER, HOOD (MLD OFF-WHITE)	P						
007	02	71493723	2	1		PC PEDESTAL, VX (OFF WHITE)	P		15259			8237	
008	01	71493303	3	1		PC BEZEL, MONITOR (MLD BLACK)	P						
009	02	71493672	1	1		PC BUTTON, POWER SWITCH (PLSTC)	P		15166			8227	
010	01	71493325	6	1		PC ROD, PWR SW ACTUATOR (PLSTC)	P						
011	01	71493327	2	1		PC TRACK, DRAWER (PLSTC)	P						
012	01	71493652	3	1		PC SPG, KYBD CBL GNDING (BECU)	P						
013	01	71493447	8	1		PC INSERT, GND FEED-THRU (CRS/ZP)	P						
014	01	91975723	7	1		PC NUT, HEX M4 STL ZP	B						
016	02	15164913	4	2		PC MSCR HEX/W-LK PLN M4X12MM STL	B		15259			8237	
017	01	91976658	4	2		PC MSCR PAN PHL M5X25MM STL ZP	B						
018	01	91976662	6	2		PC MSCR PAN PHL M5X40MM STL ZP	B						
019	01	91975692	4	4		PC WSHR, M5 LOCK SPG-STL ZP	B						
020	01	91975669	2	2		PC WSHR, M3 EXT/T SPG-STL ZP	B						
021	01	51917791	9	2		PC SCR TPG HEX/W SLT (8) 5/BL B	B						
022	01	91976839	0	2		PC MSCR FLT PHL M3X10MM STL ZP	B						

BUILD ARC 440

ASSEMBLY PARTS LIST

PRINT DATE 06-21-83 PAGE 2 FILE CHANGE NO. 00015909

DIV	ASSEMBLY NUMBER	CD	REV.	DWG.	DESCRIPTION	MC	STATUS	STATUS DATE	ENG. RESP.	FILE DATE			
0860	15632814	B	G	D	TERM, VX I/O DSPL 60HZ (TA)	G	REL	04-15-82	CC634A	06-21-83			
TFIND NO	LI	PART NUMBER	CD	QTY	U/M	PART DESCRIPTION	MC	YLD	ECO. NO. IN	ECO. NO. OUT	S/N	WR IN	WR OUT
023	01	93651041	1	4		PC WSHR, .442ID BELVIL SPR-STL	B		15909	15909		8327	8327
023	02	93651042	9	4		PC WSHR, .138ID BELVIL SPR-STL	B		15909			8327	
024	01	51941222	5	2		PC NUT, U-TYP FSTNR 8-18 TPG-SCR	B		15623	15623		8310	8310
024	02	51941223	3	2		PC FASTENER U TYPE NUT	B						
025	01	10128318	2	2		PC CSCR FIL SKT M4X8MM STL B0	B						
026	01	15165170	0	2		PC PIN, HOOD-PED MTG 81.5MM LONG	P		15909	15909		8327	8327
026	02	10126512	2	2		PC SCR MX HD CAP 1/4-20 3.000L	B						
027	01	15165175	9	2		PC NUT, CASTELLATED HEX M10X1.0	P		15909	15909		8327	8327
027	02	10125301	1	2		PC NUT, HEX 1/4-20 MSCR STL ZP	B		15909			8327	
028	01	91975621	3	4		PC WSHR, M10 FLAT STL ZP	B		15909	15909		8327	8327
028	02	94047858	8	4		PC WSHR, .734 .281 .063 STL ZC PL	B		15909			8327	
029	01	94205208	5	1		PC SPG, COMP .75L 2.8LB/IN MW	P						
030	02	09038204	5	2		PC PIN, COTTER 1.0LG 1/16DIA STL	B		15259	15909		8327	8327
030	03	71494084	8	2		PC SPACER ROUND	B		15909			8327	
031	01	61409248	4	1		PC WIRE ASSY, SHLD GROUND 8IN	A						
032	01	10126404	2	2		PC WSHR, (1/4) EXT/T LK STL ZP	B		15909			8327	
033	01	61409246	8	1		PC KYBD ASSY, VX 106-KEY SER I/O	G						
037	01	51803904	5	3	488	FT TAPE, 1/4WX1/8T NEO ADH-IS	B			15819	15819	8319	8319
037	02	51803906	0	3	488	FT TAPE NEOPRENE 1/8WIDE 1/8THK	B						
038	01	91975670	0	2		PC WSHR, M4 EXT/T SPG-STL ZP	B						
039	01	51941283	7	1		PC KNOB, CONTRAST (PLSTC/BLK)	P						
040	01	51941284	5	1		PC KNOB, BRIGHTNESS (PLSTC/BLK)	P						
043	01	91975722	9	2		PC NUT, HEX M3 STL ZP	B						
045	01	94846100	9	010		OZ GREASE, SILICONE (DOW NO.44)	B						

BUILD ARC 440

ASSEMBLY PARTS LIST

PRINT DATE 06-21-83 PAGE 3 FILE CHANGE NO. 00015909

DIV		ASSEMBLY NUMBER		CD	REV.	DWG.	DESCRIPTION		MC	STATUS	STATUS DATE	ENG. RESP.	FILE DATE	
0860		15632814		8	G	D	TERM, VX I/O DSPL 60HZ (TA)		G	REL	04-15-82	CC634A	06-21-83	
FOUND NO.	LI	PART NUMBER	CD	QUANTITY	U/M	PART DESCRIPTION		MC	YLD	ECO. NO. IN	ECO. NO. OUT	S/N	WK IN	WK OUT
046	01	71493725	7	1		PC PLUNGER, TILT SUPPORT NYL/WHT		P		15259				8237
047	01	51941639	0	1		PC SP8, COMP 1.6L 28.1LB/IN HW		P		15259				8237
0047 TOTAL LINES														

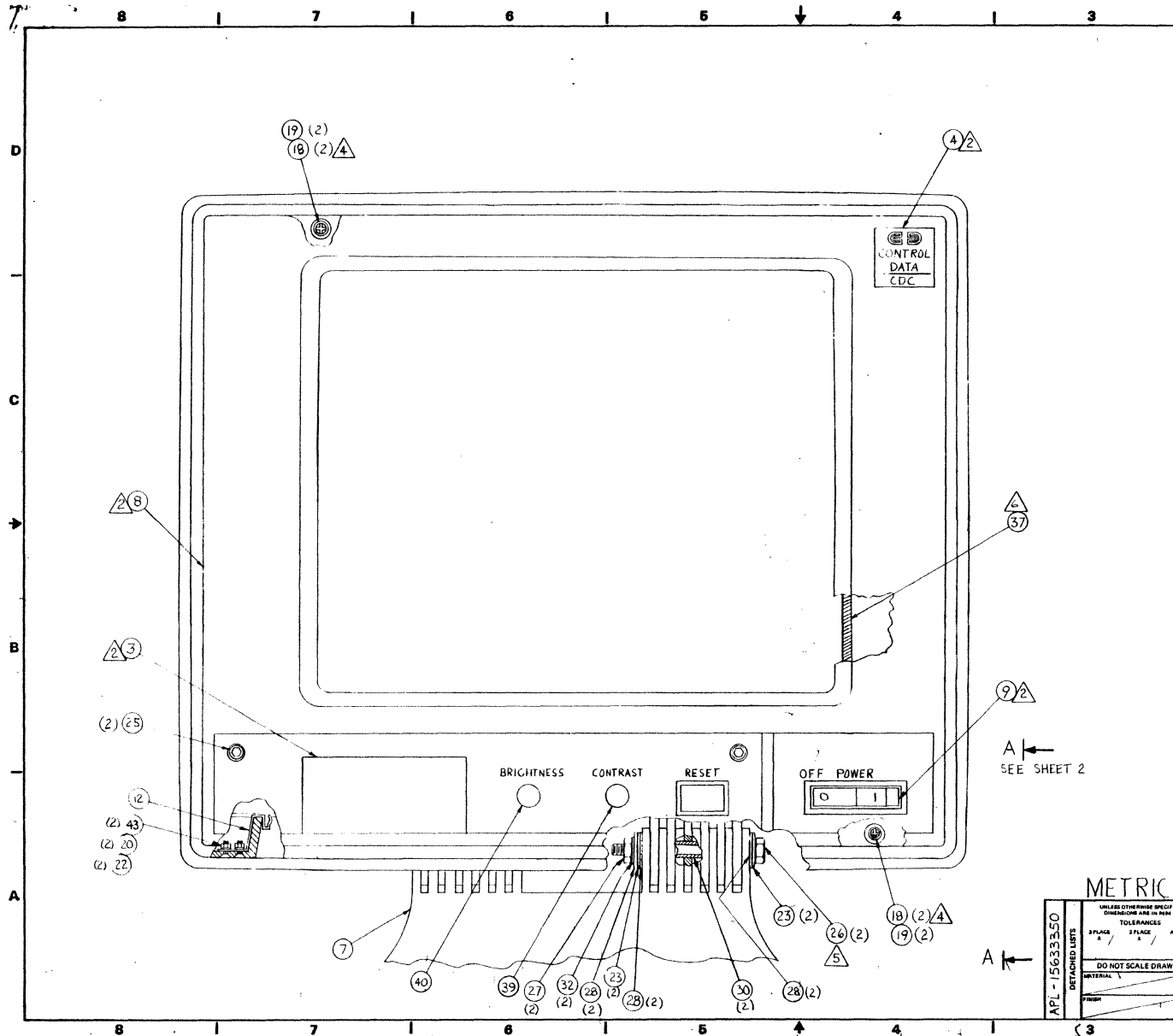

SHEET REVISION STATUS		REVISION RECORD				
REV	ECO	DESCRIPTION	DATE	CHKD	APP	
2	1	RELEASED CLASS P				
01	E2187	ENCL CLASS ADDEN 4 28 89	4/28/89			
02	52209	ENCL NOTE 5, ENCL 1, 2, 4, 5, 7, 8, 9, 10, 11, 12, 13, 14, 15, 16, 17, 18, 19, 20, 21, 22, 23, 24, 25, 26, 27, 28, 29, 30, 31, 32, 33, 34, 35, 36, 37, 38, 39, 40, 41, 42, 43, 44, 45, 46, 47, 48, 49, 50, 51, 52	7/10/89			
03	52215	CHG FIN 16	7/10/89			
A	A	1563350				
A	B	10117				
A	C	1416B				

- NOTES:
- 1 MARK "ASSY 1563350" ON BOTTOM OF FIN 7 PER CDC SPEC 10121508.
 - 2 NOMENCLATURE SHOWN AS REF ONLY.
 - 3 TORQUE TO 22-26 INCH POUNDS.
 - 4 APPLY A MINIMUM TORQUE OF 18 CM-KG. ADDITIONAL TORQUE MAY BE REQUIRED TO INSURE THAT THE DISPLAY REMAINS STABLE IN ANY SELECTED POSITION THROUGHOUT THE TILT RANGE. THE FINAL TORQUE VALUE SHOULD ENABLE DELIBERATE YET RELATIVELY EFFORTLESS CHANGES TO DISPLAY POSITION.
 - 5 ADHERE FIN 37 TO F/N 8. TAPE TO BE POSITIONED ON OUTER EDGE OF AREA SHOWN.
 - 6 APPLY F/N 43 TO F/N 9 IN ANG. INDICATED.
 - 7 F/N 33, KYBD ASSY, TO BE TERMINATED IN N.H.A.

METRIC

DETACHED LISTS A-PL-1563350-1-1V	UNLESS OTHERWISE SPECIFIED DIMENSIONS ARE IN MM		CONTROL DATA		TITLE
	TOLERANCES	FINISH	CC639-B	CC639-B	DISPLAY TERMINAL
	3 PLACE / 2 PLACE / ANGLES	BY	ERSFELD	5-25-89	
	DO NOT SCALE DRAWING	CHECKED BY	5-2-89	5/20/89	
INTERNAL	ENGINEER				CODE UNIT
	MFG				15920
	APPROVED				1563350
					SCALE 1/1
					SHEET 1 OF 1

BUILD ARC 430

ASSEMBLY PARTS LIST

PRINT DATE: 10-24-83 PAGE: 1 FILE CHANGE NO: 00016237

DIV.		ASSEMBLY NUMBER	CD	REV.	DWG.	DESCRIPTION		MC	STATUS	STATUS DATE	ENG. RESP.	PHS DATE	
0000		15633350	2	0	0	TERM: VHM I/O DSPL 60HZ (TA)	0	REL		07-29-83	CC6348	10-24-83	
ITEM NO	LT	PART NUMBER	CD	QTY	U/M	PART DESCRIPTION	MC	TLR	ECO. NO. IN	ECO. NO. OUT	L/N	WE IN	WE OUT
001	01	61409173	4	1		PC ADPTR ASSY, VX DSPL/BEZEL		0					
002	01	61409644	4	1		PC DRAWER ASSY		0					
003	01	71493332	2	1		PC LABEL, LED INDICATOR DECAL		P					
004	01	51941442	9	1		PC EMBLEM, CDC PROD ID RV3-C MED		P					
005	01	71493313	2	1		PC HOOD (MOLDED OFF-WHITE)		P					
006	01	71494141	0	1		PC REPLACED BY 71494174 16111		P	16111	16111		0336	0336
006	02	71494174	7	1		PC COVER TOP ACCESS METRIC		P					
007	01	71493723	2	1		PC PEDESTAL, VX (OFF WHITE)		P					
008	01	71493303	3	1		PC BEZEL, MONITOR (HLD BLACK)		P					
009	01	71493672	1	1		PC BUTTON, POWER SWITCH (PLSTC)		P					
010	01	71493325	6	1		PC ROD, PWR SW ACTUATOR (PLSTC)		P					
011	01	71493327	2	1		PC TRACK, DRAWER (PLSTC)		P					
012	01	71493652	3	1		PC SPB, KYBD CBL GNDING (BECU)		P					
013	01	71493447	8	1		PC INSERT, GND FEED-THRU (CRS/ZP)		P					
014	01	91975723	7	1		PC NUT, HEX M4 STL ZP		B					
016	01	71494144	0	2		PC SCREW, MODIFIED, METRIC		V					
017	01	91976050	4	2		PC MSCR PAN PHL M5X25MM STL ZP		B		16160			0339
018	01	91976662	6	2		PC MSCR PAN PHL M5X40MM STL ZP		B	16160	16160		0339	0339
018	02	91976662	6	4		PC MSCR PAN PHL M5X40MM STL ZP		B					
019	01	91975692	4	4		PC WSHR, M5 LOCK SPB-STL ZP		B					
020	01	91975669	2	2		PC WSHR, M3 EXT/T SPB-STL ZP		B					
021	01	81017791	9	2		PC SCR TPB HEX/W SLT (0) 5/8L 0		B					

BUILD ARC 430

ASSEMBLY PARTS LIST

PRINT DATE: 10-24-83 PAGE: 2 FILE CHANGE NO: 00016237

DIV.		ASSEMBLY NUMBER	CD	REV.	DWG.	DESCRIPTION		MC	STATUS	STATUS DATE	ENG. RESP.	PHS DATE	
0000		15633350	2	0	0	TERM: VHM I/O DSPL 60HZ (TA)	0	REL		07-29-83	CC6348	10-24-83	
ITEM NO	LT	PART NUMBER	CD	QTY	U/M	PART DESCRIPTION	MC	TLR	ECO. NO. IN	ECO. NO. OUT	L/N	WE IN	WE OUT
022	01	91976039	0	2		PC MSCR FLT PHL M3X10MM STL ZP		B					
023	01	93691044	9	4		PC WSHR, .255ID BELVIL SPR-STL		B					
024	01	81941223	3	2		PC FASTENER U TYPE NUT		B					
025	01	10120310	2	2		PC CSCR FIL SKT M4X8MM STL 00		B					
026	01	10126512	2	2		PC SCR HR HD CAP 1/4-20 3.000L		B					
027	01	10125301	1	2		PC NUT, HEX 1/4-20 MSCR STL ZP		B					
028	01	94047050	6	6		PC WSHR, .734 .201 .063 STL ZC PL		B					
029	01	94285200	5	1		PC SPB, COMP .75L 2.8L8/IN MW		P					
030	01	71494084	0	2		PC SPACER ROUND		P					
031	01	61409240	4	1		PC WIRE ASSY, SHLD GROUND 0IN		A					
032	01	10126404	2	2		PC WSHR, (1/4) EXT/T LK STL ZP		B					
033	01	61409656	0	1		PC KEYBOARD ASSY		0					
037	01	51003904	0	3	400	FT TAPE NEOPRENE 1/8WIDE 1/8THK		B					
038	01	91975670	0	2		PC WSHR, M4 EXT/T SPB-STL ZP		B					
039	01	51941203	7	1		PC KNOB, CONTRAST (PLSTC/BLK)		P					
040	01	51941204	8	1		PC KNOB, BRIGHTNESS (PLSTC/BLK)		P					
043	01	91975722	9	2		PC NUT, HEX M3 STL ZP		B					
045	01	94046100	9	010		OZ GREASE, SILICONE (DOW NO.44)		B					
046	01	71493725	7	1		PC PLUNGER, TILT SUPPORT NYL/WHT		P					
047	01	51941039	0	1		PC SPB, COMP 1.6L 20.1L8/IN MW		P					
048	01	81017779	4	1		PC SCR TPB HEX/W SLT (0) 3/8L 0		B					

BUILD ARC 430

ASSEMBLY PARTS LIST

PRINT DATE: 10-24-83
 PAGE: 3
 FILE CHANGE NO.: 00016237

DIV		ASSEMBLY NUMBER		REV.	DWG.	DESCRIPTION	MC	STATUS	STATUS DATE	ENG. DESIG.	FILE DATE		
0860		15033350		2	D	TERM. VHM I/O DSPL 60HZ (7A)	0	REL	07-29-83	CC6340	10-24-83		
P/NO	LI	PART NUMBER	CD	QTY	U/M	PART DESCRIPTION	MC	YLD	ECO. NO. IN	ECO. NO. OUT	S/N	WE IN	WE OUT
049	01	71494100	5	1		PC REPLACED BY 71494220 10237		P		10237			
049	02	71494220	8			PC CATCH TOP COVER		P	10237			0340	8346
						0045 TOTAL LINES							

2-6.6

D

C

B

A

62940037 H

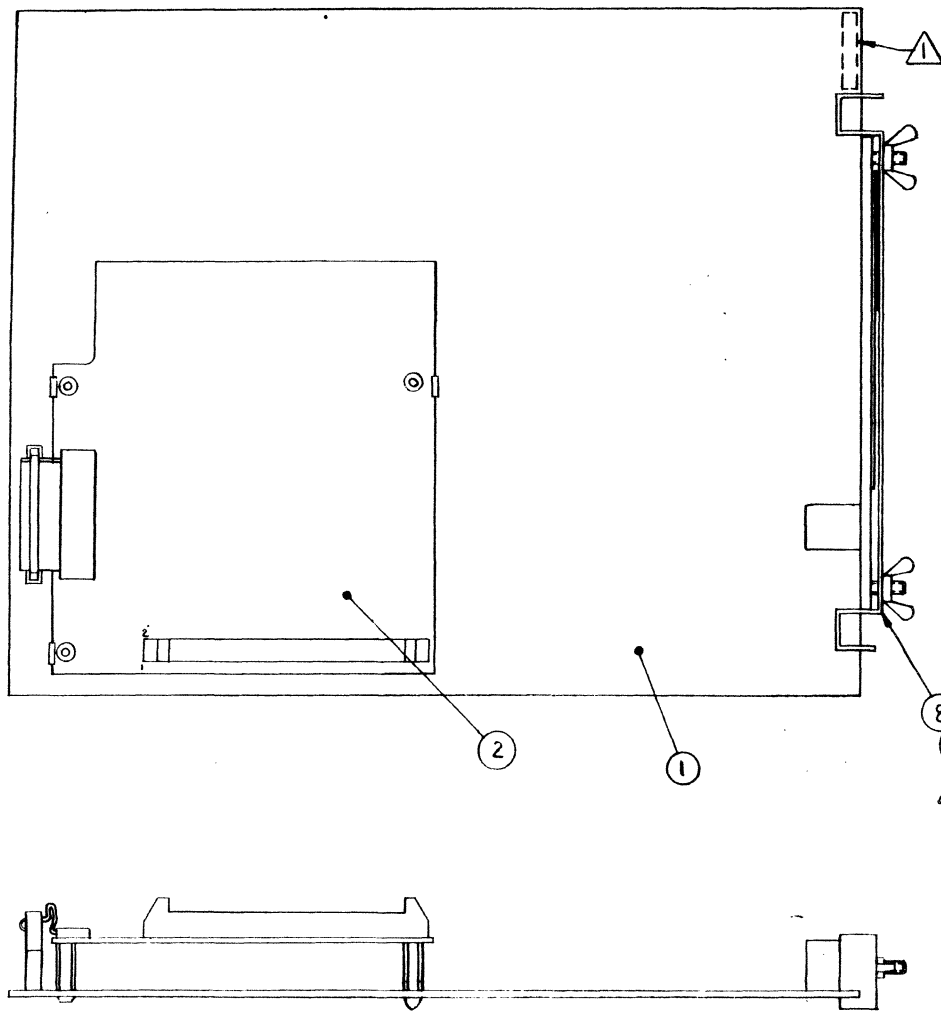

REVISION RECORD						
REV	ECO	DESCRIPTION	DRFT	DATE	CHKD	APVD
00	Scale: 2:1	RELEASED CLASS B		1/28/83		EAH
01	51779	CHG CABLE VIEW	WJG	2-9-83	WJG	EAH
02	52056	ADD F/N 3	WJG	4-13-83	WJG	EAH
03	52064	CORRECT PICTORIALY	WJG	7-20-83	WJG	EAH
04	52116	ADD F/N 4	WJG	5-25-83	WJG	EAH
05	52177	CHG F/N 1-6	WJG	6-30-83	WJG	EAH
06	52311	ADDED F/N 7	DS	10-3/83		EAH
A	16200-57	RELEASED CLASS A		11-30-83		EAH
B	16454	DELETE F/N 7 & NOTE 3	WJG	1-16-84	WJG	EAH
C	16710	ADD F/N 8, NOTE 3A DELETE F/N 3, A	WJG	7-31-84		EAH
D	16868	INACTIVE SERVICE USE ONLY. REPLACED BY 15633014	EE	1/18/85	WJG	EAH

NOTES:

- 1 MARK WITH CDC PART NUMBER PER CDC SPEC 10121508.
- 2 PLACE F/N 6 ON TOP OF F/N 5 AS SHOWN.
- 3 SHIPPING BRACKET (F/N 9) AND WINGNUTS (F/N 8) TO BE INSTALLED AFTER FINAL QA TEST.
- 4 SHIPPING BRACKET (F/N 9) NOT SHOWN IN THIS VIEW.

INACTIVE

APL 15633014

DETACHED LISTS

UNLESS OTHERWISE SPECIFIED DIMENSIONS ARE IN MM		DWN	WJG (date) 1-25-85	CONTROL DATA CORPORATION
TOLERANCES		CHKD	WJG	
PLACE	PLACE	ENGR	WJG	TITLE
±	±	MFG	WJG	1200/1200 MODEM (TLA)
±	±	APVD	WJG	SIZE FSCM NO. DWG NO.
MATERIAL				C 15920 15633014
FINISH		EQUIP NO.	XA360-A	SCALE 1/1 NHA 15633013 SHEET 1 OF 1
		THIRD ANGLE PROJECTION		

15633014

ASSEMBLY PARTS LIST

PUILO ARC 230										PRINT DATE		PAGE		FILE CHANGE NO.	
										12-04-84		1		00016668	
										STATUS DATE		ENG. RESP.		FILE DATE	
										11-19-84		XA360A		12-04-84	
GRAC	ASSEMBLY NO.	CD	REV.	DWG.	DESCRIPTION	MC	STATUS								
TIME NO.	U	PART NO.	CD	QTY	U/M	YLD	ECO NO. IN	ECO NO. OUT	S.N.	WK IN	WK OUT				
001	01	51941136	7	1	PC MODEM, 1200BPS FULL-DPLX 2-W	P									
002	01	90446512	7	1	PC REPLACED BY 90446686 16868	S									
003	01	51918916	1	4	PC SPACER, HEX NYLON 4-40X.875	B		16710			8425				
004	01	93749086	0	4	PC MSCR PAN/W PHL 4-40X3/8 STL 2	H		16710			8425				
005	01	51942294	3	1	PC LABEL, COMPLIANCE FCC	P									
006	01	51942304	0	1	PC LABEL, MODEM CERT	P									
007	01	71494225	7	1	PC REPLACED BY NONE 16454	P		16454			8345				
008	01	95968451	5	2	PC NUT WING MAXO.7 20W 10H	B	16710A				8425				
009	01	71494474	1	1	PC BRACKET SHIPPING MODEM	P	16710A				8425				
0009 TOTAL LINES															

2-8

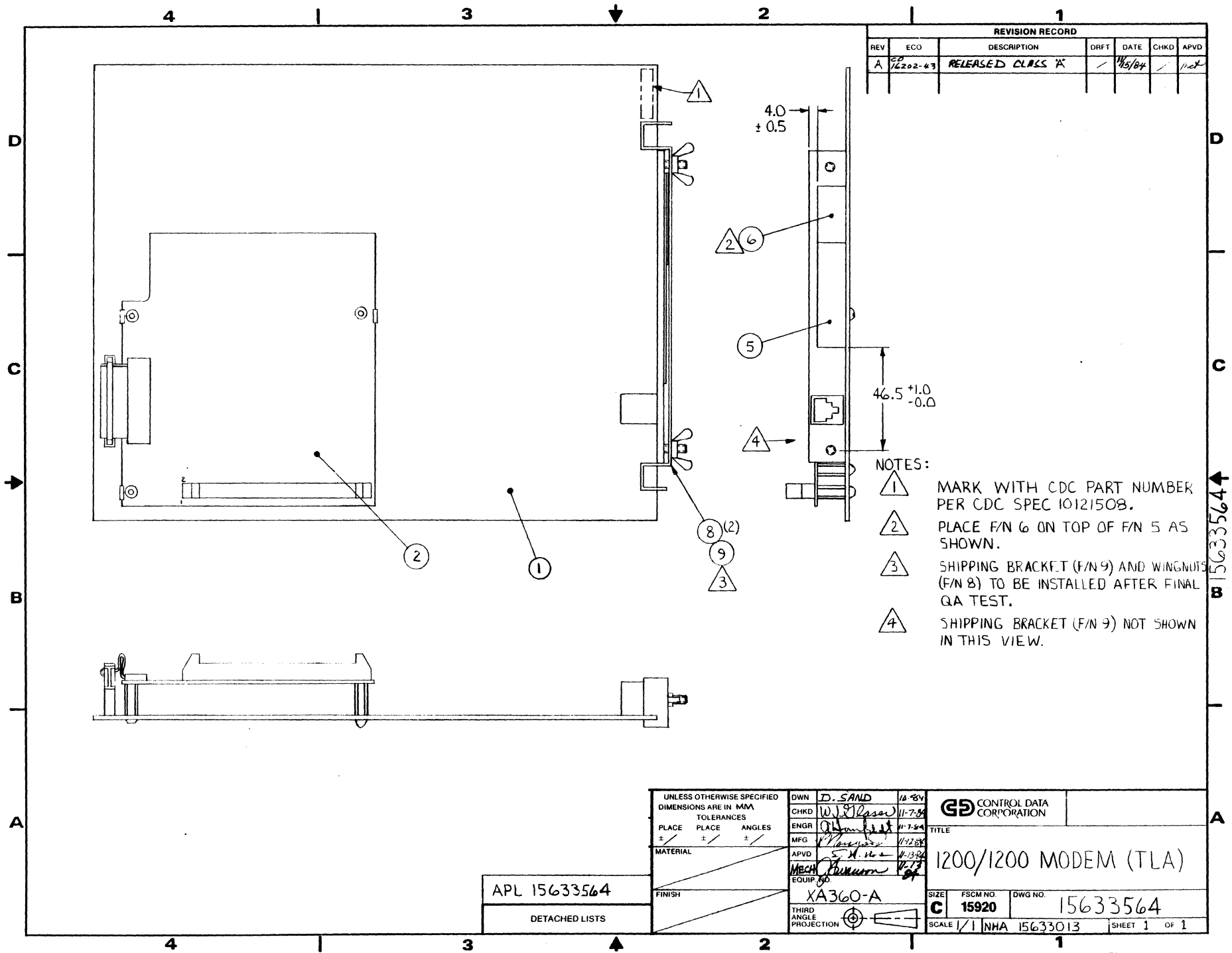

- NOTES:
- 1 MARK WITH CDC PART NUMBER PER CDC SPEC 10121508.
 - 2 PLACE F/N 6 ON TOP OF F/N 5 AS SHOWN.
 - 3 SHIPPING BRACKET (F/N 9) AND WINGNUTS (F/N 8) TO BE INSTALLED AFTER FINAL QA TEST.
 - 4 SHIPPING BRACKET (F/N 9) NOT SHOWN IN THIS VIEW.

62940037 H

APL 15633564
DETACHED LISTS

UNLESS OTHERWISE SPECIFIED DIMENSIONS ARE IN MM			DWN	D. SAND	10-84	CONTROL DATA CORPORATION
TOLERANCES			CHKD	W. J. Kassar	11-7-84	
PLACE	PLACE	ANGLES	ENGR	W. J. Kassar	11-7-84	TITLE 1200/1200 MODEM (TLA)
±	±	±	MFG	W. J. Kassar	11-7-84	
MATERIAL			APVD	S. M. Ho	11-13-84	SIZE C FSCM NO. 15920 DWG NO. 15633564
FINISH			MECH EQUIP. NO.	W. J. Kassar	11-13-84	
THIRD ANGLE PROJECTION			XA360-A		SCALE 1/1 NHA 15633013	SHEET 1 OF 1

ASSEMBLY PARTS LIST

BUILD ARC 230						PRINT DATE		PAGE		FILE CHANGE NO.				
DIV.		ASSEMBLY NO.		CD	REV.	DWG.		DESCRIPTION		MC	STATUS	11-20-84	1	16202-43
Q860		15633564		8	A	C		1200/1200 MODEM (TLA)		A	REL	11-15-84	XA360A	11-22-84
T/NO	LI	PART NO.	CD	QTY	U/M	PART DESCRIPTION		MC	YLD	ECO. NO. IN	ECO. NO. OUT	S/N	WK IN	WK OUT
001	01	51941136	7	1		PC	MODEM, 1200BPS FULL-DPLX 2-W	P						
002	01	9J446666	9	1		PC	CD ASSY 82AMD-1 MODEM I/F.	S						
005	01	51942294	3	1		PC	LABEL, COMPLIANCE FCC	P						
006	01	51942304	0	1		PC	LABEL, MODEM CERT	P						
008	01	95968451	5	2		PC	NUT WING M4X0.7 20W 10H	B						
009	01	71494474	1	1		PC	BRACKET SHIPPING MODEM	P						
						0006 TOTAL LINES								

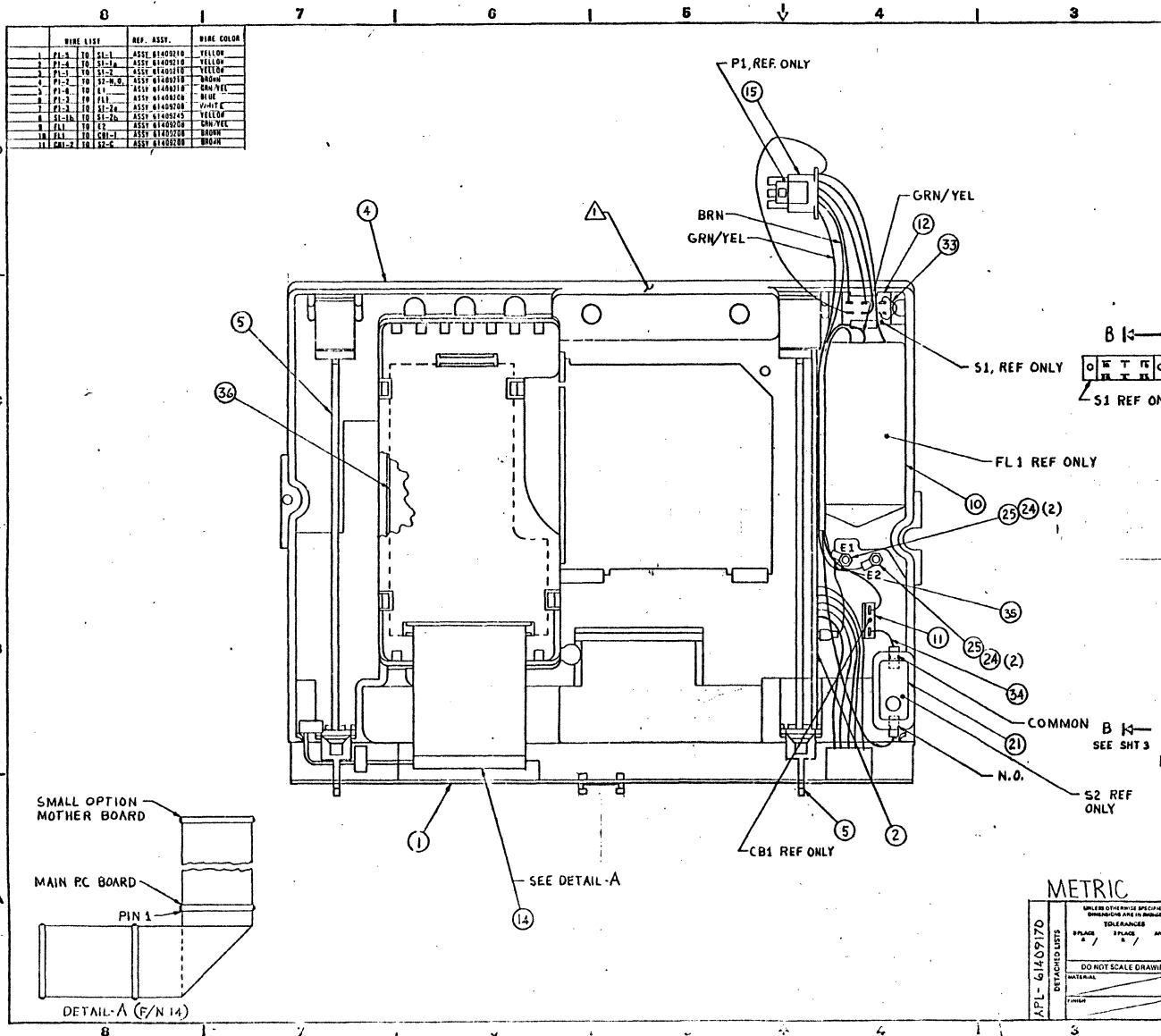

SHEET REVISION STATUS		REVISION RECORD					
REV	ECO	DESCRIPTION	DATE	BY	CHKD	APL	
1	00	RELEASED CLASS B	05-11-77	DS	WJG	WJG	
2	01	REVISED PER ECO	05-11-77	DS	WJG	WJG	
3	02	REPLACE PINS 23, 24, 25, 26, 27, 28	05-11-77	WJG	WJG	WJG	
4	03	REPLACE PINS 23, 24, 25, 26, 27, 28	05-11-77	WJG	WJG	WJG	
5	04	ADD P/N 35	05-11-77	WJG	WJG	WJG	
6	05	ADD NOTE 2	05-11-77	WJG	WJG	WJG	
7	06	CHG P/N 23	05-11-77	WJG	WJG	WJG	
8	07	CHG P/N 24, 25, 26, 27, 28	05-11-77	WJG	WJG	WJG	
9	08	CHG P/N 25	05-11-77	WJG	WJG	WJG	
10	09	DELETE P/N 22, 43	05-11-77	WJG	WJG	WJG	
11	10	REPLACE PINS 23, 24, 25, 26, 27, 28	05-11-77	WJG	WJG	WJG	
12	11	REPLACE PINS 23, 24, 25, 26, 27, 28	05-11-77	WJG	WJG	WJG	
13	12	ADD P/N 39	05-11-77	WJG	WJG	WJG	
14	13	CHANGED P/N 1 P/L	05-11-77	WJG	WJG	WJG	
15	14	CHANGED P/N 1	05-11-77	WJG	WJG	WJG	
16	15	CHG P/N 38	05-11-77	WJG	WJG	WJG	
17	16	CHG P/N 2	05-11-77	WJG	WJG	WJG	
18	17	REVISED PER ECO	05-11-77	WJG	WJG	WJG	
19	18	REVISED PER ECO	05-11-77	WJG	WJG	WJG	
20	19	CHANGED P/N 2	05-11-77	WJG	WJG	WJG	
21	20	CHANGED P/N 2	05-11-77	WJG	WJG	WJG	
22	21	REMOVED P/N 20 & NOTE 2	05-11-77	WJG	WJG	WJG	
23	22	CHANGED P/N 39	05-11-77	WJG	WJG	WJG	
24	23	CHANGED P/N 1	05-11-77	WJG	WJG	WJG	

NOTES:

- △ MARK WITH CDC PART NUMBER PER CDC SPEC 10121500.
- △ TORQUE TO 3.5 TO 4.7 INCH-POUNDS.

METRIC

UNLESS OTHERWISE SPECIFIED DIMENSIONS ARE IN MILLIMETERS TOLERANCES	CC634-A	TITLE	DRAWER ASSY
PLACE # /	ANGLS # /	FAST POSITION	15920
DO NOT SCALE DRAWING	INCHES	APPROVED	61409170
MATERIAL	APPROVED	DATE	15C52214
FINISH	APPROVED	DATE	15C52214

APL-61409170	DETACHED LISTS	15920	D	61409170	SHEET 1 OF 3
--------------	----------------	-------	---	----------	--------------

61409170

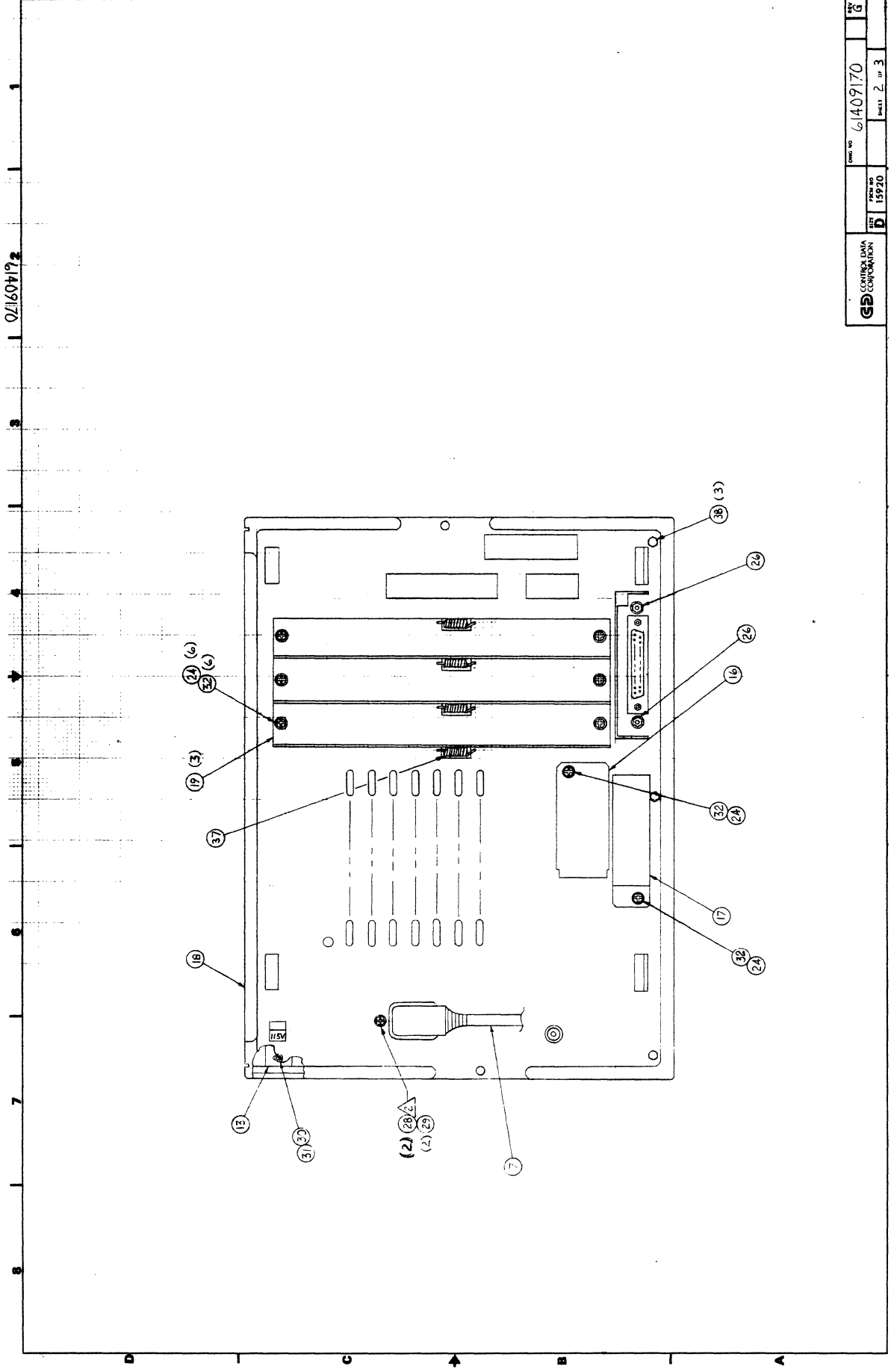

GD CONTROL DATA CORPORATION	REV. NO.	61409170	SHEET 2 OF 3
	PROJ. NO.	15920	
	REV.	D	

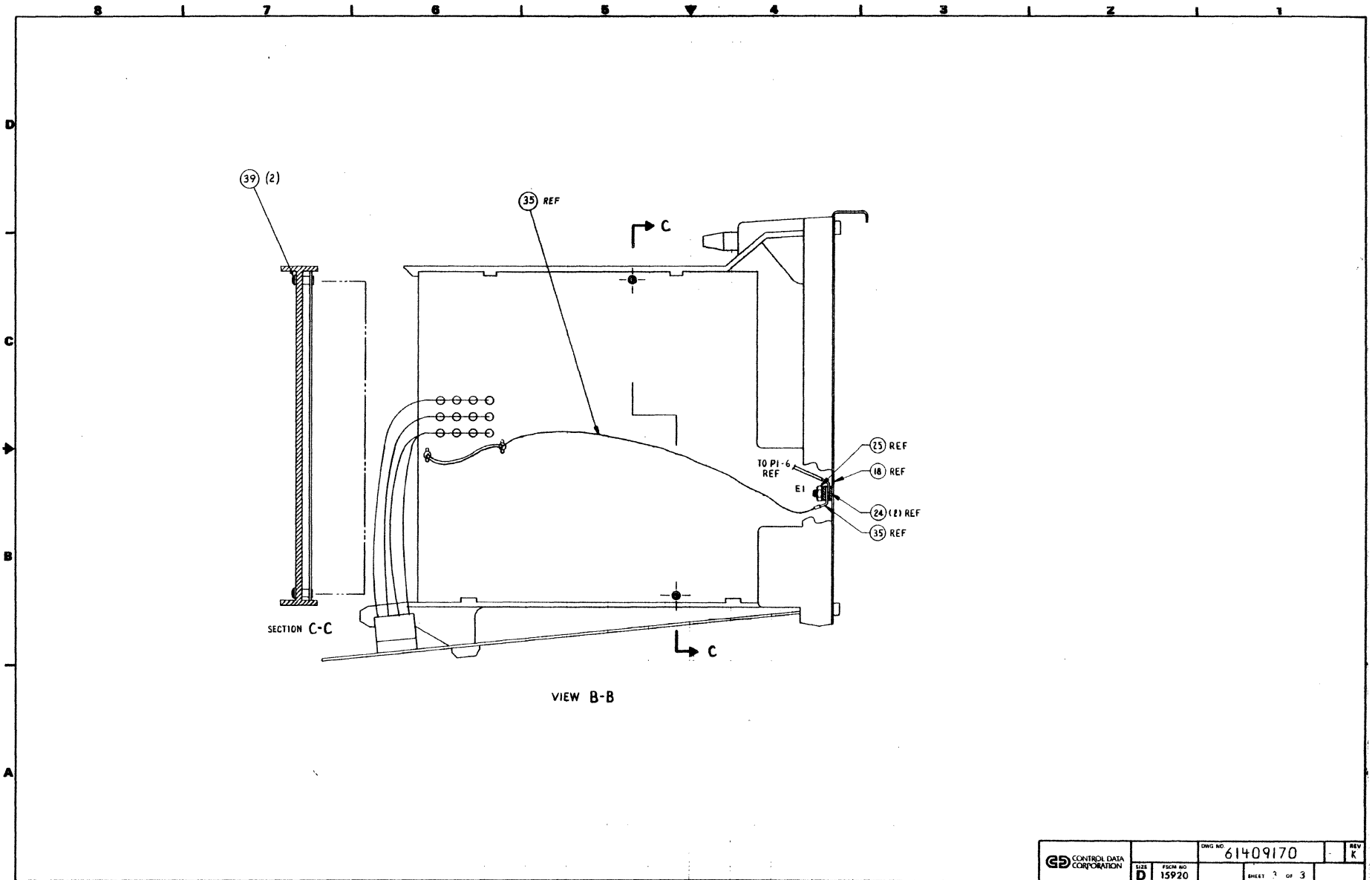

CD CONTROL DATA CORPORATION	SIZE	DWG NO.	REV
	D	61409170	K
FORM NO.	SHEET 3 OF 3		
15920			

ASSEMBLY PARTS LIST

614C917C	H	A	C	DRABER ASSY, VX MAIN	CD	CC634A	C7/29/85	017571	09/27/85	1 / 1
ASSEMBLY NUMBER	REV	CL	REV	ASSEMBLY DESCRIPTION	DRAWN SOURCE	PRINT USAGE	RELEASE DATE	CHANGE ORD. NUMBER	PROCESSING DATE	PAGE NUMBER

PF

LINE NUMBER	REV	PART NUMBER	QUANTITY	UNIT	DESCRIPTION	IN/OUT	CHANGE ORD. NUMBER	DATE EFFECTIVE	REPLACES PART TYPE	PC	Q
21	A	15002342	1.00	PC	SW, INTLK FIG-1 PNL-MTD SPST	IN			PPP4	N	
12	A	15002347	1.00	PC	VOLTAGE SWITCH	IN			PPP4	N	
26	A	15165000	2.00	PC	NUT, HEX/FIG-LK P4 STL ZP	IN			PPP3	N	
7	A	15165425	1.00	PC	CBL, 9FT-10IA PWR FIG-1 125V	IN			PPP4	N	
11	C	51782149	1.00	PC	CB, THRM 250VAC 2.5A .21R F-2	IN			PPP4	N	
28	A	51917779	3.00	PC	SCR TPG HEX/W SLT (6) 3/8L B	IN	015549	102982	PPP3	N	
14	A	61409164	1.00	PC	CBL ASSY, 90-CNDCT SHLD RIB	IN			AYM4	N	
10	A	61409208	1.00	PC	FILTER ASSY, RFI LINE	IN			AYM4	N	
34	A	61409209	1.00	PC	WIRE ASSY, CKT BKR/PWR SW 3IN	IN			AYM4	N	
15	A	61409210	1.00	PC	WIRE ASSY, PWR SPLY CONNECTOR	IN			AYM4	N	
32	A	61409245	1.00	PC	WIRE ASSY JUMPER 3.75	IN			AYM4	N	
25	A	61409419	1.00	PC	WIRE ASSY, GROUND 3.75/11.5IN	IN			AYM4	N	
19	C	61409446	3.00	PC	COVER ASSY, OPTION BOARD	IN			AYM4	N	
18	D	61409447	1.00	PC	PANEL ASSY, REAR METAL	IN			AYM4	N	
16	C	71493328	1.00	PC	COVER, BATTERY (CR5/2P)	IN			PPP4	N	
17	C	71493329	1.00	PC	COVER, ROM PAK ACCESS (CR5/2P)	IN			PPP4	N	
13	B	71493356	1.00	PC	COVER, VOLTAGE SEL (CR5/2P)	IN			PPP4	N	
5	D	71493715	2.00	PC	FRAME, PC BOARD PTG (PLSTC)	IN	015224	660482	PPP4	N	
4	D	71494113	1.00	PC	FRAME (PTION BOARD METRIC	IN	017399	C80185	PPP4	N	
36	D	90446328	1.00	PC	CD ASSY 1AUD VIK X MOTHER BD	IN			AYM4	N	
1	D	90446515	1.00	PC	PCA 1AJD-2 (VX LOGIC BOARD)	IN	015337	081382	AYM4	N	
1	D	90446515	1.00	PC	PCA 1AJD-2 (VX LOGIC BOARD)	OUT	017571	C92085	AYM4	N	
2	D	90446687	1.00	PC	CD ASSY 81AND-4 (POWER SUPPLY	IN	016972	120784	AYM4	N	
1	D	90446749	1.00	PC	CD ASSY 1AJD-4	IN	017571	C92085	AYM4	N	
24	A	91975670	12.00	PC	NSHR, P4 EXT/T SPG-STL ZP	IN			PPP3	N	
31	A	91975685	1.00	PC	NSHR, P2 LOCK SPG-STL ZP	IN			PPP3	N	
29	A	91975690	2.00	PC	NSHR, P3 LOCK SPG-STL ZP	IN			PPP3	N	
25	A	91975723	2.00	PC	NUT, HEX M4 STL ZP	IN			PPP3	N	
30	A	91976336	1.00	PC	RSCR PAN SLT P2X10PH SST PASS	IN			PPP3	N	
28	A	91976626	2.00	PC	SCREW-PACHINE PAN HEAD	IN			PPP3	N	
32	A	91976638	8.00	PC	RSCR PAN PHL MAXEMM STL ZP	IN			PPP3	N	
35	C	93660009	2.00	PC	SCR-PAN HD/WASH LK 4-4CX .375	IN	016891	C92184	PPP3	N	
37	C	94203459	1.00	PC	SPG, EXT .62L 4.3LR/IN MM	IN			PPP4	N	
					NUMBER OF LINE ITEMS = 33						
					HIGHEST FIND NUMBER = 39						

AASTON REV 4-80 CDG
RVLEPS PFC INFO

PRINTED IN U.S.A.

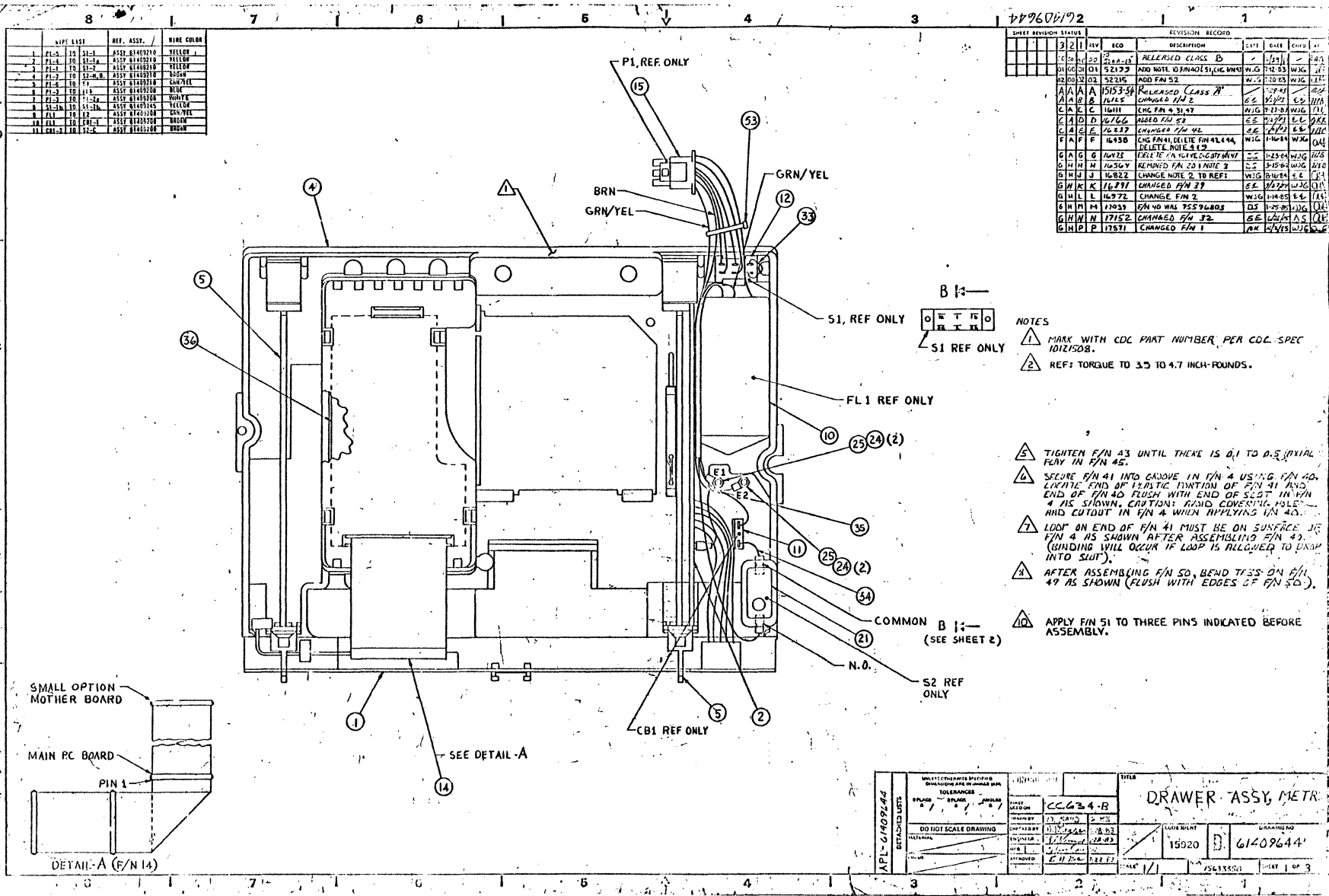

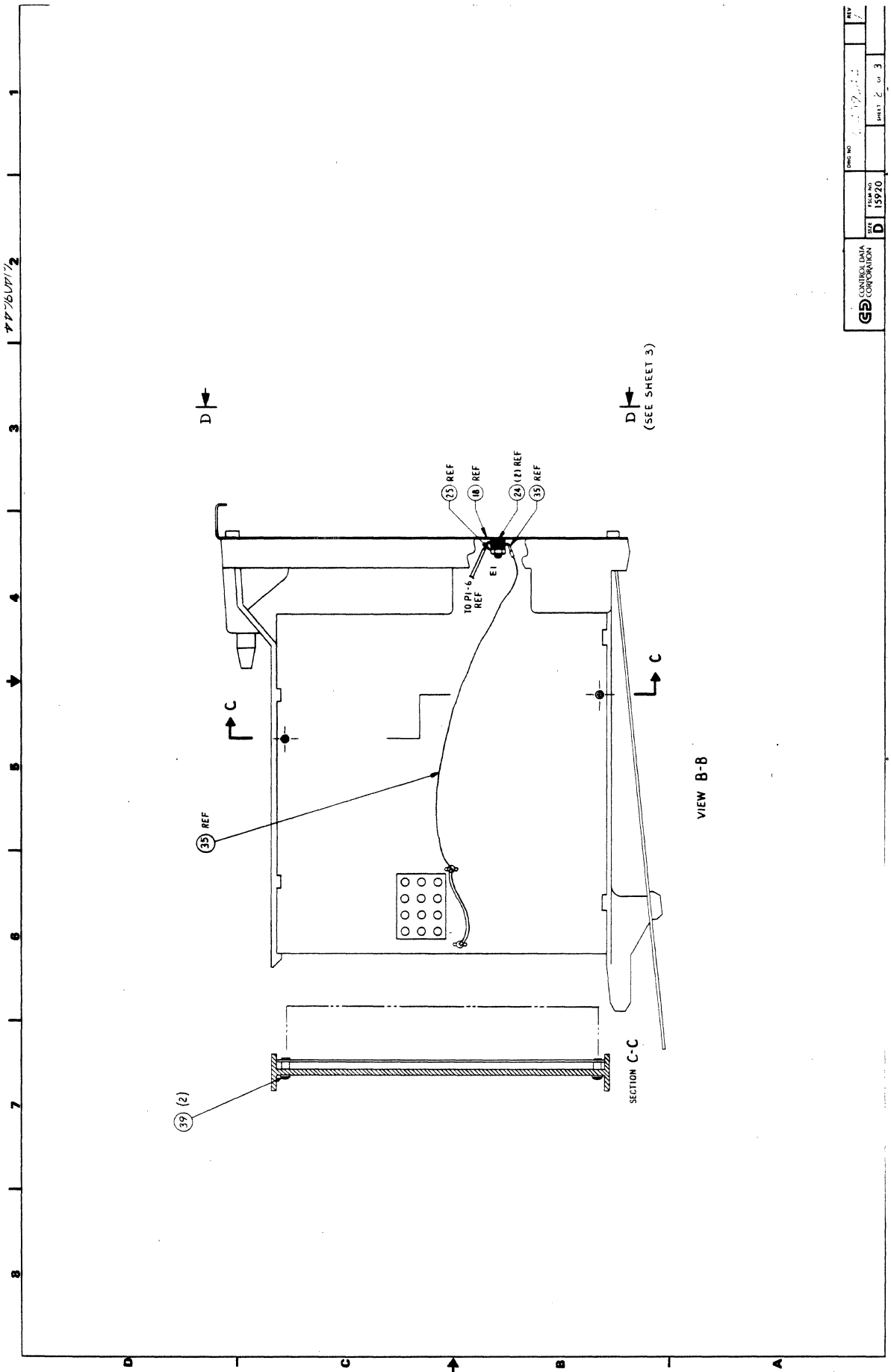

GENERAL DATA CORPORATION	DRAWING NO. 15920	SHEET NO. 2 OF 3	REV. 1
	SIZE D	SHEET NO. 2 OF 3	REV. 1

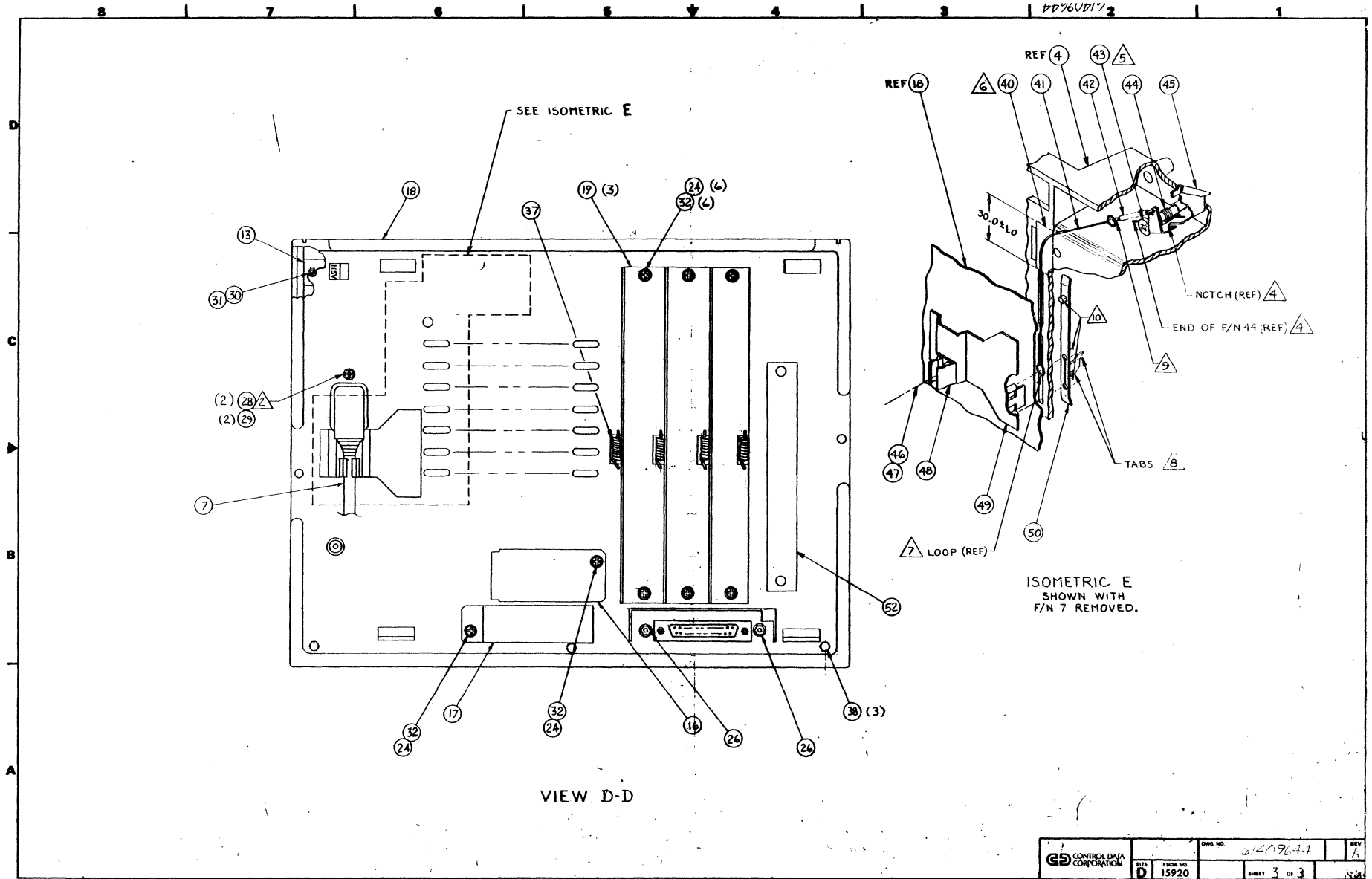

VIEW D-D

ISOMETRIC E
SHOWN WITH
F/N 7 REMOVED.

CONTROL DATA CORPORATION	SIZE	FROM NO.	DRAWING NO.	REV.
	D	15920	62940037-1	h
		SHEET	3 OF 3	

ASSEMBLY PARTS LIST

E14C9644		P	A	C	DRABER ASSY	CD	CC634A	07/29/85	017571	09/27/85	1 / 2
ASSEMBLY NUMBER		REV	CL	REV	ASSEMBLY DESCRIPTION	DESIGN SOURCE	PART USAGE	RELEASE DATE	CHANGE ORD. NUMBER	PROCESSING DATE	PAGE NUMBER

PF

FIND NUMBER	REV	PART NUMBER	QUANTITY	UNIT MEAS.	PART DESCRIPTION	IN/OUT STATUS	CHANGE ORD. NUMBER	DATE EFFECTIVE	MARK/MTY PART TYPE	PH	QTY
47	A	1C1256C0	1.00	PC	SPRING LOCK WASHERS (MED.)	IN	016473	C12084	PPP1	N	N
21	A	15002342	1.00	PC	SW, INTLK FIG-1 PNL-MTO SPST	IN			PPP4	N	N
12	A	15002347	1.00	PC	VOLTAGE SWITCH	IN			PPP4	N	N
26	A	15165C00	2.00	PC	NUT, HEX/FIG-LK #4 STL ZP	IN			PPP3	N	N
7	A	15165425	1.00	PC	CBL, 9FT-101A PWR FIG-1 125V	IN			PPP4	N	N
11	C	51782149	1.00	PC	CB, 1HRM 25GVAC 2.5A .21R F-2	IN			PPP4	N	N
38	A	51917779	3.00	PC	SCR TPG HEX/M SLT (6) 3/8L B	IN			PPP3	N	N
40	A	51942572	1.20	IN	TAPE PRESS SENSITIVE TRANSP	IN	017039	030885	PPP3	N	N
32	A	51942585	8.00	PC	SCREW MACH METRIC #4 8MM	IN	017152	C92785	PPP3	N	N
14	A	61409164	1.00	PC	CBL ASSY, 50-CNOCT SHLD RIB	IN			AYH4	N	N
10	A	61409200	1.00	PC	FILTER ASSY, RFI LINE	IN			AYH4	N	N
34	A	61409209	1.00	PC	WIRE ASSY, CMT BKR/PWR SW 3IN	IN			AYH4	N	N
15	A	61409210	1.00	PC	WIRE ASSY, PWR SPLY CGNECTOR	IN			AYH4	N	N
33	A	61409245	1.00	PC	WIRE ASSY JUMPER 3.75	IN			AYH4	N	N
35	A	61409419	1.00	PC	WIRE ASSY, GROUND 3.75/11.5IN	IN			AYH4	N	N
19	C	61409446	3.00	PC	COVER ASSY, OPTICON BOARD	IN			AYH4	N	N
52	B	61409647	1.00	PC	COVER SNAP ASSY	IN			AYH4	N	N
18	D	61409657	1.00	PC	PANEL ASSY METAL METRIC	IN			AYH4	N	N
16	C	71493328	1.00	PC	COVER, BATTERY (CRS/ZP)	IN			PPP4	N	N
17	C	71493329	1.00	PC	COVER, RCM PAN ACCESS (CRS/ZP)	IN			PPP4	N	N
13	B	71493356	1.00	PC	COVER, VOLTAGE SEL (CRS/ZP)	IN			PPP4	N	N
5	D	71493315	2.00	PC	FRAME, PC BOARD MTG (PLSTC)	IN			PPP4	N	N
49	C	71494109	1.00	PC	COVER A.C.CGMN	IN			PPP4	N	N
45	C	71494111	1.00	PC	PANL DMR LATCH (METRIC)	IN			PPP4	N	N
50	B	71494112	1.00	PC	STRIP RETAINER METRIC	IN			PPP4	N	N
4	D	71494113	1.00	PC	FRAME OPTICON BOARD METRIC	IN	016111	C90983	PPP4	N	N
41	C	71494301	1.00	PC	CABLE, LATCH, METRIC	IN	016438	C30284	PPP4	N	N
36	D	90446328	1.00	PC	CD ASSY 1AJD VIK X MOTHER BD	IN			AYH4	N	N
1	D	90446597	1.00	PC	CD ASSY 1AJD-3 LOGIC BD	OUT	017571	092085	AYH4	N	N
2	D	90446687	1.00	PC	CD ASSY 1AHC-4 IPCWER SUPPLY	IN	016972	122884	AYH4	N	N
1	C	90446749	1.00	PC	CD ASSY 1AJD-4	IN	017571	092085	AYH4	N	N
24	A	91975670	12.00	PC	WSHR, #4 EXT/T SPG-STL ZP	IN			PPP3	N	N
25	A	91975650	2.00	PC	WSHR, #3 LOCK SPG-STL ZP	IN			PPP3	N	N
23	A	91975723	2.00	PC	NUT, HEX #4 STL ZP	IN			PPP3	N	N
30	A	91976336	1.00	PC	MSCR PAN SLT #2X10PM SST PASS	IN			PPP3	N	N
28	A	91976626	2.00	PC	SCREW-MACHINE PAN HEAD	IN			PPP3	N	N

AA8708 REV 4-80 CDC
RVLCPS PFC INFO

PRINTED IN U.S.A.

ASSEMBLY PARTS LIST

E14C9644		P	A	C	DRABER ASSY	CD	CC634A	07/29/85	017571	09/27/85	2 / 2
ASSEMBLY NUMBER		REV	CL	REV	ASSEMBLY DESCRIPTION	DESIGN SOURCE	PART USAGE	RELEASE DATE	CHANGE ORD. NUMBER	PROCESSING DATE	PAGE NUMBER

PF

FIND NUMBER	REV	PART NUMBER	QUANTITY	UNIT MEAS.	PART DESCRIPTION	IN/OUT STATUS	CHANGE ORD. NUMBER	DATE EFFECTIVE	MARK/MTY PART TYPE	PH	QTY
32	A	91976638	8.00	PC	MSCR PAN PHL #4X8HP STL ZP	OUT	017152	C92785	PPP3	N	N
43	A	91976662	1.00	PC	MSCR PAN PHL #5X40MM STL ZP	IN			PPP3	N	N
35	C	93680C09	2.00	PC	SCR-PAN HD/WASH LK 4-4CX .375	IN	016891	092184	PPP3	N	N
37	C	94263459	1.00	PC	SPG, EXT .62L 4.3LB/IN MM	IN			PPP4	N	N
53	C	94277400	1.00	PC	STRAP CABLE TIE	IN	016166	C90983	PPP1	N	N
51	B	94846100	0.01	OZ	GREASE, SILICONE (OOM NO.44)	IN			RFE4	N	N

NUMBER OF LINE ITEMS = 42
HIGHEST FIND NUMBER = 53

AA8708 REV 4-80 CDC
RVLCPS PFC INFO

PRINTED IN U.S.A.

NOTE:

Page 3 of 61409644 Parts List has been deleted. Information contained on page 3 is now compiled on page 1 and 2 of revised parts list.

SHY	REV	ECO	DESCRIPTION	DFT	DATE	CHKD	APVD
00	00	00	RELEASED CLASS 6		12-81		
01	01	01	REVISED PER ECO	D.S.	12-81		
02	02	02	ADD NOTE 8 & SEC 6, PAR 14.7	WJC	12-22-81		
03	03	03	CHG NOTE 8, F/N 2, 8, 10, 11, 13	WJC	12-22-81		
04	04	04	REVISED PER ECO	D.S.	12-22-81		
05	05	05	ADD LED WIRES SHOW WIRE	WJC	12-22-81		
06	06	06	ADD F/N 6	D.S.	12-22-81		
07	07	07	RELEASED CLASS 6	JAC	11-12-83		
08	08	08	ADD NOTE 9	JAC	11-12-83		
09	09	09	REV 3 AT 64-23.5 WAS 28.1	WJC	12-22-83		
10	10	10	ADD F/N 19, NOTES 7-9	WJC	11-9-83		

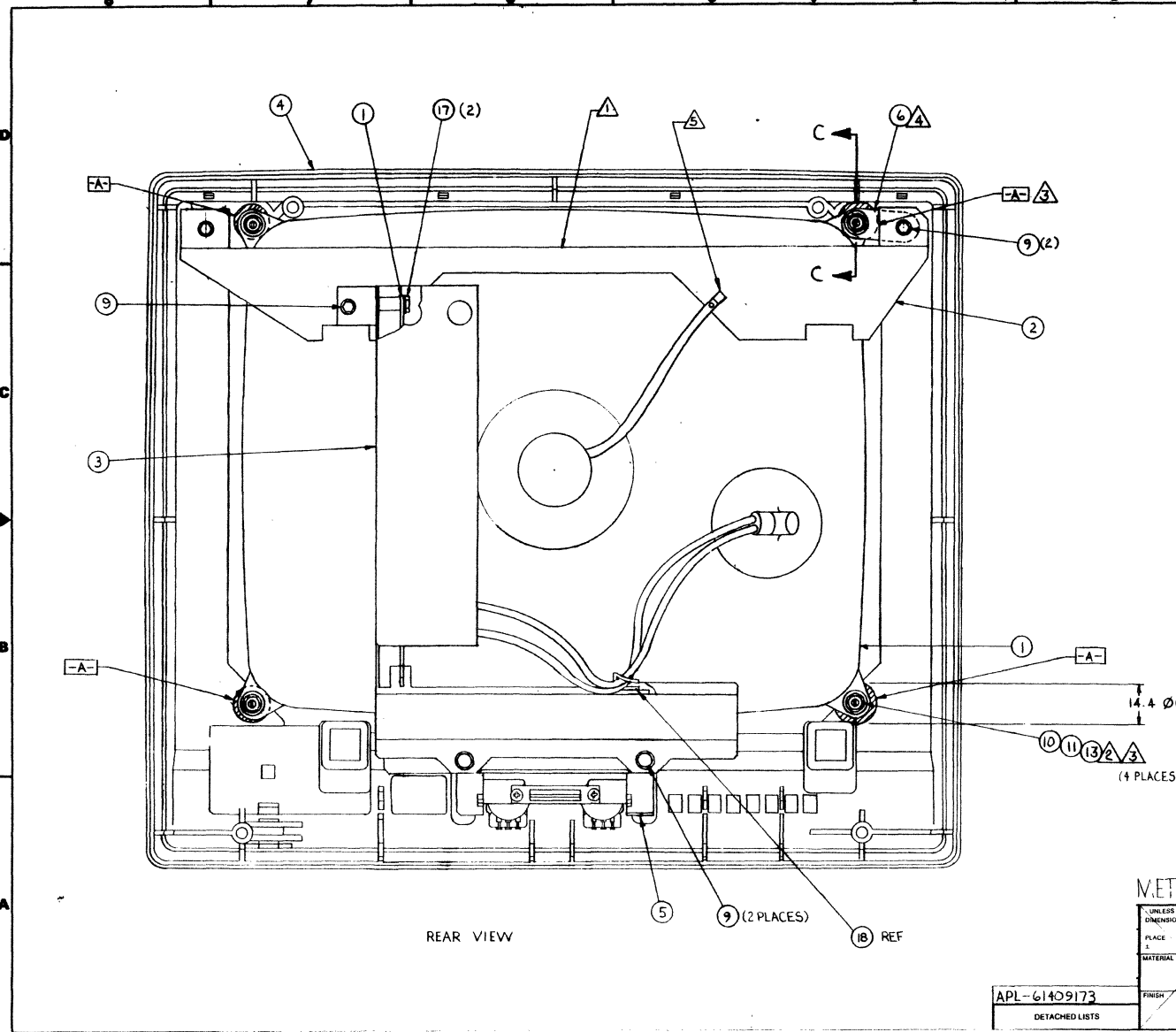

- NOTES:
- ▲ MARK ASSY 61409173 IN AREA SHOWN PER LDC SPEC 10121508.
 - ▲ TORQUE CRT FASTENERS 18-22 IN-LB FROM A FULLY TIGHTENED POSITION, BACK OUT F/N 11 (4) UNTIL "Z" PLANE ON FACE OF CRT IS LOCATED WITHIN SPECIFIED DISTANCE FROM CRT MOUNTING "M" PLANE. "M" PLANE IS DEFINED BY A-A (4), 14.4 ± 0.4 ZONES CENTERED AT MOUNTING STUD LOCATIONS, AND BEING ON THE MOLDED SURFACE OF F/N 4.
 - ▲ DEFORMING OF F/N 6 PERMISSIBLE.
 - ▲ CONNECT YELLOW CAG CABLE FROM CRT MONITOR ASSEMBLY TO F/N 2 AS SHOWN.
 - ▲ TERMINATE F/N 5 CABLE ASSY TO F/N 11 AS SHOWN.
 - ▲ APPLY F/N 19 WITH EQUAL AMOUNTS ON SURFACES INDICATED. DEPRESS FIRMLY BUT DO NOT RUB IF EMBOSSED DESIGN IS FLATTENED, THE CONDUCTIVITY OF COPPER TO APPLIED SURFACES, IS REDUCED.
 - ▲ CLEAN TENSION BAND ON CRT (2 PLACES) WITH ISOPROPYL ALCOHOL PRIOR TO APPLYING F/N 19. CAUTION: DO NOT GET ANY ALCOHOL ON THE CRT CONDUCTIVE COATING OR TAPE. CLEAN STEEL BAND ONLY USING A DAMPENED CLOTH OR EQUIVALENT.
 - ▲ TAPE MUST NOT TOUCH TABS.

METRIC

UNLESS OTHERWISE SPECIFIED DIMENSIONS ARE IN:		OWN: 10/22/81	DATE: 11/12/83	GENERAL DATA CORPORATION DISPLAY / BEZEL ADAPTER ASSY
TOLERANCES:		ENG: 11/12/83	DATE: 11/12/83	
PLACE	PLACES	ANGLES		
MATERIAL		APVD: E. M. HARRIS	DATE: 11/12/83	
FINISH		EQUIP. NO: CC634-A	DRAWN: 15920	DATE: 61409173
DETACHED LISTS		THIRD ANGLE PROJECTION	SCALE: 1:1	SHEET 1 OF 3

REVISION RECORD		DATE	BY	CHKD	APPD
REV	NO				

E/L160P1/2

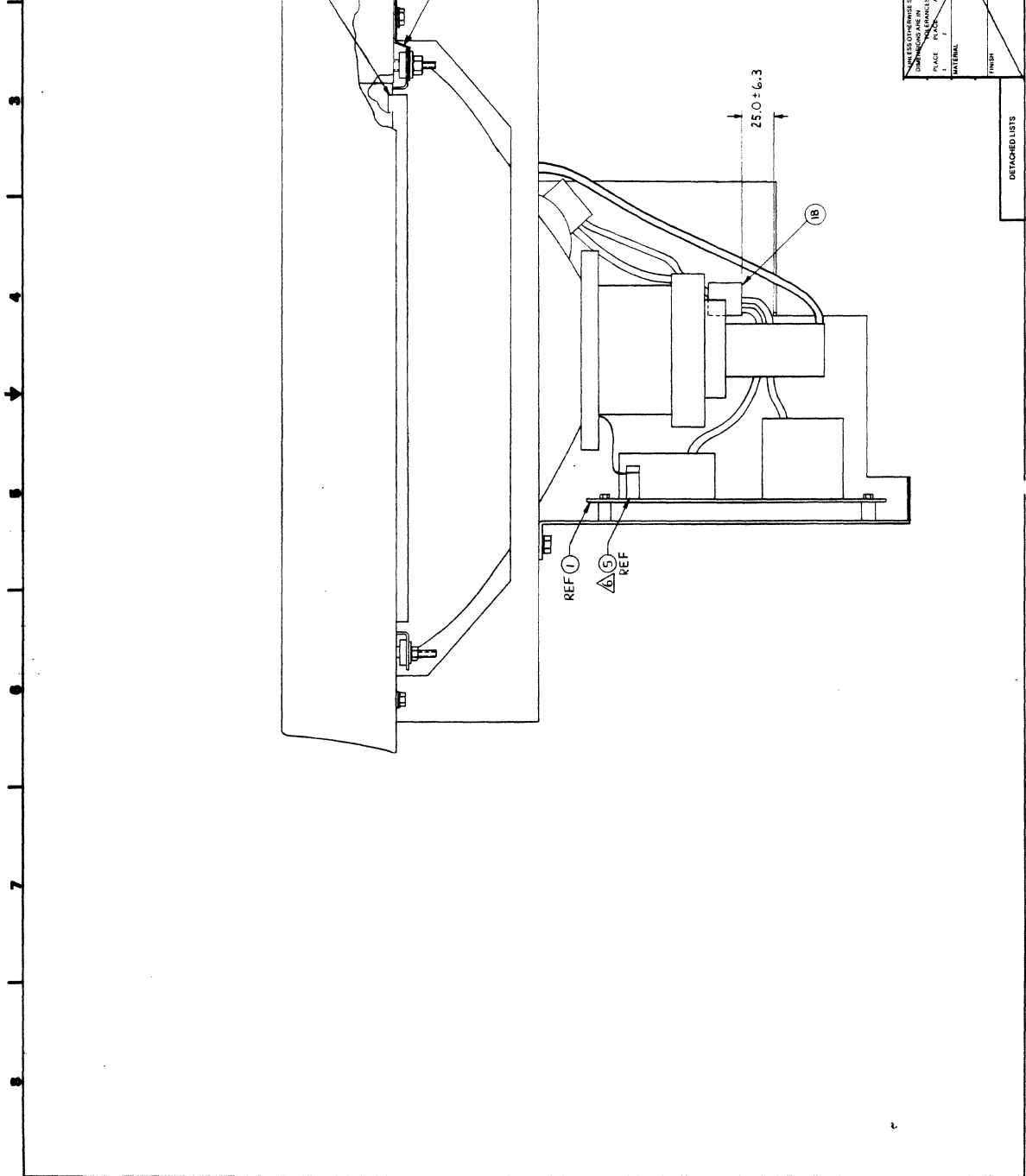

		GENERAL CONSTRUCTION	
DISPLAY/BEZEL ADAPTER ASSY			
SHEET NO. 15920		DRAWING NO. 61409173	
SCALE		REF. D	
SHEET 2 OF 3		DETACHED LISTS	

2-14

REVISION RECORD					
REV	ECO	DESCRIPTION	DRFT	DATE	CHRD

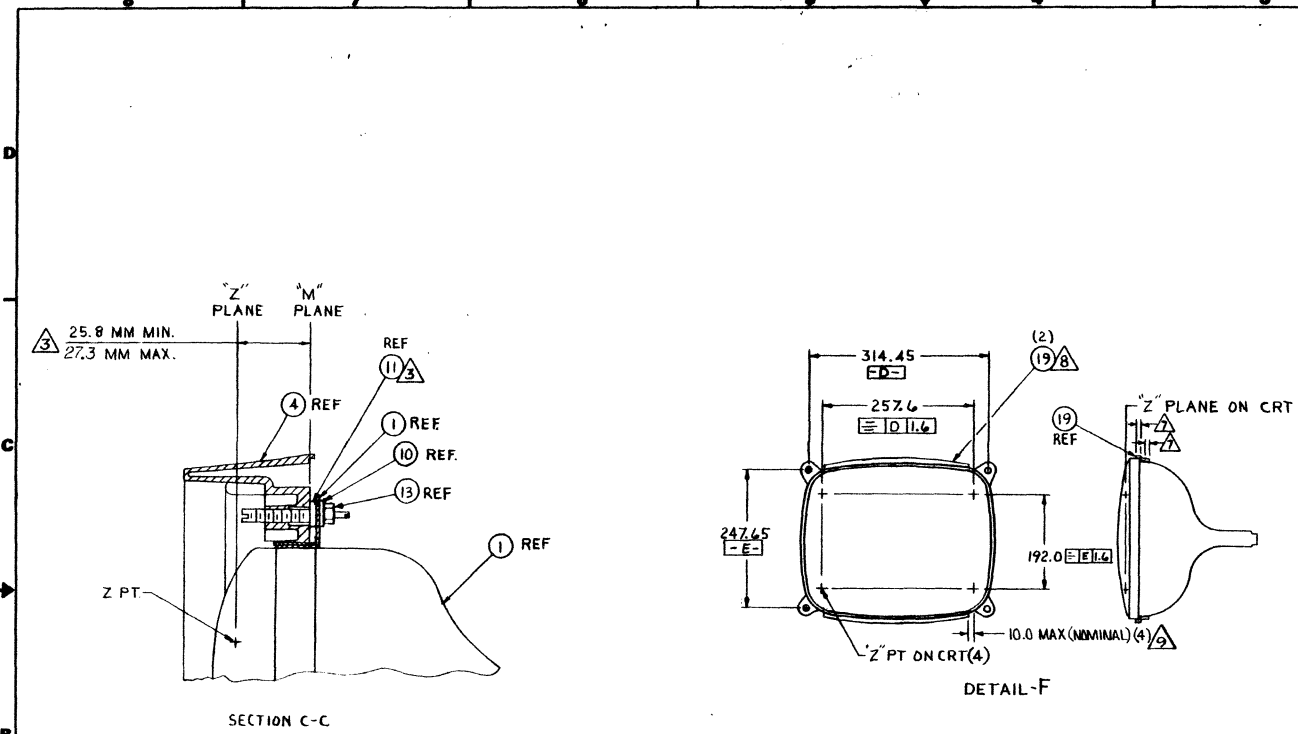

62940037 D

UNLESS OTHERWISE SPECIFIED DIMENSIONS ARE IN MILLIMETERS		<table border="1"> <tr><td>DRAWN</td><td> </td></tr> <tr><td>CHECKED</td><td> </td></tr> <tr><td>ENG'G</td><td> </td></tr> <tr><td>PLACED</td><td> </td></tr> <tr><td>MFG</td><td> </td></tr> <tr><td>MATERIAL</td><td> </td></tr> <tr><td>EQUIP NO.</td><td> </td></tr> <tr><td>FINISH</td><td> </td></tr> <tr><td>THIRD ANGLE PROJECTION</td><td> </td></tr> </table>	DRAWN		CHECKED		ENG'G		PLACED		MFG		MATERIAL		EQUIP NO.		FINISH		THIRD ANGLE PROJECTION		<table border="1"> <tr><td>CONTROL DATA CORPORATION</td></tr> <tr><td>TITLE</td><td>DISPLAY/BEZEL ADAPTER ASSY</td></tr> <tr><td>SIZE</td><td>D</td></tr> <tr><td>SCALE</td><td> </td></tr> <tr><td>FORM NO.</td><td>15920</td></tr> <tr><td>DWG NO.</td><td>61409173</td></tr> <tr><td>REV</td><td>D</td></tr> <tr><td>SHEET</td><td>3 OF 3</td></tr> </table>	CONTROL DATA CORPORATION	TITLE	DISPLAY/BEZEL ADAPTER ASSY	SIZE	D	SCALE		FORM NO.	15920	DWG NO.	61409173	REV	D	SHEET	3 OF 3
DRAWN																																				
CHECKED																																				
ENG'G																																				
PLACED																																				
MFG																																				
MATERIAL																																				
EQUIP NO.																																				
FINISH																																				
THIRD ANGLE PROJECTION																																				
CONTROL DATA CORPORATION																																				
TITLE	DISPLAY/BEZEL ADAPTER ASSY																																			
SIZE	D																																			
SCALE																																				
FORM NO.	15920																																			
DWG NO.	61409173																																			
REV	D																																			
SHEET	3 OF 3																																			

BUILD ARC 440

ASSEMBLY PARTS LIST

PRINT DATE	PAGE	FILE CHANGE NO.
03-31-83	1	00015826

DIV	ASSEMBLY NUMBER	CD	REV.	DWG.	DESCRIPTION	MC	STATUS	STATUS DATE	ENG. RESP	FILE DATE			
0860	61409173	4	0	0	ADPTR ASSY, VX DSPL/BEZEL	G	REL	4-14-82	CC634A	03-31-83			
TRND NO	LI	PART NUMBER	CD	QTY	U/M	PART DESCRIPTION	MC	YLD	ECO. NO. IN	ECO. NO. OUT	S/N	WE IN	WE OUT
001	01	51941006	2	1		PC DSPL (15IN) H-RSLTN Y/GRN P39	P						
002	01	71493578	0	1		PC BRK, SHIELD M7G (CRS/ZP)	P						
003	01	71493653	1	1		PC SHIELD, MONITOR BOARD (ALUM)	P						
004	01	71493298	5	1		PC ADAPTER, BEZEL (MLD OFF-WHT)	P						
005	01	61409244	3	1		PC CBL ASSY, VX MONITOR POT MTG	A						
006	01	71493674	7	1		PC STRAP, GROUNDING (BRASS/TIN)	P						
009	01	15164911	8	5		PC MSCR HEX/W-LK PLN M4X8MM STL	B						
010	01	71493541	8	4		PC WASHER, SHIM 1.5MM THK CRS/ZP	P						
011	01	71493539	2	4		PC STUD, CRT MOUNTING (STL/ZP)	P						
013	01	15165000	9	4		PC NUT, HEX/FLG-LK M4 STL ZP	B						
017	01	15164913	4	2		PC MSCR HEX/W-LK PLN M4X12MM STL	B						
018	01	94241017	6	1		PC CLIP, CARLE ADH-BACK TYP-VII	P						
019	01	51916986	6	1	800	FT COPPER FOIL TAPE 1.00W	W		15826			8315	
						0013 TOTAL LINES							

2-16

62940037

61409447

REVISION RECORD						
REV	EDD	DESCRIPTION	DRFL	DATE	CHKD	APVD
00	2000-07-04	RELEASED CLASS B		11/15/00		GA
01	2001-07-07	PAN 3 WARS 74893626		01-22-01		GA
02	2002-07-07	RELEASED CLASS B		07-22-02		GA

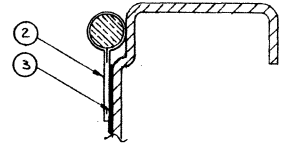
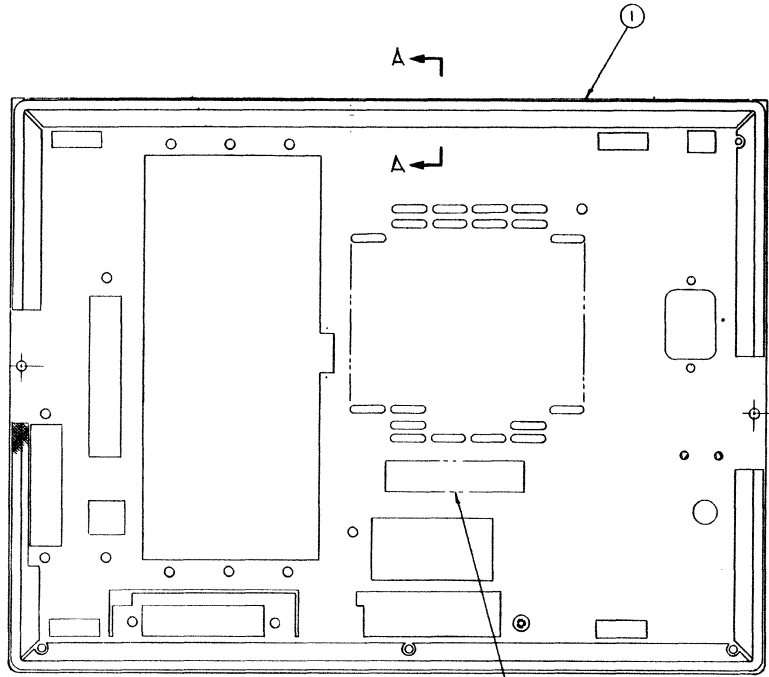

SECTION A-A
SCALE: 4/1

260 +3.0 / -0.0 (4)

- △ MARK WITH CDC PART NO. PER CDC SPEC 10121508
- 2 CUT GASKET AND ADHESIVE TO CLEAR CUTOUTS AND HOLES IN PANEL

METRIC

UNLESS OTHERWISE SPECIFIED DIMENSIONS ARE IN MILLIMETERS		DRWN: <i>[Signature]</i> 1-2-00	CD CONTROL DATA CORPORATION
CHCKD: <i>[Signature]</i> 07-02	TOLERANCES	ENGR: <i>[Signature]</i> 07-02	
PLACE: <i>[Signature]</i> 07-02	PLACE: <i>[Signature]</i> 07-02	ENGR: <i>[Signature]</i> 07-02	TITLE
MATERIAL: <i>[Signature]</i> 07-02	APVD: <i>[Signature]</i> 07-02	MFG: <i>[Signature]</i> 07-02	METAL PANEL ASSY
EQUIP NO: CC634 - A		FINISH: <i>[Signature]</i>	SIZE: D 15920
DETACHED LISTS		THIRD ANGLE PROJECTION	OWG NO: 61409447
			SCALE: 1/1 NHA 61409170 SHEET 1 OF 1

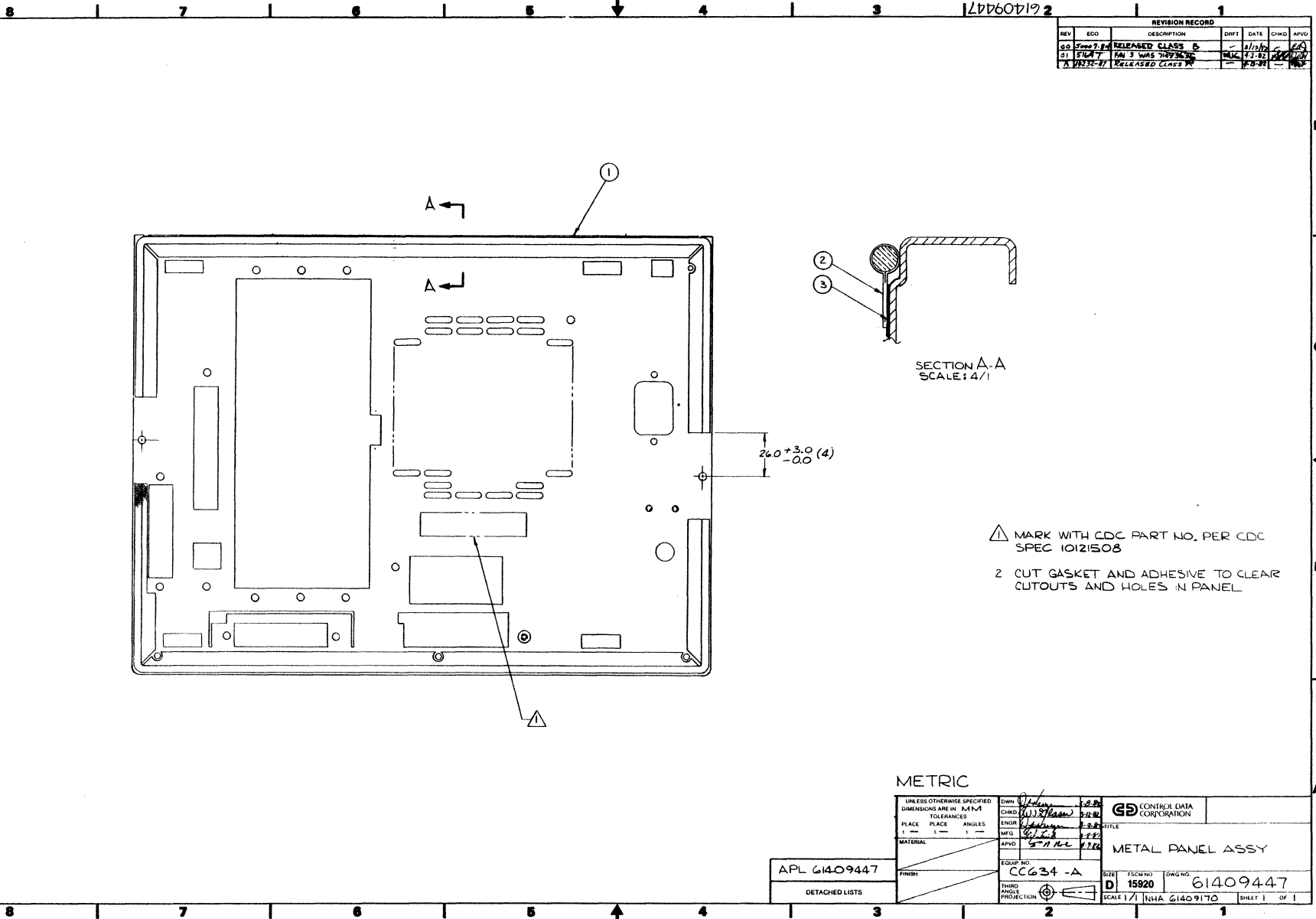

BUILD ARC 440

ASSEMBLY PARTS LIST

PRINT DATE	PAGE	FILE CHANGE NO.
04-15-82	1	14232-87

0860	61409447	2	A	D	METAL PANEL ASSY		N	REL	04-13-82	CC634A	04-15-82		
TRND NO	LI	PART NUMBER	CD	QTY	U/M	PART DESCRIPTION	MC	YLD	ECO. NO. IN	ECO. NO. OUT	S/N	WK IN	WK OUT
001	01	71493629	1	1		PC PANEL, BACK METAL							
002	01	17743506	2	4		PC NO DOC GASKET RFI SINGLE							
003	01	51941567	3	4		FT TAPE, ADHESIVE TRANSFER							
						0003 TOTAL LINES							

2-16.2

62940037 D

6409657

REVISION RECORD						
REV	ECO	DESCRIPTION	DRFT	DATE	CHKD	APVD
001	211-15	RELEASED CLASS B		6/21/81		6/21/81
01	52193	CORRECT F/N 1		7/2/83	WJG	7/2/83
02	52222	CORRECT F/N 3 QTY		7/25/83	WJG	7/25/83
A	1015332	RELEASED CLASS B		8/1/83		8/1/83

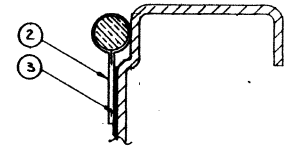
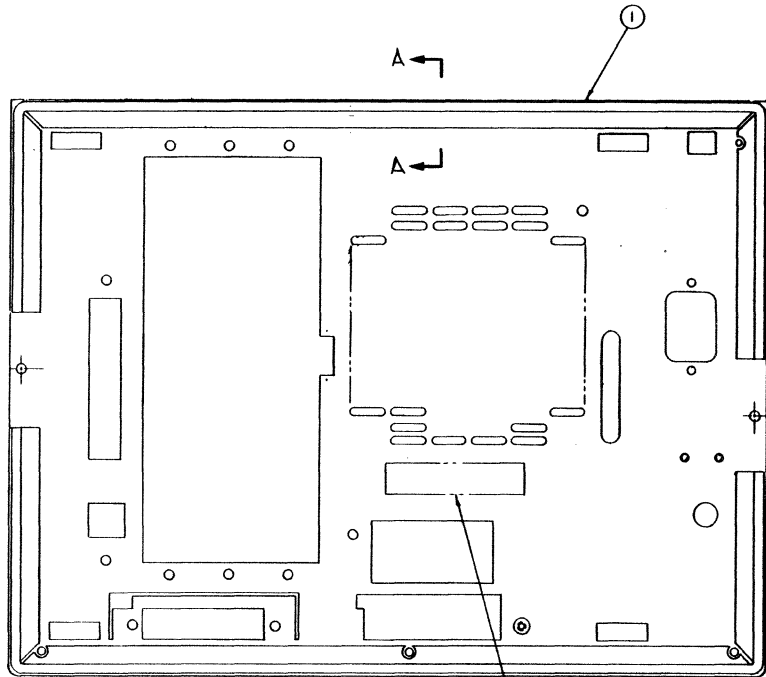

26.0 +3.0 (4)
-0.0

- NOTES:
- MARK WITH CDC PART NO. PER CDC SPEC 10121508.
 - CUT GASKET TO CLEAR CUTOUTS AND HOLES IN PANEL.
 - APPLY F/N 3 TO F/N 1 PRIOR TO INSTALLING F/N 2.

UNLESS OTHERWISE SPECIFIED DIMENSIONS ARE IN MM		DRWN	WJG	6/21/81	6/21/81	CD CONTROL DATA CORPORATION	TITLE PANEL ASSY, METAL, METRIC
PLACE	PLACE	ENGINEER	WJG	6/21/81	6/21/81		
±	±	APPROVED	WJG	6/21/81	6/21/81	SIZE	D 15920
MATERIAL		EQUIP NO	CC634 - B		DRWN NO	61409657	
FINISH		SHRD ANGLE	PROJECTION		SCALE	1/1 N/A 61409644 SHEET 1 OF 1	

APL 6409657
DETACHED LISTS

BUILD ARC 440

ASSEMBLY PARTS LIST

DIV.		ASSEMBLY NUMBER		CD	REV.	DWG.	DESCRIPTION	MC	STATUS	PRINT DATE	PAGE	FILE CHANGE NO.		
0860		61409657		6	A	D	PANEL ASSY METAL METRIC	N	REL	08-01-83	1	15153-52		
T		PL	LI	CD	Q	U/M	PART DESCRIPTION	MC	YLB	ECO. NO. IN	ECO. NO. OUT	S/N	WE IN	WE OUT
	001	01	71494139	0	1		PC PANEL BACK MOD OF METRIC		P					
	002	01	17743506	2	4		FT GSKT, RFI SGL MESH/NEO 1/80		P					
	003	01	71493834	7	1		PC TAPE-ADHESIVE, DIE CUT		B					
							0003 TOTAL LINES							

2-18

62940037

REVISION RECORD						
REV	ECO	DESCRIPTION	DRFT	DATE	CHKD	APVD
<<	Spec. FD	RELEASED CLASS B	-	3/1/82	✓	MB
A	1423277	RELEASED CLASS A	-	4-5-82	-	MB

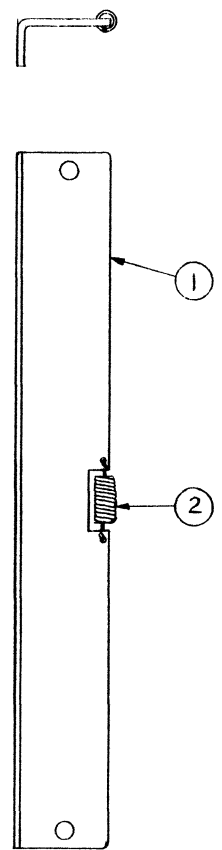

NOTES:

- 1. BULK IDENTIFY WITH CDC PART NO.

METRIC

APL 61409446

DETACHED LISTS

UNLESS OTHERWISE SPECIFIED DIMENSIONS ARE IN MM		DWN	W. J. Blaser	3-5-82	CONTROL DATA CORPORATION
TOLERANCES		CHKD	D. Lamb	3-5-82	
PLACE	PLACE	ANGLES	ENGR	D. Friedman	3-10-82
±	±	±	MFG	AP	4-5-82
MATERIAL		APVD	Z. H. Lee	4-5-82	OPTION BOARD COVER ASSY
FINISH		EQUIP. NO.	CC634-A		
THIRD ANGLE PROJECTION		SCALE	SIZE	FSCM NO.	DWG NO.
		C	15920	61409446	
		SCALE		NHA 61409170	SHEET OF

B 61409446 ↑

A

BUILD ARC 440

ASSEMBLY PARTS LIST

PRINT DATE	PAGE	FILE CHANGE NO.
04-07-82	1	14232-72

DIV.	ASSEMBLY NUMBER	CD	REV.	DWG.	DESCRIPTION	MC	STATUS	STATUS DATE	ENG. RESP.	FILE DATE			
0860	61409446	4	A	C	OPTION COVER ASSY	N	REL	04-05-82	CC634A	04-07-82			
FINDING	LI	PART NUMBER	CD	QUANTITY	U/M	PART DESCRIPTION	MC	YLD	ECO. NO. IN	ECO. NO. OUT	S/N	WK IN	WK OUT
	001	01 71493627	5	1		PC COVER OPTION BOARD		P					
	002	01 94203499	2	1		PC SPRING EXTENSION		P					
						0002 TOTAL LINES							

61409647

SHEET REVISION STATUS										REVISION RECORD					
REV	ECO	DESCRIPTION				DRFT	DATE	CHKD	APP						
00	80011-15	RELEASED CLASS B				-	6/29/83	-	EAG						
A	15153-52	RELEASED CLASS M				-	4-1-83	-	MCP						

NOTES:
 ⚠ MARK WITH CDC PART NUMBER PER CDC SPEC 10121508.

UNLESS OTHERWISE SPECIFIED DIMENSIONS ARE IN MM TOLERANCES			DWN	W. J. Blaser	5-31-83	CONTROL DATA CORPORATION	TITLE		
PLACE	PLACE	ANGLES	CHKD	W. J. Blaser	6-28-83		COVER / SNAP ASSY		
±	±	±	ENGR	<i>[Signature]</i>	6-28-83	SIZE	FSCM NO.	DWG NO.	
MATERIAL			MFG	<i>[Signature]</i>	6-28-83	B	15920	61409647	
FINISH			APVD	E. H. Noel	7-20-83	SCALE	NHA	15633350	
APL 61409647			EQUIP. NO.	CC634-B		SHEET 1 OF 1			
DETACHED LISTS			THIRD ANGLE PROJECTION						

BUILD ARC 440

ASSEMBLY PARTS LIST

PRINT DATE	PAGE	FILE CHANGE NO.
8-1-83	1	15153-52

DIV.		ASSEMBLY NUMBER	CD	REV.	DWG.	DESCRIPTION	MC	STATUS	STATUS DATE	ENG. RESP.	FILE DATE			
0040		61409447	7	A	B	COVER SNAP ASSY	N	REL	8-1-83	CC63AA	8-1-83			
TRND NO.	LI	PART NUMBER	CD	IN	QUANTITY	U/R	PART DESCRIPTION	MC	YLD	ECO. NO. IN	ECO. NO. OUT	S/N	WE IN	WE OUT
001	01	71494097	0		1		PC COVER CONN OPENING METRIC	P						
002	01	51942400	6		2		PC PLUS HOLE	P						
							0002 TOTAL LINES							

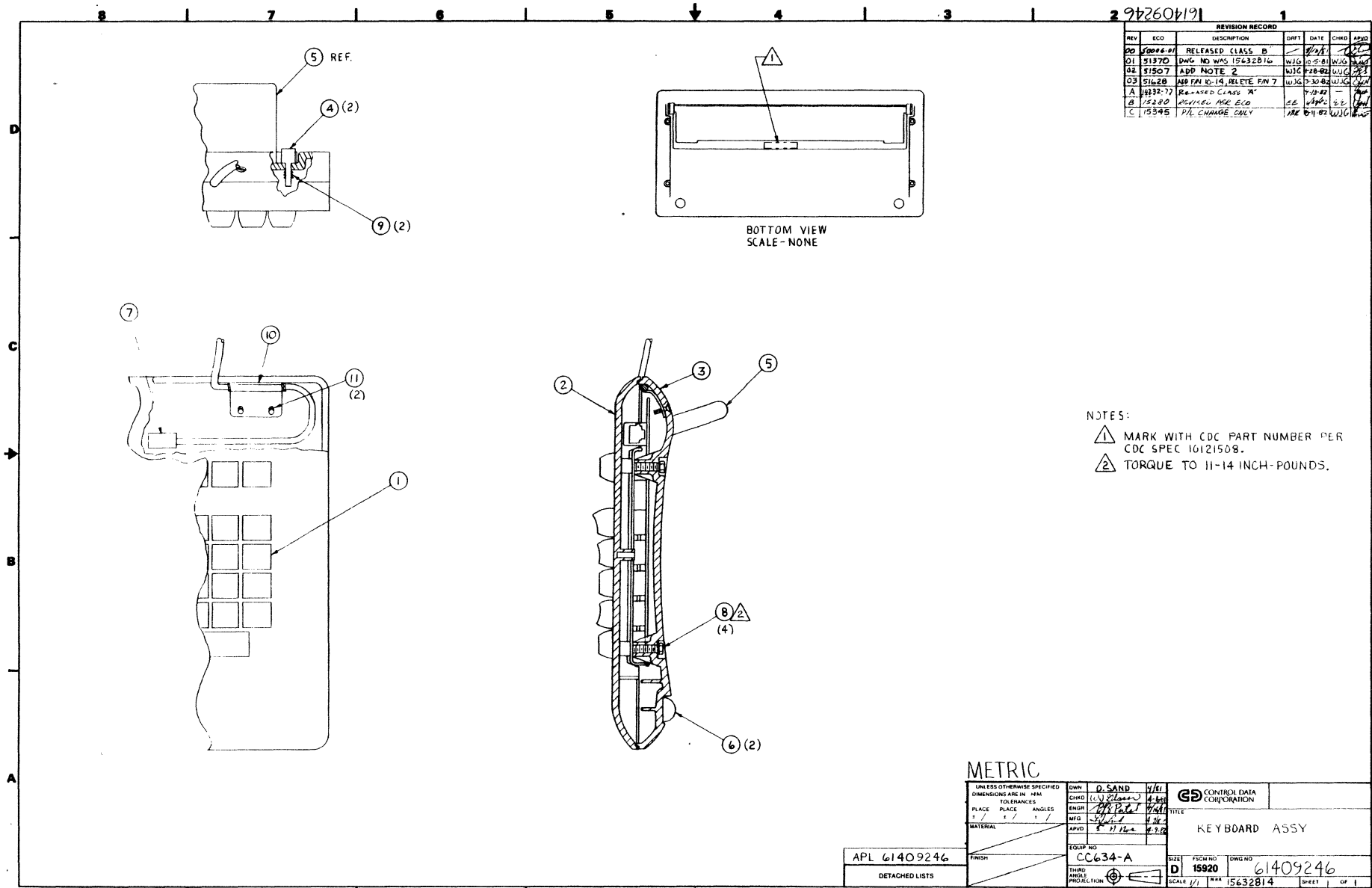

BUILD ARC 440

ASSEMBLY PARTS LIST

PRINT DATE	PAGE	FILE CHANGE NO.
07-27-82	1	00010345

DIV.		ASSEMBLY NUMBER	CD	REV.	DWG.	DESCRIPTION	MC	STATUS	STATUS DATE	ENG. RESP.	FILE DATE		
0860		61409246	B	C	D	KYBD ASSY	0	REL	04-13-82	CC034A	07-27-82		
FIND NO	LT	PART NUMBER	CD	QTY	U/M	PART DESCRIPTION	MC	YLD	ECO. NO. IN	ECO. NO. OUT	S/N	WK IN	WK OUT
001	01	51941115	1	1		PC KYBD 85 KEY SERIAL I/O	P						
002	01	71493276	1	1		PC COVER TOP KEYBOARD	P						
003	01	71493279	5	1		PC COVER BOTTOM KYBD	P						
004	01	71493238	1	2		PC RETAINER KEYBOARD LEG	P						
005	01	71493241	5	1		PC LEG KEYBOARD	P						
006	01	51805803	7	2		PC BUMPER, RUBBER .330H SLF-STK0	B						
007	01	61409451	4	1		PC KYBD CABLE ASSY	A		15345	15345		0232	
007	02	61409530	5	1		PC KEYBOARD CABLE ASSY	A					0232	
008	01	15164916	7	4		PC MSCR HEX=LK PLN MAX22MM STL 2	B						
009	01	94205715	9	2		PC SPRING COMPRESSION	P						
010	01	71493635	8	1		PC REPLACED BY 71493739 15280	P						0301
010	02	71493739	8	1		PC CLAMP CABLE	P		15280	15280		0301	0301
011	01	91975795	5	2		PC SCREW METRIC M3 10 MM	B			15280			0301
011	02	18862901	8	2		PC SCREW TND PH 4-40X3/8	B		15280			0301	0301
012	01	91975669	2	2		PC WSHR METRIC SCREW SZ 3	B			15280			0301
013	01	91975722	9	2		PC NUT METRIC HEX SZ MM3	B			15280			0301
						0016 TOTAL LINES							

227007172

REV	BY	DATE	DESCRIPTION
1	1	1/11/58	RELEASED CLASS B
2	1	1/11/58	RELEASED CLASS A

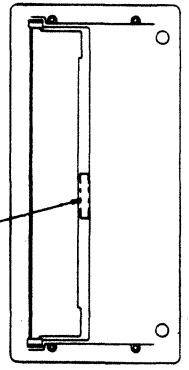

BOTTOM VIEW
SCALE - NONE

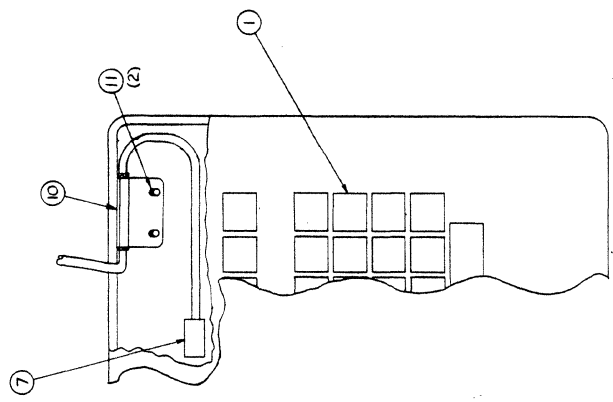
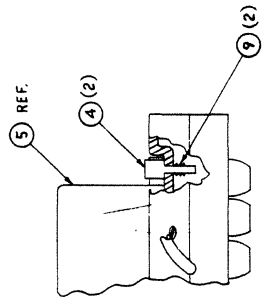
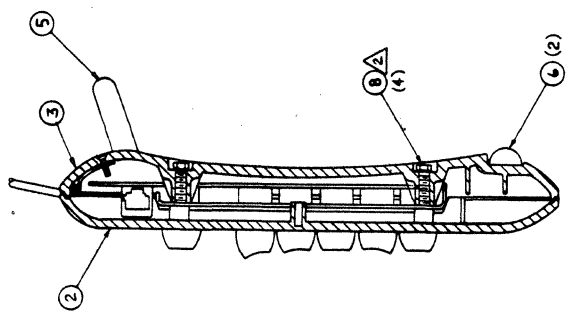

NOTES:
 ▲ MARK WITH CDC PART NUMBER PER CDC SPEC 10121508.
 ▲ TORQUE TO 11-14 INCH-POUNDS.

UNLESS OTHERWISE SPECIFIED		FORM	D. S. SANDS	4-62
DIMENSIONS ARE IN INCHES		CONTRACT DATA	CDR (A) J. M. KELLY	1-58
PLATE PLACE		ENGINEER	W. H. HARRIS	1-58
MATERIAL		DATE	5/11/58	1-58
FINISH		GROUP NO.	CC634-B	
APL 6/409656		THIRD PRODUCTION		
DETACHED LISTS		REVISION RECORD		
		REVISION RECORD		
		DESCRIPTION		
		RELEASED CLASS B		
		RELEASED CLASS A		
		FORM NO.	15920	
		SCALE	1/16"	
		KEYBOARD ASSY, METRIC		
		APL 6/409656		
		FORM NO.	15920	
		SCALE	1/16"	
		KEYBOARD ASSY, METRIC		
		APL 6/409656		
		FORM NO.	15920	
		SCALE	1/16"	
		KEYBOARD ASSY, METRIC		
		APL 6/409656		

BUILD ARC 210				ASSEMBLY PARTS LIST				PRINT DATE	PAGE	FILE CHANGE NO.			
				REPLACED BY 90446496 15224				06-10-82	1	1659 90015224			
Q888	ASSEMBLY NUMBER	CD	REV.	DWG.	DESCRIPTION	MC	STATUS	STATUS DATE	ENG. DESG.	FILE DATE			
Q888	90446296	7	CM	D	REPLACED BY 90446496 15224	A	INA	06-03-82	CC034A	06-10-82			
Q888	LI	PART NUMBER	CD	QUANTITY	U/M	PART DESCRIPTION	MC	YLD	ECO. NO. IN	ECO. NO. OUT	S/N	WE IN	WE OUT
001	01	90446295	9	1		PC PW 80 1AHD VIKING X PWR SPLY	P						
002	01	15112100	1	1		PC IC NE555 910 TIMER 8-PIN	P						
003	01	15125501	5	1		PC IC OP AMP	P						
004	01	15163403	7	1		PC IC LM317 ADJ 4V RGLTR 10-220	P						
005	01	15163404	7	1		PC IC TL494 PULSE W/MOD	P						
006	01	15191402	3	1		PC IC UAY900-12 356C NEG V RGLTR	P						
007	01	15151503	0	1		PC IC UAY900-12 357D POS V RGLTR	P						
008	01	15167039	1	1		PC IC LM 250 3AMP	P						
009	01	91906600	5	2		PC HT SINK, SEMI FIG 2 ALUM BLK	P						
010	01	91911000	1	2		PC HT SINK, TO-3 SEMI ALUM BLK	P						
011	01	91911001	9	1		PC HEAT SINK	P						
012	01	91910101	0	2		PC HT/SK PLSTC SEMI FIG1 AND2	P						
013	01	94397113	5	1		PC CAP ALI ELECT 470 UF 50V	P						
014	01	91906103	9	1		PC CONN, 6 PIN PC MTD TIN FIG 2	P						
015	01	91906105	5	1		PC CONN, 12PIN PC MTD TIN FIG 4	P						
016	01	91906101	4	1		PC CONN, 3 PIN PC MTD TIN FIG 1	P						
017	01	95691501	1	2		PC RECTIFIER 1N5617	P						
018	01	91903000	4	4		PC LED, 5-8 GAP RED 1.0MCD 100MV	P						
019	01	10126937	1	2		PC XFMR, 20-40KHZ DRIVER 12V	P						
020	01	10126941	3	1		PC XFMR, 20-40KHZ CURR SENSE 4A	P						
021	01	10126945	4	1		PC XFMR, 20-40KHZ MULTI-OUTPUT 2	P						

BUILD ARC 210				ASSEMBLY PARTS LIST				PRINT DATE	PAGE	FILE CHANGE NO.			
				REPLACED BY 90446496 15224				06-10-82	2	1659 90015224			
Q888	ASSEMBLY NUMBER	CD	REV.	DWG.	DESCRIPTION	MC	STATUS	STATUS DATE	ENG. DESG.	FILE DATE			
Q888	90446296	7	CM	D	REPLACED BY 90446496 15224	A	INA	06-03-82	CC034A	06-10-82			
Q888	LI	PART NUMBER	CD	QUANTITY	U/M	PART DESCRIPTION	MC	YLD	ECO. NO. IN	ECO. NO. OUT	S/N	WE IN	WE OUT
022	01	10126999	1	1		PC XFMR, 50-60HZ STEP-DOWN PC MT	P						
023	01	91910625	9	1		PC INDUCTOR	P						
024	01	91910619	1	2		PC INDUCTOR 26ANG 1.0 AMP	P						
025	01	91910624	1	1		PC INDUCTOR	P						
026	01	91900601	1	2		PC THMS, DISC 5 OHM 10P 15MW	P						
027	01	91903092	7	2		PC XSTR 2N2222 HI SPEED MPN SIL	P						
028	01	91904500	5	1		PC XSTR TO-18 EPITPLANAR N-CHSE	P						
029	01	91714000	0	4		PC XSTR 2N2907 PNP SIL	P						
030	01	99770000	4	2		PC TRANSISTOR 2N6300	P						
031	01	93314010	5	1		PC RECTIFIERSIL 50PRV CASE FIG 1	P						
032	01	15166627	9	1		PC RECTIFIER DUAL SCHOTTKY	P						
033	01	15165590	9	1		PC RECTIFIER, DUAL	P						
034	01	15165603	0	1		PC RECT, BRIDGE 10A	P						
035	01	91907305	1	4		PC DIO IN4140 10MA MICRO SIL 30V	P						
036	01	95691506	0	4		PC RECT, 1N5410 P-R SIL 3 AMP	P						
037	01	50240107	0	1		PC DIODE SIL ZEN 5.0V	P						
038	01	50240112	0	1		PC DIODE SIL ZEN 9.1V	P						
039	01	50240116	9	1		PC DIODE SILICON ZENER	P						
040	01	95637304	7	9		PC DIO IN4004 400PIV SIL 1.0V/1A	P						
041	01	94240433	6	1		PC CAP CER 3300PF 50V 10P	P						
042	01	94240401	3	2		PC CAP CER 1000PF 50V 10P	P						

BUILD ARC 210

ASSEMBLY PARTS LIST

PRIME DATE 06-10-82 PAGE 3 FILE CHANGE NO. 1654 00019224

QTY	ASSEMBLY NUMBER	CD	REV.	DWG.	DESCRIPTION	MC	STATUS	STATUS DATE	ENG. RESP.	FILE DATE			
0000	90446290	7	C	D	REPLACED BY 90446490 19224	A	INA	06-03-82	CC034A	06-10-82			
ITEM NO	LI	PART NUMBER	CD	QTY	U/M	PART DESCRIPTION	MC	YTD	ECO. NO. IN	ECO. NO. OUT	S/N	WE IN	WE OUT
043	01	24506801	0	1		PC CAP FXD MYL .001MFD 10P 100V	P						
044	01	36180753	0	1		PC CAP FXD MYL .001MFD 600V	P						
045	01	94858601	1	2		PC CAPACITOR CER .01UF 3000V 20P	P						
046	01	94240411	2	2		PC CAP CER 10000 PF 50V 10P	P						
047	01	24506807	7	1		PC CAP FXD MYL .01UF 10P 100VDC	P						
048	02	24504857	4	1		PC RES FXD COMP 560 OHM 5P 2WATT	P						
049	01	94240440	4	5		PC CAP CER 100000PF 50V 10P	P						
050	01	94240482	0	1		PC CAP CER 220000 50V 10P	P						
051	01	36180706	0	2		PC CAP NYLAR 1.0MFD 50VDC	P						
052	01	36180721	7	1		PC CAP NYLAR 1.0MFD 200VDC	P						
054	01	12009273	2	1		PC CAP ALI ELCYLT 10UF 10P 25VDC	P						
055	01	94400612	1	2		PC CAP FXD AL 15UF*100-10P 25V	P						
056	01	94400622	0	1		PC CAP ELECT 47UF 20V	P						
057	01	05691133	2	2		PC CAP ELEC 270UF -10*100P 25VDC	P						
058	01	15002220	0	2		PC CAP ALI 390UF -10*30P 250VDC	P						
059	01	94397119	2	1		PC CAP ALI ELECT 600 UF 50V	P						
060	01	94397148	7	2		PC CAP ALI ELECT 2700UF 12V	P						
061	01	51918876	7	2		PC RES VAR CER 1K OHM 20P 1/2W	P						
062	01	94402187	2	1		PC RES 20K OHM 1/4W CARBON	P						
063	01	51918878	2	1		PC RES VAR CER 5KOHMS 20P 1/2W	P						
064	01	51903000	1	1		PC RES FXD MW .01 OHM 5P 2WATT	P						

BUILD ARC 210

ASSEMBLY PARTS LIST

06-10-82 4 1654 00019224

QTY	ASSEMBLY NUMBER	CD	REV.	DWG.	DESCRIPTION	MC	STATUS	STATUS DATE	ENG. RESP.	FILE DATE			
0000	90446290	7	C	D	REPLACED BY 90446490 19224	A	INA	06-03-82	CC034A	06-10-82			
ITEM NO	LI	PART NUMBER	CD	QTY	U/M	PART DESCRIPTION	MC	YTD	ECO. NO. IN	ECO. NO. OUT	S/N	WE IN	WE OUT
065	01	24504813	2	1		PC RES FXD COMP 10 OHM 5P 2WATT	P						
066	01	24504827	7	1		PC RES FXD COMP 33 OHM 5P 2W	P						
067	01	17720612	0	2		PC RES FXD COMP 0.1MEG 1W 5P	P						
068	01	24500123	0	2		PC RES FXD COMP 22 OHM 5P 1/2W	P						
069	01	24500166	4	2		PC RES FXD COMP 1300 OHM 5P 1/2W	P						
070	01	94402220	4	4		PC RES FM 1.0M OHM 1/4W CARBON	P						
071	01	17709900	7	1		PC RES FXD COMP 10M OHM 5P 1/4W	P						
072	01	94402132	0	2		PC RES FM 100 OHM 1/4W CARBON	P						
073	01	94402190	0	1		PC RES FM 27K OHM 1/4W CARBON	P						
075	01	94360236	7	2		PC RES FXD FM 237 OHM 1P 1/4W	P						
075	02	94360232	7	1		PC RES FXD FM 237 OHM 1P 1/4W	P	16541	16541			8417	8417
076	01	94402148	4	2		PC RES FM 470 OHM 1/4W CARBON	P						
076	02	94402148	4	2		PC RES FM 470 OHM 1/4W CARBON	P	16541	16541			8417	8417
077	01	95596520	7	2		PC RES FXD MW 600 OHM 10P 2WATT	P						
078	01	94360300	1	6		PC RES FXD FM 1000 OHM 1P 1/4W	P						
078	02	94360300	1	7		PC RES FXD FM 1000 OHM 1P 1/4W	P	16541	16541			8417	8417
079	01	94402160	0	1		PC RES FM 1.0K OHM 1/4W CARBON	P						
080	01	94360320	2	1		PC RES FXD FM 1000 OHM 1P 1/4W	P						
080	02	94360323	0	1		PC RES FXD FM 1740 OHM 1P 1/4W	P	16541	16541			8417	8417
081	01	94360329	0	1		PC RES FXD FM 2000 OHM 1P 1/4W	P						
082	01	94360353	0	1		PC RES FXD FM 3570 OHMS 1/4W 1P	P						
083	01	94402160	0	4		PC RES FM 2.7K OHM 1/4W CARBON	P						
084	01	94402169	0	1		PC RES FM 3.6K OHMS 1/4W CARBON	P						
085	01	94360357	1	1		PC RES FXD FM 3000 OHM 1P 1/4W	P						
086	01	94402197	1	1		PC RES FM 51K OHM 1/4W CARBON	P						

BUILD ARC 210				ASSEMBLY PARTS LIST				PRINT DATE	PAGE	FILE CHANGE NO.			
				REPLACED BY 90446496 15224				06-10-82	6	16541 00015224			
QTY	ASSEMBLY NUMBER	CD	REV.	DWG.	DESCRIPTION	MC	STATUS	STATUS DATE	ENG. RESP.	FILE DATE			
0000	90446296	7	C	D	REPLACED BY 90446496 15224	A	INA	06-03-82	CC634A	06-10-82			
ITEM NO	LI	PART NUMBER	CD	QTY	U/M	PART DESCRIPTION	MC	YLD	ECO. NO. IN	ECO. NO. OUT	I/M	WE IN	WE OUT
007	01	94402179	9	1		PC RES FM 9.1K OHM 1/4W CARBON	P						
008	01	94402178	1	2		PC RES FM 8.2K OHMS 1/4W CARBON	P						
009	01	94402176	5	1		PC RES FM 6.8K OHM 1/4W CARBON	P						
000	01	94402180	7	7		PC RES FM 10K OHM 1/4W CARBON	P						
001	01	94402184	9	1		PC RES FM 15K OHM 1/4W CARBON	P						
002	01	94360481	2	1		PC RES FXD FM 34.5K OHM 1P 1/4W	P						
003	01	94402193	0	1		PC RES FM 36K OHM 1/4W CARBON	P						
004	01	94402221	9	2		PC RES FM 510K OHM 1/4W CARBON	P						
009	01	91003962	1	001		OZ PASTE, HEAT XPR COMPD NON-COND	B						
006	01	10127163	9	4		PC WSCR PAN PHL 4-40X.312 STL ZP	B						
007	01	10126400	9	4		PC WSCR, NO.4 EXT/T LK STL ZP	B						
008	01	10120103	1	4		PC NUT, HEX 4-40 WSCR STL ZP	B						
009	01	00009901	9	0		PC NUT, HEX 6-32 WSCR SMALL DIA	B						
100	01	10120401	0	0		PC WSCR, NO.6 EXT/T LK STL ZP	B						
101	01	92700164	7	4		PC WSCR PAN SLT 6-32X1/2 SST P.	B						
102	01	90446204	2	REF		PC SCH DIA0 1AHO VIKING X P SPLY	D						
103	01	10006000	9	REF		PC FABRICATION SPECIFICATION	D						
104	01	10126600	4	1		PC IC LH339 341 QUAD COMPARTOR	P						
105	01	94402168	0	1		PC RES FM 2.4K OHM 1/4W CARBON	P						
106	01	94402194	0	1		PC RES FM 30K OHMS 1/4W CARBON	P						
107	01	24000172	2	2		PC RES FXD COMP 2400 OHM 5P 1/2W	P						

BUILD ARC 210				ASSEMBLY PARTS LIST				PRINT DATE	PAGE	FILE CHANGE NO.			
				REPLACED BY 90446496 15224				06-10-82	6	16541 00015224			
QTY	ASSEMBLY NUMBER	CD	REV.	DWG.	DESCRIPTION	MC	STATUS	STATUS DATE	ENG. RESP.	FILE DATE			
0000	90446296	7	C	D	REPLACED BY 90446496 15224	A	INA	06-03-82	CC634A	06-10-82			
ITEM NO	LI	PART NUMBER	CD	QTY	U/M	PART DESCRIPTION	MC	YLD	ECO. NO. IN	ECO. NO. OUT	I/M	WE IN	WE OUT
100	01	24000159	9	2		PC RES FXD COMP 600 OHM 5P 1/2W	P						
109	01	94402150	3	4		PC RES FM 1.2KOHM 1/4W CARBON	P						
110	01	95601141	0	1		PC CAP ELEC 270UF +10-100P 40VDC	P						
111	01	24027109	3	0		PC WASHER SCREW 02 6	B						
112	01	94395009	9	3		PC CAP FXD TANT 22UF 25V 20P	P						
113	01	91910046	0	2		PC RES VAR CER 1K OHM 20P 1/2W	P						
114	01	94402170	0	1		PC RES FM 3.9K OHM 1/4W CARBON	P						
115	01	94402177	3	1		PC RES FM 7.5K OHM 1/4W CARBON	P						
116	01	71493576	4	1		PC INSULATOR	B						
117	01	91910920	6	2		PC SPACER HEX 6-32 NYLON	B						
118	01	93343150	7	2		PC SCREW NYLON 6-32X1/4	B						
119	01	91609429	6	2		PC TERM, G-DISC P10 7, 250W	P						
120	01	30038005	7	0		PC TERM TUR SUBM 0002 TIN	P						
121	01	92700160	0	2		PC WSCR PAN SLT 6-32X3/4 SST P.	B						
122	01	91911002	7	1		PC HEAT SINK	P						
123	01	94402167	4	1		PC RES FM 3K OHM 1/4W CARBON	P						
124	01	24047501	7	1		PC PLATE WARNING DANGER HV	P						
						0122 TOTAL LINES							
130	01	74360229		1		PC RES FXD 2000HM 1P 1/4W	P		16541			8417	

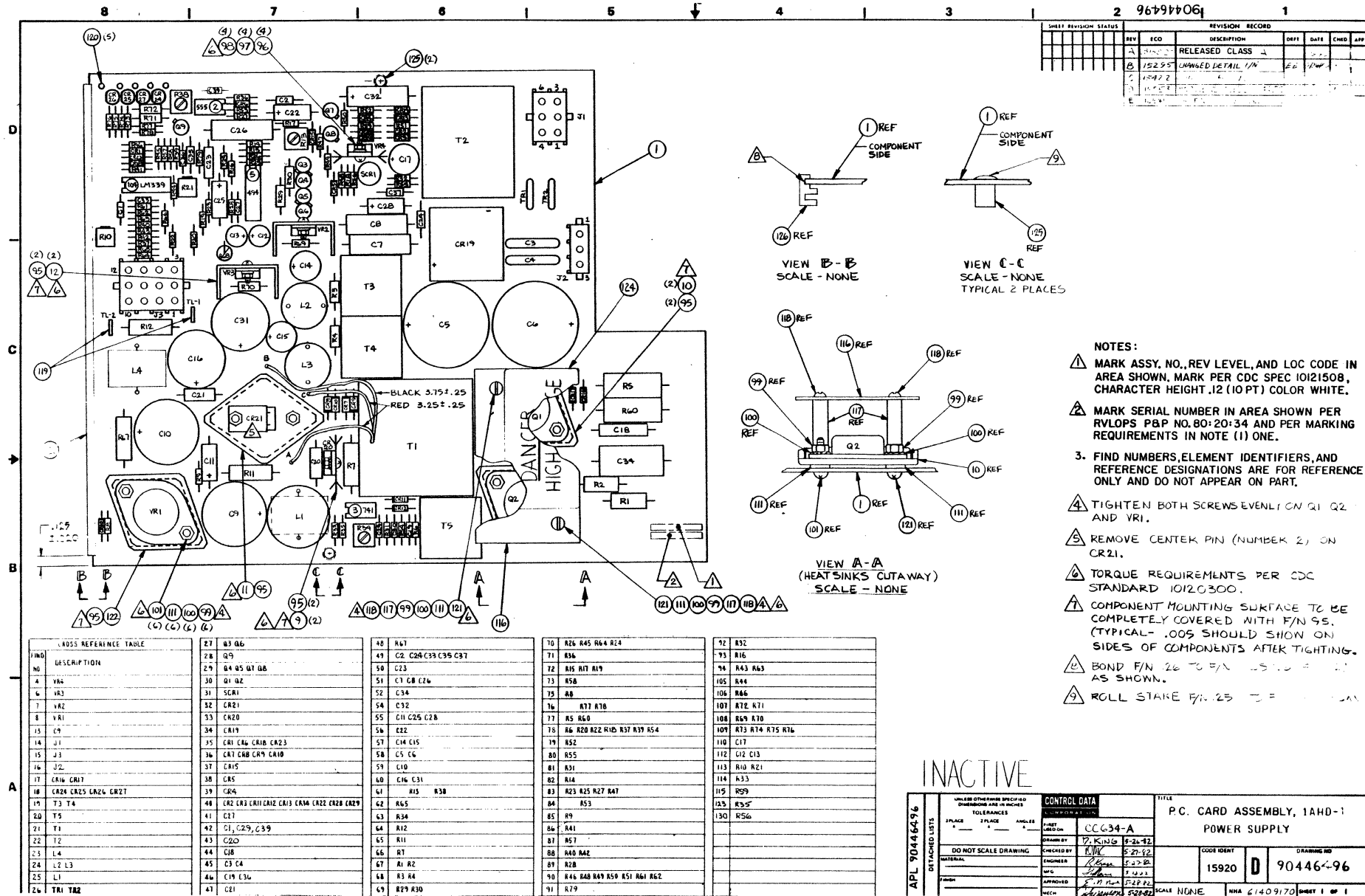

SHEET REVISION STATUS		REVISION RECORD				
REV	ECO	DESCRIPTION	DEFF	DATE	CHGD	APP
A	122	RELEASED CLASS				
B	122	UNMATED DETAIL 1/4				
C	122					
D	122					
E	122					

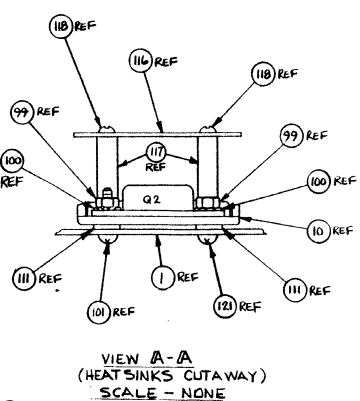
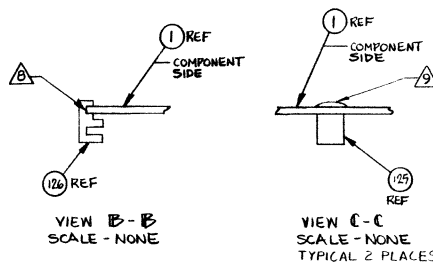

- NOTES:**
- ▲ MARK ASSY. NO., REV LEVEL, AND LOC CODE IN AREA SHOWN, MARK PER CDC SPEC 10121508, CHARACTER HEIGHT .12 (10 PT) COLOR WHITE.
 - ▲ MARK SERIAL NUMBER IN AREA SHOWN PER RVLOPS P&P NO. 80:20:34 AND PER MARKING REQUIREMENTS IN NOTE (1) ONE.
 - 3. FIND NUMBERS, ELEMENT IDENTIFIERS, AND REFERENCE DESIGNATIONS ARE FOR REFERENCE ONLY AND DO NOT APPEAR ON PART.
 - ▲ TIGHTEN BOTH SCREWS EVENLY ON Q1 Q2 AND VR1.
 - ▲ REMOVE CENTER PIN (NUMBER 2) ON CR21.
 - ▲ TORQUE REQUIREMENTS PER CDC STANDARD 10120300.
 - ▲ COMPONENT MOUNTING SURFACE TO BE COMPLETELY COVERED WITH F/N 95. (TYPICAL-.005 SHOULD SHOW ON SIDES OF COMPONENTS AFTER TIGHTING.
 - ▲ BOND F/N 26 TO F/N 25 AS SHOWN.
 - ▲ ROLL STAKE P/N 25

CROSS REFERENCE TABLE					
IND	DESCRIPTION	IND	DESCRIPTION	IND	DESCRIPTION
1	VR1	27	Q3 Q6	48	R67
2	VR2	28	Q9	49	C2 C2A C39 C35 C37
3	VR3	29	B4 B5 B1 QB	50	C23
4	VR4	30	Q1 Q2	51	C7 C8 C26
5	VR5	31	SCR1	52	C34
6	VR6	32	CR21	54	C32
7	VR7	33	CR20	55	C11 C25 C28
8	VR8	34	CR19	56	C22
9	VR9	35	CR1 CR6 CR10 CR23	57	C14 C15
10	VR10	36	CR7 CR8 CR9 CR10	58	C5 C6
11	VR11	37	CR15	59	C10
12	VR12	38	CR5	60	C16 C31
13	VR13	39	CR4	61	R13 R38
14	VR14	40	CR2 CR3 CR11 CR12 CR13 CR14 CR22 CR28 CR29	62	R65
15	VR15	41	C17	63	R34
16	VR16	42	C1, C29, C39	64	R12
17	VR17	43	C20	65	R11
18	VR18	44	C18	66	R7
19	VR19	45	C3 C4	67	R1 R2
20	VR20	46	C19 C36	68	R3 R4
21	VR21	47	C21	69	R29 R30
22	VR22				
23	VR23				
24	VR24				
25	VR25				
26	VR26				

INACTIVE

APL 90446496 ATTACHED LISTS	TOLERANCES DIMENSIONS ARE IN INCHES		CONTROL DATA		TITLE	
	PLACE	PLACE	DATE	BY	P.C. CARD ASSEMBLY, 1AH0-1 POWER SUPPLY	
	DO NOT SCALE DRAWING	CHECKED BY	ENGINEER	CHECKED BY	CODE IDENT	DRAWING NO
	APPROVED	APPROVED	SCALE NONE	DATE	15920	904464-96

BUILD ARC 220

ASSEMBLY PARTS LIST

PRINT DATE 11-22-82 PAGE 1 FILE CHANGE NO. 1654 00015553

QTY.	ASSEMBLY NUMBER	CD	REV.	DWG.	DESCRIPTION	MC	STATUS	STATUS DATE	END. BSNP.	PRJ DATE			
0860	90446496	3	E D	D	REPLACED BY 90446543 15553	A	INA	11-19-82	CC634A	11-22-82			
ITEM NO	LT	PART NUMBER	CD	QTY	U/M	PART DESCRIPTION	MC	YLD	ECO. NO. IN	ECO. NO. OUT	S/W	WE IN	WE OUT
001	02	90446295	9	1		PC PWB 1AHD (VX POWER SUPPLY)	P		15295	15295		8238	8238
001	03	90446495	5	1		PC PWB 81AHD-1 (VX PWR SPLY)	P						
002	01	15112100	1	1		PC IC NE555 916 TIMER	P						
003	01	15125501	5	1		PC IC 741C 301 OPERATIONAL AMPL	P						
004	01	15163403	7	1		PC IC LM317 317 ADJ POS V RGLTR	P						
005	01	15163404	7	1		PC IC TL494 PULSE-WD MOD CONTROL	P						
006	01	15151402	3	1		PC IC UA7912 356C NEG V RGLTR	P						
007	01	15151503	8	1		PC IC UA7812 357D POS V RGLTR	P						
008	01	15107839	1	1		PC IC LM250 3A ADJ POS V RGLTR	P						
009	01	51906600	5	2		PC HT/SK, SEMICNDOCT FIG-1 AL/BLK	P						
010	01	51911000	1	2		PC HT/SK, SEMICNDOCT FIG-1 AL/BLK	P						
011	01	51911001	9	1		PC HT/SK, SEMICNDOCT FIG-3 AL/BLK	P						
012	01	51918101	0	2		PC HT/SK, SEMICNDOCT FIG-1B AL/BL	P						
013	01	94397113	5	1		PC CAP AL ELEC 470UF-10*100P 50V	P						
014	01	51906103	0	1		PC CONN, PC-MTD 6 PIN NYL/SN F-2	P						
015	01	51906105	5	1		PC CONN, PC-MTD 12PIN NYL/SN F-4	P						
016	01	51906101	4	1		PC CONN, PC-MTD 3 PIN NYL/SN F-1	P						
017	01	95691501	1	2		PC RECT, SIL IN5617 1A 400V F-R	P						
018	01	51903800	4	4		PC LED, S-S GAP RED 1.0MCD 180MW	P						
019	01	10126937	1	2		PC XFMR, 20-40KHZ DRIVER 12V/4V	P						
020	01	10126941	3	1		PC XFMR, 20-40KHZ CURR SENSE 4A	P						

BUILD ARC 220

ASSEMBLY PARTS LIST

PRINT DATE 11-22-82 PAGE 2 FILE CHANGE NO. 1654 00015553

QTY.	ASSEMBLY NUMBER	CD	REV.	DWG.	DESCRIPTION	MC	STATUS	STATUS DATE	END. BSNP.	PRJ DATE			
0860	90446496	3	E D	D	REPLACED BY 90446543 15553	A	INA	11-19-82	CC634A	11-22-82			
ITEM NO	LT	PART NUMBER	CD	QTY	U/M	PART DESCRIPTION	MC	YLD	ECO. NO. IN	ECO. NO. OUT	S/W	WE IN	WE OUT
021	01	10126945	4	1		PC XFMR, 20-40KHZ MULTI-OUT F-2	P						
022	01	10126999	1	1		PC XFMR, 50/60HZ STEP-ON PC-MT	P						
023	01	51910625	0	1		PC IND, RF-CHOKE 31UH 11A F-3	P						
024	01	51918619	1	2		PC IND, RF-CHOKE 3000UH 1A F-2	P						
025	01	51918624	1	1		PC IND, RF-CHOKE 55UH 1.5A F-3	P						
026	01	51908601	1	2		PC THMS, DISC 5 OHM 10P 15MW	P						
027	01	51003092	7	2		PC XSTR, 2N2222 HI-SPEED NPN SI	P						
028	01	51684500	5	1		PC XSTR, 2N4091 FLD-EFF N-TYP SI	P						
029	01	51714000	0	4		PC XSTR, 2N2907 BI-POLAR PNP SI	P						
030	01	09770800	4	2		PC XSTR, 2N6308 POWER NPN SIL	P						
031	01	93314010	5	1		PC RECT, SIL 50PRV 1.6A FIG-1 LC	P						
032	01	15165627	9	1		PC RECT, DUAL SCHOTTKY 15A 40V	P						
033	01	15165590	9	1		PC RECT, CTR-TAP 15A 200V F-R	P						
034	01	15165603	0	1		PC RECT, BRIDGE 10A 600V	P						
035	01	51007385	1	4		PC DIO 1N4148 SIL MICRO 30V 10MA	P						
036	01	95691506	0	4		PC RECT, SIL IN5616 3A 100V F-R	P						
037	01	50240107	0	1		PC DIO 1N752A ZEN 5.6V 5P 20MA	P						
038	01	50240112	0	1		PC DIO 1N757A ZEN 9.1V 5P 20MA	P						
039	01	50240116	9	1		PC DIO 1N964B ZEN 13V 5P 9.5MA	P						
040	01	95637304	7	9		PC RECT, SIL IN4004 1A 400V MIN	P						
041	01	94240433	6	1		PC CAP FXD CER 3300PF 10P 50VDC	P						

BUILD ARC 220

ASSEMBLY PARTS LIST

PRINT DATE 11-22-82 PAGE 3 FILE CHANGE NO. 00015553

DIV.		ASSEMBLY NUMBER	CD	REV.	DWG.	DESCRIPTION	MC	STATUS	STATUS DATE	ENG. RESP.	FILE DATE		
0860		90446496	3	E	D	REPLACED BY 90446543 15553	A	INA	11-19-82	CC634A*	11-22-82		
ITEM NO.	LI	PART NUMBER	CD	QTY	U/M	PART DESCRIPTION	MC	YLD	ECO. NO. IN	ECO. NO. OUT	S/N	WE IN	WE OUT
042	01	94240401	3	3		PC CAP FXD CER 1000PF 10P 50VDCW	P						
043	01	24506801	0	1		PC CAP FXD MYL .001UF 10P 100VDC	P						
044	01	36180753	0	1		PC CAP MYL FM .001UF 10P 600VDCW	P						
045	01	94858601	1	2		PC CAP CER DISC .01UF 20P 3000V	P						
046	01	94240411	2	2		PC CAP FXD CER 10K PF 10P 50VDCW	P						
047	01	24506807	7	1		PC CAP FXD MYL .01UF 10P 100VDCW	P						
048	01	24504957	4	1		PC RES FXD COMP 560 OHM 5P 2WATT	P						
049	01	94240448	4	5		PC CAP FXD CER 100KPF 10P 50VDCW	P						
050	01	94240452	6	1		PC CAP FXD CER 220KPF 10P 50VDCW	P						
051	01	36180706	8	3		PC CAP MYL FM 1UF 10P 50VDCW	P						
052	01	36180721	7	1		PC CAP MYL FM 1UF 20P 200VDCW	P						
054	01	12089273	2	1		PC CAP ALI ELC TLT 10UF 10P 25VDCW	P						
055	01	94400612	1	3		PC CAP ALI ELEC 15UF-10+100P 25V	P						
056	01	94400622	0	1		PC CAP ALI ELEC 47UF-10+100P 16V	P						
057	01	95691133	3	2		PC CAP ELECT 270UF -10+100P 25V	P						
058	01	15002220	0	2		PC CAP ALI ELC 390UF -10+30P 250V	P						
059	01	94397119	2	1		PC CAP ALI ELEC 680UF-10+100P 40V	P						
060	01	94397145	7	2		PC CAP ALI ELEC 2700UF-10+100 12V	P						
061	01	51918876	7	2		PC RES VAR CRM 1K R 20P 1/2W 3	P						
062	01	94402187	2	1		PC RES FXD C FM 20K OHM 5P 1/4W	P						
063	01	51918878	3	1		PC RES VAR CRM 5K R 20P 1/2W 3	P						

BUILD ARC 220

ASSEMBLY PARTS LIST

PRINT DATE 11-22-82 PAGE 4 FILE CHANGE NO. 00015553

DIV.		ASSEMBLY NUMBER	CD	REV.	DWG.	DESCRIPTION	MC	STATUS	STATUS DATE	ENG. RESP.	FILE DATE		
0860		90446496	3	E	D	REPLACED BY 90446543 15553	A	INA	11-19-82	CC634A*	11-22-82		
ITEM NO.	LI	PART NUMBER	CD	QTY	U/M	PART DESCRIPTION	MC	YLD	ECO. NO. IN	ECO. NO. OUT	S/N	WE IN	WE OUT
064	01	51903000	1	1		PC RES FXD WW .01 OHM 5P 2WATT	P						
065	01	24504815	2	1		PC RES FXD COMP 10 OHM 5P 2WATT	P						
066	01	24504827	7	1		PC RES FXD COMP 33 OHM 5P 2WATT	P						
067	01	17720612	5	2		PC RES FXD COMP .1MEG OHM 5P 1W	P						
068	01	24500123	5	2		PC RES FXD COMP 22 OHM 5P 1/2W	P						
069	01	24500166	4	2		PC RES FXD COMP 1300 OHM 5P 1/2W	P						
070	01	94402228	4	4		PC RES FXD C FM 1.0M OHM 5P 1/4W	P						
071	01	17705960	7	1		PC RES FXD COMP 10M OHM 5P 1/4W	P						
072	01	94402132	8	3		PC RES FXD C FM 100 OHM 5P 1/4W	P						
073	01	94402190	6	1		PC RES FXD C FM 27K OHM 5P 1/4W	P						
075	01	94360236	7	2		PC RES FXD FM 237 OHM 1P 1/4W	P						
075	02	94360236	7	1		PC RES FXD FM 237 OHM 1P 1/4W	P		16541	16541		8417	8417
076	01	94402148	4	3		PC RES FXD C FM 470 OHM 5P 1/4W	P						
076	02	94402148	4	2		PC RES FXD C FM 470 OHM 5P 1/4W	P		16541	16541		8417	8417
077	01	95596520	7	2		PC RES FXD WW 600 OHM 10P 5WATT	P						
078	01	94360300	1	6		PC RES FXD FM 1000 OHM 1P 1/4W	P						
078	02	94360300	1	7		PC RES FXD FM 1000 OHM 1P 1/4W	P		16541	16541		8417	8417
079	01	94402160	9	1		PC RES FXD C FM 1.5K OHM 5P 1/4W	P						
080	01	94360328	2	1		PC RES FXD FM 1960 OHM 1P 1/4W	P						
080	02	94360323	3	1		PC RES FXD FM 1740 OHM 1P 1/4W	P		16541	16541		8417	8417
081	01	94360329	0	1		PC RES FXD FM 2000 OHM 1P 1/4W	P						
082	01	94360353	0	1		PC RES FXD FM 3570 OHM 1P 1/4W	P						
083	01	94402166	6	4		PC RES FXD C FM 2.7K OHM 5P 1/4W	P						
084	01	94402169	0	1		PC RES FXD C FM 3.6K OHM 5P 1/4W	P						
085	01	94360357	1	1		PC RES FXD FM 3920 OHM 1P 1/4W	P						

BUILD ARC 220

ASSEMBLY PARTS LIST

PRINT DATE 11-22-82 PAGE 3 FILE CHANGE NO. 40015553
1654

QTY	REV.	DWG.	DESCRIPTION	MC	STATUS	STATUS DATE	ENG. RESP.	FILE DATE					
0860	3	E	D	REPLACED BY 90446543 15553	A	INA	11-19-82	CC634A	11-22-82				
FIG NO	LI	PART NUMBER	CD	QTY	U/M	PART DESCRIPTION	MC	YLD	ECO. NO. IN	ECO. NO. OUT	S/W	WE IN	WE OUT
086	01	94402197	1	1		PC RES FXD C FM 51K OHM 5P 1/4W	P						
087	01	94402179	9	1		PC RES FXD C FM 9.1K OHM 5P 1/4W	P						
088	01	94402178	1	2		PC RES FXD C FM 8.2K OHM 5P 1/4W	P						
089	01	94402176	5	1		PC RES FXD C FM 6.8K OHM 5P 1/4W	P						
090	01	94402180	7	7		PC RES FXD C FM 10K OHM 5P 1/4W	P						
091	01	94402184	9	1		PC RES FXD C FM 15K OHM 5P 1/4W	P						
092	01	94360451	2	1		PC RES FXD FM 34.0K OHM 1P 1/4W	P						
093	01	94402193	0	1		PC RES FXD C FM 36K OHM 5P 1/4W	P						
094	01	94402221	9	2		PC RES FXD C FM 510K OHM 5P 1/4W	P						
095	01	51083962	1	001		OZ PASTE, HEAT XFR CHPD NON-COND	B						
096	01	10127103	9	4		PC MSCR PAN PHL 4-40X.312 STL ZP	B						
097	01	10126400	0	4		PC WSHR. (4) EXT/T LK STL ZP	B						
098	01	10125103	1	4		PC NUT. HEX 4-40 MSCR STL ZP	B						
099	01	00869901	9	0		PC NUT. HEX 6-32 MSCR SMALL DIA	B						
100	01	10126401	0	0		PC WSHR. (6) EXT/T LK STL ZP	B						
101	01	92780144	7	0		PC MSCR PAN SLT 6-32X1/2 SST P	B						
102	01	90446294	2	REF		PC SCH DIA 1AMD VIKING X P SPLY	D						
103	01	16006500	9	REF		PC FABRICATION SPECIFICATION	D						
104	01	15126600	4	1		PC IC LM339 341 QUAD COMPARATOR	P						
105	01	94402165	0	1		PC RES FXD C FM 2.4K OHM 5P 1/4W	P						
106	01	94402194	0	1		PC RES FXD C FM 39K OHM 5P 1/4W	P						

BUILD ARC 220

ASSEMBLY PARTS LIST

PRINT DATE 11-22-82 PAGE 6 FILE CHANGE NO. 40015553
1654

QTY	REV.	DWG.	DESCRIPTION	MC	STATUS	STATUS DATE	ENG. RESP.	FILE DATE					
0860	3	E	D	REPLACED BY 90446543 15553	A	INA	11-19-82	CC634A	11-22-82				
FIG NO	LI	PART NUMBER	CD	QTY	U/M	PART DESCRIPTION	MC	YLD	ECO. NO. IN	ECO. NO. OUT	S/W	WE IN	WE OUT
107	01	24500172	2	2		PC RES FXD COMP 2400 OHM 5P 1/2W	P						
108	01	24500159	9	2		PC RES FXD COMP 680 OHM 5P 1/2W	P						
109	01	94402150	3	4		PC RES FXD C FM 1.2K OHM 5P 1/4W	P						
110	01	95601141	6	1		PC CAP ELECT 270UF -10+100P 40V	P						
111	01	24527109	3	0		PC WSHR. (6) .062T INSUL PHENOLIC	B						
112	01	94395509	6	2		PC CAP AL. ELEC 22UF -10+75P 25V	P						
113	01	51918046	0	2		PC RES VAR CRM 1K R 20P 1/2W 1	P						
114	01	94402170	0	1		PC RES FXD C FM 3.9K OHM 5P 1/4W	P						
115	01	94402177	3	1		PC RES FXD C FM 7.5K OHM 5P 1/4W	P						
116	01	71493576	4	1		PC INSULATOR. HV COVER (PLSTC)	P						
117	01	51918920	0	2		PC SPACER. HEX NYLON 6-32X.875	B						
118	01	93343150	7	2		PC MSCR RND SLT 6-32X1/4 NYL BLK	B						
119	01	51669429	6	2		PC TERM. Q-DISC FIG-7 BRASS/SN	P						
120	01	38838005	7	5		PC TERM. SUBMN TUR/SN .062T-BD	P						
121	01	92780160	0	2		PC MSCR PAN SLT 6-32X3/4 SST P	B						
122	01	51911002	7	1		PC HT/SK. SEMICONDCT FIG-4 AL/BLK	P						
123	01	94402167	4	1		PC RES FXD C FM 3.0K OHM 5P 1/4W	P						
124	01	24547501	7	1		PC PLATE. DANGER HIGH VOLTAGE	P						
125	01	51940680	0	2		PC STOFF. SWAGE BR5 4-40 FIG-1	P						
125	02	51940689	6	2		PC STOFF. SWAGE BR5 4-40 FIG-2	P		15422	15422		8237	8237
126	01	71493704	2	1		PC STIFFENER. PC BOARD (PLSTC)	P						

BUILD ARC 220

ASSEMBLY PARTS LIST

FORM DATE	PAGE	PRE CHANGE NO
11-22-82	7	68015553

QTY.	ASSEMBLY NUMBER	CD	REV.	DWG.	DESCRIPTION	MC	STATUS	STATUS DATE	ENG. DESP.	FILE DATE			
0800	90446498	3	E D	D	REPLACED BY 90446543 15553	A	INA	11-19-82	CC634A*	11-22-82			
									16541				
LINE NO	LI	PART NUMBER	CD	QUANTITY	U/M	PART DESCRIPTION	MC	YLD	ECO. NO. IN	ECO. NO. OUT	S/N	WE IN	WE OUT
127	01	62019900	0	001	OZ	EPOXY, 2-PART 5-MINUTE CLEAR	B						
						0127 TOTAL LINES							
130	01	74360229		1	PC	RES FXD 200 OHM 1P 1/4W	P		16541			8417	

BUILD ARC 220

ASSEMBLY PARTS LIST

PRINT DATE		PAGE	FILE CHANGE NO.										
03-15-84		1	00015541										
DIV.	ASSEMBLY NUMBER	REV.	DWG.										
0860	90446556	2	U										
DESCRIPTION													
REPLACED BY 90446556 16125													
MC	STATUS	STATUS DATE	ENG. DESP.										
A	INA	08-24-83	CC634A										
FILE DATE		03-15-84											
P/NB NO.	LI	PART NUMBER	CR	QUANTITY	U/M	PART DESCRIPTION	MC	YLD	ECO. NO. IN	ECO. NO. OUT	1/N	WE IN	WE OUT
001	01	90446495	5	1		PC REPLACED BY 90446555 16125	P						
002	01	15112100	1	1		PC IC NE555 916 TIMER	P						
003	01	15125301	5	1		PC IC 741C 301 UPR-AMPL (8-PIN)	P						
004	01	15163403	7	1		PC IC LM317 317 ADJ PUS V RGLTR	P						
005	01	15163484	7	1		PC IC TL494 PULSE-WD MOD CONTROL	P						
006	01	15151402	3	1		PC IC UA7912 350C NEG V RGLTR	P						
007	01	15151503	8	1		PC IC UA7812 357D PUS V RGLTR	P						
008	01	15107939	1	1		PC IC LM250 3A ADJ POS V RGLTR	P						
009	01	51906300	5	2		PC HT/SK, SEMICNDCT FIG-1 AL/BLK	P						
010	01	51911303	5	2		PC HEAT SINK FIGURE 5	P						
011	01	51911304	3	1		PC HEAT SINK FIGURE 6	P						
012	01	51918101	0	2		PC HT/SK, SEMICNDCT FIG-1B AL/BL	P						
013	01	94397113	9	1		PC CAP AL ELEC 470UF-10+100P 50V	P						
014	01	51906103	0	1		PC CONN, PC-MTD 6 PIN NYL/SN F-2	P						
015	01	51906105	5	1		PC CONN, PC-MTD 12PIN NYL/SN F-4	P						
016	01	51906101	4	1		PC CONN, PC-MTD 3 PIN NYL/SN F-1	P						
017	01	95691301	1	2		PC RECT, SIL 1N5617 1A 400V F-R	P						
018	01	51903300	4	4		PC LED, S-S GAP RED 1.0MCD 180M	P						
019	01	10126937	1	2		PC XFMR, 20-40KHZ DRIVER 12V/4V	P						
020	01	10126941	3	1		PC XFMR, 20-40KHZ CURR SENSE 4A	P						
021	01	10126945	4	1		PC XFMR, 20-40KHZ MULTI-OUT F-2	P						

BUILD ARC 220

ASSEMBLY PARTS LIST

PRINT DATE		PAGE	FILE CHANGE NO.										
03-15-84		2	00016541										
DIV.	ASSEMBLY NUMBER	REV.	DWG.										
0860	90446556	2	U										
DESCRIPTION													
REPLACED BY 90446556 16125													
MC	STATUS	STATUS DATE	ENG. DESP.										
A	INA	08-24-83	CC634A										
FILE DATE		03-15-84											
P/NB NO.	LI	PART NUMBER	CR	QUANTITY	U/M	PART DESCRIPTION	MC	YLD	ECO. NO. IN	ECO. NO. OUT	1/N	WE IN	WE OUT
022	01	10126999	1	1		PC XFMR, 50/60HZ STEP-DN PC-MT	P						
023	01	51918525	8	1		PC IND, RF-CHUKE 31UH 11A F-3	P						
024	01	51918519	1	2		PC IND, RF-CHUKE 3000UH 1A F-2	P						
025	01	51918524	1	1		PC IND, RF-CHUKE 550UH 1.5A F-3	P						
026	01	51906501	1	2		PC THMS, UTSC 5 OHM 10P 154W	P						
027	01	51003392	7	2		PC XSTR 2N2222 HI-SPEED NPN SIL	P						
028	01	51684300	5	1		PC XSTR, 2N4091 FLD-EFF N-TYP SI	P						
029	01	51714300	0	4		PC XSTR, 2N2907 BI-POLAR PNP SI	P						
030	01	89770300	4	2		PC XSTR, 2N6308 POWER NPN SIL	P						
031	01	93314310	5	1		PC RECT, SIL 50PRV 1.6A FIG-1 LC	P						
032	01	15165527	9	1		PC RECT, DUAL SCHOTTKY 15A 40V	P						
033	01	15165390	9	1		PC RECT, CTR-TAP 15A 200V F-R	P						
034	01	15165303	0	1		PC RECT, BRIDGE 10A 600V	P						
035	01	51007385	1	5		PC DIO 1N4148 SIL MICRO 30V 10MA	P						
036	01	95691306	0	4		PC RECT, SIL 1N5616 3A 100V F-R	P						
037	01	50240107	8	1		PC DIO 1N752A ZEN 9.6V 5P 20MA	P						
038	01	50240112	8	1		PC DIO 1N757A ZEN 9.1V 5P 20MA	P						
039	01	50240116	9	1		PC DIO 1N964B ZEN 13V 5P 9.5MA	P						
039	02	50240117	7	1		PC DIO 1N965B ZEN 15V 5P 8.5MA	P		16376	16376		8346	8346
040	01	95637304	7	9		PC RECT, SIL 1M4006 1A 400V MIN	P						
041	01	94240433	6	1		PC CAP FXD CER 3300PF 10P 50VUCW	P						

BUILD ARC 223

ASSEMBLY PARTS LIST

PRINT DATE 03-15-84 PAGE 3 FILE CHANGE NO. 00016541

QTY.	ASSEMBLY NUMBER	CD	REV.	DWG.	DESCRIPTION	MC	STATUS	STATUS DATE	ENG. DESP.	FILE DATE			
0860	90446556	2	J	U	REPLACED BY 90446556 16125	A	INA	08-24-83	CC634A	03-15-84			
ITEM NO.	LT	PART NUMBER	CD	QTY.	U/M	PART DESCRIPTION	MC	YLD	ECO. NO. IN	ECO. NO. OUT	S/N	WE IN	WE OUT
042	01	94240101	3	3		PC CAP FXD CER 1000PF 10P 50VDCM	P						
043	01	24506901	0	1		PC CAP FXD NYL .001UF 10P 100VDC	P						
044	01	36180753	0	1		PC CAP NYL FM .001UF 10P 600VDCM	P						
045	01	94858501	1	2		PC CAP CER DISC .01UF 20P 3000V	P						
046	01	94240111	2	2		PC CAP FXD CER 10K PF 10P 50VDCM	P						
047	01	24506907	7	1		PC CAP FXD NYL .01UF 10P 100VDCM	P						
048	01	24504357	4	1		PC RES FXD COMP 560 OHM 5P 2WATT	P						
049	01	94240148	4	5		PC CAP FXD CER 100KPF 10P 50VDCM	P						
050	01	94240152	6	1		PC CAP FXD CER 220KPF 10P 50VDCM	P						
051	01	36180708	8	3		PC CAP NYL FM 1UF 10P 50VDCM	P						
052	01	36180721	7	1		PC CAP NYL FM 1UF 20P 200VDCM	P						
054	01	12089273	2	1		PC CAP AL ELCTLT 10UF 10P 25VDCM	P						
055	01	94400612	1	3		PC CAP AL ELEC 15UF-10+100P 25V	P						
056	01	94400522	0	1		PC CAP AL ELEC 47UF-10+100P 16V	P						
057	01	95691133	3	2		PC CAP ELECT 270UF -10+100P 25V	P						
058	01	15002220	0	2		PC CAP AL ELC 390UF -10+30P 250V	P						
059	01	94397119	2	1		PC CAP AL ELEC 680UF-10+100P 40V	P						
060	01	94397145	7	2		PC CAP AL ELEC 2700UF-10+100 12V	P						
061	01	51918976	7	2		PC RES VAR CRM 1K R 20P 1/2W 3	P						
062	01	94402187	2	1		PC RES FXD C FM 20K OHM 5P 1/4W	P						
063	01	51918978	3	1		PC RES VAR CRM 5K R 20P 1/2W 3	P						

BUILD ARC 223

ASSEMBLY PARTS LIST

PRINT DATE 03-15-84 PAGE 4 FILE CHANGE NO. 00016541

QTY.	ASSEMBLY NUMBER	CD	REV.	DWG.	DESCRIPTION	MC	STATUS	STATUS DATE	ENG. DESP.	FILE DATE			
0860	90446556	2	J	U	REPLACED BY 90446556 16125	A	INA	08-24-83	CC634A	03-15-84			
ITEM NO.	LT	PART NUMBER	CD	QTY.	U/M	PART DESCRIPTION	MC	YLD	ECO. NO. IN	ECO. NO. OUT	S/N	WE IN	WE OUT
064	01	51903300	1	1		PC RES FXD MW .01 OHM 5P 2WATT	P						
065	01	24504315	2	1		PC RES FXD COMP 10 OHM 5P 2WATT	P						
066	01	24504327	7	1		PC RES FXD COMP 33 OHM 5P 2WATT	P						
067	01	17720512	5	2		PC RES FXD COMP .1MEG OHM 5P 1W	P						
068	01	24500129	5	2		PC RES FXD COMP 22 OHM 5P 1/2W	P						
069	01	24500166	4	2		PC RES FXD COMP 1300 OHM 5P 1/2W	P						
070	01	94402228	4	4		PC RES FXD C FM 1.0M OHM 5P 1/4W	P						
071	01	17705360	7	1		PC RES FXD COMP 10M OHM 5P 1/4W	P						
072	01	94402132	8	3		PC RES FXD C FM 100 OHM 5P 1/4W	P						
073	01	94402190	5	1		PC RES FXD C FM 27K OHM 5P 1/4W	P						
075	01	94360236	7	2		PC RES FXD FM 237 OHM 1P 1/4W	P						
075	02	94360236	7	1		PC RES FXD FM 237 OHM 1P 1/4W	P		16541	16541		8417	8417
076	01	94402148	4	3		PC RES FXD C FM 470 OHM 5P 1/4W	P						
076	02	94402148	4	2		PC RES FXD C FM 470 OHM 5P 1/4W	P		16541	16541		8417	8417
077	01	95596520	7	2		PC RES FXD MW 600 OHM 10P 5WATT	P						
078	01	94360300	1	6		PC RES FXD FM 1000 OHM 1P 1/4W	P						
078	02	94360300	1	7		PC RES FXD FM 1000 OHM 1P 1/4W	P		16541	16541		8417	8417
079	01	94402160	9	1		PC RES FXD C FM 1.5K OHM 5P 1/4W	P						
080	01	94360326	6	1		PC RES FXD FM 1870 OHM 1P 1/4W	P						
080	02	94360326	2	1		PC RES FXD FM 1960 OHM 1P 1/4W	P		15806	16541		8311	8417
080	03	94360323	3	1		PC RES FXD FM 1740 OHM 1HP 1/4W	P		16541	16541		8311	8417
081	01	94360329	0	1		PC RES FXD FM 2000 OHM 1P 1/4W	P						
082	01	94360353	0	1		PC RES FXD FM 3570 OHM 1P 1/4W	P						

BUILD ARC 220

ASSEMBLY PARTS LIST

PRINT DATE		PAGE		FILE CHANGE NO.									
03-15-84		5		00016541									
QTY.	ASSEMBLY NUMBER	CD	REV.	DWG.	DESCRIPTION	MC	STATUS	STATUS DATE	ENG. DESP.	FILE DATE			
0860	90446513	2	J	D	REPLACED BY 90446556 16125	A	INA	08-29-83	CC634A	03-15-84			
FOUND NO.	LI	PART NUMBER	CD	QUANTITY	U/M	PART DESCRIPTION	MC	YLD	ECO. NO. IN	ECO. NO. OUT	S/N	WE IN	WE OUT
083	01	94402166	5	4		PC RES FXD C FM 2.7K OHM 5P 1/4W	P						
084	01	94402169	0	1		PC RES FXD C FM 3.6K OHM 5P 1/4W	P						
085	01	94360357	1	1		PC RES FXD FM 3920 OHM 1P 1/4W	P						
086	01	94402197	1	1		PC RES FXD C FM 51K OHM 5P 1/4W	P						
087	01	94402179	9	1		PC RES FXD C FM 9.1K OHM 5P 1/4W	P						
088	01	94402178	1	2		PC RES FXD C FM 8.2K OHM 5P 1/4W	P						
089	01	94402176	5	1		PC RES FXD C FM 6.8K OHM 5P 1/4W	P						
090	01	94402180	7	7		PC RES FXD C FM 10K OHM 5P 1/4W	P						
091	01	94402184	9	1		PC RES FXD C FM 15K OHM 5P 1/4W	P						
092	01	94360451	2	1		PC RES FXD FM 34.0K OHM 1P 1/4W	P						
093	01	94402193	0	1		PC RES FXD C FM 36K OHM 5P 1/4W	P						
094	01	94402221	9	2		PC RES FXD C FM 910K OHM 5P 1/4W	P						
095	01	51003762	1		001	02 PASTE, HEAT XFR CMPD MUY-CUND	D						
096	01	10127103	9	4		PC NSCR PAN PHL 4-40X.312 STL ZP	B						
097	01	10126400	0	4		PC WSHR, (4) EXT/T LK STL ZP	B						
098	01	10125103	1	4		PC NUT, HEX 4-40 NSCR STL ZP	B						
099	01	00869701	9	7		PC NUT, HEX 6-32 NSCR SMALL DIA	B		15862	15862		8315	8315
099	02	00869701	9	6		PC NUT, HEX 6-32 NSCR SMALL DIA	B						
100	01	10125903	6	1		PC WSHR, NO.6 SPG LOCK STL ZP	B		15862	15862		8315	8315
100	02	10125903	6	7		PC WSHR, NO.6 SPG LOCK STL ZP	B						
101	01	93114214	5	1		PC STANDOFF 6-32 .500	B						
102	01	90446294	2	REF		PC REPLACED BY NONE 16125	D						

BUILD ARC 220

ASSEMBLY PARTS LIST

PRINT DATE		PAGE		FILE CHANGE NO.									
03-15-84		6		00016541									
QTY.	ASSEMBLY NUMBER	CD	REV.	DWG.	DESCRIPTION	MC	STATUS	STATUS DATE	ENG. DESP.	FILE DATE			
0860	90446513	2	J	D	REPLACED BY 90446556 16125	A	INA	08-29-83	CC634A	03-15-84			
FOUND NO.	LI	PART NUMBER	CD	QUANTITY	U/M	PART DESCRIPTION	MC	YLD	ECO. NO. IN	ECO. NO. OUT	S/N	WE IN	WE OUT
103	01	16006500	9	REF		PC FABRICATION SPECIFICATION	D						
104	01	19126500	4	1		PC IC LM339 361 QUAD COMPARATOR	P						
105	01	94402165	8	1		PC RES FXD C FM 2.4K OHM 5P 1/4W	P						
106	01	94402194	8	1		PC RES FXD C FM 39K OHM 5P 1/4W	P						
107	01	24500172	2	2		PC RES FXD COMP 2400 OHM 5P 1/2W	P						
108	01	24500159	9	2		PC RES FXD COMP 680 OHM 5P 1/2W	P						
109	01	94402158	3	4		PC RES FXD C FM 1.2K OHM 5P 1/4W	P						
110	01	95691141	6	1		PC CAP ELECT 270UF -10+100P 40V	P						
112	01	94395509	6	2		PC CAP AL ELEC 22UF -10+75P 25V	P						
113	01	51918946	0	2		PC RES VAR CRN 1K R 20P 1/2W 1	P						
114	01	94402170	8	1		PC RES FXD C FM 3.9K OHM 5P 1/4W	P						
115	01	94402177	3	1		PC RES FXD C FM 7.5K OHM 5P 1/4W	P						
116	01	71493576	4	1		PC INSULATOR, HV COVER (PLSTC)	P						
117	01	51918928	5	2		PC SPACER, HEX NYLON 6-32X.875	B						
118	01	93343158	7	2		PC NSCR RND SLT 6-32X1/4 NYL BLK	B						
119	01	51669129	6	2		PC TERM, Q-DISC FIG-7 BRASS/5N	P						
120	01	38838709	7	5		PC TERM, SUBMN TUR/5N .062T-80	P		16443				8401
122	01	51911305	0	1		PC HEAT SINK FIGURE 7	P						
123	01	94402167	4	1		PC RES FXD C FM 3.0K OHM 5P 1/4W	P						
124	01	24547901	7	1		PC PLATE, DANGER HIGH VOLTAGE	P						
125	01	51940589	6	2		PC STUFF, SWAGE BKS 4-40 FIG-2	P						

ASSEMBLY PARTS LIST

17725

BUILC ARC 210										PRINT DATE		PAGE		FILE CHANGE NO.	
C860 90446543 2 K 0										04-29-85		7		0000000	
REPLACED BY 90446556 16125										STATUS DATE		ENGR. RESP.		FILE DATE	
A INA										08-24-83		CC634A		04-29-85	
TRND NO.	U	PART NO.	CD	QTY	U/M	PART DESCRIPTION	MC	YTD	ECO. NO. IN	ECO. NO. OUT	S/N	WK IN	WK OUT		
126	Q1	71493704	2	1		PC STIFFENER, PC BOARD (PLSTC)	P								
127	Q1	62019900	0		001	02 REPLACED BY 95C48500 16964	B			17131		8517	8517		
127	C2	95048500	3		001	02 EPCXY, 2-PART 5-MINUTE CLEAR	B								
128	Q1	24563701	2		062	FT SLVG, 22AWG H-TEPP UL NAT-INS	B			15993		8323			
129	Q1	61409137	9	1		PC CBL ASSY, 7IN POWER	A			16564		8410			
130	Q1	94360229	2	1		PC RES FXD FR 200 OHM 1P 1/4W	P			16541A		8417			
0135 TOTAL LINES															

95594406

SHEET REVISION STATUS		REVISION RECORD			
REV	ECO	DESCRIPTION	DATE	BY	APP'D
01	02	Released Class 'B'	10/23/53
01	52097	REVISED MAIN VIEW	DC	11/1/53	...
02	52231	CORRECT 102 19	W.G.	8/1/53	...
A	1515350	RELEASED CLASS 'A'	E.E.	10/20/53	...
B	16493	RELEASED P/N 120	E.E.	10/20/53	...
C	16591	ENG NOTES C46, ADD TO ENG. TR. LAG. P/N 175, 76, 78, 80, 81, 82, 83, 84	W.G.	5/28/54	...
D	16972	INACTIVE SERVICE USE ONLY. SUPERSEDED BY 90446557	W.G.	1/10/55	...
E	17275	ADDED NOTE 11	E.E.	2/20/55	...

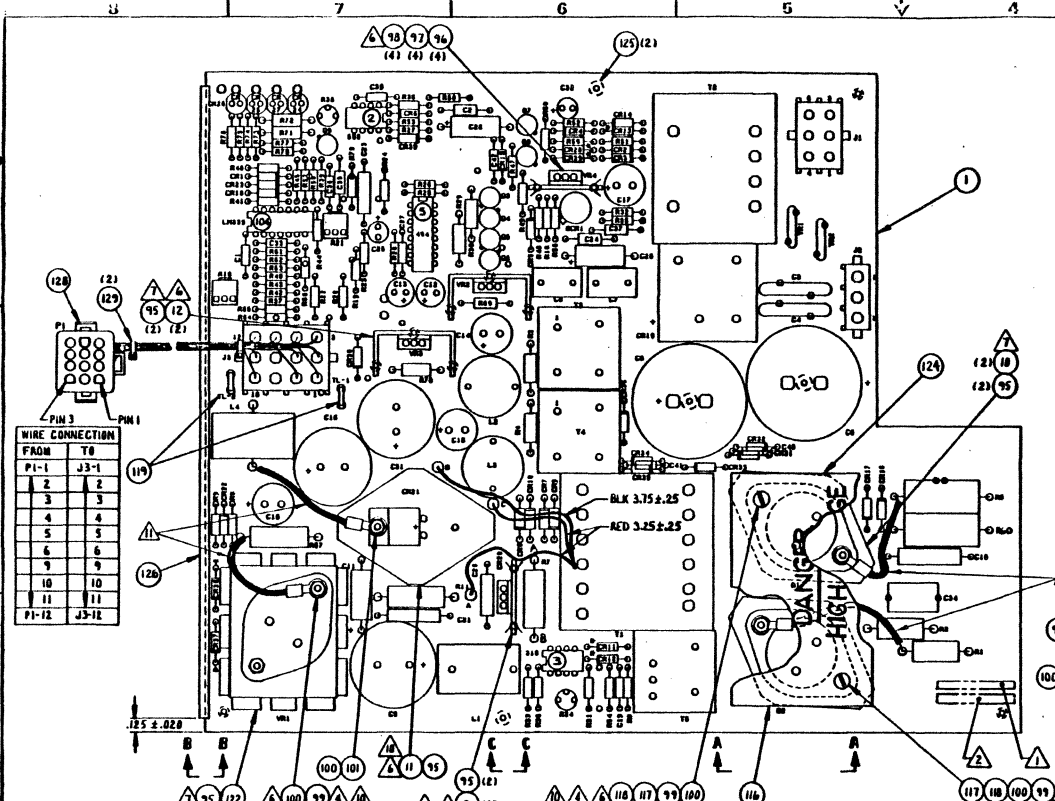

FROM	TO
P1-1	J3-1
2	2
3	3
4	4
5	5
6	6
7	7
8	8
9	9
10	10
11	11
P1-12	J3-12

FINA NO	DESCRIPTION
4	V84
6	V83
7	V82
8	V81
13	C9
14	J1
17	CR16 CR17 CR33 CR36
18	CR24 CR25 CR26 CR27
19	T3 T4
20	T5
21	T1
22	T2
23	L4
24	L2 L3
25	L1
26	TR1 TR2
27	Q3 Q6
28	Q9

29	Q4 Q5 Q7 Q8
30	Q1 Q2
31	SCR1
32	CR21
33	CR20
34	CR19
35	CR1 CR6 CR18 CR23 CR30 CR38 CR39
36	CR7 CR8 CR9 CR10
37	CR15
38	CR5
39	CR4
40	CR2 CR3 CR11 CR12 CR14 CR22 CR28 CR29 CR31 CR32 CR34 CR35
41	CR7
42	CR40 CR41
43	CR0
44	CR18
45	CR3 CR4
46	CR19 CR36 CR39
47	CR21
48	CR7

49	CR2 CR4 CR13 CR15 CR17 CR40
50	CR3
51	CR28
52	CR36
54	CR5 CR2
55	CR11 CR26 CR22
56	R26
57	CR1 CR5
58	CR5 CR6
59	CR16 CR1
61	R30
62	R65
63	R36
65	R11
66	R7
67	R1 R2
68	R3 R4
69	R29 R30
70	R24 R45 R64
71	R36
72	R19 R00

73	R50
75	R8
76	R6 R7 R7B
77	R5 R60
78	R20 R22 R37 R39 R54 R10
79	R33 R52
80	R55
83	R23 R25 R27 R47
84	R31 R51
85	R9
86	R41
87	R57
88	R40 R42
89	R28
90	R46 R48 R49 R50 R51 R61 R62
91	R79
92	R32
94	R43 R63
105	R44
106	R66
107	R71 R72

108	R69 R70
109	R73 R74 R75 R76
110	CR1 CR7
112	CR1 CR3
113	R10 R21
115	R59
123	R35
51	CR37
16	J2
130	R56

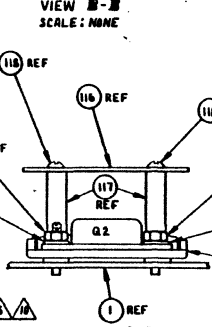
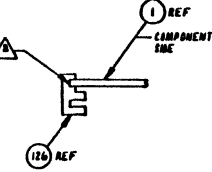
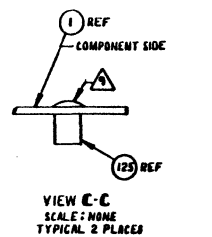

FOR PWB 90446555 REV02 ONLY

Deletions	Additions
CUT FOIL: 1) BETWEEN PADS OF R80 2) R60 TO CR2-55 3) R60 TO R67 5.5, 2) 11-12 TO R7 (END BY 11) 4) R7 TO CR10 5.5, (30 GA. P/N 24501808) 55	ADD WIRE: 1) CR2-6 TO R57 (END BY 6) 2) (30 GA. P/N 51827982) 5.5, 55 3) 11-12 TO R7 (END BY 11) 4) R7 TO CR10 5.5, (30 GA. P/N 24501808) 55

- NOTES:
- ⚠ JUMPER WIRES (P/N 61409795) INSTALLED AT REPAIR CENTER UPON FAILURE. SOLDER ONE END OF WIRES TO R67, L4, R1, AND R5 AS SHOWN. AT EACH OTHER END TO VR1, CR21, Q1 AND Q2 BETWEEN 2 STAR WASHERS (P/N 10124401) USING EXISTING WTG. NUT AND DISCARDING SPLIT LOCKWASHER.
 - ⚠ MARK ASSEMBLY NUMBER, REVISION LEVEL AND LOCATION IN AREA SHOWN PER CDC SPECIFICATION 10121508. CHARACTER HEIGHT .12 (10 POINT), COLOR WHITE.
 - ⚠ MARK SERIAL NUMBER IN AREA SHOWN PER RYLOPS P & P NO. 80-20:34 AND PER MARKING REQUIREMENTS IN NOTE (1) ONE.
 - 3. FIND NUMBERS, ELEMENT IDENTIFIERS AND REFERENCE DESIGNATIONS ARE FOR REFERENCE ONLY AND DO NOT APPEAR ON PART.
 - ⚠ TIGHTEN BOTH SCREWS EVENLY ON R1, Q2, AND VR1.
 - ⚠ REMOVE CENTER PIN (NUMBER 2) ON CR21.
 - ⚠ TORQUE 6-32 SCREWS TO 10±1 INCH POUNDS. TORQUE 4-40 SCREWS TO 8±1 INCH POUNDS. COMPONENT MOUNTING SURFACE TO BE COMPLETELY COVERED WITH F/M 95. TYPICAL .005 SHOULD SHOW ON SIDES OF COMPONENTS AFTER TIGHTENING.
 - ⚠ BOND F/M 84 TO F/M 1 USING F/M 127 AS SHOWN.
 - ⚠ ROLL STAKE F/M 125 INTO F/M 1 AS SHOWN.
 - ⚠ F/M 7 ASSEMBLIES WERE BUILT USING SCREWS (P/N 92780164) AND STEEL WASHERS (P/N 10124401) TO MOUNT THE LARGE HEATSINKS. THE FINAL VERSION UTILIZES HEATSINKS WITH INTEGRAL MOUNTING STUDS.

INACTIVE

APL 90446556	DETACHED LISTS		
P.C. CARD ASSEMBLY		81AHD-3 POWER SUPPLY	
90446556		90446556	

BUILD ARC 220

ASSEMBLY PARTS LIST

PRINT DATE		PAGE		P/B CHANGE NO.									
03-15-84		1		00716541									
REV.	QTY	U/M	DESCRIPTION	MC	STATUS	STATUS DATE	ENG. RESP.	FILE DATE					
0860	90446536	A	C	U	PCA 81AHD-3 (POWER SUPPLY)	A	HFL	08-08-83	CC634A	03-15-84			
U/PND NO	LI	PART NUMBER	CB	QTY	U/M	PART DESCRIPTION	MC	YLD	ECO. NO. IN	ECO. NO. OUT	I/W	WE IN	WE OUT
001	01	90446555	6	1		PC REPLACED BY 90446633 16541	P			16541			8417
001	02	90446533	1	1		PC PM BU 81AHD-3 PWR SUPPLY	P					8417	
002	01	15112100	1	1		PC IC ME555 916 TIMER	P						
003	01	15164406	9	1		PC IC LM318 AMP	P						
004	01	15163403	7	1		PC IC LM317 317 ADJ PDS V RGLTR	P						
005	01	15163484	7	1		PC IC TL494 PULSE-WD MOD CONTROL	P						
006	01	15151402	3	1		PC IC UA7912 356C NEG V RGLTR	P						
007	01	15151503	8	1		PC IC UA7812 357D PDS V RGLTR	P						
008	01	15107840	9	1		PC IC TYPE 250, 350 3AMP 35V	P						
009	01	51906500	5	2		PC HT/SK, SEMICNDCT FIG-1 AL/BLK	P						
010	01	51911303	5	2		PC HEAT SINK FIGURE 5	P						
011	01	51911304	3	1		PC HEAT SINK FIGURE 6	P						
012	01	51918101	0	2		PC HT/SK, SEMICNDCT FIG-1B AL/BL	P						
013	01	94397113	5	1		PC CAP AL ELEC 470UF-10+100P 50V	P						
014	01	51906103	0	1		PC CONN, PC-MTD 6 PIN NVL/SN F-2	P						
016	01	51906101	4	1		PC CONN, PC-MTD 3 PIN NVL/SN F-1	P						
017	01	95691501	1	4		PC RECT, SIL IN5617 1A 400V F-R	P						
018	01	51903100	4	4		PC LED, S-S GAP RED 1.0MCD 180HM	P						
019	01	10126738	9	2		PC TRANSFORMER DRIVER 6V 3P	P						
020	01	10126741	3	1		PC XFMR, 20-40KHZ CURR SENSE 4A	P						
021	01	10126745	4	1		PC XFMR, 20-40KHZ MULTI-OUT F-2	P						

BUILD ARC 220

ASSEMBLY PARTS LIST

PRINT DATE		PAGE		P/B CHANGE NO.									
03-15-84		2		00716541									
REV.	QTY	U/M	DESCRIPTION	MC	STATUS	STATUS DATE	ENG. RESP.	FILE DATE					
0860	90446536	A	C	U	PCA 81AHD-3 (POWER SUPPLY)	A	HFL	08-08-83	CC634A	03-15-84			
U/PND NO	LI	PART NUMBER	CB	QTY	U/M	PART DESCRIPTION	MC	YLD	ECO. NO. IN	ECO. NO. OUT	I/W	WE IN	WE OUT
022	01	10126799	1	1		PC XFMR, 50/60HZ STEP-DN P:-HT	P						
023	01	51918525	8	1		PC IND, RF-CHOKE 31UH 11A F-3	P						
024	01	51918519	1	2		PC IND, RF-CHOKE 3000UH 1A F-2	P						
025	01	51918624	1	1		PC IND, RF-CHOKE 550UH 1.5A F-3	P						
026	01	51906501	1	2		PC THMS, DTSC 5 OHM 10P 15MW	P						
027	01	51003392	7	2		PC XSTR 2N2222 HI-SPEED NPN SIL	P						
028	01	51684500	5	1		PC XSTR, 2N4091 FLO-EFF N-TYP SI	P						
029	01	51714300	0	4		PC XSTR, 2N2907 BI-POLAR PNP SI	P						
030	01	89770400	4	2		PC XSTR, 2N6308 POWER NPN SIL	P						
031	01	93314310	5	1		PC RECT, SIL 50PRV 1.6A FIG-1 LC	P						
032	01	15165527	9	1		PC RECT, DUAL SCHOTTKY 15A 40V	P						
033	01	15165390	9	1		PC RECT, CTR-TAP 15A 200V F-R	P						
034	01	15165503	0	1		PC RECT, BRIDGE 10A 600V	P						
035	01	51007385	1	7		PC DTU IN4148 SIL MICRO 30V 10MA	P						
036	01	95691506	0	4		PC RECT, SIL IN5616 3A 100V F-R	P						
037	01	50240107	8	1		PC DTD IN752A ZEN 5.6V 5P 20MA	P						
038	01	50240112	8	1		PC DTD IN757A ZEN 9.1V 5P 20MA	P						
039	01	50240117	7	1		PC DTD IN965B ZEN 15V 5P 8.5MA	P						
040	01	95637304	7	13		PC RECT, SIL IN4004 1A 400V NIM	P						
041	01	94240433	6	1		PC CAP FXD CER 3300PF 10P 50VDCW	P						
042	01	94240401	3	3		PC CAP FXD CER 1000PF 10P 50VDCW	P						

BUILD ARC 220

ASSEMBLY PARTS LIST

PRINT DATE	PAGE	PRE CHANGE NO.
03-15-84	3	00016541

DIV.	ASSEMBLY NUMBER	CD	REV.	QTY.	DESCRIPTION	MC	STATUS	STATUS DATE	ENG. RESP.	FILE DATE			
0860	90446556	4	C	D	PCA 81AHU-3 (POWER SUPPLY)	A	REL	08-08-83	CC634A	03-15-84			
FOUND NO.	LI	PART NUMBER	CD	QTY.	U/M	PART DESCRIPTION	MC	YLD	ECO. NO. IN	ECO. NO. OUT	S/N	WE IN	WE OUT
043	01	24506923	4	1		PC CAP FXD NYL .001UF 10P 200VDC	P						
044	01	36180753	0	1		PC CAP NYL FM .001UF 10P 600VDCW	P						
045	01	94858501	1	2		PC CAP CER DISC .01UF 20P 300UV	P						
046	01	94240411	2	3		PC CAP FXD CER 10K PF 10P 50VDCW	P						
047	01	24506909	3	1		PC CAP FXD NYL .022UF 10P 100VDC	P						
048	01	24504857	4	1		PC RES FXD COMP 560 OHM 5P 2WATT	P						
049	01	94240448	4	6		PC CAP FXD CER 100KPF 10P 50VDCW	P						
050	01	94240452	6	1		PC CAP FXD CER 220KPF 10P 50VDCW	P						
051	01	94400320	1	2		PC CAP POLY 1.00UF	P						
052	01	94400321	9	1		PC CAP POLY 1UF 250V	P						
053	01	50240105	2	1		PC DIO 1N750A ZEN 4.7V 5P 20RA	P						
054	01	94259912	7	2		PC CAP TANT ELECT 10.0UF 24GA	P						
055	01	94400512	1	3		PC CAP AL ELEC 15UF-10+100P 25V	P						
056	01	94402225	0	1		PC RES FXD C FM 750K OHM 5P 1/4W	P						
057	01	95691133	3	2		PC CAP ELECT 270UF -10+100P 25V	P						
058	01	15002220	0	2		PC CAP AL ELC 390UF -10+30P 250V	P						
060	01	94397149	7	2		PC CAP AL ELEC 2700UF-10+100 12V	P						
061	01	51918976	7	1		PC RES VAR CRM 1K R 20P 1/2W 3	P						
062	01	94402187	2	1		PC RES FXD C FM 20K OHM 5P 1/4W	P						
063	01	51918978	3	1		PC RES VAR CRM 5K R 20P 1/2W 3	P						
065	01	24504915	2	1		PC RES FXD COMP 10 OHM 5P 2WATT	P						

BUILD ARC 221

ASSEMBLY PARTS LIST

PRINT DATE	PAGE	PRE CHANGE NO.
03-15-84	4	00016541

DIV.	ASSEMBLY NUMBER	CD	REV.	QTY.	DESCRIPTION	MC	STATUS	STATUS DATE	ENG. RESP.	FILE DATE			
0860	90446556	4	C	D	PCA 81AHU-3 (POWER SUPPLY)	A	KFL	08-08-83	CC634A	03-15-84			
FOUND NO.	LI	PART NUMBER	CD	QTY.	U/M	PART DESCRIPTION	MC	YLD	ECO. NO. IN	ECO. NO. OUT	S/N	WE IN	WE OUT
066	01	24504927	7	1		PC RES FXD COMP 33 OHM 5P 2WATT	P						
067	01	17720512	5	2		PC RES FXD COMP .1MEG OHM 5P 1W	P						
068	01	24500123	5	2		PC RES FXD COMP 22 OHM 5P 1/2W	P						
069	01	24500166	4	2		PC RES FXD COMP 1300 OHM 5P 1/2W	P						
070	01	94402228	4	3		PC RES FXD C FM 1.0M OHM 5P 1/4W	P						
071	01	17705960	7	1		PC RES FXD COMP 10M OHM 5P 1/4W	P						
072	01	94402132	8	2		PC RES FXD C FM 100 OHM 5P 1/4W	P						
073	01	94402190	6	1		PC RES FXD C FM 27K OHM 5P 1/4W	P						
075	01	94360236	7	2		PC RES FXD FM 237 OHM 1P 1/4W	P						
075	02	94360236	7	1		PC RES FXD FM 237 OHM 1P 1/4W	P		16541	16541		8417	8417
076	01	94402148	4	4		PC RES FXD C FM 470 OHM 5P 1/4W	P			16541		8417	8417
076	02	94402148	4	3		PC RES FXD C FM 470 OHM 5P 1/4W	P		16541			8417	
077	01	95996520	7	2		PC RES FXD MM 600 OHM 10P 5WATT	P						
078	01	94360300	1	5		PC RES FXD FM 1000 OHM 1P 1/4W	P			16541		8417	8417
078	02	94360300	1	6		PC RES FXD FM 1000 OHM 1P 1/4W	P		16541			8417	
079	01	94402160	9	2		PC RES FXD C FM 1.5K OHM 5P 1/4W	P						
080	01	94360330	8	4		PC RES FXD FM 2050 OHM 1P 1/4W	P			16541		8417	8417
080	02	94360323	3	1		PC RES FXD FM 1740 OHM 1HP 1/4W	P		16541			8417	
083	01	94402166	6	4		PC RES FXD C FM 2.7K OHM 5P 1/4W	P						
084	01	94402169	0	2		PC RES FXD C FM 3.6K OHM 5P 1/4W	P						
085	01	94360357	1	1		PC RES FXD FM 3920 OHM 1P 1/4W	P						
086	01	94402197	1	1		PC RES FXD C FM 51K OHM 5P 1/4W	P						
087	01	94402179	9	1		PC RES FXD C FM 9.1K OHM 5P 1/4W	P						

SHEET REVISION STATUS		REVISION RECORD			
REV	DATE	BY	CHKD	APPD	DESCRIPTION
A	10/22/55				Released Class A
B	1/7/65				ADDED P/N 133 & NOTE 12
C	1/17/65				DELETE P/N 120

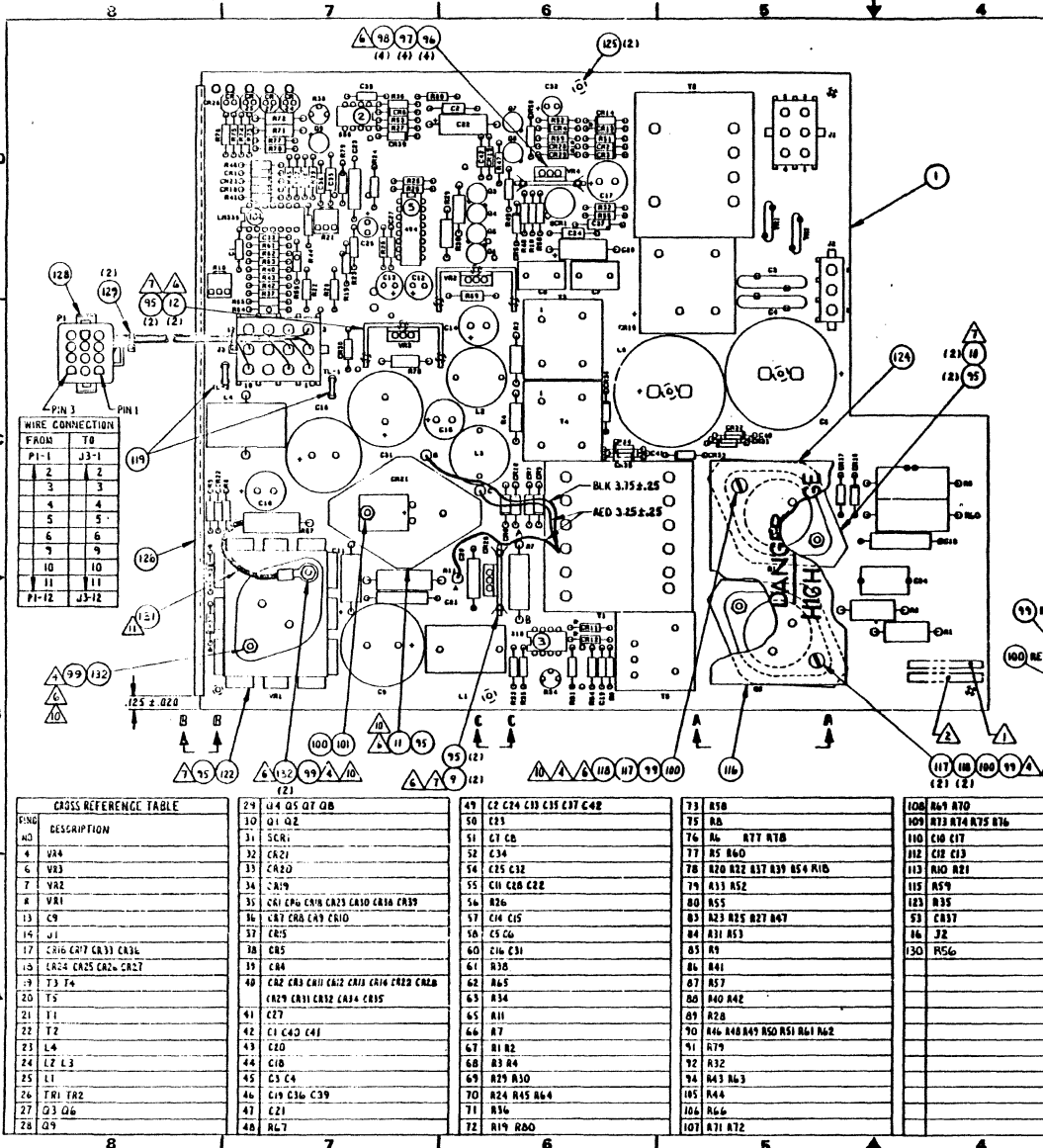

WIRE CONNECTION FROM TO

FROM	TO
P1-1	J3-1
2	2
3	3
4	4
5	5
6	6
7	7
8	8
9	9
10	10
11	11
P1-12	J3-12

CROSS REFERENCE TABLE	
P/N	DESCRIPTION
4	V44
6	V43
7	V42
8	V41
13	C9
14	J1
17	C216 C217 C218 C219
18	C220 C221 C222 C223
20	T5
21	T1
22	T2
23	L4
24	L7 L3
25	L1
26	F1 F2
27	Q1 Q2
28	Q9

29	Q4 Q5 Q7 Q8
30	Q1 Q2
31	SCR1
32	CR21
33	CR20
34	A19
35	C21 C22 C23 C24 C25 C26 C27
36	C28 C29 C30
37	CR5
38	CR8
39	CR4
40	CR3 CR4 CR5 CR6 CR7 CR8 CR9 CR10 CR11 CR12 CR13 CR14 CR15 CR16
41	CR17 CR18 CR19 CR20 CR21 CR22 CR23 CR24 CR25
42	C1 C2 C3
43	C4
44	C10
45	C5 C4
46	C10 C14 C19
47	C21
48	R17

49	C2 C24 C10 C15 C17 C42
50	C23
51	C7 C8
52	C34
54	C25 C32
55	C10 C20 C22
56	R26
57	C14 C15
58	C5 C6
60	C16 C31
61	CR4
62	R45
63	R34
64	R7
65	R11
66	R7
67	R1 R2
68	R3 R4
69	R29 R30
70	R24 R45 R46
71	R36
72	R19 R20

73	R10
75	R6
76	R6 R77 R78
77	R5 R60
78	R20 R22 R37 R39 R54 R10
79	R31 R52
80	R55
83	R23 R25 R27 R47
84	R31 R53
85	R9
86	R41
87	R57
88	R40 R42
89	R28
90	R46 R48 R49 R50 R51 R61 R62
91	R79
92	R32
94	R43 R63
105	R44
106	R66
107	R71 R72

100	R69 R70
109	R73 R74 R75 R76
110	C16 C17
112	C16 C17
113	R10 R21
115	R59
123	R35
53	CR37
146	J2
150	R56

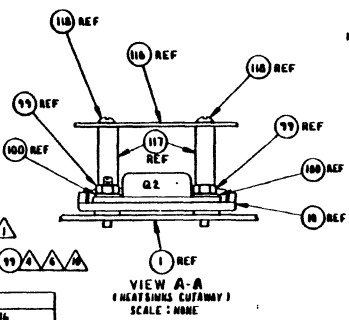
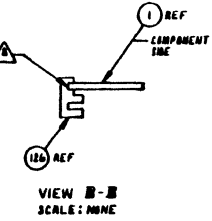
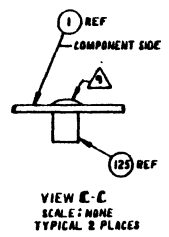

FOR DWB 9046555 REV02 ONLY

CHANGE TABLE	
Deletions	Additions
1) BETWEEN PADS OF R60	1) C31* TO R57 (END BY F/W)
2) R60 TO C32	2) C30A. P/N 5812 (R59) 5.5
3) R60 TO R57	3) T1-E TO R7 (END BY L1)
R37 TO C810	R37 TO C810

- NOTES:
- ▲ MARK ASSEMBLY NUMBER, REVISION LEVEL AND LOCATION IN AREA SHOWN. MARK PER CDC SPECIFICATION 10121508, CHARACTER HEIGHT .12 (10 POINT), COLOR WHITE.
 - ▲ MARK SERIAL NUMBER IN AREA SHOWN PER RVLOPS P & P NO. 80:20:34 AND PER MARKING REQUIREMENTS IN NOTE (1) ONE.
 - 3. FIND NUMBERS, ELEMENT IDENTIFIERS AND REFERENCE DESIGNATIONS ARE FOR REFERENCE ONLY AND DO NOT APPEAR ON PART.
 - ▲ TIGHTEN BOTH SCREWS EVENLY ON R1, R2, AND V41.
 - ▲ REMOVE CENTER PIN (NUMBER 2) ON CR21.
 - ▲ TORQUE 6-32 SCREWS TO 10.1 INCH POUNDS. TORQUE 4-40 SCREWS TO 1.1 INCH POUNDS. COMPONENT MOUNTING SURFACE TO BE COMPLETELY COVERED WITH F/W 95. TYPICAL .085 SHOULD SHOW ON SIDES OF COMPONENTS AFTER TIGHTENING.
 - ▲ BOND F/W R6 TO F/W 1 USING F/W 127 AS SHOWN.
 - ▲ MOLL STAKE F/W 125 INTO F/W 1 AS SHOWN.
 - ▲ FIRST ASSEMBLIES WERE BUILT USING SCREWS (P/N 9278064) AND STEEL WASHERS (P/N 1018481) TO BRIDGE THE LARGE HEATSHINKS. THE FUTURE VERSION UTILIZES BRASS WASHERS WITH INTEGRAL MOUNTING STUDS.
 - ▲ SOLDER ONE END OF F/W 131 TO R67 AS SHOWN. ATTACH OTHER END TO V41 BETWEEN TWO STAR WASHERS, F/W 132 USING NUT, F/W 99.
 - 12. AFTER ALIGNING R34 AND R30, SEAL THEM WITH GLYPTAL CDC P/N 51873600.

APL 90446687

<p>DATE: 10/22/55</p> <p>DESIGNED BY: [Signature]</p> <p>CHECKED BY: [Signature]</p> <p>APPROVED BY: [Signature]</p> <p>SCALE: NONE</p>	<p>E. SPESLID</p> <p>CONSIDER DATA CORPORATION</p> <p>P.C. CARD ASSEMBLY</p> <p>81AHD-4 POWER SUPPLY</p> <p>CC634-B</p> <p>D 15920</p> <p>90446687</p> <p>15920</p> <p>90446687</p> <p>SHEET 1 OF 1</p>
---	---

ASSEMBLY PARTS LIST

BUILD ARC 214										PRINT DATE		PAGE		FILE CHANGE NO.	
086C ASSEMBLY NO. 90446687 7										07-02-85		1		00017183	
CD ASSY 81AHU-4 (POWER SUPPLY)										STATUS DATE		ENG. RESP.		FILE DATE	
CD ASSY 81AHU-4 (POWER SUPPLY)										11-15-84		CC6348		07-04-85	
TRND NO.	U	PART NO.	CD	REV.	QTY	U/M	DESCRIPTION	MC	STATUS	ECO. NO. IN	ECO. NO. OUT	S/N	WK IN	WK OUT	
001	01	90446633	1		1		PC PM BD 81AHU-3 PWR SUPPLY	A	P						
002	01	15112100	1		1		PC IC NE555 916 TIMER	A	P						
003	01	15164406	9		1		PC IC LM318 AMP	A	P						
004	01	15163403	7		1		PC IC LM317 317 ADJ POS V RGLTR	A	P						
005	01	15163484	7		1		PC IC TL494 PULSE-WO MOD CONTROL	A	P						
006	01	15151402	3		1		PC IC UA7912 356C NEG V-RGLTR	A	P						
007	01	15151503	8		1		PC IC UA7812 357D POS V RGLTR	A	P						
008	01	15107840	9		1		PC IC TYPE 250, 350 3AMP 35V	A	P						
009	01	51906600	5		2		PC HT/SK, SEMICNDCT FIG-1 AL/BLK	A	P						
010	01	51911003	5		2		PC HEAT SINK FIGURE 5	A	P						
011	01	51911004	3		1		PC HEAT SINK FIGURE 6	A	P						
012	01	51918101	0		2		PC HT/SK, SEMICNDCT FIG-1B AL/BL	A	P						
013	01	94397113	5		1		PC CAP AL ELEC 470UF-10+100P 50V	A	P						
014	01	51906103	0		1		PC CONN, PC-MTD 6 PIN NYL/SN F-2	A	P						
016	01	51906101	4		1		PC CONN, PC-MTD 3 PIN NYL/SN F-1	A	P						
017	01	95691501	1		4		PC RECT, SIL IN5617 1A 400V F-R	A	P						
018	01	51903900	4		4		PC LED, S-S GAP RED 1.0MCD 180MW	A	P						
019	01	10126938	9		2		PC XFMR, 20-40KHZ DRIVER 6V 3P	A	P						
020	01	10126941	3		1		PC XFMR, 20-40KHZ CURR SENSE 4A	A	P						
021	01	10126945	4		1		PC XFMR, 20-40KHZ MULTI-OUT F-2	A	P						
022	01	10126949	1		1		PC XFMR, 50/60HZ STEP-DN PC-MT	A	P						

ASSEMBLY PARTS LIST

BUILD ARC 214										PRINT DATE		PAGE		FILE CHANGE NO.	
086C ASSEMBLY NO. 90446687 7										07-02-85		2		00017183	
CD ASSY 81AHU-4 (POWER SUPPLY)										STATUS DATE		ENG. RESP.		FILE DATE	
CD ASSY 81AHU-4 (POWER SUPPLY)										11-15-84		CC6348		07-04-85	
TRND NO.	U	PART NO.	CD	REV.	QTY	U/M	DESCRIPTION	MC	STATUS	ECO. NO. IN	ECO. NO. OUT	S/N	WK IN	WK OUT	
023	01	51918625	8		1		PC IND, RF-CHOKE 31UH 11A F-3	A	P						
024	01	51918619	1		2		PC IND, RF-CHOKE 3000UH 1A F-2	A	P						
025	01	51918624	1		1		PC IND, RF-CHOKE 550UH 1.5A F-3	A	P						
026	01	51908601	1		2		PC THMS, DISC 5 OHM 10P 15MW	A	P						
027	01	51003092	7		2		PC XSTR 2N2222 HI-SPEED NPN SIL	A	P						
028	01	51694500	5		1		PC XSTR, 2N4091 FLD-EFF N-TYP SI	A	P						
029	01	51714000	0		4		PC XSTR, 2N2907 BI-POLAR PNP SI	A	P						
030	01	89770800	4		2		PC XSTR, 2N6308 POWER NPN SIL	A	P						
031	01	93314010	5		1		PC RECT, SIL 50PRV 1.6A FIG-1 LC	A	P						
032	01	15165627	9		1		PC RECT, DUAL SCHOTTKY 15A 40V	A	P						
033	01	15165590	9		1		PC RECT, CTR-TAP 15A 200V F-R	A	P						
034	01	15165603	0		1		PC RECT, BRIDGE 10A 600V	A	P						
035	01	51007385	1		7		PC DIO 1N4148 SIL MICRO 30V 10MA	A	P						
036	01	95691506	0		4		PC RECT SIL 1N5416 3A 100V F-R	A	P						
037	01	50240107	8		1		PC DIO 1N752A ZEN 5.6V 5P 20MA	A	P						
038	01	50240112	8		1		PC DIO 1N757A ZEN 9.1V 5P 20MA	A	P						
039	01	50240117	7		1		PC DIO 1N965R ZEN 15V 5P 8.5MA	A	P						
040	01	95637304	7		13		PC RECT, SIL 1N4004 1A 400V MIN	A	P						
041	01	94240433	6		1		PC CAP FXD CFR 3300PF 10P 50VDC	A	P						
042	01	94240401	3		3		PC CAP FXD CFR 1000PF 10P 50VDC	A	P						
043	01	24576923	4		1		PC CAP FXD NYL .001UF 16P 200VDC	A	P						

ASSEMBLY PARTS LIST

BUILD ARC 214										PRINT DATE	PAGE	FILE CHANGE NO.				
										07-02-85	3	00017193				
Q860	ASSEMBLY NO.	CD	REV.	DWG.	DESCRIPTION					MC	STATUS	STATUS DATE	ENG. RESP.	FILE DATE		
Q860	90446887	7	C	U	CD ASSY BIAHD-4 (POWER SUPPLY)					A	RFL	11-15-84	CC634B	07-04-85		
TRD NO.	U	PART NO.	CD	REV.	QTY	U/M	PART DESCRIPTION			MC	YLD	ECO. NO. IN	ECO. NO. OUT	S/M	WK IN	WK OUT
044	01	36180753	0		1		PC	CAP	MYL	FM	.001UF	10P	600VDCW	P		
045	01	94858601	1		2		PC	CAP	CER	DISC	.01UF	20P	3000V	P		
046	01	94240411	2		3		PC	CAP	FXD	CER	.01UF	10P	50VDCW	P		
047	01	24506809	3		1		PC	CAP	FXD	MYL	.022UF	10P	100VDC	P		
048	01	24504857	4		1		PC	RES	FXD	COMP	560	OHM	5P	2WATT	P	
049	01	94240448	4		6		PC	CAP	FXD	.1UF	10P	50VDCW	P			
050	01	94240452	6		1		PC	CAP	FXD	CER	.22UF	10P	50VDCW	P		
051	01	94400320	1		2		PC	CAP	POLY	1.00UF				P		
052	01	94400321	9		1		PC	CAP	POLY	1UF	250V			P		
053	01	50240105	2		1		PC	DIU	IN750A	ZEM	4.7V	5P	20MA	P		
054	01	94259912	7		2		PC	CAP	TANT	ELECT	10.0UF	24GA		P		
055	01	94400612	1		3		PC	CAP	AL	ELEC	15	UF-10+100P	25V	P		
056	01	94402225	0		1		PC	RES	FXD	C	FM	750K	OHM	5P	1/4W	P
057	01	45691133	3		2		PC	CAP	ELECT	270UF	-10+100P	25V		P		
058	01	15002220	0		2		PC	CAP	AL	ELC	390UF	-10+30P	250V	P		
060	01	94397145	7		2		PC	CAP	AL	ELEC	2700UF	-10+100	12V	P		
061	01	51918876	7		1		PC	MFS	VAR	CRM	1K	R	20P	1/2W	3	P
062	01	94402187	2		1		PC	RES	FXD	C	FM	20K	OHM	5P	1/4W	P
063	01	51918878	3		1		PC	RES	VAX	CRM	5K	K	20P	1/2W	3	P
065	01	24504415	7		1		PC	RES	FXD	COMP	10	OHM	5P	2WATT	P	
066	01	24504827	7		1		PC	RES	FXD	COMP	33	OHM	5P	2WATT	P	

ASSEMBLY PARTS LIST

BUILD ARC 214										PRINT DATE	PAGE	FILE CHANGE NO.				
										07-02-85	4	00017193				
Q860	ASSEMBLY NO.	CD	REV.	DWG.	DESCRIPTION					MC	STATUS	STATUS DATE	ENG. RESP.	FILE DATE		
Q860	90446887	7	C	U	CD ASSY BIAHD-4 (POWER SUPPLY)					A	RFL	11-15-84	CC634B	07-04-85		
TRD NO.	U	PART NO.	CD	REV.	QTY	U/M	PART DESCRIPTION			MC	YLD	ECO. NO. IN	ECO. NO. OUT	S/M	WK IN	WK OUT
067	01	17720612	5		2		PC	RES	FXD	COMP	.1MEG	OHM	5P	1W	P	
068	01	24500123	5		2		PC	RES	FXD	COMP	22	OHM	5P	1/2W	P	
069	01	24500166	4		2		PC	RES	FXD	COMP	1300	OHM	5P	1/2W	P	
070	01	94402228	4		3		PC	RES	FXD	C	FM	1.0M	OHM	5P	1/4W	P
071	01	17705460	7		1		PC	RES	FXD	COMP	10M	OHM	5P	1/4W	P	
072	01	94402132	8		2		PC	RES	FXD	C	FM	100	OHM	5P	1/4W	P
073	01	94402130	6		1		PC	RES	FXD	C	FM	27K	OHM	5P	1/4W	P
075	01	94360236	7		1		PC	RES	FXD	FM	237	OHM	1P	1/4W	P	
076	01	94402148	4		3		PC	RES	FXD	C	FM	470	OHM	5P	1/4W	P
077	01	95596520	7		2		PC	RES	FXD	WM	600	OHM	10P	5WATT	P	
078	01	94360300	1		6		PC	RES	FXD	FM	1000	OHM	1P	1/4W	P	
079	01	94402160	9		2		PC	RES	FXD	C	FM	1.5K	OHM	5P	1/4W	P
080	01	94360323	3		1		PC	RES	FXD	FM	1740	OHM	1HP	1/4W	P	
083	01	94402166	6		4		PC	RES	FXD	C	FM	2.7K	OHM	5P	1/4W	P
084	01	94402169	0		2		PC	RES	FXD	C	FM	3.6K	OHM	5P	1/4W	P
085	01	94360357	1		1		PC	RES	FXD	FM	3920	OHM	1P	1/4W	P	
086	01	94402197	1		1		PC	RES	FXD	C	FM	51K	OHM	5P	1/4W	P
087	01	94402179	9		1		PC	RES	FXD	C	FM	9.1K	OHM	5P	1/4W	P
088	01	94402178	1		2		PC	RES	FXD	C	FM	4.2K	OHM	5P	1/4W	P
089	01	94402176	5		1		PC	RES	FXD	C	FM	6.8K	OHM	5P	1/4W	P
090	01	94402160	7		7		PC	RES	FXD	C	FM	10K	OHM	5P	1/4W	P

ASSEMBLY PARTS LIST

BUILD ARC 214										PRINT DATE	PAGE	FILE CHANGE NO.		
DIV. ASSEMBLY NO. CD REV. DWG. DESCRIPTION MC STATUS										07-02-85	5	00017183		
U 860 904466477 7 C D CD ASSY 81AHD-4 (POWER SUPPLY) A REL										STATUS DATE	ENG. RESP.	FILE DATE		
T/PNO	U	PART NO.	CD	REV.	QTY	U/M	PART DESCRIPTION	MC	T/D	ECO. NO. IN	ECO. NO. OUT	S/N	WK IN	WK OUT
091	01	94402184	9		1		PC RES FXD C FM 15K OHM 5P 1/4W	P						
092	01	94360451	2		1		PC RES FXD FM 34.0K OHM 1P 1/4W	P						
094	01	94402221	9		2		PC RES FXD C FM 510K OHM 5P 1/4W	P						
095	01	51003962	1			001	OZ PASTE, HEAT XFR CMPD NON-COND	B						
096	01	10127103	9		4		PC MSCR PAN PHL 4-40X.312 STL ZP	B						
097	01	10126400	0		4		PC WSHR, (4) EXT/T LK STL ZP	B						
098	01	10125103	1		4		PC NUT, HEX 4-40 MSCR STL ZP	B						
099	01	00869901	9		6		PC NUT, HEX 6-32 MSCR SMALL DIA	B						
100	01	10125903	6		5		PC WSHR, NO.6 SPG LOCK STL ZP	B						
101	01	93114214	5		1		PC STANDOFF 6-32 .500	B						
102	01	90446563	0			REF	PC SCH DIAG 81AHD-3 POWER SUPPLY	D						
103	01	16006900	9			REF	PC FAB SPEC, DOUBLE-SIDED PWB	D						
104	01	15126600	4		1		PC IC LM339 341 QUAD COMPARATOR	P						
105	01	94402165	8		1		PC RES FXD C FM 2.4K OHM 5P 1/4W	P						
106	01	94402194	8		1		PC RES FXD C FM 39K OHM 5P 1/4W	P						
107	01	24500172	2		2		PC RES FXD COMP 2400 OHM 5P 1/2W	P						
108	01	24500159	9		2		PC RES FXD COMP 680 OHM 5P 1/2W	P						
109	01	94402158	3		4		PC RES FXD C FM 1.2K OHM 5P 1/4W	P						
110	01	95091141	6		2		PC CAP ELECT 270UF -10+100P 40V	P						
112	01	94395509	6		2		PC CAP AL ELEC 22UF -10+75P 25V	P						
113	01	51918446	0		2		PC RES VAR CRM 1K R 20P 1/2W 1	P						

ASSEMBLY PARTS LIST

BUILD ARC 214										PRINT DATE	PAGE	FILE CHANGE NO.		
DIV. ASSEMBLY NO. CD REV. DWG. DESCRIPTION MC STATUS										07-02-85	6	00017183		
U 860 904466477 7 C D CD ASSY 81AHD-4 (POWER SUPPLY) A REL										STATUS DATE	ENG. RESP.	FILE DATE		
T/PNO	U	PART NO.	CD	REV.	QTY	U/M	PART DESCRIPTION	MC	T/D	ECO. NO. IN	ECO. NO. OUT	S/N	WK IN	WK OUT
115	01	94402177	3		1		PC RES FXD C FM 7.5K OHM 5P 1/4W	P						
116	01	71493576	4		1		PC INSULATOR, HV COVER (PLSTC)	P						
117	01	51918928	6		2		PC SPACER, HEX NYLON 6-32X.875	B						
118	01	93343158	7		2		PC MSCR RND SLT 6-32X1/4 NYL BLK	B						
119	01	51669429	6		2		PC TERM, 0-DISC FIG-7 BRASS/SN	P						
120	01	38838005	7		1		PC TERM, SUBMN TUR/SN .062T-80	P			17183			8527
122	01	51911007	6		1		PC HEAT SINK	P						
123	01	94402173	2		1		PC RES FXD C FM 5.1K OHM 5P 1/4W	P						
124	01	24547501	7		1		PC PLATE, DANGER HIGH VOLTAGE	P						
125	01	51440689	6		2		PC STUFF, SWAGE BKS 4-40 FIG-2	P						
126	01	71493704	2		1		PC STIFFENER, PC BOARD (PLSTC)	P						
127	01	62019900	0			001	OZ REPLACED BY 95048500 16964	B						
127	02	95048500	3			001	OZ EPOXY, 2-PART 5-MINUTE CLEAR	B		17131	17131		8517	8517
128	01	61409555	2		1		PC CABLE ASSY, POWER	A						
129	01	94277400	1		2		PC STRAP, CBL TIE TYP-1 TU 5/8	B						
130	01	94360229	2		1		PC RES FXD FM 200 OHM 1P 1/4W	P						
131	01	61409795	4		1		PC WIRE JUMPER 1.51W 18GA BLACK	G						
132	01	10126401	8		3		PC WSHR, (6) EXT/T LK STL ZP	B						
133	01	51873600	4			015	OZ VARNISH INSUL RED GLPT	B		17143			8525	

17715

BUILD ARC 214										PRINT DATE	PAGE	FILE CHANGE NO.	
										04-29-85	5	00000000	
										STATUS DATE	ENG. RESP.	FILE DATE	
										11-30-84	CC634A	04-29-85	
DIV	ASSEMBLY NO.	CD	REV.	DWG.	DESCRIPTION		MC	STATUS					
0860	90446556	4	0	0	REPLACED BY 90446687 16972		A	INA					
T/PND NO.	U	PART NO.	CD	QTY	U/M	PART DESCRIPTION	MC	YLD	ECO. NO. IN	ECO. NO. OUT	S/M	WK IN	WK OUT
088	01	94402178	1	2		PC RES FXD C FH 8.2K OHM 5P 1/4W	P						
089	01	94402176	5	1		PC RES FXD C FH 6.8K OHM 5P 1/4W	P						
090	01	94402180	7	7		PC RES FXD C FH 1CK OHM 5P 1/4W	P						
091	01	94402184	9	1		PC RES FXD C FH 15K OHM 5P 1/4W	P						
092	01	94360491	2	1		PC RES FXD FR 34.0K OHM 1P 1/4W	P						
094	01	94402221	9	2		PC RES FXD C FH 510K OHM 5P 1/4W	P						
095	01	51003962	1		001 02	PASTE, HEAT XFR CPPD NON-COND	B						
096	01	10127103	9	4		PC MSCR PAN PHL 4-40X.312 STL ZP	B						
097	01	10126400	0	4		PC WSHR. (4) EXT/T LK STL ZP	B						
098	01	10125103	1	4		PC NUT, HEX 4-40 PSCR STL ZP	B						
099	01	00869901	9	6		PC NUT, HEX 6-32 PSCR SPALL DIA	B						
100	01	10125803	6	7		PC WSHR. NO.6 SPG LOCK STL ZP	B						
101	01	93114214	5	1		PC STANDOFF 6-32 .500	B						
102	01	90446563	0	REF		PC SCM DIAG 81AM0-3 POWER SUPPLY	D						
103	01	16006500	9	REF		PC FAB SPEC. DOUBLE-SIDED PWB	D						
104	01	15126600	4	1		PC IC LM339 341 QUAD COMPARTOR	P						
105	01	94402165	8	1		PC RES FXD C FH 2.4K OHM 5P 1/4W	P						
106	01	94402194	8	1		PC RES FXD C FH 39K OHM 5P 1/4W	P						
107	01	24900172	2	2		PC RES FXD COPP 2400 OHM 5P 1/2W	P						
108	01	24900199	9	2		PC RES FXD COPP 680 OHM 5P 1/2W	P						
109	01	94402158	3	4		PC RES FXD C FH 1.2K OHM 5P 1/4W	P						

17715

BUILD ARC 214										PRINT DATE	PAGE	FILE CHANGE NO.	
										04-29-85	6	00000000	
										STATUS DATE	ENG. RESP.	FILE DATE	
										11-30-84	CC634A	04-29-85	
DIV	ASSEMBLY NO.	CD	REV.	DWG.	DESCRIPTION		MC	STATUS					
0860	90446556	4	0	0	REPLACED BY 90446687 16972		A	INA					
T/PND NO.	U	PART NO.	CD	QTY	U/M	PART DESCRIPTION	MC	YLD	ECO. NO. IN	ECO. NO. OUT	S/M	WK IN	WK OUT
110	01	95691141	6	2		PC CAP ELECT 270UF -10+100P 40V	P						
112	01	94395509	6	2		PC CAP. AL ELEC 22UF -10+75P 25V	P						
113	01	51918846	0	2		PC RES VAR CRF 1K R 20P 1/2W 1	P						
115	01	94402177	3	1		PC RES FXD C FH 7.5K OHM 5P 1/4W	P						
116	01	71493576	4	1		PC INSULATOR, HV COVER (PLSTC)	P						
117	01	51918928	6	2		PC SPACER, HEX NYLON 6-32X.875	B						
118	01	93343156	7	2		PC MSCR RND SLT 6-32X1/4 NYL BLK	B						
119	01	51669429	6	2		PC TERM. 0-01SC FIG-7 BRASS/SN	P						
120	01	38838005	7	1		PC TERM. SUBRM TUR/SN .062T-80	P			16443			8401
122	01	51911007	6	1		PC HEAT SINK	P						
123	01	94402173	2	1		PC RES FXD C FH 5.1K OHM 5P 1/4W	P						
124	01	24947501	7	1		PC PLATE, DANGER HIGH VOLTAGE	P						
125	01	51940689	6	2		PC STOPP. SWAGE BPS 4-40 FIG-2	P						
126	01	71493704	2	1		PC STIFFENER, PC BOARD (PLSTC)	P						
127	01	62019900	0		001 02	REPLACED BY 95040500 16964	B						
127	02	95040500	3		001 02	EPOXY, 2-PART 5-MINUTE CLEAR	B		17131	17131		8517	8517
128	01	61409595	2	1	1	PC CABLE ASSY. POWER	B						
129	01	94277400	1	2		PC STRAP, CBL TIE TYP-1 TO 5/8	B						
130	01	94360229	2	1		PC RES FXD FR 200 OHM 1P 1/4W	P		16541			8417	

17715

BUILD ARC 214										PRINT DATE	PAGE	FILE CHANGE NO.	
										04-29-85	7	00000000	
										STATUS DATE	ENG. RESP.	FILE DATE	
										11-30-84	CC634A	04-29-85	
DIV	ASSEMBLY NO.	CD	REV.	DWG.	DESCRIPTION		MC	STATUS					
0860	90446556	4	0	0	REPLACED BY 90446687 16972		A	INA					
T/PND NO.	U	PART NO.	CD	QTY	U/M	PART DESCRIPTION	MC	YLD	ECO. NO. IN	ECO. NO. OUT	S/M	WK IN	WK OUT
0126 TOTAL LINES													

REVISIONS		REVISIONS	
NO.	DATE	BY	REASON
1	12/22/65	PL	Released Class A
2	1/27/66	PL	ADDED F/M 133 & NOTE 12
3	1/27/66	PL	DELETED F/M 120
4	1/27/66	PL	DELETED F/M 120

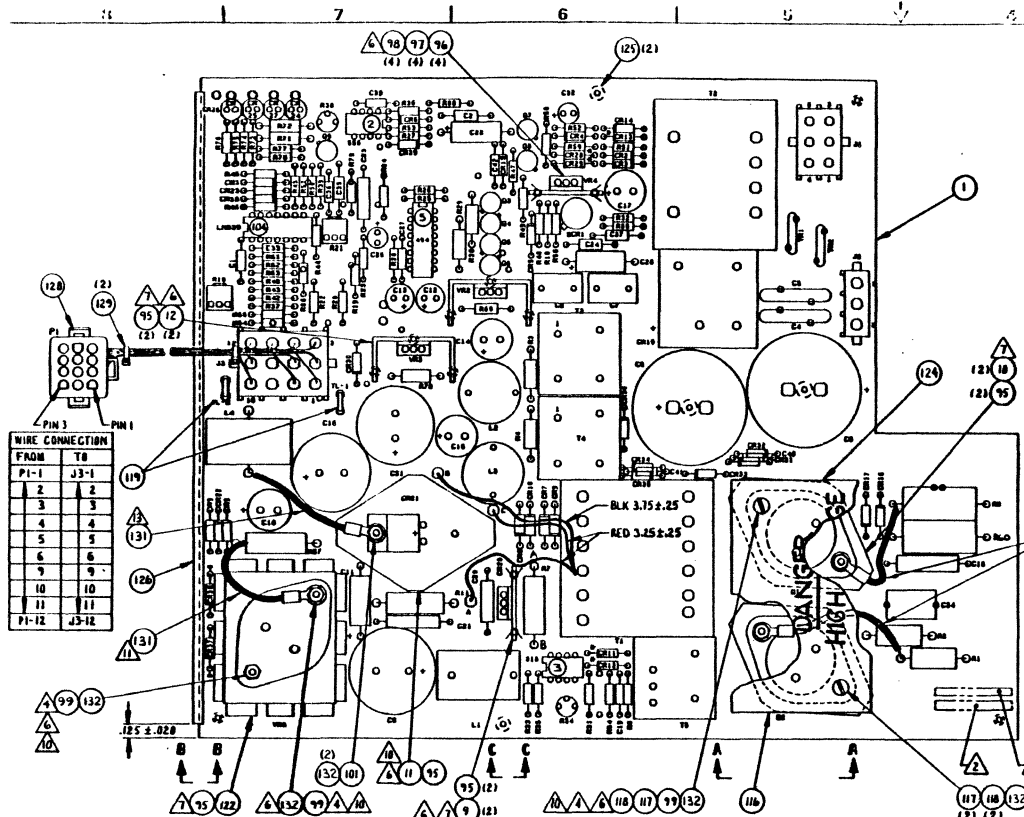

WIRE CONNECTION	
FROM	TO
P1-1	J3-1
2	2
3	3
4	4
5	5
6	6
7	7
10	10
11	11
P1-12	J3-12

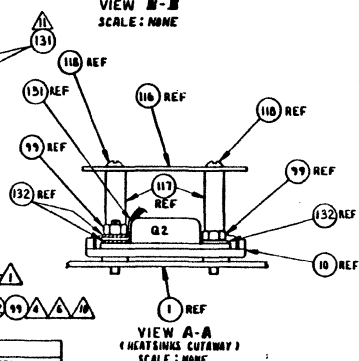
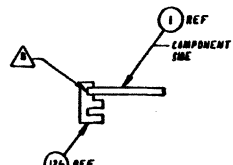
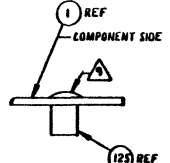

- NOTES:
- ▲ SOLDER ONE END OF F/M 131 TO L4 AS SHOWN, AT EACH OTHER END TO CR21 BETWEEN 2 STAR WASHERS, F/M 132 USING STANDOFF, F/M 101.
 - ▲ MARK ASSEMBLY NUMBER, REVISION LEVEL AND LOCATION IN AREA SHOWN. MARK PER CDC SPECIFICATION 10121508, CHARACTER HEIGHT .12 (10 POINT), COLOR WHITE.
 - ▲ MARK SERIAL NUMBER IN AREA SHOWN PER RVLOPS P & P NO. 80-2034 AND PER MARKING REQUIREMENTS IN NOTE (1) ONE.
 3. FIND NUMBERS, ELEMENT IDENTIFIERS AND REFERENCE DESIGNATIONS ARE FOR REFERENCE ONLY AND DO NOT APPEAR ON PART.
 - ▲ TIGHTEN BOTH SCREWS EVENLY ON R1, Q2, AND VRI.
 - ▲ REMOVE CENTER PIN (NUMBER 2) ON CR21.
 - ▲ TORQUE 6-32 SCREWS TO 108 INCH POUNDS.
 - ▲ TORQUE 4-40 SCREWS TO 811 INCH POUNDS.
 - ▲ COMPONENT MOUNTING SURFACE TO BE COMPLETELY COVERED WITH F/M 95. TYPICAL .005 SHOULD SHOW ON SIDES OF COMPONENTS AFTER TIGHTENING.
 - ▲ BOND F/M 26 TO F/M 1 USING F/M 127 AS SHOWN.
 - ▲ ROLL STAKE F/M 125 INTO F/M 1 AS SHOWN.
 - ▲ FIRST ASSEMBLIES WERE BUILT USING SCREWS (F/M 92780164) AND STEEL WASHERS (F/M 10126401) TO MOUNT THE LARGE HEAT SINKS. THE FINAL VERSION UTILIZES HEAT SINKS WITH INTEGRAL MOUNTING STUDS.
 - ▲ SOLDER ONE F/M 131 TO EACH OF THE FOLLOWING R67, R1, AND R5 AS SHOWN. AT EACH OTHER ENDS TO VRI, Q1, AND Q2, BETWEEN TWO STAR WASHERS, F/M 132 USING NUT, F/M 99.
 12. AFTER ALIGNING R34 AND R30, SEAL THEM WITH GLYPTAL CDC P/M 51B73600.

CROSS REFERENCE TABLE	
FIND NO	DESCRIPTION
4	VR4
6	VR3
7	VR2
8	VR1
13	C9
14	J1
17	CR16 CR17 CR18
18	CR24 CR25 CR26 CR27
19	T3 T4
20	T5
21	T1
22	T2
23	L4
24	L7 L3
25	L1
26	F01 F02
27	Q3 Q6
28	Q9

29	Q4 Q5 Q7 Q8
30	Q1 Q2
31	SCR1
32	CR22
33	CR20
34	CR19
35	CR16 CR18 CR19 CR20 CR21 CR22
36	CR7 CR8 CR9 CR10
37	CR5
38	CR5
39	CR6
40	CR2 CR3 CR4 CR12 CR13 CR14 CR15 CR16 CR17 CR18 CR19 CR20 CR21 CR22 CR23 CR24 CR25 CR26 CR27
41	CR7
42	C1 CAD C41
43	C20
44	C10
45	C5 C4
46	C7 C36 C39
47	C21
48	R67

49	C2 C24 C35 C37 C42
50	C23
51	C7 CB
52	C34
54	C25 C32
55	C11 C20 C22
56	R26
57	C4 C15
58	C5 C6
60	C16 C31
61	R30
62	R65
63	R34
64	R11
65	R7
66	R7
67	R1 R2
68	R3 R4
69	R29 R30
70	R24 R45 R46
71	R36
72	R19 R20

73	R50
75	R8
76	R6 R77 R78
77	R5 R60
78	R20 R22 R37 R39 R54 R10
79	R33 R52
80	R55
83	R25 R25 R27 R47
84	R31 R53
85	R9
86	R41
87	R57
88	R40 R42
89	R28
90	R46 R48 R49 R50 R51 R61 R62
91	R79
92	R32
94	R43 R63
95	R44
106	R66
107	R71 R72

108	R69 R70
109	R73 R74 R75 R76
110	C10 C37
112	C12 C13
113	R10 R21
115	R59
123	R35
53	CR37
16	J2
130	R56

FOR PWB 90446555 REV02 ONLY
CHANGE TABLE

Deletions	Additions
CUT F/W:	
1) BETWEEN PADS OF R60	1) C23 TO R57 (END BY R5)
2) R60 TO C32*	55 (30GA. F/M 51A2947) S.S.
3) R60 TO R57	5.5 2) T1-B TO R7 (END BY L1)
4) R7 TO CR10	9.5 (10GA. F/M 24501808) S.S.

APL 90446687
DETACHED LISTS

E. E. ERFELD		GENERAL DATA CORPORATION	
P.C. CARD ASSEMBLY		81AHD-4 POWER SUPPLY	
CC634-B	D 15920	90446687	SHEET 1 OF 1

90446687	D	A	C	CD ASSY 81AHD-4 (POWER SUPPLY	CD	CC6348	07/29/85	017775	05/14/86	1/ 4
ASSEMBLY NUMBER	REV	CL	REV	ASSEMBLY DESCRIPTION	DESIGN SOURCE	PART USAGE	RELEASE DATE	CHANGE ORG NUMBER	PROCESSING DATE	PAGE NUMBER

MI

PNL NO	REV	PART NUMBER	QUANTITY	JST HEAD	PART DESCRIPTION	H/OUT STATUS	CHANGE ORG NUMBER	DATE EFFECTIVE	MAKE/BUY PART TYPE	PN NC	LN
99	C	00869901	6.00	PC	NUT HEX 6-32X1/4X3/32	IN			PPP3		N
98	A	10125103	4.00	PC	HEXAGON NUT 4-40	IN			PPP1		N
100	A	10125803	5.00	PC	SPRING LOCK WASHERS (MED) #6	OUT	017775	050986	PPP1		N
97	A	10126400	4.00	PC	EXT TOOTH LOCK WASHERS #4	IN			PPP1		N
132	A	10126401	3.00	PC	EXT TOOTH LOCK WASHERS NO.6	OUT	017775	050986	PPP1		N
132	A	10126401	11.00	PC	EXT TOOTH LOCK WASHERS NO.6	IN	017775	050986	PPP1		N
19	A	10126938	2.00	PC	XFMR, 20-40KHZ DRIVER 6V 3P	IN			PPP4		N
20	A	10126941	1.00	PC	XFMR, 20-40KHZ CURR SENSE 4A	IN			PPP4		N
21	A	10126945	1.00	PC	XFMR, 20-40KHZ MULTI-OUT F-2	IN			PPP4		N
22	A	10126999	1.00	PC	XFMR, 50/60HZ STEP-ON PC-MT	IN			PPP4		N
96	A	10127103	4.00	PC	SCR MACH PAN PHL 4-40 X 5/16	IN			PPP1		N
58	A	15002220	2.00	PC	CAP AL ELC 390UF -10+30P 250V	IN			PPP4		N
8	A	15107840	1.00	PC	IC TYPE 250, 350 3AMP 35V	IN			PPP4		N
2	A	15112100	1.00	PC	IC NE555 916 TIMER	IN			PPP5		N
104	A	15126600	1.00	PC	I.C. M-QUAD COMP. DIP LM339	IN			PPP5		N
6	A	15151402	1.00	PC	IC -12V REG 356C 7912	IN			PPP4		N
7	A	15151503	1.00	PC	IC-POS. VOLTAGE REG UA7812	IN			PPP4		N
4	A	15163403	1.00	PC	IC LM317 317 ADJ POS V RGLTR	IN			PPP4		N
5	A	15163484	1.00	PC	IC TL494 PULSE-WO MOD CONTROL	IN			PPP5		N
3	A	15164406	1.00	PC	IC LM318 AMP	IN			PPP5		N
33	A	15165590	1.00	PC	RECT, CTR-TAP 15A 200V F-R	IN			PPP4		N
34	A	15165603	1.00	PC	RECT, BRIDGE 10A 600V	IN			PPP4		N
32	A	15165627	1.00	PC	RECT, DUAL SCHOTTKY 15A 40V	IN			PPP4		N
103	A	16006500	REF	PC	SNGL * DBL SIDED PC BD FAB SPC	IN			REF4		N
71	A	17705960	1.00	PC	RES FXD .25W 10.0 MEG	IN			PPP5		N
67	A	17720612	2.00	PC	RES, FXD COMP 1W 5 PCT 0.1 MEG	IN			PPP5		N
68	C	24500123	2.00	PC	RES FXD COMP .50W 220HMS 5PCT	IN			PPP5		N
108	C	24500159	2.00	PC	RES FXD COMP .50W 6800HMS 5PCT	IN			PPP5		N
69	A	24500166	2.00	PC	RES- FXD CMPSN, 1/2W 13000HMS	IN			PPP5		N
107	C	24500172	2.00	PC	RES FXD COMP .50W 2.4KOHM 5PCT	IN			PPP5		N
65	C	24504815	1.00	PC	RES FXD 2W 10 OHMS	IN			PPP5		N
66	A	24504827	1.00	PC	RES-FXD CMPTN 2W 5PCT 330HMS	IN			PPP5		N
48	C	24504857	1.00	PC	RES FXD 2W 560 OHMS	IN			PPP4		N
47	C	24506409	1.00	PC	CAP FXD NYLAR .022 MF	IN			PPP5		N
43	C	24506823	1.00	PC	CAP,FXD,NYLAR 200V .001MFD	IN			PPP5		N
124	C	24547501	1.00	PC	PLATF WARNING	IN			PPP4		N

R V4238 Rev 4.00 COMP F G I:HF U

PRINTED IN U.S.A.

90446687	D	A	C	CD ASSY 81AHD-4 (POWER SUPPLY	CD	CC6348	07/29/85	017775	05/14/86	2/ 4
ASSEMBLY NUMBER	REV	CL	REV	ASSEMBLY DESCRIPTION	DESIGN SOURCE	PART USAGE	RELEASE DATE	CHANGE ORG NUMBER	PROCESSING DATE	PAGE NUMBER

PNL NO	REV	PART NUMBER	QUANTITY	JST HEAD	PART DESCRIPTION	H/OUT STATUS	CHANGE ORG NUMBER	DATE EFFECTIVE	MAKE/BUY PART TYPE	PN NC	LN
44	C	36180753	1.00	PC	CAP FXD NYL .001MFD 600V	IN			PPP4		N
120	A	38838005	1.00	PC	TERM,TUR-SUBMIN,TIN DIP .062	OUT	017183	070585	PPP4		N
53	C	50240105	1.00	PC	DIODE SILICON ZENER 4.7V	IN			PPP5		N
37	C	50240107	1.00	PC	DIODE VOLT REG 1N752A 5.6V	IN			PPP5		N
38	C	50240112	1.00	PC	DIODE-RW 9ADM 1N757A 9.1V	IN			PPP5		N
39	C	50240117	1.00	PC	DIODE RW 9ADM	IN			PPP5		N
27	A	51003092	2.00	PC	XSTR-2N2222,SIL,NPN,HIGH SPEED	IN			PPP5		N
95	A	51003962	0.01	OZ	HEAT SINK TRANSFER COMPOUND	IN	017399	080185	REF4		N
35	A	51007385	7.00	PC	DIODE SI 10V 1N4148	IN			PPP5		N
119	A	51669429	2.00	PC	TERM-ADAPTER, SCR- .250 BLADE	IN			PPP4		N
28	A	51684500	1.00	PC	XSTR, 2N4091 FLD-EFF N-TYP SI	IN			PPP4		N
29	A	51714000	4.00	PC	XSTR-2N2907,PNP,SI TO-18	IN			PPP5		N
133	A	51873600	0.02	OZ	VARNISH INSUL RED GLPT	IN	017143	062185	REF4		N
18	A	51903800	4.00	PC	DIO LED SLD 5T RED EPOXY	IN			PPP4		N
16	A	51906101	1.00	PC	CONN, PC-MTD 3 PIN NYL/SN F-1	IN			PPP4		N
14	A	51906103	1.00	PC	CONN P.C. 6POS TIN PLY	IN			PPP4		N
9	A	51906600	2.00	PC	HEAT SINK	IN			PPP4		N
26	A	51908601	2.00	PC	THMS, DISC 5 OHM 10P 15MM	IN			PPP4		N
10	A	51911003	2.00	PC	HEAT SINK FIGURE 5	IN			PPP4		N
11	A	51911004	1.00	PC	HEAT SINK FIGURE 6	IN			PPP4		N
122	A	51911007	1.00	PC	HEAT SINK	IN			PPP4		N
12	A	51918101	2.00	PC	HEAT SINK FOR PLASTICS PWR DVC	IN			PPP4		N
24	A	51918619	2.00	PC	IND, RF-CHOK 3000UH 1A F-2	IN			PPP4		N
25	A	51918624	1.00	PC	IND, RF-CHOK 550UH 1.5A F-3	IN			PPP4		N
23	A	51918625	1.00	PC	IND, RF-CHOK 31UH 11A F-3	IN			PPP4		N
113	A	51918846	2.00	PC	RES VAR CRM 1K R 20P 1/2W 1	IN			PPP4		N
61	A	51918876	1.00	PC	RES VAR CRM 1K R 20P 1/2W 3	IN			PPP4		N
63	A	51918878	1.00	PC	RES VAR CRM 5K R 20P 1/2W 3	IN			PPP4		N
117	A	51918928	2.00	PC	SPACER, HEX NYLON 6-32X.875	IN			PPP3		N
125	A	51940689	2.00	PC	STOFF, SWAGE BRS 4-40 FIG-2	IN			PPP4		N
128	A	61409555	1.00	PC	CABLE ASSY,POWER	IN			AYM4		N
131	A	61409795	1.00	PC	WIRE JUMPER	OUT	017775	050986	AYM4		N
116	B	71493576	1.00	PC	INSULATOR, HV COVER (PLSTC)	IN	017775	050986	AYM4		N
126	C	71493704	1.00	PC	STIFFENER, PC BOARD (PLSTC)	IN			PPP4		N
30	A	89770800	2.00	PC	(RISK) TRANSISTOR,NPN SIL,PWR	IN			PPP4		N

R V4238 Rev 4.00 COMP F G I:HF U

ASSEMBLY PARTS LIST

90446687	D	A	C	CD ASSY 81AHD-4 (POWER SUPPLY	CD	CC6348	07/29/85	017775	05/14/86	3/ 4
ASSEMBLY NUMBER	REV	CL	REV	ASSEMBLY DESCRIPTION	DESIGN SOURCE	FIRST USAGE	RELEASE DATE	CHANGE ORD. NUMBER	PROCESSING DATE	PAGE NUMBER

FIND NUMBER	QTY	PART NUMBER	QUANTITY	UNIT	PART DESCRIPTION	IN/OUT	CHANGE ORD. NUMBER	DATE EFFECTIVE	NAME/BUY	PN	QTY
102	C	904466563	REF		PC SCH DIAG 81AHD-3 POWER SUPPLY	IN			RFE4	N	
1	D	90446633	1.00		PC PW 8D 81AHD-3 PWR SUPPLY	IN			PPP3	N	
101	C	93114214	1.00		PC STANDOFF-TAPPED POST-TYPE C	IN			PPP3	N	
31	C	93314010	1.00		PC RECTIFIER SILICON CONTROL 16A	IN			PPP4	N	
118	C	93343158	2.00		PC MSCR RND SLT 6-32X1/4 NYL BLK	IN			PPP3	N	
42	A	94240401	3.00		PC CAPACITOR MONO CERAMIC 1000PF	IN			PPP5	N	
46	A	94240411	3.00		PC CAP, CER, X7R, 50V 10% 10K .01	IN			PPP5	N	
41	A	94240433	1.00		PC CAP CER 3300PF 50V 10P	IN			PPP5	N	
49	A	94240448	6.00		PC CAP, CER, X7R, 50V+-10%100KPF	IN			PPP5	N	
50	A	94240452	1.00		PC CAP FXD CER 220KPF 10P 50VDCW	IN			PPP5	N	
54	C	94259912	2.00		PC CAP TANT ELECT 10.0UF 24GA	IN			PPP4	N	
129	C	94277400	2.00		PC STRAP CABLE TIE	IN			PPP1	N	
130	A	94360229	1.00		PC RES FXD FM 200 OHM 1/4W 1P	IN			PPP5	N	
75	A	94360236	1.00		PC RES 1/4 WATT 1PCT 237 OHMS	IN			PPP5	N	
78	A	94360300	6.00		PC RES 1/4 WATT 1 PCT 1.00K OHMS	IN			PPP5	N	
80	A	94360323	1.00		PC RES 1/4 WATT 1 PCT 1.74K OHMS	IN			PPP5	N	
85	A	94360357	1.00		PC RES-3.92K OHMS 1/4W 1PCT	IN			PPP5	N	
92	A	94360451	1.00		PC RES FXD FM 34.0K OHM 1P 1/4W	IN			PPP5	N	
112	A	94395509	2.00		PC CAP AL ELEC 22UF -10+75P 25V	IN			PPP4	N	
13	A	94397113	1.00		PC CAP AL ELEC 470UF-10+100P 50V	IN			PPP4	N	
60	A	94397145	2.00		PC CAP AL ELEC 2700UF-10+100 12V	IN			PPP4	N	
51	A	94400320	2.00		PC CAP POLY 1.00UF	IN			PPP4	N	
52	A	94400321	1.00		PC CAP POLY 1UF 250V	IN			PPP4	N	
55	A	94400612	3.00		PC CAP AL ELEC 15 UF-10+100P 25V	IN			PPP5	N	
72	A	94402132	2.00		PC RES .25W 100 OHM	IN			PPP5	N	
76	A	94402146	3.00		PC RES 1/4W CARBON FILM 470 OHMS	IN			PPP5	N	
109	A	94402158	4.00		PC RESISTOR-1/4W CARBON 1200 OHMS	IN			PPP5	N	
79	A	94402160	2.00		PC RES 1/4W CARBON FILM 1.5K OHMS	IN			PPP5	N	
105	A	94402165	1.00		PC RES. 1/4CARBON FILM 2400 OHMS	IN			PPP5	N	
83	A	94402166	4.00		PC RES 1/4W CARBON FILM 2.7K OHMS	IN			PPP5	N	
84	A	94402169	2.00		PC RES. 3.6K, CARBON FILM .25 WAT	IN			PPP5	N	
123	A	94402173	1.00		PC RESISTOR 5.1K 1/4W	IN			PPP5	N	
89	A	94402176	1.00		PC RESISTOR CARBON FILM .25W 6.8K	IN			PPP4	N	
115	A	94402177	1.00		PC RES FXD C FM 7.5K OHM 5P 1/4W	IN			PPP5	N	
88	A	94402178	2.00		PC RES Y4W CARBON FILM 8.2K	IN			PPP5	N	
87	A	94402179	1.00		PC RES FXD C FM 9.1K OHM 5P 1/4W	IN			PPP5	N	

PAGE 03 REV 480 CORR FG (1 P. 1)

ASSEMBLY PARTS LIST

90446687	D	A	C	CD ASSY 81AHD-4 (POWER SUPPLY	CD	CC6348	07/29/85	017775	05/14/86	4/ 4
ASSEMBLY NUMBER	REV	CL	REV	ASSEMBLY DESCRIPTION	DESIGN SOURCE	FIRST USAGE	RELEASE DATE	CHANGE ORD. NUMBER	PROCESSING DATE	PAGE NUMBER

FIND NUMBER	QTY	PART NUMBER	QUANTITY	UNIT	PART DESCRIPTION	IN/OUT	CHANGE ORD. NUMBER	DATE EFFECTIVE	NAME/BUY	PN	QTY
90	A	94402180	7.00		PC RES 1/4W CARBON FILM 10K OHMS	IN			PPP5	N	
91	A	94402184	1.00		PC RESISTOR 1/4WATT 15K OHMS	IN			PPP5	N	
62	A	94402187	1.00		PC RESISTOR 20K 1/4 W	IN			PPP4	N	
73	A	94402190	1.00		PC RESISTOR 1/4 WATT	IN			PPP5	N	
106	A	94402194	1.00		PC RES FM 39K OHM 1/4W CARBON	IN			PPP5	N	
86	A	94402197	1.00		PC RES FM 51K OHM 1/4W CARBON	IN			PPP5	N	
94	A	94402221	2.00		PC RES FXD C FM 510K OHM 5P 1/4W	IN			PPP5	N	
56	A	94402225	1.00		PC RES FXD C FM 750K OHM 5P 1/4W	IN			PPP5	N	
70	A	94402228	3.00		PC RES 1 MEG OHM .25 WATT	IN			PPP5	N	
45	C	94858601	2.00		PC CAP-CERAMIC DISC .01MF, 3KV	IN			PPP4	N	
127	A	95048500	0.01		OZ EPOXY, TWO PART, 5 MINUTE	IN	017131	042685	RFE4	N	
77	C	95596520	2.00		PC RES FXD 600 OHM 5W	IN			PPP4	N	
40	C	95637304	13.00		PC DIODE 1N4004	IN			PPP5	N	
57	A	95691133	2.00		PC CAP ELECT 270MFD 25V -10+100P	IN			PPP4	N	
110	C	95691141	2.00		PC CAP ELECT 270UF -10+100P 40V	IN			PPP4	N	
17	A	95691501	4.00		PC RECT, 51L IN5617 1A 400V F-R	IN			PPP5	N	
36	A	95691506	4.00		PC RECT, 51L IN5416 3A 100V F-R	IN			PPP4	N	

NUMBER OF LINE ITEMS = 125
HIGHEST FIND NUMBER = 133

PAGE 04 REV 480 CORR FG (1 P. 1)

DWN	D. Sand	8/81	CONTROL DATA CORPORATION	TITLE	LINE FILTER ASSY	PREFIX	DOCUMENT NO	REV
CHKD	D. Sand	9/81		A	61409208	A		
ENG			FIRST USED ON	CC634-A	AIWA	61409170	SHEET	1 OF 2
MFG			CODE IDENT	15920				
APPR	C. H. Ho	7-5-82						

SHEET REVISION STATUS				REVISION RECORD			
REV	ECO	DESCRIPTION	DRFT	DATE	APP		
01	01	01	51373	ADD F/N 9	D5	10/19/81	WLB
02	02	02	51404	CHANGE F/N 1	D5	11-9-81	JGH
02	02	03	51654	CHG F/N 2	WLB	4/6/82	WLB
A	A	A	14232-91	RELEASED CLASS A		4-6-82	WLB

NOTES:

- Bulk identify with CDC part number.
- The end's of this wire shall be labeled as shown.

APL 61409208
DETACHED LISTS

AA3180 REV. 8 71

PRINTED IN U.S.A.

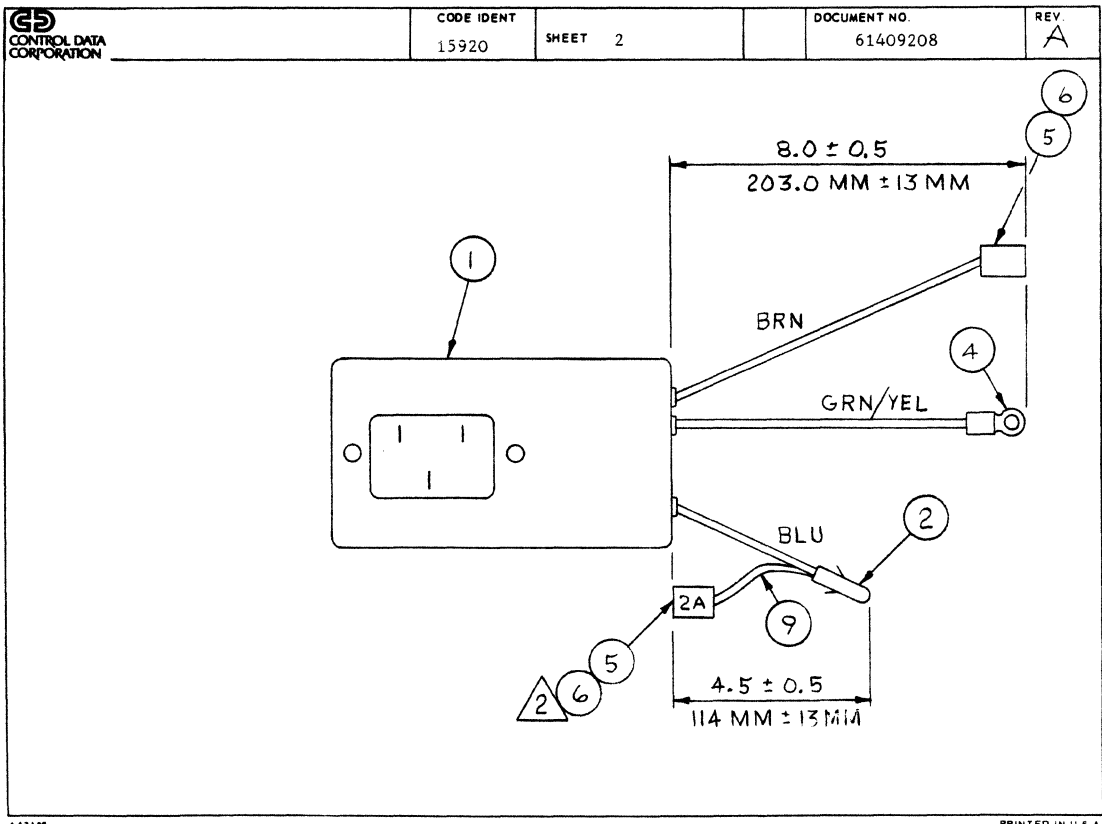

AA3180

PRINTED IN U.S.A.

BUILD ARC 174

ASSEMBLY PARTS LIST

PRINT DATE	PAGE	FILE CHANGE NO.
04-08-82	1	14232-91

DIV.	ASSEMBLY NUMBER	CD	REV.	DWG.	DESCRIPTION	MC	STATUS	STATUS DATE	ENG. RESP.	FILE DATE			
0860	61409208	8	A	A	LINE FILTER ASSY	A	REL	04-06-82	CC634A	04-08-82			
TRND NO	LI	PART NUMBER	CD	QUANTITY	U/M	PART DESCRIPTION	MC	YLD	ECO. NO. IN	ECO. NO. OUT	S/N	WK IN	WK OUT
001	01	15002415	6	1		PC FILTER, RFI 115-260 VAC	P						
002	01	51906201	2	1		PC CONT, SKT 20-14GA .2001 T STR	P						
004	01	51797214	7	1		PC LUG, NO. 8 CPMP-R 22-18AWG	P						
005	01	93747301	1	2		PC CONT, RCPT 22-18AWG B/TIN 5	P						
006	01	62020700	1	2		PC LUG HSG, FIG 1 RCPT STRAIGHT	B						
009	01	52810009	2	375	FT	WIR 18GA STRD WHT 600V UL PVC	W						
						0006 TOTAL LINES							

2-38

62940037

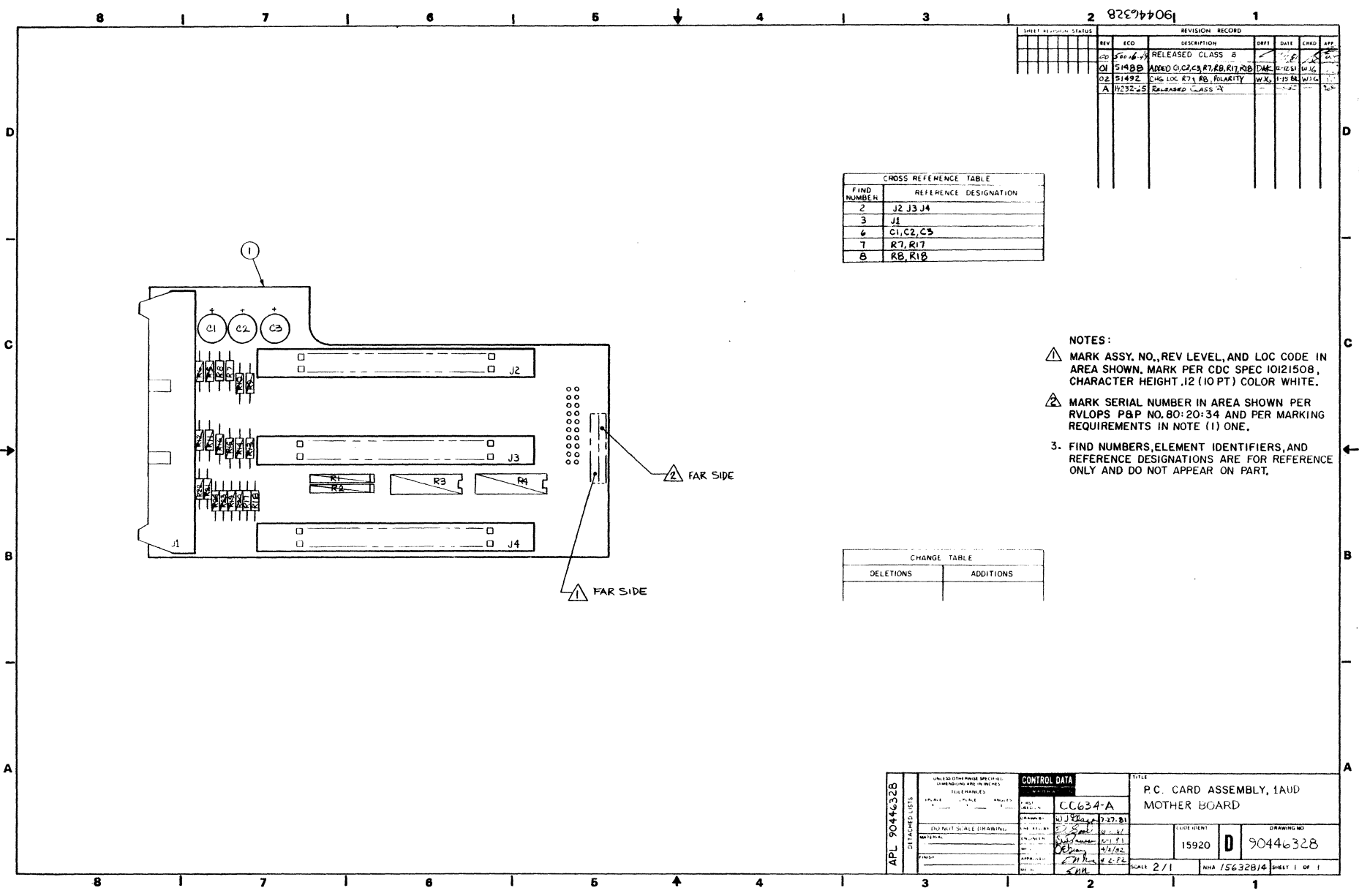

SHEET REVISION STATUS		REVISION RECORD					
REV	ECO	DESCRIPTION	DRFT	DATE	CHKD	APP.	
01	51492	RELEASED CLASS B					
01	51492	ADDED C1, C2, C3, R7, R8, R17, R8B	DAK	12/10/51	WJG		
02	51492	CHG LOC R7, R8, POLARITY	WJK	1/15/52	WJG		
A	1/23/52	RELEASED CLASS A					

FIND NUMBER	REFERENCE DESIGNATION
2	J2, J3, J4
3	J1
6	C1, C2, C3
7	R7, R17
8	R8, R18

- NOTES:
- 1. MARK ASSY. NO., REV LEVEL, AND LOC CODE IN AREA SHOWN. MARK PER CDC SPEC 10121508, CHARACTER HEIGHT .12 (10 PT) COLOR WHITE.
 - 2. MARK SERIAL NUMBER IN AREA SHOWN PER RVLOPS P&P NO. 80-20-34 AND PER MARKING REQUIREMENTS IN NOTE (1) ONE.
 - 3. FIND NUMBERS, ELEMENT IDENTIFIERS, AND REFERENCE DESIGNATIONS ARE FOR REFERENCE ONLY AND DO NOT APPEAR ON PART.

DELETIONS	ADDITIONS

APL 90446328 DETACHED LISTS	UNLESS OTHERWISE SPECIFIED ALL DIMENSIONS ARE IN INCHES		TOLERANCES		CONTROL DATA		TITLE	
	DATE	SCALE	QUANTITY	CLASS.	NO.	CC634-A	P.C. CARD ASSEMBLY, 1A UD MOTHER BOARD	
DESIGNED BY	DATE	BY	DATE	BY	DATE	BY	DATE	BY
ENGINEER	DATE	BY	DATE	BY	DATE	BY	DATE	BY
DRWING	DATE	BY	DATE	BY	DATE	BY	DATE	BY
SCALE	2/1	ANA 156328/4	SHEET 1 OF 1	15920	D	90446328		

BUILD ARC 214

ASSEMBLY PARTS LIST

PRINT DATE	PAGE	FILE CHANGE NO.
04-07-82	1	14232-69

DIV.		ASSEMBLY NUMBER		CD	REV.	DWG.	DESCRIPTION		MC	STATUS	STATUS DATE	ENG. RESP.	FILE DATE	
0860		90446328		B	A	D	CD ASSY 1AUD MTHR BD		S	REL	04-05-82	CC634A	04-07-82	
TRND NO	LI	PART NUMBER	CD	QUANTITY	U/M	PART DESCRIPTION		MC	YLD	ECO. NO. IN	ECO. NO. OUT	S/N	WK IN	WK OUT
001	01	90446327	0	1		PC	PW BD 1AUD MTHR BD							
002	01	51863202	1	3		PC	CONN, BRD EDGE 60 PIN							
003	01	94393210	3	1		PC	HDR, PCB 50PIN R-A SHLD TYP A							
004	01	90446326	2	REF		PC	SCH DIA 1AUD MTHR BD							
005	01	16006500	9	REF		PC	FABRICATION SPECIFICATION							
006	01	94395520	3	3		PC	CAP AL ELECT 100UF 8V							
007	01	94402138	5	2		PC	RES FM 180 OHM 1/4W CARBON							
008	01	94402142	7	2		PC	RES FM 270 OHM 1/4W CARBON							
							0008 TOTAL LINES							

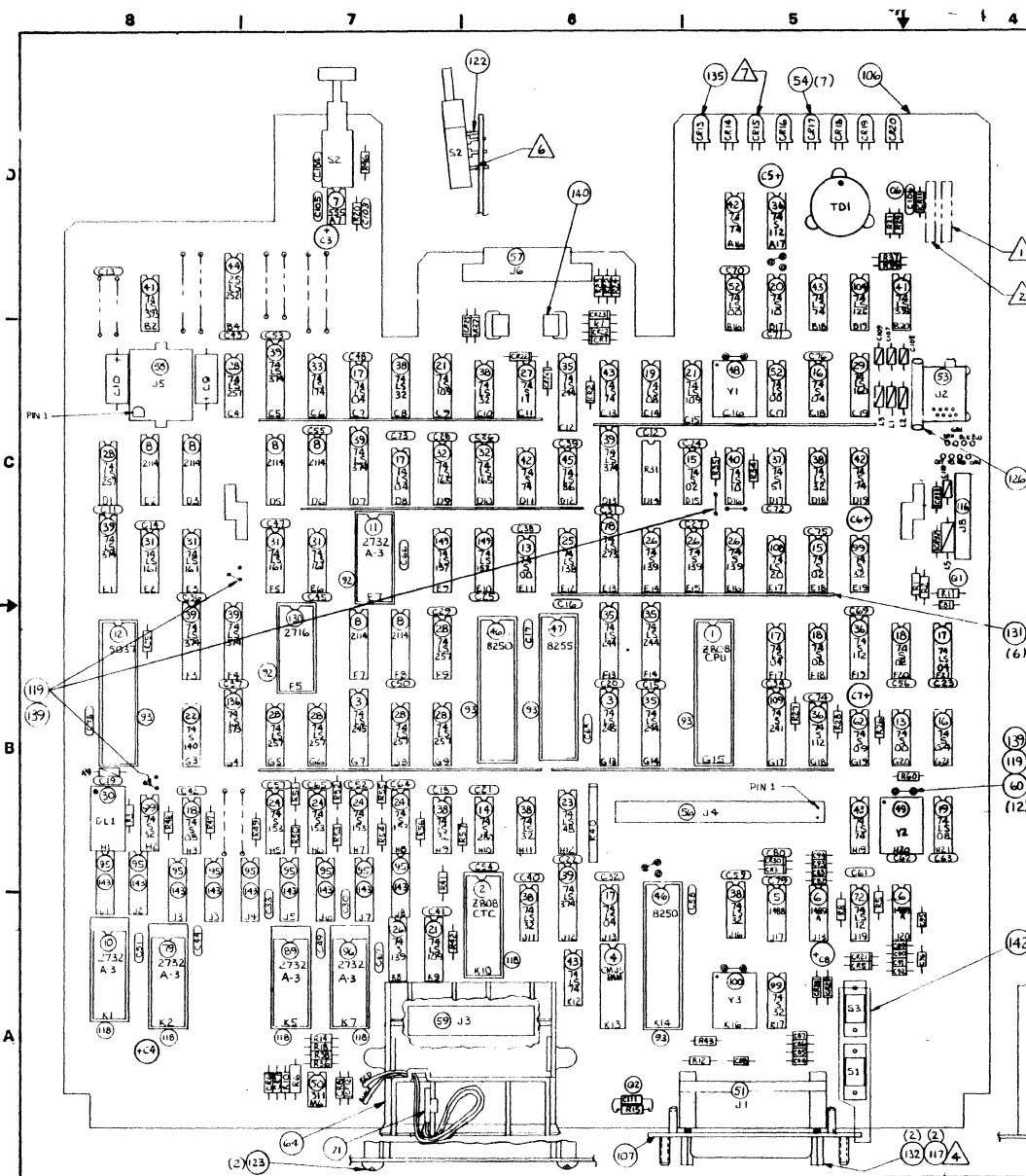

CROSS REFERENCE TABLE	
FIND NUMBER	REFERENCE DESIGNATION
51	S1 S3
61	C11 THRU C34, C36 THRU C45,
63	C104
65	C81
66	C42 THRU C96
67	Q1
68	D6
69	CR1 CR5 CR6 CR7 CR8 CR11 CR21 CR28
70	CR12
73	TDI
74	RL
75	C3 THRU C6
76	R2
77	R7
80	K6
81	R10
82	R11
83	S2
84	R12
85	R14
88	R18
90	K20 R15
91	R40
94	R21
98	R24
101	R25 R26 R27 R28
102	R29
105	R31
112	R34 R35
113	R36
114	R38
115	C9 C10
121	CR22 THRU CR27 CR30 CR31
124	R5 R8 R91 R42 R46
125	R47 THRU R57, R60
127	R37
128	R22 R23
129	R43
137	O2
138	R3
144	R39

REWORK INSTRUCTIONS	
DELETES	ADDITIONS

SEE SHEET 2

SHEET REVISION STATUS		REVISION RECORD			
REV	ECO	DESCRIPTION	DATE	BY	CHKD
2	11	REV			
1	00	RELEASED CLASS B	7/1/79		
0	01	ADD NOTE 7 CHG APL	10/17/78		
0	02	REVISED PER ECO	E.E. 11/24/78	E.E.	
0	03	REVISED PER ECO	E.E. 11/24/78	E.E.	
0	04	REVISED PER ECO	E.E. 11/24/78	E.E.	
0	05	% CHANGE ONLY	E.E. 11/24/78	E.E.	
A	A	RELEASED CLASS X	11/22/78		
B	B	REVISED PER ECO	E.E. 5/14/79	E.E.	
B	C	% CHANGE ONLY	E.E. 11/24/78	E.E.	
D	D	CHG IN 147 - PERMANENT MOUNTING	E.E. 11/24/78	E.E.	
E	E	INACTIVE REPAIRED BY SUPPLIERS	8/26/79		

- NOTES:
- 1. MARK ASSY. NO., REV LEVEL, AND LOC CODE IN AREA SHOWN. MARK PER CDC SPEC 10121508, CHARACTER HEIGHT .12 (10 PT) COLOR WHITE.
 - 2. MARK SERIAL NUMBER IN AREA SHOWN PER RVLOPS P&R NO. 80-20-34 AND PER MARKING REQUIREMENTS IN NOTE (1) ONE.
 - 3. FIND NUMBERS, ELEMENT IDENTIFIERS, AND REFERENCE DESIGNATIONS ARE FOR REFERENCE ONLY AND DO NOT APPEAR ON PART.
 - 4. REMOVE 2 SCREWS AND REPLACE WITH F/N 132.
 - 5. USE P/N 71493236 TO MAINTAIN CORRECT HEIGHT FROM P.C. BOARD.
 - 6. SEAT PLASTIC PEG OF S2 ON P.C. CARD.
 - 7. FLUSH WITH BOARD EDGE TO .050 MAX OVER AND PLACED PERPENDICULAR WITHIN ±.03/LED'S TO LAY FLAT WITHIN ±.03 TO SURFACE OF P.C. BOARD.
 - 8. FIXTURE F/N 106 FLAT, ALIGN F/N 148 USING C77 GND LEAD, C35 GND LEAD AND J3 PIN 34 AS SHOWN IN BOTTOM VIEW. SOLDER USING F/N 119 HOLDING F/N 148 TIGHT TO F/N 106.

INACTIVE

APL 50446453 DETACHED LISTS	UNLESS OTHERWISE SPECIFIED ALL DIMENSIONS ARE IN INCHES		CONTROL DATA		TITLE P.C. CARD ASSEMBLY, 1A1D	
	TOLERANCES FINISH PLACE ANGLE		PART CC634-A		CODE IDENT 15920	
	DO NOT SCALE DRAWING		CHECKED BY R. K. RENE 11/1/78		DRAWING NO 90446453	
	DATE 11/1/78		ENGINEER R. K. RENE 11/1/78		SCALE NONE	
APPROVED BY R. K. RENE 11/1/78		CHECKED BY R. K. RENE 11/1/78		SHEET 1 OF 2		

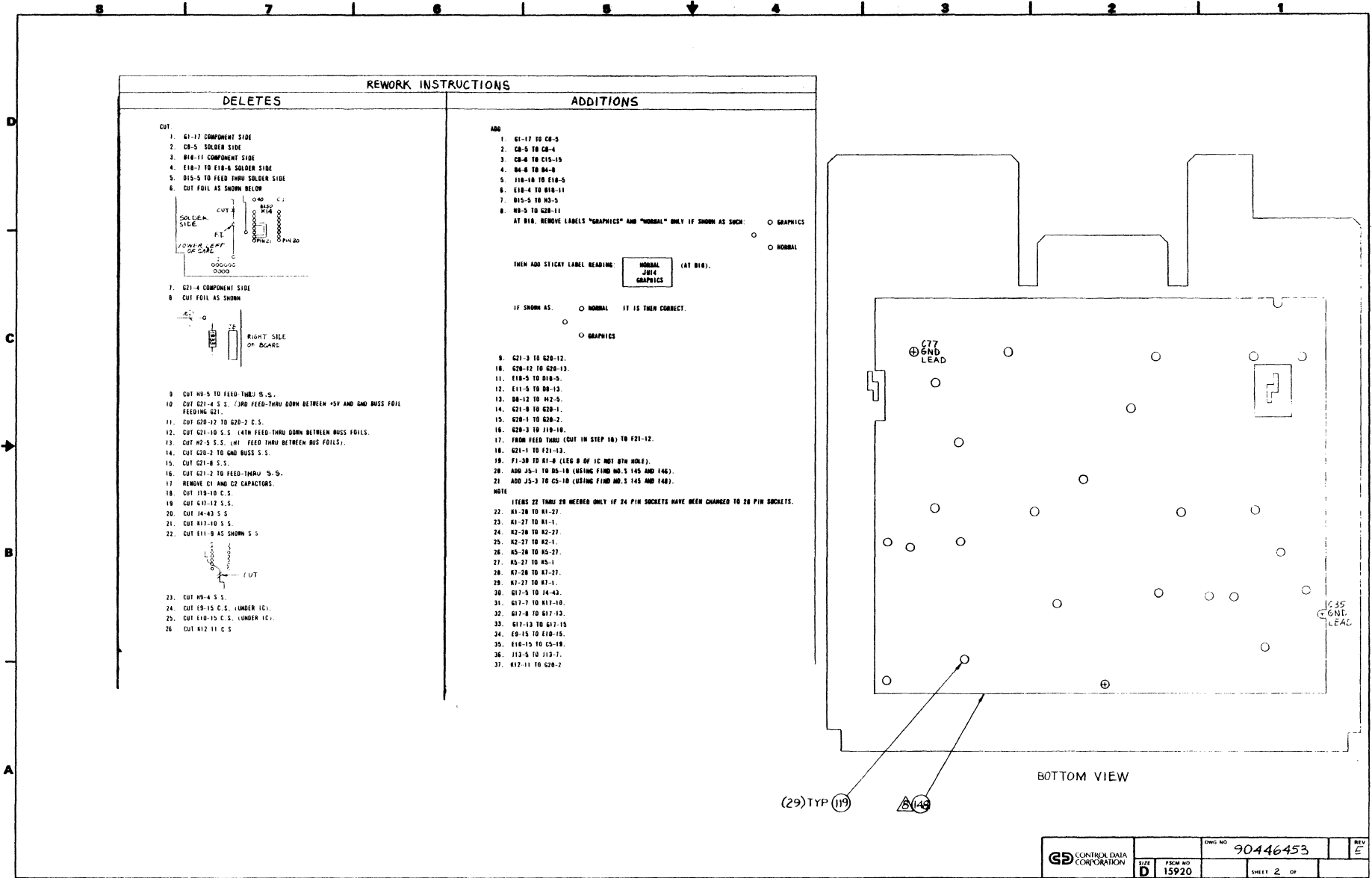

BUILD ARC 214

ASSEMBLY PARTS LIST

PRINT DATE	PAGE	FILE CHANGE NO.
07-27-82	1	00013344

DIV.		ASSEMBLY NUMBER	CD	REV.	DWG.	DESCRIPTION	MC	STATUS	STATUS DATE	ENG. RESP.	FILE DATE		
0000		90446453	4	E	D	REPLACED BY 90446485 15344	S	INA	07-23-82	CC634A	07-27-82		
ITEM NO	LI	PART NUMBER	CD	QTY	U/M	PART DESCRIPTION	MC	YLD	ECO. NO. IN	ECO. NO. OUT	S/N	WK IN	WK OUT
001	01	15163480	5	1		PC IC 2808-CPU (VIK X)	P						
002	01	15163481	3	1		PC IC 2808-CTC (VIK X)	P						
003	01	15163324	5	2		PC IC 74LS245 OCTAL BUS XCEIVER	P						
004	01	15163471	4	1		PC IC CMOS RAM (VIK X)	P						
005	01	15163463	1	1		PC IC 1488 QUAD LINE DRV	P						
006	01	15163326	0	2		PC IC 1489A	P						
007	01	15112100	1	1		PC IC NE555 916 TIMER 8-PIN	P						
008	01	15163472	2	6		PC MICROCIRCUIT 2114	P						
010	03	66315347	6	1		PC REPLACED BY 66315351 15132	G		15132	15132		8209	
010	04	66315351	8	1		PC RESIDENT POSITION 1 VIK X	G		15217	15217		8209	8221
010	05	66315355	9	1		PC FIRMWARE RESIDENT	G		18217			8221	
011	01	66315039	9	1		PC E-ROM PROGRAMMED CHGEN	G						
012	01	15163473	0	1		PC IC 5037	P						
013	01	88884500	5	2		PC IC 74500 1405 TTL QD 2IN NAND	P						
014	01	89933400	7	1		PC I C 74S280 TTL 9 BIT	P						
015	01	15158500	7	2		PC IC 74502 TTL QUAD 2I/P NOR	P						
016	01	88883700	2	2		PC IC 74504 1465 TTL HEX INVTR	P						
017	01	15148100	2	5		PC IC 74LS04 146LS TTL HEX INV	P						
018	01	15150900	7	3		PC IC 74508 TTL QUAD 2 I/P AND	P						
019	01	15145400	6	2		PC IC 74LS08 201LS Q2INP AND	P						
020	01	88884200	2	1		PC IC 74S10 141S TTL 3 3-IN NAND	P						
021	01	15148000	1	3		PC I C 74LS109 TTL JKFF DUAL	P						

BUILD ARC 214

ASSEMBLY PARTS LIST

PRINT DATE	PAGE	FILE CHANGE NO.
07-27-82	2	00013344

DIV.		ASSEMBLY NUMBER	CD	REV.	DWG.	DESCRIPTION	MC	STATUS	STATUS DATE	ENG. RESP.	FILE DATE		
0000		90446453	4	E	D	REPLACED BY 90446485 15344	S	INA	07-23-82	CC634A	07-27-82		
ITEM NO	LI	PART NUMBER	CD	QTY	U/M	PART DESCRIPTION	MC	YLD	ECO. NO. IN	ECO. NO. OUT	S/N	WK IN	WK OUT
022	01	15158700	3	1		PC IC 7748140 TTL DUAL 4 I/P GAT	P						
023	01	15163418	5	1		PC IC 74LS148 ENCODER 8-3LINE PR	P						
024	01	15142600	4	4		PC IC 74S153	P						
025	01	15147400	4	1		PC IC 74LS138 563LS TTL DECODER	P						
026	01	15117200	4	4		PC IC 74S139-5385	P						
027	01	88884100	4	1		PC IC 74S11 213S TTL 3 3-IN AND	P						
028	03	15164402	8	9		PC IC 74LS257 TTL SELECTOR/MUX	P		15132	15132		8209	8209
028	04	15164402	8	7		PC IC 74LS257 TTL SELECTOR/MUX	P						
029	01	15163439	1	1		PC IC 74LS160 BCD DECADE COUNTER	P						
030	01	94282304	2	1		PC DELAY LINE TAPPED 1.7 OHMS	P						
031	01	15146800	6	4		PC IC 72LS161 158LS 4BIT COUNTER	P						
032	01	15163415	1	2		PC IC 74LS165 8B SHIFT REGISTER	P						
033	01	15147500	1	1		PC IC 74LS174 TTL 6 BIT 16 PIN	P						
035	01	15163414	4	4		PC IC 74LS244 OCTAL BFR 3-8 OP	P						
036	01	15158600	5	3		PC IC 74S112 TTL DUAL J-K NET	P						
037	01	15164421	8	1		PC IC TYPE 74S51 TTL	P						
038	01	15146200	9	7		PC IC 74LS32 218LS Q2INP OR	P						
039	01	15163404	5	7		PC IC 74LS374 OCTAL D-EDGE F-F	P						
040	01	15145600	1	1		PC IC 74LS10 141LS TTL 3I/P NAND	P						
041	01	15163419	3	2		PC IC 74LS393 DL 4B BIN COUNTER	P						
042	01	88923000	9	3		PC I C 74S74 TTL DUAL	P						

BUILD ARC 214

ASSEMBLY PARTS LIST

PRINT DATE 07-27-82 PAGE 3 FILE CHANGE NO. 00019344

DIV.		ASSEMBLY NUMBER	CD	REV.	DWG.	DESCRIPTION		MC	STATUS	STATUS DATE	ENG. RESP.	FILE DATE		
0860		90446453	4	E	D	REPLACED BY 90446485 15344		S	INA	07-22-82	CC634A	07-27-82		
ITEM NO.	LI	PART NUMBER	CD	REV.	QTY	U/M	PART DESCRIPTION	MC	YLD	ECO. NO. IN	ECO. NO. OUT	S/N	WK IN	WK OUT
043	01	15146300	7		4		PC IC 74LS74 175LS F/F DUAL D	P						
044	01	15163431	8		1		PC IC 25LS2521 AMD	P						
045	01	15146400	5		1		PC IC 74LS86 149LS TTL 2I/P OR	P						
046	01	15163462	3		2		PC IC 78250 COMM UNIT BRAUD RATE	P						
047	01	15164427	5		1		PC IC 8255A PPI (FOR 8080 SYS)	P						
048	01	51904114	9		1		PC OSC. TTL DIP 12.936MHZ 500MW	P						
049	01	96860409	0		1		PC OSCILLATOR 6.00 MHZ	P						
050	01	15163443	3		1		PC IC LM311N VOLT COMP HI IMP	P						
051	01	10129668	9		1		PC CONN RCPT, 25 SKT HSG PC-MTG	P						
052	01	15144900	6		2		PC IC 74LS00 140LS QUAD 2-INP	P						
053	01	51917916	2		1		PC CONN TEL FIG 8 8COND	P						
054	01	51903802	0		7		PC LED, S-S GAP RED 3.0MCD 180MW	P						
055	01	51630901	0		2		PC SW. DT DETENTED SLIDE FIG 2	P						
056	01	94394745	7		1		PC HEADER SHIELD STR PIN 50	P						
057	01	10130611	6		1		PC CONN RCPT, 20-CONT R-A PC-MTG	P						
058	01	51906105	5		1		PC CONN, 12PIN PC MTO TIN FIG 4	P						
059	01	51860821	1		1		PC CONN, PC 34POS FIG 6	P						
060	01	65832100	5		12		PC SOCKET MINI SPRING	P						
061	03	19115400	4		72		PC CAP FXD CER .01UF 50V 20P	P		15132	15132		8209	8209
061	04	19115400	4		70		PC CAP FXD CER .01UF 50V 20P	P						
062	01	15151900	6		1		PC IC 74609 (VIK X)	P						

BUILD ARC 214

ASSEMBLY PARTS LIST

PRINT DATE 07-27-82 PAGE 4 FILE CHANGE NO. 00019344

DIV.		ASSEMBLY NUMBER	CD	REV.	DWG.	DESCRIPTION		MC	STATUS	STATUS DATE	ENG. RESP.	FILE DATE		
0860		90446453	4	E	D	REPLACED BY 90446485 15344		S	INA	07-22-82	CC634A	07-27-82		
ITEM NO.	LI	PART NUMBER	CD	REV.	QTY	U/M	PART DESCRIPTION	MC	YLD	ECO. NO. IN	ECO. NO. OUT	S/N	WK IN	WK OUT
063	01	19115401	2		1		PC CAP FXD CER 0.1UF 50V 20P	P						
064	01	71493330	6		1		PC CRADLE ROM PAK	P						
065	01	94240417	9		1		PC CAP CER 33PF 50V 10P	P						
066	01	94240427	8		15		PC CAP CER 390PF 50V 10P	P						
067	01	51714000	0		1		PC XSTR 2N2907 PNP SIL	P						
068	01	51003092	7		1		PC XSTR 2N2222 HI SPEED NPN SIL	P						
069	01	51007385	1		12		PC DIO IN4148 10MA MICRO SIL 30V	P						
070	01	50240107	8		1		PC DIODE SILI ZEN 5.6V	P						
071	01	51941144	1		1		PC CLIP-BATTERY	P						
072	01	15145800	7		1		PC INT CKT 74LS12	P						
073	01	51941074	0		1		PC TRANSDUCER	P						
074	01	94402116	1		1		PC RES FM 22 OHM 1/4W CARBON	P						
075	01	94395520	3		6		PC CAP AL ELECT 100UF 8V	P						
076	01	94402140	1		1		PC RES FM 220 OHM 1/4W CARBON	P						
077	01	94402143	5		1		PC RES FM 300 OHM 1/4W CARBON	P						
078	01	15163420	1		1		PC IC 74LS273 OCTAL D FLIP FLOP	P						
079	03	66315348	4		1		PC REPLACED BY 66315352 15132	0		15132	15132		8209	8209
079	04	66315352	6		1		PC RESIDENT POSITION 2 VIK X	0		15132	15217		8209	8221
079	05	66315356	7		1		PC FIRMWARE RESIDENT	0		15217			8221	
080	01	24500145	8		1		PC RES FXD COMP 180 OHM 5P 1/2W	P						
081	01	94402213	6		1		PC RES FM 240K OHM 1/4W CARBON	P						
082	01	94402158	3		1		PC RES FM 1.2KOHM 1/4W CARBON	P						

BUILD ARC 214

ASSEMBLY PARTS LIST

PRINT DATE 07-27-82 PAGE 5 FILE CHANGE NO. 00013344

DIV.		ASSEMBLY NUMBER		CD	REV.	DWG.	DESCRIPTION		MC	STATUS	STATUS DATE	ENG. RESP.	FILE DATE	
0800		90446453		4	E	D	REPLACED BY 90446485 15344		S	INA	07-22-82	CC634A	07-27-82	
TRFNO	LI	PART NUMBER	CD	QTY	U/M	PART DESCRIPTION		MC	YLD	ECO. NO. IN	ECO. NO. OUT	S/N	WK IN	WK OUT
083	01	15002348	9	1		PC SWITCH, MOMENTARY PUSH-BUTTON		P						
084	01	94402166	6	1		PC RES FM 2.7K OHM 1/4W CARBON		P						
085	01	94402172	4	1		PC RES FM 4.7K OHM 1/4W CARBON		P						
088	01	94402204	5	1		PC RES FM 100K OHM 1/4W CARBON		P						
089	03	66315349	2	1		PC REPLACED BY 66315353 15132		G		15132	15132		8209	8209
089	04	66315353	4	1		PC RESIDENT POSITION 3 VIK X		G					8209	8221
089	05	66315357	5	1		PC FIRMWARE RESIDENT		G		15217			8221	
090	01	94402228	4	2		PC RES FM 1.0M OHM 1/4W CARBON		P						
091	01	96752406	7	1		PC RES 10PIN SIP 1000 OHM 2P		P						
092	01	51848404	3	2		PC SOCKET, IC 24 POS D-I-L TIN		P						
093	01	51848406	8	5		PC SOCKET, IC 40 POS D-I-L TIN		P						
094	01	94402188	0	1		PC RES 22K OHMS 1/4W CARBON FILM		P						
095	01	51848401	9	9		PC SOCKET, IC 16 POS D-I-L TIN		P						
096	03	66315350	0	1		PC REPLACED BY 66315354 15132		G		15132	15132		8209	8209
096	04	66315354	2	1		PC RESIDENT POSITION 4 VIK X		G					8209	8221
096	05	66315358	3	1		PC FIRMWARE RESIDENT		G		15217			8221	
098	01	94402126	0	1		PC RES FM 56 OHM 1/4W CARBON		P						
099	01	15154800	5	3		PC IC SN74S32 QUAD 2 I/P		P						
100	01	51904115	6	1		PC OSC TTL DIP 1.8+32MHZ 500MW		P						
101	01	94402144	3	4		PC RES FM 330 OHM 1/4W CARBON		P						
102	01	94402196	3	1		PC RES FM 47K OHM 1/4W CARBON		P						
104	01	15163322	9	1		PC IC 74LS125		P						
105	01	75738605	7	1		PC A RES 150 OHM 1.50W FIG 1		P						

BUILD ARC 214

ASSEMBLY PARTS LIST

PRINT DATE 07-27-82 PAGE 6 FILE CHANGE NO. 00013344

DIV.		ASSEMBLY NUMBER		CD	REV.	DWG.	DESCRIPTION		MC	STATUS	STATUS DATE	ENG. RESP.	FILE DATE	
0800		90446453		4	E	D	REPLACED BY 90446485 15344		S	INA	07-22-82	CC634A	07-27-82	
TRFNO	LI	PART NUMBER	CD	QTY	U/M	PART DESCRIPTION		MC	YLD	ECO. NO. IN	ECO. NO. OUT	S/N	WK IN	WK OUT
106	01	90446447	6	1		PC REPLACED BY 90446484 15344		P						
107	01	71493343	9	1		PC PLATE, I/O CONN		P						
108	01	15145900	5	1		PC IC 74LS20 208LS TTL 4I/P NAND		P						
109	01	15163311	2	1		PC IC 74S241 VIKINGX		P						
112	01	94402168	2	2		PC RES FM 3.3K OHM 1/4W CARBON		P						
113	01	94402163	3	1		PC RES FM 2K OHM 1/4W CARBON		P						
114	01	94402167	4	1		PC RES FM 3K OHM 1/4W CARBON		P						
115	01	94400612	1	2		PC CAP FXD AL 15UF+100-10P 25V		P						
116	01	51860812	0	1		PC CONN PC 10 POS 20 CONT		P						
117	01	10126400	0	2		PC WSMR, NO.4 EXT/T LK STL ZP		B						
118	01	51868405	0	5		PC SOCKET, IC 28 POS D-I-L TIN		P						
119	02	24501806	4	833		FT WIRE BUSS 24GA SOLID CU TP		W		15132	15132		8209	8209
119	03	24501806	4	150		FT WIRE BUSS 24GA SOLID CU TP		W						
121	01	95637304	7	8		PC DIO IN4004 400PIV SIL 1.1V/1A		P						
122	01	71493357	9	1		PC SPACER RESET SWITCH		B						
123	01	36155629	3	2		PC SCREW SELF TP6 8-18X1/2		B						
124	01	94402156	7	5		PC RES FM 1K OHM 1/4W CARBON		P						
125	01	94402124	5	12		PC RES FM 47 OHM 1/4W CARBON		P						
126	01	51941272	0	83		FT BELT CORD		P						
127	01	94402162	5	1		PC RES FM 1.8K OHM 1/4W CARBON		P						
128	01	94402134	4	2		PC RES FM 120 OHM 1/4W CARBON		P						

BUILD ARC 214

ASSEMBLY PARTS LIST

PRINT DATE 07-27-82 PAGE 7 FILE CHANGE NO. 00013344

DIV.		ASSEMBLY NUMBER	CD	REV.	DWG.	DESCRIPTION		MC	STATUS	STATUS DATE	ENG. RESP.	FILE DATE		
0860		90446453	4	E	D	REPLACED BY 90446485 15344		S	INA	07-22-82	CC63AA	07-27-82		
ITEM NO.	LI	PART NUMBER	CD	QTY	U/M	PART DESCRIPTION		MC	YLD	ECO. NO. IN	ECO. NO. OUT	S/N	WK IN	WK OUT
129	01	94402180	7	1		PC RES FM 10K OHM 1/4W CARBON		P						
130	01	66307826	9	1		PC BIT MAP 2716		Q						
131	01	51941212	6	6		PC BUS BAR		P						
132	01	18252501	4	2		PC SCREW LOCK ASSY		P						
133	01	90446452	6	REF		PC REPLACED BY NONE 15344		Q						
134	01	16042912	2	REF		PC FAB SPEC MED LINE DBLSIDE		D						
135	01	51903803	8	1		PC LED, S-S GP GRN 2.0MCD 105MW		P						
136	01	15163434	2	1		PC IC 74LS373 OCTAL D LATCH		P						
137	01	51684500	5	1		PC XSTR TO-18 EPITPLANAR N-CHSI		P						
138	01	94402132	8	1		PC RES FM 100 OHM 1/4W CARBON		P						
139	01	24563700	4	300		FT INSUL SLEEVE		B						
140	01	71493326	4	1		PC SLIDE DRAWER		P						
141	01	61409413	4	1		PC GUIDE ASSY		V			15132			8209
142	01	71493324	9	1		PC HANDLE LOOPBACK SWITCH		P						
143	01	15163493	8	9		PC IC 4164 MEM (120 NS VX)		P						
144	01	94402185	6	1		PC RES FM 16K OHMS 1/4W CARBON		P						
145	01	24563702	0	333		FT INS SLVNG HI TEMP 20 AWG		B						
146	01	24501808	0	333		FT WIRE BUSS 20GA SOLID CU TP		W						
147	01	52629949	0	4	500	FT WIR WW 30GA SLD WHT UL KYNAR		W						
147	02	52629949	0	5		FT WIR WW 30GA SLD WHT UL KYNAR		W		15236	15236		8222	8222
148	01	71493678	8	1		PC GROUND PLANE		P		15132			8209	

BUILD ARC 214

ASSEMBLY PARTS LIST

PRINT DATE 07-27-82 PAGE 8 FILE CHANGE NO. 00013344

DIV.		ASSEMBLY NUMBER	CD	REV.	DWG.	DESCRIPTION		MC	STATUS	STATUS DATE	ENG. RESP.	FILE DATE		
0860		90446453	4	E	D	REPLACED BY 90446485 15344		S	INA	07-22-82	CC63AA	07-27-82		
ITEM NO.	LI	PART NUMBER	CD	QTY	U/M	PART DESCRIPTION		MC	YLD	ECO. NO. IN	ECO. NO. OUT	S/N	WK IN	WK OUT
149	01	15146700	8	2		PC IC 74LS187 189LS TTL QD MPX		P		15132				8209
						0152 TOTAL LINES								

2584944061

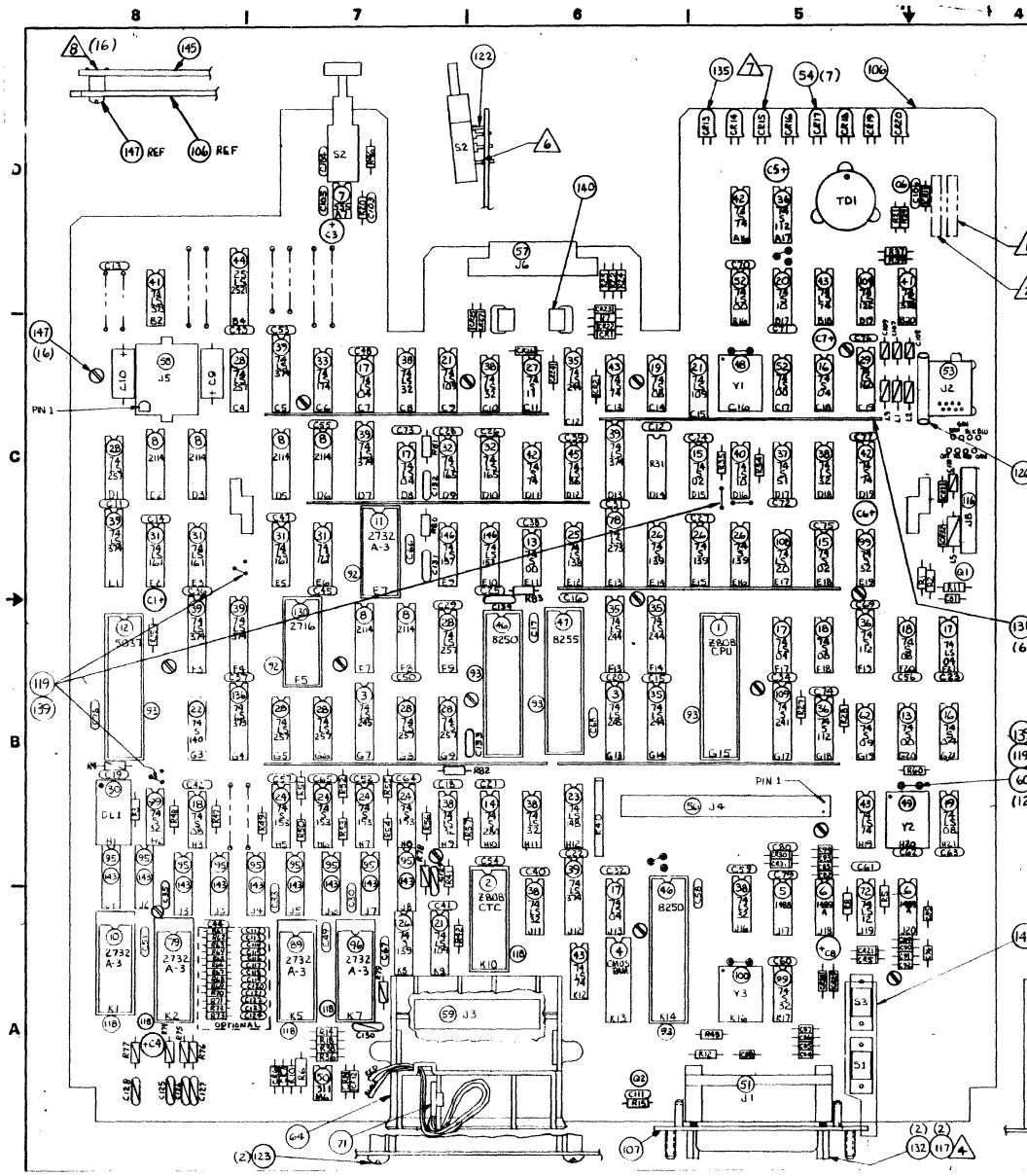

CROSS REFERENCE TABLE	
FIND NUMBER	REFERENCE DESIGNATION
51	S1 S3
61	C11 THRU C34, C35 THRU C45, C47 THRU C60
62	C104
63	C91
64	C82 THRU C96
67	C11
68	C16
69	CR1 CR5 CR6 CR7 CR8 CR11 CR21 CR28
70	CR12
73	CR2 CR9 CR32 CR33
74	RL
75	C1 C3 THRU C8
76	R2
77	R7
80	RL
81	R10
82	R11
83	S2
84	R12
85	R14
88	R18
90	R20 R15
91	R40
94	R21
96	R24
101	R25 R27 R28
102	R29
105	R31
112	R34 R35
113	R36
114	R38
115	C9 C10
121	CR22 THRU CR27 CR30 CR31
124	R5 R8 R91 R42 R46
125	R47 THRU R57, R60
127	R37
128	R22 R23 R80 THRU R83
129	R43
137	R2
138	R3
144	R39
148	C131, C132, C133, C134

CHANGE TABLE	
DELETIONS	ADDITIONS
1. CUT FOIL: K12-11 CS	1. K12-11 TO G20-2
2. CUT FOIL: D18-5 CS (2 PLACES)	2. D18-5 TO E18-5
3. CUT FOIL: K12-10 CS (BOTTOM COIL BETWEEN PINS 4 & 5)	3. G20-11 TO H9-5
	4. K12-10 TO G12-39

SHEET REVISION STATUS		REVISION RECORD			
REV	ECO	DESCRIPTION	DRY	DATE	CHKD
20	10001-7	RELEASED CLASS "B"		7-2-72	2
A	15150-48	REWORKED CLASS "A"		7-2-72	1
B	15837	INACTIVE, REWORKED BY 10464515	66	6/2/73	66

- NOTES:**
- △ MARK ASSY. NO., REV LEVEL, AND LOC CODE IN AREA SHOWN, MARK PER CDC SPEC 10121508, CHARACTER HEIGHT .12 (10 PT) COLOR WHITE.
 - △ MARK SERIAL NUMBER IN AREA SHOWN PER RVLOPS P&P NO. 80120134 AND PER MARKING REQUIREMENTS IN NOTE (1) ONE.
 - 3. FIND NUMBERS, ELEMENT IDENTIFIERS, AND REFERENCE DESIGNATIONS ARE FOR REFERENCE ONLY AND DO NOT APPEAR ON PART.
 - △ REMOVE 2 SCREWS AND REPLACE WITH F/N 132.
 - △ USE P/N 71493236 TO MAINTAIN CORRECT HEIGHT FROM P.C. BOARD.
 - △ SEAT PLASTIC PEG OF S2 ON P.C. CARD.
 - △ FLUSH WITH BOARD EDGE TO .050 MAX OVER AND PLACED PERPENDICULAR WITHIN ±.03/LED'S TO LAY FLAT WITHIN ±.03 TO SURFACE OF P.C. BOARD.
 - △ APPLY FIND NO. 148 TO AREA SHOWN.

INACTIVE

APL 9044 6485 DETACHED LISTS	UNLESS OTHERWISE SPECIFIED DIMENSIONS ARE IN INCHES		CONTROL DATA		TITLE	
	TOLERANCES	FINISH	PART NUMBER	CC634-A	P.C. CARD ASSEMBLY, 1AJD-1	
PLAGA	3 PLACE	ANGLES	DESIGNED BY	M. W. H. 7/12/72	LOGIC BOARD (2 LAYER)	
DO NOT SCALE DRAWING	CHECKED BY	DATE	ENGINEER	W. H. 6/21/72	CODE IDENT	15920
	APPROVED	DATE	DATE	7/14/72	DRAWING NO	90446485
				7-18-72	SCALE	NONE
					SHEET	1 OF 1

BUILD ARC 214

ASSEMBLY PARTS LIST

PRINT DATE 08-18-82 PAGE 1 FILE CHANGE NO 00015337

DIV.	ASSEMBLY NUMBER	CD	REV.	DWG.	DESCRIPTION	MC	STATUS	STATUS DATE	ENG. RESP.	FILE DATE				
0860	90446485	6	B	D	REPLACED BY 90446515 15337	S	INA	08-12-82	CC634A	08-18-82				
TRIND NO	LI	PART NUMBER	CD	IN	QUANTITY	U/M	PART DESCRIPTION	MC	YLD	ECO. NO. IN	ECO. NO. OUT	S/N	WK IN	WK OUT
001	01	15163480	5		1		PC IC 2808-CPU (VIK X)	P						
002	01	15163481	3		1		PC IC 2808-CTC (VIK X)	P						
003	01	15163324	5		2		PC IC 74LS245 OCTAL BUS XCEIVER	P						
004	01	15163471	4		1		PC IC CMOS RAM (VIK X)	P						
005	01	15163463	1		1		PC IC 1488 QUAD LINE DRVR	P						
006	01	15163326	0		2		PC IC 1489A	P						
007	01	15112100	1		1		PC IC NE555 916 TIMER 8-PIN	P						
008	01	15163472	2		6		PC MICROCIRCUIT 2114	P						
010	01	66315355	9		1		PC FIRMWARE RESIDENT	Q						
011	01	66315339	9		1		PC E-ROM PROGRAMMED CHGEN	Q						
012	01	15163473	0		1		PC IC 5037	P						
013	01	88884500	5		2		PC IC 74500 1405 TTL QD 2IN NAND	P						
014	01	89933400	7		1		PC I C 74S280 TTL 9 BIT	P						
015	01	15158500	7		2		PC IC 74502 TTL QUAD 2I/P NOR	P						
016	01	88883700	2		2		PC IC 74504 146S TTL HEX INVTR	P						
017	01	15145100	2		5		PC IC 74LS04 146LS TTL HEX INV	P						
018	01	15150900	7		3		PC IC 74508 TTL QUAD 2 I/P AND	P						
019	01	15145400	6		2		PC IC 74LS08 201LS Q2INP AND	P						
020	01	88884200	2		1		PC IC 74510 141S TTL 3 3-IN NAND	P						
021	01	15148000	1		3		PC I C 74LS109 TTL JKFF DUAL	P						
022	01	15158700	3		1		PC IC 74S140 TTL DUAL 4 I/P GAT	P						

BUILD ARC 214

ASSEMBLY PARTS LIST

PRINT DATE 08-18-82 PAGE 2 FILE CHANGE NO 00015337

DIV.	ASSEMBLY NUMBER	CD	REV.	DWG.	DESCRIPTION	MC	STATUS	STATUS DATE	ENG. RESP.	FILE DATE				
0860	90446485	6	B	D	REPLACED BY 90446515 15337	S	INA	08-12-82	CC634A	08-18-82				
TRIND NO	LI	PART NUMBER	CD	IN	QUANTITY	U/M	PART DESCRIPTION	MC	YLD	ECO. NO. IN	ECO. NO. OUT	S/N	WK IN	WK OUT
023	01	15163418	5		1		PC IC 74LS148 ENCODER 8-3LINE PR	P						
024	01	15142600	4		4		PC IC 74S153	P						
025	01	15147400	4		1		PC IC 74LS138 563LS TTL DECODER	P						
026	01	15117200	4		4		PC IC 74S139-5385	P						
027	01	88884100	4		1		PC IC 74S11 213S TTL 3 3-IN AND	P						
028	01	15164402	8		7		PC IC 74LS257 TTL SELECTOR/MUX	P						
029	01	15163439	1		1		PC IC 74LS160 BCD DECADE COUNTER	P						
030	01	94262304	2		1		PC DELAY LINE TAPPED 1.7 OHMS	P						
031	01	15146800	6		4		PC IC 74LS161 158LS 4BIT COUNTER	P						
032	01	15163415	1		2		PC IC 74LS165 88 SHIFT REGISTER	P						
033	01	15147500	1		1		PC IC 74LS174 TTL 6 BIT 16 PIN	P						
035	01	15163414	4		4		PC IC 74LS244 OCTAL BFR 3-5 OP	P						
036	01	15158600	5		3		PC IC 74S112 TTL DUAL J-K NET	P						
037	01	15164421	8		1		PC IC TYPE 74S51 TTL	P						
038	01	15146200	9		7		PC IC 74LS32 218LS Q2INP OR	P						
039	01	15163404	5		7		PC IC 74LS374 OCTAL D-EDGE F-F	P						
040	01	15145600	1		1		PC IC 74LS10 141LS TTL 3I/P NAND	P						
041	01	15163419	3		2		PC IC 74LS393 DL 4B BIN COUNTER	P						
042	01	88923000	9		3		PC I C 74S74 TTL DUAL	P						
043	01	15146300	7		4		PC IC 74LS74 175LS F/F DUAL D	P						
044	01	15163431	8		1		PC IC 25LS2521 AND	P						

BUILD ARC 214

ASSEMBLY PARTS LIST

PRINT DATE 08-18-82 PAGE 3 FILE CHANGE NO. 00013337

DIV.	ASSEMBLY NUMBER	CD	REV.	DWG.	DESCRIPTION	MC	STATUS	STATUS DATE	ENG. RESP.	FILE DATE			
0800	90446485	B	D		REPLACED BY 90446515 15337	S	INA	08-12-82	CC634A	08-18-82			
ITEM NO	LI	PART NUMBER	CD	QTY	U/M	PART DESCRIPTION	MC	YLD	ECO. NO. IN	ECO. NO. OUT	S/N	WK IN	WK OUT
045	01	15146400	5	1		PC IC 74LS86 149LS TTL 2I/P OR	P						
046	01	15163462	3	2		PC IC T8250 COMM UNIT BRAUD RATE	P						
047	01	15164427	5	1		PC IC 8255A PPI (FOR 8080 SYS)	P						
048	01	51904114	9	1		PC OSC, TTL DTP 12.936MHZ 500MW	P						
049	01	96860409	U	1		PC OSCILLATOR 6.00 MHZ	P						
050	01	15163443	3	1		PC IC LM311N VOLT COMP HI IMP	P						
051	01	10129668	9	1		PC CONN RCPT, 25 SKT HSG PC-MTG	P						
052	01	15144900	6	2		PC IC 74LS00 140LS QUAD 2-IMP	P						
053	01	51917916	2	1		PC CONN TEL FIG 8 BCOND	P						
054	01	51903802	0	7		PC LED, S-S GAP RED 3.0MCD 180MW	P						
055	01	51630901	0	2		PC SW, DT DETENTED SLIDE FIG 2	P						
056	01	94394745	7	1		PC HEADER SHIELD STR PIN 50	P						
057	01	10130611	6	1		PC CONN RCPT, 20-CONT R-A PC-MTG	P						
058	01	51906105	5	1		PC CONN, 12PIN PC MTD TIN FIG 4	P						
059	01	51860821	1	1		PC CONN, PC 34POS FIG 6	P						
060	01	65832100	5	12		PC SOCKET MINI SPRING	P						
061	01	19115400	4	73		PC CAP FXD CER .01UF 50V 20P	P						
062	01	15151900	6	1		PC IC 74509 (VIK X)	P						
063	01	19115401	2	1		PC CAP FXD CER 0.1UF 50V 20P	P						
064	01	71493330	6	1		PC CRADLE ROM PAK	P						
065	01	94240417	9	1		PC CAP CER 33PF 50V 10P	P						

BUILD ARC 214

ASSEMBLY PARTS LIST

PRINT DATE 08-18-82 PAGE 4 FILE CHANGE NO. 00013337

DIV.	ASSEMBLY NUMBER	CD	REV.	DWG.	DESCRIPTION	MC	STATUS	STATUS DATE	ENG. RESP.	FILE DATE			
0800	90446485	B	D		REPLACED BY 90446515 15337	S	INA	08-12-82	CC634A	08-18-82			
ITEM NO	LI	PART NUMBER	CD	QTY	U/M	PART DESCRIPTION	MC	YLD	ECO. NO. IN	ECO. NO. OUT	S/N	WK IN	WK OUT
066	01	94240427	8	15		PC CAP CER 390PF 50V 10P	P						
067	01	51714000	0	1		PC XSTR 2N2907 PNP SIL	P						
068	01	51003092	7	1		PC XSTR 2N2222 HI SPEED NPN SIL	P						
069	01	51007385	1	12		PC DIO IN4148 10MA MICRO SIL 30V	P						
070	01	50240107	8	1		PC DIODE SILI ZEN 5.6V	P						
071	01	51941144	1	1		PC CLIP-BATTERY	P						
072	01	15145800	7	1		PC INT CKT 74LS12	P						
073	01	51941074	0	1		PC TRANSDUCER	P						
074	01	94402116	1	1		PC RES FM 22 OHM 1/4W CARBON	P						
075	01	94395520	3	7		PC CAP AL ELECT 100UF 8V	P						
076	01	94402140	1	1		PC RES FM 220 OHM 1/4W CARBON	P						
077	01	94402143	5	1		PC RES FM 300 OHM 1/4W CARBON	P						
078	01	15163420	1	1		PC IC 74LS273 OCTAL D FLIP FLOP	P						
079	01	66315356	7	1		PC FIRMWARE RESIDENT	G						
080	01	24500145	8	1		PC RES FXD COMP 180 OHM 5P 1/2W	P						
081	01	94402213	6	1		PC RES FM 240K OHM 1/4W CARBON	P						
082	01	94402158	3	1		PC RES FM 1.2KOHM 1/4W CARBON	P						
083	01	15002348	9	1		PC SWITCH, MOMENTARY PUSH-BUTTON	P						
084	01	94402166	6	1		PC RES FM 2.7K OHM 1/4W CARBON	P						
085	01	94402172	4	1		PC RES FM 4.7K OHM 1/4W CARBON	P						
088	01	94402204	5	1		PC RES FM 100K OHM 1/4W CARBON	P						

BUILD ARC 214

ASSEMBLY PARTS LIST

PRINT DATE 08-18-82 PAGE 5 FILE CHANGE NO. 00019337

DIV.		ASSEMBLY NUMBER		CD	REV.	DWG.	DESCRIPTION		MC	STATUS	STATUS DATE	ENG. RESP.	FILE DATE	
0860		90446485		6	B	D	REPLACED BY 90446515 15337		S	INA	08-12-82	CC634A	08-18-82	
T/IND NO	LI	PART NUMBER	CD	QTY	U/M	PART DESCRIPTION		MC	YLD	ECO. NO. IN	ECO. NO. OUT	S/N	WK IN	WK OUT
089	01	66315357	5	1		PC	FIRMWARE RESIDENT	G						
090	01	94402228	4	2		PC	RES FM 1.0M OHM 1/4W CARBON	P						
091	01	96752406	7	1		PC	RES 10PIN SIP 1000 OHM 2P	P						
092	01	51848404	3	2		PC	SOCKET, IC 24 POS D-I-L TIN	P						
093	01	51848406	8	5		PC	SOCKET, IC 40 POS D-I-L TIN	P						
094	01	94402188	0	1		PC	RES 22K OHMS 1/4W CARBON FILM	P						
095	01	51848401	9	9		PC	SOCKET, IC 16 POS D-I-L TIN	P						
096	01	66315358	3	1		PC	FIRMWARE RESIDENT	G						
098	01	94402126	0	1		PC	RES FM 56 OHM 1/4W CARBON	P						
099	01	15154800	5	3		PC	IC SN74S32 QUAD 2 I/P	P						
100	01	51904115	6	1		PC	OSC TTL DIP 1.8432MHZ 500MW	P						
101	01	94402144	3	3		PC	RES FM 330 OHM 1/4W CARBON	P						
102	01	94402196	3	1		PC	RES FM 47K OHM 1/4W CARBON	P						
104	01	15163322	9	1		PC	IC 74LS125	P						
105	01	75738605	7	1		PC	RES PAK 150 OHM 2P 1.5W FIO-1	P						
106	01	90446484	9	1		PC	PW BD 1AJD-1	P						
107	01	71493343	9	1		PC	PLATE, I/O CONN	P						
108	01	15145900	5	1		PC	IC 74LS20 208LS TTL 4I/P NAND	P						
109	01	15163311	2	1		PC	IC 74S241 VIKINGX	P						
112	01	94402168	2	2		PC	RES FM 3.3K OHM 1/4W CARBON	P						
113	01	94402163	3	1		PC	RES FM 2K OHM 1/4W CARBON	P						

BUILD ARC 214

ASSEMBLY PARTS LIST

PRINT DATE 08-18-82 PAGE 6 FILE CHANGE NO. 00019337

DIV.		ASSEMBLY NUMBER		CD	REV.	DWG.	DESCRIPTION		MC	STATUS	STATUS DATE	ENG. RESP.	FILE DATE	
0860		90446485		6	B	D	REPLACED BY 90446515 15337		S	INA	08-12-82	CC634A	08-18-82	
T/IND NO	LI	PART NUMBER	CD	QTY	U/M	PART DESCRIPTION		MC	YLD	ECO. NO. IN	ECO. NO. OUT	S/N	WK IN	WK OUT
114	01	94402167	4	1		PC	RES FM 3K OHM 1/4W CARBON	P						
115	01	94400612	1	2		PC	CAP FXD AL 15UF*100-10P 25V	P						
116	01	51860812	0	1		PC	CONN PC 10 POS 20 CONT	P						
117	01	10126400	0	2		PC	WSHR, NO.4 EXT/T LK STL ZP	G						
118	01	51848405	0	5		PC	SOCKET, IC 28 POS D-I-L TIN	P						
119	01	24501806	4	833	FT	WIRE BUSS 24GA SOLID CU TP	W							
121	01	95637304	7	8		PC	DIO IN4004 400PIV SIL 1.1V/1A	P						
122	01	71493357	9	1		PC	SPACER RESET SWITCH	B						
123	01	36155629	3	2		PC	SCREW SELF TP6 8-18X1/2	B						
124	01	94402156	7	5		PC	RES FM 1K OHM 1/4W CARBON	P						
125	01	94402124	5	12		PC	RES FM 47 OHM 1/4W CARBON	P						
126	01	51941272	0	083	FT	BELT CORD	P							
127	01	94402162	5	1		PC	RES FM 1.8K OHM 1/4W CARBON	P						
128	01	94402134	4	6		PC	RES FM 120 OHM 1/4W CARBON	P						
129	01	94402180	7	1		PC	RES FM 10K OHM 1/4W CARBON	P						
130	01	66307826	9	1		PC	BIT MAP 2716	G						
131	01	51941212	6	6		PC	BUS BAR	P						
132	01	14252501	4	2		PC	SCREW LOCK ASSY	P						
133	01	94444483	1	REF		PC	SCH DIAG 1AJD-1 (MAIN LOGIC)	U						
134	01	14042912	2	REF		PC	FAB SPEC MED LINE DBLSIDE	D						
135	01	51903803	4	1		PC	LED, S-5 GP GRN 2.0MCD 105MW	P						

BUILD ARC 214

ASSEMBLY PARTS LIST

PRINT DATE 08-18-82 PAGE 7 FILE CHANGE NO 00015337

DIV.		ASSEMBLY NUMBER	CD	REV.	DWG.	DESCRIPTION	MC	STATUS	STATUS DATE	ENG. RESP.	FILE DATE		
0800		90446485	6	B	D	REPLACED BY 90446515 15337	S	INA	08-12-82	CC634A	08-18-82		
TRND NO	LI	PART NUMBER	CD	QUANTITY	U/M	PART DESCRIPTION	MC	YLD	ECO. NO. IN	ECO. NO. OUT	S/N	WK IN	WK OUT
136	01	15163434	2	1		PC IC 74LS373 OCTAL D LATCH	P						
137	01	51684500	5	1		PC XSTR TO-18 EPITPLANAR N-CHSI	P						
138	01	94402132	8	1		PC RES FM 100 OHM 1/4W CARBON	P						
139	01	24563700	4	300		FT INSUL SLEEVE	B						
140	01	71493326	4	1		PC SLIDE DRAWER	P						
142	01	71493324	9	1		PC HANDLE LOOPBACK SWITCH	P						
143	01	15163493	8	9		PC IC 4164 MEM (120 NS VX)	P						
144	01	94402185	6	1		PC RES FM 16K OHMS 1/4W CARBON	P						
145	01	71493695	2	1		PC GROUND PLANE	P						
146	01	15146700	8	2		PC IC 74LS157 189LS TTL QD MPX	P						
147	01	10127166	6	16		PC MSCR PAN PHL 2-56X.250 STL ZP	B						
148	01	95125321	0	001	OZ	LOCTITE SEALANT 222 PURPLE	B						
149	01	94240404	7	4		PC CAP CER 100PF 50V 10P	P						
150	01	52629949	0	1	083 FT	WIR WW 30GA SLD WHT UL KYNAR	W						
						0140 TOTAL LINES							

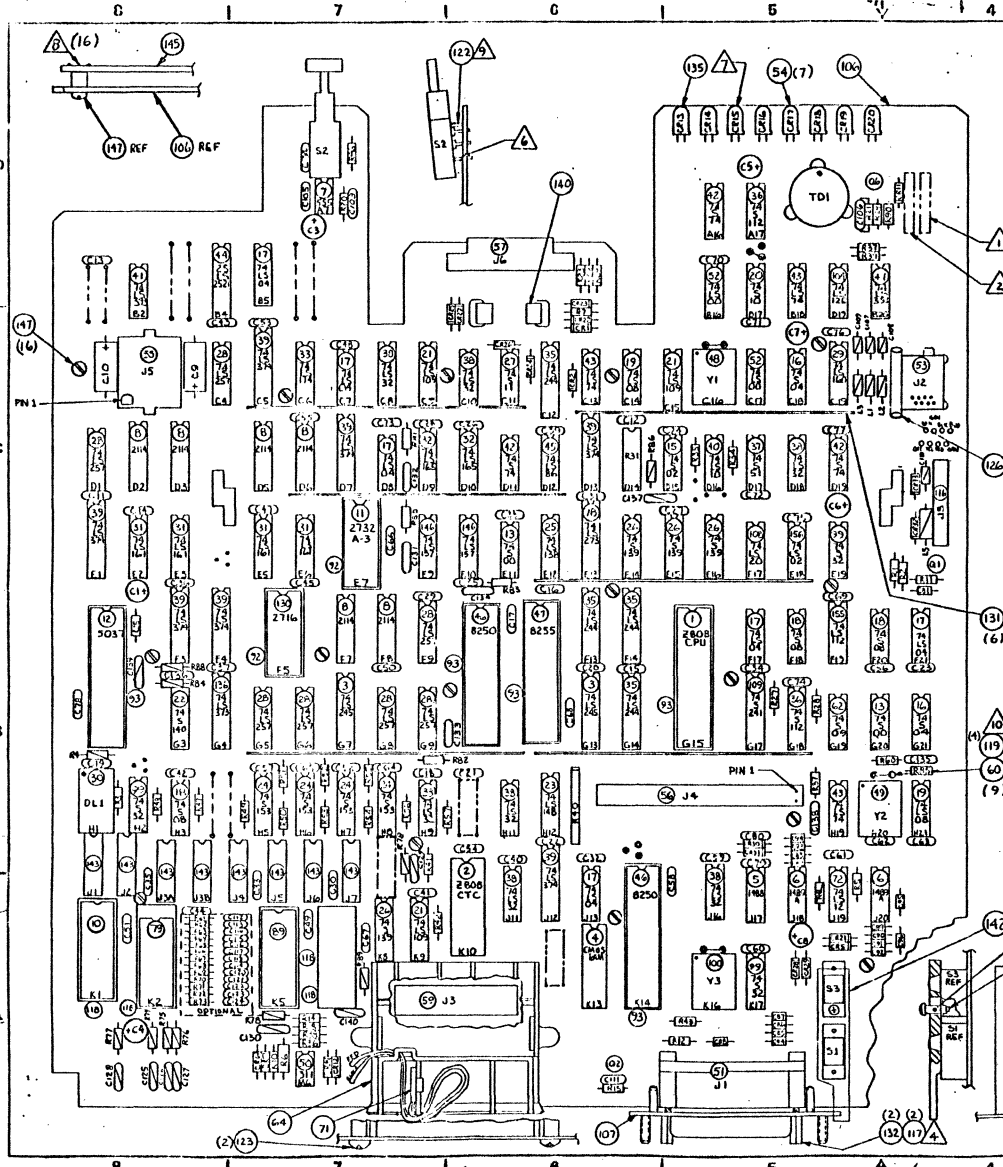

CROSS REFERENCE TABLE	
FIND NUMBER	REFERENCE DESIGNATION
55	S1 S3
61	C1 THRU C34, C35 THRU C45,
63	C47 THRU C80
66	C81
68	C82 THRU C96
69	C103, C105, C106
67	C111
64	Q11
65	Q12
70	CR1
73	CR2 THRU CR7
74	CR8 CR9 CR10 CR11
75	CR12
76	CR13 CR14 CR15
77	CR16
78	CR17
79	CR18
80	CR19
81	CR20
82	CR21
83	CR22
84	CR23
85	CR24
86	CR25
87	CR26
88	CR27
89	CR28
90	CR29
91	CR30
92	CR31
93	CR32
94	CR33
95	CR34
96	CR35
97	CR36
98	CR37
99	CR38
100	CR39
101	CR40
102	CR41
103	CR42
104	CR43
105	CR44
106	CR45
107	CR46
108	CR47
109	CR48
110	CR49
111	CR50
112	CR51
113	CR52
114	CR53
115	CR54
116	CR55
117	CR56
118	CR57
119	CR58
120	CR59
121	CR60
122	CR61
123	CR62
124	CR63
125	CR64
126	CR65
127	CR66
128	CR67
129	CR68
130	CR69
131	CR70
132	CR71
133	CR72
134	CR73
135	CR74
136	CR75
137	CR76
138	CR77
139	CR78
140	CR79
141	CR80
142	CR81
143	CR82
144	CR83
145	CR84
146	CR85
147	CR86
148	CR87
149	CR88
150	CR89
151	CR90
152	CR91
153	CR92
154	CR93
155	CR94
156	CR95
157	CR96
158	CR97
159	CR98
160	CR99
161	CR100

CHANGE TABLE	
DELETIONS	ADDITIONS
1. CUT FOIL FROM 618-1 TO 618-13	1. 618-5 TO 618-5
	2. 618-8 TO 618-13
	3. F/N 61(10) ACCESS R21
	4. 618-15 TO 618-15
	5. 618-2 TO 618-1

SHEET REVISION STATUS		REVISION RECORD	
REV	ECO	DESCRIPTION	DATE
A	15100-Y	RELEASED CLASS 'A'	10/20/62
B	15435	REPLACED F/N 151	11/20/62
C	15487	CHANGED F/N 142	11/20/62
		ADDED F/N 154, 153	
D	15517	REPLACED F/N 260	12/10/62
E	15519	CHG. F/N 123	12/10/62
F	15659	REVISED F/N 135	12/10/62
G	15675	CHG. F/N 33	1/17/63
H	15677	REVISED PER ECO	2/10/63
I	15980	REVISED PER ECO	2/10/63
J	16067	ADD F/N 10, 15, 14, 13, 12, 11	2/10/63
K	16210	CHG. F/N 11	2/10/63
L	16488	ADD A16 TO J3 LOCATION	4/10/64
M	16520	REVISE F/N 152 (53) NOTE B	4/10/64
N	16754	CHANGED F/N 123	2/10/64
O	16884	CHANGED F/N 127 & 144	2/10/64
P	16972	REPLACED F/N 123	2/10/64
Q	16972	REPLACED F/N 123	2/10/64
R	16972	REPLACED F/N 123	2/10/64
S	16972	REPLACED F/N 123	2/10/64
T	16972	REPLACED F/N 123	2/10/64
U	16972	REPLACED F/N 123	2/10/64
V	16972	REPLACED F/N 123	2/10/64
W	16972	REPLACED F/N 123	2/10/64
X	16972	REPLACED F/N 123	2/10/64
Y	16972	REPLACED F/N 123	2/10/64
AA	17571	INACTIVE, SERVICE USE ONLY	11/10/65

- NOTES:
- 1. MARK ASSY. NO., REV LEVEL, AND LOC CODE IN AREA SHOWN. MARK PER CDC SPEC 1012108, CHARACTER HEIGHT .12 (10 PT) COLOR WHITE.
 - 2. MARK SERIAL NUMBER IN AREA SHOWN PER RVLOPS P&P NO. 80-20-34 AND PER MARKING REQUIREMENTS IN NOTE (1) ONE.
 - 3. FIND NUMBERS, ELEMENT IDENTIFIERS, AND REFERENCE DESIGNATIONS ARE FOR REFERENCE ONLY AND DO NOT APPEAR ON PART.
 - 4. REMOVE 2 SCREWS AND REPLACE WITH F/N 132.
 - 5. USE P/N 71493236 TO MAINTAIN CORRECT HEIGHT FROM P.C. BOARD.
 - 6. SEAT PLASTIC PEG OF S2 ON P.C. CARD.
 - 7. FLUSH WITH BOARD EDGE TO .050 MAX OVER AND PLACED PERPENDICULAR WITHIN ±.03 / LED'S TO LAY FLAT WITHIN ±.03 TO SURFACE OF P.C. BOARD.
 - 8. SECURE F/N 1474152 USING F/N 148.
 - 9. F/N 122 (P/N 71493357) FOR ASSEMBLY OR REPLACEMENT ONLY.
 - 10. FABRICATE JUMPERS TO THE FOLLOWING DIMENSIONS

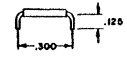

INACTIVE

APL 90446515		TITLE	
P.C. CARD ASSEMBLY, 1AJD-2		LOGIC BOARD (2 LAYER)	
DESIGNED BY	CC634-A	GOODS IDENT	15920
CHECKED BY	E. EISENBERG	DRAWING NO	90446515
APPROVED BY	M. H. FLETCHER	SCALE	NONE
DATE	11/12/62	SHEET NO.	1
REV	1	DATE	11/12/62
APPROVED BY	M. H. FLETCHER	SHEET NO.	1
DATE	11/12/62	SHEET NO.	1

50446515	AA	I	D	PCA 1AJD-2 (VX LOGIC BOARD)	CD	CC634A	07/29/85	017571	09/27/85	1 / 4
ASSEMBLY NUMBER	REV	CL	BY	ASSEMBLY DESCRIPTION	FORM SOURCE	PART USAGE	RELEASE DATE	CHANGE ORD. NUMBER	PROGRAMING DATE	PAGE NUMBER

PF

PART NUMBER	REV	BY	QUANTITY	UNIT	PART DESCRIPTION	INPUT STATUS	CHANGE ORD. NUMBER	DATE EFFECTIVE	MAKE/BUY	PC	NC
117	A		2.00	PC	EXTERNAL TOOTH LCCK WASHERS	IN			PPP1	N	
152	A		1.00	PC	SCR PACH PAN PHL 4-40	IN	016520	C41384	PPP1	N	
147	A		1.00	PC	SCR PACH PAN PHL 2-56	IN			PPP1	N	
51	C		1.00	PC	CONN.-RECEPT, P.C. 25 POSITION	IN			PPPA	N	
57	A		1.00	PC	CONNECTOR,2C CONTACT	IN			PPPA	N	
83	A		1.00	PC	SH. P/PB FIG-1 PC-MTD 2POT	IN			PPPA	N	
46	A		2.00	PC	IC ASYNC COMM TYPE 825CA	IN	017184	C71985	PPPA	N	
7	A		1.00	PC	IC NE555	IN			PPPA	N	
26	A		4.00	PC	1-C TTL DCRD2	IN			PPPA	N	
24	A		4.00	PC	1-C 74S153	IN			PPPA	N	
52	A		2.00	PC	IC TTL QUAD 2-IN NAND 74LS00	IN			PPPA	N	
156	A		1.00	PC	IC TTL QUAD 2-INPUT NOR 74LS02	IN	016652	082484	PPPA	N	
17	A		6.00	PC	IC TTL HEX INVERTER 74LS04	IN	016652	082484	PPPA	N	
19	A		2.00	PC	IC TTL QUAD 2INPUT AND 74LS08	IN			PPPA	N	
40	A		1.00	PC	IC TTL TRPL 3INPUT NAND 74LS10	IN			PPPA	N	
72	A		1.00	PC	IC TTL3 3-IN NAND 74LS12	IN			PPPA	N	
168	A		1.00	PC	IC TTL DUAL 4INPUT NAND 74LS20	IN			PPPA	N	
38	A		7.00	PC	IC TTL QUAD 2INPUT OR 74LS32	IN			PPPA	N	
43	A		3.00	PC	IC TTL DUAL D-TYPE F/F 74LS74	IN	015980	C70883	PPPA	N	
45	A		1.00	PC	IC TTL QUAD 2INPUT EXC 74LS06	IN			PPPA	N	
155	A		1.00	PC	IC TTL DUAL J-K KEY FF 74LS112	IN	016652	082484	PPPA	N	
146	A		2.00	PC	IC MULT1,TTL QUAD 2 74LS157	IN			PPPA	N	
31	A		4.00	PC	I C TYPE 74LS161J	IN			PPPA	N	
25	A		1.00	PC	IC, DECODER-5TTL 74LS138	IN			PPPA	N	
21	A		3.00	PC	IC TTL JK FF, DUAL 74LS109	IN			PPPA	N	
62	A		1.00	PC	IC 74509	IN			PPPA	N	
59	A		3.00	PC	IC 74S32	IN			PPPA	N	
15	A		1.00	PC	IC-TTL QUAD 2 INPUT NOR 74S02	IN	016652	C82484	PPPA	N	
36	A		2.00	PC	I C 74S112	IN	016652	082484	PPPA	N	
22	A		1.00	PC	IC 74S140 TTL DUAL 4INPUT GATE	IN			PPPA	N	
169	A		1.00	PC	IC-74S241	IN			PPPA	N	
164	A		1.00	PC	IC 74LS125	IN			PPPA	N	
3	A		2.00	PC	IC 74LS245 OCTAL BUS TRANSVR	IN			PPPA	N	
6	C		2.00	PC	IC 1485A RECEIVER RS232C CTL	IN			PPPA	N	
35	A		7.00	PC	MICROCIRCUIT 74LS374 TYPE	IN			PPPA	N	
35	A		4.00	PC	IC 74LS244	IN			PPPA	N	

AA8708 REV 4-80 CDC
RVLCPS PFC INFO

PRINTED IN U.S.A.

50446515	AA	I	D	PCA 1AJD-2 (VX LOGIC BOARD)	CD	CC634A	07/29/85	017571	09/27/85	2 / 4
ASSEMBLY NUMBER	REV	CL	BY	ASSEMBLY DESCRIPTION	FORM SOURCE	PART USAGE	RELEASE DATE	CHANGE ORD. NUMBER	PROGRAMING DATE	PAGE NUMBER

PF

PART NUMBER	REV	BY	QUANTITY	UNIT	PART DESCRIPTION	INPUT STATUS	CHANGE ORD. NUMBER	DATE EFFECTIVE	MAKE/BUY	PC	NC
32	A		2.00	PC	IC 74LS165 TYPE	IN			PPP5	N	
23	A		1.00	PC	IC 74LS148 TTL 8-INPUT PRIORITY	IN			PPP5	N	
41	A		2.00	PC	MICROCIRCUIT 74LS393 TYPE	IN			PPP5	N	
78	A		1.00	PC	IC 74LS273 FLIP-F	IN			PPP5	N	
44	A		1.00	PC	I.C. TYPE 29LS2521	IN			PPP5	N	
136	A		1.00	PC	74LS373 OCTAL C LATCH	IN			PPP5	N	
25	A		1.00	PC	I.C.	IN			PPP5	N	
50	A		1.00	PC	IC-LM311N VOLTAGE COMPARATOR	IN			PPPA	N	
46	A		2.00	PC	MICROCIRCUIT TYPE 8250	OUT	017184	C71985	PPPA	N	
9	A		1.00	PC	I.C. DRIVER, TYPE 1488	IN			PPPA	N	
4	A		1.00	PC	IC 6501 450MS CMOS 256X4 RAM	IN			PPPA	N	
8	A		6.00	PC	IC 2114 120MS TTL 1024X4 RAM	IN			PPPA	N	
12	A		1.00	PC	IC 5037 POS/TTL CRT VIDEO T/C	IN			PPPA	N	
1	A		1.00	PC	I.C. MICROPROCESSOR 2808-CPU	IN			PPPA	N	
2	A		1.00	PC	I.C. COUNTER TYPE 2808-CTC	IN			PPPA	N	
143	A		8.00	PC	IC 4164 130MS MOS 65536B DRAM	IN	015980	C70883	PPPA	N	
10	A		3.00	PC	IC 74S08	IN	015613	C56683	PPPA	N	
20	A		7.00	PC	IC 74LS257 MULTIPLEXER	IN			PPPA	N	
37	A		1.00	PC	MICROCIRCUIT 74S51 DUAL 2 WIDE	IN			PPPA	N	
47	A		1.00	PC	IC-8255A	IN			PPPA	N	
134	A		REF	PC	FAB SPEC MED LINE OBLSIDE	IN			REF4	N	
132	C		2.00	PC	SCREWS LOCK CONNECTOR	IN			PPPA	N	
123	C		2.00	PC	SCR TPG PAN PHL 181 1/2L STL	IN	015639	112682	PPP3	N	
61	C		73.00	PC	CAP. FXD CERAM 50VDC .01MFD	IN			PPPA	N	
63	C		1.00	PC	CAP. FIXED CERAMIC 50VDC .1MFD	IN			PPPA	N	
80	C		1.00	PC	RES FXD COMP .50W 180OHMS 5PCT	IN			PPPA	N	
70	C		1.00	PC	DIODE VOLT REG	IN			PPPA	N	
65	A		12.00	PC	DIODE SI 10V	IN			PPPA	N	
55	A		2.00	PC	SH. SLIDE FIG-2 PC-MTD 6PDT	IN			PPPA	N	
137	A		1.00	PC	XSTR, 2N4091 FLO-EFF N-TYP SI	IN			PPPA	N	
67	A		1.00	PC	XSTR-2A2907,PMP,SI TO-18	IN			PPPA	N	
52	A		2.00	PC	CONN SKT DUAL IN LINE 24 PGS	IN			PPPA	N	
118	A		4.00	PC	CONNECTOR SOCKET DUAL IN LINE	IN	015613	121782	PPPA	N	
53	A		5.00	PC	CONN SKT DUAL IN LINE 40 POS	IN			PPPA	N	
116	A		1.00	PC	CONN-P.C., 1C POSITION	IN			PPPA	N	
55	A		1.00	PC	CONN, 34POS R-ANGLE FIG-6 PCB	IN			PPPA	N	

AA8708 REV 4-80 CDC
RVLCPS PFC INFO

PRINTED IN U.S.A.

ASSEMBLY PARTS LIST

90446515		AA	I	D	PCA 1AJ0-2 (VX LOGIC BOARD)	CD	CC634A	C7/29/85	017571	09/27/85	3/ 4	PF
ASSEMBLY NUMBER	REV	CL	BY	DATE	ASSEMBLY DESCRIPTION	DESIGN SOURCE	FIRST USAGE	RELEASE DATE	CHANGE ORD. NUMBER	PROCESSING DATE	PAGE NUMBER	
PNP NUMBER	REV	BY	DATE	QUANTITY	UNIT MEAS.	PART DESCRIPTION	IN/OUT STATUS	CHANGE ORD. NUMBER	DATE EFFECTIVE	MAKE/BUY PART TYPE	PH NO.	D OR N
60	A			1.00	PC	TRANSISTOR APN SI TO IB	IN	015679	012183	PPP4		N
54	A			7.00	PC	DIO LED SLD ST RED EPOXY	IN			PPP4		N
135	A			1.00	PC	LED, S-S GP GRN 7.0MCD 120MW	IN	015659	032583	PPP4		N
46	A			1.00	PC	OSCILLATOR TTL DIP (12.936MHZ)	IN			PPP5		N
100	A			1.00	PC	OSCILLATOR	IN			PPP4		N
50	A			1.00	PC	CONN P.C. 12POS TIN PLT	IN			PPP4		N
53	A			1.00	PC	JACK, PNL MTG 8-CNDCT FIG-8	IN			PPP4		N
73	A			1.00	PC	XOCR, PIEZOCERAMIC 50V FIG-1	IN			PPP4		N
71	A			1.00	PC	CLIP, 9V BATTERY CONN FIG-1	IN			PPP4		N
131	A			6.00	PC	BUS BAR, VERT PC MTG FIG-1	IN			PPP4		N
126	A			1.00	IN	BELTING ROUND	IN	016885	100584	PPP5		N
150	C			60.00	IN	WIRE ELEC 30 GA WHITE	IN			PPP5		N
60	A			9.00	PC	SOCKET MINI SPRING	IN	015679	012183	PPP4		N
130	A			1.00	PC	F/W ASSY, PGM 2716 EPROM IC	IN			AYR4		N
11	A			1.00	PC	C/G ASSY, PGM 2732A EPROM	IN	016214	092383	AYR4		N
10	A			1.00	PC	F/W ASSY(1), PGM 2764-4 EPROM	IN			AYR4		N
79	A			1.00	PC	F/W ASSY(2), PGM 2732A EPROM	IN			AYR4		N
89	A			1.00	PC	F/W ASSY(3), PGM 2764-4 EPROM	IN			AYR4		N
140	C			1.00	PC	SLIDE, DRAWER (PLSTC)	IN			PPP4		N
64	D			1.00	PC	CRADLE, ROM PAK (PLSTC)	IN			PPP4		N
107	C			1.00	PC	PLATE, I/O CONN (CRS/TIN)	IN			PPP4		N
122	B			1.00	PC	SPACER, RESET SWITCH (PLSTC)	IN			PPP4		N
153	B			1.00	PC	SPACER, 7.00L ACTR SW (BRSS)	IN	016520	C41384	PPP4		N
145	D			1.00	PC	GROUND PLANE (MAIN LOGIC BD)	IN			PPP4		N
142	C			1.00	PC	HANDLE, LOOPBACK SW (PLSTC)	IN	015457	111282	PPP4		N
105	A			1.00	PC	RESISTOR CHIP-150 OHM	IN			PPP5		N
16	A			2.00	PC	IC 745C4 SCHOTTKY TTL HEX INV	IN			PPP5		N
27	A			1.00	PC	IC 74511 SCHOTTKY TTL TPL 3-1	IN			PPP5		N
20	A			1.00	PC	IC 74510 SCHOTTKY TTL 3-1 NAND	IN			PPP5		N
13	A			2.00	PC	IC 74500 SCHOTTKY TTL GUAC 2-1	IN			PPP5		N
42	A			3.00	PC	IC 74574 TTL DUAL C EGGE F/F	IN			PPP5		N
133	C			REF	PC	SCH DIAG 1AJ0-1 (MAIN LOGIC)	IN			RFE4		N
108	D			1.00	PC	PW BD 1AJ0 LCGIC BOARD	IN	015679	012183	PPP4		N
149	A			7.00	PC	CAPACITOR-MONOLITHIC CERAMIC	IN	015679	012183	PPP5		N
65	A			1.00	PC	CAP, CERAMIC, X7R, 50V 10Z	IN			PPP5		N
66	A			15.00	PC	CAPACITOR 390 PF	IN			PPP5		N

AA2708 REV 4-80 CDC
RVLCPS PFC INFO

PRINTED IN U.S.A.

ASSEMBLY PARTS LIST

90446515		AA	I	D	PCA 1AJ0-2 (VX LCGIC BOARD)	CD	CC634A	C7/29/85	017571	09/27/85	4/ 4	PF
ASSEMBLY NUMBER	REV	CL	BY	DATE	ASSEMBLY DESCRIPTION	DESIGN SOURCE	FIRST USAGE	RELEASE DATE	CHANGE ORD. NUMBER	PROCESSING DATE	PAGE NUMBER	
PNP NUMBER	REV	BY	DATE	QUANTITY	UNIT MEAS.	PART DESCRIPTION	IN/OUT STATUS	CHANGE ORD. NUMBER	DATE EFFECTIVE	MAKE/BUY PART TYPE	PH NO.	D OR N
30	A			1.00	PC	DELAYLINE TAPPED	IN			PPP5		N
56	A			1.00	PC	MDR, 50POS SHLD STR STY-8 PCB	IN			PPP4		N
75	A			7.00	PC	CAP AL ELEC 100UF-10V75P 6.3V	IN			PPP4		N
115	A			2.00	PC	CAP AL ELEC 15 UF-10V1COP 25V	IN			PPP5		N
74	A			1.00	PC	RES FXD C FM 22 OHM 5P 1/4W	IN			PPP4		N
125	A			12.00	PC	RES FXD C FM 47 OHM 5P 1/4W	IN			PPP5		N
98	A			1.00	PC	RES FXD C FM 56 OHM 5P 1/4W	IN			PPP4		N
130	A			1.00	PC	RES .25W 100 OHM	IN			PPP5		N
120	A			9.00	PC	RESISTOR 1/4 WATT	IN	015679	012183	PPP5		N
76	A			1.00	PC	RESISTOR 1/4 WATT	IN			PPP5		N
77	A			1.00	PC	RESISTOR 300 OHMS	IN			PPP5		N
101	A			3.00	PC	RESISTOR 1/4 WATT	IN			PPP4		N
124	A			4.00	PC	RES 1/4W CARBON FILM 1K OHMS	IN	222222	070883	PPP5		N
82	A			1.00	PC	RESISTOR-1/4W CARBON 1200 OHMS	IN			PPP5		N
127	A			1.00	PC	RES 1.8K, CARBON FILM, .25W	IN	016884	083184	PPP5		N
113	A			1.00	PC	RESISTOR 1/4 WATT	IN			PPP5		N
64	A			1.00	PC	RES 1/4W CARBON FILM 2.7K OHMS	IN			PPP5		N
114	A			1.00	PC	RESISTOR FIXED	IN			PPP5		N
112	A			2.00	PC	RES CARBON FILM 3.3KOHMS .25W	IN			PPP5		N
85	A			1.00	PC	RES 1/4W CARBON FILM 4.7K OHMS	IN			PPP5		N
94	A			1.00	PC	RES .25 WATT CARBON FILM	IN	016754	070684	PPP4		N
144	A			1.00	PC	RES 1/4W CARBON FILM 8.2K	IN	016884	083184	PPP5		N
129	A			1.00	PC	RES 1/4W CARBON FILM 10K OHMS	IN			PPP5		N
88	A			2.00	PC	RES CARBON FILM 100KOHMS .25W	IN	222222	012183	PPP5		N
154	A			1.00	PC	RES FXD C FM 150K OHM 5P 1/4W	IN	015679	012183	PPP5		N
81	A			1.00	PC	RES 240 K CARBON FILM .25W	IN			PPP5		N
90	A			2.00	PC	RES 1 PEG OHM .25 WATT	IN			PPP5		N
119	C			3.60	IN	WIRE,SOL,COP,TIN,24 GA WHT	IN	016029	062483	PPP5		N
148	A			0.01	GZ	SEALANT, LOCTITE PURPLE 222	IN	017399	072685	RFE4		N
121	C			8.00	PC	DIODE	IN			PPP5		N
33	A			1.00	PC	IC LATCH 6BIT D TYPE74LS174	IN	015675	062483	PPP5		N
91	A			1.00	PC	RES NETWORK,10 PIN SIP 1000OHM	IN			PPP5		N
49	A			1.00	PC	OSCILLATOR-HY8D CLK 6.000C MHZ	IN			PPP4		N

AA2708 REV 4-80 CDC
RVLCPS PFC INFO

PRINTED IN U.S.A.

NOTE

Pages 5 and 6 of parts list 90446515 have been deleted. Information contained on these pages is now compiled on pages 1 through 4 of the revised parts list.

NOTE

Pages 7 and 8 of parts list 90446515
have been deleted. Information
contained on these pages is now
compiled on pages 1 through 4 of the
revised parts list.

ASSEMBLY PARTS LIST

90446597	N	A	D	CD ASSY 1AJD-3 LOGIC BD	CD	CC634B	07/29/85	017184	08/06/85	3/ 5
ASSEMBLY NUMBER	REV	CL	REV	ASSEMBLY DESCRIPTION	DESIGN SOURCE	PART USAGE	RELEASE DATE	CHANGE ORD NUMBER	PROCESSING DATE	PAGE NUMBER

PR

FINO NUMBER	REV	PART NUMBER	QUANTITY	UNIT MEAS	PART DESCRIPTION	IN/OUT STATUS	CHANGE ORD NUMBER	DATE EFFECTIVE	MAKE/BUY PART TYPE	PN	OR
68	A	51887100	1.00	PC	TRANSISTOR NPN SI TO IB	IN			PPP4	N	N
54	A	51903802	7.00	PC	DIO LED SLD ST RED EPOXY	IN			PPP4	N	N
135	A	51903811	1.00	PC	LED, S-S GP GRN 7.0MCD 120MW	IN			PPP4	N	N
48	A	51904114	1.00	PC	OSCILLATOR TTL DIP (12.936MHZ)	IN			PPP5	N	N
100		51904115	1.00	PC	OSCILLATOR	IN			PPP4	N	N
58	A	51906105	1.00	PC	CONN P.C. 12POS TIN PLT	IN			PPP4	N	N
53	A	51917916	1.00	PC	JACK, PNL MTG 8-CNDCT FIG-8	IN			PPP4	N	N
73	A	51941074	1.00	PC	XDCR, PIEZOCERAMIC 50V FIG-1	IN			PPP4	N	N
71	A	51941144	1.00	PC	CLIP, 9V BATTERY CONN FIG-1	IN			PPP4	N	N
131	A	51941212	6.00	PC	BUS BAR, VERT PC MTG FIG-1	OUT	017177	062185	PPP4	N	N
126	A	51942324	1.00	IN	BELTING ROUND	IN	016885	100584	PPP5	N	N
155	C	51942411	1.00	PC	PLUG JUMPER	IN	016127	021084	PPP4	N	N
150	C	52629949	60.00	IN	WIRE ELEC 30 GA WHITE	IN			PPP5	N	N
60		65832100	9.00	PC	SOCKET MINI SPRING	IN			PPP4	N	N
130	A	66307828	1.00	PC	F/W ASSY, PGM 2716 EPROM IC	IN			AYM4	N	N
11	A	66319040	1.00	PC	C/G ASSY, PGM 2732A EROM	IN			AYM4	N	N
10	A	66319365	1.00	PC	VIKINGXM RESIDENT POSITION 1	IN			AYM4	N	N
79	A	66319366	1.00	PC	VIKINGXM RESIDENT POSITION 2	IN			AYM4	N	N
89	A	66319367	1.00	PC	VIKINGXM RESIDENT POSITION 3	IN			AYM4	N	N
140	C	71493326	1.00	PC	SLIDE, DRAWER (PLSTC)	IN			PPP4	N	N
64	D	71493330	1.00	PC	CRADLE, ROM PAK (PLSTC)	IN			PPP4	N	N
107	C	71493343	1.00	PC	PLATE, I/O CONN (CRS/TIN)	IN			PPP4	N	N
122	B	71493357	1.00	PC	SPACER, RESET SWITCH (PLSTC)	IN			PPP4	N	N
156	B	71493495	1.00	PC	SPACER, 7.00L ACTR SW (BRS)	IN	016520	041384	PPP4	N	N
145	D	71493695	1.00	PC	GROUND PLANE (MAIN LOGIC BD)	OUT	017177	062185	PPP4	N	N
142	C	71493781	1.00	PC	HANDLE, LOOPBACK SW (PLSTC)	IN			PPP4	N	N
105	A	75738605	1.00	PC	RESISTOR CHIP-150 OHM	IN			PPP4	N	N
16	A	88883700	2.00	PC	IC 74504 SCHOTTKY TTL HEX INV	IN			PPP5	N	N
27	A	88884100	1.00	PC	IC 74511 SCHOTTKY TTL TPL 3-I	IN			PPP5	N	N
20	A	88884200	1.00	PC	IC 74510 SCHOTTKY TTL 3-I NAND	IN			PPP5	N	N
13	A	88884500	2.00	PC	IC 74500 SCHOTTKY TTL QUAD 2-I	IN			PPP5	N	N
42	A	88923000	3.00	PC	IC 74574 TTL DUAL D EDGE F/F	IN			PPP5	N	N
133	C	90446483	REF	PC	SCH DIAG 1AJD-1 (MAIN LOGIC)	IN			REF4	N	N
106	D	90446532	1.00	PC	PW BD 1AJD LOGIC BOARD	OUT	017177	062185	PPP4	N	N
106	D	90446667	1.00	PC	PW BD 1AJD LOG BD 6 LAYER	IN	017177	062185	PPP4	N	N
149	A	94240404	7.00	PC	CAPACITOR-MONOLITHIC CERAMIC	IN			PPP5	N	N

A42708 REV 4-80 CDC
ARDEN HILLS MFG INFO

PRINTED IN U.S.A.

ASSEMBLY PARTS LIST

90446597	N	A	D	CD ASSY 1AJD-3 LOGIC BD	CD	CC634B	07/29/85	017184	08/06/85	4/ 5
ASSEMBLY NUMBER	REV	CL	REV	ASSEMBLY DESCRIPTION	DESIGN SOURCE	PART USAGE	RELEASE DATE	CHANGE ORD NUMBER	PROCESSING DATE	PAGE NUMBER

PR

FINO NUMBER	REV	PART NUMBER	QUANTITY	UNIT MEAS	PART DESCRIPTION	IN/OUT STATUS	CHANGE ORD NUMBER	DATE EFFECTIVE	MAKE/BUY PART TYPE	PN	OR
65	A	94240417	1.00	PC	CAP, CERAMIC, X7R, 50V 10% CAPACITOR 390 PF	IN			PPP5	N	N
66	A	94240427	15.00	PC	DELAYLINE TAPPED	IN			PPP4	N	N
30	A	94262304	1.00	PC	HDR, 50POS SHLD STR STY-8 PCB	IN			PPP4	N	N
56	A	94394745	7.00	PC	CAP AL ELEC 100UF-10+75P 6.3V	IN			PPP4	N	N
75	A	94395520	2.00	PC	CAP AL ELEC 15 UF-10+100P 25V	IN			PPP4	N	N
115	A	94400612	1.00	PC	RES FXD C FM 22 OHM 5P 1/4W	IN			PPP4	N	N
74	A	94402116	12.00	PC	RES FXD C FM 47 OHM 5P 1/4W	IN			PPP4	N	N
125	A	94402124	1.00	PC	RES FXD C FM 56 OHM 5P 1/4W	IN			PPP4	N	N
98	A	94402126	1.00	PC	RES .25W 100 OHM	IN			PPP5	N	N
138	A	94402132	9.00	PC	RESISTOR 1/4 WATT	IN			PPP5	N	N
128	A	94402134	1.00	PC	RESISTOR 1/4 WATT	IN			PPP5	N	N
76	A	94402140	1.00	PC	RESISTOR 300 OHMS	IN			PPP5	N	N
77	A	94402143	3.00	PC	RESISTOR 1/4 WATT	IN			PPP4	N	N
101	A	94402144	4.00	PC	RES 1/4W CARBON FILM 1K OHMS	OUT	017177	062185	PPP5	N	N
124	A	94402156	1.00	PC	RESISTOR-1/4W CARBON 1200 OHMS	IN	017177	062185	PPP5	N	N
82	A	94402158	1.00	PC	RES 1.8K, CARBON FILM, .25W	IN	016884	083184	PPP4	N	N
127	A	94402162	1.00	PC	RESISTOR 1/4 WATT	IN			PPP4	N	N
113	A	94402163	1.00	PC	RES 1/4W CARBON FILM 2.7K OHMS	IN			PPP5	N	N
84	A	94402166	1.00	PC	RESISTOR FIXED	IN			PPP4	N	N
114	A	94402167	2.00	PC	RES CARBON FILM 3.3KOHMS .25W	IN			PPP5	N	N
112	A	94402168	1.00	PC	RES 1/4W CARBON FILM 4.7K OHMS	IN			PPP5	N	N
85	A	94402172	1.00	PC	RES .25 WATT CARBON FILM	IN	016754	070684	PPP4	N	N
94	A	94402176	1.00	PC	RES Y4W CARBON FILM 8.2K	IN	016884	083184	PPP4	N	N
144	A	94402178	1.00	PC	RES 1/4W CARBON FILM 10K OHMS	IN			PPP5	N	N
129	A	94402180	2.00	PC	RES CARBON FILM 100KOHMS .25W	IN			PPP5	N	N
88	A	94402204	1.00	PC	RES FXD C FM 150K OHM 5P 1/4W	IN			PPP4	N	N
154	A	94402208	1.00	PC	RES 240 K CARBON FILM .25W	IN			PPP4	N	N
81	A	94402213	2.00	PC	RES 1 MEG OHM .25 WATT	IN			PPP4	N	N
90	A	94402228	3.60	IN	WIRE,SOL,COP,TIN,24 GA WHT	IN			PPP5	N	N
119	C	94624999	8.00	PC	DIODE	IN			PPP5	N	N
121	C	95637304	1.00	PC	IC LATCH 6BIT D TYPE74LS174	IN			PPP5	N	N
33	A	95965100	1.00	PC	RES NETWORK,10 PIN SIP 1000OHM	IN			PPP5	N	N
91	A	96752406	1.00	PC	OSCILLATOR-HYBD CLK 6.0000 MHZ	IN			PPP4	N	N
49	A	96860409	1.00	PC		IN					

A42708 REV 4-80 CDC
ARDEN HILLS MFG INFO

PRINTED IN U.S.A.

BUILD ARC 214

ASSEMBLY PARTS LIST

BUILD ARC 214										PRINT DATE		PAGE		FILE CHANGE NO.			
										09-10-84		3		0016885			
DIV.	ASSEMBLY NO.	CD	REV.	DWG.	DESCRIPTION					MC	STATUS	STATUS DATE		ENG. RESP.	FILE DATE		
0860	90446597	8	L	D	CD ASSY 1AJD-3 LOGIC BD					S	REL	07-29-83		CC6348	09-10-84		
TRND NO.	U	PART NO.	CD	REV.	QTY	U/M	PART DESCRIPTION				MC	YLD	ECO. NO. IN	ECO. NO. OUT	S/N	WK IN	WK OUT
044	01	15163431	8		1		PC	IC	25LS2521	TTL	88	COMPARATOR	P				
045	01	15164400	5		1		PC	IC	74LS86	149LS	TTL	2	2IN EOR	P			
046	01	15163462	3		2		PC	IC	8250	MOS/TTL	ASYN	COMM	P				
047	01	15164427	5		1		PC	IC	8255A	974A	MOS	PCI (8080)	P				
048	01	51904114	9		1		PC	OSC.	TTL	DIP	12.936MHZ	500MH	P				
049	01	96860409	0		1		PC	OSC.	TTL	DIP	6.0000MHZ	600MH	P				
050	01	15163443	3		1		PC	IC	LM311N	311	VOLT	COMPARATOR	P				
051	01	15186840	3		1		PC	CONN	RECEPT	25	POS		P		16107		8331
051	02	10129668	9		1		PC	CONN	RCPT.	25	SKT	MSG	PC-MTG	P	16107	16155	8331
051	03	15186840	3		1		PC	CONN	RECEPT	25	POS		P	16155			8342
052	01	15144900	6		2		PC	IC	74LS00	140LS	TTL	4	2IN NND	P			
053	01	51917916	2		1		PC	JACK,	PNL	MTG	8-CNDCT	FIG-8	P				
054	01	51903802	0		7		PC	LED,	S-S	GAP	RED	3.0MCD	180MH	P			
055	01	51630901	0		2		PC	SW.	SLIDE	FIG-2	PC-MTD	6PCT	P				
056	01	94394745	7		1		PC	HDR,	50POS	SHLD	STR	STY-8	PCB	P			
057	01	10130611	6		1		PC	CONN	RCPT.	20-CONT	R-A	PC-MTG	P				
058	01	51906105	5		1		PC	CONN,	PC-MTD	12PIN	NVL/SN	F-4	P				
059	01	51860821	1		1		PC	CONN,	34POS	R-ANGLE	FIG-6	PCB	P				
060	01	65832100	5		9		PC	SKT,	MINI-5PG	.018-.020	SN/SN	P					
061	01	19115400	4		73		PC	CAP	FXD	CER	.01UF	+8C-20P	50V	P			
062	01	15151900	6		1		PC	IC	74S09	229S	TTL	4	2IN AND	P			
063	01	19115401	2		1		PC	CAP	FXD	CER	.1UF	+8C-20P	50V	P			

BUILD ARC 214

ASSEMBLY PARTS LIST

BUILD ARC 214										PRINT DATE		PAGE		FILE CHANGE NO.			
										09-10-84		4		0016885			
DIV.	ASSEMBLY NO.	CD	REV.	DWG.	DESCRIPTION					MC	STATUS	STATUS DATE		ENG. RESP.	FILE DATE		
0860	90446597	8	L	D	CD ASSY 1AJD-3 LOGIC BD					S	PFL	07-29-83		CC6348	09-10-84		
TRND NO.	U	PART NO.	CD	REV.	QTY	U/M	PART DESCRIPTION				MC	YLD	ECO. NO. IN	ECO. NO. OUT	S/N	WK IN	WK OUT
064	01	71493330	6		1		PC	CRADLE,	RCM	PAK	(PLSTC)	P					
065	01	94240417	9		1		PC	CAP	FXD	CER	33PF	13P	50VDCW	P			
066	01	94240427	5		15		PC	CAP	FXD	CER	390PF	10P	50VDCW	P			
067	01	51714000	0		1		PC	XSTR,	242407	HI-POLAR	PAP	SI	P				
068	01	51887100	9		1		PC	XSTR	TD-13	LOW	LVL	NPN	SIL	P			
069	01	51007365	1		12		PC	DIG	1N4148	SIL	MICRO	30V	10MA	P			
070	01	50240107	3		1		PC	DIG	1N752A	ZEN	5.6V	5P	20MA	P			
071	01	51941144	1		1		PC	CLIP,	9V	BATTERY	CONN	FIG-1	P				
072	01	15145800	7		1		PC	IC	74LS12	230LS	TTL	3	3IN NND	P			
073	01	51941074	0		1		PC	XDCR,	PIE7	CERAMIC	50V	FIG-1	P				
074	01	94402116	1		1		PC	RES	FXD	C	FM	22	OHM	5P	1/4W	P	
075	01	94395520	3		7		PC	CAP	AL	ELEC	100UF	-10+75P	6.3V	P			
076	01	94402140	1		1		PC	RES	FXD	C	FM	220	OHM	5P	1/4W	P	
077	01	94402143	5		1		PC	RES	FXD	C	FM	300	OHM	5P	1/4W	P	
078	01	15163420	1		1		PC	IC	74LS273	TTL	8	D	FLIP/FLOP	P			
079	01	66315366	6		1		PC	VIKINGXM	RESIDENT	POSITION	2	G					
080	01	24500145	3		1		PC	RES	FXD	CCMP	180	OHM	5P	1/2W	P		
081	01	94402213	6		1		PC	RES	FXD	C	FM	240K	OHM	5P	1/4W	P	
082	01	94402158	3		1		PC	RES	FXD	C	FM	1.2K	OHM	5P	1/4W	P	
083	01	15002348	9		1		PC	SW,	M/PB	FIG-1	PC-MTD	2POT	P				
084	01	94402166	6		1		PC	RES	FXD	C	FM	2.7K	OHM	5P	1/4W	P	

ASSEMBLY PARTS LIST

BUILD APC 214										PRINT DATE	PAGE	FILE CHANGE NO.	
QTY	ASSEMBLY NO.	CD	REV.	DWG.	DESCRIPTION	MC	STATUS	STATUS DATE	ENG. RESP.	FILE DATE			
C860	90446597	B	L	D	CD ASSY 1AJD-3 LOGIC HD	S	REL	07-29-83	CC634B	09-10-84	00016885		
T/PND NO.	U	PART NO.	CD	QTY	U/M	PART DESCRIPTION	MC	YLD	ECO. NO. IN	ECO. NO. OUT	S/N	WK IN	WK OUT
015	01	94402172	4	1		PC RES FXD C FM 4.7K OHM 5P 1/4W	P						
068	01	94402204	5	2		PC RES FXD C FM 100K OHM 5P 1/4W	P						
069	01	66315367	4	1		PC VIKINGXM RESIDENT POSITION 3	G						
090	01	94402226	4	2		PC RES FXD C FM 1.0M OHM 5P 1/4W	P						
091	01	96752406	7	1		PC RES 10PIN SIP 1K OHM 2P .8W	P						
092	01	51848404	3	2		PC SOCKET, IC 24-POS DIL F-1 5N	P						
093	01	51848406	8	5		PC SOCKET, IC 40-POS DIL F-1 5N	P						
094	01	94402188	0	1		PC RES FXD C FM 22K OHM 5P 1/4W	P			16754	16754	8427	8427
094	02	94402176	5	1		PC RES FXD C FM 6.8K OHM 5P 1/4W	P		16754			8427	
098	01	94402126	0	1		PC RES FXD C FM 56 OHM 5P 1/4W	P						
099	01	15154800	5	3		PC IC 74532 2185 TTL 4 2IN DR	P						
100	01	51904115	6	1		PC OSC, TTL DIP 1.8432MHZ 500MW	P						
101	01	94402144	3	3		PC RES FXD C FM 330 OHM 5P 1/4W	P						
104	01	15163322	9	1		PC IC 74LS125 TTL 4 BUS BUFFER	P						
105	01	75738605	7	1		PC RES 16PIN DIP 150 R 2P 1.5W 1P	P						
106	01	90446532	5	1		PC PW 9D 1AJD LOGIC BOARD	P						
107	01	71493343	9	1		PC PLATE, I/O CONN (CRS/TIN)	P						
108	01	15145900	5	1		PC IC 74LS20 208LS TTL 2 4IN NND	P						
109	01	15163311	2	1		PC IC 74S241 OCTAL BUS DRIVER	P						
112	01	94402106	2	2		PC RES FXD C FM 3.3K OHM 5P 1/4W	P						
113	01	94402163	3	1		PC RES FXD C FM 2.0K OHM 5P 1/4W	P						

ASSEMBLY PARTS LIST

BUILD APC 214										PRINT DATE	PAGE	FILE CHANGE NO.	
QTY	ASSEMBLY NO.	CD	REV.	DWG.	DESCRIPTION	MC	STATUS	STATUS DATE	ENG. RESP.	FILE DATE			
C860	90446597	B	L	D	CD ASSY 1AJD-3 LOGIC HD	S	REL	07-29-83	CC634B	09-10-84	00016885		
T/PND NO.	U	PART NO.	CD	QTY	U/M	PART DESCRIPTION	MC	YLD	ECO. NO. IN	ECO. NO. OUT	S/N	WK IN	WK OUT
114	01	94402167	4	1		PC RES FXD C FM 3.0K OHM 5P 1/4W	P						
115	01	94400612	1	2		PC CAP AL ELEC 15UF-10+100P 25V	P						
116	01	94394709	3	1		PC HDR, 20POS SHLD STR	P						
116	02	51847506	6	1		PC CONN, 20POS STR FIG-2 PCB	P		16107	16107		8331	8331
117	01	10126400	0	2		PC WSRP, (4) EXT/T LK STL 2P	P						
118	01	51848405	0	4		PC SOCKET, IC 28-POS DIL F-1 5N	P						
119	01	94624999	2	300	FT	WIRE SOL COP TIN 24GA WHT	W						
121	01	95637304	7	8		PC RECT, SIL IN4004 1A 400V MIN	P						
122	01	71493337	9	1		PC SPACER, RESET SWITCH (PLSTC)	P						
123	01	18607904	2	2		PC SCR TPG PAN PHL (8) 1/2L STL	P						
124	01	94402156	7	4		PC RES FXD C FM 1.0K OHM 5P 1/4W	P						
125	01	94402124	5	12		PC RES FXD C FM 47 OHM 5P 1/4W	P						
126	01	51941272	0	083	FT	BELT CORD, EXTR POLYURETHANE	P			16885	16885	8440	8440
126	02	51942324	8	083	FT	REFLECTING ROUND	P						
127	01	94402162	5	1		PC RES FXD C FM 1.8K OHM 5P 1/4W	P						
127	02	94402179	1	1		PC RES FXD C FM 3.2K OHM 5P 1/4W	P		16754	16754		8427	8427
127	03	94402162	5	1		PC RES FXD C FM 1.8K OHM 5P 1/4W	P		16884	16884		8435	8435
128	01	94402134	4	4		PC RES FXD C FM 120 OHM 5P 1/4W	P						
129	01	94402180	7	1		PC RES FXD C FM 10K OHM 5P 1/4W	P						
130	01	66307828	5	1		PC F/W ASSY, PGM 2716 EPROM IC	G						
131	01	51941212	6	6		PC BUS BAR, VERT PC MTG FIG-1	P						
132	01	13252501	4	2		PC SCR-LOCK, CONNECTOR CONFIG-A	P						
133	01	90446483	1	*EF		PC SCH DIAG 1AJD-1 (MAIN LOGIC)	D						

ASSEMBLY PARTS LIST

90446597	N	A	D	CD ASSY 1AJD-3 LOGIC 80	CD	CC6348	07/29/85	017184	08/06/85	5 / 5
ASSEMBLY NUMBER	REV	CL	DW	ASSEMBLY DESCRIPTION	ORIGIN SOURCE	PRIOR USAGE	RELEASE DATE	CHANGE ORD. NUMBER	PROCESSING DATE	PAGE NUMBER

PR

FIND NUMBER	QTY	PART NUMBER	QUANTITY	UNIT	PART DESCRIPTION	IN/OUT	CHANGE ORD.	DATE	MAKE/BUY	PN	QTY
REV	REQ.			MEAS.		STATUS	NUMBER	EFFECTIVE	PART TYPE	NC	IN
NUMBER OF LINE ITEMS = 143 HIGHEST FIND NUMBER = 158											

AA2709 REV 4-80 CDC
ARLEN HILLS MFG INFO

PRINTED IN U.S.A.

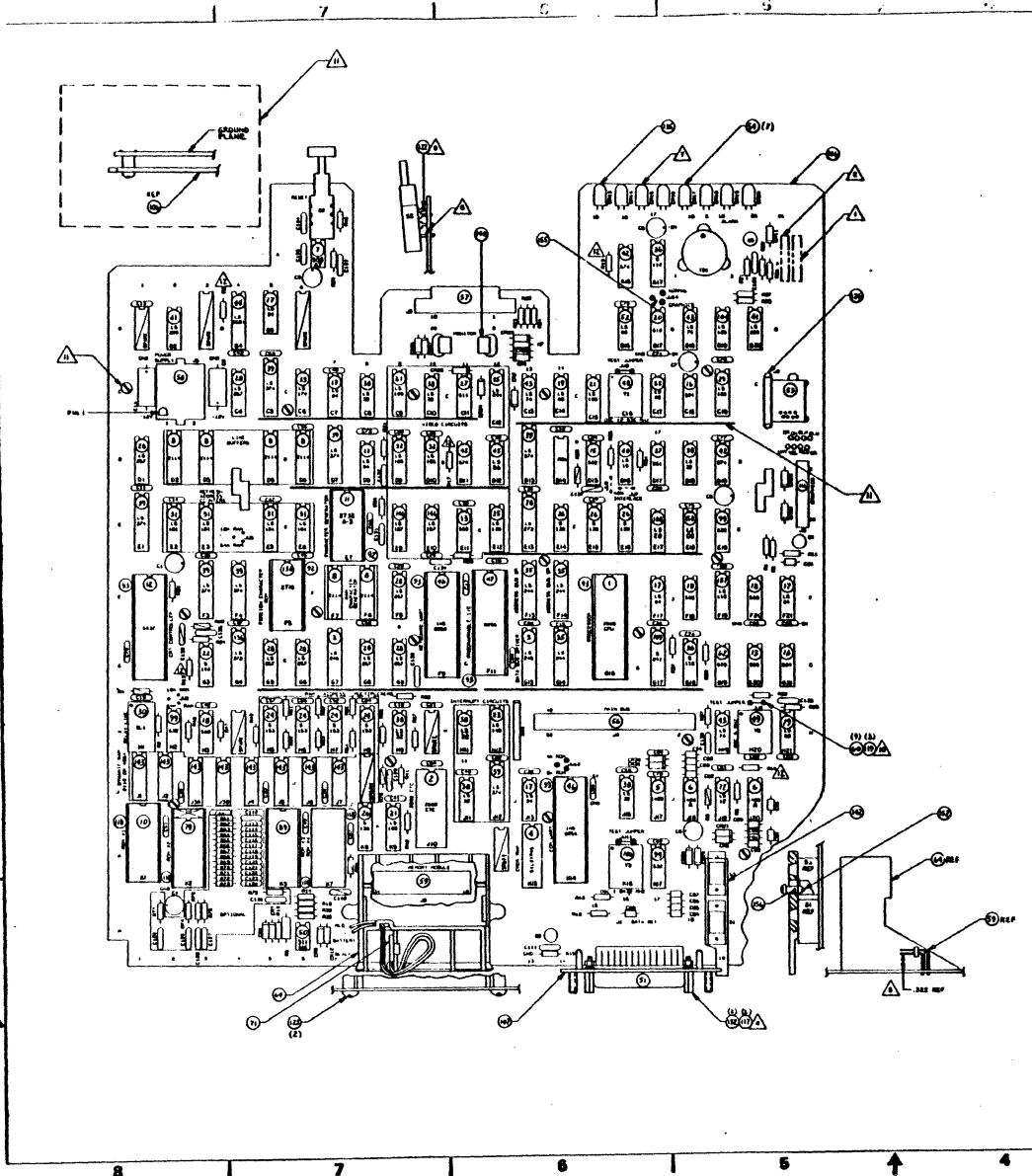

REV	DATE	BY	CHKD	DESCRIPTION
A	11/20/65	RELEASED CLAS. A
B	11/26/65	ADD CHANGE TABLE

Find No	Reference Designation
55	SI, S3
61	C11 THRU C34, C35 THRU C45, C47 THRU C60, C103, C106, C108, C111
63	C104
65	C81
66	CR2 THRU CR6
67	Q1
68	Q6
69	CR1, CR3, CR6, CR7, CR8, CR11, CR21, CR28, CR2, CR29, CR32, CR33
70	CR12
73	T01
74	R1
75	C1, C3 THRU C8
76	R2
77	BT
80	R6
81	R10
82	R11
83	S2
84	R12
85	R14
88	R18, R29
90	R15, R20
91	R40
94	R21
98	R24
101	R25, R27, R28
105	R31
112	R34, R35
113	R36
114	R38
115	C9, C10
121	CR22 THRU CR27, CR30, CR31
124	R5, R9, R13, R16, R17, R19, R41, R42, R46
125	R47 THRU R57, R60
127	R37
128	R22, R23, R80 THRU R85, R87
129	R43
137	R2
138	R3
144	R39
149	C131, C132, C133, C134, C135, C136, C138
154	R90

CHANGE TABLE FOR (REF ONLY) BOARD BLANK 90446312	
DELETIONS	ADDITIONS
1) C11-F11 THRU C14-F11 TO C12-F11	1) R10-5 TO C10-5
2) LIST PINS AT: R6-13	2) R12-8 TO C12-13
3) F/N R1 (C104) ACROSS R21	3) R10-11 TO C10-13
4) C12-15 TO R5-1	4) R10-8 TO C10-2
5) R5-2 TO C16-1	5) R8-11 TO C8-1
6) R8-12 TO C8-4	6) R12-10 TO C16-1
7) R8-12 TO C8-7	7) R12-8 TO C10-7
8) R16-11 TO R16-13	8) R16-8 TO R16-2
9) R6-3 TO R6-9	9) R6-3 TO R6-9
10) R11-3 TO R11-6	10) R11-3 TO R11-6
11) R11-10 TO R11-11	11) R11-4 TO R11-8
12) R11-4 TO R11-8	12) R11-4 TO R11-8
13) R11-4 TO R11-8	13) R11-4 TO R11-8
14) R11-10 TO R11-13	14) R11-10 TO R11-13
15) R11-13 TO R11-4	15) R11-13 TO R11-4

- ⚠ NOT PRESENT ON EARLIER ASSY'S.
- ⚠ THESE PARTS ARE NOT PRESENT IN NEW BUILD ASSY'S. THEY ARE FOR REFERENCE ONLY AND ARE PRESENT ON ASSEMBLIES WHICH HAVE BEEN UPDATED FROM ASSEMBLY NUMBERS 90446515 AND 90446597.

- NOTES:
- ⚠ MARK ASSEMBLY NUMBER, REVISION LEVEL AND LOCATION CODE IN AREA SHOWN. MARK PER CDC SPECIFICATION 10121608, CHARACTER HEIGHT .12 (10 POINT), COLOR WHITE.
 - ⚠ MARK SERIAL NUMBER IN AREA SHOWN PER RVLPS P & P NO. 80:20:34 AND PER MARKING REQUIREMENTS IN NOTE (1) ONE.
 - 3. FIND NUMBERS, ELEMENT IDENTIFIERS AND REFERENCE DESIGNATIONS ARE FOR REFERENCE ONLY AND DO NOT APPEAR ON PART.
 - ⚠ REMOVE 2 SCREWS AND REPLACE WITH F/N 132.
 - ⚠ USE PART NUMBER 71493236 TO MAINTAIN CORRECT HEIGHT FROM P.C. BOARD.
 - ⚠ SEAT PLASTIC PEG OF S2 ON P.C. CARD.
 - ⚠ FLUSH WITH BOARD EDGE TO .050 MAX OVER AND PLACED PERPENDICULAR WITHIN ±.03/L.E.D. TO LAY FLAT WITHIN ±.03 TO SURFACE OF P.C. BOARD.
 - ⚠ F/N 122 (PART NUMBER 71493357) FOR ASSEMBLY OR REPLACEMENT ONLY.
 - ⚠ FABRICATE JUMPERS TO THE FOLLOWING DIMENSIONS.

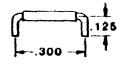

UNLESS OTHERWISE SPECIFIED DIMENSIONS ARE IN INCHES	DESIGNED BY	E. ERSFELD	DATE	8-20-65
	DRWING	...	DATE	...
PLATE	PLACE	ANGLE		
...		
MATERIAL		
FINISH	CC634-B	SIZE	D	15920
APL 90446749	DETACHED LISTS	FORM NO.	DWG NO.	90446749
		SCALE	1/1	NHA 6149644

GS CONIX DATA CORPORATION

PRINTED WIRING ASSEMBLY
(AJD-4 LOGIC BOARD (6 LAYER))

1 OF 1

ASSEMBLY PARTS LIST

90446749		B	A	D	CD ASSY 1AJD-4	CD	CC6348	09/18/85	017601	10/18/85	1/ 4		
ASSEMBLY NUMBER	REV	CL	REV	REV	ASSEMBLY DESCRIPTION	DESIGN SOURCE	PRINT LEGEND	RELEASE DATE	CHANGE ORD. NUMBER	PROCESSING DATE	PAGE NUMBER		
PWG NUMBER	REV	REV	REV	REV	PART NUMBER	QUANTITY	UNIT	PART DESCRIPTION	IN/OUT STATUS	CHANGE ORD. NUMBER	DATE EFFECTIVE	MAKE/BUY PART TYPE	PH OR N
117	A				10126400	2.00	PC	EXTERNAL TOOTH LOCK WASHERS	IN			PPP1	N
152	A				10127104	1.00	PC	SCR NACH PAN PHL 4-40	IN			PPP1	N
57	A				10130611	1.00	PC	CONNECTOR,20 CONTACT	IN			PPP4	N
83	A				15002348	1.00	PC	SW. N/PB FIG-1 PC-MTD 2PDT	IN			PPP4	N
46	A				15107884	2.00	PC	IC ASYNC COMM TYPE 8250A	IN			PPP4	N
7	A				15112100	1.00	PC	IC NE555	IN			PPP5	N
24	A				15117200	4.00	PC	I-C TTL DCRO2	IN			PPP5	N
24	A				15142600	4.00	PC	I-C 74S153	IN			PPP5	N
52	A				15144900	2.00	PC	IC TTL QUAD 2-IN NAND 74LS00	IN			PPP5	N
158	A				15145000	1.00	PC	IC TTL QUAD 2-INPUT NOR 74LS02	IN			PPP5	N
17	A				15145100	6.00	PC	IC TTL HEX INVERTER 74LS04	IN			PPP5	N
19	A				15145400	2.00	PC	IC TTL QUAD 2INPUT AND 74LS08	IN			PPP5	N
40	A				15145600	1.00	PC	IC TTL TRPL 3INPUT NAND 74LS10	IN			PPP5	N
72	A				15145800	1.00	PC	IC TTL 3-IN NAND 74LS12	IN			PPP5	N
108	A				15145900	1.00	PC	IC TTL DUAL 4INPUT NAND 74LS20	IN			PPP5	N
38	A				15146200	7.00	PC	IC TTL QUAD 2INPUT OR 74LS32	IN			PPP5	N
43	A				15146300	3.00	PC	IC TTL DUAL D-TYPE F/F 74LS74	IN			PPP5	N
45	A				15146400	1.00	PC	IC TTL QUAD 2INPUT EXC 74LS86	IN			PPP4	N
157	A				15146500	1.00	PC	IC TTL DUAL J-K MET FF 74LS112	IN			PPP5	N
146	A				15146700	2.00	PC	IC MULTI,TTL QUAD 2 74LS157	IN			PPP5	N
31	A				15146800	4.00	PC	I C TYPE 74LS161J	IN			PPP5	N
29	A				15147400	1.00	PC	IC, DECODER-STTL 74LS138	IN			PPP5	N
21	A				15148000	3.00	PC	IC TTL JK FF, DUAL 74LS109	IN			PPP5	N
62	A				15151400	1.00	PC	IC 74509	IN			PPP5	N
99	A				15154800	3.00	PC	IC 74S32	IN			PPP5	N
15	A				15158500	1.00	PC	IC-TTL QUAD 2 INPUT NOR 74S02	IN			PPP5	N
36	A				15158600	2.00	PC	I C 74S112	IN			PPP5	N
22	A				15158700	1.00	PC	IC 74S140 TTL DUAL 4INPUT GATE	IN			PPP5	N
109	A				15163311	1.00	PC	IC-74S241	IN			PPP5	N
104	A				15163322	1.00	PC	IC 74LS125	IN			PPP5	N
3	A				15163324	2.00	PC	IC 74LS245 OCTAL BUS TRANSVCR	IN			PPP5	N
6	C				15163326	2.00	PC	IC 1489A RECEIVER RS232C DTL	IN			PPP5	N
39	A				15163404	7.00	PC	MICROCIRCUIT 74LS374 TYPE	IN			PPP5	N
35	A				15163414	4.00	PC	IC 74LS244	IN			PPP5	N
32	A				15163415	2.00	PC	IC 74LS165 TYPE	IN			PPP5	N
23	A				15163418	1.00	PC	IC 74LS148 TTL 8-INPUT PRIORITY	IN			PPP5	N

A42708 REV 4-80 CDC

PRINTED IN U.S.A.

ASSEMBLY PARTS LIST

90446749		B	A	D	CD ASSY 1AJD-4	CD	CC6348	09/18/85	017601	10/18/85	2/ 4		
ASSEMBLY NUMBER	REV	CL	REV	REV	ASSEMBLY DESCRIPTION	DESIGN SOURCE	PRINT LEGEND	RELEASE DATE	CHANGE ORD. NUMBER	PROCESSING DATE	PAGE NUMBER		
PWG NUMBER	REV	REV	REV	REV	PART NUMBER	QUANTITY	UNIT	PART DESCRIPTION	IN/OUT STATUS	CHANGE ORD. NUMBER	DATE EFFECTIVE	MAKE/BUY PART TYPE	PH OR N
41	A				15163419	2.00	PC	MICROCIRCUIT 74LS393 TYPE	IN			PPP5	N
78	A				15163420	1.00	PC	IC 74LS273 FLIP-F	IN			PPP5	N
44	A				15163431	1.00	PC	I.C. TYPE 25LS2521	IN			PPP5	N
136	A				15163434	1.00	PC	74LS373 OCTAL D LATCH	IN			PPP5	N
29	A				15163439	1.00	PC	I.C.	IN			PPP5	N
50	A				15163443	1.00	PC	IC-LW311N VOLTAGE COMPARATOR	IN			PPP4	N
5	A				15163463	1.00	PC	I.C. DRIVER, TYPE 1488	IN			PPP5	N
4	A				15163471	1.00	PC	IC 6501 450MS CMOS 256X4 RAM	IN			PPP5	N
8	A				15163472	6.00	PC	IC 2114 120MS TTL 1024X4 RAM	IN			PPP5	N
12	A				15163473	1.00	PC	IC 5037 MOS/TTL CRT VIDEO T/C	IN			PPP4	N
1	A				15163480	1.00	PC	I.C. MICROPROCESSOR Z80B-CPU	IN			PPP5	N
2	A				15163481	1.00	PC	I.C. COUNTER TYPE Z80B-CTC	IN			PPP4	N
143	A				15163493	8.00	PC	IC 4164 130MS MOS 65536B DRAM	IN			PPP5	N
18	A				15163600	3.00	PC	IC 74S08	IN			PPP5	N
28	A				15164402	7.00	PC	IC 74LS257 MULTIPLEXER	IN			PPP4	N
37	A				15164421	1.00	PC	MICROCIRCUIT 74S51 DUAL 2 WIDE	IN			PPP5	N
47	A				15164427	1.00	PC	IC-8255A	IN			PPP4	N
51	A				15186640	1.00	PC	CONN RECEPT 25 POS	IN			PPP4	N
134	A				16042912	REF	PC	FAB SPEC MED LINE DBLSIDE	IN			RFE4	N
132	C				18252501	2.00	PC	SCREW LOCK CONNECTOR	IN			PPP5	N
123	C				18607904	2.00	PC	SCR TPG PAN PHL (8) 1/2L STL	IN			PPP3	N
61	C				19115400	73.00	PC	CAP, FXD CERAM 50VDC .01MFD	IN			PPP5	N
63	C				19115401	1.00	PC	CAP. FIXED CERAMIC 50VDC .1MFD	IN			PPP5	N
80	C				24500145	1.00	PC	RES FXD COMP .50W 180QHMS 5PCT	IN			PPP5	N
70	C				50240107	1.00	PC	DIODE VOLT REG	IN			PPP5	N
69	A				51007385	12.00	PC	DIODE SI 10V	IN			PPP5	N
55	A				51630901	2.00	PC	SW, SLIDE FIG-2 PC-MTD 6PDT	IN			PPP4	N
137	A				51684500	1.00	PC	XSTR, 2N4091 FLD-EFF N-TYP SI	IN			PPP4	N
67	A				51714C00	1.00	PC	XSTR-2N2907,PNP,SI TO-18	IN			PPP5	N
116	A				51847506	1.00	PC	CONNECTOR,P.C. 20 POSITION	IN			PPE4	N
92	A				51848404	2.00	PC	CONN SMT DUAL IN LINE 24 POS	IN			PPP4	N
118	A				51848405	4.00	PC	CONNECTOR SOCKET DUAL IN LINE	IN			PPP4	N
93	A				51848406	5.00	PC	CONN SMT DUAL IN LINE 40 POS	IN			PPP4	N
59	A				51860821	1.00	PC	CONN, 34POS R-ANGLE FIG-6 PCB	IN			PPP4	N
68	A				51887100	1.00	PC	TRANSISTOR NPN SI TO 18	IN			PPP4	N
54	A				51903802	7.00	PC	DIO LED SLO ST RED EPOXY	IN			PPP4	N

A42708 REV 4-80 CDC

ASSEMBLY PARTS LIST

90446749		B	A	D	CD ASSY 1AJD-4	CD	CC6348	09/18/85	017601	10/18/85	3/ 4	
ASSEMBLY NUMBER	REV	CL	BY	DATE	ASSEMBLY DESCRIPTION	DESIGN SOURCE	PART MODEL	RELEASE DATE	CHANGE ORD. NUMBER	PROCESSING DATE	PAGE NUMBER	
FINO NUMBER	REV	BY	DATE	QUANTITY	UNIT	PART DESCRIPTION	IN/OUT	CHANGE ORD. NUMBER	DATE EFFECTIVE	MAKE/BUY PART TYPE	PC	IN
135	A			1.00	PC	LED, S-S GP GRN 7.0MCD 120MW	IN			PPP4	N	
48	A			1.00	PC	OSCILLATOR TTL DIP (12.936MHZ)	IN			PPP5	N	
100				1.00	PC	OSCILLATOR	IN			PPP4	N	
58	A			1.00	PC	CONN P.C. 12POS TIN PLT	IN			PPP4	N	
53	A			1.00	PC	JACK, PNL MTG 8-CNDCT FIG-8	IN			PPP4	N	
73	A			1.00	PC	XOCR, PIEZOCERAMIC 50V FIG-1	IN			PPP4	N	
71	A			1.00	PC	CLIP, 9V BATTERY CONN FIG-1	IN			PPP4	N	
126	A			1.00	IN	BELTING ROUND	IN			PPP5	N	
155	C			1.00	PC	PLUG JUMPER	IN			PPP4	N	
60				9.00	PC	SOCKET MINI SPRING	IN			PPP4	N	
130	A			1.00	PC	F/W ASSY, PGM 2716 EPROM IC	IN			AYM4	N	
11	A			1.00	PC	C/G ASSY, PGM 2732A EPROM	IN			AYM4	N	
10	A			1.00	PC	VIKINGXM RESIDENT POSITION 1	IN			AYM4	N	
79	A			1.00	PC	VIKINGXM RESIDENT POSITION 2	IN			AYM4	N	
89	A			1.00	PC	VIKINGXM RESIDENT POSITION 3	IN			AYM4	N	
140	C			1.00	PC	SLIDE, DRAWER (PLSTC)	IN			PPP4	N	
64	D			1.00	PC	CRADLE, ROM PAK (PLSTC)	IN			PPP4	N	
107	C			1.00	PC	PLATE, I/O CONN (CRS/TIN)	IN			PPP4	N	
122	B			1.00	PC	SPACER, RESET SWITCH (PLSTC)	IN			PPP4	N	
156	B			1.00	PC	SPACER, 7.00L ACTR SW (BRSS)	IN			PPP4	N	
142	C			1.00	PC	HANDLE, LOOPBACK SW (PLSTC)	IN			PPP4	N	
105	A			1.00	PC	RESISTOR CHIP-150 OHM	IN			PPP5	N	
16	A			2.00	PC	IC 74504 SCHOTTKY TTL HEX INV	IN			PPP5	N	
27	A			1.00	PC	IC 74511 SCHOTTKY TTL TPL 3-1	IN			PPP5	N	
20	A			1.00	PC	IC 74510 SCHOTTKY TTL 3-I NAND	IN			PPP5	N	
13	A			2.00	PC	IC 74500 SCHOTTKY TTL QUAD 2-1	IN			PPP5	N	
42	A			3.00	PC	IC 74574 TTL DUAL D EDGE F/F	IN			PPP5	N	
133	C			REF	PC	SCM DIAG 1AJD-1 (MAIN LOGIC)	IN			RFE4	N	
106	D			1.00	PC	PW BD 1AJD LOG BD 6 LAYER	IN			PPP4	N	
149	A			7.00	PC	CAPACITOR-MONOLITHIC CERAMIC	IN			PPP5	N	
65	A			1.00	PC	CAP, CERAMIC, X7R, 50V 10Z	IN			PPP5	N	
66	A			15.00	PC	CAPACITOR 390 PF	IN			PPP5	N	
30	A			1.00	PC	DELAYLINE TAPPED	IN			PPP5	N	
56	A			1.00	PC	HDR, 50POS SHLD STR STY-8 PCB	IN			PPP4	N	
75	A			7.00	PC	CAP AL ELEC 100UF-10+75P 6.3V	IN			PPP4	N	
115	A			2.00	PC	CAP AL ELEC 15 UF-10+LOOP 25V	IN			PPP5	N	

AA2708 REV 4-80 CDC

ASSEMBLY PARTS LIST

90446749		B	A	D	CD ASSY 1AJD-4	CD	CC6348	09/18/85	017601	10/18/85	4/ 4	
ASSEMBLY NUMBER	REV	CL	BY	DATE	ASSEMBLY DESCRIPTION	DESIGN SOURCE	PART MODEL	RELEASE DATE	CHANGE ORD. NUMBER	PROCESSING DATE	PAGE NUMBER	
FINO NUMBER	REV	BY	DATE	QUANTITY	UNIT	PART DESCRIPTION	IN/OUT	CHANGE ORD. NUMBER	DATE EFFECTIVE	MAKE/BUY PART TYPE	PC	IN
74	A			1.00	PC	RES FXD C FM 22 OHM 5P 1/4W	IN			PPP4	N	
125	A			12.00	PC	RES FXD C FM 47 OHM 5P 1/4W	IN			PPP5	N	
98	A			1.00	PC	RES FXD C FM 56 OHM 5P 1/4W	IN			PPP4	N	
138	A			1.00	PC	RES .25W 100 OHM	IN			PPP5	N	
128	A			9.00	PC	RESISTOR 1/4 WATT	IN			PPP5	N	
76	A			1.00	PC	RESISTOR 1/4 WATT	IN			PPP5	N	
77	A			1.00	PC	RESISTOR 300 OHMS	IN			PPP5	N	
101	A			3.00	PC	RES 1/4 W 330 OHMS	IN			PPP4	N	
124	A			9.00	PC	RES 1/4W CARBON FILM 1K OHMS	IN			PPP5	N	
82	A			1.00	PC	RESISTOR-1/4W CARBON 1200 OHMS	IN			PPP5	N	
127	A			1.00	PC	RES 1.8K, CARBON FILM, .25W	IN			PPP5	N	
113	A			1.00	PC	RESISTOR 1/4 WATT	IN			PPP5	N	
84	A			1.00	PC	RES 1/4W CARBON FILM 2.7K OHMS	IN			PPP5	N	
114	A			1.00	PC	RESISTOR FIXED	IN			PPP5	N	
112	A			2.00	PC	RES CARBON FILM 3.3KOHMS .25W	IN			PPP5	N	
85	A			1.00	PC	RES 1/4W CARBON FILM 4.7K OHMS	IN			PPP5	N	
94	A			1.00	PC	RES .25 WATT CARBON FILM	IN			PPP4	N	
144	A			1.00	PC	RES Y4W CARBON FILM 8.2K	IN			PPP5	N	
129	A			1.00	PC	RES 1/4W CARBON FILM 10K OHMS	IN			PPP5	N	
88	A			2.00	PC	RES CARBON FILM 100KOHMS .25W	IN			PPP5	N	
154	A			1.00	PC	RES FXD C FM 150N OHM 5P 1/4W	IN			PPP5	N	
81	A			1.00	PC	RES 240 K CARBON FILM .25W	IN			PPP5	N	
90	A			2.00	PC	RES 1 MEG OHM .25 WATT	IN			PPP5	N	
119	C			3.60	IN	WIRE,SOL,COP,TIN,24 GA	WHT	IN		PPP5	N	
121	C			6.00	PC	DIODE	IN			PPP5	N	
33	A			1.00	PC	IC LATCH 6BIT D TYPE74LS174	IN			PPP5	N	
91	A			1.00	PC	RES NETWORK,10 PIN SIP 1000OHM	IN			PPP5	N	
49	A			1.00	PC	OSCILLATOR-HY80 CLK 6.0000 MHZ	IN			PPP4	N	

NUMBER OF LINE ITEMS = 136
HIGHEST FINO NUMBER = 158

AA2708 REV 4-80 CDC

2-58.4

62940037 B

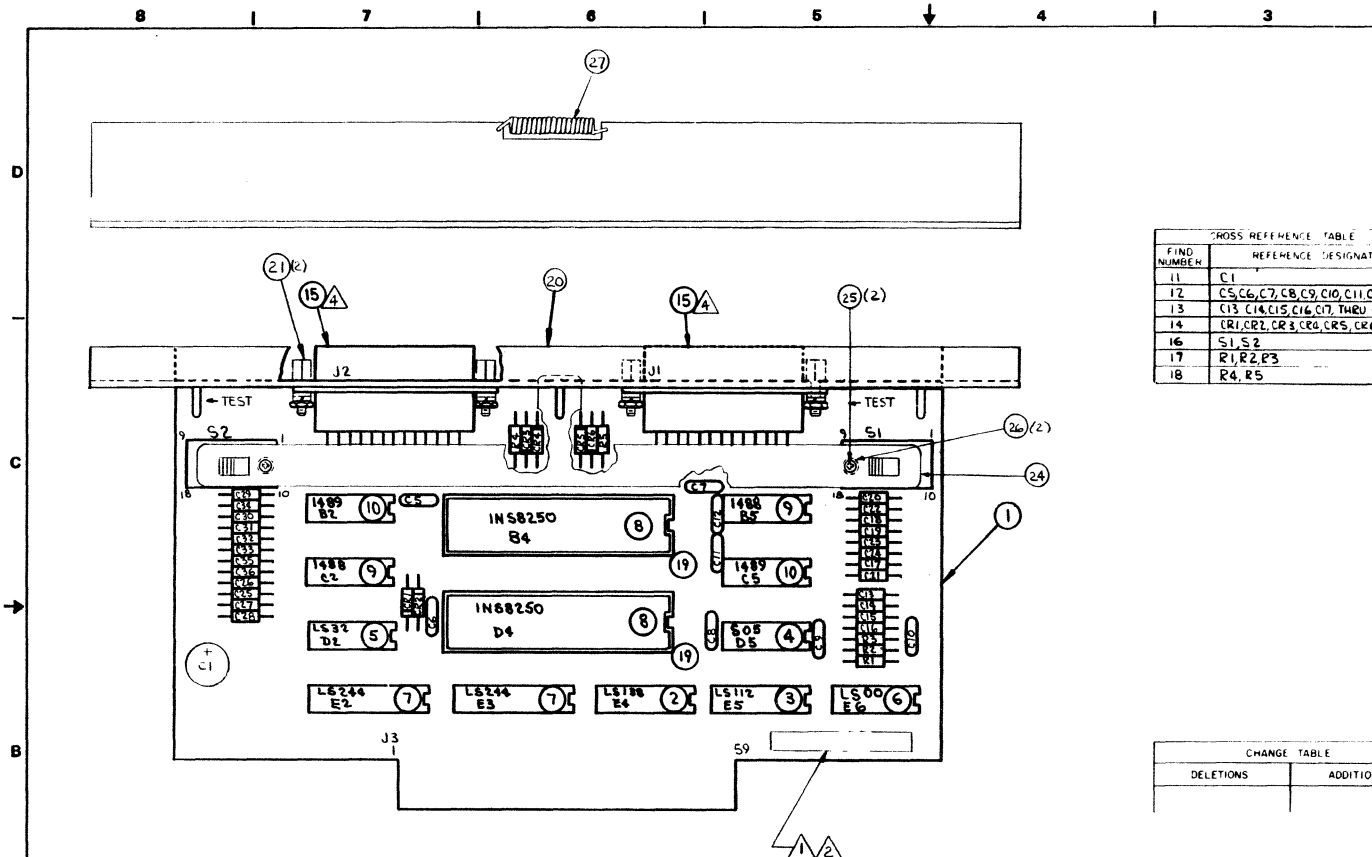

CROSS REFERENCE TABLE

FIND NUMBER	REFERENCE DESIGNATION
11	C1
12	C5, C6, C7, C8, C9, C10, C11, C12
13	C13, C14, C15, C16, C17, THRU C36
14	CR1, CR2, CR3, CR4, CR5, CR6
16	S1, S2
17	R1, R2, R3
18	R4, R5

REVISION RECORD

REV	ECO	DESCRIPTION	DATE	CHKD	APP
00	9006-34	RELEASED CLASS "B"	4/78		
01	51378	REPAIR ADD 1N1 M26 26 PIN	4/78		
02	51408	ADD PIN 27	4/78		
03	51490	C2, C3 & C4 ARE OPTIONAL	4/78		
04	51574	ENG PIN 26, 21, 17	4/78		
A	23247	RELEASED CLASS "A"	4/78		
B	15322	INACTIVE-REPLACED BY 90446335	4/78		

- NOTES:
- MARK ASSY. NO., REV LEVEL, AND LOC CODE IN AREA SHOWN. MARK PER CDC SPEC 10121508, CHARACTER HEIGHT .12 (10 PT) COLOR WHITE.
 - MARK SERIAL NUMBER IN AREA SHOWN PER RVLOPS P&P NO.80:20:34 AND PER MARKING REQUIREMENTS IN NOTE (1) ONE.
 - FIND NUMBERS, ELEMENT IDENTIFIERS, AND REFERENCE DESIGNATIONS ARE FOR REFERENCE ONLY AND DO NOT APPEAR ON PART.
 - REMOVE SCREWS AND RIGHT ANGLE BRACKET FROM CONNECTOR BODY AND DISCARD.

CHANGE TABLE

DELETIONS	ADDITIONS

INACTIVE

APL 90446335	CONTROL DATA	TITLE	
	YR101-A	P.C. CARD ASSEMBLY, 1AWD (DUAL ASYNC)	
DATE: 4/78	BY: [Signature]	CODE IDENT	DRAWING NO
REV: 01	CHKD: [Signature]	15920	D 90446335
APP: [Signature]	DATE: 4/78	SCALE: 2/1	SHEET 1 OF 1

BUILD ARC 214

ASSEMBLY PARTS LIST

PRINT DATE	PAGE	FILE CHANGE NO.
07-27-82	1	00013322

DIV.		ASSEMBLY NUMBER	CD	REV.	DWG.	DESCRIPTION	MC	STATUS	STATUS DATE	ENG. RESP.	FILE DATE		
0860		90446335	3	B	D	REPLACED BY 90446514 15322	S	INA	07-22-82	YR101A	07-27-82		
ITEM NO	LI	PART NUMBER	CD	QTY	U/M	PART DESCRIPTION	MC	YLD	ECO. NO. IN	ECO. NO. OUT	S/N	WK IN	WK OUT
001	01	90446334	6	1		PC PW 3D 1AED (DUAL ASYNC)	P						
002	01	15147400	4	1		PC IC 74LS138 563LS TTL DECODER	P						
003	01	15158600	5	1		PC IC 74S112 TTL DUAL J-K NET	P						
004	01	88914700	5	1		PC IC 74S05 TTL HEX INV	P						
005	01	15146200	9	1		PC IC 74LS32 218LS Q2INP OR	P						
006	01	15144900	6	1		PC IC 74LS00 140LS QUAD 2-INP	P						
007	01	15163414	4	2		PC IC 74LS244 OCTAL BFR 3-5 OP	P						
008	01	15163462	3	2		PC IC T8250 COMM UNIT BRAUD RATE	P						
009	01	15163463	1	2		PC IC 1488 QUAD LINE DRVR	P						
010	01	15163326	0	2		PC IC 1489A	P						
011	01	94395520	3	1		PC CAP AL ELECT 100UF 8V	P						
012	01	19115400	4	8		PC CAP FXD CER .01UF 50V 20P	P						
013	01	94240427	8	24		PC CAP CER 390PF 50V 10P	P						
014	01	95637304	7	6		PC DIO IN4004 400PIV SIL 1.1V/1A	P						
015	01	10129668	9	2		PC CONN RCPT, 25 SKT HSG PC-MTG	P						
016	01	51630901	0	2		PC SW, DT DETENTED SLIDE FIG 2	P						
017	01	94402156	7	3		PC RES FM 1K OHM 1/4W CARBON	P						
018	01	94402174	0	2		PC RES FM 5.6K OHM 1/4W CARBON	P						
019	01	51848406	8	2		PC SOCKET, IC 40 POS D-I-L TIN	P						
020	01	71493624	2	1		PC COVER OPTION BOARD	P						
021	01	18252501	4	2		PC SCREW LOCK ASSY	P						

BUILD ARC 214

ASSEMBLY PARTS LIST

PRINT DATE	PAGE	FILE CHANGE NO.
07-27-82	2	00013322

DIV.		ASSEMBLY NUMBER	CD	REV.	DWG.	DESCRIPTION	MC	STATUS	STATUS DATE	ENG. RESP.	FILE DATE		
0860		90446335	3	B	D	REPLACED BY 90446514 15322	S	INA	07-22-82	YR101A	07-27-82		
ITEM NO	LI	PART NUMBER	CD	QTY	U/M	PART DESCRIPTION	MC	YLD	ECO. NO. IN	ECO. NO. OUT	S/N	WK IN	WK OUT
022	01	16006500	9	REF		PC FABRICATION SPECIFICATION	D						
023	01	90446333	8	REF		PC SCH DIAG 1AWD	D						
024	01	71493489	0	1		PC SWI ACTUATOR ALUM	P						
025	01	10127101	3	2		PC MSCR PAN PHL 4-40X.188 STL ZP	B						
026	01	71493494	0	2		PC SPACER ACT SWI BRASS	B						
027	01	94203499	2	1		PC SPRING EXTENSION	P						
						0027 TOTAL LINES							

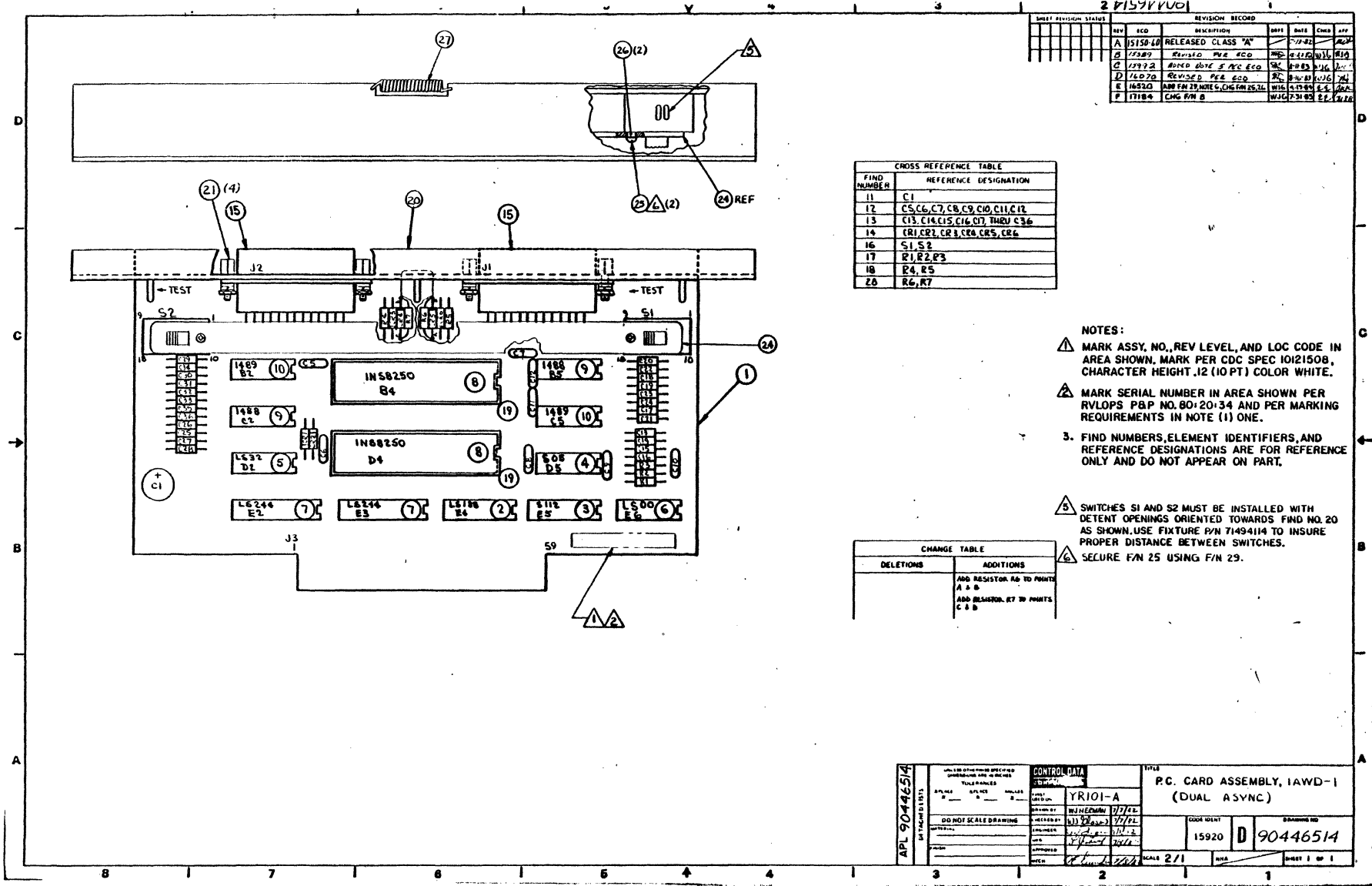

2 1597 K001

SHEET REVISION STATUS		REVISION RECORD				
REV	ECO	DESCRIPTION	DATE	CHKD	APP	
A	1515P-10	RELEASED CLASS "A"	7/7/72			
B	1528P	REVISED PWR ECO	8/1/72			
C	1529P	ADDED DATE PWR ECO	8/23/72			
D	1602P	REVISED PWR ECO	8/23/72			
E	1632P	AMP FAN 25 WIRE G. CHG FAN 25.3L	8/23/72			
F	1718P	CHG FAN B	8/23/72			

CROSS REFERENCE TABLE

FIND NUMBER	REFERENCE DESIGNATION
11	C1
12	C5, C6, C7, C8, C9, C10, C11, C12
13	C13, C14, C15, C16, C17, THRU C36
14	CR1, CR2, CR3, CR4, CR5, CR6
16	S1, S2
17	R1, R2, R3
18	R4, R5
20	R6, R7

- NOTES:
- ▲ MARK ASSY. NO., REV LEVEL, AND LOC CODE IN AREA SHOWN. MARK PER CDC SPEC IOI21508, CHARACTER HEIGHT .12 (10 PT) COLOR WHITE.
 - ▲ MARK SERIAL NUMBER IN AREA SHOWN PER RVLOPS P&P NO. 80-20-34 AND PER MARKING REQUIREMENTS IN NOTE (1) ONE.
 - 3. FIND NUMBERS, ELEMENT IDENTIFIERS, AND REFERENCE DESIGNATIONS ARE FOR REFERENCE ONLY AND DO NOT APPEAR ON PART.

- ▲ SWITCHES S1 AND S2 MUST BE INSTALLED WITH DETENT OPENINGS ORIENTED TOWARDS FIND NO 20 AS SHOWN. USE FIXTURE P/N 71494114 TO INSURE PROPER DISTANCE BETWEEN SWITCHES.
- ▲ SECURE FAN 25 USING F/M 29.

CHANGE TABLE

DELETIONS	ADDITIONS
	ADD RESISTOR A6 TO PRINTS A & B
	ADD RESISTOR R7 TO PRINTS C & D

APL 90446514

CONTROL DATA		TITLE	
DESIGNED BY	YR101-A	P.C. CARD ASSEMBLY, IAWD-1 (DUAL ASYNC)	
CHECKED BY	5/1/72	CODE IDENT	15920
DO NOT SCALE DRAWING	7/7/72	DRAWING NO	D 90446514
DATE	7/7/72	SCALE	2/1
BY		SHEET	1 OF 1

ASSEMBLY PARTS LIST

90446514	F A D	PCA 1AWD-1 (VX DUAL ASYNC)	CD	YR101A	07/29/85	D17184	08/06/85	L / 1
ASSEMBLY NUMBER	REV. CL. DT	ASSEMBLY DESCRIPTION	DESIGN SOURCE	PART VERSION	RELEASE DATE	CHANGE ORD. NUMBER	PROCESSING DATE	PAGE NUMBER

PR

FINO NUMBER	REV	PART NUMBER	QUANTITY	UNIT MEAS.	PART DESCRIPTION	IN/OUT STATUS	CHANGE ORD. NUMBER	DATE EFFECTIVE	MAKE/BUY PART TYPE	PC ON N
25	A	10127101	2.00	PC	SCR MACH PAN PHL 4-40	IN	016520	041384	PPP1	N
8	A	15107884	2.00	PC	IC ASYNC COMM TYPE 8250A	IN	017184	071985	PPP4	N
6	A	15144900	1.00	PC	IC TTL QUAD 2-IN NAND 74LS00	IN			PPP5	N
5	A	15146200	1.00	PC	IC TTL QUAD 2INPUT OR 74LS32	IN			PPP5	N
2	A	15147400	1.00	PC	IC, DECODER-STTL 74LS138	IN			PPP5	N
3	A	15158600	1.00	PC	I C 74S112	IN			PPP5	N
10	C	15163326	2.00	PC	IC 1489A RECEIVER RS232C DTL	IN			PPP5	N
7	A	15163414	2.00	PC	IC 74LS244	IN			PPP5	N
8	A	15163462	2.00	PC	MICROCIRCUIT TYPE 8250	OUT	017184	071985	PPP4	N
9	A	15163463	2.00	PC	I.C. DRIVER, TYPE 1488	IN			PPP5	N
15	A	15186840	2.00	PC	CONN RECEPT 25 POS	IN	016070	111883	PPP4	N
22	A	16006500	REF	PC	SINGL + DBL SIDED PC BD FAB SPC	IN			RFE4	N
21	C	18252501	4.00	PC	SCREW LOCK CONNECTOR	IN	015589	112682	PPP5	N
12	C	19115400	8.00	PC	CAP, FXD CERAM 50VDC .01MFD	IN			PPP5	N
16	A	51630901	2.00	PC	SW, SLIDE FIG-2 PC-MTD 6PDT	IN			PPP4	N
19	A	51848406	2.00	PC	CONN SKT DUAL IN LINE 40 POS	IN			PPP4	N
24	C	71493489	1.00	PC	SW ACTR, SM OPT BD (CRS/ZP)	IN			PPP4	N
26	B	71493494	2.00	PC	SPACER, 2.16L ACTR SW (BRS)	IN	016520	041384	PPP4	N
20	C	71493624	1.00	PC	COVER, SER OPT BD (CRS/TIN)	IN			PPP4	N
4	A	88914700	1.00	PC	IC 74S05 TTL HEX INVERTER (OC)	IN			PPP5	N
23	C	90446333	REF	PC	SCH DIAG 1AWD	IN			RFE4	N
1	D	90446334	1.00	PC	PW BD 1AWD VIK X DUAL ASYNC	IN			PPP4	N
27	C	94203499	1.00	PC	SPG, EXT .62L 4.3LB/IN MW	IN			PPP4	N
13	A	94240427	24.00	PC	CAPACITOR 390 PF	IN			PPP5	N
11	A	94395520	1.00	PC	CAP AL ELEC 100UF-10+75P 6.3V	IN			PPP4	N
17	A	94402156	3.00	PC	RES 1/4W CARBON FILM 1K OHMS	IN			PPP5	N
18	A	94402174	2.00	PC	RESISTOR CF 5.6K 5% 1/4 W	IN			PPP5	N
28	A	94402180	2.00	PC	RES 1/4W CARBON FILM 10K OHMS	IN			PPP5	N
29	A	95125321	0.01	OZ	SEALANT, LOCTITE PURPLE 222	IN	016520	041384	PPP3	N
14	C	95637304	6.00	PC	DIODE	IN			PPP5	N

NUMBER OF LINE ITEMS = 30
 HIGHEST FINO NUMBER = 29

2-62

62940037 C

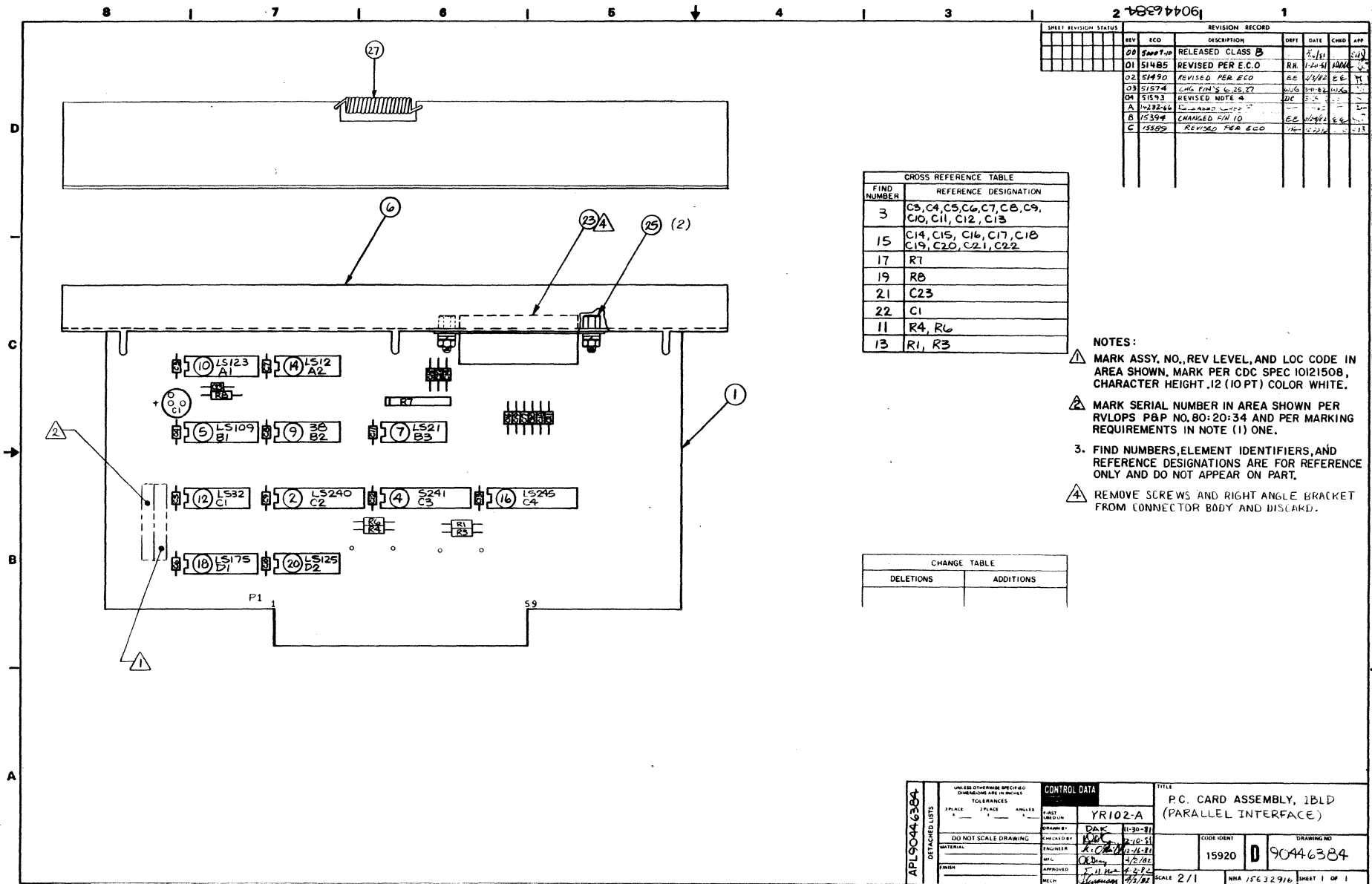

SHEET REVISION STATUS		REVISION RECORD				
REV	ECO	DESCRIPTION	DRFT	DATE	CHKD	APP
00	50007-10	RELEASED CLASS B		2/1/51		
01	51485	REVISED PER E.C.O		1/10/51	RH	
02	51490	REVISED PER ECO		2/1/52	GE	
03	51574	CHG FIN'S 6, 25, 27		10/6/52	W/G	
04	51593	REVISED NOTE 4		1/2/53	JDC	
A	1-232-45	CHANGED FIN 10		1/2/53	W/G	
B	1-334	CHANGED FIN 10		1/2/53	W/G	
C	1-335	REVISED PER ECO		1/2/53	W/G	

CROSS REFERENCE TABLE	
FIND NUMBER	REFERENCE DESIGNATION
3	C3, C4, C5, C6, C7, C8, C9, C10, C11, C12, C13
15	C14, C15, C16, C17, C18, C19, C20, C21, C22
17	R7
19	R8
21	C23
22	C1
11	R4, R6
13	R1, R3

- NOTES:
- 1. MARK ASSY. NO., REV LEVEL, AND LOC CODE IN AREA SHOWN. MARK PER CDC SPEC 10121508, CHARACTER HEIGHT .12 (10 PT) COLOR WHITE.
 - 2. MARK SERIAL NUMBER IN AREA SHOWN PER RVLOPS P&P NO. 80:20:34 AND PER MARKING REQUIREMENTS IN NOTE (1) ONE.
 - 3. FIND NUMBERS, ELEMENT IDENTIFIERS, AND REFERENCE DESIGNATIONS ARE FOR REFERENCE ONLY AND DO NOT APPEAR ON PART.
 - 4. REMOVE SCREWS AND RIGHT ANGLE BRACKET FROM CONNECTOR BODY AND DISCARD.

CHANGE TABLE	
DELETIONS	ADDITIONS

APL90446384 DETACHED LIST	UNLESS OTHERWISE SPECIFIED OR OTHERWISE INDICATED	CONTROL DATA		TITLE	
	TOLERANCES	FIRST ANGLE	YR102-A	P.C. CARD ASSEMBLY, 1BLD (PARALLEL INTERFACE)	
	SPALLS 1/16 PLACES 1/16 ANGLES 1/16	DRAWN BY: DAK 11-30-51	CHECKED BY: KDC 2-10-51	CODE IDENT	DRAWING NO
	DO NOT SCALE DRAWING	ENGINEER: R.C. 11-16-51	APPROVED: E.J. 11-16-51	15920	D 90446384
MATERIAL:	MPL: 4/2/52	APPROVED: E.J. 11-16-51	SCALE 2/1	NHA 15632976	SHEET 1 OF 1
FINISH:	MEL: 1/3/52				

BUILD ARC 214

ASSEMBLY PARTS LIST

PRINT DATE	PAGE	FILE CHANGE NO.
11-29-82	1	00015589

DIV.		ASSEMBLY NUMBER	CD	REV.	DWG.	DESCRIPTION	MC	STATUS	STATUS DATE	ENG. RESP.	FILE DATE		
0860		90446384	1	C	D	PCA 18LD (VX PARALLEL I/F)	S	REL	04-05-82	YR102A	11-29-82		
TRND NO	LI	PART NUMBER	CD	QTY	U/M	PART DESCRIPTION	MC	YLD	ECO. NO. IN	ECO. NO. OUT	S/N	WK IN	WK OUT
001	01	90446383	3	1		PC PWB 18LD (VX PARALLEL I/F)	P						
002	01	15163433	4	1		PC IC 74LS240 TTL 8 INVT BUFFER	P						
003	01	19115400	4	11		PC CAP FXD CER .01UF .80-20P 50V	P						
004	01	15163311	2	1		PC IC 74S241 OCTAL BUS DRIVER	P						
005	01	15148000	1	1		PC IC 74LS109 TTL DUAL JK F/F	P						
006	01	71493625	9	1		PC COVER, PRL OPT BD (CRS/TIN)	P						
007	01	15163457	3	1		PC IC 74LS21 TTL 2 4IN AND	P						
009	01	15158300	2	1		PC IC 7438 204 TTL 4 2IN NAND BF	P						
010	01	50254300	2	1		PC IC 74123 193 TTL 2 RETOR MVB	P		15396	15396		8235	
010	02	15163422	7	1		PC IC 74LS123 TTL DUAL MVB	P					8235	
011	01	94402142	7	2		PC RES FXD C FM 270 OHM 5P 1/4W	P						
014	01	15146200	9	1		PC IC 74LS32 218LS TTL 4 2IN OR	P						
015	01	94402138	5	2		PC RES FXD C FM 180 OHM 5P 1/4W	P						
014	01	15145800	7	1		PC IC 74LS12 230LS TTL 3 3IN NND	P						
015	01	94240427	8	9		PC CAP FXD CER 390PF 10P 50VDCW	P						
016	01	15163324	5	1		PC IC 74LS245 TTL 8 BUS XCEIVER	P						
017	01	91938536	9	1		PC RES 8PIN SIP 1000 OHM 2P 1.1W	P						
018	01	15146900	4	1		PC IC 74LS175 520LS TTL 4B LATCH	P						
019	01	94402204	5	1		PC RES FXD C FM 100K OHM 5P 1/4W	P						
020	01	15163322	9	1		PC IC 74LS125 TTL 4 BUS BUFFER	P						
021	01	94240430	2	1		PC CAP FXD CER 1200PF 10P 50VDCW	P						

BUILD ARC 214

ASSEMBLY PARTS LIST

PRINT DATE	PAGE	FILE CHANGE NO.
11-29-82	2	00015589

DIV.		ASSEMBLY NUMBER	CD	REV.	DWG.	DESCRIPTION	MC	STATUS	STATUS DATE	ENG. RESP.	FILE DATE		
0860		90446384	1	C	D	PCA 18LD (VX PARALLEL I/F)	S	REL	04-05-82	YR102A	11-29-82		
TRND NO	LI	PART NUMBER	CD	QTY	U/M	PART DESCRIPTION	MC	YLD	ECO. NO. IN	ECO. NO. OUT	S/N	WK IN	WK OUT
022	01	94395520	3	1		PC CAP AL ELEC 100UF+10-75P 6.3V	P						
023	01	10130668	6	1		PC CONN PLUG, 25POS R=MA PC=MTG	P						
024	01	90446382	5	REF		PC SCH DIA8 18LD	D						
025	01	18252501	4	1		PC SCR=LOCK, CONNECTOR CONFIG=8	P		15589	15589		8248	8248
025	02	18252501	4	2		PC SCR=LOCK, CONNECTOR CONFIG=8	P					8248	
026	01	16006500	9	REF		PC FABRICATION SPECIFICATION	D						
027	01	94203499	2	1		PC SP8, EXT .62L 4x3LB/IN MW	P						
						0028 TOTAL LINES							

2-64

62940037 C

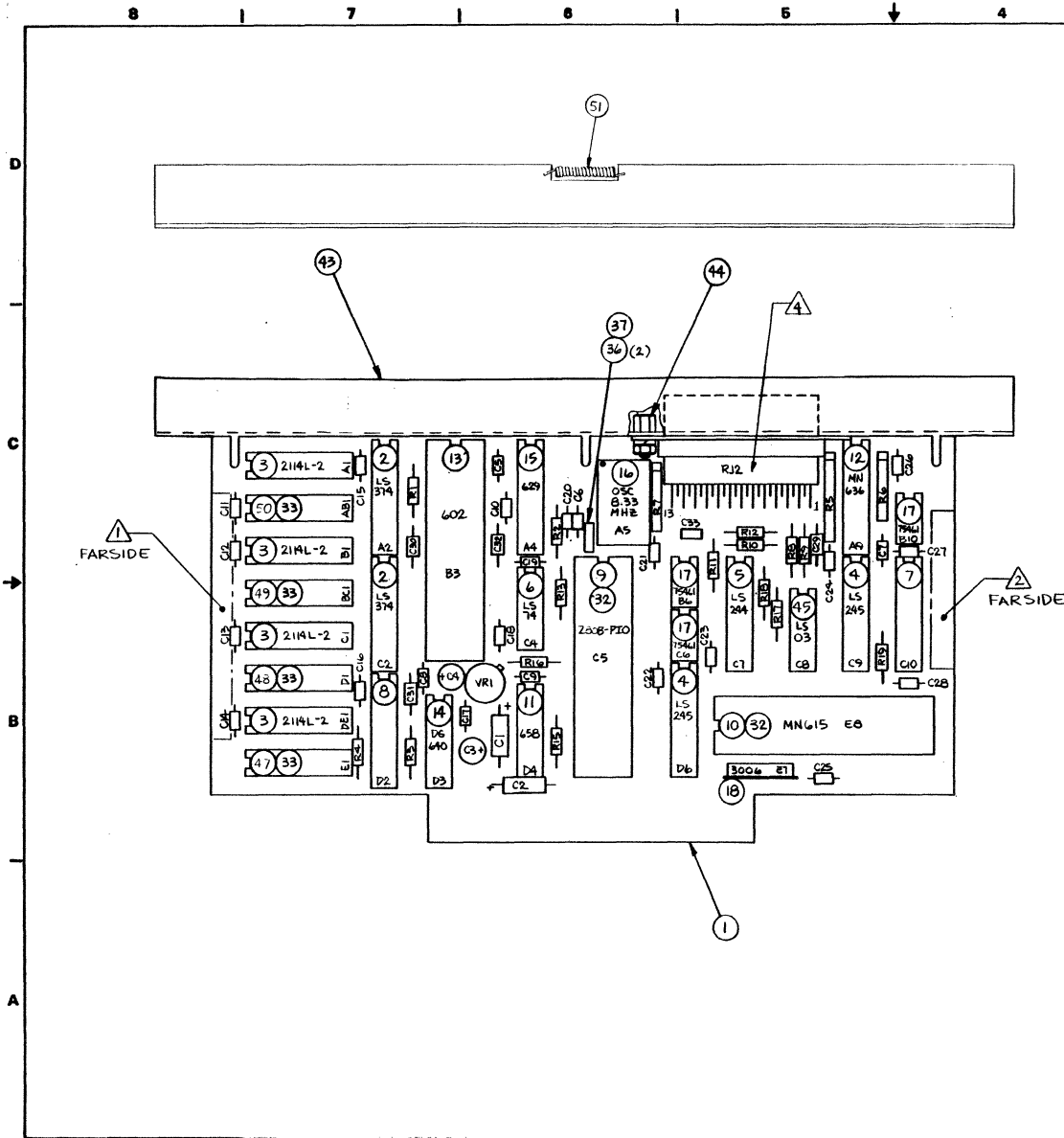

SHEET REVISION STATUS		REVISION RECORD			
REV	ECO	DESCRIPTION	DATE	CHKD	APP
00	5/6/72	RELEASED CLASS "B"			
01	5/19/72	REVISED TO 30, 47, 51	5/19/72		
02	5/19/72	REVISED PER ECO	5/19/72		
03	5/19/72	ENG. P.N. 16	5/19/72		
04	5/19/72	ENG. I.N.D. NOTE 2	5/19/72		

CROSS REFERENCE TABLE	
FIND NUMBER	REFERENCE DESIGNATION
19	R8, R9
20	R15, R16
21	R4, R3
22	R1, R2, R13
23	R17, R18
24	VR1
25	C29, C30, C31, C32
26	C1
27	C3
28	C4
29	C5, C6, C7 THRU C28
30	R5
31	R7, R6
34	R32
40	C2
41	C33
42	R19
46	R10, R11, R12

- NOTES:
- 1. APPLY ASSY NO., REV. LEVEL, AND LOC. CODE IN AREA SHOWN. MARK PER CDC SPEC 10121508; CHARACTER HEIGHT .12 (12 PT) COLOR WHITE.
 - 2. MARK SERIAL NO. IN AREA SHOWN PER CDC SPEC 10121508; .12 HEIGHT, COLOR WHITE.
 - 3. FIND NUMBERS, ELEMENT IDENTIFIERS AND REFERENCE DESIGNATIONS ARE FOR REFERENCE ONLY AND DO NOT APPEAR ON PART.
 - 4. KEY CONNECTION BY BREAKING OFF APPROPRIATE PIN: R12 - PIN 10.

CHANGE TABLE	
DELETIONS	ADDITIONS
CUT FOIL:	ADD WIRE:

APL 504639	UNLESS OTHERWISE SPECIFIED ALL DIMENSIONS ARE IN INCHES		TOLERANCES		CONTROL DATA		TITLE	
	SPRUE	PLATE	ANGLES	FRACTIONAL	VA-C3-A	P.C. CARD ASSEMBLY, ICCD RIGID DISK INTERFACE		
	DO NOT SCALE DRAWING		DATE:	DESIGNED BY:	DATE:	1-3-72	CODE IDENT	D
DRAWN:		DATE:	ENGINEER:	DATE:	5-25-72	15920		90446439
CHECKED:		DATE:	APPROVED:	DATE:	2-2-72	SCALE 2/1		
MATERIAL:		DATE:	DATE:	DATE:	2-2-72	NHA 3-3-147 SHEET 1 OF 1		

BUILD ARC 210

ASSEMBLY PARTS LIST

PRINT DATE: 02-23-83
PAGE: 1
FILE CHANGE NO.: 15152-27

DIV.	ASSEMBLY NUMBER	CD	REV.	DWG.	DESCRIPTION	MC	STATUS	STATUS DATE	ENG. RESP.	FILE DATE				
0860	90446439	3	A	D	PC CD ASSY ICCD RIGID DISK	A	REL	02-15-83	XA363A	02-23-83				
FOUND NO.	LI	PART NUMBER	CD	REV.	QTY	U/M	PART DESCRIPTION	MC	YLD	ECO. NO. IN	ECO. NO. OUT	S/N	WK IN	WK OUT
001	01	90446438	5		1		PC PW 8D ICCD	P						
002	01	15163404	5		2		PC IC 74LS374 TTL 8 D FLIP/FLOP	P						
003	01	15163472	2		4		PC IC 2114 120NS TTL 1024X4 RAM	P						
004	01	15163324	5		2		PC IC 74LS245 TTL 8 BUS XCEIVER	P						
005	01	15163414	4		1		PC IC 74LS244 TTL 8 3-STATE DRVR	P						
006	01	15146300	7		1		PC IC 74LS74 175LS TTL 2 D F/F	P						
007	01	66328345	5		1		PC FIRMWARE CONTROL	G						
008	01	66328347	1		1		PC FIRMWARE CONTROL	G						
009	01	15107883	9		1		PC IC, Z80B-P10,Z8420B PROG	P						
010	01	15163486	2		1		PC IC MN615 MOS I/O CONTROLLER	P						
011	01	15163488	8		1		PC IC MN658 DUAL 3-IN AND GATE	P						
012	01	15163487	0		1		PC IC MN636 5BT I/O CNTLR XCVR	P						
013	01	15107880	5		1		PC IC, MN602,16BIT	P						
014	01	15107881	3		1		PC IC, MN640 DUAL 3-I/P+GATE	P						
015	01	15107882	1		1		PC IC, MN629 CPU I/O TRANSCEIVER	P						
016	01	51904118	0		1		PC OSCILLATOR	P						
017	01	15161600	0		3		PC IC 75461 TTL DUAL	P						
018	01	15163354	2		1		PC IC MH 3006 Z80 CLOCK DRIVER	P						
019	01	94360258	1		2		PC RES FXD FM 402 OHM 1P 1/4W	P						
020	01	94402118	7		2		PC RES FXD C FM 27 OHM 5P 1/4W	P						
021	01	94360268	0		2		PC RES FXD FM 511 OHM 1P 1/4W	P						

BUILD ARC 210

ASSEMBLY PARTS LIST

PRINT DATE: 02-23-83
PAGE: 2
FILE CHANGE NO.: 15152-27

DIV.	ASSEMBLY NUMBER	CD	REV.	DWG.	DESCRIPTION	MC	STATUS	STATUS DATE	ENG. RESP.	FILE DATE				
0860	90446439	3	A	D	PC CD ASSY ICCD RIGID DISK	A	REL	02-15-83	XA363A	02-23-83				
FOUND NO.	LI	PART NUMBER	CD	REV.	QTY	U/M	PART DESCRIPTION	MC	YLD	ECO. NO. IN	ECO. NO. OUT	S/N	WK IN	WK OUT
022	01	94402156	7		3		PC RES FXD C FM 1.0K OHM 5P 1/4W	P						
023	01	94402173	2		2		PC RES FXD C FM 5.1K OHM 5P 1/4W	P						
024	01	15130400	3		1		PC IC 7905/320-5 354A NEG V RGLT	P						
025	01	94240419	5		4		PC CAP FXD CER 47PF 10P 50VDCW	P						
026	01	24504362	5		1		PC CAP FXD TANT 3.3UF 20P 15VDCW	P						
027	01	94259906	9		1		PC CAP TANT ELECT 1.0 UF 30P	P						
028	01	94259908	5		1		PC CAP TANT ELECT 2.2UF .24AWG	P						
029	01	19115400	4		24		PC CAP FXD CER .01UF +80-20P 50V	P						
030	01	94375180	0		1		PC RES 8SIP NTWK 390 OHMS	P						
031	01	91938415	6		2		PC RES 130 OHMS 6PIN	P						
032	01	51848406	8		2		PC SOCKET, IC 40-POS DIL F-1 SN	P						
033	01	51848402	7		4		PC SOCKET, IC 18-POS DIL F-1 SN	P						
034	01	10130668	6		1		PC CONN PLUG, 25POS R-A PC-MTG	P						
036	01	51903400	3		2		PC PIN, .025 IN SQ PC MTG 2A	P						
037	01	77612624	5		1		PC CONNECTOR, JUMPER	P						
038	01	90446437	7		REF		PC SCH DIAG ICCD RIGID DISK ADP!	D						
039	01	16042912	2		REF		PC FAB SPEC MED LINE OBLSIDE	D						
040	01	24504312	0		1		PC CAP FXD TANT 6.8UF 20P 6VDC	P						
041	01	77830562	3		1		PC CAP .22UF 25V CASE A	P						
042	01	94402149	2		1		PC RES FXD C FM 510 OHM 5P 1/4W	P						
043	01	71493443	7		1		PC COVER	P						

BUILD ARC 210

ASSEMBLY PARTS LIST

PRINT DATE	PAGE	FILE CHANGE NO.
02-23-83	3	15152-27

DIV.	ASSEMBLY NUMBER	CD	REV.	DWG.	DESCRIPTION	MC	STATUS	STATUS DATE	ENG. RESP.	FILE DATE			
0860	90446439	3	A	0	PC CD ASSY ICCD RIGID DISK	A	REL	02-15-83	XA363A	02-23-83			
LINE NO.	LI	PART NUMBER	CD	QTY	U/M	PART DESCRIPTION	MC	TLD	ECO. NO. IN	ECO. NO. OUT	S/N	WK IN	WK OUT
044	01	18252501	4	2		PC SCR-LOCK, CONNECTOR CONFIG=8							
045	01	15145200	0	1		PC IC 74LS03 202LS TTL 4 2-I NAND							
046	01	94402132	8	3		PC RES FXD C FM 100 OHM SP 1/4W							
047	01	66328245	7	1		PC FIRMWARE RESIDENT							
048	01	66328246	5	1		PC FIRMWARE RESIDENT							
049	01	66328247	3	1		PC FIRMWARE RESIDENT							
050	01	66328248	1	1		PC FIRMWARE RESIDENT							
051	01	94203499	2	1		PC SP6, EXT .62L 4.3LB/IN MW							
						0050 TOTAL LINES							

62940037 H

2-66.1/2-66.2

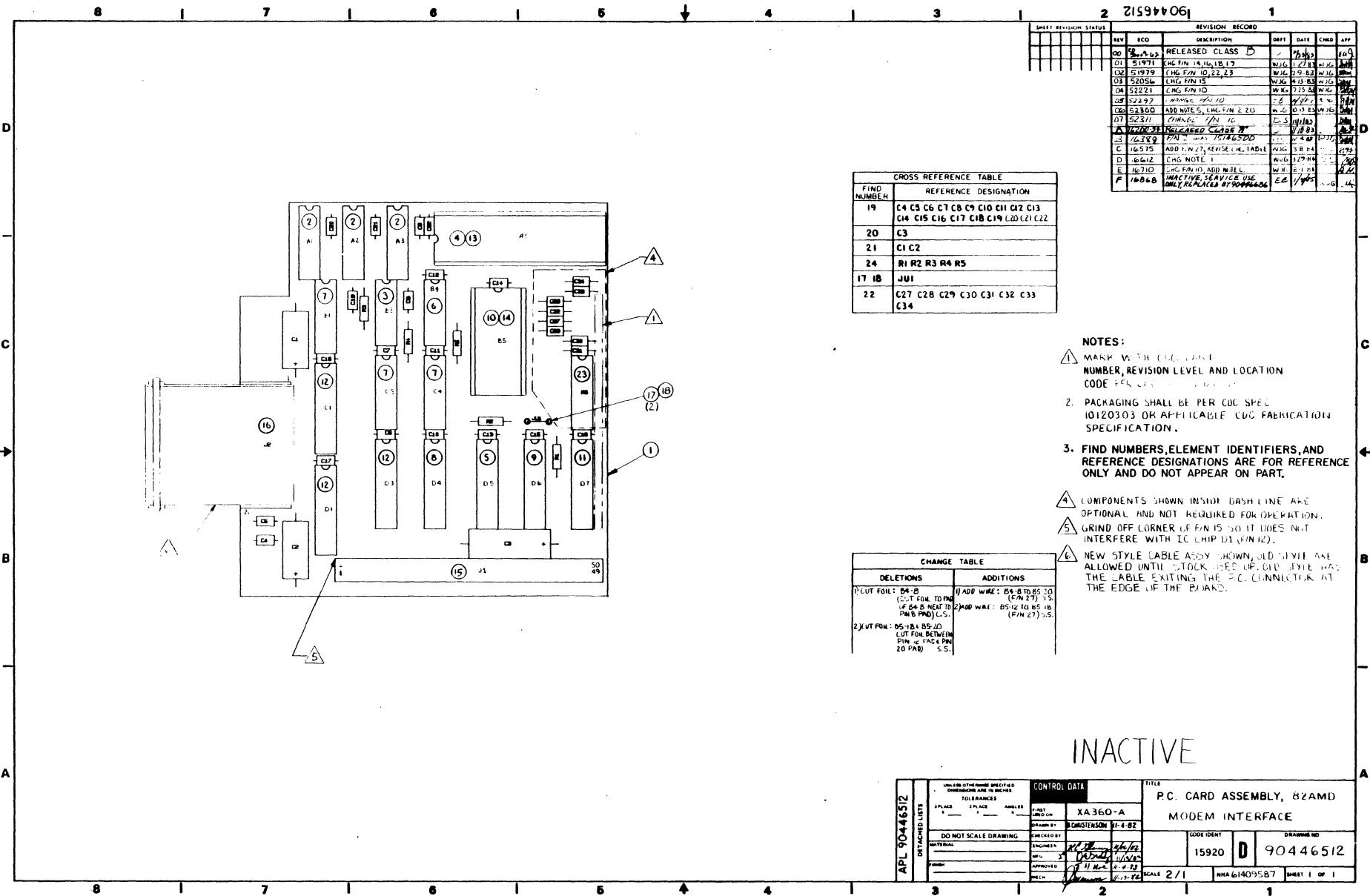

SHEET REVISION STATUS		REVISION RECORD			
REV	ECO	DESCRIPTION	BY	DATE	CHKD APP
00	1634	RELEASED CLASS B	WJG	7/28/82	WJG
01	51971	CHG FIN 18 TO 18.17	WJG	12/8/82	WJG
02	51979	CHG FIN 10, 22, 23	WJG	7/5/83	WJG
03	52056	CHG FIN 15	WJG	4/18/83	WJG
04	52221	CHG FIN 10	WJG	7/25/83	WJG
05	52297	CHANGE FIN 10	WJG	7/27/83	WJG
06	52300	ADD NOTE 5, CHG FIN 2, 20	WJG	8/17/83	WJG
07	52311	CHANGE FIN 10	WJG	8/18/83	WJG
A	1010031	RELEASED CLASS B	WJG	7/18/83	WJG
B	16389	FIN - WAS TOTAL 5000	WJG	2/24/87	WJG
C	16575	ADD I.N. 27, REVISE I.N. TABLE	WJG	3/8/84	WJG
D	16612	CHG NOTE 1	WJG	3/29/84	WJG
E	16710	CHG FIN 10, ADD MILL	WJG	5/17/84	WJG
F	18868	INACTIVE SERVICE USE ONLY, REPLACED BY 90446512	WJG	1/19/87	WJG

FIND NUMBER	REFERENCE DESIGNATION
19	C4 C5 C6 C7 C8 C9 C10 C11 C12 C13 C14 C15 C16 C17 C18 C19 C20 C21 C22
20	C3
21	C1 C2
24	R1 R2 R3 R4 R5
17 18	JU1
22	C27 C28 C29 C30 C31 C32 C33 C34

- NOTES:**
- 1. MARK WITH ELEMENT NUMBER, REVISION LEVEL AND LOCATION CODE PER *PCB FABRICATION SPECIFICATION*.
 - 2. PACKAGING SHALL BE PER CDC SPEC 10120303 OR APPLICABLE CDC FABRICATION SPECIFICATION.
 - 3. FIND NUMBERS, ELEMENT IDENTIFIERS, AND REFERENCE DESIGNATIONS ARE FOR REFERENCE ONLY AND DO NOT APPEAR ON PART.
 - 4. COMPONENTS SHOWN INSIDE DASH LINE ARE OPTIONAL AND NOT REQUIRED FOR OPERATION.
 - 5. GRIND OFF CORNER OF FIN 15 SO IT DOES NOT INTERFERE WITH IC CHIP 13 (FIN 12).
 - 6. NEW STYLE LABEL ASSEMBLY SHOWN, OLD STYLE ARE ALLOWED UNTIL STOCK USED UP. OLD STYLE HAS THE LABEL EXITING THE P.C. CONNECTOR AT THE EDGE OF THE BOARD.

DELETIONS	ADDITIONS
1. CUT FOL: D4-D (CUT FOL TO PAD IF 64-B NEXT TO PIN 8 PAD) C.S.	1. ADD WIRE: 64-B TO 65-20 (FIN 27) >S.
2. CUT FOL: D5-18A-85-20 CUT FOL BETWEEN PIN 14 PAD & PIN 20 PAD) S.S.	2. ADD WIRE: 85-16 TO 85-18 (FIN 27) >S.

INACTIVE

APL 90446512 ATTACHED LISTS	UNLESS OTHERWISE SPECIFIED DIMENSIONS ARE IN DECIMALS		CONTROL DATA		TITLE	
	TOLERANCES		PART AND OR		P.C. CARD ASSEMBLY, 82AMD	
	FINISH	DO NOT SCALE DRAWING	APPROVED BY	DATE	SCALE	REV
	APPROVED	DATE	DATE	DATE	SCALE	REV
DRAWN BY: CHRISTENSON W-4-82			CHECKED BY: [Signature]		CODE IDENT: 15920 D	
DRAWING NO: 90446512			DRAWING NO: 90446512		SHEET 1 OF 1	

ASSEMBLY PARTS LIST

BUILD ARC 214										PRINT DATE		PAGE		FILE CHANGE NO.		
										12-04-84		1		00016868		
										STATUS DATE		ENG. RESP.		FILE DATE		
										11-19-84		XA360A		12-04-84		
										ECO. NO. IN		ECO. NO. OUT		S/N		
										16389		16389		9331		
0860	ASSEMBLY NO.	CD	REV.	DWG.	DESCRIPTION					MC	STATUS					
	90446512	7	F	D	REPLACED BY 90446666 16868					5	INA					
TRND NO.	U	PART NO.	CD	QTY	U/M	PART DESCRIPTION				MC	YLD	ECO. NO. IN	ECO. NO. OUT	S/N	WK IN	WK OUT
001	01	90446511	9	1		PC PWB 82AMD (MODEM INTERFACE)				P						
002	02	15146500	2	3		PC IC 74LS112 243LS TTL DUAL F/F				P		16389	16389			8331
002	03	15158603	5	3		PC IC 74LS112 243S TTL 2 J-K F/F				P						
003	01	15151900	6	1		PC IC 74S09 229S TTL 4 2IN AND				P						
004	01	15163462	3	1		PC IC 8250 MOS/TTL ASYNC CCM				P						
005	01	15163324	5	1		PC IC 74LS245 TTL 8 BUS XCEIVER				P						
006	01	15144900	6	1		PC IC 74LS00 14GLS TTL 4 2IN NND				P						
007	01	15147400	4	3		PC IC 74LS138 563LS TTL 1-8 DCDR				P						
008	01	15163414	4	1		PC IC 74LS244 TTL 8 3-STATE DRVR				P						
009	01	15163311	2	1		PC IC 74S241 GCTAL BUS DRIVER				P						
010	01	66315374	0	1		PC REPLACED BY 66315377 16710				G		16710	16710			8425
010	02	66315377	3	1		PC REPLACED BY 66315378 16974				G		16710				8425
011	01	15163433	4	1		PC IC 74LS240 TTL 8 INVT BUFFER				P						
012	01	15163404	5	3		PC IC 74LS374 TTL 8 D FLIP/FLOP				P						
013	01	51848406	8	1		PC SOCKET, IC 40-POS DIL F-1 5M				P						
014	01	51848404	3	1		PC SOCKET, IC 24-POS DIL F-1 5M				P						
015	01	94394721	8	1		PC HEADER 2X25 POSITIONS T TY KD				P						
016	01	61409588	3	1		PC CBL ASSY, I/F CARD TO MODEM				G						
017	01	65832100	5	2		PC SKT. MINI-SPG .018-.020 5M/5M				P						
018	01	24501906	4	100		FT WIRE, BUSS 24AWG SOLID CU/SN				W						
019	01	19115400	4	19		PC CAP FXD CER .01UF +80-20P 50V				P						
020	01	24504356	7	1		PC CAP FXD TANT 100UF 20P 10VDCW				P						

ASSEMBLY PARTS LIST

BUILD ARC 214										PRINT DATE		PAGE		FILE CHANGE NO.		
										12-04-84		2		00016868		
										STATUS DATE		ENG. RESP.		FILE DATE		
										11-19-84		XA360A		12-04-84		
										ECO. NO. IN		ECO. NO. OUT		S/N		
										16575		16575		8409		
0860	ASSEMBLY NO.	CD	REV.	DWG.	DESCRIPTION					MC	STATUS					
	90446512	7	F	D	REPLACED BY 90446666 16868					5	INA					
TRND NO.	U	PART NO.	CD	QTY	U/M	PART DESCRIPTION				MC	YLD	ECO. NO. IN	ECO. NO. OUT	S/N	WK IN	WK OUT
021	01	94400512	1	2		PC CAP AL FLEC 15UF-10+100P 25V				P						
022	01	94240422	9	REF		PC CAP FXD CER 120PF 10P 50VDCW				P						
023	01	75738604	0	REF		PC RES 16PIN DIP 110 R 2P 1.5W 1P				P						
024	01	94402160	9	5		PC RES FXD C FM 1.5K OHM 5P 1/4W				P						
025	01	16042912	2	REF		PC FAB SPEC MED LINE DBLSIDE				D						
026	01	90446510	1	REF		PC SCH DIAG 82AMD				D						
027	01	52629949	0	400		FT WIR 30GA SLD WH WHT UL KYNAR				W		16575	16575			8409
										0029 TOTAL LINES						

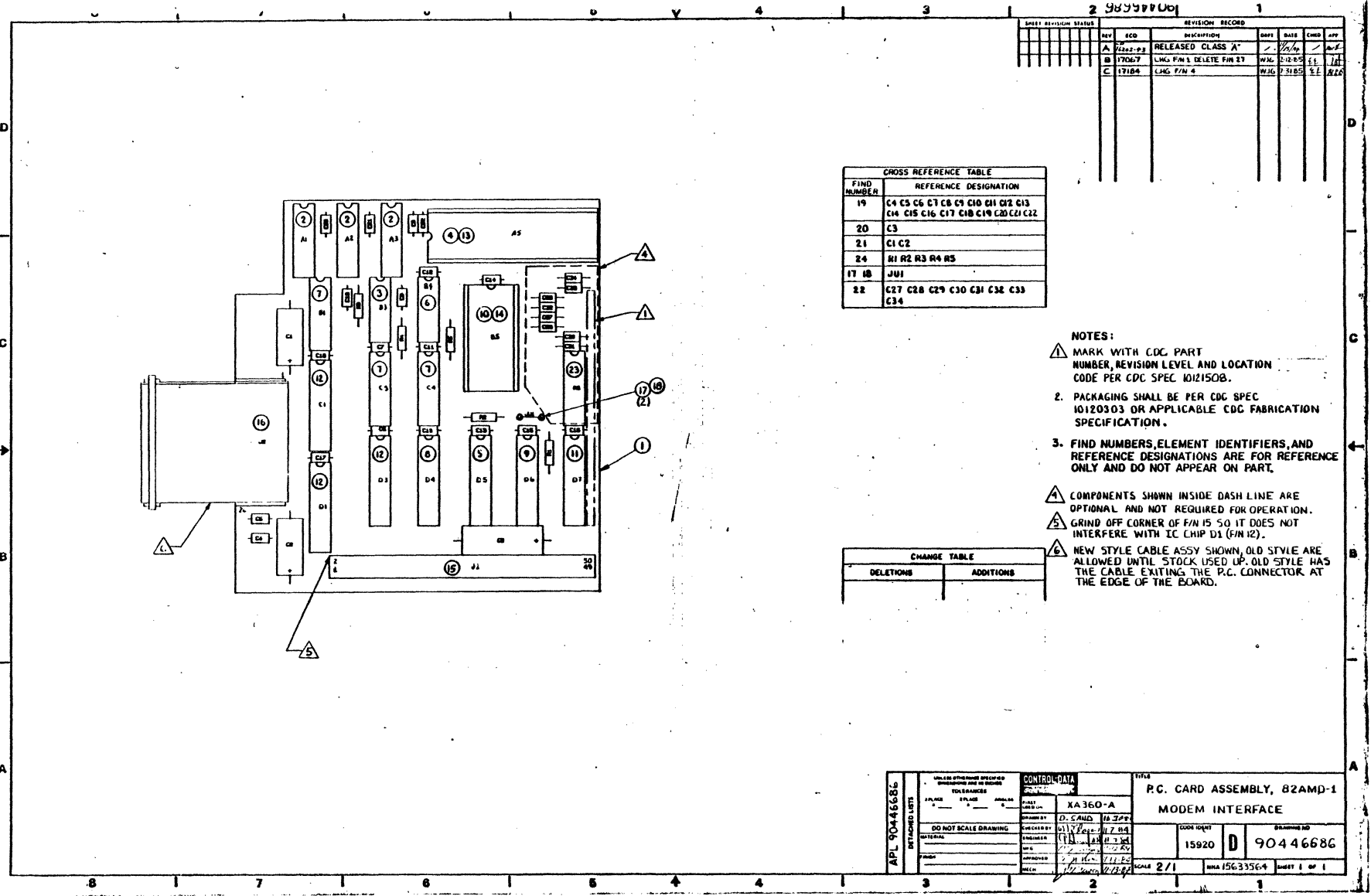

SHEET REVISION STATUS		REVISION RECORD				
REV	ECO	DESCRIPTION	DRFT	DATE	CHKD	APP
A	2202-03	RELEASED CLASS 'A'		7/1/64		
B	17067	LMG F/W 1 DELETE F/W 27		7/12/65	EE	JH
C	17184	LMG F/W 4		7/31/65	EE	JH

CROSS REFERENCE TABLE	
FIND NUMBER	REFERENCE DESIGNATION
19	C4 C5 C6 C7 C8 C9 C10 C11 C12 C13 C14 C15 C16 C17 C18 C19 C20 C21 C22
20	C3
21	C1 C2
24	R1 R2 R3 R4 R5
17 18	JU1
22	C27 C28 C29 C30 C31 C32 C33 C34

- NOTES:**
- 1. MARK WITH CDC PART NUMBER, REVISION LEVEL AND LOCATION CODE PER CDC SPEC 1012150B.
 - 2. PACKAGING SHALL BE PER CDC SPEC 10120303 OR APPLICABLE CDC FABRICATION SPECIFICATION.
 - 3. FIND NUMBERS, ELEMENT IDENTIFIERS, AND REFERENCE DESIGNATIONS ARE FOR REFERENCE ONLY AND DO NOT APPEAR ON PART.
 - 4. COMPONENTS SHOWN INSIDE DASH LINE ARE OPTIONAL AND NOT REQUIRED FOR OPERATION.
 - 5. GRIND OFF CORNER OF F/W IS 50 IT DOES NOT INTERFERE WITH IC CHIP D1 (F/W 12).
 - 6. NEW STYLE CABLE ASSY SHOWN, OLD STYLE ARE ALLOWED UNTIL STOCK USED UP. OLD STYLE HAS THE CABLE EXITING THE P.C. CONNECTOR AT THE EDGE OF THE BOARD.

CHANGE TABLE	
DELETIONS	ADDITIONS

APL 90446686 DRAWING LIST	CHECKED BY: [Signature]		CONTROL DATA		TITLE	
	DO NOT SCALE DRAWING		PART NUMBER: XA360-A		P.C. CARD ASSEMBLY, 82AMP-1 MODEM INTERFACE	
	MATERIAL: 15920		DRAWN BY: [Signature]		DRAWING NO: 90446686	
	DATE: 7/1/64		CHECKED BY: [Signature]		SCALE: 2/1	

ASSEMBLY PARTS LIST

90446686	C	A	D	CD ASSY 82AMD-1 MODEM I/F	CD	KA360A	07/29/85	017184	08/06/85	1/ 1
ASSEMBLY NUMBER	REV	CL	OP	ASSEMBLY DESCRIPTION	DESIGN SOURCE	FIRST USAGE	RELEASE DATE	CHANGE ORD. NUMBER	PROCESSED DATE	PAGE NUMBER

PR

FIND NUMBER	OP	PART NUMBER	QUANTITY	UNIT	PART DESCRIPTION	IN/OUT	CHANGE ORD.	DATE	WAS/IS	PH	Q
NUMBER	SE			MEAS.		STATUS	NUMBER	EFFECTIVE	PART TYPE	INC	TY
4	A	15107884	1.00	PC	IC ASYNC COMM TYPE 8250A	IN	017184	071985	PPP4		N
6	A	15144900	1.00	PC	IC TTL QUAD 2-IN NAND 74LS00	IN			PPP5		N
7	A	15147400	3.00	PC	IC, DECODER-STTL 74LS138	IN			PPP5		N
3	A	15151900	1.00	PC	IC 74509	IN			PPP4		N
2	A	15158600	3.00	PC	I C 74S112	IN			PPP5		N
9	A	15163311	1.00	PC	IC-74S241	IN			PPP5		N
5	A	15163324	1.00	PC	IC 74LS245 OCTAL BUS TRANSCVR	IN			PPP5		N
12	A	15163404	3.00	PC	MICROCIRCUIT 74LS374 TYPE	IN			PPP5		N
8	A	15163414	1.00	PC	IC 74LS244	IN			PPP5		N
11	A	15163433	1.00	PC	I.C.74LS240	IN			PPP5		N
4	A	15163462	1.00	PC	MICROCIRCUIT TYPE 8250	OUT	017184	071985	PPP4		N
25	A	16042912	REF	PC	FAB SPEC MED LINE DRLSIDE	IN			RFE4		N
19	C	19115400	19.00	PC	CAP, FXD CERAM 50VDC .01MFD	IN			PPP5		N
18	C	24501806	1.20	IN	WIRE ELECT SOLID COPPER 24 GA	IN			PPP2		N
20	C	24504356	1.00	PC	CAP FXD TANT 100 UF 10 WVDC	IN			PPP5		N
14	A	51848404	1.00	PC	CONN SKT DUAL IN LINE 24 POS	IN			PPP4		N
13	A	51848406	1.00	PC	CONN SKT DUAL IN LINE 40 POS	IN			PPP4		N
27	C	52629949	4.80	IN	WIRE ELEC 30 GA WHITE	OUT	017067	051785	PPP5		N
16	A	61409588	1.00	PC	CABLE	IN			AYM4		N
17		65832100	2.00	PC	SOCKET MINI SPRING	IN			PPP4		N
10	A	66315378	1.00	PC	VIKINGXM RESIDENT POS	IN			AYM4		N
23	A	75738604	REF	PC	RESISTOR MODULE 110 OHMS	IN			PPP4		N
26	C	90446510	REF	PC	SCH DIAG 82AMD	IN			RFE4		N
1	D	90446511	1.00	PC	REPLACED BY 90446644 17067	OUT	017067	051785	PPP4		N
1	D	90446644	1.00	PC	PW 8D 82AMD MODEM INTERFACE	IN	017067	051785	PPP4		N
22	A	94240422	REF	PC	CAP, CERAMIC	IN			PPP4		N
15	A	94394721	1.00	PC	HEADER 2X25	IN			PPP4		N
21	A	94400612	2.00	PC	CAP AL ELEC 15 UF-10+100P 25V	IN			PPP4		N
24	A	94402160	5.00	PC	RES 1/4W CARBON FILM 1.5K OHMS	IN			PPP5		N

NUMBER OF LINE ITEMS = 29
HIGHEST FIND NUMBER = 27

DWN	W GLASER	1-82	CONTROL DATA	TITLE	TLA	PREFIX	DOCUMENT NO.	REV
CHKD	<i>E. Smith</i>	<i>1/5</i>			DOT GRAPHICS & TOUCH PANEL ASSY	TLA	15632921	<i>H</i>
ENG	<i>E. Smith</i>	<i>1/5</i>		FIRST USED ON		N/A		
MFG	<i>E. Smith</i>	<i>1-9-82</i>	CODE IDENT	XA358-A		15632920	SHEET	1 of 1
APPR	<i>E. H. Noel</i>	<i>1-9-82</i>	15920					

SHEET REVISION STATUS				REVISION RECORD					
REV	ECO	DESCRIPTION	DRFT	DATE	APP				
00	5000742	RELEASED CLASS B	/	1/5/82	<i>[Signature]</i>				
01	51603	REVISED PER ECO	RM	3-25-82					
A	14232-78	RELEASED CLASS A	/	4-12-82	<i>MLK</i>				
B	15137	ADDED F/N 11 & 12, ^{CHG} _{CHG}	EE	5/4/82	<i>[Signature]</i>				
C	15251	CHANGE TO F/N 2	ML	8/4/82	<i>EBO</i>				
D	15347	CHANGE TO F/N 3	ML	8/16/82	<i>[Signature]</i>				
E	15659	CHG F/N 7	WJG 1-12-83	1/13/83	<i>[Signature]</i>				
F	16723	CHG F/N 8, ADD NOTE 1	EE	7/10/84	<i>[Signature]</i>				
G	16896	REVISED PER ECO	MD	4-26-84	<i>[Signature]</i>				
H	17023	ADDED F/N 13, CHG NOTE 1	EE	1/22/85	<i>[Signature]</i>				

NOTES:

1. F/N's 9, 10 & 13 (Qty 2 ea.) are required for early units already in the field.

APL 15632921
DETACHED LISTS

443780 REV. 3 71

PRINTED IN U.S.A.

ASSEMBLY PARTS LIST

DIV.		ASSEMBLY NO.		REV.	DWG.	DESCRIPTION		MC	STATUS	PRINT DATE	PAGE	FILE CHANGE NO.	
C&C		15632921		1	F	CPT, VV GRAPH/TOUCH PNL (TAI)		G	REL	01-16-85	1	CCC17C23	
T/NO	U	PART NO.	CD	QTY	U/A	PART DESCRIPTION	MC	YLD	ECO. NO. IN	ECO. NO. OUT	S/N	WK IN	WK OUT
CC1	C1	614C9143	5	1		PC CBL ASSY, 1.5"IA 2G-CNDCT RIB	S						
CC2	C2	614A14C4	4	1		PC TOUCH PANEL, CRT ANTI GLARE	P		15251			8225	
CC3	C2	9C446516	8	1		PC PCA IALC-1 (VV GRAPHIC LOGIC)	S		15347			8224	
CC4	C1	71493586	9	2		PC REPLACED BY 71494524 16896	P			16896		86C1	86C1
CC4	C2	71494524	3	4		PC MIC TAB TOUCH PANEL METRIC	P		16896			86C1	86C1
CC5	C2	71493585	7	1		PC REPLACED BY 71494524 16896	P		15137	16896		8217	86C1
CC6	C1	151650C2	5	4		PC NUT, HEX/FLG-LH #6 STL 2P	B						
CC7	C1	71493658	0	1		PC BRKT, CABLE CIRCULCING (ALUM)	P			15659		8312	8312
CC7	C2	71493833	9	1		PC CLAMP CABLE	P		15659			8312	8312
CC8	C1	15164913	4	2		PC MSCR HEX/W-LK FLN #4X12MM STL	P			16723		8428	8428
CC8	C2	15164911	8	2		PC MSCR HEX/W-LK FLN #4X8MM STL	P		16723			8428	8428
CC9	C1	91575723	7	2		PC NUT, HEX #4 STL 2P	B			17023		8502	8502
CC9	C2	91575723	7	REF		PC NUT, HEX #4 STL 2P	B		17023			8502	8502
CC10	C1	9157567C	0	2		PC WSPR, #4 EXT/T SPG-STL 2P	P			17023		8502	8502
CC10	C2	9157567C	0	REF		PC WSPR, #4 EXT/T SPG-STL 2P	P		17023			8502	8502
CC11	C1	614C9475	3	1		PC REPLACED BY 71494524 16896	N		15137	16896		8217	86C1
CC12	C1	2648590C	9	1		PC WSPR, .257E-TOCLE FLAT CRS/CDP	P		15137			8217	8217
CC13	C1	15164913	4	REF		PC MSCR HEX/W-LK FLN #4X12MM STL	P		17023			8502	8502

CC18 TOTAL LINES

DWN	E. Ersfeld	5/83	 CONTROL DATA CORPORATION	TITLE	TLA GRAPHICS OPTION	PREFIX	TLA	DOCUMENT NO.	15633354	REV.	A
CHKD	<i>W.J. [Signature]</i>	6-83		FIRST USED ON	XA368-A	N/A	15633353	SHEET	1 of 1		
ENG	<i>R. [Signature]</i>	5-83		CODE IDENT	15920						
MFG											
VPR											

SHEET REVISION STATUS										REVISION RECORD				
REV	ECO	DESCRIPTION		DRFT	DATE	APP								
00	^{CD} 50010-85	RELEASED CLASS B		-	6-3-83	<i>EA</i>								
A	15153-54	RELEASED CLASS R		/	7-29-83	<i>[Signature]</i>								

NOTES

APL 15633354
DETACHED LISTS

AA3180 REV. 8-71 PRINTED IN U.S.A.

BUILD ARC 440

ASSEMBLY PARTS LIST

PRINT DATE	PAGE	FILE CHANGE NO.
08-01-83	1	15153-54

DIV	ASSEMBLY NUMBER	CD	REV.	DWG.	DESCRIPTION		MC	STATUS	STATUS DATE	ENG. RESP.	FILE DATE				
0800	15633354	A	A		OPT: VX*VXM GRAPHICS PCB (TA)		N	REL	07-29-83	XA368A	08-01-83				
TRND NO	LI	PART NUMBER	CD	AM	QUANTITY	U/M	PART DESCRIPTION		MC	YLD	ECO. NO. IN	ECO. NO. OUT	I/N	WE IN	WE OUT
	001	01	61409163	S	1		PC CBL ASSY. 1.5IN 20-CONDCT RIB	S							
	002	01	90446516	B	1		PC PCA 1ALD-1 (VX GRAPHIC LOGIC)	S							
					0002		TOTAL LINES								

62940037 B

2-69

2 50E94061

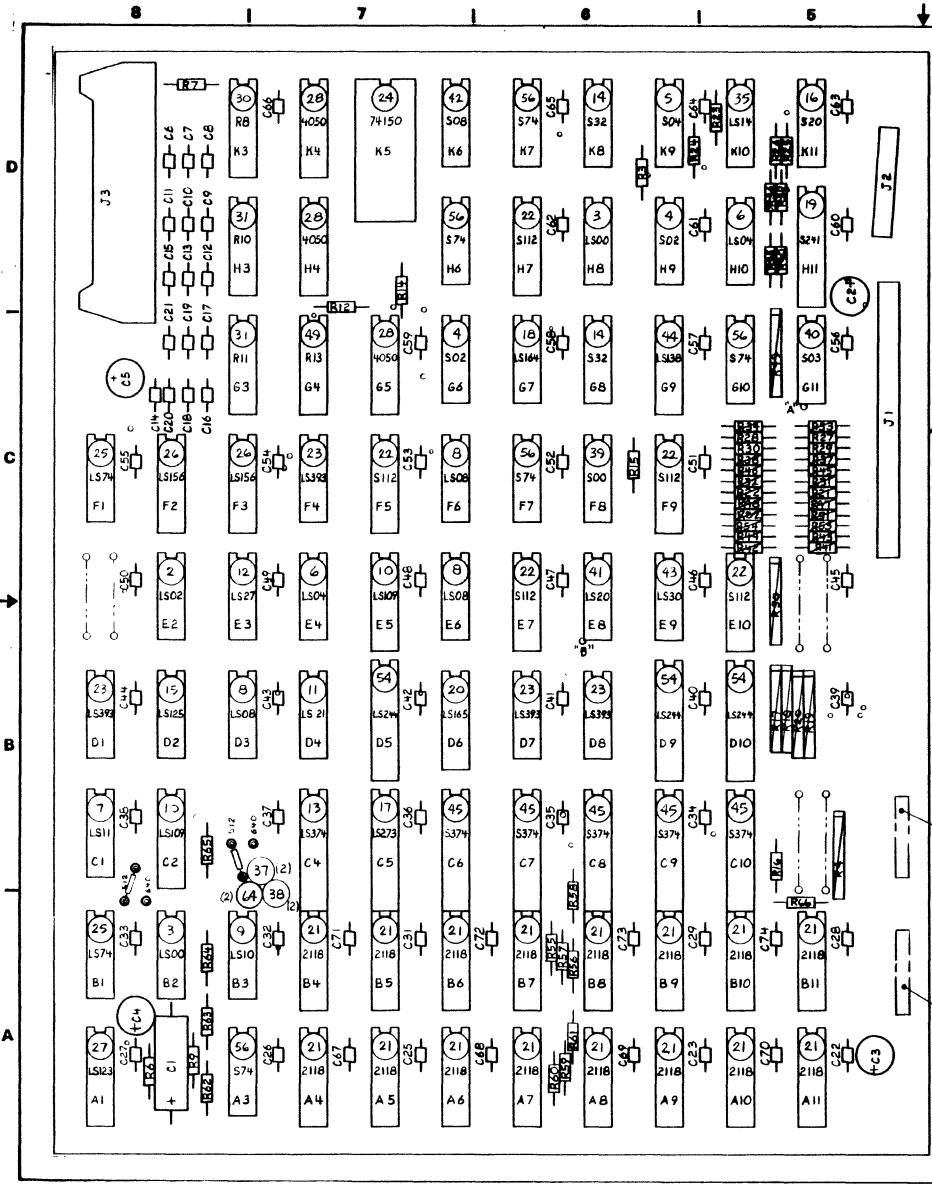

REVISION RECORD											
REV	ECO	DESCRIPTION	DRY	DATE	CHKD	APP					
00	560344	RELEASED CLASS B									
01	51558	REVISED PER ECO									
02	51629	CHANGED FROM 62									
A	1923244	UNLARGED CLASS A									
B	15134	REVISED PER ECO									
C	15347	INACTIVE-REPLACED BY 90446316									

FIND NUMBER	REFERENCE DESIGNATION
63	R55 THRU R62, R64, R16
29	R3, R23 THRU R30, R63, R65, R66
48	R6, R14, R15
34	R9
41	R7
46	R12
32	C1
33	C6 THRU C21
53	C2 THRU C5
50	C22 C23 C25 THRU C29
	C31 THRU C73, C74
59	J2
60	J3
36	J1

- NOTES:
- MARK ASSY. NO., REV LEVEL, AND LOC CODE IN AREA SHOWN. MARK PER CDC SPEC IOI21508, CHARACTER HEIGHT .12 (10 PT) COLOR WHITE.
 - MARK SERIAL NUMBER IN AREA SHOWN PER RVLOPS P&P NO. 80-20-34 AND PER MARKING REQUIREMENTS IN NOTE (1) ONE.
 - FIND NUMBERS, ELEMENT IDENTIFIERS, AND REFERENCE DESIGNATIONS ARE FOR REFERENCE ONLY AND DO NOT APPEAR ON PART.

DELETIONS	ADDITIONS
CUT: H11-5 (55)	G11-7 TO FEED-THRU "A" (GND).
	EB-7 TO FEED-THRU "B" (GND).
	H11-5 TO C1-5
	K1-11 TO C1-4
	C1-14 TO D1-3
	C1-6 TO G1-4

INACTIVE

APL 90446305		CONTROL DATA		TITLE	
UNLESS OTHERWISE SPECIFIED DIMENSIONS ARE IN INCHES		PART DESIGNATION		P.C. CARD ASSEMBLY, 1ALD	
TOLERANCES		X A358-A		GRAPHICS LOGIC	
DO NOT SCALE DRAWING		DATE		CODE IDENT	
MATERIAL		DRAWN BY		DRAWING NO	
FINISH		CHECKED BY		15920	
		ENGINEER		D 90446305	
		APPROVED		SCALE 2/1	
		DATE		RMA 15632921	
				SHEET 1 OF 1	

BUILD ARC 214

ASSEMBLY PARTS LIST

PRINT DATE 07-26-82 PAGE 1 FILE CHANGE NO. 00013347

DIV.		ASSEMBLY NUMBER		CD	REV.	DWG.	DESCRIPTION			MC	STATUS	STATUS DATE		ENG. RESP.	FILE DATE	
0860		90446305		6	C	D	REPLACED BY 90446516 15347			S	INA	07-22-82		KAZUBA	07-26-82	
TP	IND NO	LI	PART NUMBER	CD	IN	QUANTITY	U/M	PART DESCRIPTION		MC	YLD	ECO. NO. IN	ECO. NO. OUT	S/N	WK IN	WK OUT
001	01		90446304	9		1		PC	PW BD 1ALD GRAPHICS LOGIC							
002	01		15145000	4		1		PC	IC 74LS02 148LS Q2INP NOR							
003	01		15144900	6		2		PC	IC 74LS00 140LS QUAD 2=1NP							
004	01		15158500	7		2		PC	IC 74S02 TTL QUAD 2I/P NOR							
005	01		88883700	2		1		PC	IC 74S04 146S TTL HEX INVTR							
006	01		15145100	2		2		PC	IC 74LS04 146LS TTL HEX INV							
007	01		15145700	9		1		PC	IC 74LS11 TRIPLE 3 I/P AND							
008	01		15145400	6		3		PC	IC 74LS08 201LS Q2INP AND							
009	01		15145600	1		1		PC	IC 74LS10 141LS TTL 3I/P NAND							
010	01		15148000	1		2		PC	I C 74LS109 TTL JKFF DUAL							
011	01		15163457	3		1		PC	IC 74LS21 DUAL GT							
012	01		15146000	3		1		PC	IC 74LS27 224LS TTL 3I/P NOR							
013	01		15163404	5		1		PC	IC 74LS374 OCTAL D-EDGE F-F							
014	01		15154800	5		2		PC	IC SN74S32 QUAD 2 I/P							
015	01		15163322	9		1		PC	IC 74LS125							
016	01		88885300	9		1		PC	IC 74S20 TTL DUAL 4 I/P							
017	01		15163420	1		1		PC	IC 74LS273 OCTAL D FLIP FLOP							
018	01		15163303	9		1		PC	IC 74LS164 527LS TTL 8B ROTR							
019	01		15163311	2		1		PC	IC 74S241 VIKINGX							
020	01		15163415	1		1		PC	IC 74LS165 88 SHIFT REGISTER							
021	01		15163718	8		16		PC	IC-2118 MEM, MOS 120 NS							

BUILD ARC 214

ASSEMBLY PARTS LIST

PRINT DATE 07-26-82 PAGE 2 FILE CHANGE NO. 00013347

DIV.		ASSEMBLY NUMBER		CD	REV.	DWG.	DESCRIPTION			MC	STATUS	STATUS DATE		ENG. RESP.	FILE DATE	
0860		90446305		6	C	D	REPLACED BY 90446516 15347			S	INA	07-22-82		KAZUBA	07-26-82	
TP	IND NO	LI	PART NUMBER	CD	IN	QUANTITY	U/M	PART DESCRIPTION		MC	YLD	ECO. NO. IN	ECO. NO. OUT	S/N	WK IN	WK OUT
022	01		15158600	5		5		PC	IC 74S112 TTL DUAL J-K NET							
023	01		15163419	3		4		PC	IC 74LS393 DL 4B BIN COUNTER							
024	01		17183500	2		1		PC	IC 74150 531 TTL DATA SEL MPX							
025	01		15146300	7		2		PC	IC 74LS74 175LS P/F DUAL D							
026	01		15163440	9		2		PC	IC 74LS156							
027	01		15163422	7		1		PC	IC 74LS123 DUAL MULTIVIBRATOR							
028	01		15134800	0		3		PC	IC 4050 CMOS HEX RFR NON=INV							
029	01		94402143	5		12		PC	RES FM 300 OHM 1/4W CARBON							
030	01		75738670	1		1		PC	RES PAK 47.0K OHM 1.50W FIG 2							
031	01		75738617	2		2		PC	RES PAK 10.0K OHM 1.5W FIG 1							
032	01		12089270	8		1		PC	CAP AL ELCTLT 25UF 10P 25VDCW							
033	01		94240430	2		16		PC	CAP CER 1200PF							
034	01		94402188	0		1		PC	RES 22K OHMS 1/4W CARBON FILM							
035	01		15148500	0		1		PC	IC 74LS14 943LS TTL 6 ND RCVR							
036	01		51860819	5		1		PC	CONN PTD CKT 50 CONTACTS							
037	01		24501806	4		166		PT	WIRE BUSS 24GA SOLID CU TP							
038	01		65832100	5		6		PC	SOCKET MINI SPRING							
039	01		88884500	5		1		PC	IC 74S00 140S TTL QD 2IN NAND							
040	01		15161500	2		1		PC	IC TTL 4=20=5							
041	01		15145900	5		1		PC	IC 74LS20 208LS TTL 4I/P NAND							
042	01		15163600	8		1		PC	IC 74S00 201S TTL QD 2I/P AND							

BUILD ARC 214

ASSEMBLY PARTS LIST

PRINT DATE: 07-26-82 PAGE: 3 FILE CHANGE NO.: 00019347

DIV.		ASSEMBLY NUMBER		CD	REV.	DWG.	DESCRIPTION		MC	STATUS	STATUS DATE	ENG. DESK	FILE DATE
0800		90446305		6	C	D	REPLACED BY 90446516 15347		S	INA	07-22-82	X-330A 00034	07-26-82
TRIPIND NO.	LI	PART NUMBER	CD	QTY	U/M	PART DESCRIPTION	MC	YLD	ECO. NO. IN	ECO. NO. OUT	S/N	WK IN	WK OUT
043	01	15146100	1	1		PC IC 74LS30 206LS TTL 8I/P NAND	P						
044	01	15147400	4	1		PC IC 74LS138 563LS TTL DECODER	P						
045	01	15163310	4	5		PC IC 749374 OCTAL D TYPE	P						
046	01	94402204	5	1		PC RES FM 100K OHM 1/4W CARBON	P						
047	01	94402196	3	1		PC RES FM 47K OHM 1/4W CARBON	P						
048	01	94402156	7	3		PC RES FM 1K OHM 1/4W CARBON	P						
049	01	75738672	7	1		PC RES PAK 100.0 OHM 1.50W FIG 2	P						
050	01	19115400	4	51		PC CAP FXD CER .01UF 50V 20P	P						
053	01	94395520	3	4		PC CAP AL ELECT 100UF 8V	P						
054	01	15163414	4	3		PC IC 74LS244 OCTAL BFR 3-8 OP	P						
056	01	88923000	9	5		PC IC 74874 TTL DUAL	P						
059	01	51860812	0	1		PC CONN PC 10 POS 20 CONT	P						
060	01	51847514	0	1		PC CONN PCB 34 POS 2RX17P FIG 3	P						
061	01	90446303	1	REF		PC SCH DIAG 1ALD	D						
062	01	16006500	9	REF		PC FABRICATION SPECIFICATION	D						
063	01	94402120	3	10		PC RES FM 33 OHM 1/4W CARBON	P						
064	01	24563706	1	166	FT	INS SLVNG HI TEMP 16 AWG	B						
065	01	52629949	0	1 500	FT	WIR WW 30GA SLD WMT UL KYNAR	W		15134			8216	
							0060 TOTAL LINES						

291994061 1

SHEET REVISION STATUS		REVISION RECORD			
REV	DATE	BY	DESCRIPTION	CHKD	DATE
A	0500-N		Released Class "A"		12/14
B	0503		P/L CHANGE ONLY		11/26
C	0504		REVISED PER ECO		11/26
D	0509		CHG F/W 34, 35		11/26
E	0512		REVISED B REDRAWN		11/26
F	06/910		CHG F/W 65 ADD NOTE 5		11/20/83
G	10/9/87		CHG F/W 1, DELETE F/W 65		11/18/85
H	12/7/84		CHANGED DIR F/W 27		12/28/85

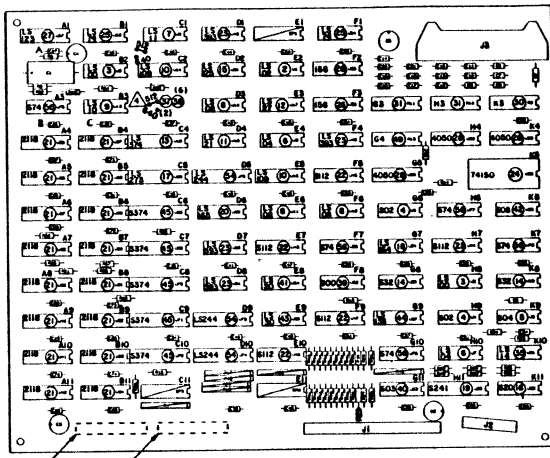

CROSS REFERENCE	
Find No.	Reference Designation
29	R3,R23 THRU R30
32	C1
33	C6 THRU C21
34	R9
36	J1
46	R12
47	R7
48	R6,R14,R15
50	C22,C23,C25 THRU C29,C31 THRU C74
53	C2 THRU C5
59	J2
60	J3
63	R55 THRU R62,R64,R16

NOTES:

- 1. MARK ASSEMBLY NUMBER, REVISION LEVEL AND LOCATION CODE IN AREA SHOWN MARK PER CDC SPECIFICATION 10121606, CHARACTER HEIGHT .12 (10 POINT), COLOR WHITE.
- 2. MARK SERIAL NUMBER IN AREA SHOWN PER RVLOPS P & P NO. 80:20:34 AND PER MARKING REQUIREMENTS IN NOTE (1) ONE.
- 3. FIND NUMBERS, ELEMENT IDENTIFIERS AND REFERENCE DESIGNATIONS ARE FOR REFERENCE ONLY AND DO NOT APPEAR ON PART.
- 4. FABRICATE JUMPETS TO THE FOLLOWING DIMENSIONS.
- 5. MAKE THE FOLLOWING ADDITIONS TO ASSEMBLIES WITH PWB 90446629 INCORPORATED VIA REVISION E.
 - 1. A1-B TO INCOMPLETE PATH LEADING FROM SIDE A OF C27.
 - 2. A3-7 TO INCOMPLETE PATH LEADING FROM SIDE B OF C26.
 - 3. C26 (SIDE B) TO C32 (SIDE C).

CHANGE TABLE	
Deletions	Additions
	△

APL 90446516
DETACHED LISTS

DESIGNED BY <i>[Signature]</i>	CHECKED BY <i>[Signature]</i>	DATE 11/26	CONTROL DATA CORPORATION PRINTED WIRING ASSEMBLY 81ALD-3 GRAPHICS LOGIC
DATE 11/26	DATE 11/26	DATE 11/26	
XA358-A 		D 15920 SCALE 1/11 NHA 1043700	90446516 SHEET 1 OF 1

ASSEMBLY PARTS LIST

90446516	H	A	D	PCA 1ALD-1 (VX GRAPHIC LOGIC)	CD	XA358A	07/29/85	C17714	02/14/86	1 / 2
ASSEMBLY NUMBER	REV	CL	BY	DATE	DESIGN SOURCE	PART USAGE	RELEASE DATE	CHANGE ORD NUMBER	PROCESSING DATE	PAGE NUMBER

PART NUMBER	REV	QTY	UNIT	DESCRIPTION	IN/OUT	CHANGE ORD NUMBER	DATE EFFECTIVE	MAKE/BUY	PN	IN
32	C	1.00	PC	CAP ELECT LO LEAK 25MFD	IN			PPP4	N	N
28	C	3.00	PC	IC HEX BUFFER 4050	IN			PPP5	N	N
3	A	2.00	PC	IC TTL QUAD 2-IN NAND 74LS00	IN			PPP5	N	N
2	A	1.00	PC	IC TTL QUAD 2-INPUT NOR 74LS02	IN			PPP5	N	N
6	A	2.00	PC	IC TTL HEX INVERTER 74LS04	IN			PPP5	N	N
8	A	3.00	PC	IC TTL QUAD 2INPUT AND 74LS08	IN			PPP5	N	N
9	A	1.00	PC	IC TTL TRPL 3INPUT NAND 74LS10	IN			PPP5	N	N
7	A	1.00	PC	I.C. 74LS11	IN			PPP5	N	N
41	A	1.00	PC	IC TTL DUAL 4INPUT NAND 74LS20	IN			PPP5	N	N
12	A	1.00	PC	IC TTL TRPL 3INPUT NOR 74LS27	IN			PPP5	N	N
43	A	1.00	PC	I.C. 74LS30	IN			PPP5	N	N
25	A	2.00	PC	IC TTL DUAL 0-TYPE F/F 74LS74	IN			PPP5	N	N
44	A	1.00	PC	IC, DECODER-STTL 74LS138	IN			PPP5	N	N
10	A	2.00	PC	IC TTL JK FF, DUAL 74LS109	IN			PPP5	N	N
35	A	1.00	PC	IC 74LS14 RECYR TTL HEX NAND	IN			PPP5	N	N
14	A	2.00	PC	IC 74S32	IN			PPP5	N	N
4	A	2.00	PC	IC-TTL QUAD 2 INPUT NOR 74S02	IN			PPP5	N	N
22	A	5.00	PC	I C 74S112	IN			PPP5	N	N
40	A	1.00	PC	IC 74S03	IN			PPP5	N	N
18	A	1.00	PC	IC-74LS164 TTL 8-BIT SHIFT REG	IN			PPP5	N	N
45	A	5.00	PC	IC 74S374 OCTAL LATCH TTL	IN			PPP5	N	N
19	A	1.00	PC	IC-74S241	IN			PPP5	N	N
15	A	1.00	PC	IC 74LS125	IN			PPP5	N	N
13	A	1.00	PC	MICROCIRCUIT 74LS374 TYPE	IN			PPP5	N	N
54	A	3.00	PC	IC 74LS244	IN			PPP5	N	N
20	A	1.00	PC	IC 74LS165 TYPE	IN			PPP5	N	N
23	A	4.00	PC	MICROCIRCUIT 74LS393 TYPE	IN			PPP5	N	N
17	A	1.00	PC	IC 74LS273 FLIP-F	IN			PPP5	N	N
27	A	1.00	PC	IC 74LS123 DUAL RETRIG MONO MV	IN			PPP5	N	N
11	A	1.00	PC	IC 74LS21 QUAD 2-INPUT AND	IN			PPP5	N	N
42	A	1.00	PC	IC 74S08	IN			PPP5	N	N
21	A	1.00	PC	IC-2116 MEM,MOS,120 NS	IN			PPP5	N	N
59	A	1.00	PC	HDR, .100SP 2" POS FIG-1 GOLD	IN	227222	390503	PPP4	N	N
36	A	1.00	PC	CONN CARD HEADER 50 CONTACT	IN	222222	080583	PPP4	N	N
62	A	KFF	PC	SNGL * DBL SIDFD PC BD FAB SPC	IN			RFE4	N	N
50	C	51.00	PC	CAP, FXD CERAM 50VDC .01MFD	IN			PPP5	N	N

APP 207 REV 4-80 CDC/EG 12/11

ASSEMBLY PARTS LIST

90446516	H	A	D	PCA 1ALD-1 (VX GRAPHIC LOGIC)	CD	XA358A	07/29/85	017714	02/14/86	2 / 2
ASSEMBLY NUMBER	REV	CL	BY	DATE	DESIGN SOURCE	PART USAGE	RELEASE DATE	CHANGE ORD NUMBER	PROCESSING DATE	PAGE NUMBER

PART NUMBER	REV	QTY	UNIT	DESCRIPTION	IN/OUT	CHANGE ORD NUMBER	DATE EFFECTIVE	MAKE/BUY	PN	IN
37	A	1.99	IN	WIR 24GA SLD YEL 700V UL MYL	IN	015994	081283	PPP5	N	N
60	A	1.00	PC	CONN-HEADER, RT ANGLE 2X17	IN			PPP4	N	N
65	C	1.20	IN	WIRE ELEC 30 GA WHITE	IN	016910	100584	PPP5	N	N
65	C	1.20	IN	WIRE ELEC 30 GA WHITE	OUT	016957	071285	PPP5	N	N
38	A	6.00	PC	SOCKET MINI SPRING	IN			PPP4	N	N
31	A	2.00	PC	RESISTOR MODULE 10 JK	IN			PPP5	N	N
30	A	1.00	PC	RES 16PIN DIP 47K R 2P 1.5W 2	IN			PPP5	N	N
49	A	1.00	PC	RESISTOR MODULE-16 PIN,100.0K	IN			PPP5	N	N
24	A	1.00	PC	IC 74150 TTL 16-BIT SEL/MUX	IN	015613	050683	PPP5	N	N
26	A	2.00	PC	IC 74156 TTL 2/4 L/DECD/DEMUX	IN			PPP5	N	N
5	A	1.00	PC	IC 74S04 SCHOTTKY TTL HEX INV	IN			PPP5	N	N
39	A	1.00	PC	IC 74S00 SCHOTTKY TTL QUAD 2-I	IN			PPP5	N	N
16	A	1.00	PC	IC 74S20 SCHOTTKY TTL DUAL 4-I	IN			PPP5	N	N
58	A	5.00	PC	IC 74S74 TTL DUAL 0 EDGE F/F	IN			PPP5	N	N
61	C	REF	PC	SCH DIAG 1ALD	IN			RFE4	N	N
1	U	1.00	PC	REPLACED BY 90446671 16957	IN	016512	020185	PPP4	N	N
1	U	1.00	PC	REPLACED BY 90446671 14957	OUT	016512	102585	PPP4	N	N
1	U	1.00	PC	PW BD 81ALD-4 GRAPHICS LOGIC	IN	016957	102585	PPP4	N	N
33	A	16.00	PC	CAP FXD CER 1200PF 10P 50VDC	IN			PPP5	N	N
53	A	4.00	PC	CAP AL ELEC 100UF-10479P 6.3V	IN			PPP4	N	N
63	A	16.00	PC	RES FXD C FM 33 OHM 5P 1/4W	IN			PPP5	N	N
28	A	12.00	PC	RESISTOR 300 OHMS 1/4W	OUT	017714	021486	PPP5	N	N
29	A	9.00	PC	RESISTOR 300 OHMS 1/4W	IN	017714	021486	PPP5	N	N
48	A	3.00	PC	RES 1/4W CARBON FILM 1K OHMS	IN			PPP5	N	N
34	A	1.00	PC	RESISTOR CARBON 22K OHM .25W	IN			PPP5	N	N
47	A	1.00	PC	RES 1/4W CARBON FILM 47K OHMS	IN			PPP5	N	N
46	A	1.00	PC	RES CARBON FILM 100KOHMS .25W	IN			PPP5	N	N

NUMBER OF LINE ITEMS = 63
HIGHEST FIND NUMBER = 65

APP 207 REV 4-80 CDC/EG 12/11

NOTE

Pages 3 of 90446516 parts list has been deleted. Information contained on page 3 has now been compiled on page 1 and page 2 of revised parts list.

2-76

62940037 G

SHEET REVISION STATUS	
REV	ECO

REVISION RECORD						
REV	ECO	DESCRIPTION	DRFT	DATE	CHKD	APP
		RELEASED CLASS B				
01	51418	ADD F/N 12, 13, & 14	D.S.	11-16-81	WJG	
02	51603	REVISED PER ECO	WJG	3-29-82		
A	14232-63	RELEASED CLASS A		4-6-82		
B	15240	DELETE DIMENSION	EE	12-2-82		
C	15523	ADDED F/N 12	EE	12-2-82		
D	15555	CHANGE F/N 1, ADDED F/N 2	EE	12-2-82		
E	15661	CHG F/N 5, 6, 7, DELETE F/N 8	BG	2-15-83		
F	16436	ADD F/N 14 & NOTE 4	WJG	1-6-84	WJG	
G	16634	CHG QTY F/N 3	DS	4-9-84	WJG	
H	16667	ADDED R1, R2, P6 & WIRE CONN.	DS	4-26-84	WJG	
J	16686	CHG F/N 9, ADD F/N 15 & SEC. A-A	WJG	5-10-84		
K	16687	CHG F/N 4, 9 DELETE F/N 15	EE	7-24-84	D.S.	
L	16845	CHANGE QTY F/N 14	EE	12-2-84		

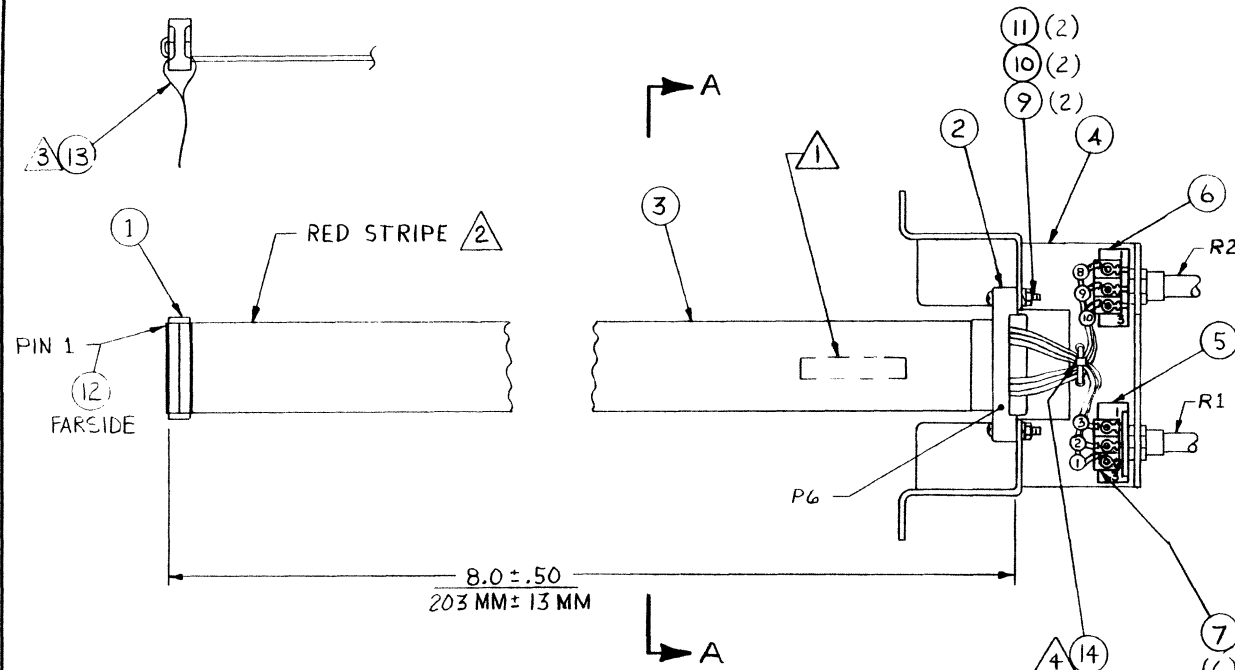

NOTES:

- 1 MARK WITH CDC PART NUMBER PER CDC SPEC IOI21508.
- 2 DO NOT TERMINATE RED STRIPE WIRE AT FIND NO. 2.
- 3 INSTALL PULL TAB F/N 13 IN STRAIN RELIEF, LOOP CABLE F/N 3 THROUGH STRAIN RELIEF.
- 4 TY-WRAP WIRES TO BRACKET AS SHOWN.

WIRE CONNECTIONS	
FROM	TO
P6-1	R1-3
P6-2	R1-2
P6-3	R1-1
P6-8	R2-1
P6-9	R2-2
P6-10	R2-3

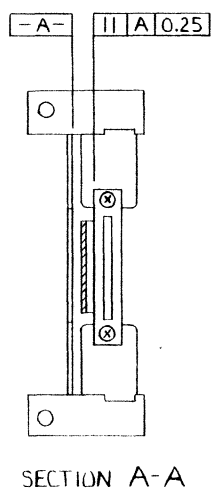

METRIC

DETAILED LISTS		CONTROL DATA		TITLE	
APL - 61409244	UNLESS OTHERWISE SPECIFIED DIMENSIONS ARE IN MM TOLERANCES	FIRST USED ON		MONITOR, CABLE ASSY	
	3 PLACE ± / ± / ± ANGLES	CC634-A			
	DO NOT SCALE DRAWING	CHKD	D. SAND 9-15-81		
	MATERIAL	ENGR			
FINISH	MFG				
	APPR	E. H. H. 12-5-82			
		SCALE	1/1	CODE IDENT	15920
				DRAWING NO	61409244
				SHEET	1 OF 1

61409244

BUILD ARC 230

ASSEMBLY PARTS LIST

PRINT DATE	PAGE	FILE CHANGE NO.
08-21-84	1	00016845

DIV.	ASSEMBLY NUMBER	CD	REV.	DWG.	DESCRIPTION	MC	STATUS	STATUS DATE	ENG. RESP.	FILE DATE				
0860	61409243	L	C		CBL ASSY, VX MONITOR POT MTG	A	REL	04-06-82	CC634A*	08-21-84				
T	WIND NO	LI	PART NUMBER	CD	QTY	U/M	PART DESCRIPTION	MC	YLD	ECO. NO. IN	ECO. NO. OUT	S/N	WK IN	WK OUT
	001	01	6583405	2	1		PC CONN, 20-CONT FLAT/CBL FIG-1	P			15555	15555		8304
	001	02	10130434	3	1		PC CONN, 20-PIN FLAT-CBL CL/COV	P		15555			8304	
	002	01	10130626	4	1		PC CONN PLUG, 20-PIN RIBBON/CBL	P						
	003	01	65832210	2	833		FT CBL, FLAT 20-CHOCT 28GA FIG-1	P		16634	16634		8414	8414
	003	02	65832210	2	1		FT CBL, FLAT 20-CHOCT 28GA FIG-1	P		16634			8414	
	004	01	71493396	7	1		PC BRKT, POT MOUNTING (CRS/ZP)	P		16687	16687		8433	8433
	004	02	71494399	0	1		PC BRACKET POT MOUNTING	P		16687			8433	
	005	01	51940832	2	1		PC RES VAR CRP 500 R 30P 1/3W 2	P		15681	15681		8338	8338
	005	02	51940844	7	1		PC RES VAR CRP 500 BLK FIG 3	P		15681			8338	
	006	01	51940839	7	1		PC RES VAR CRP 100K R 30P 1/3W 2	P		15681	15681		8338	8338
	006	02	51940845	4	1		PC RES VAR CRP 100K R 30P 1/3W 3	P		15681			8338	
	007	01	51857822	4	6		PC CONN RCPT, 1 CKT CBL-MTG F-2	P		15681	15681		8338	8338
	007	02	24500803	2	6		PC INS SLV 1/2 LENGTH U/L	B		15681			8338	
	008	01	51857702	0	6		PC CONT, SQ/W 22-26AWG F-2 CHAIN	P			15681		8338	
	009	01	91976628	7	2		PC NSCR PAN PHL M3X12MM STL ZP	B		16686	16686		8420	8420
	009	02	91976629	5	2		PC NSCR PAN PHL M3X16MM STL ZP	B		16687	16687		8433	8433
	009	03	91976628	7	2		PC NSCR PAN PHL M3X12MM STL ZP	B		16687			8433	
	010	01	91975690	0	2		PC NSHR, M3 LOCK SPG-STL ZP	B						
	011	01	91975722	9	2		PC NUT, HEX M3 STL ZP	B						
	012	01	77830889	0	1		PC PLUG, POLARIZING KEY	P		15523			8243	
	013	01	92004801	4	1		PC PULL TAB, CONN 1X3LG (PLSTC)	P		15555			8304	
	014	01	94277400	1	2		PC STRAP, CBL TIE TYP-1 TO 5/8	B		16436	16436		8401	8434
	014	02	94277400	1	1		PC STRAP, CBL TIE TYP-1 TO 5/8	B		16436			8434	
	015	01	71494398	2	2		PC SPACER METRIC	P		16686	16687		8420	8433

BUILD ARC 230

ASSEMBLY PARTS LIST

PRINT DATE	PAGE	FILE CHANGE NO.
08-21-84	2	00016845

DIV.	ASSEMBLY NUMBER	CD	REV.	DWG.	DESCRIPTION	MC	STATUS	STATUS DATE	ENG. RESP.	FILE DATE				
0860	61409243	L	C		CBL ASSY, VX MONITOR POT MTG	A	REL	04-06-82	CC634A*	08-21-84				
T	WIND NO	LI	PART NUMBER	CD	QTY	U/M	PART DESCRIPTION	MC	YLD	ECO. NO. IN	ECO. NO. OUT	S/N	WK IN	WK OUT
							0024 TOTAL LINES							

DWN	D. Sand	10/81	CONTROL DATA	TITLE	PREFIX	DOCUMENT NO	REV
CHKD	(W. J. Hana)	10-28-81		CABLE ASSY, RIBBON	A	61409163 Thru 61409166	H
ENG	(S. J. Hana)	10-12-81		FIRST USED ON	NHA	15632921	SHEET 1 OF 5
MFG	(S. J. Hana)	4-5-82	CODE IDENT	CC634-A, XA 358-A	61409170		
APPR	(S. H. Hana)	4-5-82	15920				

SHEET REVISION STATUS					REVISION RECORD					
5	4	3	2	1	REV	ECO	DESCRIPTION	DRFT	DATE	APP
-	-	-	00	00	00	50006-58	RELEASED CLASS B	WJG	10/26/81	(Signature)
-	-	01	01	01	01	51535	ADD TAB 64	WJG	2-17-82	(Signature)
-	-	02	01	02	02	51568	REVISED PER ECO	EE	3/9/82	RC
-	-	A	A	A	A	14232-63	RELEASED CLASS A		4-6-82	(Signature)
-	-	B	A	B	B	15189	ADDED TOLERANCE TO DIM.	EE	4/22/82	(Signature)
-	C	C	A	C	C	15642	REVISED SHEET 3 ADDED SHEET 4	WJG	1-5-83	(Signature)
	D	C	C	A	D	15886	ADDED SHEET 5	WJG	6-9-83	(Signature)
	D	C	E	A	E	15982	REVISED SHTS 1 & 3	BG	7/26/83	(Signature)
	D	C	F	A	F	16249	CHG QTY FIN 1 & 3	D.S.	10-6-83	(Signature)
	C	C	G	A	G	16320	REMOVED SHIELD CIRCUITS SHCS	D.S.	11-15-83	(Signature)
	H	C	G	A	H	16710	CHG TAB 65 PICTORIALY	WJG	8-14-84	(Signature)

NOTES

- 1 Bulk identify with CDC part number.
- 2 Strain relief this conn only retain others for breakage.

APL 61409165
APL 61409164
APL 61409163
DETACHED LISTS

AA3180 REV. 8/71

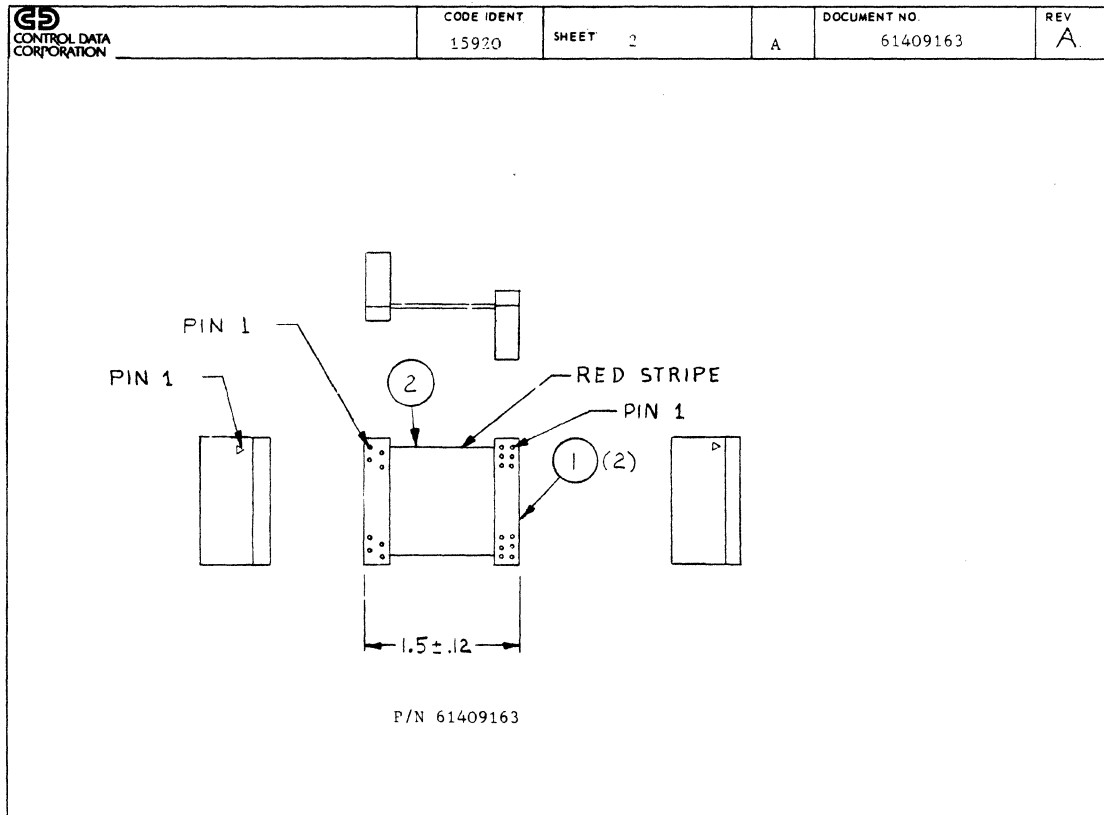

AA3185

PRINTED IN U.S.A.

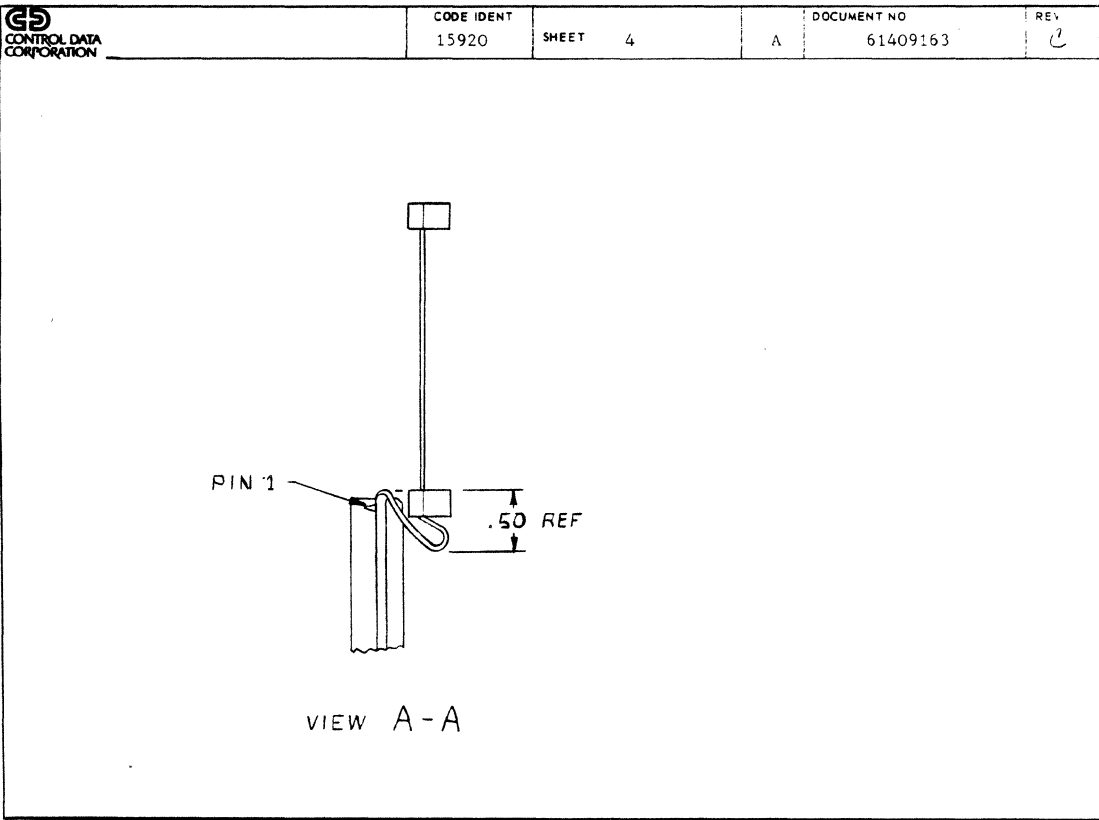
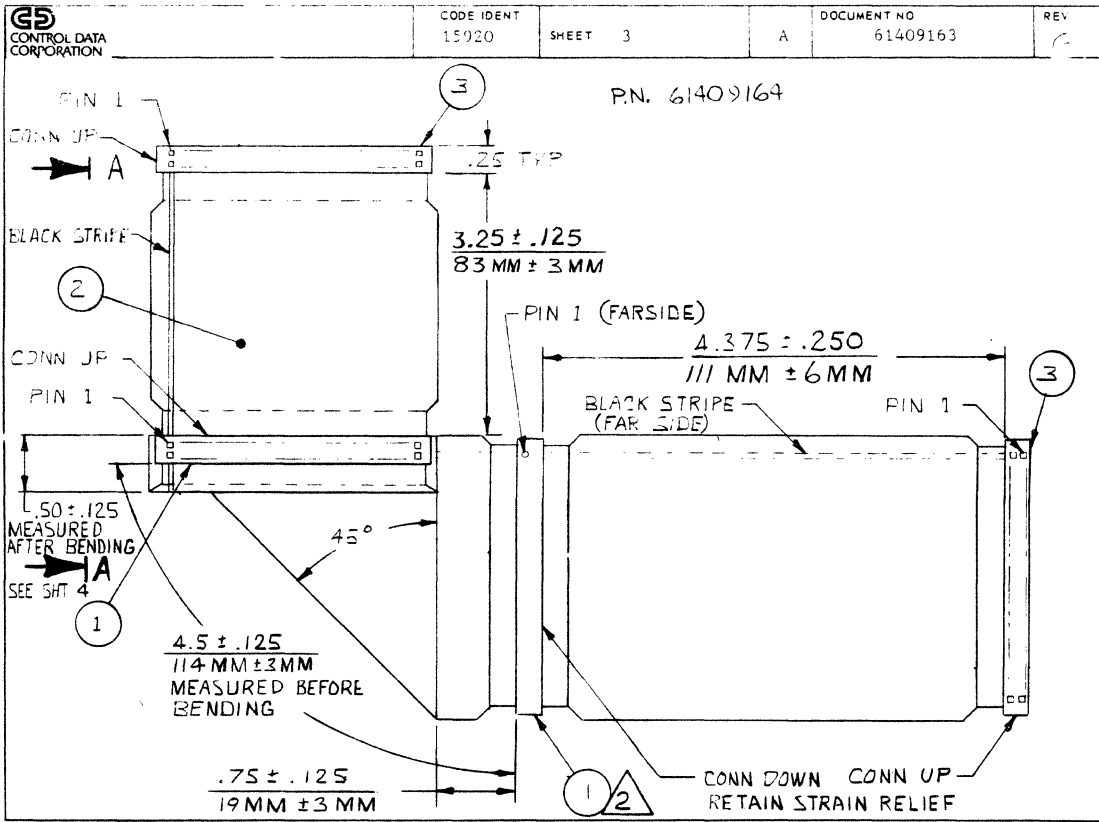

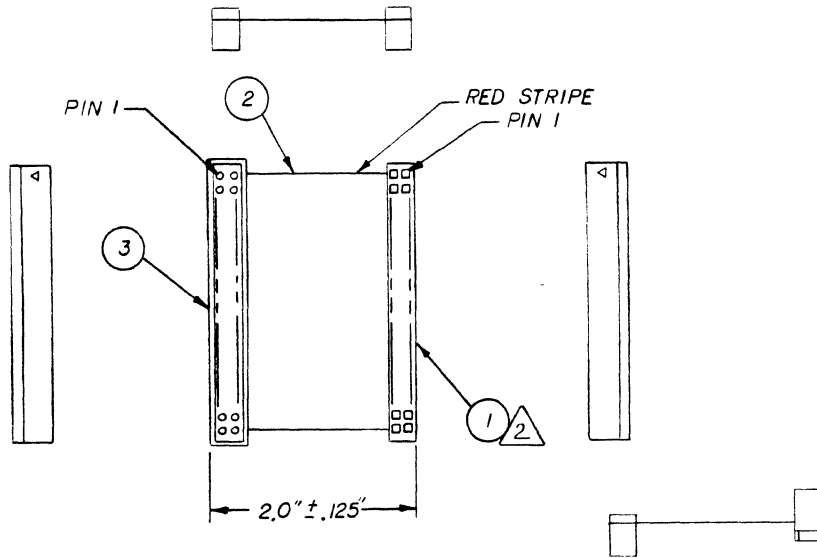

P/N 61409163
SHOWN WITHOUT STRAIN RELIEF

ASSEMBLY WITH STRAIN RELIEF

BUILD ARC 104										ASSEMBLY PARTS LIST				PRINT DATE		PAGE		FILE CHANGE NO.	
										06-26-84		1		00016710					
DEV.	ASSEMBLY NUMBER	CD	REV.	DWG.	DESCRIPTION			MC	STATUS	STATUS DATE	ENG. RESP.	FILE DATE							
0860	61409153	5	H	A	CBL ASSY, 1.5IN 20-CNDCT RIB			S	REL	04-06-82	CC634A+	06-26-84							
T/FIND NO	LI	PART NUMBER	CD	IN	QUANTITY	U/M	PART DESCRIPTION	MC	YLD	ECO. NO. IN	ECO. NO. OUT	S/N	WK IN	WK OUT					
001	01	65853405	2		2		PC CONN, 20-CONT FLAT/CBL FIG-1	P											
002	01	65832210	2		125	FT	CBL, FLAT 20-CNDCT 28GA FIG-1	P											
0002 TOTAL LINES																			

BUILD ARC 104										ASSEMBLY PARTS LIST				PRINT DATE		PAGE		FILE CHANGE NO.	
										06-26-84		1		00016710					
DEV.	ASSEMBLY NUMBER	CD	REV.	DWG.	DESCRIPTION			MC	STATUS	STATUS DATE	ENG. RESP.	FILE DATE							
0860	61409154	3	H	A	CBL ASSY, 50-CNDCT SHLD RIB			A	REL	04-06-82	CC634A+	06-26-84							
T/FIND NO	LI	PART NUMBER	CD	IN	QUANTITY	U/M	PART DESCRIPTION	MC	YLD	ECO. NO. IN	ECO. NO. OUT	S/N	WK IN	WK OUT					
001	01	10130447	5		3		PC CONN, 50-PIN FLAT-CBL OP/COV	P					16249	8350					
001	02	10130447	5		2		PC CONN, 50-PIN FLAT-CBL OP/COV	P		16249				8350					
002	01	95028513	0		1	032	FT CBL, FLAT 50-CNDCT 28GA TYP-3	P			15982			8327					
002	02	95028513	0		1	115	FT CBL, FLAT 50-CNDCT 28GA TYP-3	P		15982	16320			8327 8345					
002	03	61409726	9		1		PC CABLE ASSY, RIBBON, PREP	V		16320				8345					
003	01	92014159	5		1		PC CONN, 2X25POS FLT-CBL NON-POL	P			16249			8350					
003	02	92014159	5		2		PC CONN, 2X25POS FLT-CBL NON-POL	P		16249				8350					
0007 TOTAL LINES																			

BUILD ARC 104										ASSEMBLY PARTS LIST				PRINT DATE		PAGE		FILE CHANGE NO.	
										06-26-84		1		00016710					
DEV.	ASSEMBLY NUMBER	CD	REV.	DWG.	DESCRIPTION			MC	STATUS	STATUS DATE	ENG. RESP.	FILE DATE							
0860	61409155	0	H	A	CBL ASSY RIBBON			A	RFL	04-06-82	CC634A	06-26-84							
T/FIND NO	LI	PART NUMBER	CD	IN	QUANTITY	U/M	PART DESCRIPTION	MC	YLD	ECO. NO. IN	ECO. NO. OUT	S/N	WK IN	WK OUT					
001	01	10130447	5		1		PC CONN, 50-PIN FLAT-CBL OP/COV	P											
002	01	65832240	9		020	FT	CBL, FLAT 50-CNDCT 28GA FIG-1	P											
003	01	92010911	3		1		PC CONN PLUG 50 POS FLAT CABLE	P											
0003 TOTAL LINES																			

BUILD ARC 104

ASSEMBLY PARTS LIST

PRINT DATE	PAGE	FILE CHANGE NO.
12-29-82	1	00015642

DIV.	ASSEMBLY NUMBER	CD	REV.	DWG.	DESCRIPTION	MC	STATUS	STATUS DATE	ENG. RESP.	FILE DATE			
0860	61409163	5	C	A	CBL ASSY, 1.5IN 20-CNDCT RTB	S	REL	04-06-82	CC634A	12-23-82			
TRND NO	LI	PART NUMBER	CD	QUANTITY	U/M	PART DESCRIPTION	MC	YLD	ECO. NO. IN	ECO. NO. OUT	S/N	WK IN	WK OUT
001	01	65853405	2	2		PC CONN, 20-CONT FLAT/CBL FIG-1	P						
004	01	65832210	4	125		FT CBL, FLAT 20-CNDCT 28GA FIG-1	P						
0002 TOTAL LINES													

BUILD ARC 104

ASSEMBLY PARTS LIST

PRINT DATE	PAGE	FILE CHANGE NO.
12-29-82	1	00015642

DIV.	ASSEMBLY NUMBER	CD	REV.	DWG.	DESCRIPTION	MC	STATUS	STATUS DATE	ENG. RESP.	FILE DATE			
0860	61409164	3	C	A	CBL ASSY, 50-CNDCT SHLD RTB	A	REL	04-06-82	CC634A	12-23-82			
TRND NO	LI	PART NUMBER	CD	QUANTITY	U/M	PART DESCRIPTION	MC	YLD	ECO. NO. IN	ECO. NO. OUT	S/N	WK IN	WK OUT
001	01	10130447	5	3		PC CONN, 50PIN FLAT-CBL CP/COV	P						
004	01	95028513	0	1	034	FT CBL, FLAT 50-CNDCT 28GA TYP-3	P						
009	01	92014159	5	1		PC CONN, 2X25POS FLT-CBL NON-POL	P						
0003 TOTAL LINES													

DWN	<i>[Signature]</i>	5-25-82	CONTROL DATA CORPORATION	TITLE	KEYBOARD CABLE ASSY	PREFIX	A	DOCUMENT NO.	61409451	REV.	D
CHKD	<i>[Signature]</i>	5-25-82		FIRST USED ON	CC634-A						
ENG	<i>[Signature]</i>	5-25-82									
MFG	<i>[Signature]</i>	4-9-82									
APPR	<i>[Signature]</i>	4-9-82	CODE IDENT	15920		NH4		SHEET	1 OF 2		

SHEET REVISION STATUS					REVISION RECORD						
REV	ECO	DESCRIPTION	DRFT	DATE	APP	REV	ECO	DESCRIPTION	DRFT	DATE	APP
-	00	00 50008-02	✓	3-26-82	EGJ			RELEASED CLASS B			
-	01	01 51636	WJG	3-31-82	JH			FIN 4 WAS 51941503			
-	A	A 14232-77	✓	4-13-82	MLT			RELEASED CLASS A*			
B	B	B 15178	EE	5/1/82	JH			ADDED FIN 5 & SHEET 2			
C	C	C 15298	ML	8/4/82	ML			REMOVED SLEEVING (FIN 5)			
D	D	D 16127	BG	9/83	TAB			INACTIVE, REPLACED BY 61409530			

INACTIVE

NOTES:

- Bulk identify with CDC part number.

⚠ Overlap ferrule insulation onto cable jacket.

APL 61409451
DETACHED LISTS

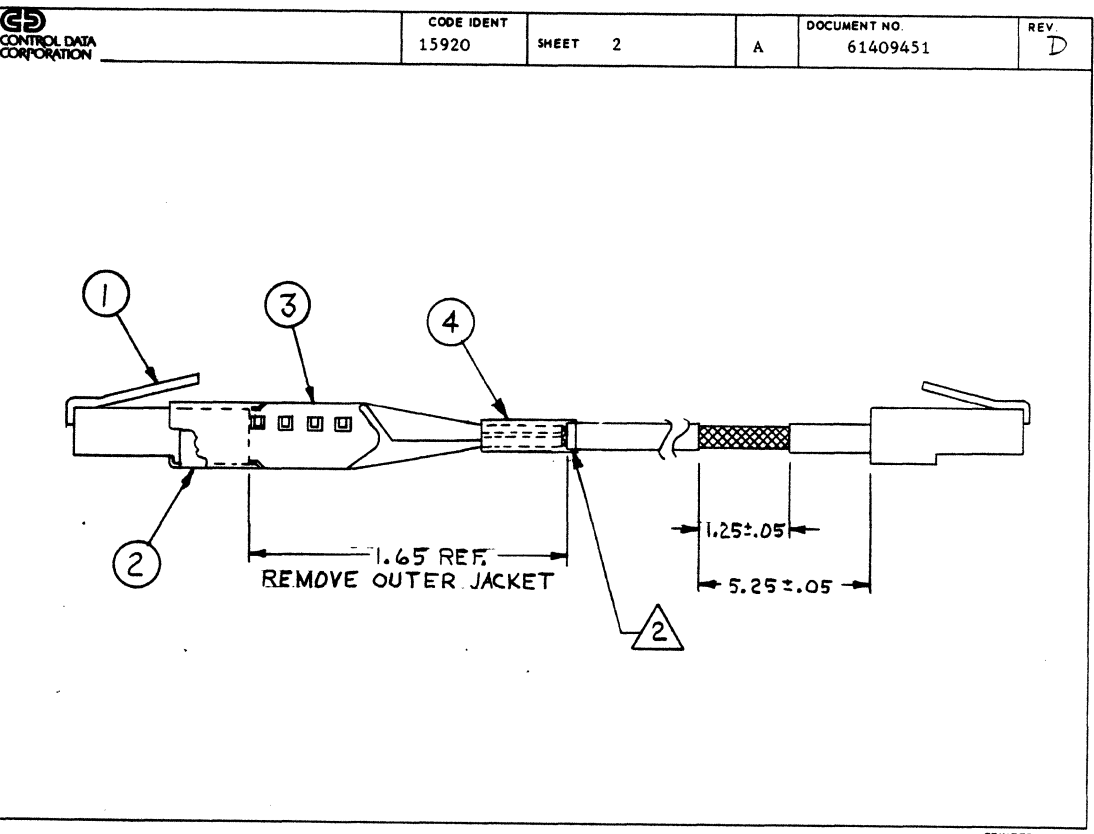

BUILD ARC 104

ASSEMBLY PARTS LIST

PRINT DATE	PAGE	FILE CHANGE NO.
09-06-83	1	00016127

REV.	ASSEMBLY NUMBER	CD	REV.	QTY.	DESCRIPTION	MC	STATUS	STATUS DATE	ENG. RESP.	FILE DATE			
0000	61409451	4	D	A	REPLACED BY 61409530 16127	A	INA	08-29-83	CC634A	09-05-83			
TRND NO	LI	PART NUMBER	CD	QTY	U/M	PART DESCRIPTION	MC	YLR	ECO. NO. IN	ECO. NO. OUT	S/M	WE IN	WE OUT
001	01	51941492	4	1		PC CBL, 4.6FT 8-CNDR F10-1		P					
002	01	71493655	6	1		PC SHIELD, INSIDE CONN (BRS/SN)		P					
003	01	71493656	4	1		PC SHIELD, OUTSIDE CONN (BRS/SN)		P					
004	01	51941505	3	1		PC FERRULE, YEL WRAP AROUND CU		P					
						0004 TOTAL LINES							

DWN	W GLASER	7/82	CONTROL DATA CORPORATION	TITLE	PREFIX	DOCUMENT NO.	REV
CHKD	<i>D. Glaser</i>	7-82		KEYBOARD CABLE ASSY	A	61409530	D
ENG	<i>D. Glaser</i>	1-82		FIRST USED ON	NHA		
MFG	<i>D. Glaser</i>	7-82		CC634-A	61409246	SHEET	1 of 2
APPR	<i>S. H. H. H.</i>	7-21-82	CODE IDENT				
			15920				

SHEET REVISION STATUS				REVISION RECORD								
				REV	ECO	DESCRIPTION	DRFT	DATE	APP			
				2	1							
				A	A	A		15150-82	RELEASED CLASS "A"	/	7-22-82	<i>McP</i>
				B	B	B		15580	REVISED PER ECO	BG	12/82	<i>EBB</i>
				C	C	C		16395	ADD NOTE 3 & BOTTOM VIEW	WJG 12-15-83	12/15/83	<i>WJB</i>
				D	D	D		16668	CHG FIG 3, DELETE NOTE 3	EE	6/21/84	<i>DL</i>

NOTES:
 1. Bulk identify with CDC part number.
 2. Overlap ferrule insulation onto cable jacket.

APL 61409530
DETACHED LISTS

AA3180 REV. 8 71 PRINTED IN U.S.A.

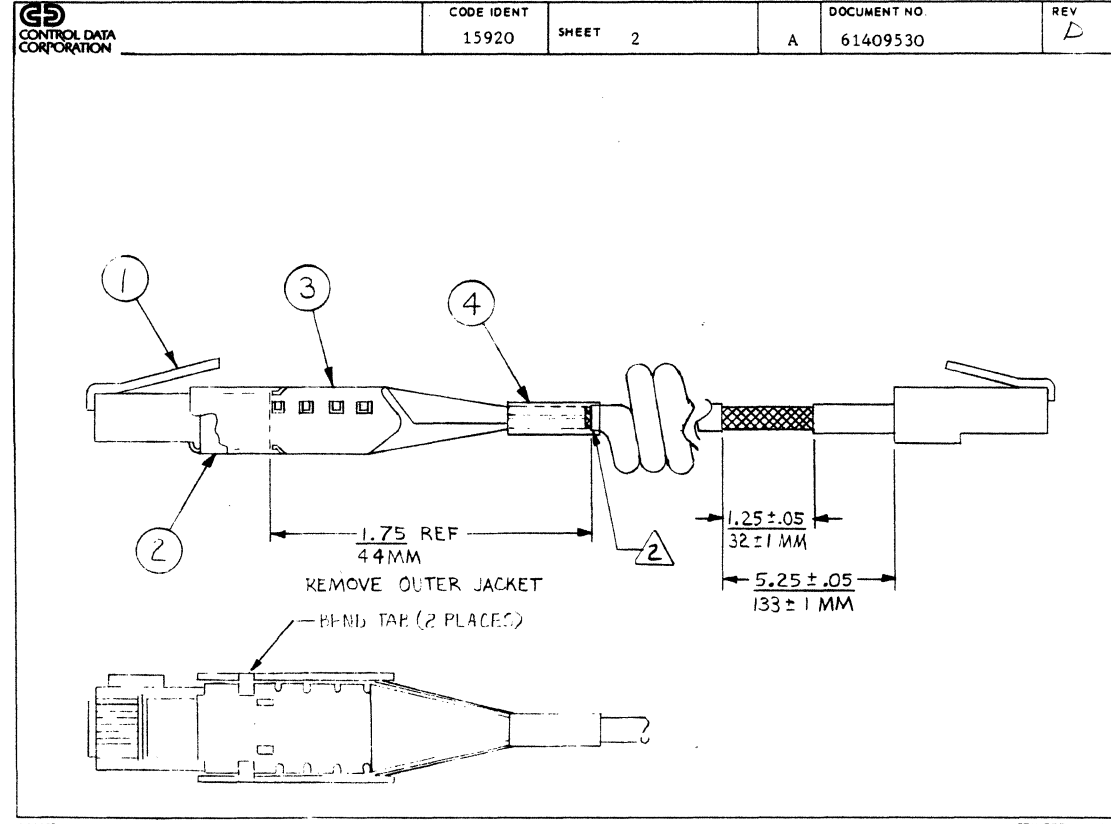

AA3180 PRINTED IN U.S.A.

BUILD ARC 104

ASSEMBLY PARTS LIST

PRINT DATE	PAGE	FILE CHANGE NO.
07-25-84	1	00016668

DIV.	ASSEMBLY NUMBER	CD	REV.	DWG.	DESCRIPTION	MC	STATUS	STATUS DATE	ENG. RESP.	FILE DATE			
0860	61409530	5	0	A	CBL ASSY, YX SHLD KEYBOARD	A	REL	07-22-82	CC83AA*	07-25-84			
TRND NO	LI	PART NUMBER	CD	QUANTITY	U/M	PART DESCRIPTION	MC	YLD	ECO. NO. IN	ECO. NO. OUT	S/H	WE IN	WE OUT
001	01	51941493	2	1		PC CBL, 10FT SHLD 8-CNTR FIG-2							
002	01	71493655	6	1		PC SHIELD, INSIDE CONN (8RS/SN)							
003	01	71493656	4	1		PC REPLACED BY 71494388 16668				16668			8443
003	02	71494388	3	1		PC SHIELD CONNECTOR OUTSIDE MET			16668			8443	
004	01	51941505	3	1		PC FERRULE, YEL WRAP AROUND CU							
0005 TOTAL LINES													

DWN	W. GLASER	9/81	CONTROL DATA	TITLE	PREFIX	DOCUMENT NO.	REV
CHKD	<i>D. J. ...</i>	9-81	WIRE JUMPER ASSY	A	61409245	C	
ENG	<i>D. J. ...</i>	10-181	FIRST USED ON				
MFG	<i>...</i>	1/1/82	CC634A			SHEET 1 of 2	
APPR	<i>W. H. ...</i>	8-27-82	CODE IDENT 15920				

SHEET REVISION STATUS				REVISION RECORD			
REV	ECO	DESCRIPTION	DRFT	DATE	APP		
01	00	RELEASED CLASS B	/	10/18/81	<i>[Signature]</i>		
01	01	ADD NOTE 2.	D.S.	11-9-81	<i>[Signature]</i>		
01	02	CHG. EQUIP. NO.	EQ	3-26-82	<i>[Signature]</i>		
A	A	RELEASED CLASS 'R'		3-20-82	<i>[Signature]</i>		
B	B	DELETE NOTE 2-MARKINGS	WJ36 9-30-83	10-5-83	<i>[Signature]</i>		
C	C	LENGTHEN WIRE PER ECO	WJ36 9-30-83	11-27-84	<i>[Signature]</i>		

NOTES:
1. Bulk identify with CDC part number.

APL 61409245
DETACHED LISTS

AA3180 REV. 8-71

PRINTED IN U.S.A.

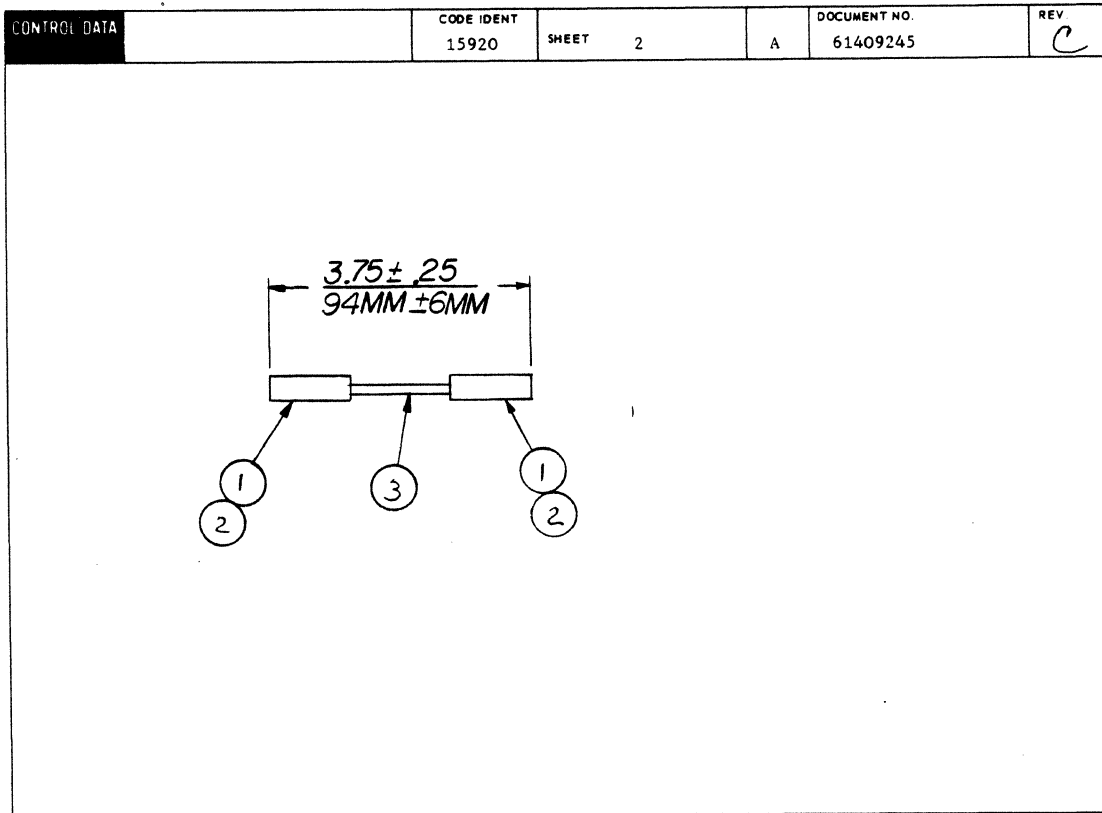

AA3185

PRINTED IN U.S.A.

ASSEMBLY PARTS LIST

BUILD ARC 104										PRINT DATE		PAGE		FILE CHANGE NO.			
										11-20-84		1		00016956			
										STATUS DATE		ENG. RESP.		FILE DATE			
										03-30-82		CC634A+		11-22-84			
Q860	ASSEMBLY NO.	CD	REV.	DWG.	DESCRIPTION				MC	STATUS							
TIME NO.	U	PART NO.	CD	QTY	U/M	PART DESCRIPTION				MC	YLD	ECO. NO. IN	ECO. NO. OUT	S/N	WK IN	WK OUT	
001	01	93747001	1	2		PC	RCPT, 22-18GA .02X.11 BR5/5M										
002	01	62020700	1	2		PC	HSG FIG-1 TERM LUG RECPT										
003	01	92810004	3	208		FT	WIR 18GA STRO YEL 600V UL PVC W						16956	16956			8448
003	02	92810004	3	313		FT	WIR 18GA STRO YEL 600V UL PVC W						16956			8448	
0004 TOTAL LINES																	

DWN	W. GLASER	8/81	CONTROL DATA	TITLE	PREFIX	DOCUMENT NO	REV
CHKD	<i>[Signature]</i>	8-81	INFORMATION	WIRE ASSY, CB/PWR SWITCH	A	61409209	C
ENG	<i>[Signature]</i>	10-1-81		FIRST USED ON	NHA		
MFG	<i>[Signature]</i>	4-82	CODE IDENT	CC634-A	61409170	SHEET	1 of 2
APPR	<i>[Signature]</i>	7-1-82	15920				

SHEET REVISION STATUS										REVISION RECORD					
REV	ECO	DESCRIPTION	DRFT	DATE	APP	2	1	REV	ECO	DESCRIPTION	DRFT	DATE	APP		
00	00	50006-49	RELEASED CLASS B	DS	11/1/80			00							
01	01	51404	CHANGE F/N 2, ADD F/N 5	DS	11-5-84			01							
01	02	51465	CHG F/N 3 & 4	WJG 12-26-81	12-28-81			02							
01	03	51499	F/N 3 WAS 24534709	WJG 1-21-82				03							
A	A	14232-51	RELEASED CLASS 'A'		4-6-82			A							
A	B	16563	F/N 4 WAS 93747026	DS	3-6-84			B							
C	C	16831	DELETE F/N 3	WJG 8-28-84	8-29-84			C							

NOTES:
1. Bulk identify with CDC part number.

APL 61409209
DETACHED LISTS

AA3180 REV. 8-71

PRINTED IN U.S.A.

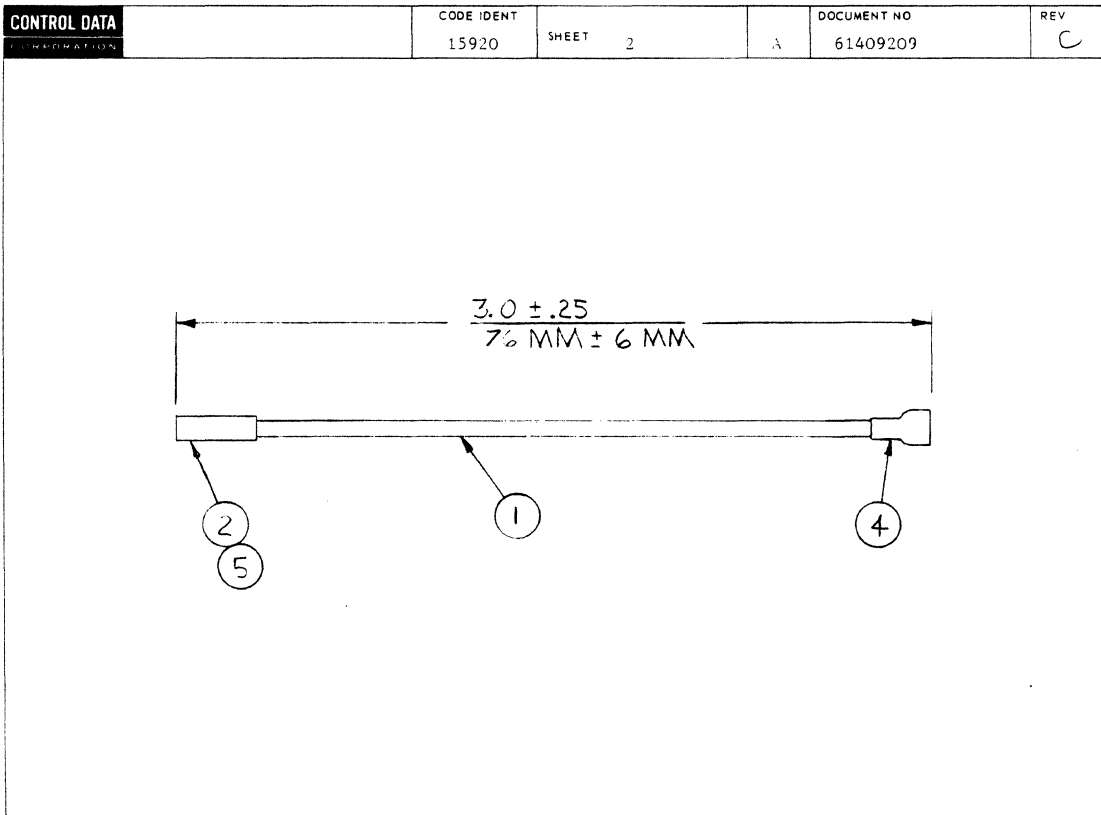

AA3185

PRINTED IN U.S.A.

BUILD ARC 1C4

ASSEMBLY PARTS LIST

										PRINT DATE	PAGE	FILE CHANGE NO.													
										08-20-84	1	00016831													
DIV	ASSEMBLY NUMBER	CD	REV.	DWG.	DESCRIPTION	MC	STATUS	STATUS DATE	ENG. RESP.	FILE DATE															
C860	61469209	A	C	A	WIRE ASSY. CKT BRK/PMR SW 3IN	A	REL	04-06-82	CC639A*	08-20-84	TRIP NO	LI	PART NUMBER	CD	QUANTITY	U/M	PART DESCRIPTION	MC	YLD	ECO. NO. IN	ECO. NO. OUT	S/N	WK IN	WK OUT	
	001	C1		52810001	9			250	FT	WIR 18GA STRD BRN 6CCV UL PVC	M														
	002	C1		93747001	1	1				PC RCPT, 22-18GA .02X.11 BR5/SN	P														
	003	C1		24534709	1		083		FT	SLVG, 1/4 FT/SPRINK UL BLACK	B										16831			8434	
	004	C1		93747026	8	1				PC RCPT, 22-18GA .032X.25 BR5/SN	P										16563	16563		8427	8427
	004	C2		51896502	5	1				PC TERMINAL, QUICK DISCONNECT	P														
	005	C1		62020700	1	1				PC MSG FIG-1 TERM LUG RECPT	P														
										0006 TOTAL LINES															

DWN	D. Sand	8/81	CONTROL DATA	TITLE	P.S. CONN ASSY	PREFIX	DOCUMENT NO	REV
CHKD	<i>D. Sand</i>	9-91	CORPORATION			A	61409210	A
ENG				FIRST USED ON		NHA		
MFG	<i>E. N. Roe</i>	2-9-82	CODE IDENT	CC634-A		61409170	SHEET	1 OF 2
APPR			15920					

SHEET REVISION STATUS				REVISION RECORD						
REV	ECO	DESCRIPTION	DRFT	DATE	APP					
00	00	OR 5006-49								
01	01	51404								
02	02	51465								
02	03	51499								
A	A	14232-51								

NOTES:

- Bulk identify with CDC part number.
- The end's of these wires shall be labeled as shown.

APL 61409210
DETACHED LISTS

AA3180 REV. 8-71

PRINTED IN U.S.A.

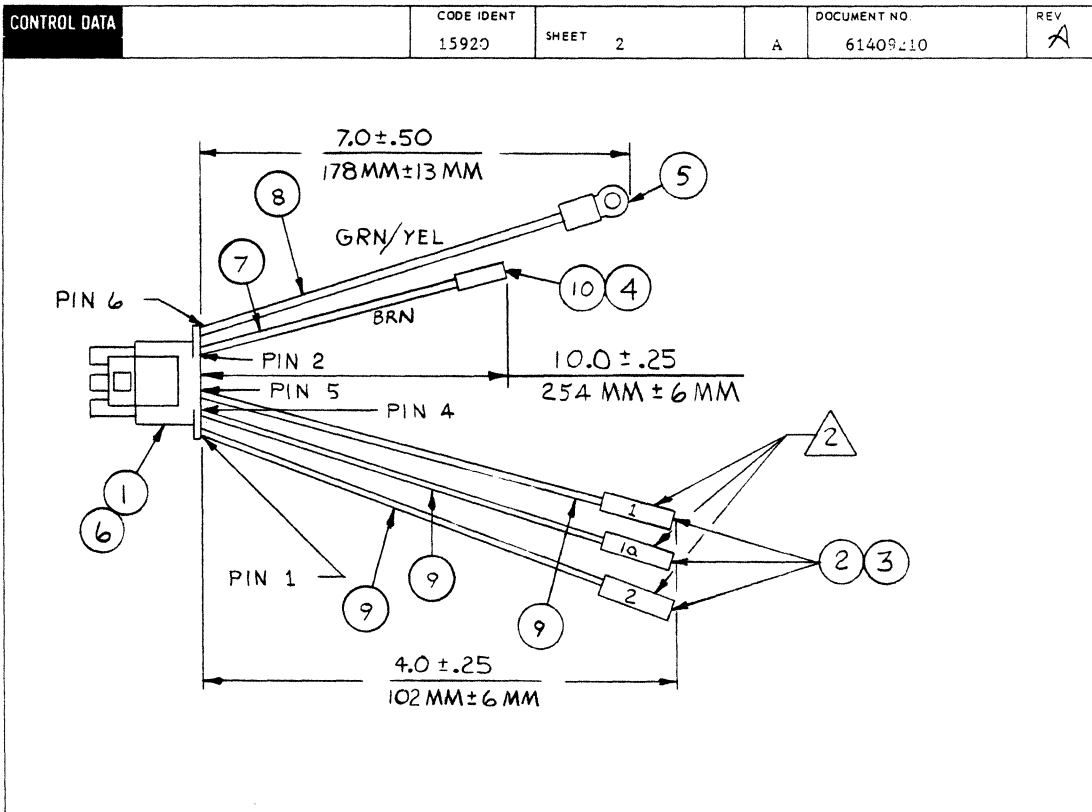

PRINTED IN U.S.A.

BUILD ARC 104

ASSEMBLY PARTS LIST

PRINT DATE	PAGE	FILE CHANGE NO.
04-08-82	1	14232-51

DIV.	ASSEMBLY NUMBER	CD	REV.	DWG.	DESCRIPTION	MC	STATUS	STATUS DATE	ENG. RESP.	FILE DATE				
0860	61409210	4	A	A	WIRE ASSY PWR CONN	A	REL	04-06-82	CC634A	04-08-82				
T/WIND	NO	LI	PART NUMBER	CD	QUANTITY	U/M	PART DESCRIPTION	MC	YLD	ECO. NO. IN	ECO. NO. OUT	S/N	WK IN	WK OUT
	001	01	51906003	2	1		PC CONN, 6 SKT PLUG FIG 2 NYLON	P						
	002	01	93747001	1	3		PC CONT, RCPT 22-18AWG B/TIN S	P						
	003	01	62020700	1	3		PC LUG HSG, FIG 1 RCPT STRAIGHT	B						
	004	01	24534709	1	083		FT SLVG, 1/4 HT/SHRINK BLK UL	B						
	005	01	51797214	7	1		PC LUG, NO. 8 CRMP-R 22-18AWG	P						
	006	01	51906200	4	5		PC CONT, SKT 20-14GA .130IT STR	P						
	007	01	52810001	9	833		FT WIR 18GA STRD BRN 600V UL PVC	W						
	008	01	52810020	9	583		FT WIR 18GA STRD GRN YEL STRIPE	W						
	009	01	52810004	3	1		FT WIR 18GA STRD YEL 600V UL PVC	W						
	010	01	93747026	8	1		PC CONT RCPT 22-18AWG B/TIN	P						
							0010 TOTAL LINES							

DWN	D. Sand	8/81	CONTROL DATA	TITLE	CABLE ASSY, POWER	PREFIX	DOCUMENT NO.	REV				
CHKD	D. Sand	8-81		FIRST USED ON	CC634-A	A	61409137	B				
ENG	D.W. Legner	11-81		CODE IDENT	15920	NHA	61409170	SHEET 1 OF 3				
MFG	P. J. Park	6-82										
APPR	E. H. Rose	8-31-82										
SHEET REVISION STATUS				REVISION RECORD								
				3	2	1	REV	ECO	DESCRIPTION	DRFT	DATE	APP
				00	00	00	00	50006-49	RELEASED CLASS B	/	10/1/81	[Signature]
				00	01	01	01	51466	CHG DRAWING F/N 1	D.S	12/24-81	[Signature]
				02	02	02	02	51494	ADD F/N 4, FIX W/L	WJG 1-25-82	2/22/81	[Signature]
				A	A	A	A	14232-51	RELEASED CLASS 'A'	-	4-6-82	[Signature]
				A	A	A	A	9401-80	Added INT-DIU LABEL	-	12-22-82	GE
				A	A	B	B	15699	Change Find No. 2	BG	1/83	WCB
NOTES:												
1. Bulk identify with CDC part number.												
										APL 61409137		
										DETACHED LISTS		

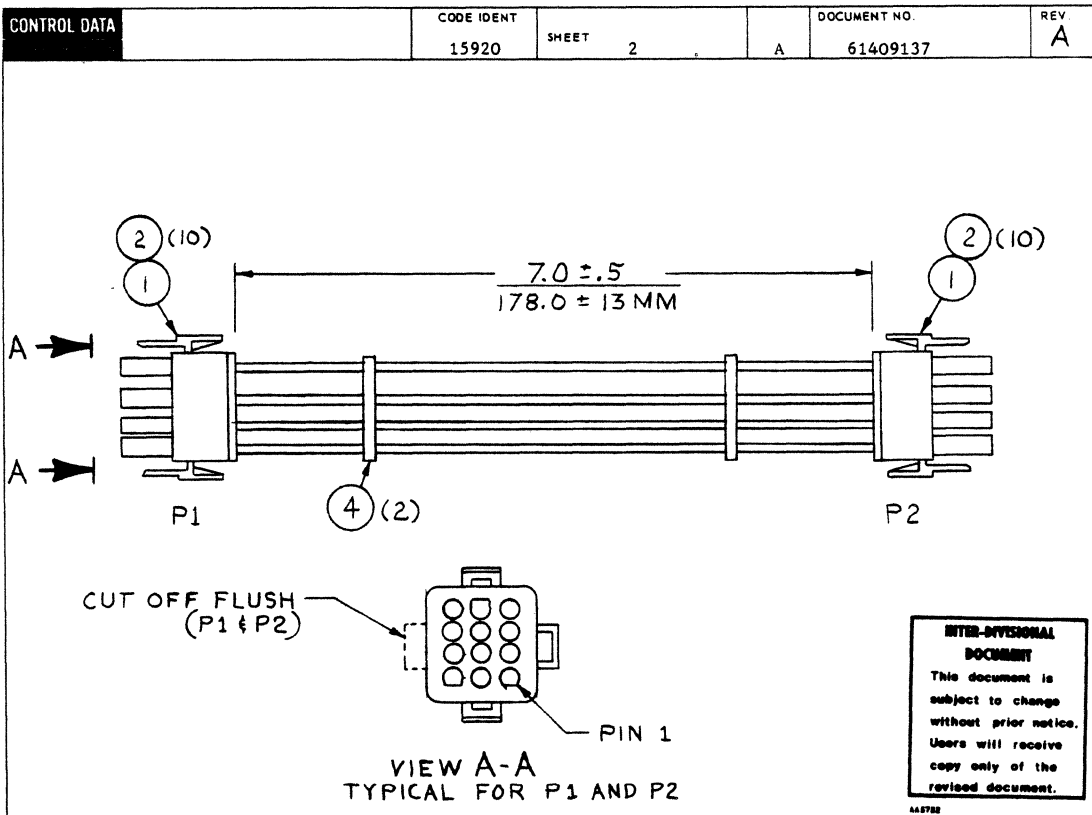

BUILD ARC 104

ASSEMBLY PARTS LIST

DIV.		ASSEMBLY NUMBER		CD	REV.	OWG.	DESCRIPTION		MC	STATUS	PRINT DATE	PAGE	FILE CHANGE NO.		
0060		61409137		9	B	A	CBL ASSY, 7IN POWER		S	REL	01-18-83	1	00015699		
TRFNO	LI	PART NUMBER	CD	IN	QUANTITY	U/M	PART DESCRIPTION		MC	YLD	ECO. NO. IN	ECO. NO. OUT	S/N	WK IN	WK OUT
001	01	51906005	7		2		PC CONN, PLUG 12 CKT NYL/NAT F-2		P						
002	01	51906200	4		20		PC CONT, SKT 20-14AWG SN STRIP		P			15699	15699		8302
002	02	51906201	2		20		PC CONT, SKT 20-14AWG SN STRIP		P					8302	
003	01	52810019	1		5	833	FT WIR 16GA STRO WHT 600V UL PVC		W						
004	01	94277400	1		2		PC STRAP, CBL TIE TYP-1 TO 5/8		B						
0005 TOTAL LINES															

DWN	W. Glaser	6/83	 CONTROL DATA CORPORATION	TITLE	FIRMWARE OPTION 4.0	PREFIX	DOCUMENT NO.	REV	
CHKD	<i>W. Glaser</i>	6-1-83		FIRST USED ON	YR109-A	NHA	15633357	SHEET	1 of 1
ENG	<i>H. J. Burmeister</i>	6-1-83		CODE IDENT	15920				
MFG	<i>H. J. Burmeister</i>	6/83							
APPR	<i>E. H. Rowe</i>	7-22-83							

SHEET REVISION STATUS						REVISION RECORD					
REV	ECO	DESCRIPTION	DRFT	DATE	APP	REV	ECO	DESCRIPTION	DRFT	DATE	APP
						00	CD	50010-85		6-2-83	JJ
						A	15153-54	RELEASED CLASS B		7-21-83	JJ
								RELEASED CLASS B			

NOTES

- This is the resident firmware used in the CC634B and CC638B Terminals.
- Special handling per 66202822.

APL 15633358
 DETACHED LISTS

PRINTED IN U.S.A.

BUILD ARC 440						ASSEMBLY PARTS LIST					PRINT DATE	PAGE	FILE CHANGE NO.
						15153-5D			1		07-29-83		
DIV	ASSEMBLY NUMBER	CD	REV.	DWG.	DESCRIPTION	MC	STATUS	STATUS DATE	ENG. RESP.	FILE DATE			
0860	15633358	5	A	A	FIRMWARE OPTION 4.0	N	REL	07-29-83	YR109A	07-29-83			
ITEM NO.	LI	PART NUMBER	CD	QUANTITY	U/M	PART DESCRIPTION	MC	YLD	ECO. NO. IN	ECO. NO. OUT	S/N	WK IN	WK OUT
001	01	66315365	B	1		PC NO D0C FIRMWARE RESIDENT	G						
002	01	66315366	6	1		PC NO D0C FIRMWARE RESIDENT	G						
003	01	66315367	4	1		PC NO D0C FIRMWARE RESIDENT	G						
						0003 TOTAL LINES							

DWN	E. Ersfeld	5/83	 CONTROL DATA CORPORATION	TITLE	GRAPHICS	PREFIX	DOCUMENT NO.	REV
CHKD	W. J. ...	6-1-83		TLA VIKING X DISPLAY TERMINAL	TLA	15633352		
ENG		FIRST USED ON	NHA	15633351	SHEET	1 of 1
MFG		CC638-B				
APPR		CODE IDENT				
			15920					

SHEET REVISION STATUS										REVISION RECORD				
REV	ECO	DESCRIPTION	DRFT	DATE	APP									
CD														
00	50010-85	RELEASED CLASS B		5-2-85										
01	52225	DELETE FROM 50010-85		5-22-85										
A	15153-54	RELEASED CLASS B		7-27-85										

NOTES

APL 15633352

DETACHED LISTS

AA3180 REV. 8/71 PRINTED IN U.S.A.

BUILD ARC 440										ASSEMBLY PARTS LIST										PRINT DATE	PAGE	PRI CHANGE NO.
																				08-01-83	1	15153-54
DIV.	ASSEMBLY NUMBER	CD	REV.	DWG.	DESCRIPTION	MC	STATUS	STATUS DATE	ENG. RESP.	FILE DATE												
0000	15633352	0	A	A	TERM, VXM W/GRPH/TP 60HZ (TA)	0	REL	07-29-83	CC0300	08-01-83												
TRIND NO	LI	PART NUMBER	CD	IN	QUANTITY	U/M	PART DESCRIPTION	MC	YLR	ECO. NO. IN	ECO. NO. OUT	S/N	WE IN	WE OUT								
001	01	15633350	2		1		PC TERM, VXM I/O DSPL 60HZ (TA)	0														
002	01	15632921	1		1		PC OPT, VX GRPH/TOUCH PNL (TA)	N														
004	01	66315003	0	REF			PC DWS, 721 LARGE OPTION INSTL	D														
007	01	15165000	0		4		PC NUT, HEX/FLG-LK M4 STL ZP	0														
0000 TOTAL LINES																						

DWN	E. Ersfeld	5/83	 CONTROL DATA CORPORATION	TITLE	TLA TOUCH PANEL OPTION	PREFIX	DOCUMENT NO.	REV.
CHKD	W. J. ...	6-1-83		FIRST USED ON	XA369-A	TLA	15633356	C
ENG		CODE IDENT	15920	NHA	15633355	SHEET 1 of 1
MFG						
APPR						

SHEET REVISION STATUS				REVISION RECORD			
REV	ECO	DESCRIPTION	DRFT	DATE	APP		
00	CD	RELEASED CLASS B	/	6-3-83	EE		
A	15153-54	RELEASED CLASS "A"	/	6-29-83	ME		
B	16723	CHG P/N 7, ADD NOTE 1	EE	7/10/84	EE		
C	17023	ADDED P/N 11 CHG NOTE 1	EE	7/27/85	EE		

NOTES

1. F/N's 9,10 & 11 (Qty 2 ea.) are required for early units already in the field.

AFL 15633356
DETACHED LISTS

AA3180 REV. 8-71

PRINTED IN U.S.A.

ASSEMBLY PARTS LIST

BUILD ARC 43C		PRINT DATE		PAGE		FILE CHANGE NO.							
G86G		01-16-85		1		C0017023							
ASSEMBLY NO. 15633356		STATUS DATE		ENG. RESP.		FILE DATE							
CD REV. C A		C7-29-83		XA369A		01-16-85							
TRND NO.	U	PART NO.	CD	QUANTITY	U/M	PART DESCRIPTION	MC	YLD	ECO. NO. IN	ECO. NO. OUT	S/N	WK. IN	WK. OUT
CC1	C1	51541404	9	1		PC TOUCH PANEL, CPT ANTIGLARE	P						
CC2	C1	71493588	9	2		PC REPLACED BY 71494524 16896	P						
CC3	C1	71493589	7	1		PC REPLACED BY 71494524 16896	P						
CC4	C1	61409475	3	1		PC REPLACED BY 71494524 16896	N						
CC5	C1	71493833	9	1		PC CLAMP CABLE	P						
CC6	C1	15165002	5	4		PC NUT, HEX/FLG-LK #6 STL ZP	B						
CC7	C1	15164913	4	2		PC MSCR HEX/W-LK PLN #4X12MM STL	B		16723	16723		8428	8428
CC7	C2	15164911	8	2		PC MSCR HEX/W-LK PLN #4X8MM STL	B					8428	
CC8	C1	36485900	9	1		PC WSHR, .2570-HOLE FLAT CRS/CDP	B						
CC9	C1	91975723	7	2		PC NUT, HEX #4 STL ZP	B			17023		8502	8502
CC9	C2	91975723	7	REF		PC NUT, HEX #4 STL ZP	B		17023			8502	
CC10	C1	91975670	0	2		PC WSHR, #4 EXT/T SPG-STL ZP	B			17023		8502	8502
CC10	C2	91975670	0	REF		PC WSHR, #4 EXT/T SPG-STL ZP	B		17023			8502	
CC11	C1	15164913	4	REF		PC MSCR HEX/W-LK PLN #4X12MM STL	B		17023			8502	
0014 TOTAL LINES													

DWN	J. Gronski	2/82	CONTROL DATA CORPORATION	TITLE	PREFIX	DOCUMENT NO.	REV.
CHKD				Keyboard Conversion Kit, U.K.	TLA	66315930	B
ENG	<i>J. J. Church</i>	3/82		FIRST USED ON			
MFG	<i>J. H. Lee</i>	4/82		CC634-A	NHA		
APPR	<i>J. H. Lee</i>	4/5/82	CODE IDENT		15633078	SHEET	1 OF 1
E.S.			15920				

SHEET REVISION STATUS				REVISION RECORD						
REV	ECO	DESCRIPTION	DRFT	DATE	APP	4	3	2	1	
						A	A	A	A	
	14232-59	RELEASED CLASS "A"		4-13-82	<i>met</i>	-	-	-	-	
	15428	REVISED PER ECO	<i>met</i>	10-15/82	<i>dec</i>	-	-	-	B	

NOTES:

APL 66315930
 DETACHED LISTS

WP0160a
CD4987R

BUILD ARC 440										ASSEMBLY PARTS LIST				PRINT DATE	PAGE	FILE CHANGE NO.
														10-06-82	1	00015428
DIV.	ASSEMBLY NUMBER	CD	REV.	DWG.	DESCRIPTION	MC	STATUS	STATUS DATE	ENG. RESP.	FILE DATE						
0860	66315930	9	B	A	KIT, UK VX-KYBD INSTL (TA)	N	REL	04-33-82	YA274A	10-06-82						
TRND NO	LI	PART NUMBER	CD	QUANTITY	U/M	PART DESCRIPTION	MC	YLD	ECO. NO. IN	ECO. NO. OUT	S/N	WK IN	WK OUT			
001	01	66302320	8	1		PC KEYCAP	P									
002	01	66310438	8	1		PC KEYCAP 3 L 1H 2H COLOR B	P									
003	01	66302322	4	1		PC KEYCAP	P									
004	01	66302020	4	1		PC KEYCAP	P									
005	01	66302040	2	1		PC KEYCAP	P									
006	01	66302041	0	1		PC KEYCAP	P									
007	01	66302049	3	1		PC KEYCAP	P									
008	01	66302050	1	1		PC KEYCAP	P									
009	01	66312525	0	2		PC CAPACITIVE SPRING	P									
010	01	66312526	8	4		PC SINGLE RETURN SPRING	P									
011	01	71493510	3	1		PC KEYCAP REMOVAL TOOL	P									
012	01	66328195	4	1		PC KEYBOARD CONVERSION KIT U.K. INSTALLATION AND OPERATION	D		15428					8236		
												0012 TOTAL LINES				

DWN	J. Gronski	2/82	CONTROL DATA CORPORATION	TITLE	PREFIX	DOCUMENT NO.	REV.
CHKD					TLA	66315931	C
ENG	<i>A. J. Chynoweth</i>	3/82		Keyboard Conversion Kit, Spanish			
MFG	<i>A. J. Chynoweth</i>	4/82		FIRST USED ON			
APPR	<i>S. W. H. H.</i>	4-5-82	CODE IDENT	YA274B	NHA	SHEET	1 OF 1
E.S.			15920		15633079		

SHEET REVISION STATUS				REVISION RECORD						
4	3	2	1	REV	ECO	DESCRIPTION	DRFT	DATE	APP	
	A	A	A	A	14232-59	RELEASED CLASS X	-	4-13-82	<i>MK</i>	
	B	A	B	B	15290	REVISED PER ECO	MK	8-12-82	<i>AWG</i>	
	-	-	-	C	15428	REVISED PER ECO	EE	1/27/82	<i>AWG</i> 10/2/82	

NOTES:

APL 66315931
 DETACHED LISTS

WPO160a
CD4988R

BUILD ARC 440		ASSEMBLY PARTS LIST				PRINT DATE	PAGE	FILE CHANGE NO.					
						10-06-82	1	00015428					
DIV.	ASSEMBLY NUMBER	CD	REV.	QTY.	DESCRIPTION	MC	STATUS	STATUS DATE	ENG. RESP.	FILE DATE			
0840	66315931	T	C	A	KEYBOARD CONVERSION KIT - SPANISH	N	REL	04-13-82	YA274B	10-06-82			
ITEM NO.	LI	PART NUMBER	CD	QTY.	U/M	PART DESCRIPTION	MC	YLD	ECO. NO. IN	ECO. NO. OUT	S/N	WK IN	WK OUT
001	01	66302186	3	1		PC KEYCAP	P						
002	01	66302322	4	1		PC KEYCAP	P						
003	01	66302020	4	1		PC KEYCAP	P						
004	01	66302323	2	1		PC KEYCAP	P						
004	02	66302363	8	1		PC KEYCAP	P	15290	15290			0232	0232
005	01	66302324	0	1		PC KEYCAP	P						
006	01	66301025	4	1		PC KEYCAP	P			15290			0232
006	02	66302364	6	1		PC KEYCAP	P	15290	15290			0232	0232
007	01	66302037	8	1		PC KEYCAP	P						
008	01	66302040	2	1		PC KEYCAP	P						
009	01	66302041	0	1		PC KEYCAP	P						
010	01	66302049	3	1		PC KEYCAP	P			15290			0232
010	02	66302342	2	1		PC KEYCAP	P	15290	15290			0232	0232
011	01	66302050	1	1		PC KEYCAP	P			15290			0232
011	02	66302343	0	1		PC KEYCAP	P	15290	15290			0232	0232
012	01	66312525	0	2		PC CAPACITIVE SPRING	P						
013	01	66312526	0	1		PC SINGLE RETURN SPRING	P						
014	01	71493510	3	1		PC KEYCAP REMOVAL TOOL	P						
015	01	66320196	2	1		PC KEYBOARD CONVERSION KIT SPANISH INSTALLATION AND OPERATION 0019 TOTAL LINES	D	15428					0236

BUILD ARC 440

ASSEMBLY PARTS LIST

PRINT DATE	PAGE	FILE CHANGE NO.
10-06-82	1	00015428

DIV.	ASSEMBLY NUMBER	CD	REV.	DWG.	DESCRIPTION	MC	STATUS	STATUS DATE	ENG. RESP.	FILE DATE				
0860	66315932	S	B	A	<i>KEYBD CONV KIT FOR GERMAN KIT ON VR KEYBD INSTL (TA)</i>	N	REL	04-13-82	YA274C	10-06-82				
TP	IND NO	LI	PART NUMBER	CD	QUANTITY	U/M	PART DESCRIPTION	MC	YLD	ECO. NO. IN	ECO. NO. OUT	S/N	WK IN	WK OUT
			001 01	66302325	7	1	PC KEYCAP	P						
			002 01	66302326	5	1	PC KEYCAP	P						
			003 01	66302327	3	1	PC KEYCAP	P						
			004 01	66302328	1	1	PC KEYCAP	P						
			005 01	66302329	9	1	PC KEYCAP	P						
			006 01	66302330	7	1	PC KEYCAP	P						
			007 01	66302331	5	1	PC KEYCAP	P						
			008 01	66302332	3	1	PC KEYCAP	P						
			009 01	66302333	1	1	PC KEYCAP	P						
			010 01	66302334	9	1	PC KEYCAP	P						
			011 01	66302322	4	1	PC KEYCAP	P						
			012 01	66302020	4	1	PC KEYCAP	P						
			013 01	66302335	6	1	PC KEYCAP	P						
			014 01	66302336	4	1	PC KEYCAP	P						
			015 01	66302337	2	1	PC KEYCAP	P						
			016 01	66302338	0	1	PC KEYCAP	P						
			017 01	66302339	8	1	PC KEYCAP	P						
			018 01	66302340	6	1	PC KEYCAP	P						
			019 01	66302040	2	1	PC KEYCAP	P						
			020 01	66302041	0	1	PC KEYCAP	P						
			021 01	66302341	4	1	PC KEYCAP	P						

BUILD ARC 440

ASSEMBLY PARTS LIST

PRINT DATE	PAGE	FILE CHANGE NO.
10-06-82	2	00015428

DIV.	ASSEMBLY NUMBER	CD	REV.	DWG.	DESCRIPTION	MC	STATUS	STATUS DATE	ENG. RESP.	FILE DATE				
0860	66315932	S	B	A	<i>KEYBD CONV KIT FOR GERMAN KIT ON VR KEYBD INSTL (TA)</i>	N	REL	04-13-82	YA274C	10-06-82				
TP	IND NO	LI	PART NUMBER	CD	QUANTITY	U/M	PART DESCRIPTION	MC	YLD	ECO. NO. IN	ECO. NO. OUT	S/N	WK IN	WK OUT
			022 01	66302342	2	1	PC KEYCAP	P						
			023 01	66302343	0	1	PC KEYCAP	P						
			024 01	66302344	8	1	PC KEYCAP	P						
			025 01	66312525	0	2	PC CAPACITIVE SPRING	P						
			026 01	66312526	8	4	PC SINGLE RETURN SPRING	P						
			027 01	71493510	3	1	PC KEYCAP REMOVAL TOOL	P						
			028 01	66328197	0	1	PC <i>KEYBD CONVERSION KIT GERMAN INSTALLATION AND OPERATION 0028 TOTAL LINES</i>	D	15428				8236	

DWN	J. Gronski	2/82	CONTROL DATA CORPORATION	TITLE	PREFIX	DOCUMENT NO.	REV.								
CHKD				Keyboard Conversion Kit, French	TLA	66315933	B								
ENG	<i>John Grogan</i>	3/82													
MFG	<i>L. J. Smith</i>	4/82													
APPR	<i>E. V. Hill</i>	4-5-82	CODE IDENT	FIRST USED ON	NHA	SHEET									
E.S.			15920		15633081	1 OF 1									
				CC634-A											
SHEET REVISION STATUS					REVISION RECORD										
					5	4	3	2	1	REV	ECO	DESCRIPTION	DRFT	DATE	APP
					A	A	A	A	A	A	1423259	RELEASED CLASS A	-	4-13-82	11:4
					-	-	-	-	B	B	15920	REVISED PER ECO	EE	11/27/82	82
NOTES:															
APL 66315933 DETACHED LISTS															

WP0160a
CD4990R

BUILD ARC 440

ASSEMBLY PARTS LIST

PRINT DATE 10-06-82 PAGE 1 FILE CHANGE NO. 00015428

DIV.	ASSEMBLY NUMBER	CD	REV.	DWG.	DESCRIPTION	MC	STATUS	STATUS DATE	ENG. RESP.	FILE DATE				
0860	66315933	3	B	A	KYBD CONV KIT FRENCH KIT. FR. VLS KYBD INSTL (FR)	N	REL	04-13-82	YA2740	10-06-82				
TRIND NO	LI	PART NUMBER	CD	AM	QUANTITY	U/M	PART DESCRIPTION	MC	YLD	ECO. NO. IN	ECO. NO. OUT	S/N	WK IN	WK OUT
001	01	66302325	7		1		PC KEYCAP	P						
002	01	66302326	5		1		PC KEYCAP	P						
003	01	66302327	3		1		PC KEYCAP	P						
004	01	66302345	5		1		PC KEYCAP	P						
005	01	66302329	9		1		PC KEYCAP	P						
006	01	66302330	7		1		PC KEYCAP	P						
007	01	66302331	5		1		PC KEYCAP	P						
008	01	66302332	3		1		PC KEYCAP	P						
009	01	66302346	3		1		PC KEYCAP	P						
010	01	66302347	1		1		PC KEYCAP	P						
011	01	66302322	4		1		PC KEYCAP	P						
012	01	66302020	4		1		PC KEYCAP	P						
013	01	66302348	9		1		PC KEYCAP	P						
014	01	66302349	7		1		PC KEYCAP	P						
015	01	66310439	6		1		PC KEYCAP E E 1M 2J COLOR B	P						
016	01	66302351	3		1		PC KEYCAP	P						
017	01	66302352	1		1		PC KEYCAP	P						
018	01	66302040	2		1		PC KEYCAP	P						
019	01	66302041	0		1		PC KEYCAP	P						
020	01	66302342	2		1		PC KEYCAP	P						
021	01	66302343	0		1		PC KEYCAP	P						

BUILD ARC 440

ASSEMBLY PARTS LIST

PRINT DATE 10-06-82 PAGE 2 FILE CHANGE NO. 00015428

DIV.	ASSEMBLY NUMBER	CD	REV.	DWG.	DESCRIPTION	MC	STATUS	STATUS DATE	ENG. RESP.	FILE DATE				
0860	66315933	3	B	A	KYBD CONV KIT FRENCH KIT. FR. VLS KYBD INSTL (FR)	N	REL	04-13-82	YA2740	10-06-82				
TRIND NO	LI	PART NUMBER	CD	AM	QUANTITY	U/M	PART DESCRIPTION	MC	YLD	ECO. NO. IN	ECO. NO. OUT	S/N	WK IN	WK OUT
022	01	66302344	8		1		PC KEYCAP	P						
023	01	66312525	0		2		PC CAPACITIVE SPRING	P						
024	01	66312526	8		4		PC SINGLE RETURN SPRING	P						
025	01	71493510	3		1		PC KEYCAP REMOVAL TOOL	P						
026	01	66328198	8		1		PC KYBD CONVERSION KIT FRENCH INSTALLATION AND OPERATION 0026 TOTAL LINES	D	15428				8236	

DWN	J. Gronski	2/82	CONTROL DATA CORPORATION	TITLE	PREFIX	DOCUMENT NO.	REV.			
CHKD				Keyboard Conversion Kit, Swedish/Finnish	TLA	66315934	E			
ENG	<i>E. G. Johnson</i>	<i>3/82</i>	CODE IDENT 15920	FIRST USED ON	NHA	SHEET 1 OF 1				
MFG	<i>E. G. Johnson</i>	<i>4/82</i>		YA274E	15633082					
APPR	<i>E. G. Johnson</i>	<i>4-5-82</i>								
E.S.										
SHEET REVISION STATUS					REVISION RECORD					
				5 4 3 2 1	REV	ECO	DESCRIPTION	DRFT	DATE	APP
				A A A A A	A	14232-59	RELEASED CLASS "A"	-	4-13-82	MJK
				B A A B B	B	15290	REVISED PER ECO	MK	8-12-82	ONG
				- - - - C	C	15428	REVISED PER ECO	EE	1/27/82	MJK
				- - - - -	D	15781	CHG F/N 17 & 22	WJG 4-18-83	4/21/83	SFK
					E	16145	CHANGED FN 16	EE	7/26/83	A:B
NOTES:										
					<div style="border: 1px solid black; padding: 2px;"> APL 66315934 DETACHED LISTS </div>					

WP0160a
CD4991R

BUILD ARC 430		ASSEMBLY PARTS LIST				PRINT DATE	PAGE	FILE CHANGE NO.					
						10-24-83	1	00010145					
DIV	ASSEMBLY NUMBER	CD	REV	DWG	DESCRIPTION	MC	STATUS	STATUS DATE	ENG. RESP.	FILE DATE			
0860	66315934	1	E	A	KYBD CONV KIT TLA SWED/PIN	N	REL	04-13-82	YA274E	10-24-83			
FIND NO.	U	PART NUMBER	CD	QTY	U/M	PART DESCRIPTION	MC	YLD	ECO. NO. IN	ECO. NO. OUT	S/N	WK IN	WK OUT
001	01	66302325	7	1		PC KEYCAP, SYM CHAR 2AE/1M CC-E	P						
002	01	66302326	5	1		PC KEYCAP (2 + SYM) 20/1M CC-E	P						
003	01	66302328	1	1		PC KEYCAP (6 + SYM) 20/1M CC-E	P						
004	01	66302329	9	1		PC KEYCAP (7/) 20/1M CC-E	P						
005	01	66302330	7	1		PC KEYCAP (8/()) 20/1M CC-E	P						
006	01	66302331	5	1		PC KEYCAP (9/) 20/1M CC-E	P						
007	01	66302332	3	1		PC KEYCAP (0 + SYM) 20/1M CC-E	P						
008	01	66302353	9	1		PC KEYCAP, SYM CHAR 2AE/1M CC-E	P						
009	01	66302354	7	1		PC KEYCAP, SYM CHAR 2A/1M CC-E	P						
010	01	66302322	4	1		PC KEYCAP, SYM CHAR 2L/1AE CC-F	P						
011	01	66302020	4	1		PC KEYCAP, SYM CHAR 2U/1F CC-F	P						
012	01	66302355	4	1		PC KEYCAP, SYM CHAR 2A/1L CC-E	P						
013	01	66302336	4	1		PC KEYCAP, SYM CHAR 2A/1L CC-E	P						
014	01	66302338	0	1		PC KEYCAP, SYM CHAR 2A/1A CC-E	P						
015	01	66302339	8	1		PC KEYCAP, SYM CHAR 2A/1A CC-E	P						
016	01	66302356	2	1		PC KEYCAP, SYM CHAR 2AE/1A CC-E	P						
016	02	66302381	0	1		PC KEYCAP 2AE 1A E	P		10145	10145		0335	0335
017	01	66302040	2	1		PC KEYCAP, SYM CHAR 20/1M CC-F	P						
017	02	66302380	2	1		PC KEYCAP LEGENDS COLOR F	P		15781	15781		0311	0311
018	01	66302041	0	1		PC KEYCAP, SYM CHAR 2AE/1L CC-E	P						
019	01	66302342	2	1		PC KEYCAP, SYM CHAR 2F/1L CC-E	P						
020	01	66302343	0	1		PC KEYCAP, SYM CHAR 2F/1L CC-E	P						

BUILD ARC 430		ASSEMBLY PARTS LIST				PRINT DATE	PAGE	FILE CHANGE NO.					
						10-24-83	2	00010145					
DIV	ASSEMBLY NUMBER	CD	REV	DWG	DESCRIPTION	MC	STATUS	STATUS DATE	ENG. RESP.	FILE DATE			
0860	66315934	1	E	A	KYBD CONV KIT TLA SWED/PIN	N	REL	04-13-82	YA274E	10-24-83			
FIND NO.	U	PART NUMBER	CD	QTY	U/M	PART DESCRIPTION	MC	YLD	ECO. NO. IN	ECO. NO. OUT	S/N	WK IN	WK OUT
021	01	66302344	8	1		PC KEYCAP (-/-) 2AE/1L CC-E	P						
022	01	66312525	0	2		PC CHERRY-010-0340 SP6, DUAL-RTN	P						
023	01	66312526	8	4		PC CHERRY-010-0341 SP6, SGL-RTN	P						
024	01	71493510	3	1		PC TOOL, KEYCAP REMOVAL (STL/NI)	P						
025	01	66302362	0	1		PC KEYCAP (4 + SYM) 20/1M CC-E	P		10290			0232	
026	01	66328199	6	1		PC INSTR, SW/FN KYBD CONV INSTL	D		15428			0234	
0028 TOTAL LINES													

DWN	J. Gronski	2/82	CONTROL DATA CORPORATION	TITLE	PREFIX	DOCUMENT NO.	REV.								
CHKD				Keyboard Conversion Kit, Danish/Norwegian	TLA	66315935	E								
ENG	<i>E.J. Croush</i>	<i>3/82</i>													
MFG	<i>D.J. ...</i>	<i>4/82</i>													
APPR	<i>E.H. ...</i>	<i>4-8-82</i>	CODE IDENT	FIRST USED ON	NHA	SHEET									
E.S.			15920	YA274F	15633083	1 OF 1									
SHEET REVISION STATUS					REVISION RECORD										
					5	4	3	2	1	REV	ECO	DESCRIPTION	DRAFT	DATE	APP
					-	A	A	A	A	A	14232-52	RELEASED CLASS A	-	4-13-82	<i>Rif</i>
						B	A	B	B	B	15290	REVISED PER ECO	MC	9-12-82	<i>Sub</i>
						-	-	-	-	C	15220	RE 11566 PER ECO	EG	10/27/82	<i>H2</i>
						-	-	-	-	D	15781	CHG F/N 18 & 23	WJG 4-18-83	4/21/83	<i>Rif</i>
										E	16195	CHANGED F/N 17	EE	9/26/83	<i>203A</i>
NOTES:															
APL 66315935 DETACHED LISTS															

WP0160a
CD4992R

BUILD ARC 430

ASSEMBLY PARTS LIST

PRINT DATE 10-24-83 PAGE 1 FILE CHANGE NO 00016145

DIV	ASSEMBLY NUMBER	CD	REV	DWG	DESCRIPTION	MC	STATUS	STATUS DATE	ENG. RESP	FILE DATE			
0000	66315935	B	E	A	KYBD CONV KIT TLA DAN/NORW	N	REL	04-13-82	YA274F	10-24-83			
ITEM NO	LI	PART NUMBER	CD	QTY	U/M	PART DESCRIPTION	MC	YLD	ECO. NO. IN	ECO. NO. OUT	S/N	WK IN	WK OUT
001	01	66302325	7	1		PC KEYCAP, SYM CHAR 2AE/1M CC-E	P						
002	01	66302326	5	1		PC KEYCAP (2 + SYM) 20/1M CC-E	P						
004	01	66302328	1	1		PC KEYCAP (6 + SYM) 20/1M CC-E	P						
005	01	66302329	9	1		PC KEYCAP (7/) 20/1M CC-E	P						
006	01	66302330	7	1		PC KEYCAP (8/()) 20/1M CC-E	P						
007	01	66302331	5	1		PC KEYCAP (9/) 20/1M CC-E	P						
008	01	66302332	3	1		PC KEYCAP (0 + SYM) 20/1M CC-E	P						
009	01	66302353	9	1		PC KEYCAP, SYM CHAR 2AE/1M CC-E	P						
010	02	66302360	4	1		PC KEYCAP, SYM CHAR 2AE/1M CC-E	P		15290			8232	
011	01	66302322	4	1		PC KEYCAP, SYM CHAR 2L/1AE CC-F	P						
012	01	66302020	4	1		PC KEYCAP, SYM CHAR 2U/1F CC-F	P						
013	01	66302355	4	1		PC KEYCAP, SYM CHAR 2A/1L CC-E	P						
014	02	66302361	2	1		PC KEYCAP, SYM CHAR 2AE/1P CC-E	P		15290			8232	
015	01	66302350	5	1		PC KEYCAP (AE) 2A/1A CC-E	P						
016	01	66302321	6	1		PC KEYCAP (0) 2A/1A CC-E	P						
017	01	66302356	2	1		PC KEYCAP, SYM CHAR 2AE/1A CC-E	P			16145			8335
017	02	66302301	0	1		PC KEYCAP 2AE 1A E	P		16145			8335	
018	01	66302040	2	1		PC KEYCAP, SYM CHAR 20/1N CC-F	P			15781			8311
018	02	66302300	2	1		PC KEYCAP LEGENDS COLOR F	P		15781			8311	
019	01	66302041	0	1		PC KEYCAP, SYM CHAR 2AE/1L CC-E	P						
020	01	66302342	2	1		PC KEYCAP, SYM CHAR 2F/1L CC-E	P						
021	01	66302343	0	1		PC KEYCAP, SYM CHAR 2F/1L CC-E	P						

BUILD ARC 430

ASSEMBLY PARTS LIST

PRINT DATE 10-24-83 PAGE 2 FILE CHANGE NO 00016145

DIV	ASSEMBLY NUMBER	CD	REV	DWG	DESCRIPTION	MC	STATUS	STATUS DATE	ENG. RESP	FILE DATE			
0000	66315935	B	E	A	KYBD CONV KIT TLA DAN/NORW	N	REL	04-13-82	YA274F	10-24-83			
ITEM NO	LI	PART NUMBER	CD	QTY	U/M	PART DESCRIPTION	MC	YLD	ECO. NO. IN	ECO. NO. OUT	S/N	WK IN	WK OUT
022	01	66302344	0	1		PC KEYCAP (-/-) 2AE/1L CC-E	P						
023	01	66312525	0	2		PC CHERRY-010-0340 SPG, DUAL-RTN	P						
024	01	66312526	0	4		PC CHERRY-010-0341 SPG, SGL-RTN	P						
025	01	71493510	3	1		PC TOOL, KEYCAP REMOVAL (STL/NI)	P						
026	01	66320200	2	1		PC INSTR, DN/NW KYBD CONV INSTL	D		15428			9236	
0027 TOTAL LINES													

LTR	ECO	DESCRIPTION	DATE	APPROVAL
A	14232-27	RELEASED CLASS A	3-11-82	<i>[Signature]</i>
B	15493	REVISED CROSS REF. LIST	EE 12/19/82	<i>[Signature]</i>
C	15942	REVISED SHEETS 2 & 3	6-2-73	<i>[Signature]</i>

RECORD OF REVISION STATUS OF EACH SHEET

1	2	3	4	5	6	7	8	9											
A	A	A	A	A	A	A	A	A											
B	A	B	A	A	A	A	A	A											
C	C	C	A	A	A	A	A	A											

DRAWN BY J. Gronski	DATE 02/82	TITLE SOURCE/CROSS REFERENCE LIST VIKING X KEYBOARD		CONTROL DATA CORPORATION CODE IDENT 15920
CHECKED <i>[Signature]</i>	2/82	DRAWING NUMBER 66316288 THROUGH 66316299		
APPROVAL <i>[Signature]</i>	2/82	REV C		
APPROVAL <i>[Signature]</i>	3-1-82	SHEET 1 OF 9		
APPROVAL <i>[Signature]</i>	3/2/82			
APPROVAL <i>[Signature]</i>	3/10/82			

WP0103a
CD5076R

The tabulation of Control Data Corporation part number 66316288 constitutes those items available from:

Cherry Electrical Products Corporation
 3600 Sunset Avenue
 Waukegan, IL 60085

as replacement parts for the Control Data Viking X Keyboard, CDC P/N 51941115. When used in the specified application (Keyboard 51941115) the vendor (Cherry Electric) guarantees satisfactory operation.

Parts and assemblies or their containers shall be permanently and legibly marked with the vendor's symbol and part number. Bulk identify with Control Data part number.

SOURCE LIST

CDC PART NUMBER	DESCRIPTION	VENDOR PART NUMBER	TEST REQUIREMENTS
66316289	UART	35AM-1048	A1
66316290	Connector	0007-0824	A2
66316291	Keycap Set	B99-43AJ	A3

SOURCE CONTROL DRAWING

CONTROL DATA CORPORATION	SOURCE/CROSS REFERENCE LIST VIKING X KEYBOARD	CODE IDENT	A	DWG NO	REV
		15920		66316288 THRU 66316299	C
				SHEET 2 OF 9	

WP0103b
 CD5076R

CROSS REFERENCE LIST

VENDOR PART NUMBER	DESCRIPTION	CDC PART NUMBER	VENDOR SYMBOL
010-0340	Dual Return Spring (1.25 oz)	66312525	-
010-0341	Single Return Spring (2.50 oz)	66312526	-
010-0342	Space Bar Return Spring (2.80 oz)	66312527	-
M03-0001	Keyswitch Module Assy.	66312532	-
B99-35AF	Space Bar Assy (8 Keys Wide)	66313913	-
B99-43AJ	Keycap Set (103 Keycaps)	66316291	-
0007-0824	Connector	66316290	J1
350C-2014	IC CS2014 Sense Amplifier	66315832	U3, U4
350C-L004	IC 74LS04	15145100	U9
350C-L123	IC 74LS123	15163422	U8
350C-L157	IC 74LS157	15146700	U5, U6
350J-T154	IC 74154	96744174	U2
35AM-1048	IC 6402 UART	66316289	U7
0032-0081	Transistor	18192100	Q1
350C-L132	IC 74LS132	15161700	U10
35AM-9103	IC PIC 1650 Microprocessor	66315833	U1

SOURCE CONTROL DRAWING

CONTROL DATA CORPORATION	SOURCE/CROSS REFERENCE LIST VIKING X KEYBOARD	CODE IDENT	A	DWG NO	REV
		15920		66316288 THRU 66316299	C
		SHEET 3 OF 9			

WP0103b
CD5076R

APPENDIX A
TEST REQUIREMENTS

SOURCE CONTROL DRAWING

CONTROL DATA CORPORATION	SOURCE/CROSS REFERENCE LIST VIKING X KEYBOARD	CODE IDENT	A	DWG NO	REV
		15920		66316288 THRU 66316299	A
		SHEET 4 OF 9			

WP0103b
CD5076R

TEST REQUIREMENT A1

Burn-In Requirement:

Not required.

Description: IC - 6402 UART

- A. IC may be plastic or ceramic
- B. 40 Lead dual in-line package
- C. Leads on 0.100 inch centers nominal
- D. Rows on 0.600 inch centers nominal
- E. Length of IC body 2.00 inch nominal
- F. Width of IC body 0.594 inch nominal

Test Procedure:

51941115 Keyboard - Test per CDC-SPEC 51941115 Paragraph 3.3.1 and Table A1 (output codes).

SOURCE CONTROL DRAWING

CONTROL DATA CORPORATION	SOURCE/CROSS REFERENCE LIST VIKING X KEYBOARD	CODE IDENT	A	DWG NO	REV
		15920		66316288 THRU 66316299	A
		SHEET 5 OF 9			

WP0103b
CD5076R

TEST REQUIREMENT A2

Burn-In Requirement:

Not required.

Description: Connector, Keyboard

Test Procedure:

Check per similarity to Figure 1.

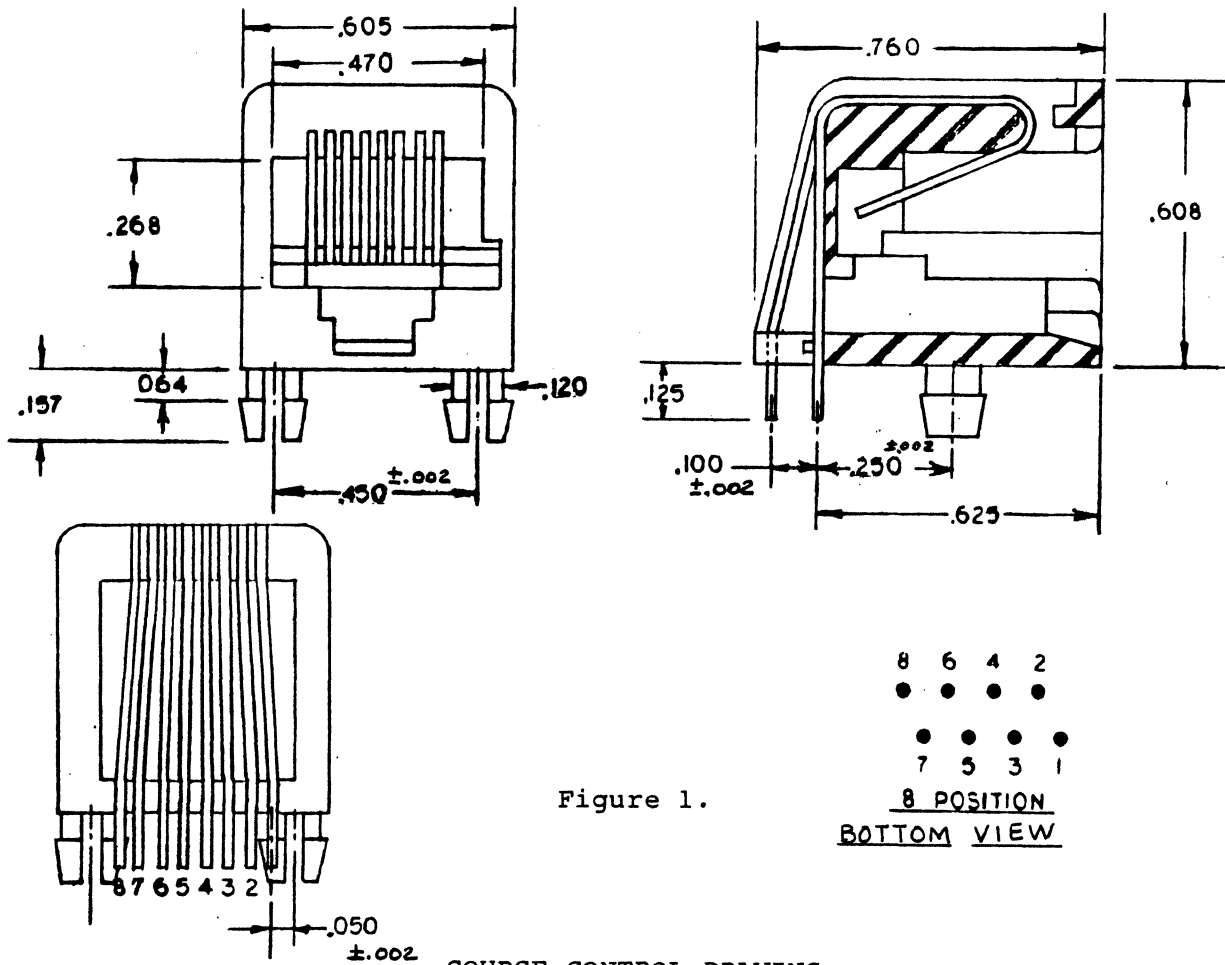
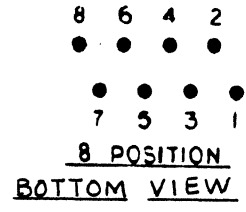

Figure 1.



CONTROL DATA CORPORATION	SOURCE/CROSS REFERENCE LIST VIKING X KEYBOARD	CODE IDENT	A	DWG NO	REV
		15920		66316288 THRU 66316299	A
				SHEET 6 OF 9	

WP0103b
CD5076R

TEST REQUIREMENT A3

Burn-In Requirement:

Not required.

Description: Keycap Set, Viking X - 103 key

Test Procedures:

51941115 Keyboard - Inspect per CDC-SPEC 51941115 Paragraphs 3.2.3, 3.2.3.1, 3.2.3.2, 3.2.3.3, 3.2.3.4, 3.2.4, 3.2.5, 3.2.7, Tables 2 and A1, Figures 1, 2, 3, 4, and A1.

The Viking X Keycap Set shall consist of the following keycaps.

<u>PART NUMBER</u>	<u>QUANTITY</u>	<u>DESCRIPTION</u>	<u>STATION NUMBER</u>
66301657	1	Keycap PRINT	1
66302288	1	Keycap SETUP	2
66301360	7	Keycap (BLANK)	3 through 9
66301014	1	Keycap ←	10
66300994	1	Keycap SUPER	11
66300995	1	Keycap SUB	12
66302289	1	Keycap MICRO	13
66302290	1	Keycap FONT	14
66302291	1	Keycap +/DOWN	15
66302292	1	Keycap →	16/32
66302261	1	Keycap 1	17
66302003	1	Keycap @ 2	18
66302004	1	Keycap # 3	19
66302005	1	Keycap \$ 4	20
66302006	1	Keycap % 5	21
66302265	1	Keycap ^ 6	22
66302008	1	Keycap & 7	23
66302009	1	Keycap * 8	24
66302010	1	Keycap (9	25
66302011	1	Keycap) 0	26

SOURCE CONTROL DRAWING

CONTROL DATA CORPORATION	SOURCE/CROSS REFERENCE LIST VIKING X KEYBOARD	CODE IDENT	A	DWG NO	REV
		15920		66316288 THRU 66316299	A
				SHEET 7 OF 9	



WP0103b
CD5076R

<u>PART NUMBER</u>	<u>QUANTITY</u>	<u>DESCRIPTION</u>	<u>STATION NUMBER</u>
66302012	1	Keycap -	27
66302013	1	Keycap + =	28
66302186	1	Keycap ~ \	29
66302293	1	Keycap ←	30
66302294	1	Keycap - / UP	31
66302295	1	Keycap Q / ↖	33
66302296	1	Keycap W / ↑	34
66302297	1	Keycap E / ↗	35
66302024	1	Keycap R	36
66302025	1	Keycap T	37
66302026	1	Keycap Y	38
66302027	1	Keycap U	39
66302028	1	Keycap I	40
66302029	1	Keycap O	41
66302030	1	Keycap P	42
66302190	1	Keycap] [43
66302032	1	Keycap ; \	44
66302359	1	Keycap ←	45
66302298	1	Keycap X / FWD	46
66302299	1	Keycap ⊕	47
66302300	1	Keycap A / ←	48
66301631	1	Keycap S	49
66302301	1	Keycap D / →	50
66301633	1	Keycap F	51
66301634	1	Keycap G	52
66301635	1	Keycap H	53
66301636	1	Keycap J	54
66301637	1	Keycap K	55
66301638	1	Keycap L	56
66301025	1	Keycap : ;	57
66302037	1	Keycap " ' ;	58
66302196	1	Keycap } {	59
66302303	1	Keycap NEXT ←	60/75
66302302	1	Keycap ÷ / BKW	61
66302304	1	Keycap ◁	62/63
66302316	1	Keycap Z / ↙	64
66302317	1	Keycap X / ↓	65
66302318	1	Keycap C / ↘	66
66302045	1	Keycap V	67

SOURCE CONTROL DRAWING

CONTROL DATA CORPORATION	SOURCE/CROSS REFERENCE LIST VIKING X KEYBOARD	CODE IDENT	A	DWG NO	REV
		15920		66316288 THRU 66316299	A
		SHEET 8 OF 9			

WP0103b
CD5076R

<u>PART NUMBER</u>	<u>QUANTITY</u>	<u>DESCRIPTION</u>	<u>STATION NUMBER</u>
66302046	1	Keycap B	68
66302047	1	Keycap N	69
66302048	1	Keycap M	70
66302201	1	Keycap < ,	71
66302202	1	Keycap > .	72
66302051	1	Keycap ? /	73
66302305	1	Keycap 	74
66302306	1	Keycap CTRL	76
66301045	1	Keycap (Space Bar)	77
66302307	1	Keycap CR DEL	78
66301012	1	Keycap HELP	79
66300996	1	Keycap TERM ANS	80
66301010	1	Keycap ERASE	81
66300997	1	Keycap COPY	82
66301027	1	Keycap EDIT	83
66301013	1	Keycap 	84
66301028	1	Keycap BACK	85
66301029	1	Keycap LAB	86
66301043	1	Keycap DATA	87
66301044	1	Keycap STOP	88
66302308	1	Keycap L INSRT C	89
66302309	1	Keycap L DLETE C	90
66302310	1	Keycap P CLEAR EOL	91
66302311	1	Keycap LF ESC	92
66302312	1	Keycap M REL BREAK	93
66302187	1	Keycap 7	94
66302188	1	Keycap ↑ 8	95
66302189	1	Keycap 9	96
66302192	1	Keycap ← 4	97
66302313	1	Keycap 5/HOME	98
66302194	1	Keycap → 6	99
66302197	1	Keycap 1	100
66302198	1	Keycap ↓ 2	101
66302199	1	Keycap 3	102
66302319	1	Keycap ,	103
66302314	1	Keycap 0	104
66302205	1	Keycap .	105
66302315	1	Keycap NEXT	106

SOURCE CONTROL DRAWING

CONTROL DATA CORPORATION	SOURCE/CROSS REFERENCE LIST VIKING X KEYBOARD	CODE IDENT	A	DWG NO	REV
		15920		66316288 THRU 66316299	A
				SHEET 9 OF 9	

WP0103b
CD5076R

SPECIFICATION CONTROL DRAWING

LTR	ECO	DESCRIPTION	DATE	APPROVAL
A	14232-70A	RELEASED CLASS "A"	4-5-82	M.C.T.
E	15408	REVISED AND REKEYED PER ECO	8/25/82	
C	15705	REVISED PER ECO	3/21/83	
D	15923	REVISED SHEET 1,4,5 & 7 PER ECO	7/26/83	MRE 7/27/83
E	16831	CHG CDC P/N ON VENDOR P/N 540024-00	8-29-84	AK

RECORD OF REVISION STATUS OF EACH SHEET

1	2	3	4	5	6	7	8	9	10	11													
A	A	A	-	-	-	-	-	-	-	-													
B	B	E	E	E	E	E	E	E	E	F													
C	B	C	C	C	C	C	C	C	C	C													
D	B	C	D	D	C	D	B	C	C	C													
E	B	E	D	D	C	E	B	C	C	C													

DRAWN BY	DATE	TITLE	CONTROL DATA CORPORATION CODE IDENT 15920
CHECKER <i>W. Houtledge</i>	3/4/82	SOURCE/CROSS REFERENCE LIST FOR VIKING X AUDIOTRONICS VIDEO DISPLAY HEAD	
APPROVAL <i>P. Anderson</i>	7/29/82		
APPROVAL <i>M. J. Admell</i>	7/30/82		
APPROVAL <i>E. H. H. Lee</i>	7/30/82	DRAWING NUMBER	
APPROVAL <i>M. H. H. Lee</i>	8/9/82	66314813 through 66314892 SHEET 1 OF 11	REV E

WP0105a
CD5753R

The CDC Part Numbers listed in the following tabulation (66314813-66314892) describe replacement items available from:

Audiotronics Video Display Division (AVDD)
 7428 Bellaire Avenue
 North Hollywood, CA 91605
 and
 8299 Central Avenue, N.E.
 Spring Lake Park, MN 55432

as replacement parts for the CDC equipment specified in CDC Specification Control Drawing 51941006. Satisfactory operation is guaranteed by the vendor (AVDD) if one or more defective components are replaced by an equivalent part from this tabulation.

Parts and assemblies or their containers shall be permanently and legibly marked with the vendor's part number. Bulk parts shall be identified with CDC Part Numbers.

Tabulation includes:

- o Source Listing
- o Cross Reference Listing

Note: For additional Source/Cross Reference Listing refer to Source Control Drawing 66327968/8067.

SPECIFICATION CONTROL DRAWING

CONTROL DATA CORPORATION	SOURCE/CROSS REFERENCE LIST FOR VIKING X AUDIO-TRONICS VIDEO DISPLAY HEAD	CODE IDENT 15920	A	DWG NO 66314813 THRU 66314892	REV E
			SHEET 2 OF 11		

WP0105b
CD5753R

SOURCE LIST

CDC PART NUMBER	DESCRIPTION	VENDOR PART NUMBER	TEST REQUIREMENTS
66314813	CRT, Yoke/Magnet Assy	190029-00	A1
66314815	CRT-CE689M15P39GHMH	320034-00	
66314817	Resistor, CF, 2.7K, 5% 1/2 W	420082-00	
66314818	Resistor, MF, 1K, 5%, 10 W	440078-00	
66314819	Resistor, CF, 56, 5%, 1/2 W	420042-00	
66314820	Resistor, CF, 680, 5%, 1 W	430068-00	
66314822	Resistor, CF, 120, 5%, 2 W	440088-00	
66314823	Resistor, CF, 15K 5%, 1 W	430101-00	
66314824	Resistor, CF, 82, 5%, 1/2 W	420046-00	
66314825	Resistor, WW 10, 5%, 2 W	440079-00	
66314826	Resistor, CF, 150, 5%, 2 W	440090-00	
66314827	Resistor, CF, 1.8, 5%, 1/2 W	420006-00	
66314828	Resistor, CF, 220, 5%, 1 W	430056-00	
66314829	Control, 100, 10%, 1 W, VPC	470108-00	
66314830	Control, 5K, 25%, 0.2 W, VPC	470113-10	
66314831	Control, 50M, 30%, CER	470111-00	
66314832	Control, 2.5M, 30%, VPC	470047-00	
66314833	Control, 10K, VPC	470110-10	
66314834	Control 100K, VPC	470116-10	
66314836	Control 250K, 5%	470112-00	
66314837	Cap, 0.1 MFD, Poly P, 100 V	520088-00	
66314838	Cap, 220 PF, CER, 100 V	500029-00	
66314839	Cap, 0.0047 MFD, Met Poly, 630 V	520089-00	
66314840	Cap, 470 MFD, Elect, 35 V	540067-00	
66314841	Cap, 1 MFD, Elect, 50 V	540072-00	
66314842	Cap, 4.7 MFD, Non-Polar, 50 V	540081-00	
66314843	Cap, 100 MFD, Elect, 35 V	540070-00	
66314844	Cap, 0.039 MFD, MPP, 1 kV	520087-00	
66314845	Cap, 0.33 MFD, MP, 100 V	520091-00	
66314846	Cap, 0.1 MFD, CER, 500 V	500079-00	
66314847	Cap, 180 PF, CER/MICA, 400 V	500069-00	
66314848	Cap, 0.02 MFD, CER, 2 kV	500080-00	
66314849	Cap, 330 PF, CER, 1 kV	500041-00	
66314850	Cap, 0.001 MFD, CER, 1 kV	500081-00	
66314851	Cap, 0.1 MFD, MPP, 100 V	520103-00	

SPECIFICATION CONTROL DRAWING

CONTROL DATA CORPORATION	SOURCE/CROSS REFERENCE LIST FOR VIKING X AUDIO-TRONICS VIDEO DISPLAY HEAD	CODE IDENT	A	DWG NO	REV
		15920		66314813 THRU 66314892	≡
				SHEET	3 OF 11

WP0105b
CD5753R

SOURCE LIST

CDC PART NUMBER	DESCRIPTION	VENDOR PART NUMBER	TEST REQUIREMENTS
66314852	Cap, 1000 MFD, Elect, 35 V	540068-00	
66314853	Cap, 0.01 MFD, MP, 400 V	520104-00	
66314854	Cap, 68 MFD, Elect., 35 V	540103-00	
66314855	Zener, 6.8 V, 5% - 1N4736A	300047-00	
66314856	Diode, Fast Rec, 1 Amp-1N4935	300041-00	
66314858	Zener, 12 V, 5 W, 5% - 1N5349B	300107-00	
66314859	Zener, 150 V, 0.6 W, 5%-1N5276B	300105-00	
66314860	Zener, 68 V, 1 W, 1N4760A	300057-00	
66314862	Diode, Fast Rec, 1A - 1N4937	300042-00	
66314863	Zener, 20 V, 1 W, 5% - 1N4747A	300050-00	
66314864	Transistor, PNP, 2N3906	300099-00	
66314865	Transistor, NPN, MPSU07	300103-00	
66314866	Transistor, NPN, MPS2369	300101-00	
66314867	Transistor, NPN, MPSA14	300106-00	
66314868	Transistor, NPN, BU806	300104-00	
66314869	Transistor, PNP, MPSA92	300102-00	
66314870	Transistor, NPN, 2N3904	300100-00	
66314871	IC, Vertical - TDA1670	310030-00	
66314872	Coil, Horizontal Centering	660053-00	
66314873	Transformer, Focus	600046-00	
66314874	Choke, 1 MHY	640024-00	
66314875	Coil, Width	660055-00	
66314876	Replaced by 66327982		
66314877	Yoke Plug Assy (PWB Female)	160280-00	
66314878	Coil, Linearity	160282-00	
66314879	Socket, CRT, Assy	370311-00	
66314881	Bleeder, 240 MEG	440080-10	
66314882	Resistor, 1.0 ohm, 5%, 1/4W	410000-00	
66314883	Resistor, 1 CF,100 ohm,5%,1/4 W	410048-00	
66314884	Resistor, 330 ohm, 5%, 1/4 W	410060-00	
66314885	Resistor, CF, 1K, 5%, 1/4 W	410072-00	
66314886	Resistor, 1.8K, 5%, 1/4 W	410078-00	
66314887	Resistor, CF, 2.2K, 5%, 1/4 W	410080-00	
66314888	Resistor, CF, 2.7K, 5%, 1/4 W	410082-00	
66314889	Resistor, CF, 8.2K, 5%, 1/4 W	410095-00	
66314890	Resistor, CF, 12K, 5%, 1/4 W	410099-00	
66314891	Resistor, CF, 68K, 5%, 1/4 W	410117-00	
66314892	Resistor, CF, 82K, 5%, 1/4 W	410119-00	

SPECIFICATION CONTROL DRAWING

CONTROL DATA CORPORATION	SOURCE/CROSS REFERENCE LIST FOR VIKING X AUDIO-TRONICS VIDEO DISPLAY HEAD	CODE IDENT 15920	A	DWG NO 66314813 THRU 66314892	REV D
				SHEET 4 OF 11	

WP0105b
CD5753R

CROSS REFERENCE LIST

VENDOR PART NUMBER	DESCRIPTION	CDC PART NUMBER	SYMBOL
160280-00	Yoke Plug Assy (PWB Female)	66314877	
160282-00	Coil, Linearity	66314878	L2
185107-00	Printed Wiring Board Assy	66327973	△1
190029-00	CRT, Yoke-Magnet Assy	66314813	
300033-00	Diode, Signal - 1N4148A	51007385	CR14, CR18, CR20
300040-10	Diode, Fast Rec, 2 kV, LM20	51919759	CR11
300041-00	Diode, Fast Rec, 1A, 1N4935	66314856	CR2, CR5, CR6, CR7, CR8, CR17
300042-00	Diode, Fast Rec, 1A, 1N4937	66314862	CR12, CR15
300047-00	Zener, 6.8 V, 5%, 1N4736A - 1 W	66314855	CR1, CR13
300050-00	Zener, 20 V, 1 W, 5%, 1N4747A	66314863	CR16
300053-00	Zener, 51 V, 1 W, 5%, 1N4757A	51919765	CR3
300057-00	Zener, 68 V, 1 W, 1N4760A	66314860	CR19
300099-00	Transistor, PNP, 2N3906	66314864	Q1, Q11
300100-00	Transistor, NPN, 2N3904	66314870	Q10
300101-00	Transistor, NPN, MPS2369	66314866	Q3
300102-00	Transistor, PNP, MPSA92	66314869	Q7, Q9
300103-00	Transistor, NPN, MPSU07	66314865	Q2, Q4
300104-00	Transistor, NPN, BU806	66314868	Q6
300105-00	Zener, 150 V, 5%, 1N5276B-600MW	66314859	CR9, CR10
300106-00	Transistor, NPN, MPSA14	66314867	Q5, Q8
300107-00	Zener, 12 V, 5%, IN5349B - 5 W	66314858	CR4
310016-00	IC, Horizontal, MC1391P	51919778	U1
310030-00	IC, Vertical, TDA1670	66314871	U2
320034-00	CRT-CE689M15P39GHMH	66314815	
370311-00	Socket, CRT, Assy	66314879	J1
410000-00	Resistor, 1.0 ohm, 5%, 1/4 W	66314882	R54
410024-00	Resistor, CF, 10 ohm, 5%, 1/4 W	94402108	R5
410048-00	Resistor, CF, 100 ohm, 5%, 1/4 W	66314883	R1, R3, R30, R52
410052-00	Resistor, CF, 150 ohm, 5%, 1/4 W	94402136	R7
410060-00	Resistor, 330 ohm, 5%, 1/4 W	66314884	R54
410072-00	Resistor, CF, 1K, 5%, 1/4 W	66314885	R12, R38, R51, R63
410078-00	Resistor, 1.8K, 5%, 1/4 W	66314886	R50
410080-00	Resistor, CF, 2.2K, 5%, 1/4 W	66314887	R15
410082-00	Resistor, CF, 2.7K, 5%, 1/4 W	66314888	R6, R14, R20, R25

△1 Was Vendor P/N 181107-00 (CDC P/N 66314814).

SPECIFICATION CONTROL DRAWING

CONTROL DATA CORPORATION	SOURCE/CROSS REFERENCE LIST FOR VIKING X AUDIO- TRONICS VIDEO DISPLAY HEAD	CODE IDENT	A	DWG NO	REV
		15920		66314813 THRU 66314892	D
		SHEET 5 OF 11			

WP0105b
CD5753R

CROSS REFERENCE LIST

VENDOR PART NUMBER	DESCRIPTION	CDC PART NUMBER	SYMBOL
410091-00	Resistor, CF, 5.6K, 5%, 1/4 W	94402174	R42
410095-00	Resistor, CF, 8.2K, 5%, 1/4 W	66314889	R21
410099-00	Resistor, CF, 12K, 5%, 1/4 W	66314890	R2, R18, R31, R40, R41
410117-00	Resistor, CF, 68K, 5%, 1/4 W	66314891	R39
410119-00	Resistor, CF, 82K, 5%, 1/4 W	66314892	R27, R48
420000-00	Resistor, 1 ohm, 5% 1/2 W	51919744	R55
420006-00	Resistor, 1.8 ohm, 5%, 1/2 W	66314827	R58
420042-00	Resistor, CF, 56 ohm, 5%, 1/2 W	66314819	R9
420046-00	Resistor, CF, 82 ohm, 5%, 1/2 W	66314824	R24
420082-00	Resistor, CF, 2.7K, 5%, 1/2 W	66314817	R4, R17
430056-00	Resistor, 220 ohm, 5%, 1 W	66314828	R59
430068-00	Resistor, CF, 680 ohm, 5%, 1 W	66314820	R13
430101-00	Resistor, CF, 15K, 5%, 1 W	66314823	R23
440078-00	Resistor, MF, 1K, 5%, 10 W	66314818	R8, R11
440079-00	Resistor, WW, 10 ohm, 5%, 2 W	66314825	R46
440080-10	Resistor, Bleeder, 240 MEG	66314881	R32
440088-00	Resistor, CF, 120, 5%, 2 W	66314822	R22
440090-00	Resistor, CF, 150 ohm, 5%, 2 W	66314826	R56
470047-00	Control, 2.5 MEG, 30%, VPC	66314832	R37
470108-00	Control, 100 ohm, 10%, 1 W, VPC	66314829	R10
470110-10	Control, 10K, VPC	66314833	R43
470111-00	Control, 50 MEG, 30%, CER	66314831	R26, R34
470112-00	Control, 250K, 5%	66314836	R45
470113-10	Control, 5K, 25%, 0.2 W, VPC	66314830	R16, R57
470116-10	Control, 100K, VPC	66314834	R47
500029-00	Cap, 220 PF, CER, 100 V	66314838	C2
500041-00	Cap, 330 PF, CER, 1 kV	66314849	C26
500069-00	Cap, 180 PF, CER/MICA, 400 V	51919733	C19
500079-00	Cap, 0.1 MFD, CER, 500 V	66314846	C18, C21, C25
500080-00	Cap, 0.02 MFD, CER, 2 kV	66314848	C20, C24
500081-00	Cap, 0.001 MFD, CER, 1 kV	66314850	C27
520029-00	Cap, 0.018 MFD, Film, 200 V	66318931	C9
520068-00	Cap, 0.0068 MFD, Poly C, 100 V	66318924	C6
520087-00	Cap, 0.039 MFD, MPP, 1 kV	66314844	C16
520088-00	Cap, 0.1 MFD, Poly P, 100 V	66314837	C1, C4, C5, C8, C22, C28, C29, C34, C36

SPECIFICATION CONTROL DRAWING

CONTROL DATA CORPORATION	SOURCE/CROSS REFERENCE LIST FOR VIKING X AUDIO-TRONICS VIDEO DISPLAY HEAD	CODE IDENT	A	DWG NO	REV
		15920		66314813 THRU 66314892	C
		SHEET 6 OF 11			

WP0105b
CD5753R

CROSS REFERENCE LIST

VENDOR PART NUMBER	DESCRIPTION	CDC PART NUMBER	SYMBOL
520089-00	Cap, 0.0047 MFD, Met Poly, 630 V	66314839	C7
520091-00	Cap, 0.33 MFD, MP, 100 V	66314845	C17
520103-00	Cap, 0.1 MFD, MPP, 100 V	66314851	C30, C31
520104-00	Cap, 0.01 MFD, MP, 400 V	66314853	C40
540017-00	Cap, 4.7 MFD, Elect, 50 V	51919719	C14
540024-00	Cap, 10 MFD, Elect, 150 V	66308943	C23
540033-00	Cap, 47 MFD, Elect, 100 V	51919726	C3
540067-00	Cap, 470 MFD, Elect, 35 V	66314840	C10
540068-00	Cap, 1000 MFD, Elect, 35 V	66314852	C33, C38
540070-00	Cap, 100 MFD, Elect, 35 V	66314843	C13, C15, C41, C32, C39
540072-00	Cap, 1 MFD, Elect, 50 V	66314841	C11
540081-00	Cap, 4.7 MFD, Non-Polar, 50 V	66314842	C12
600046-00	Transformer, Focus	66314873	T3
620034-10	Transformer, Flyback	66327971 ¹	T2
640024-10	Choke, 1 MHY	66314874	L1
660053-00	Coil, Horizontal, Centering	66314872	T1
660055-00	Coil, Horizontal, Width	66314875	L3

Note: For additional part numbers refer to PN 66327968/8067.

¹ Was Vendor P/N 620034-00 (CDC P/N 66314816).

SPECIFICATION CONTROL DRAWING

CONTROL DATA CORPORATION	SOURCE/CROSS REFERENCE LIST FOR VIKING X AUDIO- TRONICS VIDEO DISPLAY HEAD	CODE IDENT	A	DWG NO	REV
		15920		66314813 THRU 66314892	==
				SHEET	7 OF 11

WP0105b
CD5753R

APPENDIX A
TEST REQUIREMENTS

SPECIFICATION CONTROL DRAWING

CONTROL DATA CORPORATION	SOURCE/CROSS REFERENCE LIST FOR VIKING X AUDIO-TRONICS VIDEO DISPLAY HEAD	CODE IDENT	A	DWG NO	REV
		15920		66314813 THRU 66314892	B
		SHEET 8 OF 11			

WP0105b
CD5753R

TEST REQUIREMENT A1

Marking: The parts shall be legibly marked with the manufacturers name or symbol and part number (AVDD PN 190029-00). Bulk identify with CDC PN 66314813.

Description: CRT and Yoke Assembly

- a) 15-inch CRT, P39 Phosphor, Clinton Type (VPN 320034-00) CE689M15P39GHMH
- b) 110° deflection yoke (VPN 160281-00)
 - 1. Magnet compensated using fixed and trimmer type magnets
 - 2. Leads terminated in 4-pin female connector to mate with connector on CDC PN 66327973.
 - 3. 2-ring adjustable centering magnets
 - 4. Yoke clamp and screw

Vendor to install magnets for geometric distortion correction with yoke mounted on CRT neck and using a typical video display board (CDC PN 66327973) as a driving source. CDC to be responsible for any magnet adjustments.

SPECIFICATION CONTROL DRAWING

CONTROL DATA CORPORATION	SOURCE/CROSS REFERENCE LIST FOR VIKING X AUDIO-TRONICS VIDEO DISPLAY HEAD	CODE IDENT	A	DWG NO	REV
		15920		66314813 THRU 66314892	C
		SHEET 9 OF 11			

WP0105b
CD5753R

Test Procedure:

1. Install CRT/yoke assembly in a test fixture and connect to the Video Display Board, CDC PN 66327973.
2. Apply the required TTL signals to the Video Display board using a CDC CC634 source or an equivalent signal generator.
3. Energize the Video Display system and check visually the items listed below for satisfactory operation.
 - a) Size
 - b) Linearity
 - c) Centering
 - d) Video Noise
 - e) Light Output
 - f) Focus
 - g) Screen Blemish
 - h) Geometric Distortion

Refer to Video Display Spec 51941006 for details.

SPECIFICATION CONTROL DRAWING

CONTROL DATA CORPORATION	SOURCE/CROSS REFERENCE LIST FOR VIKING X AUDIO-TRONICS VIDEO DISPLAY HEAD	CODE IDENT	A	DWG NO	REV
		15920		66314813 THRU 66314892	C
		SHEET 10 OF 11			

WP0105b
CD5753R

TEST REQUIREMENT A2

Burn-In: All PC boards shall be subjected to the burn-in period specified in CDC Spec 51941006.

Marking: The PC board assembly shall be legibly marked with the vendor name or symbol, part number and vendor revision level. Bulk identify with CDC PN 66327973. \triangle 2

Description: PC Board Assembly

- a) Number of trimmer pots on board----7
- b) Number of coil slug adjustments----3
- c) One (1) Static focus control
- d) One (1) Dynamic focus control
- e) Other PC board components -
 - o Resistors, capacitors, one fixed coil, IC chips (2), large fly-back transformer, small transformer, transistors (11) \triangle 3
- f) Vendor UL designation and component symbol marking.
- g) Board size - 152.4mm (6 inches) x 203.2mm (8 inches) x 1.57mm (.062 inch)
- h) One 20-Pin male connector - dual in line.
- i) Cable harness - 7 leads to CRT socket, 4 leads to yoke connector.
- j) One flat ribbon ground wire attached to CRT socket 250mm long (10 inches).

Test Procedure: Install in Viking X test Terminal or connect to an equivalent TTL signal source and test for compliance with CDC Specification 51941006.

\triangle 2 Replaces CDC P/N 66314814 (Vendor P/N 181107-00).

\triangle 3 Was quantity 9 on CDC P/N 66314814.

SPECIFICATION CONTROL DRAWING

CONTROL DATA CORPORATION	SOURCE/CROSS REFERENCE LIST FOR VIKING X AUDIO-TRONICS VIDEO DISPLAY HEAD	CODE IDENT	A	DWG NO	REV
		15920		66314813 THRU 66314892	C
				SHEET 11 OF 11	

WP0105b
CD5753R

The CDC part numbers listed in the following tabulation (66317968 through 66318067) describe replacement items available from:

Audiotronics Video Display Division (AVDD)
 7428 Bellaire Avenue
 North Hollywood, California 91605

and

8299 Central Avenue Northeast
 Spring Lake Park, Minnesota 55432

as replacement parts for the CDC equipment specified in CDC Specification Control Drawing 51941006. Satisfactory operation is guaranteed by the vendor (AVDD) if one or more defective components are replaced by an equivalent part from this tabulation.

Parts and assemblies or their containers shall be permanently and legibly marked with the vendors part number. Bulk parts shall be identified with CDC part numbers.

Tabulation includes:

- o Source listing
- o Cross Reference listing

Note: For additional Source/Cross Reference listing refer to Source Control Drawing 66314813/66314892.

SOURCE CONTROL DRAWING

CONTROL DATA CORPORATION	SOURCE/CROSS REFERENCE LIST FOR VIKING X AUDIO-TRONICS VIDEO DISPLAY HEAD	CODE IDENT	A	DWG NO	REV
		15920		66327968 THRU 66328067	A
				SHEET 2 OF 4	

WP0103b
 CD5832P

SOURCE LIST

CDC PART NUMBER	DESCRIPTION	VENDOR PART NUMBER	TEST REQUIREMENT
66327968	Resistor, CF, 100K, 5%, 1/4 W	410121-00	
66327969	Resistor, CF, 18M, 5%, 1/4 W	410174-00	
66327970	Resistor, MF, 392K, 1% 1/4 W	410176-00	
66327971	Flyback Transformer (Plessey)	620034-10	△ 1
66327972	Printed Circuit Board Blank	155107-50	
66327973	Printed Circuit Board Assy	185107-00	△ 2 A2
66327974	Dag Spring	370151-00	
66327975	Yoke and Plug Assy (Male Plug)	160281-00	
66327976	Tubing Shrinkable	060113-00	
66327977	Resistor, CF, 221K, 1%, 1/4 W	410186-00	
66327978	Resistor, CF, 150K, 5%, 1/4 W	410125-00	
66327979	Resistor, CF, 1.5, 5%, 1/2 W	420004-00	
66327980	Control, 200K, VPC	470124-00	
66327981	Terminal Strain Relief	370358-00	
66327982	Header 20 Pin	370309-00	
66327983	Washer Glass Filled Shoulder	210285-00	
66327984	Cap, 33 MFD, Elect, 35 V	540111-00	
66327985	Resistor, CF, 15K, 5%, 1/4 W	410101-00	
66327986	Resistor, CF, 9.1K, 5%, 1/4 W	410096-00	
66327987	Terminal, Aqua Dag	370378-00	
66327988	Rivet	210289-00	
66327989	Resistor, MF, 2.67K, 1%, 1/4 W, 100 PPM	410194-20	△ 4

△
1 Was CDC P/N 66314816 (Vendor P/N 620034-00).

△
2 Was CDC P/N 66314814 (Vendor P/N 181107-00).

SOURCE CONTROL DRAWING

CONTROL DATA CORPORATION	SOURCE/CROSS REFERENCE LIST FOR VIKING X AUDIO- TRONICS VIDEO DIS- PLAY HEAD	CODE IDENT 15920	A	DWG NO 66327968 THRU 66328067	REV <i>E</i>
	SHEET 3 OF 4				

WP0103b
CD5832R

CROSS REFERENCE LIST

VENDOR PART NUMBER	DESCRIPTION	CDC PART NUMBER	SYMBOL
060113-00	Tubing, Shrinkable	66327976	
155107-50	Printed Circuit Board Blank	66327972	
160281-00	Yoke and Plug Assy (Male Plug)	66327975	
210285-00	Washer, Glass Filled Shoulder	66327983	
210289-00	Rivet	66327988	
370151-00	Dag Spring	66327974	
370309-00	Header 20 pin	66327982	P1
370358-00	Terminal, Strain Relief	66327981	
370378-00	Terminal, Aqua Dag	66327987	
410096-00	Resistor, CF, 9.1K, 5%, 1/4 W	66327986	R62
410101-00	Resistor, CF, 15K, 5%, 1/4 W	66327985	R41
410121-00	Resistor, CF, 100K, 5%, 1/4 W	66327968	R19
410125-00	Resistor, CF, 150K, 5%, 1/4 W	66327978	R48, R35
410137-00	Resistor, CF, 470K, 5%, 1/4 W	94402220	R33 \triangle ₃
410143-00	Resistor, CF, 820K, 5%, 1/4 W	94402223	R28 \triangle ₃
410174-00	Resistor, CF, 18M, 5%, 1/4 W	66327969	R36
410176-00	Resistor, MF, 392K, 1%, 1/4 W	66327970	R29,
410186-00	Resistor, CF, 221K, 5%, 1/4 W	66327977	R44
410194-20	Resistor, MF, 2.67K, 1%, 1/4 W 100 PPM	66327989	R14 \triangle ₄
420004-00	Resistor, CF, 1.5, 5%, 1/2 W	66327979	R55
470124-00	Control, 200K, VPC	66327980	R47
540111-00	Cap, 33 MFD, Elect, 35 V	66327984	C37

\triangle ₃ The value of R28 and R33 depend on the resistance value of bleeder resistor R32.

R32 = 240 MEG (440080-10) R32 = 80 MEG (440097-00)
 R28 = 1.5 MEG (PN 94402232) R28 = 820K
 R33 = 1.5 MEG (PN 94402232) R33 = 470K

\triangle ₄ Was VPN 410082-00 (CDC P/N 66314888) - 2.7K, 5%. If the 5% part is replaced with the 1% part for R14 on repair assemblies, R15 must also be replaced with a 1% resistor (Vendor P/N 410195-20, CDC P/N 66314887, Value 2.15K 1/4 W 1%).

SOURCE CONTROL DRAWING

CONTROL DATA CORPORATION	SOURCE/CROSS REFERENCE LIST FOR VIKING X AUDIO-TRONICS VIDEO DISPLAY HEAD	CODE IDENT	A	DWG NO	REV
		15920		66327968 THRU 66328067	E
		SHEET 4 OF 4			

WP0103b
CD5832R

SPECIFICATION CONTROL DRAWING

LTR	ECO	DESCRIPTION	DATE	APPROVAL
A	142327M	RELEASED CLASS "A"	4-5-82	M.C.T.
B	15408	REVISED AND REDRAWN PER ECO	8/25/82	P.G. 9/8/82
C	15705	REVISED PER ECO	2/21/83	P.G. 3/21/83
D	15923	REVISED SHEET 1,4,5 & 7 PER ECO	7/26/83	MRT 7/27/83
E	16831	CHG CDC PIN ON VENDOR P/N 540024-00	8-29-84	OK
F	16984	UPDATED SOURCE/CROSS REF LIST	1/8/85	PG
G	17120	REVISED PER ECO	5/28/85	EE 5/28/85

RECORD OF REVISION STATUS OF EACH SHEET

	1	2	3	4	5	6	7	8	9	10	11									
A	A	A	-	-	-	-	-	-	-	-	-									
B	B	B	B	B	B	B	B	B	B	B	B									
C	C	C	C	C	C	C	C	C	C	C	C									
D	D	D	D	D	D	D	D	D	D	D	D									
E	E	E	E	E	E	E	E	E	E	E	E									
F	F	F	F	F	F	F	F	F	F	F	F									
G	G	G	G	G	G	G	G	G	G	G	G									

DRAWN BY		DATE	TITLE		CONTROL DATA CORPORATION CODE IDENT 15920
CHECKER	<i>W. J. Hawthorne</i>	8/4/82	SOURCE/CROSS REFERENCE LIST FOR VIKING X AUDIOTRONICS VIDEO DISPLAY HEAD		
APPROVAL	<i>J. Anderson</i>	7/29/82	DRAWING NUMBER		
APPROVAL	<i>M. J. Admell</i>	7/30/82	66314813 through 66314892	REV G	
APPROVAL	<i>E. H. Hove</i>	7/30/82	SHEET 1 OF 11		
APPROVAL	<i>M. J. Admell</i>	8/3/82			

WP0105a
CD5753R

The CDC Part Numbers listed in the following tabulation (66314813-66314892) describe replacement items available from:

Audiotronics Video Display Division (AVDD)
 7428 Bellaire Avenue
 North Hollywood, CA 91605
 and
 8299 Central Avenue, N.E.
 Spring Lake Park, MN 55432

as replacement parts for the CDC equipment specified in CDC Specification Control Drawing 51941006. Satisfactory operation is guaranteed by the vendor (AVDD) if one or more defective components are replaced by an equivalent part from this tabulation.

Parts and assemblies or their containers shall be permanently and legibly marked with the vendor's part number. Bulk parts shall be identified with CDC Part Numbers.

Tabulation includes:

- o Source Listing
- o Cross Reference Listing

Note: For additional Source/Cross Reference Listing refer to Source Control Drawing 66327968/8067.

SPECIFICATION CONTROL DRAWING

CONTROL DATA CORPORATION	SOURCE/CROSS REFERENCE LIST FOR VIKING X AUDIO-TRONICS VIDEO DISPLAY HEAD	CODE IDENT 15920	A	DWG NO 66314813 THRU 66314892	REV E
			SHEET 2 OF 11		

WP0105b
 CD5753R

SOURCE LIST

CDC PART NUMBER	DESCRIPTION	VENDOR PART NUMBER	TEST REQUIREMENTS
66314813	CRT, Yoke/Magnet Assy	190029-00	A1
66314814	INA. Replaced by 66327973		
66314815	CRT-CE689M15P39GHMH	320034-00	
66314816	INA. Replaced by 66327971		
66314817	Resistor, CF, 2.7K, 5% 1/2 W	420082-00	
66314818	Resistor, MF, 1K, 5%, 10 W	440078-00	
66314819	Resistor, CF, 56, 5%, 1/2 W	420042-00	
66314820	Resistor, CF, 680, 5%, 1 W	430068-00	
66314821	INA. R/B None		
66314822	Resistor, CF, 120, 5%, 2 W	440088-00	
66314823	Resistor, CF, 15K 5%, 1 W	430101-00	
66314824	Resistor, CF, 82, 5%, 1/2 W	420046-00	
66314825	Resistor, WW 10, 5%, 2 W	440079-00	
66314826	Resistor, CF, 150, 5%, 2 W	440090-00	
66314827	Resistor, CF, 1.8, 5%, 1/2 W	420006-00	
66314828	Resistor, CF, 220, 5%, 1 W	430056-00	
66314829	Control, 100, 10%, 1 W, VPC	470108-00	
66314830	Control, 5K, 25%, 0.2 W, VPC	470113-10	
66314831	Control, 50M, 30%, CER	470111-00	
66314832	Control, 500K, 20%, VPC	470180-00	
66314833	Control, 10K, VPC	470110-10	
66314834	Control 100K, VPC	470116-10	
66314835	INA. R/B None		
66314836	Control 250K, 5%	470112-00	
66314837	Cap, 0.1 MFD, Poly P, 100 V	520088-00	
66314838	Cap, 220 PF, CER, 100 V	500029-00	
66314839	Cap, 0.0047 MFD, Met Poly, 630 V	520089-00	
66314840	Cap, 470 MFD, Elect, 35 V	540067-00	
66314841	Cap, 1 MFD, Elect, 50 V	540072-00	
66314842	Cap, 4.7 MFD, Non-Polar, 50 V	540107-00	
66314843	Cap, 100 MFD, Elect, 35 V	540070-00	
66314844	Cap, 0.039 MFD, MPP, 600 V	520087-00	
66314845	Cap, 0.33 MFD, MP, 100 V	520091-00	
66314846	Cap, 0.1 MFD, CER, 500 V	500079-00	
66314847	Cap, 180 PF, CER/MICA, 400 V	500069-00	
66314848	Cap, 0.02 MFD, CER, 2 kV	500080-00	
66314849	Cap, 470 PF, MICA, 500 V, 5%	500104-00	
66314850	Cap, 0.001 MFD, CER, 1 kV	500081-00	
66314851	Cap, 0.1 MFD, MPP, 100 V	520103-00	

SPECIFICATION CONTROL DRAWING

CONTROL DATA CORPORATION	SOURCE/CROSS REFERENCE LIST FOR VIKING X AUDIO-TRONICS VIDEO DISPLAY HEAD	CODE IDENT	A	DWG NO	REV
		15920		66314813 THRU 66314892	G
		SHEET 3 OF 11			

WP0105b
CD5753R

SOURCE LIST

CDC PART NUMBER	DESCRIPTION	VENDOR PART NUMBER	TEST REQUIREMENTS
66314852	Cap, 1000 MFD, Elect, 35 V	540068-00	
66314853	Cap, 0.01 MFD, MP, 400 V	520104-00	
66314854	Cap, 68 MFD, Elect., 35 V	540103-00	
66314855	Zener, 6.8 V, 5% - 1N4736A	300047-00	
66314856	Diode, Fast Rec, 1 Amp-1N4935	300041-00	
66314857	Inactive, R/B None		
66314858	Zener, 12 V, 5 W, 5% - 1N5349B	300107-00	
66314859	Zener, 150 V, 0.6 W, 5%-1N5276B	300105-00	
66314860	Zener, 68 V, 1 W, 1N4760A	300057-00	
66314861	Inactive, R/B None		
66314862	Diode, Fast Rec, 1A - 1N4937	300042-00	
66314863	Zener, 20 V, 1 W, 5% - 1N4747A	300050-00	
66314864	Transistor, PNP, 2N3906	300099-00	
66314865	Transistor, NPN, MPSU07	300103-00	
66314866	Transistor, NPN, MPS2369	300101-00	
66314867	Transistor, NPN, MPSA14	300106-00	
66314868	Transistor, NPN, BU806	300104-00	
66314869	Transistor, PNP, MPSA92	300102-00	
66314870	Transistor, NPN, 2N3904	300100-00	
66314871	IC, Vertical - TDA1670	310030-00	
66314872	Coil, Horizontal Centering	660053-00	
66314873	Transformer, Focus	600046-00	
66314874	Choke, 1 MHY	640024-00	
66314875	Coil, Width	660055-00	
66314876	Replaced by 66327982		
66314877	Yoke Plug Assy (PWB Female)	160280-00	
66314878	Coil, Linearity	160282-00	
66314879	Socket, CRT, Assy	370311-00	
66314880	Inactive, R/B None		
66314881	Bleeder, 80 MEG	440097-00	
66314882	Resistor, 1.0 ohm, 5%, 1/4W	410000-00	
66314883	Resistor, 1 CF, 100 ohm, 5%, 1/4 W	410048-00	
66314884	Resistor, 330 ohm, 5%, 1/4 W	410060-00	
66314885	Resistor, CF, 1K, 5%, 1/4 W	410072-00	
66314886	Resistor, 1.8K, 5%, 1/4 W	410078-00	
66314887	Resistor, MF, 2.15K, 1%, 1/4 W 100 PPM	410195-20	
66314888	Resistor, CF, 2.7K, 5%, 1/4 W	410082-00	
66314889	Resistor, CF, 8.2K, 5%, 1/4 W	410095-00	
66314890	Resistor, CF, 12K, 5%, 1/4 W	410099-00	
66314891	Resistor, CF, 68K, 5%, 1/4 W	410117-00	
66314892	Resistor, CF, 82K, 5%, 1/4 W	410119-00	

SPECIFICATION CONTROL DRAWING

CONTROL DATA CORPORATION	SOURCE/CROSS REFERENCE LIST FOR VIKING X AUDIO-TRONICS VIDEO DISPLAY HEAD	CODE IDENT	A	DWG NO	REV
		15920		66314813 THRU 66314892	G
				SHEET	4 OF 11

WP0105b
CD5753R

CROSS REFERENCE LIST

VENDOR PART NUMBER	DESCRIPTION	CDC PART NUMBER	SYMBOL
160280-00	Yoke Plug Assy (PWB Female)	66314877	
160282-00	Coil, Linearity	66314878	L2
185107-00	Printed Wiring Board Assy	66327973	△ 1
190029-00	CRT, Yoke-Magnet Assy	66314813	
300033-00	Diode, Signal - 1N4148A	51007385	CR14, CR18, CR20
300040-10	Diode, Fast Rec, 2 kV, LM20	51919759	CR11
300041-00	Diode, Fast Rec, 1A, 1N4935	66314856	CR2, CR5, CR6, CR7, CR8, CR17
300042-00	Diode, Fast Rec, 1A, 1N4937	66314862	CR12, CR15
300047-00	Zener, 6.8 V, 5%, 1N4736A - 1 W	66314855	CR1, CR13
300050-00	Zener, 20 V, 1 W, 5%, 1N4747A	66314863	CR16
300053-00	Zener, 51 V, 1 W, 5%, 1N4757A	51919765	CR3
300057-00	Zener, 68 V, 1 W, 1N4760A	66314860	CR19
300099-00	Transistor, PNP, 2N3906	66314864	Q1, Q11
300100-00	Transistor, NPN, 2N3904	66314870	Q10
300101-00	Transistor, NPN, MPS2369	66314866	Q3
300102-00	Transistor, PNP, MPSA92	66314869	Q7, Q9
300103-00	Transistor, NPN, MPSU07	66314865	Q2, Q4
300104-00	Transistor, NPN, BU806	66314868	Q6
300105-00	Zener, 150 V, 5%, 1N5276B-600MW	66314859	CR9, CR10
300106-00	Transistor, NPN, MPSA14	66314867	Q5, Q8
300107-00	Zener, 12 V, 5%, IN5349B - 5 W	66314858	CR4
310016-00	IC, Horizontal, MC1391P	51919778	U1
310030-00	IC, Vertical, TDA1670	66314871	U2
320034-00	CRT-CE689M15P39GHMH	66314815	
370311-00	Socket, CRT, Assy	66314879	J1
410000-00	Resistor, 1.0 ohm, 5%, 1/4 W	66314882	R53
410024-00	Resistor, CF, 10 ohm, 5%, 1/4 W	94402108	R5
410048-00	Resistor, CF, 100 ohm, 5%, 1/4 W	66314883	R1, R3, R30, R52
410052-00	Resistor, CF, 150 ohm, 5%, 1/4 W	94402136	R7
410060-00	Resistor, 330 ohm, 5%, 1/4 W	66314884	R54
410072-00	Resistor, CF, 1K, 5%, 1/4 W	66314885	R12, R38, R51, R63
410078-00	Resistor, 1.8K, 5%, 1/4 W	66314886	R50
410082-00	Resistor, CF, 2.7K, 5%, 1/4 W	66314888	R6, R20, R25

SPECIFICATION CONTROL DRAWING

CONTROL DATA CORPORATION	SOURCE/CROSS REFERENCE LIST FOR VIKING X AUDIO- TRONICS VIDEO DISPLAY HEAD	CODE IDENT	A	DWG NO	REV
		15920		66314813 THRU 66314892	5
				SHEET	5 OF 11

WP0105b
CD5753R

CROSS REFERENCE LIST

VENDOR PART NUMBER	DESCRIPTION	CDC PART NUMBER	SYMBOL
410091-00	Resistor, CF, 5.6K, 5%, 1/4 W	94402174	R42
410095-00	Resistor, CF, 8.2K, 5%, 1/4 W	66314889	R21
410099-00	Resistor, CF, 12K, 5%, 1/4 W	66314890	R2,R18,R31, R40,R41
410117-00	Resistor, CF, 68K, 5%, 1/4 W	66314891	R39
410119-00	Resistor, CF, 82K, 5%, 1/4 W	66314892	R27,R48
410195-20	Resistor, MF, 2.15K, 1%, 1/4 W 100 PPM	66314887	R15 \triangle
420000-00	Resistor, 1.5 ohm, 5% 1/2 W	51919744	R55
420006-00	Resistor, 1.8 ohm, 5%, 1/2 W	66314827	R58
420042-00	Resistor, CF, 56 ohm, 5%, 1/2 W	66314819	R9
420046-00	Resistor, CF, 82 ohm, 5%, 1/2 W	66314824	R24
420082-00	Resistor, CF, 2.7K, 5%, 1/2 W	66314817	R4, R17
430056-00	Resistor, 220 ohm, 5%, 1 W	66314828	R59
430068-00	Resistor, CF, 680 ohm, 5%, 1 W	66314820	R13
430101-00	Resistor, CF, 15K, 5%, 1 W	66314823	R23
440078-00	Resistor, MF, 1K, 5%, 10 W	66314818	R8, R11
440079-00	Resistor, WW, 10 ohm, 5%, 2 W	66314825	R46
440088-00	Resistor, CF, 120, 5%, 2 W	66314822	R22
440090-00	Resistor, CF, 150 ohm, 5%, 2 W	66314826	R56
440097-00	Resistor, Bleeder, 80 MEG	66314881	R32 \triangle
470108-00	Control, 100 ohm, 10%, 1 W, VPC	66314829	R10
470110-10	Control, 10K, VPC	66314833	R43
470111-00	Control, 50 MEG, 30%, CER	66314831	R26, R34
470112-00	Control, 250K, 5%	66314836	R45
470113-10	Control, 5K, 25%, 0.2 W, VPC	66314830	R16, R57
470116-10	Control, 100K, VPC	66314834	R47
470180-00	Control, 500K, 20%, VPC	66314832	R37
500029-00	Cap, 220 PF, CER, 100 V	66314838	C2
500041-00	Cap, 330 PF, CER, 1 kV	66314849	C26
500069-00	Cap, 180 PF, CER/MICA, 400 V	51919733	C19
500079-00	Cap, 0.1 MFD, CER, 500 V	66314846	C18, C21, C25
500080-00	Cap, 0.02 MFD, CER, 2 kV	66314848	C20, C24
500081-00	Cap, 0.001 MFD, CER, 1 kV	66314850	C27
500104-00	Cap, 470 PF, 5%, MICA, 500 V	66314849	C26
520029-00	Cap, 0.018 MFD, Film, 200 V	66308931	C9
520068-00	Cap, 0.0068 MFD, Poly C, 100 V	66308924	C6
520087-00	Cap, 0.039 MFD, MPP, 600 V	66314844	C16
520088-00	Cap, 0.1 MFD, Poly P, 100 V	66314837	C1, C4, C5, C8, C22, C28, C29, C34, C36

SPECIFICATION CONTROL DRAWING

CONTROL DATA CORPORATION	SOURCE/CROSS REFERENCE LIST FOR VIKING X AUDIO- TRONICS VIDEO DISPLAY HEAD	CODE IDENT	A	DWG NO	REV
		15920		66314813 THRU 66314892	G
		SHEET 6 OF 11			

WP0105b
CD5753R

CROSS REFERENCE LIST

VENDOR PART NUMBER	DESCRIPTION	CDC PART NUMBER	SYMBOL
520089-00	Cap, 0.0047 MFD, Met Poly, 630 V	66314839	C7
520091-00	Cap, 0.33 MFD, MP, 100 V	66314845	C17
520103-00	Cap, 0.1 MFD, MPP, 100 V	66314851	C30, C31
520104-00	Cap, 0.01 MFD, MP, 400 V	66314853	C40
540017-00	Cap, 4.7 MFD, Elect, 50 V	51919719	C14
540024-00	Cap, 10 MFD, Elect, 150 V	66308943	C23
540033-00	Cap, 47 MFD, Elect, 100 V	51919726	C3
540067-00	Cap, 470 MFD, Elect, 35 V	66314840	C10
540068-00	Cap, 1000 MFD, Elect, 35 V	66314852	C33, C38
540070-00	Cap, 100 MFD, Elect, 35 V	66314843	C13, C15, C41, C32, C39
540072-00	Cap, 1 MFD, Elect, 50 V	66314841	C11
540107-00	Cap, 4.7 MFD, Non-Polar, 50 V	66314842	C12
600046-00	Transformer, Focus	66314873	T3
620034-10	Transformer, Flyback	66327971 ⁴	T2
640024-10	Choke, 1 MHY	66314874	L1
660053-00	Coil, Horizontal, Centering	66314872	T1
660055-00	Coil, Horizontal, Width	66314875	L3

Note: For additional part numbers refer to PN 66327968/8067.

SPECIAL NOTES:

- 1 Was Vendor P/N 181107-00 (CDC P/N 66314814).
- 2 Was Vendor P/N 440080-10 (CDC P/N 66314881) - 240 MEG.
- 3 Was Vendor P/N 410080-00 (CDC P/N 66314887) - 2.2K, 5%. If the 5% part is replaced with the 1% part for R15 on repair assemblies, R14 must also be replaced with a 1% resistor (Vendor P/N 410194-10, CDC P/N 66327989, value 2.67K 1/4 W 1%).
- 4 Was Vendor P/N 620034-00 (CDC P/N 66314816).

SPECIFICATION CONTROL DRAWING

CONTROL DATA CORPORATION	SOURCE/CROSS REFERENCE LIST FOR VIKING X AUDIO- TRONICS VIDEO DISPLAY HEAD	CODE IDENT	A	DWG NO	REV
		15920		66314813 THRU 66314892	G
		SHEET 7 OF 11			

WP0105b
CD5753R

APPENDIX A
TEST REQUIREMENTS

SPECIFICATION CONTROL DRAWING

CONTROL DATA CORPORATION	SOURCE/CROSS REFERENCE LIST FOR VIKING X AUDIO- TRONICS VIDEO DISPLAY HEAD	CODE IDENT 15920	A	DWG NO 66314813 THRU 66314892	REV B
				SHEET 8 OF 11	

WP0105b
CD5753R

TEST REQUIREMENT A1

Marking: The parts shall be legibly marked with the manufacturers name or symbol and part number (AVDD PN 190029-00). Bulk identify with CDC PN 66314813.

Description: CRT and Yoke Assembly

- a) 15-inch CRT, P39 Phosphor, Clinton Type (VPN 320034-00) CE689M15P39GHMH
- b) 110° deflection yoke (VPN 160281-00)
 - 1. Magnet compensated using fixed and trimmer type magnets
 - 2. Leads terminated in 4-pin female connector to mate with connector on CDC PN 66327973.
 - 3. 2-ring adjustable centering magnets
 - 4. Yoke clamp and screw

Vendor to install magnets for geometric distortion correction with yoke mounted on CRT neck and using a typical video display board (CDC PN 66327973) as a driving source. CDC to be responsible for any magnet adjustments.

SPECIFICATION CONTROL DRAWING

CONTROL DATA CORPORATION	SOURCE/CROSS REFERENCE LIST FOR VIKING X AUDIO-TRONICS VIDEO DISPLAY HEAD	CODE IDENT	A	DWG NO	REV
		15920		66314813 THRU 66314892	C
				SHEET	9 OF 11

WP0105b
CD5753R

Test Procedure:

1. Install CRT/yoke assembly in a test fixture and connect to the Video Display Board, CDC PN 66327973.
2. Apply the required TTL signals to the Video Display board using a CDC CC634 source or an equivalent signal generator.
3. Energize the Video Display system and check visually the items listed below for satisfactory operation.
 - a) Size
 - b) Linearity
 - c) Centering
 - d) Video Noise
 - e) Light Output
 - f) Focus
 - g) Screen Blemish
 - h) Geometric Distortion

Refer to Video Display Spec 51941006 for details.

SPECIFICATION CONTROL DRAWING

CONTROL DATA CORPORATION	SOURCE/CROSS REFERENCE LIST FOR VIKING X AUDIO-TRONICS VIDEO DISPLAY HEAD	CODE IDENT	A	DWG NO	REV
		15920		66314813 THRU 66314892	C
				SHEET 10 OF 11	

WP0105b
CD5753R

TEST REQUIREMENT A2

Burn-In: All PC boards shall be subjected to the burn-in period specified in CDC Spec 51941006.

Marking: The PC board assembly shall be legibly marked with the vendor name or symbol, part number and vendor revision level. Bulk identify with CDC PN 66327973. \triangle 2

Description: PC Board Assembly

- a) Number of trimmer pots on board----6
- b) Number of coil slug adjustments----3
- c) One (1) Static focus control
- d) One (1) Dynamic focus control
- e) Other PC board components -
 - o Resistors, capacitors, one fixed coil, IC chips (2), large fly-back transformer, small transformer, transistors (11) 3
- f) Vendor UL designation and component symbol marking.
- g) Board size - 152.4mm (6 inches) x 203.2mm (8 inches) x 1.57mm (.062 inch)
- h) One 20-Pin male connector - dual in line, polarized.
- i) Cable harness - 7 leads to CRT socket, 4 leads to yoke connector.
- j) One flat ribbon ground wire attached to CRT socket 250mm long (10 inches).
- k) One (1) G2 control

Test Procedure: Install in Viking X test Terminal or connect to an equivalent TTL signal source and test for compliance with CDC Specification 51941006.

\triangle 2 Replaces CDC P/N 66314814 (Vendor P/N 181107-00).

\triangle 3 Was quantity 9 on CDC P/N 66314814.

SPECIFICATION CONTROL DRAWING

CONTROL DATA CORPORATION	SOURCE/CROSS REFERENCE LIST FOR VIKING X AUDIO-TRONICS VIDEO DISPLAY HEAD	CODE IDENT	A	DWG NO	REV
		15920		66314813 THRU 66314892	F
				SHEET 11 OF 11	

WP0105b
CD5753R

OPTION-BOARD INSTALLATION DRAWINGS

A

This appendix contains installation drawings for the small and large option boards.

DWN	D SAND	4-82	CONTROL DATA CORPORATION	TITLE	INSTALLATION DRAWING SMALL OPTION	PREFIX	DOCUMENT NO.	REV.
CHKD	<i>[Signature]</i>	4-2-82		FIRST USED ON	CC634-A, YR101A, YR102A		66316553	A
ENG	<i>[Signature]</i>	4-2-82		CODE IDENT	15920		SHEET	1 of 2
MFG	<i>[Signature]</i>	4-2-82						
APPR	S. H. Hurd	4-2-82						

SHEET REVISION STATUS				REVISION RECORD						
				REV	ECO	DESCRIPTION	DRFT	DATE	APP	
				2	1					
				A	A	RELEASED CLASS A		4/5/82	<i>[Signature]</i>	

NOTES:

DETACHED LISTS

CD CONTROL DATA CORPORATION	CODE IDENT	SHEET	DOCUMENT NO.	REV.
	15920	2	66316553	A

SMALL OPTION INSTALLATION INSTRUCTIONS

- Turn the Terminal Power Actuator to "OFF".

CAUTION: An Option Module must never be installed/removed when power is ON!

- Select any blank cover in position I/F 1, I/F 2 or I/F 3 as shown in the figure below and remove the 2 screws and lock washers securing it. Save the screws and washers. Store cover for possible re-installation at a future date.
- Install Option Module as shown below (note orientation). Start gently pushing the Option Module into position. Locating guides in the plastic housing help locate the module when it is half way in. Gently push the Option Module until it is secure in mating connector.
- Install the 2 screws and lockwashers (previously removed) and tighten until snug.
- Save packaging of Option Module for possible future return to Control Data Corp.
- If applicable, connect peripheral to this option and then turn the Power Actuator to "ON".
- Refer to the Operators Guide (CDC P/N 62940019) for changes required in parameter settings.

62940037 L

USED ON	INSTALLATION DESCRIPTION	FIGURE	APPLICABLE NOTES
CC634-A	VIDEO FILTER	3, 4	
CC638-A	DOT GRAPHICS	1, 2, 4	
XA358-A	DOT GRAPHICS (FIELD INSTALL)	1, 2	TABLE 1
XA360-A	1200/1200 MODEM (FIELD INSTALL)	5	TABLE 2
XA368-A	GRAPHICS OPTION (FIELD INSTALL)	2, 4	TABLE 3
XA369-A	TOUCH PANEL (FIELD INSTALL)	1, 2, 3	TABLE 4
YR109-A	4.0 FIRMWARE OPTION (FIELD INSTALL)	5, 6	TABLE 5

SHIPT REV STATUS							REVISION RECORD						
G	S	4	3	2	1	REV	ECO	DESCRIPTION	DRPT	DATE	CHKD	APVD	
A	A	A	A	A	A	A	14232-24	RELEASED CLASS A					
A	B	A	A	A	A	B	15337	ADDED VIEW B-B	EE	1/2/75	EE	EE	
H	C	A	A	C	C	C	15642	REVISED PER ECO	WJG	1/2/75	WJG	WJG	
A	C	D	A	D	D	D	15659	REVISED PER ECO	WJG	1-12-75	WJG	WJG	
F	F	F	F	F	F	F	16044	REVISED PER ECO	WJG	7-27-75	WJG	WJG	
F	F	F	F	F	F	F	16133	REVISED PER ECO	WJG	11/1/75	WJG	WJG	
G	G	F	F	G	G	G	16710	REVISED PER ECO	WJG	8-2-74	WJG	WJG	
H	G	F	H	G	H	H	16896	REVISED PER ECO	WJG	11-23-74	WJG	WJG	
H	G	J	H	G	J	J	17023	ENG NOTES IN SEC B-1 SHIP #	WJG	1/2/75	WJG	WJG	
H	K	J	H	K	K	K	17107	ADDED NOTE 2	WJG	1/2/75	WJG	WJG	
H	K	J	H	L	L	L	17518	ADDED NOTE TO TABLE 1 & 3	EE	1/2/75	WJG	WJG	

NOTES

1. TORQUE M6 NUTS 12.7-16.1 CM-KG (11-14 IN-LB) FOR FACTORY INSTALL. FOR FIELD INSTALLATION M6 NUTS SHOULD BE HAND TIGHTENED USING 3 FINGERS AND THUMB TO GRASP TOOL PER ILLUSTRATION:

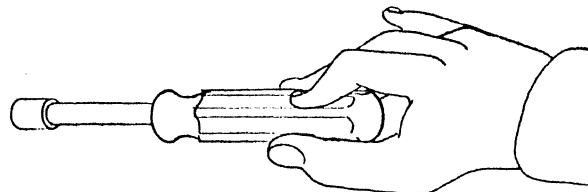

2. ON LATER UNITS PART NUMBERS 61409475, 71493588, AND 71493589 HAVE ALL BEEN CHANGED TO 71494524.

3. COPPER FOIL APPLIES TO F/N 61409475 ONLY.

4. REFER TO FIGURE 3. IF THE BEZEL ADAPTOR IS RECESSED IN AREA SHOWN CONTINUE WITH NEXT STEP OF INSTRUCTION. IF NOT (EARLIER UNITS) PERFORM THE FOLLOWING TEST: TEMPORARILY INSTALL THE BEZEL YOU NEED NOT FASTEN ALLEN SCREWS BUT APPLY PRESSURE WHERE THEY ATTACH INSPECT THE TOUCH PANEL FOR DIMPLING CAUSED BY THE BEZEL PRESSING INTO IT. IF DIMPLING OCCURS, REMOVE THE TOUCH PANEL AND REMOVE 4 TRIANGULAR SPACERS ON THE BACK CORNERS OF THE TOUCH PANEL.

UNLESS OTHERWISE SPECIFIED DIMENSIONS ARE IN TOLERANCES			DWN	1/3/75	15337	CONTROL DATA CORPORATION
PLACE	PLACE	ANGLES	CHKD	1/2/75	15337	
±	±	±	ENGR	1/2/75	15337	TITLE
MATERIAL			MFG	1/2/75	15337	INSTALLATION DRAWING, LARGE OPTION
FINISH			APVD	1/2/75	15337	
DETAILED LIST			EQUIP. NO.	CC634-A		DWG NO. 66315803
			DATE	15/70		

A-3 ●

A-4

62940037 L

REV	ECO	DESCRIPTION	DRFT	DATE	CHKD	APP
-----	-----	-------------	------	------	------	-----

TABLE 1 XA358-A FIELD INSTALLATION NOTES

1. REMOVE TOP ACCESS COVER PER HMM (HARDWARE MAINTENANCE MANUAL) (62940034).
2. REMOVE LOGIC DRAWER ASSEMBLY PER PROCEDURE DESCRIBED IN THE DISPLAY TERMINAL HMM.
3. REMOVE BEZEL ASSEMBLY AS SHOWN IN FIGURE 1.
4. REMOVE VIDEO FILTER ASSEMBLY (REFER TO FIGURE 3).
5. MOUNT TOUCH PANEL ASSEMBLY WITH HARDWARE AS SHOWN IN FIGURE 1. PASS CABLE BETWEEN ADAPTER AND CRT AS PANEL IS INSTALLED. SEE NOTE 1 (SHEET 1) FOR TORQUE SPECIFICATION.
- 5A. SEE NOTE 4.
6. SECURE TOUCH PANEL CABLE (SHIELDED PORTION) WITH BRACKET (71493833) AS SHOWN IN FIGURE 2.
- 6A. REMOVE AND DISCARD CHANNEL (51942165 SHOWN IN FIGURE 4) TO RELEASE END OF 50 PIN RIBBON CABLE. NOTE: THE CABLES AND JUMPER PLUG INSTALLED IN STEPS 7, 8 & 9 SHOULD BE INSERTED AND REMOVED 3 TIMES TO REMOVE ANY CONTAMINATION WHICH MAY BE PRESENT.
7. INSTALL CARD ASSEMBLY (1ALD) AND CABLE ASSEMBLY (61409163) AS SHOWN IN FIGURE 2.
8. POSITION JUMPER ON CARD ASSEMBLY 1AJD AS SHOWN IN FIGURE 2 VIEW A-A.
9. CONNECT 50 PIN RIBBON CABLE AS SHOWN IN FIGURE 2.
10. REPLACE LOGIC DRAWER ASSEMBLY PER PROCEDURE IN HMM.
11. ATTACH TOUCH PANEL CABLE TO CARD ASSEMBLY (1ALD).
12. REPLACE BEZEL AND ACCESS COVER PER PROCEDURE IN HMM.
13. ADD THE EQUIPMENT IDENTIFICATION NUMBER, SERIES CODE, PART NUMBER AND SERIAL NUMBER TO THE EQUIPMENT CONFIGURATION LOG. INFORMATION IS CONTAINED ON QUALITY ASSURANCE TAG OF THIS OPTION.
14. ADJUST VIDEO ALIGNMENT WITH GRAPHICS TOUCH PANEL PER PROCEDURE IN HMM.
15. SET TERMINAL INSTALLATION PARAMETERS (CONFIGURATION F2-2 AND F3-3 SET TO 1) AND CHECKOUT PER OPERATORS GUIDE (62940019 FOR CC634A/CC638A) OR (62950101 FOR CC634B/CC638B).

TABLE 2 XA360-A FIELD INSTALLATION NOTES

NOTE: THESE INSTRUCTIONS ARE FOR INSTALLATION INTO A CC634-A OR CC638-A ONLY. INSTALLATION INTO A CC634-B OR CC638-B ARE COVERED IN THE HARDWARE INSTALLATION INSTRUCTIONS - PUB 62950119.

1. REMOVE LOGIC DRAWER ASSEMBLY AND TOP ACCESS COVER PER PROCEDURE DESCRIBED IN THE DISPLAY TERMINAL HMM (HARDWARE MAINTENANCE MANUAL) (62940034).
2. REMOVE COVER PLATE AT 1/F 4 POSITION. REFER TO FIGURE 4.
3. REMOVE, FROM THE MODEM, THE SHIPPING BRACKET THAT IS SECURED WITH TWO (2) WING NUTS. SAVE THE WING NUTS, THEY WILL BE USED IN STEP 5.
4. CONNECT THE SHORT 50 PIN EXTENSION CABLE PROVIDED. REFER TO FIGURE 5.
5. SLIDE MODEM CARD ASSEMBLY INTO 1/F 4 SLOT. SECURE WITH THE 2 NUTS PROVIDED. CAUTION: ASSURE THAT THE EXTENSION CABLE AND CONNECTOR TO THE BUS CABLE ARE HELD AWAY FROM THE MODEM SLOT AS THE MODEM IS INSERTED.
6. PUSH THE 50 PIN EXTENSION CABLE CONNECTION (END CONNECTED TO THE BUS CABLE) UNDER THE SMALLER BOARD 50 PIN CONNECTOR. REFER TO FIGURE 5.
7. CONNECT THE FREE END OF THE 50 PIN EXTENSION CABLE TO THE SMALLER BOARD. REFER TO FIGURE 5.
8. REPLACE LOGIC DRAWER ASSEMBLY AND TOP ACCESS COVER PER PROCEDURE IN HMM.
9. ADD THE EQUIPMENT IDENTIFICATION NUMBER, SERIES CODE AND PART NUMBER TO THE EQUIPMENT CONFIGURATION LOG. INFORMATION IS CONTAINED ON QUALITY ASSURANCE TAG OF THIS OPTION.
10. REMOVE ANY TELEPHONE CABLE FROM THE WALL MOUNTED JACK FOR THE TELEPHONE TO BE USED WITH THE MODEM. INSERT THE DUPLEX PLUG (P/N 51817018) INTO THE WALL JACK. REINSERT THE TELEPHONE CABLE INTO THE DUPLEX PLUG. PLUG ONE END OF THE MODEM CABLE INTO THE DUPLEX PLUG. PLUG THE OTHER END OF THE MODEM CABLE INTO THE 1/F 4, RJ-11 JACK OF THE MODEM.
11. SET TERMINAL INSTALLATION PARAMETERS (CONFIGURATION F3-1 EQUAL TO 1), SET MODEM INSTALLATION PARAMETERS AS APPLICABLE AND CHECKOUT PER OPERATORS GUIDE (62940019 FOR CC634A/CC638A).

TABLE 3 XA 368-A FIELD INSTALLATION NOTES

1. REMOVE LOGIC DRAWER ASSEMBLY PER PROCEDURE DESCRIBED IN THE DISPLAY TERMINAL HMM (HARDWARE MAINTENANCE MANUAL) (62940034).
2. REMOVE AND DISCARD CHANNEL (51942165 SHOWN IN FIGURE 4) TO RELEASE END OF 50 PIN RIBBON CABLE. NOTE: THE CABLES AND JUMPER PLUG INSTALLED IN STEPS 3, 4 & 5 SHOULD BE INSERTED AND REMOVED 3 TIMES TO REMOVE ANY CONTAMINATION WHICH MAY BE PRESENT.
3. INSTALL CARD ASSEMBLY (1ALD) AND CABLE ASSEMBLY (61409163) AS SHOWN IN FIGURE 2.
4. POSITION JUMPER ON CARD ASSEMBLY 1AJD AS SHOWN IN FIGURE 2 VIEW A-A.
5. CONNECT 50 PIN RIBBON CABLE AS SHOWN IN FIGURE 2.
6. REPLACE LOGIC DRAWER ASSEMBLY PER PROCEDURE IN HMM.
7. ADD THE EQUIPMENT IDENTIFICATION NUMBER, SERIES CODE, PART NUMBER AND SERIAL NUMBER TO THE EQUIPMENT CONFIGURATION LOG. INFORMATION IS CONTAINED ON QUALITY ASSURANCE TAG OF THIS OPTION.
8. SET TERMINAL INSTALLATION PARAMETER (CONFIGURATION F3-3 SET TO 1) AND CHECKOUT PER OPERATORS GUIDE (62940019 FOR CC634A/CC638A) OR (62950101 FOR CC634B/CC638B).

TABLE 4 XA 369-A FIELD INSTALLATION NOTES

1. REMOVE LOGIC DRAWER ASSEMBLY AND TOP ACCESS COVER PER PROCEDURE DESCRIBED IN THE DISPLAY TERMINAL HMM (HARDWARE MAINTENANCE MANUAL) (62940034).
2. REMOVE BEZEL ASSEMBLY AS SHOWN IN FIGURE 1.
3. REMOVE VIDEO FILTER ASSEMBLY (REFER TO FIGURE 3).
4. MOUNT TOUCH PANEL ASSEMBLY WITH HARDWARE AS SHOWN IN FIGURE 1. PASS CABLE BETWEEN ADAPTER AND CRT AS PANEL IS INSTALLED. SEE NOTE 1 (SHEET 1) FOR TORQUE SPECIFICATION.
- 4A. SEE NOTE 4.
6. SECURE TOUCH PANEL CABLE (SHIELDED PORTION) WITH BRACKET (71493833) AS SHOWN IN FIGURE 2.
8. ATTACH TOUCH PANEL CABLE TO CARD ASSEMBLY (1ALD).
7. REPLACE BEZEL AND ACCESS COVER PER PROCEDURE IN HMM.
8. ADD THE EQUIPMENT IDENTIFICATION NUMBER, SERIES CODE, PART NUMBER AND SERIAL NUMBER TO THE EQUIPMENT CONFIGURATION LOG. INFORMATION IS CONTAINED ON QUALITY ASSURANCE TAG OF THIS OPTION.
9. ADJUST VIDEO ALIGNMENT WITH GRAPHICS TOUCH PANEL PER PROCEDURE IN HMM.
10. SET TERMINAL INSTALLATION PARAMETER (CONFIGURATION F2-2 SET TO 1) AND CHECKOUT PER OPERATORS GUIDE (62940019 FOR CC634A/CC638A) OR (62950101 FOR CC634B/CC638B).

TABLE 5 YR 109 FIELD INSTALLATION NOTES

1. REMOVE LOGIC DRAWER ASSEMBLY AND TOP ACCESS COVER PER PROCEDURE DESCRIBED IN THE DISPLAY TERMINAL HMM (HARDWARE MAINTENANCE MANUAL) (62940034).
2. REMOVE "MAIN LOGIC PCB" PER PROCEDURE IN HMM, DO NOT DISCONNECT THE BATTERY.
3. REMOVE FIRMWARE CHIPS FROM LOCATIONS K1, K2 AND K5 ON MAIN LOGIC BOARD (SEE FIGURE 5 & 6 NOTE CHIP ORIENTATION AS REPLACEMENT CHIPS WILL BE ORIENTATED THE SAME).
4. INSTALL CHIP P/N 66315365 IN LOCATION K1, 66315366 AT K2 AND 66315367 AT K5.
5. REPLACE "MAIN LOGIC PCB" PER PROCEDURE IN HMM.
6. REPLACE LOGIC DRAWER ASSEMBLY AND TOP ACCESS COVER PER PROCEDURE IN HMM.
7. ADD THE EQUIPMENT IDENTIFICATION NUMBER, SERIES CODE AND PART NUMBER TO THE EQUIPMENT CONFIGURATION LOG. INFORMATION IS CONTAINED ON QUALITY ASSURANCE TAG OF THIS OPTION.
8. CHECKOUT PER OPERATORS GUIDE (62940019 FOR CC634A/CC638A) OR (62950101 FOR CC634B/CC638B).

INSTALLATION DRAWING,
LARGE OPTION

CODE IDENT	DWG NO
15920	66315803

D

C

66315803↑

A

62940037 H

A-5

REVISION RECORD						
REV	ECO	DESCRIPTION	DRFT	DATE	CHKD	APP

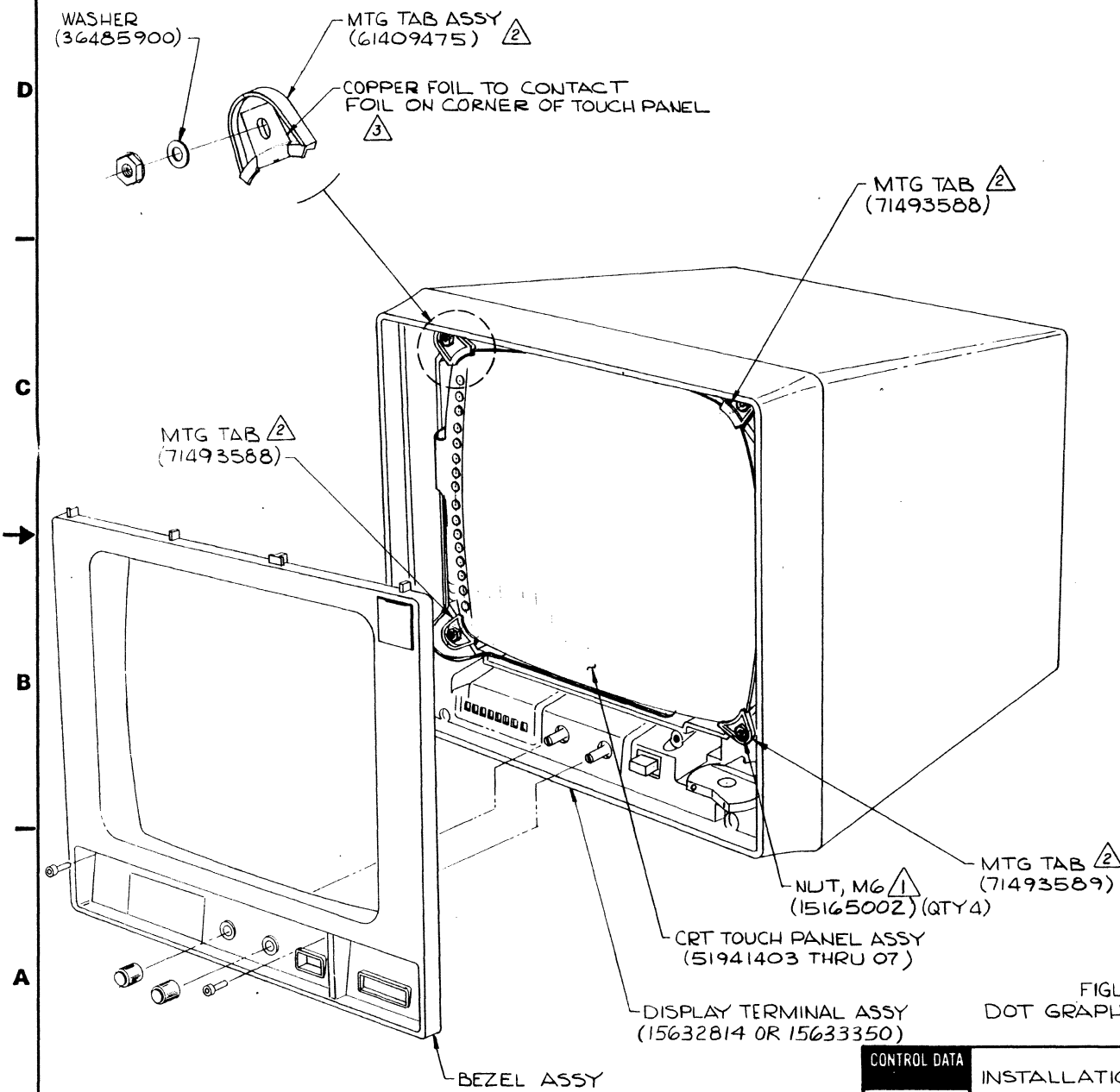
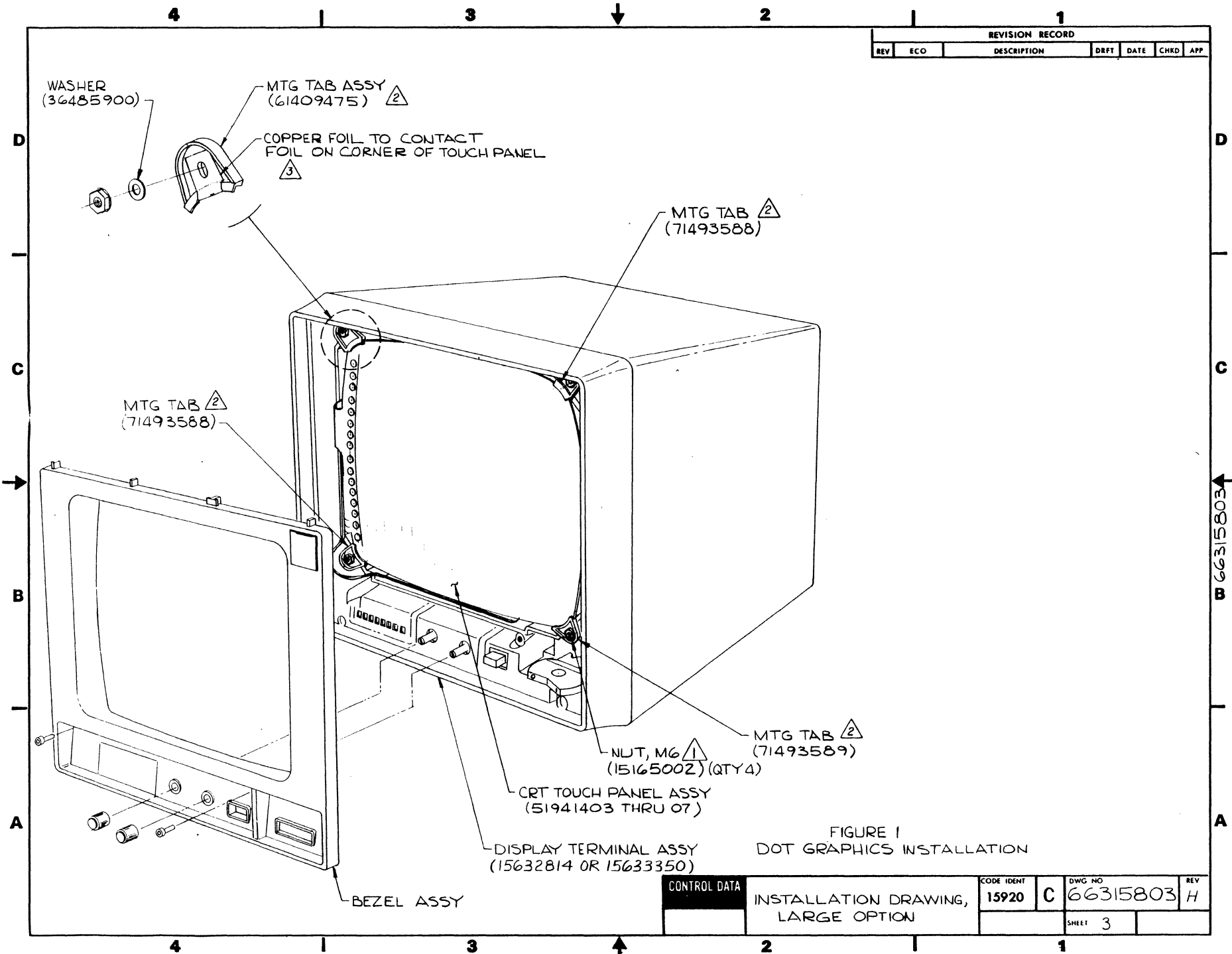

FIGURE 1
DOT GRAPHICS INSTALLATION

CONTROL DATA	INSTALLATION DRAWING, LARGE OPTION		CODE IDENT 15920	C	DWG NO 66315803	REV H
			SHEET 3			



A-6

62940037 H

CARD ASSY IAJD

LOCATE JUMPER AS SHOWN

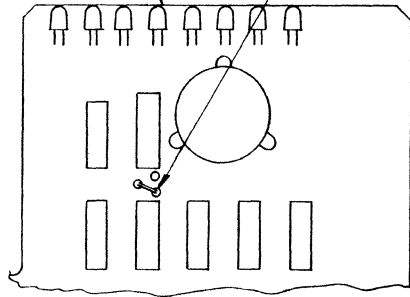

VIEW A-A

REVISION RECORD					
REV	ECO	DESCRIPTION	DRFT	DATE	CHKD APP

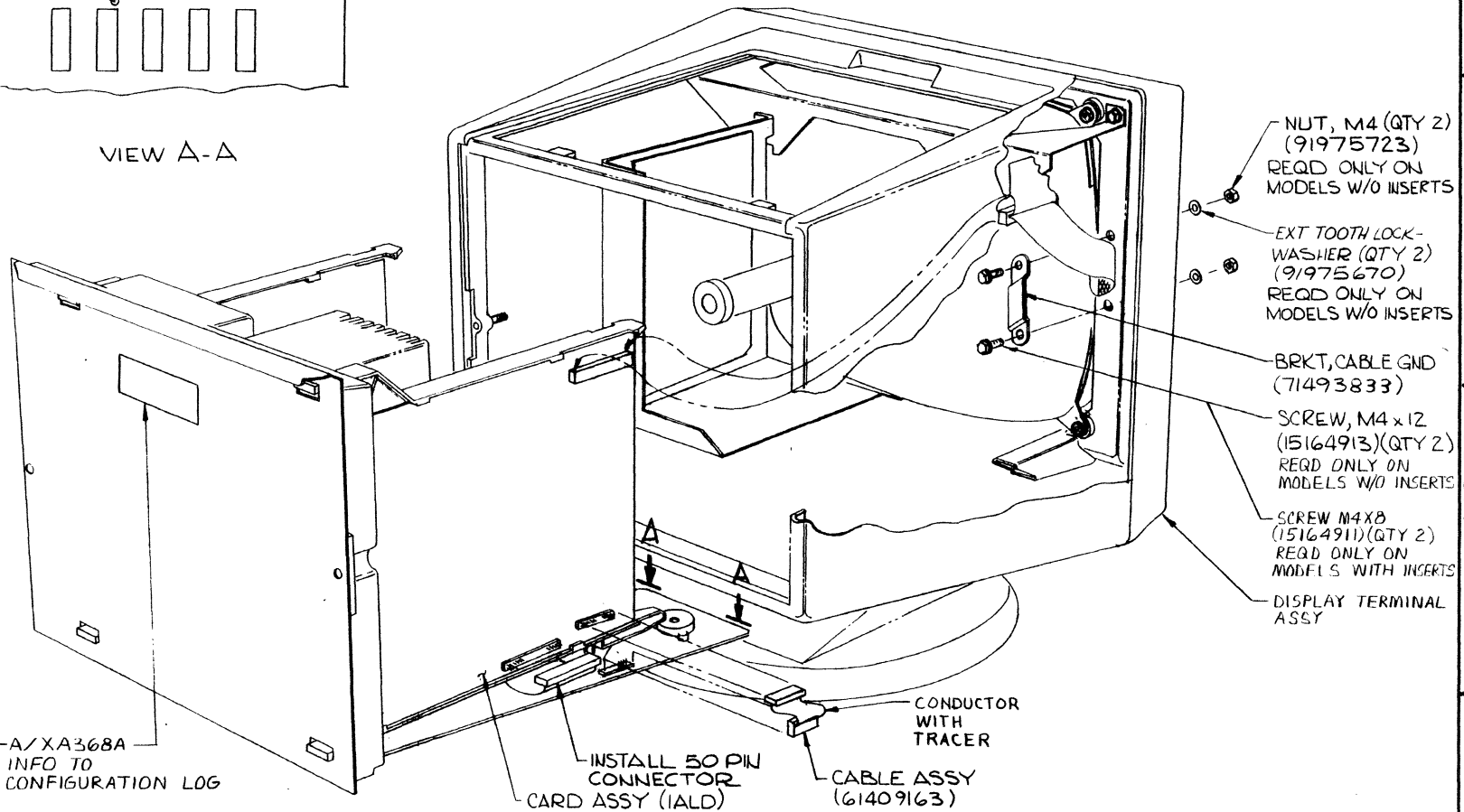

FOR XA35B-A/XA368A
ADD IDENT INFO TO
EQUIPMENT CONFIGURATION LOG

NUT, M4 (QTY 2)
(91975723)
REQD ONLY ON
MODELS W/O INSERTS

EXT TOOTH LOCK-
WASHER (QTY 2)
(91975670)
REQD ONLY ON
MODELS W/O INSERTS

BRKT, CABLE GND
(71493833)

SCREW, M4 x 12
(15164913) (QTY 2)
REQD ONLY ON
MODELS W/O INSERTS

SCREW M4 x 8
(15164911) (QTY 2)
REQD ONLY ON
MODELS WITH INSERTS

DISPLAY TERMINAL
ASSY

INSTALL 50 PIN
CONNECTOR
CARD ASSY (IAJD)

CONDUCTOR
WITH
TRACER

CABLE ASSY
(61409163)

FIGURE 2
DOT GRAPHICS INSTALLATION

CONTROL DATA	INSTALLATION DRAWING, LARGE OPTION	CODE IDENT 15920	REV C	DWG NO 66315803	REV J
				SHEET 4	

66315803

62940037 J

A-7

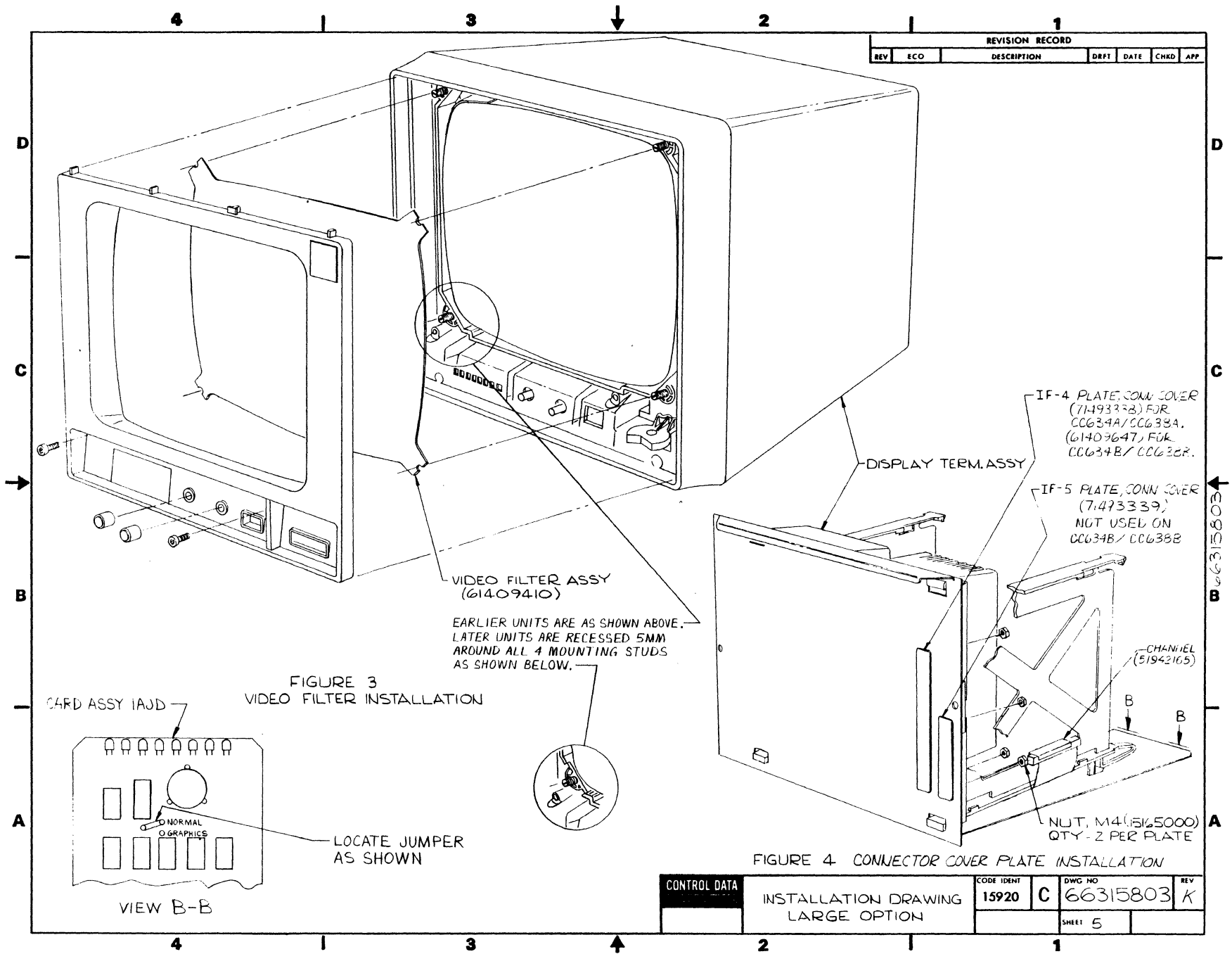

REVISION RECORD						
REV	ECO	DESCRIPTION	DRFT	DATE	CHKD	APP

FIGURE 3
VIDEO FILTER INSTALLATION

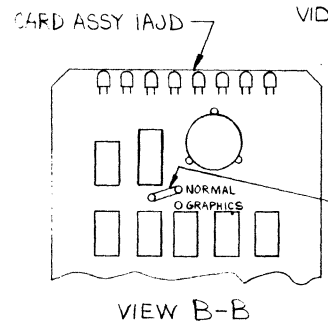

LOCATE JUMPER AS SHOWN

EARLIER UNITS ARE AS SHOWN ABOVE.
LATER UNITS ARE RECESSED 5MM
AROUND ALL 4 MOUNTING STUDS
AS SHOWN BELOW.

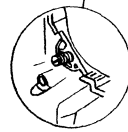

FIGURE 4 CONNECTOR COVER PLATE INSTALLATION

CONTROL DATA		CODE IDENT	DWG NO	REV
INSTALLATION DRAWING LARGE OPTION		15920	C 66315803	K
			SHEET 5	

A-8

62940037 H

REVISION RECORD					
REV	ECO	DESCRIPTION	DRFT	DATE	CHKD APP

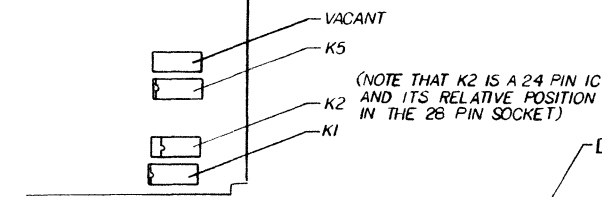

FIGURE 6
4.0 FIRMWARE INSTALLATION

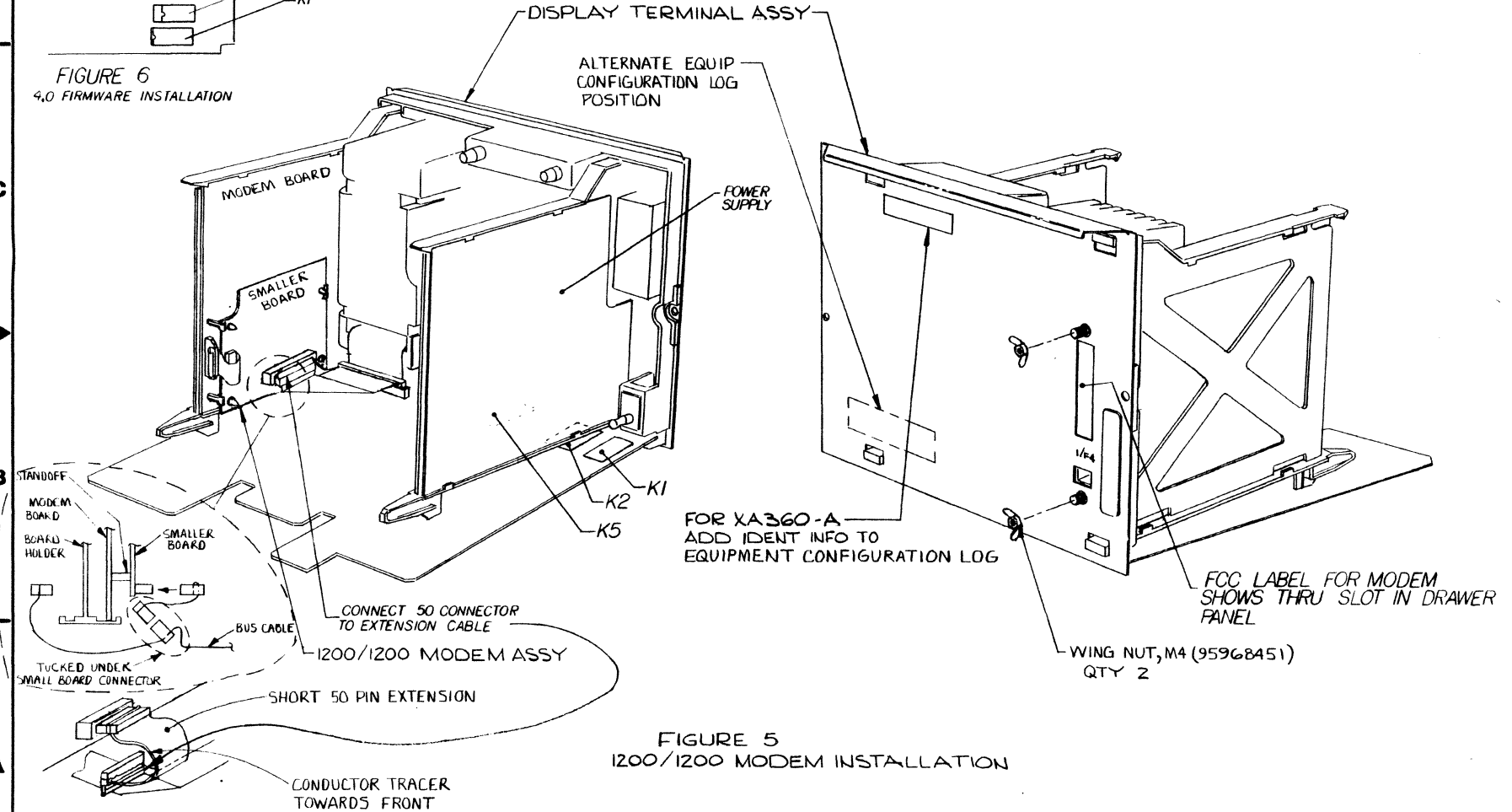

FIGURE 5
1200/1200 MODEM INSTALLATION

FOR XA360-A
ADD IDENT INFO TO
EQUIPMENT CONFIGURATION LOG

CONTROL DATA	INSTALLATION DRAWING, LARGE OPTION	CODE IDENT	DWG NO	REV
		15920	C 66315803	H
		SHEET	6	

66315803

DWI	D. SAND	12/82	CONTROL DATA	TITLE	INSTALLATION DRAWING XA363A	PREFIX	DOCUMENT NO	66328494	REV	B
CHD	W. J. Mason	7-3-82	ORIGINATOR	FIRST USED ON	CC634-A, CC638-A,		SHEET	1 of 2		
ENG	M. J. Lynch	12/82								
MFG	R. N. V. B.	12/82	CODE IDENT	15920						
APPR										

SHEET REVISION STATUS										REVISION RECORD							
										2	1	REV	ECO	DESCRIPTION	DRFT	DATE	APP
										A	A	A	15151-86	RELEASED CLASS "A"		12-10-82	Mot
										B	B	B	16097	REVISED PER ECO	BG	8/16/83	C

NOTES:

DETACHED LISTS

443160 REV. 8/71

PRINTED IN U.S.A.

	CODE IDENT	15920	SHEET	2	DOCUMENT NO.	66328494	REV	B
---	------------	-------	-------	---	--------------	----------	-----	---

SMALL OPTION INSTALLATION INSTRUCTIONS

- Turn the Terminal Power Actuator to "OFF".
CAUTION: An Option Module must never be installed/removed when power is ON!
- Select any blank cover in position I/F 2 of I/F 3 as shown in the figure below and remove the 2 screws and lock washers securing it. Save the screws and washers. Store cover for possible re-installation at a future date.
- Install Option Module as shown below (note orientation). Start gently pushing the Option Module into position. Locating guides in the plastic housing help locate the module when it is half way in. While supporting the terminal, so it does not slide, gently push the Option Module until it is secure in mating connector.
- Install the 2 screws and lockwashers (previously removed) and tighten until snug.
- Log the equipment number, serial code, and serial number on a space provided on the Terminal Configurator Log located on the back of the terminal.
- Save packaging of Option Module for possible future return to Control Data Corporation.
- Refer to the 110 owner manual (CDC P/N 62940071) for changes required in parameter setting and systems installation information.

WHEN INSTALLATING XA363A

NOTE: Save terminator (CDC P/N 61409220) for installation of Rigid Disk Peripheral.

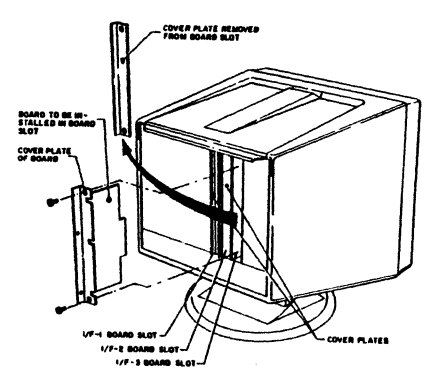

443160

PRINTED IN U.S.A.

PACKING INFORMATION

B

This appendix contains packing information for the display terminals and options.

PACKAGING INSTRUCTIONS

NO. 90538400

For VIKING - X DISPLAY

Sheet 1 of 4

Rev. C

721-10 CC634

DRAWN BY <u>KB</u>		DATE <u>1-82</u>	CHKD. BY <u>[Signature]</u>	DATE <u>1-2-82</u>	APRV. BY <u>CPZ</u>	DATE <u>1-11-82</u>																					
OPR NO.	ITEM CHKD APPLS. TO			DESCRIPTION																							
	VAN	AIR	TRUCK				SHIP																				
X	X				<u>DIMENSION</u> <u>CUBE</u> <u>WEIGHT</u> 21.5 x 20.7 x 27.5 in. 7.08 Cu Ft 49.0 LBS X X 54.6 x 52.5 x 69.8 cm .20 Cu M 22.0 KGS																						
X	X				<p style="text-align: center;"><u>LIST OF MATERIALS</u></p> <table style="width:100%; border-collapse: collapse;"> <thead> <tr> <th style="text-align: left;"><u>DESCRIPTION</u></th> <th style="text-align: left;"><u>QTY.</u></th> <th style="text-align: left;"><u>PART NUMBER</u></th> </tr> </thead> <tbody> <tr> <td>Display-Foam end caps</td> <td>1 Set</td> <td>90538401</td> </tr> <tr> <td>Shipping R.S.C. Container</td> <td>1</td> <td>90538402</td> </tr> <tr> <td>Display-R.S.C. Container</td> <td>1</td> <td>90538403</td> </tr> <tr> <td>Keyboard-R.S.C. Container</td> <td>1</td> <td>90538404</td> </tr> <tr> <td>Keyboard-Corrugated Cover</td> <td>1</td> <td>90538405</td> </tr> <tr> <td>Keyboard-Foam end caps</td> <td>1 Set</td> <td>90538406</td> </tr> </tbody> </table>		<u>DESCRIPTION</u>	<u>QTY.</u>	<u>PART NUMBER</u>	Display-Foam end caps	1 Set	90538401	Shipping R.S.C. Container	1	90538402	Display-R.S.C. Container	1	90538403	Keyboard-R.S.C. Container	1	90538404	Keyboard-Corrugated Cover	1	90538405	Keyboard-Foam end caps	1 Set	90538406
<u>DESCRIPTION</u>	<u>QTY.</u>	<u>PART NUMBER</u>																									
Display-Foam end caps	1 Set	90538401																									
Shipping R.S.C. Container	1	90538402																									
Display-R.S.C. Container	1	90538403																									
Keyboard-R.S.C. Container	1	90538404																									
Keyboard-Corrugated Cover	1	90538405																									
Keyboard-Foam end caps	1 Set	90538406																									
DATE REVISED																											
ENGINEER																											

PREPARED BY: CORPORATE PACKAGING AND MATERIAL HANDLING ENGINEERING HQW03N
 PH (612)853-3175 or CN#321-3175

AA2997 11/75 * 79

PRINTED IN U.S.A.



PACKAGING INSTRUCTIONS

NO. 90538400Sheet 2 of 4For VIKING - X DISPLAY
721-10 CC634

DRAWN BY <u>RD</u>		DATE <u>1-82</u>	CHKD. BY <u>A - 2</u>	DATE <u>1-8-82</u>	APRV. BY <u>J P L</u>	DATE <u>1-11-82</u>
OPR NO.	ITEM CHKD APPLS. TO				DESCRIPTION	
	VAN	AIR	TRUCK	SHIP		
					<p style="text-align: center;"><u>REVISION RECORD</u></p> <p>Rev. A: Initial Release 1-82 R.P.BAKUS</p> <p>Rev. B: Changed R.S.C. Burst from 350# D.W. to 275#. 3-82 R. P. Bakus</p> <p>Rev. C: Changed Keyboard Pkg. design from corrugated inserts to P.E. end caps and clarified pkg. instructions 4-82 R. Bakus</p>	
					DATE REVISED	
					ENGINEER	

AA2997 11/75 * 79

PRINTED IN U.S.A.

PACKAGING INSTRUCTIONS

For VIKING-X DISPLAY

DRAWN BY		DATE		CHKD. BY		DATE		APRV. BY		DATE	
RB		1-82		HEP		4/82		HEP		4/82	
OPR NO.	ITEM CHKD APPLS. TO				DESCRIPTION						
	VAN	AIR	TRUCK	SHIP							
1.	X	X			Assemble display package as illustrated on page 4 of 4 of this document. NOTE: Front of display must align with CDC logo on container 90538403.						
2.	X	X			Place foam end caps on display and position into container 90538403.						
3.	X	X			Place the larger of the two cushioning legs toward the rear of display in the "cutouts" provided.						
4.	X	X			Place the smaller cushioning legs toward the displays front in the cutouts provided.						
5.	X	X			Place power cord in appropriately sized poly bag and secure to wall of container 90538403 with tape.						
6.	X	X			Close container 90538403, but do not seal.						
7.	X	X			Assemble keyboard package as illustrated on page 4 of 4 of this document.						
8.	X	X			After placing corrugated cover over keyboard place manuals, supplementals, etc, into container 90538405, but do not seal.						
9.	X	X			Place containers 90538403/4 into container 90538402 and seal. NOTE: For a correct fit of the packages, position "CDC" logo's in the same direction on all three containers before consolidation.						
10.	X	X			Place packaging/unpackaging instruction CDC publication 62940038 in adhesive backed envelope, seal, and place on outside container 90538402.						
DATE REVISD											
ENGINEER					7901b						

AA2997 11/75 * 79

PRINTED IN U.S.A.

PACKAGING INSTRUCTIONS

For VIKING X DISPLAY
721-10 CC634

DRAWN BY	DATE	CHKD. BY	DATE	APRV. BY	DATE
----------	------	----------	------	----------	------

OPR NO.	ITEM CHKD APPLS. TO				DESCRIPTION
	VAN	AIR	TRUCK	SHIP	

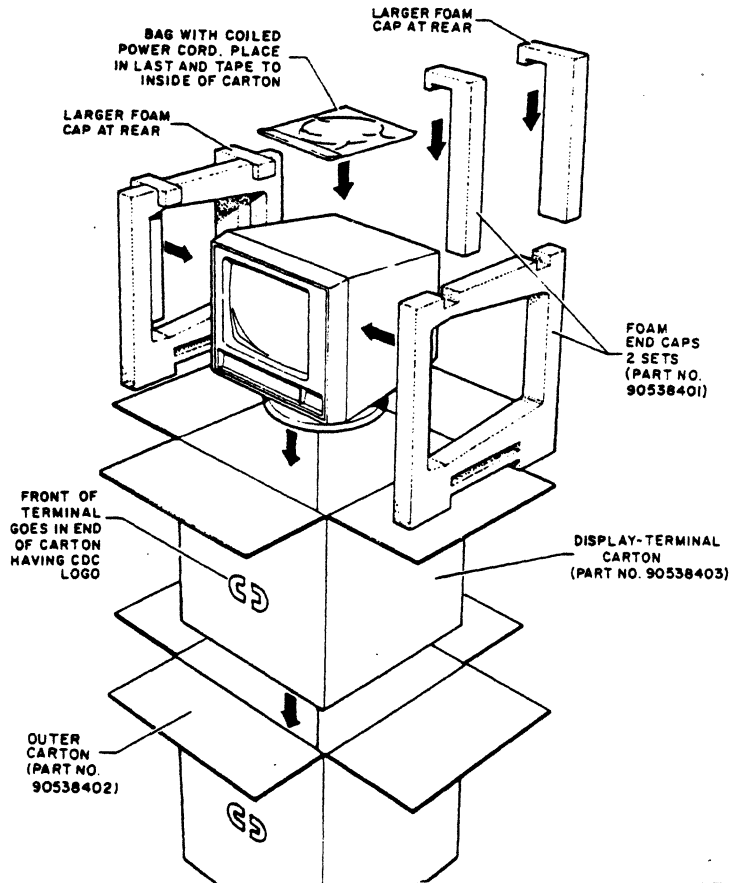
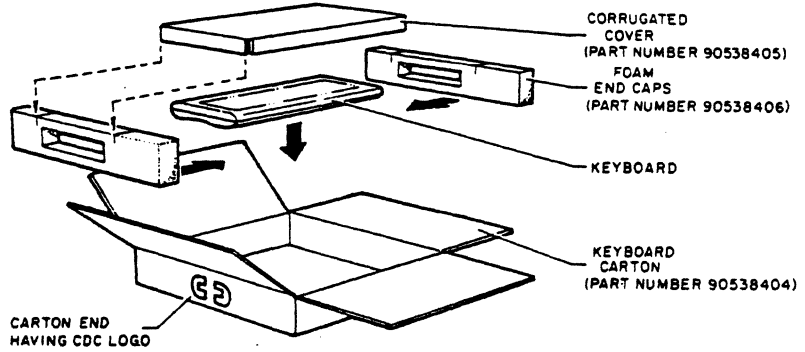

AA2997 11/75 * 79

DATE REVISED							
ENGINEER							

PRINTED IN U.S.A.

PACKAGING INSTRUCTIONS

NO. 90534500

For GENERAL PACKAGING SPECIFICATION

Sheet 1 of 1
REV. A

DRAWN BY <u>RB</u>		DATE <u>3-81</u>	CHKD. BY <u>JG</u>	DATE <u>3-81</u>	APRV. BY <u>J.P.A.</u>	DATE <u>3-12-31</u>
OPR NO.	ITEM CHKD APPLS. TO				DESCRIPTION	
	VAN	AIR	TRUCK	SHIP		
					<p>NOTE: This document may be utilized as a packaging guideline for equipments which have been issued an equipment number in accordance with CDC Standard 1.01.007, but do not require a specific detailed package document. Equipments such as cables, cards, etc. may also fall into this category. It will be the responsibility of the Facility Packaging Engineer to determine if this document is applicable to the respective part or a specific detailed packaging document is required. The intent and general packaging scope of CDC Specification 10120303 will be interpreted as sufficient packaging for equipments referencing this document.</p> <p>PREPARED BY: CORPORATE PACKAGING & MATERIAL HANDLING ENGINEERING HQWO3M PH: (612) 853-3175</p>	
DATE REVISED						
ENGINEER						

AA2997 11/75 * 79

PRINTED IN U.S.A.

COMMENT SHEET

MANUAL TITLE: CC63X Display Terminal, Hardware Maintenance
Manual (Repair-Center Information)

PUBLICATION NO.: 62940037

REVISION: L

NAME: _____

COMPANY: _____

STREET ADDRESS: _____

CITY: _____ **STATE:** _____ **ZIP CODE:** _____

This form is not intended to be used as an order blank. Control Data Corporation welcomes your evaluation of this manual. Please indicate any errors, suggested additions or deletions, or general comments below (please include page number references).

Please Reply

No Reply Necessary

CUT ALONG LINE

REV. 5/86 PRINTED IN U.S.A.

NO POSTAGE STAMP NECESSARY IF MAILED IN U.S.A.

FOLD ON DOTTED LINES AND TAPE

FOLD

FOLD



BUSINESS REPLY MAIL

FIRST CLASS PERMIT NO. 8241 MINNEAPOLIS, MN

POSTAGE WILL BE PAID BY ADDRESSEE

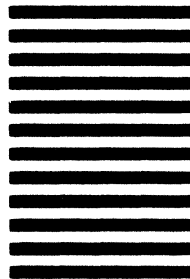
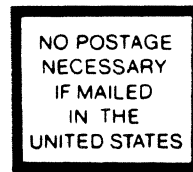

CONTROL DATA
Technology and Publications Division
ARH219
4201 North Lexington Avenue
Saint Paul, MN 55126-6198

CUT ALONG LINE

FOLD

FOLD



CORPORATE HEADQUARTERS, P.O. BOX 0, MINNEAPOLIS, MINN 55440
SALES OFFICES AND SERVICE CENTERS IN MAJOR CITIES THROUGHOUT THE WORLD

LITHO IN U.S.A.

 CONTROL DATA