



311538-001

Copyright 1997 Exabyte Corporation. All rights reserved. EXABYTE, EXAPAK, EXAFacts, EXASoft, EXATAPE, and Nest are trademarks of Exabyte Corporation. Eagle, EXA, and EXB are registered trademarks of Exabyte Corporation. All other product names are trademarks or registered trademarks of their respective companies.



# Quick Installation

## 8mm Half-High Tape Drives

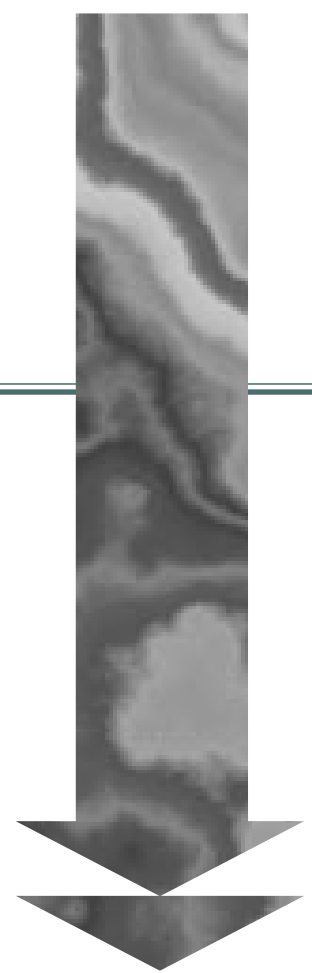
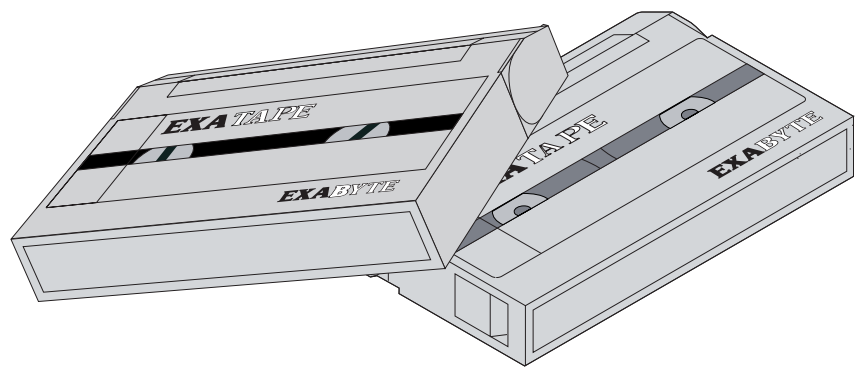

# Preparation

Use these instructions to install your Exabyte 8mm half-high tape drive.

**Note:** If you have an Exabyte Mammoth 8mm tape drive, order *Quick Installation—Exabyte Mammoth 8mm Tape Drives* (321410) from Exabyte, or refer to Exabyte's World Wide Web site ([www.exabyte.com](http://www.exabyte.com)).

These instructions assume that you are installing the tape drive in a computer drive bay. If you are installing the tape drive in a library or other enclosure, you will need to adapt the instructions to your specific situation.

Before you begin, read through the instructions to determine what you will need. Depending on your setup and existing equipment, you may need to obtain the following items:

- ♦ Small flat-nose pliers, flat-blade and Phillips screwdrivers
- ♦ SCSI adapter card (must be installed in your computer)
- ♦ SCSI ID jumpers
- ♦ Terminators
- ♦ SCSI cable
- ♦ Drive bay mounting rails

All of these items (except tools) are available from Exabyte. Call 1-800-EXATAPE (1-800-392-8273).

## Protect the tape drive from ESD

Protect the tape drive from electrostatic discharge (ESD) by following these precautions: Use an antistatic mat and wristband, if possible. Leave the tape drive in its packaging until you are ready to install it. Touch a known grounded surface (such as a metal table) before handling the tape drive.

## Prepare the computer and tape drive

### CAUTION

Turn off all devices attached to your computer, then turn off the computer. Disconnect all power cables from your computer and attached devices.

1. Remove your computer's cover.
2. Remove the cover plate from the drive bay you intend to use. Save any screws or clips you remove.

**Note:** You may need to remove a device, such as an extra floppy disk drive, to provide a drive bay for the tape drive. **Do not remove your floppy drive A.** If you remove a device, be sure to modify your system configuration to reflect the change.

3. Determine whether the tape drive needs rails for mounting in the drive bay. If devices in other drive bays use rails, or if the tape drive fits loosely, you should use rails. You can obtain rails from a computer supplier or from Exabyte. If necessary, install the rails as follows:

**Using the screws provided with the rails**, fasten a rail to each side of the tape drive. Use whichever set of mounting holes allows the front of the tape drive to be even with devices in other drive bays. (You may want to leave the screws holding the rails loose until you have determined the exact position of the tape drive.)

### CAUTION

To avoid damaging the tape drive, use only the screws provided with the rails.

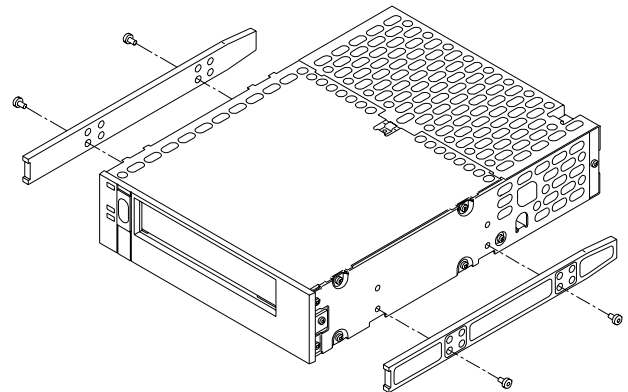

## Set the SCSI ID

The tape drive attaches to a SCSI bus, which consists of the SCSI adapter card in your computer, one or more SCSI cables, and up to eight SCSI devices (including the adapter card). **Each device on the bus must have its own SCSI ID.**

To set the SCSI ID, use a pair of flat-nose pliers to position the jumpers on the SCSI ID jumper block on the back of the tape drive, as shown below. (Depending on your model, the jumper block may be in a different location.)

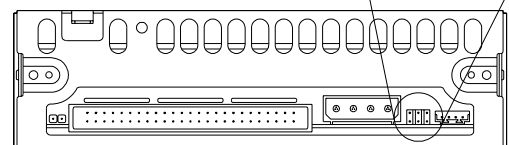
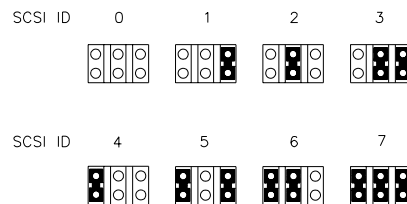

**Note:** If you are using a remote switch to set the SCSI ID, remove the jumpers from the jumper block and attach the switch connector. Make sure that the switch is no more than 30.5 cm (12 inches) from the jumper block.

---

## Terminate the SCSI bus

---

The devices at each end of a SCSI bus must be terminated. The SCSI adapter card is typically at one end of the bus and has its own terminators. If the tape drive will be located at the other end of the bus, it must be terminated also.

The method for termination depends on whether your tape drive has a single-ended or differential SCSI configuration.

### *Single-ended tape drive*

Most single-ended models use three resistor terminators (R-packs) for termination. Others use external terminators. Check for the R-packs just above the SCSI connector on the back of the tape drive, as shown below.

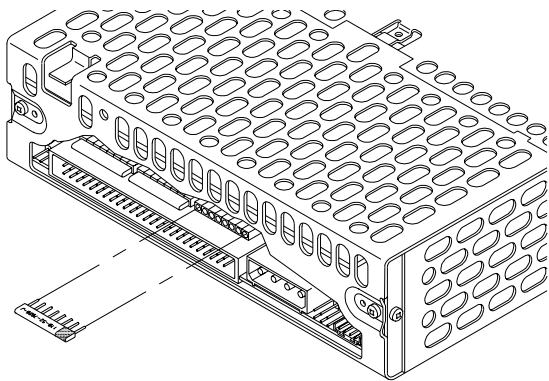

**If the tape drive uses R-packs:** Make sure the R-packs are installed if the tape drive is at the end of the SCSI bus. If you need to install R-packs, make sure that pin 1 of each R-pack is aligned with pin 1 of the socket and that no pins are bent. If the tape drive is not at the end of the SCSI bus, use a pair of flat-nose pliers to carefully grasp each R-pack at the center and pull it straight out.

**If the tape drive does not use R-packs:** Install an external pass-through terminator on the SCSI connector if the tape drive is at the end of the SCSI bus. External terminators are available from Exabyte.

### *Differential tape drive*

If you need to terminate a differential tape drive, install an external pass-through terminator on the tape drive's SCSI connector. External terminators are available from Exabyte.

---

## Connect to the SCSI bus

---

The method you use to connect the tape drive to the SCSI bus depends on whether the tape drive is the only device on the bus or you have other devices on the bus.

### *If the tape drive is the only device on the SCSI bus*

1. If it is not already connected, connect the SCSI cable to the SCSI adapter card, and thread the cable out through the front of the open drive bay.
2. Attach the SCSI cable to the tape drive's SCSI connector.

If the cable connector is not keyed, make sure that the colored stripe on the cable (indicating pin 1) corresponds to pin 1 of the tape drive's SCSI connector (on the right side as you look at the back of the tape drive).

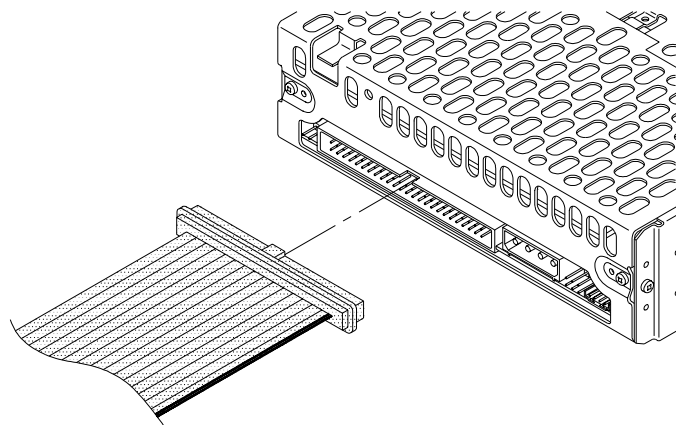

3. Making sure that no cables are in the way, carefully slide the tape drive into the bay.

### *If there are additional devices on the SCSI bus*

1. Make sure that the devices at each end of the bus are terminated correctly. These instructions assume that the tape drive is not at the end of the bus and is therefore not terminated.
2. If it is not already connected, connect one end of the SCSI cable to the SCSI adapter card and the other end to the device that terminates the SCSI bus.
3. Making sure that no cables are in the way, carefully slide the tape drive into the bay.

4. Connect an available connector on the SCSI cable to the tape drive's SCSI connector. Make sure that the colored stripe on the cable (indicating pin 1) corresponds to pin 1 of the tape drive's connector (on the right side as you look at the back of the tape drive).
5. If not already connected, connect your other SCSI devices to available connectors on the cable.

## Connect to power

### CAUTION

Make sure the computer is disconnected from power.

1. Locate a free power cable from your computer's power supply. Push the keyed connector ❶ into the tape drive's power connector.

### CAUTION

Do not force the power cable into the tape drive's power connector.

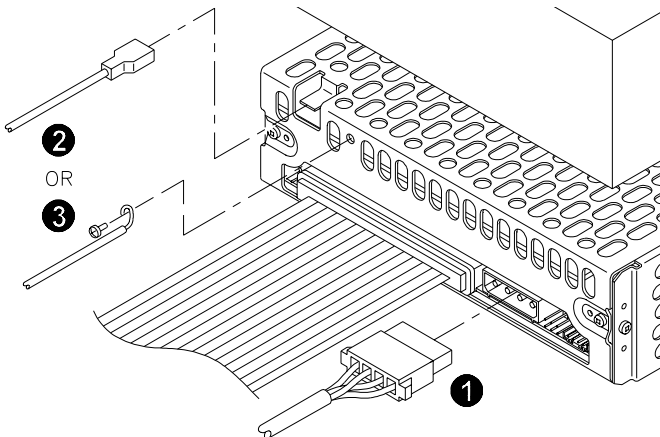

2. If your computer uses a grounding wire for additional grounding of internal devices, locate the wire. Use a 1/4-inch female spade connector ❷ to attach the wire to the grounding tab on the back of the tape drive. Or, use an M3-0.5 x 6 mm self-tapping screw ❸ to attach the wire to the grounding hole. (Depending on your model, the grounding tab and hole may be in different locations.)
3. Secure the tape drive to the drive bay as instructed in your computer manual. You may need to use the clips or screws from the drive bay's cover plate. Make sure that the front of the tape drive is even with devices in other drive bays. (If you used mounting rails, adjust their position as necessary and tighten the rail screws.)
4. Replace the computer's cover.

5. Reconnect the power cords to your computer and all attached devices. Turn on the computer and devices.
6. Wait about 30 seconds while the tape drive performs its power-on self-test. When the self-test is complete, the top and bottom LEDs turn off. The middle LED will be off or flashing irregularly. If the top LED does not go out after the self-test, contact your vendor for assistance.

## Troubleshooting

If you encounter problems that you cannot resolve by referring to this section, contact your dealer or service provider. Or, check Exabyte's World Wide Web site at:

[www.exabyte.com](http://www.exabyte.com)

If you do not have access to the World Wide Web, you can contact Exabyte Technical Support at 1-800-445-7736 or 1-303-417-7792.

## Installation checklist

- ✓ Make sure that the SCSI adapter card and all SCSI connectors are completely seated.
- ✓ Make sure that the SCSI bus is terminated correctly.
- ✓ Verify that the total length of all SCSI cables on the bus does not exceed 6 meters (19.7 feet) for a single-ended configuration or 25 meters (82 feet) for a differential configuration.
- ✓ Verify that the tape drive's SCSI ID is not the same as the ID used by any other device on the bus.
- ✓ Verify that all devices on the SCSI bus are either single-ended or differential. Do not mix the two types.
- ✓ Check your SCSI adapter card documentation to make sure that you have set all jumpers and switches correctly.
- ✓ Try replacing SCSI cables with known good ones.
- ✓ Try resetting the SCSI bus by turning the computer off and back on.

## Operation checklist

- ✓ Make sure that your application software is compatible with your tape drive. You can check the software compatibility database on Exabyte's web site.
- ✓ Make sure that your application software is installed and configured correctly. If you continue to experience problems with the software, contact the software vendor.
- ✓ Check the setting of the cartridge's write-protect switch, and be sure to insert the cartridge correctly.

- ✓ Use only the EXATAPE™ Data Cartridges recommended for your model of tape drive. Check your owner's manual or Exabyte's web site for cartridge recommendations.
- ✓ Try using a new data cartridge if you think the cartridge might be damaged or worn.
- ✓ Check the tape drive's LEDs. If the top and bottom LEDs flash quickly in unison, the tape drive needs cleaning. If the top LED flashes while the bottom LED is off, an error has occurred. Check your owner's manual or Exabyte's web site for other LED definitions for your tape drive.
- ✓ Try cleaning the tape drive. Check your tape drive owner's manual or Exabyte's web site for cleaning instructions. Make sure you use the Exabyte Premium 8mm Cleaning Cartridge.

### *Safety and EMI*

When installed in a manner consistent with Exabyte's installation instructions (that is, in an enclosure using proper cables and grounding), the tape drive can be expected to maintain its compliance with the safety and EMI (electromagnetic interference) standards listed in its original documentation. It is the responsibility of the system integrator to certify and/or verify the final product to the relevant standards.