

CONTENTS (continued)

SECTION V - SYSTEM VERIFICATION

Paragraph	Page
OFF-LINE VERIFICATION	5-3
ON-LINE VERIFICATION	5-3
WORKOUT2	5-5
System Power Fail Recovery Verification	5-8
System Backup	5-9

SECTION VI - TRAINING THE NEW SYSTEM OPERATOR

6-1

APPENDIX A - MECHANICAL CONNECTION OF THE PROCESSOR CABINETS

Paragraph	Page
TABLE TOP REMOVAL AND REPLACEMENT	A-2
PROCESSOR CABINET SEPARATION AND REASSEMBLY	A-3

APPENDIX B - ISOLATION TRANSFORMER RESTRAPPING AND PRIMARY VOLTAGE RESTRAPPING

B-1

APPENDIX C - HARDWARE CONFIGURATION

C-1

APPENDIX D - UPGRADE INSTALLATION

Paragraph	Page
INTRODUCTION	D-1
UPGRADING THE SERIES 30/33 TO SERIES 44	D-1
Modifying the Series 30/33 System Console	D-2
Preparing the Existing System For Upgrade	D-3
UPGRADING PRE-SERIES II, AND SERIES II/III TO SERIES 44 ..	D-5
UPGRADING THE HP 300 TO HP 3000 SERIES 44	D-8
PERIPHERAL UPGRADES	D-10

ILLUSTRATIONS

Title	Page
Front/Side View	2-1
Rear View	2-2
Card Cage View	2-3
Top View	2-4
Side and Rear Junction Panels	2-6
Side Junction Panel Identification Chart	2-7
Rear Junction Panel Identification Chart	2-8
Power Line Connection (50 Hz)	2-10
PCM Strain Relief Hardware	2-11
Panel-to-Console Cable Routing	3-4
Master/Slave Disc Cabling	3-6
System Disc HP-IB Device Select Switch	3-7
HP 2613A/2617A/2619A	3-10
Magnetic Tape HP-IB Device Address Switch and HP-IB Cable and Connector	3-13
Processor Cabinet Without Table Top	A-1
Table Mechanical Joining	A-2
Frame Mechanical Joining	A-3
Isolation Transformer Location	B-2
Strapping Options	B-3
Slot Locations (Initial Configuration)	C-4
Slot Locations (Maximum Configuration)	C-5

TABLES

Title	Page
HP 3000/44 Peripheral Devices	3-2
Test Point Voltages	4-2
Available Device Tests	5-2
Suggested System Configuration	C-1
Configuration Restrictions	C-2
Series 30 to Series 44 Upgrade Inventory	D-11
Series 33 to Series 44 Upgrade Inventory	D-13
Pre-Series II to Series 44 Upgrade Inventory	D-15
Series II to Series 44 Upgrade Inventory	D-17
Series III to Series 44 Upgrade Inventory	D-19
HP 300 to Series 44 Upgrade Inventory	D-21

PREFACE

This manual describes the installation activities for an HP 3000 Series 44 Computer System. These descriptions are intended for use by Hewlett-Packard Customer Engineers trained for the HP 3000/44 Computer Systems.

Before the system can be installed, the site must be adequately prepared as described in the Site Preparation and Planning Guide (part no. 30000-90206).

Additional manuals which may be helpful in installing the system are:

Product Support Package	30090-67801	
Reference/Training Manual	30090-90001	
Diagnostic Manual	30070-60068	(Copy with system)
Diagnostic Utility System	32231A	(Copy with system)
C.E. Handbook	30070-90010	
Console Operator's Guide	30090-90025	(Copy with system)
System Manager/System Supervisor Ref. Manual	30090-90014	(Copy with system)
MPE Utilities Manual	30000-90044	(Copy with system)

Service and installation manual(s) for the peripheral devices installed with the system may also be helpful and should be taken on site if familiarity with the device is limited.

The organization of this manual presents the system installation activities in six sections, as follows:

Section I-Defines Hewlett-Packard and Customer responsibilities in receiving the system.

Section II-Presents mechanical and electrical considerations for the processor.

Section III-Presents general installation instructions for the system hardware and software.

PREFACE (continued)

Section IV-Provides system/peripheral turn-on procedures.

Section V-presents system configuration and verification.

Section VI-Areas in which the HP customer engineer will familiarize the new system operator.

Appendix A- Provides mechanical connection information for the processor cabinets.

Appendix B-Provides strapping information for the isolation transformer.

Appendix C Provides the hardware configuration data for the Series 44.

Appendix D-Includes the upgrade installation information for upgrading Series 30/33, Series II/III, and Pre-Series II systems to Series 44.

BITTE SORGFÄLTIG LESEN
HP 3000 SERIE 44 INSTALLATIONS UND EINSCHALTUNGSRICHTLINIEN

Installation

Ihr HP Kunden Ingenieur ist verantwortlich für Installation und Instandhaltung Ihrer HP 3000 Serie 44.

Vergewissern Sie sich, daß die HP 3000 Serie 44 für die richtige Netzspannung eingerichtet ist. Diese ist an der Rückseite des Gerätes neben dem Netzkabel-Eingang markiert. Das Gerät kann für eine der folgenden Kombinationen eingerichtet sein:

<u>Netzspannung</u>	<u>Frequenz</u>	<u>Max. Strom</u>
200 V~	50 oder 60 Hz	24 A
210 V~	50 oder 60 Hz	24 A
220 V~	50 oder 60 Hz	24 A
230 V~	50 oder 60 Hz	24 A
240 V~	50 oder 60 Hz	24 A

Falls das Gerät nicht für die richtige Netzspannung/Frequenz eingerichtet ist, setzen Sie sich bitte mit Ihrem HP Kunden Ingenieur in Verbindung.

WARNUNG

Öffnen des Geräts zur Bedienung nicht, erforderlich.
Wartung nur durch qualifiziertes Personal.

50 Hz systems werden ohne netzkabel ausgeliefert. Anschlußklemmen und Zulentlastung für ein Kabel mit mindestens 2.5 mm² Leiterquerschnitt (4.0 mm² vorzugsweise) werden mitgeliefert. Bitte wenden Sie sich an Ihren HP Kunden Ingenieur.

Lokale Vorschriften können die Installation eines zusätzlichen Wandschalters erforderlich machen. Dies ist normalerweise der Fall, wenn das Gerät fest an das Netz angeschlossen wird.

Einschaltung

Ihre HP 3000 Serie 44 wird durch den ON/OFF Hauptschalter eingeschaltet, der sich an der Rückseite der am weitesten links liegenden Sektion des Computers befindet. Der Prozessor ON/OFF Schalter befindet sich auf der linken unteren Frontseite.

HP3000 Series 44 Installation/Power-on Instructions

Installation

Your HP Customer Engineer will provide installation and maintenance for your computer system.

For proper operation, make sure the unit is configured for a voltage compatible with that available at your facility. The voltage for which the unit is configured is marked on the rear of the unit near the power cord inlet. The unit can be configured for any one of the following:

<u>Volts</u>	<u>Frequency</u>	<u>Max. Current</u>
200 VAC	50 or 60 HZ	24 Amps
210 VAC	50 or 60 HZ	24 Amps
220 VAC	50 or 60 HZ	24 Amps
230 VAC	50 or 60 HZ	24 Amps
240 VAC	50 or 60 HZ	24 Amps

If the configured voltage is not correct, contact your HP Customer Engineer.

WARNING

There are no operator serviceable parts inside this product. Refer all servicing to your HP Customer Engineer.

50 Hz systems are not provided with a power cord. Wiring terminals and a strain relief bushing are provided for the attachment of a cable with a minimum conductor size of 2.5mm² (4.0mm preferred). Consult your HP Customer Engineer.

As part of the installation, local codes may require a wall disconnect device in a readily accessible location. This is typically required when the unit is permanently connected to the mains power.

Power On

Your HP 3000 Series 44 is powered on by the main ON/OFF disconnect located on the lower rear, leftmost sections of the computer and the processor ON/OFF switch located on the lower left wall of the computer's front section.

RECEIVING THE SYSTEM

SECTION

I

The Hewlett-Packard Customer Engineer (CE) is primarily responsible for the installation of the HP 3000/44 Computer System according to the information presented in this text. This includes installation and verification of the HP 3000/44 central processor and any HP 3000/44 peripheral devices which are part of the system order. Hewlett-Packard data terminals should be installed when appropriate. Refer to the policy on installing HP Data Terminals as described by the Computer Support Division.

The customer should report any flaws in the shipment immediately to the carrier or to the carrier's agent and to the HP Customer Engineer. Be sure to save all crates, cartons, boxes, and packing materials for inspection. Do not make any verbal reports of damage or missing items without making a written report. The Customer Engineer should report problems which are HP's responsibility to the Support Engineer at the appropriate HP division.

Missing or damaged items will be replaced without waiting for the settlement of claims. Items shipped to replace damaged parts will be billed to the customer until the damaged parts are returned to Hewlett-Packard. The customer should not release the carrier until the shipment is verified to be in good order.

The customer is responsible for initial unpacking, inspecting, and locating of the system. The disposing of packing material is also the responsibility of the customer.

Each Hewlett-Packard shipment has a packing list on one of the cartons specifying material shipped. In addition, unpacking instructions are provided, as required.

PROCESSOR GENERAL DESCRIPTION

SECTION

II

2-1. PHYSICAL DESCRIPTION

The processor is a completely tested and assembled unit prior to shipment. As a result the processor system will arrive at the site requiring no involved mechanical assembly.

Figures 2-1, 2-2, 2-3, and 2-4 illustrate the system processor. These illustrations are referenced throughout the text.

If the processor cabinet presents entry problems on site, refer to Appendix A.

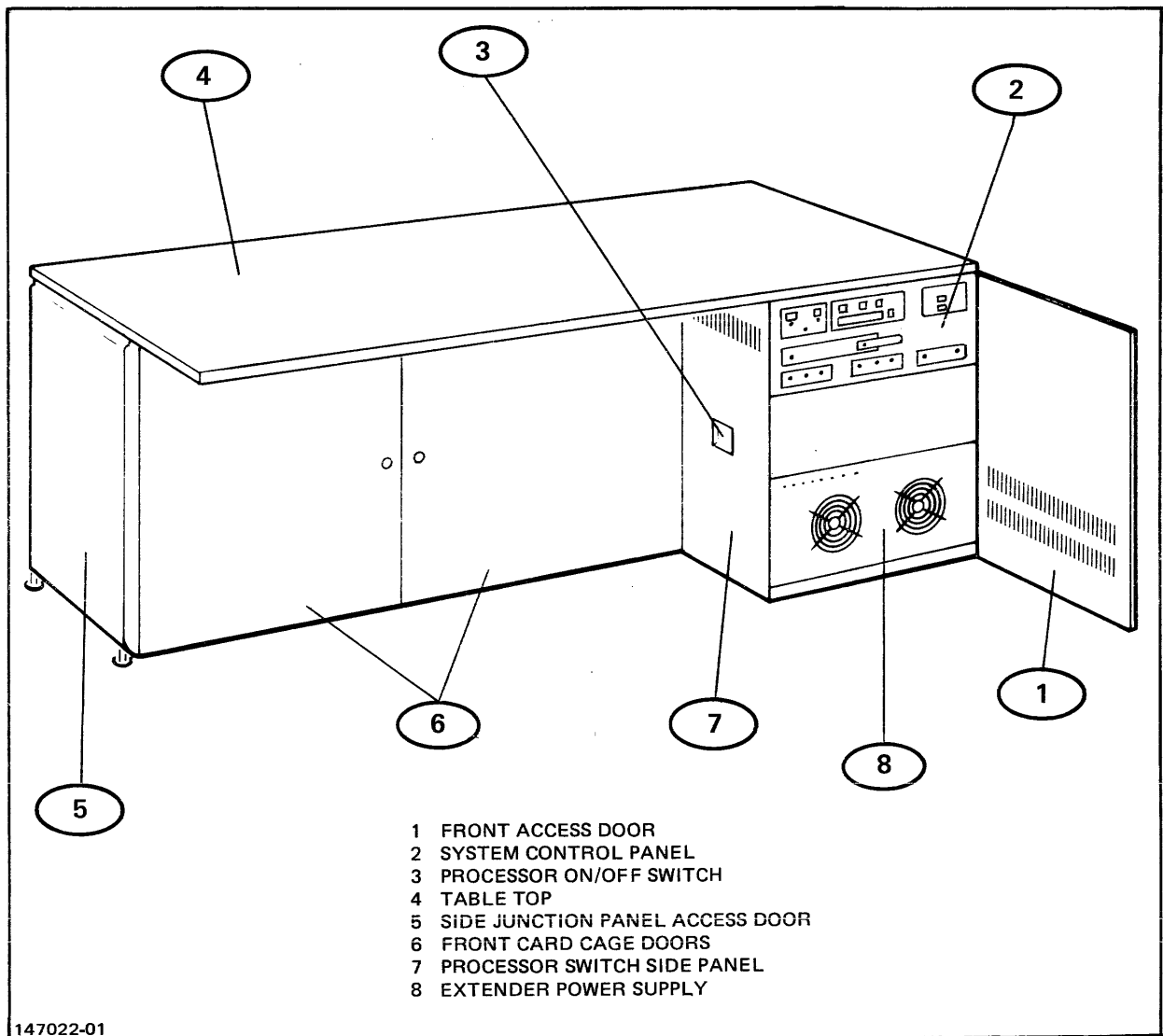

147022-01

Figure 2-1. Front/Side View

Processor General Description

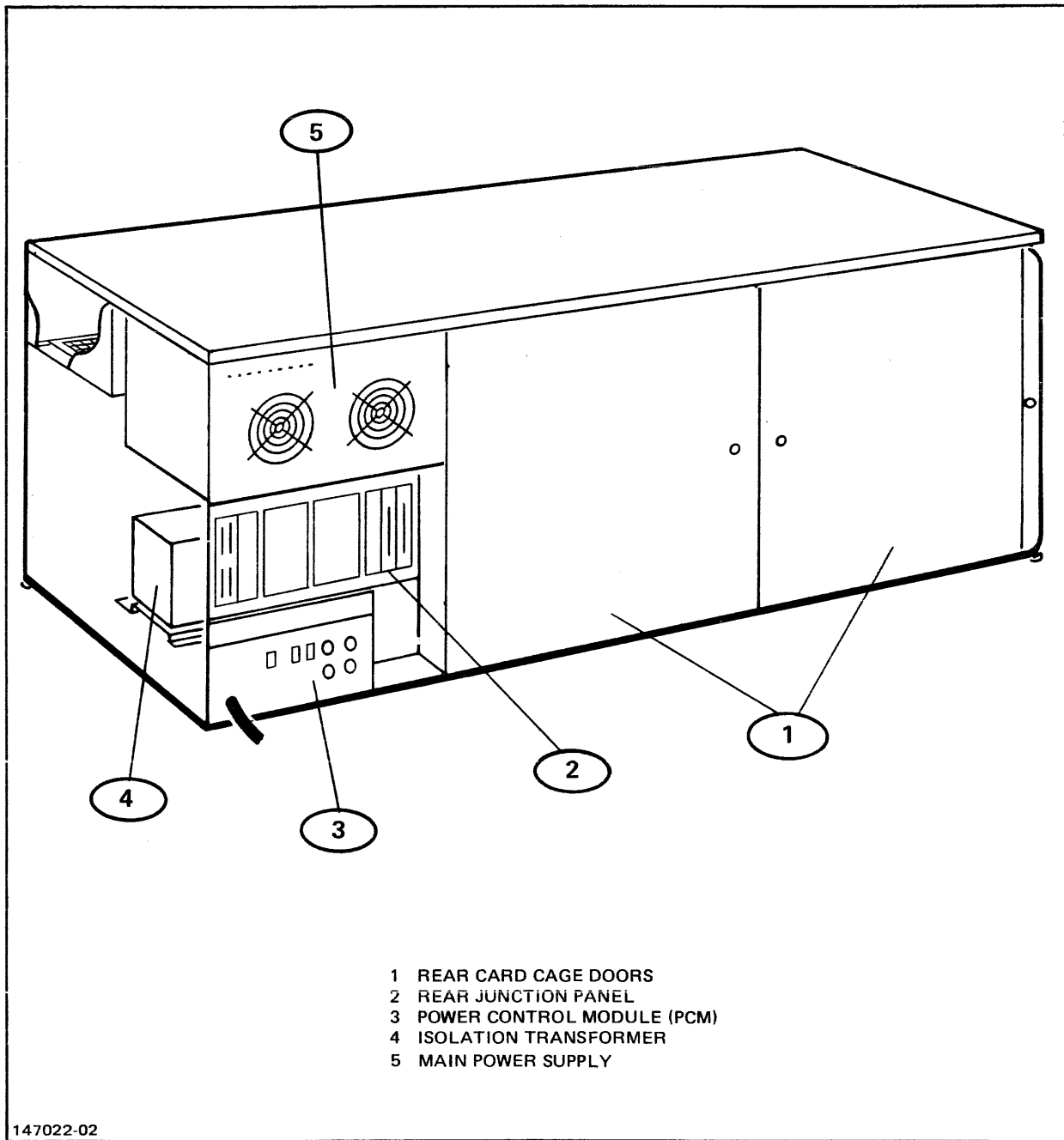

Figure 2-2. Rear View

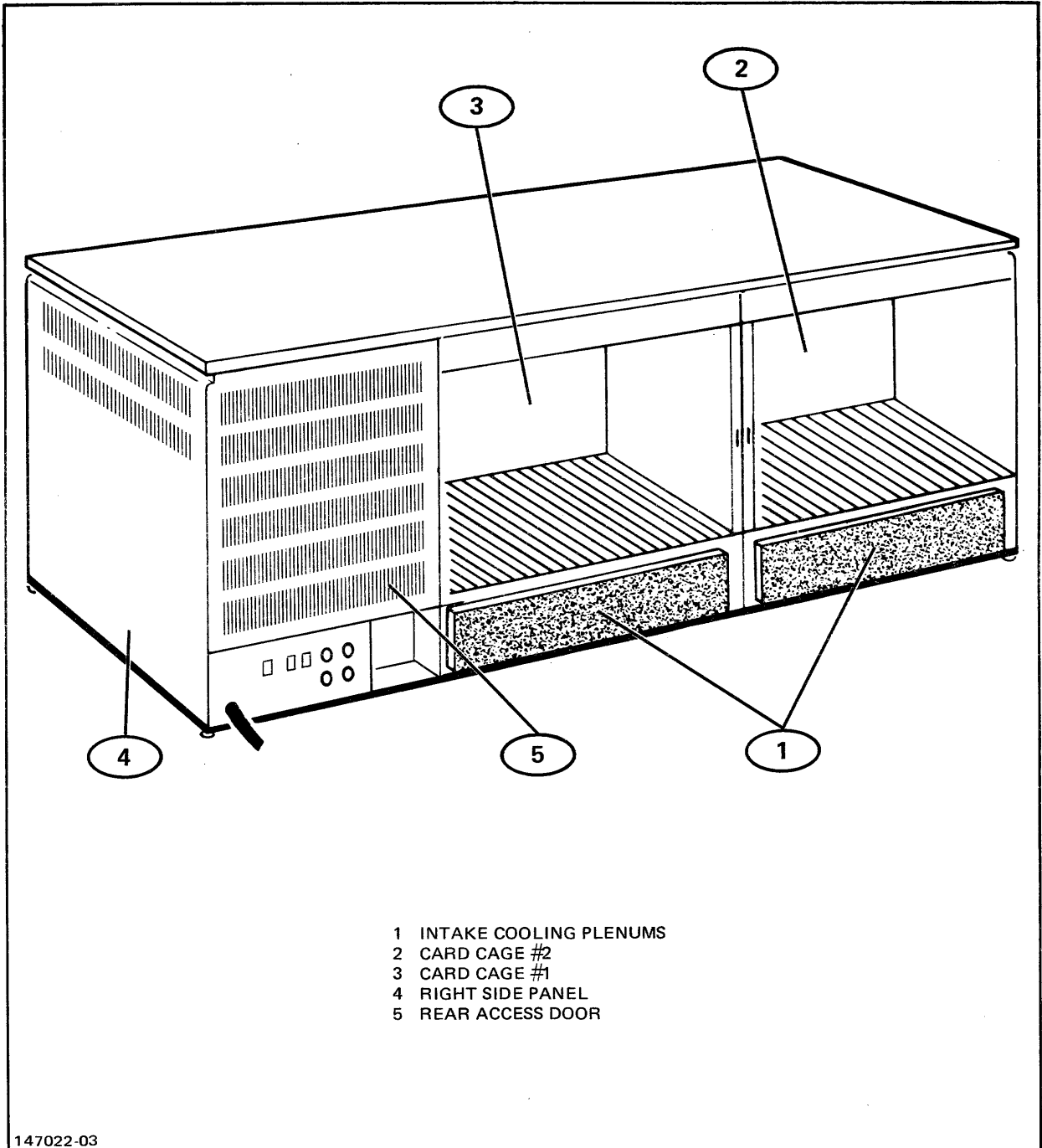

Figure 2-3. Card Cage View

Processor General Description

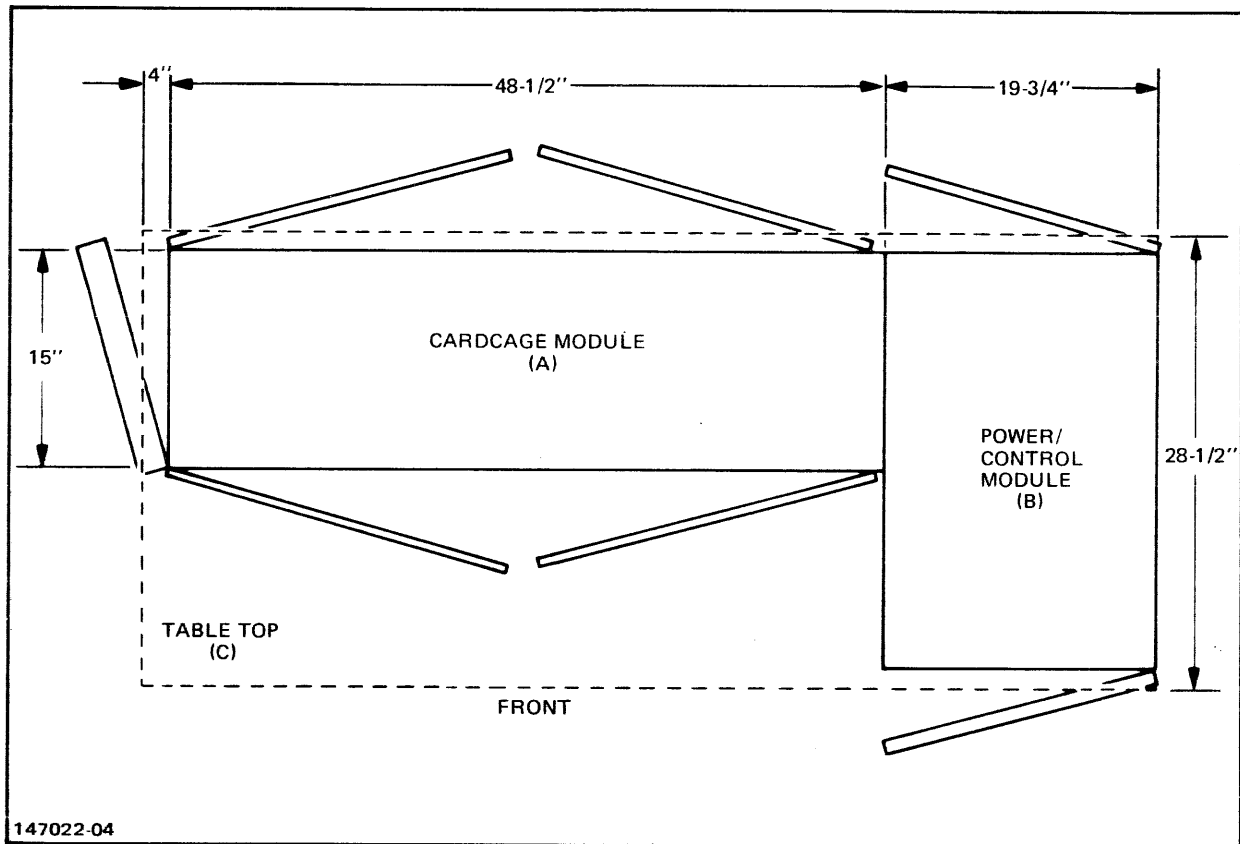

Figure 2-4. Top View

2-2. JUNCTION PANELS

Two junction panels are installed on the processor cabinet which provide twelve identical mounting locations to mount ADCC cables, GIC cables, INP cables, or printer cables. Figure 2-5 shows the physical layout of the panels with related inserts. Depending upon the cable type used, each mounting location will support from 1 to 12 external cables.

When mounting internal cables on the junction panels, the following rules should be followed:

- Cables should be mounted in positions specified on the identification charts mounted on the access doors to the panels. (See figures 2-6 and 2-7.) This configuration has been developed to minimize internal cable bundling and cable movement as system size increases.

Processor General Description

- In 60-terminal systems, the fifteenth ADCC cable should be installed in the upper right position on the Side Junction Panel (which is normally reserved for INP's). There will be no conflict in this condition since 60-terminal systems are slot-limited to only four INP's.
- In systems with GIC's for channels 12 and 13, the GIC position provided on the Side Junction Panel should be used for channel 13 and the PTR position immediately to its left should be used for channel 12.
- As cables are installed, the blank plates provided with the system (located in the accompanying pouch) should be used to close up all partial openings. This is essential to minimize electromagnetic radiation emitted by the processor.

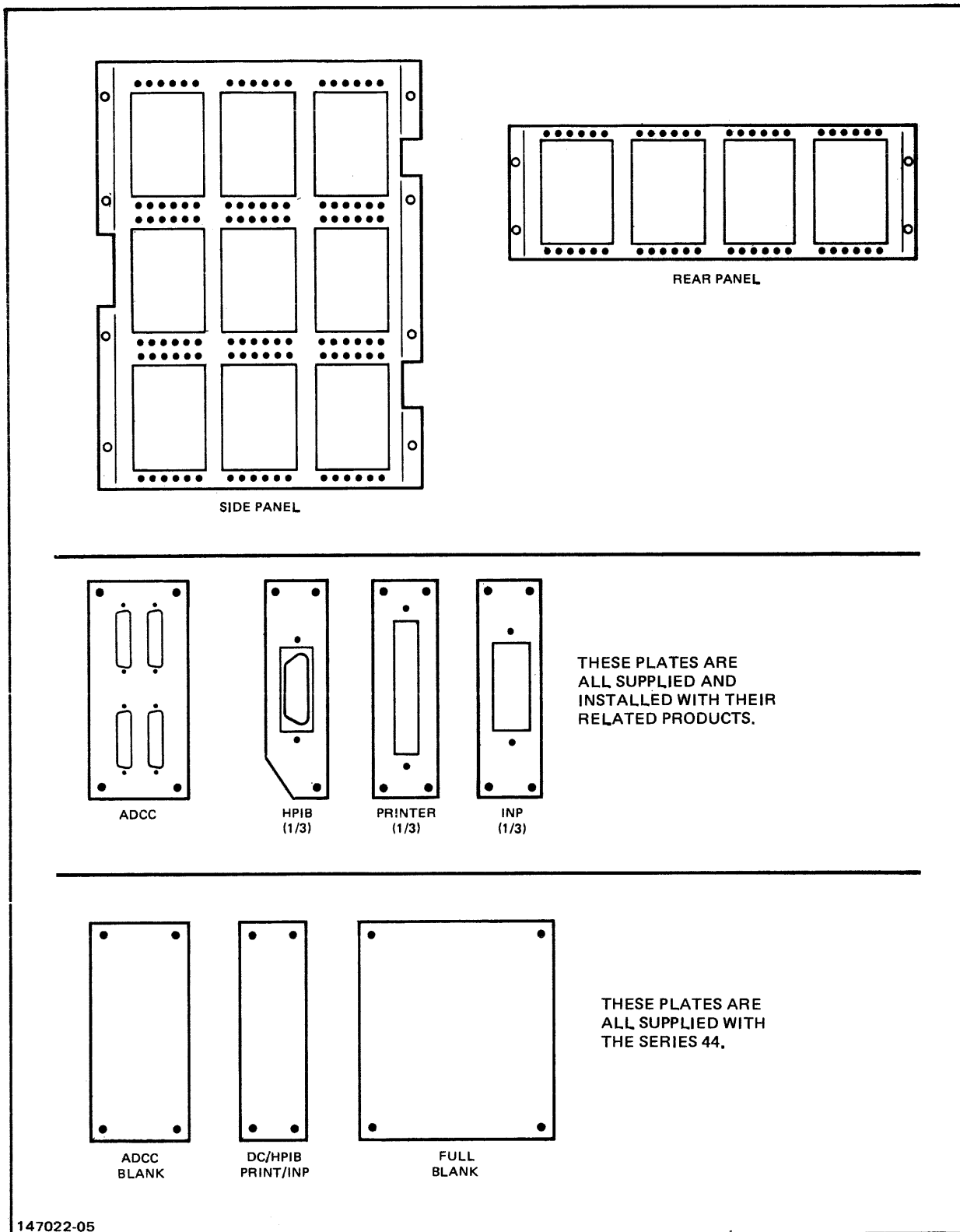
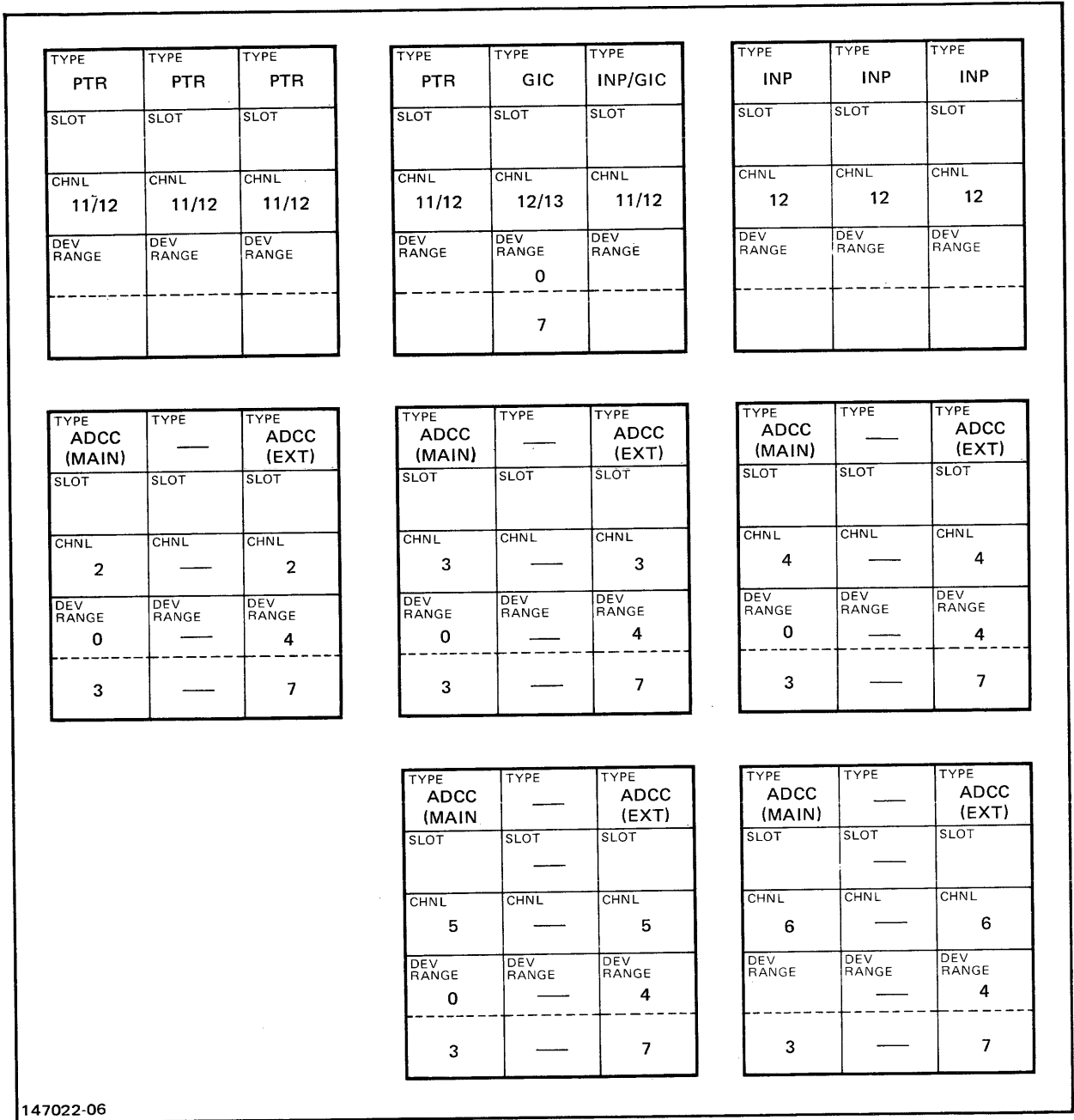

Figure 2-5. Side and Rear Junction Panels



147022-06

Figure 2-6. Side Junction Panel Identification Chart

TYPE CMP/ ADCC			TYPE —			TYPE ADCC (EXT)			TYPE ADCC (MAIN)			TYPE —			TYPE ADCC (EXT)			TYPE INP			TYPE INP			TYPE INP		
SLOT	SLOT	SLOT	SLOT	SLOT	SLOT	SLOT	SLOT	SLOT	SLOT	SLOT	SLOT	SLOT	SLOT	SLOT	SLOT	SLOT	SLOT	SLOT	SLOT	SLOT	SLOT	SLOT	SLOT	SLOT	SLOT	SLOT
14	—	15	—	—	—	—	—	—	7	—	7	—	—	—	12	12	12	—	—	—	9	10	11	—	—	—
CHNL	CHNL	CHNL	CHNL	CHNL	CHNL	CHNL	CHNL	CHNL	CHNL	CHNL	CHNL	CHNL	CHNL	CHNL	CHNL	CHNL	CHNL	CHNL	CHNL	CHNL	CHNL	CHNL	CHNL	CHNL	CHNL	CHNL
1	—	1	—	—	—	—	—	—	7	—	7	—	—	—	12	12	12	—	—	—	9	10	11	—	—	—
DEV RANGE	DEV RANGE	DEV RANGE	DEV RANGE	DEV RANGE	DEV RANGE	DEV RANGE	DEV RANGE	DEV RANGE	DEV RANGE	DEV RANGE	DEV RANGE	DEV RANGE	DEV RANGE	DEV RANGE	DEV RANGE	DEV RANGE	DEV RANGE	DEV RANGE	DEV RANGE	DEV RANGE	DEV RANGE	DEV RANGE	DEV RANGE	DEV RANGE	DEV RANGE	DEV RANGE
0	—	4	—	—	—	—	—	—	0	—	4	—	—	—	—	—	—	0	0	0	—	—	—	—	—	—
3	—	7	—	—	—	—	—	—	3	—	7	—	—	—	—	—	—	7	7	7	—	—	—	—	—	—

047022-07

Figure 2-7. Rear Junction Panel Identification Chart

2-3. ELECTRICAL DESCRIPTION

The processor unit is available for either 50-Hz or 60-Hz operation. The difference in hardware is the power control module (PCM), one type for each frequency. Both PCM units contain four AC receptacles (CEE-22 for 50-Hz; 5-15R for 60-Hz), two of which are controlled by separate switches on the PCM panel. Two receptacles are used for the system console and disc. Each 60-Hz duplex receptacle will supply up to 10 amperes. A total of 8 amperes can be supplied from the four 50-Hz receptacles. All processor units can operate at any 200, 210, 220, 230, or 240 (+4%/-10%) VAC inputs.

2-4. 60-Hertz Installations

The processor is shipped with a pre-connected, single-phase power cord and plug. The built-in single-phase isolation transformer is designed to operate within the power line specifications described in the Site Planning and Preparation Guide. The transformer has voltage strapping options on its primary input transformer windings which have been preset at the factory for 208-VAC operation.

If 208 VAC is not available at the site and an alternate voltage has been installed, the transformer must be strapped to accommodate this voltage. (Refer to Appendix B for the strapping procedure.) The power cord and plug supplied with the processor is suitable for any specified 60-Hz installation. The plug will fit

the NEMA Type 6-30R receptacle, as specified in the Site Planning and Preparation Guide.

2-5. 50-Hertz Installations

The 50-Hz processors are similar to the 60-Hz units except that a power cord and plug are not included. The appropriate hard line or cord connection must be supplied by the customer. A detailed illustration of connecting a power line to the processor PCM is shown in figure 2-8. The Customer Engineer is responsible only for inspecting the installation of the power line before power is applied to the system. Figure 2-9 shows the electrical connections.

Processor General Description

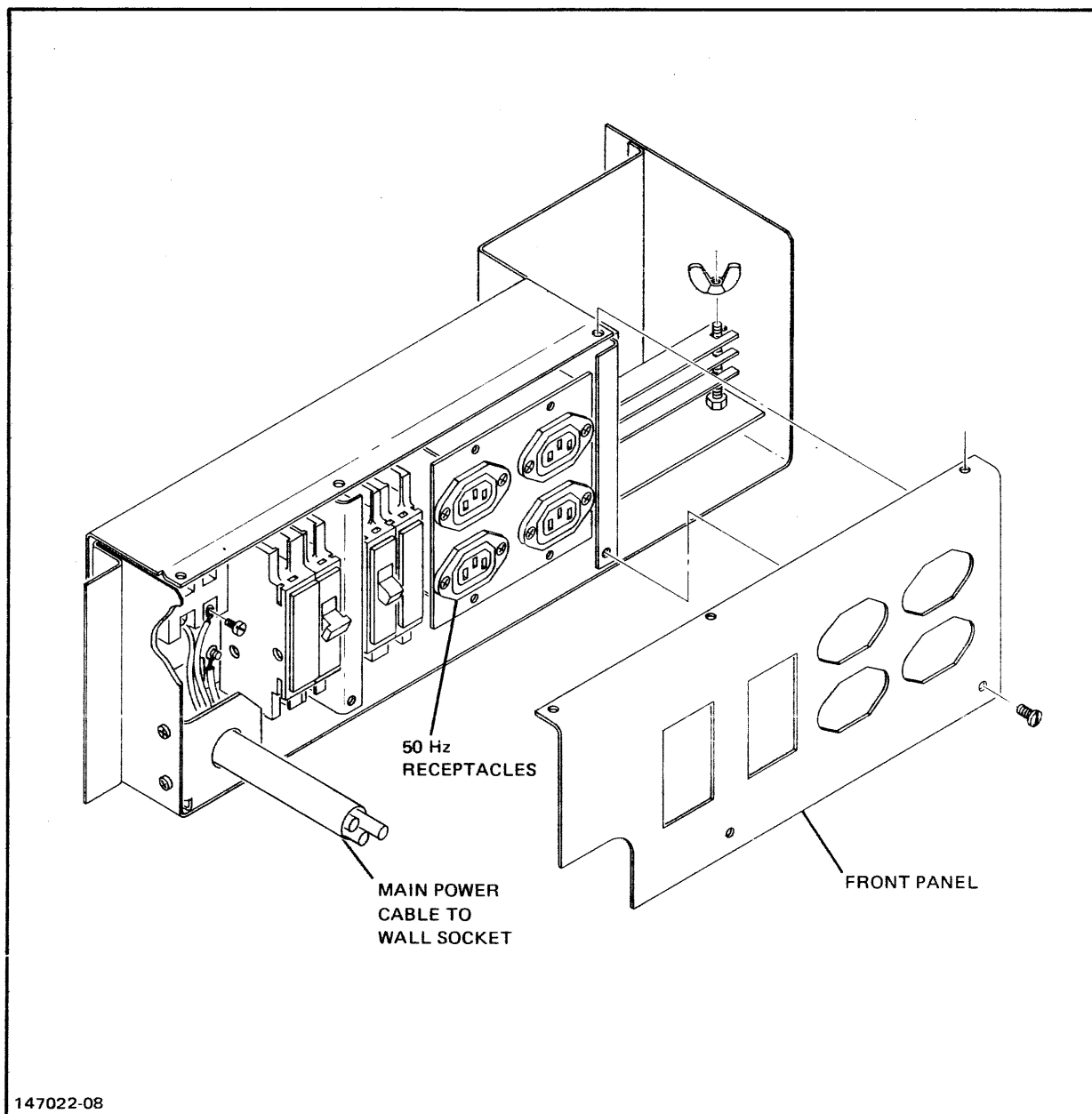
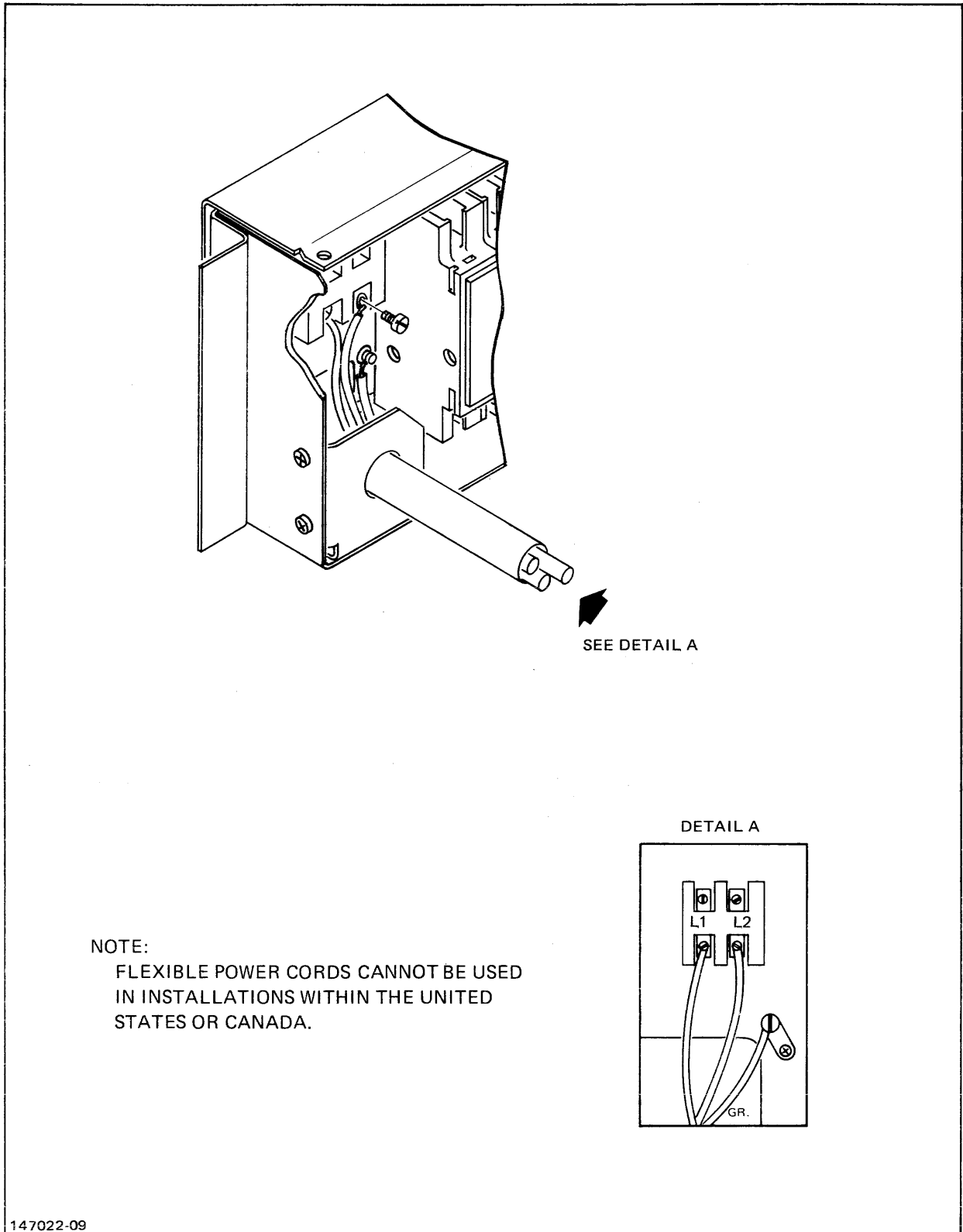

Figure 2-8. Power Line Connection (50 Hz)

WARNING

When the cover plate is removed, hazardous voltages are present unless breaker at the branch circuit panel is set to OFF.



147022-09

Figure 2-9. PCM Terminal Block Connections

SYSTEM INSTALLATION

SECTION

III

System installation consists of integration of the processor, the peripheral devices, and the system operating software. The peripheral devices interface with the processor through the Terminal and I/O Panels. Technical descriptions on the I/O system and other related hardware are available in the Reference/Training Manual. Topics covered in this section are listed below.

- Installing the Processor
- Installing the System Console
- Installing Disc Drives
- Installing the Magnetic Tape Drives
- Installing Printers
- Installing Card Readers

The HP3000/44 Computer System consists of a processor unit and associated peripheral devices. Supported peripherals which are part of the system are listed in table 3-1. Supported RS-232-C devices interface to the system through Asynchronous Data Communication Channels (ADCC) and all other devices connect through General I/O Channels (GIC).

In general, installation of a peripheral device consists of connecting either an HP-IB or RS-232-C interface cable and an AC power cord. If questions arise or problems occur with any device, refer to the appropriate service manual. Unpack and move each device into place, then install according to the procedures given in this section. After installation, identify the device on receptacle tags on the junction panels.

System Installation

Table 3-1. HP 3000/44 Peripheral Devices

Device	Model	Channel Type
Terminals	264x series	ADCC
	262x series	ADCC
Printing Terminals	263x series	ADCC
	2601A	ADCC
Line Printer	2608A opt 344	GIC
Line Printer	2613A opt 344	GIC
Line Printer	2617A opt 344	GIC
Line Printer	2619A opt 344	GIC
Line Printer	2631B opt 331	ADCC
Page Printer	2680A opt 344	GIC
Mag Tape(master)	7970E opt 426	GIC
Mag Tape(slave)	7970E opt 421	N/A
Disc Drives	7906M	GIC
	7906S	N/A
	7920M	GIC
	7920S	N/A
	7925M	GIC
	7925S	N/A
Flexible Disc	9895A	GIC

WARNING

Hazardous voltages are present inside the processor and peripheral cabinets when AC power is applied. Therefore, do not connect the processor or any peripheral to a source of AC power until all units are installed in place and interconnections have been completed.

NOTE

The following procedures should be started only after Sections I and II have been completed. Procedures in this section should be followed in the sequence in which they are presented.

3-1. INSTALLING THE PROCESSOR

The processor (figures 2-1, 2-2, and 2-3) is installed as described in the following steps.

1. Ensure that the unit is positioned in an area which allows for complete cabinet door access and AC power receptacle access.
2. Secure and level the unit by adjusting the rubber feet near the casters.
3. Ensure that the PROCESSOR, MAIN ~ POWER, and OUTLET ~ POWER switches are in the OFF position.
- Preset the following system control panel switches as shown:

Thumbwheel	Channel Number	Device Number
LOAD (from mag. tape)	9	1
START (sys. disc)	11	0
DUMP	11	0

3-2. INSTALLING THE SYSTEM CONSOLE

The standard system console is the HP 2621A; however, any of the Hewlett-Packard terminals or printing terminals can be used as the system console. The following procedure is given for the standard system console, and also applies to the other terminals.

1. Place the terminal to be used as the system console on the processor table top.
2. Ensure that the terminal ON/OFF switch is in the OFF position.
3. Connect the AC power cord from the console to a processor power control module (PCM) AC receptacle.
4. Connect the console keyboard cable hood connector to the printed circuit card edge connector that has been notched to match the cable connector.
5. Connect the console data cable to the port marked CONSOLE on the rear junction panel.

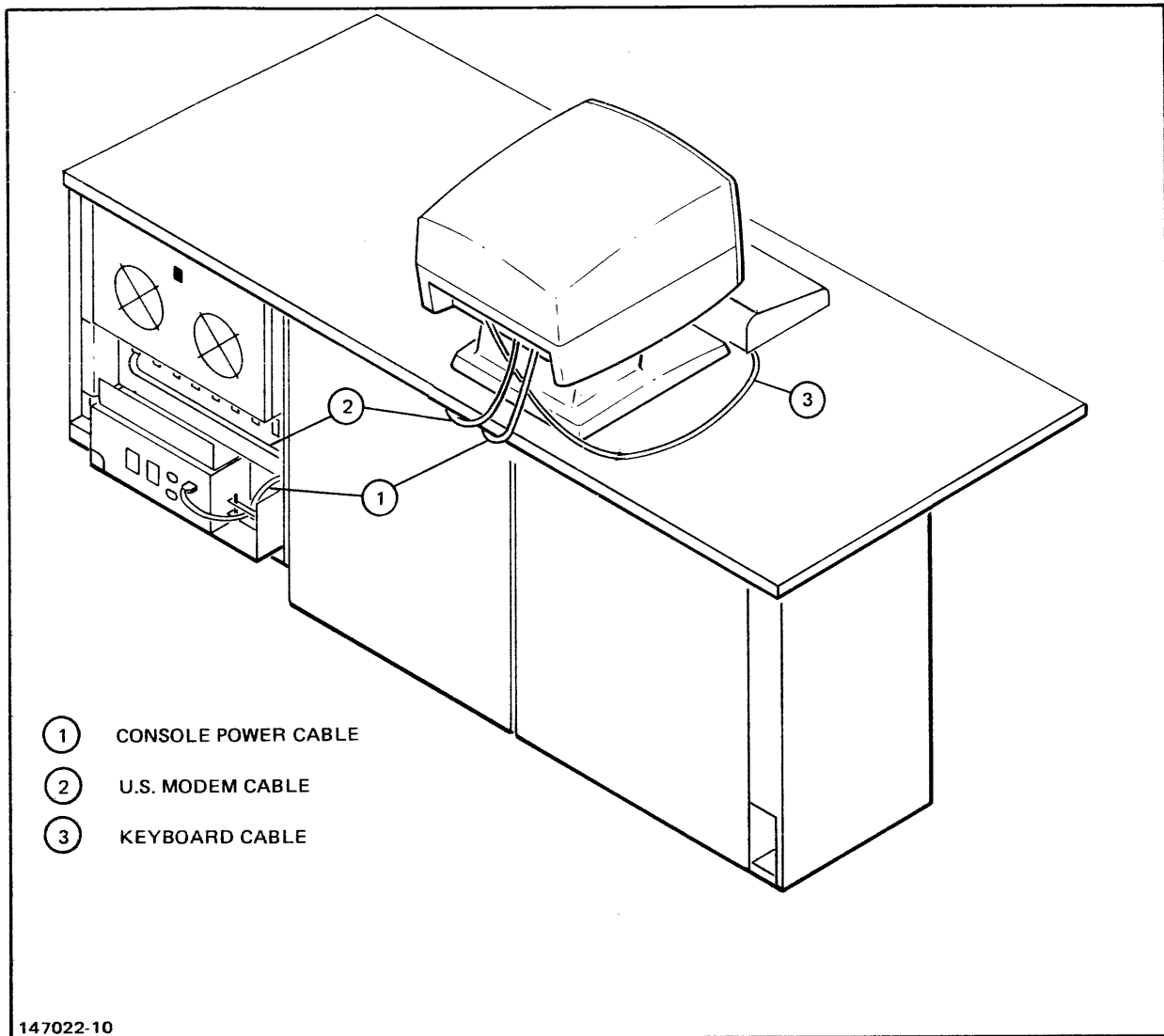

Figure 3-1. Panel-to-Console Cable Routing and Connection View

3-3. INSTALLING DISC DRIVES

An HP 7906B, 7920B, or 7925B disc drive may be configured as the system or slave disc drives for the HP 3000/44. The general installation of these discs are described in the following paragraphs and illustrations. The appropriate disc service and installation manual(s) should be referenced for detailed set-up instructions and parts lists.

Position the system disc drive on the one side of the processor cabinet allowing for the full opening of any access doors. The system disc drive cabinet contains the HP 13037B disc controller. (identified with an "M" designator in the cabinet serial tag). Next, position slave disc(s) near the master disc unit.

3-4. System Disc (Master)

The system disc interfaces to the system through the HP 10833C HP-IB device I/O cable. The cable has one end pre-connected onto the disc HP-IB I/O connector. Connect the free end to the system as described below and as shown in figure 3-2.

1. Route the HP-IB I/O cable to the assigned connector on one of the junction panels, as given in Appendix C. Record the device type, slot, channel, and device numbers on the associated identification chart.
2. Configure the CPU number select switch (S1) and the HP-IB device address switch (S2), located on the HP 12745A disc HP-IB controller board as follows:
S1=0
S2=0

The HP 12745A is located in slot A-1 of the HP 13037B disc controller. (See figure 3-3.)

3. Ensure that the disc drive POWER switch is set to off (0).
4. Connect the disc drive AC power cord to an OUTLET™ POWER receptacle on the processor PCM.

3-5. Slave Disc(s)

1. Ensure that the disc drive POWER switch is set to off (0).
2. Connect the disc drive power cord to a dedicated power source that has an isolated ground (or to a power line treatment device, if planned).
3. Connect the slave disc(s) data cables as depicted in figure 3-2 and the appropriate disc service manuals.

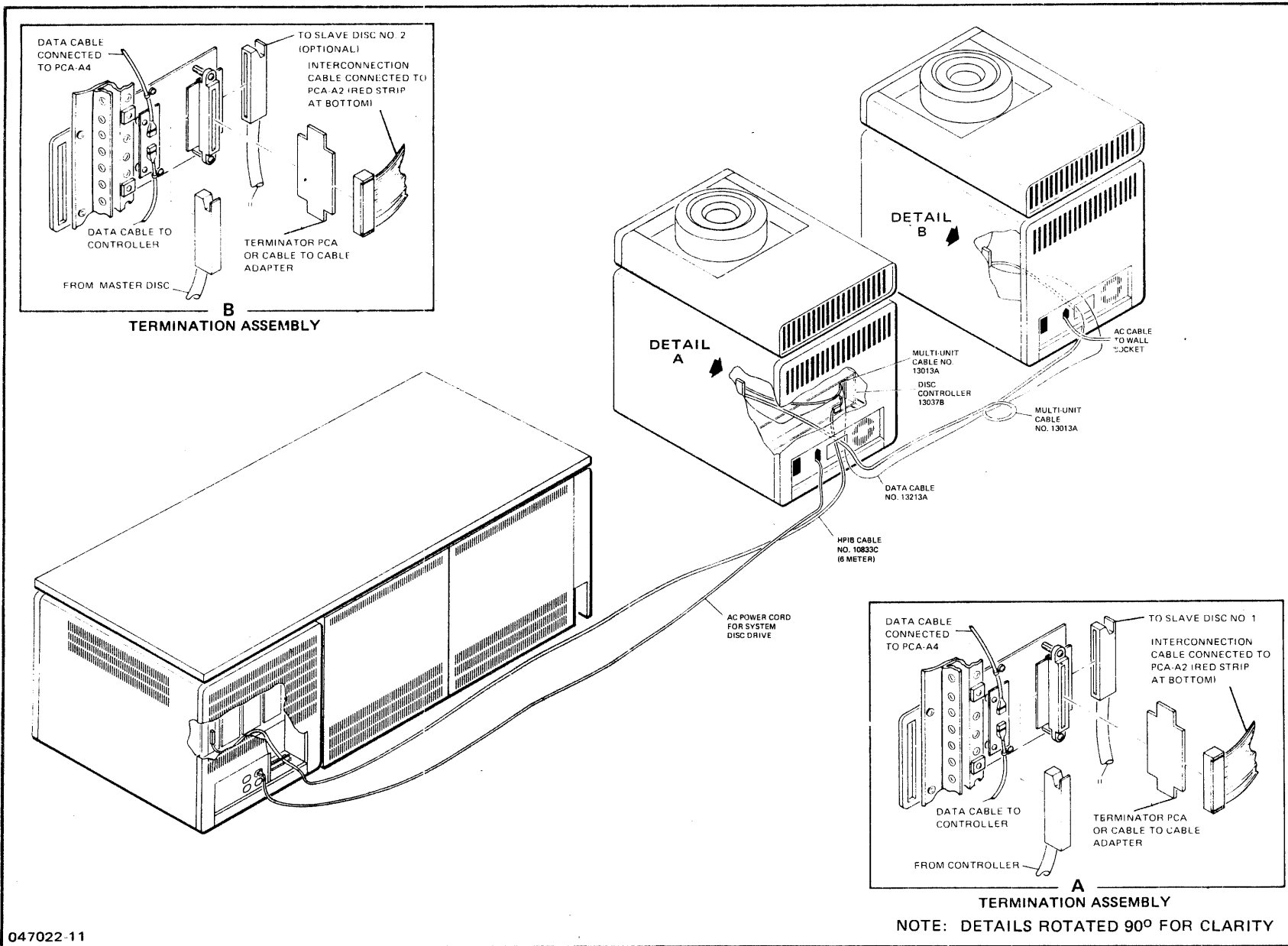
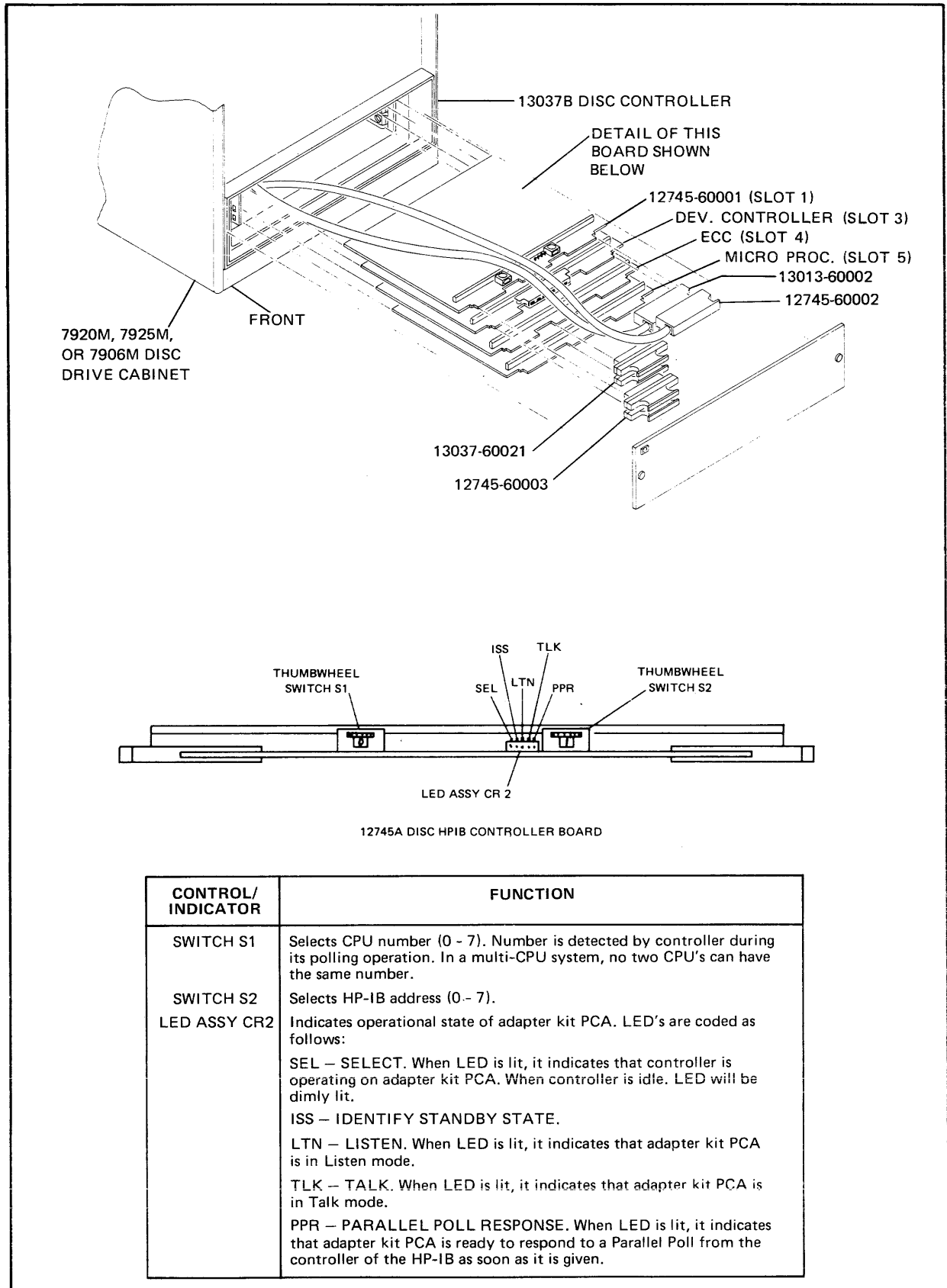

Figure 3-2. Master/Slave Disc Cabling



047017-09

Figure 3-3. System Disc HP-IB Device Select Switch

System Installation

3-6. HP 9895A Flexible Disc Drive

The flexible disc drive may be installed in the system and used as the primary or an alternate device for system backup. The following procedure applies to single or multiple flexible disc installations.

1. Connect the HP-IB I/O cable from the flexible disc drive to the assigned receptacle on the junction panel. (Refer to Appendix C for configuration data.)
2. Ensure that the AC power switch on the flexible disc drive is set to OFF.
3. On the flexible disc controller, set the device address number in accordance with configuration data contained in Appendix C.
4. Connect the flexible disc drive power cord to a dedicated power source with an isolated ground.
5. If the 9895A is sharing a GIC with other devices, it should remain powered-on at all times, or the HP-IB cable length must be limited to meet specifications without its active load.

3-7. INSTALLING PRINTERS

3-8. HP 2608A Line Printer

The following steps apply to installation of single or multiple HP 2608A printers. If necessary, refer to 2608A Service manual (part no. 02608-90904) or Technical Reference manual (part no. 02608-90903).

1. Ensure that the main power switch on the back of the printer is set to OFF.
2. Verify that the source voltage matches the requirements of the printer. (See the HP 2608A Power Label.)
3. Configure the line printer to respond to a PARALLEL POLL by removing the WT5 to WT6 jumper on the 02608-60026 HP-IB PCA.
4. Connect the power cable to the printer and to the power source.
5. Configure the printer's HP-IB Device Address as specified in Appendix C. Five mini rocker switches at the rear of the printer, next to the HP-IB cable connector, select the HP-IB Device Address. The logic of the switches is defined in octal as follows:
ON = Logic 1
LSB = Switch 1
MSB = Switch 5

System Installation

6. Fasten the HP-IB cable(s) to the HP-IB connector at the rear of the printer(s).
7. Daisy chain the HP-IB cable from printer no. 2 to the HP-IB connector on printer no. 1, fastening the two HP-IB connectors together.

3-9. HP 2613A/2617A/2619A Line Printers

The following steps apply to the installation of a single HP 2613A, HP2617A, or 2619A unit, and also applies for multiple unit installations. (See figure 3-4.)

1. Ensure that the processor MAIN ~ POWER breaker is set to OFF.
2. Open the card cage doors of the processor.
3. Install the HP-IB translator PCA(s) in the slot(s) assigned. (Refer to Appendix C for slot assignments.)
4. Open the access door leading to the side junction panel.
5. Remove the four screws that secures the assigned blank panel and install the interconnecting cable with connector and bracket in its place.
6. Attach the free end of the interconnecting cable assembly with the hood connector J2 on the HP-IB translator PCA.
7. Connect the ribbon cable assembly to J3 edge connector on the translator PCA and to the J3 edge connector on the assigned GIC.
8. On the translator PCA, set the HP-IB address switch to the device address number specified in Appendix C.
9. Connect interconnecting cable assembly to the mating connector on the receptacle bracket and the printer.
10. Close processor doors.
11. Ensure that the printer POWER switch is set to OFF.
12. Connect the printer AC power cord to a dedicated power receptacle.

System Installation

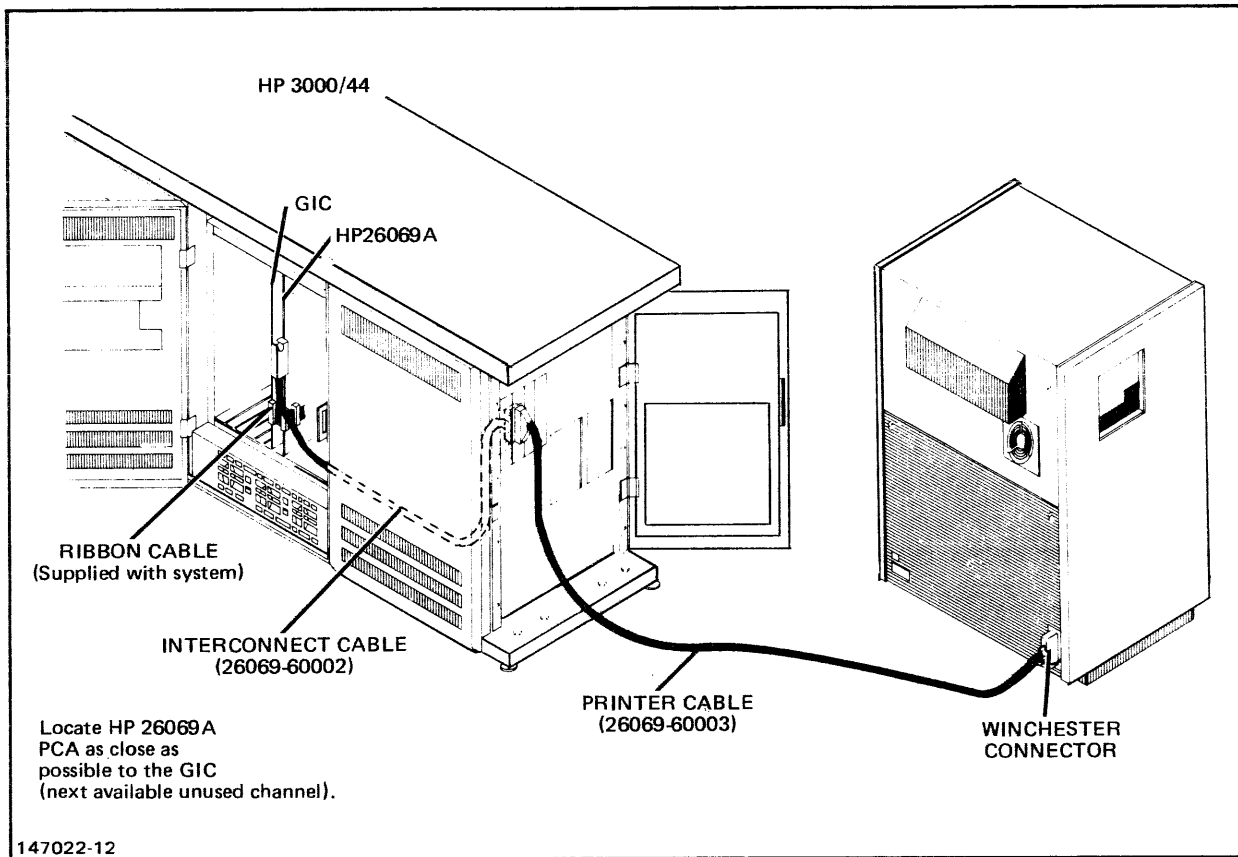

Figure 3-4. HP 2613A/2617A/2619A Printer Installation

3-10. HP 2631B Line Printer

The following applies to the installation of single or multiple HP 2631B printers.

1. Follow steps outlined for terminals except observe the following difference concerning the HP-IB Device Address switches. Seven mini rocker switches at the rear of the printer (next to the HP-IB cable connector) select the HP-IB Device Address, Service Request (SRQ), and Listen Always (LA) modes. The logic of the switches is defined in octal as follows:

ON = Logic 1
LSB = Switch 5
MSB = Switch 1
Listen Always = Switch 6
Service Request = Switch 7

NOTE

Always set switch 6 (LA) and switch 7 (SRQ) to OFF position when this printer is used on the HP 3000/44 System.

3-12. HP 2680A Page Printer

To install the HP 2680A page printer, refer to detailed instructions provided in the accompanying documentation. The HP 2680A must be connected to a dedicated GIC which must be designated as channel 13. Device number for the unit may be 0 or 1.

CAUTION

The page printer contains a laser device. Although the device is a low power device, the safety precautions given in the service documentation must be followed. Only qualified personnel should install and service the unit.

3-11. INSTALLING MAGNETIC TAPE DRIVES

3-13. HP 7970E Option 426 Magnetic Tape (Master)

1. Ensure that the magnetic tape drive POWER switch, located on behind the front door, is set to OFF.

System Installation

2. Ensure that the source voltage matches the requirements of the magnetic tape. (See the HP 7970E Power Label.)
3. Connect the power cord from the magnetic tape drive to a dedicated power receptacle with an isolated ground.
4. Configure the magnetic tape drive HP-IB device address switch, located as illustrated in figure 3-5, to the address specified in Appendix C.
5. Connect the HP-IB device I/O cable to the magnetic tape HP-IB connectors.
6. Route the free end of the HP-IB I/O cable to the assigned connector on one of the junction panels. (Refer to Appendix C for the proper connector location.)

3-14. The HP 7070E Option 425 Magnetic Tape (Slave)

1. Ensure that the magnetic tape drive POWER switch, located behind the front door of the unit, is set to OFF.
2. Ensure that the source voltage matches the requirements of the magnetic tape. (See the HP 7970E Power Label.)
3. Connect the power cord from the magnetic tape drive to a dedicated power receptacle with an isolated ground.
4. Follow cabling instructions as described in the HP 7970E Magnetic Tape Unit Service Manual (part no. 07970-90919).

3-15. INSTALLING TERMINALS AND PRINTING TERMINALS

The terminals include all 264x series and 262x series. The printing terminals include the HP 2635A and HP 2601A.

1. Ensure that the terminal main power switch is set to OFF.
2. Ensure that the power source voltage matches terminal requirements (see the power label).
3. Connect the power cord from the terminal to a dedicated power receptacle with an isolated ground.
4. Connect the keyboard and RS-232 compatible cables to the connectors which match the cable connectors on the terminal.
5. Route the free end of the RS-232 cable from the terminal to the installed connector on either junction panel, according to channel and device assignments given in Appendix C.

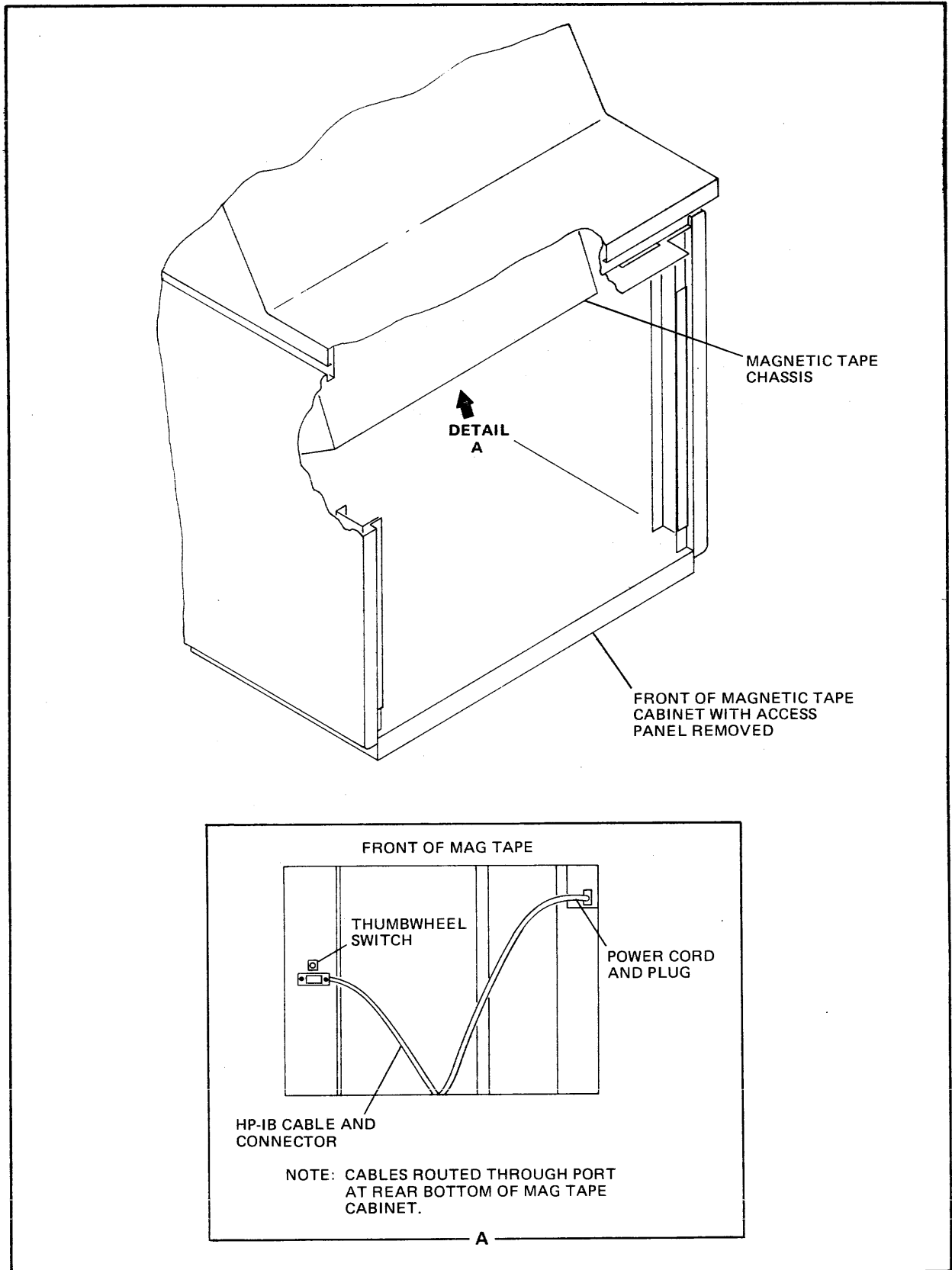

047017-10

Figure 3-5. Magnetic Tape HP-IB Device Address Switch and HP-IB Cable and Connector

TURNING ON THE NEW SYSTEM

SECTION

IV

4-1. PROCESSOR/PERIPHERAL TURN-ON

1. Ensure that the processor voltage (including isolation transformer strapping) matches that of the dedicated power source. When the system is connected to the power source, the power source must be within $\pm 4\%$ of the input voltage requirement.
2. Plug in the supplied power cord, and plug into the 60-Hz NEMA 6-30R or appropriate 50-Hz receptacle.
3. Turn on the breaker labeled "MAIN POWER" located next to the power cord on the power control unit.
4. Turn on the peripheral power breaker(s) to enable power to the PCM receptacles.
5. Turn on and place all peripheral devices on line.
6. Turn on the switch labeled "PROCESSOR" located on the front side of the processor.
7. Ensure the operation of all processor fan assemblies (See figures 2-1, 2-2 and 2-3), and observe the following events associated with the power supplies.
 - a. The two power supply fans on each power supply should rotate.
 - b. The red light on the power supply front panel should activate.
 - c. The red and yellow LEDs on the printed circuit side of the appropriate backplane should activate. (Open the front card cage access doors for viewing; see below.)

In addition, the POWER LED on the system control panel should be on and the all POWER LOW LEDs should be off.

Turning on the New System

- d. With an HP 970A voltmeter (or equivalent) measure the test point voltages on the power supply. Follow the specifications in table 4-1.

Table 4-1. Test Point Voltages

Voltage Test Points	Min. Reading	Max. Reading	Ripple Voltage
+5v Volts	+4.90	+5.10	0.05 v p.p.
+12v Volts	+11.80	+12.20	0.075 v p.p.
-12v Volts	-12.20	-11.80	0.075 v p.p.
+5m Volts	+5.0	+5.2	
+12m Volts	+11.86	+12.34	
-12m Volts	-13.80	-10.20	
BATT.	16.45 Approx.		
PON.	4.99 Approx.		

Refer to the HP3000/44 Reference/Training Manual if adjustment is required.

4-2. DISC DRIVE HEAD ALIGNMENT

Because of MPE support of private volumes, disc pack/cartridge inter-changeability must be guaranteed. Therefore, all disc drives installed on the system must be checked for proper head alignment as described in their respective service manuals.

SYSTEM VERIFICATION

SECTION

V

The system is verified in two steps:

The first is an OFF-LINE verification which checks the following areas:

- Cold Load Path
- Selected Assemblies
- Peripheral devices

Step two is an ON-LINE activity which accomplishes the following:

- System Cold Load from Magnetic Tape
- System Configuration
- System Utilization.
- Workout2
- Power Fail Verification

Refer to your HP 3000/44 diagnostic binder when information is required to run diagnostics or self tests. If a step does not successfully complete, corrective action is required before proceeding. Use the diagnostics and associated manuals to identify hardware problems. Use your HP 3000/44 Reference/Training Manual for any required technical descriptions of the processor components. Use the appropriate peripheral device service manuals for their specific hardware and maintenance descriptions. Table 5-1 lists the available device tests that can be performed.

System Verification

Table 5-1. Available Device Tests

Device	Standalone	Sleuth Verifier	Self-Test	Sleuth Sim.	CMP* Self Test
79XXB		x		x	
13037B	x			x	
2608A			x	x	
2617A					
2618A					
2619A					
2631A			x	x	
7970E	x			x	
9895A	x		x	x	
262XX					
264XA			x		
GIC	x				x
ADCC (Chan1)	x				x
MEMORY	x				x**
CPU			x		x
CMP					x

* The CMP self test checks the CMP, CPU, memory, system control panel, the ADCC at channel 1, and all GICs.

** First 128K Words of Memory tested only in self test.

5-1. Off-Line Verification

1. Run the System Console Self Test.
3. Run the CMP self test and IOMAP.
4. Run the GIC, ADCC, and MEMORY standalone diagnostics
5. Run all appropriate diagnostics, self tests, and sleuth verifiers on any of the peripheral devices installed, including:
 - Printers
 - Magnetic Tape Drives
 - Disc Drives
 - Flexible Disc Drive

(Refer to table 5-1.)

NOTE

Format and verify all disc packs/carttridges. Upon completion of format procedure, flag all defective tracks. Refer to CE Handbook part no. 30070-90010, contributed SLEUTHSM program.

6. Cold load the Diagnostic/Utility System as described in the diagnostic manual.
7. Type:"IOMAP"; a map of the I/O configuration of the devices connected to the system will be output to the console. Verify that all device and channel numbers correspond to the configuration matrix (See Appendix C.)

5-2. On-Line Verification

1. Ready all disc drives, referencing disc drive unit "0" as the system disc drive.
2. Ensure that the cold load thumb wheel switch on the system front panel is set to Channel=9; Device=1.
3. Cold load and configure I/O devices onto the system as described in the following procedure. The description is a summary intended to illustrate a general guide line. Specific information must be obtained from the System Manager/System Supervisor Reference Manual.

System Verification

- | STEP | PROCEDURE |
|------|--|
| 1 | On the System Control Panel, set the LOAD thumbwheel switch to the octal value of the DRT number (channel address and device address) of the cold load device. |
| 2 | For startup from the System Control Panel, press the LOAD key. For startup from the System Console, type LOAD on the keyboard. |
| 3 | Press RETURN on the System Console and respond to the Initiator prompts. |

```
HP 32002v.uu.ff      return
WHICH OPTION <COLDSTART/RELOAD/UPDATE>? COLDSTART
ANY CHANGES? YES
LOAD MAP? return
MEMORY SIZE=nnn.? return
I/O CONFIGURATION CHANGES? YES
LIST I/O DEVICES? YES
LIST CS DEVICES? YES
HIGHEST DRT?=nnn.? return or higher number
LOGICAL DEVICE #? nnn
DRT #? nnn
UNIT #? nnn
SOFTWARE CHANNEL #? n
TYPE?
SUB TYPE?
RECORD WIDTH?
OUTPUT DEVICE?
ACCEPT JOBS/SESSIONS? YES or NO
ACCEPT DATA? YES or NO
INTERACTIVE? YES or NO
DUPLICATIVE? YES or NO
INITIALLY SPOOLED? YES or NO
INPUT OR OUTPUT? IN or OUT      (Spooled devices only)
DRIVER NAME? (See Appendix D; of the HP 3000/44 Con-
              sole Operators Guide)
DEVICE CLASSES? device class name
LOGICAL DEVICE #? return
MAX # OF OPEN SPOOLFILES=nn.? return
LIST I/O DEVICES? return
LIST CS DEVICES? return
CLASS CHANGES? return
LIST I/O DEVICES? YES
DISC VOLUME CHANGES? return
MAX # OF SPOOLFILES KILOSECTORS=nnn? return
RECOVER LOST DISC SPACE? return
```

System Verification

STEP	PROCEDURE
4	Dismount and mount magnetic tapes as indicated to completely bring up the system. When the following message appears, the system is completely up. DATE (M/D/Y)? mm/dd/yy TIME (H:M)? hh:mm (24hr clock)

5-3. WORKOUT2

WORKOUT2 is an on-line program that exercises the Disc and Magnetic Tape Drive units.

Operator entries, in the example, are underlined. Pressing "RETURN" key in response to questions automatically selects the default answer.

NOTE

The program will allow only one more try after an invalid entry to a prompt is given. For example; the proper response to "NUMBER OF DISC FILES?" should be a number from 0-64. If a number greater than 64 is inadvertently entered the program response would be "BAD INPUT--TRY ONCE MORE". A second invalid entry would result in a program response of "SORRY--YOU LOSE" and program termination. Which means, of course, you start all over.

```
:HELLO FIELD.SUPPORT,HP32231
```

```
-----
```

```
:LISTF
```

```
-----
```

(Check to ensure that WORKOUT2 is included in the listed files. If it is not restore it)

System Verification

:RUN FREE2.PUB.SYS

(examine the "FREE" sectors shown. Each WORKOUT2 file requires 4096 sectors; smaller fragments cannot be used. For example, if 8000 sectors are available only one WORKOUT2 file will fit. If the disc is heavily fragmented, it may be necessary to do a Coolstart and "Recover Lost Disc Space" or a Reload.)

:SWITCHLOG

LOG FILE LOGxxxx IS yy% FULL
LOG FILE NUMBER nnnn ON

(You have closed Log File #xxxx and opened Log File #nnnn. Write down the number nnnn for use later on when LISTLOG2 is run. Press RETURN key to get ":" prompt back.)

:RUN WORKOUT2[;PARM=]

(Three options are available but not mandatory:

;PARM=1 Eliminates comparing data buffers after each READ ,and should not be used except for performance measurement.
;PARM=2 Causes END OF PASS messages to be displayed at System Console as well as with \$STDLIST.
;PARM=3 Accomplishes both of the above.)

NUMBER OF DISC FILES?2

-
(Assuming sufficient space was shown during "RUN FREE2" enter any number from 0-64. WORKOUT2 will attempt to open that number of files. Default is 0.)

LDN FOR FILE #1?1

-
LDN FOR FILE #2?1

-
(The above example assumes that only the system disc is on-line at this time. If more discs are present, any number from 0-255 may be specified. When zero is entered, WORKOUT2 spreads its files over all devices in class DISC. Default is 0.)

IS A SORT TO BE DONE? NO

--
(This question will not be asked unless the answer to "NUMBER OF DISC FILES?" above was 2 or greater. If a "YES" answer is given, it causes file #1 to be sorted

System Verification

and written to file #n; where "n" is the last file specified. For example, if you specified 2 disc files above and answered this question with "Y" the program would write to file #1, read back the data, sort it, then write it to file #2. Doing a sort significantly lengthens the program run time, thus it is not recommended. Default is NO.)

NUMBER OF TAPE FILES?1 (if a tape unit is available)

(Enter a number from 0-4. Default is 0. If a tape is not used the next question and it's reply will not be required.)

NUMBER OF PASSES?1

(Any number from 0-32766 may be entered. Default is 0, which causes the program to terminate immediately.)

?TIME/SESSION #/PIN #/LDEV #FOR "WORKTAPE1" ON TAPE (NUM)?

=REPLY PIN#, LDEV#

(Be sure you have mounted a "scratch" tape or one whose current contents you do not object to losing.)

TIME START

(WORKOUT2 now attempts to open the files. If all are successfully opened, no message will appear. If any file cannot be opened, a message to that effect will appear, followed by a message telling how many files were successfully opened.)

TIME END OF PASS 1

END OF PROGRAM

:LISTF LOG@.PUB.SYS

(The purpose here is to learn if there have been any new logs opened after number nnnn above.)

:HELLO MANAGER.SYS

(In order to run LISTLOG2, below, you must have System Manager capability. Thus we exited from FIELD.SUPPORT and logged onto MANAGER.SYS.)

System Verification

:RUN LISTLOG2.PUB.SYS

ENTER FIRST AND LAST LOG FILE TO BE ANALYZED

FIRST? _____ (Enter nnnn from above)

LAST? _____ (If no new logs have been opened after number nnnn,
LAST will also be nnnn.)

ENTER EVENTS TO BE PRINTED

TYPE NO.	EVENT
0	LOG FAILURE
:	:
:	:
~	~
~	~
:	:
11	I/O ERRORS
:	:

ENTER EVENT NUMBERS SEPARATED BY COMMAS. A CARRIAGE RETURN ASSUMES ALL EVENTS WILL BE EVALUATED.

11 (An entry of 11 is shown, since we are only interested in
-- I/O errors.)

The Listlog2 output will be directed to the Line Printer,
ensure it is on-line.

DO YOU WANT TO PURGE LOG FILES? NO

--
(If the previous FREE2 listing indicated the disc was
getting low on space, you may wish to enter YES to
purge the log files.)

DO YOU WISH TO RUN AGAIN (Y OR N? N

END OF PROGRAM

Examine LISTLOG2 printout for Disc and/or Tape errors.

5-4. System Power Fail Recovery Verification

Now that the system is up and WORKOUT2 has completed one pass, the Power Fail test should be performed.

Prior to performing the Power Fail test the following conditions should exist:

a) SYSDISC configured as LDEV #1

System Verification

- b) SYSDISC pack installed on master drive
- c) Master drive plugged into Power Control Module (convenience outlet next to main system breaker)
- d) System Console plugged into Power Control Module

To perform the Power Fail test run WORKOUT2 again, only this time:

- a) Answer 0 to "NUMBER OF TAPE FILES?"
- b) Answer "NUMBER OF PASSES?" with a number high enough to ensure the program runs long enough for Power Fail test to be accomplished (approximately 3).

Power fail the system by either tripping the main system breaker or by disconnecting the system power plug from the wall outlet. If the Customer's site permits, use Customer's breaker box to simultaneously power fail the system and all discs associated with the system.

Reconnect power after approximately 30 seconds. Verify successful recovery, by the following:

- a) WORKOUT2 resumes execution
- b) Depending on terminal timing, a power fail message may be displayed on the console when SYSDISC goes ready.
- c) System console does not "hang"
- d) System does not HALT or go into 100% utilization

Repeat this procedure for two additional cycles, using power fail periods of approximately 15 and 5 seconds.

5-5. System Back-Up

Back up the system back to the magnetic tapes shipped with the system, as follows:

- a. Log on to MANAGER.SYS and do a "Date 0" Sysdump. Refer to the Console Operators Guide for help, if required.
- b. Give all system magnetic tapes to the customer for safekeeping.

System Verification

- c. Complete the GSD System Installation Report form in the in the System Support Log.

Conduct System Operator training as outlined in Section 6 and then release the system to the customer for use.

TRAINING THE NEW SYSTEM OPERATOR

SECTION

VI

The CE is responsible for familiarizing the operator with the operation and the periodic customer maintenance of the HP3000/44 Computer System. The main sources of information the CE should use are the Functions of the Console Operator section of the Console Operator's Guide and the customer preventive maintenance section of the System Support Log. General information covering the the following topics should be discussed.

- The documentation supplied with the system
- Power on/off
- System Control Panel and CMP operation
- Daily maintenance
- Connecting data terminals
- Other peripheral device operation
- Self test
- Remote maintenance facility
- Warmstart
- Coldload
- Dump
- Shutdown
- System backup
- Conditioning private volume disc using VINIT
- Serialize disc packs/cartridges

MECHANICAL CONNECTION OF THE PROCESSOR CABINETS

APPENDIX

A

The processor enclosure is composed of two cabinets which may be separated for moving, if necessary. The two cabinets are mechanically fastened together as illustrated below.

Removal of the rectangular table top will reduce the overall processor cabinet dimensions from 29 in. by 72 in. (1.8m x 75cm), to that of figure A-1.

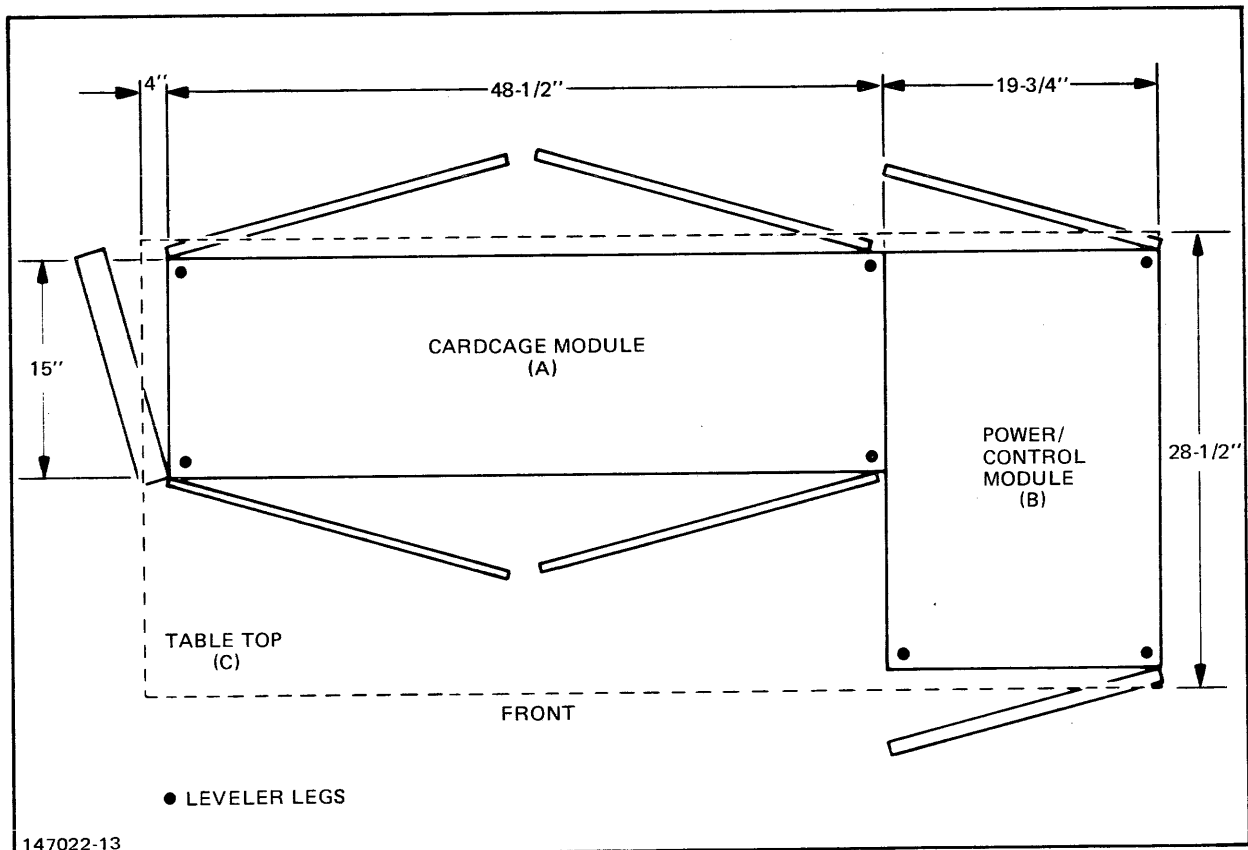

Figure A-1. Processor Cabinet Without Table Top

Appendix A

A-1. PROCESSOR TABLE TOP REMOVAL AND REPLACEMENT

PROCEDURE

Weight: 240 lbs. (109 kg) approximately

People required: 2

1. Remove the 7 allen screws, located as illustrated in figure A-2.

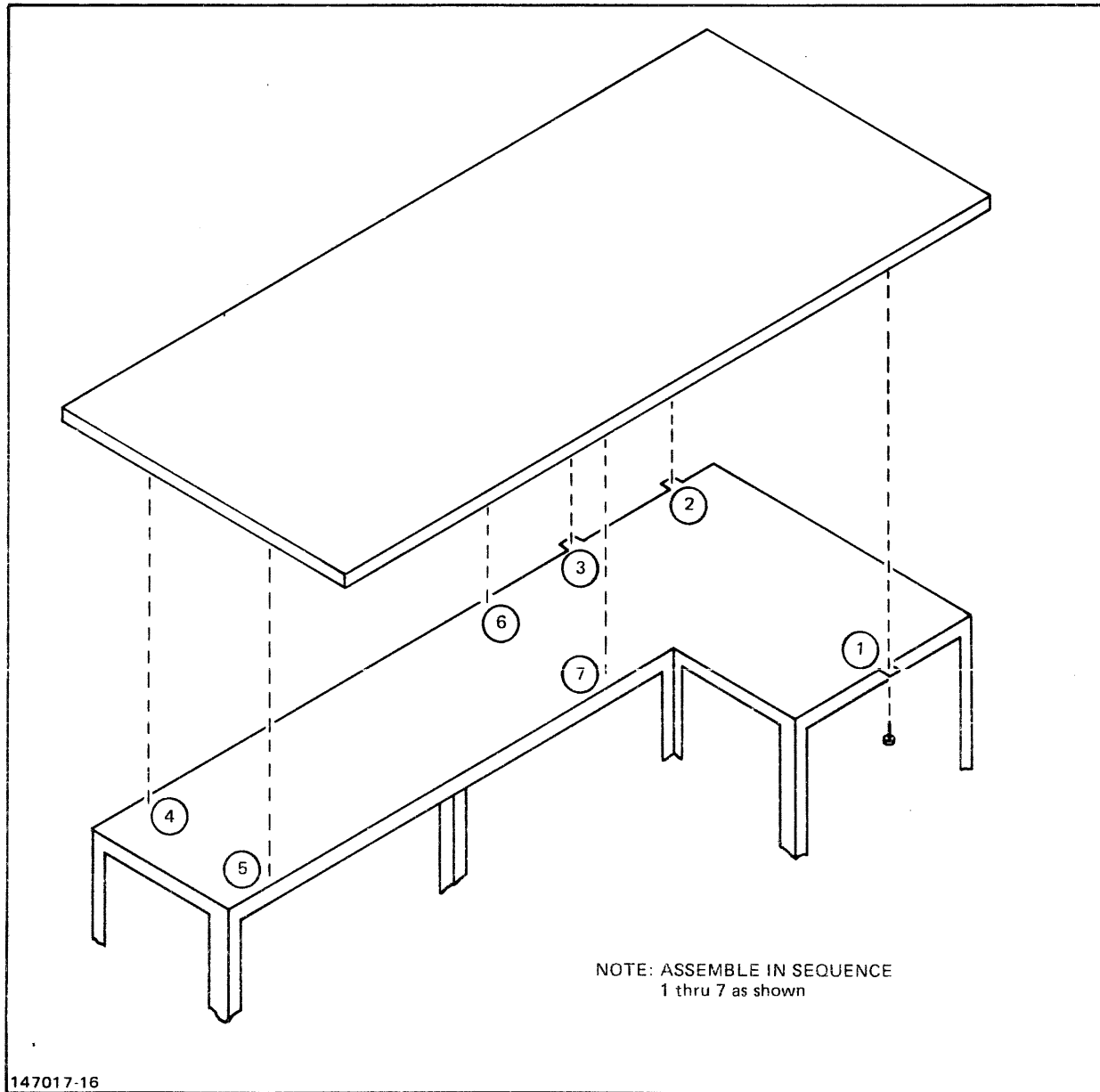

Figure A-2. Table Mechanical Joining

2. Table top is now free to be removed.
3. Reverse the procedure to replace the table top, keeping the following things in mind.
 - a. DO NOT exert any lateral force on the fixed nuts in the top.
 - b. Locate the top on the cabinet, using the screws in the sequence shown in figure A-2.
 - c. Loosely start all screws, then tighten in the sequence shown in figure A-2.

A-2. PROCESSOR CABINET SEPARATION AND REASSEMBLY

PROCEDURE

Tools required: 3/8" socket set with 3/16" socket.
Posidrive.
#26 Allen Drive.

People Required: 2

1. Remove the processor table top.
2. Remove the PROCESSOR switch side panel. Push panel up and pull off.
3. Fully extend power supplies on their slides.
4. To remove the right side panel, remove four 3/16" cap screws, pull panel out and push up.
5. Disconnect the orange, the blue, and the brown DC power cables from rear of the power supplies.
7. Disconnect the system control panel flat cable from the card cage 1 backplane.
8. Disconnect the Temperature Sense Cable (30070-60031) from the top right rear of the card cage #1 frame.
10. Disconnect the right-most plenum power connector below card cage #1.
11. Disconnect all GIC hood connectors, ADCC, and the CMP hood

Appendix A

connectors from the PCA(s) connected to the rear junction panel and remove the cables from the cable run.

12. Extend the two right-most card cage cabinet leveler legs to the ground.
13. Remove the nine 3/16" cap screws, located as illustrated in figure A-3, and partially separate the chassis halves. Carefully feed all the cables through the side panel and through the power supply chassis until cabinets are fully separated.

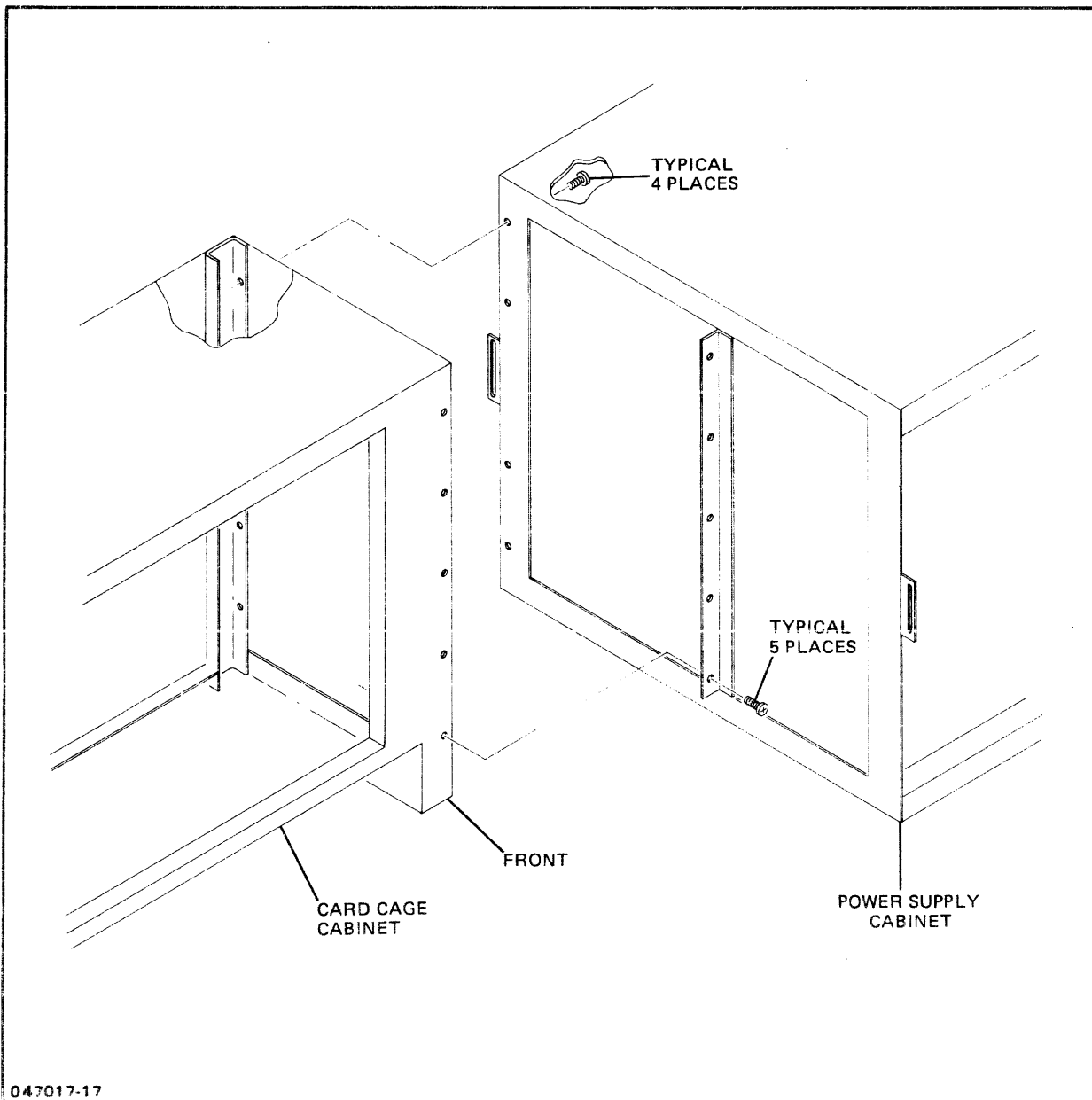

Figure A-3. Frame Mechanical Joining.

15. Reverse the procedure to reassemble the cabinets, paying particular attention to the following points:
 - a. Make sure that the over-temperature cable (30070-60031) goes over the card cage to chassis ground strap on card cage #1.
 - b. Adjust leveler legs to line up bolt holes for joining the two cabinet halves.
 - c. Use the cap screws to pull the cabinets together in the sequence shown in figure A-2, adjusting leveler legs as required. After all screws are installed, tighten snugly.
 - d. Ensure that no cables are being pinched.

ISOLATION TRANSFORMER PRIMARY VOLTAGE RESTRAPPING

APPENDIX

B

The following description and illustrations provide information for restrapping the primary windings for 200, 210, 220, 230, or 240 Volt AC operation. Standard strappings for the transformer are: 210 VAC for 60 Hz, 230 VAC for 50 Hz.

NOTE

Strap the Isolation transformer for 210 VAC if 208 VAC is being used on site.

Perform the following mechanical procedure when transformer restrapping is required. The isolation transformer is located as illustrated in figure B-1.

WARNING

Primary AC power is exposed when covers are removed. Turn OFF the processor switch and the main power breaker, and remove all input power to the system by disconnecting the power cord from the wall receptacle.

PROCEDURE

1. Remove the doors and the cabinet right side panel.
2. Remove the isolation transformer primary winding side cover plate.
3. Restrap the primary windings as illustrated in figure B-2.
4. Ensure that the connectors are tight and no loose strands of wire are protruding from the terminal block.
5. Ensure that resistance between transformer connectors and ground lug measures open (infinite resistance).
6. Reconfigure input VAC rating plates, located below main breaker, to indicate present AC voltage strappings.
7. Reassemble.

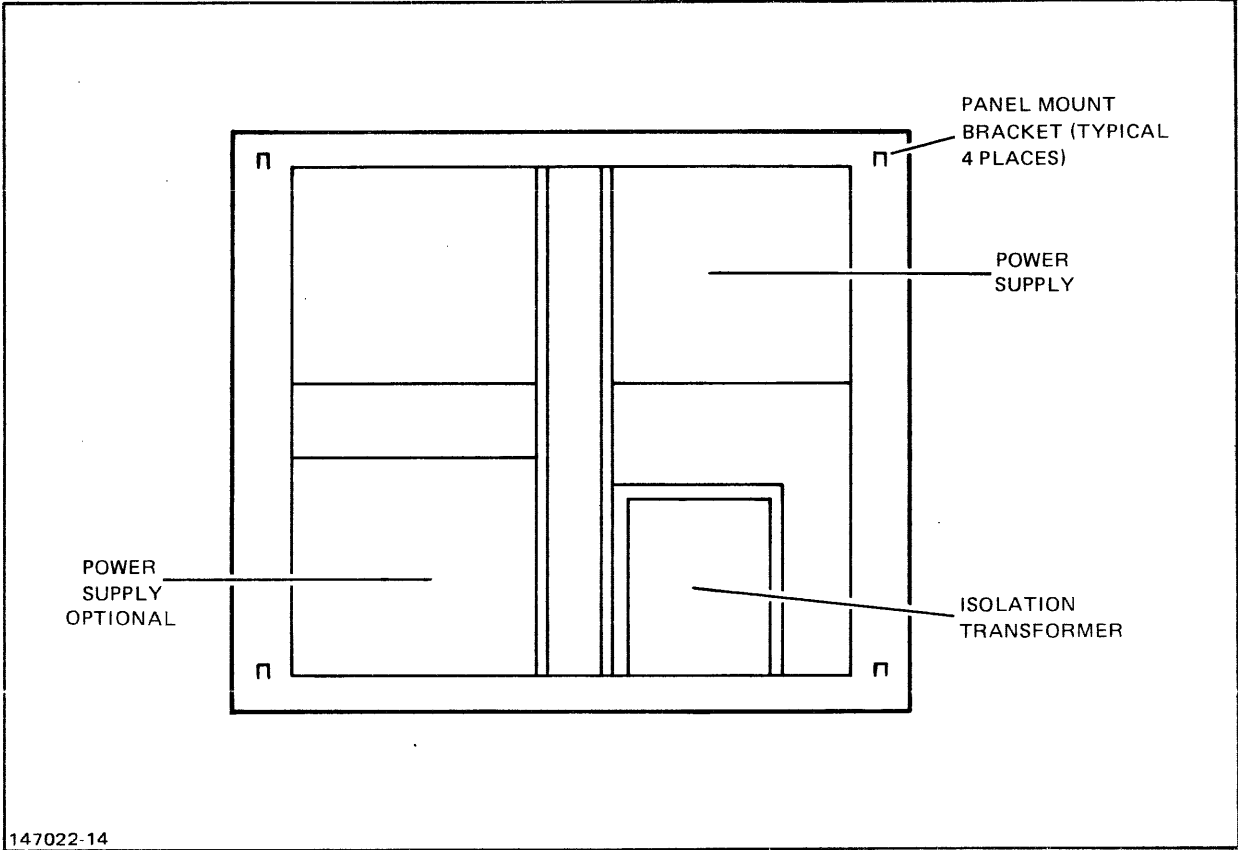
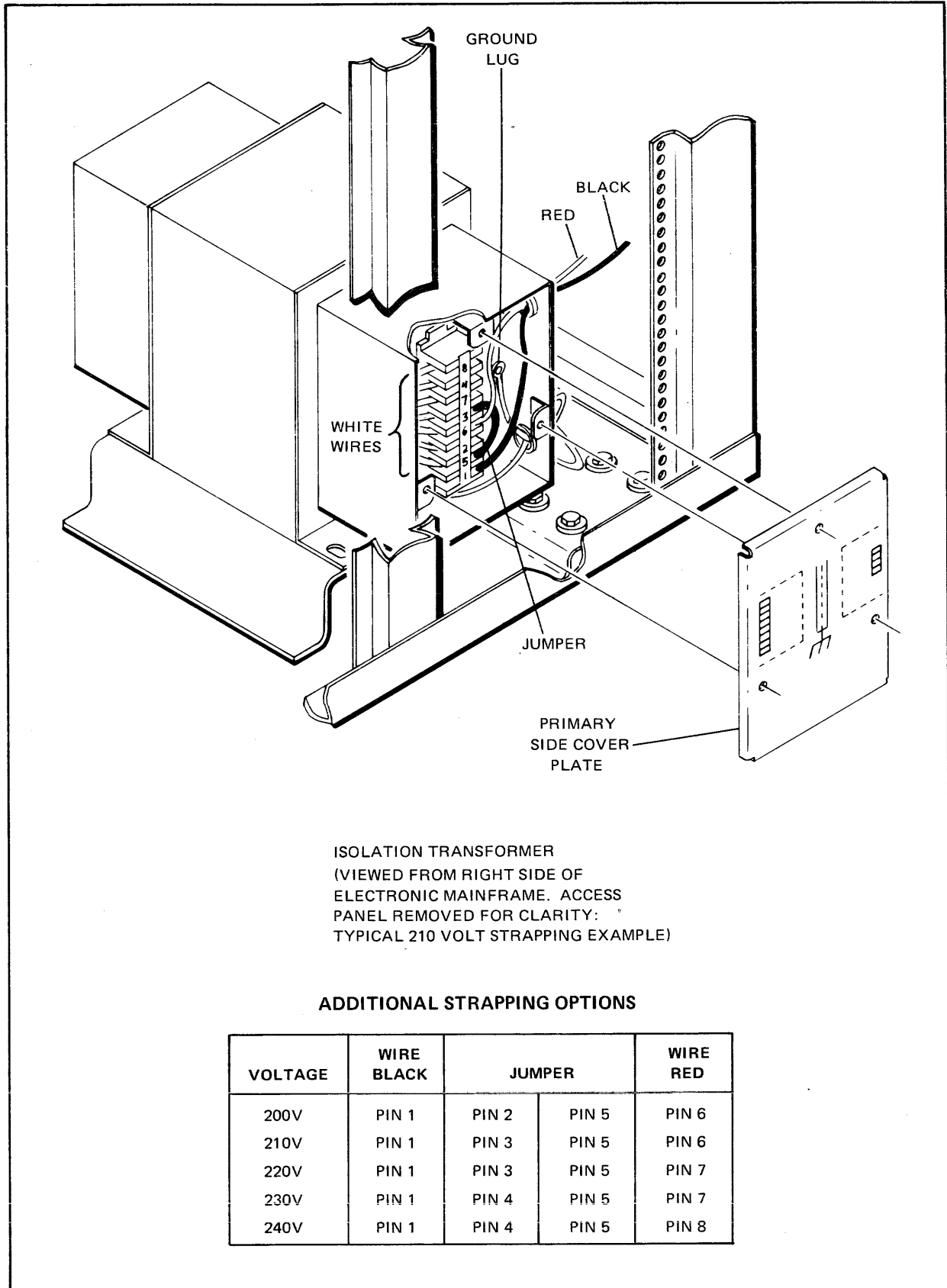

Figure B-1. Isolation Transformer Location



047017-19

Figure B-2. Strapping Options

HARDWARE CONFIGURATION

APPENDIX

C

Single and double card cage configurations are considered for installing hardware. Channel assignments are predetermined while slots assignments vary according to system size. Junction panel usage varies somewhat upon system size also, however, certain slots are reserved for specific devices. The tables and illustrations in this appendix provide guidelines for assigning slots, channels, and device numbers.

Table C-1. Suggested System Configuration

Device Type	Channel No.	Device No.
Terminals	1 thru 8	0 thru 7
Tape Drives (1 thru 4)	9	1
Tape Drives (5 thru 8)	10	1
System Disc Cntrlr	11	0,1
Line Printers (Except 2608)	11	1 thru 4
INP's	11	5 thru 7
Flexible Disc Drive	12	0
Additional Line Printers (Including 2608)	12	0 thru 3
Additional INP's	12	4 thru 7
HP 2680A Printer	13	1

Table C-2. Configuration Restrictions

PRINTER HP-IB TRANSLATORS:

One printer translator PCA (26069-60001) is supplied with each Option 344 on the 2613A, 2617A, and 2619A printers. This PCA must be installed in a mainframe slot and is referred to as "Printer Interface".

SLOT/POWER RESTRICTIONS:

Single Card-Cage Systems:

GIC's + ADCC's + INP's + Printer Interfaces =/
11
INP's + Printer Interfaces =/
6
INP's =/
3

Dual Card-Cage Systems:

GIC's + ADCC's + INP's + Printer Interfaces =/
18
INP's + Printer Interfaces =/
6
INP's =/
3

Dual Card-Cage Systems with a Channel 12 GIC:

GIC's + ADCC's + INP's over 4 =/
18
INP's =/
7

GIC RESTRICTIONS:

- Channel 9: One tape drive master only
- Channel 10: One tape drive master only
- Channel 11: Disc drives and internal peripherals only
- Channel 12: No disc drives, three external peripherals only, up to eight internal peripherals.
- Channel 13: One 2680A laser printer only.

In order to extend total beyond 2 megabytes, a 30086A Expansion Kit (second card cage) and a 30094A Memory Controller must first be installed.

SLOT LOCATIONS

Figures C-1 and C-2 specify slot locations to be used for all PCA's that are reinstalled in the first or second card cages. The following rules apply in all systems:

- The four CPU PCA's must be installed in the order shown.
 - The first memory array PCA must be installed in the location furthest from the memory controller to prevent the memory cable from hanging free or loosening.
 - The first ADCC (Main) must be installed in slot 14 so that it can be reached by the CMP cable.
 - The ADCC (Main) and ADCC (Extender) PCA's should be installed in pairs of adjacent slots to facilitate interconnection.
 - The GIC's must be installed in the following channel number order: 11, 9, 10, 13, 12.
 - In the first card cage, INP's and printer translators must be installed in slots adjacent to the associated GIC. This allows the internal HP-IB cables to be connected without passing over other PCA's.
- At the time the second card cage is installed in a system, it
- should be determined whether channel 12 had previously been installed. If so, move this PCA to slot 7 of the second card cage, then move any INP's and printer translators connected to it to slots 17 through 24. The long internal GIC cable provided with the system should be used only in the second card cage on channel 12. This allows the cable to pass over the Memory PCA's.

NOTE

All internal HP-IB cables required for system configuration are provided with the system in a pouch inside the left front door. These cables should never be cut to reduce their length since they may be needed to support larger configurations in the future.

1	2	3	4	5	6	7	8	9	10	11	12	13	14	15	16	17	18	19	20	21	22	23	24	
MEM ARRAY 0	MEM ARRAY 1	MEM ARRAY 2	MEM ARRAY 3	MEM ARRAY 4	MEM ARRAY 5	MEM ARRAY 6	MEM ARRAY 7	MEMORY CONTROLLER	CMP	CTL	ALU	PCS	ADCC M (CH 1)	ADCC E	GIC (CH 11)									

ADDITIONAL GIC'S,
ADCC'S, INP'S, AND
PRINTER TRANSLATORS

NOTES:

1. GIC's must be installed in the following channel number order: 11, 9, 10, 13, 12.
2. INP's and printer translator PCA's must be installed in slots adjacent to their controlling GIC.

147022-15

Figure C-1. Slot Locations (Initial Configuration)

CARD CAGE 1

SLOT NO.	1	2	3	4	5	6	7	8	9	10	11	12	13	14	15	16	17	18	19	20	21	22	23	24
	MEMORY ARRAY 0	MEMORY ARRAY 1	MEMORY ARRAY 2	MEMORY ARRAY 3	MEMORY ARRAY 4	MEMORY ARRAY 5	MEMORY ARRAY 6	MEMORY ARRAY 7	MEMORY CONTROL & LOGGING	CMP	CTL	ALU	PCS	ADCC (M) (CH 1)	ADCC (E)	GIC (CH 11)	ADCC (M) / INP / PTR	ADCC (E) / INP / PTR	ADCC (M) / INP	ADCC (E)	ADCC (M)	ADCC (E) / GIC	ADCC (M) / GIC	GIC

CARD CAGE 2

SLOT NO.	E 1	E 2	E 3	E 4	E 5	E 6	E 7	E 8	E 9	E 10	E 11	E 12	E 13	E 14	E 15	E 16	E 17	E 18	E 19	E 20	E 21	E 22	E 23	E 24
	ADCC (E)	ADCC (M) (CH 4)	ADCC (E)	ADCC (M) (CH 3)	ADCC (E)	ADCC (M) (CH 2)	GIC (CH 12)	MEMORY CONTROL & LOGGING	MEMORY ARRAY 7	MEMORY ARRAY 6	MEMORY ARRAY 5	MEMORY ARRAY 4	MEMORY ARRAY 3	MEMORY ARRAY 2	MEMORY ARRAY 1	MEMORY ARRAY 0	INP	INP	INP	INP	PTR	PTR	PTR	PTR

NOTES:

1. At the time the second card cage is installed, the channel 12 GIC and any INP's or printer translators attached to it should be moved to locations shown to free up additional IMB slots.
2. After slots 14 and 15 are filled, ADCC's should be installed in the expansion card cage first before filling the remaining slots in the main card cage.
3. Slot in card cage 2 are designated E1, E2, etc., to correspond with associated cable designations.

147022-16

Figure C-2. Slot Locations (Maximum Configuration)

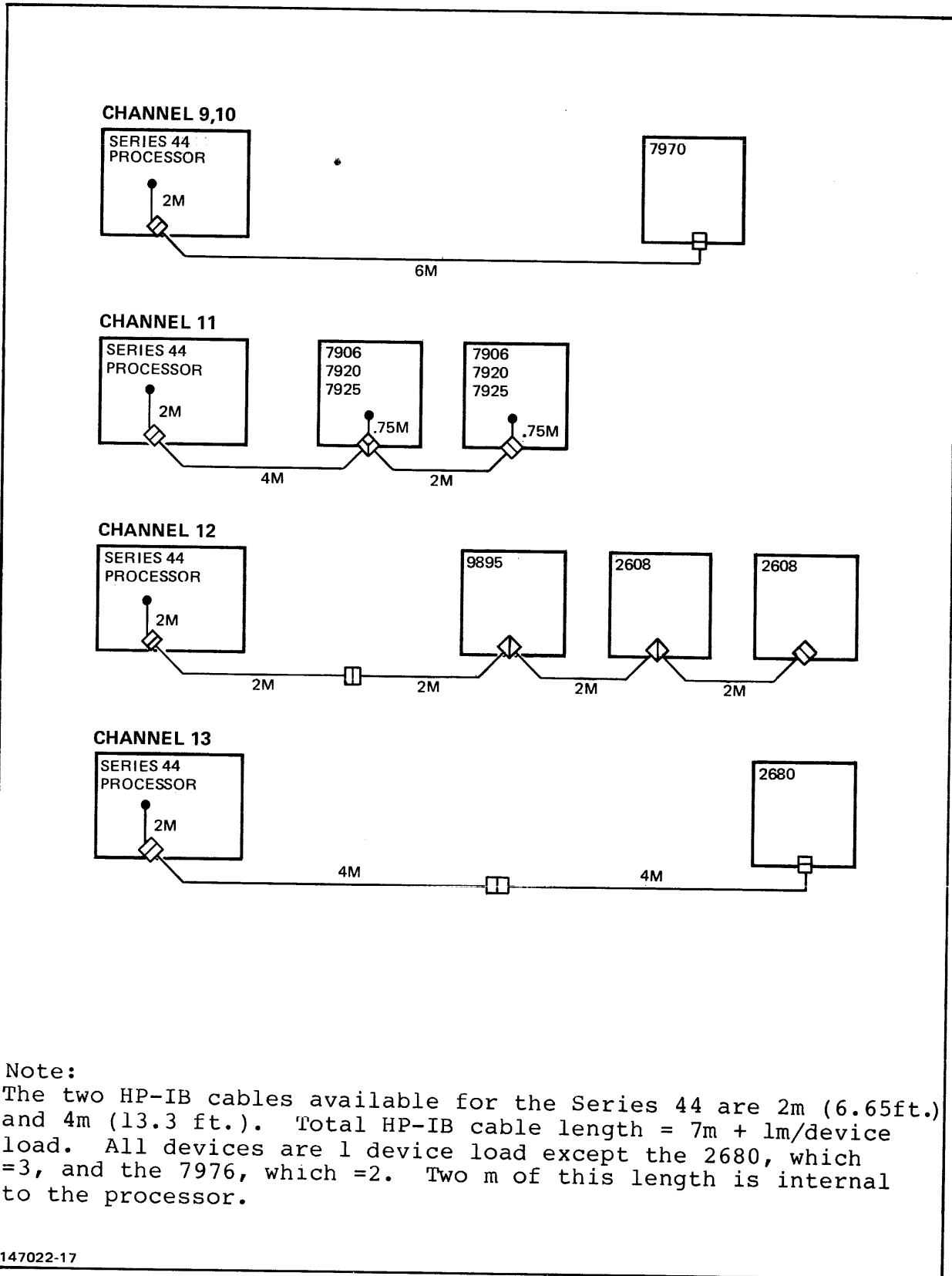

Figure C-3. External HP-IB Cable Configurations

UPGRADE INSTALLATION INFORMATION

APPENDIX

D

D-1. INTRODUCTION

This appendix contains instructions for upgrading HP 300 Computers and HP 3000 Series 30/33, HP 3000 Series II/III, and HP 3000 Pre-Series II Computers to an HP 3000 Series 44 Computer. Procedures appear in three parts. The first provides instructions for upgrading a Series 30 or Series 33 to a Series 44. The second provides instructions for upgrading a Pre-Series II, Series II, or Series III Computer to a Series 44. The third provides instructions for upgrading an HP 300 Computer to an HP 3000 Series 44 Computer.

This appendix deals primarily with the dismantling, packing, and disposition of the existing system, and refers to the main body of this installation manual for the installation of the Series 44 Computer System.

D-2. UPGRADING THE SERIES 30/33 TO SERIES 44

Product numbers 30072A and 30073A are for the Series 33 to Series 44 upgrade. The 30072A covers 60-Hz systems and the 30073A covers 50-Hz systems. Product numbers 30089A and 30091A are for the Series 30 to Series 44 upgrade. The 30089A covers 60-Hz systems and the 30091A covers 50-Hz systems.

Upgrading either the HP 3000/30 or HP 3000/33 involves the same tasks. First, the system console may be modified, the I/O channel PCA's are removed and reserved, and the equipment to be upgraded is prepared for shipment. After, the Series 44 is installed and brought to operating status.

The system console is modified only if Option 10 or Option 20 has been ordered with the upgrade. If either Option 11 or Option 21 have been ordered, the existing system console and its cable are to be returned to the factory.

Before installing the Series 44 upgrade, the CE will test the existing HP 3000 system to ensure that it is operational. Equipment can be upgraded and returned to Hewlett-Packard only if it is operational.

An inventory of the equipment to be returned to Hewlett-Packard must be performed. The Return Equipment Checklist given in tables D-1 or D-2 list hardware by system type. The CE should fill out the checklist according to the customer's system configuration. Also, any damage to each piece of equipment should be noted on the checklist prior to shipment.

NOTE

Before modifying, deinstalling, or installing, be sure to remove AC power from all units of the system at the main system power panel. Then disconnect all power and signal cables connected to the processor unit.

D-3. Modifying the Series 30/33 System Console

NOTE

Before attempting to modify the system console, check to ensure which options have been ordered with the upgrade system. The following procedure is to be performed only if Option 10 or Option 20 has been ordered. If Option 11 or Option 21 has been ordered, DO NOT perform the following procedure.

To modify the system console, proceed as follows:

1. Inventory the kit in which the required replacement parts are stored. The kit should contain the following:

Part No.	Description
-----	-----
1818-0287	ROM
02645-00010	Bezel Insert for HP 2645A
0370-0620	"0" Key for standard HP 2645A
0370-2312	"1" " " " " "
0370-2313	"2" " " " " "
0370-2315	"4" " " " " "
0370-2316	"5" " " " " "
0370-2317	"6" Key for standard HP 2645A
5040-7433	Keycap removal tool
02640-60021	Two-wide top plane connector

2. On the system console, remove the special 0, 1, 2, 4, 5, and 6 keys from the numeric pad using the keycap removal tool. Replace with new standard 2645 keys.
3. Open the top cover of the system console. From the inside and using the keycap removal tool, push out the system console bezel. (3000 SERIES 33 for the Series 33 or 3000 for the Series 30.) Insert new bezel included in the upgrade kit.

4. Remove the HP-IB Interface PCA. Also, remove the associated cable and load box.
5. There are two Control Memory PCA's and a Processor PCA that are mounted adjacent to one another and interconnected by a three-wide top-plane connector. Remove the top-plane connector and the two Control Memory PCA's.
6. One Control Memory PCA has two ROM's installed while the other PCA has only one ROM installed. On the PCA with only one ROM (part no. 1818-0501), replace the installed ROM with that provided in the upgrade kit (part no. 1818-0287).
7. Install the Control Memory with the replaced ROM in the slot adjacent to the Processor PCA. Interconnect the two PCA's with the new two-wide top plane connector supplied in the upgrade kit.
8. If the console has a GP Async Datacomm PCA, remove it's connecting cable. Then set all switches, except A9, All, FC0, and FCl, to open. This PCA will not be used by the system console but could be used as a printer interface or for special datacomm applications.
9. Close the system console and set aside until the processor is installed. Package the removed parts and reserve.

D-4. Preparing the Existing System for Upgrade

To prepare the system for upgrade, proceed as follows:

1. Remove all GIC's, ADCC's, INP's and printer translator PCA's (Series 30 and 33 only). Set them aside for installation into the Series 44.
2. Reserve all signal cables.
3. As part of the upgrade installation procedure, the CE must complete the forms necessary to process the returned system. These forms include the Notice of Return and Return Equipment Checklist.
 - a. The Notice of Return (NOR) form will be used by Computer Systems Division (CSY) to track the replaced equipment when it arrives at the factory. The NOR form will be shipped to the customer site with the new equipment packing list.

The NOR will be completed by the CE and returned to CSY in the return equipment packing lists. The CE will also supply the NOR number to the Field Sales and Service Office administrator who schedules the return shipment carrier.

- b. The Return Equipment Checklist will be used by CSY Manufacturing to check incoming equipment for missing or damaged parts. The completed checklist will be returned to CSY in the return equipment packing list.
4. When the upgrade installation is completed, the CE will notify the local Field Sales and Service Office that the replaced equipment is ready to be shipped to the divisions and supply the Office with the NOR number.

The Field Sales and Service Office will schedule a freight carrier to return the replaced equipment to the responsible Hewlett-Packard divisions. The Field Sales and Service Office will coordinate shipment of the equipment between the customer and the divisions.

For upgrades installed in the U.S., the Service Administration Organization of the Field Sales and Service Office will arrange for the return shipments. Replaced equipment will be shipped to the divisions freight collect by padded van.

The freight carrier to be used for all domestic return shipments is United Van Lines. The Field Sales and Service Office will obtain the name of the United Van Lines representative in their area by contacting:

Three-Way Van Lines, Inc.
Traffic Department
1120 Karlstad Drive
Sunnyvale, CA 94086
(408) 745-7500, Extensions 234, 236, 239

The Traffic Manager at CSY should be contacted for any questions or problems with the shipment procedures.

For upgrades installed in Europe and ICON, the shipping arrangements will be made by the Traffic Office of the local Field Sales and Service Office in Europe and ICON. Europe and ICON will handle return freight charge payments on an individual country basis.

The replaced equipment must be returned to Hewlett-Packard within 30 days of the installation of the upgrade, as explained in the customer's quotation from Hewlett-Packard. If the equipment is not returned within 30 days, the customer will be billed for the equipment.

5. After the return unit is packed, affix the appropriate adhesive-backed shipping label (contained in this appendix) to the front of the unit. For European returns, ship to:

HEWLETT-PACKARD GmbH
 Boeblingen General Systems Division
 Herrenberger Strasse 110
 D-7030 Boeblingen, West Germany

Attention: Max Fallett
 Traffic Manager

For all other returns, ship to:

HEWLETT-PACKARD CO.
 Computer Systems Division, Bldg. 53U
 5303 Stevens Creek Blvd.
 Santa Clara, CA 95050

Attention: Rey Seijas
 Traffic Manager

6. Move the new processor unit into place and install the upgrade and associated peripherals in accordance with the instructions given in the main body of this manual.

D-5. UPGRADING PRE-SERIES II, AND SERIES II/III TO SERIES 44

The product numbers and associated upgrades are as follows:

Product Number	Upgrade
30066A	Series III to Series 44 (60 Hz)
30067A	Series III to Series 44 (50 Hz)
30068A	Series II to Series 44 (60 Hz)
30069A	Series II to Series 44 (50 Hz)
30013A	Pre-Series II to Series 44 (60 Hz)
30014A	Pre-Series II to Series 44 (50 Hz)

Upgrading these products to Series 44 involves the same tasks. Remove power from all units before proceeding to disassemble the bays.

Before installing the Series 44 upgrade, the CE will test the existing HP 3000 computer system to ensure that it is operational. Equipment can be upgraded and returned to Hewlett-Packard only if it is operational.

An inventory of the equipment to be returned to Hewlett-Packard must be performed. The Return Equipment Checklist given in tables D-3 through D-5 list the hardware by system type. The CE should complete the checklist according to the customer's system configuration. Also, any damage to each piece of equipment should be noted on the checklist prior to shipment.

To prepare a system for upgrade, proceed as follows:

1. Separate the CPU, I/O, and peripheral bays (as applicable.)
2. Dress all cables so that they are within their respective bays. Tape cables and loose components to the frame.
3. As part of the upgrade installation procedure, the CE must complete the forms necessary to process the returned system. These forms include the Notice of Return and Return Equipment Checklist.

- a. The Notice of Return (NOR) form will be used by Computer Systems Division (CSY) and Boise Division Order Processing to track the replaced equipment when it arrives at the factory. There are NOR forms for both the Series 44 System Processor Unit (SPU) upgrade and magnetic tape drive trade-in program. The NOR form for the Series 44 upgrade will be found in the new equipment packing list; the form for the magnetic tape drive trade-in program will be found inside the cover door of the new magnetic tape drive.

The NOR's will be completed by the CE and returned to CSY and Boise Divisions in the return equipment packing lists. The CE will also supply the NOR number to the Field Sales and Service Office administrator who schedules the return shipment carrier.

- b. The Return Equipment Checklist will be used by CSY Manufacturing to check incoming equipment for missing or damaged parts. The checklist is used for the Series 44 SPU upgrade only, not the magnetic tape drive trade-in program. The completed checklist will be returned to CSY in the return equipment packing list.
4. When the upgrade installation is completed, the CE will notify the local Field Sales and Service Office that the replaced equipment is ready to be shipped to the divisions and supply the Office with the NOR number.

The Field Sales and Service Office will schedule a freight carrier to return the replaced equipment to the responsible Hewlett-Packard divisions. The Field Sales and Service office will coordinate shipment of the equipment between the customer and the divisions.

For upgrades installed in the U.S., the Service Administration Organization of the Field Sales and Service Office will arrange for the return shipments. Replaced equipment will be shipped to the divisions freight collect by padded van. One truck will be used to pick up equipment destined for both Boise and CSY divisions.

The freight carrier to be used for all domestic return shipments is United Van Lines. The Field Sales and Service Office will obtain the name of the United Van Lines representative in their area by contacting:

Three-Way Van Lines, Inc.
Traffic Department
1120 Karlstad Drive
Sunnyvale, CA 94086
(408) 745-7500, Extensions 234, 236, 239

The Traffic managers at Boise and CSY Divisions should be contacted for any questions or problems with the return shipment procedures.

For upgrades installed in Europe and ICON, the shipping arrangements will be made by the Traffic Office of the local Field Sales and Service Office in Europe and ICON. Europe and ICON will handle return freight charge payments on an individual country basis.

The replaced equipment must be returned to Hewlett-Packard within 30 days of the installation of the upgrade, as explained in the customer's quotation from Hewlett-Packard. If the equipment is not returned within 30 days, the customer will be billed for the equipment.

Affix the appropriate shipping label contained in this appendix to each bay. For magnetic tape drives, use only the packing pouch supplied in the new magnetic tape drive. Do not use the shipping label provided in this document.

6. Magnetic tape bays are to be shipped to:

Hewlett-Packard Co.
Boise Division
11311 Chinden Blvd.
P.O. Box 15
Boise, ID 83707

Attention: John Fisher
Traffic Manager

For all other returns, ship to:

Hewlett-Packard Co.
Computer Systems Division, Bldg. 53U
5303 Stevens Creek Blvd.
Santa Clara, CA 95050
Attention: Rey Seijas
Traffic Manager

7. Move the new processor into place and install the upgrade and peripherals in accordance with the instructions given in the main body of this manual.

D-6. UPGRADING THE HP 300 TO HP 3000 SERIES 44

Product numbers 30074A and 30074A Opt. 015 apply to the HP 300 to HP 3000 Series 44 upgrades. Number 30074A applies to 60-Hz systems and number 30074A Opt. 015 applies to 50-Hz systems.

In either case the same tasks are involved. First, the I/O channel PCA's are removed and reserved. Next, the HP 300 is prepared for its return shipment to the factory. Then, the Series 44 is installed and brought to operation.

Before starting the upgrade, the CE should test the HP 300 Computer to ensure it is operational. It can be returned to Hewlett-Packard only if it is operational. An inventory of the returned equipment must be performed. The Return Equipment Checklist in table D-6 lists the hardware that must be inventoried. The CE should complete the checklist according to the customer's computer configuration. Additionally, any damage to any piece of equipment should be noted on the checklist before shipment.

NOTE

Before modifying, deinstalling, or installing, be sure to remove AC power from all units of the system at the main system power panel. Then disconnect all power and signal cables connected to the processor unit.

D-7. Preparing the HP 300 for Upgrade

To prepare the HP 300 for upgrade, proceed as follows:

1. Remove all GIC and ADCC PCA's and set them aside for installation into the HP 3000 Series 44.
2. Reserve all signal cables.
3. Locate the HP 31030A Workstation, if the customer's system included one.
4. As part of the upgrade installation procedure, the CE must complete the forms necessary to process the returned system. These forms include the Notice of Return and Return Equipment Checklist.
 - a. The Notice of Return (NOR) form will be used by Computer Systems Division (CSY) to track the replaced equipment when it arrives at the factory. The NOR form will be shipped to the customer site with the new equipment pack-

ing list.

The NOR will be completed by the CE and returned to CSY in the return equipment packing lists. The CE will also supply the NOR number to the Field Sales and Service Office administrator who schedules the return shipment carrier.

- b. The Return Equipment Checklist will be used by CSY Manufacturing to check incoming equipment for missing or damaged parts. The completed checklist will be returned to CSY in the return equipment packing list.
5. When the upgrade installation is completed, the CE will notify the local Field Sales and Service Office that the replaced equipment is ready to be shipped to the divisions and supply the Office with the NOR number.

The Field Sales and Service Office will schedule a freight carrier to return the replaced equipment to the responsible Hewlett-Packard divisions. The Field Sales and Service Office will coordinate shipment of the equipment between the customer and the divisions.

For upgrades installed in the U.S., the Service Administration Organization of the Field Sales and Service Office will arrange for the return shipments. Replaced equipment will be shipped to the divisions freight collect by padded van.

The freight carrier to be used for all domestic return shipments is United Van Lines. The Field Sales and Service Office will obtain the name of the United Van Lines representative in their area by contacting:

Three-Way Van Lines, Inc.
Traffic Department
1120 Karlstad Drive
Sunnyvale, CA 94086
(408) 745-7500, Extensions 234, 236, 239

The Traffic Manager at CSY should be contacted for any questions or problems with the shipment procedures.

For upgrades installed in Europe and ICON, the shipping arrangements will be made by the Traffic Office of the local Field Sales and Service Office in Europe and ICON. Europe and ICON will handle return freight charge payments on an individual country basis.

The replaced equipment must be returned to Hewlett-Packard within 30 days of the installation of the upgrade, as explained in the customer's quotation from Hewlett-Packard. If the equipment is not returned within 30 days, the customer will be billed for the equipment.

6. After the return unit is packed, affix the appropriate adhesive-backed shipping label (contained in this appendix) to the front of the unit. For European returns, ship to:

HEWLETT-PACKARD GmbH
Boeblingen General Systems Division
Herrenberger Strasse 110
D-7030 Boeblingen, West Germany

Attention: Max Fallett
Traffic Manager

For all other returns, ship to:

HEWLETT-PACKARD CO.
Computer Systems Division, Bldg. 53U
5303 Stevens Creek Blvd.
Santa Clara, CA 95050

Attention: Rey Seijas
Traffic Manager

7. Move the HP 3000 Series 44 into place and install it and its peripherals in accordance with the instructions given in the main body of this manual.

D-8. PERIPHERAL UPGRADES

Peripherals that are to be used with the Series 44 must be HP-IB compatible devices. All peripheral devices that are used on Series 30 or 33 systems which are to be upgraded to Series 44 are compatible and require only connecting to the processor in accordance with the instructions given in the main body of this manual. However, peripherals that were used with Pre-Series II, Series II or III, or HP 300 Computers require replacement or modifying to make them HP-IB compatible.

The following peripherals may be used directly on the Series 44:

7920S	50 Mb Slave Disc Drive
7925S	120 Mb Slave Disc Drive
9895A	Flexible Disc Drive
7970E	1600 bpi Magnetic Tape Drive (low-boy cabinet)
7976A	1600 bpi/6250 cpi Magnetic Tape Drive
2601A	Daisy Wheel Printer
2680A	Intelligent Page Printer
2631B	Character Printer (attached to Async. Terminal Controller)
2635A/B	Printing Terminal
262X	Interactive Display Terminals
264X	Interactive Display Terminals
2641A	APL Display Station (supported as a 2645A but APL features not supported)

The following peripherals may be upgraded to operate on the Series 44:

7920M	50 Mb Master Disc Drive
7925M	120 Mb Mster Disc Drive
7920	50 Mb Disc Drive (SPU resident controller)
7925	120 Mb Disc Drive (SPU resident controller)
7970E	1600 bpi Master Magnetic Tape Drive (low-boy cabinet)
2608A	400 lpm Line Printer
2613A/17A/19A	300/600/1000 lpm Line Printers
30106A	2893A Card Reader

The following peripherals, which were used on the Series III, Series II, Pre-Series II and HP 300 systems, are not supported on the Series 44:

2660A	Fixed Head Disc
2888A	47 Mb Disc Drive
7900A	5 Mb Disc Drive
7905A	15 Mb Disc Drive
7970B	800 bpi Magnetic Tape Drive
7970E	1600 bpi Magnetic Tape Driv(in high-bay cabinet)
2607A	200 lpm Line Printer
2610A	200 lpm Line Printer
2614A	600 lpm Line Printer
26128A	1250 lpm Line Printer
2749B	Teleprinter
2762A/B	Printing Terminal
30031A	Clock/Console
30104A	Paper Tape Reader
30105A	Paper Tape Punch
30119A	2894A Card Reader/Punch
30126A	CalComp Plotter Interface

Table D-1.

**SERIES 30 TO SERIES 44 UPGRADE INVENTORY
RETURN EQUIPMENT CHECK LIST**

COMPONENT	PART NO.	QTY.	FACTORY INSPECTION	
			REC'D	FACTORY TEST
CABINET ASSEMBLY	30080-60002			
FRONT PANEL	30080-00010			
REAR PANEL	31000-60081			
CARD CAGE ASSEMBLY	30080-60003			
REMOTE SWITCH BOX ASSEMBLY	30080-60024			
SYSTEM CONTROL PANEL	30080-60005			
POWER SUPPLY UNIT	31000-60002			
FLEXIBLE DISC DRIVE	7902			
FLEXIBLE DISC CONTROLLER PCA	07902-60024			
CENTRAL PROCESSOR UNIT PCA	30070-60012			
BUS INTERFACE CONTROLLER	31000-60053			
EXTENDED FIRMWARE PCA	30070-60090			
MAINTENANCE INTERFACE PCA	30070-60013			
MEMORY CONTROLLER PCA	31202-60001			
MEMORY ARRAY PCA'S	31204-60001			

This Return Equipment Checklist inventories the replaced equipment resulting from the upgrade of an HP 3000 Series 30 to Series 44. Please review the inventory for accuracy, then sign and date the Checklist.

The HP 3000 upgrade includes credit for the replaced equipment. This equipment is the property of Hewlett-Packard and must be returned within 30 days following installation of the upgrade. The Hewlett-Packard Sales Office will arrange shipment to Hewlett-Packard for the replaced equipment. If the equipment is not received within 30 days, Hewlett-Packard shall issue an invoice for these products subject to Hewlett-Packard's standard terms.

Signatures: _____ Date: _____
Customer Representative

_____ Date: _____
HP Customer Engineer

Note: Please include this Checklist with the returned equipment.

Table D-2.

SERIES 33 TO SERIES 44 UPGRADE INVENTORY RETURN EQUIPMENT CHECK LIST

**FACTORY
INSPECTION**

COMPONENT	PART NO.	QTY.	REC'D	FACTORY TEST
HP-IB JUNCTION PANEL	30070-60014			
REAR DOOR (POWER SUPPLY)	30070-00084			
SHORT SIDE PANEL	30070-00054			
FULL SIDE PANEL	30070-00055			
FRONT DOOR (CONTROL PANEL)	30070-00083			
TERMINAL JUNCTION PANEL DOOR	30070-00080			
FRONT DOOR, RIGHT (CARD CAGES)	30070-00074			
FRONT DOOR, LEFT (CARD CAGES)	30070-00077			
REAR DOOR, RIGHT (CARD CAGES)	30070-00078			
REAR DOOR, LEFT (CARD CAGES)	30070-00079			
CENTRAL PROCESSOR UNIT PCA	30070-60012			
MEMORY CONTROLLER	31202-60001			
BUS INTERFACE CONTROLLER PCA	31000-60053			
EXTENDED FIRMWARE PCA	30070-60090			
MAINTENANCE INTERFACE	30070-60013			
SYSTEM CONTROL PANEL	30070-60008			
ISOLATION TRANSFORMER	9100-4062			
FLEXIBLE DISC DRIVE	7902			
FLEXIBLE DISC CONTROLLER PCA	07902-60024			
POWER DISTRIBUTION UNIT, 60Hz	30016-60001			
POWER DISTRIBUTION UNIT, 50Hz	30017-60001			
CARD CAGE #1	30070-60003			
CARD CAGE #2	30070-60057			
TABLE TOP	30070-00056			

This Return Equipment Checklist inventories the replaced equipment resulting from the upgrade of an HP 3000 Series 33 to Series 44. Please review the inventory for accuracy, then sign and date the Checklist.

The HP 3000 upgrade includes credit for the replaced equipment. This equipment is the property of Hewlett-Packard and must be returned within 30 days following installation of the upgrade. The Hewlett-Packard Sales Office will arrange shipment to Hewlett-Packard for the replaced equipment. If the equipment is not received within 30 days, Hewlett-Packard shall issue an invoice for these products subject to Hewlett-Packard's standard terms.

Signatures: _____ Date: _____

Customer Representative

_____ Date: _____

HP Customer Engineer

Note: Please include this Checklist with the returned equipment.

Table D-3.

**RETURN EQUIPMENT CHECK LIST
PRE-SERIES II TO SERIES 44 UPGRADE INVENTORY**

				FACTORY INSPECTION	
COMPONENT	PART NO.	QTY.	REC'D	FACTORY TEST	
READ-ONLY MEMORY PCA	30001-60001				
SKIP AND SPECIAL FIELD PCA	30001-60002				
ARITHMETIC AND LOGIC UNIT PCA	30001-60003				
R-BUS PCA	30001-60004				
S-BUS PCA	30001-60005				
CURRENT INSTRUCTION REGISTER PCA	30001-60006				
MODULE CONTROL UNIT PCA	30001-60007				
INPUT/OUTPUT PROCESSOR PCA	30001-60008				
CENTRAL DATA BUS TERMINATOR PCA	30001-60009				
INPUT/OUTPUT PROCESSOR BUS TERMINATOR	30001-60016				
POWER BUS TERMINATOR PCA	30001-60021				
CONTROL BOARD PCA	30001-60010				
MEMORY LOAD PCA	30005-60001				
MEMORY DATA AND CONTROL PCA	30005-60002				
MEMORY DRIVE AND SENSE PCA	30006-60002				
SYSTEM CLOCK/CONSOLE INTERFACE PCA	30031-60001				
MULTIPLEXER CHANNEL PCA	30035-60001				
TERMINATOR PCA	30035-60033				
CHANNEL SELECTOR PORT CONTROLLER PCA	30030-60005				
SELECTOR CHANNEL REGISTER PCA	30030-60001				
SELECTOR CHANNEL SEQUENCER PCA	30030-60011				
SELECTOR CHANNEL CONTROL PCA	30030-60003				
SELECTOR CHANNEL BUS TERMINATOR PCA	30030-60015				
UPPER ROM PCA	30011-60001				
UPPER ROM PCA	30011-60002				
UPPER ROM PCA	30011-60003				
UNIVERSAL INTERFACE (TTL) PCA	30050-60001				
UNIVERSAL INTERFACE (DIFFERENTIAL) PCA	30051-60001				
UNIVERSAL INTERFACE (TTL) PCA	30050-60003				
SYNCHRONOUS SINGLE LINE CONTROLLER PCA	30055-60001				
TERMINAL DATA INTERFACE PCA	30032-60001				
TERMINAL DATA INTERFACE PCA	30060-60001				
TERMINAL CONTROL INTERFACE PCA	30061-60001				
PLOTTER INTERFACE PCA	30226-90007				
HARDWIRED SERIAL INTERFACE	30360-60001				
DISC FILE READ/WRITE PCA	30202-60001				

Table D-3.

**RETURN EQUIPMENT CHECK LIST
PRE-SERIES II TO SERIES 44 UPGRADE INVENTORY
(Cont.)**

				FACTORY INSPECTION
COMPONENT	PART NO.	QTY.	REC'D	FACTORY TEST
DISC FILE BUS PCA	30202-60002			
DISC CONTROLLER PROCESSOR PCA	30202-60003			
DISC MEMORY CONTROLLER PCA	30203-60001			
DISC MEMORY DATA PCA	30203-60002			
CARD READER INTERFACE PCA	30206-60001			
CARTRIDGE DISC CONTROLLER PCA	30210-60001			
MAGNETIC TAPE (9 TRACK) CONTROLLER PCA	30215-60001			
MAGNETIC TAPE CONTROLLER PROCESSOR PCA	30215-60002			
CARD PUNCH CONTROLLER	2890-60001			
	2890-60002			
	2890-60003			
POWER SUPPLY	30310A			
52" CABINET & DOORS	30390A			
HARDWARE MAINTENANCE PANEL	30352A			
AUXILIARY CONTROL PANEL	30350A			
AUXILIARY CONTROL PANEL INTERFACE PCA	30350-60006			

This Return Equipment Checklist inventories the replaced equipment resulting from the upgrade of an HP 3000 Pre-Series II to Series 44. Please review the inventory for accuracy, then sign and date the Checklist.

The HP 3000 upgrade includes credit for the replaced equipment. This equipment is the property of Hewlett-Packard and must be returned within 30 days following installation of the upgrade. The Hewlett-Packard Sales Office will arrange shipment to Hewlett-Packard for the replaced equipment. If the equipment is not received within 30 days, Hewlett-Packard shall issue an invoice for these products subject to Hewlett-Packard's standard terms.

Signatures: _____ Date: _____

Customer Representative

_____ Date: _____

HP Customer Engineer

Note: Please include this Checklist with the returned equipment.

Table D-4.

RETURN EQUIPMENT CHECK LIST SERIES II TO SERIES 44 UPGRADE INVENTORY

				FACTORY INSPECTION
COMPONENT	PART NO.	QTY.	REC'D	FACTORY TEST
READ ONLY MEMORY	30003-60001			
SKIP AND SPECIAL FIELD PCA	30003-60002			
ARITHMETIC AND LOGIC UNIT PCA	30003-60003			
R-BUS PCA	30003-60004			
S-BUS PCA	30003-60005			
CONTROL INSTRUCTION REGISTER PCA	30003-60006			
MODULE CONTROL UNIT PCA	30003-60007			
INPUT/OUTPUT PROCESSOR PCA	30003-60008			
SYSTEM CONTROL PANEL (FRONT PANEL)	30003-60012			
MEMORY CONTROL LOGIC PCA	30007-60002			
SEMICONDUCTOR MEMORY ARRAY PCA	30008-60002			
FAULT CORRECTION ARRAY PCA	30009-60001			
FAULT LOGGING INTERFACE PACE	30009-60002			
EXTENDED INSTRUCTION SET PCA	30012-60001			
SELECTOR CHANNEL CONTROL PCA	30030-60003			
SELECTOR CHANNEL SEQUENCER PCA	30030-60011			
PORT CONTROLLER PCA	30030-60016			
SELECTOR CHANNEL REGISTER PCA	30030-60018			
SYSTEM CLOCK/CONSOLE INTERFACE PCA	30031-60001			
TERMINAL DATA INTERFACE PCA	30032-60001			
TERMINAL CONTROL INTERFACE PCA	30061-60001			
MULTIPLEXER CHANNEL PCA	30036-60001			
DIAGNOSTIC HARDWARE ASSEMBLY	30049-60003			
UNIVERSAL INTERFACE (TTL) PCA	30050-60001			
UNIVERSAL INTERFACE (DIFFERENTIAL) PCA	30051-60001			
SYNCHRONOUS SINGLE LINE CONTROLLER PCA	30055-60001			
DISC FILE READ/WRITE PCA	30202-60001			
DISC FILE BUS PCA	30202-60002			
DISC CONTROLLER PROCESSOR PCA	30202-60003			
CARTRIDGE DISC CONTROLLER INTERFACE	30229-60001			
DISC MEMORY CONTROLLER PCA	30203-60001			
DISC MEMORY DATA PCA	30203-60002			
CARD READER INTERFACE PCA	30206-60001			
CARTRIDGE DISC CONTROLLER PROCESSOR	30202-60003			
CARTRIDGE DISC CONTROLLER PCA	30210-60001			

Table D-4.

**RETURN EQUIPMENT CHECK LIST
SERIES II TO SERIES 44 UPGRADE INVENTORY (Cont.)**

COMPONENT	PART NO.	QTY.	FACTORY INSPECTION	
			REC'D	FACTORY TEST
MAGNETIC TAPE (9 TRACK) CONTROLLER PCA	30215-60006			
MAGNETIC TAPE CONTROLLER PROCESSOR PCA	30215-60002			
CARD READER/PUNCH INTERFACE PCA	30050-60008			
PLOTTER INTERFACE PCA	30226-60001			
HP 30310A POWER SUPPLY	30310-60024			
SEMICONDUCTOR MEMORY POWER SUPPLY	30311-60001			
POWER SUPPLY	30312-60001			
56" CABINET & DOORS	29402B			

This Return Equipment Checklist inventories the replaced equipment resulting from the upgrade of an HP 3000 Series II to Series 44. Please review the inventory for accuracy, then sign and date the Checklist.

The HP 3000 upgrade includes credit for the replaced equipment. This equipment is the property of Hewlett-Packard and must be returned within 30 days following installation of the upgrade. The Hewlett-Packard Sales Office will arrange shipment to Hewlett-Packard for the replaced equipment. If the equipment is not received within 30 days, Hewlett-Packard shall issue an invoice for these products subject to Hewlett-Packard's standard terms.

Signatures: _____ Date: _____
Customer Representative

_____ Date: _____
HP Customer Engineer

Note: Please include this Checklist with the returned equipment.

Table D-5.

RETURN EQUIPMENT CHECK LIST SERIES III TO SERIES 44 UPGRADE INVENTORY

FACTORY
INSPECTION

COMPONENT	PART NO.	QTY.	REC'D	FACTORY TEST
EXTENDED INSTRUCTION SET PCA	30012-60001			
READ ONLY MEMORY PCA	30003-60021			
SKIP AND SPECIAL FIELD PCA	30003-60022			
ARITHMETIC AND LOGIC UNIT PCA	30003-60003			
R-BUS PCA	30003-60004			
S-BUS PCA	30003-60025			
CONTROL INSTRUCTION REGISTER PCA	30003-60006			
MODULE CONTROL UNIT PCA	30003-60007			
INPUT/OUTPUT PROCESSOR PCA	30003-60028			
CPU BACKPLANE PCA	30003-60029			
MEMORY CONTROL & LOGGING PCA	30007-60005			
SEMICONDUCTOR MEMORY ARRAY PCA	30008-60003			
SYSTEM CONTROL PANEL (FRONT PANEL)	30003-60012			
SELECTOR CHANNEL PORT CONTROLLER PCA	30030-60020			
SELECTOR CHANNEL REGISTER PCA	30030-60021			
SELECTOR CHANNEL SEQUENCER PCA	30030-60011			
SELECTOR CHANNEL CONTROL PCA	30030-60003			
MULTIPLEXER CHANNEL PCA	30036-60002			
SYSTEM CLOCK/FAULT LOGGING INTERFACE	30135-60063			
OR				
SYSTEM CLOCK PCA	30031-60001			
FAULT LOGGING INTERFACE PCA	30009-60002			
TERMINAL DATA INTERFACE PCA	30032-60001			
TERMINAL CONTROL INTERFACE PCA	30061-60001			
UNIVERSAL INTERFACE (TTL) PCA	30050-60001			
UNIVERSAL INTERFACE (DIFFERENTIAL) PCA	30051-60001			
MAGNETIC TAPE CONTROLLER PCA	30215-60006			
MAGNETIC TAPE CONTROLLER PROCESSOR PCA	30215-60002			
CARTRIDGE DISC INTERFACE PCA	30229-60002			
ASYNCHRONOUS TERMINAL CONTROLLER PCA	30062-60017			
CARD READER INTERFACE PCA	30206-60001			
PLOTTER INTERFACE PCA	30226-60001			

Table D-5.

**RETURN EQUIPMENT CHECK LIST
SERIES III TO SERIES 44 UPGRADE INVENTORY (Cont.)**

				FACTORY INSPECTION
COMPONENT	PART NO.	QTY.	REC'D	FACTORY TEST
SYNCHRONOUS SINGLE LINE CONTROLLER PCA	30055-60001			
CARD READER/PUNCH INTERFACE PCA	30050-60008			
HARDWARE SERIAL INTERFACE PCA	30360-60001			
MAGNETIC TAPE DRIVE	7970E			
POWER SUPPLY	63312F-P02			
POWER SUPPLY	61315D-P07			
POWER SUPPLY	63312F-P09			
POWER SUPPLY	62605M-P41			
POWER SUPPLY	30310A			

This Return Equipment Checklist inventories the replaced equipment resulting from the upgrade of an HP 3000 Series III to Series 44. Please review the inventory for accuracy, then sign and date the Checklist.

The HP 3000 upgrade includes credit for the replaced equipment. This equipment is the property of Hewlett-Packard and must be returned within 30 days following installation of the upgrade. The Hewlett-Packard Sales Office will arrange shipment to Hewlett-Packard for the replaced equipment. If the equipment is not received within 30 days, Hewlett-Packard shall issue an invoice for these products subject to Hewlett-Packard's standard terms.

Signatures: _____ Date: _____
Customer Representative

_____ Date: _____
HP Customer Engineer

Note: Please include this Checklist with the returned equipment.

Table D-6

HP 300 TO SERIES 44 UPGRADE INVENTORY RETURN EQUIPMENT CHECKLIST

COMPONENT	PART NO.	QTY.	FACTORY INSPECTION	
			REC'D	FACTORY TEST
IDS Display Memory PCA	31000-60038			
IDS Display Processor PCA	31000-60039			
IDS Scan PCA	31000-60040			
CPU Processor PCA	31000-60052			
CPU Bus Interface PCA	31000-60053			
IDS Controller	31000-60075			
Memory Controller PCA	31202-60001			
128KB Array PCA	31204-60001			
FDU Control PCA	07902-60024			
DSU Control PCA	07910-60001 07910-60039			
DSU Analog PCA	07910-60003			

This Return Equipment Checklist inventories the replaced equipment resulting from the upgrade of an HP 300 to a HP 3000 Series 44. Please review the inventory for accuracy, then sign and date the Checklist.

The HP 3000 Series 44 upgrade includes credit for the replaced equipment. This equipment is the property of Hewlett-Packard and must be returned within 30 days following installation of the upgrade. The Hewlett-Packard Sales Office will arrange shipment to Hewlett-Packard for the replaced equipment. If the equipment is not received within 30 days, Hewlett-Packard shall issue an invoice for these products subject to Hewlett-Packard's standard terms.

Signatures: _____ Date: _____
Customer Representative

_____ Date: _____
HP Customer Engineer

Note: Please include this Checklist with the returned equipment.