



HEWLETT  
PACKARD

HP 3000  
and HP 9000  
PA-RISC  
Computer  
Systems

CE Handbook  
Series 9x7 Family and  
Model 8x7S Family

---

**HP 3000 and HP 9000 PA-RISC Computer Systems**

# **CE Handbook**

**Series 9x7 Family and Model 8x7S Family**



**HP Part No. A1707-90016  
Printed in U.S.A. 1992**

**Edition 2 - E0292  
For HP Internal Use Only**

---

## Notice

**Hewlett-Packard makes no warranty of any kind with regard to this material, including, but not limited to, the implied warranties of merchantability and fitness for a particular purpose.** Hewlett-Packard shall not be liable for errors contained herein or for incidental or consequential damages in connection with the furnishing, performance, or use of this material.

Hewlett-Packard assumes no responsibility for the use or reliability of its software on equipment that is not furnished by Hewlett-Packard.

This document contains proprietary information which is protected by copyright. All rights are reserved. No part of this document may be photographed, reproduced, or translated to another language without prior written consent of Hewlett-Packard Company.

The information contained in this document is subject to change without notice.

---

## Printing History

New editions are complete revisions of the manual. Update packages, which are issued between editions, contain additional and replacement pages to be merged into the manual by the customer. The dates on the title page change only when a new edition or a new update is published. No information is incorporated into a reprinting unless it appears as a prior update; the edition does not change when an update is incorporated.

Many product updates and fixes do not require manual changes and, conversely, manual corrections may be done without accompanying product changes. Therefore, do not expect a one-to-one correspondence between product updates and manual updates.

First Edition ..... August 1991  
Second Edition ..... February 1992

## List of Effective Pages

The List of Effective Pages gives the date of the current edition and of any pages changed in updates to that edition. Within the manual, any page changed since the last edition is indicated by printing the date the changes were made on the bottom of the page. No information is incorporated into a reprinting unless it appears as a prior update.

All ..... February 1992

---

## Safety and Regulatory Information

For your protection this product has been tested to various national and international regulations and standards. The scope of this regulatory testing includes electrical/mechanical safety, radio frequency interference, ergonomics, acoustics, and hazardous materials. Where required, approvals obtained from third-party test agencies are shown on the product label. In addition, various regulatory bodies require some information under the following headings.

### United Kingdom Telecom Statement (For the United Kingdom Only)

Pursuant to Section 22 of Telecommunications Act of 1984, this product is approved for indirect connection to Public Telecommunications systems within the United Kingdom under the General Approval number NS/G/1234/J/100003.

The following notice is required by the British Approvals Board for Telecoms (BABT). Please contact your HP Sales Office if there are any questions.

---

### Warning



**Interconnection directly, or by way of other apparatus, of ports marked with "United Kingdom Safety Warning: Refer to users instructions" with ports marked or not so marked may produce hazardous conditions on the telecom network. Advice should be obtained from a competent engineer before such a connection is made.**

---

To prevent an electrical shock to the operator, disconnect this product from the BT network before the mains plug is removed. Do not hard-wire the BT network connection.

The United Kingdom Safety Warning applies to all ports.

### Battery Notice

This product may contain a sealed Lead-Acid and a Lithium battery. Replace only with the same type and part number! Recycle used batteries or send to the following address for proper disposal:

Hewlett Packard  
Environmental Health and Safety Dept.  
8000 Foothills Blvd.  
Roseville, CA 95678

## TURVALLISUUSYHTEENVETO

### LASERTURVALLISUUS

#### LUOKAN 1 LASERLAITE KLASS 1 LASER APPARAT

HP 9000 Model 8x7S tietokoneisiin voidaan asentaa muistilaitteeksi laitteensisäinen CD-ROM-levyasema, joka on laserlaite. Tällöin myös päälaitteena toimiva tietokone katsotaan laserlaitteeksi.

Kyseinen CD-ROM-levyasema on käyttäjän kannalta turvallinen ruokan 1 laserlaite. Normaalisissa käytössä levyaseman suojakotelo estää lasersäteen pääsyn laitteen ulkopuolelle.

HP 9000 Model 8x7S-tietokoneet on tyyppihyväksynyt Suomessa laserturvallisuuden osalta Työsuojeluhallitus, Työsuojeluhallituksen hyväksyntänumero TSH 386/6019/91. Laitteiden turvallisuusluokka on määritetty valtioneuvoston päätöksen N:o 472/1985 ja standardin SFS-IEC 825 mukaisesti.

Tiedot CD-ROM-levyasemassa käytettävän laserdiodin säteilyominaisuuksista:

Aallonpituus 780 nm  
Teho 0,4 mW  
Luokan 1 laser

## Safety Considerations

This product and related documentation must be reviewed for familiarization with safety markings and instructions before operation. The following figure shows some of the safety symbols used on the product to indicate various safety considerations.



Instruction manual symbol: the product will be marked with this symbol when it is necessary for the user to refer to the instruction manual in order to protect the product against damage.



Indicates hazardous voltages.



Indicates earth (ground) terminal (sometimes used in manual to indicate circuit common connected to grounded chassis).

---

### Warning



**The WARNING sign denotes a hazard. It calls attention to a procedure, practice, of the like, which if not done correctly or adhered to, could result in injury. Do not proceed beyond a WARNING sign until the indicated conditions are fully understood and met.**

---

### Caution



The CAUTION sign denotes a hazard. It calls attention to an operating procedure, practice, of the like, which if not done correctly or adhered to, could damage or destroy part or all of the product. Do not proceed beyond a CAUTION sign until the indicated conditions are fully understood and met.

---

---

## Preface

This edition of the *CE Handbook* contains technical information about HP 3000 Series 9x7 Family and HP 9000 Model 8x7 Family Computer Systems. At the time of publication, this family included the following models:

HP 3000	HP 9000
Series 917LX	Model 807S
Series 927LX	Model 817S
Series 937LX	Model 827S
Series 947LX	Model 837S
Series 957LX	Model 847S
Series 967LX	Model 857S
Series 937	Model 867S
Series 947	Model 877S
Series 957	
Series 967	
Series 977	





# Contents

---

<b>1. Product Information</b>	
General Description . . . . .	1-1
Major Assemblies . . . . .	1-6
Multifunction I/O Card Connection . . . . .	1-9
System Operation . . . . .	1-10
Introduction . . . . .	1-10
System Status Displays . . . . .	1-10
System Front Panel and Status Displays . . . . .	1-10
DDS Front Panels and Status Displays . . . . .	1-13
Ordering HP DDS cassettes . . . . .	1-15
CD-ROM Front Panel and Status Displays . . . . .	1-17
Quarter-inch Cartridge (QIC) Tape Drive Front Panel and Status Displays . . . . .	1-18
Processor Dependent Code (PDC) Commands . . . . .	1-19
Access Port Commands . . . . .	1-20
Normal Power-on Sequence . . . . .	1-21
<b>2. Environmental Information</b>	
Specifications . . . . .	2-1
<b>3. Installation and Preventive Maintenance</b>	
Introduction . . . . .	3-1
Stand-alone System Installation . . . . .	3-3
Rack System Installation . . . . .	3-3
A-Series Rack Installation . . . . .	3-3
C-Series Rack Installation . . . . .	3-4
Preventive Maintenance . . . . .	3-4
Quarter-inch Cartridge (QIC) Tape Drive Maintenance . . . . .	3-4
Read/Write Head Cleaning Procedure . . . . .	3-4
Capstan Cleaning Procedure . . . . .	3-5
<b>4. Configuration</b>	
I/O Slot Configurations and Restrictions . . . . .	4-1
Multifunction I/O Card Configuration . . . . .	4-5
SCSI Configuration . . . . .	4-5
LAN Configuration . . . . .	4-5
SCSI Configuration Rules . . . . .	4-8
HP-IB Configuration Rules . . . . .	4-12
Load Factors . . . . .	4-12
HP-IB Cable Length . . . . .	4-12
Memory Subsystem Configuration . . . . .	4-13
Overview . . . . .	4-13
Memory Configuration Rules . . . . .	4-13

Remote Support Modem Configuration . . . . .	4-15
HP Support Link (HP50759A) . . . . .	4-15
Hayes Smartmodem 2400 . . . . .	4-16
Black Box V.32 Plus (Version 2.01.01) . . . . .	4-17
Multitech MT224EH7 . . . . .	4-18
HP 37212B . . . . .	4-20
Modem Cable Pin-out . . . . .	4-21
Multifunction I/O PCA Modem Line Behavior . . . . .	4-21
CCITT Mode - AP protocol 0 . . . . .	4-21
Bell Mode - AP protocol 1 . . . . .	4-21
CCITT_BIS Mode - AP protocol 2 . . . . .	4-21
Determining Hardware Device Paths . . . . .	4-22
5.25-inch Hard Disk Drive Configuration . . . . .	4-24
Options . . . . .	4-24
SCSI Address . . . . .	4-27
Status Indicator Connector . . . . .	4-30
3.5-inch Hard Disk Drive Configuration . . . . .	4-31
Options . . . . .	4-31
SCSI Address . . . . .	4-31
Status Indicator Connector . . . . .	4-31
5.25-inch DDS-Format DAT Drive Configuration (C1502A) . . . . .	4-38
SCSI Address . . . . .	4-38
Orientation Switch . . . . .	4-39
3.5-inch DDS-Format DAT Drive Configuration (C1503B) . . . . .	4-40
Options . . . . .	4-40
SCSI Address . . . . .	4-40
Optional Configuration Jumper Switch . . . . .	4-42
3.5-inch DDS-Format DAT Drive Configuration (C1504B) . . . . .	4-43
CD-ROM Drive Configuration . . . . .	4-44
Options . . . . .	4-44
SCSI Address . . . . .	4-44
Quarter-inch Cartridge (QIC) Tape Drive Configuration . . . . .	4-47
Cabinet Configuration Rules . . . . .	4-48
<b>5. Troubleshooting</b>	
Introduction . . . . .	5-1
Troubleshooting Flowcharts . . . . .	5-4
Error Codes and Messages . . . . .	5-11
Introduction . . . . .	5-11
PDC Codes . . . . .	5-11
IODC Codes and Messages . . . . .	5-16
ISL Boot Codes . . . . .	5-16
HP-UX ISL Boot Codes . . . . .	5-16
MPE/iX ISL Boot Codes . . . . .	5-17
MPE/iX Operating System Halts . . . . .	5-18
HP-UX Operating System Errors . . . . .	5-24
HP-UX System Panic Codes . . . . .	5-24
HP-UX OS Display Codes . . . . .	5-25
Access Port Error Messages . . . . .	5-27
Informational messages . . . . .	5-29
SCSI/Console/LAN PCA Access Port Error Codes . . . . .	5-30

Integrated Access Port Selftest Failure Codes . . . . .	5-31
Error Logs . . . . .	5-33
HPMC Error Logs . . . . .	5-33
System Log File Procedure . . . . .	5-34
Multifunction I/O Card Status LEDs . . . . .	5-36
Troubleshooting SCSI Problems . . . . .	5-38
3.5-inch and 5.25-inch Hard Disk Drive Troubleshooting . . . . .	5-39
Drive Status Light . . . . .	5-39
Diagnostic Information . . . . .	5-40
Logs . . . . .	5-40
Usage Log . . . . .	5-40
Data Error Log . . . . .	5-42
Hardware Error Log . . . . .	5-42
REQUEST SENSE Data Fields . . . . .	5-43
3.5-inch and 5.25-inch DDS-Format DAT Drive Troubleshooting . . . . .	5-52
Status Lights . . . . .	5-54
5.25-inch DDS-Format DAT Drive Status Lights . . . . .	5-54
3.5-inch DDS-Format DAT Drive Status Lights . . . . .	5-54
Solving Media Warning Problems . . . . .	5-55
Solving High Humidity Problems . . . . .	5-55
Removing a Jammed Cassette From a 5.25-inch DDS-Format Drive . . . . .	5-56
Removing a Jammed Cassette From a 3.5-inch DDS-Format Drive . . . . .	5-58
Diagnostic Information . . . . .	5-60
Logs . . . . .	5-60
Fault Log . . . . .	5-60
Error Rate Log . . . . .	5-60
Tape Log . . . . .	5-60
REQUEST SENSE Data Fields . . . . .	5-60
CD-ROM Drive Troubleshooting . . . . .	5-73
Drive Status Light . . . . .	5-73
Diagnostic Information . . . . .	5-73
REQUEST SENSE Data Fields . . . . .	5-73
Quarter-inch Cartridge (QIC) Tape Drive Troubleshooting . . . . .	5-76
QIC Troubleshooting Tools . . . . .	5-76
Troubleshooting Sequence . . . . .	5-76
<b>6. Diagnostics and Utilities</b>	
Online Diagnostics and Utilities . . . . .	6-2
Using the Online Diagnostics . . . . .	6-3
Offline Utilities . . . . .	6-3
Support Tape . . . . .	6-3
Booting Up . . . . .	6-3
Support Tape Main/Utilities Menus . . . . .	6-5

<b>7. Supported Peripherals</b>	
Disk Drives . . . . .	7-2
Tape Drives . . . . .	7-3
Printers . . . . .	7-5
Terminals . . . . .	7-7
Plotters . . . . .	7-8
Data Communication Devices . . . . .	7-9
Other Peripherals . . . . .	7-10
<b>8. Replaceable Parts</b>	
Introduction . . . . .	8-1
Parts List . . . . .	8-2
Rack-Mount Cabinet Replaceable Parts . . . . .	8-6
Removal and Replacement . . . . .	8-7
Before You Begin Removal Procedures . . . . .	8-7
Required Tools . . . . .	8-8
System Identification . . . . .	8-8
Turn Off System . . . . .	8-10
Standard Chassis Removal Procedures . . . . .	8-11
Remove Front Bezel . . . . .	8-11
Remove Peripherals . . . . .	8-13
Remove Peripheral Drawer . . . . .	8-13
Remove 5.25-inch Digital Data Storage (DDS) Device . . . . .	8-16
Remove Internal 5.25-inch Disk . . . . .	8-19
Remove 3.5-inch Digital Data Storage (DDS) Device . . . . .	8-20
Remove CD-ROM . . . . .	8-23
Remove Quarter-inch Cartridge Tape Driver (QIC) . . . . .	8-26
Remove Internal 3.5-inch Disks . . . . .	8-29
Remove Power Supply . . . . .	8-33
Power Supply Control PCA Connectors . . . . .	8-33
Remove Power Supply Battery . . . . .	8-36
Remove Filler Panels . . . . .	8-37
Remove I/O PCAs . . . . .	8-38
Remove Multifunction I/O PCA . . . . .	8-39
Remove Rear Bezel . . . . .	8-40
Remove Cover Plate . . . . .	8-41
Remove Processor PCA . . . . .	8-42
Remove Memory Extender and Memory PCAs . . . . .	8-44
Remove Backplane . . . . .	8-46
Remove Left and Right Side Panels . . . . .	8-49
Remove Light Pipes . . . . .	8-50
Remove DC On/Off Switch . . . . .	8-51
Standard Chassis Replacement Procedures . . . . .	8-52
Expanded Chassis Removal Procedures . . . . .	8-52
Remove Front Bezel . . . . .	8-53
Remove Peripherals . . . . .	8-54
Remove Left Peripheral Drawer . . . . .	8-54
Remove Right Peripheral Drawer . . . . .	8-56
Remove Power Supplies . . . . .	8-57
Power Supply Control PCA Connectors . . . . .	8-57
Remove Left Power Supply . . . . .	8-58

Remove Right Power Supply . . . . .	8-58
Remove Power Supply Battery . . . . .	8-60
Remove Filler Panels . . . . .	8-61
Remove I/O PCAs . . . . .	8-62
Remove Multifunction I/O PCA . . . . .	8-63
Remove Rear Bezel . . . . .	8-64
Remove Cover Plate . . . . .	8-65
Remove Processor PCA . . . . .	8-66
Remove Memory Extender and Memory PCAs . . . . .	8-68
Remove Backplane . . . . .	8-70
Expanded Chassis Replacement Procedures . . . . .	8-72
Quick Reference Removal Procedures . . . . .	8-73
Backplane Removal . . . . .	8-73
Digital Data Storage (DDS) Removal . . . . .	8-73
Internal Disk Removal . . . . .	8-73
CD-ROM Removal . . . . .	8-73
QIC Removal . . . . .	8-73
Light Pipe Removal . . . . .	8-74
Memory PCA Removal . . . . .	8-74
Power Supply Removal . . . . .	8-74
Processor PCA Removal . . . . .	8-74
Floating Point Chip Installation and Removal . . . . .	8-75
Install Floating Point Chip . . . . .	8-75
Verify Floating Point Chip Installation . . . . .	8-77
Remove Floating Point Chip . . . . .	8-78
Internal Peripheral Assembly and Disassembly . . . . .	8-79
5.25-inch Hard Disk Drive Assembly and Disassembly . . . . .	8-79
Replaceable Assemblies . . . . .	8-79
Disk Mechanism . . . . .	8-79
SCSI Controller PCA . . . . .	8-79
Firmware ROM . . . . .	8-82
3.5-inch Hard Disk Drive Assembly and Disassembly . . . . .	8-83
Replaceable Assemblies . . . . .	8-83
Disk Mechanism . . . . .	8-83
SCSI Controller PCA . . . . .	8-83
Firmware ROM . . . . .	8-86
5.25-inch DDS-Format DAT Drive Assembly and Disassembly . . . . .	8-86
3.5-inch DDS-Format DAT Drive Assembly and Disassembly . . . . .	8-87
Replaceable Assemblies . . . . .	8-87
Front Panel . . . . .	8-88
CD-ROM Drive Assembly and Disassembly . . . . .	8-89
Laser Safety . . . . .	8-89
Handling Precautions . . . . .	8-89
Replaceable Assemblies . . . . .	8-89
Front Panel . . . . .	8-90
Door . . . . .	8-91
Cabinet Removal and Replacement . . . . .	8-92
Removal and Replacement Procedures . . . . .	8-95
Rear Door . . . . .	8-95
Top Cap . . . . .	8-95
Side Cover . . . . .	8-95

Forehead Assembly . . . . .	8-96
Base Cover . . . . .	8-96
Rear Door Hinge . . . . .	8-97
Rail Assembly . . . . .	8-97
Fan Assembly . . . . .	8-97
Fan . . . . .	8-99
PDU . . . . .	8-100
Cabinet Leveler or Caster . . . . .	8-101
Magnetic Door Catch . . . . .	8-102
Door Bumper . . . . .	8-102
<b>9. Functional Description</b>	
Introduction . . . . .	9-1
Hardware Components . . . . .	9-1
System Power . . . . .	9-1
Power-on Sequence . . . . .	9-4
Over-temperature Detection . . . . .	9-4
Single Power System Error Detection . . . . .	9-4
Dual Power System Error Detection . . . . .	9-4
Power Fail with Battery . . . . .	9-4
Power Fail without Battery . . . . .	9-5
CPU PCA . . . . .	9-5
Processor-Dependent Hardware (PDH) . . . . .	9-8
Processor Dependent Code (PDC) . . . . .	9-8
Stable Storage . . . . .	9-8
Real-Time Clock (RTC) . . . . .	9-9
Non-Volatile Memory (NVM) . . . . .	9-9
Memory Subsystem . . . . .	9-9
Memory and I/O Controller Chip . . . . .	9-11
Backplane PCA . . . . .	9-11
Memory Extender . . . . .	9-12
Memory Array PCA . . . . .	9-12
Memory Array Controller . . . . .	9-12
System Startup Overview . . . . .	9-12
I/O Subsystem . . . . .	9-13
Hewlett-Packard Precision Bus (HP-PB) . . . . .	9-14
HP-PB Device Adapters . . . . .	9-14
Precision Bus Adapter . . . . .	9-14
SCSI Bus Description . . . . .	9-15
SCSI Bus Termination Requirements . . . . .	9-16
SCSI Single-Ended Pin Assignments . . . . .	9-18
Access Port . . . . .	9-19
General Description . . . . .	9-19
Access Port Operation . . . . .	9-19
Local/Remote Console . . . . .	9-19
Access Port Functions . . . . .	9-19
Access Port Modes . . . . .	9-19
Session Mode . . . . .	9-19
Console Mode . . . . .	9-19
Control Mode . . . . .	9-19
Integrated Access Port Commands . . . . .	9-20

Access Port Commands Overview . . . . .	9-20
Access Port Command Description . . . . .	9-21
CA: Configure Remote Support Modem Port . . . . .	9-21
CO: Return to Console Mode . . . . .	9-21
CS: Copy Local Console Screen . . . . .	9-21
DI: Disconnect Remote Console . . . . .	9-22
DR: Disable Remote Operator Access . . . . .	9-22
DS: Disable SPU Status Display . . . . .	9-22
ER: Enable Remote Operator Access . . . . .	9-22
ES: Enable SPU Status Display . . . . .	9-23
HE: Print Help Menu . . . . .	9-23
LR: Lock Remote Support Modem Access . . . . .	9-24
RS: Reset SPU . . . . .	9-25
SE: Enter Session Mode On Remote Port . . . . .	9-25
TC: Initiate Transfer Of Control . . . . .	9-25
TA: Initiate IAP Self-Test . . . . .	9-25
TE: Tell . . . . .	9-26
UR: Unlock Remote Support Modem Access . . . . .	9-26
Access Port Special Characters . . . . .	9-27
Special Characters Description . . . . .	9-27
^^B: Enter Control Mode . . . . .	9-27
^^Q: XON Pacing Character . . . . .	9-27
^^S: XOFF Pacing Character . . . . .	9-27
^^V: Escape Character . . . . .	9-27
BREAK: Change Console Keyboard Master . . . . .	9-28
IAP Initiated Self Tests . . . . .	9-28

<b>10. Reference</b>	
HP System Acronyms . . . . .	10-1

**11. Service Notes**

**Index**



## Figures

---

1-1. HP 3000 Series 9x7 Family and HP 9000 Model 8x7S Family Systems . . . . .	1-2
1-2. Standard Chassis Major Assemblies - Front . . . . .	1-7
1-3. Standard Chassis Major Assemblies - Rear . . . . .	1-8
1-4. Multifunction I/O Card Connector Layout . . . . .	1-9
1-5. System Front Panel Switches and Indicators . . . . .	1-10
1-6. Front Panel and System Console Indicators . . . . .	1-12
1-7. HP C1502A 5.25-inch DDS-Format Tape Drive Front Panel . . . . .	1-13
1-8. HP C1503B and C1504B 3.5-inch DDS-Format Tape Drive Front Panel . . . . .	1-13
1-9. CD-ROM Drive Front Panel . . . . .	1-17
1-10. Quarter-inch Cartridge (QIC) Tape Drive Front Panel . . . . .	1-18
2-1. 2-Slot Chassis Backplane Layout and Minimum Load . . . . .	2-4
2-2. 6-Slot Chassis Backplane Layout and Minimum Load . . . . .	2-8
2-3. 12-Slot Chassis Backplane Layout and Minimum Load . . . . .	2-8
4-1. HP 3000 Series 9x7 Multifunction I/O Card Layout . . . . .	4-6
4-2. HP 9000 Series 8x7 Multifunction I/O Card Layout . . . . .	4-7
4-3. Standard Chassis Internal SCSI Cabling and Configuration . . . . .	4-10
4-4. Typical External SCSI Device Rear Panel and Switch Configuration . . . . .	4-10
4-5. Standard Chassis External SCSI Cabling and Configuration . . . . .	4-11
4-6. HP-IB Configuration Example . . . . .	4-12
4-7. Memory System Slot Locations . . . . .	4-14
4-8. Memory System Slot Locations - 64 MHz Backplane . . . . .	4-14
4-9. Option Connector 1 Pin-sets, Revision B . . . . .	4-25
4-10. Option Connector 2 Pins and Pin-sets, Revision B . . . . .	4-28
4-11. Status Indicator Connector Configurations . . . . .	4-30
4-12. Type 1 Controller Default Configuration, Revision A . . . . .	4-32
4-13. Option Pin-sets, Revision A . . . . .	4-33
4-14. Pin-sets, Option Connectors 1 and 2, Revision B . . . . .	4-34
4-15. Pins and Pin-sets, Option Connector 3, Revision B . . . . .	4-36
4-16. Setting the DAT Drive SCSI Address . . . . .	4-38
4-17. DAT Drive Orientation Switches . . . . .	4-39
4-18. Option Connector Pin-sets and SCSI Address Options . . . . .	4-41
4-19. Optional Configuration Jumper Switch . . . . .	4-42
4-20. Configuration Pin-sets . . . . .	4-45
4-21. QIC Tape Drive Controller PCA Configuration . . . . .	4-47
4-22. QIC Tape Drive Motor Driver PCA Configuration . . . . .	4-48
4-23. 1.6 Meter Cabinet Configuration Example . . . . .	4-49
4-24. 1.1 Meter Cabinet Configuration Example . . . . .	4-50
5-1. Power System Troubleshooting Flowchart (page 1 of 2) . . . . .	5-5
5-1. Power System Troubleshooting Flowchart (page 2 of 2) . . . . .	5-6
5-2. Bus Error Troubleshooting Flowchart . . . . .	5-7
5-3. PCA Troubleshooting Flowchart . . . . .	5-8
5-4. Internal Disk Troubleshooting Flowchart . . . . .	5-9

5-5. MPE/iX Operating System Troubleshooting Flowchart . . . . .	5-10
5-6. Multifunction I/O Card Status LEDs . . . . .	5-36
5-7. Internal Disk Termination Resistor Orientation . . . . .	5-39
5-8. DDS Drive Troubleshooting Flowchart . . . . .	5-53
5-9. HP C1502A 5.25-inch DDS-Format DAT Drive Front Panel . . . . .	5-54
5-10. HP C1503B and C1504B 3.5-inch DDS-Format DAT Drive Front Panel . . . . .	5-54
5-11. Manually Unthreading a DAT Tape . . . . .	5-57
5-12. Manually Ejecting a DAT Tape . . . . .	5-57
5-13. Manually Ejecting a DDS Tape . . . . .	5-59
8-1. Thread-forming TORX Chassis Screw . . . . .	8-7
8-2. HP 3000 Series 9x7 and HP 9000 Series 8x7 Standard System . . . . .	8-9
8-3. HP 3000 Series 9x7 and HP 9000 Series 8x7 Expanded System . . . . .	8-10
8-4. Standard Chassis Front Bezel Removal . . . . .	8-12
8-5. Peripheral Drawer Removal . . . . .	8-14
8-6. 5.25-inch Digital Data Storage (DDS) Device and Disk Cabling . . . . .	8-15
8-7. Digital Data Storage (DDS) Device EMI Clips . . . . .	8-17
8-8. 5.25-inch Digital Data Storage (DDS) Device Removal . . . . .	8-18
8-9. Internal 5.25-inch Disk Removal . . . . .	8-19
8-10. 3.5-inch Digital Data Storage (DDS) Device Cabling . . . . .	8-21
8-11. 3.5-inch Digital Data Storage (DDS) Device Removal . . . . .	8-22
8-12. CD-ROM Cabling . . . . .	8-24
8-13. CD-ROM Removal . . . . .	8-25
8-14. QIC Cabling . . . . .	8-27
8-15. QIC Removal . . . . .	8-28
8-16. Internal Disk Cabling . . . . .	8-30
8-17. Internal Disk Carrier Removal . . . . .	8-31
8-18. Internal Disk Removal . . . . .	8-32
8-19. Power Supply Removal . . . . .	8-34
8-20. Power Supply Control PCA Connectors . . . . .	8-35
8-21. Power Supply Battery Removal . . . . .	8-36
8-22. Filler Panel Removal . . . . .	8-37
8-23. I/O PCA Removal . . . . .	8-38
8-24. Multifunction I/O PCA Removal . . . . .	8-39
8-25. Rear Bezel Removal . . . . .	8-40
8-26. Cover Plate Removal . . . . .	8-41
8-27. Processor PCA Removal . . . . .	8-43
8-28. Standard Memory Extender and Memory PCA Removal . . . . .	8-44
8-29. 64 MHz Memory Extender and Memory PCA Removal . . . . .	8-45
8-30. Backplane Retaining Clip Removal . . . . .	8-47
8-31. Backplane Removal . . . . .	8-48
8-32. Left and Right Side Panel Removal . . . . .	8-49
8-33. Light Pipe Removal . . . . .	8-50
8-34. DC On/Off Switch Removal . . . . .	8-51
8-35. Expanded Chassis Front Bezel Removal . . . . .	8-53
8-36. Left Peripheral Drawer Removal . . . . .	8-55
8-37. Right Peripheral Drawer Removal . . . . .	8-56
8-38. Power Supply Control PCA Connectors . . . . .	8-58
8-39. Power Supply Removal . . . . .	8-59
8-40. Power Supply Battery Removal . . . . .	8-60
8-41. Filler Panel Removal . . . . .	8-61
8-42. I/O PCA Removal . . . . .	8-62

8-43. Multifunction I/O PCA Removal . . . . .	8-63
8-44. Rear Bezel Removal . . . . .	8-64
8-45. Cover Plate Removal . . . . .	8-65
8-46. Processor PCA Removal . . . . .	8-67
8-47. Standard Memory Extender and Memory PCA Removal . . . . .	8-68
8-48. 64 MHz Memory Extender and Memory PCA Removal . . . . .	8-69
8-49. Backplane Retaining Clip Removal . . . . .	8-71
8-50. Backplane Removal . . . . .	8-72
8-51. Processor PCA Layout . . . . .	8-75
8-52. Jumpers . . . . .	8-76
8-53. Floating Point Chip Alignment . . . . .	8-76
8-54. Mount Heat Sink on Floating Point Chip . . . . .	8-77
8-55. Floating Point Chip Removal . . . . .	8-78
8-56. Replacing the SCSI Controller PCA . . . . .	8-81
8-57. ROM Socket . . . . .	8-82
8-58. Replacing the SCSI Controller PCA . . . . .	8-85
8-59. Firmware ROM Socket . . . . .	8-86
8-60. Removing the Front Panel . . . . .	8-88
8-61. Removing the Front Panel . . . . .	8-90
8-62. Removing the CD-ROM Door . . . . .	8-91
8-63. Cabinet Exploded View Front . . . . .	8-93
8-64. Cabinet Exploded View Rear . . . . .	8-94
8-65. Fan Assembly . . . . .	8-98
8-66. Fan Diagram . . . . .	8-100
9-1. HP 3000 and HP 9000 System Block Diagram . . . . .	9-2
9-2. Power System Block Diagram . . . . .	9-3
9-3. CPU PCA Block Diagram . . . . .	9-6
9-4. Memory Block Diagram - Standard and Expanded Chassis . . . . .	9-10
9-5. Memory Array PCA Block Diagram . . . . .	9-11
9-6. I/O Subsystem Block Diagram . . . . .	9-13
9-7. Precision Bus Adapter Block Diagram . . . . .	9-14
9-8. Precision Bus Adapter . . . . .	9-15
9-9. Internal SCSI Bus with no External Devices . . . . .	9-17
9-10. Internal SCSI Bus with one External Device . . . . .	9-17
9-11. Internal SCSI Bus with two External Devices . . . . .	9-18

## Tables

---

1-1. HP 3000 Series 9x7LX Standard Chassis Description . . . . .	1-3
1-2. HP 3000 Series 9x7 Expanded Chassis Description . . . . .	1-4
1-3. HP 9000 Model 8x7S Description . . . . .	1-5
1-4. Operating State Indicators . . . . .	1-11
1-5. HP C1502A 5.25-inch DDS-Format Tape Drive . . . . .	1-14
1-6. HP C1503B and C1504B 3.5 inch DDS-Format Tape Drive . . . . .	1-15
1-7. DDS Tape Requirements . . . . .	1-16
1-8. Drive Status Light Indications . . . . .	1-17
1-9. QIC Tape Drive Read and Write Formats . . . . .	1-18
1-10. QIC Device Files and Formats . . . . .	1-19
1-11. PDC Commands . . . . .	1-19
1-12. Access Port Command Summary . . . . .	1-20
1-13. Normal Power-On Sequence . . . . .	1-21
2-1. Environmental Specifications . . . . .	2-1
2-2. 2-Slot Chassis Power Specifications . . . . .	2-2
2-3. 2-Slot Chassis DC Power Specifications <sup>3</sup> . . . . .	2-3
2-4. Electromagnetic Susceptibility Specifications . . . . .	2-3
2-5. 2-Slot Chassis Physical Specifications . . . . .	2-3
2-6. 6-Slot Chassis Power Specifications <sup>1</sup> . . . . .	2-5
2-7. 12-Slot Chassis Power Specifications <sup>1</sup> . . . . .	2-6
2-8. 6-Slot and 12-Slot Chassis DC Power Specifications <sup>1</sup> . . . . .	2-7
2-9. 6-Slot and 12-Slot Chassis Physical Specifications . . . . .	2-7
3-1. Recommended Preventive Maintenance Schedule . . . . .	3-4
4-1. 2-Slot System Power Supply Current Budgeting <sup>1</sup> . . . . .	4-2
4-2. 6-Slot and 12-Slot System Power Supply Current Budgeting (Slots 1 - 10) <sup>1</sup> . . . . .	4-3
4-3. 12-Slot System Power Supply Current Budgeting (Slots 11 and 12) <sup>1</sup> . . . . .	4-4
4-4. I/O Card Configuration Guidelines . . . . .	4-5
4-5. SCSI Cable Lengths . . . . .	4-8
4-6. SCSI Bus Specifications . . . . .	4-9
4-7. 8-Position DIP Switch Option Settings . . . . .	4-16
4-8. 4-Position DIP Switch Option Settings . . . . .	4-16
4-9. Switch Option Settings . . . . .	4-17
4-10. Slot Path Addresses and Device Path Addresses . . . . .	4-22
4-11. Slot 13 and 14 Path Addresses for Multifunction I/O Cards . . . . .	4-23
4-12. Option Connector 1 Settings for 8x7S and 9x7 Systems . . . . .	4-25
4-13. Option Connector 1 Functions . . . . .	4-26
4-14. Option Connector 2 Settings for 8x7S and 9x7 Systems . . . . .	4-28
4-15. Option Connector 2 Functions . . . . .	4-29
4-16. Option Settings for 8x7S and 9x7 Systems . . . . .	4-33
4-17. Option Connector 1 and 2 Settings for 8x7S and 9x7 Systems . . . . .	4-34
4-18. Pin-set Functions, Option Connectors 1 and 2, Revision B . . . . .	4-35
4-19. Option Connector 3 Settings for 8x7S and 9x7 Systems . . . . .	4-36
4-20. Pin-set Functions, Option Connector 3, Revision B . . . . .	4-37

4-21. Option Connector Settings for 8x7S and 9x7 Systems . . . . .	4-41
4-22. Configuration Settings for 8x7S and 9x7 Systems . . . . .	4-45
4-23. Option Connector Pin-set Functions . . . . .	4-46
5-1. States of Operation . . . . .	5-1
5-2. System Troubleshooting Reference Guide . . . . .	5-2
5-3. PDC Selftest and Diagnostic Test Section Summary . . . . .	5-11
5-4. PDC Status and Error Codes . . . . .	5-12
5-5. HPMC Error Halt Codes . . . . .	5-12
5-6. CPU/TLB Self-test Error Codes . . . . .	5-13
5-7. Cache Self-test Error Codes . . . . .	5-14
5-8. PDC Floating Point Coprocessor Selftest Error Codes . . . . .	5-14
5-9. Bus Self-test Transactions . . . . .	5-14
5-10. Stable Store, ROM, and EEPROM Error Code . . . . .	5-15
5-11. Memory Subsystem Self-test Error Codes and Slot Numbers . . . . .	5-15
5-12. I/O Device Error Codes . . . . .	5-15
5-13. ISL Boot Codes . . . . .	5-16
5-14. HP-UX ISL Boot Codes . . . . .	5-16
5-15. MPE/iX ISL Boot Codes . . . . .	5-17
5-16. MPE/iX System Initialization Codes . . . . .	5-17
5-17. MPE/iX Halt 0 Operating System Error Codes . . . . .	5-20
5-18. MPE/iX Halt 7 Operating System Error Codes . . . . .	5-23
5-19. HP-UX System Initialization Codes . . . . .	5-25
5-20. HP-UX System Panic Codes . . . . .	5-25
5-21. HP-UX System Shutdown Codes . . . . .	5-25
5-22. HP-UX System Run Codes . . . . .	5-26
5-23. TA Command Tests and Power-on Selftests . . . . .	5-30
5-24. Selftest Failure Codes . . . . .	5-31
5-25. Integrated Access Port Selftest Failure Codes . . . . .	5-32
5-26. Multifunction I/O Card Status LEDs . . . . .	5-37
5-27. ADP Panel Status LEDs . . . . .	5-37
5-28. Status Light Indications . . . . .	5-40
5-29. Hard Disk Drive Access Count Range Values . . . . .	5-41
5-30. Hard Disk Drive Error Type and Error Byte . . . . .	5-42
5-31. REQUEST SENSE Data Format . . . . .	5-43
5-32. Sense Key Codes . . . . .	5-45
5-33. Additional Sense Codes . . . . .	5-46
5-34. Vendor Unique ESDI Status Codes . . . . .	5-47
5-35. Device Error Codes ESDI Status Byte 25 . . . . .	5-51
5-36. Device Error Codes SCSI Status Bytes 26, 27 . . . . .	5-51
5-37. DDS-Format DAT Drive REQUEST SENSE Extended Data Format . . . . .	5-61
5-38. Sense Key Codes . . . . .	5-64
5-39. Additional Sense Codes/Additional Sense Code Qualifiers . . . . .	5-65
5-40. Drive Error Codes . . . . .	5-67
5-41. Drive Status Light Indications . . . . .	5-73
5-42. REQUEST SENSE Data Format . . . . .	5-74
5-43. Sense Key Codes . . . . .	5-74
5-44. Additional Sense Codes . . . . .	5-75
5-45. Recommended Preventive Maintenance Schedule . . . . .	5-76
7-1. Supported External Disk Drives . . . . .	7-2
7-2. Supported Internal Disk Drives . . . . .	7-3
7-3. Other Supported Mass Storage Peripherals . . . . .	7-3

7-4. Supported Internal Tape Drives . . . . .	7-3
7-5. Supported External Tape Drives . . . . .	7-4
7-6. Supported Centronics/Parallel Printers . . . . .	7-5
7-7. Supported Printers . . . . .	7-6
7-8. Supported Terminals . . . . .	7-7
7-9. Supported Terminals as Consoles . . . . .	7-7
7-10. Supported Plotters . . . . .	7-8
7-11. Supported Data Communication Devices . . . . .	7-9
7-12. Supported PCAs . . . . .	7-10
7-13. Other Supported Peripherals . . . . .	7-11
8-1. Replaceable Parts . . . . .	8-2
8-2. HP 3000 Series 9x7 Boards . . . . .	8-5
8-3. HP 9000 Model 8x7S Boards . . . . .	8-5
8-4. Rack-mount Cabinet Replaceable Parts . . . . .	8-6
8-5. Floating Point Chips and CPU Boards . . . . .	8-75
9-1. Power System Signals . . . . .	9-3
9-2. PDC Commands . . . . .	9-8
9-3. SCSI Bus Specifications . . . . .	9-16
9-4. SCSI Connector (J1) Single-Ended Pin Assignments . . . . .	9-18
9-5. Access Port Command Summary . . . . .	9-20
9-6. Access Port Special Character Summary . . . . .	9-27
10-1. HP System Acronyms . . . . .	10-1



## Product Information

---

### General Description

The HP 3000 Series 9x7 Family and the HP 9000 Model 8x7S Family computers are shown in Figure 1-1. The standard chassis is shown on the right. The expanded chassis is shown on the left. The standard chassis systems have two I/O slots. The expanded chassis systems have two configurations - 6 and 12 I/O slots.

The basic system is made up of a processor PCA, memory, power supply, backplane, Multifunction I/O card, one or more disks, and a DDS-format tape drive. It can include a CD-ROM drive. It can also include a Quarter-inch Cartridge (QIC) tape drive. The electrical and environmental specifications, functional description, and troubleshooting are similar for all models.

HP 3000 models use the MPE-iX operating system. Table 1-1 summarizes the characteristics of the HP 3000 standard chassis systems. Table 1-2 summarizes the characteristics of the expanded chassis systems. Table 8-2 lists the backplane, processor, and multifunction I/O card of each of the HP 3000 systems.

HP 9000 models use the HP-UX operating system. Table 1-3 summarizes the characteristics of the HP 9000 standard and expanded chassis systems.



**For HP Internal Use Only**

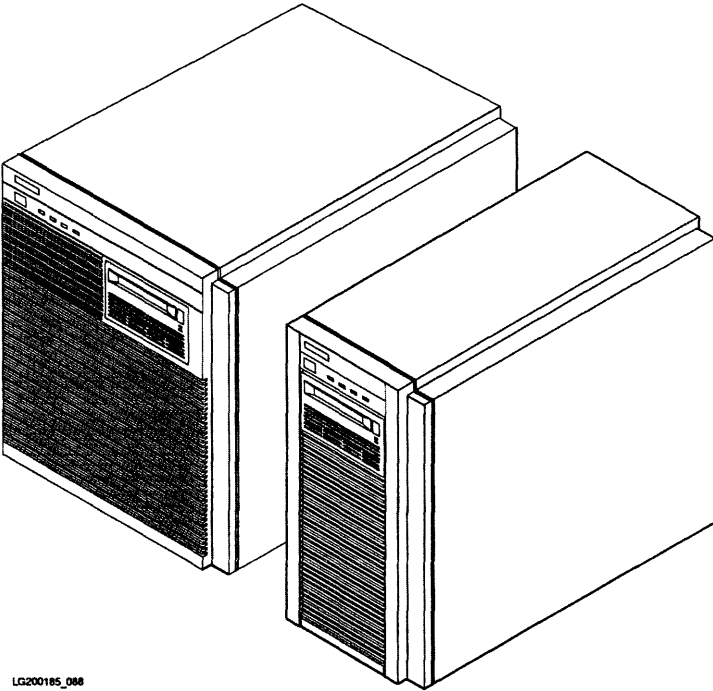

LG200185\_088

**Figure 1-1. HP 3000 Series 9x7 Family and HP 9000 Model 8x7S Family Systems**

**For HP Internal Use Only**

**Table 1-1. HP 3000 Series 9x7LX Standard Chassis Description**

HP 3000						
	Series 917LX	Series 927LX	Series 937LX	Series 947LX	Series 957LX	Series 967LX
<b>CPU Type</b>	PCX-S	PCX-S	PCX-S	PCX-S	PCX-S	PCX-S
<b>Clock Speed</b>	32 MHz	32 MHz	32 MHz	32 MHz	48MHz	48 MHz
<b>Floating Point</b>	option	option	option	option	option	option
<b>Data Cache</b>	64 KB	64 KB	64 KB	64 KB	64 KB	256 KB
<b>Instruction Cache</b>	32 KB	32 KB	32 KB	32 KB	64 KB	256 KB
<b>Main Memory (minimum)</b>	24 MB	24 MB	32 MB	64 MB	64 MB	64 MB
<b>Main Memory (maximum)</b>	192 MB	192 MB	192 MB	192 MB	192 MB	192 MB
<b>OS Release (minimum)</b>	XL 3.1	XL 3.1	XL 3.1	XL 3.1	XL 3.1	XL 3.1
<b>Internal 5.25 in. SCSI Disk(s)</b>	1	1	1	1	1	1
<b>Internal 3.5 in. SCSI Disk(s)</b>	0	0	0	0	0	0
<b>Internal DDS</b>	1	1	1	1	1	1
<b>HP-PB I/O Slots</b>	2	2	2	2	2	2
<b>External SCSI Connector</b>	Y	Y	Y	Y	Y	Y
<b>Console Connection</b>	Y	Y	Y	Y	Y	Y
<b>Remote Modem Connection</b>	Y	Y	Y	Y	Y	Y
<b>LAN Connector</b>	Y	Y	Y	Y	Y	Y
<b>Internal SCSI I/O Bus</b>	Y	Y	Y	Y	Y	Y
<b>Rack Mount Option</b>	Y	Y	Y	Y	Y	Y
<b>Customer Installable</b>	Y	Y	Y	N	N	N

**For HP Internal Use Only**

**Table 1-2. HP 3000 Series 9x7 Expanded Chassis Description**

<b>HP 3000</b>					
	<b>Series 937</b>	<b>Series 947</b>	<b>Series 957</b>	<b>Series 967</b>	<b>Series 977</b>
<b>CPU Type</b>	PCX-S	PCX-S	PCX-S	PCX-S	PCX-S
<b>Clock Speed</b>	32 MHz	32 MHz	48 MHz	48 MHz	64MHz
<b>Floating Point</b>	option	option	option	option	option
<b>Data Cache</b>	64 KB	64 KB	64 KB	256 KB	256KB
<b>Instruction Cache</b>	32 KB	32 KB	64 KB	256 KB	256 KB
<b>Main Memory (minimum)</b>	32 MB	64 MB	64 MB	64 MB	64 MB
<b>Main Memory (maximum)</b>	192 MB	192 MB	192 MB	192 MB	384 MB
<b>OS Release (minimum)</b>	XL 3.1	XL 3.1	XL 3.1	XL 3.1	XL 3.1
<b>Internal 5.25 in. SCSI Disk(s)</b>	1 - 3	1 - 3	1 - 3	1 - 3	1 - 3
<b>Internal 3.5 in. SCSI Disk(s)</b>	0	0	0	0	0
<b>Internal DDS</b>	1	1	1	1	1
<b>HP-PB I/O Slots</b>	12	12	12	12	12
<b>External SCSI Connector</b>	Y	Y	Y	Y	Y
<b>Console Connection</b>	Y	Y	Y	Y	Y
<b>Remote Modem Connection</b>	Y	Y	Y	Y	Y
<b>LAN Connector</b>	Y	Y	Y	Y	Y
<b>Internal SCSI I/O Bus</b>	Y	Y	Y	Y	Y
<b>Rack Mount Option</b>	Y	Y	Y	Y	Y
<b>Customer Installable</b>	N	N	N	N	N

F10      F20      H20      F30      G30      H30  
 For HP Internal Use Only      G40      H40  
 Table 1-3. HP 9000 Model 8x7S Description      F30      I40

HP 9000								
	Model 807S	Model 817S	Model 827S	Model 837S	Model 847S	Model 857S	Model 867S	Model 877S
CPU Type	PCX-S	PCX-S	PCX-S	PCX-S	PCX-S	PCX-S	PCX-S	PCX-S
Clock Speed	32 MHz	48 MHz	48 MHz	48 MHz	48 MHz	48 MHz	64 MHz	64 MHz
Floating Point	option	option	option	option	option	option	option	option
Data Cache	64 KB	64 KB	64 KB	256 KB	256 KB	256 KB	256 KB	256 KB
Instruction Cache	32 KB	64 KB	64 KB	256 KB	256 KB	256 KB	256 KB	256 KB
Main Memory (minimum)	8 MB	16 MB	16 MB	16 MB	16 MB	16 MB	16 MB	16 MB
Main Memory (maximum)	64 MB	192 MB	192 MB	192 MB	192 MB	192 MB	384 MB	384 MB
OS Release (minimum)	UX 8.02	UX 8.02	UX 8.02	UX 8.02	UX 8.02	UX 8.02	UX 8.02	UX 8.02
Internal 5.25 in. SCSI Disk(s) <sup>1</sup>	0 - 1	0 - 1	0 - 3	0 - 1	0 - 3	0 - 3	0 - 3	0 - 3
Internal 3.5 in. SCSI Disk(s) <sup>1</sup>	0 - 2	0 - 2	0 - 2	0 - 2	0 - 2	0 - 2	0 - 2	0 - 2
Internal DDS <sup>1</sup>	0 - 1	0 - 1	0 - 1	0 - 1	0 - 1	0 - 1	0 - 1	0 - 1
CD-ROM <sup>1</sup>	0 - 1	0 - 1	0 - 1	0 - 1	0 - 1	0 - 1	0 - 1	0 - 1
QIC Tape Drive <sup>1</sup>	0 - 1	0 - 1	0 - 1	0 - 1	0 - 1	0 - 1	0 - 1	0 - 1
HP-PB I/O Slots	2 <sup>2</sup>	2 <sup>2</sup>	6 <sup>3</sup>	2 <sup>2</sup>	6 <sup>3</sup>	12 <sup>3</sup>	12 <sup>3</sup>	12 <sup>3</sup>
External SCSI Connector	N	Y	Y	Y	Y	Y	Y	Y
External DDC Connector	Y	N	N	N	N	N	N	N
Parallel Port	N	Y	Y	Y	Y	Y	Y	Y
8-Port MUX Connector	N	Y	Y	Y	Y	Y	Y	Y
Console Connector	Y	N	N	N	N	N	N	N
Remote Modem Connector	Y	N	N	N	N	N	N	N
Internal SCSI I/O Bus	Y	Y	Y	Y	Y	Y	Y	Y
Rack Mount Option	Y	Y	Y	Y	Y	Y	Y	Y
Customer Installable	Y	Y	Y	Y	Y	Y	Y	Y

<sup>1</sup> Represents the maximum number of each device that can be installed. The total number of supported internal peripheral devices depends on the types and quantities of internal peripherals installed.

<sup>2</sup> Standard Chassis

<sup>3</sup> Expanded Chassis

G50  
G60

I50  
I60  
I70

887

897

96MHz

96MHz

## **Major Assemblies**

Figure 1-2 and Figure 1-3 show the major assemblies in the standard chassis. The figures and the list of major assemblies represent a generalized system and do not represent any one system.

The major assemblies are:

- Digital Data Storage (DDS) Device
- Peripheral Drawer
- Power Supply and Fan
- Multifunction I/O Card (system dependent)
- Processor Card
- Memory Subsystem

The peripheral drawer contains the DDS and one 5.25-inch internal disk or one to two 3.5-inch disks.

For HP Internal Use Only

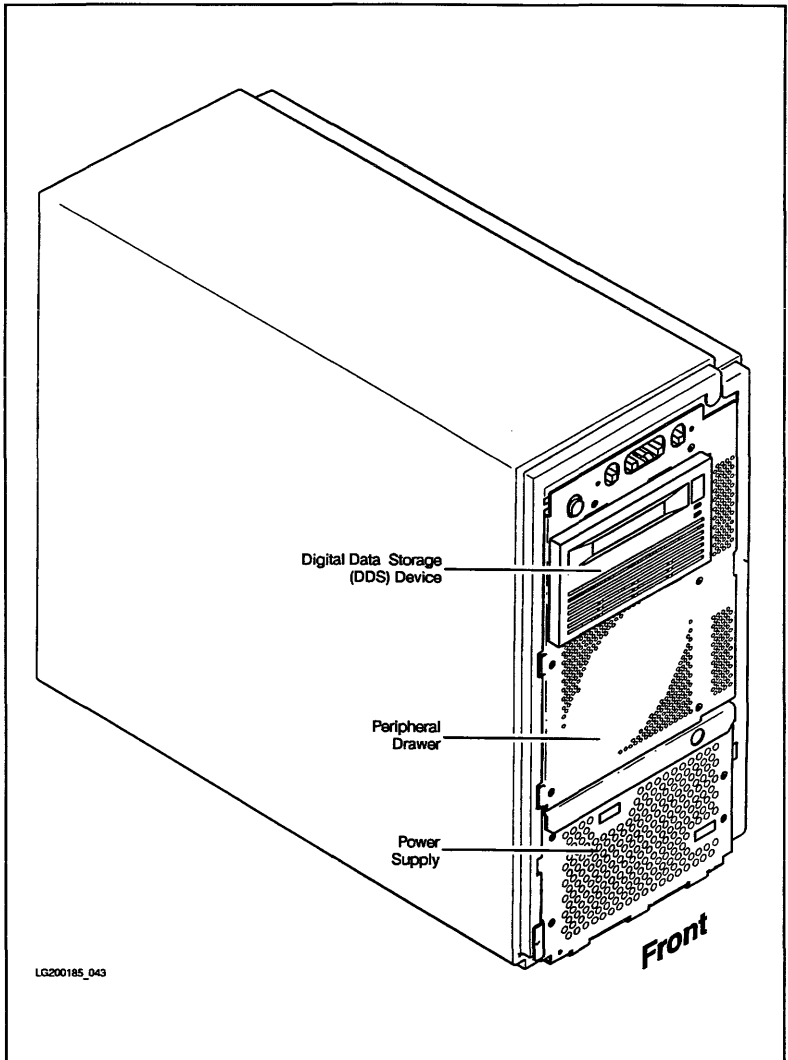

Figure 1-2. Standard Chassis Major Assemblies - Front

For HP Internal Use Only

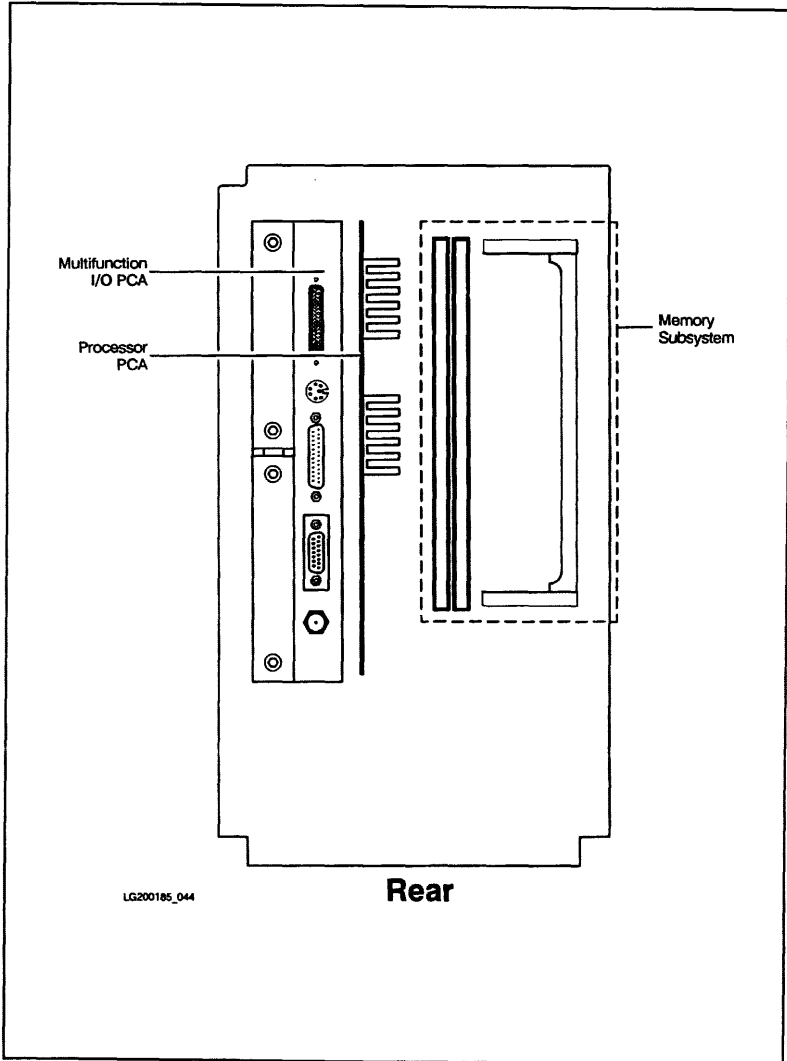

Figure 1-3. Standard Chassis Major Assemblies - Rear

## Multifunction I/O Card Connection

Each of the systems has a special I/O slot reserved for a Multifunction I/O card. The card provides connections for internal and external I/O devices. Figure 1-4 shows the external connectors for each of the three versions.

The **SCSI/Console/LAN** card, P/N A1703-60003, is used in the HP 3000 systems.

The **SCSI/Parallel/APMUX** cards, P/N A1703-60004 and P/N A1703-60022, are used in all HP 9000 systems, except the HP 9000/807S.

The **SCSI/APMUX** card, P/N A1751-60001, is used only in the HP 9000/807S system.

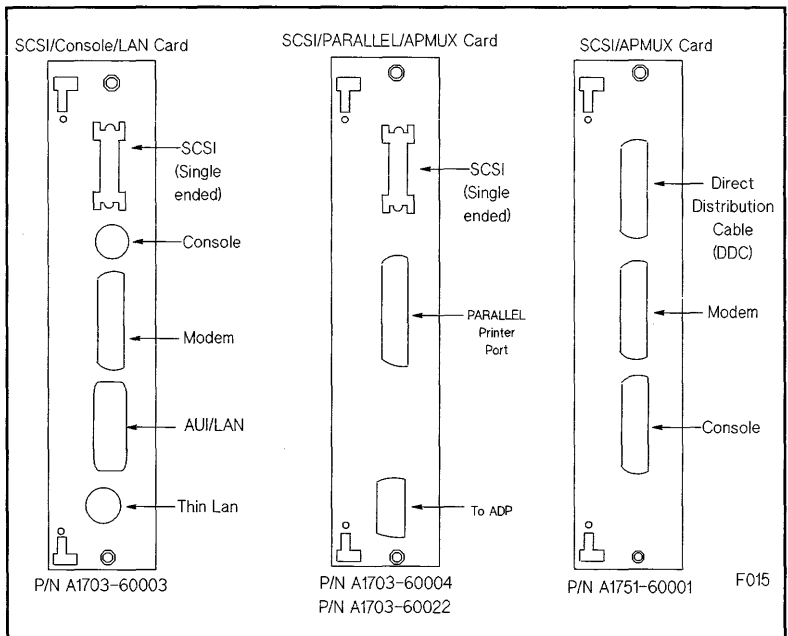

Figure 1-4. Multifunction I/O Card Connector Layout



## System Operation

### Introduction

The status of system operation is displayed on the system front panel and on the console. Tape drive operation is displayed on the tape drive front panel. System operation can be controlled and modified with the Processor Dependent Commands (PDC) and the Access Port commands.

### System Status Displays

#### System Front Panel and Status Displays

The system front panel switch and indicators are shown in Figure 1-5. The DC ON/OFF switch controls the application of DC power to the system. Table 1-4 shows the valid states of the Operating State indicators.

The Remote Indicator is lit if the system remote console path has been enabled.

If the Operating State Indicators show a Fault condition and the Battery Indicator is lit, the battery is discharging.

If the Operating State Indicators do not show a Fault condition and the Battery indicator is lit, the battery is charging.

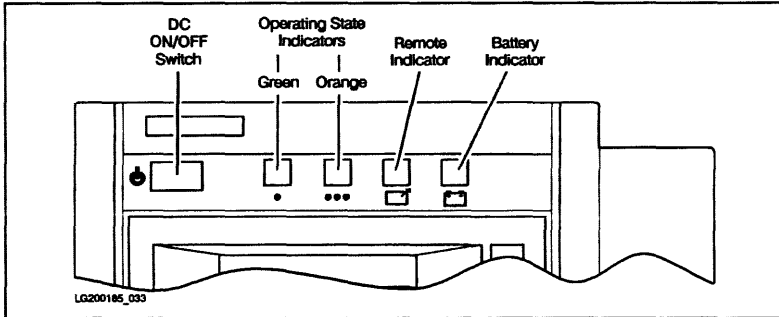

Figure 1-5. System Front Panel Switches and Indicators

**For HP Internal Use Only**

**Table 1-4. Operating State Indicators**

<b>Green Run LED</b>	<b>Orange Fault LED</b>	<b>OSTAT Display</b>	<b>System State</b>
Off	Off	<b>OFF</b>	The system is shut down and power is off. <sup>1</sup>
Off	On	<b>FauLT</b>	The system is in a fault state and halted.
On	Off	<b>RUN</b>	Normal system operation.
On	On	<b>TEST</b>	The system is executing selftest.
On	On	<b>INITialize</b>	The system is initializing.
On	On	<b>SHUTdown</b>	The operating system is being shut down.
On	On	<b>WARNing</b>	This is a warning state.
On	On	<b>ALL on</b>	Normal system operation.

**Note**



<sup>1</sup> Early versions of MPE/iX will turn off the Operating State Indicators if an OS Shutdown is performed.

Figure 1-6 shows how the front panel indicators are related to the fields of the system console banner. The OSTAT field contains the alphabetic characters shown in the OSTAT Display field of Table 1-4.

**For HP Internal Use Only**

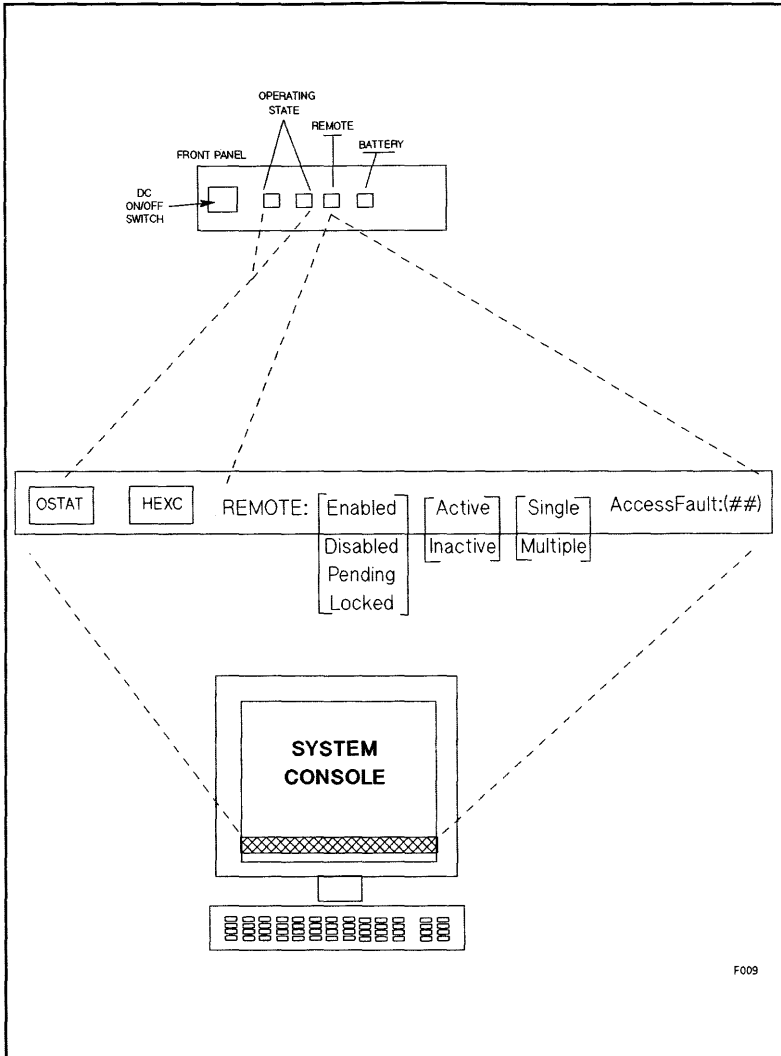

F009

**Figure 1-6. Front Panel and System Console Indicators**

**For HP Internal Use Only**

**DDS Front Panels and Status Displays**

The tape drives in the HP 3000/9x7 and HP 9000/8x7S systems are shown in Figure 1-7 and Figure 1-8.

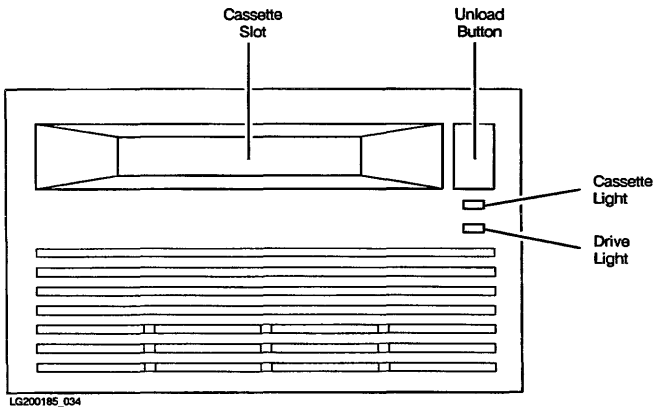

**Figure 1-7. HP C1502A 5.25-inch DDS-Format Tape Drive Front Panel**

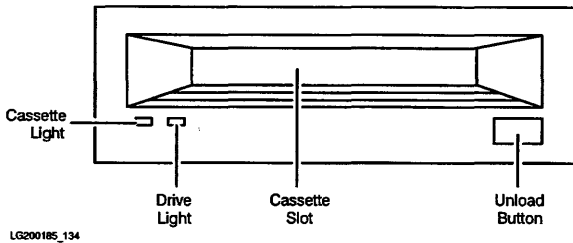

**Figure 1-8. HP C1503B and C1504B 3.5-inch DDS-Format Tape Drive Front Panel**

**Cassette Slot:** is where the tape cassette is inserted and removed.

**Unload Button:** stops any tape operation, rewinds the tape, and ejects the cassette from the tape drive.

**Cassette Light and Drive Light:** indicate the status of the tape drive. Both lights are capable of displaying yellow or green colors. The combinations of colors plus being off (no light) show normal operation status, operation with write protect, and caution states, as listed below.

**For HP Internal Use Only**

The various status states you will see the indicators display are shown in the following tables. Table 1-5 is for the 5.25 inch tape drive, and Table 1-6 is for the 3.5 inch tape drive.

The Cassette indicator and the Drive indicator are bi-color Light Emitting Diodes (LEDs). They can show green or yellow light.

**Table 1-5. HP C1502A 5.25-inch DDS-Format Tape Drive**

Cassette Light	Drive Light	Condition
<b>Normal Operation</b>		
Off	Off	No cassette loaded or power is off.
Off	Flash Green	No cassette loaded, tape drive is active.
Pulsing Green	Pulsing Green	Cassette is loading or unloading, tape drive is active.
On Green	Off	Cassette is loaded, tape drive is offline.
On Green	Flash Green	Cassette is loaded, tape drive is active.
On Green	On Green	Cassette is loaded, tape drive is online.
<b>Normal Operation With A Read Only Tape</b>		
Pulsing Yellow	Pulsing Green	Cassette is loading and is read only, tape drive is loading or unloading.
On Yellow	Off	Cassette is loaded as a read only tape, tape drive is offline.
On Yellow	Flash Green	Cassette is loaded as a read only tape, tape drive is active.
On Yellow	On Green	Cassette is loaded as a read only tape, tape drive is online.
<b>Caution States</b>		
On Green 4.5 sec, Off 0.5 sec	Off	Caution Signal.
On Yellow	On Yellow	High humidity, moisture detected by tape drive., (Too high)
Flash Yellow	Flash Yellow	Running Selftest

**For HP Internal Use Only**

**Table 1-6. HP C1503B and C1504B 3.5 inch DDS-Format Tape Drive**

Cassette Light	Drive Light	Condition
<b>No Cassette States</b>		
Off	Off	No cassette loaded or power is off.
Flash Yellow	Flash Yellow	Self-test in progress.
Off	Flash Green	No cassette, tape drive is active.
<b>Write Enable States</b>		
On Green	On Green	Cassette loaded, tape drive online.
On Green	Flash Green	Cassette loaded, tape drive active.
Pulse Green	Pulse Green	Loading, unloading, or ejecting cassette.
On Green	Off	Tape drive offline. Cassette loaded.
<b>Write Protect States</b>		
On Yellow	On Green	Read only cassette loaded, tape drive online.
On Yellow	Flash Green	Read only cassette loaded, tape drive active.
Pulse Yellow	Pulse Green	Loading, unloading, or ejecting cassette.
On Yellow	Off	Tape drive offline. Read-only cassette loaded.
<b>Error States</b>		
On Green	Pulse Green/Yellow	Caution <sup>1</sup> (media warning).
On Yellow	On Yellow	Moisture detected or no termination resistors <sup>2</sup> .
Pulse Yellow	On Yellow	Fault <sup>3</sup> .

<sup>1</sup> This occurs during writes where an excessive number of read after write errors occur and during reads where an excessive level of C3 correction being applied. This indication would persist until the cassette is unloaded.

<sup>2</sup> The termination resistor problem would only occur at power on time and the tape drive will appear to have *hung* during self-test.

<sup>3</sup> Indicates a failure of the DDS Field Replaceable Unit.

**Ordering HP DDS cassettes.** The 60 meter cassette tape, product number *HP 92283A*, can hold up to 1.3 gigabytes (1300 megabytes) of data. They are packaged in a red box of 5 cassettes. Use the 60 meter cassettes in either the full height (5.25 inch) DDS tape drive, or the half height (3.5 inch) DDS tape drive.

The 90 meter cassette tape, product number *HP 92283B*, can hold up to 2 gigabytes (2000 megabytes) of data and are packaged in yellow. Use the 90 meter cassettes only in the half height (3.5 inch) DDS tape drive.

The cleaning cassette tape is product number *HP 92283K*.

**For HP Internal Use Only**

Table 1-7 shows the types of DDS tapes available and which tape drive they are compatible with. This is important to know before loading a DDS cassette into a tape drive for operation.

**Table 1-7. DDS Tape Requirements**

	<b>HP 5.25 inch</b>	<b>HP 3.5 inch</b>	<b>Non-HP DDS Device</b>
60M (red)	Read (yes) Write (yes)	Read (yes) Write (yes)	Read (yes) Write (yes)
90M (yellow)	Read (no) Write (no)	Read (yes) Write (yes)	Read (*) Write (*)

\* Refer to the manufactures specification.

**For HP Internal Use Only**

**CD-ROM Front Panel and Status Displays**

Figure 1-9 shows the CD-ROM controls and indicators.

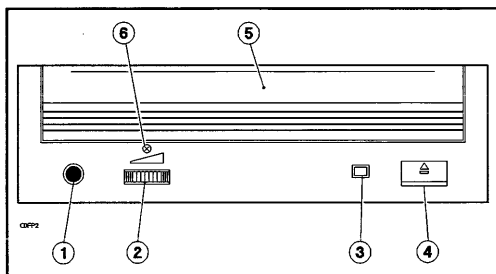

**Figure 1-9. CD-ROM Drive Front Panel**

- |                        |                                        |
|------------------------|----------------------------------------|
| 1. Headphone Jack      | 4. CD-ROM Eject Button <sup>1</sup>    |
| 2. Volume Control Knob | 5. Door (CD-ROM Caddy Loading Slot)    |
| 3. Drive Status Light  | 6. Emergency Eject Access <sup>2</sup> |

<sup>1</sup>Ejects a CD-ROM within 5 seconds; will not function if there is no power or if a software application has disabled operations

<sup>2</sup>To eject a CD-ROM when drive power is off, remove screw and insert the end of a paper clip into this hole.

Table 1-8 shows drive status light indications during normal operation and fault conditions.

**Table 1-8. Drive Status Light Indications**

Status	Explanation
ON	No CD-ROM detected, CD-ROM insertion error detected, or no CD-ROM is in the caddy.
OFF	Drive power is off, self-test passed, or no activity with the host.
FLASHING	Activity with the host.



**For HP Internal Use Only**

**Quarter-inch Cartridge (QIC) Tape Drive Front Panel and Status Displays**

Figure 1-10 shows the QIC tape drive front panel and indicator.

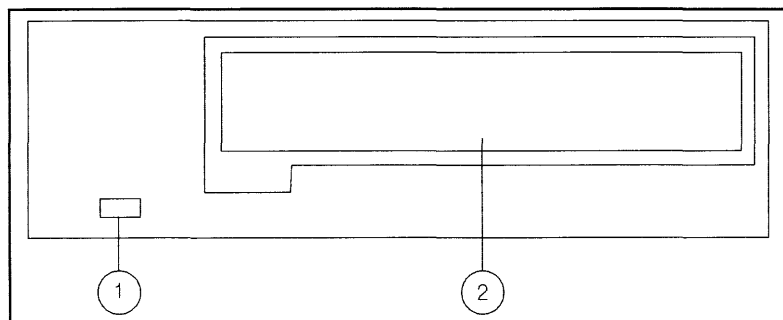

**Figure 1-10. Quarter-inch Cartridge (QIC) Tape Drive Front Panel**

1. Drive Activity Light      2. Tape Access Door

**Drive Activity Light:** is lit when the drive is being accessed, such as when the motor is running, when the heads are being positioned, when a command is being executed, and when data is being transferred.

The QIC drive can store up to 525 Mbytes, depending upon the QIC format in which the data is written. The QIC drive reads and writes the formats shown in Table 1-9.

**Table 1-9. QIC Tape Drive Read and Write Formats**

Read	Write
QIC 24	
QIC 120	QIC 120
QIC 150	QIC 150
QIC 320/525	QIC 320/525

The drive reads tapes by sensing the previously written format and by sensing the cartridge type. The drive writes a tape in a particular QIC format only if the cartridge supports recording that format. For example, a QIC 120 tape can be written with a QIC 24 format or a QIC 120 format. A QIC 150 tape supports all of the formats supported by a QIC 120 tape, in addition to the QIC 150 format.

You specify the format to be written through specific device files. Refer to Table 1-10.

### For HP Internal Use Only

**Table 1-10. QIC Device Files and Formats**

Device File	QIC Format Written
/dev/rmt/xl	QIC 120
/dev/rmt/xm	QIC 150
/dev/rmt/xh	QIC 320/525

Although QIC tapes support multiple QIC formats, you cannot write data on a tape in more than one format. For example, a QIC 150 tape supports both the QIC 120 and QIC 150 formats. However, you must either write data in the QIC 120 format or the QIC 150 format. If a cartridge has data recorded in a particular format, it can be overwritten with a different format.

ALL HP-supplied QIC backup media, such as the Install Tape, Update/SE Tape, User Enhancement Environment Tape, and Support Tape will be in the QIC-525 format.

---

**Note**

The QIC drive is **NOT** compatible with the 914x drives. You should not load a QIC tape into a 914x tape drive, or vice versa.



---

### Processor Dependent Code (PDC) Commands

Table 1-11 provides a brief summary of the PDC commands used to control or modify system operation. Type **HELP**, **?**, or **HELP <item>** for an explanation of each of the PDC commands and their syntax.

**Table 1-11. PDC Commands**

Command	Description
AUTOBOOT <on/off>	Set Autoboot flag on or off
AUTOSEARCH <on/off>	Set Autosearch flag on or off
AUTO	Display Autoboot and Autosearch flags
BOOT	Boot after primary, alternate, or specified boot path
BOOT TIMER	Display/Set boot device timer
DEFAULT	Set default paths in Primary Storage
FASTSIZE	Display/Set FASTSIZE memory parameter
HELP or ?	Print Help menu
HELP <item>	Print Help information for <item>
INFO	Display I/O map, memory, and revision information
PATH	Display/Modify path information
PIM	Display LPMC PIM and HPMC PIM information
RESET	Reset the system
STABLE	Display contents of Stable Storage
TIME	Read/Set real time clock

**For HP Internal Use Only**

**Access Port Commands**

Table 1-12 provides a brief summary of the Access Port commands. The commands are available after you type **(Ctrl)B** at the console. A complete discussion of these commands is provided in “Access Port” in Chapter 9.

**Table 1-12. Access Port Command Summary**

CONTROL MODE COMMANDS		Valid At	
Command	Description	LC	RC
CA	Configure Remote Support Modem Port	Y	Y
CO	Return to Console Mode	Y	Y
CS	Copy Screen	Y	Y
DI	Disconnect Remote Console	N	Y
DR	Disable Remote Operator Access	Y	Y
DS	Disable SPU Status Display	Y	Y
ER	Enable Remote Operator Access	Y	N
ES	Enable SPU Status Display	Y	Y
HE	Print Help Menu	Y	Y
LR	Lock Remote Support Modem Access	Y	Y
RS	Reset SPU	Y	Y
SE	Enter Session Mode on Remote Port	N	Y
TC	Initiate SPU Transfer of Control	Y	Y
TA	Initiate Self Test	Y	Y
TE	Tell	Y	Y
UR	Unlock Remote Support Modem Access	Y	N

- LC = Local Console
- RC = Remote Console

**For HP Internal Use Only**

**Normal Power-on Sequence**

Table 1-13 describes each of the steps and the results of the power-on sequence. The Access port described in Table 1-13 is located on the Multifunction I/O card.

**Table 1-13. Normal Power-On Sequence**

Step	Description	Results
1	System power-on by pressing DC On/Off switch	All front panel indicators will momentarily light. The orange and green indicators will remain lit throughout system selftest.
2a	Access Port Selftest begins. (The Access Port is on the Multifunction I/O card)	Selftest LED on Multifunction I/O card is lit. Console LAN Selftest LED - HP 3000. Mux Status LED - HP 9000.
2b	System Selftest begins execution.	CPU, memory, and I/O are tested.
3	Access Port Selftest completes.	Selftest LED goes out.
4	Access Port sends the system banner to the system console.	The system console displays the HEX code and the OSTAT fields in the system banner.
5	Access Port sends System Selftest HEX codes and OSTAT data to the console.	Access Port updates the banner information as System Selftest proceeds.
6	System Selftest finishes. Console path is tested.	Bootpath message appears on the system console. <b>Note:</b> If the system status banner has not been enabled with the ES command, the status banner will disappear at this time.

## Environmental Information

### Specifications

**Table 2-1. Environmental Specifications**

Operating Temperature	5°C to 40°C (41°F to 104°F)
Non-operating Temperature	-40°C to 65°C (-40°F to 149°F) (without internal DDS-format drive)  -40°C to 45 °C (-40°F to 113°F) (with internal DDS-format drive - tape media limit)
Maximum Rate of Temperature Change	20°C (36°F)/hour (without tape media) 10°C (18°F)/hour (with tape media)
High Speed Fan (Activated)	30°C to 38°C (86°F to 100.4°F)
Overtemp Warning	40°C to 48°C (104°F to 118.4°F)
Overtemp Hardware Shutdown	<b>Overtemp Warning +2°C (≈3°F)</b>
Operating Humidity	20% to 80% RH max wet bulb = 26°C, non-condensing
Non-operating Humidity	5% to 80% RH, non-condensing, less than 30% RH/hr rate of change
Operating Altitude	0 to 3048 meters (10,000 ft)
Nonoperating Altitude	0 to 4573.2 meters (15,000 ft)
Heat Dissipation Standard chassis (max load)	1300 BTU/hr
Heat Dissipation Expanded chassis (max load)	2600 BTU/hr
Operating Vibration (random)	0.0001 g <sup>2</sup> /Hz, 5 to 350 Hz -6dB/Octave, 350-500 Hz 0.00005 g <sup>2</sup> /Hz, 500 Hz (≈ 0.21 G <sub>rms</sub> )
Non-operating Vibration (sine)	0.5g (peak), 5 to 500 Hz
Shock (nonoperating)	Edge drop from 2.5 in. above floor
Sound Power	≈5.8 Bels (A weighted) @ < 37°C (Standard chassis) ≈6.2 Bels (A weighted) @ < 37°C (Expanded chassis)

**For HP Internal Use Only**

**Table 2-2. 2-Slot Chassis Power Specifications**

Description	Specification
AC Input Voltage Range <sup>1</sup>	90 to 132 VAC and 180 to 264 VAC
AC Input Current <sup>2</sup>	6.5 A maximum load @ 100 VAC 3.5 A maximum load @ 240 VAC  3.9 A typical load @ 100 VAC & 50 Hz 3.2 A typical load @ 120 VAC & 60 Hz 2.0 A typical load @ 208 VAC & 60 Hz 1.9 A typical load @ 220 VAC & 50 Hz 1.8 A typical load @ 240 VAC & 50 Hz
AC Inrush Current	50 amperes peak, one cycle
AC Input Power <sup>2</sup>	380 watts maximum, 230 watts typical
Power Supply Output Rating	240 watts DC continuous
AC Input Line Frequency	47 to 63 Hz
Transient Tolerance	
Low Energy	3000 volts, 10 $\mu$ s, 500 ns rise/fall
High Energy	1000 volts, 1.2 $\mu$ s rise
Holdup without System Reset	20 ms @ 50 Hz (1 cycle)
Battery Backup Time	15 minutes with optional battery

**Note**



<sup>1</sup> The power supply is an auto-ranging power supply. It does not have to be reconfigured to operate over its rated operating ranges. However, the system should not be operated at voltages between the two input voltage ranges.

<sup>2</sup> Typical load assumes 192MB memory, three internal peripherals, the 64 MHz CPU, and the PBA-HPIB card.

The power supply can provide power for up to three internal peripherals.

**For HP Internal Use Only**

**Table 2-3. 2-Slot Chassis DC Power Specifications <sup>3</sup>**

Nominal Voltage	Minimum Current	Maximum Current	Minimum Voltage	Maximum Voltage	P-P Ripple
+5V <sup>4</sup>	3A	27A	+5.10V	+5.25V	50 mV
+5V_S	0A	5A	+5.10V	+5.25V	100 mV
+12V	0A	6.67A	+11.69V	+12.36V	100 mV
-12V	0A	2A	-11.69V	-12.60V	100 mV



<sup>3</sup> Total power must not exceed 240 watts.

<sup>4</sup> +5V current includes +5V\_S current.

**Table 2-4. Electromagnetic Susceptibility Specifications**

Radiated	3V/m, 14 kHz to 1 GHz
Conducted	3V rms, 30 Hz to 50 kHz 1V rms, 50 kHz to 400 MHz
Radiated Magnetic Field Immunity	1 gauss p-p, 48 Hz to 198 kHz
Electrostatic Air Discharge	10 kV - no effect 25 kV - no hardware failure

**Table 2-5. 2-Slot Chassis Physical Specifications**

Description	Specification
Width	222 mm (8.74 in.)
Height	430 mm (16.93 in.)
Depth	533 mm (20.98 in.)
Weight	31.8 kg (70 lbs)

**For HP Internal Use Only**

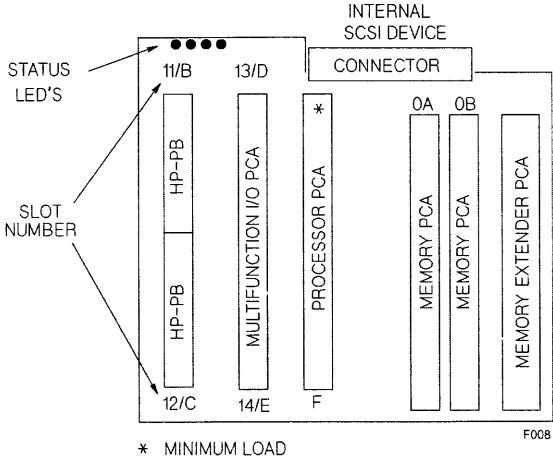

**Figure 2-1. 2-Slot Chassis Backplane Layout and Minimum Load**



For HP Internal Use Only

Table 2-6. 6-Slot Chassis Power Specifications<sup>1</sup>

Description	Specification
AC Input Voltage Range <sup>2</sup>	90 to 132 VAC or 180 to 264 VAC
AC Input Current <sup>3</sup>	12 A maximum load @ 100 VAC 6 A maximum load @ 240 VAC  7.0 A typical load @ 100 VAC & 50 Hz 6.0 A typical load @ 120 VAC & 60 Hz 3.7 A typical load @ 208 VAC & 60 Hz 3.8 A typical load @ 220 VAC & 50 Hz 3.5 A typical load @ 240 VAC & 50 Hz
AC Inrush Current	100 amperes peak, one cycle
AC Input Power <sup>3</sup>	650 watts maximum, 435 watts typical
Power Supply Output Rating	480 watts DC continuous (240 watts from each supply)
AC Input Line Frequency	47 to 63 Hz
Transient Tolerance	
Low Energy	3000 volts, 10 $\mu$ s, 500 ns rise/fall
High Energy	1000 volts, 1.2 $\mu$ s rise
Holdup without System Reset	20 ms @ 50 Hz (1 cycle)
Battery Backup Time	15 minutes with optional batteries

**Caution**



Systems with two power supplies must have both power cords connected to AC outlets. If one of the power cords is not connected, the system will not turn on.

Both AC outlets must be protected by the same fuse.

**Note**



<sup>1</sup> The data reflects power input from two power cords to two power supplies.

Each power supply can provide power for up to three internal peripherals.

<sup>2</sup> The power supplies are auto-ranging power supplies. They do not have to be reconfigured to operate over their rated operating ranges. However, the system should not be operated at voltages between the two input voltage ranges.

<sup>3</sup> Typical load assumes 384MB memory, six internal peripherals, the 64 MHz CPU, and three PBA-FL Interface cards.

**For HP Internal Use Only**

**Table 2-7. 12-Slot Chassis Power Specifications<sup>1</sup>**

Description	Specification
AC Input Voltage Range <sup>2</sup>	90 to 132 VAC or 180 to 264 VAC
AC Input Current <sup>3</sup>	12 A maximum load @ 100 VAC 6 A maximum load @ 240 VAC  7.7 A typical load @ 100 VAC & 50 Hz 6.5 A typical load @ 120 VAC & 60 Hz 4.1 A typical load @ 208 VAC & 60 Hz 4.1 A typical load @ 220 VAC & 50 Hz 3.8 A typical load @ 240 VAC & 50 Hz
AC Inrush Current	100 amperes peak, one cycle
AC Input Power <sup>3</sup>	760 watts maximum, 510 watts typical
Power Supply Output Rating	480 watts DC continuous (240 watts from each supply)
AC Input Line Frequency	47 to 63 Hz
Transient Tolerance	
Low Energy	3000 volts, 10 $\mu$ s, 500 ns rise/fall
High Energy	1000 volts, 1.2 $\mu$ s rise
Holdup without System Reset	20 ms @ 50 Hz (1 cycle)
Battery Backup Time	15 minutes with optional batteries

**Caution**



Systems with two power supplies must have both power cords connected to AC outlets. If one of the power cords is not connected, the system will not turn on.

Both AC outlets must be protected by the same fuse.

**Note**



<sup>1</sup> The data reflects power input from two power cords to two power supplies.

Each power supply can provide power for up to three internal peripherals.

<sup>2</sup> The power supplies are auto-ranging power supplies. They do not have to be reconfigured to operate over their rated operating ranges. However, the system should not be operated at voltages between the two input voltage ranges.

<sup>3</sup> Typical load assumes 384MB memory, six internal peripherals, the 64 MHz CPU, three PBA-FL Interface cards, two 802.3 LAN cards, and two SCSI Interface cards.

**For HP Internal Use Only**

**Table 2-8. 6-Slot and 12-Slot Chassis DC Power Specifications<sup>1</sup>**

Nominal Voltage	Minimum Current	Maximum Current	Minimum Voltage	Maximum Voltage	P-P Ripple
+5V <sup>2</sup>	6A <sup>3</sup>	54A	+5.10V	+5.25V	50 mV
+5V_S	0A	10A	+5.10V	+5.25V	100 mV
+12V	0A	13.3A	+11.69V	+12.36V	100 mV
-12V	0A	4.0A	-11.69V	-12.60V	100 mV

**Note**



<sup>1</sup> Total power must not exceed 480 watts.

<sup>2</sup> +5V current includes +5V\_S current.

<sup>3</sup> 3A for each power supply. Refer to Figure 2-2 and Figure 2-3 for expanded chassis minimum power supply loading.

**Table 2-9. 6-Slot and 12-Slot Chassis Physical Specifications**

Description	Specification
Width	444 mm (17.48 in.)
Height	430 mm (16.93 in.)
Depth	533 mm (20.98 in.)
Weight	50 kg (110 lbs)

**For HP Internal Use Only**

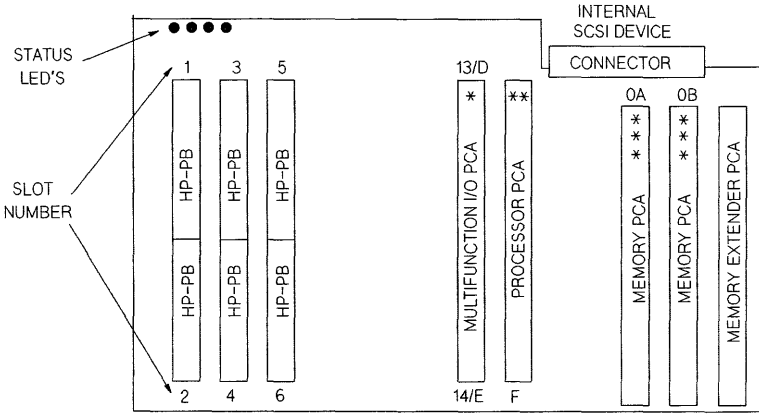

- \* MINIMUM LOAD FOR RIGHT POWER SUPPLY
- \*\* MINIMUM LOAD FOR LEFT POWER SUPPLY
- \*\*\*SLOTS NOT PRESENT ON 64MHZ BACKPLANE

F005A

**Figure 2-2. 6-Slot Chassis Backplane Layout and Minimum Load**

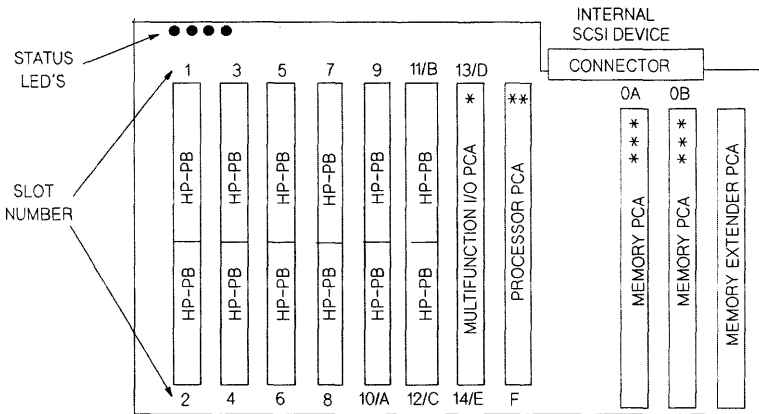

- \* MINIMUM LOAD FOR RIGHT POWER SUPPLY
- \*\* MINIMUM LOAD FOR LEFT POWER SUPPLY
- \*\*\*SLOTS NOT PRESENT ON 64MHZ BACKPLANE

F005

**Figure 2-3. 12-Slot Chassis Backplane Layout and Minimum Load**

## Installation and Preventive Maintenance

---

### Introduction

This chapter provides a checklist of the steps required to install the system and the peripherals shipped with the system. More complete installation information is provided in the installation manuals shipped with the system. If a problem occurs at any point in the installation process, refer to Chapter 5.

Preventive maintenance information is also provided.

---

**Warning**

**The power cord is the main AC power disconnect device. The system must be positioned near an AC outlet that is free of obstacles and is easily accessible.**

---

For HP Internal Use Only

**Warning**



- A wheel is located in the center of the expanded-chassis system so it can be easily positioned.
- Use care when moving the system on a cart. Do not allow the system to move or roll off the cart.
- The system is designed as a floor standing product. It could be used on a table top if precautions are taken:
  - Make sure the table will support the weight, and
  - Make sure the table is stable (will not tip over), and
  - Do not allow the system to move on the table, and
  - Do not push the system when it is on the table.

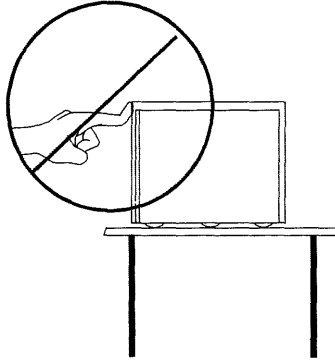

- Failure to follow these procedures may result in personal injury.

## Stand-alone System Installation

1. Unpack the system.
2. Inspect for damage.
3. Move the equipment to where it will be used.
4. Install any additional I/O PCAs.
5. Install and configure any external peripherals.

---

**Note**

If no SCSI peripherals are connected to the Multifunction I/O PCA, install SCSI terminator, P/N 1252-3932, on the SCSI connector.

---

6. Cable everything to the system.
7. Power up the external peripherals.
8. Power up the system.
9. At the ISL prompt, verify the I/O configuration with IOMAP.
10. Boot the operating system.
11. Customize the system.

---

## Rack System Installation

### A-Series Rack Installation

1. Unpack the system.
2. Inspect for damage.
3. Move the system to where it will be used.
4. Cable the LAN, if necessary.
5. Connect power to the rack.
6. Power up the system.
7. At the ISL prompt, verify the I/O configuration with IOMAP.
8. Boot the operating system.
9. Customize the system.

## For HP Internal Use Only

### C-Series Rack Installation

1. Unpack the system.
2. Inspect for damage.
3. Move the system to where it will be used.
4. Install equipment in the rack.
5. Install any additional I/O PCAs.
6. Install and configure any external peripherals.
7. Connect power to all equipment.
8. Connect power to the rack.
9. Power up the system.
10. At the ISL prompt, verify the I/O configuration with IOMAP.
11. Boot the operating system.
12. Customize the system.

---

## Preventive Maintenance

### Quarter-inch Cartridge (QIC) Tape Drive Maintenance

See Table 3-1 for the suggested drive preventive maintenance schedule.

**Table 3-1. Recommended Preventive Maintenance Schedule**

Item	Interval (hours)
Head Cleaning	8 (or as required) (2 hours with new tapes)
Capstan Cleaning	20 (or as required) with used tapes

### Read/Write Head Cleaning Procedure

Head cleaning ensures that the head is free of contamination for proper tape-to-head contact and to prevent the loss of data. The head should be cleaned after two hours of use with a new tape. Thereafter, it should be cleaned after every eight hours of use.

It is recommended that you use the QIC Drive Cleaning Cartridge to clean the heads. Before inserting the cartridge, apply a few drops of the cleaning solution to the pad. Insert the cartridge and move the handle up and down to clean the head surface.

If you have to manually clean the read/write head, you may have to dock the head assembly to access the head. To dock the head, open the tape access door, press in on the black tape carriage plate where the tape is usually inserted. Stop pushing when travel is restricted and the latching mechanism releases. The carriage plate automatically slides out about 3/8-inch. At this point, the head is docked.

### 3-4 Installation and Preventive Maintenance



**For HP Internal Use Only**

Clean the head using a lint-free polyurethane swab soaked with head cleaning solution.

**Capstan Cleaning Procedure**

The capstan should be cleaned using a cotton swab soaked with **water only**. Wipe the cotton swab around the circumference of the capstan until the debris is removed. Allow the capstan to dry completely before inserting a tape cartridge. **NEVER** clean the capstan with the head cleaning solution. Severe head damage will result.

## Configuration

---

### I/O Slot Configurations and Restrictions

Table 4-1, Table 4-2, Table 4-3, and Table 4-4 show how the HP-PB I/O slots of the standard and expanded systems can be configured.

All 2-slot system I/O configurations must meet the guidelines in Table 4-1.

All 6-slot system I/O configurations must meet the guidelines in Table 4-2.

All 12-slot system I/O configurations must meet the guidelines in Table 4-2 and Table 4-3.

Use Table 4-1, Table 4-2, and Table 4-3 to calculate the amount of current required for your configuration. Compare the Total Current Required with the Total Current Available.

If the configuration passes this test, it is supported.

If the configuration exceeds the maximum current rating by less than 5 percent, it is supported.

If the configuration exceeds the maximum current rating by more than 5 percent, the configuration is not supported.

Table 4-4 shows the form factor and allowable slot locations of some of the cards that can be installed in in the systems.

---

**Caution**

If you do not follow these configuration rules, you may experience random overtemperature warning conditions, random power supply latch-off, or other power system problems.

---

**Note**

If you encounter special configurations that do not follow these rules, call the On-Line Support organization.

---

**Note**

Please consult with the factory for additional configurations of new HP-PB cards.

---

**For HP Internal Use Only**

**Table 4-1. 2-Slot System Power Supply Current Budgeting <sup>1</sup>**

I/O Card	Quantity	Current Required per Card (amp)			Total Current Required (amp)		
		+12V	+5V	-12V	+12V	+5V	-12V
8 Port MUX 40299B		0.16	1.40	0.13			
16 Port MUX J2092A, J2093A, J2094A		0.30	1.70	0.15			
802.3 LAN J2146A		0.50	2.13	0.00			
802.5 Token Ring J2166A		0.00	1.66	0.00			
SCSI Interface 28642A		0.00	0.90	0.00			
SCSI Interface 28655A		0.00	0.90	0.00			
HP-IB Interface 28650B		0.00	2.10	0.00			
PBA-IB Interface A1747A		0.10	5.62	0.06			
PBA-FL Interface A1749A		0.08	6.77	0.07			
X.25 36960A		0.08	1.91	0.08			
SNA Link 98173A		0.08	1.91	0.08			
<b>Total Current Required <sup>2</sup></b>							
<b>Total Current Available</b>					2.20	5.60	1.50

**Note**



<sup>1</sup> The maximum power available for I/O cards is 72 watts. The remaining power is dedicated to other subsystem functions.

<sup>2</sup> The total current required must not exceed the total current available.

For HP Internal Use Only

Table 4-2.  
6-Slot and 12-Slot System Power Supply Current Budgeting (Slots 1 - 10)<sup>1</sup>

I/O Card	Quantity	Current Required per Card (amp)			Total Current Required (amp)		
		+12V	+5V	-12V	+12V	+5V	-12V
8 Port MUX 40299B		0.16	1.40	0.13			
16 Port MUX J2092A, J2093A, J2094A		0.30	1.70	0.15			
802.3 LAN J2146A		0.50	2.13	0.00			
802.5 Token Ring J2166A		0.00	1.66	0.00			
SCSI Interface 28642A		0.00	0.90	0.00			
SCSI Interface 28655A		0.00	0.90	0.00			
HP-IB Interface 28650B		0.00	2.10	0.00			
PBA-IB Interface A1747A		0.10	5.62	0.06			
PBA-FL Interface A1749A		0.08	6.77	0.07			
X.25 36960A		0.08	1.91	0.08			
SNA Link 98173A		0.08	1.91	0.08			
802.4 MAP BB 36970A Card 1 of 2		0.6	1.25	0.30			
802.4 MAP BB 36970A Card 2 of 2		0.0	1.03	0.0			
802.4 MAP CB 36969A Card 1 of 2		0.0	1.00	0.0			
802.4 MAP CB 36969A Card 2 of 2		0.0	1.03	0.00			
<b>Total Current Required</b> <sup>2</sup>							
<b>Total Current Available</b>					3.20	24.00	2.00

**Note**



<sup>1</sup> The maximum power available for I/O cards is 182 watts. The remaining power is dedicated to other subsystem functions.

<sup>2</sup> The total current required must not exceed the total current available.

For HP Internal Use Only

Table 4-3.  
12-Slot System Power Supply Current Budgeting (Slots 11 and 12)<sup>1</sup>

I/O Card	Quantity	Current Required per Card (amp)			Total Current Required (amp)		
		+12V	+5V	-12V	+12V	+5V	-12V
8 Port MUX 40299B		0.16	1.40	0.13			
16 Port MUX J2092A, J2093A, J2094A		0.30	1.70	0.15			
802.3 LAN J2146A		0.50	2.13	0.00			
802.5 Token Ring J2166A		0.00	1.66	0.00			
SCSI Interface 28642A		0.00	0.90	0.00			
SCSI Interface 28655A		0.00	0.90	0.00			
HP-IB Interface 28650B		0.00	2.10	0.00			
PBA-IB Interface A1747A		0.10	5.62	0.06			
PBA-FL Interface A1749A		0.08	6.77	0.07			
X.25 36960A		0.08	1.91	0.08			
SNA Link 98173A		0.08	1.91	0.08			
802.4 MAP BB 36970A Card 1 of 2		0.6	1.25	0.30			
802.4 MAP BB 36970A Card 2 of 2		0.0	1.03	0.0			
802.4 MAP CB 36969A Card 1 of 2		0.0	1.00	0.0			
802.4 MAP CB 36969A Card 2 of 2		0.0	1.03	0.00			
<b>Total Current Required</b> <sup>2</sup>							
<b>Total Current Available</b>					1.10	3.00	1.50

**Note**

<sup>1</sup> The maximum power available for I/O cards is 46 watts. The remaining power is dedicated to other subsystem functions.

<sup>2</sup> The total current required must not exceed the total current available.

**For HP Internal Use Only**

**Table 4-4. I/O Card Configuration Guidelines**

Product No.	Description	Form Factor	Slot Locations
40299B	8-port MUX	Single-high	1 through 12
J2092A	16-port RS-232 MUX	Single-high	1 through 12
J2093A	16-port RS-432 MUX	Single-high	1 through 12
J2094A	16-port Modem MUX	Single-high	1 through 12
J2146A	802.3 LAN	Single-high	1 through 4
J2166A	802.5 Token Ring LAN	Single-high	1 through 4
28642A	SCSI Interface	Single-high	1 through 12
28655A	SCSI Interface	Single-high	1 through 12
28650B	HP-IB Interface	Single-high	1 through 12
A1747A	PBA-IB Interface	Double-high	1 through 6
A1749A	PBA-FL Interface	Double-high	1 through 6
36960A	X.25 WAN	Single-high	1 through 12
98173A	SNA Link	Single-high	1 through 12
36970A	MAP 3.0 Broad Band	2 Double-high	3 through 6
36969A	MAP 3.0 Carrier Band	2 Double-high	3 through 6

---

## **Multifunction I/O Card Configuration**

### **SCSI Configuration**

Figure 4-1 and Figure 4-2 show the location of the SCSI terminator fuse and the SCSI address switch on each of the Multifunction I/O cards. The SCSI address switches are preset at the factory. The default setting is address = 7, parity = enable.

### **LAN Configuration**

Refer to Figure 4-1. The LAN Connector Configuration jumper allows the card to be connected to Thin LAN or Thick LAN. You cannot connect to Thin LAN and Thick LAN at the same time. Figure 4-1 shows the jumper positions for both options. The AUI port allows connection to twisted-pair and fiber optic cabling as well.

For HP Internal Use Only

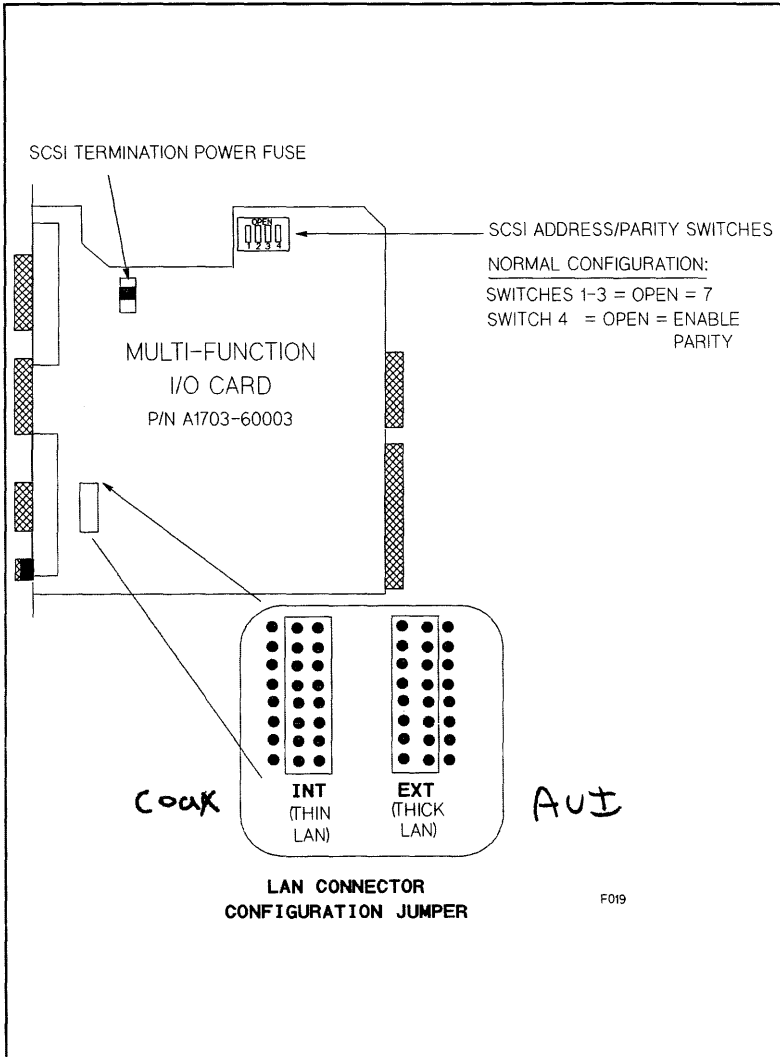
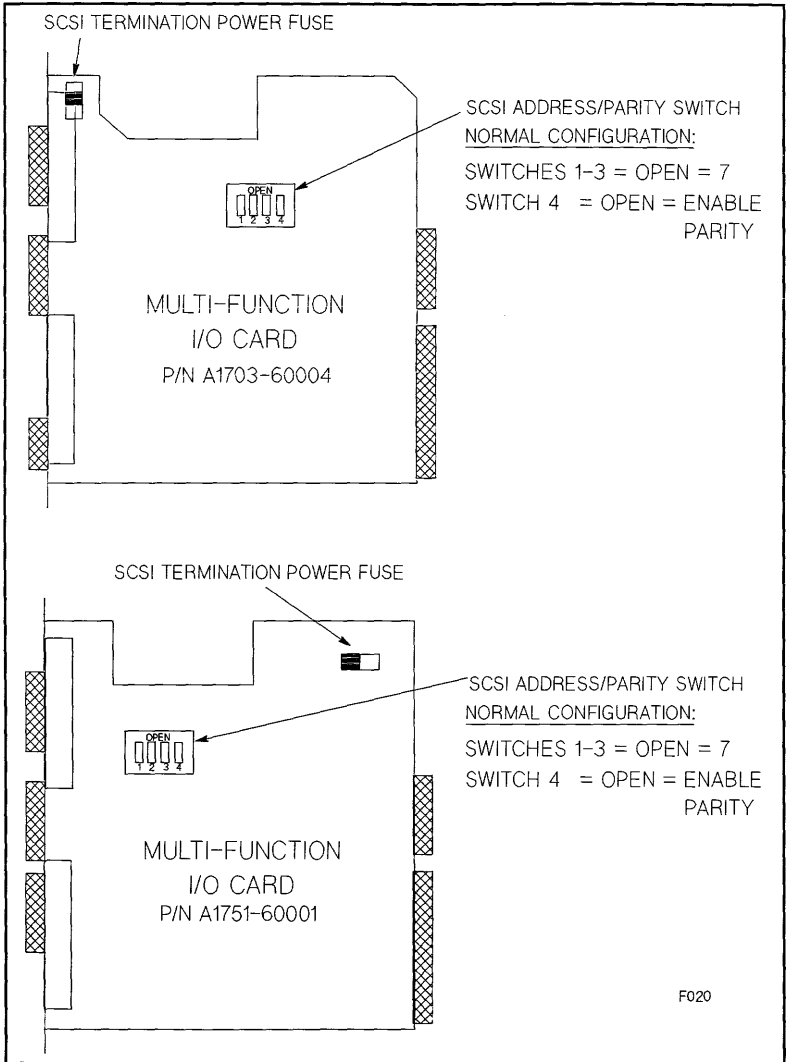

Figure 4-1. HP 3000 Series 9x7 Multifunction I/O Card Layout

**For HP Internal Use Only**



**Figure 4-2. HP 9000 Series 8x7 Multifunction I/O Card Layout**



---

## SCSI Configuration Rules

Table 4-5 shows the amount of internal SCSI cabling in the systems. It also shows the resulting maximum external SCSI cable that can be attached to the system Multifunction I/O PCA.

Table 4-6 lists the specifications of the SCSI bus.

Figure 4-3 is an example of internal SCSI cabling and configuration. Disk 0 always has termination for the internal SCSI bus. A separate SCSI terminator is added to the end of the SCSI internal bus in a diskless system.

Figure 4-4 shows a typical external SCSI device rear panel. It shows the location of the address and parity switches.

Figure 4-5 is an example of external SCSI cabling and configuration.

**Table 4-5. SCSI Cable Lengths**

System	Internal SCSI Cable	Maximum External SCSI Cable
Standard Chassis	1.5 meter <sup>1</sup>	4.5 meters
Expanded Chassis	3.0 meters <sup>1</sup>	3.0 meters

---

### Note

<sup>1</sup> A high-to-low density SCSI cable is required to connect external peripherals to the Multifunction I/O card. Refer to Table 8-1 for the correct part number.



**For HP Internal Use Only**

**Table 4-6. SCSI Bus Specifications**

Parameter	Characteristics
Features	8-bit bus. Connects up to 7 devices per adapter. Bus arbitration Parity Checking (default = parity enabled)
Maximum Cable Length (single-ended SCSI bus)	6 meters, including any internal lengths in all devices.
SCSI Bus Connection	Single-ended
Termination Requirement	The SCSI bus requires termination. The terminator <b>MUST</b> be connected to the last device on each end of the bus.
Active Terminator <sup>1</sup>	The last SCSI device must have +5V termination power enabled.
Address	0 - 7 7 = host (highest priority) 0 = lowest priority

---

**Note**



<sup>1</sup>Active termination is required outside the system cabinet. Passive termination is allowed in the system cabinet.

---

**For HP Internal Use Only**

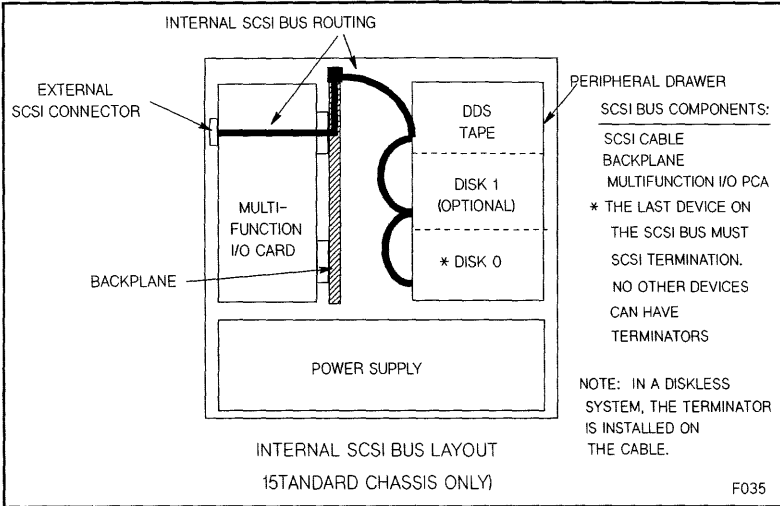

**Figure 4-3. Standard Chassis Internal SCSI Cabling and Configuration**

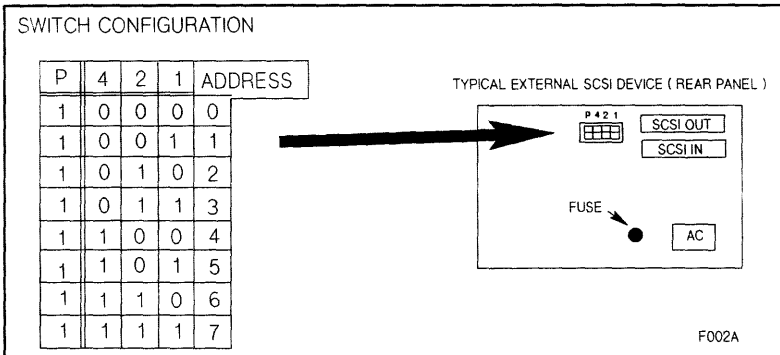

**Figure 4-4. Typical External SCSI Device Rear Panel and Switch Configuration**

For HP Internal Use Only

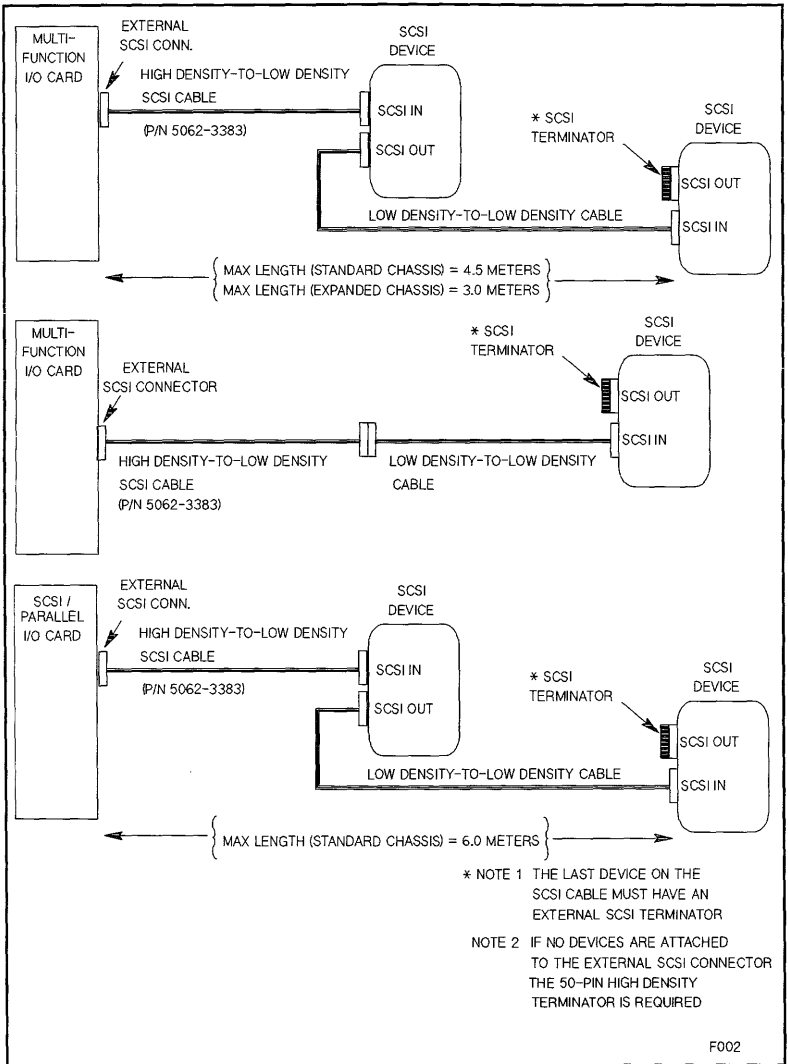

Figure 4-5. Standard Chassis External SCSI Cabling and Configuration

## HP-IB Configuration Rules

Refer to Figure 4-6 for the following discussion.

### Load Factors

Two load factors must be considered when calculating the cabling parameters of the HP-IB:

1. **Internal Load Factor.** The internal load factor of the Device adapter is seven loads.
2. **External Load Factor.** The external load factor of the peripherals is dependent upon the individual peripherals and interconnect cables. (Refer to *HP 3000 Computer Systems Configuration Guide, P/N 5954-9354, Appendix 1* for peripheral load values.) A basic rule for determining load values is you must have at least one electrical load for each meter of HP-IB cable.

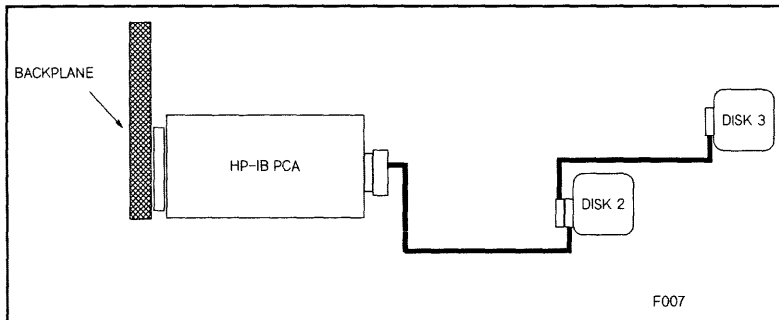

Figure 4-6. HP-IB Configuration Example

### HP-IB Cable Length

The maximum total length of HP-IB cable that can be connected to a device adapter is 15 meters. When testing a configuration, use the following rules:

1. No more than eight HP-IB devices per HP-IB Device Adapter. It is recommended that no more than six devices be connected.
2. Maximum of 15 device loads (internal + external).
3. Maximum HP-IB cable length must not exceed one meter per device load (maximum = 15 meters).
4. Daisy-chain (serial) cabling only
5. "Star" cabling not supported.

---

## Memory Subsystem Configuration

### Overview

The memory subsystem consists of memory arrays and hardware that resides on the CPU card, backplane assembly, and memory extender. Refer to Chapter 9 (Theory of Operations) for more information.

Figure 4-7 shows the backplane and memory extender PCA memory slot numbering scheme of the original systems. Slot 0A and 0B are located on the system backplane. The remaining slots are located on the memory extender.

Figure 4-8 shows the memory extender PCA memory slot numbering scheme of systems with 64 MHz or greater processor PCAs. There is no memory on the backplane.

---

<b>Note</b> 	HP Computer Models 977, 867S, and 877S <b>DO NOT</b> have memory slots on the backplane and the memory extender PCA (A1703-60031) is not compatible with any other HP computer system. Likewise, memory extender PCA A1703-60005 is not compatible with the HP 977, 867S, and 877S computers.  If the computer being upgraded does not have a memory extender PCA, contact the local Hewlett-Packard Sales representative.
--------------------------------------------------------------------------------------------------	----------------------------------------------------------------------------------------------------------------------------------------------------------------------------------------------------------------------------------------------------------------------------------------------------------------------------------------------------------------------------------------------------------------------------------

---

---

<b>Note</b> 	Model 8x7S and Series 9x7 memory boards are not interchangeable with Model 700 memory boards.
--------------------------------------------------------------------------------------------------	-----------------------------------------------------------------------------------------------

---

### Memory Configuration Rules

The following configuration guidelines apply to all HP 3000 9X7/9X7LX and HP 9000 8X7S computers.

1. Memory array cards **MUST** be installed in pairs.
2. Memory pairs can be installed in any pair of slot (e.g., 1A and 1B, 4A and 4B, etc). See Figure 4-7 and Figure 4-8.
3. Each memory card installed in a pair of slots must be the same size (e.g., 4MB and 4MB, 8MB and 8MB, 16MB and 16MB, etc)
4. Memory can be installed in slots 0A and 0B on the system backplane, and also in slots on the memory extender.
5. When a memory extender card is installed, it has to have at least one pair of memory cards inserted in it.
6. The HP 977, 867S, and 877S memory extender (A1703-60031) card does not work in the other HP 9X7/9X7LX or 8X7S computers. Likewise, the HP 9X7/9X7LX or 8X7S memory extender (A1703-60005) card does not work with the HP 977, 867S, or 877S computers.

For HP Internal Use Only

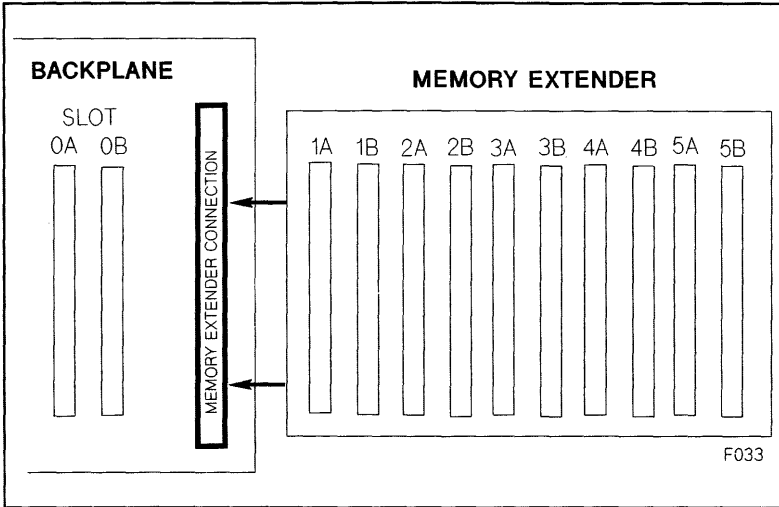

Figure 4-7. Memory System Slot Locations

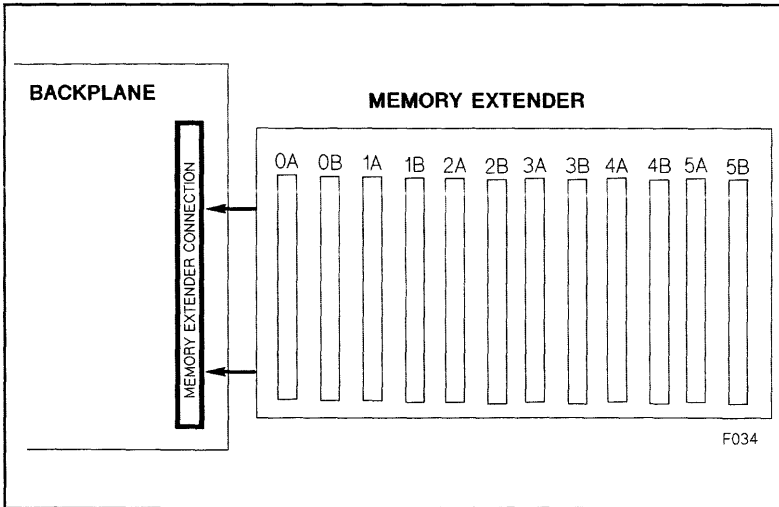

Figure 4-8. Memory System Slot Locations - 64 MHz Backplane

---

## Remote Support Modem Configuration

This section contains information for connecting specific modems to the HP 3000 Series 9x7 Family and HP 9000 Model 8x7 Family system Multifunction I/O (MFIO) modem interface connectors. This section also discusses the signal line behavior of the Multifunction I/O modem interface to aid in configuring modems that are not listed.

General rules for configuring modems:

- The modem must be set up to respond to DTR.
- CTS should follow RTS.
- DSR must follow OH, not DCD.
- For Bell mode, the modem should disregard RTS.
- Both modems should either be set to the same compression mode or both should be set to no data compression. If you have problems connecting two modems, usually the fault is that one is enabled for some MNP level and the other modem is set for no data compression.

If the modem sends up-modem dialog with all of the signals asserted, it is possible that the user will be logged off immediately when a password is enabled for the Access Port (AP). Fix this by setting the modem so it does not report connection status via the data path.

---

**Note** V.22bis/V.25bis modes are not supported on the HP 9000 8x7 Multi-function I/O interfaces.



---

The supported modems are described below.

### HP Support Link (HP50759A)

Supported modes:

- Bell
- CCITT\_OM
- CCITT\_AM
- CCITT\_BIS\_OM
- CCITT\_BIS\_AM

Supported cables:

- HP 92219Q - Bell, CCITT\_OM, CCITT\_AM
- A1703-63006 - CCITT\_BIS\_OM, CCITT\_BIS\_AM

Autodial modes: Hayes

This modem is the standard HP Support Link. It supports V.22bis line discipline, but does not support V.25bis autodialing. In order for V.22bis answer mode to work properly, DSR must follow OH. Data Compression should be set *OFF*. Setting data compression *ON* can cause problems when connecting to other modems that do not have data compression.



**For HP Internal Use Only**

**Table 4-7. 8-Position DIP Switch Option Settings**

Switch	Position	Description	Option Command
SW1	up	DTR Normal	&D2
SW2	<b>xx</b>	Verbose Responses	V1
SW3	up	Suppress Responses	&Q0
SW4	up	Enable Echo of commands	E1
SW5	up	Enable Auto Answer	S0=1
SW6	up	DCD/DSR Normal	&C1 &S1
SW7	<b>xx</b>	Depends on phone line	
SW8	down	Enable Command Mode	

**Note**      **xx** means do not care.



**Table 4-8. 4-Position DIP Switch Option Settings**

Switch	Position	Description	Option Command
SW1	down	CTS Normal	&R0
SW2	down	DSR Follows OH	&S1
SW3	down	Use HP Defaults	&E0 &E3 &E6 &E10 &E14 \$B A1
SW4	down	No ENQ/ACK Pacing	&E8

**Note**      An AT1517 command should have the following output:



```

BO E1 M1 Q0 V1 X0 &E0 &E3 &E6 &E8 &E10 &E14 &Q0
$MB2400 $SB2400 $BA1 &W1

&A0 $A0 &B0 &BS1 &C1 &D2 $D0 $F1 &G0 &I0 &M0 $MIO &R0 $R0 &S1 &T5 &V1 &W1

OK
    
```

**Hayes Smartmodem 2400**

Supported modes:

- Bell
- CCITT\_OM
- CCITT\_AM

Supported cables:

- Must use 92219Q modem cable.

Autodial modes: Hayes.

### For HP Internal Use Only

This modem drives circuit 111 (Pin 23) instead of using it as an input. With either cable (92219Q or A1703-63006), the Multifunction I/O PCA drives this line and the modem drives the same line.

#### Caution



This modem should not be used because all HP cables connect circuit 111 to the modem. If this modem is connected, both the Multifunction I/O PCA and the modem drive circuit 111. This modem has been used in the past with the CIO-based AP card and had the same problem.

Turn off all data compression modes.

The Hayes defaults for the modem lines must be changed to the following:

**Table 4-9. Switch Option Settings**

Switch	Position	Description	Option Command
SW1	up	DTR normal	AT&D3&W
SW2	xx		
SW3	down	Result codes disabled	ATQ1&W
SW4	up	Characters echoed	ATE1&W
SW5	up	Auto-Answer enabled	ATS0=1&W
SW6	up	Detect Carrier	AT&C1&S1&W
SW7	up	RJ-11	AT&J0&W
SW9	down	CCITT	ATB0&W
SW10	down	Return to command state	AT&D3&W

#### Note

xx means do not care.



### Black Box V.32 Plus (Version 2.01.01)

Supported modes:

- Bell
- CCITT\_OM
- CCITT\_AM

Supported cables:

- Must use 92219Q modem cable.

Autodial modes: Hayes.

This modem does not work with v.22bis because it does not supply 112 and because the sense of 111 is backwards (TRUE means low speed, FALSE means high speed). The fact that 111 is backwards is not too big a problem because the modem can be configured to ignore 111. Change so that DTE Fallback is *Disabled*. This is the factory default. Not supplying 112 means that the Multifunction I/O PCA always thinks it is running at the lower speed. If you set the speed for twice the desired speed, then it will work at the desired speed. It is best not to use this modem with any of the CCITT bis protocols.

### For HP Internal Use Only

The Black Box defaults for all of the modem lines are incorrect and must be changed before this modem will work properly. To do this from the front panel, go into the Change DTE Parameters and set the following:

- Responds to DTR
- DSR is Normal
- DCD is Normal
- CTS follows RTS

This can be done with the following AT command: `AT&D2&S1&C1&R`

For Hayes dialing, make certain that the AT command set is enabled. It is normally good to disable status messages to the host by using the `ATQ1` command.

The current configuration can become the power-on configuration by using the `AT&W` command.

This modem does not do any rate shifting. So the DTE rate and the DCE rate must be the same.

This modem seems to work in AP mode with the protocol set to either Bell or CCITT. It does not work with the modem protocol set to CCITT\_BIS. Make certain to configure the modem to ignore 111, or configure the Access Port to set FS low. It also seems to work fine in normal mode (i.e. under host control).

### Multitech MT224EH7

Supported modes:

- Bell
- CCITT\_OM
- CCITT\_AM
- CCITT\_BIS\_OM
- CCITT\_BIS\_AM

Supported cables:

- HP 92219Q - Bell, CCITT\_OM, CCITT\_AM
- A1703-64006 - CCITT\_BIS\_OM, CCITT\_BIS\_AM

Autodial modes: Hayes, V.25bis.

### Note



The version of the modem has a problem when dialing with V.25bis where if the number that is dialed is busy, DSR does not drop. This same problem causes V.25bis error indications to be improperly decoded, meaning that the modem timeout timer must expire before we know that the attempt failed. This also means that multiple dialing attempt will always fail. If the DSR jumper is set so that DSR follows DCD, this problem goes away.

The configuration of the hardware switches on the modem are:

8-position DIP-Switch:

Switch:	1	2	3	4	5	6	7	8
-----								
	UP	UP	DOWN	UP	UP	UP	DOWN	DOWN

### For HP Internal Use Only

4-position DIP-Switch:

```
Switch:  1    2    3    4
-----
        DOWN UP  UP  DOWN
```

For Hayes mode to work correctly, AT&R0 must be set so that it drops CTS when the connection goes down. For Hayes, AT&V0 must be set. For V.25bis dialing, VT&V1 and AT&BA1 must be set.

Hayes dialing parameters:

```
B0 E1 M1 Q0 R0 V1 X0 &E1 &E4 &E6 &E8 &E10 &E13 &E15
$MB2400 $SB2400 $BA1 &W0
```

```
S0 S2 S3 S4 S5 S6 S7 S8 S9 S10 S11 S12 S24 S25 S30
001 043 013 010 008 002 030 002 006 007 070 050 020 000 000
```

```
&A0 &A0 &B0 &BS1 &C1 $D0 &D2 #DB0 $EBO $F1 &GO #LO $MIO &MO
&PO #P2 &Q0 &Q3 $R0 &R1 &S1 $T1 &T4 $V0 $VDO &X0 YO
$MB2400 $SB2400 $BA1 &W0
```

OK

For V.22bis autoanswer, internal jumper DSR must be set so that DSR follows OH. The factory default is for DSR to follow CD. This is different from the Support Link where the factory default was for DSR to follow OH. There does not seem to be an AT command that does this.

V.25bis dialing parameters:

```
B0 E1 M1 Q0 R0 V1 X0 &E1 &E4 &E6 &E8 &E10 &E13 &E15
$MB2400 $SB2400 $BA1 &W0
```

```
S0 S2 S3 S4 S5 S6 S7 S8 S9 S10 S11 S12 S24 S25 S30
001 043 013 010 008 002 030 002 006 007 070 050 020 000 000
```

```
&A0 &A0 &B0 &BS1 &C1 $D0 &D2 #DB0 $EBO $F1 &GO #LO $MIO &MO
&PO #P2 &Q0 &Q3 $R0 &R1 &S1 $T1 &T4 $V1 $VDO &X0 YO
$MB2400 $SB2400 $BA1 &W0
VAL
```

To modify a MT224E7B:

- Open modem and change the DSR jumper.
- Set switches on the bottom of the box to above.
- Send AT&R0
- For Hayes dialing, send AT&V0.
- For V.25bis dialing, send AT&V1.

**For HP Internal Use Only**

**HP 37212B**

Supported modes:

- Bell
- CCITT\_OM
- CCITT\_AM
- CCITT\_BIS\_OM
- CCITT\_BIS\_AM

Supported cables:

- HP 92219Q - Bell, CCITT\_OM, CCITT\_AM
- A1703-64006 - CCITT\_BIS\_OM, CCITT\_BIS\_AM

Autodial modes: None

It is best to use this modem in CCITT mode because it causes the Access Port to hang up if used in Bell mode at 1200 baud. It can be used in Bell mode at 2400 baud, or either 1200 or 2400 in CCITT mode. This modem can not be dialed with either Hayes or V.25BIS autodial protocols.

S1	down	
S2	down	Computer mode operation (HP command set)
S3	up	
S4	down	Primary channel
S5	down	1 start, 8 data and 1 stop
S6	down	
S7	down	Error correction disabled
S8	up	No Flow control
S9	up	
S10	down	DSR/CTS/CD to RS-232-C definition
S11	up	
S2	up	DTR behaves to RS-232-C definition

---

**Note**



Although this modem claims to be able to dial using V.25bis, it only uses the V.25bis line discipline. The command set does not match the set specified in the V.25bis specification.

---

## For HP Internal Use Only

### Modem Cable Pin-out

The following pin-out is for the 92219Q cable, which is most often used to connect the Access Port to the support modem.

Computer End		Modem End
2	TD	3
3	RD	2
8	RTS	4
22	CTS	5
20	DSR	6
6	DTR	20
9	RI	22
4,5	DCD	8
23	FS	23
7	GROUND	7

The pinout for the A1703-63006 cable is the same except that pin 9 on the computer end is routed to pin 12 on the modem end and that Line functions as Rate Select (RS). This cable is only used with the A1703-60003 SCSI/Console/LAN Multifunction I/O interface for V.22bis/V.25bis applications.

### Multifunction I/O PCA Modem Line Behavior

#### CCITT Mode - AP protocol 0

This protocol is known as HP-UX CCITT. The card waits for RI before raising DTR. It also raises RTS when it raises DTR. If DSR does not come up within 25 seconds, DTR goes back down. The connection also depends on CTS and DCD. DCD can drop for up to 400ms before the connection will drop. CTS must stay high always. Once CTS drops, the connection starts to drop. A new connection cannot occur until DSR, DCD and CTS all drop. FS can be programmed to either state via the CA command.

#### Bell Mode - AP protocol 1

This is sometimes called Bell simple protocol. It raises DTR when it can accept a connection. The connection is valid when it sees DCD. It drives RTS whatever it was when Remote is enabled (usually, RTS is low) and does not look at DSR or CTS. When a disconnect is done, DCD must drop before a new connection can be made (i.e. it will not raise DTR until DCD drops).

#### CCITT\_BIS Mode - AP protocol 2

This protocol is CCITT V.22bis. It requires the special cable A1703-63006 which is just like the 92219Q cable with the exception that pin 9 on the computer end is routed to pin 12 (RS) rather than pin 22 (RI). DTR is raised whenever a connection is allowed. RTS follows DSR. A connection is established when DSR is high. CTS can drop for an indefinite amount of time without dropping the connection. The card will not send data to the modem when CTS is low. DCD can drop for up to 400ms before the connection is dropped. Once the connection is dropped, DSR, DCD and CTS must all go low before a new connection can be made. RS controls what speed the card sends to the modem. If RS is high, the programmed baud rate is

**For HP Internal Use Only**

used. If RS is low, half of the programmed baud rate is used. If you use the 92219Q cable, the baud rate will most certainly be half the programmed baud rate, since RI will almost always be down. FS can be programmed to either state via the CA command.

---

## Determining Hardware Device Paths

Use Table 4-10 and Table 4-11 to determine which valid device path addresses are associated with the backplane slot numbers.

The device path address is calculated with this formula.

$$\langle (\text{HP-PB slot number} * 4) + \text{module number} \rangle . \langle \text{device address} \rangle = \text{device path address}$$

**Table 4-10. Slot Path Addresses and Device Path Addresses**

Slot Number	Device Path Address (without Precision Bus Adapter)	Device Path Address (with Precision Bus Adapter)
1	4.<device address>	Not useable
2	8.<device address>	8.0.<device address>
3	12.<device address>	Not useable
4	16.<device address>	16.0.<device address>
5	20.<device address>	Not useable
6	24.<device address>	24.0.<device address>
7	28.<device address>	Not useable
8	32.<device address>	32.0.<device address>
9	36.<device address>	Not useable
10	40.<device address>	40.0.<device address>
11	44.<device address>	Not useable
12	48.<device address>	48.0.<device address>
13	Special slot. Refer to Table 4-11	
14	Special slot. Refer to Table 4-11	

**For HP Internal Use Only**

**Table 4-11. Slot 13 and 14 Path Addresses for Multifunction I/O Cards**

System Model	Slot Number	Device Path Address	Path Name
HP 9000/807S	13	52.<device address>	SCSI
	14	56.0	Console
	14	56.1	Remote Console
All other HP 9000 Systems	13	52.<device address>	SCSI
	13	53.0<device address>	Parallel Printer Port
	14	56.0	Console
	14	56.1	Remote Console
HP 3000 Systems	13	52.<device address>	SCSI
	14	56.0	Console
	14	56.1	Remote Console
	14	56	LAN



## 5.25-inch Hard Disk Drive Configuration

---

**Caution**



The drive configuration is set for the system it is installed in. Changing the configuration may cause the drive to malfunction.

Devices outside the system will be configured differently.

---

**Options**

The drive configuration is set with jumpers on option connectors 1 and 2 (see Figure 4-9 and Figure 4-10). A pin-set is shorted with a jumper installed, or open without a jumper. Table 4-13 lists pin-set functions for option connector 1. Table 4-15 lists pin-set functions for option connector 2.

**Caution**



The jumpers for option connector 1 and option connector 2 are not interchangeable. Interchanging the jumpers may damage the connectors.

---

For HP Internal Use Only

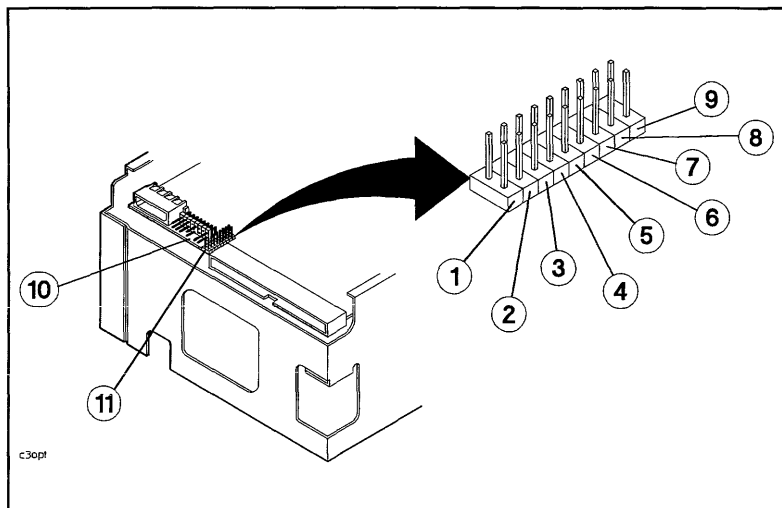

Figure 4-9. Option Connector 1 Pin-sets, Revision B

- |                                                 |                             |
|-------------------------------------------------|-----------------------------|
| 1. Pin-set 1 (Reset Enable)                     | 8. Pin-set 8 (Parity)       |
| 2,3. Pin-sets 2,3 (Sync Spindle Signal Routing) | 9. Pin-set 9 (Auto Spin-up) |
| 4,5. Pin-sets 4,5 (Terminator Power)            | 10. Option Connector 2      |
| 6. Pin-set 6 (Unit Attention)                   | 11. Option Connector 1      |
| 7. Pin-set 7 (SDTR <sup>1</sup> )               |                             |

<sup>1</sup>Synchronous Data Transfer Request

Table 4-12. Option Connector 1 Settings for 8x7S and 9x7 Systems

Pin-set	Setting
1 - 4	Open
5	Jumpered
6	Open
7 - 9	Jumpered

For HP Internal Use Only

Table 4-13. Option Connector 1 Functions

**Pin-set 1 (Reset Enable):**

- 1 = shorted      Reset enabled. Used in multiuser systems to provide fault tolerance. A Reset signal from the power supply is routed to the drive microproces
- 1 = open          Reset disabled.

**Pin-sets 2,3 (Sync Spindle Signal Routing):**

- 2 = shorted      Pin 29 of SCSI connector connected to ground. Note: when pin-set 3 is open, pin-set 2 *must* be shorted to connect pin 29 to ground.
- 3 = open
- 2 = open          Synchronized spindle sync signal routed to pin 29 of SCSI connector. Note: when pin-set 3 is shorted, pin-set 2 *must* be open.
- 3 = shorted

**Pin-sets 4,5 (Terminator Power):**

- 4 = open          **All Drives:** Drive +5 V not connected to terminator resistors; initiator supplied +5 V not connected to terminator resistors.
- 5 = open

- 4 = shorted      **All Drives:** Drive +5 V connected to terminator resistors but not to SCSI connector pins.
- 5 = open

- 4 = open          **Single-ended Drives:** Initiator supplies +5 V input to SCSI connector pin 26.
- 5 = shorted      **Differential Drives:** Initiator supplies +5 V input to SCSI connector pins 25 and 26.

- 4 = shorted      **Single-ended Drives:** Drive +5 V connected to terminator resistors and to SCSI connector pin 26.
- 5 = shorted      **Differential Drives:** Drive +5 V supplied to terminator resistors and to SCSI connector pins 25 and 26.

**Pin-set 6 (Unit Attention):**

- 6 = open          Enable Unit Attention
- 6 = shorted      Inhibit Unit Attention

**Pin-set 7 (SDTR):**

- 7 = open          Inhibit drive initiation of SDTR message
- 7 = shorted      Enable drive initiation of SDTR message at Power-On and Reset

**Pin-set 8 (Parity):**

- 8 = open          Inhibit parity checking
- 8 = shorted      Enable parity checking

**Pin-set 9 (Auto Spin-up):**

- 9 = open          Drive spins up when Initiator sends Start Unit command
- 9 = shorted      Drive will spin up automatically at Power-on

**For HP Internal Use Only**

**SCSI Address**

---

**Note**



Some drives include an address cable that is connected only to the SCSI Address pin-sets or is connected to the SCSI Address pin-sets and to the Reset pin. Refer to Table 4-15 for information on the function of the Reset pin.

---

On drives that do not include an address cable, the SCSI address is set using jumpers. Figure 4-10 shows jumper settings for SCSI address 0 through 7. Avoid using address 7. It is usually reserved for the host bus adapter (HBA).

For HP Internal Use Only

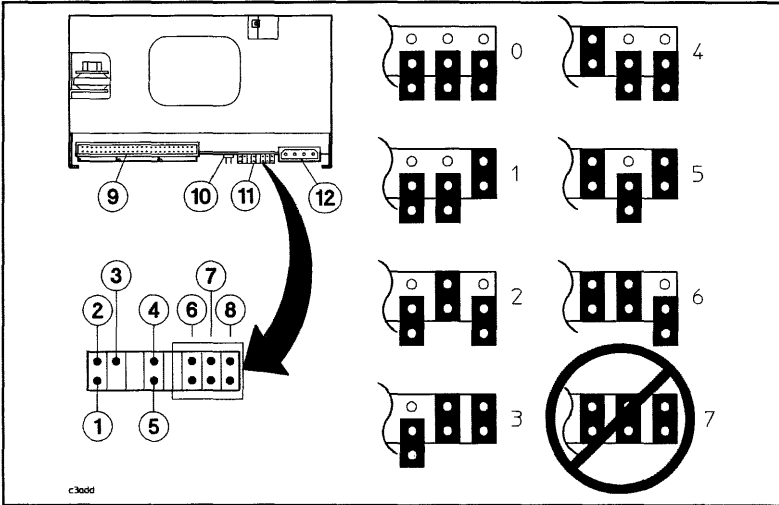

Figure 4-10. Option Connector 2 Pins and Pin-sets, Revision B

- |                                |                                      |
|--------------------------------|--------------------------------------|
| 1. Pin 1 (Sync Spindle Ground) | 6,7,8. Pin-sets 6,7,8 (SCSI Address) |
| 2. Pin 2 (Slave)               | 9. SCSI Connector                    |
| 3. Pin 3 (Master)              | 10. Option Connector 1               |
| 4. Pin 4 (Reset)               | 11. Option Connector 2               |
| 5. Pin 5 (NOT USED)            | 12. DC Power Connector               |

Table 4-14. Option Connector 2 Settings for 8x7S and 9x7 Systems

Pin-set	Setting
1 - 5	Open
6,7,8	Set to SCSI address

**For HP Internal Use Only**

**Table 4-15. Option Connector 2 Functions**

**Pin 1 (Sync Spindle Ground):** Provides a dedicated ground for synchronized spindle modes.

**Pin 2 (Slave):** Used as an input or output for synchronized spindle modes.

**Pin 3 (Master):** Used as an input or output for synchronized spindle modes.

**Pin 4 (Reset):** Used in multiuser systems to provide fault tolerance. A Reset signal from the power supply is routed to this pin, via a wire from the address cable, to warn of impending power loss.

**Pin 5 (NOT USED):** No connection to this pin.

**Pin-sets 6,7,8 (SCSI Address):** See Figure 4-10 for address settings.

**For HP Internal Use Only**

**Status Indicator Connector**

Figure 4-11 shows two configurations for the status indicator connector:

- If the drive is installed in a minitower cabinet, connect the status LED, with the cathode side of the LED facing the left edge of the PCA, to the status indicator connector.
- If the drive is installed in a rack cabinet, connect the status cable, white dot on the status cable connector facing downward, to the status indicator connector. The status cable routes the status signal to the cabinet front panel.

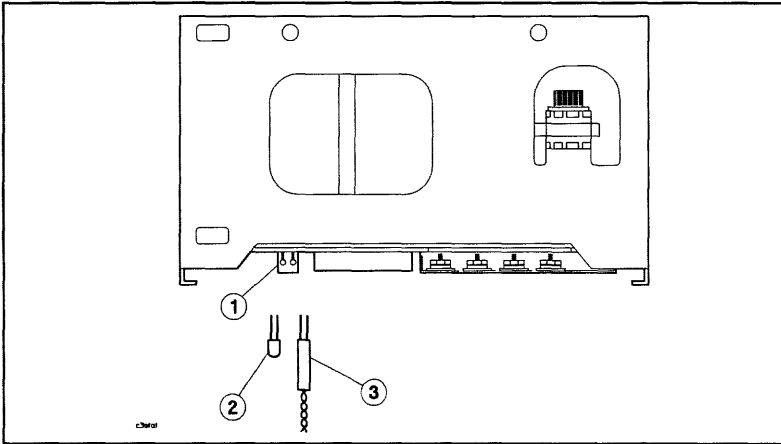

**Figure 4-11. Status Indicator Connector Configurations**

- |                               |                 |
|-------------------------------|-----------------|
| 1. Status Indicator Connector | 3. Status Cable |
| 2. Status LED                 |                 |

---

## 3.5-inch Hard Disk Drive Configuration

---

### Caution



The drive configuration is set for the system it is installed in. Changing the configuration may cause the drive to malfunction.

Devices installed outside the system will be configured differently.

---

### Options

The drive configuration is set with jumpers on option connectors 1, 2, and 3 (see Figure 4-14 and Figure 4-15). A pin-set is shorted with a jumper installed, or open without a jumper. Table 4-18 lists pin-set functions for option connectors 1 and 2. Table 4-20 lists pin-set functions for option connector 3.

### SCSI Address

---

### Note



Some drives include an address cable that is connected to the SCSI Address pin-sets and to the Reset pin. Refer to Table 4-20 for information on the function of the Reset pin.

---

On drives that do not include an address cable, the SCSI address is set using jumpers. Figure 4-15 shows jumper settings for SCSI address 0 through 7.

### Status Indicator Connector

The status indicator connector is used for routing the status indicator signal to the front panel via the hard disk status cable (see Figure 4-15).



For HP Internal Use Only

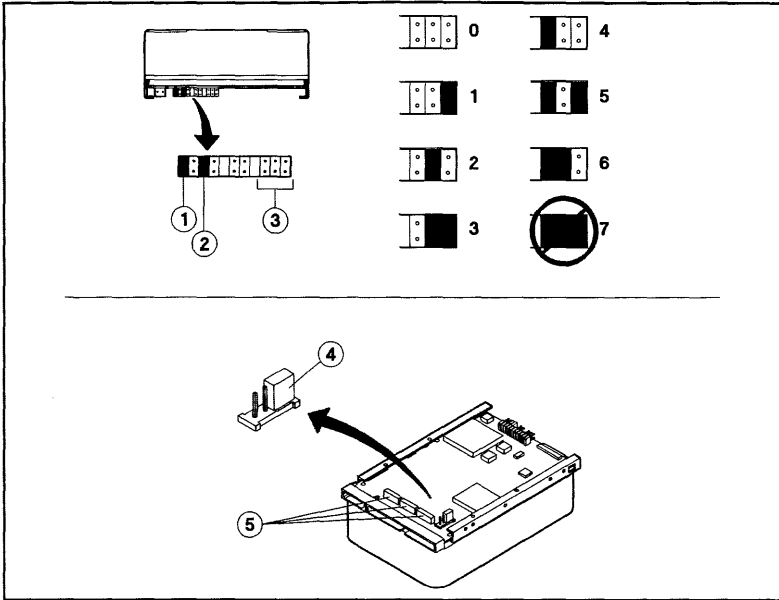
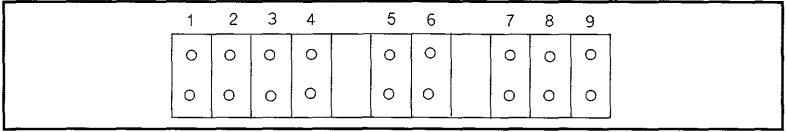

Figure 4-12. Type 1 Controller Default Configuration, Revision A

- |                                                                 |                             |
|-----------------------------------------------------------------|-----------------------------|
| 1. Unit Attention Jumper                                        | 4. Termination Power Jumper |
| 2. Parity Jumper                                                | 5. Resistor Packs           |
| 3. Address Connector<br>(use jumpers to set addresses as shown) |                             |

**For HP Internal Use Only**

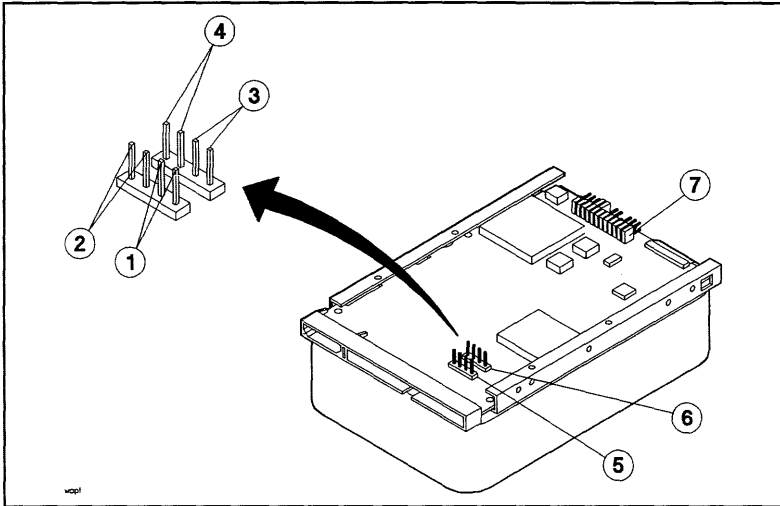

**Figure 4-13. Option Pin-sets, Revision A**

**Table 4-16. Option Settings for 8x7S and 9x7 Systems**

Pin-set	Setting
1	Open
2,3,4	Jumpered
5 - 9	Open

**For HP Internal Use Only**



**Figure 4-14. Pin-sets, Option Connectors 1 and 2, Revision B**

- 1. Pin-set 1 (Term Power 1)
- 2. Pin-set 2 (Term Power 2)
- 3. Pin-set 3 (Term Enable)
- 4. Pin-set 4 (Reset Enable)
- 5. Option Connector 1
- 6. Option Connector 2
- 7. Option Connector 3

**Table 4-17. Option Connector 1 and 2 Settings for 8x7S and 9x7 Systems**

Pin-set	Setting
1	Open
2,3	Jumpered
4	Open

**For HP Internal Use Only**

**Table 4-18. Pin-set Functions, Option Connectors 1 and 2, Revision B**

<b>Pin-sets 1,2,3 (Term Power 1, Term Power 2, Term Enable):</b>	
1 = open	■ Terminator resistor packs disabled. Terminator resistors not connected to SCSI connector.
2 = open	■ Initiator +5 V not connected to on-board terminators.
3 = open	■ Drive +5 V not connected to on-board terminators or to SCSI connector pin 26.
1 = shorted	■ Drive +5 V connected to on-board terminators but not to SCSI connector pin 26.
2 = open	
3 = shorted	
1 = open	■ Initiator supplies +5 V input to SCSI connector pin 26 for on-board terminators.
2 = shorted	
3 = shorted	
1 = shorted	■ Drive +5 V connected to on-board terminators and to SCSI connector pin 26.
2 = shorted	
3 = shorted	
<b>Pin-set 4 (Reset Enable):</b>	
4 = shorted	Reset enabled. Used in multiuser systems to provide fault tolerance. A Reset signal from the power supply is routed to the drive microprocessor to warn of impending power loss (see Figure 4-15, pin 1). The drive finishes writing the current sector, then stops writing to prevent data loss.
4 = open	Reset disabled.

For HP Internal Use Only

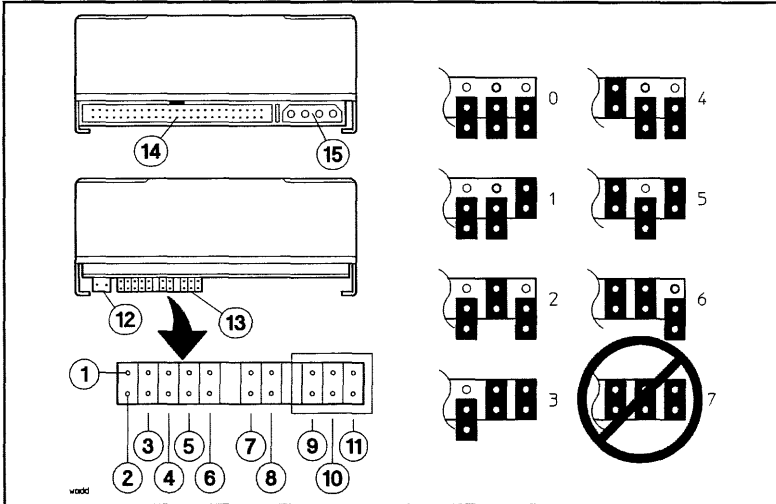

Figure 4-15. Pins and Pin-sets, Option Connector 3, Revision B

- |                                   |                                          |
|-----------------------------------|------------------------------------------|
| 1. Pin 1 (Reset)                  | 7,8. Pin-sets 7,8 (Sync Spindle)         |
| 2. Pin 2 (NOT USED)               | 9,10,11. Pin-sets 9,10,11 (SCSI Address) |
| 3. Pin-set 3 (Unit Attention)     | 12. Status Indicator Connector           |
| 4. Pin-set 4 (SDTR <sup>1</sup> ) | 13. Option Connector 3                   |
| 5. Pin-set 5 (Parity)             | 14. SCSI Connector                       |
| 6. Pin-set 6 (Auto Spin-up)       | 15. DC Power Connector                   |

<sup>1</sup>Synchronous Data Transfer Request

Table 4-19. Option Connector 3 Settings for 8x7S and 9x7 Systems

Pin-set	Setting
1 - 2	Open
3,4,5	Jumpered
6 - 8	Open
9 - 11	Set to SCSI address

For HP Internal Use Only

Table 4-20. Pin-set Functions, Option Connector 3, Revision B

<b>Pin 1 (Reset):</b>	
Used in multiuser systems to provide fault tolerance. A Reset signal from the power supply is routed to this pin, via a wire from the address cable, to warn of impending power loss.	
<b>Pin 2 (NOT USED):</b> No connection to this pin.	
<b>Pin-set 3 (Unit Attention):</b>	
3 = open	Unit Attention Enabled
3 = shorted	Unit Attention Disabled
<b>Pin-set 4 (SDTR):</b>	
4 = open	Inhibit drive Initiation of SDTR message
4 = shorted	Enable drive Initiation of SDTR message at Power-on and Reset
<b>Pin-set 5 (Parity):</b>	
5 = open	Inhibit parity checking
5 = shorted	Enable parity checking
<b>Pin-set 6 (Auto Spin-up):</b>	
6 = open	Drive spins up when Initiator sends Start Unit command
6 = shorted	Drive will spin up automatically at Power-on
<b>Pin-sets 7,8 (Sync Spindle):</b>	
7 = shorted	Pin-set 6, upper pin, is sync output in Master Mode, or sync input in Slave Mode. Lower pin is connected to ground. <b>NOTE:</b> when pin-set 7 is open, pin-set 6 <i>must</i> be shorted in order to connect pin 29 of the SCSI connector to ground.
8 = open	
7 = open	Connects sync signal line to pin 29 of SCSI connector. Pin 29 then becomes sync output in Master Mode, or sync input in Slave Mode. <b>NOTE:</b> when pin-set 7 is shorted, pin-set 6 <i>must</i> be open.
8 = shorted	
<b>Pin-sets 9,10,11 (SCSI Address):</b> (See Figure 4-15 for address settings.)	

## 5.25-inch DDS-Format DAT Drive Configuration (C1502A)

The only hardware configuration required on the DAT drive is changing the SCSI address during installation if the default address (typically 4) conflicts with another device.

### SCSI Address

The SCSI address for the DAT is set using the jumpers shown highlighted in Figure 4-16. The remaining jumpers should be left in the default positions shown.

Set the SCSI address using the patterns shown. Avoid using address 7 since it is usually reserved for the HBA.

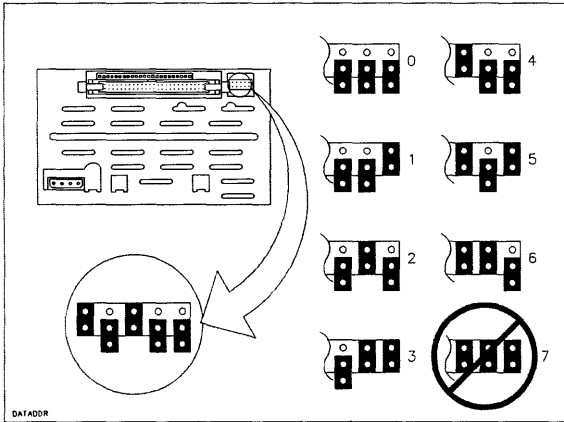
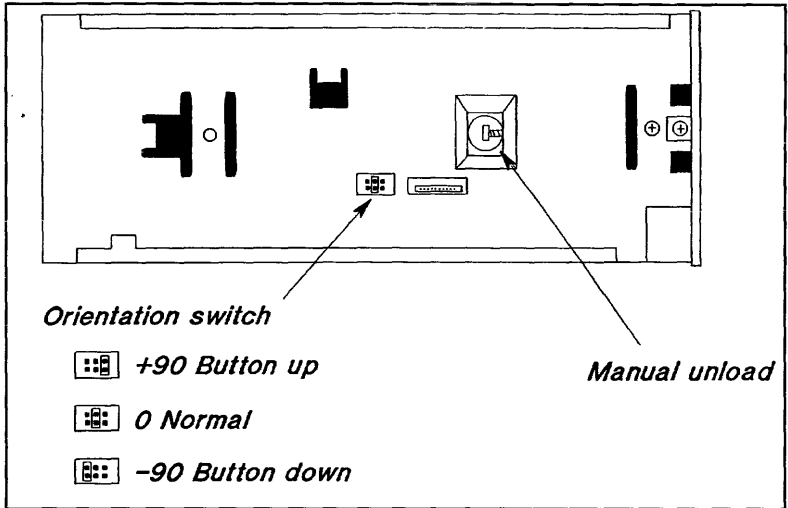

Figure 4-16. Setting the DAT Drive SCSI Address

**For HP Internal Use Only**

**Orientation Switch**

The DAT drive orientation switch is located on the left side of the drive. When a standard-chassis system is installed in a cabinet, it is installed on its side. Before the system is installed in a cabinet, set the DAT drive orientation switch to the **-90** position. See Figure 4-17.



**Figure 4-17. DAT Drive Orientation Switches**



---

## 3.5-inch DDS-Format DAT Drive Configuration (C1503B)

---

### Caution



The drive configuration is set for the system it is installed in. Changing the configuration may cause the drive to malfunction.

Devices installed outside the system will be configured differently.

---

### Options

The drive configuration is set with jumpers on the option connector (see Figure 4-18). A pin-set is shorted with a jumper installed, or open without a jumper.

### SCSI Address

---

### Note



Some drives include an address cable that is connected to the SCSI Address pin-sets.

---

On drives that do not include an address cable, the SCSI address is set using jumpers. Figure 4-18 shows jumper settings for SCSI address 0 through 7. Avoid using address 7. It is usually reserved for the host bus adapter (HBA).

For HP Internal Use Only

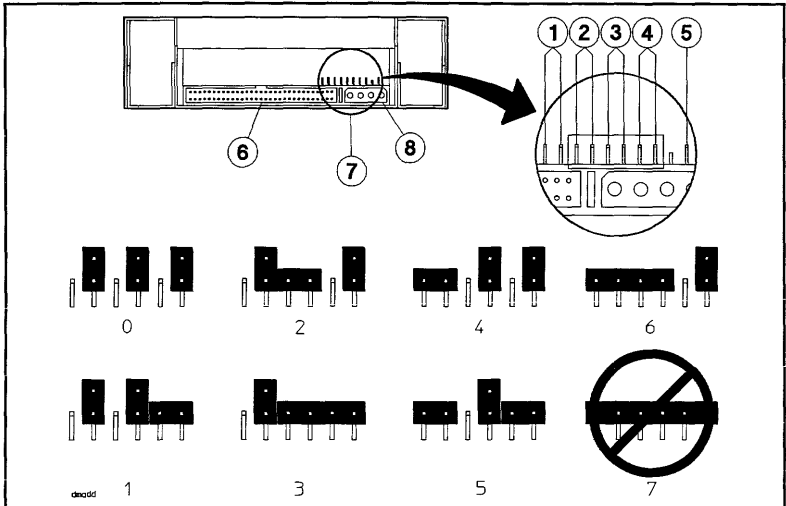

Figure 4-18. Option Connector Pin-sets and SCSI Address Options

- 1. Pin-set 1 (Terminator Power)
- 2,3,4. Pin-sets 2,3,4 (SCSI Address)
- 5. Pin 5 (NO CONNECTION)
- 6. SCSI Connector
- 7. Option Connector
- 8. DC Power Connector

Table 4-21. Option Connector Settings for 8x7S and 9x7 Systems

Pin-set	Setting
1	Open
2,3,4	Set to SCSI address
5 - 8	Open

**For HP Internal Use Only**

**Optional Configuration Jumper Switch**

Set the switches on the bottom of the drive as shown in Figure 4-19.

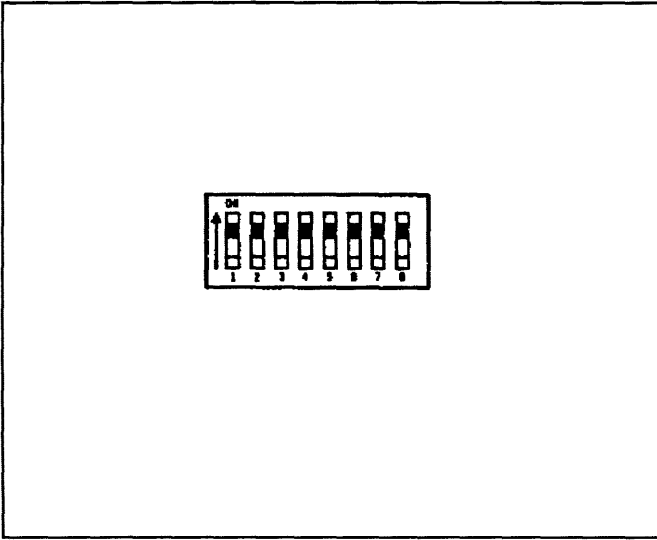

**Figure 4-19. Optional Configuration Jumper Switch**

**For HP Internal Use Only**

---

### **3.5-inch DDS-Format DAT Drive Configuration (C1504B)**

All of the configuration information for the C1504B 3.5-inch DAT drive is the same as that for the C1503B 3.5-inch DAT drive

---

## CD-ROM Drive Configuration

---

**Caution**  The drive configuration is set for the system it is installed in. Changing the configuration may cause the drive to malfunction.

Device installed outside the system will be configured differently.

---

### Options

The drive configuration is set with jumpers on the option connector (see Figure 4-20). A pin-set is shorted with a jumper installed, or open without a jumper. Table 4-23 list the option connector pin-set functions.

### SCSI Address

---

**Note**  Some drives include an address cable that is connected to the SCSI Address pin-sets.

---

On drives that do not include an address cable, the SCSI address is set using jumpers. Figure 4-20 shows jumper settings for SCSI address 0 through 7. It is usually reserved for the host bus adapter (HBA).

For HP Internal Use Only

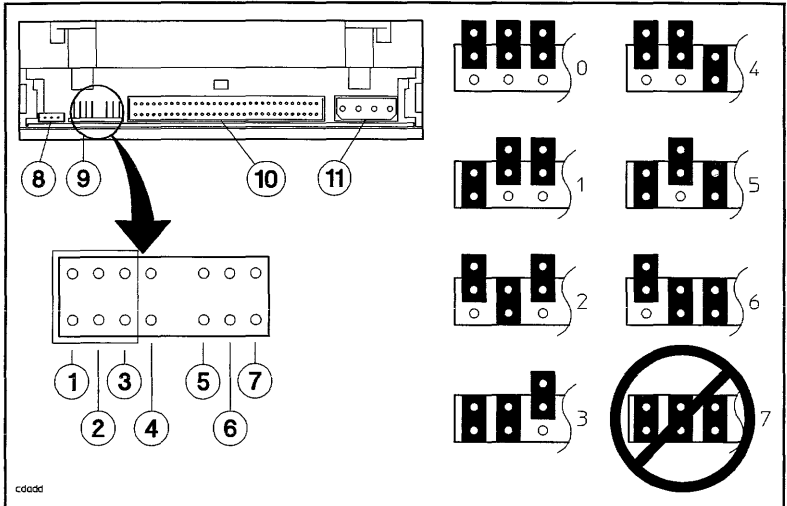

Figure 4-20. Configuration Pin-sets

- 1,2,3. Pin-sets 1,2,3 (SCSI Address)
- 4. Pin-set 4 (Parity)
- 5. Pin-set 5 (Prevent/Allow)
- 6. Pin-set 6 (Test)
- 7. Pin-set 7 (Terminator Power)

Table 4-22. Configuration Settings for 8x7S and 9x7 Systems

Pin-set	Setting
1,2,3	Set to SCSI address
4	Jumpered
5 - 7	Open

**For HP Internal Use Only**

**Table 4-23. Option Connector Pin-set Functions**

**Pin-sets 1,2,3 (SCSI Address):** (See Figure 4-20 for address settings.)

**Pin-set 4 (Parity):**

open	Disable parity
shorted	Enable parity

**Pin-set 5 (Prevent/Allow):**

open	Allow the CD-ROM to be ejected from the drive.
shorted	Prevent the CD-ROM from being ejected from the drive. The eject button will not function.

**Pin-set 6 (Test):**

open	Disable continuous audio on a CD.
shorted	Enable continuous audio on a CD.

**Pin-set 7 (Terminator Power):**

open	Terminator power is supplied by the host computer.
shorted	Terminator power is supplied by the drive.

## Quarter-inch Cartridge (QIC) Tape Drive Configuration

### Caution



The drive configuration is set for the system it is installed in. Changing the configuration may cause the drive to malfunction.

Devices installed outside the system will be configured differently.

The location of the jumpers and termination resistors on the Drive Controller PCA is shown in Figure 4-21. The location of the jumpers on the Motor Driver PCA is shown in Figure 4-22.

See Figure 4-21. JP1 determines the SCSI address of the QIC drive. In this system, the internal tape drive is always set to address zero. No jumpers are installed.

JP2 pin 1 determines the type of SCSI interface. A jumper is always installed on pin 1 to select the SCSI-2 interface.

JP2 pin 2 through 9 are never jumpered.

The termination resistors are located at RN1, RN2, and RN3. All termination resistors must be removed before the tape unit is installed.

See Figure 4-22. JP1 is always jumpered. The jumper provides a logic ground to chassis ground connection.

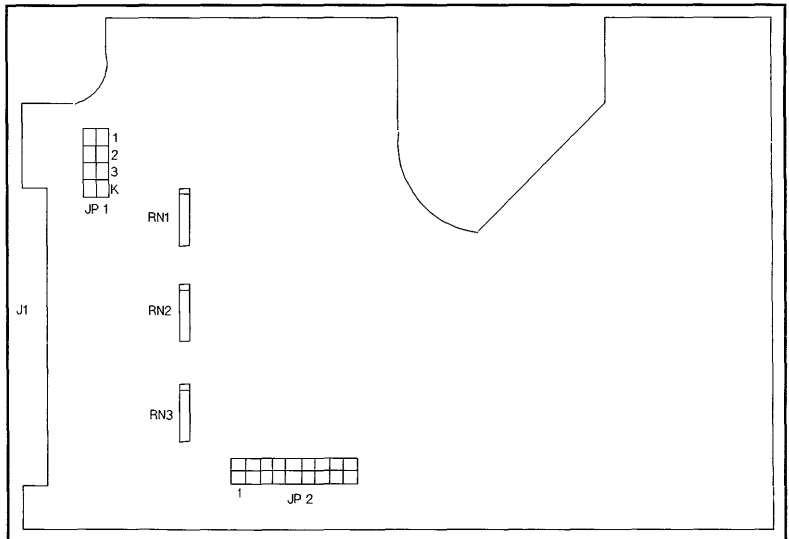
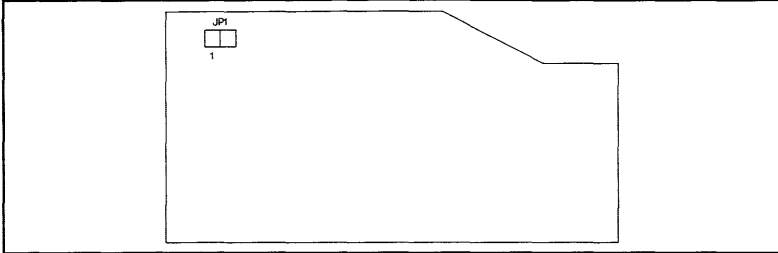

Figure 4-21. QIC Tape Drive Controller PCA Configuration



**For HP Internal Use Only**



**Figure 4-22. QIC Tape Drive Motor Driver PCA Configuration**

---

## **Cabinet Configuration Rules**

Although the cabinets are designed to accommodate a variety of components mounted in just about any configuration, there are some basic rules that apply to mounting a computer system. These rules allow for weight distribution, accessibility of the components, and cable management inside the rack-mount cabinet. The rules are as follows:

- The computer is always mounted on top.
- The HP 2345A (DTC-48) is always mounted on the bottom.
- The C246XR (disk drive cabinet) goes under the computer unless an HP 7980S/SX (tape drive) is being put in, then the HP 7980S/SX goes under the computer first.
- The installation of an HP 7980S/SX also requires the installation of counter ballast weights (C2786-60017 at 13.61 kg each with three required).
- ADPs are mounted on an ADP mounting bracket, starting as low as possible on the rear mounting columns.

These rules are noted in case the customer wants to add any optional equipment or change the position of the components in the cabinet. Figure 4-23 and Figure 4-24 show examples of the cabinet configuration for the HP computer system. The cabinet can also be used to house the peripherals for a computer system.

For HP Internal Use Only

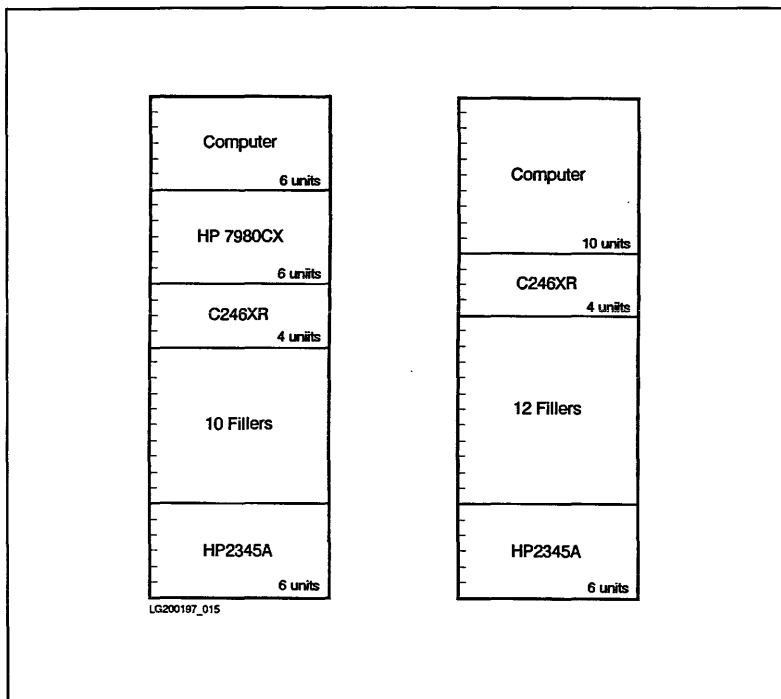

Figure 4-23. 1.6 Meter Cabinet Configuration Example

For HP Internal Use Only

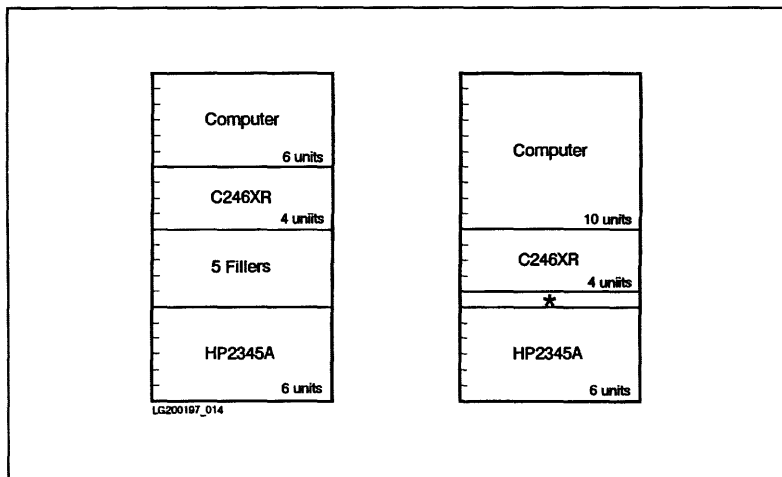

Figure 4-24. 1.1 Meter Cabinet Configuration Example

\* 1 filler panel.

## Troubleshooting

---

### Introduction

Table 5-1 shows the major steps in system execution and the displays that indicate normal completion.

**Table 5-1. States of Operation**

Major State	Normal Completion Indicator
1. Power On	Green and orange front panel LEDs lit
2. Selftest Execution	Boot message on console
3. Console Communication	Boot message on console
4. IPL Boot Attempt	Hex code = CE00 (console banner)
5. ISL Boot Attempt	ISL message
6. OS Boot Attempt	Login message
7. OS Run Time	System prompt

Table 5-2 is a hardware system troubleshooting reference guide. It summarizes the sequence of events from system power-on to a running operating system. The major steps of system execution are shown. Possible error indicating states and the associated corrective action are shown.

In the following procedures, if replacement is recommended for more than one part, replace the parts one at a time in the recommended order and test to see if the problem is solved.

**For HP Internal Use Only**

**Table 5-2. System Troubleshooting Reference Guide**

Step	State of Indicators	Action
1. DC POWER ON	All front panel indicators out.	Replace power supply with Fault LED on. Refer to Figure 5-1.
2. SELFTEST EXECUTION		
a. CPU, Memory	Hex code = 0000 Hex code = 10xx - 40xx Hex code = 503F  Hex code = 7000  Hex code = 707D  Hex code = 70xx	Go to Step 2b. Replace Processor PCA HPMC. Refer to Figure 5-2. Replace PCA(s) listed in the HPMC Error Log table (PDC PIM command). HPMC. Refer to Figure 5-3. Replace Memory PCA listed in the HPMC Error Log table (PDC PIM command). No memory found. Can also be caused by Backplane or Memory Extender. Replace Memory PCA in memory slot (xx), Backplane, Memory Extender.
b. Multifunction I/O PCA and ADP	SCSI Selftest LED = ON MUX Status LED = ON LINK Status LED = ON Term Power LED = OFF  ADP Power On LED = OFF	Replace Multifunction I/O PCA Replace Multifunction I/O PCA Replace ADP, ADP cable Remove Multifunction I/O PCA and replace on-board termination power fuse. Check cable connection or replace Multifunction I/O PCA
c. DDS Tape Drive	Drive LED = yellow Drive LED = yellow and Cassette LED = yellow Cassette jam	Replace DDS Tape Drive assembly Overhumidity condition. Do not use tape drive until LED pattern changes. Hold button in for 10 seconds to eject.
d. Internal Disk(s)	Disk Status LED = blinking or flashing (Only valid prior to an IPL boot attempt)	Refer to Figure 5-4. Replace Disk Controller PCA

**For HP Internal Use Only**

**Table 5-2. System Troubleshooting Reference Guide (continued)**

Step	State of Indicators	Action
3. CONSOLE COMMUNICATION	HEX code = C4xx, C6xx, or A088	Check terminal configuration and cable connection or replace Multifunction I/O PCA
4. IPL BOOT ATTEMPT	Hex code = A008 IODC Error Status message on console	Attempt to boot from another device. Replace I/O card you attempted to boot from. Replace boot device attached to I/O card.
5. ISL BOOT ATTEMPT	Hex code = 800x  Hex code = C5x0  Hex code = C7xx	Change boot path address to match device address.  Primary path initialization failed. Reboot from alternate path.  Alternate or other path initialization failed. Reboot from primary path.
6. OS BOOT ATTEMPT	Orange fault indicator lit on front panel  Green Run indicator lit on front panel but no message.	Go to Step 7.  Go to Step 2b.
7. OS RUN TIME	Hex Code = 2040  Hex code = 503F  Hex code = 7000  Hex code = CBFF	Replace Processor PCA  Refer to Figure 5-2. Replace I/O PCA(s) listed in HPMC Error Log (PDC PIM command).  Refer to Figure 5-3. Replace Memory PCA listed in HPMC Error Log (PDC PIM command).  Multiple HPMC's from above list. Act only on first recorded HPMC.
8. Degraded Performance	Normal run-time indicators	Go to <i>System Log File Procedures</i>

## **Troubleshooting Flowcharts**

The following troubleshooting flowcharts are used to isolate faults to the FRU.

- Power Troubleshooting
- Bus Fault Troubleshooting
- PCA Troubleshooting
- Internal Disk Troubleshooting
- MPE/iX OS Troubleshooting

For HP Internal Use Only

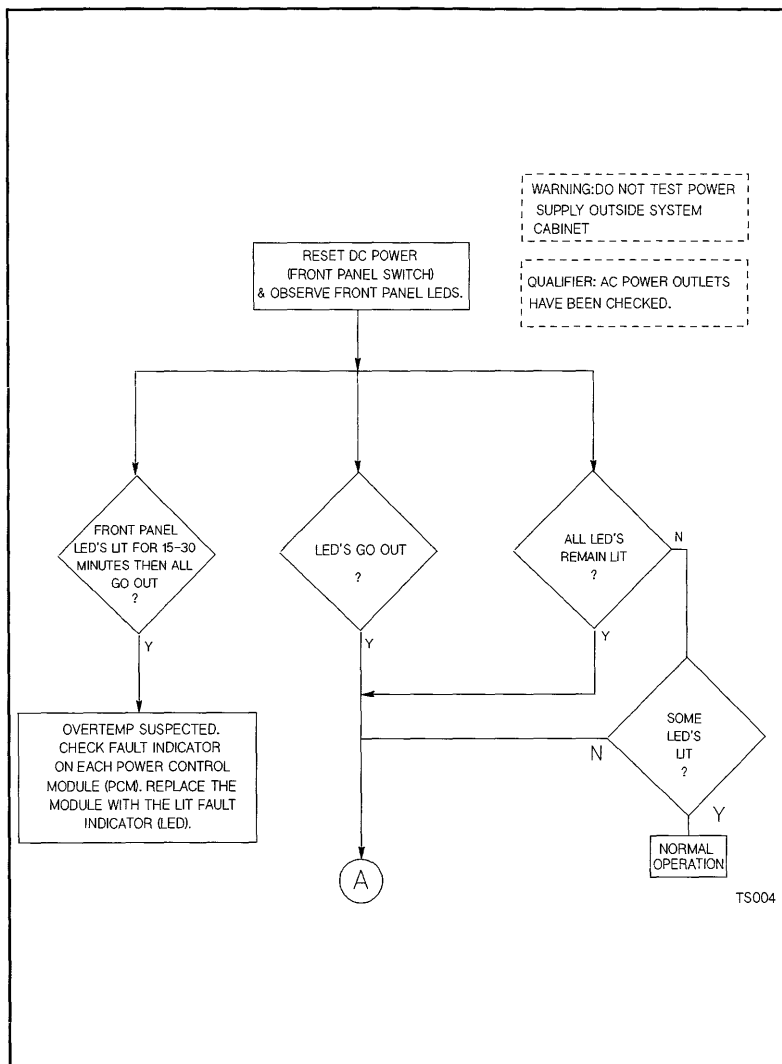
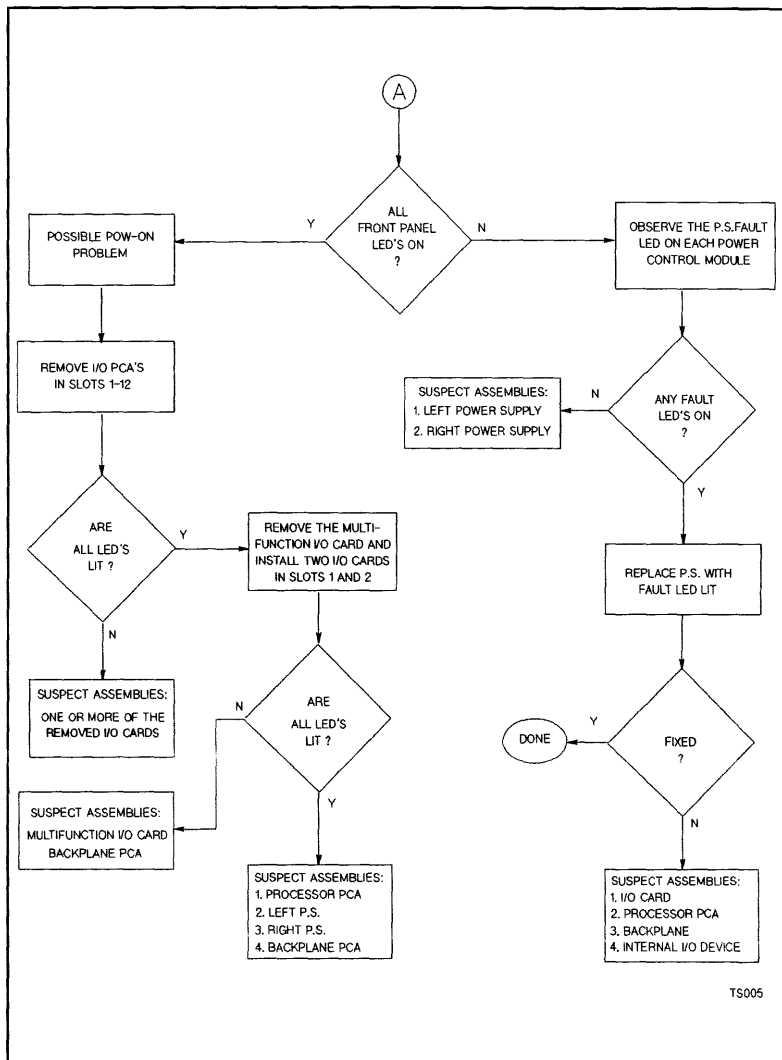

Figure 5-1. Power System Troubleshooting Flowchart (page 1 of 2)



For HP Internal Use Only



TS005

Figure 5-1. Power System Troubleshooting Flowchart (page 2 of 2)

For HP Internal Use Only

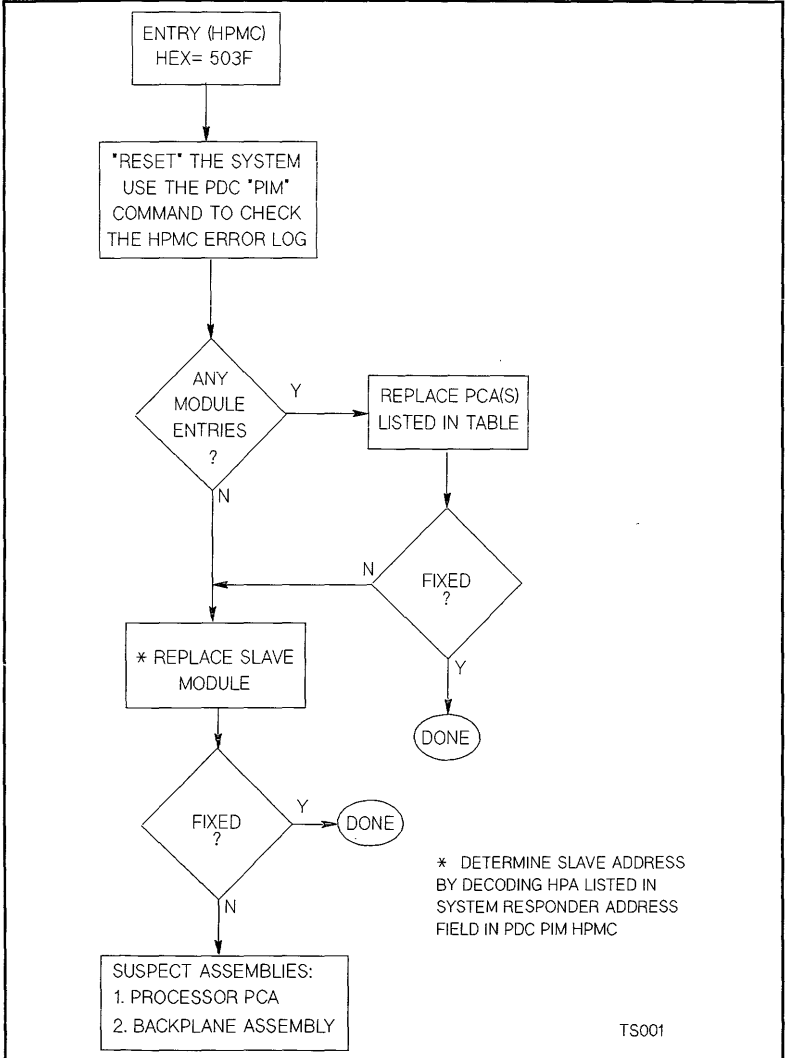

Figure 5-2. Bus Error Troubleshooting Flowchart

For HP Internal Use Only

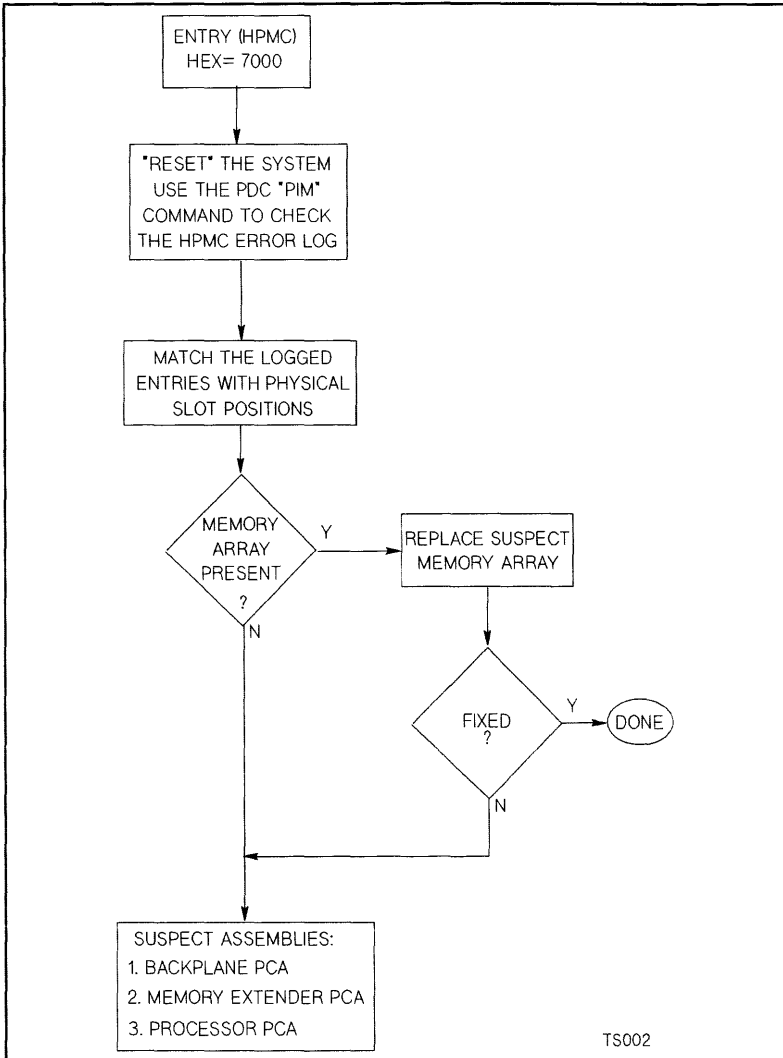

Figure 5-3. PCA Troubleshooting Flowchart

For HP Internal Use Only

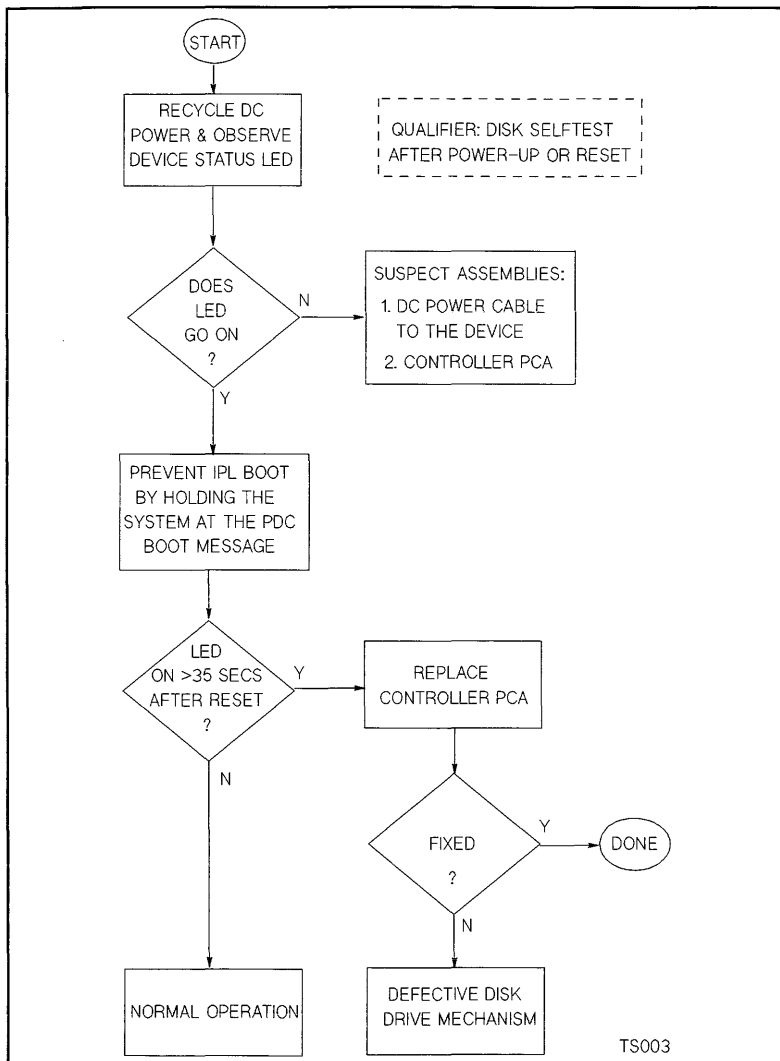
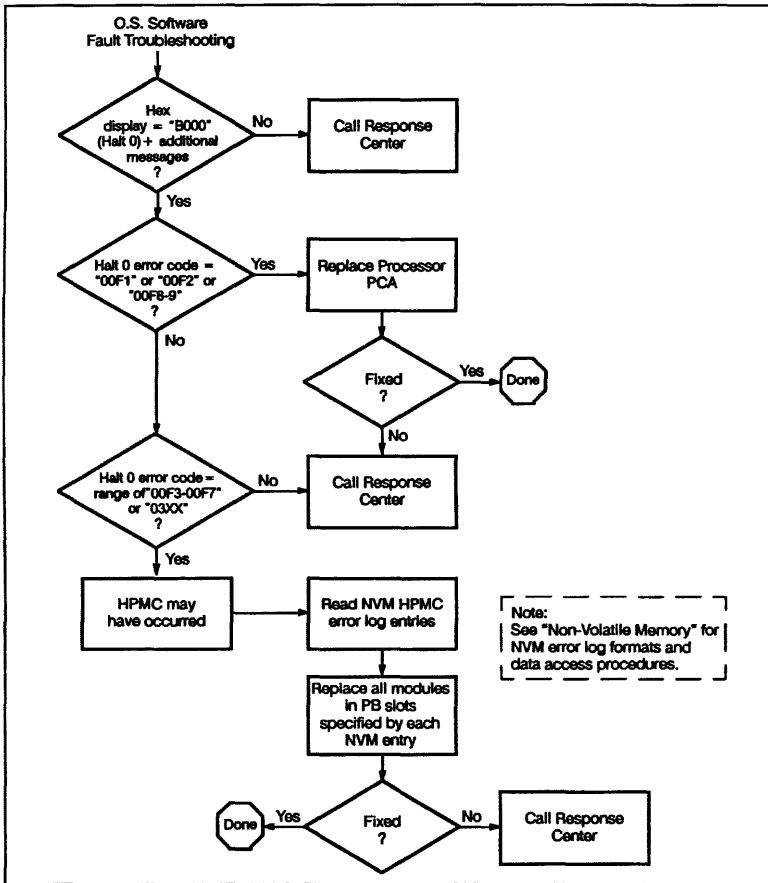

Figure 5-4. Internal Disk Troubleshooting Flowchart

For HP Internal Use Only



LQ200153\_018a

Figure 5-5. MPE/iX Operating System Troubleshooting Flowchart

---

## Error Codes and Messages

### Introduction

Error codes and messages come from the following sources:

- PDC
- ISL
- Operating Systems
- Access port
- Error logs

### PDC Codes

The PDC Selftest codes can be used to identify field replaceable units.

Table 5-3 summarizes the major test sections of PDC selftest. Table 5-4 lists the major PDC selftest error and status codes.

Table 1-4 shows how the OSTAT field is displayed in the system console banner and how it is associated with the front panel operating state indicators. The PDC codes are displayed in the HEXC field of the banner.

**Table 5-3. PDC Selftest and Diagnostic Test Section Summary**

Test Section	Description
1xxx	CPU and TLB
2xxx	Cache
3xxx	Processor Dependent Hardware (PDH)
4xxx	Floating Point Coprocessor
5xxx	Bus Transactions
3xxx	Stable Store, ROM, and EPROM
7xxx	RAM Cards
8xxx	I/O Device Errors
9xxx	Console Initialization Errors
Axxx	Boot Device Initialization Errors
Bxxx	OS Panic
Cxxx	System Initialization

**For HP Internal Use Only**

**Table 5-4. PDC Status and Error Codes**

Code	Description
1000	Unexpected interrupt occurred during PDC execution
3000	Start ROM checksum selftest
3001	Error reading from Stable Storage. Contents invalid
3002	Error occurred writing to EEPROM
9000	Stable storage console not found
9001	Alternate console not found
9EAA	Floating point data path failure
A008	No bootable device found
A088	No console. Unable to boot
C201	Starting the process of initializing memory destructively
C202	Starting the process of initializing memory non-destructively
C5FF	Branching to IPL, primary path
C7FF	Branching to IPL, other paths
CB00	TOC handler entered - OSTAT=INIT
CB00	TOC handler fault - OSTAT=FLT
CB0B	Branching to OS_TOC handler
CBF0	HPMC handling initiated
CBFB	Branching to OS_HPMC handler

**Table 5-5. HPMC Error Halt Codes**

Code	Description
2040	HPMC due to cache error
503F	HPMC due to bus error
7000	HPMC due to memory error
CBFF	Nested HPMC occurred, hanging the machine. This error code is alternately displayed with one of the error codes above.

**For HP Internal Use Only**

Table 5-6 through Table 5-12 list all of the PDC selftest sections by major category.

**Table 5-6. CPU/TLB Self-test Error Codes**

Code	OSTAT Display	Test
1080	TEST	CPU_DIAG
1081	TEST	CPU_BASIC
1082	TEST	CPU_ALU_BR
1083	TEST	CPU_SHADOW
1086	TEST	CPU_BIT_OP
1087	TEST	CPU_ARITH_COND
108A	TEST	CPU_AR_SIDE_EFF
108B	TEST	CPU_CR
108C	TEST	CPU_EXT_INT
10D0	TEST	VIPER_DIAG
10D1	TEST	VIPER_EIR
10D2	TEST	VIPER_HPMC
10D3	TEST	VIPER_TOC
10D4	TEST	VIPER_MEM_INTERFACE
10D5	TEST	VIPER_INVALID_ADDR
10D6	TEST	VIPER_BUFF_AND_QUEUE
10D7	TEST	VIPER_EDC



**For HP Internal Use Only**

**Table 5-7. Cache Self-test Error Codes**

Code	OSTAT Display	Test	Multiplexed Error Displays
2040	FauLT	CACHE_ERR_HPMC	
2041	FauLT	ICACHE_BAD_SIZE	
2042	FauLT	DCACHE_BAD_SIZE	
2090	TEST	CACHE_DLINE	000F, 000D (tag or data) 0111, 0ddd (I-cache or D-cache) Bit position (left to right)
2091	TEST	CACHE_ALINE	most significant 1/2 data word - expected least significant 1/2 data word - expected 2091 displayed again most significant 1/2 data word - actual least significant 1/2 data word - actual
2092	TEST	ICACHE_RAM	0ff, 0ddd (tag, data) Bit number (in hex)
2093	TEST	DCACHE_RAM	0ff, 0ddd (tag, data) Bit number (in hex)
2094	TEST	CACHE_TAG	
2095	TEST	CACHE_ERR	
2096	TEST	CACHE_CONFIG	
2097	TEST	CACHE_FLUSH	
2098	TEST	CACHE_BYTE	
2099	TEST	ICACHE_MISS	
209A	TEST	DCACHE_MISS	
209B	TEST	CACHE_DONE	

**Table 5-8. PDC Floating Point Coprocessor Selftest Error Codes**

Code	OSTAT Display	Test
4080	TEST	TIMEX_REG
4081	TEST	TIMEX_INSTR
4082	TEST	TIMEX_TRAPS
4083	TEST	TIMEX_DONE

**Table 5-9. Bus Self-test Transactions**

Code	OSTAT Display	Test
503F	FauLT	BUS_ERR_HPMC
50FF	FauLT	BOA_BAD_SPEED_BITS

**For HP Internal Use Only**

**Table 5-10. Stable Store, ROM, and EEPROM Error Code**

Code	OSTAT Display	Test
3000	TEST	ROM_XSUM
3001	FauLT	SS_FATAL_ERROR
3002	WARNIing	ERR_WRITING_EEPROM
3003	TEST	FATAL_ERR_WRITING_EEPROM

**Table 5-11. Memory Subsystem Self-test Error Codes and Slot Numbers**

Code	OSTAT Display	Slot Number
700A	TEST	0A
700B	TEST	0B
701A	TEST	1A
701B	TEST	1B
702A	TEST	2A
702B	TEST	2B
703A	TEST	3A
703B	TEST	3B
704A	TEST	4A
704B	TEST	4B
705A	TEST	5A
705B	TEST	5B
707D	TEST	No memory found
7000	FauLT	MEM_ERR_HPMC
C200	INITialize	Initializing RAM
C201	INITialize	BEG_DESTR_MEM_INIT
C202	INITialize	BEG_NONDESTR_MEM_INIT

**Table 5-12. I/O Device Error Codes**

Code	OSTAT Display	Test
8003	TEST	ERR_READING_IODC_BYTES
8004	TEST	ERR_READING_EINIT
8005	TEST	ERR_EXEC_EINIT
8006	TEST	ERR_READING_EIO
8007	TEST	ENTRY_IO_ERR
8008	TEST	INVALID_DEV_CLASS

**For HP Internal Use Only**

**Table 5-13. ISL Boot Codes**

Code	Description
0x00	No error currently detected. In process of initializing or using this device
0x01	Could not find ENTRY_INIT (IODC Driver)
0x02	Error while executing ENTRY_INIT (IODC Driver)
0x03	Could not find ENTRY_IO (IODC Driver)
0x04	Error while executing ENTRY_IO (IODC Driver)
0x05	Device class of device indicates it is not bootable
0x06	LIF Magic on boot media is not 0x8000
0x07	IPL address on boot media is either 0 or not 2K aligned
0x08	IPL size on boot media is 0, greater than maximum, or not 2K aligned
0x09	IPL entry address on boot media is not within range of IPL addresses or is not word aligned
0x0A	IPL on boot media does not checksum correctly

---

## IODC Codes and Messages

---

### ISL Boot Codes

#### HP-UX ISL Boot Codes

**Table 5-14. HP-UX ISL Boot Codes**

Display	Description
CB00	Transfer-of control initiated by the firmware (also see the D*** codes)
CEC0	Hpuxboot has been loaded and initialization begun (realmain() has been entered)
CED0	Hpuxboot has entered main()
CED2	Hpuxboot is about to configure the I/O system
CED4	Hpuxboot is about to mount the root file system
CEDA	Hpuxboot is about to list the contents of a directory
CEDB	Hpuxboot is about to load the kernel into memory
CEDC	Hpuxboot is about to start a copy operation
CEDD	Hpuxboot is about to stop (return to rdb)
CEDE	Hpuxboot is about to return to ISL
CEDF	Hpuxboot is about to launch the kernel

For HP Internal Use Only

**MPE/iX ISL Boot Codes**

**Table 5-15. MPE/iX ISL Boot Codes**

Display	Description
CE40	MMSAVE Launched
CE41	Establish first available free memory
CE42	Align input buffers for DMA transfer
CE43	Initialize I/O driver pointers
CE44	Write welcome message to console
CE46	Reading LIF volume label
CE47	Getting values from volume label
CE48	Reading LIF directory
CE49	Find disk address and size of DUMPAREA LIF file
CE4A	DUMPAREA found. Start writing to disk
CE4B	Memory written to DUMPAREA. Proceeding to ISL
CE4C	Finding ISL disk address and size
CE4D	Reading ISL
CE4E	Launching ISL
CE4F	Writing error message
CE50	Calling IODC to write message to console
CE51	Configuring memory controllers
CE52	Completed memory controller configuration

**Table 5-16. MPE/iX System Initialization Codes**

Display	Description
CF00	Entering launch
CF02	Mapped system state
CF04	Allocating memory
CF08	Backing out into Genesis
CF0A	Entering Genesis
CF30	Initializing Genesis completed
CF40	Initializing resident kernel completed
CF50	Initializing non-resident kernel completed
CF60	CM SL binding completed
CF70	Configuring system I/O completed
CF80	System volume initialized and mounted
CF90	Initializing CM OS completed

## For HP Internal Use Only

### MPE/iX Operating System Halts

Factors contributing to system halts can be isolated by referring to the hex display on the SPU control panel. In the hex display, a series of four-character codes will be sequentially displayed; the number of codes in a sequence can vary from one to four.

The first four-character number displayed identifies the source of the halt. When the monitor is the source of the halt (Halt 0 error), the first number is Bx00; a system abort (Halt 7 error) is identified as Bx07 (where x = the processor module number).

Subsequent display numbers identify the reason for the halt. The subsequent numbers are displayed in the form 0xnn, where "x" is a sequence number that begins at 1 and increments, and "nn" is an informational number. The reason for the halt can be interpreted by stringing all the informational ("nn") numbers together to form the hexadecimal error code.

#### Description of Display Sequence:

```
B800          MONITOR HALT 03A1 (Hex) - Non-functional TLB
0103
02A1
DNZZ
```

```
First Number Displayed:   B 8 0 0
                          /  |  \ \
                          B = OS Fault |  \-\ Halt Number
                              |
                              Processor Module Number
```

```
Subsequent Numbers:      0 1 0 3
                          /  |  \ \
                          0 = Continuation |  \-\ Informational Number
                              |
                              Sequence Number
```

```
                          0 2 A 1
                          /  |  \ \
                          0 = Continuation |  \-\ Informational Number
                              |
                              Sequence Number
```

```
                          D N Z Z
                          /  |  \ \
                          D = System Shutdown |  \-\ Informational Number
                              |
                              Forced Shutdown (140% complete)
```

**For HP Internal Use Only**

**Examples of Display Sequences:**

B000                    MONITOR HALT 0300 (Hex) - A "critical" HPMC occurred.  
0103  
0200  
DEAD

B007                    SYSTEM ABORT 0003 (Hex) - Genesis Module Error  
0103  
DEAD

B000                    MONITOR HALT 008F (Hex) - Data page fault without  
018F                                                         RDB, MPE/iX not ready.  
DEAD

B007                    SYSTEM ABORT 0315 (Hex) - NM Ports Module Error  
0103  
0215  
DEAD

---

**Note**



Leading zeroes are assumed when only a single sequence (01xx) information number is displayed, as shown in the two middle examples above (0003 and 008F). The error codes listed in Table 5-17 and Table 5-18 include these leading zeroes, where applicable.

---

**For HP Internal Use Only**

**Table 5-17. MPE/iX Halt 0 Operating System Error Codes**

<b>Code</b>	<b>Type</b>	<b>Cause</b>	<b>Action</b>
0001 thru 0019	Info	The breaker handler to (RDB) was re-entered.	Unless otherwise noted, for all Halt 0 error codes: Take memory dump; then call Response Center.
0020	Info	A breaker 0 instruction was encountered without R.	
0021	Info	An unknown HPMC occurred.	
0022	Info	A non-recoverable LPMC occurred.	
0028	Info	Reinit_idoc failed to read entry_init.	
0029	Info	Reinit_idoc failed to read entry_io.	
0030	Info	Image larger than first memory controller.	
0031	Info	Series 800 processor will not function in Series 900 system.	Call Response Center.
003E	Info	A non-recoverable branch taken or break trap occurred.	
003F	Info	A bad instruction received from RDB.	
0040	Info	A configured module was lost on power fail.	
0041	Info	A bus converter was lost on power fail.	
0042	Info	A bus converter was added on power fail.	
0043	Info	Memory was added on power fail.	
0044	Info	A module was added on power fail and generated an address conflict.	
0045	Info	Memory self-test failed in map_system_state.	
0046 thru 004E	Info	Error on call to entry_init in reinit_IODC (error return number is 0x50).	

**For HP Internal Use Only**

**Table 5-17. MPE/iX Halt 0 Operating System Error Codes (continued)**

Code	Type	Cause	Action
005B thru 005F	Info	The parallel card driver (RDB communications) encountered something that it could not interpret.	Unless otherwise noted, for all Halt 0 error codes: Take memory dump; then call Response Center.
0066 thru 006E	Info	Error on call to entry_io in CONSOLE_READ or CONSOLE_WRITE (error return number is 0x50).	
0080 thru 0099	Info	A trap that neither RDB or MPE/iX could interpret occurred (080n is the hex trap number from Section 5 of the processor ACD).	
00F1	Info	Non-recoverable instruction TLB error.	Take memory dump. Replace CPU. May be OS bug.
00F2	Info	Non-recoverable data TLB error.	Take memory dump. Replace CPU. May be OS bug.
00F3	Info	Non-recoverable bus address error.	Take memory dump. Replace CPU. May be OS bug.
00F4	Info	Non-recoverable bus error on I/O space read.	Follow OS Troubleshooting Flowchart Figure 5-5.
00F5	Info	Non-recoverable bus error on memory read or write.	Follow OS Troubleshooting Flowchart Figure 5-5.
00F6	Info	Non-recoverable bus error on I/O space write.	Follow OS Troubleshooting Flowchart Figure 5-5.
00F7	Info	Non-recoverable bus error with processor slave.	Follow OS Troubleshooting Flowchart Figure 5-5.
00F8	Info	Non-recoverable cache tag error.	Take memory dump. Replace CPU. May be OS bug.
00F9	Info	Non-recoverable data cache error.	Take memory dump. Replace CPU. May be OS bug.
00FA	Info	Non-recoverable assist coprocessor error.	Take memory dump. Replace CPU. May be OS bug.
00FB	Info	Non-recoverable instruction cache error.	Take memory dump. Replace CPU. May be OS bug.



**For HP Internal Use Only**

**Table 5-17. MPE/IX Halt 0 Operating System Error Codes (continued)**

<b>Code</b>	<b>Type</b>	<b>Cause</b>	<b>Action</b>
0300	Info	A "critical" HPMC occurred.	Unless otherwise noted, for all Halt 0 error codes: Take memory dump; then call Response Center.
0301	Info	Bad state prevented HPMC recovery.	Follow OS Troubleshooting Flowchart Figure 5-5.
0302	Info	Bad reserved bits prevented HPMC recovery.	Follow OS Troubleshooting Flowchart Figure 5-5.
0303	Info	HPMC handling corrupted the real mode stack.	Follow OS Troubleshooting Flowchart Figure 5-5.
0321	Info	Cache data was corrupted and cannot be located.	Replace CPU.
0322	Info	Cache data for a known address was corrupted.	Replace CPU.
0340	Info	A bus error resulted in an HPMC.	Follow OS Troubleshooting Flowchart Figure 5-5.
0361	Info	A coprocessor other than 0 asserted HPMC.	Follow OS Troubleshooting Flowchart Figure 5-5.
0362	Info	An SFU asserted HPMC.	Follow OS Troubleshooting Flowchart Figure 5-5.
03A1	Info	The TLB is non-functional.	Follow OS Troubleshooting Flowchart Figure 5-5.

**For HP Internal Use Only**

**Table 5-18. MPE/iX Halt 7 Operating System Error Codes**

<b>Hex Code Range</b>	<b>Decimal Range</b>	<b>OS Module Error</b>	<b>Action</b>
0000 - 0013	0 - 19	Genesis	All Halt 7 error codes: Perform memory dump, then call Response Center.
0032 - 0045	50 - 69	Configuration for Genesis	
0046 - 0063	70 - 99	Softdump	
0064 - 00C7	100 - 199	Start	
00C8 - 018F	200 - 399	Update/Install	
01C2 - 01D5	450 - 469	Job/Session	
01F4 - 0212	500 - 530	Storage Management	
0258 - 02BB	600 - 699	File System	
02BC - 0383	700 - 899	NM Ports	
0384 - 03B5	900 - 949	High Level I/O	
03E8 - 0513	1000 - 1299	Memory Manager	
0514 - 0527	1300 - 1319	Switch	
0528 - 053B	1320 - 1339	Clocks	
053C - 054F	1340 - 1359	Traps	
0550 - 0559	1360 - 1369	Support Management and VSM	
0564 - 056D	1380 - 1389	External INT Handler	
0578 - 0581	1400 - 1409	IOSERV	
0582 - 058B	1410 - 1419	System Logging	
058C - 0595	1420 - 1429	Table Management	
05AA - 05DB	1450 - 1499	Process Management	
05DC - 0671	1500 - 1649	Dispatcher	
06A4 - 07CF	1700 - 1999	Virtual Space Management	
07D0 - 0833	2000 - 2099	SEC Storage Management	
0834 - 08C9	2100 - 2249	Transaction Management	
0960 - 09F5	2400 - 2549	CM Ports	
09F6 - 09FE	2550 - 2558	CM Support	
09FF	2559	CM Fatal	
0A00 - 0A13	2560 - 2579	CM Stack Size Management	
0A14 - 0A27	2580 - 2599	CM Object Management	
0A8C - 0A95	2700 - 2709	Command Interpreter	
0AF0 - 0B53	2800 - 2899	Break	
0B54 - 0BB7	2900 - 2999	Turbo Image	
0BB8 - 0BC1	3000 - 3009	QA Testing	
0BCC - 0BD5	3020 - 3029	Network Interface	

For HP Internal Use Only

Table 5-18. MPE/iX Halt 7 Operating System Error Codes (continued)

Hex Code Range	Decimal Range	OS Module Error	Action
0BE0 - 0BE9	3040 - 3049	Internet Protocol	
0BF4 - 0BFD	3060 - 3069	Mapping Table	
0C08 - 0C11	3080 - 3089	Transmission Protocol	
0C12 - 0C1B	3090 - 3099	Buffer Manager	
0FA0 - 1387	4000 - 4999	NS Transport Modules	
1388 - 13EC	5000 - 5100	Bug Cache	

### HP-UX Operating System Errors

When HP-UX detects a panic or HPMC, it will automatically execute a Transfer-of-Control (TOC) and save memory contents to the swap area of the disk. Immediately after this memory dump, the system automatically reboots.

The memory contents stored in the swap area are put into a file and directory (usually /tmp/savecore), as specified by the savecore command, in the etc/rc script.

### HP-UX System Panic Codes

The system will display a panic code if the kernel panics, in the following format:

```
B800
||||-----Panic_types: 0 = General purpose panic
|||                      9 = Dump completed, disks not fully sync'ed
|||                      A = Dump completed, disks fully sync'ed
|||
|||
|||-----Panic_code: 0 = Not known
||                      1 = Transfer-of-Control
||                      2 = High Priority Machine Check
||
||
||-----Processor Module Number: 0-F
|
|
|-----Operating System Fault Code
```

Refer to Table 5-20 for examples of HP-UX system panic codes.

### For HP Internal Use Only

#### Note



Regardless of the processor module number or the panic\_code (the two middle positions in the four-character system panic code), the “Action” in Table 5-20 will always be to analyze the memory dump or panic tombstone to find the cause of the panic. An exception is when an HPMC is indicated. Use the HPMC Error-Log Table.

**Table 5-19. HP-UX System Initialization Codes**

Display	Description
CEE0	Kernel was loaded and initialization has begun (realmain() was entered)
CEF0	Kernel has entered main()
CEF2	Kernel is about to configure the I/O system
CEF4	Kernel is about to mount the root file system
CEF6	Kernel is about to set up the page-out daemon
CEF8	Kernel is about to start the init process

#### HP-UX OS Display Codes

**Table 5-20. HP-UX System Panic Codes**

Display	Description
B000	Kernel panic
B009	Panic dump completed (disks not fully synchronized)
B00A	Panic dump completed (disks fully synchronized)

**Table 5-21. HP-UX System Shutdown Codes**

Display	Description
D000	Shutdown begun (boot() has been entered)
D400	Shutdown in progress (returned from update(), about to wait for buffers to be flushed)
D600	Shutdown in progress (busy-wait after update() has completed)
D900	Shutdown completed (disks not fully synchronized)
DA00	Shutdown completed (disks fully synchronized)
D004	Transfer-of-control core dump begun
D904	TOC dump completed (disks not synchronized)
D010	High-priority machine-check core dump begun
D910	HPMC dump completed (disks not synchronized)

**For HP Internal Use Only**

**Table 5-22. HP-UX System Run Codes**

<b>Display</b>	<b>Description</b>
FX1F	System running. An F in the first and fourth digits indicates the system is running normally. The second digit (X) is updated every 5 seconds with the length of the run queue at that time (an instantaneous reading, NOT an average). It indicates the number of processes. Loads higher than 9 display as A. The third digit indicates the number of processors. In HP 9000 8x7S systems, it is always set to 1.

## Access Port Error Messages

Error Codes	Error Codes and Causes Error Messages and Error Causes
02	<p><b>Cannot verify deassertion of POW_ON signal. (APERR 02)</b></p> <p>The AP did its best to de-assert the POW_ON signal, but doesn't see it de-asserted when reading it back. The circuitry that pulls on the line might be broken, or the circuitry used to read back the line might be broken. In any case, this is a major failure. Call your HP representative ...</p>
05	<p><b>AP failed self-test number xx (APERR 05).</b></p> <p>This message is emitted when a failure occurs during the execution of a self-test launched from the command interpreter. XX gives the decimal number of the failing self-test.</p>
08	<p><b>Permitted accesses to AP NVM exceeded. (APERR 08)</b></p> <p>This message is emitted each time that the AP writes NVM after the counter in the NVM indicates that the permitted number of accesses to the last block if NVM have been exhausted. The AP should be replaced at the next visit by HP service personnel. The NVM may survive for up to 20,000 more writes after this message begins to occur, or it may fail almost immediately.</p>
10	<p><b>Illegal command, type HE for help. (APERR 10)</b></p> <p>The first 2 characters entered in a command line for the AP command interpreter are not the mnemonic for an AP command. Help gives the mnemonics for all legal commands.</p>
11	<p><b>Expecting "Y" or "N" (APERR11)</b></p> <p>The AP is expecting one of the letters Y or N, in either upper or lower case, as the reply to the query displayed on the screen. Y stands for Yes. N stands for No.</p>
12	<p><b>Expecting "H" or "L" (APERR 12)</b></p> <p>The AP is expecting one of the letters H or L, in either upper or lower case, as the reply to the query displayed on the screen. H stands for High, and if chosen, will cause the specified signal to be set to the high the voltage level, which is nominally +9 Volts referenced to ground. L stands for Low, and if chosen will cause the specified signal to be set to the low voltage level which is nominally -9 Volts referenced to ground.</p>
13	<p><b>Command may not be executed by a remote user. (APERR 13)</b></p> <p>This command is a valid AP command, but is intended for use from the local console port (port 0) only. No action has been taken.</p>

**For HP Internal Use Only**

**Error Codes and Causes continued**

<b>Error Codes</b>	<b>Error Messages and Error Causes</b>
14	<p><b>Your selection is outside of the legal range. (APERR 14)</b></p> <p>Either numeric data has been entered when alphabetic input is expected, alphabetic input has been entered when numeric input is expected, or the value of numeric data entered is outside of the permissible range of values.</p>
15	<p><b>Command may not be executed by a local user. (APERR 15)</b></p> <p>This command is a valid AP command, but is intended for use from the remote support modem port (port 7) only. No action has been taken.</p>
16	<p><b>Expecting "S" or "M" (APERR 16)</b></p> <p>The only permissible input at this time is the single letter S for Single, or the single letter M for Multiple. They may be entered either in upper or lower case.</p>
20	<p><b>SE failed: OS did not respond (check OS vs. AP configurations). (APERR 20)</b></p> <p>No modem connection was successfully established by the host after the user typed SE. Likely causes are: 1) the OS isn't booted yet; 2) no getty is running on port 7; 3) the device special file attached to port 7 does not match the AP configuration (e.g., the OS considers the port as a simple protocol/BELL port, while the AP has it configured as a CCITT port).</p>
21	<p><b>Fatal error: POW_ON never came back. Waiting until it's reasserted ... (APERR 21)</b></p> <p>The AP did its best to de-assert the POW_ON signal, but doesn't see it de-asserted when reading it back. The circuitry that pulls on the line might be broken, or the circuitry used to read back the line might be broken. In any case, this is a major failure. Call your HP representative ...</p>
22	<p><b>Timeout error on NVM. (APERR 22)</b></p> <p>The NVM chip did not become ready within the specified time period. It is most likely broken. The write was probably not successful. Call your HP representative.</p>

**For HP Internal Use Only**

**Informational messages**

<b>Codes</b>	<b>Codes, Messages and Causes</b>
	<b>Messages and Causes</b>
01	<p><b>All tests passed. (APMSG 01)</b></p> <p>The AP has executed all tests in the test list, and none have terminated with a fatal error.</p>
02	<p><b>SPU hardware was successfully reset. (APMSG 02)</b></p> <p>Well ...</p>
04	<p><b>String was truncated to 23 characters. (APMSG 04)</b></p> <p>Only 23 displayable characters are permitted in the answer to the query on the screen. All characters past the twenty-third were discarded. No action is necessary if the resulting truncated string is acceptable and the answer to the query. If the resulting sting is not acceptable, re-execute the command and change it at the appropriate prompt.</p>
05	<p><b>AP configuration lost. Use CA and ER commands to recover. (APMSG 05)</b></p> <p>If this message reoccurs after each reset or power on, then the AP is defective.</p>
06	<p><b>SE terminated: returning to console/control mode. (APMSG 06)</b></p> <p>The remote console operator just terminated the connection it had initiated with the SE command. The AP is reconnecting the port as a remote console.</p> <p>Note that this message can also appear spuriously after SE is typed if the previous SE session was not cleanly terminated (e.g., the modem hung up before the remote console operator had time to type 'exit' at the shell prompt). In this latter case, just hit break and type SE again.</p>



---

## SCSI/Console/LAN PCA Access Port Error Codes.

This is a list of the error codes that can occur when the TA command is used on SCSI/Console/LAN PCA, P/N A1703-60003.

**Table 5-23. TA Command Tests and Power-on Selftests**

Test Number	Test Description
1	OCTART tests ( Never runs because octart is always busy)
2	Flash ROM test
3	Firmware ROM test
4	IODC ROM test
5	EEPROM test
6	Local port ENQ/ACK test
7	Remote port ENQ/ACK test
8	LAN loopback test

If a test fails, the following message is displayed:

Additional Failure Information : TTTTSSSS HHHHHHHH HHHHHHHH

TTTT is the first two bytes of the self test number in ASCII hex.

SSSS is the second two bytes of the self test number in ASCII hex.

HHHHHHHH is for internal use only.

The selftest failure test codes are shown in Table 5-24.

**For HP Internal Use Only**

**Table 5-24. Selftest Failure Codes**

Test	Word 0
All-purpose Chip DTACK	80010000
OCTART DTACK	80020000
LAN Controller DTACK	80030000
ISR DTACK	80040000
DMA Controller DTACK	80050000
Key DTACK	80060000
SRAM	80070000
DRAM	80080000
DRAM parity	81080000
Power-on SRAM	82070000
Power-on DRAM	82080000
Power-on DRAM parity	83080000
OCTART tests	80090000
DMA Controller register	800a0000
Key Chip register	800b0000
fw ROM tests	800c0000
EEPROM tests	800dnnnn <sup>1</sup>
IODC ROM tests	800e0000
Backplane DMA	800fnnnn <sup>1</sup>
LAN Controller tests	80100000
FLASH tests	80120000
fw patch test	80130000
All-purpose Chip register test	80140000
front panel lb test	8015nnnn <sup>1</sup>
fw fatal error	80160000
Spurious Interrupt occurred	80170000
parity test	80180000

---

**Note**

<sup>1</sup> Subtests are indicated in this field. They are for internal use only.



---

**Integrated Access Port Selftest Failure Codes**

The Integrated Access Port (IAP) selftest failure messages appear as:

AP failed selftest number xx(APERR 05)

where xx is defined in Table 5-25 .

- SE - Supervisor Element
- OCTART - Chip containing 8 serial I/O ports
- QANAT - Bus interface chip

**For HP Internal Use Only**

**Table 5-25. Integrated Access Port Selftest Failure Codes**

<b>Element Number</b>	<b>Part Under Test</b>	<b>Description</b>	<b>Destructive Test</b>
0		Reserved.	
1	8-port MUX	8-port MUX short test.	Yes
2	8-port MUX	Complete test contains all tests that check the 8-port MUX board only.	Yes
3	68000	68000 test.	Yes
4	ROM	ROM test (C.R.C).	Yes
5	RAM	RAM test.	Yes
7	OCTART	Test channel registers port x.	No
8-14		Reserved.	
15	OCTART	Check various statuses ... port x.	No
16-22		Reserved.	
23	OCTART	Check channel hardware (Mux) port x.	No
24-30		Reserved.	
31	ADP	Test with quadriloop on ADP port x	No
32-38		Reserved.	
39	OCTART	Check Xon/Xoff at global level.	Yes
40	OCTART	Test w/r OCTART global registers.	Yes
41	OCTART	Test all ports with global link at the OCTART's output.	Yes
42	OCTART	Check interrupt capabilities.	Yes
43	OCTART	Check modem features.	Yes
44	OCTART	Check global timer.	Yes
45	OCTART	Check vector generation.	Yes
46	QANAT	Check QANAT hard. related to port x.	No
47-53		Reserved.	
54	QANAT	Check QANAT hardware related to SE.	Yes
55-79		Available.	
80	8-port MUX	Poweron selftest.	Yes
81	8-port MUX	Non-destructive selftest for AP.	Yes
82	8-port MUX	Test list called by AP's TA command.	No
83	EEPROM	CRC test for EEPROM.	No
84	OCTART	Front panel loopback test.	Yes
85	RAM	Harmless RAM test	No
86	EEPROM	Manufacturing NVM Test.	No
87	EEPROM	NVM Status check. Note: always fails.	No
88-90		Available.	
91	ADP	Test ADP with loopback connector.	No
92-99		Available.	

**For HP Internal Use Only**

**Table 5-25. Integrated Access Port Selftest Failure Codes (continued)**

Element Number	Part Under Test	Description	Destructive Test
100	OCTART	Test interr. priority in channel x.	No
101-107		Reserved.	
108	OCTART	Test break features in channel x.	No
109-115		Reserved.	
116	OCTART	Test timer features in channel x.	No
117-123		Reserved.	
124	OCTART	Test xon/xoff features in channel x	No
125-131		Reserved.	
132	ADP	Check channel hardware (Adp) port x.	No
133-139		Reserved.	
140	ADP	Check global link at CREM input on ADP.	Yes
141		Complete test of 8-port MUX and RS232 ADP	Yes
142		Complete test of ADP only	Yes
143		Complete test of 8-port MUX and RS422 ADP	Yes
144-251		Available.	
252		Returns MUX id., plus added info.	No
253		Returns ADP type (quadriloop or not).	Yes
254		Backplane loopback (through QANAT).	Yes
255		Get the rest of error data structure.	Yes

---

## **Error Logs**

### **HPMC Error Logs**

The HPMC type codes are;

- 503F - Bus Error
- 7000 - Memory Double Bit Error
- 2040 - Data Cache Parity Error

If the HPMC type is a Bus Error, the PDC handler uses a module table to identify which precision bus slots have I/O modules installed. Each I/O module is polled for the IO\_STATUS word. If the *he* or *fe* bit is set, the logging routine writes the slot number, module type, and *estat* value into the I/O Module Error Log Information portion of the log.

If the HPMC type is a Memory Double Bit error, the PDC handler uses the SPA and a memory map in Page zero to log the failing memory card slot number. It also indicates the "A" or "B" side of the slot.

If the HPMC type is a Data Cache Parity error, no information is displayed in the I/O Module Error Log area.

### For HP Internal Use Only

#### Note



Some cards that do not implement the IO\_STATUS Register will log an entry in the I/O Module Error Log Information area. In this case, the *estat* value will be "3F" or "00". Currently, the only I/O module of this type is the Centronics module. The Centronics module is usually in slot 13 and is a *Type A Direct* module type. This log entry should be ignored. The Centronics card is screened out in PDC version 1.4 and above.

The contents of the HPMC Error Log is shown below.

- HPMC Type Code
- Status Entry for each Precision Bus module with IO\_STATUS bits *se*, *he*, or *fe* set. ( Only the *he* and *fe* bits are valid in PDC version 1.3 and above.)
- Format
  - HPMC Error Log Information
  - HPMC Type = xxxx
  - I/O Module Error Log Information
    - I/O Slot nn: Module Type Info ESTAT = 0xee
    - Memory Slot nn: Processor Dependent Memory ESTAT = 0x19

#### System Log File Procedure

Perform the following procedure to display the system logs. Enter the commands that are underlined.

```
CS80DIAG> HELP
> SYSDIAG
DUI> LOGTOOL
LOGTOOL> STATUS           Reports the number of records in each log. Record the
                             log number for later use.

LOGTOOL> SWITCHLOG        Closes the current file.

LOGTOOL> LIST LOG = Log number
                             LIST LOG = Range       Lists entries for a range of numbers.
```

**For HP Internal Use Only**

An example of an LPMC log in the System Logfile Summary Report is shown below. Report the contents of the log to the Response Center.

**System Logfile Summary Report**

```
*****
-----
MONZ, FEB 03, 1992    2:22PM /usr/adm/diag/LOGO216    (SYSTEM (PIN 0)
LPMC
10241
TAG DEFINITION NOT GIVEN - FIELD WILL BE DISPLAYED IN HEX:
   1  2  3  4  5  6  7  8  9  10 11 12
   -- -- -- -- -- -- -- -- -- -- --
1: FF FB E0 00 00 00 00 2C 00 00 00 00
13: 00 00 00 00 00 00 00 00 00 00 00 00
25: 00 00 00 00 00 00 00 00 00 00 00 00
37: 00 00 00 00 00 00 00 00 00 00 00 00
-----
```

## Multifunction I/O Card Status LEDs

The Multifunction I/O cards have LED status indicators on the bulkheads. Figure 5-6 shows the name and location of LEDs on each version of the card. To determine the status of a particular function on a card, locate and identify the LED (e.g., LINK Status, SCSI Selftest, etc). Match the LED pattern with the descriptions in Table 5-26 and Table 5-27.

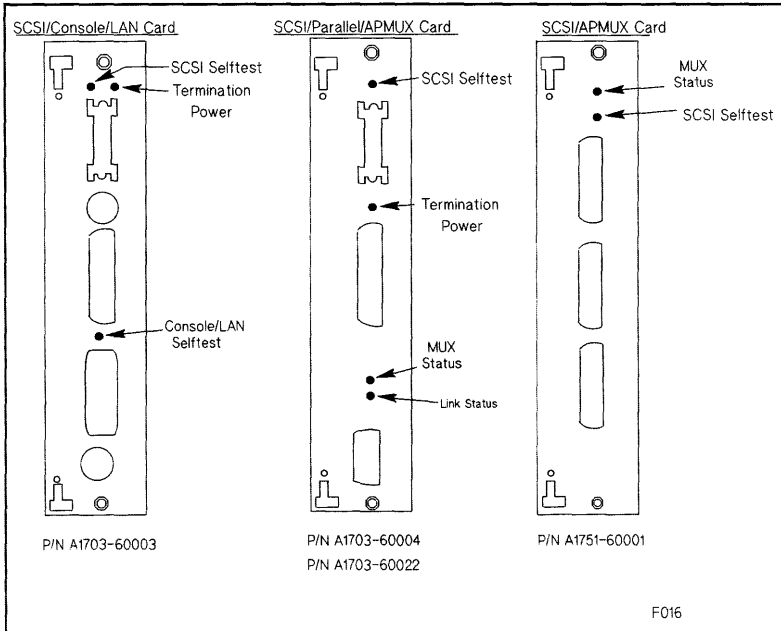

Figure 5-6. Multifunction I/O Card Status LEDs

**For HP Internal Use Only**

**Table 5-26. Multifunction I/O Card Status LEDs**

LED Name	LED Display	Description
Link Status	ON Momentarily at Power-Up	Selftest
	ON Steadily	Link to Mux not receiving data from ADP
	Blinking	ADP to Mux not working
	OFF	Normal
Mux Status	Blinking	Testing
	ON	Test Failed
	OFF	Normal
SCSI Selftest	ON	Failed Selftest
	OFF	Normal
Termination Power	ON	Normal
	OFF	No power (check fuse)
Console/LAN Selftest	ON	Failed Selftest
	Blinking	LAN network error external to card
	OFF	Normal

**Table 5-27. ADP Panel Status LEDs**

LED Name	LED Display	Description
Link Status	ON Momentarily at Power-Up	ADP to Link not working
	ON Steadily	Mux to ADP not receiving data from Mux
	OFF	Normal
Power	ON	Power to ADP good
	OFF	No power from Mux



---

## Troubleshooting SCSI Problems

There have been several cases reported to us, where the system log files were getting full with SCSI errors on HP9000 Model 8X7 systems. The log analysis has showed that the SCSI bus was being reset by system software.

A high level of signal noise in the SCSI bus can cause the SCSI controller chip to hang. When this occurs, the SCSI driver

1. times out,
2. sends a reset to the chip,
3. logs the event, and
4. retries the transaction.

This causes the system log files to fill with SCSI error messages.

If this occurs, check the following items. They can cause noise problems in the SCSI bus:

1. **External SCSI terminator:** If the configuration contains an external device, make sure that the last device in the chain contains an ACTIVE terminator. The active terminator is product number K2291 (part number: 1252-3920). The active terminator can be identified by its construction material (chrome-color plastic). Do not use terminators made of black or grey plastic, or chrome metal.
2. **High density terminator:** If there are no external devices, make sure that the high density terminator is installed on the Multifunction I/O card.
3. **Cable length:** Make sure that the total cable length does not exceed six meters. Count both internal and external cable lengths. The internal cable length for 2-slot standard chassis systems is 1.5 meters. The internal cable length for 6-slot and 12-slot expanded chassis is 3.0 meters.
4. **Old SCSI cables:** Old SCSI cables are known to generate noise in the SCSI bus. Do not use old SCSI cables. Old SCSI cables are grey color. New cables are parchment white.
5. **Excessive termination:** Ensure the ONLY device with termination SIP (Single In-line Package) resistor packs installed is the device at the end of the internal bus, which normally is the system disk at SCSI address 52.6. No other internal or external devices should have termination resistor packs installed.
6. **Ensure the SIP resistor packs are correctly installed:** For the C247xS mechanisms shipped as the system disk, the orientation of the resistors depends on the revision of the disk controller PCA. For Revision-A PCAs (identified by the jumper wires on the controller board) pin 1 (identified by a black dot) should face toward the DC power connector. For Revision-B PCAs (identified by the letter "B" below the "HP" logo), pin 1 should face the opposite direction. Most shipments will be Revision-B PCAs. Figure 5-7 shows how the termination resistors should be oriented on the internal disk drives.
7. **Internal cable damage:** Ensure the internal SCSI ribbon cable has not been pinched by any of the sheetmetal causing wires to be cut or the insulation to be scraped off.
8. **Termination Power:** Ensure the option pin-sets on each device are selected such that the host supplies power to the termination resistors.

**For HP Internal Use Only**

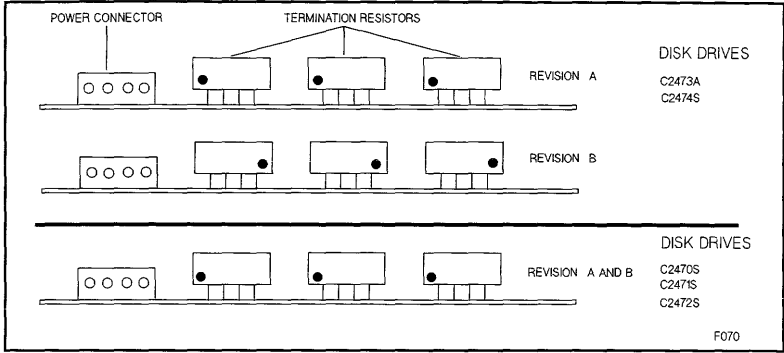

**Figure 5-7. Internal Disk Termination Resistor Orientation**

### 3.5-inch and 5.25-inch Hard Disk Drive Troubleshooting

The hard disk drive includes two replaceable subassemblies: the disk mechanism and the SCSI controller PCA. The firmware ROM on the SCSI controller PCA is also replaceable.

1. Turn off system power.
2. Remove the SCSI controller PCA from the disk mechanism.
3. Install a known good SCSI controller PCA on the disk mechanism. Make sure the configuration jumpers on the good SCSI controller PCA assembly are set to the same positions as the jumpers on the suspect assembly.
4. Remove the firmware ROM from the faulty SCSI controller PCA, and install it on the replacement SCSI controller PCA.
5. Reinstall the disk drive.
6. Check to see if the problem is solved.
7. If the problem persists, change the ROM.
8. Check to see if the problem is solved.

If the problem persists, replace the disk mechanism.

#### Drive Status Light

Table 5-28 shows drive status light indications during normal operation and fault conditions.

**For HP Internal Use Only**

**Table 5-28. Status Light Indications**

Status	Explanation
OFF	This is the normal indication when the hard disk drive is idle. This may also indicate that there is no power to the hard disk drive.
ON	If the status light remains on more than 20 seconds after the self-test begins, it indicates a self-test failure.
FLASHING (1 Hz)	If the status light continues flashing at a 1 Hz rate more than 20 seconds after the self-test begins, it indicates a self-test failure.
FLASHING (10 Hz)	This indicates that the hard disk drive is performing its internal self-test diagnostic. This pattern should only continue as long as the self-test is in progress.
RANDOM FLASHING	The status light flashes when the hard disk drive is accessed by the host. This indicates normal operation.

## Diagnostic Information

The following paragraphs provide information on the hard disk drive internal status logs and the Extended Sense data returned by the hard disk drive in response to a REQUEST SENSE command.

The method of accessing this information depends on the diagnostic tool you are using. Refer to the appropriate diagnostic documentation for information on retrieving device information.

### Logs

There are three internal hard disk drive logs: the Usage Log, the Data Error Log, and the Hardware Error Log. These logs are maintained in two locations: on the disk media and in SCSI controller RAM. The controller RAM is initialized from the disk at power-on or following a reset. During disk drive operation, the controller RAM is continually updated. The contents of the controller RAM are only posted to the disk media when an error entry is added.

**Usage Log.** The Usage Log includes the following fields: Area, Access Count, Blocks Accessed, First Retry Count, Multiple Retry Count.

The Area field indicates which part of the hard disk media the Data Error Log is reporting on.

The Access Count field indicates the number of media accesses performed since the last hardware error occurred, or the log was cleared. When an entry is added to the Hardware Error Log, the contents of this field are included and this field is reset to zero. Thus, to determine the total number of media accesses, you must add the contents of this field to any Hardware Error Log Access Count entries. If there are no Hardware Error Log entries, this value represents the total media accesses. Table 5-29 lists the access count ranges corresponding to the values reported in this field.

**For HP Internal Use Only**

The Blocks Accessed field indicates the number of blocks read from the hard disk drive.

The First Retry Count field indicates the number of times read retries were performed and data was recovered on the first retry.

The Multiple Retry Count field indicates the number of times data was not recovered on the first retry. This field is incremented only once per completed recovery.

**Table 5-29. Hard Disk Drive Access Count Range Values**

VALUE (HEX)	MINIMUM OF ACCESS RANGE	MAXIMUM OF ACCESS RANGE
0	No Accesses	No Accesses
1	1	1
2	2	10
3	11	100
4	101	1,000
5	1,001	10,000
6	10,001	100,000
7	100,001	500,000
8	500,001	1,000,000
9	1,000,001	5,000,000
A	5,000,001	10,000,000
B	10,000,001	50,000,000
C	50,000,001	100,000,000
D	100,000,001	500,000,000
E	500,000,001	1,000,000,000
F	1,000,000,001	>1,000,000,001

### For HP Internal Use Only

**Data Error Log.** The Data Error Log includes the following fields: Logical Block Address, Error Type, Count, and Error.

The Logical Block Address field contains the logical block address of a data block that encountered multiple read retries during one or more data error recovery attempts.

The Error Type field indicates the type of data error the block encountered (refer to Table 5-30).

The Count field is incremented each time a block is uncorrectable or requires multiple retries during a transaction. This field is incremented only once for each data recovery attempt.

The Error field contains encoded data error byte information as listed in Table 5-30.

**Table 5-30. Hard Disk Drive Error Type and Error Byte**

<b>Error type:</b>	
REC-E =	Recovered data with ECC
REC-R =	Recovered data with retries
UNR =	Unrecoverable error
<b>Error byte:</b>	
1XXXXXXXX =	Unclassifiable error
X1XXXXXXXX =	Error occurred in header field
XX1XXXXXX =	Error occurred in data field
XXX1XXXXX =	Unrecoverable data
XXXX1XXX =	Data recovered with ECC
XXXXX1XX =	Data recovered with retries
XXXXXXX1X =	Write fault
XXXXXXXXX1 =	Reserved

**Hardware Error Log.** The Hardware Error Log includes the following fields: Logical Block Address, Internal Drive Status, and Access Count.

The Logical Block Address field contains the logical block address of a data block that was being accessed when the error occurred.

The Internal Device Status field contains an error code corresponding to the Additional Sense Code field returned by the REQUEST SENSE command.

The Access Count field indicates the number of media accesses that had been performed when the hardware fault occurred. To determine the total number of media accesses, add these values to the Access Count field of the Usage Log. Table 5-29 lists the access count ranges corresponding to the values in this field.

**For HP Internal Use Only**

**REQUEST SENSE Data Fields**

Table 5-31 shows the data format for the following data fields returned by the drive in response to a REQUEST SENSE command. Reserved fields always contain zeros.

**Table 5-31. REQUEST SENSE Data Format**

	BIT							
BYTE	7	6	5	4	3	2	1	0
00	Valid	Error Class			Reserved			Error Code
01	Segment Number = 0							
02	FM = 0	EOM = 0	ILI	Reserved	Sense Key			
03–06	(MSB=03) Information Bytes			(LSB=06)				
07	Additional Sense Length = 20							
08–11	Command Specific Information							
12	Additional Sense Code							
13	Additional Sense Code Qualifier = 0							
14	Field Replaceable Unit Code = 0							
15	SKSV=0	Sense Key Specific						
16–17	Sense Key Specific							
18	Retry=0	Reass=0	HERR=0	Reserved				
19–23	Reserved							
<b>Device Error Field: (Bytes 24–27)</b>								
24	Vendor Unique ESDI Status Code							
25	ESDI Status Byte							
26–27	SCSI Status Bytes							

### For HP Internal Use Only

**Error Code.** A value of 0 specifies current error; a value of 1 specifies deferred error.

**Error Class.** Always set to 7.

**Valid.** A value of 1 indicates that the Information bytes contain valid information. The exact significance of the Information bytes depends on the status of the Sense Key field.

**Segment Number.** Always set to 0.

**FM (File Mark), EOM (End of Media), ILI (Incorrect Length Indicator).** All set to zero (0).

**Sense Key.** Indicates the type of error that has occurred, and the recovery action that should be taken by the initiator. Refer to Table 5-32.

**Additional Sense Code.** Provides additional information about the error condition reported in the Sense Key field. Refer to Table 5-33.

**Information.** Contains information relative to specific commands and specific devices.

**Additional Sense Length.** Specifies the number of Additional Sense bytes to follow. Always set to 20.

**Command Specific Information.** Contains information dependent on the command that was executed.

**Additional Sense Code Qualifier.** Always set to 0.

**Failed Field Replaceable Unit (FRU).** Always set to 0.

**SKSV (Sense Key Specific Valid).** Always set to 0.

**Device Error Field.** Indicates device unique error codes designed to aid service personnel in more detailed analysis of any drive faults. This field consists of four bytes:

Byte	Description
24	Vendor Unique ESDI Status Codes (refer to Table 5-34)
25	ESDI Status Byte (refer to Table 5-35)
26-27	SCSI Status Bytes (refer to Table 5-36)

For HP Internal Use Only

Table 5-32. Sense Key Codes

Value (hex)	Description
0	<b>No Sense.</b> Indicates that there is no specific sense key information to be reported for the designated logical unit.
1	<b>Recovered Error.</b> Indicates that the last command completed successfully with some recovery action performed by the Target. Details may be determined by examining the additional sense bytes and the information bytes.
2	<b>Not Ready.</b> Indicates that the logical unit addressed cannot be accessed.
3	<b>Media Error.</b> Indicates that the command terminated with a nonrecovered error condition that was probably caused by a flaw in the media or an error in the recorded data.
4	<b>Hardware Error.</b> Indicates that the Target detected a nonrecoverable hardware failure (for example, controller failure, device failure, parity error, etc.) while performing the command or during a selftest.
5	<b>Illegal Request.</b> Indicates that there was an illegal parameter in the command descriptor block or in the additional parameters supplied as data for some commands.
6	<b>Unit Attention.</b> Indicates that the Target has been reset or there has been a power on.
B	<b>Aborted Command.</b> Indicates that the Target aborted the command due to Initiator request/action.
E	<b>Miscompare.</b> Indicates data in buffer may have been corrupted between READ BUFFER and WRITE BUFFER commands, or a MISCOMPARE occurred during a VERIFY (with BYTCK enabled).



For HP Internal Use Only

Table 5-33. Additional Sense Codes

Value (hex)	Description
00	No Additional Sense Information
01	No Index/Sector signal
02	No Seek Complete
03	Write Fault
04	Drive Not Ready
08	Logical Unit Communication Failure
09	Servo lost while track following
10	ID CRC or ECC error
11	Unrecovered Read error of data blocks
14	No record found
15	Seek Positioning error
17	Recovered Read data with Target's Read retries (not with ECC)
18	Recovered Read data with Target's ECC correction (not with retries)
19	Defect List error
1A	Parameter Overrun
1B	Synchronous Transfer error
1D	Compare error
20	Invalid Command Operation Code
21	Illegal Logical Block Address. Address greater than the maximum LBA returned by the READ CAPACITY data with PMI not set.
24	Illegal field in CDB
25	Invalid LUN
26	Invalid field in Parameter List
27	Write Protected
29	Power On or Reset or Bus Device Reset occurred
2A	Mode Select Parameters changed.
31	Media Format Corrupted
32	No Defect Spare Location Available
33	Spare Operation Failed
40	RAM failure
41	Data Path Diagnostic failure
42	Power-On Diagnostic Failure
43	Message Reject Error
44	Internal Controller Error
45	Select/Reselect failed
46	Unsuccessful Soft Reset
47	SCSI Interface Parity Error
48	Initiator Detected Error
49	Inappropriate/Illegal Message

For HP Internal Use Only

Table 5-34. Vendor Unique ESDI Status Codes

Error Code Hex (Dec)	Description
00 (0)	Not an error condition.
02 (2)	EEPROM checksum failed.
03 (3)	Timed out waiting for DSP to complete Power On Self-Test.
04 (4)	After power-on, DSP became Command Ready without Finished being asserted.
05 (5)	DSP reported a revision value incompatible with this firmware version.
06 (6)	Power-On DSP RAM test failed.
07 (7)	Parity error on command received.
09 (9)	Timed out transferring data to ESDI controller.
0A (10)	Received illegal command.
0B (11)	Address of Seek command was outside legal address space.
0C (12)	An attempt was made to set an illegal EEPROM address.
0D (13)	An attempt was made to access the EEPROM while mechanism was spinning.
0E (14)	Timed out waiting for EEPROM write to complete.
0F (15)	DSP did not spinup after a spinup command was executed.
10 (16)	Timed out waiting for DSP to become ready for a short term command.
11 (17)	Timed out waiting for DSP to become ready for a long term command.
12 (18)	A Seek was attempted when the spindle was not spun up and locked.
13 (19)	The DSP did not end up in tracking mode after a Recalibrate command was executed.
14 (20)	Bounds test of Track Offset command failed.
15 (21)	A fault is still set after clearing Gate Array fault flip/flops.
16 (22)	Retries were exhausted while trying to verify position during a Recalibrate.
17 (23)	The DC bias adaptation failed to null NPES within the maximum iteration limit.
18 (24)	Maximum iteration limit reached during head alignment SPES null.
19 (25)	DSP sync lost during head alignment SPES measurement.
1A (26)	The drive has entered the Head Alignment Needed state.
1B (27)	The drive has entered the Head Alignment Critical state.
1C (28)	The maximum total (AC+DC) head alignment correction limit was exceeded.
1D (29)	Head alignment fault recovery failed.
1E (30)	DSP failed to complete a Read Track Number command in allotted time.
1F (31)	DSP failed to complete a Spin Down command in allotted time.
20 (32)	Reserved.
21 (33)	DSP failed to complete a Spin Up command in allotted time.
22 (34)	DSP failed to complete a Recalibrate command in allotted time.
23 (35)	DSP failed to complete an Introduce Tracking Offset command in allotted time.
24 (36)	DSP failed to complete a Seek command in allotted time.
25 (37)	DSP failed to complete a Measure Alignment Band command in allotted time.

**For HP Internal Use Only**

**Table 5-34. Vendor Unique ESDI Status Codes (continued)**

Error Code Hex (Dec)	Description
26 (38) thru 31 (49)	Reserved.
32 (50)	The long term DSP command completed with Alert signal set in status register.
33 (51)	The DSP Alert signal was set when attempting to send a command to the DSP.
34 (52)	Request Status logged a Servo Fault from the fault register.
35 (53)	DSP failure code indicates other than Reset at power-on.
36 (54)	Reserved.
37 (55)	Reserved.
38 (56)	Maximum DC head alignment correction capability was exceeded.
39 (57)	Maximum AC head alignment correction capability was exceeded.
3A (58)	Maximum iteration limit was exceeded in calibrating the NPES gain.
3B (59) thru 3E (62)	Reserved.
3F (63)	That command requires a special test enable to be executed.
40 (64)	Unknown write fault.
41 (65)	Write during loss of servo timing sync.
42 (66)	Write during momentary spindle off-speed indication.
43 (67)	Write during momentary actuator off-track indication.
44 (68)	Write during a seek operation.
45 (69)	Write after settle or tracking failure.
46 (70)	Reserved.
47 (71)	Reserved.
48 (72)	Write was attempted while ESDI attention was asserted.
49 (73)	Write was attempted while an illegal head was selected.
4A (74)	Write was attempted while a recalibrate was in process.
4B (75)	Write was attempted on a head that was in the head alignment critical state.
4C (76)	Write was attempted while a head alignment was in process.
4D (77)	Write was attempted after a fatal head alignment occurred.
4E (78)	Write was attempted while spun down or after a recalibrate failure.
80 (128)	No failure detected.
81 (129)	Unsupported command.
82 (130)	Illegal command sequence.
83 (131)	Servo heartbeat time out.

For HP Internal Use Only

Table 5-34. Vendor Unique ESDI Status Codes (continued)

Error Code Hex (Dec)	Description
84 (132)	Spindle stuck.
85 (133)	Spindle could not reach full speed.
86 (134)	Servo PLL did not lock
87 (135)	Index pattern fault.
88 (136)	TMR2 Alignment failure
89 (137)	Servo PLL came unlocked.
8A (138)	Bad hard track number.
8B (139)	Settle failure.
8C (140)	Alignment Band AGC voltage not within legal range.
8D (141)	Heroics invoked during spin up.
8E (142)	DSP reset detected.
8F (143)	Minimum spindle speed could not be detected.
90 (144)	Tracking failure after a successful settle to a new setpoint.
91 (145) thru C0 (192)	Reserved.
C1 (193)	PLL came unlocked in Slow Acceleration Phase.
C2 (194)	Seek timed out in Slow Acceleration Phase.
C3 (195)	Velocity too high in Slow Acceleration Phase.
C4 (196) thru C8 (200)	Unassigned seek fault in Slow Acceleration Phase.
C9 (201)	PLL came unlocked in Fast Acceleration Phase.
CA (202)	Seek timed out in Fast Acceleration Phase.
CB (203)	Velocity too high in Fast Acceleration Phase.
CC (204) thru D0 (208)	Unassigned seek fault in Fast Acceleration Phase.
D1 (209)	PLL came unlocked in the Coasting Phase.
D2 (210)	Seek timed out in the Coasting Phase.
D3 (211)	Velocity too high in the Coasting Phase.
D4 (212) thru D8 (216)	Unassigned seek fault in the Coasting Phase.

**For HP Internal Use Only**

**Table 5-34. Vendor Unique ESDI Status Codes (continued)**

Error Code Hex (Dec)	Description
D9 (217)	PLL came unlocked in Fast Deceleration Phase.
DA (218)	Seek timed out in Fast Deceleration Phase.
DB (219)	Velocity too high in Fast Deceleration Phase.
DC (220) thru E0 (224)	Unassigned seek fault in Fast Deceleration Phase.
E1 (225)	PLL came unlocked in Slow Deceleration Phase
E2 (226)	Seek timed out in Slow Deceleration Phase
E3 (227)	Velocity too high in Slow Deceleration Phase
E4 (228) thru E8 (232)	Unassigned seek fault in Slow Deceleration Phase.
E9 (233)	PLL came unlocked in the Flare Phase.
EA (234)	Seek timed out in the Flare Phase.
EB (235)	Velocity too high in the Flare Phase.
EC (236) thru F0 (240)	Unassigned seek fault in the Flare Phase.
F1 (241)	PLL came unlocked in the Gross Settle Phase.
F2 (242)	Seek timed out in the Gross Settle Phase.
F3 (243)	Velocity too high in the Gross Settle Phase.
F4 (244) thru F9 (249)	Unassigned seek fault in the Gross Settle Phase.
FA (250)	Seek timed out in the Fine Settle Phase.
FB (251)	Velocity too high in the Fine Settle Phase.
FC (252) thru FF (255)	Unassigned seek fault in the Fine Settle Phase.

**For HP Internal Use Only**

**Table 5-35.  
Device Error Codes  
ESDI Status Byte 25**

Bit	Description
7	Spindle motor stopped
6	Command data parity fault
5	Interface Fault
4	Invalid command fault
3	Seek fault
2	Write gate with track offset fault
1	Vendor Unique ESDI status available; SCSI (CCS)=byte 21, SCSI-2=byte 27
0	Write fault

**Table 5-36.  
Device Error Codes  
SCSI Status Bytes 26, 27**

Bit	Description
<b>Byte 26</b>	
7	BPF: Buffer parity fault
6	UNF: FIFO underflow fault
5	OVF: FIFO overflow fault
4	SOS: Start-of-sector not detected
3	ATN: ESDI Attention bit
2	SIL: Reserved: internal use only
1	CTO: Command Timeout
0	EOS: Early end of sector
<b>Byte 27</b>	
7	FTL: Fatal fault: refer to previous byte, bits 0 thru 4
6	DE3: Data ECC, interleave 3, syndrome fault
5	DE1: Data ECC, interleave 1, syndrome fault
4	HE1: Header ECC, interleave 1, syndrome fault
3	DSF: Data sync field fault
2	HSF: Header sync field fault
1	HCP: Header compare failed
0	OTH: Other fault: refer to previous byte, bits 5 thru 7

### **3.5-inch and 5.25-inch DDS-Format DAT Drive Troubleshooting**

The DDS drive is replaced as an entire assembly, but before replacing it you must make sure the problem is caused by a hardware failure. This means you must rule out problems caused by the environment or the tape media.

Use the following sequence to isolate DDS drive problems (see Figure 5-8).

1. Check the DDS drive status lights.
  - If the lights indicate a high humidity fault, refer to Solving High Humidity Problems.
  - If the lights indicate a media warning fault, refer to Solving Media Warning Problems.
2. Try cleaning the tape heads and see if the problem is solved.
3. Determine if the problem is media-related by installing a new DDS cassette and retrying the failed operation. If a cassette is jammed in the DDS drive tape mechanism, refer to Removing Jammed Cassettes.
4. If the preceding steps have not solved the problem, replace the entire DDS drive.
5. Check system operation to make sure the problem is solved.

For HP Internal Use Only

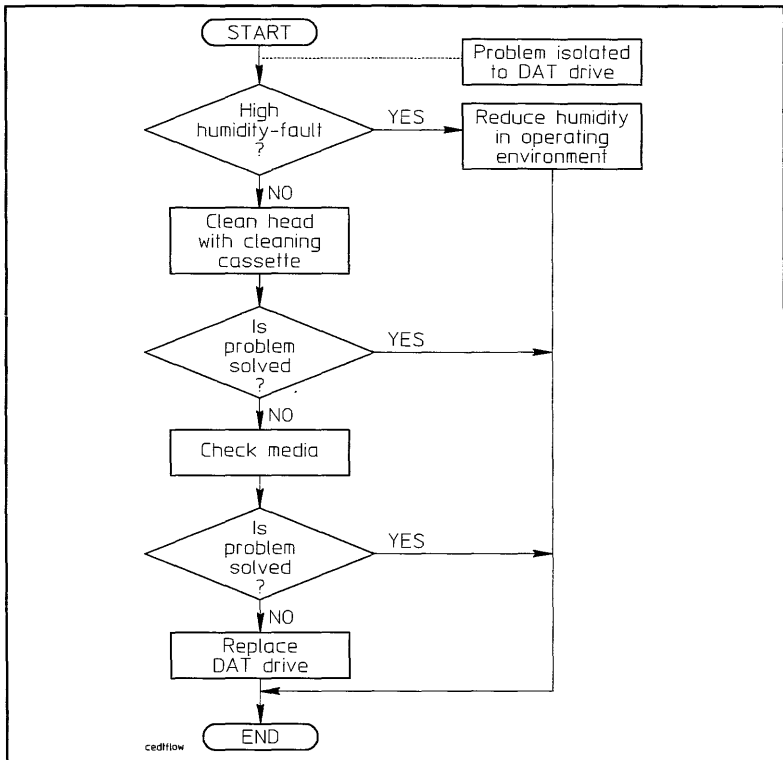

Figure 5-8. DDS Drive Troubleshooting Flowchart



**For HP Internal Use Only**

**Status Lights**

The status of the DDS drives is indicated by the cassette status light and the drive status light.

**5.25-inch DDS-Format DAT Drive Status Lights**

See Figure 5-9 for the location of the lights on the 5.25-inch drive. Refer to Table 1-5 for the states of the lights during normal operation and when fault conditions occur..

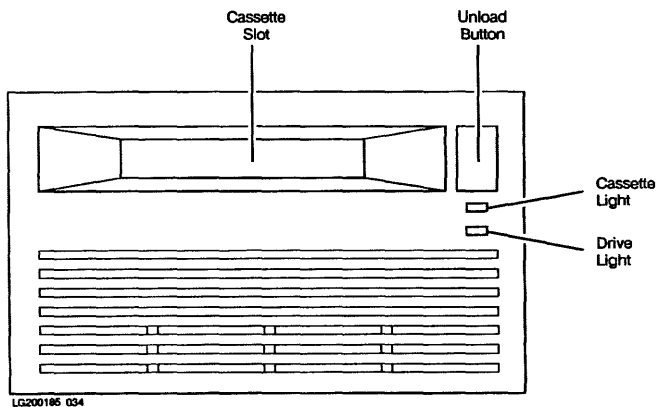

**Figure 5-9. HP C1502A 5.25-inch DDS-Format DAT Drive Front Panel**

**3.5-inch DDS-Format DAT Drive Status Lights**

See Figure 5-10 for the location of the lights on the 3.5-inch drive. Refer to Table 1-6 for the states of the lights during normal operation and when fault conditions occur.

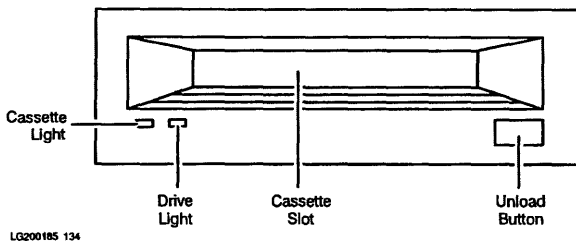

**Figure 5-10. HP C1503B and C1504B 3.5-inch DDS-Format DAT Drive Front Panel**

### Solving Media Warning Problems

A media warning fault usually indicates that either the tape head is dirty, or the tape cassette is nearing the end of its useful life.

To correct a media warning problem,

1. Eject the suspect cassette from the DDS drive.
2. Clean the tape head using a cleaning cassette.
3. Insert the suspect cassette and repeat the operation that was being performed when the media warning occurred.

If the media warning does not recur, the tape head was simply dirty. The cassette can continue to be used; however, you should remind the customer to clean the tape head regularly.

If cleaning the tape head did not fix the media warning fault, it may indicate a problem with the cassette itself. In this case, continue with the following steps:

1. Copy the data from the suspect cassette onto a hard disk drive.
2. Eject the suspect cassette and install a new cassette.
3. Copy the data from the hard disk drive to the new cassette.
4. Retry the operation that was being performed when the media warning occurred.

In the unlikely event that the problem still occurs, it may indicate a problem with the DDS drive hardware, in which case the entire drive must be replaced.

### Solving High Humidity Problems

If a sensor in the DDS drive detects that the humidity has risen above a safe operating level, the drive stops whatever it is doing, unthreads the tape, and waits for the humidity to drop. The DDS drive will not respond to any commands until the sensor detects an acceptable level of humidity. This protects the drive and the tape media from damage.

Once the humidity has dropped to an acceptable level, the DDS drive must be power cycled before it can be used again.

---

#### Note



A high humidity fault indicates that the customer needs to exercise tighter control on the operating environment. Subjecting the DDS drive (and the other computer equipment as well) to environmental extremes may shorten the life of the drive. The operating environment should be maintained within the range recommended in the system specifications.

---

### For HP Internal Use Only

#### Removing a Jammed Cassette From a 5.25-inch DDS-Format Drive

If a DAT cassette becomes jammed in the DAT drive, try either power-cycling the drive or a hard reset. If this fails to release the cassette, the cassette can be manually extracted from the drive as follows.

1. Switch off power to the DAT drive and remove the DAT drive from the cabinet.
2. Remove the top cover of the DAT drive. The cover is held in place with four screws.
3. If the tape is not threaded onto the tape heads, go to step 4. To unthread the tape from the heads
  - a. Locate the pulley on the tape threading motor. See Figure 5-11.
  - b. Turn the pulley in the direction indicated in Figure 5-11. The tape guide rollers will begin to slowly retract toward the front of the DAT drive.
  - c. Continue turning the pulley until the guide rollers are fully retracted. When the rollers are fully retracted, the pulley will become difficult to turn. **DO NOT** try to turn the pulley any further or you may damage the tape threading motor.
4. Remove the belt from the pulley on the tape threading motor. See Figure 5-11.
5. Reinstall the DAT drive in the cabinet and connect the power cable.
6. Apply power to the DAT drive to retension the tape on the cassette.
7. Try ejecting the cassette using the eject button. If the cassette ejects, go to step 8. To eject the cassette manually:
  - a. Switch off power to the DAT drive.
  - b. Remove the plastic plate covering the thumbwheel on the side of the DAT drive. See Figure 5-12. The cover plate is attached to the DAT drive chassis with adhesive.
  - c. Turn the thumbwheel in the indicated direction to eject the cassette.
  - d. Reinstall the cover plate over the thumbwheel.
8. Replace the belt on the pulley on the tape threading motor.
9. Install the cover on the DAT drive and reinstall it in the cabinet.

For HP Internal Use Only

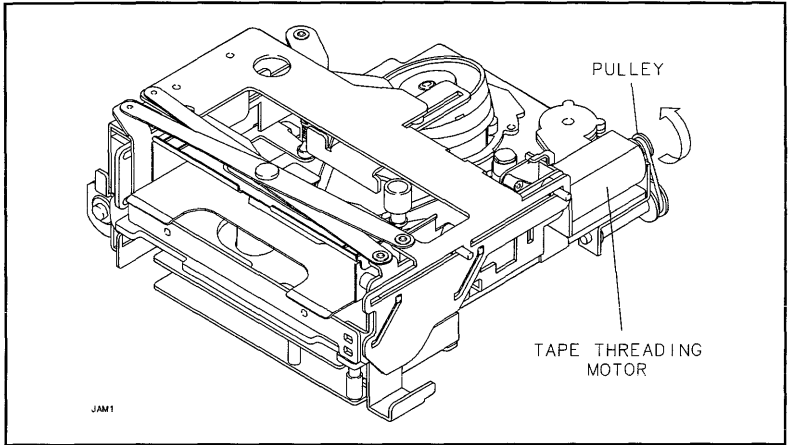

Figure 5-11. Manually Unthreading a DAT Tape

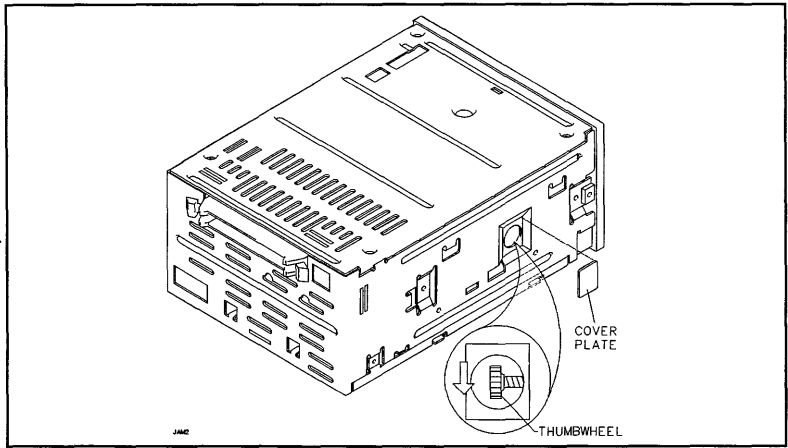

Figure 5-12. Manually Ejecting a DAT Tape

## For HP Internal Use Only

### Removing a Jammed Cassette From a 3.5-inch DDS-Format Drive

If a DDS cassette becomes jammed in the DDS drive, try either power-cycling the drive or a hard reset. If this fails to release the cassette, the cassette can be manually extracted from the drive as follows (see Figure 5-13):

1. Rewind the tape to the Beginning of Media (BOM).
2. Switch off power to the DDS drive and remove the DDS drive from the cabinet.
3. Remove the cabinet mounting bracket from the drive.
4. Remove the two adapter brackets from the drive.
5. Insert a flat-blade screwdriver between the drive chassis and the side of the top cover. Pry up the top cover at two points on each side of the top cover and remove the top cover.
6. Insert a size 00 flat-blade screwdriver through the emergency eject access hole (1).
7. View the tip of the screwdriver from the left-hand side of the drive, and angle the screwdriver down into the slotted head of the worm gear (2).
8. Rotate the screwdriver counter-clockwise and watch the worm gear to make sure it is rotating. You must rotate the worm gear several hundred times because of its small diameter.

---

#### Caution



- When the tape is unthreaded, a loop of tape will be hanging out of the cassette. Be careful not to let any grease in the threading slots contaminate the tape.
  - As the cassette is ejected, the cassette door will close on the loop of tape and may crease the tape. If the tape was at BOM before starting this procedure, the crease will occur where no data is written. However, if the tape was not at BOM, damage to the tape may occur and data may be lost.
- 

9. Continue rotating the screwdriver counter-clockwise for several hundred revolutions until the cassette (4) moves forward from the read/write station (5) and is ejected. At times, it may seem that the tape is not moving, such as when the reel spindles drop. This is normal.
10. Remove the cassette from the cassette slot (6).

For HP Internal Use Only

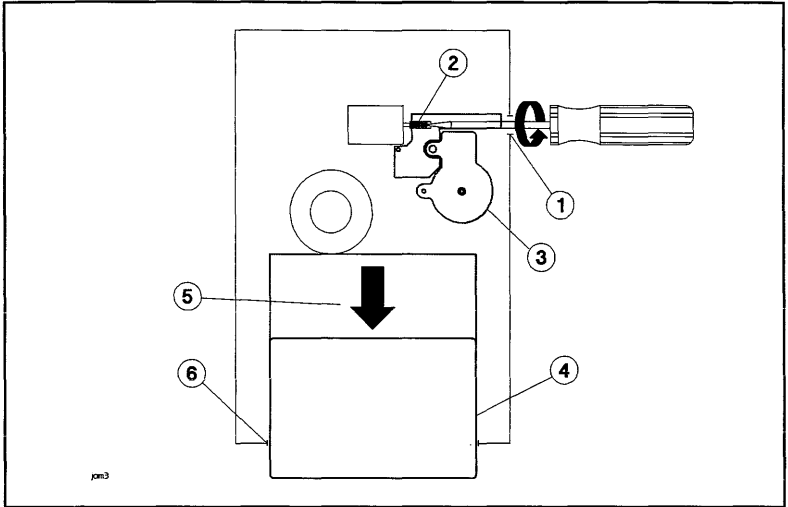

Figure 5-13. Manually Ejecting a DDS Tape

- |                                |                       |
|--------------------------------|-----------------------|
| 1. Emergency Eject Access Hole | 4. Cassette           |
| 2. Worm Gear                   | 5. Read/Write Station |
| 3. Cam Gear                    | 6. Cassette Slot      |

## For HP Internal Use Only

### Diagnostic Information

The following paragraphs provide information on the DDS drive internal status logs and the Extended Sense data returned by the DDS drive in response to a REQUEST SENSE command.

The method of accessing this information depends on the diagnostic tool you are using. Refer to the appropriate diagnostic documentation for information on retrieving device information.

#### Logs

The DDS drive maintains three internal logs: the fault log, the error rate log, and tape log.

**Fault Log.** The Fault Log contains information about hardware faults that have occurred since the log was last cleared. The Fault Log is located in DDS drive controller RAM and is *not* transferred to the tape. The Fault Log is cleared when the DDS drive power is cycled or reset, or when the CLEAR LOGS command is executed. The Fault Log has a maximum limit of 30 entries and operates on a first-in-first-out (FIFO) basis. The Fault Log entries are organized by event and time of occurrence.

**Error Rate Log.** The Error Rate Log contains information about the types and counts of errors that have occurred on the tape during the current tape load or since the Error Rate Log was last cleared. The Error Rate Log is cleared when the DDS drive power is cycled or reset, when the CLEAR LOGS command is executed, or as an option when initiating an error rate test. The log is not saved on the tape when the tape is unloaded.

**Tape Log.** The Tape Log contains information about the number of groups read, written, and retried for the current tape load and the last (previous) tape load. The Tape Log also contains the totals since the tape was initialized, including the current load. The Tape Log cannot be cleared. It is copied to RAM when the tape is loaded, updated in RAM during the load, then copied back to the tape during the unload sequence. This means that if the drive is power-cycled with the tape loaded, the current information is lost.

---

#### Note



If a DDS cassette is write-protected, the drive cannot update the Tape Log when the cassette is unloaded. Consequently, the Tape Log on a write-protected tape will not reflect the true usage of the tape.

---

#### REQUEST SENSE Data Fields

Table 5-37 shows the data format for the following data fields returned by the drive in response to a REQUEST SENSE command. Reserved fields always contain zeros.

**For HP Internal Use Only**

**Table 5-37. DDS-Format DAT Drive REQUEST SENSE Extended Data Format**

	BIT							
BYTE	7	6	5	4	3	2	1	0
00	Valid	Error Class			Error Code			
01	Segment Number							
02	FM	EOM	ILI	Reserved	Sense Key			
03—06	(MSB=03)		Information Bytes			(LSB=06)		
07	Additional Sense Length							
08—11	Command Specific Information = 00							
12	Additional Sense Code							
13	Additional Sense Code Qualifier							
14	Field Replaceable Unit Code							
15	SKSV	C/D	Reserved = 0		BPV	Bit Pointer		
16—17	(MSB=16)		Field Pointer/Drive Error Code			(LSB=17)		
18	Reserved = 0							
19	Copy Target Status							
20—51	Copy Target Sense							



### For HP Internal Use Only

**Valid.** A value of 1 indicates that the Information bytes contain valid information. The exact significance of the Information bytes depends on the status of the Sense Key field.

**Error Class.** Always set to 7.

**Error Code.** A value of 0 specifies current error; a value of 1 specifies deferred error.

**Segment Number.** Contains the number of the current segment descriptor when the REQUEST SENSE command is in response to a COPY command. Otherwise, this field is set to 0.

**FM (File Mark).** A value of 1 indicates the logical position is at a filemark or setmark.

**EOM (End of Media).** Indicates the physical position is at End Of Media. Sense Key is set to No Sense. The Additional Sense Code is set to 04 for Beginning Of Partition or 02 for End Of Partition. Beginning Of Partition is reported after a Space command encounters BOP. End Of Partition is reported when a Write or Write File Marks command leaves the tape positioned in the Early Warning region near the End Of Partition.

---

#### Note



On a DDS-formatted tape, there are two indicators toward the physical end of the partition. EOT occurs 500 mm before the EOM mark. EOM indicate the end of usable tape. The drive will never write data to the tape after encountering EOM. The drive uses EOT to generate Early Warning EOP on writes. The host may write approximately 10 megabytes of data to the tape following the Early Warning EOP before encountering the physical EOM.

---

**ILI (Incorrect Length Indicator).** Indicates the requested block length did not match the actual block length. Only Read and Verify may cause this bit to be set.

**Sense Key.** Indicates the type of error that has occurred, and the recovery action that should be taken by the initiator. Refer to Table 5-38.

**Information.** These bytes are valid only if the Valid field is set to 1. They contain residue information following the failure of a Read, Write, Write Filemarks, or Space command.

**Additional Sense Length.** Specifies the number of Additional Sense bytes to follow. Always set to 0B.

**Command Specific Information.** Normally set to 0. If, however, the Sense data is for a check conditioned Copy command, and the Additional Sense is Copy Aborted, then the first two bytes are set to 19 and the last two are set to 0.

**Additional Sense Code and Additional Sense Code Qualifier.** Provide additional information about the cause of the Check Condition or the current tape position. Refer to Table 5-39.

**Field Replaceable Unit (FRU) Code.** The value of this field indicates the FRU that failed, as follows:

**For HP Internal Use Only**

<u>Value</u>	<u>Assembly</u>
0	No failing FRU
1	Controller PCA
2	Mechanism

**SKSV (Sense Key Specific Valid).** Set to 1 if the Sense Key specific bytes (bytes 15 through 17) are valid. These bytes are valid only when they assume the role of Field Pointer bytes. This will occur when an Illegal Field Check detects an error in a command parameter list. If this bit is not set, the CD, BPV, and Bit Pointer fields will be set to 0, the top byte of the Field Pointer field will be 0, and the bottom byte of the Field Pointer field will contain a product-specific error code.

**C/D.** If set, the Field Pointer information applies to the command descriptor block. If not set, the Field Pointer information applies to the parameter list for the command (Only valid if SKSV is set.)

**BPV.** Indicates the Bit Pointer field is valid. Set if SKSV is set.

**Bit Pointer.** Identifies the bit position of the field in error. (Only valid if SKSV is set.)

**Field Pointer/Drive Error Code.** This field is dependent on the SKSV field as follows:

If SKSV is set to 1, this field identifies which byte of the command descriptor/parameter list an error was detected in. If SKSV is set to 0, the top byte of this field contains the drive error code associated with the failure of the previous command, or it contains zero in the case of no failure/no appropriate error code ( refer to Table 5-40 for a list of drive error codes).

**Copy Target Status.** Returned only if the Sense Key is Copy Aborted. Set to the value of the status byte returned to the drive from a Copy Target which resulted in the failure of the last Copy operation.

**Copy Target Sense.** Returned only if the Sense Key is Copy Aborted. Contains the Sense data returned to the drive by the last copy target the drive communicated with. The drive would have requested this data by issuing a REQUEST SENSE command to the copy target in response to receiving a non-good status from the copy target.

**For HP Internal Use Only**

**Table 5-38. Sense Key Codes**

<b>VALUE (HEX)</b>	<b>DESCRIPTION</b>
0	NO SENSE. No specific Sense Key information to be reported, or the command executed prior to the REQUEST SENSE command completed successf
1	RECOVERED ERROR. Last command completed successfully with some recovery action performed by the logical unit.
2	NOT READY. Logical unit cannot be accessed.
3	MEDIA ERROR. READ or WRITE command terminated with an error condition, or drive encountered problems loading or unloading tape.
4	HARDWARE ERROR. Controller detected a hardware failure while executing a command or performing a self-test.
5	ILLEGAL REQUEST. Illegal parameter in the command descriptor block or in additional parameters supplied as data for a command.
6	UNIT ATTENTION. Media has been exchanged, logical unit has been reset, or MODE SELECT parameters have been changed.
7	WRITE-PROTECTED. Logical unit attempted to write on a write-protected tape.
8	BLANK CHECK. Logical unit encountered End Of Data (EOD).
A	COPY ABORTED. COPY or COPY AND VERIFY command aborted due to an error condition on the source device, destination device, or both.
B	ABORT COMMAND. Command was aborted.

**For HP Internal Use Only**

**Table 5-39. Additional Sense Codes/Additional Sense Code Qualifiers**

VALUE (HEX)	DESCRIPTION
00 00	No Additional Sense Information
00 01	Filemark Detected
00 02	End Of Partition/Medium Detected
00 03	Setmark Detected
00 04	Beginning Of Partition Detected
00 05	End Of Data Detected
04 00	LUN Not Ready, cause not reportable
04 01	LUN Becoming Ready
04 02	LUN Not Ready, initializing command required
09 00	Track Following Error
0C 00	Write Error
11 00	Unrecovered Read Error
14 03	End Of Data Not Found
15 00	Mechanical Positioning Error
17 00	Recovered Data With No Error Correction
17 01	Recovered Data With Retries
18 00	Recovered Data With Error Correction
1A 00	Parameter List Length Error
20 00	Invalid Command Operation Code
24 00	Invalid Field in Command Descriptor Block
25 00	LUN Not Supported
26 00	Invalid Field in Parameter List
27 00	Operator Selected Write Protect
28 00	Not Ready to Transition
29 00	Power-On, Reset, Bus Device Reset
2A 01	Mode Parameters Changed
2B 00	Copy Cannot Execute
30 02	Cannot Read Media, Incompatible Format

**For HP Internal Use Only**

**Table 5-39.**

**Additional Sense Codes/Additional Sense Code Qualifiers (continued)**

<b>VALUE (HEX)</b>	<b>DESCRIPTION</b>
30 03	Cleaning Cartridge Installed
31 00	Medium Format Corrupted
33 00	Tape Length Error
37 00	Rounded Parameter
3A 00	Medium Not Present
3B 00	Sequential Positioning Error
3B 01	Tape Position Error at BOM
3D 00	Invalid Bits in Identify Message
3E 00	LUN Not Self-Configured
40 XX	Diagnostic Failure On Component
43 00	Message Error
44 00	Internal Target Failure
45 00	Select/Reselect Failure
47 00	SCSI Parity Error
48 00	Initiator Detected Error Message
49 00	Invalid Message Error
4A 00	Command Phase Error
4B 00	Data Phase Error
4E 00	Overlapped Commands Attempted
50 00	Write Append Error
51 00	Erase Failure
52 00	Cartridge Fault
53 00	Media Load/Eject Failed
53 02	Medium Removal Prevented
82 80	Humidity Too High
82 81	Dryness

For HP Internal Use Only

Table 5-40. Drive Error Codes

VALUE (HEX)	DESCRIPTION
01	Faulty 12V
02	High Humidity
03	Mode Sensor Fault
04	Tension Fault
05	Bad Reel Diameter
06	Capstan Not Moving
07	Drum Phase Lock Lost
08	Drum Not Moving
09	Drum DREF Lost
0A	Drum PG Lost
10	Supply reel stuck while threading
11	Supply reel stuck while in Capstan mode
12	Cleaning tape slipped on capstan
13	Take-up reel stuck while in Capstan mode
14	Reels stuck in Reel mode
18	RAM Test Failure
19	ROM Check Failure
1A	Supply Reel Brake Failure
1B	Take-up Reel Brake Failure
1C	Duncan Test Failure
20	File Mark Encountered
21	Save Set Mark Encountered
22	Illegal Length Record
23	Bad Group Blocking
24	Position Lost
25	Buffer Parity Error
26	Transfer Complete

**For HP Internal Use Only**

**Table 5-40. Drive Error Codes (continued)**

VALUE (HEX)	DESCRIPTION
27	Buffer Firmware Defect
28	Invalid Buffer Command
29	Invalid Buffer Parameters
2A	Entity Encountered
2B	Count Overflow
40	Unknown Algorithm
80	Bad Write Command Received
81	Getting Write Command Problems
82	Write Command Queue Problems
83	Report Problems During Write
84	Group Read-After-Write Retry Limit Exceeded
85	Write Frames Command Retry for Read-After-Write
86	No SUSHI Message Within Timeout
87	Bad Read Command Received
88	Getting Read Command Problems
89	Read Command Queue Problems
8A	Report Problems During Read
8B	RAM Parity Error Detected
8C	C3 Row Calculation Failure
8D	Streamfail During Map Command
8E	Too Many Bad Subdata Frames
8F	Too Many Gussed Logical Frame IDs
90	Group not complete when expected
91	Positive track bad, 22-frame group
92	Negative track bad, 22-frame group

For HP Internal Use Only

Table 5-40. Drive Error Codes (continued)

VALUE (HEX)	DESCRIPTION
93	Track conflict, 22-frame group
94	Timeout exceeded for C3 syndromes
95	Positive track checksum bad after C3
96	Negative track checksum bad after C3
97	Not enough good tracks after C3
98	Mini data bad, 23-frame group
99	C3 correction calculations failed
9A	C3 syndromes calculation failed
9B	Message window missed
9C	Checksum bad after recalculation, positive track
9D	Checksum bad after recalculation, negative track
9E	Track conflict after checksum recalculation
A0	SUSHI register test failed
A1	Internal error on message loopback test
A2	Data miscompare on message loopback test
A3	Illegal AFC search requested
A4	Timed out waiting for BOM or EOM
A5	Unexpected BOM or EOM
A6	Internal error on data loopback test
A7	Data miscompare on data loopback test
A8	Unexpected ISR value on data loopback test
A9	Wrong header on data loopback test
AA	Wrong checksum on data loopback test
AB	Drum ramp too slow
AC	Capstan ramp too slow
AD	Supply reel ramp too slow
AE	Take-up reel ramp too slow



For HP Internal Use Only

Table 5-40. Drive Error Codes (continued)

VALUE (HEX)	DESCRIPTION
AF	Mode change too slow
B0	Unable to clean up after test
B1	Utility data not valid
B2	Diagnostic command aborted by host
B3	Illegal diagnostic requested
B4	Illegal loopcount specified
B5	Diagnostic required tape
B6	Diagnostic required no tape
B7	Diagnostic test not supported
B8	Error on calibration, reel did not start
B9	Error on calibration, reel did not stop
BA	Timed out, waiting for Done state
BB	No ATF lock
BC	ATF edge not found
BD	Bad ATF window
BE	Invalid Malcolm firmware revision
C0	Invalid DDS Group
C1	Invalid DDS End Of Data
C2	Invalid DDS System
C3	No Group Subdata
C4	Append Point Unreadable
C5	Unreadable Subdata
C6	Position Lost
C7	Drive Timeout
C8	Tape Snapped
C9	Write Velocity Fault

For HP Internal Use Only

Table 5-40. Drive Error Codes (continued)

VALUE (HEX)	DESCRIPTION
CA	EOD Encountered
CB	BOM Encountered
CC	EOM Encountered
CD	Overshot Target
CE	ATF Locking Timeout
CF	Pre Stream Timeout
D0	Pretry Proximity
D1	Positioning Timeout
D2	SUSHI Command Timeout
D3	Drum Speed Timeout
D4	Outside Message Window
D5	Message Period Timeout
D6	Unexpected Position Counter
D7	Unexpected Reel Diameter
D8	Tape Unavailable
D9	Invalid When Threaded
DA	No Cassette Present
DB	Unexpected Cassette Present
DC	Finding AFC Timeout
DD	Initialization Error
DE	SUSHI Data Underflow
DF	SUSHI Data Overflow
E0	Bad SUSHI Parity
E1	SUSHI Message Overflow
E2	Failed To Read Log
E3	Blank Tape

**For HP Internal Use Only**

**Table 5-40. Drive Error Codes (continued)**

<b>VALUE (HEX)</b>	<b>DESCRIPTION</b>
E4	Non-DDS Tape
E5	Bad Checksum Buffer Parity
E6	Unexplained Positioning Failure
E7	Unable To Locate Target
F0	Previous Error
F1	Invalid Command Sequence
F2	Tape Length
F3	Unsupported Tape
F4	Cleaning Tape
F5	Invalid Device Command
F6	Invalid Device Parameter
F7	Device Firmware Defect
F8	Invalid Tape Format
F9	No Tape Loaded

## CD-ROM Drive Troubleshooting

If the drive status light indicates a problem with the drive, first replace the media. If the problem persists, replace the CD-ROM drive. There are no replaceable PCAs within the drive.

### Drive Status Light

Table 5-41 shows drive status light indications during normal operation and fault conditions.

**Table 5-41. Drive Status Light Indications**

Status	Explanation
ON	No CD-ROM detected, CD-ROM insertion error detected, or no CD-ROM is in the caddy.
OFF	Drive power is off, self-test passed, or no activity with the host.
FLASHING	Activity with the host.

### Diagnostic Information

The following paragraphs provide information about the data returned by the drive in response to a REQUEST SENSE command.

The method of accessing this information depends on the diagnostic tool you are using. Refer to the appropriate diagnostic documentation for information on retrieving device information.

#### REQUEST SENSE Data Fields

Table 5-42 shows the data format for the following data fields returned by the drive in response to a REQUEST SENSE command. Reserved fields always contain zeros.

**Valid.** A value of one for the Valid bit indicates the Information bytes contain valid information. The significance of the Information bytes depends on the status of the Sense Key field.

**Error Class.** Always returns a value of 7.

**Error Code.** Always returns a value of 7.

**Sense Key.** Indicates the type of error which has occurred, and the recovery action which should be taken by the Initiator. Sense Key codes are listed in Table 5-43.

**Information.** Contains the logical block address associated with the Sense Key field.

**Additional Sense Length.** Specifies the number of Additional Sense bytes that follow.

**Additional Sense Code.** Provides additional information about the error condition reported in the Sense Key field (refer to Table 5-44). If the disk drive does not have further information, this field contains zeros.

**For HP Internal Use Only**

**Table 5-42. REQUEST SENSE Data Format**

BYTE	BIT								
	7	6	5	4	3	2	1	0	
00	Valid	Error Class = 7			Error Code = 0				
01	Segment Number = 0								
02	FM = 0	EOM = 0	ILI	Reserved	Sense Key				
03--06	(MSB=03) Information Bytes			(LSB=06)					
07	Additional Sense Length = 0A								
08--11	Command Specific Information = 00								
12	Additional Sense Code								
13	Additional Sense Code Qualifier = 00								
14	Field Replaceable Unit Code = 00								
15	FPV = 0	C/D = 0	Reserved	BPV = 0	Bit Pointer = 0				
16--17	(MSB=00) Field Pointer			(LSB=00)					

**Table 5-43. Sense Key Codes**

VALUE (HEX)	DESCRIPTION
0	NO SENSE. No specific sense data to return; successful completion of command executed prior to the REQUEST SENSE command.
1	RECOVERED ERROR. Last command completed successfully with an error recovery operation, retries or error correction.
2	NOT READY. Drive cannot be accessed.
3	MEDIA ERROR. Command execution terminated with a nonrecoverable error condition caused by a media defect.
4	HARDWARE ERROR. Drive detected a nonrecoverable hardware failure while executing a command or performing a self-test.
5	ILLEGAL REQUEST. Illegal parameter in the command descriptor block (CDB) or in additional parameters.
6	UNIT ATTENTION. Media has been changed, the drive has been reset by a power-on or reset condition, or a BUS DEVICE RESET message.
8	BLANK CHECK. Drive encountered format-defined end-of-data block; attempted to read audio track.
B	ABORTED COMMAND. Drive aborted command execution.

For HP Internal Use Only

Table 5-44. Additional Sense Codes

VALUE (HEX)	DESCRIPTION
00	No additional sense information (NO SENSE).
04	Drive not ready (NOT READY).
11	Unrecoverable read error (MEDIA ERROR). Unable to recover data with retries or ECC.
12	Unable to read header of target block (MEDIA ERROR).
15	Seek operation did not complete within specified time limit (HARDWARE ERROR or MEDIA ERROR).
17	Recovered data with read retries, not with ECC (RECOVERED ERROR).
18	Recovered data with ECC correction, not with retries (RECOVERED ERROR).
20	Invalid command operation code (ILLEGAL REQUEST).
21	Illegal logical block address (ILLEGAL REQUEST). Maximum logical block address exceeded.
24	Illegal field in CDB (ILLEGAL REQUEST).
25	Invalid LUN (ILLEGAL REQUEST).
26	Invalid field in parameter list (ILLEGAL REQUEST).
28	Media exchanged (UNIT ATTENTION). Tray OPEN/CLOSE operation was executed.
29	Power-on reset, reset condition, or BUS DEVICE RESET occurred (UNIT ATTENTION).
2A	Block length or error recovery parameter of MODE SELECT command changed (UNIT ATTENTION).
30	Incompatible disk in disk tray (MEDIA ERROR).
44	Internal controller error (HARDWARE ERROR or ABORTED COMMAND).
45	Select/Reselect failed (HARDWARE ERROR or ABORTED COMMAND).
47	SCSI Interface parity error (HARDWARE ERROR or ABORTED COMMAND).
49	Inappropriate/illegal message (HARDWARE ERROR or ABORTED COMMAND).
88	Object address of an AUDIO TRACK SEARCH command is a data track address (ILLEGAL REQUEST).
89	Object address of a READ, SEEK, READ EXTENDED, or SEEK EXTENDED command is an audio track address (ILLEGAL REQUEST).
8A	The CD-ROM drive is not in continuous audio mode while on an audio track (ILLEGAL REQUEST).

---

## Quarter-inch Cartridge (QIC) Tape Drive Troubleshooting

The QIC drive is replaced as an entire assembly, but before replacing it you must make sure the problem is caused by a QIC hardware failure. This means you must rule out problems caused by the tape media or dirty heads.

Use the following sequence to isolate QIC drive problems.

1. Try cleaning the tape heads and see if the problem is solved.
2. Determine if the problem is media-related by installing a new QIC cassette and retrying the failed operation.
3. If the preceding steps have not solved the problem, replace the entire QIC drive.
4. Check system operation to make sure the problem is solved.

### QIC Troubleshooting Tools

1. Power-on Selftest - tests drive only
2. QIC diagnostic
  - Execute Selftest
  - Read error logs (contained on drive)
    - Write Error Count Log
    - Read Error Count Log
  - Read Error Rate Test (non-destructive)
    - QIC formats 24, 120, 150, and 320 are fixed block size formats. You must specify a block size of 512.
    - QIC format 525 is a variable block size format. You do not have to specify the block size.
    - Read/Write Error Rate Test - (destroys data)
3. Support tape
  - I/O MAP. I/O MAP will return Unidentified Device until HPUNIX 9.0.
4. Operating System
  - System support logs

### Troubleshooting Sequence

1. Clean heads according to the schedule in Table 5-45.

**Table 5-45. Recommended Preventive Maintenance Schedule**

Item	Interval (hours)
Head Cleaning	8 (or as required) (2 hours with new tapes)
Capstan Cleaning	20 (or as required) with used tapes

2. For read/write errors, run the Read/Write Error test.
3. Test with new media.

**For HP Internal Use Only**

- If errors do not recur, replace media.
- If errors recur, replace drive.

4. Format compatibility.

This may occur if the media is from a non-HP source.

- Verify data format
- Clean heads and retest
- If possible, test with new media
- Retest media on another system

5. If all else fails, replace the drive.



## Diagnostics and Utilities

---

This chapter provides information about the following diagnostic aids:

- Online diagnostics and utilities
- Offline diagnostics and utilities
- Procedure for booting up the system from the HP-UX Support Tape

For detailed information on diagnostic subsystems and utilities, refer to the most current editions of the following manuals:

- *Offline Diagnostics System Manual*  
(HP part number 30190-90010)
- *Online Diagnostics Subsystem Manual, Volume 1: SPU*  
(HP part number 09740-90028)
- *Online Diagnostics Subsystem Manual, Volume 2: Device Adapters*  
(HP part number 09740-90031)
- *Online Diagnostics Subsystem Manual, Volume 3: LAN/SCSI/MUX*  
(HP part number 09740-90034)
- *Online Diagnostics Subsystem Manual, Volume 4: Disks/Printers*  
(HP part number 09740-90040)
- *Online Diagnostics Subsystem Manual, Volume 5: Tapes*  
(HP part number 09740-90042)
- *Online Diagnostics Subsystem Utilities Manual*  
(HP part number 09740-90021).

## Online Diagnostics and Utilities

The alphabetical list below shows the available disk-resident online diagnostics.

CARTDIAG  
CENTPBA  
CIPERLPD  
CONSOLAN  
CS80DIAG  
DIAG7478  
DASSDIAG  
DTDUTIL  
FLEXDIAG  
HPIBDAD  
HPIBDDS  
HPFLDIAG  
LAN3PBB  
MEMDIAG  
OSI4DAD  
PMUXDIAG  
PSIDAD  
REELDIAG  
SCSICD  
SCSIDDS  
SCSIDISK  
SCSIPBA  
SCSIREEL  
LOGTOOL  
SYSMAP

## For HP Internal Use Only

### Using the Online Diagnostics

To start the online diagnostics, do the following:

Log on the system

Type `\SYSDIAG`

SYSDIAG loads the Diagnostic user Interface (DUI)

Type `HELP` to list the commands.

Type `HELP command_name` to display information about any command.

Type `HELP diagnostic_name` to display information about any diagnostic.

Type `HELP diagnostic_name SECTIONS` to display the test sections for a specific diagnostic.

Type `HELP diagnostic_name SECTIONS=nn` to display the commands that apply to specific test sections of a specific diagnostic.

---

### Offline Utilities

Offline utilities are available under the ISL environment. ISL-based offline utilities are implemented on the support tape. Some utilities are also implemented on the boot disk.

Note that MPE/iX and HP-UX have different support tapes.

Once you are at the ISL> prompt, type `HELP` to list the commands.

---

### Support Tape

The support tape allows you to diagnose problems when the HP-UX operating system cannot be booted from the system disk. For additional information on use of the support tape, refer to the most current *Support Tape Users Manual*.

To use the support tape, you need this minimum hardware configuration:

- 8 Mbyte memory
- Console
- Magnetic tape drive

### Booting Up

If the system has halted and cannot be booted from the system disk, you need to boot from the support tape. The procedure is as follows:

1. Select a tape drive to boot from and determine the drive's physical address.
2. Load support tape on tape drive and put drive online.
3. Press system reset button and wait about 30 seconds.
4. If autoboot is enabled, the following appears on the console:

### For HP Internal Use Only

Autoboot from primary boot path enabled.

To override, press any key within 10 seconds.

When a console key is pressed, this prompt appears on the console:

Boot from primary boot path (Y or N)?>

5. Respond by typing **(N)** to this prompt. The next prompt is:

Boot from alternate boot path (Y or N)?>

6. Respond to this prompt by typing **(Y)** if the support tape is loaded on the tape drive that corresponds to the alternate boot path.

Respond by typing **(N)** if the support tape is not loaded on the tape drive that corresponds to the alternate boot path. The following prompt appears:

Enter boot path, command or ?>

Respond by entering the physical address of the drive from which the support tape was loaded. After the appropriate response is given, the tape starts spinning and this prompt appears:

ISL>

At this point, typeHELP to see which ISL utilities are available.

If you want to run the mini-kerne, type support. The following menu is displayed.

#### SUPPORT TAPE MAIN MENU

- s. Search for a file
- b. Reboot
- l. Load a file
- d. On-line Diagnostics
- m. Display manual page for a specific command
- r. Recover an unbootable HP-UX system (a contributed utility)
- u. Utilities
- x. Exit to shell

---

#### Note

If autoboot is not enabled, the sequence of prompts and responses shown above occurs, with one exception. The first prompt, which allows the primary boot path to be overridden, does not appear.

---

7. Enter the boot command to the ISL> prompt as indicated:

ISL> support

8. After the HP-UX command is entered, the appropriate files from the support tape are loaded.
9. After a successful boot, the tape is positioned at the beginning of section 1. The login prompt appears on the System Console. Log in as "root." The password is "support." After you log in, the support tape Main Menu is displayed on the console.

**For HP Internal Use Only**

**Support Tape Main/Utilities Menus**

To select from the support tape Main Menu, type the name of the alphabet character preceding the command description. Type d to display the *On Line Diagnostics Menu* .

The support tape *Main Menu* is:

- s. Search for file
- b. Reboot
- l. Load a file
- d. On-line diagnostics
- m. Display Manual page for specific command
- r. Recover an unbootable HP-UX system
- u. Utilities
- x. Exit to shell

## Supported Peripherals

---

This section lists the peripherals supported on HP 3000 Series 9x7 Family and HP 9000 Model 8x7S Family computer systems. The supported peripherals are disk drives, tape drives, printers, terminals, system consoles, graphics devices, and data communication devices.

---

**Note**

Unless otherwise noted, a supported peripheral is supported by all series or models of the system. Exceptions are noted in parentheses next to the peripheral model number.

---

**Note**

The following terms and acronyms for interface standards are used in this chapter:

HP-IB	Hewlett-Packard Interface Bus
HP-FL	Hewlett-Packard Fiber-Optic Link
LAN	Local Area Network
RS-232	Standard for Serial Communication Interface
SCSI	Small Computer System Interface
HP-CS	Hewlett-Packard Common SCSI

---

**For HP Internal Use Only**

**Disk Drives**

**Table 7-1. Supported External Disk Drives**

Disk Drive	HP-UX	MPE/iX	Description	Interface
HPC1700A	x		20.8 GB Optical Disk Drive	HP-CS
HPC1701A	x		20.8 GB Optical Disk Drive	HP-CS
HPC1707A	x		Model 600/A CD-ROM	HP-IB
HPC2200A	x	x	335 MB Disk	HP-IB
HPC2201A	x	x	670 MB Disk with Fiber-Optic Link	HP-FL
HPC2202A		x	670 MB Disk with Cache	HP-IB
HPC2203A	x	x	670 MB Disk	HP-IB
HPC2204A	x	x	1340 MB Disk with Fiber-Optic Disk	HP-FL
HPC2212A	x		332 MB Disk	HP-CS
HPC2213A	x		664 MB Disk	HP-CS
HPC246xF	x		Floor-standing Disk Cabinet	HP-CS
HPC2460F	x		422 MB Disk	HP-CS
HPC2460R	x		422 MB Disk	HP-CS
HPC2461F	x	x	677 MB Disk	HP-CS
HPC2461R	x	x	677 MB Disk	HP-CS
HPC2462F	x	x	1.363 GB Disk	HP-CS
HPC2462R	x	x	1.363 GB Disk	HP-CS
HPC246xA	x		Rack-mounted Disk Cabinet	HP-CS
HP 7935H	x		404 MB Removable Disk Drive	HP-IB
HP 7936/H/XP		x	307 MB Disk with Cache (XP)	HP-IB
HP 7937H	x		571 MB 8-inch Disk	HP-IB
HP 7937FL	x		571 MB 8-inch Disk with Fiber-Optic Link (FL)	HP-FL
HP 7937/H/XP		x	571 MB Disk with Cache (XP)	HP-IB
HP 7957B	x <sup>1</sup>		81 MB Disk	HP-IB
HP 7958B	x <sup>1</sup>		152 MB Disk	HP-IB
HP 7962B		x	152 - 456 MB Disk	HP-IB
HP 7963B		x	304 - 912 MB Disk	HP-IB
HP 9122C	x		2 MB 3.5-inch Floppy Disk Drive	HP-IB
HP 9127A	X		Single 5.25-inch Flex Disk Drive	HP-IB
HP 9153C	x		40 MB Winchester/2 MB 3.5-inch Floppy	HP-IB

**Note**

<sup>1</sup>Not supported as system disk.



<sup>2</sup>Do not support powerfail recovery.

**7-2 Supported Peripherals**

**For HP Internal Use Only**

**Table 7-2. Supported Internal Disk Drives**

Disk Drive	HP-UX	MPE/iX	Description	Interface
HPC2470S	x <sup>3</sup>		234 MB Disk	HP-CS
HPC2471S	x		328 MB Disk	HP-CS
HPC2472S	x		422 MB Disk	HP-CS
HPC2473S	x	x	677 MB Disk	HP-CS
HPC2474S	x	x	1.363 GB Disk	HP-CS

**Note** <sup>3</sup>HP 9000 Model 807S system disk.



**Table 7-3. Other Supported Mass Storage Peripherals**

Product Number	HP-UX	MPE/iX	Description	Interface
TXM3301A	x <sup>5</sup>		Toshiba CD-ROM (3301)	HP-CS

**Note** <sup>4</sup>Not supported as system disk.



<sup>5</sup>Boot device only.

## Tape Drives

**Table 7-4. Supported Internal Tape Drives**

Tape Drive	HP-UX	MPE/iX	Description	Interface
HPC1502A	x	x	1.3 GB DDS-format Tape Drive	HP-CS
HPC1503B	x	x	2.0 GB DDS-format Tape Drive	HP-CS
HPC1504B	x	x	4-to-8 GB DDS-format Tape Drive	HP-CS
HPD2034A	x		Quarter-inch Cartridge Tape Drive	HP-CS



**For HP Internal Use Only**

**Table 7-5. Supported External Tape Drives**

<b>Tape Drive</b>	<b>HP-UX</b>	<b>MPE/iX</b>	<b>Description</b>	<b>Interface</b>
HPC1511A	x	x	1.3 GB DDS-format Tape Drive	HP-IB
HPC1512A	x		1.3 GB DDS-format Tape Drive	HP-IB
HPC2292A	x		Tape Drive	HP-CS
HPC2463F	x		1.3 GB DDS-format Tape Drive - floor-standing	HP-CS
HPC2463R	x		1.3 GB DDS-format Tape Drive - rack-mount	HP-CS
HP 7974A	x	x	1600 CPI Streamer	HP-IB
HP 7978B	x	x	6250 CPI Streamer	HP-IB
HP 7979A	x	x	1600 CPI Streamer	HP-IB
HP 7980A	x	x	6250 CPI Streamer	HP-IB
HP 7980S/SX	x		6250 CPI	HP-CS
HP 7980XC	x	x	6250 CPI Data Comp	HP-IB
HP 9144A	x		67 MB 1/4" Cartridge Tape Drive	HP-IB
HP 9145A	x		134 MB 1/4" Cartridge Tape Drive	HP-IB

## Printers

Table 7-6. Supported Centronics/Parallel Printers

Line Printer	HP-UX	MPE/iX	Description	Interface
HP2225C/D/P	x		ThinkJet	Centronics
HP2227A	x		QuietJet Plus	Centronics
HP2228A	x		QuietJet	Centronics
HP2235A/C/D	x		Ruggedwriter	Centronics
HP2276A	x		DeskJet	Centronics
HP2277A	x		DeskJet Plus	Centronics
HP2562C	x		400 LPM	Centronics
HP2564C	x		840 LPM	Centronics
HP2565C	x		600 LPM	Centronics
HP2566B	x		900 LPM	Centronics
HP2566C	x		1200 LPM	Centronics
HP2567B/C	x		1200 LPM	Centronics
HP2684A	x		LaserJet 2000	Centronics
HP2684D	x		LaserJet 2000	Centronics
HP2684P	x		LaserJet 2000	Centronics
HP2934A	x		200 cps Printer	Centronics
HP33440A	x		LaserJet II	Centronics
HP33447A	x		LaserJet IID	Centronics
HP33449A	x		LaserJet III	Centronics
HP33459A	x		LaserJet IIID	Centronics
HP33471A	x		LaserJet IIP	Centronics
HP3630A	x		PaintJet Color	Centronics
HPC1202A	x		Asian High Speed Serial	Centronics
HPC1602A	x		PaintJet XL Color Graphics	Centronics
HPC2106A	x		DeskJet 5000	Centronics

**For HP Internal Use Only**

**Table 7-7. Supported Printers**

Line Printer	HP-UX	MPE/iX	Description	Interface
HP2225D	x		ThinkJet	RS-232
HP2227A	x		QuietJet Plus	RS-232
HP2228A	x		QuietJet	RS-232
HP2276A	x		DeskJet	RS-232
HP2277A	x		DeskJet Plus	RS-232
HP2562C	x	x	400 LPM	HP-IB/RS-232
HP2563C		x	420 LPM	HP-IB/RS-232
HP2564B		x	600 LPM	HP-IB/RS-232
HP2564C	x	x	840 LPM	HP-IB/RS-232
HP2566C	x	x <sup>6</sup>	1200 LPM	RS-232
HP2567A/B	x	x <sup>6</sup>	1200 LPM	RS-232
HP2567C	x	x <sup>6</sup>	1200 LPM	RS-232
HP2684A	x	x	LaserJet 2000	RS-232
HP2934A	x		200 cps printer	RS-232
HP33440A	x	x	LaserJet II	RS-232
HP33447A	x	x	LaserJet IID	RS-232
HP33449A	x	x	LaserJet III	RS-232
HP33459A	x	x	LaserJet IIID	RS-232
HP33471A	x		LaserJet IIP	RS-232
HP33491A		x	LaserJet IIISi	RS-232
HP3630A	x		PaintJet Color	RS-232
HP41063A	x		Asian Printer	RS-232
HPC1200A	x	x	Asian System Printer	RS-232
HPC1202A		x	Asian System Printer	RS-232
HPC1602A	x		PaintJet XL Color Graphics	RS-232
HPC2106A	x		DeskJet 500	RS-232

**Note**

<sup>6</sup>HP-IB only



**For HP Internal Use Only**

## Terminals

**Table 7-8. Supported Terminals**

Terminal	HP-UX	MPE/iX	Description	Interface
HP3081A		x	Industrial Workstation	RS-232
HP3082A/B		x	Industrial Touch Terminal	RS-232
C1001A/G/W	x	x	HP 700/92	RS-232
C1002A/G/W	x	x	HP 700/94	RS-232
C1004A/G/W	x		HP 700/22	RS-423
C1006A/G/W	x		HP 700/43	RS-232
C1007A/G/W	x		HP 700/44	RS-232
C1010C	x	x	Simplified Chinese Terminal	RS-232
C1010J	x	x	Japanese Terminal	RS-232
C1010T	x	x	Traditional Chinese Terminal	RS-232
C1017A	x		HP 700/32 - Amber Display	RS-232
Vectra ES 16/20		x		RS-232
Vectra RS		x		RS-232
Vectra QS 386/25		x		RS-232
Vectra 486		x		RS-232
Vectra 286/12		x		RS-232

**Table 7-9. Supported Terminals as Consoles**

Terminal	HP-UX	MPE/iX	Description	Interface
C1002A/G/W	x	x	HP 700/94 Terminal	RS-232
C1010C	x		Simplified Chinese Terminal	RS-232
C1010J	x	x	Japanese Terminal	RS-232
C1010T	x	x	Traditional Chinese Terminal	RS-232

**For HP Internal Use Only**

**Plotters**

**Table 7-10. Supported Plotters**

<b>Plotter</b>	<b>HP-UX</b>	<b>MPE/iX</b>	<b>Description</b>	<b>Interface</b>
C1600A	x		HP7600 Series Model 240D A1/D size Plotter	HP-IB, Centronics
C1601A	x		HP7600 Series Model 240E A0/E size Plotter	HP-IB, Centronics
C1620A	x		HP7600 Series 355 Electrostatic Plotter	Centronics, RS-232, HP-IB
C1625A	x		HP 7600 Series Model 250 Monochrome Electrostatic D-size Plotter	Centronics, RS-232, HP-IB
C1627A	x		HP 7600 Series Model 255 Monochrome Electrostatic D-size Plotter	Centronics, RS-232, HP-IB
7440A	x		Color plotter, 8 pen, A size	RS-232, HP-IB
7475A	x		Color plotter, 6 pen, A/B size	RS-232, HP-IB
7550A	x	x	Color Plotter, 8 Pen, A4/A and A3/B Size	RS-232, HP-IB
7550B	x	x	Color Plotter, 8 Pen, A4/A and A3/B Size	Centronics, RS-232, HP-IB
7586B	x		Rollfeed Drafting Plotter	RS-232
7595A	x		Draftmaster I Plotter, 8 Pen, A4/A - A0/E Size	RS-232, HP-IB
7595B	x		DraftMaster SX Plotter	RS-232, HP-IB
7596A	x		Draftmaster II Plotter, A4 - A0 Rollfeed	RS-232, HP-IB
7596B	x		DraftMaster RX plotter	RS-232, HP-IB
7599A	x		DraftMaster MX plotter	RS-232, HP-IB

---

**Data Communication Devices**
**Table 7-11. Supported Data Communication Devices**

Data Comm Device	HP-UX	MPE/iX	Description	Interface
HP50795A		x	Remote Support Modem	RS-232
3400	x		Racal-Vadic Modem USR Courier Modem 2400	RS-232
35141A	x		Auto answer	RS-232
37204A	x		High-speed Multipoint HP-IB Extender	HP-IB
37212B	x		300/1200 Baud, 212/V22, Auto Dial/Answer	RS-232
92205A/C	x		Hayes 1200 Smart Modem	RS-232
92205B	x		Hayes 1200/2400 Smart Modem	RS-232
Bell 212A	x		Dial-in Modem	RS-232
Bell 103J	x		Dial-up, Auto-answer	RS-232
Bell 202T	x		4-wire leased line modem	RS-232
MPS 1222	x		Racal-Milgo Dial-in Modem	RS-232
Telebit T2500	x		PEP/V.32 modem	RS-232
Trailblazer	x		Telebit 19.2 modem	RS-232
USR HST/V.32	x		HST/V.32 modem	RS-232
USR 2400	x		Courier 2400 modem	RS-232
USR 9600	x		Courier HST modem	RS-232

For HP Internal Use Only

Other Peripherals

Table 7-12. Supported PCAs

HP Product Number	HP-UX	MPE/iX	Description
28606-60001	x	x	PSI (Programmable Serial Interface) Card
28650B	x		HP-IB Card
J2146A	x		LAN 802.3
A1747A		x	PBA-IB (PB to CIO with HP-IB)
A1748A		x	PBA-FL (PB to CIO with HP-FL)
A1749A	x		PBA-FL (PB to CIO with HP-FL)
28642A		x	HP-PB SCSI/Parallel Adapter
28655A	x		HP-PB SCSI/Parallel Adapter
A1703-60003		x	SCSI/Console/LAN Multifunction I/O Card
A1703-60004	x		SCSI/Parallel/APMUX Card
A1703-60022	x		SCSI/Parallel/APMUX Card
A1751-60001	x		SCSI/APMUX Card
27113B <sup>7</sup>		x	HP-IB Device Adapter
36923A <sup>7</sup>		x	LAN 802.3 Local Area Network
27111A <sup>7</sup>	x		HP-FL Fiber Optic Disk Interface
27115A <sup>7</sup>		x	HP-FL Fiber Optic Disk Interface
A1749A <sup>8</sup>	x		HP-PB FL Kit. Contains the following: 27111A CIO HP-FL kit, containing 27111-60001 A1700-60001 NIO/CIO Chan-Span Card
J2092A	x		16-channel RS-232 Direct Connect
J2093A	x		16-channel RS-422 Direct Connect
J2094A	x		16-channel RS-232 Modem Connect
J2146A	x		LAN Kit (contains 28640-60001)
28655A	x		SCSI/Centronics Interface
36969A	x		802.4 Carrier band OSI Exp MAP 3.0
40299B	x		AP/MUX Terminal Connect

Note

<sup>7</sup> Requires PBA adapter.



<sup>8</sup> Expanded chassis only.

**For HP Internal Use Only**

**Table 7-13. Other Supported Peripherals**

<b>HP Product Number</b>	<b>HP-UX</b>	<b>MPE/iX</b>	<b>Description</b>
HP 2334A	x	x	X.25 Multiplexer
HP 2335A		x	X.25 Multiplexer
HP 2340A		x	DTC-16
HP 2345A		x	Distributed Terminal Controller (DTC-48)
HP 37203A		x	HP-IB Extender
HP 37204A	x	x	Multipoint HP-IB Extender



## Replaceable Parts

---

### Introduction

This section provides names and part numbers of Field Replaceable Units (FRUs). Exchange and non-exchange parts are listed in Table 8-1.

It contains a list of replaceable parts for the HP A1883A/84A and HP A1896A/97A rack-mount cabinet.

It contains procedures for removing and replacing the field-replaceable components of the systems.

It contains a procedure for installing and removing the floating point chip on the processor PCA.

It also contains removal and replacement procedures for the HP A1883A/84A and HP A1896A/97A rack-mount cabinet.

**For HP Internal Use Only**

## Parts List

**Table 8-1. Replaceable Parts**

Description	New Part No.	Exchange Part No.
Active Distribution Panel I (ADP I)	5062-3070	
Active Distribution Panel II (ADP II)	5062-3054	
AUI Retainer Clip	5062-3351	
Backplane, 2-slot	A1703-60002	
Backplane, 12-slot	A1703-60013	A1703-69013
Backplane, 12-slot (64 MHz)	A1703-60036	A1703-69036
Backplane, 6-slot	A1703-60037	A1703-69037
Backplane, 6-slot (64 MHz)	A1703-60038	A1703-69038
Backplane Clip, Right	A1703-40006	
Backplane Clip, Left	A1703-40007	
Backup Battery	1420-0507	
Bezel, Front, Standard	A1703-60023	
Bezel, Front, Expanded	A1703-60033	
Bezel, Rear, Standard	A1703-40002	
Bezel, Rear, Expanded	A1703-40010	
Cable, 16-port to ADP and DDP	A1703-63005	A1703-69305
Cable, 8-port to ADP II	5060-3074	
Cable, 8-port to ADP I	40299-60003	
Cable, Power	8120-1751	
Cable, SCSI, Internal, Standard (1 meter)	A1703-63001	
Cable, SCSI, Internal, Expanded (2.5 meter)	A1703-63004	
Cable, SCSI, Internal, Standard (1.5 meter)	A1703-63007	
Cable, SCSI, Internal, Expanded (3 meter)	A1703-63008	
Cable, SCSI External (high-to-low density) 1.0 M	5062-3383	
Cable, SCSI External (high-to-low density) 1.5 M	5062-3388	
Card Guide, 2-slot	A1703-40008	
Card Guide, 8-slot	5041-2455	
CD-ROM Drive 3301B	1150-1895	
CD-ROM Caddy	C2293-80001	
Chassis, Standard	A1703-60072	
Chassis, Expanded	A1703-60073	
Cover Plate, Mechanism	A1703-60075	
CPU Bulkhead, Standard	A1703-60028	
CPU Bulkhead, Expanded	A1703-60032	

### 8-2 Replaceable Parts

For HP Internal Use Only

Table 8-1. Replaceable Parts (continued)

Description	New Part No.	Exchange Part No.
CPU (807)	A1751-60003	A1751-69003
CPU w/o Floating Point (917LX,927LX,937,937LX,947,947LX)	A1751-60003	A1751-69003
CPU with Floating Point (917LX,927LX,937,937LX,947,947LX)	A1751-60013	A1751-69003
CPU w/o Floating Point (817,827,957,957LX)	A1703-60016	A1703-69016
CPU w/o Floating Point (837,847,857,967)	A1703-60017	A1703-69017
CPU w/o Floating Point (867,877,977)	A1703-60043	A1703-69043
CPU with Floating Point (867,877,977)	A1703-60035	A1703-69035
Direct Distribution Panel (DDP)	5062-3066	
Disk Drive, 234 MB	C2233-60162	C2233-69162
Disk Drive, 328 MB	C2234-60162	C2234-69162
Disk Drive, 422 MB	C2235-60162	C2235-69162
Disk Controller PCA for 234 MB, 328 MB, 422 MB disks	C2235-60009	C2235-69009
Disk Drive, 670 MB	97556-60162	97556-69162
Disk Drive, 1.3 GB	97560-60162	97560-69162
Disk Controller PCA for 670 MB, 1.3 GB disks	97560-60021	97560-69021
Firmware Removal Tool	8710-1982	
Floating Point Chip Kit (48 MHz)	A2293-60001	
Floating Point Chip Kit (64 MHz)	A2293-60002	
Light Pipe	A1703-40004	
Memory Board, 4 MB	A2230-60001	A2230-69001
Memory Board, 8 MB	A2231-60001	A2231-69001
Memory Board, 16 MB	A2232-60001	A2232-69001
Memory Board, 32 MB	A2511-60001	A2511-69001
Memory Card Guide, 2-slot	A1703-40008	
Memory Card Guide, 8-slot	5041-2455	
Memory Extender	A1703-60005	
Memory Extender (64 MHz systems)	A1703-60031	
Multifunction I/O PCA (SCSI/Console/LAN)	A1703-60003	A1703-69003
Multifunction I/O PCA (AP/MUX/SCSI/Centronics)	A1703-60004	A1703-69004
Multifunction I/O PCA (AP/MUX/SCSI)	A1751-60001	A1703-69001
Multifunction I/O PCA 8/16 port	A1703-60022	A1703-69022
On/Off Switch	A1703-60015	
Peripheral Tray, Disk/Tape/CDROM	A1703-60071	
Peripheral Tray, Disk only	A1703-60074	
Peripheral Tray. 3.5-inch Disk	A1703-00010	

**For HP Internal Use Only**

**Table 8-1. Replaceable Parts (continued)**

Description	New Part No.	Exchange Part No.
Precision Bus Adapter	A1700-60005	
Precision Bus Adapter Interface	A1700-60001	
CIO Bulkhead	A1027-60017	
CIO/HP-IB Cable	27113-63003	
HP-IB PCA	27113-60301	
HP-IB Firmware	27113-67801	
Power Supply	A1703-60041	
SCSI Terminator, High Density	1252-3932	
SCSI Terminator (DMK part number)	K2289	
SCSI Terminator Fuse	2110-0517	
Screw, Chassis, No. 10 TORX, Thread Forming	0624-0740	
Screw, CD-ROM, QIC Drive, and Internal Disk Mounting	2360-0515	
Screw, DDS Mounting	0515-0430	
Side Panel, Left, Expanded	A1703-00030	
Side Panel, Left, Standard	A1703-00012	
Side Panel, Standard/Expanded	A1703-00013	
Side Panel, 6-slot Expanded	A1703-00029	
Tape Drive, Quarter-inch Cartridge (QIC)	D2034-60001	D2034-69001
Tape Drive, C1502A, 5.25-inch DDS-format,	C1502-67203	C1502-69203
Tape Drive, C1503B, 3.5-inch DDS-format	C1503-67201	C1503-69201
3.5-inch Disk Bracket	A1703-00010	
Terminator, Cable	1252-4414	
Termination Resistor, Disk <sup>1</sup>	1810-1176	
Termination Resistor, C1502A DDS Tape Drive <sup>1</sup>	1810-1176	
HP-PB SCSI/Parallel PCA	28655-60001	28655-69001
HP-PB HP-IB PCA	28650-60101	28650-69101
CIO HP-IB PCA	27113-60301	27113-69301
CIO HP-FL (MPE/iX and HP-UX) PCA	27115-60001	5062-3308

**Note** <sup>1</sup> Three termination resistors required.



**For HP Internal Use Only**

**Table 8-2. HP 3000 Series 9x7 Boards**

<b>Model</b>	<b>Backplane</b>	<b>Processor</b>	<b>Multifunction I/O Card</b>
917LX	A1703-60002	A1751-60003	A1703-60003
927LX	A1703-60002	A1751-60003	A1703-60003
937LX	A1703-60002	A1751-60003	A1703-60003
947LX	A1703-60002	A1751-60003	A1703-60003
957LX	A1703-60002	A1703-60016	A1703-60003
967LX	A1703-60002	A1703-60017	A1703-60003
937	A1703-60013	A1751-60003	A1703-60003
947	A1703-60013	A1751-60003	A1703-60003
957	A1703-60013	A1703-60016	A1703-60003
967	A1703-60013	A1703-60017	A1703-60003
977	A1703-60036	A1703-60043	A1703-60003

**Table 8-3. HP 9000 Model 8x7S Boards**

<b>Model</b>	<b>Backplane</b>	<b>Processor</b>	<b>Multifunction I/O Card</b>
807	A1703-60002	A1751-60003	A1751-60001
817	A1703-60002	A1703-60016	A1703-60004
827	A1703-60037	A1703-60016	A1703-60004
837	A1703-60002	A1703-60017	A1703-60004
847	A1703-60037	A1703-60017	A1703-60004
857	A1703-60013	A1703-60017	A1703-60004
867	A1703-60038	A1703-60043	A1703-60022
877	A1703-60036	A1703-60043	A1703-60022

---

**Rack-Mount Cabinet Replaceable Parts**
**Table 8-4. Rack-mount Cabinet Replaceable Parts**

Description	Part Number
Rear door, 1.6 meter	C2786-60009
Rear door, 1.1 meter	C2785-60008
Rear hinge	C2786-00012
Vented top cap	C2786-60015
Non-vented top cap	C2785-60007
Side cover, 1.6 meter	C2786-60014
Side cover, 1.1 meter	C2785-60006
Forehead assembly (with on/off switch)	C2786-60004
Base cover, 1.6 meter	C2786-00014
Base cover, 1.1 meter	C2785-00004
Rail assembly	C2786-60018
230V Fan assembly	C2786-60024
115V Fan assembly	C2786-60005
230V Fan	3160-0378
115V Fan	3160-0228
US 208-240V PDU, 1.6 meter	C2786-63006
EURO 230V PDU, 1.6 meter	C2786-63007
US 120V PDU, 1.1 meter	C2785-63000
EURO 230V PDU, 1.1 meter	C2785-63003
PDU Support Bracket	C2786-00021
Caster	1492-0159
Nut- Wiz, M8 x 1.25 (caster)	0535-0096
Leveler	0403-0778
Ballast assembly	C2786-60017
Nut- Tinnerman 10/32	0590-0804
Screw, T15 10/32 w/washer	2680-0278
Screw, T25 10/32	2680-0281
Strike Plate	1390-0489
Magnetic Door Catch	1390-0265
Door Bumper	0403-0780
1U Filler assembly	C2786-60001
Rack device Power cord, 20 inches	8120-5470
Rack device power cord, 30 inches	8120-1396
ADP mounting bracket	C2786-00036

---

## Removal and Replacement

This chapter provides removal and replacement procedures of the

- Standard Chassis
- Expanded Chassis
- Cabinet

Quick reference removal procedures are also provided for the major components of the standard and expanded chassis.

It also provides assembly and disassembly procedures for the

- 5.25-inch Hard Disk
- 3.5-inch Hard Disk
- 5.25-inch DDS-Format DAT Drive
- 3.5-inch DDS-Format DAT Drive
- CD-ROM
- Quarter-inch Cartridge Tape Drive (QIC)

### Before You Begin Removal Procedures

---

#### Warning



**Hazardous voltages are present inside the cabinet. To prevent shock, turn off DC power using the front panel DC On/Off switch AND disconnect the AC power cord from the outlet before opening the unit.**

**Wait one minute before disassembling the system.**

---

#### Caution



Handle all FRUs carefully. Dropping or otherwise jarring the FRUs will damage them.

Follow ESD procedures. Always use an ESD grounding wrist strap during service.

---

#### Caution



Do not mix thread-forming TORX chassis screws (Figure 8-1) and peripheral mounting TORX screws when you disassemble the system. They are not interchangeable. If thread-forming TORX chassis screws are inserted where peripheral mounting TORX screws should be used, they will damage the internal peripherals.

---

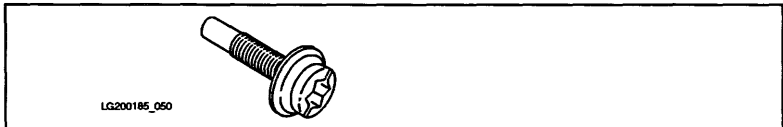

Figure 8-1. Thread-forming TORX Chassis Screw

## **For HP Internal Use Only**

### **Required Tools**

- No. 10 TORX head driver
- No. 15 TORX head driver
- Small flat blade screw driver
- Small needle-nose pliers
- Anti-static protective containers
- Grounding wrist strap

### **System Identification**

Figure 8-2 shows the standard system.

Figure 8-3 shows the expanded system.



**For HP Internal Use Only**

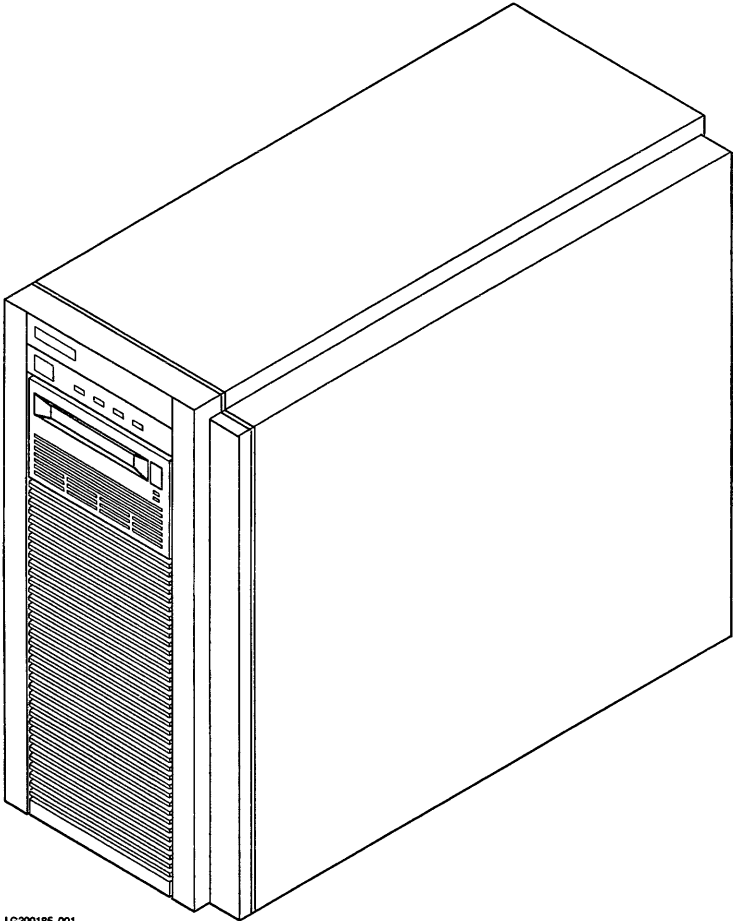

LG200185\_001

**Figure 8-2. HP 3000 Series 9x7 and HP 9000 Series 8x7 Standard System**

**For HP Internal Use Only**

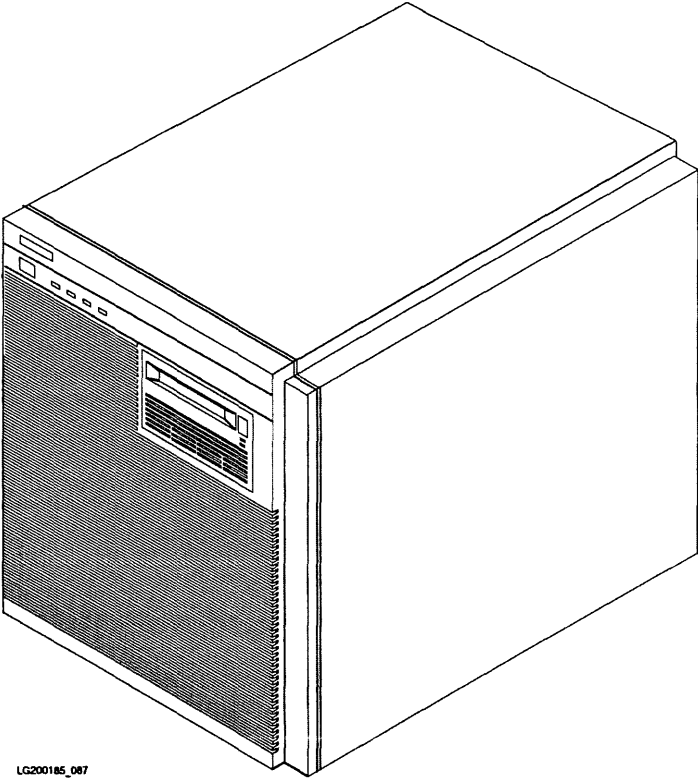

LG200185\_087

**Figure 8-3. HP 3000 Series 9x7 and HP 9000 Series 8x7 Expanded System**

#### **Turn Off System**

1. Press the On/Off switch to remove DC power from the system.
2. For the standard system, disconnect the power cord from the wall socket to remove AC power from the system.
3. For the expanded system, disconnect two power cords from the wall socket to remove AC power from the system.

## **Standard Chassis Removal Procedures**

The removal procedures are in the order they should be performed. In general, each procedure assumes that you have performed all of the procedures before it.

### **Remove Front Bezel**

1. See Figure 8-4.
2. Remove two screws from the bottom of the front bezel.
3. Slide the bezel straight up about 0.25 inches.
4. Pull the bottom of the front bezel about one inch away from the system.
5. Lift the bezel away from the system.

For HP Internal Use Only

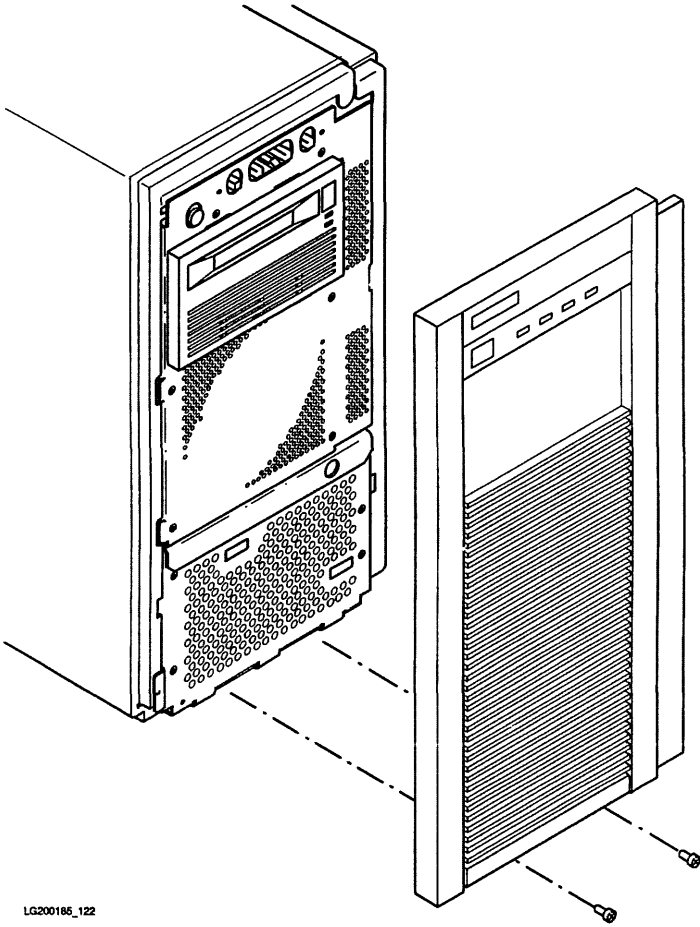

LG200185\_122

Figure 8-4. Standard Chassis Front Bezel Removal

**For HP Internal Use Only**

**Remove Peripherals**

1. Remove bezel.

**Remove Peripheral Drawer**

1. See Figure 8-5.
2. Remove two TORX screws.
3. Lift the peripheral drawer to clear the locks on the system cabinet and pull it out of the system cabinet. Be careful not to strain the power and SCSI cables.
4. Set the peripheral drawer on a supporting surface.
5. See Figure 8-6.
6. Disconnect the SCSI flat ribbon cable from the DDS and the disk.
7. Disconnect the power connectors from the DDS and the disk.

For HP Internal Use Only

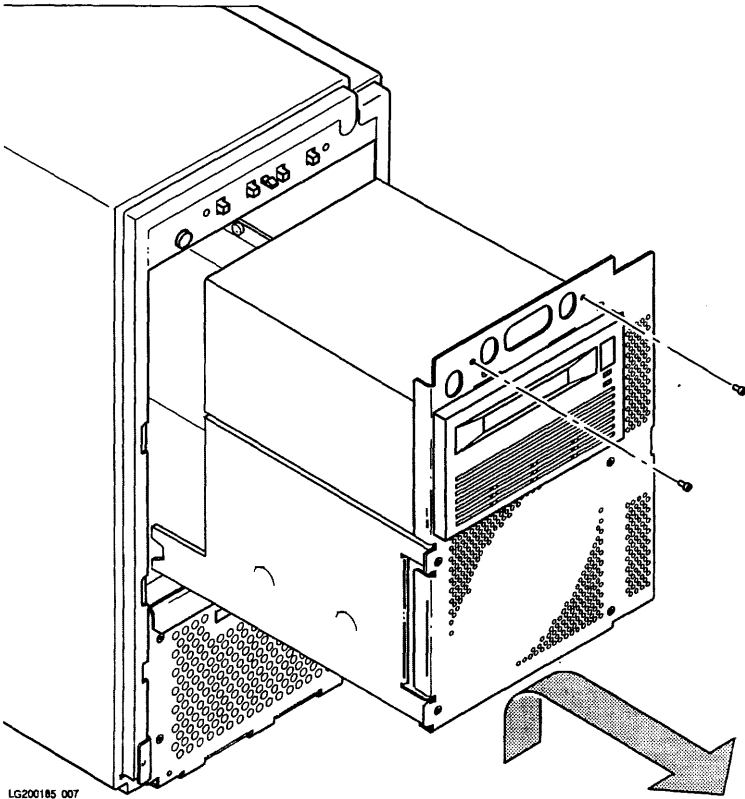

LG200185\_007

Figure 8-5. Peripheral Drawer Removal

**For HP Internal Use Only**

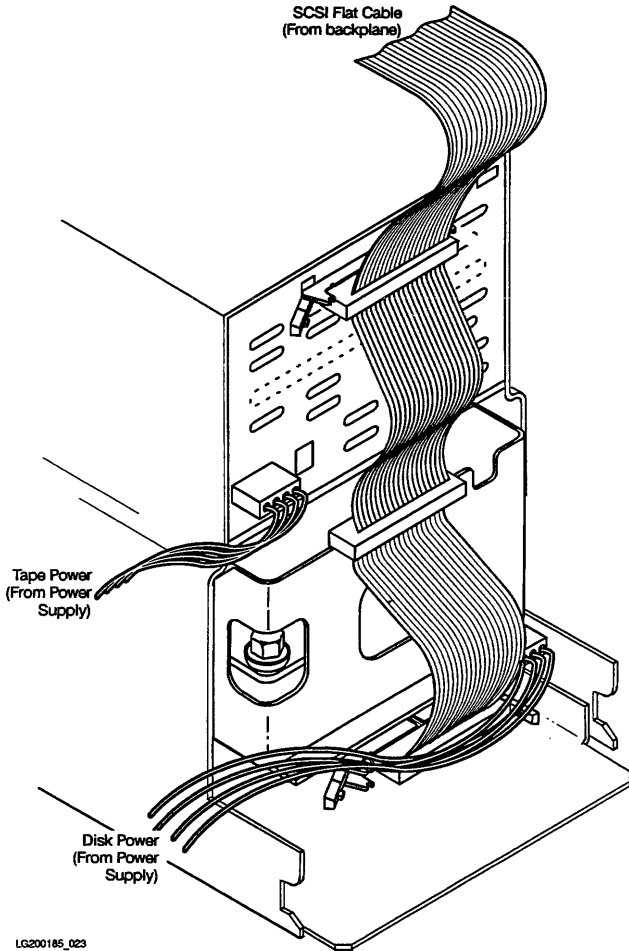

LG200185\_023

**Figure 8-6. 5.25-inch Digital Data Storage (DDS) Device and Disk Cabling**

**For HP Internal Use Only**

**Remove 5.25-inch Digital Data Storage (DDS) Device**

1. See Figure 8-7.
2. Remove the two EMI clips indicated by the arrows.
3. See Figure 8-8.
4. Remove four TORX screws and remove the DDS from the front of the peripheral drawer.

---

**Warning**



**Do not mix these screws with the system chassis screws or the disk support screws. You will damage the DDS if you attempt to mount it with the system chassis screws or the disk support screws.**

---

**Warning**



**To maintain emission performance, ensure the two EMI clips are replaced when the DDS is reinstalled.**

---



For HP Internal Use Only

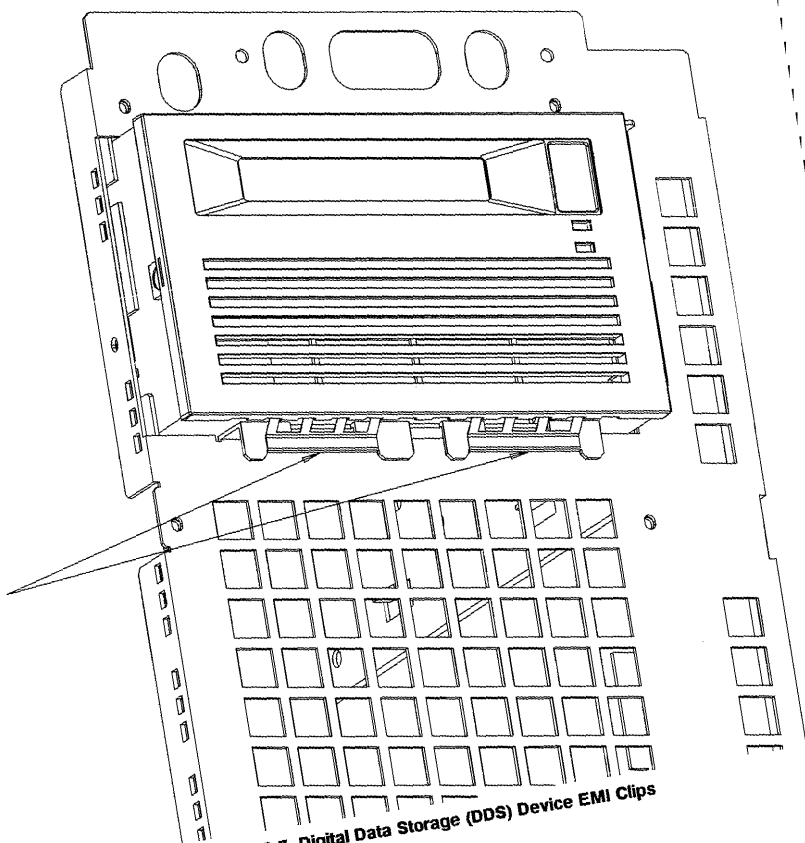
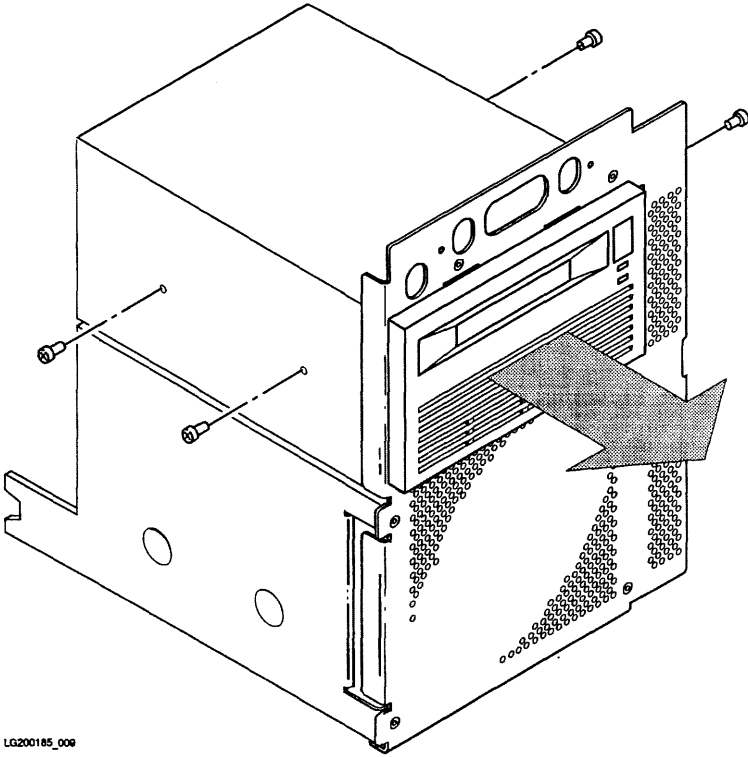

Figure 8-7. Digital Data Storage (DDS) Device EMI Clips

For HP Internal Use Only



LG200185\_009

Figure 8-8. 5.25-inch Digital Data Storage (DDS) Device Removal

For HP Internal Use Only

**Remove Internal 5.25-inch Disk**

1. See Figure 8-9.
2. Remove four TORX screws and remove the disk from the rear of the peripheral drawer.

**Warning**



Do not mix these screws with the system chassis screws or the DDS support screws. You will damage the disk if you attempt to mount it with the system chassis screws or the DDS support screws.

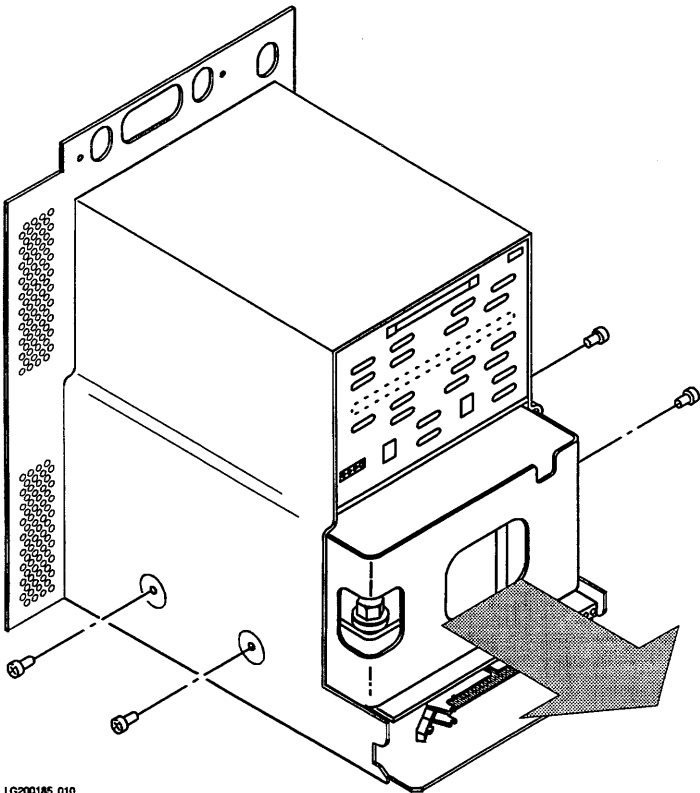

LG200185\_010

Figure 8-9. Internal 5.25-inch Disk Removal

**For HP Internal Use Only**

**Remove 3.5-inch Digital Data Storage (DDS) Device**

1. See Figure 8-10.
2. Disconnect the SCSI flat ribbon cable from the DDS.
3. Disconnect the power cable from the DDS.
4. Remove the EMI clips.
5. See Figure 8-11.
6. Remove four TORX screws and remove the DDS from the front of the peripheral drawer.

---

**Warning**



**Do not mix these screws with the system chassis screws or the disk support screws. You will damage the DDS if you attempt to mount it with the system chassis screws or the disk support screws.**

---

**Warning**



**To maintain emission performance, ensure the two EMI clips are replaced when the DDS is reinstalled.**

---

For HP Internal Use Only

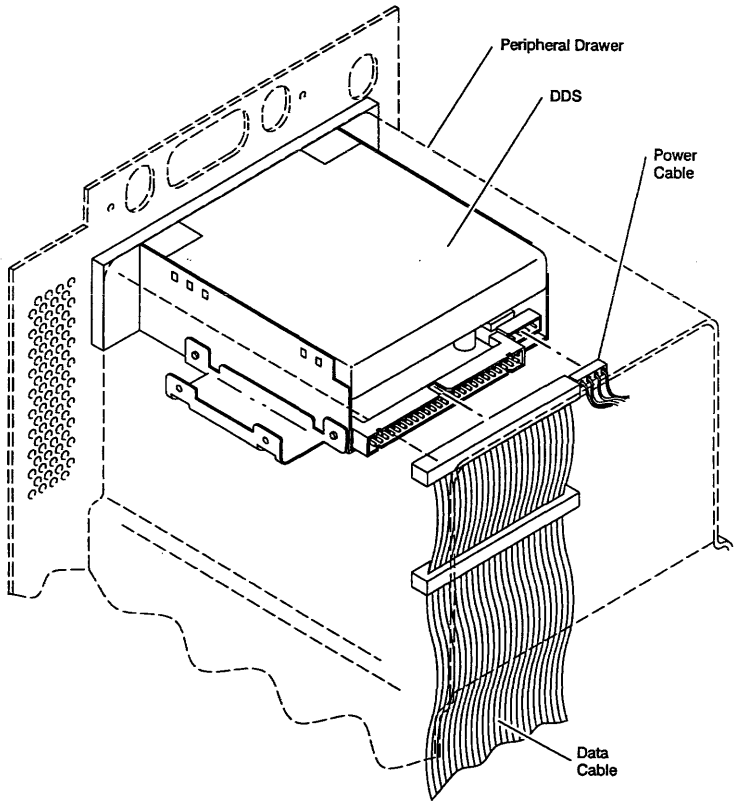

LG200185\_139

Figure 8-10. 3.5-inch Digital Data Storage (DDS) Device Cabling

For HP Internal Use Only

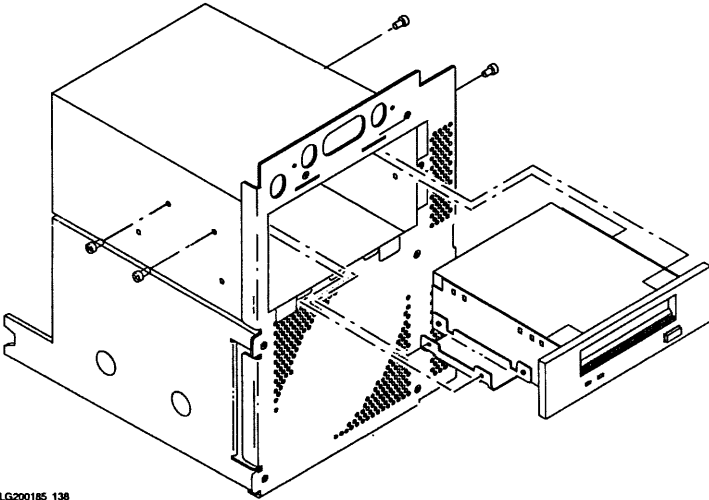

LG200185\_138

Figure 8-11. 3.5-inch Digital Data Storage (DDS) Device Removal

**For HP Internal Use Only**

**Remove CD-ROM**

1. See Figure 8-12.
2. Disconnect the SCSI flat ribbon cable from the CD-ROM.
3. Disconnect the power connector from the CD-ROM.
4. Remove two EMI clips.
5. See Figure 8-13.
6. Remove four TORX screws and remove the CD-ROM from the front of the peripheral drawer.

---

**Warning**



**Do not mix these screws with the system chassis screws. You will damage the CD-ROM if you attempt to mount it with the system chassis screws.**

---

**Warning**



**To maintain emission performance, ensure the two EMI clips are replaced when the CD-ROM is reinstalled.**

---

**For HP Internal Use Only**

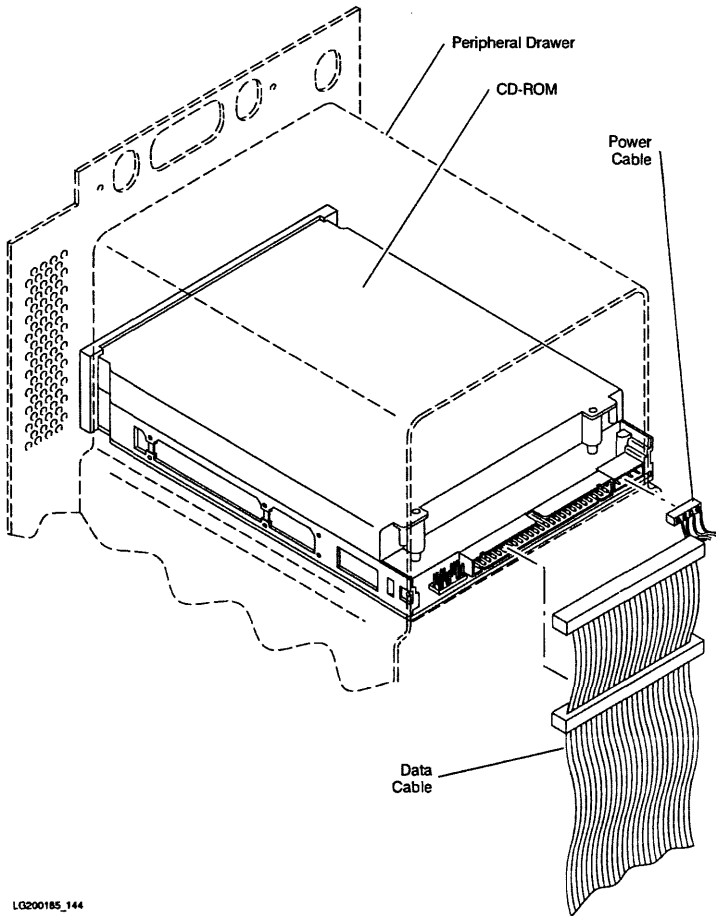

LQ200185\_144

**Figure 8-12. CD-ROM Cabling**



For HP Internal Use Only

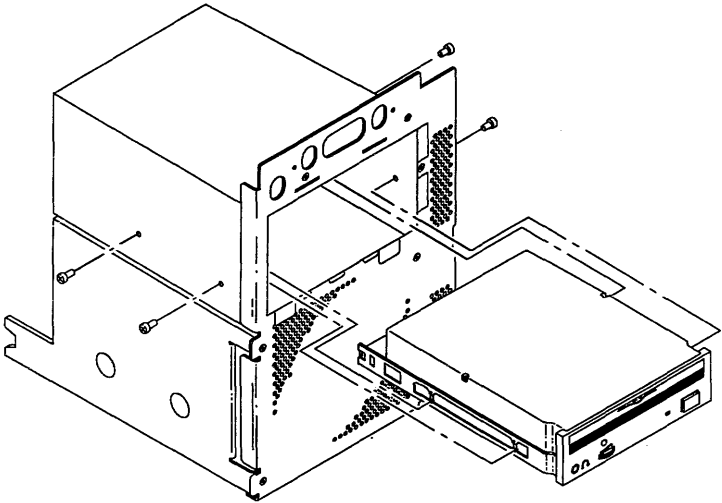

LG200185\_137

Figure 8-13. CD-ROM Removal

**For HP Internal Use Only**

**Remove Quarter-inch Cartridge Tape Driver (QIC)**

1. See Figure 8-14.
2. Disconnect the SCSI flat ribbon cable from the QIC drive.
3. Disconnect the power connector from the QIC drive.
4. Remove two EMI clips.
5. See Figure 8-15.
6. Remove four TORX screws and remove the QIC drive from the front of the peripheral drawer.

---

**Warning**



**Do not mix these screws with the system chassis screws. You will damage the QIC tape drive if you attempt to mount it with the system chassis screws.**

---

**Warning**



**To maintain emission performance, ensure the two EMI clips are replaced when the QIC tape drive is reinstalled.**

---

For HP Internal Use Only

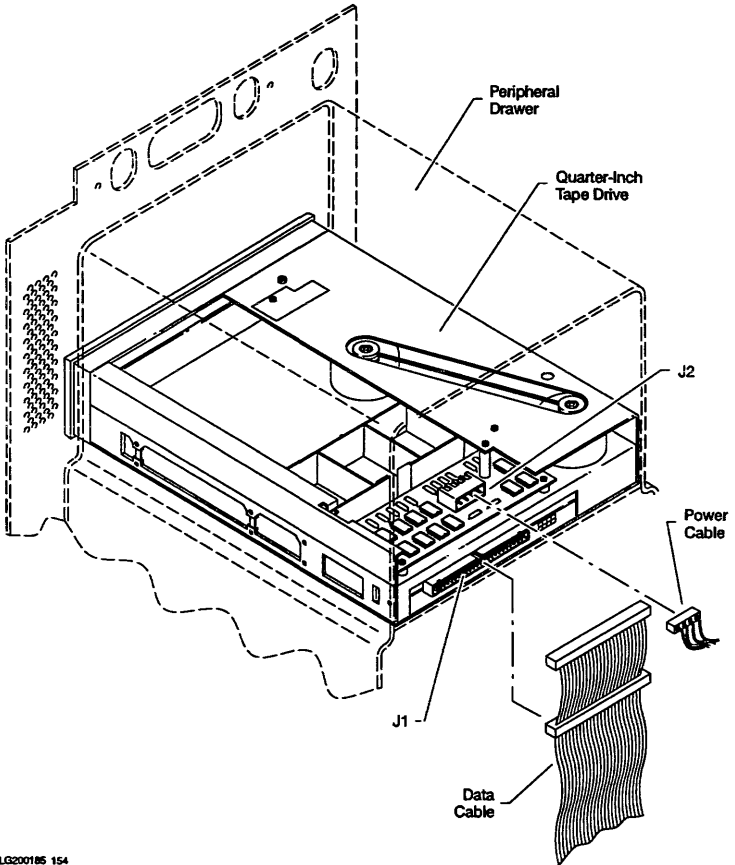

L0200185\_154

Figure 8-14. QIC Cabling

For HP Internal Use Only

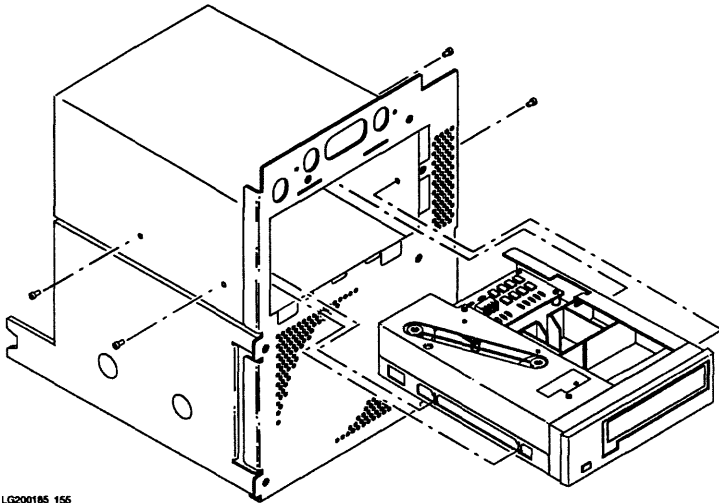

LG200185\_156

Figure 8-15. QIC Removal

**For HP Internal Use Only**

**Remove Internal 3.5-inch Disks**

1. See Figure 8-16.
2. Disconnect the SCSI flat ribbon cable from each disk
3. Disconnect the power connectors from each disk.
4. See Figure 8-17.
5. Remove four TORX screws and remove the disk carrier from the rear of the peripheral drawer.

---

**Warning**



**Do not mix these screws with the system chassis screws or the DDS support screws. You will damage the disk if you attempt to mount it with the system chassis screws or the DDS support screws.**

---

6. See Figure 8-18.
7. Remove eight TORX screws and remove the two disks from the disk carrier.

**For HP Internal Use Only**

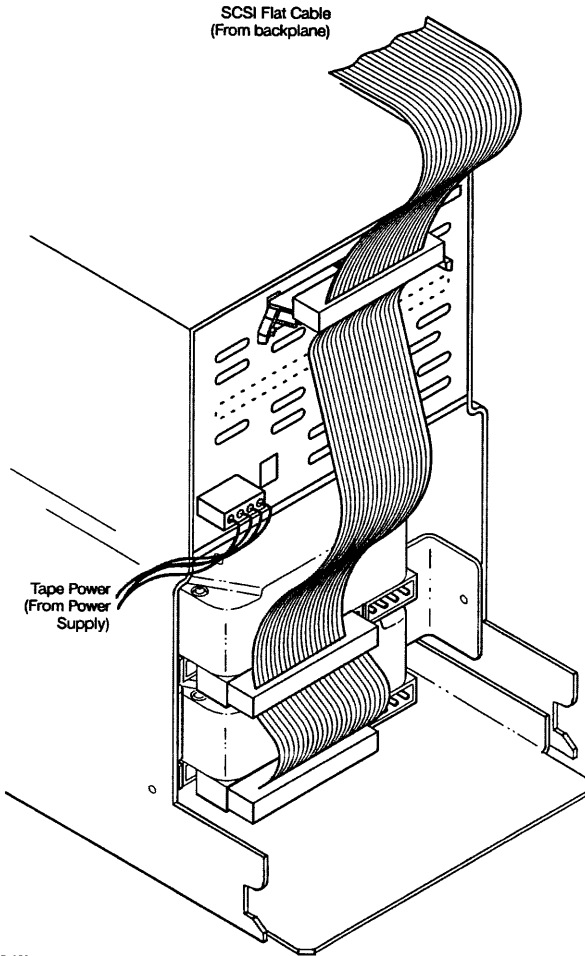

LG200185\_052

**Figure 8-16. Internal Disk Cabling**

For HP Internal Use Only

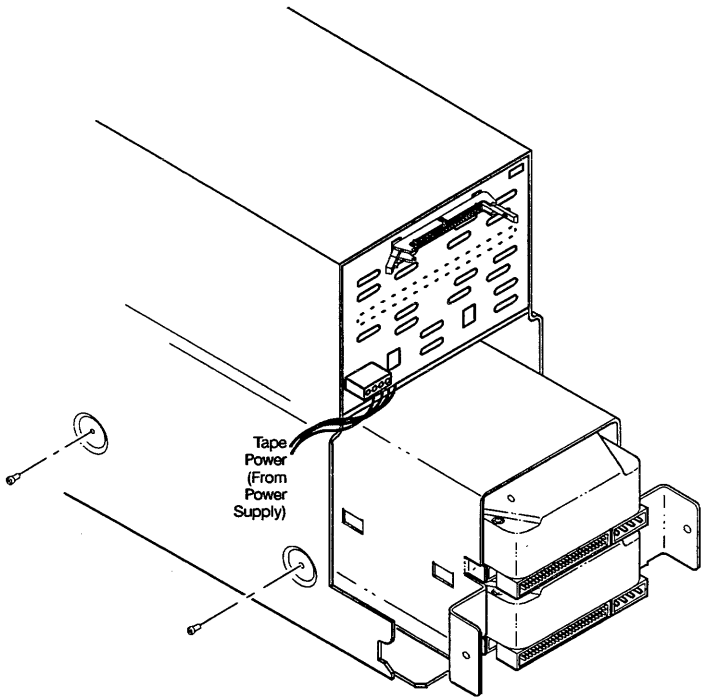

LG200185\_063

Figure 8-17. Internal Disk Carrier Removal

For HP Internal Use Only

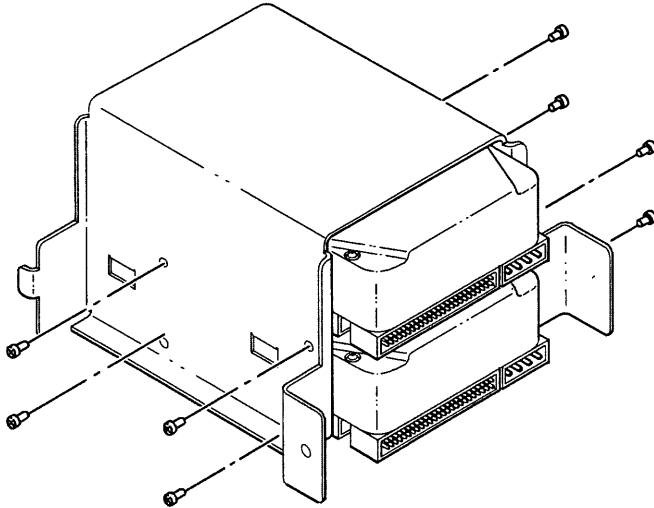

LG200185\_046

Figure 8-18. Internal Disk Removal



## Remove Power Supply

---

**Warning**

**Shock Hazard. Do not attempt to power-up the power system outside the system chassis. The power system requires a load and a VON\_L enabling signal to operate.**

---

**Caution**

The rear connector on the power supply plugs into the backplane. Be careful that you do not twist the power supply and damage the backplane power connector.

---

**Note**

You must remove the peripheral drawer before you perform this step.

---

1. Disconnect the power cord from the rear of the cabinet.
2. See Figure 8-19.
3. Remove two TORX screws and gently pull the power supply one quarter of the way out of the cabinet.
4. Disengage the DC On/Off power cable from the cable clamps on the side of the peripheral drawer.
5. Disconnect the DC On/Off power cable.
6. Pull the power supply out. This may require force.

### Power Supply Control PCA Connectors

Refer to Figure 8-20 to identify the connectors on the power supply control PCA.

**For HP Internal Use Only**

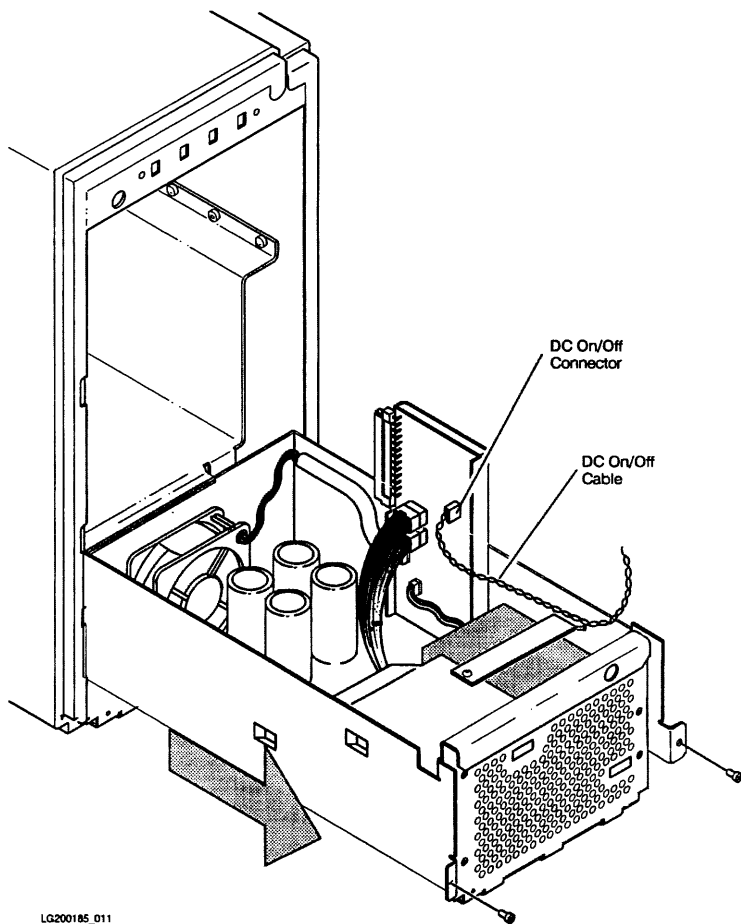

LQ200185\_011

**Figure 8-19. Power Supply Removal**

**For HP Internal Use Only**

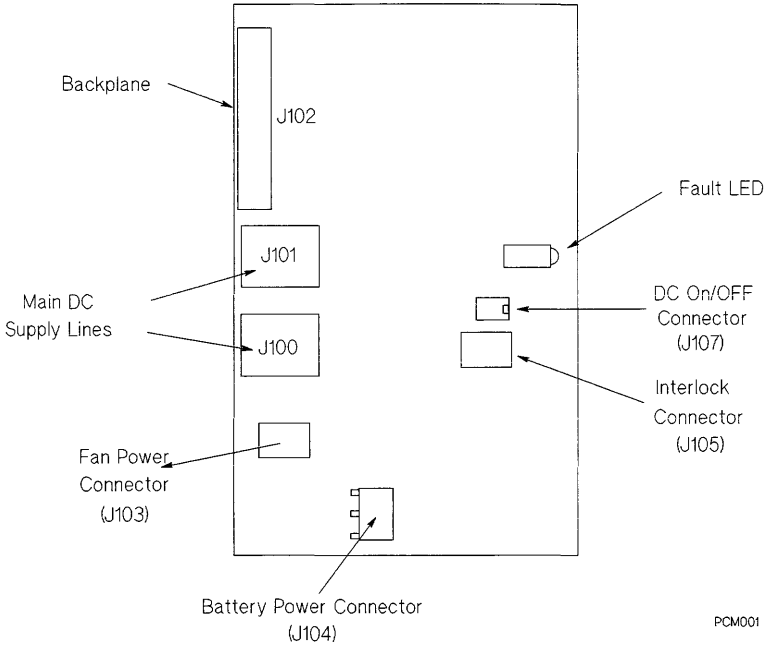

**Figure 8-20. Power Supply Control PCA Connectors**

PCM001

**For HP Internal Use Only**

**Remove Power Supply Battery**

1. See Figure 8-21.
2. Remove one screw and remove the battery retainer bar.
3. Slide the power supply control PCA up to gain access to the battery power connector.
4. Disconnect cable connectors as necessary to access the battery power connector.
5. Disconnect the battery power connector from the power supply control PCA.

**Caution**

To prevent the battery fuse from blowing, make sure the circuit side of the power supply control PCA does not touch the metal chassis.



6. Lift the battery out of the power supply.

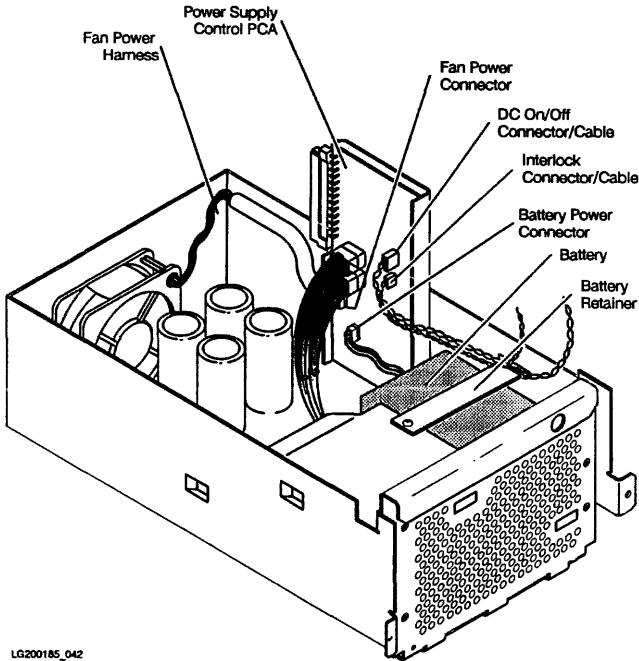

LG200185\_042

**Figure 8-21. Power Supply Battery Removal**

**For HP Internal Use Only**

### **Remove Filler Panels**

See Figure 8-22. Loosen the upper and lower captive TORX screws and remove the filler panels.

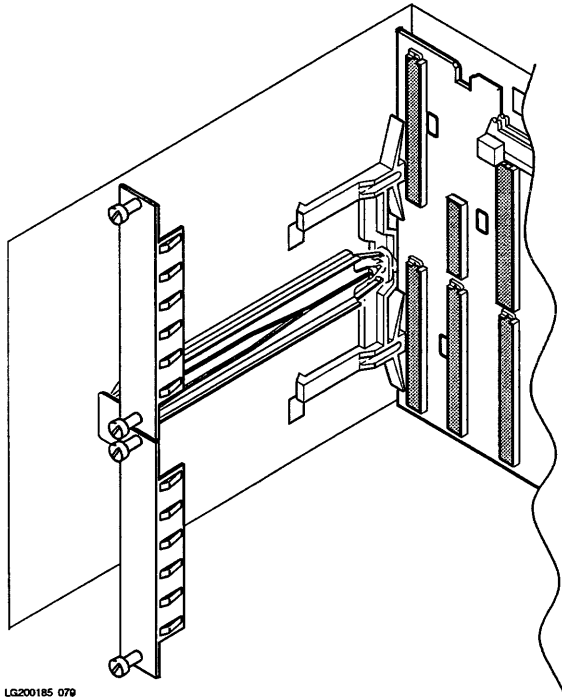

LG200185\_079

**Figure 8-22. Filler Panel Removal**

**For HP Internal Use Only**

**Remove I/O PCAs**

1. See Figure 8-23.
2. Loosen two captive TORX screws on each I/O PCA bulkhead, lift two extractor levers, and remove each I/O PCA.
3. Remove the two-board adapter by firmly pulling straight back.

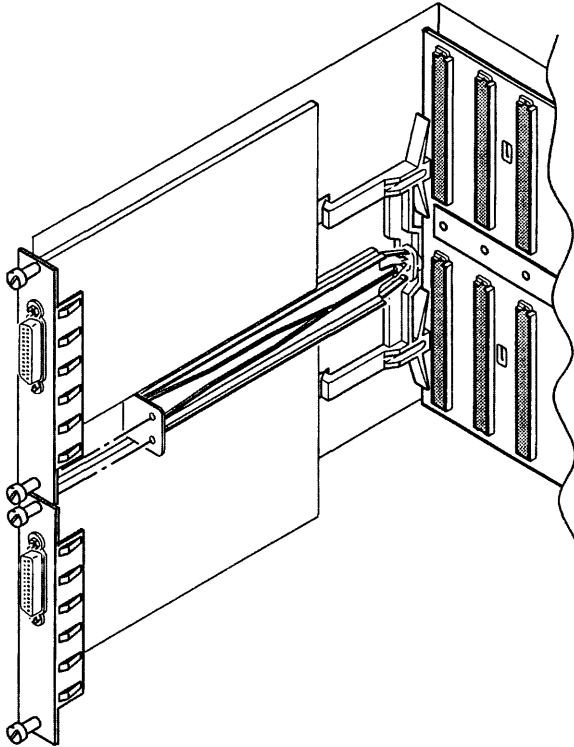

LG200185\_108

**Figure 8-23. I/O PCA Removal**

For HP Internal Use Only

### Remove Multifunction I/O PCA

1. See Figure 8-24.
2. Loosen two captive TORX screws, lift two extractor levers, and remove the Multifunction I/O PCA.

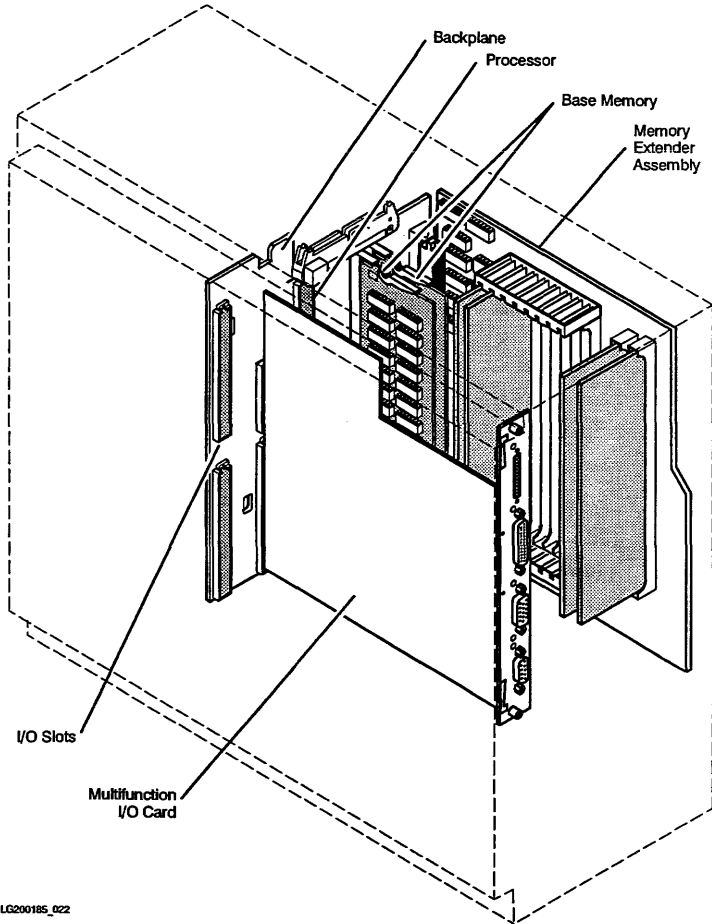

LG200185\_022

Figure 8-24. Multifunction I/O PCA Removal

For HP Internal Use Only

### Remove Rear Bezel

1. See Figure 8-25.
2. Remove six TORX screws and remove the rear bezel from the cabinet.

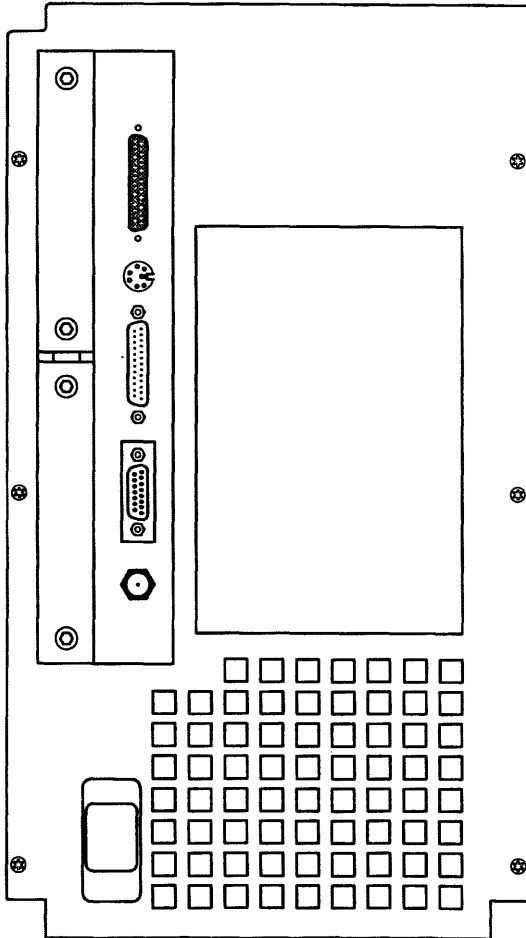

LG200195\_037

Figure 8-25. Rear Bezel Removal



For HP Internal Use Only

**Remove Cover Plate**

1. See Figure 8-26.
2. Loosen four captive TORX screws and remove the cover plate.

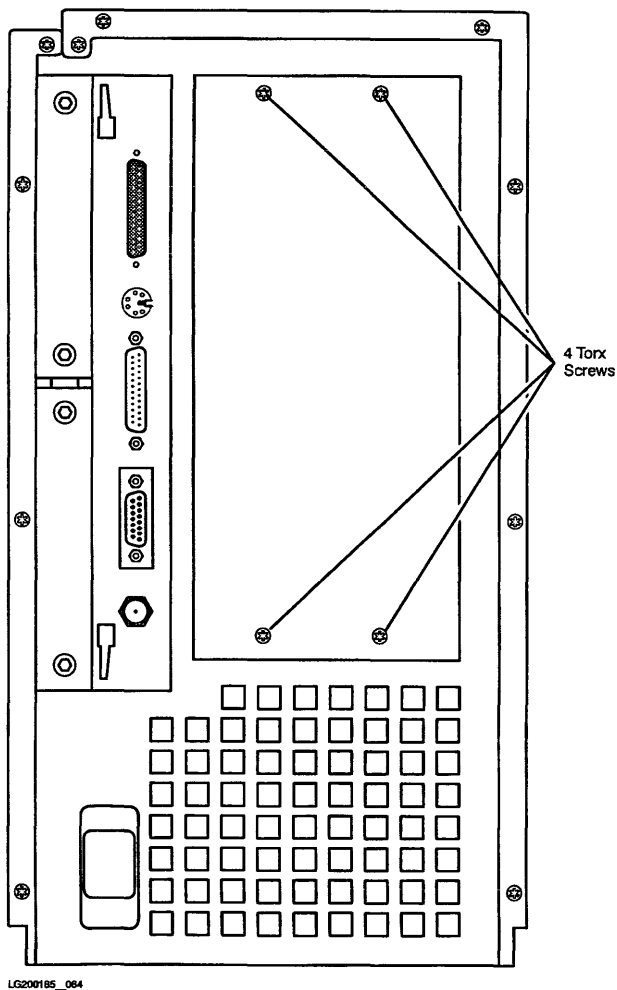

Figure 8-26. Cover Plate Removal

**For HP Internal Use Only**

**Remove Processor PCA**

1. See Figure 8-27.
2. Lift the two board extractor levers and remove the processor PCA.
3. Place PCAs in anti-static containers and set aside.

---

**Caution**

Do not stack PCAs on top of each other. Severe damage can occur to components.



---

**Note**

If you remove a faulty processor PCA that has a floating point chip, remove the floating point chip and put it on the replacement processor PCA. Refer to the “Floating Point Chip Installation and Removal” section for more information.



For HP Internal Use Only

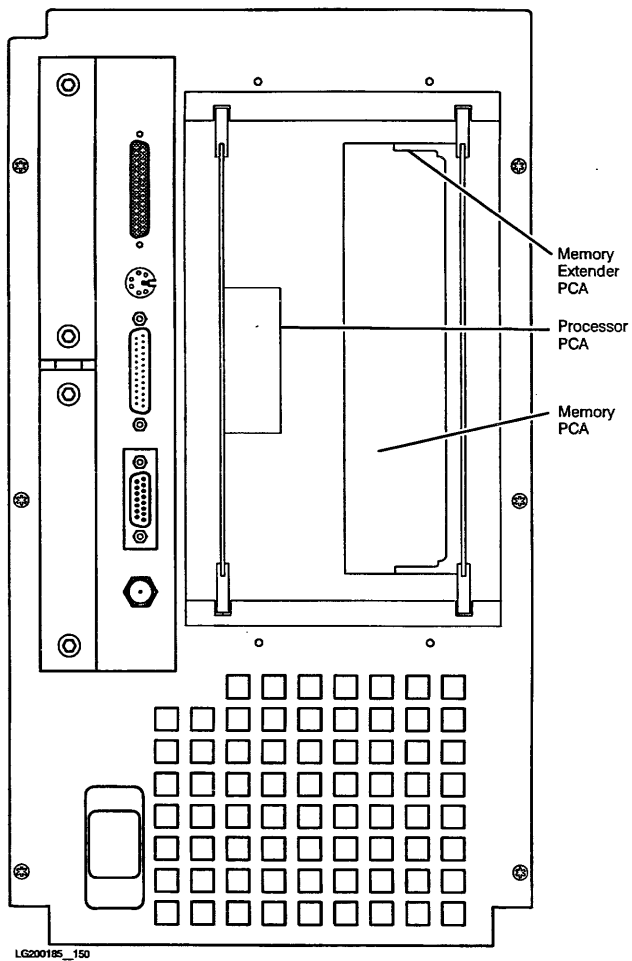

Figure 8-27. Processor PCA Removal

For HP Internal Use Only

### Remove Memory Extender and Memory PCAs

1. Figure 8-28 shows Memory PCAs on the standard backplane and a partially populated Memory Extender.
2. Figure 8-29 shows Memory PCAs on the 64 MHz backplane and a partially populated Memory Extender. Note there is no memory on the 64 MHz backplane.
3. Lift two extractor levers and remove the Memory Extender PCA.
4. Lift the extractor levers and remove the Memory PCAs on the backplane.

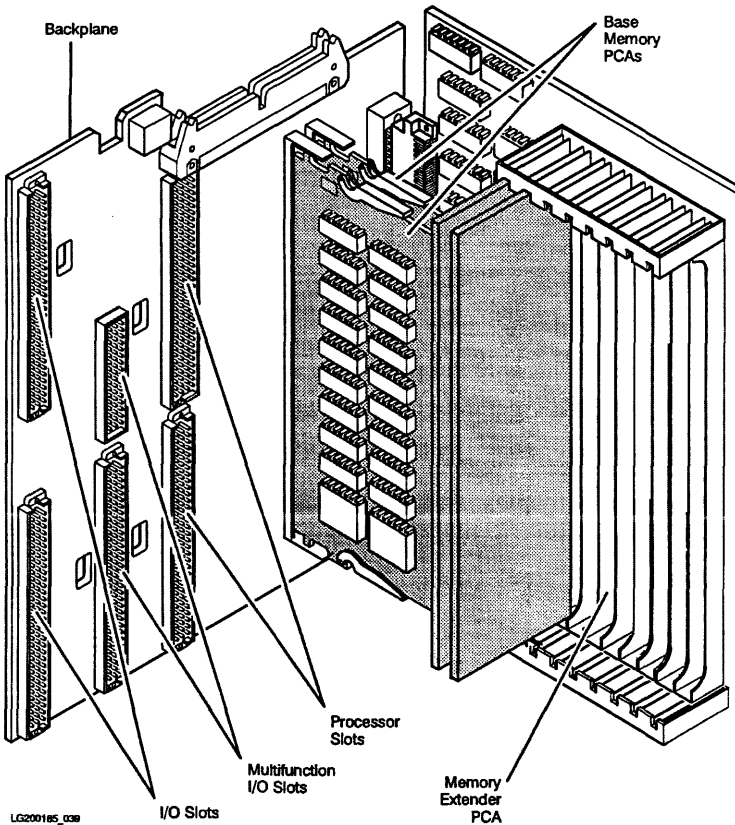

Figure 8-28. Standard Memory Extender and Memory PCA Removal

For HP Internal Use Only

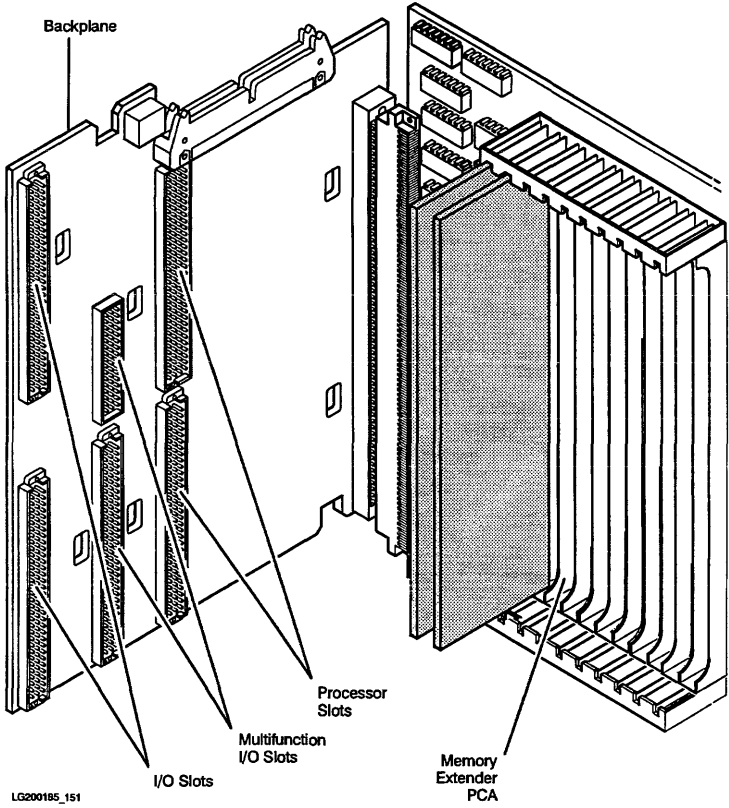

Figure 8-29. 64 MHz Memory Extender and Memory PCA Removal

**For HP Internal Use Only**

**Remove Backplane**

**Note**

You must disconnect the power supply from the backplane before you perform this step. Pull the power supply out about one inch.



1. Remove the I/O PCAs, processor PCA, memory PCAs, and memory extender from the backplane.
2. Disconnect the internal SCSI flat ribbon cable from the backplane.
3. See Figure 8-30.
4. Use a flat-blade screwdriver, lift each leg of the left backplane retaining clip, and remove the clip. The clip is labeled **LEFT**. The hole in the left clip is used to align the adapter.
5. Use a flat-blade screwdriver, lift each leg of the right backplane retaining clip, and remove the clip. The clip is labeled **RIGHT**.
6. See Figure 8-31.
7. Lift the backplane from the alignment tabs and remove it from the system cabinet.

For HP Internal Use Only

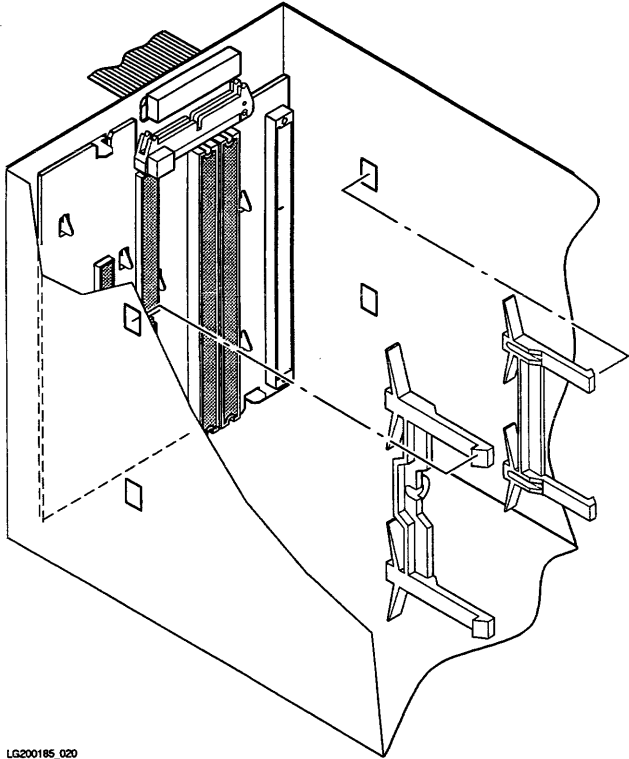

LG200185\_020

Figure 8-30. Backplane Retaining Clip Removal

**For HP Internal Use Only**

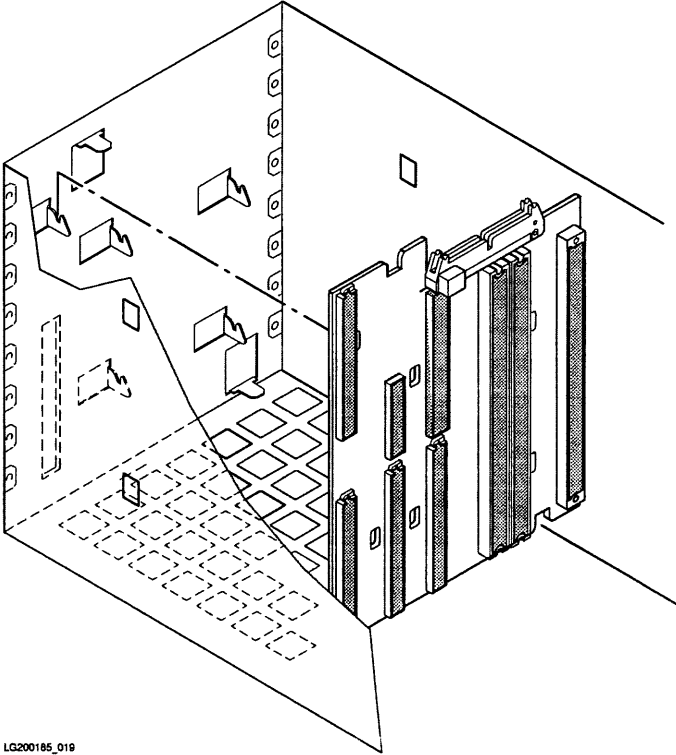

LG200185\_019

**Figure 8-31. Backplane Removal**



For HP Internal Use Only

### Remove Left and Right Side Panels

1. See Figure 8-32.
2. Remove two chassis screws from the front of the right panel.
3. Remove two chassis screws from the rear of the right panel.
4. Lift the panel up and then lift away from the chassis.
5. Remove two chassis screws from the front of the left panel.
6. Remove two chassis screws from the rear of the left panel.
7. Lift the panel up and then lift away from the chassis.

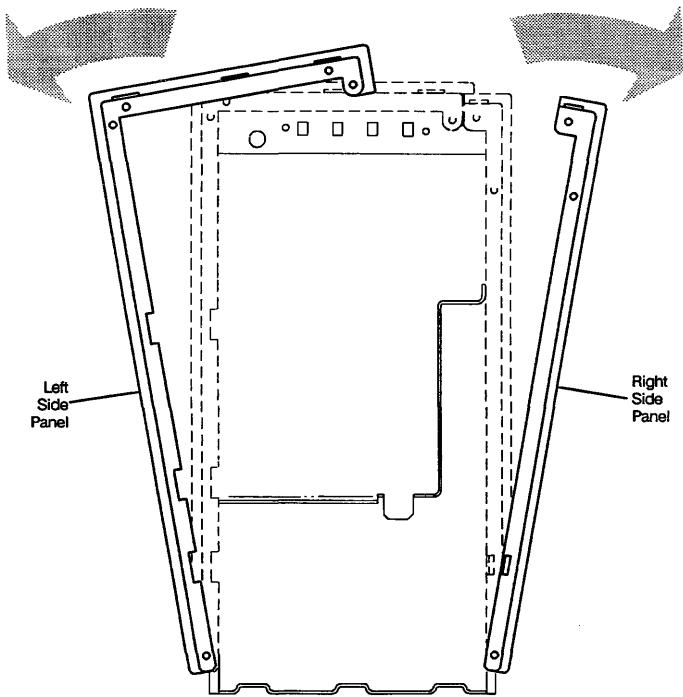

Note: Screw hole locations indicated by arrows

LG200185\_025

Figure 8-32. Left and Right Side Panel Removal

**For HP Internal Use Only**

**Remove Light Pipes**

1. See Figure 8-33.
2. Gently press down on the locator tab at the front of the light pipe to release the light pipe from the chassis.
3. Slide the light pipe to the rear and then lift out of the chassis.

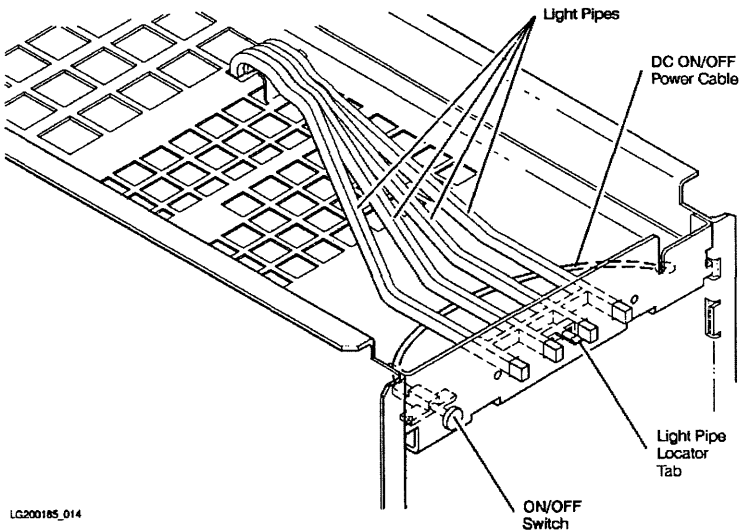

LC200185\_014

**Figure 8-33. Light Pipe Removal**

**For HP Internal Use Only**

### **Remove DC On/Off Switch**

1. See Figure 8-34.
2. Using a pair of small needle-nose pliers, bend the four tabs on the switch retainer bracket to a vertical position.
3. Lift the switch out of the bracket.
4. Disengage the cable from the cable retaining tabs on the right side of the cabinet.
5. Disconnect the DC On/Off cable from the power control module in the power supply.

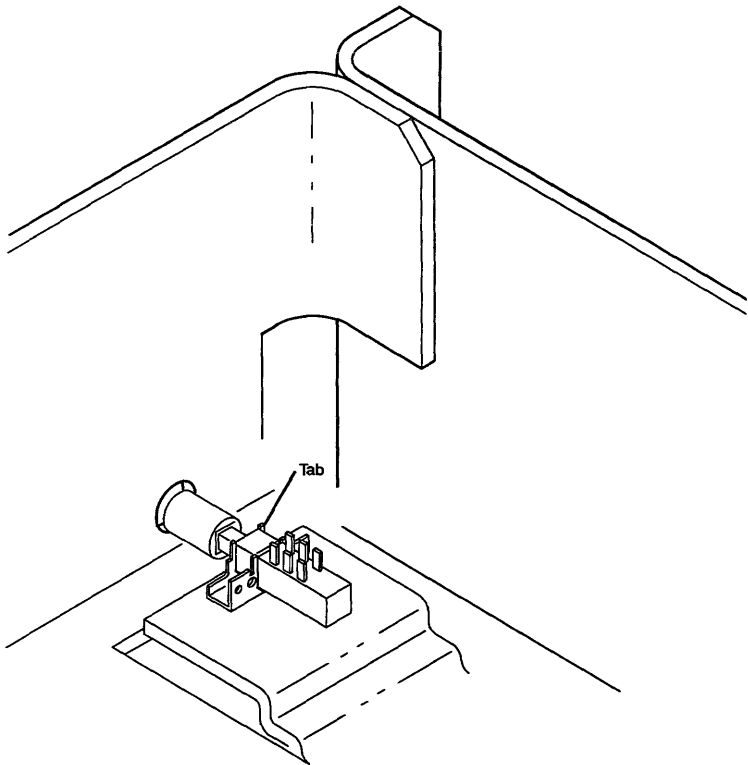

LG200185\_152

**Figure 8-34. DC On/Off Switch Removal**

**For HP Internal Use Only**

---

## **Standard Chassis Replacement Procedures**

Replacement procedures are performed in the reverse order of the removal procedures. Refer to the appropriate removal procedure for replacement instructions.

---

### **Note**



Before you insert the power supply in the cabinet, dress any unused peripheral power cables in the cable retaining clip on the side of the peripheral drawer.

---

## **Expanded Chassis Removal Procedures**

The removal procedures are in the order they should be performed. In general, each procedure assumes that you have performed all of the procedures before it.

**For HP Internal Use Only**

**Remove Front Bezel**

1. See Figure 8-35.
2. Remove two screws from the bottom of the front bezel.
3. Slide the bezel straight up about 0.25 inches.
4. Pull the bottom of the front bezel about one inch away from the system.
5. Lift the bezel away from the system.

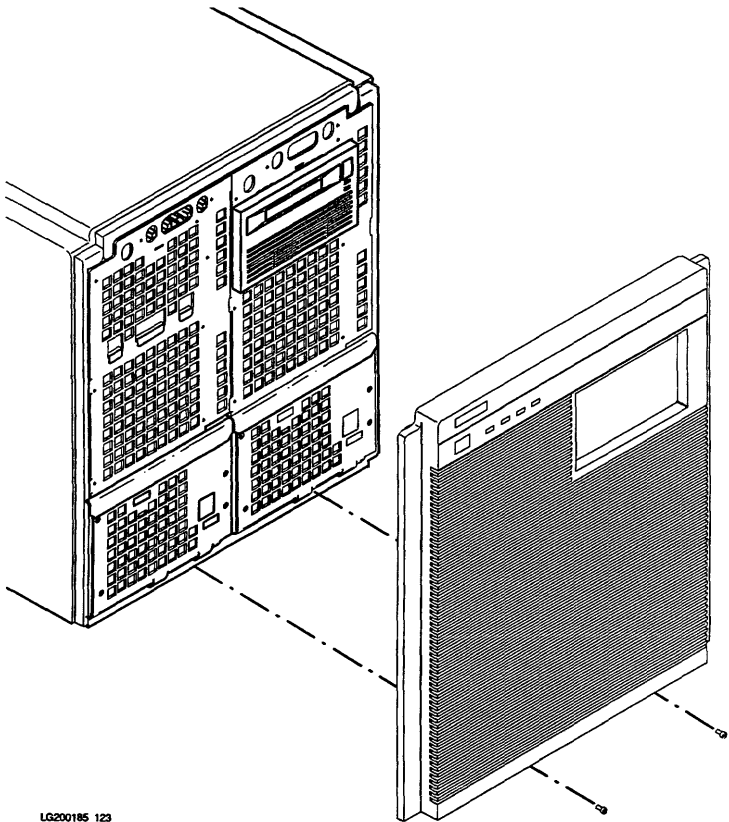

LG200185\_123

**Figure 8-35. Expanded Chassis Front Bezel Removal**

**For HP Internal Use Only**

**Remove Peripherals**

1. Remove bezel.
2. Remove peripherals as described in “Standard Chassis Removal Procedures” after you have removed the peripheral drawers.

**Remove Left Peripheral Drawer**

1. See Figure 8-36.
2. Remove two TORX screws.
3. Lift the peripheral drawer to clear the locks on the system cabinet and pull it out of the system cabinet. Be careful not to strain the power and SCSI cables.
4. Set the peripheral drawer on a supporting surface.

For HP Internal Use Only

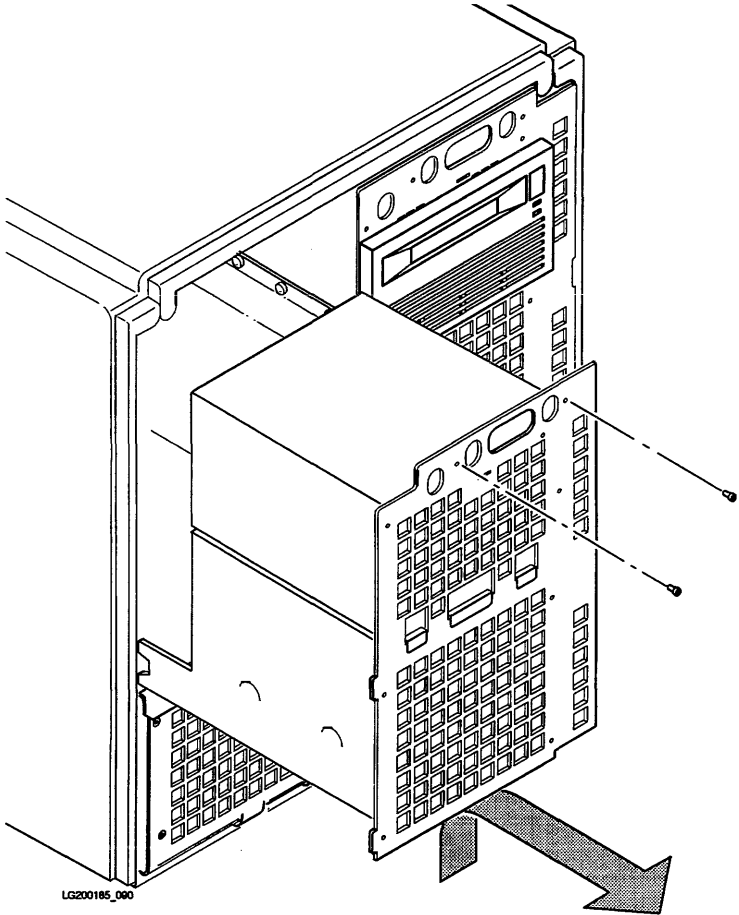
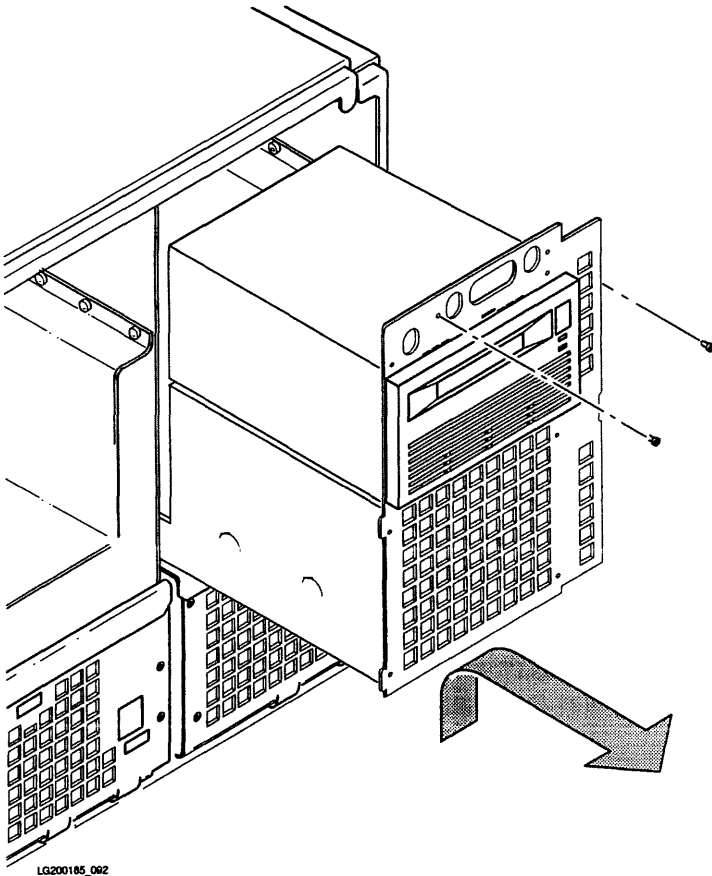

Figure 8-36. Left Peripheral Drawer Removal

**For HP Internal Use Only**

**Remove Right Peripheral Drawer**

1. See Figure 8-37.
2. Remove two TORX screws.
3. Lift the peripheral drawer to clear the locks on the system cabinet and pull it out of the system cabinet. Be careful not to strain the power and SCSI cables.
4. Set the peripheral drawer on a supporting surface.



**Figure 8-37. Right Peripheral Drawer Removal**



For HP Internal Use Only

## Remove Power Supplies

---

**Warning**



Hazardous voltages are present inside the cabinet. To prevent shock, turn off DC power using the front panel DC On/Off switch AND disconnect the AC power cords from the outlets before opening the unit.

---

**Warning**



Shock Hazard. Do not attempt to power-up the power system outside the system chassis. The power system requires a load and a VON.L enabling signal to operate.

---

**Caution**



The rear connector on each power supply plugs into the backplane. Be careful that you do not twist the power supply and damage the backplane power connector.

---

**Note**



You must remove the peripheral drawers above the power supplies before you perform the following steps.

---

### Power Supply Control PCA Connectors

Refer to Figure 8-38 to identify the connectors on the power control module.

**For HP Internal Use Only**

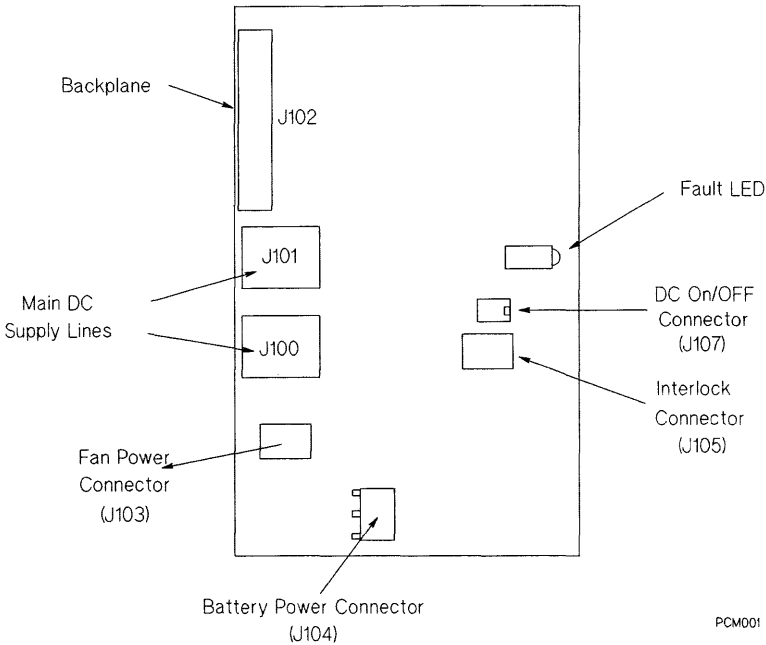

**Figure 8-38. Power Supply Control PCA Connectors**

**Remove Left Power Supply**

1. Disconnect the power cord from the rear of the cabinet.
2. See Figure 8-39.
3. Remove two TORX screws and gently pull the power supply one quarter of the way out of the cabinet.
4. Disengage the DC On/Off power cable from the cable clamps on the side of the peripheral drawer.
5. Disconnect the DC On/Off power cable
6. Pull the power supply out. This may require force.

**Remove Right Power Supply**

The removal procedure for the right power supply is the same as that for the left power supply, except the right power supply does not have a DC On/Off power cable.

For HP Internal Use Only

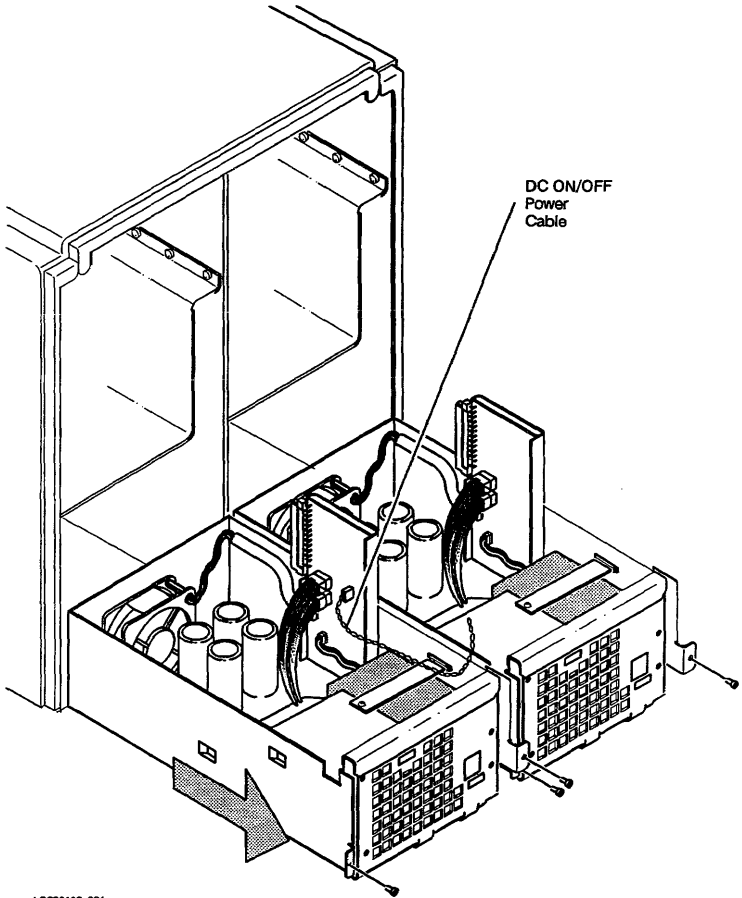

Figure 8-39. Power Supply Removal

**For HP Internal Use Only**

**Remove Power Supply Battery**

1. See Figure 8-40.
2. Remove one screw and remove the battery retainer bar.
3. Slide the power supply control PCA up to gain access to the battery power connector.
4. Disconnect cable connectors as necessary to access the battery power connector.
5. Disconnect the battery power connector from the power supply control PCA.

---

**Caution** To prevent the battery fuse from blowing, make sure the circuit side of the power supply control PCA does not touch the metal chassis.



6. Lift the battery out of the power supply.

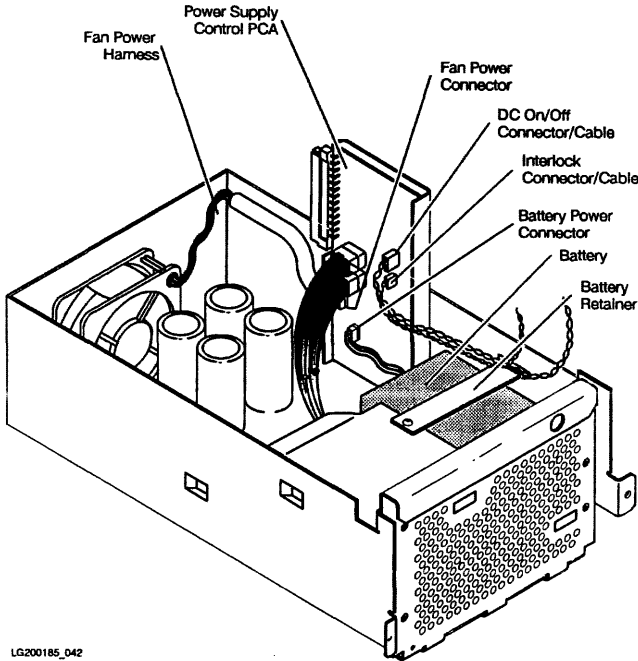

LG200185\_042

**Figure 8-40. Power Supply Battery Removal**

For HP Internal Use Only

### Remove Filler Panels

See Figure 8-41. Loosen the upper and lower captive TORX screws and remove the filler panels.

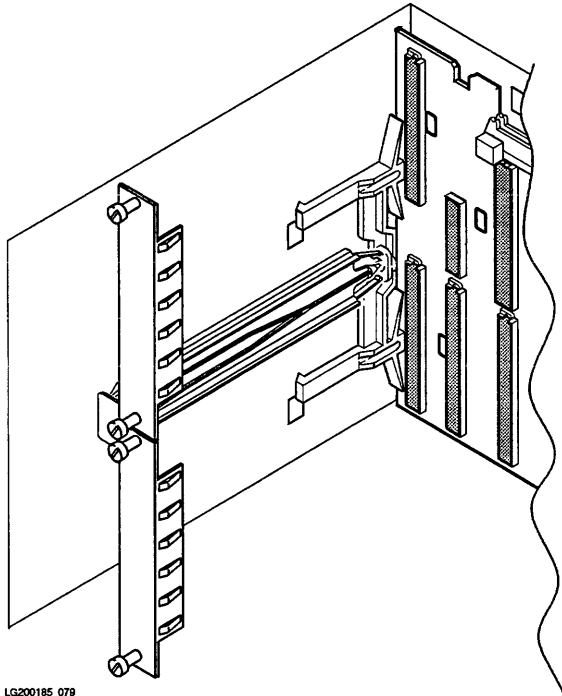

LG200185\_079

Figure 8-41. Filler Panel Removal

**For HP Internal Use Only**

### **Remove I/O PCAs**

1. See Figure 8-42.
2. Loosen two captive TORX screws on each I/O PCA bulkhead, lift two extractor levers, and remove each I/O PCA.
3. Remove the two-board adapter by firmly pulling straight back.

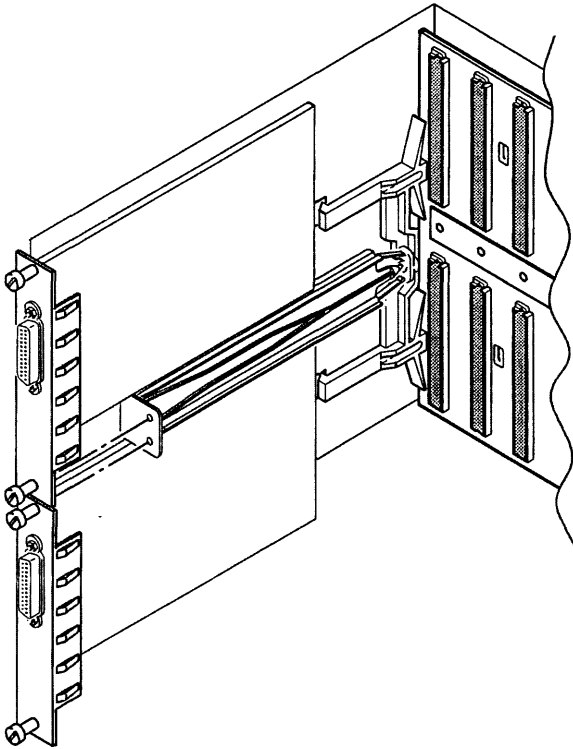

LQ200185\_108

**Figure 8-42. I/O PCA Removal**

For HP Internal Use Only

### Remove Multifunction I/O PCA

1. See Figure 8-43.
2. Loosen two captive TORX screws, lift two extractor levers, and remove the Multifunction I/O PCA.

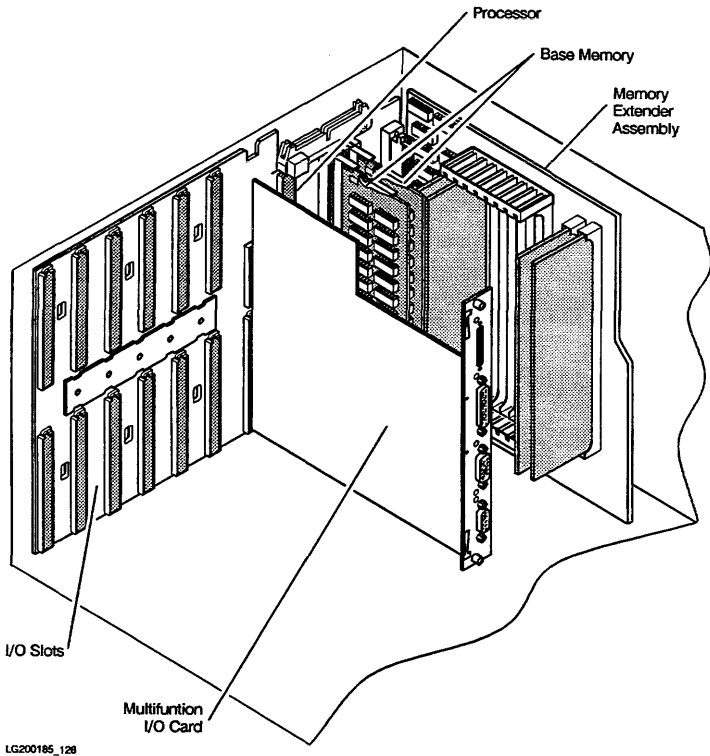

LG200185\_128

Figure 8-43. Multifunction I/O PCA Removal

**For HP Internal Use Only**

**Remove Rear Bezel**

1. See Figure 8-44.
2. Remove six TORX screws and remove the rear bezel from the cabinet.

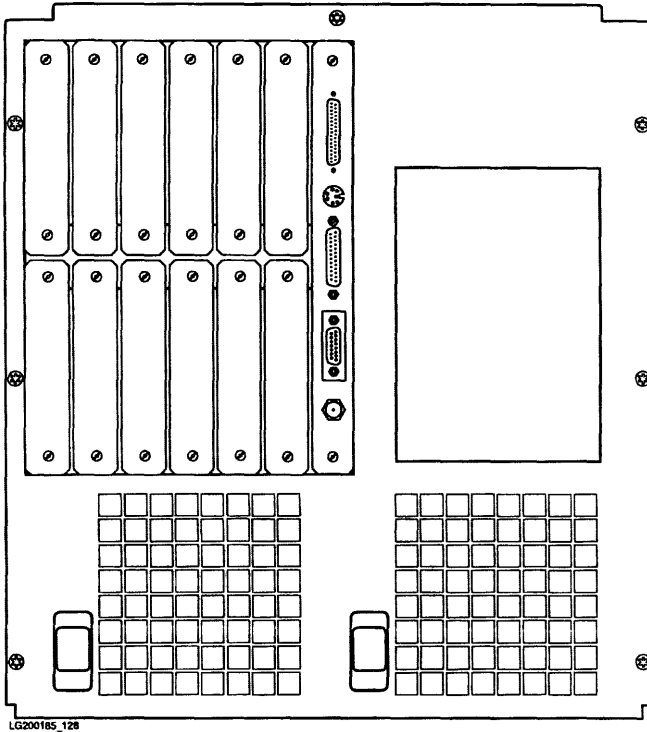

**Figure 8-44. Rear Bezel Removal**



For HP Internal Use Only

### Remove Cover Plate

1. See Figure 8-45.
2. Loosen four captive TORX screws and remove the cover plate.

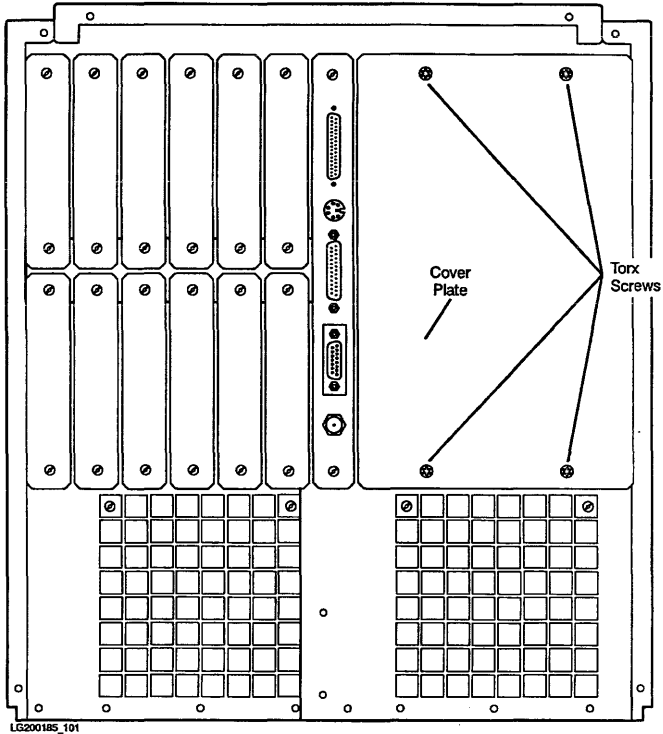

LG200185\_101

Figure 8-45. Cover Plate Removal

**For HP Internal Use Only**

**Remove Processor PCA**

1. See Figure 8-46.
2. Lift the two board extractor levers and remove the processor PCA.
3. Place PCAs in anti-static containers and set aside.

---

**Caution**

Do not stack PCAs on top of each other. Severe damage can occur to components.



---

**Note**

If you remove a faulty processor PCA that has a floating point chip, remove the floating point chip and put it on the replacement processor PCA. Refer to the "Floating Point Chip Installation and Removal" section for more information.



For HP Internal Use Only

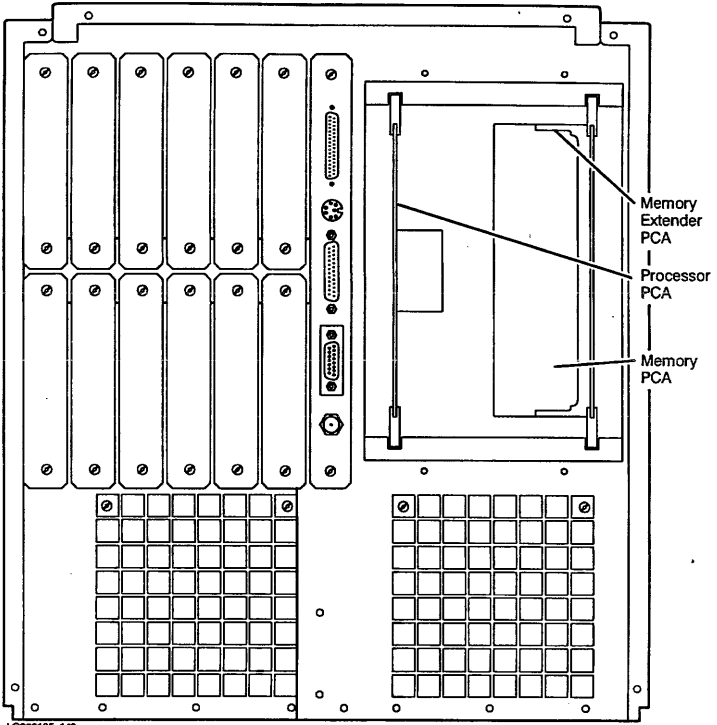

LC200185\_149

Figure 8-46. Processor PCA Removal

### Remove Memory Extender and Memory PCAs

1. Figure 8-47 shows Memory PCAs on the standard backplane and a partially populated Memory Extender.
2. Figure 8-48 shows Memory PCAs on the 64 MHz backplane and a partially populated Memory Extender. Note there is no memory on the 64 MHz backplane.
3. Lift two extractor levers and remove the Memory Extender PCA.
4. Lift the extractor levers and remove the Memory PCAs on the backplane.

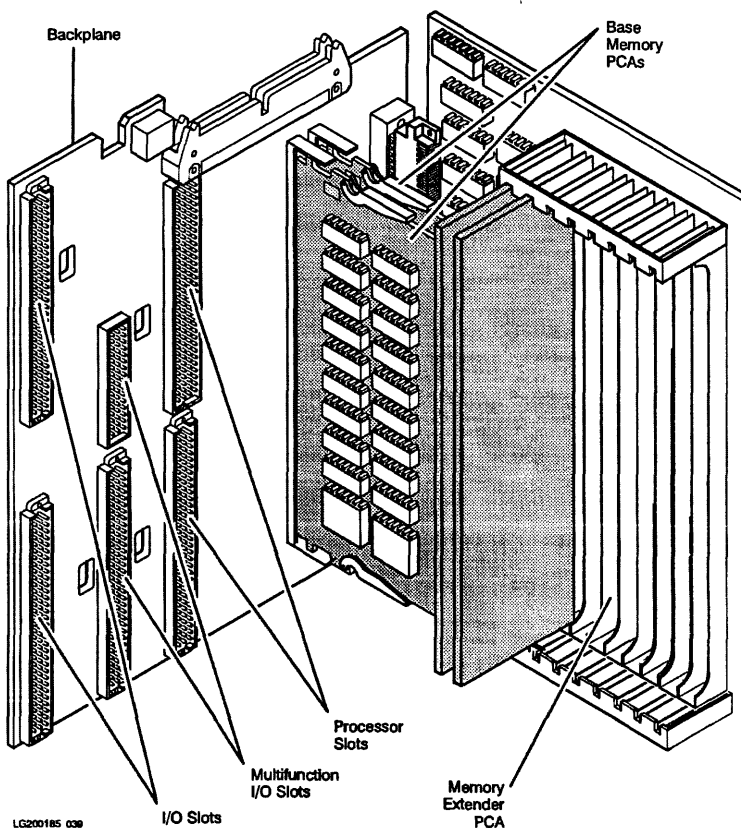

Figure 8-47. Standard Memory Extender and Memory PCA Removal

For HP Internal Use Only

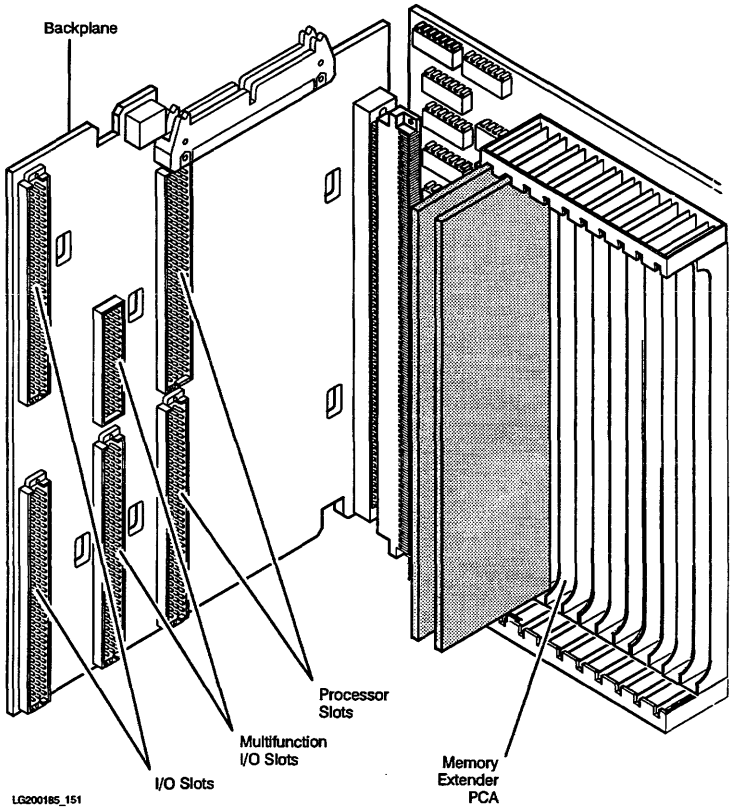

Figure 8-48. 64 MHz Memory Extender and Memory PCA Removal

**For HP Internal Use Only**

## **Remove Backplane**

---

**Note**

You must disconnect both power supplies from the backplane before you perform this step. Pull each power supply out about one inch.



- 
1. Remove the I/O PCAs, processor PCA, memory PCAs, and memory extender from the backplane.
  2. Disconnect the SCSI flat ribbon cable from the backplane.
  3. See Figure 8-49.
  4. Use a flat-blade screwdriver, lift each leg of the left backplane retaining clip, and remove the clip. The left clip is labeled **LEFT**. The hole in the left clip is used to align the adapter.
  5. Use a flat-blade screwdriver, lift each leg of the right backplane retaining clip, and remove the clip. The right clip is labeled **RIGHT**.

For HP Internal Use Only

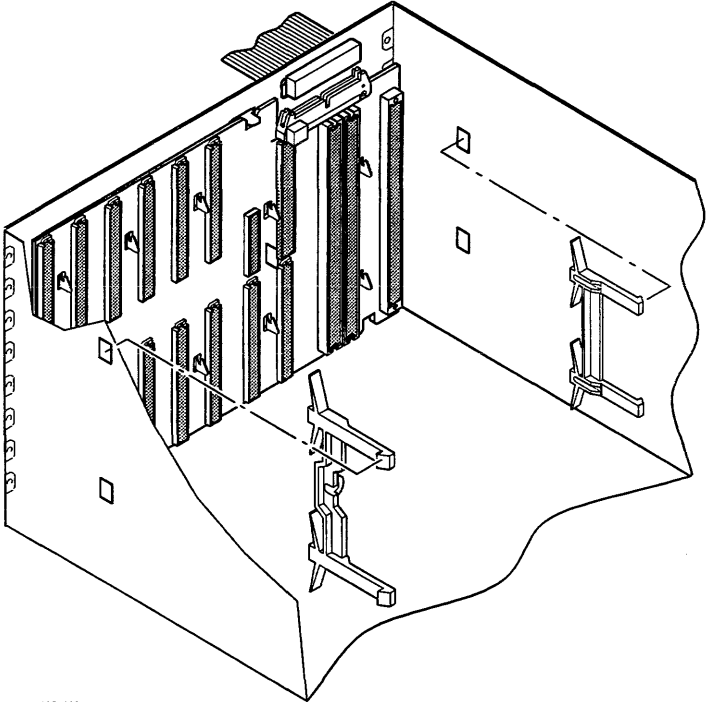

LG200185\_103

**Figure 8-49. Backplane Retaining Clip Removal**

6. See Figure 8-50.
7. Lift the backplane from the alignment tabs and remove it from the system cabinet.

**For HP Internal Use Only**

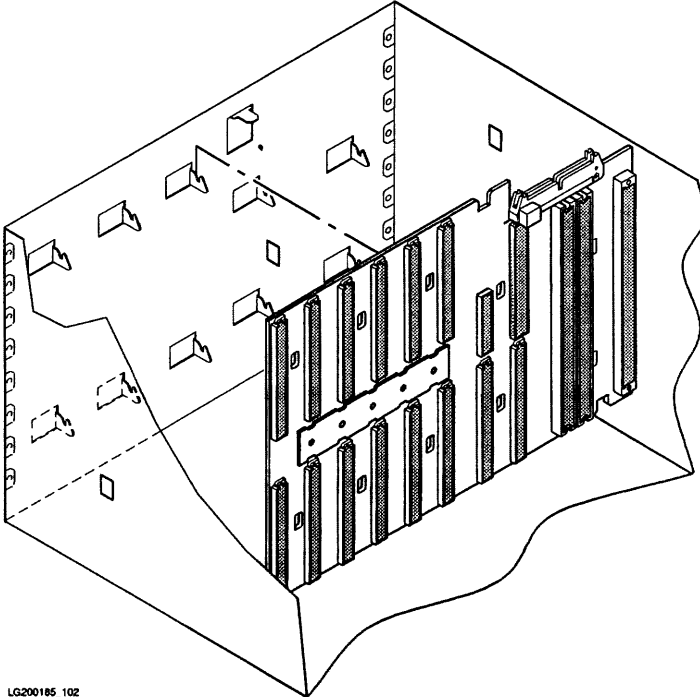

LG200185\_102

**Figure 8-50. Backplane Removal**

---

## Expanded Chassis Replacement Procedures

Replacement procedures are performed in the reverse order of the removal procedures. Refer to the appropriate removal procedure for replacement instructions.



## **Quick Reference Removal Procedures.**

These procedures are checklists of the steps required to perform specific tasks. They are intended to be used as a quick guide by CEs who are familiar with all of the steps in each task.

### **Backplane Removal**

1. Remove front bezel
2. Pull power supply one inch out of the cabinet
3. Remove rear bezel
4. Remove all I/O cards
5. Remove Multifunction I/O card
6. Remove Processor card
7. Remove Memory extender
8. Remove SCSI cable
9. Remove backplane retaining clips
10. Remove backplane

### **Digital Data Storage (DDS) Removal**

1. Remove front bezel
2. Remove peripheral drawer
3. Disconnect cables
4. Remove EMI clips
5. Remove DDS

### **Internal Disk Removal**

1. Remove front bezel
2. Remove peripheral drawer
3. Disconnect cables
4. Remove disk

### **CD-ROM Removal**

1. Remove front bezel
2. Remove peripheral drawer
3. Disconnect cables
4. Remove CD-ROM

### **QIC Removal**

1. Remove front bezel
2. Remove peripheral drawer
3. Disconnect cables
4. Remove QIC drive

**For HP Internal Use Only**

**Light Pipe Removal**

1. Remove front bezel
2. Remove left and right side panels
3. Remove top panel, if expanded chassis
4. Remove light pipes

**Memory PCA Removal**

1. Remove rear bezel
2. Remove cover plate
3. Remove Memory extender
4. Remove memory on backplane

**Power Supply Removal**

1. Remove front bezel
2. Remove peripheral drawer above the power supply
3. Pull power supply partially out.
4. Disconnect DC On/Off power cable
5. Remove power supply

**Processor PCA Removal**

1. Remove rear bezel
2. Remove cover plate
3. Remove Processor PCA

For HP Internal Use Only

## Floating Point Chip Installation and Removal

This procedure describes how to install the floating point chip on the processor PCA. Table 8-5 shows which floating point chips are used with which CPU boards.

Table 8-5. Floating Point Chips and CPU Boards

Floating Point Chip Part Number	New CPU Board Part Number	Exchange CPU Board Part Number	Jumpers
1820-8504	A1703-60016 A1703-60017	A1703-69016 A1703-69017	300 and 301
1820-8504	A1751-60003	A1751-69003	601 and 602
1820-8505	A1703-60043	A1703-69043	300 and 301

**Caution** Be sure to observe ESD procedures while performing the floating point chip installation procedure.



### Install Floating Point Chip

1. Remove the processor PCA from the system and place it on an anti-static mat.
2. Unpack the floating point chip upgrade kit. Place the floating point chip on the anti-static mat.
3. Position the processor PCA as shown in Figure 8-51.

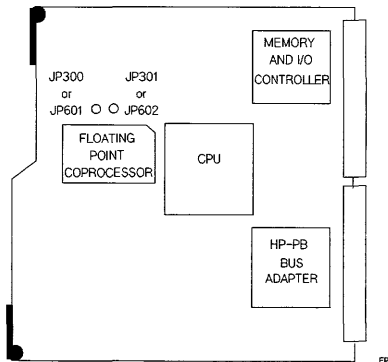
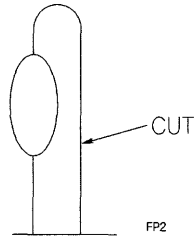

Figure 8-51. Processor PCA Layout

4. Using a pair of side cutters, cut one lead of each of the jumpers, as shown in Figure 8-52. Form the leads so the cut ends can not make contact with each other or with any other components on the PCA.

**For HP Internal Use Only**



**Figure 8-52. Jumpers**

5. See Figure 8-53. Position the floating point chip so the square open-pin location on the floating point chip is aligned with the unused hole on the socket. Observe the polarity of the chip and the socket.

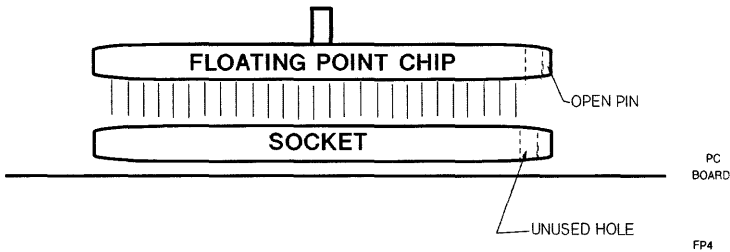

**Figure 8-53. Floating Point Chip Alignment**

**Caution**



Do not install the heat sink on the floating point chip before it is installed on the processor PCA. If you attempt to install the chip with the heat sink attached, you may crack the chip when it is pressed into the socket.

6. Align the floating point chip pins with the socket.
7. Install the chip by applying even pressure to the chip (about 30 pounds) until the chip snaps into place.
8. Position the floating point chip heat sink so that the fins point in the same direction as the rest of the heat sinks on the processor PCA.
9. See Figure 8-54. Align the holes on the heat sink with the alignment pin on the floating point chip.
10. Using a flat-blade screwdriver or screw starter, attach the heat sink to the floating point chip.
11. Install the correct upgrade label on the rear panel of the system. Destroy the rest of the labels.

**Warning** For proper operation, ensure the metal panel and plastic bezels are replaced.

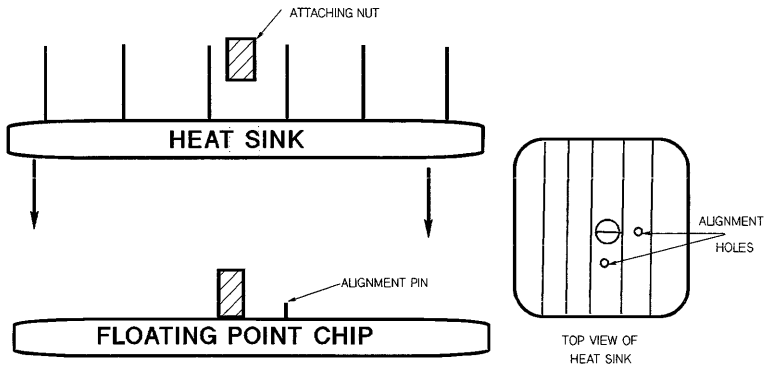

**Figure 8-54. Mount Heat Sink on Floating Point Chip**

### Verify Floating Point Chip Installation

Execute the PDC INFO command to verify that the processor PCA recognizes the floating point chip. If the INFO command indicates a floating point chip is present, the processor has successfully located the floating point chip.

You should also run sections 90 through 117 of the ISL-based MULTIDIAG diagnostic to further test the floating point chip. Any errors will be displayed on the console.

**For HP Internal Use Only**

**Remove Floating Point Chip**

At some time, you may have to remove the floating point chip from the processor PCA. Remove the floating point chip by performing this procedure.

1. Place the processor PCA on the anti-static mat.
2. See Figure 8-55. Insert the firmware removal tool between the pins at one corner of the floating point chip.
3. Gently pry up the corner of the chip, using the floating point chip socket as a fulcrum.
4. Do this at the corner diagonally opposite from the first corner.
5. Continue this process until the chip is free of the socket.

---

**Caution** If you have cut jumpers JP601 and JP602, or jumpers JP300 and JP301, and have removed the floating point chip from the processor PCA, the processor PCA will not work correctly.

---

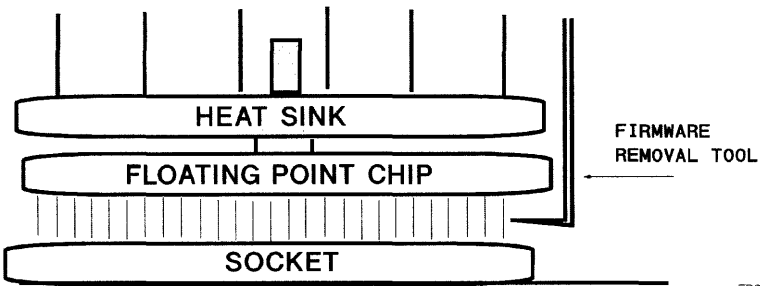

**Figure 8-55. Floating Point Chip Removal**

FP3

---

## Internal Peripheral Assembly and Disassembly

The following sections describe the removal and replacement of the replaceable assemblies of each of the internal peripherals.

### 5.25-inch Hard Disk Drive Assembly and Disassembly

This section describes the removal and replacement of the drive replaceable assemblies.

---

#### Note



- New drives do not include mounting hardware. You must remove the mounting hardware from the old drive and install it on the new drive.

---

#### Replaceable Assemblies

The hard disk drive contains two replaceable assemblies: the hard disk mechanism and the SCSI controller PCA.

Whenever a faulty SCSI controller PCA is replaced, the firmware ROM should be transferred from the old PCA to the new PCA. However, the firmware ROM may also be ordered separately.

#### Disk Mechanism. To remove the disk mechanism:

- Follow the procedure for removing the SCSI controller PCA to separate the disk mechanism from the SCSI controller PCA.

#### To replace the disk mechanism:

- Follow the procedure for replacing the SCSI controller PCA.

#### SCSI Controller PCA.

---

#### Caution



- The drive must be placed upside-down to remove the SCSI controller PCA. In this position, the drive is very susceptible to mechanical shock and vibration.
- Make sure you observe the proper ESD precautions when removing the SCSI controller PCA.
- Make sure the configuration jumpers on the new PCA are in the same positions as those on the old PCA (refer to Table 4-13).

### For HP Internal Use Only

#### To remove the SCSI controller PCA (see Figure 8-56):

1. Remove the mounting bracket from the drive.
2. Carefully place the drive upside-down on a padded surface.
3. Remove the four PCA mounting screws. One of the mounting screws is located on the side of the disk mechanism.
4. Carefully tilt the PCA from side to side while pulling up until it is free of the two connectors on the bottom of the disk mechanism.

#### To replace the SCSI controller PCA (see Figure 8-56):

#### Note



Before replacing the SCSI controller PCA, check the insulator sheets on the disk mechanism for any signs of damage. These sheets prevent the PCA from shorting out against the disk mechanism. If there are any holes or tears in the insulator sheets, they should be replaced.

1. Position the PCA on the disk mechanism so that the four mounting holes in the PCA are aligned with the mounting holes in the disk mechanism. This will align the connectors on the disk mechanism with the corresponding connectors on the PCA.
2. Press the PCA down firmly onto the disk mechanism connectors.

#### Caution



Failure to install the PCA mounting screws in the correct holes may damage the SCSI controller PCA.

3. Install the four PCA mounting screws. The screws are of three different types and must be installed in the proper mounting holes as follows:
  - The screw with the captive washer goes in the side mounting hole on the disk mechanism.
  - The screw with the unthreaded shoulder goes in the corner mounting hole of the PCA near the status LED.
  - The remaining two screws go in the other two mounting holes in the PCA.



For HP Internal Use Only

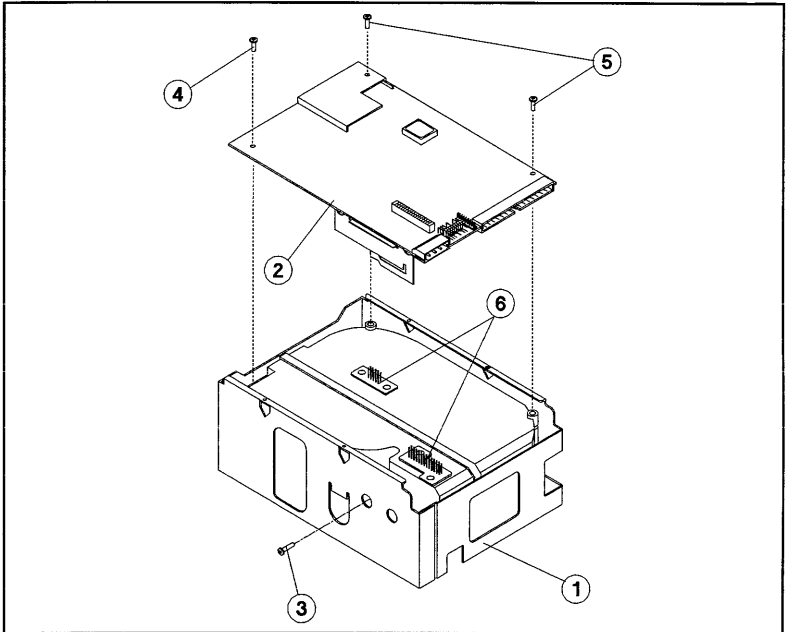

Figure 8-56. Replacing the SCSI Controller PCA

- |                                    |                                    |
|------------------------------------|------------------------------------|
| 1. Disk Drive                      | 4. Mounting Screw (unth. shoulder) |
| 2. SCSI Controller PCA             | 5. Mounting Screws                 |
| 3. Mounting Screw (captive washer) | 6. PCA Connectors                  |

**For HP Internal Use Only**

**Firmware ROM.**

**Note**

Whenever a faulty SCSI controller PCA is removed, the firmware ROM should be transferred from the faulty PCA to the replacement PCA.



**To remove the firmware ROM (see Figure 8-57):**

1. Insert the tapered end of the extraction tool, part no. 8710-1982, into one of the extraction slots in the socket.
2. Pry up on the corner of the chip.
3. Repeat steps 1 and 2 for the opposite corner of the chip.
4. Remove the firmware ROM.

**To replace the firmware ROM (see Figure 8-57):**

1. Match the beveled corner of the ROM with the locator key in the socket (see Figure 8-57).
2. Place the ROM on the socket.
3. Push the ROM gently into the socket.

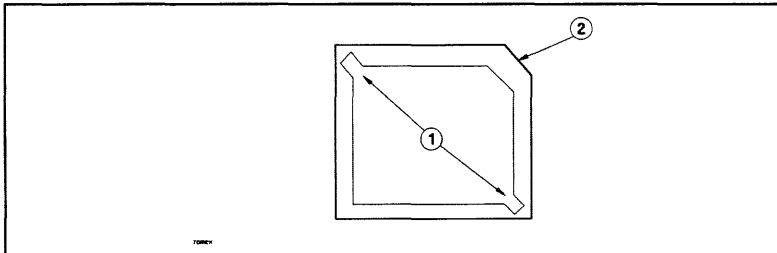

**Figure 8-57. ROM Socket**

1. ROM Extraction Slots

2. ROM Locator Key

### 3.5-inch Hard Disk Drive Assembly and Disassembly

This section describes the removal and replacement of the drive replaceable assemblies.

---

#### Note



- New disk mechanisms do not include mounting hardware. You must remove the mounting hardware from the old mechanism and install it on the new mechanism.
  - Make sure the configuration of the new drive is the same as the old drive (see Figure 4-14 and Figure 4-15).
- 

#### Replaceable Assemblies

The hard disk drive contains two replaceable subassemblies: the hard disk mechanism and the SCSI controller PCA. The front panel may also be replaced as a subassembly.

Whenever a faulty SCSI controller PCA is replaced, the firmware ROM should be transferred from the old PCA to the new PCA. However, the firmware ROM may also be ordered separately.

#### Disk Mechanism. To remove the disk mechanism:

- Follow the procedure for removing the SCSI controller PCA to separate the disk mechanism from the SCSI controller PCA and the PCA mounting brackets.

#### To replace the disk mechanism:

- Follow the procedure for replacing the SCSI controller PCA.

#### SCSI Controller PCA.

---

#### Caution



- The drive must be placed upside-down to remove the SCSI controller PCA. In this position, the drive is very susceptible to mechanical shock and vibration. Be extremely careful to avoid bumping or jarring the drive while it is upside down. Place the drive on a padded surface while replacing the SCSI controller PCA.
  - Make sure you observe the proper ESD precautions when removing the SCSI controller PCA.
  - Make sure the configuration jumpers on the new PCA are in the same positions as those on the old PCA (refer to Table 4-13).
- 

#### To remove the SCSI controller PCA (see Figure 8-58):

1. Disconnect the status indicator cable from the status indicator connector on the PCA.
2. Remove the cabinet mounting bracket from the drive.

**For HP Internal Use Only**

3. Carefully place the drive upside-down on a padded surface.
4. Remove the four PCA mounting screws.
5. Lift the PCA up far enough to remove the two PCA mounting brackets.
6. Disconnect the spindle flex circuit and the actuator flex circuit from the PCA as follows:
  - a. Using the tabs at the ends of the locking bar on each flex circuit connector, pull the locking bar away from the connector.
  - b. Carefully pull the flex circuit out of the connector.
7. Lift the PCA off the mounting posts on the disk mechanism.

**To replace the SCSI controller PCA:**

1. Make sure all of the jumpers on the new PCA are in the same positions as those on the PCA you are replacing. The jumper settings are listed in Table 4-18 and Table 4-20.
2. Place the PCA on the disk mechanism so the PCA mounting holes are aligned with the mounting posts. Also make sure the corner of the PCA near the status LED fits into the slot in the PCA support tab.
3. Connect the spindle flex circuit and the actuator flex circuit as follows:
  - a. Make sure the locking bar on each flex circuit connector is pulled away from the connector.
  - b. Slide each flex circuit into its corresponding connector. The spindle flex circuit goes *under* the locking bar; the actuator flex circuit goes *over* the locking bar.
  - c. Press on the tabs at each end of the locking bar until the bar makes contact with the connector.
  - d. Pull gently on the flex circuit to make sure it is held firmly in the connector.
4. Install the two PCA mounting brackets. Make sure the corner of the PCA remains under the PCA support tab.
5. Install the four PCA mounting screws.
6. Install the cabinet mounting bracket on the drive.
7. Connect the status indicator cable to the status indicator connector on the PCA.

For HP Internal Use Only

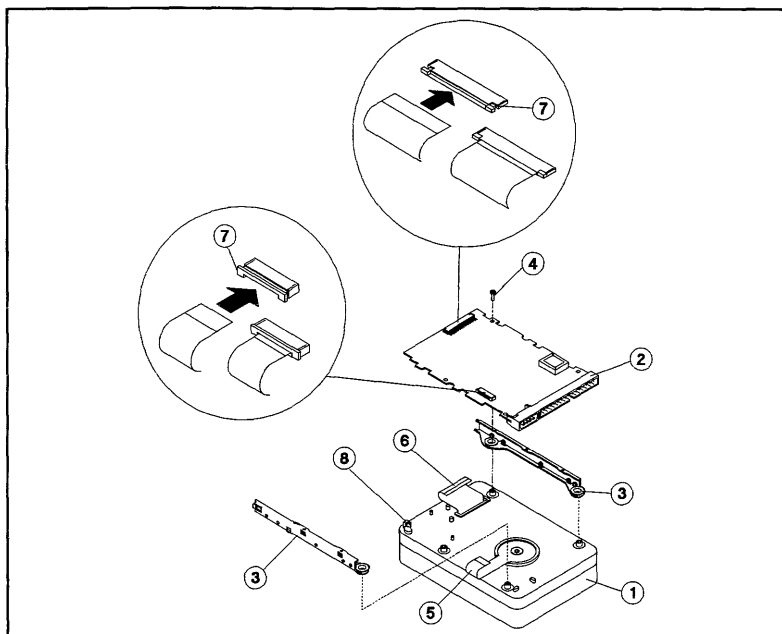

Figure 8-58. Replacing the SCSI Controller PCA

- |                            |                          |
|----------------------------|--------------------------|
| 1. Disk Drive              | 5. Spindle Flex Circuit  |
| 2. SCSI Controller PCA     | 6. Actuator Flex Circuit |
| 3. PCA Mounting Brackets   | 7. Connector Locking Bar |
| 4. PCA Mounting Screws (4) | 8. PCA Support Tab       |

**For HP Internal Use Only**

**Firmware ROM.**

---

**Note** Whenever a faulty SCSI controller PCA is removed, the firmware ROM should be transferred from the faulty PCA to the replacement PCA.

---



**To remove the firmware ROM (see Figure 8-59):**

1. Insert the tapered end of the extraction tool, part no. 8710-1982, into one of the extraction slots in the socket (see Figure 8-59).
2. Pry up on the corner of the chip.
3. Repeat steps 1 and 2 for the opposite corner of the chip.
4. Remove the firmware ROM.

**To replace the firmware ROM (see Figure 8-59):**

1. Match the beveled corner of the ROM with the locator key in the socket (see Figure 8-59).
2. Place the ROM on the socket.
3. Push the ROM gently into the socket.

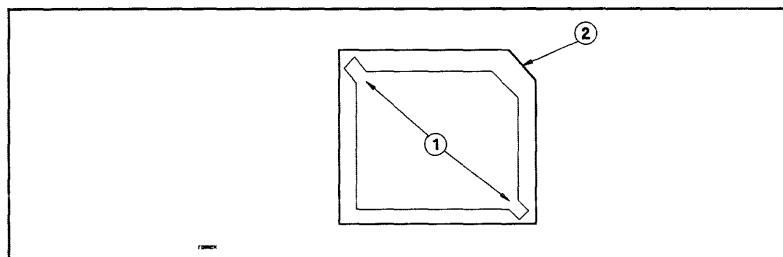

**Figure 8-59. Firmware ROM Socket**

1. ROM Extraction Slots

2. ROM Locator Key

**5.25-inch DDS-Format DAT Drive Assembly and Disassembly**

The 5.25-inch DDS-format DAT drive is replaced as a unit and should not be disassembled. There are no replaceable assemblies in the drive.

**For HP Internal Use Only**

**3.5-inch DDS-Format DAT Drive Assembly and Disassembly**

This section describes the removal and replacement of the drive replaceable assemblies.

---

**Note**



- New drives do not include mounting hardware. You must remove the mounting hardware from the old drive and install it on the new drive.
  - Make sure the configuration of the new drive is the same as the old drive (see Figure 4-18).
- 

**Replaceable Assemblies**

The DDS drive is normally replaced as an entire assembly. However, the front panel may be replaced as a subassembly.

**For HP Internal Use Only**

**Front Panel. To remove the front panel (see Figure 8-60):**

1. Press in the locking tab (2) on the right-hand side with a small screwdriver and pull the right corner of the front panel (1) away from the mechanism chassis.
2. Repeat step 1 for the locking tab on the left-hand side.
3. Press in the front panel door and rotate the front panel up until the locator tabs (3) can be lifted out of the chassis.

**To replace the front panel:**

1. Lower the front panel locator tabs into the chassis.
2. Rotate the front panel down and press the front panel locking tabs into place.

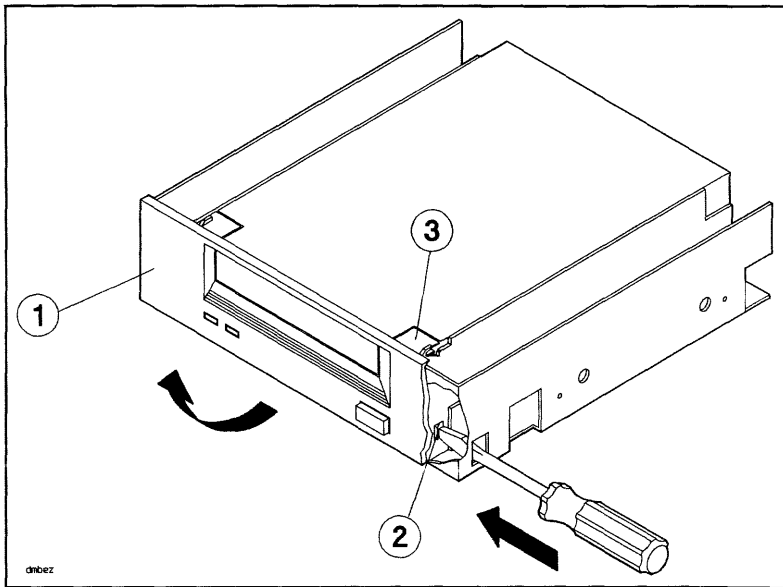

**Figure 8-60. Removing the Front Panel**

1. Front Panel
2. Locking Tab

3. Locator Tab



## CD-ROM Drive Assembly and Disassembly

This section describes the removal and replacement of the drive replaceable assemblies.

### Laser Safety

---

#### Warning



- Use of controls, adjustments, or performing procedures other than those specified in this manual may result in hazardous invisible laser radiation exposure.
  - Do NOT disassemble the CD-ROM drive for any reason. The CD-ROM drive becomes a Class 1 laser mechanism when disassembled. If the CD-ROM disk drive is disassembled, exposure to the invisible laser beam and hazardous invisible laser radiation could result in blindness.
- 

### Handling Precautions

---

#### Caution



- Make sure you eject the media from the drive before removing the drive from the cabinet. Damage to the drive may occur if media is in the drive and the drive is moved while the power is off.
  - Make sure you observe the proper ESD precautions when servicing the drive.
- 

---

#### Note



- New drives do not include mounting hardware. You must remove the mounting hardware from the old drive and install it on the new drive.
  - Make sure the configuration of the new drive is the same as the old drive (see Figure 4-20).
- 

### Replaceable Assemblies

The CD-ROM drive is normally replaced as an entire assembly. However, the front panel and door may be replaced as subassemblies.

**For HP Internal Use Only**

**Front Panel. To remove the front panel (see Figure 8-61):**

1. Gently pry out the two locking tabs (2) on the right-hand side of the front panel.
2. Repeat step 1 for the locking tabs on the left-hand side of the front panel.
3. Gently pry out the locking tab from the bottom center of the front panel and pull the front panel away from the front of the drive.

**To replace the front panel:**

Gently push the front panel onto the drive chassis until the locking tabs lock into place.

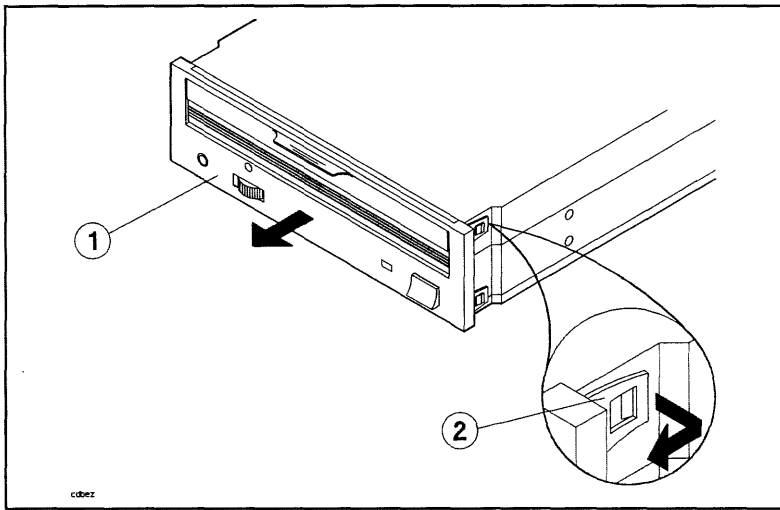

**Figure 8-61. Removing the Front Panel**

1. Front Panel

2. Locking Tab (5)

**For HP Internal Use Only**

**Door.** To remove the door (see Figure 8-62):



A coil spring is used to keep the door closed. Make sure the spring is reinstalled when the door is replaced.

1. Slide the door cam off of the door.
2. Pull the hinge pin out of the door.
3. Detach the door spring from the drive chassis and pull the door away from the front of the drive.

**To replace the door:**

1. Insert the free end of the door spring into the hole below the CD-ROM slot.
2. Position the door over CD-ROM slot.
3. Insert the hinge pin.
4. Orient the door cam as shown and slide it onto the door.

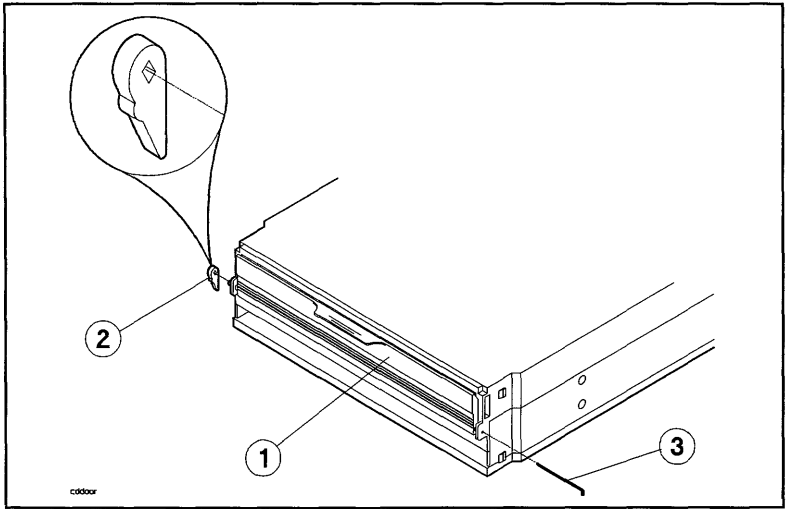

**Figure 8-62. Removing the CD-ROM Door**

- |             |              |
|-------------|--------------|
| 1. Door     | 3. Hinge Pin |
| 2. Door Cam |              |

## **Cabinet Removal and Replacement**

This section describes the procedure for replacing a damaged part. Refer to Table 8-4 for a list of the cabinet parts that can be replaced if damaged.

The 1.1 meter and 1.6 meter cabinet are identical except for vertical height. All parts are removed and replaced the same. For this reason, only the 1.6 meter cabinet is shown. The only parts that are different between the 1.1 meter cabinet and 1.6 meter cabinet are the rear door, top cap, base cover, and side covers.

Refer to Figure 8-63 and Figure 8-64 while performing the procedures outlined in this section.

For HP Internal Use Only

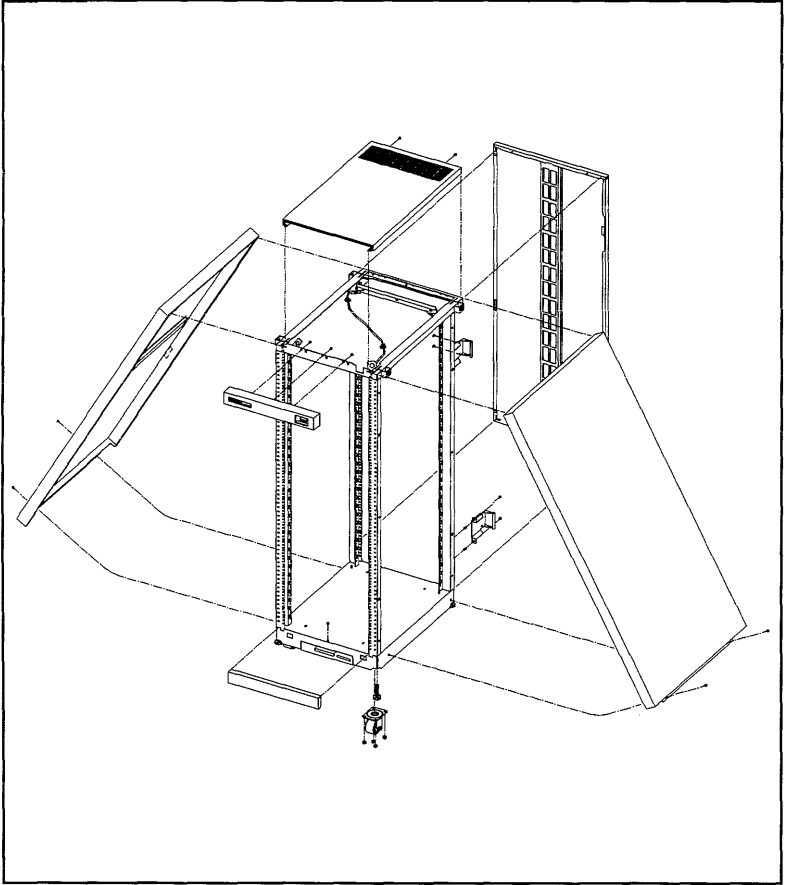

Figure 8-63. Cabinet Exploded View Front

For HP Internal Use Only

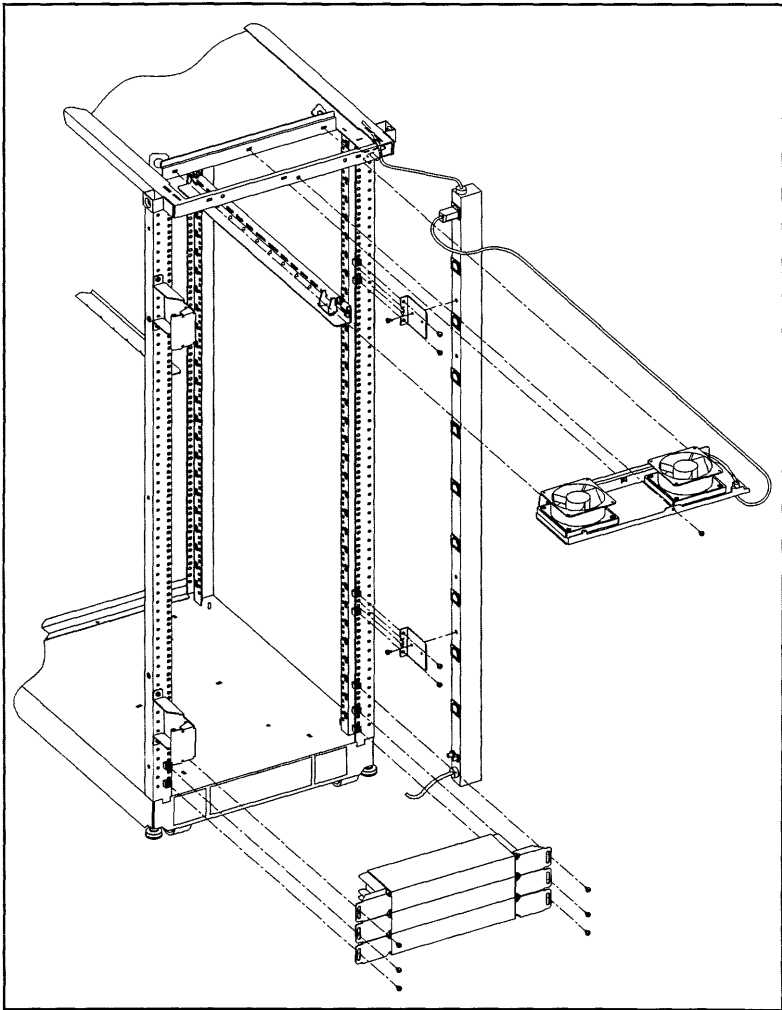

Figure 8-64. Cabinet Exploded View Rear

## For HP Internal Use Only

### Removal and Replacement Procedures

The following procedures are for the HP Field Replaceable Units (FRUs) contained in the HP A1883A/84A or HP A1896A/97A rack-mount cabinets.

#### Rear Door

Refer to Figure 8-63 while performing these procedures.

##### Rear Door Removal:

1. Remove the rear door of the cabinet by opening the door.
2. Disconnect the bonding wire from the door.
3. Grasp the rear door support and lift the door straight up and away from the cabinet.

##### Rear Door Replacement:

1. Hold the rear door by the support column, in an open position.
2. Align the door hinge pins over the cabinet hinge holes.
3. lower the door onto the cabinet hinge.
4. Reconnect the bonding wire to the door.

#### Top Cap

Refer to Figure 8-63 while performing these procedures.

##### Top Cap Removal:

1. Turn the cabinet power switch off and unplug the cabinet power cord.
2. Open the rear door all the way.
3. Remove the two outside mounting screws at the top rear of the cabinet.
4. Then, from the rear of the cabinet, pull the top cap toward the back, a few inches.
5. Lift the top cap off the cabinet.

##### Top Cap Replacement:

1. From the rear of the cabinet, place the top cap between the side covers and slide it forward until it stops.
2. Insert the two mounting screws at the top rear. Tighten the screws.
3. Close the rear door. Plug the cabinet power cord into the wall outlet and power up the computer system.

#### Side Cover

Refer to Figure 8-63 while performing these procedures.

##### Side Cover Removal:

1. Remove the two mounting screws at the bottom of the cabinet.
2. On the right side cover, open the rear door and remove the two mounting screws on the upper door hinge (that secure the hinge to the side panel).

### **For HP Internal Use Only**

3. Grasp the sides of the side cover (pulling the bottom of the panel away from the cabinet offers a better grip), then lift up and away.

#### **Side Cover Replacement:**

1. Grasp the side cover on the sides and align it with the cabinet at a vertical angle with the bottom out and the top toward the top of the cabinet.
2. Lower the side onto the top edge of the cabinet side so the top of the side cover hooks onto the top of the cabinet.
3. With the side cover flush with the cabinet frame and insert the two mounting screws in the bottom. Tighten the screws.
4. On the right side cover, insert the mounting screws through the upper door hinge into the side panel and tighten screws.

#### **Forehead Assembly**

To remove the forehead assembly, the power has to be turned off and the top cap has to be removed first. Refer to Figure 8-63 while performing these procedures.

#### **Forehead Assembly Removal:**

1. Turn the power off (refer to Chapter 4 for power off procedures).
2. Unplug the cabinet power cord.
3. Remove the top cap (refer to top cap removal).
4. Unplug the PDU harness from the back of the ON/OFF switch.
5. Remove the three mounting screws behind the forehead assembly.
6. Pull the forehead assembly away from the cabinet frame.

#### **Forehead Assembly Replacement:**

1. Align the forehead assembly at the top of the cabinet frame, so the three mounting holes match the frame holes, and the mounting hooks on each side engage the mounting slots.
2. Insert the three mounting screws through the frame into the forehead assembly. Tighten the screws.
3. Attach the PDU harness to the ON/OFF switch lugs as indicated:  

Red:	switch terminal 1
Black:	switch terminal 2
White:	switch terminal 6
4. Replace the top cap (refer to top cap replacement).
5. Plug the cabinet power cord into the wall outlet.

#### **Base Cover**

Refer to Figure 8-63 while performing these procedures.

#### **Base Cover Removal:**

1. Remove the mounting screw located on the top edge, center, of the base cover.
2. Pull the base cover away from the bottom of the cabinet.

### **8-96 Replaceable Parts**



## **For HP Internal Use Only**

### **Base Cover Replacement:**

1. Align the base cover hooks on the bottom of the cabinet frame and roll the base cover until the mounting holes in the cabinet and base cover align.
2. Insert the mounting screw. Tighten the screw.

### **Rear Door Hinge**

Refer to Figure 8-63 while performing these procedures.

#### **Rear Door Hinge Removal:**

1. Remove the rear door (refer to rear door removal).
2. Remove the two mounting screws from the cabinet column (on the upper hinge, also remove the two mounting screws in the side panel), and lift the door hinge away.

#### **Rear Door Hinge Replacement:**

1. Align door hinge with the pressed nuts in the rear cabinet column.
2. Insert the two mounting screws through the hinge into the column (on the upper hinge insert the two mounting screws into the side panel). Tighten the screws.

### **Rail Assembly**

This procedure is also used to remove or replace a rail clamp. Refer to Figure 8-63 while performing these procedures.

#### **Rail Removal:**

1. Remove the component mounted on the rail to be replaced. Removing the component could involve a lot of cable handling. Be sure to tag the removed cables for replacement later.
2. Remove the two rail mounting screws.
3. Lift the rail out of the rail support notch in the cabinet column.
4. If the rail clamp needs to be removed, remove the clamp screw, and slide the clamp out of the rail groove.

#### **Rail Replacement:**

1. Slide the rail clamp into the rail.
2. Insert the rail tab into the appropriate inside cabinet column support notch.
3. Insert the two mounting screws through the rail into the slip nuts on the column. Tighten the screws.
4. Re-install the component that was previously removed.
5. Slide the rail clamp up to the rear of the component and insert the clamp screw. Tighten the screw.

### **Fan Assembly**

Refer to Figure 8-65 and Figure 8-64 while performing these procedures.

#### **Fan Assembly Removal:**

**For HP Internal Use Only**

1. Turn off the cabinet power. Refer to the power off procedures in Chapter 5.
2. Open the rear door.
3. disconnect the fan power cord from the PDU.
4. Remove the one mounting screw at the top rear cabinet frame bar.
5. Grasp the fan assembly from the bottom and pull toward the rear of the cabinet.
6. The fan assembly should release from the cabinet, and can be lowered out of the cabinet.

**Fan Assembly Replacement:**

1. Raise the fan assembly into the rear cabinet frame opening.
2. Slide the fan assembly forward engaging the tabs on the fan assembly into the slots in the cabinet frame.
3. Insert the mounting screw. Tighten the screw.
4. Connect the fan power cord from the fan assembly to the PDU.
5. The rear door can now be closed and the system powered up.

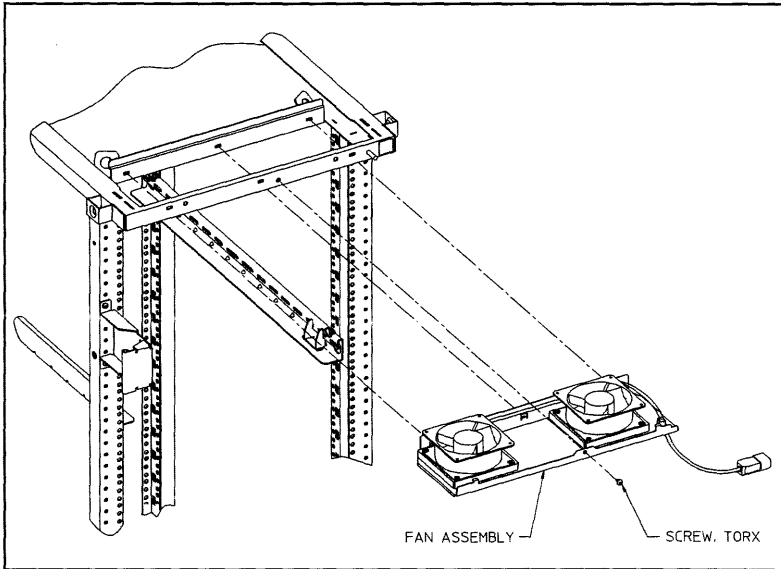

**Figure 8-65. Fan Assembly**

## **For HP Internal Use Only**

### **Fan**

Refer to Figure 8-66 while performing these procedures.

#### **Fan Removal:**

1. Remove the fan assembly (refer to fan assembly removal).
2. Remove the power cable connectors from the fan.
3. Remove the two mounting screws and nuts holding the fan to the fan tray.
4. The fan bracket stays with the fan tray.

#### **Fan Replacement:**

1. Position the fan over the fan bracket/tray mounting holes so that the power lugs are at the rear of the fan tray, and on the right side of the fan (as viewed from the back of the assembly). Also verify the air flow arrow points up.
2. Insert the mounting screws up through the bottom of the fan tray/bracket and fan.
3. Attach mounting nuts/washers on the mounting screw. Tighten screws and nuts.
4. Attach power cord lugs to spades on the fan (polarity does not matter).
5. Replace fan assembly (refer to fan assembly replacement).

**For HP Internal Use Only**

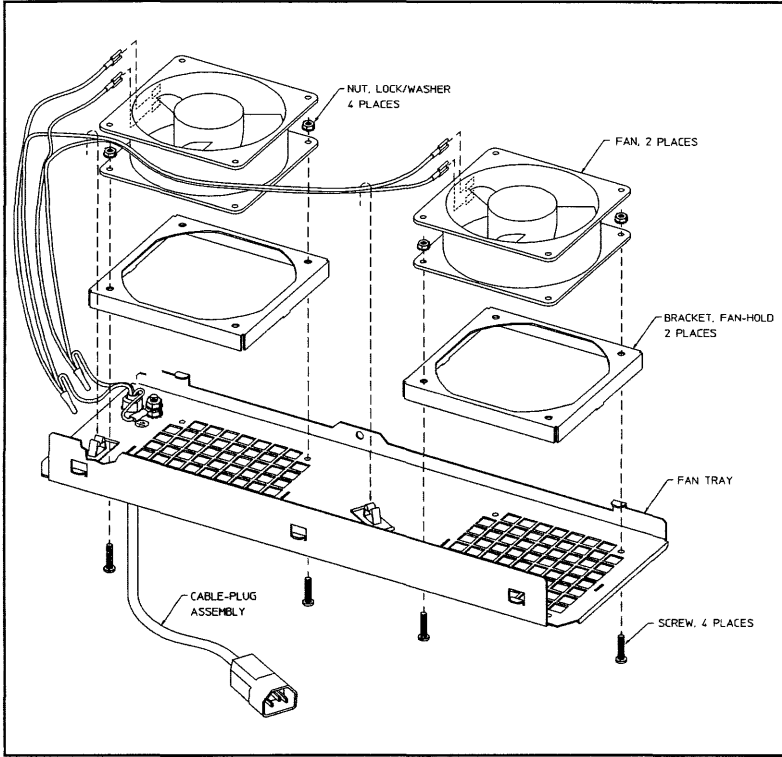

**Figure 8-66. Fan Diagram**

**PDU**

Refer to Figure 8-64 while performing these procedures.

**PDU Removal:**

1. Turn OFF the power switch on the front of the cabinet.
2. Unplug the cabinet power cord from the wall outlet.
3. Remove the top cap (refer to top cap removal).
4. Unplug the PDU harness from the back of the ON/OFF switch.
5. Unclip the PDU harness from the cable clamps on the cabinet frame top and pull the PDU harness down through the top frame.
6. Remove all component power cords from the PDU.

**8-100 Replaceable Parts**

### For HP Internal Use Only

7. Remove the four (two on each bracket) mounting screws from the PDU mounting brackets that attach to the frame columns.
8. Lift the PDU up to disengage, the PDU mounting bracket hooks from the frame column.
9. Pull the PDU out of the cabinet.

---

**Note** The PDU mounting brackets could be removed at this point if necessary.



---

#### **PDU Replacement:**

1. Align the PDU (with the brackets attached) on the right rear column of the cabinet frame.
2. Insert the PDU bracket hooks into the column holes and lower the PDU until it rests on the column.
3. Insert the PDU mounting screws through the brackets into the column with slip nuts attached.
4. Route the PDU harness up through the top of the cabinet and through the cable clamps.
5. Plug the PDU harness onto the ON/OFF switch.
6. Replace the top cap (refer to top cap replacement).
7. Reconnect all the cabinet components to the PDU.
8. Plug the power cord into the wall outlet.
9. The cabinet and computer are ready to be powered up.

#### **Cabinet Leveler or Caster**

Refer to Figure 8-63 while performing these procedures.

#### **Leveler or Caster Removal:**

1. Turn Off the cabinet power switch.
2. Unplug the cabinet power cord from the wall outlet.
3. Carefully move the cabinet to an area with enough room to allow the cabinet to be laid on its side.
4. Remove all computer components mounted in the cabinet.
5. Carefully lay the cabinet over on one of its sides.
6. unscrew the desired leveler. Or, remove the desired caster by removing four mounting nuts and pulling the caster off.

#### **Leveler or Caster Replacement:**

1. With the cabinet still on its side, screw in the leveler. Or, place the caster over the four mounting studs, and attach the four mounting nuts. Tighten the nuts.
2. Carefully lift the cabinet back up to an upright position.
3. Install all computer components that were removed previously.
4. Carefully move the cabinet to its install site.

### **For HP Internal Use Only**

5. Plug the cabinet power cord into the wall outlet.
6. The cabinet is now ready for operation.

#### **Magnetic Door Catch**

The magnetic door catch is located in the rear door, with catch plate on the left side cover.

#### **Magnetic Door Catch Removal:**

1. Open the rear door.
2. Grasp the magnetic door catch on the top and bottom. It is inside the rear door fold.
3. Simultaneously press the top and bottom mounting tabs of the door catch, while pushing the door catch out of the rear door.
4. When the door catch mounting tabs are clear of the rear door opening, pull the door catch out.
5. If the door catch plate needs to be removed, pry it off with a flat blade screwdriver. It is stuck on the side cover.

#### **Magnetic Door Catch Replacement:**

1. Align the magnetic door catch back to the mounting hole in the rear door.
2. Firmly press the door catch into the rear door mounting hole.
3. Press the door catch until the mounting tabs snap into place and the door catch is firmly locked into place.
4. If the door catch plate needs to be replaced, peel the adhesive cover off the back of the catch plate. Then align it with the magnetic door catch and press it against the side cover until firmly stuck.

#### **Door Bumper**

The rear door bumpers (one top and one bottom) are self-adhesive rubber bumpers stuck to the rear door. To remove, pry it off with a flat blade screwdriver. To put a bumper on, peel off the adhesive cover, and press the bumper on the appropriate corner of the rear door.

## Functional Description

---

### Introduction

This chapter describes the major hardware components of the system, the Access Port and its associated commands, and the Processor Dependent Code (PDC) commands.

---

### Hardware Components

This section identifies each major group of functional hardware components. It also provides a brief description of the operation of these components. Figure 9-1 is a functional block diagram of the HP 3000 and HP 9000 systems.

### System Power

System power is supplied by one or two power systems. The standard chassis systems have one power system. The extended chassis systems have two power systems. Each power system is a single replaceable unit. A power system consists of a power supply and a power control module (PCM). The power system connects directly to the backplane assembly. It has three DC power harnesses to provide DC to the internal peripherals.

Figure 9-2 shows the block diagram of a power system. The signals are described in Table 9-1. AC and DC power specifications are listed in Chapter 2.

Figure 9-1. HP 3000 and HP 9000 System Block Diagram

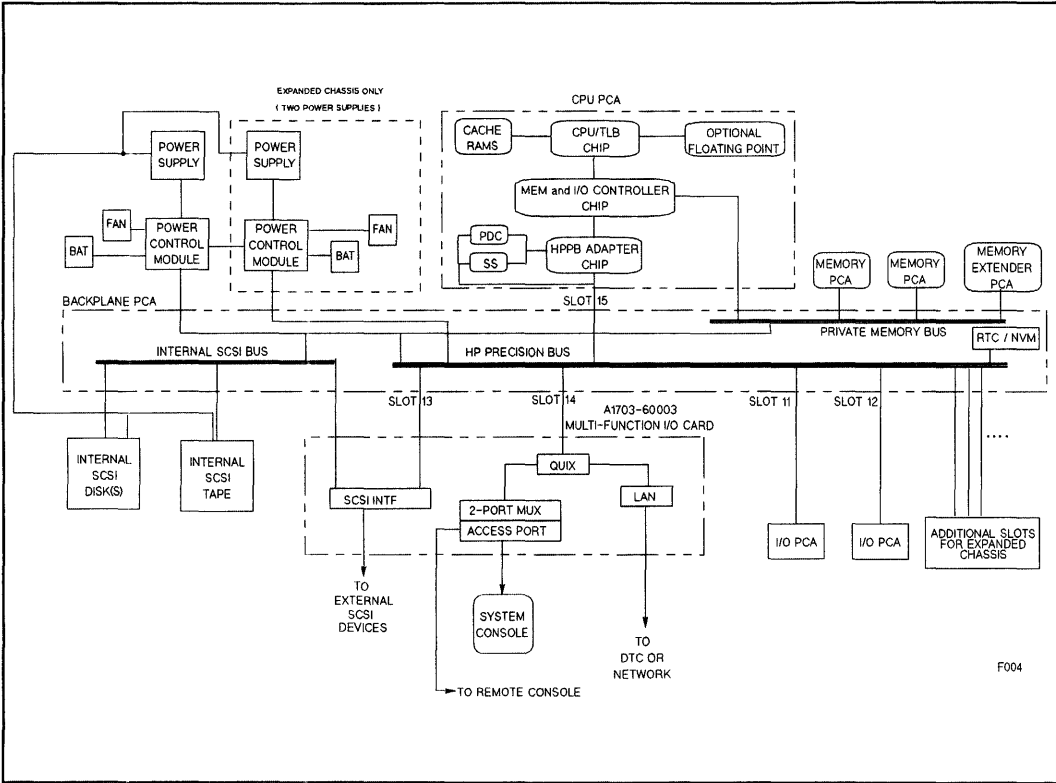

For HP Internal Use Only



**For HP Internal Use Only**

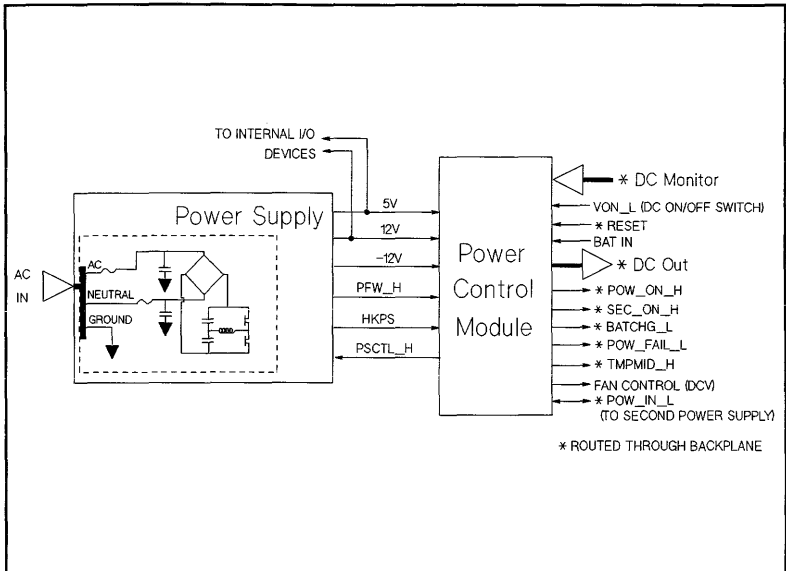

**Figure 9-2. Power System Block Diagram**

**Table 9-1. Power System Signals**

Signal	Description
PFW_H	DC output will fail after 6 milliseconds
HKPS	Unregulated 15 VDC for Power Control Module. Active with AC power
PSCTL_H	Power Control Module-generated On/Off control to power supply
VON_L	DC On/Off signal from front panel switch
RESET	System-generated reset signal to Power Control Module
POW_ON_H	Power Control Module-generated. Indicates DC levels good
SEC_ON_H	Indicates memory valid after power loss
BATCHG_L	Battery is being charged
POW_FAIL_L	Warning to system. Power will be lost in 6 milliseconds
TMPMID_H	Overtemp signal to system
POW_IN_L	Error inhibit signal to second power system

## For HP Internal Use Only

### Power-on Sequence

When AC power is applied to the system chassis, unregulated +15VDC is supplied to the Power Control Module (PCM). This initializes the PCM, which detects the VON\_L signal from the front panel DC On/Off switch.

When the DC On/Off switch is depressed, the DC enable signal VON\_L, which is lowered to ground potential, is distributed to the PCM. As DC voltages come up, DC monitor lines are sampled by the PCM to check DC levels. If DC levels reach specified levels within 120 milliseconds, the PCM generates POW\_ON\_H. Normal system execution begins when POW\_ON is generated.

### Over-temperature Detection

Temperature is monitored by an analog circuit on the PCM. This circuit measures ambient air temperature as air flows through the power system. The circuit determines fan speed and the state of TMPMID\_H computer system status line.

Fan speed changes from normal to high speed if the ambient temperature is greater than 30°C.

TMPMID\_H is reported to the system if the temperature rises above 40°C. If the temperature rises above 42°C, the PCM issues POW\_FAIL\_L to the system and turns off the DC power system.

### Single Power System Error Detection

During system operation, if DC overvoltage or overcurrent occurs, the PCM latches all DC voltages off, except unregulated +15VDC. This condition can be verified by observing the Error LED, located on the PCM. If the LED is lit, this condition exists. As long as the AC fuses are good and AC power is supplied to the power system, +15VDC keeps the PCM active for error detection.

### Dual Power System Error Detection

Both power systems have the same error detection mechanism. The Error Disable signal provides communication between the two power systems. The signal is routed across the backplane. The signal is initiated by the first power system to detect a fault or error condition. The power system asserts the Error Disable signal to the second supply and prevents it from also signaling an error. This ensures that the error is isolated to the faulty power system.

### Power Fail with Battery

When AC power is lost, the POW\_ON signal drops, while SEC\_ON (battery) stays high. This sequence signals the system that battery backup is successfully executing. In addition, the overtemp sensor is disabled, preventing a self-induced overtemp shutdown sequence. If the battery voltage drops below a specific trip point during battery backup operation, all DC voltages will latch off. After AC returns, power can only be restored by recycling the DC On/Off switch.

## 9-4 Functional Description

## For HP Internal Use Only

### Power Fail without Battery

A battery is optional on this system, therefore some systems may not have battery backup. When AC power is lost, PDC stores a PFAIL bit in non-volatile memory (NVM). NVM is an un-architected address space residing in a 50-byte RAM area in the Real Time Clock (RTC) chip. When power is applied, PDC reads NVM and places the PFAIL information in Stable Storage. This information is then accessible by the operating system for logging. In addition, the following message is displayed on the system console - **Last system interruption caused by power failure**. The message will only be displayed once. If the system reboots, the message will roll off the screen.

### CPU PCA

The CPU PCA provides control and processing for the system. Figure 9-3 is a block diagram of the CPU PCA. The chips on the CPU PCA are:

- CPU
- Memory and I/O Controller
- Memory and I/O Buffers
- Floating Point Coprocessor
- HP-PB Bus Adapter
- PDC
- Stable Storage

**For HP Internal Use Only**

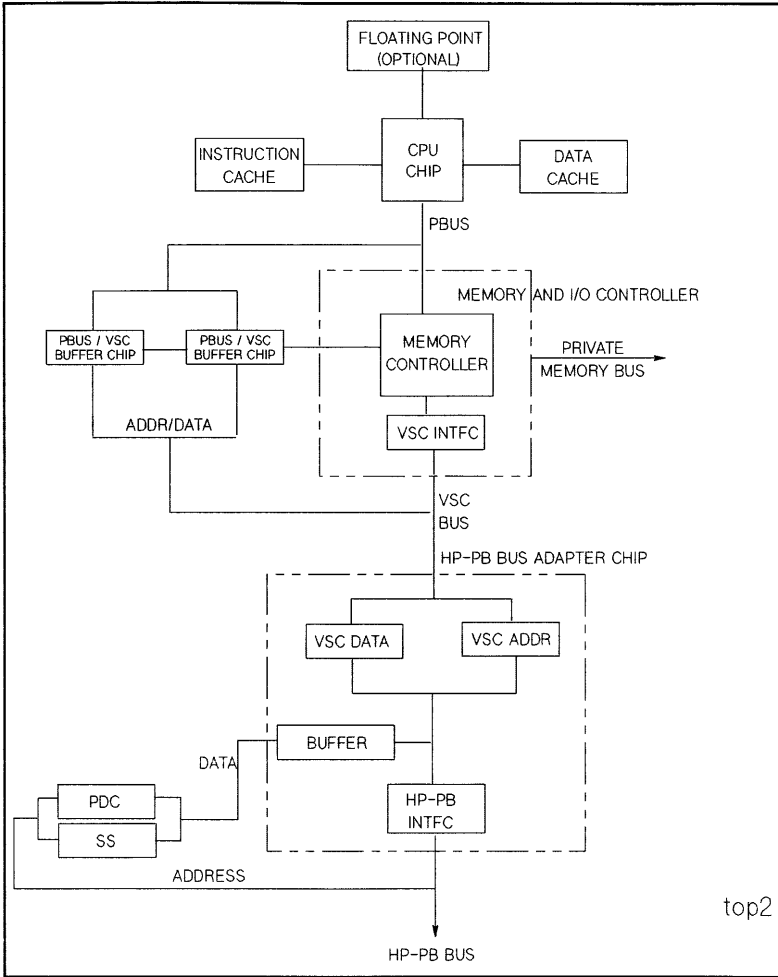

**Figure 9-3. CPU PCA Block Diagram**

There are several price/performance versions of the CPU PCA, which account for the various range of clock speeds, cache and main memory sizes. Three clock rates are supported - 32, 48, and 64 MHz. Instruction cache and data cache sizes range from 64Kb to 256Kb. The HP 9000 Series 807 supports a minimum of 8MB of main memory. The rest of the HP 9000 and

**9-6 Functional Description**

### For HP Internal Use Only

HP 3000 models support 16MB to 384MB of main memory. The major chip functions are described below.

#### CPU

- Contains the ALU (arithmetic logic unit), TLB (translation lookaside buffer) and separate I-CACHE and D-CACHE controllers.
  - The ALU performs all of the addition and subtraction operations (except floating point).
  - The TLB is a memory management unit. It manages information about the location of code sections in cache and memory.
  - The I-CACHE and D-CACHE controllers control all accesses to their respective caches. They also provide parity detection, encoding and reporting. The I-CACHE and D-CACHE RAMs are external to the CPU chip.

#### Memory and I/O Controller

- Acts as a controller and interface between the Processor bus (Pbus) and the VSC bus. It provides the following functions for system operation.
  - Main memory controller
  - Provides error detection and correction for main memory (single-bit correction, multi-bit detection).
  - Drives the private memory bus.
  - Drives and receives all control signals to/from the VSC bus.
  - Stores the current most severe memory error in an internal register. The register is accessible by the operating software for system logging.

#### PBus/VSC Interface

- A pair of chips that buffer all addresses and data transferred to/from the Pbus and VSC bus. This includes the following:
  - Addresses and data to/from the CPU to I/O address space.
  - Addresses and data to/from main memory (Memory and I/O Controller) and I/O address space.
  - Addresses and data to/from PDH (part of I/O address space) and the CPU.

#### HP-PB Bus Adapter

- Acts as an interface or buffer between the VSC bus and I/O (HP Precision Bus). It also provides a register for packing byte reads from PDC and Stable Storage into words for transfer to the CPU.
- Also provides refresh clocks to main memory during power fail.

#### Private Memory Bus (PMB)

The system has a Private Memory Bus (PMB). All single inline memory modules (SIMM) use this bus to communicate with the Memory and I/O Controller.

## For HP Internal Use Only

### Processor-Dependent Hardware (PDH)

Processor-dependent hardware (PDH) consists of processor-dependent code (PDC), Stable Storage, non-volatile memory (NVM), and the real-time clock (RTC). Stable Storage resides on the CPU PCA. NVM and RTC are located on the backplane PCA and are addressed across the HP Precision Bus (HP-PB). NVM and RTC are implemented in a single chip design, which also includes a built-in battery for backup.

### Processor Dependent Code (PDC)

- Processor Dependent Code (PDC) is implemented in ROM. PDC contains code for selftest diagnostics, system error handling, powerfail recovery, transfer of control, boot code and several routines required for system operation. When fetching PDC code, address and control signals are passed to the HP-PB as I/O addressing. The PDC ROM supplies data across a special line to the HP-PB Bus Adapter chip, not across the HP-PB. The HP-PB Bus Adapter chip packs the data into words and passes it to the CPU for execution.

Table 9-2 lists the PDC commands and provides a brief explanation of their functions.

The PDC commands can be executed at the boot prompt. The boot prompt is displayed after successful completion of Selftest, which occurs after System Power-up or after System Reset.

**Table 9-2. PDC Commands**

Command	Description
AUTOBOOT <on/off>	Set Autoboot flag on or off
AUTOSEARCH <on/off>	Set Autosearch flag on or off
AUTO	Display Autoboot and Autosearch flags
BOOT	Boot after primary, alternate, or specified boot path
BOOT TIMER	Display/Set boot device timer
DEFAULT	Set default paths in Primary Storage
FASTSIZE	Diaplay/Set FASTSIZE memory parameter
HELP or ?	Print Help menu
HELP <command>	Print Help information for <command>
INFO	Display I/O map, memory, and revision information
PATH	Display/Modify path information
PIM	Display PIM information
RESET	Reset the system
STABLE	Display contents of Stable Storage
TIME	Read/Set real time clock

### Stable Storage

- Implemented in EEPROM, Stable Storage access is identical to PDC. The EEPROM holds the following information:
  - System Boot Paths
  - Power fail information (non-battery operation only)
  - Software ID
  - Hardware ID

### 9-8 Functional Description

### For HP Internal Use Only

- Software and user cap limits
- Flags for Autoboot, Autosearch and Fastsize

#### **Real-Time Clock (RTC)**

- Keeps track of date and time. Time is referenced to GMT and is accessed by the operating system to set local time.

#### **Non-Volatile Memory (NVM)**

- This is a 50-byte RAM area in the RTC chip. NVM is un-architected. It is not implemented in the same manner as previous systems. NVM provides the following special functions for this system.
  - Contains power-fail information for non-battery backed up systems.
  - Maintains calibration constants for the RTC circuit.
  - Stores a bit map of I/O modules. The bit map is referenced by PDC when HPMC Bus Error - 503F occurs to identify all installed I/O modules. The modules are checked for an error state and logged to the HPMC Error Log.

#### **Memory Subsystem**

The memory subsystem is located on several assemblies. Figure 9-4 shows three major assemblies, CPU PCA, Backplane PCA and the Memory Extender. An assembly not shown in Figure 9-4 is the memory array PCA. The memory arrays are accessed by a private memory bus. Figure 9-5 shows the block diagram of the memory array PCA.

For HP Internal Use Only

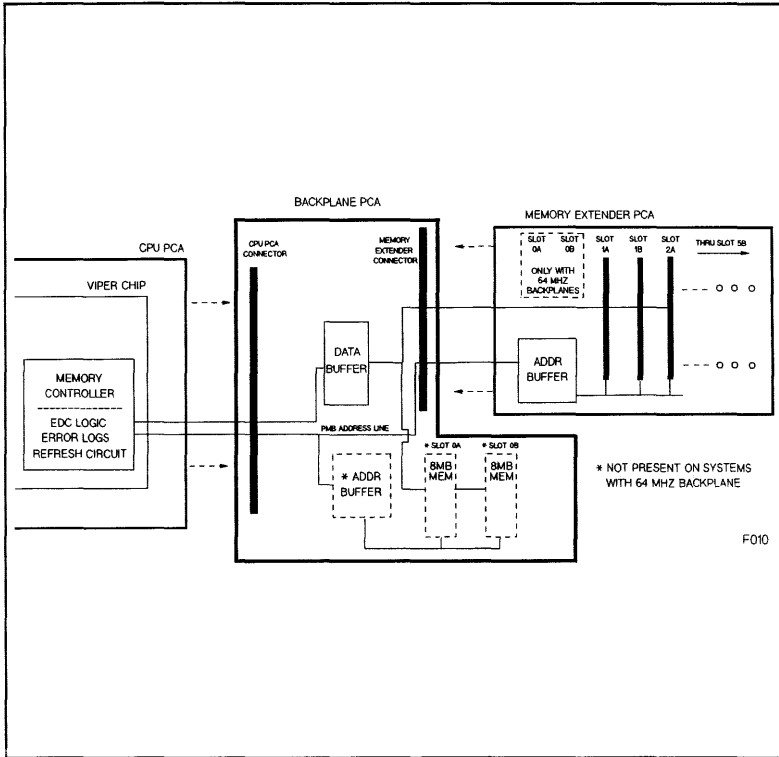



**For HP Internal Use Only**

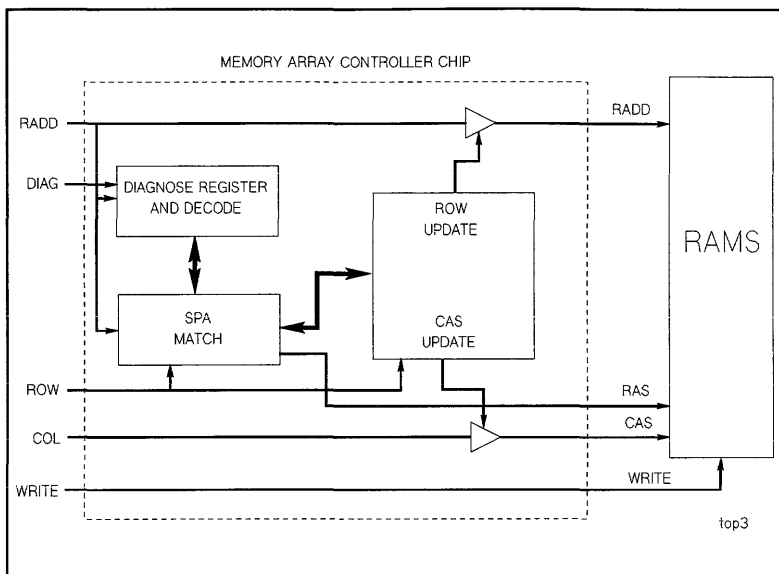

**Figure 9-5. Memory Array PCA Block Diagram**

The memory configuration rules are defined in “Memory Subsystem Configuration” in Chapter 4.

Each memory subsystem component is described below.

**Memory and I/O Controller Chip**

The Memory and I/O Controller chip contains the memory controller for all of main memory. This includes the error correction circuit, single-event error log and the RAM refresh circuitry. The chip also drives address, data, and control signal on the private memory bus to the memory arrays via the backplane.

**Backplane PCA**

The backplane contains the following active components of the memory subsystem:

- Data buffer for all memory,
- Memory slot positions 0A/0B,
- Address buffer circuitry for slots 0A/0B
- A connector for the memory extender PCA.

## For HP Internal Use Only

### Memory Extender

The memory extender has five additional slot pairs for memory arrays. The extender also contains the address buffer circuitry for the slots.

### Memory Array PCA

Figure 9-5 shows a Memory Array Controller and RAM chip. The memory arrays can have several Memory Array Controller chips with in-line sets of RAMs.

**Memory Array Controller.** During system initialization, PDC sets up the controller with the soft physical address and the size of the memory array. Once the array is configured, it responds to memory requests that fall within the range set by the soft physical address. The configuration is not changed unless a hard reset occurs.

### System Startup Overview

System operation begins when the CPU chip receives the POW\_ON signal from the power system. POW\_ON forces a preset address of F0000004 (PDC selftest entry point) on the cache line input to the ALU. This initiates a Fetch operation to PDC code. As PDC begins sending bytes of information, the HP-PB Bus Adapter chip packs the information into words. The requested data is sent back to the CPU chip via the VSC Bus, the two PBus/VSC Interface chips, and the CPU Instruction Register. The PDC code is executed directly from the CPU Instruction Register because the cache RAMs and main memory have not been initialized at this early stage of execution.

PDC selftest code tests the CPU and main memory. Main Memory is initialized by sending a specific range of addresses and data to each pair of memory arrays. The response to each range of addresses determines the size of the memory arrays. Based on this information, PDC programs the Memory Array Controller chips with the size and the hard physical address of each set of RAMs. PDC tests and initializes the data and instruction caches. Cache initialization consists of marking each cache entry as invalid. This purges all cache storage. Following this process, PDC tests all available memory and initializes Page 0 of main memory. Page 0 includes information on memory array sizes, slot locations, and their soft physical address.

As address and data are sent to memory via the Pbus, it is received by the Memory and I/O Controller chip, packed into two double words and appended with check bits. It is then sent to a pair of memory arrays. When data is fetched from the arrays, the Memory and I/O Controller chip recalculates the check bits and compares the two check bit patterns for errors. If an error is detected, the error is stored in a Memory and I/O Controller chip register, where it is accessed by the operating system for logging.

PDC then initializes the system console by fetching IODC code from the IODC ROM located on the Multifunction I/O card. The code is loaded into main memory where an instruction fetch can retrieve the code and load it into the Instruction cache for execution.

## I/O Subsystem

Figure 9-6 is a block diagram of the I/O subsystem.

The SPU I/O subsystem provides an interface between I/O devices, main memory and the CPU. The I/O subsystem consists of both software and hardware components that work together to transfer data between peripheral devices and main memory in DMA transactions, or between the CPU and an external device operating in direct I/O mode. The I/O subsystem hardware consists of the following components.

- Hewlett-Packard Precision Bus
- HP-PB Device Adapter
- Precision Bus Adapter

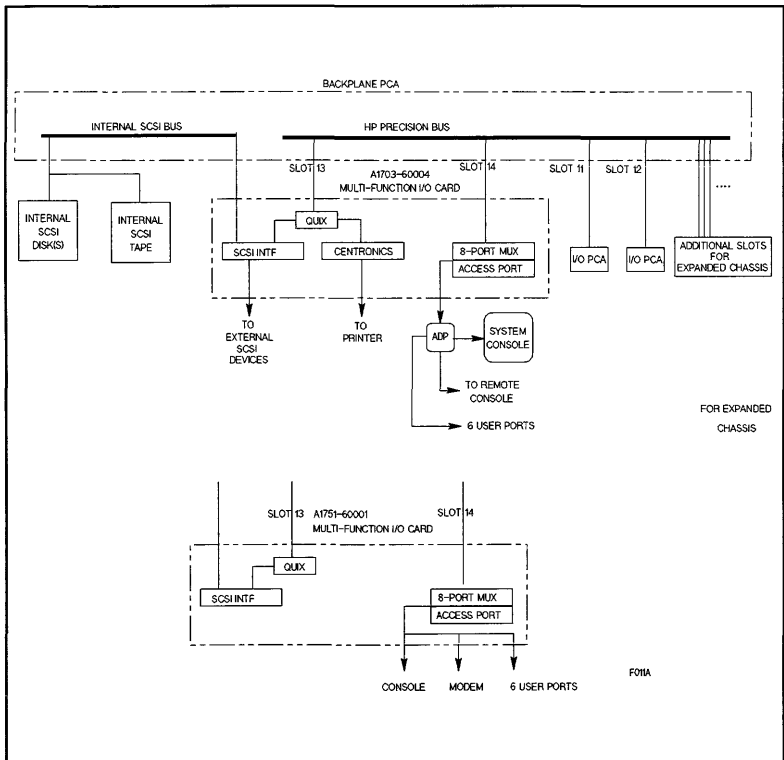

Figure 9-6. I/O Subsystem Block Diagram

**For HP Internal Use Only**

### **Hewlett-Packard Precision Bus (HP-PB)**

The Hewlett-Packard Precision Bus is a high performance 32-bit bus. The HP-PB interconnects the physical modules within the system package. Features of the bus are:

- High performance 32-bit synchronous operation
- Structured arbitration
- Bus Parity
- Software configurability

### **HP-PB Device Adapters**

HP-PB I/O device adapters are used to connect peripheral devices to the HP-PB bus. Currently supported HP-PB device adapters are listed under Chapter 7.

### **Precision Bus Adapter**

The bus adapter features an integrated channel adapter for interconnecting CIO device adapters to the HP Precision Bus. It is designed so that it can be installed in any double high I/O slot position that is not reserved for special boards.

The supported CIO device adapters are:

- |        |                                    |
|--------|------------------------------------|
| 27111A | CIO/HP-FL Device Adapter (HP 9000) |
| 27113B | HP-IB Device Adapter (HP 3000)     |
| 27115A | CIO/HP-FL Device Adapter (HP 3000) |

Figure 9-7 is a block diagram of the precision bus adapter.

Figure 9-8 shows the precision bus adapter.

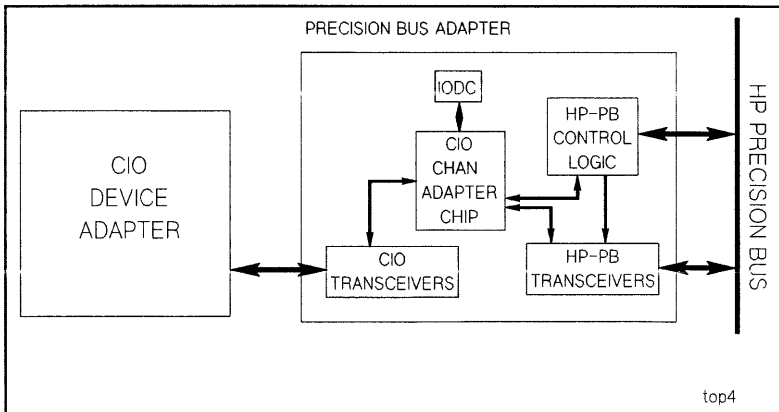

**Figure 9-7. Precision Bus Adapter Block Diagram**

For HP Internal Use Only

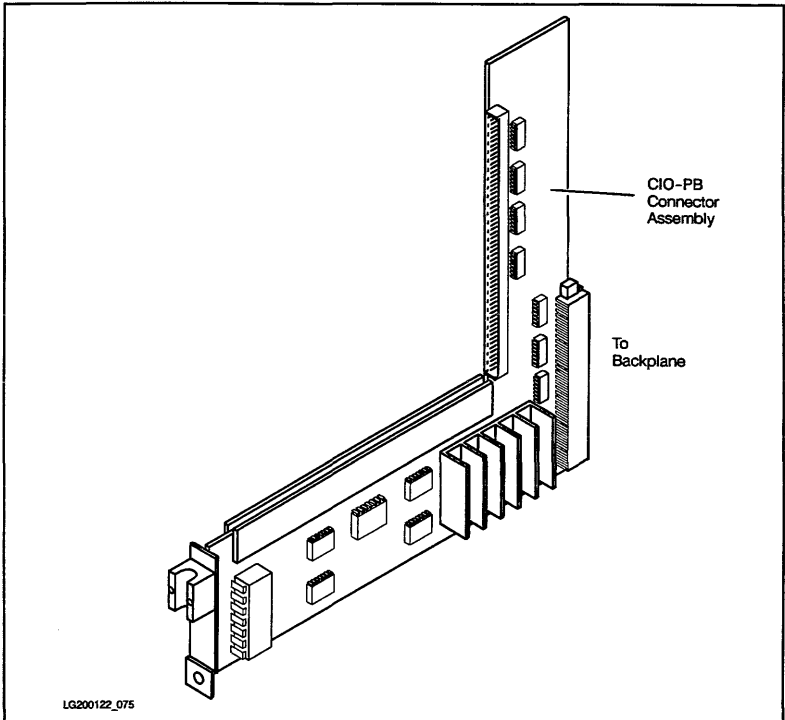

Figure 9-8. Precision Bus Adapter

## SCSI Bus Description

This system features internal peripherals that are connected to the system via a SCSI (Small Computer System Interface) bus. SCSI provides a standard bus for connecting peripheral devices, such as disk and tape drives. Because SCSI is an industry standard, non-HP devices can be connected to the system chassis. Operation of non-HP devices is not guaranteed by HP.

SCSI offers high performance and connectivity for a growing variety of peripheral devices. SCSI bus specifications are listed in Table 9-3.

**For HP Internal Use Only**

**Table 9-3. SCSI Bus Specifications**

Parameter	Characteristics
Features	8-bit bus. Connects up to 7 devices per adapter. Bus arbitration Parity Checking (via enable/disable switch)
Maximum Cable Length (single-ended SCSI bus)	6 meters, including any internal lengths in all devices.
SCSI Bus Connection	Single-ended
Termination Requirement	The SCSI bus requires termination. The terminator <b>MUST</b> be connected to the last device on each end of the bus.

**Caution**

Connecting more than one terminator to a SCSI bus cabling scheme will cause electrical damage to SCSI device controllers.



This system has an integrated SCSI bus, located on the Multifunction I/O card. Figure 9-6 shows how the SCSI bus originates on the multifunction card and is routed through the backplane to the internal SCSI devices. Some versions of the Multifunction card offer external connections for external SCSI devices. In the case where the SCSI controller acts as a node (Y-connection), both ends of the SCSI bus must have SCSI terminators (last device on the chain).

**SCSI Bus Termination Requirements**

Internal SCSI devices are connected together with internal SCSI bus ribbon cable. External SCSI devices are connected via a standard SCSI cable.

Both ends of the SCSI bus must be terminated. The internal SCSI bus is terminated with internal terminator packs, which must be installed only on the last device on the bus.

Figure 9-9 shows how the internal SCSI bus is terminated. Note the high-density SCSI terminator on the external connector. This terminates the other end of the SCSI bus.

For HP Internal Use Only

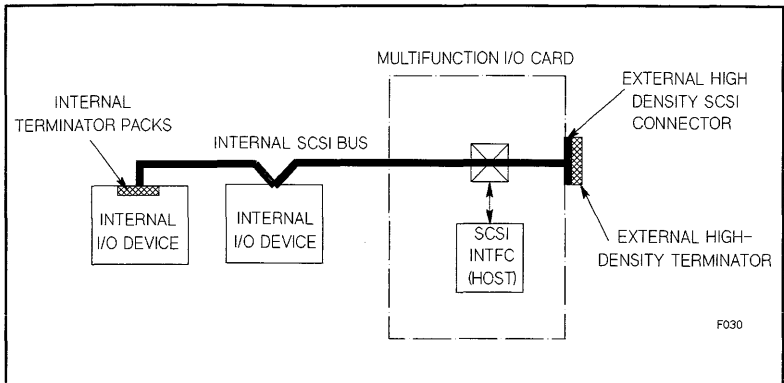

Figure 9-9. Internal SCSI Bus with no External Devices

Figure 9-10 shows the internal SCSI bus with one external SCSI device connected to it. The external SCSI connector on the Multifunction I/O card is a high-density connector. It requires a high-to-low density SCSI cable to connect the external I/O device. A SCSI terminator is used on the external I/O device to properly terminate the bus.

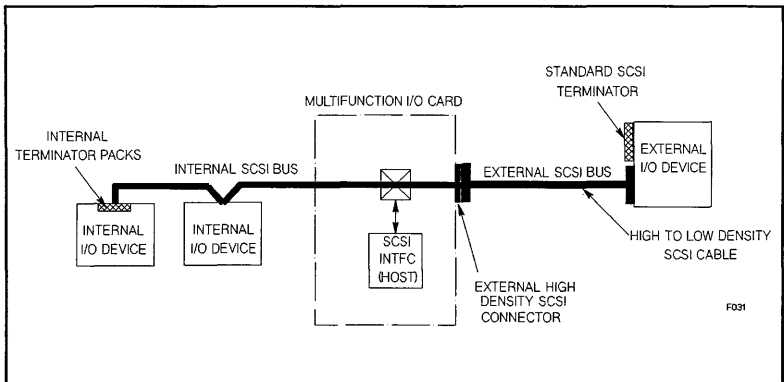
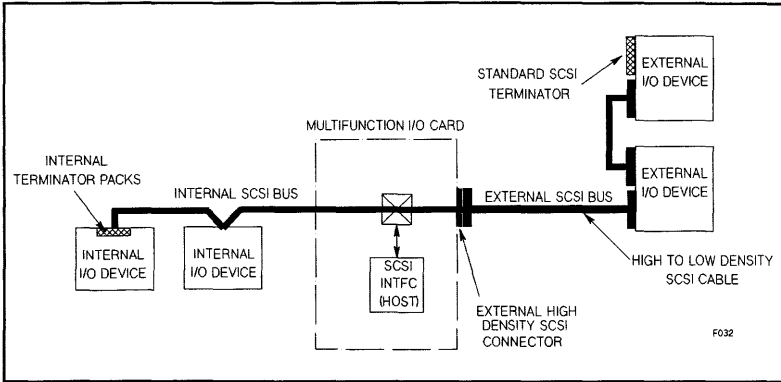

Figure 9-10. Internal SCSI Bus with one External Device

Figure 9-11 shows the internal SCSI bus with two external SCSI devices connected to it. Note that the standard SCSI terminator has been moved to the last device on the SCSI cable. Both ends of the SCSI bus are properly terminated with terminator packs on the last internal SCSI I/O device and a standard SCSI terminator on the last external I/O device.

**For HP Internal Use Only**



**Figure 9-11. Internal SCSI Bus with two External Devices**

**Caution**

Do not connect a differential SCSI device to the single-ended SCSI bus. Single-ended and differential SCSI devices are electrically different and must not be configured onto the same bus.



**SCSI Single-Ended Pin Assignments**

**Table 9-4. SCSI Connector (J1) Single-Ended Pin Assignments**

PIN SIGNAL	PIN SIGNAL	PIN SIGNAL
2 -DATA BIT 0	20 GROUND	36 -BSY
4 -DATA BIT 1	22 GROUND	38 -ACK
6 -DATA BIT 2	24 GROUND	40 -RST
8 -DATA BIT 3	26 TERMPWR	42 -MSG
10 -DATA BIT 4	28 GROUND	44 -SEL
12 -DATA BIT 5	30 GROUND	46 -C/D
14 -DATA BIT 6	32 -ATN	48 -REQ
16 -DATA BIT 7	34 GROUND	50 -I/O
18 -DATA BIT P		

Note 1: All odd numbered pins are connected to ground. Pin 25 is required to remain open.

If the single-ended convention is used, all odd numbered pins, except pin 25, are connected to ground. Pin 25 is left open. All assigned signals are terminated with 220 ohms to +5 volts (nominal) and 330 ohms to ground at each end of the cable.

**9-18 Functional Description**



## Access Port

### General Description

The Access Port is located on the Multifunction I/O card. The Integrated Access Port is designed for use with PA-RISC HP-PB I/O base systems to provide a minimal level of remote supportability for the systems. The Access Port gives the console operator the ability to read system status and to generate system resets through the console terminal instead of through the system's front panel display and switches. It also provides the ability to connect a second console in parallel with the local console terminal. This "mirrored" console port is connected to a modem through which the second or remote console is attached. This provides the same system support functionality to a remote terminal as is available to a console operator sitting next to the system.

### Access Port Operation

#### Local/Remote Console

The I/O card provides an interface for the host based PDC and card based IODC or the operating system's I/O driver to communicate with the console terminal and the support modem. When the support modem is not being used for remote console operation, it is available for use by the host system. When it is being used for remote console operation, the modem port is connected in parallel with the system's console port, making it unavailable for use as an independent terminal connection.

#### Access Port Functions

The Access Port may be considered as a type of support server. It acts as an agent to pass characters between the frontplane (terminal input and output) and the backplane (the host system interface). At certain times, the Access Port may be given commands to suspend character transfer between host and terminals to allow the console operator to interact directly with the Access Port. This gives the operator the ability to check the operating status of the host, enable or disable remote operator accesses, lock the remote support modem for increased system security, force a system reset, or to initiate a Transfer of Control (TOC). After the operator completes Access Port related tasks, communication with the host may be resumed without loss of data.

#### Access Port Modes

Terminal ports connected to the Access Port may be in one of three modes:

**Session Mode.** Session mode is defined as a direct connection from the terminal to the host system with the Access Port monitoring but not acting on any characters transmitted between the terminal and the host.

**Console Mode.** Console mode is defined as a connection in which the Access Port monitors the data being transferred and will take special action on some characters.

**Control Mode.** Control mode is defined as a mode in which the terminal is in communication with the Access Port only.

## For HP Internal Use Only

### Integrated Access Port Commands

When the Integrated Access Port is in control mode, there are several commands that are available to the local and remote console operators. These commands allow the operator to configure the Access Port functions of the I/O interface card, enable or disable remote console access as well as modify remote access security features, view the system's status display, and initiate a system reset or transfer of control.

Unless otherwise specified, all commands may be performed by both the local and remote consoles. Also, all commands may be entered in upper or lower case characters.

### Access Port Commands Overview

**Table 9-5. Access Port Command Summary**

CONTROL MODE COMMANDS		Valid At	
Command	Description	LC	RC
CA	Configure Remote Support Modem Port	Y	Y
CO	Return to Console Mode	Y	Y
CS	Copy Screen	Y	Y
DI	Disconnect Remote Console	N	Y
DR	Disable Remote Operator Access	Y	Y
DS	Disable SPU Status Display	Y	Y
ER	Enable Remote Operator Access	Y	N
ES	Enable SPU Status Display	Y	Y
HE	Print Help Menu	Y	Y
LR	Lock Remote Support Modem Access	Y	Y
RS	Reset SPU	Y	Y
SE	Enter Session Mode on Remote Port	N	Y
TC	Initiate SPU Transfer of Control	Y	Y
TA	Initiate Self Test	Y	Y
TE	Tell	Y	Y
UR	Unlock Remote Support Modem Access	Y	N

- LC = Local Console
- RC = Remote Console

## Access Port Command Description

### CA: Configure Remote Support Modem Port

#### Definition:

This command allows the local console operator to set the modem protocol, bit rate, CCITT Rate Select, and the optional system identification.

- Modem Protocol: Bell or CCITT
- Bit Rate: 300, 1200, 2400, 4800, 9600 bits/sec
- CCITT Rate Select (Circuit 111): HIGH (ON) or LOW (OFF)
- System Identification: 0 to 23 ROMAN-8 characters (non control)

**Valid From:** Local Console Port, Remote Modem Port

This new configuration is written to Nonvolatile memory at the end of command processing. The new configuration will not be used by the IAP for configuring the remote support modem port until the next incoming call is answered after the current operator session has been disconnected. If an incorrect entry was made resulting in an incorrect configuration, the CA command should be re-executed.

### CO: Return to Console Mode

#### Definition:

Switches the console terminal from control mode to console mode. If the Close Console Path was last active, characters that are inbound from the master port will be placed in the CCP transmit buffer and characters received from the CCP will be transmitted to the console terminal (or terminals). If the Close Console Path was not active, characters that are inbound from the master port will be placed in the inbound console backplane buffer, and characters that are in the outbound console backplane buffer will be transmitted to the connected console terminals.

If background command processing for busy ports is not supported on the I/O card, returning to console mode also requires that the any buffered commands be completed and the Estat field of the IO\_STATUS register be cleared if no errors need to be reported.

**Valid From:** Local Console Port, Remote Modem Port

### CS: Copy Local Console Screen

#### Definition:

The local console operator can copy the contents of the local console screen memory to the remote console by entering the Copy Screen (CS) command. If the local operator enabled remote copy screen when remote operator access was enabled (ER command), the remote operator can copy the contents of the local console screen to the remote console.

This feature is guaranteed to work only if the local console is a 700/92 or later terminal.

**Valid From:** Local Console Port, Remote Modem Port

## For HP Internal Use Only

### **DI: Disconnect Remote Console**

#### **Definition:**

This command causes the IAP to initiate a modem disconnect sequence on the remote support modem if it is being used as a remote console. After executing this command the IAP de-asserts the modem control lines, thus forcing the modem to “hang up” the telephone line. The remote support modem port is then no longer connected as a mirrored console, and the local console port becomes master.

If the remote access mode (see ER command) was set to be single, remote operator access is disabled and must be re-enabled by using the ER command to once again allow remote operator access. If the remote access mode was set to be multiple, the IAP will connect the next incoming call on the remote support modem port to the IAP as a remote operator connection.

**Valid From:** Remote Modem Port

### **DR: Disable Remote Operator Access**

#### **Definition:**

This command disables remote operator access on the support modem port. If an operator is connected as a parallel console at the time this command is executed, the remote console is disconnected. Any future incoming calls to the remote support modem will be handled by the system as a user session. If remote operator access was already disabled when this command is executed, this command has no effect.

If background command processing for busy ports is not supported on the I/O card, the following applies: When switching from Remote Operator Enabled to Remote Operator Disabled, any buffered commands posted to the host's remote modem port should be completed and the Estat field of that port's IO\_STATUS register set appropriately. This indicates to the driver that the port is no longer busy. A “ready to connect” connection status will be sent to the driver.

**Valid From:** Local Console Port, Remote Modem Port

### **DS: Disable SPU Status Display**

#### **Definition:**

Disable display of the system's OSTAT and hex display to the console terminals when in console mode. See ES: Enable SPU Status Display command.

**Valid From:** Local Console Port, Remote Modem Port

### **ER: Enable Remote Operator Access**

#### **Definition:**

This command, available only on the local console, enables remote console access to a user on the modem port and configures the connection security parameters. The mode parameter establishes how many times the remote user may connect, disconnect, and reconnect the remote console before remote console access is automatically disabled. The password parameter is set by the local console operator and stored in nonvolatile memory. The password fault parameter sets the number of password faults allowable (3 password attempts per fault) before remote console access is automatically disabled.

## **9-22 Functional Description**

### For HP Internal Use Only

If background processing of I/O commands received in the remote port's IO\_COMMAND register is not supported, the port must be placed in a busy state. This means that any commands received at that time must not be executed. Instead, the driver that issued the command should be notified that the command was not executed because the port was busy, but that it will be executed as soon as the port is available to the driver again. Only one command will be buffered in this manner. If a second command is written over a command that was not completed due to the port being busy, undefined things may occur.

On initial power up the remote configuration defaults to:

- Remote Operator Access Disabled (see DR command)
- Mode = Multiple
- Password = None
- Password Faults = 3
- Remote Copy Screen = Disabled

The following two paragraphs describe how the mode and password fault parameters are used to enhance console security.

#### **Access Mode: Single—**

The remote user only has three attempts to enter the correct password. If the user succeeds, the remote console session is begun and remains until the user disconnects or until the user is disconnected by the local console operator. If the user fails, the line is disconnected. In either case, after the disconnection, the line is dropped, the remote console is disabled, and the port becomes a normal session port. To use the remote port as a remote console once again, the remote console capability must be re-enabled by the local console.

#### **Access Mode: Multiple—**

The remote user has three attempts to enter the correct password. If the user succeeds, the remote console session is begun and remains until the user disconnects or until the user is disconnected by the local console operator. If the user fails, the line is disconnected. After disconnection, the line is dropped and becomes available for future calls through the modem. If the user does not succeed in providing the correct password, a password fault count is increased, the caller is disconnected, and the line is dropped. When the password fault count exceeds an operator set limit, the remote operator access capability is disabled. The modem port may only be used as a normal session port until the local console operator re-enables the remote capability by using the ER command.

**Valid From:** Local Console Port

#### **ES: Enable SPU Status Display**

##### **Definition:**

This command enables display of the system's status line (system OSTAT and hex code) on the console terminals in place of the softkey labels when the console has returned to console mode. (The console status line is always enabled when in control mode.)

**Valid From:** Local Console Port, Remote Modem Port

#### **HE: Print Help Menu**

##### **Definition:**

### For HP Internal Use Only

Execution of this command (either HE or HELP are acceptable) displays the following information to the console terminal:

nnnnnn Access Port Revision xxxx - dddd

CA: Configure remote support modem  
CO: Return to console mode  
CS: Copy local console screen  
DI: Disconnect remote console  
DR: Disable remote operator access  
DS: Disable SPU hex status display  
ER: Enable remote operator access  
ES: Enable SPU hex status display  
HE: Help  
LR: Lock Remote Support Modem Access  
RS: Reset SPU  
SE: Enter session mode on remote port  
SP: Enter support processor mode  
TA: Initiate self-test  
TC: Initiate transfer of control  
TE: Tell  
UR: Unlock Remote Support Modem Access

nnnnnn is the product number of the I/O card the Integrated Access Port is implemented on.

xxxx is the Integrated Access Port firmware revision number. dddd is a date code indicating the year and week that the code revision was last updated.

**Valid From:** Local Console Port, Remote Modem Port

#### **LR: Lock Remote Support Modem Access**

##### **Definition:**

This command allows the local console operator to prohibit usage of the remote support modem by the system or by a remote operator. Once this command is issued from the console terminal, the remote support modem is disabled. Active sessions will be disconnected (either a user session or a remote operator). Incoming calls will be ignored. Requests by the system for establishing a modem connection will also be ignored. This command may be issued by the local or remote console operators, although a remote operator issuing this command will cause a loss of connection to the system. If the modem was already in the locked state, this command will have no additional effect.

This command does not affect the state of remote operator access (either enabled or disabled), although after executing this command, no remote operator connection can be established. After unlocking the remote support modem access, if remote operator access was enabled before locking, it will continue to be enabled. If it was disabled, it will continue to be disabled.

The local console operator must use the UR (Unlock Remote support modem access) command to re-enable usage of the remote support modem.

The state of the lock (either locked or unlocked) is saved in nonvolatile memory so that if power fails, the same state as existed before the power failure will exist after power is restored. Initially, the lock is set to the unlocked state.

#### **9-24 Functional Description**

## For HP Internal Use Only

**Valid From:** Local Console Port, Remote Modem Port

### **RS: Reset SPU**

#### **Definition:**

This command resets the system, IAP I/O card excluded, by deasserting the backplane POW\_ON and SEC\_ON signals. For multiple bus systems, a reset signal is provided on the support cable. The IAP firmware controls the length of time that POW\_ON and SEC\_ON are forced to the off state and the support cable RSTSYS\_L signal is asserted. The reset condition should be held for a minimum of 5 milliseconds.

In order to ensure proper functioning of this command, the processor must mask off the reset from the backplane.

The proper SPU reset sequence is as follows:

- Determine that the Operator really wants to reset the system by requiring that the operator confirm that a system reset is desired.
- Firmware notifies the operator that the system reset has been successful.
- Reset the I/O functions on the IAP I/O card.
- The AP is placed in Console Mode to prepare for rebooting the system.

**Valid From:** Local Console Port, Remote Modem Port

### **SE: Enter Session Mode On Remote Port**

#### **Definition:**

This command may only be entered from the remote port and allows the user to leave control mode and enter session mode. To re-enter control mode, the user need only exit the user session. The IAP will reconnect the operator as a parallel console after the driver releases the connection.

After entering the SE command, the Access Port should send a “ready to connect” connection status to the driver through the IO\_DATA\_IN\_IOE7 FIFO. Assuming that no other error precludes clearing error information in the IO\_STATUS register, the Se bit should be cleared and 0 placed in the Estat field of the IO\_STATUS register for port 7.

**Valid From:** Remote Modem Port

### **TC: Initiate Transfer Of Control**

#### **Definition:**

This command initiates a system Transfer Of Control by asserting the TOC line connected to the host's SPU through the support cable. After completion of this command, the AP is placed in console mode in preparation for rebooting the system.

**Valid From:** Local Console Port, Remote Modem Port

### **TA: Initiate IAP Self-Test**

#### **Definition:**

This command causes the IAP card to execute its self-test. Execution of the self-test does not alter the configuration or disconnect the modem port if on line. However, any data sent to the I/O card during self-test will be lost.

### **For HP Internal Use Only**

**Valid From:** Local Console Port, Remote Modem Port

**TE: Tell**

**Definition:**

This command treats all displayable characters following the TE command as a comment. Since characters are echoed to the local console terminal and to the remote console terminal if it is connected, this has the effect of sending a message to the other terminal. The comment string, including the command mnemonic, is limited to a maximum of 80 characters.

**Valid From:** Local Console Port, Remote Modem Port

**UR: Unlock Remote Support Modem Access**

**Definition:**

This command allows the local console operator to allow usage of the remote support modem by the system or by a remote operator. Once this command is issued from the console terminal, the remote support modem is enabled.

If remote operator access had been enabled previously, the card will return to the remote operator enabled state, allowing incoming calls to be connected as a mirrored console.

If remote operator access had been disabled previously, the card will return to the remote operator disabled state, allowing system usage of this port for user sessions.

If the modem was already in the unlocked state, this command will have no additional effect.

This command does not affect the state of remote operator access (either enabled or disabled). After unlocking the remote support modem access, if remote operator access was enabled before locking, it will continue to be enabled. If it was disabled, it will continue to be disabled.

The state of the lock (either locked or unlocked) is saved in nonvolatile memory so that if power fails, the same state as existed before the power failure will exist after power is restored. Initially, the lock is set to the unlocked state.

A remote operator may only enter this command when the remote support modem port is in the unlocked state. In this situation, the UR command does nothing, so the remote operator effectively cannot issue this command, but the IAP will not complain if it is typed.

**Valid From:** Local Console Port, Remote Modem Port



## For HP Internal Use Only

### Access Port Special Characters

Table 9-6. Access Port Special Character Summary

Character	Description
BREAK	Change Console Master
^^B	Switch From Console to Control Mode
^^V	Special Character Escape
^^S	XOFF
^^Q	XON

### Special Characters Description

#### ^^B: Enter Control Mode

##### Definition:

Entering this character when in console mode causes a change to control mode. Some special consideration needs to be added for flow control lock ups. Upon entering control mode, the Set bit should be set and SERR\_PORTBUSY should be placed in the IO\_STATUS register of port 0.

#### ^^Q: XON Pacing Character

##### Definition:

This character causes the IAP to resume passing characters to the console terminal (or terminals) if all connected console terminals are not in the XOFF state. This character is flagged as a special character and passed on to the host system. See the section on Console Flow Control for more details.

#### ^^S: XOFF Pacing Character

##### Definition:

This character causes the IAP to stop passing characters to the console terminals. This flow control character may be sent by either the master or the slave console terminal, and the IAP must respond to either terminal sending the XOFF by stopping the flow of characters to the terminal. The IAP will not send characters to either console terminal if one of them has sent an XOFF. To prevent both terminals from being locked up, each time an XOFF is received, a two second timer is initiated for the port at which the XOFF was received. After two seconds elapse with no XON character from that port, the transmitter will be re-enabled and character transmission will resume. See the section on Console Flow Control for more details.

#### ^^V: Escape Character

##### Definition:

Entering this character on the active console terminal nullifies any special character processing of the following character (with the exception of the XON and XOFF character) and the ^^V

### **For HP Internal Use Only**

character is ignored. Thus, for example: vi users will need to enter ^^B preceded by a ^^V to page backwards while in console mode.

#### **BREAK: Change Console Keyboard Master**

##### **Definition:**

Entering this character from the slave console immediately switches the slave console to console master and the break character is put in the bit bucket. When this character is entered from the console master however, it is sent on to the host system.

#### **IAP Initiated Self Tests**

The Integrated Access Port also has the ability to initiate a card self test (using the TA command). While parts of the I/O card with the Integrated Access Port must be completely functional in order to have the IAP start the self test, there may be some critical function that is required to boot the system that is not used by the IAP to communicate with the console terminal. The self test that the IAP initiates should provide a sufficient test to verify the card is functional, as far as it is capable of testing itself. Since this card is the first line of defense for supporting the SPU hardware, this test must be complete.

## Reference

---

This section contains a list of HP system acronyms to aid the Customer Engineer (CE) in recognizing the terminology used when correcting or solving an SPU problem in HP 3000 Series 9x7 Family and HP 9000 Model 8x7S Family Computer Systems.

### HP System Acronyms

Table 10-1. HP System Acronyms

Acronym	Description	Acronym	Description
AP	Access Port	HP-PA	Hewlett-Packard Precision Architecture
ACD	Architecture Control Document	HP-PB	Hewlett-Packard Precision Bus
CA	Channel Adapter	HP-UX	Hewlett-Packard UNIX
CCU	Cache Control Unit	I/O	Input/Output
CIO	Channel I/O	IODC	I/O Dependent Code
CPU	Central Processor Unit	IPL	Initial Program Loader
DA	Device Adapter	ISL	Initial System Loader
DIO	Direct I/O	LANIC	Local Area Network Interface Controller
DMA	Direct Memory Access	LED	Light Emitting Diode
DUI	Diagnostic User Interface	LPMC	Low Priority Machine Check
ECC	Error Correction Circuitry	MAU	Media Attachment Unit
FRU	Field Replaceable Unit	MUX	Multiplexer
HP-IB	Hewlett-Packard Interface Bus		
HPMC	High Priority Machine Check		

**For HP Internal Use Only**

**Table 10-1. HP System Acronyms (continued)**

<b>Acronym</b>	<b>Description</b>	<b>Acronym</b>	<b>Description</b>
OS	Operating System	RTC	Real Time Clock
PDC	Processor Dependent Code	SPU	System Processor Unit
PDH	Processor Dependent Hardware	TC	Transfer of Control
PFR	Powerfail Recovery	TCU	Translation lookaside Control Unit
PON	Power On	TLB	Translation Lookaside Buffer
RAM	Random Access Memory	TOC	Transfer of Control
RISC	Reduced Instruction Set Computer	VLSI	Very Large Scale Integration
ROM	Read Only Memory		
RS-232C	Standard for Serial Communication Interface		

**Service Notes**

---

# READER COMMENT SHEET

Systems Technology Division

HP 3000 Series 9x7 Family and  
HP 9000 Model 8x7 Family Computer Systems  
CE Handbook

Manual Part Number A1707-90016 February 1992

A reader comment sheet helps us to improve the readability and accuracy of the document. It is also a vehicle for recommending enhancements to the product or manual. Please use it to suggest improvements.

**SERIOUS ERRORS**, such as technical inaccuracies that may render a program or a hardware device inoperative should be reported to your HP Response Center or directly to a Support Engineer. An engineer will enter the problem on HP's STARS (Software Tracking and Reporting System). This will ensure that critical and serious problems receive appropriate attention as soon as possible.

Editorial suggestions (please include page numbers): \_\_\_\_\_

\_\_\_\_\_  
\_\_\_\_\_  
\_\_\_\_\_

Recommended improvements (attach additional information, if needed):

\_\_\_\_\_  
\_\_\_\_\_  
\_\_\_\_\_  
\_\_\_\_\_

Name: \_\_\_\_\_ Date: \_\_\_\_\_

Job Title: \_\_\_\_\_ Phone: \_\_\_\_\_

Company: \_\_\_\_\_

Address: \_\_\_\_\_

HP 3000 Series \_\_\_\_\_ (e.g., 37, 68, 930, etc.)

HP 9000 Series \_\_\_\_\_ (e.g., 300, 840, etc.)

Check here if you would like a reply.

Hewlett-Packard has the right to use submitted suggestions without obligation, with all such ideas becoming property of Hewlett-Packard.

*Fold and tape bottom edge.*



NO POSTAGE  
NECESSARY  
IF MAILED  
IN THE  
UNITED STATES

**BUSINESS REPLY MAIL**

FIRST CLASS PERMIT NO. 1070, CUPERTINO, CA 95014

- POSTAGE WILL BE PAID BY ADDRESSEE -

**STD Hardware Documentation**  
**Hewlett-Packard Company**  
Systems Technology Division  
19483 Pruneridge Avenue  
Mailstop 42UK  
Cupertino, California 95014-9786





**Manual Part No.  
A1707-90016**

**Copyright© 1992  
Hewlett-Packard Company  
Printed in USA 0292  
Edition 2**