

BASIC 3.0 Programming Techniques

```
30 CALL BuildArray(N)
40 CALL SortArray(N)
50 PRINT FNSumArray(N)
60 END
70 SUB BuildArray(N)
80 ! X(*) is the array
90 ! N tells how many elements are assumed
```

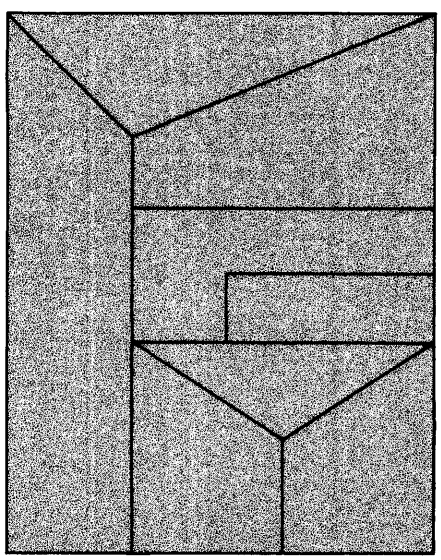

```
done:=FALSE; btm:=0; top:=
FOR loop:=1 TO top DO alpha[
WRITELN('Type uppercase char
READ(key); WRITELN;
WHILE NOT done DO
```

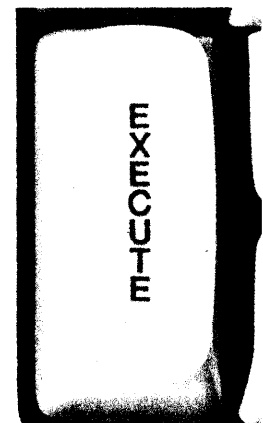
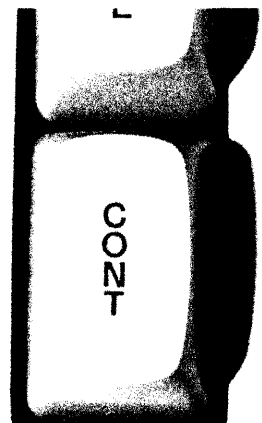
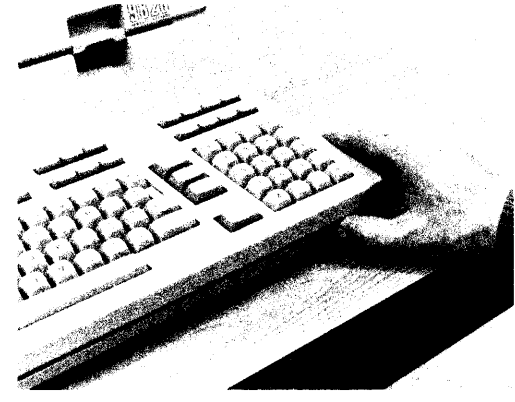

```
drive D:\;cat cat
for I=1 to 7;red "d
ent "Destination d
ent "Destination s
red "cat",A#;if le
end
```

BASIC 3.0 Programming Techniques

for the HP 9000 Series 200 Computers

Manual Part No. 98613-90010

© Copyright 1984, 1985 Hewlett-Packard Company.

This document contains proprietary information which is protected by copyright. All rights are reserved. No part of this document may be photocopied, reproduced or translated to another language without the prior written consent of Hewlett-Packard Company. The information contained in this document is subject to change without notice.

Restricted Rights Legend

Use, duplication, or disclosure by the Government is subject to restrictions as set forth in paragraph (b)(3)(B) of the Rights in Technical Data and Software clause in DAR 7-104.9(a).

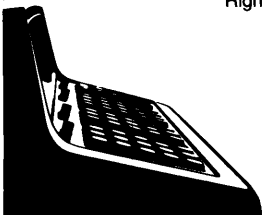

Hewlett-Packard Company
3404 East Harmony Road, Fort Collins, Colorado 80525

Printing History

New editions of this manual will incorporate all material updated since the previous edition. Update packages may be issued between editions and contain replacement and additional pages to be merged into the manual by the user. Each updated page will be indicated by a revision date at the bottom of the page. A vertical bar in the margin indicates the changes on each page. Note that pages which are rearranged due to changes on a previous page are not considered revised.

The manual printing date and part number indicate its current edition. The printing date changes when a new edition is printed. (Minor corrections and updates which are incorporated at reprint do not cause the date to change.) The manual part number changes when extensive technical changes are incorporated.

May 1984...First Edition

November 1984 Update

January 1985...First Edition with update merged.

Warranty Statement

Hewlett-Packard products are warranted against defects in materials and workmanship. For Hewlett-Packard computer system products sold in the U.S.A. and Canada, this warranty applies for ninety (90) days from the date of shipment.* Hewlett-Packard will, at its option, repair or replace equipment which proves to be defective during the warranty period. This warranty includes labor, parts, and surface travel costs, if any. Equipment returned to Hewlett-Packard for repair must be shipped freight prepaid. Repairs necessitated by misuse of the equipment, or by hardware, software, or interfacing not provided by Hewlett-Packard are not covered by this warranty.

HP warrants that its software and firmware designated by HP for use with a CPU will execute its programming instructions when properly installed on that CPU. HP does not warrant that the operation of the CPU, software, or firmware will be uninterrupted or error free.

NO OTHER WARRANTY IS EXPRESSED OR IMPLIED, INCLUDING BUT NOT LIMITED TO, THE IMPLIED WARRANTY OF MERCHANTABILITY AND FITNESS FOR A PARTICULAR PURPOSE. HEWLETT-PACKARD SHALL NOT BE LIABLE FOR CONSEQUENTIAL DAMAGES.

HP 9000 Series 200

For the HP 9000 Series 200 family, the following special requirements apply. The Model 216 computer comes with a 90-day, Return-to-HP warranty during which time HP will repair your Model 216, however, the computer must be shipped to an HP Repair Center.

All other Series 200 computers come with a 90-Day On-Site warranty during which time HP will travel to your site and repair any defects. The following minimum configuration of equipment is necessary to run the appropriate HP diagnostic programs: 1) 1/2 Mbyte RAM; 2) HP-compatible 3 1/2" or 5 1/4" disc drive for loading system functional tests, or a system install device for HP-UX installations; 3) system console consisting of a keyboard and video display to allow interaction with the CPU and to report the results of the diagnostics.

To order or to obtain additional information on HP support services and service contracts, call the HP Support Services Tele-marketing Center at (800) 835-4747 or your local HP Sales and Support office.

* If in other countries, contact your local Sales and Support Office to determine warranty terms.

Table of Contents

Chapter 1: Manual Organization

Welcome.....	1
What's in This Manual.....	2

Chapter 2: Entering, Running, and Storing Programs

Introduction.....	5
Some BASIC Vocabulary.....	5
What Is a Program?.....	5
What Is a Command?.....	6
Enter or Execute.....	6
Using EDIT Mode.....	7
Getting Into EDIT Mode.....	7
Editing the Current Line.....	8
Entering Program Lines.....	8
Inserting Lines.....	9
Deleting and Recalling Lines.....	10
Renumbering a Program.....	10
Listing a Program.....	11
Using Comments.....	11
Getting Out of EDIT Mode.....	14
Running a Program.....	15
Prerun.....	15
Normal Program Execution.....	15
Non-Executed Statements.....	16
Live Keyboard.....	16
Wholesale Program Editing.....	20
Moving Program Segments.....	20
Copying Program Segments.....	21
Search and Replace Operations.....	21
Using Subprogram Libraries.....	23
Indenting.....	23
Cross-references.....	26
Program Storage and Retrieval.....	27
Find a Usable Volume.....	27
Recording a Program.....	28
Retrieving a Program.....	30
Autostart of a PROG File.....	35
System Configuration.....	37
Loading BINs.....	37
Storing the System.....	37
Scratching BINs.....	37
Other Mass Storage Operations.....	38

Softkeys	39
Default Softkey Definitions	39
Defining Softkeys	39
Softkey Definitions	41
Listing Softkey Definitions	41
Softkey Files	41
Defining Softkeys Programmatically	42
Clearing the Computer	43
Chapter 3: Program Structure and Flow	
Introduction	45
The Program Counter	45
Sequence	46
Linear Flow	46
Halting Program Execution	46
Simple Branching	48
Selection	51
Conditional Execution of One Segment	51
Choosing One of Two Segments	54
Choosing One of Many Segments	56
Repetition	59
Fixed Number of Iterations	59
Conditional Number of Iterations	61
Arbitrary Exit Points	63
Event-Initiated Branching	66
Enabling Events	66
Using the Knob	68
Deactivating Events	69
Disabling Events	71
Chapter 4: Numeric Computation	
Introduction	73
Numeric Data Types	73
Internal Numeric Formats	75
Evaluating Scalar Expressions	77
The Hierarchy	77
Operators	79
Resident Numerical Functions	82
Array Operations	85
Dimensioning an Array	85
Finding Out the Dimensions of an Array	91
Filling an Array	92
Extracting Values From Arrays	94
Redimensioning Arrays	95
Arrays and Arithmetic Operators	96
Boolean Arrays	98
Reordering Arrays	99
Sorting Arrays	100

Matrices and Vectors	103
Solving Simultaneous Equations	108
Singular Matrices	110
The Determinant of a Matrix	111
Ill-Conditioned Matrices	112
Using Arrays for Code Conversion	116

Chapter 5: String Manipulation

Introduction	119
String Storage	120
String Arrays	120
Evaluating Expressions Containing Strings	121
Evaluation Hierarchy	121
String Concatenation	121
Relational Operations	121
Substrings	122
Single-Subscript Substrings	122
Double-Subscript Substrings	123
Special Considerations	123
String-Related Functions	125
String Length	125
Substring Position	125
String-to-Numeric Conversion	126
Numeric-to-String Conversion	127
CRT Character Set	128
String Functions	129
String Reverse	129
String Repeat	129
Trimming a String	129
Case Conversion	130
Searching and Sorting	131
MAT Functions and String Arrays	132
Reordering an Array	135
Searching for Strings	136
Number-Base Conversion	138
Introduction to Lexical Order	139
Why Lexical Order?	139
How it Works	139
The ASCII Character Set	140
The Extended Character Set	143
Predefined Lexical Order	145
Lexical Tables	146
Notation	146
ASCII Lexical Order	146
FRENCH Lexical Order	148
GERMAN Lexical Order	150
SPANISH Lexical Order	152
SWEDISH Lexical Order	154
User-defined LEXICAL ORDER	156

User-Defined Lexical Orders	158
Sequence Numbers	159
Mode Entries	159
Bits, Bytes, and Mode Types	160

Chapter 6: User-Defined Functions and Subprograms

Introduction	165
Some Startup Details	166
Location	166
Naming	166
For Example	166
The Difference Between a Function and a Subprogram	167
REAL Precision Functions and String Functions	168
Calling and Executing a Subprogram	169
Communication	170
Context Switching	176
Live Keyboard	178
Speed Considerations	178
Using Subprogram Libraries	180
Loading Subprograms One at a Time	180
Loading Several Subprograms at Once	180
Loading Subprograms Prior to Execution	180
Deleting Subprograms Programmatically	181
Editing Subprograms	182
SUBEND and FNEND	183
Recursion	184
Top-Down Design	185
The Problem	185
A Data Structure	185

Chapter 7: Data Storage and Retrieval

Storing Data in Programs	194
Storing Data in Variables	194
Data Input by the User	194
Using DATA and READ Statements	194
Mass Storage Tutorial	198
What is Mass Storage?	198
The Structure of Model 226/236 Discs	198
The Structure of Data Files	203
Mass Storage Techniques	208
Initializing a Disc	208
Disc Labels	209
Overview of Mass Storage Access	210
Media Specifiers	211
Internal Disc Drives	214
External Devices Available	214
Non-Disc Mass Storage	220
Accessing Files	222

Reading and Writing BDAT Files	225
System Sector	225
Defining Records	225
Choosing A Record Length	226
EOF Pointers	228
Writing Data	229
Serial OUTPUT	229
Random OUTPUT	234
Reading Data From BDAT Files	237
Single-Byte Access	239
General Mass Storage Operations	240
Trapping EOF and EOR Conditions	240
Protecting Files	242
Securing Program Lines	243
Copying Files and Volumes	244
Purging Files	245
Accessing Directories	246
Extended Access of Directories	247
Chapter 8: Using a Printer	
Introduction	253
Fundamentals	253
Device Selectors	254
Primary Addresses	254
Using Device Selectors	256
Using the External Printer	257
Control Characters	257
Escape-Code Sequences	258
Formatted Printing	259
Using Images	260
Special Considerations	264
Chapter 9: The Real-Time Clock	
Introduction	266
Clock Time	266
Setting the Time	268
Setting the Date	270
Using the Routines	272
Day of the Week	273
Days Between Two Dates	273
Interval Timing	274
Accuracy	275
Powerfail Protection	275
Branching on Clock Events	276
Cycles and Delays	276
Time of Day	277
Priority Restrictions	277
Branching Restrictions	279

Chapter 10: Communicating with the Operator

Introduction	281
Displaying and Prompting	282
Determining Screen Width	282
Clearing the CRT	282
An Expanded Softkey Menu	285
Moving a Pointer	289
Accepting Keyboard Input	292
Get Past the First Trap	292
Entering a Single Item	293
LINPUT with Multiple Fields	296
Yes and No Questions	297
Custom Interfaces	298

Chapter 11: Error Handling

Introduction	299
Anticipating Operator Errors	300
Boundry Conditions	300
REAL Numbers and Comparisons	301
Error Trapping	302
ON/OFF ERROR	302
ERRN/ERRL/ERRM\$	302

Chapter 12: Program Debugging

Introduction	307
Using Live Keyboard	308
Stepping	310
Tracing	311
TRACE ALL	311
PRINTALL IS	313
TRACE PAUSE	313
TRACE OFF	313
The CLR I/O Key	314

Chapter 13: Efficient Use of the Computer's Resources

Introduction	315
Data Storage	315
Data Storage in Read/Write Memory	315
Data Storage on Mass Memory Devices	316
Comments and Multicharacter Identifiers	317
Variable and Array Initialization	317
Mass Memory Performance	318
Program Files	318
Data Files	318
Benchmarking Techniques	319

INTEGER Variables	321
Minimum and Maximum Values	321
Mathematical Operations	321
Loops	322
Array Indexing	323
REAL Numbers	324
Minimum and Maximum Values	324
Type Conversions	324
Constants	325
Polynomial Evaluations	325
Logical Comparisons for Equality on REAL Numbers	326
Saving Time	327
Multiply vs. Add	327
Exponentiation vs. Multiply and SQR	327
Array Fetches vs. Simple Variables	327
Concatenation vs. Substring Placement	327
Saving Memory	329
Chapter 14: Graphics	
Introduction	331
Graphics Fundamentals	332
The First Step	332
Pencil and Paper	332
Graphic Display Units	336
Labeling the Image	337
Setting the Limits	338
User-Defined Units	340
Saving an Image	441
External Output Devices	342
Initialization	342
Graphics with Printers	344
Graphics Using HPGL	345
Graphics Using Files	346
Using the Color Output Interface	347
Color Graphics Techniques	347
Interactive Graphics	353
Compatible Devices	354
Setting Up a Session	354
Interactive Graphics Techniques	355
Example Graphics Programs	360
Chapter 15: Transporting Programs	
Configuring BASIC	380
Helpful Documentation	380
Missing Language Extensions BIN Files	380
Missing Driver BIN Files	381
Statement Changes	381
CSUBs	381

PHYREC 382

Knob 382.01

 The KNOBX Function 382.01

 Keyboards with Built-in Knob 382.02

 HP-HIL Keyboards with Mouse 382.03

 Programming for Both Versions and Keyboards 382.03

 KNB2_0 382.04

Graphics 382.05

 Default Plotter 382.05

 Implicit GCLEAR 382.05

 Input Device Viewport 382.05

 Graphics Tablet DIGITIZE 382.05

 The VIEWPORT Statement 382.06

 The PIVOT Statement 382.09

Display Functions 382.13

Prerun On LOADSUB 382.14

Special Case of I/O Transfers 382.14

Appendix

Error Messages 383

Second Byte of Non-ASCII Key Codes 394

US ASCII Character Codes 395

Subject Index 397

Manual Organization

Chapter

1

Welcome

This manual is intended to introduce you to the Series 200 computer's BASIC programming language and to provide some helpful hints on getting the most utility from it. Although this manual assumes that you have had some previous programming experience, you need not have a high skill level, nor does your previous experience need to be in BASIC. If you have never programmed a computer before, it will probably be more comfortable for you to start with one of the many beginner's text books available from various publishing companies. However, some beginners may find that they are able to start in this manual by concentrating on the fundamentals presented in the first few chapters. If you are a programming expert or are already familiar with the BASIC language of other HP desktop computers, you may start faster by going directly to the *BASIC Language Reference* manual and checking the keywords you normally use. You can always come back to this manual when you have extra time to explore the computer's capabilities, or if you bump into an unfamiliar concept.

Durability is a built-in feature of this easy-to-operate computer, so don't be afraid to test it. After reading each section and trying the examples shown, try your own examples. Experiment. You cannot damage the computer by pressing the wrong keys. The worst that can happen is an error message will appear. These messages help you learn its language and needs by communicating with you. All error codes are listed at the back of this manual.

What's In This Manual?

No matter what your skill level, it is helpful to understand the contents and organization of this manual. First of all, there are some things that it is **not**. Because it is organized by topics and concepts, it is not a good place to find an individual keyword in a hurry. Keywords can be found using the index, but even so, they are often imbedded in discussions, contained in more than one place, or only partially explained. Also, this is not a good place to find complete syntactical details. Program statements are often presented only in the form that applies to the specific concept being discussed, even though there may be other forms of the statement that accomplish different purposes. If you want to quickly find the complete formal syntax of a keyword, use the *BASIC Language Reference*. It is specifically intended for that purpose.

This manual contains explanations and programming hints organized topically. A program performs various “sub-tasks” as it completes its overall job. Many of these tasks can, or should be, viewed separately to be understood more easily and used more effectively. For example, perhaps you have experience in another programming language. You know exactly what a “loop” does, but you didn’t find the statement you were looking for in the *BASIC Language Reference*. In the chapter on “Program Flow”, there is a section called “Repetition” which explains the kinds of loops available and all the statements needed to create them. The following is an overview of the chapters in this manual.

Chapter 1: Manual Organization

Chapter 2: Entering, Running, and Storing Programs

This chapter explains the mechanics of the programming process. It discusses ways to type in a program, modify it, run it, print it, make it more readable, and save it on a disc so you can continue improving it tomorrow.

Chapter 3: Program Structure and Flow

This chapter tells how the computer finds its way around your program and offers ideas on getting it to follow the proper path efficiently.

Chapter 4: Numeric Computation

This chapter covers mathematical operations and the use of numeric variables. It includes discussions on types of variables, expression evaluation, arrays, and methods of managing data memory.

Chapter 5: String Manipulation

Although string data can be used for any purpose the programmer desires, it is most often used for the processing of characters, words, and text. Since words are more pleasant than numbers to humans, skillful use of strings can make the input and output of programs much more natural to those using the programs. This chapter explains the programming tools available for processing string data.

Chapter 6: User-Defined Functions and Subprograms

An outstanding feature of this language is its ability to change program contexts and the speed with which it can do so. Alternate contexts (or environments) are available as user-defined functions or subprograms. These are discussed in this chapter.

Chapter 7: Data Storage and Retrieval

This chapter shows many of the alternatives available for storing the data that is intended as program input or created as program output. Topics range from convenient ways to define constants to a discussion of the computer's unified mass storage system.

Chapter 8: Using a Printer

This chapter tells how to connect and use an external printer. Also covered are the formatting techniques (useful on both printer and CRT) to create organized, highly-readable printouts.

Chapter 9: Using the Real-Time Clock

An accurate real-time clock is available with timing resolution to the hundredth of a second and a range of years. Its capabilities are covered in this chapter.

Chapter 10: Communicating with the Operator

It is very frustrating for operator and programmer alike when the operator cannot figure out what is expected next, or the program crashes every time a wrong key is pressed. The chapter presents some programming techniques that help ease the interaction between the computer and a human operator.

Chapter 11: Error Handling

This chapter discusses techniques for intercepting (or trapping) errors that might occur while a program is running. Many errors can be dealt with easily by a programmer. Error trapping keeps the program running and provides valuable assistance to the computer operator.

Chapter 12: Program Debugging

We all wish that every program would run perfectly the first time and every time. Unfortunately, there is little evidence in real life to support that fantasy. The next best thing is to get the computer to do most of the debugging work for you. This chapter explains the powerful debugging features available on the computer.

Chapter 13: Efficient Use of the Computer's Resources

Which takes longer, calculating a square root or raising a number to the .5 power? Does a program run faster if the variable names are shorter? If you have a time-critical or memory-critical application, you will be interested in these answers and others provided in this chapter.

Chapter 14: Graphics

Another of the computer's significant features is its fast, precise graphics capability. Graphics is very useful for generating results in a human-compatible form. This chapter introduces the techniques of programming with graphics.

Chapter 15: Translating Programs

This chapter helps the user who is transporting programs from previous versions of BASIC. It discusses changes and enhancements.

4 Manual Organization

This is a manual of programming techniques, helpful hints, and explanations of capabilities. It is not a rigorous derivation of the BASIC language. Any statements appropriate to the topic being discussed are included in each chapter, whether they have been previously introduced or not. Since most users will not read this manual from cover to cover anyway, the approach chosen should not present any significant problems. In those cases when you have difficulty getting the meaning of certain items from context, consult the Index to find additional information.

Entering, Running, and Storing Programs

Chapter

2

Introduction

The first thing a programmer needs to know is how to get a program into the computer. If your background is punched cards and batch jobs, you will be delighted to discover how easy program writing is on Series 200 computers. If you have experience on other HP desktops, you should find the computer's programming procedures familiar, with some improvements. Whatever your starting point, it makes sense to learn the mechanics of program writing before you become absorbed in a study of all the available program statements.

Some BASIC Vocabulary

What Is a Program?

A **main program** is a list of program lines, with an END statement on the last line. A **program line** contains at least a line number followed by a statement¹. A **statement** is a keyword (sometimes optional) followed by any parameters, lists, specifiers, and secondary keywords that are allowed with that keyword and fit in the program line. The maximum length of a program line is 256 characters. When entering programs from the keyboard, the maximum length is reduced to two CRT lines. A **keyword** is a group of uppercase characters that is understood by the computer's language system to represent some predefined action.

The computer also allows subprograms to be appended to a main program. Subprograms are also lists of program lines, but they have special requirements for their first and last lines. Subprograms are a useful programming tool, but the computer is capable of running just fine without them. Therefore, most of the concepts in this manual are presented using examples in a main program context. Subprograms are covered in depth in "User-Defined Functions and Subprograms" Chapter.

¹ A line number may be optionally followed by a line label. A line label is a name that is placed after the line number and is terminated by a colon. Chapter 3 tells more about labels.

What Is a Command?

This manual makes frequent reference to “statements” and “commands”. As previously mentioned, a **statement** is a keyword followed by any other elements that are appropriate for that keyword. If a statement is placed after a line number and entered, it becomes a program line. If a statement is typed without a line number and executed, it is called a **command**. There are some commands that cannot be stored as program lines, such as those using DEL and SCRATCH. There are also statements that can’t be executed as commands, such as those using DIM and RETURN. However, many statements are both programmable and executable, such as those using PRINT and CALL.

When a keyword is described, the most descriptive term (statement, command, or function) is used and any restrictions are noted in the text. Since these terms are not necessarily mutually exclusive, read more than just the one term to determine the legal uses of a keyword. For example, the use of the term “statement” does not imply that a certain keyword is not keyboard executable; but the phrase “cannot be executed as a command” clearly indicates that a keyword can only be used in a program line.

Enter or Execute

Entering a program line means that you type a line number followed by a valid statement and then press one of these keys: **RETURN**, **ENTER**, **EXECUTE** or **EXEC**. The line is stored in memory as part of a program. The line performs no function until you run the program.

Executing a command means that you type a statement (no line number) and press one of the keys listed above. The command is executed immediately. It is not stored in a program.

Depending on the keyboard, you have at least one of the keys listed. In most cases it does not matter which key you use. (In some Edit modes such as FIND there is a difference between **ENTER** and **EXECUTE**.)

KEYS

Throughout the BASIC manuals you will see a word, letter or symbol enclosed in a box. This indicates an actual key on the keyboard, or a function key shown on the menu on the display.

There are several different keyboards for the Series 200 computers. Each keyboard has slightly different key labels. (The BASIC User’s Guide describes all keyboards in detail.) Within this manual the keys are listed once the first time they are used in a topic. Thereafter, only one of the keys is used. If you have any confusion over which key to use, refer to the BASIC User’s Guide which includes a table of keys.

Using EDIT Mode

It is possible to enter a program by typing entire program lines (line number and statement) on the normal input line of the CRT and pressing the **ENTER** or **RETURN** key. There are some disadvantages to this method. First, it forces you to type in the line number (which means you have to remember what line number needs to be supplied). Second, the program lines disappear after they are entered, so it is difficult to keep track of where you are in the program and what the lines above are doing. Third, there is no way to review the program except the LIST command. Listing to a printer gives a readable copy of the program, but is slow and paper-consuming during program development. A program listed to the CRT goes by so fast that you won't be able to read anything but the end. Listing program portions to the CRT requires you to remember the line numbers of every segment you want to see. The solution to all these problems is the EDIT mode.

Getting Into EDIT Mode

To get into EDIT mode, either press the **EDIT** key or type the word EDIT, then press **RETURN** or **EXECUTE**. As a result, the format of the CRT display is transformed as shown in the following diagram.

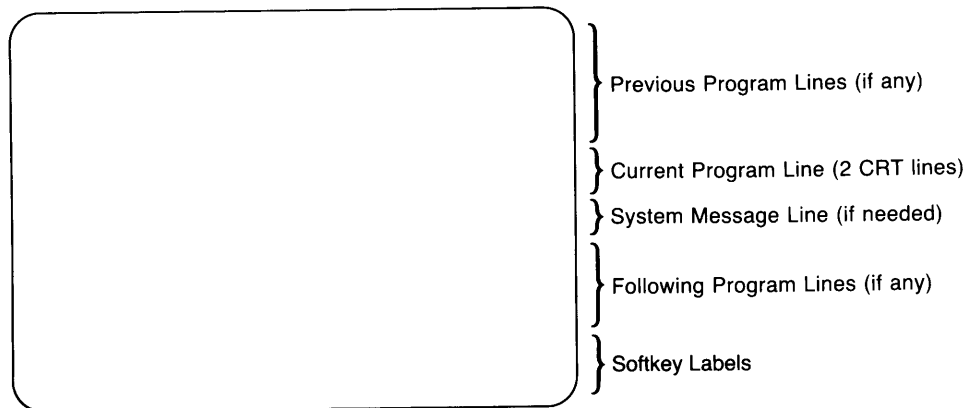

In this mode, you can view several lines before and after the line you are editing. The system supplies the line number for the current line and program portions can be viewed by simple scrolling.

The EDIT command allows two parameters. The first is a line identifier and the second is the increment between line numbers. For example:

```
EDIT 140,20
```

This command tells the computer to place the program on the CRT so that line 140 is in the current-line position. Also, any lines that are added to the program get a line number 20 greater than the previous line.

8 Entering, Running, and Storage Programs

If the increment parameter is not specified, the computer assumes a value of 10. For example:

```
EDIT 1000
```

This command tells the computer to place the program on the CRT so that line 1000 is in the current-line position, and added lines get a line number 10 greater than the previous line.

When the line identifier is not supplied, the computer has some interesting ways of assuming a line number. If this is the first EDIT after a power-up, SCRATCH, SCRATCH A, SCRATCH BIN or LOAD, the assumed line number is 10. If EDIT is performed immediately after a program has paused because of an error, the number of the line that generated the error is assumed. At any other time, EDIT assumes the number of the line that was being edited the last time you were in EDIT mode.

The line identifier also can be a line label. This makes it very easy to find a specific program segment without needing to remember its line number. For example, assume that you want to edit a sorting routine that begins with a line labeled "Go_sort". Simply execute:

```
EDIT GO_SORT
```

The line labeled "Go_sort" is placed in the current-line position and the next several lines of the routine are displayed below it.

The EDIT command is not programmable and cannot be used while a program is running.

Editing the Current Line

The BASIC User's Guide explains the keyboards and its use for typing and editing on the input line. All of these normal editing features are available in EDIT mode, plus some additional actions specific to programming. The extra EDIT mode features are explained in subsequent sections.

Entering Program Lines

Program lines are entered by typing them after the line number and pressing **ENTER**, **RETURN** or **EXECUTE**. Before storing the line, the computer checks for syntax errors and converts letter case to the required form for names and keywords.

Although the computer supplies a line number automatically, you are not forced to use that number if you don't want to. To change the line number, simply back up the cursor and type in the line number you want to use. This can be done to existing lines as a way of copying them to another part of the program. When you change a line number, the program is moved on the CRT so that the line just stored is one line above the current-line position. In other words, when you move a line to a new location, the new location is displayed.

Here are some points to keep in mind when changing the line numbers supplied by the computer. Changing the line number of an existing line causes a copy operation, not a move. The line still exists in its original location. Existing lines are replaced by any line entered with their same line number. Be careful that you don't accidentally replace a line because of a typing mistake in the line number.

Syntax Checking

Syntax is a term used to describe the elements that compose a line and their order. Immediate syntax checking is one big advantage of writing programs in HP BASIC instead of turning in a batch of punched cards. A great many programming errors can be detected at program entry time, which increases the chances of having a program run properly and cuts down debugging time. If the syntax of the line is proper, the line is stored, and the next line number appears in front of the cursor.

If the system detects an error in the input line, it displays an error message immediately below the line and places the cursor at the location it blames for the error. Keep in mind that there is an endless variety of human mistakes that might occur and the computer is acting on erroneous input. As a result, you might not always agree with its diagnosis of the exact error or the error's location. However, an error message is proof that something needs to be fixed. There is a complete list of error messages and their meanings in the last chapter of this manual.

Uppercase or Lowercase?

Program entry is simplified by the computer's ability to recognize the uppercase and lowercase requirements for most elements in a statement. An entire statement can be typed using all uppercase or all lowercase letters. If the statement's syntax is otherwise correct and there are no keyword conflicts, the computer places all keywords in uppercase and all variable names in lowercase with an uppercase first letter. In other words, you don't usually have to bother with the **SHIFT** key when you enter a line, because the computer knows what the line is supposed to look like. If there is a keyword conflict, an error occurs. A keyword conflict occurs when the letters of a keyword are used as an identifier (variable name, line label, or subprogram name). When this happens, simply change the case of at least one letter in the identifier name and enter the line again. A word containing a mixture of uppercase and lowercase letters is assumed to be an identifier.

The computer's assumptions about the appearance of a line won't cause any problems if your line has the proper syntax. However, if you are guessing at a keyword or syntax, don't assume that you got the line right just because the computer stored it. Take a close look at what was stored. If the computer put lowercase letters in something that you thought was a keyword, then it wasn't really a keyword. That misspelled "keyword" was perceived as a subprogram call or a variable name by the computer.

Inserting Lines

Lines can be easily inserted into a program. As an example, assume that you want to insert some lines between line 90 and line 100 in your program. Place line 100 in the current-line position and press the insert line key. The program display "opens" and a new line number appears between line 90 and line 100. Type and store the inserted lines in the normal manner. Appropriate line numbers will appear automatically. The insert mode can be cancelled by pressing the insert line key again or by performing an operation that causes a new current line to appear (such as scrolling).

While inserting lines, the computer maintains the established interval between line numbers, if possible. If the interval between lines in the preceding example was 5, the first line number appearing would be 95. When the normal interval between lines can no longer be maintained, an interval of 1 is used. Thus, after line 95 is stored, the next line number supplied is 96. When there are no line numbers available between the current line and the next line, enough of the program below the current line is renumbered to allow the insert operation to continue. In the example, this would happen after line 99 is stored. The original line 100 is renumbered to 101 and the number 100 appears in the current line.

Deleting and Recalling Lines

Lines can be deleted one at a time or in blocks. The delete line key is used to delete the current line. If delete line is pressed by mistake, the line can be recovered by pressing **RECALL**, then **ENTER** or **RETURN**. The computer has a recall buffer that holds the last several lines entered, deleted, or executed.

The DEL command can also be used to delete lines. When the keyword DEL is followed by a single line identifier, only a single line is deleted. The line identifier can be a line number or a line label. A combination of an EDIT command and a press of the delete line key produces the same results, but has some advantages. There is a typing aid key to start the command, you can see the line before you delete it, and the delete line key saves the line in the recall buffer (the DEL command does not). Therefore, DEL is more useful for deleting blocks of lines.

Blocks of program lines can be deleted by using two line identifiers in the DEL command. The first number or label identifies the start of the block to be deleted, and the second number or label identifies the end of the block to be deleted. The line identifiers must appear in the same order they do in the program. Here are some examples.

DEL 100,200	Deletes lines 100 thru 200, inclusive.
DEL Block2,32766	Deletes all the lines from the one labeled "Block2" to the end of the program.
DEL 250,10	Does nothing except generate an error.

If you have subprograms or user-defined functions in your program, they can only be deleted in certain ways. Primarily, the SUB or DEF FN statement cannot be deleted without deleting the entire subprogram or function. This is explained fully in the "User-defined Functions and Subprograms" chapter. A CSUB line can be deleted, and doing so removes the entire subprogram.

The DEL command is not programmable and cannot be used while a program is running.

Renumbering a Program

After an editing session with many deletes and inserts, the appearance of your program can be improved by renumbering. This also helps make room for long inserts. Renumbering is done by the REN command. The starting line number, the interval between lines and the range can be specified. For example:

```
REN 100,5 IN 1,500
```

This command renumbers current lines 1 thru 500, using 100 for the first line number and an increment of 5. If the increment (second parameter) is not specified, 10 is assumed. If a range is not specified, the entire program is renumbered. For example:

```
REN 1000
```

This command renumbers the entire program, using 1000 for the first line number and an increment of 10. When no parameters are specified (REN), 10 is assumed for the first line number and the increment, and the entire program is renumbered.

Listing a Program

All or part of your program can be displayed or printed by executing a LIST statement. The LIST statement allows parameters that specify both the range of lines to be listed and the device to which the listing should be sent. If the keyword LIST is executed without any parameters, the assumed action is to list the entire program on the system printer. The default system printer after a power-on or SCRATCH A is the CRT. (The system printer is defined by the PRINTER IS statement.)

Starting and ending line numbers can be specified in the LIST statement. The line identifiers can be labels. For example:

LIST 100,200	Lists lines 100 thru 200, inclusive.
LIST 1850	Lists the last portion of the program, from line 1850 to the end.
LIST Rocket	Lists the program from the line labeled "Rocket" to the end.

Directing the listing to a device other than the CRT is easy, but involves concepts that have not been introduced yet. If you want a listing on an external printer and you don't understand the brief examples here, refer to the beginning of the "Using a Printer" chapter for an explanation of device selectors. One way to get a listing on an external printer is to specify a different system printer. This is done with the PRINTER IS statement described in the "Using a Printer" chapter. However, it is often desirable to keep the CRT as system printer and still get program listings on an external printer. This is done by specifying the printer in the LIST statement. For example:

```
LIST #701
```

This statement sends the entire program listing to an HP-IB printer (address 01) without changing the system printer selection. When both the printer and the line range are specified, the printer number is specified first and terminated with a semicolon. The following example lists lines 200 thru 500 on the device serviced by interface select code 12.

```
LIST #12;200,500
```

Using Comments

When first learning how to program, most people view the use of comments, long variable names, descriptive printouts, and other documentation tools as merely extra typing that isn't really necessary in their short programs. As time passes, old programs are expanded, new programs are written, and more people use the available software. Eventually, software support activities become necessary. Some obscure bug is found or some exciting enhancement is requested. The programmer picks up a copy of a program written a year ago and can't begin to remember what "X1" was or why you would ever want to divide it by "X2". Program documentation can make the difference between a supportable tool that adapts to the needs of the users and a support nightmare that never really does exactly what the current user wants. Keep in mind that the local software support person just might be you.

12 Entering, Running, and Storage Programs

The BASIC language on Series 200 computers makes it easy to write self-documenting programs. In addition to BASIC's standard REM (remark) capability, its primary documentation features are line labels, 15-character names, and end-of-line comments. Although this section deals primarily with commenting methods, all of these features work together to make a readable program. The following example shows two versions of the same program. The first version is uncommented and uses "traditional" BASIC variable names. The second version uses the features of HP's BASIC language to make the program more easily understood. Which version would you rather work with?

```
100 PRINTER IS 1
110 A=.03
120 B=.02
130 X=0
140 Y=0
150 C=A+B
160 PRINT "  Item          Total          Total"
170 PRINT "  Price          Tax          Cost"
180 PRINT "-----"
190 P=0
200 INPUT "Input item price",P
210 IF P<0 THEN 290
220 D=P*C
230 E=P+D
240 X=X+D
250 Y=Y+E
260 DISP "Tax =" ;D;"Item cost =" ;E
270 PRINT P,X,Y
280 GOTO 190
290 END

100 ! This program computes the sales tax for
110 ! a list of prices. Item prices are input
120 ! individually. The tax and total cost for
130 ! each item are displayed. The running
140 ! totals for tax and cost are printed on
150 ! the CRT. Modify line 220 to change the
160 ! the system printer.
170 !
180 ! Sales tax rates are assigned on lines 230
190 ! and 240. The rates used in this version
200 ! of the program were in effect 1/1/81.
210 !
220 PRINTER IS 1          ! Use CRT for printout
230 State_tax=.03        ! Local tax rates
240 City_tax=.02
250 !
260 Total_tax=0          ! Initialize variables
270 Total_cost=0
280 Tax_rate=State_tax+City_tax
290 ! Print column headers
300 PRINT "  Item          Total          Total"
310 PRINT "  Price          Tax          Cost"
320 PRINT "-----"
330 !
340 Get_price:           ! Start of main loop
350 Price=0              ! Don't change totals if no entry
360 INPUT "Input item price",Price
370 IF Price<0 THEN Done ! Negative entry stops program
380 Tax=Price*Tax_rate
390 Item_cost=Price+Tax
400 Total_tax=Total_tax+Tax ! Accumulate totals
410 Total_cost=Total_cost+Item_cost
420 DISP "Tax =" ;Tax;" Item cost =" ;Item_cost
430 PRINT Price,Total_tax,Total_cost
440 GOTO Get_price       ! Repeat loop for next item
450 Done: END
```

There are two methods for including comments in your programs. The use of an exclamation point is demonstrated in the second example program. The exclamation point marks the boundary between an executable statement and comment text. There does not have to be an executable statement on a line containing a comment. Therefore, the exclamation point can be used to introduce a line of comments, to add comments to a statement, or simply to create a “blank” line to separate program segments. Exclamation points may be indented as necessary to help keep the comments neat.

The REM statement can also be used for comments. The exclamation point is neater and more flexible, but the REM statement provides compatibility with other BASIC languages. The REM keyword must be the first entry after the line identifier and must be followed by at least one blank. Here are some examples of proper and improper REM statements.

RIGHT	WRONG
10 REM Check Book Balance	20 REMinitialize array
40 Start2: REM Subtotal loop	50 X=PI*R^2 REM Area of circle

Each programmer has an individual style in the use of comments. Therefore, the following is not a list of rules. It is simply some suggestions on the effective use of comments.

- Include a heading on programs that tells the purpose of the program. Why was the program written, what does it do, and who would probably be using it?
- Give any helpful support information, such as the author of the program, the revision date, where to call or write for help, and instructions for any modifications that might be made by a normal user.
- Identify all significant variables, especially global variables. A descriptive variable name may do the job, or a more detailed explanation may be needed.
- Describe any input or output devices that are required for the proper running of the program. This may even include an explanation of how to modify the program to accommodate alternate devices (when such changes are reasonable).
- Make major blocks and entry points visible. Many tools are available for this, including descriptive labels, indenting, spacing, and comments describing program flow.
- Use comments freely to describe the action of complex lines, equations, fancy manipulations, and “low-level” operations like CONTROL statements and escape code sequences. These heavily coded operations can be very important to the computer and very mysterious to the human trying to read the program.

Getting Out of EDIT Mode

There are many ways to terminate the EDIT mode. Your choice depends upon what you want to do next. If you simply want to return the CRT to its “normal” mode (input line on the bottom and printout area above), press **PAUSE**, **CLR SCR** or **Clear display**. Either of these keys terminates EDIT mode and returns the screen to the normal format.

Another way to leave EDIT mode is to proceed with another operation. The key choices in this case are **RESET**, **RUN**, **STEP**, and **CONTINUE**. All of these keys terminate EDIT mode and perform their normal function. A detailed list of the items affected by **RESET** is contained in the “Useful Tables” chapter at the back of the *BASIC Language Reference*. The **RUN** key starts normal program execution. This is described in the “Running a Program” section of this chapter. The **STEP** key starts single-step program execution, as described in the “Program Debugging” chapter.

CONTINUE is not always a valid way to leave EDIT mode. If you paused a program and used EDIT mode only as a means of looking at various program segments, **CONTINUE** may be pressed to resume program execution. However, if any program lines are changed while in EDIT mode, the program moves from the paused state into the stopped state. In that case, CONTINUE is not a valid operation and results in an error. This is covered in the next section, “Running a Program”

EDIT mode is also terminated by a GET or LOAD operation or by an operation that uses the CRT (for example: CAT).

Running a Program

The normal running of a program is started by the **RUN** key or the RUN command. Pressing the **RUN** key is equivalent to typing RUN and pressing **EXECUTE**, **ENTER** or **RETURN**. This tells the computer to go through a **prerun** phase and then begin normal program execution with the lowest numbered line in the main program. The RUN command can also be followed by a line identifier that lets you specify where the program execution is to begin.

Prerun

There are three primary reasons for the prerun. The first purpose is to reserve sufficient memory for all the variables in the program (except those that are ALLOCATED). This includes all variables in COM statements, those declared in DIM, REAL, and INTEGER statements, and all implicitly declared variables. The “Number Computation” chapter explains the declaration of numeric variables, and the “String Manipulation” chapter covers the dimensioning of string variables.

The second purpose is to locate all the context boundaries. These are defined by the END, SUB, SUBEND, DEF FN, and FNEND statements.

The third purpose of the prerun is to detect errors that involve interaction between lines. The previous section explained that the computer checks for syntax errors before it stores a program line. Although this is true, there are some errors that can't be detected by looking at a single line. For example, a program line that uses properly placed subscripts can appear to be correct when it is stored. However, if that line references three dimensions in an array that had previously been declared to have only two dimensions, it is in error. To detect an error of that kind, the computer needs to “look at” the entire program to see all the dimension statements as well as the variables used in each line. Some other examples of this kind of error are specifying a ON...GOTO to a line that does not exist or improper matching of statements like FOR...NEXT and IF...END IF.

Normal Program Execution

Program execution is not a method for destroying programs (although there are some reported cases of programmers having an urge to kill). The term **execution** is used to describe the process used by the computer while it is completing the tasks described in its program. The process of program execution is summarized below.

1. Determine which program line is to be acted on next.
2. Identify the statement that follows the line number and label (if any) on that line.
3. If the statement has a run-time action, perform the action described in the statement.
4. Repeat steps 1 thru 4 until an END, STOP, or PAUSE statement is executed.

The continuing process of determining which line is to be executed next is discussed in detail in the next chapter, “Program Structure and Flow”. The RUN command determines which line is acted on first. Executing RUN with no parameters, or pressing the **RUN** key, causes the execution process to begin at the first (lowest-numbered) line of the main program. Execution can be started anywhere in the main program by using the RUN command with a line identifier. For example:

```
RUN 220
```

This command causes execution to begin at line 220, if there is such a line. If there is no line 220 in the main program, execution begins with the line whose number is closest to and greater than 220. The line identifier can also be a label. For example:

```
RUN SPOT_RUN
```

This command causes execution to begin with the line labeled “Spot_run”. If there is no such label, an error results.

Note that the prerun phase is always the same, whether the actual execution begins at the program start or somewhere in the middle. Also, if a starting line is specified, that line must be in the main program. An error 3 results if you attempt to start a program in a user-defined function or subprogram. Even if the starting point is correctly specified, be alert to the effects of starting a program in the middle. Skipping over a section of the program may result in null values for some of the variables. Although it is legal to start in the middle of a subroutine, an error is generated when the RETURN statement is executed.

Non-Executed Statements

In the preceding summary of normal execution, step 3 mentioned that only statements with run-time actions are executed. The term **run-time** refers to the state that exists after the prerun, when the computer is actually performing the actions described in the program. Some statements are not executed in the course of normal program flow, but are merely “looked at” and then bypassed. The following is a list of some statements that do not cause an action as a result of run-time execution.

- Comments and REM statements. These never cause an action.
- Variable declarations; COM, DIM, REAL, and INTEGER. These are executed during prerun and skipped over at run-time. The OPTION BASE statement is part of the declaring process.
- DATA statements. These are accessed by the READ statement, not executed.
- SUB and DEF FN statements. These are used during prerun to establish the program structure and are skipped over at run-time.
- Structuring statements, such as LOOP, END LOOP, ELSE, END IF, etc. These are matched and checked for proper nesting at prerun.

Live Keyboard

When a program is running, the keyboard is still active. Commands can be executed, variables can be inspected and changed, and the state of the computer can be changed. The term **live keyboard** is used when talking about commands that are executed during a running program. One of the principal uses for live keyboard commands is the troubleshooting and debugging of programs in the development stage. This application is covered in the “Program Debugging” chapter. The discussions presented here are intended to demonstrate the various machine states (running, paused, and stopped).

Pausing and Stopping

If the operator does not intervene, a program will run until it reaches an END, STOP, or PAUSE statement, or until it pauses to input some data or report an error. If you wish to pause or stop a program before its normal completion, the **PAUSE**, **STOP**, or **RESET** keys can be used. Here is a summary of the action of these keys. (**CLR I/O** has an action very similar to **PAUSE** if the computer is executing an I/O statement.)

- **RESET** — This stops the program immediately, aborting any I/O operations and resetting any interface cards. **RESET** does not affect the printout area of the CRT, program or variable memory, tabs, or the recall buffer. CONTINUE is not allowed after a RESET.
- **STOP** — This stops the program after the computer finishes executing the current line. STOP does not affect the interfaces, the CRT, program memory, the values of variables, tabs, or the recall buffer. STOP returns the program to the main context. CONTINUE is not allowed after a STOP.
- **PAUSE** — This pauses program execution after the computer finishes the current line and any I/O operations in progress. PAUSE leaves all necessary internal information intact, so that program execution can be resumed again with the **CONTINUE** key. Pressing **CONTINUE** after a PAUSE causes program execution to resume in a normal manner from the place where it was paused.
- **CLR I/O** — This aborts any I/O statement in progress and pauses the program. The program counter is returned to the beginning of the aborted I/O statement, so that CONTINUE causes the program to resume with that same statement. This is useful when the computer is “hung” trying to output to a device that is down, or for pausing a program that is executing an INPUT statement.

On an HP 46020A keyboard, STOP is **SHIFT STOP**, PAUSE is **STOP**, CLR I/O is **BREAK**.

The current state of the computer is indicated in the lower right-hand corner of the CRT. The character in this corner is referred to as the “run light”. The following table shows the various indications of the run light and their meaning.

Indicator	Computer State
(blank)	Program stopped; CONTINUE not allowed
⊗	Program running
-	Program paused; may be continued
I O	Program paused, but a TRANSFER is still active
?	Computer is waiting for an input from the keyboard
*	Computer is executing a command from the keyboard

For Example

To demonstrate some of the interaction between a program and the keyboard, enter the following simple program.

```

10 DISP "NEXT COMMAND?"
20 X=0
30 PRINT X;
40 X=X+1
50 WAIT .1
60 GOTO 30
70 END

```

1. After you have entered the program, press **RUN** and observe the CRT. Notice that the DISP message appears in the display line, the printout area fills with a sequence of numbers, and the run light indicates that a program is running.
2. Press **PAUSE**. The printout of numbers stops, and all the data on the CRT remains unchanged. The run light now indicates that the program is paused and can be continued. The program line that appears at the bottom of the CRT is the next line that will be executed when program execution resumes.
3. Press **STEP** a number of times. The program is executed one line at a time, as indicated by the lines changing at the bottom of the CRT. Notice that the program is still paused and continuable after each press of the **STEP** key. The **STEP** key can be a great help when you are trying to find certain kinds of problems. Chapter 12 “Program Debugging” gives the details of this and other debugging tools.
4. Press **CONTINUE**. The printout on the CRT resumes with the next number in the sequence. The run light again indicates that a program is running.
5. Press **STOP**. The printout of numbers stops, and all the data on the CRT remains unchanged. However, the run light is off, indicating a stopped condition.
6. Press **CONTINUE**. An error results. A stopped program cannot be continued.
7. Press **RUN**. The program runs again, but the number sequence has restarted from the beginning, not from the next number in the sequence. RUN causes the program to restart, not resume.
8. Type `X=1` and press **EXECUTE** or **RETURN**. Notice that the numbers being printed start over with “1”. The live keyboard was used to change the value of “X”, and the program used the new value from the keyboard.
9. Press **RESET**. The program stops and the data remains in the printout area, but the display line is cleared and the message `BASIC Reset` appears at the bottom of the CRT. Although the clearing of the display line seems like a minor effect, it indicates an important point. **RESET** and **STOP** have different effects on interfaces and peripheral devices. This aspect of **RESET** is summarized in the RESET Tables in the back of the *BASIC Language Reference* and is discussed fully in the *BASIC Interfacing Techniques* manual.
10. Press **RUN**, then type `WAIT 5` and press `execute`. Notice that the run light changes to indicate that a keyboard command is being executed and the printout is delayed for five seconds while the live keyboard command is processed. Actually, the run light changed when the `X=1` command was executed in step 8, but it happened so fast that you didn’t see it.

11. Press **PAUSE**, then type `EDIT` and press **EXECUTE** or **RETURN**. The display on the CRT changes to show the program. The line you were editing last appears in the current-line position. Notice that the run light is still visible in the lower right-hand corner and it indicates that the program is paused.
12. Press **CONTINUE**. The CRT returns to normal mode, and the printout of numbers continues in sequence. However, the previous data on the display was lost when the CRT was used for EDIT mode.
13. Press **PAUSE**, then type `EDIT 50` and press **EXECUTE** or **RETURN**. The CRT changes to EDIT mode, and the program appears again. This time, line 50 is in the current-line position. Notice that the run light indicates that the program is paused. Change line 50 to `WAIT .2` and press **ENTER** or **RETURN**. The new line 50 is entered, but the run light goes out. Changing the program caused it to move from the paused state to the stopped state.
14. Press **CONTINUE**. An error results. As mentioned earlier, a program can be viewed while it is paused, but it cannot be changed. Once any program line has been changed, the program is no longer paused, and CONTINUE is not allowed.

This simple demonstration covers most of the highlights of live keyboard, program states, and the run light. The “waiting for input” indication can be seen when using the `INPUT` and `LINPUT` statements described in Chapter 10, “Communicating with the Operator”. The “paused with TRANSFER completing” indication is not described in this manual. It is a special state that results from the use of overlapped I/O and is discussed in the *BASIC Interfacing Techniques* manual.

Wholesale Program Editing

There are some commands which make it easy to do large amounts of program editing very quickly. Among these are commands to move blocks of text, copy blocks of text, replace occurrences of one string with another string, find occurrences of a string, cross-reference the program, selectively load and delete subprograms, and more. A detailed explanation of these commands follows. Some commands require the PDEV or XREF extensions.

Moving Program Segments

Often during program development, you enter a section of code that performs some function, thinking that this function will only be needed in that one place. Sure enough, a short time later you find that you need it here and here, too. It becomes obvious that the section of code would be much better as a subprogram. But how on earth do you move those thirty-five lines of code? You certainly don't want to retype the whole thing. The non-programmable MOVE LINES command is made for just this type of problem. What you need to do is:

1. Go to the end of the program (after *everything else*).
2. Enter the subprogram header (because you can't enter a SUB or DEF FN statement if there are other statements following it).
3. Move the text from its old position to a line number greater than the line number of the SUB or DEF FN statement you entered in Step 2.
4. Terminate the new subprogram with a SUBEND or FNEND.
5. Go back to the place where the code came from, and enter a line which invokes the new subprogram.

Another situation in which MOVE LINES is very useful is in a large program which is developed over a period of time. You eventually come to the point where it would be nice to have the logically-connected subprograms together in their respective areas of the program. A typical example follows.

Your program has these main functions:

- Load the data
- Edit the data
- Print a report
- Plot a graph
- Store the data

The Editing, Printing, and Plotting options may each have options of their own. You'd like the Load subprogram to be followed by all the Edit subprograms, followed by all the Printing subprograms, etc. The MOVE LINES command is a tremendous aid in doing this; however, there is one restriction: you cannot move a subprogram to a point where there would be lines of code after it. That is, you cannot move a subprogram to a line number which is less than or equal to the largest line number. Nevertheless, the same thing is accomplished *by moving other things to the end of the program*. Say you have subprograms A, C, D, and B in that order, and you want them in A, B, C, D order. You'd like to move subprogram B to a position between A and C. You can't do this. But you *can* do something else which amounts to the same thing: move *both* C and D to a point after B.

Note that when dealing with entire subprograms with either `MOVELINES` or `COPYLINES` (discussed next), any comments which occur after the `SUBEND` or `FNEND` must be moved/copied also.

This is a good way to insure that the many utility subprograms used by large programs can be found in an extensive listing: put them in alphabetical order.

Copying Program Segments

The non-programmable `COPYLINES` command is similar to the `MOVELINES` command, except it leaves the code in the old location also. This is desirable when you want a section of code that is very similar, but not identical to a section of code you already have. (If it were identical, you'd probably put it into a subprogram.) It is often easier to copy code and modify one version than to type two separate, only slightly different, versions. Here is an example of where `COPYLINES` is useful.

You are working in the Personnel department of your company, and you're writing a program which will need to be run on several Series 200 computers with standard keyboards. Both the Model 216 and the Model 236 have 80-column screens, whereas the Model 226 has a 50-column screen. This means that the softkey labels must have different lengths. On the Model 226, they are eight characters long, and on the Model 216 and Model 236, they are fourteen characters long. In the section of code you're writing you'd like the `ON KEY` labels to be as descriptive as possible; you want to use all fourteen characters if you have them.

```

100  IF PDS(SYSTEM$("CRT ID"),"50") THEN  ! 50-columns; short labels
110    ON KEY 1 LABEL "VAC SCHD" CALL Vacation_sched
120    ON KEY 2 LABEL "SICK LV"  CALL Sick_leave
130    ON KEY 3 LABEL "PAYROLL" CALL Payroll
140    ON KEY 4 LABEL "CRDT UN"  CALL Credit_union
150    ON KEY 5 LABEL "WRK HIST" CALL Work_history
160  ELSE                                ! 80-columns; long labels
170    ON KEY 1 LABEL "VACATION SCHED" CALL Vacation_sched
180    ON KEY 2 LABEL "SICK LEAVE"  CALL Sick_leave
190    ON KEY 3 LABEL "PAYROLL"    CALL Payroll
200    ON KEY 4 LABEL "CREDIT UNION" CALL Credit_union
210    ON KEY 5 LABEL "WORK HISTORY" CALL Work_history
220  END IF

```

As you can tell by looking at this code, lines 170 through 210 are almost identical to lines 110 through 150. Therefore, copying those five lines to the new place and editing the key labels would be much faster than retyping the entire line.

Search and Replace Operations

The non-programmable `FIND` command finds all the occurrences of a particular string in a program. Suppose, for example, you have a variable called "Tax" in your program, and you want to change it to either "State_tax" or "City_tax", but which one you change it to depends on the context of the statement. A `FIND` command finds each occurrence of the string "Tax". Once there, you can look at the statement and decide whether it should be changed to "State_tax" or "City_tax".

22 Entering, Running, and Storage Programs

When a program line has been found, just edit the line in the normal way and press **ENTER** or **RETURN**. If your change results in a syntax error, correct it and press **ENTER** or **RETURN** again; the FIND is not cancelled. If you want to delete the line found, press **DEL LN**; the line is deleted and the FIND is immediately resumed. If you don't want to change the line, press **CONTINUE**, and the search resumes where it left off.

To cancel a search operation before it is finished, press **↑**, **↓**, or **EXECUTE**.

Literal replacement is done with the non-programmable CHANGE command. CHANGE is like FIND in that it looks through your program and finds occurrences of the specified string. However, it also makes a tentative change that you can confirm by pressing **ENTER** or **RETURN**, or deny by pressing **CONTINUE**. If you are positive that you don't need to verify each replacement, appending **!ALL** will cause the search-and-replace to be done with no further user intervention.

Here is an example where you replace one variable name with *two* variable names: You discover, to your dismay, that after writing twenty-five subprograms, all of which use a particular COM statement, that you need another variable in the middle of that COM statement. The CHANGE command just cries out to be used in this case. Say, for example, that your COM statement looks like:

```
COM /Hardware/ Plotter_is,Plotter_spec$,Printer_is
```

where `Plotter_is` is the currently specified device selector for the plotter, `Plotter_spec$` is the plotter specifier and `Printer_is` is the device selector for the printer. You want to put `Dump_dev` into the COM statement, right after the variable `Plotter_spec$`. Your CHANGE command could look like this:

```
CHANGE "_spec$,Pri" TO "_spec$,Dump_dev,Pri" IN 1,32766
```

Note that the string you're changing **from** contains a comma. This helps narrow down the number of occurrences that match the string selected and it is desirable for this reason: if you just changed `Plotter_spec$` to `Plotter_spec$,Dump_dev`, the computer would change all the occurrences you *want* to be changed, but it would also change many you *don't* want to change. In this case, you would also cause all the places which either use or define `Plotter_spec$` to be changed, even though you wouldn't want them to be. You would change

```
Plotter_spec$="INTERNAL"
```

to

```
Plotter_spec$,Dump_dev="INTERNAL"
```

and this, of course, would cause a syntax error. You will learn efficient ways to specify searches after using the command several times.

To search the entire program, you could either go to the top of program memory with a **SHIFT**-**↑** or use the line range of `IN 1,32766`. The former method is faster, and fewer keystrokes, but if you need to stay in a particular place in memory in order to type a long search key, the latter method is useful.

Using Subprogram Libraries

Often, a programmer has a program which is quite large, along with sizable data arrays, and an `Error 2: Memory Overflow` becomes all too common an occurrence. And neither the program nor the data can be reduced in any way. There are two keywords, `LOADSUB` and `DELSUB` which address this problem. They are mentioned here because they are part of Entering, Running and Storing Programs, which is the subject of this chapter, however, they are not necessary to get started. This subject will be covered later.

See Chapter 6 “User-defined Functions and Subprograms” for a detailed discussion on subprogram libraries.

Indenting

`INDENT` is a non-programmable command which scans the entire program and indents in appropriate places. What is meant by “appropriate places” is this: Whenever there is the beginning or end of a program statement which causes looping, is conditionally executed, or is a separate program segment (subprogram), the first character of each program line *contained* in that segment—**excluding** the line number—is moved to the right or left to make the structure of the program more intuitively obvious. For a list of how each kind of statement affects the indentation, see the *BASIC Language Reference* manual.

An example dealing with the `INDENT` command’s capabilities follows. This program is not to be noted for its efficiency (or lack thereof—the conditions could better be checked with a `SELECT` statement); it is merely for the purpose of demonstrating the `INDENT` command. The program is shown after having been indented with various parameters. Notice how the indented structures make it easier to understand the logic flow.

This example was indented with the command

```

INDENT 7,2

10   FOR I=1 TO 5
20     REPEAT
30       INPUT "How old are you?";Age
40       Reasonable=1 ! Assume they're telling the truth...
50       IF Age<0 THEN
60         DISP "Aw, c'mon! You can't be ";Age;"years old. You gotta be born!"
70         Reasonable=0
80       ELSE
90         IF Age>120 THEN
100        DISP "Oh, pshaw! I don't believe you."
110        Reasonable=0
120       ELSE
130        IF Age>100 THEN
140        DISP "Hmm...you're well nigh a fossil, huh?"
150       ELSE
160        IF Age>60 THEN
170        DISP "Wow! Most people your age don't use computers much."
180       ELSE
190        DISP "Glad to meet you."
200       END IF
210     END IF
220   END IF
230   END IF
240   WAIT 4
250   UNTIL Reasonable
260   DISP "You were";Age*365.242198781;"days old on your last birthday."
270   WAIT 3
280   NEXT I
290   END

```

And this example was indented with the command

```

INDENT 10,1

10      FOR I=1 TO 5
11      REPEAT
12      INPUT "How old are you?",Age
13      Reasonable=1 ! Assume they're telling the truth...
14      IF Age<0 THEN
15      DISP "Aw, c'mon! You can't be ";Age;"years old. You gotta be born!"
16      "
17      Reasonable=0
18      ELSE
19      IF Age>120 THEN
20      DISP "Oh, pshaw! I don't believe you."
21      Reasonable=0
22      ELSE
23      IF Age>100 THEN
24      DISP "Hmm...you're well nigh a fossil, huh?"
25      ELSE
26      IF Age>60 THEN
27      DISP "Wow! Most people your age don't use computers much."
28      ELSE
29      DISP "Glad to meet you."
30      END IF
31      END IF
32      END IF
33      WAIT 4
34      UNTIL Reasonable
35      DISP "You were";Age*365.242198781;"days old on your last birthday."
36      WAIT 3
37      NEXT I
38      END

```

If one generalizes from the previous examples, the question arises: "What happens if the indented code goes completely off the right edge of the screen?" There are two ways that this could happen: either the starting column parameter is too large, or the number of nesting levels is too great for the specified indentation increment. If, for either of these two reasons, a line of code gets longer than the listable length of the machine, an asterisk (*) is placed immediately after the line number of that line, and the right end of the line is not visible.

To correct a problem of program lines longer than the listable length of the machine, execute another INDENT statement whose parameters are smaller.

A program which contains lines longer than 256 characters still executes, STOREs and LOADs properly, but if you SAVE the program without correcting the problem, it will not syntax properly when you do a GET operation. What is sent to the file is the line number, the asterisk, and as much of the program line as possible. The asterisk will prevent the proper syntaxing of the statement when the GET is attempted, in addition to the fact that part of the statement is missing.

Note that you can create a program on one model computer using the maximum line length and then get that program and run it on a model with a smaller CRT. You cannot, however, modify any program line which is longer than the maximum length for the current CRT without shortening it.

When indentation parameters attempt to force program statements to start too far to the right, they are bounded by the width of the screen minus eight characters. That is, the first character of a program line (excluding the line number) will never start to the right of the screen width - 8. When this is attempted, there may be several lines of code (which *should* differ in indentation) starting in column screen width - 8. Therefore, until the nesting level gets back down to a manageable point, indentation will be disabled. Note, however, that an internal indentation counter is maintained, so statements at the same nesting level will continue to have matching indentation. See the example below which was indented with the command

```
INDENT 10,15
```

Note that this was done on a machine with an eighty-column screen. Had it been done on a Model 226, with its fifty-column screen, the right-hand limit would have been reached more quickly.

```

10      FOR I=1 TO 5
20          REPEAT
30              INPUT "How old are you?";Age
40              Reasonable=1! Assume they're telling the
truth...
50              IF Age<0 THEN
60                  DISP "Aw, c'mon! You can't
t be ";Age;"years old. You gotta be born!"
70                  Reasonable=0
80              ELSE
90                  IF Age>120 THEN
100                     DISP "Oh, p
shaw! I don't believe you."
110                     Reasonable=
0
120                     ELSE
130                         IF Age>100
THEN
140                             DISP "Hmm
...you're well nigh a fossil, huh?"
150                             ELSE
160                                 IF Age>60
THEN
170                                     DISP "Wow
! Most people your age don't use computers much."
180                                     ELSE
190                                         DISP "Gla
d to meet you."
200                                         END IF
210                                         END IF
220                                     END IF
230                                 END IF
240                             WAIT 4
250                         UNTIL Reasonable
260                             DISP "You were";Age*365.242198781;"days old on your last
birthday."
270                             WAIT 3
280                         NEXT I
290                     END

```

Observe that there are several lines (140 and 160 through 200) which should be indented farther to the right. But since the column position of the screen width minus eight is the boundary on the right edge, they are not permitted to go as far right as they "should." Note, however, that indentation recovers and is still correct after the point at which they attempt to exceed the right-hand limit.

Cross-references

The non-programmable XREF command prints a cross-reference listing on the device of your choice. You can get a cross-reference listing for everything in memory, or just a selected subprogram. The uses for a cross-reference listing are many. Here are a few of its uses.

When debugging a program, something goes wrong and you haven't a clue as to what it is, a cross-reference is useful because it lists variable names in alphabetical order. If you've misspelled a variable name somewhere, it can throw the program into a tizzy in a very subtle (hard-to-find) way. If you've narrowed the problem down to one subprogram, (`REPORT_1`, for example) you could execute

```
XREF Report_1
```

The computer will print a cross-reference listing for the subprogram `REPORT_1`, and, among other things, would list the variable names. Be especially careful about variable names that are different but still are perfectly reasonable variable names. For example, `Xvelocity` and `X_velocity`. Obviously, changing one would have no effect on the other.

Example

Here is an example of a cross-reference listing dealing with the little program in the *Defining Softkeys Programmatically* section at the end of this chapter.

```
>>>>  Cross Reference  <<<<

*  Numeric Variables
I          60      90
Key_number 30 <-DEF   70      80

*  String Variables
Key_value$ 20 <-DEF   70      80

*  I/O Path Names
@Keys      50      80    100

Unused entries =      7
```

This is not an exhaustive list of the XREF outputs, since there were no common blocks, subprogram calls, line labels, etc., but it gives an idea of the general format of a cross-reference listing. Note the `<-DEF` which appears in some of the line number lists. This appears when:

- The identifier is a variable in a formal parameter list; i.e., in a SUB or DEF FN statement,
- The identifier is a variable declared in a COM, DIM, REAL, or INTEGER statement, or
- The identifier is a line label for that line.

The number entitled "Unused entries" deals with the internal workings of the system. It tells how many symbol table entries are available for which space has already been made, but which are not currently defined. Prerun will convert unreferenced symbol table entries (entries which are defined, but not used in the program) into unused entries. Unreferenced entries can arise because you changed your mind about a variable name or corrected a typing error. They can also arise in the syntaxing of some statements where a numeric variable is entered which turns out to be a line label or a subprogram name. Also, REN can cause line numbers to merge if you have unsatisfied line number references. This shows up in the cross-reference as separate (but adjacent) entries for the multiple symbol table entries for the line number.

Another way of using a cross-reference listing is when you need to find every place a particular variable name is used, but the computer (and therefore the FIND command) is not available. It is often advisable to get a cross-reference listing at the end of a hard-copy program listing, **especially** if it is a large program. In this way, finding each occurrence of a variable is made easier.

Program Storage and Retrieval

The previous sections in this chapter have shown how to enter, edit, and run a program. The next logical step is to save the program for future use or further development. Mass storage devices can be used to keep programs or data. The operations required to keep programs are simple. Recording data requires a greater understanding of mass storage operations and is described in Chapter 7 “Data Storage and Retrieval”.

Find a Usable Volume

The exact procedure for storing and retrieving programs depends upon the type of mass storage device you are using. Your Series 200 computer may have an internal 5.25-inch disc drive, an SRM system, or one of the many external disc drives that are compatible with your system.

All mass storage operations, including program storage, require a properly initialized volume. With 5.25-inch discs, one disc contains one volume. With SRM, there are many volumes on-line, and a directory can be thought of as a volume. Some external disc drives have one volume per disc, and others have multiple volumes on a disc. In BASIC, volumes are specified by using a **mass storage unit specifier**. This is a string expression which tells the computer where to look for the desired volume. Mass storage unit specifiers (**msus**) are discussed in detail in Chapter 7. Most mass storage operations will use a default msus if you do not include one in your mass storage statement.

One easy way to see if a mass storage volume has been properly initialized is to execute a CAT command for that volume. A CAT command displays the contents of a volume’s directory. To see the directory of the default mass storage device, execute:

```
CAT
```

If the CRT displays a catalog listing, then you are looking at the directory of the default mass storage volume. Therefore, that volume is properly initialized and can be used for program storage. If you get an Error 80, then there is no disc in the default disc drive, or the disc has not been inserted properly. If you get a different error number, then some other problem is indicated. It is beyond the scope of this introductory section to explain all possible mass storage errors. If you get an error, there are several things you might want to do, depending upon your situation.

- Be sure the appropriate driver BINs have been loaded.
- If the error is caused by a missing disc or improperly inserted disc, you can correct the error by inserting a disc properly.
- If the error is caused by a disc that is uninitialized or improperly initialized (typically errors 78, 84, or 85), you can execute an INITIALIZE command. Refer to Chapter 7 or the *BASIC Language Reference* if you are not familiar with this command. Be careful! When you initialize a disc, **all data on the disc is destroyed**.

- The error might have occurred because you couldn't (or didn't want to) use the default volume. To be sure that your mass storage system is configured properly, refer to the appropriate manual, for example, the SRM manual, the disc drive manual, or the operating manual for your computer. To specify a different volume to be the default volume, use the MASS STORAGE IS command. (Refer to Chapter 7 or the *BASIC Language Reference*.)
- If you have determined that the error is caused by a hardware failure, then call your local HP Sales and Service Office and describe the error message and the system configuration.

Recording a Program

To record a program, you can use a SAVE or STORE command with a suitable file name. A file name is the identifier that is stored in the disc's directory and used to access the program. When recording a program, it is logical to use the program name as the file name. Series 200 computers permit a maximum of ten characters in a file name. Those characters can be any uppercase or lowercase letters (including foreign characters), the numerals 0 thru 9, and the underbar (_) character.¹

Either the SAVE or STORE operation can be used to record a program. There is no "right" or "wrong" choice; your choice depends upon the type of file you want. If you aren't sure what kind of file you want, use STORE. You can always LOAD the program and create another file type later if you have that need.

If a SAVE command is used, the actual text of the program is recorded in an ASCII file. If a STORE command is used, an internal representation of the program is recorded in a PROG file. The main advantage of an ASCII file is that it can be read as data by another program or any LIF-compatible² device (such as an HP 2642 disc-based terminal). The main advantage of a PROG file is rapid access. The following table gives a brief summary of the differences between SAVE and STORE. Note that this table uses the typical performance of a Model 226 internal drive as a basis for comparison. The actual speed of external devices will be different from that shown, but similar relationships will exist.

	SAVE	STORE
File type created:	ASCII	PROG
Retrieved by:	GET	LOAD
Approximate storage speed:	900 bytes/s	13k bytes/s ⁴
Approximate retrieval speed:	300 bytes/s ³	14k bytes/s ⁴
Can file be read as data?	Yes	No
LIF compatible file?	Yes	No
Arbitrary program segments allowed?	Yes	No

¹ If you want an LIF-compatible file name, you must restrict the characters to uppercase English letters and the numerals 0 thru 9. Also, the first character must be a letter.

² "LIF" stands for "Logical Interchange Format". This is an HP standard for the format of the directory and files on a mass storage device.

³ The retrieval speed for GET is very data-dependent. It can vary from 20 bytes/s to 600 bytes/s (and maybe beyond those limits) according to the contents of the file and the syntax checking required to enter the lines into program memory.

⁴ The speeds for LOAD and STORE are approximate for an interleave of one. Interleave factors greater than one will cause a corresponding decrease in speed.

To STORE a program, simply insert an initialized disc, type the keyword STORE followed by a file name, and press **EXECUTE** or **RETURN**. For example, the command to create a program file called "Mortage" is:

```
STORE "Mortage"
```

If you should happen to get an error 54, that means that there is already a file on the disc with the name you are using. In this event, you have three choices. First, pick a different name that doesn't already exist. To determine which file names are already being used, execute a CAT command. Second, you may want to replace the existing file with a new one (like when you are updating program files with new, improved versions). To replace an existing file a RE-STORE command is used. For example, the command to replace a program file called "BEAMS" is:

```
RE-STORE "BEAMS"
```

Note that the hyphen must be used in the RE-STORE statement. (RESTORE without a hyphen is used for an entirely different operation described in Chapter 7.) The third choice is to PURGE the old file, then STORE the new one.

Before a program is run, the computer goes through an operation called "prerun." This creates the symbol table and other information tables. These tables can be stored onto the PROG file created by the STORE command. To make sure these tables exist before you STORE the program, press **STEP**. This will do the prerun processing and pause before executing the first line of code. Now STORE the program, and the newly-created internal information tables are stored along with the program. Whenever the program is loaded, the symbol table already exists and does not need to be re-created. In a very large program, prerun processing could take several seconds. You can insulate your users from this delay by prerunning your programs before you store them.

The SAVE procedure is similar, with one exception. The SAVE statement allows line identifiers that specify what portion of the program you want to save. This is especially helpful when moving or appending program segments during major editing operations. Here are some examples of using the SAVE statement. To save all of a program in an ASCII file called "WHALES", execute the following command:

```
SAVE "WHALES"
```

The next command saves the last part of a program, from line 500 to the end, in an ASCII file called "TEMP".

```
SAVE "TEMP",500
```

When both the starting and ending lines are specified, any arbitrary portion of a program can be saved. Executing the command

```
SAVE "sort_code",Sort,Printout
```

saves that portion of a program that is between the lines labeled "Sort" and "Printout" (inclusive) in an ASCII file called "sort_code".

There is also a RE-SAVE statement that allows an existing file to be replaced by a newly created file with the same name. For example, to update an ASCII file called "Analysis" with a new version of the program, the following command would be used:

```
RE-SAVE "Analysis"
```

Retrieving a Program

Programs saved in an ASCII file are retrieved with the GET statement. Programs stored in a PROG file are retrieved with the LOAD statement. These statements can be executed from the keyboard as commands or included in a program. When executed as commands, they are used to bring a program into the computer's memory so that it can be edited or run. When included in a program, they are used to link together the segments of large programs.

To retrieve a program you need to know the name and type of the file in which it is stored. If you are not sure of either of these, execute a CAT command. The catalog display shows the name and type of all files on the disc. The options available for ASCII files are discussed first.

Using GET as a Command

The GET command is used to bring in programs or program segments from an ASCII file, with the options of appending them to an existing program and/or beginning program execution at a specified line. To clear any existing program from the computer's memory and bring in the contents of an ASCII file, the command is simply the keyword GET followed by the file name. For example:

```
GET "FORMULA"
```

This command clears the BASIC program memory and brings in the contents of the ASCII file called "FORMULA", assuming that the file contains valid program lines. If the first line does not start with a valid line number, the GET is not performed and an error 68 is reported. If the file is not an ASCII file, the GET is not performed and an error 58 is reported.

Assuming that the file contains valid program lines that were placed in the file by a SAVE operation, and their line numbers are still valid after any renumbering that is specified, the lines will be entered into program memory. If there is a syntax error in any of the program lines in the file, the lines in error are turned into comments, an error 68 is reported, and the syntax error message is sent to the system printer. This might happen if the program was written and saved on a computer that had a different version of BASIC than the one being used for the GET operation.

To append the contents of an ASCII file to an existing program, a line identifier is added to the GET command. For example, assume that there is a program already in the computer that ends with line number 740, and you want to append the contents of a file called "George". The following command could be used.

```
GET "George",750
```

This appends the program lines from file "George" to the existing program, renumbering them to start with line number 750. If the command `GET "George",100` were used in the same situation, all existing program lines from 100 to the end of the program in memory would be deleted and the contents of file "George" would be appended to the lines that remained at the beginning of the program. The program lines in file "George" would be renumbered to start with line 100.

Sometimes it is not possible to enter a line into the program. This can happen, for example, if the specified renumbering would create an invalid line number. In these cases, the line in error is sent to the system printer with an error message, but it is not entered into program memory.

The GET command can also specify that program execution is to begin. This is done by adding two line identifiers: one specifies the placement and renumbering just described, and the other specifies the line at which execution is to begin. For example, assume that there is no program in memory and that an ASCII file "RATES" contains valid program lines. A typical command to bring the contents of this file into memory and begin execution at the first line is:

```
GET "RATES",10,10
```

If there is already a program in memory, an append and run is allowed. For example:

```
GET "RATES",250,100
```

This command specifies that any existing lines from 250 to the end are to be deleted, the contents of file "RATES" is to be renumbered and appended beginning at line 250, and then normal program execution is to begin at line 100. Although any combination of line identifiers is allowed, the line specified as the start of execution must be in the main program segment (not in a SUB or user-defined function). Execution will not begin if there was an error during the GET operation.

Using GET in a Program Line

The GET statement can be used in a program to transfer execution from one program segment to another. When used in a program line, the actions of the GET statement are the same as those described for the GET command, except as noted in the following paragraphs. Two examples of a programmed GET are shown here. One demonstrates a simple linkage of two program segments, as might occur when the entire program is too long to fit in memory. The second shows a simple example of keeping a file manager in memory to GET and run various routines.

A large program can be divided into smaller segments that are connected by using a GET statement to move from one to the next. The following short example shows this technique.

First Program Segment:

```
10  COM Ohms,Amps,Volts
20  Ohms=120
30  Volts=240
40  Amps=Volts/Ohms
50  GET "wattage"
60  END
```

File "wattage":

```
10  COM Ohms,Amps,Volts
20  Watts=Amps*Volts
30  PRINT "Resistor Ohms =";Ohms
40  PRINT "Resistor Wattage =";Watts
50  END
```

One important point to note is the use of a COM statement. The COM statement places variables in a section of memory that is preserved during the GET operation. Since the program saved in the file "wattage" also has a COM statement that contains three REAL scalar variables, the values assigned to those variables in the previous program segment are preserved. If the program segments did not contain equivalent COM statements, all variables in the mismatched COM blocks would be rendered undefined by the prerun that is performed after the GET operation. Therefore, to effectively use the GET statement to link program segments, all variables that need to be preserved must be placed in COM statements, and all program segments using those variables must have equivalent COM statements.

Note also the form of the GET statement. If this particular statement were executed from the keyboard, no program execution would take place. However, the computer understands that a GET in a program is meant to cause execution to resume. When no parameters are specified in a programmed GET, the entire old program segment is replaced by the new segment, and execution resumes with the first line in the new program segment.

If a single line identifier is used in a programmed GET (such as `GET "format",150`), the last part of the old program segment is deleted (from the specified line to the end), the new program segment is renumbered and appended to the remaining portion of the old segment, and execution resumes with the first line of the resulting program. If two line identifiers are specified, the action is the same as described for the GET command from the keyboard. In these cases, it is usually not necessary to repeat the COM statement in the second program segment. Since the COM statement is usually in the first (undeleted) part of the program, it remains after the second segment is in place. If there are two identical COM statements in the same program context, an error 12 results. Program segments that are linked in with the GET statement should repeat the original COM statement only if that original COM statement is deleted as a result of the GET operation.

An example of programming a GET statement with two line identifiers is a "file executive" program that gets and runs other program files. This technique is sometimes used when most of the computer's memory is needed to store data and the various program files perform individual operations on that data. A small example of the general technique follows. Admittedly, the tasks shown are all simple enough to be contained in a single program with plenty of room left for data. The example merely demonstrates the structures involved with this type of file linking.

In this example, a large portion of memory is used to hold weights input from an electronic scale. The "file executive" gives the operator a menu of operations to choose from and gets the requested file. The requested file performs its task and returns control to the "executive". The individual tasks shown here are the printout of the weights and the statistical analysis of the weights. Assumed, but not shown, is a routine that entered the weights from the scale and stored them in the array. (The input of data from external devices is covered in the *BASIC Interfacing Techniques* manual.)

Main Executive:

```

100 ! This program manages the utility files for
110 ! some hypothetical data. Data was stored
120 ! in the REAL array "Weights". The device
130 ! selector for the external printer is
140 ! is assigned in line 200. Each utility
150 ! file sends control back to line "Start"
160 ! when it is done. The program disc must be
170 ! present when this executive is used.
180 !
185 OPTION BASE 1
190 COM Weights(5000),Samples,Printer
200 Printer=701 ! External printer for data
210 Samples=5000 ! Also see array declaration
220 !
230 Start: ! Main entry point
240 PRINTER IS 1 ! For program messages
250 PRINT
260 PRINT "Enter P to print weights"
270 PRINT "Enter A for an analysis"
280 !
290 Ask: INPUT "Enter Command Letter",In$
300 IF In$="P" THEN GET "Printout",330,330
310 IF In$="A" THEN GET "Analysis",330,330
320 GOTO Ask ! Incorrect entry
330 END

```

File "Printout":

```

100 ! This routine prints the data in the array
110 ! "Weights" to an external printer.
120 ! Necessary variables are initialized in
130 ! the main executive.
140 !
150 PRINTER IS Printer ! Use external printer
160 FOR I=1 TO Samples ! Print all weights
170 PRINT "Sample #";I;" weighs";Weights(I)
180 NEXT I
190 PRINT CHR$(12) ! Form-feed
200 GOTO Start ! Return to executive
210 END

```

File "Analysis":

```

100  ! This routine finds the mean and standard
110  ! deviation of the data in "Weights",
120  ! Necessary variables are initialized in
130  ! the main executive.
140  !
150  Sumx=0           ! Clear sum of X
160  Sumx2=0         ! Clear sum of X squared
170  FOR I=1 TO Samples ! Calculate summations
180      Sumx=Sumx+Weights(I)
190      Sumx2=Sumx2+Weights(I)^2
200  NEXT I
210  Mean=Sumx/Samples
220  Stddev=SQR((Sumx2-Sumx^2/Samples)/(Samples-1))
230  PRINT
240  PRINT "Number of samples =" ;Samples
250  PRINT "Mean weight =" ;Mean
260  PRINT "Standard deviation =" ;Stddev
270  GOTO Start      ! Return to executive
280  END

```

Notice that any information that is shared by all the routines is placed in COM. The individual task files do not contain COM statements because the COM statement in the executive routine is never deleted. Values that are shared by all routines are initialized by the executive. In that manner, a standard characteristic can be changed in the executive, with no alterations required in any of the other files. The "shared" values used in this example are the number of weights in the array (Samples) and the device selector of the external printer (Printer).

Using LOAD as a Command

The LOAD command is used to bring in programs from a PROG file, with the option of beginning program execution at a specified line. To clear any existing program from the computer's memory and load the contents of a PROG file, the command is simply the keyword LOAD followed by the file name. For example:

```
LOAD "Cannon"
```

This command clears the program memory and brings in the contents of the PROG file called "Cannon". If the file is not a PROG file, the LOAD is not performed and an error 58 is reported. If any lines require a language extension that is not currently installed, those lines cannot be executed. However, the LOAD proceeds without error.

The LOAD command can also specify that program execution is to begin. This is done by adding a line identifier. For example:

```
LOAD "STONE",10
```

This command causes the computer to load the program in file "STONE" and begin execution at line 10. The line identifier may be a label or a line number, but it must identify a line in the main program segment (not in a SUB or user-defined function).

The LOAD command cannot be used to bring in arbitrary program segments or append to a main program like GET can. Subprogram segments can be appended using the LOADSUB command. This is described in Chapter 7.

Using LOAD in a Program Line

When used in a program line, the actions of the LOAD statement are the same as those described for the LOAD command, except program execution resumes whether a line identifier is specified or not. For example:

```
120  LOAD "PART2"
```

When this program statement is executed, the existing program is replaced by the contents of the PROG file called "PART2" and program execution resumes with the first line in the new program. When a line identifier is included in a programmed LOAD statement, execution resumes with the specified line after the file is loaded.

Remember to include in a COM statement any variables that must be shared by more than one program segment. The COM statement must be present before and after the LOAD if you want all the data in COM to be preserved. The section describing GET has an example of using COM to preserve data.

Autostart of a PROG File

Your computer can be configured to LOAD and RUN a program automatically when the power is switched on. To use this feature, STORE a PROG file called "AUTOST". Then when the power is switched on, the computer automatically loads that file and begins executing the program from the first line. No action is taken if there is no "AUTOST" file present.

If you want to give your program file a more meaningful name than "AUTOST", create an "AUTOST" file that simply loads the desired file. For example, if you want to autostart a program called "ALARM", store this in the "AUTOST" file:

```
10  ! This is the AUTOST file for program ALARM
20  LOAD "ALARM"
30  END
```

On a dual-drive machine like the Model 236, the autostarted program is not restricted to the space remaining on the language system disc because there are two disc drives. A short AUTOST file on drive 0 can load a long program file from drive 1. The following example shows this technique.

```
10  ! This is the AUTOST file for program ALARM
20  MASS STORAGE IS ":INTERNAL,4,1"
30  LOAD "ALARM"
40  END
```

By using the appropriate mass storage unit specifier, this general technique can be extended to use external disc drives.

36 Entering, Running, and Storage Programs

The AUTOST program can also load the BIN files automatically. For example,

```
10  !This is the AUTOST file.
20  LOAD BIN "DISC:HP,702"
30  LOAD BIN "HPIB:HP,702"
40  MASS STORAGE IS ":HP,702" !Specify if different from where SYSTM
50  LOAD BIN "MS"             !was loaded.
60  LOAD BIN "IO"
70  LOAD BIN "GRAPH"
80  END
```

Be sure to load the drivers for the mass storage device and the card driver before you load the other BINs.

If you load BASIC from an SRM, the system looks for a file in the SYSTEMS directory named AUTOSTNN where NN is your node number. If this file is not found, the system looks for a file named AUTOST in the root directory.

System Configuration

The BASIC Language System is contained in several files. The SYSTM file contains what is sometimes called "core" BASIC. Extensions to core BASIC and device drivers are in BIN files. The language extensions add statements to BASIC. For example, the PDEV extension gives you the MOVELINES and COPYLINES commands. The device drivers allow you to use mass storage devices other than the internal discs and memory. Whenever you need an extension for an example in this manual, the BIN file name is given.

Loading BINs

As shown in the previous example, you load an extension or driver with the LOAD BIN statement.

```
LOAD BIN "GRAPHX:HP,700"
LOAD BIN "ERR"
LOAD BIN "DISC:INTERNAL,4,1"
```

If you attempt to execute a statement that requires a language extension, error 1 occurs. You can load the required BIN and then continue your programming.

You can LOAD a STOREd program that requires language extensions not present in the computer, but you cannot run it. Error 1 occurs and the option number, or extension name if ERR is loaded, is displayed. The option numbers are listed in the Useful Tables section of the BASIC Language Reference manual.

You can GET a SAVEd program that requires language extensions, but errors occur during the GET. Each statement that requires a missing option is made a comment. An ! is placed before the line. You can load the missing BIN and then edit the program.

Storing the System

Once you have all the BINs in memory, you may want to save that configuration for the next time you boot up the system. The STORE SYSTEM command stores core BASIC and all the BINs into one file.

```
STORE SYSTEM "SYSTEM_B:HP,702,1"
STORE SYSTEM "SYSTEM_2:REMOTE"
STORE SYSTEM "SYS_MINE"
```

The boot ROM looks for a SYSTM file which begins with "SYSTEM_". A 3.0 and 4.0 ROM also looks for SYSTM files which begin with "SYS_". A SYSTM file which has a different prefix cannot be booted. If there is more than one loadable file, and you press the space bar on the keyboard after power up and before the file is loaded, all loadable files are listed. You can choose the one you want loaded. If you do not press the space bar, the boot ROM loads the first SYSTM file it finds.

Since core BASIC uses most of a 5 ¼ - inch flexible disc, you cannot store more than one system on the disc. You also cannot store several BINs with core BASIC on this disc.

Scratching BINs

You can delete the BINs from memory with the SCRATCH BIN statement. This statement deletes all the BINs, except the one which drives the CRT. Note that it also scratches any program in memory.

Other Mass Storage Operations

The general mass storage capabilities of the computer are discussed in Chapter 7. Because many of the operations are applicable to program files as well as data files, certain operations are summarized here. If these brief examples do not provide sufficient information, refer to Chapter 7 for more details.

The name of a file can be changed without disturbing the file's contents. This is done with the RENAME statement. For example, to change the name of a file from "George" to "Frank", use the statement:

```
RENAME "George" TO "Frank"
```

A file entry can be removed from the disc directory with the PURGE statement. This prevents any further access to the file. For example:

```
PURGE "Myfile"
```

This statement eliminates the file "Myfile" from the disc directory.

A file can be given a protect code by using the PROTECT statement. A protect code is a 2-character string that must be specified to modify the file, but it does not appear in the catalog display. For example, to protect the file "SECRET" with the protect code "BS", use this statement:

```
PROTECT "SECRET", "BS"
```

The protect code is placed after the file name to allow access. For example, to PURGE the previously protected file "SECRET", the statement is:

```
PURGE "SECRET<BS>"
```

Files can be copied with the COPY statement. Some examples:

```
COPY "MYPROG" TO "MYPROG:INTERNAL,4,1"
COPY "MYPROG:HP8290X,700,0" TO "MYPROG:HP8290X,700,1"
```

These statements create a backup copy of the file MYPROG. The first example copies from the right-hand drive to the left-hand drive on a Model 236. The second example copies a file from the left-hand drive to the right-hand drive on an external device such as the HP 82901 or HP 9121.

Softkeys

There is a set of keys on your keyboard labeled either **k0** thru **k9** or **f1** thru **f8**. These are softkeys. You can define the function of these keys as typing aids. That is, you define one softkey to contain any combination of keystrokes. You may include all the ASCII characters, as well as non-ASCII keys, such as arrow keys, insert and delete character, continue, etc. This has nothing to do with programmatic ON KEY definitions; they are discussed in future chapters.

The KBD extension is required to use typing aids. When you load KBD, the typing aids are given default definitions. These default definitions include some commonly used commands. For example, **k5** and **f3** are defined as SCRATCH. **k7** and **f5** are defined as CAT. You can see the definitions in the softkey menu on your display.

If you have an HP 46020A keyboard, your softkeys are labeled **f1** thru **f8**. There are System defined softkeys and User softkeys. You cannot change the definitions for the System keys. These keys represent physical keys on other keyboards. There are three sets of Users softkeys which gives you 24 definable softkeys. You can change any of them. In general, the menu which is displayed shows the definitions of the softkeys. To change the menu and the definition, press the **SHIFT** and **Menu** keys. To go from the User menu to the System menu (or System to User) press the **User**/**System** key.

If you have the HP 98203A keyboard (the standard keyboard for the Model 216), you have five softkeys. Each softkey can have two definitions. When you press **SHIFT** and a softkey, you access **k0** thru **k4**. When you press just the softkey, you access **k5** thru **k9**. All ten definitions are displayed on the menu.

If you have the HP 98203B keyboard (the standard keyboard for the Model 236), you have ten softkeys labeled **k0** thru **k9**. These keys also have a shifted version. When you press **SHIFT** and a softkey, you access **k10** thru **k19**. The softkey menu displays the first 10 softkey definitions. The second 10 definitions cannot be displayed.

Default Softkey Definitions

Several typing aid definitions are loaded when you load KBD. These definitions are loaded for your convenience. You can change the definitions, load your own definitions or delete the definitions. The following sections explain how you do this.

Defining Softkeys

To define a typing aid, type EDIT KEY and the number of the softkey you want to define. For example,

```
EDIT KEY 2
```

You could also press **EDIT** **k2** or **EDIT** **f2**, which is the same as the EDIT KEY command.

When you execute this command, the following message is displayed:

```
Editing Key 2
```

If softkey 2 is currently defined, its definition is displayed. If it is not defined, the input line is blank.

To enter the new definition, use the keyboard. Type ASCII characters directly. To get non-ASCII keystrokes, use the **CTRL** key and the function key you want to use. For example type the following:

CTRL - **CLR LN** **L** **I** **S** **T** **CTRL** - **EXECUTE**

Note

This technique will not work for some non-ASCII keys on an HP 98203A keyboard. To enter non-ASCII keystrokes, refer to the Second Byte of Non-ASCII Key Sequences table in the Useful Table section of the BASIC Language Reference manual. Press **ANY CHAR** **2** **5** **5** followed by the character associated with the desired key.

(You may have keys other than **CLR LN** or **EXECUTE**. Use the key which means clear line and execute or return.)

By pressing **CTRL** and **CLR LN** together, you get **K#**. **CTRL** - **EXECUTE** gives you **KX**. The **K** means you have pressed a system key. The **#** or **X** means you have pressed **CLR LN** or **EXECUTE**.

Now, press **ENTER** or **RETURN**. The definition is stored and the softkey menu changes.

Press **k2** or **f2**.

The LIST command is entered on the input line and then executed. You may not be able to see the command displayed because it is executed immediately.

If you do not want the command executed, leave out **CTRL** - **EXECUTE**.

Besides commands, you can define the softkeys to display any sequence of characters. For example, if you are writing a program and want to separate each subprogram with a line of asterisks you could define a softkey to do this.

! ***** **ENTER**

If a **CLR LN** is the first character in the definition, it will not show in the label. If you want a softkey label which “looks nice” - it doesn’t have a lot of inverse-video Ks in it - you can have the visible character be an aesthetically pleasing label, the next thing a **CLR LN**, which erases the label which prints when the key is invoked, and the next n characters be the functional “core” of what the key is supposed to do. The result of this strategy is that when you press a softkey, the aesthetically-pleasing label is displayed, immediately erased, and the characters following the label are displayed and, if you specified, processed with an **ENTER**, **EXECUTE** or **RETURN**, etc.

Softkey Definitions

There is 1024 bytes of memory set aside for softkey definitions. Since there is a certain amount of overhead necessary for each one, there are approximately one thousand characters available for softkey definitions.

The maximum number of characters which may be entered in a definition is two full CRT lines. If you define the softkeys on one Series 200 and store the definitions, you can load the definitions on another Series 200 even if the definitions are greater than two of the loading computer's CRT lines. You will not be able to modify the long definitions, but you can delete the old and enter a new definition. Attempting to use an overlong typing aid will cause the typing aid buffer to overflow. Some characters will be lost.

Listing Softkey Definitions

You can list the softkey definitions. All of the currently defined softkeys are listed. To list to the system printer execute:

```
LIST KEY
```

To specify a device that is not the current system printer, include a device selector in the command. To send the listing to the printer execute:

```
LIST KEY #PRT
```

The listing does not look like what you typed for the definition if you included system keys. Since most printers cannot print an inverse video K, the term System key: is listed. Each system key is listed on a separate line. For example, if you entered the definition for in the first example, your listing is:

```
Key 2:
System Key: #
LIST
System Key: X
```

Softkey Files

When you have the typing-aid softkey definitions as you want them, you can store them on a file which can be loaded at your convenience. To store the currently-defined typing-aid definitions onto a file, use a STORE KEY command. For example, the following commands store the current key definitions onto a file called AIDS:

```
STORE KEY "AIDS"
```

or

```
RE-STORE KEY "AIDS"
```

Later, when you want to load those definitions you stored, type:

```
LOAD KEY "AIDS"
```

Executing a LOAD KEY command without a file name causes the default, power-up definitions to be restored.

Defining Softkey Files Programmatically

When you type `STORE KEY "KEYS"`, the computer takes the current softkey definitions, and writes them to a BDAT file in a format which can be understood by a `LOAD KEY` command. The `LOAD KEY` command, however, doesn't know (or particularly care) *how* that BDAT file got there, as long as it's in the correct format.

The correct format for key definitions on file is this:

- The file must be a BDAT (Binary DATA) file.
- The file must be created with `FORMAT OFF`. This causes the data to be written to the file in internal format, not ASCII representation.
- Each key's data consists of an integer (the key number—zero through twenty-three) followed by a string—the key's value.

See the example program below. Note that all of the keys do not have to be put onto the file, nor do the key definitions sent to the file have to be in numerical order.

```

10      ! File "DoKeyFile",                ! Name of file which holds Program
20      DIM Key_value$(160)              ! In case you have a LONG key def.
30      INTEGER Key_number                ! Must be 16-bit key number
40      CREATE BDAT "SOFTKEYS",3          ! Create a 3-record BDAT file
50      ASSIGN @Keys TO "SOFTKEYS"       ! Open file (FORMAT OFF is default)
60      FOR I=0 TO 9                      ! First ten keys...
70          READ Key_number,Key_value$    ! Get key number and definition
80          OUTPUT @Keys;Key_number,Key_value$ ! Write them to the file
90      NEXT I                            ! et cetera
100     ASSIGN @Keys TO *                  ! Write EOF, close the file
110     LOAD KEY "SOFTKEYS"               ! See if it worked
120     ! --- Key data -----
130     DATA 9,"work!";5,"that";8,"would";0,"You";4,"you";7,"thing";2,"I";1,"see?"
        ,3,"told";6,"this"
140     END

```

In this way, a program can define made-to-order typing-aid key definitions.

Clearing the Computer

When power is first switched on and the language system is loaded, the memory is clear and various system elements are assigned default values. (For example, the CRT is assigned as the system printer.) This condition is called the “power-on state” of the computer. A detailed list of the conditions established at power-on is given in the “Useful Tables” chapter at the back of the *BASIC Language Reference*. Turning power off, then back on again is one way to clear the computer’s memory. However, this is not necessary and often is not convenient.

The most useful method of clearing the computer is to use the SCRATCH command. There are four forms of this command to allow a choice of clearing actions. The following paragraphs give the details of the choices.

SCRATCH — This command clears all program statements from the computer’s memory. It also clears any data which has not been placed in COM (see Chapter 6 for a description of COM).

SCRATCH C — This command clears **all** variables from the computer’s memory, including COM variables.

SCRATCH A — This command clears almost everything from the computer’s memory. The only exceptions are the recall buffer, the real-time clock and BINs.

SCRATCH BIN — This command clears all BINs except the one which drives the CRT from the computer’s memory. It also performs a SCRATCH A.

SCRATCH KEY — This allows you to clear individual softkeys, or all of them at once. If you want to scratch a particular key, you can do this two ways. The following example clears the typing-aid definition for softkey 4.

- SCRATCH KEY 4, or
- SCRATCH k4

To erase *all* softkey definitions, execute

```
SCRATCH KEY
```

No SCRATCH commands are allowed in a program, and they may not be executed while a program is running.

Notes

Program Structure and Flow

Chapter

3

Introduction

Two of the most significant characteristics of a computer are its ability to perform computations and its ability to make decisions. If the execution sequence could never be changed within a program, the computer could do little more than plug numbers into a formula. Series 200 computers have powerful computational features, but the heart of a computer's intelligence is its ability to make decisions.

The computational power of your computer is exercised as it evaluates the expressions contained in the program lines. Chapters 4 and 5 present the various data manipulation tools available. The decision-making power is used to determine the order in which lines will be executed. This chapter discusses the ways of controlling the "flow" of program execution.

The Program Counter

The key to the concept of decision making in a computer is an understanding of the program counter. The **program counter** is the part of the computer's internal system that tells it which line to execute. Unless otherwise specified, the program counter automatically updates at the end of each line so that it points to the next program line. This is illustrated in the following drawing.

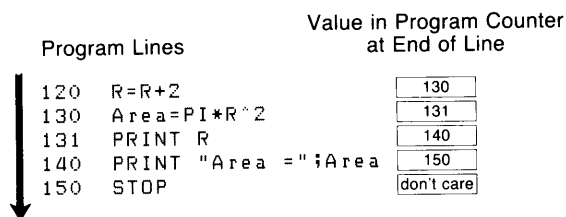

This fundamental type of program flow is called "linear flow". As shown by the arrow, you can visualize the flow of statement execution as being a straight line through the program listing. Although linear flow seems very elementary, always remember that this is the computer's normal mode of operation. Even experienced programmers are sometimes embarrassed to discover that a "bug" in their program was caused by the simple incrementing of the program counter into the wrong portion of the program.

As stated in the introduction of this chapter, a computer would be little more than a glorified adding machine if it were limited to linear flow. There are three general categories of program flow. These are **sequence**, **selection** (conditional execution), and **repetition**. In addition to capabilities in all three of these categories, your computer also has a powerful special case of selection, called **event-initiated branching**. The rest of this chapter shows how to use all of these types of program flow and gives suggestions for choosing the type of flow that is best for your application.

Sequence

Linear Flow

The simplest form of sequence is linear flow. The preceding section showed an example of this type of flow. Although linear flow is not at all glamorous, it has a very important purpose. Most operations required of the computer are too complex to perform using one line of BASIC. Linear flow allows many program lines to be grouped together to perform a specific task in a predictable manner. Although this form of flow requires little explanation, keep these characteristics in mind:

- Linear flow involves **no** decision making. Unless there is an error condition, the program lines involved in this type of flow will always be executed in exactly the same order, regardless of the results of or arguments to any expression.
- Linear flow is the default mode of program execution. Unless you include a statement that stops or alters program flow, the computer will always “fall through” to the next higher-numbered line after finishing the line it is on.

Halting Program Execution

One of the obvious alternatives to executing the next line in sequence is not to execute anything. There are three statements that can be used to block the execution of the next line and halt program flow. Each of these statements has a specific purpose, as explained in the following paragraphs.

Chapter 2 defined a main program as a list of program lines with an **END** statement on the last line. Marking the end of the main program is the primary purpose of the **END** statement. Therefore, a program can contain only one **END** statement. The secondary purpose of the **END** statement is stopping program execution. When an **END** statement is executed, program flow stops and the program moves into the stopped (non-continuable) state.

It is often necessary to stop the program flow at some point other than the end of the main program. This is the purpose of the **STOP** statement. A program can contain any number of **STOP** statements in any program context. When a **STOP** statement is executed, program flow stops and the program moves into the stopped (non-continuable) state. Also, if the **STOP** statement is executed in a subprogram context, the main program context is restored. (Subprograms and context switching are explained in Chapter 6.)

As an example of the use of **STOP** and **END**, consider the following program.

```
100  Radius=5
110  Circum=PI*2*Radius
120  PRINT INT(Circum)
130  STOP
140  Area=PI*Radius^2
150  PRINT INT(Area)
160  END
```

When the **RUN** key is pressed, the computer prints 31 on the CRT and the Run Indicator (lower right corner of CRT) goes off. This first press of the **RUN** key caused linear execution of lines 100 thru 130, with line 130 stopping that execution. If the **RUN** key is pressed again, the same thing

will happen; the program does **not** resume execution from its stopping point in response to a RUN command. However, RUN can specify a starting point. So, execute RUN 140. The computer prints 0 and stops. This command caused linear execution of lines 140 thru 160, with line 160 stopping that execution. However, a RUN command also causes a prerun initialization (see Chapter 2 if this is an unfamiliar term) which zeroed the value of the variable Radius.

You could try pressing **CONTINUE** in the preceding example, but you will get an error. A stopped program is not continuable. This leads up to the third statement for halting program flow. Replace the STOP statement on line 130 with a PAUSE statement, yielding the following program.

```
100  Radius=5
110  Circum=PI*2*Radius
120  PRINT INT(Circum)
130  PAUSE
140  Area=PI*Radius^2
150  PRINT INT(Area)
160  END
```

Now press **RUN**, and the computer prints 31 on the CRT. Then press **CONTINUE**, and the computer prints 78 on the CRT. The purpose of the PAUSE statement is to **temporarily** halt program execution, leaving the program counter intact and the program in a continuable state. One common use for the PAUSE statement is in program troubleshooting and debugging. This is covered in Chapter 12. Another use for PAUSE is to allow time for the computer user to read messages or follow instructions. Interfacing with a human is covered in greater depth in Chapter 14, but here is one example of using the PAUSE statement in this way.

```
100  PRINT "This program generates a cross-reference"
110  PRINT "Printout. The file to be cross-referenced"
120  PRINT "must be an ASCII file containing a BASIC"
130  PRINT "Program."
140  PRINT
150  PRINT "Insert the disc with your files on it and"
160  PRINT "Press CONTINUE."
170  PAUSE
180  !      Program execution resumes here after CONTINUE
```

Lines 100 thru 160 are instructions to the program user. Since a user will often just load a program and press **RUN**, the programmer cannot assume that the user's disc is in place at the start of the program. The instructions on the CRT remind the user of the program's purpose and review the initial actions needed. The PAUSE statement on line 170 gives the user all the time he needs to read the instructions, remove the program disc, and insert the "data disc". It would be ridiculous to use a WAIT statement to try to anticipate the number of seconds required for these actions. The PAUSE statement gives freedom to the user to take as little or as much time as necessary.

When **CONTINUE** is pressed, the program resumes with any necessary input of file names and assignments. Questions such as "Have you inserted the proper disc?" are unnecessary now. The user has already indicated compliance with the instructions by pressing **CONTINUE**.

Simple Branching

An alternative to linear flow is branching. Although conditional branching is one of the building blocks for selection structures, the unconditional branch is simply a redirection of sequential flow. The keywords which provide unconditional branching are GOTO, GOSUB, CALL, and FN. The CALL and FN keywords invoke new contexts, in addition to their branching action. This is a complex action that is the topic of an entire chapter (Chapter 6). This section discusses the use of GOSUB and GOTO.

Using GOTO

First, you should be aware that the structuring capabilities available in BASIC make it possible to avoid the use of the unconditional GOTO in most applications. You should also be aware that this is a highly desirable goal. The problem is not anything inherent in the GOTO statement. The problem lies in the programmer's tendency to "glue together" pieces of an algorithm, using more and more GOTOs with each revision. Then comes that inevitable day when a fatal bug reveals that it is impossible to "GET BACK FROM" the last "GO TO". The excessive use of GOTO has been appropriately named **spaghetti coding**. Keep this very descriptive term in mind when you are deciding whether to "just throw something together" or "do it right the first time". (See the section on "Top-Down Design" in Chapter 6.)

The only difference between linear flow and a GOTO is that the GOTO loads the program counter with a value that is (usually) different from the next-higher line number. The GOTO statement can specify either the line number or the line label of the destination. The following drawing shows the program flow and contents of the program counter in a program segment containing a GOTO.

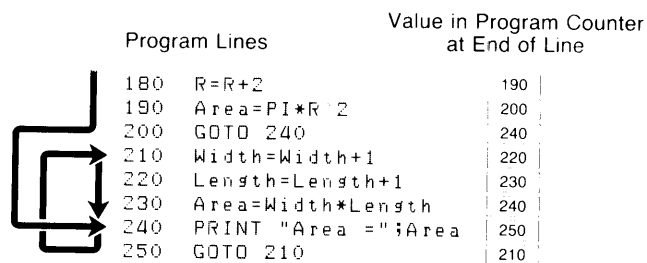

As you can see, the execution is still sequential and no decision making is involved. The first GOTO (line 200) produces a forward jump, and the second GOTO (line 250) produces a backward jump. A forward jump is used to skip over a section of the program. An unconditional backward jump can produce an **infinite loop**. This is the endless repetition of a section of the program. In this example, the infinite loop is line 210 thru 250.

An infinite loop by itself is not usually a desirable program structure. However, it does have its place when mixed with conditional branching or event-initiated branching. Examples of these structures are given later in this chapter.

Using GOSUB

The GOSUB statement is used to transfer program execution to a subroutine. Note that a subroutine and a subprogram are very different in HP BASIC. Calling a **subprogram** invokes a new context. Subprograms can declare formal parameters and local variables. A **subroutine** is simply a

segment of a program that is entered with a GOSUB and exited with a RETURN. Subroutines are always in the same context as the program line that invokes them. There are no parameters passed and no local variables. If you are a newcomer to HP's BASIC, be careful to distinguish between these two terms. They have been used differently in some other programming languages.

The GOSUB is very useful in structuring and controlling programs. The similarity it has to a procedure call is that program flow can automatically return to the proper line when the subroutine is finished. The GOSUB statement can specify either the line label or the line number of the desired subroutine entry point. The following drawing shows the program flow and contents of the program counter in a program segment containing a GOSUB.

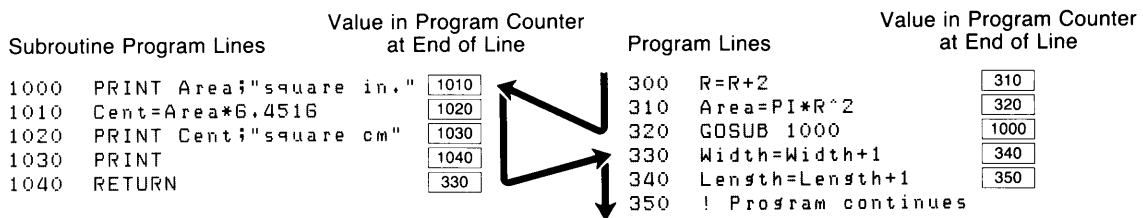

Program execution is sequential and no decision making is involved. The main reason that a GOSUB is a more desirable action than a GOTO is the effect of the RETURN statement. The RETURN statement always returns program execution to the line that would have been executed if the GOSUB had not occurred. This is especially useful when using an event-initiated GOSUB. Since it is usually impossible to predict when a user might press a softkey (for example), it is usually impossible to predict what program line should be returned to at the end of a service routine. By using GOSUB and RETURN, the computer does the work for you.

Another common advantage gained from the use of GOSUB is program economy resulting from the consolidation of common tasks. For example, assume that you are writing a page formatter program to neatly print letters, reports, etc. The actions taken at the end of each page might be such things as:

1. Skip two blank lines
2. Print the page number
3. Update the page counter
4. Print a form-feed
5. Zero the line counter

These end-of-page actions might be necessary at many places in the program. For example: in the new-page segment, in the conditional-page algorithm, in the normal line-printing segment, and in the end-of-file process. It would be wasteful duplication to repeat all those end-of-page steps every place they are needed.

That kind of duplication also opens the door to updating problems. Suppose that you wanted to modify the end-of-page action to make it print line-feeds instead of a form-feed for the benefit of a printer that doesn't use form-feeds. If you had duplicated the end-of-page routine in five different places in the program (or was that six?), you will be doing five times as much typing to make the change, and you will probably miss a spot.

The solution is a subroutine. For the sake of completeness in this example, the hypothetical end-of-page subroutine is shown below.

```
540 End_Page:  !
550   PRINT USING "2/,K";PageNumber
560   PageNumber=PageNumber+1
570   PRINT CHR$(12);
580   Lines=0
590   RETURN
```

There are no “rules” to say when a program action should be made into a subroutine and when it should be left in linear-flow. The following suggestions may help you decide.

- There is no significant speed penalty for using a subroutine. The time required to process the GOSUB and RETURN is extremely small. If you are having trouble getting your application to run fast enough, it is doubtful that your problems will be solved by removing a couple of GOSUBs. In fact, the resulting loss of “readability” may actually make it more difficult to identify and correct the real problem in timing.
- The “cross-over point” in line overhead is a subroutine that is only three lines long and is called from only two places in the program. In other words, it takes the same number of program lines to duplicate three lines as it does to stick a RETURN on the end of them and add two GOSUB statements. However, there is nothing “magical” about this observation. It does not mean that you shouldn’t have a subroutine shorter than three lines, or that you should go around making a subroutine out of every three-line sequence you see repeated. It should simply make you aware of possible improvements that could be made if you see the same sequence repeated in several places in your program.
- Decisions about subroutines are best made on a conceptual level. Although there is nothing wrong with accidentally discovering that you repeated ten lines which would make a good subroutine, it is better to identify the appropriateness of subroutines during planning. One question to ask yourself is, “Does it make sense to handle this task in a subroutine?” If it takes a dozen flags and status variables to select all the variations that are needed from one call to the next, a subprogram is probably a cleaner solution. Lines of code that “just happen” to be repeated in several places are not good candidates for a subroutine. A subroutine should have some identifiable task, like opening a file, normalizing a variable, processing an end-of-page, decoding a keypress, parsing a string, and so forth.

Selection

The heart of a computer's decision-making power is the category of program flow called **selection**, or **conditional execution**. As the name implies, a certain segment of the program either is or is not executed according to the results of a test or condition. This is the basic action which gives the computer an appearance of possessing intelligence. Actually, it is the intelligence of the programmer which is remembered by the program and reflected in the pattern of conditional execution.

Consider a chemistry lab application as an example. There would be little use for a computer whose only function was to turn on a valve when a technician pressed the "START" button. The technician might just as well turn the valve himself. However, if the computer turned on a valve when the "START" was pressed and turned off the valve when a specified pH level occurred, then it is performing a much more useful task. If the example is extended to include state-of-the-art remote-control valves and electronic pH measuring devices, the computer is now significantly outperforming the technician. In this example, (in spite of any fancy instrumentation) the quality that moved the computer from "useless" to "useful" was its ability to **decide** when to turn off the valve. It was the programmer (you) who actually specified the criteria for the decision. Those criteria were then communicated to the computer using conditional-execution program structures. As a result, the computer was able to repeat the programmer's intention with much greater speed and accuracy than a human.

This section presents the conditional-execution statements according to various applications. The following is a summary of these groupings.

1. Conditional execution of one segment.
2. Conditionally choosing one of two segments.
3. Conditionally choosing one of many segments.

Conditional Execution of One Segment

The basic decision to execute or not execute a program segment is made by the IF...THEN statement. This statement includes a numeric expression that is evaluated as being either true or false. If true (non-zero), the conditional segment is executed. If false (zero), the conditional segment is bypassed. Although the expression contained in an IF...THEN is treated as a Boolean expression, note that there is no "BOOLEAN" data type. Any valid numeric expression is allowed.

The conditional segment can be either a single BASIC statement or a program segment containing any number of statements. The first example shows conditional execution of a single BASIC statement.

```
100 IF Ph>7.7 THEN OUTPUT Valve USING "#,B";0
```

Notice the test ($Ph > 7.7$) and the conditional statement (`OUTPUT Valve...`) which appear on either side of the keyword THEN. When the computer executes this program line, it evaluates the expression $Ph > 7.7$. If the value contained in the variable `Ph` is 7.7 or less, the expression evaluates to 0 (false), and the line is exited. If the value contained in the variable `Ph` is greater than 7.7, the expression evaluates as 1 (true), and the OUTPUT statement is executed. If you don't already understand logical and relational operators, refer to Chapter 4 (numbers) or Chapter 5 (strings).

By the way, the image specifier # ,B causes the output of a single byte. In the example, the value for that byte is specified as zero (all bits cleared). Presumably, this turns off all devices connected to a GPIO interface. That interface is specified by the value contained in the device selector `Value`. It is beyond the scope of this manual to explain the details of controlling valves and instruments. If you want to do this kind of control, refer to the *BASIC Interfacing Techniques* manual and study the appropriate Interface Installation manual.

The same variable is allowed on both sides of an IF...THEN statement. For example, the following statement could be used to keep a user-supplied value within bounds.

```
IF Number>9 THEN Number=9
```

When the computer executes this statement, it checks the initial value of `Number`. If the variable contains a value less than or equal to nine, that value is left unchanged, and the statement is exited. If the value of `Number` is greater than nine, the conditional assignment is performed, replacing the original value in `Number` with the value nine.

Prohibited Statements

Certain statements are not allowed as the conditional statement in a single-line IF...THEN. The disallowed statements are used for various purposes, but the “common denominator” is that the computer needs to find them during prerun as the first keyword on a line. (A possible exception to this reasoning is REM, which is not allowed because it makes no sense to allow it. Comments certainly aren’t executed conditionally. If comments are necessary on an IF...THEN line, the exclamation point can be used.) The following statements are not allowed in a single-line IF...THEN.

Keywords used in the declaration of variables:

```
COM          OPTION BASE
DIM          REAL
INTEGER
```

Keywords that define context boundaries:

```
DEF FN      FNEND
SUB         SUBEND
END
```

Keywords that define program structures:

```
CASE        FOR
CASE ELSE   IF
ELSE        LOOP
END IF      NEXT
END LOOP    REPEAT
END SELECT  SELECT
END WHILE   UNTIL
EXIT IF     WHILE
```

Keywords used to identify lines that are literals:

```
DATA
REM
```

Conditional Branching

Powerful control structures can be developed by using branching statements in an IF...THEN. Here are some examples.

```
110 IF Free_sPace<100 THEN GOSUB Expand_file
120 ! The line after is always executed
```

This statement checks the value of a variable called `Free_sPace`, and executes a file-expansion subroutine if the value tested is not large enough. The same technique can be used with a `CALL` statement to invoke a subprogram conditionally. One important feature of this structure is that the program flow is essentially linear, except for the conditional “side trip” to a subroutine and back. This is illustrated in the following drawing.

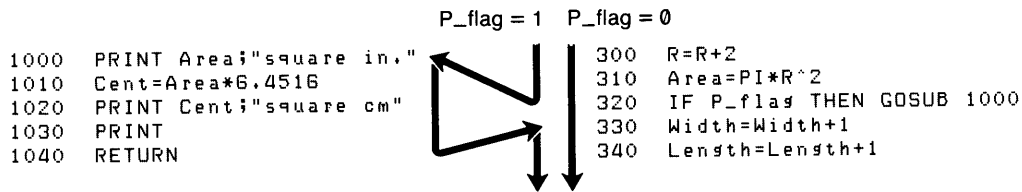

The conditional `GOTO` is such a commonly used technique that the computer allows a special case of syntax to specify it. Assuming that line number 200 is labeled “Start”, the following statements will all cause a branch to line 200 if `X` is equal to 3.

```
IF X=3 THEN GOTO 200
IF X=3 THEN GOTO Start
IF X=3 THEN 200
IF X=3 THEN Start
```

When a line number or line label is specified immediately after `THEN`, the computer assumes a `GOTO` statement for that line. (This improves the readability of programs, because phrases like “then start” sound more like English and less like computer jargon.) If execution is redirected by a conditional `GOTO` (implied or expressed), the program flow does not automatically return to the line following the `IF...THEN`. Thus, a conditional `GOTO` acts like a switch on a railroad track. This is illustrated in the following drawing.

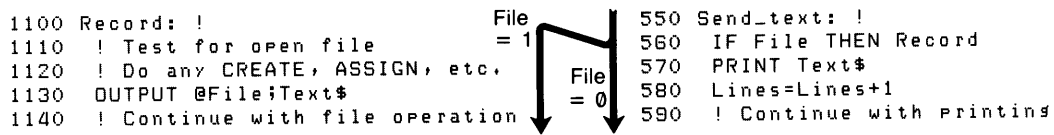

Multiple-Line Conditional Segments

If the conditional program segment requires more than one statement, a slightly different structure is used. Let's expand the valve-control example.

```

100  IF Ph>7.7 THEN
110      OUTPUT Valve USING "#,B";0
120      PRINT "Final Ph =" ;Ph
130      GOSUB Next_tube
140  END IF
150  ! Program continues here

```

Any number of program lines can be placed between a THEN and an END IF statement. In executing this example, the computer evaluates the expression $Ph > 7.7$ in the IF...THEN statement. If the result is false, the program counter is set to 150, and execution resumes with the line following the END IF statement. If the condition is true, the program counter is set to 110, and the three conditional statements (lines 110, 120, 130) are executed. Program flow then picks up at line 150, because the END IF is only used during prerun.

When using multiple-line IF...THEN structures, remember to mark the end of the structure with an END IF statement and don't put any of the statements on the same line as the IF...THEN. If the beginning and end of the structure are not properly marked, the computer reports error 347 during prerun.

The conditional segment can contain any statement except one which is use to set context boundaries (such as END or DEF FN). In the previous example, the GOSUB Next_tube could have been a GOTO Next_tube. In that case, program execution does not pass through 150 when the condition is true. A false condition would cause a branch to line 150, while a true condition would send execution from line 100, to 110, to 120, to 130, and then to the line labeled "Next_tube".

If structuring statements are used within a multiple-line IF...THEN, the entire structure must be contained in one conditional segment. This is called **nested** constructs. The following example shows some properly nested constructs. Notice that the use of indenting improves the readability of the code.

```

1000  IF Flag THEN
1010      IF End_of_Page THEN
1020          FOR I=1 TO Skip_length
1030              PRINT
1040              Lines=Lines+1
1050          NEXT I
1060      END IF
1070  END IF

```

Choosing One of Two Segments

Often you want a program flow that passes through only one of two paths depending upon a condition. This type of decision is represented pictorially by the following diagram. If you have ever been forced to program this type of structure using only the conditional GOTO, you know that the result is much more confusing than it needs to be.

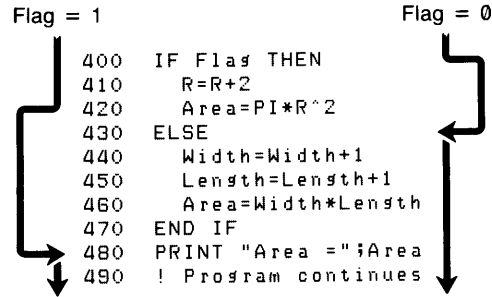

This language has an IF...THEN...ELSE structure which makes the one-of-two choice easy and readable. The following example looks at a device selector which may or may not contain a primary address. The variable `Isc` is needed later in the program and must be only an interface select code. If the operator-supplied device selector is greater than 31, the interface select code is extracted from it. If it is equal to or less than 31, it already is an interface select code. (This example assumes that no secondary addressing is used.)

```

500 IF Select>31 THEN
510   Isc=Select DIV 100
520 ELSE
530   Isc=Select
540 END IF

```

Notice that this structure is similar to the multiple-line IF...THEN shown previously. The only difference is the addition of the keyword ELSE. Like the previous example, the structure is terminated by END IF, and the proper nesting of other structures is allowed. The next example shows a program segment that removes certain “escape sequences” from a string. The number of bytes in the escape sequence varies, but can be determined by inspecting the characters following the escape code. Notice the nesting of structures and the conditional branch. When no more escape sequences remain in the string, program execution continues at `Next_seg`.

```

3800 Escape: !
3810 Point=POS(A$,Esc$)
3820 IF NOT Point THEN Next_seg
3830 IF A$[Point+1;1]<>"&" THEN
3840   A$[Point]=A$[Point+2] ! 2-byte sequence
3850 ELSE
3860   IF A$[Point+2;1]="d" THEN
3870     A$[Point]=A$[Point+4] ! 4-byte sequence
3880   ELSE
3890     A$[Point]=A$[Point+5] ! 5-byte sequence
3900   END IF
3910 END IF
3920 GOTO Escape ! Look for more
3930 !
3940 Next_seg: ! Program continues here

```

Choosing One of Many Segments

Using SELECT Constructs

Consider as an example the processing of readings from a voltmeter. In this example, we assume that the reading has already been entered, and it contained a function code. These hypothetical function codes identify the type of reading and are shown in the following table.

Function Code	Type of Reading
DV	DC Volts
AV	AC Volts
DI	DC Current
AI	AC Current
OM	Ohms

The first example shows the use of the SELECT construct. The function code is contained in the variable `Funct$`. For the sake of simplicity, the example does not show any actual processing. Comments are used to identify the location of the processing segments. The rules about illegal statements and proper nesting are the same as those discussed previously in the IF...THEN section.

```

2000  SELECT Funct$
2010  CASE "DV"
2020    !
2030    ! Processing for DC Volts
2040    !
2050  CASE "AV"
2060    !
2070    ! Processing for AC Volts
2080    !
2090  CASE "DI"
2100    !
2110    ! Processing for DC Amps
2120    !
2130  CASE "AI"
2140    !
2150    ! Processing for AC Amps
2160    !
2170  CASE "OM"
2180    !
2190    ! Processing for Ohms
2200    !
2210  CASE ELSE
2220    BEEP
2230    PRINT "INVALID READING"
2240  END SELECT
2250  ! Program execution continues here

```

Notice that the SELECT construct starts with a SELECT statement specifying the variable to be tested and ends with an END SELECT statement. The anticipated values are placed in CASE statements. Although this example shows a string tested against simple literals, the SELECT statement works for numeric or string variables or expressions. The CASE statements can contain constants, variables, expressions, comparison operators, or a range specification. The anticipated values, or **match items**, must be of the same type (numeric or string) as the tested variable.

The CASE ELSE statement is optional. It defines a program segment that is executed if the tested variable does not match any of the cases. If CASE ELSE is not included and no match is found, program execution simply continues with the line following END SELECT.

The following example shows a numeric variable tested with comparison operators and a range specifier.

```

1500  SELECT Ds
1510  CASE <1
1520    ! Processing for invalid device selector
1530  CASE 1 TO 31
1540    ! Processing for interface select code
1550  CASE >31
1560    ! Contains primary address
1570  END SELECT

```

A CASE statement can also specify multiple matches by separating them with commas, as shown below.

```
CASE -1,1,3 TO 7,>15
```

The following CASE statement shows the use of a string expression, rather than a simple constant.

```
CASE CHR$(27)&"")@"&Eol$
```

You should be aware that if an error occurs when the computer tries to evaluate an expression in a CASE statement, the error is reported for the line containing the SELECT statement. This is a result of the nature of SELECT constructs and is not a bug. However, it can make things a bit confusing if you aren't aware of it. An error message pointing to a SELECT statement actually means that there was an error in that line or in one of the CASE statements. It requires more "detective work" on your part to locate the line which actually contains the erroneous expression.

Using the ON Statement

This type of program flow can also be generated with the ON statement and some additional processing. Let's do a string example first, using the previous voltmeter example. All the anticipated values are placed in a simple string. This string is then searched using the POS function. The results of the POS function are adjusted to become consecutive integers beginning with one. This result can then be used in the ON statement.

```

100  Match$="DVAVDIAIOM"
.
.
.
500  Pointer=POS(Match$,Funct$)
510  Pointer=INT((Pointer-1)/2+1)
520  ON Pointer+1 GOSUB Case_else,Case_dv,Case_av,
Case_di,Case_ai,Case_om

```

Notice that a match can only cause values of 1, 3, 5, 7, or 9 from the POS function. A “match not found” gives a value of 0. Line 510 converts these to consecutive integers from 0 thru 5. The `Pointer+1` expression in line 520 shifts the values to a range 1 thru 6, which is acceptable to the ON statement.

The values of the match characters will determine the “pre-processing” necessary. If you are trying to match single bytes, simply adding one to the results of the POS is all that is necessary. Finding 3-letter sequences requires a line like 510, only with a division by 3. Note also that, except for single bytes, this method may not always work. For example, if the current ranges had been indicated by DA and AA (instead of DI and AI), `Match$` would be “DVAVDAAAOM”. A subsequent search for “AA” would return 6 instead of 7 — not good. In a case like that, there are two choices. One approach is to rearrange the string being searched; “DVAVDAOMAA” would work. Perhaps the items in the string could be separated with a “pad” character and the calculation adjusted accordingly. The other approach is to make each match value a separate element of a string array. The array could then be “searched” with a FOR...NEXT loop. This approach works well to resolve conflicts, especially with long match strings. However, the extra code lines and array accesses slow the process down significantly.

The ON statement can also be used for numeric values. If the numeric values you are trying to match just happen to be consecutive integers starting with one, the variable to be tested can be used in the ON statement. However, programmers don’t usually get that lucky. To match arbitrary values, the following trick can be used. This example tests the three cases: <0, 1, and >1.

```
700  Pointer=1*(X<0)+2*(X=1)+3*(X>1)
710  ON Pointer GOSUB Negative,One,Greater
```

Assuming that you use non-overlapping comparison tests, only one of the values in parentheses will be true. The system returns a value of “1” for true. This is multiplied times the corresponding factor to give the final value to `Pointer`. All the other factors drop out because their comparison result is zero. Programmers who like strong type checking may raise an eyebrow at this technique, but it works.

Another way of testing for numbers that are integers between 0 and 255 is to use the `CHR$` function to create string bytes and apply the POS function as explained previously.

Repetition

Humans usually prefer tasks with variety that avoid tedious repetition. A computer does not have this shortcoming. You have four structures available for creating repetition. The FOR...NEXT structure is used for repeating a program segment a predetermined number of times. Two other structures (REPEAT...UNTIL and WHILE) are used for repeating a program segment indefinitely, waiting for a specified condition to occur. The LOOP...EXIT IF structure is used to create an iterative structure that allows multiple exit points at arbitrary locations.

The FOR...NEXT structure is used for repeating a program segment a predetermined number of times. Two other structures (REPEAT...UNTIL and WHILE) are used for repeating a program segment indefinitely, waiting for a specified condition to occur. The LOOP...EXIT IF structure is used to create an iterative structure that allows multiple exit points at arbitrary locations.

Fixed Number of Iterations

The general concept of repetitive program flow can be shown with the FOR...NEXT structure. With this structure, a program segment is executed a predetermined number of times. The FOR statement marks the beginning of the repeated segment and establishes the number of repetitions. The NEXT statement marks the end of the repeated segment. This structure uses a numeric variable as a **loop counter**. This variable is available for use within the loop, if desired. The following drawing shows the basic elements of a FOR...NEXT loop.

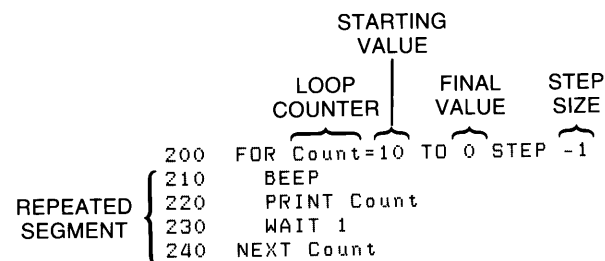

The number of loop iterations is determined by the FOR statement. This statement identifies the loop counter, assigns a starting value to it, specifies the desired final value, and determines the step size that will be used to take the loop counter from the starting value to the final value. When the loop counter is an INTEGER, the number of iterations can be predicted using the following formula:

$$\text{INT} \left(\frac{\text{Step Size} + \text{Final Value} - \text{Starting Value}}{\text{Step Size}} \right)$$

Note that the formula applies to the values in the variables, not necessarily the numbers in the program source. For example, if you use an INTEGER loop counter and specify a step size of 0.7, the value will be rounded to one. Therefore, 1 should be used in the formula, not 0.7.

The loop counter can be a REAL number, with REAL quantities for the step size, starting, or final values. In some cases, using REAL numbers will cause the number of iterations to be off by one from the preceding formula. This is because the NEXT statement performs an “increment and compare”, and there is a slight inaccuracy in the comparison of REAL numbers. If you are interested, this is discussed in the next chapter. However, there is no “clean” way around it with FOR...NEXT loops. Here is an example:

```
200  Count=0
210  FOR X=10 TO 20
220    Count=Count+1
230    PRINT Count
240  NEXT X
```

According to the formula, this loop should execute 11 times: $\text{INT}((1 + 20 - 10)/1 = 11)$. The result on the CRT confirms this when the loop is executed. If line 210 is changed to:

```
210  FOR X=1 TO 2 STEP .1
```

the formula still yields 11 as the number of iterations. However, executing the loop produces only 10 repetitions. This is because of a very, very small accumulated error that results from the successive addition of one-tenth. The error is less significant than the 15th digit, but discernable to the computer. In this case, rounding cannot be performed at a time that would help. When you find yourself in this situation, one solution is to add a slight adjustment factor to the final value. One half of the step size is a convenient adjustment factor. The following line does give the 11 iterations predicted by the formula.

```
210  FOR X=1 TO 2.05 STEP .1
```

Remembering the “increment and compare” operation at the bottom of the loop is helpful. After the loop counter is updated, it is compared to the final value established by the FOR statement. If the loop counter has **passed** the specified final value, the loop is exited. If it has **not passed** the specified final value, the loop is repeated. The loop counter retains its exit value after the loop is finished. This is not necessarily one full step past the final value. For example:

```
FOR I=1 TO 9.9
```

This statement establishes a loop that executes nine times (the default step size is one). The variable I has the value 10 when the loop is exited.

```
FOR Count=12 TO 1 STEP -.3
```

This statement establishes a loop that executes 37 times. The variable Count has the value .9 when the loop is exited. Notice that negative step sizes are allowed using the same keywords as positive step sizes.

The final points to mention concern the execution of the FOR statement. If any variables are present to the right of the equal sign, the value used is the value they have when the FOR statement is executed. Remember that the FOR statement is only executed once before the loop begins. Also, if the number of iterations evaluates to zero or less, the loop is not executed and program execution goes immediately to the line following the NEXT statement. Here are some examples.

```

400 FOR Item=First TO Last
410   GOSUB Process
420   Last=Last+1
430 NEXT Item
440 ! Execution continues here

```

This loop would not be executed if Last were less than First. This is almost always desirable, since it prevents the subroutine Process from being invoked with a null item. Also notice that the number of iterations is fixed at loop entry when line 400 is executed. That number of iterations does not change when the value of Last is changed.

```
FOR Item=Item+1 TO Last
```

The variable Item is used as the loop counter. It receives a starting value that is one greater than the value it had when this line is executed.

Conditional Number of Iterations

The FOR...NEXT loop produces a fixed number of iterations, established by the FOR statement before the loop is executed. Some applications need a loop that is executed until a certain condition is true, without specifically stating the number of iterations involved. Consider a very simple example. The following segment asks the operator to input a positive number. Presumably, negative numbers are not acceptable. A looping structure is used to repeat the entry operation if an improper value is given. Notice that it is not important **how many times** the loop is executed. If it only takes once, that is just fine. If the poor operator takes ten tries before he realizes what the computer is asking for, so be it. What is important is that a **specific condition** is met. In this example, the condition is that a value be non-negative. As soon as that condition has been satisfied, the loop is exited.

```

800 REPEAT
810   INPUT "Enter a positive number",Number
820 UNTIL Number>=0

```

A typical use of this is an iterative problem involving non-linear increments. One example is musical notes. Performing the same operation on all the notes in a 3-octave band is a repetitive process, but not a linear one. Musical notes are related geometrically by the 12th root of two. The following example simply prints the frequencies involved, but your application could involve any number of operations.

```

1200 Note=110      ! Start at low A
1210 REPEAT
1220   PRINT Note;
1230   Note=Note*2^(1/12)
1240 UNTIL Note>880 ! End at high A

```

For this example, a FOR...NEXT loop might have been used, with the loop counter appearing in an exponent. That would work because it is relatively easy to know how many notes there are in three octaves of the musical scale. However, the REPEAT...UNTIL structure is more flexible than FOR...NEXT when working with exponential data in general. Examples often occur in the area of graphics. The following segment could be used to plot audio frequency data, where the x-axis is logarithmic.

```

1500  Freq=20
1510  MOVE LOG(Freq),FNFunction(Freq)
1520  REPEAT
1530    DRAW LOG(Freq),FNFunction(Freq)
1540    Freq=Freq*1.2
1550  UNTIL Freq>20000

```

The flexibility of this structure is in line 1540. By increasing the frequency with a factor of 1.2, a very fast but rough graph is generated. (You need the GRAPH BIN to run this example.) This lets you place axes, labels, markers, etc. where you want them without waiting for a time-consuming plot for each cosmetic change. Once you have the desired appearance, you could change line 1540 to `Freq=Freq*1.01`. This would greatly increase the resolution of the plot (and reduce its speed). To take it one step further, you could make the “resolution factor” a variable and input its value at the start of the program. That would make it easy to try many different increments to achieve the best compromise between resolution and smoothness. Attempting a similar technique with FOR...NEXT loops would involve many extra (and unnecessary) calculations.

The WHILE loop is used for the same purpose as the REPEAT loop. The only difference between the two is the location of the test for exiting the loop. The REPEAT loop has its test at the bottom. This means that the loop is always executed at least once, regardless of the value of the condition. The WHILE loop has its test at the top. Therefore, it is possible for the loop to be skipped entirely (if the conditions so dictate). The following segment shows the same plotting example using a WHILE loop.

```

1500  Freq=20
1510  MOVE LOG(Freq),FNFunction(Freq)
1520  WHILE Freq<=20000
1530    DRAW LOG(Freq),FNFunction(Freq)
1540    Freq=Freq*1.2
1550  END WHILE

```

The next segment shows the use of conditional branching to simulate a REPEAT...UNTIL structure.

```

1500  Freq=20
1510  MOVE LOG(Freq),FNFunction(Freq)
1520  Loop_top:  !
1530    DRAW LOG(Freq),FNFunction(Freq)
1540    Freq=Freq*1.2
1550  IF Freq<=20000 THEN Loop_top

```

The WHILE structure can also be simulated using GOTO statements. The following segment shows this technique.

```

1500  Freq=20
1510  MOVE LOG(Freq),FNFunction(Freq)
1520  Loop_top:  !
1530  IF Freq>20000 THEN Loop_exit
1540    DRAW LOG(Freq),FNFunction(Freq)
1550    Freq=Freq*1.2
1560  GOTO Loop_top
1570  Loop_exit:  !

```

The REPEAT...UNTIL and WHILE structures are especially useful for tasks that are impossible with a FOR...NEXT loop. One such situation is a loop where both the loop counter and the final value are changing. Consider the example of stripping all control characters from a string. This can't be done in a loop that starts FOR I=1 TO LEN(A\$), because the length of A\$ changes each time a character is deleted. Therefore, the loop counter used as a subscript will eventually exceed the length of the string by more than one, generating an error. The WHILE loop does not have this problem. Note that the test at the top of the loop prevents the subscripting from being attempted on a null string. This is necessary to avoid an error.

```

600  I=1
610  WHILE I<=LEN(A$)
620    IF A#[I;1]<CHR$(32) THEN
630      A#[I]=A#[I+1]
640    ELSE
650      I=I+1
660    END IF
670  END WHILE

```

Arbitrary Exit Points

A pass through any of the loop structures discussed so far included the entire program segment between the top and the bottom of the loop. There are times when this is not the desired program flow. The LOOP structure defines a repeated program segment and allows any number of conditional exits points in that segment.

For the first example, consider a search and replace operation on string data. In this example, the "shift out" control character is being used to initiate underlining on a printer that understands standard escape sequences. The "shift in" control character is used to turn off the underline mode. (There is nothing significant about this choice of characters. Any combination of characters could serve the same purpose.)

One approach is to use a loop to search every character in every string to see if it is one of the special characters. There are two problems with this method. First, it is a little cumbersome when the replacement string is a different length than the target string. Second, it is slow. Admittedly, speed is not a significant consideration when driving common mechanical printers. But the destination might eventually be a laser printer or mass storage file, making the program's speed more visible.

A better approach is to use the POS function to locate the target string. Since this function locates only the first occurrence of a pattern, it must be placed in a loop to insure that multiple occurrences will be found. The LOOP structure is well suited to this task, as shown in the following example.

```

2000 LOOP
2010   Position=POS(A$,CHR$(14))
2020 EXIT IF NOT Position
2030   A$[Position]=CHR$(27)&"&dD"&A$[Position+1]
2040 END LOOP
2050 !
2060 LOOP
2070   Position=POS(A$,CHR$(15))
2080 EXIT IF NOT Position
2090   A$[Position]=CHR$(27)&"&d@"&A$[Position+1]
2100 END LOOP
2110 ! Last EXIT goes to here

```

In this segment, all occurrences of “shift out” are replaced by “escape &dD” to enable underline mode. All occurrences of “shift in” are replaced by “escape &d@” to disable underlining. Notice that there is no problem replacing one character with four (assuming that A\$ is large enough). Lines containing no special characters are processed by only two POS functions, which is much faster and cleaner than performing two comparisons for every character in every line.

Another common use for this structure is the processing of operator input. Recall the REPEAT...UNTIL example that tested for the input of a positive number. Although this structure kept the computer happy, it left the operator in the dark. The LOOP structure provides for the additional processing needed, as shown in the following example.

```

200 LOOP
210   INPUT "Enter a positive number.",Number
220 EXIT IF Number>=0
230   BEEP
240   PRINT
250   PRINT "Negative numbers are not allowed."
260   PRINT "Repeat entry with a positive number."
270 END LOOP

```

Another point to remember is that the LOOP structure permits more than one exit point. This allows loops that are exited on a “whichever comes first” basis. Also, the EXIT IF statement can be at the top or bottom of the loop. This means that the LOOP structure can serve the same purposes as REPEAT...UNTIL and WHILE, if that suits your programming style.

The EXIT IF statement must appear at the same nesting level as the LOOP statement for a given loop. This requirement is best shown with an example. In the “WRONG” example, the EXIT IF statement has been nested one level deeper than the LOOP statement because it was placed in an IF...THEN structure.

WRONG

```
600 LOOP
610   Test=RND-.5
620   IF Test<0 THEN
630     GOSUB Negative
640   ELSE
650     EXIT IF Test>.4
660     GOSUB Positive
670   END IF
680 END LOOP
```

RIGHT

```
600 LOOP
610   Test=RND-.5
620 EXIT IF Test>.4
630   IF Test<0 THEN
640     GOSUB Negative
650   ELSE
660     GOSUB Positive
670   END IF
680 END LOOP
```

Event-Initiated Branching

Your computer has a special kind of program flow that provides some very powerful tools. This tool, called **event-initiated branching**, uses interrupts to redirect program flow. The process can be visualized as a special case of selection. Everytime program flow leaves a line, the computer executes an “event-checking” routine. This is set of machine-language “if...then” statements concerning interrupts. If an event is enabled and “true”, this “event-checking” routine causes the program to branch.

The process of “event checking” is represented in the following lines. Notice that it is possible for event-initiated branching to occur at the end of any program line, which includes the lines of a subprogram. This can give the appearance of “middle-of-line” branching when it occurs during a user-defined function. subprogram. These potential branching points are marked by the words “gosub event_check”. This does not refer to a BASIC subroutine, but is just a symbolic reminder of where event-initiated branching can occur. If the operating system finds a “true” event, a branch is taken. If not, program execution resumes with the “normal” program flow.

```
10 PRINT X( gosub event_check)
20 X=X+1 (gosub event_check)
30 GOTO 10 (gosub event_check)
```

Enabling Events

Event-initiated branching is established by the ON-event statements. Here is a list of the statements that fall in this category:

ON END	ON ERROR	ON CYCLE	ON EOR
ON KBD	ON KEY	ON DELAY	ON EOT
ON KNOB	ON INTR	ON TIME	
ON TIMEOUT	ON SIGNAL		

The ON END event is used to detect when the end of a mass storage file is reached. This is discussed in Chapter 7.

The ON CYCLE, ON DELAY and ON TIME statements are used to direct program flow using the clock. They are discussed in Chapter 9.

The ON ERROR event is used to trap run-time errors and provide for error-recovery routines. This is discussed in Chapter 11.

The ON KBD, ON KEY, and ON KNOB events pertain to various parts of the keyboard and are used to enhance the “human interface” of programs. ON KBD lets you re-define the entire keyboard to suit the needs of your program. This is discussed in the *BASIC Interfacing Techniques* manual. The ON KEY statement is used to define and label the softkeys on the keyboard. The ON KNOB statement lets you capture turns of the knob. This chapter has some examples of ON KEY and ON KNOB.

The ON EOR, ON EOT, ON SIGNAL, ON INTR and ON TIMEOUT events pertain to data transfer, interfaces and I/O operations. These are discussed in the *BASIC Interfacing Techniques* manual.

The best way to understand how event-initiated branches operate in a program is to sit down at the computer and try a few examples. Start by entering the following short program.

```

110 ON KEY 1 LABEL "Inc" GOSUB Plus
120 ON KEY 5 LABEL "Dec" GOSUB Minus
130 !
140 Spin: DISP X
150 GOTO Spin
160 !
170 Plus: X=X+1
180 RETURN
190 !
200 Minus: X=X-1
210 RETURN
220 END

```

Notice the various structures in this sample program. The ON KEY statements are executed only once at the start of the program. Once defined, these event-initiated branches remain in effect for the rest of the program. (Disabling and deactivating are discussed later.) The program segment labeled "Spin" is an infinite loop. If it weren't for interrupts, this program couldn't do anything except display a zero. However, there is an implied IF...THEN at the end of lines 140 and 150 because of the ON KEY action. This allows a selection process to occur. Either the "Plus" or the "Minus" subroutine can be selected as a result of softkey presses. These are normal subroutines terminated with a RETURN statement. (In the context of interrupt programming, these subroutines are called **service routines**.) The following section of pseudocode shows what the program flow of the "Spin" segment actually looks like to the computer.

```

Spin: display X
      if Key1 then gosub Plus
      if Key5 then gosub Minus
      goto Spin

```

This pseudocode is an over-simplification of what is actually happening, but it shows that the "Spin" segment is not really an infinite loop with no decision-making structure. Actually, most programs that use event-initiated branching to control program flow will contain what appears to be an infinite loop. That is the easiest way to "keep the computer busy" while it is waiting for an interrupt.

Now run the sample program you just entered. Notice that the bottom of the CRT displays an inverse-video label area. These labels are arranged to correspond to the layout of the softkeys. The labels are displayed when the softkeys are active and are not displayed when the softkeys are not active. Any label which your program has not defined is blank. The label areas are defined in the ON KEY statement by using the keyword "LABEL" followed by a string.

The starting value in the display line is zero, since numeric variables are initialized to zero at prerun. Each time you press or , the displayed value of X is incremented. Each time you press for , the displayed value of X is decremented. This simple demonstration should acquaint you with the basic action of the softkeys.

It is possible to make structures that are much more elaborate, with assignable priorities for each key, and keys that interrupt the service routines of other keys. There are many applications where priorities are not of any real significance, such as the example program running now. However, priorities will sometimes cause unexpected flow problems. One type of priority problem can be shown with a simple modification to our example program. Insert the following line right after line 170.

```
171  GOTO 171
```

Now run the program and press or . Notice that the program “locks up” and all subsequent presses of either softkey do nothing. This is not simply because line 171 creates an infinite loop. The program segment at “Spin” was an infinite loop and that didn’t bother the softkeys at all. The problem is that the priority for the “Plus” service routine is higher than the main program priority. None of the softkeys have been assigned a high enough priority to interrupt another service routine. A full discussion on interrupt priority can be found in the “Interface Events” chapter of the *BASIC Interfacing Techniques* manual. If you think you have an application that is “priority sensitive”, read that section carefully.

Using the Knob

One characteristic of interrupt-driven program flow is that the computer’s decisions can be more easily synchronized with the actions of devices connected to it. This type of application is often called **real-time programming**. An important example of real-time programming is machine control. A computer running an automatic packing machine must turn off the flow immediately when the jar is full. It is not acceptable for the computer to wait until the inventory printout is done and peanut butter is dumped all over the conveyor belt. Although machine control applications are very important, their extensive interfacing makes them inconvenient or impossible to use as demonstration programs in a manual such as this.

Another common example of real-time programming is computer games. The computer is expected to respond “instantly” to button presses, lever movement, etc. The operator expects immediate correlation between their input and the computer’s output or display. Your BASIC Utilities Disc has a couple of simple games on it that demonstrate interaction between the CRT, softkeys, and knob. Feel free to list any of the programs on that disc if you want further examples of various techniques.

The following program is a very short example that demonstrates a real-time interaction between the knob and the CRT. If you run this example program and turn the knob, you will see the kind of interaction that might be used for cursor control in a text editor. Obviously, a real cursor-control routine would be much more sophisticated, but this demonstrates the basic idea.

```

10     ON KNOB ,1 GOSUB Move_blip
20 Spin:      GOTO Spin
30     !
40 Move_blip: !
50     PRINT TABXY(SPotx,SPoty);" ";
60     SPotx=SPotx+KNOBX/5
70     SPoty=SPoty+KNOBY/5
80     IF SPoty<1 THEN SPoty=1
90     IF SPoty>18 THEN SPoty=18
100    IF SPotx<1 THEN SPotx=1
110    IF SPotx>50 THEN SPotx=50
120    PRINT TABXY(SPotx,SPoty);CHR$(127);
130    RETURN
140    END

```

This example uses a short infinite loop to wait for pulses from the knob (line 20). Interrupts from the knob are enabled by the ON KNOB statement in line 10. The service routine erases the old “blip”, performs some scaling and range checking on the knob input, and prints the new “blip”.

The scaling and range checking are very important in this kind of interactive routine. Humans expect their interface to have a certain “feel”. Displays should not change too quickly or too slowly. Certain kinds of displays are expected to change logarithmically, others are expected to change linearly. The boundary values of variables are expected to conform to the boundaries of the display. To initiate yourself to some of these concepts, try modifying this simple example. Remove one or more of the range checking lines. (An easy way to do this kind of editing is to place an exclamation point in front of the statement. This turns it into a comment, removing it from the flow of execution. But it can be easily returned to the program by deleting the exclamation point.) Also try changing the scaling factor in lines 60 and 70. Notice the “feel” that results from larger and smaller increments, or even logarithmic scaling.

Deactivating Events

Knowing how to “turn off” the interrupt mechanism is just as important as knowing how to enable it. Often, an event is a desired input during one part of the program, but not during another. You might use softkeys to set certain process parameters the start of a program, but you don’t want interrupts from those keys once the process starts. For example, a report generating program could use a softkey to select single or double spacing. This key should be disabled once the printout starts so that an accidental keypress does not cause the computer to abort the printout and return to the questions at the beginning of the program. On the other hand, you might want an “Abort” key that does precisely that. The important thing is that you decide on the desired action and make the computer obey your wishes.

Before going any further, let’s explain some important terminology. There are two general methods for “turning off” an interrupt. If an interrupt source is **deactivated**, it no longer has any influence on program flow. You can press a deactivated key all day long and nothing will happen. However, if an event is **disabled**, its action has only been temporarily postponed. The computer remembers that a key was pressed while it was disabled, and the action for that key will occur at the earliest opportunity once the disabled state is removed. There are examples in this section to demonstrate the difference between these two conditions.

All the “ON-event” statements have a corresponding “OFF-event” statement. This is one way to deactivate an interrupt source.

- OFF KEY deactivates interrupts from the softkeys. If a softkey is pressed while deactivated, it does nothing.
- OFF KNOB deactivates the ON KNOB interrupts. Turning the knob while ON KNOB is deactivated causes normal scrolling on the CRT.

The following example shows one use of OFF KEY to disable the softkeys. (Note that `kn` is used in the description. If you have an HP 46020A keyboard, just substitute `fn`.) A softkey is used to select a parameter for a small printing routine. Each press of `k1` increments and displays the step size that will be used as an interval between the printed numbers. When the desired step size has been selected, `k4` is pressed to start the printout. Enter and run this example. Notice that with line 240 and 250 commented out, the **softkey menu**, or label area, never changes.

```

100 Begin: !
110 ON KEY 1 LABEL " DELTA" GOSUB Step_size
120 ON KEY 4 LABEL " START" GOTO Process
130 Inc=1
140 DISP "Step Size = 1"
150 !
160 Spin: GOTO Spin ! Wait for KeyPress
170 !
180 Step_size: !
190 Inc=Inc+1 ! Change increment
200 DISP "Step Size =" ;Inc
210 RETURN
220 !
230 Process: !
240 ! OFF KEY ! Deactivate first choices
250 ! ON KEY 8 LABEL " ABORT" GOTO Leave
260 Number=0
270 FOR I=1 TO 10
280 Number=Number+Inc
290 PRINT Number;
300 WAIT ,6
310 NEXT I
320 Leave: !
330 OF KEY 8 ! Deactivate ABORT
340 PRINT ! End line
350 GOTO Begin ! Start over
360 END

```

Now run the example again and press `k1` or `k4` while the printout is in progress. Notice that the keys are still active and produce undesired effects on the printing process. To “fix this bug”, remove the exclamation point from line 240. This disables all the softkeys when the printing process starts. Notice that the softkey menu goes away when no softkeys are active. This is a very handy feature while you are experimenting with interrupts. It provides immediate feedback to indicate when interrupts are active and when they are not.

Finally, remove the exclamation point from line 250. Now, the softkey menu appears during the printing process. However, the choices are different than at the start of the program. The keys used to select the parameter and start the process are not active, because they are not needed at this point in the program. Instead, `k8` can be used to “gracefully” abort the process and return to the start of the program.

The OFF KEY statement can include a key number to deactivate a selected key. This was done in line 330.

Disabling Events

All the previous examples have shown complete deactivation of the softkeys. It is also possible to temporarily disable an event-initiated branch. This is done when an active event is desired in a process, but there is a special section of the program that you don't want to be interrupted. Since it is impossible to predict when an external event will occur, the special section of code can be "protected" with a DISABLE statement. This is sometimes necessary to prevent a certain variable from being changed in the middle of a calculation or to insure that an interface polling sequence runs to completion. It is difficult in a short, simple example to show **why** you would need to do this. But it is not difficult to show **how** to do it.

```

100  ON KEY 9 LABEL " ABORT" GOTO Leave
110  !
120  Print_line:  !
130  DISABLE
140  FOR I=1 TO 10
150    PRINT I;
160    WAIT .3
170  NEXT I
180  PRINT
190  ENABLE
200  GOTO Print_line
210  !
220  Leave: END

```

This example shows a DISABLE and ENABLE statement used to "frame" the Print_line segment of the program. The "ABORT" key is active during the entire program, but the branch to exit the routine will not be taken until an entire line is printed. The operator can press the "ABORT" key at any time. The keypress will be **logged**, or remembered, by the computer. Then when the ENABLE statement is executed, the event-initiated branch is taken. Enter and run the example to observe this method of delaying interrupt servicing.

Notes

Numeric Computation

Chapter

4

Introduction

When most people think about computers, the first thing that they think of is number-crunching, the giant calculator with a brain. Whether this is an accurate impression or not, numeric computations are an important part of computer programming.

Numeric computations deal exclusively with numeric values. Thus, adding two numbers and finding a sine or a logarithm are all numeric operations; while converting bases and converting a number to a string or a string to a number are not. (Converting bases and converting numbers to strings and strings to numbers are covered in the chapter on String Operations.)

The most fundamental numeric operation is the assignment operation, achieved with the LET statement. The LET statement originally required the keyword LET for BASIC interpreters, but your computer makes it optional. Thus the following statements are equivalent:

```
LET A = A + 1
A = A + 1
```

Numeric Data Types

There are two numeric data types in BASIC that you are using, INTEGER and REAL. Any numeric variable that is not declared an INTEGER is a REAL variable. The valid range for REAL numbers is approximately:

– 1.797 073 134 862 315 X 10³⁰⁸ thru 1.797 073 134 862 315 X 10³⁰⁸

the smallest non-zero REAL value allowed is approximately:

± 2.225 073 858 507 202 X 10⁻³⁰⁸

A REAL can also have the value of zero.

An INTEGER can have any whole-number value from:

– 32 768 thru + 32 767

Both REAL and INTEGER variables may be grouped into arrays.

Declarations

It is good programming practice to declare all variables, and both INTEGER and REAL statements are provided for declaring variables:

```
INTEGER I, J, Days(5), Weeks(5:17)
REAL X, Y, Voltage(4), Hours(5,8:13)
```

Each of the above statements declares two scalar and two array variables. A scalar is a variable which can, at any given time, represent a single value. An array is a subscripted variable, and can contain multiple values, accessed by subscripts. It is possible to specify both the lower and upper bounds of an array, or to specify the upper bound only, and use the existing OPTION BASE as the lower bound. Details on declarations of arrays and how to use them are provided later in this chapter when arrays are dealt with in detail. The DIM statement may also be used to declare a REAL array.

```
DIM R(4,5)
```

An ALLOCATE statement can be used to declare both REAL and INTEGER arrays.

```
ALLOCATE REAL Co_ords(2,1:Points), INTEGER Status(1:Points)
```

The ALLOCATE statement allows you to dynamically allocate memory in programs which need tight control over memory use.

Type Conversions

The computer will automatically convert between REAL and INTEGER values in assignment statements and when parameters are passed by value in function and subprogram calls. When parameters are passed by reference the conversion will not be made and a type mismatch error will be reported. Whenever numbers are converted from REAL to INTEGER representations, information can be lost. There are two potential problem areas in this conversion, rounding errors and range errors.

The computer will automatically convert between types when an assignment is made, and this presents no problem when an INTEGER is converted to a REAL. However, when a REAL is converted to an INTEGER, the REAL is rounded to the closest INTEGER value. When this is done, all information about the number to the right of the radix (decimal point) is lost. If the fractional information is truly not needed, there is no problem, but converting back to a REAL will not reconstruct the lost information — it stays lost.

Another potential problem with REAL to INTEGER conversions is the difference in ranges. While REAL values range from approximately -10^{308} to $+10^{308}$, the INTEGER range is only from $-32\,768$ to $+32\,767$ (approximately -10^4 thru $+10^4$). Obviously, not all REAL values can be rounded into an equivalent INTEGER value. This problem can generate INTEGER Overflow errors.

While the rounding problem is important, it does not generate an execution error. The range problem **can** generate an execution error, and you should protect yourself from crashing the program by either testing values before assignments are made, or by using ON ERROR to trap the error, and making corrections after the fact.

The following fragment shows a method to protect against INTEGER overflow errors:

```

200 IF X > 32767 THEN X= 32767
210 IF X < -32768 THEN X = -32768
220 Intx = X
    
```

It is possible to achieve the same effect using MAX and MIN functions:

```

200 Y = MAX(MIN(X, 32767), -32768)
    
```

Both these methods limit the excursion, but lose the fact that the values were originally out of range. If out-of-range is a meaningful condition, an error handling trap is more appropriate.

```

200 IF (-32768<=X) AND (X<=32767) THEN
210     Y = X
220 ELSE
230     GOSUB Out_of_range
240 END IF
    
```

Internal Numeric Formats

The storage format for REAL and INTEGER numbers in memory are as follows:

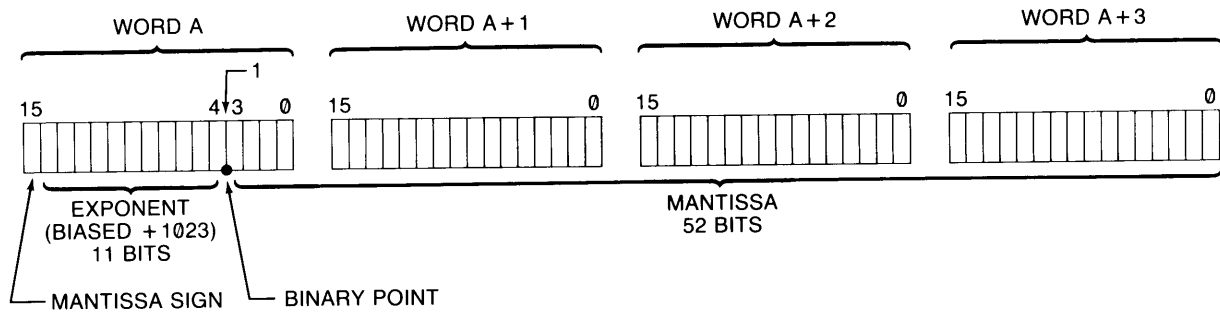

$$-1^{\text{mantissa sign}} \times 2^{\text{exponent} - 1023} \times 1.\text{mantissa}$$

Storage Format for REAL Variables

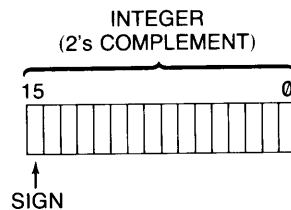

Storage Format for INTEGER Variables

Precision and Accuracy: The Machine Limits

Your computer stores all REAL variables with a sign, approximately 15 significant digits, and the exponent value. For most engineering and other applications, rounding errors are not a problem because the resolution of the computer is well beyond the limitations of most scientific measuring devices. However, when high-resolution numerical analysis requires accuracy approaching the limits of the computer, round-off errors must be considered.

Rounding errors should be considered when conversions are made between decimal digits and binary form. Input and output operations are one time when this occurs. Given the format used for REALs, the conversion REAL \rightarrow decimal \rightarrow REAL will yield an identity only if the REAL \rightarrow decimal conversion produces a 17-decimal-digit mantissa and the calculations for the conversions are done in extra precision. This is not the case on the Series 200. Therefore, several things can be said about these conversions on the Series 200 computers:

- Up to and including 16 decimal digits are allowed when storing a number in internal form. If there are more digits, they are ignored.
- Up to and including 15 decimal digits may be output when converting a REAL for printing, display, etc. A full 16-digit conversion is not allowed because there are not 16 full digits of precision.
- It is possible for two distinct decimal numbers to map onto the same REAL number because the binary mantissa does not have enough bits to represent all 16 decimal digits. This can happen only if the decimal numbers are specified to 16-digits.
- It is possible for two distinct REAL numbers to convert to the same decimal number even if the conversion is done to 15-decimal-digit accuracy. Therefore, you cannot use a comparison of the digits in printed or displayed numbers to check for equality.
- All distinct 15 digit decimal strings have a correct distinct REAL representation, but it is not always possible to map them onto their correct representation because REAL multiplies are not done in extra precision, and the table entries are only 64 bits. In other words, the decimal \rightarrow REAL conversion may produce a REAL that differs from the true representation by a maximum of two bits.

There are references at the end of this chapter to documents that contain further information on the subject of representing real numbers.

Evaluating Scalar Expressions

The Hierarchy

If you look at the expression $2 + 4/2 + 6$, it can be interpreted several ways:

- $2 + (4/2) + 6 = 10$
- $(2 + 4)/2 + 6 = 9$
- $2 + 4/(2 + 6) = 2.5$
- $(2 + 4)/(2 + 6) = .75$

Computers do not deal well with ambiguity, so an arbitrary hierarchy is used for evaluating expressions to eliminate any questions about the meaning of an expression. When the computer encounters a mathematical expression, an expression evaluator is called. If you do not understand the expression evaluator, you can easily be surprised by the value returned for a given expression. In order to understand the expression evaluator, it is necessary to understand the valid elements in an expression and the evaluation hierarchy (the order of evaluation of the elements).

Six items can appear in a numeric expression; operators, constants, variables, intrinsic functions, user-defined functions and parentheses. Operators modify other elements of the expression. Constants and variables represent numeric values in the system. Functions, both intrinsic and user-defined, return a value which replaces them in the evaluation of the expression. Parentheses are used to modify the evaluation hierarchy.

The following table defines the hierarchy used by the computer in evaluating numeric expressions.

Math Hierarchy

Precedence	Operator
Highest	Parentheses; they may be used to force any order of operation Functions, both user-defined and machine-resident Exponentiation: ^ Multiplication and division: * / MOD DIV MODULO Addition, subtraction, monadic plus and minus: + - Relational Operators: = < > < > < = > =
	NOT
	AND
Lowest	OR EXOR

When an expression is being evaluated it is read from left to right and operations are performed as encountered, unless a higher precedence operation is encountered immediately to the right of the operation encountered, or unless the hierarchy is modified by parenthesis. If the computer cannot deal immediately with the operation, it is stacked, and the evaluator continues to read until it encounters an operation it can perform. It is easier to understand if you see how an expression is actually handled. The following expression is complex enough to demonstrate most of what goes on in expression evaluation.

$$A = 5 + 3 * (4 + 2) / \text{SIN}(X) + X * (1 > X) + \text{FNNeg1} * (X < 5 \text{ AND } X > 0)$$

In order to evaluate this expression, it is necessary to have some historical data. We will assume that DEG has been executed, that $X = 90$, and that `FNNeg1` returns -1. Evaluation proceeds as follows:

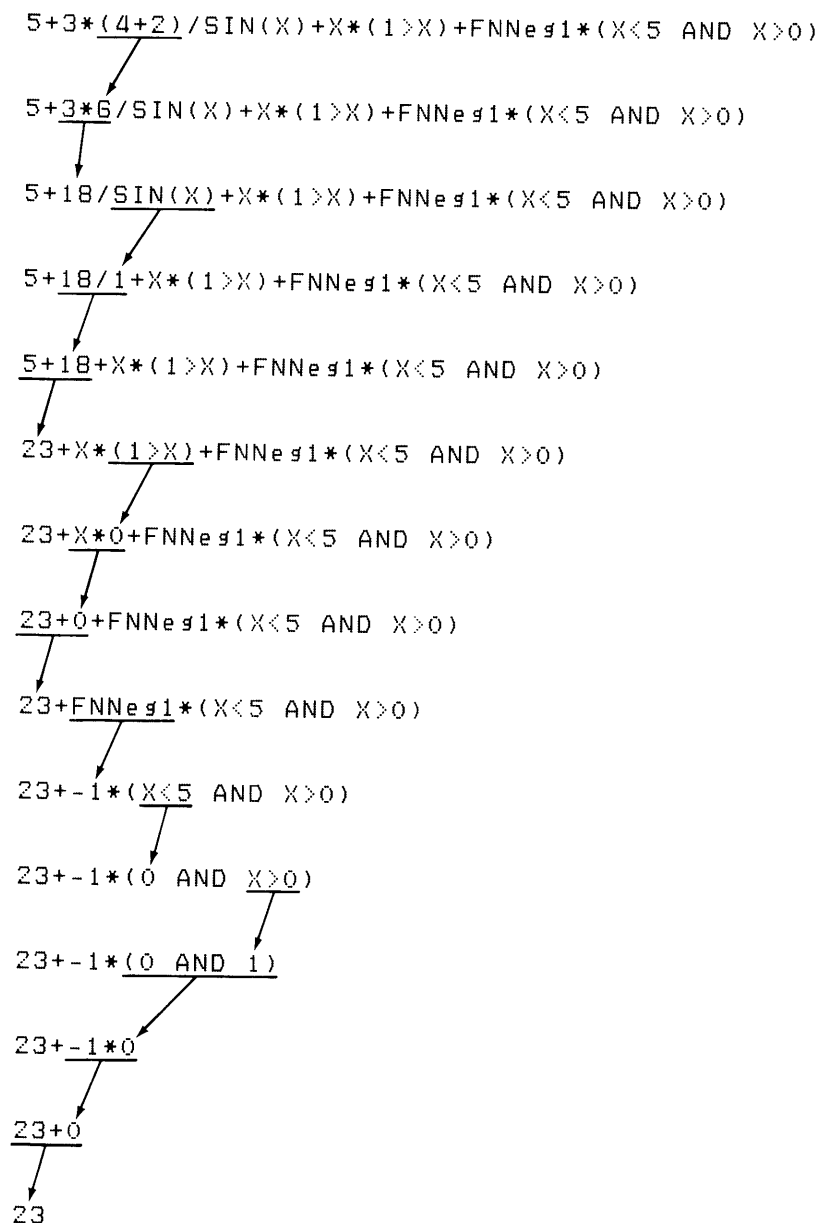

The Delayed Binding Surprise

The computer delays binding of a variable to its value as long as possible. In the actual evaluation, a pointer to the location of a variable is what is stacked. This means that if a variable exists in an area of COM accessible to both the main program and a user-defined-function, is used in an expression that also calls the user-defined-function, and is modified in the function, the value of the expression can be surprising, although not unpredictable. For example, if we define a function `FNNES1` that returns a minus 1, we would expect the following lines to print 2.

```
10 COM X
20 X = 3
30 Y = X + FNNES1
40 PRINT Y
```

However, if the user-defined-function looks like this:

```
1000 DEF FNNES1
1010     COM X
1020     X = 500
1030     RETURN -1
1040 FN END
```

The actual result will be 499. Surprising, but not unpredictable. The same thing will happen if the variable is passed by reference and modified in the user-defined-function. This general case of occurrences is lumped together under the term side-effects, and should be avoided. Therefore, don't use a user-defined-function to modify values of variables. They are designed for returning a single value, and are best reserved for that.

Operators

There are three types of operators in BASIC, monadic, dyadic, and comparison.

- A **monadic** operator performs its operation on the expression immediately to its right.

```
+ - NOT
```

- A **dyadic** operator performs its operation on the two values it is between.

```
^ * / MOD MODULO DIV + - = <> < > <= >= AND OR EXOR
```

- A **comparison** operator returns a 1 (true) or a zero (false) based on the result of a relational test of the operands it separates. The comparison operators are a subset of the dyadic operators that are considered to produce *boolean* results.

```
< > <= >= = <>
```

While the use of most operators is obvious from the descriptions in the language reference, some of the operators have uses and side-effects that are not always apparent.

Expressions, Calls, and Functions

All numeric expressions are passed by value to subprograms. Thus `5 + X` is obviously passed by value. Not quite so obviously, `+ X` is also passed by value. The monadic operator makes it an expression.

Strings in Numeric Expressions

String expressions can be directly included in numeric expressions if they are separated by comparison operators. The comparison operators always yield boolean results, and boolean results are numeric values in BASIC.

Step Functions

The comparison operators are obviously useful for conditional branching (IF...THEN statements), but are also valuable for creating numeric expressions representing step-functions. For example, let's try to represent the function:

- IF `Select < 0`
Then `Result = 0`
- IF `0 <= Select < 1`
Then `Result` equals the square root of $A^2 + B^2$.
- IF `Select >= 1` (any other value)
Then `Result = 15`

It is possible to generate the required response through a series of IF . . . THEN statements, but it can also be done with the following expression:

```
1210 Result=(Select<0)*0+(Select>=0 AND Select<1)*SQR(A^2+B^2)+(Select>1)*15
```

While the technique may not please the purist, it actually represents the step function very well. The boolean expressions each return a 1 or 0 which is then multiplied by the accompanying expression. Expressions not matching the selection return 0, and are not included in the result. The value assigned to `Select` before the expression is evaluated determines the computation placed in the result. This technique can be used to represent other functions, but the program statement cannot exceed the maximum allowable line length.

Making Comparisons Work

If you are comparing INTEGER numbers, no special precautions are necessary. However, if you are comparing REAL values, especially those which are the results of calculations and functions, it is possible to run into problems due to rounding and other limits inherent in the system. For example, consider the use of comparison operators in IF..THEN statements to check for equality in any situation resembling the following:

```
1220   DEG
1230   A=25.3765477
1240   IF SIN(A)^2+COS(A)^2=1 THEN
1250     PRINT "Equal"
1260   ELSE
1270     PRINT "Not Equal"
1280   END IF
```

You may find that the equality test fails due to rounding errors or other errors caused by the inherent limitations of finite machines. A repeating decimal or irrational number cannot be represented exactly in any finite machine.

A good example of equality error occurs when multiplying or dividing data values. A product of two non-integer values nearly always results in more digits beyond the decimal point than exists in either of the two numbers being multiplied. Any tests for equality must consider the **exact** variable value to its greatest resolution. If you cannot guarantee that all digits beyond the required resolution are zero, there are three techniques that can be used to eliminate equality errors:

- Use the DROUND function to eliminate unwanted resolution **before** comparing results.
- Use the absolute value of the difference between the two values, and test for the difference less than a specified limit.
- Use the absolute value of the relative difference between two values, and test for the difference less than a specified limit:

```
IF ABS((C-F)/C) < 10^-Delta_Power THEN PRINT "C is equal to F"
```

The following example shows the DROUND technique:

```
1050  A=32.5087
1060  B=31.625
1070  C=A*B          ! Product is 1028.08763750
1080  D=32.5122
1090  E=31.621595509
1100  F=D*E          ! Product is 1028.08763751
1110  IF C=F THEN 1130
1120  PRINT "C is not equal to F"
1130  C=DROUND(C,7)
1140  F=DROUND(F,7)
1150  IF C=F THEN
1160  PRINT "C equals F after DROUND"
1170  ELSE
1180  PRINT "C not equal to F after DROUND"
1190  END IF
1200  END
```

You can experiment with the concept by substituting other values for variables A, B, D, and E, and by changing the number of digits specified in the DROUND function.

Here is an example of the absolute value method of testing equality. In this case, a difference of less than 0.001 is assumed to be evidence of adequate equality. Using the previous example, we change technique at line 1130.

```
1130  IF ABS(C-F)<.001 THEN
1140  PRINT "C is equal to F within 0.001"
1150  ELSE
1160  PRINT "C is not equal to F within 0.001"
1170  END IF
1180  END
```

This technique has the advantage that no additional statements are invested in overhead while preparing the data for evaluation. It also enables you to easily establish tolerance limits in making value comparisons, a capability that is useful in production and testing applications.

Finally, here is an example of the relative difference method. Once again, we change the technique at line 1130.

```

1130 IF ABS((C-F)/C) < 10^-3 THEN
1140     PRINT "Relative difference between C and F less than 10^-3"
1150 ELSE
1160     PRINT "Relative difference between C and F greater than 10^-3"
1170 END IF
1180 END

```

Resident Numerical Functions

The resident functions are the functions that are part of the BASIC language (also called intrinsic). Numerous functions are included in the BASIC you are using to make mathematical modeling easier. The following functions are available:

Function	Description
ABS	Returns the absolute value of an expression.
ACS	Returns the arccosine of an expression.
ASN	Returns the arcsine of an expression.
ATN	Returns the arctangent of an expression.
BASE	Returns the lower subscript bound of a dimension of an array. (Requires MAT)
BINAND	Returns the bit-by-bit logical-and of two arguments.
BINCMP	Returns the bit-by-bit complement of two arguments.
BINEOR	Returns the bit-by-bit exclusive-or of two arguments.
BINIOR	Returns the bit-by-bit inclusive-or of two arguments.
BIT	Returns the state of a bit of the argument.
COS	Returns the cosine of the angle represented by the expression.
CRT	Returns the INTEGER 1. This is the select code of the internal CRT.
DATE	Takes a string expression and returns the number of seconds between midnight on the morning of the date represented by the string expression and 24 November -4713. (Requires CLOCK)
DET	Returns the determinant of a matrix. (Requires MAT)
DOT	Returns the inner (dot) product of two vectors. (Requires MAT)
DROUND	Rounds a number to a number of digits.
DVAL	Returns the whole number value of a binary, octal, decimal, or hexadecimal 32-bit integer. The argument is a string.
EXP	Raise the Napierian e to an power. $e \approx 2.718\ 281\ 828\ 459\ 05$.
FRACT	Returns the "fractional" part of the argument.
INT	Returns the greatest integer that is less than or equal to an expression. The result is of the same type (INTEGER or REAL) as the original number.
IVAL	Returns the INTEGER value of a binary, octal, decimal, or hexadecimal 16-bit integer. The argument is a string.
KBD	Returns the INTEGER 2. This is the select code of the keyboard.
LGT	Returns the base 10 logarithm of an expression.

Function	Description
LOG	Returns the natural logarithm (Napierian base e) of an expression.
MAX	Returns the larger of a list of expressions. (Requires MAT)
MAXREAL	Returns the largest REAL number.
MIN	Returns the smaller of a list of expressions. (Requires MAT)
MINREAL	Returns the smallest REAL number.
PI	Returns the constant 3.141 592 653 589 79, an approximate value for π .
PROUND	Returns the value of the argument rounded to a power of ten.
PRT	Returns the INTEGER 701. This is the default (factory set) device selector for an external printer.
RANK	Returns the number of dimensions in an array. (Requires MAT)
RES	Returns the last live keyboard numeric result.
RND	Returns a pseudo-random number that is greater than 0 but less than 1.
ROTATE	Returns a value obtained by shifting an INTEGER representation of an argument a specific number of bit positions, with wraparound.
SC	Returns the interface select code associated with an I/O path name.
SIN	Returns the sine of the angle represented by an expression.
SIZE	Returns the number of elements in a dimension of an array. (Requires MAT)
SGN	Returns the sign of an expression: 1 if positive, 0 if 0, -1 if negative.
SHIFT	Returns a value obtained by shifting an INTEGER representation of an argument a specific number of bit positions, without wraparound.
SQR	Returns the square root of an expression.
SUM	Returns the sum of all the elements in an array. (Requires MAT)
TAN	Returns the tangent of the angle represented by an expression.
TIME	Returns the number of seconds between midnight and the time represented by the string argument. (Requires CLOCK)

Dealing with Angles and Such

Six functions are provided for dealing with angles and angular measure (SIN, ASN, COS, ACS, TAN, ATN). The default mode for all angular measure is radians. Degrees can be selected with the DEG statement. Radians may be re-selected by the RAD statement. It is a good idea to explicitly set a mode for any angular calculations, even if you are using the default (radian) mode. This is especially important in writing subprograms, as the subprogram inherits the angular mode from the context that calls it. When the calling context is restored, the angle mode is also restored.

Range Limits

It is sometimes necessary to limit the range of excursion of a variable (as in the discussion of REAL to INTEGER conversions mentioned in the introduction to this chapter). While it is possible to do this with IF...THEN statements:

```
200 IF X>Maxx THEN X = Maxx
210 IF X<Minx THEN X = Minx
```

it is more convenient to use the MAX and MIN functions.

```
200 X = MIN(MAX(X,Minx),Maxx)
```

Note that MAX is used to establish the lower bound, and MIN is used to establish the upper bound. If you think about it a minute, it makes sense.

Rounding

Rounding occurs frequently in computer operations. The most common rounding occurs in printouts and displays, where it can be handled effectively with a USING clause in the output operation. For details see the section on Formatted Output in the Using a Printer chapter. This works in statements such as PRINT, LABEL, OUTPUT and DISP.

Sometimes it is necessary to round a number in a calculation, to eliminate unwanted resolution. There are two basic types of rounding; rounding to a total number of decimal digits and rounding to a number of decimal places (limiting fractional information) . Both types of rounding have their own application in programming.

There is a tendency for the number of decimal places to grow as calculations are performed on the results of other calculations. One of the first things covered in training for engineering and the sciences is how to handle the growth of the number of decimal places in a calculation. If the initial measurements from an experiment produced three digits of information per reading, it is very misleading to produce a seven-digit number as the result of a long series of calculations. The DROUND function allows you to eliminate the unwanted digits, to produce more realistic calculations and answers.

```
X=DROUND(SQR(Y^3+Gr^3),3)
```

It is also possible to round to a number of decimal places. The idea is to eliminate decimal representation beyond a specific power of ten. The PROUND function allows you to perform a round to any specified power of ten.

```
200 X=PROUND(X1,Places)
```

Random Numbers

The RND function returns a psuedo-random random number between 0 and 1. Since many modeling systems require random numbers with arbitrary ranges, it is necessary to scale the numbers.

```
200 R=INT(RND*Range)+Offset
```

The above statement will return an integer between `Offset` and `Offset + Range`.

The random number generator is seeded with the value 37 480 660 at power-on, SCRATCH, SCRATCH A, and prerun. The pattern period is $2^{31} - 2$. You can change the seed with the RANDOMIZE statement, which will give a new pattern of numbers.

Binary Operations

In actuality, all operations the computer performs are binary. There are, however, some logical and bit-level operations available on the computer that are commonly called binary operations. When any of these operations are used, the arguments are first converted to INTEGER (if they are not already in the correct form) and then the specified operation is performed. It is best to restrict bit-oriented binary operations to declared INTEGERS. If it is necessary to operate on a REAL, make sure the precautions described under Conversions, at the beginning of this chapter, are employed, to avoid INTEGER overflow.

Array Operations

An array is a multi-dimensional structure of variables that are given a common name. The array can have one through six dimensions. Each location in an array can contain one variable value, and each value has the characteristics of a single variable, depending on whether the array consists of REAL or INTEGER values (string arrays are discussed in Chapter 5, “String Manipulation”). Note that many of the statements that deal with arrays (such as MAT) require the MAT BIN.

A one-dimensional array consists of n elements, each identified by a single subscript. A two-dimensional array consists of m times n elements where m and n are the maximum number of elements in the two respective dimensions. Arrays require a subscript in each dimension, in order to locate a given element of the array. Up to six dimensions can be specified for any array in a program. REAL arrays require eight bytes of memory for each element, plus overhead; so you can see that large arrays can demand massive memory resources.

An undeclared array is given as many dimensions as it has subscripts in its lowest-numbered occurrence. Each dimension of an undeclared array has an upper bound of ten. Space for these elements is reserved whether you use them or not.

Dimensioning an Array

Before you use an array, you should tell the system how much memory to reserve for it. This is called “dimensioning” an array. You can dimension arrays with the DIM, COM, ALLOCATE, INTEGER, or REAL statements. An array is a type of variable and as such follows all rules for variable names. Unless you explicitly specify INTEGER type in the dimensioning statement, arrays default to REAL type. The same array can only be dimensioned once in a context¹. However, as we explain later in this section, arrays can be REDIMENSIONED.

When you dimension an array, the system reserves space in internal memory for it. The system also sets up a table which it uses to locate each element in the array. The location of each element is designated by a unique combination of subscripts, one subscript for each dimension. For a four-dimensional array, for instance, each element is identified by four subscript values. Each unique set of subscript values points to one, and only one, array element.

The actual size of an array is governed by the number of dimensions and the subscript range of each dimension. If **A** is a three-dimensional array with a subscript range of 1 thru 4 for each dimension, then its size is 4 x 4 x 4, 64 elements.

When you dimension an array, therefore, you must give not only the number of dimensions but also the subscript range of each dimension. Subscript ranges can be specified by giving the lower and upper bounds, or by giving just the upper bound. If you give only the upper bound, the lower bound defaults to the current option base setting.

¹ There is one exception to this rule: If you ALLOCATE an array, and then DEALLOCATE it, you can dimension the array again.

Each context initializes to an option base of 0 (but arrays appearing in COM statements with an (*) will keep the base with which they were originally dimensioned). However, you can set the option base to 1 with the OPTION BASE command. You can have only one OPTION BASE statement in a context, and it must precede all explicit variable declarations.

The following examples illustrate some of the flexibility you have in dimensioning arrays.

```
10 OPTION BASE 1
20 DIM A(3,4,0:2)
```

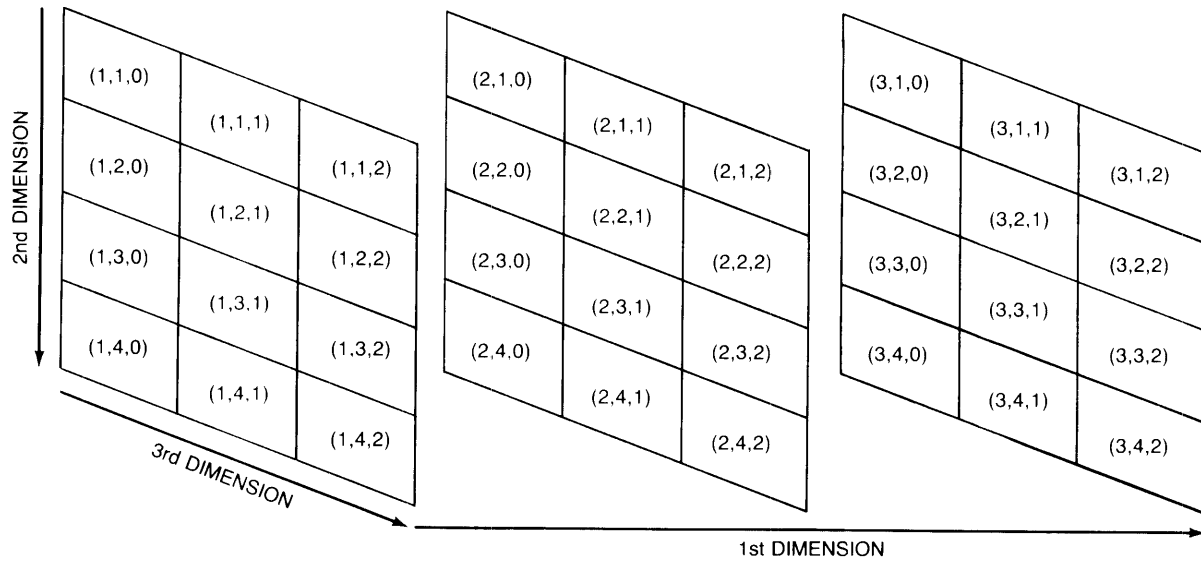

	Size	Lower Bound	Upper Bound
1st Dimension	3	1	3
2nd Dimension	4	1	4
3rd Dimension	3	0	2

In this example we portray the first dimension as planes, the second dimension as rows, and the third dimension as columns. In general, the last two dimensions of any array always refer to rows and columns, respectively. When we discuss two-dimensional arrays, the first dimension will always represent rows, and the second dimension will always represent columns. Note also in the above example that the first two dimensions use the default setting of 1 for the lower bound, while the third dimension explicitly defines 0 as the lower bound. The numbers in parentheses are the subscript values for the particular elements. These are the numbers you use to identify each array element.

```

10 OPTION BASE 1
20 COM B(1:5,2:6)
    .
    .
    
```

(1,2)	(1,3)	(1,4)	(1,5)	(1,6)
(2,2)	(2,3)	(2,4)	(2,5)	(2,6)
(3,2)	(3,3)	(3,4)	(3,5)	(3,6)
(4,2)	(4,3)	(4,4)	(4,5)	(4,6)
(5,2)	(5,3)	(5,4)	(5,5)	(5,6)

	Size	Lower Bound	Upper Bound
1st Dimension	5	1	5
2nd Dimension	5	2	6

```

10 OPTION BASE 1
20 ALLOCATE INTEGER C(2:4,-2:2)
    .
    .
    
```

(2,-2)	(2,-1)	(3,0)	(2,1)	(2,2)
(3,-2)	(3,-1)	(3,0)	(3,1)	(3,2)
(4,-2)	(4,-1)	(4,0)	(4,1)	(4,2)

	Size	Lower Bound	Upper Bound
1st Dimension	3	2	4
2nd Dimension	5	-2	2

88 Numeric Computation

```

10  OPTION BASE 0
20  REAL D(1,0)
      *
      *

```

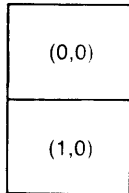

	Size	Lower Bound	Upper Bound
1st Dimension	2	0	1
2nd Dimension	1	0	0

```

10  COM E(-3:0)
      *
      *

```

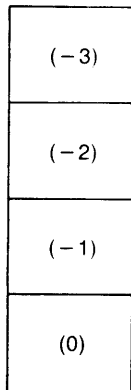

	Size	Lower Bound	Upper Bound
1st Dimension	4	-3	0

```
10 OPTION BASE 0
20 INTEGER F(1,4,-1:2)
   *
```

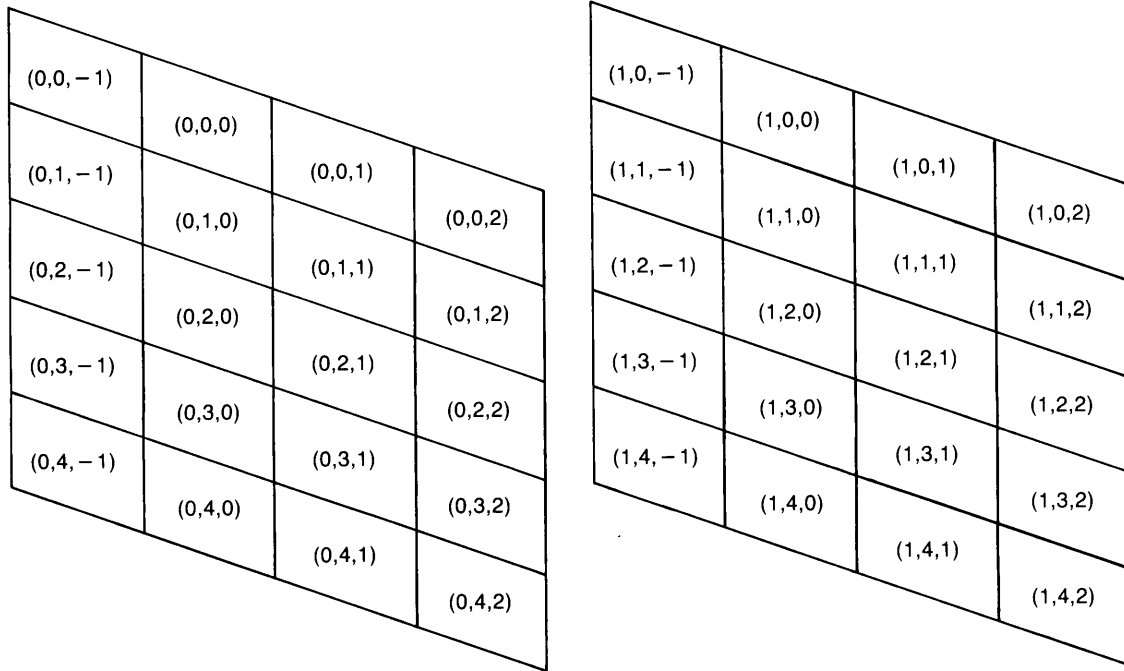

	Size	Lower Bound	Upper Bound
1st Dimension	2	0	1
2nd Dimension	5	0	4
3rd Dimension	4	-1	2

Arrays are limited to six dimensions, and the subscript range for each dimension must lie between -32767 and 32767 . (REDIM and ALLOCATE allow the subscript range to go down to -32768 , but the total size of each dimension must be less than 32768 elements.) For the most part, we use only two-dimensional examples since they are easier to illustrate. However, the same principles apply to arrays of more than two dimensions as well.

Note

Throughout this chapter we will be using DIM statements without specifying what the current option base setting is. Unless explicitly specified otherwise, all examples in this chapter use option base 1.

As an example of a four-dimensional array, consider a five-story library. On each floor there are 20 stacks, each stack contains 10 shelves, and each shelf holds 100 books. To specify the location of a particular book you would give the number of the floor, the stack, the shelf, and the particular book on that shelf. We could dimension an array for the library with the statement:

```
DIM Library(5,20,10,100)
```

This means that there are 100,000 book locations. To identify a particular book you would specify its subscripts. For instance, `Library(2,12,3,35)` would identify the 35th book on the 3rd shelf of the 12th stack on the 2nd floor.

We can imagine accessing a particular page of a book by using a 5-dimensional array. For instance, if we dimension an array,

```
DIM Page(5,20,10,100,200)
```

then `Page(1,7,2,19,130)` would designate page 130 of the 19th book on the 2nd shelf of the 7th stack on the 1st floor.

We could specify words on pages by using a 6-dimensional array. Six dimensions is the maximum, though, so we could not specify letters of words.

Also, you can dimension more than one array in a single statement by separating the declarations with a comma. For instance,

```
10 DIM A(1,3,4),B(-2:0,2:5),C(5)
```

would dimension all three arrays: A, B, and C.

Problems with Implicit Dimensioning

In any environment, an array must have a dimensioned size. This size can be passed into an environment through a passed parameter list or a COM statement. It may be explicitly dimensioned through COM, INTEGER, REAL or ALLOCATE. It can also be implicitly dimensioned through a subscripted reference to it in a program statement **other than** a MAT or a REDIM statement. An attempt to use an array that does not have a dimensioned size in the current environment in a MAT or REDIM statement will result in an error. In other words, MAT and REDIM statements cannot be used to implicitly dimension an array.

Finding Out the Dimensions of an Array

There are a number of statements that allow you to determine the size and shape of an array. To find out how many dimensions are in an array, use the RANK function. For instance:

```
OPTION BASE 0
DIM F(1,4,-1:2)
PRINT RANK (F)
```

would print 3.

The SIZE function returns the size (number of elements) of a particular dimension. For instance,

```
SIZE (F,2)
```

would return 5, the number of elements in F's second dimension.

To find out what the lower bound of a dimension is, use the BASE statement. Referring again to array F

```
BASE (F,1)
```

would return a 0, while,

```
BASE (F,3)
```

would return a -1.

By using the SIZE and BASE statements together, you can determine the upper bounds of any dimension (e.g., $\text{SIZE} + \text{BASE} - 1 = \text{Upper Bound}$).

It may seem pointless to have all these functions that return the dimension specifications which you yourself assigned. After all, if you assigned the dimensions, you should know what they are; and if you forget, you can always look at the appropriate dimensioning statement. However, these functions are powerful tools for writing programs that perform functions on an array regardless of the array's size or shape. In addition, the system automatically redimensions arrays during certain operations. The functions discussed above provide you with a means for determining the new dimensions. As an example of a general purpose program utilizing these statements, consider the subprogram below which prints a two-dimensional array in rows and columns.

```
100 SUB Printmat(Array(*))
110 OPTION BASE 1
120 FOR Row=BASE(Array,1) TO SIZE(Array,1)+BASE(Array,1)-1
130   FOR Column=BASE(Array,2) TO SIZE(Array,2)+BASE(Array,2)-1
140     PRINT USING "DDDD.DD,XX,#" ;Array(Row,Column)
150   NEXT Column
160   PRINT
170 NEXT Row
180 SUBEND
```

Filling an Array

Once an array has been dimensioned, the next step is to fill it with useful values. Initially, every element in an array equals zero. There are a number of different ways to change these values. The most obvious is to assign a particular value to each element. This is done by specifying the element's subscripts. For instance, the statement,

```
A(3,4)=13
```

would assign the value 13 to the element in the third row and fourth column of A. You must give enough subscripts for the system to identify a single element. For a three-dimensional array, for instance, you would provide three subscripts. All subscripts, moreover, must lie within the dimensioned range. If you use out-of-range subscripts, the system returns an error.

For some applications, you may want to initialize every element in an array to some particular value. You can do this by assigning a value to the array name. However, you must precede the assignment with the MAT keyword. For example,

```
MAT A= (10)
```

will assign the value 10 to every element in array A regardless of A's size. Note that the numeric expression on the right-hand side of the assignment must be enclosed in parentheses.

Another way to assign values to an array is by using the READ and DATA statements. The DATA statement allows you to create a stream of data items, and the READ statement enables you to enter the data stream into an array. For example:

```
10 OPTION BASE 1
20 DIM A(3,3)
30 DATA -4,36,2,3,5,89,17,-6,-12,42
40 READ A(*)
50 END
```

The asterisk in line 40 is used to designate the entire array rather than a single element. Note also that the right-most subscript varies fastest. In this case, it means that the system fill an entire row before going to the next one. The READ/DATA statements are discussed further in Chapter 7.

If we use the Printmat subprogram (shown on previous page) to display A, we get:

```
-4.00      36.00      2.30
 5.00      89.00      17.00
-6.00     -12.00     42.00
```

Copying Arrays

A fourth way to fill an array is to copy the elements from one array into another. Suppose, for example, that you have the two arrays A and B shown below.

A	B
$\begin{bmatrix} 0 & 0 & 0 \\ 0 & 0 & 0 \\ 0 & 0 & 0 \end{bmatrix}$	$\begin{bmatrix} 3 & 5 \\ 8 & 2 \\ 1 & 7 \end{bmatrix}$

Note that A is a 3x3 array which is filled entirely with 0's, while B is a 3x2 array filled with non-zero values. To copy B to A, we would execute:

```
MAT A=B
```

Again, you must precede the assignment with MAT. The system will automatically redimension the "result array" (the one on the left-hand side of the assignment) so that it is the same size as the "operand array" (the one on the right side of the equation.) There are two restrictions on redimensioning an array.

- The two arrays must have the same rank (e.g., the same number of dimensions.)
- The dimensioned size of the result array must be at least as large as the current size of the operand array.

If the system cannot redimension the result array to the proper size, it returns an error.

Automatic redimensioning of an array will not affect the lower bounds, only the upper bounds. So the BASE values of each dimension of the result array will remain the same. Also keep in mind that the size restriction applies to the *dimensioned* size of the result array and the *current* size of the operand array. Suppose we dimension arrays A, B and C to the following sizes:

```
10  OPTION BASE 1
20  DIM A(3,3),B(2,2),C(2,4)
      .
      .
```

We can execute,

```
MAT A=B
```

since A is dimensioned to 9 elements and B is only 4 elements. The copy automatically redimensions A to a 2x2 array. Nevertheless, we can still execute:

```
MAT A=C
```

This is because the nine elements originally reserved for A remain available until the program is scratched. A now becomes a 2x4 matrix. After MAT A=C, we could not execute:

```
MAT B=A
or
MAT B=C
```

since in each of these cases, we are trying to copy a larger array into a smaller one. But we could execute

```
MAT C=A
```

after the original MAT A=B assignment, since C's dimensioned size (8) is larger than A's current size (4).

Extracting Values From Arrays

As with entering values into arrays, there are a number of ways to extract values as well. To extract the value of a particular element, simply specify the element's subscripts. For instance, the statement,

```
X=A(3,4,2)
```

would assign the value of the element occupying the given location in A to the variable X. The system will automatically convert variable types. For example, if you assign an element from a Real array to an Integer variable, the system will perform the necessary rounding.

Certain operations (e.g., PRINT, OUTPUT, ENTER and READ) allow you to access all elements of an array merely by using an asterisk in place of the subscript list. The statement,

```
PRINT A(*) ;
```

would display every element of A on the current PRINTER IS device. The elements are displayed in order, with the rightmost subscripts varying fastest. The semi-colon at the end of the statement is equivalent to putting a semi-colon between each element. When they are displayed, therefore, they will be separated by a space. (The default is to place elements in successive columns.)

The asterisk is also used to pass an array as a parameter to a function or subprogram. For instance, to pass an array A to the Printmat subprogram listed earlier, we would write:

```
Printmat (A(**))
```

In addition to extracting the values of elements in an array, there are also functions that compute the sum of an entire row or column of an array. However, since these functions are limited to two-dimensional arrays, we will reserve their discussion for the section on matrices. The statement that returns the sum of *all* elements in an array, however, works for arrays of any dimension. Given the array A below,

$$A = \begin{bmatrix} 4 & 2 & -1 \\ 3 & 8 & 16 \\ -5 & 2 & 0 \end{bmatrix}$$

the function,

```
SUM(A)
```

would return 29.

Redimensioning Arrays

In our discussion of copying arrays we saw that the system automatically redimensions an array if necessary. You can also explicitly redimension an array with the REDIM statement. As with automatic redimensioning, the following two rules apply to all REDIM statements:

- A REDIMed array must maintain the same number of dimensions.
- You cannot REDIM an array so that it contains more elements than it was originally dimensioned to hold.

Suppose A is the 3x3 array shown below.

$$\begin{array}{c} \mathbf{A} \\ \left[\begin{array}{ccc} 1 & 2 & 3 \\ 4 & 5 & 6 \\ 7 & 8 & 9 \end{array} \right] \end{array}$$

To redimension it to a 2x4 array, you would execute:

```
REDIM A(2,4)
```

The new array now looks like the figure below:

$$\begin{array}{c} \mathbf{A} \\ \left[\begin{array}{cccc} 1 & 2 & 3 & 4 \\ 5 & 6 & 7 & 8 \end{array} \right] \end{array}$$

Note that it retains the values of the elements, though not necessarily in the same locations. For instance, A(2,1) in the original array was 4, whereas in the redimensioned array it equals 5. If we REDIMed A again, this time to a 2x2 array, we would get:

```
REDIM A(0:1,0:1)
```

$$\begin{array}{c} \mathbf{A} \\ \left[\begin{array}{cc} 1 & 2 \\ 3 & 4 \end{array} \right] \end{array}$$

We could then initialize all elements to 0:

```
MAT A= (0)
```

$$\begin{array}{c} \mathbf{A} \\ \left[\begin{array}{cc} 0 & 0 \\ 0 & 0 \end{array} \right] \end{array}$$

It is also important to realize that elements that are out of range in the REDIMed array still retain their values. The fifth thru ninth elements in A still equal 5 thru 9 even though they are now inaccessible. If we REDIM A back to a 3x3 array, these values will reappear. For example:

```
REDIM A(3,3)
```

produces:

$$\begin{array}{c} \mathbf{A} \\ \left[\begin{array}{ccc} 0 & 0 & 0 \\ 0 & 5 & 6 \\ 7 & 8 & 9 \end{array} \right] \end{array}$$

One of the major strengths of the REDIM statement is that it allows you to use variables for the subscript ranges: this is not allowed when you originally dimension an array. In effect, this enables you to dynamically dimension arrays. This should not be confused with the ALLOCATE statement which allows you to dynamically reserve memory for arrays. In the example below, for instance, we enter the dimensions from the keyboard.

```
10  OPTION BASE 1
20  DIM A(100,100)  ! 1000 ELEMENT ARRAY
30  INPUT "Enter lower and upper bounds of dimensions",
    Low1,UP1,Low2,UP2
40  IF (UP1-Low1+1)*(UP2-Low2+1)>10000 THEN Too_big
50  REDIM A(Low1:UP1,Low2:UP2)
```

Line 40 tests to see whether the new dimensions are too big. If so, program control is passed to a line labelled "Too_big". If line 40 were not present, the REDIM statement would return an error if the dimensions were too large.

Arrays and Arithmetic Operators

It is possible to multiply, divide, add, and subtract scalars to an array, as well as to add, subtract, multiply, and divide one array to another. All arithmetic functions involving arrays must be preceded by the MAT keyword. The specified operation is performed on each individual element in the operand array(s) and the results are placed in the result array. The result array must be dimensioned to be at least as large as the current size of the operand array(s). If it is of a different shape than the operand array(s), the system will redimension it. Given the array A below, note how these arithmetic functions are performed.

$$\begin{array}{c} \mathbf{A} \\ \left[\begin{array}{ccc} 1 & 2 & 3 \\ 4 & 5 & 6 \\ 7 & 8 & 9 \end{array} \right] \end{array}$$

```
MAT B= A+(3)
```

$$\begin{array}{c} \mathbf{B} \\ \left[\begin{array}{ccc} 4 & 5 & 6 \\ 7 & 8 & 9 \\ 10 & 11 & 12 \end{array} \right] \end{array}$$

```
MAT C= B/(2)
```

$$\begin{array}{c} \mathbf{C} \\ \left[\begin{array}{ccc} 2 & 2.5 & 3 \\ 3.5 & 4 & 4.5 \\ 5 & 5.5 & 6 \end{array} \right] \end{array}$$

```
MAT C= C*(1+1+1)
```

$$\begin{array}{c} \mathbf{C} \\ \left[\begin{array}{ccc} 6 & 7.5 & 9 \\ 10.5 & 12 & 13.5 \\ 15 & 16.5 & 18 \end{array} \right] \end{array}$$

Note that the result array can be the same as the operand array. Also, the scalar must be enclosed in parentheses.

In addition to performing arithmetic operations with scalars, you can also add, subtract, divide and multiply two arrays together. Except for multiplication with an asterisk, which is described later, these functions proceed as follows: Corresponding elements of each operand array are processed according to the specified operation, and the result is placed in the result array. The two operand arrays must be exactly the same size though their particular subscript ranges can be different. For multiplication, use a period rather than an asterisk. Using arrays A and B above, the statement,

```
MAT D= A+B
```

would give the array:

$$\begin{array}{c} \mathbf{D} \\ \left[\begin{array}{ccc} 5 & 7 & 9 \\ 11 & 13 & 15 \\ 17 & 19 & 21 \end{array} \right] \end{array}$$

The statement,

```
MAT B= A.B
```

would give:

$$\begin{array}{c} \mathbf{B} \\ \left[\begin{array}{ccc} 4 & 10 & 18 \\ 28 & 40 & 54 \\ 70 & 88 & 108 \end{array} \right] \end{array}$$

Again, the dimensioned size of the result array must be as large as the current size of each operand array. The two operand arrays must be identical in shape and size, but not necessarily in subscript ranges. For instance, A and B could have been dimensioned:

```
10 DIM A(1:3,2:4),B(-1:1,0:2)
```

Boolean Arrays

In addition to the arithmetic operators, you can also use relational operators with arrays. The result is a boolean¹ array (e.g., an array composed entirely of 1's and 0's). Given array B above, suppose you wanted to know how many elements were greater than 50. First you execute the statement,

```
MAT F= B>(50)
```

which results in the array:

$$\begin{array}{c} \mathbf{F} \\ \left[\begin{array}{ccc} 0 & 0 & 0 \\ 0 & 0 & 1 \\ 1 & 1 & 1 \end{array} \right] \end{array}$$

Then you execute the statement,

```
PRINT SUM(F)
```

which causes the computer to display "4" on the current PRINTER IS device.

You can also compare two arrays to each other. If, for example, you wanted to compare the two arrays below,

$$\begin{array}{cc} \mathbf{A} & \mathbf{B} \\ \left[\begin{array}{ccc} 1 & 3 & 5 \\ 2 & 8 & 7 \\ 1 & 4 & 6 \end{array} \right] & \left[\begin{array}{ccc} 1 & 3 & 4 \\ 2 & 0 & 7 \\ 1 & 4 & 4 \end{array} \right] \end{array}$$

you could execute the statement:

```
MAT C= A=B
```

By looking at C, you can tell which elements are the same for both A and B.

$$\begin{array}{c} \mathbf{C} \\ \left[\begin{array}{ccc} 1 & 1 & 0 \\ 1 & 0 & 1 \\ 1 & 1 & 0 \end{array} \right] \end{array}$$

¹ Strictly speaking, these are not really boolean arrays since the values of the elements are not TRUE and FALSE.

Reordering Arrays

The `MAT REORDER` statement allows you to re-arrange an array so that one dimension is in a particular order. The new order is specified in a vector (a vector is a one-dimensional array). The vector contains the subscripts of the reordered dimension in their new order. The subscripts must correspond to the array's current dimensions and subscript ranges. Suppose `A` is the array below. Let us also assume that `A` has been dimensioned in `OPTION BASE 1`, and that the upper bound to both dimensions is 3.

$$\begin{array}{c} \mathbf{A} \\ \left[\begin{array}{ccc} 1 & 3 & 2 \\ 4 & 5 & 7 \\ 6 & 8 & 9 \end{array} \right] \end{array}$$

To reverse the order of the rows, we would first dimension a vector,

```
10 DIM Reverse(3)
```

and then assign its elements the following values:

```
Reverse(1)=3
Reverse(2)=2
Reverse(3)=1
```

The array `Reverse` now appears:

$$\begin{array}{c} \mathbf{Reverse} \\ \left[\begin{array}{ccc} 3 & 2 & 1 \end{array} \right] \end{array}$$

If we execute the statement,

```
MAT REORDER A BY Reverse
```

the result array will be:

$$\begin{array}{c} \mathbf{A} \\ \left[\begin{array}{ccc} 6 & 8 & 9 \\ 4 & 5 & 7 \\ 1 & 3 & 2 \end{array} \right] \end{array}$$

Note that the rows are exchanged, rather than the columns. This is because the default is to re-order the 1st dimension. However, you can override the default by specifying a particular dimension to be re-ordered. For example, if we wanted to reverse columns rather than rows, we could use the same vector, but this time specify dimension 2:

```
MAT REORDER A BY Reverse,2
```

The transformation would be:

$$\begin{array}{c} \mathbf{A} \\ \left[\begin{array}{ccc} 6 & 8 & 9 \\ 4 & 5 & 7 \\ 1 & 3 & 2 \end{array} \right] \end{array} \Rightarrow \begin{array}{c} \mathbf{A} \\ \left[\begin{array}{ccc} 9 & 8 & 6 \\ 7 & 5 & 4 \\ 2 & 3 & 1 \end{array} \right] \end{array}$$

Remember that although our examples are confined to two dimensions for illustrative purposes, the same principles apply to arrays of three and more dimensions. In a three-dimensional array, for instance, reordering the 1st dimension would reorder planes rather than rows or columns.

In most cases, rather than creating a reorder vector and assigning values to it, you will already have a vector as the result of a sort operation. This is described in the next section.

Sorting Arrays

A frequent operation performed on arrays is a sort. Sorting an array rearranges the array so that one dimension (which you specify) is in numerical order. Given the array A below, watch how the MAT SORT changes it.

$$\begin{array}{c} \mathbf{A} \\ \left[\begin{array}{ccc} 5 & 6 & 8 \\ 3 & 5 & 1 \\ 2 & 4 & 8 \end{array} \right] \end{array}$$

```
MAT SORT A(*,1)
```

$$\begin{array}{c} \mathbf{A} \\ \left[\begin{array}{ccc} 2 & 4 & 8 \\ 3 & 5 & 1 \\ 5 & 6 & 8 \end{array} \right] \end{array}$$

The asterisk specifies the dimension to be sorted, and the subscript(s) tells which elements in that dimension to use as the sorting values. In the example above, we told the system to sort rows (asterisk is located in the first subscript position), and to use the first element in each row as the sorting value. With the new array A (from the sort performed above), the following statement will sort columns using the second element in each column as the sorting value.

```
MAT SORT A(2,*)
```

$$\begin{array}{c} \mathbf{A} \\ \left[\begin{array}{ccc} 8 & 2 & 4 \\ 1 & 3 & 5 \\ 8 & 5 & 6 \end{array} \right] \end{array}$$

The key values in this sort are 1, 3 and 5, the second elements in each column. Sorting by placing the lowest values first is known as sorting by “ascending” order. This is the default. You can also sort by “descending” order by specifying the secondary keyword DES. For instance, the statement,

```
MAT SORT A(*,2) DES
```

would produce the following transformation:

$$\begin{array}{c} \mathbf{A} \\ \left[\begin{array}{ccc} 8 & 2 & 4 \\ 1 & 3 & 5 \\ 8 & 5 & 6 \end{array} \right] \end{array} \Rightarrow \begin{array}{c} \mathbf{A} \\ \left[\begin{array}{ccc} 8 & 5 & 6 \\ 1 & 3 & 5 \\ 8 & 2 & 4 \end{array} \right] \end{array}$$

Sometimes the values of two or more sorting elements are the same. For instance, if we sorted A by rows using the first element,

```
MAT SORT A(*,1)
```

we get:

$$\begin{matrix} & \mathbf{A} \\ \begin{bmatrix} 8 & 5 & 6 \\ 1 & 3 & 5 \\ 8 & 2 & 4 \end{bmatrix} & \Rightarrow & \begin{bmatrix} 1 & 3 & 5 \\ 8 & 5 & 6 \\ 8 & 2 & 4 \end{bmatrix} \\ & \mathbf{A} \end{matrix}$$

The first elements in the last two rows are the same, so the system leaves them in the order they held before the sort. However, you can specify a second sort element to be used in the case of ties. We could execute:

```
MAT SORT A(*,1),(*,2)
```

This tells the system to sort by rows using the first element as the sorting value; and in the case of ties, to use the second element. The result array would be:

$$\begin{matrix} & \mathbf{A} \\ \begin{bmatrix} 1 & 3 & 5 \\ 8 & 5 & 6 \\ 8 & 2 & 4 \end{bmatrix} & \Rightarrow & \begin{bmatrix} 1 & 3 & 5 \\ 8 & 2 & 4 \\ 8 & 5 & 6 \end{bmatrix} \\ & \mathbf{A} \end{matrix}$$

The maximum number of sorting keys is 25.

If a key is specified that is recognized by the system as rendering all other keys redundant (such as a non-substringed key for a one dimensional string array) no other keys can be specified. However, if the computer cannot tell that keys are redundant (such as `MAT SORT A(*,X),A(*,Y)` with X equal to Y) it will permit redundant keys. Redundant keys will slow down execution of the `MAT SORT` statement. If you include the `DES` secondary word, it refers only to the sort element which immediately precedes it.

Sorting to a Vector

So far, all of our sort examples have actually re-arranged the array in question. Alternatively, you can record the new order in a vector and leave the array intact. The vector must have been dimensioned to have at least as many elements as the current size of the array being sorted. If necessary, the system will redimension the vector. Thus, executing the statement:

```
MAT SORT A(3,*) TO Vect
```

with the array A:

$$\begin{matrix} & \mathbf{A} \\ \begin{bmatrix} 1 & 3 & 5 \\ 8 & 2 & 4 \\ 8 & 5 & 6 \end{bmatrix} \end{matrix}$$

The array A remains unchanged, but the vector `Vect` now contains the values:

$$\begin{matrix} & \mathbf{Vect} \\ \begin{bmatrix} 2 & 3 & 1 \end{bmatrix} \end{matrix}$$

This assumes that the array *A* has been dimensioned so that the subscript range is 1 thru 3. If *A* had been dimensioned.

```
10 DIM A(1:3,-1:1)
```

then *Vect* would contain the values:

$$\begin{matrix} \text{Vect} \\ [0 & 1 & -1] \end{matrix}$$

This vector should look very reminiscent of the vectors used to reorder arrays. And, in fact, you can use these vectors in a *MAT REORDER* statement to rearrange the array. That is, we could now execute:

```
MAT REORDER A BY Vect,*
```

and the new array would be:

$$\begin{matrix} \text{A} \\ \begin{bmatrix} 3 & 5 & 1 \\ 2 & 4 & 8 \\ 5 & 6 & 8 \end{bmatrix} \end{matrix}$$

Note that the dimension number in the *MAT REORDER* statement corresponds to the position of the asterisk in the *MAT SORT* statement.

Sorting to a vector is particularly useful if you want to sort the same array along different dimensions or using different sort elements. Each sort can be stored in a vector to be used later. Meanwhile, the original array remains unchanged.

In addition, sorting to a vector allows you to use the same sorting order with parallel arrays. That is, if you have several arrays that contain data about the same elements, you can sort one of them, and then use that same sorting order to reorder the others.

Finally, sorting to a vector enables you to manipulate an unsorted array as if it were sorted. For instance, suppose you have the array shown below:

$$\begin{matrix} \text{A} \\ \begin{bmatrix} 2 & 7 & 4 \\ 0 & 1 & 8 \\ 5 & 3 & 1 \end{bmatrix} \end{matrix}$$

Let us also assume that the subscript range for each dimension in *A* is 1 thru 3. If we sort *A* to a vector *B*,

```
MAT SORT A(*,1) TO B
```

we can then use *B* to define elements in *A*. For instance, to get the value of *A*(1,1) in its sorted form, we could write:

```
X=A(B(1),1)
```

In this case, X would equal 0. By incrementing the subscript value of B, we can simulate a sorted A.

We should point out again that although these examples are two-dimensional, the same principles apply to arrays of any rank. You must have one, and only one, asterisk in the subscript list of a sort. The other subscripts specify the particular elements to be used as the sorting keys.

Matrices and Vectors

A two-dimensional numeric array is called a “matrix” and a one-dimensional numeric array is called a “vector”. An entire branch of mathematics is devoted to matrices and vectors, and their applications are surprisingly broad. There are certain operations that are frequently performed on matrices which have been incorporated in BASIC. Keep in mind that the functions described in this section apply only to two-dimensional, and occasionally one-dimensional arrays, but never to arrays of more than two dimensions.

Matrix Multiplication

You may recall from our discussion of arrays and arithmetic operations that the asterisk (*) is reserved for matrix multiplication. If A is an *i-by-k* matrix and B is a *k-by-j* matrix, then $C = A * B$ is defined by the following equation:

$$C_{ij} = \sum_{k=1}^n A_{ik} B_{kj}$$

Translated into english, this equation means that the element in the *ith* row and *jth* column of the product (C) is the sum of the products by pairs of the elements in the *ith* row of A and the *jth* column of B. A couple of examples will help make this clear.

Suppose A and B are the matrices shown below.

$$\begin{array}{ccc}
 & \mathbf{A} & \\
 & \begin{bmatrix} 3 & 8 & 2 \\ 1 & 6 & 5 \\ 4 & 2 & 0 \end{bmatrix} & \\
 & & \mathbf{B} \\
 & & \begin{bmatrix} 1 & -2 & 3 \\ -6 & 4 & 7 \\ 0 & 8 & 2 \end{bmatrix}
 \end{array}$$

If $C = A * B$, then :

$$\begin{aligned}
 C(1,1) &= A(1,1) * B(1,1) + A(1,2) * B(2,1) + A(1,3) * B(3,1) = (3*1) + (8*-6) + (2*0) = -45 \\
 C(2,1) &= A(2,1) * B(1,1) + A(2,2) * B(2,1) + A(2,3) * B(3,1) = (1*1) + (6*-6) + (5*0) = -35 \\
 C(3,2) &= A(3,1) * B(1,2) + A(3,2) * B(2,2) + A(3,3) * B(3,2) = (4*-1) + (2*4) + (0*8) = 0
 \end{aligned}$$

Following this procedure for each element in C, we get the matrix shown below.

MAT C=A*B

$$\begin{array}{ccc}
 & \mathbf{C} & \\
 & \begin{bmatrix} -45 & 42 & 69 \\ -35 & 62 & 55 \\ -8 & 0 & 26 \end{bmatrix} &
 \end{array}$$

Note that the product is a 3x3 matrix. There are three general rules to matrix multiplication:

- Multiplication between two matrices is legal only if the second dimension of the first array is the same size as the first dimension of the second array. That is, the two inner dimensions must be the same.
- The result matrix will have the same number of rows as the first operand matrix and the same number of columns as the second operand matrix. That is, the dimensions of the result matrix will be the same as the outer dimensions of the operand matrices.
- The result array cannot be the same as either of the operand arrays. For example,

MAT A= A*B

is an illegal statement.

If A is a 2x3 matrix and B is a 3x2 matrix, A*B will result in a 2x2 matrix. B*A, on the other hand, produces a 3x3 matrix. Given the two matrices below, you can see how their position in the equation affects the product.

$$\begin{array}{cc}
 \mathbf{A} & \mathbf{B} \\
 \begin{bmatrix} 6 & 8 & -1 \\ 2 & -3 & 4 \end{bmatrix} & \begin{bmatrix} -1 & 1 \\ 2 & -2 \\ 3 & 4 \end{bmatrix} \\
 \\
 \mathbf{A*B} & \mathbf{B*A} \\
 \begin{bmatrix} 7 & -14 \\ 4 & 24 \end{bmatrix} & \begin{bmatrix} -4 & -11 & 5 \\ 8 & 22 & -10 \\ 26 & 12 & 13 \end{bmatrix}
 \end{array}$$

Multiplication With Vectors

We described a vector as a one-dimensional array. For instance,

10 DIM A(3)

would create a vector with three elements and a rank of 1. Suppose we give A the values shown below.

$$\begin{array}{c}
 \mathbf{A} \\
 [1 \ 2 \ 3]
 \end{array}$$

Notice that we have portrayed A as a row vector. We could have just as easily portrayed A as a column vector:

$$\begin{array}{c}
 \mathbf{A} \\
 \begin{bmatrix} 1 \\ 2 \\ 3 \end{bmatrix}
 \end{array}$$

So which is it? A row vector or a column vector? Actually, a vector can behave like either depending on its position in an equation. If a vector is the first operand in a multiplication, then it acts like an $1 \times n$ array (row vector); if it's the second operand, it behaves like a $n \times 1$ array (column vector); and if it's the result array, it can act like either. A few examples will help illustrate these principles. Let A be the vector shown above, and B , C , and D be the arrays shown below.

$$\begin{array}{ccc} \mathbf{B} & \mathbf{C} & \mathbf{D} \\ \begin{bmatrix} 1 & 2 & 3 \\ 4 & 5 & 6 \\ 7 & 8 & 9 \end{bmatrix} & \begin{bmatrix} 0 & 0 & 0 \\ 0 & 0 & 0 \\ 0 & 0 & 0 \end{bmatrix} & \begin{bmatrix} 2 \\ 2 \\ 2 \end{bmatrix} \end{array}$$

Let us suppose that D has been explicitly defined as a two-dimensional array:

```
10 DIM D(3,1)
```

If we execute:

```
MAT C= A*D
```

we get:

$$\begin{array}{c} \mathbf{C} \\ [12] \end{array}$$

Since A is the first operand, it behaves like a 1×3 matrix. The equation, therefore, is:

$$C = [1 \ 2 \ 3] * \begin{bmatrix} 2 \\ 2 \\ 2 \end{bmatrix}$$

The result is a 1×1 matrix. If we try to reverse the order:

```
MAT C=D*A
```

the system returns:

```
ERROR 16 IMPROPER DIMENSIONS
```

This is because we tried to multiply a 3×1 matrix by a 3×1 matrix:

$$C = \begin{bmatrix} 2 \\ 2 \\ 2 \end{bmatrix} * \begin{bmatrix} 1 \\ 2 \\ 3 \end{bmatrix}$$

Since the inner dimensions are not the same, the system returns an error. Suppose we try:

```
MAT C=B*A
```

In this case, we are multiplying a 3x3 array to a column vector.

$$C = \begin{bmatrix} 1 & 2 & 3 \\ 4 & 5 & 6 \\ 7 & 8 & 9 \end{bmatrix} * \begin{bmatrix} 1 \\ 2 \\ 3 \end{bmatrix}$$

The result is a 3x1 matrix:

$$C = \begin{bmatrix} 14 \\ 32 \\ 50 \end{bmatrix}$$

If the result array is a vector, then it will behave like either a row vector or a column vector depending on which is called for. The only other possibility is if both operand arrays are vectors. In this case, the result is always a 1x1 array. For instance, if A and B are the vectors below,

$$A = \begin{bmatrix} 2 \\ 4 \\ 6 \end{bmatrix} \quad B = \begin{bmatrix} 0 \\ 1 \\ -1 \end{bmatrix}$$

then multiplying A by B results in the equation:

`MAT C=A*B`

$$C = [2 \ 4 \ 6] * \begin{bmatrix} 0 \\ 1 \\ -1 \end{bmatrix}$$

C equals -2. Reversing the operand arrays, we get:

`MAT C=B*A`

$$C = [0 \ 1 \ -1] * \begin{bmatrix} 2 \\ 4 \\ 6 \end{bmatrix}$$

Again, C equals -2. Because the product of two vectors is always a single element, BASIC has a DOT function that multiplies two vectors and comes up with a Real or Integer numeric. For example,

`X=DOT(A,B)`

would assign the value -2 to X. If both vectors are Integer, then the product is an Integer. Otherwise, the product is Real. The two vectors must be the same size or the system will return an error.

Identity Matrix

An “identity matrix” is defined as a matrix which, when multiplied to another matrix A , produces the same matrix A . It is analogous to a 1 in normal arithmetic. For example, if I stands for an identity matrix, then $A = I * A$ and also $A = A * I$. In order for an identity matrix to exist at all, A must be a square matrix (e.g., it must have the same number of columns as rows).

As it turns out, all identity matrices have the same form. They are square and consist of 1’s along the main diagonal, and 0’s everywhere else. For example, if A is a 3x3 matrix, then the identity matrix for A is:

$$\begin{array}{c} \mathbf{I} \\ \left[\begin{array}{ccc} 1 & 0 & 0 \\ 0 & 1 & 0 \\ 0 & 0 & 1 \end{array} \right] \end{array}$$

For a 4x4 matrix, I would be:

$$\begin{array}{c} \mathbf{I} \\ \left[\begin{array}{cccc} 1 & 0 & 0 & 0 \\ 0 & 1 & 0 & 0 \\ 0 & 0 & 1 & 0 \\ 0 & 0 & 0 & 1 \end{array} \right] \end{array}$$

Since identity matrices are used frequently in matrix arithmetic, BASIC has a special function (IDN) that turns a square matrix into an identity matrix. For instance:

```
10 OPTION BASE 1
20 DIM I(2,2)
30 MAT I=IDN
   *
```

The matrix I now contains the elements:

$$\begin{array}{c} \mathbf{I} \\ \left[\begin{array}{cc} 1 & 0 \\ 0 & 1 \end{array} \right] \end{array}$$

If I was not a square matrix, line 20 would have returned an error.

Inverse Matrix

Although division is not defined for matrices, there is a similar operation which involves finding the inverse of a matrix. As with identity matrices, a matrix must be square in order to have an inverse. Inverse matrices are notated by a superscript -1 . If A is a square matrix, then A^{-1} denotes its inverse. The inverse is defined by the equation:

$$A * A^{-1} = I$$

where I is the identity matrix. You can see how similar this is to division since, if A were a real number, then:

$$A * (1/A) = 1$$

The inverse of a matrix is found by using the INV function. For instance, the inverse of:

$$\mathbf{A} = \begin{bmatrix} 0 & 2 & 0 \\ -1 & 2 & 0 \\ 2 & 0 & 2 \end{bmatrix}$$

is found by executing:

```
MAT A_inv=INV(A)
```

The system computes the values of the inverse and places them in the matrix `A_inv`:

$$\mathbf{A_inv} = \begin{bmatrix} 1 & -1 & 0 \\ .5 & 0 & 0 \\ -1 & 1 & .5 \end{bmatrix}$$

To check that this is really the inverse, you could execute the statement:

```
MAT B= A*A_inv
```

As expected, `B` turns out to be an identity matrix:

$$\mathbf{B} = \begin{bmatrix} 1 & 0 & 0 \\ 0 & 1 & 0 \\ 0 & 0 & 1 \end{bmatrix}$$

Unfortunately, these expectations are not always fulfilled. Some matrices do not have an inverse. In other words, for a certain matrix called `A`, there exists no other matrix that, when multiplied to `A` produces an identity matrix. Matrices that don't have an inverse are called "singular". Singular matrices are easily detected and therefore aren't too dangerous. A more troublesome type of matrix is one that is "ill-conditioned". Ill-conditioned matrices are ones whose inverse can't be found by the computer because of round-off errors. These are difficult to detect and almost impossible to correct. We'll talk more about singular and ill-conditioned matrices, but before we do, we should discuss why you'd use an inverse in the first place.

Solving Simultaneous Equations

One of the most common applications of matrices is in the solution of simultaneous equations. Suppose we have the three equations shown below:

$$\begin{aligned} 4X + 2Y - Z &= 5 \\ 2X - 3Y + 3Z &= 5 \\ X + Y - 2Z &= -3 \end{aligned}$$

Note that there are three unknowns (`X`, `Y`, and `Z`) and three equations. This is a necessity for solving by matrix arithmetic: you must have the same number of equations as unknowns. We can re-write these equations in matrix format as the product of two arrays:

$$\begin{bmatrix} 4 & 2 & -1 \\ 2 & -3 & 3 \\ 1 & 1 & -2 \end{bmatrix} * \begin{bmatrix} X \\ Y \\ Z \end{bmatrix} = \begin{bmatrix} 5 \\ 5 \\ -3 \end{bmatrix}$$

For the sake of simplicity, let's name these three arrays A, B, and C. The equation, therefore, is:

$$A * B = C$$

If we multiply both sides of the equation by the inverse of A, we get:

$$A^{-1} * A * B = A^{-1} * C$$

Since $A^{-1} * A$ is simply a 3x3 identity matrix, the equation simplifies to:

$$I * B = A^{-1} * C$$

which further simplifies to:

$$B = A^{-1} * C$$

Remember, B is the matrix that contains the three variables X, Y and Z. To solve for these variables, therefore, all we have to do is multiply the matrix C by A^{-1} . This is accomplished in the program lines listed below.

```

      .
      .
200  DIM Solution(3),A_inv(3,3)
220  MAT A_inv=INV(A)
230  MAT Solution=A_inv*C
240  PRINT "X=";Solution(1)
250  PRINT "Y=";Solution(2)
260  PRINT "Z=";Solution(3)
      .
      .

```

When we run this program, it will print the values of X, Y, and Z. The values are:

```

X=1
Y=2
Z=3

```

For any set of simultaneous equations where there are the same number of unknown variables as there are equations, there are three possible classes of solution.

- There is no solution (e.g., there exist no values for the variables such that all of the equations are true).
- There are an infinite number of solutions.
- There is one, and only one, solution.

The first two cases are called “singular” sets of equations. You may recall that a singular matrix is one that has no inverse. It should not be surprising, therefore, that singular sets of equations always result in singular matrices when they are translated to matrix form. This is explained in the next section.

Singular Matrices

Any set of equations that has no solution or an infinite number of solutions is singular. Likewise, the matrix formed from these equations is also singular. More specifically, we mean the matrix on the left-hand side of the equation, what we've been calling matrix A. Consider the two equations listed below:

$$\begin{aligned} 4X + 6Y &= 5 \\ 4X + 6Y &= 6 \end{aligned}$$

Obviously, there is no solution to this set of equations because any values assigned to X and Y will make only one of the equations true, not both. It is important to realize, however, that the singularity of these equations has nothing to do with the values on the right hand side of the equation. If, for example, we made the two equations the same,

$$\begin{aligned} 4X + 6Y &= 6 \\ 4X + 6Y &= 6 \end{aligned}$$

then there would be an infinite number of solutions. For instance, X could equal 0 and Y equal 1, or X could equal 1.5 and Y could equal 0. In fact, so long as $X = 1.5(1 - Y)$, the two equations will always be true. What is important here is that the two equations,

$$\begin{aligned} 4X + 6Y &= \\ 4X + 6Y &= \end{aligned}$$

will be singular regardless of what we put on the right-hand side of the equal sign. If we translate these equations into matrix form, we get:

$$\begin{bmatrix} 4 & 6 \\ 4 & 6 \end{bmatrix} * \begin{bmatrix} X \\ Y \end{bmatrix}$$

The matrix,

$$\begin{bmatrix} 4 & 6 \\ 4 & 6 \end{bmatrix}$$

is singular: it has no inverse. If, however, we call this matrix A and do an INV on it, the system will not report an error. On the contrary, it will go ahead and find what it thinks is an inverse. However, whatever matrix it comes up with will not be the inverse. Let's see what happens with our singular matrix A.

```
MAT A_inv=INV(A)
PRINT A_inv(*)
```

When we execute these statements, the system will display the following:

```
.666666666667   .166666666667   0   -1
```

Arranging these values in the proper rows and columns, we get:

$$\begin{matrix} & \mathbf{A_inv} \\ \begin{bmatrix} .666666666667 & 0 \\ .166666666667 & -1 \end{bmatrix} \end{matrix}$$

To see whether this is a real inverse, we can multiply it by A. If it is the inverse, the product should be an identity matrix.

```
MAT I=A*A_inv
```

$$I = \begin{bmatrix} 3.333333333333 & 5 \\ -4 & -6 \end{bmatrix}$$

Obviously, the system has made a mistake — `A_inv` is not the inverse of A. So how do we know if an inverse is valid? Or, to put it another way, how do we detect a singular matrix? We have just seen one method: multiply the matrix by its inverse and see whether you get an identity matrix. There is, however, a much easier method. You simply look at the “determinant” of the matrix.

The Determinant of a Matrix

The determinant of a matrix is defined somewhat mysteriously as the sum of all possible products formed by taking one element from each row in order starting from the top and one element from each column, where the sign of each product depends on the permutation of the column indices.

It’s not really important that you understand how to calculate a determinant since the computer does it for you whenever you use the `DET` function. For instance, to print the determinant of matrix A, you would write:

```
PRINT DET(A)
```

Also the determinant is a byproduct of inversions. Thus, whenever you invert a matrix, the system computes the determinant and stores it. If you use `DET` without specifying a matrix, the system will return the determinant of the matrix most recently inverted. For example,

```
MAT A_inv=INV(A)
PRINT DET
```

would print the determinant of A.

Although the computation of the determinant is quite complex, its significance is very simple. If the determinant of a matrix equals 0, either a `REAL` underflow occurred during the inversion or **the matrix is singular**. To find out if an inversion is invalid, therefore, you merely test the matrix’s determinant. If the determinant is zero, then the inverse is invalid. For example, if A is a square matrix, we could execute:

```

      *
      *
100  MAT A_inv=INV(A)
110  IF DET=0 THEN Singular
      *
      *
```

If A is singular, program control is passed to a line named "Singular". Note that we did not have to specify a matrix in line 110 since A was the last matrix inverted.

Unless you know for certain that a matrix is not singular, we recommend that you use the determinant test after each inversion. Otherwise, you may perform calculations using an invalid inverse.

Ill-Conditioned Matrices

In a few unusual cases, the inverse of a matrix will be invalid even though the determinant of the matrix is non-zero. These situations occur due to round-off errors internal to the computer. They are difficult to detect and even more difficult to correct. Fortunately, they occur very rarely. Unless you are having problems with a program involving matrix operations producing unexpected results, you can skip over to "Miscellaneous Matrix Functions." If you **are** having problems, listed below is an example of an ill-conditioned set of equations.

$$\begin{aligned} X_1 + 0X_2 + 3X_3 + 8X_4 &= 12 \\ 2X_1 + X_2 + 6X_3 + 15.9X_4 &= 24.9 \\ 3X_1 + X_2 + 8.9X_3 + 24X_4 &= 36.9 \\ 4X_1 + X_2 + 11.9X_3 + 32X_4 &= 48.9 \end{aligned}$$

We have selected the numbers on the right-hand side of the equation so that all of the X's equal 1. Watch what happens though when we try to solve these equations through matrix inversion. First, we set up the equations in matrix format.

$$\begin{array}{c} \mathbf{A} \\ \left[\begin{array}{cccc} 1 & 0 & 3 & 8 \\ 2 & 1 & 6 & 15.9 \\ 3 & 1 & 8.9 & 24 \\ 4 & 1 & 11.9 & 32 \end{array} \right] \end{array} * \begin{array}{c} \mathbf{Var} \\ \left[\begin{array}{c} X_1 \\ X_2 \\ X_3 \\ X_4 \end{array} \right] = \begin{array}{c} \mathbf{Ans} \\ \left[\begin{array}{c} 12 \\ 24.9 \\ 36.9 \\ 48.9 \end{array} \right] \end{array}$$

Then we execute the program statements below.

```

      *
      *
100   MAT A_inv=INV(A)
110   MAT Var=A_inv*Ans
120   FOR Y=1 TO 4
130     PRINT USING "X("";D,"")="";K";Y,Var(Y)
140   NEXT Y
      *
      *
```

The computer displays:

```

X(1)=256
X(2)=0
X(3)=-32
X(4)=-16
```

Obviously something has gone wrong. The problem is that the inverse found by the computer is far off the mark from the actual inverse. The system of equations, though, is not singular. The determinant, though small, does not equal zero.

Detecting Ill-conditioned Matrices

Now that you've seen how ill-conditioning can affect the solutions to a set of simultaneous equations, you're probably wondering how you can tell an ill-conditioned matrix when you see one. There are a number of different techniques, none of which is entirely fail-proof. Used together, however, they are quite dependable.

In general, the determinant of an ill-conditioned matrix is very small compared with the elements of the matrix. So one of the first steps you can take is to look at the determinant. The term "very small" is, of course, relative. If a matrix contained elements all greater than 1000, then a determinant that equaled 10 would be very small. On the other hand, if all the elements in an array were less than 20 then a determinant of 10 would be quite reasonable. One equation for determining whether the determinant is "too small" is given below:

$$\frac{\text{DET}(A)}{\sqrt{\sum_{i=1}^n \sum_{j=1}^n A_{ij}^2}} \ll 1$$

We can execute this equation in a program as follows.

```

    *
    *
100 FOR X=(BASE A,1) TO (SIZE A,1)+(BASE A,1)-1
120   FOR Y=(BASE A,2) TO (SIZE A,2)+(BASE A,2)-1
130     Total=Total+A(X,Y)^2
140   NEXT Y
150 NEXT X
160 Test=DET(A)/SQR(Total)
170 IF Test<.001 THEN Ill_con
    *
    *

```

Note that line 170 can be changed depending on how much accuracy you require for your particular application. If we execute this program for the ill-conditioned matrix discussed earlier, the value of "Test" comes out to 9.527E-19. Since this value is much smaller than .001, this test would have correctly identified A as an ill-conditioned matrix.

Another technique for detecting ill-conditioned matrices is to multiply the matrix by its inverse and compare the product with the identity matrix. Again, you can demand as much accuracy as necessary. In the program below, we look for any elements in the product that differ by more than .001 from the identity matrix.

```

    *
    *
100 MAT I=IDN
110 MAT A_inv=INV(A)
120 MAT Product=A_inv*A
130 MAT Differ=(Product-I)
140 MAT Compare=Differ>(.001)
150 MAT Compare1=Differ<(-.001)
160 IF SUM(Compare)+SUM(Compare1)>0 THEN Ill_con
    *
    *

```

Applying this algorithm to our ill-conditioned matrix, we get:

$$\begin{array}{c} \mathbf{A * A_inv} \\ \left[\begin{array}{cccc} 0 & 0 & 0 & 0 \\ 0 & 1 & -.5 & 0 \\ -2 & -.5 & -4 & -16 \\ -2 & -.5 & -8 & -16 \end{array} \right] \end{array}$$

As you can see, 12 of the 16 elements differ from the identity matrix by more than 1, so this test also would have worked.

One drawback of this method is that it requires several additional matrices. If you are strapped for memory, this method could be unsatisfactory.

A third technique is to take the inverse of the inverse and compare it to the original matrix. The program below utilizes this method. Again, we are looking for differences greater than 0.001.

```

      *
      *
100  MAT A_inv=INV(A)
120  MAT A_inv_inv=INV(A_inv)
130  MAT Differ=(A_inv_inv-A)
140  MAT Compare=Differ>(,001)
150  MAT Compare1=Differ<(-,001)
160  IF SUM(Compare)+SUM(Compare1)>0 THEN Ill_con
      *
      *

```

Applying this technique to our ill-conditioned matrix, we find that all 16 elements of `A_inv_inv` differ from `A` by more than .001.

This technique will in general find more ill-conditioned matrices than the previous one. This is because any round-off errors are exaggerated by the second inverse. By the same token, it will occasionally detect an ill-conditioned matrix which might actually have been alright before the second inverse.

As stated before, none of these methods alone is decisive. What it all comes down to is that the precision of `MAT INV` falls off as a matrix approaches singularity. By using combinations of the tests described above, it is possible to determine how much precision has been lost, and then compare it to the precision actually required by your application.

Miscellaneous Matrix Functions

There are a few matrix functions that we haven't discussed yet. One of these is the transpose function (TRN). The transpose of a matrix is derived by exchanging rows for columns and columns for rows. If A is the matrix below,

$$\begin{matrix} \mathbf{A} \\ \begin{bmatrix} 1 & 2 & 3 \\ 4 & 5 & 6 \\ 7 & 8 & 9 \end{bmatrix} \end{matrix}$$

then,

```
MAT B=TRN(A)
```

would result in:

$$\begin{matrix} \mathbf{B} \\ \begin{bmatrix} 1 & 4 & 7 \\ 2 & 5 & 8 \\ 3 & 6 & 9 \end{bmatrix} \end{matrix}$$

A matrix does not have to be square to have a transpose. If A is,

$$\begin{matrix} \mathbf{A} \\ \begin{bmatrix} 0 & 1 & 8 & 3 \\ 2 & 9 & 7 & -2 \end{bmatrix} \end{matrix}$$

then,

```
MAT B=TRN(A)
```

would result in:

$$\begin{matrix} \mathbf{B} \\ \begin{bmatrix} 0 & 2 \\ 1 & 9 \\ 8 & 7 \\ 3 & -2 \end{bmatrix} \end{matrix}$$

The result array cannot be the same as the array being transposed. For example,

```
MAT A=TRN(A)
```

is an illegal statement and will cause an error.

The transpose function is useful for manipulating tables of data. It also has special significance for a small set of matrices called "orthogonal" matrices. An orthogonal matrix is defined as one whose transpose and inverse are the same.

Summing Rows and Columns

BASIC has two functions that return the sum of all rows and columns in an array. The totals are stored in a vector which you must dimension beforehand. Let A be the matrix shown below.

$$A = \begin{bmatrix} 3 & 6 & 18 & 7 \\ 1 & 0 & 41 & 2 \\ 4 & 3 & 12 & 11 \end{bmatrix}$$

If we execute:

```

10  OPTION BASE 1
20  DIM Row_sum(3),Col_sum(4)
30  MAT Row_sum=RSUM(A)
40  MAT Col_sum=CSUM(A)
50  PRINT "The sum of rows is";Row_sum(*);
60  PRINT "The sum of columns is";Col_sum(*);
70  END

```

The system will display:

```

The sum of rows is 34 44 30
The sum of columns is 8 9 71 20

```

Using Arrays for Code Conversion

Suppose you have an input device that provides information in 8-bit ASCII code. On the other hand, an output device in the same system uses a non-ASCII specialized 8-bit code. Examples might include specialized instrumentation, typesetting equipment, or a multitude of other devices. For each ASCII character, there is a corresponding code for the output device. There may be some ASCII characters (such as control characters) that are not to be converted. Let us assume that a null character (all bits set to zero) is used for those special characters. Here is how a conversion array is set up:

1. First, an array is created with 256 elements (0 thru 255). Each element address corresponds to the 8-bit INTEGER numeric equivalent of the ASCII character code. The contents of a given array element contains the output code for the corresponding ASCII input code. The array can be REAL or INTEGER. Usually, it is more efficient to use INTEGER arrays for converting 16-bit or shorter codes. The array must be filled by individual program statements (assignments or DATA and READ statements), or it can be filled from a mass storage file. If a file is used, the data must be created by some prior means. Fixed conversion codes can sometimes be generated by an algorithm in the introductory part of the program that performs the conversions.
2. Input data is placed in a string variable (see Chapter 5 for string variables techniques). Characters are then picked off, one character at a time, for conversion. Refer to *BASIC Interfacing Techniques* for more information about output operations.

Here is an example of how such an operation could be implemented:

```

1000  INTEGER Convert(0:255)
1010  DIM In$(80)
1020  Source=18      ! Source device selector
1030  Dest=22       ! Destination device selector
      .
      .
      .
      Initialize the conversion array here.
      .
      .
      .
2470  ENTER Source;Input$  ! Input line of ASCII
2480  FOR I=1 TO LEN(In$)  ! Send converted bytes
2490    OUTPUT Dest;CHR$(Convert(NUM(In$(I,I)))));
2500  NEXT I

```

Note that the semicolon in line 2490 prevents sending a carriage-return and line-feed character pair at the end of each output line. This is usually necessary to prevent unwanted behavior when using ASCII strings to output non-ASCII data. This technique can be applied to arbitrary data conversions with virtually no limitations.

It is also possible to handle code conversions automatically in OUTPUT statements with the CONVERT options of the ASSIGN statement. See the ASSIGN Attributes discussion in BASIC Interfacing Techniques.

For further information about the topics in this chapter, see:

- 1 Coonen, Jerome T.; "An Implementation Guide to the Proposed Floating Point Standard", Computer Magazine, Jan. 1980.
- 2 Cody, William J. Jr. and William Waite; Software Manual for the Elementary Functions, Prentice Hall, 1980.
- 3 Sterbenz, Pat H.; Floating Point Computation, Prentice Hall, 1974.
- 4 Signum Newsletter, Oct. 1979.

Notes

String Manipulation

Chapter

5

Introduction

It is often desirable to store non-numerical information in the computer. A word, a name or a message can be stored in the computer as a **string**. Any sequence of characters may be used in a string. Quotation marks are used to delimit the beginning and ending of the string. The following are valid string assignments.

```
LET A$="COMPUTER"
Fail$="The test has failed."
File_name$="INVENTORY"
Test$=Fail$[5,8]
```

The left-hand side of the assignment (the variable name) is equated to the right-hand side of the assignment (the literal).

String variable names are identical to numeric variable names with the exception of a dollar sign (\$) appended to the end of the name.

The **length** of a string is the number of characters in the string. In the previous example, the length of A\$ is 8 since there are eight characters in the literal "COMPUTER".

BASIC allows the dimensioned length of a string to range from 1 to 32 767 characters and the current length (number of characters in the string) to range from zero to the dimensioned length. A string of zero characters is often called a null string or an empty string.

The default dimensioned length of a string is 18 characters. The DIM, COM, and ALLOCATE statements are used to define string lengths up to the maximum length of 32 767 characters. An error results whenever a string variable is assigned more characters than its dimensioned length.

A string may contain any character. The only special case is when a quotation mark needs to be in a string. Two quotes, in succession, will embed a quote within a string.

```
10 Quote$="The time is ""NOW""."
20 PRINT Quote$
30 END
```

Produces: The time is "NOW".

String Storage

Strings whose length exceeds the default length of 18 characters must have space reserved before assignment. The following statements may be used.

- `DIM Long$[400]` Reserve space for a 400 character string.
- `COM Line$[80]` Reserve an 80 character common variable.
- `ALLOCATE Search$[Length]` Dynamic length allocation.

The maximum length of any string must not exceed 32 767 characters. A string may also be dimensioned to a length less than the default length of 18 characters.

The DIM statement reserves storage for strings.

```
DIM Part_number$[10],Description$[64],Cost$[5]
```

The COM statement defines common variables that can be used by subprograms.

```
COM Name$[40],Phone$[14]
```

The ALLOCATE statement allows dynamic allocation of string storage. When the maximum length of a string cannot be determined ahead of time, the ALLOCATE statement can be used to reserve enough memory space for the string without wasting space.

```
ALLOCATE Line$[Length]
```

Strings that have been dimensioned but not assigned return the null string.

String Arrays

Large amounts of text are easily handled in arrays. For example:

```
DIM File$(1000)[80]
```

This statement reserves storage for 1000 lines of 80 characters per line. Do not confuse the brackets, which define the length of the string, with the parentheses which define the number of strings in the array. Each string in the array can be accessed by an index. For example:

```
PRINT File$(27)
```

Prints the 27th element in the array. Since each character in a string uses one byte of memory and each string in the array requires as many bytes as the length of the string, string arrays can quickly use a lot of memory.

A program saved on a disc as an ASCII type file can be entered into a string array, manipulated, and written back out to disc.

Evaluating Expressions Containing Strings

Evaluation Hierarchy

Evaluation of string expressions is simpler than evaluation of numerical expressions. The three allowed operations are extracting a substring, concatenation, and parenthesization. The evaluation hierarchy is presented in the following table.

Order	Operation
High	Parentheses
-	Substrings and Functions
Low	Concatenation

String Concatenation

Two separate strings are joined together by using the concatenation operator "&". The following program combines two strings into one.

```
10 One$="WRIST"
20 Two$="WATCH"
30 Concat$=One$&Two$
40 PRINT One$,Two$,Concat$
50 END
```

Prints:

```
WRIST      WATCH      WRISTWATCH
```

The concatenation operation, in line 30, appends the second string to the end of the first string. The result is assigned to a third string. An error results if the concatenation operation produces a string that is longer than the dimensioned length of the string being assigned.

Relational Operations

Most of the relational operators used for numeric expression evaluation can also be used for the evaluation of strings.

The following examples show some of the possible tests.

"ABC" = "ABC"	True
"ABC" = " ABC"	False
"ABC" < "AbC"	True
"6" > "7"	False
"2" < "12"	False
"long" <= "longer"	True
"RE-SAVE" >= "RESAVE"	False

Any of these relational operators may be used: <, >, <=, >=, =, <>.

Testing begins with the first character in the string and proceeds, character by character, until the relationship has been determined.

The outcome of a relational test is based on the characters in the strings not on the length of the strings. For example:

```
"BRONTOSAURUS" < "CAT"
```

This relationship is true since the letter "C" is higher in ASCII value than the letter "B".

Note

When LEX is loaded, the outcome of a string comparison is based on the character's lexical value rather than the character's ASCII value. See the LEXICAL ORDER IS statement later in this chapter for more details.

Substrings

A subscript can be appended to a string variable name to define a **substring**. A substring may comprise all or just part of the original string. Brackets enclose the subscript which can be a constant, variable, or numeric expression. For instance:

```
String$[4]      Specifies a substring starting with the fourth character of the original string.
```

The subscript must be in the range: 1 to the dimensioned length of the string plus 1. Note that the brackets now indicate the substring's starting position instead of the total length of the string as when reserving storage for a string.

Subscripted strings may appear on either side of the assignment.

Single-Subscript Substrings

When a substring is specified with only one numerical expression, enclosed with brackets, the expression is evaluated and rounded to an integer indicating the position of the first character of the substring within the string.

The following examples use the variable A\$ which has been assigned the literal "DICTIONARY".

Statement	Output
PRINT A\$	DICTIONARY
PRINT A\$[0]	(error)
PRINT A\$[1]	DICTIONARY
PRINT A\$[5]	IONARY
PRINT A\$[10]	Y
PRINT A\$[11]	(null string)
PRINT A\$[12]	(error)

When a single subscript is used it specifies the starting character position, within the string, of the substring. An error results when the subscript evaluates to zero or greater than the current length of the string plus 1. A subscript that evaluates to 1 plus the length of the string returns the null string (" ") but does not produce an error.

Double-Subscript Substrings

A substring may have two subscripts, within brackets, to specify a range of characters. When a comma is used to separate the items within brackets, the first subscript marks the beginning position of the substring, while the second subscript is the ending position of the substring. The form is: A\$[Start,End]

“JABBERWOCKY”[4,6] Specifies the substring: “BER”

When a semicolon is used in place of a comma, the first subscript again marks the beginning position of the substring, while the second subscript is now the length of the substring. The form is: A\$[Start;Length]

“JABBERWOCKY”[4;6] Specifies the substring: “BERWOC”

In the following examples the variable B\$ has been assigned to the literal “ENLIGHTENMENT”:

Statement	Output
PRINT B\$	ENLIGHTENMENT
PRINT B\$[1,13]	ENLIGHTENMENT
PRINT B\$[1;13]	ENLIGHTENMENT
PRINT B\$[1,9]	ENLIGHTEN
PRINT B\$[1;9]	ENLIGHTEN
PRINT B\$[3,7]	LIGHT
PRINT B\$[3;7]	LIGHTEN
PRINT B\$[13,13]	N
PRINT B\$[13;1]	N
PRINT B\$[13,26]	(error)
PRINT B\$[13;13]	(error)
PRINT B\$[14;1]	(null string)

An error results if the second subscript in a comma separated pair is greater than the current string length plus 1 or if the sum of the subscripts in a semicolon separated pair is greater than the current string length plus 1.

Specifying the position just past the end of a string returns the null string.

Special Considerations

All substring operations allow a subscript to specify the first position past the end of a string. This allows strings to be concatenated without the concatenation operator. For instance:

```
10  A$="CONCAT"
20  A$[7]="ENATION"
30  PRINT A$
40  END
```

Produces: CONCATENATION

124 String Manipulation

The substring assignment is only valid if the substring already has characters up to the specified position. Access beyond the first position past the end of a string results in the error:

```
ERROR 18 String ovfl. or substring err
```

A good practice is to dimension all strings including those shorter than the default length of eighteen characters.

Some very interesting assignments can be attempted. For example, a 14-character string can be assigned to a 3-character substring.

```
10   Big$="Too big to fit"
20   Small$="Little string"
30   !
40   Small$[1,3]=Big$
50   !
60   PRINT Small$
70   END
```

Prints: T o o l e s t r i n g

When a substring assignment specifies fewer characters than are available, any extra trailing characters are truncated.

The alternate assignment is shown in the next example. Here a 4-character string is assigned to a 8-character substring.

```
10   Big$="A large string"
20   Small$="tiny"
30   !
40   Big$[3,10]=Small$
50   !
60   DISP Big$
70   END
```

Prints: A t i n y r i n g

Since the subscripted length of the substring is greater than the length of the replacement string, enough blanks (ASCII spaces) are added to the end of the replacement string to fill the entire specified substring.

String-Related Functions

Several intrinsic functions are available in BASIC for the manipulation of strings. These functions include conversions between string and numeric values.

String Length

The “length” of a string is the number of characters in the string. The LEN function returns an integer whose value is equal to the string length. The range is from 0 (null string) thru 32 767. For example:

```
PRINT LEN("HELP ME")
```

Prints: 7

The following example program prints the length of a string that is typed on the keyboard.

```
10 DIM In$(160)
20 INPUT In$
30 Length=LEN(In$)
40 DISP Length;"characters in ";In$;" "
50 END
```

Try finding the length of a string containing only spaces. When the INPUT statement is used, any leading or trailing spaces are removed from items typed on the keyboard. Change INPUT to LINPUT in line 20 to allow leading and trailing spaces to be entered.

Substring Position

The “position” of a substring within a string is determined by the POS function. The function returns the value of the starting position of the substring or zero if the entire substring was not found. For instance:

```
PRINT POS("DISAPPEARANCE","APPEAR")
```

Prints: 4

The following example prints the positions of substrings found within a string.

```
10 DIM Sentence$(40),Word$(1:6)[8]
20 DATA CAT,ON,A,HOT,TIN,NATION
30 READ Word$(*)
40 Sentence$="WHERE IS THE CAT IN CONCATINATION"
50 !
60 FOR I=1 TO 6
70   Position=POS(Sentence$,Word$(I)) ! <- POS function
80   IF Position THEN
90     PRINT Sentence$
100    PRINT TAB(Position);Word$(I);TAB(35);"is at ";Position
110    PRINT
120   ELSE
130    PRINT "'";Word$(I);" ' was not found"
140    PRINT
150   END IF
160 NEXT I
170 END
```

If POS returns a non-zero value, the entire substring occurs in the first string and the value specifies the starting position of the substring.

Note that POS returns the first occurrence of a substring within a string. By adding a subscript, and indexing through the string, the POS function can be used to find all occurrences of a substring. The following program uses this technique to extract each word from a sentence.

```

10   DIM A$(80)
20   A$="I know you think you understand what I said, but you don't."
30   INTEGER Scan,Found
40   Scan=1
50   PRINT A$
60   REPEAT
70     Found=POS(A$[Scan]," ")
80     IF Found THEN
90       PRINT A$[Scan,Scan+Found-1]
100      Scan=Scan+Found
110     ELSE
120      PRINT A$[Scan]
130     END IF
140   UNTIL NOT Found
150   END

```

As each occurrence is found, the new subscript specifies the remaining portion of the string to be searched.

String-to-Numeric Conversion

The VAL function converts a string expression into a numeric value. The string must evaluate to a valid number or error 32 will result.

```
ERROR 32 String is not a valid number
```

The number returned by the VAL function will be converted to and from scientific notation when necessary. For example:

```
PRINT VAL("123.4E3")
```

Prints: 123400

The following program converts a fraction into its equivalent decimal value.

```

10   INPUT "Enter a fraction (i.e. 3/4)";Fraction$
20   !
30   ON ERROR GOTO Err
40   Numerator=VAL(Fraction$)
50   !
60   IF POS(Fraction$,"/") THEN
70     Delimiter=POS(Fraction$,"/")
80     Denominator=VAL(Fraction$[Delimiter+1])
90   ELSE
100  PRINT "Invalid fraction"
110  GOTO Quit
120  END IF
130  !
140  PRINT Fraction$;" = ";Numerator/Denominator
150  GOTO Quit
160 Err: PRINT "ERROR Invalid fraction"
170  OFF ERROR
180 Quit: END

```

Similar techniques can be used for converting: feet and inches to decimal feet or hours and minutes to decimal hours.

The NUM function converts a single character into its equivalent numeric value. The number returned is in the range: 0 to 255. For example:

```
PRINT NUM("A")
```

Prints: 65

The next program prints the value of each character in a name.

```
10 INPUT "Enter your first name",Name$
20 !
30 PRINT Name$
40 PRINT
50 FOR I=1 TO LEN(Name$)
60 PRINT NUM(Name$[I]); ! Print value of each character
70 NEXT I
80 PRINT
90 END
```

Entering the name: JOHN will produce the following.

```
74 79 72 78
```

Numeric-to-String Conversion

The VAL\$ function converts the value of a numeric expression into a character string. The string contains the same characters (digits) that appear when the numeric variable is printed. For example:

```
PRINT 1000000,VAL$(1000000)
```

Prints: 1.E+6 1.E+6

The next program converts a number into a string so the POS function can be used to separate the mantissa from the exponent.

```
10 CONTROL 2,0;1 ! CAPS LOCK ON
20 INPUT "Enter a number with an exponent",Number
30 !
40 Number$=VAL$(Number)
50 !
60 PRINT Number$
70 E=POS(Number$,"E")
80 IF E THEN
90 PRINT "Mantissa is",Number$[1;E-1]
100 PRINT "Exponent is",Number$[E+1]
110 ELSE
120 PRINT "No exponent"
130 END IF
140 END
```

The CHR\$ function converts a number into an ASCII character. The number can be of type INTEGER or REAL since the value is rounded, and a modulo 255 is performed. For example:

```
PRINT CHR$(97);CHR$(98);CHR$(99)
```

Prints: abc

The next program prints the values in the data statement as characters.

```

10 PRINT CHR$(12) ! CLEAR SCREEN
20 PRINT CHR$(7) ! RING THE BELL
30 !
40 DATA 34,130,89,111,117,32,103,111,116,32,105,116,33,128,34
50 INTEGER N(1:15)
60 READ N(*)
70 FOR I=1 TO 15
80 PRINT CHR$(N(I));
90 NEXT I
100 PRINT CHR$(7)
110 END

```

CRT Character Set

The following program prints the character set on the screen of the CRT.

```

10 ! Program: CRT Character Set,
20 !
30 PRINT CHR$(12);"CRT Character Set"
40 STATUS 1,9;Line_length ! 50 or 80 Column
50 Left=Line_length/2-16
60 !
70 FOR I=0 TO 255
80 Col=I MOD 16*2+Left
90 Row=I DIV 16+3
100 IF Col=Left THEN
110 PRINT TABXY(Left-5,Row);
120 PRINT USING "3D";I
130 END IF
140 PRINT TABXY(Col,Row);
150 CONTROL 1,4;1 ! Display Functions on
160 PRINT CHR$(I); ! PRINT the Character
170 CONTROL 1,4;0 ! Display Functions off
180 NEXT I
190 PRINT
200 I=127
210 ON KNOB .08 GOSUB Change
220 DISP USING "5A,5D,X,2A,B,B";"ASCII",I,"=",128,I
230 GOTO 220
240 Change: I=I-KNOBX/10
250 IF I<0 THEN I=0
260 IF I>255 THEN I=255
270 RETURN
280 END

```

ASCII character values from 128 to 159 are treated differently by different systems. Refer to the section "The Extended Character Set" found later in this chapter.

String Functions

String Reverse

The REV\$ function returns a string created by reversing the sequence of characters in the given string.

```
PRINT REV$("Snack cans")
```

Prints: snac kcanS

A common use for the REV\$ function is to find the last occurrence of an item in a string.

```
10 DIM List$(30)
20 List$="3.22 4.33 1.10 8.55 12.20 1.77"
30 Length=LEN(List$)
40 Last_space=POS(REV$(List$)," ") ! "SPACE" is delimiter
50 DISP "The last item is:";List$[1+Length-Last_space]
60 END
```

Displays: The last item is: 1.77

String Repeat

The RPT\$ function returns a string created by repeating the specified string, a given number of times.

```
PRINT RPT$("* *",10)
```

Prints: * * * * * * * * * *

Here is a short program that uses RPT\$ to create an image for a formatted print statement.

```
10 Items=7
20 DATA 50,900,2,444,37,2001,32768
30 ALLOCATE Array(1:Items)
40 READ Array(*)
50 FOR I=1 TO Items
60   Digits=INT(1+LGT(Array(I)))
70   IF Digits>Maxdigits THEN Maxdigits=Digits
80 NEXT I
90 Form$="XX,"&RPT$("D",Maxdigits)&".DD"
100 PRINT "Using the image: ";Form$
110 PRINT USING Form$;Array(*)
120 END
```

Trimming a String

The TRIM\$ function returns a string with all leading and trailing blanks (ASCII spaces) removed.

```
PRINT "*" ; TRIM$("   1.23   ") ; "*"
```

Prints: *1.23*

TRIM\$ is often used to extract fields from data statements or keyboard input.

```

10 INPUT "Enter your full name",Name$
20 First$=TRIM$(Name$[1,POS(Name$," ")])
30 Last$=TRIM$(Name$[1+LEN(Name$)-POS(REV$(Name$)," ")])
40 PRINT Name$,LEN(Name$)
50 PRINT Last$,LEN(Last$)
60 PRINT First$,LEN(First$)
70 END

```

Note that the INPUT statement trims leading and trailing blanks from whatever is typed. If you need to enter leading or trailing spaces, use the LINPUT statement.

Case Conversion

The case conversion functions, UPC\$ and LWC\$, return strings with all characters converted to the proper case. UPC\$ converts all lowercase characters to their corresponding uppercase characters and LWC\$ converts any uppercase characters to their corresponding lowercase characters. Roman Extension characters will be converted according to the current lexical order. See the LEXICAL ORDER IS statement later in this chapter for the case conversion listings.

```

10 DIM Word$[160]
20 LINPUT "Enter a few characters",Word$
30 PRINT
40 PRINT "You typed: ";Word$
50 PRINT "Uppercase: ";UPC$(Word$)
60 PRINT "Lowercase: ";LWC$(Word$)
70 END

```

A more general character replacement method is obtained by using a buffer that was assigned an indexed conversion. Indexed conversion uses the incoming character's ASCII value as an index into a string of characters and returns the character in that position. In the following program, the conversion string is created in lines 30 and 50. The conversion string specifies all lowercase characters are to be replaced by their corresponding uppercase character.

```

10 DIM Cipher$[256],A$[80]
20 FOR I=1 TO 255
30 Cipher$=Cipher$&UPC$(CHR$(I)) ! Create conversion string
40 NEXT I
50 Cipher$=Cipher$&LWC$(CHR$(0))
60 ASSIGN @F TO BUFFER [160];CONVERT OUT BY INDEX Cipher$
70 LOOP
80 INPUT A$
90 OUTPUT @F;A$ ! Conversion occurs
100 ENTER @F;A$
110 PRINT A$
120 END LOOP
130 END

```

Searching and Sorting

Information stored in a string array often requires sorting. There are over a dozen common algorithms that may be used. Each algorithm has certain advantages depending on the number of items to be sorted, the current order of the items, the time allowed to sort the items, and the complexity of the algorithm. One of the simplest (and most inefficient) sorts to implement is the “bubble” sort. The following program is a slight variation of the bubble sort.

```

10      ! Program: SORT
20      !
30      READ N
40      DATA 10      ! NUMBER OF ITEMS TO SORT
50      ALLOCATE Word$(N)[5],Temp$[5]
60      READ Word$(*) ! READ ENTIRE ARRAY
70      DATA zero,one,two,three,four,five,six,seven,eight,nine,ten
80      PRINT Word$(*)
90      PRINT
100     Sort:FOR I=0 TO N-1
110         IF Word$(I)>Word$(I+1) THEN
120             Temp$=Word$(I)
130             Word$(I)=Word$(I+1)
140             Word$(I+1)=Temp$
150             GOTO Sort
160         END IF
170     NEXT I
180     PRINT Word$(*)
190     END

```

This example prints the contents of the array before and after sorting.

Before sorting:

zero	one	two	three	four	five
six	seven	eight	nine	ten	

After sorting:

eight	five	four	nine	one	seven
six	ten	three	two	zero	

The strings are sorted in ascending order. If the relational operator in line 110 is changed from the greater than sign “>” to the less than sign “<”, the strings will be sorted in descending order.

MAT Functions and String Arrays

MAT functions (available with MAT) are commonly used to manipulate data in numeric arrays. However, several of these functions can be used with string arrays. For example, a string array is copied into another string array by the following.

```
MAT Copy$ = Original$
```

Note that only the variable name is necessary. The array specifier “(*)” need not be included when using the MAT statement.

Every element in a string array will be initialized to a constant value by the following statement.

```
MAT Array$ = (Null$)
```

The constant value can be a literal or a string expression and is enclosed in parentheses to distinguish it from being an array name.

A list of items can be sorted very quickly by the MAT SORT statement.

```
10    ! Program: SORT_LIST
20    DIM List$(1:5)[6]
30    DATA Bread,Milk,Eggs,Bacon,Coffee
40    READ List$(*)
50    !
60    PRINT "original order"
70    PRINT List$(*)
80    !
90    PRINT "ascending order"
100   MAT SORT List$(*)
110   PRINT List$(*)
120   !
130   PRINT "descending order"
140   MAT SORT List$(*) DES
150   PRINT List$(*)
160   END
```

Running this program produces:

```
original order
Bread    Milk      Eggs      Bacon     Coffee

ascending order
Bacon    Bread     Coffee    Eggs      Milk

descending order
Milk     Eggs      Coffee    Bread     Bacon
```

Sorting by Substrings

A substring range can be appended to the end of a MAT SORT statement. Items will then be sorted by the characters within the substring specified. No error results from specifying a substring position beyond the current length of the string.

```

10 PRINT CHR$(12) ! Program: SUBSORT
20 DATA 1 OLD ORANGE,2 TINY TOADS,3 TALL TREES,4 FAT FOWLS,5 FRIED FISH
30 DATA 6 SLOW SNAILS,7 SLIMY SLUGS,8 AWFUL HOURS,9 NASTY KNIVES
40 DIM Thing$(1:9)[38]
50 READ Thing$(*)
60 First=1
70 Length=1
80 DISP "Use KNOB and SHIFT-KNOB to change sort field."
90 ON KNOB ,15 GOTO Slide
100 Go:MAT SORT Thing$(*)[First;Length]
110 FOR I=1 TO 9
120 PRINT TABXY(10,I);Thing$(I);" "
130 NEXT I
140 W:GOTO W
150 !
160 Slide: !
170 S=SGN(KNOBY)
180 H=SGN(KNOBX)
190 IF S THEN
200 Length=Length+S*(S>0 AND Length<16)+S*(S<0 AND Length>1)
210 END IF
220 IF H THEN
230 First=First+H*(H>0 AND First<18)+H*(H<0 AND First>1)
240 END IF
250 DISP "MAT SORT Thing$(*)[";First;" ";Length;"]"
260 PRINT TABXY(9,10);RPT$(" ",First);RPT$("^",Length);RPT$(" ",10)
270 GOTO Go
280 END

```

Adding Items to a Sorted List

Lists of strings can be maintained in sorted order. Every time a new item is added to the list, the list is sorted by the MAT SORT statement. To prevent overwriting any of the items already in the list, items should be added to the top (first array element) of a list sorted in ascending order and to the bottom (last array element) of a list sorted in descending order.

```

10 PRINT CHR$(12)
20 ! Since arrays are in COM, they "remember" old values.
30 ! After running, execute SCRATCH C to clear the arrays.
40 !
50 COM Ascend$(1:18)[18],Descend$(1:18)[18]
60 Again:I=I+1
70 INPUT "Enter a word",Word$
80 Ascend$(1)=Word$ ! Fill array at top
90 Descend$(18)=Word$ ! Fill array at bottom
100 CALL See
110 IF I<18 THEN Again
120 BEEP
130 END
140 !-----
150 SUB See ! DISPLAY THE ARRAYS
160 COM Ascend$(*),Descend$(*)
170 MAT SORT Ascend$ ! <- ascending sort
180 MAT SORT Descend$ DES ! <- descending sort
190 FOR J=1 TO 18
200 PRINT TABXY(1,J);RPT$(" ",49)
210 PRINT TABXY(1,J);J;TABXY(11,J);Ascend$(J);TABXY(31,J);Descend$(J)
220 NEXT J
230 SUBEND

```

Sorting by Multiple Keys

When sorting a multi-dimension array, it is possible to specify more than one key. The array will be sorted by the first key then the second key and so on until the key specifiers are exhausted. Once the first key sorts items into similar groups, the items within a group can be arranged in any order you choose.

```

10   COM Tool$(1:8,1:3)[10]
20   DATA PENCIL,RED,35,PENCIL,BLUE,12,PENCIL,GREEN,0,PENCIL,BLACK,17
30   DATA PEN,BLACK,17,PEN,BLUE,127,PEN,RED,55,PEN,GREEN,43
40   READ Tool$(*)
50   PRINT
60   PRINT "*** UNSORTED LIST ***"
70   Display
80   PRINT "*** SORT BY COLOR ***"
90   MAT SORT Tool$(*,2)[1,3]      ! Sort color by first three letters.
100  Display
110  PRINT "*** SORT BY COLOR THEN BY NAME ***"
120  MAT SORT Tool$(*,2),(*,1)     ! Two Key sort.
130  Display
140  PRINT "*** SORT BY NAME THEN BY COLOR ***"
150  MAT SORT Tool$(*,1),(*,2)[1;3] DES
160  Display
170  END
180  !-----
190  SUB Display
200    COM Tool$(*)
210    K=K+1
220    FOR I=1 TO 8
230      FOR J=1 TO 3
240        PRINT Tool$(I,J),
250      NEXT J
260    PRINT
270  NEXT I
280  SUBEND

```

Sorting to a Vector

It is possible to determine the sorting order of items in an array without disturbing the array. This is accomplished by “sorting” to a single-dimensioned numeric array (vector). The vector will then contain the subscripts of the items in the order that the items would have been arranged.

```

10   DIM Month$(1:12)[3],Fix(1:12)
20   DATA JAN,FEB,MAR,APR,MAY,JUN,JUL,AUG,SEP,OCT,NOV,DEC
30   READ Month$(*)
40   MAT SORT Month$ TO Fix      ! Sort to vector
50   PRINT Month$(*)
60   PRINT Fix(*)
70   FOR I=1 TO 12
80     PRINT Month$(Fix(I)),    ! Print months alphabetically
90   NEXT I
100  END

```

Running this program produces:

```

JAN  FEB  MAR  APR  MAY  JUN  JUL  AUG  SEP  OCT  NOV  DEC
4  8  12  2  1  7  6  3  5  11  10  9
APR  AUG  DEC  FEB  JAN  JUL  JUN  MAR  MAY  NOV  OCT  SEP

```

The first element of the vector contains a four (4), indicating the fourth element in the array would be the first element if the array were actually sorted.

Reordering an Array

The rows and columns of multiple dimension arrays can be reordered. Reordering is made according to a reorder vector (single dimension array). The vector contains the values of the subscripts of the array. When the array is reordered, the columns (or rows) are arranged according to the the order of the subscripts in the reorder vector. See the following program for an example of reordering.

```

10 PRINT CHR$(12); ! SORT_DEMO
20 DIM Size$(0:1)[5],Color$(0:2)[5],Shape$(0:1)[5]
30 COM Ident$(0:3)[5],Array$(0:3,0:11)[6],Order(0:3),Field,Down
40 DATA COUNT,SIZE,COLOR,SHAPE
50 DATA small,large,blue,red,green,cube,ball,1,2,3,0
60 READ Ident$(*),Size$(*),Color$(*),Shape$(*),Order(*)
70 FOR I=0 TO 11
80 Array$(0,I)=RPT$(" ",I<9)&VAL$(I+1)
90 Array$(1,I)=Size$(I DIV 6)
100 Array$(2,I)=Color$(I DIV 2 MOD 3)
110 Array$(3,I)=Shape$(I MOD 2)
120 NEXT I
130 ON KBD CALL Do_Key
140 Again:D$=" Ascending"
150 IF Down THEN D$="Descending"
160 DISP D$;" sort on field #";Field+1
170 Sort
180 Display
190 GOTO Again
200 END
210 !-----
220 SUB Display
230 COM Ident$(*),Array$(*),Order(*),Field,Down
240 PRINT TABXY(1,1);
250 PRINT "Press: A for ascending sort"
260 PRINT " D for descending sort"
270 PRINT " R to reorder array"
280 PRINT " 1-4 for sort field";TABXY(1,5)
290 PRINT USING "*,3X,5A";Ident$(*)
300 FOR I=0 TO 11
310 PRINT TABXY(1,I+7);
320 FOR J=0 TO 3
330 PRINT USING "*,3X,5A";Array$(J,I)
340 NEXT J
350 NEXT I
360 SUBEND
370 !-----
380 SUB Sort
390 COM Ident$(*),Array$(*),Order(*),Field,Down
400 IF Down THEN
410 MAT SORT Array$(Field,*) DES
420 ELSE
430 MAT SORT Array$(Field,*)
440 END IF
450 SUBEND
460 !-----
470 SUB Do_Key
480 COM Ident$(*),Array$(*),Order(*),Field,Down
490 Key$=KBD$
500 SELECT Key$
510 CASE "1" TO "4"
520 Field=VAL(Key$)-1
530 CASE "A","a"
540 Down=0
550 CASE "D","d"
560 Down=1

```

```

570     CASE "R","r"
580         MAT REORDER Array$ BY Order
590         MAT REORDER Ident$ BY Order
600     CASE ELSE
610         BEEP
620     END SELECT
630     SUBEND

```

Searching for Strings

The following program outlines a method for replacing a word in a string.

```

10     ! Program: Word-Replace
20     !
30     DIM Text$(80)
40     !
50     Search$="bad"
60     Replace$="good"
70     Text$="I am a bad string."
80     !
90     PRINT Text$
100    S_length=LEN(Search$)
110    Position=POS(Text$,Search$)
120    IF NOT Position THEN Quit
130    !
140    Text%=Text$[1,Position-1]&Replace$&Text$[Position+S_length]
150    !
160    PRINT Text$
170    Quit: END

```

Prints: I am a bad string.
I am a good string.

Large groups of strings are usually maintained in arrays. Searching an array for a particular value is shown in the following example.

```

10     OPTION BASE 1
20     DIM List$(4)[20]
30     INTEGER I
40     DATA BLACK BILL $100.00
50     DATA BROWN JEFF $150.00
60     DATA GREEN JIM $200.00
70     DATA WHITE WILL $125.00
80     READ List$(*)
90     PRINT USING "20A,/" ;List$(*)
100    I=1
110    LOOP
120    EXIT IF I>4
130    EXIT IF List$(I)[1,5]="BROWN"
140    I=I+1
150    END LOOP
160    !
170    IF I<=4 THEN PRINT List$(I)[1,5] ;": ";List$(I)[14,17]
180    END

```

Results:

BLACK	BILL	\$100.00
BROWN	JEFF	\$150.00
GREEN	JIM	\$200.00
WHITE	WILL	\$125.00

BROWN : \$150

It is often necessary to find the minimum and maximum values in a string array. The following program illustrates one method.

```
10  OPTION BASE 1
20  INTEGER I,Items
30  Items=5
40  ALLOCATE Stringsearch$(Items)[3]
50  DATA ABC,BCD,CDE,DEF,EFG
60  READ Stringsearch$(*)
70  PRINT Stringsearch$(*)
80  Max%=Stringsearch$(1)  ! Start with first item for max.
90  Min%=Max%             ! Assume same item is min.
100 FOR I=2 TO Items
110   IF Max%<Stringsearch$(I) THEN Max%=Stringsearch$(I)
120   IF Min%>Stringsearch$(I) THEN Min%=Stringsearch$(I)
130 NEXT I
140 DISP "MAXIMUM = ";Max%,"MINIMUM = ";Min%
150 END
```

Results: MAXIMUM = FGH MINIMUM = ABC

Number-Base Conversion

Utility functions are available to simplify the calculations between different number bases. The two functions IVAL and DVAL convert a binary, octal, decimal, or hexadecimal string value into a decimal number. The IVAL\$ and DVAL\$ functions convert a decimal number into a binary, octal, decimal, or hexadecimal string value. The IVAL and IVAL\$ functions are restricted to the range of INTEGER variables (−32 768 thru 32 767). The DVAL and DVAL\$ functions allow “double length” integers and thus allow larger numbers to be converted (−2 147 483 648 thru 2 147 483 647).

If you are familiar with binary notation, you will probably recognize the fact that IVAL and IVAL\$ operate on 16-bit values while DVAL and DVAL\$ operate on 32-bit values.

```

10 PRINT CHR$(12)
20 DIM Radix$(1:4)[7],Radix(1:4),V#[33]
30 DATA Binary,Octal,Decimal,Hex,2,8,10,16
40 READ Radix$(*),Radix(*)
50 R=3 ! Default to decimal mode
60 ON KEY 5 LABEL "NEW RADIX" GOTO Radix
70 ON KBD GOTO Key
80 Erase:V$=""
90 V=0
100 See:FOR I=1 TO 4
110 PRINT TABXY(1,10+I);Radix$(I),DVAL$(V,Radix(I));TABXY(49,10+I)
120 NEXT I
130 DISP "Enter a ";Radix$(R);" number";TAB(28);"(press SPACE to clear)"
140 W:GOTO W
150 Key:ON ERROR GOTO Bad ! Trap overrange
160 Key$=UPC$(KBD$)
170 Test=POS("0123456789ABCDEF",Key$)
180 IF Test AND Test<=Radix(R) THEN
190 V$=V$&Key$
200 V=DVAL(V$,Radix(R))
210 ELSE
220 IF Key$="-" THEN Toggle
230 BEEP 900,.02 ! Not a digit Key
240 END IF
250 IF Key$=" " THEN Erase
260 GOTO See
270 Bad:DISP ERRM$
280 BEEP
290 WAIT 1.5
300 GOTO Erase
310 Radix:R=1+R MOD 4
320 GOTO Erase
330 Toggle:IF V#[1;1]="-" THEN
340 V#[1,1]="0"
350 ELSE
360 V$="-"&V$
370 END IF
380 V=DVAL(V$,Radix(R))
390 GOTO See
400 END

```

The program starts by prompting for a decimal number to be entered. As the digits are typed, the number is displayed in each of the possible number bases. The softkey **k5** or **f5** lets you select the different number bases. Pressing the spacebar will clear the display.

Introduction to Lexical Order

The `LEXICAL ORDER IS` statement¹ lets you change the collating sequence (sorting order) of the character set. Changing the lexical order will affect the results of all string relational operators and operations, including the `MAT SORT` and `CASE` statements. In addition to redefining the collating sequence, the case conversion functions, `UPC$` and `LWC$`, are adjusted to reflect the current lexical order.

Predefined lexical orders include: `ASCII`, `FRENCH`, `GERMAN`, `SPANISH`, `SWEDISH`, and `STANDARD`. You can create lexical orders for special applications. The `STANDARD` lexical order is determined by an internal keyboard jumper, set at the factory to correspond to the keyboard supplied with the computer. The setting can be determined by examining the proper keyboard status register (`STATUS 1,4;Language`). Thus, the `STANDARD` lexical order on a computer equipped with a French keyboard will actually invoke the `FRENCH` lexical order.

Why Lexical Order?

A common task for computers is to arrange (sort) a group of items in alphabetical order. However, “alphabetical order” for a computer is normally based on the character sequence of the `ASCII`² character set. While the `ASCII` character sequence is adequate for many English Language applications, most foreign language alphabets include accented characters which are not part of the standard `ASCII` character set but must be included in the sequence to correctly sort the characters used in the language.

Since special character combinations often appear in some languages, these combinations and other special cases can be included in the lexical table to simplify working in other languages.

How It Works

The `LEXICAL ORDER IS` statement modifies the collating sequence by assigning a new value to each character. The new value, called a sequence number, is used in place of the character’s `ASCII` value whenever characters are compared. Internally the characters retain their `ASCII` value; however, the outcome of a comparison will be based on the sequence number assigned to the character instead of the character’s `ASCII` value. In the process of comparing two strings, each of the strings is converted to a series of sequence numbers and the test is determined by the greater sequence numbers rather than the greater `ASCII` values.

¹ Available with `LEX`.

² `ASCII` stands for “American Standard Code for Information Interchange”.

The ASCII Character Set

The ASCII set consists of 128 distinct characters including uppercase and lowercase alpha, numeric, punctuation, and control characters.

The table to the right shows the complete ASCII character set, as displayed on the CRT. Each character is preceded by its ASCII value. The character's value is actually the decimal representation of the binary value (bit pattern) used internally, by the computer, to represent the character.

The characters are arranged in ascending value, which is to say, in ascending lexical order. A character is "less than" another character if its ASCII value is smaller. From the table it can be seen that "A" is less than "B" since the value of the letter "A" (65) is less than the value of the letter "B" (66).

If you have experimented with string comparisons based on the ASCII collating sequence, you may have noticed a few shortcomings. Consider the following words.

RESTORE, RE-STORE, and RE_STORE

Sorting these items according to the ASCII collating sequence will arrange them in the following order.

RE-STORE < RESTORE < RE_STORE

This points out a limitation of string comparisons based on ASCII sequence. Since the hyphen's value (45) is less than any alpha-numeric character, and the underbar's value (95) is greater than all uppercase alpha characters, a word containing a hyphen will be less than the same word without the hyphen, and a word containing an underbar will be greater than the same word without the underbar. The LEXICAL ORDER IS statement lets you overcome these limitations by changing the sorting order of the character set.

Displaying Control Characters

Several special display features are available through the use of STATUS and CONTROL registers. Normally, ASCII characters 0 through 31 (control characters) are not displayed on the CRT. To enable the display of control characters, execute the following statement.

```
CONTROL 1,4;1
```

Printing a line of text to the CRT will now show the trailing carriage-return and linefeed. Although this mode is useful for some applications, control characters are usually not displayed on the CRT.

```
CONTROL 1,4;0
```

Turns off the special display functions mode.

ASCII Character Set for CRT

Num.	Chr.	Num.	Chr.	Num.	Chr.	Num.	Chr.
0	NUL	32		64	@	96	`
1	SHT	33	!	65	A	97	a
2	SHX	34	"	66	B	98	b
3	SHX	35	#	67	C	99	c
4	SHX	36	\$	68	D	100	d
5	SHX	37	%	69	E	101	e
6	SHX	38	&	70	F	102	f
7	SHX	39	'	71	G	103	g
8	SHX	40	(72	H	104	h
9	SHX	41)	73	I	105	i
10	SHX	42	*	74	J	106	j
11	SHX	43	+	75	K	107	k
12	SHX	44	,	76	L	108	l
13	SHX	45	-	77	M	109	m
14	SHX	46	.	78	N	110	n
15	SHX	47	/	79	O	111	o
16	SHX	48	0	80	P	112	p
17	SHX	49	1	81	Q	113	q
18	SHX	50	2	82	R	114	r
19	SHX	51	3	83	S	115	s
20	SHX	52	4	84	T	116	t
21	SHX	53	5	85	U	117	u
22	SHX	54	6	86	V	118	v
23	SHX	55	7	87	W	119	w
24	SHX	56	8	88	X	120	x
25	SHX	57	9	89	Y	121	y
26	SHX	58	:	90	Z	122	z
27	SHX	59	;	91	[123	{
28	SHX	60	<	92	\	124	
29	SHX	61	=	93]	125	}
30	SHX	62	>	94	^	126	~
31	SHX	63	?	95	_	127	⌘

Extended Character Set for CRT

Num.	Chr.	Num.	Chr.	Num.	Chr.	Num.	Chr.
128	C	160		192	à	224	Á
129	L	161	À	193	é	225	Â
130	V	162	Á	194	ò	226	ã
131	B	163	È	195	û	227	Ð
132	G	164	É	196	á	228	đ
133	T	165	Ë	197	é	229	±
134	U	166	Ě	198	ó	230	ı
135	L	167	Ě	199	ú	231	ó
136	I	168	ˆ	200	à	232	ò
137	V	169	˘	201	è	233	õ
138	B	170	ˆ	202	ò	234	ö
139	G	171	˘	203	ù	235	š
140	T	172	˘	204	ä	236	š
141	U	173	Ù	205	ë	237	Ú
142	L	174	Û	206	ö	238	Ý
143	M	175	£	207	ü	239	ÿ
144	G	176	—	208	À	240	ÿ
145	B	177	ı	209	í	241	ÿ
146	K	178	ı	210	ø	242	ÿ
147	O	179	·	211	Ā	243	ÿ
148	S	180	Ç	212	à	244	ÿ
149	S	181	Ç	213	í	245	ÿ
150	S	182	Ñ	214	ø	246	ÿ
151	S	183	Ñ	215	æ	247	ÿ
152	S	184	ı	216	Ä	248	ÿ
153	S	185	ı	217	ı	249	ÿ
154	S	186	ı	218	Ö	250	ÿ
155	S	187	ı	219	Ü	251	ÿ
156	S	188	ı	220	É	252	ÿ
157	S	189	ı	221	ı	253	ÿ
158	S	190	f	222	ß	254	ı
159	S	191	ç	223	Ö	255	ı

The Extended Character Set

Only 128 characters are defined in the ASCII character set. An additional 128 characters are available in the extended character set. The extended set includes CRT enhancement control, special symbols, and Roman Extension characters (accented vowels and other characters used in many non-English languages).

Note

Some printers produce different extended characters than those displayed on the CRT. Check the printer manual for details on alternate character sets.

Highlight Characters

The first 32 characters in the extended character set are reserved for controlling various aspects of the CRT. The definition of these characters has been evolving with upgrades to both hardware and system software. Therefore, the action of these characters depends upon your model of computer and the level of BASIC (and Extensions) you have loaded.

With BASIC 3.0, there is a possibility of having CRT highlights such as inverse video and blinking. The first eight characters (ASCII values 128 thru 135) are used to control these highlights, if the hardware supports this feature. The Model 236 is an example of a display that has highlights, while the Model 226 is an example of a display without highlights.

The SYSTEM\$ function is available and can be used to determine what CRT highlights are present. The expression SYSTEM\$("CRT ID") returns a string containing the information such as the CRT width and available highlights. The string returned by this expression is of the following general form.

```
G: 80H G
```

The "80" is the width of the CRT in characters and the "H" indicates that monochrome highlights are available. If there were a space instead of the "H", then the CRT does not have highlights.

You can also determine if you have CRT highlights by sending a highlight control to the CRT and see if anything happens.

For example:

```
PRINT CHR$(132);"This is important.;"CHR$(128)
```

On a display with highlights, this produces:

```
This is important.
```

On a display without highlights, the control characters are ignored and the line is displayed as normal text. Note that these control characters produce an action only in PRINT and DISP statements. When viewed in EDIT mode or on the system message line, these control characters appear as ^P.

Alternate CRT Characters

There is a keyboard control register for the CRT mapping of character codes. Changing the contents of the register may cause different characters to be displayed.

Try the following.

```
PRINT CHR$(247)
CONTROL 1,11;1
PRINT CHR$(247)
CONTROL 1,11;0
```

The first print statement will produce the character expected from the character tables. The second print statement should show a character (double arrow) from an alternate character set. Note that the alternate character set changes some of the characters in the extended character set.

Finding Missing Characters

By now, you may have noticed that there are more possible CRT characters than keys on the keyboard. If your particular keyboard does not have a key for the character you need, locate the **ANY CHAR** key (every keyboard has this key).

When you press the **ANY CHAR** key, the message, "Enter 3 digits, 000 to 255" appears in the lower left corner of the CRT. Enter the three digits: 065 and the character whose value is 65 (the letter "A") will be placed on the screen. Any character can be input by this method. Pressing a non-digit key or entering a value outside the range will cancel the function.

Predefined Lexical Order

When BASIC is first loaded or after a SCRATCH A, the computer executes a LEXICAL ORDER IS STANDARD statement. This will be the correct lexical order for the language on the keyboard. This can be checked by examining the keyboard status register (STATUS 2,8;Language) or by either of the following statements.

```
SYSTEM$("LEXICAL ORDER IS")
SYSTEM$("KEYBOARD LANGUAGE")
```

The table below shows the language indicated by the value returned by the STATUS statement. Thus, if the value returned indicates a French keyboard, the STANDARD lexical order will be the same as the FRENCH lexical order. The STANDARD lexical order for the Katakana keyboard is ASCII.

Value	Keyboard Language	Lexical Order
0	ASCII	ASCII
1	FRENCH	FRENCH
2	GERMAN	GERMAN
3	SWEDISH	SWEDISH
4	SPANISH ¹	SPANISH
5	KATAKANA	ASCII
6	CANADIAN ENGLISH	ASCII
7	UNITED KINGDOM	ASCII
8	CANADIAN FRENCH	FRENCH
9	SWISS FRENCH	FRENCH
10	ITALIAN	FRENCH
11	BELGIAN	GERMAN
12	DUTCH	GERMAN
13	SWISS GERMAN	GERMAN
14	LATIN ²	SPANISH
15	DANISH	SWEDISH
16	FINNISH	SWEDISH
17	NORWEGIAN	SWEDISH

Either the CHR\$ function or **ANY CHAR** may be used to produce characters not readily available on the keyboard.

¹ This is the European Spanish keyboard.

² This is the Latin Spanish keyboard.

Lexical Tables

The following tables show the five predefined lexical orders available with the LEXICAL ORDER IS statement.

Notation

All of the lexical tables use the following notation.

sequence number →	113
character displayed →	a
ASCII value →	(97)

Characters not available on the keyboard can be entered by pressing the **ANY CHAR** key and typing the value enclosed in parentheses (with leading zeros, if needed). The character will be collated according to the sequence number shown above the character.

ASCII Lexical Order

The ASCII lexical order uses the character's ASCII value as the sequence number. There are no special cases (mode table entries) used in the ASCII lexical order.

Case Conversions

The following lists show the UPC\$ and LWC\$ transformations for the ASCII lexical order.

UPC\$

abcdefghijklmnopqrstuvwxyzñâéôúáéóúàèòùäëöüíáíøæìï ß ð ñ ö š ý Þ

ABCDEFGHIJKLMNPOQRSTUVWXYZÇÑÂÊÔÚÁÉÓÚÀÈÒÙÄËÖÜÍÁÍØÆÌÏ ß ð ñ ö š ý Þ

LWC\$

ABCDEFGHIJKLMNPOQRSTUVWXYZÀÁÈÊËÌÏÙÒÇÑÀØÆÀÖËÓÁÃÐÍÍÓÒÖŠÝÞ

abcdefghijklmnopqrstuvwxyzàâèêëìïùçñàøæàöëóáãðííóòöšýþ

Note

There are slight variations in the operation of the UPC\$ and LWC\$ functions depending on the lexical order in effect. In other words, the lexical order determines which character will be returned by the UPC\$ and LWC\$ functions. The case conversion lists show which characters should be expected for each lexical order. To simplify the lists, characters not affected have been excluded.

LEXICAL ORDER IS ASCII

Seq.	Chr.	Num.	Seq.	Chr.	Num.	Seq.	Chr.	Num.	Seq.	Chr.	Num.	Seq.	Chr.	Num.
0	N	(0)	52	4	(52)	104	h	(104)	156	ᶆ	(156)	208	À	(208)
1	U	(1)	53	5	(53)	105	i	(105)	157	ᶆ̄	(157)	209	Á	(209)
2	S	(2)	54	6	(54)	106	j	(106)	158	ᶆ̅	(158)	210	Â	(210)
3	X	(3)	55	7	(55)	107	k	(107)	159	ᶆ̆	(159)	211	Ã	(211)
4	E	(4)	56	8	(56)	108	l	(108)	160	ᶆ̇	(160)	212	ä	(212)
5	O	(5)	57	9	(57)	109	m	(109)	161	À	(161)	213	í	(213)
6	K	(6)	58	:	(58)	110	n	(110)	162	Ā	(162)	214	ø	(214)
7	U	(7)	59	;	(59)	111	o	(111)	163	Ê	(163)	215	æ	(215)
8	B	(8)	60	<	(60)	112	p	(112)	164	Ě	(164)	216	Ä	(216)
9	H	(9)	61	>	(61)	113	q	(113)	165	Ě̄	(165)	217	ı	(217)
10	L	(10)	62	=	(62)	114	r	(114)	166	±	(166)	218	ö	(218)
11	V	(11)	63	?	(63)	115	s	(115)	167	±̄	(167)	219	ü	(219)
12	F	(12)	64	@	(64)	116	t	(116)	168	˘	(168)	220	é	(220)
13	C	(13)	65	A	(65)	117	u	(117)	169	˙	(169)	221	ì	(221)
14	S	(14)	66	B	(66)	118	v	(118)	170	˘̄	(170)	222	β	(222)
15	T	(15)	67	C	(67)	119	w	(119)	171	˙̄	(171)	223	ô	(223)
16	D	(16)	68	D	(68)	120	x	(120)	172	˘̄̄	(172)	224	Á	(224)
17	P	(17)	69	E	(69)	121	y	(121)	173	Û	(173)	225	Å	(225)
18	P	(18)	70	F	(70)	122	z	(122)	174	Ü	(174)	226	ǎ	(226)
19	P	(19)	71	G	(71)	123	{	(123)	175	£	(175)	227	Đ	(227)
20	P	(20)	72	H	(72)	124		(124)	176	—	(176)	228	đ	(228)
21	N	(21)	73	I	(73)	125	}	(125)	177	ᵇ¹	(177)	229	±̄	(229)
22	S	(22)	74	J	(74)	126	~	(126)	178	ᵇ²	(178)	230	±̄̄	(230)
23	B	(23)	75	K	(75)	127	⌘	(127)	179	˘̄̄̄	(179)	231	ó	(231)
24	C	(24)	76	L	(76)	128	⌘̄	(128)	180	Ç	(180)	232	ò	(232)
25	H	(25)	77	M	(77)	129	⌘̄̄	(129)	181	ç	(181)	233	õ	(233)
26	B	(26)	78	N	(78)	130	⌘̄̄̄	(130)	182	Ñ	(182)	234	ö	(234)
27	E	(27)	79	O	(79)	131	⌘̄̄̄̄	(131)	183	ñ	(183)	235	š	(235)
28	F	(28)	80	P	(80)	132	⌘̄̄̄̄̄	(132)	184	ı̄	(184)	236	š̄	(236)
29	S	(29)	81	Q	(81)	133	⌘̄̄̄̄̄̄	(133)	185	ı̄̄	(185)	237	ú	(237)
30	S	(30)	82	R	(82)	134	⌘̄̄̄̄̄̄̄	(134)	186	ı̄̄̄	(186)	238	ÿ	(238)
31	U	(31)	83	S	(83)	135	⌘̄̄̄̄̄̄̄̄	(135)	187	£	(187)	239	ÿ̄	(239)
32	((32)	84	T	(84)	136	⌘̄̄̄̄̄̄̄̄̄	(136)	188	¥	(188)	240	ƒ	(240)
33	!	(33)	85	U	(85)	137	⌘̄̄̄̄̄̄̄̄̄̄	(137)	189	§	(189)	241	ƒ̄	(241)
34	"	(34)	86	V	(86)	138	⌘̄̄̄̄̄̄̄̄̄̄̄	(138)	190	f	(190)	242	ƒ̄̄	(242)
35	#	(35)	87	W	(87)	139	⌘̄̄̄̄̄̄̄̄̄̄̄̄	(139)	191	ç̄	(191)	243	ƒ̄̄̄	(243)
36	\$	(36)	88	X	(88)	140	⌘̄̄̄̄̄̄̄̄̄̄̄̄̄	(140)	192	à	(192)	244	ƒ̄̄̄̄	(244)
37	%	(37)	89	Y	(89)	141	⌘̄̄̄̄̄̄̄̄̄̄̄̄̄̄	(141)	193	ê	(193)	245	ı̄̄̄	(245)
38	&	(38)	90	Z	(90)	142	⌘̄̄̄̄̄̄̄̄̄̄̄̄̄̄̄	(142)	194	ô	(194)	246	—	(246)
39	'	(39)	91	[(91)	143	⌘̄̄̄̄̄̄̄̄̄̄̄̄̄̄̄̄	(143)	195	û	(195)	247	¼	(247)
40	((40)	92	\	(92)	144	⌘̄̄̄̄̄̄̄̄̄̄̄̄̄̄̄̄̄	(144)	196	á	(196)	248	½	(248)
41)	(41)	93]	(93)	145	⌘̄̄̄̄̄̄̄̄̄̄̄̄̄̄̄̄̄̄	(145)	197	é	(197)	249	¾	(249)
42	*	(42)	94	^	(94)	146	⌘̄̄̄̄̄̄̄̄̄̄̄̄̄̄̄̄̄̄̄	(146)	198	é̄	(198)	250	⊘	(250)
43	+	(43)	95	—	(95)	147	⌘̄̄̄̄̄̄̄̄̄̄̄̄̄̄̄̄̄̄̄̄	(147)	199	ú	(199)	251	«	(251)
44	,	(44)	96	˘	(96)	148	⌘̄̄̄̄̄̄̄̄̄̄̄̄̄̄̄̄̄̄̄̄̄	(148)	200	à̄	(200)	252	■	(252)
45	-	(45)	97	a	(97)	149	⌘̄̄̄̄̄̄̄̄̄̄̄̄̄̄̄̄̄̄̄̄̄̄	(149)	201	è	(201)	253	»	(253)
46	.	(46)	98	b	(98)	150	⌘̄̄̄̄̄̄̄̄̄̄̄̄̄̄̄̄̄̄̄̄̄̄̄	(150)	202	ò	(202)	254	±̄	(254)
47	/	(47)	99	c	(99)	151	⌘̄̄̄̄̄̄̄̄̄̄̄̄̄̄̄̄̄̄̄̄̄̄̄̄	(151)	203	ù	(203)	255	☒	(255)
48	0	(48)	100	d	(100)	152	⌘̄̄̄̄̄̄̄̄̄̄̄̄̄̄̄̄̄̄̄̄̄̄̄̄̄	(152)	204	ä	(204)			
49	1	(49)	101	e	(101)	153	⌘̄̄̄̄̄̄̄̄̄̄̄̄̄̄̄̄̄̄̄̄̄̄̄̄̄̄	(153)	205	è̄	(205)			
50	2	(50)	102	f	(102)	154	⌘̄̄̄̄̄̄̄̄̄̄̄̄̄̄̄̄̄̄̄̄̄̄̄̄̄̄̄	(154)	206	ó	(206)			
51	3	(51)	103	g	(103)	155	⌘̄̄̄̄̄̄̄̄̄̄̄̄̄̄̄̄̄̄̄̄̄̄̄̄̄̄̄̄	(155)	207	ü	(207)			

FRENCH Lexical Order

The FRENCH lexical order table contains two special entries. The hyphen character (-) is assigned as a “don’t care” character and a “2 for 1” character replacement is made for the “ß” character.

ß = ss

A string containing the hyphen will match the same string without the hyphen and a string containing only a hyphen will match the null string. For example:

```
LEXICAL ORDER IS FRENCH
IF "RE-STORE"="RESTORE" THEN PRINT "TRUE"
```

Prints: TRUE

Case Conversions

The following lists show the UPC\$ and LWC\$ transformations for the FRENCH lexical order.

UPC\$

abcdefghijklmnopqrstu vwxyzçñâéôúáéóúàèòùæöüïáíøæïïßãðšÿ†

ABCDEFGHIJKLMN O PQRSTU VWXYZÇÑÂÉÔÚÁÉÓÚÀÈÒÙÆÖÜÏÁÍØÆÏÏßãðšÿ†

LWC\$

ABCDEFGHIJKLMN O PQRSTU VWXYZÀÁÈÈÈÏÏÙÙÇÑÀØÆÀÖÙÉÓÀÃĐÏÏÓÒŠÛÿ†

abcdefghijklmnopqrstu vwxyzàáèèèïïùùçñâæöüéóáãđïïóòšÛÿ†

LEXICAL ORDER IS FRENCH

Seq.	Chr.	Num.	Seq.	Chr.	Num.	Seq.	Chr.	Num.	Seq.	Chr.	Num.	Seq.	Chr.	Num.
	—	(45)	51	4	(52)	81	P	(80)	113	l	(108)	153	½	(248)
0	0	(0)	52	5	(53)	82	Q	(81)	114	m	(109)	154	¾	(249)
1	1	(1)	53	6	(54)	83	R	(82)	115	n	(110)	155	∞	(250)
2	2	(2)	54	7	(55)	84	S	(83)	116	ñ	(183)	156	«	(251)
3	3	(3)	55	8	(56)	85	Š	(235)	117	o	(111)	157	■	(252)
4	4	(4)	56	9	(57)	86	T	(84)	117	ô	(194)	158	»	(253)
5	5	(5)	57	:	(58)	87	U	(85)	117	ó	(198)	159	±	(254)
6	6	(6)	58	;	(59)	87	Ù	(173)	117	ò	(202)	160	⊗	(127)
7	7	(7)	59	<	(60)	87	Û	(174)	117	ö	(206)	161		(160)
8	8	(8)	60	=	(61)	87	Ü	(219)	117	ø	(214)	162	ß	(177)
9	9	(9)	61	>	(62)	87	ú	(237)	117	ø	(234)	163	B ₁	(178)
10	L	(10)	62	?	(63)	88	V	(86)	118	p	(112)	164	F ₂	(242)
11	l	(11)	63	@	(64)	89	W	(87)	119	q	(113)	165	F ₃	(243)
12	L	(12)	64	A	(65)	90	X	(88)	120	r	(114)	166	F ₄	(244)
13	l	(13)	64	À	(161)	91	Y	(89)	121	s	(115)	167	I ₀	(245)
14	l	(14)	64	Â	(162)	91	ÿ	(238)	121	β	(222)	168	C _L	(128)
15	l	(15)	64	Ä	(208)	92	Z	(90)	122	š	(236)	169	I _V	(129)
16	l	(16)	64	Å	(211)	93	ẞ	(240)	123	t	(116)	170	B _G	(130)
17	l	(17)	64	Å	(216)	94	[(91)	124	u	(117)	171	I _B	(131)
18	l	(18)	64	Å	(224)	95	\	(92)	124	û	(195)	172	U _L	(132)
19	l	(19)	64	Å	(225)	96	J	(93)	124	ú	(199)	173	I _V	(133)
20	l	(20)	65	B	(66)	97	^	(94)	124	ù	(203)	174	B ₅	(134)
21	l	(21)	66	C	(67)	98	_	(95)	124	ü	(207)	175	I _B	(135)
22	l	(22)	66	Ç	(180)	99	`	(96)	125	v	(118)	176	H _H	(136)
23	l	(23)	67	D	(68)	100	a	(97)	126	w	(119)	177	B _D	(137)
24	l	(24)	68	Ð	(227)	100	â	(192)	127	x	(120)	178	Y _E	(138)
25	l	(25)	69	E	(69)	100	á	(196)	128	y	(121)	179	C _R	(139)
26	l	(26)	69	È	(163)	100	à	(200)	128	ÿ	(239)	180	C _Y	(140)
27	l	(27)	69	Ê	(164)	100	ä	(204)	129	z	(122)	181	B _U	(141)
28	l	(28)	69	Ë	(165)	100	ä	(212)	130	þ	(241)	182	M _G	(142)
29	l	(29)	69	É	(220)	100	æ	(215)	131	{	(123)	183	B _K	(143)
30	l	(30)	70	F	(70)	100	ǎ	(226)	132		(124)	184	B _O	(144)
31	l	(31)	71	G	(71)	101	b	(98)	133	}	(125)	185	B _I	(145)
32	l	(32)	72	H	(72)	102	c	(99)	134	~	(126)	186	B ₂	(146)
33	!	(33)	73	I	(73)	103	ç	(181)	135	˘	(168)	187	B ₃	(147)
34	"	(34)	73	Î	(166)	104	d	(100)	136	˙	(169)	188	B ₄	(148)
35	#	(35)	73	Ï	(167)	105	đ	(228)	137	ˆ	(170)	189	B ₅	(149)
36	\$	(36)	73	Í	(229)	106	e	(101)	138	˘	(171)	190	B ₆	(150)
37	%	(37)	73	Ë	(230)	106	ê	(193)	139	˘	(172)	191	B ₇	(151)
38	&	(38)	74	J	(74)	106	é	(197)	140	£	(175)	192	B ₈	(152)
39	'	(39)	75	K	(75)	106	è	(201)	141	—	(176)	193	B ₉	(153)
40	((40)	76	L	(76)	106	è	(205)	142	·	(179)	194	B _A	(154)
41)	(41)	77	M	(77)	107	f	(102)	143	¡	(184)	195	B _B	(155)
42	*	(42)	78	N	(78)	108	g	(103)	144	¿	(185)	196	B _O	(156)
43	+	(43)	79	Ñ	(182)	109	h	(104)	145	¤	(186)	197	B _D	(157)
44	,	(44)	80	O	(79)	110	i	(105)	146	£	(187)	198	B _E	(158)
45	.	(46)	80	Ø	(210)	110	î	(209)	147	¥	(188)	199	B _F	(159)
46	/	(47)	80	ö	(218)	110	í	(213)	148	§	(189)	200	☒	(255)
47	0	(48)	80	ó	(223)	110	ì	(217)	149	f	(190)			
48	1	(49)	80	ó	(231)	110	ï	(221)	150	¢	(191)			
49	2	(50)	80	ò	(232)	111	j	(106)	151	–	(246)			
50	3	(51)	80	õ	(233)	112	k	(107)	152	‡	(247)			

GERMAN Lexical Order

The GERMAN lexical order table contains seven “2 for 1” character replacements. When the following individual characters are found in a string, two sequence numbers are generated, as if two characters were found in the string.

ä = ae

ö = oe

ü = ue

Ä = AE or Ae

Ö = OE or Oe

Ü = UE or Ue

ß = ss

Case Conversions

The following lists show the UPC\$ and LWC\$ transformations for the GERMAN lexical order.

UPC\$

abcdefghijklmnopqrstuvwxyzçñâêôûáéóúàèòùäëöüíáíøæïïßăđõšÿ†

ABCDEFGHIJKLMNOPQRSTUVWXYZÇÑÂÊÔÛÁÉÓÚÀÈÒÙÄËÖÜÍÁÍØÆÏÏßĂĐÕŠŸ†

LWC\$

ABCDEFGHIJKLMNOPQRSTUVWXYZÀÁÈÉÊÏÏÛÜÇÑÀØÆÏÀÔÛÉÓÁĂĐÏÏÓÒŠÛŸ†

abcdefghijklmnopqrstuvwxyzàáèèêèïïüçñàøæïàôûéóáăđííóòšúÿ†

LEXICAL ORDER IS GERMAN

Seq.	Chr.	Num.	Seq.	Chr.	Num.	Seq.	Chr.	Num.	Seq.	Chr.	Num.	Seq.	Chr.	Num.
0	N	(0)	52	4	(52)	102	P	(80)	152	l	(108)	201	½	(248)
1	S	(1)	53	5	(53)	103	Q	(81)	153	m	(109)	202	¾	(249)
2	X	(2)	54	6	(54)	104	R	(82)	154	n	(110)	203	∞	(250)
3	E	(3)	55	7	(55)	105	S	(83)	155	ñ	(183)	204	«	(251)
4	E	(4)	56	8	(56)	106	š	(235)	156	o	(111)	205	■	(252)
5	O	(5)	57	9	(57)	107	T	(84)	156	ö	(206)	206	±	(253)
6	K	(6)	58	:	(58)	108	U	(85)	157	ó	(198)	207	±	(254)
7	U	(7)	59	;	(59)	108	Ü	(219)	158	ò	(202)	208	⌘	(127)
8	B	(8)	60	<	(60)	109	ú	(237)	159	ø	(194)	209		(160)
9	H	(9)	61	=	(61)	110	û	(173)	160	ø	(234)	210	B ₁	(177)
10	L	(10)	62	>	(62)	111	Û	(174)	161	ø	(214)	211	B ₂	(178)
11	T	(11)	63	?	(63)	112	V	(86)	162	p	(112)	212	F ₂	(242)
12	F	(12)	64	@	(64)	113	W	(87)	163	q	(113)	213	F ₃	(243)
13	R	(13)	65	A	(65)	114	X	(88)	164	r	(114)	214	F ₄	(244)
14	O	(14)	65	Ä	(216)	115	Y	(89)	165	s	(115)	215	I _O	(245)
15	T	(15)	66	Å	(211)	116	ÿ	(238)	165	ß	(222)	216	C _L	(128)
16	L	(16)	67	Á	(208)	117	Z	(90)	166	š	(236)	217	I _V	(129)
17	D ₁	(17)	68	À	(224)	118	Ẑ	(240)	167	t	(116)	218	B _G	(130)
18	D ₂	(18)	69	À	(161)	119	[(91)	168	u	(117)	219	T _B	(131)
19	D ₃	(19)	70	À	(162)	120	\	(92)	168	ü	(207)	220	U _L	(132)
20	D ₄	(20)	71	Å	(225)	121]	(93)	169	ú	(199)	221	T _L	(133)
21	N	(21)	72	B	(66)	122	^	(94)	170	ù	(203)	222	B _B	(134)
22	E	(22)	73	C	(67)	123	_	(95)	171	û	(195)	223	I _B	(135)
23	E	(23)	74	Ç	(180)	124	`	(96)	172	v	(118)	224	H _H	(136)
24	C	(24)	75	D	(68)	125	a	(97)	173	w	(119)	225	R _D	(137)
25	H	(25)	76	Ð	(227)	125	ä	(204)	174	x	(120)	226	Y _E	(138)
26	E	(26)	77	E	(69)	126	æ	(215)	175	y	(121)	227	C _R	(139)
27	E	(27)	78	É	(220)	127	á	(212)	176	ÿ	(239)	228	C _Y	(140)
28	E	(28)	79	È	(163)	128	à	(196)	177	z	(122)	229	B _U	(141)
29	E	(29)	80	Ê	(164)	129	à	(200)	178	þ	(241)	230	H _G	(142)
30	E	(30)	81	È	(165)	130	á	(192)	179	{	(123)	231	B _K	(143)
31	U	(31)	82	F	(70)	131	ǎ	(226)	180		(124)	232	S _O	(144)
32	U	(32)	83	G	(71)	132	b	(98)	181	}	(125)	233	S ₁	(145)
33	!	(33)	84	H	(72)	133	c	(99)	182	~	(126)	234	S ₂	(146)
34	"	(34)	85	I	(73)	134	ç	(181)	183	˘	(168)	235	S ₃	(147)
35	#	(35)	86	í	(229)	135	d	(100)	184	˘	(169)	236	S ₄	(148)
36	\$	(36)	87	±	(230)	136	đ	(228)	185	˘	(170)	237	S ₅	(149)
37	%	(37)	88	±	(166)	137	e	(101)	186	˘	(171)	238	S ₆	(150)
38	&	(38)	89	±	(167)	138	é	(197)	187	˘	(172)	239	S ₇	(151)
39	'	(39)	90	J	(74)	139	è	(201)	188	£	(175)	240	S _B	(152)
40	((40)	91	K	(75)	140	ê	(193)	189	—	(176)	241	S _S	(153)
41)	(41)	92	L	(76)	141	è	(205)	190	˘	(179)	242	S _A	(154)
42	*	(42)	93	M	(77)	142	f	(102)	191	i	(184)	243	S _B	(155)
43	+	(43)	94	N	(78)	143	g	(103)	192	¿	(185)	244	S _C	(156)
44	,	(44)	95	Ñ	(182)	144	h	(104)	193	Ɔ	(186)	245	S _O	(157)
45	-	(45)	96	O	(79)	145	i	(105)	194	£	(187)	246	S _E	(158)
46	.	(46)	96	ö	(218)	146	í	(213)	195	¥	(188)	247	S _F	(159)
47	/	(47)	97	ó	(231)	147	ì	(217)	196	§	(189)	248	☒	(255)
48	0	(48)	98	ò	(232)	148	î	(209)	197	f	(190)			
49	1	(49)	99	ó	(223)	149	i	(221)	198	¢	(191)			
50	2	(50)	100	š	(233)	150	j	(106)	199	-	(246)			
51	3	(51)	101	ø	(210)	151	k	(107)	200	¼	(247)			

LEXICAL ORDER IS SPANISH

Seq.	Chr.	Num.	Seq.	Chr.	Num.	Seq.	Chr.	Num.	Seq.	Chr.	Num.	Seq.	Chr.	Num.
0	N	(0)	52	4	(52)	84	P	(80)	116	l	(108)	157	¼	(248)
1	Ñ	(1)	53	5	(53)	85	Q	(81)	118	m	(109)	158	½	(249)
2	Ń	(2)	54	6	(54)	86	R	(82)	119	n	(110)	159	¾	(250)
3	Ň	(3)	55	7	(55)	87	S	(83)	120	ñ	(183)	160	«	(251)
4	Ŧ	(4)	56	8	(56)	88	Š	(235)	121	o	(111)	161	■	(252)
5	Š	(5)	57	9	(57)	89	T	(84)	121	ø	(194)	162	»	(253)
6	Ṧ	(6)	58	:	(58)	90	U	(85)	121	ó	(198)	163	±	(254)
7	Š̈	(7)	59	;	(59)	90	Û	(173)	121	ò	(202)	164	⌘	(127)
8	Š̉	(8)	60	<	(60)	90	Ü	(174)	121	ö	(206)	165	⌘	(160)
9	Š̊	(9)	61	=	(61)	90	Û	(219)	121	ø	(214)	166	ß	(177)
10	Š̋	(10)	62	>	(62)	90	Ú	(237)	121	ø	(234)	167	ß	(178)
11	Š̌	(11)	63	?	(63)	91	V	(86)	122	p	(112)	168	ß	(242)
12	Š̍	(12)	64	@	(64)	92	W	(87)	123	q	(113)	169	ß	(243)
13	Š̎	(13)	65	A	(65)	93	X	(88)	124	r	(114)	170	ß	(244)
14	Š̏	(14)	65	À	(161)	94	Y	(89)	125	s	(115)	171	ß	(245)
15	Š̐	(15)	65	Á	(162)	94	ÿ	(238)	125	ß	(222)	172	ß	(128)
16	Š̑	(16)	65	Â	(208)	95	Z	(90)	126	š	(236)	173	ß	(129)
17	Š̒	(17)	65	Ã	(211)	96	Ẑ	(240)	127	t	(116)	174	ß	(130)
18	Š̓	(18)	65	Ä	(216)	97	[(91)	128	u	(117)	175	ß	(131)
19	Š̔	(19)	65	Å	(224)	98	\	(92)	128	û	(195)	176	ß	(132)
20	Š̕	(20)	65	Æ	(225)	99]	(93)	128	ú	(199)	177	ß	(133)
21	Š̖	(21)	66	B	(66)	100	^	(94)	128	ù	(203)	178	ß	(134)
22	Š̗	(22)	67	C	(67)	101	_	(95)	128	ü	(207)	179	ß	(135)
23	Š̘	(23)	67	Ç	(180)	102	`	(96)	129	v	(118)	180	ß	(136)
24	Š̙	(24)	69	D	(68)	103	a	(97)	130	w	(119)	181	ß	(137)
25	Š̚	(25)	70	Ð	(227)	103	á	(192)	131	x	(120)	182	ß	(138)
26	Š̛	(26)	71	E	(69)	103	á	(196)	132	y	(121)	183	ß	(139)
27	Š̜	(27)	71	È	(163)	103	à	(200)	132	ÿ	(239)	184	ß	(140)
28	Š̝	(28)	71	Ê	(164)	103	ä	(204)	133	z	(122)	185	ß	(141)
29	Š̞	(29)	71	Ë	(165)	103	â	(212)	134	ẑ	(241)	186	ß	(142)
30	Š̟	(30)	71	É	(220)	103	æ	(215)	135	{	(123)	187	ß	(143)
31	Š̠	(31)	72	F	(70)	103	Ǽ	(226)	136		(124)	188	ß	(144)
32	Š̡	(32)	73	G	(71)	104	b	(98)	137	}	(125)	189	ß	(145)
33	Š̢	(33)	74	H	(72)	105	c	(99)	138	~	(126)	190	ß	(146)
34	Ṣ̌	(34)	75	I	(73)	105	ç	(181)	139	˘	(168)	191	ß	(147)
35	Š̤	(35)	75	Î	(166)	107	d	(100)	140	˙	(169)	192	ß	(148)
36	Š̥	(36)	75	Ï	(167)	108	đ	(228)	141	˚	(170)	193	ß	(149)
37	Ș̌	(37)	75	Í	(229)	109	e	(101)	142	˛	(171)	194	ß	(150)
38	Ş̌	(38)	75	İ	(230)	109	ê	(193)	143	˜	(172)	195	ß	(151)
39	Š̨	(39)	76	J	(74)	109	é	(197)	144	£	(175)	196	ß	(152)
40	Š̩	(40)	77	K	(75)	109	è	(201)	145	˘	(176)	197	ß	(153)
41	Š̪	(41)	78	L	(76)	109	ë	(205)	146	˙	(179)	198	ß	(154)
42	Š̫	(42)	80	M	(77)	110	f	(102)	147	ı	(184)	199	ß	(155)
43	Š̬	(43)	81	N	(78)	111	g	(103)	148	ˆ	(185)	200	ß	(156)
44	Š̭	(44)	82	Ñ	(182)	112	h	(104)	149	˜	(186)	201	ß	(157)
45	Š̮	(45)	83	O	(79)	113	i	(105)	150	£	(187)	202	ß	(158)
46	Š̯	(46)	83	Ø	(210)	113	î	(209)	151	¥	(188)	203	ß	(159)
47	Š̰	(47)	83	Ò	(218)	113	í	(213)	152	§	(189)	204	ß	(255)
48	Š̱	(48)	83	Ó	(223)	113	ì	(217)	153	f	(190)			
49	Š̲	(49)	83	Ô	(231)	113	ï	(221)	154	ç	(191)			
50	Š̳	(50)	83	Õ	(232)	114	j	(106)	155	-	(246)			
51	Š̴	(51)	83	Ö	(233)	115	k	(107)	156	¼	(247)			

SWEDISH Lexical Order

The SWEDISH lexical order table includes one “2 for 1” character replacement entry. When the “ß” character is found in a string, two sequence numbers are generated, as if two characters were found in the string.

ß = ss

Case Conversions

The following lists show the UPC\$ and LWC\$ transformations for the SWEDISH lexical order.

UPC\$

abcdefghijklmnopqrstuvwxyzçñâéóúáéóúàèòúæouíáíøæííßãðõšÿ†

ABCDEFGHIJKLMNOPQRSTUVWXYZÇÑÂÉÓÚÁÉÓÚÀÈÒÚÆOUÍÁÍØÆÍÍßÃÐÕŠŸ†

LWC\$

ABCDEFGHIJKLMNOPQRSTUVWXYZÀÁÊËÈÍÌÙÒÇÑÀØÆAOUÉÓÁÃÐÍÍÓÒÕŠÿ†

abcdefghijklmnopqrstuvwxyzàáêëèíìùòçñàøæaouéóáãðííóòõšÿ†

LEXICAL ORDER IS SWEDISH

Seq.	Chr.	Num.	Seq.	Chr.	Num.	Seq.	Chr.	Num.	Seq.	Chr.	Num.			
0	N	(0)	52	4	(52)	104	±	(229)	154	æ	(215)	206	½	(248)
1	U	(1)	53	5	(53)	105	±	(230)	155	á	(212)	207	¾	(249)
2	H	(2)	54	6	(54)	106	±	(166)	156	á	(196)	208	o	(250)
3	X	(3)	55	7	(55)	107	±	(167)	157	à	(200)	209	«	(251)
4	E	(4)	56	8	(56)	108	Ñ	(182)	158	â	(192)	210	■	(252)
5	O	(5)	57	9	(57)	109	ó	(231)	159	ä	(204)	211	»	(253)
6	K	(6)	58	; (58)	110	ò	(232)	160	ǣ	(226)	212	±	(254)	
7	Q	(7)	59	; (59)	111	ò	(223)	161	ç	(181)	213	⌘	(127)	
8	B	(8)	60	<	(60)	112	ö	(218)	162	ç	(228)	214		(160)
9	H	(9)	61	=	(61)	113	ö	(233)	163	è	(201)	215	B ₁	(177)
10	L	(10)	62	>	(62)	114	ø	(210)	164	ê	(193)	216	B ₂	(178)
11	T	(11)	63	?	(63)	115	š	(235)	165	ë	(205)	217	F ₂	(242)
12	F	(12)	64	@	(64)	116	ú	(237)	166	í	(213)	218	F ₃	(243)
13	R	(13)	65	A	(65)	117	û	(173)	167	ì	(217)	219	F ₄	(244)
14	O	(14)	66	B	(66)	118	ü	(174)	168	î	(209)	220	I ₀	(245)
15	S	(15)	67	C	(67)	119	ü	(219)	169	ï	(221)	221	C _L	(128)
16	L	(16)	68	D	(68)	120	ÿ	(238)	170	ñ	(183)	222	I _V	(129)
17	P ₁	(17)	69	E	(69)	121	þ	(240)	171	ó	(198)	223	B ₀	(130)
18	P ₂	(18)	70	F	(70)	122	[(91)	172	ò	(202)	224	I _B	(131)
19	P ₃	(19)	71	G	(71)	123	\	(92)	173	ô	(194)	225	U _L	(132)
20	P ₄	(20)	72	H	(72)	124] (93)	174	ö	(206)	226	I _V	(133)	
21	N	(21)	73	I	(73)	125	^ (94)	175	ø	(234)	227	B ₀	(134)	
22	E	(22)	74	J	(74)	126	˘ (95)	176	ø	(214)	228	I _B	(135)	
23	B	(23)	75	K	(75)	127	˘ (96)	177	š	(236)	229	H _W	(136)	
24	C	(24)	76	L	(76)	128	a (97)	178	ú	(199)	230	R _D	(137)	
25	M	(25)	77	M	(77)	129	b (98)	179	ù	(203)	231	Y _E	(138)	
26	N	(26)	78	N	(78)	130	c (99)	180	û	(195)	232	G _R	(139)	
27	O	(27)	79	O	(79)	131	d (100)	181	ü	(207)	233	C _V	(140)	
28	P	(28)	80	P	(80)	132	e (101)	182	ÿ	(239)	234	B _U	(141)	
29	Q	(29)	81	Q	(81)	132	é (197)	183	þ	(241)	235	M _G	(142)	
30	R	(30)	82	R	(82)	133	f (102)	184	{ (123)	236	B _K	(143)		
31	S	(31)	83	S	(83)	134	g (103)	185	(124)	237	S ₀	(144)		
32	T	(32)	84	T	(84)	135	h (104)	186	} (125)	238	S ₁	(145)		
33	!	(33)	85	U	(85)	136	i (105)	187	~ (126)	239	S ₂	(146)		
34	"	(34)	86	V	(86)	137	j (106)	188	˘ (168)	240	S ₃	(147)		
35	#	(35)	87	W	(87)	138	k (107)	189	˘ (169)	241	S ₄	(148)		
36	\$	(36)	88	X	(88)	139	l (108)	190	˘ (170)	242	S ₅	(149)		
37	%	(37)	89	Y	(89)	140	m (109)	191	˘ (171)	243	S ₆	(150)		
38	&	(38)	90	Z	(90)	141	n (110)	192	˘ (172)	244	S ₇	(151)		
39	'	(39)	91	Å	(211)	142	o (111)	193	£ (175)	245	S ₈	(152)		
40	((40)	92	Á	(208)	143	p (112)	194	˘ (176)	246	S ₉	(153)		
41)	(41)	93	À	(224)	144	q (113)	195	˘ (179)	247	S _A	(154)		
42	*	(42)	94	À	(161)	145	r (114)	196	ı	(184)	248	S _B	(155)	
43	+	(43)	95	Â	(162)	146	s (115)	197	ı	(185)	249	S _C	(156)	
44	,	(44)	96	Ä	(216)	146	ß (222)	198	œ	(186)	250	S _D	(157)	
45	-	(45)	97	Å	(225)	147	t (116)	199	£ (187)	251	S _E	(158)		
46	.	(46)	98	Ç	(180)	148	u (117)	200	¥ (188)	252	S _F	(159)		
47	/	(47)	99	Đ	(227)	149	v (118)	201	§ (189)	253	⊠	(255)		
48	0	(48)	100	É	(220)	150	w (119)	202	f (190)					
49	1	(49)	101	È	(163)	151	x (120)	203	ç (191)					
50	2	(50)	102	Ê	(164)	152	y (121)	204	- (246)					
51	3	(51)	103	Ë	(165)	153	z (122)	205	¼ (247)					

User-defined LEXICAL ORDER

The following program will generate the worksheet on the next page. The worksheet is handy when creating a user-defined lexical order.

```

10   DIM Lb$(1),F1$[23],F2$[23],F3$[14],F4$[20],Falt$[96],F1P$[22],F2P$[22]
20   INTEGER I
30   OUTPUT PRT;"LEXICAL ORDER TABLE WORKSHEET      !seq-num:mode-type,mode-entr
y!"
40   OUTPUT PRT
50   Lb$="*"
60   F1P$=" ,DD,X,""! : , !!"
70   F1$=" ,DDD,X,""! : , !!"
80   F2P$=" ,X,A,X,""! : , !!"
90   F2$=" ,XX,A,X,""! : , !!"
100  F4$=" ,DD,X,""! : !!"
110  F3$=",""Mode Length""
120  Falt$=F1P$&F2$&F1$&F2$
130  FOR I=0 TO 63
140    SELECT I
150    CASE 0
160      OUTPUT PRT USING Lb$&Falt$&F3$;I,CHR$(I+64),I+128,CHR$(I+192)
170    CASE <32
180      OUTPUT PRT USING Lb$&Falt$&F4$;I,CHR$(I+64),I+128,CHR$(I+192),I-1
190    CASE ELSE
200      OUTPUT PRT USING Lb$&F2P$&RPT$(F2$,3)&F4$;CHR$(I),CHR$(I+64),CHR$(I+12
8),CHR$(I+192),I-1
210    END SELECT
220  OUTPUT PRT
230  NEXT I
240  END

```

LEXICAL ORDER TABLE WORKSHEET

[seq-num:mode-type,mode-entry]

									Mode	Length
0	:	.	@	:	.	128	:	.		
1	:	.	A	:	.	129	:	.	0	:
2	:	.	B	:	.	130	:	.	1	:
3	:	.	C	:	.	131	:	.	2	:
4	:	.	D	:	.	132	:	.	3	:
5	:	.	E	:	.	133	:	.	4	:
6	:	.	F	:	.	134	:	.	5	:
7	:	.	G	:	.	135	:	.	6	:
8	:	.	H	:	.	136	:	.	7	:
9	:	.	I	:	.	137	:	.	8	:
10	:	.	J	:	.	138	:	.	9	:
11	:	.	K	:	.	139	:	.	10	:
12	:	.	L	:	.	140	:	.	11	:
13	:	.	M	:	.	141	:	.	12	:
14	:	.	N	:	.	142	:	.	13	:
15	:	.	O	:	.	143	:	.	14	:
16	:	.	P	:	.	144	:	.	15	:
17	:	.	Q	:	.	145	:	.	16	:
18	:	.	R	:	.	146	:	.	17	:
19	:	.	S	:	.	147	:	.	18	:
20	:	.	T	:	.	148	:	.	19	:
21	:	.	U	:	.	149	:	.	20	:
22	:	.	V	:	.	150	:	.	21	:
23	:	.	W	:	.	151	:	.	22	:
24	:	.	X	:	.	152	:	.	23	:
25	:	.	Y	:	.	153	:	.	24	:
26	:	.	Z	:	.	154	:	.	25	:
27	:	.	[:	.	155	:	.	26	:
28	:	.	\	:	.	156	:	.	27	:
29	:	.]	:	.	157	:	.	28	:
30	:	.	>	:	.	158	:	.	29	:
31	:	.	^	:	.	159	:	.	30	:
!	:	.	_	:	.	á	:	.	31	:
"	:	.	`	:	.	â	:	.	32	:
#	:	.	a	:	.	ã	:	.	33	:
\$:	.	b	:	.	ä	:	.	34	:
%	:	.	c	:	.	å	:	.	35	:
&	:	.	d	:	.	æ	:	.	36	:
'	:	.	e	:	.	ç	:	.	37	:
(:	.	f	:	.	è	:	.	38	:
)	:	.	g	:	.	é	:	.	39	:
*	:	.	h	:	.	ê	:	.	40	:
+	:	.	i	:	.	ë	:	.	41	:
,	:	.	j	:	.	ì	:	.	42	:
-	:	.	k	:	.	í	:	.	43	:
.	:	.	l	:	.	î	:	.	44	:
/	:	.	m	:	.	ï	:	.	45	:
0	:	.	n	:	.	ï	:	.	46	:
1	:	.	o	:	.	ð	:	.	47	:
2	:	.	p	:	.	é	:	.	48	:
3	:	.	q	:	.	ë	:	.	49	:
4	:	.	r	:	.	ì	:	.	50	:
5	:	.	s	:	.	í	:	.	51	:
6	:	.	t	:	.	î	:	.	52	:
7	:	.	u	:	.	ï	:	.	53	:
8	:	.	v	:	.	ï	:	.	54	:
9	:	.	w	:	.	ð	:	.	55	:
:	:	.	x	:	.	é	:	.	56	:
:	:	.	y	:	.	ë	:	.	57	:
:	:	.	z	:	.	ì	:	.	58	:
<	:	.	[:	.	í	:	.	59	:
=	:	.	\	:	.	î	:	.	60	:
>	:	.]	:	.	ï	:	.	61	:
?	:	.	^	:	.	ï	:	.	62	:

User-Defined Lexical Orders

A lexical order can be created for applications that require special collating sequences. If you can use one of the predefined lexical orders, you may wish to only skim this section.

A program called LEX_AID has been supplied (on the BASIC Utilities Library disc) to simplify the creation of user-defined lexical orders. Before running the program it will be necessary to have an understanding of the terms used in this section. Using the LEX_AID program is described in the BASIC Utilities Library manual.

Basically, a 321 element (0 thru 320) INTEGER array is dimensioned, filled with sequence numbers and mode entries, and the new lexical order is established by the following statement.

```
LEXICAL ORDER IS Table(*)
```

Where Table(*) is any valid INTEGER array name.

The following illustration shows the general construction of a user-defined lexical table created in an INTEGER array.

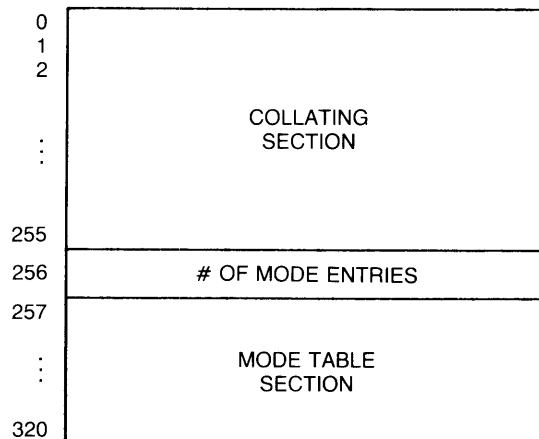

The first 256 elements (0 through 255) contain the sequence number to be used in place of the character's ASCII value. For special characters, a mode type and mode table pointer are also stored in these elements.

The next element (256) contains the number of entries in the mode table. This value can range from 0 (no mode table) thru 64 (a full mode table).

The remaining 64 elements (257 thru 320) contain the optional mode table entries assigned to special characters.

Sequence Numbers

Normally, comparing two strings results in the computer comparing the ASCII values of the characters. When the computer makes the string comparison “A” < “B”, the ASCII value of “A” (65) is compared to the ASCII value of the letter “B” (66) resulting in the comparison: 65 < 66, which is true.

Now suppose that a new value (sequence number) could be assigned to each of the ASCII characters. We might wish to assign the letter “A” a sequence number greater than the sequence number assigned to the letter “B”. If such an assignment were made, the comparison “A” < “B”, would now be false.

Once a lexical order is invoked, if two strings are compared, the strings are first converted into two series of sequence numbers and the comparison is then based on the sequence numbers.

The LEXICAL ORDER IS statement’s primary purpose is to assign a sequence number to each character. However, this is not always enough to handle certain character combinations and special cases encountered in other languages. Special characters have a mode entry included with the sequence number.

Mode Entries

Each of the first 256 array elements (0 thru 255) contains the sequence number to be used in place of the character’s ASCII value. Optionally, a mode entry can be included.

Internally, an integer array element uses two bytes (16 bits) of memory. In the following diagram, the array element is divided into its upper, and lower bytes. The upper byte contains the sequence number and the lower byte is used if the character has a mode entry.

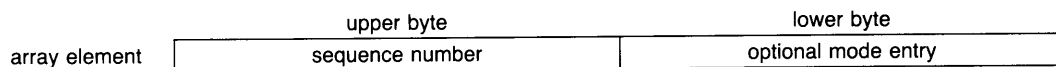

The lower byte is further divided into two parts. The upper-most 2-bits are used to represent one of the four mode types. The remaining 6-bits store an index (pointer) to the actual mode table entries. This method allows all the necessary information, for each character, to be stored as a single element in the INTEGER array.

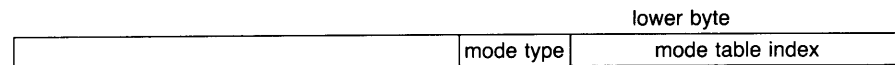

Mode Type

Any one of the following mode types can be assigned to a character.

- Don’t Care Characters (Mode type: 0)
- “1 for 2” Character Replacements (Mode type: 1)
- “2 for 1” Character Replacements (Mode type: 2)
- Accent Priority (Mode type: 3)

Mode Index

The mode index points to the actual mode table entry associated with the particular character. Up to 64 indexes are allowed (0 thru 63); however, some mode types use more than one table entry.

Bits, Bytes, and Mode Types

Each INTEGER array element stores a signed-integer in the range: -32768 thru 32767 . Internally, the number is stored as a 16-bit 2's complement value.

Bits are usually numbered in descending order and include bit 0, so 16 bits are numbered as follows.

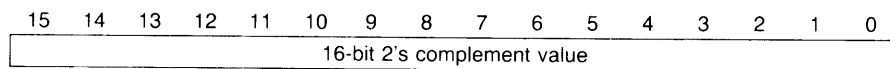

However, we want to store one of 256 possible sequence numbers and optionally, a mode type and mode table index. Since there are 256 characters used with the LEXICAL ORDER IS statement, and 8 bits are needed to store one of 256 possible values ($2^8 = 256$), it is convenient to think of the bits arranged as two bytes (a byte contains 8 bits).

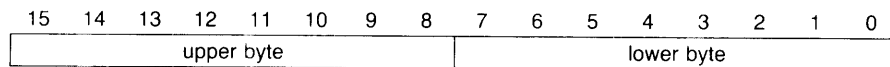

The upper byte is used to hold the sequence number and the lower byte contains the mode entry information. The algorithm below will produce a signed 16-bit integer from two unsigned 8-bit bytes.

```
Integer = (256*UPPER + Lower) - (UPPER>127)*65536
```

The process can be reversed.

```
IF Integer<0 THEN Integer=Integer+65536
UPPER=Integer DIV 256
Lower=Integer MOD 256
```

The lower byte is further divided into two groups. Two bits hold one of four mode types ($2^2 = 4$) and the remaining six bits are for one of 64 mode indexes ($2^6 = 64$).



A “1 for 2” entry is signified by bit-6 being set. Therefore the value of the lower byte can range from 64 thru 126. (a “1 for 2” requires at least 2 entries.)

A “2 for 1” entry has bit-7 set. The value of the lower byte can range from 128 thru 191.

An “Accent priority” entry has both bit-6 and bit-7 set. The value of the lower byte ranges from 192 thru 255.

”Don’t Care” Characters

A character can be removed from the collation sequence. To mark a character as a “don’t care”, the mode type is 0 (the same as a regular character) but the mode table index is set to 1.

sequence number	type	index
any value	0	1

The mode index need not point to a valid table entry, but must be a “1” to indicate a “don’t care” character.

For example, the FRENCH lexical table lists the hyphen (-) as a “don’t care” character. Thus, the hyphen is ignored when a string comparison is being made. The entry appears:

	sequence number	type	index
(45)	45	0	1

You may wish to include “don’t care” characters in your own lexical tables. A string containing only “don’t care” characters will match the null string.

The following short program illustrates the operation of a “don’t care” character.

```

10 Return$="RESTORE"
20 Again$="RE-STORE"
30 !
40 LEXICAL ORDER IS ASCII
50 IF Restore$=Again$ THEN PRINT "True for ASCII"
60 LEXICAL ORDER IS FRENCH
70 IF Restore$=Again$ THEN PRINT "True for FRENCH"
80 END

```

Results:

```
True for FRENCH
```

“1 for 2” Character Replacement

This type of mode table entry indicates that one sequence number is to be used for two consecutive characters. It should be remembered that no characters are actually replaced by this operation, only that a single sequence number is to be used when the two characters are found adjacent to each other.

The following entry is placed in the collating section of the lexical table.

sequence number	type	mode index
normal sequence number	1	index

If a character marked as a “1 for 2” is found in a string, the next character is accessed and compared to the list of possible secondary characters in the mode table section.

(257 + index)	number of entries to check	
	second character	sequence number for this pair
	second character	sequence number for this pair

If the character does not match any of the secondary characters in the mode table, the original character’s sequence number is used and processing continues. If a match is found, the sequence number for the pair is used and processing continues with the character following the secondary character.

For example, the SPANISH collating sequence has a “1 for 2” replacement for the letters “CH” or “Ch”. The letter “C” is marked as a “1 for 2” character. When the letter is encountered in a string, the next character is accessed and compared to the list of possible secondary characters (uppercase H and lowercase h). The appropriate sequence number is then used for the pair. If the character following the letter “C” is not found in the list of possible secondary characters, the sequence number for “C” is used and processing continues with the next character.

You can override a “1 for 2” character replacement by inserting a “Don’t Care” character between the two characters that would otherwise be replaced by a single sequence number.

The SPANISH table entry for the character sequence “CH” is below. In the collating section, the first letter of the sequence has the following entry:

	sequence number	type	mode index
(67)	67 (C)	1	1
(68)	69 (D)	0	0

(257 + 1)	number of entries to check (2)	
(257 + 2)	second character (H)	sequence number for pair (68)
(257 + 3)	second character (h)	sequence number for pair (68)

The sequence number assigned to the two-character combination is greater than the sequence number for the letter “C” and less than the sequence number for the letter “D”. Therefore, a word beginning with the characters “CH” will collate after all words starting with the letter “C” followed by any other character.

The following program shows the sorting order for the letters “CH” in the SPANISH lexical order.

```

5 DIM A$(3)[3]
10 A$(1)="CGA"
20 A$(2)="CHA"
30 A$(3)="CIA"
40 LEXICAL ORDER IS SPANISH
50 MAT SORT A$(*)
60 PRINT A$(*)
70 END

```

Produces:

```
CGA CIA CHA
```

It should be noted that a character may have more than one secondary character combination. This is demonstrated by having both upper and lower case entries. Other secondary characters could have been included in the same manner. The first mode table entry contains the number of secondary characters to check and must be in the range: 0 thru 63.

“2 for 1” Character Replacement

When a “2 for 1” mode entry is specified, it indicates that the character should be represented by two sequence numbers (as if there were two characters in the string). The first sequence number is stored with the character as usual. The mode index points to the mode table entry that contains the second sequence number to be used for that character.

sequence number	type	mode index
1st sequence number	2	index

The mode table entry actually contains two sequence numbers. If the original character was upper case, the next character in the string will determine whether the upper or the lower sequence number is used. If the original character was a lower case letter, the lower sequence number is always used.

	upper	lower
(257 + index)	2nd sequence number (UPC)	2nd sequence number (LWC)

Several “2 for 1” characters are in the GERMAN lexical order. For instance, the character “Ä” is equivalent to “AE” and has the following entry in the collating section.

	sequence number	type	mode index
(216)	65 (A)	2	index

The index points to the following entry in the mode table.

	upper	lower
(257 + index)	75 (E)	124 (e)

In some cases, such as the character “ß”, both upper and lower bytes contain the sequence number for the same character(s). This results in the same sequence numbers being generated regardless of the case of the next character.

Accent Priority

Accent Priority can be used as the final arbitrator of string comparisons. If you examine the lexical tables you will often find the same sequence number assigned to more than one character. Therefore, it is possible for two different strings to produce identical series of sequence numbers. The two strings will be considered equal unless at least one character, in each string, has been assigned different accent priorities.

Accent priority is established by assigning a value, in the range: 0 thru 63, to the character. Any character not already assigned a mode type may be assigned a priority. A priority of zero is assumed for all characters that haven't been assigned a priority.

sequence number	type	mode index
normal sequence number	3	priority

In the FRENCH lexical order, the characters: A, Á, and À have been assigned the same sequence number (64). Assume the characters were assigned the following priorities.

Character	Priority	
A	0	(default priority)
Á	1	
À	2	

The characters can now be distinguished from one another and will collate in the following order.

$$A < \acute{A} < \grave{A}$$

When two strings are compared, each string is first converted into a series of sequence numbers. The comparison is then determined (in most cases) by the greater sequence numbers or the longer series of sequence numbers.

In the event both strings produce identical series of sequence numbers, the series of priorities are checked. The string containing the characters with the higher priority is the greater string.

User-Defined Functions and Subprograms

Chapter

6

Introduction

One of the most powerful constructs available in any language is the subprogram (a user-defined function is a special form of subprogram). A subprogram can do everything a main program can do except that it must be invoked or “called” before it is executed, whereas a main program is executed by pressing the RUN key. In a sense, pressing the RUN key is how you “call” a main program.

A subprogram has its own “context” or state as distinct from a main program and all other subprograms. This means that every subprogram has its own set of variables, its own softkey definitions, its own DATA blocks, and its own line labels. There are several benefits to be realized by taking advantage of subprograms:

- The subprogram allows the programmer to take advantage of the “Top-Down” method of designing programs. In this technique, the problem to be solved is broken up into a set of smaller and more easily solvable problems. These smaller problems can in turn be broken up into smaller problems yet, and so on. This technique has been shown to greatly improve the design, coding, and testing of programs, and will be discussed further at the end of the chapter.
- By separating all the details of performing the subtasks from the overall logic flow of the main program, the program is much easier to read from the subprogram calls. The programmer can see at a high level what he’s trying to accomplish, rather than immediately getting lost in the details of each little sub-task.
- One of the most time-consuming parts of writing a program is debugging it, or forcing it to run correctly. The time consuming part of fixing bugs in a program is finding where the bug is in the first place. By using subprograms and testing each one independently of the others, it is easier to locate problems, and hence to fix them.
- Often, a programmer may want to perform the same task from several different areas of his program. For example, a set of readings may need to be taken from a voltmeter after each of four different input signals are fed through a circuit being tested. The same subprogram may be used to set up the voltmeter and take the readings, while different pieces of code would have to be used to set up the differing input conditions. Thus, subprograms can be used to economize on the overall size of the program.
- Finally, libraries of commonly used subprograms can be assembled for widespread use. Many different users doing diverse types of problems still may require some identical subprograms. For instance, an engineer may be using a subprogram to plot an array of data that he gathered from a spectrum analyzer, while the marketing person down the hall may be using the same subprogram to plot an array of data representing next year’s sales forecast.

Some Startup Details

Location

A subprogram is located after the body of the main program, following the main program's END statement. (The END statement must be the last statement in the main program except for comments.) Subprograms may not be nested with other subprograms, but are physically delimited from each other with their heading statements (SUB or DEF) and ending statements (SUBEND or FNEND).

Naming

A subprogram has a name which may be up to fifteen characters long, just as with line labels and variable names. Here are some legal subprogram names:

```
Initialize
Read_dvm
Sort_2_d_array
Plot_data
(Katakana name)
```

Because up to 15 characters are allowed for naming subprograms, it is easy and convenient to name subprograms in such a way as to reflect the purpose for which the subprogram was written.

For Example

The following example shows a program which uses subprograms.

```
10  OPTION BASE 1
20  DIM Numbers(20)
30  CALL Build_array(Numbers(*),20)
40  CALL Sort_array(Numbers(*),20)
50  PRINT FNSum_array(Numbers(*),20)
60  END
70  SUB Build_array(X(*),N)
80  ! X(*) is the array to be defined
90  ! N tells how many elements are in the array
100 ! (1 is assumed to be the lower index)
110 FOR I=1 TO N
120   DISP "ELEMENT #";I;
130   INPUT "?",X(I)
140 NEXT I
150 SUBEND
160 SUB Sort_array(A(*),N)
170 ! A(*) is array to be sorted
180 ! N tells how many elements are in the array (1 is assumed
190 ! to be the lower bound)
200 ! Sort the array (elements 1-N) in increasing order
210 ! Algorithm used: Shell sort or Diminishing increment sort
220 ! Ref: Knuth, Donald E., The Art of Computer Programming,
230 ! Vol. 3 (Sorting and Searching), (Addison-Wesley 1973)
240 ! pp. 84-85
250 INTEGER T,S,H,I,J
260 REAL Temp
270 T=INT(LOG(N)/LOG(2)) ! # of diminshing increments
280 FOR S=T TO 1 STEP -1
290   H=2^(S-1) ! ...16,8,4,2,1
300   FOR J=H+1 TO N
310     I=J-H
320     Temp=A(J)
330   Decide: IF Temp>=A(I) THEN Insert
```

```

340 Switch: A(I+H)=A(I)
350     I=I-H
360     IF I>=1 THEN Decide
370 Insert: A(I+H)=Temp
380     NEXT J
390 NEXT S
400 SUBEND
410 DEF FNSum_array(A(*),N)
420 ! Add A(1)...A(N)
430 INTEGER I
440 REAL Array_total
450 FOR I=1 TO N
460     Array_total=Array_total+A(I)
470 NEXT I
480 RETURN Array_total
490 FNEND

```

Lines 10 through 60 are the main program. As you can see, it does nothing but call subprograms, which in turn do all the work. Line 70 is the header for the subprogram which asks the user to enter the values stored in his array. Notice that the main program has declared the array's name to be Numbers(*), but the subprogram uses the name X(*) to deal with the same array. The subprogram can name its variables whatever it wants without interfering with variables used outside the subprogram's context. The only variables that can be affected outside the subprogram's context are those passed through the parameter list (as shown here) or through COM (discussed later). In both cases, the matching between the subprogram and the outside world is done through the position of the variable(s) in the parameter list or COM block, not the actual name of the variable(s).

Starting at line 160 is the next subprogram which sorts the array into ascending order. The comments at the front of the subprogram serve to discuss the definition of the parameters used, and what effect the subprogram has on them. Also, the algorithm used is given, along with the proper reference material. It is an excellent idea to give a list of such pertinent details at the front of all subprograms. This makes debugging, modifying, optimizing, and re-using the subprogram much easier.

Starting at line 410 we see an example of a function subprogram. Functions are similar to SUB subprograms in concept. This particular example just adds the elements of the array together and returns the final value to the main program, which prints it.

The Difference Between a Function and a Subprogram

A SUB subprogram (as opposed to a function subprogram) is invoked explicitly using the CALL statement. A function subprogram is called implicitly by using the function name in an expression. It can be used in a numeric or string expression the same way a constant would be used, or it can be invoked from the keyboard. A function's purpose is to return a single value (either a real number or a string).

There are several functions that are built into the BASIC language which can be used to return values, such as SIN, SQR, EXP, etc.

```

Y=SIN(X)+Phase
Root1=(-B+SQR(B*B-4*A*C))/(2*A)

```

Using the capability of defining your own function subprograms, you can essentially extend the language if you need a feature not provided in BASIC.

```
X=1/FNSinh(Y^4)
Angle=FNAtnZ(Y,X)
```

A general rule of thumb for using subprograms is that if you want to take a set of data and analyze it to generate a single value, then you probably want to implement the subprogram as a function. On the other hand, if you want to actually change the data itself, generate more than one value as a result of the subprogram, or perform any sort of I/O activity, it is better to use a SUB subprogram.

REAL Precision Functions and String Functions

A function is allowed to return either a REAL value or a string value. Above, we saw some examples of functions returning real numbers. Let's examine one which returns a string. There are two primary differences: The first is that a \$ must be added to the name of a function which is to return a string. This is used both in the definition of the function (the DEF statement) and when the function is invoked. The second difference is that the RETURN statement in the function returns a string instead of a number.

```
.
.
.
200 PRINT FNAscii_to_hex$(A$)
.
.
.
1550 DEF FNAscii_to_hex$(A$)
1560 ! Each ASCII byte consists of two hex
1570 ! digits; pretty formatting dictates that
1580 ! a space be inserted between every pair
1590 ! of hex digits. Thus, the output string
1600 ! will be three times as long as the input
1610 ! string.
1620 !
1630 ! upper four bits      lower four bits
1640 ! UUUU LLLL          UUUU LLLL
1650 ! shift 4 bits       0000 1111 mask (15)
1660 ! 0000 UUUU          0000 LLLL final
1670 !
1680 INTEGER I,Length,Hexupper,Hexlower
1690 Length=LEN(A$)
1700 ALLOCATE Temp$[3*Length]
1710 FOR I=1 TO Length
1720   Hexupper=SHIFT(NUM(A#[I]),4)
1730   Hexlower=BINAND(NUM(A#[I]),15)
1740   Temp$[3*I-2;1]=FNHex$(Hexupper)
1750   Temp$[3*I-1;1]=FNHex$(Hexlower)
1760   Temp$[3*I;1]=" "
1770 NEXT I
1780 RETURN Temp$
1790 FNEND
1800 DEF FNHex$(INTEGER X)
1810 ! Assume 0<=X<=15)
1820 ! Return ASCII representation of the
1830 ! hex digit represented by the four
1840 ! bits of X.
1850 ! If X is between 0 and 9, return
```

```

1860 ! "0"...9"
1870 ! If X > 9, return "A"...F"
1880 IF X<=9 THEN
1890     RETURN CHR$(48+X) ! ASCII 48 through 57
1900         ! represent "0" - "9"
1910 ELSE
1920     RETURN CHR$(55+X) ! ASCII 65 through 70
1930         ! represent "A" - "F"
1940 END IF
1950 FNEND

```

Lines 200, 1740, and 1750 show examples of how to call a string function. Lines 1550 and 1800 show where the two string function subprograms begin. Notice that the program could be optimized slightly by deleting lines 1720 and 1730 and modifying lines 1740 and 1750:

```

1740     Temp$(3*I-2;1)=FNHex$(SHIFT(NUM(A$(I)),4))
1750     Temp$(3*I-1;1)=FNHex$(BINAND(NUM(A$(I)),15))

```

Thus it is perfectly legal to use expressions in the pass parameter list of a subprogram. (By the way, such expressions may also invoke function subprograms.)

Calling and Executing a Subprogram

We have seen in the above examples how the two types of subprograms are called — SUBs are invoked explicitly using the CALL statement, while functions are invoked implicitly just by using the name in an expression, an output list, etc. A nuance of SUB subprograms is that the CALL keyword is optional when invoking a SUB subprogram. Thus our example of the main program which causes an array of numbers to be sorted could look like this:

```

10  OPTION BASE 1
20  DIM Numbers(20)
30  Build_array(Numbers(*),20)
40  Sort_array(Numbers(*),20)
50  PRINT FNSum_array(Numbers(*),20)
60  END

```

The omission of the CALL keyword when invoking a SUB subprogram is left solely to the discretion of the programmer; some will find it more aesthetic to omit CALL, others will prefer its inclusion. There are, however, three instances which require the use of CALL when invoking a subprogram:

CALL is required:

1. If the subprogram is called from the keyboard,
2. If the subprogram is called after the THEN keyword in an IF statement
3. In an ON <event> CALL statement

Communication

As mentioned earlier, there are two ways for a subprogram to communicate with the main program or with other subprograms: parameter lists, and COM (blank and labeled).

Parameter Lists

The formal parameter list is part of the subprogram's definition, just like the subprogram's name. The formal parameter list tells how many values may be passed to a subprogram, the types of those values (string, INTEGER, REAL, array, I/O path name), and the names the subprogram will use to refer to those values. The subprogram has the power to demand that the calling context match the types declared in the formal parameter list exactly — otherwise an error results. The calling context provides a pass parameter list which corresponds with the formal parameter list provided by the subprogram. The pass parameter list provides the values for those inputs required by the subprogram, and also provides the storage for the output values. It is perfectly legal for both the formal and pass parameter lists to be null, or nonexistent.

Here is a sample formal parameter list showing which types each parameter demands:

```
SUB Read_dvm(@Dvm,A(*),INTEGER Lower,Upper,Status$,Errflag)
```

`@Dvm` is an I/O path name which may refer to either an I/O device or a mass storage file. Its name here implies that it is a voltmeter, but it is perfectly legal to redirect I/O to a file just by using a different ASSIGN with `@Dvm`.

`A(*)` is a REAL array. Its size is declared by the calling context. Without MAT, there is no way to find the size of the array except through information supplied explicitly by the calling context; hence the parameters `Lower` and `Upper`.

`Lower` and `Upper` are declared here to be INTEGERS. Thus, when the calling program invokes this subprogram, it must supply either INTEGER variables or INTEGER expressions, or an error will occur.

`Status$` is a simple string which presumably could be used to return the status of the voltmeter to the main program. The length of the string is defined by the calling context.

`Errflag` is a REAL number. The declaration of the string `Status$` has limited the scope of the INTEGER keyword which caused `Lower` and `Upper` to require INTEGER pass parameters.

There are two ways for the calling context to send values to a subprogram — pass by value, and pass by reference. Using pass by value, the calling context supplies a value and nothing more. Using pass by reference, the calling context actually gives the subprogram access to the calling context's value area. The distinction is that a subprogram can not alter the value of data in the calling context if the data is passed by value, while the subprogram **can** alter the value of data in the calling context if the data is passed by reference.

The subprogram has no control over whether its parameters are sent using pass by value or pass by reference. That is determined by the calling context's pass parameter list. In order for a parameter to be passed by reference, the pass parameter list (in the calling context) must use a variable for that parameter. In order for a parameter to be passed by value, the pass parameter list must use an expression for that parameter. Note that enclosing a variable in parentheses is sufficient to create an expression. Using pass by value, it is possible to pass an integer expression to a REAL formal parameter (the INTEGER is converted to its REAL representation) without causing a type mismatch error. Likewise, it is possible to pass a REAL expression to an INTEGER formal parameter (the value of the expression is rounded to the nearest INTEGER) without causing a type mismatch error (an integer overflow error is generated if the expression is out of range for an INTEGER). Let's look at our previous example from the calling side:

```
CALL Read_dvm(@Voltmeter,Readings(*),1,400,Status$,Errflag)
```

`@Voltmeter` is the pass parameter which matches the formal parameter `@Dvm` in the subprogram. I/O path names are always passed by reference, which means the subprogram can close the I/O path or assign it to a different file or device.

`Readings(*)` matches the array `A(*)` in the subprogram's formal parameter list. Arrays too, are always passed by reference.

`1, 400` are the values passed to the formal parameters `Lower` and `Upper`. Since constants are classified as expressions rather than variables, these parameters have been passed by value. Thus, if the subprogram used either `Lower` or `Upper` on the left hand side of an assignment operator, no change would take place in the calling context's value area.

`Status$` is passed by reference here. If it were enclosed in parentheses, it would be passed by value. Notice that if it were passed by value, it would be totally useless as a method for returning the status of the voltmeter to the calling context.

`Errflag` is passed by reference.

OPTIONAL Parameters

Another important feature of formal parameter lists is the `OPTIONAL` keyword. Any formal parameter list (the one defining the subprogram) may contain the keyword `OPTIONAL` somewhere, although it isn't required to. The `OPTIONAL` keyword indicates that any parameters that follow it are not required in the pass parameter list of a calling context — they are optional. On the other hand, all parameters preceding the `OPTIONAL` keyword are required. If no `OPTIONAL` appears in the subprogram's parameter list, then all the parameters must be specified, or an error will be generated. The rules requiring matching of parameter types apply to `OPTIONAL` parameters as well as to ordinary parameters. There is a standard function called `NPAR` which can be used inside the subprogram to find out how many pass parameters the calling context actually did use. (`NPAR` will return 0 if used inside the main program, or if no parameters were passed to a subprogram.)

The `OPTIONAL/NPAR` combination is very effectively used in situations requiring external instrument setups. Most instruments have several different ranges, modes, settings, etc., which can be used depending upon the requirements of the user. Often, the user doesn't require the entire flexibility the instrument has to offer, and would rather use some reasonable defaults.

Consider the HP 3437A Digital Voltmeter. Among other things, this device has two data formats (packed and ASCII), three trigger modes (internal, external, and hold/manual), three voltage ranges (0.1V, 1V, and 10V), and also has programmable values for delay between readings, and numbers of readings taken. Naturally, the values used for the various settings will depend entirely upon the application for which the voltmeter is being used, but let's make some assumptions:

- The values for delay and number of readings are going to be changed frequently, so they will not be OPTIONAL parameters.
- Of the remaining OPTIONAL parameters, the range is most likely to be altered.

A reasonable setup routine for the voltmeter might look like this:

```

2010 SUB Setup_dvm(@Dvm,INTEGER Readings,REAL Delay,OPTIONAL INTEGER Prange,Pt
trigger,Pformat)
2020 SELECT NPAR
2030 CASE 3
2040     Format=1                ! Default ASCII format
2050     Trigger=1             ! Default internal trigger
2060     Range=2               ! Default 1 volt range
2070 CASE 4
2080     Format=1
2090     Trigger=1
2100     Range=Prange
2110 CASE 5
2120     Format=1
2130     Trigger=Ptrigger
2140     Range=Prange
2150 CASE 6
2160     Format=Pformat
2170     Trigger=Ptrigger
2180     Range=Prange
2190 END SELECT
2200 OUTPUT @Dvm;"N";VAL$(Readings);"SD";VAL$(Delay);"SR";VAL$(Range);"T";VAL$(
Trigger);"F";VAL$(Format)
2210 SUBEND

```

Legal invocations of the Setup_dvm subprogram are:

```

570 Setup_dvm(@Dvm,100,.001)      ! Default Range,Trigger,Format
630 Setup_dvm(@Dvm,500,.05,3)     ! Default Trigger,Format
850 Setup_dvm(@Dvm,50,.005,1,2)   ! Default Format
1010 Setup_dvm(@Dvm,70,.075,2,1,2) ! Explicitly declare all values

```

Notice in the example above that local variables are used instead of the formal parameters. This is because it is illegal to use an OPTIONAL parameter variable if that variable was not passed from the calling context.

Other applications of the OPTIONAL/NPAR feature are limited only by the imagination, but here are a few ideas:

Write a subprogram which sorts an array in ascending order unless an OPTIONAL parameter tells it to sort in descending order.

Write a rootfinder routine which has an acceptance tolerance of $\pm 10^{-6}$ unless overridden with an OPTIONAL parameter.

Write a program which keeps track of departmental expenses, including the account billed, the item or service purchased, the person incurring the expense, and optionally, the person authorizing the expense.

COM Blocks

Since we've discussed parameter lists in detail, let's turn now to the other method a subprogram has of communicating with the main program or with other subprograms, the COM block.

There are two types of COM (or common) blocks, blank and labeled. Blank COM is simply a special case of labeled COM (it is the COM whose name is nothing) with the exception that blank COM must be declared in the main program, while labeled COM blocks don't have to be declared in the main program. Both types of COM blocks simply declare blocks of data which are accessible to any context having matching COM declarations.

A blank COM block might look like this:

```
10 OPTION BASE 1
20 COM Conditions(15),INTEGER,Cmin,Cmax,@Nuclear_File,
   File_status#[20],Tolerance
```

A labeled COM might look like this:

```
30 COM /Valve/ Main(10),Subvalves(10,15),@Valve_ctrl
```

A COM block's name, if it has one, will immediately follow the COM keyword, and will be set off with slashes, as shown above. The same rules used for naming variables and subprograms are used for naming COM blocks.

Any context need only declare those COM blocks which it needs to have access to. If there are 150 variables declared in 10 COM blocks, it isn't necessary for every context to declare the entire set — only those blocks that are necessary to each context need to be declared. COM blocks with matching names must have matching definitions. As in parameter lists, matching COM blocks is done by position and type, not by name.

There are several characteristics of COM blocks which distinguish them from parameter lists as a means of communications between contexts.

- COM survives pre-run — In general, any numeric variable is set to 0, strings are set to the null string, and I/O path names are set to undefined after pushing the RUN key, or upon entering a subprogram. This is true of COM the first time the RUN key is pressed, but after COM block variables are defined, they retain their values until:
 1. SCRATCH A or SCRATCH C is executed,
 2. A statement declaring a COM block is modified by the user,
 3. A new program is brought into memory using the GET or LOAD commands which doesn't match the declaration of a given COM block, or which doesn't declare a given COM block at all.
- COM blocks can be arbitrarily large — One limitation on parameter lists (both pass and formal parameter lists) is that they must fit into a single program line along with the line's number, possibly a label, the invocation or subprogram header, and possibly (in the case of

a function) a string or numeric expression. Depending upon the situation, this can impose a restriction on the size of your parameter lists.

COM blocks can take as many statements as necessary. COM statements can be interwoven with other statements (though this is considered a poor practice). All COM statements within a context which have the same name will be part of the definition of that COM block.

- COM blocks can be used for communicating between contexts that do not invoke each other — Information such as modes and states can be an integral part of communicating between contexts, even though those contexts don't explicitly call each other. For instance, one routine might be responsible for setting the voltage range on a voltmeter, while another routine which may need to know what the current voltage range is in order to set up the scale on a graph properly.
- COM blocks can be used to communicate between subprograms that are not in memory simultaneously — Similar to the case above, subprograms can communicate with each other through COM blocks even though combinations of LOADSUB/DELSUB may preclude their simultaneous presence in memory.
- COM blocks can be used to retain the value of "local" variables between subprogram calls — In general, the variables used by a subprogram are discarded when the subprogram is exited. However, there are situations where it might be useful for a subprogram to "remember" a value. A machine which tests capacitors in an incoming inspection department may require calibration after every 100 tests are performed. If the subprogram which does the testing has a way to count how many tests it has already performed (using a labeled COM block), then this task can be left to the testing routine, simplifying the rest of the system.
- COM blocks allow subprograms to share data without the intervention of the main program — Subprogram libraries may consist of elaborate relationships of both programs and data structures. In many cases, a major portion of the data structures are only used for support of the task being performed, rather than being integral to the task itself. Thus the main program does not need to declare the supportive data structures.

Examples of this situation might include data base management libraries (hashing tables may need to be maintained for accessing data quickly) or three dimensional graphics libraries (window, viewport, and clip information need to be kept, as well as object definitions and related transformations).

Hints for Using COM Blocks

Any COM blocks needed by your program must be resident in memory at prerun time (prerun is caused by pressing **RUN**, executing a RUN command, executing LOAD or GET from the program, or executing a LOAD or GET from the keyboard and specifying a run line.) Thus if you want to create libraries of subprograms which share their own labeled COM blocks, it is wise to collect all the COM declarations together in one subprogram to make it easy to append them to the rest of the program for inclusion at prerun time. (The subprogram need not contain anything but the COM declarations.)

COM can be used to communicate between programs which overlay each other using LOAD or GET statements, if you remember a few rules.

1. COM blocks which match each other exactly between the two programs will be preserved intact. "Matching" requires that the COM blocks are named identically (except blank COM), and that corresponding blocks have exactly the same number of variables declared, and that the types and sizes of these variables match.
2. Any COM blocks existing in the old program which are not declared in the new program (the one being brought in with the LOAD or GET) are destroyed.
3. Any COM blocks which are named identically, but which do not match variables and types identically, are defined to match the definition of the new program. All values stored in that COM block under the old program are destroyed.
4. Any new COM blocks declared by the new program (including those mentioned above in #3) are initialized implicitly. Numeric variables and arrays are set to zero, strings are set to the null string, and I/O path names are set to undefined.

The first occurrence in memory of a COM block is used to define or set up the block. Subsequent occurrences of the COM block must match the defining block, both in the number of items, and the types of the items. In the case of strings and arrays, the actual sizes need be specified only in the defining COM blocks. Subsequent occurrences of the COM blocks may either explicitly match the size specifications by re-declaring the same size, or they may implicitly match the size specifications. In the case of strings, this is done by not declaring any size, just declaring the string name. In the case of arrays, this is done by using the (*) specifier for the dimensions of the array instead of explicitly re-declaring the dimensions.

Consider the following COM block definition:

```
10    COM /Dvm_state/ INTEGER Range,Format,N,REAL
      Delay,Lastdata(1:40),Status#[20]
```

The following occurrence of the same COM block within a subprogram matches the COM block explicitly and is legal:

```
2000 COM /Dvm_state/ INTEGER Range,Format,N,REAL
      Delay,Lastdata(1:40),Status#[20]
```

The following block within a different subprogram uses implicit matching and is also legal:

```
4010 COM /Dvm_state/ INTEGER Range,Format,N,REAL
      Delay,Lastdata(*),Status#
```

The following declaration is illegal, since it uses explicit size specifications on the array and string which do not match the original definition from line 10.

```
5020 COM /Dvm_state/ INTEGER Range,Format,N,REAL
      Delay,Lastdata(1:30),Status#[15]
```

The following declaration is also illegal, since it violates the types set forth by the defining block.

```
6010 COM /Dvm_state/ Range,Format,N,REAL
      Delay,Lastdata(*),Status#
```

In general, the implicit size matching on arrays and strings is preferable to the explicit matching because it makes programs easier to modify. If it becomes necessary to change the size of an array or string in a COM block, it only needs to be changed in one statement, the one which defines the COM block. If all other occurrences of the COM block use the `(*)` specifier for arrays, and omit the length field in strings, none of those statements will have to be changed as a result of changing an array or string size.

Context Switching

As mentioned in the introduction to this chapter, a subprogram has its own **context** or state as distinct from a main program and all other subprograms. In between the time that a `CALL` statement is executed (or an FN name is used) and the time that the first statement in the subprogram gets executed, the computer performs a “prerun” on the subprogram. This “entry” phase is what defines the context of the subprogram. The actions performed at subprogram entry are similar, but not identical, to the actual prerun performed at the beginning of a program. Here is a summary:

- The calling context has a DATA pointer which points to the next item in the current DATA block which will be used the next time a `READ` is executed (assuming of course that a DATA block even exists in the calling program). This pointer is saved whenever a subprogram is called, and then the DATA pointer is reset to the first DATA statement in the new subprogram context.
- The `RETURN` stack for any `GOSUBs` in the current context is saved and set to the empty stack in the new context.
- The system priority of the current context is saved, and the called subprogram inherits this value. Any change to the system priority which takes place within the subprogram (or any of the subprograms which it calls in turn) is purely local, since the system priority is restored to its original value upon subprogram exit. This is an important consideration: If the subprogram is called as a result of an event-initiated `GOSUB/CALL` statement, any `ON <event> GOTO/GOSUB/CALL/RECOVER` condition set up in the called subprogram must have a higher priority assigned to it than the event responsible for the subprogram’s invocation. Otherwise, the event is guaranteed **not** to cause an end of line branch.
- Any event-initiated `GOTO/GOSUB` statements are disabled for the duration of the subprogram. If any of the specified events occur, this will be logged, but no action will be taken. (The fact that an event did occur will be logged, but only once — multiple occurrences of the same event will not be serviced.) Upon exiting the subprogram, these event-initiated conditions will be restored to active status, and if any of these events occurred while the subprogram was being executed, the proper branches will be taken.
- Any event-initiated `CALL/RECOVER` statements are saved upon entering a subprogram, but the subprogram still inherits these `ON` conditions since `CALL/RECOVER` are global in scope. However, it is legal for the subprogram to redefine these conditions, in which case the original definitions are restored upon subprogram exit.
- The current value of `OPTION BASE` is saved, and the value for the subprogram (0 or 1, explicitly declared or defaulted) is used.
- The current `DEG` or `RAD` mode for trigonometric operations and graphics rotations is saved. The subprogram will inherit the current `DEG` or `RAD` setting, but if it gets changed within the subprogram, the original setting will be restored when the subprogram is exited.

Variable Initialization

Space for all arrays and variables declared is set aside, whether they are declared explicitly with DIM, REAL, or INTEGER, or implicitly just by using the variable. The entire value area is initialized as part of the subprogram's prerun. All numeric values are set to zero, all strings are set to the null string, and all I/O path names are set to undefined.

Subprograms and Softkeys

ON KEYs are a special case of the event-initiated conditions that are part of context switching. They are special because they are the only <event> conditions which give visible evidence of their existence to the user through the softkeys labels at the bottom of the CRT. These key labels are saved just as the event conditions are, and the labels get restored to their original state when the subprogram is exited, regardless of any changes the subprogram made in the softkey definitions. This means the programmer doesn't have to make any special allowances for re-enabling his keys and their associated labels after calling a subprogram which changes them — the language system handles this automatically.

It is important to remember that the called subprogram inherits the softkey labels. All the keys are still active in some sense; ON KEY...CALL/RECOVER will cause their original program branches to take place immediately if the proper key is pressed, and ON KEY...GOTO/GOSUB will log the fact that a key is pressed until the subprogram is exited, at which time the proper branch will occur. This latter case may cause some consternation on the part of the user if he presses a softkey expecting immediate action and nothing happens since the key was temporarily disabled due to a called subprogram. If the called subprogram is expected to take a noticeably long time to execute, it might be a good idea to explicitly remove the labels from the disabled softkeys using the OFF KEY statement. Thus, the user won't expect anything to happen as a result of pressing a softkey. This technique is also useful for guaranteeing that a given subprogram is **not** interrupted prematurely. (The DISABLE statement is useful for preventing program branches as a result of an event-initiated happening, although it will not turn off the softkey labels.)

Subprograms and the RECOVER Statement

The event-initiated RECOVER statement allows the programmer to cause the program to resume execution at any given place in the context defining the ON...RECOVER as a result of a specified event occurring, regardless of subprogram nesting.

Thus, if a main program executes an ON...RECOVER statement (for example a softkey or an external interrupt from the SRQ line on an HP-IB), and then calls a subprogram, which calls a subprogram, which calls a subprogram, etc., program execution can be caused to immediately resume within the main program as a result of the specified event happening.

By way of illustration, consider the following example:

Suppose you are performing an exhaustive component test on a circuit board. The program may be designed like so:

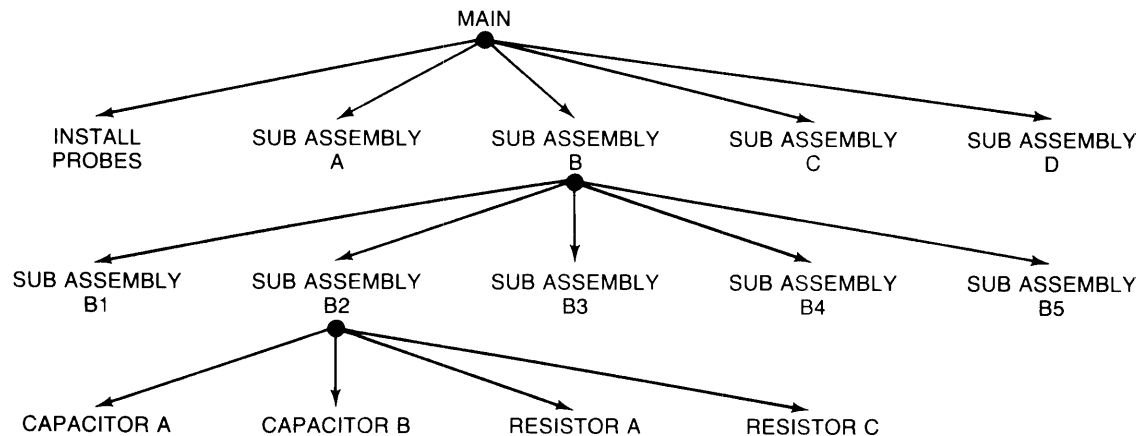

When lunch break comes around, you may want to halt the current test so you can use the computer to play chess, or your boss might wander by and want to see the results of the rest of the tests performed this week. In either case, if the test program is nested three or four levels deep in subprograms, it might take a while for the test to complete. By defining a softkey to RECOVER to the main program, you can instantly terminate the test at any time, and make the computer available for something else. The RECOVER will discard anything being done in any of the subprograms between the context declaring the event-initiated RECOVER, and the subprogram being executed when the specified event occurs.

Again, the DISABLE statement can be used within any subprograms in which it is critical not to allow interruptions.

Live Keyboard

Functions and subprograms can be called from live keyboard by the user. There are some restrictions:

- Since variables cannot be created by the user from the keyboard (variables can only be defined by the program), it is legal to use only parameters that already exist in the current context.
- Constants may be used in the pass parameter list.
- When calling a SUB subprogram from the keyboard, the CALL keyword is not optional.

Speed Considerations

In some programs, speed is of the essence. In these cases, programmers will be reluctant to incur any unnecessary overhead in executing their task. There is a certain amount of overhead incurred in calling subprograms, although the overhead is fairly small, and shouldn't be an impediment to the use of subprograms. ("Overhead" is loosely defined to be the time it takes to perform those activities which aren't explicitly asked for by the user's program, but which are still necessary to keep the user's program running in a correct manner. The tasks discussed earlier under context switching are an excellent example of such overhead.)

Let's look at how much time it takes just to get in and out of the subprogram regardless of the task being performed by the subprogram. (The times in this discussion are approximate and apply to the Model 226.)

The time it takes to enter a subprogram depends upon the number of parameters being passed, the types of parameters being passed, and the number of variables declared local to the subprogram itself. To get in and out of a subprogram which has no parameters and which does nothing (in other words, a SUB followed by a SUBEND) takes 572 microseconds, meaning if you call it 1748 times, you'll lose about a second. (By way of comparison, 572 microseconds is about what it takes to perform four floating point additions. To perform four floating point additions and store the result from each one in a variable will take about 1080 microseconds, or just over a millisecond.)

Entry conditions	Approximate execution speed ¹
No parameters	572 μ sec.
1 simple numeric	+ 105 μ sec.
1 simple string	+ 128 μ sec.
1 numeric array	+ 141 μ sec.
1 string array	+ 141 μ sec.
1 I/O path name	+ 123 μ sec.
OPTION BASE in sub	+ 31 μ sec.
REAL or INTEGER in sub	+ 32 μ sec.
1st numeric array declaration	+ 18 μ sec.
other numeric array declarations	+ 11 μ sec.
1st string array declaration	+ 21 μ sec.
other string array declarations	+ 12 μ sec.

As you can see from the table, subprograms are a bargain in terms of speed. The relatively small amount of overhead required for invoking a subprogram is more than made up for by the benefits to be derived.

¹ These speeds apply to computers without an HP 98635A, floating point.

Using Subprogram Libraries

If you have a program which is quite large, along with sizable data arrays, you could run out of memory in your computer. But the program you're working on just **has** to remain one program, and external factors prevent your reducing data array size. What to do? There are several options which address this problem.

If you want to load a specific subprogram from a PROG file, you would use the `LOADSUB <subprogram name> FROM` statement. If you want to load all the subprograms from a specific PROG file, you would use the `LOADSUB ALL FROM` statement. And, if you wanted to see which subprograms are still missing or load all those still needed, you would use the `LOADSUB FROM` command. Note that this is a *command*, and not a statement. Therefore `LOADSUB FROM` cannot be invoked programmatically.

Loading Subprograms One at a Time

Suppose your program has several options to select from, and each one needs many subprograms and much data. All the options, however, are mutually exclusive; that is, whichever option you choose, it does not need anything that the other options use. This means that you can clean up everything you've used when you are through with that option.

If all of your subprograms can be put onto one file, you can selectively retrieve them as needed with this sort of statement:

```
LOADSUB SubProg_1 FROM "SUBFILE"
LOADSUB SubProg_2 FROM "SUBFILE"
LOADSUB FNnumeric_fn FROM "SUBFILE"
LOADSUB FNstring_function$ FROM "SUBFILE"
```

Note that only one subprogram per line can be loaded with this form of `LOADSUB`. If, for any program option, you need so many subprograms that this method would be cumbersome, you could use the following form of the command.

Loading Several Subprograms at Once

For this method, you store **all** the subprograms needed for each option on its own file. Then, when the program's user selects Program Option 1, you could have this line of code execute:

```
LOADSUB ALL FROM "OPT1SUBFL"
```

and if the user selects Option 2,

```
LOADSUB ALL FROM "OPT2SUBFL"
```

and so forth.

There is one other form of `LOADSUB`, but it cannot be used programmatically. This is covered next.

Loading Subprograms Prior to Execution

In the `LOADSUB FROM` form, for which you need `PDEV`, neither `ALL` nor a subprogram name is specified in the command. This is used prior to program execution. It looks through the program in memory, notes which subprograms are needed (referenced) but not loaded, goes to the specified file and attempts to load all such subprograms. If the subprograms are found on the file, they are loaded into memory; if they are not, an error message is displayed and a list of the subprograms still needed but not found in the file is printed.

This can be handy in two ways. The first and obvious way is that subprograms can be loaded quickly. The other way is this: suppose that you are developing a program and as you are coding, you realize you need a subprogram that does such-and-such. But your train of thought is chugging along so smoothly, you do not want to interrupt your coding of the routine you are working on to do the other little subprogram. But when the big one is done, you have forgotten all about coding the little one. If you suspect you've done this, the LOADSUB FROM command is very useful. Type a LOADSUB FROM command where the file name is a file on which you **know** there are none of the subprograms you need (perhaps a null PROG file). Of course, no subprograms will be loaded, but *a list of those yet undefined will be printed*. These are the ones you still need to code. Naturally, if you have already coded them and stored them somewhere, go get them. But if you haven't, this is a simple way of listing those still to be entered.

Any COM blocks declared in subprograms brought into memory with a LOADSUB by a running program must already have been declared. LOADSUB does not allow new COM blocks to be added to the ones already in memory. Furthermore, any COM blocks in the subprograms brought in must match a COM block in memory in both the number and type of the variables. Otherwise, an error occurs.

Note

If a main program is in a file referenced by a LOADSUB, it will **not be loaded**; only subprograms can be loaded with LOADSUB. Main programs are loaded with the LOAD command.

With all this talk of loading subprograms from files, one question arises: How do you get the subprograms **on** the file? Easily: type in the subprograms you want to be on one file, and then STORE them onto the desired file name. You must use STORE and not SAVE, because the LOADSUB looks for a PROG-type file. If you can't type in your subprograms error-free the first time (and who can?), what you can do is this: type in your program with all the subprograms it needs, and debug them. **After storing everything on a file for safekeeping**, delete what you do **not** want on the file, and STORE everything else on the subprogram file from which you will later do a LOADSUB. In this way, you know the subprograms will work when you load them.

Deleting Subprograms Programmatically

The utility of the LOADSUB commands would be greatly reduced if one could not delete subprograms from memory at will. So, there is a way to delete subprograms during execution of a program: DELSUB. If you want to delete only selected ones, you could type something like:

```
DELSUB Sort_data,Print_report_1,FNPoly_solve
```

If you are sure of the positioning of the subprograms in memory, here is a method of deleting whole groups of subprograms:

```
DELSUB Print_report TO END
```

You can combine these methods:

```
DELSUB Sort_data,Print_report,FNGet_name$ TO END
```

The subprograms to be deleted do not have to be contiguous in memory, nor does the order in which you specify the subprograms in a DELSUB statement have to be the order in which they occur in memory. The computer deletes each subprogram before moving on to the next name.

If there are any comments after a FNEND or SUBEND, but before the next SUB or DEF FN, these will be deleted as well as the rest of the subprogram body.

If the computer attempts to delete a nonexistent subprogram, an error occurs, and the DELSUB statement is terminated. This means that subprograms whose names occur after the error-causing one will not be deleted.

A subprogram can be deleted only if it is not currently active and if it is not referenced by a currently active ON RECOVER/CALL statement. This means:

1. A subprogram cannot delete itself.
2. A subprogram cannot delete a subprogram that called it, either directly or indirectly. (Otherwise it wouldn't have anywhere to return to when it finished!)

Between the time that a subprogram is entered and the time it is exited, the computer keeps track of an *activation record* for that subprogram. Thus, if a subprogram calls a subprogram that calls a subprogram, etc., none of the subsequently-called subprograms can delete the original one or any of the ones in between because the system knows from the activation record that control will eventually need to return to the original calling context. A similar situation exists with active event-initiated CALL/RECOVER statements. As long as the possibility of the specified event occurring exists, the system will not let the subprogram be deleted. In essence, the system will not let you execute two mutually-exclusive contradictory commands simultaneously.

Editing Subprograms

Inserting Subprograms

There are some rules to remember when inserting SUB and DEF FN statements:

It is not possible to insert a DEF FN or SUB statement in the middle of the program. All DEF FN and SUB statements must be appended to the **end** of the program. If you want to insert a subprogram in the middle of your program because you prefer to see it listed in a given order, you must perform the following sequence:

1. STORE the program.
2. Delete all lines **above** the point where you want to insert your subprogram (refer to the DEL statement).
3. STORE the remaining segment of the program in a new file.
4. LOAD the original program stored in step 1.
5. Delete all lines **below** the point where you want to insert your subprogram.
6. Type in the new subprogram.
7. Do a LOADSUB ALL from the new file in step 3.

With PDEV, the job is much easier:

1. Write your new subprogram *at the end* of the program.
2. Perform a MOVELINES command where:
 - a. the Starting Line in the MOVELINES command is the line which you want to immediately follow your new subprogram,
 - b. the Ending Line in the MOVELINES command is the line immediately prior to the SUB or DEF FN of the new subprogram, and
 - c. The destination line is any line number greater than the highest line number currently in memory.

In either case there is an optional final step. It is not *required* that you do a REN to renumber the program at this point, but often it is desirable to close up the void left in the program line numbering which resulted from the block of subprograms being moved to the end of memory.

Deleting Subprograms

It is not possible to delete either DEF FN or SUB statements with the delete line key unless you first delete all the other lines in the subprogram. This includes any comments after the SUBEND or FNEND. Another way to delete DEF FN and SUB statements is to delete the entire subprogram, up to, but **not** including, the next SUB or DEF FN line (if any). This can be done either with the DEL command, or with the DELSUB command.

Merging Subprograms

If you want to merge two subprograms together, first examine the two subprograms carefully to insure that you don't introduce conflicts with variable usage and logic flow. If you've convinced yourself that merging the two subprograms is really necessary, here's how you go about it:

1. SAVE everything in your program **after** the SUB or DEF statement you want to delete.
2. Delete everything in your program from the unwanted SUB statement to the end.
3. GET the program segment you saved away in step 1 back into memory, taking care to number the segment in such a way as not to overlay the part of the program already in memory.

Once again, with PDEV, your job is greatly simplified:

Execute a MOVELINES command in which you move everything from one subprogram—**excluding the SUB/DEF FN and SUBEND/FNEND statements**—into the desired position in the other subprogram. If there are any declarative statements in the moved code, you will probably want to move those up next to the declarative statements in the receiving code. Don't forget to go back to the place where the code came from and delete the SUB/DEF FN statement and the SUBEND/FNEND statements.

SUBEND and FNEND

The SUBEND and FNEND statements must be the last statements in a SUB or function subprogram, respectively. These statements don't ever have to be executed; SUBEXIT and RETURN are sufficient for exiting the subprogram. (If SUBEND is executed, it will behave like a SUBEXIT. If FNEND is executed, it will cause an error.) Rather, SUBEND and FNEND are delimiter statements that indicate to the language system the boundaries between subprograms. The only exception to this rule is the comment statements (either REM or !), which are allowed after SUBEND and FNEND.

Recursion

Both function subprograms and SUB subprograms are allowed to call themselves. This is known as recursion. Recursion is a useful technique in several applications.

The simplest example of recursion is the computation of the factorial function. The factorial of a number N is denoted by $N!$ and is defined to be $N \times (N-1)!$ where $0! = 1$ by definition. Thus $N!$ is simply the product of all the whole numbers from 1 through N inclusive. A recursive function which computes N factorial is:

```
DEF FNFactorial(N)
  IF N=0 THEN RETURN 1
  RETURN N*FNFactorial(N-1)
FNEND
```

Consider also the example of nested multiplication when evaluating a polynomial. A polynomial has the form:

$$A_N X^N + A_{N-1} X^{N-1} + \dots + A_2 X^2 + A_1 X + A_0$$

One way to evaluate a polynomial is to use the technique of nested multiplication:

$$A_0 + X \times (A_1 + X \times (A_2 + X \times (\dots (A_{N-1} + X \times (A_N)) \dots)))$$

If the polynomial is evaluated the way it is written, there are N multiplications, N additions, and $N-1$ exponentiations performed. Using the nested multiplication technique, there are still N multiplications and N additions, but **no** exponentiations.

The following function implements the nested multiplication recursively:

```
1000 DEF FNPoly_evaluate(A(*),N,X)
1010 ! A(*) is the coefficient array,
1020 !   with N the order of the polynomial,
1030 ! X is the value at which the polynomial
1040 !   is being evaluated,
1050 RETURN FNPoly(A(*),0,N,X)
1060 FNEND

1120 DEF FNPoly(A(*),M,N,X)
1130 ! A(*) is the coefficient array of order N
1140 ! M is the outside coefficient
1150 ! X is the value at which the polynomial
1160 !   is being evaluated,
1170 IF M=N THEN RETURN A(N)
1180 RETURN A(M)+X*FNPoly(A(*),M+1,N,X)
1190 FNEND
```

The above examples are cited because they are easily understood, not because they are elegant ways to compute factorials or evaluate polynomials (both are performed much faster, and use much less memory, in a FOR/NEXT loop). They are included here because they are easy to understand. We'll consider a more useful application of recursion in the following section on Top-Down Design.

Top-Down Design

A major problem that every programmer faces is designing programs that can be easily implemented and tested. A lot has been written on this subject over the past 15 years or so, and several references are cited at the end of the chapter. A method of program design that has become widely recommended is Top-Down Design, also known as Stepwise Refinement.

The general approach is to consider a problem at its highest level, and break it down into a small number of identifiable subtasks. Each subtask is in turn considered as a large problem which is to be broken down into smaller problems, and so on until the “smaller problems” which have to be solved turn out to be lines of code, which the computer knows how to solve! At the higher levels of this process, the various subtasks are implemented as subprogram calls. It is best to define exactly what each subprogram is supposed to do long before the subprogram is actually written. Furthermore, this should be done at each level of refinement. By considering what each subprogram requires as input and what it returns as output from the topmost levels, the most serious problems of programming (namely defining your data structures and the communications paths between subprograms) are attacked at the beginning of the problem solving process, rather than at the end when all the small pieces are trying to jumble together. It is best to tackle these questions at the beginning because then you have the most flexibility — no code has been written and it’s not necessary to try and save any investment in programming time.

Let’s look at a simple example and apply these techniques.

The Problem

In a certain production department in a large manufacturing facility, there are eighty people who build and test widgets. The manager of this department has asked you to write a program to keep track of the total number of widgets each person builds each week. Furthermore it is also necessary to track failure rates during the production process for each person. The manager wants to be able to ask for reports sorted either by employee name, number of units built, or failure rate.

A Data Structure

Before proceeding any further, we need to come up with a data structure which will support the stated requirements.

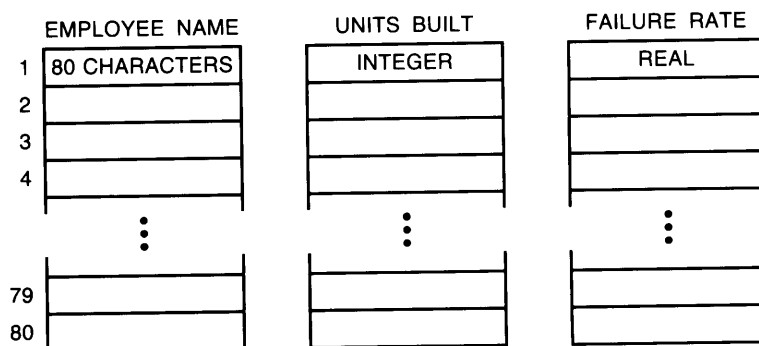

The above structure is simple and holds all the necessary information. The J th entry in the Units Built array tells how many units were built by the employee whose name is given by the J th entry in the Employee Name array, and the J th entry in the Failure Rate array gives the failure rate that the J th employee experienced in building the given number of units.

The only problem unsolved by the given data structure is that of ordering. The manager wants to be able to see a report sorted by any one of the three arrays. One way to solve this problem is to provide a sort subprogram as part of the package, but you would have to remember to carry along the other two fields associated with the one on which you are sorting whenever you switch the elements in the array. An alternate way is simply to leave all the data in place and construct a pointer array associated with whichever array you elect to do the report with. A very handy way to construct this pointer array in such a way as to be conducive to printing sorted results is to construct a binary tree.

The binary tree is a simple data structure used for a variety of applications from data management to parsing computer languages. Knuth⁴ defines a binary tree as “a finite set of nodes which either is empty, or consists of a root and two disjoint binary trees called the left and right subtrees of the root.” Note that this definition is recursive — it uses the term being defined (binary tree) in its own definition. Thus, a binary tree either consists of two subtrees (which in turn can have two subtrees, etc.), or it is empty. Consider the following illustration of a binary tree:

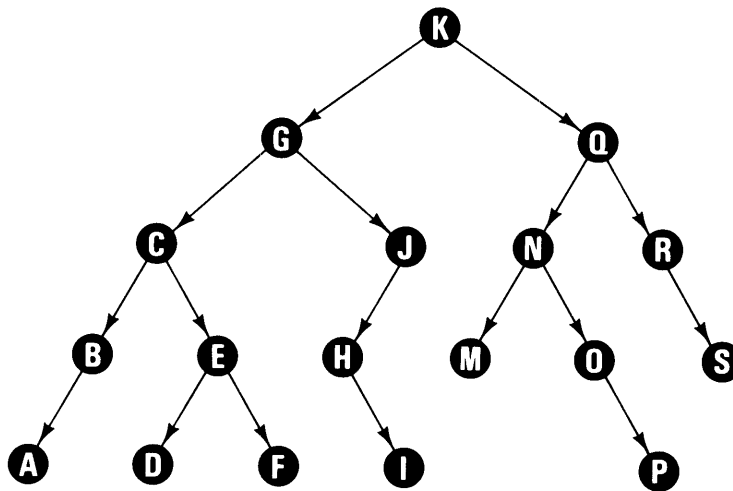

Every node (represented here by a letter) has at most two subtrees. The subtrees are ordered on a lexical basis. Every letter belonging to any node’s left subtree will be lexically “less” than the node itself, which in turn will be lexically “less” than the letters in that node’s right subtree. Because the binary tree is defined recursively, this relationship will hold true at all levels of the tree. Furthermore, there are extremely simple recursive algorithms for traversing (or in our case printing) a binary tree which is organized lexically in sorted order.

Graphically, the tree is easy to understand. You have a piece of data (or a “node”) and you have a couple of little arrows which point to the next nodes. Inside a computer, these little

arrows are called “pointers” because they point to a location in memory where the next node is to be found.

Our binary tree is going to be implemented as an 80 by 2 integer array. Any element of this array $A(I,1)$ will be a pointer to the left subtree, while $A(I,2)$ will be a pointer to the right subtree. I is simply the location within the other three arrays of the pertinent data. The first item in each array is defined to be the root of the tree.

Thus our data structure will now look like so:

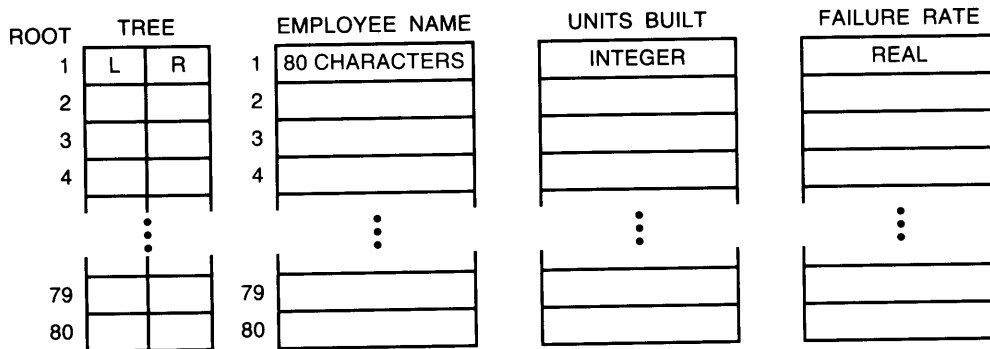

The manager can choose which field to sort on when the report is printed, and the `Pointers(*)` array will be constructed accordingly.

The amount of detail we’ve spent studying and understanding the data structure emphasizes the importance of this phase of the design.

Let’s proceed now with designing our program. At the highest level, what we would really like to have is a command which does everything at one fell swoop:

```
10 Do_it
20 END
```

Top-Down design calls for breaking this massive task down into a set of smaller problems. First we’ll declare the data structure and define what actions we want to take on the data. Note that in an actual application, there would be some sort of menu to let the user choose the action he desired. The human interface has been left off this example for the sake of simplicity.

```
10 OPTION BASE 1
20 DIM Name$(80)[80],Failure_rate(80)
30 INTEGER Units_built(80),Max,Howmany
40 Max=80
50 Input_data(Name$(*),Units_built(*),Failure_rate(*),Max,Howmany)
60 Store_data(Name$(*),Units_built(*),Failure_rate(*),Max,Howmany)
70 Report(Name$(*),Units_built(*),Failure_rate(*),Max,Howmany)
80 END
90 SUB Input_data(Name$(*),INTEGER Units(*),REAL Failures(*),INTEGER Max,Howmany)
SUBEND
100 SUB Store_data(Name$(*),INTEGER Units(*),REAL Failures(*),INTEGER Max,Howmany)
SUBEND
120 SUB Report(Name$(*),INTEGER Units(*),REAL Failures(*),INTEGER Max,Howmany)
SUBEND
140
```

Notice that we haven't worried about the tree structure yet. This is because the tree is only used to provide ordering information to be used in printing out the report. Since the tree is not necessary except for the report, we'll let the report subprogram worry about it. The variables Max and Howmany are introduced for the sake of flexibility. It is possible that the department may have to hire more people at some time in the future, or that some people may leave the company or accept jobs in other departments. In this case, the program will have to be changed to allow for a different number of people. By making the maximum number of people, and the actual number of people, variables instead of constants, modifying the program becomes very easy.

Also, notice that each of the subprograms has been "stubbed in". The reason for doing this is that you can immediately run the program to test the communications between modules. So far, the program will not do anything, but it does allow you to make sure that your pass parameter lists match the formal parameter lists in the number and types of parameters. Furthermore, this process can be repeated every step of the way. As each subprogram is designed, the modules called by it can be "stubbed in" in a similar fashion, insuring that the parameter lists and communications paths are well defined and properly implemented at every level of your design. The most difficult part of testing your program is done as the program is being designed.

Let's step down to the next level of the design and consider each of the subprograms mentioned above:

```

90  SUB Input_data(Name$(*),INTEGER Units(*),REAL Failures(*),INTEGER Max,Howma
ny)
91  DIM Which$[3]
92  INPUT "New Data or Old?",Which$
93  IF Which$="New" THEN
94      Enter_new(Name$(*),Units(*),Failures(*),Max,Howmany)
95  ELSE
96      Edit_old(Name$(*),Units(*),Failures(*),Max,Howmany)
97  END IF
100 SUBEND
101 !
110 SUB Store_data(Name$(*),INTEGER Units(*),REAL Failures(*),INTEGER Max,Howma
ny)
111   Setup_file(@File)
112   OUTPUT @File;Name$(*),Units(*),Failures(*)
113   ASSIGN @File TO *
120 SUBEND
121 !
130 SUB Report(Name$(*),INTEGER Units(*),REAL Failures(*),INTEGER Max,Howmany)
132   OPTION BASE 1
133   INTEGER Root,I,Whichfield
134   ALLOCATE INTEGER Tree(Howmany,2)
135   Init_tree(Root,Tree(*))
136   Ask: INPUT "Which field (1=Name,2=Units,3=Failures)?",Whichfield
137   IF Whichfield<1 OR Whichfield>3 THEN Ask
138   FOR I=2 TO Howmany
139       SELECT Which_field
140           CASE 1
141               Buildstring(Root,Tree(*),I,Name$(*))
142           CASE 2
143               Buildnum(Root,Tree(*),I,Units(*))
144           CASE 3
145               Buildnum(Root,Tree(*),I,Failures(*))
146       END SELECT
148   NEXT I
149   Inorder(Root,Tree(*),Name$(*),Units(*),Failures(*))
150 SUBEND

```

Here we haven't gone through the exercise of providing the dummy subprograms, though in actual practice we would. In lines 94 and 96 of the data entry program, we see two more subprograms that need to be designed. The module for entering new data from the keyboard will be straightforward and need not be considered in further detail for this example. The module for editing old data will involve loading a set of data from the diskette and then allowing the user to modify those values. This will involve a little more detail and perhaps another level of subprograms, but the techniques to be used are still straightforward enough not to demand further attention here.

Line 111 calls for a module to setup a data file to store the data on, and passes an I/O path name back out that's ready for use. This means that the subprogram must:

1. Ask the user for a file
2. Create the file if necessary
3. ASSIGN it for use

The Report subprogram is by far the most interesting one in this example, since it deals with the initialization, construction, and traversal of a binary tree, as discussed above. The `Init_tree` subprogram called in line 135 simply initializes the root node's (first element, remember) subtrees to be empty. Subsequently, the `Buildstring` subprogram called in line 140 simply enters the `I`th string in the `Name$(*)` array into the structure of `Tree(*)`, assuming that the user asked for the report to be sorted by `Name$(*)`. Similarly, if the user wanted either `Units(*)` or `Failures(*)` to be the sort key, then the `Buildnum` subprogram (called in lines 143 and 145) would be used to construct the tree.

Finally, the `Inorder` subprogram traverses the structure in "inorder" once the tree has been built. "Inorder" simply means that every node is printed in between that node's subtrees. This traversal mechanism, as you will see, is quite short, and is a truly elegant expression of the task being performed.

Here are the `Init_tree`, `Buildstring`, and `Inorder` subprograms (`Buildnum` is so similar to `Buildstring` that it isn't necessary to list it too):

```

200 SUB Init_tree(INTEGER Root,Tree(*))
210 COM /Tree/ INTEGER Nil,Left,Right
220 Nil=0
230 Left=1
240 Right=2
250 Root=1
260 Tree(Root,Left)=Nil
270 Tree(Root,Right)=Nil
280 SUBEND
281 !
290 SUB Buildstring(INTEGER Root,Tree(*),Index,A$(*))
300 COM /Tree/ INTEGER Nil,Left,Right
310 IF A$(Index)<=A$(Root) THEN      ! Search the left subtree
320   IF Tree(Root,Left)=Nil THEN    ! Once a leaf is found (link is
330     Tree(Root,Left)=Index       ! nil) point to the new node
340     Tree(Index,Left)=Nil        ! (Index) with the leaf's left
350     Tree(Index,Right)=Nil       ! pointer and set up the new
351                                   ! node as a leaf.
360   ELSE
370     Buildstring(Tree(Root,Left),Tree(*),Index,A$(*))
380   END IF
390 ELSE
400   IF Tree(Root,Right)=Nil THEN  ! Search the right subtree
410     Tree(Root,Right)=Index      ! Once a leaf is found (link is
420     Tree(Index,Left)=Nil        ! nil) point to the new node
430     Tree(Index,Right)=Nil       ! from the right pointer instead
440                                   ! of the left.
450   ELSE
460     Buildstring(Tree(Root,Right),Tree(*),Index,A$(*))
470   END IF
480 SUBEND
481 !
490 SUB Inorder(INTEGER Root,Tree(*),Name$(*),INTEGER Units(*),REAL Failures(*)
)
500 COM /Tree/ INTEGER Nil,Left,Right
510 IF Root<>Nil THEN
520   Inorder(Tree(Root,Left),Tree(*),Name$(*),Units(*),Failures(*))
530   PRINT Name$(Root),Units(Root),Failures(Root)
540   Inorder(Tree(Root,Right),Tree(*),Name$(*),Units(*),Failures(*))
550 END IF
560 SUBEND

```

Let's step through a sample input stream and see how the tree is constructed using the `Buildstring` subprogram:

Name\$(*)

1. Perriwinkle
2. Jones
3. Smith
4. Snodgrass
5. Figby
6. Brown
7. Thompson
8. Richards
9. Hughes
10. Davenport

Tree structure after Init_tree is executed



Tree structure after subsequent insertions into the tree by the Buildstring subprogram:

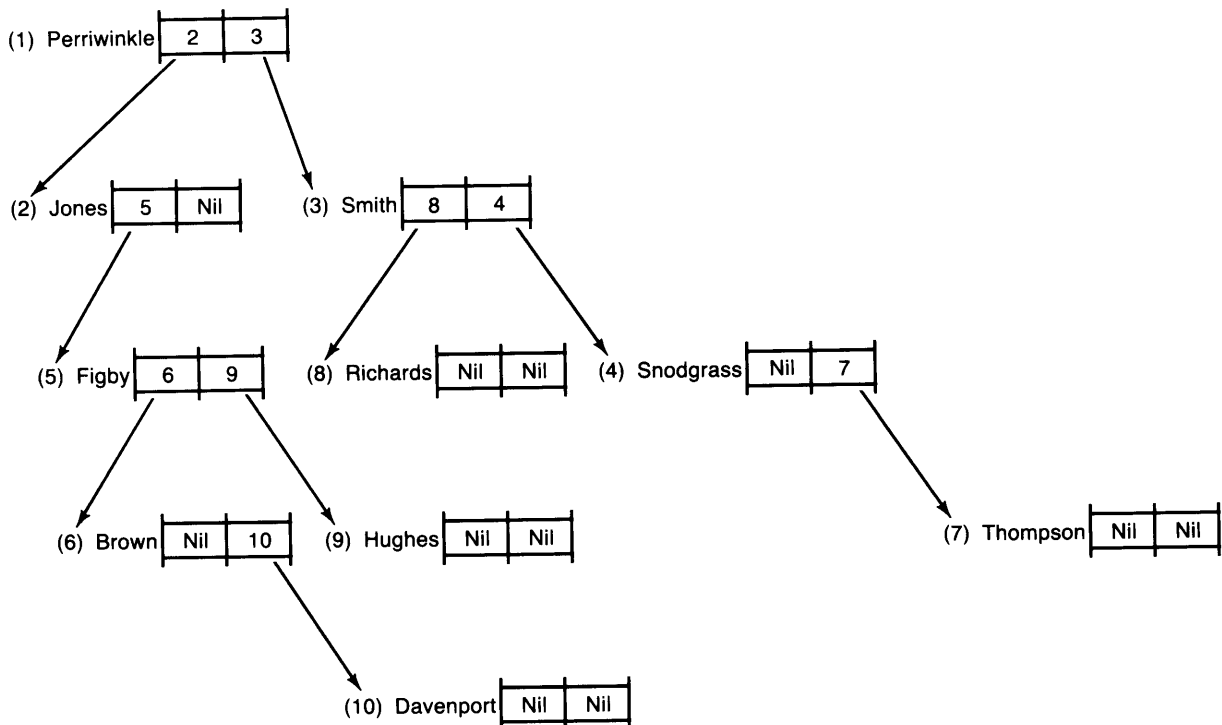
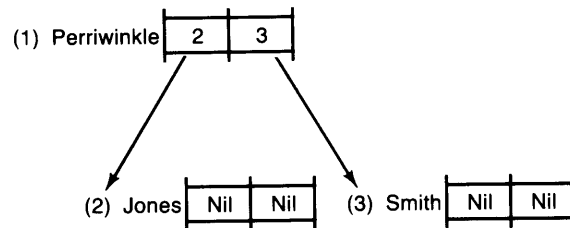
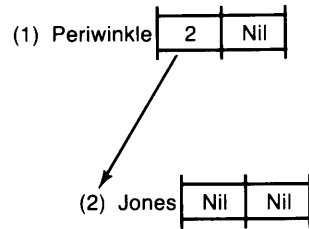

These three subprograms illustrate several points that were discussed in this chapter:

They share a labeled COM block which is not declared in the main program, nor in the Report program. The information in the COM block was only relevant to the the three subprograms, yet the programs never called each other — they were all called from Report.

Both the Inorder and Buildstring subprograms are recursive — they call themselves. This technique was an appealing way to solve the problem because of the recursive nature of the data structure. (Many types of data structures are recursively defined.)

The use of subprograms to build and traverse the data structure turned out to execute faster than a sort subprogram which physically moved the items in the three fields into a given order based on sorting one of the arrays. (The difference was about 40% using Donald Shell's algorithm⁵.)

The method of Top-Down Design led to the orderly design, creation, and testing of each subprogram, module by module, layer by layer. Communication paths and data structures/types were forced to be clearly defined at each step of the way.

References:

- 1 Wirth, Niklaus. "Program Development by Stepwise Refinement", *Communications of the ACM*, April 1971, Vol. 14, No. 4, pp. 221-227
- 2 Yourdan, Edward, *Techniques of Program Structure and Design*, (Prentice-Hall, Englewood Cliffs, NJ, 1975)
- 3 Dahl, Dijkstra, & Hoare. *Structured Programming* (Academic Press, New York, 1972)
- 4 Knuth, Donald E., *The Art of Computer Programming*, Vol. 1, Fundamental Algorithms (Addison-Wesley, Reading, Mass, 1973), pp. 308-309,316-317
- 5 Knuth, Donald E., *The Art of Computer Programming*, Vol. 3, Sorting and Searching (Addison-Wesley, Reading, Mass, 1973), pp. 84-85

Data Storage and Retrieval

Chapter**7**

This chapter describes some useful techniques for storing and retrieving data. First we describe how to store and retrieve data that is part of the BASIC program. With this method, DATA statements specify data to be stored in the memory area used by BASIC programs; thus, the data is always kept with the program, even when the program is stored in a mass storage file. The data items can be retrieved by using READ statements to assign the values to variables. This is a particularly effective technique for small amounts of data that you want to maintain in a program file.

For larger amounts of data, mass storage files are more appropriate. Files provide means of storing data on mass storage devices. The two types of data files available with Series 200 computers — ASCII and BDAT files — are described in this chapter. A number of different techniques for accessing data in BDAT files are described in detail. General disc structure is also described.

Series 200 computers can use a number of different mass storage devices, including disc drives (internal and external), SRM systems, and magnetic bubble memories. This chapter gives guidelines for accessing many kinds of devices.

Storing Data in Programs

This section describes a number of ways to store values in memory. In general, these techniques involve using program variables to store data. The data are kept with the program when it is stored on a mass storage device (with STORE and SAVE). These techniques allow extremely fast access of the data. They provide good use of the computer's memory for storing relatively small amounts of data.

Storing Data in Variables

Probably the simplest method of storing data is to use a simple assignment, such as the following LET statements:

```
100 LET Cm_Per_inch=2.54
110 Inch_Per_cm=1/Cm_Per_inch
```

The data stored in each variable can then be retrieved simply by specifying the variable's name. This technique works well when there are only a relatively few items to be stored or when several data values are to be computed from the value of a few items. The program will execute faster when variables are used than when expressions containing constants are used; for instance, using the variable `Inch_Per_cm` in the preceding example would be faster than using the constant expression `1/2.54`. In addition, it is easier to modify the value of an item when it appears in only one place (i.e., in the LET statement).

Data Input by the User

You also can assign values to variables at run-time with the INPUT and LINPUT statements as shown in the following examples.

```
100 INPUT "Type in the value of X, please.",Id
    *
    *
    *
200 DISP "Enter the value of X, Y, and Z."
10 LINPUT Response$
```

Note that with this type of storage, the values assigned to the corresponding variables are *not* kept with the program when it is stored; they must be entered each time the program is run. This type of data storage can be used when the data are to be checked or modified by the user each time the program is run. As with the preceding example, the data stored in each variable can then be retrieved simply by specifying the variable's name.

Using DATA and READ Statements

The DATA and READ statements provide another technique for storing and retrieving data from the computer's read/write (R/W) memory. The DATA statement allows you to store a stream of data items in memory, and the READ statement allows you retrieve data items from the stream.

You can have any number of READ and DATA statements in a program in any order you want. When you RUN a program, the system concatenates all DATA statements in the same context into a single "data stream." Each subprogram has its own data stream. The following DATA statements distributed in a program would produce the following data stream.

```
100 DATA 1,A,50
```

```
:
```

```
200 DATA "BB",20,45
```

```
:
```

```
300 DATA X,Y,77
```

DATA STREAM:

1	A	50	BB	20	45	X	Y	77
---	---	----	----	----	----	---	---	----

As you can see from the example above, a data stream can contain both numeric and string data items; however, each item is stored as if it were a string.

Each data item must be separated by a comma and can be enclosed in optional quotes. Strings that contain a comma, exclamation mark, or quote mark must be enclosed in quotes. In addition, you must enter two quote marks for every one you want in the string. For example, to enter the string QUOTE"QUO"TE into a data stream, you would write:

```
100 DATA "QUOTE""QUO""TE"
```

To retrieve a data item, assign it to a variable with the READ statement. Syntactically, READ is analogous to DATA; but instead of a data list, you use a variable list. For instance, the statement:

```
100 READ X,Y,Z$
```

would read three data items from the data stream into the three variables. Note that the first two items are numeric and the third is a string variable.

Numeric data items can be READ into either numeric or string variables. If the numeric data item is of a different type than the numeric variable, the item is converted (i.e., REALs are converted to INTEGERS, and INTEGERS to REALs). If the conversion cannot be made, an error is returned. Strings that contain non-numeric characters must be READ into string variables. If the string variable has not been dimensioned to a size large enough to hold the entire data item, the data item is truncated.

The system keeps track of which data item to READ next by using a “data pointer”. Every data stream has its own data pointer which points to the next data item to be assigned to the next variable in a READ statement. When you run a program segment, the data pointer is placed initially at the first item of the data stream. Every time you READ an item from the stream, the pointer is moved to the next data item. If a subprogram is called by a context, the position of the data pointer is recorded and then restored when you return to the calling context.

Starting from the position of the data pointer, data items are assigned to variables one by one until all variables in a READ statement have been given values. If there are more variables than data items, the system returns an error, and the data pointer is moved back to the position it occupied before the READ statement was executed.

Examples

The following example shows how data is stored in a data stream and then retrieved. Note that DATA statements can come after READ statements even though they contain the data being READ. This is because DATA statements are linked during program pre-run, whereas READ statements aren't executed until the program actually runs.

```

10 DATA November,26
20 READ Month$,Day,Year$
30 DATA 1981,"The date is"
40 READ Str$
50 Print Str$;Month$,Day,Year$
60 END

```

The date is November 26 1981

Storage and Retrieval of Arrays

In addition to using READ to assign values to string and numeric variables, you can also READ data into arrays. The system will match data items with variables one at a time until it has filled a row. The next data item then becomes the first element in the next row. You must have enough data items to fill the array or you will get an error. In the example below, we show how DATA values can be assigned to elements of a 3-by-3 numeric array.

```

10 OPTION BASE 1
20 DIM Example(3,3)
30 DATA 1,2,3,4,5,6,7,8,9,10,11
40 READ Example(*)
50 PRINT USING "3(K,X),/" ;Example(*)
60 END

```

```

1 2 3
4 5 6
7 8 9

```

The data pointer is left at item 10; thus, items 10 and 11 are saved for the next READ statement.

Moving the Data Pointer

In some programs, you will want to assign the same data items to different variables. To do this, you have to move the data pointer so that it is pointing at the desired data item. You can accomplish this with the RESTORE statement. If you don't specify a line number or label, RESTORE returns the data pointer to the first data item in the data stream. If you do include a line identifier in the RESTORE statement, the data pointer is moved to the first data item in the first DATA statement at or after the identified line. The example below illustrates how to use the RESTORE statement.

```

100  DIM Array1(1:3)      ! Dimensions a 3-element array.
110  DIM Array2(0:4)     ! Dimensions a 5-element array.
120  DATA 1,2,3,4      ! Places 4 items in stream.
130  DATA 5,6,7        ! Places 3 items in stream.
140  READ A,B,C         ! Reads first 3 items in stream.
150  READ Array2(*)     ! Reads next 5 items in stream.
160  DATA 8,9          ! Places 2 items in stream.
170                      !
180  RESTORE            ! Re-positions pointer to 1st item.
190  READ Array1(*)     ! Reads first 3 items in stream.
200  RESTORE 140       ! Moves data pointer to item "8".
210  READ D             ! Reads "8".
220                      !
230  PRINT "Array1 contains:";Array1(*);" "
240  PRINT "Array2 contains:";Array2(*);" "
250  PRINT "A,B,C,D equal:";A;B;C;D
260  END

```

```

Array1 contains: 1 2 3
Array2 contains: 4 5 6 7 8
A,B,C,D equal: 1 2 3 8

```

Mass Storage Tutorial

The rest of this chapter describes the second general class of data storage and retrieval methods — that of using mass storage devices. This material is broken up into two main parts. The first part presents a general tutorial regarding disc and file structures. The second part presents techniques for accessing mass storage devices and files with BASIC statements. If you are anxious to “get going,” turn to “Mass Storage Techniques” (about 10 pages ahead) and refer back to the tutorial as needed.

What Is Mass Storage?

As the adjective “mass” suggests, mass storage devices are data-storage devices which are generally capable of storing “large” amounts of data. Just how much data constitutes a large amount depends on the device itself. Most mass storage devices are capable of storing on the order of hundreds of thousands to several million items.

Besides having the ability to store data, mass storage devices are capable of providing means for keeping data organized so that logical groups may be accessed systematically and efficiently. Data items are organized into logical groups of data known as *files*; a file is merely a collection of data items. Mass storage *volumes* are composed of one or more files. On most HP mass storage devices, a volume consists of all files on the mass storage *media*; mass storage media are the actual physical means by which data are stored. For instance, the media used by the internal drives of the Model 226 and Model 236 consist of magnetic particles on a plastic disc which can be magnetized to store data.

The Structure of Model 226/236 Discs

This section describes the specific structure of discs used with built-in Model 226/236 drives. This specific structure is similar to the general structure of all HP discs. Some of the information in this section (directory format and disc interleave) is useful to the advanced programmer; however, it is not a prerequisite for general mass storage usage.

Most HP mass storage devices use magnetic discs as their storage media. Magnetic discs possess features of both records and recording tape. Like a record, it is circular, has tracks (most have tracks on both sides), and rotates. Like a tape, data is written and read by an electromagnetic head.

The internal disc drive(s) of the Model 226 and 236 use 5.25-inch diameter, flexible disc media. These flexible discs have two usable sides with 33 *tracks* on each side. Each track is further divided into sixteen *sectors*, each of which contain 256 contiguous bytes of data. A track, therefore, contains 4096 bytes, and an entire disc is capable of holding over 270,000 bytes of information. However, some of this space is reserved for system use and cannot be used for data storage.

In addition to the internal disc drive(s), you can also use external drives with your computer. There are several types of drives that are compatible with HP Series 200 computers. Some mass storage devices use the same 5.25-inch diameter flexible discs as the internal drives, while others use 3.5-inch or 8-inch flexible discs and/or hard discs. We describe how to access external drives later in this chapter.

As previously mentioned, information is stored on a disc by placing it in a file. A file is a logical unit that occupies a certain number of sectors on the storage media. Files can be used to store either programs or data. In this chapter, we are concerned primarily with data files, although parts of the discussion relate to program files as well.

When you SAVE a program, the system automatically creates an ASCII file of sufficient size to store the program in its “source form” — as ASCII characters. When you create a data file with the CREATE ASCII or CREATE BDAT statements, you give it a name and specify how much disc space should be reserved for it. In general, the only limit to the size of a file is the amount of contiguous, unreserved space left on the media, since files cannot span disc volumes.

Let’s take a brief look at how the the system accesses the information in the file. (More complete details of file access will be described later.) In order to access the information in a file, you assign an I/O path name to the file’s name. When this I/O path is used to send and receive information to and from the file, the system handles the details of the access operation. The important point here is that the system *always* reads and/or writes an entire sector of data whenever a disc is accessed. For instance, if only one byte of data is to be written in a file, an entire sector must be read, the single byte changed, and the (modified) sector re-written.

Disc Interleave

The INITIALIZE statement allows you to specify an interleave factor. Interleaving a disc causes the sectors on each track to be numbered according to a specified interval. An interleave factor of 1 causes sectors to be numbered consecutively. A factor of 2, on the other hand, tells the system to skip every other sector. The following drawing shows how these interleaves are implemented on the 5.25-inch flexible discs used by the Model 226 and Model 236 internal drives.

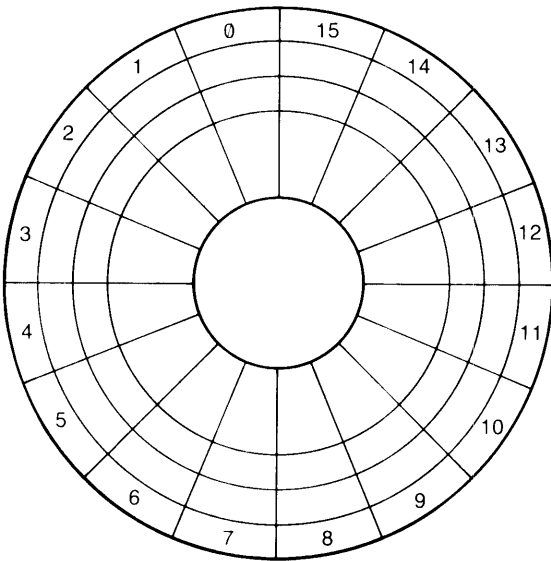

A track of a disc with interleave factor of 1.

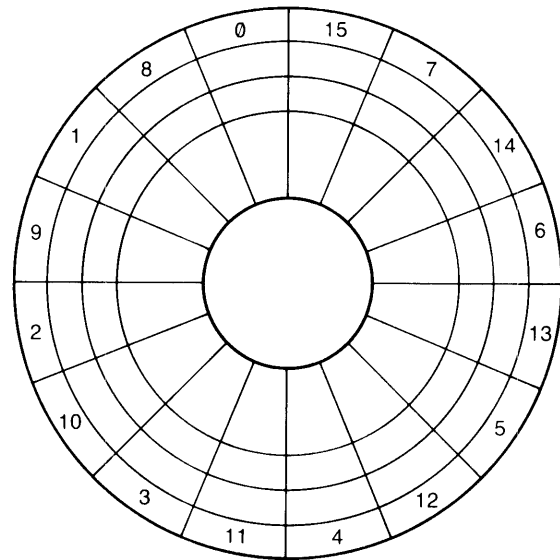

A track of a disc with interleave factor of 2.

The system numbers each sector on each track according to the pattern specified by the interleave factor. All tracks on a disc have the same interleave factor.

The purpose of disc interleave is to increase data-transfer rates, as demonstrated in the following example. Suppose that we are entering data from a disc; suppose also that the data have formats which are different from the computer's internal data formats. Consequently, after each item is read, the computer must change the data from the disc's data format to the computer's internal data format. Note that during this processing time the disc is still spinning.

If the processing of all items in a sector takes more time than the disc drive takes to reach the next sector, the computer must wait (slightly longer than one full revolution of the disc) until the next sector again comes under the head. By interleaving a disc, you can allow for this processing time, which results in faster transfer rates.

The default interleave factor for each type of drive is designed to give maximum transfer rates for LOAD and STORE operations (and for OUTPUT and ENTER of numeric arrays using BDAT files with the FORMAT OFF attribute). The default interleave factor is 1 for internal drives of the Model 226 and Model 236. For other HP drives, the optimum interleave may differ. All default interleave factors are shown later in this chapter.

If you use the default interleave factors, you should be aware that discs initialized on one drive may show a performance degradation if used on another drive. For instance, suppose you INITIALIZE a disc on the internal drive (default interleave factor is 1) and then use that disc in an HP 82901 drive (default interleave factor of 4). You probably will get slower transfer rates than if the default interleave for the HP 82901 had been used. *In summary, if you need maximum transfer rates, experiment to determine the optimal interleave for your particular application.*

When estimating optimal interleave factors, it is better to use a factor too large than one too small. For instance, suppose that an interleave of 2 is optimal for a particular operation. If an interleave of 1 is improperly chosen, the operation is slowed down approximately by a factor of eight. On the other hand, using an interleave of 3 only slows the operation approximately by a factor of two. If in doubt about which of two interleave factors is optimal for a particular situation, it is *generally* better to choose the *larger*.

Volume Label

The first sector on every disc contains information about the disc volume. It contains the name of the volume, the starting address of the directory, and the length of the directory. The figure below shows the values and locations of this information for LIF-compatible discs.

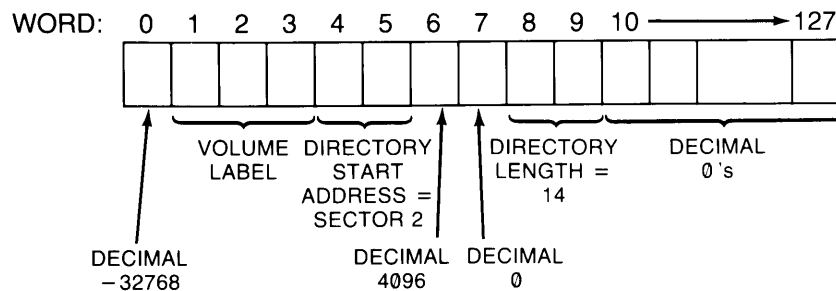

Directory

A directory is an index of all files on the disc. Every disc volume has a directory. On Model 226/236 internal disc volumes initialized with BASIC, the directory occupies sectors 2 thru 15. Other discs or discs initialized in other languages may have a different directory size. However, the general structure of the directory entries is the same. In this directory, there is a 16-word entry for every file; each directory sector can thus hold 8 entries. Since this directory contains 14 sectors, it can hold up to 112 entries; therefore, the limit on the number of files in a volume is 112. The figure below shows the format of a directory entry.

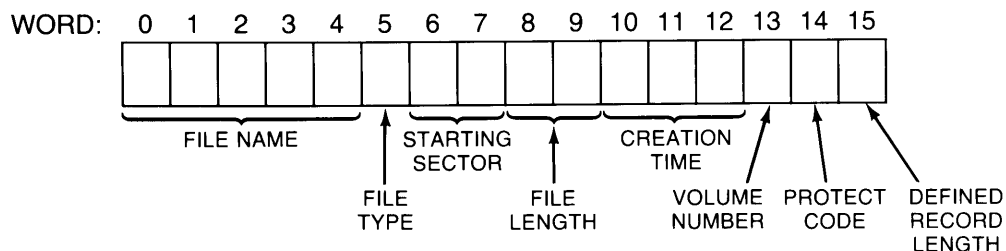

File Name — Every file is given a name when it is created. File names can be up to 10 characters long.

File Type — BASIC supports five file types: ASCII, BDAT, BIN, PROG and SYSTM. We discuss BDAT and ASCII data type files later in this chapter.

Starting Sector — The address of the file's first sector. Files always start at the beginning of a sector.

Length of File — Length is given in sectors. If a file ends in the middle of a sector, the whole sector is counted.

Time of Creation — Not used. Entry is filled with zeros.

Volume Number — The least significant 15 bits give the volume number, which is always 1 on Series 200 computers. The most significant bit tells whether the file is continued in another volume (0 for yes, 1 for no). Since files on these computers cannot span volumes, this bit is always set to 1.

Protect Code — Any BDAT, BIN or PROG type file can be given a two-character protect code with the PROTECT statement. ASCII and SYSTM type files cannot be protected. This word is always 0 with ASCII files; it has a different use with SYSTM files. Protect codes are discussed later in this chapter.

Defined-Record Length — If a file is of BDAT type, it can have defined records from 1 thru 65 534 bytes long. This is described in detail later in this chapter. Defined records in all other file types are always one sector (256 bytes) long. The defined record length is encoded into word 15 as $\text{length}/2$. (If $\text{length} = 1$, then $\text{word } 15 = 0$.) This word is always 0 with ASCII files; it has a different use with SYSTM files.

The Structure of Data Files

There are two file types that you can use to store data: BDAT and ASCII. BDAT files have several advantages: they allow more flexibility in data formats and access methods, allow faster transfer rates, and are generally more space-efficient than ASCII data files. They can be randomly or serially accessed, and they allow data to be stored in either ASCII format, internal format, or a specialized format (defined by the user with IMAGE statements).

ASCII files allow *only* serial access and *only* ASCII format. They have these advantages: the files are compatible with other HP computers that support this file type, the format provides very compact storage for string data, and there is no chance of reading the contents into the wrong data type (a problem for BDAT files). The full name of ASCII files is “LIF ASCII”. LIF stands for Logical Interchange Format, a directory and data storage format that is used by many HP computer divisions. Understanding the characteristics of each file type will help you choose the best one for your specific application.

BDAT Files

BDAT files are designed to be storage-space efficient, have high data-transfer rates, and allow *both* random and serial access. Random access means that you can directly read from and write to any record within the file, while serial access only permits you to access the file from the beginning. Serial access can waste a lot of time if you’re trying to access data at the end of a file. On the other hand, if you want to access the entire file sequentially, you are better off using serial access than random access. BDAT files can be accessed both randomly and serially, while ASCII files can only be accessed serially.

BDAT files allow you to store and retrieve data using internal format, ASCII format, or user-defined formats. With internal format, items are represented with the same format the system uses to store data in internal computer memory¹. With ASCII format, items are represented by ASCII characters. User-defined formats are implemented with programs that employ OUTPUT and ENTER statements that reference IMAGE specifiers. Complete descriptions of ASCII and user-defined formats are given in Chapters 4, 5, and 10 of *BASIC Interfacing Techniques*.

In most applications, you will use internal format for BDAT files. Unless we specify otherwise, you can assume that when we talk about retrieving and storing data in BDAT files, we are also talking about internal format. This format is synonymous with the FORMAT OFF attribute, which is described later in this chapter.

Because BDAT files use almost the same format as internal memory, very little interpretation is needed to transfer data from the computer to a BDAT file, or vice versa. BDAT files, therefore, not only save space but also time.

Data stored in internal format in BDAT files require the following number of bytes per item:

INTEGER	2 bytes
REAL	8 bytes
String	1 byte per character (plus 1 pad byte if the string length is an odd number), plus a 4-byte length header

¹ Actually, the format for BDAT files is slightly different than internal format. Instead of using a 2-byte length header for strings, BDAT files use a 4-byte length header. Besides this, the two formats are identical, so we refer to both as “internal”.

INTEGER numbers are represented in BDAT files by using a 16-bit, two's-complement notation, which provides a range -32 768 thru 32 767. If bit 15 (the MSB) is 0, the number is positive. If bit 15 equals 1, the number is negative; the value of the negative number is obtained by changing all ones to zeros, and all zeros to ones, and then adding one to the resulting value.

Examples

Binary Representation	Decimal Equivalent
00000000 00010111	23
11111111 11101000	-24
10000000 00000000	-32768
01111111 11111111	32767
11111111 11111111	-1
00000000 00000001	1
00100011 01000111	9031
11011100 10111001	-9031

REAL numbers are stored in BDAT files by using their internal format: the IEEE-standard, 64-bit, floating-point notation. Each REAL number is comprised of two parts: an exponent (11 bits), and a mantissa (53 bits). The mantissa uses a sign-and-magnitude notation. The sign bit for the mantissa is not contiguous with the rest of the mantissa bits; it is the most significant bit (MSB) of the entire eight bytes. The 11-bit exponent is offset by 1 023 and occupies the 2nd through the 12th MSB's. Every REAL number is internally represented by the following equation. (Note that the mantissa is in binary notation):

$$-1^{\text{mantissa sign}} \times 2^{\text{exponent} - 1023} \times 1.\text{mantissa}$$

The figure below shows how the real number "1/3" would be stored in a BDAT file.

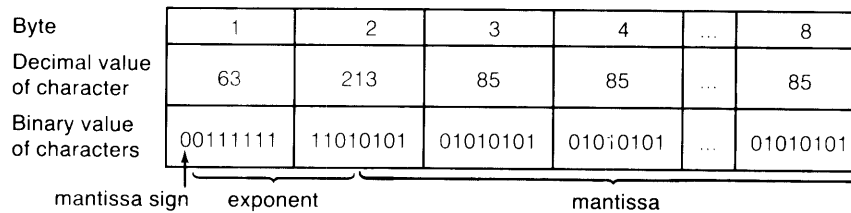

String data are stored in BDAT files in their internal format (plus two additional, leading bytes of length header, which are always 0 for Series 200 computers). Every character in a string is represented by one byte which contains the character's ASCII code. The four-byte length header contains a value that specifies the length of the string. If the length of the string is odd, a pad character is appended to the string to get an even number of characters; however, the length header does not include this pad character.

Examples

If stored as a string value, the number "45" would be:

00000000 00000000 00000000 00000010	00110100	00110101
Length = 0002 (binary)	ASCII 52	ASCII 53

The string "A" would be stored:

00000000 00000000 00000000 00000001	01000001	00100000
Length = 0001 (binary)	ASCII 65	ASCII 32

In this case, the space character (ASCII code 32) is used as the pad character; however, not all operations use the space as the pad character.

When using the ASCII data format for BDAT files, all data items are represented with ASCII characters. With user-defined formats, the image specifiers referenced by the OUTPUT or ENTER statement are used to determine the data representation. Using both of these formats with BDAT files produce results identical to using them with devices. The entire subject is described fully in Chapters 4, 5, and 10 of *BASIC Interfacing Techniques*. The topic of advanced transfer techniques for BDAT files is described in Chapter 11 of the same manual. Refer to this material after reading "Mass Storage Techniques" later in this chapter.

ASCII Files

You have already been introduced to ASCII files as a way to SAVE programs. ASCII files can also be used to store data. In an ASCII file, every data item, whether string or numeric, is represented by ASCII characters: one byte represents one ASCII character. Each data item is preceded by a two-byte length header which indicates how many ASCII characters are in the item. However, there is no “type” field for each item; data items contain no indication (in the file) as to whether the item was stored as string or numeric data. For instance, the number 456 would be stored as follows in an ASCII file:

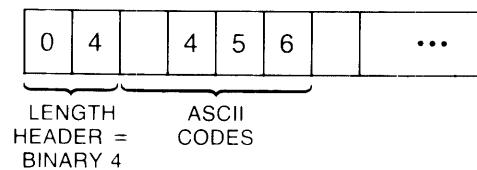

Note that there is a space at the beginning of the data item. This signifies that the number is positive. If a number is negative, a minus sign precedes the number. For instance, the number -456, would be stored as follows:

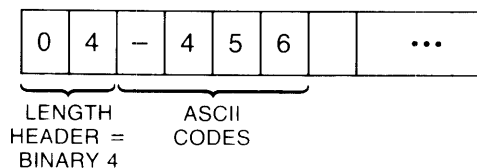

If the length of the data item is an odd number, the system “pads” the item with a space to make it come out even. The string “ABC”, for example, would be stored as follows:

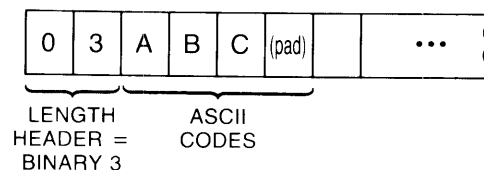

There is often a relatively large amount of overhead for numeric data items. For instance, to store the integer 12 in an ASCII file requires the following six bytes:

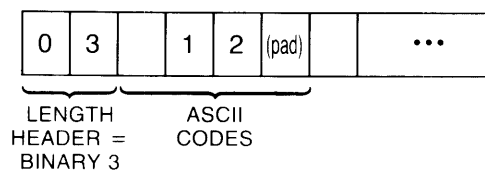

Similarly, reading numeric data from an ASCII file can be a complex and relatively slow operation. The numeric characters in an item must be entered and evaluated individually by the system's "number builder" routine, which derives the number's internal representation. (Keep in mind that this routine is called automatically when data are entered into a numeric variable.) For example, suppose that the following item is stored in an ASCII file:

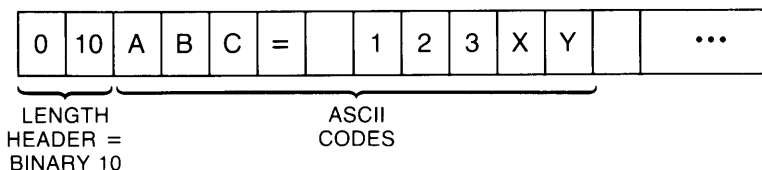

Although it may seem obvious that this is not a numeric data item, the system has no way of knowing this since there is no type-field stored with the item. Therefore, if you attempt to enter this item into a numeric variable, the system uses the number-builder routine to strip away all non-numeric characters and spaces and assign the value 123 to the numeric variable. When you add to this the intricacies of real numbers and exponential notation, the situation becomes more complex. For more information about how the number builder works, see Chapter 5 of *BASIC Interfacing Techniques*.

Because ASCII files require so much overhead (for storage of "small" items), and because retrieving numeric data from ASCII files is sometimes a complex process, they are not the preferred file type. However, as we mentioned before, ASCII files are interchangeable with many other HP products.

In this chapter, we refer to the data representation described above as ASCII-file format. As mentioned earlier, you can also store data in BDAT files in ASCII format (by using the FORMAT ON attribute). However, be careful not to confuse ASCII-file format with the ASCII data format.

In general, you should only use ASCII files when you want to transport data between HP Series 200 computers and other HP machine(s). There may be other instances where you will want to use ASCII files, but you should be aware that they cause a noticeable performance degradation compared to BDAT files.

Mass Storage Techniques

This section presents BASIC programming techniques useful for accessing mass storage devices and files. The first section gives a brief introduction to the steps you might take to store data in a file. Subsequent sections describe further details of these steps. If you feel that you need additional background information while reading this material, refer to the preceding tutorial section.

Initializing a Disc

Before a disc is used for the first time, it must be initialized. If the disc has already been initialized on a LIF-compatible device, and it contains data you wish to retain, then it can be used on a Series 200 computer without initialization. However, if a previously initialized disc does not have any data on it (or you don't need the data on it), it might be advantageous to re-initialize it on your computer to get maximum performance. The point is this: a disc must be properly initialized before your computer can use it, but initializing a disc **destroys all the data on the disc**.

The following steps show a typical initialization process using an internal disc drive of a Model 226 or 236 as an example. The procedure for initializing external discs is very similar, but specific details will change. For example, an external disc drive will have a different specifier (not :INTERNAL), may have a different write-protect convention, and will probably take a different length of time to initialize. For other examples, look in your operating manual or check the *BASIC Language Reference* under "MASS STORAGE IS" and "INITIALIZE"

To initialize a 5.25-inch disc on an internal disc drive, follow these steps:

1. Make sure that the disc does not contain any important data or programs. Many types of computers and word processors use similar discs. When a disc is initialized, all the data on it is destroyed!
2. Ensure that the disc is not "write protected". The disc envelope has a small notch on one side. When this notch is open, the computer is allowed to write on the disc. If this notch is covered, data may be read from the disc, but recording is not allowed. Trying to initialize a write-protected disc results in error number 83.
3. Be sure the disc is properly inserted in the right-hand disc drive.
4. Execute `INITIALIZE " : INTERNAL "`. This command tells the computer to erase all data from the disc, format it for use in your computer, check the quality of the media, and create the directory area.

An initialize operation takes about three minutes. The CRT displays the system's progress during this operation. When the initialization is complete, the run light turns off and a message similar to the following is displayed.

```
INITIALIZE: TRACK 32, SIDE 1, SPARED 0
```

During initialization, the disc is checked for bad areas on the tracks. If a bad spot is found, that particular track is rejected (or "spared"). If track 0 is bad or more than four tracks are spared, the initialize operation fails and error number 66 is issued. Although a disc with less than 5 rejected tracks can be used, rejected tracks are an indication that the magnetic surface is not in very good condition.

After the initialization has completed successfully, the disc is ready for storing programs and data.

Disc Labels

After you initialize the disc, you may want to give it a label. The PRINT LABEL statement prints the label in the disc directory. Once the label is there, a READ LABEL statement can retrieve it. The disc label is included in a CATalog of the disc.

For example, to give the disc in the INTERNAL disc drive the label VOL1, execute the following:

```
PRINT LABEL "VOL1" TO ":INTERNAL"
```

To read the label, enter:

```
10 READ LABEL Name$ FROM ":INTERNAL"
```

Disc labels are useful in many cases. When a program asks the operator to insert a particular disc in the disc drive, the program can read the label to insure the correct disc was inserted.

```
1000  Insert:  !Insert disc
1010  DISP "Insert disc VOL1 in the INTERNAL disc drive then Press CONT"
1020  PAUSE
1030  READ LABEL Label$ FROM ":INTERNAL"
1040  IF Label$<>"VOL1" THEN
1050      DISP "You have inserted an incorrect disc"
1060      BEEP
1070      WAIT 3
1080      GOTO Insert
1090  END IF
1100  RETURN
```

If several disc drives are connected to the computer, a program can read the label of each disc to find the disc it needs to access.

```
2000  !Read the disc labels
2010  READ LABEL Drive0$ FROM ":INTERNAL"
2020  READ LABEL Drive1$ FROM ":INTERNAL,4,1"
2040  SELECT 1
2050  CASE Drive0$="VOL1"
2060      ! Access files from ":INTERNAL"
2070  CASE Drive1$="VOL1"
2080      ! Access files from ":INTERNAL,4,1"
2090  CASE ELSE
2100      ! Disc not in drive
2110  END SELECT
```

Overview of Mass Storage Access

Storing data in files requires a few simple steps. The following program segment shows a simplistic example of placing several items in a data file. Assume that this program is run on a Model 236.

```

.
.
390 ! Specify left drive as "system" mass storage.
400 MASS STORAGE IS ":INTERNAL,4,1"
410 !
420 ! Create BDAT data file with ten (256-byte) records
430 ! on the system mass storage (left drive).
440 CREATE BDAT "File_1",10
450 !
460 ! Assign (open) an I/O path to the file.
470 ASSIGN @Path_1 TO "File_1"
480 !
490 ! Send an array of numeric values.
500 OUTPUT @Path_1;Array1(*)
510 !
520 ! Close the I/O path (may be optional).
530 ASSIGN @Path_1 TO *
.
.
790 ! Open another I/O path to the file.
800 ASSIGN @F_1 TO "File_1:INTERNAL,4,1"
810 !
820 ! Read data into another array (same size and type).
830 ENTER @F_1;Array2(*)
840 !
850 ! Close I/O path.
860 ASSIGN @F_1 TO *

```

Line 400 specifies the “system mass storage device,” or the “default” device which is to be used whenever a mass storage device is not explicitly specified during subsequent mass storage operations. The term *mass storage unit specifier (msus)* describes the string expression used to uniquely identify which device is to be the mass storage. In this case, “:INTERNAL,4,1” is the msus.

In order to store data in mass storage, a data file must be created (or already exist) on the mass storage media. In this case, line 440 creates a BDAT file for data storage; the file created contains 10 defined records of 256 bytes each. (Defined records and record size are discussed later in this chapter.)

The term “file specifier” describes the string expression used to uniquely identify the file. In this example, the file specifier is simply “File_1,” which is the file’s name. If the file is to be created (or already exists) on a mass storage device *other than the system mass storage*, the appropriate msus must be appended to the file name.

Then, in order to store data in (or retrieve data from) the file, you must assign an I/O path name to the file. Line 470 shows an example of assigning an I/O path name to the file (also called opening an I/O path to the file). Line 500 shows an array of numeric data being sent to the file through the I/O path.

The I/O path is closed after all data have been sent to the file. In this instance, closing the I/O path may have been optional, because another I/O path name is assigned to the file later in the program. (All I/O path names are automatically closed by the system at the end of the program.) Closing an I/O path to a file updates the file pointers.

If this array of data is to be retrieved from the file, another ASSIGN statement is executed (line 800). Notice that a different I/O path name has been used; this is an arbitrary choice of names. Opening this I/O path name to the file sets the file pointer to the beginning of the file. (Re-opening the I/O path name @File_1 would have also reset the file pointer.)

Notice also that the msus is included with the file name. This shows that the mass storage device, here the left drive of the Model 236, does not have to be the current system mass storage in order to be accessed. The subsequent ENTER statement reads the data into another numeric array (which must be of the *same* data type when a BDAT file is used in this manner).

As you can see, this is a very simplistic example, in which several assumptions have been made. However, it shows the general steps you must take to access files. The rest of this section expands on these basic steps.

Media Specifiers

Once the mass storage is connected, you need a way of specifying which mass storage device to be accessed. This is done with a media specifier. The syntax for a media specifier is illustrated below.

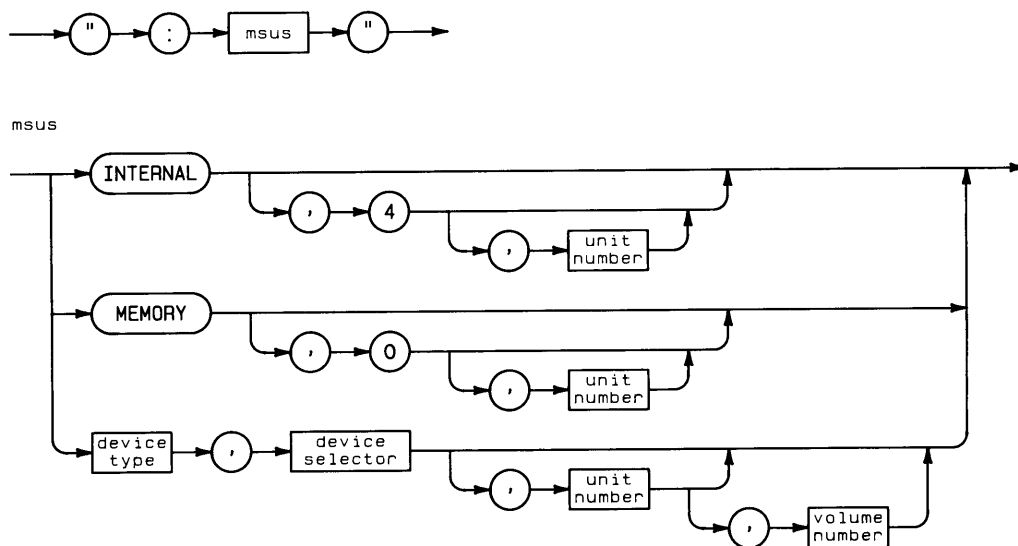

Device type — effectively describes the mass storage device to the system. The system then knows the capacity of the device, the directory structure, and other information required to determine the access method for the device. Examples are INTERNAL, CS80, and HP82901.

The following table shows the **valid** device types. Most device types require an option BIN for the statement to execute.

BIN Required	Device Type
none	INTERNAL MEMORY
DISC & HPIB or FHPIB	HP 9895 HP 9121 HP 9133 HP 9134 HP 9135 (5¼ inch uses HPIB not FHPIB) HP 913X
DISC & HPIB	HP 82901 HP 82902 HP 8290X
CS80 & HPIB or FHPIB	CS80 (7908, 7911, 7912, 7914, 9122...)
HP9885 & GPIO	HP 9885
SRM & DCOMM	REMOTE
BUBBLE	BUBBLE
EPROM	EPROM

Note the 98625 Card (which requires the FHPIB BIN) cannot be used with external 5¼ inch discs.

If the device type specified is not valid, the system tests the device to determine its type. There are two exceptions to this.

1. If the device selector is 0 and the device type is invalid, the device type is assumed to be **MEMORY**.
2. If the device type is valid and the driver BIN for the device is not loaded, the system considers the device an invalid device type.

Device selector — tells the system the select code of the interface connected to the device; if the interface is an HP-IB, it also tells the system the device's primary address. The system then knows which interface connects the device to the computer (and the device's address, if an HP-IB is used).

A device selector can be just an interface select code or a combination of select code and primary address. To derive a device selector with a primary address, multiply the interface select code by 100 and then add the address. For instance, the device selector 703 would select the device with primary address 3 which is connected to the interface at select code 7. Note that interface select code 7 is the built-in HP-IB interface; this is the interface you will probably use to attach external disc drives.

The device selector for the internal drive(s) is 4. Note that there is no default device selector for external drives; in other words, you could not use just the device type to specify an external drive.

Unit number — tells the system additional information about the device's unit-number setting. Many devices have hard-wired unit numbers, while others use the unit number to identify different portions of one disc. For instance, the unit number of the right drive of a Model 236 is 0, while it is 1 for the left drive.

Volume number — a volume is a subdivision of a unit if the device supports volumes. If the volume number is not given, the default 0 is used.

Examples

The following statements set the system mass storage to an HP 82901 drive at interface select code 7; the HP 82901 is set to primary address 0 and has a unit number of 1.

```
MASS STORAGE IS ":HP82901,700,1"
or
MASS STORAGE IS ":HP,700,1"
```

Executing the following statements catalog the disc in the HP 9121 drive at interface select code 8 with primary address 2 and unit number 0.

```
CAT ":HP9121,702"
CAT ":HP,702"
```

Again, note that there is no default device selector for external drives; in other words, you cannot use just the device type to specify an external drive.

The following statement creates an ASCII file named "Fred" on the disc in unit 3 of an HP 9134 drive, connected through interface select code 7; the device has a primary address of 0.

```
CREATE ASCII "Fred:HP9134,700,3"
```

Internal Disc Drives

There are two ways to specify which mass storage device is to be used for an operation. The first way is to use a media specifier to specify the system mass storage with the MASS STORAGE IS statement. The following statement specifies that the right drive of a Model 236 (the only drive of a Model 226) is to be system mass storage.

```
MASS STORAGE IS ":INTERNAL"
```

Now whenever you perform a mass storage operation and don't specify a mass storage device, the system will automatically use this mass storage device. This default mass storage remains effective until you either execute a new MASS STORAGE IS statement or a SCRATCH A. After a power-up or SCRATCH A, the MASS STORAGE IS device is set to the device from which the system was booted.

The second method is to specify a media specifier for the operation. For example, the following statement directs the system to catalog the disc media in the left drive (of a Model 236).

```
CAT ":INTERNAL ,4 ,1"
```

Note that, with this second method, using a media specifier overrides the default mass storage for the particular operation but does not modify the system mass storage (i.e., the default msus).

The following statement sets the default mass storage to the left drive of a Model 236. Note that "MASS STORAGE IS" can be abbreviated as "MSI."

```
MSI ":INTERNAL ,4 ,1"
```

Executing this statement on a computer other than a Model 236 results in an error, since it has no left drive.

The "4" parameter is the internal drive's interface select code, and the "1" is the unit number of the left drive. It is possible (but redundant) to use the parameters which specify the right-hand drive, since the default values also specify the right drive. For example, all of the following statements direct the system to catalog the disc in the right drive.

```
CAT ":INTERNAL ,4 ,0"
CAT ":INTERNAL ,4"
CAT ":INTERNAL"
CAT " : ,4"
```

You can also specify external mass storage devices by using the proper media specifier. The next section describes the following topics: external HP drives which are supported by the BASIC language of Series 200 Computers and non-disc mass storage devices such as magnetic bubble memories. If you aren't going to use external mass storage, you can skip to the section that describes file access.

External Disc Drives

HP Series 200 computers support a number of external HP disc drives. The following table shows the external drives which can be used. The Total Storage Capacity values given are on a per-media basis *before* the system writes directory information on the media.

HP Device	Type of Media	Total Storage Capacity:	
		Bytes	Files
HP 7908	hard disc (optional tape backup)	16 576 000	2 584
HP 7911	hard disc (optional tape backup)	28 114 944	4 392
HP 7912	hard disc (optional tape backup)	65 601 536	10 248
HP 7914	hard disc (optional tape backup)	132 120 576	20 640
HP 9121S	3.5-inch flexible disc (single-drive)	270 336	112
HP 9121D	3.5-inch flexible disc (dual-drive)	270 336	112
HP 9133 (flexible disc for all versions)	3.5-inch flexible disc	270 336	112
HP 9133A	5.25-inch hard disc	1 152 000 per unit	464 per unit
HP 9133A, Option 010	5.25-inch hard disc	4 825 088	752
HP 9133B	5.25-inch hard disc	9 581 920	1 512
HP 9133V	5.25-inch hard disc	4 825 088	752
HP 9133V, Option 004	5.25-inch hard disc	1 152 000 per unit	464 per unit
HP 9133XV	5.25-inch hard disc	14 522 880	2 264
HP 9133XV, Option 010	5.25-inch hard disc	9 681 920	1 512
HP 9134A	5.25-inch hard disc	1 152 000 per unit	464 per unit
HP 9134A, Option 010	5.25-inch hard disc	4 825 088	752
HP 9134B	5.25-inch hard disc	9 681 920	1 512
HP 9134XV	5.25-inch hard disc	14 522 880	2 264
HP 9134XV, Option 010	5.25-inch hard disc	9 681 920	1 512
HP 9135 (flexible disc for all versions)	5.25-inch flexible disc	270 336	112
HP 9135A	5.25-inch hard disc	1 152 000	464
HP 9135A, Option A	5.25-inch hard disc	4 825 088	752
HP 9885	8-inch flexible disc	483 840	224
HP 9895	8-inch flexible disc (single-sided media)	483 840	224
HP 9895	8-inch flexible disc (double-sided media)	1 152 000	464
HP 82901	5.25-inch flexible disc (dual-drive)	270 336	112
HP 82902	5.25-inch flexible disc (single-drive)	270 336	112

You can have nearly any number and any combination of these drives connected to your computer; the only restriction is imposed by the number of and the limitations of the interface(s) used to connect the drives to the computer.

The next sections summarize configuring and accessing external devices currently available. The following table summarizes pertinent information regarding the available drives.

All of the entries in the table may not make complete sense to you at this time; however, once you connect your drive, you will be able to better understand the data and use the information as a handy quick reference.

HP Device	Device Type	Interface Required	Factory Settings:		Default Interleave
			Address	Unit No.	
HP 7908 (h)	C580	HP-IB or fast HP-IB	0	0	1
HP 7908 (t)	C580	HP-IB or fast HP-IB	0	1	—
HP 7911 (h)	C580	HP-IB or fast HP-IB	0	0	1
HP 7911 (t)	C580	HP-IB or fast HP-IB	0	1	—
HP 7912 (h)	C580	HP-IB or fast HP-IB	0	0	1
HP 7912 (t)	C580	HP-IB or fast HP-IB	0	1	—
HP 7914 (h)	C580	HP-IB or fast HP-IB	0	0	1
HP 9121S (t)	HP9121	HP-IB or fast HP-IB	0	0	2
HP 9121D (l)	HP9121	HP-IB or fast HP-IB	0	0	2
HP 9121D (r)	HP9121	HP-IB or fast HP-IB	0	1	4
HP 9133 (f, all versions)	HP913X	HP-IB or fast HP-IB	2	0	2
HP 9133A (h)	HP913X	HP-IB or fast HP-IB	0	0 thru 3	9
HP 9133A, Opt. 010 (h)	HP913X	HP-IB or fast HP-IB	0	0	9
HP 9133B (h)	HP913X	HP-IB or fast HP-IB	0	0	9
HP 9133V (h)	HP913X	HP-IB or fast HP-IB	0	0	9
HP 9133V, Opt. 004 (h)	HP913X	HP-IB or fast HP-IB	0	0 thru 3	9
HP 9133 XV (h)	HP913X	HP-IB or fast HP-IB	0	0	9
HP 9133XV, Opt. 010 (h)	HP913X	HP-IB or fast HP-IB	0	0	0
HP 9134A	HP913X	HP-IB or fast HP-IB	0	0 thru 3	9
HP 9134A, Opt. 010 (h)	HP913X	HP-IB or fast HP-IB	0	0	9
HP 9134B	HP913X	HP-IB or fast HP-IB	0	0	—
HP 9134XV	HP913X	HP-IB or fast HP-IB	0	0	—
HP 9134XV, Opt. 010 (h)	HP913X	HP-IB or fast HP-IB	0	0	—
HP 9135 (f, all versions)	HP913X	HP-IB	2	0	4
HP 9135A (h)	HP913X	HP-IB or fast HP-IB	0	0 thru 3	9
HP 9135A, Opt. 010 (h)	HP913X	HP-IB or fast HP-IB	0	0	9
HP 9885M	HP9885	GPIO & DMA	—	0	1
HP 9885S	HP9885S	GPIO & DMA	—	1	1
HP 9895M (l)	HP9895	HP-IB or fast HP-IB	0	0	3
HP 9895M (r)	HP9895	HP-IB or fast HP-IB	0	1	3
HP 9895S (l)	HP9895	HP-IB or fast HP-IB	0	2	3
HP 9895S (r)	HP9895	HP-IB or fast HP-IB	0	3	3
HP 82901M (l)	HP82901	HP-IB	0	0	4
HP 82901M (r)	HP82901	HP-IB	0	1	4
HP 82901S (l)	HP82901	HP-IB	0	2	4
HP 82901S (r)	HP82901	HP-IB	0	3	4
HP 82902M	HP82902	HP-IB	0	0	4
HP 82902S	HP82902	HP-IB	0	2	4

(h) indicates hard-disc drive
(f) indicates flexible disc drive
(t) indicates tape drive

(l) indicates right drive (of dual-drive machine)
(r) indicates left drive (of dual-drive machine)
— indicates “not applicable”

Now let's take a closer look at each of these drives and briefly summarize the configuration considerations.

HP 7908, 7911, 7912, and 7914 Disc/Tape Drives

These machines all have a hard disc drive and tape (backup) drive; the differences between model numbers are primarily disc (and tape) capacities. Tape drives may be optionally deleted when ordering the machine. Using these drives requires CS80 and HPIB or FHPIB.

If the disc and tape drive have only one controller, both are located at the same primary address; this address has a random factory setting in the range 0 through 7. If disc and tape each have their own controller, each also has its own address setting. The address switch setting(s) are located on the rear panel below the HP-IB connector; see the installation manual for the switch definitions. The unit number of the disc is 0, and the unit number of the tape is 1.

To specify any of these drives, use the device type CS80. For instance, to specify the disc at interface select code 7 with primary address 0, use :CS80,700; to specify the tape on the same machine, use :CS80,700,1.

The default interleave factor for all CS80 discs is 1, which is optimal for an HP 7908 while using DMA. For the HP 7912, an interleave of 3 is optimal (while using DMA). Time-critical operations may perform better with an interleave of 3, 7, or 12.

Note that you should not use the COPY statement to do media backup between the disc drive and the tape drive. The utility program "TAPEBACKUP" has been provided with the BASIC Utilities Library for this purpose.

HP 9121S and 9121D Drives

The HP 9121S is a single-drive machine, and the HP 9121D is a dual-drive machine. Both use 3.5-inch flexible discs. Using these drives requires DISC and HPIB or FHPIB.

The factory default setting of the primary address is 0. The address switches are located on the rear panel; see the installation manual for switch definitions. With the HP 9121D, the left drive is set to unit 0, and the right drive is set to unit 1.

To specify these drives, use any of the device types HP9121, HP8290X, or HP913X. To specify the right drive on an HP 9121D at interface select code 7 with primary address 0, use :HP9121,700,1. To specify the drive of an HP 9121S at select code 8 with primary address 2, use :HP9121,802.

The default interleave factor is 2 for HP 9121 drives.

HP 9133, 9134, and 9135 Drives

All of these drives feature a 5.25-inch hard-disc drive. The HP 9133 contains an additional 3.5-inch flexible disc drive, which uses media compatible with HP 9121 drives. The HP 9135 contains an additional 5.25-inch flexible disc drive, which uses media compatible with internal and HP 8290X drives. Using these drives requires DISC and HPIB for flexible disc drives or FHPIB for other devices.

The drives are available in the following sizes and configurations:

Option	Size	Volumes
A	4 825 088	4
A, Option 010	4 825 088	1
B	9 681 920	1
V	4 825 058	1
V, Option 004	4 825 088	4
XV	14 522 880	1
XV Option 010	9 681 920	1

The available combinations are:

HP 9133	HP 9134	HP 9135	Options
Yes	Yes	Yes	A
Yes	Yes	Yes	A, Option 010
Yes	Yes	No	B
Yes	No	No	V
Yes	No	No	V, Option 004
Yes	Yes	No	XV
Yes	Yes	No	XV, Option 010

The factory default setting of the primary address switches for the hard disc on all three of these devices is 0; for the flexible discs (HP 9133 and HP 9135), the default address is 2. The switches are located on the rear panel; see the installation manual for switch definitions.

The default interleave factor for these drives is 2 (for flexible discs) and 9 (for hard discs). The interleave of the hard discs is 9 and cannot be changed.

HP 9885 Drives

The HP 9885 is a single-drive, single-sided, 8-inch, flexible disc drive. Unlike the other disc drives, using this device *requires* a GPIO Interface (HP 98622) and a DMA Interface (HP 98620). The factory default setting of the GPIO Interface' select code is 12; the range of allowable select codes is 8 through 31, as long as no other interface is set to the same select code. The DMA Interface has no select code setting. Using this drive requires HP9885 and GPIO.

The "INT LVL" switches are irrelevant when using the HP 9885. All "Option Select" switches (PCTL, PFLG, PSTS, HSHK, DIN, and DOUT) *must* be set to the "1" position (open). The "Data-In Clock Source" switches *must* be set as follows:

	Switch Name	Required Setting
LOWER	READ	1 (open)
	BSY	0 (closed)
	RDY	1 (open)
UPPER	READ	1 (open)
	BSY	0 (closed)
	RDY	1 (open)

There is no primary address setting for the HP 9885 drives, since these drives are connected to the computer through a GPIO Interface. The factory default settings for unit numbers depend on whether or not the drive is a master or slave drive; HP 9885M drives are masters, and HP 9885S drives are slaves. Master drives have a default unit number of 0, while the slaves have defaults of 1. Each master can control up to three slaves. The unit-number switch is a rotary switch located on the rear panel.

To specify an HP 9885 at interface select code 12 and with unit number 0, use :HP9885,12; to specify a drive at the same select code but with unit number 1, use :HP9885,12,1.

HP 9895 Drives

The HP 9895 disc drives are dual-drive machines which can use either single-sided or double-sided, 8-inch, flexible-disc media. The single-sided media are compatible with HP 9885 drive. Using these drives requires DISC and HPIB or FHPIB.

The primary address switch is located behind the removable front panel; the factory default address setting is 0. The unit number of the left drive is 0; for the right drive, it is 1.

To specify an HP 9895 drive, use the HP9895 device type. For instance, to specify the right drive of an HP 9895 located at interface select code 7 with primary address 0, use :HP9895,700,1; to specify the left drive of the same machine, use :HP9895,700.

The default interleave factor for HP 9895 discs is 3.

HP 82901 and HP 82902 Drives

The HP 82901 drives are dual-drive machines, while the HP 82902 drives are single-drive machines. The M suffix (of the part number) denotes that the machine is a master drive; master drives can control one slave drive (either an HP 82901 or HP 82902 which has an S suffix). The media used with both of these 5.25-inch flexible disc drives are compatible with the internal and HP 9135 flexible disc drives. Using these drives requires DISC and HPIB

The primary address switches are located on the master drive's rear panel under the HP-IB connector. The factory default primary address setting is 0; see the installation manual for switch definitions. On the HP 82901M, the left drive is unit 0, and the right drive is unit 1; the single drive of the HP 82902M is unit 0. On an HP 82901S, the left drive is unit 2, and the right drive is unit 3; the single drive of an HP 82902S is unit 2.

To access these drives, use any of the HP8290X device types. For instance, to specify the left drive of an HP 82901 at select code 7 with primary address 0, use HP82901,700; to specify the right drive of the same machine, you could use HP8290X,700,1.

Non-Disc Mass Storage

Although mass storage is traditionally implemented using a magnetic surface such as a disc or drum, the protocols of file management can be applied to any device which stores data. Here is a summary.

- EPROM (Erasable, Programmable Read-Only Memory) cards. Although EPROMs store user-supplied data, they are much harder to write than to read. This, combined with their ruggedness and non-volatile storage, makes them well suited to read-only applications in environments too harsh for a disc. Because of their specialized nature, EPROMs are not discussed in this chapter on generalized mass storage. They are covered in their own chapter of *BASIC Interfacing Techniques*.
- Magnetic Bubble Memory cards. Like EPROMs, these devices provide non-volatile storage that is more rugged than a disc. Unlike EPROMs, bubble memory can be written to just as easily as it can be read.
- RAM Memory Volumes. Areas of the computer's RAM can be treated as though they were mass storage devices. Obviously, a RAM volume is volatile. However, they can be accessed faster than any other mass storage device. Some special tasks can benefit from this increased speed for intermediate operations and then copy the RAM volume to a non-volatile volume at the end of the job.

The next two sections describe some of the programming techniques needed to access bubble memory and RAM volumes.

Bubble memory

The Bubble Memory Card is very similar to an interface card. It has interface select code switches and installs in an accessory slot. The Installation Note for this card shows how to set the switches. Note that hardware interrupt level of 6 is recommended. The BUBBLE BIN is required to use this card.

The follow example show typical mass storage unit specifiers for a bubble memory card set to interface select code 30.

```
MASS STORAGE IS ":BUBBLE,30"
ASSIGN @File TO "data1:BUBBLE,30"
```

A bubble memory card always has only one unit (unit 0). This could be specified in the media specifier, such as `:BUBBLE,28,0`. However, zero is the default unit number in a media specifier, so there is really no point in specifying it.

All mass storage operations work with the bubble memory card. Just use the card's interface select code in the BUBBLE media specifier. There are *very rare* instances when hardware conflicts might occur during a bubble memory access. These pertain to hardware interrupt levels, which are described in *BASIC Interfacing Techniques*. Essentially, if an interrupt (at the same or higher priority) occurs during a bubble memory access, BASIC might not be able to service the bubble memory card quickly enough. If this happens, error 314 is reported. The cure is to lower the hardware interrupt level of the cards in conflict with the bubble card or restructure the program so that the conflicting operations (e.g. TRANSFER) do not occur at the same time.

When the bubble memory device was first initialized at the factory, any bad loops (memory locations) were logged and this information, called the Boot Loop, was stored in the bubble memory device itself. If you obtain repeated "read" errors or "buffer overflow" errors from the bubble memory card, try to re-initialize the volume. If the initialization fails, it is likely the Boot Loop information has been lost and the card should be returned to re-establish the Boot Loop.

RAM Volumes

Areas of the computers RAM may be treated as mass storage devices. These "memory volumes" or "RAM volumes" are volatile (all information is lost when the power goes off), but high speed. A typical use for RAM volumes is to copy a disc volume into memory, perform all necessary manipulations using the RAM volume, then copy the new information back to disc. Obviously, there are only certain applications which would benefit from this technique.

All mass storage operations work with RAM volumes. After they are created (described next), RAM volumes are accessed by using their unit number in a MEMORY media specifier. The following examples show typical mass storage unit specifiers for a RAM volume with unit number 7.

```
MASS STORAGE IS ":MEMORY,0,7"
ASSIGN @Ram TO "TEMP:MEMORY,0,7"
```

RAM volumes are created by the INITIALIZE statement. A special form of this statement is used, with a unit size parameter is the position normally occupied by the interleave factor. The device type is always MEMORY, and the device selector is always 0. Unit numbers 0 thru 31 may be used. Here are some examples.

```
INITIALIZE ":MEMORY,0,1",220
```

This creates a RAM volume that is 220 sectors long and is given unit number 1. Note that the unit size parameter is in 256-byte sectors, just like LIF file sizes.

If the unit size parameter is omitted, the result is a RAM volume that is the same size as a 5.25-inch or 3.5-inch disc. This is 1056 sectors, or 270 336 bytes. Although the default size RAM volume provides only 80 directory entries while the discs may contain up to 112 directory entries, if a disc is copied into the RAM volume, the entire directory will be copied.

The unit size of a RAM volume must be at least 4 sectors and can be as large as available memory permits. Two sectors are taken for system use, and about 1 sector of directory is created for each 100 sectors of unit size. The following table shows examples of size data for RAM volumes.

Specified Unit Size (sectors)	Total Overhead (sectors)	Maximum Number of Files in Directory
4	3	8
200	3	8
201	4	16
300	4	16
512	7	40
1000	11	72
1056	12	80
2000	21	152
2048	22	160

With BASIC 3.0 RAM volumes can be initialized while a program is running.

No RAM volumes exist at power-up or after a SCRATCH A. It is recommended that all BIN programs be loaded before RAM volumes are initialized. If a BIN program is loaded after a RAM volume is initialized, the memory used for the RAM volume cannot be recovered until the computer is turned off and back on again.

A RAM volume can be reinitialized to the same or different size. If the size is different, memory space may be lost until the next SCRATCH A.

Accessing Files

Before you can access a data file, you must assign an I/O path name to the file. Assigning an I/O path name to the file sets up a table in computer memory that contains various information describing the file, such as its type, which mass storage device it is stored on, and its location on the media. The I/O path name is then used in I/O statements (OUTPUT, ENTER, and TRANSFER) which move the data to and from the file. I/O path names are also used to transfer data to and from devices. Chapters 4, 5, 10, and 11 of *BASIC Interfacing Techniques* explain data transfers with devices and provide several relevant insights into data representations. However, in this chapter we deal only with I/O paths to files.

Every I/O path to a file maintains the following information:

Validity Flag — Tells whether the path is currently opened (assigned) or closed (not assigned).

Type of Resource — Holds the file type (ASCII or BDAT).

Device Selector — Stores the device selector of the drive. (I/O paths can also be associated with devices and buffers. See *BASIC Interfacing Techniques* for further details.)

Attributes — Such as FORMAT OFF and FORMAT ON.

File Pointer — There is a file pointer that points to the place in the file where the next data item will be read or written. The file pointer is updated whenever the file is accessed.

End-Of-File Pointer — An I/O path has an EOF pointer that points to the byte that follows the last byte of the file.

Opening an I/O Path

I/O path names are similar to other variable names, except that I/O path names are preceded by the “@” character. When an I/O path name is used in a statement, the system looks up the contents of the I/O path name and uses them as required by the situation.

To open an I/O path to a file (to set the validity flag to Open), assign the I/O path name to a file specifier by using an ASSIGN statement. For example, executing the following statement:

```
ASSIGN @Path1 TO "Example"
```

assigns an I/O path name called @Path1 to the file "Example". The file that you open must already exist and must be a data file. If the file does not satisfy one of these requirements, the system will return an error. If you do not use an msus in the file specifier, the system will look for the file on the current MASS STORAGE IS device. If you want to access a different device, use the msus syntax described earlier. For instance, the statement:

```
ASSIGN @Path2 TO "Example:HP9895,707"
```

opens an I/O path to the file "Example" on an HP 9895 disc drive, interface select code 7 and primary address 7. You must include the protect code if the file has one.

ASSIGNing an I/O path name to a file has the following effect on the I/O path table:

- If the I/O path is currently open, the system *closes* the I/O path and then *re-opens* it. If the I/O path is not currently open, it is opened. In both cases, the system sets the validity flag to Open.
- The file type (ASCII or BDAT) and its msus are recorded.
- The specified attributes are assigned to the I/O path name. If an attribute is not specified, the appropriate default attribute is assigned.
- The file pointer is positioned to the beginning of the file.
- If the path name is associated with a BDAT file, the EOF pointer from the system sector is copied to the I/O path table.

Once an I/O path has been opened to a file, you always use the path name to access the file. An I/O path name is only valid in the context in which it is opened, unless you pass it as a parameter or put it in the COM area. To place a path name in the COM area, simply specify the path name in a COM statement before you ASSIGN it. For instance the two statements below would declare an I/O path name in an unnamed COM area and then open it:

```
100   COM @Path3
110   ASSIGN @Path3 TO "File1"
```

Assigning Attributes

When you open an I/O path, certain attributes are assigned to it which define the way data is to be read and written. There are two attributes which control how data items are represented: FORMAT ON and FORMAT OFF. With FORMAT ON, ASCII data representations are used; with FORMAT OFF, the system's internal data representations are used. Additional attributes are available, which provide control of such functions as parity generation and checking, converting characters, and changing end-of-line (EOL) sequences. See the *BASIC Language Reference* or Chapter 10 of *BASIC Interfacing Techniques* for further details.

As mentioned in the tutorial section, BDAT files can use either data representation; however, ASCII files only permit ASCII-file format. Therefore, if you specify FORMAT OFF for an I/O path to an ASCII file, the system ignores it. The following two examples of ASSIGN statements specify a FORMAT attribute.

```
ASSIGN @Path1 TO "File1";FORMAT OFF
```

If “File1” is a BDAT file, the FORMAT OFF attribute specifies that the internal data formats are to be used when sending and receiving data through the I/O path. If the file is of type ASCII, the attribute will be ignored. *Note that FORMAT OFF is the default FORMAT attribute for BDAT files.*

Executing the following statement directs the system to use the ASCII data representation (if possible) when sending and receiving data through the I/O path.

```
ASSIGN @Path2 TO "File2";FORMAT ON
```

If “File2” is a BDAT file, data will be written using ASCII format, and data read from it will be interpreted as being in ASCII format. For an ASCII file, this attribute is redundant since ASCII-file format is the only data representation allowed anyway.

If you want to change the attribute of an I/O path, you can do so by specifying the I/O path name and attribute in an ASSIGN statement while excluding the file specifier. For instance, if you wanted to change the attribute of @Path2 to FORMAT OFF, you could execute:

```
ASSIGN @Path2;FORMAT OFF
```

Alternatively, you could re-enter the entire statement:

```
ASSIGN @Path2 TO "File2";FORMAT OFF
```

These two statements, however, are not identical. The first one only changes the FORMAT attribute. The second statement resets the entire I/O path table (e.g., resets the file pointer to the beginning of the file).

It is important to note that once a file is written, changing the FORMAT attribute of an I/O path to the file should only be attempted by experienced programmers. *In general, data should always be read in the same manner as it was written.* For instance, data written to a BDAT file with FORMAT OFF should also be read with FORMAT OFF, and vice versa. In addition, the same data types should be used to write the file as to read the file. For instance, if data items were written as INTEGERS, they should also be read as INTEGERS.

In theory, there is no limit to the number of I/O paths you can ASSIGN to the same file. Each I/O path, however, has its own file pointer and EOF pointer, so that in practice it can become exceedingly difficult to keep track of where you are in a file if you use more than one I/O path. *We recommend that you use only one I/O path for each file.*

Closing I/O Paths

I/O path names not in the COM area are closed whenever the system moves into a stopped state (e.g., STOP, END, SCRATCH, EDIT, etc.). I/O path names local to a context are closed when control is returned to the calling context. Re-ASSIGNing an I/O path name will also cancel its previous association.

You can also explicitly cancel an I/O path by ASSIGNing the path name to an * (asterisk). For instance, the statement:

```
ASSIGN @Path2 TO *
```

closes @Path2 (sets the validity flag to Closed). @Path2 cannot be used again until it is Re-ASSIGNed. You can Re-ASSIGN a path name to the same file or to a different file.

Reading and Writing BDAT Files

There are many alternatives for storing and retrieving data when using BDAT files. You can choose internal ASCII or user-defined formats and serial or random access. The following descriptions of OUTPUTing and ENTERing data apply only to BDAT files using FORMAT OFF. For more information about OUTPUT, ENTER, IMAGE specifiers, and additional attributes, see the *BASIC Interfacing Techniques* manual.

System Sector

On the disc, every BDAT file is preceded by a system sector that contains an End-Of-File pointer and the number of defined records in the file. All data is placed in succeeding sectors. You cannot directly access the system sector. However, as you shall see later, it is possible to indirectly change the value of an EOF pointer.

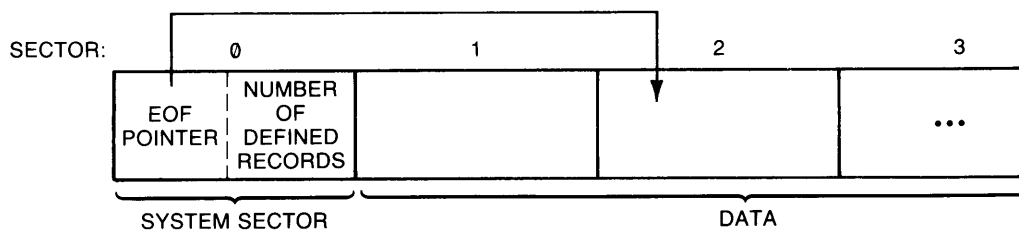

Defined Records

To access a BDAT file randomly, you specify a particular defined record. Records are the smallest units in a file directly addressable by a random OUTPUT or ENTER. They can be anywhere from 1 through 65 534 bytes long. Both the length of the file and the length of the defined records in it are specified when you create the file. For example, the statement:

```
CREATE BDAT "Example",7,128
```

would create a file called "Example" with 7 defined records, each record being 128 bytes long. If you don't specify a record length in the CREATE BDAT statement, the system will set each record to the default length of 256 bytes.

Both the record length and the number of records are rounded to the nearest integer. Further, the record length is rounded up to the nearest even integer. For example, the statement:

```
CREATE BDAT "Odd",3.5,28.7
```

would create a file with 4 records, each 30 bytes long. On the other hand, the statement:

```
CREATE BDAT "Odder",3.49,28.3
```

would create a file with three records, each 28 bytes long.

Once a file is created, you cannot change its length or the length of its records. You must therefore calculate the record size and file size required before you create a file.

Choosing A Record Length

The most important consideration in selecting of a proper record length is the type of data being stored and the way you want to retrieve it. Suppose, for instance, that you want to store 100 real numbers in a file, and be able to access each number individually. Since each REAL number uses 8 bytes, the data itself will take up 800 bytes of storage.

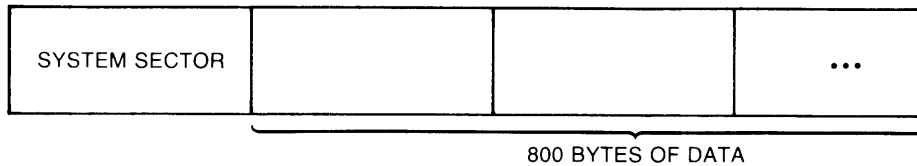

The question is how to divide this data into records. If you define the record length to be 8 bytes, then each REAL number will fill a record. To access the 15th number, you would specify the 15th record. If the data is organized so that you are always accessing two data items at a time, you would want to set the record length to 16 bytes.

The worst thing you can do with data of this type is to define a record length that is not evenly divisible by eight. If, for example, you set the record length to four, you would only be able to randomly access half of each real number at a time. In fact, the system will return an End-Of-Record condition if you try to randomly read data into REAL variables from records that are less than 8 bytes long.

So far, we have been talking about a file that contains only REAL numbers. For files that contain only INTEGERS, you would want to define the record length to be a multiple of two. To access each INTEGER individually, you would use a record length of two; to access two INTEGERS at a time, you would use a record length of four, and so on.

Files that contain string data present a slightly more difficult situation since strings can be of variable length. If you have three strings in a row that are 5, 12, and 18 bytes long, respectively, there is no record length less than 22 that will permit you to randomly access each string. If you select a record length of 10, for instance, you will be able to randomly access the first string but not the second and third.

If you want to access strings randomly, therefore, you should make your records long enough to hold the largest string. Once you've done this, there are two ways to write string data to a BDAT file. The first, and easiest, is to output each string in random mode. In other words, select a record length that will hold the longest string and then write each string into its own record. Suppose, for example, that you wanted to OUTPUT the following 5 names into a BDAT file and be able to access each one individually by specifying a record number.

John Smith
 Steve Anderson
 Mary Martin
 Bob Jones
 Beth Robinson

The longest name, "Steve Anderson", is 14 characters. To store it in a BDAT file would require 18 bytes (four bytes for the length header). So you could create a file with record length of 18 and then OUTPUT each item into a different record:

```

100 CREATE BDAT "Names",5,18      ! Create a file.
110 ASSIGN @File TO "Names"      ! Open an I/O path
120 OUTPUT @File,1;"John Smith"  ! Write names to
130 OUTPUT @File,2;"Steve Anderson" ! successive records
140 OUTPUT @File,3;"Mary Martin" ! in file
150 OUTPUT @File,4;"Bob Jones"
160 OUTPUT @File,5;"Beth Robinson"

```

On the disc, the file "Names" would look like the figure below. The four-byte length headers show the decimal value of the bytes in the header. The data are shown as ASCII characters.

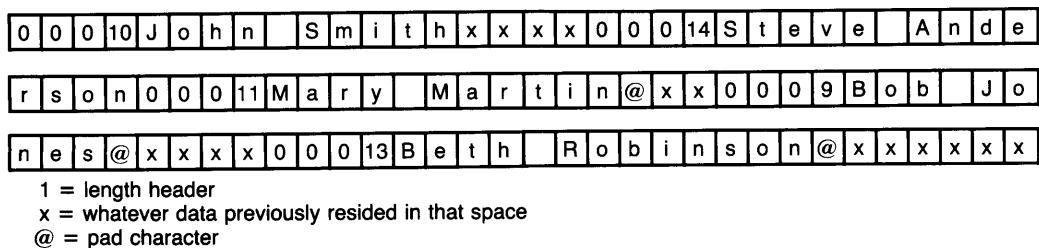

The unused portions of each record contain whatever data previously occupied that physical space on the disc.

The other method for writing strings to a BDAT file is to pad each entry so that they are all of uniform length. While this method involves more programming, it allows you to pad the unused portions of each record with whatever characters you choose. It also permits you to read and write the data serially as well as randomly. The program below shows how you might enter the five names into a file by padding each name with spaces.

```

100 CREATE BDAT "Names",5,18      ! Create file.
110 ASSIGN @Path1 TO "Names"      ! Open I/O path to file.
120 FOR Entry=1 TO 5
130     LINPUT Name#[1;14]        ! Get names from keyboard
140     OUTPUT @Path1;Name#      ! Write name to file
150 NEXT Entry

```

In this program, we input each name from the keyboard and so that it is padded with spaces to a length of 14 bytes. With the length header, each entry is 18 bytes, or one record. In line 140, we write the name serially to the file. Since every data item is 18 bytes, there is no need to write randomly, although we could if we wanted to. Since the LINPUT statement is limited to 14 bytes, any names that are longer than 14 characters are automatically truncated.

If we had used the second program to enter the names, file "Names" would look like the figure below:

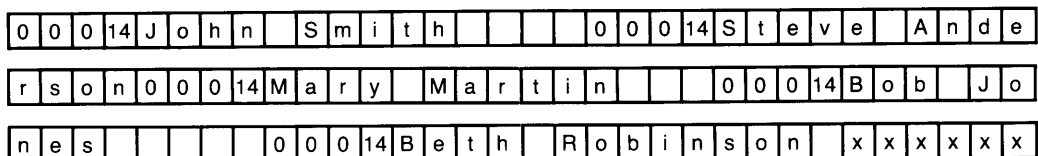

EOF Pointers

There are two types of End-Of-File pointers. One is maintained internally in the I/O path table and the other resides in the system sector. The two pointers are always updated at the same time so that they always agree with one another. (This may not be true if you use more than one I/O path to OUTPUT data to one file.) The two pointers are updated when either of the two conditions below occur.

- If, after an OUTPUT statement has been executed, the file pointer value is greater than the EOF pointers, the EOF pointers are moved to the file pointer position.
- If an OUTPUT statement contains the “END” secondary word, the EOF pointers are moved to the file pointer position regardless of their current values.

The function of EOF pointers is to mark the logical end of a data file. Every file also has a physical EOF — the last byte reserved for the file when you create it. The EOF pointers cannot point beyond the physical EOF. The EOF pointer marks the point at which no more data can be read. Also, you cannot randomly write data more than one record past the EOF position.

If you have a 100-record file, and the EOF pointers point to the 50th record, records 50 through 100 cannot be read. If you attempt to read data beyond an EOF, an EOF condition occurs. EOF conditions can be trapped with an ON END statement. If you do not trap it, an EOF condition will cause Error 59. Attempting to read or write beyond the physical EOF will also result in an EOF condition. EOF conditions are described in more detail later in this chapter.

Moving EOF Pointers

When you first create a file, the EOF pointer in the system sector points to the first byte in the file. When you ASSIGN an I/O path to a file, the pointer in the system sector is copied to the I/O path table. As you OUTPUT data items to the file, both EOF pointers are changed so that they point to the next byte. This is also where the file pointer is positioned.

If you overwrite a file, however, the EOF pointers will not necessarily agree with the file pointer. For example, suppose you write 100 bytes to a file, and then re-ASSIGN the I/O path. By re-ASSIGNing, you move the file pointer back to the first byte in the file. The EOF markers, though, still point to the 101st byte. They will not be changed until the file pointer value is greater than 101, or until you specify an “END” in an OUTPUT statement.

The secondary word “END” is used to move the EOF pointers backwards. It forces the EOF pointers to be re-positioned to the file pointer byte, even if the new position is “earlier” in the file than their current position. In effect, this “shrinks” the file, causing data that lies past the new EOF position to become inaccessible.

Writing Data

Data is always written to a file with an OUTPUT statement via an I/O path. You can OUTPUT numeric and string variables, numeric and string expressions, and arrays. When you OUTPUT data with the FORMAT OFF, data items are written to the file in internal format (described earlier).

There is no limit to the number of data items you can write in a single OUTPUT statement, except that program statements are limited to two CRT lines. Also, if you try to OUTPUT more data than the file can hold, or the record can hold (if you are using random access), the system will return an EOF or EOR condition. If an EOF or EOR condition occurs, the file retains any data output ahead of the end condition.

There is also no restriction on mixing different types of data in a single OUTPUT statement. The system decides which data type each item is before it writes the item to the disc. Any item enclosed in quotes is a string. Numeric variables and expressions are OUTPUT according to their type (8 bytes for REALs and 2 bytes for INTEGERS). Arrays are written to the file in row major order (rightmost subscript varies quickest).

Each data item in an OUTPUT statement should be separated by either a comma or semi-colon (there is no operational difference between the two separators with FORMAT OFF). Punctuation at the end of an OUTPUT statement is ignored with FORMAT OFF.

Serial OUTPUT

Data is written serially to BDAT files whenever you do not specify a record number in an OUTPUT statement. When data is written serially, each data item is stored immediately after the previous item without any type of separator. Sector and record boundaries are ignored. Data items are written to the file one by one, starting at the current position of the file pointer. As each item is written, the file pointer is moved to the next byte. After all of the data items have been OUTPUT, the file pointer points to the first byte following the last byte just written.

There are a number of circumstances where it is faster and easier to use serial access instead of random access. The most obvious case is when you want to access the entire file at once. If, for example, you have a list of data items that you want to store in a file and you know that you will never want to read any of the items individually, you should write the data serially. The fastest way to write data serially is to place the data in an array and then OUTPUT the entire array at once.

Another situation where you might want to use serial access is if the file is so small that it can fit entirely into internal memory at once. In this case, even if you want to change individual items, it might be easier to treat the entire file as one or more arrays, manipulate as desired, and then write the entire array(s) back to the file.

The examples below illustrate how data is stored serially in a file. The statement:

```
OUTPUT @Path1;"First",24;2.6,
```

would result in the following storage format:

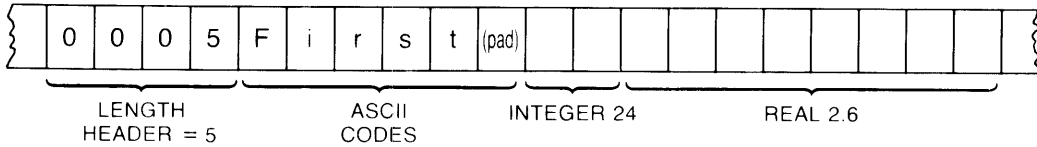

Note that quotation marks around a string are not written to the file. To write quote marks to a file, enter two quote marks for every one you want to OUTPUT. Note also that separators are not written to the file. To write a comma or semi-colon to a file, you must enclose it in quotes. For instance, the statement:

```
OUTPUT @Path1; ""QUO"TES","Next"
```

would be stored:

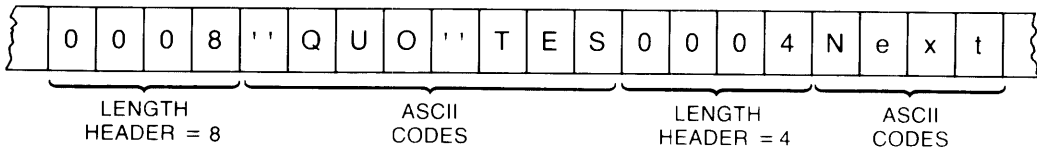

The following sequence of serial OUTPUT statements show how data is written to a BDAT file and how the file pointer and EOF pointers are updated.

```
CREATE BDAT "Example",4,128
```

I/O PATH TABLE

FILE POINTER
EOF POINTER

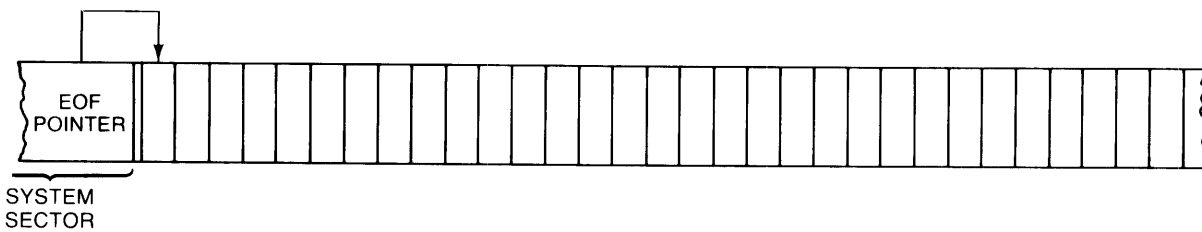

Creates a BDAT file with four 128-byte records. The EOF pointer in the system sector points to the first byte in the file.

```
ASSIGN @Path1 TO "Example"
```

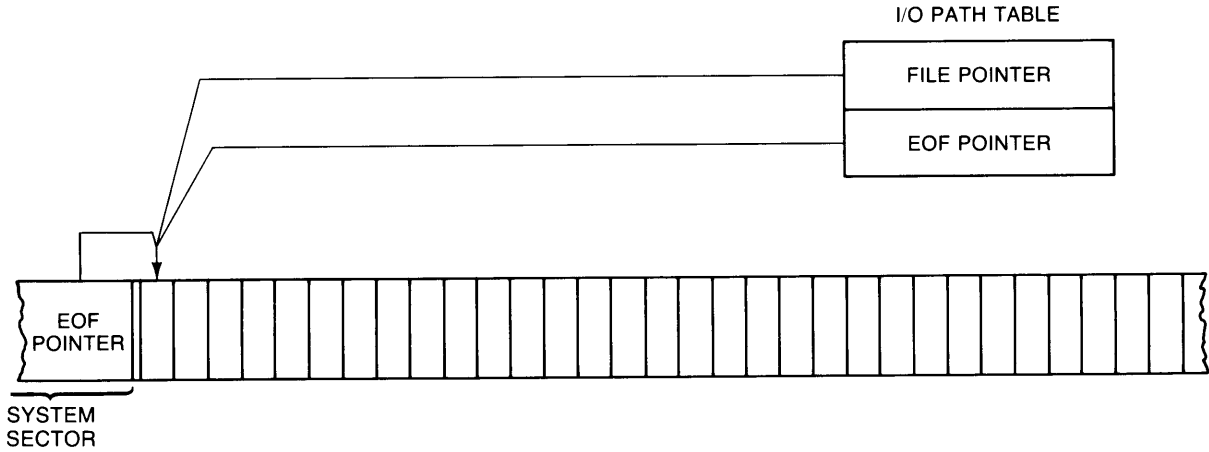

Opens an I/O path to "Example". The EOF marker in the system sector is copied to the I/O path table. The file pointer is positioned to the beginning of the file.

```
OUTPUT @Path1;"TEN CHARS."
```

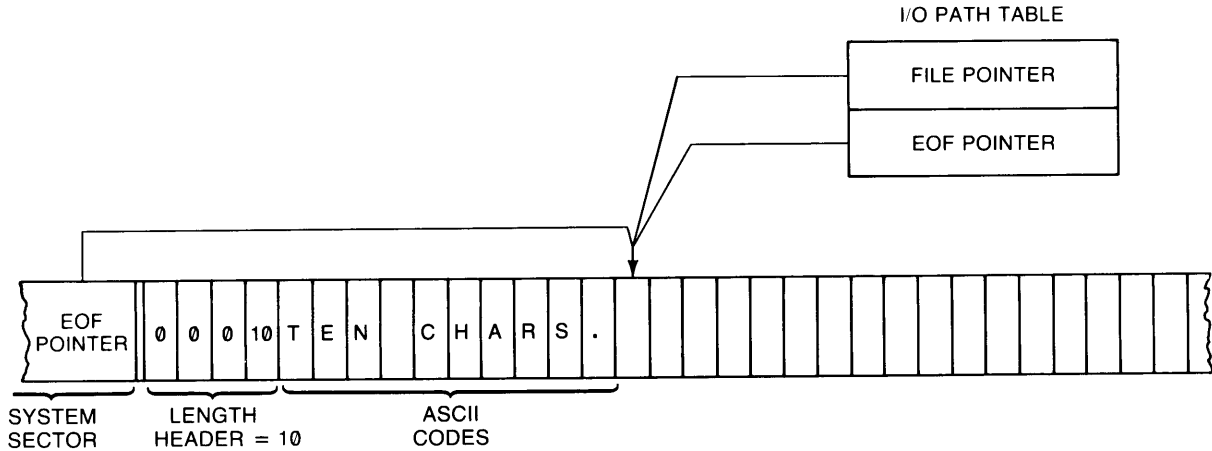

Fourteen bytes are written to the file. The EOF pointers are moved to the 15th byte. The file pointer also points to the 15th byte.

OUTPUT @Path1;12.5,END

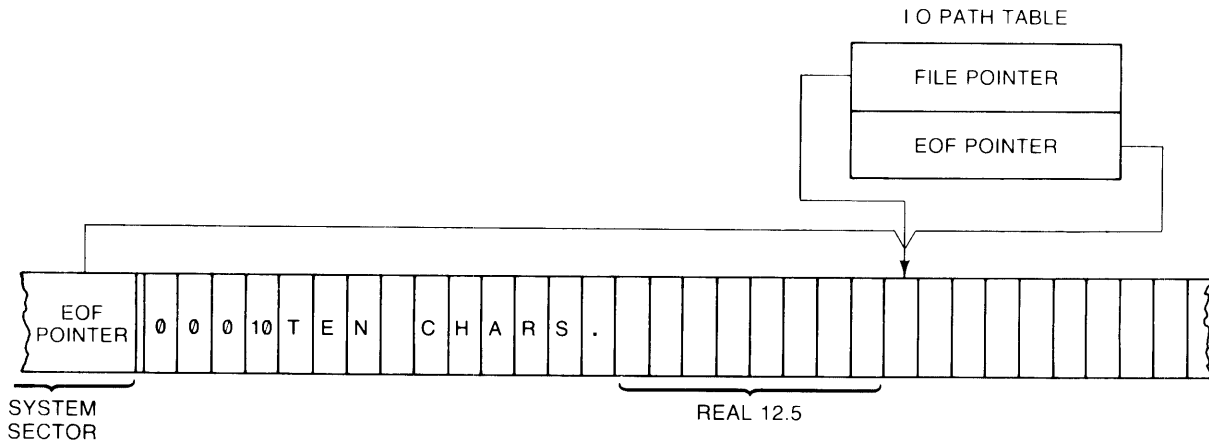

Eight more bytes are written to the file. The file pointer now points to the 31st byte. Both the EOF in the I/O path table and the EOF in the system sector are updated to 31.

OUTPUT @Path1;"FOUR"

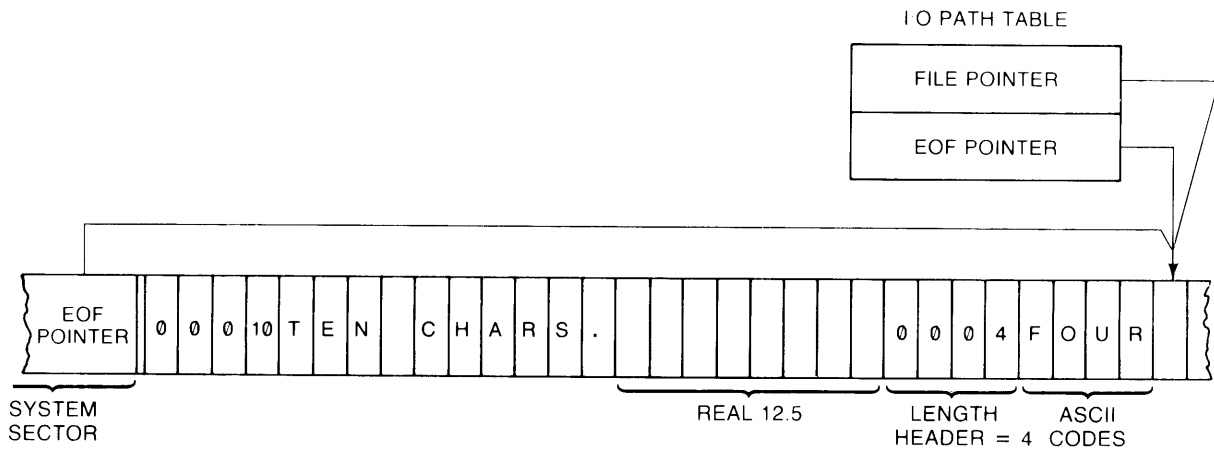

Eight more bytes are written to the file. The file pointer now points to the 31st byte. The EOF markers are updated to 31 because 31 is greater than 23, the current EOF value.

```
ASSIGN @Path1 TO "Example"
```

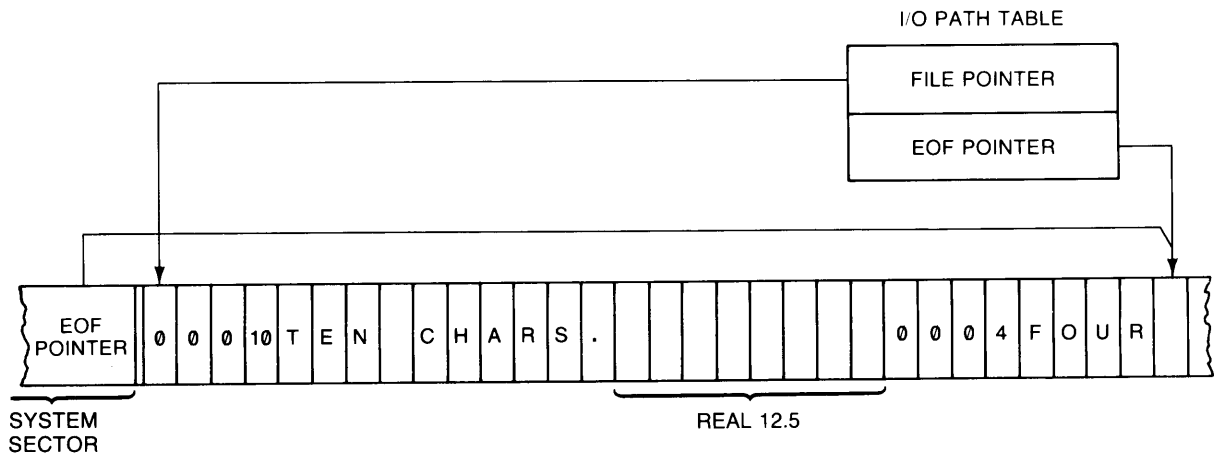

Re-ASSIGNs the I/O path name. The file pointer is positioned back to the beginning of the file. The system sector EOF value is copied to the I/O path table.

```
OUTPUT @Path1;13,7.665,1/3,END
```

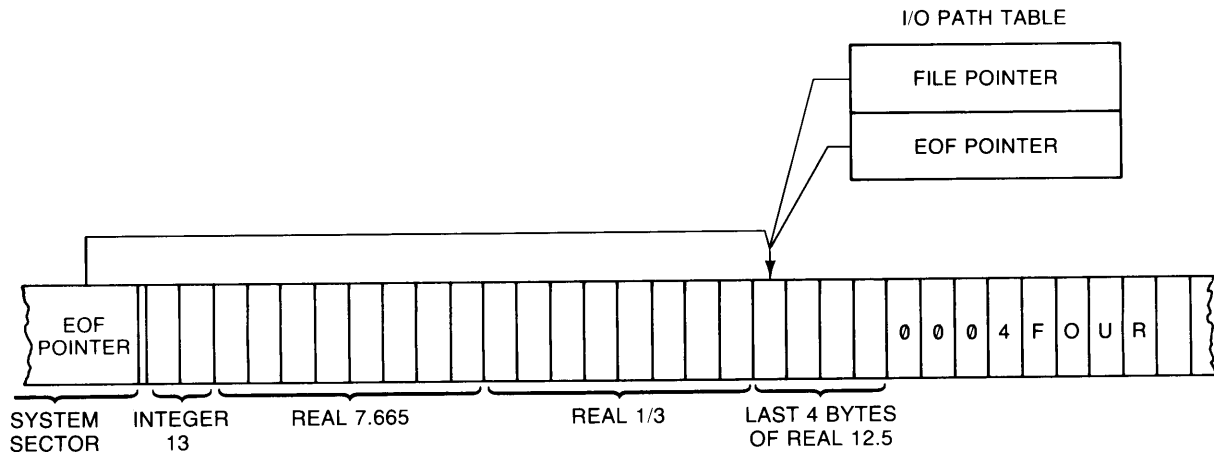

18 bytes (one INTEGER and two REALs) are OUTPUT, starting at the beginning of the file. The original data, therefore, is overwritten. The file pointer points to the 19th byte. The EOF markers are also positioned to 19 because the statement contains the "END" secondary word.

Random OUTPUT

Random OUTPUT allows you to write to one record at a time. As with serial OUTPUT, there are EOF and file pointers that are updated after every OUTPUT. The EOF pointers follow the same rules as in serial access. The file pointer positioning is also the same, except that it is moved to the beginning of the specified record before the data is OUTPUT. If you wish to write randomly to a newly created file, either use a CONTROL statement to position the EOF in the last record, or start at the beginning of the file and write some “dummy” data into every record.

If you attempt to write more data to a record than the record will hold, the system will return an End-Of-Record (EOR) condition. An EOR condition will result if you try to write data more than one record past the EOF position. EOR conditions are treated by the system just like EOF conditions, except that they return Error 60 instead of 59 if they are not trapped by ON END. Data already written to the file before an EOR condition arises will remain intact. The examples below illustrate how data is stored randomly.

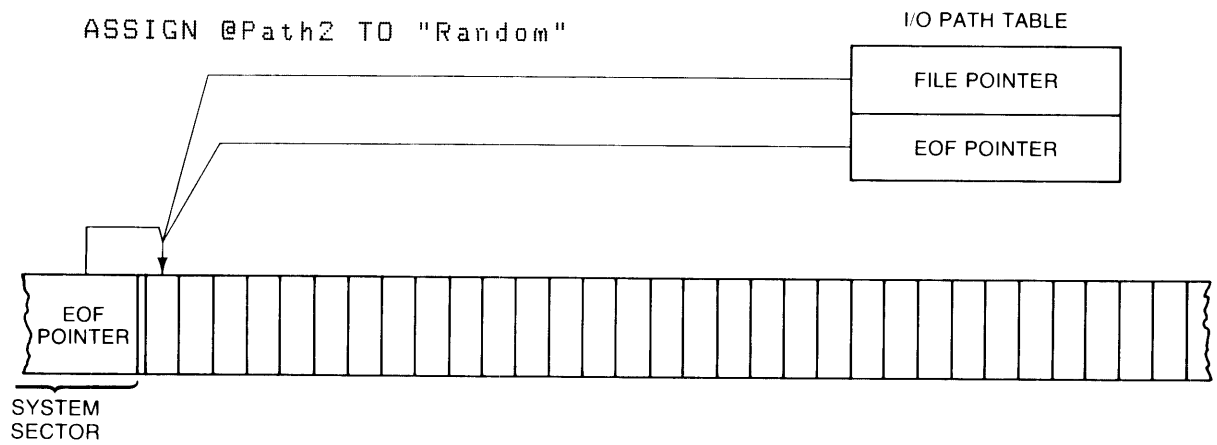
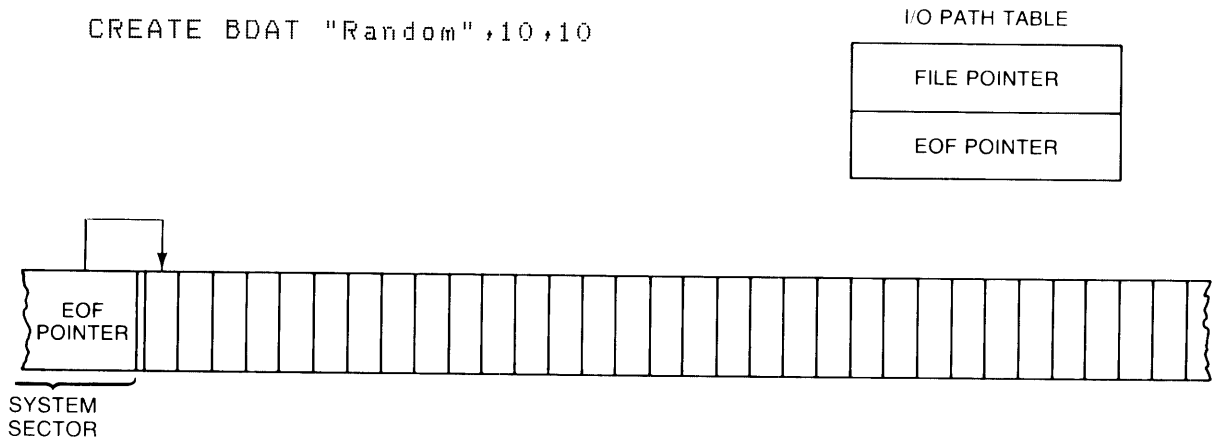

OUTPUT @Path2,1;"TOO LONG TO FIT IN RECORD"

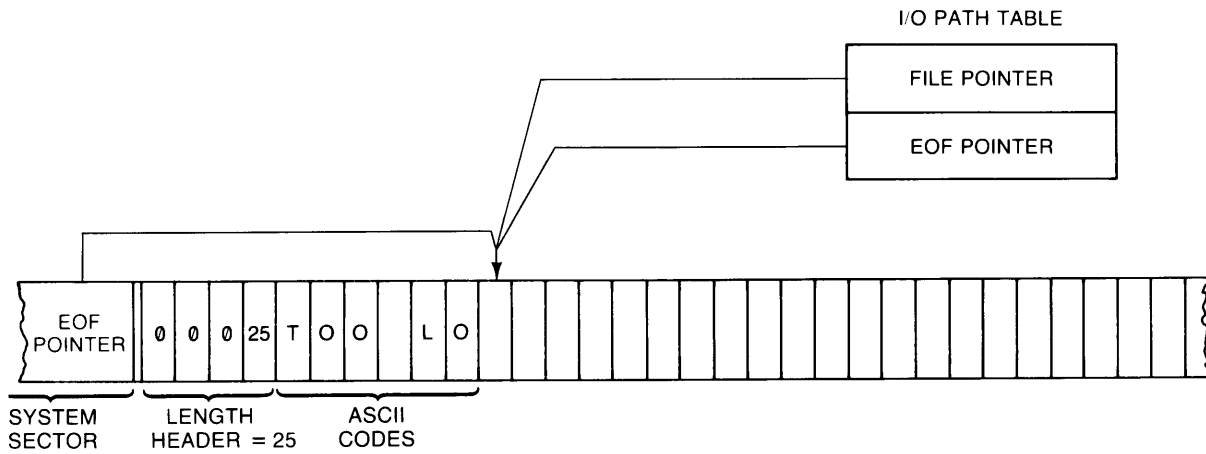

Even though this statement produces an EOR condition, the EOF markers and file pointer are still updated. The ON END statement can be used to trap their error. Also, the length header represents the length of the string characters sent to the file, since the whole string is not written out.

OUTPUT @Path2,2;2

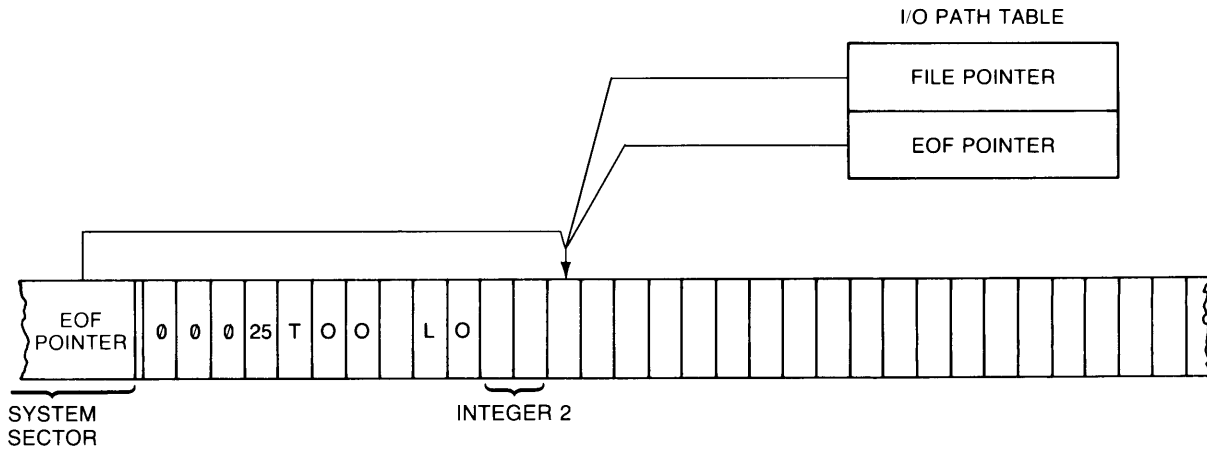

OUTPUT @Path2,3;"THIRD"

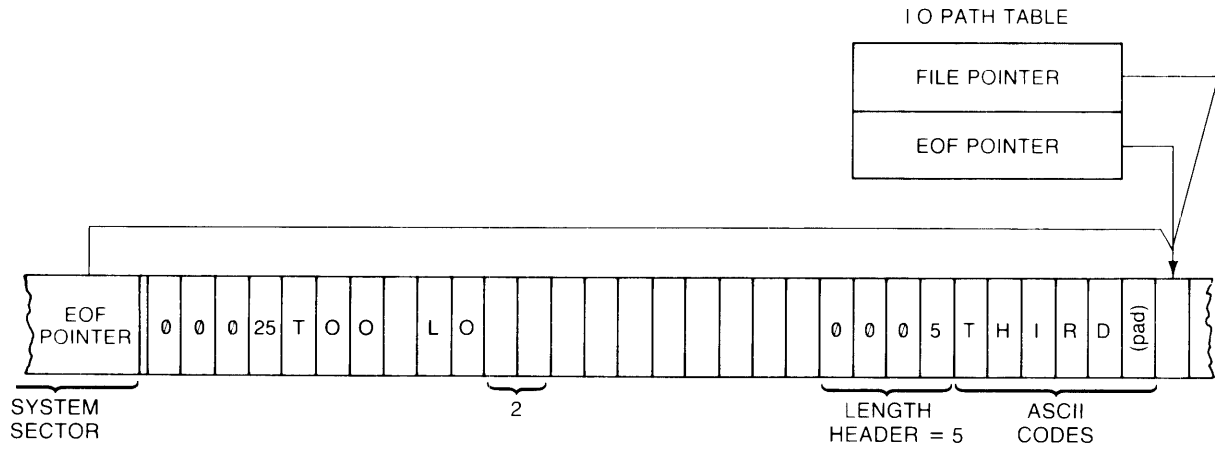

OUTPUT @Path1,2;45.78

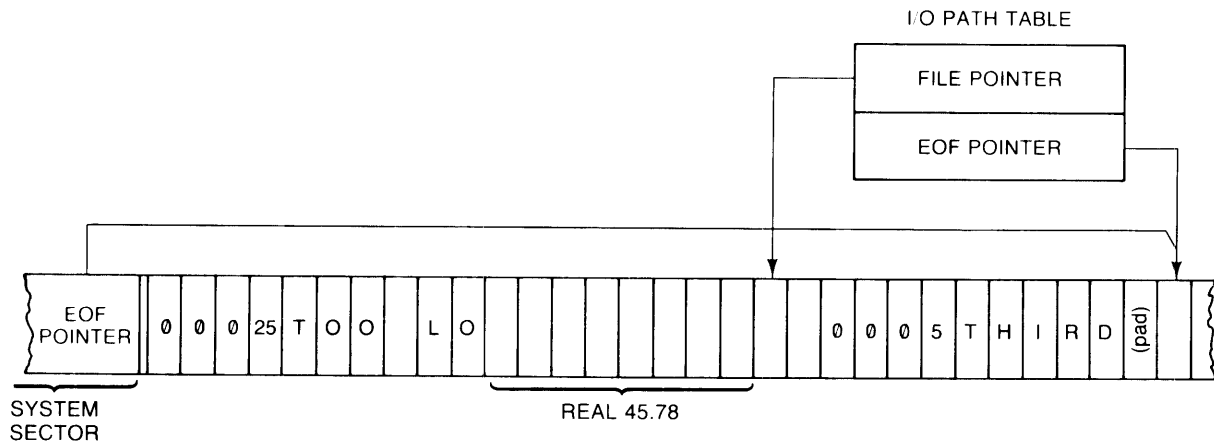

Reading Data From BDAT Files

Data is read from files with the ENTER statement. As with OUTPUT, data is passed along an I/O path. You can use the same I/O path you used to OUTPUT the data or you can use a different I/O path.

You can have several variables in a single ENTER statement. Each variable must be separated by either a comma or semi-colon. It is extremely important to make sure that your variable types agree with the data types in the file. If you wrote a REAL number to a file, you should ENTER it into a REAL variable; INTEGERS should be entered into INTEGER variables; and strings into string variables. The rule to remember is: "Read it the way you wrote it."

When reading data into a string variable, it is important to remember that the system will interpret the first four bytes after the file pointer as a length header. It will then try to ENTER as many characters as the length header indicates. If the string has been padded by the system to make its length even, the pad character is not read into the variable.

After an ENTER statement has been executed, the file pointer is positioned to the next unread byte. If the last data item was a padded string, the file pointer is positioned after the pad. If you use the same I/O path name to read and write data to a file, the file pointer will be updated after every ENTER and OUTPUT statement. If you use different I/O path names, each will have its own file pointer which is independent of the other. However, be aware that each also has its own EOF pointer and that these pointers may not match, which causes problems.

Entering data does not affect the EOF pointers. However, you cannot read data at or beyond the byte marked by the EOF pointers. If you attempt to read past an EOF marker, the system will return an EOF condition.

In addition to making sure that data types agree, it is also advisable to make sure that access modes agree. If you wrote data serially, you should read it serially; and if you wrote it randomly, you should read it randomly. There are a few exceptions to this rule which we discuss later. However, you should be aware that mixing access modes will often lead to erroneous results unless you are aware of the precise mechanics of the file system.

Serial ENTER

When you read data serially, the system enters data into variables starting at the current position of the file pointer and proceeds byte by byte until all of the variables in the ENTER statement have been filled. If there is not enough data in the file to fill all of the variables, the system returns an EOF condition. All variables that have already taken values before the condition occurs retain their values.

In the program below, we OUTPUT five data items serially, and then retrieve the data items with a serial ENTER statement.

```

10  CREATE BDAT "STORAGE",1
20  ASSIGN @Path TO "STORAGE"
30  INTEGER Num,First,Fourth
40  Num=5
60  OUTPUT @Path;Num,"squared"," equals",Num*Num,".",END
70  ASSIGN @Path TO "STORAGE"
80  ENTER @Path;First,Second$,Third$,Fourth,Fifth$
90  PRINT First;Second$;Third$,Fourth,Fifth$
100 END

```

```

5 squared equals 25.

```

Note that we re-ASSIGNED the I/O path in line 70. This was done to re-position the file pointer to the beginning of the file. If we had omitted this statement, the ENTER would have produced an EOF condition. Note also that the OUTPUT statement includes END, which specifies that the EOF pointer is to be moved to match the file pointer at statement completion. In this case, the END is redundant.

Random ENTER

When you ENTER data in random mode, the system starts reading data at the beginning of the specified record and continues reading until either all of the variables are filled or the system reaches the EOR or EOF. If the system comes to the end of the record before it has filled all of the variables, an EOR condition is returned.

In the following example, we randomly OUTPUT data to 10 successive records, and then ENTER the data into an array in reverse order.

```

10  CREATE BDAT "SQ_ROOTS,5,2*8
20  ASSIGN @Path TO "SQ_ROOTS"
30  FOR Inc=1 to 5
40  OUTPUT @Path,Inc;Inc,SQR(Inc)
50  NEXT Inc
60  FOR Inc=5 TO 1 STEP -1
70  ENTER @Path,Inc;Num(Inc),Sqrroot(Inc)
80  NEXT Inc
90  PRINT "Number","Square Root"
100 FOR Inc=1 TO 5
110 PRINT Num(Inc),Sqrroot(Inc)
120 NEXT Inc
130 END

```

Number	Square Root
1	1
2	1.41421356237
3	1.73205080757
4	2
5	2.2360679775

In this example, there was no need to re-ASSIGN the I/O path because the random ENTER automatically re-positions the file pointer.

Executing a random ENTER without a variable list has the effect of moving the file pointer to the beginning of the specified record. This is useful if you want to serially access some data in the middle of a file. Suppose, for instance, that you have a file containing 100 8-byte records, and each record has a REAL number in it. If you want to read the last 50 data items, you can position the file pointer to the 51st record and then serially read the remainder of the file into an array.

```

.
.
.
100    REAL Array(1:50)
110    ENTER @RealPath,51
120    ENTER @RealPath;Array(*)
.
.
.

```

Single-Byte Access

You can define records to be just one byte long. In this case, it doesn't make sense to read or write one record at a time since even the shortest data type require two bytes to store a number.

Random access to one-byte records, therefore, has its own set of rules. When you access a one-byte record, the file pointer is positioned to the specified byte. From there, the access proceeds in serial mode. Random OUTPUTs write as many bytes as the data item requires, and random ENTERs read enough bytes to fill the variable. The example below illustrates how you can read and write randomly to one-byte records.

```

10     INTEGER Int
20     CREATE BDAT "BYTE",100,1
30     ASSIGN @Bytepath TO "BYTE"
40     OUTPUT @Bytepath,1;3.67
50     OUTPUT @Bytepath,9;3
60     OUTPUT @Bytepath,11;"string"
70     ENTER @Bytepath,9;Int
80     ENTER @Bytepath,1;Real
90     ENTER @Bytepath,11;Str$
100    PRINT Real
110    PRINT Int
120    PRINT Str$
130    END

3.67
3
string

```

Note that we had to declare the variable "Int" as an INTEGER. If we hadn't, the system would have given it the default type of REAL and would therefore have required 8 bytes (also 8 records).

General Mass Storage Operations

Trapping EOF and EOR Conditions

An EOF condition exists whenever the system attempts to read data at, or beyond, the byte marked by the EOF pointers. The EOR condition will arise if you attempt to randomly read or write beyond the particular record specified. If, for example, you try to randomly OUTPUT a 20-character string into a 10-byte record, an EOR condition will occur. EOF conditions will also result whenever you try to read or write beyond the physical end-of-file.

EOF and EOR conditions can be trapped with an ON END statement. ON END is similar to ON ERROR except that it only traps EOF/EOR conditions and is only applicable to the specified I/O path. If you do not have an ON END statement in a program, the EOF/EOR condition will produce an error that is trappable by the ON ERROR statement. Encountering a logical or physical end of file will produce Error 59. Encountering an end of record in random mode produces Error 60.

You can have any number of ON END statements in a program context. ON END statements that refer to different I/O paths will not interfere with each other, even if the paths go to the same file. If you have more than one ON END to the same I/O path, the system will use whichever one it most recently executes during program flow.

An ON END is cancelled by the OFF END statement. OFF END only cancels the ON END branch for the specified I/O path. Re-ASSIGNing an I/O path will also cancel any existing ON END branch for the particular path.

The example below illustrates some of the more common situations that cause an EOF condition.

```

100  CREATE BDAT "ONEND",10,8
110  ASSIGN @Endpath TO "ONEND"
120  ON END @Endpath GOTO Eof1
130  FOR Inc=1 TO 20
140    OUTPUT @Endpath,Inc;SQR(Inc)
150  NEXT Inc
160 Eof1: !
170  PRINT "EOF CONDITION -- ATTEMPT TO RANDOMLY WRITE BEYOND PHYSICAL END OF F
FILE."
180  PRINT
190  !
200  ON END @Endpath GOTO Eof2
210  OUTPUT @Endpath,5;"THIS IS A STRING."
220 Eof2: !
230  PRINT "EOR CONDITION -- ATTEMPT TO RANDOMLY WRITE DATA  ITEM LONGER THAN
RECORD."
240  PRINT
250  !
260  ON END @Endpath GOTO Eof3
270  ENTER @Endpath,5;Str$
280 Eof3: !
290  PRINT "EOR CONDITION -- ATTEMPT TO READ DATA ITEM LONGER THAN RECORD."
300  PRINT
310  !

```

```

320  ASSIGN @Endpath TO "ONEND"
330  ON END @Endpath GOTO Eof4
340  FOR Inc=1 TO 100
350    OUTPUT @Endpath;"A"
360  NEXT Inc
370 Eof4: !
380  PRINT "EOF CONDITION -- ATTEMPT TO SERIALY WRITE BEYOND PHYSICAL END OF F
ILE."
390  PRINT
400  !
410  ASSIGN @Endpath TO "ONEND"
420  ON END @Endpath GOTO Eof5
430  FOR Inc=1 TO 100
440    ENTER @Endpath;Str$
450  NEXT Inc
460 Eof5: !
470  PRINT "EOF CONDITION -- ATTEMPT TO SERIALY READ BEYOND  PHYSICAL END OF F
ILE."
480  PRINT
490  !
500  ON END @Endpath GOTO Eof6
510  OUTPUT @Endpath,5;5,END
520  ENTER @Endpath,6;X
530 Eof6: !
540  PRINT "EOF CONDITION -- ATTEMPT TO RANDOMLY READ BEYOND  LOGICAL END OF FI
LE."
550  !
560  END

```

EOF CONDITION -- ATTEMPT TO RANDOMLY WRITE BEYOND
PHYSICAL END OF FILE.

EOR CONDITION -- ATTEMPT TO RANDOMLY WRITE DATA
ITEM LONGER THAN RECORD.

EOR CONDITION -- ATTEMPT TO READ DATA ITEM LONGER
THAN RECORD.

EOF CONDITION -- ATTEMPT TO SERIALY WRITE BEYOND
PHYSICAL END OF FILE.

EOF CONDITION -- ATTEMPT TO SERIALY READ BEYOND
PHYSICAL END OF FILE.

EOR CONDITION -- ATTEMPT TO RANDOMLY READ BEYOND
LOGICAL END OF FILE.

This example highlights a number of interesting points. First, in line 210 we try to randomly write a 17-byte string into an 8-byte record. The system returns an EOR condition. The length header for the string, however, is still 17. So when we try to read the string in line 270, we again receive an EOR condition.

In line 320 we re-ASSIGN the I/O path name in order to position the file pointer to byte 1. Then we redefine the ON END branch. These two statements must appear in this order since re-ASSIGNing an I/O path has the effect of canceling any ON END branch previously associated with the path.

In line 510, we shrink the file by moving the EOF pointer to the end of record 5 with the "END" secondary word. When we try to read record 6 in line 520 we get an EOF condition.

Protecting Files

Protect codes are two-character strings that can be assigned to any BDAT, BIN or PROG type file with the PROTECT statement. Protect codes are not unbreakable; they are only intended to prevent accidentally writing in files and directories.

For instance, the following statement assigns the protect code "AA" to the file named "FILE1."

```
PROTECT "FILE1","AA"
```

File specifiers in mass storage statements that write to a file or directory must include the protect code, if the file has one. Mass storage statements that read a file or directory do not require the protect code (e.g., CAT, LOAD, LOAD BIN, LOADSUB ALL FROM, GET and COPY). A protect code is specified by placing it in brackets right after the file name. To assign an I/O path name to the file named "FILE1," you would now have to include the protect code.

```
ASSIGN @Path1 TO "FILE1<AA>"
```

If you assign a protect code longer than two characters, the system will ignore everything after the second (non-blank) character. For example, the protect codes LONGPASS, LOLLYPOP, and LOST all result in the same protect code: LO. This rule holds both for PROTECTing a file and for specifying the protect code in a file specifier. For instance:

```
PROTECT "FILE1","Protect1"
```

would assign the protect code "Pr" to FILE1. To rename the file, we could write:

```
RENAME "FILE1<Prattle>" TO "FILE2"
```

"Prattle" is an acceptable protect code, since it starts with "Pr." Note that we do not include a protect code in the new file name. If you do, the system ignores it since the old protect code is passed to the new file name. FILE2 still has the protect code "Pr". To rename the file again, we might write:

```
RENAME "FILE2<Pr>" TO "FILE3"
```

Renaming a file has the effect of changing the file name in the directory and leaving everything else intact.

In addition to using the PROTECT statement, you can also assign a protect code to a BDAT file when you create it. For example:

```
CREATE BDAT "Example<xx>",10
```

creates a 10-record BDAT file called "Example" and gives it a protect code of "xx". You can also do this to PROG files with the STORE and STORE BIN statements. However, since ASCII files cannot be protected, a protect code cannot be included in any CREATE ASCII, SAVE, or RE-SAVE statement.

To change a protect code, simply execute a new PROTECT statement. To change the protect code of "Example" to "yy," execute:

```
PROTECT "Example<xx>","yy"
```

Note that you must include the current protect code in the file specifier.

To completely remove a protect code from a file, PROTECT the file with a code consisting of two blanks. For example, to remove the protect code from file "Example," execute:

```
PROTECT "Example<yy>", "  "
```

When specifying a file that does not have a protect code, you can either ignore the code entirely or include a code of two spaces:

```
PURGE "Example"
      or
PURGE "Example<  >"
```

Securing Program Lines

While PROTECT prevents unintentional writing into files and directories, it does not prevent a programmer from looking at lines in a program. The SECURE statement prevents program lines from being listed.

For example, the following statement secures lines 10 thru 100 of the program currently in memory.

```
SECURE 10,100
```

If you want the entire program to be secure just execute:

```
SECURE
```

Note

Once a program is secured, it cannot be UNsecured. You should keep a backup copy of all programs in their unsecured form.

When you list a program, the secured lines are listed with asterisks after the line numbers. For example, lines 30 thru 60 are secured in the following listing.

```
10  !Example of Secured
20  !Begin password check
30*
40*
50*
60*
70  !End of password check
80
```

Copying Files and Volumes

The COPY statement allows you to duplicate individual files or an entire disc volume. Any type of file may be copied.

COPY of a file duplicates the existing file and places the new file name in the directory. A new file can be created either on the same disc or on another disc. If you copy a file to the same disc, the new file name must be different from the existing file name. If the file is of BDAT, BIN or PROG type, you can also assign a protect code to the new file. If there is not enough room on the disc for the file to be copied, the system cancels the statement and returns an error.

If the COPY statement specifies two mass storage volumes and no file names, a copy of the entire source volume is created. The purpose of this COPY option is to duplicate discs or make back-up copies. Note that you will **lose any old information** in the directory of the destination volume. A volume copy does not append to the contents of the destination; when the copy is finished, the source and destination volumes will be identical. You cannot copy a larger volume to a smaller volume, regardless of the amount of data on the larger volume. You can quickly purge all the files on a volume by copying an empty disc onto a full disc.

Examples

The following statement copies "File1" from the current system mass storage device to a new file called "File2" on the same mass storage.

```
COPY "File1" TO "File2"
```

The following statement copies "File1" from the current system mass storage to the drive at interface select code 7, primary address 0, unit number 1. Note that both files can be named "FILE1" if they are on different volumes.

```
COPY "File1" TO "File1:HP,700,1"
```

The following statement copies a file from an HP 82901 drive to the current system mass storage device. The new file "DATA" is given the protect code "xx."

```
COPY "File1:HP82901,700,0" TO "DATA<xx>"
```

The following statement copies the entire disc from the right-hand internal drive to the left-hand drive of a Model 236.

```
COPY ":INTERNAL" TO ":INTERNAL,4,1"
```

Purging Files

You can purge a file from the directory by using the PURGE statement. Purging a file deletes the directory entry for the file and releases the reserved space in the data area. Purging a file, therefore, creates two "gaps" on the disc: one in the data area and one in the directory. When you create a file, the system looks at all the gaps in the data area to see if the newly created file will fit in any of them.

Directory entries must be in the same order as the files in the data area. The fourth directory entry, for example, must correspond to the fourth file in the data area. Consequently, if you PURGE a file, and then create a smaller file, you may lose disc space. The following examples illustrate this principle.

Suppose that you have three consecutive files on a disc with the following names and sizes.

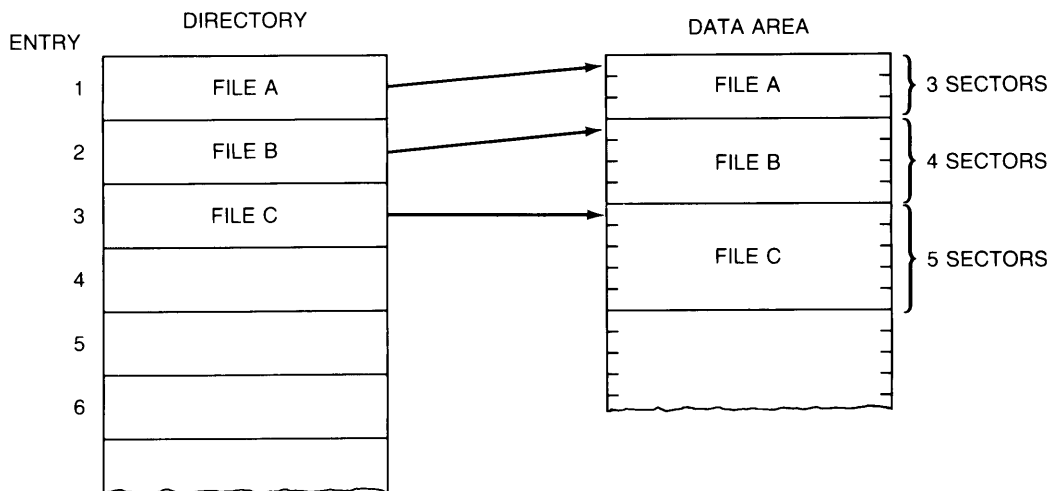

Executing the following statement:

```
PURGE "FILEB"
```

creates a 1-entry gap in the directory and a 4-sector gap in the data area.

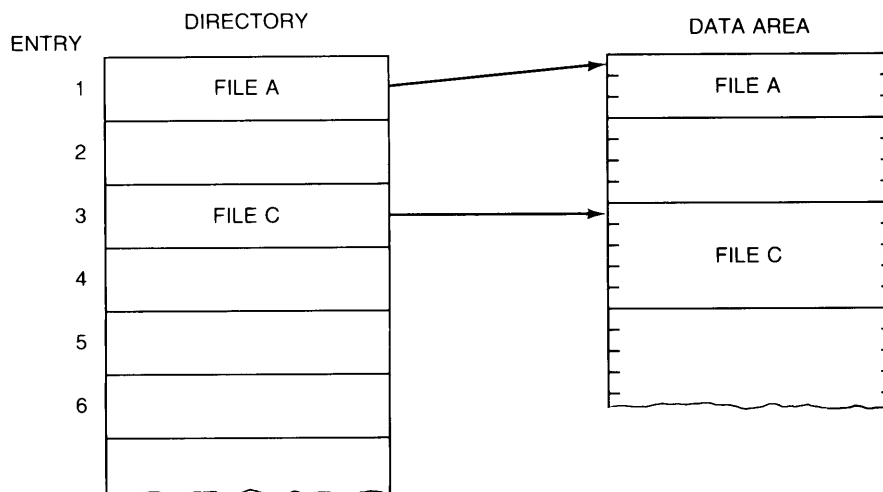

Now, suppose you create a 2-sector file:

```
CREATE ASCII "FILED" ,2
```

The system will place this file in the data-area gap and place the directory entry in the directory gap.

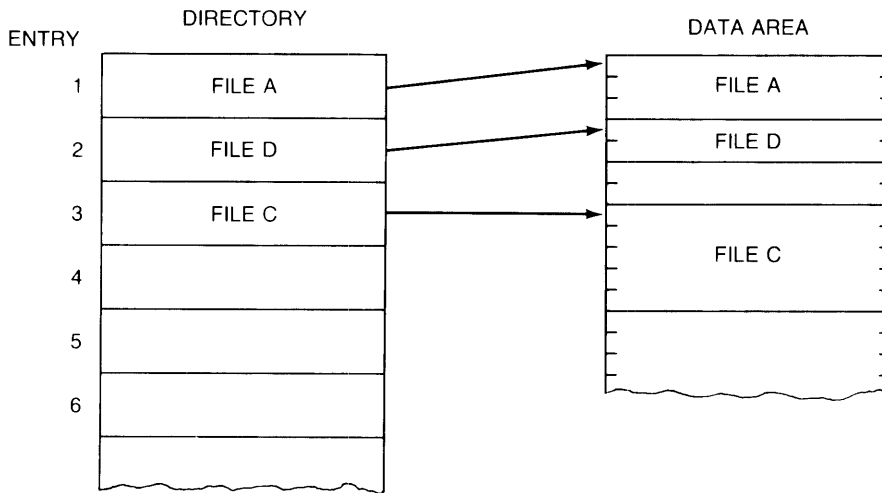

You now have a 2-sector gap in the data area but no gaps in the directory. If you create another file, the system will fill entry 4 in the directory and will reserve space in the data area past FILEC. The two unused sectors will not be reclaimed unless you PURGE one of the adjacent files, FILED or FILEC.

Accessing Directories

Disc structure and mass storage directories were briefly described earlier in this chapter. As you may recall, a directory is merely an index to the files on a mass storage media. The BASIC language has several features that allow you to obtain information from the directories of mass storage media. This section presents several techniques that will help you access this information.

To get a catalog listing of a directory, you will use the CAT statement. Executing CAT with no media specifier directs the system to get a catalog of the current system mass storage directory.

```
CAT
```

Including a media specifier directs the system to get a catalog of the specified mass storage. For instance, executing the following statement returns a catalog of the directory of the left drive of a Model 236.

```
CAT " : INTERNAL ,4 ,1 "
```

Both of the preceding statements sent the catalog listings to the current system printer (the one specified in the last PRINTER IS statement; the default system printing device is the CRT).

Sending Catalogs to External Printers

The CAT statement normally directs its output to the current PRINTER IS device. The CAT statement can also direct the catalog to a specified device, as shown in the following examples:

```
CAT TO #701
CAT TO #External_Prttr
CAT TO #Device_selector
```

The parameter following the # is known as a device selector and is further described in Chapter 8, "Using a Printer," and in the Glossary of the *BASIC Language Reference*.

Extended Access of Directories

With MS, the CAT statement has the following additional capabilities:

- additional information about PROG files may be obtained
- the mass storage directory can be sent to a string array
- files to be cataloged may be selected by name or by beginning letter(s) of the file name
- the number of selected file entries may be counted
- the CAT operation may be directed to "skip" a specific number file entries before sending entries to the destination
- the catalog header may be suppressed

Cataloging Individual PROG Files

Performing CAT operations on an individual PROG file returns additional information about the file. A catalog of a PROG files yields the following information:

- a list of the binary program(s) contained in the program file and the size of each (in bytes)
- the size of the main program (in bytes).
- a list of contexts (SUB and FN subprograms) and their sizes (in bytes)

The following catalog listing is an example of a CAT performed on an individual PROG file. Note that this catalog format only requires 45 columns.

```
NEWPAGER_A
NAME                SIZE TYPE
=====
MAIN                62002 BASIC
FNBar$              3680 BASIC
FNroman$            656 BASIC
Killkeys            426 BASIC
FNtrim$             414 BASIC
FNupc$              344 BASIC
FNLwc$              416 BASIC
Table_formatter     6810 BASIC
Strip               1260 BASIC
AVAILABLE ENTRIES = 0
```

The AVAILABLE ENTRIES table entry is not currently used.

If the program contains a binary or PHYREC program, a warning and the version codes of both the BASIC system and the binary program are included in the catalog information. PHYREC programs are not supported with BASIC 3.0. The following example shows the format of the message returned.

```

Prog_Phy
NAME                               SIZE TYPE
=====
PHYREC 2.0                          1734 BASIC BINARY
*** WARNING: System level 3, Bin level 2.
MAIN                                 222 BASIC
AVAILABLE ENTRIES = 0

```

Cataloging to a String Array

The following example program segment shows an example of directing the catalog of mass storage file entries to the CRT and then to a string array.

```

100 PRINT "          CAT to CRT,"
110 PRINT "-----"
120 CAT TO #CRT;COUNT Files_and_headr ! Includes 5-line header.
130 PRINT "Number of files=";Files_and_headr-5
140 PRINT
150 !
160 PRINT "          CAT to a string array."
170 PRINT "-----"
180 Array_size=Files_and_headr+2 ! Allow for 7-line header.
190 ALLOCATE Catalog$(1:Array_size)[B0]
200 CAT TO Catalog$(*)
210 FOR Entry=1 TO Array_size
220   PRINT Catalog$(Entry)
230 NEXT Entry
240 PRINT "Number of files=";Array_size-7
250 PRINT
260 !
270 END

```

The program produces the following output.

```

CAT to CRT.
-----
:INTERNAL
VOLUME LABEL: B9826
FILE NAME PRO TYPE REC/FILE BYTE/REC ADDRESS
Data1      ASCII      3      256      16
Chap1      BDAT        3      256      20
Prog1      PRDG        2      256      23
Chap2      BDAT        7      256      26
Prog2      PRDG        2      256      33
Data2      ASCII      9      256      35
Chap3      BDAT        6      256      45
Data3      ASCII      5      256      51
BCD_INTR   ASCII      3      256      56
BCD_CONFIG ASCII      9      256      59
BCD_ENT1   ASCII      2      256      68
BCD_OUT1   ASCII      1      256      70
BCD_ENTBIN ASCII      2      256      71
BCD_ENTFMT ASCII     10      256      73
Number of files= 14

CAT to a string array.
-----
:INTERNAL, 4
LABEL: B9826
FORMAT: LIF
AVAILABLE SPACE: 892
SYS FILE NUMBER RECORD MODIFIED PUB OPEN
FILE NAME LEV TYPE TYPE RECORDS LENGTH DATE TIME ACC STAT
=====
Data1      1      ASCII      3      256      MRW
Chap1      1 98X6 BDAT      3      256      MRW
Prog1      1 98X6 PRDG     2      256      MRW
Chap2      1 98X6 BDAT     7      256      MRW
Prog2      1 98X6 PRDG     2      256      MRW
Data2      1      ASCII     9      256      MRW
Chap3      1 98X6 BDAT     6      256      MRW
Data3      1      ASCII     5      256      MRW
BCD_INTR   1      ASCII     3      256      MRW
BCD_CONFIG 1      ASCII     9      256      MRW
BCD_ENT1   1      ASCII     2      256      MRW
BCD_OUT1   1      ASCII     1      256      MRW
BCD_ENTBIN 1      ASCII     2      256      MRW
BCD_ENTFMT 1      ASCII    10      256      MRW
Number of files= 14

```

Including the keyword COUNT followed by a numeric variable returns the total number of file entries plus header lines to that variable; here, the variable `Files_and_header` is used. In this example, a value of 2 is added to this variable to compensate for the 7-line header which is sent instead of the usual 5-line header. This new value, stored in `Array_size`, is then used to direct the computer to ALLOCATE just enough space in a string-array variable to hold the directory listing. The program can then search the directory listing for further information, if desired.

You may have noticed that the format for catalogs sent to string arrays (the second catalog listing) is different from catalogs sent to the PRINTER IS device. This catalog format requires that each array element must be dimensioned to hold at least 80 characters with this type of CAT operation. Again, the header contains 7 lines, not 5 as with catalogs sent to devices.

If the CAT operation would not have filled the string array, the unused array elements would have been set to the null string (i.e., strings of length 0). If there are more catalog lines than string-array elements, the operation stops when the array is filled. No indication of the “overflow” is reported; the count returned is equal to the number of array elements.

Suppressing the Catalog Header

To suppress the catalog header that would otherwise be sent automatically to the destination, use the following syntax:

```
CAT;NO HEADER
CAT TO String_array$(*);NO HEADER
CAT "Prog_2";NO HEADER
```

Using NO HEADER suppresses the 5-line or 7-line heading of each catalog format shown above, respectively. The catalog listing of a PROG file would be 3 lines shorter. The first line of each catalog listing contains the first directory entry, the second element contains the second entry, and so forth.

Cataloging Selected Files

The directory entry of file(s) that begin with certain character(s) can be obtained by using the secondary keyword SELECT. For this example, assume that the directory contains the following entries:

```
:INTERNAL
VOLUME LABEL: B9826
FILE NAME PRO TYPE REC/FILE BYTE/REC ADDRESS
Data1 ASCII 3 256 16
Chap1 BDAT 3 256 20
Prog1 PROG 2 256 23
Chap2 BDAT 7 256 26
Prog2 PROG 2 256 33
Data2 ASCII 9 256 35
Chap3 BDAT 6 256 45
Data3 ASCII 5 256 51
BCD_INTR ASCII 3 256 56
BCD_CONFIG ASCII 9 256 59
BCD_ENT1 ASCII 2 256 68
BCD_OUT1 ASCII 1 256 70
BCD_ENTBIN ASCII 2 256 71
BCD_ENTFMT ASCII 10 256 73
```

Suppose that you want to catalog only files beginning with the letters “Prog”. The following examples show how this may be accomplished. Notice that this is **not** the same operation as getting a catalog of a PROG file.

```
Beginning_chars$="Prog"
CAT;SELECT Beginning_chars$

CAT;SELECT "Prog";COUNT Files_and_headr
```

The directory entries of the three files beginning with the letters "Prog" are sent to the PRINTER IS device. In the second CAT statement above, the variable `Files_and_headr` is filled with the number of selected files found on the current default mass storage device (plus the 5 header lines). (Keep in mind that the variable `Files_and_headr` must be currently defined in the current program context.)

The following result would be sent to the system printing device.

```
:INTERNAL, 4
VOLUME LABEL: B9826
FILE NAME PRO TYPE REC/FILE BYTE/REC ADDRESS
Prog1      PROG      2      256      23
Prog2      PROG      2      256      33
Prog3      PROG      2      256      533
```

SELECT may also be used to get the catalog of an individual file entry by selecting the entire file name, as shown in the following statement:

```
CAT;SELECT "Chap3"
```

Getting a Count of Selected Files

It is often desirable to determine the total number of files on a disc, or the number that begin with a certain character or group of characters. The COUNT option directs the computer to return the number of selected files in the variable that follows the COUNT keyword.

```
CAT;COUNT Files_and_headr
CAT;SELECT "Data",COUNT Selected_files
```

The first CAT operation returns a count of all files in the directory (plus 5 header lines), since not including SELECT defaults to "select all files". The second operation returns a count of the specifically selected files (plus 5).

Skipping Selected Files

If there are many files that begin with the same characters, it is often useful to be able to skip some of the directory entries so that the catalog is not as long. This may be especially useful when using a drive such as an HP 7912, which has the capability of storing more than 10 000 files.

The following statement shows an example of skipping file entries before sending selected entries to the destination.

```
CAT;SELECT "BCD",SKIP 5

:INTERNAL, 4
VOLUME LABEL: B9826
FILE NAME PRO TYPE REC/FILE BYTE/REC ADDRESS
BCD_ENTFMT ASCII      10      256      73
```

The first five "selected" files (that begin with the specified characters) are "skipped" (i.e., not sent with the rest of the catalog information).

Including COUNT in the previous CAT operation (as shown below) returns a count of the selected files (plus header lines), not just the catalog lines sent to the destination. Remember that selected files includes all files skipped, if any. In this case, a value of 11 is returned, not 1 (or 6) as might be expected.

```
CAT;SELECT "BCD",SKIP 5,COUNT Catalog_lines
```

Note that if SKIP is included, the count remains the same (as long as at least one file is cataloged). If the number of files to be skipped equals the number of files selected, COUNT returns a value of zero.

```
CAT;SELECT "BCD",SKIP 6,COUNT Files_and_headr
```

The following program shows an example of looking at the files in a catalog by viewing a small "window" of files at one time. The technique is useful for decreasing the amount of memory required to hold a catalog listing in a string array.

```
100 ! Declare a small string array (7 elements).
110 DIM Array$(1:7)[80]
120 !
130 ! Send header to the array.
140 CAT TO Array$(*)
150 ! Print header.
160 FOR Element=1 TO 7
170     PRINT Array$(Element)[1,45]
180 NEXT Element
190 !
200 ! Now get 7-line "windows" and print files therein.
210 First_file=1 ! Begin with first file in directory.
220 REPEAT ! Send file entries to Array$ until last file sent.
230     !
240     ! Send files to Array$; SKIP files already printed;
250     ! return index (with COUNT) of last file sent to Array$.
260     CAT TO Array$(*);SKIP First_file-1,COUNT Last_file,NO HEADER
270     DISP "First file=";First_file;" Last file=";Last_file
280     !
290     ! Print file entries (no entry printed when Last_file=0).
300     FOR Element=1 TO (Last_file-First_file)+1 ! (6 or less)+1.
310         PRINT Array$(Element)[1,45]
320     NEXT Element
330     !
340     First_file=Last_file+1 ! Point to next "window."
350     !
360 UNTIL Last_file=0 ! Until SKIP >= number of files.
370 !
380 END
```

It is also important to note the order of options in the CAT statement. This order is required when several options are used. If the NO HEADER option is used, it must be the last option in the list, as shown in the following example.

```
CAT;SELECT "BCD",SKIP 5,COUNT Selected_files,NO HEADER
```

Using a Printer

Chapter

8

Introduction

Sooner or later it needs to be printed. A wide range of printers, supported by BASIC, can be connected to the Series 200 computers. This chapter covers the statements commonly used to communicate with external printers. The following list names some of the printers that work with Series 200 computers:

- HP 2631 Dot Matrix Printer
- HP 2671 Thermal Printer
- HP 2673 Intelligent Thermal Printer
- HP 9866 Thermal Printer (with interface)
- HP 9876 Thermal Graphics Printer
- HP 82905 Dot Matrix Printer
- HP 2601 Daisy-Wheel Printer

All these printers, except the HP 9866, can be directly connected to the computer's internal HP-IB interface. The HP 9866 requires its own interface.

Fundamentals

The PRINT statement normally directs text to the screen of the CRT. Text may be re-directed to an external printer by using the PRINTER IS statement. The default **system printer** is the screen of the CRT. The PRINTER IS statement is used to change the system printer.

Before a printer will print the first character, several steps are required to set up the printer. These steps are fully documented in the appropriate printer installation manual.

After the printer is switched on and the computer and printer have been connected via an interface cable, there is only one piece of information needed before printing can begin. The computer needs to know the correct **device selector** for the printer. This is analogous to knowing the correct telephone number before making a call.

Device Selectors

A device selector is a number that uniquely identifies a particular device connected to the computer. When only one device is allowed on a given interface, it is uniquely identified by the **interface select code**. In this case, the device selector is the same as the interface select code.

For example, the internal CRT is the only device at the interface whose select code is 1. To direct the output of PRINT statements to the CRT, use the following statement.

```
PRINTER IS 1
```

This statement defines the screen of the CRT to be the system printer. Until changed, the output of PRINT statements will appear on the screen of the CRT.

When more than one device can be connected to an interface, such as the internal HP-IB interface, (interface select code 7) the interface select code no longer uniquely identifies the printer. Extra information is required. This extra information is the **primary address**.

Primary Addresses

Each printer has a set of switches, usually located on the back panel, which determine the primary address of the printer.

The following photographs show the switch locations on various printers. In addition to the primary address switch segments there are usually segments that control the printers response to other signals on the HP-IB bus.

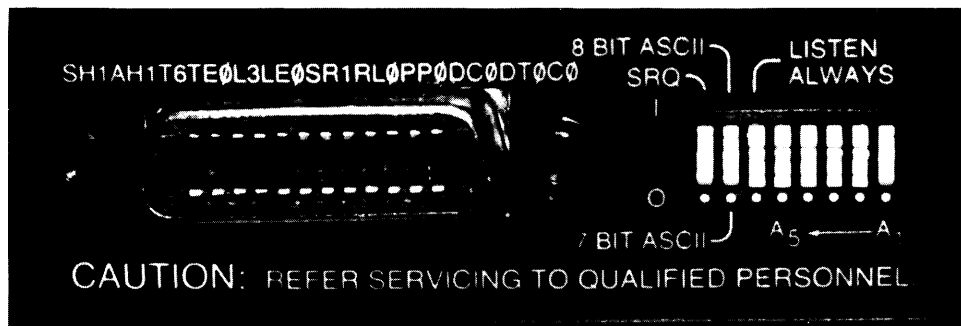
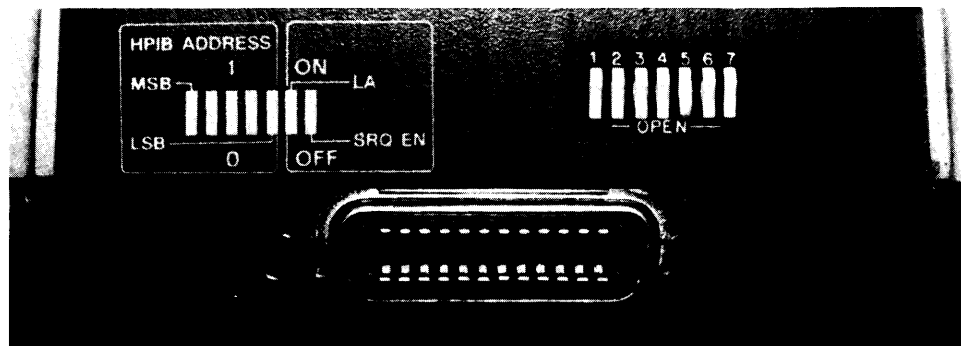

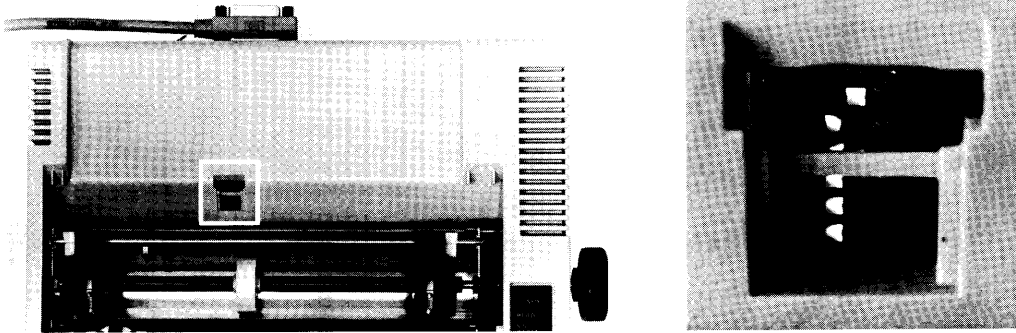

The primary address, determined by the switch settings, is combined with the interface select code to make up the device selector. In the following example the primary address **01** is appended to the interface select code **7** to produce the device selector **701**.

```
PRINTER IS 701
```

This statement tells the computer to use a the internal HP-IB interface (select code 7) to communicate with a printer whose switches are set to the primary address “01”. If the printer’s primary address is set to “11”, the device selector would be “711”.

A device selector can be created mathematically by multiplying the interface select code by 100 and adding the primary address. For example, a printer on the internal HP-IB bus whose primary address is set to 9 would have the device selector 709 ($7 \times 100 + 9 = 709$).

Switch Settings

Five switch segments, dedicated to setting the primary address, allow thirty-two possible addresses. In the following decimal-to-binary conversion table, each binary digit corresponds to one of the switch segments. A '1' indicates the switch segment is **on**, while a '0' indicates the switch segment is **off**.

Decimal	Binary	Decimal	Binary
0	00000	16	10000
1	00001	17	10001
2	00010	18	10010
3	00011	19	10011
4	00100	20	10100
5	00101	21	10101
6	00110	22	10110
7	00111	23	10111
8	01000	24	11000
9	01001	25	11001
10	01010	26	11010
11	01011	27	11011
12	01100	28	11100
13	01101	29	11101
14	01110	30	11110
15	01111	31	11111

A quick glance at the switch segments lets you confirm the primary address.

Using Device Selectors

A device selector is used by several different statements. In each of the following, the numeric constant is a device selector.

PRINTER IS 1	Specifies the internal CRT. (default)
PRINTER IS 701	Specifies a printer with interface select code 7 and switch selected to primary address 01.
PRINTER IS 22	Specifies a printer connected through interface select code 22.
CAT TO #701	Prints a disc directory at 701.
PRINTALL IS 707	Logs information on a printer whose select code is 7 and whose switches are set to primary address 07 (binary 00111).
LIST #701	Lists the program in memory to a HP-IB printer set to primary address 01.

Most statements allow a device selector to be assigned to a variable. Either INTEGER or REAL variables may be used.

```
PRINTER IS Ha1
CAT TO #Dog
```

The following three-letter mnemonic functions have been assigned useful values.

Mnemonic	Value
PRT	701
KBD	2
CRT	1

For example, the following statements perform the same action.

```
PRINTER IS PRT
PRINTER IS 701
```

The mnemonic may be used anywhere the numeric device selector can be used.

Another method may be used to identify the printer within a program. An I/O path name may be assigned to the printer; the printer is subsequently referenced by the I/O path name. This technique is fully explained in the *BASIC Interfacing Techniques* manual.

Using the External Printer

Most ASCII characters are printed on an external printer just as they appear on the screen of the CRT. Depending on your printer, there will be exceptions. Several printers will also support an alternate character set: either a foreign character set, a graphics character set, or an enhanced character set. If your printer supports an alternate character set, it usually is accessed by sending a special command to the printer.

Control Characters

In addition to a “printable” character set, printers usually respond to control characters. These non-printing characters generally produce a response from the printer. The following table shows some of the control characters and their effect.

Printer's Response	Control Character	ASCII Value
ring printer's bell	ctrl-G	7
backspace one character	ctrl-H	8
horizontal tab	ctrl-I	9
line-feed	ctrl-J	10
form-feed	ctrl-L	12
carriage-return	ctrl-M	13

One way to send control characters to the printer is the CHR\$ function. Execute the following.

```
PRINTER IS 701
PRINT CHR$(12)
```

The printer responds with a formfeed. To resume printing on the internal CRT, execute the following.

```
PRINTER IS 1
PRINT "Back to the CRT."
```

Other control characters may be valid for your printer. For example, sending a control-N to the HP 82905A printer changes the character size (font) of subsequent text.

```
10 PRINTER IS 701
20 Biꞑ$=CHR$(14)
30 PRINT BIT$;"Double-Width Text"
40 PRINTER IS CRT
50 END
```

Refer to the appropriate printer manual for a complete listing of control characters and their effect on your printer. Some control characters will only affect the current line of text.

Escape-Code Sequences

Similar in use to control characters, escape-code sequences allow additional control over most printers. These sequences consist of the escape character, CHR\$(27), followed by one or more characters.

For example, the HP 2631 printer is capable of printing characters in several different fonts. To print extended characters on the HP 2631 an escape code sequence is sent to the printer before the actual text to be printed is sent.

```

10  PRINTER IS 701
20  Esc$=CHR$(27)
30  Big$="&k1S"
40  Regular$="&k0S"
50  PRINT Esc$;Big$;"Extended-Font Text"
60  PRINT Esc$;Regular$;"Back to normal."
70  PRINTER IS 1
80  END

```

Many escape code sequences can be used by more than one printer. For instance, the HP 2671 and the HP 2631 share the same escape code sequence for underlining text.

```

10    PRINTER IS PRT
20    Under$=CHR$(27)&"&dD"
30    Normal$=CHR$(27)&"&d@"
40    PRINT "This is not underlined"
50    PRINT Under$&"This is underlined"&Normal$
60    PRINT "Done."
70    PRINTER IS CRT
80    END

```

Since each printer may respond differently to control characters and escape code sequences, check the manual that came with your printer for details concerning their use.

Formatted Printing

For many applications the PRINT statement provides adequate formatting. The simplest method of print formatting is by specifying a comma or semicolon between printed items.

When the comma is used to separate items the printer will print the items on field boundaries. Fields start in column one and occur every ten columns (columns 1,11,21,31,...). Using the values: $A = 1.1$ $B = -22.2$ $C = 3E + 5$ $D = 4.4E + 8$

```
PRINT A,B,C,D
```

Produces:

```
123456789012345678901234567890123456789
 1.1      -22.2      300000      5.1E+8
```

Note the form of numbers in a normal PRINT statement. A positive number has a leading and a trailing space printed with the number. A negative number uses the leading space position for the “-” sign. This is why the positive numbers in the previous example appear to print one column to the right of the field boundaries. The next example shows how this form prevents numeric values from running together.

```
PRINT A;B;C;D,E
```

```
123456789012345678901234567890123
 1.1 -22.2 300000 5.1E+8
```

Using the semicolon as the separator caused the numbers to be printed as closely together as the “compact” form allows. The compact form always uses one leading space (except when the number is negative) and one trailing space.

The comma and semicolon are often all that is needed to print a simple table. By using the ability of the PRINT statement to print the entire contents of of a array, the comma or semicolon can be used to format the output.

If each array element contained the value of its subscript, the statement:

```
PRINT Array(*);
```

Produces:

```
0 1 2 3 4 5 6 7 8 9 10 11 12 13 14 ...
```

Another method of aligning items is to use the tabbing ability of the PRINT statement.

```
PRINT TAB(25);-1.414
```

```
123456789012345678901234567890123
                               -1.414
```

While PRINT TAB works with an external printer, PRINT TABXY will not. PRINT TABXY may be used to specify both the horizontal and vertical position when printing to the internal CRT.

A more powerful formatting technique employs the ability of the PRINT statement to allow an image to specify the format.

Using Images

Just as a mold is used for a casting, an image can be used to format printing. An image specifies how the printed item should appear. The computer then attempts to print the item according to the image.

One way to specify an image is to include it in the PRINT statement. The **image specifier** is enclosed within quotes and consists of one or more **field specifiers**. A semicolon then separates the image from the items to be printed.

```
PRINT USING "D,DDD" ;PI
```

This statement prints the value of pi (3.141592659...) rounded to three digits to the right of the decimal point.

```
3.142
```

For each character "D" within the image, one digit is to be printed. Whenever the number contains more non-zero digits to the right of the decimal than provided by the field specifier, the last digit is rounded. If more precision is desired, more characters can be used within the image.

```
PRINT USING "D,10D" ;PI
```

```
3.1415926536
```

Instead of typing ten "D" specifiers, one for each digit, a shorter notation is to specify a repeat factor before each field specifier character. The image "DDDDDD" is the same as the image "6D".

The image specifier can be included in the PRINT statement or on its own line. When the specifier is on a different line, the PRINT statement accesses the image by either the line number or the line label.

```
100  Format: IMAGE "6Z,DD"
110  PRINT USING Format;A,B,C
120  PRINT USING 100;A,B,C
```

Both PRINT statements use the image in line 100.

Numeric Image Specifiers

Several characters may be used within an image to specify the appearance of the printed value.

Image Specifier	Purpose
D	Replace this specifier with one digit of the number to be printed. If the digit is a leading zero, print a space. If the value is negative, the position may be used by the negative sign.
Z	Same as "D" except that leading zeros are printed.
E	Prints two digit of the exponent after printing the sequence "E+". This specifier is equal to "ESZZ". See the Language Reference for more details.
K	Print the entire number without leading or trailing spaces.
S	Print the sign of the number: either a "+" or "-".
M	Print the sign if the number is negative; if positive, print a space.
.	Print the decimal point.
H	Similar to K, except the number is printed using the European number format (comma radix). (Requires IO)
R	Print the comma (European radix) (Requires IO)
*	Like Z, except that asterisks are printed instead of leading zeros. (Requires IO)

To better understand the operation of the image specifiers examine the following examples and results.

Statement	Output
PRINT USING "K" ;33,666	33,666
PRINT USING "DD,DDD" ;33,666	33,666
PRINT USING "DDD,DD" ;33,666	33,67
PRINT USING "ZZZ,DD" ;33,666	033,67
PRINT USING "ZZZ" ;,444	000
PRINT USING "ZZZ" ;,555	001
PRINT USING "SD,3DE" ;6,023E+23	+6,023E+23
PRINT USING "S3D,3DE" ;6,023E+23	+602,300E+21
PRINT USING "S5D,3de" ;6,023E+23	+60230,000E+19
PRINT USING "H" ;3121,55	3121,55
PRINT USING "DDRDD" ;19,95	19,95
PRINT USING "***" ;,555	**1

To specify multiple fields within the image, the field specifiers are separated by commas.

Statement	Output
PRINT USING "K,5D,5D" ;100,200,300	100 200 300
PRINT USING "DD,ZZ,DD" ;1,2,3	102 3

If the items to be printed can use the same image, the image need be listed only once. The image will then be re-used for the subsequent items.

```
PRINT USING "5D,DD" ;3.98,5.95,27.50,139.95
```

```
123456789012345678901234567890123
   3.98    5.95    27.50   139.95
```

The image is re-used for each value. An error will result if the number cannot be accurately printed by the field specifier.

String Image Specifiers

Similar to the numeric field image characters, several characters are provided for the formatting of strings.

Image Specifier	Purpose
A	Print one character of the string. If all characters of the string have been printed, print a trailing blank.
K	Print the entire string without leading or trailing blanks
X	Print a space.
'literal'	Print the characters between the quotes.

The following examples show various ways to use string specifiers.

```
PRINT USING "5X,10A,2X,10A" ;"Tom","Smith"
```

```
12345678901234567890123456789
   Tom           Smith
```

```
PRINT USING "5X, ""John"",2X,10A" ;"Smith"
```

```
12345678901234567890123456789
   John  Smith
```

```
PRINT USING ""PART NUMBER",2x,10d" ;90001234
```

```
12345678901234567890123456789
PART NUMBER    90001234
```

Additional Image Specifiers

The following image specifiers serve a special purpose.

Image Specifier	Purpose
B	Print the corresponding ASCII character. This is similar to the CHR\$ function.
#	Suppress automatic end-of-line sequence.
L	Send the current end-of-line (EOL) sequence; with IO, see the PRINTER IS statement in the <i>BASIC Language Reference</i> manual for details on re-defining the EOL sequence.
/	Send a carriage-return and a linefeed.
@	Send a formfeed.
+	Send a carriage-return as the EOL sequence. (Requires IO)
-	Send a linefeed as the EOL sequence. (Requires IO)

For example:

```
PRINT USING "@,#" outputs a formfeed.
```

```
PRINT USING "D,X,3A,""OR NOT"" ,X,B,X,B,B";2,"BE",50,66,69
```

Special Considerations

If nothing prints, check if the printer is ON LINE. When the printer is OFF LINE the computer and printer can communicate but no printing will occur.

Sending text to a non-existent printer will cause the computer to wait indefinitely for the printer to respond. ON TIMEOUT may be used within a program to test for the printer. To clear the error press **(CLR I/O)**, check the interface cable, and switch settings then try again.

Since the printer's device selector may change, keep track of the locations in the program where a device selector is used. If most of the program's output is sent to a printer, you may wish to use the PRINTER IS statement at the beginning of the program and then send messages to the CRT screen by using the OUTPUT statement.

```
PRINTER IS 701
PRINT "Text to the printer."
OUTPUT 1;"Screen Message"
PRINT "Back to the printer."
```

If the program must use the PRINTER IS statement frequently, assign the device selector to a variable; then if the device selector changes, only one program line will need to be changed.

The Real-Time Clock

Chapter

9

Introduction

The internal clock provides the date, time of day, and interval timing to one-hundredth of a second resolution. In this chapter you will find the statements and functions used to set and read the clock. Additional statements, allow you to define event-initiated branches based on the clock's value.

Many of the statements presented in this chapter require CLOCK.

Internally, the clock maintains the year, month, day, hour, minute, and second as a single real number. This number is scaled to an arbitrary "dawn of time" thus allowing it to also represent the Julian date. The current value of the clock is returned by the TIMEDATE function.

```
PRINT TIMEDATE
```

While the value returned contains all the information necessary to uniquely specify the date and time to the nearest one-hundredth of a second, it needs to be "unpacked" to provide understandable information.

The following functions are available to extract the date and time of day from TIMEDATE.

The DATE\$ function extracts the date from the value of TIMEDATE.

```
PRINT DATE$(TIMEDATE)
```

```
Prints: 1 Mar 1900
```

This is the default power-up date for machines without the powerfail option.

The TIME\$ function returns the time of day.

```
PRINT TIME$(TIMEDATE)
```

```
Prints: 00:05:27
```

Until the clock has been set to the correct time of day, the TIME\$ function returns the time since power-up (on machines without the powerfail option).

The SET TIMEDATE statement is used to set the clock

```
SET TIMEDATE DATE("1 OCT 1982") + TIME("8:37:30")
```

The time of day can be changed without affecting the date by the SET TIME statement.

```
SET TIME TIME("9:55")
```

Clock Time

To minimize the space required to store the date and time, and yet insure a unique value for each point in time, both time and date are combined as a single real number. This value is the Julian date multiplied by the number of seconds in a day. By recalling that there are 86400 seconds in a day, the date and time of day can be extracted from TIMEDATE by the following simple algorithms.

```
TIMEDATE MOD 86400 returns the time of day, and
```

```
TIMEDATE DIV 86400 returns the Julian date.
```

The time of day is expressed in seconds past midnight and is easily divided into hours, minutes, and seconds. The Julian date requires a bit more processing to extract the month, day, and year but this method insures a unique value for each day over the entire range of the clock (1 Mar 1900 through 4 Aug 2079).

Clock Time

Year	Clock Value	Hours	Seconds
1900	2.086578144E+11	1	3600
1910	2.089733472E+11	2	7200
1920	2.092888800E+11	3	10800
1930	2.096044992E+11	4	14400
1940	2.099200320E+11	5	18000
1950	2.102356512E+11	6	21600
1960	2.105511840E+11	7	25200
1970	2.108668032E+11	8	28800
1980	2.111823360E+11	9	32400
1990	2.114979552E+11	10	36000
2000	2.118134880E+11	11	39600
2010	2.121291072E+11	12	43200
2020	2.124446400E+11	13	46800
2030	2.127602592E+11	14	50400
2040	2.130757920E+11	15	54000
2050	2.133914112E+11	16	57600
2060	2.137069440E+11	17	61200
2070	2.140225632E+11	18	64800
2080	2.143380960E+11	19	68400
		20	72000
		21	75600
		22	79200
		23	82800
		24	86400

Setting the Time

The time of day is changed by SET TIME X, where X is the number of seconds past midnight. The value of X must be in the range: 0 through 86399.99 seconds. The TIME function will convert twenty-four hour formatted time (HH:MM:SS) into the value needed to set the clock.

The TIME function converts an ASCII string representing a time of day, in twenty-four hour format, into the number of seconds past midnight. For example:

```
SET TIME TIME("15:30:10")
```

Is equivalent to:

```
SET TIME 55810
```

Either of these statements will set the time of day without changing the date. Use the SET TIMEDATE statement to change the date.

To display the new time, the TIME\$ function formats the clock's value (TIMEDATE) into hours, minutes, and seconds.

```
PRINT TIME$(TIMEDATE)
```

Prints: 15:30:16

Even though TIMEDATE returns a value containing both time of day and the Julian date, TIME\$ performs an internal modulo 86400 on the value passed to the function and will always return a string in the range: 00:00:00 thru 23:59:59.

The following program contains the routines to set and display the time of day. The routines are written as user-defined functions that may be appended to a program. Once appended to a program, the routines duplicate the TIME and TIME\$ functions available with CLOCK. The formatted time can then be displayed by the following statement.

```
PRINT FNTIME$(TIMEDATE)
```

Prints: 15:31:05

Given the clock's value, the FNTIME\$ function returns the time of day in 24 hour format (HH:MM:SS). The FNTIME function converts the time of day to seconds and is used to set the clock.

```

10 Show_time:DISP FNTIME$(TIMEDATE)
20   GOTO Show_time
30   END
40   !
50   ! While the program is running, type:
60   ! SET TIME FNTIME("11:5:30")
70   ! then Press <EXECUTE> to show the new time.
80   !
90   !*****
100  !
110  DEF FNTIME$(Now) ! Given 'SECONDS' Return 'hh:mm:ss'
120  !
130  Now=INT(Now) MOD 86400
140  H=Now DIV 3600
150  M=Now MOD 3600 DIV 60
160  S=Now MOD 60
170  OUTPUT T$ USING "#,ZZ,K";H,":",M,":",S
180  RETURN T$
190  FNEND
200  !
210  DEF FNTIME(T$) ! Given 'hh:mm:ss' Return 'SECONDS'
220  !
230  ON ERROR GOTO Err
240  ENTER T$;H,M,S
250  RETURN (3600*H+60*M+S) MOD 86400
260 Err:OFF ERROR
270  RETURN TIMEDATE MOD 86400
280  FNEND

```

After entering the program, follow the instructions at the beginning of the program to verify correct operation. Store this program in a file named "FUNTIME". The functions can be extracted from this program and appended to other programs by the LOADSUB statement.

Note that the FNTIME function requires hours, minutes, and seconds, while the TIME function only requires hours and minutes.

Setting the Date

The date is changed by SET TIMEDATE X, where X is the Julian date multiplied by the number of seconds in a day (86400). The DATE function converts a formatted date (DD MMM YYYY) into the value needed to set the clock. Due to the wide range of values allowed by the DATE function, negative years can be specified, but not when using the function to set the clock.

The following statement will set the clock to the proper date.

```
SET TIMEDATE DATE("1 June 1984")
```

When programming without CLOCK, the user-defined function FNDate can be used.

```
SET TIMEDATE FNDate("1 June 1984")
```

Both of these statements are equivalent to the following statement.

```
SET TIMEDATE 2,113216992E+11
```

The DATE and FNDate functions convert the accompanying string (or string expression) into the numeric value needed to set the clock. To read the clock, the DATE\$ and FNDate\$ functions format the clock's value as the day, month, and year. For example, the following line will print the date.

```
PRINT DATE$(TIMEDATE)
```

Prints: 1 Jun 1984

Programs that need to run without can use the following user-defined functions appended to the end of the program. These functions simulate the DATE and DATE\$ keywords available in CLOCK. The algorithm is valid over the entire range of the clock.

Note the following functions are restricted to values the clock will accept, the DATE and DATE\$ functions available with CLOCK allow a much wider range of values (including negative years).

```
10 Show_date:   DISP FNDate$(TIMEDATE)
20             GOTO Show_date
30             END
40             !
50             ! While the program is running, type:
60             ! SET TIMEDATE FNDATE("1 JAN 82") <EXECUTE>
70             !
80             !*****
90             !
100            DEF FNDate$(Seconds) ! Given 'SECONDS' Return 'dd mmm yyyy'
110            !
120            DATA JAN,FEB,MAR,APR,MAY,JUN,JUL,AUG,SEP,OCT,NOV,DEC
130            DIM Month$(1:12)[3]
140            READ Month$(*)
150            !
160            Julian=Seconds DIV 86400-1721119
170            Year=(4*Julian-1) DIV 146097
180            Julian=(4*Julian-1) MOD 146097
190            Day=Julian DIV 4
200            Julian=(4*Day+3) DIV 1461
210            Day=(4*Day+3) MOD 1461
220            Day=(Day+4) DIV 4
230            Month=(5*Day-3) DIV 153      ! Month
240            Day=(5*Day-3) MOD 153
```

```

250     Day=(Day+5) DIV 5           ! Day
260     Year=100*Year+Julian      ! Year
270     IF Month<10 THEN
280         Month=Month+3
290     ELSE
300         Month=Month-9
310         Year=Year+1
320     END IF
330     OUTPUT D$ USING "#,ZZ,X,3A,X,4Z";Day,Month$(Month),Year
340     RETURN D$
350 FNEND
360 !
370 DEF FNDate(Dmy$) ! Given 'dd mmm yyyy' Return 'SECONDS'
380 !
390     DATA JAN,FEB,MAR,APR,MAY,JUN,JUL,AUG,SEP,OCT,NOV,DEC
400     DIM Month$(1:12)[3]
410     READ Month$(*)
420     !
430     ON ERROR GOTO Err
440     I$=Dmy$&" "
450     ENTER I$ USING "DD,4A,5D";Day,M$,Year
460     IF Year<100 THEN Year=Year+1900
470     FOR I=1 TO 12
480         IF POS(M$,Month$(I)) THEN Month=I
490     NEXT I
500     IF Month=0 THEN Err
510     IF Month>2 THEN
520         Month=Month-3
530     ELSE
540         Month=Month+9
550         Year=Year-1
560     END IF
570     Century=Year DIV 100
580     Remainder=Year MOD 100
590     Julian=146097*Century DIV 4+1461*Remainder DIV 4+(153*Month+2) DIV 5+Day
+1721119
600     Julian=Julian*86400
610     IF Julian<2.08662912E+11 OR Julian>=2.143252224E+11 THEN Err
620     RETURN Julian ! Return Julian date in SECONDS
630 Err:OFF ERROR ! ERROR in input.
640     RETURN TIMEDATE ! Return current date.
650 FNEND

```

Store the program in a file named "FUNDATE". Later the functions can be appended to other programs by the LOADSUB statement.

The functions FNDate\$ and FNDate format the date as "DD MMM YYYY", where DD is the day of the month, MMM is the first three letters of the month, and YYYY is the year. The function FNDate will accept the last two digits of the year. See line 460. Note that the FNDate function requires two digits for the day, while the DATE function does not.

Different formats require only slight modification. By changing the following lines, the date is formatted as "MM/DD/YYYY".

```

330 OUTPUT D$ USING "#,2D,A,2D,A,2D";Month;" / ";Day;" / ";Year

450 ENTER I$ USING "#,ZZ,K";Month;Day;Year

```

European date format is obtained by swapping the month and day in the above statements. When changing the format, be sure to switch both functions.

If the all numeric format is chosen, delete the three lines in each function that load the array with the month mnemonics.

Using the Routines

The following statements summarize setting and displaying the clock.

```

SET TIMEDATE FNDate("12 DEC 1981") + FNTime("13:44:15")

SET TIME FNTime("8:30:00")

PRINT FNTime$(TIMEDATE)

DISP FNDate$(TIMEDATE)

```

It is important to note that SET TIMEDATE expects a date and time while the DATE function and the user-defined function FNDate return only a date. This effectively sets the clock to midnight of the date specified.

To keep the functions short, minimal parameter checking is performed. Additional checking may be incorporated within the functions or within the calling context. If FNDate or FNTime cannot correctly decode the input, the current value of the clock is returned.

The date and time functions can be used with the following program shell to provide a “friendly” interface to the clock.

```

10      ! PROGRAM SHELL FOR SETTING TIME AND DATE.
20      !
30      ! REQUIRES THE TIME AND DATE FUNCTIONS.
40      !
50      DIM Day$(0:6)[9]
60      DATA Monday,Tuesday,Wednesday,Thursday,Friday,Saturday,Sunday
70      READ Day$(*)
80      !
90      ON ERROR GOTO Nofun      ! Test if functions
100     Dmy$=FNDate$(TIMEDATE) ! have been loaded
110     Hms$=FNTime$(TIMEDATE)
120     OFF ERROR
130 Main:      ! Get NEW date
140     GOSUB Clear_screen
150     F$=CHR$(255)&CHR$(72)
160     !
170     PRINT TABXY(1,14);"Enter the date, and press CONTINUE."
180     OUTPUT 2 USING "#,11A,2A";Dmy$,F$
190     !
200     INPUT Dmy$      ! WAIT for INPUT
210     !
220     ENTER Dmy$ USING "2D,4A,5D";D,M$,Y
230     GOSUB Clear_screen
240     !
250     PRINT TABXY(1,14);"Enter the time of day and press CONTINUE"
260     OUTPUT 2 USING "#,11A,2A";Hms$,F$
270     INPUT Hms$
280     ENTER Dmy$ USING "2D,4A,5D";D,M$,Y
290     !
300     SET TIMEDATE FNDate(Dmy$)+FNTime(Hms$)
310     !
320     GOSUB Clear_screen
330     W=(TIMEDATE DIV 86400) MOD 7 ! Day of week
340     PRINT TABXY(1,1);"The clock has been set to:"
350     PRINT TABXY(1,3);Day$(W);" " ;Dmy$;" " ;FNTime$(TIMEDATE)
360     GOTO Quit

```

```

370  !
380  ! ***** SUBROUTINES *****
390  !
400 Clear_screen:OUTPUT 2 USING "#,B";255,75
410  RETURN
420 Nofun:PRINT "The TIME & DATE FUNCTIONS must be appended,"
430  PRINT "(via LOADSUB) before program will work."
440 Quit:END
450  !
460  ! ***** FUNCTIONS *****
470  !
480  ! append time and date functions here

```

The program tests to see if the functions have been loaded by trying to use them. If they are not loaded the program ends with an error message. With CLOCK, this program can still be used. Replace the calls to the user-defined functions with the appropriate keywords. The error trapping can then be deleted.

To append the functions, execute the following statements while the demonstration program is in memory.

```

LOADSUB ALL FROM "FUNDATE"

LOADSUB ALL FROM "FUNTIME"

```

Examine the program to be sure the functions have been loaded.

The program will prompt for the date and time, then set the clock accordingly. A program such as this may be used as the system start-up program for applications requiring the date or time.

Day of the Week

An advantage of Julian dates is the simplicity of finding the day of the week. `TIMEDATE DIV 86400 MOD 7` returns a number which represents the day of the week. Monday is represented by zero (0), and the numbering continues through the week to Sunday which is represented by six (6). See the previous program for an example of using this routine.

Days Between Two Dates

The number of days between two dates is easily calculated as the following program demonstrates.

```

10  ! Days between two dates
20  INPUT "ENTER THE FIRST DATE (DD MMM YYYY)",D1$
30  INPUT "ENTER THE SECOND DATE (DD MMM YYYY)",D2$
40  Days=(DATE(D2$)-DATE(D1$)) DIV 86400
50  DISP Days;"days between '"D1$"' and '"D2$"'
60  END

```

Interval Timing

Timing a single event of short duration is quite simple.

```

10   T0=TIMEDATE           ! Start
20   FOR J=1 TO 5555
30   !
40   NEXT J
50   T1=TIMEDATE           ! Finish
60   !
70   PRINT "It took";DROUND(T1-T0,3);"seconds"
80   END

```

Programs can and should be written so that they do not change the setting of the clock. A short program, which simulates a stopwatch, allows interval timing without changing the clock.

```

10   ! Program: STOPWATCH
20   ! Interval timing without changing the clock
30   ON KEY 5 LABEL " START " GOTO Start
40   ON KEY 6 LABEL " STOP " GOTO Hold
50   ON KEY 7 LABEL " RESET " GOTO Reset
60   ON KEY 8 LABEL " LAP " GOSUB Lap
70   !
80   Reset:PRINT CHR$(12)           ! form-feed
90   H=0                             ! Set all
100  M=0                             ! to
110  S=0                             ! zero.
120  !
130  Hold:DISP TAB(9);H;";";M;";";S   ! Wait til
140  GOTO Hold                       ! Keypress
150  !
160  Lap:PRINT H;";";M;";";S         ! Print lap
170  RETURN
180  !
190  Start:Z=3600*H+60*M+S-TIMEDATE   ! Elapsed-
200  Loop:T=(TIMEDATE+Z) MOD 86400    ! time
210  T=INT(T*100)/100                ! .01 sec.
220  H=T DIV 3600                     ! Hours
230  M=T MOD 3600 DIV 60              ! Minutes
240  S=T MOD 60                       ! Seconds
250  DISP TAB(9);H;";";M;";";S       ! Show time
260  GOTO Loop                         ! Do again
270  END

```

Accuracy

The computer's crystal controlled clock maintains the time to one one-hundredth of a second, however when timing events over a long period of time, the accuracy of the crystal must be considered. Under normal operating conditions, this error will be less than ± 5 seconds per day.

If the powerfail option is installed, accuracy is improved. Under normal operating conditions, the powerfail clock error is less than ± 2.5 seconds per day.

Powerfail Protection

Without the powerfail option, each time power is applied the date is initialized to March 1, 1900 (2.08662912E+11 seconds). If powerfail is installed, a second clock located on the powerfail board takes over the timekeeping function and maintains the date and time when the computer is turned off. (The powerfail option is not available on the Model 216.)

Branching on Clock Events

Several additional branching statements, available with CLOCK, allow end-of-statement branches to be triggered according to the real-time clock's value.

- ON TIME enables a branch to be taken when the clock reaches a specified time of day.
- ON DELAY enables a branch to be taken after a specified number of seconds has elapsed.
- ON CYCLE enables a recurring branch to be taken with each passage of a specified number of seconds.

The specified time can range from 0.01 thru 167772.15 seconds for the ON CYCLE and ON DELAY statements and 0 thru 86399.99 seconds for ON TIME. The value specified with ON TIME indicates the time of day (in seconds past midnight) for the branch to occur.

Each of these statements has a corresponding statement to cancel the branch (OFF TIME, OFF DELAY, and OFF CYCLE). A statement is also canceled by executing another ON TIME, ON DELAY, or ON CYCLE statement.

All of the statements use the internal real-time clock. Care should be taken to avoid writing programs that could change the clock's setting during execution. Since only one resource is dedicated to each statement, certain restrictions apply to the use of these statements.

Cycles and Delays

Both the ON CYCLE and ON DELAY statements enable a branch to be taken as soon as the specified number of seconds has elapsed. ON CYCLE remains in effect, re-enabling a branch with each passage of time. For example:

```

10   ON CYCLE 1 GOSUB Five  ! Print 5 random numbers every second.
20   ON DELAY 6 GOTO Quit  ! After 6 seconds quit.
30   !
40 T: DISP TIME$(TIMEDATE) ! Show the time.
50   GOTO T
60   !
70 Five:FOR I=1 TO 5
80     PRINT RND;
90   NEXT I
100  PRINT
110  RETURN
120  !
130 Quit:END

```

The program will print five random numbers every second for six seconds and then stop.

Only one ON CYCLE and one ON DELAY statement can be active in a program context. Executing a second ON CYCLE or ON DELAY statement in the same program context deactivates the first ON CYCLE or ON DELAY statement. If a branch is missed, due to priority restrictions or execution of a subprogram, the event is logged and the branch will be taken when the restriction is removed or the original context is restored. If an active ON CYCLE or ON DELAY statement gets canceled in an alternate context (subprogram) the branch is restored when execution returns to the defining context. (See Branching Restrictions for more information about this).

Time of Day

The ON TIME statement allows you to define and enable a branch to be taken when the clock reaches a specified time of day, where time of day is expressed as seconds past midnight. Using the TIME function simplifies setting an ON TIME statement by allowing a formatted time of day to be used. For example:

```
ON TIME TIME("11:30") GOTO Lunch
```

Typically, the ON TIME statement is used to cause a branch at a specified time of day. By adding an offset to the current clock value, the ON TIME statement can be used as an interval timer. In the following example, both ON DELAY and ON TIME are used as interval timers.

```
10   ON DELAY 5 GOSUB Takeoff           ! delay 5 seconds
20   ON TIME (TIMEDATE+10) MOD 86400 GOSUB Touchdown ! delay 10 seconds
30   PRINT "STARTING... ",TIME$(TIMEDATE)
40   Clock:DISP TIME$(TIMEDATE)
50   GOTO Clock
60   !
70   Takeoff:PRINT "TAKEOFF at ",TIME$(TIMEDATE)
80   RETURN
90   Touchdown:PRINT "TOUCHDOWN at ",TIME$(TIMEDATE)
100  RETURN
110  END
```

The starting time is printed when the program is executed. Five seconds later the first subroutine is executed. Ten seconds after the program starts, the second subroutine is executed.

Only one ON TIME statement can be active in a program context. If a branch is missed, due to priority restrictions or execution of a subprogram, the event is logged and the branch will be taken when the restriction is removed or the original context is restored. If an active ON TIME statement gets canceled in an alternate context (subprogram) the branch is restored when execution returns to the defining context. (See Branching Restrictions for more information about this).

Due to the “match an exact time” nature of the ON TIME statement, if the specified time occurs when the statement is temporarily canceled (by an OFF TIME in an alternate context), no branch will be taken when the defining context is restored.

Priority Restrictions

A priority can be assigned to the branch defined by ON CYCLE, ON DELAY, and ON TIME. For example:

```
ON CYCLE Seconds,Priority GOTO Label
```

If the system priority is higher than the branch priority at the time specified for the branch, the event will be logged but the branch will not be taken until the system priority falls below the branch priority. An example program follows.

```

10   COM Start
20   P=0
30   UP:P=P+1
40   IF P>15 THEN Quit           ! Priority from 1 thru 15
50   PRINT
60   PRINT "Priority:";P;
70   Start=TIMEDATE              ! Save the start-time for subProgram.
80   ON CYCLE 1,P RECOVER UP     ! New priority every second if not Busy.
90   ON DELAY .5,6 CALL Busy     ! DELAY overrides CYCLE until priority
100                                ! (P) is greater than 6.
110  W:GOTO W
120  Quit:END
130  !----- SUB has Priority of 6 -----
140  SUB Busy
150    COM Start
160    PRINT "SUB";
170    WHILE I<10
180      IF TIMEDATE>Start+1 THEN ! Has ON CYCLE time been exceeded?
190        PRINT "*";           ! YES (only prints if Priority<7)
200      ELSE
210        PRINT ",";           ! NO
220      END IF
230      I=I+1                  ! Loop ten times
240      WAIT .1
250    END WHILE
260    PRINT "DONE";
270  SUBEND

```

Once the priority assigned to the ON CYCLE statement is greater than the priority assigned to the ON DELAY statement (6) the subprogram will be interrupted. After running the program, change line 80 in the above program to the following:

```
80   ON CYCLE 1,P GOTO UP
```

Running the new version of the program will show that GOTO (or GOSUB) will not interrupt a subprogram regardless of the assigned priority. The branch will be logged but not taken until execution returns to the main program. If you write a program that makes extensive use of subprograms and branching statements, use CALL and RECOVER to insure proper operation.

Branching Restrictions

Certain restrictions apply to the use of ON TIME, ON CYCLE, and ON DELAY because only one resource is dedicated to each statement. Assuming an active branch has been defined in the main program, execution of a subprogram which sets up a new branch, will cause the loss of the original time. When the main program context is restored, the original branch will be restored, but at the time defined in the subprogram. The following program will illustrate this effect.

```

10   COM Counter
20   Counter=0
30   GINIT
40   GRID 1,1           ! Fill graphics raster with grid.
50   DISP Counter
60   ON CYCLE 2 CALL Flash ! Flash graphics every 2 seconds.
70 W: GOTO W
80   END
90   !----- SUB to flash graphics raster -----
100  SUB Flash
110   COM Counter
120   GRAPHICS ON
130   Counter=Counter+1
140   DISP Counter
150   IF Counter=5 THEN           ! Change CYCLE value during fifth CALL.
160     ON CYCLE .1,2 CALL Quit ! New value (.1) will replace old (2).
170                                   ! Flash will end before Quit gets called.
180   END IF
190   GRAPHICS OFF
200  SUBEND
210  !----- SUB that won't get called -----
220  SUB Quit
230   PRINT "PROGRAM HAS STOPPED"
240   STOP
250  SUBEND

```

The program starts out by flashing the graphics raster on and off every two seconds. When the subprogram's ON CYCLE statement is activated during the fifth call to the subprogram, the new value (0.1 second) replaces the old value (2.0 seconds) and the program begins flashing the graphics raster at the new rate. Note that the branch to the second subprogram (Quit) is not executed because the first subprogram is finished before the specified time. To see the second subprogram execute, insert the following line.

```

191   WAIT 1

```

The delay caused by the WAIT statement allows the subprogram's ON CYCLE statement to branch to the second subprogram and stop execution.

If an active branch defined in the main program is canceled in a subprogram (by OFF TIME, OFF DELAY, or OFF CYCLE) any branch missed during the execution of the subprogram will be lost. When the context containing the original statement is restored, the branch will be reactivated and processing will continue as if no branch was missed.

```

10  ON DELAY 1 GOTO Done      ! GOTO "Done" in one second.
20  CALL Busy                ! Call to "Busy" takes two seconds.
30  !
40  PRINT "THIS WON'T BE PRINTED UNLESS BRANCH IS CANCELED BY THE SUB"
50  !
60 Done:PRINT "THIS LINE WILL BE PRINTED EVERY TIME"
70  END
80  ! -----
90  SUB Busy
100 WAIT 2
110 ! OFF DELAY ! RUN then remove the "!" on this line and RUN again.
120 SUBEND

```

By removing the comment symbol (!) from the beginning of line 110, the OFF DELAY statement will be executed causing any branch that has already been logged to be canceled and allow line 40 to be printed.

Since branches only occur at the end of a line, no branch can be taken during an INPUT or LINPUT statement. The following program shows a method of monitoring the keyboard without preventing branches to be taken.

```

10  ON KBD GOTO Yes          ! If Key is pressed go get new value.
20  ON DELAY 3 GOTO Gone    ! If no Keypress in 3 seconds use defaults
30  DISP "PRESS A KEY"
40 W: GOTO W                ! Wait here until Keypress or end of delay.
50  !
60 Yes:OFF DELAY           ! Someone is there.
70  OFF KBD
80  LINPUT "NEW VALUE?",A$
90  DISP "USING",A$
100 GOTO More
110 !
120 Gone:DISP              ! Nobody there.
130 DISP "USING DEFAULTS"
140 !
150 More:WAIT 2
160 DISP "Program continues...."
170 END

```

The program waits a few seconds for a response. Processing continues with default values if no key is pressed. Pressing a key will cause the program to accept the new information.

Communicating with the Operator

Chapter**10**

Introduction

It is very unlikely that a computer could perform useful work without receiving input. Much of that input is from electronic devices: instruments, mass storage devices, other computers, and so on. Because a computer is an electronic device, it is very good at these tasks. There are also times when the computer's input must come from the human sitting in front of the computer.

Good human interfaces do not happen without some effort from the programmer. In many programs, at least one fourth of the code is dedicated to human interface. It is not unusual to use one half of a good program for operator interaction, error trapping, explanatory messages, etc. Obviously, these estimates depend upon many factors, like the task being performed and the intended operators. If you are the only person who uses a program, that program may not need a quality human interface. However, the demands for a good human interface rise greatly if a program is used by many people with different backgrounds. When the intended users do not understand computers, your program must be very skillfully written so that it does not intimidate the operator or make great demands.

This chapter introduces two of the elements of a human interface: displaying text for the operator to read and accepting operator input from the keyboard. These are certainly not the only elements in a human interface. A good human interface can involve the placement of hardware, use of graphic and voice communication, data base management, artificial intelligence theories, and much more. However, you must begin somewhere. Despite the incredible technology growing up around them, many programmers fail at the basic task of sending and receiving text. Hopefully, the hints in this chapter will help your present programs and whet your appetite for more elaborate improvements in future programs.

Displaying and Prompting

One of the simpler things to do for the operator is to display an explanation of what is happening or what is expected. In the early days of computers, memory was a scarce and expensive resource. Old-time programmers were encouraged to use as little memory as possible. It seemed as though there was a contest to see who could put the most information into a 32-character message. Please realize that those days are over. For example, in the Model 236, there is no significant restriction on program size, the standard machine is shipped with over a half-million characters of memory, and there are 18 lines of 80 characters visible at all times on the CRT. If you are sending your operator tiny, cryptic 32-character messages, you are making an unnecessary mistake.

Giving instructions to the operator can be viewed as two basic steps:

1. Clear the CRT.
2. Use as much of the CRT as necessary to give readable instructions.

Determining Screen Width

The first step in dealing with the CRT is finding out the size of the CRT. Programs written for Series 200 computers can be used on either 50, 80 or 128-column displays. There is a CRT status register that contains the width of the CRT. If you are developing programs that will be transported between models, status register 9 will be very helpful to you. The screen width is useful in centering displays, labeling softkeys, formatting tabular data, and other display tasks. The following statement places the screen width in a variable called `Crt_width`.

```
STATUS 1,9;Crt_width
```

There is also a `SYSTEM$` function that returns useful information about the CRT. The specifier "CRT ID" returns a string containing (among other things) the screen width and availability of highlights and graphics. The following example shows one method of determining the screen width with `SYSTEM$`.

```
120 Test$=SYSTEM$("CRT ID")
130 Screen=VAL(Test$[3,6])
```

Clearing the CRT

It is embarrassing to the programmer and confusing to the operator when two or more displays combine in an unplanned manner. The culprits are "left-over" alpha and "left-over" graphics. Left-over alpha can occur for a number of reasons:

- The operator may have used the knob or cursor-control keys to scroll text from the off-screen buffer.
- With `TABXY`, the `PRINT` statement overwrites any old characters on a line with new characters. However, if the old text is longer than the new text, the end of the old line remains visible. Therefore, the following sequence does **not** print three blank lines. It just moves the print position. Any old lines will still be on the screen.

```
100 PRINT
110 PRINT
120 PRINT
```

- If the `PRINTALL` mode is on, all interactions on the display line and keyboard input line are sent to the output area.

Turning Off Unwanted Modes

There are several modes that affect the appearance of the CRT. These are very useful for certain purposes, but generally undesirable for the display of simple text. Graphics is an obvious example. Left-over graphics can be removed by the following statement on non-bit mapped displays.

```
GRAPHICS OFF
```

The PRINTALL mode is canceled by writing a zero in the PRINTALL control register. This is keyboard register 1, so it has an interface select code of 2. The following statement turns off the PRINTALL mode.

```
CONTROL 2,1;0
```

The DISPLAY FUNCTIONS mode can make a display look sloppy. This is CRT register 4, so it has an interface select code of 1. The following statement turns off the DISPLAY FUNCTIONS mode.

```
CONTROL 1,4;0
```

Printing Blank Lines

To print a line that is blank is a different operation from sending only an end-of-line sequence. A PRINT statement with no parameters simply sends an end-of-line sequence. If the print position is at the start of a blank line when PRINT is executed, that line remains blank. However, if there is text on that line, the text remains. This is not to say that it is “wrong” to use PRINT with no parameters. It just means that you cannot guarantee the output of a blank line by using PRINT with no parameters.

To print a blank line, blanks must be printed. One of the most convenient ways to send a line full of blanks is the TAB function. Here is a sequence that prints three blank lines:

```
100 STATUS 1,9;Screen
110 PRINT TAB(Screen)
120 PRINT TAB(Screen)
130 PRINT TAB(Screen)
```

Using OUTPUT KBD...

The PRINT statement does not provide functions like “home” and “clear”, but the keyboard drivers do. Note that this is true even for keyboards which do not have a “home” key. These functions are invoked by sending a “Non-ASCII Key Sequence” to interface select code 2 (KBD). Sending characters with OUTPUT KBD is like telling the computer to press its own keys. Although some techniques that use the keyboard buffer are very complex (see Chapter 9 of *BASIC Interfacing Techniques*), controlling the CRT output area is simple.

To see how this technique works, let’s use the **CLR SCR** Key (**Clear display** on HP 46020A) as an example. Open your *BASIC Language Reference* to the end of the “Useful Tables” section. Find the heading “Second Byte of Non-ASCII Key Sequences (Numeric)”. Locate the **CLR SCR** key on your computer. It is a shifted **CLR LN** (on non-HP 46020A keyboards). The number in that position is 75. Like the heading says, that is the value of the **second** byte of a sequence. The first byte always has a value of 255 for non-ASCII keys. Therefore, to “press” the **CLR SCR** key, send the bytes 255 and 75 to the keyboard; interface select code 2.

You can store non-ASCII key sequences in your program without looking for them in the *Language Reference*. Here is an example. Get into EDIT mode on your computer. Type the following:

```
10 OUTPUT KBD;"
```

Now hold down the **CTRL** key and press **CLR SCR** at the same time. The characters **␣K** should appear. Finish the statement with a closing quote and a trailing semicolon. Press **ENTER** or **RETURN** to store the line. This should be the result:

```
10 OUTPUT KBD;"␣K";
```

Notice in the other *Language Reference* table that “K” corresponds to the **CLR SCR** key. An “inverse video K” is the first byte of this sequence; it represents CHR\$(255). The trailing semicolon is used to prevent an end-of-line sequence from appearing in the keyboard buffer when this statement is executed.

There are advantages and disadvantages to this method. Two advantages are that no image specifiers are needed in the OUTPUT statement and no reference tables are needed to look up the byte values. Three disadvantages are:

- You need a reference table to “decode” your program when you try to read it back later. Some of the one-letter codes for these keys are meaningless.
- Your printer may not be able to print an accurate listing of the program. Most printers have no inverse-video K, and some printers completely ignore a CHR\$(255).
- You are limited to the keys that can be generated by this method on your keyboard. For example, it is impossible to use this method to generate a “home” key on the small keyboard of the Model 216. Additionally, many of the “non-ASCII” keys on this keyboard generate ASCII characters when pressed with **CTRL**.

You can overcome the last two problems with the OUTPUT KBD USING “#,B” method, but the result is still very cryptic to someone reading the program listing. The following technique uses the best features of the other methods and provides readable code. Define a string variable for each non-ASCII key you may need, and use that variable name each time you want to “press the key”.

```
20 DIM Clear_crt$(2),Home$(2)
30 Clear_crt$=CHR$(255)&CHR$(75)
40 Home$=CHR$(255)&CHR$(84)
.
.
.
350 OUTPUT KBD;Clear_crt$;
```

Now that you understand the general technique, let’s look at some applications for non-ASCII keystrokes. Although there are many keystrokes available for various applications, this section focuses on the use of “clear” and “home”. For a summary of all available non-ASCII sequences, refer to the tables at the back of the *BASIC Language Reference*.

An Expanded Softkey Menu

Input from the keyboard is discussed in the second half of this chapter. However, a good human interface often involves the coordination of multiple resources. The softkeys are a very good tool for accepting operator input. The biggest problem with using softkeys is the severe limitation on the number of prompt characters associated with each key. Therefore, a softkey interface is an appropriate task to demonstrate the increased use of CRT space.

The goal of this technique is to display a readable and informative menu that monitors the operator's input. The following program segment displays a summary of the parameters that are controlled by softkeys. This summary is updated every time a softkey is pressed, providing immediate feedback to the operator. This example uses many of the CRT-control techniques already presented. It also helps to show why the human interface of a program can require so much code. This segment simply logs the operator's choice of a four items, and it is over 100 lines long. The purpose of each section of code is explained after the listing.

```

1000 DIM Disc$(5),Clear$(2),Home$(2),Cmd$(1)
1010 INTEGER Std_fmt,Roman,Screen,Center
1020 !
1030 Clear%=CHR$(255)&CHR$(75) ! CLEAR SCR key
1040 Home%=CHR$(255)&CHR$(84) ! HOME key
1050 Disc$="RIGHT" ! Default Parameters
1060 Cmd$="\ "
1070 Std_fmt=1
1080 Roman=0
1090 STATUS 1,9;Screen ! Get screen width
1100 Center=(Screen-36)/2 ! Leading spaces for centering
1110 MASS STORAGE IS ":INTERNAL"
1120 PRINTER IS 1 ! Use CRT for displaying menu
1130 GRAPHICS OFF
1140 CONTROL 2,1;0 ! PRT ALL off
1150 CONTROL 1,4;0 ! DISPLAY FCTNS off
1160 OUTPUT 2;Clear%; ! Clear CRT
1170 !
1180 Menu: !
1190 OUTPUT KBD;Home%; ! Home display
1200 PRINT TABXY(1,1) ! Start at top with blank line
1210 PRINT TAB(Center);"KEY PURPOSE";TAB(Center+30);"VALUE"
1220 PRINT TAB(Center);"-----"
1230 PRINT
1240 PRINT TAB(Center);" 5 Command Delimiter";TAB(Center+31);Cmd$
1250 PRINT
1260 PRINT TAB(Center);" 6 Source Disc Drive";TAB(Center+30);Disc$
1270 PRINT
1280 PRINT TAB(Center);" 7 Standard Format DK?";TAB(Center+30);
1290 IF Std_fmt THEN
1300 PRINT "YES"
1310 ELSE
1320 PRINT "NO "
1330 END IF
1340 PRINT
1350 PRINT TAB(Center);" 8 Use Roman Numerals?";TAB(Center+30);
1360 IF Roman THEN
1370 PRINT "YES"
1380 ELSE
1390 PRINT "NO "
1400 END IF
1410 PRINT
1420 PRINT TAB(Center);" 9 START PRINTOUT"
1430 !
1440 IF Screen=50 THEN ! Use short labels
1450 ON KEY 5 LABEL " Delim " GOTO Command
1460 ON KEY 6 LABEL " Disc " GOTO Drive
1470 ON KEY 7 LABEL " Format " GOTO Standard

```

```

1480   ON KEY 8 LABEL " Roman " GOTO Numbers
1490   ON KEY 9 LABEL " START " GOTO Begin
1500   ELSE                                     ! Use long labels
1510   ON KEY 5 LABEL "Command Delim " GOTO Command
1520   ON KEY 6 LABEL " Select Drive " GOTO Drive
1530   ON KEY 7 LABEL " Stand, Fmt.? " GOTO Standard
1540   ON KEY 8 LABEL "Roman Numeral?" GOTO Numbers
1550   ON KEY 9 LABEL " START PRINT " GOTO Begin
1560   END IF
1570   ON KEY 0 GOTO Not_used                   ! Turn off unused keys
1580   ON KEY 1 GOTO Not_used
1590   ON KEY 2 GOTO Not_used
1600   ON KEY 3 GOTO Not_used
1610   ON KEY 4 GOTO Not_used
1620   !
1630   Spin:  GOTO Spin                        ! Wait for softkey interrupt
1640   !
1650   Not_used:  !
1660   BEEP 300,.1                             ! Feedback for unused keys
1670   GOTO Spin
1680   !
1690   Command:  !
1700   IF Cmd$="\ " THEN                       ! Choose command delimiter
1710     Cmd$="^"
1720   ELSE
1730     Cmd$="\ "
1740   END IF
1750   GOTO Menu
1760   !
1770   Drive:  !
1780   IF Disc$="RIGHT" THEN                   ! Choose text source
1790     MASS STORAGE IS ":INTERNAL,4,1"
1800     Disc$="LEFT "
1810   ELSE
1820     MASS STORAGE IS ":INTERNAL,4,0"
1830     Disc$="RIGHT"
1840   END IF
1850   GOTO Menu
1860   !
1870   Standard:  !
1880   IF Std_fmt THEN                         ! Choose text format
1890     Std_fmt=0
1900   ELSE
1910     Std_fmt=1
1920   END IF
1930   GOTO Menu
1940   !
1950   Numbers:  !
1960   IF Roman THEN                          ! Choose numeral type
1970     Roman=0
1980   ELSE
1990     Roman=1
2000   END IF
2010   GOTO Menu
2020   !
2030   Begin:  !
2040   OUTPUT 2;Clear$;                       ! Clear CRT
2050   OFF KEY                                 ! Remove selection menu
2060   !
2070   ! Program continues here when user presses "START"
2080   !

```

The program uses softkeys 5 through 9. If you have an HP 46020A keyboard, your softkeys are labeled 1 through 8. You can modify the program to use the softkeys most useful for your applications.

It is always good programming practice to declare all variables. The first two lines do this. Next, the variables are given their starting values. Initialization is completed by turning off unwanted modes and clearing the CRT.

The section at “Menu” displays a description and current status for each menu item. This example shows some of the parameters that might be used by a simple text-printing program. The items used are representative only. A real text formatter would have many more parameters (all the more reason to present them clearly). The operator can choose the following:

- Back-slash or up-caret as a command delimiter
- Right or left disc drive for the source of the text
- Standard or alternate format for the text
- Page numbering with Arabic or Roman numerals

Notice some important aspects of this menu. All items have default values and all defaults are visible simultaneously. This is very important. It is irritating and confusing when an operator must answer question after question to get a program to begin. It is far better to show the default environment and allow a single keypress to start the program if the defaults are acceptable. If any defaults need to be changed, the operator changes only those items he wants to change. He can press “START” at any time, and in this simple case, never answers any questions. The operator wants a printout, not a game of “20 questions”.

The current state of all items is displayed in a form that is meaningful to the operator. It is reasonably safe to assume that all operators know what “RIGHT” and “LEFT” mean. Very few would have any idea what “:INTERNAL,4,1” means. Programmers need to learn about concepts like “mass storage unit specifier”. Operators shouldn’t be bothered by such things. Likewise, don’t expect anyone to answer “1” or “0” to a question that should be answered “YES” or “NO”.

A more technical aspect of this menu is the method used to update the display. Since the scrolling keys are on one side of the softkeys and the knob is on the other side, it is reasonable to assume that the operator might accidentally move the display out of place. One way to correct this would be to start each display update with a “clear screen” sequence. This guarantees the state of the CRT and the print position. Unfortunately, it also causes a very undesirable “blinking off” of the display each time a key is pressed. A constantly disappearing menu is very distracting.

The objective is to give the impression that nothing changed except the selected item. Therefore, the “clear” sequence is sent before the first display only. Subsequent updates use a “home” sequence to ensure the position of the text, and a TABXY to set the print position. As a result, the new menu is written on top of the old menu. (The same visual effect could be achieved by using individual TABXY functions to access each item display, but that is a more difficult program to write.)

Since the old display is overwritten each time, it is important to erase all unneeded characters. Notice that the “NO” displays are padded with a trailing blank to erase the “S” left over from “YES”. This technique can be extended to clear old displays of unknown length. The following example displays a number and erases any remaining digits from the old number. The variable `Screen` contains the screen width.

```
1300 PRINT Value;TAB(Screen)
```

The example also uses screen width for centering. Centering is not as important as keeping the display properly updated, and centering slows down the update process slightly. However, the technique is shown here in case you want to use it. During the initialization of variables, the current screen width is determined. This might be 50, 80 or 128 characters if the program is used on different models of computers. The width of the menu display is subtracted from the screen width to determine the amount of left-over space. If half of this space is sent at the beginning of the line, the remaining half will be at the end of the line. This produces a centered display. The amount to be sent at the beginning of the line is placed in the variable `CENTER`. This value is used to position the start of each line and is also used as a reference point to position the second column.

Models with HP 46020A keyboards allow 16 characters (2 rows of 8) in a softkey label. Models with 80-column CRTs allow 14 characters in a softkey label. Models with 50-column CRTs allow only 8 characters for these labels. Therefore, the variable `SCREEN` is also used to control the display of softkey labels. This is the purpose of the segment at line 1440. The alternative is to restrict all softkey labels to 8 characters. This is possible, but undesirable. It is difficult to say anything meaningful in 8 characters. Users with 80-column CRTs will appreciate the extra meaning that is available with longer labels. The 128 column CRT can use longer labels, but this program uses the 14 character labels.

The `ON KEY` statements for keys 0 through 4 are used to turn off any typing-aid definitions that might exist for those keys. An `ON KEY` definition overrides a typing-aid definition when the program is running. However, if no `ON KEY` definition is supplied, the typing-aid definition remains active. This is not desirable when you are trying to achieve a program-controlled softkey menu. Therefore, the unused keys are given a “dummy” `ON KEY` definition to keep the menu clean. For HP 46020A keyboards, you should “turn off” all 24 softkeys.

Notice also that when five or less softkeys are used, keys 5 through 9 are defined. This is to accommodate the Model 216. On its keyboard, those are the unshifted keys. Why make the operator press the shift key? If you have an HP 46020A keyboard, use keys 1 through 5.

The softkeys are defined to send program execution to a parameter-changing routine. Each such routine ends by sending program execution to the display-update routine. In this example, there is no demonstrated reason for repeating the `ON KEY` definitions for every keypress. Those definitions could have been placed above the “Menu” line and executed only once. However, some applications might need to change the key definitions in response to changes in program variables. For example, a key that produces an “insert” operation would be disabled when enough inserts had been performed to fill an array. Also, it is possible to include the value of a string variable in a key label. Therefore, the key labels may need to be rewritten as new selections are made. In cases like these, the `ON KEY` statements need to be in the update path.

The final “cleanup” action takes place when the operator presses “START”. This is the signal that the selection menu is no longer needed. The menu display is cleared to reflect the fact that it is no longer in use. The `OFF KEY` statement performs two functions. It turns off the softkey label area, which helps keep the CRT neat. More importantly, it cancels all the `ON KEY` branches. If this were not done, the operator could cause the program to jump back to the selection menu at any time. This is probably not desirable. You may want to define some sort of “Abort” key that lets the operator stop a lengthy operation. But it is not likely that the selection menu would be the destination of an abort operation. Remember, `ON KEY` definitions stay around forever unless you turn them off or the program stops.

Not much has been said about the parameter-changing routines. The examples shown use a simple IF...THEN...ELSE structure to select between two alternatives. This concept can be expanded to allow selection of more than two choices. The MOD function is handy when you want to cycle through several choices. The following example shows a routine that rotates through four choices. This routine is intended to fit into our menu selection process. Accent protocols for different languages are shown here, but the technique is applicable to any selection item.

```

1910 Accents: !
1920 Lang=(Lang+1) MOD 4 ! Choose accent protocol
1930 SELECT Lang
1940 CASE 0
1950   Language$="ENGLISH"
1960 CASE 1
1970   Language$="FRENCH "
1980 CASE 2
1990   Language$="SPANISH"
2000 CASE 3
2010   Language$="GERMAN "
2020 END SELECT
2030 GOTO Menu

```

Moving a Pointer

Many programs have a main menu from which the operator chooses a subtask. An example might be an editing program that gives the choice of getting a file, storing a file, editing a file, merging files, listing a file, protecting a file, deleting a file, etc. As with all other tasks, there are many ways to present this choice to the operator. Each task might be assigned to a softkey. The ON KBD statement might be used to equate individual keys to each task. For example, E for edit, M for merge, G for get, and so on. Depending on the application, one of these methods may be good. However, there are some considerations. There might be more choices than softkeys, or the arrangement of the softkeys might be awkward. The single-letter method is always just a little “dangerous”. What if the operator tries to type a word? Did “P” stand for “protect” or “purge”?

One alternative is to display all the choices, with a pointer to the current selection. When the operator is sure that the selection is proper, a single press of a softkey tells the computer “Do it”. The menu choices can be full phrases with no abbreviations, since the whole CRT is available for the display. The pointer can be moved by softkeys or by the knob. Since we just discussed the softkeys, let’s use the knob for this example.

The following example clears the CRT, displays seven selections, and allows the knob to cycle a pointer through the selections in either direction. In a real application, meaningful phrases would be used to identify the selections, and a softkey would be defined to start the selected process. Softkeys could also be used to move the pointer up and down. This could be in addition to the knob or in place of it. A detailed discussion follows the listing.

```

100 DIM Marker$(4),Home$(2),Clear$(2)
110 INTEGER Point
120 !
130 Clear%=CHR$(255)&CHR$(75)      ! CLEAR SCR Key
140 Home%=CHR$(255)&CHR$(84)      ! HOME key
150 Marker%="=>"&CHR$(8)&CHR$(8) ! Pointer arrow
160 Point=1                       ! Default selection
170 PRINTER IS 1                  ! Use CRT for menu display
180 GRAPHICS OFF
190 CONTROL 2,1;0                 ! PRT ALL off
200 CONTROL 1,4;0                 ! DISPLAY FCTNS off
210 OUTPUT KBD;Clear%;           ! Clear CRT
220 !
230 PRINT "Use shift and knob to move marker"
240 PRINT "  Selection 1"        ! Display menu
250 PRINT "  Selection 2"
260 PRINT "  Selection 3"
270 PRINT "  Selection 4"
280 PRINT "  Selection 5"
290 PRINT "  Selection 6"
300 PRINT "  Selection 7"
310 PRINT TABXY(Point,1);Marker%; ! Display starting marker
320 !
330 ON KNOB ,2 GOTO Move_Pointer ! Enable knob
340 Spin: GOTO Spin              ! Wait for knob interrupt
350 !
360 Move_Pointer: !
370 IF KNOBY>0 THEN              ! Check knob direction
380   Point=Point+1
390 ELSE
400   Point=Point-1
410 END IF
420 IF Point<1 THEN Point=7      ! Keep pointer within limits
430 IF Point>7 THEN Point=1
440 OUTPUT 2;Home%;              ! Home the display
450 PRINT "  ";                  ! Erase old marker
460 PRINT TABXY(Point,1);Marker%; ! Display new marker
470 GOTO Spin
480 !

```

The program starts by declaring and initializing the variables. The “clear” and “home” sequences should look familiar to you by now. The `Marker$` string is a contrived arrow followed by two backspace characters. The backspace characters return the print position to the beginning of the arrow each time it is displayed. This facilitates the erase operation that is part of moving the arrow.

After the display is cleared, the menu selections are printed. This is done only once, since the choices do not include any changing parameters. The `TABXY` function is used to position a marker to the left of the default selection. Then the knob is enabled, and the program sits in an idle loop waiting for an interrupt from the knob.

When the knob is turned, program execution branches to the pointer-moving routine. In this example, the amount of knob movement is not used, only its direction is extracted from the `KNOBY` function. It is possible to add an algorithm that accumulates the counts from the knob so that a fixed amount of rotation is needed to move the pointer. Such an improvement would give a more positive “linkage” between the knob and the display, but is not necessary to this demonstration.

The pointer value is stored in the variable `Point`. This variable is increased or decreased depending upon the direction of knob rotation. After the variable is updated, it is necessary to keep it within the limits of the available selections. The option used here was to “wrap around” when the pointer reached either end of the list. Another option is to “freeze” the pointer when it reaches an end position. To do this, lines 410 and 420 would be modified as follows:

```
410  IF Point<1 THEN Point=1
420  IF Point>7 THEN Point=7
```

After the pointer value is updated, the display must be changed to reflect the new value. First, the display is returned to home position. Although the knob no longer scrolls the display, the scrolling keys are still active. They may have been pressed (perhaps accidentally) and moved the display out of position. Since the print position is always at the beginning of the old pointer, that pointer can be erased by printing two blanks. The new pointer is then printed using a `TABXY` function. Notice that end-of-line sequences are not needed or desired. All the `PRINT` statements used in this updating process use a trailing semicolon to suppress the EOL sequence.

In this example, the x-coordinate was always 1. If needed, the x-coordinate is available in the `TABXY` function to work with multi-column displays.

Assumed, but not shown, is an `ON KEY` statement that would start the selected process. This key would branch to a routine that cleared the display, turned off the knob, and used the variable `Point` in a `SELECT` or `ON` statement to access the chosen routine.

Accepting Keyboard Input

The examples in the first half of the chapter used only softkeys to get input from the operator. When possible, this is a very good choice. It eliminates the need for translating an endless variety of typing mistakes that might be supplied as input to program variables. Softkey input is very tightly controlled by the programmer. Unfortunately, it is often necessary to leave that comfortable, controlled world. Suppose you need to get a device selector from the operator. You can't very well define a softkey that increments a variable and expect the operator to press it 701 times!

The proper handling of keyboard input may be one of the most neglected areas of applications programs. Programmers often fail to see the program as users see it, underestimate the potential for operator error, and balk at the amount of code needed to skillfully handle incoming text. However, you need not write input routines that can parse broken English with misspelled words. The objective is simply to keep the program from terminating and to take some unnecessary pressure off the operator. Obviously, a program can't tell if the operator misspelled a file name until it accesses the disc. Therefore, error trapping is an important part of handling operator input.

One task that can be performed by the input routine is **anticipating common problems**. Many of these are covered in this section's examples, but here is a preview. You know that exceeding the dimensioned length of a string gives error 18. So don't use short strings in an INPUT statement. You know that CAPS LOCK might be on or off when the operator starts typing. So use an uppercase function to compare input with constants. You know that an operator is likely to just press **CONTINUE** if he isn't sure how to respond. So use reasonable defaults and don't try to send a null string to a NUM function.

Get Past the First Trap

Before you can do anything with a keyboard input, the computer must satisfy the items in the input list and complete the input statement. There are two keywords available for accepting input from the keyboard line: INPUT and LINPUT. Let's start by looking at the features of these two statements.

The main advantages of INPUT are:

- Either numeric or string values can be input.
- If a variable does not receive a value from the keyboard, the value of that variable is left unchanged.
- A single INPUT statement can process multiple fields, and those fields can be a mix of string and numeric data.

The INPUT statement can be powerful and flexible. When you know the skill level of the person running the program, INPUT can save some programming effort. However, this statement does demand that the operator enter the requested fields properly. To find out the details of INPUT, see the *BASIC Language Reference*. This section discusses an alternative to INPUT that can make fewer demands on the operator. Some of the **disadvantages** of INPUT are:

- Improper entries to numeric variables can cause errors such as "string is not a valid number" and overflows.
- Certain characters can cause problems. Commas and quote marks have special meanings and are the primary offenders.
- If DISP is used to supply a prompt, and multiple values are entered separately, the prompt is lost.

The problem with INPUT is that the program is powerless to overcome the disadvantages. If you are asking for a numeric quantity, and the operator keeps trying to enter a name, the program will never leave the INPUT statement. The operating system will beep and display error 32 until the operator gets tired or gets smart. In the event of an error, the computer automatically re-executes the INPUT statement until the operator satisfies all the requirements. Your program never gets a look at his input and you can't trap the errors.

The LINPUT statement can help with these potential problems. LINPUT stands for "Literal INPUT". The result of any LINPUT statement is a single string that contains an exact image of what the operator typed. If (CONTINUE) is pressed with no entry, the result is the null string. (Nothing typed, nothing returned.) If you need things like default values, numeric quantities, and multiple values, you will need to process the string after you get it.

Since LINPUT accepts any characters without any special considerations, the only normal error would be string overflow. If the string used to hold the LINPUT characters is dimensioned to 256 characters or more, it becomes impossible to overflow the string from the keyboard line. Therefore, LINPUT is a very "safe" way to get data from the keyboard line. The following example shows some common techniques for accepting operator input.

Entering a Single Item

This program segment requests the current month for use later in the program. A detailed discussion follows the listing. Note that the general techniques presented can be used to process many kinds of input. Entering a month is merely a convenient example.

```

100  OPTION BASE 1
110  DIM In$[256],Months$(12)[3]
120  INTEGER Temp,Current_month
130  OUTPUT KBD;"SCRATCH KEY X";           ! Typing aids distracting if not needed
140  FOR Temp=1 TO 12
150    READ Months$(Temp)                 ! String data for month names
160  NEXT Temp
170  DATA JAN,FEB,MAR,APR,MAY,JUN,JUL,AUG,SEP,OCT,NOV,DEC
180  Current_month=3                       ! Default value
190  !
200  Try_numeric:  !
210  DISP "Enter the month.  Default = ";Months$(Current_month);
220  LINPUT "",In$                          ! Ask for operator input
230  IF NOT LEN(In$) THEN                  ! Check for no input
240    Temp=Current_month                 ! Use default value
250    GOTO Found
260  END IF
270  ON ERROR GOTO String                 ! If no numerals, may be a string name
280  ENTER In$;Temp                       ! Try to extract a number
290  OFF ERROR                             ! ENTER worked; change error trap
300  IF Temp<1 OR Temp>12 THEN Not_valid  ! Check for impossible month value
310  GOTO Found                          ! Value is OK; use it
320  !
330  String:  !
340  OFF ERROR                             ! ENTER error trap no longer needed
350  In$=UPC$(In$)
360  FOR Temp=1 TO 12                     ! Search for 1st three letters of month
370    IF POS(In$,Months$(Temp)) THEN Found ! Match found; use that value
380  NEXT Temp                            ! If loop finishes, no match was found
390  !
400  Not_valid:  !
410  BEEP
420  DISP "Not a valid month. Please try again."
430  WAIT 2
440  GOTO Try_numeric
450  !
460  Found:  !
470  Current_month=Temp
480  !
490  ! Program execution continues here

```

The first statement after the variable declarations removes the typing-aid key definitions. This is done with an OUTPUT to the keyboard because SCRATCH commands cannot be stored as a program line. You may or may not want to include this in your programs. If you are not using softkeys, the presence of softkey labels may be distracting to the operator. They may indicate that many response choices are available when the keys are actually unrelated to the current question. On the other hand, your program may have loaded the typing aids with responses intended to help the operator. This is possible, but was not done in the example. Obviously, if KBD is not present, the SCRATCH KEY command will generate an error and shouldn't be included.

An interesting feature of this example is that the operator may respond with the number of the month, the name of the month, or an abbreviation of the name of the month. The array MONTHS\$ is loaded with the first three letters of each month name so that name responses can be identified.

The final initialization step is to provide a default for the current month. When possible, requests for input should be accompanied by a default. If the default is well chosen, this increases the chances that the operator will not have to do any typing. Even if the default will usually be changed, it can help show the operator an acceptable format for the response.

The prompts available with INPUT and LINPUT statement must be literals and therefore cannot shown any program variables. This restriction is easily overcome. Prompts appear in the same line as DISP items. The DISP statement can contain variables. To use DISP items as a prompt, a trailing semicolon is used in the DISP statements, and a null prompt is used in the LINPUT statement. This is a very useful technique that is applicable to both LINPUT and single-prompt INPUT statements.

After the keyboard input is received, the first check determines if any data was entered. It is reasonable to assume that the space bar might have been bumped accidentally during any keyboard input. The TRIM\$ function corrects this "problem". A null input indicates that the operator wanted the default value, so no further processing is done.

The next check is to see if the number of the month was entered. Numerals can be converted to numeric data with the VAL function, but this demands the same strict format as INPUT. A much more powerful and flexible way to extract numeric data from a string is by using the ENTER statement. Admittedly, it is not likely that an operator would enter extra text with the number — but why generate an error if he does? The LINPUT/ENTER combination can extract the month from responses like these:

```
4
"4"
MONTH=4
4th month
```

If a number is found, the error trap is disabled. In actual applications, the OFF ERROR statement would be replaced by an ON ERROR statement that re-establishes the normal error trapping used in the program. The final check ensures that the month is within a meaningful range. You want to give the operator maximum flexibility, but accepting the 54th month is **too** flexible. Range checking is a technique that should be used in all good operator interfaces.

Although ENTER can do a lot, it cannot extract a number from a string that has no numerals. Since the operator is permitted (and encouraged) to use the name of the month, the program must handle this case. That is the purpose of the ON ERROR statement before the ENTER. If the ENTER cannot find any numeric value, the error trap directs program execution to the segment labeled `String`. This segment changes the error trap, since it has served its purpose. Then the input data is searched for the presence of a month name. A string comparison could be used, but that requires that the month name be in a fixed location within the response. Again, there is no reason for such a restriction. The POS function will find the desired letters anywhere in the line. The UPC\$ function eliminates any requirements about letter case. Thus, responses like the following would all be valid:

```
JAN
January
MONTH=JAN
"january"
```

In any keyboard-input situation, there is always some possibility that the operator entered pure garbage. If all the attempts to find a meaningful number or name fail, an error message is displayed, and the entire process is repeated. Another programming choice is to assume the default if no meaningful input is found. You must judge for yourself which choice is best. If an accurate operator input is very important to the program, then the program should keep asking until the operator gets smart. If the value in question is not important, it might be best to assume a default and move on to the next stage of the program.

Note that the desired variable, `Current_month`, is not updated unless a valid input was received. All the testing and searching is done using a temporary variable. This is done so that the default value is not destroyed by an invalid input.

LINPUT with Multiple Fields

This example requests the entire date: day, month, and year. As in the previous example, there is nothing special about dates. The techniques shown have general applications. A detailed discussion follows the listing.

```

100  OPTION BASE 1
110  DIM In$[256],Months$(12)[3],Left$[2]
120  INTEGER Temp,Current_day,Current_month,Current_year
130  Fmt:  IMAGE #,2D,"",3A,"",K,K      ! Format of date input
140  FOR Temp=1 TO 12
150    READ Months$(Temp)              ! String data for month names
160  NEXT Temp
170  DATA JAN,FEB,MAR,APR,MAY,JUN,JUL,AUG,SEP,OCT,NOV,DEC
180  Left$=CHR$(255)&CHR$(72)           ! Moves cursor to beginning of line
190  Current_day=1                      ! Set up default values...
200  Current_month=11                   ! In real applications, these might
210  Current_year=1982                 ! come from the clock or a file.
220  !
230  Get_date:  !
240  OUTPUT KBD USING Fmt;Current_day,Months$(Current_month),Current_year,Left$
250  LINPUT "Enter the date, using this format.",In$
260  ON ERROR GOTO Not_valid           ! No numerals = error for ENTER
270  ENTER In$;Temp                    ! Extract the day
280  OFF ERROR                          ! ENTER worked; change error trap
290  IF Temp<1 OR Temp>31 THEN Not_valid ! Check for impossible day-of-month
300  Current_day=Temp                  ! Value OK; use it
310  !
320  Temp=POS(In$,"")                  ! Look for first delimiter
330  IF NOT Temp THEN Not_valid         ! No delimiter = bad format
340  In$=UPC$(In$[Temp+1])             ! Remove date field; make uppercase
350  FOR Temp=1 TO 12                  ! Try to find 1st three letters
360    IF POS(In$,Months$(Temp)) THEN Found_month
370  NEXT Temp
380  !
390  Not_valid:  !
400  OFF ERROR                          ! Change ENTER error trapping
410  BEEP
420  DISP "Improper entry. Please try again,"
430  WAIT 2
440  GOTO Get_date                      ! Start over with this routine
450  !
460  Found_month:  !
470  Current_month=Temp                ! Value OK; use it
480  ON ERROR GOTO Not_valid           ! No numerals = error for ENTER
490  ENTER In$;Temp                    ! Extract the year
500  OFF ERROR                          ! ENTER worked; change error trap
510  IF Temp<100 THEN Temp=Temp+1900  ! Maybe there is no century?
520  Current_year=Temp                 ! Value OK; use it
530  !
540  ! Program execution continues here

```

The first segment declares the variables, stores the month abbreviations, establishes some defaults, and contains an IMAGE statement that specifies the desired date format. Although defaults are important, program constants are not always the best way to supply defaults. Using the constant "12" as a default for a GPIO interface select code makes sense. But the date will almost always be different from a constant stored in the program. A real program should adopt some other method of assuming the date. If your computer has a continuous clock provided by the Powerfail option, the date might be extracted from the clock value. If the program uses a file with the date stored in it, the last access date might be close to the current date.

A significant feature of this example is the handling of multiple fields. Multiple fields bring with them two special considerations. First, there is the need to show the operator the proper format for the fields. Second, there is the need to extract those fields from a single string, assuming that LINPUT is used.

The proper format for the fields is shown to the operator by using an OUTPUT to the keyboard. The default values are sent to the keyboard line, formatted by an IMAGE statement. This not only gives the operator the choice of simply pressing (CONTINUE), but it also shows the appearance of a correct response. If the default date is generated by a good source, it is reasonable to expect that the “day” field will be changed more often than the month or year. Therefore, the OUTPUT to the keyboard finishes by placing the cursor at the beginning of the line, in the day field.

The ON ERROR/ENTER technique is similar to the previous example. The ENTER statement extracts only the day because the comma terminates that field. The day is checked against reasonable limits and assigned to the actual variable if it is acceptable. This range checking could be expanded to check for the maximum day allowed in a specific month.

After the day is extracted, the string is searched for the comma delimiter, and the day field is removed. This is done to prevent the day number from interfering with the extraction of the year number. The resulting string is searched for the month name using the same technique as the previous example.

The year is extracted using the ENTER technique. If a valid number is found, one last test is performed. The response might have contained only the last two digits of the year. This is not likely, since the recommended format showed all four digits; but why complain if it happens? If only two digits are found, the program supplies the 1900 automatically. By the way, this technique is not too effective if the dates being entered might cross century boundaries.

Yes and No Questions

Frequently, all the computer needs from the operator is a simple “yes” or “no”. The “Expanded Softkey Menu” example showed one way to handle yes/no states. However, that much processing is not always desired. If you only need to ask a single question, why program 10 softkeys and 18 CRT lines? The following user-defined function shows some simple, but friendly, processing for yes/no answers.

The objective of this routine is to provide as much flexibility as possible. This means that we don’t bother the operator about such things as bumping the space bar, pressing (CAPS LOCK), or responding with a simple (CONTINUE). The main program provides a prompt or explanation and performs a LINPUT with a 256-character string. It then passes that string to this function and tests the results.

The function uses a local copy of the string just in case you need the actual input for some other purpose in the main program. The response is trimmed and placed in uppercase. Then the first letter is tested. Four cases are identified: the answer was “Y” (for yes), the answer was “N” (for no), no answer was given, or the answer was not recognized.

```

2000 DEF FNYes(X$)
2010   DIM Temp$[1]
2020   Temp$[1,1]=TRIM$(X$)
2030   SELECT Temp$
2040   CASE "Y","y"
2050     RETURN 1
2060   CASE "N","n"
2070     RETURN 0
2080   CASE " "
2090     RETURN -1
2100   CASE ELSE
2110     RETURN -2
2120   END SELECT
2130 FNEND

```

As mentioned previously, every question should have a default answer. The default answer for a yes/no question depends greatly upon the nature of the question. If you are asking the operator for permission to use standard, reasonable parameters for an operation, then “yes” is a helpful default. If you are asking for permission to initialize a disc and destroy all files, then the default answer had better be “NO”! When a question or choice occurs more than once in a program, it is usually a good technique to use the operator’s previous response as the default. Put yourself in the user’s place and think about how the program should run.

To use this function to best advantage, the result must be tested thoughtfully. If the operator simply presses **CONTINUE**, the result will be -1 . Therefore, the default should be assumed if $FNYes = -1$. A “yes” answer is indicated by $FNYes = 1$; whereas a **non-negative** answer can be tested simply as $IF FNYes$. A **non-affirmative** answer is $FNYes < 1$. Any result less than zero is a noncommittal reply. Perhaps the default could be assumed for any negative result, or perhaps a negative result should cause the question to be repeated. The test $IF NOT FNYes$ reveals a negative reply. As you can see, many shades of interpretation are possible.

Custom Interfaces

The ON KBD statement can be used to design very effective keyboard interfaces. However, these are usually very complex to program. In fact, using ON KBD to accept keyboard input, CRT highlights to display a cursor, and PRINT TABXY to position cursor and text is essentially writing a text editor. Unfortunately, programs of that magnitude are beyond the scope of this manual. Information about the applicable keywords can be found in the *BASIC Language Reference*, and some examples of CRT control and ON KBD can be found in Chapters 8 and 9 of *BASIC Interfacing Techniques*.

Error Handling

Chapter**11**

Introduction

Most programs are subject to errors happening at run time, even if all the typographical/syntactical errors have been shaken out in the process of entering the program into the computer in the first place. There are three courses of action to take with respect to errors:

1. Try to prevent the error from happening in the first place
2. Once an error occurs, try to recover from it and continue execution
3. Do nothing — let the program roll over and die if an error happens

The last alternative, which may seem frivolous at first glance, is certainly the easiest to implement, and the nature of HP desktop computers is such that this is often a feasible choice. Upon encountering a run-time error, the computer will pause program execution, and display a message giving the error number and the line in which the error happened, and the programmer can then examine the program in light of this information and fix things up. The key word here is “programmer”. If the person running the program is also the person who wrote the program, this approach works fine. If the person running the program did not write it, or worse yet, does not know how to program, some attempt should be made to prevent errors from happening in the first place, or to recover from errors and continue running.

Anticipating Operator Errors

When a programmer writes a program, he or she knows exactly what the program is expected to do, and what kinds of inputs make sense for the problem. Given this viewpoint, there is a strong tendency for the programmer not to take into account the possibility that other people using the program might **not** understand the boundary conditions. A programmer has no choice but to assume that every time a user has the opportunity to feed an input to a program, a mistake can be made and an error can be caused. If the programmer's outlook is noble, he or she will try to save the user from needless anguish and frustration. If the programmer's outlook is self-centered, he or she will try to keep from getting involved in future support problems. In either case, an effort must be made to make the program foolproof.

Boundary Conditions

A classic example of anticipating an operator error is the "division by zero" situation. An INPUT statement is used to get the value for a variable, and the variable is used as a divisor later in the program. If the operator should happen to enter a zero, accidentally or intentionally, the program crashes with an error 31. It is far better to be watching for an out-of-range input and respond gracefully. One method is shown in the following example.

```

100 INPUT "Miles traveled and total hours",Miles,Hours
110 IF Hours=0 THEN
120     BEEP
130     PRINT "Improper value entered for hours."
140     PRINT "Try again!"
150     GOTO 100
160 END IF
170 Mph=Miles/Hours

```

Consider another simple example of giving a user the choice of six colors for a certain bar graph. It might be preferable to have the user pick a number corresponding to the color he wished to choose instead of having to type in up to six characters. In this case, the program wouldn't have to check for each number, but rather it could use the logical comparators to check for an entire range:

```

4030 OUTPUT KBD;Clear$; ! Clear the screen
4040 DATA GREEN,BLUE,RED,YELLOW,PURPLE,PINK
4050 ALLOCATE Colors$(1:6)[6]
4060 READ Colors$(*)
4070 FOR I=1 TO 6
4080     PRINT USING "DD,X,K";I,Colors$(I)
4090 NEXT I
4100 Ask: INPUT "Pick the number of a color",I
4110 IF I>=1 AND I<=6 THEN Valid_Color
4140 BEEP
4150 DISP "Invalid answer -- ";
4160 WAIT 1
4170 GOTO Ask

```

The above example needs a little extra safeguarding. I, the variable being input, should be declared to be an integer, since the only valid inputs are 1, 2, 3, 4, 5, and 6. An answer like "pick the 3.14th color listed" does not make sense.

Real number boundaries are tested for in a manner similar to that of integers:

```

7010 INPUT "Enter the waveform's frequency (in KHz)",Frequency
7020 IF Frequency<=0 THEN 7010
7030 INPUT "Enter the amplitude (0-10 volts)",Amplitude
7040 IF Amplitude<0 OR Amplitude>10 THEN 7030
7050 INPUT "Enter the phase angle (in degrees)",Angle
7060 IF Angle<0 OR Angle>180 THEN 7050
7070 Angle=Angle*PI/180

```

REAL Numbers and Comparisons

A word of caution is in order about the use of the = comparator in conjunction with REAL (full precision) numbers. Numbers on this computer are stored in a binary form, which means that the information stored is not guaranteed to be an exact representation of a decimal number — but it will be real close! What this means is that a program should not use the = comparator in an IF statement where the comparison is being performed on REAL numbers. The comparison will yield a 'false' or '0' value if the two are different by even one bit, even though the two numbers might really be equal for all practical purposes.

There are two ways around this problem. The first is to state the comparison in terms of the <= or >= comparators. However if it's absolutely necessary to do an equality comparison with a pair of REAL numbers, then the second method must be used. This involves picking an error tolerance for how close to being equal the two numbers can be to satisfy the test.



So if the difference between two REAL numbers X1 and X2 is less than or equal to a tolerance T0, we'll say that X1 and X2 are "equal" to each other for all practical purposes. The value of T0 will depend upon the application, and must be chosen with care.

For an example, assume that we've picked a tolerance of 10^{-12} for comparing two REAL numbers for equality. The proper way to compare the two numbers would be:

```

950 IF ABS(X1-X2)<=1E-12 THEN Numbers_equal
960 ! Otherwise they're not equal

```

Another technique for comparing REAL values is to use the DROUND function. This is especially suited to applications where the data is known to have a certain number of significant digits. For more details on binary representations of decimal numbers, refer to Chapter 4.

Error Trapping

Despite the programmer's best efforts at screening the user's inputs in order to avoid errors, sometimes an error will still happen. It is still possible to recover from run time errors, provided the programmer predicts the places where errors are most likely to happen.

ON/OFF ERROR

The ON ERROR command sets up a branching condition which will be taken any time a recoverable error is encountered at run time. The branching action taken may be either GOTO, GOSUB, CALL, or RECOVER. GOTO and GOSUB are purely local in scope — that is, they are active only within the context in which the ON ERROR is declared. CALL and RECOVER are global in scope — after the ON ERROR is set up, the CALL or RECOVER will be executed any time an error occurs, regardless of subprogram environment.

When an ON ERROR statement is executed, the language system will make sure that the specified line or subprogram exists in memory before the program will proceed. If ON ERROR GOTO/GOSUB/RECOVER are specified, then the line identifier must exist in the current context. If an ON ERROR CALL is given, then the specified subprogram must currently be in memory. In either case, if the system can't find the given line, an error 49 is issued.

If either ON ERROR GOSUB or ON ERROR CALL are used and an error occurs, the specified branch will take place, and when the RETURN or SUBEXIT is executed, then program execution will resume at the line which caused the error, and an attempt will be made to execute the line again.

ON ERROR has a priority of 16, which means that it will always take priority over any other ON <event> since the highest user-specifiable priority is 15.

The OFF ERROR statement will cancel the effects of the ON ERROR statement, and no branching will take place if an error is encountered.

The DISABLE statement has no effect on ON ERROR branching.

ERRN/ERRL/ERRM\$

ERRN is a function which returns the error number which caused the branch to be taken. ERRN is a global function, meaning it can be used from the main program or from any subprogram, and it will always return the number of the most recent error.

ERRM\$ is a string function which returns the text of the error which caused the branch to be taken.

ERRL is a function which is used to find the line in which the error was encountered. ERRL is a boolean function. The program feeds it a line identifier, and either a 1 or a 0 is returned, depending upon whether or not the specified identifier indicates the line which caused the error. ERRL is a local function, which means it can only be used in the same environment as the line which caused the error. This implies that ERRL cannot be used in conjunction with ON ERROR CALL, and that it can be used with ON ERROR GOTO and ON ERROR GOSUB. ERRL can be used with ON ERROR RECOVER only if the error did not occur in a subprogram which was called by the environment which set up the ON ERROR RECOVER.

The ERRL function will accept either a line number or a line label.

```
1140  DISP ERRL(710)
910   IF ERRL(Compute) THEN Fix_compute
```

ON ERROR GOSUB

The ON ERROR GOSUB statement should only be used when you can guarantee that the problem causing the error can be fixed and the line can be re-executed safely. Remember that if the action taken in the error service routine is not sufficient to correct the problem, the program will dive into an infinite loop. Every time an error occurs, a GOSUB will cause a branch to the error service routine which will RETURN execution to the line causing the error.

When an error triggers a branch as a result of an ON ERROR GOSUB statement being active, system priority is set at the highest possible level (16) until the RETURN statement is executed, at which point the system priority is restored to the value it was when the error happened.

```
100  Radical=B*B-4*A*C
110  Imaginary=0
120  ON ERROR GOSUB ESR
130  Partial=SQR(Radical)
140  OFF ERROR
.
.
.
350 ESR: IF ERRN=30 THEN
360      Imaginary=1
370      Radical=ABS(Radical)
380  ELSE
390      BEEP
400      DISP "Unexpected Error (";ERRN;)"
410      PAUSE
420  END IF
430  RETURN
```

ON ERROR GOTO

The ON ERROR GOTO statement is generally more useful than ON ERROR GOSUB, especially if you are trying to service more than one error condition. The only advantage that ON ERROR GOSUB has over ON ERROR GOTO is that system priority is maintained at the highest possible level until the error subroutine is finished.

By using the ON ERROR GOTO statement, the same error service routine can be used to service all the error conditions in a given context. By testing both the ERRN (what went wrong) and the ERRL (where it went wrong) functions, proper recovery procedures can be taken.

304 Error Handling

```

10  RESTORE
20  PRINT
30  PRINT
40  PRINT "Coefficients of quadratic equation A"
50  DATA 0,0,0
60  READ A,B,C
70  Maxreal=1.79769313486231E+308
80  Overflow=0
90  Coefficients:  !
100 INPUT "A?",A
110 IF A=0 THEN
120   DISP "Must be quadratic"
130   WAIT 1.5
140   GOTO Coefficients
150 END IF
160 PRINT "A=";A
170 INPUT "B?",B
180 PRINT "B=";B
190 INPUT "C?",C
200 PRINT "C=";C
210 Compute_roots:  !
220 ON ERROR GOTO Esr
230 Imaginary=0
240 Part1=-B/(2.*A)
250 Part2=SQR(B*B-4*A*C)/(2.*A)
260 IF NOT Imaginary THEN
270   Root1=Part1+Part2
280   Root2=Part1-Part2
290 END IF
300 OFF ERROR
310 Print_roots:  !
320 IF Imaginary=0 THEN
330   PRINT "Root 1 =" ;Root1
340   PRINT "Root 2 =" ;Root2
350 ELSE
360   PRINT "Root 1 =" ;Part1;" +";Part2;" i"
370   PRINT "Root 2 =" ;Part1;" -";Part2;" i"
380 END IF
390 IF Overflow THEN PRINT "OVERFLOW"
400 STOP
410 Esr:  !
420 IF ERRN=30 THEN  ! SQR OF NEGATIVE NUMBER
430   Part2=SQR(ABS(B*B-4*A*C))/(2.*A)
440   Imaginary=1
450   Branch=1
460   GOTO 270
470 ELSE
480   IF ERRN=22 THEN  ! REAL OVERFLOW
490     Overflow=1
500     SELECT 1
510       CASE ERRL(240)
520         Part1=SGN(B)*SGN(A)*Maxreal
530         Branch=2
540       CASE ERRL(250)
550         Part2=Maxreal
560         Branch=3
580       CASE ERRL(270)
590         Root1=Maxreal*SGN(Part1)
600         Branch=4
620       CASE ERRL(280)
630         Root2=Maxreal*SGN(Part1)
640         Branch=5
660         PRINT "UNEXPECTED OVERFLOW"
670         Branch=6
680       CASE ELSE
690         DISP "UNEXPECTED ERROR";ERRN
700         Branch=6
710     END SELECT
720   END IF
730 END IF
740 ON Branch GOTO 270,250,260,280,290,10
750 END

```

ON ERROR CALL

ON ERROR CALL is global, meaning once it is activated, the specified subprogram will be called immediately whenever an error is encountered regardless of the current context. System priority is set to level 16 inside the subprogram, and remains that way until the SUBEXIT is executed, at which time the system priority will be restored to the value it was when the error happened.

The ON ERROR CALL statement should only be used when you can guarantee that the problem causing the error can be fixed and the line can be re-executed safely. Remember that if the action taken in the error service routine is not sufficient to correct the problem, the program will dive into an infinite loop. Every time an error occurs, a CALL will cause a branch to the error service routine which will return execution to the line causing the error when a SUBEXIT statement is executed.

Bear in mind that an ON...CALL statement cannot pass parameters to the specified subprogram, so the only way to communicate between the environment in which the error is declared and the error service routine is through a COM block.

The ERRL function will not work in a different environment than the one in which the ON ERROR statement is declared, so when using an ON ERROR CALL, you should set things up in such a manner that the line number either doesn't matter, or can be guaranteed to always be the same one when the error occurs. This can be accomplished by declaring the ON ERROR immediately before the line in question, and immediately using OFF ERROR after it.

```

5010  ON ERROR CALL Fix_disc
5020  ASSIGN @File TO "Data_file"
5030  OFF ERROR
5040  !
5050  !
5060  !
7020  SUB Fix_disc
7030  SELECT ERRN
7040  CASE 80
7050      DISP "Door open -- shut it and Press CONT"
7060      PAUSE
7080  CASE 83
7090      DISP "Write protected -- fix and Press CONT"
7100      PAUSE
7120  CASE 85
7130      DISP "Disc not initialized -- fix and Press CONT"
7140      PAUSE
7160  CASE 56
7170      DISP "Creating Data_file"
7180      CREATE BDAT "Data_file",20
7190  CASE ELSE
7200      DISP "Unexpected error ";ERRN
7210      PAUSE
7220  SUBEND

```

ON ERROR RECOVER

The ON ERROR RECOVER statement sets up an immediate branch to the specified line whenever an error occurs. The line specified must be in the context of the ON...RECOVER statement. ON ERROR RECOVER is global in scope — it is active not only in the environment in which it is defined, but also in any subprograms called by the segment in which it is defined.

If an error is encountered while an ON ERROR RECOVER statement is active, the system will restore the context of the program segment which actually set up the branch, including its system priority, and will resume execution at the given line.

```
.  
. .  
. .  
3250 ON ERROR RECOVER Give_up  
3260 CALL Model_universe  
3270 DISP "Successfully completed"  
3280 STOP  
3290 Give_up: DISP "Failure ";ERRN  
3300 END  
. .  
. .
```

Program Debugging

Chapter**12**

Introduction

The problem of debugging a program is distinct from the issues raised in Chapter 11, Error Handling. Chapter 11 is based on the premise that the programmer is satisfied that the program works as it should, and that it then should be made as foolproof as possible. This could be construed as putting the cart before the horse — before you can make a program foolproof, you must get it to run correctly in the first place. One of the key characteristics of a “bug” is that it doesn’t necessarily have to cause an error condition to occur — it only has to cause your program to give a wrong answer. This chapter deals with the methods available on this computer to diagnose problems in logic and semantics.

Naturally, the ideal way to debug a program is to write it correctly the first time through, and all programmers should strive constantly to achieve this state of nirvana. Hopefully, the techniques that have been discussed in this manual will help you get a little closer to this goal. The practice of writing self documenting code and designing programs in a top down fashion should help immensely.

Aside from recommended methods of writing software, the computer itself has several features which aid in the process of debugging.

Using Live Keyboard

One of the pleasing characteristics of this computer is that its keyboard is “live” even during program execution. That is, you can issue commands to the computer while it is running a program the same way that you issue commands to it while it is idle. For instance, you can add two numbers together, examine the catalogue of the disc currently installed in the drive, list the running program to a printer, scroll the CRT alpha buffer up and down, enter and exit either the graphics or alpha displays, or output a command to a function generator over HP-IB. Practically the only thing you can't do from live keyboard while a program is running is write or modify program lines, or attempt to alter the control structures of the program. (A complete list of illegal keyboard operations is given a little later on.)

By way of illustration, key in the following program, press **RUN**, and then execute the commands shown underneath the listing.

```

10  FOR I=1 TO 1,E+5
20  NEXT I
30  END

CAT
Z+Z
SQR(6^2+17.2^2)
PRINT "THE QUICK BROWN FOX"
TIMEDATE

```

Now, this program will take a fair amount of time to complete (about 18 seconds), so to find out how far the program has gone, merely type I and press **EXECUTE** or **RETURN**. The current value of I will be displayed at the bottom of the screen. Now if you don't want to wait for the program to go through all one hundred thousand iterations, you can merely change the value of I by executing the command

```
I=99999
```

Thus, we have seen that live keyboard can be used to examine and/or change the contents of the program's variables.

One aspect of live keyboard to be aware of is that the computer will only recognize variables that exist in the current program environment. For instance, suppose that we change our example program to call a subprogram inside the loop.

```

10  FOR I=1 TO 1,E+5
15  CALL Dummy
20  NEXT I
30  END
40  SUB Dummy
50  FOR J=1 TO 10
60  NEXT J
70  SUBEND

```

While this program is running and you test the variable I from the keyboard, chances are that you will only get a message saying that I doesn't exist in the current context — most of the time will be spent in the subprogram. On the other hand, if you test the value of J, it is highly likely that you will get an answer.

Similarly, operations like ASSIGN and ALLOCATE, which are declarative types of statements, must use variables that are already known to the current environment when they are executed from the keyboard. For example, in the following program, it is perfectly legal to perform the operation `ASSIGN @Dvm TO *` from the keyboard, although it is not legal to perform `ASSIGN @File TO "DATA"` from the keyboard.

```

1   ASSIGN @Dvm TO 724
10  FOR I=1 TO 1.E+5
20  NEXT I
30  END

```

Live keyboard operations are allowed to use variables already known by the running program. Live keyboard operations are not allowed to create variables.

Although the GOTO and GOSUB commands are illegal from the keyboard, it is perfectly legal to call subprograms from the keyboard. The only restriction on using SUB and function subprograms from the keyboard is that the parameters that are passed must either be constants or must be variables that exist in the current context.

Here is an example:

```

10  FOR I=1 TO 1.E+5
20  NEXT I
30  END
31  !
40  SUB Gather(INTEGER X)
50  OPTION BASE 1
60  DIM A(32)
70  CREATE BDAT "File"&VAL$(X),1
80  ASSIGN @Dvm TO 724
90  ASSIGN @File TO "File"&VAL$(X)
100 OUTPUT @Dvm;"N100S"
110 ENTER @Dvm;A(*)
120 OUTPUT @File;A(*)
130 PRINT A(*),
140 SUBEND
141 !
150 DEF FNPoly(X)
160 RETURN X^3+3*X^2+3*X+X
170 FNEND

```

By executing `CALL Gather(1)` from the keyboard, the main program will be suspended while the subprogram is called, at which time a 1 record file will be opened, 32 readings will be taken from the voltmeter and stored in the file, and the readings will be printed on the screen. Then main program execution will resume where it left off.

Similarly, by typing `FNPoly(1)`, the value of the polynomial will be computed for $X=1$ and the answer (8) will be displayed at the bottom of the screen.

Here is a list of commands which may not be executed from the keyboard while a program is running, although they may be executed from the keyboard if the computer is idle:

RUN	SCRATCH	GET
CONT	SCRATCH A	LOAD
EDIT	SCRATCH C	LOAD BIN
DEL	SCRATCH BIN	SYSBOOT

Stepping

One of the most powerful debugging tools available is the capability of single stepping a program, one line at a time. This process allows the programmer to examine the values of his variables and the sequence in which the program is running at each statement. This is done with the **STEP** key.

There are three ways to use the **STEP** key:

1. If the program is stopped (i.e., a prerun has to be performed), pressing the **STEP** key will cause the system to perform a prerun on the program, but no program lines will actually be executed. The first line that will be executed will appear in the system message line at the bottom of the screen. Pressing the **STEP** key again will cause that line to be executed, and the next line after that to be executed will appear in the message line. If the **STEP** key is pressed causing the next line to appear in the display, and a live keyboard operation (such as examining the value of a variable) is performed, the contents of the message line will change. Pressing the **STEP** key again will still cause the line to be executed, even though it is no longer visible in the implied display line. After the statement has completed, the next line will again appear.
2. If the program is in an INPUT or LINPUT statement, pressing the **STEP** key is sufficient to terminate the operation. Any data entered from the keyboard will be entered into the correct variables, just as though **CONTINUE** or **ENTER** had been pressed, but program execution will be PAUSEd, and the statement immediately following the INPUT or LINPUT will appear in the system message line.
3. If the program is in a PAUSEd state, pressing the **STEP** key will cause the next line to be executed. The program counter will not be reset, nor will a prerun be performed. Again, the next line to be executed will appear in the system message line after the last one has been completed. A paused state is indicated by a dash in the run light in the lower right hand corner of the screen.

Type in the following example and execute it by pressing the **STEP** key repeatedly.

```

10 DIM A(1:5)
20 ! This is an example
30 S=0
40 FOR I=1 TO 5
50 INPUT "Enter a number",A(I)
60 S=S+A(I)
70 NEXT I
80 PRINT S
90 PRINT A(*)
100 END

```

Notice that the **STEP** key caused every statement to appear in the system message line, one at a time, even those statements that are not really executed, like DIM and comments.

Tracing

The process of single stepping, wonderful though it is, can be quite slow, especially if the programmer has little or no idea which part of his program is causing the bug. An alternative way of examining variable changes and program flow is available in the form of the TRACE ALL statement.

TRACE ALL

When the TRACE ALL command is executed, it causes the system to issue a message prior to executing every line (this shows the order in which the statements were executed), and if the statement caused any variables to change value, a message telling the variables involved and their new values is also issued. The messages are issued to the system message line, and the most useful way to use the TRACE ALL feature is to turn Print All On (use the **PRT ALL** key), unless of course you're a very fast reader. (The printall mode will cause all information from the DISP line, the keyboard input line, and the system message line to be logged on the PRINTALL IS device.)

Turn Print All ON and key in the following example to see how TRACE ALL works:

```

10  TRACE ALL
20  FOR I=1 TO 10
30      PRINT I;
40      IF I MOD 2 THEN
50          PRINT " is odd."
60      ELSE
70          PRINT " is even."
80      END IF
90  NEXT I
100 END

```

There are two optional parameters that can be used with TRACE ALL. Both parameters are line identifiers (line numbers or line labels). The first parameter tells the system when to start tracing, and the second one (if it's specified) tells the system when to stop tracing. The following example illustrates the use of one optional line specifier:

```

1    TRACE ALL 40
10   DIM A(1:10)
20   FOR I=1 TO 100
30   NEXT I
40   FOR J=1 TO 10
50   A(J)=J
60   NEXT J
70   END

```

It is usually more useful to use the TRACE ALL command from the keyboard rather than from the program because a program modification is not necessary if you want to trace a different part of the program. All that's necessary is to type in a new TRACE ALL command from the keyboard to override the old one. In the above example, to trace the loop from 20 to 30 instead of the one from 40 to 60, simply delete line 1 and type in TRACE ALL 20,40 from the keyboard.

```

10  DIM A(1:10)
20  FOR I=1 TO 100
30  NEXT I
40  FOR J=1 TO 10
50  A(J)=J
60  NEXT J
70  END

```

The program will begin tracing at line 20, and keep on tracing until it's ready to execute line 40, at which time it will terminate the trace messages and will continue executing the program normally.

If the TRACE ALL statement uses a line label instead of a line number, be aware of what happens if you have more than one occurrence of a given line label in your program. For instance, it is perfectly legal to have the same line label in two or more different program environments — line labels are local to subprograms and branching operations addressing a given line label are treated separately in different subprograms. However, when a TRACE ALL using a line label is executed, the first line label in memory is the one that gets used, regardless of the environment the program was in when the TRACE ALL statement was executed. Thus in the following program, even though the TRACE ALL Printout statement is executed inside the subprogram, tracing does not commence until the subprogram has been exited and the Printout statement in the main program has been executed.

```

10  DIM A(1:10)
20  FOR I=1 TO 10
30      CALL Dummy(A(*),I)
40      GOSUB Printout
50  NEXT I
60  STOP
70 Printout: !
80  FOR J=1 TO 10
90  PRINT A(J);", ";
100 NEXT J
105 PRINT
110 RETURN
120 END
130 SUB Dummy(X(*),Z)
140 TRACE ALL Printout
150 FOR I=1 TO 10
160     X(I)=Z*100+I
170 NEXT I
180 GOSUB Printout
190 SUBEXIT
200 Printout: !
210 PRINT "Dummy routine executed";Z
220 RETURN
230 SUBEND

```

If two line identifiers are used, their location with respect to each other does not matter. Tracing will start when the line specified first is encountered, and it will stop when (or if) the second line is encountered.

PRINTALL IS

The PRINTALL IS command is useful for switching the tracing messages between the CRT and a hardcopy printer. (Again, to get any record at all of the trace messages, Print All must be On.) To cause the trace messages to be logged on the CRT, execute PRINTALL IS CRT. (The CRT is the default PRINTALL IS device that the system assumes when it wakes up.) To cause the messages to be logged on a printer, merely change the device selector to the appropriate value (PRINTALL IS 701).

TRACE PAUSE

The TRACE PAUSE command can be used to set a “break point” in the program. The program will execute at a reduced speed until the specified line is reached, at which time the program will pause, and the specified line will be shown in the implied display line, indicating that the program will execute it when execution is resumed. Execution may be resumed with the **CONTINUE** key, the **STEP** key (which will only cause one line to be executed), or by executing CONT from the keyboard (the specified line identifier must be located in the current environment).

By executing the command TRACE PAUSE Printout from the keyboard, the following program will pause every time it reaches line 70.

```

10  DIM A(1:10)
20  FOR I=1 TO 10
40      GOSUB Printout
50  NEXT I
60  STOP
70 Printout: !
80  FOR J=1 TO 10
90  PRINT A(J);";";
100 NEXT J
110 PRINT
120 RETURN
130 END

```

Try the following ways of continuing execution:

```

press STEP
press CONTINUE
execute CONT 110

```

As with TRACE ALL, a new TRACE PAUSE statement overrides a previous one. The same rules are applied when a line label is used in a TRACE PAUSE statement as are applied to the TRACE ALL statement — the first line in memory having that label is used.

TRACE OFF

TRACE OFF cancels the effects of any active TRACE ALL or TRACE PAUSE statements. The status of Print All and the PRINTALL IS device will be unchanged.

TRACE OFF may be executed either from the program, or from the keyboard.

The CLR I/O Key

The **CLR I/O** key (**BREAK** on HP 46020A keyboards) suspends any active I/O operation and pauses the program in such a way that the suspended statement will restart once **CONTINUE** or **STEP** is pressed. This is useful for operations which appear to “hang” the machine, such as printing to a printer which isn’t turned on.

Most devices will not respond to ENTER requests unless they have first been instructed to respond. If improper values are sent to a device, it may refuse to respond. Therefore, **CLR I/O** can help in debugging these situations.

Here are the operations that can be suspended with **CLR I/O**.

PRINT	SEND	ASSIGN
LIST	PRINTALL outputs	PURGE
CAT	ENTER	CREATE
OUTPUT	INPUT	Some graphics commands
DUMP GRAPHICS	HP-IB commands	
DUMP ALPHA	External plotter commands	

Efficient Use of the Computer's Resources

Chapter

13

Introduction

Every model of computer has certain characteristics which can result in better performance, provided the programmer knows what those characteristics are and how he can take advantage of them. This chapter consists of a potpourri of such items.

Data Storage

Data Storage in Read/Write Memory

There are four data types on this computer: REAL, INTEGER, strings, and I/O path names. The R/W memory occupied by data is made up of two parts: the memory it actually takes to hold the intended information, and the memory that the system uses to keep track of the information's location and form (this is called overhead). Strings, INTEGERS, and REALs can be declared either as simple variables or as arrays. Arrays take different amounts of overhead than simple variables, but each element of an array uses the same amount of memory that a corresponding simple variable uses to actually store information.

The overhead required for any given symbol is kept in three tables: the symbol table, the token table and the dimension table. The symbol table contains pointers to the value area, where the actual information is kept, and to the other two tables. The token table contains the names of the various symbols. The dimension table contains length information for strings and arrays, and is not used for numeric scalars. The tables are not constructed in single units as symbols are added and deleted. Rather, as new space is required, the system will first look to see if there are any unused entries in the tables — if new space is allocated, usually enough for several entries is allocated. For instance, the symbol table is built in increments of five entries.

Symbol Table Overhead:	10 bytes per symbol
Token Table Overhead:	number of characters in the name + 1 (if the above number is odd, it is rounded up to an even number). Note that the name for I/O path names, strings, and functions includes the @, \$, and FN, respectively.
Dimension Table Overhead:	<p>For arrays: 3 bytes (total size) 1 byte (number of dimensions) 4 bytes for each dimension (for the lower bound, and the size of each dimension)</p> <p>For strings: 2 bytes (maximum length)</p> <p>For string arrays — all of the normal array overhead, plus two bytes for the maximum allowed length of an element</p>

Note that line labels, COM labels, and subprograms are considered as symbols, and occupy space in both the symbol and token tables. Line numbers used in statements, like GOTO 20, also occupy space in the symbol table.

Every subprogram (or context) has its own set of tables. In addition, there is a global set of COM tables, where all information concerning COM blocks is kept. Symbols that belong to a COM block will occur in both the COM tables and in any local tables in which that COM block is declared. Since each context may define the names by which it refers to COM block variables, there will be no entry in the COM token table for each variable, but an entry in the COM token table **will** occur for COM labels.

ALLOCATED variables require four bytes of overhead in addition to the overhead already discussed for the symbol, token, and dimension tables.

The following table summarizes the storage requirements for various data types. This table does not show the extra requirements just mentioned for ALLOCATED and COM variables.

Type	Overhead	Information Storage
Simple INTEGER	10 bytes + name overhead	2 bytes
Simple REAL	10 bytes + name overhead	8 bytes
Simple string	12 bytes + name overhead	1 byte per char. up to declared length (padded to even number of chars.) + 2 bytes (length information)
I/O path name	10 bytes + name overhead	100 bytes
INTEGER array	14 bytes + name overhead + 4 bytes per dimension	2 bytes per element
REAL array	14 bytes + name overhead + 4 bytes per dimension	8 bytes per element
String array	16 bytes + name overhead + 4 bytes per dimension	1 byte per char. up to declared length (padded to even number of chars.) + 2 bytes (length information) per element

Data Storage on Mass Memory Devices

The amount of storage that data takes on mass storage media is similar to the amount of R/W memory that data takes internally, except that no overhead is required (on BDAT files). Arrays and single values are interchangeable on mass storage — no distinguishing information is kept on the media.

INTEGERS (and INTEGER arrays)	2 bytes (per element)
REALs (and REAL arrays)	8 bytes (per element)
Strings (and string arrays)	4 bytes + 1 byte per char up to current length, padded to even number of chars. (per element)

For ASCII files, all information is converted to string (or ASCII) form, and a two-byte length field is tacked onto the front of every field.

INTEGERS (and INTEGER arrays)	2 bytes + 1 byte per digit (per element)
REALs (and REAL arrays)	2 bytes + 1 byte per digit (per element)
Strings (and string arrays)	2 bytes + 1 byte per char (per element)

Comments and Multicharacter Identifiers

Self-documenting features such as in-line comments and multicharacter variables and line labels are useful because of the benefits to be reaped in terms of developing, testing, debugging, and maintaining programs. They do take extra memory, but this shouldn't be a problem if you keep the following points in mind.

Comments take 1 byte of R/W memory for every character in the comment. If memory space becomes a problem, many people resort to keeping two copies of their programs around — one fully commented to use as reference material, and the other uncommented to use as the “production version”, which is the one that is actually used.

Multicharacter identifiers are only spelled out in their entirety once — not every time they are used. The program actually stores pointers whenever a reference to the identifier is used, so using short identifiers won't result in any appreciable savings in memory used.

Variable and Array Initialization

Care should be taken to initialize any variables before using them in an expression (on the right hand side of an =, as a left-hand subscript in a function or subprogram parameter list, as an argument to a built-in function, or in a PRINT/OUTPUT/DISP list). The system will set variables to zero, strings to null, and I/O path names to undefined at program prerun, but depending upon defaults like this is considered bad programming practice and could lead to subtle errors. For instance, the first time a certain line is executed, the variables used may be assumed to be zero because of the prerun operations. Once this assumption has been made, the danger is that the programmer will branch back to the same section of code and forget that the zeroing process has not been performed — an error may result that didn't occur previously.

Mass Memory Performance

Program Files

There are two ways to store programs — they can be saved either as ASCII source strings using the SAVE command, or they can be stored in an intermediate form that the BASIC language system understands using the STORE command.

If the time it takes to load the program is important, always use the STORE command to store the program instead of the SAVE command. The LOAD command, which reads in files created by the STORE command, will execute about fifty times faster than the GET command. This is because the LOAD command does not require that the information on the file be processed in any way. Since the program is already in the form the system needs it in, all that is necessary is to funnel the program directly into memory as fast as the disc can spin (assuming an interleave of one).

SAVE files, on the other hand, require that the system parse and check the lines as they are read, just the same as if a user had typed them in from the keyboard. Consequently, the speed at which the program gets loaded into memory with the GET command will be drastically slower than the LOAD command. Using the Models 226 and 236 internal drives as an example of the relative speeds, a typical 8K byte program will take about 30 seconds to GET, but only about one second to LOAD.

One advantage of the GET/SAVE commands is that it is possible to deal with programs as string data.

Data Files

As with program files, there are two types of data files: ASCII and BDAT. ASCII files require that all data be in string form, while BDAT files are interpreted as internal data representations.

When reading or writing data to an ASCII file, the number formatter is required to convert the data in between its internal representation and its ASCII form. When reading or writing data to a BDAT file the data may stream directly back and forth with no conversion required. Using the Models 226 and 236 internal drives as an example, an 8K element REAL array (64K bytes) may take around 200 seconds to write in an ASCII file, while the same array will only take about 5 seconds to write to a BDAT file.

The primary benefit of the ASCII data file is the transportation of data between different models of Hewlett-Packard computers and terminals and between discs used with different language systems.

Benchmarking Techniques

This section discusses the techniques used to determine how fast various operations execute. Ideally, you should separate the measurement time from elapsed time:

```

10  T1=TIMEDATE
20  T2=TIMEDATE
30  PRINT T1-T2;"seconds used to read clock"
40  END

```

In actuality, the clock only has a resolution of 10 ms, so you won't usually be able to time this operation.

Next, most operations are performed inside a loop in order to be able to time operations that are faster than the resolution of the clock (clock resolution is 10 ms.). This also tends to "smooth out" varying system overhead characteristics.

```

10  INTEGER I
20  T1=TIMEDATE
30  FOR I=1 TO 10000
40  NEXT I
50  T2=TIMEDATE
60  PRINT T2-T1;"seconds of loop overhead"
70  END

```

A certain amount of time used in computational operations will involve moving information around. The time will be different depending upon the type of the information being moved (string, REAL, or INTEGER), and for strings, the length.

```

10  REAL A,B,C
20  INTEGER I
30  B=PI
40  T1=TIMEDATE
50  FOR I=1 TO 10000
60  A=B
70  NEXT I
80  T2=TIMEDATE
90  PRINT T2-T1;"seconds of loop overhead"
100 END

```

The next step is to actually time the operation of interest. It should be noted that for arithmetic operations, the time spent performing the operation will vary depending upon the two operands (number of digits and relative magnitudes).

```

10  REAL A,B,C
20  INTEGER I
30  B=PI*1.E+53
40  C=EXP(SQR(2)^13.81)
50  PRINT "B=";B,"C=";C
60  T1=TIMEDATE
70  FOR I=1 TO 10000
80    A=B
90  NEXT I
100 T2=TIMEDATE
110 FOR I=1 TO 10000
120  A=B+C
130 NEXT I
140 T3=TIMEDATE
150 OP_time=DROUND(T3-T2-T2+T1,3)
160 PRINT OP_time*100;"us. Per operation"
170 END

```

The above program will show anywhere from 148 to 150 microseconds per operation for addition.

Here is a list of a few other operations:

Addition	150 μ s
Subtraction	165 μ s
Multiplication	301 μ s
Division	460 μ s
Exponentiation	7590 μ s

These times vary for different processor boards. Use these times and others throughout this chapter to compare the speeds of different operations.

INTEGER Variables

We have seen in the first section of this chapter that INTEGER variables don't take as much memory as REAL variables (2 bytes instead of 8). Now we shall discover that some operations with INTEGERS are much faster than the same operations with REALs.

Minimum and Maximum Values

The INTEGER variable type may store any whole number from $-32\,768$ to $+32\,767$ inclusive.

Mathematical Operations

There are two sets of math routines provided for the MOD, DIV, +, -, and * operations: REAL and INTEGER. Depending upon the types of the operands used, the execution times for these operations will vary widely. The tradeoffs are:

INTEGER math is the faster of the two, since it doesn't require as much "work". This is because:

1. There are only two bytes of data to process instead of eight
2. Operations do not have to deal with a combination of mantissa and exponent.
3. The results don't have to be normalized.
4. INTEGER math can be done directly in the hardware.

REAL math, though slower, is generally more widely used because it allows numbers with fractional parts to be analyzed. REAL numbers carry about 16 decimal digits of precision and have an exponent range of -308 to $+308$.

Note

All times specified are without the floating point card. If you have this card, your times will be faster for REAL math.

For instance, suppose you want to compute your monthly pay. Assume that you're making \$5.17 an hour, that you work twenty four days per month and that you work 14 hours per day. The calculation that you would use is $5.17 * 24 * 14$ or \$1737.12. In this problem, you definitely want your computer to use REAL precision math (or you'll lose 17 cents per hour!) even though you're only using 6 of the 16 digits available.

The computer will pick whatever math routines it needs to solve the current problem. However, the programmer can exercise control over which math routines get executed if the following rules are understood.

- INTEGER math is used if both arguments of a MOD, DIV, *, +, or - operation are of type INTEGER. If the results of the operation cannot be stored in an INTEGER, then an error is generated (INTEGER overflow).
- REAL math is used if either or both arguments of a MOD, DIV, *, +, or - operation is of type REAL. If one of the arguments is of type INTEGER, then that argument is first converted to REAL.
- REAL math is always used for exponentiation and division (slash).

The following table gives some approximate time comparisons between INTEGER and REAL operations for +, -, and *. The times are approximations because REAL math routines do different things depending upon the values of the operands. All times shown here were found on operations with numbers having no fractional parts. The multiplication times were found for operands in the range of -200 to +200.

	REAL	INTEGER
MOD	160 μ s	91 μ s
DIV	352 μ s	88 μ s
Addition	142 μ s	68 μ s
Subtraction	174 μ s	68 μ s
Multiplication	152 μ s	77 .113s

Multiplication, like most math operations, will execute faster on INTEGER values. However, bear in mind that it's much easier to get an INTEGER overflow on multiplications than on additions and subtractions. For instance, $200*200$ will give an INTEGER overflow. If you are performing multiplication on INTEGERS, you should carefully examine your program to ensure that the range of your answers doesn't force you to use REALs, even if the requirement for fractional precision doesn't.

Loops

In general, any FOR/NEXT loop using an index which has been declared to be an INTEGER will execute about 2.4 times faster than a loop whose loop counter is a REAL. Type in the two programs below and run them to see the difference.

```

10 REAL I
20 TO=TIMEDATE
30 FOR I=1 TO 10000
40 NEXT I
50 PRINT TIMEDATE-TO;"seconds"
60 END

```

Time is about 1.67 seconds.

```

10 INTEGER I
20 TO=TIMEDATE
30 FOR I=1 TO 10000
40 NEXT I
50 PRINT TIMEDATE-TO;"seconds"
60 END

```

Time is about .69 seconds.

Bear in mind that the 2.4 speed improvement is only on the time devoted to actually incrementing and testing the loop variable (in these examples, I). So, any loop that iterates for 10 000 times will run about a second faster if the index is an INTEGER instead of a REAL. Now, saving a second on a loop that executes 10 000 times may not sound like much by itself, and it's not. But what if that loop is nested inside **another** one that executes 10 000 times? Now your time savings is 10 000 seconds, or two hours and forty-five minutes! Just for declaring the loop counters to be INTEGER.

Naturally, making a loop index into an `INTEGER` will only work if the loop is not stepping in fractions, and if the minimum and maximum values of the loop index do not exceed the range of `-32 768` thru `+32 767`.

Array Indexing

Accessing individual array elements is faster if the variables or expressions giving the indices into the array are `INTEGER` instead of `REAL`. This is because the system has to convert floating point numbers into an `INTEGER` in order to find the offset from the beginning of the array. If the index is already in `INTEGER` form, the conversion isn't necessary. The following example illustrates this point.

```

10  REAL I
20  DIM A(1:1000)
30  X=17.568
40  T0=TIMEDATE
50  FOR I=1 TO 1000
60    A(I)=X
70  NEXT I
80  PRINT TIMEDATE-T0;"seconds"
90  END

10  INTEGER I
20  DIM A(1:1000)
30  X=17.568
40  T0=TIMEDATE
50  FOR I=1 TO 1000
60    A(I)=X
70  NEXT I
80  PRINT TIMEDATE-T0;"seconds"
90  END

```

You will find a difference of .14 seconds between the two programs' execution times, due to a combination of the loop counter being `INTEGER` and the `INTEGER` indexing of the array. Again, if you're operating on a much larger array, or if you're working on a multi-dimensional array this number can become noticeable.

REAL Numbers

Minimum and Maximum Values

The minimum REAL number that can be stored on this computer is approximately $\pm 2.225\ 073\ 858\ 507\ 202 \times 10^{-308}$

The maximum REAL number that can be stored on this computer is approximately $\pm 1.797\ 693\ 134\ 862\ 315 \times 10^{308}$

A REAL number can also have the value zero.

Type Conversions

Earlier, it was mentioned that any time a MOD, DIV, *, +, or - operation is performed on two numbers of different type (one INTEGER, and one REAL), a type conversion has to take place to convert the INTEGER to a REAL. This section will address other situations where type conversions have to take place.

Any time an INTEGER is used in an exponentiation or division operation, it must first be converted to a REAL.

All of the following functions require a REAL argument (with the exception of VAL and RND), and all of them return a REAL value (with the exception of RANDOMIZE). If an INTEGER is passed in, or if the result is to be stored in an INTEGER, then the appropriate type conversion must be made: EXP, LGT, LOG, RANDOMIZE, SQR, DROUND, RND, ACS, COS, ASN, SIN, ATN, TAN, VAL.

All of the comparison operators (=, <>, <, >, <=, >=) will return INTEGER values (0 or 1) but will accept either INTEGERS or REALs as arguments. The logical operators AND, EXOR, OR, and NOT will convert any arguments to the INTEGER values 0 or 1 before the operation is performed, and an INTEGER 0 or 1 will be returned.

The binary bit functions (BINAND, SHIFT, ROTATE, BINIOR, BINCMP, BIT, BINEOR) require INTEGER inputs and provide INTEGER outputs. Type conversions will be performed if REALs are supplied as inputs, or if the results are to be stored in a REAL variable.

SGN returns an INTEGER (-1, 0, 1) regardless of the type of the argument passed to it. ABS and INT return the type of the argument that's passed to them.

If two INTEGERS are used to perform a MOD, DIV, *, +, or - operation, but the result is to be stored in a REAL variable instead of an INTEGER, then the result must be converted from INTEGER to REAL.

Here is how long each type conversion takes:

INTEGER to REAL: 42 microseconds

REAL to INTEGER: 34 microseconds

Constants

All constants that are within the range of $-32\,767$ to $32\,767$ that aren't entered with a decimal point or an "E" (for scientific notation) are stored in the machine as INTEGERS. Integer constants should always be used with INTEGER variables, but if they are used with REAL variables they will have to be converted to REAL first. This operation will slow down the execution of the program, as shown in the previous section. Any numbers entered with decimal points (1.0, 3., .7, etc.), with an E (1E-304, .2E48, 0E0, etc.), or outside the valid INTEGER range (40000, -75986, etc.) will be stored as REAL constants.

Polynomial Evaluations

The polynomial can waste much of computer time because programmers tend to pick the most obvious, and also the most time-consuming, method of evaluating them. Polynomials are usually written mathematically as:

$$y = a_n x^n + a_{n-1} x^{n-1} + \dots + a_1 x + a_0$$

or

$$y = \sum_{i=0}^n a_i x^i$$

hence the temptation is strong to evaluate a polynomial on a computer as:

```

2000 DEF FNPoly(X,Coefficient(*),INTEGER N)
2010 INTEGER I
2020 Y=0
2030 FOR I=0 TO N
2040     Y=Y+Coefficient(I)*(X^I)
2050 NEXT I
2060 RETURN Y
2070 FNEND

```

In the above program, there are $N+1$ additions, $N+1$ multiplies, $N+1$ exponentiations, and $N+1$ INTEGER to REAL conversions (I is converted to a REAL when the exponentiation operation is performed). Now suppose the polynomial is written in the equivalent form:

$$y = a_0 + x(a_1 + x(a_2 + \dots + x(a_n) \dots))$$

Then the corresponding program would be:

```

2000 DEF FNPoly(X,Coefficient(*),INTEGER N)
2010 INTEGER I
2020 Y=Coefficient(N)
2030 FOR I=N-1 TO 0 STEP -1
2040     Y=Coefficient(I)+X*Y
2050 NEXT I
2060 RETURN Y
2070 FNEND

```

Now there are only N additions and N multiplies, and NO exponentiations or INTEGER to REAL conversions! The following chart shows the time savings as a function of the order of the polynomial. For example, if the polynomial is of order 10, it is 70 milliseconds faster to use the nested multiply method to evaluate the polynomial than to use exponentiation. If you're plotting a thousand points on a graph, nested multiplication will save you more than a minute!

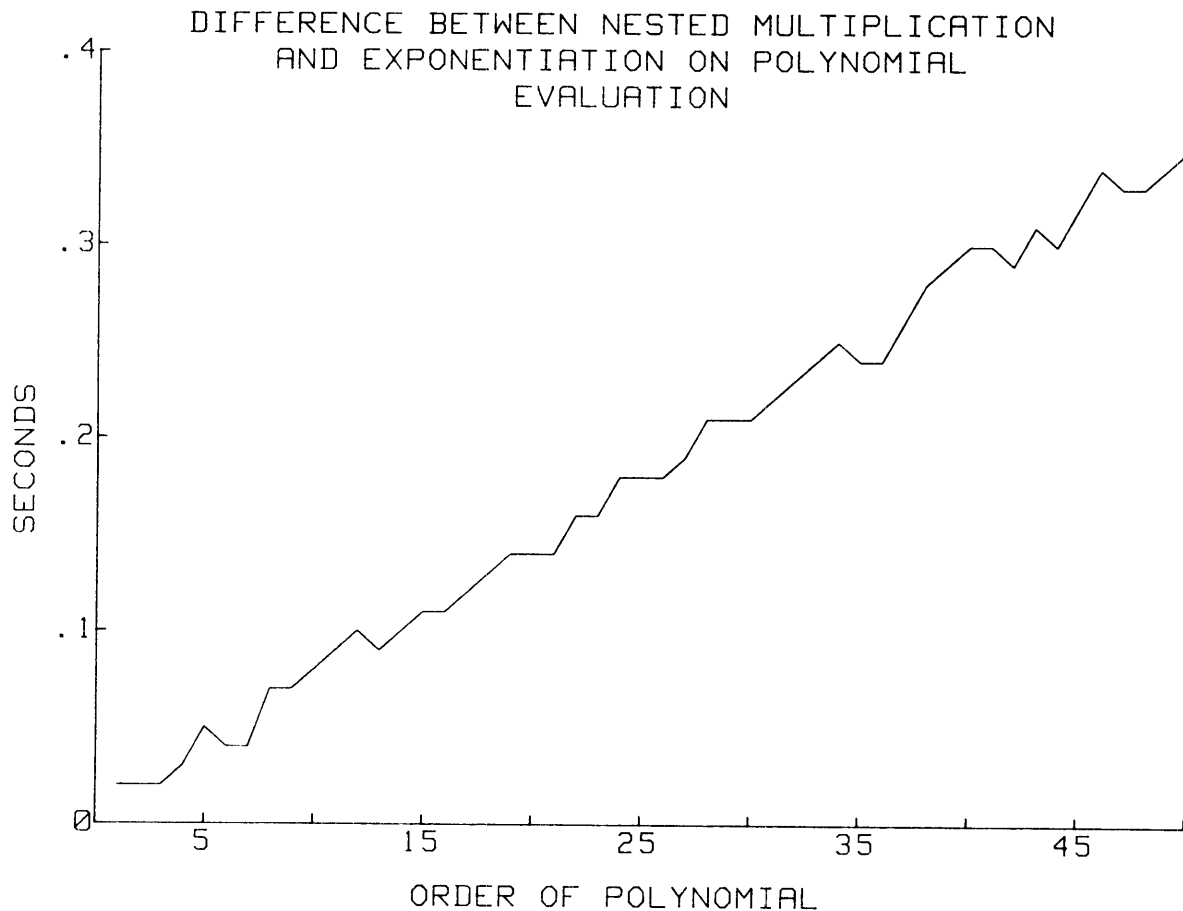

Logical Comparisons for Equality on REAL Numbers

Don't do it.

If you are performing mathematical operations on REAL numbers, and then comparing them for equality, the chances are that they will never come up equal. For example, in the previous section on polynomial evaluation, you can pass the same value for X and the same coefficient array to each of the two functions, and although the results will look equal when you print them out, they won't show equality if you compare them. (Try it and see.) A shorter example is to type out this expression from the keyboard and press **EXECUTE**:

```
.1+.1+.1+.1+.1+.1+.1=.7
```

The 0 at the bottom of the screen means that the machine doesn't consider the two numbers to be equal. This is characteristic of the way that binary math works.

Any REAL numbers should be rounded first before being tested for equality. This is one of the purposes of the DROUND function.

```
DROUND(.1+.1+.1+.1+.1+.1+.1,12)=DROUND(.7,12)
```

After rounding both numbers to 12 digits, the computer will now accept them as being equal. See Chapter 4 for more discussion on the comparison of REAL numbers.

Saving Time

Multiply vs. Add

It is always faster to add a number to itself than it is to multiply it by 2. For instance, to perform $2*PI$ a thousand times takes .22 seconds, while to perform $PI + PI$ a thousand times takes .13 seconds.

However, if you want to multiply by 3, that is faster than adding the number three times. $3*PI$ executed a thousand times takes about the same as $2*PI$ (.22 seconds), but adding $PI + PI + PI$ a thousand times takes about .28 seconds.

Exponentiation vs. Multiply and SQR

Exponentiation is very slow when compared to other mathematical operations. The results are worth the wait when the exponent has a fractional part; raising a REAL number to a REAL power is a complex operation. However, time can be saved if you are alert to some special cases. The most common examples are squaring a number or finding a square root. Using `SQR(X)` takes only about one-fourth the time required by the expression X^2 . Even more dramatic savings can be gained when raising numbers to an integer power. Using $X*X$ yields a 22-to-1 time savings over the expression X^2 . When using powers greater than 2 or 3, the expressions needed to achieve the repeated multiplication can be somewhat cumbersome, and may not even fit on a program line. However, repeated multiplication is so much faster than exponentiation that time savings can be realized (for powers up to 14) even if a FOR...NEXT loop has to be added to repeat the multiplication.

Array Fetches vs. Simple Variables

It takes more time to access an array element than it does a simple variable. This is because the address of the array element has to be computed from the starting address of the array and the offset within the array based on the specified indices. A simple variable's address does not require this computation.

Thus, if you access a given array element often enough, especially within a loop, it will often be faster to store the array element into a simple variable and then operate on the simple variable.

Time to fetch a simple variable and store it:	136 μ s
Time to fetch an array variable and store it:	260 μ s
Difference:	124 μ s

This means that it is faster to fetch three simple variables than it is to fetch two array elements.

Concatenation vs. Substring Placement

The concatenation operator (&) allows you to combine two or more strings to construct another string. This operation is discussed in Chapter 5. However, there is a special case that can be accomplished faster without the concatenation operator. This is the case where the new string is built by appending to the end of an existing string. For example, `A$=A$&B$`.

Concatenation works by constructing a temporary workspace in which all the components are assembled. Then the result is moved to its destination. In the example above, A\$ is moved to a temporary workspace, B\$ is appended to it, and the result is moved back to A\$. Thus, the original contents of A\$, which weren't changed, have been moved twice unnecessarily. A faster way to accomplish the same thing is:

```
A$[LEN(A$)+1]=B$
```

Another benefit of this approach is that the temporary workspace is not created. If memory is tight and A\$ is very large, concatenation could create a memory overflow.

The following chart shows the time savings that result from using substring placement instead of concatenation.

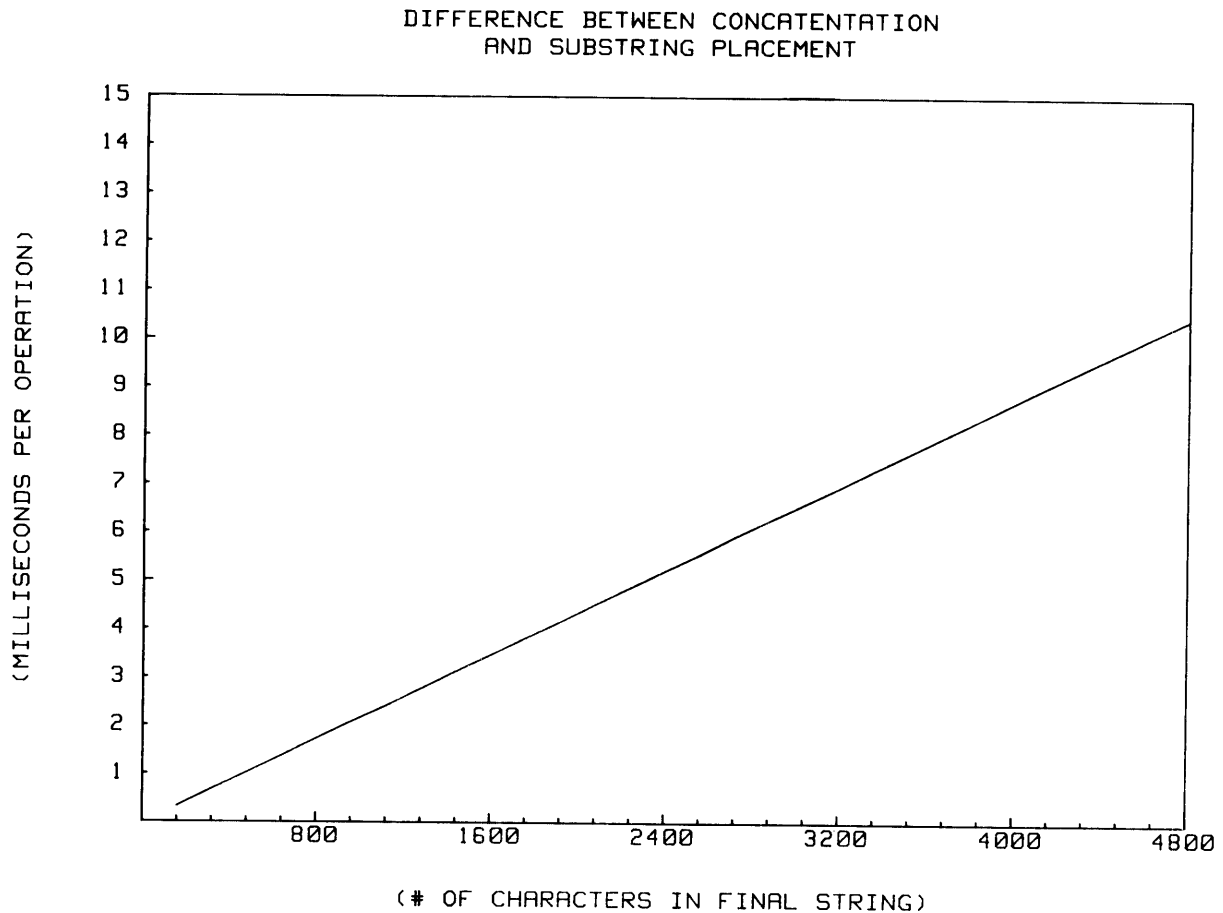

Saving Memory

The ALLOCATE and DEALLOCATE statements can be used to make efficient use of memory space in certain applications. They are useful in programs that contain a number of large variables that are not all needed simultaneously. For example: during data collection, a large string array is needed; during data processing a large numeric look-up table is needed; and during output formatting, a string array is needed again. Because a mass storage device is used to hold the data between processes, the same memory area can be used for all these arrays.

To use ALLOCATE effectively, it is necessary to understand how the system reclaims areas that have been DEALLOCATED. Space for allocated variables is built using a stack discipline. The DEALLOCATE statement marks a space as unused. Unused space can be reclaimed only if it is the *last* space on the stack. There are two operations that use space in this stack. One is ALLOCATE, and the other is ON <event>.

Keeping other allocated variables from blocking deallocated space is relatively simple. If you have only one allocated variable at any given time, this is not a problem. If you have allocated variables in existence simultaneously, ALLOCATE them in the opposite order of the DEALLOCATE statements. Think of this in the same way you would think about nesting FOR...NEXT loops.

Preventing blockage by ON conditions is more complicated. ON conditions, with one exception, create control blocks that are *permanent* entries on the stack. As soon as you declare an ON (or OFF) condition, all the previous entries on the stack are "locked in" for the duration of the context and cannot be reclaimed. Therefore, all the control blocks should be created *before* any variables are allocated. Once a control block is created, it will be used by all subsequent ON and OFF statements that refer to the same resource. A good technique is to include an OFF statement for each desired event before allocating any variables.

The exception mentioned above is an ON condition declared for an I/O path name. This includes ON END, ON EOT, and ON EOR. For these, subsequent ON and OFF statements behave as previously described. However, if the I/O path is closed, any control blocks associated with the path are marked as unused. This has two implications. One, the reclaiming of the stack will not be blocked after the I/O path is closed. Two, you cannot force the system to leave these control blocks at the beginning of the stack. Here is an example:

```

200 ASSIGN @File to "FRED"
210 ON END @File GOTO Label1
220 ALLOCATE Array(255,4)
.
.
.
600 ASSIGN @File TO "SUSAN"
610 ON END @File GOTO Label2
620 DEALLOCATE Array(*)

```

At first, the array and control block are allocated in the proper order. The ASSIGN statement in line 600 closes the original path and opens a new path with the same name. When the ON END control block for the new path is created, it is placed after the array on the stack. Therefore, no memory space can be recovered by deallocating the array.

Notes

Graphics

Chapter

14

Introduction

Graphics is a powerful tool for presenting information. Computer graphics can be equally powerful but an extra step is required between the conception of the idea and the final image. This step is the construction of a mathematical model of the image within the computer.

Since computers only do what they are told, it is essential to have a complete knowledge of the commands that communicate between the real world and the computer's world. This knowledge is needed to create the model within the computer's memory and to understand the resulting image of the model.

This chapter introduces basic graphics techniques. For more extensive information and examples, see the *BASIC Graphics Techniques* manual.

A good place to start is the screen of the CRT. The screen serves a dual role; as an output device for text and as a plotting device for graphics. Although many applications require a plotter to produce the final image on paper, it is easier to develop the model on the screen. Then with minor changes the image can be sent to an external plotter.

A non-bit mapped display is capable of displaying two rasters (images) either individually or combined. The alpha raster displays alpha-numeric characters while the graphics raster displays pixels (picture elements). The arrangement for the Model 216 and Model 226 is 400 columns of 300 pixels; for the Model 236, 512 columns of 390 pixels. (Other monitors are available. The arrangement for all monitors is listed in the *BASIC Language Reference* manual in the GSTORE statement.)

Display of the rasters is controlled by program statements (commands when executed immediately) or by keys located in the upper right corner of the keyboard.

- Press **GRAPHICS** to turn on the graphics raster. A second press turns off the alpha raster.
- Press **ALPHA** to turn on the alpha raster. A second press turns off the graphics raster.

The rasters are also controlled by the BASIC statements:

```
GRAPHICS ON and GRAPHICS OFF
ALPHA ON and ALPHA OFF
```

Initially the alpha raster is on and the graphics raster is off. During execution of a graphics program the alpha raster may be turned off but execution of an input statement turns the alpha raster back on and leaves it on.

Bit mapped displays do not have a separate alpha and graphics raster. Both are combined and always on.

Graphics Fundamentals

The First Step

One statement initializes the system by setting default values. Several operations are actually performed by this statement.

Execute the command.

```
GINIT
```

This statement (or its equivalent series of statements) should precede any other graphic statements. The system is now ready but nothing will be displayed until it is told to turn on the graphics raster.

Either execute the command,

```
GRAPHICS ON
```

or press the **GRAPHICS** key once.

Whenever you wish to clear the graphics raster, execute GCLEAR. GINIT also clears graphics raster but not until the execution of a graphics statement that selects a default plotter.

If the alpha raster is not clear, press the **CLR SCR** key.

Pencil and Paper

Traditionally, a drawing requires pencil and paper. Here the paper is replaced by a display screen (CRT raster) and the pencil is replaced by the PEN statement.

There are three currently defined pens for the monochrome graphics raster.

```
PEN 1  turns pixels on. (white pen)
PEN -1  turns pixels off. (black pen)
PEN 0  complements pixels. (magic pen)
```

When drawing with PEN 0, black pixels become white and white pixels become black. If you plan to send the image to an external plotter, do not expect a pen to erase a line. Check the plotter's manual for different pen definitions.

After selecting a pen, several statements, and their variations, control the motion of the pen on the drawing surface.

```
DRAW X,Y  draws a line to point X,Y.
MOVE X,Y  moves the pen to point X,Y.
PLOT X,Y,P  moves or draws to point X,Y.
```

DRAW and MOVE do exactly what their names imply. PLOT will do both moves and draws with optional pen control.

Try the following.

```
GINIT
GRAPHICS ON
DRAW 60,50
```

A white line should appear from the lower left corner to the middle of the screen. Why the lower left corner? Executing the statement GINIT returns the pen to location 0,0. This is currently the lower left corner of the display.

Execute the following commands to see their effect.

```
GCLEAR
PEN 1
MOVE 0,50
DRAW 100,50
MOVE 50,50
PEN -1
DRAW 0,50
PEN 0
DRAW 100,50
```

A white line is drawn across the screen, the pen moved to the midpoint of the line, a black pen draws a line to the left endpoint, and the line is then complemented.

To show the size of the current drawing area, the next statements draw a line around the perimeter, similar to the frame around a painting.

```
GCLEAR
PEN 1
MOVE 0,0
DRAW 100*RATIO,0
DRAW 100*RATIO,100
DRAW 0,100
DRAW 0,0
```

There is a statement that duplicates the result of the previous example. Try the following.

```
GCLEAR
FRAME
```

The Standard View

The default scale for the Model 226 and Model 216 display is 133 horizontal units by 100 vertical units. For the Model 236 it is 131 horizontal by 100 vertical. For the Model 237 (HP 98781A display) it is 133 horizontal by 100 vertical. These units are called **Graphic Display Units**. The origin (location 0,0) is in the lower left corner of the graphics raster. The pen can be positioned anywhere, even outside the drawing area. You may wish to experiment some more to verify this.

Pen Control

Pen action is automatically defined for the MOVE and DRAW statements. The pen is raised for a move and lowered for a draw. The PLOT statement has an optional pen control parameter that determines the pen's action according to the following table.

P value	Result
Odd	Pen down
Even	Pen up
Positive	Change pen after motion
Negative	Change pen before motion

The following example shows pen control by the optional pen control parameter.

```
GCLEAR
PLOT 20,20,1
PLOT 40,20
PLOT 40,40,0
PLOT 20,20,1
PLOT 20,40
```

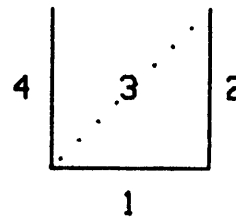

Incremental Pen Positioning

Often when plotting it does not matter where the pen has been, only the distance to the next desired pen position.

```
IMOVE X,Y   positive X moves pen to the right.
             negative X moves pen to the left.
IDRAW X,Y   positive Y moves pen up.
             negative Y moves pen down.
IPLLOT X,Y,P positive P changes pen after move.
             negative P changes pen before move.
```

Execute the following and watch the results.

```
GCLEAR
MOVE 50,50
IDRAW 10,0
IDRAW 0,10
IMOVE -10,0
IDRAW 0,-10
```

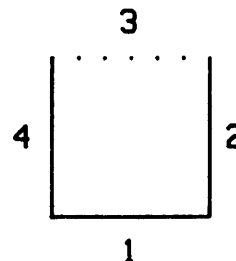

With each incremental motion of the pen, a new origin is created for any subsequent incremental pen statement. A third method of moving and drawing involves specifying the relative movements of the pen from a local origin.

Relative Pen Positioning

The relative plot statement uses the current pen position as a local origin to define a second coordinate system. Pen motion is then relative to the local origin until the pen position is changed by a statement other than another RPLLOT statement.

RPLLOT X,Y,P where X and Y are relative displacements.

Execute these commands to draw a triangle.

```
GCLEAR
MOVE 50,50
RPLLOT 20,10,-1
RPLLOT 20,0
RPLLOT 0,0
```

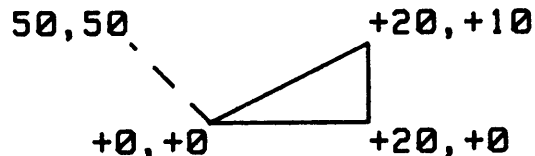

Note that the command RPLLOT 0,0 returns the pen to the local origin (50,50) not the real origin (0,0). Since RPLLOT creates a local origin it is useful when drawing a figure that needs to be repeated at different locations on the display.

Line Rotation

Lines generated by move, draw, and plot can be rotated by the PIVOT statement. The current angle mode is used to specify the rotation.

```
DEG
GCLEAR
PIVOT 45
MOVE 0,0
DRAW 100,0
```

PIVOT 0 will return the system to normal.

Graphic Display Units

Every plotting device has an aspect ratio (width/height). This ratio, maintained by the computer, is available from the following function.

```
RATIO
```

Graphic Display Units are specifically chosen so the shorter of the two axes is exactly 100 units long. When the vertical axis is shorter than the horizontal axis, $RATIO \times 100$ gives the number of units across the horizontal axis.

If the horizontal axis is shorter than the vertical axis, indicated by $RATIO$ returning a value less than one, $100 \div RATIO$ gives the number of units along the vertical axis.

Executing $RATIO$ when the internal CRT is the plotting device returns 1.33444816054 on the Model 216 and Model 226, and returns 1.31362467866 on the Model 236 and returns 1.33376792699 on the Model 237. This number indicates a near 4:3 aspect ratio.

Since a Graphic Display Unit (GDU) is one percent of the shorter axis in length, several statements use GDU measurements to relieve you from the burden of additional calculations. An example of this is the $AXES$ statement where the length of the tick mark is specified in Graphic Display Units.

The Origin

There is a big difference between a cosine and a sine function but no difference between their curves. Only by knowing the location of the origin can you determine which curve is being displayed. Unless changed, the origin will be located in the lower left corner of the screen. The $axes$ statement can be used to show the current location of the origin.

With all parameters the statement appears.

```
AXES Xtick,Ytick,XlocY,YlocX,Xmajor,Ymajor,Size
```

The $Xtick$ and $Ytick$ parameters specify the number of units between the tick marks. $XlocY$ and $YlocX$ specify the location of the intersection of the axes. $XlocY$ is the location of the y-axis, measured along the x-axis. Ticks are normally two GDU in length. $Xmajor$ and $Ymajor$ specify which ticks are to major ticks (their length determined by the $Size$ parameter) and which are to be minor ticks (half the length of a major tick). If $Xmajor$ is equal to four (4) then every fourth tick will be a major tick.

Try the following.

```
GINIT
AXES 10,10
AXES 20,20,50,30
```

The $axes$ statement has a related statement; $GRID$. This statement is best thought of as a pair of axes with very long tick marks. $GRID$ uses the same variables as $AXES$.

```
GRID Xtick,Ytick,XlocY,YlocX,Xmajor,Ymajor,Size
```

Here the value of $Size$ specifies the major tick length. The minor tick length is $\frac{1}{2}$ the major tick length.

Execute these statements.

```
GINIT
GRID 10,10

GCLEAR
GRID 20,20,0,0,3,2,4
```

What's my line

Since GRID, AXES, and FRAME draw several lines at once, they are useful when exploring the LINE TYPE statement. There are ten different types of lines available with the LINE TYPE statement. The *BASIC Language Reference* shows what to expect. Two parameters are allowed with the line type statement; the type and the repeat length.

The repeat length defaults to five and the line type defaults to one (a solid line). Thus the default value is LINE TYPE 1,5.

Try these commands.

```
GINIT
LINE TYPE 3
FRAME
LINE TYPE 8,10
AXES
```

When the CRT is used as the plotting device, the repeat factor should be a multiple of five. If any other repeat factor is specified, the next lower multiple of five is used.

Labeling the Image

Although images can convey a great deal of information, a few labels help explain what is being presented. Although it might seem simple to label via the alpha raster, it is better to use the LABEL statement.

Try the following to label (print) directly on the graphics raster.

```
GINIT
MOVE 50,50
LABEL "Sin X"
```

LABEL USING allows formatted labels to be plotted just as PRINT USING allows formatted text to be printed.

Several statements affect the printing of labels.

```
Csize controls the character height and width.
LDIR specifies the printing angle of the label.
LORG adjusts the location of the label.
```

Each of the following examples illustrates one of the above statements.

```
GCLEAR
MOVE 20,80
CSIZE 10,.2
LABEL "WIDE"
MOVE 20,60
CSIZE 20,.2
LABEL "TALL"
```

Unless the external plotter has the same aspect ratio as the internal CRT, a "good looking" character on the screen will not reproduce correctly on an external plotter. Adjustment may be necessary.

```
DEG
GINIT
MOVE 40,60
LDIR 90
LABEL "VERTICAL"
MOVE 20,60
LDIR 180
LABEL "UPSIDE DOWN"
```

Label direction is specified in the current angle mode. Either degrees and radians may be used.

```
GINIT
MOVE 60,80
LORG 1
LABEL "LEFT"
MOVE 60,50
LORG 9
LABEL "RIGHT"
MOVE 60,20
LORG 5
LABEL "CENTER"
```

LEFT

RIGHT

CENTER

There are nine possible label origins used for adjusting the location of the label.

Setting the Limits

An obvious limitation to the size of a drawing is the physical dimensions of the display surface. These limits are called **hard clip** limits. The edge of the raster is the hard clip limit for the CRT. The hard clip limits of a plotter are adjustable, provided they are set within the dimensions of the platen. You will not be able to draw beyond the hard clip limits of a device.

It is often desirable to set the **soft clip** limits to prevent a line from being drawn outside a specified area. Under program control, a portion of the drawing surface can be designated as the allowed drawing area. The part of a line extending outside this area will not be drawn. Plotting will resume whenever the pen returns within the soft clip limits.

The CLIP statement sets the soft clip limits. The first use of CLIP specifies the boundaries.

```
CLIP Left,Right,Bottom,Top
```

Try these commands.

```
GINIT  
GRAPHICS ON  
FRAME  
CLIP 10,50,10,50  
FRAME
```

The soft clip limits are now set to the values used in the statement. Subsequent use of the CLIP statement need only specify whether the soft clip should be on or off.

Continue the previous example with these commands.

```
MOVE 0,0  
DRAW 90,60  
CLIP OFF  
DRAW 0,0
```

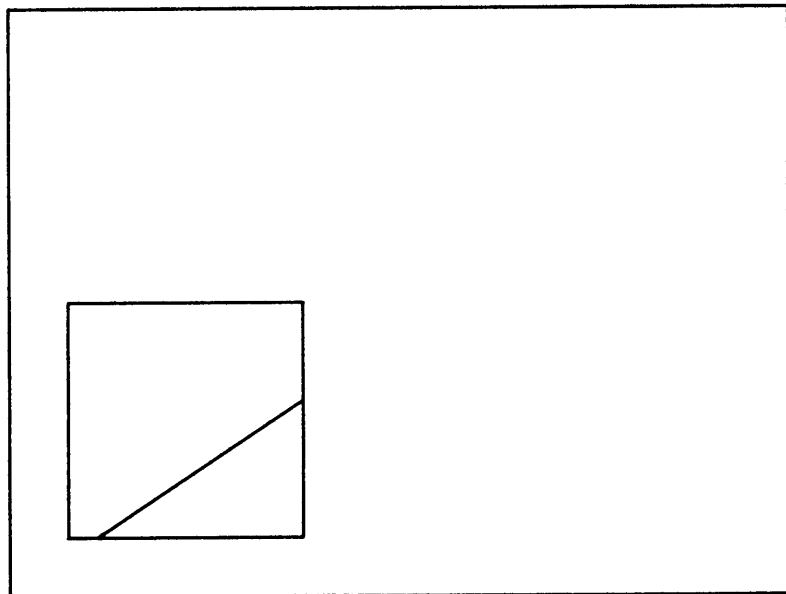

User-Defined Units

Until now, all examples have used the default scale (measured in Graphic Display Units). Two statements allow setting your own scale (User-Defined Units). User-Defined Units may be larger or smaller than Graphic Display Units.

```
SHOW Left,Right,Bottom,Top (isotropic view)
WINDOW Left,Right,Bottom,Top (non-isotropic view)
```

These statements allow an image created in User Defined Units to be completely displayed on the screen.

The two statements are similar but differ in their use of units. The `SHOW` statement has equal units on both axes (isotropic view). `WINDOW` allows different units for each axis (non-isotropic view). An example will shed some light on this difference.

```
GINIT
WINDOW -55,55,-100,100
AXES 10,10
```

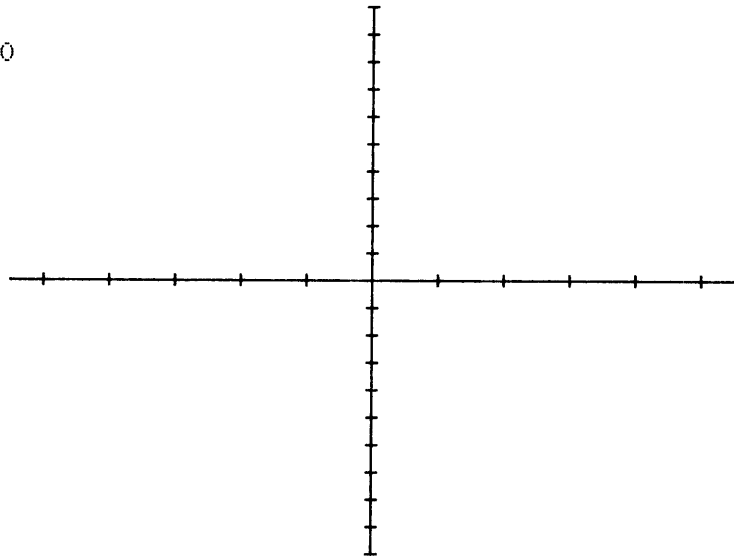

```
GINIT
SHOW -55,55,-100,100
AXES 10,10
```

Note the difference in the tick spacing.

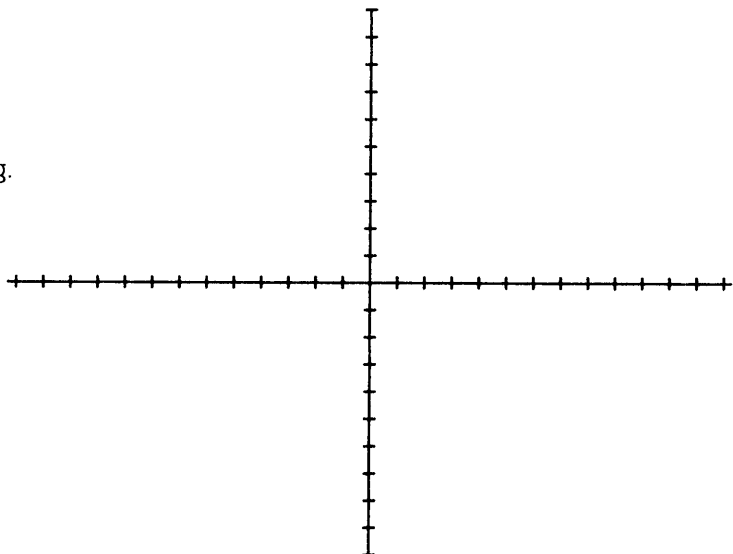

WINDOW and SHOW are often used in conjunction with the next statement.

```
VIEWPORT Left,Right,Bottom,Top
```

As the name implies, VIEWPORT is analogous to creating a “window” into the computer’s world. Unlike the CLIP statement, which defines a section of the surface of the plotting device as the allowed plotting area, VIEWPORT specifies a section into which a scaled view of the image is drawn.

Try these commands.

```
GINIT
VIEWPORT 0,60,0,60
SHOW 0,200,0,100
GRID 25,25
VIEWPORT 70,130,0,60
WINDOW 0,200,0,100
GRID 25,25
```

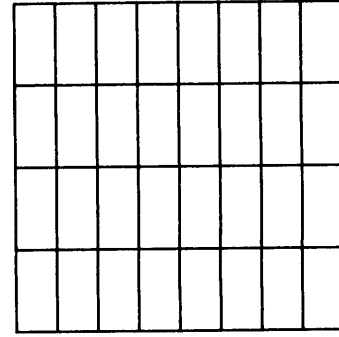
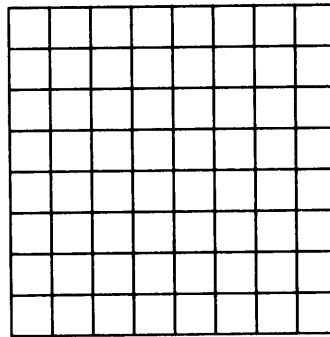

Saving an Image

One last point about the internal CRT as a plotting device. The image created on the CRT can be stored in an integer array. This is done with the statement,

```
GSTORE Array(*)
```

The contents of the array can be stored in memory or saved in a disc file for later use. The image can be returned to the graphics raster from an array by the statement,

```
GLOAD Array(*)
```

The size of the array to be dimensioned must be large enough to hold the entire contents of the raster. To calculate the required size of the array use the following conversion.

$$[(H_pixel \times V_pixel) / 16] \times \text{number of planes}$$

Where H_pixel is the number of pixels per horizontal row and V_pixel is the number of pixels per vertical column.

Model 226	$(400 \times 300) / 16 = 7500$
Model 236	$(512 \times 390) / 16 = 12\,480$
Model 236 Color Monitor	$[(512 \times 390) / 16] \times 4 = 49\,920$
Model 237	$(2024 \times 768) / 16 = 49\,152$
HP 98627 Monitor	$[(512 \times 812) / 16] \times 3 = 49\,152$

Choose the correct INTEGER statement for your computer and try the following.

```

INTEGER I(1:7500) or INTEGER I(1:12480)

GINIT
WINDOW -100,100,-100,100
AXES 10,10
GSTORE I(*)
GCLEAR
GLOAD I(*)

```

The raster can be rapidly cleared and reloaded with different array images.

External Output Devices

Now that you have used most of the commands available for the internal plotter, it is time to expand this knowledge to include external devices. Before proceeding it will be useful to revisit the GINIT command. One new statement is introduced here and that is the PLOTTER IS statement. It tells the computer where to output the image.

Initialization

GINIT is one statement that performs several operations,

```

AREA PEN 1
CLIP OFF
CSIZE 5,0.6
LDIR 0
LINE TYPE 1,5
LORG 1
MOVE 0,0
PDIR 0
PEN 1
PIVOT 0
GESCAPE CRT,4 (PEN mode normal)

```

At this point it appears that GINIT is of limited use since it specifies the internal CRT as the plotter with the first statement, but GINIT is not finished. GINIT then executes the following statements.

```

PLOTTER IS CRT, "INTERNAL"
GCLEAR
IF RATIO>1 THEN
  VIEWPORT 0,RATIO*100,0,100
  WINDOW 0,RATIO*100,0,100
ELSE
  VIEWPORT 0,100,0,100/RATIO
  WINDOW 0,100,0,100/RATIO
END IF

```

Ratio is always the ratio of the internal graphics device.

Finding the Plotter

The PLOTTER IS statement contains two parameters.

```
PLOTTER IS 3,"INTERNAL" (default plotting device is CRT)
```

The numeric value specified is the device selector which tells the computer where to look for the plotter. The literal "INTERNAL" is the plotter specification and tells what type of device is to be expected.

If the interface select code uniquely identifies the plotter it may be used as the device selector for the plotter. Select codes 1 through 7 are reserved for internal interfaces (including the internal HP-IB interface). If an external plotter is connected to the HP-IB interface, the primary address is also required to identify the plotter. The primary address is determined by a set of switches located on the plotter. Refer to the plotter manual for the switch settings.

```
PLOTTER IS 705,"HPGL"
```

This statement specifies a plotter connected through the internal HP-IB interface whose switches are set to primary address 05.

```
PLOTTER IS 28,"98627A"
```

This statement tells the computer to use an HP 98627A Color Output Interface, located in one of the accessory slots, that has been set to interface select code 28.

Blots of Luck

There are several special considerations when using an external plotter. One statement that has not been mentioned is the PENUP statement. PENUP lifts the pen from the surface of the paper. The electronic pen used with raster graphics could care less where it sits. But real pens with real ink make a real mess unless lifted from the paper. Lift the pen whenever the it is not moving. After plotting, either cap the pen or execute PEN 0 to put the pen away.

The image ratio of an external plotter is often different than the ratio of the internal CRT. Character size is susceptible to this difference.

Lines drawn by the LINE TYPE statement will differ from those defined for the CRT. Check the plotter's manual.

Graphics with Printers

There are printers capable of reproducing the image on the graphics raster. Usually there is a one for one correspondence between a pixel on the screen and a dot on the printed paper. Since these devices are not plotters, there is a special statement for them.

```
DUMP DEVICE IS (printer with graphics capability)
```

For example, if the default dump device (701) is not desired, a printer may be specified as follows.

```
DUMP DEVICE IS 702
DUMP DEVICE IS 707,EXPANDED
```

Once the dump device has been specified, the image on the graphics raster can be sent to the external printer by either the statement,

```
DUMP GRAPHICS
```

or by the key **DUMP GRAPHICS**.

The contents of the alpha raster can be sent to the device by the statement,

```
DUMP ALPHA
```

or by the key **DUMP ALPHA**.

When the expanded mode is specified, on printers that allow it, the entire raster may not be reproduced. Check the printer manual.

Since bit-mapped displays do not have separate alpha and graphics, using the DUMP command results in the entire contents of the display to be sent to the printer.

Graphics Using HPGL

To simplify communicating with the wide variety of HP graphics devices, a standard set of graphic commands has been adopted. The Hewlett-Packard Graphics Language (HPGL) consists of about sixty two-letter commands that can be used to control the operation of most HP plotters. In fact, when BASIC statements are used to control an external plotter, they are first converted (by the computer) into series of HPGL commands. Refer to the plotter's manual for details concerning which HPGL commands are recognized by your plotter.

While most plotting applications can be accomplished by using BASIC statements, some plotters have capabilities that can only be accessed by using HPGL commands. When it is necessary (or desirable) to communicate directly with the plotter, the OUTPUT statement can be used to send HPGL commands. For example:

```
OUTPUT 705;"DF;" ;
```

This statement sends the HPGL command to restore the default conditions of the plotter. Many of the HPGL commands have one or more parameters. For instance:

```
OUTPUT 705;"LT 6;" ;
```

This statement sets the line type to pattern number 6. The line type is plotter dependent and not likely to be the same pattern displayed on the CRT by the LINE TYPE statement in BASIC.

In general, an HPGL command is terminated by either a semicolon or a linefeed. The parameters are usually separated by a comma. In the previous example statement, a semicolon is included in the string sent to the external plotter to indicate the end of a HPGL command. The OUTPUT statement's trailing semicolon suppresses the current end-of-line sequence from being sent to the plotter.

Some HPGL commands request the plotter to send back information to the computer. The ENTER statement is used to receive the information. For example,

```
OUTPUT 705;"OP;" ;
ENTER 705;P1x,P1y,P2x,P2y
```

The OUTPUT statement sends the "output P1 and P2" command to the plotter and the ENTER statement accepts the X and Y coordinates for P1 (lower-left corner) and P2 (upper-right corner) sent by the plotter. The values returned are in plotter units and not in GDU's.

You might wonder how the mapping of GDU's and plotter units is accomplished. Consider the following statement.

```
PLOTTER IS 705,"HPGL"
```

This statement actually sends several HPGL commands to the plotter and accepts the current setting of P1 and P2 for use by the computer in converting the values used by BASIC statements into the values needed for HPGL commands. The previous BASIC statement produces the following HPGL commands.

```
;IM56;OP
(plotter sends back P1 and P2)
PU
LT
SP1
```

The first line consists of a semicolon (to clear any previous command), an "input mask" command (to set error conditions which will illuminate the plotter's error lamp), and an "output P1 and P2" command. The plotter responds by sending the current values of P1 and P2 back to the computer. The computer then sends a "pen up" command, a command to restore the default "line type", and a command to "select pen 1".

If you wish to change the settings of P1 and P2, it will be necessary to re-execute the PLOTTER IS statement (after changing P1 and P2) to allow BASIC to perform the correct conversion.

Graphics Using Files

Plotting to files is very similar to HPGL plotters. The ASCII file will contain the same HPGL commands which are sent to a plotter. The following statement sets up file plotting

```
PLOTTER IS "FILE","HPGL",P1X,P2X,P1Y,P2Y
```

Because a file cannot return P1 and P2 coordinates, you must specify them. The units are interpreted in millimetres. Consult your plotter manual for information on standard sizes. If no size is specified the size will default to a D-size drawing on an HP 7580 or HP 7585 plotter.

If your system is connected to an SRM with plotter, the plotter will plot this file when the file is put in the plotter spool directory.

Using the Color Output Interface

The HP 98627A interface can be used as a plotting device. Several compatible color-monitor display formats are available. The *HP 98627 Color Output Interface Installation* manual describes the details of the available display formats; this section describes how to choose the required display format and how to access this interface from BASIC programs.

The interface has the following capabilities:

- All BASIC graphics capabilities can be used with the Color Output Interface.
- Several different colors can be drawn, erased, and complemented.
- Screen memory can be stored in a numeric array, loaded from an array, and dumped to a compatible external device.
- The interface may be used as the output device for interactive graphics, as described in a subsequent section called "Interactive Graphics".

Color Graphics Techniques

This section describes using the BASIC graphics statements with the Color Output Interface. In general, all BASIC graphics statements can be used with the Color Output Interface; the statements' definitions, if necessary, have been updated to support the use of the color interface.

Specifying the Display Format

Several different display formats are available with the color interface. To select one of the formats, specify the interface's **interface select code** and **plotter specifier**, as in the following statement:

```
PLOTTER IS 28,"98627A"
```

The following list shows the available plotter specifiers and resultant display formats.

Desired Display Format	Plotter Specifier
Standard Graphics 512 by 390 pixels, 60 Hz, non-interlaced	"98627A", or "98627A;US STD"
512 by 390 pixels, 50 Hz, non-interlaced	"98627A;EURO STD"
High-Resolution Graphics 512 by 512 pixels, 46.5 Hz, non-interlaced	"98627A;HI RES"
TV Compatible Graphics 512 by 474 pixels, 30 Hz, interlaced	"98627A;US TV"
512 by 512 pixels, 25 Hz, interlaced	"98627A;EURO TV"

Once the color interface has been chosen as the plotting device, lines and labels may be drawn upon it with graphics statements.

Drawing Lines

Several different pen colors can be specified when drawing lines on the screen; seven colors can be drawn, and seven colors can be erased. The following program draws eight horizontal "bars" using different pen colors and illustrates several details of how the display operates.

```

100  GINIT
110  PLOTTER IS 28,"98627A" ! Define plotter.
120  !
130  Xmax=512                ! Same for all formats.
140  Ymax=INT(512/RATIO+.5) ! Calc. for each format.
150  !
160  WINDOW 1,Xmax,1,Ymax  ! Define units-of-measure.
170  FRAME                  ! Draw bounds.
180  DEG                    ! Use degrees mode.
190  !
200  Bar_ht=Ymax/8         ! Define "bar" height.
210  !
220  FOR Color=0 TO 7     ! Show all 7 pen colors.
230    PEN Color          ! Select PEN color.
240    !
250    FOR Horz_line=1 TO Bar_ht ! Draw "bars".
260      Y=INT(Color*Bar_ht+Horz_line+.5)
270      MOVE 1,Y
280      DRAW Xmax,Y
290    NEXT Horz_line
300    ! Then LABEL Pen Colors
310    PEN 0              ! using complement PEN.
320    MOVE Xmax/2,Color*Bar_ht+Bar_ht/2
330    LABEL "PEN Color";Color
340  NEXT Color
350  !
360  PEN 0                ! Now complement the
370  FOR Y=1 TO Ymax     ! entire screen.
380    MOVE 1,Y
390    DRAW Xmax,Y      ! Draw each Horz. line.
400  NEXT Y
410  !
420  END

```

The units-of-measure of the graphics display are defined with the WINDOW statement; in this case, each line and column of pixels is given one unit. The origin is also defined by WINDOW; here, the lower-left corner of the display is given the X and Y coordinates of 1 and 1, respectively. This coordinate system has been chosen so that the routine that complements the screen colors will draw each row of pixels only once. As an experiment, you may want to see the effects of using different units-of-measure.

How Colored Lines Are Drawn

Color displays compatible with the HP 98627 work on the principle of using combinations of three primary colors to represent the available colors. The primary colors are Red, Green, and Blue. Secondary colors are Yellow (Red combined with Green), Cyan (Green combined with Blue), and Magenta (Red combined with Blue). White is produced by combining the three primary colors, and Black is the lack of all three colors.

The primary colors may be conceptually grouped into three “planes” of dots, which are superimposed to create the visual color image. Thus, each pixel on the screen is composed of one primary-color dot from each of the three primary-color planes; the different colors are produced by turning on different combinations of dots.

When a line is drawn using one of the primary colors, dots in the primary-color plane are turned on by setting the appropriate bit in the corresponding primary-color memory plane. When a line is drawn using one of the secondary colors, two dots, one dot from each of two color planes, are turned on for each point drawn. For example, when Yellow is drawn, Red and Green dots are turned on at each point of the line to produce this secondary color. When White is drawn, all three primary colors are turned on at each point plotted. Drawing with the Complement pen may be more easily understood by studying the following chart and accompanying text.

Pen Number	Resultant Action	Effect on Each Color Plane:		
		Red	Green	Blue
-7	Erase Magenta	0	—	0
-6	Erase Blue	—	—	0
-5	Erase Cyan	—	0	0
-4	Erase Green	—	0	—
-3	Erase Yellow	0	0	—
-2	Erase Red	0	—	—
-1	Erase White	0	0	0
0	Complement	Invert Bit in Each Plane		
1	Draw White	1	1	1
2	Draw Red	1	0	0
3	Draw Yellow	1	1	0
4	Draw Green	0	1	0
5	Draw Cyan	0	1	1
6	Draw Blue	0	0	1
7	Draw Magenta	1	0	1

The chart shows how bits of each primary-color memory plane are affected by drawing lines with each pen color. A “1” in a column indicates that a bit in that color plane is set when the color is drawn, a “0” indicates that a bit is cleared, and a “—” indicates that bits in that color plane are unaffected by drawing (or erasing) with the pen color.

Note

When using the PLOT statements, keep in mind that the optional pen control parameter affects only the up/down movement of the current pen; it does not change the pen color. See the language reference descriptions of the IPLOT, PLOT, and RPLOT statements for further details.

Storing and Loading Display Memory

The HP 98627A's display memory is composed of three "color planes" of 32 768 (= 32K) bytes each, for a total of 96 Kbytes of memory. When this memory is displayed, the color planes are visually superimposed; that is, the color of each point on the display is determined by the combination of Red, Green, and Blue dots which are on at that point. Each color dot is turned on when the corresponding bit in that color plane is 1 and turned off when the bit is 0.

In order to store the current display, use the GSTORE statement. This storage of the HP 98627A's display memory into computer memory requires **exactly** 49 152 ($= 3 \times 16\,384$) INTEGER elements. The following program stores the current display memory in the INTEGER array `Array(*)`.

```

100  PLOTTER IS 28,"98627A" ! Define Plotter.
110  !
120  INTEGER Array(1:3,1:16384) ! 49152 elements.
130  GSTORE Array(*)
140  DISP "Display Stored."
150  BEEP
160  WAIT 2
170  !
180  GCLEAR
190  DISP "Display Cleared."
200  BEEP
210  WAIT 2
220  !
230  GLOAD Array(*)
240  DISP "Display Re-Loaded."
250  BEEP
260  !
270  END

```

Refer to GLOAD and GSTORE in the *BASIC Language Reference* manual for more information on loading and storing the display.

The number of pixels in the vertical direction is dependent on the current display format. If the "High Resolution" format is in effect, all array elements are shown. If a smaller display format is in use, only the first elements of each memory plane are displayed. Thus, if the "Standard graphics" format is being used (512 by 390 pixels), only the first 12 480 elements of each primary-color plane are displayed.

The GLOAD statement can be used to load the display. Either a previously stored display or a software-generated numeric array can be used.

Dumping to an External Device

The DUMP GRAPHICS statement or the **DUMP GRAPHICS** key can be used to dump the screen contents to the current DUMP DEVICE IS device. Each pixel sent to the destination device is represented by the state of one bit, and the state of each bit is determined by performing an inclusive-OR function on corresponding bits of each primary-color memory plane; thus, no color information is sent to the dump device by this type of operation. Examples are as follows.

```

100  PLOTTER IS 28,"HP98627A"
110  DUMP DEVICE IS Printer

400  DUMP GRAPHICS                ! 98627 to Printer,
650  DUMP GRAPHICS #801           ! 98627 to device 801,
810  DUMP GRAPHICS CRT TO #702    ! INTERNAL GRAPHICS to device 702.
```

If EXPANDED is specified in the DUMP DEVICE IS statement, the image is doubled in both X and Y directions before being sent to the destination device. However, if both source and destination are explicitly specified, no expansion is performed. Examples are as follows.

```

100  DUMP DEVICE IS 701,EXPANDED

200  DUMP GRAPHICS                ! Expand and send,
450  DUMP GRAPHICS 28 TO #701    ! Send without expanding,
```

Interactive Graphics

The GRAPHX extension provides the computer with the abilities of accepting inputs from a graphics device and optionally “echoing” these inputs on the graphics output device. The following abilities are provided.

- The ability to digitize individual points on the input (GRAPHICS INPUT IS) device. Each point is selected by first positioning the input device’s locator (typically a cursor or stylus) and pressing the “Digitize” button (or the stylus).
- The ability to track the locator’s position on the output (PLOTTER IS) device while waiting for a point to be digitized. The locator’s position is shown by either a “cross-hair” or by the output device’s pen position, depending on the type of plotter device.
- The ability to “continuously” monitor the locator’s coordinates.
- The ability to move the output device’s cross-hair (or pen), independent of the locator’s position.
- The ability to monitor the Digitize button to determine whether or not it is currently being pressed.

Compatible Devices

This software is intended for use with Hewlett-Packard Graphics Language (HPGL) graphics devices. The software currently supports several different types of input and output devices.

Output Devices

At this time, the software can be used with the following HP graphics-output (PLOTTER IS) devices.

- HP 98627A Color Output Interface driving an external color monitor.
- The internal graphics device of Series 200 computers.
- HPGL plotters, in general: examples include the HP 7470 and HP 7580 plotters.

Input Devices

At this time, compatible graphics-input (GRAPHICS INPUT IS) devices include the following:

- HP 9111 Graphics Tablet.
- HP 9874 Digitizer.
- HPGL plotters, in general.
- Keyboards (arrow keys, knob, mouse, etc.)

Setting Up a Session

Using the interactive graphics capabilities requires a few simple program steps and programmer considerations. Both input and output graphics devices must be defined by the program. Your main consideration is how the usable area of the input device maps onto the usable area of the output device, which is discussed in the "Graphics Regions and Mapping" section that follows the first programming example.

Specifying the Output Device

The PLOTTER IS statement is used to specify which device is to be the output device. Several example statements are shown below.

```
PLOTTER IS 28,"98627A"
PLOTTER IS 705,"HPGL"
PLOTTER IS 3,"INTERNAL"
```

Specifying the Input Device

The GRAPHICS INPUT IS statement is used to specify which device is to be used for graphics input. Example statements are shown below.

```
GRAPHICS INPUT IS 706,"HPGL"
GRAPHICS INPUT IS 805,"HPGL"
GRAPHICS INPUT IS KBD,"KBD"
```

Interactive Graphics Techniques

The programming techniques in this section show the most common uses of the interactive graphics capabilities. The examples show digitizing single points, digitizing with tracking, and drawing continuous lines.

Digitizing Single Points

“Digitizing a point” simply means that the point’s “X” and “Y” coordinates are determined. The point to be digitized is specified by locating the point with the input device’s locator and then pressing the Digitize button (or pressing the stylus). The following program shows a simple technique for single-point digitizing. The input device is an HP 9111 Graphics Tablet.

```

100  GINIT                               ! Initialize.
110  GRAPHICS INPUT IS 706,"HPGL" ! 9111 Graphics Tablet.
120  !
130  Point: DIGITIZE X,Y,Status$ ! Request coords.
140                                ! and status.
150  ! Print coords.
160  DISP USING "#,""X="",K,2X,""Y="",K,2X";X,Y
170  !
180  ! Which region is point in?
190  Region$=Status$[3;1] ! Read 3rd character.
200  SELECT Region$           ! Determine region.
210     CASE ="2"
220         DISP "(Inside VIEWPORT)"
230     CASE ="1"
240         DISP "(Outside VIEWPORT,";
250         DISP " but inside P1,P2)"
260     CASE ="0"
270         DISP "(Outside P1,P2)"
280  END SELECT
290  !
300  GOTO Point
310  !
320  END

```

Executing the DIGITIZE statement causes the following action. The computer first tells the GRAPHICS INPUT IS device that it is to digitize a point. The input device then waits for the Digitize button to be pressed (in this case, for the stylus to be pressed), at which time it determines the point’s coordinates. The input device then returns the point’s coordinates to the computer. The computer can then execute the next BASIC statement. If no point is selected, the computer will “hang” on the DIGITIZE statement. Pressing **(CLR I/O)** will pause the computer, if desired.

The optional string variable (`Status$` in the preceding program) is used to return information about the input device. Here, only the third byte is examined; the value of this byte shows the region in which the point is located. The values 2, 1, and 0 can be returned; the respective definitions are shown in the program.

Graphics Regions and Mapping

As previously mentioned, the **maximum usable area** of a graphics device is bounded by its **hard clip limits**; for example, the pen cannot be made to draw outside these limits on an output device.

The **current usable area** is bounded by the rectangle defined by the points P1 and P2; the **lower-left corner is P1**, and the **upper-right corner is P2**. On many devices, these points can be moved manually or by the program.

When the GINIT statement or a PLOTTER IS statement is executed, points P1 and P2 are read from the plotting device; with GINIT, the plotting device is assumed to be the internal CRT. The value of RATIO is then set to the result of the following calculation:

$$\text{RATIO} = (P2x - P1x) / (P2y - P1y)$$

The operating system then automatically scales the P1,P2 rectangle. When GINIT is executed, the following VIEWPORT and WINDOW statements are executed, scaling the rectangle in Graphic Display Units and User Defined Units, respectively.

If RATIO >= 1:

```
VIEWPORT 0,100*RATIO,0,100
WINDOW 0,100*RATIO,0,100
```

If RATIO < 1:

```
VIEWPORT 0,100,0,100/RATIO
WINDOW 0,100,0,100/RATIO
```

As seen above, the X and Y coordinates of P1 are always both 0 Graphic Display Units. The default Graphic Display Unit coordinates of P2 depend on the device; however, the smaller coordinate of this point is always 100 Graphic Display Units. Two examples are shown below.

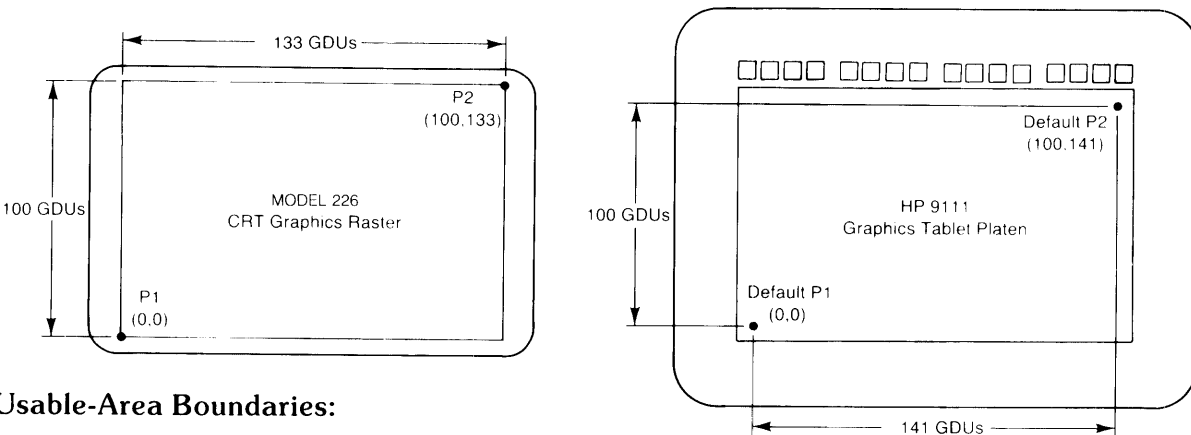

Usable-Area Boundaries:

- Left edge = X coordinate of P1
- Bottom edge = Y coordinate of P1
- Right edge = X coordinate of P2
- Top edge = Y coordinate of P2

Default Locations of P1 and P2 on the Model 226 and HP 9111

When a PLOTTER IS statement is executed, the locations of points P1 and P2 on the specified device are determined. The current VIEWPORT statement parameters are then used to define the physical area (in GDUs) which is to be scaled (in UDUs) by the WINDOW or SHOW statement currently in effect.

When a subsequent GRAPHICS INPUT IS statement is executed, the operating system attempts to apply the current VIEWPORT and WINDOW (or SHOW) parameters to the P1,P2 rectangle of the input device. In the preceding example, the two usable areas are not identical in size (in Graphic Display Units), since the HP 9111 has a smaller horizontal-to-vertical aspect ratio. The P2 of the input device will automatically be adjusted to equal the GDU's of the output device.

Digitizing with Tracking

The locator may also be "tracked" on the output device while it is being moved (before a point is digitized). Executing the TRACK...IS ON statement accesses this feature, as shown in the following example program.

```

100  GINIT                                ! Restore defaults.
110  GRAPHICS INPUT IS KBD,"KBD"         ! Keyboard is input.
120  PLOTTER IS CRT,"INTERNAL"          ! (Redundant.)
130  TRACK CRT IS On                    ! Enable tracking.
140  !
150  GRAPHICS ON
160  WINDOW -50,50,-20,20              ! Define UDUs.
170  FRAME                              ! Draw bounds.
180  AXES 10,10,0,0,5,5                ! Draw axes.
190  MOVE 0,0                           ! Begin at Origin.
200  !
210  !
220  Track: DIGITIZE X,Y,Status$       ! Request coords.,
230          ! updating cursor until coords. received.
240  !
250          DRAW X,Y                   ! Connect points.
260  !
270  GOTO Track
280  !
290  END

```

The TRACK...IS ON statement merely enables the tracking feature; the actual tracking is performed while the DIGITIZE statement is being executed. The locator is "tracked" by moving the output device's "cross-hair" (or pen) correspondingly. Notice that the definition of the DIGITIZE statement has been modified slightly — now its execution causes the locator to be tracked and "echoed" on the output device until the stylus (or Digitize button) is pressed.

After a key satisfying the digitize is pressed, the DIGITIZE statement has finished execution and the DRAW statement is executed. This program draws lines between the digitized points, but you may want to change this response as desired with the appropriate software.

Drawing Continuous Lines

Other common uses of interactive graphics are to draw lines or track the cursor continuously without digitizing. The READ LOCATOR and SET ECHO statements are used in order to determine the input device's locator position and to echo the position on the output device, independent of the Digitize button being pressed. The following program shows an example of implementing this graphics capability in a BASIC program.

```

100  GINIT                                ! Restore defaults.
110  GRAPHICS INPUT IS 706,"HPGL" ! Define input.
120  PLOTTER IS CRT,"INTERNAL"
130  GRAPHICS ON
140  WINDOW 0,100,0,100                ! Define UDUs.
150  FRAME                              ! Draw limits.
160  !
170  LOOP
180      READ LOCATOR X,Y,Status$
190      SET ECHO X,Y
200      Button$=Status$[1,1]
210      GOSUB Action
220  END LOOP
230  !
240 Action: IF Button$="0" THEN MOVE X,Y
250          IF Button$="1" THEN DRAW X,Y
260          RETURN
270          !
280  END

```

The preceding program continuously tracks the input locator and monitors the pressed/not-pressed status of the Digitize button (or stylus). The cursor position is continuously echoed on the output device, and lines are drawn if the Digitize button (or stylus point) is pressed.

Interactive Color Graphics

The interactive graphics statements can also be used with the Color Output Interface. The following program shows a typical example of using the interface for this type of graphics application.

```

100 PLOTTER IS 28,"98627A"      ! Define output.
110 GRAPHICS INPUT IS 706,"HPGL" ! Define input.
120 ! May want to match aspect ratios with VIEWPORT;
130 ! parameters depend on color-display format.
140 ! May also want to move P1,P2 with HPGL commands.
150 !
160 ! Define sfk's.
170 ON KEY 0 LABEL "White " GOSUB White
180 ON KEY 1 LABEL "Red  " GOSUB Red
190 ON KEY 2 LABEL "Yellow" GOSUB Yellow
200 ON KEY 3 LABEL "Green " GOSUB Green
210 ON KEY 5 LABEL "Erase " GOSUB Erase
220 ON KEY 9 LABEL "Clear " GOSUB Clear
230 !
240 LOOP
250     READ LOCATOR X,Y,Status$
260     SET ECHO X,Y
270     Action$=Status#[1,1]
280     GOSUB Action
290     !
300 END LOOP
310 !
320 White:  PEN 1
330         RETURN
340         !
350 Red:    PEN 2
360         RETURN
370         !
380 Yellow: PEN 3
390         RETURN
400         !
410 Green:  PEN 4
420         RETURN
430         !
440 Erase:  PEN -1
450         RETURN
460         !
470 Clear:  GCLEAR
480         RETURN
490         !
500 Action: IF Action$="0" THEN MOVE X,Y
510         IF Action$="1" THEN DRAW X,Y
520         RETURN
530         !
540 END

```

The program uses special function keys to change the color of the lines drawn by pressing the stylus onto the platen. The program can be expanded easily to draw and erase all colors, if desired.

Example Graphics Programs

The following programs use graphics to help illustrate the operation of several of the graphics statements available in BASIC. You may wish to modify or entirely rewrite the programs to better understand how the statements work.

Sine

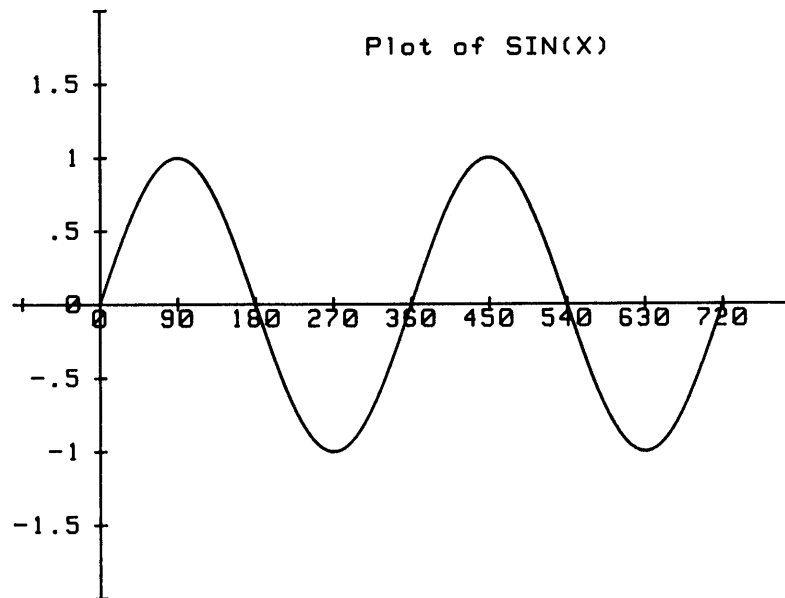

```

10  ! Program: SINE
20  !
30  ! Shows some basics of drawing and labeling.
40  !
50  DEG                                ! DEGREES
60  GINIT                               ! INITIALIZE
70  GRAPHICS ON                          ! RASTER ON
80  PRINT CHR$(12);                      ! CLEAR ALPHA
90  WINDOW -100,800,-2,2                 ! SET WINDOW
100 AXES 90,.5                           ! DRAW AXES
110 !
120 LORG 6                                ! LABEL X AXIS
130 FOR I=0 TO 720 STEP 90
140 MOVE I,0
150 LABEL I
160 NEXT I
170 !
180 LORG 8                                ! LABEL Y AXIS
190 FOR I=-1.5 TO 1.5 STEP .5
200 MOVE 0,I
210 LABEL I
220 NEXT I
230 !
240 LORG 5                                ! LABEL PLOT
250 MOVE 450,1.75
260 LABEL "Plot of SIN(X)"
270 !
280 MOVE 0,0                              ! PLOT SINE
290 FOR X=0 TO 720
300 DRAW X,SIN(X)
310 NEXT X
320 !
330 END

```

Axes

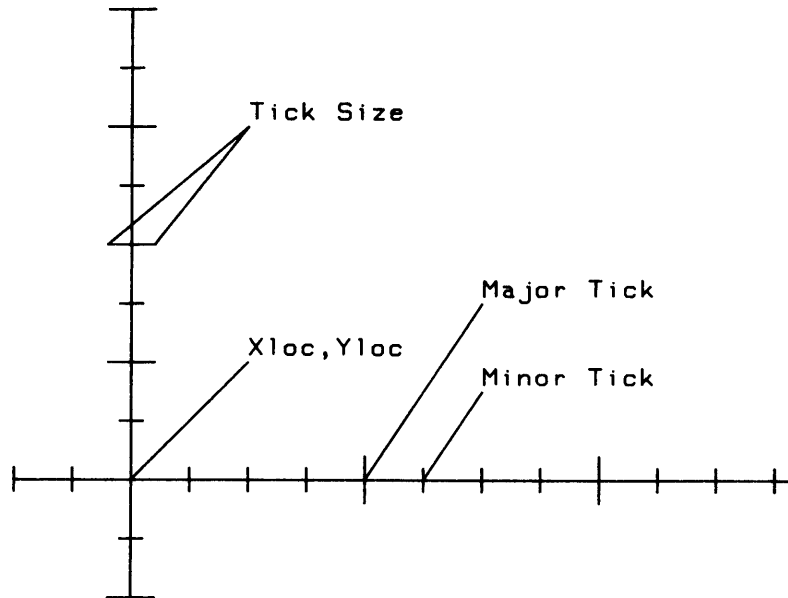

```

10  ! Program: AXES
20  !
30  ! Draw and label the AXES statement.
40  !
50  GINIT
60  GRAPHICS ON
70  ALPHA OFF
80  !
90  Xloc=20          ! X AXIS LOCATION
100 Yloc=20         ! Y AXIS LOCATION
110 Xmaj=4          ! MAJOR TICK COUNT
120 Ymaj=2          ! MAJOR TICK COUNT
130 Size=8         ! LENGTH OF TICKS
140 !
150 FOR I=100 TO 10 STEP -1
160 PEN -1
170 AXES Xtic,Ytic,Xloc,Yloc,Xmaj,Ymaj,Size
180 Xtic=I
190 Ytic=I
200 PEN 1
210 AXES Xtic,Ytic,Xloc,Yloc,Xmaj,Ymaj,Size
220 NEXT I
230 !
240 MOVE Xloc,Yloc      ! LABEL THE AXES
250 IDRAW 20,20
260 LABEL "Xloc,Yloc"
270 MOVE Xloc+40,Yloc
280 IDRAW 20,30
290 LABEL "Major Tick"
300 MOVE Xloc+50,Yloc
310 IDRAW 10,15
320 LABEL "Minor Tick"
330 MOVE Xloc-Size/2,Yloc+40
340 DRAW 40,80
350 MOVE Xloc+Size/2,Yloc+40
360 DRAW 40,80
370 LABEL "Tick Size"
380 !
390 END

```

Grid

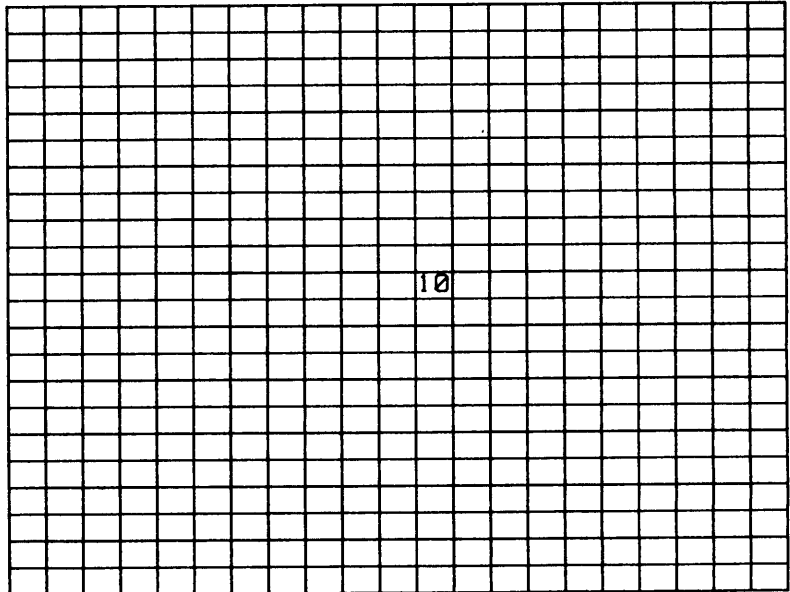

```

10  ! Program: GRID
20  !
30  ! Shows various size grids.
40  !
50  GINIT
60  GRAPHICS ON
70  PRINT CHR$(12);
80  !
90  WINDOW -110,100,-110,110
100 !
110 Yloc=0           ! CENTER AT 0,0
120 Xloc=0
130 Xmaj=6
140 Ymaj=2
150 Size=20
160 !
170 LORG 4
180 !
190 FOR I=10 TO 100 STEP 2
200   Xtic=I
210   Ytic=I
220   GCLEAR
230   MOVE I/2,0
240   LABEL I
250   GRID Xtic,Ytic,Xloc,Yloc,Xmaj,Ymaj,Size
260   WAIT (100-I)/100
270 NEXT I
280 !
290 WAIT 2
300 GRAPHICS OFF
310 END

```

Csize

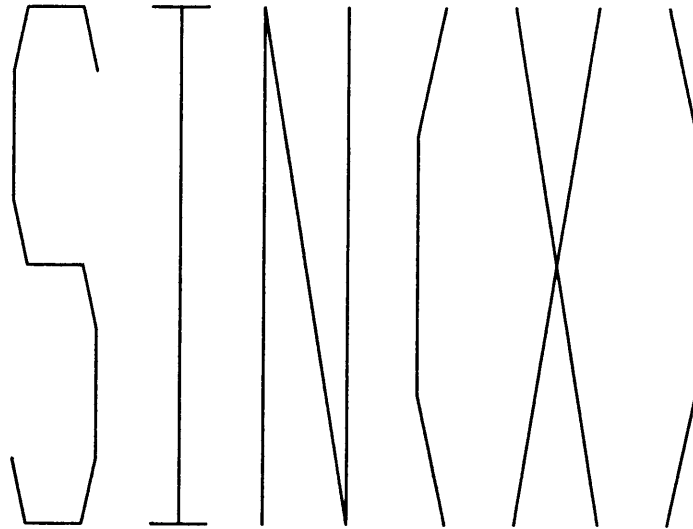

```

10  ! Program: CSIZE
20  !
30  ! VARIABLE SIZE CHARACTERS
40  !
50  ON KEY 0 LABEL " HEIGHT" GOSUB Flag_off
60  ON KEY 1 LABEL " RATIO" GOSUB Flag_on
70  ON KEY 4 LABEL " QUIT" GOTO Quit
80  PRINT CHR$(12);
90  DISP "ROTATE KNOB TO CHANGE SIZE.";
100 ON KNOB .2 GOTO Change
110 !
120 H=5                ! HEIGHT
130 W=.6              ! HEIGHT/WIDTH RATIO
140 GOTO Size
150 !
160 Change: ! CHANGE THE CHARACTER SIZE
170 IF Flag THEN
180   W=W+KNOB*100
190   IF W<.01 AND W>0 THEN W=0
200   ELSE
210   H=H+KNOB*10
220 END IF
230 DISP
240 DISP USING "2X,3A,3D.D";"H = ";H;"R = ";W
250 !
260 Size: GINIT
270   GRAPHICS ON
280   CSIZE H,W
290   MOVE 67,50
300   LOG 5
310   LABEL "SIN(X)"
320   GOTO 320           ! WAIT HERE
330 !
340 Flag_on:  Flag=1
350           RETURN
360 !
370 Flag_off: Flag=0
380           RETURN
390 !
400 Quit: GRAPHICS OFF
410   OUTPUT 2 USING "#,B";255,75
420   END

```

Label

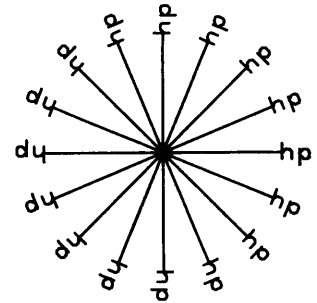
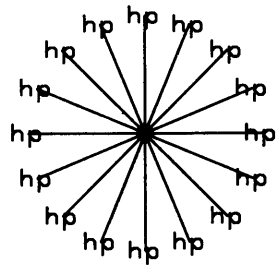

```

10  ! Program: LABEL
20  !
30  DEG
40  GINIT
50  GRAPHICS ON
60  Clear_crt%=CHR$(255)&CHR$(75)
70  OUTPUT 2;Clear_crt%;
80  SHOW -100,100,-100,100
90  !
100 FOR I=0 TO 360 STEP 22.5 ! NON-ROTATED
110   MOVE -60,0
120   PIVOT I
130   IDRAW 40,0
140   LORG 5
150   LABEL "hp"
160 NEXT I
170 !
180 FOR I=0 TO 360 STEP 22.5 ! ROTATED
190   MOVE 60,0
200   PIVOT I
210   IDRAW 40,0
220   LORG 2
230   LDIR I           ! NOTE LDIR USED
240   LABEL "hp"
250 NEXT I
260 !
270 END

```

Ginit

Reverse Graphics

```
10   ! Program: GINIT
20   !
30   ! This program does a specialized 'GINIT'
40   !
50   PRINT CHR$(12); ! CLEAR SCREEN
60   !
70   ! CUSTOMIZED 'GINIT'
80   !
90   PLOTTER IS 3,"INTERNAL"
100  CLIP OFF
110  PIVOT 0
120  PEN 1
130  LINE TYPE 1,5
140  LORG 5
150  CSIZE 8,-.6
160  LDIR 0
170  MOVE 90,60
180  GCLEAR
190  VIEWPORT 0,RATIO*100,0,100
200  WINDOW 0,RATIO*100,0,100
210  !
220  GRAPHICS ON
230  LABEL "Reverse Graphics"
240  LIST 60,230
250  END
```

Rose

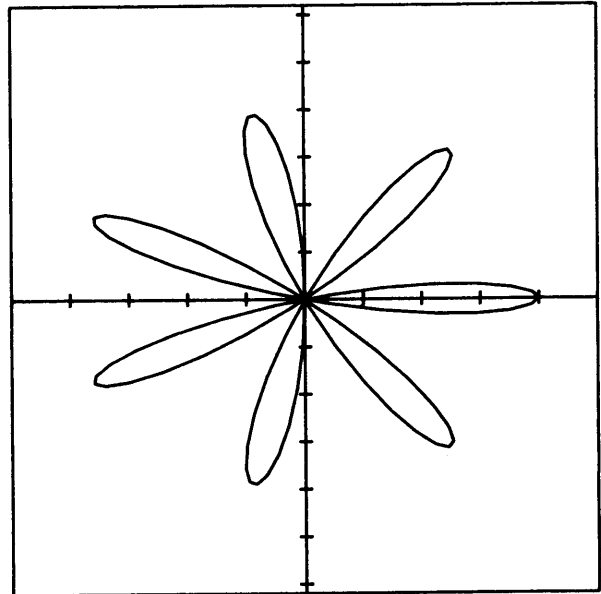

```

10  ! Program: ROSE
20  !
30  ! Rotate the knob, change the view.
40  !
50  DEG
60  GINIT
70  GRAPHICS ON
80  PRINT CHR$(12);
90  ON KNOB .1 GOTO Scale
100 !
110 Max=40 ! starting value
120 !
130 Scale: Max=Max+KNOBX
140 IF Max<1 THEN Max=1
150 DISP Max
160 !
170 IF Max>72 THEN
180   Dx=Max-72
190   SHOW -51+Dx,50-Dx,-63+Dx,62-Dx
200   ELSE
210   VIEWPORT 62-Max,62+Max,50-Max,50+Max
220   WINDOW -50,50,-62,62
230   END IF
240   GCLEAR
250   FRAME
260   AXES 10,10,0,0
270   FOR I=0 TO 180 STEP 2
280     P=40*COS(7*I)
290     X=P*COS(I)
300     Y=P*SIN(I)
310     IF I=0 THEN MOVE X,Y
320     DRAW X,Y
330   NEXT I
340   !
350   GOTO 170
360   END

```

Rplot

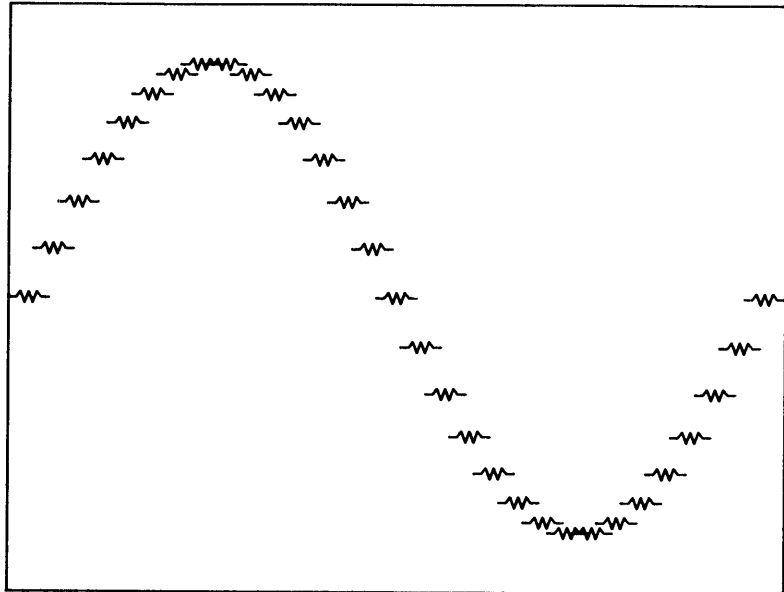

```

10   ! Program: RPLOT
20   !
30   ! Repeats an image at various locations.
40   !
50   DEG
60   GINIT
70   GRAPHICS ON
80   WINDOW -10,370,-100,100
90   PRINT CHR$(12); ! CLEAR SCREEN
100  DISP " RPLOT"
110  FRAME
120  !
130  FOR I=0 TO 360 STEP 12
140    MOVE I,SIN(I)*80
150    GOSUB Shape
160  NEXT I
170  !
180  GOTO Quit
190  !
200 Shape: ! DRAW A RESISTER
210  !
220  RPLOT -10,0,1
230  RPLOT -6,0
240  RPLOT -4,2
250  RPLOT -2,-2
260  RPLOT 0,2
270  RPLOT 2,-2
280  RPLOT 4,2
290  RPLOT 6,0
300  RPLOT 10,0
310  RETURN
320  !
330 Quit:  END

```

Randomview

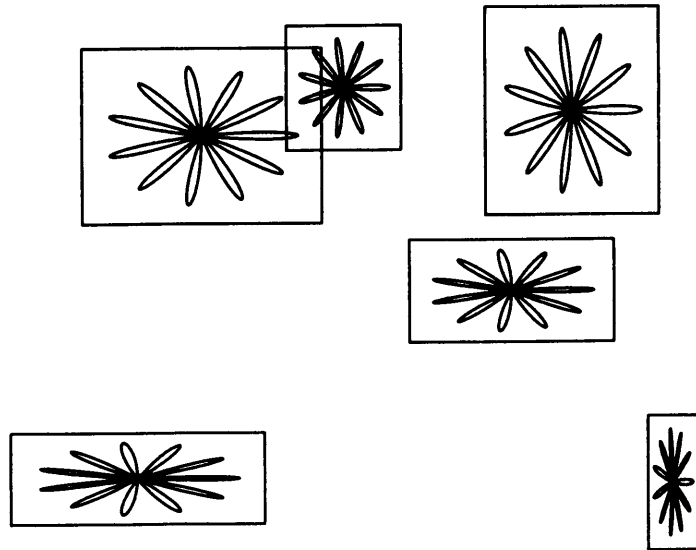

```

10   ! Program: RANDOMVIEW
20   !
30   RANDOMIZE
40   !
50 Start: ! Demonstration of VIEWPORT and WINDOW
60   !
70   DEG
80   GINIT
90   GRAPHICS ON
100  ALPHA OFF
110  !
120  ! Generate some random numbers
130  !
140  Xmin=RND*131
150  Xmax=Xmin+RND*(131-Xmin)
160  Ymin=RND*100
170  Ymax=Ymin+RND*(100-Ymin)
180  !
190  ! Set VIEWPORT to random area
200  !
210  VIEWPORT Xmin,Xmax,Ymin,Ymax
220  WINDOW -50,50,-50,50
230  FRAME
240  !
250  ! Draw a rose within the area
260  !
270  FOR I=0 TO 200
280     P=40*COS(11*I)           ! ELEVEN LEAF ROSE
290     X=P*COS(I)
300     Y=P*SIN(I)
310     DISP INT(Xmax-Xmin);" ";INT(Ymax-Ymin)
320     IF I=0 THEN MOVE X,Y
330     DRAW X,Y
340  NEXT I
350  !
360  GOTO Start                 ! DO IT AGAIN
370  END

```

Color

WHITE	WHITE	WHITE	WHITE
RED	RED	RED	RED
YELLOW	YELLOW	YELLOW	YELLOW
GREEN	GREEN	GREEN	GREEN
CYAN	CYAN	CYAN	CYAN
BLUE	BLUE	BLUE	BLUE
MAGENTA	MAGENTA	MAGENTA	MAGENTA

```

10      ! Program: COLOR
20      !
30      ! This program works with the 98627A
40      ! Color Output Interface
50      !
60      ! Note that a 'PLOTTER IS' statement must
70      ! immediately follow 'GINIT' statement.
80      !
90      ! Note different pen assignments.
100     !
110     GINIT
120     PLOTTER IS 28,"98627A"
130     GRAPHICS ON
140     PEN 1
150     FRAME
160     !
170     FOR X=0 TO 120 STEP 40
180     MOVE X,70
190     PEN 1
200     LABEL "WHITE"
210     PEN 2
220     LABEL "RED"
230     PEN 3
240     LABEL "YELLOW"
250     PEN 4
260     LABEL "GREEN"
270     PEN 5
280     LABEL "CYAN"
290     PEN 6
300     LABEL "BLUE"
310     PEN 7
320     LABEL "MAGENTA"
330     NEXT X
340     END

```

Meter

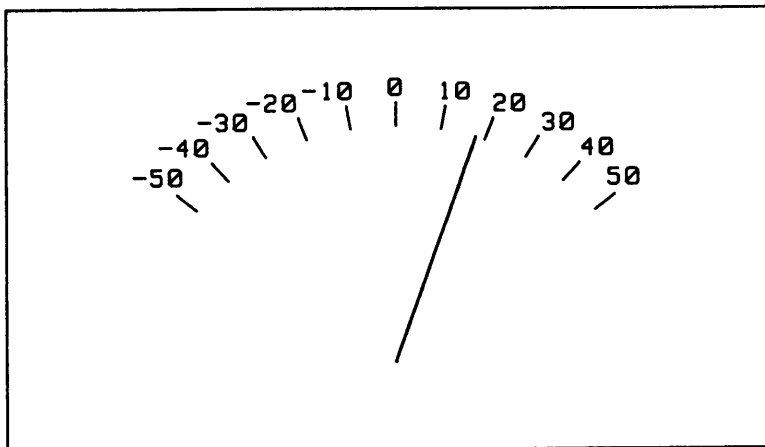

```

10  ! Program: METER
20  !
30  ! Simulation of a analog meter
40  ! KNOB and RANDOM needle movement.
50  !
60  DEG
70  GINIT
80  GRAPHICS ON
90  CLIP 0,131,25,100
100 WINDOW -150,150,-100,150
110 OUTPUT 2 USING "#,B";255,75 ! CLEAR SCREEN
120 !
130 FRAME ! CREATE METER
140 FOR Tic=-50 TO 50 STEP 10
150     MOVE 0,0
160     PIVOT Tic
170     LORG 4
180     MOVE 0,100
190     IDRAW 0,10
200     LABEL -Tic
210 NEXT Tic
220 !
230 ON KNOB .2 GOTO Meter
240 !
250 Meter: ! GENERATE RANDOM METER MOVEMENT
260 PEN -1
270 MOVE 0,0
280 DRAW 100,0 ! UNDRAW NEEDLE
290 P=(P+4*RND-2) MOD 60+KNOB*10
300 MOVE 0,0
310 PIVOT 90-P
320 DISP INT(P)
330 PEN 1
340 MOVE 0,0
350 DRAW 100,0 ! REDRAW NEEDLE
360 WAIT .07
370 GOTO Meter
380 !
390 END

```

Pivot

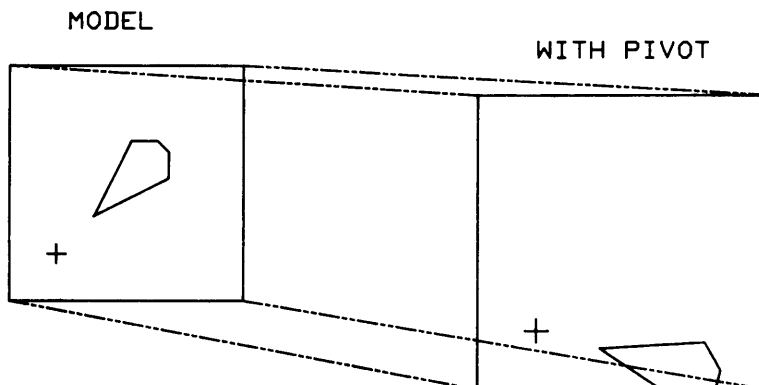

```

10  ! Program: PIVOT
20  !
30  ! Shows pivoting around a point.
40  !
50  DEG
60  GINIT
70  GRAPHICS ON
80  PRINT CHR$(12);
90  DIM X(4),Y(4)
100 DATA 40,20,0,14,-6,6,-14,0,-20,-40 ! SHAPE
110 FOR I=0 TO 4
120   READ X(I),Y(I)
130 NEXT I
140 !
150 DATA 80,130,35,85,0,40,50,90 ! 'WINDOWS'
160 READ S1,Sr,Sb,St,M1,Mr,Mb,Mt
170 !
180 DIM Orsx(3),Orsy(3)
190 DATA 40,60,40,40,20,20,0,0 ! ORIGINS
200 FOR I=0 TO 3
210   READ Orsx(I),Orsy(I)
220 NEXT I
230 MOVE 10,95
240 LABEL "MODEL"
250 MOVE 90,90
260 LABEL "WITH PIVOT"
270 LINE TYPE 8
280 MOVE M1,Mb           ! CONNECT LINES
290 DRAW S1,Sb
300 MOVE Mr,Mb
310 DRAW Sr,Sb
320 MOVE Mr,Mt
330 DRAW Sr,St
340 MOVE S1,St
350 DRAW M1,Mt
360 !
370 MOVE M1,Mt
380 P=1
390 LINE TYPE 1
400 Ox=Orsx(Index)
410 Oy=Orsy(Index)
420 GOSUB Model
430 !

```

```

440 VIEWPORT S1,Sr,Sb,St
450 SHOW -25,100,-25,100
460 GOSUB Shape
470 DISP "Angle =";Angle
480 Angle=Angle+5
490 IF Angle<361 THEN 460
500 CALL Cursor(Ox,Oy,-1)          ! PIVOT POINT
510 P=-1
520 GOSUB Model
530 Angle=0
540 Index=Index+1
550 IF Index>3 THEN Quit
560 GOTO 380
570 !
580 Model: VIEWPORT M1,Mr,Mb,Mt
590 SHOW -25,100,-25,100
600 FRAME
610 GOSUB Shape
620 RETURN
630 Shape: ! DRAW IN CURRENT 'WINDOW'
640 PEN -1
650 MOVE 20,20
660 FOR I=0 TO 4
670 IDRAW X(I),Y(I)
680 NEXT I
690 MOVE Ox,Oy
700 PEN 1
710 CALL Cursor(Ox,Oy,P)
720 PIVOT Angle
730 PEN 1
740 FRAME
750 MOVE 20,20
760 FOR I=0 TO 4
770 IDRAW X(I),Y(I)
780 NEXT I
790 RETURN
800 Quit:DISP
810 END
820 !
830 ! ----- SUB PROGRAM -----
840 !
850 SUB Cursor(X,Y,P)
860 PEN P
870 PIVOT 0
880 MOVE X,Y
890 IMOVE 5,0
900 IDRAW -10,0
910 IMOVE 5,5
920 IDRAW 0,-10
930 MOVE X,Y
940 SUBEXIT
950 SUBEND

```

Showwindow

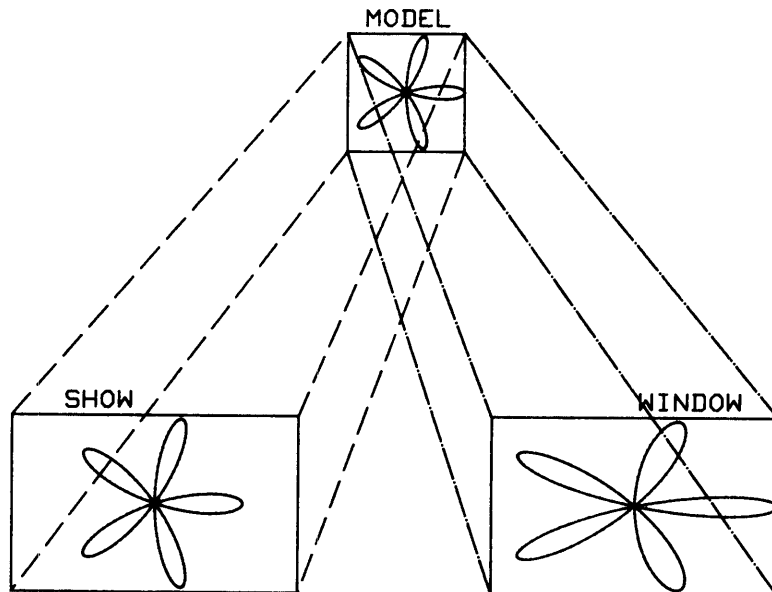

```

10      ! PROGRAM: SHOWWINDOW
20      !
30      ! Compares the mapping of SHOW and WINDOW
40      !
50      DEG
60      GINIT
70      GRAPHICS ON
80      DISP "WINDOW AND SHOW"
90      DIM X(200),Y(200),Center$(40)
100     FOR I=0 TO 180
110     R=100*COS(5*I)
120     X(I)=R*COS(I)
130     Y(I)=R*SIN(I)
140     NEXT I
150     !
160     ! Determine if running on a 9826 or 9836.
170     ! Needed for centering of prompt.
180     IF RATIO>1.32 THEN
190       Space=20
200     ELSE
210       Space=35
220     END IF
230     FOR I=1 TO Space
240       Center$=Center$&" "
250     NEXT I
260     !
270     !
280     DATA 0,30,0,50,57,77,75,95
290     READ S1,Sr,Sb,St,M1,Mr,Mb,Mt
300     !
310 Loop: ! FRAME THE PLOTTING AREAS
320     GINIT
330     PRINT CHR$(12);
340     ALPHA OFF
350     Wr=131
360     Wl=Wr-Sr
370     Wt=St
380     Wb=Sb
390     VIEWPORT S1,Sr,Sb,St
400     FRAME
410     VIEWPORT M1,Mr,Mb,Mt
420     FRAME
430     VIEWPORT Wl,Wr,Wb,Wt

```

```

440  FRAME
450  VIEWPORT 0,131.36,0,100
460  !
470  LINE TYPE 5                ! 'SHOW' LINES
480  MOVE M1,Mb
490  DRAW S1,Sb
500  MOVE Mr,Mb
510  DRAW Sr,Sb
520  MOVE Mr,Mt
530  DRAW Sr,St
540  MOVE S1,St
550  DRAW M1,Mt
560  LINE TYPE 6                ! 'WINDOW' LINES
570  MOVE M1,Mb
580  DRAW W1,Wb
590  MOVE Mr,Mb
600  DRAW Wr,Wb
610  MOVE Mr,Mt
620  DRAW Wr,Wt
630  MOVE M1,Mt
640  DRAW W1,Wt
650  !
660  LINE TYPE 1
670  VIEWPORT 0,131.36,0,100 ! LABELS
680  WINDOW 0,131.36,0,100
690  LORG 1
700  MOVE M1,Mt
710  LABEL "MODEL"
720  MOVE S1,St
730  LORG 1
740  LABEL "SHOW"
750  MOVE Wr,Wt
760  LORG 7
770  LABEL "WINDOW"
780  !
790  FOR I=1 TO 180              ! DRAW A ROSE IN THREE
800  LINE TYPE 1                ! PLACES AT ONCE
810  VIEWPORT M1,Mr,Mb,Mt
820  SHOW -100,100,-100,100
830  MOVE X(I-1),Y(I-1)
840  DRAW X(I),Y(I)
850  VIEWPORT S1,Sr,Sb,St
860  SHOW -100,100,-100,100
870  MOVE X(I-1),Y(I-1)
880  DRAW X(I),Y(I)
890  VIEWPORT W1,Wr,Wb,Wt
900  WINDOW -100,100,-100,100
910  MOVE X(I-1),Y(I-1)
920  DRAW X(I),Y(I)
930  NEXT I
940  !
950  DISP Center$;"NEW RATIO";
960  OUTPUT 2;Center$;
970  INPUT "",Ra
980  IF Ra<=0 THEN Quit
990  IF Ra>=1 THEN
1000     Sr=49
1010     St=60/Ra
1020  ELSE
1030     St=60
1040     Sr=49*Ra
1050  END IF
1060  GOTO Loop
1070  !
1080  Quit:GRAPHICS OFF
1090     OUTPUT 2 USING "*,B";255,75
1100  END

```

Gload

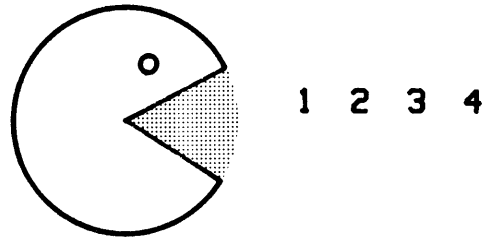

```

10   ! Program: GLOAD
20   !
30   ! DIMENSION 'PICTURE' ARRAYS
40   !
50   OPTION BASE 1
60   A=7500                               ! ARRAY SIZE FOR 9826
70   IF RATIO<1.32 THEN A=12480         ! ARRAY SIZE FOR 9836
80   ALLOCATE INTEGER P1(A),P2(A),P3(A),P4(A)
90   !
100  DEG
110  GINIT
120  GRAPHICS ON
130  PRINT CHR$(12);
140  DISP "GLOAD/GSTORE"
150  SHOW -800,800,-800,800
160  !
170  GCLEAR
180  FOR I=0 TO 90 STEP .5                ! HEAD
190      MOVE 0,0
200      PIVOT I
210      MOVE -200,0
220      DRAW 200,0
230      MOVE 0,0
240      PIVOT -I
250      MOVE -200,0
260      DRAW 200,0
270  NEXT I
280  !
290  PEN -1
300  FOR I=0 TO 360 STEP 8                ! EYE
310      MOVE 40,100
320      PIVOT I
330      IDRAW 10,0
340  NEXT I
350  !
360  PEN 1
370  MOVE 300,0
380  LABEL "1"
390  GSTORE P1(*) ! SAVE PICTURE IN ARRAY 'P1'
400  BEEP 3400,,.02
410  PEN -1
420  MOVE 300,0
430  LABEL "1"
440  !

```

```
450 A=0
460 B=10
470 GOSUB Mouth
480 MOVE 400,0
490 LABEL "2"
500 GSTORE P2(*) ! SAVE PICTURE IN ARRAY 'P2'
510 BEEP 3400,.02
520 PEN -1
530 MOVE 400,0
540 LABEL "2"
550 !
560 A=10
570 B=20
580 GOSUB Mouth
590 MOVE 500,0
600 LABEL "3"
610 GSTORE P3(*) ! SAVE PICTURE IN ARRAY 'P3'
620 BEEP 3400,.02
630 PEN -1
640 MOVE 500,0
650 LABEL "3"
660 !
670 A=20
680 B=40
690 GOSUB Mouth
700 MOVE 600,0
710 LABEL "4"
720 GSTORE P4(*) ! SAVE PICTURE IN ARRAY 'P4'
730 BEEP 3400,.02
740 PEN -1
750 MOVE 600,0
760 LABEL "4"
770 !
780 Movie: ! animation loop
790     GLOAD P1(*)
800     GLOAD P2(*)
810     GLOAD P3(*)
820     GLOAD P4(*)
830     GOTD Movie
840     !
850 Mouth: PEN -1
860     FOR I=A TO B STEP .2
870         MOVE 0,0
880         PIVOT I
890         DRAW 200,0
900         MOVE 0,0
910         PIVOT -I
920         DRAW 200,0
930     NEXT I
940     PEN 1
950     PIVOT 0
960     RETURN
970     END
```

Notes

Transporting Programs

Chapter**15**

If you have programs which were written on previous Series 200 BASIC systems, you can use these same programs with little or no changes. The major task you have to perform is to configure the BASIC 3.0 system with the necessary BIN files.

This chapter describes the differences between BASIC 2.0/2.1 extensions and BASIC 3.0. The following areas require consideration when transporting programs from BASIC 2.0/2.1 to BASIC 3.0. They are listed in the order in which they're discussed in this chapter.

- Configuring BASIC
- Statement changes
- CSUBs
- PHYREC
- Knob
- Graphics
 - Default plotter
 - Implicit GCLEAR
 - Input device viewport
 - Graphics Tablet DIGITIZE
 - The VIEWPORT Statement
 - The PIVOT Statement
- Display functions
- Prerun on LOADSUB
- Special case of I/O transfers

Configuring BASIC

This section contains procedures that help you ensure you have loaded all the required language extensions and drivers. It also tells you where to find related information in your BASIC 3.0 manual set.

Helpful Documentation

The BASIC 3.0 manuals can help you determine which BIN files you need. Chapter 8 of the *BASIC 3.0 User's Guide*, "Configuring Your BASIC System", contains a brief description of each BIN file. It also lists the functions and statements supported by each Language Extensions BIN file.

The Language History section of the *BASIC 3.0 Language Reference* manual contains an alphabetical list of all keywords showing which BIN file, if any, is needed for each keyword. The Keyword Dictionary in the *BASIC 3.0 Language Reference* manual also indicates which BIN file is required for each keyword. Keep in mind that some keywords are partially supported by just core BASIC (SYSTEM_BA3) and that additional capabilities may require a BIN file. The Keyword Dictionary uses shading in the syntax diagram to show which aspects of a statement require an additional BIN file. For example, CAT is supported by core BASIC, but the MS BIN file is needed to support SELECT and other advanced features.

Missing Language Extensions BIN Files

Follow this procedure to make sure that you have all the language extensions BIN files that a program needs. The procedure ensures that each program unit is not prerun and then preruns all program units. Prerun reports the first missing BIN file that it finds. Editing a program unit ensures that it is not in the prerun state. Stepping a stopped program preruns it.

Load the program and the BIN files PDEV and ERR. Enter the first line of the program to ensure that the main program is not in a prerun state. Find every SUB statement (using the FIND command enabled by the PDEV BIN file) and enter it. Find every DEF FN statement and enter it. Now no program unit is in a prerun state. Stepping preruns every subprogram. If prerun finds a statement or option that requires a missing BIN file, error 1 is given along with the name (if the ERR BIN file is loaded) of the missing BIN file. After loading the missing BIN file, step again to prerun the program. If a BIN file is missing, error 1 and its name are given. Repeat this process until stepping gives no errors. At that point, all language extensions BIN files needed by the program are present. If the program loads subprograms or other programs, repeat this process for each of them.

This process does not work for a secured program. The best approach in this case is to ask the author or vendor for a list of the BIN files required. If this is not possible, load the ERR BIN file and run the program. Whenever a statement is executed that requires a missing BIN file, an error 1 and the name of the BIN file are given. After loading the BIN file, the program can be continued. However, it may be difficult to force the execution of all paths in the program. This can be a serious problem if a real-time control program is surprised by a missing BIN file at a critical moment.

Remember, if you have enough memory, you can load all the BIN files. **However, only load KNB2_0 if you want KNOBX to function as it does in BASIC 2.0/2.1 and KNOBY to always return a zero. Refer to the Knob section later in this chapter for more information.**

Missing Driver BIN Files

To ensure that all required driver BIN files are loaded, load the appropriate BIN file for each interface card and I/O port used (including the built-in HP-IB and RS-232 serial interface, if present). Also load the appropriate disc driver BIN file for each disc drive used.

If an operation is attempted to a device but the card driver BIN file is missing, the message “ERROR 163 I/O interface not present” is usually provided. Examples of this are: CAT“:,700” or PRINTER IS 701 with the HPIB BIN file missing.

If the card BIN file is present but the disc driver BIN file is missing, an attempt to access the disc causes error 1. If the ERR BIN file is loaded, the message “ERROR 1 Configuration error” is provided.

If both the card driver and disc driver BIN files are missing, error 163 is usually given but error 1 can also occur.

Statement Changes

There are several statements added with BASIC 3.0. These are listed below.

KNOBY	PRINTER IS file
LIST BIN	READ LABEL
MAXREAL	RES
MINREAL	SCRATCH BIN
MODULO	SECURE
PDIR	SET LOCATOR
PLOTTER IS file	STORE SYSTEM
PRINT LABEL	SYSBOOT

Two statements were deleted, STORE BIN and RE-STORE BIN.

CSUBs

If you used Pascal-compiled subprograms (CSUBs) in your BASIC 2.0/2.1 programs, you need to purchase a Pascal 3.0 system upgrade and a CSUB Utility upgrade to use those CSUBs with BASIC 3.0. You must recompile the Pascal routine on Pascal 3.0 and re-execute the CSUB utility to make the routine look like a BASIC subprogram. If you are using a CSUB supplied by a vendor, you must have the supplier update the CSUB for you.

PHYREC

The PHYREC routine that allowed you to read from and write to physical records on a disc is changed from a binary program to a CSUB with BASIC 3.0. The PHYREC CSUB is located on the *BASIC Utilities Disc 1*.

You must append the PHYREC CSUB to your program and change PHYREAD/PHYWRITE statements. If the PHYREC binary is appended to a program, a warning message is displayed and the binary is ignored by BASIC 3.0.

Use the following steps to locate all the lines for an application that uses PHYREC and change them to call and append the PHYREC CSUB.

1. Boot a BASIC 2.0/2.1 system.
2. Delete the PHYREC binary.

```
LOAD "Program"
SAVE "Program2" - This saves the program without the binary.
SCRATCH A - This deletes the program and binary from memory.
GET "Program2" - Calls to PHYREC are commented. Write down the line numbers.
RE-STORE "Program"
PURGE "Program2"
```

3. Attach the PHYREC CSUB.

```
LOADSUB ALL FROM "PHYREC"
```

This file is located on *BASIC Utilities Disc 1*. **Do not try to run your application until you have completed all steps.**

4. Uncomment and change all the calls to PHYREC. These are the lines you noted in step 2 above.

```
PHYREAD Sector,Int_array(*) > Phyread(Sector,Int_array(*)
PHYWRITE Sector,Int_array(*) > Phywrite(Sector,Int_array(*)
```

5. If Sector is declared to be an INTEGER, you need to put it into parentheses so that PHYREC will interpret it as a REAL.

```
Phyread((Sector),Int_array(*)
```

6. The syntax for a conditional call must be changed from:

```
IF condition THEN PHYREAD Sector,Int_array(*)
```

to:

```
IF condition THEN
  Phyread(Sector,Int_array(*)
END IF
```

or to:

```
IF condition THEN CALL Phyread(Sector,Int_array(*)
```

7. RE-STORE "Program" after you have completed the changes.
8. Boot BASIC 3.0 and run your application.

Knob

In BASIC 3.0, unshifted knob movement causes horizontal cursor movement, and shifted knob movement results in vertical movement. This allows for greater compatibility between the knob and the HP-HIL mouse. (In BASIC 2.0/2.1, horizontal and vertical modes are toggled and interlocked.)

The KNOBX Function

The BASIC 2.0/2.1 definition of KNOBX, which we will refer to as all-pulse mode, is as follows: When an ON KNOB statement is executed to trap knob movement, knob pulses are accumulated and accessed via the KNOBX statement. Since the KNOBX function returns information on X-axis movement, a method of tracking Y-axis movement is not directly available with BASIC 2.0/2.1. The common method used to track Y-axis movement, is to interrogate keyboard status register 10 for information on the state of the CTRL and SHIFT keys at the time of the last knob interrupt. Using this information, SHIFTed and/or CTRLed knob movement could be interpreted differently; in fact, an example program showing this was included in the 2.0/2.1 manual set. Following is another sample 2.0/2.1 program with this type of knob interpretation:

```

      *
      *
      *
30   ON KNOB ,1 GOSUB Knobsvc
40   Loop:  GOTD Loop
50   STOP
60   !
70   Knobsvc:  !
80       STATUS KBD,10;State      ! was SHIFT or CTRL key pressed?
90       Shift=BIT(State,0)      ! bit 0 set = SHIFT key pressed
100      Ctrl=BIT(State,1)       ! bit 1 set = CTRL key pressed
110      SELECT Shift
120          CASE 0              ! if shift not pressed, X direction
130              IF Ctrl THEN    ! if ctrl pressed, give finer resolution
140                  X=X+KNOBX/10
150              ELSE
160                  X=X+KNOBX
170              ENDIF
180          CASE 1              ! if shift pressed, Y direction
190              IF Ctrl THEN    ! if ctrl pressed, give finer resolution
200                  Y=Y+KNOBX/10
210              ELSE
220                  Y=Y+KNOBX
230              ENDIF
240      END SELECT
      *
      *
      *

```

With the introduction of the new HP-HIL keyboards (no built-in knob but optional mouse), the intent was to allow the mouse to emulate knob behavior in situations where a knob is no longer present. The all-pulse mode of interpretation, however, is unacceptable when using a mouse because the mouse is not a unidirectional device, yet movement information in only one direction is available. It is virtually impossible to move the mouse in one direction only. To be able to distinguish movement in each direction, the keyword KNOBY has been added to BASIC 3.0. KNOBY returns the net number of Y-direction knob pulses counted since the last time the KNOBY counter was zeroed.

Keyboards with Built-in Knob

To convert your programs which run on hardware with a built-in knob from 2.0/2.1 to 3.0, simply replace KNOBX with KNOBX + KNOBY in situations where total knob movement is being recorded. The major difference in 3.0 operation is that knob pulses in the X-direction are accessed via KNOBX and knob pulses in the Y-direction are accessed via KNOBY. One way to modify the above program for 3.0 is:

```

      .
      .
      .
30   DN KNOB ,1 GOSUB Knobsvc
40   Loop: GOTO Loop
50   STOP
60 !
70   Knobsvc: !
80     STATUS KBD,10;State      ! was SHIFT or CTRL Key Pressed?
90     Shift=BIT(State,0)      ! bit 0 set = SHIFT Key Pressed
100    Ctrl=BIT(State,1)       ! bit 1 set = CTRL Key Pressed
110    SELECT Shift
120      CASE 0                ! if shift not pressed, X direction
130        IF Ctrl THEN       ! if ctrl pressed, give finer resolution
140          X=X+KNOBX/10
150        ELSE
160          X=X+KNOBX
170        ENDIF
180      CASE 1                ! if shift pressed, Y direction
190        IF Ctrl THEN       ! if ctrl pressed, give finer resolution
200          Y=Y+KNOBY/10
210        ELSE
220          Y=Y+KNOBY
230        ENDIF
240    END SELECT
      .
      .
      .

```

However, this does not work with the HP-HIL mouse. A method that works with the HP-HIL mouse as well as with the built-in knob is:

```

      .
      .
      .
30   DN KNOB ,1 GOSUB Knobsvc
40   Loop: GOTO Loop
50   STOP
60 !
150  Knobsvc: !
160    X=X+KNOBX
170    Y=Y+KNOBY
      .
      .
      .

```

HP-HIL Keyboards with Mouse

If your ON KNOB routine reads keyboard status register 10 for shift-knob or control-knob actions you will need to make some other changes to convert 2.0/2.1 programs to 3.0. On HP-HIL input devices (i.e., the mouse), keyboard status register 10 has a different interpretation: bit 0 (SHIFT key pressed) is set if last data processed at the last knob interrupt was Y-axis information (data accessed via KNOBY) and cleared if last data processed was X-axis data; bit 1 (CTRL key pressed) is never set. If unidirectional HP-HIL devices were to become available, a toggle switch would exist on the device to switch between X-axis and Y-axis directions and the shift bit on keyboard status register 10 would be set when in the Y-direction mode.

The previous program segment shows recommended servicing of the mouse.

Programming for Both Versions and Keyboards

In the most complicated case, you may wish to write code that runs on both BASIC 2.0/2.1 and BASIC 3.0 with either a built-in knob or HP-HIL mouse. Write knob service routines for the BASIC 2.0/2.1 program and the BASIC 3.0 program and LOADSUB the appropriate routine based on the current version of BASIC. The following program segments show one method of handling this situation:

```

      .
      .
      .
30   GOSUB Whichversion
40   IF Version=3 THEN
50     LOADSUB ALL FROM "KNOBSVC3_0"
60   ELSE
70     LOADSUB ALL FROM "KNOBSVC2_0"
80   END IF
      .
      .
      .
110  Whichversion:      ! running BASIC 2.0/2.1 or 3.0 ?
120    ON ERROR GOTO B2_0
130    STATUS 2,2:A     ! KBD register 2 does not exist for 2.0/2.1, error
140    Version=3       ! if line 130 didn't error out, must be 3.0
150    GOTO Versionfound
160  B2_0: !
170    Version=2
180  Versionfound: !
190    OFF ERROR
200    RETURN
      .
      .
      .

```

KNB2_0

Because these modifications to the KNOB facilities may prevent your 2.0/2.1 programs from running on BASIC 3.0 without making a few changes, we have developed a way to return to the all-pulse mode of KNOB operation in which all knob pulses are accessed via KNOBX. **This mode is not recommended for the HP-HIL mouse.** To switch to this mode, execute CONTROL KBD,11;1.

Note

If you select all-pulse mode, KNOBY always returns a zero.

Executing CONTROL KBD,11;0 returns you to the 3.0 mode of operation in which Y-direction pulses are accessed via KNOBY. To determine the mode, execute STATUS KBD,11;M. If M=0, KNOBX is in horizontal-pulse mode; if M=1, KNOBX is in all-pulse mode.

In some cases, it may be desirable to make this mode change implicitly. This can be accomplished by loading the BIN file KNB2_0 from the *Language Extensions* disc. A LIST BIN describes the new BIN file as 2.0 KNOBX Definition. The only effect of KNB2_0 being loaded is that it executes CONTROL KBD,11;1 for you automatically. When KNB2_0 is loaded, executing SCRATCH A also automatically executes CONTROL KBD,11;1. Note that if this binary is included in a stored system (e.g. created with the STORE SYSTEM statement), the effects are the same as loading it afterwards.

Note

All-pulse mode (KNB2_0 loaded) is not recommended for the HP-HIL mouse.

Graphics

Several graphics statements function differently with BASIC 3.0 than they did in BASIC 2.0/2.1. This section explains the differences.

Default Plotter

The initialization of graphics system variables and devices has changed slightly in BASIC 3.0. When GINIT is executed, several operations are performed automatically such as setting line type and character size. In addition to these operations, BASIC 2.0/2.1 also implicitly does a PLOTTER IS 3, "INTERNAL" to select the CRT as the default plotting device. In BASIC 3.0, the default plotting device is not selected until a statement is executed that affects it (e.g., DRAW, LABEL, GLOAD). At this time, the appropriate PLOTTER IS statement is executed along with GCLEAR, VIEWPORT and WINDOW statements. Refer to GINIT in the *BASIC 3.0 Language Reference* manual for more information.

Implicit GCLEAR

In BASIC 2.0/2.1, any graphics statement following GINIT except PLOTTER IS, GINIT, and DUMP DEVICE causes the implicit execution of GCLEAR, VIEWPORT, and WINDOW. With BASIC 3.0, if a statement that requires a plotter is executed after GINIT, a PLOTTER IS CRT, "INTERNAL" is executed followed by GCLEAR, VIEWPORT, and WINDOW. Refer to GINIT in the *BASIC 3.0 Language Reference* manual for more information.

Input Device Viewport

The GRAPHICS INPUT IS statement sets the hard clip limits of the input device to the largest space possible that has the same aspect ratio as the output device. Since this was not so in earlier versions, there were two potential problems. The first problem is that it is possible to move to positions on the input device that do not exist on the output device. The extent of this problem may be reduced with BASIC 3.0, but the problem is not eliminated. The second problem is that the aspect ratios of the input and output devices may differ causing pictures on the devices to appear different. BASIC 3.0 solves this problem by automatically setting the hard clip limits of the input device to the largest possible space that has the same aspect ratio as the output device.

Graphics Tablet DIGITIZE

A stylus press on the HP 9111A Graphics Tablet prior to execution of a DIGITIZE statement does not satisfy the DIGITIZE with BASIC 3.0 as it does with BASIC 2.0/2.1. An output of the string "SG" to the graphics tablet after the GRAPHICS INPUT IS statement causes BASIC 3.0 to work like BASIC 2.0/2.1.

The VIEWPORT Statement

VIEWPORT was changed in BASIC 3.0 to make it compatible with the Series 500 and the industry standard. In BASIC 3.0, VIEWPORT rescales immediately. In BASIC 2.0/2.1, VIEWPORT does not rescale; only WINDOW and SHOW statements rescale.

An example helps demonstrate the difference. The following program behaves the same way in BASIC 2.0/2.1 and 3.0 because it does not have a VIEWPORT statement. It draws a large frame with a large quadrangle in it as shown in the following figure titled "BASIC 2.0/2.1 and 3.0 without VIEWPORT".

```
10 GINIT
20 GRAPHICS ON
30 FRAME
40 CLIP OFF
50 MOVE 0,50
60 DRAW 100,100
70 DRAW RATIO*100,50
80 DRAW 100,0
90 DRAW 0,50
100 END
```

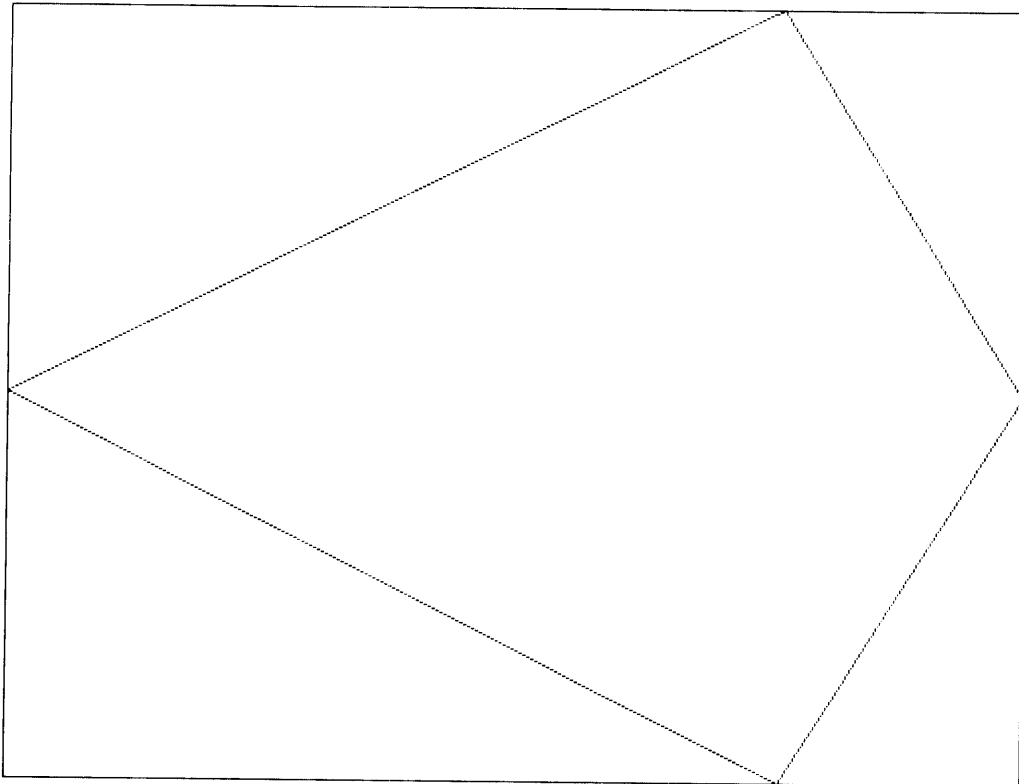

BASIC 2.0/2.1 and 3.0 without VIEWPORT

If a VIEWPORT statement is placed in the program, BASIC 2.0/2.1 and BASIC 3.0 give different results. The program becomes:

```
10  GINIT
20  GRAPHICS ON
30  VIEWPORT 80,100,20,80
40  FRAME
50  CLIP OFF
60  MOVE 0,50
70  DRAW 100,100
80  DRAW RATIO*100,50
90  DRAW 100,0
100 DRAW 0,50
110 END
```

With BASIC 2.0/2.1, the result is a small frame with a large quadrangle around it (see figure titled "BASIC 2.0/2.1 with VIEWPORT"). The frame is what one would expect from the VIEWPORT; it is tall and thin. The quadrangle is the same as the one drawn by the program without the VIEWPORT because the VIEWPORT has not caused the DRAW's to be rescaled.

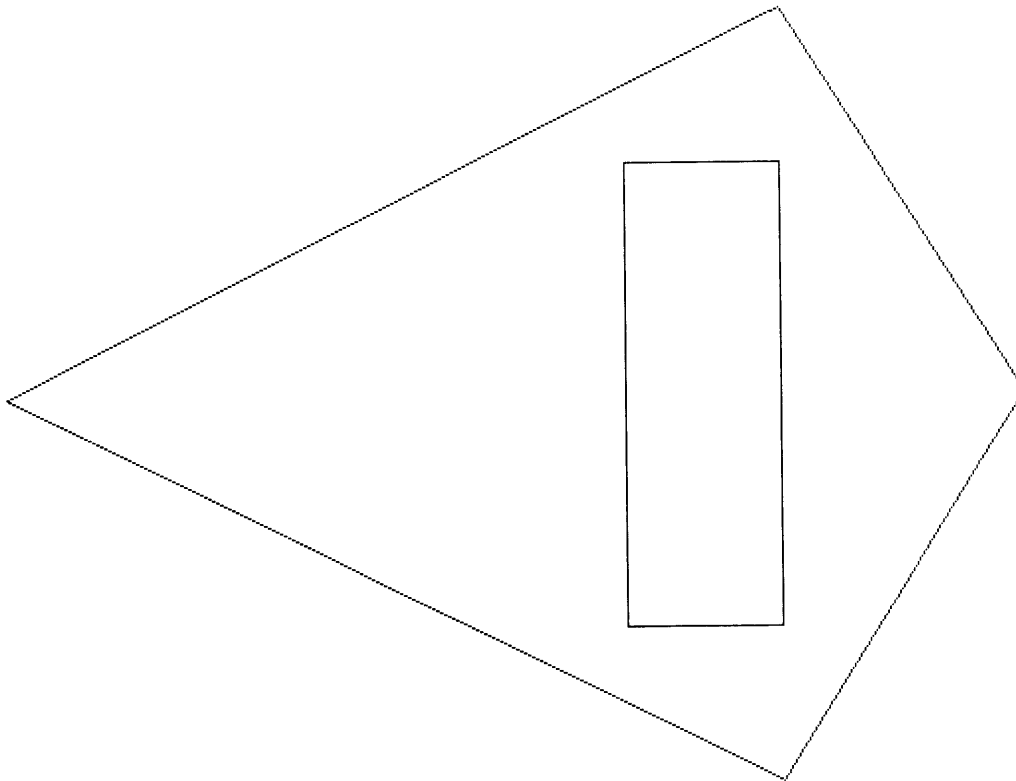

BASIC 2.0/2.1 with VIEWPORT

With BASIC 3.0, the result is a small frame with a small quadrangle inside the frame (see figure titled "BASIC 3.0 with VIEWPORT"). The frame is the same frame as given by BASIC 2.0/2.1. The quadrangle fits inside the frame because the VIEWPORT in BASIC 3.0 causes all subsequent DRAW's to be rescaled.



BASIC 3.0 with VIEWPORT

The VIEWPORT change usually does not affect programs because most programs used a sequence such as:

```
VIEWPORT 20,100,20,80
WINDOW Xmin,Xmax,Ymin,Ymax
```

The result of these two statements in order is the same in BASIC 2.0/2.1 and BASIC 3.0.

Some BASIC 2.0/2.1 programs used the following order:

```
VIEWPORT 20,100,20,80
WINDOW Xmin,Xmax,Ymin,Ymax
VIEWPORT 0,100*RATIO,0,100
```

The second VIEWPORT was used to change the soft clip limits. In BASIC 2.0/2.1, the second VIEWPORT did not rescale so that the scale defined by the WINDOW and the first VIEWPORT remains effective. When the above sequence is run in BASIC 3.0, the second VIEWPORT rescales all subsequent plotting.

The best solution to this problem is to change the sequence to:

```
VIEWPORT 20,100,20,80
WINDOW Xmin,Xmax,Ymin,Ymax
CLIP OFF
```

The PIVOT Statement

In BASIC 3.0, the local origin of RPLLOT and LABEL is affected by the PIVOT statement. The best way to see the differences between BASIC 2.0/2.1 and BASIC 3.0 is by studying the following examples.

RPLLOT with PIVOT

The following program illustrates the effects of PIVOT on RPLLOT statements. Outputs of the program with BASIC 2.0/2.1 and 3.0 are shown after the program.

```

10  DEG
20  GINIT
30  GRAPHICS ON
40  VIEWPORT 0,64,51,100
50  Pivot(0)
60  VIEWPORT 66,130,51,100
70  Pivot(30)
80  VIEWPORT 0,64,0,49
90  Pivot(60)
100 VIEWPORT 66,130,0,49
110 Pivot(90)
120 END
130 SUB Pivot(P)
140 WINDOW 0,131,0,100
150 FRAME
160 MOVE 30,80
170 LABEL "PIVOT",P
180 MOVE 40,20
190 PIVOT P
200 Tri
210  MOVE 80,20
220 Tri
230 PIVOT 0
240 SUBEND
250 SUB Tri
260 RPLLOT 20,0,-1
270 RPLLOT 20,20
280 RPLLOT 0,0
290 SUBEND

```

382.10 Transporting Programs

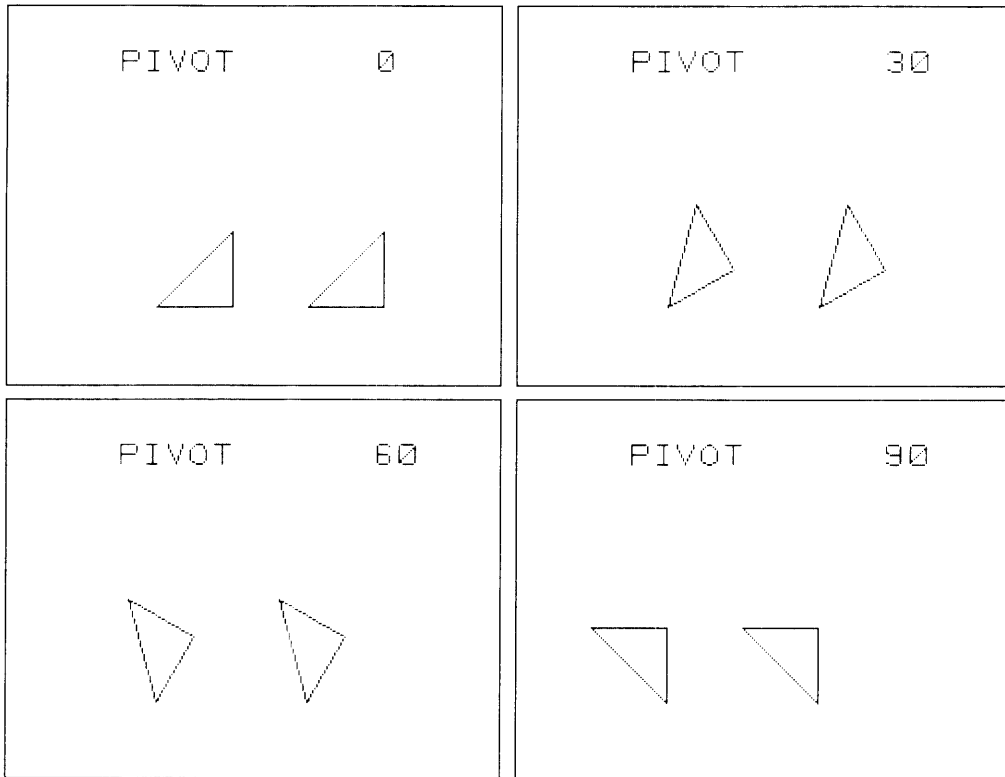

BASIC 2.0/2.1 RPLOT with PIVOT

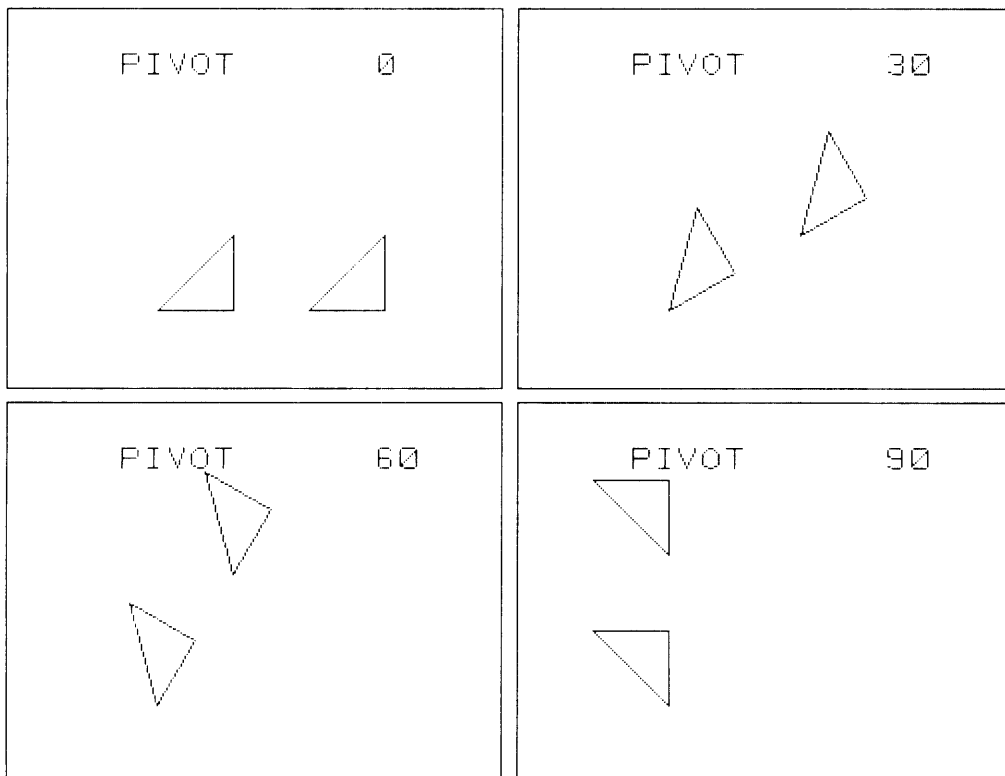

BASIC 3.0 RPLOT with PIVOT

LABEL with PIVOT

The following program illustrates the effects of PIVOT on LABEL statements. Outputs of the program with BASIC 2.0/2.1 and 3.0 are shown after the program.

```
10    DEG
20    GINIT
30    GRAPHICS ON
40    VIEWPORT 0,64,51,100
50    FRAME
60    Pivot(0)
70    VIEWPORT 66,130,51,100
80    FRAME
90    Pivot(30)
100   VIEWPORT 0,64,0,49
110   FRAME
120   Pivot(60)
130   VIEWPORT 66,130,0,49
140   FRAME
150   Pivot(90)
160   END
170   SUB Pivot(P)
180   WINDOW 0,131,0,100
190   MOVE 40,80
200   LABEL "PIVOT",P
210   MOVE 60,60
220   PIVOT P
230   IDRAW 0,0
240   LABEL "L1"
250   LABEL "L2"
260   LABEL "L3"
270   IDRAW 0,0
280   PIVOT 0
290   IDRAW 0,0
300   LABEL "L4"
310   LABEL "L5"
320   LABEL "L6"
330   SUBEND
```

382.12 Transporting Programs

<pre>PIVOT 0 L1 L2 L3 L4 L5 L6</pre>	<pre>PIVOT 30 L1 L2 L3 L4 L5 L6</pre>
<pre>PIVOT 60 L1 L2 L3 L4 L5 L6</pre>	<pre>PIVOT 90 L1 L2 L3 L4 L5 L6</pre>

BASIC 2.0/2.1 LABEL with PIVOT

<pre>PIVOT 0 L1 L2 L3 L4 L5 L6</pre>	<pre>PIVOT 30 L1 L2 L3 L4 L5 L6</pre>
<pre>PIVOT 60 L1 L4 L2 L5 L3 L6</pre>	<pre>PIVOT 90 L4 L1 L5 L2 L6 L3</pre>

BASIC 3.0 LABEL with PIVOT

Display Functions

The effect of turning Display Functions mode on is to display special control characters on the screen. In BASIC 2.0/2.1, Display Functions has no effect on control characters 128 through 159. With BASIC 3.0, the appropriate character is displayed on the screen when control characters 128 through 159 are displayed and Display Functions is enabled. For example, on a Model 236 running BASIC 2.0/2.1,

```
PRINT CHR$(129)&"HI THERE"&CHR$(128)
```

results in:

```
HI THERE
```

With BASIC 3.0, the result is:

```
hp HI THERE hpcR  
LF
```

The h_p symbols are machine dependent; the actual characters displayed may vary with other models.

Prerun On LOADSUB

To speed the execution of the LOADSUB statement, BASIC 3.0 does not prerun each subprogram loaded by the execution of the LOADSUB statement if the subprogram has been stored in a “prerun state”. This differs from BASIC 2.0/2.1 in that BASIC 2.0/2.1 does prerun on the entire program every time LOADSUB is executed. The only effect seen by this change is improved performance when loading subprograms with the LOADSUB statement. For more information on prerun, refer to Chapter 2 in the *BASIC Programming Techniques* manual.

Special Case of I/O Transfers

A special case of decreased I/O performance has occurred with BASIC 3.0 due to a missed interleave caused by the increased overhead for handling multiple processors. Outbound transfers without DMA to the 913xA/B/V/XV Winchester disc drives perform at 11.75 Kbytes/second in BASIC 3.0. In BASIC 2.0/2.1, those transfers perform at a rate of 50 Kbytes/second. This degradation occurs only if all the following conditions are met:

- 8 MHz processor board (no cache)
- Not using DMA
- Using outbound TRANSFER (not OUTPUT) to 913xA/B/V/XV drive

This performance degradation affects users who are logging test data onto their discs. Adding DMA can increase the outbound transfer rate to 50 Kbytes/second. (Inbound transfers without DMA from those drives perform at 11.75 Kbytes/second in both BASIC 2.0/2.1 and BASIC 3.0.)

Error Messages

- 1** Missing option or configuration error. If a statement requires an option which is not loaded, the option number or option name is given along with error 1. These numbers are listed in the Useful Tables section. Error 1 without an option number indicates other configuration errors.
- 2** Memory overflow. If you get this error while loading a file, the program is too large for the computer's memory. If the program loads, but you get this error when you press RUN, then the overflow was caused by the variable declarations. Either way, you need to modify the program or add more read/write memory.
- 3** Line not found in current context. Could be a GOTO or GOSUB that references a non-existent (or deleted) line, or an EDIT command that refers to a non-existent line label.
- 4** Improper RETURN. Executing a RETURN statement without previously executing an appropriate GOSUB or function call. Also, a RETURN statement in a user-defined function with no value specified.
- 5** Improper context terminator. You forgot to put an END statement in the program. Also applies to SUBEND and FNEND.
- 6** Improper FOR...NEXT matching. Executing a NEXT statement without previously executing the matching FOR statement. Indicates improper nesting or overlapping of the loops.
- 7** Undefined function or subprogram. Attempt to call a SUB or user-defined function that is not in memory. Look out for program lines that assumed an optional CALL.
- 8** Improper parameter matching. A type mismatch between a pass parameter and a formal parameter of a subprogram.
- 9** Improper number of parameters. Passing either too few or too many parameters to a subprogram. Applies only to non-optional parameters.
- 10** String type required. Attempting to return a numeric from a user-defined string function.
- 11** Numeric type required. Attempting to return a string from a user-defined numeric function.
- 12** Attempt to redeclare variable. Including the same variable name twice in declarative statements such as DIM or INTEGER.
- 13** Array dimensions not specified. Using the (*) symbol after a variable name when that variable has never been declared as an array.
- 14** OPTION BASE not allowed here. The OPTION BASE statement must appear before any declarative statements such as DIM or INTEGER. Only one OPTION BASE statement is allowed in one context.
- 15** Invalid bounds. Attempt to declare an array with more than 32 767 elements or with upper bound less than lower bound.
- 16** Improper or inconsistent dimensions. Using the wrong number of subscripts when referencing an array element.
- 17** Subscript out of range. A subscript in an array reference is outside the current bounds of the array.
- 18** String overflow or substring error. String overflow is an attempt to put too many characters into a string (exceeding dimensioned length). This can happen in an assignment, an ENTER an INPUT, or a READ. A substring error is an attempted violation of the rules for substrings. Watch out for null strings where you weren't expecting them.

- 19 Improper value or out of range. A value is too large or too small. Applies to items found in a variety of statements. Often occurs when the number builder overflows (or underflows) during an I/O operation.
- 20 INTEGER overflow. An assignment or result exceeds the range allowed for INTEGER variables. Must be $-32\,768$ thru $32\,767$.
- 22 REAL overflow. An assignment or result exceeds the range allowed for REAL variables.
- 24 Trig argument too large for accurate evaluation. Out-of-range argument for a function such as TAN or LDIR.
- 25 Magnitude of ASN or ACS argument is greater than 1. Arguments to these functions must be in the range -1 thru $+1$.
- 26 Zero to non-positive power. Exponentiation error.
- 27 Negative base to non-integer power. Exponentiation error.
- 28 LOG or LGT of a non-positive number.
- 29 Illegal floating point number. Does not occur as a result of any calculations, but is possible when a FORMAT OFF I/O operation fills a REAL variable with something other than a REAL number.
- 30 SQR of a negative number.
- 31 Division (or MOD) by zero.
- 32 String does not represent a valid number. Attempt to use "non-numeric" characters as an argument for VAL, data for a READ, or in response to an INPUT statement requesting a number.
- 33 Improper argument for NUM or RPT\$. Null string not allowed.
- 34 Referenced line not an IMAGE statement. A USING clause contains a line identifier, and the line referred to is not an IMAGE statement.
- 35 Improper image. See IMAGE or the appropriate keyword in the *BASIC Language Reference*.
- 36 Out of data in READ. A READ statement is expecting more data than is available in the referenced DATA statements. Check for deleted lines, proper OPTION BASE, proper use of RESTORE, or typing errors.
- 38 TAB or TABXY not allowed here. The tab functions are not allowed in statements that contain a USING clause. TABXY is allowed only in a PRINT statement.
- 40 Improper REN, COPYLINES, or MOVELINES command. Line numbers must be whole numbers from 1 to 32 766. This may also result from a COPYLINES or MOVELINES statement whose destination line numbers lie within the source range.
- 41 First line number greater than second line number. Parameters out of order in a statement like SAVE, LIST, or DEL.
- 43 Matrix must be square. The MAT functions: IDN, INV, and DET require the array to have equal numbers of rows and columns.
- 44 Result cannot be an operand. Attempt to use a matrix as both result and argument in a MAT TRN or matrix multiplication.
- 46 Attempting a SAVE when there is no program in memory.
- 47 COM declarations are inconsistent or incorrect. Includes such things as mismatched dimensions, unspecified dimensions, and blank COM occurring for the first time in a subprogram.
- 49 Branch destination not found. A statement such as ON ERROR or ON KEY refers to a line that does not exist. Branch destinations must be in the same context as the ON...statement.

- 51 File not currently assigned. Attempting an ON/OFF END statement with an unassigned I/O path name.
- 52 Improper mass storage unit specifier. The characters used for a msus do not form a valid specifier. This could be a missing colon, too many parameters, illegal characters, etc.
- 53 Improper file name. File names are limited to 10 characters. Foreign characters are allowed, but punctuation is not.
- 54 Duplicate file name. The specified file name already exists in directory. It is illegal to have two files with the same name on one volume.
- 55 Directory overflow. Although there may be room on the media for the file, there is no room in the directory for another file name. Discs initialized by BASIC have room for over 100 entries in the directory, but other systems may make a directory of a different size.
- 56 File name is undefined. The specified file name does not exist in the directory. Check the contents of the disc with a CAT command.
- 58 Improper file type. Many mass storage operations are limited to certain file types. For example, LOAD is limited to PROG files and ASSIGN is limited to ASCII and BDAT files.
- 59 End of file or buffer found. For files: No data left when reading a file, or no space left when writing a file. For buffers: No data left for an ENTER, or no buffer space left for an OUTPUT. Also, WORD-mode TRANSFER terminated with odd number of bytes.
- 60 End of record found in random mode. Attempt to ENTER a field that is larger than a defined record.
- 62 Protect code violation. Failure to specify the protect code of a protected file, or attempting to protect a file of the wrong type.
- 64 Mass storage media overflow. There is not enough contiguous free space for the specified file size. The disc is full.
- 65 Incorrect data type. The array used in a graphics operation, such as GLOAD, is the wrong type (INTEGER or REAL).
- 66 INITIALIZE failed. Too many bad tracks found. The disc is defective, damaged, or dirty.
- 67 Illegal mass storage parameter. A mass storage statement contains a parameter that is out of range, such as a negative record number or an out of range number of records.
- 68 Syntax error occurred during GET. One or more lines in the file could not be stored as valid program lines. The offending lines are usually listed on the system printer. Also occurs if the first line in the file does not start with a valid line number.
- 72 Disc controller not found or bad controller address. The msus contains an improper device selector, or no external disc is connected.
- 73 Improper device type in mass storage unit specifier. The msus has the correct general form, but the characters used for a device type are not recognized.
- 76 Incorrect unit number in mass storage unit specifier. The msus contains a unit number that does not exist on the specified device.
- 77 Attempt to purge an open file. The specified file is assigned to an I/O path name which has not been closed.
- 78 Invalid mass storage volume label. Usually indicates that the media has not been initialized on a compatible system. Could also be a bad disc.
- 79 File open on target device. Attempt to copy an entire volume with a file open on the destination disc.

- 80 Disc changed or not in drive. Either there is no disc in the drive or the drive door was opened while a file was assigned.
- 81 Mass storage hardware failure. Also occurs when the disc is pinched and not turning. Try reinserting the disc.
- 82 Mass storage unit not present. Hardware problem or an attempt to access a left-hand drive on the Model 226.
- 83 Write protected. Attempting to write to a write_protected disc. This includes many operations such as PURGE, INITIALIZE, CREATE, SAVE, OUTPUT, etc.
- 84 Record not found. Usually indicates that the media has not been initialized.
- 85 Media not initialized. (Usually not produced by the internal drive.)
- 87 Record address error. Usually indicates a problem with the media.
- 88 Read data error. The media is physically or magnetically damaged, and the data cannot be read.
- 89 Checkread error. An error was detected when reading the data just written. The media is probably damaged.
- 90 Mass storage system error. Usually a problem with the hardware or the media.
- 93 Incorrect volume code in MSUS. The MSUS contains a volume number that does not exist on the specified device.
- 100 Numeric IMAGE for string item.
- 101 String IMAGE for numeric item.
- 102 Numeric field specifier is too large. Specifying more than 256 characters in a numeric field.
- 103 Item has no corresponding IMAGE. The image specifier has no fields that are used for item processing. Specifiers such as * X / are not used to process the data for the item list. Item-processing specifiers include things like K D B A.
- 105 Numeric IMAGE field too small. Not enough characters are specified to represent the number.
- 106 IMAGE exponent field too small. Not enough exponent characters are specified to represent the number.
- 107 IMAGE sign specifier missing. Not enough characters are specified to represent the number. Number would fit except for the minus sign.
- 117 Too many nested structures. The nesting level is too deep for such structures as FOR, SELECT, IF, LOOP, etc.
- 118 Too many structures in context. Refers to such structures as FOR/NEXT, IF/THEN/ELSE, SELECT/CASE, WHILE, etc.
- 120 Not allowed while program running. The program must be stopped before you can execute this command.
- 121 Line not in main program. The run line specified in a LOAD or GET is not in the main context.
- 122 Program is not continuable. The program is in the stopped state, not the paused state. CONT is allowed only in the paused state.
- 126 Quote mark in unquoted string. Quote marks must be used in pairs.
- 127 Statements which affect the knob mode are out of order.
- 128 Line too long during GET.
- 131 Unrecognized non-ASCII keycode. An output to the keyboard contained a CHR\$(255) followed by an illegal byte.

- 132 Keycode buffer overflow. Trying to send too many characters to the keyboard buffer with an OUTPUT 2 statement.
- 133 DELSUB of non-existent or busy subprogram.
- 134 Improper SCRATCH statement.
- 135 READIO/WRITEIO to nonexistent memory location.
- 136 REAL underflow. The input or result is closer to zero than 10^{-308} (approximately).
- 140 Too many symbols in the program. Symbols are variable names, I/O path names, COM block names, subprogram names, and line identifiers.
- 141 Variable cannot be allocated. It is already allocated.
- 142 Variable not allocated. Attempt to DEALLOCATE a variable that was not allocated.
- 143 Reference to missing OPTIONAL parameter. The subprogram is trying to use an optional parameter that didn't have any value passed to it. Use NPAR to check the number of passed parameters.
- 145 May not build COM at this time. Attempt to add or change COM when a program is running. For example, a program does a LOADSUB and the COM in the new subprogram does not match existing COM.
- 146 Duplicate line label in context. There cannot be two lines with the same line label in one context.
- 150 Illegal interface select code or device selector. Value out of range.
- 152 Parity error.
- 153 Insufficient data for ENTER. A statement terminator was received before the variable list was satisfied.
- 154 String greater than 32 767 bytes in ENTER.
- 155 Improper interface register number. Value out of range or negative.
- 156 Illegal expression type in list. For example, trying to ENTER into a constant.
- 157 No ENTER terminator found. The variable list has been satisfied, but no statement terminator was received in the next 256 characters. The # specifier allows the statement to terminate when the last item is satisfied.
- 158 Improper image specifier or nesting images more than 8 deep. The characters used for an image specifier are improper or in an improper order.
- 159 Numeric data not received. When entering characters for a numeric field, an item terminator was encountered before any "numeric" characters were received.
- 160 Attempt to enter more than 32 767 digits into one number.
- 163 Interface not present. The intended interface is not present, set to a different select code, or is malfunctioning.
- 164 Illegal BYTE/WORD operation. Attempt to ASSIGN with the WORD attribute to a non-word device.
- 165 Image specifier greater than dimensioned string length.
- 167 Interface status error. Exact meaning depends upon the interface type. With HP-IB, this can happen when a non-controller operation by the computer is aborted by the bus.
- 168 Device timeout occurred and the ON TIMEOUT branch could not be taken.

- 170 I/O operation not allowed. The I/O statement has the proper form, but its operation is not defined for the specified device. For example, using an HP-IB statement on a non-HP-IB interface or directing a LIST to the keyboard.
- 171 Illegal I/O addressing sequence. The secondary addressing in a device selector is improper or primary address too large for specified device.
- 172 Peripheral error. PSTS line is false. If used, this means that the peripheral device is down. If PSTS is not being used, this error can be suppressed by using control register 2 of the GPIO.
- 173 Active or system controller required. The HP-IB is not active controller and needs to be for the specified operation.
- 174 Nested I/O prohibited. An I/O statement contains a user-defined function. Both the original statement and the function are trying to access the same file or device.
- 177 Undefined I/O path name. Attempting to use an I/O path name that is not assigned to a device or file.
- 178 Trailing punctuation in ENTER. The trailing comma or semicolon that is sometimes used at the end of OUTPUT statements is not allowed at the end of ENTER statements.
- 301 Cannot do while connected.
- 303 Not allowed when trace active.
- 304 Too many characters without terminator.
- 306 Interface card failure. The datacomm card has failed self-test.
- 308 Illegal character in data. Datacomm error.
- 310 Not connected. Datacomm error.
- 313 USART receive buffer overflow. Overrun error detected. Interface card is unable to keep up with incoming data rate. Data has been lost.
- 314 Receive buffer overflow. Program is not accepting data fast enough to keep up with incoming data rate. Data has been lost.
- 315 Missing data transmit clock. A transmit timeout has occurred because a missing data clock prevented the card from transmitting. The card has disconnected from the line.
- 316 CTS false too long. The interface card was unable to transmit for a predetermined period of time because Clear-To-Send was false on a half-duplex line. The card has disconnected from the line.
- 317 Lost carrier disconnect. Data Set Ready (DSR) or Data Carrier Detect (if full duplex) went inactive for too long.
- 318 No activity disconnect. The card has disconnected from the line because no data was transmitted or received for a predetermined length of time.
- 319 Connection not established. Data Set Ready or Data Carrier Detect (if full duplex) did not become active within a predetermined length of time.
- 324 Card trace buffer overflow.
- 325 Illegal databits/parity combination. Attempting to program 8 bits-per-character and a parity of "1" or "0".
- 326 Register address out of range. A control or status register access was attempted to a non-existent register.
- 327 Register value out of range. Attempting to place an illegal value in a control register.
- 328 USART Transmit underrun.

- 330 User-defined LEXICAL ORDER IS table size exceeds array size.
- 331 Repeated value in pointer. A MAT REORDER vector has repeated subscripts. This error is not always caught.
- 332 Non-existent dimension given. Attempt to specify a non-existent dimension in a MAT REORDER operation.
- 333 Improper subscript in pointer. A MAT REORDER vector specifies a non-existent subscript.
- 334 Pointer size is not equal to the number of records. A MAT REORDER vector has a different number of elements than the specified dimension of the array.
- 335 Pointer is not a vector. Only single-dimension arrays (vectors) can be used as the pointer in a MAT REORDER or a MAT SORT statement.
- 337 Substring key is out-of-range. The specified substring range of the sort key exceeds the dimensioned length of the elements in the array.
- 338 Key subscript out-of-range. Attempt to specify a subscript in a sort key outside the current bounds of the array.
- 340 Mode table too long. User-defined LEXICAL ORDER IS mode table contains more than 63 entries.
- 341 Improper mode indicator. User-defined LEXICAL ORDER IS table contains an illegal combination of mode type and mode pointer.
- 342 Not a single-dimension integer array. User-defined LEXICAL ORDER IS mode table must be a single-dimension array of type INTEGER.
- 343 Mode pointer is out of range. User-defined LEXICAL ORDER IS table has a mode pointer greater than the existing mode table size.
- 344 1 for 2 list empty or too long. A user-defined LEXICAL ORDER IS table contains an entry indicating an improper number of 1 for 2 secondaries.
- 345 CASE expression type mismatch. The SELECT statement and its CASE statements must refer to the same general type, numeric or string.
- 346 INDENT parameter out-of-range. The parameters must be in the range: 0 thru eight characters less than the screen width.
- 347 Structures improperly matched. There is not a corresponding number of structure beginnings and endings. Usually means that you forgot a statement such as END IF, NEXT, END SELECT, etc.
- 349 CSUB has been modified. A contiguous block of compiled subroutines has been modified since it was loaded. A single module that shows as multiple CSUB statements has been altered because program lines were inserted or deleted.
- 353 Data link failure.
- 370-399 Errors in this range are reported if a run-time Pascal error occurs in a CSUB. To determine the Pascal error number, subtract 400 from the BASIC error number. Information on the Pascal error can be found in the *Pascal User's Manual*.
- 401 Bad system function argument. An invalid argument was given to a time, date, base conversion, or SYSTEM\$ function.
- 403 Copy failed; program modification incomplete. An error occurred during a COPYLINES or MOVELINES resulting in an incomplete operation. Some lines may not have been copied or moved.
- 427 Priority may not be lowered.

- 450 Volume not found—SRM error.
- 451 Volume labels do not match—SRM error.
- 453 File in use—SRM error.
- 454 Directory formats do not match—SRM error.
- 455 Possibly corrupt file—SRM error.
- 456 Unsupported directory operation—SRM error.
- 457 Passwords not supported—SRM error.
- 458 Unsupported directory format—SRM error.
- 459 Specified file is not a directory—SRM error.
- 460 Directory not empty—SRM error.
- 462 Invalid password—SRM error.
- 465 Invalid rename across volumes—SRM error.
- 471 TRANSFER not supported by the interface.
- 481 File locked or open exclusively—SRM error.
- 482 Cannot move a directory with a RENAME operation—SRM error.
- 483 System down—SRM error.
- 484 Password not found—SRM error.
- 485 Invalid volume copy—SRM error.
- 488 DMA hardware required. HP 9885 disc drive requires a DMA card or is malfunctioning.
- 511 The result array in a MAT INV must be of type REAL.
- 600 Attribute cannot be modified. The WORD/BYTE mode cannot be changed after assigning the I/O path name.
- 601 Improper CONVERT lifetime. When the CONVERT attribute is included in the assignment of an I/O path name, the name of a string variable containing the conversion is also specified. The conversion string must exist as long as the I/O path name is valid.
- 602 Improper BUFFER lifetime. The variable designated as a buffer during an I/O path name assignment must exist as long as the I/O path name is valid.
- 603 Variable was not declared as a BUFFER. Attempt to assign a variable as a buffer without first declaring the variable as a BUFFER.
- 604 Bad source or destination for a TRANSFER statement. Transfers are not allowed to the CRT, keyboard, or tape backup on CS80 drives. Buffer to buffer or device to device transfers are not allowed.
- 605 BDAT file type required. Only BDAT files can be used in a TRANSFER operation.
- 606 Improper TRANSFER parameters. Conflicting or invalid TRANSFER parameters were specified, such as RECORDS without and EOR clause, or DELIM with an outbound TRANSFER.
- 607 Inconsistent attributes. Such as CONVERT or PARITY with FORMAT OFF.
- 609 IVAL or DVAL result too large. Attempt to convert a binary, octal, decimal, or hexadecimal string into a value outside the range of the function.
- 612 BUFFER pointers in use. Attempt to change one or more buffer pointers while a TRANSFER is in progress.

- 700 Improper plotter specifier. The characters used as a plotter specifier are not recognized. May be misspelled or contain illegal characters.
- 702 CRT graphics hardware missing. Hardware problem.
- 704 Upper bound not greater than lower bound. Applies to P2< = P1 or VIEWPORT upper bound and CLIP limits.
- 705 VIEWPORT or CLIP beyond hard clip limits.
- 708 Device not initialized.
- 713 Request not supported by specified device. Trying to equate color CRT characteristics with an external device; such as COLOR MAP on a plotter.
- 733 GESCAPE opcode not recognized. Only values 1 thru 5 can be used.
- 900 Undefined typing aid key.
- 901 Typing aid memory overflow.
- 902 Must delete entire context. Attempt to delete a SUB or DEF FN statement without deleting its entire context. Easiest way to delete is with DELSUB.
- 903 No room to renumber. While EDIT mode was renumbering during an insert, all available line numbers were used between insert location and end of program.
- 904 Null FIND or CHANGE string.
- 905 CHANGE would produce a line too long for the system. Maximum line length is two lines on the CRT.
- 906 SUB or DEF FN not allowed here. Attempt to insert a SUB or DEF FN statement into the middle of a context. Subprograms must be appended at the end.
- 909 May not replace SUB or DEF FN. Similar to deleting a SUB or DEF FN.
- 910 Identifier not found in this context. The keyboard-specified variable does not already exist in the program. Variables cannot be created from the keyboard; they must be created by running a program.
- 911 Improper I/O list.
- 920 Numeric constant not allowed.
- 921 Numeric identifier not allowed.
- 922 Numeric array element not allowed.
- 923 Numeric expression not allowed.
- 924 Quoted string not allowed.
- 925 String identifier not allowed.
- 926 String array element not allowed.
- 927 Substring not allowed.
- 928 String expression not allowed.
- 929 I/O path name not allowed.
- 930 Numeric array not allowed.
- 931 String array not allowed.
- 932 Excess keys specified. A sort key was specified following a key which specified the entire record.
- 935 Identifier is too long: 15 characters maximum.

- 936 Unrecognized character. Attempt to store a program line containing an improper name or illegal character.
- 937 Invalid OPTION BASE. Only 0 and 1 are allowed.
- 939 OPTIONAL appears twice. A parameter list may have only one OPTIONAL keyword. All parameters listed before it are required, all listed after it are optional.
- 940 Duplicate formal parameter name.
- 942 Invalid I/O path name. The characters after the E are not a valid name. Names must start with a letter.
- 943 Invalid function name. The characters after the FN are not a valid name. Names must start with a letter.
- 946 Dimensions are inconsistent with previous declaration. The references to an array contain a different number of subscripts at different places in the program.
- 947 Invalid array bounds. Value out of range, or more than 32 767 elements specified.
- 948 Multiple assignment prohibited. You cannot assign the same value to multiple variables by stating $X=Y=Z=0$. A separate assignment must be made for each variable.
- 949 This symbol not allowed here. This is the general "syntax error" message. The statement you typed contains elements that don't belong together, are in the wrong order, or are misspelled.
- 950 Must be a positive integer.
- 951 Incomplete statement. This keyword must be followed by other items to make a valid statement.
- 961 CASE expression type mismatch. The CASE line contains items that are not the same general type, numeric or string.
- 962 Programmable only: cannot be executed from the keyboard.
- 963 Command only: cannot be stored as a program line.
- 977 Statement is too complex. Contains too many operators and functions. Break the expression down so that it is performed by two or more program lines.
- 980 Too many symbols in this context. Symbols include variable names, I/O path names, COM block names, subprogram names, and line identifiers.
- 982 Too many subscripts: maximum of six dimensions allowed.
- 983 Wrong type or number of parameters. An improper parameter list for a machine-resident function.
- 985 Invalid quoted string.
- 987 Invalid line number: must be a whole number 1 thru 32 766.

Second Byte of Non-ASCII Key Sequences

Holding the CTRL key and pressing a non-ASCII key generates a two-character sequence on the CRT. The first character is an “inverse-video” K. This table can be used to look up the key that corresponds to the second character of the sequence.

Character	Value	Key	Character	Value	Key
space		1	P	80	PAUSE
!	33	STOP	Q		1
"		1	R	82	RUN
#	35	CLR LN	S	83	STEP
\$	36	ANY CHAR	T	84	SHIFT - ↓
%	37	CLR - END	U	85	CAPS LOCK
&	38	Select	V	86	↓
'	39	Prev	W	87	SHIFT - ↑
(40	SHIFT - TAB	X	88	EXECUTE
)	41	TAB	Y	89	Roman Mode
*	42	INS LN	Z		1
+	43	INS CHR	[91	CLR TAB
,	44	Next	\	92	▼
-	45	DEL CHR]	93	SET TAB
.	46	Ignored	^	94	↑
/	47	DEL LN	_	95	SHIFT - ◀
0	48	k ₀	`		1
1	49	k ₁	a	97	k ₁₀
2	50	k ₂	b	98	k ₁₁
3	51	k ₃	c	99	k ₁₂
4	52	k ₄	d	100	k ₁₃
5	53	k ₅	e	101	k ₁₄
6	54	k ₆	f	102	k ₁₅
7	55	k ₇	g	103	k ₁₆
8	56	k ₈	h	104	k ₁₇
9	57	k ₉	i	105	k ₁₈
:	58	SHIFT -system f ₆ ²	j	106	k ₁₉
;	59	SHIFT -system f ₇ ²	k	107	k ₂₀
<	60	←	l	108	k ₂₁
=	61	RESULT	m	109	k ₂₂
>	62	→	n	110	k ₂₃
?	63	RECALL	o	111	SHIFT -system f ₁ ²
@	64	SHIFT - RECALL	p	112	SHIFT -system f ₂ ²
A	65	PRT ALL	q	113	SHIFT -system f ₃ ²
B	66	BACK SPACE	r	114	SHIFT -system f ₄ ²
C	67	CONTINUE	s	115	SHIFT -user f ₁ ²
D	68	EDIT	t	116	SHIFT -user f ₂ ²
E	69	ENTER	u	117	SHIFT -user f ₃ ²
F	70	DISPLAY FCTNS	v	118	SHIFT -user f ₄ ²
G	71	SHIFT - →	w	119	SHIFT -user f ₅ ²
H	72	SHIFT - ←	x	120	SHIFT -user f ₆ ²
I	73	CLR IO	y	121	SHIFT -user f ₇ ²
J	74	Katakana Mode	z	122	SHIFT -user f ₈ ²
K	75	CLR SCR	}	123	System
L	76	GRAPHICS		124	Menu
M	77	ALPHA	~	125	User
N	78	DUMP GRAPHICS	~	126	SHIFT - Menu
O	79	DUMP ALPHA	⌘		1

¹ These characters cannot be generated by pressing the CTRL key and a non-ASCII key. If one of these characters follows CHR\$(255) in an output to the keyboard, an error is reported (Error 131 Bad non-alphanumeric Keycode.).

² System and user refer to the softkey menu which is currently active.

US ASCII Character Codes

ASCII Char.	EQUIVALENT FORMS				HP-IB
	Dec	Binary	Oct	Hex	
NUL	0	00000000	000	00	
SOH	1	00000001	001	01	GTL
STX	2	00000010	002	02	
ETX	3	00000011	003	03	
EOT	4	00000100	004	04	SDC
ENQ	5	00000101	005	05	PPC
ACK	6	00000110	006	06	
BEL	7	00000111	007	07	
BS	8	00001000	010	08	GET
HT	9	00001001	011	09	TCT
LF	10	00001010	012	0A	
VT	11	00001011	013	0B	
FF	12	00001100	014	0C	
CR	13	00001101	015	0D	
SO	14	00001110	016	0E	
SI	15	00001111	017	0F	
DLE	16	00010000	020	10	
DC1	17	00010001	021	11	LLO
DC2	18	00010010	022	12	
DC3	19	00010011	023	13	
DC4	20	00010100	024	14	DCL
NAK	21	00010101	025	15	PPU
SYNC	22	00010110	026	16	
ETB	23	00010111	027	17	
CAN	24	00011000	030	18	SPE
EM	25	00011001	031	19	SPD
SUB	26	00011010	032	1A	
ESC	27	00011011	033	1B	
FS	28	00011100	034	1C	
GS	29	00011101	035	1D	
RS	30	00011110	036	1E	
US	31	00011111	037	1F	

STD-LL-60182

ASCII Char.	EQUIVALENT FORMS				HP-IB
	Dec	Binary	Oct	Hex	
space	32	00100000	040	20	LA0
!	33	00100001	041	21	LA1
"	34	00100010	042	22	LA2
#	35	00100011	043	23	LA3
\$	36	00100100	044	24	LA4
%	37	00100101	045	25	LA5
&	38	00100110	046	26	LA6
'	39	00100111	047	27	LA7
(40	00101000	050	28	LA8
)	41	00101001	051	29	LA9
*	42	00101010	052	2A	LA10
+	43	00101011	053	2B	LA11
,	44	00101100	054	2C	LA12
-	45	00101101	055	2D	LA13
.	46	00101110	056	2E	LA14
/	47	00101111	057	2F	LA15
0	48	00110000	060	30	LA16
1	49	00110001	061	31	LA17
2	50	00110010	062	32	LA18
3	51	00110011	063	33	LA19
4	52	00110100	064	34	LA20
5	53	00110101	065	35	LA21
6	54	00110110	066	36	LA22
7	55	00110111	067	37	LA23
8	56	00111000	070	38	LA24
9	57	00111001	071	39	LA25
:	58	00111010	072	3A	LA26
;	59	00111011	073	3B	LA27
<	60	00111100	074	3C	LA28
=	61	00111101	075	3D	LA29
>	62	00111110	076	3E	LA30
?	63	00111111	077	3F	UNL

ASCII Char.	EQUIVALENT FORMS				HP-IB
	Dec	Binary	Oct	Hex	
@	64	01000000	100	40	TA0
A	65	01000001	101	41	TA1
B	66	01000010	102	42	TA2
C	67	01000011	103	43	TA3
D	68	01000100	104	44	TA4
E	69	01000101	105	45	TA5
F	70	01000110	106	46	TA6
G	71	01000111	107	47	TA7
H	72	01001000	110	48	TA8
I	73	01001001	111	49	TA9
J	74	01001010	112	4A	TA10
K	75	01001011	113	4B	TA11
L	76	01001100	114	4C	TA12
M	77	01001101	115	4D	TA13
N	78	01001110	116	4E	TA14
O	79	01001111	117	4F	TA15
P	80	01010000	120	50	TA16
Q	81	01010001	121	51	TA17
R	82	01010010	122	52	TA18
S	83	01010011	123	53	TA19
T	84	01010100	124	54	TA20
U	85	01010101	125	55	TA21
V	86	01010110	126	56	TA22
W	87	01010111	127	57	TA23
X	88	01011000	130	58	TA24
Y	89	01011001	131	59	TA25
Z	90	01011010	132	5A	TA26
[91	01011011	133	5B	TA27
\	92	01011100	134	5C	TA28
]	93	01011101	135	5D	TA29
^	94	01011110	136	5E	TA30
_	95	01011111	137	5F	UNT

ASCII Char.	EQUIVALENT FORMS				HP-IB
	Dec	Binary	Oct	Hex	
`	96	01100000	140	60	SC0
a	97	01100001	141	61	SC1
b	98	01100010	142	62	SC2
c	99	01100011	143	63	SC3
d	100	01100100	144	64	SC4
e	101	01100101	145	65	SC5
f	102	01100110	146	66	SC6
g	103	01100111	147	67	SC7
h	104	01101000	150	68	SC8
i	105	01101001	151	69	SC9
j	106	01101010	152	6A	SC10
k	107	01101011	153	6B	SC11
l	108	01101100	154	6C	SC12
m	109	01101101	155	6D	SC13
n	110	01101110	156	6E	SC14
o	111	01101111	157	6F	SC15
p	112	01110000	160	70	SC16
q	113	01110001	161	71	SC17
r	114	01110010	162	72	SC18
s	115	01110011	163	73	SC19
t	116	01110100	164	74	SC20
u	117	01110101	165	75	SC21
v	118	01110110	166	76	SC22
w	119	01110111	167	77	SC23
x	120	01111000	170	78	SC24
y	121	01111001	171	79	SC25
z	122	01111010	172	7A	SC26
{	123	01111011	173	7B	SC27
	124	01111100	174	7C	SC28
}	125	01111101	175	7D	SC29
~	126	01111110	176	7E	SC30
DEL	127	01111111	177	7F	SC31

Subject Index

a

ABS	82
Accessing Directories	246
Accessing Files	222
Accessing Mass Storage	210
Accuracy	76
Accuracy of the Clock	275
ACS	82
ALLOCATE	74, 120
ALPHA Key	331
ALPHA OFF	331
ALPHA ON	331
Angle Functions	83
ANY CHAR Key	40, 144
AP2.0	379
Appending Program Lines	30
Arrays	74
Copying	92
Declaring	74
Dimensioning	85
Indexing	321
Operations	85
Operators	96
Reordering	99
Sorting	100
String	120
ASCII Character Codes	394
ASCII Character Set	140
ASCII Files	206
ASN	82
ASSIGN @	223
ATN	82
Auto Line Numbering	7
AUTOST	35
Autostart	35
Autostart on SRM	36
AXES	336

b

BASE	82, 91
Base Conversion	138
BASIC 2.0	379
BDAT Files	203
Reading	225
Writing	225
Benchmarking	319
BINAND	82
Binary Tree	186
BINCMP	82
BINEOR	82
BINIOR	82
BINs	37
Deleting from Memory	43
Loading	37
Scratching	37, 43
BIT	82
Blank Lines	283
Boolean Arrays	98
Boundary Conditions	300
Boxing the Screen	333
BUBBLE	212
Bubble Memory	220
Bugs	299, 307

c

CALL	169
Calling a Subprogram	169
CASE	57
Case Conversion	130
CAT	27, 246
Catalog Header, Suppressing	250
Cataloging the Disc	247
Cataloging, Skipping Files	251
CHANGE	22
Character Height	337
Character Set, Extended	143
Character Set, Highlights	143
Character Width	337

CHR\$	127
Clearing the Computer	43
Clearing the CRT	282
CLIP	339
Clipping	338
Clock	265
Accuracy	275
Events	276
Setting	268, 270
Closing an I/O Path	223
CLR I/O	314
CLR I/O Key	17
Color Graphics	347
Color Lines	349
COM	32, 120
COM Blocks	173
Command	6
Comments	11, 13, 317
Common	316
Common and GET	34
Comparing REAL Numbers	301
Comparison Operators	79
Concatenation, Strings	121
Conditional Branching	53
Conditional Execution	51
Configuring a System	37
Constants	325
Context Switching	176
CONTINUE	47
CONTROL	283
Control Characters	257
Control Characters, Displaying	140
COPY	38, 244
Copying	
Arrays	92
Files	38, 244
Program Segments	21
Volumes	244
COPYLINES	21
COS	82
CREATE ASCII	246
CREATE BDAT	225
Cross References	26
CRT	82, 256
Clearing	282
Size	331, 341
CS80	212
CSIZE	337
CSUBs	379, 380
CSUM	116

d

DATA	92, 194
Data Files	318
Structure	203
Data	
Input	194
Pointer, Moving	197
Retrieval	193
Storage	193, 315, 316
Structure	185
Type Conversion	74
Types, Numeric	73
DATE	82, 266
DATE\$	265
Deactivating Events	69
Debugging	307
Declaring Arrays	74
Declaring Variables	74
DEF	168
Default Dimensioning	119
Defined Records	225
Defining Softkeys	39
Degrees	83
DEL Command	10
Deleting Lines	10
Deleting Subprograms	23, 181, 182
DELSUB	23, 181
DET	82, 111
Determinant of a Matrix	111
Device Selectors	212, 253, 256
Device Type	211
DIGITIZE	355
Digitizing	355
DIM	120, 74
Dimension Table	315
Dimensioning an Array	85
Directories, Accessing	246
Directories, Reading	246
Disabling Events	69, 71
Disc	
Cataloging	247
Copying	244
Directory	201
Initialization	208
Interleave	200
Labels	209
Structure	198
Disc Drives, External	214

Disc Drives, Internal	214
Displaying Control Characters	140
Displays	282
DOT	82, 106
Double Subscripted Substrings	123
DRAW	332
Drawing	332
Axes	336
Grids	336
in Color	349
DROUND	81, 82, 84
DUMP DEVICE IS	344
DVAL	82, 138
DVAL\$	138
Dyadic Operators	79

e

Edit	7
EDIT KEY	39
Edit Mode, Exiting	14
Editing Softkeys	39
Editing Subprograms	182
Editor	7
Enabling Events	66
END	46
END IF	54
END LOOP	64
END WHILE	62
End-of-File	240
End-Of-File Pointers	228
End-of-Record	240
Ending Functions	183
Ending Subprograms	183
ENTER	6, 238
Entering a Single Item	293
Entering Program Lines	8
EOF Pointers	228
EPROM	212
ERRL	302
ERRM\$	302
ERRN	302
Error Messages	383
Error Numbers	302
Error Trapping	302
Errors	299, 383
Errors, Operator	300
Escape Code Sequences	258
Event-Initiated Branching	45, 66

Events	66
Deactivating	69
Disabling	69
Enabling	66
EXEC	6
EXECUTE	6
Executing a Subprogram	169
EXIT IF	64
Exiting Edit Mode	14
EXP	82
Expressions, Evaluating	77
Extended Character Set	143
External Disc Drives	214
External Printers	257

f

Files	
Accessing	222
ASCII	206
BDAT	203
Copying	38, 244
Data	318
Names	28, 202
Opening	222
Plotting to	346
Program	318
Protecting	38, 242
Purging	38, 245
Renaming	38
Types	202
FIND	21
FN	168
FNEND	183
FOR NEXT	59
Formatted Printing	259
FRACT	82
FRAME	333
Function or Subprogram	167
Functions	
Ending	183
String	125, 129
User-Defined	165

g

GDUs	333
GET	30
GINIT	332, 342
GLOAD	341
GOSUB	48
GOTO	48
Graphic Display Units	333, 336
Graphic Units	336, 340
Graphics	331
Color	347
Initializing	332, 342
Interactive	354
Monitors	331
Output Devices	342
Saving an Image	341
Storing	351
GRAPHICS Key	331
GRAPHICS OFF	283, 331
GRAPHICS ON	331
GRID	336
GSTORE	341

h

Halting Program Execution	46
Hard Clip Limits	338
Hardware	382
Hierarchy	121
Hierarchy of Numeric Operating	77
Highlight Characters	143
HPGL	345

i

I/O Path	222
Closing	223
Opening	222
Identifiers	317
Identity Matrix	107
IDN	107
IDRAW	334

IF THEN	51
IF THEN ELSE	55
Ill-Conditioned Matrices	112
IMAGE	260
Image Specifiers, Numeric	261
Image Specifiers, String	262
Images	260
IMOVE	334
Implicit Dimensioning	90
Incremental Moves	334
INDENT	23
Indenting a Program	23
Initializing a Disc	208
Initializing Graphics	332, 342
Inputting Multiple Fields	296
INSERT LINE Key	9
Inserting Lines	9
Inserting Subprograms	182
INT	82
INTEGER	73
Integer Numbers	204
INTEGER Variables	321
Interactive Graphics	353
Interleave on Discs	200
INTERNAL	212
Internal Disc Drives	214
Internal Numeric Formats	75
Interval Timing	274
Introduction	1
INV	108
Inverse Matrix	107
IPLOT	334
Isotropic View	340
IVAL	82

k

KBD	39, 82, 256
Keyboard Input	292
Keyboards	8
Keyword	5
Knob, Using	68
KNOBX	69
KNOBY	69, 380

I

LABEL	337
Label Location	337
Labels, Disc	209
LDIR	337
LEN	125
Length of a String	119, 125
Lexical Order	139
LEXICAL ORDER IS	130, 139
Lexical Order, Predefined	145
Lexical Order, User-Defined	156
Lexical Tables	146
LEX_AID	158
LGT	82
Line Rotation	335
LINE TYPE	337
Linear Program Flow	45, 46
LINPUT	296
LIST	11
LIST KEY	41
Listing a Program	11
Live Keyboard	16, 308
LOAD	28, 34
LOAD KEY	41
Loading BINs	37
Loading Softkeys	41
Loading Subprograms	23, 180
LOADSUB	23, 180
LOG	83
Logical Comparisons	326
LOOP	59, 63
Loop Counter	60
Loops	322
LORG	337
LWC\$	130

m

Main Program	5
Mapping	356
Mass Memory Performance	318
Mass Storage	198
Mass Storage Access	210
MASS STORAGE IS	214
Mass Storage Unit Specifier	27
Mass Storage, Non-Disc	220
MAT	93
MAT Functions	132
MAT REORDER	99
MAT SORT	100

Math Hierarchy	77
Mathematical Operations	321
Matrix	103
Determinant	111
Identity	107
Ill-Conditioned	112
Inverse	107
Multiplication	103
Singular	110
Summing Columns	116
Summing Rows	116
Transposition	115
MAX	83
MAXREAL	83
Media Specifiers	211
MEMORY	212
Memory, Saving	329
Menus	285
Merging Subprograms	182
MIN	83
MINREAL	83
Monadic Operators	79
MOVE	332
MOVELINES	20
Moving a Data Pointer	197
Moving EOF Pointers	228
Moving Program Segments	20
Moving the Pen	332
MSUS	27, 211
Multiple Fields Input	296

n

Naming Files	28
Naming Subprograms	165
Nesting Structures	54
Non-ASCII Keys	284, 393
Non-ASCII Keystrokes	40
Non-Disc Mass Storage	220
NPAR	172
Number Base Conversion	138
Numbers, Comparing	301
Numeric	
Accuracy	76
Computation	73
Data Types	73
Formats, Internal	75
Functions	82
Image Specifiers	261
Precision	76
Numeric to String Conversion	127

O

OFF-event	70
ON CYCLE	276, 66
ON DELAY	276, 66
ON END	240, 66
ON EOR	66
ON EOT	66
ON ERROR	302, 303, 66
ON INTR	66
ON KBD	66
ON KEY	66, 67
ON KNOB	66, 68
ON SIGNAL	66
ON Statement	57
ON TIME	276, 66
ON TIMEOUT	66
ON-event	66
Opening a File	222
Opening an I/O Path	222
Operator Errors	300
Operator Hierarchy	77
Operators	79
Comparison	79
Dyadic	79
Monadic	79
OPTION BASE	86
Optional Parameters	171
OUTPUT	229, 230
OUTPUT KBD	283
Overhead	315

p

Parameters	170
Parameters, Optional	171
PAUSE	47
PAUSE Key	17
Pausing a Program	17
PDEV	20
PEN	332
Pen Control	334
Pen, Moving	332
Pen, Moving Incremental	334
Performance	318
PHYREC	379, 381
PI	83

PIVOT	335
PLOT	332
PLOTTER IS	342
PLOTTER IS file	346
Plotting to a File	346
Polynomial Evaluations	325
POS	125
Position of a Substring	125
Powerfail	275
Precision	76
Prerun	15
Primary Address	254
PRINT	259
PRINT USING	260
PRINTALL IS	256, 313
PRINTER IS	254
Printer Switch Setting	254
Printers	253
Control Characters	257
Escape Codes	258
External	257
Printing, Formatted	259
PROG Files	28
Program Counter	45
Program Execution	15, 310
Program Execution, Selection	51
Program Files	318
Program Flow	
Linear	45
Repetition	45
Selection	45
Sequence	45
Program Line	5
Programming a LOAD	35
Programming GET	31
Programs	
Recording	28
Replacing	29
Retrieving	27, 30
Storing	27
Prompts	282
PROTECT	242, 38
Protecting Files	38, 242
PROUND	83, 84
PRT	256, 83
PURGE	245, 38
Purging Files	38, 245

R

Radians	83
RAM Volumes	220
Random ENTER	238
Random Numbers	84
Random OUTPUT	234
RANK	83
RATIO	336
RE-SAVE	29
RE-STORE	29
RE-STORE BIN	381
RE-STORE KEY	41
READ	92, 194
READ LOCATOR	358
Reading BDAT Files	225
Reading Data From BDAT Files	237
Reading Directories	246
REAL	73
REAL Number Comparisons	301
Real Numbers	204, 324
Real-Time Clock	265
Recalling Lines	10
Record Lengths	226
Recording a Program	28
RECOVER	176
Recursion	184
REDIM	95
Redimensioning Arrays, Automatic	93
Redimensioning Arrays, Explicit	95
Relational Operations	121
Relative Moves	335
REM	12
REMOTE	212
REN Command	10
RENAME	38
Renaming a File	38
Renumbering a Program	10
Reordering Arrays	99, 135
REPEAT UNTIL	59, 61
Repeating a String	129
Repetition	59
Replacing Programs	29
RES	83
RESET Key	17
Resources	315
RESTORE	197
Retrieving Programs	27, 30
RETURN	48
Returning from a Subprogram	49
REV\$	129
Reversing a String	129

RND	83, 84
ROTATE	83
Rotating Lines	335
Rounding	84
Rounding Numbers	81
RPLOT	335
RPT\$	129
RSUM	116
RUN	15
Run Light	17
Run-time	16
Running a Program	15

S

SAVE	28
Saving an Image	341
Saving Memory	329
Saving Time	327
SC	83
Scalar Expressions	77
SCRATCH	43
SCRATCH A	43
SCRATCH BIN	43
SCRATCH C	43
SCRATCH KEY	43
Scratching BINs	37
Screen Width	282
Search and Replace	21
Searching for Strings	136
SECURE	243
Securing Program Lines	243
SELECT	56
SELECT CASE	57
Serial ENTER	237
Serial OUTPUT	229
SET ECHO	358
SET TIME	268
SET TIMEDATE	266
Setting the Clock	268, 270
SGN	83
SHIFT	83
SHOW	340
Simple Branching	48
SIN	83
Single Byte Access	239
Single-Subscripted Substrings	122
Singular Matrices	110
SIZE	83, 91
Soft Clip Limits	338

Tracking	357
Transporting Programs	379
Transposing Matrices	115
Trapping Errors	302
TRIM\$	129
Trimming a String	129
Type Conversion	324
Typing Aids	39

u

UDUs	340
Unit Number	213
UNTIL	61
UPC\$	130
Upgrading BASIC Programs	379
Upper and Lower Case	130
Uppercase and Lowercase	9
User Defined Units	340
User-Defined	
Functions	165
Lexical Order	156
Subprograms	165

v

VAL	126
VAL\$	127
Variables	317
Variables, Declaring	74
VIEWPORT	341
Volume Label	201
Volume Number	213
Volumes, Copying	244

w

WAIT	47
WHILE	59, 62
WINDOW	340
Writing Data	229
Writing to BDAT Files	225

x

XREF	20, 26
----------------	--------

Manual Comment Sheet Instruction

If you have any comments or questions regarding this manual, write them on the enclosed comment sheets and place them in the mail. Include page numbers with your comments wherever possible.

If there is a revision number, (found on the Printing History page), include it on the comment sheet. Also include a return address so that we can respond as soon as possible.

The sheets are designed to be folded into thirds along the dotted lines and taped closed. Do not use staples.

Thank you for your time and interest.

MANUAL COMMENT SHEET

BASIC 3.0 Programming Techniques
for the HP 9000 Series 200

98613-90010

January 1985

Update No. _____

(See the Printing History in the front of the manual)

Name: _____

Company: _____

Address: _____

Phone No: _____

fold fold

fold fold

BUSINESS REPLY MAIL

FIRST CLASS PERMIT NO. 37 LOVELAND, COLORADO

POSTAGE WILL BE PAID BY ADDRESSEE

Hewlett-Packard Company
Fort Collins Systems Division
Attn: Customer Documentation
3404 East Harmony Road
Fort Collins, Colorado 80525



NO POSTAGE
NECESSARY
IF MAILED
IN THE
UNITED STATES

