

HP 9000 Networking
Installing and Administering
HP FDDI/9000 Software

HP Part No. J2157-90006
Printed in U.S.A.
07/95

Edition 3

© Hewlett-Packard Company, 1995. All rights reserved.



Legal Notices

The information in this document is subject to change without notice.

Hewlett-Packard makes no warranty of any kind with regard to this manual, including, but not limited to, the implied warranties of merchantability and fitness for a particular purpose. Hewlett-Packard shall not be held liable for errors contained herein or direct, indirect, special, incidental or consequential damages in connection with the furnishing, performance, or use of this material.

Warranty. A copy of the specific warranty terms applicable to your Hewlett-Packard product and replacement parts can be obtained from your local Sales and Service Office.

Restricted Rights Legend. Use, duplication or disclosure by the U.S. Government is subject to restrictions as set forth in subparagraph (c) (1) (ii) of the Rights in Technical Data and Computer Software clause at DFARS 252.227-7013 for DOD agencies, and subparagraphs (c) (1) and (c) (2) of the Commercial Computer Software Restricted Rights clause at FAR 52.227-19 for other agencies.

HEWLETT-PACKARD COMPANY
3000 Hanover Street
Palo Alto, California 94304 U.S.A.

Use of this manual and flexible disk(s) or tape cartridge(s) supplied for this pack is restricted to this product only. Additional copies of the programs may be made for security and back-up purposes only. Resale of the programs in their present form or with alterations, is expressly prohibited.

Copyright Notices. ©copyright 1983-95 Hewlett-Packard Company, all rights reserved.

Reproduction, adaptation, or translation of this document without prior written permission is prohibited, except as allowed under the copyright laws.

©copyright 1979, 1980, 1983, 1985-93 Regents of the University of California

This software is based in part on the Fourth Berkeley Software Distribution

under license from the Regents of the University of California.

©copyright 1980, 1984, 1986 Novell, Inc.

©copyright 1986-1992 Sun Microsystems, Inc.

©copyright 1985-86, 1988 Massachusetts Institute of Technology.

©copyright 1989-93 The Open Software Foundation, Inc.

©copyright 1986 Digital Equipment Corporation.

©copyright 1990 Motorola, Inc.

©copyright 1990, 1991, 1992 Cornell University

©copyright 1989-1991 The University of Maryland

©copyright 1988 Carnegie Mellon University

Trademark Notices UNIX is a registered trademark in the United States and other countries, licensed exclusively through X/Open Company Limited.

X Window System is a trademark of the Massachusetts Institute of Technology.

MS-DOS and Microsoft are U.S. registered trademarks of Microsoft Corporation.

OSF/Motif is a trademark of the Open Software Foundation, Inc. in the U.S. and other countries.

Printing History

The manual printing date and part number indicate its current edition. The printing date will change when a new edition is printed. Minor changes may be made at reprint without changing the printing date. The manual part number will change when extensive changes are made.

Manual updates may be issued between editions to correct errors or document product changes. To ensure that you receive the updated or new editions, you should subscribe to the appropriate product support service. See your HP sales representative for details.

Edition 1	June 1994
Edition 2	January 1995
Edition 3	July 1995

HP FDDI Documentation Map

The following documentation map is intended to be a general guideline to the manuals containing information related to FDDI. You may need information from one or all the manuals listed here.

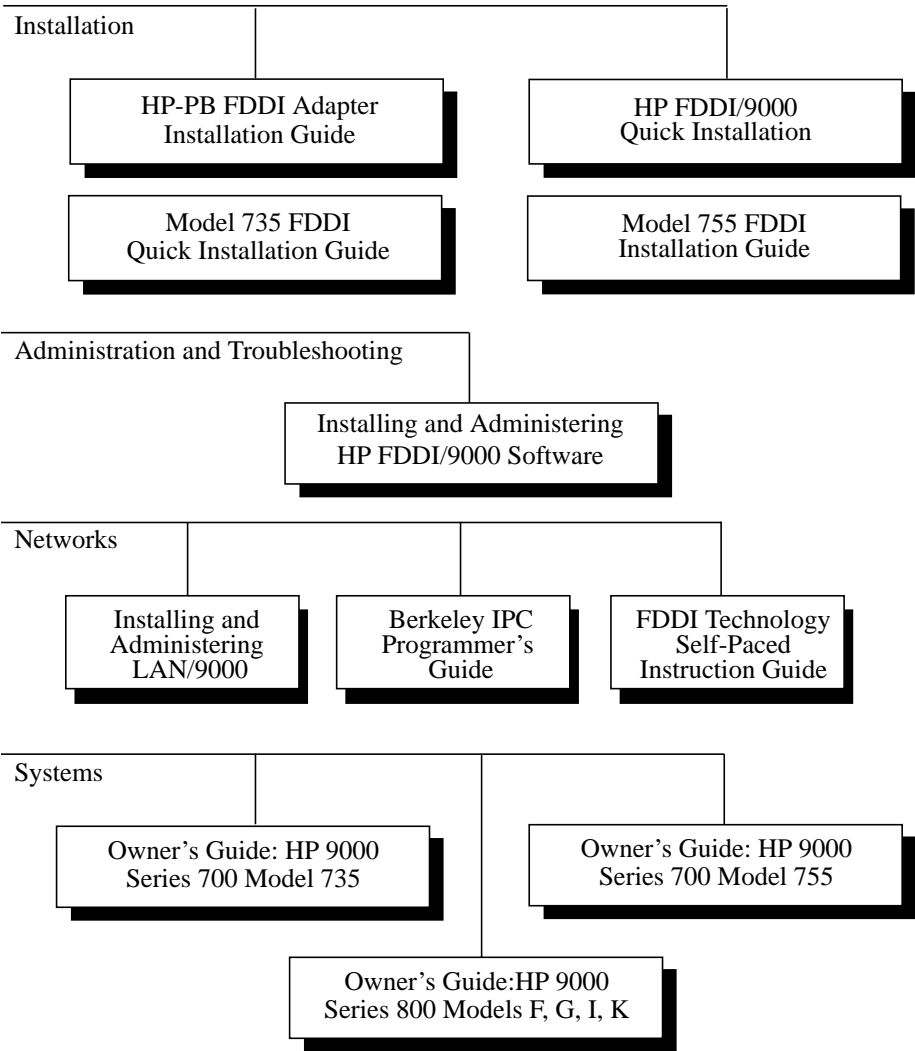

In This Book

This manual describes how to install and troubleshoot HP FDDI/9000. The information in this manual is intended for network managers who install and administer FDDI networks. It is assumed the reader is experienced with the basics of local and wide area networking.

- Chapter 1** “FDDI Resources” provides references to other useful tools for installing, configuring, and maintaining HP FDDI/9000 software.
- Chapter 2** “Installing HP FDDI” provides step-by-step instructions on installing the FDDI software.
- Chapter 3** “Configuring HP FDDI Using SAM” provides step-by-step instructions on configuring the FDDI software.
- Chapter 4** “Troubleshooting HP FDDI” provides flowcharts to help diagnose FDDI/9000 software and hardware problems. Follow the steps described in these flowcharts to quickly isolate and diagnose FDDI networking problems.

New for the 10.01 Release

A summary of the changes made for the HP-UX 10.01 release that will impact HP FDDI/9000 is shown below.

- A disconnected cable now causes the network interface state to be set DOWN, a HP-UX error to be returned from the DLPI interface (if applicable), and a message to be reported to the console and log file. The driver queries the card at 1 second intervals for proactive cable reconnect and disconnect detections.
- The *update* utility that was used to install 9.0 software has been replaced with the *Software Distribution* product for the 10.01 release.
- The *ver_link* script that was used to verify all cards in the backplane for the 9.0 release has been discontinued for the 10.01 release. Use the *lanscan(IM)*, *linkloop(IM)*, and *ping(IM)* commands to verify all cards.
- The HP-UX 10.01 file system layout has been changed to follow the AT&T SVR4 and OSF/1 models. The FDDI/9000 tools are now located in */usr/bin*, */usr/sbin*, and */sbin*.
- In the SAM configuration utility, the Networking/Communications screen has been changed to Networking and Communications. The items on this screen have also been reordered.
- The new “Advanced Options” window for LAN card configuration in SAM allows you to set the station address and the Internet broadcast address.
- The *lanscan(IM)* command has one new field (DLPI Support) and two modified fields (Device LU is replaced by Card Instance Number and Encapsulation Method is replaced by MAC Type). The type of LLC packets supported will be displayed under the LLC Encapsulation Method when you use the *-v* option. The Card Instance Number is the same as the Network Interface Unit number. In addition, the *lanadmin(IM)* and *linkloop(IM)* commands now use the NMID value in place of the LAN device file name. Each device may be described in two lines.
- The *landiag(IM)* command has been replaced with the *lanadmin(IM)* command to reflect the fact that it performs more than troubleshooting tasks. *lanadmin(IM)* displays FDDI MIB statistics. In addition, the command line interface allows you to set the station address.
- All log message cause and action statements are now online and can be displayed

New for the 10.01 Release

using the *netfmt(1M)* command with the *-v* option.

- All installation and troubleshooting commands are documented only in online manual (man) pages. These include *ifconfig(1M)*, *route(1M)*, *lanadmin(1M)*, *lanscan(1M)*, *linkloop(1M)*, *netstat(1M)*, and *ping(1M)*.
- The network logging and tracing utility (*nettl(1M)*) and formatting utility (*netfmt(1M)*) are documented only in online manual (man) pages. Example commands are located in the “FDDI Resources” chapter.
- After upgrading your operating system to HP-UX 10.01, your network products’ interface names, device file names, and NMIDs may change, depending on the placement of your network adapters.
- All information about manually configuring the product is located only in the *Installing and Administering LAN/9000 Software* manual. The names of the HP-PB and Integrated FDDI adapters’ major numbers and hardware paths are located in the “FDDI Resources” chapter.

Contents

Installing and Administering HP FDDI/9000 Software 1

In This Book 6

1 FDDI Resources

HP-UX Manual Reference Pages 14

Logging and Tracing Messages 16

Manual Installation and Configuration 18

HP FDDI Device Files 19

Series 700 Device Files Example 19

Series 800 Device Files Example 20

Contacting Your HP Representative 21

FDDI Concepts 23

FDDI Network Map 24

The FDDI Dual Ring During Normal Operation 26

The FDDI Dual Ring in Wrap Mode 28

FDDI Single-Attached Stations 30

FDDI Error Detection 30

2 Installing FDDI

Checking FDDI Installation Prerequisites 36

Loading the FDDI Software 37

Contents

Gaining Access to the System Adapter Bay 39

Installing the FDDI Hardware 40

Connecting the Adapter to the Network 41

3 Configuring HP FDDI/9000

Overview of Configuration Using SAM 45

Configuring the Local FDDI Adapter 47

Verifying the Installation 49

Configuring Network Connectivity 50

Verifying Remote System Configuration 52

Reconfiguring IP Addresses 54

4 Troubleshooting HP FDDI/9000

Troubleshooting Overview 56

Diagnostic Flowcharts 57

Flowchart 1: FDDI Connections Test 58

Flowchart 1 Procedures 59

Flowchart 2: Configuration Test 62

Flowchart 2 Procedures 63

Flowchart 3: Configuration Test cont. 66

Flowchart 3 Procedures 67

Flowchart 4: Configuration Test cont. 68

Contents

Flowchart 4 Procedures	69
Flowchart 5: Configuration Test cont.	70
Flowchart 5 Procedures	71
Flowchart 6: Network Level Loopback Test	72
Flowchart 6 Procedures	73
Flowchart 7: Network Level Loopback Test cont.	74
Flowchart 7 Procedures	75
Flowchart 8: Transport Level Loopback Test (using ARPA)	76
Flowchart 8 Procedures	77
Flowchart 9: Link Level Loopback Test	78
Flowchart 9 Procedures	79
Flowchart 10: Gateway Configuration Test	80
Flowchart 10 Procedures	81
Flowchart 11: Gateway Loopback Test	82
Flowchart 11 Procedures	83

Index	85
--------------	-----------

Contents

FDDI Resources

In addition to this manual, use the following resources to maintain and administer HP FDDI/9000 software.

HP-UX Manual Reference Pages

While installing, configuring, or troubleshooting HP FDDI/9000, you may need to refer to any of the following online manual reference pages (man pages) for useful HP-UX operating system or HP FDDI commands. To display a man page, type the following at the system prompt:

```
man <command name>
```

- *arp(1M)* displays and modifies the Internet-to-Ethernet and Internet-to-Fibre Channel address translation tables used by the Address Resolution Protocol.
- *fddiinit(1M)* initializes the HP FDDI network interface and connects the system to the HP FDDI network.
- *fddinet(1M)* displays connection information about the local ring, a specified remote node, or all nodes connected to the same HP FDDI ring.
- *fddisetup(1M)* initializes all the HP FDDI network interfaces on a system and connects to the HP FDDI network.
- *fddistat(1M)* displays information about the status of the HP FDDI interface.
- *fddistop(1M)* stops and resets the HP FDDI interfaces
- *ifconfig(1M)* assigns an address to a network interface and configures parameters.
- *ioscan(1M)* scans system hardware, usable I/O system devices, or kernel I/O system data structures as appropriate, and lists the results.
- *lanadmin(1M)* is a local area network administration program that allows you to display and change various aspects of your interface cards.
- *lanscan(1M)* displays information about LAN adapters that are successfully bound to the system.
- *linkloop(1M)* verifies network connectivity through the Data Link Layer.
- *mknod(1M)* creates device files with user-specified major and minor numbers.
- *netfmt(1M)* formats the nettl tracing and logging binary files.
- *netstat(1)* provides network statistics and information about network connections.
- *nettl(1M)* captures and controls network tracing and logging information.
- *ping(1M)* verifies network connectivity through the Network Layer and reports

round-trip time of communications between the local and remote hosts.

- *rmfn(1M)* removes HP-UX functionality (partitions and filesets).
- *route(1M)* adds and deletes entries to the network routing table, allowing your system to communicate through a gateway.
- *sam(1M)* configures networking software.
- *swinstall(1M)* loads software filesets onto HP-UX 10.0 systems.
- *swverify(1M)* verifies the software installation onto HP-UX 10.0 systems.

Logging and Tracing Messages

HP FDDI/9000 comes with an online message catalog that reports HP FDDI problems, probable causes, and actions for you to take to correct the problems. Messages are sent either to the system console or log files, and come in the following format:

```
1041 MESSAGE  HP-PB FDDI LAN driver received an
              error from the adapter in path %s
              indicating length mismatch on
              transmission of a data packet.
```

```
CAUSE (Disaster) This is probably due to a
hardware problem on the adapter.
```

```
ACTION Execute the lanscan command to
identify the device logical unit of
the LAN adapter. Re-initialize the
adapter using fddiinit. If
initializing the adapter does not
solve the problem, reboot. If
rebooting is ineffective, notify
your HP representative.
```

HP FDDI/9000 uses the *nettl* logging and tracing facility supplied with HP-UX to capture, control, and format messages produced by HP FDDI. When using *nettl*, note the following:

- log and trace messages are sent to the files `/var/adm/nettl.LOG##` or `/var/adm/nettl.TRC##`
- all disaster messages are sent to the system console
- tracing and logging have an impact on system performance and should be used judiciously

Listed below are some example commands.

- To examine the log file with message, cause, and action:

```
netfmt -v -file /var/adm/nettl.LOG00 -t 50
```
- To check network logging and tracing status:

```
nettl -status
```

- To start all tracing to the file */var/adm/tracefile*:

```
nettl -traceon all hdrin hdrout pduin pduout -file  
/usr/adm/tracefile
```

- To stop tracing:

```
nettl -traceoff
```

- To format the trace file into the file */usr/adm/traceout*:

```
netfmt -file /var/adm/tracefile.TRC0 > /var/adm/  
traceout
```

Manual Installation and Configuration

If you want to manually install and configure your HP FDDI/9000 product, refer to the detailed instructions in chapter 3 of the *Installing and Administering LAN/9000 Software* manual.

You may need some of the following HP FDDI/9000-specific information when you follow those steps:

- The hardware path of an Integrated FDDI card is **2.0.9**.
- The major number for Models 8x7, E, F, G, H, I, K, and T500 HP-PB FDDI cards is **191**.
- The major number for Integrated FDDI Models 735 and 755 is **111**.
- The HP FDDI “keyword” for Models 8x7, E, F, G, H, I, K, and T500 is **fddi**.
- The HP FDDI “keyword” for Integrated FDDI Models 735 and 755 is **fddi2**.

HP FDDI Device Files

Device files are used to identify the HP FDDI driver and card. Each driver/card is associated with a device file. By convention, device files are kept in a directory called */dev*, with each device file having a name and device number to uniquely identify the above characteristics. For each HP FDDI card that is bound successfully to the I/O subsystem at boot-up, the system creates FDDI device files by default: */dev/lanX*. The card instance number is concatenated to the device file names.

Once your system is rebooted, log on and follow the steps below to verify the FDDI device files. If the major numbers or minor numbers are not correct, delete the device file entries from your */dev* directory and recreate them with the correct numbers using the *mknod(1M)* command.

- 1 Execute the *lanscan* command.
- 2 Obtain a listing of the LAN device files.

```
ls -l /dev/lan*
```
- 3 Compare the *lanscan* output with the device file listing to verify that the major and minor numbers are correct.

When looking at the device file listing, the fifth column is the major number. The sixth column is the minor number, *0xnm0000* where *nm* is the byte for the card instance number.

Series 700 Device Files Example

This example is for a Series 735 with one LAN interface and one FDDI interface. The *lanscan* command provides the following output. (The HP DLPI Support field has been removed from this output.)

Hardware Path	Station Address	Crdr In#	Hardware State	Net-Interface Name	Interface Unit State	NM ID	MAC Type	Mjr Num
2/0/2	0x08000962FCBC	0	UP	lan0	UP	4	ETHER	52
2/0/9	0x08000914640C	1	UP	lan1	UP	5	FDDI	111

FDDI Resources
HP FDDI Device Files

To create device files manually for an FDDI device at hardware path 2.0.9, run the command: `/usr/sbin/mknod /dev/lan1 c 111 0x01000`. In this example, the *c* is for character device, the *111* is the major number, and the *nn* in *0xnn0000* is the card instance number (Crd In#) 1 = 01, 2 = 02. See the *mknod(1M)* man page for detailed information.

The LAN device files should be as follows:

```
crw-rw-rw- 1 root      sys 52 0x000000 Jan 1 1995  /dev/lan0
crw-rw-rw- 1 root      sys 52 0x000001 Jan 1 1995  /dev/ether0
crw-rw-rw- 1 root      sys 111 0x010000 Jan 1 1995  /dev/lan1
```

Series 800 Device Files Example

This example is for a Series 800 Model F20 with one LAN interface and one FDDI interface. The *lanscan* command provides the following output. (The HP DLPI Support field has been removed from this output.)

Hardware Path	Station Address	Crd In#	Hardware State	Net-Interface Name	Unit State	NM ID	MAC Type	Mjr Num
44.1	0x080009266C3F	0	UP	lan0	UP	4	ETHER	185
48	0x080009266C3F	1	UP	lan1	UP	5	FDDI	191

To create device files manually for an FDDI device at hardware path 48, run the command: `/usr/sbin/mknod /dev/lan1 c 191 0x01000`. In this example, the *c* is for character device, the *191* is the major number, and the *nn* in *0xnn0000* is the card instance number (Crd In#) 1 = 01, 2 = 02. See the *mknod(1M)* man page for detailed information.

The device files should be as follows:

```
crw-rw-rw- 1 bin      bin 185 0x000100Jan 28 08:58  /dev/lan0
crw-rw-rw- 1 bin      bin 185 0x000101Jan 28 08:58  /dev/ether0
crw-rw-rw- 1 bin      bin 191 0x010000Jan 28 08:58  /dev/lan1
```

Contacting Your HP Representative

If you have no service contract with HP, you may follow the procedure described below, but you will be billed accordingly for time and materials.

If you have a service contract with HP, document the problem as a Service Request (SR) and forward it to your HP representative. Include the following information where applicable:

- A characterization of the problem. Describe the events and symptoms leading up to the problem. Attempt to describe the source of the problem.

Your characterization should include: HP-UX commands; communication subsystem commands; functionality of user programs; result codes and messages; and data that can reproduce the problem.

- Obtain the version, update, and fix information for all software. To check your ARPA or HP FDDI/9000 version, execute the command:

```
what /stand/vmunix
```

To check the version of your kernel, execute *uname -r*.

This allows HP to determine if the problem is already known, and if the correct software is installed at your site.

- Illustrate as clearly as possible the context of any message(s). Record all error messages and numbers that appear at the user terminal and the system console.
- Save all network log files. Prepare the formatted output and a copy of the log file for your HP representative to further analyze.
- Prepare a listing of the HP-UX I/O configuration you are using for your HP representative to further analyze.
- Try to determine the general area within the software where you think the problem exists. Refer to the appropriate reference manual and follow the guidelines on gathering information for that product.
- Document your interim, or “workaround,” solution. The cause of the problem can sometimes be found by comparing the circumstances in which it occurs with the circumstances in which it does not occur.
- Create copies of any ARPA or HP FDDI/9000 link trace files that were active when the problem occurred for your HP representative to further analyze.

FDDI Resources

Contacting Your HP Representative

- **In the event of a system failure, obtain a full memory dump.** If the directory */var/adm/crash* exists, the HP-UX utility */sbin/savecore* automatically executes during reboot to save the memory dump. Send the output of your system failure memory dump to your HP representative.

FDDI Concepts

The **Fiber Distributed Data Interface (FDDI)** is a high speed local area network which has been defined as a standard by an American National Standards Institute committee, ANSI X3T9.5 and by ISO. This second generation LAN is characterized by a fiber-optic dual token ring transmission medium which is capable of transmitting data at 100 megabits per second, ten times the speed of Ethernet.

Figure 1 shows the four ANSI FDDI standards and how they combine to form a completely functional fiber optic network. This figure also shows how these standards fit into the OSI model.

Application		
Presentation		
Session		
Transport		
Network		
Data Link	802.2 Logical Link Control (LLC) ISO 8802-2:1989 IEEE 802.2-1981	
	Media Access Control (MAC) ISO 9314-2:1989 ANSI X3.139-1987	Station Management
Physical	Physical Layer Protocol (PHY) ISO 9314-1:1989 ANSI X3.148-1988	ISO to be determined ANSI X3T9.5/84-49
	Physical Medium Department (PMD) ISO 9314-3:1990 ANSI X3.166-1990	Revision 7.2

Figure 1

FDDI Standards and the OSI Model

The physical layer includes two pieces, the **Physical Medium Dependent (PMD)** layer that provides the point-to-point communications between stations in the network, and the **Physical Layer Protocol (PHY)** layer that handles synchronization between higher layer data and control symbols, and the code bit representation which is transmitted on the medium.

The data link layer includes the **Media Access Control (MAC)** standard and the **Logical Link Control (LLC)** standard. The MAC's primary function is the scheduling, routing and delivery of Frames, the vehicles used to transmit information on and off the ring. In an FDDI network, information is transmitted sequentially, within frames, as a stream of encoded symbols from one station to the next. The order of the symbols within the frames is predetermined by the MAC standard. The LLC provides a common protocol between the MAC and the network layer. In addition to FDDI, the LLC standard also applies to 802.3, 802.4, and 802.5

The **Station Management (SMT)** standard is a layer management entity which interfaces with the other sublayers. It manages connections with the ring as well as station configuration and ring configuration. HP FDDI/9000 supports SMT version 7.2.

FDDI Network Map

The example network map in Figure 2 shows HP Series 700 workstations connected to an FDDI dual ring through a concentrator. The FDDI network is connected to an 802.3/Ethernet LAN via a router.

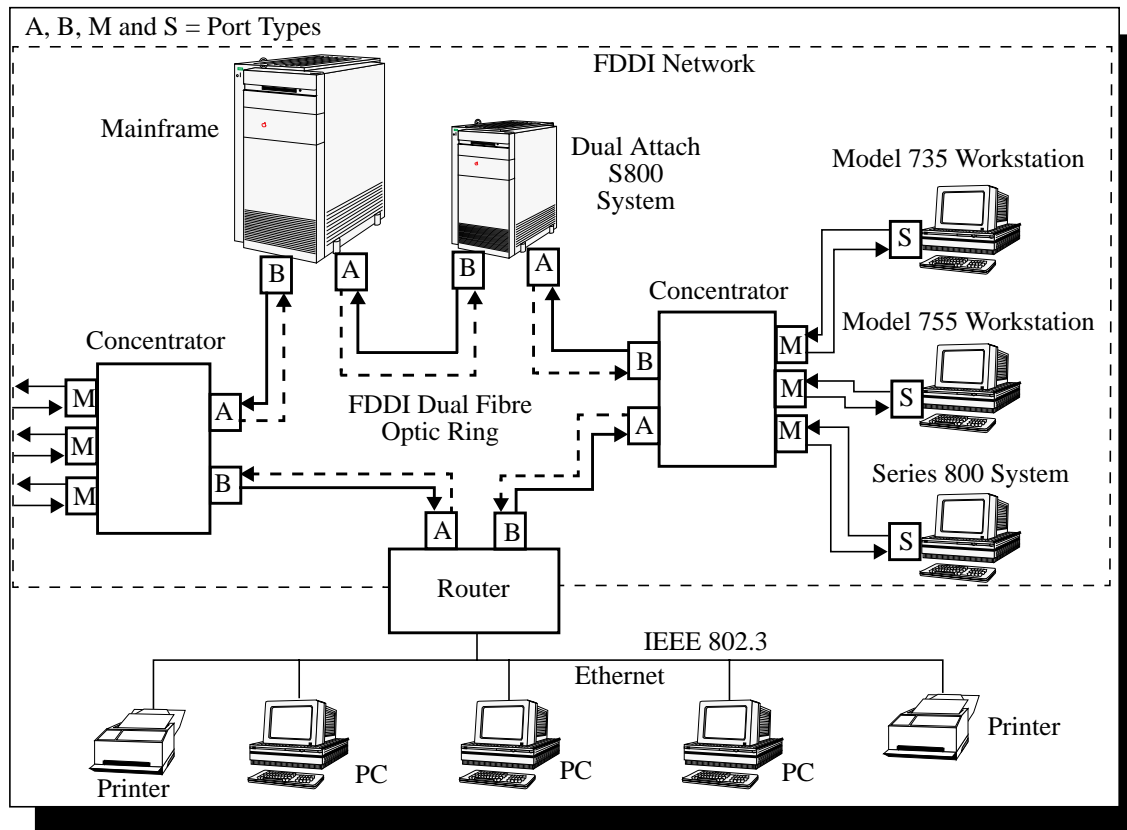

Figure 2 FDDI Network Map

During normal operation, the two rings in an FDDI network are independent and the primary ring, represented by the solid line, actively transmits data in accordance with a timed-token protocol. The secondary ring, represented by the dotted line, remains inactive, providing a redundant LAN capability, until a fault occurs to break the primary ring.

In the example above, the mainframe, concentrator and router are connected to both the primary and secondary rings simultaneously via A and B port types. These stations can access either or both rings for data transmission and can reconfigure the network, if necessary. Stations directly connected to

the dual fiber optic ring are referred to as **dual-attached stations (DAS)** or **dual-attached concentrators (DAC)**. HP FDDI/9000 supports dual attach and dual homing capabilities on Series 800 systems.

HP S700 workstations connect to the dual ring network through a device called a concentrator which is directly attached to both rings via A ports and B ports. The workstations connect to the concentrator via M ports. Stations connected to a ring via a concentrator are referred to as **single-attached stations (SAS)**. The FDDI concentrator provides another type of fault tolerance. When a station is removed from the network via a concentrator, the station is bypassed within the concentrator and the topology of the FDDI network is not affected.

Ring access is controlled by a **Token**, a frame comprised of a unique sequence of symbols, which circulates according to the value of a **Target Token Rotation Time (TTRT)**. The TTRT is negotiated by all stations during ring initialization. During the initialization process, each station on the ring submits a **Requested Token Rotation Time (T_Req)**. All active stations then negotiate a TTRT value (T_Neg) that becomes the final TTRT value upon successful ring initialization.

When the ring is operational, the token rotates continuously and sequentially around the ring. The token is the means by which the right to transmit is passed from one station to another. If a station has data to transmit, it must first capture the token from the ring. The station may then transmit data until all its data has been sent or the **Token Holding Timer (THT)** expires. The THT limits the length of time a station may have the token before issuing a new one. After a transmission is complete, the station creates and transmits a new token onto the ring. The token continues to circulate, providing other stations the chance to gain access to the ring, until it is captured by another (or same) station waiting to transmit data.

The FDDI Dual Ring During Normal Operation

The portion of the network map shown in Figure 3 illustrates the data path through the primary ring and dual-attached stations during normal operation. In this example, the value of the **Ring Management State (RMT)**, (the function of FDDI Station Management (SMT) which manages MAC layer components) is RingOp for every MAC station on the ring, indicating that every station is part of an operational FDDI ring. (Refer to the `fdstat` manpage for more information.) Data enters each dual-attached station or

concentrator on the primary ring via Port A and leaves via Port B. Data is transmitted to the single-attached stations via the concentrator M ports. The secondary ring remains inactive during normal operation.

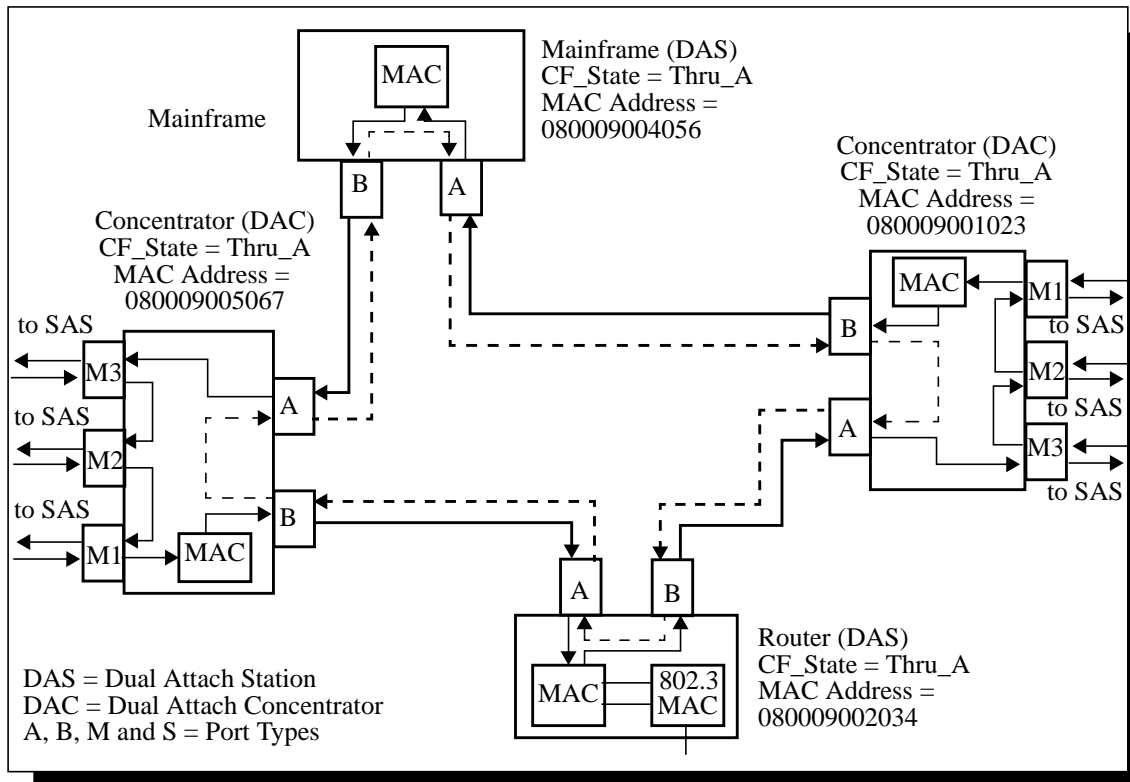

Figure 3 FDDI Dual Ring During Normal Operation

By definition, information is always received by a station from the nearest station upstream, the **Upstream Neighbor (UNA)**, and transmitted to the nearest station downstream, the **Downstream Neighbor (DNA)**. In the example in Figure 3, the concentrator with MAC address 080009001023 receives data from its Upstream Neighbor at MAC address 080009005034 (see Figure 5 for that section of the network map) and transmits to its Downstream Neighbor, the concentrator at MAC address 080009004056. In this example, when the ring is up and functioning normally, the **Station State** of the concentrator is listed as Rooted, indicating that the concentrator

has active A, B, or S ports in tree mode, and the Station State of the single-attached stations is listed as **Wrapped** indicating the MAC in that station can transmit data frames on the FDDI network. (Refer to the `fdinet` for more information.)

During normal operation, the two rings in an FDDI network are independent. The primary ring actively transmits data in accordance with timed-token protocol, while the secondary ring remains inactive, providing a redundant LAN capability, until a fault occurs to break the primary ring.

When stations on an FDDI network are connected to both the primary and secondary rings simultaneously, these stations can access either or both rings for data transmission and can reconfigure the network, if necessary. Stations directly connected to the dual fiber optic ring are referred to as dual-attached stations. Dual-attached stations do not require connection to the FDDI network through a concentrator.

Dual homing improves network availability by allowing the dual fiber connections on the FDDI adapter card to be connected into two separate concentrators simultaneously. If one connection is broken, the system will still be able to communicate on the FDDI ring. HP FDDI/9000 supports dual attach and dual homing capabilities for Series 800 systems.

The FDDI Dual Ring in Wrap Mode

In Figure 4 a fault has occurred on the primary ring because the mainframe computer is not operational. The FDDI fault tolerant capability allows the rings to reconfigure automatically and form a new ring between the two concentrators and the router. An optical bypass could also be used. In that case, the ring would not wrap. The dotted lines illustrate connections to the mainframe which are no longer active. In this new configuration, the concentrator at MAC Address 080009001023 will have an attachment state (CF_State) of **Wrap_A**, indicating frames are now being transmitted via the A port, and a new downstream neighbor, the router at MAC Address 080009002034.

The CF_State of individual stations on the ring varies depending on the ring configuration at any given time. In Figure 3, which shows an FDDI ring in normal operation, all the dual-attached stations on the ring have a CF_State of **Thru_A**, with the data stream entering each MAC through the A port and exiting through the B port.

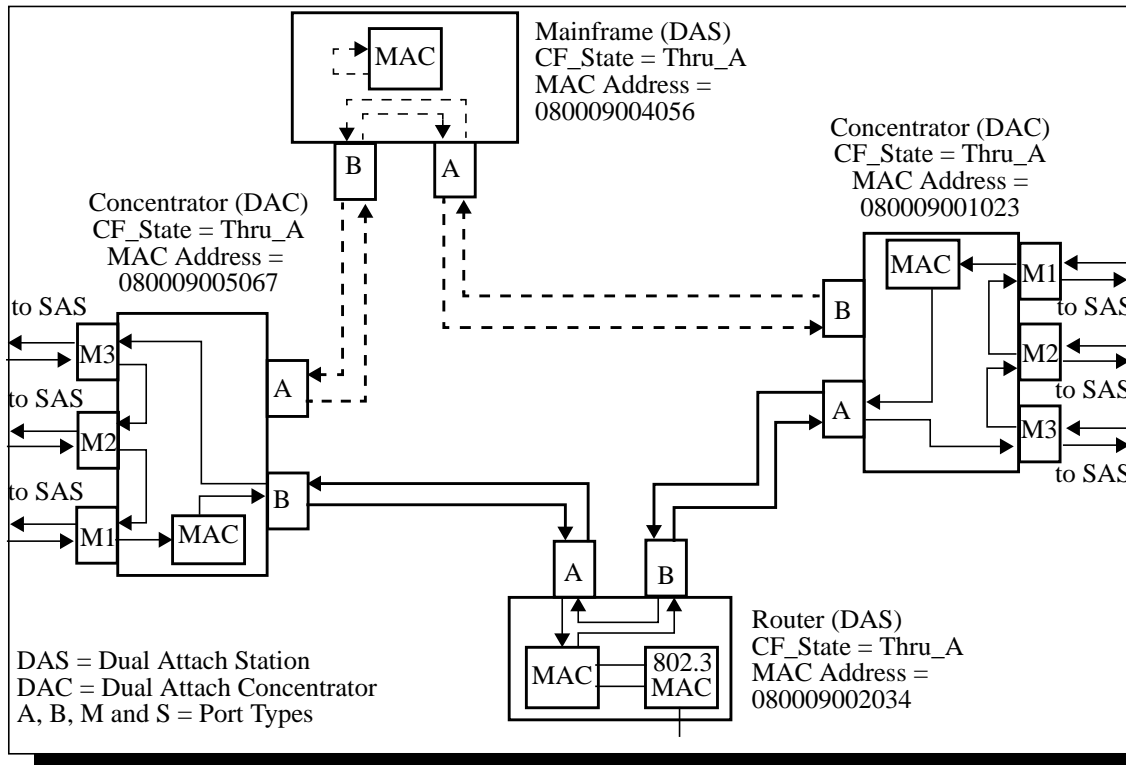

Figure 4 FDDI Dual Ring In Wrap Mode

Together the A and B ports determine the attachment configuration of the station or concentrator. In Figure 4 showing an FDDI ring in wrap mode, the CF_State of both the inactive and active stations has changed to reflect the new ring configuration. The CF_State of the mainframe, which is no longer operational, is now Isolated, the CF_State of the concentrator at MAC address 080009001023 is Wrap_A, because its MAC is now transmitting the data stream back out the A port, and the CF_State of the concentrator at MAC address 080009005067, is Wrap_B because its MAC is now transmitting the data stream back out the B port. The possible attachment states of single-attached stations are Wrap_S or Isolated. Wrap_A and Wrap_B are fault recovery states. Wrap_S is a normal state. (Refer to Figure 5 for an illustration of single-station attachment configurations. Refer to the *fd distat(1M)* manpage for more information.)

FDDI Single-Attached Stations

Figure 5 shows the data path through the concentrator after one of the workstations has been detached from the FDDI network. In this case the fault tolerant capability of the concentrator enables the station that is not operational to be bypassed.

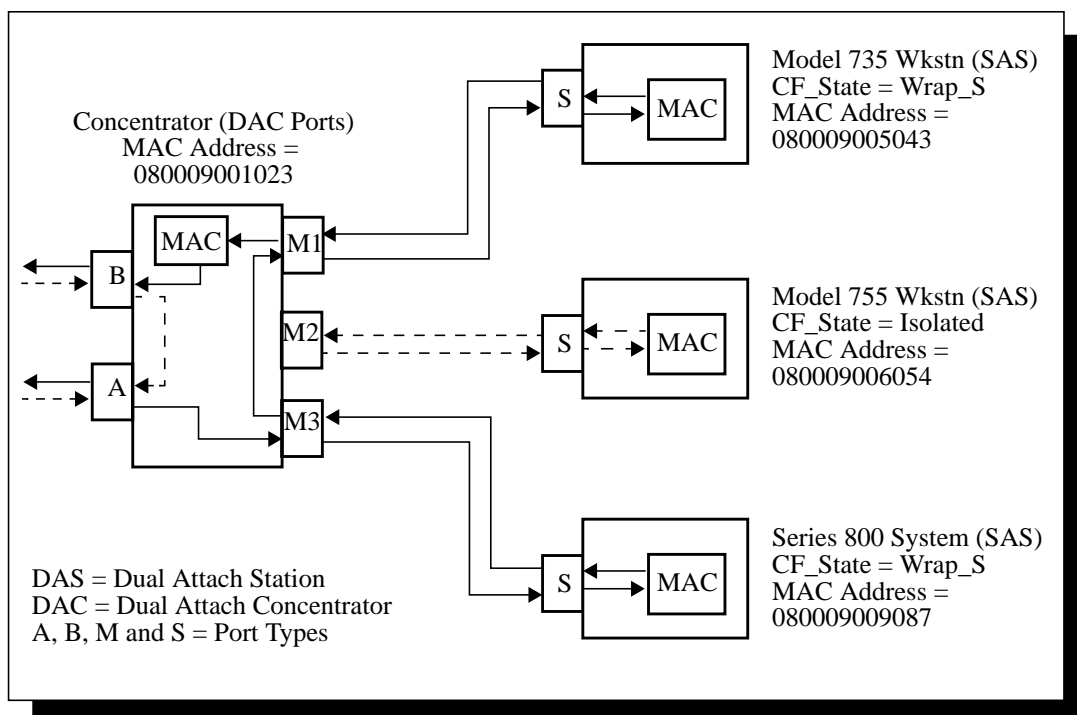

Figure 5 FDDI Single Attached Station When Bypassed

FDDI Error Detection

The FDDI **Link Error Monitor (LEM)** is a fault detection service that continually examines the **Link Error Rate (LER)** of an active link. The detector function of the LEM monitors the link quality and identifies link error events. Whenever the link error rate exceeds the predetermined cutoff threshold, the link is automatically removed from the ring. The **Link Error Rate Estimate (LER_Estimate)** provides the long term average link error rate. (Refer to the *fddistat(1M)* manpage for more information.)

For error detection and performance analysis, the MAC entity in each station maintains statistics on all frames received at and transmitted from the station. The MAC counter, **Frame Count (Frame_Ct)**, specifies the total number of frames received at the station. To be counted as a frame, the frame must conclude with an ending delimiter, the symbol that indicates the ending of tokens and frames. The MAC also monitors the **Receive Count (Receive_Ct)**, which indicates the total number of SMT or LLC frames successfully received by the station, the **Transmit Count (Transmit_Ct)**, which indicates the total number of frames originated by the station, the **Lost Count (Lost_Ct)**, which indicates the total number of frames received with a format error detected, and the **Error Count (Error_Ct)**, which indicates the total number of frames received with the error indicator as E and not yet set to S. All stations on the ring inspect repeated frames for errors. If an error is detected and the received E indicator was not set to S, then an error is counted. The E indicator is set to S by a station when either an error to be counted is detected or the received E indicator is set to S. (Refer to the *fddistat(1M)* manpage for additional details about these fields and how to display them at your workstation.)

FDDI Resources
FDDI Concepts

Installing FDDI

This chapter describes how to load HP FDDI/9000 software onto your system.

WARNING:

Please note the following BEFORE continuing with the installation process:

Update your HP-UX operating system to version 10.01 ONLY when compatible FDDI software is available. If you update to HP-UX 10.01, you must update your FDDI software to a compatible version. Contact your HP representative for the specific HP-UX 10.01 compatible FDDI software.

Also, the *HP FDDI Quick Installation* card lists the steps required to install your FDDI hardware and software. The Quick Installation card refers you to complete descriptions of the software installation steps in this manual. Use the Quick Installation card as your primary reference to installation and configuration procedures. Refer to this manual and the *HP-PB FDDI Adapter Installation Guide* for further details.

If this is a new installation, perform all the steps in this chapter. If you already have an earlier version of HP FDDI/9000 installed, perform the “Checking Installation Prerequisites” step and the “Loading FDDI Software” step described in this chapter, then proceed to the verification steps described in chapter 2.

WARNING:

If you intend to upgrade your HP-UX operating system from 9.x to 10.01, please note the following BEFORE continuing with the installation/upgrade process:

During the upgrade from HP-UX 9.x to HP-UX 10.01, the */etc/netlinkrc* file is transitioned to the appropriate */etc/rc.config.d/** files. If you upgrade your operating system before the rest of your networking products, you may receive a failure on startup for the network (the *HP-UX Start-up in progress* list, the *Configure LAN interfaces* item shown during system boot). This may be due to an attempt to configure a non-existent link (one of your networking products that needs to be upgraded to the 10.01 version.) Continue with the upgrade. If, after upgrading your networking products, you still receive a startup failure for networking, use the *lanscan* command to verify the configuration in SAM and view the */etc/rc.log* file for any failure statements. Also note the following:

- Upgrade to HP-UX operating system version 10.01 ONLY when 10.01-compatible networking products are available. Upgrading the operating system without compatible networking products will cause the loss of network functionality. To recover that functionality, upgrade the appropriate networking products.
- Upgrade the HP-UX operating system to 10.01 before installing any new

networking products.

- If possible, upgrade your existing networking products at the same time you upgrade the HP-UX operating system.
 - If upgrading all products at the same time isn't possible, upgrade the software/hardware products (for example, Token Ring, FDDI, Fibre Channel) before the software-only products (software products which rely on a separate network hardware product to function, for example, OSI Transport Services, Netware).
 - DO NOT move or reposition any network adapter cards before or during the upgrade process.
 - Stop all applications running over the network before starting the upgrade process.
 - Note that Hewlett-Packard does not support non-HP product upgrades to HP-UX version 10.01. Contact the representative for your non-HP products for information on upgrading.
 - Note that device file names, interface names, and NMID numbers may change to reflect your upgraded system.
 - If problems arise during the upgrade process, check the following files: `/etc/rc.log`, `/var/adm/sw/snoop.log`, `/var/adm/sw/swagent.log`.
-

Checking FDDI Installation Prerequisites

Prior to loading the FDDI product onto your system, check that you have met the following hardware and software prerequisites:

- 1 Check that the `/usr/bin`, `/usr/sbin` and `/sbin` directories are in your PATH using the command: `echo $PATH`.
- 2 The operating system has been upgraded to 10.01 software.
To obtain this information, use the `uname -a` command.
- 3 You have a fiber cable terminated with a MIC connector to connect your FDDI adapter to your concentrator.
- 4 **Series 800 HP-PB:** The system backplane contains available empty HP-PB slots for the FDDI adapter. (The HP-PB FDDI card is a double-high card; therefore, it needs two slots, above and below, rather than side-by-side. See the *HP-PB Adapter Installation Guide* for more details.)
Integrated FDDI/Models 735 and 755: The Integrated FDDI adapter has been installed, or installed as an upgrade. The slot on the I/O board for Model 735 must contain an adapter card. The Model 735 will not boot if the slot on the I/O board is empty. Refer to the hardware manual for installation of the Integrated FDDI adapter.
- 5 You have an IP address, subnet mask (optional), and host name alias for your new FDDI adapter.
- 6 You have super-user status.

NOTE:

Prior to the installation of HP FDDI/9000, FDDI fiber optic cabling must be installed by a non-HP third party cabling vendor, and all networking appliances must be correctly attached and configured including concentrators.

Loading the FDDI Software

Follow the steps below to load HP FDDI/9000 software using the HP-UX *swinstall* program. If you have an earlier version of HP FDDI/9000 already installed, perform these steps then proceed to the verification steps described in chapter 2. See the note at the end of this section for information on unloading the FDDI software.

- 1 Log in as **root**.
- 2 Insert the software media (tape or disk) into the appropriate drive.
- 3 Run the *swinstall* program using the command:

```
/usr/sbin/swinstall
```

This opens the Software Selection Window and Specify Source Window.

- 4 Change the Source Host Name if necessary, enter the mount point of the drive in the *Source Depot Path* field, and activate the **OK** button to return to the *Software Selection* Window. Activate the Help button to get more information.

The *Software Selection* Window now contains a list of available software to install.

- 5 Highlight the HP FDDI/9000 software for your system type.
- 6 Choose **Mark for Install** from the “Actions” menu to choose the product to be installed.
- 7 Choose **Install** from the “Actions” menu to begin product installation and open the Install Analysis Window.
- 8 Activate the OK button in the *Install Analysis* Window to confirm that you want to install the software. *swinstall* displays the *Install Window*.

swinstall loads the fileset, runs the control scripts for the filesets, and builds the kernel. Estimated time for processing: 3 to 5 minutes.

View the *Install Window* to read processing data while the software is being installed. When the Status field indicates Ready, the *Note Window* opens.

- 9 Activate the **OK** button on the Note Window to reboot. The user interface disappears and the system reboots.
- 10 Once the system comes back up, log in as **root** and view the **/var/adm/sw/swagent.log** and **/var/adm/sw/swinstall.log** files to view any

Installing FDDI
Loading the FDDI Software

error or warning messages that may have occurred during the installation.

11 Go to the following section, “Gaining Access to the System Adapter Bay.”

NOTE:

Using the *rmfn* command to remove FDDI filesets disables all FDDI cards on the system. After using *rmfn*, re-install the desired software.

Gaining Access to the System Adapter Bay

HP FDDI/9000 is supported on Series 800 Model F, G, I, and K workstations and Series 700 Model 735 and 755 workstation. For more detailed information and illustrations, see the appropriate owner's guides for each of the models.

- 1 Shut down the system:

```
/usr/sbin/shutdown -h
```
- 2 Wait until the system responds with "OK to press reset" or "Halted, you may now cycle power", then power off the workstation.
- 3 HP FDDI/9000 contains electronic components that can easily be damaged by small amounts of static electricity. To avoid damage, follow these guidelines:
 - Store adapters in their conductive plastic bag until you are ready to install them.
 - If possible, work in a static-free area.
 - Handle the adapter only by the edges. Do not touch electronic components or electrical traces.
 - Use the disposable grounding wrist strap provided with this product (HP 9300-1408). Follow the instructions provided with the strap.
 - A suitable electrical ground is any exposed metal surface on the computer chassis.
- 4 Remove the workstation cover according to the instructions in workstation's owner's guide, then go to the next section, "Installing the FDDI Hardware."

Installing the FDDI Hardware

Review the steps below to prepare the system for installation of FDDI hardware. See the *HP-PB FDDI Adapter Installation Guide*, the *Model 735 FDDI Installation Guide* or the *HP Model A2254A FDDI Installation Guide* for complete details.

- 1 Remove the slot cover and set aside the slot cover retaining screw.
- 2 With the grounding wrist strap on, hold the adapter by its edges or faceplate with both hands.
- 3 **Series 800 HP-PB:** Install the card in the lowest slot available. Follow the instructions in the *HP-PB FDDI Adapter Installation Guide*.

Integrated FDDI/Models 735 and 755: Integrated FDDI, option 009 is factory-installed. Go to the next section, “Connecting the Adapter to the Network.” For the add-on Integrated FDDI product, see the appropriate installation guide for your model listed above.

WARNING:

Hewlett-Packard recommends not rearranging any network interface cards installed in your system. If you do, you may need to reconfigure IP addresses. See “Reconfiguring IP Addresses” in the next chapter.

- 4 Press the adapter firmly into place.
- 5 Secure the adapter by replacing the slot cover screw and reassemble the workstation. Reconnect the power cord.
- 6 Go to the next section, “Connecting the Adapter to the Network.”

Connecting the Adapter to the Network

- 1 Attach one end of the MIC terminated fiber optic cable to the workstation's FDDI adapter. Align the slotted plug with the keyed connector. Push the connector in until you hear it click.
- 2 For Single Attach FDDI, attach the free end of the cable to any master (M) port on the FDDI concentrator. For Dual Attach FDDI, see the *HP-PB FDDI Adapter Installation Guide* (P/N 28670-96003).
- 3 Reconnect the power cord, if necessary, and power up the workstation. The FDDI adapter will run an automatic self-test. Any error messages will appear on the terminal display or console.

The Single Attach HP-PB FDDI adapter contains three LEDs. Normal operation is if the amber Self-test Fail LED turns on briefly during power up, then turns off, and the green Signal Detect LED is on. The Ring_Op turns on only after the firmware is downloaded.

The Dual Attach FDDI adapter has two signal detect LEDs, one for both the A and B ports. The Models 735/755 FDDI adapters do not have LEDs.

- 4 When the system is up, log in as **root**, then run **/usr/sbin/dmesg** to verify adapter status. Look for the statement, "FDDI Card found at select code 0x4X" where "X" is the slot number.
- 5 Continue with the next chapter, "Configuring HP FDDI/9000."

Installing FDDI
Connecting the Adapter to the Network

Configuring HP FDDI/9000

This chapter describes how to configure HP FDDI/9000 using SAM, the System Administration Manager.

WARNING:

Please note the following **BEFORE** continuing with the installation process:

Update your HP-UX operating system to version 10.01 **ONLY** when compatible FDDI software is available. If you update to HP-UX 10.01, you must update your FDDI software to a compatible version. Contact your HP representative for the specific HP-UX 10.01 compatible FDDI software.

Also, the *HP FDDI/9000 Quick Installation* card lists the steps required to install your FDDI hardware and software. The Quick Installation card refers you to complete descriptions of the software installation steps in this manual. Use the Quick Installation card as your primary reference to installation and configuration procedures. Refer to this manual for further details.

If this is a new installation, perform all the steps in chapter 1 and in this chapter. If you already have an earlier version of HP FDDI/9000 installed, perform the “Checking Installation Prerequisites” step and the “Loading FDDI Software” step described in chapter 1, then perform the “Verifying the Installation” step and the “Verifying Remote System Configuration” step described in this chapter.

Overview of Configuration Using SAM

These instructions describe how to configure FDDI on HP-UX version 10.01 or above. To determine the operating system version you are using, type the following command:

```
uname -a
```

Once you have installed FDDI hardware and software, you can use SAM to automatically configure networking.

SAM stands for System Administration Manager, a menu-driven utility for system administration tasks, including configuration of networking software. SAM has two user interfaces, an X-Windows system interface and a text terminal interface. The primary components and functionality of SAM are the same for both interfaces. The differences are the screen appearance and the navigation methods.

You can get to the SAM online help system using the following methods:

- Choose an item from the “Help” menu (located in the menubar). This gives you information about the current SAM screen, keyboard navigation within SAM, using the SAM help system, and displaying the version of SAM you are currently running.
- Activate the HELP button from a dialog or message box. This gives you information about the attributes and tasks you can do from the currently displayed window.
- Press the F1 key. This gives you context-sensitive information for the object at the location of the cursor.

Using SAM, configuring HP FDDI/9000 can be divided into two procedures:

- Configuring the FDDI Link.
- Configuring Network Connectivity.

Follow step 1 to add the IP address, any alias names, and, if the FDDI card is on a subnetwork, the subnet mask for your FDDI card. This procedure will automatically initialize the FDDI link and attach your node to the local area

Configuring HP FDDI/9000
Overview of Configuration Using SAM

network (LAN). Follow step 2 to add remote system names and remote system IP addresses for network connectivity, and to specify default gateway information.

NOTE:

Using SAM is the preferred method for HP FDDI/9000 configuration. However, SAM currently does not support the domain name format. The domain name format is used with the BIND name service provided with Internet Services/9000. If you are using the BIND name service, you can configure the Network Interface Card, but you cannot configure remote connectivity. You may want to configure FDDI manually. See the *Installing and Administering LAN/9000* manual for detailed instructions on how to install and configure software manually. See the “FDDI Resources” chapter for FDDI-specific configuration information.

Configuring the Local FDDI Adapter

NOTE:

Make sure the HP FDDI/9000 card and driver are installed in the system before you use SAM to configure the software. If you've updated existing Fibre Channel software to the latest version, skip this step and go to "Verifying the Installation."

Log in as root and do the following:

- 1 At the HP-UX prompt, type: **sam**
- 2 Double-click on *Networking and Communications* in the SAM main window.
- 3 Double-click *Network Card Configuration* in the *Networking and Communications* window.
- 4 Highlight the FDDI card that you want to configure from the object list.
- 5 Verify that the hardware path is correct for your FDDI card.

Series 800: The hardware path of an HP-PB FDDI card should equal 4 times the hardware module number in which the card has been installed. For example, if the hardware path is 32, then the HP-PB FDDI card should be in hardware module 8.

Integrated FDDI/Models 735 and 755: The hardware path of an Integrated FDDI card is 2.0.9.

- 6 Choose **Configure** from the "Actions" menu to open the *Configure LAN Card* window.
 - a Enter the information about the FDDI card. To do so, press the Tab key to move through the data entry fields.

NOTE:

SAM displays the Card Name, Hardware (H/W) Path, and Station Address fields with the appropriate values. These fields cannot be modified.

- b Choose **FDDI** as the interface type for your FDDI card. The default is **IEEE802.3/Ethernet**.

- c Enter the Internet address for your FDDI card.

Upon exiting the *Internet Address* field, SAM checks to make sure that the IP address you entered is correctly formatted and is not currently in use.

- d Specify whether your FDDI card will be on a subnetwork.

Configuring HP FDDI/9000

Configuring the Local FDDI Adapter

If you choose YES, enter the subnet mask for your subnetwork.

- e Optionally, enter comments about your FDDI card.
- f Choose *Add Aliases for Internet Address* to open the *Add Aliases* window.

NOTE:

You must complete this step if you have more than one Fibre Channel card installed in your system.

- g Add, modify, or remove alias names for your FDDI card.
 - h Activate the OK button to perform the task and return to the Configure LAN Card window.
- 7 Activate the OK button at the *Configure LAN Card* window to enable your FDDI card.

NOTE:

If the software is correctly configured, SAM displays the *Network Interface Cards* object list with the status Enabled for your FDDI card; otherwise, SAM displays an error message.

- 8 At the *Networking and Communications* window, choose *Exit SAM* from the “File” menu.

NOTE:

If you have moved or removed any FDDI cards from the system, HP recommends that you verify the IP address of every card in the backplane before leaving SAM.

- 9 Go to the next section, “Verifying the Installation.”

Verifying the Installation

- 1 Use the `ls -l` command to verify that the HP FDDI/9000 device files, with major numbers of 191 (for Series 800) or 111 (for Models 735/755), have been created correctly for each FDDI adapter installed. Type the following HP-UX commands:

```
cd /dev
```

```
ls -l lan*
```

Series 800: Series 800 device files are created and bound to the I/O subsystem during system boot-up.

The major number for HP-PB FDDI cards on Models 8x7, E, F, G, H, I, K, and T500 computers is 191. The minor number is 0xnn0000 where *nn* is the byte for the card instance number. The first card has a card instance number of 0. If additional cards are added to the system, index values will be assigned in numerical sequence as the cards are installed on the system.

Integrated FDDI/Models 735 and 755: The major number for Integrated FDDI is 111 for both Models 735 and 755. The minor number is the instance number as shown in SAM.

- 2 Check that the network interface state and hardware state of your FDDI adapter are both up using the `lanscan` command:

```
/usr/sbin/lanscan
```

If the major numbers, minor numbers, or device file names are not correct, delete the device file entries from your `/dev` directory and recreate them with the correct numbers using the `mknod(1M)` command.

If you want to configure your system for network connectivity, continue with the next section, “Configuring Network Connectivity.” If not, continue with “Verifying Remote System Configuration.”

Configuring Network Connectivity

Your system may not be able to communicate with other systems (for example, PCs, workstations, servers, etc.) until you configure system-to-system connections. You can use SAM to do this automatically by completing the following steps:

- 1 Log in as **root**.
- 2 At the HP-UX prompt, type: **sam**
- 3 Double-click on *Networking and Communications* in the SAM main window.
- 4 Double-click on *Internet Addresses* in the *Networking and Communications* window.

SAM displays the remote system names and IP addresses that are already configured.

- 5 Choose Add from the “Actions” menu to open the *Add Internet Connectivity* window.

Use the SAM online help system for information about adding remote system connections.

- a Enter the Internet Address for the remote system.

NOTE:

Upon exiting the *Internet Address* field, SAM checks to make sure you have entered a valid IP address. SAM also determines if a gateway is required for the connection.

- b Enter the remote system name.

NOTE:

Upon exiting the *Remote System Name* field, SAM checks to make sure that connectivity has not already been configured for this system. If it has, SAM displays an error message.

- c Optionally, choose *Add Aliases* to open the *Add Aliases* window for remote systems.
- d Add, modify, or remove alias names for the remote system.
- e Activate the OK button to perform the task and return to the *Add Internet Connectivity* window.
- f Proceed to step 5 if a gateway is not required for this remote connection.

NOTE: SAM displays fields for entering gateway information if a gateway is required for this remote system connection. Use the SAM online help system for information about gateways.

- 6 Activate the OK button to enable your system to communicate with this system and return to the Internet Addresses window.

SAM updates the object list to include the remote system you configured.

NOTE: You can modify or remove remote systems and modify default gateways by highlighting the Remote System Name from the object list and choosing Modify, Remove, or Modify Default Gateway from the “Actions” menu.

- 7 Exit the *Internet Addresses* window, then exit SAM.

To verify that you can communicate with a remote system using HP FDDI/9000, continue to “Verifying Remote System Configuration.”

Verifying Remote System Configuration

Once your HP FDDI/9000 software is installed, fully configured and running, you should execute the following commands to verify LAN hardware and software installation. See the man pages for complete descriptions of the commands listed below.

- 1 View the list of remote systems you can communicate with, using a symbolic name, by typing the following command at the HP-UX prompt:

```
more /etc/hosts
```

- 2 View the configured destinations reached through gateways and the gateways used to reach those destinations, by typing the following command at the HP-UX prompt:

```
netstat -r
```

- 3 Test for link level loopback connectivity by using the station address of the interface you want to test. Use the MNID to select the interface. (You can obtain the station address (typically 0x080009#####) from the *lanscan* output.) Use the following syntax:

```
linkloop -i <NMID> <station address>
```

For example:

```
linkloop -i 5 0x080009266C3F
```

- 4 To check that your system can communicate with other systems, type the ping command at the HP-UX prompt. In this example, 191.2.1.2 is the IP address of the remote system. Type [CNTRL]-C to stop ping.

```
ping 191.2.1.2
```

- 5 Check the state of all FDDI hardware and interfaces. Execute the *lanscan* command and verify that the *Hardware State* and the *Net-Interface State* is **UP**.

```
lanscan
```

If the FDDI device file has not been created, execute the following command, where *<devfile>* is the name you wish to give the FDDI device file:

```
/usr/sbin/hpfddi_init <devfile>
```

- 6 Verify the link level encapsulation with the *lanconfig* command. The example below will provide information about Net-Interface NameUnit *lan1*.

```
lanconfig lan1
```

- 7 Verify that the appropriate device files have been created. In the example below the first line lists the HP FDDI/9000 device files, the second line lists the diagnostic device files.

```
ls -l /dev/lan*  
ls -l /dev/nettrace /dev/netlog
```

HP FDDI/9000 installation is verified if the steps above succeed.

Reconfiguring IP Addresses

If you have rearranged any network interface cards in the system, you may need to reconfigure the IP addresses. Follow the steps below:

- 1 At the HP-UX prompt, type: **sam**
- 2 At the main menu, select *Networking and Communications*.
- 3 Select *Network Interface Cards*.
- 4 Verify the IP addresses of all the adapters in the system by reviewing the Card Name, Hardware Path, and Internet Address displayed in the *Network Interface Cards* window.
- 5 For adapters with incorrect IP addresses, follow the steps below:
 - a Select the adapter you wish to modify.
 - b Select *Configure* from the Actions menu.
 - c Modify the Internet Address and select **OK**.

Troubleshooting HP FDDI/9000

This chapter provides guidelines for troubleshooting HP FDDI/9000. It contains a troubleshooting overview, diagnostic flowcharts, and instructions for contacting your HP representative for more help.

Troubleshooting Overview

Troubleshooting FDDI problems can be difficult because a variety of hardware and software components may be involved and because the problem affecting your system may originate in another part of the FDDI network.

As with any troubleshooting, a systematic approach is helpful. The following flowcharts provide a logical sequence of steps to follow when troubleshooting HP FDDI/9000. Using the diagnostic flowcharts provided in this chapter, identify whether the problem is with HP FDDI/9000 or any of the connections to the concentrator, or whether it is in some other part of the FDDI network, verify your assumptions and, if it is limited to HP FDDI/9000 software and hardware, correct the problem.

If you cannot solve the problem on your own, contact your HP representative. Use the guidelines in chapter 1, “FDDI Resources,” to help you effectively communicate what is wrong.

NOTE:

To quickly isolate and diagnose HP FDDI/9000 problems, follow the steps in the troubleshooting flowcharts in sequence, beginning with Flowchart 1, and stay with the flowcharts until the problems are resolved.

Diagnostic Flowcharts

Below is a summary of the types of network tests in the diagnostic flowcharts. Follow the flowcharts in sequence, beginning with Flowchart 1, to diagnose your problem.

Flowchart	Description
1	FDDI Connections Test
2, 3, 4 & 5	Configuration Test
6 & 7	Network Level Loopback Test
8	Transport Level Loopback Test (using ARPA)
9	Link Level Loopback Test
10	Gateway Configuration Test
11	Gateway Loopback Test

FDDI Connections Test: Checks that all the hardware connections between your system and the FDDI network are connected and operational.

Configuration Test: Verifies the configuration of the network interface on a host using the lanscan(1M), fddiinit, and ifconfig(1M) commands.

Network Level Loopback Test: Checks roundtrip communication between Network Layers on the source and target host using the ping(1M) diagnostic.

Transport Level Loopback Test: Checks roundtrip communication between Transport Layers on the source and target host using ARPA services telnet and ftp commands.

Link Level Loopback Test: Checks roundtrip communication between Link Levels on the source and target host using the linkloop(1M) diagnostic.

Gateway Configuration Test: Checks the configuration of multiple network interfaces on a host.

Gateway Loopback Test: Checks general network connections through a gateway.

Flowchart 1: FDDI Connections Test

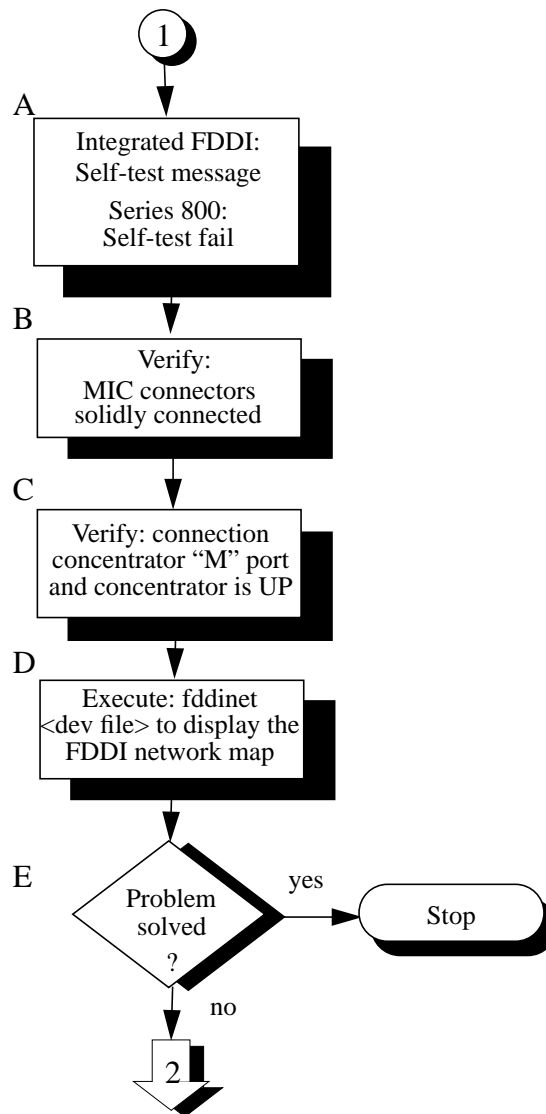

Flowchart 1 Procedures

- A. Series 800: Self-test fail; Ring Op; Signal Detect.**
During normal operation when the adapter is connected in an operational FDDI ring, the self-test should be off and the other LEDs should be glowing (Dual Attach FDDI has two signal detect LEDs). During power up or while using `fddiinit`, self-test will turn on briefly and the Ring Op will turn off, then self-test will turn off and Ring Op will turn on. If signal detect is off, the cables are not connected properly or the card failed completely. If Ring Op is off, either the card has not downloaded properly, or the FDDI ring is not operating. Go to B.
- Integrated FDDI: Check: Self-test message.** An Integrated FDDI self-test failure sends a message to the console and a log file. Go to B.
- B. Verify: MIC connectors solidly connected.** Without powering down the system, make sure the MIC connectors on your fiber-optics cable match the keyed connectors on the adapter and concentrator (or wall plug) and are solidly connected. Go to C.
- C. Verify: Connection to concentrator “M” port and concentrator is UP.** If using a concentrator, make sure that your FDDI cable is fully connected to the concentrator M port and that the concentrator state is UP. Follow the instructions in your concentrator manual to check the concentrator state. Go to D.
- D. Execute: `fddinet <dev file>`.** Execute `fddinet` on the device file of your FDDI adapter to display all the active stations on the FDDI ring. For example, if `/dev/lan1` is the device file corresponding to your FDDI adapter, enter:
- ```
fddinet /dev/lan1
```
- If the MAC address of the destination station is not listed, it is not attached to the FDDI network. If so, inform your network administrator about the problem with the destination station.

If an error message is displayed on the screen instead of the logical ring map, proceed to Flowchart 2. For detailed information on the `fdinet` command, refer to the manpage. Go to E.

- E.**           **Problem solved?** Check that you are reconnected to the FDDI network and can communicate with a remote host by executing the ping diagnostic or one of the other verification tools described in “Verifying the Installation.” If so, stop. If this is not the case, proceed to Flowchart 2.

This page intentionally  
left blank

**Flowchart 2: Configuration Test**

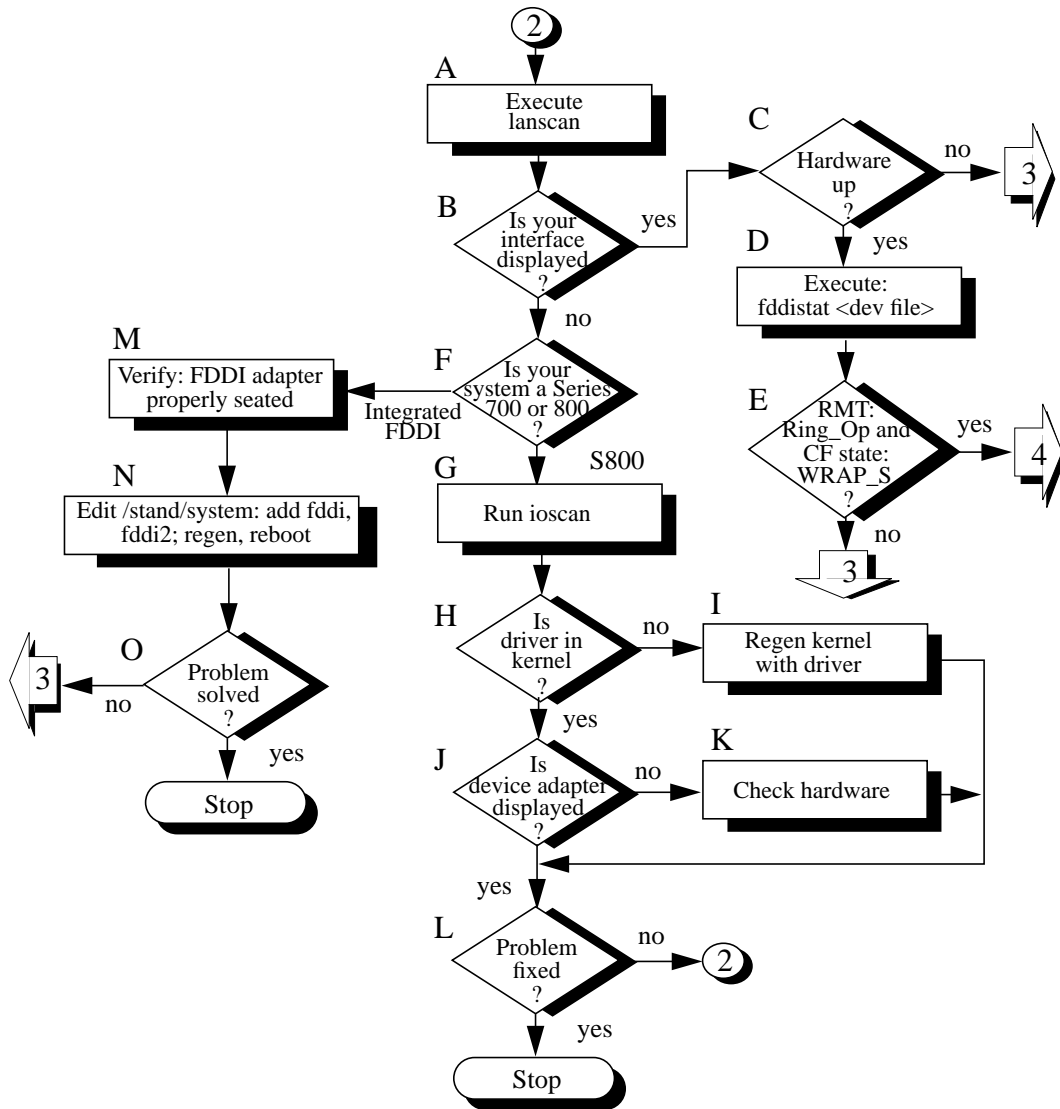

## Flowchart 2 Procedures

---

**NOTE:**

---

Check that your fiber-optic connectors to the adapter and concentrator (or wall plug) are fully connected before beginning this flowchart.

- A.**           **Execute: lanscan.** Enter the lanscan command to display information about LAN adapters that are successfully bound to the system. For example, enter `/etc/lanscan`. For more information, see the lanscan manpage. Go to B.
- B.**           **Is your interface displayed?** lanscan shows information about every LAN adapter in the system backplane. The Hardware Path of one of the entries should correspond to your FDDI adapter. If the FDDI interface is displayed, go to C; if not, go to F.
- Series 800:** For example, hardware path 8 corresponds to slot 2 HP-PB bus.
- Integrated FDDI/Models 735 and 755:** For example, a hardware path of 2.0.9 corresponds to an Integrated FDDI adapter.
- C.**           **Hardware up?** The hardware state is operational if up is displayed for the FDDI adapter under the Hardware State heading. If so, go to D. If it is not, go to Flowchart 3.
- D.**           **Execute: fddistat <dev file>.** Execute fddistat on the device file you wish to test. For example, if `/dev/lan1` is the device file corresponding to your FDDI adapter, enter `fddistat /dev/lan1`. Go to E.
- E.**           **RMT: Ring\_Op and CF state: Wrap\_S?** If the fddistat screen display indicates that the ring is operational, Ring\_Op, and the line state of the station connection is WRAP\_S, proceed to Flowchart 4. If not, proceed to Flowchart 3.
- F.**           **Is your system a Series 800 or Integrated FDDI?** Go to step M if your system is Integrated FDDI; go to step G if your system is a Series 800.

**G. Run ioscan.** ioscan will scan the system hardware and list the results. If you execute ioscan -f, output similar to the following will be displayed:

| Class | I | H/W Path | Driver | H/W Status | S/W Status |
|-------|---|----------|--------|------------|------------|
| lan   | 0 | 44       | lan3   | ok(0x5280) | ok         |
| lan   | 1 | 48       | fddi   | ok(0x5f80) | ok         |

**H. Is driver in kernel?** If yes, go to J. If no, the driver has not been generated into the kernel and the ioscan -f output will look like the following. Go to I.

| Class   | I | H/W Path | Driver | H/W Status  | S/W Status |
|---------|---|----------|--------|-------------|------------|
| unknown | - | 44       | ?      | ok (0x5280) | No_Driver  |

**I. Regen kernel with driver.** See your system's System Administration Tasks manual for instructions on how to create a new kernel. Then go to L.

**J. Is device adapter displayed?** If the device adapter is broken, no entry for the hardware path in which the adapter is inserted will be displayed. Go to L.

**K. Check hardware.** Verify that the network adapter is seated correctly and that it is operational. Go to L.

**L. Problem fixed?** If you have found and corrected the FDDI adapter problem, stop. If not, start again with Flowchart 2. If the problem still exists after two iterations, call your HP representative.

**M. Verify: FDDI adapter properly seated.** Shutdown your system using the command `/usr/sbin/shutdown -h`, power down the system and disconnect the cables, remove the EISA interface or the I/O board containing the Integrated FDDI adapter, and check that the adapter is properly seated in the backplane. To verify, power up the system.



- N.**            **Edit /stand/system, add fddi, fddi2, regen, and reboot.**  
Add the fddi keyword to the /stand/system (or the fddi2 keyword for Integrated FDDI), regenerate the kernel following the instructions in your system's System Administration Tasks manual, and reboot. After completing this procedure, start again with Flowchart 2.
- O.**            **Problem solved?** If so, stop. If you still have a problem, you may have a failed FDDI adapter, or a problem with the transmit or receive function of the concentrator. If this is not the case, proceed to Flowchart 3.

**Flowchart 3: Configuration Test cont.**

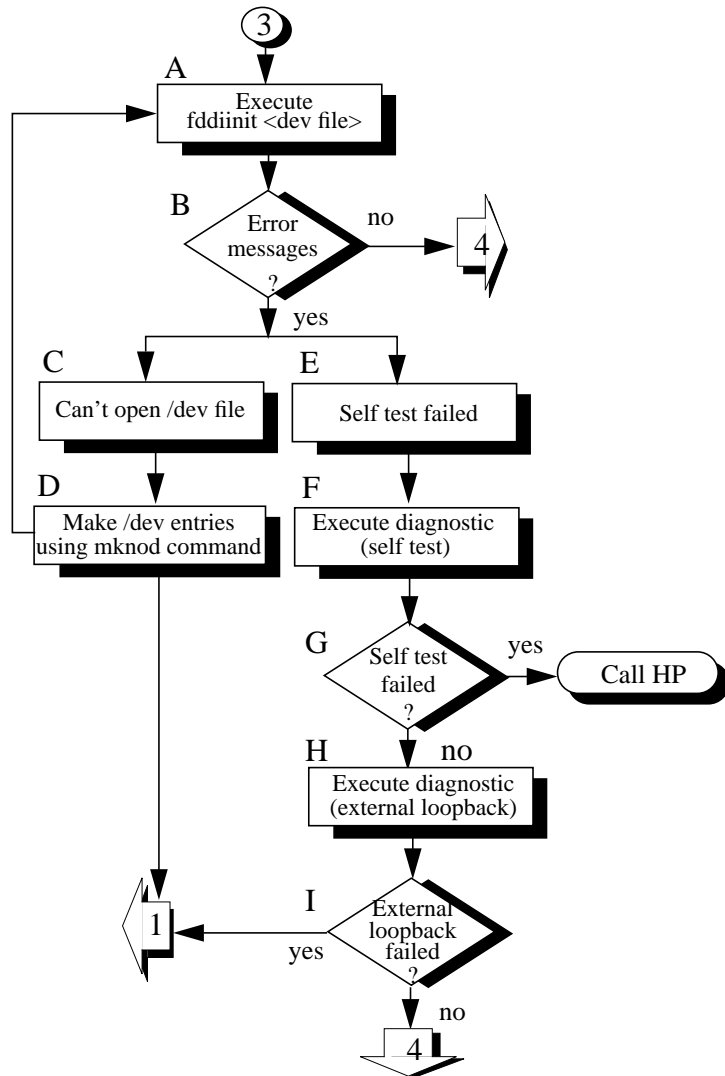

### Flowchart 3 Procedures

- A.** **Execute: fddiinit <dev file>.** Reset the adapter and download the adapter firmware by executing fddiinit. For example, if /dev/lan1 is the device file corresponding to your FDDI adapter, enter /usr/sbin/fddiinit /dev/lan1. For Integrated FDDI Model 735, use lan0; for Integrated FDDI Model 755, use lan1.
- B.** **Error messages?** If fddiinit is not successful, and an error message appears, proceed to the appropriate error message (C or E). If there are no messages, go to Flowchart 4.
- C.** **Can't open /dev file.** If this message is displayed, no device file exists. Go to D.
- D.** **Make /dev entries using mknod command.** Create a new device file using the HP-UX mknod command for Models 735 and 755, or the mksf or mknod commands for Series 800. Start over with Flowchart 1.
- E.** **Self-test failed.** If this message is displayed, the hardware adapter may not be operational.
- F.** **Execute diagnostic (self-test).** Run the self-test of the FDDI hardware diagnostics to ensure that the adapter is good.
- G.** **Self test failed?** If the test did not fail, the problem may be that you are not connected to the FDDI network. Go to H. If the test failed, call your HP representative for help.
- H.** **Execute diagnostic (external loopback).** Execute the external loopback test of the hardware diagnostics to verify network connectivity.
- I.** **External loopback failed?** If the diagnostic is successful, proceed to Flowchart 4. If not, return to Flowchart 1 to recheck your FDDI hardware connections.

**Flowchart 4: Configuration Test cont.**

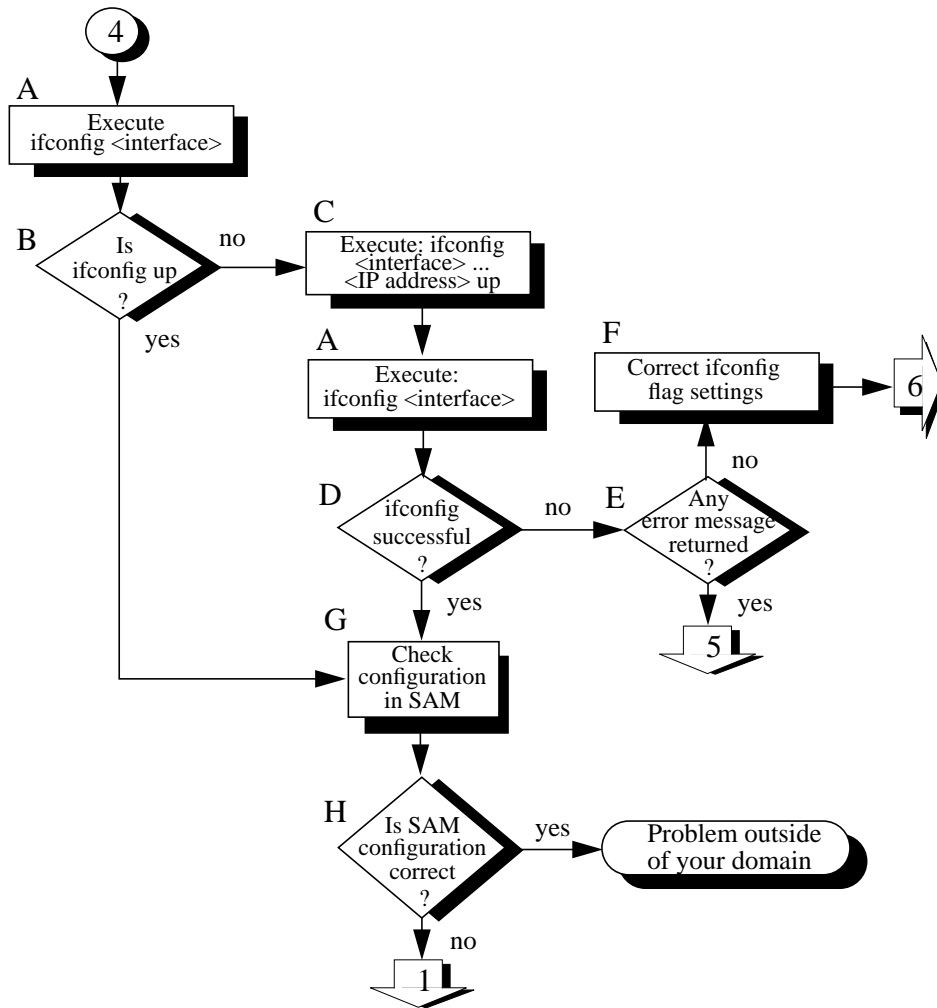

#### Flowchart 4 Procedures

- A.** **Execute: ifconfig <interface>.** Execute ifconfig without the up parameter on the interface you want to test, to check the flag setting for the up parameter. For example, to check FDDI interface lan1, type:
- ```
/usr/sbin/ifconfig lan1
```
- B.** **Is ifconfig up?** Check the results of the ifconfig command to see if the interface is up. If it is, go to G. If not, go to C.
- C.** **Execute: ifconfig <interface> <IP address> up.** Check to see if ifconfig is up. If not, execute ifconfig on the interface you want to test. For example, to check FDDI interface lan1, enter:
- ```
/usr/sbin/ifconfig lan1 ip_address up
```
- Type ifconfig <interface> again to see if the interface is up, then go to D.
- D.** **ifconfig successful?** ifconfig is successful if the output shows the correct Internet address and the flags: <UP, BROADCAST, ROUTE, NOTRAILERS, RUNNING>. Note: Make sure the UP flag is displayed. Also, ROUTE may or may not be present. If yes, go to G. If not, go to E.
- E.** **Any error message returned?** If ifconfig is not successful, and an error message appears, go to Flowchart 5. Flowchart 5 shows common error messages and what to do for each. If no error messages appear, go to F.
- F.** **Correct ifconfig flag settings.** If ifconfig returns an incorrect flag setting, re-execute the command with the proper setting. Go to Flowchart 6.
- G.** **Check configuration in SAM.** Check that the FDDI in SAM is correct. See chapter 3 for the configuration steps.
- H.** **Is SAM configuration correct?** If yes, the problem is outside your domain. If not, correct the configuration in SAM and start over with Flowchart 1.

**Flowchart 5: Configuration Test cont.**

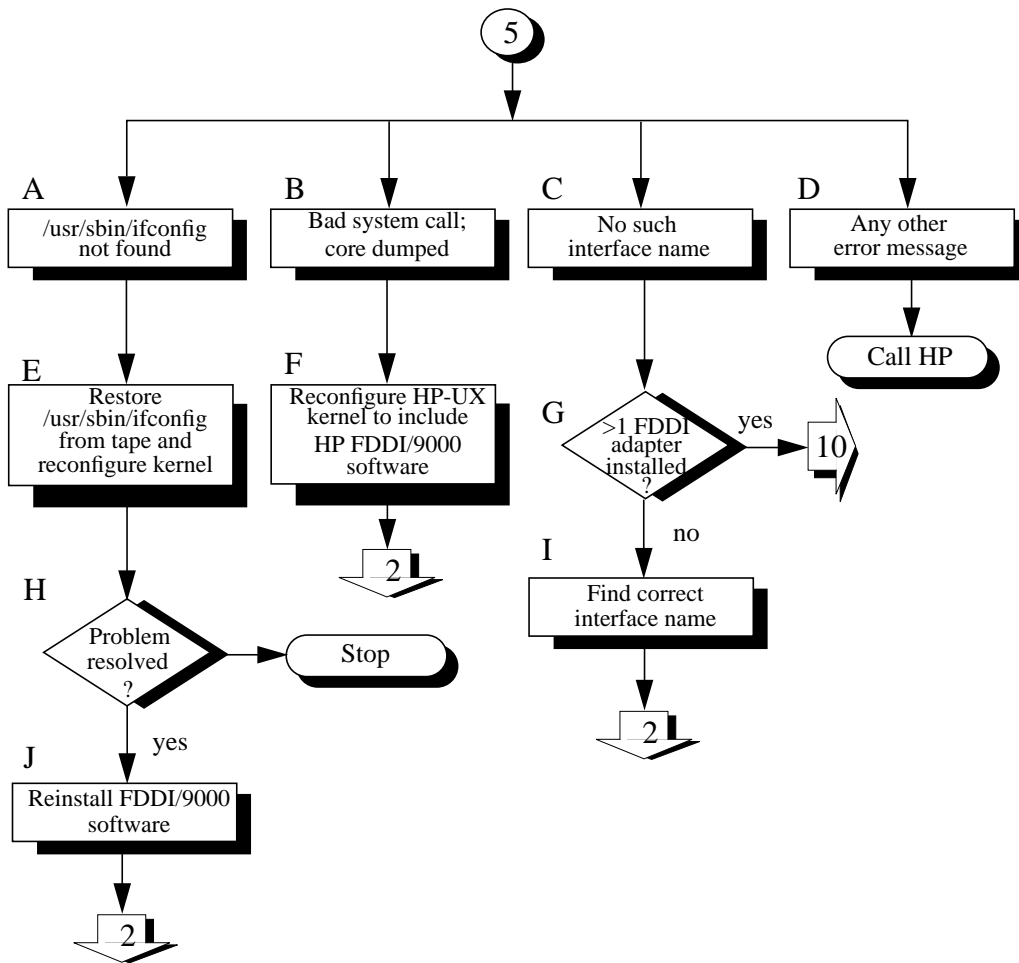

#### Flowchart 5 Procedures

- A.** **/usr/sbin/ifconfig not found.** The command has been relocated on the system or deleted. Go to E.
- B.** **Bad system call; core dumped.** Networking is not configured into the HP-UX kernel. Go to F.
- C.** **No such interface name.** The interface name passed to ifconfig does not exist on the system. Check spelling and names of interfaces on the system using netstat -i.

If you have more than one FDDI adapter, make sure the number of FDDI adapters has been configured into the kernel and that an ifconfig command has been executed for each. Go to G.
- D.** **Any other error message.** If you received an error message not listed on this flowchart, interpret the message and take the appropriate action. See “Contacting Your HP Representative” and call HP.
- E.** **Restore /usr/sbin/ifconfig from tape and reconfigure kernel.** You can restore ifconfig from the last good backup tape or your install/update tape. Go to H.
- F.** **Reconfigure HP-UX kernel to include HP FDDI/9000 software.** See the *Installing and Administering LAN/9000* manual for information on how to create a new kernel. Go to Flowchart 2.
- G.** **More than 1 FDDI adapter installed?** If you installed more than one FDDI adapter, go to Flowchart 10. If not, go to I.
- H.** **Problem resolved?** If so, stop. If not, re-install the entire HP FDDI/9000 software product. Start again with Flowchart 2, as necessary.
- I.** **Find correct interface name.** Using the correct interface name, start again with Flowchart 2.
- J.** **Reinstall HP FDDI/9000 software.** Re-install the entire HP FDDI/9000 software product. If necessary, start again with Flowchart 2.

**Flowchart 6: Network Level Loopback Test**

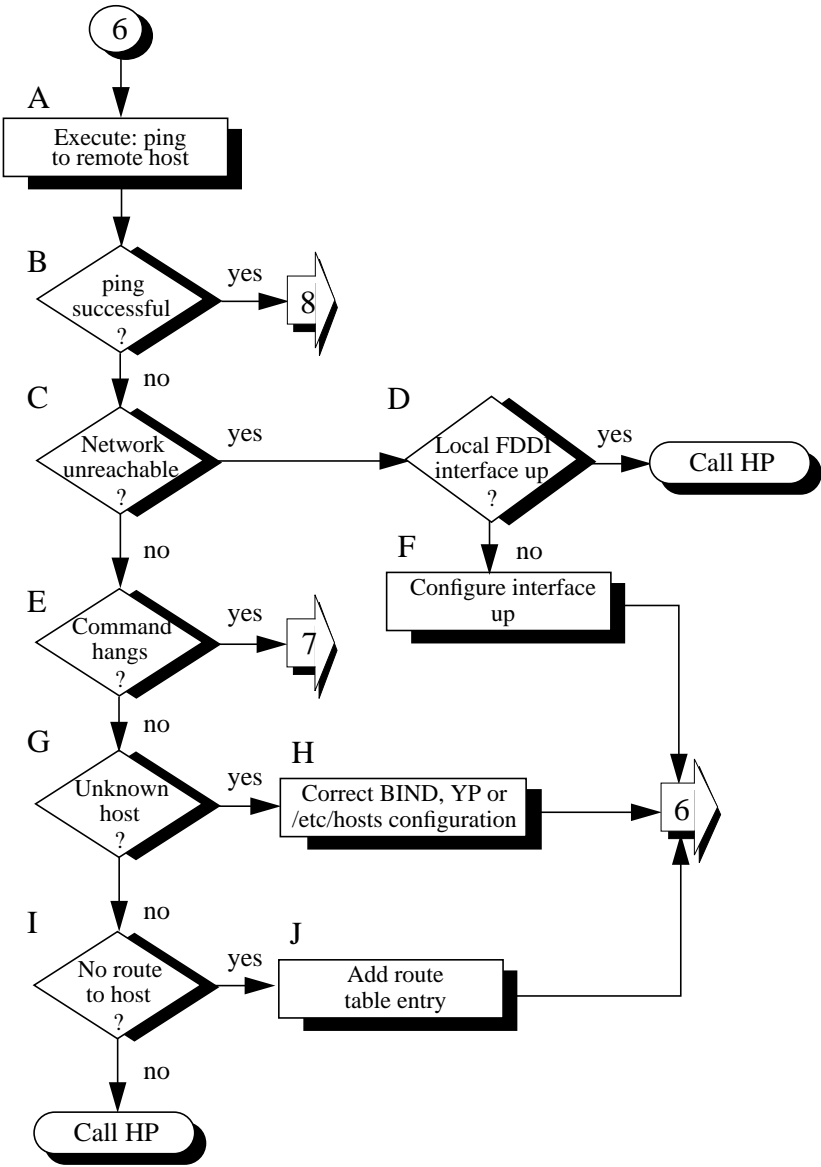



#### Flowchart 6 Procedures

- A.** **Execute: ping to remote host.** Using ping(1M), send a message to the remote host you are having problems connecting to. For example:
- ```
/usr/sbin/ping bunny
```
- B.** **ping successful?** If packets are being returned, your system has network level connectivity to the remote host. Note what percentage of the total packets are lost, if any. Losing ten percent or more may indicate the network or remote host is extremely busy. Also note the round-trip transmission times. Periodically high transmission times may indicate that the network or remote host is extremely busy. Consistently high transmission times may indicate the local host is extremely busy. Go to Flowchart 8.
- C.** **Network unreachable?** If so, check the status of the local FDDI interface first. Go to D. If network is reachable, go to E.
- D.** **Local FDDI interface up?** If yes, call HP. If no, go to F.
- E.** **Command hangs?** If a message is not returned after executing ping, go to Flowchart 7.
- F.** **Configure interface up.** If you find the local interface is not up, execute ifconfig with the appropriate flags set. Start again with Flowchart 6.
- G.** **Unknown host?** If you received an unknown host error, go to H. If not, go to I.
- H.** **Correct BIND, YP or /etc/hosts configuration.** Add the missing host name and start again with Flowchart 6.
- I.** **No route to host?** If you received a “No route to host” error, go to J; otherwise, see “Contacting Your HP Representative” and call HP.
- J.** **Add route table entry.** Using /usr/sbin/route, add a route table entry for that host.

Flowchart 7: Network Level Loopback Test cont.

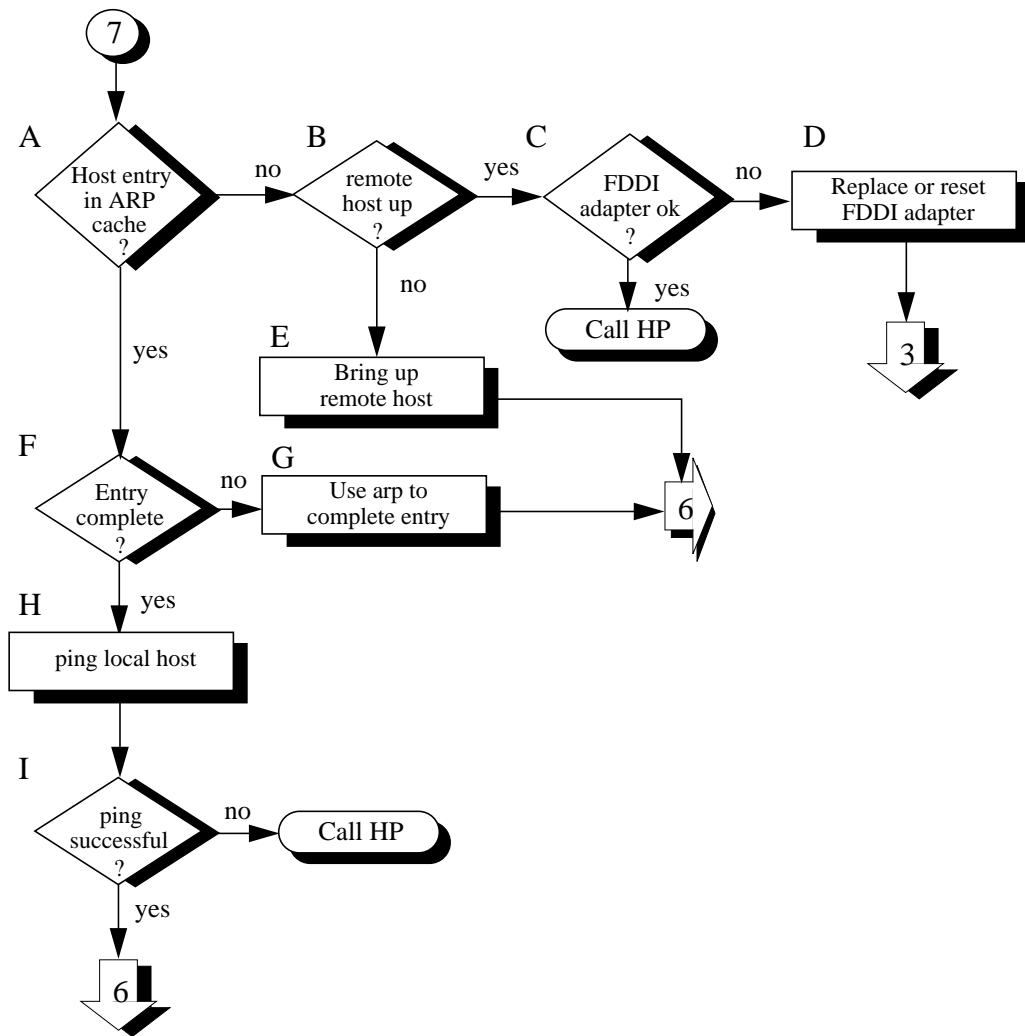

Note: This time ping from remote host to local host.

Flowchart 7 Procedures

- A.** **Host entry in ARP cache?** Using arp, check that an entry exists for the remote host in your system's ARP cache. For example: `/usr/sbin/arp bunny`
- If the host entry is not in the ARP cache, go to B; otherwise, go to F.
- B.** **Remote host up?** If yes, go to C. If no, the remote host has not broadcast an ARP message, and that likely is why there is no entry in the ARP cache. Go to E.
- C.** **FDDI adapter okay?** If yes, call HP. If no, use the FDDI hardware diagnostics to ensure the FDDI adapter is operational. go to D.
- D.** **Replace or reset FDDI adapter.** When the FDDI adapter is operational, use `fddiinit(1M)` to reset. Go to Flowchart 3.
- E.** **Bring-up remote host.** Have the node manager of the remote host bring that system up. Go to Flowchart 6.
- F.** **Entry complete?** If yes, go to H. If not, perhaps there is an ARP cache entry, but it is wrong or not complete. Go to G.
- G.** **Use arp to complete entry.** Using arp, enter the correct Station Address. For more information, refer to the `arp(1M)` manual page. Go to Flowchart 6.
- H.** **ping local host.** Using ping, do an internal loopback on your own system. In other words, ping your own system.
- I.** **ping successful?** If the internal loopback is successful, your system is operating properly to the Network Layer (OSI Layer 3). In addition, you know an ARP cache entry for the remote host exists on your system. If this is true, the network interface or software on the remote host is suspect. Start again with Flowchart 6, but this time ping from the remote host to your system. If the ping in Step H was not successful, call HP.

Flowchart 8: Transport Level Loopback Test (using ARPA)

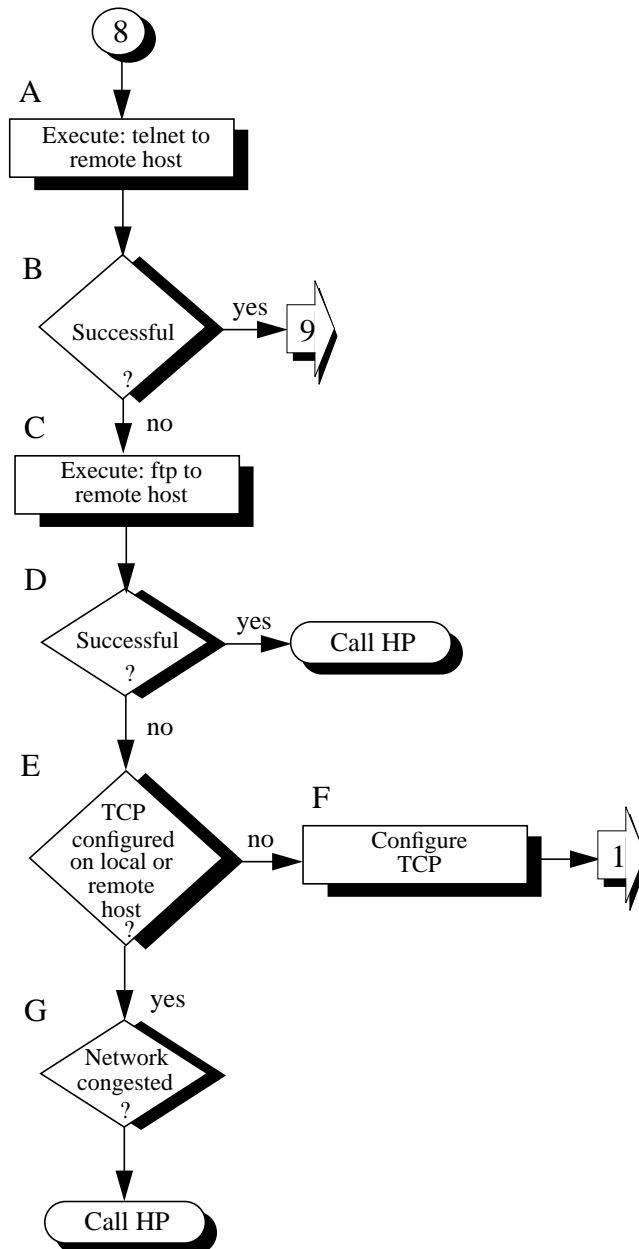

Flowchart 8 Procedures

- A.** **Execute: telnet to remote host.** Try to establish a telnet connection to the remote host.
- B.** **Successful?** If your telnet attempt was successful, the connection has been made through the Transport Layer (OSI Layer 4). Go to Flowchart 9.
- C.** **Execute: ftp to remote host.** Unlike telnet, ftp does not go through a pseudoterminal driver (pty) on your system. This step tests to see if the pty is why telnet failed.
- D.** **Successful?** If ftp is successful, you likely have a problem with a pty on your system. Contact your HP representative. If not, go to E
- E.** **TCP configured on local or remote host?**
Neither telnet nor ftp will work if TCP is not configured on either side of the connection. Check the /etc/protocols file on both hosts to be sure TCP is installed and configured. If it is not, go to F. If yes, go to G.
- F.** **Configure TCP.** If necessary, install TCP on either or both hosts. Start over with Flowchart 1.
- G.** **Network congested?** If TCP is installed on both hosts, do a file transfer to another remote host on the network. Use netstat to check for lost packets.
- If 10 percent or more packets are lost, the network is extremely busy. If you cannot determine the cause, contact your HP representative for help.
- If network congestion is not the cause, more detailed diagnostics are required. Again, contact your HP representative.

Flowchart 9: Link Level Loopback Test

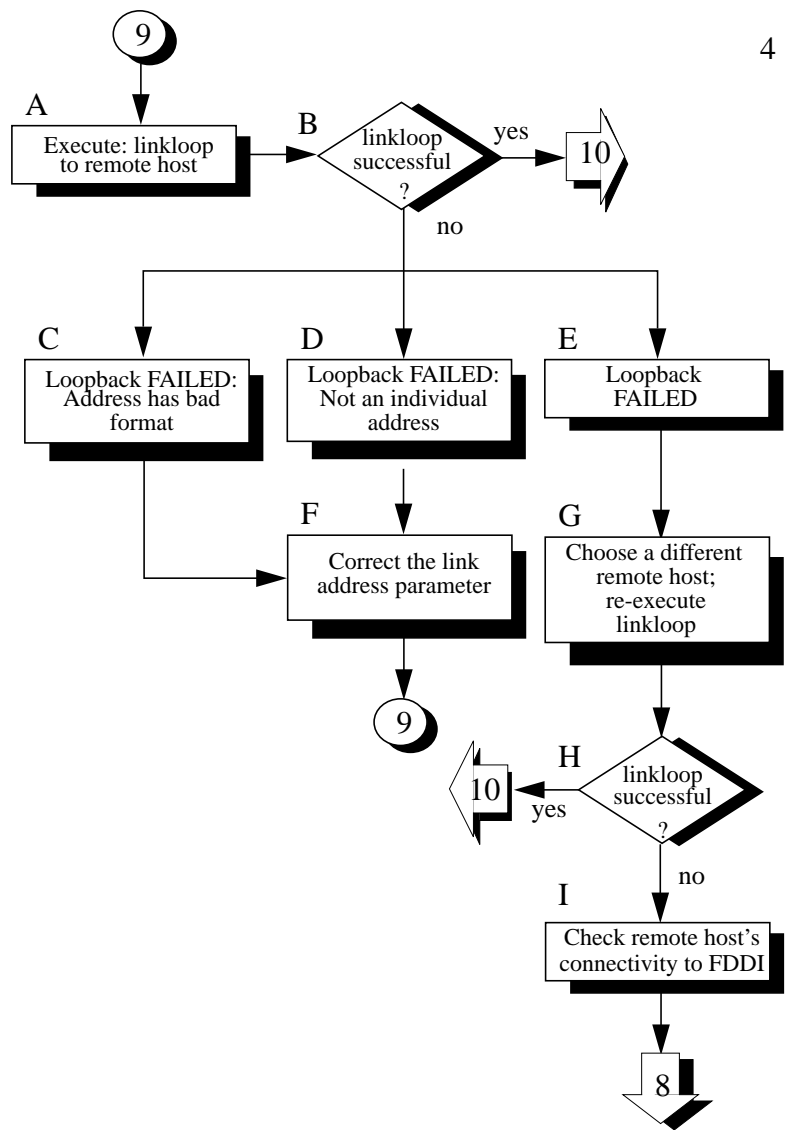

4

Flowchart 9 Procedures

- A.** **Execute: linkloop to remote host.** Enter the link level address (station address) of the remote host in hexadecimal form (preceded by “0x”). Execute lanscan (1M) to find the link level address (station address) on the remote host or obtain it from your network map.
- B.** **linkloop successful?** If the test was successful, network connectivity is okay through the Link Layer (OSI Layer 2). Go to Flowchart 10. If it failed, note which error was returned and continue with this flowchart. NOTE: Make sure the remote host is an HP 9000 Series 700/800 and try again.
- C.** **Loopback FAILED; Address has bad format.**
The link level address is not correct. Go to F.
- D.** **Loopback FAILED; Not an individual address.**
The link level address is not correct. The second hexadecimal digit is odd. This means it is a multicast or broadcast address, which is not allowed. The address must be unique to one remote host. Go to F.
- E.** **Loopback FAILED.** The remote host did not respond. Go to G.
- F.** **Correct the link address parameter.** Change the link level address to an allowed value and start again with Flowchart 9.
- G.** **Choose a different host; re-execute linkloop.** Restart this flowchart using a different remote host.
- H.** **linkloop successful?** If the test was successful, go to Flowchart 10. Network connectivity is okay through the Link Layer (OSI Layer 2). If not successful, go to I.
- I.** **Check remote host's connectivity to FDDI.**
Contact the node manager of the remote host. Check that the host is configured correctly and that its network interface is up. If necessary, use Flowchart 8 to verify configuration of the remote host.

Flowchart 10: Gateway Configuration Test

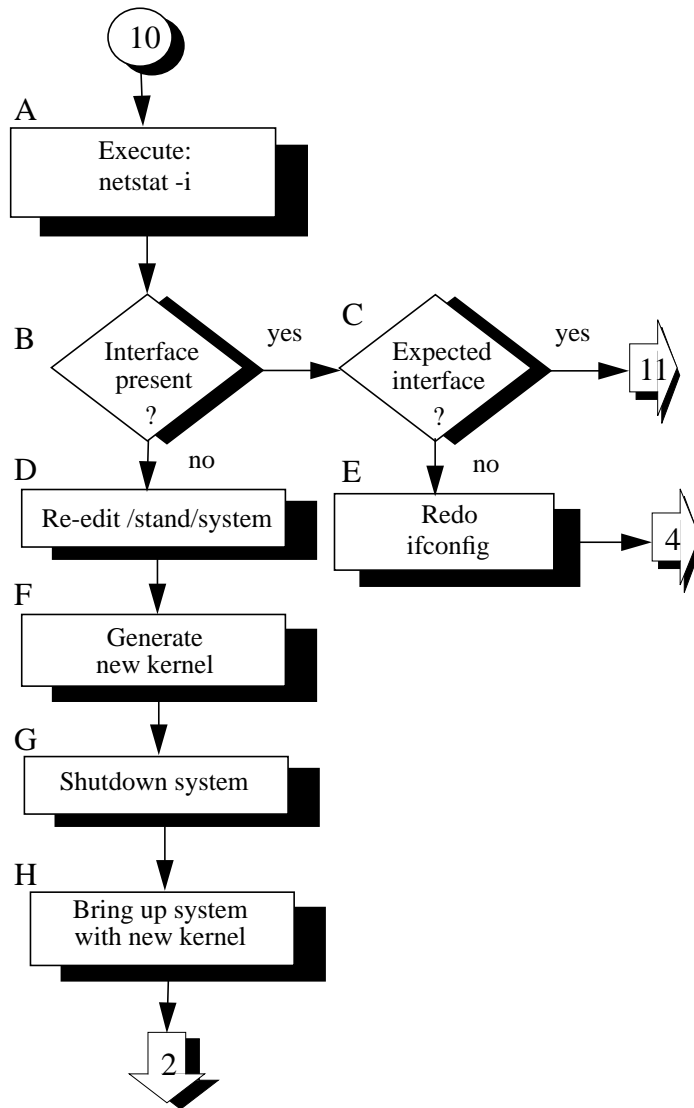

Flowchart 10 Procedures

- A.** **Execute netstat -i.** Check that the network interface exists. At the system prompt, type:
- ```
netstat -i
```
- B.**           **Interface present?** Check that the network interface exists. If it does, but with a network interface name you do not expect, go to C to reassign the network interface. If the network interface does not exist, proceed to step D.
- C.**           **Expected interface?** If it exists but with a network interface name you do not expect, go to E to reassign the network interface. If it has the expected interface, go to Flowchart 11.
- D.**           **Re-edit /stand/system.** Add entries for an extra FDDI adapter. Go to F.
- E.**           **Redo ifconfig(1M).** Specify the network interface returned in step A. Start again with Flowchart 4.
- F.**           **Generate new kernel.** Generate a new kernel and go to G.
- G.**           **Shutdown system.** Shutdown the system and go to H.
- H.**           **Bring-up system with new kernel.** Bring up the system and start again with Flowchart 2.

### Flowchart 11: Gateway Loopback Test

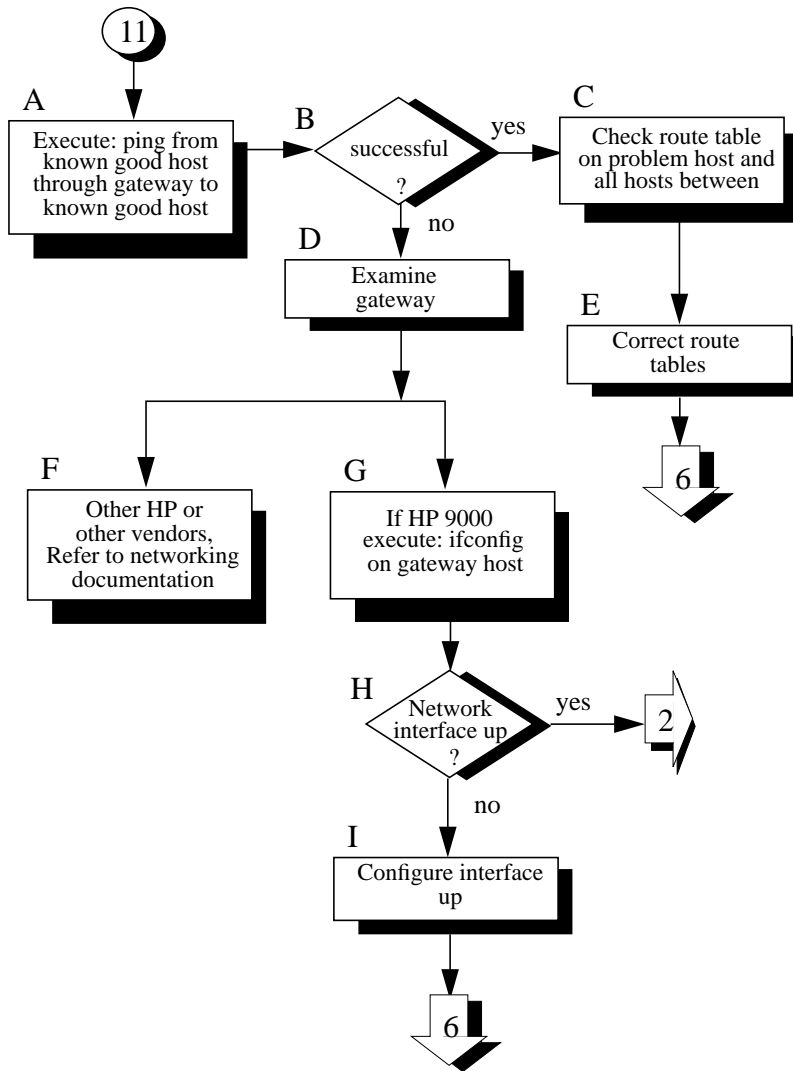

#### Flowchart 11 Procedures

- A.**            **Execute: ping from known good host through gateway to known remote host.** This will test gateway connectivity to the remote network.
- B.**            **Successful?** If ping was successful, the problem may exist in the routing table for the problem host. Go to C. If not, go to D.
- C.**            **Check route table on problem host and all hosts between.** Execute netstat -r to examine a route table. Go to E.
- D.**            **Examine gateway.** If the gateway is an HP 9000, go to G. If it is not, go to F.
- E.**            **Correct route tables.** Ensure that the proper IP addresses are assigned in the Destination and Gateway fields. If you are using subnetting, make sure that the destination is what you expect: a network or a host. Go to Flowchart 6.
- F.**            **If other HP or other vendors, refer to networking documentation.** Refer to the documentation that came with the gateway for additional diagnostics.
- G.**            **If HP 9000, execute: ifconfig on gateway host.** Execute ifconfig for all network interfaces on the gateway.
- H.**            **Network interface up?** If the output from ifconfig does not include the UP parameter, the network interface is down. Execute netstat -i to check the status of the network interfaces. An asterisk (\*) indicates that the interface is down. If the network interface is down, go to I. If the network interfaces are UP, go to Flowchart 2. Test all network interfaces on the gateway. Running is always displayed. It indicates only that there is OS support for the interface.

Troubleshooting HP FDDI/9000  
Diagnostic Flowcharts

- I.           **Configure interface up.** Execute ifconfig on each interface to bring it up. Start again with Flowchart 6. Test all network interfaces on the gateway.

---

## Index

---

### Symbols

/etc/dmesg, 41  
/etc/hosts, 52  
  editing with SAM, 50  
/etc/route  
  and SAM, 50

### A

A port, 25, 29  
Adapter  
  and MIC connector, 59  
  configuring, 47  
  installing, 40  
  moving, 48  
adapter bay, gaining access, 39  
Address Resolution Protocol, 75  
ANSI X3T9.5, 23  
arp  
  manpage, 14

### B

B port, 25, 29  
BIND name service, 46

### C

Concentrator, 26, 59  
Configuration State (CF\_State), 28  
Configuring  
  FDDI adapters, 47  
  gateways, 50  
  network connectivity, 50  
contacting HP, 21  
Counter  
  error, 31  
  frame, 31  
  receive, 31  
  transmit, 31

### D

Device files  
  creating, 19  
  S700, 19  
  S800, 20  
Diagnostics  
  ping(1M), 52  
DNA, see Downstream NeighborsAddress  
documentation  
  related FDDI, 5

documenting problems, 21  
Domain name format, 46  
Downstream Neighbors Address, 27  
dual attach, 28  
dual homing, 28  
Dual-attached  
  concentrators, 26  
  stations, 26

### E

E indicator, 31  
EISA interface, 40, 64  
Encapsulation method, 47  
error messages, 16

### F

Fault, 25  
FDDI  
  connections test, 59  
  dual ring, 26  
  fault tolerance, 28  
  network map, 24  
  reconfiguration, 28  
  related documentation, 5  
  ring state, 63  
  standard, 23  
  topology, 26  
fddiinit  
  manpage, 14  
fddinet, 59  
  manpage, 14  
fddissetup  
  manpage, 14  
fddistat, 63  
  manpage, 14  
fddistop  
  manpage, 14  
Fiber-optic  
  cable, 36, 59  
  ring, 26  
Filesets, removing FDDI, 36  
Format, domain name, 46

### G

Gateway  
  configuring, 50  
  testing, 80, 81  
grounding wrist strap, 39

### H

Hardware  
  diagnostic, 67  
  path, 47, 63  
  selftest, 67  
  slot numbers, 47  
hosts file, 52

### I

ifconfig(1M)  
  configuration testing, 69, 81  
  error messages, 71  
  manpage, 14  
installation  
  verifying, 49  
installing  
  FDDI/9000 software, 33  
  hardware, 40  
  prerequisites, 36  
Instance number, 19  
ioscan(1M), 64  
IP address  
  configuring with SAM, 45  
IP addresses  
  reconfiguring, 54  
Isolated, 29

### K

kernel  
  driver status, 64

### L

LAN adapter  
  configuring, 47  
  initializing, 47  
LAN network interface, power-up, 48  
lanscan  
  command, 49  
  manpage, 14  
LEM, see Link Error Monitor  
LER  
  Link Error Rate, 30  
LER\_Estimate  
  Link Error Rate Estimate, 30  
Link Error Monitor (LEM), 30  
Link Error Rate (LER), 30  
Link Error Rate Estimate (LER\_Estimate),  
  30

---

## Index

---

- linkloop, 79
  - manpage, 14
- LLC, see Logical Link Control
- Loading software, 37
- logging, 16
- Logical Link Control (LLC), 24
- Loopback tests
  - gateway, 83
  - link level, 57
  - network level, 72
  - transport level (ARPA), 76
- ls command, 49
  
- M**
- M port, 26, 59
- MAC, see Media Access Control
- manpage
  - arp, 14
  - fddiinit, 14
  - fddinet, 14
  - fddissetup, 14
  - fddistat, 14
  - fddistop, 14
  - ifconfig, 14
  - lanscan, 14
  - linkloop, 14
  - netfmt, 14
  - netstat, 14
  - nettl, 14
  - ping, 14
  - route, 15
- manual reference page, see manpage
- Master port
  - M port, 59
- Media Access Control (MAC), 24, 28
- messages, 16
  - logging and tracing, 16
- MIC connector, 59
  
- N**
- Negotiated Target Token Rotation Time (T\_Neg), 26
- netfmt
  - manpage, 14
- netstat
  - command, 52
  - configuration testing, 81
  - manpage, 14
  
- nettl, 16
  - manpage, 14
- Network
  - interface, 47
  - map, 24
- network interface cards
  - if you've rearranged, 54
  
- O**
- Optical bypass, 28
- OSI model, 23
  
- P**
- PHY
  - Physical Layer Protocol, 24
- Physical Layer Protocol (PHY), 24
- Physical Medium Dependent (PMD) layer, 24
- ping
  - manpage, 14
  - network level loopback test, 73
- ping(1M), 52
- PMD, see Physical Medium Dependent layer
- prerequisites for installation, 36
  
- R**
- Reboot using shutdown(1M), 65
- reconfiguring
  - IP addresses, 54
- Removing FDDI filesets, 36
- Requested Token Rotation Time (T\_Req), 26
- Ring Management State (RMT), 26, 63
- route
  - manpage, 15
  
- S**
- S port, 28
- SAM, see System Administration Manager
- shutdown(1M), 64
- Single attached stations, 26
- Slave port
  - S port, 28
- SMT
  - Station Management unit, 26
- Software
  - configuring with SAM, 47
  
- loading, 37
- unloading, 38
- static electricity, safeguarding against, 39
- Station Management standard, 24
- Station Management unit (SMT), 26
- Station state, 28
- Stations
  - dual-attached, 26
  - single-attached, 26
- System Administration Manager
  - configuring FDDI adapters, 47
  - configuring network connectivity, 50
  - description of, 45
  - domain name format, 46
  - initializing FDDI adapters, 47
  
- T**
- T\_Req
  - Requested Token Rotation Time, 26
- Target Token Rotation Time (TTRT), 26
- TCP, see Transmission Control Protocol
- Testing
  - configuration, 62
  - connections, 59
  - gateway loopback, 83
  - link level loopback, 79
  - Network level loopback, 76
  - network level loopback, 72
- THT, see Token Holding Timer
- Token, 26
- Token Holding Timer (THT), 26
- tracing, 16
- Transmission Control Protocol
  - transport level loopback test, 77
- Troubleshooting
  - contacting HP representative, 21
  - software, 62
- TTRT, see Target Token Rotation Time
  
- U**
- uname(1), 21, 36
- Unloading software, 38
- update(1M), 37
- Upstream NeighborsAddress, 27
  
- V**
- Verifying
  - LAN installation, 52

---

## Index

---

**W**  
Wrap\_A, 29  
Wrap\_B, 29  
Wrap\_S, 29