

VOLUME A07 MACHINE 4381- -0010900 MODEL R03 SYSTEM 0000LBH MODE

SCHED SHIP 84/10/30

LOGIC TYPE -0- SYSTEMS DIAGRAMS

DOC COUNTER

PAGE	NUM	SH	TITLE	PART NUM	EC NUM	FEATURE B/M OR B/MS
GA005				0006169378	A20558	.W. 0002676380
GA007			LOCATIONS	0000446141	A02214	.W. 0002676380
GA010			LOC 011	0006169577	A20560	.W. 0002676380
GA015			LOC 015	0006169578	A20558	.W. 0002676380
GA020			LOC 021	0006169579	A20558	.W. 0002676380
GA025			LOC 025	0006169580	A20560	.W. 0002676380
GA030			LOC 031	0006169581	A20558	.W. 0002676380
GA035			LOC 035	0006169582	A20560	.W. 0002676380
GA040			LOC 041	0006169583	A20562	.W. 0002676380
GA045			LOC 045	0006169584	A20562	.W. 0002676380
GA050			LOC 051	0006169585	A20562	.W. 0002676380
GA055			LOC 055	0006169586	A20558	.W. 0002676380
GA060			LOC 061	0006169587	A20560	.W. 0002676380
GA065			LOC 065	0006169588	A20560	.W. 0002676380
GA070			LOC 071	0006169589	A20559	.W. 0002676380
GB003			TOOLS	0000446158	A02214	.W. 0002676380
GB005			TOOLS 005	0006169613	A20560	.W. 0002676380
GB010			TOOLS 011	0006169614	A20560	.W. 0002676380
GB015			TOOLS 015	0006169615	A20562	.W. 0002676380
GB020			TOOLS 021	0006169616	A20558	.W. 0002676380
GC003			REMOVALS	0000446163	A02214	.W. 0002676380
GC005			REM 001	0006169557	A20562	.W. 0002676380
GC010			REM 003	0006169558	A20562	.W. 0002676380
GC015			REM 015	0006169559	A20562	.W. 0002676380
GC020			REM 021	0006169560	A20562	.W. 0002676380
GC025			REM 025	0006169561	A20562	.W. 0002676380
GC030			REM 031	0006169562	A20562	.W. 0002676380
GC035			REM 035	0006169563	A20562	.W. 0002676380
GC040			REM 041	0006169564	A20562	.W. 0002676380
GC045			REM 045	0006169565	A20562	.W. 0002676380
GC050			REM 051	0006169566	A20562	.W. 0002676380
GC055			REM 055	0006169567	A20562	.W. 0002676380
GC060			REM 061	0006169568	A20562	.W. 0002676380
GC065			REM 065	0006169569	A20562	.W. 0002676380
GC070			REM 071	0006169570	A20562	.W. 0002676380
GC075			REM 075	0006169571	A20562	.W. 0002676380
GC080			REM 081	0006169572	A20562	.W. 0002676380
GC085			REM 085	0006169573	A20562	.W. 0002676380
GC090			REM 091	0006169574	A20562	.W. 0002676380
GC095			REM 095	0006169575	A20562	.W. 0002676380
GC100			REM 101	0006169576	A20562	.W. 0002676380
GD003			PREVENTIVE	0000446181	A02214	.W. 0002676380
GD005			PM 001	0006169617	A20558	.W. 0002676380
GE003			DIAGNOSTICS	0000446183	A02214	.W. 0002676380
GE005			DIAG 001	0006169394	A20558	.W. 0002676380
GE010			DIAG 005	0006169395	A20562	.W. 0002676380
GE015			DIAG 015	0006169396	A20558	.W. 0002676380
GE020			DIAG 025	0006169397	A20558	.W. 0002676380
GE025			DIAG 035	0006169398	A20558	.W. 0002676380
GE030			DIAG 045	0006169399	A20558	.W. 0002676380
GE035			DIAG 055	0006169400	A20558	.W. 0002676380
GE040			DIAG 075	0006169401	A20558	.W. 0002676380
GE045			DIAG 085	0006169402	A20558	.W. 0002676380
GE050			DIAG 095	0006169403	A20558	.W. 0002676380
GE055			DIAG 105	0006169404	A20558	.W. 0002676380
GE060			DIAG 115	0006169405	A20558	.W. 0002676380
GE065			DIAG 125	0006169406	A20558	.W. 0002676380
GE070			DIAG 135	0006169407	A20558	.W. 0002676380
GE075			DIAG 145	0006169408	A20562	.W. 0002676380
GE080			DIAG 155	0006169409	A20558	.W. 0002676380
GE085			DIAG 165	0006169410	A20558	.W. 0002676380
GE090			DIAG 175	0006169411	A20559	.W. 0002676380
GF003			LOGS	0000446204	A02214	.W. 0002676380
GF005			LOG 001	0006169379	A20560	.W. 0002676380
GF010			LOG 015	0006169380	A20558	.W. 0002676380
GF015			LOG 031	0006169381	A20558	.W. 0002676380
GF020			LOG 035	0006169382	A20558	.W. 0002676380
GF025			LOG 045	0006169383	A20558	.W. 0002676380
GF030			LOG 075	0006169384	A20559	.W. 0002676380
GF035			LOG 085	0006169385	A20558	.W. 0002676380
GG003			SYS TEST	0000446215	A02214	.W. 0002676380
GG005			SYS TEST 001	0006169386	A20558	.W. 0002676380
GG010			SYS TEST 015	0006169387	A20560	.W. 0002676380
GG015			SYS TEST 025	0006169388	A20558	.W. 0002676380
GG020			SYS TEST 035	0006169389	A20558	.W. 0002676380
GG025			SYS TEST 045	0006169390	A20560	.W. 0002676380
GG030			SYS TEST 065	0006169391	A20558	.W. 0002676380
GG035			SYS TEST 095	0006169392	A20558	.W. 0002676380
GG040			SYS TEST 125	0006169393	A20558	.W. 0002676380
GH003			INSTALLATION	0000446226	A02214	.W. 0002676380
GH005			INST 001	0006169590	A20562	.W. 0002676380
GH010			INST 011	0006169591	A20562	.W. 0002676380
GH015			INST 015	0006169592	A20559	.W. 0002676380
GH020			INST 021	0006169593	A20562	.W. 0002676380
GH025			INST 025	0006169594	A20560	.W. 0002676380
GH030			INST 031	0006169595	A20560	.W. 0002676380

VOLUME A07 MACHINE 4381- -0010900 MODEL R03 SYSTEM 0000LBH MODE

SCHED SHIP 84/10/30

LOGIC TYPE -0- SYSTEMS DIAGRAMS

DOC COUNTER

PAGE NUM	SH	TITLE	PART NUM	EC NUM	FEATURE B/M OR B/MS
GH035		INST 035	0006169596	A20560	.W. 0002676380
GH040		INST 041	0006169597	A20560	.W. 0002676380
GH045		INST 045	0006169598	A20562	.W. 0002676380
GH050		INST 051	0006169599	A20560	.W. 0002676380
GH055		INST 055	0006169600	A20560	.W. 0002676380
GH060		INST 061	0006169601	A20562	.W. 0002676380
GI003		INSPECTION	0000446238	A02214	.W. 0002676380
GI005		INSP 001	0006169618	A20558	.W. 0002676380
GI010		INSP 003	0006169619	A20562	.W. 0002676380
GI015		INSP 005	0006169620	A20558	.W. 0002676380
GI020		INSP 007	0006169621	A20558	.W. 0002676380
GI025		INSP 009	0006169622	A20558	.W. 0002676380
GI030		INSP 011	0006169623	A20558	.W. 0002676380
GI035		INSP 013	0006169624	A20558	.W. 0002676380
GI040		INSP 015	0006169625	A35269	.W. 0002676380
GI045		INSP 017	0006169626	A20558	.W. 0002676380

TOTAL PART NUMBERS THIS VOLUME 102

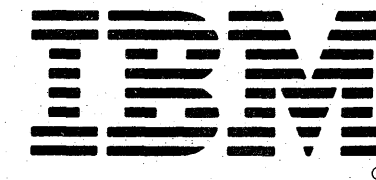

Maintenance Information

4381-3 S/N MI	4381-3 S/N MI	4381-3 S/N MI	4381-3 S/N MI	4381-3 S/N MI	4381-3 S/N MI	4381-3 S/N MI	4381-3 S/N MI
MAINTENANCE INFORMATION	MAINTENANCE INFORMATION	MAINTENANCE INFORMATION	MAINTENANCE INFORMATION	MAINTENANCE INFORMATION	MAINTENANCE INFORMATION	MAINTENANCE INFORMATION	MAINTENANCE INFORMATION
SAFETY INDEX TERMS/ABBREVIATIONS INTRODUCTION START PU REPAIR CHNL REPAIR MSS REPAIR END OF REPAIR	PWR REPAIR (HWS AND MBC) PR 001 THRU PR 999	PWR REPAIR (PROC) PR 1001 THRU PR 13 XX	PWR REPAIR (PROC) PR 1401 THRU PR 18 XX	PWR REPAIR (PROC) PR 1901 THRU PR 5001	SERVICE AIDS	LOCATIONS TOOLS REMOVAL/REPLACEMENT PREVENTIVE MAINTENANCE DIAGNOSTICS LOGS SYSTEM TEST INSTALLATION SAFETY INSP	CONSOLE FUNCTIONS MESSAGES
VOL A01	VOL A02	VOL A03	VOL A04	VOL A05	VOL A06	VOL A07	VOL A08



Processor
Maintenance Information

The drawings and specifications contained herein shall not be reproduced in whole or in part without written permission.

IBM has prepared this maintenance manual for you in the use for installation, maintenance, or repair of the specific machine indicated. IBM makes no representation that it is suitable for any other purpose.

Information contained in this manual is subject to change from time to time. Any such change will be reported in subsequent revisions or Technical Newsletters.

It is possible that this material may contain reference to, or information about IBM products (machines and programs), programming, or services that are not announced in your country. Such references or information must not be construed to mean that IBM intends to announce such IBM products, programming, or services in your country.

Publications are not stocked at the address below; requests for IBM publications should be made to your IBM representative or to the IBM branch office serving your locality.

A form for reader's comments is provided in Volume A01, Introduction. If the form has been removed, comments may be addressed to IBM Corporation, Processor MIM Development, Department X65, P.O. Box 6, Endicott, NY, U.S.A. 13760. IBM may use or distribute whatever information you supply in any way it believes appropriate without incurring any obligation to you.

4381
B/M 2676380

Mi Seq GA005	PN 6169378 2 of 2	EC A20558 01 Oct 84				
-----------------	----------------------	------------------------	--	--	--	--



LOCATIONS

LOC 011

Contents

Machine Layout	LOC 012
Gate Layouts	LOC 015
Gate 01A	LOC 015
Front View	LOC 015
Right-Side View	LOC 015
Rear View	LOC 016
Gate 01B	LOC 021
Right-Side View	LOC 021
Rear View/Gate 01B Open	LOC 021
Gate 01C	LOC 022
Front View	LOC 022
Rear View	LOC 022
Gates 01D, 01F, 01G, and 01H	LOC 025
Gate 01E	LOC 026
Board Layouts	LOC 031
Board 01A-A1	LOC 031
Functional Locations	LOC 031
Board 01A-A2	LOC 032
Functional Locations	LOC 032
Board 01A-A3	LOC 035
Functional Locations	LOC 035
Board 01A-A4 (1 Megabyte Cards)	LOC 036
Functional Locations	LOC 036
Board 01A-A4 (2 Megabyte Cards)	LOC 037
Functional Locations	LOC 037
Board 01A-A4 (1 and 2 Megabyte Cards Intermixed)	LOC 038
Functional Locations	LOC 038
Board 01B-A1	LOC 041
Functional Locations	LOC 041
Pin Layout for Boards 01A-A1 to 01A-A4 and 01B-A1	LOC 042
Board 01A-B1 or 01A-B2	LOC 045
Functional Locations	LOC 045
Board 01A-B1 or 01A-B2 Resistor Pin Layout	LOC 046
Board 01A-B1 or 01A-B2 Module Pin and I/O Signal Pin Layout	LOC 047
Board 01A-B1 or 01A-B2 Terminals	LOC 048
Connectors	LOC 051
Top Card Crossover (TCC) Connectors	LOC 052
Service Panel	LOC 055
Operator Control Panel (OCP)	LOC 056
Power Supplies	LOC 061
Sense Capacitors	LOC 062
Transformers	LOC 065
Primary Control Compartment (PCC)	LOC 066
Relays and Circuit Protectors (CPs)	LOC 071

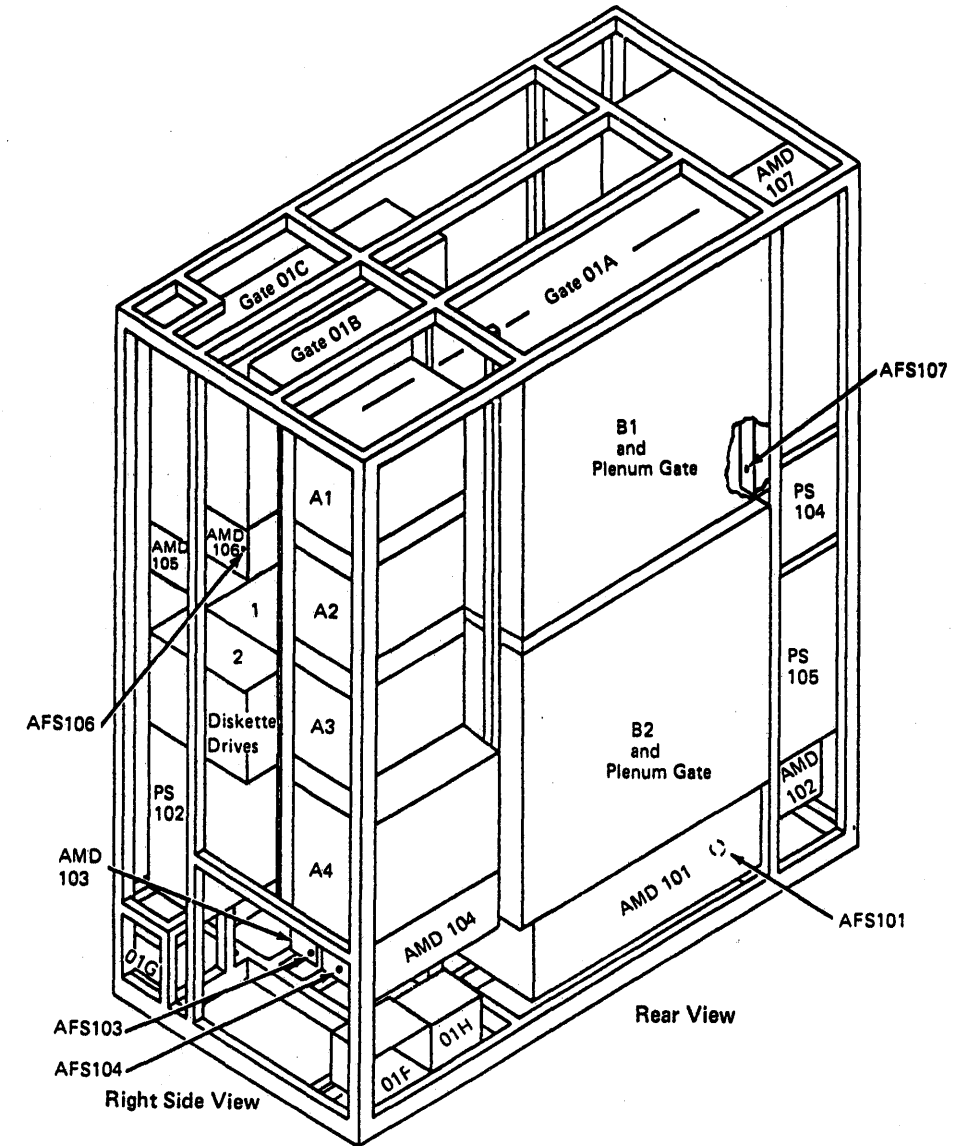
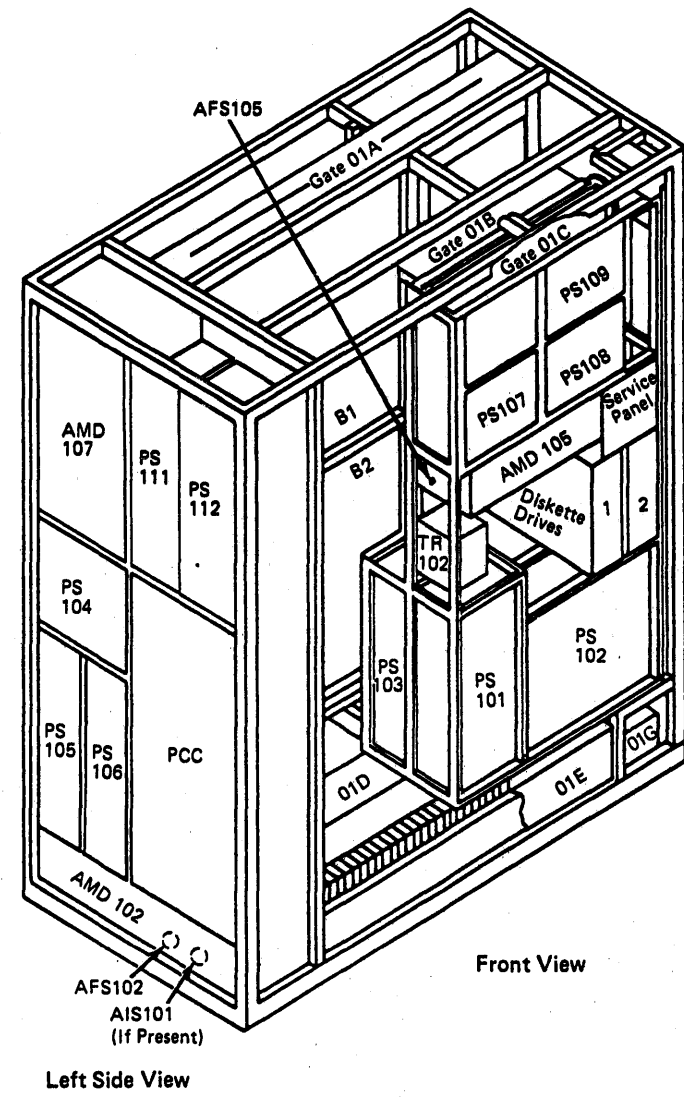

4381-3	MI	PN 6169577	EC A20558	EC A20560			
B/M 2676380	Seq GA010	2 of 2	01 Oct 84	18 Feb 85			

© Copyright IBM Corp. 1984

Gate Layouts

LOC 015

Gate 01A

Front View

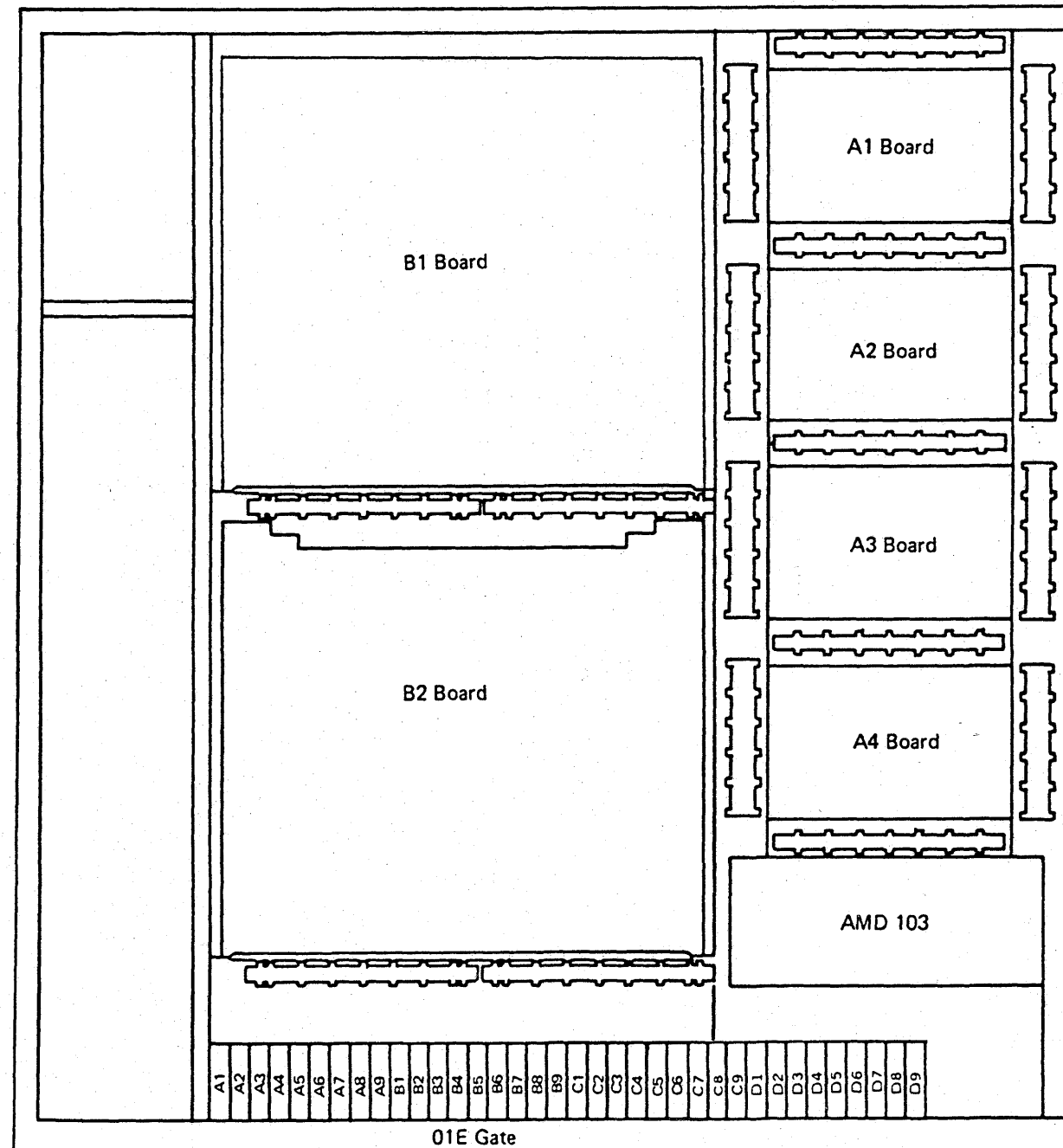

Gate 01A Pin Side
(Behind Gate 01C)

Right-Side View

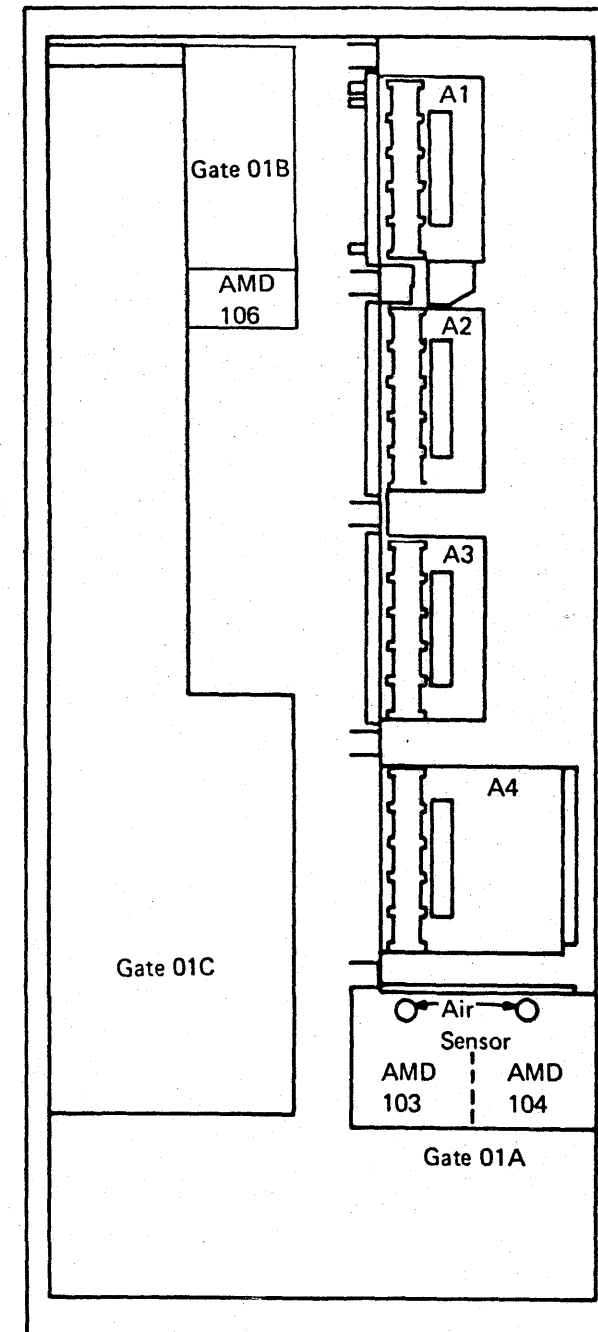

Gate 01A

Rear View

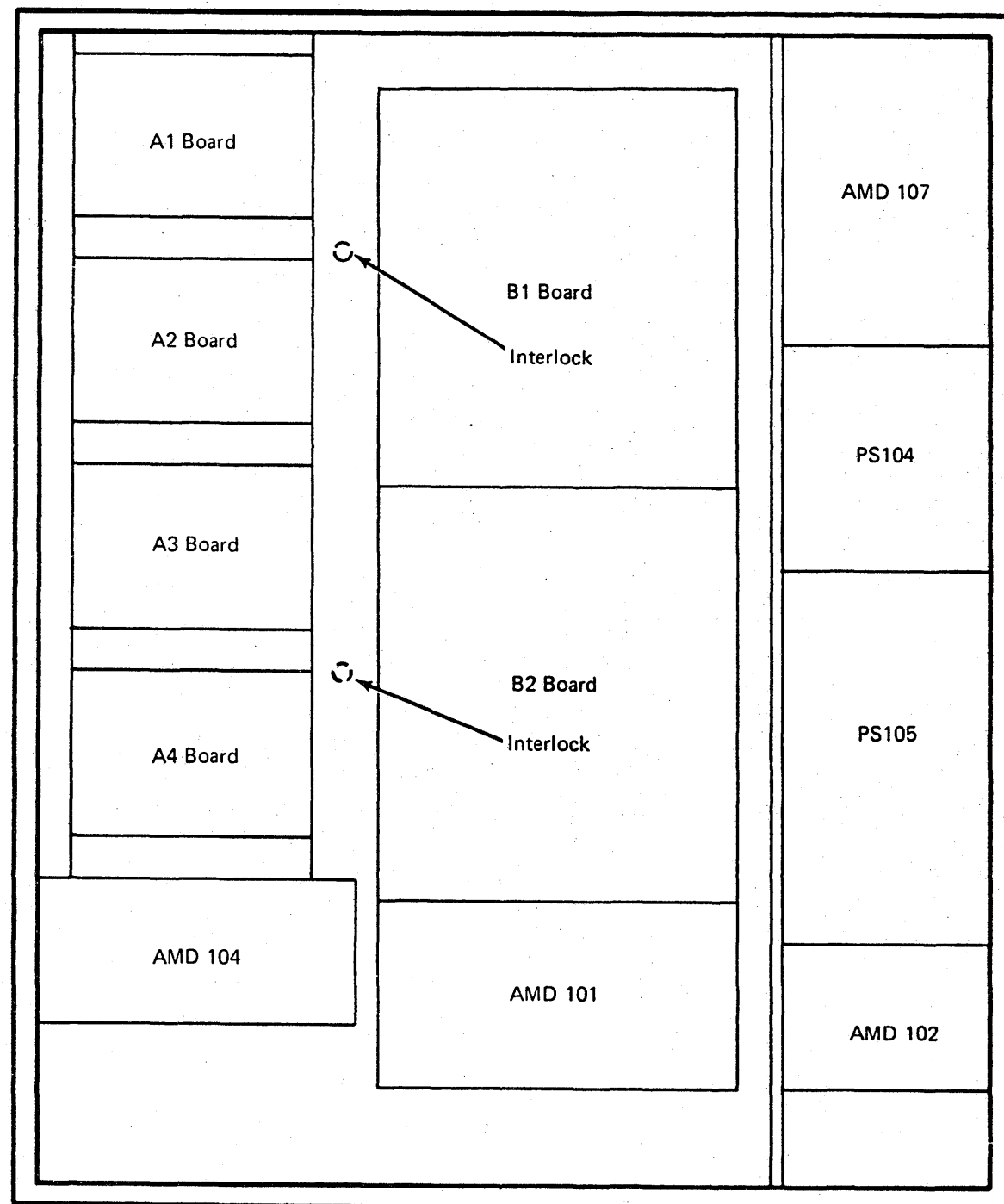

4381	MI	PN 6169578	EC A20558				
B/M 2676380	Seq GA015	2 of 2	01 Oct 84				

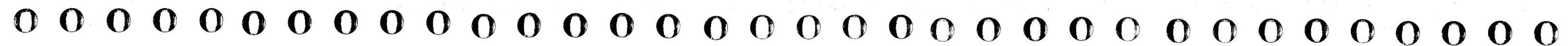

Gate 01B

Right-Side View

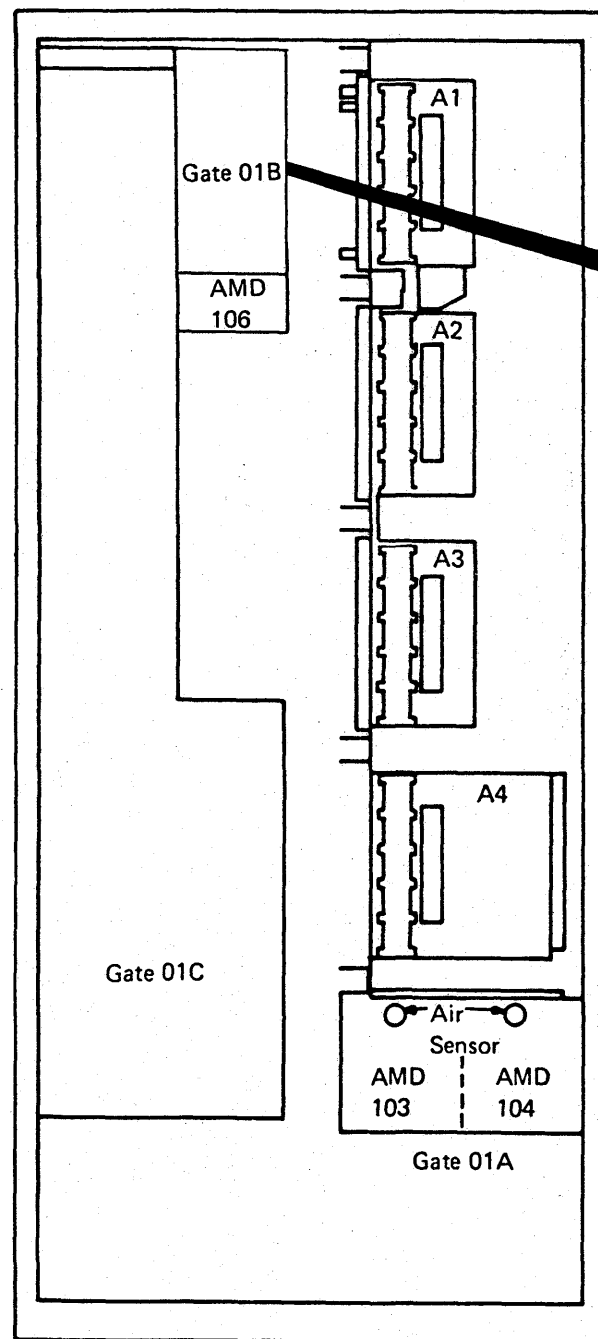

Rear View/Gate 01B Open

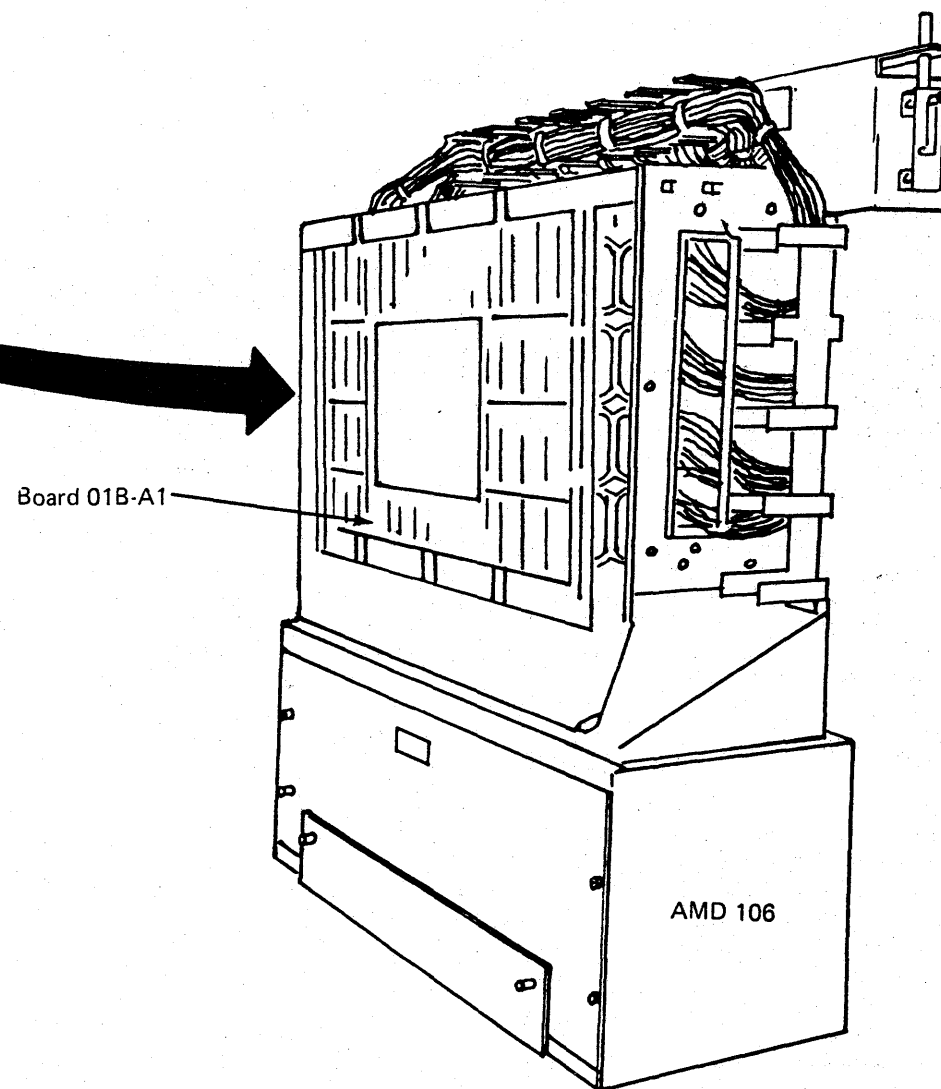

Gate 01C

Front View

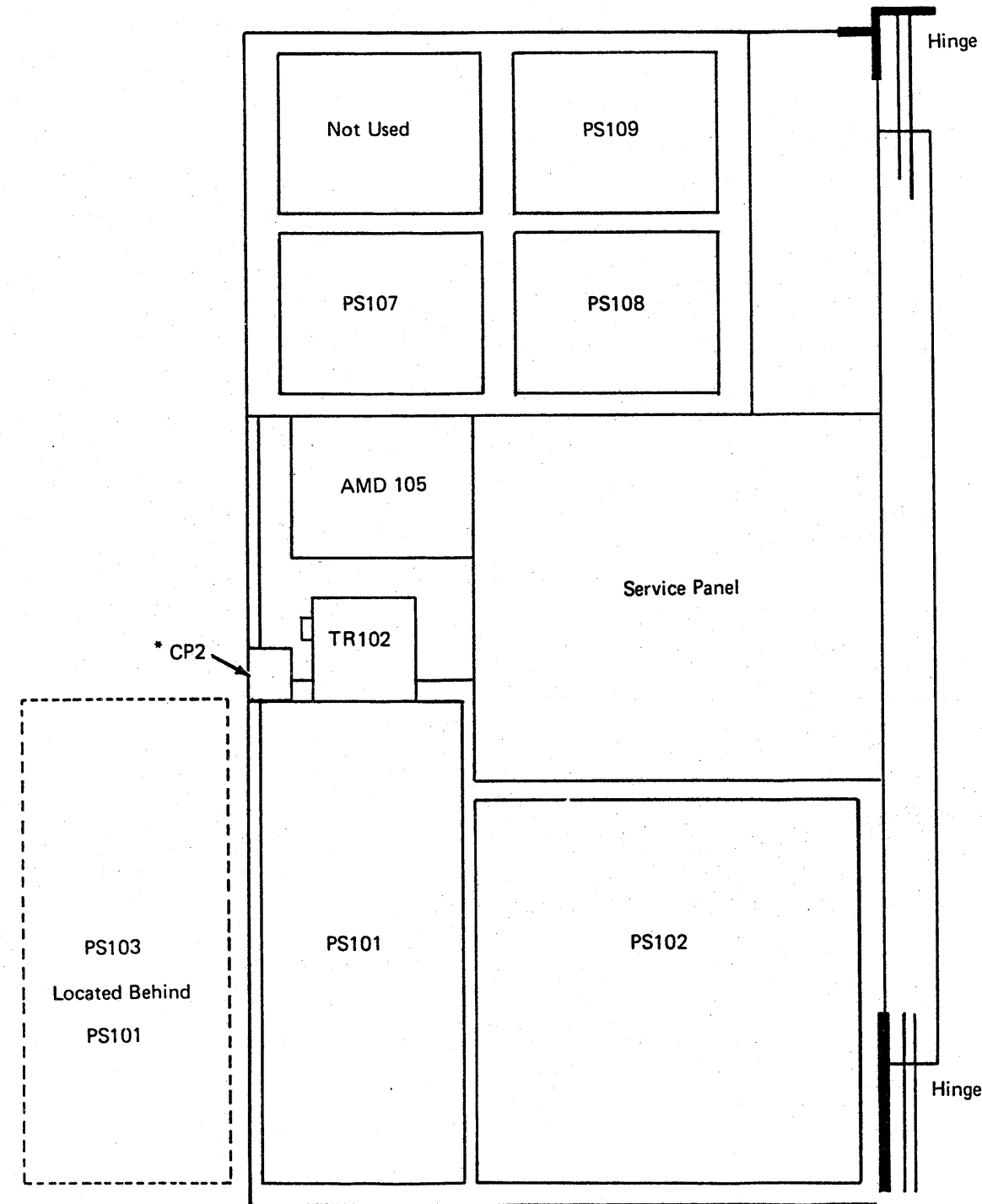

Rear View

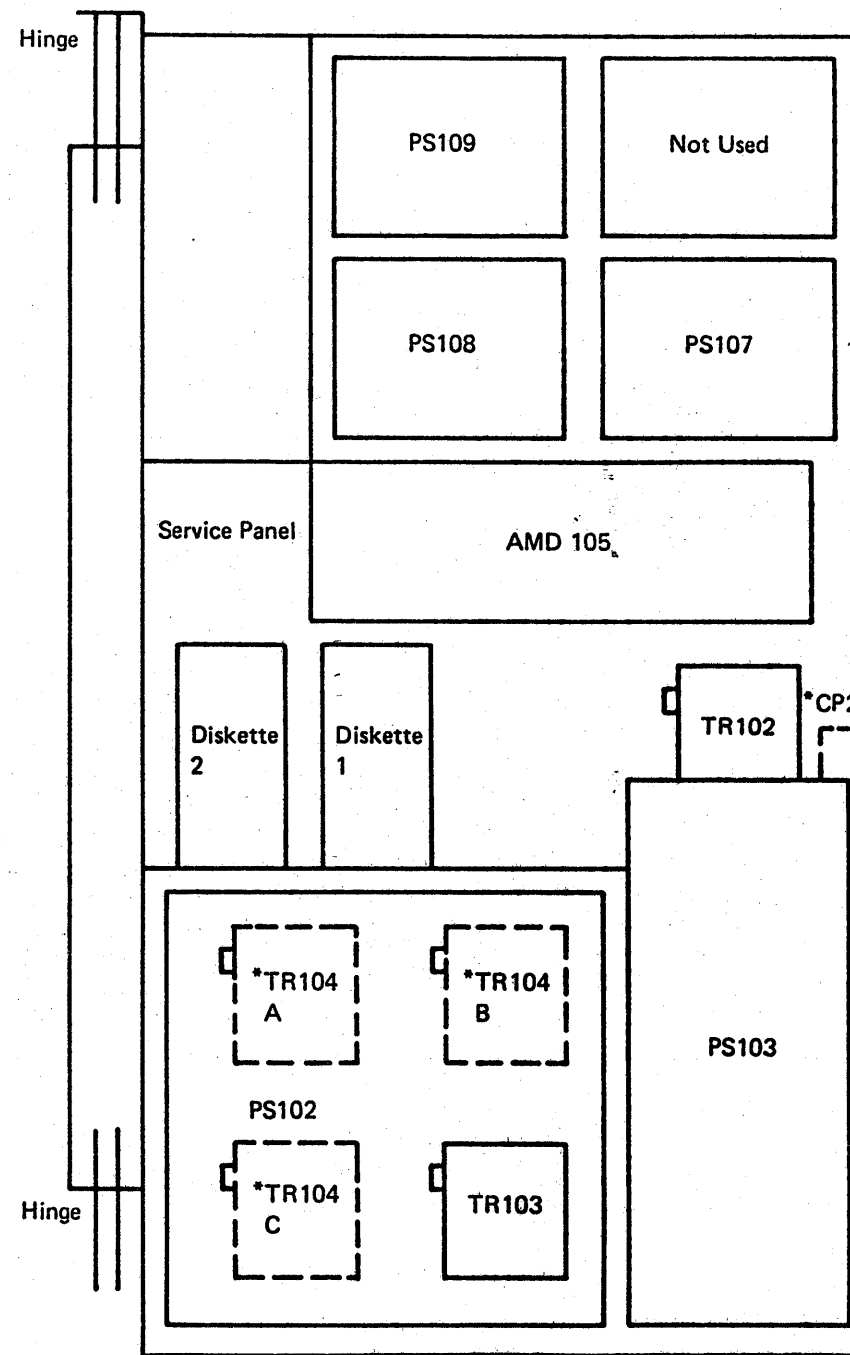

*TR104A, B, C, and CP2
Only on all 50 Hz and 60 Hz Japan machines

4381	MI	PN 6169579	EC A20558				
B/M 2676380	Seq GA020	2 of 2	01 Oct 84				

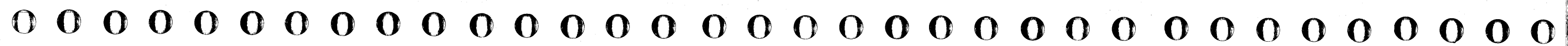

Gates 01D, 01F, 01G, and 01H

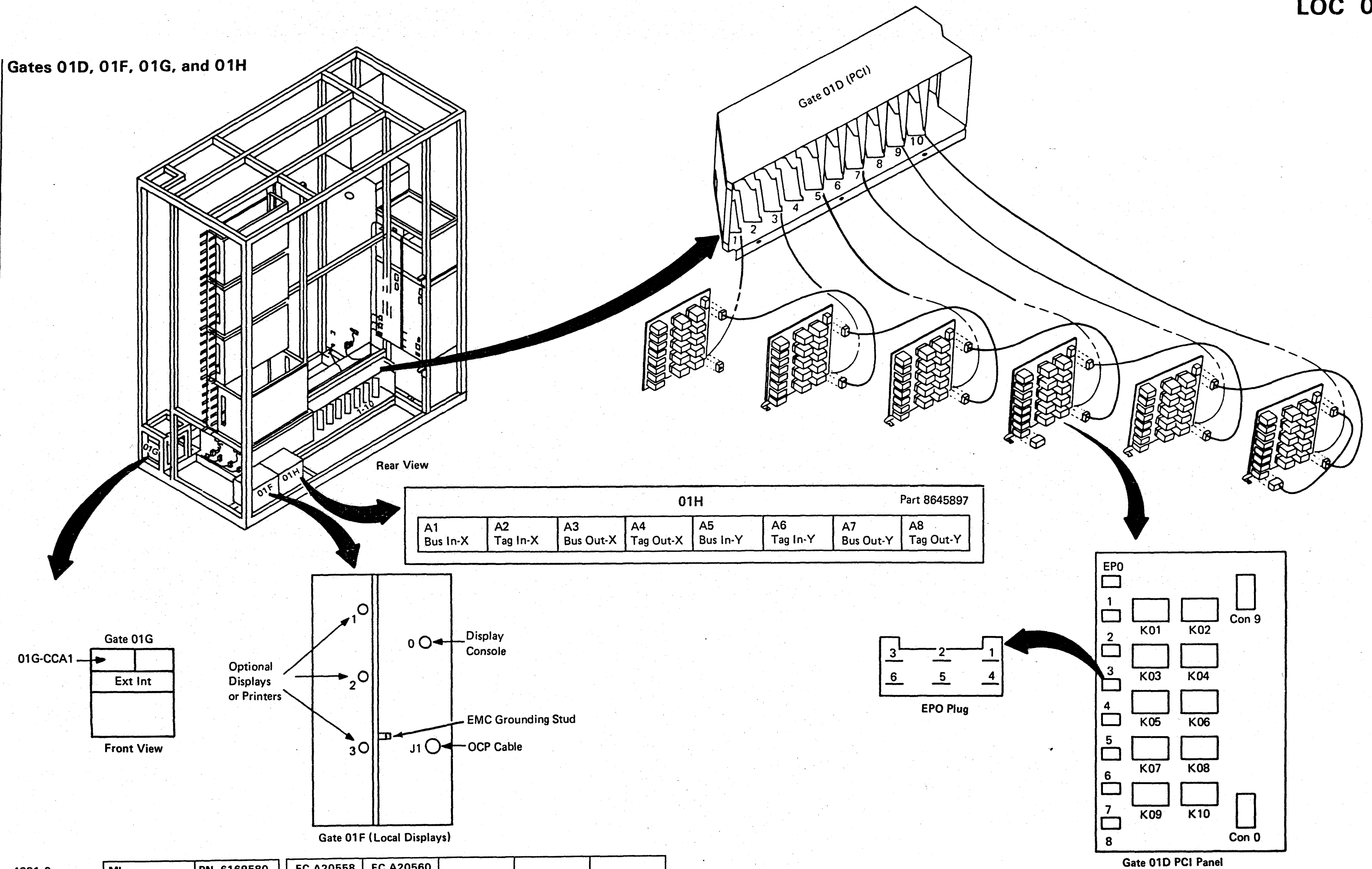

01H								Part 8645897
A1	A2	A3	A4	A5	A6	A7	A8	
Bus In-X	Tag In-X	Bus Out-X	Tag Out-X	Bus In-Y	Tag In-Y	Bus Out-Y	Tag Out-Y	

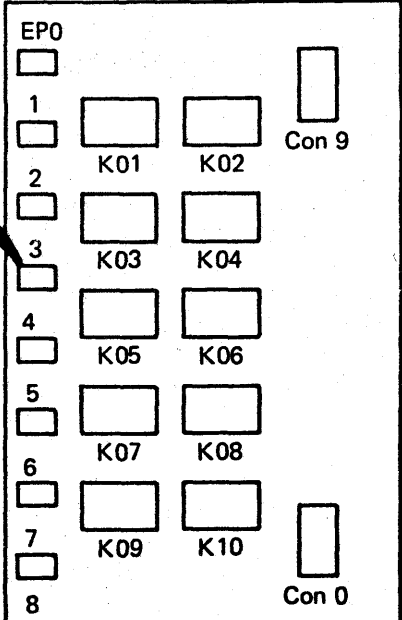
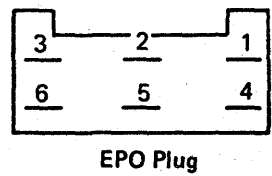
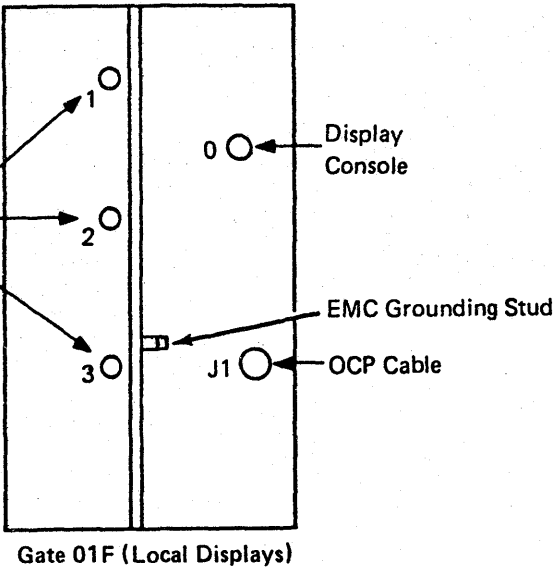

Gate 01E

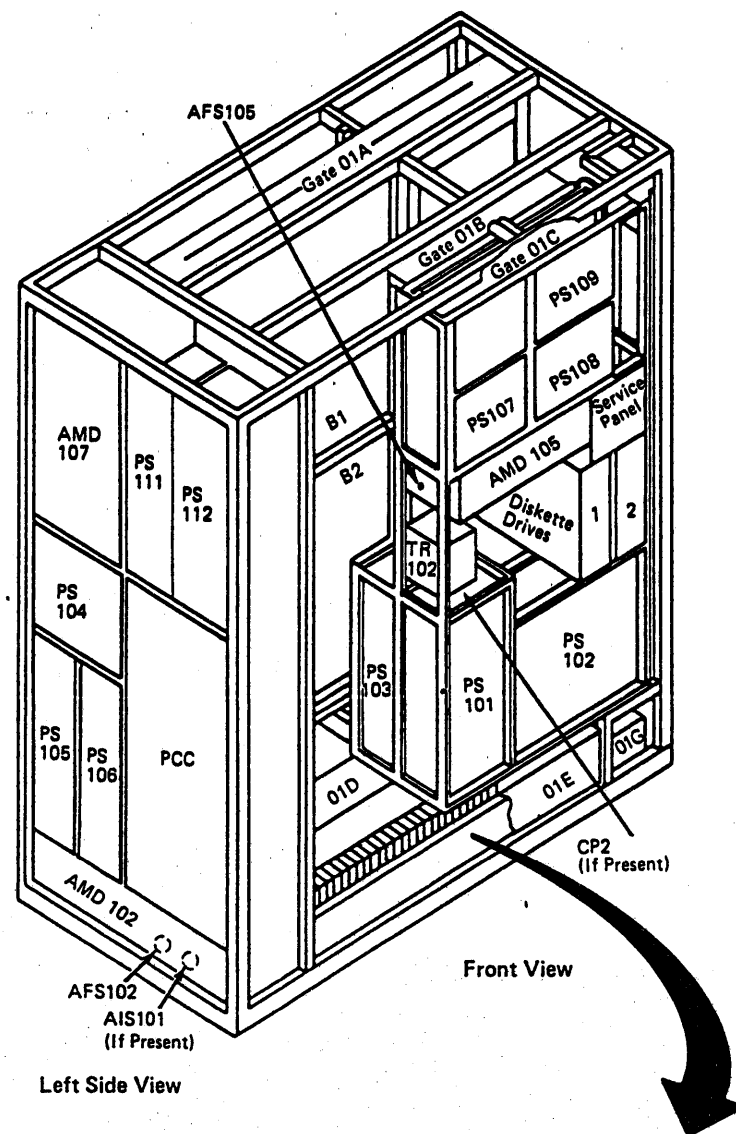

PU 0									PU 1																										
Channel 0	Channel 1	Channel 2	Channel 3	Channel 4	Channel 5	Channel 6	Channel 7	Channel 8	Channel 0	Channel 1	Channel 2	Channel 3	Channel 4	Channel 5	Channel 6	Channel 7	Channel 8																		
A1	A2	A3	A4	A5	A6	A7	A8	A9	B1	B2	B3	B4	B5	B6	B7	B8	B9	C1	C2	C3	C4	C5	C6	C7	C8	C9	D1	D2	D3	D4	D5	D6	D7	D8	D9
Bus	Tag	Bus	Tag	Bus	Tag	Bus	Tag	Bus	Tag	Bus	Tag	Bus	Tag	Bus	Tag	Bus	Tag	Bus	Tag	Bus	Tag	Bus	Tag	Bus	Tag	Bus	Tag	Bus	Tag	Bus	Tag	Bus	Tag	Bus	Tag

Gate 01E (Channel Interface)

4381-3 B/M 2676380 MI Seq GA025 PN 6169580 2 of 2 EC A20558 01 Oct 84 EC A20560 18 Feb 85

Board Layouts

Board 01A-A1

Functional Locations

Channel To Channel Adapter (CTCA)

Card Locations:

CTCA X B2
CTCA Y C2

Maintenance Bias Control (MBC)

Card Locations:

Reset Card U2
MBC V2

Card Plug Positions

- A2 X Bus I/O Cable
- A3 X Tag I/O Cable
- A4 Y Bus I/O Cable
- A5 Y Tag I/O Cable
- B2 CTCA X
- C2 CTCA Y
- D2 Spare
- E2 Spare
- F2 Spare
- G2 Spare
- H2 Spare
- J2 Spare
- K2 Spare
- L2 Spare
- M2 Spare
- N2 Spare
- P2 Spare
- Q2 Spare
- R2 Spare
- S2 Spare
- T2 Spare
- U2 Reset Card
- V2 MBC Card
- W2 Terminator Card
- X2 PPC Cable
- X3 Service Panel Cable
- X4 Service Panel Cable
- X5 Operator Control Panel

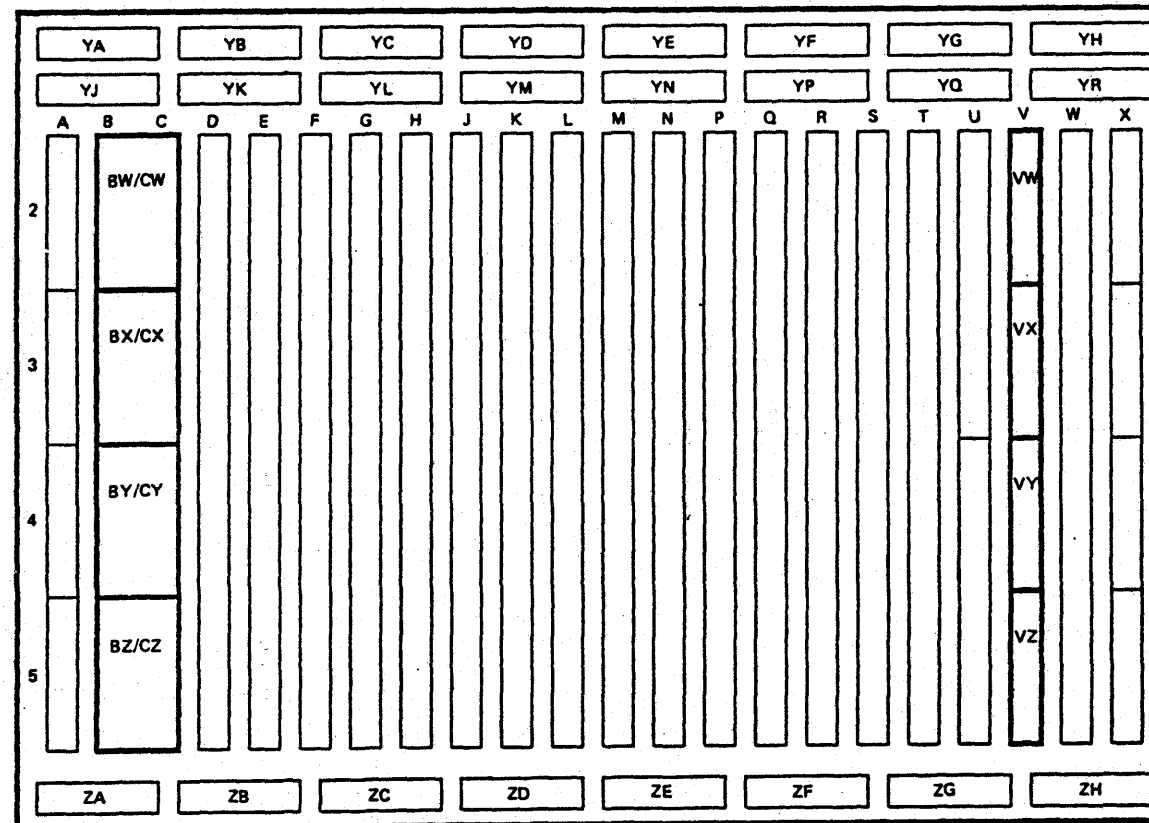

Note: Highlighted areas show the locations of Top Card Crossover (TCC) Connectors.

Top Card Connectors

Position	Part Number
BW/CW	8645658
BX/CX	8645658
BY/CY	8645658
BZ/CZ	8645658
VW	8645678
VX	8645678
VY	8645678
VZ	8645678

Cable Plug Positions

- YA Channel X Bus I/O
- YB Channel X Tag I/O
- YC Spare
- YD Spare
- YE Spare
- YF Spare
- YG PS101 Control
- YH Airflow Sensor (AFS)/PS102
- YJ Spare
- YK Spare
- YL Spare
- YM Power Control Lines and MBC
- YN Reset and T Lines
- YP Spare
- YQ Spare
- YR Spare
- ZA Channel Y Bus I/O
- ZB Channel Y Tag I/O
- ZC CTCA Voltage Sense to/from PCC
- ZD Spare
- ZE Spare
- ZF Volt Sense to MBC
- ZG Spare
- ZH Spare

Board 01A-A2

Functional Locations

Diskette Drive Adapter (DDA)

Card Locations:

Drive 1 K2
Drive 2 L2

Cable Locations:

Drive 1 ZD
Drive 2 ZF

Device Cluster Adapter (DCA)

Card Locations:

Q2, R2

Cable Locations:

Ports YN

Latch Display Card

Card Location:

G4

Local Channel Adapter (LCA)

Card Locations:

LCA 1 V2
LCA 2 X2
LCA 4 W2

Cable Locations:

LCA from CH/SP YQ
LCA to CH/SP YR
LCA Tailgate ZG
LCA Tailgate ZH

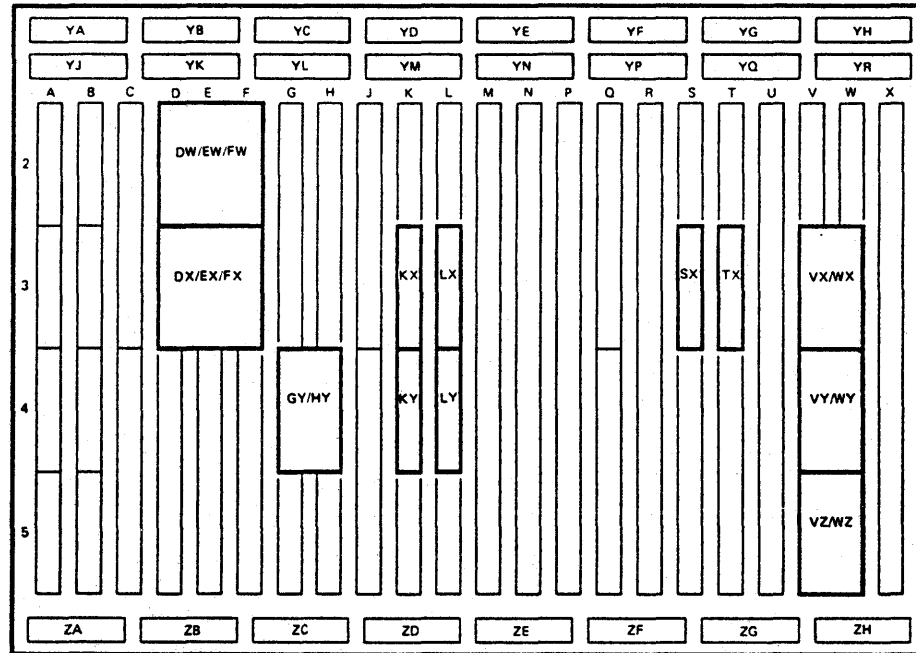

Note: Highlighted areas show the locations of Top Card Crossover (TCC) Connectors.

Power Control Adapter (PCA)

Card Locations:

PC Isolation C2
PC Isolation C4
PC Sense D2
PC Sense E2
PC Interface F2

Cable Locations:

A2,A3,A4,A5,
B2,B3,B4,B5

Remote Support Facility Adapter (RSF)

Card Locations:

P2,Q4

Cable Locations:

ZE

Serial Number Card

Card Locations:

F4

Support Bus Adapter (SBA)

Card Locations:

SBA 2 S2
SBA 1 T2
Convert Card U2

Cable Locations:

YE,YF,YG,YH

Support Processor (SP) and SP Storage (Volume 0)

Card Locations:

H2

Support Processor Storage (SPS) (Volume 1)

Card Location:

J2

Top Card Connectors

Position	Part Number
DW/EW/FW	8645778
DX/EX/FX	8645779
GY/HY	8645777
KX,LX,KY,LY,SX,TX	8645776
VX/WX,VY/WY,VZ/WZ	8645777

Card Plug Positions

- A2 PCA Cable
- A3 PCA Cable
- A4 PCA Cable
- A5 PCA Cable
- B2 PCA Cable
- B3 Spare Digitals Term
- B4 Not Used
- B5 PCA Cable
- C2 PC Isolation Card
- C4 PC Isolation Card
- D2 PC Sense
- E2 PC Sense
- F2 PC Interface
- F4 Serial Read Card
- G4 Latch Display Card
- H2 Support Processor
- J2 Support Processor Storage
- K2 DDA 1
- L2 DDA 2
- M2 Reserved
- N2 Reserved
- P2 Common Communication Adapter (RSF)
- Q2 DCA
- Q4 38LS (RSF)
- R2 DCA
- S2 SBA 2
- T2 SBA 1
- U2 Convert Card
- V2 LCA 1
- W2 LCA 4
- X2 LCA 2

Cable Plug Positions

- YA MBC
- YB Reset
- YC Volt Convert to PC
- YD Volt Sense
- YE SBA EXT
- YF SBA EXT
- YG SBA EXT Processor
- YH Spare
- YJ Volt Sense
- YK Spare
- YL Spare
- YM Spare
- YN DCA
- YP SPA Spare
- YQ LCA from CH/SP
- YR LCA to CH/SP
- ZA Spare
- ZB Spare
- ZC SP Display/Service Panel
- ZD DDA 1
- ZE RSF
- ZF DDA 2
- ZG LCA Tailgate
- ZH LCA Tailgate

4381	Mi	PN 6169581	EC A20558			
B/M 2676380	Seq GA030	2 of 2	01 Oct 84			

Board 01A-A3

Functional Locations

IFA Channel Cards for PU0

Card Locations:

Channel 0	K2
Channel 1	E2
Channel 2	F2
Channel 3	G2
Channel 4	H2
Channel 5	J2
Channel 6	P2
Channel 7	Q2
Channel 8	R2

Scan Cards

Card Locations:

Channel 0-5	N2
Channel 6-8	N4

Oscillator Card

Card Location:

L2

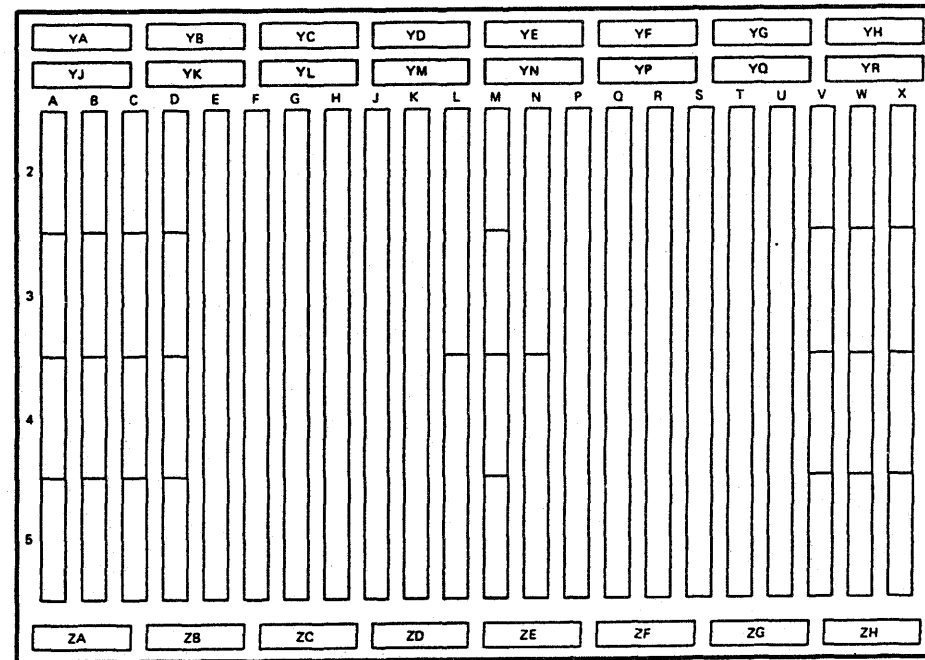

Cable Plug Positions

YA	Spare	YN	Channel 6 Bus/Tag Out
YB	Spare	YP	Channel 7 Bus/Tag Out
YC	Spare	YQ	Channel 8 Bus/Tag Out
YD	Oscillator	YR	Spare
YE	Oscillator	ZA	Channel 3 Bus/Tag In
YF	Oscillator	ZB	Channel 4 Bus/Tag In
YG	Spare	ZC	Channel 5 Bus/Tag In
YH	Power Sense	ZD	Channel 0 Bus/Tag In
YJ	Channel 3 Bus/Tag Out	ZE	Channel 6 Bus/Tag In
YK	Channel 4 Bus/Tag Out	ZF	Channel 7 Bus/Tag In
YL	Channel 5 Bus/Tag Out	ZG	Channel 8 Bus/Tag In
YM	Channel 0 Bus/Tag Out	ZH	Spare

Card Plug Positions

A2	Spare
A3	Special Access
A4	IPU Oscillator
A5	Spare
B2	Channel 2 Bus/Tag Out
B3	Channel 1 Bus/Tag Out
B4	Channel 1 Bus/Tag In
B5	Channel 2 Bus/Tag In
C2	Channel Control 3,4,5
C3	Channel Control 3,4,5
C4	Channel Control 3,4,5
C5	Channel Control 3,4,5
D2	Channel Control 0,1,2
D3	Channel Control 0,1,2
D4	Channel Control 0,1,2
D5	Channel Control 0,1,2
E2	Channel 1
F2	Channel 2
G2	Channel 3
H2	Channel 4
J2	Channel 5
K2	Channel 0
L2	Oscillator
L4	Spare
M2	Spare
M3	Spare
M4	Spare
M5	Spare
N2	Scan Channel 0-5
N4	Scan Channel 6-8
P2	Channel 6
Q2	Channel 7
R2	Channel 8
S2	Spare
T2	Spare
U2	Spare
V2	Channel Control 6,7,8
V3	Channel Control 6,7,8
V4	Channel Control 6,7,8
V5	Channel Control 6,7,8
W2	Unused
W3	Unused
W4	Unused
W5	Unused
X2	Spare
X3	Spare
X4	Spare
X5	Spare

Board 01A-A4 (1 Megabyte Cards)

Functional Locations

Storage Cards

Card Locations:

4 Megabytes 0-3	W2
4 Megabytes 4-7	R2
4 Megabytes 8-11	K2
4 Megabytes 12-15	E2
8 Megabytes 0-3	V2
8 Megabytes 4-7	Q2
8 Megabytes 8-11	J2
8 Megabytes 12-15	D2
12 Megabytes 0-3	U2
12 Megabytes 4-7	P2
12 Megabytes 8-11	H2
12 Megabytes 12-15	C2
16 Megabytes 0-3	T2
16 Megabytes 4-7	N2
16 Megabytes 8-11	G2
16 Megabytes 12-15	B2

Terminator Cards

Card Locations:

A2,A4,F2,F4,M2,M4,S2,S4.

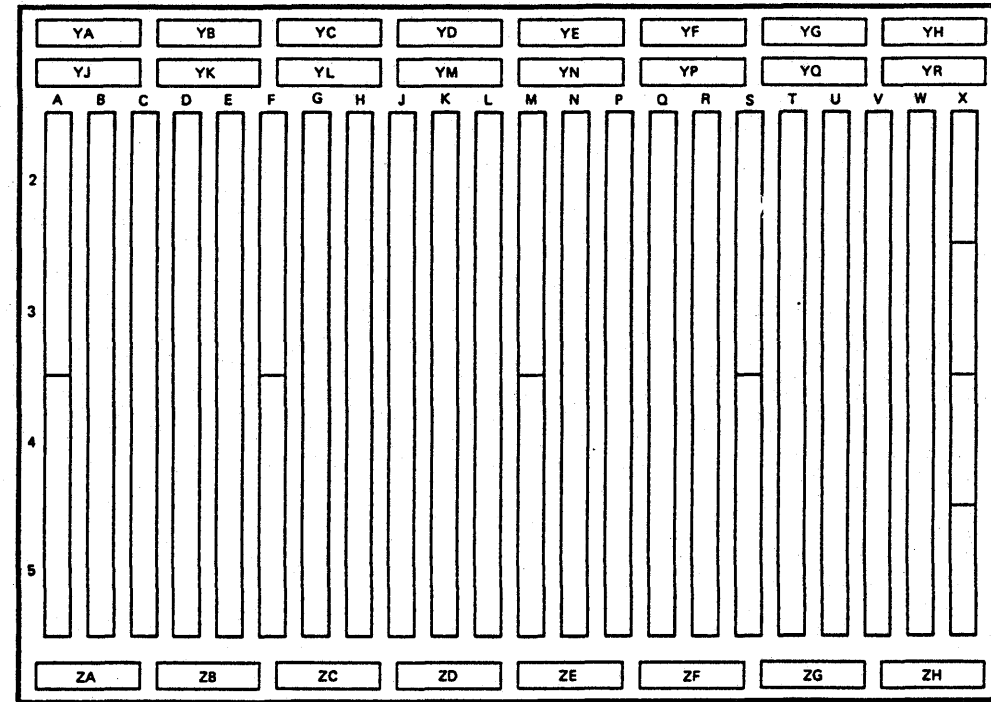

Card Plug Positions

A2 Terminator Card (Odd)	N2 Data Bytes 4-7 (16 megabytes)
A4 Terminator Card (Odd)	P2 Data Bytes 4-7 (12 megabytes)
B2 Data Bytes 12-15 (16 megabytes)	Q2 Data Bytes 4-7 (8 megabytes)
C2 Data Bytes 12-15 (12 megabytes)	R2 Data Bytes 4-7 (4 megabytes)
D2 Data Bytes 12-15 (8 megabytes)	S2 Terminator Card (Even)
E2 Data Bytes 12-15 (4 megabytes)	S4 Terminator Card (Even)
F2 Terminator Card (Odd)	T2 Data Bytes 0-3 (16 megabytes)
F4 Terminator Card (Odd)	U2 Data Bytes 0-3 (12 megabytes)
G2 Data Bytes 8-11 (16 megabytes)	V2 Data Bytes 0-3 (8 megabytes)
H2 Data Bytes 8-11 (12 megabytes)	W2 Data Bytes 0-3 (4 megabytes)
J2 Data Bytes 8-11 (8 megabytes)	X2 BSM Data Bytes 8/9
K2 Data Bytes 8-11 (4 megabytes)	X3 BSM Data Bytes 10/11
L2 Clock	X4 BSM Data Bytes 12/13
M2 Terminator Card (Even)	X5 BSM Data Bytes 14/15
M4 Terminator Card (Even)	

Cable Plug Positions

YA Oscillator/Channel Spec
YB Spare
YC Spare
YD BSM Control
YE BSM Control
YF BSM Control
YG BSM Control/Address
YH Spare
YJ Spare
YK Spare
YL BSM Control/Address
YM BSM Control/Address
YN BSM Data Bytes 6/7
YP BSM Data Bytes 4/5
YQ BSM Data Bytes 2/3
YR BSM Data Bytes 0/1
ZA Power
ZB Spare
ZC Spare
ZD Spare
ZE Spare
ZF Spare
ZG Spare
ZH Spare

4381-3	M!	PN 6169582	EC A20558	EC A20560			
B/M 2676380	Seq GA035	2 of 4	01 Oct 84	18 Feb 85			

Board 01A-A4 (2 Megabyte Cards)

Functional Locations

Storage Cards

Card Locations:

8 Megabytes	0-3	W2
8 Megabytes	4-7	R2
8 Megabytes	8-11	K2
8 Megabytes	12-15	E2
16 Megabytes	0-3	V2
16 Megabytes	4-7	Q2
16 Megabytes	8-11	J2
16 Megabytes	12-15	D2
24 Megabytes	0-3	U2
24 Megabytes	4-7	P2
24 Megabytes	8-11	H2
24 Megabytes	12-15	C2
32 Megabytes	0-3	T2
32 Megabytes	4-7	N2
32 Megabytes	8-11	G2
32 Megabytes	12-15	B2

Terminator Cards

Card Locations:

A2,A4,F2,F4,M2,M4,S2,S4.

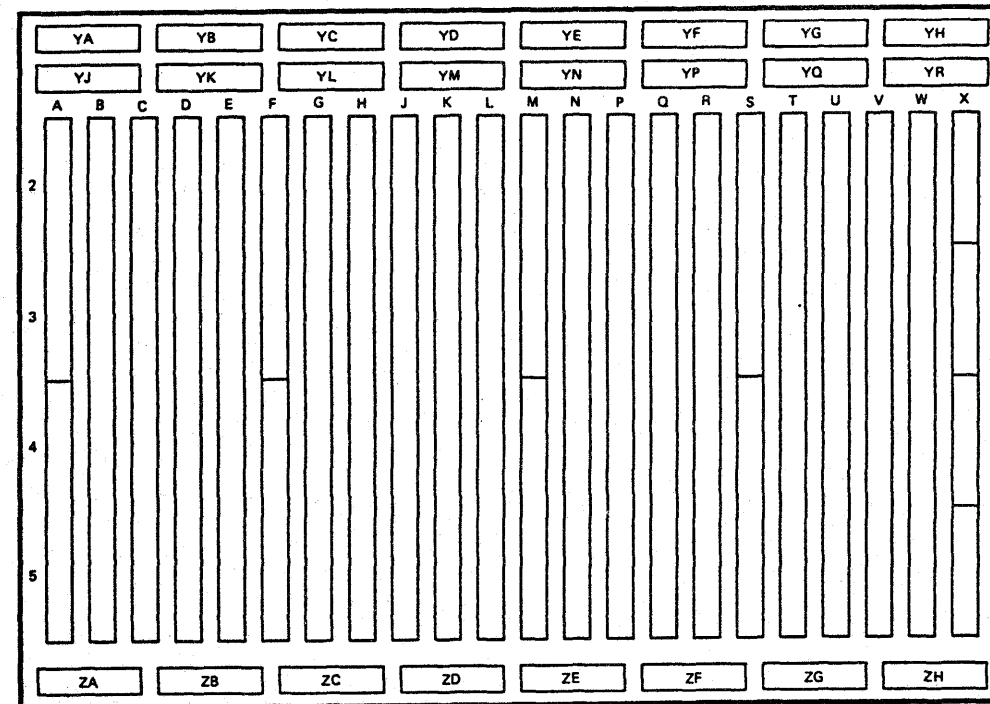

Card Plug Positions

A2	Terminator Card (Odd)	N2	Data Bytes 4-7 (32 megabytes)
A4	Terminator Card (Odd)	P2	Data Bytes 4-7 (24 megabytes)
B2	Data Bytes 12-15 (32 megabytes)	Q2	Data Bytes 4-7 (16 megabytes)
C2	Data Bytes 12-15 (24 megabytes)	R2	Data Bytes 4-7 (8 megabytes)
D2	Data Bytes 12-15 (16 megabytes)	S2	Terminator Card (Even)
E2	Data Bytes 12-15 (8 megabytes)	S4	Terminator Card (Even)
F2	Terminator Card (Odd)	T2	Data Bytes 0-3 (32 megabytes)
F4	Terminator Card (Odd)	U2	Data Bytes 0-3 (24 megabytes)
G2	Data Bytes 8-11 (32 megabytes)	V2	Data Bytes 0-3 (16 megabytes)
H2	Data Bytes 8-11 (24 megabytes)	W2	Data Bytes 0-3 (8 megabytes)
J2	Data Bytes 8-11 (16 megabytes)	X2	BSM Data Bytes 8/9
K2	Data Bytes 8-11 (8 megabytes)	X3	BSM Data Bytes 10/11
L2	Clock	X4	BSM Data Bytes 12/13
M2	Terminator Card (Even)	X5	BSM Data Bytes 14/15
M4	Terminator Card (Even)		

Cable Plug Positions

YA	Oscillator/Channel Spec
YB	Spare
YC	Spare
YD	BSM Control
YE	BSM Control
YF	BSM Control
YG	BSM Control/Address
YH	Spare
YJ	Spare
YK	Spare
YL	BSM Control/Address
YM	BSM Control/Address
YN	BSM Data Bytes 6/7
YP	BSM Data Bytes 4/5
YQ	BSM Data Bytes 2/3
YR	BSM Data Bytes 0/1
ZA	Power
ZB	Spare
ZC	Spare
ZD	Spare
ZE	Spare
ZF	Spare
ZG	Spare
ZH	Spare

Board 01A-A4 (1 and 2 Megabyte Cards Intermixed)

Functional Locations

Storage Cards

Card Locations:

4 Megabytes 0-3	W2
4 Megabytes 4-7	R2
4 Megabytes 8-11	K2
4 Megabytes 12-15	E2
8 Megabytes 0-3	V2
8 Megabytes 4-7	Q2
8 Megabytes 8-11	J2
8 Megabytes 12-15	D2
16 Megabytes 0-3	U2
16 Megabytes 4-7	P2
16 Megabytes 8-11	H2
16 Megabytes 12-15	C2
24 Megabytes 0-3	T2
24 Megabytes 4-7	N2
24 Megabytes 8-11	G2
24 Megabytes 12-15	B2

One Megabyte Cards (16 or 24 Mb Storage)

Card Locations:

D2,E2,J2,K2,Q2,R2,V2,W2.

Two Megabyte Cards (16 Mb Storage)

Card Locations:

C2,H2,P2,U2.

Two Megabyte Cards (24 Mb Storage)

Card Locations:

B2,C2,G2,H2,N2,P2,T2,U2.

Terminator Cards

Card Locations:

A2,A4,F2,F4,M2,M4,S2,S4.

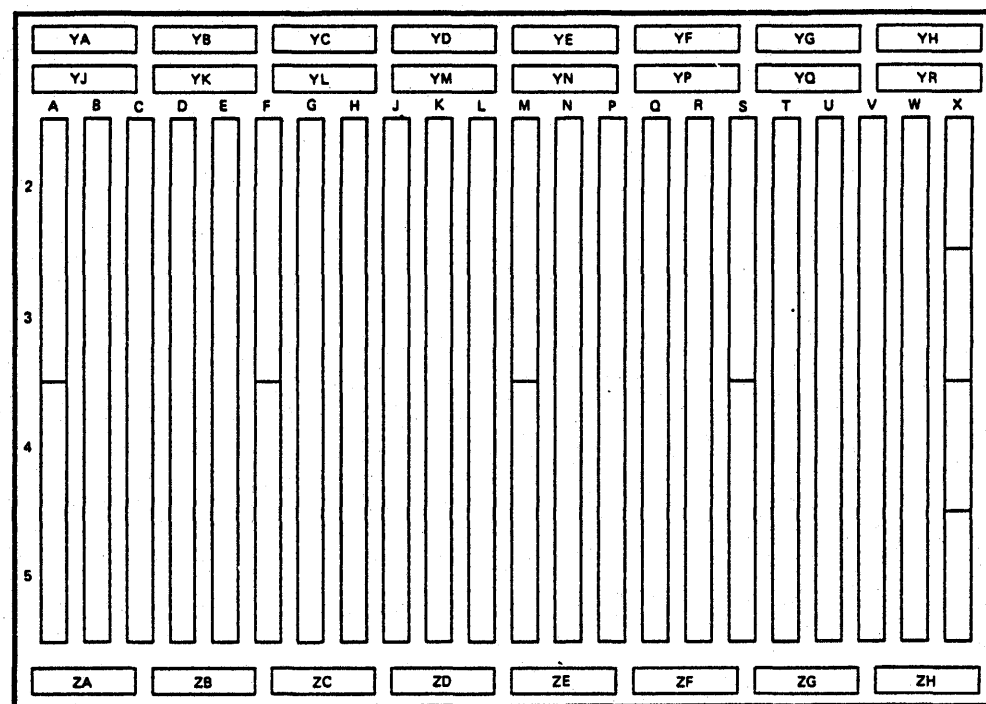

Card Plug Positions

A2	Terminator Card (Odd)	N2	Data Bytes 4-7 (24 megabytes)
A4	Terminator Card (Odd)	P2	Data Bytes 4-7 (16 megabytes)
B2	Data Bytes 12-15 (24 megabytes)	Q2	Data Bytes 4-7 (8 megabytes)
C2	Data Bytes 12-15 (16 megabytes)	R2	Data Bytes 4-7 (4 megabytes)
D2	Data Bytes 12-15 (8 megabytes)	S2	Terminator Card (Even)
E2	Data Bytes 12-15 (4 megabytes)	S4	Terminator Card (Even)
F2	Terminator Card (Odd)	T2	Data Bytes 0-3 (24 megabytes)
F4	Terminator Card (Odd)	U2	Data Bytes 0-3 (16 megabytes)
G2	Data Bytes 8-11 (24 megabytes)	V2	Data Bytes 0-3 (8 megabytes)
H2	Data Bytes 8-11 (16 megabytes)	W2	Data Bytes 0-3 (4 megabytes)
J2	Data Bytes 8-11 (8 megabytes)	X2	BSM Data Bytes 8/9
K2	Data Bytes 8-11 (4 megabytes)	X3	BSM Data Bytes 10/11
L2	Clock	X4	BSM Data Bytes 12/13
M2	Terminator Card (Even)	X5	BSM Data Bytes 14/15
M4	Terminator Card (Even)		

Cable Plug Positions

YA	Oscillator/Channel Spec
YB	Spare
YC	Spare
YD	BSM Control
YE	BSM Control
YF	BSM Control
YG	BSM Control/Address
YH	Spare
YJ	Spare
YK	Spare
YL	BSM Control/Address
YM	BSM Control/Address
YN	BSM Data Bytes 6/7
YP	BSM Data Bytes 4/5
YQ	BSM Data Bytes 2/3
YR	BSM Data Bytes 0/1
ZA	Power
ZB	Spare
ZC	Spare
ZD	Spare
ZE	Spare
ZF	Spare
ZG	Spare
ZH	Spare

4381-3	MI	PN 6169582	EC A20558	EC A20560		
B/M 2676380	Seq GA035	4 of 4	01 Oct 84	18 Feb 85		

Board 01B-A1

Functional Locations

IFA Channel Cards for PU1

Card Locations:

Channel 0	K2
Channel 1	E2
Channel 2	F2
Channel 3	G2
Channel 4	H2
Channel 5	J2
Channel 6	P2
Channel 7	Q2
Channel 8	R2

Scan Cards

Card Locations:

Channel 0-5	N2
Channel 6-8	N4

Cable Plug Positions

YA	Spare
YB	Spare
YC	Spare
YD	Spare
YE	Spare
YF	Spare
YG	Spare
YH	Power Sense
YJ	Channel 3 Bus/Tag Out
YK	Channel 4 Bus/Tag Out
YL	Channel 5 Bus/Tag Out
YM	Channel 0 Bus/Tag Out
YN	Channel 6 Bus/Tag Out
YP	Channel 7 Bus/Tag Out
YQ	Channel 8 Bus/Tag Out
YR	Spare
ZA	Channel 3 Bus/Tag In
ZB	Channel 4 Bus/Tag In
ZC	Channel 5 Bus/Tag In
ZD	Channel 0 Bus/Tag In
ZE	Channel 6 Bus/Tag In
ZF	Channel 7 Bus/Tag In
ZG	Channel 8 Bus/Tag In
ZH	Spare

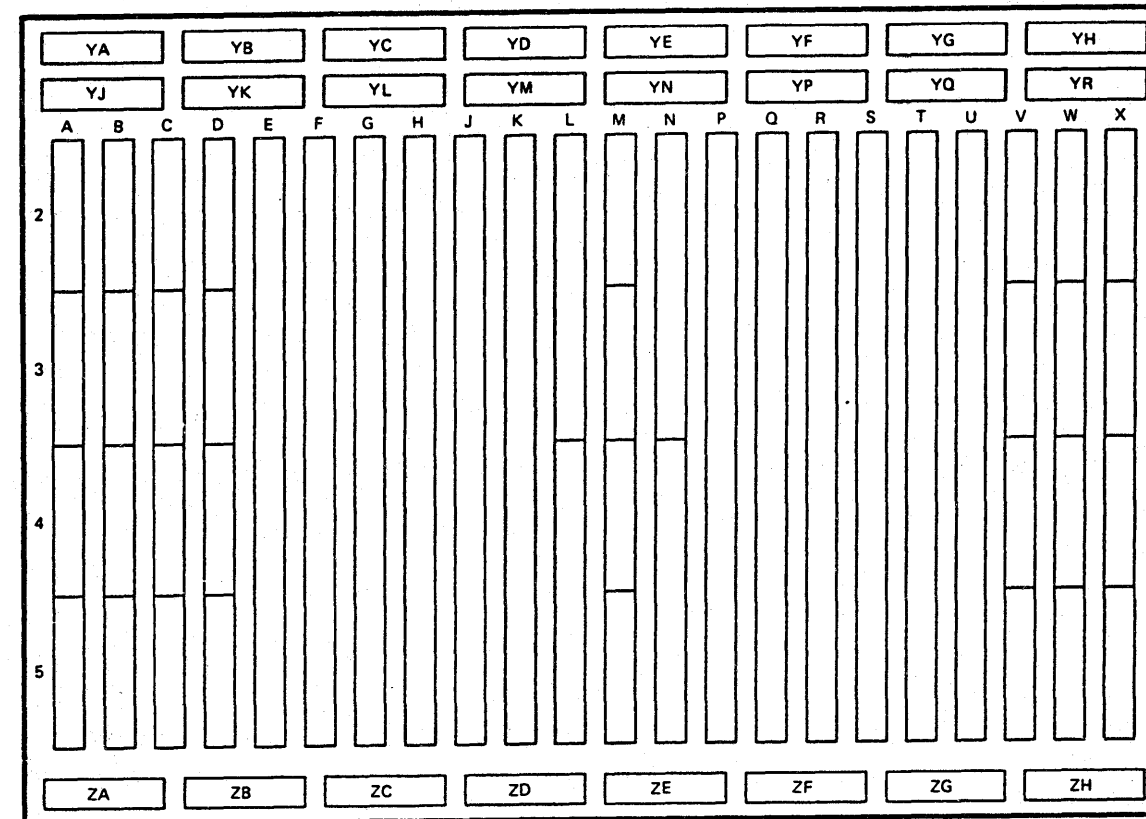

Card Plug Positions

A2	Spare
A3	Special Access
A4	Spare
A5	Spare
B2	Channel 2 Bus/Tag Out
B3	Channel 1 Bus/Tag Out
B4	Channel 1 Bus/Tag In
B5	Channel 2 Bus/Tag In
C2	Channel Control 3,4,5
C3	Channel Control 3,4,5
C4	Channel Control 3,4,5
C5	Channel Control 3,4,5
D2	Channel Control 0,1,2
D3	Channel Control 0,1,2
D4	Channel Control 0,1,2
D5	Channel Control 0,1,2
E2	Channel 1
F2	Channel 2
G2	Channel 3
H2	Channel 4
J2	Channel 5
K2	Channel 0
L2	Spare
L4	Spare
M2	Spare
M3	Spare
M4	Spare
M5	Spare
N2	Scan Channel 0-5
N4	Scan Channel 6-8
P2	Channel 6
Q2	Channel 7
R2	Channel 8
S2	Spare
T2	Spare
U2	Spare
V2	Channel Control 6,7,8
V3	Channel Control 6,7,8
V4	Channel Control 6,7,8
V5	Channel Control 6,7,8
W2	Spare
W3	Spare
W4	Spare
W5	Spare
X2	Spare
X3	Spare
X4	Spare
X5	Spare

Pin Layout for Boards 01A-A1 to 01A-A4 and 01B-A1

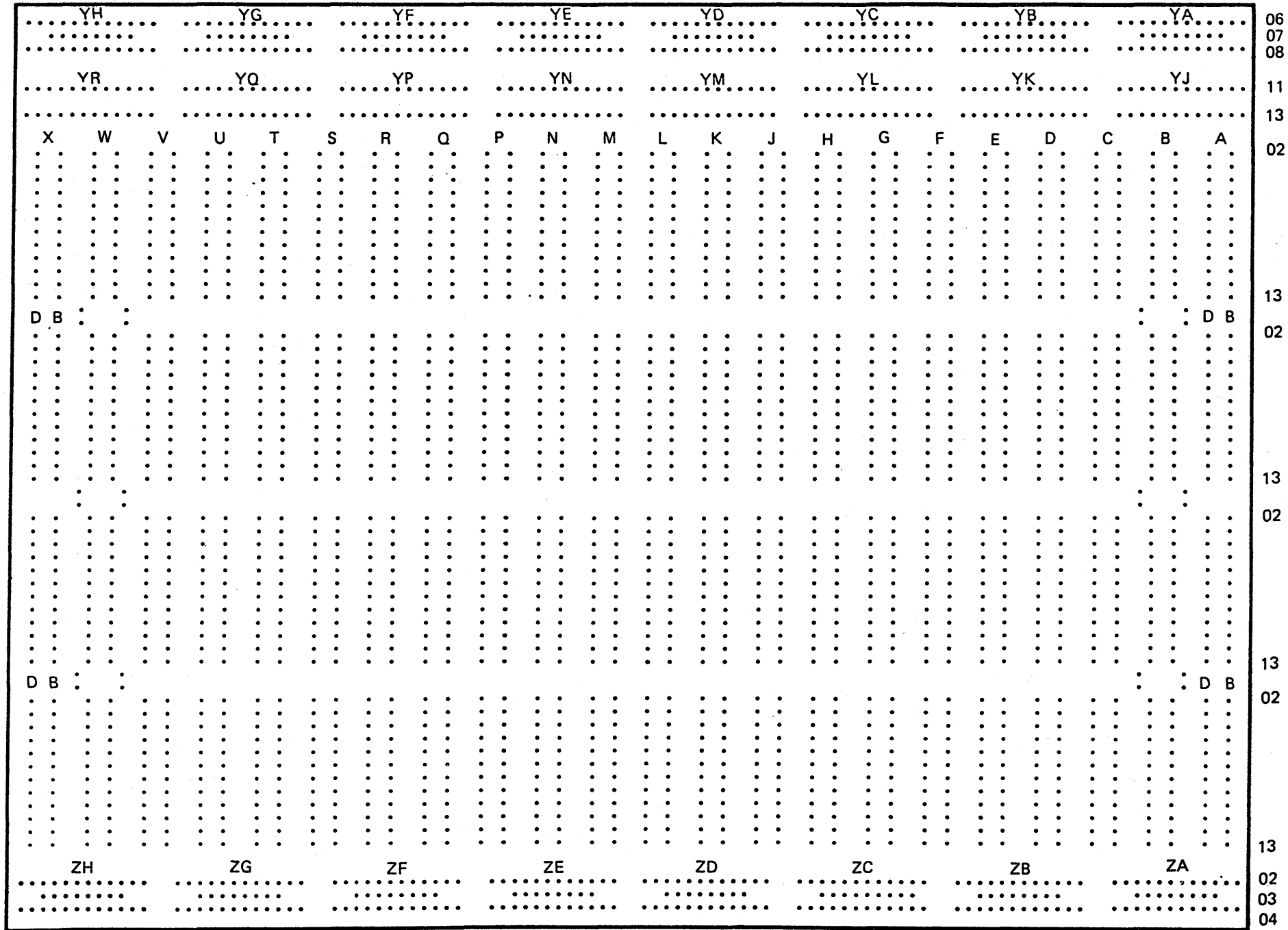

Note: Board/Retention Cover hardware may be present and may have to be removed to probe pins. For removal of the Board/Retention Cover, see Vol. A07, Removals and Replacements.

4381-3
B/M 2676380

MI Seq GA040	PN 6169583 2 of 2	EC A20558 01 Oct 84	EC A20560 18 Feb 85	EC A20562 30 Aug 85		
-----------------	----------------------	------------------------	------------------------	------------------------	--	--

© Copyright IBM Corp. 1984

Board 01A-B1 or 01A-B2

Functional Locations

Arithmetic Logic Unit (ALU)

Module Location:

HE

Cache

Module Locations:

Cache 0/1 MA
 Cache 2/3 ME
 Cache 4/5 RA
 Cache 6/7 RE

Channels

Module Locations:

Channel Controls RN
 Channel Interface 0-5 RS
 Channel Interface 6-8 VN

Channel Data Buffer (CDB)

Module Location:

DA

CREG

Module Locations:

CREG 0 DN
 CREG 1 HS
 CREG 2 DJ
 CREG 3 MS

Clock

Module Location:

MJ

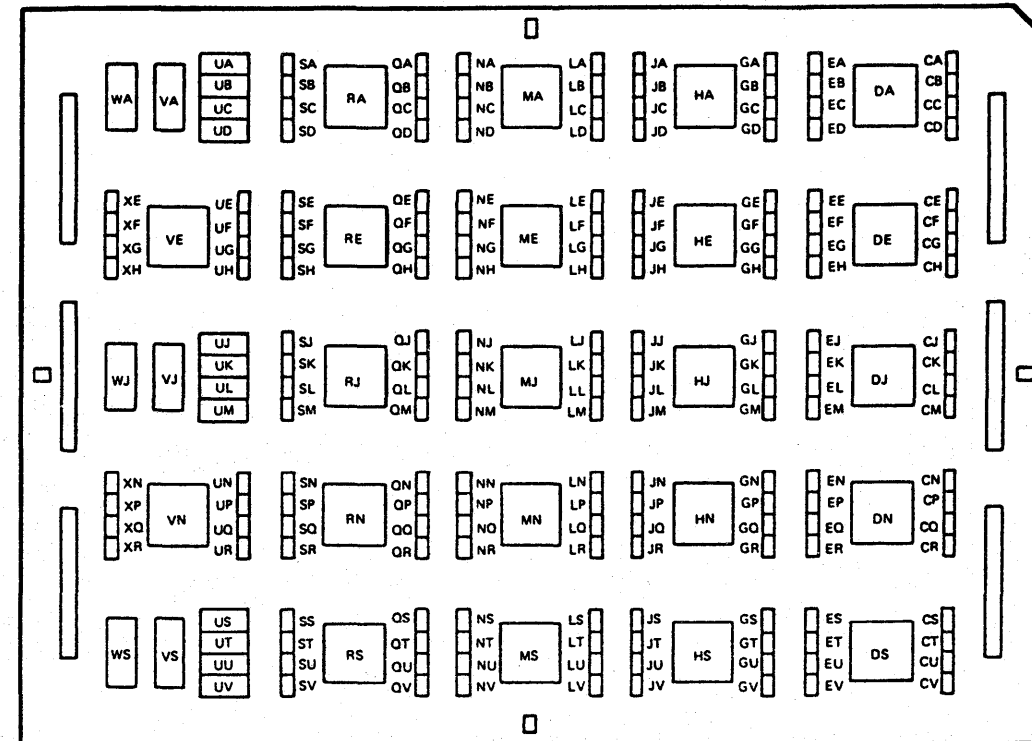

Module Side

Control Storage (CS) Control

Module Location:

DS

Directory Lookaside Table (DLAT)

Module Location:

MN

Error Checking and Correction 1 (ECC 1)

Module Location:

RJ

Error Checking and Correction 2 (ECC 2)

Module Location:

VE

Keys

Module Locations:

HN

Local Storage External (LS EXT)

Module Location:

HJ

Processing Unit Storage Address Register (PUSAR)

Module Location:

DE

Shifter

Module Location:

HA

Module Plug Positions

DA CDB
 DE PUSAR
 DJ CREG 2
 DN CREG 0
 DS CS Control
 HA Shifter
 HE ALU
 HJ LS EXT
 HN Keys
 HS CREG 1
 MA Cache 0/1
 ME Cache 2/3
 MJ Clock
 MN DLAT/DIR
 MS CREG 3
 RA Cache 4/5
 RE Cache 6/7
 RJ ECC 1
 RN Channel Control
 RS Channel Interface 0/5
 VE ECC 2
 VN Channel Interface 6/8

Cable Plug Positions

VA
 VJ
 VS
 WA
 WJ
 WS

Board 01A-B1 or 01A-B2 Resistor Pin Layout

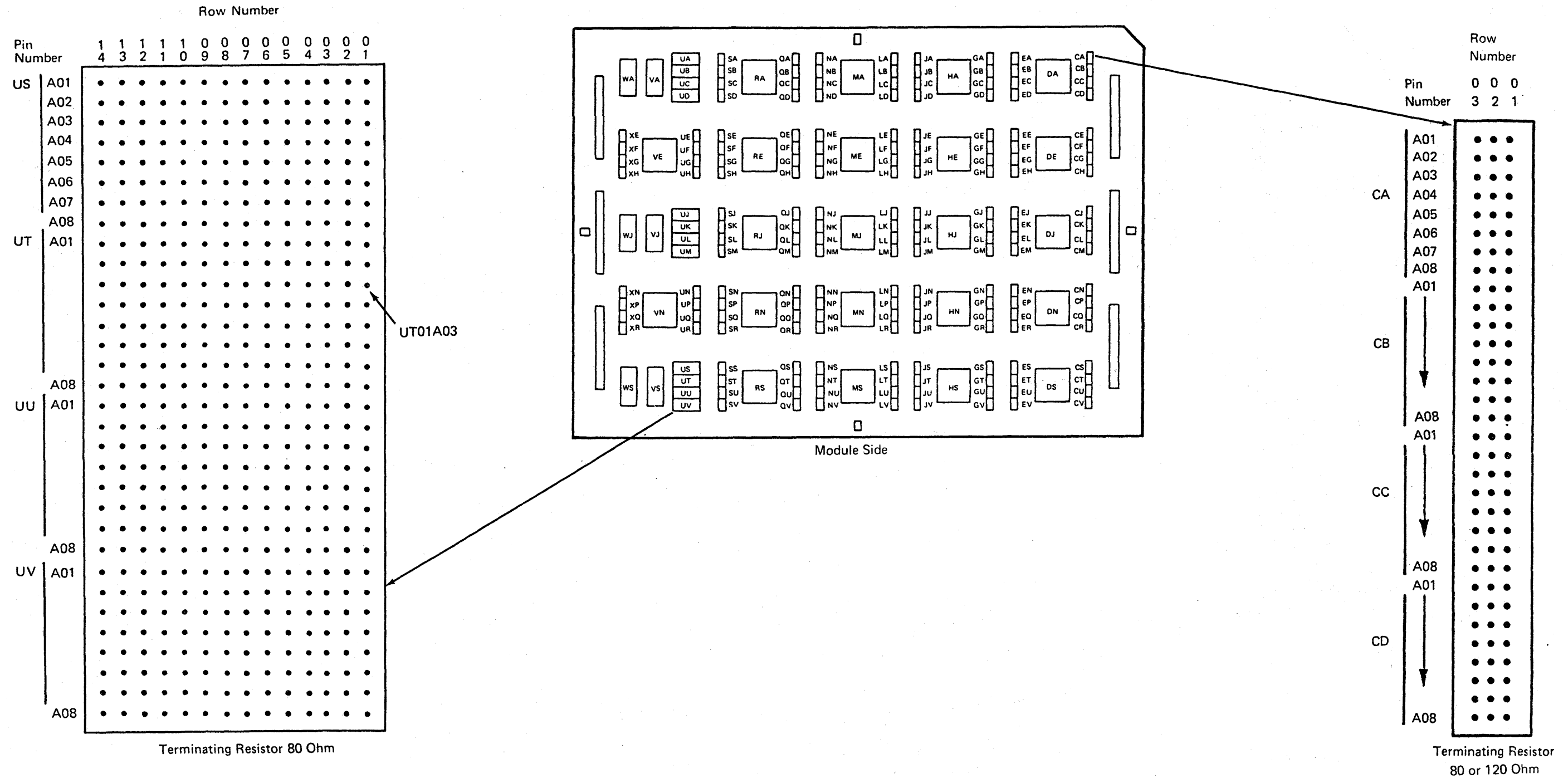

4381-3 B/M 2676380	MI Seq GA045	PN 6169584 2 of 4	EC A20558 01 Oct 84	EC A20562 30 Aug 85			
-----------------------	-----------------	----------------------	------------------------	------------------------	--	--	--

© Copyright IBM Corp. 1984



Board 01A-B1 or 01A-B2 Module Pin and I/O Signal Pin Layout

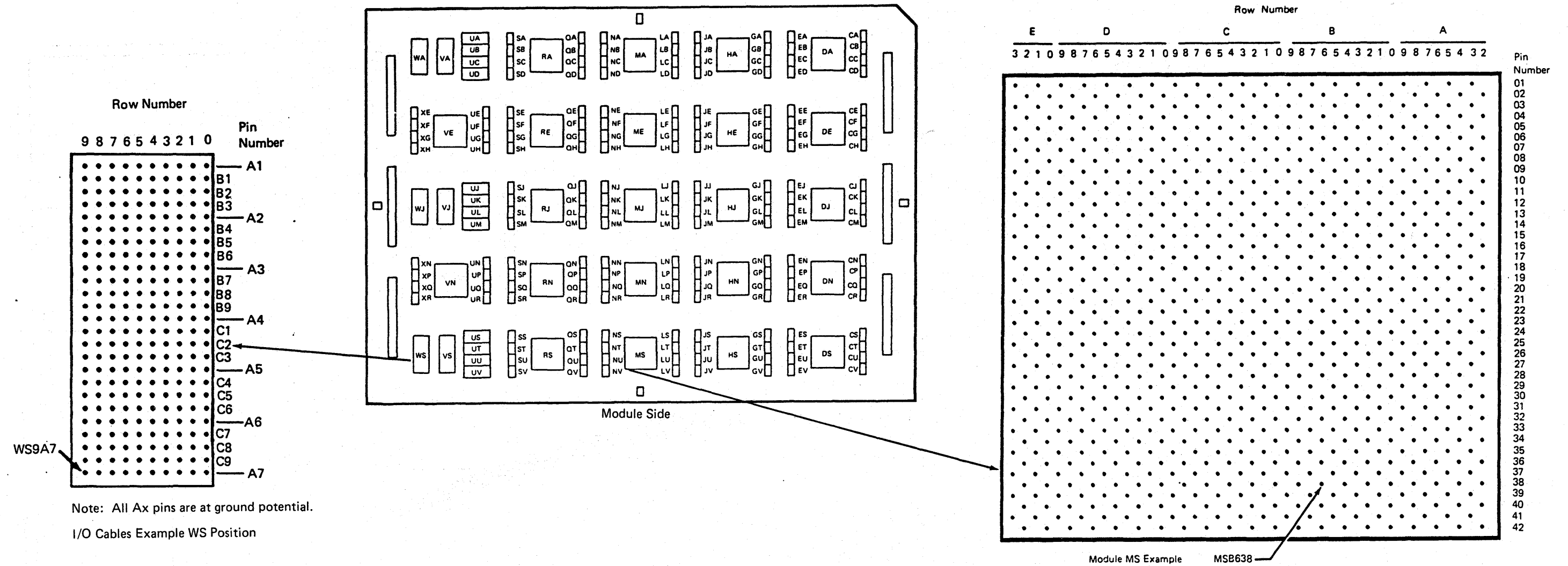

4381-3	MI	PN 6169584	EC A20558	EC A20562			
B/M 2676380	Seq GA045	3 of 4	01 Oct 84	30 Aug 85			

Board 01A-B1 or 01A-B2 Terminals

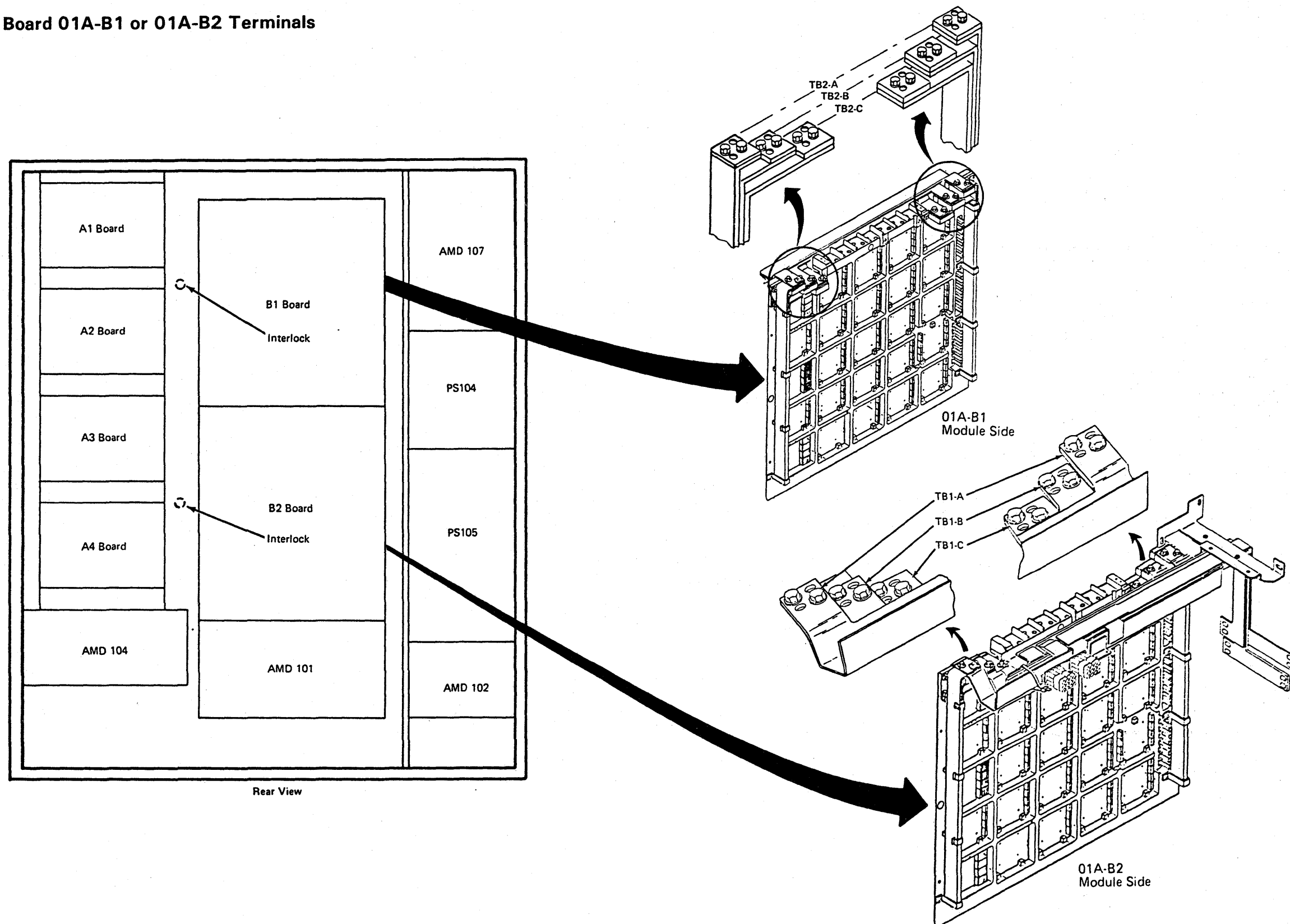

4381-3	MI	PN 6169584	EC A20558	EC A20562			
B/M 2676380	Seq GA045	4 of 4	01 Oct 84	30 Aug 85			

© Copyright IBM Corp. 1984



Connectors

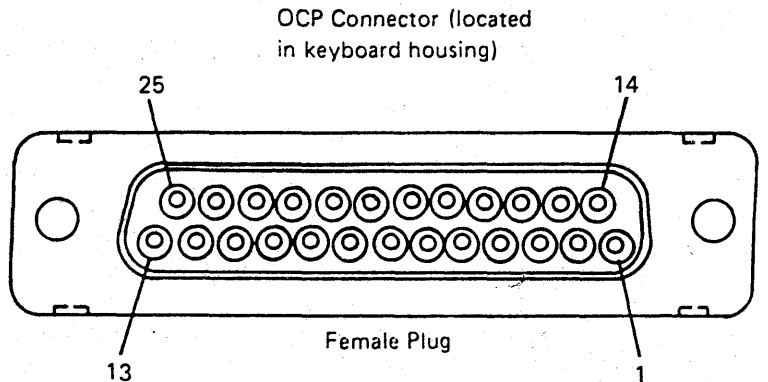
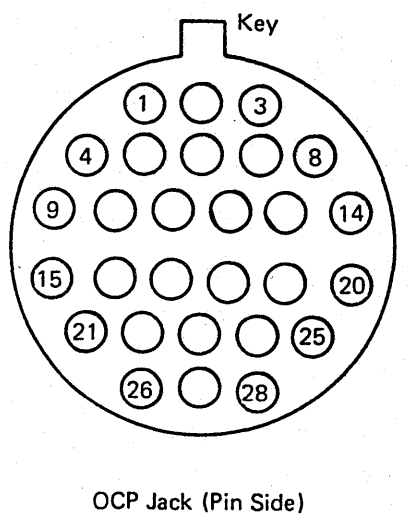
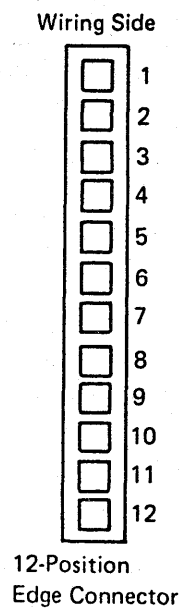
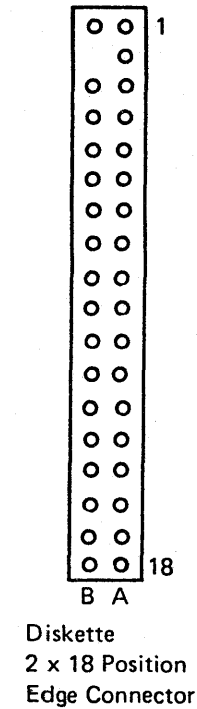
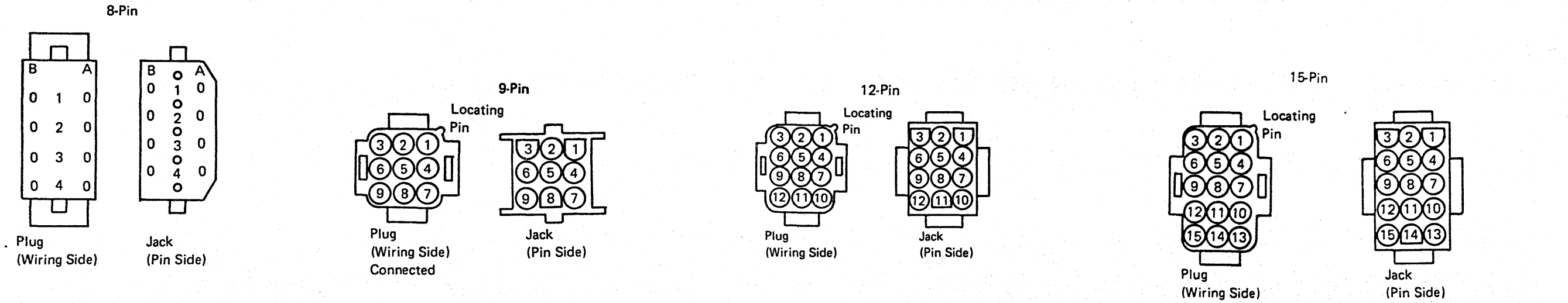
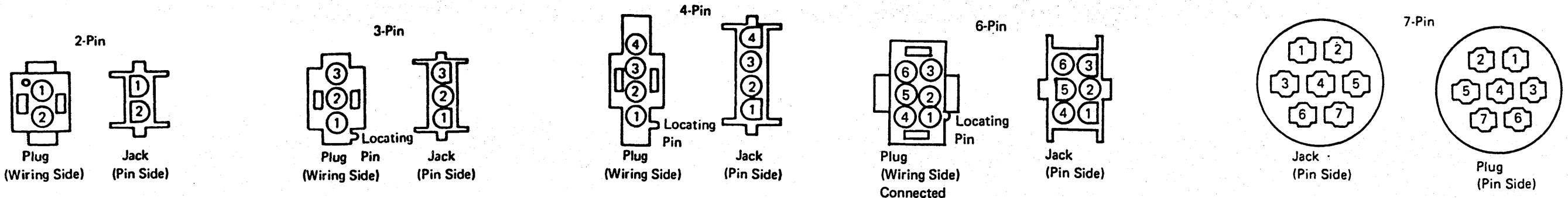

4381-3	MI	PN 6169585	EC A20558	EC A20560	EC A20562		
B/M 2676380	Seq GA050	1 of 2	01 Oct 84	18 Feb 85	30 Aug 85		

Pin Numbering

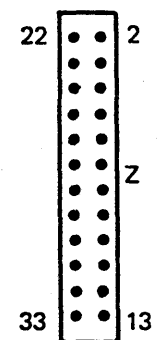
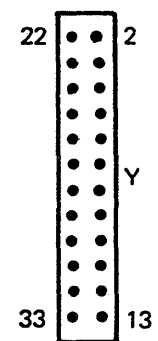
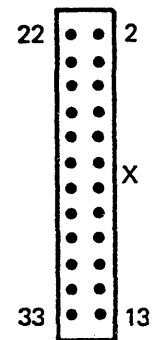
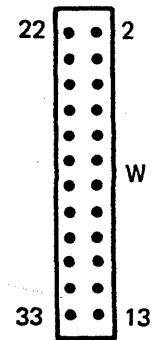

Component Side

01A-A1
8645658

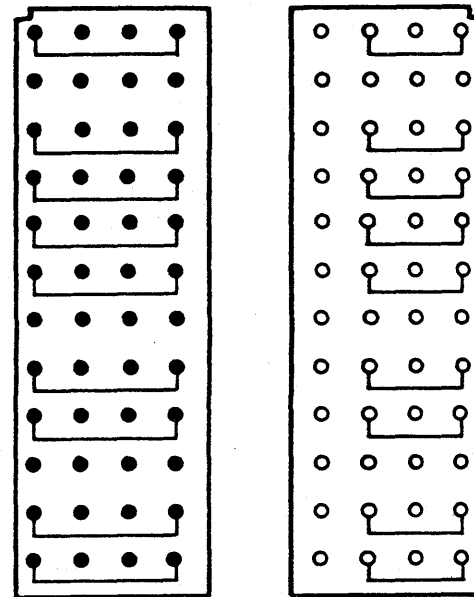

Front

Back

8645678

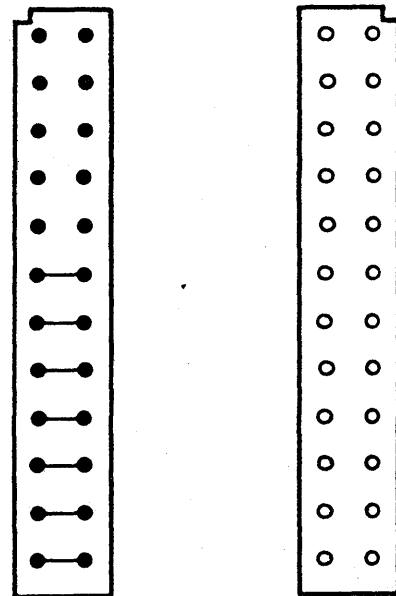

Front

Back

01A-A2

8645778

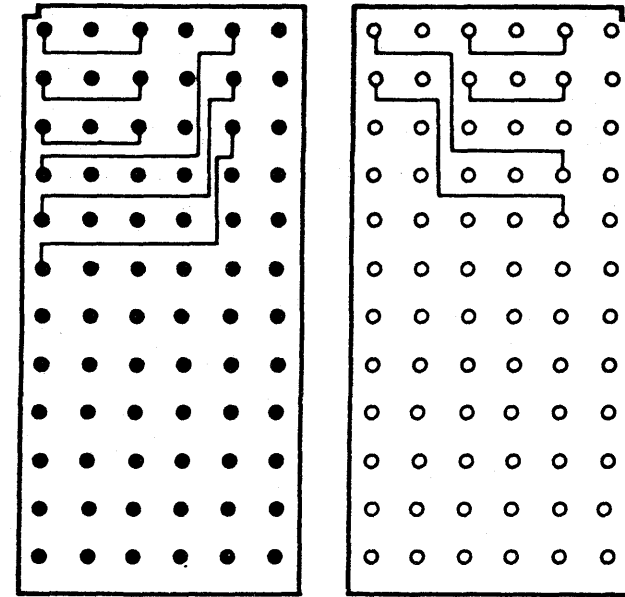

Front

Back

8645777

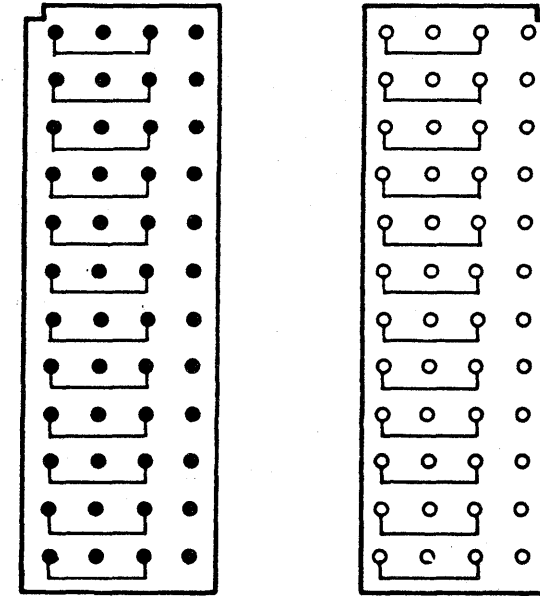

Front

Back

8645779

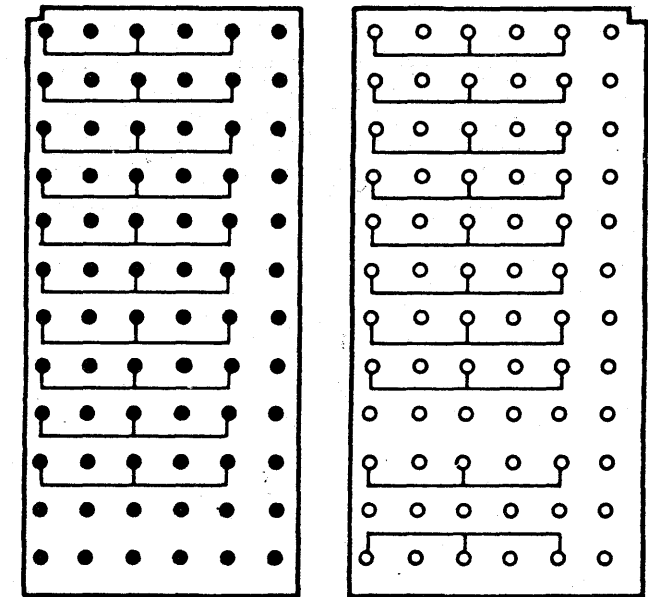

Front

Back

8645776

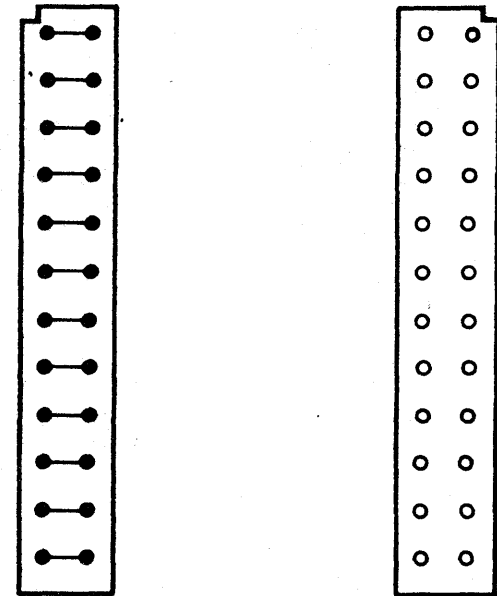

Front

Back

4381-3 B/M 2676380	MI Seq GA050	PN 6169585 2 of 2	EC A20558 01 Oct 84	EC A20560 18 Feb 85	EC A20562 30 Aug 85		
-----------------------	-----------------	----------------------	------------------------	------------------------	------------------------	--	--



Service Panel

LOC 055

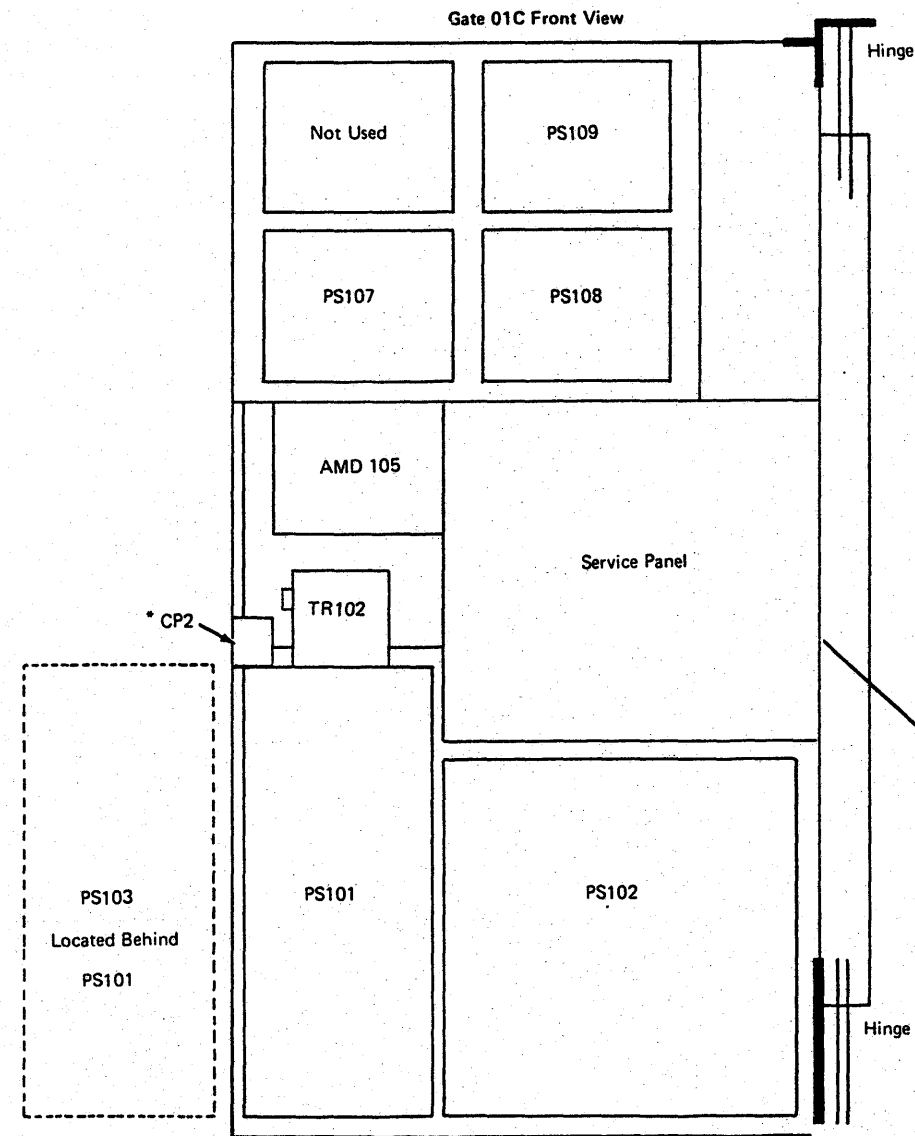

*TR104A, B, C, and CP2
Only on all 50 Hz and 60 Hz Japan machines

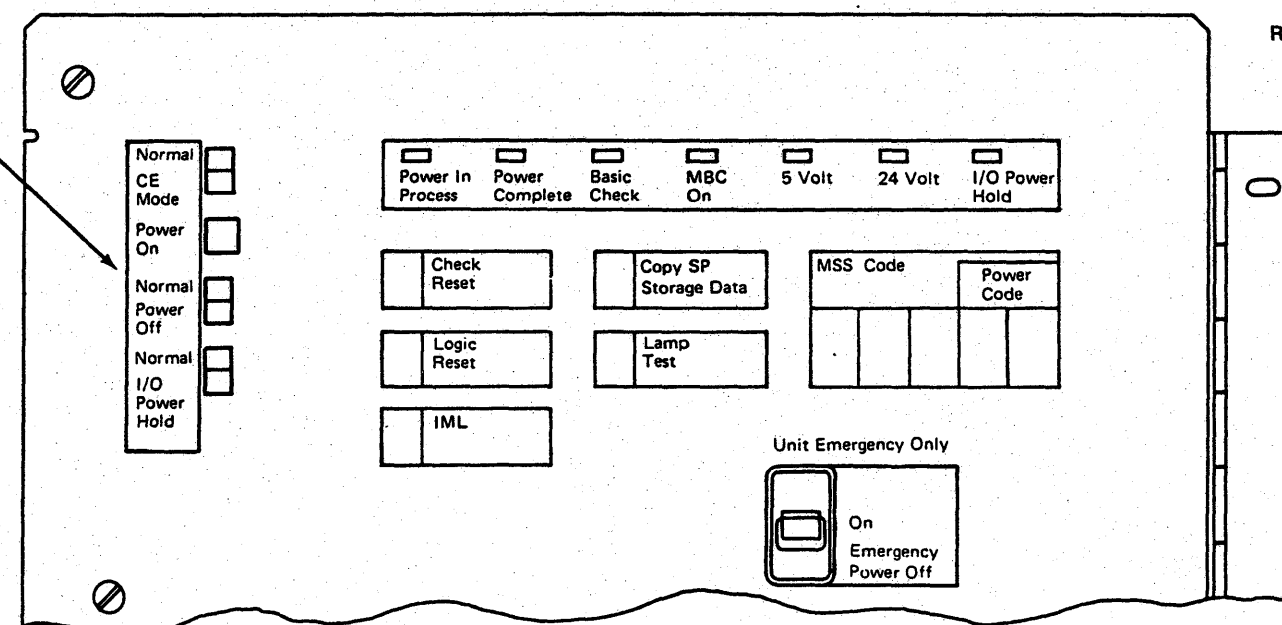
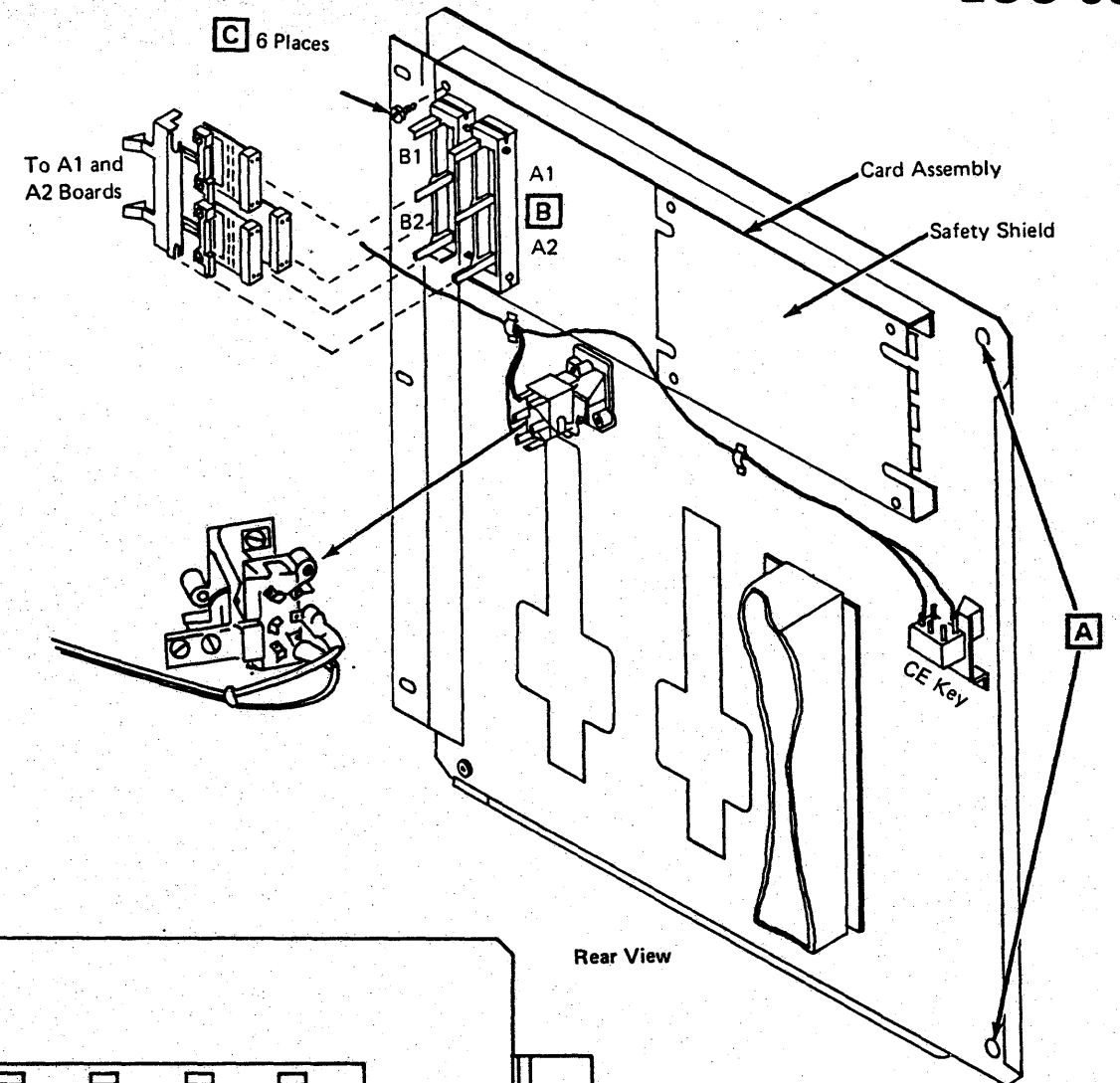

Service Panel (Front View)

4381	MI	PN 6169586	EC A20558				
B/M 2676380	Seq GA055	1 of 2	01 Oct 84				

LOC 055

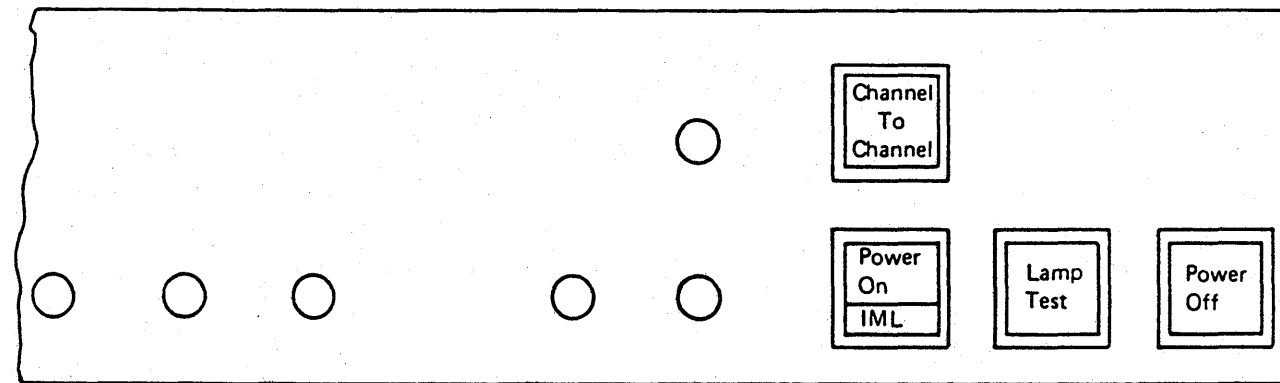

3278-2A and 3279-2C

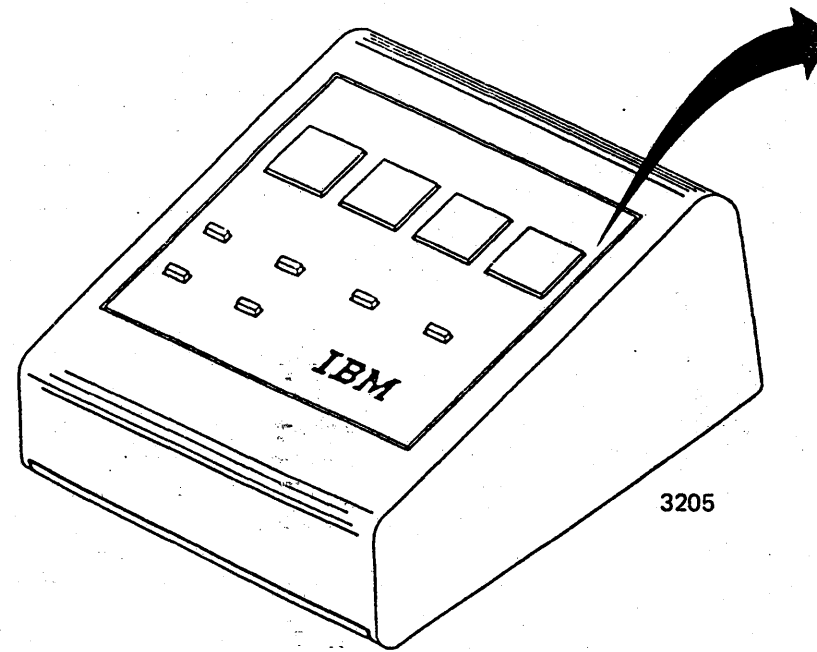

3205

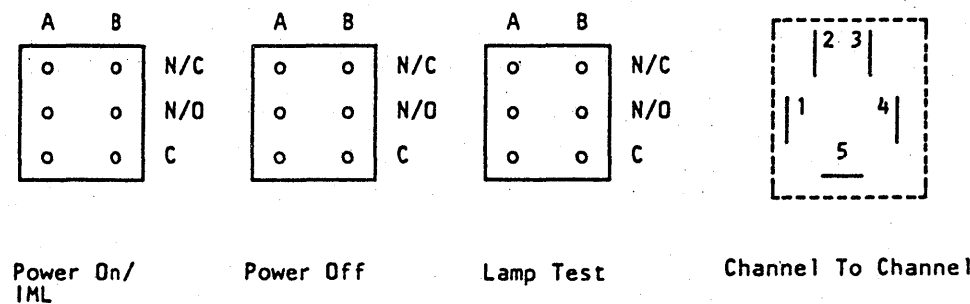
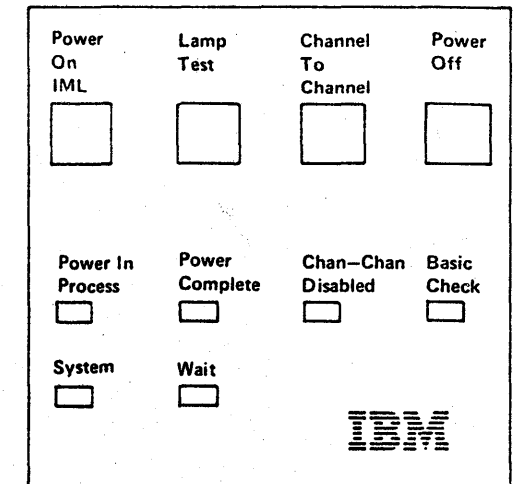

Power On/
IML

Power Off

Lamp Test

Channel To Channel

OCP Switch Pin Layout

4381	MI	PN 6169586	EC A20558				
B/M 2676380	Seq GA055	2 of 2	01 Oct 84				



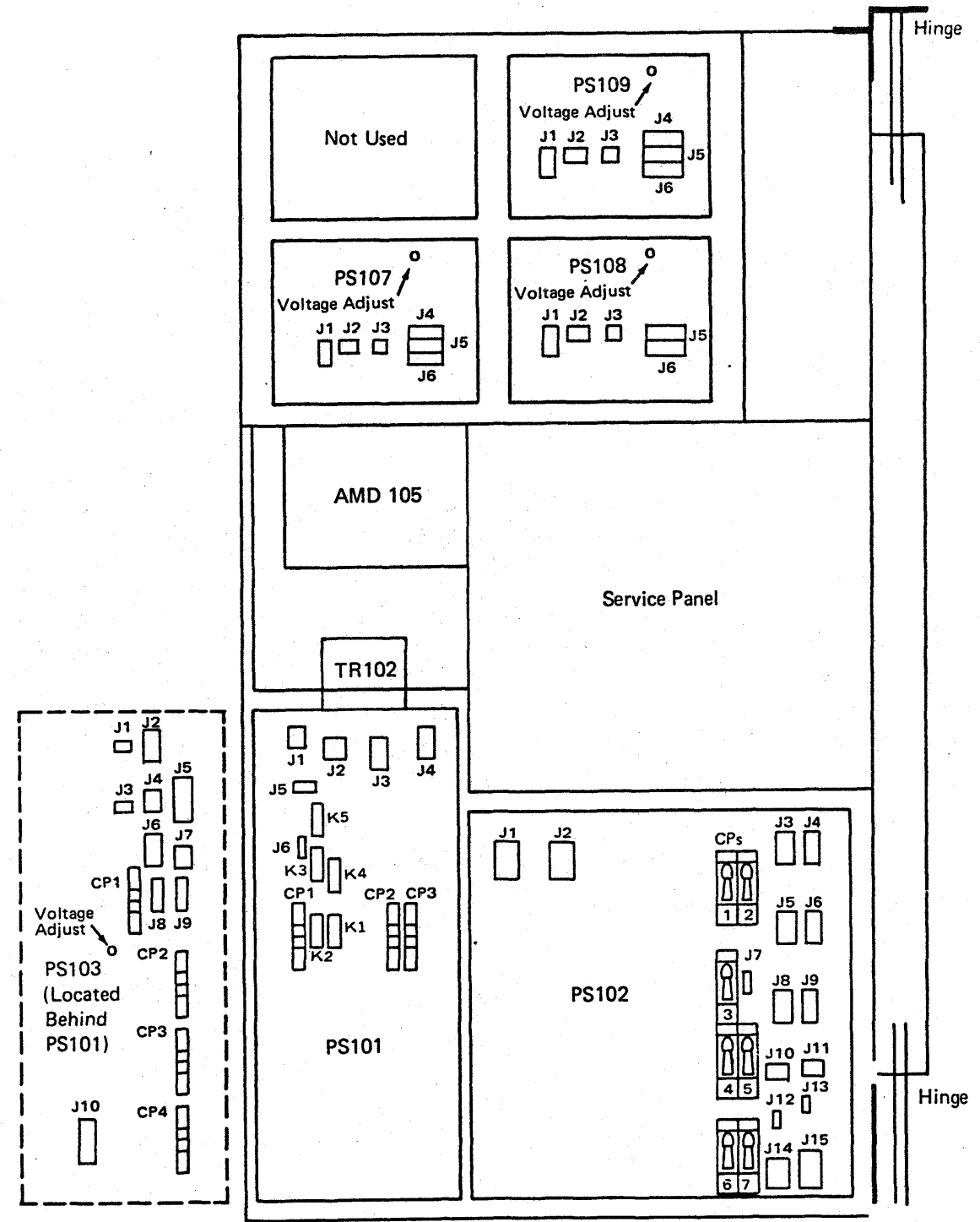

Gate 01C Front View

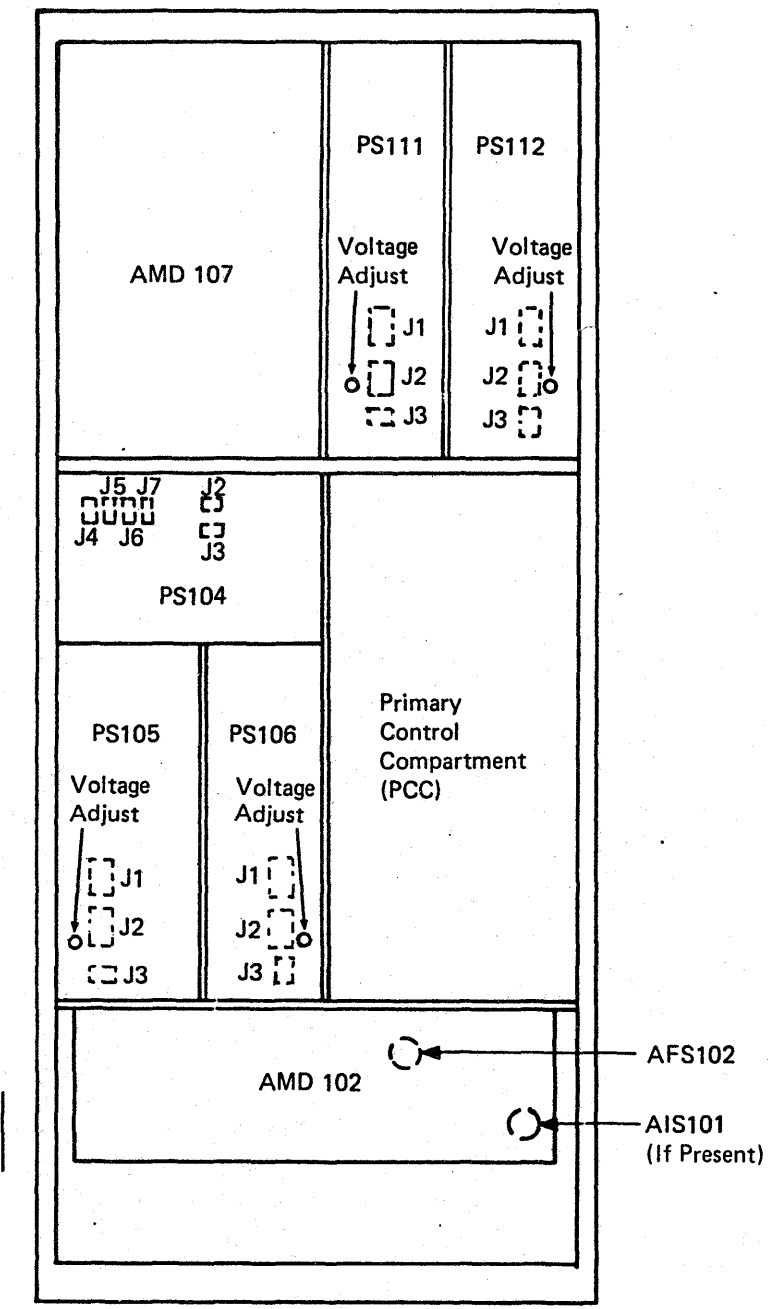

Left Side View

4381-3	MI	PN 6169587	EC A20558	EC A20560			
B/M 2676380	Seq GA060	1 of 2	01 Oct 84	18 Feb 85			

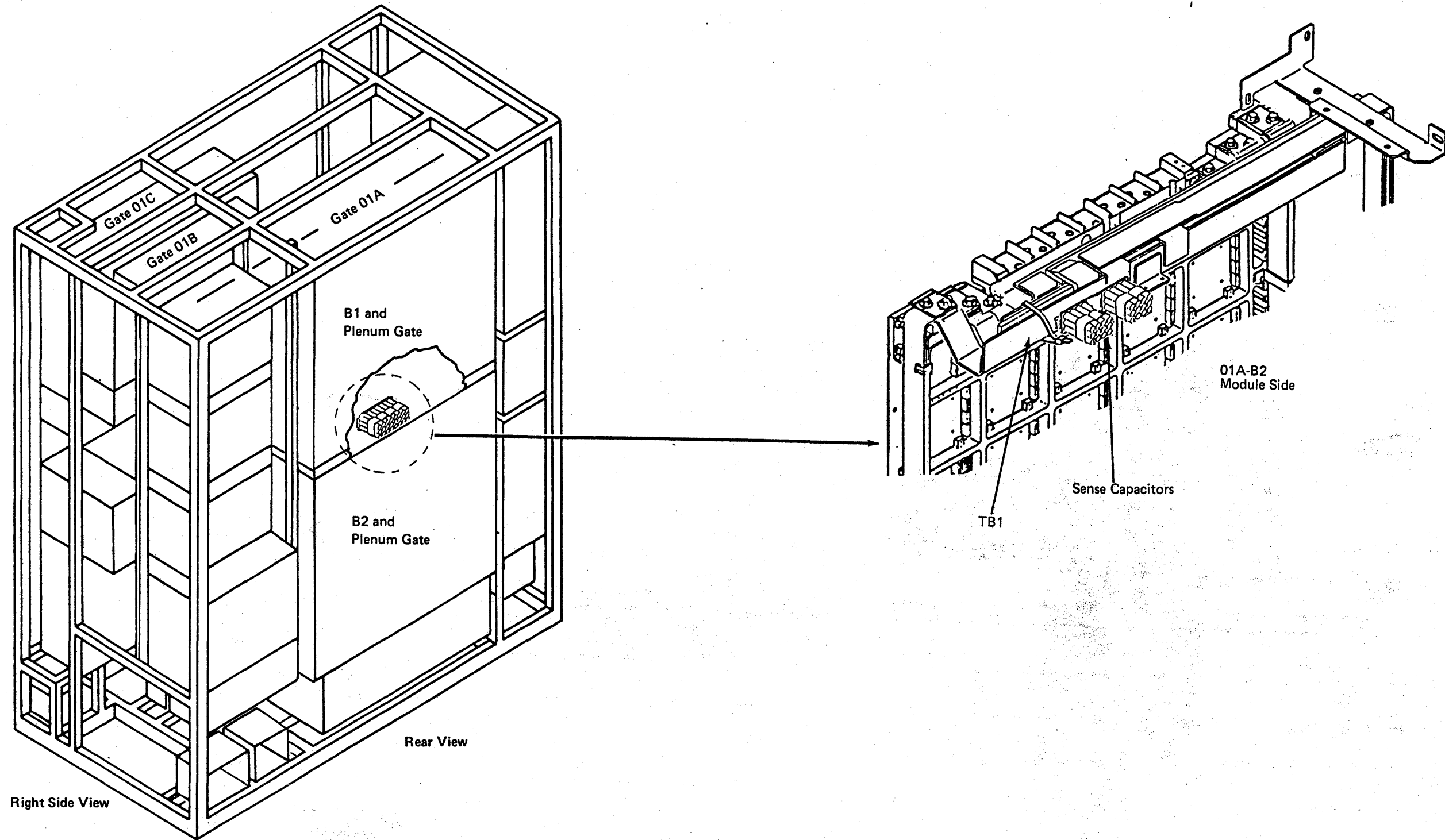

4381-3
B/M 2676380

MI
Seq GA060

PN 6169587
2 of 2

EC A20558
01 Oct 84

EC A20560
18 Feb 85

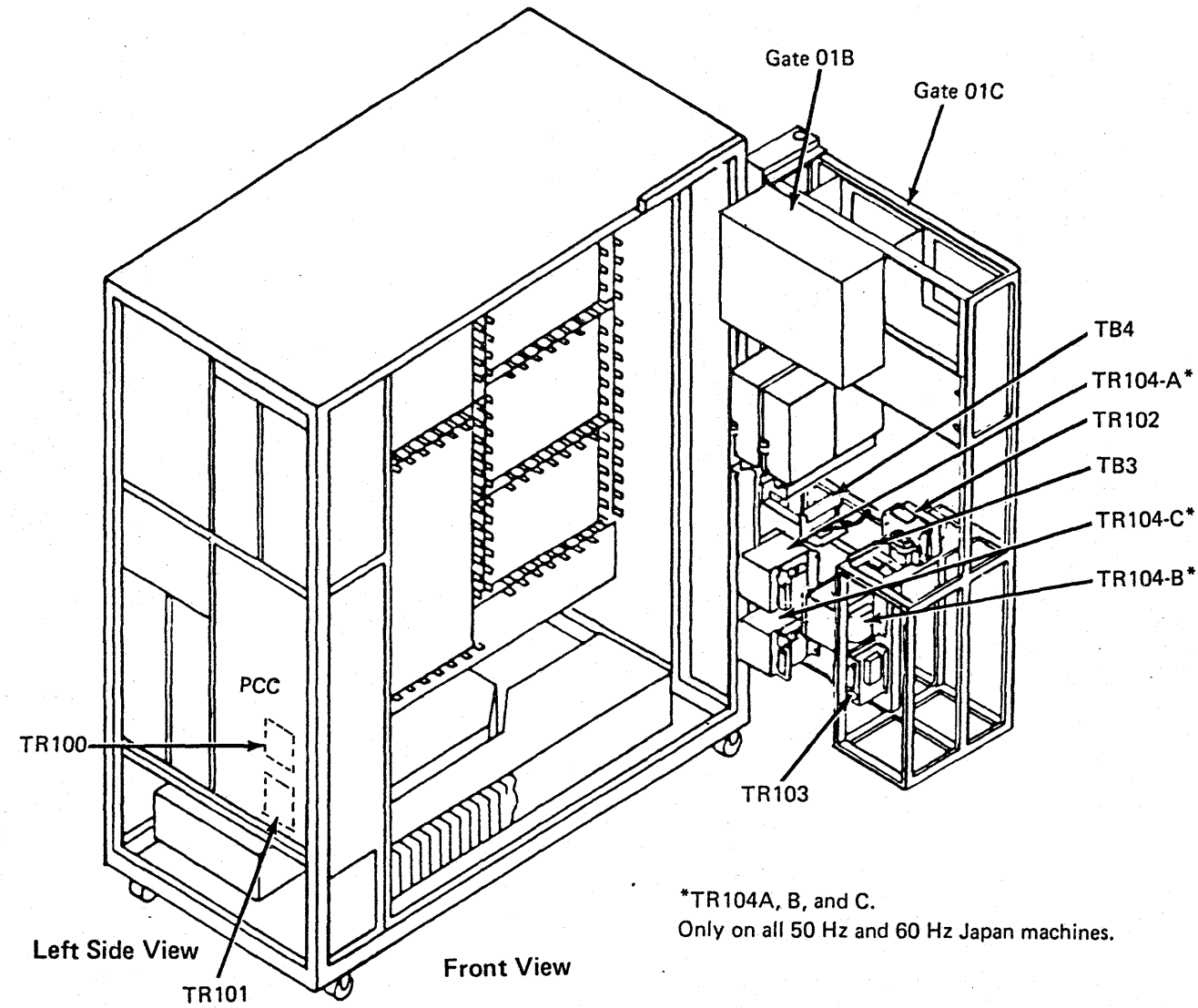

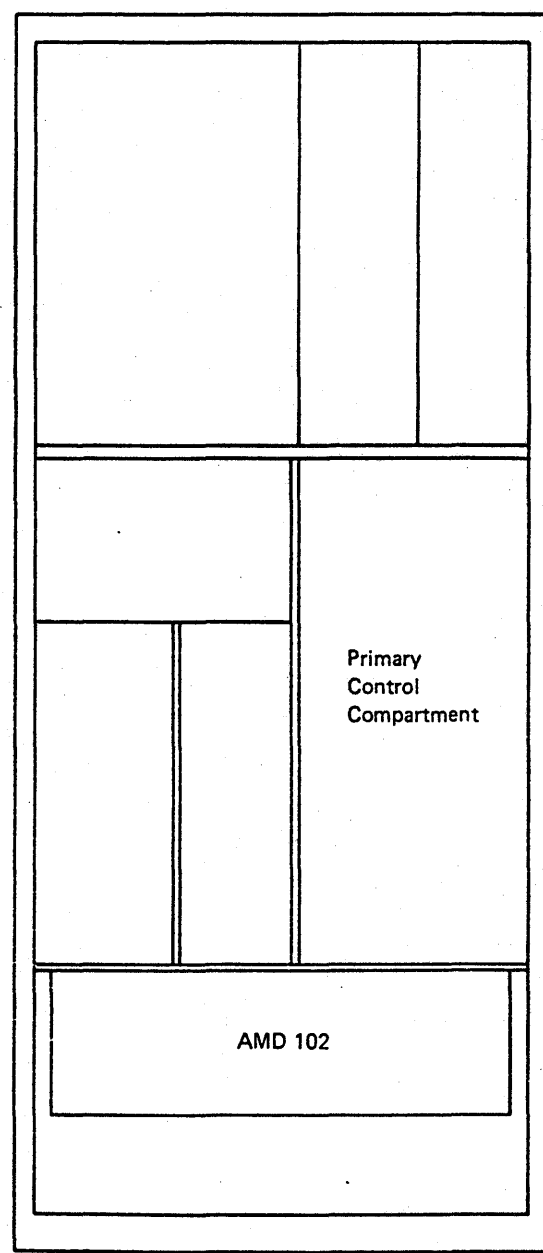

Left Side View

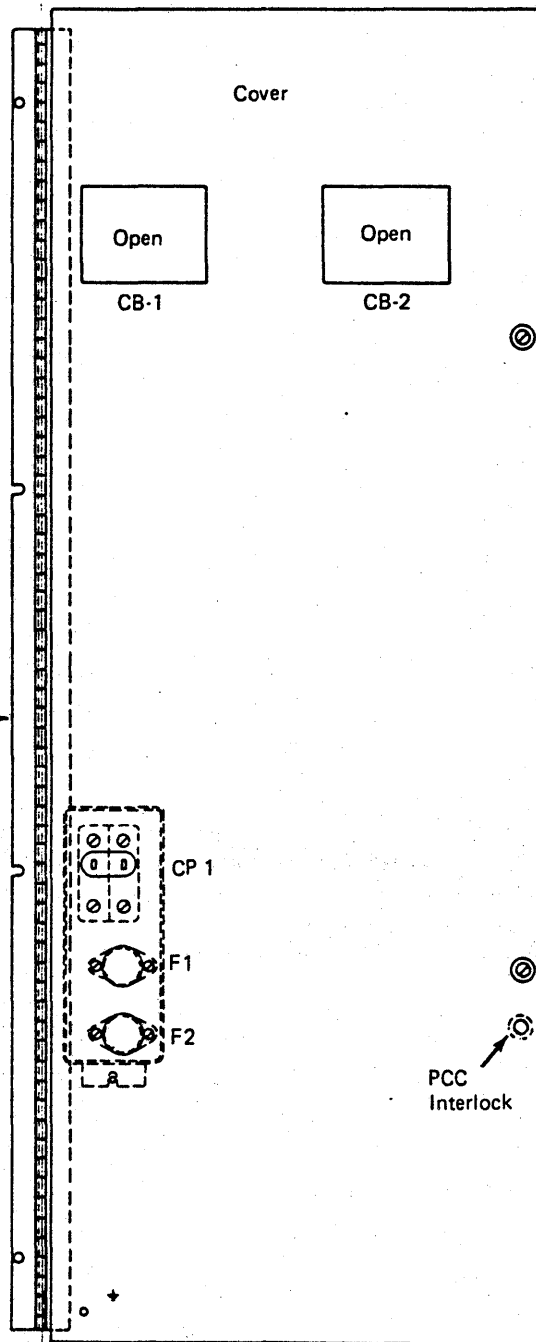

Cover

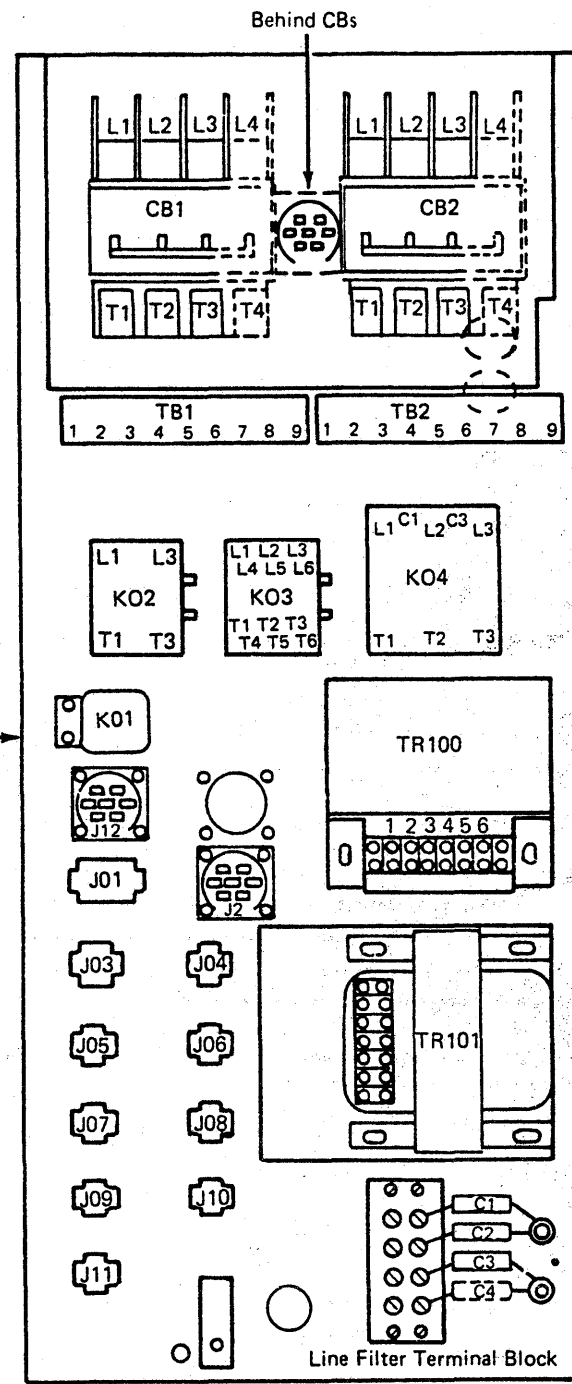

Primary Control Compartment (PCC)

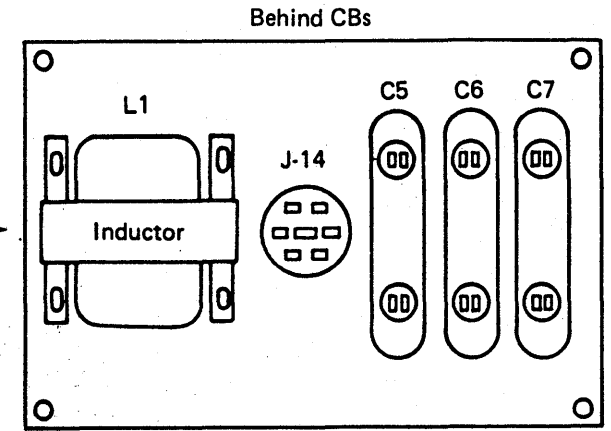

Mounted on rear of PCC

* Line filter capacitors are not present on Japan machines.

4381-3	M/	PN 6169588	EC A20558	EC A20560		
B/M 2676380	Seq GA065	2 of 2	01 Oct 84	18 Feb 85		

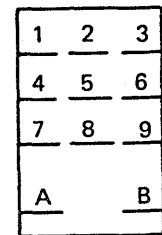

PCC K1
(Pin Side)

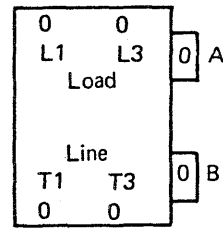

PCC K2

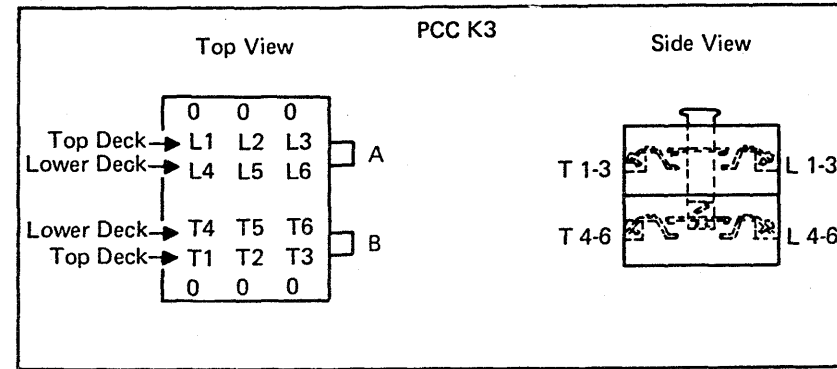

PCC K3

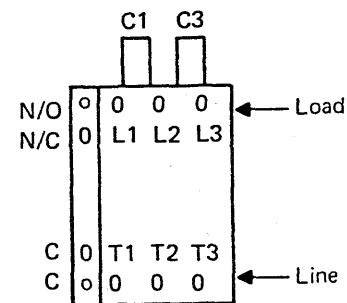

PCC K4 (Three Pole)

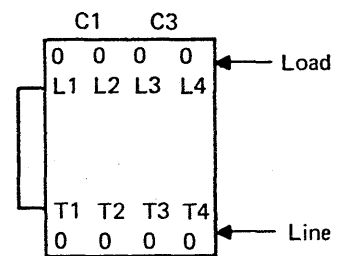

PCC K4 (Four Pole)

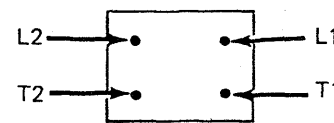

CP1
(Rear)

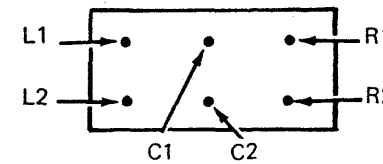

CP2
(Front)

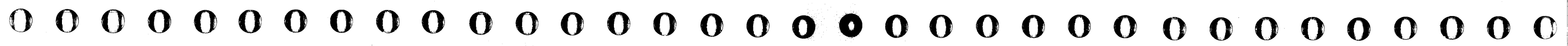

TOOLS

Contents

Maintenance Tools List	TOOLS 005
Tool Figures	TOOLS 006
Actuation Tool (Part 2360092)	TOOLS 006
Actuation Tool (Part 4134750)	TOOLS 006
Conductive Parts Caddy (Part 6428141)	TOOLS 006
Continuity Checker (Part 453587)	TOOLS 006
I/O Signal Cable Unlatch Tool (Part 2360349)	TOOLS 006
Lighted Magnifier (Part 452642)	TOOLS 011
Module Pin Template (Part 5665902)	TOOLS 011
Probe Mask (Part 9953923)	TOOLS 011
Module Pin Aligner (Part 2360424)	TOOLS 011
Probe Mask Probe Assembly (Part 401064)	TOOLS 011
Torque Wrench (Part 5665903)	TOOLS 012
1/4 to 3/8 Drive Adapter (Part 1805216)	TOOLS 012
Modular Jack Test Adapter (Part 6339647)	TOOLS 012
Actuation Tools	TOOLS 015
Operation	TOOLS 015
Continuity Checker	TOOLS 016
Operation	TOOLS 016
Maintenance	TOOLS 016
Battery Replacement	TOOLS 016
Lamp Replacement	TOOLS 016
Module Pin Aligner	TOOLS 021

Maintenance Tools List

TOOLS 005

Use the following tools to maintain the 4381 Processor.

Tool Description	Part Number	Figure Page
Actuation Tool (I/O Cables)	2360092	TOOLS 006
Actuation Tool (Boards 01A-A1 to 01A-A4 and 01B-A1)	4134750	TOOLS 006
Conductive Parts Caddy	6428141	TOOLS 006
Continuity Checker		
• Continuity checker	453587	TOOLS 006/016
• Adapter	453954	TOOLS 016
• Battery 1.35V	453119	TOOLS 016
• Battery 2.8V	453120	TOOLS 016
• Extension	5500731	TOOLS 016
• Lamp	5353889	TOOLS 016
I/O Signal Cable Unlatch Tool	2360349	TOOLS 006
Lighted Magnifier	452642	TOOLS 011
Modular Jack Test Adapter	6339647	TOOLS 012
Module Pin Aligner	2360424	TOOLS 011/021
Module Pin Alignment Template	5665902	TOOLS 011
MCM Probe Kit Assembly		
• MCM Probe Kit	9990129	TOOLS 011
• Probe Mask	9953923	TOOLS 011
• Probe Assembly	401064	TOOLS 011
Torque Wrench for Power Bus	5665903	TOOLS 012
1/4 to 3/8 Drive Adapter	1805216	TOOLS 012

Actuation Tool (Part 2360092)

(I/O signal cables)

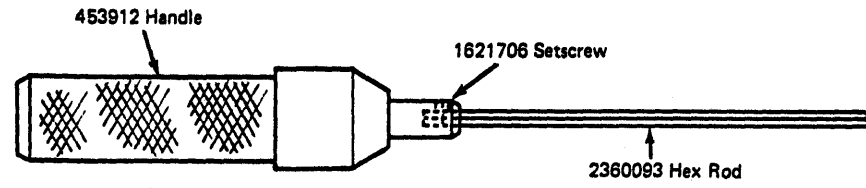

Actuation Tool (Part 4134750)

(Torque leaf springs)



Conductive Parts Caddy (Part 6428141)

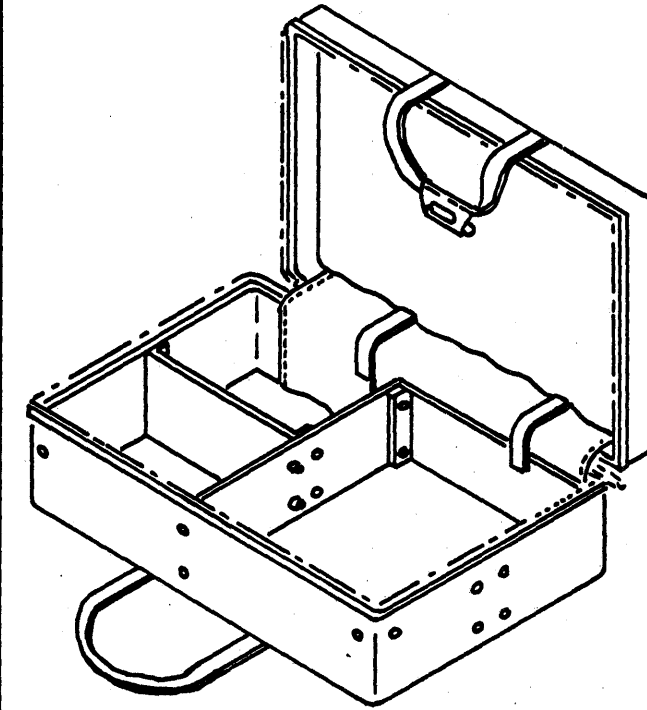

Continuity Checker (Part 453587)

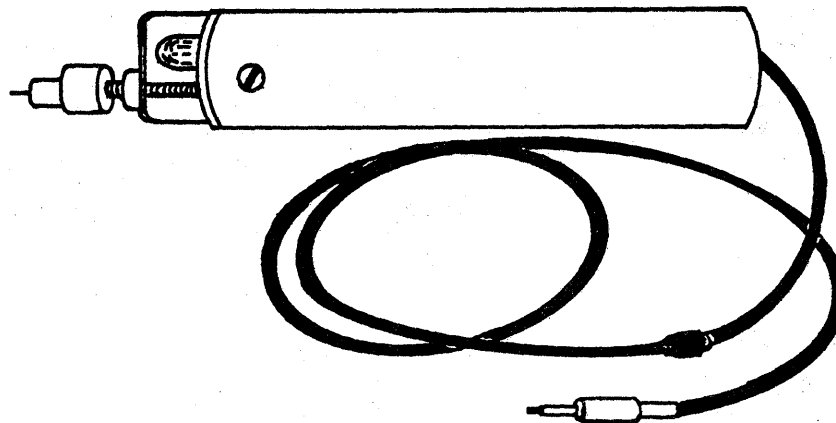

I/O Signal Cable Unlatch Tool (Part 2360349)

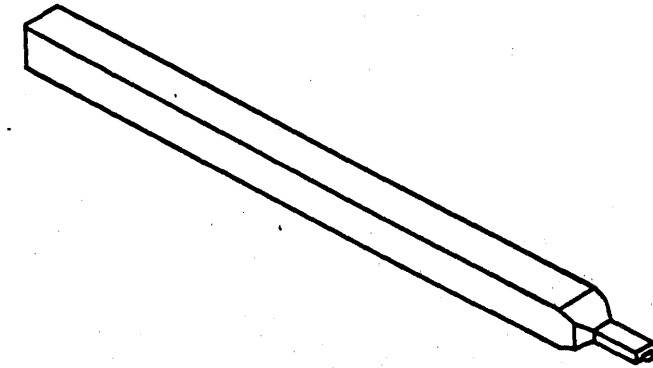

4381-3
B/M 2676380

MI	PN 6169613	EC A20558	EC A20560			
Seq GB005	2 of 2	01 Oct 84	18 Feb 85			

© Copyright IBM Corp. 1984



Lighted Magnifier (Part 452642)

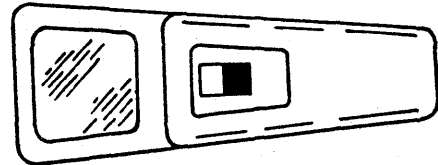

Module Pin Aligner (Part 2360424)



Probe Mask (Part 9953923)

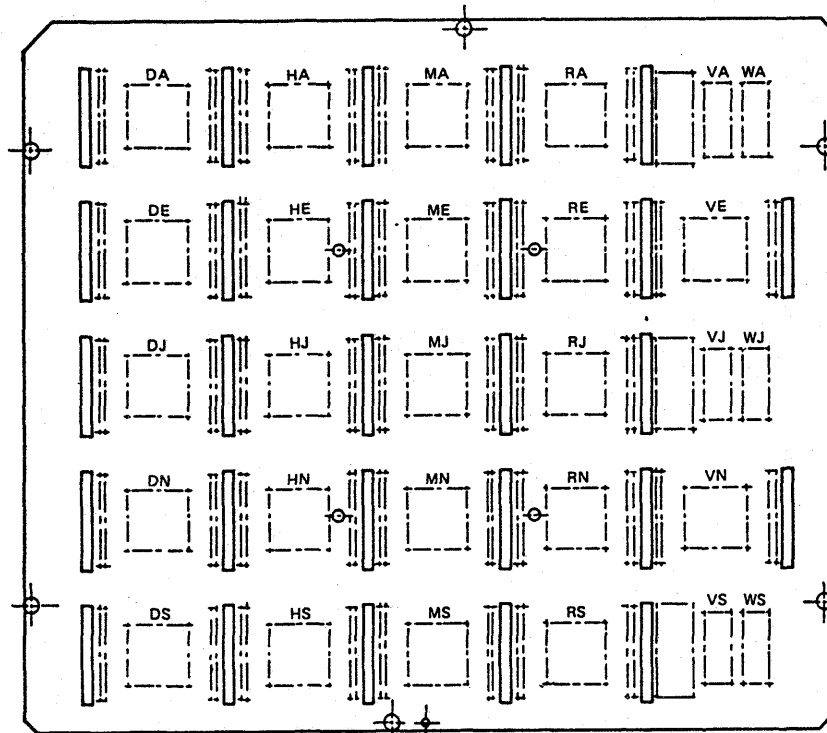

Probe Mask Probe Assembly (Part 401064)

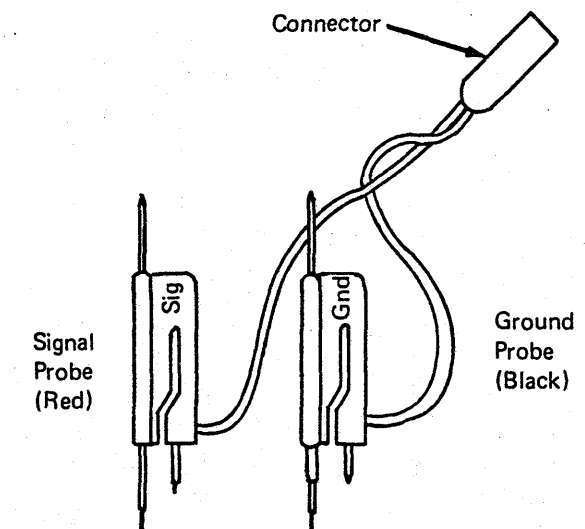

Module Pin Template (Part 5665902)

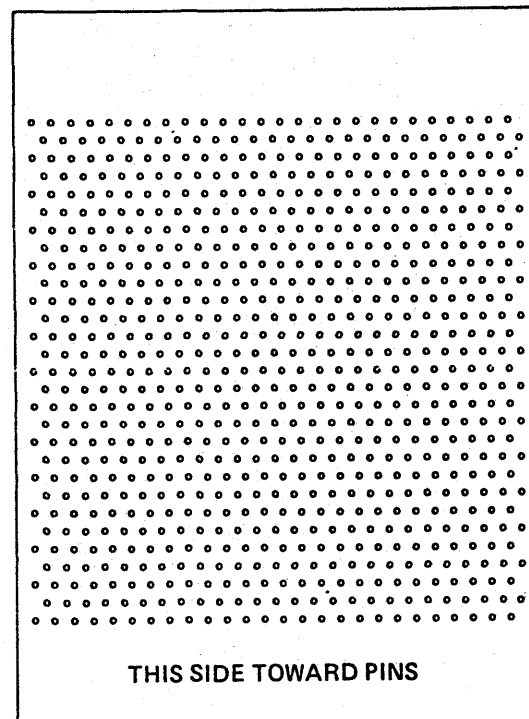

Torque Wrench (Part 5665903)

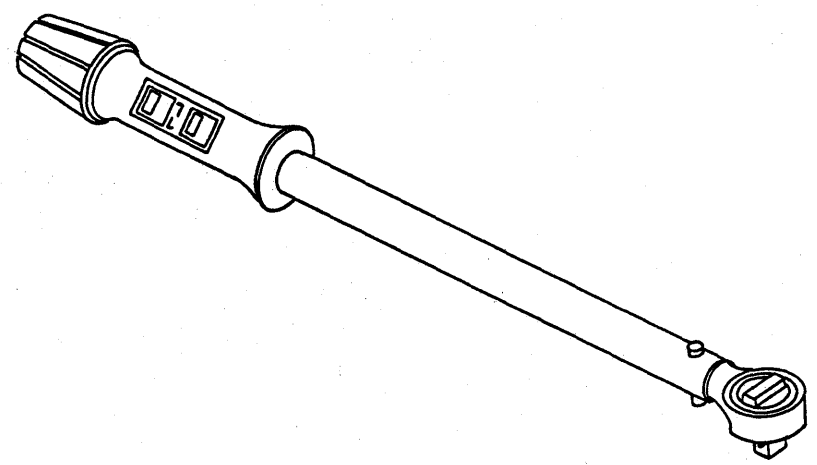

1/4 to 3/8 Drive Adapter (Part 1805216)

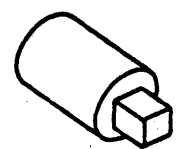

Modular Jack Test Adapter (Part 6339647)

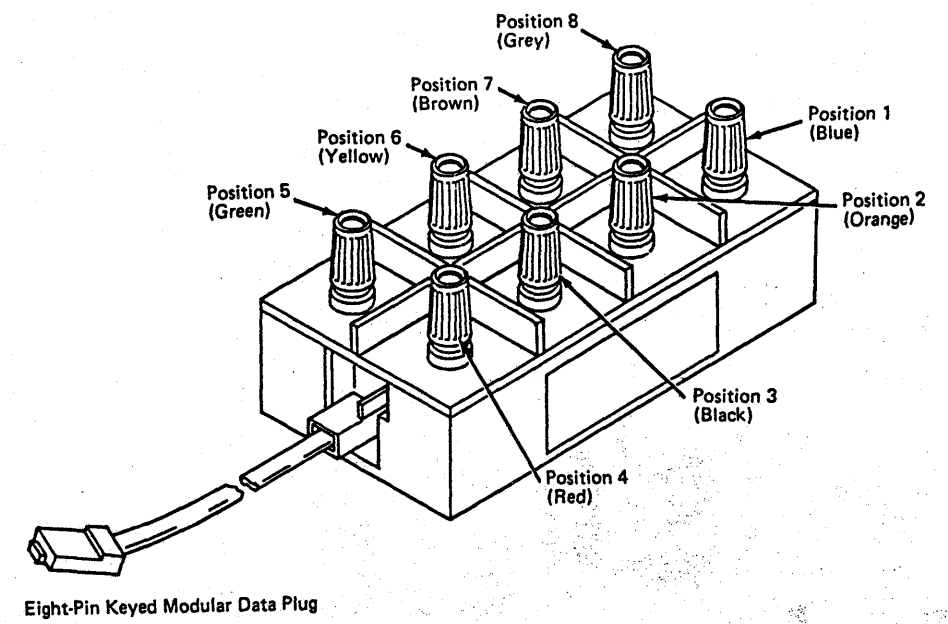

4381-3	MI	PN 6169614	EC A20558	EC A20560			
B/M 2676380	Seq GB010	2 of 2	01 Oct 84	18 Feb 85			

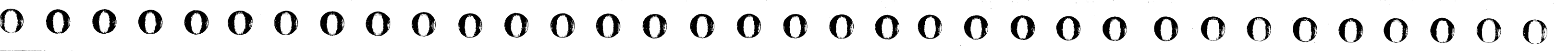

Actuation Tools

This actuation tool (part 2360092) is used to remove and replace I/O signal cables groupers. It is a hand-operated tool with a preset torque setting when turned in a clockwise direction. Torque control is needed to prevent damage to the screw threads and inserts.

Note: The part number for the blade of the actuation tool is 2360093.

Operation

Ensure the tip of the tool is seated in the socket head screw to be removed or replaced. When tightening the screw, turn the tool in a clockwise direction until you feel the tool slip and hear a clicking sound. Screw is now fully tightened. When removing a screw, ensure the tip is fully seated in the socket head screw. The actuation tool has a positive drive in a counterclockwise direction.

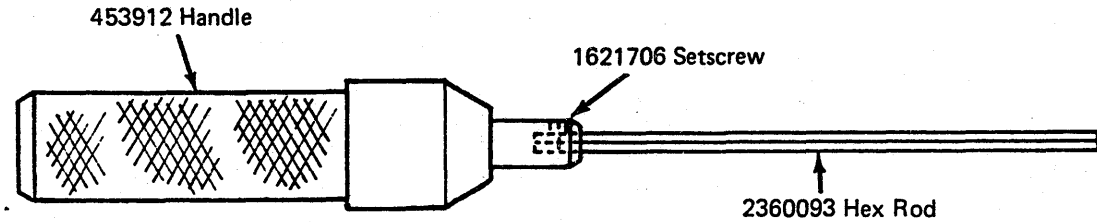

This actuation tool (part 4134750) is used to torque the horizontal cable retention bars and mounting screws for the card cages on boards 01A-A1 through 01A-A4 and 01B-A1. It is a hand-operated tool with a preset torque setting when turned in a clockwise direction. Torque control is needed to prevent damage to the screw threads, inserts, and boards.

Note: The part number for the blade of the actuation tool is 4138537.

Operation

Ensure the tip of tool is seated in the socket head screw to be removed or replaced. When tightening the screw, turn the tool in a clockwise direction until you feel the tool slip and hear a clicking sound. Screw is now fully tightened. When removing a screw, ensure the tip is fully seated in the socket head screw. The actuation tool has a positive drive in a counterclockwise direction.

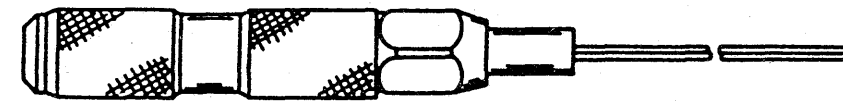

4381-3	MI	PN 6169615	EC A20558	EC A20562			
B/M 2676380	Seq GB015	1 of 2	01 Oct 84	30 Aug 85			

Continuity Checker

The continuity checker is a plastic housing with a clear plastic lens that contains an indicator. A 6-32 threaded rod extends from one end to a flexible lead with a 6-32 threaded stud extending from the other end. Various probe tips can be adapted to the continuity checker.

Operation

Assemble the necessary probe tip to the continuity checker. Connect the probe tip on the flexible lead to a convenient checkpoint. Probe with the threaded rod (with probe tip) protruding from the other end of the continuity checker.

Warning: Do not use the CE ohmmeter on LSI logic. Circuits could be damaged.

Maintenance

Maintenance consists of replacement of the following:

- 1.35V battery (part 453119)
- 2.8V battery (part 453120)
- Indicator lamp (part 5353889)

Battery Replacement

Remove the lockscrew near the front of the continuity checker. Hold the body, and pull the clear plastic end until the two parts are separated. Replace the defective batteries (observe the polarity). Reverse this procedure for reassembly.

Lamp Replacement

Disassemble the tool as in the "Battery Replacement" procedure. Loosen the locknut, and remove the circuit card assembly from the plastic lens. Remove the defective lamp. Remove the lens cap from the new lamp, and insert in the circuit card assembly.

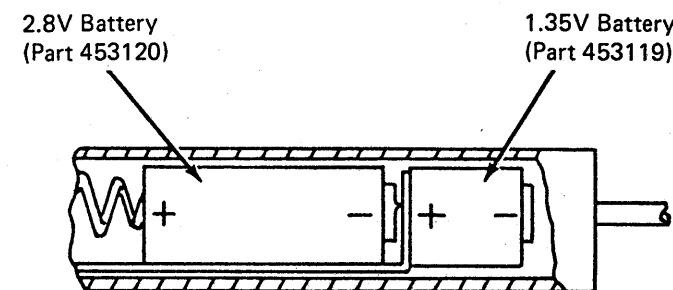
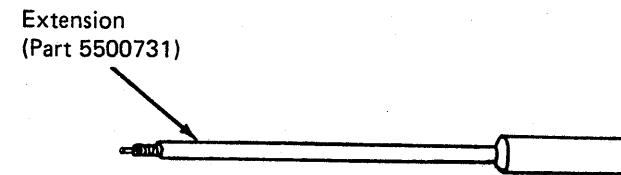
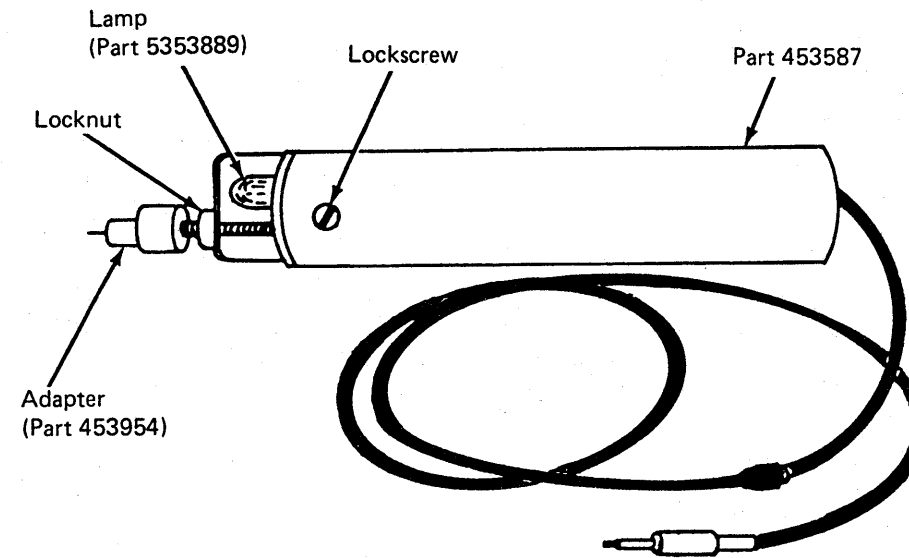

Module Pin Aligner

TOOLS 021

Warning: A module can be destroyed by touching the pins because of ESD (Electrostatic Discharge). Always wear the wrist band when handling a module.

Pins may become bent on the module so that it cannot be installed properly without causing severe damage to the system. To ensure against this potential damage, the pins must be straightened so that the alignment between them and the spring connectors is maintained for a smooth insertion.

Note: Do not attempt to straighten a pin that is bent more than the distance to the next row of pins or equivalent. A tool, as shown, is provided for aligning these pins. One end of the tool is for straightening a single pin and the other end is for straightening multiple pins.

As an aid in observing the spring connectors, use the Lighted Magnifier (part 452642). A visual inspection must be made by sighting down the row of pins. Any pins in question should be checked with the multiple end of the tool to ensure alignment. **Never install a module before checking the pin alignment.**

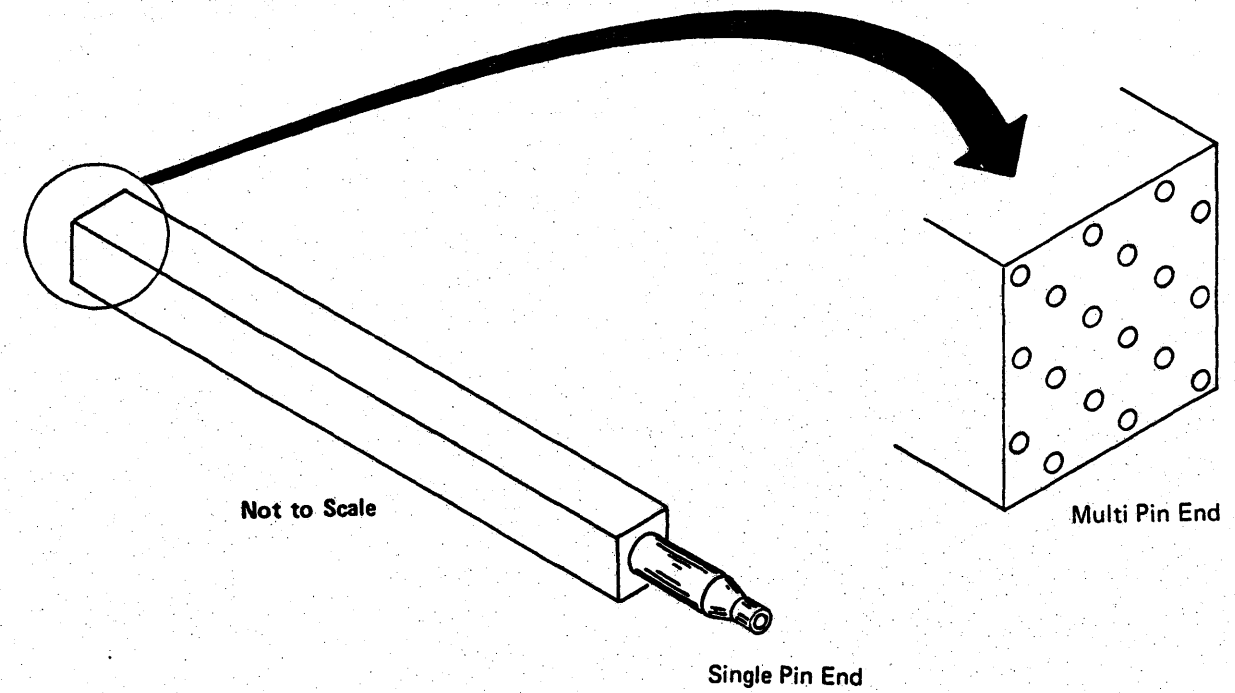

TOOLS 021



REMOVALS AND REPLACEMENTS

REM 001

Contents

Boards 01A-A1 to 01A-A4	REM 003
Board 01B-A1	REM 004
Board/Retention Cover	REM 006
LSI Cards	REM 015
Board 01A-B1	REM 021
Removal	REM 021
Replacement	REM 022
Board 01A-B2	REM 023
Removal	REM 023
Replacement	REM 024
64 MM Pluggable Module	REM 025
Actuator Bail	REM 025
Bail Retaining Latch	REM 025
Pluggable Terminator Resistor	REM 026
Sense Capacitors	REM 031
Cables	REM 032
I/O Signal Cables	REM 032
Flat Cables	REM 032
Power Supplies	REM 035
Power Supply 101	REM 035
Power Supply 102	REM 036
Power Supply 103	REM 041
Power Supply 104	REM 042
Power Supply 105	REM 045
Power Supply 106	REM 046
Power Supply 107	REM 051
Power Supply 108	REM 052
Power Supply 109	REM 055
Power Supply 111	REM 056
Power Supply 112	REM 061
Transformers	REM 065
Transformer 100	REM 065
Transformer 101	REM 066
Transformer 102	REM 071
Transformer 103	REM 072
Transformer 104	REM 075
Air Moving Devices	REM 081
Air Moving Device 101	REM 081
Air Moving Device 102	REM 082
Air Moving Device 103	REM 085
Air Moving Device 104	REM 086
Air Moving Device 105	REM 091
Air Moving Device 106	REM 092
Air Moving Device 107	REM 095
Service Panel	REM 101
Diskette Drive	REM 102

4381-3
B/M 2676380

MI Seq GC005	PN 6169557 1 of 1	EC A20558 01 Oct 84	EC A20560 18 Feb 85	EC A20562 30 Aug 85		
-----------------	----------------------	------------------------	------------------------	------------------------	--	--



Boards 01A-A1 to 01A-A4

REM 003

Tools required:

Conductive Parts Caddy (part 6428141)

Actuation Tool (part 4134750).

1. Press Power Off on the operator control panel.
2. Open left side cover of frame.
3. Locate the Primary Control Compartment (PCC), and place CB1 and CB2 in the OFF position.
4. Open rear cover of frame.
5. Determine board to be removed, and remove the card cover **A**.

Warning: A module can be destroyed by touching the card contacts and/or the exposed module pins on the back of a card. Whenever handling a card, be extremely careful not to touch the card contacts or module pins before discharging yourself to ground.

6. Compare the part number and EC level of the old board to the new board. Verify that you have the correct board for replacement.
7. Ensure that the cards and connectors are labeled for proper repositioning before they are removed from the board assembly.
8. Remove top card crossover connectors if applicable.
9. Remove the cards from the board, and place in the conductive parts caddy (part 6428141).

10. Remove air baffle(s) **B**.
11. Loosen cable opening cover screws **C**, slide the cover out of the way, and tighten the screws.
12. Loosen leaf spring torque screws **D** using the actuation tool (part 4134750) until all tension has been removed.
13. Remove upper and lower cable retainer brackets **E**.
14. Remove I/O cable connectors.
15. Open front cover of frame.
16. Open gate 01C.

Note: The upper cable retainer bracket has two grooves and the lower has one.

17. Unlatch all cable retainers **J**.

18. Remove the four board/retention cover mounting screws **K**.
19. Remove the board/retention cover **F**.
20. Remove all voltage crossover connectors, minibus connectors, and discrete components from pin side of board (label if required).
21. Remove the four latch rail mounting screws **G**.
22. Remove the latch rail **H**.
23. Remove the 14 board mounting screws (18 if board/retention hardware is not present).
24. Remove board and guide assembly by sliding the assembly towards you.
25. Reverse procedure for board replacement.

Note: When reinstalling the latch rail, ensure the latching surface is away from the board.

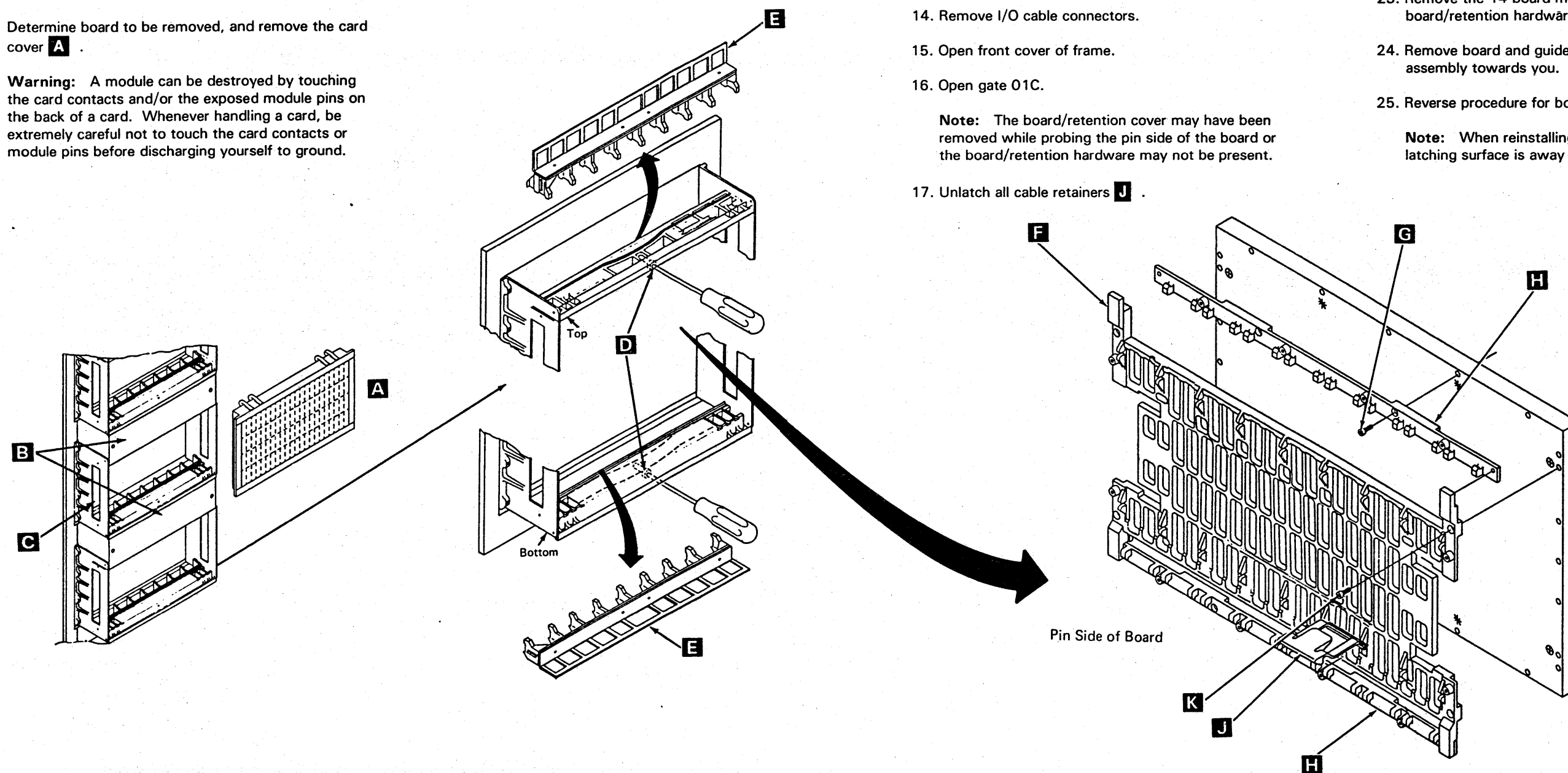

4381-3
B/M 2676380

MI
Seq GC010

PN 6169558
1 of 4

EC A20558
01 Oct 84

EC A20560
18 Feb 85

EC A20562
30 Aug 85

Tools required:

Conductive Parts Caddy (part 6428141)

Actuation Tool (part 4134750).

1. Press Power Off on the operator control panel.
2. Open left side cover of frame.
3. Locate the Primary Control Compartment (PCC), and place CB1 and CB2 in the OFF position.
4. Open front cover of the machine.
5. Open gate 01C and then open gate 01B.

Warning: A module can be destroyed by touching the card contacts and/or the exposed module pins on the back of a card. Whenever handling a card, be extremely careful not to touch the card contacts or module pins before discharging yourself to ground.

6. Remove the gate card cover **A**.
7. Compare the part number and EC level of the old board to the new board. Verify that you have the correct board for replacement.
8. Ensure that the cards and connectors are labeled for proper repositioning before they are removed from the board assembly.
9. Remove top card crossover connectors if applicable.
10. Remove the cards from the board, and place in the conductive parts caddy (part 6428141).
11. Loosen cable opening cover screws **B**, slide the cover out of the way, and tighten the screws.
12. Loosen leaf spring torque screws **C** using the actuation tool (part 4134750) until all tension is removed.

13. Remove upper and lower cable retainer brackets **D**.

Note: The upper cable retainer bracket has two grooves and the lower has one.

14. Remove I/O cable connectors.

Note: The board/retention cover may have been removed while probing the pin side of the board or the board/retention hardware may not be present.

15. Unlatch all cable retainers **H**.

16. Remove the four board/retention cover mounting screws **J**.

17. Remove the board/retention cover **E**.

18. Remove all voltage crossover connectors, minibus connectors, and discrete components from pin side of board (label if required).

19. Remove the four latch rail mounting screws **F**.

20. Remove the latch rail **G**.

21. Remove the 14 board mounting screws (18 if board/retention hardware is not present).

22. Remove board and guide assembly by sliding the assembly towards you.

23. Reverse the procedure for board replacement.

Note: When reinstalling the latch rail, ensure the latching surface is away from the board.

MI Seq GC010	PN 6169558 2 of 4	EC A20558 01 Oct 84	EC A20560 18 Feb 85	EC A20562 30 Aug 85		
-----------------	----------------------	------------------------	------------------------	------------------------	--	--

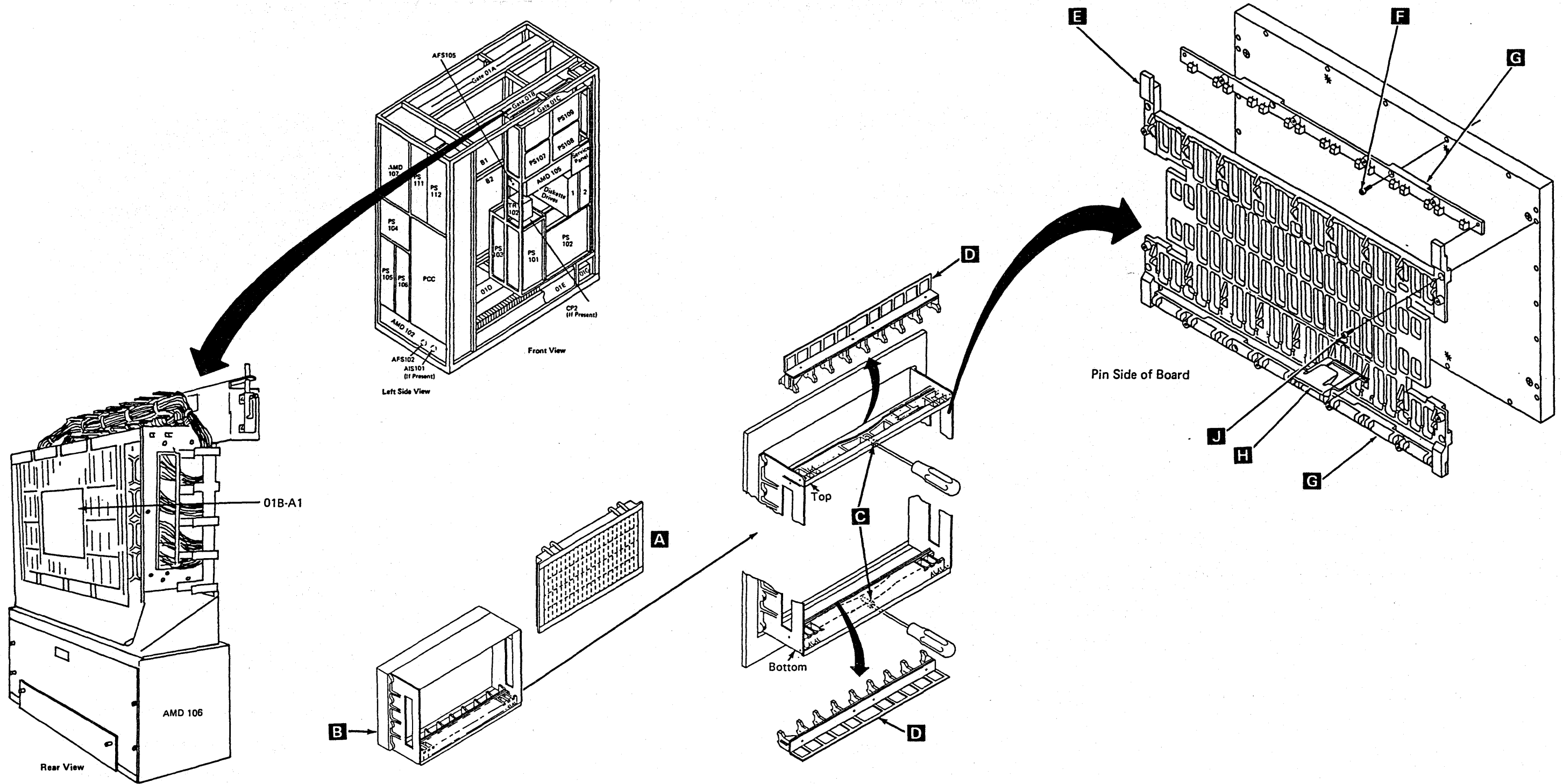

4381-3
B/M 2676380

MI
Seq GC010

PN 6169558
3 of 4

EC A20558
01 Oct 84

EC A20560
18 Feb 85

EC A20562
30 Aug 85

Board/Retention Cover

Tool required:

Actuation Tool (part 4134750).

Note: This procedure enables you to probe the pins on boards 01A-A1 through 01A-A4 and 01B-A1 that are covered by the board/retention cover.

1. Unlatch the cable retainers **C**.
2. Remove the four mounting screws **B**.
3. Remove the board/retention cover **A** from the board.
4. Reverse the procedure for board/retention cover replacement.

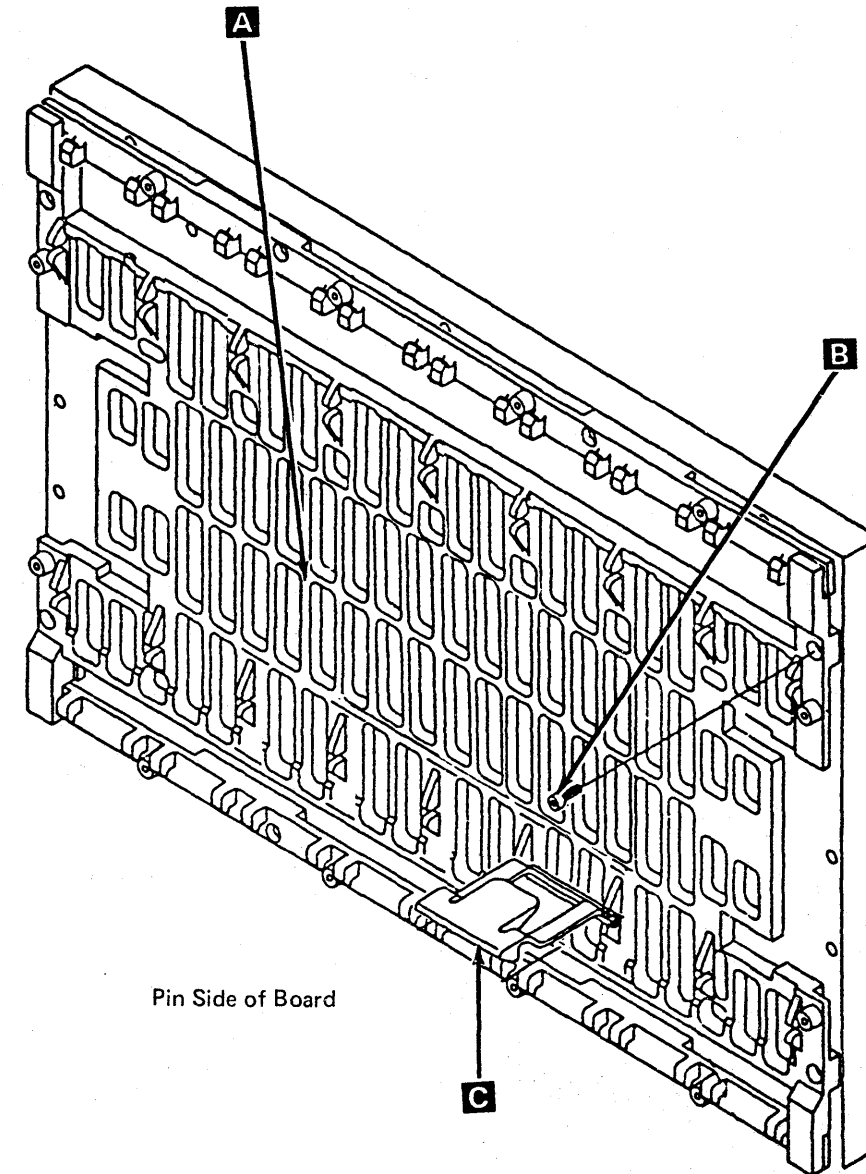

4381-3	MI	PN 6169558	EC A20558	EC A20560	EC A20562		
B/M 2676380	Seq GC010	4 of 4	01 Oct 84	18 Feb 85	30 Aug 85		

Warning: Damage results if cards are removed with power on. Do not remove any FRU until you power down the processor.

1. Power down the processor using the following procedure unless you are instructed differently by a repair procedure.
 - a. Ensure that you are in CE Mode.
 - b. Ensure that the I/O Power Hold switch on the service panel is set to I/O Power Hold.
 - c. Set the Power Off switch on the service panel to Power Off.
 - d. Wait until the service panel displays 00000.
 - e. If you exchange cards on board 01A-A1, set CB1 and CB2 to the off position.

2. Open the frame covers.

Warning: A module or card can be destroyed by Electrostatic Discharge (ESD). See your ESD kit for safety and maintenance instructions.

3. Remove the board card cover.
4. Determine the card to be removed.
5. To remove, unlock the extractor levers **A** at the same time until the card disengages.
6. To replace, open both extractor levers fully. Insert the card guide into the slotted guide grooves (card components to the right). Apply firm finger pressure to the card holder to ensure proper seating. After reseating, lock both of the extractor levers at the same time.

7. Install the board card cover.

8. Power up the processor using the following procedure unless you are instructed differently by a repair procedure.
 - a. If you exchanged cards on board 01A-A1, set CB1 and CB2 to the on position.
 - b. Set the Power Off switch on the service panel to Normal.
 - c. Press Power On.
 - d. When the Local Time Clock displays, enter the date and time in the fields on the screen and press ENTER.
 - e. When the Power Up/Down screen displays, key in UC and press ENTER.
 - f. Set the I/O Power Hold switch on the service panel to Normal.

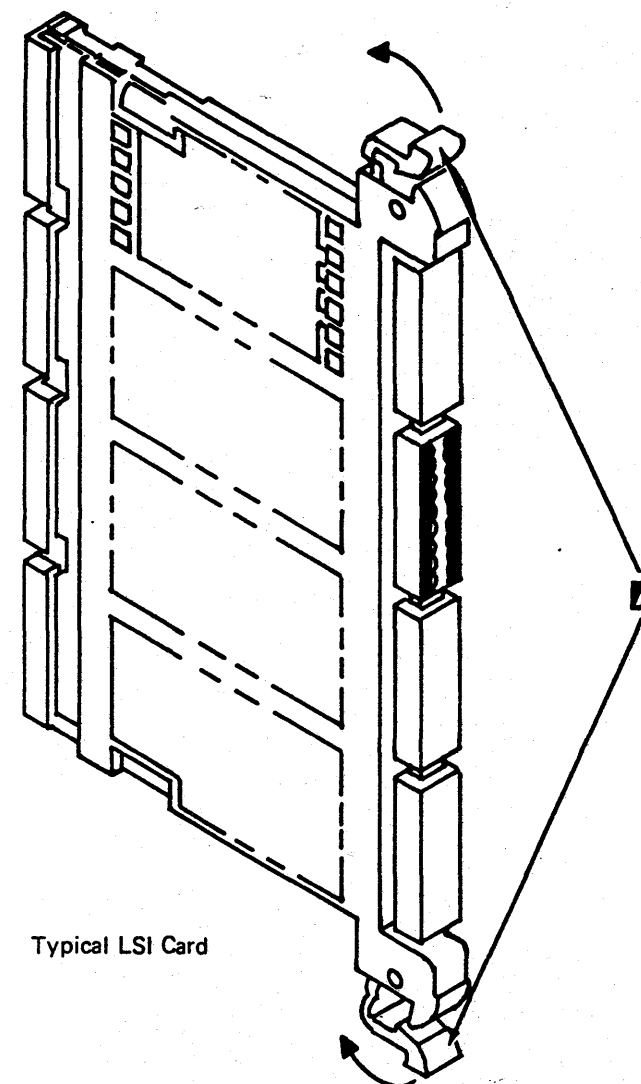

Typical LSI Card



Board 01A-B1

CAUTION

The weight of the board is approximately 36 kg (80 lb). Two persons are needed to remove and install the board.

Tools Required:

Actuation Tool for Cable Grouper (part 2360092)

1/4 to 3/8 Drive Adapter (part 1805216)

Torque Tool for Commoning Bus (part 5665903).

Removal

1. Press Power Off on the operator control panel.
2. Open left side cover of frame.
3. Locate the Primary Control Compartment (PCC), and place CB1 and CB2 in the OFF position.

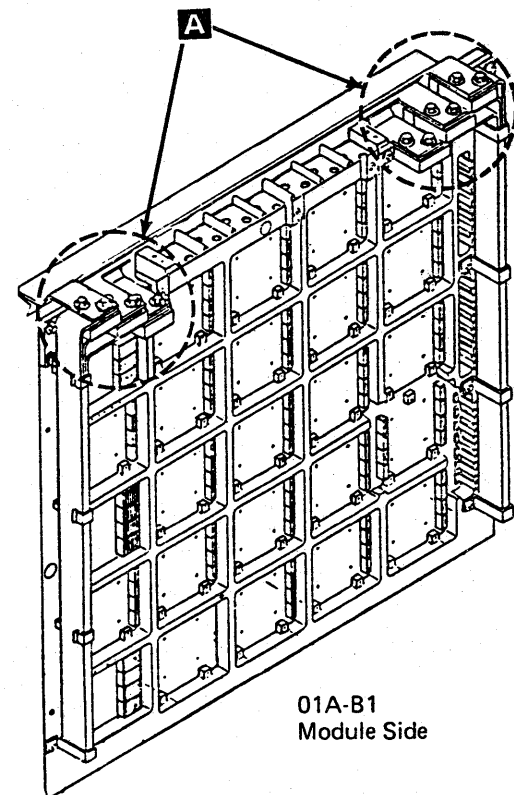

4. Open rear frame cover.
5. Loosen one screw, and open B1 plenum.
6. Ensure that the cable groupers are labeled for proper repositioning before they are removed from the board assembly.
7. Remove all cable groupers starting with the bottom positions and work toward the top.
8. Remove the conductive mat from your ESD kit and place it on the floor near the processor.

Note: See your ESD kit for safety and maintenance instructions.
9. Open the new board shipping container.
10. Remove the new board from the shipping container and place it on one-half of the conductive mat (handles down).
11. Remove the module guard located at the bottom of the board assembly **B**, and install it on the board that is to be removed.
12. Remove the 12 commoning bus screws at the board terminal blocks **A** left and right side.
13. Remove and label any additional wires connected to the commoning bus.

14. Open the front frame cover.
15. Open gate 01C.
16. Remove the three connectors (J1, J2, and J3) from PS111.
17. Remove the ground wire located at the top right corner of the board.
18. Remove the eight board mounting screws, leaving the top two screws for last.

Note: Before removing the board, ensure that you have work space large enough for two boards.
19. As the last two screws are removed, pull out the base of the board and set it on the lower support ledge of the frame.
20. Remove the board assembly by pulling the right side away from the frame first. Then remove the board assembly, and place it on the conductive mat (handles down).

21. Remove the module guard from the old board assembly.
22. Fasten the ESD wrist band to the wrist of the person who will be transferring the modules from the old board to the new board.

Note: See your ESD kit for safety and maintenance instructions.
23. Transfer the modules at this time, and ensure that they are properly plugged.

Note: For the correct module removal procedure, see page REM 025.
24. Remove the wrist band and store it in the ESD kit.

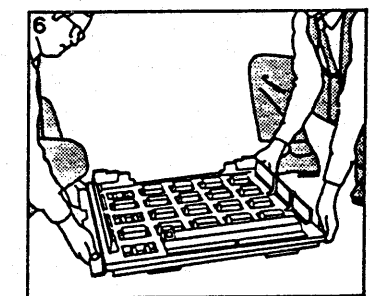
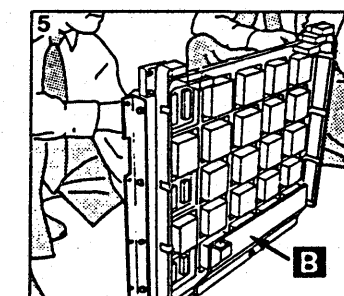
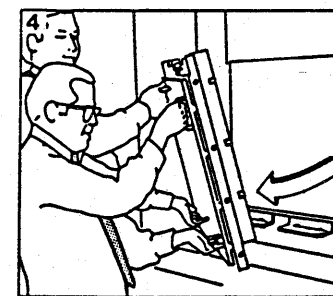
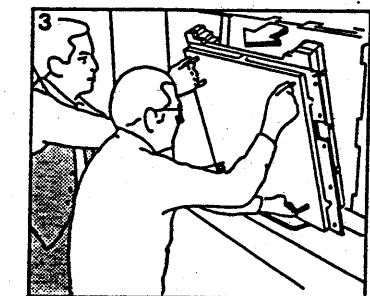
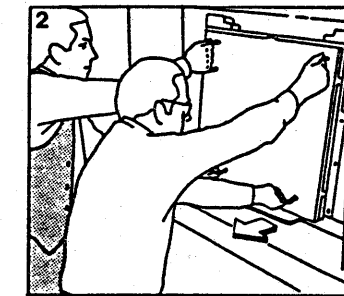
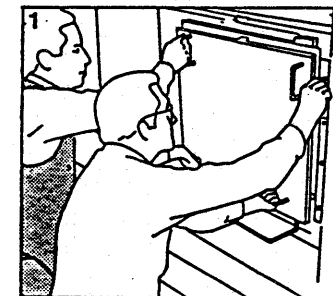

Replacement

1. Install the module guard on the new board assembly.
2. To install the board, first lift and rest the board assembly on the lower support ledge in front of the opening with the bottom of the board assembly against the lip of the support ledge.
3. Slide the board assembly to the extreme left of the frame, aligning the board bus terminal block tabs with the commoning bus tabs.
4. With the board in this position, tilt the top of the board assembly inward against the frame, aligning the board bus terminal block tabs with the commoning bus tabs.
5. In a continuous motion, lift the board assembly against the commoning bus until the bottom of the board assembly clears the main support ledge. Position the bottom edge of the board assembly against the machine frame.
6. Install the eight board mounting screws, finger tight only.
7. Remove the module guard from the new board assembly, install it on the old board assembly, and pack the old board in the shipping container.
8. Remove the ESD cable and store it along with the conductive mat in your ESD kit.
9. Install all cable groupers starting at the top of the board.
10. Install the 12 commoning bus screws. (Align board if necessary by shifting the board to the right or to the left to align the distribution bus to the commoning bus.)
11. Tighten the 12 screws. All screws must be torqued at SR 27 ±4 Newton meter (20 ±3 ft lbs).

12. Install the board ground wire.

Note: Measure the ground integrity of the replaced FRU using a digital multimeter (part 8496278) for 0.1 ohm or less before any connectors are reconnected. Place one probe on the machine frame near the replaced FRU ensuring the painted surface is penetrated. Place the other probe on any bare metal area of the replaced FRU. If the measurement is 0.1 ohm or less, you have a good ground. If the measurement is greater than 0.1 ohm, check for an improperly installed ground wire.

CAUTION

If the measurement is still greater than 0.1 ohm, invoke your support structure.

13. Close and tighten B1 plenum.
14. Close frame cover.
15. Go to the wire side of the board and torque the eight board mounting screws to SR 12 ±2 Newton meter (9 ±1.5 ft lbs).
16. Reinstall connectors J1, J2, and J3 into PS111.
17. Place CB1 and CB2 to the ON position. Press Power On/IML on the OCP.
18. Run the MSS diagnostics and PU diagnostics Option V test.

MI Seq GC020	PN 6169560 2 of 4	EC A20558 01 Oct 84	EC A20559 03 Dec 84	EC A20560 18 Feb 85	EC A20562 30 Aug 85	
-----------------	----------------------	------------------------	------------------------	------------------------	------------------------	--

CAUTION

The weight of the board is approximately 36 kg (80 lb). Two persons are needed to remove and install the board.

Tools Required:

Actuation Tool for Cable Grouper (part 2360092)

1/4 to 3/8 Drive Adapter (part 1805216)

Torque Tool for Commoning Bus (part 5665903).

Removal

1. Press Power Off on the operator control panel.
2. Open left side cover of frame.
3. Locate the Primary Control Compartment (PCC), and place CB1 and CB2 in the OFF position.
4. Open rear frame cover.
5. Loosen one screw, and open B2 plenum.

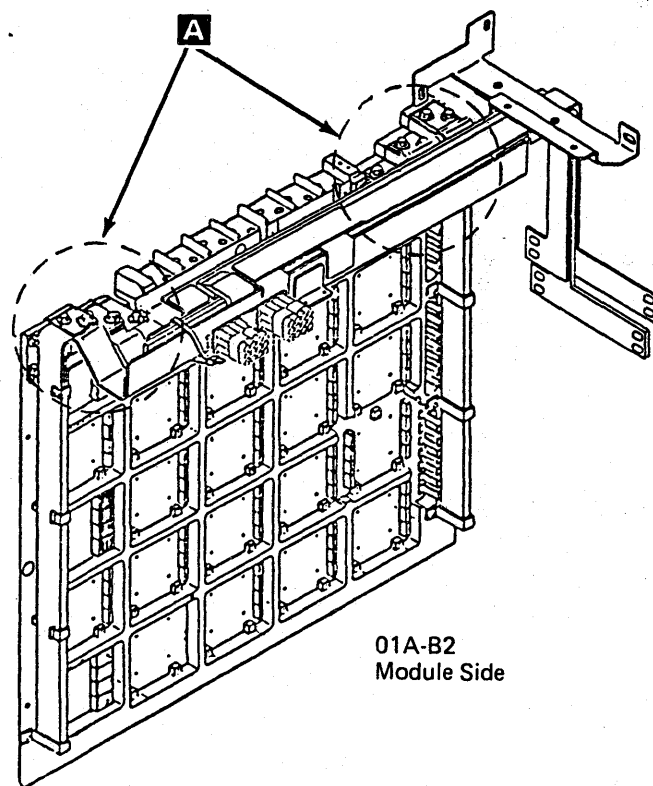

6. Ensure that the cable groupers are labeled for proper repositioning before they are removed from the board assembly.
7. Remove all cable groupers starting with the bottom positions and work toward the top.
8. Remove the conductive mat from your ESD kit and place it on the floor near the processor.

Note: See your ESD kit for safety and maintenance instructions.
9. Open the new board shipping container.
10. Remove the new board from the shipping container and place it on one-half of the conductive mat (handles down).
11. Remove the module guard located at the bottom of the board assembly **C**, and install it on the board that is to be removed.
12. Remove the upper bus safety shield.
13. Remove the 12 commoning bus screws at the board terminal blocks **A** left and right side.
14. Remove and label any additional wires connected to the commoning bus.

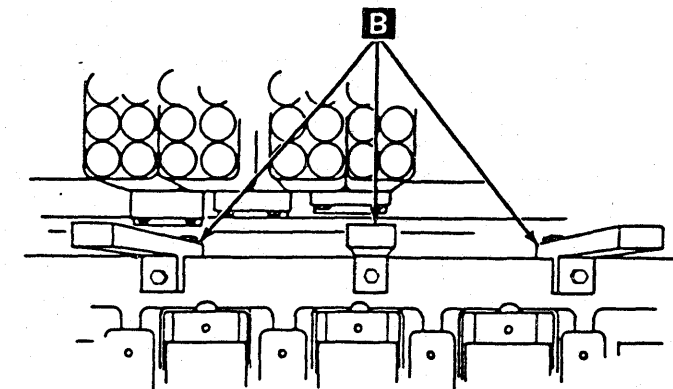

15. Perform the following two steps if a two piece bus bar is installed:
 - a. Using a quarter-inch drive socket set, remove the three screws holding the commoning bus and distribution bus terminal block **B**.
 - Note:** There may be six screws on early level boards.
 - b. Remove the terminal block; be careful not to drop the block.
16. Open the front frame cover.
17. Open gate 01C.
18. Remove the three connectors (J1, J2, and J3) from PS106.
19. Remove the ground wire located at the top right corner of the board.
20. Remove the eight board mounting screws, leaving the top two screws for last.

Note: Before removing the board, ensure that you have work space large enough for two boards.
21. As the last two screws are removed, pull out the base of the board and set it on the lower support ledge of the frame.

22. Remove the board assembly by pulling the right side away from the frame first. Then remove the board assembly, and place it on the conductive mat (handles down).
23. Remove the module guard from the old board assembly.
24. Fasten the ESD wrist band to the wrist of the person who will be transferring the modules from the old board to the new board.

Note: See your ESD kit for safety and maintenance instructions.
25. Transfer the modules at this time, and ensure that they are properly plugged.

Note: For the correct module removal procedure, see page REM 025.
26. Remove the wrist band and store it in the ESD kit.

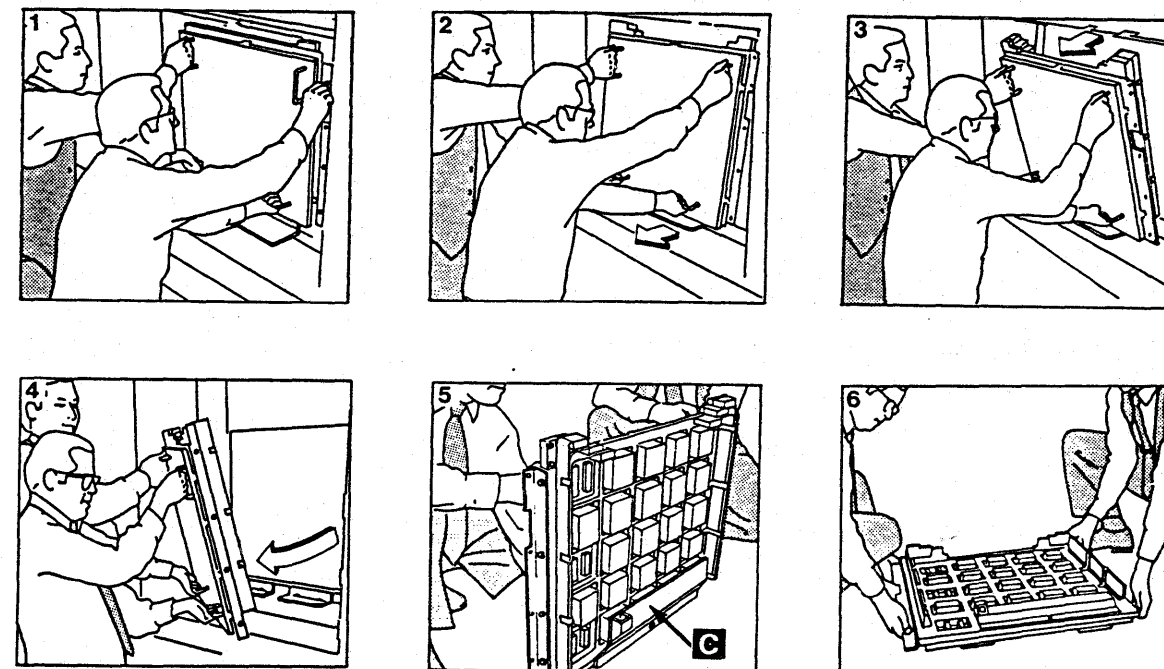

4381-3	MI	PN 6169560	EC A20558	EC A20559	EC A20560	EC A20562
B/M 2676380	Seq GC020	3 of 4	01 Oct 84	03 Dec 84	18 Feb 85	30 Aug 85

Replacement

1. Install the module guard on the new board assembly.
2. To install the board, first lift and rest the board assembly on the lower support ledge in front of the opening with the bottom of the board assembly against the lip of the support ledge.
3. Slide the board assembly to the extreme left of the frame, aligning the board bus terminal block tabs with the commoning bus tabs.
4. With the board in this position, tilt the top of the board assembly inward against the frame, aligning the board bus terminal block tabs with the commoning bus tabs.
5. In a continuous motion, lift the board assembly against the commoning bus until the bottom of the board assembly clears the main support ledge. Position the bottom edge of the board assembly against the machine frame.
6. Install the eight board mounting screws, finger tight only.
7. Remove the module guard from the new board assembly, install it on the old board assembly, and pack the old board in the shipping container.
8. Remove the ESD cable and store it along with the conductive mat in your ESD kit.
9. Install all cable groupers starting at the top of the board.
10. Install the 12 commoning bus screws. (Align board if necessary by shifting the board to the right or to the left to align the distribution bus to the commoning bus.)
11. Tighten the 12 screws. All screws must be torqued at SR 27 ±4 Newton meter (20 ±3 ft lbs).

12. Reattach the terminal block (if present) with three screws.

Note: Only three screws are needed if replacing an early level board.

13. Install the board ground wire.

Note: Measure the ground integrity of the replaced FRU using a digital multimeter (part 8496278) for 0.1 ohm or less before any connectors are reconnected. Place one probe on the machine frame near the replaced FRU ensuring the painted surface is penetrated. Place the other probe on any bare metal area of the replaced FRU. If the measurement is 0.1 ohm or less, you have a good ground. If the measurement is greater than 0.1 ohm, check for an improperly installed ground wire.

CAUTION

If the measurement is still greater than 0.1 ohm, invoke your support structure.

14. Install the safety shield.
15. Close and tighten B2 plenum.
16. Close frame cover.
17. Go to the wire side of the board and torque the eight board mounting screws to SR 12 ±2 Newton meter (9 ±1.5 ft lbs).
18. Reinstall connectors J1, J2, and J3 into PS106.
19. Place CB1 and CB2 to the ON position. Press Power On/IML on the OCP.
20. Run the MSS diagnostics and PU diagnostics Option V test.

4381-3
B/M 2676380

MI Seq GC020	PN 6169560 4 of 4	EC A20558 01 Oct 84	EC A20559 03 Dec 84	EC A20560 18 Feb 85	EC A20562 30 Aug 85	
-----------------	----------------------	------------------------	------------------------	------------------------	------------------------	--

64 MM Pluggable Module

REM 025

Tools required:

Module Pin Aligner (part 2360424)

Module Pin Alignment Template (part 5665902).

Warning: Do not remove any screws from the spring housing. Attempting to remove the spring housing results in permanent damage to the B1 or B2 board.

1. Press Power Off on the operator control panel unless instructed differently by a repair procedure.
2. Open rear cover of the machine.
3. Open B1 or B2 plenum by loosening one screw.

Warning: A module can be destroyed by touching the pins because of Electrostatic Discharge (ESD). Never touch the pins of a module unless you are wearing a wrist band.

4. Remove the wrist band and the ESD cable from the ESD kit.

Note: See your the ESD kit for safety and maintenance instructions.

5. Plug the wrist band and the ESD cable into the B1 or B2 plenum latch bracket.
6. Fasten the ESD wrist band to the wrist of the person who will be removing and installing the modules.
7. Attach the ESD cable to the the protective container of the new module.
8. Determine which pluggable module is to be removed.
9. Hold the two bail-retaining latches **A** on both sides of the module assembly, located near the top.
10. Squeeze both latches toward each other, and hold them in that position while pulling the actuator bail **B** outward with your finger.

11. Apply additional downward force on the actuator bail to drive the module free of the spring connectors.

Note: The module must be held in position because it is free to be removed.

12. Carefully remove the module away from the module site. Remove the new module from the protective container and place the old module in it.

13. Ensure that the new module pins are aligned; use the Module Pin Alignment Template (part 5665902).

Note: Do not attempt to straighten any module pin that is bent more than the distance to the next row, or equivalent. Doing this can cause the pin to break off during module insertion. Pins bent less than this distance can be straightened using the pin aligner (part 2360424).

14. Carefully place the module in position, and hold in position until the next step.

15. While holding the module in position, slowly but continuously push the actuator bail in until it hits the stop.

16. The two bail-retaining latches, located on both sides of the module assembly near the top, should be in a latched position.

17. To ensure the module is properly seated, squeeze the two bail-retaining latches toward each other and pull the actuator bail with your finger until the actuator bail is in a free state.

18. Hold the module and try to move it. If the module is tight, reactivate the actuator bail. If the module is loose, go back to step 12.

19. Remove the wrist band and ESD cable and store in the ESD kit.

20. Close the B1 or B2 plenum, and tighten the screw.

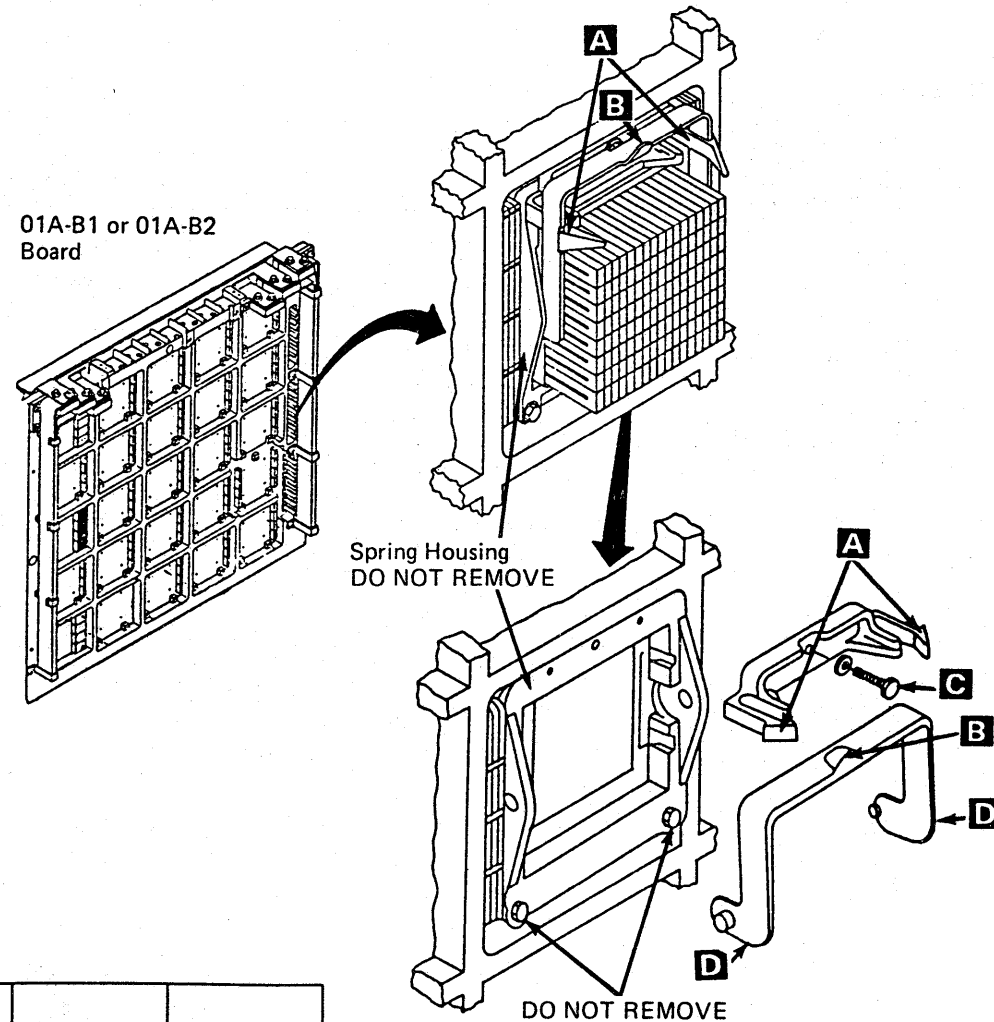

Actuator Bail

1. Remove the module.
2. Ensure that the actuator bail **B** is in the open position.
3. Squeeze the actuator bail shown at **D** until the pivot points are free from the spring housing.
4. Remove the actuator bail from the spring housing.
5. Reverse the procedure for actuator bail replacement.

Note: When reinstalling the actuator bail, ensure the bail-retaining latches **A** are on the inside of the actuator bail.

Bail-Retaining Latches

Warning: Do not remove any screws from the spring housing until instructed in this procedure. Attempting to remove the spring housing results in permanent damage to the B1 or B2 board.

1. Remove the module.
2. Remove the actuator bail.
3. Remove the one mounting screw, lockwasher, and washer **C** from the bail-retaining latches **A**.
4. Remove the bail-retaining latches.
5. Reverse the procedure for bail-retaining latches replacement.

4381-3
B/M 2676380

MI	PN 6169561
Seq GC025	1 of 2

EC A20558	EC A20560	EC A20562
01 Oct 84	18 Feb 85	30 Aug 85

Pluggable Terminator Resistor

Tool Required:

Scissor Clamp (part 9900233).

1. Press Power Off on the operator control panel.
2. Open left side cover of frame.
3. Open rear frame cover.
4. Loosen one screw, and open B1 or B2 plenum.
5. Remove retention cover(s) **A** from terminator resistor section.
6. Place scissor clamp (part 9900233) **B** in center of terminator resistor (TR) and pull straight out.

Warning: The spring housing is not fastened to the board. To prevent the spring housing from falling off the board, do not remove more than one row of TRs at a time.

7. Reverse procedure for terminator resistor replacement.

Note: When replacing TRs, ensure that the replacement resistor has the same colored part number as resistor that was removed. The two resistors that can be used are (part 4481673) black in color and (part 4481674) red in color shown at **C**.

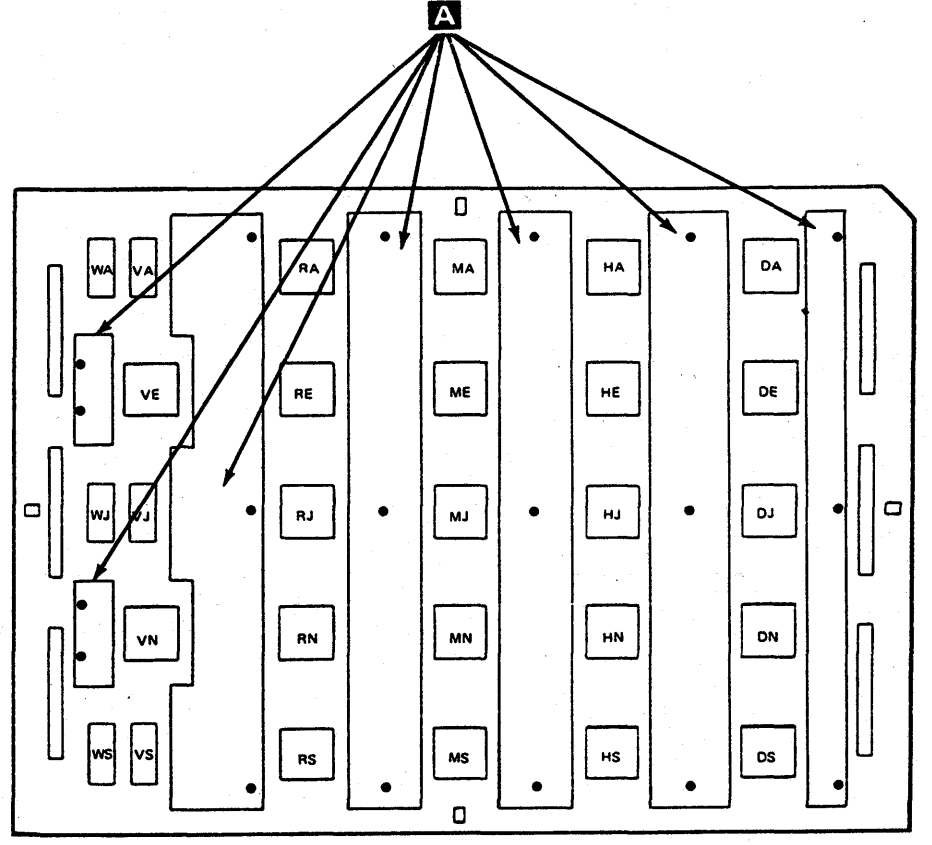

01A-B1 or B2
Module Side

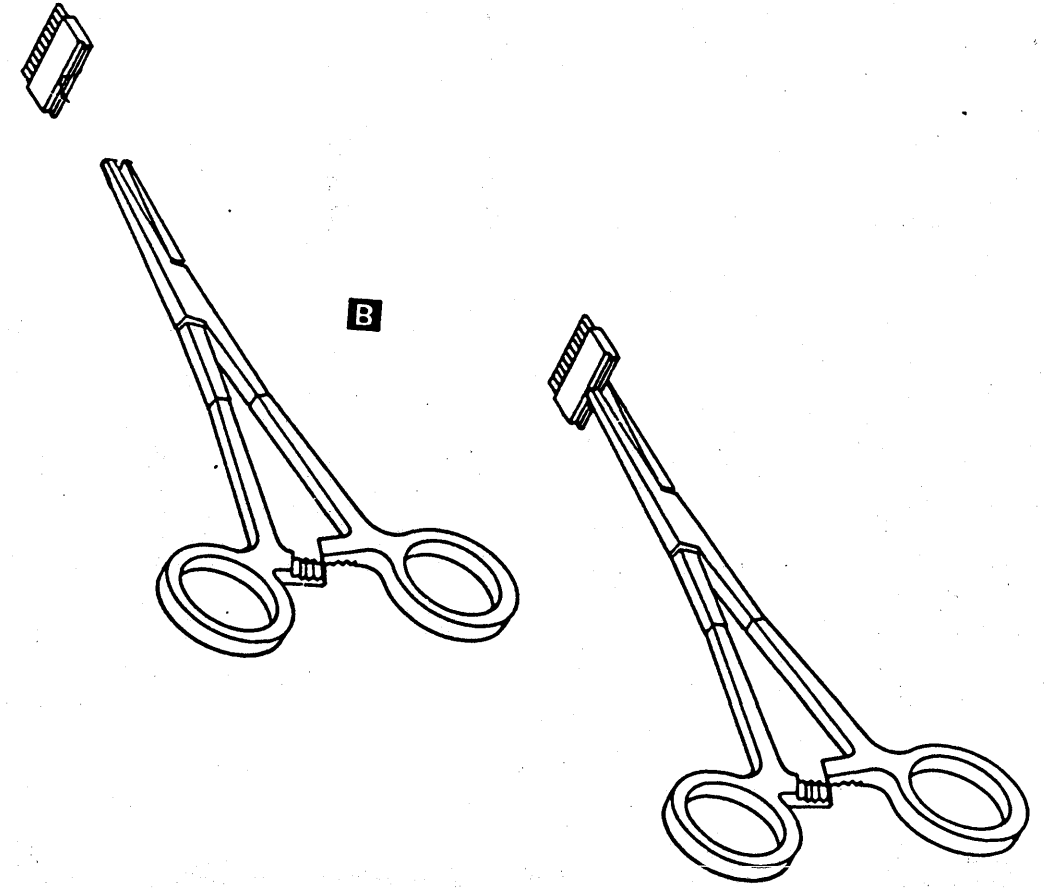
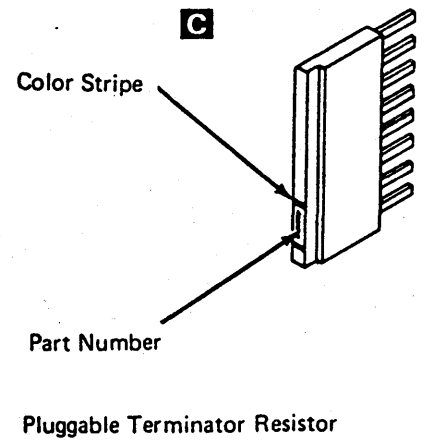

4381-3	MI	PN 6169561	EC A20558	EC A20560	EC A20562		
B/M 2676380	Seq GC025	2 of 2	01 Oct 84	18 Feb 85	30 Aug 85		

Sense Capacitors

REM 031

1. Press Power Off on the operator control panel.
2. Open left side cover of frame.
3. Locate the Primary Control Compartment (PCC), and place CB1 and CB2 in the OFF position.
4. Open rear cover of frame.
5. Open B1 and B2 plenum by loosening one screw on each.
6. Locate bus bars on top of board B2.
7. Remove the upper safety shield by loosening three mounting screws and remove the lower safety shield by loosening two mounting screws.
8. Unplug four wires **A** that are fasten to the sense capacitor assembly.
9. Remove the six screws and washers **B** that fasten the sense capacitors assembly to bus bars A, B, and C.
10. Remove the sense capacitors assembly.
11. Reverse procedure for sense capacitors replacement.

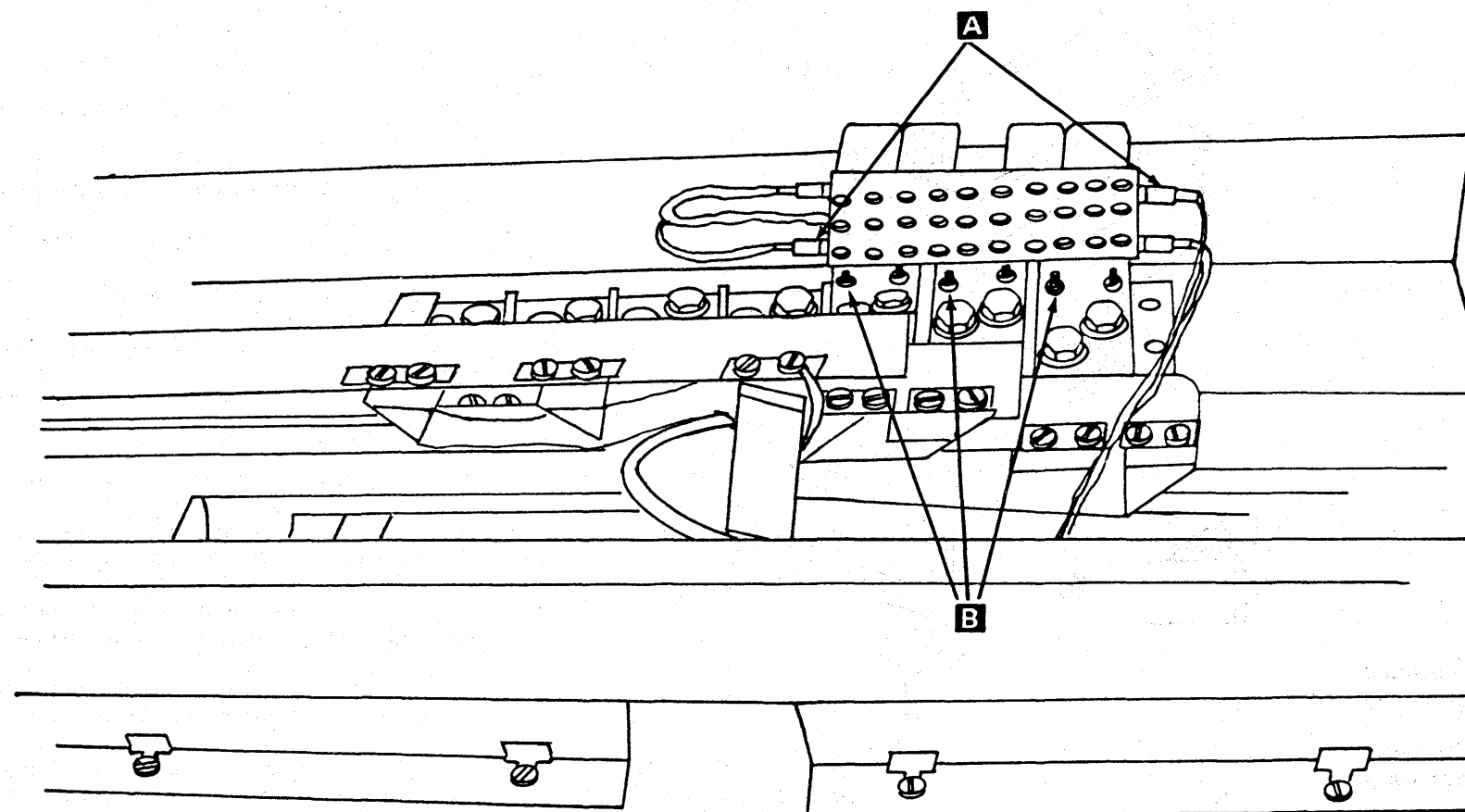

Rear view of Sense Capacitors

4381-3
B/M 2676380

MI
Seq GC030

PN 6169562
1 of 2

EC A20558
01 Oct 84

EC A20562
30 Aug 85

© Copyright IBM Corp. 1984

REM 031

Cables

I/O Signal Cables

Tools Required:

Torque Tool for Cable Grouper (part 2360092)

Cable Unlatch Tool (part 2360349).

1. Press Power Off on the operator control panel.
2. Open left side cover of frame.
3. Locate the Primary Control Compartment (PCC), and place CB1 and CB2 in the OFF position.
4. Open rear frame cover.
5. Open B1 or B2 plenum by loosening one screw.
6. Determine which cable grouper assembly is to be removed.
7. Remove grouper assembly.
8. Remove retainer arms at **D** if present.
9. Determine which 18-PAC is defective.
10. Orient the grouper housing so that one end of the housing is facing towards you.
11. Hold the cable unlatch tool (part 2360349), and position it so that the narrow end of the tool is parallel to the slot openings as shown at **A**.
12. The front end of the tool has a recessed ledge that seats against the slot ribs.

Note: With the 18-PAC cable positioned for either end, rotate the tool 180 degrees so that the recessed ledge of the tool is away from the side wall of the housing and the straight side of the tool is against the side wall.

13. Place the tip of the tool on top of the latch arm protruding out of the housing.

Warning: To prevent damage to the slot ribs, do not use excessive force when moving the latch arm.

14. Holding the tool with the tip resting on top of the latch arm, push the tool straight in until the recessed ledge of the tool comes in contact with the slot rib as shown at **B**.

15. While holding the tool in this position, press the working end of the tool down slowly moving the latch arm down below the latching shelf surface as shown at **C**.

16. Repeat this same procedure for the other end of the 18-PAC cable.

17. Hold all the trilead cables attached to the 18-PAC to be removed, and gently pull on the cables to remove the 18-PAC.

Note: Do not unlatch and remove more than one 18-PAC cable assembly at a time.

18. Remove enough cable retainers to permit tracing of cables into the cable channel.

19. Ensure that you have the correct cables and cut the cables (in the channel) at both ends.

20. Place replacement cable on top of pile in cable raceway, and replace cable retainers.

21. Reconnect both ends of replacement cable into grouper.

22. Install retainer arms if present.

23. Install grouper assembly.

24. Close B1 or B2 plenum by tightening one screw.

25. Close the rear frame cover.

26. Locate the Primary Control Compartment (PCC), and place CB1 and CB2 in the ON position.

27. Close left side cover of frame.

28. Press Power On/IML on the operator control panel.

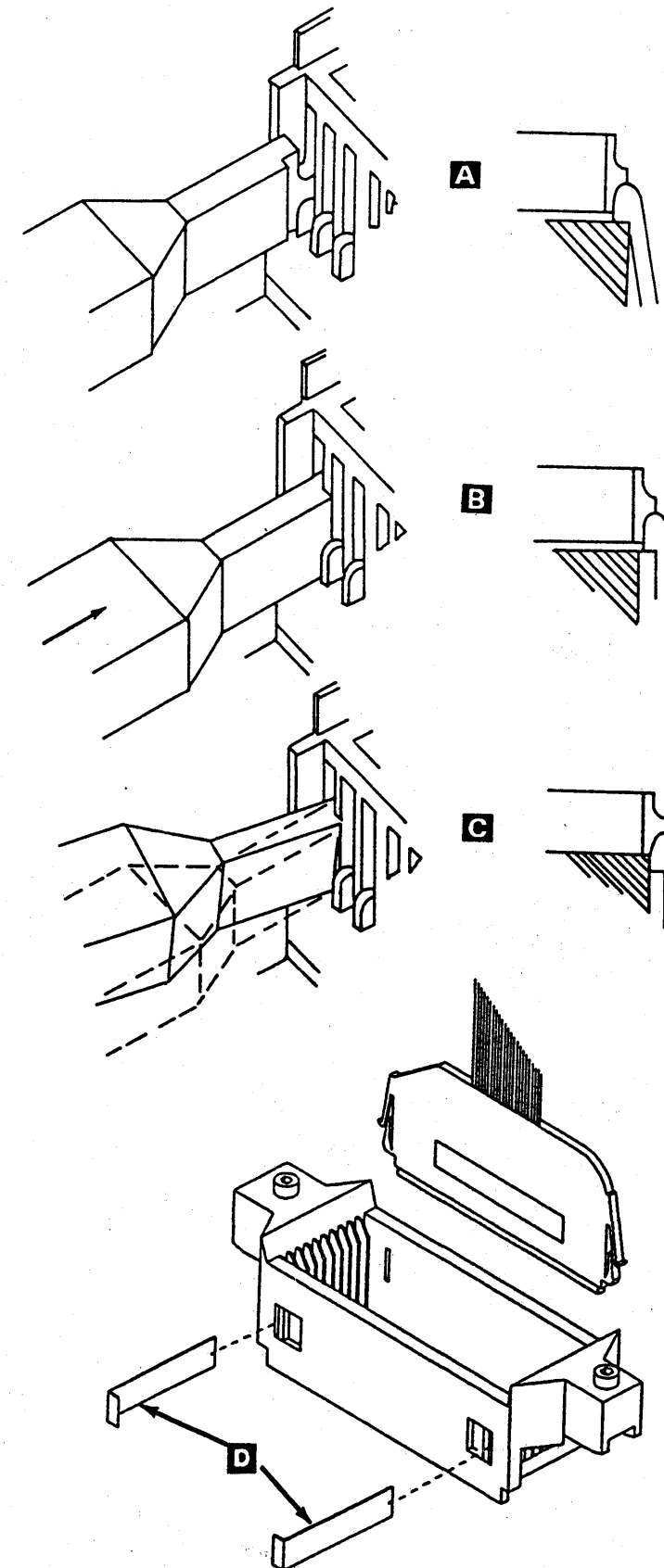

Flat Cables

Tool required if boards 01A-A1 through 01A-A4 or 01B-A1 are affected:

Actuation Tool (part 4134750).

1. Press Power Off on the operator control panel.
2. Open left side cover of frame.
3. Locate the Primary Control Compartment (PCC), and place CB1 and CB2 in the OFF position.
4. Determine which cable assembly is to be removed.
5. Remove enough cable retainers to permit tracing of cables into the cable channel.
6. Ensure that you have the correct cables and cut the cables (in the channel) at both ends.
7. Place replacement cable on top of pile in cable raceway, and replace cable retainers.
8. Reconnect both ends of replacement cable into position.

MI Seq GC030	PN 6169562 2 of 2	EC A20558 01 Oct 84	EC A20562 30 Aug 85			
-----------------	----------------------	------------------------	------------------------	--	--	--

Power Supplies

Power Supply 101

1. Press Power Off on the operator control panel.
2. Open left side cover of frame.
3. Locate the Primary Control Compartment (PCC), and place CB1 and CB2 in the OFF position.
4. Open front cover, and locate PS101.
5. Remove the front safety shield.
6. Disconnect P07 **A** .
7. Disconnect cables at **B** .
8. Disconnect ground wire **C** .
9. Remove the four mounting screws and washers **D** .
10. Carefully pull PS101 from frame.
11. Reverse procedure for PS101 replacement.

Note: After reconnecting the ground wire, measure the ground integrity of the replaced FRU using a digital multimeter (part 8496278) for 0.1 ohm or less before any connectors are reconnected. Place one probe on the machine frame near the replaced FRU ensuring the painted surface is penetrated. Place the other probe on any bare metal area of the replaced FRU. If the measurement is 0.1 ohm or less, you have a good ground. If the measurement is greater than 0.1 ohm, check for an improperly installed ground wire.

CAUTION
If the measurement is still greater than 0.1 ohm, invoke your support structure.

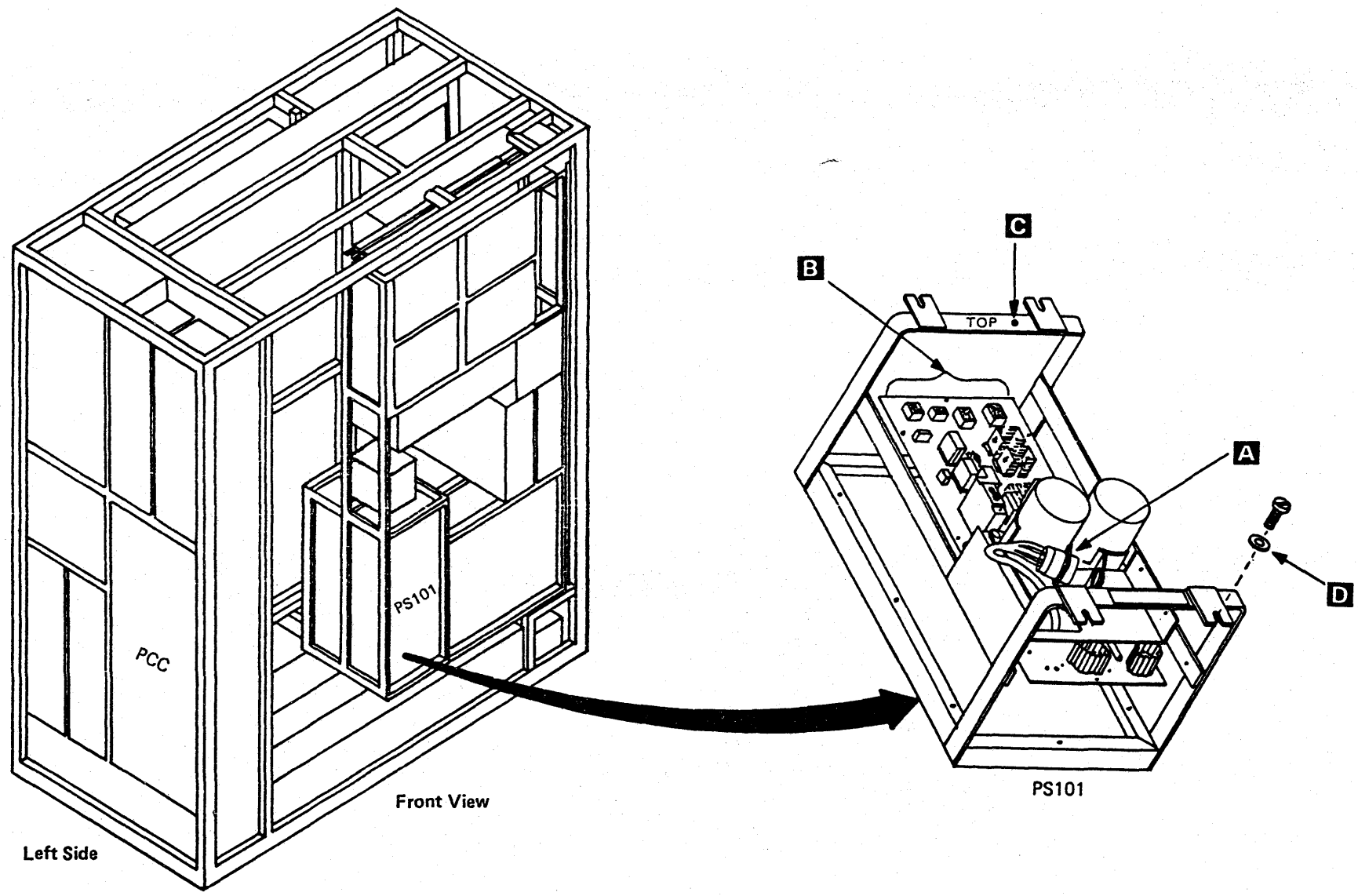

4381-3	MI	PN 6169563	EC A20558	EC A20562			
B/M 2676380	Seq GC035	1 of 2	01 Oct 84	30 Aug 85			

Power Supply 102

1. Press Power Off on the operator control panel.
2. Open left side cover of frame.
3. Locate the Primary Control Compartment (PCC), and place CB1 and CB2 in the OFF position.
4. Open front cover, and locate PS102.
5. Disconnect cables at **A** and **B**.
6. Disconnect ground wire **C**.
7. Remove the four mounting screws and washers **D**.
8. Carefully pull PS102 from frame.
9. Reverse procedure for PS102 replacement.

Note: After reconnecting the ground wire, measure the ground integrity of the replaced FRU using a digital multimeter (part 8496278) for 0.1 ohm or less before any connectors are reconnected. Place one probe on the machine frame near the replaced FRU ensuring the painted surface is penetrated. Place the other probe on any bare metal area of the replaced FRU. If the measurement is 0.1 ohm or less, you have a good ground. If the measurement is greater than 0.1 ohm, check for an improperly installed ground wire.

CAUTION
If the measurement is still greater than 0.1 ohm, invoke your support structure.

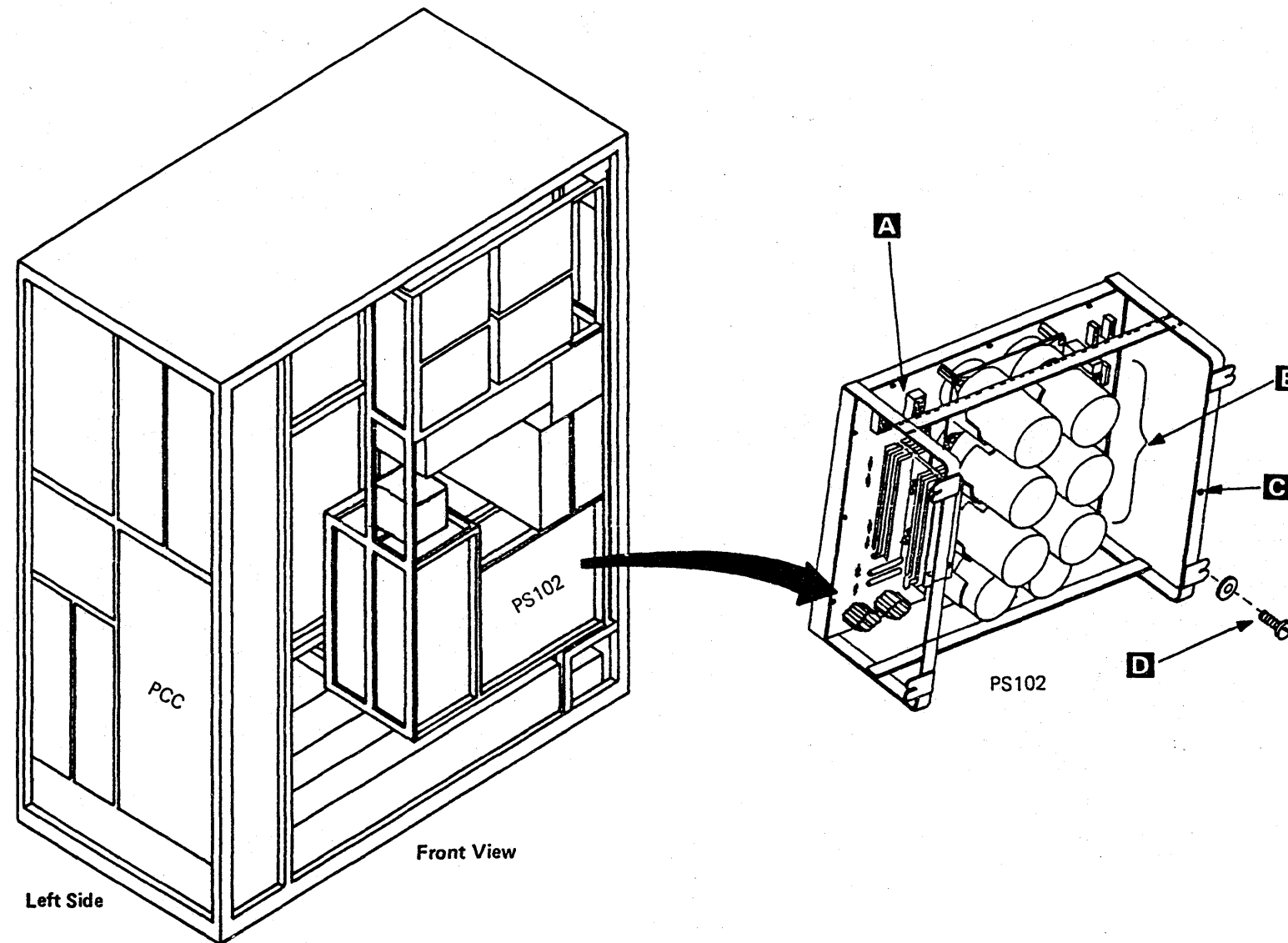

4381-3
B/M 2676380

MI
Seq GC035

PN 6169563
2 of 2

EC A20558
01 Oct 84

EC A20562
30 Aug 85

Power Supply 103

1. Press Power Off on the operator control panel.
2. Open left side cover of frame.
3. Locate the Primary Control Compartment (PCC), and place CB1 and CB2 in the OFF position.
4. Open front cover of frame.
5. Open gate 01C, and locate PS103 on rear of gate.
6. Disconnect cables at **A** .
7. Disconnect cable P10 **B** .
8. Disconnect ground wire **C** .
9. Remove the four mounting screws and washers **D** .
10. Carefully pull PS103 from frame.
11. Reverse procedure for PS103 replacement.

Note: After reconnecting the ground wire, measure the ground integrity of the replaced FRU using a digital multimeter (part 8496278) for 0.1 ohm or less before any connectors are reconnected. Place one probe on the machine frame near the replaced FRU ensuring the painted surface is penetrated. Place the other probe on any bare metal area of the replaced FRU. If the measurement is 0.1 ohm or less, you have a good ground. If the measurement is greater than 0.1 ohm, check for an improperly installed ground wire.

CAUTION
If the measurement is still greater than 0.1 ohm, invoke your support structure.

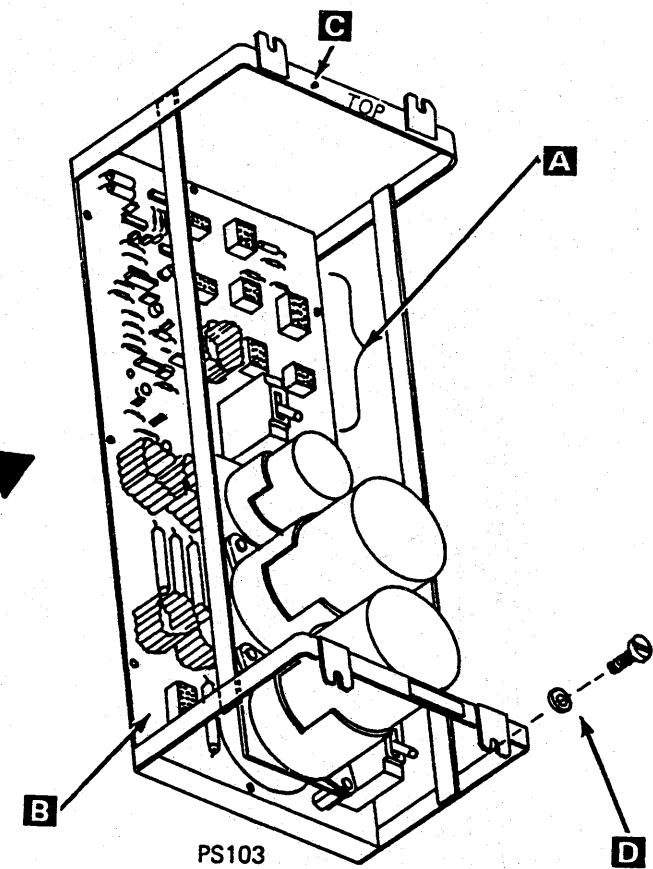
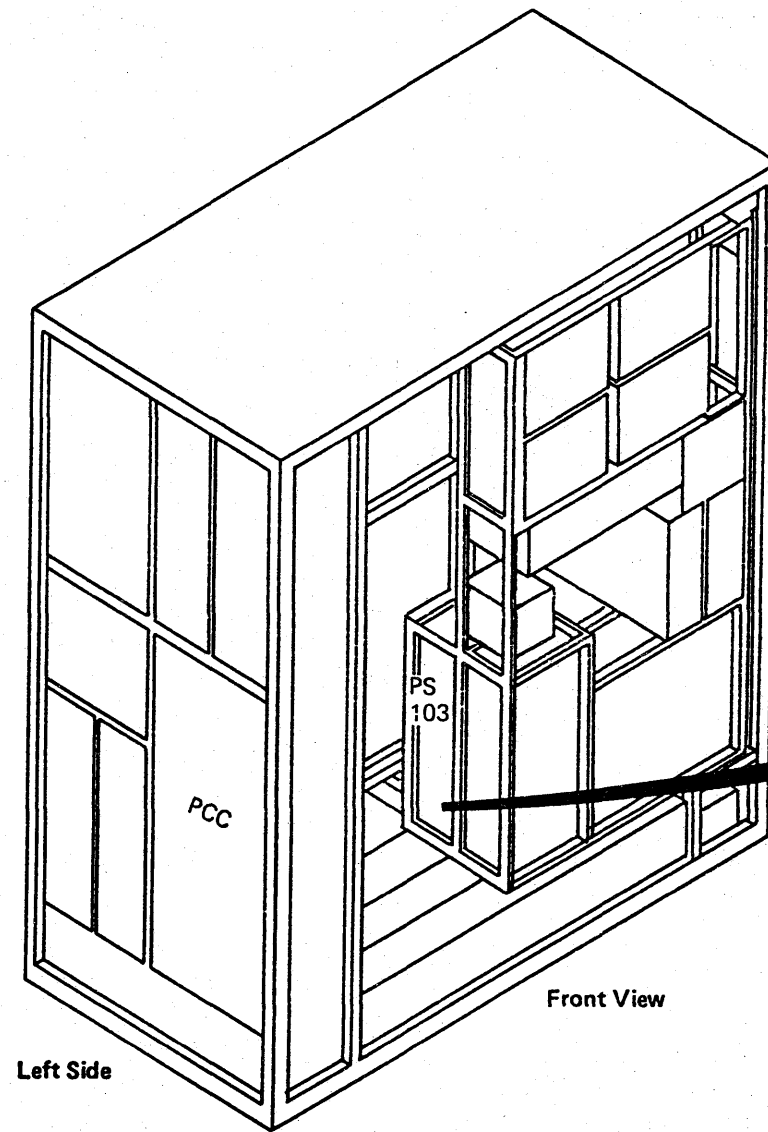

4381-3	MI	PN 6169564	EC A20558	EC A20562			
B/M 2676380	Seq GC040	1 of 2	01 Oct 84	30 Aug 85			

Power Supply 104

1. Press Power Off on the operator control panel.
2. Open left side cover of frame.
3. Locate the Primary Control Compartment (PCC), and place CB1 and CB2 in the OFF position.
4. Open rear cover of frame, and locate rear of PS104.
5. Disconnect cables at **A**.
6. Disconnect cable P14 **B** at the rear of PCC box.
7. Locate front of PS104 on left side of frame.
8. Disconnect ground wire **C**.
9. Remove the four mounting bolts, washers, and lockwashers **D**.
10. Carefully pull PS104 from frame.
11. Reverse procedure for PS104 replacement.

Note: After reconnecting the ground wire, measure the ground integrity of the replaced FRU using a digital multimeter (part 8496278) for 0.1 ohm or less before any connectors are reconnected. Place one probe on the machine frame near the replaced FRU ensuring the painted surface is penetrated. Place the other probe on any bare metal area of the replaced FRU. If the measurement is 0.1 ohm or less, you have a good ground. If the measurement is greater than 0.1 ohm, check for an improperly installed ground wire.

CAUTION
If the measurement is still greater than 0.1 ohm, invoke your support structure.

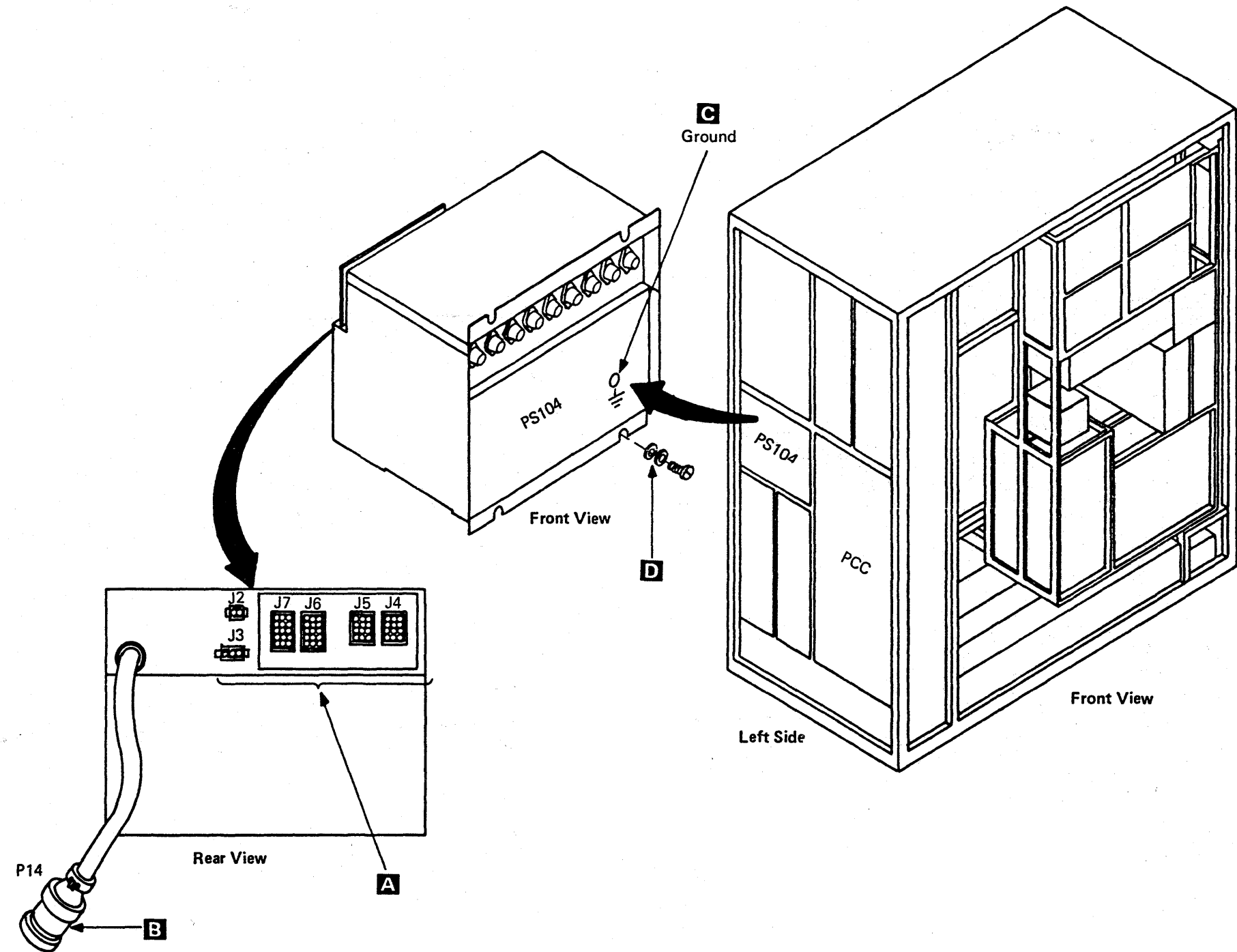

MI Seq GC040	PN 6169564 2 of 2	EC A20558 01 Oct 84	EC A20562 30 Aug 85			
-----------------	----------------------	------------------------	------------------------	--	--	--

Power Supply 105

Tools Required:

- 1/4 to 3/8 Drive Adapter (part 1805216)
- Torque Tool for Commoning Bus (part 5665903).

1. Press Power Off on the operator control panel.
2. Open left side cover of frame.
3. Locate the Primary Control Compartment (PCC), and place CB 1 and CB2 in the OFF position.
4. Open rear cover of frame.
5. Open B2 plenum to gain access to the rear of PS105.
6. Remove the safety shield covering the voltage bus bars.
7. Disconnect cables at **A**.
8. Remove two voltage bus bars fastened at **B**.
9. Locate front of PS105 on left side of frame.
10. Remove ground wire **C**.
11. Remove the two mounting bolts, washers, and lockwashers **D**.
12. Remove bolt, washer, lockwasher, and nut **E**.
13. Carefully pull PS105 from frame.

14. Perform the following.

- a. See Volume A03, page PR 1015 for the correct current settings of the new power supply.
- b. Reverse procedure for PS105 replacement.

Note: After reconnecting the ground wire, measure the ground integrity of the replaced FRU using a digital multimeter (part 8496278) for 0.1 ohm or less before any connectors are reconnected. Place one probe on the machine frame near the replaced FRU ensuring the painted surface is penetrated. Place the other probe on any bare metal area of the replaced FRU. If the measurement is 0.1 ohm or less, you have a good ground. If the measurement is greater than 0.1 ohm, check for an improperly installed ground wire.

CAUTION
If the measurement is still greater than 0.1 ohm, invoke your support structure.

- c. Torque the voltage bus bar screws shown at **B** to 27 ± 4 Newton meter (20 ± 3 ft lbs) using the torque wrench and 1/4 to 3/8 adapter.

Warning: Ensure that the voltage bus bars and terminals are not touching the machine frame.

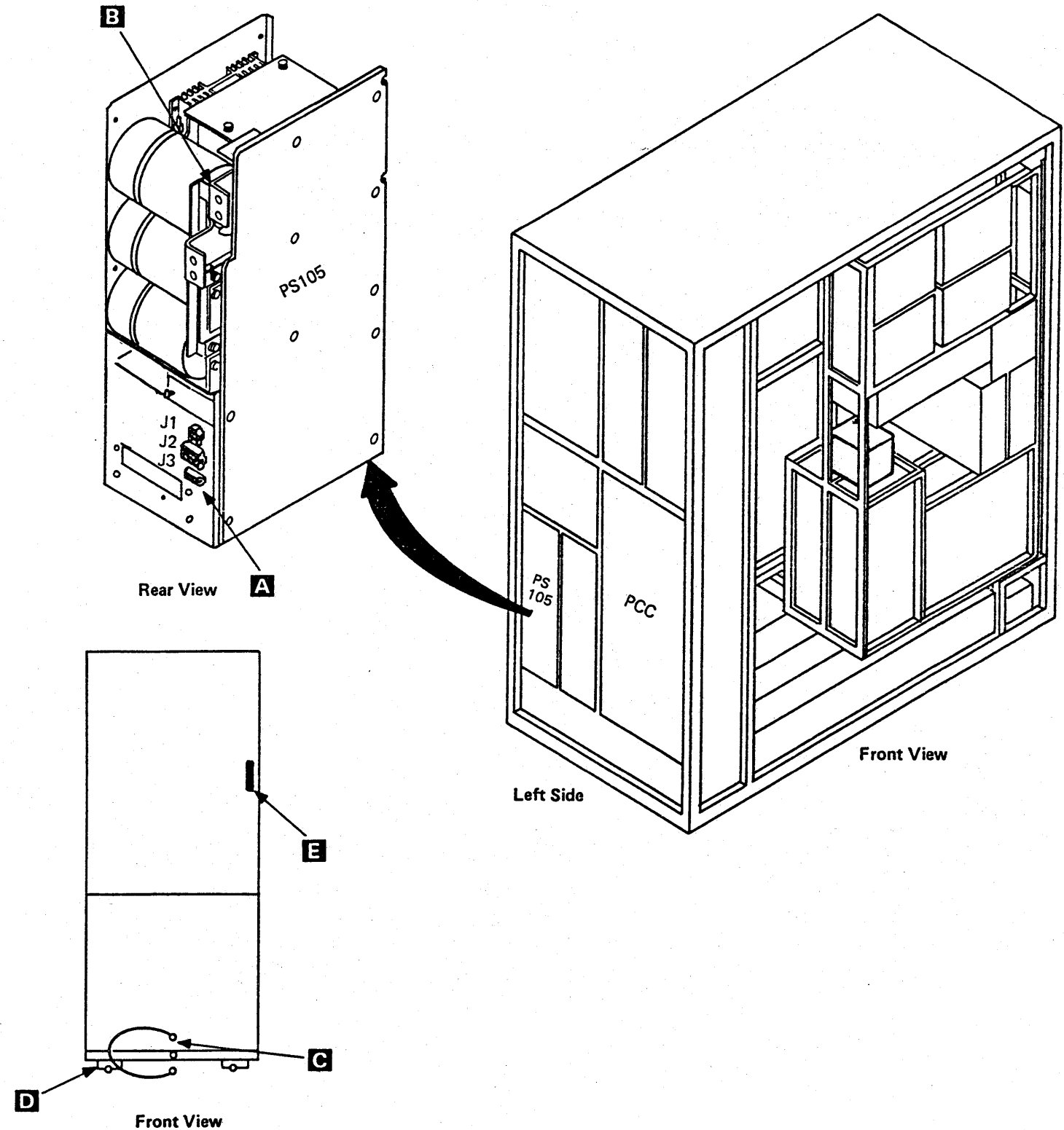

4381-3	MI	PN 6169565	EC A20558	EC A20560	EC A20562		
B/M 2676380	Seq GC045	1 of 2	01 Oct 84	18 Feb 85	30 Aug 85		

Power Supply 106

Tools Required:

- 1/4 to 3/8 Drive Adapter (part 1805216)
- Torque Tool for Commoning Bus (part 5665903).

1. Press Power Off on the operator control panel.
2. Open left side cover of frame.
3. Locate the Primary Control Compartment (PCC), and place CB1 and CB2 in the OFF position.
4. Open front cover.
5. Open gate 01C, and locate rear of PS106.
6. Remove cables at **A**.
7. Open rear cover of frame.
8. Open B2 plenum to gain access to the rear of PS106.
9. Remove the safety shield covering the voltage bus bars.
10. Remove two voltage bus bars fastened at **B**.
11. Locate front of PS106 on left side of frame.
12. Remove ground wire **C**.
13. Remove the two mounting bolts, washers, and lockwashers **D**.
14. Remove bolt, washer, lockwasher, and nut **E**.
15. Carefully pull PS106 from frame.

16. Perform the following.

- a. See Volume A03, page PR 1015 for the correct current settings of the new power supply.
- b. Reverse procedure for PS106 replacement.

Note: After reconnecting the ground wire, measure the ground integrity of the replaced FRU using a digital multimeter (part 8496278) for 0.1 ohm or less before any connectors are reconnected. Place one probe on the machine frame near the replaced FRU ensuring the painted surface is penetrated. Place the other probe on any bare metal area of the replaced FRU. If the measurement is 0.1 ohm or less, you have a good ground. If the measurement is greater than 0.1 ohm, check for an improperly installed ground wire.

CAUTION
If the measurement is still greater than 0.1 ohm, invoke your support structure.

- c. Torque the voltage bus bar screws shown at **B** to 27 ± 4 Newton meter (20 ± 3 ft lbs) using the torque wrench and 1/4 to 3/8 adapter.

Warning: Ensure that the voltage bus bars and terminals are not touching the machine frame.

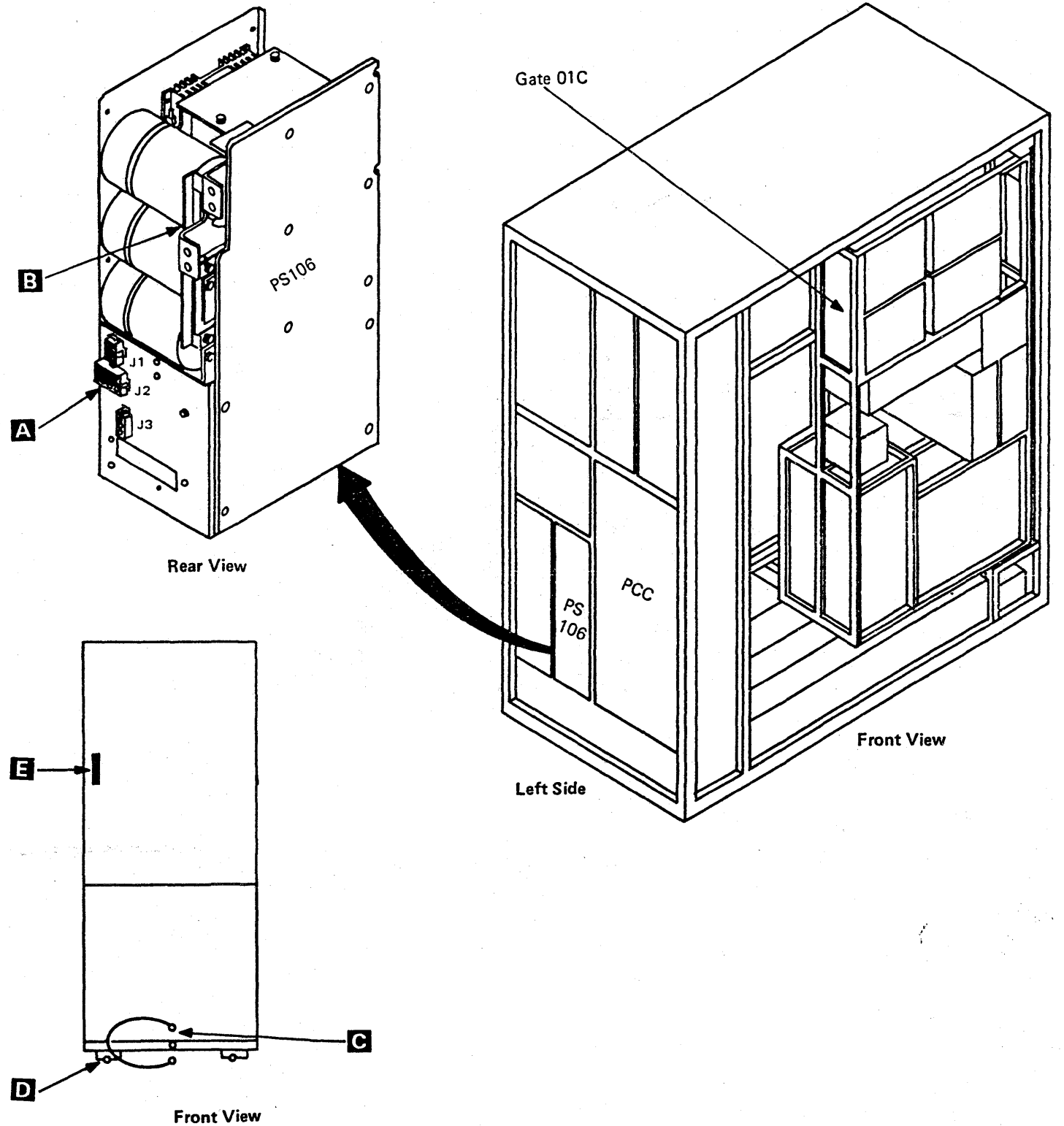

4381-3	MI	PN 6169565	EC A20558	EC A20560	EC A20562		
B/M 2676380	Seq GC045	2 of 2	01 Oct 84	18 Feb 85	30 Aug 85		

Power Supply 107

1. Press Power Off on the operator control panel.
2. Open left side cover of frame.
3. Locate the Primary Control Compartment (PCC), and place CB1 and CB2 in the OFF position.
4. Open front cover of frame, and locate the front of PS107.
5. Disconnect ground wire **A**.
6. Disconnect cables at **B**.
7. Open gate 01C.
8. Open gate 01B, and locate rear of PS107.
9. Remove the four mounting screws and washers **C**.
10. Carefully pull PS107 from frame.
11. Reverse procedure for PS107 replacement.

Note: After reconnecting the ground wire, measure the ground integrity of the replaced FRU using a digital multimeter (part 8496278) for 0.1 ohm or less before any connectors are reconnected. Place one probe on the machine frame near the replaced FRU ensuring the painted surface is penetrated. Place the other probe on any bare metal area of the replaced FRU. If the measurement is 0.1 ohm or less, you have a good ground. If the measurement is greater than 0.1 ohm, check for an improperly installed ground wire.

CAUTION
If the measurement is still greater than 0.1 ohm, invoke your support structure.

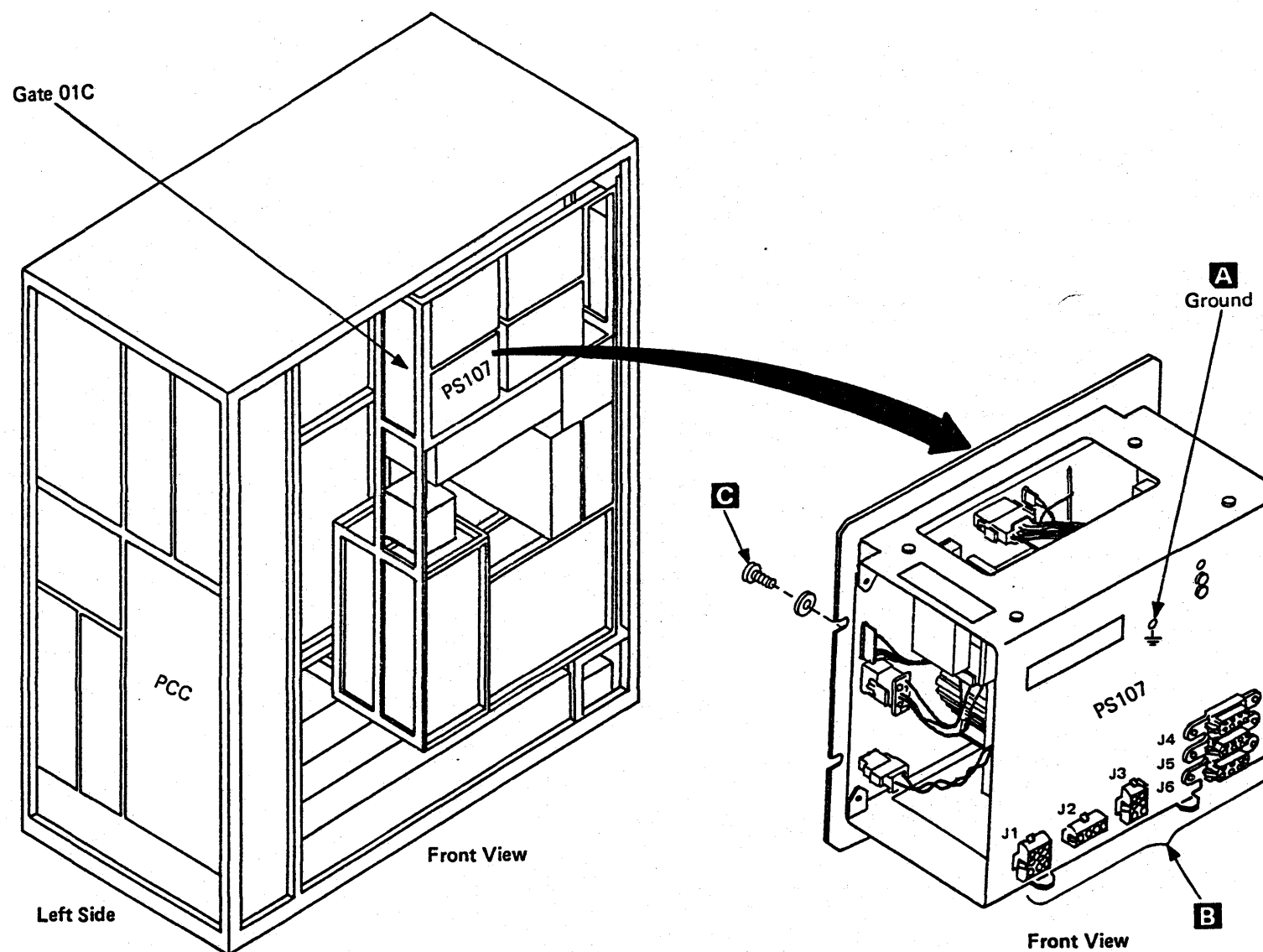

Power Supply 108

1. Press Power Off on the operator control panel.
2. Open left side cover of frame.
3. Locate the Primary Control Compartment (PCC), and place CB1 and CB2 in the OFF position.
4. Open front cover of frame, and locate front of PS108.
5. Disconnect ground wire **A**.
6. Disconnect cables at **B**.
7. Open gate 01C.
8. Open gate 01B, and locate rear of PS108.
9. Remove the four mounting screws and washers **C**.
10. Carefully pull PS108 from frame.
11. Reverse procedure for PS108 replacement.

Note: After reconnecting the ground wire, measure the ground integrity of the replaced FRU using a digital multimeter (part 8496278) for 0.1 ohm or less before any connectors are reconnected. Place one probe on the machine frame near the replaced FRU ensuring the painted surface is penetrated. Place the other probe on any bare metal area of the replaced FRU. If the measurement is 0.1 ohm or less, you have a good ground. If the measurement is greater than 0.1 ohm, check for an improperly installed ground wire.

CAUTION

If the measurement is still greater than 0.1 ohm, invoke your support structure.

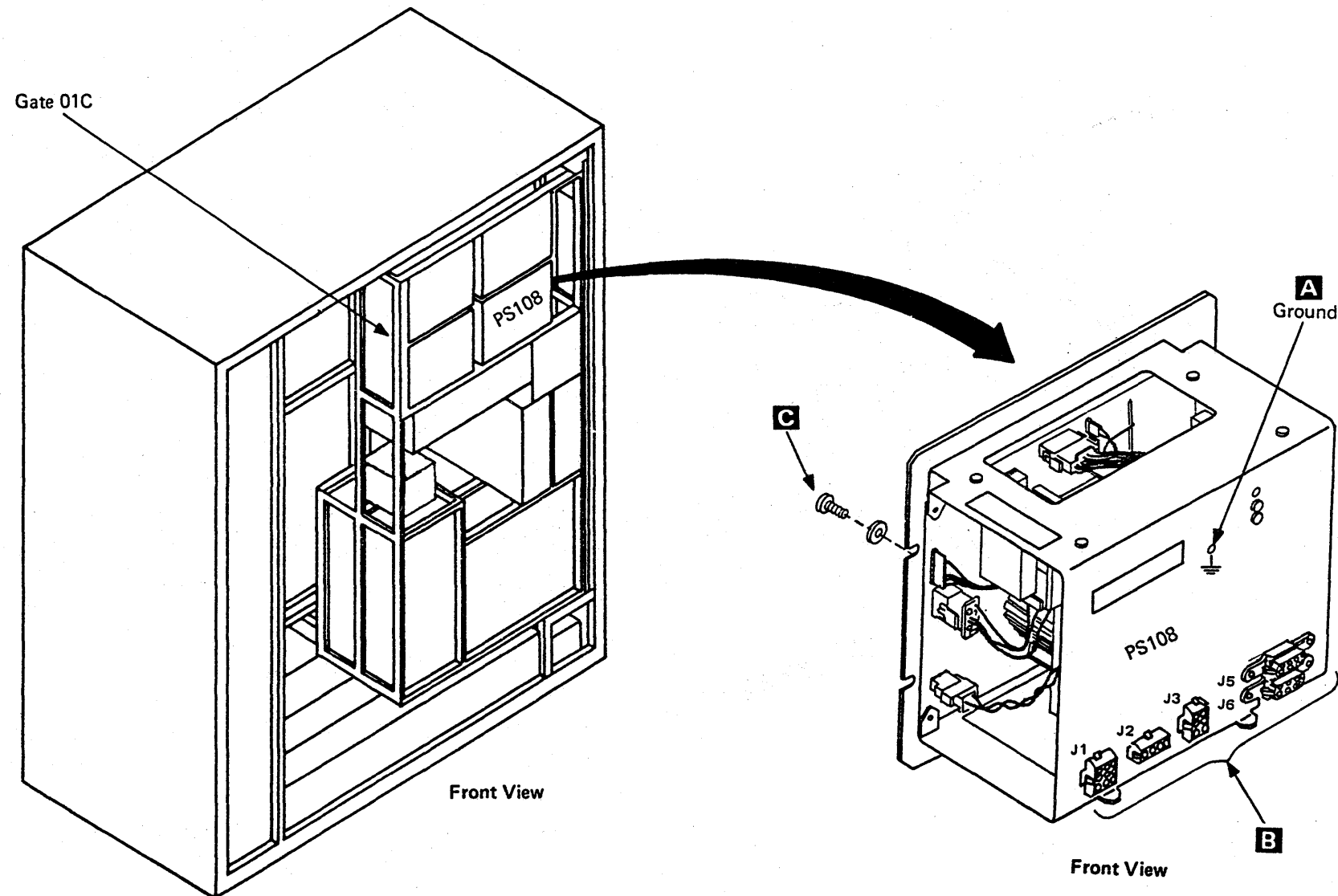

4381-3	MI	PN 6169566	EC A20558	EC A20562			
B/M 2676380	Seq GC050	2 of 2	01 Oct 84	30 Aug 85			

Power Supply 109

1. Press Power Off on the operator control panel.
2. Open left side cover of frame.
3. Locate the Primary Control Compartment (PCC), and place CB1 and CB2 in the OFF position.
4. Open front cover of frame, and locate front of PS109.
5. Disconnect ground wire **A**.
6. Disconnect cables at **B**.
7. Open gate 01C.
8. Open gate 01B, and locate rear of PS109.
9. Remove the four mounting screws and washers **C**.
10. Carefully pull PS109 from frame.
11. Reverse procedure for PS109 replacement.

Note: After reconnecting the ground wire, measure the ground integrity of the replaced FRU using a digital multimeter (part 8496278) for 0.1 ohm or less before any connectors are reconnected. Place one probe on the machine frame near the replaced FRU ensuring the painted surface is penetrated. Place the other probe on any bare metal area of the replaced FRU. If the measurement is 0.1 ohm or less, you have a good ground. If the measurement is greater than 0.1 ohm, check for an improperly installed ground wire.

CAUTION
If the measurement is still greater than 0.1 ohm, invoke your support structure.

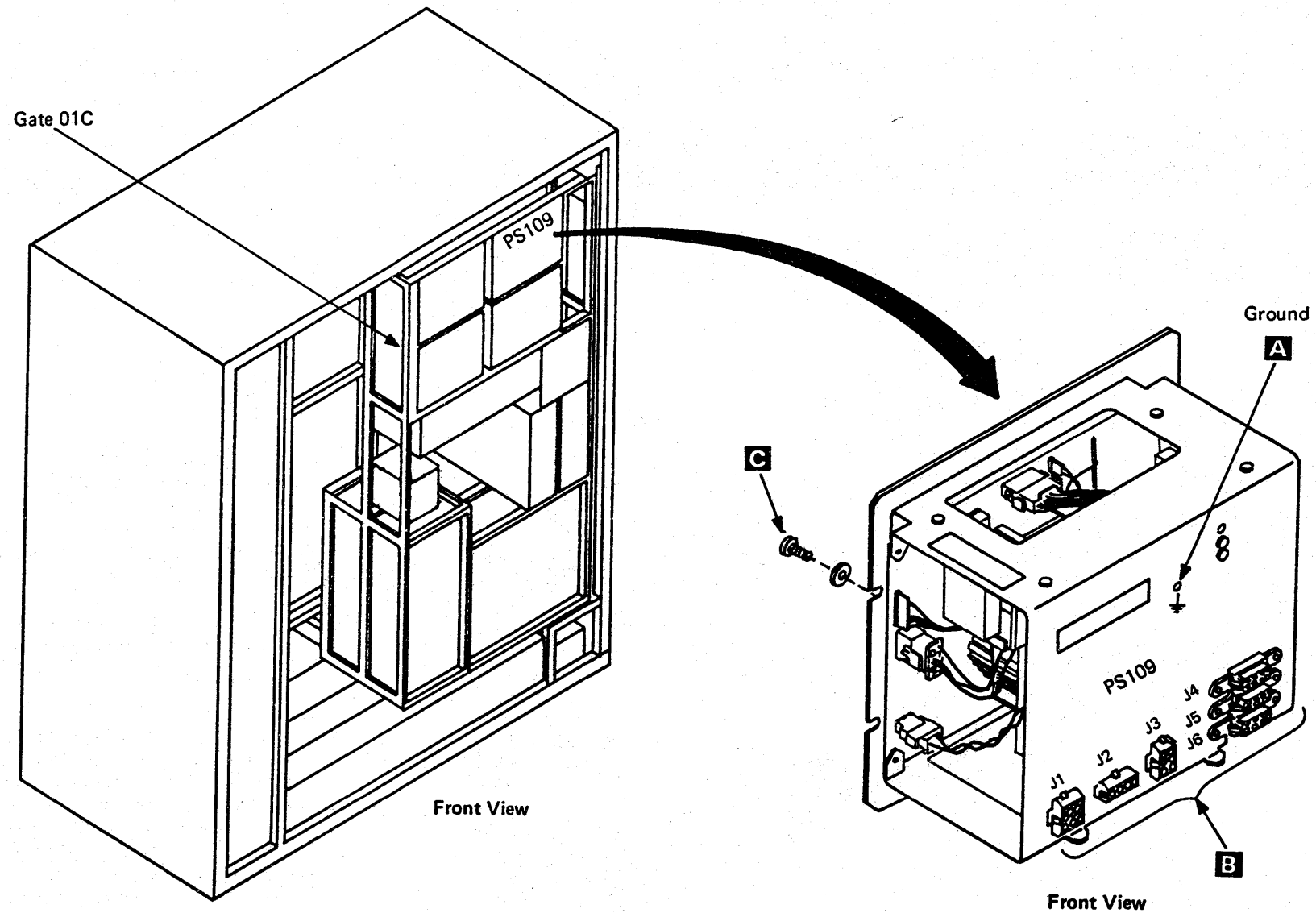

4381-3	MI	PN 6169567	EC A20558	EC A20560	EC A20562		
B/M 2676380	Seq GC055	1 of 2	01 Oct 84	18 Feb 85	30 Aug 85		

Power Supply 111

Tools Required:

- 1/4 to 3/8 Drive Adapter (part 1805216)
- Torque Tool for Commoning Bus (part 5665903).

1. Press Power Off on the operator control panel.
2. Open left side cover of frame.
3. Locate the Primary Control Compartment (PCC), and place CB1 and CB2 in the OFF position.
4. Open front cover and locate the rear of PS111.
5. Remove cables J1, J2, and J3 shown at **A**.
6. Remove the safety shield covering the voltage bus bars.
7. Remove two voltage bus bars fastened at **B**.
8. Locate front of PS111 on left side of frame.
9. Remove ground wire **C**.
10. Remove the two mounting bolts, washers, and lockwashers **D**.
11. Remove bolt, washer, lockwasher, and nut **E**.
12. Carefully pull PS111 from frame.

13. Perform the following.

- a. See Volume A03, page PR 1015 for the correct current settings of the new power supply.
- b. Reverse procedure for PS111 replacement.

Note: After reconnecting the ground wire, measure the ground integrity of the replaced FRU using a digital multimeter (part 8496278) for 0.1 ohm or less before any connectors are reconnected. Place one probe on the machine frame near the replaced FRU ensuring the painted surface is penetrated. Place the other probe on any bare metal area of the replaced FRU. If the measurement is 0.1 ohm or less, you have a good ground. If the measurement is greater than 0.1 ohm, check for an improperly installed ground wire.

CAUTION
If the measurement is still greater than 0.1 ohm, invoke your support structure.

- c. Torque the voltage bus bar screws shown at **B** to 27 ± 4 Newton meter (20 ± 3 ft lbs) using the torque wrench and 1/4 to 3/8 adapter.

Warning: Ensure that the voltage bus bars and terminals are not touching the machine frame.

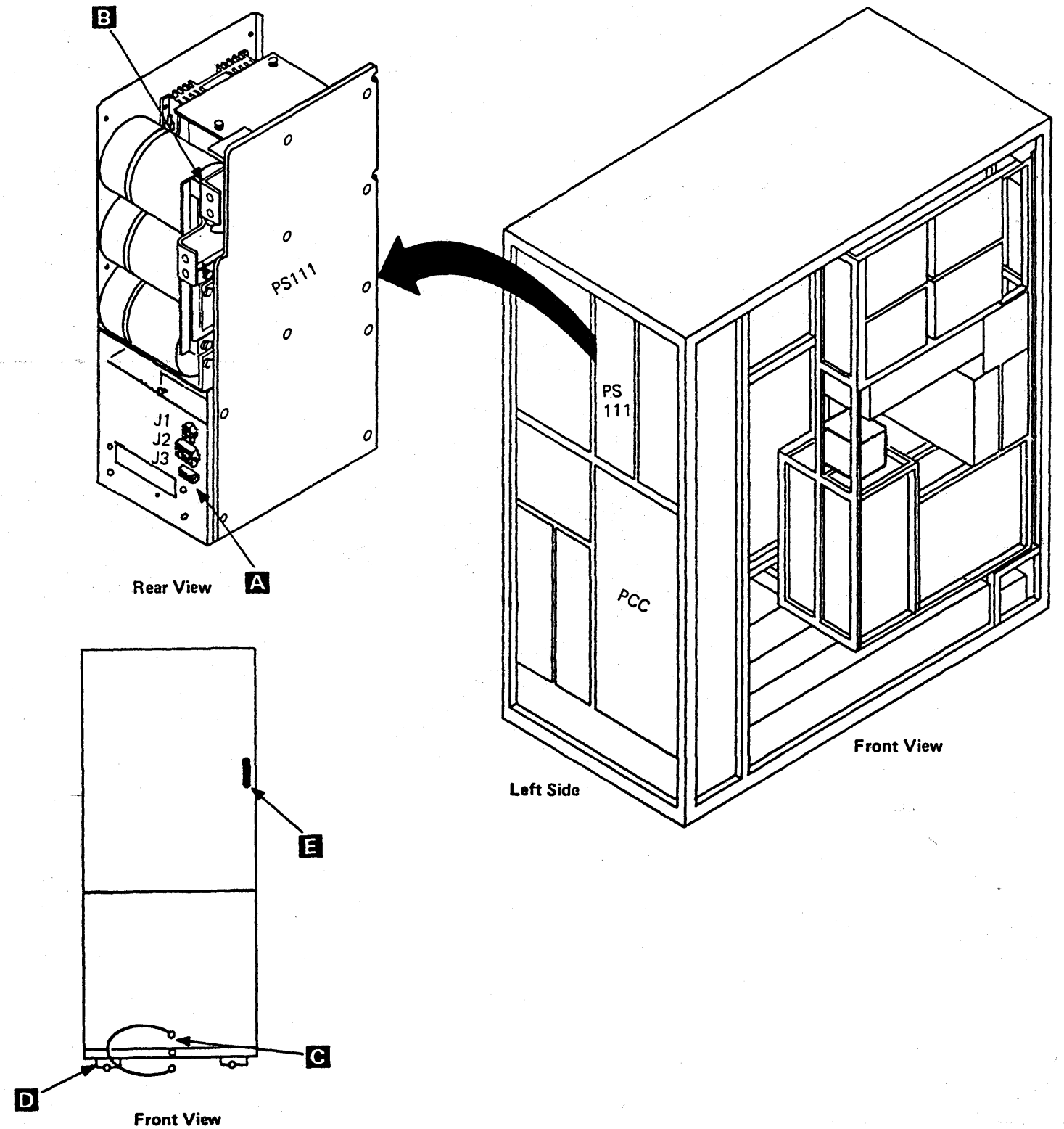

MI Seq GC055	PN 6169567 2 of 2	EC A20558 01 Oct 84	EC A20560 18 Feb 85	EC A20562 30 Aug 85		
-----------------	----------------------	------------------------	------------------------	------------------------	--	--

Power Supply 112

Tools Required:

1/4 to 3/8 Drive Adapter (part 1805216)

Torque Tool for Commoning Bus (part 5665903).

1. Press Power Off on the operator control panel.
2. Open left side cover of frame.
3. Locate the Primary Control Compartment (PCC), and place CB1 and CB2 in the OFF position.
4. Open front cover and locate the rear of PS112.
5. Remove cables J1, J2, and J3 shown at **A**.
6. Remove the safety shield covering the voltage bus bars.
7. Remove two voltage bus bars fastened at **B**.
8. Locate front of PS112 on left side of frame.
9. Remove ground wire **C**.
10. Remove the two mounting bolts, washers, and lockwashers **D**.
11. Remove bolt, washer, lockwasher, and nut **E**.
12. Carefully pull PS112 from frame.

13. Perform the following.

- a. See Volume A03, page PR 1015 for the correct current settings of the new power supply.
- b. Reverse procedure for PS112 replacement.

Note: After reconnecting the ground wire, measure the ground integrity of the replaced FRU using a digital multimeter (part 8496278) for 0.1 ohm or less before any connectors are reconnected. Place one probe on the machine frame near the replaced FRU ensuring the painted surface is penetrated. Place the other probe on any bare metal area of the replaced FRU. If the measurement is 0.1 ohm or less, you have a good ground. If the measurement is greater than 0.1 ohm, check for an improperly installed ground wire.

CAUTION
If the measurement is still greater than 0.1 ohm, invoke your support structure.

- c. Torque the voltage bus bar screws shown at **B** to 27 ± 4 Newton meter (20 ± 3 ft lbs) using the torque wrench and 1/4 to 3/8 adapter.

Warning: Ensure that the voltage bus bars and terminals are not touching the machine frame.

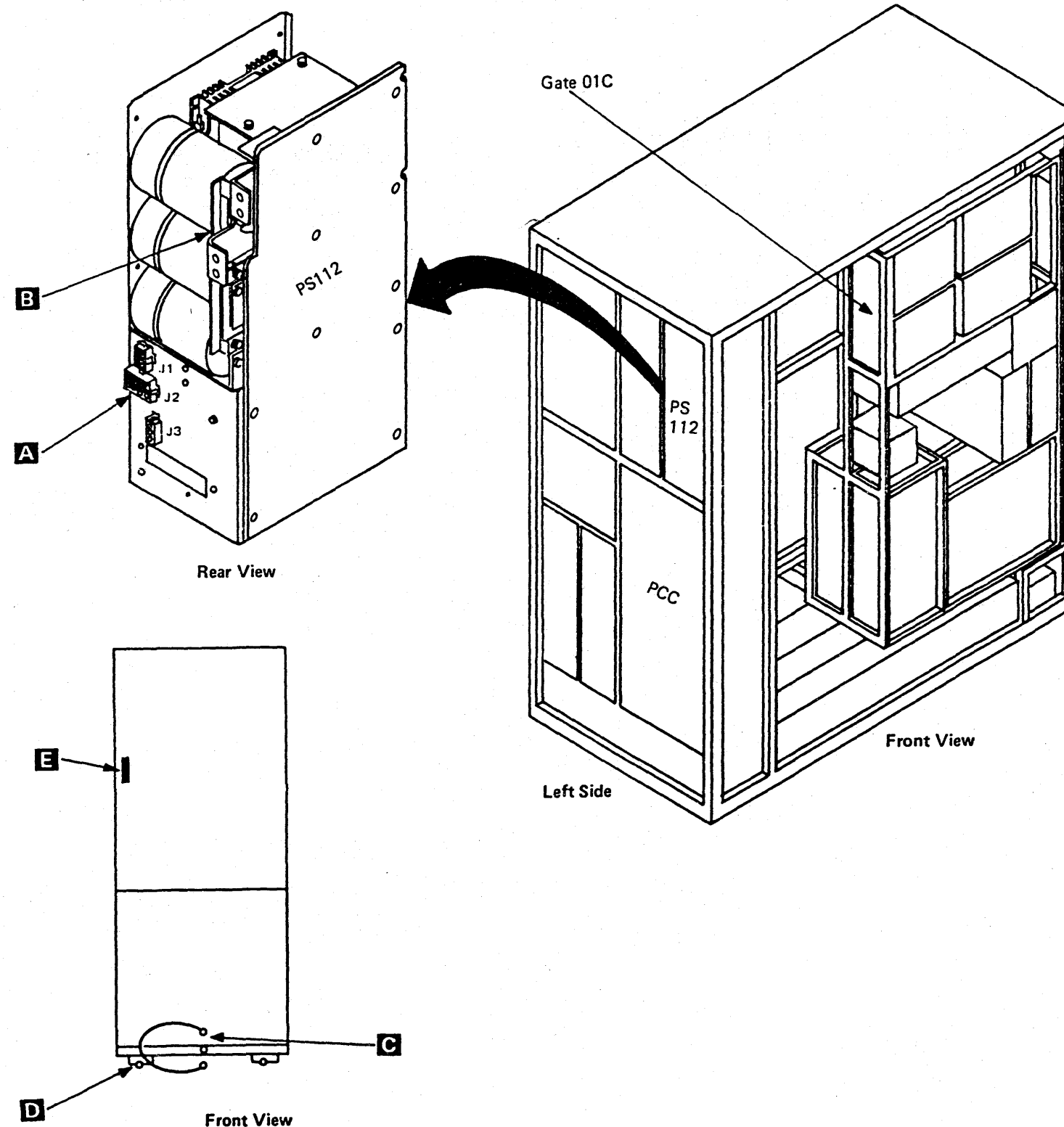

MI Seq GC060	PN 6169568 1 of 1	EC A20558 01 Oct 84	EC A20560 18 Feb 85	EC A20562 30 Aug 85		
-----------------	----------------------	------------------------	------------------------	------------------------	--	--



Transformers

Transformer 100

1. Press Power Off on the operator control panel.
2. Open left side cover of frame.
3. Locate the Primary Control Compartment (PCC), and place CB1 and CB2 in the OFF position.
4. Open PCC door, and locate TR 100.
5. Remove ground wire.
6. Remove input wires on TB1.
7. Remove four mounting nuts **A**.
8. Carefully pull TR 100 from frame.
9. Reverse procedure for TR 100 replacement.

Note: After reconnecting the ground wire, measure the ground integrity of the replaced FRU using a digital multimeter (part 8496278) for 0.1 ohm or less before any connectors are reconnected. Place one probe on the machine frame near the replaced FRU ensuring the painted surface is penetrated. Place the other probe on any bare metal area of the replaced FRU. If the measurement is 0.1 ohm or less, you have a good ground. If the measurement is greater than 0.1 ohm, check for an improperly installed ground wire.

CAUTION
If the measurement is still greater than 0.1 ohm, invoke your support structure.

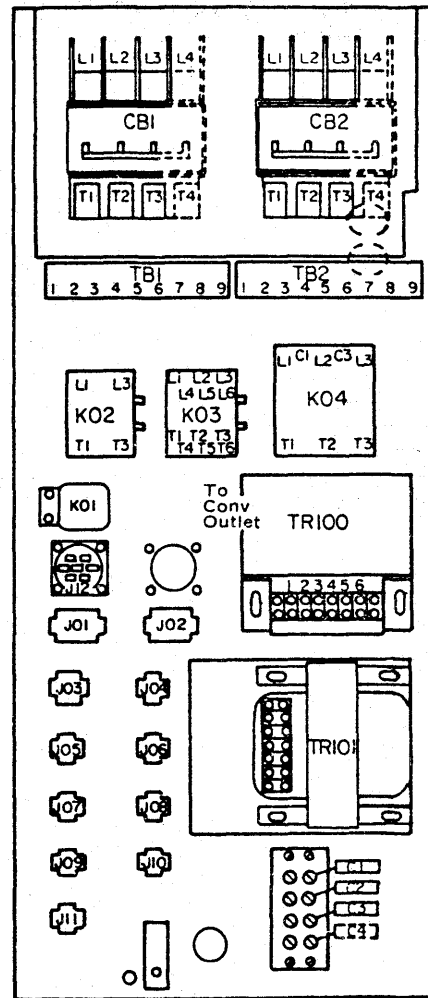

Primary Control Compartment

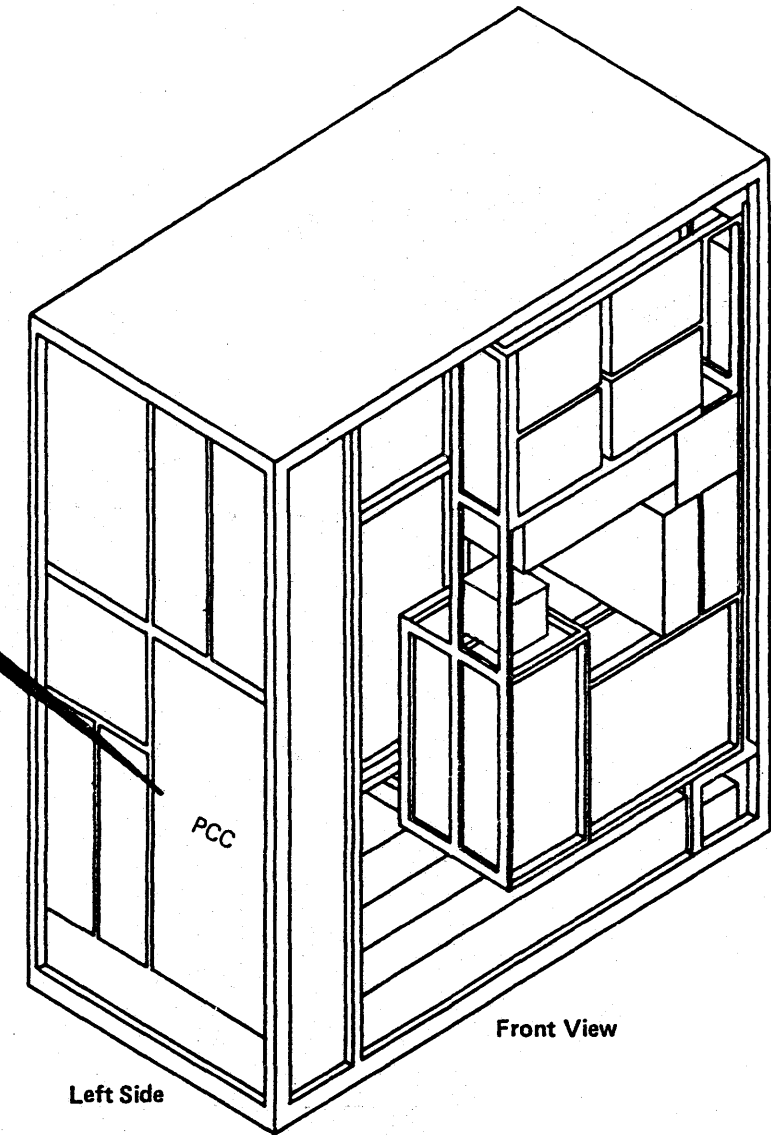

Left Side

Front View

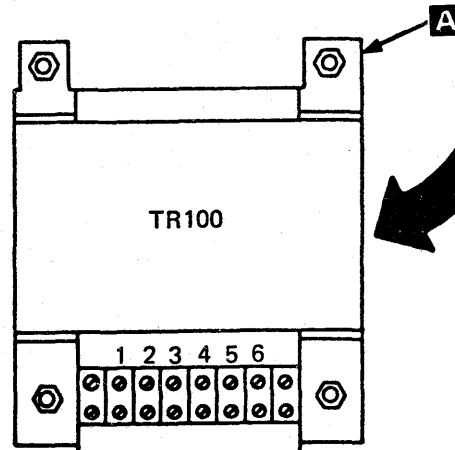

Transformer 101

1. Press Power Off on the operator control panel.
2. Open left side cover of frame.
3. Locate the Primary Control Compartment (PCC), and place CB1 and CB2 in the OFF position.
4. Open PCC door, and locate TR101.
5. Remove ground wire.
6. Remove input wires on TB1 .
7. Disconnect plug J02.
8. Remove the four mounting nuts **A** .
9. Carefully pull TR101 from frame.
10. Reverse procedure for TR101 replacement.

Note: After reconnecting the ground wire, measure the ground integrity of the replaced FRU using a digital multimeter (part 8496278) for 0.1 ohm or less before any connectors are reconnected. Place one probe on the machine frame near the replaced FRU ensuring the painted surface is penetrated. Place the other probe on any bare metal area of the replaced FRU. If the measurement is 0.1 ohm or less, you have a good ground. If the measurement is greater than 0.1 ohm, check for an improperly installed ground wire.

CAUTION
If the measurement is still greater than 0.1 ohm, invoke your support structure.

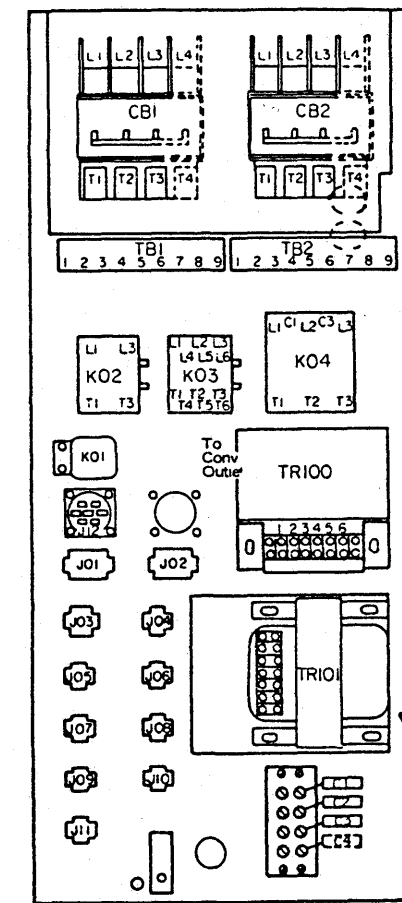

Primary Control Compartment

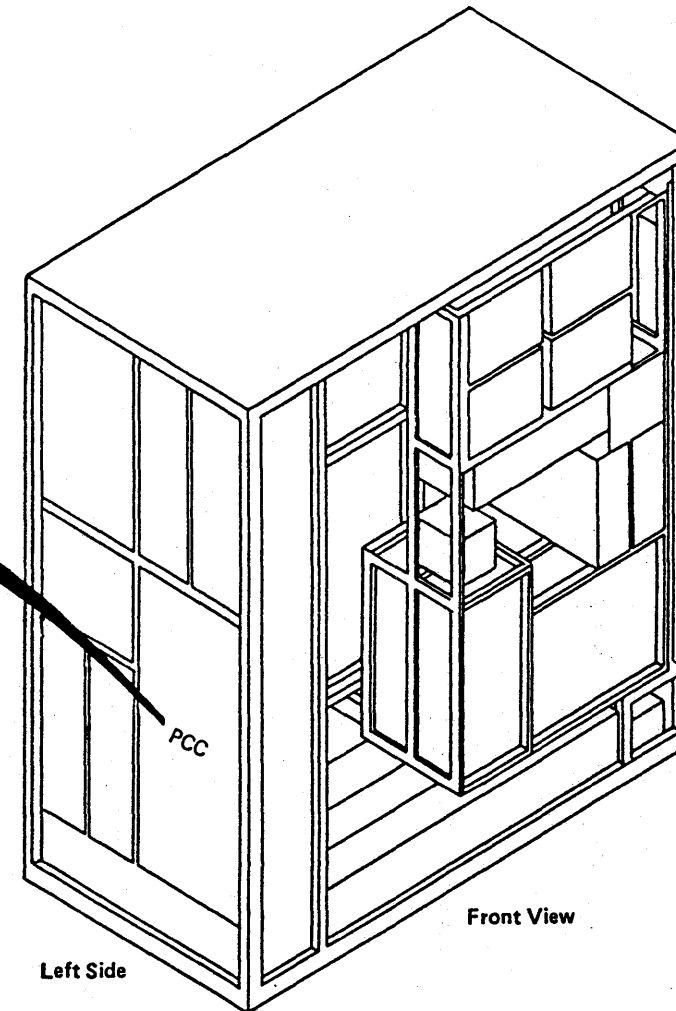

Left Side

Front View

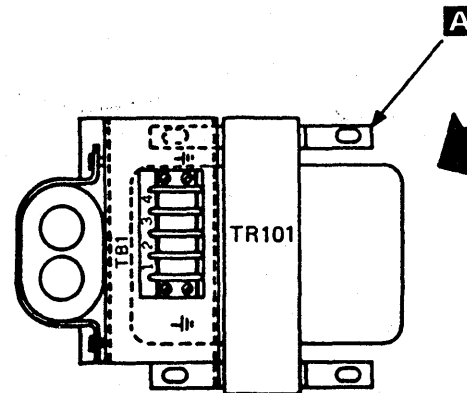

4381-3
B/M 2676380

MI Seq GC065	PN 6169569 2 of 2	EC A20558 01 Oct 84	EC A20562 30 Aug 85			
-----------------	----------------------	------------------------	------------------------	--	--	--

Transformer 102

1. Press Power Off on the operator control panel.
2. Open left side cover of frame.
3. Locate the Primary Control Compartment (PCC), and place CB1 and CB2 in the OFF position.
4. Open front cover of frame.
5. Open gate 01C, and locate TR102 on rear of gate.
6. Disconnect P01 **A** .
7. Disconnect cables P01 and P02 at J01 and J02 of PS102.
8. Cut tie wrap.
9. Remove the four mounting bolts and washers **B** .
10. Carefully pull TR102 from frame.
11. Reverse procedure for TR102 replacement.

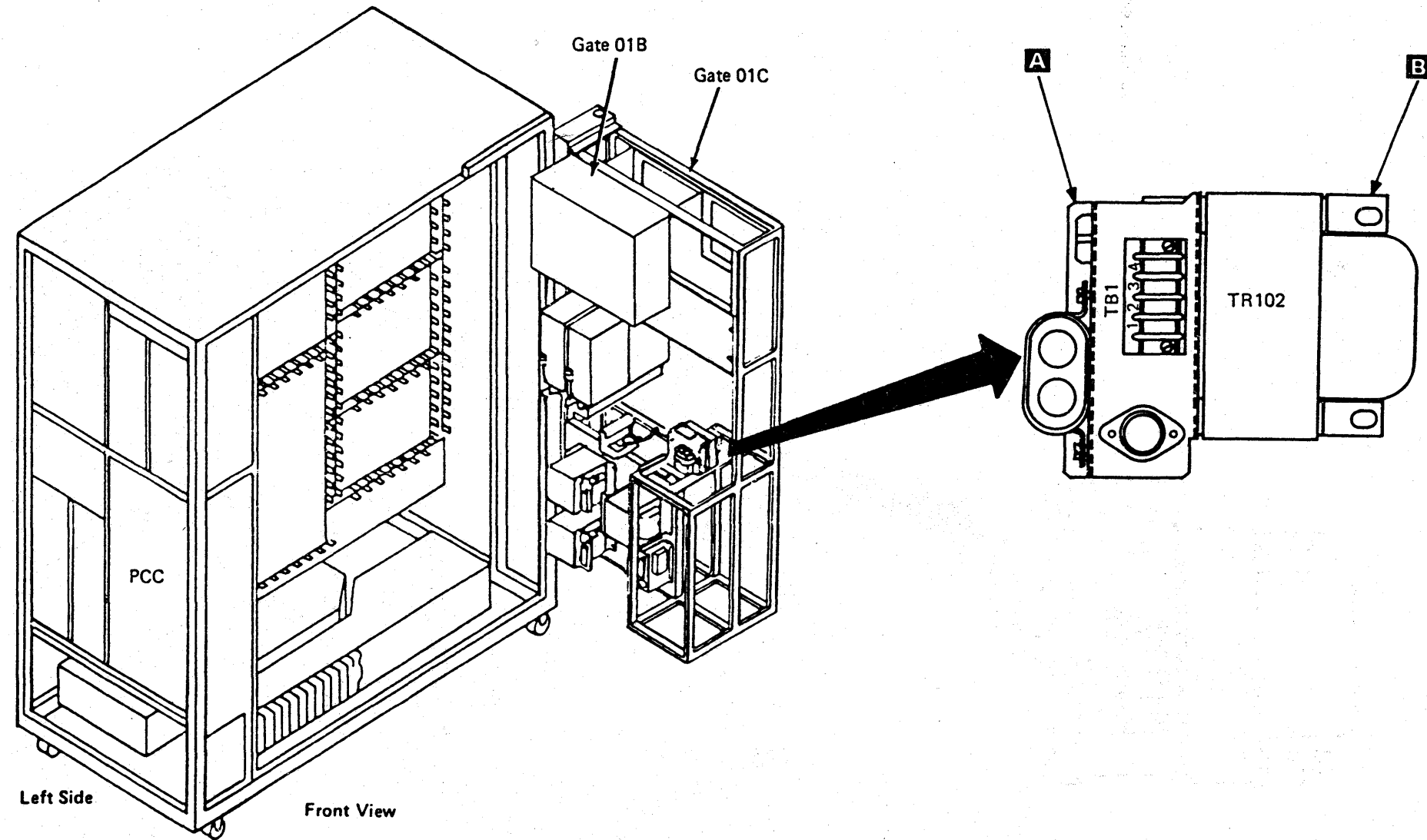

4381-3	MI	PN 6169570	EC A20558	EC A20562			
B/M 2676380	Seq GC070	1 of 2	01 Oct 84	30 Aug 85			

Transformer 103

1. Press Power Off on the operator control panel.
2. Open left side cover of frame.
3. Locate the Primary Control Compartment (PCC), and place CB1 and CB2 in the OFF position.
4. Open front cover of frame.
5. Open gate 01C, and locate TR103 on rear of gate.
6. Disconnect P01 at **A**.
7. Disconnect P10 at J10 of PS103.
8. Remove the four mounting nuts **B**.
9. Carefully pull TR103 from frame.
10. Reverse procedure for TR103 replacement.

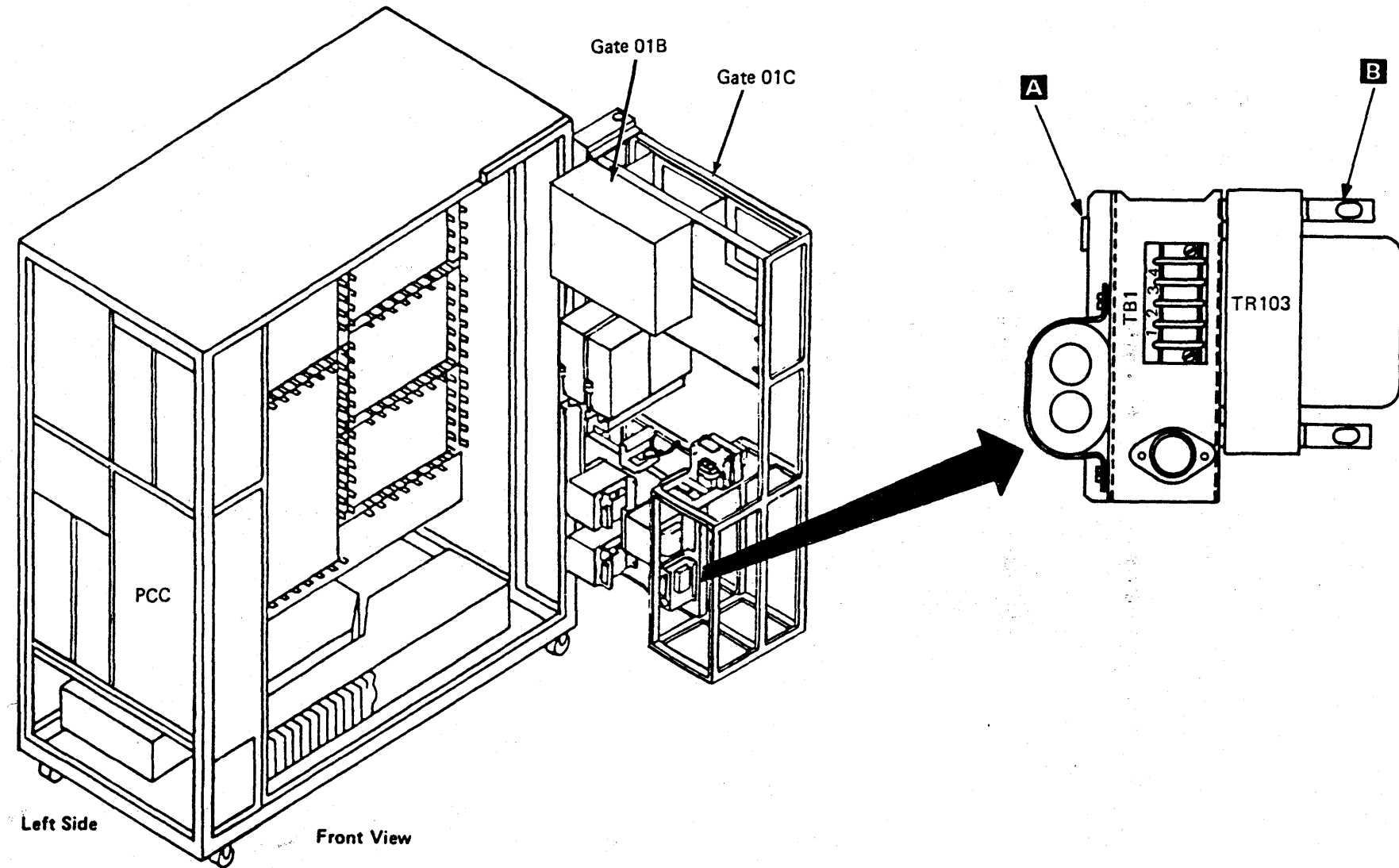

4381-3
B/M 2676380

MI	PN 6169570	EC A20558	EC A20562			
Seq GC070	2 of 2	01 Oct 84	30 Aug 85			

© Copyright IBM Corp. 1984

Transformer 104

All 50 Hz and Japan 60 Hz only.

CAUTION

TR 104-A, B, and C each weigh 25 kg (55 lb).
Obtain aid before removing or replacing.

1. Press Power Off on the operator control panel.
2. Open left side cover.
3. Locate the Primary Control Compartment (PCC), and place CB1 and CB2 in the OFF position.
4. Open front cover.
5. Open gate 01C, and locate TR104-A, B, or C on rear of gate.
6. Determine the transformer to be removed (A, B, or C).

Note: Label all wires before removing TB screws.

7. Disconnect TB-1 wires 1, 3, and 5 of the transformer to be removed. For the correct line voltage wiring sequence, refer to Volume C01, page YA081.
8. Locate and disconnect TB-4 wires running from the transformer to TB-4.
9. Cut the nylon cable tie wraps, and route the two wires back to the transformer area.
10. Remove the four mounting nuts **A**.
11. Carefully pull the transformer away from the frame.
12. Reverse procedure for TR104-A, B, or C replacement.

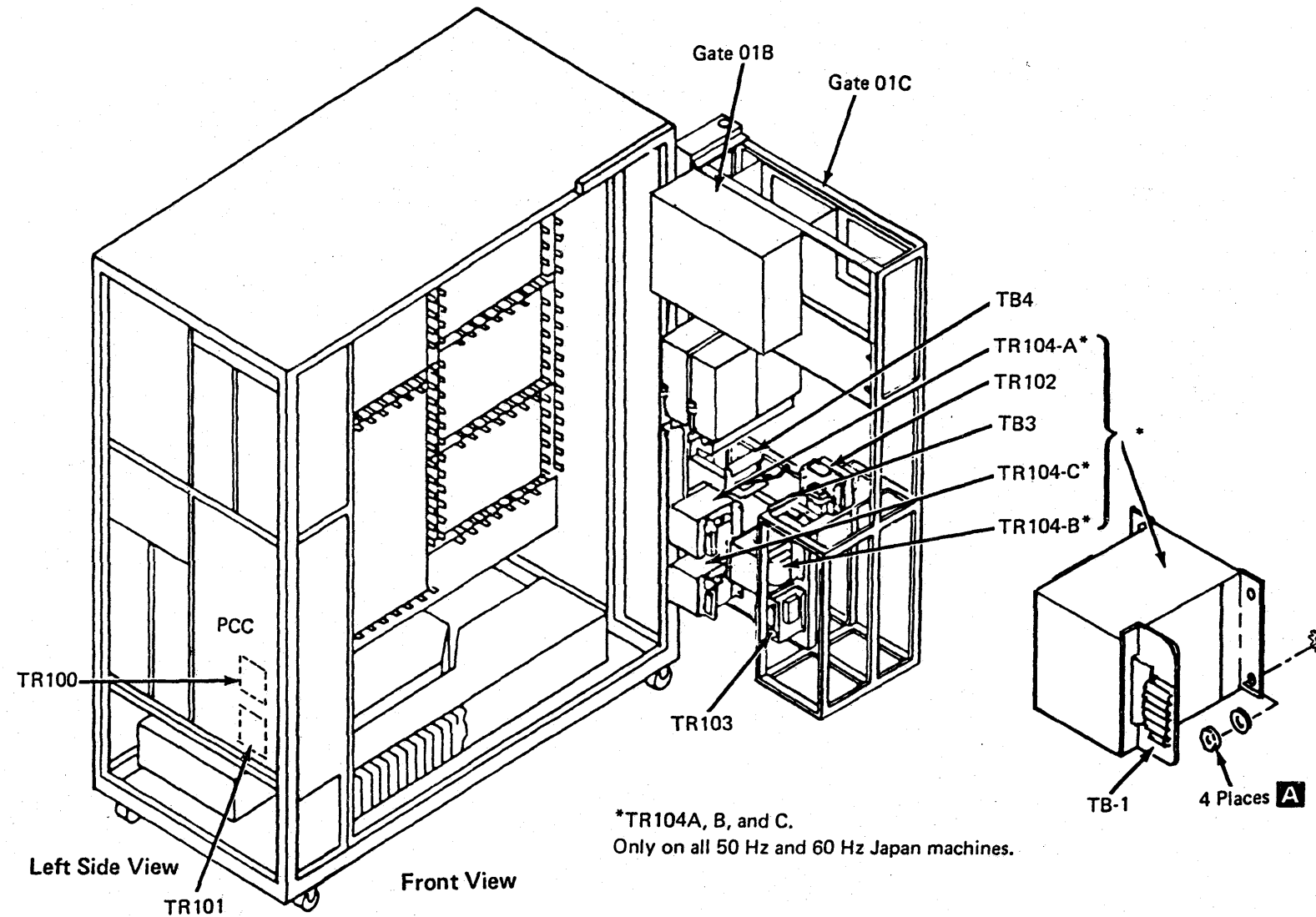

*TR104A, B, and C.
Only on all 50 Hz and 60 Hz Japan machines.

MI Seq GC075	PN 6169571 1 of 1	EC A20558 01 Oct 84	EC A20562 30 Aug 85				
-----------------	----------------------	------------------------	------------------------	--	--	--	--

BEW 012

Air Moving Devices

Air Moving Device 101

1. Press Power Off on the operator control panel.
2. Open left side cover of frame.
3. Locate the Primary Control Compartment (PCC), and place CB1 and CB2 in the OFF position.
4. Open rear cover of frame, and locate AMD 101.
5. Loosen the four cover mounting screws, and remove the cover.
6. Disconnect cable **A**.
7. Disconnect ground wire **B**.
8. Pull AMD 101 from frame.
9. Reverse procedure for AMD 101 replacement.

Note: After reconnecting the ground wire, measure the ground integrity of the replaced FRU using a digital multimeter (part 8496278) for 0.1 ohm or less before any connectors are reconnected. Place one probe on the machine frame near the replaced FRU ensuring the painted surface is penetrated. Place the other probe on any bare metal area of the replaced FRU. If the measurement is 0.1 ohm or less, you have a good ground. If the measurement is greater than 0.1 ohm, check for an improperly installed ground wire.

CAUTION
If the measurement is still greater than 0.1 ohm, invoke your support structure.

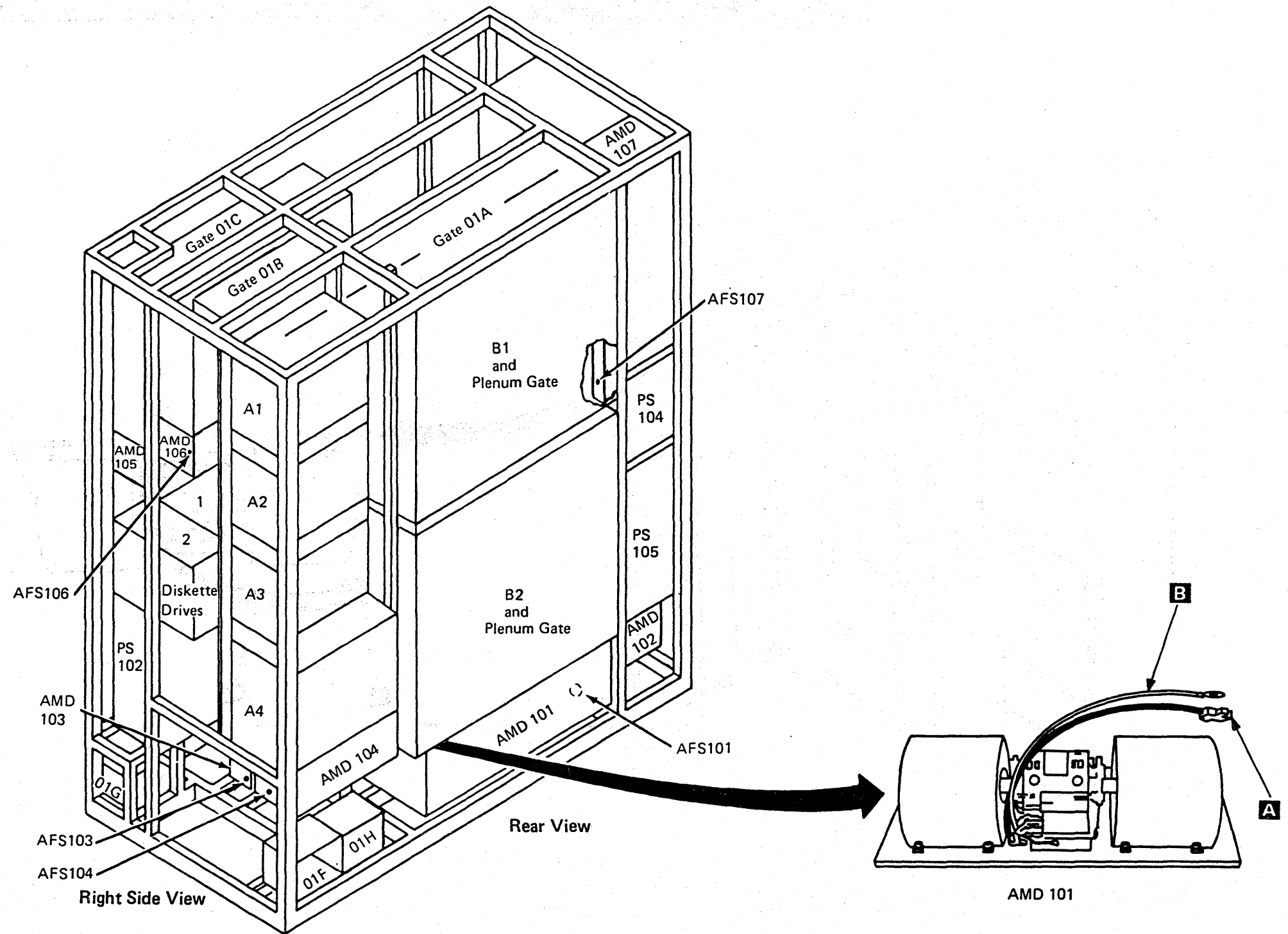

Air Moving Device 102

1. Press Power Off on the operator control panel.
2. Open left side cover of frame.
3. Locate the Primary Control Compartment (PCC), and place CB1 and CB2 in the OFF position.
4. Open left side cover of frame, and locate AMD 102.
5. Loosen the four cover mounting screws, and remove the cover.
6. Disconnect cable **A**.
7. Disconnect ground wire **B**.
8. Pull AMD 102 from frame.
9. Reverse procedure for AMD 102 replacement.

Note: After reconnecting the ground wire, measure the ground integrity of the replaced FRU using a digital multimeter (part 8496278) for 0.1 ohm or less before any connectors are reconnected. Place one probe on the machine frame near the replaced FRU ensuring the painted surface is penetrated. Place the other probe on any bare metal area of the replaced FRU. If the measurement is 0.1 ohm or less, you have a good ground. If the measurement is greater than 0.1 ohm, check for an improperly installed ground wire.

CAUTION
If the measurement is still greater than 0.1 ohm, invoke your support structure.

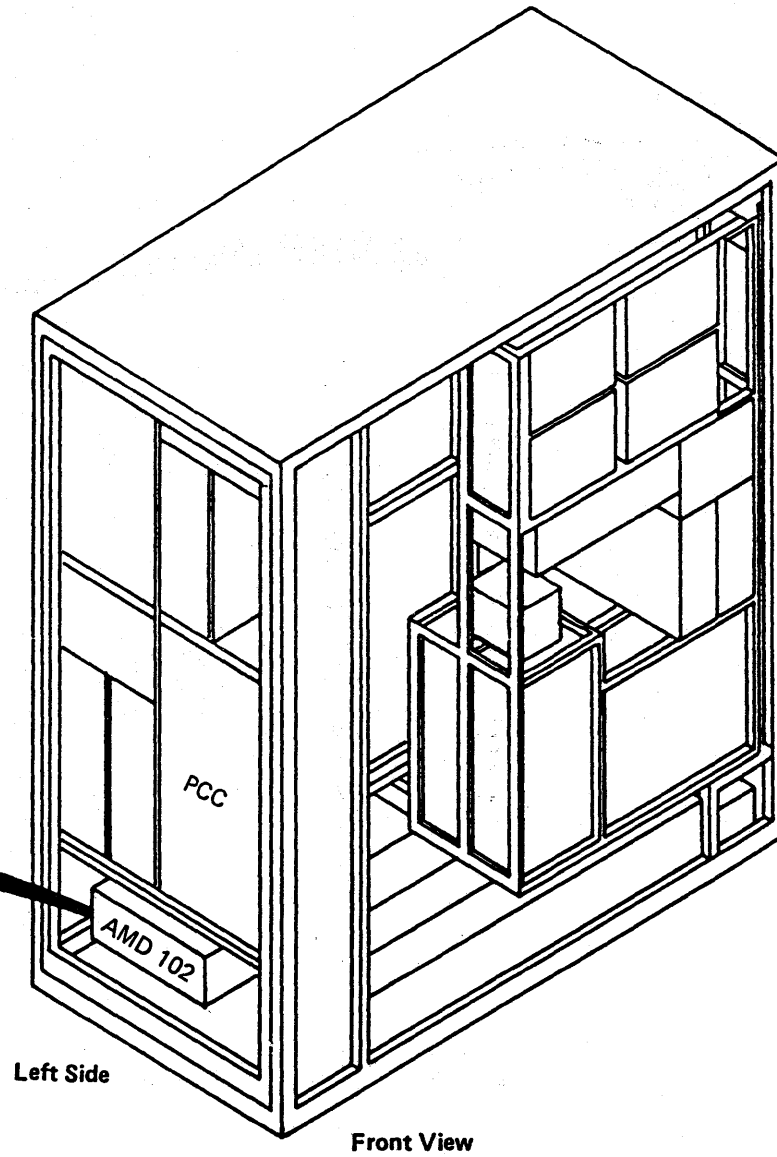
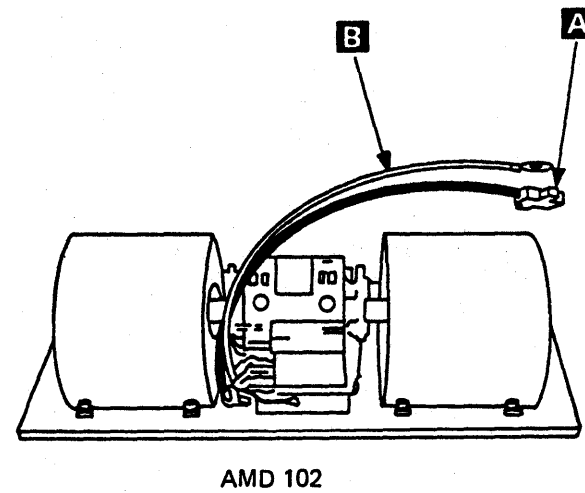

MI Seq GC080	PN 6169572 2 of 2	EC A20558 01 Oct 84	EC A20562 30 Aug 85			
-----------------	----------------------	------------------------	------------------------	--	--	--

Air Moving Device 103

1. Press Power Off on the operator control panel.
 2. Open left side cover of frame.
 3. Locate the Primary Control Compartment (PCC), and place CB1 and CB2 in the OFF position.
- Note:** AMD 104 must be removed before AMD 103.
4. Open rear cover of frame, and locate AMD 103 (AMD 103 is located behind AMD 104).
 5. Loosen the four cover mounting screws, and remove the cover.
 6. Disconnect cable **A** of AMD 104.
 7. Disconnect ground wire **B** from AMD 104.
 8. Pull AMD 104 from frame.
 9. Disconnect cable **A** of AMD 103.
 10. Disconnect ground wire **B** from AMD 103.
 11. Pull AMD 103 from frame.
 12. Reverse procedure for AMD 103 replacement.

Note: After reconnecting the ground wire, measure the ground integrity of the replaced FRU using a digital multimeter (part 8496278) for 0.1 ohm or less before any connectors are reconnected. Place one probe on the machine frame near the replaced FRU ensuring the painted surface is penetrated. Place the other probe on any bare metal area of the replaced FRU. If the measurement is 0.1 ohm or less, you have a good ground. If the measurement is greater than 0.1 ohm, check for an improperly installed ground wire.

CAUTION
If the measurement is still greater than 0.1 ohm, invoke your support structure.

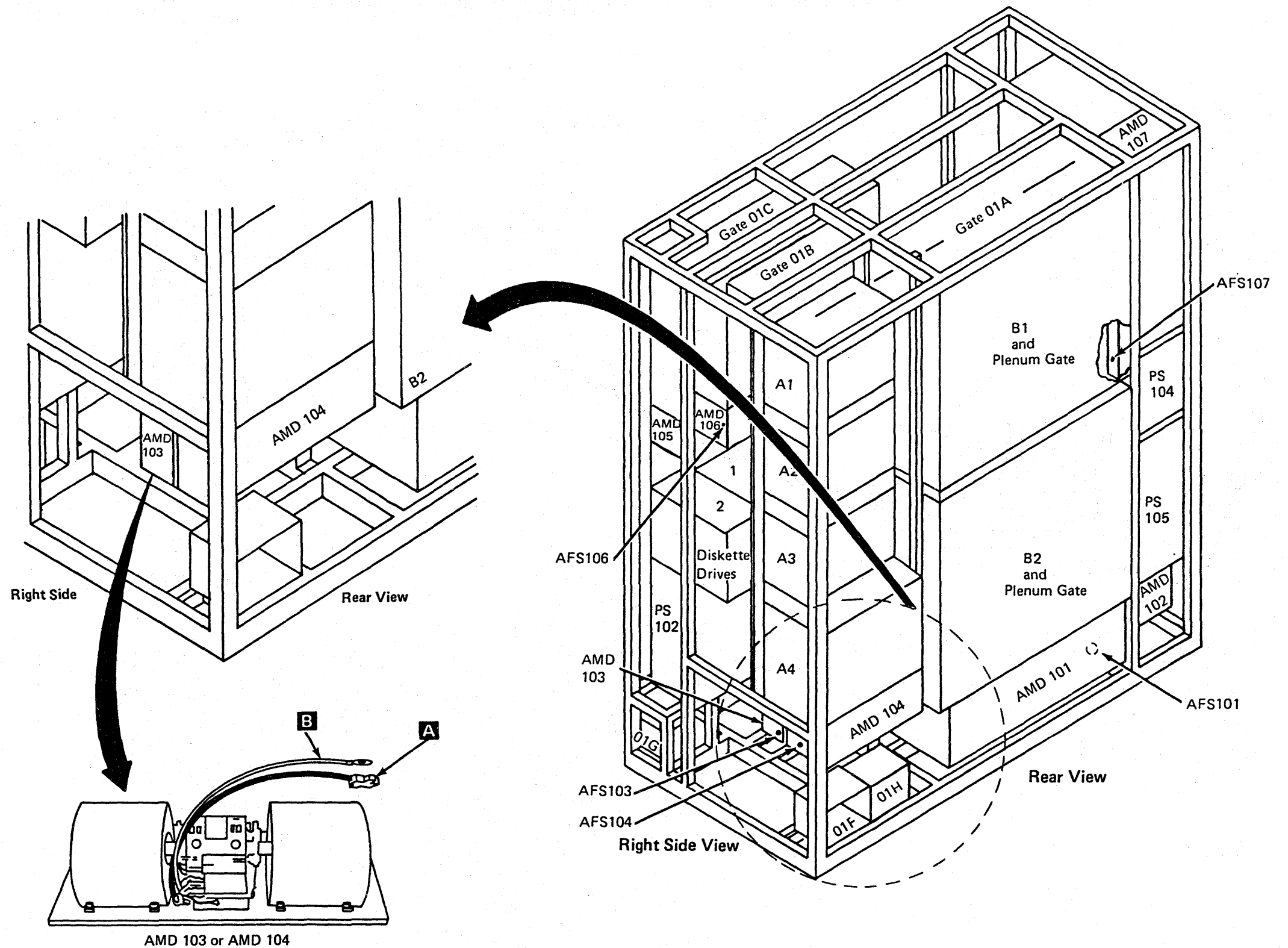

MI Seq GC085	PN 6169573 1 of 2	EC A20558 01 Oct 84	EC A20562 30 Aug 85			
-----------------	----------------------	------------------------	------------------------	--	--	--

Air Moving Device 104

1. Press Power Off on the operator control panel.
2. Open left side cover of frame.
3. Locate the Primary Control Compartment (PCC), and place CB1 and CB2 in the OFF position.
4. Open rear cover of frame, and locate AMD 104.
5. Loosen the four cover mounting screws, and remove the cover.
6. Disconnect cable **A**.
7. Disconnect ground wire **B**.
8. Pull AMD 104 from frame.
9. Reverse procedure for AMD 104 replacement.

Note: After reconnecting the ground wire, measure the ground integrity of the replaced FRU using a digital multimeter (part 8496278) for 0.1 ohm or less before any connectors are reconnected. Place one probe on the machine frame near the replaced FRU ensuring the painted surface is penetrated. Place the other probe on any bare metal area of the replaced FRU. If the measurement is 0.1 ohm or less, you have a good ground. If the measurement is greater than 0.1 ohm, check for an improperly installed ground wire.

CAUTION
If the measurement is still greater than 0.1 ohm, invoke your support structure.

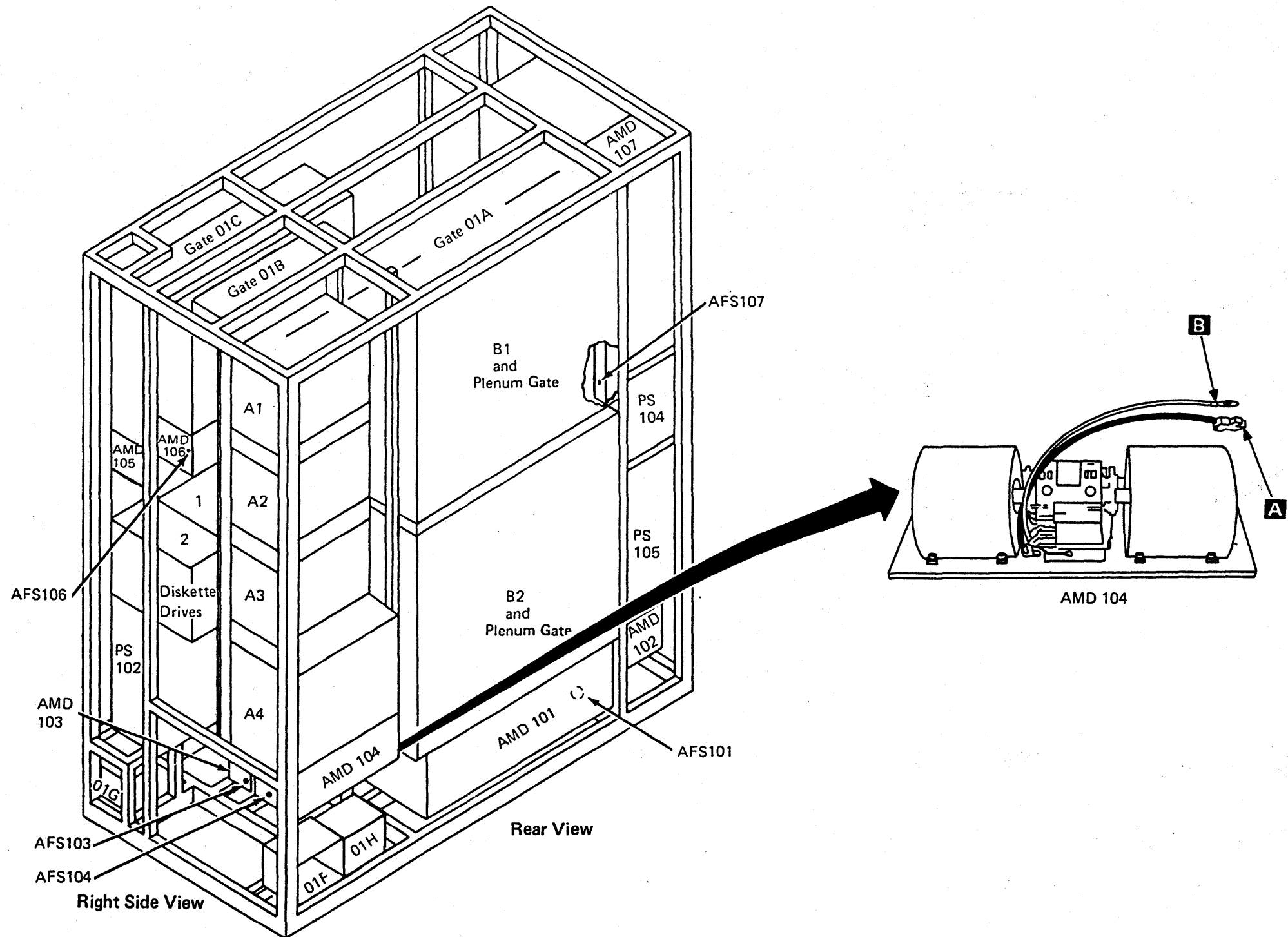

4381-3	MI	PN 6169573	EC A20558	EC A20562			
B/M 2676380	Seq GC085	2 of 2	01 Oct 84	30 Aug 85			

Air Moving Device 105

1. Press Power Off on the operator control panel.
2. Open left side cover of frame.
3. Locate the Primary Control Compartment (PCC), and place CB1 and CB2 in the OFF position.
4. Open front cover of frame.
5. Open service panel to gain access to front of AMD 105.
6. Loosen the four cover mounting screws, and remove the cover.
7. Disconnect cable **A**.
8. Disconnect ground wire **B**.
9. Pull AMD 105 from frame.
10. Reverse procedure for AMD 105 replacement.

Note: After reconnecting the ground wire, measure the ground integrity of the replaced FRU using a digital multimeter (part 8496278) for 0.1 ohm or less before any connectors are reconnected. Place one probe on the machine frame near the replaced FRU ensuring the painted surface is penetrated. Place the other probe on any bare metal area of the replaced FRU. If the measurement is 0.1 ohm or less, you have a good ground. If the measurement is greater than 0.1 ohm, check for an improperly installed ground wire.

CAUTION
If the measurement is still greater than 0.1 ohm, invoke your support structure.

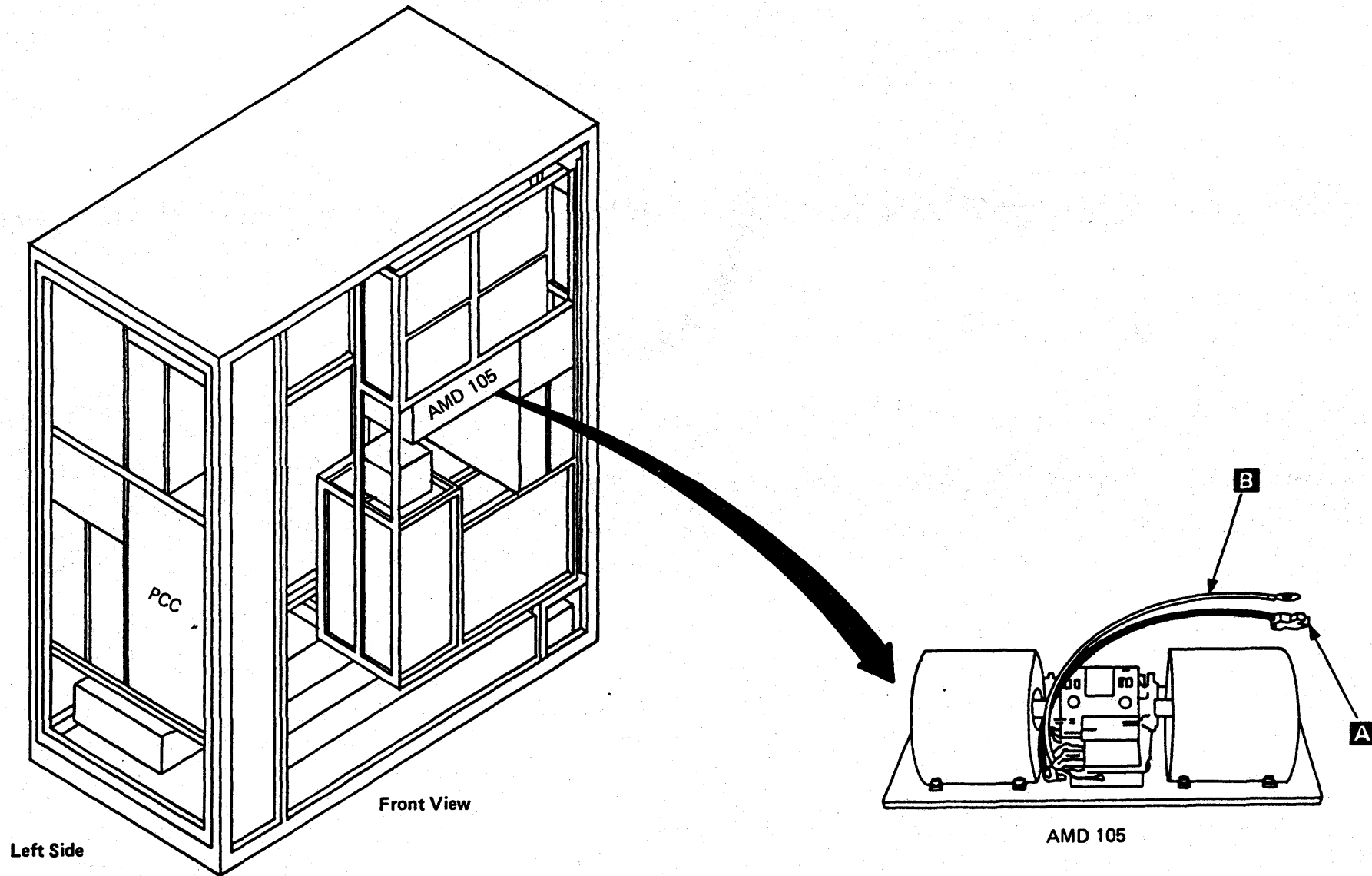

Air Moving Device 106

1. Press Power Off on the operator control panel.
2. Open left side cover of frame.
3. Locate the Primary Control Compartment (PCC), and place CB1 and CB2 in the OFF position.
4. Open front cover of frame.
5. Open gate 01C.
6. Loosen the four cover mounting screws, and remove the cover.
7. Disconnect cable **A**.
8. Disconnect ground wire **B**.
9. Pull AMD 106 from frame.
10. Reverse procedure for AMD 106 replacement.

Note: After reconnecting the ground wire, measure the ground integrity of the replaced FRU using a digital multimeter (part 8496278) for 0.1 ohm or less before any connectors are reconnected. Place one probe on the machine frame near the replaced FRU ensuring the painted surface is penetrated. Place the other probe on any bare metal area of the replaced FRU. If the measurement is 0.1 ohm or less, you have a good ground. If the measurement is greater than 0.1 ohm, check for an improperly installed ground wire.

CAUTION
If the measurement is still greater than 0.1 ohm, invoke your support structure.

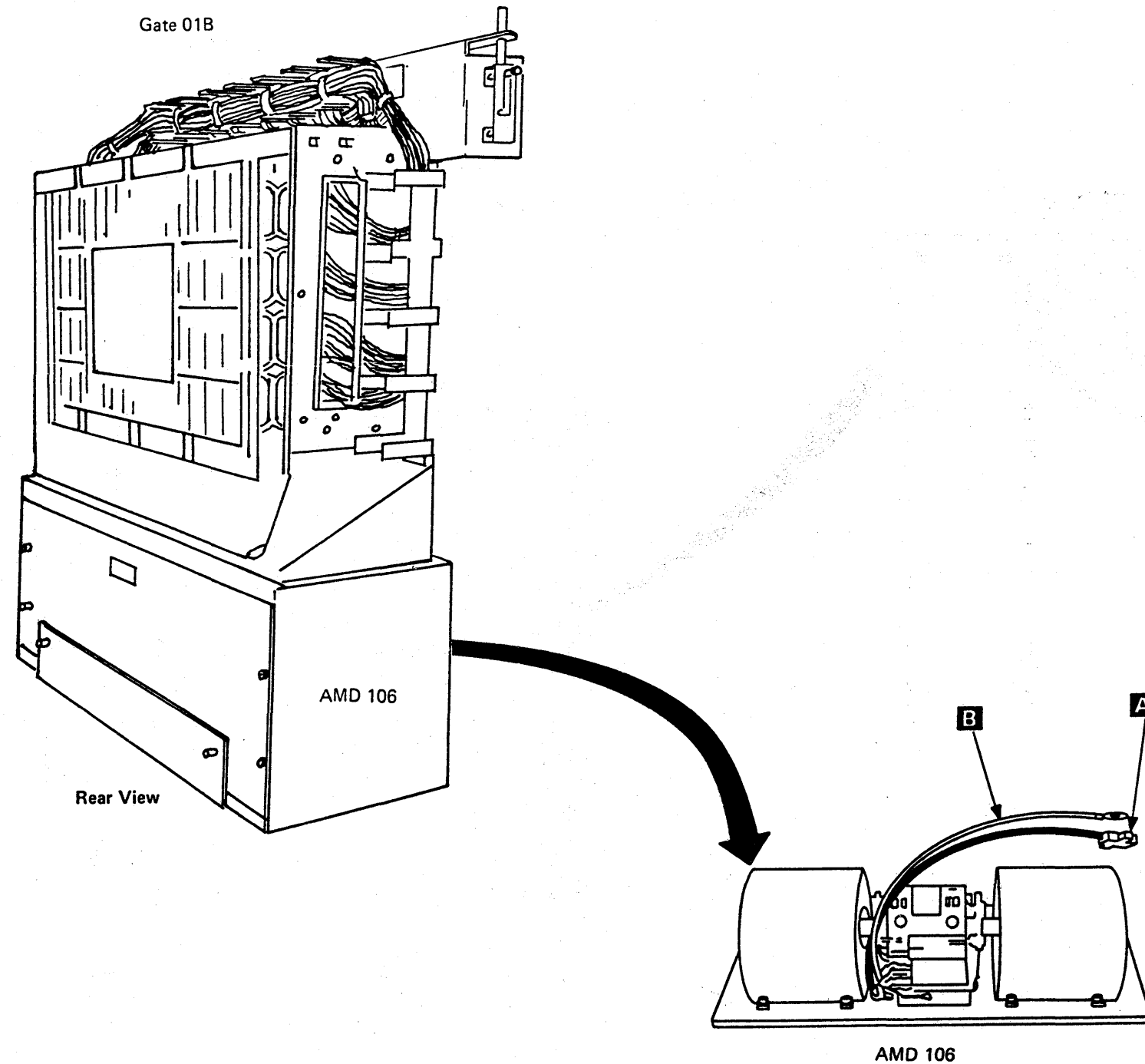

4381-3	MI	PN 6169574	EC A20558	EC A20562			
B/M 2676380	Seq GC090	2 of 2	01 Oct 84	30 Aug 85			

Air Moving Device 107

1. Press Power Off on the operator control panel.
2. Open left side cover of frame.
3. Locate the Primary Control Compartment (PCC), and place CB1 and CB2 in the OFF position.
4. Locate AMD 107 on the left side of the frame.
5. Remove the two top mounting screws, loosen the bottom mounting screw and remove the cover.
6. Remove the four mounting nuts and star washers, inside the cage assembly.
7. Disconnect cable **A**.
8. Disconnect ground wire **B**.
9. Pull AMD 107 from frame.
10. Reverse procedure for AMD 107 replacement.

Note: After reconnecting the ground wire, measure the ground integrity of the replaced FRU using a digital multimeter (part 8496278) for 0.1 ohm or less before any connectors are reconnected. Place one probe on the machine frame near the replaced FRU ensuring the painted surface is penetrated. Place the other probe on any bare metal area of the replaced FRU. If the measurement is 0.1 ohm or less, you have a good ground. If the measurement is greater than 0.1 ohm, check for an improperly installed ground wire.

CAUTION
If the measurement is still greater than 0.1 ohm, invoke your support structure.

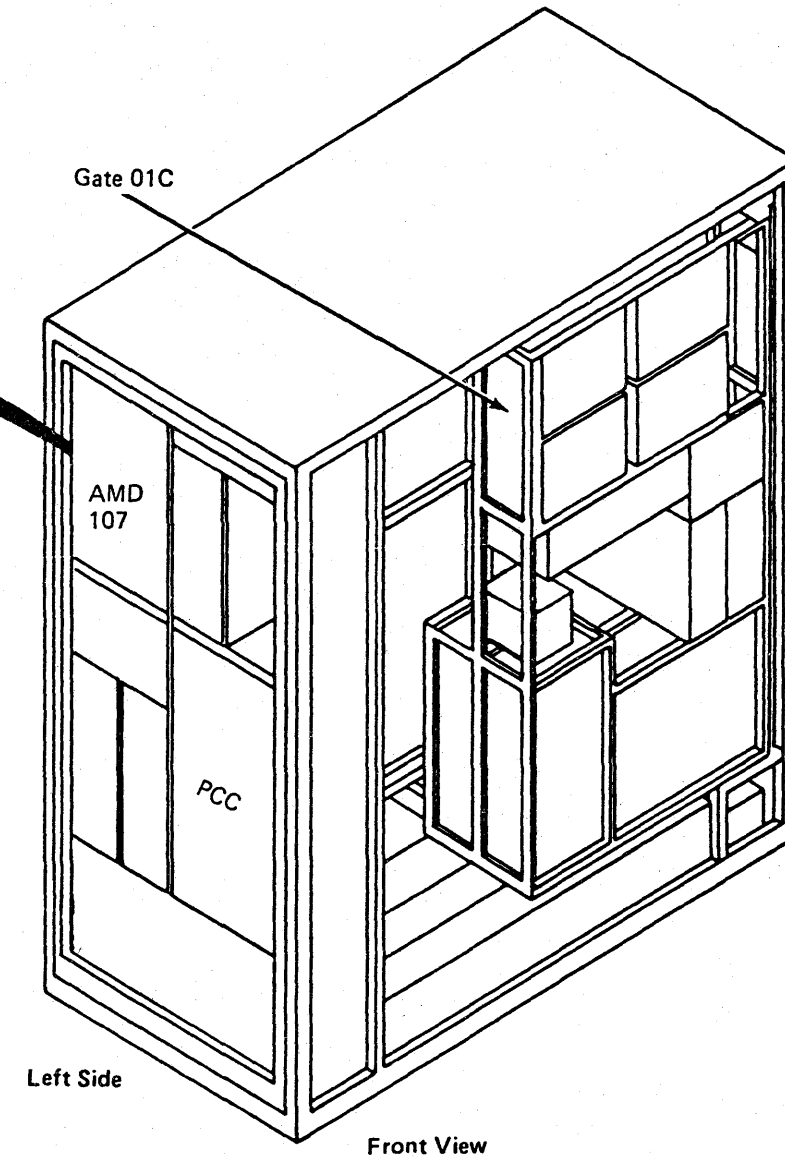
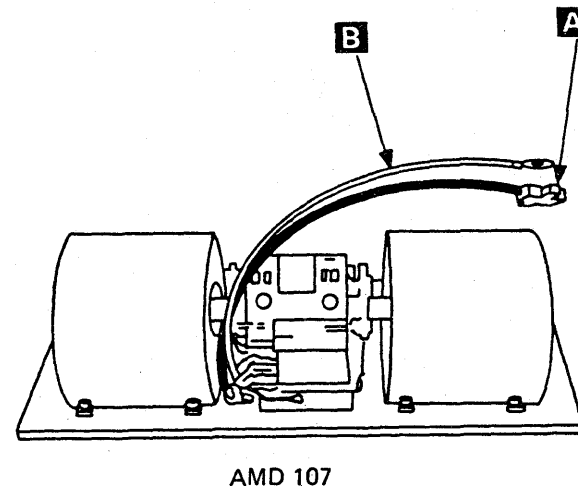



Service Panel

1. Press Power Off at the operator control panel.
2. Open left side cover of frame.
3. Locate the Primary Control Compartment (PCC), and place CB1 and CB2 in the OFF position.
4. Open front cover of frame.
5. Loosen the two screws located at **A** (top and bottom left side of the service panel).
6. Open the panel.
7. Remove connectors A1, A2, and B2 located at **B** (rear of the service panel).
8. Remove six card assembly holding screws shown at **C**.
9. Reverse procedure for service panel replacement.

Note: Reinstall the safety shield.

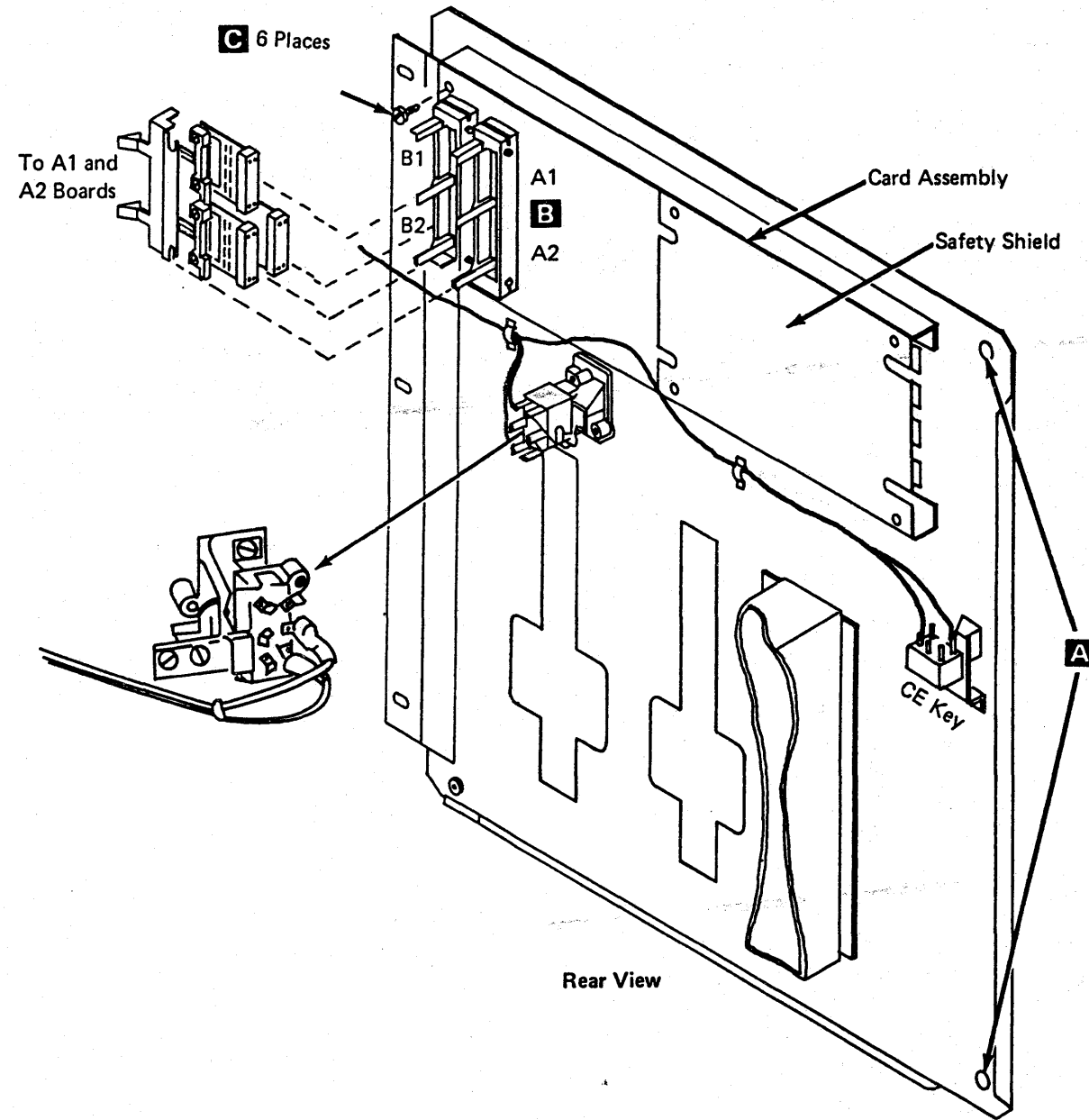

4381-3	MI	PN 6169576	EC A20558	EC A20559	EC A20562		
B/M 2676380	Seq GC100	1 of 2	01 Oct 84	03 Dec 84	30 Aug 85		

1. Press Power Off on the operator control panel (OCP).
2. Remove the diskette from the diskette drive.
3. Open the left side cover of the frame.
4. Locate the Primary Control Compartment (PCC), and place CB1 and CB2 in the OFF position.
5. Open the front cover of the frame.
6. Locate the cover stay on the upper right cover hinge.
7. Remove one end of the cover stay by slipping it over the mounting stud.
8. Open gate 01C, and locate the rear of the diskette drive to be removed.
9. Disconnect the power plug **A** from the diskette drive.
10. Remove the stop bracket at rear of the diskette drive base **B**.
11. Slide the diskette drive to the rear, permitting enough space to disconnect the ground wire at **C**.
12. Go to the front of gate 01C, and open the service panel door (two screws).
13. Slide diskette drive forward, and remove the right side plastic shield **D** which covers the circuit card on right side of the unit (Loosen three screws).
14. Remove the two shielded ground wires at **E**.
15. Cut the tie wrap at **G**.
16. Disconnect the signal cable **F** from the bottom of the circuit card.
17. Pull the diskette drive unit out from the rear.

Note: The cover **H**, top bracket **I**, bottom bracket **J**, and handle **K** must be exchanged from the old diskette drive to the new diskette drive.

18. Reverse the procedure for diskette drive replacement.

Note: After reconnecting the ground wire, measure the ground integrity of the replaced FRU using a digital multimeter (part 8496278) for 0.1 ohm or less before any connectors are reconnected. Place one probe on the machine frame near the replaced FRU ensuring the painted surface is penetrated. Place the other probe on any bare metal area of the replaced FRU. If the measurement is 0.1 ohm or less, you have a good ground. If the measurement is greater than 0.1 ohm, check for an improperly installed ground wire.

CAUTION
If the measurement is still greater than 0.1 ohm, invoke your support structure.

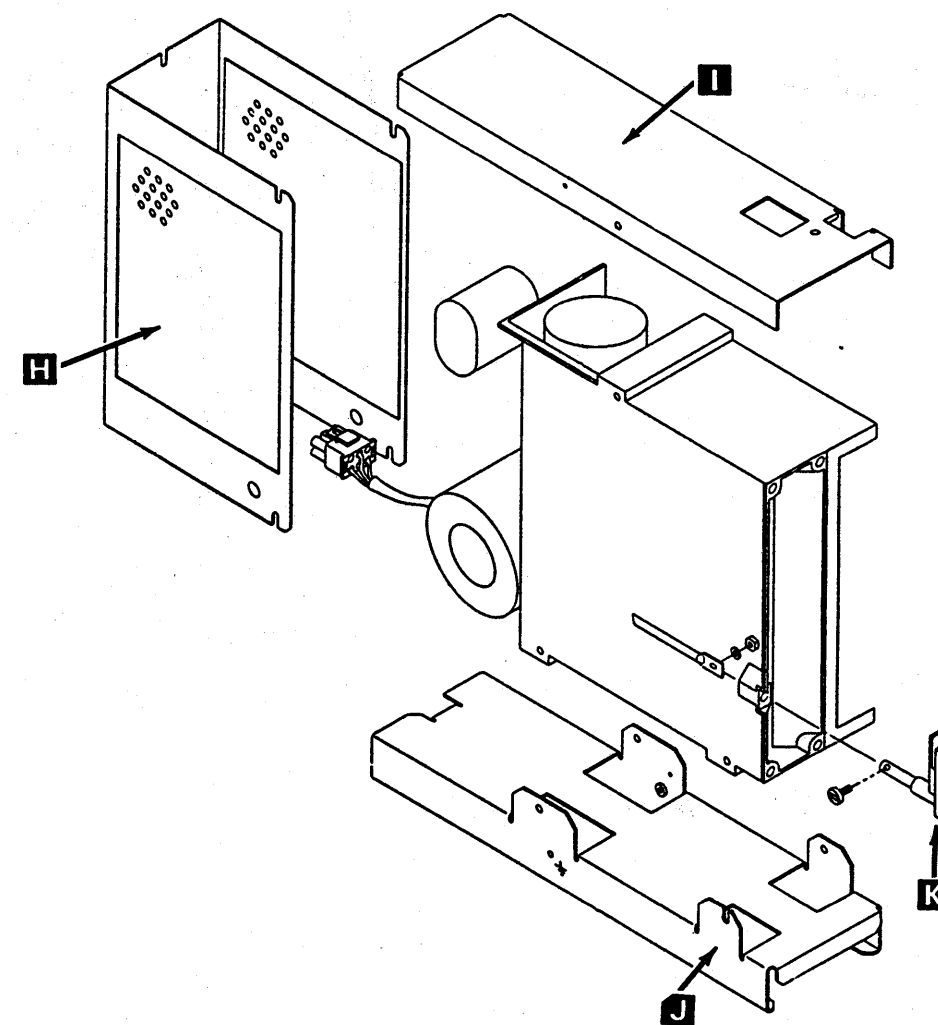
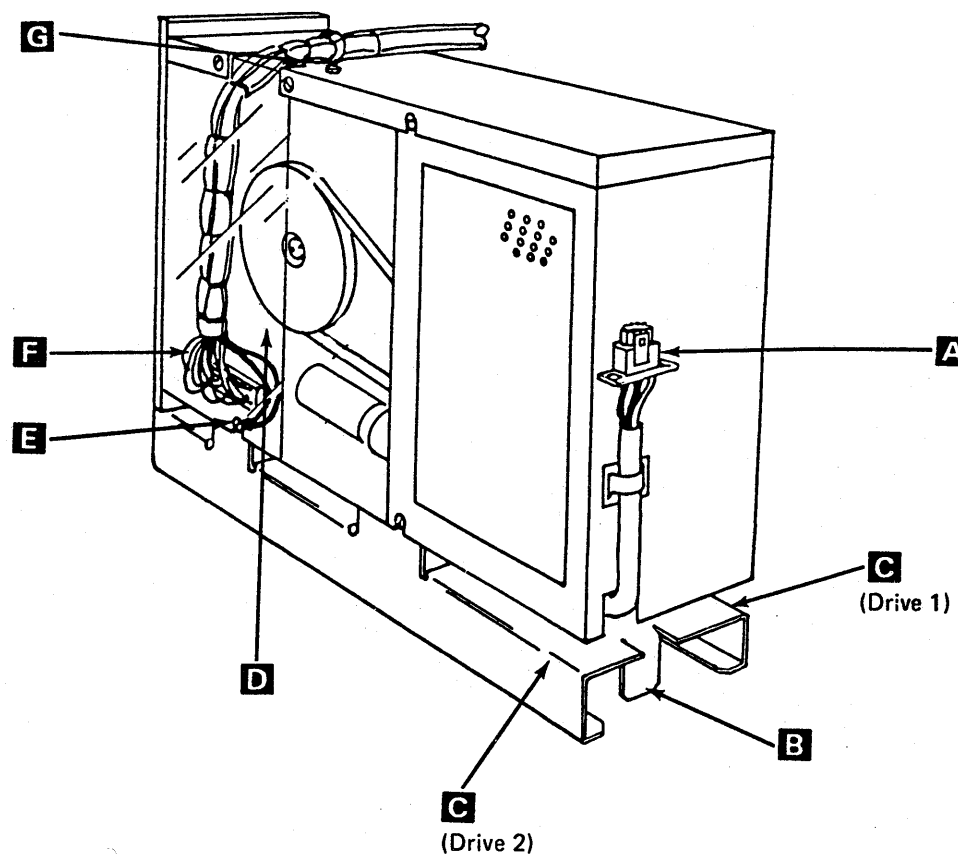

4381-3
B/M 2676380

MI Seq GC100	PN 6169576 2 of 2	EC A20558 01 Oct 84	EC A20559 03 Dec 84	EC A20562 30 Aug 85		
-----------------	----------------------	------------------------	------------------------	------------------------	--	--

© Copyright IBM Corp. 1984

PREVENTIVE MAINTENANCE

PM 001

Air Filters

Examine the air filters for dust accumulation and vacuum as necessary. Replace filters that do not pass light after vacuuming.

This procedure should be performed on a annual basis or as the environment requires.

The following filters and their locations are contained in the processor:

Part Number	Location
8645605	AMD 101
8645606	AMD 102
8645607	AMD 103 and 104
8645608	AMD 105 and 106
8645609	Left side cover

PM 001



DIAGNOSTICS

DIAG 001

Contents

Introduction	DIAG 002	Processing Unit Diagnostics	DIAG 105
Maintenance and Support Subsystem (MSS)	DIAG 002	Test Case Monitor (TCM)	DIAG 105
Processing Units (PU)	DIAG 002	MSMD Monitor	DIAG 105
Diagnostic Summary	DIAG 005	Diagnostic Mode Test Case Monitor Screen	DIAG 105
MSS	DIAG 005	Basic Diagnostics	DIAG 110
Basic and Extended MSS Diagnostics	DIAG 005	Basic Diagnostic Organization	DIAG 110
Optional MSS Diagnostics	DIAG 005	Machine Speed Microdiagnostics (MSMDS)	DIAG 115
Diskette Analysis Test	DIAG 005	MSMD Test Organization	DIAG 115
Processing Unit	DIAG 005	How to Run Processing Unit Diagnostics	DIAG 120
Processing Unit Basic Diagnostics	DIAG 005	Option I - Isolation Mode	DIAG 125
Machine Speed Microdiagnostics (MSMDs)	DIAG 005	Option V - Verification Mode	DIAG 130
Special Channel Interface Diagnostics	DIAG 005	Option C - Channel Interface Diagnostics	DIAG 135
Diagnosics by Diskette	DIAG 005	How to Run Channel Interface Tests	DIAG 135
FUNC2	DIAG 005	Mark In Test	DIAG 135
DIAG1	DIAG 005	Channel Microcoded Device Exerciser (CMDE) - Normal Mode	DIAG 140
Overview of the Maintenance Package	DIAG 010	Channel Microcoded Device Exerciser (CMDE) - Support Mode	DIAG 145
Retry	DIAG 010	Channel Wrap Test	DIAG 150
Error Log Analysis (ELA)	DIAG 010	Option T - Installation Mode	DIAG 160
Reconfiguration	DIAG 010	Option F - Field Support Center Mode	DIAG 165
Problem Analysis (PA)	DIAG 010	Test Case Monitor Messages	DIAG 200
Processing Unit Analysis (PUA)	DIAG 010		
Repair Procedures	DIAG 010		
MSS, Power and Reference Codes.	DIAG 015		
MSS and Power Codes	DIAG 015		
Reference Codes	DIAG 015		
Maintenance and Support Subsystem (MSS) Diagnostics	DIAG 020		
Basic and Extended MSS diagnostics	DIAG 020		
Basic MSS Test Descriptions	DIAG 020		
Running MSS Basic and Extended Diagnostics	DIAG 025		
Looping MSS Basic and Extended Diagnostics	DIAG 025		
Basic Diagnostic MSS Codes	DIAG 030		
Extended MSS Diagnostics by Test ID	DIAG 045		
MSS Repair Action Screens	DIAG 055		
Running the Power Controller Adapter (PCA) Tests Manually	DIAG 060		
PCA Diagnostic Reference Codes	DIAG 060		
Optional MSS Diagnostics	DIAG 070		
Running Optional MSS Diagnostics	DIAG 070		
Diskette Analysis	DIAG 100		

DIAG 001

This section contains information on processor diagnostics only. For information on System Test/4381, System Test/4381XA, or 4300-FRIEND, see "System Test" in this volume. For channel-to-channel adapter feature tests, see Volume A06, "Service Aids."

The processor has a Maintenance and Support Subsystem (MSS), two Processing Units (PU), and a power section.

Maintenance and Support Subsystem (MSS)

The MSS consists of a Support Processor (SP) and the following device adapters:

- Device Cluster Adapter (DCA) that controls the system console displays and printers
- Diskette Drive Adapters (DDA) that control the diskette drives
- Remote Support Facility (RSF)
- Service Panel
- Power Controller Adapter (PCA) that controls power to the processing unit
- Support Bus Adapters (SBA) that communicate with the processing units
- Local Channel Adapter (LCA).

Processing Units (PU)

- Contain main storage and the arithmetic units for execution of customer programs.
- Communicate with the system's I/O devices through the I/O channels.

Diagnostic programs are used with the Repair Procedures in Volumes A01 through A05 to isolate failures and verify repairs in all the areas outlined above.

Some of the MSS diagnostics are resident in the read-only portion of MSS storage. All other diagnostics are loaded from the diskette drives. The MSS diagnostics and the processing unit Basic diagnostics run in SP control storage. The remaining diagnostics are loaded into processing unit control storage and run under control of the Machine Speed Microdiagnostic (MSMD) Monitor program.

4381
B/M 2676380

MI Seq GE005	PN 6169394 2 of 2	EC A20558 01 Oct 84				
-----------------	----------------------	------------------------	--	--	--	--

© Copyright IBM Corp. 1984



Diagnostic Summary

DIAG 005

MSS

Basic and Extended MSS Diagnostics

- Located in support processor Read-Only Storage (ROS) and the DIAG1 diskette.
- Tests basic support processor and adapter operations.
- Run in support processor storage.
- Start automatically after the support processor is powered up.
- Indicate failures with five-digit MSS Codes displayed on the service panel or reference codes displayed on the console.

For more information, see page DIAG 020.

Optional MSS Diagnostics

- Located on the DIAG1 diskette.
- Supply additional testing for the support processor and adapters.
- Run in support processor storage.
- Can be selected after the Extended MSS diagnostics complete if the DIAG1 diskette is installed in diskette drive 1.
- Indicate failures by reference codes and repair screens.

For more information, see page DIAG 070.

Diskette Analysis Test

- Located on FUNC1 diskette.
- Tests any of the system diskettes for unreadable records.

For more information, see page DIAG 100.

Processing Unit

Processing Unit Basic Diagnostics

- Located on FUNC2 and DIAG1 diskettes.
- Test hardware path to ensure MSMDs can be started. These are on FUNC2.
- Test some processing unit hardware that cannot be fully tested by the MSMDs. These are on DIAG1.
- Run in support processor storage.
- Can be selected from the Diagnostic Mode PU Diagnostic Selection screen after the processing unit is powered up.
- Indicate failures by reference codes.

For more information, see page DIAG 110.

Machine Speed Microdiagnostics (MSMDs)

- Located on the FUNC2 diskette.
- Require both processing units.
- Test most of the processing unit hardware.
- Run in processing unit control storage.
- Can be selected from the Diagnostic Mode PU Diagnostic Selection screen after the processing unit is powered up.
- Indicate failures by reference codes.

For more information, see page DIAG 115.

Special Channel Interface Diagnostics

- Located on DIAG1 diskette.
- Test channel receivers, drivers, and interface cables.
- Run in processing unit control storage.
- Can be selected from the Diagnostic Mode PU Diagnostic Selection screen.
- Indicate failures by error screens on the console.

For more information, see page DIAG 135.

Diagnostics by Diskette

FUNC1

Diskette Analysis

FUNC2

MSS Basics

I/O Bus Test
DCA and Console Display Test

PCA Tests

Routine 0 Tests 1 through 8
Routine 1 Tests 1, 3, 4, 6, and 8

PU Basics

D001 through D049	Scan rings
D050 through D099	Clock maintenance commands
D100 through D199	Clock Basics
D200 through D299	PU, Control storage maintenance commands
D300 through D399	Control storage addressing
D400 through D499	Control storage
D500 through D599	Channels
D600 through D7FF	Storage, dual processing unit

MSMDs

Storage Load 1	PU data flow, branch, shifter, interrupts, timers, multiplier
Storage Load 2	SAR, cache, addressing, DLAT
Storage Load 3	Main storage, swap buffer
Storage Load 4	Channel data buffer, channel traps
Storage Load 5	I-cycles, retry, traps
Storage Load 6	Dual processing unit

DIAG1

MSS Basics and Extended

I/O Bus Test
Diskette Test 1
Diskette Test 2
Additional SP Storage Test
DCA and Console Display Test

MSS Optional

Option 90	Service Panel
Option A0	DDA/Diskettes
Option CE	Console printers/displays
Option D0	RSF
Option E0	RSF wrap

PU Basics

D900 through D999	Machine check propagation
DA00 through DA99	PU, Control storage maintenance commands
DB00 through DB99	PU, Control storage
DD00 through DD99	Channels
DE00 through DEFF	Storage

MSMD Storage Load 7

Channel Interface Diagnostics

Overview of the Maintenance Package

The following are used by the processor to analyze problems:

- Retry
- Error Log Analysis (ELA)
- Reconfiguration
- Problem Analysis (PA)
- Processing Unit Analysis (PUA)
- Repair Procedures.

A brief description of each item follows:

Retry

The retry routine runs in the support processor when a processing unit hardware failure occurs. It reads out the PU scan ring latches and stores them on the diskette, calls the ELA routines, determines if reconfiguration is needed, and if the failing operation can be tried again.

Error Log Analysis (ELA)

The ELA routines use the PU scan ring values to generate a reference code, reference code extension, and FRU list.

Reconfiguration

Special backup hardware and microcode have been added to some areas of the processor to be used if the primary hardware fails. These areas include:

- Cache
- Channel data buffer
- Control storage
- Multiply function
- Swap buffer.

In addition, sections of main and key storage can be flagged as bad so they are not used by the customer's program. If main storage, key storage, the multiply function, or multiple areas of cache are reconfigured, the system runs in a degraded mode and the customer is advised to place a call for service. The reconfiguration of the other areas does not cause a loss of system performance and does not cause the diagnostics to fail. Warning: Do not swap FRUs between locations in cache or in the swap buffer. This can cause reconfiguration data to be invalid. Follow the PU Repair Procedures for exchanging FRUs in these locations.

Problem Analysis (PA)

Special analysis routines are sent with the processor so the customer can:

- Do initial problem determination
- Run Processing Unit Analysis (PUA)
- Send error logout information to a remote support center
- Display program, channel, and I/O status data stored when a failure occurred.

Problem Analysis is run automatically for some system errors. The customer may run PA at any time.

Problem Analysis allows the customer to call in the part numbers of the FRUs that are the probable cause of the failure.

The service representative uses Problem Analysis to find the location of FRUs to be exchanged and to display information recorded when Problem Analysis ran.

Processing Unit Analysis (PUA)

Processing Unit Analysis can be run by the customer as a part of Problem Analysis (PA Option 3). The diagnostics are:

- MSMD storage loads 1 to 6.
- if MSMDs detect an error, PU Basics D001 to D7FF (FUNC2 diskette)

If a failure is detected by the PUA diagnostics, the customer is given a PA log number (PAxx) and the part numbers of the most probable failing FRUs.

Repair Procedures

Volumes A01 through A05 contain procedures for you to follow when repairing a failure on the processor. Begin all repairs at "START Repair Procedure" in Volume A01.

MI Seq GE010	PN 6169395 2 of 2	EC A20558 01 Oct 84	EC A20562 30 Aug 85			
-----------------	----------------------	------------------------	------------------------	--	--	--



MSS, POWER, AND REFERENCE CODES

DIAG 015

MSS and Power Codes

The service panel has a five-digit display used by the support processor to display error conditions until the MSS is powered up and the path to the system console is tested by MSS Basic and Extended diagnostics. If an error is detected in the power-up or power-down sequence, the error condition is displayed in the last two digits of the service panel. If an error is detected by the MSS Basic or Extended diagnostics or while the customer's program is running, all five digits display the error. The two-digit power codes and the five-digit MSS codes are used as entries to the Repair Procedures.

Note: With no error on the system, the service panel displays the present SP storage address.

MSS Codes

0Exxx or 0Fxxx	SP error detected by ROS diagnostics
8001x	I/O bus error
815xx	Error on diskette drive 1
816xx or 817xx	MSS error while functional code is running
818xx or 81Fxx	Error on diskette drive 1
82xxx	MSS error while functional code is running
835xx	Error on diskette drive while reading diagnostics
88xxx or 89xxx	DCA or console display errors

Reference Codes

Reference codes show that an error was detected either during normal machine operation or while a diagnostic was running.

Reference codes are eight-character (hex) numbers with a format of: UU RRRR IS.

Where:

- UU Defines the area of failure.
- RRRR Gives specific failure information; it does not have a fixed format.
- I Specifies the reference code source.
- S Gives status information.

An eight-digit extension field can be added to the reference code to provide information on failing FRUs. The extension field does not have a fixed format.

IS Codes

Indicator (I) field (bits 0 through 3 of IS)

- 0 Power monitor
- 1 SP check handler
- 2 Any SP CAC or access method
- 3 Processing unit IML routine
- 4 Error logging or retry routine
- 5 Processing unit microcode
- 6 Any other SP microcode
- 8 Basic diagnostics
- 9 MSMD diagnostics
- A Error Log Analysis (ELA)
- B Power failure analysis
- C Test Case Monitor (TCM)
- D MSMD monitor
- F MSS diagnostics

Status (S) field (bits 4 through 7 of IS)

- Bit 4 = 1 FRU identified
- Bit 5 = 1 Log available
- Bit 6 = 1 Irrecoverable error
- Bit 7 = 0 PU0 error
- Bit 7 = 1 PU1 error

UU Codes

1x Power problem

- 11 Processing unit power
- 14 Channel-to-channel adapter power
- 17 I/O power interface
- 1D Digital sensor failure
- 1F Undefined power problem

4x through 9x and FD Processing Unit

- 4x Storage
- 50 Control storage
- 59 PU
- 5D Clocks
- 60 Channels
- 70 Storage controller
- 71 Storage controller (Model Group 1 only)
- FD Support Bus Adapter (SBA)

Ex System problem

- EC SP microcode
- ED LCA or channel 0
- EE Processing unit microcode

Fx Maintenance and Support Subsystem (MSS)

- F0 Support Processor (SP)
- F1 Support processor storage
- F2 Local Channel Adapter (LCA)
- F4 Diskette Drive Adapter (DDA)
- F5 Diskette drive
- F6 Power Controller Adapter (PCA)
- F8 Device Cluster Adapter (DCA)
- F9 Display console and keyboard
- FD Support Bus Adapter (SBA)
- FE Common Communications Adapter (CCA)

MSS diagnostics are the primary method for isolating failures in the MSS.

The diagnostics for the MSS are:

- Basic and Extended
- Optional.

Basic and Extended MSS diagnostics

Basic and Extended MSS diagnostics are in SP ROS and on the DIAG1 diskette. They are run automatically when the processor is powered up or re-IMLed.

Errors detected while running Basic or Extended MSS diagnostics are indicated either by MSS codes displayed on the service panel or by reference codes displayed on the system console. MSS codes are five-digit codes displayed on the service panel and used for entry to the Repair Procedures. The MSS codes are used to indicate errors until the operation of the MSS and the path to the system console are tested.

Basic MSS Test Descriptions

Test	Description	MSS Code
SP Basic Test	Read from SP ROS; tests SP logic.	0Fxxx, 0Exxx
I/O Bus Test	Read from SP ROS; tests the SP bus. Failures cause two instruction loops.	8001x
Diskette Tests 1	Read from SP ROS; tests diskette drive status and diskette drive ready.	8150x
Diskette Test 2	Read from diskette; checks diskette drive operation.	8180x, 8181x
DCA and Console Display	Checks basic operation of DCA and console display.	88x0x
DCA and Console Display Test 91	Tests write instruction to console attached to port 0. Note: 89101 is displayed if the console is not powered up.	8910x
DCA and Console Display Tests 92 through 96	Test additional DCA and console display operations.	8920x - 8960x



Running MSS Basic and Extended Diagnostics

To run the MSS Basic and Extended diagnostics:

1. Set the CE Mode switch to Normal.
2. Set the I/O Power Hold switch to I/O Power Hold.
3. Set the Power Off switch to Power Off.
4. Install DIAG1 into diskette drive 1.
5. Reset the Power Off switch to Normal, and press Power On. Basic and Extended MSS diagnostics run after power up.

Notes:

1. After MSS diagnostics start running, the first visual indication is the MSS Diagnostic Test Option Selection screen with the message: BASIC MSS DIAGNOSTICS COMPLETED. If this screen does not appear within 30 seconds, a failure occurred in the MSS Basic diagnostics and an MSS Code is displayed on the service panel. The second visual indication is the addition of the message: MSS EXTENDED DIAGNOSTICS COMPLETED. A failure in the MSS Extended diagnostics results in a Repair Action screen that gives the reference code, a list of possible failing FRUs, a sequence of repair steps, and a reference to the Repair Procedures.
2. If the MSS Diagnostic Test Option Selection screen is displayed but input from the keyboard is not accepted, suspect a DCA or console keyboard problem.
3. If you run the Extended MSS diagnostics with power on the processing unit, an SBA test failure can occur.
4. Successful end of the Basic and Extended diagnostics is indicated by the message: EXTENDED DIAGNOSTICS COMPLETED.
5. If you suspect problems with the power controller adapter, use the FUNC1 diskette with the procedure outlined on page DIAG 060.
6. While looping the Basic and Extended MSS diagnostics (Option FF on the MSS Diagnostic Option Selection screen), the console goes blank during the ROS diagnostics. If the screen remains blank, look for an MSS Code on the service panel.

Looping MSS Basic and Extended Diagnostics

To loop the MSS Basic and Extended diagnostics:

1. Set the I/O Power Hold switch to I/O Power Hold.
2. Set the CE switch to Normal.
3. Set the Power Off switch to Power Off.
4. Install DIAG1 in diskette drive 1.
5. Reset the Power Off switch to Normal, and press Power On. Basic and Extended MSS diagnostics run one time, and the MSS Diagnostic Option screen is displayed.
6. If you want to loop all the MSS Basic and Extended diagnostics, key in FF and press ENTER.
7. If you want to loop a single MSS Extended diagnostic, key in TEST/RTN ID and press ENTER. For a description of extended MSS diagnostic tests and routines, see "Extended MSS Diagnostics by Test ID" on page DIAG 045.

Example: 11 will loop one of the SP storage tests.
8. To end a looping test, press Power On/IML.

Basic Diagnostic MSS Codes

Routines from SP ROS

Test SP logic.

MSS Code	Error Description
0E00x - 0E05x	SP branching error
0E06x - 0E0Cx	SP error on control instruction
0E0Dx - 0E13x	SP logic error
0E14x - 0E18x	SP storage addressing error
0E1Ax - 0E21x	SP ROS error
0E22x - 0E25x	SP logic error
0E26x - 0E29x	SP branching error
0E3Fx	SP arithmetic error
0E48x	SP register addressing error
0E56x - 0E6Bx	SP logic error
0E7Bx - 0E81x	SP branching error
0E94x - 0EB4x	SP storage addressing error
0EBAx - 0EBBx	SP storage error
0EC2x	SP cache error
0F80x - 0FC0x	SP branching error

I/O Bus Test

The SP bus is tested using the DCA card. If a failure is detected, the failing data is written to the bus repeatedly.

MSS Code	Error Description
80011	SP bus error (data = 0202 0000)
80012	SP bus error (data = 0206 B6B6)
80013	SP bus error (data = 0204 A55A)
80014	SP bus error (data = 0204 FFFF)
80015	SP bus error (data = 0200 0000)
80016	SP bus error (data = FFFF FFFF)

Diskette Drive Test 1

Tests diskette drive 1 reset, basic status, and ready.

MSS Code	Error Description
81502	Adapter check on read basic status
81504	Drive not ready in 20 seconds
81505	Basic status wrong after reset
8150A	Drive dropped ready
81513	Timeout when DDA addressed; SP enters two step loop
81523	Parity error when DDA addressed; SP enters two step loop

Diskette Test 2

Reads track 2 loader from side 0, track 0. Loads records 1 and 2 into SP storage address 0638.

MSS Code	Error Description
81801	Adapter check on seek
81802	Adapter detected error on read ID
81803	Not at track 0 after seek
8180A	Dropped ready after seek
8180C	No interrupt after read ID from track 0
8180F	No interrupt after read record
81810	Record not found on read data
81811	Data CRC error on read
81812	Drive error after read data
81820	No interrupt on seek
81F12	Data CRC error
81F20	Seek error
81F21	No interrupt seek or read record
81F29	Wrong status after seek

Additional SP Storage Test

Loads tests from tracks 3 and 4 into the first 32K and tests for storage parity errors.

MSS Code	Error Description
83501	Timeout waiting for diskette
83502	SP storage MC/PC while loading
83503	External MC/PC error
8350A	Diskette drive dropped ready
8350C	Wrong status after diskette operation
83512	CRC error on read
83520	Seek error

DCA and Console Display Tests

- Test 81 Tests adapter reset command
- Test 82 Tests load and read cycle steal byte.
- Test 83 Tests set and read basic status.
- Test 84 Tests reset adapter.
- Test 85 Tests invalid command.
- Test 86 Tests set/reset basic status.
- Test 87 Tests set/reset extended status.
- Test 88 Tests write/read control latches.
- Test 89 Tests start cycle steal.
- Test 8A Tests that start cycle steal not started with enable off.
- Test 8B Tests read to port 0.
- Test 8C Tests restart DCA.
- Test 8D Tests load, read, and reset byte counter.
- Test 8E Tests address register and controls.
- Test 8F Tests poll counter stepping.
- Test 90 Tests timer stepping.
- Test 91 Tests write to port 0. If no terminal is attached and powered up, DCA testing is terminated.
- Test 92 Tests block poll.
- Test 93 Tests clear command to terminal.
- Test 94 Tests setting/resetting over 63 counter.
- Test 95 Tests byte counter.
- Test 96 Exit routine for DCA diagnostics.

MSS Code	Error Description
88101	MC/PC error on reset
88102	Basic status bits not reset
88103	Basic status bits not reset
88201	Read cycle steal control byte error
88202	Cycle steal control byte not all ones after load
88203	Cycle steal control byte not all ones after load
88301	Reset basic status did not reset correct bits
88302	Read basic status error
88303	Read basic status error
88304	Set basic status did not set correct bits
88305	Read basic status error
88306	No DCA interrupt received
88401	Reset adapter did not reset status bits
88402	Reset adapter did not reset interrupt from DCA
88501	MC/PC register wrong at test start
88502	Invalid command did not set MC/PC in SP
88503	Invalid command did not set MC/PC in adapter
88601	All basic status bits off after reset except DCA active
88602	All basic status bits off after reset except stop poll
88603	DCA active not on after read/reset
88604	DCA active was reset on read/reset
88701	Extended status not set correctly
88702	Extended status not reset correctly
88703	Extended status not correct
88801	Read command not all zeros
88802	Write did not set status bits
88803	Control latches not reset by reset adapter
88901	Incorrect status after start cycle steal command
88902	Incorrect command queue start cycle steal command
88A01	Incorrect basic status after start cycle steal command
88A02	Cycle steal control byte wrong
88A03	Command queue wrong
88B01	Basic status wrong
88B02	Basic status not reset
88C01	Cycle steal control byte wrong
88C02	Basic status wrong
88D01	Byte counter not set to ones
88D02	Keyboard queue 2 wrong
88E01	Basic and extended status wrong
88E02	Device address wrong
88E03	Error queue wrong

MSS Code	Error Description
88F01	Diagnostic data wrong
88F02	Poll counter bits not set
88F03	Poll counter bits not reset
89001	Basic status bit not reset
89101	Stop poll or DCA active not on
89102	No power on response from port 0 display
89103	Status wrong on write command
89104	No power on reset in status
89105	Cycle steal pointer wrong for keyboard queue
89201	Extended status wrong
89202	Poll timeout data wrong
89203	Error queue pointer not updated
89301	Basic status wrong
89302	Wrong data in status queue
89401	Basic status wrong after looping 63 times
89402	Basic status wrong after looping 64 times
89403	Basic status wrong after read/reset
89404	Status change after loading cycle steal control bytes
89405	Read/reset basic status failed to reset all bits
89501	Basic status wrong after start cycle steal
89502	Received status wrong
89503	Received data wrong (one byte)
89504	More than two data bytes received
89505	Data queue pointer not updated
89506	Received data wrong (six bytes)
89507	More than six bytes received
89508	Data queue pointer not updated
89601	MC/PC set from DCA

Extended MSS Diagnostics by UU Codes

UU Code	Area Tested	Test ID	Routine ID
F0	Support Processor	0	1 to 6
F1	Support Processor Storage	1	1 to 6
FD	Support Bus Adapter	2	1 to 7
F2	Local Channel Adapter	3	1 to F
		4	1 to 5
F6	Power Controller Adapter	8	1 and 2

Example of Reference Code from MSS Extended Diagnostics

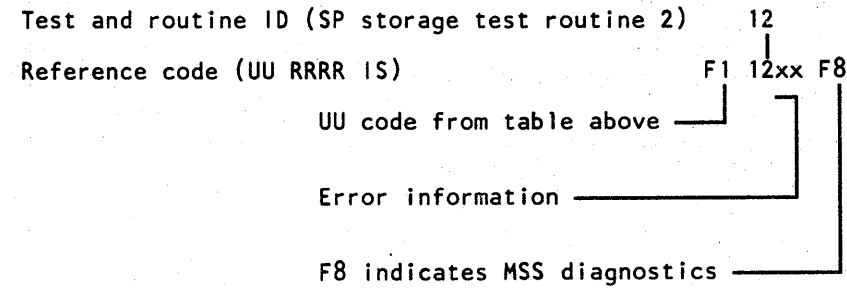

Extended MSS Diagnostics by Test ID

Test	Description
Test 0 Routine 1	<p>Tests level switching of the support processor. Reference codes are:</p> <p>FO 0101 F8 Control write to common mask failure FO 0102 F8 Failed switching to level 1 FO 0103 F8 Failed switching to level 2 FO 0104 F8 Failed switching to level 3 FO 0105 F8 Failed switching to level 4 FO 0106 F8 Failed switching to level 5 FO 0107 F8 Failed switching to level 6 FO 0108 F8 Failed switching to level 7 FO 0109 F8 Failed switching to level 0 FO 010A F8 Control read/write PSC failed FO 010B F8 PSC bits wrong FO 010C F8 Write next level failed FO 010E F8 PIRR or common mask wrong</p>
Test 0 Routine 2	<p>Invalid instruction recognition. Reference codes are:</p> <p>FO 0201 F8 No MC with invalid instruction FO 0202 F8 No MC with invalid I/O address FO 0203 F8 MC/PC bits do not set/reset correctly FO 0204 F8 Low byte parity check failed</p>
Test 0 Routine 3	<p>Test parity recognition.</p> <p>FO 0301 F8 Wrong parity</p>
Test 0 Routine 4	<p>Tests storage from X'00400' to X'OFFF' for parity and data compare. To determine the failing location if an error occurs:</p> <ol style="list-style-type: none"> Key in G and press ENTER. A reference code of FO 04xx F8 is displayed. Key in G and press ENTER. A reference code of FO 04yy F8 is displayed. <p>Where xx is the high-order storage address and yy is the low-order storage address. Reference codes are:</p> <p>FO 0401 F8 Data miscompare FO 0402 F8 Parity check (0E000 to OFFF) FO 0403 F8 Parity check (00400 to OFFF)</p>

Test	Description
Test 0 Routine 5	<p>Tests register space. Reference codes are:</p> <p>FO 0501 F8 Data miscompare FO 0502 F8 Storage parity check</p>
Test 0 Routine 6	<p>Tests storage addressing (0E000 to 0F000). Reference codes are:</p> <p>FO 0601 F8 Data miscompare FO 0602 F8 MC/PC while reading</p>
Test 1 Routine 1	<p>Writes into and reads out of the second 64K storage card. To determine location if an error occurs:</p> <ol style="list-style-type: none"> Key in G and press ENTER. A reference code of FO 11xx F8 is displayed. Key in G and press ENTER. A reference code of FO 11yy F8 is displayed. <p>Where xx is the high-order storage address and yy is the low-order storage address. Reference codes are:</p> <p>F1 1101 F8 Data miscompare F1 1102 F8 Storage parity check</p>
Test 1 Routine 2	<p>Tests addressing in second 64K card. Reference codes are:</p> <p>F1 1201 F8 Data miscompare F1 1202 F8 Storage parity error</p>
Test 1 Routine 3	<p>Stores and executes instructions in X'10000' to X'1FFFF'. Reference codes are:</p> <p>F1 1301 F8 Sum incorrect F1 1302 F8 Machine check</p>
Test 1 Routine 4	<p>Tests SP storage in virtual mode. Reference codes are:</p> <p>F1 1401 F8 Data miscompare F1 1402 F8 Storage parity check</p>

Test	Description
Test 1 Routine 5	Tests level 0 DLAT and translation tables in virtual mode. Reference codes are: F1 1501 F8 MC/PC error on routine entry F1 1502 F8 MC/PC error during routine F1 1509 F8 Error before address X'09xxx' F1 150E F8 Error before address X'0Exxx' F1 1515 F8 Error before address X'15xxx' F1 1518 F8 Error before address X'18xxx'
Test 1 Routine 6	Tests instruction DLAT during level switching in virtual. Reference codes are: F1 16x0 F8 Wrong DLAT for level x. F1 16yz F8 Wrong level switch. y is present level; z is the desired level.
Test 2 Routine 1 and Routine 9	Tests SBA reset and checks basic status. Reference codes are: FD 2x01 F8 Basic status not reset FD 2x21 F8 MC/PC timeout on reset FD 2x22 F8 MC/PC parity error on reset FD 2x71 F8 MC/PC timeout on read status FD 2x72 F8 MC/PC parity error on read status x equals 1 for SBA 1 and x equals 9 for SBA 2.
Test 2 Routine 2 and Routine A	Tests commands to SBA of reset adapter, reset status, and set status. Reference codes are: FD 2x01 F8 Set status failed (even bits) FD 2x02 F8 Reset status failed (even bits) FD 2x03 F8 Set status failed (odd bits) FD 2x04 F8 Reset status failed (odd bits) FD 2x05 F8 Reset adapter failed (all bits) FD 2x41 F8 MC/PC timeout on reset status FD 2x42 F8 MC/PC parity error on reset status FD 2x61 F8 MC/PC timeout on set status FD 2x62 F8 Parity error on set status x equals 2 for SBA 1 and x equals A for SBA 2.

Test	Description
Test 2 Routine 3 and Routine B	Tests shift data and read data commands to the SBAs. Reference codes are: FD 2x01 F8 Data error on shift 5 FD 2x02 F8 Control error on shift 5 FD 2x03 F8 Failed PIRR to level 1 on data delay FD 2x04 F8 MC/PC on data delay FD 2x05 F8 False IORR FD 2x06 F8 PIRR to level 0 on data delay fails FD 2x1y F8 y=shift count (1-8), shift register error FD 2x81 F8 MC/PC timeout error FD 2x82 F8 MC/PC parity error FD 2x91 F8 MC/PC parity error FD 2x92 F8 MC/PC timeout error x equals 3 for SBA 1 and x equals B for SBA 2.
Test 2 Routine 4 and Routine C	Tests shift data with inverted parity to the SBAs. Reference codes are: FD 2x01 F8 Shift data bad FD 2x02 F8 Control register data bad FD 2xC1 F8 MC/PC timeout error FD 2xC2 F8 MC/PC timeout error x equals 4 for SBA 1 and x equals C for SBA 2.
Test 2 Routine 5 and Routine D	Tests shift data without parity command to the SBAs. Reference codes are: FD 2x01 F8 Shift data error FD 2x02 F8 Control register data bad FD 2xA1 F8 MC/PC timeout error FD 2xA2 F8 MC/PC parity error x equals 5 for SBA 1 and x equals D for SBA 2.
Test 2 Routine 6 and Routine E	Tests write control to the SBAs. Note: Reference codes FD 2802 F8 and FD 2E02 F8 are normal if routine is looped. Other reference codes are: FD 2x01 F8 Control error on data write FD 2x02 F8 Control register data error FD 2x03 F8 Status error after two control commands FD 2xE1 F8 MC/PC timeout error FD 2xE2 F8 MC/PC parity error x equals 6 for SBA 1 and x equals E for SBA 2.

4381
B/M 2676380

MI
Seq GE030

PN 6169399
2 of 3

EC A20558
01 Oct 84

Test	Description
Test 2 Routine 7 and Routine F	Tests SBA timer interrupt (level 1). Reference codes are: FD 2701 F8 Failed to set basic status bit 7 (SBA 1) FD 2702 F8 Failed to set IORR bit 1 FD 2703 F8 Failed to reset IORR bit 1 FD 2704 F8 Interrupt in 250 msec after reset FD 2705 F8 SBA interrupt with enable bit reset FD 27x0 F8 x equals IORR; interrupt not at level 1 FD 2F01 F8 Failed to set basic status bit 7 (SBA 2)
Test 3 Routines 1 to F and Test 4 Routines 1 to 5	Test LCA over the support processor bus. Note: Reference code F2 3144 F8 can occur if the PU is powered up or the LCA was enabled before. Reference codes are: F2 3144 F8 S/370 interface not disabled F2 3155 F8 S/370 interface bit disabled F2 3180 F8 A burst mode operation caused the LCA to hang F2 4F11 F8 LCA hang in level 0 F2 4F15 F8 LCA hang in level 0 F2 RRRR F8 See below for RRRR values.

Error Codes for Tests 3 and 4

F2 RRRR F8

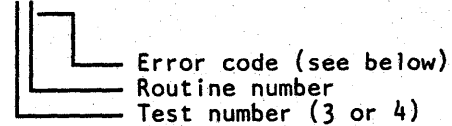

Error codes:

YY	Description
01	No I/O interrupt
02	Unexpected I/O interrupt
03	Set interrupt pending failed
04	No I/O interrupt
05	No expected machine check
06	MC/PC when not expected
07	SP write timeout
08	SP read timeout
09	SP read buffer overflow
10 to 1F	Command rejected (10 retries)
20 to 2C	Status not as expected
30 to 33	Command reject on I/O interrupt
40	I/O interrupt did not occur
55	LCA is disabled

Test	Description
Test 8 Routines 1 and 2	Tests basic PCA communication. Reference codes are: F6 81xx F8 F6 82xx F8 F6 828x F8 Sense card 1 failure F6 829x F8 Sense card 1 failure F6 82Ax F8 Sense card 2 failure F6 82Bx F8 Sense card 2 failure F6 82F1 F8 Timeout on read sense F6 82F2 F8 Support processor parity check
Diskette Loader Tracks 5 and 6	Load optional diagnostics, parity check upper 32K of storage. Reference codes are: Diskette Drive 1 F5 1B01 F8 Diskette drive 1 timeout F5 1B03 F8 Support processor check F5 1B0A F8 Diskette drive 1 not ready F5 1B0C F8 Bad status F5 1B12 F8 Data read error F5 1B15 F8 No error bypass F5 1B20 F8 Seek error F1 1C01 F8 Storage error F1 1C02 F8 Storage error on cycle steal F1 1C15 F8 No error bypass F5 1D01 F8 Timeout diskette drive 1 F5 1D0A F8 Diskette drive 1 not ready F5 1D0C F8 Wrong status F5 1D12 F8 CRC errors F5 1D15 F8 No error bypass Diskette Drive 2 F5 1B81 F8 Diskette drive 2 timeout F5 1B83 F8 Support processor check F5 1B8A F8 Diskette drive 2 not ready F5 1B8C F8 Bad status F5 1B92 F8 Data read error F5 1B95 F8 No error bypass F5 1BA0 F8 Seek error F5 1D15 F8 No error bypass F5 1D81 F8 Timeout diskette drive 2 F5 1D8A F8 Diskette drive 2 not ready F5 1D8C F8 Wrong status F5 1D92 F8 CRC errors



MSS Repair Action Screens

When an error is detected during the MSS Extended or Optional diagnostics, a Repair Action screen is displayed as a guide for the repair. The Repair Action screen lists suspected FRUs and gives a Repair Procedure reference to be used if the repair is not successful. The Repair Action screens are:

Reference Code	Option	Repair Action	Notes
F0xxxF8	FF	Reseat or exchange the following: 01AA2 H2 Support Processor	
F1xxxF8	FF	Reseat or exchange the following: 01AA2 J2 Support processor storage 01AA2 H2 Support processor	
F8xxxF8	CE	Reseat or exchange the following: 01AA2 Q2 DCA 01AA2 R2 DCA Note: F8Cx03F8 is a normal reference code if no device is attached to port x.	Cable goes to ports 0 through 3 on 01F gate
F5xx0AF8	AO	Go to "MSS Repair" on page MSS 001	Check diskette cover
F5xxxF8	AO	Go to "MSS Repair" on page MSS 001	
FDxxxF8	FF	Reseat or exchange the following: 01AA2 T2 SBA 1 01AA2 S2 SBA 2 01AA2 U2 Converter Note: FD2301F8 is a normal reference code if you did not power off before running MSS diagnostics.	
F2xxxF8	FF	Reseat or exchange the following: 01AA2 V2 LCA 01AA2 W2 LCA 01AA2 X2 LCA	
F6xxxF8	FF	Reseat or exchange the following: 01AA2 D2 PCA 01AA2 E2 PCA 01AA2 F2 PCA	Verify jumpers on D2 and E2
FExxxF8	DO	Reseat or exchange the following: 01AA2 P2 RSF 01AA2 Q4 RSF	

Running the Power Controller Adapter (PCA) Tests Manually

The diagnostics for the PCA are on the FUNC1 diskette and are run after the MSS diagnostics when the processor is IMLed. If a failure occurs, a reference code is displayed.

To run the PCA tests manually:

1. Set the I/O Power Hold switch to Normal.
2. Set the CE Mode switch to CE Mode.
3. Set the Power Off switch to Power Off.
4. Install FUNC1 in diskette drive 1.
5. Reset the Power Off switch to Normal, and press Power On.
6. When the Partial Power screen appears, move the cursor to the COMMAND field, key in QWP, and press ENTER. The PCA tests run.

Note: After running the PCA routines, the MSS must be powered off and powered on again before any MSS diagnostics are run because of the special reset used for the PCA.

PCA Diagnostic Reference Codes

Reference Code	FRUs	Description
F6 0101 FA to F6 0103 FA	01A A2F2	Latch modules cannot be reset.
F6 0201 FA to F6 0204 FA	01A A2F2,D2	Sense card 2 latch modules cannot be reset.
F6 0301 FA to F6 0313 FA	01A A2D2,E2,F2	Latch module, byte address, or data bits bad.
F6 0401 FA to F6 0410 FA	01A A2D2,F2	Sense card 2 address bad.
F6 0501 FA to F6 0504 FA	01A A2E2	Data bits for sense card 1 cannot be set.
F6 0601 FA	01A A2F2	Sense card 2 latch module data bits bad.
F6 0701 FA to F6 0704 FA	01A A2F2,E2,D2	Test sense bytes.
F6 0801 FA to F6 0808 FA	01A A2F2,E2,D2	Read digital sense bytes.
F6 0901 FA to F6 0908 FA	01A A2F2,E2,D2	Sense bytes not equal to FF.
F6 1101 FA to F6 1106 FA	01A A2D2,E2	DAC not within 25% of MSS reference voltage.
F6 1301 FA to F6 1305 FA	01A A2D2,E2	DAC do not compare equal.
F6 1401 FA	01A A2D2,E2,F2	Interrupt byte is bad.
F6 1601 FA to F6 1607 FA	01A A2D2,E2	Timeout circuit does not reset the control latches.
F6 1801 FA	01A A2F4	Serial number is wrong.

DIAG 069

THIS PAGE INTENTIONALLY LEFT BLANK

4381
B/M 2676380

MI Seq GE035	PN 6169400 3 of 4	EC A20558 01 Oct 84					
-----------------	----------------------	------------------------	--	--	--	--	--

DIAG 069

Optional MSS Diagnostics

Optional MSS diagnostics are on the DIAG1 diskette and give additional testing for:

- Service panel
- Diskette drives
- Device Cluster Adapter (DCA)
- Optional printers and displays
- RSF.

While the Optional MSS diagnostics are running, any errors detected are indicated by Repair Action screens that guide you in the repair of the problem.

Running Optional MSS Diagnostics

1. Set the CE Mode switch to Normal.
2. Set the I/O Power Hold switch to I/O Power Hold.
3. Set the Power Off switch to Power Off.
4. Install DIAG1 in diskette drive 1.
5. Reset the Power Off switch to Normal, and press Power On. Basic and Extended MSS diagnostics run after power up.
6. Key in the selected option from the MSS Optional Diagnostic Selection screen, and press ENTER.

For additional information on running the MSS Optional diagnostics, refer to the flowchart and notes on page DIAG 075.

Optional MSS Diagnostics Selection Screen

```

***** BASIC MSS DIAGNOSTICS COMPLETED *****
***** EXTENDED MSS DIAGNOSTICS COMPLETED *****

MAKE SELECTION, ENTER DESIRED OPTION:

OPTIONS
(F F) LOOP MSS BASIC AND EXTENDED DIAGNOSTICS
(90) RUN OPTIONAL SERVICE PANEL DIAGNOSTICS (9F=LOOP)
(A0) RUN OPTIONAL DDA/DRIVE TESTS (AF=LOOP)
(C E) TEST ALL CONSOLE/PRT PORTS (CF=LOOP)
(D0) RUN RSF ADAPTER DIAGNOSTICS (DF=LOOP)
(E0) RUN RSF CABLE WRAP TEST (EIA INTERFACE ONLY. EF=LOOP)
NOTE: CABLE WRAP PLUG MUST BE INSTALLED

THEN PRESS ENTER:

TO TERMINATE LOOPING, PRESS IML BUTTON.

```

4381
B/M 2676380

MI Seq GE035	PN 6169400 4 of 4	EC A20558 01 Oct 84				
-----------------	----------------------	------------------------	--	--	--	--

DIAG 075

See "Running Optional MSS Diagnostics".

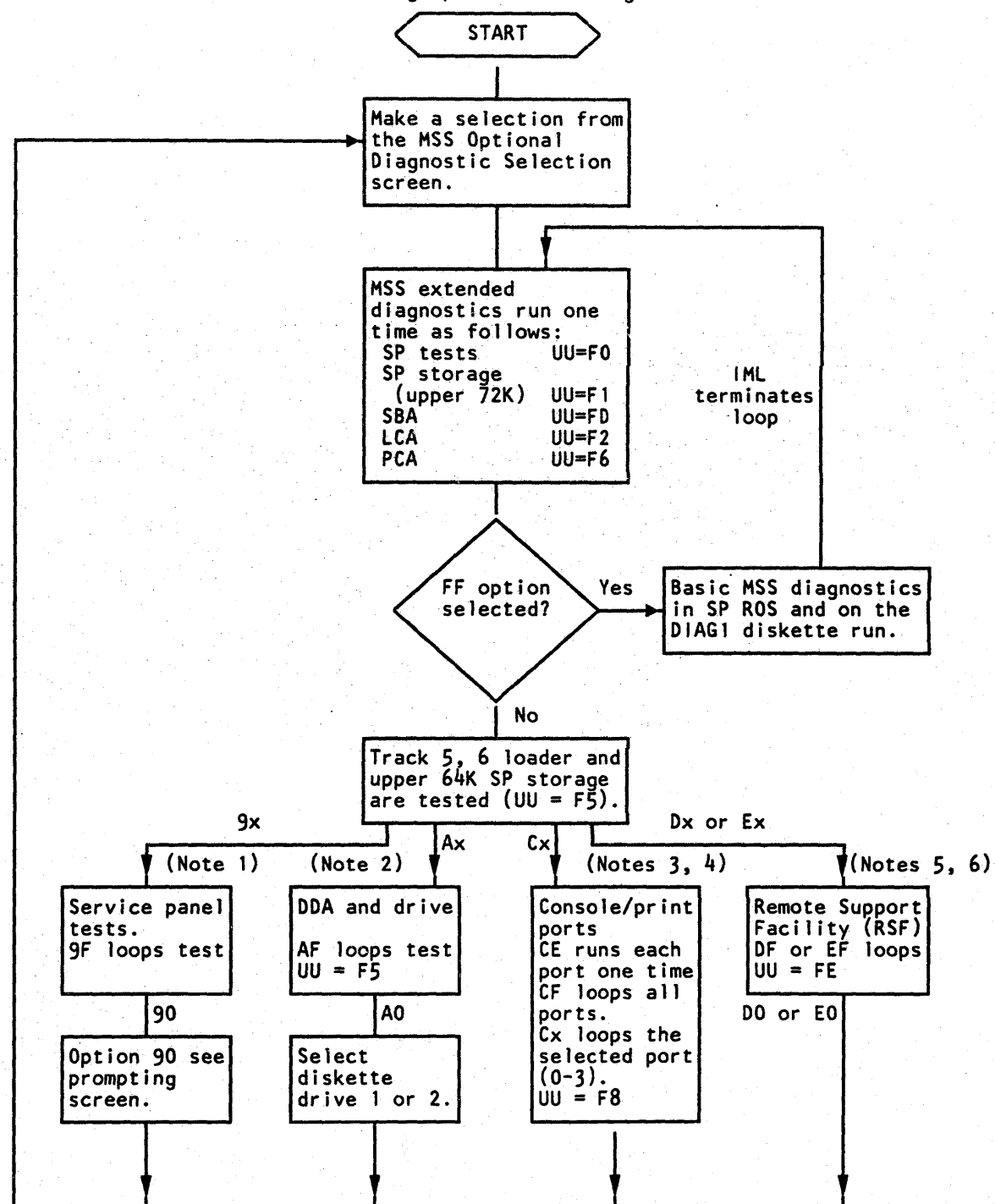

Notes:

1. When the service panel displays 80000, press and release Logic Reset. The service panel then displays the following:

80000	87777	EEEE
81111	88888	FFFF
82222	99999	F0123
83333	AAAAA	F4567
84444	BBBBB	F89AB
85555	CCCCC	FCDEF
86666	DDDDD	

The time between displays is two to four seconds. The test is complete when FCDEF is displayed. After displaying FCDEF, the service panel continues to display the current SP storage address.

2. Place the DIAG1 diskette in the diskette drive to be tested.

3. Options C0 - C3 loop the tests to the selected console (ports 0 - 3). Option CF loops all consoles. Option CE tests each console one time.

4. The reference code F8 Cx03 F8 is a normal stop if no device is attached to port ID=x or the device on port ID=x is not ready. To bypass this stop, key in G and press ENTER.

5. The D0 and DF options are for all RSF adapters. The E0 and EF options are only for the EIA interface and allow testing the cable to the external modem in wrap mode. Disconnect the EIA interface cable at the modem end, and install the wrap plug before selecting the Ex options.

6. Failures sensed by the EIA cable wrap test (Ex) are indicated by a reference code FE E0xx F8, where xx is the failing line as shown below:

FE E0EE F8 - Send or receive data (TD or RD) failure.
 FE E0FF F8 - CCA card failure.
 FE E0xx F8

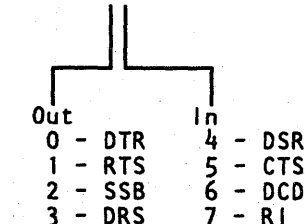

CTS Clear to send
 DCD Data carrier detect
 DRS Data rate select
 DSR Data set ready
 DTR Data terminal ready
 RI Ring indicator
 RTS Request to send
 SSB Select standby

For a wiring diagram of the EIA interface cable, see Volume A06, Service Aids, "EIA Adapter Configuration."

Optional MSS Diagnostics by UU Codes

UU Code	Area Tested	Test ID	Routine ID
F5	Diskette Drive Adapter	A	1 and 2
		B	1,6,B to E
F8	Display Console Adapter	C	1 to 3
FE	Remote Support Facility	D	1 to E
		E	1 to 5

Example of Reference Code from MSS Optional Diagnostics

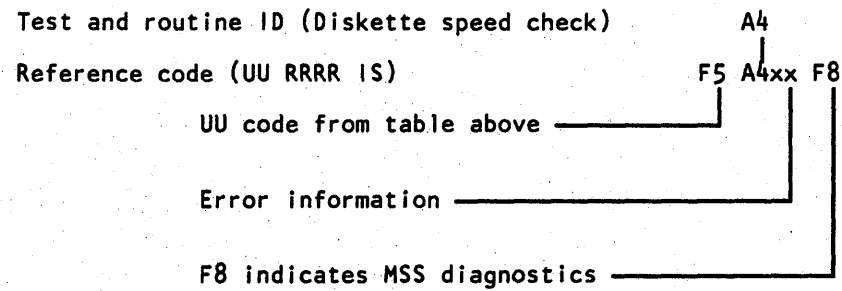

MSS Optional Diagnostics by Test ID

Diskette Tests (Option A0)

Tests A and B run on the diskette drive you select. For the error code (xx) values, see "Test A and B Error Codes" on page DIAG 085.

Test	Description	UU RRRR
Test A/B Routine 1	Verifies diskette adapter interrupts.	F5 B1xx
Test A Routine 2	Tests pointers and access lines.	F5 A2xx
Test A Routine 3	Verifies that CCA can detect wrong commands.	F5 A3xx
Test A Routine 4	Checks diskette speed.	F5 A4xx
Test A Routine 5	Checks that diskette head engages/disengages.	F5 A5xx
Test A/B Routine 6	Routine A selects head 0; routine B selects head 1. Checks cylinders 0-75 can be read. Verifies with read ID.	F5 A/B6xx
Test A/B Routine B	Routine A selects head 0; routine B selects head 1. Writes 256 bytes of X'FF' on cylinder 75, record 4.	F5 A/BBxx
Test A/B Routine C	Routine A selects head 0; routine B selects head 1. Writes 256 bytes of X'A50F' on cylinder 74, record 4.	F5 A/BCxx
Test A/B Routine D	Routine A selects head 0; routine B selects head 1. Writes 256 bytes of data on cylinder 8, record 1 and on cylinder 74, record 1 - then compares the data.	F5 A/BDxx
Test A/B Routine E	Routine A selects head 0; routine B selects head 1. Verifies busy and no record found can be detected.	F5 A/BExx

Test A and B Error Codes

- 00 Diskette adapter hang
- 01 MC/PC during cycle steal
- 02 MC/PC from storage
- 03 MC/PC from DDA
- 04 Write A buffer odd parity failed
- 05 Read A buffer odd parity failed
- 06 Read A buffer even parity failed
- 07 Write B buffer odd parity failed
- 08 Read B buffer odd parity failed
- 09 Read B buffer even parity failed
- 0C Diskette error check
- 0F Not valid command was not detected
- 11 Head not engaged
- 12 CRC error
- 13 Command reject
- 14 Hardware failed
- 15 Read control record failed
- 16 Busy
- 17 Busy not detected
- 18 Timeout
- 19 Record not found
- 1A Drive not ready
- 1B Wrong status
- 25 Error bypass not permitted
- 27 Head lifted too soon
- 28 Head lifted too late
- 29 Wrong head selected
- 38 MC/PC from I/O operation
- 39 Wrong level interrupt
- 3A More than 1 interrupt level
- 43 Record format wrong
- 44 Format data wrong
- 47 Head not engaged
- 51 Cylinder 0 ID or CRC error
- 53 Write format error
- 54 Record 3 not found
- 55 Wrong status on read
- 56 Diskette too fast
- 57 Diskette too slow
- 59 Write/read miscompare
- 5B Cylinder 74 or 75 not found
- 5C Cylinder 75 not found
- 5D Cylinder 8 not found
- 5E Flagged track
- 60 Wrong cylinder
- 61 Record not found failed to set
- 62 Interrupted with interrupt disabled
- 66 SP bus error
- 67 Level 5 interrupt from level 7 failed
- 80 Status register not reset
- 81 Status register not set
- 82 Channel pointer not reset
- 83 Read/write channel pointer failed
- 84 Extended status not reset

- 85 Load record count failed
- 86 Diagnostic request did not reset
- 87 Set control register failed
- 88 Read/write access failed
- Dx No interrupt received (x=diagnostic sense)

DCA Adapter Tests (Options C0-C3, CE, or CF)

For the values of the error codes (xx) in the diagnostic reference codes, see "Test C Error Codes." Test CE runs tests C0-C3 one time. Test CF loops tests C0-C3.

Test	Description	UU RRRR
Test C Routine 0	Tests console on port 0.	F8 C0xx
Test C Routine 1	Tests console or printer on port 1.	F8 C1xx
Test C Routine 2	Tests console or printer on port 2.	F8 C2xx
Test C Routine 3	Tests console or printer on port 3.	F8 C3xx

Test C Error Codes

- 01 DCA port failed
- 02 DCA port failed
- 03 No power on response
- 04 to 1C Device or DCA failure

Note: F8 Cx03 F8 is a normal stop if no device is attached to port x.

CCA Tests (Options D0 and E0)

Test	Description	UU RRRR
Test D Routine 1	Verifies CCA (RSF) commands. Reference codes are: FE D101 F8 Timeout FE D102 F8 Parity error FE D103 F8 Modem bits wrong	FE D1xx
Test D Routine 2	Verifies not valid CCA commands set errors. FE D201 F8 Timeout FE D202 F8 MC/PC not set by invalid command FE D203 F8 Cannot reset MC/PC bits	FE D2xx
Test D Routine 3	Verifies CCA control register reset and read. FE D301 F8 Control register wrong after reset FE D302 F8 Wrong data pattern in control register FE D303 F8 Wrong data pattern in control register FE D304 F8 Wrong control register reset FE D305 F8 Wrong control register reset	FE D3xx
Test D Routine 4	Verifies modem control register reset and read commands. FE D401 F8 Wrong modem control register reset/read FE D402 F8 Wrong modem control register write/read FE D403 F8 Write/read test data failure FE D404 F8 Load/test control register failure	FE D4xx
Test D Routine 5	Verifies modem status register (bits 2, 3, and 6 are not tested). FE D501 F8 Failed to set modem interrupt FE D502 F8 No DSR transition interrupt FE D503 F8 Failed to reset modem interrupt FE D504 F8 No modem interrupt on CTS transition FE D505 F8 Wrong modem status on CTS transition FE D506 F8 Failed to reset transition indicators FE D507 F8 No modem interrupt on CTS transition FE D508 F8 Failed to set CTS transition indicator FE D509 F8 Failed to reset modem interrupt FE D50A F8 Failed to set DSR transition FE D50B F8 Wrong status after set send command	FE D5xx

Test	Description	UU RRRR
Test D Routine 6	Verifies correct interval and reset of TI in basic status. FE D601 F8 Early timer interrupt, high byte FE D602 F8 No timer interrupt, high byte FE D603 F8 Failed to reset timer interrupt FE D604 F8 Early timer interrupt, low byte FE D605 F8 No timer interrupt, low byte FE D606 F8 Failed to reset timer interrupt	FE D6xx
Test D Routine 7	Verifies operation of timer controls. FE D701 F8 No timer interrupt, set to X'FF01' FE D702 F8 Wrong timer interrupt, set to X'0100' FE D703 F8 No interrupt, high byte set to X'80'	FE D7xx
Test D Routine 8	Check set/reset of enable/disable bit. FE D801 F8 Failed to set enable FE D802 F8 Failed to reset enable	FE D8xx
Test D Routine 9	Check set/reset of output request, input request, and adapter in sync bits. FE D901 F8 Adapter not in sync after transmit FE D902 F8 Adapter control register wrong FE D903 F8 Input request on after transmit FE D904 F8 Adapter not in sync after transmit FE D9Fx F8 (x equals 1 through 5) Timeout waiting for output request FE D9F6 F8 Adapter not in sync after transmit FE D9F7 F8 Unexpected status in transmit	FE D9xx
Test D Routine A	Check that input request is stopped if receive mode is off. FE DA01 F8 Adapter in sync not on FE DA02 F8 Adapter control register wrong FE DA03 F8 Input request not on FE DAFx F8 (x equals 1 through 5) Timeout on output request FE DAF6 F8 Adapter not in sync after transmit	FE DAxx

Test	Description	UU RRRR
Test D Routine B	Check that SDLC frame bit sets and resets FE DB01 F8 More than exception bit in status FE DB02 F8 Adapter in sync and SDLC frame not on FE DB03 F8 Control register wrong after pad transmit FE DB04 F8 Except interrupt pending not set FE DB05 F8 SDLC frame bit not set FE DB06 F8 SDLC frame bit not reset FE DBFx F8 (x equals 1 through 5) Timeout during output request FE DBF6 F8 Adapter not in sync after transmit FE DBF7 F8 Unexpected status during transmit	FE DBxx
Test D Routine C	Check that test underrun bits set and reset. FE DCB01 F8 Failed to set underrun bit FE DCB02 F8 Failed to reset underrun bit FE DCBF7 F8 Unexpected status during transmit	FE DCBx
Test D Routine D	Check that test overrun bits set and reset. FE DD01 F8 Failed to set overrun bit FE DD02 F8 Failed to reset overrun bit FE DDFx F8 (x equals 1 through 5) Timeout waiting for output request FE DDF6 F8 Adapter not in sync after transmit	FE DDxx
Test D Routine E	Check that SDLC invalid sequence bits set and reset. FE DE01 F8 Invalid sequence with no exception bit FE DE02 F8 SDLC frame bit not on FE DE03 F8 SDLC invalid sequence not set FE DE04 F8 SDLC invalid sequence not reset FE DEFx F8 (x equals 1 through 5) Timeout on output request FE DEF6 F8 Adapter not in sync after transmit	FE DExx
Test E Routine 0	Check external cable wrap (for EIA interface only). FE E0EE F8 No transmit or receive data connection FE E0FF F8 CCA card failure FE E0xy F8 Wrap in/out does not match. For x and y values, see "Test E Routine 0 Error Codes."	

Test E Routine 0 Error Codes

FE E0xy F8

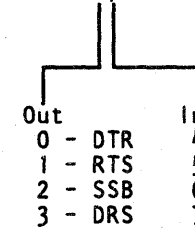

- CTS Clear to send
- DCD Data carrier detect
- DRS Data rate select
- DSR Data set ready
- DTR Data terminal ready
- RI Ring indicator
- RTS Request to send
- SSB Select standby

Test	Description	UU RRRR
Test E Routine 1	Check 15 ones recognition using SDLC. FE E101 F8 SDLC invalid sequence bit not on FE E102 F8 SDLC invalid sequence bit not reset FE E1F7 F8 Unexpected status during test	FE E1xx
Test E Routine 2	Check repeated frame insertion. FE E201 F8 Timeout waiting for output request reset FE E202 F8 No adapter in sync or frame bits FE E2F1 F8 Unexpected status error during test	FE E2xx
Test E Routines 3 and 4	Check DDA and modem data paths in wrap mode. Routine 3 is CCA wrap, routine 4 is modem wrap. (x equals 3 or 4 in the following.) FE Ex01 F8 Timer interrupt before CTS FE Ex02 F8 Timer interrupt after CTS FE Ex03 F8 All data transmitted; stop receiving FE Ex04 F8 Modem status error FE Ex05 F8 Overrun/underrun FE Ex06 F8 Output request with transmit off FE Ex07 F8 Input request; no data transmitted FE Ex08 F8 Input request; last data already received FE Ex09 F8 Received data does not equal expected data FE Ex0A F8 Input request before flag in SDLC FE Ex0B F8 Basic status invalid FE Ex0C F8 Invalid exception FE Ex0D F8 SDLC frame on; adapter not in SDLC FE Ex0E F8 Data decoded as SDLC flag FE Ex0F F8 Adapter status error FE ExFF F8 Timeout on adapter interrupt FE E3FE F8 Wrong level interrupt in SP IORR FE E4FA F8 Modem wrap with DSR off	FE ExFx
Test E Routine 5	Check if SP check is on from any preceding RSF test. FE E5xx F8 SP check (xx equals SP check register).	FE E5xx

Diskette Analysis

The Diskette Analysis test is on the FUNC1 diskette. It can be used to check any of the functional or diagnostic diskettes for unreadable records.

To run the test:

1. With the FUNC1 diskette in diskette drive 1, key in QED and press ENTER.
2. Note that a starting cylinder number (00), starting record number (01), and drive number (2) are given. Either use these default values or specify your own values for cylinder, record, and drive number.
3. Insert the diskette to be analyzed (into the diskette drive selected above).
4. Press ENTER to start the diskette analysis.

To continue the analysis if error information fills the screen, press ENTER. To cancel the analysis, press CNCL.

For an example of diskette errors, see "Diskette Analysis Test Error Display Screen." If there are more errors than one screen can display, press ENTER to display the additional error screens. For a definition of the diskette drive status bits, see "Diskette Drive Status Bits."

Diskette Drive Status Bits

Bits	Values	Meaning
0-1:	00	Good ending
	01	CRC Error
	10	Command Error
	11	Hardware Error
2-4:	000	Operation Complete
	001	Control Complete
	011	Busy
	100	Overrun/Underrun
	101	Timeout
	110	Record not found
	111	Diskette not ready
5:	1	SP Check
6:	1	Adapter enable
7:	1	Interrupt pending

Diskette Analysis Test Selection and Error Display Screens

```

*ERROR DISPLAYS*           *DISKETTE ANALYSIS*

      TO START: 1) SELECT STARTING CYLINDER AND RECORD NUMBER
                  (DEFAULT IS RECORD 1 ON CYLINDER 0).
                2) SELECT DISK DRIVE FOR ANALYSIS (DEFAULT IS DRIVE 2).
                3) INSERT DISK TO BE ANALYZED INTO SELECTED DRIVE.
                4) PRESS THE ENTER KEY.

      00 STARTING CYLINDER NUMBER (00 - 4C)
      01 STARTING RECORD NUMBER (01 - 1A BACK-HEAD)
                  (81 - 9A FRONT-HEAD)
      2 TARGET DRIVE FOR ANALYSIS (1 - 2)

      TO EXIT:  1) MAKE SURE ORIGINAL DISKETTES ARE INSTALLED.
                2) SELECT ANY SCREEN.

      NOTE: ALL NUMBERS IN HEX

Q GENERAL SELECTION
Z RETURN TO PROG SYS
COMMAND: QED                      ==>
    
```

```

*ERROR DISPLAYS*           *DISKETTE ANALYSIS*

      LINE CYLINDER HEAD   RECORD MODULE  DEVICE
      NUMB  NUMBER   FRONT  NUMBER  ID    STATUS
        0    09    FRONT    83    4351  42
        1    23    BACK    01    FFFF  42

      PARAMETERS ARE
      GIVEN IN HEX

      IF SCREEN IS FULL AND ANALYSIS IS NOT COMPLETE: PRESS ENTER
      TO CANCEL ANALYSIS: INSTALL ORIGINAL DISKETTES, PRESS CNCL KEY
      IF ANALYSIS IS COMPLETE: INSTALL ORIGINAL DISKETTES, SELECT ANY SCREEN

COMMAND: QED                      ==>
    
```

4381	MI	PN 6169403	EC A20558				
B/M 2676380	Seq GE050	2 of 2	01 Oct 84				

PROCESSING UNIT DIAGNOSTICS

DIAG 105

The two types of processing unit diagnostics available for isolation of errors and verification of repairs are:

- Basics
- Machine Speed Microdiagnostics (MSMDs).

For a description of processing unit Basic diagnostics, see page DIAG 110. For a description of Machine Speed Microdiagnostics (MSMDs), see page DIAG 115.

Test Case Monitor (TCM)

The TCM is on the FUNC1 diskette. It is loaded into SP storage when any of the processing unit diagnostics are requested.

The TCM loads either Basic diagnostics into SP control storage or MSMDs into processing unit control storage. The TCM controls the execution of the Basic diagnostics.

During the processing unit Basic diagnostics and the MSMDs, the TCM controls communication between the diagnostics and the system console.

MSMD Monitor

The MSMD Monitor is on the FUNC2 diskette and is loaded by the TCM into processing unit control storage when MSMDs are to be run.

When MSMDs are running, communication to the system console is: diagnostic to MSMD Monitor to TCM to the console.

Diagnostic Mode Test Case Monitor Screen

In Field Support Center mode, the Diagnostic Mode Test Case Monitor screen is displayed whenever PU diagnostics are running. It displays prompting and error information. For an explanation of the error and prompting messages given on the Test Case Monitor screen, see "Test Case Monitor Messages" on page DIAG 200.

While PU basic diagnostics are running, the test ID is displayed in the lower left-hand corner of the Diagnostic Mode Test Case Monitor screen. For a description of processing unit basic test IDs, see "Basic Diagnostic Organization" on page DIAG 110.

DIAG 105

Basic Diagnostics

The Basic diagnostics are located on the FUNC2 and the DIAG1 diskettes. They run in SP control storage under control of the Test Case Monitor.

The Basic diagnostics test the processing unit through the support bus adapter. If errors are detected by the diagnostics, a reference code, a FRU list, and Repair Procedure references are displayed. For a description of reference codes, see "MSS, Power, and Reference Codes" on page DIAG 015.

Some of the Basic diagnostics are used to ensure that the processing unit is capable of running MSMDs. These diagnostics are on FUNC2. The other Basic diagnostics test areas that the MSMDs cannot test. These diagnostics are on the DIAG1 diskette.

For information on running processing unit Basic diagnostics, see "How to Run Processing Unit Diagnostics" on page DIAG 120.

Basic Diagnostic Test IDs

Basic diagnostic IDs are six characters long starting with a D and ending in M3.

Example:

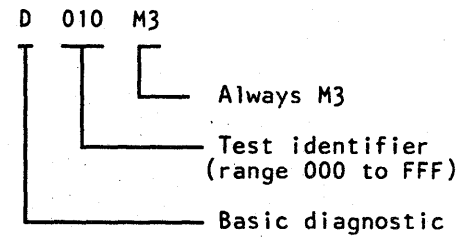

Basic diagnostic IDs are displayed in the lower left corner of the Test Case Monitor screen while the corresponding diagnostic is running and appear in the RRRR field of a diagnostic reference code when an error is detected by the Basic diagnostics.

Example of a Basic Diagnostic Test ID and Reference Code

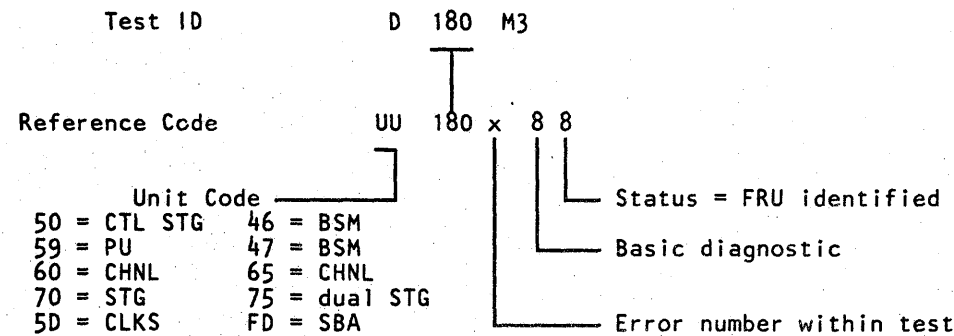

Basic Diagnostic Organization

Diskette	Test IDs	Area Tested
FUNC2	D001 to D049	Scan Rings
	D050 to D099	Clock maintenance commands
	D100 to D199	Clock basics
	D200 to D299	PU, control storage maintenance commands
	D300 to D399	PU
	D400 to D499	Control storage
	D500 to D599	Channels
DIAG1	D600 to D7FF	Storage controller, dual processor controls
	D801 to D849	Scan Rings
	D850 to D899	Clock maintenance commands
	D900 to D999	Clock Basics
	DA00 to DA99	PU, Control storage maintenance commands
	DB00 to DB99	PU
	DC00 to DC99	Control storage
	DD00 to DD99	Channels
	DE00 to DEFF	Storage controller

Machine Speed Microdiagnostics (MSMDs)

MSMDs are the main tool for isolating hardware failures and verifying repairs in the processing units. They run in processing unit control storage at machine speed. If an error is detected by the MSMDs, a reference code, FRU list, and Repair Procedure page reference are displayed.

For MSMD storage loads 1 through 5, the TCM loads a single storage load from FUNC2 into PU0 and PU1 control storage. The storage loads are run first in PU0 then in PU1.

For MSMD storage load 6, the TCM loads the storage load from FUNC2 into PU0 and PU1 control storage. The storage load is then started in both processing units to test dual processor controls. In control storage, the MSMDs run under the control of the MSMD Monitor. Console messages are passed from the MSMD Monitor to the TCM.

See "How to Run Processing Unit Diagnostics" on page DIAG 120.

MSMD Test IDs

MSMD test IDs are eight characters long starting with a Z and include the MSMD section ID and the UU and RRRR fields of the reference code that is displayed if a failure is detected.

Example:

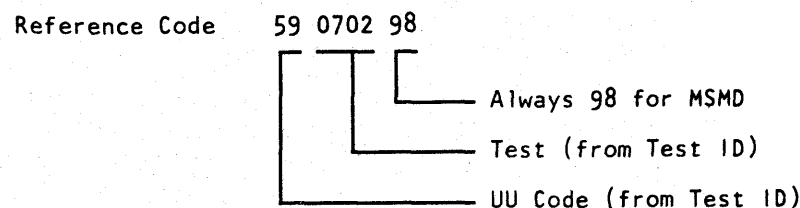
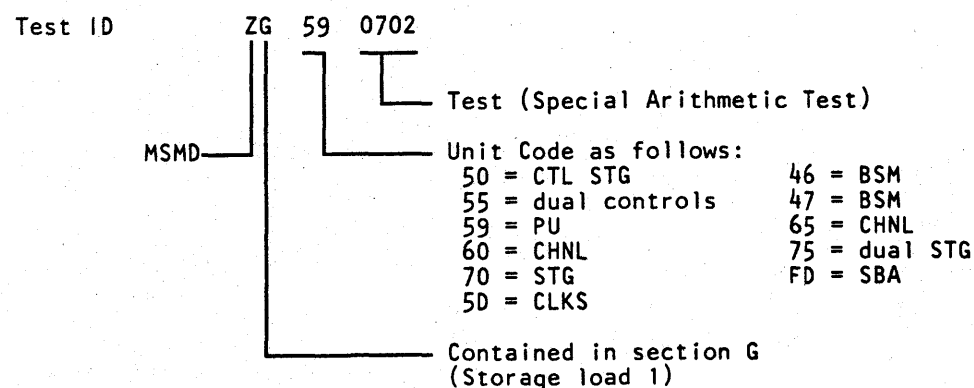

MSMD Test Organization

The first six MSMD storage loads are on the FUNC2 diskette and storage load seven is on the DIAG1 diskette. Each storage load contains one or more sections and each section contains several tests.

Storage Load	Section	Section Name	Areas Tested	First Test ID of Load
1	A	ZADATA00	PU data flow 1	ZA590101
	B	ZBDATA00	PU data flow 2	
	C	ZCBRAN00	Branching	
	D	ZDSHFT00	Shifter	
	E	ZESHFT00	Spare	
	F	ZFINTM00	Interrupt/timers	
	G	ZGIPUA00	Special arithmetic/multiplier	
2	H	ZHSTGC00	SARs, retry, cache, and keys	ZH590801
	I	ZISTGC00	ACB Traps, DLAT	
	J	ZJSTGC00	Address facilities	
3	K	ZKBSMT00	Main storage	ZK401101
	L	ZLBSMT00	Main storage	
	M	ZMBSMT00	Spare	
	N	ZNPAGE00	Swap buffer in page/out page	
4	O	ZOCHAN00	Externals, sequence counts, traps	ZO621501
	P	ZPCHAN00	Channel SARs	
	Q	ZQCHAN00	Data buffer, store, and data mode	
	R	ZRCHAN00	LCA	
	S	ZSCHAN00	High speed data	
5	T	ZTICY00	I-cycles	ZT592001
	U	ZUTRA00	Traps	
	V	ZVRTRY00	Retry	
6		ZXDSP000	Dual processor controls	ZX522401
		ZYDSP000	Dual processor controls	
7	W	ZWCMDE00	Channel interface	ZW652301

How to Run Processing Unit Diagnostics

1. Ensure the FUNC1 diskette is installed in diskette drive 1.
2. Set the CE Mode switch to CE Mode.
3. Key in QG and press ENTER. The Diagnostic Mode PU Diagnostic Selection screen displays.
4. Key in one of the following options:
 - I to isolate a failure before exchanging FRUs
 - V to verify a repair after exchanging FRUs
 - C to run special channel diagnostics
 - T to run diagnostics after installation
 - F to run diagnostics in field support center mode.
 - R to return to the General Selection screen (Q).
5. Press ENTER.
6. Follow the prompting messages on the screen.

After running diagnostics, select option R on the Diagnostic Mode PU Diagnostic Selection screen. Diagnostic mode is ended and the General Selection screen (Q) is displayed. To return to normal operation:

1. Install FUNC1 in diskette drive 1 and FUNC2 in diskette drive 2.
2. Set the CE Mode switch to Normal.
3. Key in QL and press ENTER. The Program Load screen displays.
4. If the Program Load Screen displays IML COMPLETE, the processor is ready to continue normal operation. If IML REQUIRED displays, continue with the next step.
5. Press Power On/IML.
6. When the General Selection screen displays, key in QLM and press ENTER. This IMLs the processing unit.
7. When IML COMPLETE displays, the processor is ready to continue normal operation.

Operating Tips

1. Both PUs are required for diagnostics. You cannot run diagnostics on one of the PUs while customer jobs run on the other PU.
2. When the processing unit Basic diagnostics are running, the test ID of the test running is displayed in the left-hand corner of the Test Case Monitor screen.
3. If you want to interrupt a diagnostic run, hold down the ALT key while pressing MODE SEL. This cancels the run, and displays the Diagnostic Mode PU Diagnostic Selection screen.

Note: Do not interrupt a diagnostic run if the message VERIFY HAS CLEANUP DO NOT INTERRUPT is displayed.
4. When the diagnostic run is complete or has ended because of an error, the Diagnostic Mode PU Diagnostic Selection screen is displayed if you press ENTER.
5. Before running the processing unit diagnostics, set the system control options on the following screens to normal:

Compare (QA Screen)
Operation Rate (QO Screen)

For an explanation of setting the system control options, see Volume A08, "Console Functions."

DIAGNOSTIC MODE
PU DIAGNOSTIC SELECTION SCREEN
EC xxxxxx

I - RUN DIAGNOSTICS TO ISOLATE FAILURE BEFORE EXCHANGING FRUS
V - RUN DIAGNOSTICS TO VERIFY REPAIR AFTER EXCHANGING FRUS
C - RUN SPECIAL CHANNEL INTERFACE DIAGNOSTICS
T - RUN DIAGNOSTICS FOR INSTALLATION TEST
F - RUN DIAGNOSTICS IN FIELD SUPPORT CENTER MODE

R - RETURN TO GENERAL SELECTION SCREEN

COMMAND: =====>
OPTIONS IN EFFECT:

4381	MI	PN 6169405	EC A20558				
B/M 2676380	Seq GE060	2 of 2	01 Oct 84				

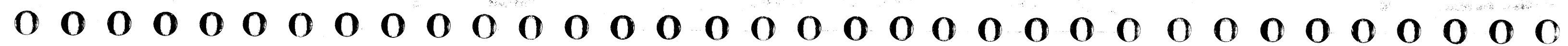

Option I - Isolation Mode

When you select this option, you are prompted to enter the reference code of the failure you are working on. The system error logs are checked for the reference code you entered. You have the option of changing your entry if it is not found; then you are asked if the processor is available for testing. Answer by keying in Y or N and pressing ENTER. If the processor is not available at this time, the FRU list generated by ELA at the time of failure is displayed. If the processor is available for testing, the failing PU is determined from the reference code you entered and a group of diagnostics is selected and run to isolate the failure. The following sequence is used to run the tests until an error occurs:

- Basic diagnostics D001 to D7FF (FUNC2 diskette)
- MSMD storage loads 1 through 6.
- Basic diagnostics D800 to DFFF (DIAG1 diskette)

Note: Not all the diagnostics are run every time. Tests are selected based on the reference code you entered.

If the diagnostics do not detect an error, the FRU list that was generated by ELA at the time of failure is displayed. If an error is detected, you are given a combined FRU list for the reference code you entered and the the diagnostic reference code. The priority of the FRUs on the FRU list is:

1. FRUs on *both* ELA and diagnostic FRU lists
2. FRUs on the diagnostic FRU list only
3. FRUs on the ELA FRU list only.

```

DIAGNOSTIC MODE
PU DIAGNOSTICS ISOLATE FAILURE OPTION
EC xxxxxx

KEY IN THE SYSTEM REFERENCE CODE AND PRESS ENTER
IF NONE IS AVAILABLE, ENTER "NONE".

COMMAND:          =====>
OPTIONS IN EFFECT: I

```

Option V - Verification Mode

When you select this option, a group of diagnostics is selected and run to verify the repair of a processing unit failure.

After you select Option V, you are requested to enter either the Problem Analysis number (PAxx) or the reference code for the failure you are working on. If neither is available, enter NONE.

Example: If this option is used to test an engineering change, enter NONE.

After your PA number or reference code is correctly entered, the Diagnostic Mode PU Diagnostics Verify Repair Option screen is displayed and you are then requested to place an x next to the FRU(s) you exchanged. If no FRUs were exchanged, press ENTER. Example: If a card was swapped or a cable reseated, press ENTER.

The reconfiguration data is then reset to primary hardware for the FRU you replaced (if the FRU has backup hardware) and diagnostics start running in the following sequence:

- Failing test (if original symptom was a PU basic failure)
- Basic diagnostics D001 to D7FF (FUNC2 diskette)
- MSMD storage loads 1 to 6
- Basic diagnostics D800 to DFFF (DIAG1 diskette).

If errors occur during the verification test, you are directed back to the Repair Procedures. If no errors occur, you are directed to the End Repair Procedure.

Notes:

1. Do not interrupt a verification run if the message: VERIFY HAS CLEANUP DO NOT INTERRUPT is displayed. Interrupting the test can leave the wrong processor reconfiguration data and cause degraded performance.
2. If the test is accidentally interrupted:
 - Reselect the verification mode option.
 - Enter the reference code you were working with or NONE.
 - Enter the FRUs exchanged when prompted.
 - Follow the instructions on the screen.

Verify Repair Option Screens

```

DIAGNOSTIC MODE
PU DIAGNOSTICS VERIFY REPAIR OPTION
EC xxxxxx

KEY IN THE PROBLEM ANALYSIS CODE (PAxx) AND PRESS ENTER
IF NONE IS AVAILABLE, ENTER "NONE".

COMMAND:          =====>
OPTIONS IN EFFECT: V
    
```

```

DIAGNOSTIC MODE
PU DIAGNOSTICS VERIFY REPAIR OPTION
EC xxxxxx

01B-A1 BOARD (C1)
E F G H J K   P Q R S T U
2
4 -----

A2 BOARD      A3 BOARD
S T V W X     E F G H J K L   N P Q R S T U
2
4 -----      2
4 -----      X

A4 BOARD
A B C D E F G H J K L M N P Q R S T U V W
2
4 -----

B1 BOARD
RA MA HA DA
RE ME HE DE
RJ MJ HJ DJ
VN RN HN DN
RS MS HS DS

B2 BOARD
RA MA HA DA
RE ME HE DE
RJ MJ HJ DJ
VN RN HN DN
RS MS HS DS

COMMAND:          ==> TYPE "x" IN INPUT FIELD(S) ASSOCIATED WITH
OPTIONS IN EFFECT:   FRU(S) JUST EXCHANGED, THEN PRESS ENTER
    
```

4381	MI	PN 6169406	EC A20558			
B/M 2676380	Seq GE065	2 of 2	01 Oct 84			

**Option C - Channel Interface
Diagnostics**

The channel interface diagnostics are in storage load 7. They include:

- **Mark In Test**—Detects a reset failure of the Mark In bit on the channel interface.
- **Channel Microcoded Device Exerciser (CMDE)**—Used to diagnose channel or I/O device problems. (See page DIAG 140.)
- **Cable Wrap Test (CWT)**—Used to isolate channel interface adapter driver and receiver and channel cable problems. (See page DIAG 150.)

How to Run Channel Interface Tests

1. Set the CE Mode switch to CE Mode.
2. Ensure FUNC1 is installed in diskette drive 1.
3. Install DIAG1 in diskette drive 2.
4. Key in QG, and press ENTER. The Diagnostic Mode PU Diagnostic Selection screen displays.
5. Key in C, and press ENTER. The first Channel Interface Diagnostic Option screen displays.
6. Key in one of the following:
 - 0 to test a channel attached to PU0.
 - 1 to test a channel attached to PU1.
7. Press ENTER, the second Channel Interface Diagnostic Option screen displays.
8. Make one of the following selections:
 - 01 Selects CMDE
 - 02 Selects CWT and the Mark In test
 - E Ends the channel interface tests.

When you select one of the tests, detailed run instructions and test options are displayed to aid you in running the test.

Mark In Test

Checks for a failure to reset an active (up) level of the Mark In interface line by wrapping Mark Out to Mark In. [For tailgate pin locations, see "Bus Wrap Terminator (Part 8483772) Wiring."]

Notes:

1. The Mark In test runs automatically after the Channel Wrap test.
2. The wrap terminators must be installed on the channel being tested when running the Mark In test.
3. An open condition of the Mark In line is reported as ground.

For details on selecting CWT and the Mark In test, see "How to Run Channel Interface Tests." After the tests are selected, detailed run instructions are displayed on the screen.

Example of Mark In Test Error Screen

```

MARK-IN TEST

ERROR DETECTED

CHANNEL 04
MARK IN IS STUCK AT GROUND

==> PRESS ENTER TO RTN TO OPTION SCREEN <==
```

Channel Microcoded Device Exerciser (CMDE) - Normal Mode

Use the CMDE to diagnose channel or I/O device problems. If this test does not detect any errors, run System Test/4381 or System Test/4381XA to isolate the problem.

For details on how to select CMDE, see "How to Run Channel Interface Tests" on page DIAG 135. After CMDE is selected, detailed run instructions are displayed on the screen.

Normally, you will run the CMDE only under the direction of the Repair Procedures. For the operation of CMDE in this mode, see the flowchart on this page. To use CMDE this way, key in the channel address (00 to 08) when prompted by the screen. CMDE sends a Test I/O, Start I/O, and Sense sequence to each device address on the channel until a response is received. When a device responds, CMDE requests that you ready the device you want to test and enter the address of that device (for example, 0E). CMDE then sends the Test I/O, Start I/O, and Sense sequence to that device and shows if a good response is received.

Note: CMDE tests the address range of 00 through EF for PU0 and the address range of 00 through FF for PU1. The address range F0 through FF is reserved for LCA on PU0.

If no response is received from any device on the channel in the first Test I/O, Start I/O, and Sense sequence, you are then prompted to ready a device on the channel and enter its address. CMDE then sends the Test I/O, Start I/O, and Sense sequence to that device and shows if a good response is received.

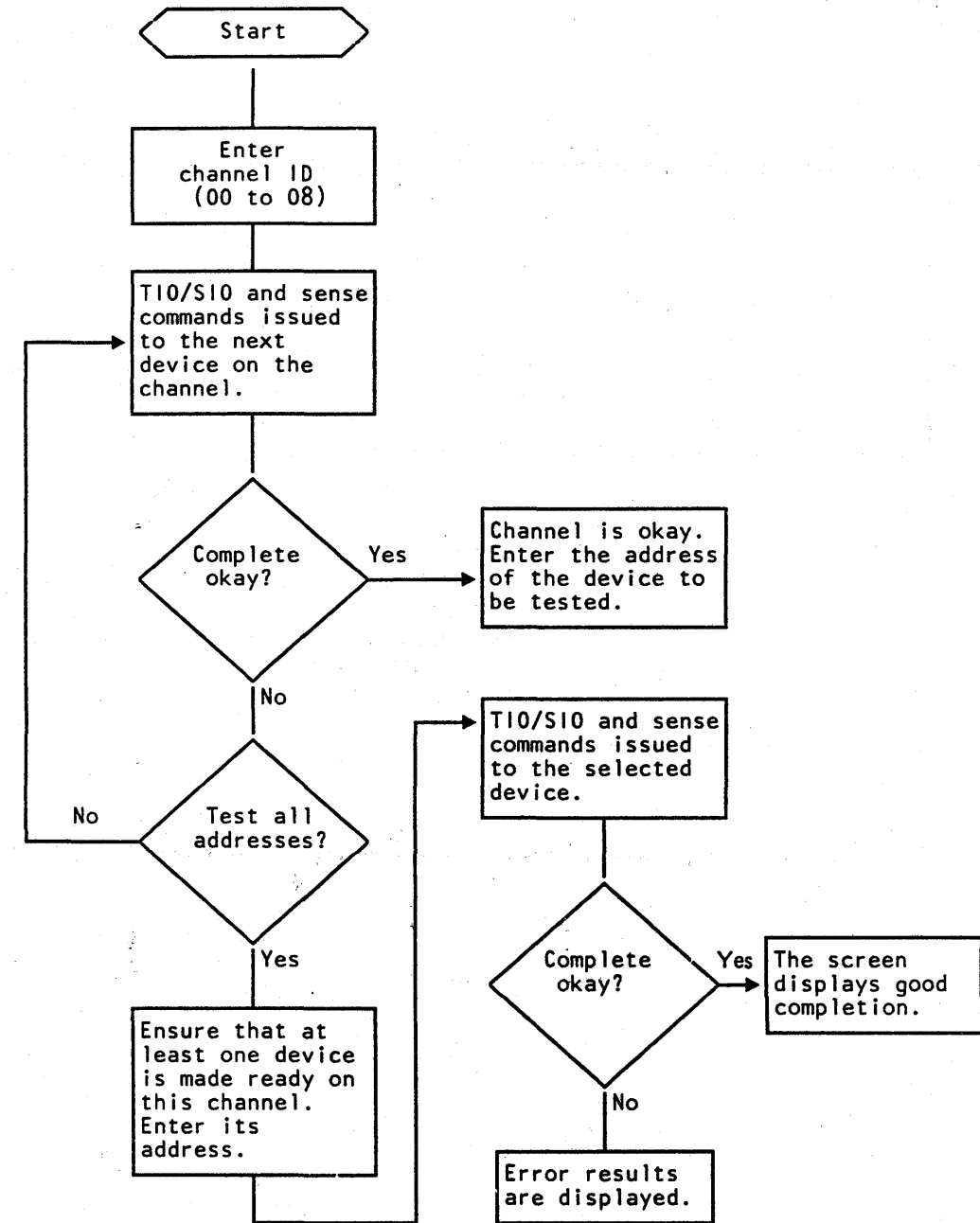

Channel Microcoded Device Exerciser (CMDE) - Support Mode

A second method for using CMDE is intended for support personnel. For the operation of CMDE in this mode, see the flowchart on this page. To use CMDE this way, key in the channel address followed by an x (for example 02x). CMDE then displays an option screen. The options on this screen let you run additional channel command sequences to devices on the channel.

Notes:

1. CMDE runs to the end for an I/O device even though the device does not have an entry in the UCW table.
2. For I/O device sense and status bit values, see "Status and Sense Bit Meanings."

Status and Sense Bit Meanings

Device (unit) Status

- 80 Attention
- 40 Status Modifier
- 20 Control Unit End
- 10 Busy
- 08 Channel End
- 04 Device End
- 02 Unit Check
- 01 Unit Exception

Channel Status

- 80 Program Controlled Interrupt
- 40 Wrong Length
- 20 Program Check
- 10 Protection Check
- 08 Channel Data Check
- 04 Channel Control Check
- 02 Interface Control Check
- 01 Chaining Check

Sense Byte 0

- 80 Command Reject
- 40 Intervention Required
- 20 Bus-Out Check
- 10 Equipment Check
- 08 Data Check
- 04 Overrun

Note: The sense information listed is not valid for all devices; it is a general guide only.

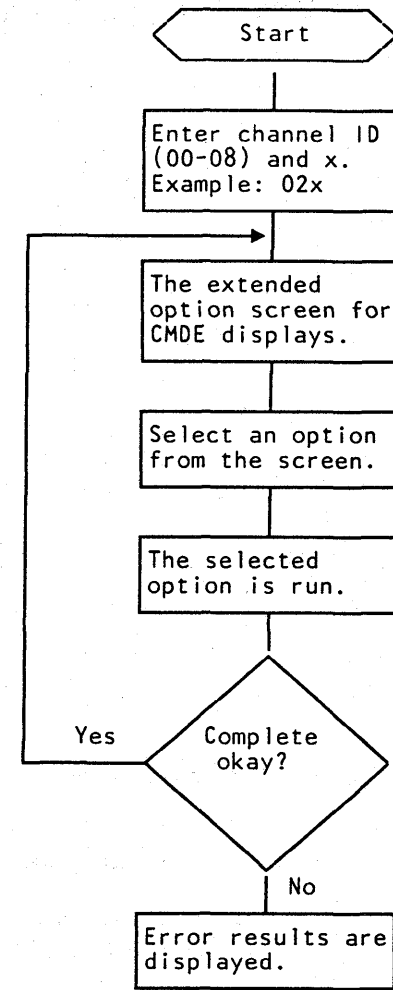

Channel Wrap Test

The Channel Wrap Test (CWT) can be used to isolate the following channel problems:

- Channel interface adapter receiver and driver failures.
- Channel interface cable and connector failures.

The CWT verifies that:

- When each bus-out or tag-out line is activated, the corresponding tag-in or bus-in line is at an active level. See "CWT Error Example 1 (Dropped Bits)."
- All tag and bus lines can be reset. See "CWT Error Example 2 (Unable to Reset Bits)."

For details on how to select CWT, see "How to Run Special Channel Tests." Before running CWT, run storage loads 1 through 6 to verify the operation of the processor up to the channel interface adapter receivers and drivers.

Two wrap terminators (bus wrap and tag wrap) must be installed before running CWT. For terminator part numbers and wiring, see "Bus Wrap Terminator (Part 8483772) Wiring" and "Tag Wrap Terminator (Part 8483773) Wiring."

The wrap terminators can be installed:

- At the I/O tailgate (O1E) instead of the I/O interface cables to test the channel interface adapter card.
- At an I/O device instead of the interface terminators or on the channel out interface cables to test the interface cables and connections on the channel.

After you have completed CWT, remove the wrap terminators and reinstall the channel terminators and the interface cables.

Notes:

1. Interrupts from I/O devices attached to the channel that you are testing can cause CWT to fail.
2. A short between DATA IN and SRV IN cannot be detected by this test.
3. METERING OUT is not tested here; see "Metering Test Repair Procedure" in Volume A01, page CHNL 061.
4. If the CWT runs successfully, the Mark In test is run automatically.
5. If your system has shared control units attached, ensure that the shared control units have the interface you are testing disabled.
6. If you have an IBM 3044 Fiber Optic Channel Extender Link attached to the channel you want to test, do not run CWT to the remote (Model D01) end of the link. To run CWT to the local (Model C01) end of the 3044 link, ensure that the Link Disable switch is in Disable.

Channel FRU Locations

PU	Channel	Adapter Card	Bus Out/Tag Out	Bus In/Tag In
0	0	01A-A3 K2	01A-A2 ZG to 01E-A1	01A-A2 ZH to 01E-A2
0	1	01A-A3 E2	01A-A3 B3 to 01E-A3	01A-A3 B4 to 01E-A4
0	2	01A-A3 F2	01A-A3 B2 to 01E-A5	01A-A3 B5 to 01E-A6
0	3	01A-A3 G2	01A-A3 YJ to 01E-A7	01A-A3 ZA to 01E-A8
0	4	01A-A3 H2	01A-A3 YK to 01E-A9	01A-A3 ZB to 01E-B1
0	5	01A-A3 J2	01A-A3 YL to 01E-B2	01A-A3 ZC to 01E-B3
0	6	01A-A3 P2	01A-A3 YN to 01E-B4	01A-A3 ZE to 01E-B5
0	7	01A-A3 Q2	01A-A3 YP to 01E-B6	01A-A3 ZF to 01E-B7
0	8	01A-A3 R2	01A-A3 YQ to 01E-B8	01A-A3 ZG to 01E-B9
1	0	01B-A1 K2	01B-A1 ZG to 01E-C1	01B-A1 ZH to 01E-C2
1	1	01B-A1 E2	01B-A1 B3 to 01E-C3	01B-A1 B4 to 01E-C4
1	2	01B-A1 F2	01B-A1 B2 to 01E-C5	01B-A1 B5 to 01E-C6
1	3	01B-A1 G2	01B-A1 YJ to 01E-C7	01B-A1 ZA to 01E-C8
1	4	01B-A1 H2	01B-A1 YK to 01E-C9	01B-A1 ZB to 01E-D1
1	5	01B-A1 J2	01B-A1 YL to 01E-D2	01B-A1 ZC to 01E-D3
1	6	01B-A1 P2	01B-A1 YN to 01E-D4	01B-A1 ZE to 01E-D5
1	7	01B-A1 Q2	01B-A1 YP to 01E-D6	01B-A1 ZF to 01E-D7
1	8	01B-A1 R2	01B-A1 YQ to 01E-D8	01B-A1 ZG to 01E-D9

Note: For channel 0 on PU0, the cables from 01AA3 to 01AA2 are:

Bus out/tag out 01A-A3 YM to 01A-A2 YQ
 Bus in/tag in 01A-A3 ZD to 01A-A2 YR

For additional information, see Volume A06, Service Aids, "Channel Failure Isolation."

Bus Wrap Terminator (Part 8483772) Wiring

Tag Wrap Terminator (Part 8483773) Wiring

Bus Bit	Bus Out	Bus In	Tag Bit (hex)	Tag Out	Pin	Tag In	Pin
P	B03	G03	0(80)	SUPR	B12	REQ	J06
0(80)	D04	J04	1(40)	OP	J13	OP	B03
1(40)	B05	G05	2(20)	HOLD	G12	DISC	J11
2(20)	D06	J06	3(10)	ADR	B10	ADR	B05
3(10)	B08	G08	4(08)	SEL	D09	SEL	B08
4(08)	D09	J09	5(04)	CMD	D11	STAT	D04
5(04)	B10	G10	6(02)	DATA	G10	DATA	G08
6(02)	D11	J11	7(01)	SRV	D13	SRV	D06
7(01)	B12	G12					
MARK	D13	J13		MTR	J04	MTR	G05

4381-3 B/M 2676380	MI Seq GE075	PN 6169408 2 of 2	EC A20558 01 Oct 84	EC A20562 30 Aug 85			
-----------------------	-----------------	----------------------	------------------------	------------------------	--	--	--

CWT Error Example 1 (Dropped Bits)

CWT Error Example 1 shows one instance of dropped bits and one instance of shorted lines on channel 4.

1. Dropped bus bit 1. Bits 1, 3, 5, and 7 (X'55') were sent on bus-out and bits 3, 5, and 7 (X'15') were returned on bus-in.

Also bit 1 (X'40') was sent on bus-out and no bits (X'00') were returned on bus-in.

2. Command Out (CD) or Status In (ST) is shorted to either Hold Out (HD) or Disconnect In (DC). Hold Out (X'20') was sent on tag-out; Disconnect In and Status In (X'24') were returned on tag-in.

Also Command Out, Data Out, and Service Out (X'07') were sent on tag-out and Disconnect In, Status In, Data In, and Service In (X'27') were returned on tag-in.

Notes:

1. Interrupts from I/O devices attached to the channel that you are testing can cause CWT to fail.
2. Suspect a bus parity bit failure if the screen shows that a failure was detected but the ACTUAL and EXPECTED bit patterns are the same.
3. For the meanings of the tag abbreviations that appear on the screen, see "CWT Tag Abbreviations."
4. For the hex values assigned to the tag lines, see "Tag Bit Values."
5. The hardware sets tag bit 7 (Service Out) on whenever tag bit 5 (Command Out) and/or tag bit 6 (Data Out) are set on.
6. For bus and tag pin locations, see Volume A06, Service Aids, "Bus and Tag Lines."

CWT Error Example 2 (Unable to Reset Bits)

CWT Error Example 2 shows a failure to reset a tag and bus line on channel 04.

1. TAGS 10. The Address out tag (X'10') cannot be reset.
2. BUS 40. Bus bit 1 (X'40') cannot be reset.

Note: The hardware sets tag bit 7 (Service Out) on whenever tag bits 5 (Command Out) or tag bit 6 (Data Out) are set on. Ignore tag bit 7 if tag bits 5 or 6 are on.

CWT TAG ABBREVIATIONS

OP	Operational
AD	Address
HD	Hold
DC	Disconnect
SE	Select
SP	Suppress
RE	Request
SR	Service
CD	Command
ST	Status
DA	Data

Tag Bit Values

Bit	Hex	Tag-Out	Tag-In
0	80	Suppress	Request
1	40	Operational	Operational
2	20	Hold	Disconnect
3	10	Address	Address
4	08	Select	Select
5	04	Command	Status
6	02	Data	Data
7	01	Service	Service

```

CABLE WRAP TEST
                                CHANNEL: 04
                                ERROR DETECTED

BUS (BIT PATTERN):
  EXPECTED  55  AA  80  40  20  10  08  04  02  01
  ACTUAL    15* AA  80  00* 20  10  08  04  02  01

TAGS (OUT/IN):
  OP/OP  AD/AD  HD/DC  SE/SE  SP/RE  SR/SR  CD/ST  DA/DA
  EXPECTED  40    10    20    08    80    03    07    03
  ACTUAL    40    10    24*  08    80    03    27*  03

==> PRESS ENTER KEY TO RETURN TO CWT OPTION SCREEN
    
```

```

CABLE WRAP TEST
CHANNEL: 04

ERROR DETECTED
*****
UNABLE TO CLEAR TAG AND BUS LINES
TAGS:  10
BUS:   40

* SPECIAL WRAP TERMINATORS *
BITS  OUT  IN(TAGS)  OUT  IN (BUS)
0     SUPR  REQ        0     0
1     OP    OP        1     1
2     HOLD  DISC       2     2
3     ADR   ADR        3     3
4     SEL   SEL        4     4
5     CMD   STA        5     5
6     SRV/DATA  SRV/DATA  6     6
7     CMD/SRV/DATA OUT (*) 7     7

== PRESS ENTER KEY TO RETURN TO CWT OPTION SCREEN
(*) FOR MORE INFORMATION ON TAG BIT (7) SEE THE "MAINTENANCE INFORMATION
MANUAL" UNDER DIAGNOSTICS: SPECIAL CHANNEL TESTS
    
```

Option T - Installation Mode

This option is to be run only at installation time to verify that all primary and backup hardware is error free.

If you select the Installation Mode option at installation time, all Basic and MSMD diagnostics are run against both primary and backup processor hardware. If the Installation Mode option is selected after installation time and primary hardware has been reconfigured, the reconfigured hardware is not tested. The following sequence is used to run the tests:

- Basic diagnostics D001 to D7FF (FUNC2 diskette)
- MSMD storage loads 1 through 6 (2 passes)
- Basic diagnostics D800 to DFFF (DIAG1 diskette).

```
DIAGNOSTIC MODE
PU DIAGNOSTIC INSTALLATION TEST OPTION
EC xxxxxx

***WARNING***

THE FOLLOWING TEST IS FOR USE DURING
PROCESSOR INSTALLATION ONLY

IS THIS AN INSTALLATION DIAGNOSTIC RUN?

COMMAND:          =====> ENTER RESPONSE-(Y/N)
OPTIONS IN EFFECT: T
```



Option F - Field Support Center Mode

Select this option only under the direction of the Field Support Center or Engineering. When you select Option F for the first time, a warning message is displayed. If you can run diagnostics on the processor at this time, press ENTER. The Field Support Center screen is displayed.

To run diagnostics from the Field Support Center screen:

1. Key in a selection from each of the following option fields: DISPLAY, PRINT, TERMINATION, and TEST SELECTION.
2. Press ENTER.
3. If you selected an option other than the default (intensified) options, press ENTER again to start running the selected tests.

If no entry is made for any of the option fields, the default (intensified) value is used. The options may be entered in any order, but you *must* have two digits for each selection and only one selection for any option.

When a selection other than the default selection is keyed in, the new selection is intensified on the screen as the default selection.

If you select options other than those offered on the screen or select conflicting options, a message prompts you to change your selections.

The options available are:

DISPLAY

- D0 Test IDs are displayed as the tests are run.
- D1 Results of a failing test are displayed.
- D2 All test IDs and results of failing tests are displayed.
- D3 Results of all tests are displayed.
- D4 No test IDs or test results are displayed.

PRINT

- P0 Test IDs are printed on the console printer as the test runs.
- P1 Test results are printed on the console printer only for failing tests.
- P2 All test IDs and the results of failing tests are printed on the console printer.
- P3 Test results are printed on the console printer for all tests.
- P4 No test IDs or results are printed.

TERMINATION

- T0 Testing stops on the first error.
- T1 Testing continues when errors are detected.

Note:

If option T1 is selected, testing continues only when actual and expected results do not agree. Testing is stopped if a machine check is detected.

TEST SELECTION

- S0 The selected processing unit Basics are run.
- S1 The selected MSMDs are run.
- S2 All MSMDs are run (except storage load 7).
- S3 All processing unit Basics on FUNC2 and all MSMDs except storage load 7 are run.

For selections D0, D2, P0, and P2, failing tests are identified by a * next to the test ID.

After the option selections are entered, one of four test input screens is displayed. The test input screen displayed depends on which test selection option (S0 to S3) was entered. The test input screens are:

Basic Test(s) Input screen. Displayed when Option S0 is selected (page DIAG 170).

MSMD Test(s) Input screen. Displayed when Option S1 is selected (page DIAG 170).

Runall MSMDs Input screen. Displayed when Option S2 is selected (page DIAG 175).

Runall Tests Input screen. Displayed when Option S3 is selected (page DIAG 175).

```

DIAGNOSTIC MODE
FIELD SUPPORT CENTER SCREEN
EC xxxxx

DISPLAY : D0 TEST ID ONLY          PRINT : P0 TEST ID ONLY
          D1 ALL RESULTS ON ERROR    P1 ALL RESULTS ON ERROR
          D2 TEST ID AND ERROR RESULTS P2 TEST ID AND ERROR RESULTS
          D3 ALL RESULTS ALWAYS      P3 ALL RESULTS ALWAYS
          D4 SUPPRESS DISPLAY        P4 SUPPRESS PRINT

TEST SELECTION : S0 BASIC TEST(S)   TERMINATION TO TERMINATE ON ERROR
                  S1 MSMD TEST(S)   T1 CONTINUE ON ERROR
                  S2 ALL MSMDS
                  S3 ALL BASICS AND MSMDS

RESTART : R RESTART DIAGNOSTIC MODE TARGET PU:  U0 PU0 ONLY
                                                  U1 PU1 ONLY
                                                  U2 BOTH PU0 AND PU1

COMMAND:          == VERIFY SELECTED OPTIONS AND
OPTIONS IN EFFECT: CD1P3TOS1 PRESS ENTER TO CONTINUE
    
```

TARGET PU

- U0 Run diagnostics on processor 0 only.
- U1 Run diagnostics on processor 1 only.
- U2 Run diagnostics on both processor 0 and processor 1.

If both processors are selected (option U2) with basic diagnostics, each basic diagnostic is run first on PU0, then on PU1.

If both processors are selected (option U2) with MSMDs, each core load (0-5, and 7) is first loaded in PU0 and PU1, run in PU0, then run in PU1. Core load 6 is loaded in PU0 and PU1 and each test case is run first in PU0, then run in PU1 before running the next test case.

Basic Tests Input Screen

Enter the start and ending test identifiers for the tests you want to run in the START TEST ID and END TEST ID fields. (For the Basic test IDs, see "Basic Diagnostic Organization" on page DIAG 110.) If you want to run only one Basic test, enter that test in the START TEST ID field and leave the END TEST ID field blank. Enter the number of times you want the test or group of tests to run in the TEST RANGE LOOP COUNT field. If you want the tests to keep looping, enter four blanks in the TEST RANGE LOOP COUNT field.

MSMD Tests Input Screen

Enter the start and ending MSMD test identifiers or section names of the MSMDs you want to run in the START TEST ID and END TEST ID fields. (For MSMD section names and a description of MSMD test IDs, see "MSMD Test Organization" and "MSMD Test IDs" on page DIAG 115.) If you want to run only one MSMD test or section, enter the test ID or section name in the START TEST ID field and leave the END TEST ID field blank. If you want to run only one MSMD storage load, enter the storage load as Mx (x=1 through 6) in the START TEST ID field and leave the END TEST ID field blank. If you want to continue running after an error, enter Y in the DISABLE MACHINE CHECKS field. If N is entered, the diagnostics stop when an error is detected with the error information displayed. To loop a test or group of tests, enter the number of times you want the loop to run in the TEST RANGE LOOP COUNT field, or enter four blanks to keep the tests looping until you press the ALT and MODE SEL keys. If you selected a group of tests, enter the number of times you want each test in the group to run in the TEST LOOP COUNT field.

```

                DIAGNOSTIC MODE
                BASIC TEST(S) INPUT SCREEN
                EC xxxxx

ENTER:
  START TEST ID =

  END TEST ID =
  (FOR A SINGLE TEST IGNORE END TEST ID)

  TEST RANGE LOOP COUNT = 0001
  (FOR INDEFINITE LOOP ENTER 4 BLANKS ABOVE)

RESTART : R RESTART DIAGNOSTIC MODE

COMMAND:          ==>
OPTIONS IN EFFECT: CD1P4S0T1
    
```

```

                DIAGNOSTIC MODE
                MSMD TEST(S) INPUT SCREEN
                EC xxxxx

ENTER:
  START TEST ID =

  END TEST ID =
  (FOR A SINGLE TEST IGNORE END TEST ID)

  DISABLE MACHINE CHECKS (Y/N) = Y

  TEST RANGE LOOP COUNT = 0001
  (FOR INFINITE LOOP ENTER 4 BLANKS ABOVE)

                TEST LOOP COUNT = 0001
RESTART : R RESTART DIAGNOSTIC MODE

COMMAND:          ==>
OPTIONS IN EFFECT: CD2P4T1S1
    
```

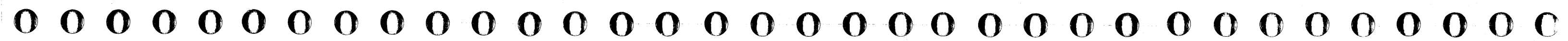

Runall Input Screen

Runs all Basic PU diagnostics on FUNC2 and MSMD storage loads 1 through 6. If you want the MSMDs to run more than one time, enter the number of times you want the MSMDs to run in the TEST LOOP COUNT field. If you want the tests to continue running when an error occurs, enter Y in the DISABLE MACHINE CHECKS field. If N is entered, the diagnostics stop when an error is detected and the error information is displayed.

All MSMDs Input Screen

Enter the number of times you want the MSMDs to run in the TEST LOOP COUNT field. If you want the tests to continue running when an error occurs, enter Y in the DISABLE MACHINE CHECKS field. If N is entered, the diagnostics stop when an error is detected and the error information is displayed.

```

DIAGNOSTIC MODE
RUNALL INPUT SCREEN
EC xxxxx

ENTER:
TEST LOOP COUNTER (RELIABILITY COUNT) = 02
DISABLE MACHINE CHECKS (Y/N) = Y

RESTART : R RESTART DIAGNOSTIC MODE

COMMAND:
OPTIONS IN EFFECT: CD1P4S3T1 ==>
    
```

```

DIAGNOSTIC MODE
ALL MSMDS INPUT SCREEN
EC xxxxx

ENTER:
TEST LOOP COUNTER (RELIABILITY COUNT) = 02
DISABLE MACHINE CHECKS (Y/N) = Y

RESTART : R RESTART DIAGNOSTIC MODE

COMMAND:
OPTIONS IN EFFECT: CD2P4T1S3 ==>
    
```

MI Seq GE090	PN 6169411 1 of 3	EC A20558 01 Oct 84	EC A20559 03 Dec 84			
-----------------	----------------------	------------------------	------------------------	--	--	--

Test Case Monitor Messages

DIAG 200

Message	Reason	User Action Required
BOTH IDS MUST BE SECTION IDS OR TEST IDS REENTER TEST ID(S)	A MSMD range consisting of one test ID and one section ID was entered. When selecting a MSMD range, both IDs must be section IDs or both must be test IDs.	Enter a valid range of MSMD test or section IDs.
CONSOLE PRINTER NOT AVAILABLE. SUPPRESS PRINT OPTION ASSUMED.	An error occurred while attempting to configure a selected printer for TCM use. The print option defaults to suppress print.	Press ENTER to continue.
CONTINUING WILL DESTROY PROCESSING UNIT DATA. PRESS ENTER TO CONTINUE.	If PU diagnostic option F is selected, IML and IPL are required before starting customer programs again.	Press ENTER to go to the Field Support Center screen or key in a new selection and press ENTER.
CONTROL STORE LOAD COMPLETE - MSMDS RUNNING	A MSMD storage load is complete and the tests have started.	None.
DIAGNOSTICS ENDED	An R option was encountered.	None. The General Selection screen is displayed.
DISPLAY ERROR	A TCM command to the console display failed probably because of a microcode error.	Press ENTER to return to the General Selection screen.
DUPLICATE IDS NOT ALLOWED REENTER TEST ID(S)	The start and end test IDs of a range were identical.	Reenter a valid test range.
END OF MSMD TEST(S). PRESS ENTER TO RESTART TCM	A MSMD run has completed.	Press ENTER to continue the TCM.
ENTER Y TO BYPASS CONTROL STORE LOAD	The requested MSMD storage load is the same as the storage load just completed.	Enter Y to request a different CS load. Press ENTER (with no Y) to run the same CS load.
INVALID LOOP COUNT REENTER LOOP COUNT	A not valid hex character was entered.	Enter a valid hex character.
INVALID INPUT - CHECK YOUR ENTRY	PU diagnostic option V was selected and a not valid character was entered.	Enter a valid character.
INVALID TEST ID: xxxxxxxx REENTER TEST ID(S)	A wrong test or section ID was entered. (The not valid ID remains in the input area.)	Reenter test or section ID(s).
INVALID OPTION: x REENTER OPTION	An invalid option was entered.	Enter a valid option.
INVALID RESPONSE - REENTER	An invalid option was entered after PU diagnostic option was selected.	Enter 0 or 1.
POWER GROUP NOT DEFINED CHECK QFS SCREEN	Power group on QFS screen is not defined.	Change the power group on QFS to a valid one.
MOUNT DIAG1 ON DRIVE 2. PRESS ENTER WHEN READY.	The requested test is not on the diskette that is now installed.	Install the requested diskette, and press ENTER.
MSMD CONTROL STORE LOAD: CSLOAD n	Informs the operator that the next MSMD storage load is loading. n = the load number (1-7).	None.
MSMD MONITOR ERROR. INVALID TEST ID. PRESS ENTER TO RESTART TCM.	The MSMD monitor detected a wrong MSMD section or test ID.	Press ENTER to return to the Diagnostic Mode PU Diagnostic Selection screen.
MSMD RESET IN PROCESS	Run status information.	None.
MULTIPLE TESTS MUST BE OF THE SAME TYPE REENTER TEST ID(S)	A range of tests was selected that included both Basic and MSMDs.	Enter a range of test IDs that includes only Basics or only MSMDs.
NO PU REQUEST PRESS ENTER TO RESTART TCM	A stop command was given to the TCM without a request from the console. This can be either a hardware failure or a diagnostic error.	Press ENTER to return to the Diagnostic Mode PU Diagnostic Selection screen. Run Problem Analysis to analyze the error.

Message	Reason	User Action Required
PRINT ERROR	A TCM command to the console printer failed. This is probably a printer problem.	Press ENTER to return to the General Selection screen.
PROCESSING UNIT POWER DOWN PRESS ENTER. USE PWR SCREENS.	Processing unit power is off.	Press ENTER to return to the General Selection screen. Power up the processing unit by the power screens (QW).
RANGE ENTERED NOT ON ONE DISKETTE REENTER TEST ID(S)	The range of tests selected are contained on more than one diskette.	Enter a range of test IDs that are contained on one diskette only.
RANGE ENTERED NOT ON ONE SECTION REENTER TEST ID(S)	The MSMD range selected is not contained in only one section.	Enter a range of MSMD test IDs that are contained in one section.
RECORD ALL INFORMATION ON THIS SCREEN. PRESS ENTER TO RESTART TCM.	A machine check occurred during a MSMD run. x = the MSMD CS load number (1 to 7), but the TCM cannot be certain of which test was running when the check occurred.	Exchange the listed FRUs, and run the selected tests again.
RDID ERROR MOD ID: xxxxx RC: xx	A diskette error occurred. Some common return codes are: 0F Diskette not ready 41 Module not found 81 Diskette read error.	Press ENTER to return to the Diagnostic Mode PU Diagnostic Selection screen.
RE-ENTER MESSAGES	A wrong response was entered to a request for information.	Follow the displayed instructions, and enter the requested information.
RUN HALTED DUE TO TERMINATE ON ERROR OPTION. PRESS ENTER TO RESTART TCM.	An error was detected while running under the stop on error option.	Press ENTER to return to the Diagnostic Mode PU Diagnostic Selection screen.

4381 MI PN 6169411 EC A20558 EC A20559
B/M 2676380 Seq GE090 2 of 3 01 Oct 84 03 Dec 84

Message	Reason	User Action Required
SECTION Zxxxxx00 ENDED (STARTED)	Run status information.	None.
SELECTED TEST(S) xxxx TO xxxx PROCESSED. PRESS ENTER TO RESTART TCM.	The selected Basic tests have run to completion.	Press ENTER to return to the Diagnostic Mode PU Diagnostic Selection screen.
SELECTED TEST(S) NOT FOUND OR BYPASSED. PRESS ENTER TO RESTART TCM.	Either no test exists in the selected range or not all tests in the selected range can be executed.	Press ENTER to return to the Diagnostic Mode PU Diagnostic Selection screen.
SELECT PU SIDE BY ENTERING "0" OR "1."	PU diagnostic C was selected and a character other than 0 or 1 was entered for the selected PU.	Enter 0 or 1.
TEST IDS MUST BE IN SEQUENCE REENTER TEST ID(S)	Selected test IDs were not entered in increasing order.	Enter test IDs in increasing order.
UNEXPECTED ERROR. GO TO START 001. USE REFERENCE CODE BELOW.	The support processor has detected an error.	Press ENTER to return to the General Selection Screen.
VERIFY SELECTED OPTIONS AND PRESS ENTER TO CONTINUE.	The selected options are highlighted. The user is given a chance to either change selections or leave it the way it is.	Press ENTER to go to the next screen.

4381
B/M 2676380

MI Seq GE090	PN 6169411 3 of 3	EC A20558 01 Oct 84	EC A20559 03 Dec 84			
-----------------	----------------------	------------------------	------------------------	--	--	--

© Copyright IBM Corp. 1984



Contents

Introduction LOG 001
 How to Display Processor Logs LOG 010

Summary of Log Screens LOG 010

Reference Code History Log LOG 015

Maintenance and Support Subsystem Logs ... LOG 025
 SP Logout Summary LOG 025
 SP Detail Log LOG 030
 SP Event Counters LOG 040
 RSF Line Error Statistics LOG 045

Processing Unit Logs LOG 050
 Processing Unit Logout Directory LOG 050
 Processing Unit Microword Directory LOG 055
 Processing Unit Logout Summary LOG 060
 PU Reconfiguration Data LOG 065

Channel Interface Control Check (IFCC) Logs . LOG 075
 Channel Interface Logout Summary LOG 075
 Channel Interface Logout Detail LOG 080

Power Logs LOG 085
 Power Error Logout Directory LOG 085
 Power Error Logout Detail LOG 090

MI	PN 6169379	EC A20558	EC A20560			
Seq GF005	1 of 2	01 Oct 84	18 Feb 85			

When a hardware failure or a microcode error is detected in the processor, status information is collected, formatted, and recorded in the logout area of the diskette. For the MSS, support processor status and device adapter latches are recorded. For the processing unit, the scan ring latches are recorded.

Error Log Analysis (ELA) routines use the logged data to isolate the failure by developing a reference code, reference code extension, and FRU list. These are used with the repair procedures to guide the service representative in a repair action. See "Diagnostics" in this volume for more information on reference codes.

The error logs are:

- Reference Code History
- Support Processor (SP)
- SP Event Counters
- Processing Unit (PU)
- Channel Interface Control Check (IFCC)
- Power.

Time-of-day Clock (TODC) Equivalent: The TODC Equivalent is recorded with each log to show the time the error occurred. The TODC Equivalent is stored in the support processor with a format of: yy/mm/dd hh mm ss.

When the processor is powered up, the TODC Equivalent is set by the customer during support processor IML. The TODC Equivalent is updated periodically during normal machine operation from the system time-of-day clock.

How to Display Processor Logs

To display a log:

1. Set the CE Mode switch to CE Mode.
2. Press MODE SEL. The General Selection screen is displayed.
3. Refer to "Summary of Log Screens." Select the log you want to display, and key in the digits shown in the **To Display, Enter** column. Then press ENTER.

Summary of Log Screens

Log Type	Screen Name	To display, Enter:	Summary
Support Processor (SP)	SP Event Counters	QESE	Running totals of SP information.
	RSF Line	QEL	RSF line operations and errors.
	SP Summary	QESD	Summary of last 16 SP logs.
	SP Detail	QESDxx	Detailed information on SP log xx.
Power	Power Log Directory	QEWD	Summary of last 16 power logs.
	Power Log Detail	QEWDxx	Detailed information on power power log xx.
Processing Unit (PU)	PU Logout Directory	QEPD	Last eight PU logs and last irrecoverable PU log.
	PU Summary	QEPS	PU error counters.
	Microword Directory	QEPM	PU control storage registers at the time of failure.
	PU Reconfiguration Data	QEPR	Areas of the processor reconfigured because of an error.
Channel	IFCC Summary	QEI	Summary of last 16 interface control checks.
	IFCC Detail	QEIDxx	Detailed information on interface control check xx.



REFERENCE CODE HISTORY LOG SCREEN

LOG 015

The Reference Code History Log screen is a record of the last 31 different power, support processor, and processing unit reference codes with the time of failure and number of times each one occurred.

To display the Reference Code History Log screen:

1. Press MODE SEL.
2. Key in QERD and press ENTER.

To clear the Reference Code History Log screen:

1. Set the CE Mode switch to CE Mode.
2. Press MODE SEL.
3. Key in QERDP and press ENTER.
4. When prompted, key in P and press ENTER again.

Label Identification

RN: Record number. Record number 00 is the latest entry.

CT: Count. The number of consecutive times the same reference code was logged. If CT is greater than 1, the TODC Equivalent gives the time of the first failure.

TODC EQUIV: The time of the failure.

REF CODE: The reference code defining the failure. For a detailed description of reference codes, see "MSS, Power, and Reference Codes" in the "Diagnostics" section.

RC EXTN: The reference code extension, if any, for the failure.

REFERENCE CODE LOGOUT FILE				CURRENT TODC EQUIVALENT: yy/mm/dd hh:mm:ss			
RN	CT	---TODC EQUIV--	REF CODE RC EXTN.	RN	CT	---TODC EQUIV--	REF CODE RC EXTN.
0	01	mm/dd hh:mm:ss	EC517464 00000000	16	00	mm/dd hh:mm:ss	00000000 00000000
1	01	mm/dd hh:mm:ss	EC517A64 00000000	17	00	mm/dd hh:mm:ss	00000000 00000000
2	00	mm/dd hh:mm:ss	00000000 00000000	18	00	mm/dd hh:mm:ss	00000000 00000000
3	00	mm/dd hh:mm:ss	00000000 00000000	19	00	mm/dd hh:mm:ss	00000000 00000000
4	00	mm/dd hh:mm:ss	00000000 00000000	20	00	mm/dd hh:mm:ss	00000000 00000000
5	00	mm/dd hh:mm:ss	00000000 00000000	21	00	mm/dd hh:mm:ss	00000000 00000000
6	00	mm/dd hh:mm:ss	00000000 00000000	22	00	mm/dd hh:mm:ss	00000000 00000000
7	00	mm/dd hh:mm:ss	00000000 00000000	23	00	mm/dd hh:mm:ss	00000000 00000000
8	00	mm/dd hh:mm:ss	00000000 00000000	24	00	mm/dd hh:mm:ss	00000000 00000000
9	00	mm/dd hh:mm:ss	00000000 00000000	25	00	mm/dd hh:mm:ss	00000000 00000000
10	00	mm/dd hh:mm:ss	00000000 00000000	26	00	mm/dd hh:mm:ss	00000000 00000000
11	00	mm/dd hh:mm:ss	00000000 00000000	27	00	mm/dd hh:mm:ss	00000000 00000000
12	00	mm/dd hh:mm:ss	00000000 00000000	28	00	mm/dd hh:mm:ss	00000000 00000000
13	00	mm/dd hh:mm:ss	00000000 00000000	29	00	mm/dd hh:mm:ss	00000000 00000000
14	00	mm/dd hh:mm:ss	00000000 00000000	30	00	mm/dd hh:mm:ss	00000000 00000000
15	00	mm/dd hh:mm:ss	00000000 00000000	TIME OF LAST PURGE:	yy/mm/dd	hh:mm:ss	

COMMAND: QERD ==>

THIS PAGE INTENTIONALLY LEFT BLANK

4381
B/M 2676380

MI Seq GF010

PN 6169380 2 of 4

EC A20558 01 Oct 84

--	--	--	--	--	--

© Copyright IBM Corp. 1984



MAINTENANCE AND SUPPORT SUBSYSTEM LOGS

Maintenance and Support Subsystem (MSS) hardware failures and microcode errors are logged if enough of the MSS is operational.

The MSS log screens are:

- SP Logout Summary
- SP Detail Log
- SP Event Counters
- Remote Support Facility (RSF) Line Error Statistics.

SP Logout Summary Screen

The SP Logout Summary contains a record of the last 16 SP error logs.

To display the SP Logout Summary screen:

1. Press MODE SEL.
2. Key in QESD and press ENTER.

To clear the SP Logout Summary screen:

1. Set the CE Mode switch to CE Mode.
2. Press MODE SEL.
3. Key in QESDP and press ENTER.
4. When prompted, key in P and press ENTER again.

SP LOGOUT SUMMARY										CURRENT TODC EQUIVALENT: yy/mm/dd hh:mm:ss					
LN	EVNT	CT	TODC	EQUIVALENT	LVL	MM	MC	--MSW--	C-IC	INST	ADPT	SIC-	LMR-	REF.CODE	
00	0003	01	mm/dd	hh:mm:ss	07	00	12	63402F2E	6340	EE05	0000	0000	3900	EC517464	
01	0002	01	mm/dd	hh:mm:ss	07	00	12	63402F2E	6340	EE05	0000	1856	96C8	EC517A64	
02	0000	00	mm/dd	hh:mm:ss	00	00	00	00000000	0000	0000	0000	0000	0000	00000000	
03	0000	00	mm/dd	hh:mm:ss	00	00	00	00000000	0000	0000	0000	0000	0000	00000000	
04	0000	00	mm/dd	hh:mm:ss	00	00	00	00000000	0000	0000	0000	0000	0000	00000000	
05	0000	00	mm/dd	hh:mm:ss	00	00	00	00000000	0000	0000	0000	0000	0000	00000000	
06	0000	00	mm/dd	hh:mm:ss	00	00	00	00000000	0000	0000	0000	0000	0000	00000000	
07	0000	00	mm/dd	hh:mm:ss	00	00	00	00000000	0000	0000	0000	0000	0000	00000000	
08	0000	00	mm/dd	hh:mm:ss	00	00	00	00000000	0000	0000	0000	0000	0000	00000000	
09	0000	00	mm/dd	hh:mm:ss	00	00	00	00000000	0000	0000	0000	0000	0000	00000000	
10	0000	00	mm/dd	hh:mm:ss	00	00	00	00000000	0000	0000	0000	0000	0000	00000000	
11	0000	00	mm/dd	hh:mm:ss	00	00	00	00000000	0000	0000	0000	0000	0000	00000000	
12	0000	00	mm/dd	hh:mm:ss	00	00	00	00000000	0000	0000	0000	0000	0000	00000000	
13	0000	00	mm/dd	hh:mm:ss	00	00	00	00000000	0000	0000	0000	0000	0000	00000000	
14	0000	00	mm/dd	hh:mm:ss	00	00	00	00000000	0000	0000	0000	0000	0000	00000000	
15	0000	00	mm/dd	hh:mm:ss	00	00	00	00000000	0000	0000	0000	0000	0000	00000000	
COMMAND: QESD										==>					

Label Identification

LN: Log number. Log number 00 is the *latest* entry.

EVENT: The total number of SP errors since the last IML.

CT: The number of consecutive times the same failure occurred.

TODC Equivalent: Time of the log.

LVL: The level the SP microcode was running in at the time of failure.

MM: The master mask value.

MC: SP check register contents. For bit values, see SPCK under "Label Identification" on page LOG 030.

MSW: Microcode status word value.

C-IC: Corrected instruction counter value.

INST: The SP microcode instruction executing at the time of failure.

ADPT: Adapter address the microcode was working with at the time of failure.

SIC: Address of the last microcode instruction.

LMR: Last module read from the diskette.

SP Detail Log Screen

The SP Detail Log screen contains detailed error information recorded at the time of a failure on the support processor.

To display the SP Detail Log screen:

1. Press MODE SEL.
2. Key-in QESDxx and press ENTER. Where xx is a log number (00-15) selected from the SP Logout Summary screen (QESD).

Two different formats are used for the SP Detail Log screen depending on the interrupt level of the SP microcode at the time of failure. The two formats are for:

Microcode levels 2 through 5 (see "SP Detail Log for Levels 2 through 5").

Microcode levels 1, 6, and 7 (see "SP Detail Log for Levels 1, 6, and 7").

Label Identification

LEVEL: Level of the SP microcode at the time of failure.

MMASK: Master mask setting.

CMASK: Common mask setting.

SPCK: SP check register contents. Bit values are:

- 0 I/O parity error
- 1 I/O timeout
- 2 SP storage parity error
- 3 SP microcode check
- 4 Burst mode change
- 5 Always zero
- 6 Instruction Counter change
- 7 Always zero

LOMC: SP check register contents after log (bits are the same as SPCK).

IOIRR: I/O interrupt request register contents at the time of failure.

MIRR: Microcode interrupt request register contents at the time of failure.

IOADPT: I/O adapter address (if error occurred during an I/O operation).

IOCMD: I/O command to a device attached directly to the SP bus.

IC: Instruction counter value.

C-IC: Corrected instruction counter value.

LMR: Last module ID read from the diskette.

LMRB: Last module ID base program read.

INST: Instruction at time of failure.

CNFG: Configuration data for devices attached to the SP bus.

DLAT: Directory lookaside tables.

REFCODE: Reference code defining the failure.

RC EXTN: Reference code extension.

MSWs: Microcode status words.

SP Detail Log for Levels 2 through 5

```

SP LOG:00 TODC EQUIV:yy/mm/dd hh:mm:ss ID:0000000000 EC:866898 EVENT:002D
=====
LEVEL 03 IOIRR 48 IC 7F00 CNFG:AB0000000000A201ED00 RC:FE400324 00000000
MMASK 01 MIRR 13 C-IC 7F00 DLAT LVL MSW LVL MSW
CMASK DF IOADT 00 LMR 9309 DATA 85 0 3010 2120 1 60DE 2322
SPCK 12 IOCMD 00 LMRB 9309 INST 80 2 0800 2524 3 7F04 2726
LOMC 00 INST EE05 4010 CHAN 85 4 9404 A928 5 208E AB2A
-----BURST MODE----- STAT 00 6 60DE AD2C 7 89A4 AF2E
LCA 8500D0 DISK 811000 -----I/O STATUS-----PLDA-----
DCA 85FA52 85FB80 DISK1 02 LCA 002000 C1 0000 C2 0000 C3 8000
DCA 85FC80 85FD80 DISK2 38 CCA 0000000000 OP 0000 CK 0000 BF 0000
DCA 85EB80 85FC00 PWR 01 DCA 0493 C4 00 DS 40 IM 90 PG 80
DCA 85FD02 85FE00 SBA 03 PU 00000000 TM 04 TP 8000 CB QLM
REGISTERS: SBA2 02 PUI 00000000
PP:26 0111 4200 2334 0000 8080 9978 0020 3AF0
SP:27 2000 1170 2020 3030 8400 8420 8440 8460
-----DEVICE CONTROL BLOCK-----
2080 0000 0000 0000 0080 00F8 0000 0000 0000 0000 0400 0000 0000 0200 0000 0000 0000
0000 A900 0000 0000 408C 0000 0000 0000 0000 0000 0000 0000 0000 0000 0000 0000 0000
COMMAND: QESD00 ==>
    
```

BURST MODE: Burst mode registers for each SP attached device.

I/O STATUS: Status of I/O devices attached to the SP. (See "I/O Status Fields" on page LOG 035.)

Note: A letter can be displayed before the value in the I/O status fields (except PU). The letters define the error condition. The error conditions are:

- C Machine check
- P Parity error
- T Timeout

PLDA: Program link data area values. (See "PLDA Fields" on page LOG 031.)

REGS: Data values in the active register pages.

PP: Primary page active at the time of error.

SP: Secondary page active at the time of failure.

SPIL CURRENT INSTRUCTION: Address and data of the current SP microcode instruction at the time of failure.

SPIL LAST INSTRUCTION: Address and data of the last SP microcode instruction at the time of failure.

SPIL BRN TABLE: Last 13 SP microcode instruction branch addresses.

DEVICE CONTROL BLOCK: Sixty-four bytes of device dependent information.

4381	MI	PN 6169380	EC A20558				
B/M 2676380	Seq GF010	4 of 4	01 Oct 84				



PLDA Fields

	C1	C2	C3	
Byte 0				
Bit 0	Soft stop	Async stop occurred	CE switch on	
Bit 1	Hard stop	Address compare	Operation rate not normal	
Bit 2	Not used	Mode or swap key	Check control not normal	
Bit 3	PU degraded	Console function request	Address control not normal	
Bit 4	Machine check	Start key disabled	Diagnostic test active	
Bit 5	Check stop	Not used	Not used	
Bit 6	Off-line	Mode key disabled	Not used	
Bit 7	Wait state	Swap key disabled	Not used	
Byte 1	No bits used	No bits used	No bits used	
	OP	CK	BF	
Byte 0				
Bit 0	Instruction step	Machine check channel detect	Block active	
Bit 1	Word step	Not used	Block invoked	
Bit 2	Clock cycle step	Not used	Block processing start	
Bit 3	Clock pulse step	Not used	Address compare command	
Bit 4	Repeat microword	Machine check no retry	Erase in progress	
Bit 5	Not used	Log machine check no retry	Save request	
Bit 6	Not used	Disable	Verify block	
Bit 7	Not used	Stop after log	Deactivate	
Byte 1	No bits used	No bits used		
Bit 0			ODD patch, special block	
Bit 1			Not used	
Bit 2			Deactivate	
Bits 3-7			Not used	
	C4	DS	IM	PG
Byte 0				
Bit 0	Not used	Not used	Cold IML	3270 mode
Bit 1	Not used	Configured	Not used	Printer/keyboard mode
Bit 2	Not used	Not used	Not used	RCS code
Bit 3	Not used	Not used	Interval timer	Not used
Bit 4	Not used	Channel to channel	Not used	Not used
Bit 5	Start key	Not used	Not used	RSAM code
Bit 6	Stop key	Not used	IPL failed	Not used
Bit 7	External interrupt	Not used	IML failed	ROCF monitor

SP Detail Log for Levels 1, 6, and 7

```

SP LOG:01 TODC EQUIV:yy/mm/dd hh:mm:ss ID:0000000000 EC:866898 EVENT:0002
=====
LEVEL 07 10IRR 00 IC 6344 CNFG:AB0000000000A201ED00 RC:EC517464 00000000
MMASK 00 MIRR 01 C-IC 6344 DLAT LVL MSW LVL MSW
CMASK DF 10ADT 00 LMR 9000 DATA 81 0 3010 2120 1 60DE 2322
SPCK 12 10CMD 00 LMRB 9000 INST 84 2 0800 2524 3 B068 2726
LOMC 00 INST EE05 8C60 CHAN 85 4 9304 A928 5 208E AB2A
-----BURST MODE----- STAT 00 6 60DE AD2C 7 6348 2F2E
LCA 8500D0 DISK 810800 -----I/O STATUS-----PLDA-----
DCA 85FABE 85FB70 DISK1 02 LCA 000000 C1 0000 C2 0B00 C3 8000
DCA 85FC70 85FD70 DISK2 00 CCA 0000008000 OP 0000 CK 0000 BF 0000
DCA 85FE7C 85FBF0 PWR C 02 DCA 0002 C4 00 DS 40 IM 90 PG 80
DCA 85FCF0 85FDF0 SBA 02 PU0 300068E0 TM C4 TP 8000 CB Q LIM
REGISTERS: SBA2 10 PU1 3C100000
PP:2E C901 5201 F00A 62E0 8262 90F6 10EE 8493
SP:2F 00DC 00D6 8000 88DC 3E00 00D8 00D0 663C
-----SPIL CURRENT INSTRUCTION-----
ADDR:00DC DATA:00EE 04F0 01A2 04F0 ADDR:00D6 DATA:5201 0000 0494 00EE
SPIL BRN TABLE 0722 00D0 007A 002C 000C 26DC 268E 266C 2646 2628 260C 0A66 0A54
COMMAND: QESD01 ==>
    
```



I/O Status Fields

Bits	DISK1 / DISK2	Bits	PWR	SBA	LCA	CCA	DCA	PU0 and PU1
0-1:	00 Good ending	0	Not used	Control parity check	Byte 0	Input request	Counter overflow	Operate
	01 CRC error	1	Not used	Data parity check	Bit 0	Output request	Read timeout	Stopword
	10 Command error	2	Not used	Command parity check	Bit 1	DCE interrupt	Line error	370 mode
	11 Hardware error	3	Not used	Address parity check	Bit 2	Timer interrupt	Read error	EC/BC mode
2-4:	000 Operation complete	4	Command check	Shift register busy	Bit 3	Exception	Stop poll	DAT
	001 Control complete	5	SP machine check	SP machine check	Bit 4	SP machine check	Timer	Wait
	010 Drive error	6	Interrupt enable	Timer interrupt enable	Bit 5	Interrupt enable	Error queue	Channel sequence match
	011 Interrupt request	7	Interrupt request	Timer interrupt request	Bit 6	Interrupt request	Not used	CS address match
	100 Overrun/underrun				Bit 7			
	101 Timeout				Byte 1			
	110 Record not found				Bit 0	Overrun	Extended status	Store address match
	111 Disk not ready				Bit 1	Underrun	Command complete	LS address match
5:	SP check				Bit 2	Receive clock	Not used	Not used
6:	Adapter enable				Bit 3	SDLC invalid	DCA active	System state
7:	Interrupt pending				Bit 4	SDLC frame	Key status	PU clock run
					Bit 5	Wrong character	Not used	Channel clock run
					Bit 6	Break byte	SP machine check	Storage clock run
					Bit 7	Adapter in sync	Interrupt enable	Instruction step
					Byte 2		Interrupt request	
					Bit 0	Receive	Not used	Microword step
					Bit 1	Transmit	Not used	Clock step
					Bit 2	Inhibit 0 insertion	Not used	Pulse step
					Bit 3	Auto, EBCDIC	Not used	Disable error
					Bit 4	ASCII, SDLC	Not used	Control store error
					Bit 5	Code length	Not used	Disable error
					Bit 6	Code length	Not used	Channel error
					Bit 7	NRZI	Not used	Instruction step
					Byte 3			
					Bit 0	DS ready	Not used	Not used
					Bit 1	CTS	Not used	Not used
					Bit 2	RLSD	Not used	Not used
					Bit 3	Ring indicator	Not used	Not used
					Bit 4	DSR transmit	Not used	Not used
					Bit 5	Not used	Not used	Not used
					Bit 6	RLSD transmit	Not used	Not used
					Bit 7	CTS transmit	Not used	Not used
					Byte 4			
					Bit 0	Terminal ready	Not used	Not used
					Bit 1	RTS	Not used	Not used
					Bit 2	Wrap	Not used	Not used
					Bit 3	Test	Not used	Not used
					Bit 4	Standby	Not used	Not used
					Bit 5	Half speed	Not used	Not used
					Bit 6	New sync	Not used	Not used
					Bit 7	DCE interface disable	Not used	Not used

SP Event Counter Screen

The SP Event Counter screen keeps a count of various events in the support processor.

To display the SP Event Counter screen:

1. Press MODE SEL.
2. Key in QESE and press ENTER.

More than one screen is needed to display the SP counters. If you want to move between screens, press and hold the ALT key and press the PAGE UP or PAGE DOWN key.

The TOTAL columns record the number of times the event occurred since the machine was installed. The TOTAL columns are not reset when you clear the counters. The DELTA columns record the number of times the event has occurred since the last time the SP Event Counters were cleared.

If a TOTAL or DELTA field reaches its maximum value, it is reset and starts counting from zero. This can result in the DELTA field at a higher value than the TOTAL field.

If you want to clear the DELTA columns on the SP Event Counter screens:

1. Set the CE Mode switch to CE Mode.
2. Key in QESER and press ENTER.
3. When prompted, key in R and press ENTER again.

```

*ERROR LOG DISPLAY*           *SP EVENT COUNTERS*
0 TOTAL POWER ON HOURS        CURRENT TODC EQUIV: yy/mm/dd hh mm ss
0 DELTA POWER ON HOURS        LAST RESET TODC EQUIV:
TOTAL DELTA                    TOTAL DELTA
0 0 TIMES POWERED ON          0 0 TIMES POWERED OFF
0 0 POWER FAULTS              0 0 HOURS IN CE MODE
0 0 HOURS IN DIAGNOSTIC MODE
0 0 SP PARITY ERR HARD RECOV  0 0 SP PARITY ERR HARD UNREC
0 0 SP PARITY ERR SOFT RECOV  0 0 SP PARITY ERR SOFT UNREC

0 0 SP REIML                  0 0 AUTO SP-REIML
0 0 SP RESETS                 0 0 AUTO SP-RESET

0 0 SUCCESSFUL LCA RETRY      0 0 UNSUCCESSFUL LCA RETRY
0 0 LCA CYCLE STEAL ERROR

0 0 SUCCESSFUL DCA RETRY      0 0 UNSUCCESSFUL DCA RETRY
0 0 DCA CYCLE STEAL ERROR

COMMAND: QESE                      ==>

```

```

*ERROR LOG DISPLAY*           *SP EVENT COUNTERS*
0 TOTAL POWER ON HOURS        CURRENT TODC EQUIV: yy/mm/dd hh mm
0 DELTA POWER ON HOURS        LAST RESET TODC EQUIV: yy/mm/dd hh mm
TOTAL DELTA                    TOTAL DELTA
0 0 SUCCESSFUL CCA RETRY      0 0 UNSUCCESSFUL CCA RETRY
0 0 SUCCESSFUL DDA RETRY      0 0 UNSUCCESSFUL DDA RETRY
0 0 DDA CYCLE STEAL ERROR

0 0 SUCCESSFUL PCA RETRY      0 0 UNSUCCESSFUL PCA RETRY
0 0 SUCCESSFUL SBA RETRY      0 0 UNSUCCESSFUL SBA RETRY

0 0 PU-IML XA MODE            0 0 PU-IML S370
0 0 PU-IPL
0 0 PU SUCCESSFUL RETRY       0 0 PU1 SUCCESSFUL RETRY
0 0 PU UNSUCCESSFUL RETRY    0 0 PU1 UNSUCCESSFUL RETRY
0 0 PU CHECK STOP            0 0 PU1 CHECK STOP
0 0 PU EXIGENT MACHINE CHECK  0 0 PU1 EXIGENT MACHINE CHECK
0 0 PU CHANNEL RESET          0 0 PU1 CHANNEL RESET

COMMAND: QESE                      ==>

```



RSF Line Error Statistics Screen

The RSF Error Statistics screen keeps a count of the number of Remote Support Facility operations and the line errors encountered.

To display the RSF Error Statistics screen:

1. Press MODE SEL.
2. Key in QEL and press ENTER.

CNFG/REMOTE	*RSF LINE ERROR STATISTICS*	
NUMBER OF OPERATIONS	SEND 0000	RECEIVE 0000
NUMBER OF ERRORS	0000	0000
NUMBER OF UNDERRUNS/OVERRUNS	0000	
Q GENERAL SELECTION		
Z RETURN TO PROG SYS		
COMMAND: QEL ==>		

The Processing Unit Log screens are:

- Processing Unit Logout Directory
- Processing Unit Microword Directory
- Processing Unit Logout Summary
- Processing Unit Reconfiguration Data.

Processing Unit Logout Directory Screen

The Processing Unit Logout Directory screen contains information on the last nine processing unit logs if at least one of them was caused by an irrecoverable error. If none of the last nine PU logs were caused by an irrecoverable error, the screen contains the last eight PU logs and the last log caused by an irrecoverable error.

To display the Processing Unit Logout Directory screen:

1. Press MODE SEL.
2. Key in QEPD and press ENTER.

To clear the Processing Unit Logout Directory screen:

1. Set the CE Mode switch to CE Mode.
2. Press MODE SEL.
3. Key in QEPDP and press ENTER.

Label Identification

ID: Log identifier number from 0001 to FFFF.

PU: The failing processing unit (0 or 1).

TODC: Time of the failure.

REFERENCE CODE: The reference code that resulted from the error, or blank if the reference code was not available.

ERR: Storage error that occurred as follows:

- DBE Double-bit error
- FSS A soft-soft double-bit error was forced by retry.
- KEY Key error

STG ADDR: The location of a storage failure if a storage error occurred or the message AD N/A if the address is not available.

PROCESSING UNIT LOGOUT DIRECTORY										MODEL: 4381	SERIAL NUMBER: 012345
ID	PU	TODC	EQUIVALENT	REF CODE	ERR	STG	ADDR	MACH STATUS	CHANNEL RST		
00C9	1	yy/mm/dd	hh:mm:ss	5DD218AE				UNSUCCESSFUL RETRY	-----		
00C8	0	yy/mm/dd	hh:mm:ss		KEY	xxxxxxx		UNSUCCESSFUL RETRY	-----		
00C7	1	yy/mm/dd	hh:mm:ss	5DD218AE				EXIGENT MACH CHK	-----		
00C6	0	yy/mm/dd	hh:mm:ss					EXIGENT MACH CHK	-----		
00C5	0	yy/mm/dd	hh:mm:ss	7093CBAE				CHANNEL ERROR	--2-----		
00C4	1	yy/mm/dd	hh:mm:ss		FSS	xxxxxxx		CHECK STOP	-----		
00C3	1	yy/mm/dd	hh:mm:ss	5DD218AE	DBE	xxxxxxx		UNSUCCESSFUL RETRY	-----		
00C2	0	yy/mm/dd	hh:mm:ss					UNSUCCESSFUL RETRY	-----		
00C1	0	yy/mm/dd	hh:mm:ss	5DD218AE				CHANNEL ERROR	-----5-----		
00C0	1	yy/mm/dd	hh:mm:ss					SUCCESSFUL RETRY	-----		

COMMAND: QEPD ==>

>

MACH STATUS: The machine status after the failure is logged and analyzed as follows:

CHANNEL ERROR

A channel error occurred. If the channel error cannot be corrected, the channel is removed from use and the failing channel ID is displayed next to the CHANNEL RST field.

CHECK STOP

An error occurred that cannot be retried.

CHECK STOP (RESET)

An error occurred during system reset.

EXIGENT MACHINE CHECK

An error occurred with processor damage or system damage.

LOGOUT NOT EXIST

No log data is available for the error.

LOGOUT PURGE

The date and time the log was cleared.

SUCCESSFUL RETRY

The error condition was retried without another error.

UNSUCCESSFUL RTY

The error condition was retried and another error occurred.

CHANNEL RST

An X indicates that the channel(s) (00 through 08) were reset because of the failure. A channel ID of 00 through 08 shows the ID of a channel that was removed from use because of an error.

4381
B/M 2676380

Mi
Seq GF025

PN 6169383
2 of 5

EC A20558
01 Oct 84

Processing Unit Microword Directory Screen

Two Processing Unit Microword Directory screens contain a record of the information stored in the PU control storage registers at the time of a failure.

To display the Processing Unit Microword Directory screens:

1. Press MODE SEL.
2. Key in QEPM and press ENTER. The first Processing Unit Microword Directory screen is displayed.
3. Press ENTER to display the second screen.

While either of the screens is displayed, pressing ENTER will display the other screen.

Label Identification

Note: A * next to one of the fields shows the field contains microinstruction address or data existing at the time of failure.

ID: The same ID as the Processing Unit Logout Directory screen.

CREG: The microinstruction performed at the time of failure.

CREGSAVEA, CREGSAVEB, and CREGSAVEC: The last three microinstructions performed.

CSARBU: Address of the microinstruction performed at the time of failure.

SAVERG: Address of the next-to-last microinstruction.

CK STOP, RTY FLAG, GHERDARD, GHERDASP, GHERDACC, and COMMUNICATION: Contain additional error information intended for engineering use only.

Examples of PU Microword Directory Screens

```

PROCESSING UNIT MICROWD LOGOUT DIRECTORY      MODEL:4381 SERIAL NUMBER:012345
ID  PU  CREG      CREGSVA  CREGSVB  CREGSVC  CSARBU  SAVERG  CK  STOP  RTY  FLAG
01B5 1   020057F1 *D0800000 00000000 00000000 008004 000004 00400000 85428810
01B4 0   7FF97FFB *D0800000 00000000 00000000 008004 000004 00400000 C4008800
01B3 0   020057F1 *D0800000 00000000 00000000 008004 000004 00400000 84200000
01B2 1   020057F1 *D0800000 00000000 00000000 008004 000004 00400000 84010000
01B1 0  *B8B06A30 F2001F00 FFFFFFFF B8B06A30 *01702C 01702C 00400000 84000000
01B0 1   020057F1 *D0800000 00000000 00000000 008000 000004 00400000 84000000
01AF 0   020057F1 *D0800000 00000000 00000000 008000 000004 00400000 84010000
01AE 1   02105079 *02105079 91423B78 1C005B71 017678 017678 00400000 84200000
01AD 1   02105079 *02105079 91423B78 1C005B71 017678 017678 00400000 84010000

COMMAND: QEPM                                ==> PRESS ENTER
>
    
```

```

PROCESSING UNIT MICROWD LOGOUT DIRECTORY      MODEL:4381 SERIAL NUMBER:012345
ID  PU  GHERDARD  GHERDASP  GHERDACC  COMMUNICATION
01B5 1   050200C0 00000014 C4008000 00000000 00000000 12019281 00000000
01B4 0   41000040 00008200 00000000 00056000 00000000 92870000 00000000
01B3 0   60000080 00005306 1440000C 680000A0 00000000 92870000 00000000
01B2 1   020080C0 0D080000 00000000 00000000 00000000 12019281 00000000
01B1 0   60000000 0000E87E 04000000 00000000 00000000 12019281 00000000
01B0 1   020057F0 0D080000 00000000 00000000 00800000 92879880 00000000
01AF 0   020057F0 0D080000 00000000 00000000 00800000 92879880 00000000
01AE 1   60000000 04000000 008000C0 00000000 00000000 911201E0 00000000
01AD 1   600000C0 00005030 04000000 00000000 00000000 12019281 00000000

COMMAND: QEPM                                ==> PRESS ENTER
>
    
```

Processing Unit Logout Summary

A Processing Unit Logout Summary screen is provided for each processing unit. The Processing Unit Logout Summary screens contain error statistics for sections of the processing units.

To display the Processing Unit Logout Summary screens:

1. Press MODE SEL.
2. Key in one of the following:
 - QEPS0 for processing unit 0 (PU0)
 - QEPS1 for processing unit 1 (PU1).
3. Press ENTER.

Each entry on the PU Logout Summary screen has two counters. The counters in the left-hand columns can be changed or reset by moving the cursor to the counter location and entering the desired value. The counters in the center columns collect over the life of the machine; they cannot be reset.

Machine status and storage error statistics are displayed in the left-hand side of the screen. The rest of the screen has error statistics for each area of the processing unit.

Label Identification

SUCCESSFUL RETRY: The processor retried a machine check successfully.

UNSUCCESSFUL RETRY: The processor did not retry a machine check successfully.

UNRTY (RETRY 1): An unretriable machine check occurred.

UNRTY (RETRY 2): An unretriable machine check occurred during retry.

UNRTY (NO RETRY): The processor was operating with check control in no retry mode when a machine check occurred.

CK ST (RETRY 1): The processor went to check stop on a machine check.

CK ST (RETRY 2): The processor went to check stop on a machine check that occurred during retry.

CK ST (SKIP LOG): The processor was operating with check control in no log. A machine check occurred during retry, the counter was updated but no log was recorded.

CK ST (MC RESET): A machine check occurred during processor IML or system reset.

KEYS: A storage key error occurred.

DBE HARD-HARD: A storage double-bit error where both bits are solid failures.

DBE HARD-SOFT: A storage double-bit error where one bit is a solid failure and the other bit is an intermittent failure.

DBE SOFT-SOFT: A storage double-bit error where both bits fail intermittently.

HARDWARE COUNTER: Records the number of single-bit main storage errors.

```

PU LOG SUMMARY MODEL: 4381 SERIAL: 012345 LOCAL TOD EQU: yy/mm/dd hh mm ss
001D 001D SUCCESSFUL RTY 0064 0064 CS CONTROL 000B 000B CH DATA BUFFR
0006 0006 UNSUCCESS. RETRY 0018 0018 CS ARRAY 0 001D 001D CH CONTROL
0022 0022 UNRTY (RETRY 1) 0014 0014 CS ARRAY 1 0015 0015 CH INTERFACE1
0014 0014 UNRTY (RETRY 2) 0015 0015 CS ARRAY 2 0019 0019 CH INTERFACE0
0000 0000 UNRTY (NO RETRY) 0011 0011 CS ARRAY 3 001D 001D ST CACHE 0
001B 001B CK ST (RETRY 1) 002D 002D IPU DATA FLOW L 000F 000F ST CACHE 1
0030 0030 CK ST (RETRY 2) 001E 001E IPU DATA FLOW H 0009 0009 ST CACHE 2
0010 0010 CK ST (SKIP LOG) 0016 0016 IPU SHIFTER 000F 000F ST CACHE 3
00E7 00E7 CK ST (MC RESET) 0027 0027 IPU SAR 0002 0002 ST CTL/ECC1 E
0007 0007 KEYS 0015 0015 IPU I-CYCLES 000B 000B ST CTL/ECC1 0
0000 0000 DBE HARD-HARD 001E 001E IPU INTRUPT 001E 001E ST BSM/ECC2 E
0000 0000 DBE HARD-SOFT 0012 0012 IPU TIMER 001E 001E ST BSM/ECC2 0
0002 0002 DBE SOFT-SOFT 0021 0021 IPU LS/EXT 000C 000C ST SAR
0002 0002 DBE UNCORRECTED 0017 0017 CL CONTROL 0 000B 000B ST KEYS
0000 0000 DBE CORRECTED 0000 0000 CL CONTROL 1 0035 0035 ST DLAT
00D8 00D8 TOTAL RETRY 0000 0000 UNSUCCESSFUL I/O 0000 0000 SUCCESS. I/O
000000 HARDWARE COUNTER

COMMAND: QEPS1 ==>
>PU1 MAN TEST >CHECK STOP CSAR: 013A80
PUO MAN TEST >CHECK STOP CSAR: 018520
370 4381 RC= 5DD218AE 00008000
    
```

4381	MI	PN 6169383	EC A20558				
B/M 2676380	Seq GF025	4 of 5	01 Oct 84				

PU Reconfiguration Data

The PU Reconfiguration Data screen records any reconfiguration that takes place because of a processing unit error. Up to thirty reconfiguration logs can be stored.

To display the last 15 reconfiguration logs:

1. Press MODE SEL.
2. Key in QEPR and press ENTER.

If there are more than 15 reconfiguration logs, the message PRESS ENTER is displayed at the bottom of the screen.

Label Identification

LOGID: The same ID as the Processing Unit Logout Directory screen (QEPD). Since all processing unit errors do not result in reconfiguration, all log IDs on the QEPD screen may not be displayed on the PU Reconfiguration Data screen.

TODC: The time of the failure.

Reconfiguration Data: Shows what areas of the processing unit have been reconfigured because of the error. The areas that can be reconfigured are:

- **CACHE**

Cache is reconfigured on a byte basis. If byte four of cache is bad, byte four is assigned to the backup area for all cache pages. The reconfigured bytes (0 through 7) are indicated by an X.

- **CACHE DIR**

If a part of the cache backup area is bad, the associated cache directory entry is used to flag the processor that this area of cache cannot be used. The cache directory has 32 associated classes (CONG. CL) with eight slots each.

- **CDB**

The channel data buffer has four extra buffers that can be used for reconfiguration: two extra buffers (X and Y) for channels 0 through 5 and two extra buffers (X and Y) for channels 6 through 8. The extra buffers are shown with the channels assigned to them.

- **STG DBE**

If a double-bit error occurs in main storage, the error type is displayed with the address of the failing doubleword. The error types are:

SS Both bits are failing intermittently (soft-soft). This error is not correctable.

HH Both bits are failing all the time (hard-hard). This error is correctable.

HS One bit is failing all the time; the other is failing intermittently (hard-soft). This error is correctable.

CR The error is correctable.

NC The error is not correctable.

ERR A machine check occurred while trying to analyze an error. The error type was not determined.

NE No error was found

The error type is displayed to the left if an even address failed and to the right if an odd address failed. The sample screen on this page shows a soft-soft, noncorrectable error for an even address.

PU.RECONFIGURATION DATA MODEL: 4381 SERIAL: 012345 TOD: yy/mm/dd hh:mm:ss										
ID	PU	TOD	EQUIVALENT	RECONFIGURATION DATA						ADDR
0008	0	yy/mm/dd	hh:mm:ss	SWAP	BUFF.	BYTE	--23-----			ADDR 0017E7C0
0007	0	yy/mm/dd	hh:mm:ss	CDB	CHANNEL	X03	Y05			ADDR 00103EC0
0006	1	yy/mm/dd	hh:mm:ss	MULT.	RECONFIG					ADDR 00087E00
0005	0	yy/mm/dd	hh:mm:ss	CACHE	BYTE	-1-----				ADDR 00000048
0004	1	yy/mm/dd	hh:mm:ss	CNT.	STG	BYTE	2/6	20=1		ADDR 00103A00
0003	1	yy/mm/dd	hh:mm:ss	CACHE	DIR.	CONG.	CL	10	SLOT 00	ADDR 0007AC00
0002	0	yy/mm/dd	hh:mm:ss	STG.	DBE.	SS	NC	--	--	ADDR 001FCFC0

LATEST LOGID: 0008
COMMAND: QEPR ==>

- **CNT STG**

Control storage is reconfigured to a 2K backup area on a byte pair basis. The screen displays the byte pair that was reconfigured, bit 20, and the address.

- **HW MULT**

If the multiply function fails, multiply instructions are done by microcode.

- **SWAP BUFF**

The swap buffer is reconfigured on a byte pair basis. The reconfigured bytes (0 through F) are indicated with an x.

LATEST LOGID: The last log that required reconfiguration.



Channel Interface Control Check (IFCC) Logs

LOG 075

Two channel IFCC log screens are available:

- Channel Interface Logout Summary
- Channel Interface Logout Detail.

Channel Interface Logout Summary Screen

The Channel Interface Logout Summary screen displays the number of Interface Control Check (IFCC) logs taken for each channel up to eight logs per channel. For channels with greater than eight logs, 8+ is displayed. The last channel to have an IFCC is displayed under LAST IFCC SAVED.

To display the Channel Interface Logout Summary screen:

1. Press MODE SEL.
2. Key in QEI and press ENTER.

Notes:

1. Only channels which are configured for the processor are displayed on the Channel Interface Logout Summary screen.
2. If a reconfiguration has taken place, the LAST IFCC SAVED field may point to a channel that is not displayed on the screen.
3. If multiple errors occur in a short time span, IFCC logging can be stopped to increase processor speed. If logging has been stopped, you can start logging again by clearing the channel interface logs or by re-IMLing. The processors must be in instruction stop while clearing the log. If a processor is in hardstop when the logs are cleared, logging will not continue when the system is started again.
4. If ** is displayed in the LAST IFCC SAVED field, no IFCCs have occurred since the IFCC logs were purged.
5. If you display one of the Channel Interface Logout screens (QEI or QEIDxxy) with the system running and an interface control check occurs, the General Selection (Q) screen is displayed. (This will occur for any console function screen.) If IFCCs are occurring and you want to display a console function screen, press STOP.

ERROR DISPLAYS		*INTERFACE CONTROL CHECK LOGOUTS*				
XXY=CHNLXX,L Y		PU/	IFCC	LAST	PU/	IFCC
DXXY DISPLAY		CHNL	LOGGED	IFCC	CHNL	LOGGED
				03		
		00	00		10	00
		01	02		11	00
P	PURGE IFCC LOGOUTS	02	00		12	00
		03	01		13	00
		04	00		14	00
		05	00		15	00
Q	GENERAL SELECT	06	00		16	08+
		07	00		17	00
		08	00		18	00
Z	RTN TO SYSTEM					
LAST PURGE: yy/mm/dd hh mm				==>		
COMMAND: QEI						

To clear the Channel Interface Logout Summary screen:

1. Set the CE Mode switch to CE Mode.
2. If either processor is running, press STOP on the operator console.
3. Key in QEIP, and press ENTER.
4. When prompted, key in P and press ENTER again. The IFCC log screens for all channels are cleared.

LOG 075

Channel Interface Logout Detail Screen

On the Channel Interface Logout Detail Screen, log 1 always contains information about the latest failure. If there are more than eight logs on the selected channel, 8+ is displayed for the selected channel on the Channel Interface Logout Summary Screen. Logs 1 through 4 contain information about the latest failures, and logs 5 through 8 contain information about the first four logs occurring after the logs were cleared. In this case, log 8 is the first error to occur after the logs were cleared.

To display the Channel Interface Logout Detail screen:

1. Press MODE SEL.
2. Key in QEIDxx and press ENTER. Where xx is the address of the PU/channel (00 through 08 for channels on PU0 or 10 through 18 for channels on PU1) that you want to display.
3. To intensify the tag lines active for a specific failure, key in QEIDxxy and press ENTER. xx is the same PU/channel and y is the log number (1 through 8) from the L field.

Note: If the sequence count (SQ) contains 68, 6C, or 78, the device address (DEVA) and logical address (SCHID) are invalid.

Label Identification

L: The log number.

TYPE: 370 if the device active at the time of failure uses 370 mode; 370X if the device uses 370XA mode.

DEVA: The address of the device the channel was working with at the time of failure.

SCHID: The operating system's logical device address (for 370XA mode only).

SQ: The microcode sequence count for the error. For information on sequence counts, see Volume A06, "Service Aids," "Catalog Numbers (S/370)" or "Catalog Numbers (S/370XA)."

ERROR LOGOUTS	---	ADDR---	-TAGS--	*CHANNEL	00	INTERFACE	LOGOUTS*	TOD: yy/mm/dd hh:mm:ss	ENGINEERING DATA			
L	TYPE	DEVA	SCHID	IN	OUT	SQ	IN	OUT	CNT	CAT	TOD	DATA
1	370X	0233	7777	44	32	11	55	77	FF	55	yy/mm/dd hh:mm:ss	00000000000000
2	370	000E	****	00	02	44	00	00	04	42	yy/mm/dd hh:mm:ss	0E00F01C20
3	370	000E	****	00	02	44	00	09	09	42	yy/mm/dd hh:mm:ss	2400201C92
4	370	000E	****	00	02	44	00	00	03	42	yy/mm/dd hh:mm:ss	0E00F01C20
5	370	000E	****	00	02	44	00	09	05	42	yy/mm/dd hh:mm:ss	2400201C92
6	370	000E	****	00	02	44	00	00	02	42	yy/mm/dd hh:mm:ss	0E00F01C20
7	370X	0233	8657	44	32	77	55	77	64	55	yy/mm/dd hh:mm:ss	00000000000000
8	370	000E	****	00	02	44	00	09	03	42	yy/mm/dd hh:mm:ss	2400201C92
TAGIN= REQ OPL DIS ADR SEL STA SRV/DAT TAGOUT= ADR CMD DAT SRV SUP OPL SEL												
COMMAND: QEID001												

TAGS IN: Tag in lines active on the channel at the time of failure as follows:

Bit:	0	1	2	3	4	5	6	7
Tag:	REQ	OPL	DIS	ADR	SEL	STA	SRV/DATA	Not used

Note: Tags In gives the tag values after the interface receivers. The interface lines can be different from the values of Tags In if a receiver fails.

TAGS OUT: Tag out lines active on the channel at the time of failure as follows:

Bit:	0	1	2	3	4	5	6	7
Tag:	Not used	ADR	CMD	DAT	SRV	SUP	OPL	SEL

Note: Tags Out gives the tag values before the interface drivers. The interface lines can be different from the values of Tags Out if a driver fails.

The abbreviations used for the tag lines are:

- ADR Address in/out
- SEL Select in/out
- CMD Command out
- SRV Service in/out
- DIS Disconnect in
- DAT Data in/out
- OPL Operational in/out
- STA Status in
- REQ Request in
- SUP Suppress out

BUS IN: Data on bus-in at the time of failure.

BUS OUT: Data on bus-out at the time of failure.

CNT: The number of times the same error occurred sequentially.

CAT NUM: The microcode catalog number for the error. For information on catalog numbers, see Volume A06, "Service Aids," "Catalog Numbers (S/370)" or "Catalog Numbers (S/370XA)."

TOD: Time-of-day equivalent of the error if the CNT field is one, or the time-of-day equivalent for the last error of the group if the CNT field is greater than one.

ENGINEERING DATA: Additional data logged to help identify the failure. The fields are all one byte long and are labeled:

Byte Field ID

- 0 CHSYNCO
- 1 CHDATA0
- 2 CHSYN1
- 3 CHDATA2
- 4 CHCMDR
- 5 CHIMODE (370XA only)
- 6 WRKPATH (370XA only)

TOD (top line): Time you requested the IFCC Logout Detail screen.

TAGIN=...TAGOUT=... (line 19): The tag lines active at the time of failure are intensified on this line for the log ID you entered.

4381	MI	PN 6169384	EC A20558	EC A20559			
B/M 2676380	Seq GF030	2 of 2	01 Oct 84	03 Dec 84			

POWER LOGS

LOG 085

Two power error logout screens are available:

- Power Error Logout Directory
- Power Error Logout Detail.

Power Error Logout Directory Screen

The Power Error Logout Directory screen displays the reference codes and times of the last 16 power logs. Line 00 represents the latest power log.

To display the Power Error Logout Directory screen:

1. Press MODE SEL.
2. Key in QEWD and press ENTER.

To clear the Power Error Logout Directory screen:

1. Key in QEWD and press ENTER.
2. When prompted, key in P and press ENTER again.

All the Power Error Logout screens are cleared.

POWER LOGOUT DIRECTORY			CURRENT TODC EQUIVALENT: yy/mm/dd hh:mm:ss
LINE	TODC EQUIVALENT	REFERENCE CODE	
00	yy/mm/dd hh:mm:ss	11A0920E	
01	yy/mm/dd hh:mm:ss	11D1600E	
02	yy/mm/dd hh:mm:ss	1141300E	
03	yy/mm/dd hh:mm:ss	11D1920E	
04	yy/mm/dd hh:mm:ss	00000000	
05	yy/mm/dd hh:mm:ss	00000000	
06	yy/mm/dd hh:mm:ss	00000000	
07	yy/mm/dd hh:mm:ss	00000000	
08	yy/mm/dd hh:mm:ss	00000000	
09	yy/mm/dd hh:mm:ss	00000000	
10	yy/mm/dd hh:mm:ss	00000000	
11	yy/mm/dd hh:mm:ss	00000000	
12	yy/mm/dd hh:mm:ss	00000000	
13	yy/mm/dd hh:mm:ss	00000000	
14	yy/mm/dd hh:mm:ss	00000000	
15	yy/mm/dd hh:mm:ss	00000000	

COMMAND: QEWD

TIME OF LAST PURGE: yy/mm/dd hh:mm:ss
==>

Power Error Logout Detail Screen

The Power Error Logout Detail Screen gives detailed information about the power system at the time an error occurs.

Note: Only the last four logs of the Power Error Logout Summary screen (00 through 03) can be displayed in detail.

To select the Power Error Logout Detail screen:

1. Enter QEWDxx; where xx is the selected line number from the Power Error Logout Summary screen (00 through 03).

Label Identification

POWER LOGOUT xx: The detail logout number you selected by entering QEWDxx.

REFERENCE CODE: The reference code that defines the power error condition.

TOD: The time of the failure.

CONTROL LATCHES AT TIME OF ERROR: The sequence of power control latches up to the failure.

POWER ERRORS: The power error(s) detected at the time of failure.

```

POWER LOGOUT: 00          REFERENCE CODE = 11D1350E   TOD = yy/mm/dd hh:mm:ss
                           CONTROL LATCHES ON AT TIME OF ERROR:
01) PICK K3              06) -1.5 PS111 START
02) PICK K4              07) -4.3 PS112 START
03) -2.2V PS103 START    08) +5V PS109 START
04) -1.5V PS105 START    09) +5V PS108 START
05) -4.3V PS106 START    10) +6V PS107 START

                           POWER ERRORS:
+6V PS107 CURRENT LIMIT

COMMAND: QEWD00          ==>

```

4381
B/M 2676380

MI Seq GF035	PN 6169385 2 of 2
-----------------	----------------------

EC A20558 01 Oct 84					
------------------------	--	--	--	--	--



SYSTEM TEST

SYS TEST 001

Contents

System Test/4381	SYS TEST 015
Introduction	SYS TEST 015
Wait State Codes	SYS TEST 015
ST4381 and ST4381XA Run Flowchart	SYS TEST 020
Channel-to-Channel	SYS TEST 025
3890 Initialization Procedures	SYS TEST 025
Using MVS Utilities to Copy System	
Test/4381XA	SYS TEST 030
4300-FRIEND	SYS TEST 035
Introduction to 4300-FRIEND	SYS TEST 035
How to Use 4300-FRIEND	SYS TEST 035
Loading 4300-FRIEND from the DIAG1	
Diskette	SYS TEST 035
Overview on Making a CCW Chain	SYS TEST 040
Specifying a Single CCW Chain	SYS TEST 040
Advanced Capabilities of 4300-FRIEND	SYS TEST 045
Specifying Multiple CCW Chains	SYS TEST 045
Symbolic I/O Areas	SYS TEST 045
CCW Chain Sequence Control and Delay	
Between CCW Chains	SYS TEST 050
Data Compare	SYS TEST 050
Increase/Decrease Counter	SYS TEST 050
Data Ripple/Random	SYS TEST 055
Predefined CCW Chains	SYS TEST 055
Storage Protection Key Modification	SYS TEST 055
Trace Function	SYS TEST 055
Special Storage Areas	SYS TEST 060
Unit Control Block (UCB)	SYS TEST 060
Information Requested by 4300-FRIEND	SYS TEST 065
4300-FRIEND Messages	SYS TEST 075
Status and Operator Messages	SYS TEST 075
Error Messages	SYS TEST 080
4300-FRIEND Commands	SYS TEST 095
Changing Existing CCW Chains	SYS TEST 115
Change Commands	SYS TEST 125
CCW Chain Execution Control	SYS TEST 125
CCW COMMANDS	SYS TEST 130
General CCWs	SYS TEST 130
Disk CCWs	SYS TEST 130
Fixed Block (FB) Commands - 3370	SYS TEST 135
Tape CCWs	SYS TEST 135
Card Reader/Punch CCWs	SYS TEST 140
Printer CCWs	SYS TEST 140
CRT and Hard-Copy Printer CCWs	
(3277/3278-3287)	SYS TEST 140
Teleprocessing CCWs (270x, 370x)	SYS TEST 145
CCW FLAGS	SYS TEST 150
CCW COMMAND MODIFIERS	SYS TEST 150

SYS TEST 001



Introduction

There are two versions of System Test for the 4381. Use System Test/4381 (abbreviation: ST4381) if your system runs in 370 mode *only*. Use System Test/4381XA (abbreviation: ST4381XA) if your system runs in 370XA mode *or* in both 370 and 370XA modes.

Note: ST4381XA is a limited use licensed maintenance program.

Use the flowcharts on this page and page SYS TEST 020 for general information on running either ST4381 or ST4381XA. The operation of either System Test is the same.

This page provides information about System Test. If you are not sure how to begin, read this page. Be especially attentive to the information about protecting customer data.

To run System Test, go to page SYS TEST 020.

For information on copying ST4381XA using MVS utilities, see page SYS TEST 030.

Note: For more information on running System Test, see the information shipped with your ST4381 tape and the information printed on the system printer after you IPL.

Wait State Codes

To display the wait state codes, press the STOP key. The code is displayed in the status area of the screen.

0000FF01: Enabled wait state at IPL time; ST4381 is waiting for the ENTER key to be pressed.

00DEAD01: An irrecoverable error on the operator console is preventing communication with the operator. More information may be available on the printer.

00DEAD02: An irrecoverable error occurred on the ST4381 load device. More information may be available on the printer.

00DEAD03: The ST4381 control program was damaged by an unexpected storage alteration or program interrupt, or a tape for S/370 mode (ST4381) was IPLed in S/370XA mode.

00DEAD04: Unrequested continuous interrupts are occurring when they are masked off. More information may be available on the printer or the operator console.

00DEAD05: An irrecoverable error occurred while changing processing units for an I/O operation.

00EEEEEE: System Test is terminated in response to the Terminate command. This is the normal end of test.

Reasons to Run ST4381

- To test the I/O configuration
- After you install an EC
- To attempt to repeat an earlier failure
- To copy your ST4381 tape.

Data Protection

Warning: Have You Protected The Customer's Data?

Magnetic Tape Drives

- Do not test a tape drive if it is shared by another system; always make it not available. Directions on how to do this are displayed, when needed, on the screen.
- Always install a scratch (spare) tape on the tape drives being tested.
- Always remove a customer's tape from a tape drive if you are not sure of its safety.
- Write a tape mark on all blank tapes (the screen gives directions when needed).
- Do not change the switches on tape control units with the communicator feature after the start of preconfiguration.

DASD Devices

- Do not test a DASD device that is shared. This slows system operation and may stop (lock out) the customer's processor. To prevent this, either make the shared DASD not available (drop it) or vary it to Test Level 2 (the screen gives you directions when they are needed).
- Install a CE pack on DASD with removable packs for level 1 testing.

To Run ST4381, You Need:

- A tape load device
- An operator console
- Two megabytes of processor storage
- The I/O devices to be tested
- An output printer (recommended).

Getting Ready To Run ST4381

1. Ensure that the processor is IMLed.
2. Ready your IPL device.
3. Display the Program Load (QL) screen, and ensure:
 - The correct mode is specified (S/370 or S/370XA).

To change the mode, display the QLI screen, and select the correct mode.

- U IPL UNIT specifies the ST4381 load device.
 - The correct processor is selected.
- To select the IPL processor key QT0 for PU0 or QT1 for PU1.

4. Display the QFO screen, and ensure that the console is in DISPLAY mode and that the display consoles have assigned addresses.

5. Make ready the devices to be tested.

Note: The hard copy output printer must be connected to the same processor used for IPL.

6. Go to the next page.

4381-3 B/M 2676380	MI Seq GG010	PN 6169387 1 of 2	EC A20558 01 Oct 84	EC A20560 18 Feb 85			
-----------------------	-----------------	----------------------	------------------------	------------------------	--	--	--

ST4381 and ST4381XA Run Flowchart

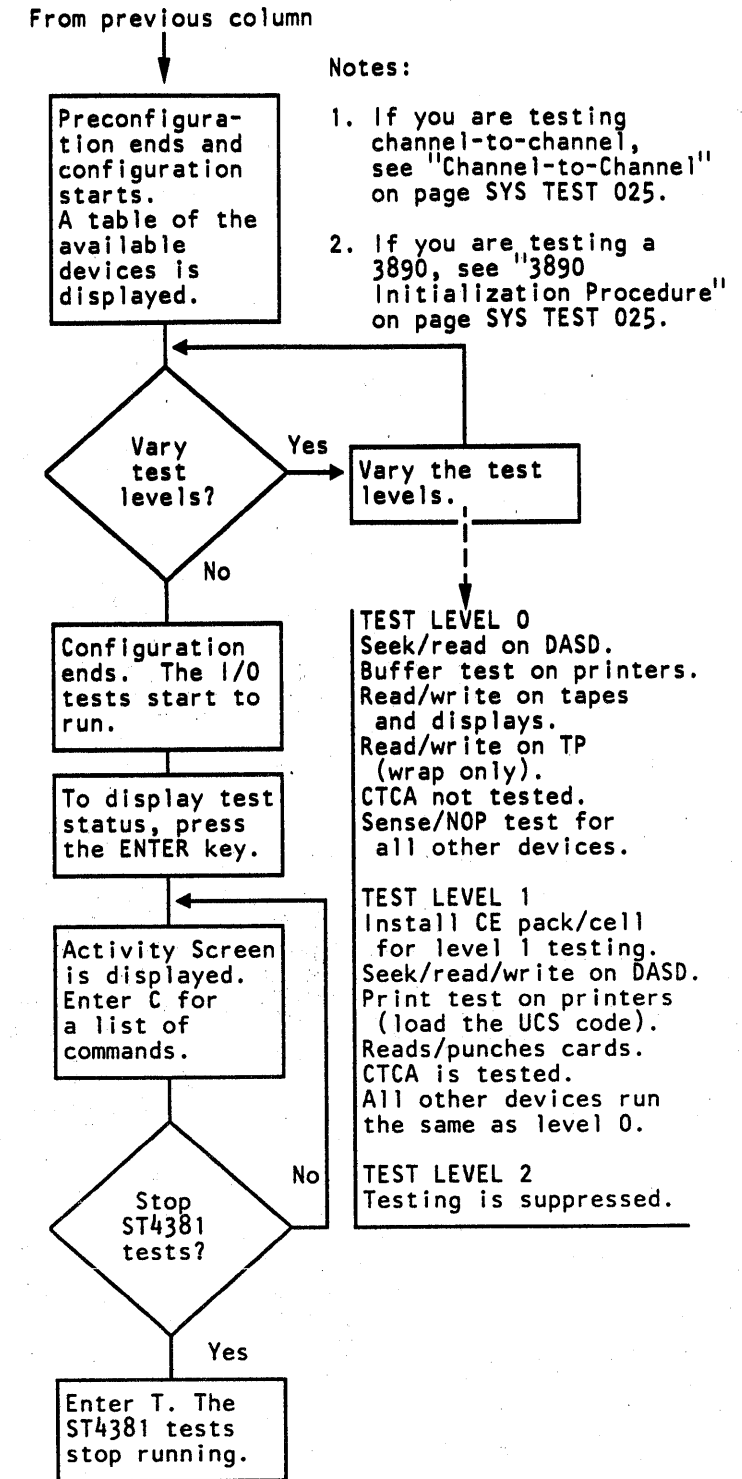
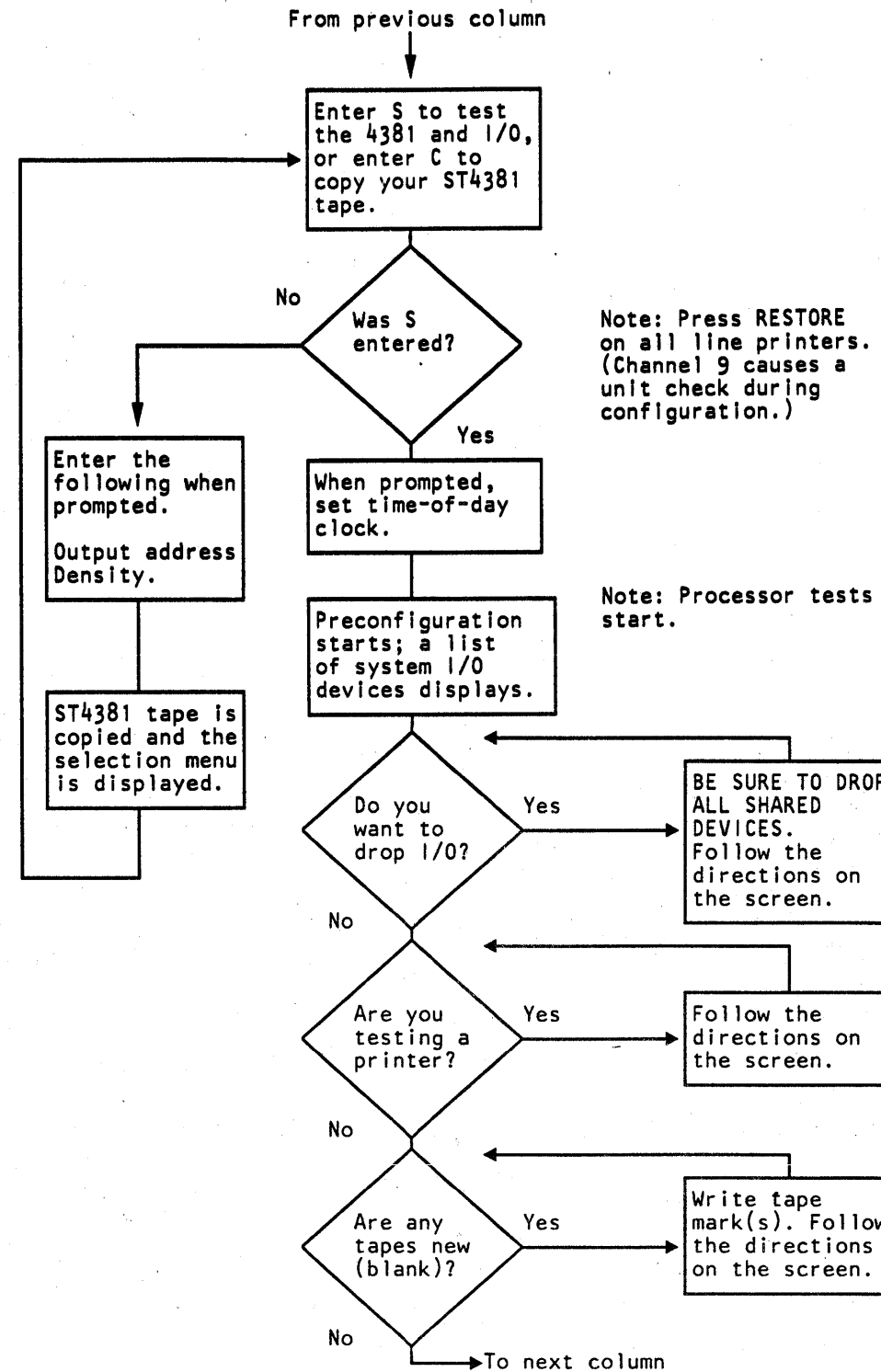
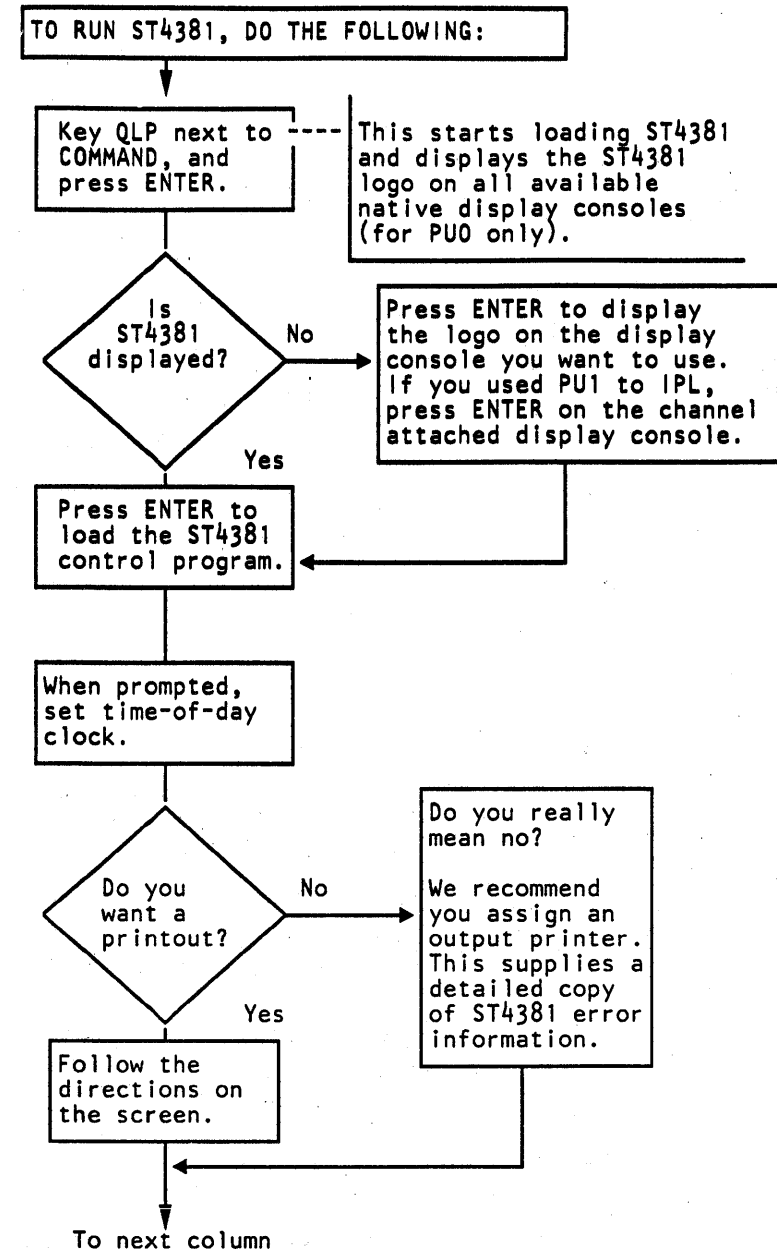

4381-3	MI	PN 6169387	EC A20558	EC A20560			
B/M 2676380	Seq GG010	2 of 2	01 Oct 84	18 Feb 85			

Channel-to-Channel

No testing is done on a channel-to-channel adapter or a 3088 unless they are varied to level 1 after configuration. Also, either run in wrap mode or run one of the following programs on the other CPU at the same time:

ST4300
ST370
NST-2
System Test/4381
System Test/4381XA.

3890 Initialization Procedures

To test a 3890 Document Processor with System Test/4381 or System Test/4381XA, do the following:

1. Ensure that functional coreload *FAO is loaded and that the test routine switch is set to image run.
2. Set all features to off using the operator panel. For details, see the *3890 Document Processor Operator's Guide*.
3. Install a jumper from 01B-C3J06 to ground. (This prevents time-outs.)
4. Set the On Line switch to On Line and press START.
5. After starting System Test/4381, make the 3890 not ready.
6. Vary the 3890 to test level 1.
7. Set the Test Routine switch to Process.
8. Place test documents in the hopper and press START. Testing of the 3890 begins.
9. Remove the time-out jumper at the end of the test.

MI Seq GG015	PN 6169388 1 of 2	EC A20558 01 Oct 84				
-----------------	----------------------	------------------------	--	--	--	--

Using MVS Utilities to Copy System Test/4381XA

Copy System Test/4381XA to one of the following Direct Access Storage Devices (DASD):

- 3330
- 3340
- 3350
- 3375
- 3380.

To copy System Test/4381XA:

1. Delete the System Test/4381XA data set if it exists.
2. Copy System Test/4381/XA to DASD.
3. Create an IPL record.

Use the following JCL for steps 1 and 2.

Note: All lowercase characters are installation dependent and must be specified by the user.

```
//COPYST      JOB      parameters
//STEP1      EXEC     PGM=IEFBR14
//DELDSN     DD       DSN=S80.SYSM,VOL=SER=valid,UNIT=disk,DISP=(OLD,DELETE)
//STEP2      EXEC     PGM=LOADER,REGION=1024K
//SYSLIN     DD       VOL=SER=S80TAP,UNIT=tape,LABEL=(3,NL),
//           DCB=(LRECL=80,BLKSIZE=2000,RECFM=FB,DEN=3),DISP=OLD
//SYSLOUT    DD       SYSOUT=A
//TAPEFILE   DD       VOL=REF=*.SYSLIN,UNIT=AFF=SYSLIN,LABEL=(,NL),
//           DCB=DEN=3,DISP=OLD
//DISKFILE   DD       DSN=S80.SYSM,VOL=REF=*.DEL.DELDSN,UNIT=disk
//           DISP=(,KEEP),SPACE=(2000,(3420,0,100),,CONTIG),
//           DCB=(LRECL=80,BLKSIZE=2000,RECFM=FB)
//SYSPRINT   DD       SYSOUT=A
```

Notes:

1. Correct execution results in a return code of 0. If the return code is not 0, refer to the SYSPRINT output for the error messages.
2. System Test/4381XA requires a new or empty data set. If the data set already exists, delete it and reallocate it prior to the copy.
3. The copy program requires a 100K region.

Use the following JCL for step 3.

Note: All lowercase characters are installation dependent and must be specified by the user.

```
//WR IPL     JOB      parameters
//STEP3     EXEC     PGM=ICKDSF
//SYSPRINT  DD       SYSOUT=A
//IPLTEXT   DD       DISP=SHR,DSN=S80.SYSM(U IPLDR),
//           VOL=SER=valid,UNIT=disk
//S80       DD       DISP=OLD,UNIT=disk,VOL=SER=valid
//SYSIN     DD       *
//          REFORMAT DDNAME(S80) VERIFY(valid) IPLDD(IPLTEXT)
//          /*
```

4381
B/M 2676380

MI Seq GG015	PN 6169388 2 of 2	EC A20558 01 Oct 84				
-----------------	----------------------	------------------------	--	--	--	--



Introduction to 4300-FRIEND

4300-FRIEND (Fast Running Interpreter Enabling Natural Diagnosis) is a test tool that lets you analyze complex I/O problems. It is a stand-alone, offline program that requires 64K bytes of customer storage and a display console.

4300-FRIEND supports all channel command words (CCWs) for most S/370 files, drums, tapes, card reader/punch units, and teleprocessing devices. You enter each channel command from the console keyboard. Channel programs for up to 99 devices can be entered and run at the same time.

If 4300-FRIEND needs any additional information about the command (such as record numbers or data length), the program asks you for the information.

How to Use 4300-FRIEND

Loading 4300-FRIEND from the DIAG1 Diskette

Note: To run 4300-FRIEND to Processing Unit 1 (PU1) requires a display console attached to channel 0 on PU1.

To load 4300-FRIEND from the DIAG1 diskette:

1. Do a system IML (S/370 mode).

Note: If your normal console keyboard language is Japanese/Katakana, use the QFL screen to select U.S. English before running 4300-FRIEND. For information on changing console keyboard language, see Volume A06, "(QFL) Language Configuration."
2. Key QCLEAR next to COMMAND, press the ENTER key.
3. Key QFO next to COMMAND and then key N next to PRT/KYBD, press the ENTER key.
4. Set the CE Mode switch to CE Mode.
5. Key either QTO or QT1 next to COMMAND to select PU0 or PU1, press the ENTER key.
6. Key QLKE next to COMMAND, press the ENTER key. Message MOUNT PROPER DISK, ENTER is displayed.
7. Remove the FUNC2 diskette from diskette drive 2, insert the DIAG1 diskette into diskette drive 2, and press the ENTER key. After 4300-FRIEND is loaded, message REMOUNT FUNCTIONAL DISK is displayed.
8. Remove the DIAG1 diskette and insert the FUNC2 diskette into diskette drive 2.
9. Press the MODE SEL key on the system display console (the keyboard near the OCP).
10. Key QRES next to COMMAND, press the ENTER key.

Note: If you are using a single console system, do steps 11 through 13; if you are using a multiple console system, skip steps 11 through 13, and go to step 14.

11. Key QZ next to COMMAND, press the ENTER key.
12. Press the ENTER key twice (4300-FRIEND starts running).
13. Enter your replies to the 4300-FRIEND requests.
14. Press the ENTER key on the display console that you want to use to control 4300-FRIEND.
15. Enter your replies to the 4300-FRIEND requests on the display console you selected in step 14. (You can now use the system display console for normal manual system console functions while the display console you selected in step 14 is controlling 4300-FRIEND.)

The following lists 4300-FRIEND requests. For details about these requests, see "Information Requested by 4300-FRIEND."

ADR=	LOG START=
ATT=	MASK=
BBCCHH=	MASK BYTE=
BL OFFS=	MLCCBCCCHRRDDS=
BLCK CNT=	MODE (BC/EC)=
CMD=	MODE CMD=
CYL=	MODEL=
DATA=	NUMBER OF TIMES=
DEV=	OP BYTE=
DEV ADDR=	PHY START=
DEV TYPE=	RCD NO=
DL=	REPL CNT=
HARD COPY(Y/N)=	SD=
HD=	SEC PRINTER ADDR=
IDAWS IN HEX=	SECOND SD=
KEY=	THIRD SD=
KL=	WCC=
LOG END=	

The following lists 4300-FRIEND commands. For details about these commands, see "4300-FRIEND Commands."

\$\$?	I
\$\$nnn,*	INCREASE
\$*=hh	INT
? or ??	KEY CAW
ACTIVATE	KEY CCW
ADD	KEY DATA
ALARM	KEY IDA
ALTER KEY	LIST
ALTER nnn	LOOP
BMPX	NO ALARM
BTS	NO BMPX
BUILD	NO COMPARE
CCW	NO DATA DUMP
CHANGE KEYBOARD	NO DECREASE
CHANGE nnn	NO HALT
CLEAR	NO INCREASE
CLEAR\$c	NO INT
COMPARE	NO TEST I/O
CONFIG	NO TIME DELAY
CONNECT	NO WAIT
COPY	POINTER CCW
COUNTER	POINTER DATA
CREATE	POINTER IDA
CSW=xxx	PRINT SENSE
DATA DUMP	PSW
DECREASE	QUIT
DEVICE=	REMOVE
DISCONNECT	REP
DISPLAY	RESET
DUMP \$	RETURN
DUMP KEY	SCOPE
DUMP	SENSE
DUMP T	SET FB
EX CLRIO	SIZE
EX HDV	START READER
EX HIO	STATUS
EX STIDC	STOP
EX TCH	SUBST
EX TIO	TEST I/O
FLAG	TIME DELAY
GO	TRACE
HALT	WAIT
HELP	

Summary on Making a CCW Chain

To make a CCW chain:

- Respond to 4300-FRIEND requests (see "Information Requested by 4300-FRIEND").
- Respond to 4300-FRIEND messages (see "4300-FRIEND Messages").
- Optionally specify a predefined CCW chain (see "Predefined CCW Chains").
- Specify 4300-FRIEND commands (see "4300-FRIEND Commands").
- Specify CCW commands (see "CCW Commands").

Specifying a Single CCW Chain

To specify a single CCW chain:

1. Specify the device address of the unit you want to test when 4300-FRIEND asks for it (DEV=).
2. When COMMAND appears on line 20, key a CCW command and press the ENTER key.
3. Key any additional information 4300-FRIEND requests.
4. After you have specified the entire CCW chain, key GO and press the ENTER key. The device performs the operation you requested.
5. If you want to specify another CCW chain, press the REQUEST key.
6. When the PROCEED indicator turns on, key RESET or I.
7. Go to step 1, and specify the new CCW chain.

Examples of a Single CCW Chain

The following example instructs 4300-FRIEND to first seek cylinder 5, head 5 and then to seek cylinder 198, head 9 on device address 260.

```
DEV=DEVICE ADDRESS=260 (Enter address)
ENTER CCW LIST IN ENGLISH
seek          (Enter command)
CYL=5        (Enter number)
HD =5        (Enter number)
seek          (Enter command)
CYL=198      (Enter number)
HD =9        (Enter number)
go
reset
```

The next example instructs 4300-FRIEND to read one block of data from a fixed block device (3370).

```
DEV= 240
I/O= 438100-337000
CHAR= 3008210102...
set fb
ENTER CCW LIST IN ENGLISH
def ext
MASK BYTE= c0
PHY.START=
LOG.START=
LOG. END = 31
locate
OP. BYTE = 06
REPL. CNT=
BLCK. CNT= 32
BL. OFFS.=
read fb
DL= 16384
loop 1
go
LOOP IS FINISHED ON UNIT 0240
```

Restrictions

4300-FRIEND inserts TIC *-8 or SET FILE MASK CCWs if you leave it out. This can cause a not valid CCW chain.

Example of an Invalid CCW Chain

```
seek
CYL= 5
HD= 1
search ha eq
write r0
N 10
SET FILE MASK INSERTED
(Placed before the WRITE RO)
KL= 0
DL= 100
```

The above CCW chain is not valid because the write r0 command is not directly preceded by a SEARCH CCW. You must specify a Set File Mask before the search ha command.

MI Seq GG020	PN 6169389 2 of 2	EC A20558 01 Oct 84				
-----------------	----------------------	------------------------	--	--	--	--

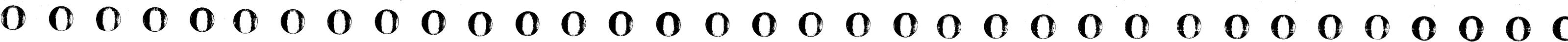

Advanced Capabilities of 4300-FRIEND

Specifying Multiple CCW Chains

To enter (and run) multiple CCW chains for the same or different devices, do the following:

1. Perform steps 1 through 4 in "Specifying a Single CCW Chain." (After you key GO and press the ENTER key, the first CCW chain begins to run.)
2. Press the ENTER key again (while the first CCW chain is running).
3. When PROCEED appears on line 20, key dev= xxx (xxx is a device address). You can enter the previously-specified device address or a different device address.
4. Do not key RESET.
5. Enter the CCW chain to be overlapped.
6. Key GO.
7. Repeat steps 2 through 6 to specify another CCW chain.

To change one or more of the CCW chains in a multiple CCW chain, see "Changing CCW Chains."

Example of a Multiple CCW Chain

This example assumes that you are overlapping a seek operation on devices 160 and 161.

```

DEV= 160
ENTER CCW LIST IN ENGLISH
seek
CYL= 0
HD = 1
seek
CYL= 100
HD = 2
go (First CCW chain starts to run)
(Press ENTER)

dev=161
(Enter address for next CCW chain)
seek
CYL= 100
HD = 3
seek
CYL= 200
HD = 4
go (Both CCW chains run)
    
```

Symbolic I/O Areas

You can reference the data address specified in one CCW from another CCW by using 4300-FRIEND. This lets you first read and then write the same data or vice versa. Also, by using the same area to read into and write from, you can conserve storage space.

For disk files, the symbolic I/O area applies only to the data area of any count-key-data (CKD) or key-data command. 4300-FRIEND uses data chaining to get the data field of these commands.

To use symbolic I/O areas:

1. Key the normal READ, WRITE, or PRINT commands followed by a comma and *into \$x* if the command is an input command, or *from \$x* if the command is an output command.

x can be any keyboard character, but we recommend you use characters a to z for easy cross-referencing. Characters entered in lowercase are converted to uppercase.
2. If your data is in character and hex format, use the CREATE/BUILD command. This command builds a symbolic output area that can be used by following write-type CCW commands.
3. If this is the first time you use a symbolic character, 4300-FRIEND asks for the more information. If you have already used the symbolic character and have not issued a RESET command, you are not asked for the data length or the data field. (The Symbolic Table generated by 4300-FRIEND contains the corresponding data address and the implied length of the data area.)

To get a list of the assigned symbolic names, use the DUMP\$ command.

Example 1: Writing Disk Records 0 and 1 from Same Area

```

DEV= 160
ENTER CCW LIST IN ENGLISH
seek
CYL= 5
HD = 1
set file mask
MASK= c0
search ha eq
tic *-8
write r0,from$a
($a points to data area)
KEY=
DATA= 500xf0f0 (1000 bytes of data)
write count key data,from $a
RCD NO.= 1
KEY=
go
    
```

Example 2: Using the CREATE/BUILD Command

```

DEV= 184
create 50,$b
(Creates area $b with length 50)
DATA= x02
DATA= 4cABCDEF1234
DATA= x03
DATA= (Press ENTER to end requests)
write,from$b
read backwards
read into $a
DL= 50
1-compare $a,$b
(Specifies data compare)
go
(Press ENTER)
counter (Prints loop counter)
01-UNIT=0184, LOOP= 0000000/0001585 -A
go (Restarts operation)
    
```

4381-3	MI	PN 6169390	EC A20558	EC A20560		
B/M 2676380	Seq GG025	1 of 4	01 Oct 84	18 Feb 85		

CCW Chain Sequence Control and Delay Between CCW Chains

The WAIT command causes 4300-FRIEND to wait until a CCW chain routine completes (device-end interrupt) before the next chain starts. You usually use the WAIT command with symbolic I/O areas when you are writing data that was read by a previous CCW chain. This ensures that all the data is read before the write CCW is run. You can also use the WAIT command for a single CCW chain.

To use WAIT:

1. Specify WAIT anytime during the entry of the CCW chain.
2. After you key WAIT in the last CCW chain, key GO.

Example 1: Tape to Printer (80/80 List)

```
DEV= 281
ENTER CCW LIST IN ENGLISH
read,into$a
DL= 80
wait
DEV= e
print,from$a
csw=01
sns=01
wait
go
```

Example 2: WAIT with Time Delay (Single CCW Chain)

```
reset
DEV= 185
ENTER CCW LIST IN ENGLISH
write
DATA= 100xf0f0
wait 500 (Causes delay of 500 ms
         after device end before
         starting the next write CCW)
go
```

Data Compare

Specify the COMPARE command anytime during the entry of a CCW chain. If you are using symbolic I/O areas, you must have already defined them. 4300-FRIEND compares the areas when it completes each CCW chain.

Example 1: Write and Read Disk Record Zero

In this example of the COMPARE command, \$r and \$s are any previously defined symbolic I/O areas. If you do not specify a compare length, 4300-FRIEND uses the length of the operand r for the amount of data to be compared.

```
DEV= 161
ENTER CCW LIST IN ENGLISH
seek
CYL= xa0
HD= 7
write ha (Writes home address
         from seek argument)
SET FILE MASK INSERTED
write r0,from$r
KEY=
DATA= 1800xf0f0
read r0,into$s
KL=
DL= 3600
compare $r,$s (Uses length of $r)
go
```

Example 2: Write and Read a Tape Record

In this example of the COMPARE command, d000 and d3e9 are the addresses of the areas you want to compare. (To obtain the addresses, use the CCW command.) 1000 is the number of bytes to be compared in decimal or hex.

```
reset
DEV= 180
ENTER CCW LIST IN ENGLISH
write
DATA= 1000xff
backspace
read
DL= 1000
ccw (Displays a CCW chain)
1-00A000 01 00D000 6000 03E8
2-00A008 27 00D3E8 6000 0001
3-00A010 02 00D3E9 6000 03E8
compare d000,d3e9,1000
(Compares data addresses)
go
```

Increase/Decrease Counter

Use the INCREASE or DECREASE command to increase or decrease a one- to four-byte field by a specified amount after each running of the CCW chain. You can use this function to change seek arguments in the data field of a CCW chain or to step a hex record counter.

Example 1: Record Counter for Tape

```
DEV= 180
write,from $a
DATA= 100c1234567890
(See data pointer address
 on the status line or enter
 STATUS command. ... C= 00A008,
 1 D= 00D3E8, 1 I=...)
To use last 4 bytes of write
data field as counter, subtract
4 from (D) data pointer.)
increase 4,d3e4,1,0,1
loop 1000 (Writes 1000 records)
go
LOOP IS FINISHED ON UNIT 0180
1-stop (Stops first CCW chain)
dev=180 (New UCB)
rewind
loop 1
go
LOOP IS FINISHED ON UNIT 0180
rep1
read,into $b
DL= 1000
increase 4,d3e4,1,0,1
(Updates old $a area)
compare $a,$b
(Compares record to expected one)
loop 1000
go
```

Example 2: Change a Device Address

This example shows how to test a certain range of device addresses for availability (see also CONFIG command).

```
DEV= 0
sense device,into$x
list=1 (Gets UCB address)
01-UNIT= 0000, UCB= 0D0000, FL=0019
00A000 E4 00D000 6000 0007
increase 2,d0000,1,xff,0
(Changes device address from
 X'000' to X'0FF')
data dump$x,*
(Dumps result of sense I/O)
go
```

MI Seq GG025	PN 6169390 2 of 4	EC A20558 01 Oct 84	EC A20560 18 Feb 85			
-----------------	----------------------	------------------------	------------------------	--	--	--



Data Ripple/Random

RIPPLE and RANDOM are CCW command modifiers that you can specify with a CCW command. If you specify RIPPLE or RANDOM, 4300-FRIEND searches for all CCWs to be rippled or randomized in the CCW chain and either ripples (moves the data pattern one byte to the left) or generates a random data pattern at each completion of the CCW chain. Random data is generated four bytes at a time, and data is rippled in blocks of 256 bytes. SEARCH, WRITE HA, and the count field of WRITE COUNT KEY DATA CCWs are bypassed.

Restrictions: Do not use RIPPLE or RANDOM with indirect data addressing (IDA) or with WRITE SPECIAL COUNT KEY DATA CCWs.

Example 1: Write Random Data on Disk

```
DEV= 161
ENTER CCW LIST IN ENGLISH
seek
CYL= 5
HD = 1
set mask
MASK= c0
write ha
write r0,random
KEY=
DATA= 3600xff (Data used for first
record and establishes data length)
read ha (Verifies home address)
read r0 (Verifies record zero written)
KL= 0
DL= 3600
go
```

Example 2: Ripple Data on Printer

```
reset
DEV= e
ENTER CCW LIST IN ENGLISH
space 1,ripple
DATA= 4cABCDEFGHIJKLMNOPQRSTUVWXYZ
csw=0100
loop
NUMBER OF TIMES= 500
go
```

Predefined CCW Chains

Specify \$\$xxx to use the predefined CCW chains (and data strings) provided by 4300-FRIEND. To display the available CCW chains, key \$\$?.

You may need to specify a RESET command or the device address (DEV=cuu) before using a predefined CCW chain. In some cases, the device address is fixed, and you must change it with the n-DEV=cuu or SUBcuu,nnn command.

The predefined chains are:

- \$\$001 Card to Printer (00C/00E)
- \$\$002 Sets Tape to 1600 BPI (181) and Copies Tape to Tape (180/181)
- \$\$010 Defines four UCS images for symbolic data areas \$A, \$H, \$1, and \$2. \$A = AN-train, \$H = HN-train, \$1 = PCS-AN train, \$2 = PCS-HN train. (Use Examples 1 and 2 below as a guide in the use of \$\$010.)
- \$\$101 3287 Ripple Print 1 (specify DEV=... before).
- \$\$102 3287 Ripple Print 2 (specify DEV=... before).
- \$\$103 3287 Color Print (specify DEV=... before).
- \$\$104 3287 Color Print of programmed symbols (specify DEV=... before).
- \$\$110 327x Display/read (specify DEV=... before). Two SIOs are used with increments on the screen buffer addresses, and the read data is compared.
- \$\$111 3278 Display/read (specify DEV=... before). Same as 110, but with a single SIO.
- \$\$119 327x Display with Increment (specify DEV=... before).
- \$\$5nn Type RESET before \$\$50n commands, and specify the device address DEV=...
- \$\$500 3310 - CE Track Initialization
- \$\$501 3310 - Read FB with Increment
- \$\$510 3370 - CE Track Initialization
- \$\$511 3370 - Read FB with Increment
- \$\$520 3370 - Verify CE Track
- \$\$521 3370 - Repair

Note: The 3262 Models 3 and 13 also run the 3287 CCW chains.

Example 1: Load 1403/3203 with PCS-AN Image

```
DEV= 00e
$$010
(Loads 4 UCS images
into symbolic area)
$$004
(Loads UCS buffer with PCS-AN image)
go
LOOP IS FINISHED ON UNIT 000E
```

Example 2: Load 1403/3203 with AN, HN, or PCS-HN Image

```
DEV= 00e
$$010
gtld (Needed for 1403 only)
load ucs,from $x
(x is either A (AN),
H (HN), or 2 (PCS-HN))
loop 1
go
LOOP IS FINISHED ON UNIT 000E
```

Example 3: Ripple Print Using the AN Image

```
This example assumes that you have loaded the UCS
buffer with the AN image (see Example 2 above).
DEV= 2e
$$010 (Gets train data images)
print,from$a,ripple
(Ripples AN-train image)
csw=01 (Masks unit exception)
sns=01 (Masks sense X'01')
loop 100 (Do 100 times)
go
LOOP IS FINISHED ON UNIT 002E
```

Storage Protection Key Modification

Use the KEY CAW, KEY CCW, KEY DATA, KEY IDA, DUMP KEY, and ALTER KEY commands to display or modify the storage keys of the different storage areas used for CCW chains. Initially, and after a RESET command, all areas are storage protected with key one (1). The current assignments are displayed on line 20 or after the STATUS command.

You can dump or alter the storage keys of any area with the DUMP KEY or ALTER KEY commands. You can alter the special areas for CCWs, data, and IDAW with the KEY CCW=, KEY DATA=, or KEY IDA= commands. You can display for each CCW chain the key used for the CAW with

the CCW= or LIST= commands in the third flag digit; you can alter it with the nn-KEY CAW= command.

Trace Function

Use the TRACE command to make a trace table in storage of all SIOs issued for, and all interrupts received from, the test devices during the running of the CCW chains. You can use the TRACE command instead of the GO command. If you specify the TRACE,* command, all SIOs, TIOs, and HIOs are traced, including those for the operator console and the secondary printer. You can restrict the trace to one device by specifying a device address with the TRACE command. The trace table start address is stored at location X'040C'; the current trace table pointer is stored at address X'0414'. Use the DUMP function after the trace loop is finished (or the running is stopped).

Example:

```
dump12,40c
00040C 000D2000000D3F70 000D28F0
```

The trace function stores trace information in 16-byte records.

The CPU timer value stored in the trace entry represents bytes 3 to 5 of the doubleword binary counter. The last digit of the stored value is decremented every 16 microseconds.

The one-byte repetition counter is incremented if identical trace entries (except the time value) are stored in sequence. The first entry is stored and all others are ignored.

An entry of 16 bytes containing all X'FF' indicates the end of the current trace area. If the trace reaches the last trace area entry, the trace again uses the first entry and all following. You can display the last trace entries or the complete trace table with the DUMP command; for example, DUMP x300,d20e0. The DUMPT command automatically displays the last trace entries (up to a maximum of 36).

Because the same storage area is used for predefined chains, these chains (command \$\$nnn) are destroyed after a trace run as well as the HELP command text.

MI Seq GG025	PN 6169390 3 of 4	EC A20558 01 Oct 84	EC A20560 18 Feb 85			
-----------------	----------------------	------------------------	------------------------	--	--	--

Special Storage Areas

- X'0300' Special TIO/SIO loop area.
- X'0400' Four-byte data area address (standard X'D000'). This address should point behind all other FRIEND areas because FRIEND uses the data space up to the end of the storage.
- X'0404' Four-byte CCW area address (standard X'A000' must start on double word boundary).
- X'0408' Four-byte IDA area address (standard X'9F80' must start on word boundary).
- X'040C' Four-byte trace area start address (standard X'4FFF' before storage end).
- X'0410' Four-byte trace area end address (standard X'2FFF' before storage end).
- X'0414' Four-byte current trace entry pointer.
- X'0418' Four-byte address of first unit control block (UCB).
- X'041C' Two-byte internal program version/level (xxyy).
- X'041E' Two-byte secondary output station (printer) address.
- X'0402' Two-byte keyboard device address.
- X'0422' Two-byte printer device address (for internal use).
- X'0424' Two-byte current test device unit address used for TIO.
- X'0426' Two-byte last test device used unit address used for HIO after 2x external interrupt (INT command).
- X'044C' Control indicator byte (INDBYTE)
 - X'01' = 3277-type console
 - X'10' = EC mode.
- X'044F' SP console control byte X'01' = SP console unit control block area; storage end = X'6FFF'.

To change where 4300-FRIEND locates the data area, the CCW area, or the IDA area, use the following patch (REP) card before the END (last) card, or alter the storage areas after 4300-FRIEND is loaded by the ALTER command. Note that CCWs start on doubleword boundaries and IDAWs on word boundaries ; these areas must not overlap. Assign the data area to the last part of the storage.

Patch Card Format

column
1234 7 17

&REP 000400 XXXX,XXXX
(XXXXXXXX is the address of the new data area)

2
9

ALTER command example:

DEV=DEVICE ADDRESS=(Any device address)
alter 8,400,xxxxxx (xxxxxx is address of new data area)

0003f8 xxxxxxxx
(Altered storage is displayed)
reset (Activates changes)
DEV=

Unit Control Block (UCB)

For each CCW chain that is made, 4300-FRIEND uses a special control block called a UCB. The address of each UCB can be displayed by the CCW= or LIST= commands. The length of one UCB entry is 48 bytes.

Byte		Size	Contents
Dec	Hex		
00	00	2	Device address
02	02	2	Chain flags:
			8000 Wait
			4000 Compare
			2000 Increase/decrease
			1000 Ripple/random/zero (plus indicator in CCW byte 5)
			0800 Data dump
			0400 Data dump on operator console
			0200 Continue if loop is finished
			0100 FB device
			00x0 CAW key
			0008 UCB is used
			0004 Device or control unit is busy
			0002 Chain being executed
			0001 Device ready (active)
04	04	4	CCW pointer = address of first CCW
08	08	2	CSW mask bytes set by CSW=command
10	0A	2	Sense bytes mask set by SENSE= command
12	0C	4	Time delay set by WAIT command
16	10	4	Time out counter for missing device end (TIME DELAY)
20	14	4	Operand one address of COMPARE
24	18	4	Operand two address of COMPARE
28	1C	2	Length of compare fields
30	1E	2	Length for DATA DUMP function
32	20	4	Address for DATA DUMP function
36	24	4	Address of the INCREASE/DECREASE table
40	28	2	Loop count; set by LOOP cmd (threshold)
42	2A	2	Number of SIOs run
44	2C	4	Not used

**Information Requested by
4300-FRIEND**

Listed below are the 4300-FRIEND requests and your replies to them. Enter decimal data with no separation; that is, 123456 (not 123,456 or 123 456). Enter an x before the hex data ; for example, x60. If you enter wrong information, 4300-FRIEND asks you to try again.

If a program loop occurs, enter the character i or perform a program (PSW) restart.

ADR=

Specify (in hex) a two-byte 3277 buffer address.

ATT=

Specify (in hex) a one-byte 3277 attribute character. The default is x60.

BBCCHH=

Specify (in hex) a six-byte 2321 seek argument.

Byte	Function/Range (hex)
0	—/00
1	Cell/00-09
2	Subcell/00-13
3	Strip/00-09
4	Head position/00-04
5	Head number/00-13

BL. OFFS.=

Specify a block offset value for the LOCATE fixed block command. Enter either a decimal value (0 to 4294967295) or a hex value (x0 to xffffff). The default value is 0.

BLCK. CNT=

Specify a block count value for the LOCATE fixed block command. Enter either a decimal value (1 to 65535) or a hex value (x1 to xffff). The default value is 1.

CMD=

Specify a 3277 command.

- 'EM' End of message - for printer
- 'EU' Erase unprotected + address
- 'FF' Forms feed - for printer
- 'IC' Insert cursor
- 'MF' Modify field + attribute character
- 'NL' New line - for printer
- 'PT' Program tabulator
- 'RA' Repeat to address + address and fill character
- 'SA' Set attribute + attribute character
- 'SB' Set buffer address + address
- 'SF' Start field + attribute character
- 'SX' Start field extended + attribute character
- ' ' ENTER = no command
- '*' End of data stream (no code generated)

CYL=

Specify (in decimal or hex) a cylinder number for a seek command. The default is 0.

DATA=

Specify data. 4300-FRIEND repeats the DATA= request until no more data is entered. (You can specify both hex and decimal data for one symbolic data area by using the CREATE/BUILD command.)

Specify the data in one of the following formats:

- nnxhhhhh or nncdddd
- nn is an optional decimal duplication factor.
- x indicates hex data.
- hhhhh is the hex data.
- c indicates EBCDIC data.
- dddd is the EBCDIC data (up to 242 characters). 4300-FRIEND does not convert lowercase characters to uppercase.

Example of DATA=

- DATA= 100xff (100 bytes of X'FF')
- DATA= 1000xf0f0 (1000 groups of X'FOFO')
- DATA= 80c1 (80 bytes of X'F1')
- DATA= 12cabC (12 groups of X'818283')
- DATA= 12cABC (12 groups of X'C1C2C3')
- DATA= 12cAaB (12 groups of X'C181C2')
- DATA= Press ENTER (after all data is entered)

DEV=DEVICE ADDRESS=

(appears first time only)

DEV=

(all other times)

Specify a device address in hex. Leading zeros are not required. If you do not specify a device address, 4300-FRIEND uses the last entered device address or enters the command input mode ,if you didn't specify a device address before. For more details, see the "DEVICE=" command.

DEV. ADDR=

Specify the device address of the new operator console or the address of the secondary output station, the printer. If the secondary output station address is set to zero, the secondary printer function is not active.

DEV. TYPE

Specify the type of new console.

- 1052 1052-type console
- 327x 327x-type console
- PRT Secondary output printer, which must accept a X'09' print command. The PRT function is not used for a 1052 and SP console.
- SP System console with X'83' op code enabled.
- TP Terminal printer as secondary output required.

DL=

Specify the data length; either a decimal (1 to 32767) or hex (x0001 to x7ffff) value. The default value is 1.

ENTER DEVICE TYPE (32xx)=

If the device did not respond to the Sense ID command, 4300-FRIEND requests the printer device type for the UCSB load.

ENTER TIME hh:mm:ss=

Enter the current time of day. The default time-of-day is zero.

HARD COPY (Y/N)=

Specify Y for a copy of all console messages; press the ENTER key if you do not want a copy (4300-FRIEND defaults to the N reply).

HD=

Specify (in decimal or hex) a head number. The default is head 0.

IDAWS IN HEX=

Specify the real storage addresses for the IDA address list (IDAWs). Enter as many addresses as required, separated by commas (leading zeros are not required). Do not use storage range X'0000' to X'A000' (the 4300-FRIEND program resides there). If data is requested for the CCW, 4300-FRIEND automatically moves the data to the specified real storage area(s).

KEY=

Specify the key for the data field. Enter the data as shown for DATA=.

KL=

Specify the key length. Enter either a decimal (0 to 255) or hex (x00 to xff) value. The default value is 0.

LOG. END=

Specify the logical end for the DEFINE EXTENT fixed block command. Enter a decimal value (up to 4294967295) or a hex value (up to xfffffff). The default is the value read by the READ DEVICE CHAR fixed block command.

LOG.START=

Specify the logical start for the DEFINE EXTENT fixed block command. Enter a decimal value (up to 4294967295) or a hex value (up to xfffffff). The default value is 0.

MASK=

Specify (in hex) a one-byte file mask for the SET FILE MASK command (for example, MASK=18). The default is X'CO' (press the ENTER key).

MASK BYTE=

Specify (in hex) a one-byte mask for the DEFINE EXTENT fixed block command. If you do not provide a mask, the default mask for the first 12 bytes of the data area is X'00'. 4300-FRIEND sets the last four bytes in the data area to the value read by the READ DEVICE CHAR command (logical end).

MLCCCBBCCHHRDDS=

Specify (in hex) 15 bytes of buffer control information for the buffer control record (this is the record transferred to the 2314 on an INIT BUF command).

- M Mode byte; 81 (needs write buffer) or 01
- L Length byte; 6D
- CCC Command 1 (00, 07, 13)
Command 2 (29, 31, 69, A9, E9)
Command 3 (05, 06, 0D, 0E, 16, 1A, 35, 3D)
- BBCCHH Seek argument
- R Record number
- DD Data length
- S Search key length

Example:

INIT BUF
MLCCCBBCCHHRDDS= 816d0731350
00000c3000101005000

WRITE BUF
DATA= 40xf0f0

MODE (BC/EC)=

Specify the control mode; BC for Basic Control mode or EC for Extended Control mode. The default is EC.

MODE CMD=

Specify (in hex) a MODE SET command code. The default is x93 (7-track tape/800 bpi).

MODEL=

Specify 81 for the processor model. This chooses the proper time calculation for the WAIT and TIME DELAY commands.

NUMBER OF TIMES=

Specify the number of times you want to run the last entered CCW chain or the CCW chain specified in the LOOP command. Enter 1 to 32767 in decimal.

OP. BYTE=

Specify (in hex) the operation byte for the LOCATE fixed block command. The default is X'06'.

PHY.START=

Specify the physical start for the DEFINE EXTENT fixed block command. Enter a decimal (up to 4294967295) or hex value (up to xfffffff). The default is 0.

RCD NO.=

Specify the record number to be used in the file identifier field. Enter a decimal (0 to 255) or hex value (x00 to xff).

REPL. CNT=

Specify the replication count for the LOCATE fixed block command. Enter a decimal (0 to 255) or hex value (x00 to xff). The default is 0.

SD=

Specify (in decimal) the defect skip displacement for the 3340/3350 home address.

SEC. PRINTER ADDRESS=

Specify either the device address of the secondary output printer on which a hard copy of all operator messages are to be printed or UCSB which invokes the UCBS load routine to load a UCS buffer. You can enter the optional LOG operand after the printer address; for example, OE,LOG. This causes the call of the PRINT LOG function. If you want to modify the secondary printer address later, use the CHANGE KEYBOARD command.

SECOND SD=

Specify (in decimal) the second defect skip displacement for the 3340/3350 home address.

SELECT UCS-TYPE (xx,xx,xx,xx)

Select a UCS buffer type from a displayed menu.

THIRD SD=

Specify (in decimal) the third defect skip displacement for the 3340/3350 home address.

WCC=

Specify (in hex) the 3277 write control character. The default is X'C3'.

XATT

Enter 327x extended data stream attribute TYPE/VALUE pair as four hex digits. If commands START FIELD EXTENDED or MODIFY FIELD were specified, you can enter more than one attribute pair. To end the sequence, enter '*'. If you press the ENTER key only, value X'C040' is entered and the sequence ends.

MI Seq GG030	PN 6169391 2 of 5	EC A20558 01 Oct 84				
-----------------	----------------------	------------------------	--	--	--	--



4300-FRIEND Messages

If a message starts with *, 4300-FRIEND waits before displaying the message so you can use the ENTER key to stop the processing. Status information is displayed as follows (the current UCB is displayed together with area pointers):

aa nn-ccuu-ff C=xx,kf D=xx,kf l=xx,kf mm

• aa indicates the following:

COMMAND	Key a 4300-FRIEND command.
REPLACE	Key a replacement CCW command.
RESPOND	Key requested information.
RUNNING	4300-FRIEND is running CCW chain(s). If stop address X'ODEADO' is displayed, 4300-FRIEND is waiting for an I/O interrupt from a device being tested. You can enter 4300-FRIEND commands during this mode without stopping the processing.
TRACING	4300-FRIEND is tracing CCW chain(s) as they run.
SCOPING	4300-FRIEND is looping on a SIO or TIO command.
TIOLOOP	4300-FRIEND is repeating a TIO command.
PRNTLOG	PRINT LOG function; copies the screen to a printer.
WORKING	4300-FRIEND commands are running; no action is required.

- nn = Chain number
- ccuu = Unit address
- ff = Flag bytes
- C=xx = CCW area address
- k = Area key
- f = Fetch protection on if F
- D=xx = Data area address
- l=xx = IDA area address
- mm = Block multiplexer mode (BMPX) or selector mode (SEL).

Status and Operator Messages

\$x aaaaaa llll

Appears after the DUMP\$ command. x = the symbolic I/O area name; aaaaaa = address (in hex) of the area; llll = length (in hex) of the area.

aaaaaa K=k,F=f,R=r,C=c

Displays the storage protection keys of a 2K storage area. Address aaaaaa is the first byte of the area; k = storage key in hex; f = fetch protection on if 1; r = reference bit on if 1; c = change bit on if 1.

CHAR= xxx...

Displays the data received for a READ DEVICE CHAR fixed block command.

COND CODE= n ON UNIT xxxx

Displays condition code n for device xxxx after an XTIO, XCLRIO, XHIO, XHDV, XTCH, or XSTIDC command. This message is also displayed to indicate the status of the Test I/O.

Condition code 0 indicates that device xxxx is ready and available. Condition code 2 indicates that the channel or subchannel to which the device is attached is busy. Condition code 3 indicates that the address is not recognized by a channel or any device on the channel. To enter commands, press the ENTER key and enter NOTEST. If SCOPE is active, 4300-FRIEND requires a PSW restart to exit from the scope loop.

COND CODE= 1 ON UNIT xxxx
CSW yy yy ... yy yy
SNS zzzzzzzzzz.zzzzzzzz

Displays the condition code, CSW, and sense bytes for device xxxx after an XTIO, XCLRIO, XHIO, XHDV, XTCH, or XSTIDC command.

This message is also displayed to indicate the status of the TEST I/O. Condition code 1 indicates that the CSW was stored.

EC-MODE SET, NO RESET POSSIBLE

Indicates that the Extended Control mode was set, and return to Basic Control Mode is not possible unless you re-IPL 4300-FRIEND.

ENTER CCW LIST IN ENGLISH

Displayed after you enter reply to DEV= at the beginning of a new CCW chain.

EXT-INTRPT BROKE CHAIN

Indicates that the INT feature was active and that the second external interrupt stopped 4300-FRIEND. The TIO mode is reset.

HALT

Displayed after 4300-FRIEND detects a condition that requires a program halt. To continue, specify GO.

HALT ON ERROR

Indicates that an error occurred during the running of a CCW chain. It also indicates a unit check or a permanent CU-busy condition at the device used for the START READER command.

ID = xxxx...

Displays the ID of the processor.

I/O= cccctt-ddddtt

Displays bytes two to seven of the Sense I/O command for the new device specified. This message does not appear if the Sense I/O command is not supported by the device (first byte is not X'FF').

LOOP IS FINISHED ON UNIT xxxx

Displayed if the CCW chain of unit xxxx has run the number of times specified by the LOOP command. The running of all active CCW chains is discontinued after waiting for outstanding I/O interrupts. If busy devices do not present their interrupt in the time specified by the TIME DELAY command, a Halt I/O is issued.

nn*UNIT=ccuu, LOOP=xxx/yyy - l

Appears after the COUNTER command. nn = CCW chain number; ccuu = unit address; xxx = loop threshold; yyy = SIO counter. l = active/stopped line indication.

nn*UNIT=ccuu, UCB=aaaaaa, FL=cccc

Indicates the UCB entry if you specified the CCW= or LIST= . nn = CCW chain number; ccuu = unit address; aaaaaa = address of 34-byte long UCB entry; cccc = active UCB flags.

nn-ccuu-ff C=xxx,kf D=yyy,kf l=zzz,kf mmm

Appears after the STATUS command. The current UCB is displayed together with area pointers. nn = CCW chain number; ccuu = unit address; ff = flag bytes; xxx = CCW area address; k = area key; f = fetch protection if F; yyy = data area address; zzz = IDA area address; C= CCW area; D= data area; l= IDA area; mmm = block multiplexer mode if BMPX or selector mode if SEL.

PRINTER NOT READY

Displayed if the secondary printer is not available or not ready. Make the printer ready or correct the device address.

SET FILE MASK INSERTED

Indicates that you did not specify a SET FILE MASK command. Therefore, 4300-FRIEND automatically inserted a Set File Mask CCW preceding the last CCW entered. Because the CCW chain being generated requires a set file mask if you specify a WRITE HA (home address) or WRITE RO (record zero) command, a not valid CCW chain may result.

START

Displayed after you start running the CCW chain by pressing the ENTER key without input GO.

STORAGE SIZE= xxxxxx

Displays (in hex) the storage size of the system.

TIC *-8 INSERTED

Indicates that you did not specify a TIC. Therefore, 4300-FRIEND automatically inserted a TIC *-8 CCW before the last CCW entered. Because the CCW chain being generated requires a TIC if you specify a Search CCW command, a not valid CCW chain may result.

UCSB LOAD SUCCESSFUL FINISHED

The UCS buffer load was successful.

UNIT=xxxx - COUNT=nnn

Indicates a DATA DUMP print out. xxxx = unit address, nnn = SIO counter.

WAIT UP TO 5 SECONDS UNTIL LOAD IS FINISHED

Indicates that the UCS buffer load is in process.

4300-FRIEND STANDARD OPTION SET

Displays all the standard options of 4300-FRIEND set during program initialization. If you want to change options, use the BMPX, NO BMPX, TIME DELAY nn, HALT, ALARM, or NO INT commands.

Error Messages

DEVICE END OR OTHER I/O INTERRUPT MISSING

Indicates that a working device did not issue an I/O interrupt within 15 seconds.

DEVICE NOT AVAILABLE, CC=3

Indicates that the specified printer is not operational.

-DEVICE QUEUE FULL, LAST CMD IGNORED

You have tried to enter more than 99 devices into the device queue. Enter RESET to clear the device queue, and start again.

-ENTER

"DEV=" OR "ADD" BEFORE CCW- You entered a CCW command with an incorrect UCB (device) assignment.

ERROR DURING UCSB LOAD

Indicates that an error was detected in the CSW during the UCSB load.

EXT-INTRPT, PSW = xxx/yyy E

4300-FRIEND detected an unexpected external interrupt. xxx is the old PSW for the interrupt.

E at the end of the message indicates an EC mode interrupt. In this case, yyy is the interruption code.

-IDAW POINTS TO PROGRAM AREA

Indicates that one of the specified IDA addresses points inside the 4300-FRIEND program. 4300-FRIEND ignores all entered IDAWs and repeats the request for IDAWs.

-INVALID MODEL, USE 31-41-81 OR 115-168 OR 25-75

Indicates that you specified the wrong model.

I/O-INTRPT, PSW = xxx/yyy E

4300-FRIEND detected an unexpected input/output interrupt (usually from other devices becoming ready). xxx is the old PSW for the interrupt. The CSW and sense data are also displayed.

E at the end of the message indicates an EC mode interrupt. In this case, yyy is the interruption code.

MCK-INTRPT, PSW = xxx/yyy E

4300-FRIEND detected an unexpected machine check interrupt. The log out area is saved so that it can be displayed by the DUMP command. xxx is the old PSW for the interrupt.

E at the end of the message indicates an EC mode interrupt. In this case, yyy is the interrupt code.

NO UCS SUPPORT FOR THIS DEVICE

The specified printer is not a 3203, 3211, 3262, or 3289 device.

PGM-INTRPT, PSW = xxx/yyy E

4300-FRIEND detected an unexpected program interrupt. xxx is the old PSW for the interrupt.

E at the end of the message indicates an EC mode interrupt. In this case, yyy is the interrupt code.

If PGM interrupts start to be displayed, do a PSW restart. If this does not help, reload 4300-FRIEND. For the DUMP, DISPLAY, or ALTER commands, this error can occur if the specified address is out of storage or the page is disconnected in VSE mode.

PRINTER NOT READY

CC=0 was not received from the printer during the UCSB load.

SVC-INTRPT, PSW = xxx/yyy E

4300-FRIEND detected an unexpected supervisor call (SVC) interrupt. xxx is the old PSW for the interrupt.

E at the end of the message indicates an EC mode interrupt. In this case, yyy is the interrupt code.

-SYMBOL TABLE FULL, LAST CMD IGNORED

You tried to enter more than 40 symbolic characters. To clear the symbol table, key CLEAR\$.

-SYNTAX ERROR-

Displayed for misspelled statements or information, invalid or wrong number of characters, undefined CCWs, missing delimiter (comma), unknown verbs, etc. Key ? and correct the error.

-SYNTAX ERROR- ON INPUT

4300-FRIEND detected an error in the information entered for a DATA=, KEY=, or BBCCHH= request. Possible data field errors are missing x or c (indicates type of data) or no data after x or c. Enter ? and correct the error.

4381	MI	PN 6169391	EC A20558				
B/M 2676380	Seq GG030	4 of 5	01 Oct 84				

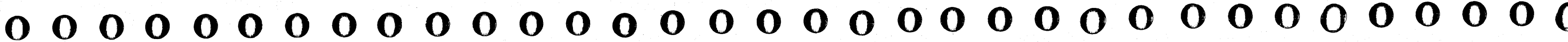

-UNDEFINED SYMBOL(S)

4300-FRIEND detected a symbol that was not previously defined. You cannot COMPARE or DUMP from a symbolic I/O area unless it has already been defined by a BUILD or CREATE command or the FROM or INTO CCW command modifier.

***UNIT=xxxx - CC=1 AFTER SIO**
CSW yyy
SNS zzz
LOOP nnn

Indicates that the Start I/O command is not accepted (condition code = 1). The CSW device status is not control unit busy or device busy or not a single channel end or device end/channel end (immediate commands). Check that the device is ready and online. LOOP counter nnn is not incremented and indicates the number of successfully initiated I/O operations.

***UNIT=xxxx - CC=3 AFTER SIO**
LOOP nnn

Indicates that the Start I/O command is not accepted (condition code = 3). LOOP counter nnn is not incremented.

***UNIT=xxxx - DATA COMPARE ERROR**
BYTE NO.=aaaa \$X=bb \$Y=cc
(one entry for each byte
that failed to compare)
LOOP nnn

Indicates a data compare error.

xxxx Device address.
 nnn Loop number that failed.
 aaaa Relative byte number of the two areas compared (first byte = 1).
 X Represents the first area and is a symbolic character if symbolic I/O areas were used (otherwise = 1).
 Y Represents the second area (= 2, if no symbolic area).
 bb Represents the hex byte in the first area.
 cc Represents the hex byte in the second area.

***UNIT=xxxx - INCORRECT CSW**
CSW yyy
LOOP nnn

Indicates any unusual status; for example, attention, unit exception, and any channel status in the CSW.

***UNIT=xxxx - I/O INTRPT,UNIT CHECK**
CSW 00 00D4E0 0E 00 0000
SNS 100020C800 0000000000 ...
LOOP 00662

Indicates that 4300-FRIEND received an I/O interrupt, and unit check is on in the CSW. 4300-FRIEND displays the device address that gave the unit check, the actual CSW, and the sense bytes received from the device. If the message ERROR ON SENSE is displayed in front of the sense data, the SIO sense ended with an not valid status.

***UNIT=xxxx - NO DEV-END OR CU-END I/O INTRPT**

Indicates that 4300-FRIEND did not receive a device end or control unit end within five to ten seconds after starting a CCW chain or receiving a control unit busy. The delay time depends on the number of devices running.

You can change the time delay with the TIME DELAY command. If a timeout occurs, 4300-FRIEND issues a HALT I/O to reset the device and then waits another time period for a device interrupt from the HALT I/O.



4300-FRIEND Commands

In general, 4300-FRIEND ignores all vowels, blanks, periods, and asterisks input except in data. You can use a comma to separate a parameter from the command.

For syntax errors or to repeat the previous input, enter a question mark (?).

If storage addresses are entered for a command, they must be entered in hex. Other numeric data (for example, data length) can be entered in either decimal or hex (an x must precede the hex value).

The first line of the commands shows the primary form of the commands; accepted alternate forms are listed after the primary form.

\$\$?

Use this command to display the first 79 source characters of all predefined CCW chains.

\$\$nnn,*

Use this command to display the source of predefined CCW chain nnn.

\$*=hh

Use this command to assign two hex digits (hh) for the characters \$ and *. The characters \$ and * in hex input fields are replaced by the digits assigned. The default value is X'FF'.

? or ??

Use this command (?) to display (and modify) the last input entered on a 3277-type console (up to 30 bytes). If you specify two question marks (??), the next to last input is displayed.

**nn-ACTIVATE,*
nn-ACT**

Use this command to reactivate a CCW chain(s). nn is the UCB number displayed by the LIST= function. If the optional parameter * is specified, all stopped CCW chains are activated (see "LOOP" command).

ADD

Use this command to add a CCW to the last CCW chain entered. (4300-FRIEND turns on the command chain bit in the preceding CCW.) For an existing CCW chain, additional CCWs can be added by using the nn-ADD command (see "Modifying Existing CCW Chains").

ALARM

Use this command to sound an audible alarm after a message appears that requires operator action.

To reset ALARM, see the "NO ALARM" command.

**ALTER KEY nnn,addr,k,f
ALTER KEY nnn,\$c,k,f
ALTER KEY \$c,k,f**

Use this command to alter the storage key for storage area addr or symbolic I/O area \$c (c can be any alphabetic character) to the key specified by k. This command also sets fetch protection on if you specify an f as the last operand. The length is nnn bytes.

**ALTER nnn,addr,hhhh
ALTER nnn,\$c,hhhh
ALTER \$c,hhhh**

Use this command to alter up to 80 bytes at address addr or symbolic I/O area \$c (c can be any alphabetic character). Data hhhh is moved to storage. The length nnn of the area to be altered can be specified in decimal or hex. After the alter operation, the changed data is dumped (this includes the preceding and following eight bytes).

BMPX

Enable block multiplexer mode

Use this command to set block multiplexer mode on (standard if you specify EC mode).

To disable block multiplexer mode, see the "NO BMPX" command.

BTS

Branch to TIO/SIO loop

Use this command to loop (using a small TIO/SIO loop at address X'300') the last CCW chain entered. Stop the loop by pressing the external interrupt button twice if INT is active. If INT is not active, do a PSW restart.

**BUILD nnn,\$c
BLD nnn,\$c
CREATE nnn,\$c
CRT nnn,\$c**

Use this command to reserve a symbolic data area \$c (c represents any alphabetic character). You can specify the length nnn of the area in decimal or hex. If you specify length zero (0), a data area with length one is created and no data is requested (pointer). The created data area can be used in all following CCWs until you specify the RESET command. (Enter data in response to message DATA=. 4300-FRIEND repeats the DATA= request until you enter no more data or the length count decrements to 0).

**CCW or CCW=xxx
LIST**

List CCWs Use this command to display the channel program being generated together with up to 16 data bytes in hex. If you specify a device address, all CCW blocks for this specific device are listed. If you specify a device address of 0 or CCW= alone, 4300-FRIEND displays all CCW blocks of all devices.

If you have not entered GO, the command chain bit is on in the last CCW. If you enter CCW immediately after an I/O error message, the displayed CCW chain is the one that detected the error. The actual failing command is flagged by ** (CCW address in CSW minus 8).

Example:

UCB= unit control block address for this CCW chain. FL= flag bytes in this UCB. Use the nn-CCW command for one UCB; for example, 2-CCW to display UCB chain two.

**CHANGE KEYBOARD
CK**

Use this command to request a new keyboard address for command input or the address of the secondary printer for CRT hard copy.

Note: 4300-FRIEND asks for the device type of the new console/secondary output station. Secondary output station printing produces a hard copy of all messages for the console. If a secondary output station is specified, make sure that it can handle the print CCW X'09'. Reset the secondary output by specifying address = 0 and type = PRT.

**CHANGE nnn,addr,cccc
CHANGE nnn,\$b,cccc
CHANGE \$b,cccc**

Use this command to alter up to 80 bytes at address addr or symbolic I/O area \$b (\$b represents any alphabetic character). Data cccc is moved to storage (lowercase characters are accepted). You can specify the length (nnn) of the area in decimal or hex. After the storage alter operation, the changed area is displayed.

CLEAR

Use this command to clear all CCW execution flags in all active UCBs and to reset the execution counters. You can use this command after an error stop to reinitialize the CCW run sequence.

**CLEAR\$c
CLRS**

Use this command to clear the reference to symbolic data area \$c or to all symbolic references if you do not specify a symbolic data area.

COLOR TEST

Use this command to invoke an interactive test case for extended data stream orders (requires 327x extended features).

COMPARE \$x,\$y,nnn
CMP addr1,addr2,nnn

Use this command to compare two data areas (addr1 to addr2 or symbolic I/O area \$x to \$y). Specify the length (nnn) of the area in decimal or hex format (maximum length is 65535 or X'ffff'). If you do not specify a length, the length of the first symbolic I/O area is used. Only two areas can be compared for one CCW chain. The two areas compared can be different in any CCW chain(s).

You can enter COMPARE anytime during the generation of a CCW chain, and you can specify it for each CCW chain entered. Any symbolic I/O areas to be used must have been defined before. 4300-FRIEND does the comparison when it completes the CCW chain.

To reset COMPARE, see the "NO COMPARE" command.

CONFIG xxx,yyy
CNFG

Use this command to test a range of devices (from address xxx to address yyy). If you do not specify device addresses, all device addresses from X'000' to X'FFF' are tested.

4300-FRIEND issues a TIO command, a SIO sense, and SIO sense I/O command to each device. The resulting condition codes, first four sense bytes, and sense I/O information bytes one to seven are displayed. In addition, TCH and STIDC commands are issued for the first device and for all following channel addresses ending with X'00'. The first byte of the channel ID means X'00' = selector channel; X'10' = byte-MPX channel; X'20' = burst-MPX channel. Devices or channels that store condition code 3 after TIO/TCH are not displayed.

All outstanding I/O interrupts are cleared before the CONFIG command. If an I/O interrupt is encountered after one device is tested, a message is displayed.

CONNECT nnn, addr
CONN nnn, \$c
CNN \$c

Use this command to connect a storage block of length nnn (full 2K blocks are used).

COPY xxx

Use this command to copy the last-entered CCW chain for device xxx. The CCW chain is not actually duplicated. Instead, the same physical CCW chain is used. This permits the same CCW chain to be run on several devices (of the same type) at the same time.

COUNTER
CNTR

Use this command to display the LOOP values and the SIO counters for all active CCW chains/UCBs.

CREATE

See the "BUILD" command.

CSW=xxxx

CSW status mask

Use this command to generate a CSW device and channel status mask. The two-byte long hex xxxx field indicates those bits that you want 4300-FRIEND to ignore. You can enter CSW= anytime during the generation of a CCW chain and you can specify it for each CCW chain entered. The device-end bit cannot be turned off.

DATA DUMP nnn,addr,*
DATA DUMP nnn,\$c,*
DTDMP \$c,*

Use this command to dump the specified data area (addr or symbolic I/O area \$c) on the secondary printer after running each CCW chain. You do not have to specify the length (nnn) of the area for a symbolic I/O area. If the secondary printer is not specified, the operator console is used for the display. If the optional parameter * is specified, the dump also appears on the operator console.

To reset DATA DUMP, see the "NO DATA DUMP" command.

DECREASE n,addr,incr,thr,ini,*
DCR n,addr,incr,thr,ini,n2,
addr2,incr2,thr2,ini2,*

Use this command to decrement a counter after each completion of a channel program. You can specify a second counter which is updated if the threshold of the first counter is reached. Use this command with the INCREASE command only. For an explanation of the parameters, see the "INCREASE" command.

To reset the DECREASE command, see the "NO DECREASE" command.

DEVICE=xxx
DEV=xxx

Use this command to create a new UCB for the next CCW chain entered with the unit address of xxx (leading zeros are not required). If the device address is *, the address of the operator console is used. The last-entered UCB entry is completed by turning the command chaining bit off in the last CCW.

Note: 4300-FRIEND analyzes the device type at this time. The following commands are run if the device is ready:

For FB device type determination: Sense I/O (X'E4')
 2321 determination (if Sense I/O not accepted):
 Seek Cylinder (X'0B') - length 4 X'FF.FF'
 Seek (X'07') X'000010000000'
 After previous checks:
 Sense (X'04') - if any error occurred before to clean status.

If the specified device does not handle the above commands, you can specify a dummy device address (for example, 0) and later specify the real device address with the nn-DEVICE= command.

DISCONNECT nnn, addr
DISC nnn, \$c
DSC \$c

Use this command to disconnect a storage block of length nnn (full 2K blocks are used). Reconnect the block(s) before using the DUMP/ALTER commands.

DISPLAY nnn,addr,xxx
DISPLAY nnn,\$c,xxx
DSPL \$c,xxx

Use this command to display the contents of storage in character format. Storage is displayed in lines of 64 bytes (maximum) along with the address of the first byte. addr indicates the beginning address; nnn indicates the length (in decimal or hex) of the area to be displayed. Optionally, you can specify a line printer address xxx for output.

DUMP \$

Use this command to dump the names of all assigned symbolic I/O areas along with their storage address and length in hex.

DUMP KEY nnn,addr
DUMP KEY nnn,\$c
DMPK \$c

Use this command to dump the storage keys of storage area addr for nnn bytes.

DUMP nnn,addr,xxx
DUMP nnn,\$c,xxx
DMP \$c,xxx

Use this command to dump nnn bytes of storage starting at address addr. You can specify nnn in decimal or hex. You can specify a line printer address xxx for output. \$c is any symbolic I/O area specified by a previous BUILD or CREATE command or by the FROM or INTO CCW command modifiers (if you do not specify a length, the one stored for the symbolic field is used). Symbolic address can be offset \$c+a (a = offset 1..F).

DUMP T

Use this command to dump the last entries (36 maximum) of the TRACE area.

EX CLRIO,xxx
XC

Execute Clear I/O Use this command to display the condition code received after running the Clear I/O command to device xxx.

MI	PN 6169392	EC A20558				
Seq GG035	2 of 5	01 Oct 84				

**EX HDV,xxx
XHD**

Execute Halt Device

Use this command to display the condition code received after running the Halt Device command to device xxx.

**EX HIO,xxx
XH**

Execute Halt I/O

Use this command to display the condition code received after running the Halt I/O command to device xxx.

**EX STIDC,xxx
XS**

Execute Store Channel ID

Use this command to display the condition code received after running the Store Channel ID command for device xxx.

**EX TCH,xxx
XTC**

Execute Test Channel

Use this command to display the condition code received after running the Test Channel command for device xxx.

**EX TIO,xxx
XT**

Execute Test I/O

Use this command to display the condition code received after running the Test I/O command to device xxx. If you do not specify device address xxx, 4300-FRIEND uses the last device address entered.

FLAG nn,xx

Modify Flag Byte

Use this command to modify the flag byte in CCW nn to hex value xx. If you specify no value, the flag is set to zero.

GO

Use this command to start running all active CCW chains. After they have started running, the CRT console accepts commands (for example, STOP, ACTIVATE, COUNTER, EXHIO, etc.) without halting the run. You can stop 4300-FRIEND with an I/O interrupt by pressing the ENTER key on the operator's console.

HALT

Use this command to halt processing after an I/O error or false PSW swap occurs. No device is restarted, but additional errors can be indicated.

To not halt after an I/O error occurs, see the "NO HALT" command.

HELP

Use this command to display operating hints.

I

Initialize

Use this command to initialize 4300-FRIEND. (This command is the same as RESET, except it is accepted in all input fields; for example, in data request.) The device queue, CCW area, data area, and IDA areas are zeroed. All references to symbolic I/O areas (\$a to \$z) are reset. A new device address is requested.

**INCREASE n,addr,inc,thr,ini,*
INCR n,addr,inc,thr,ini,
n2,addr2,inc2,thr2,ini2,***

Use this command to advance a counter after each channel program completes. You can specify a second counter that is updated if the threshold of the first counter is reached. Use this command with the DECREASE command only.

- n = length of the counter (field) 1 to 4.
- addr = hex address of the counter.
- inc = optional increase value (in decimal or hex). The default is 1.
- thr = optional threshold value (decimal or hex) of the counter at which the counter is initialized. The default = 0.
- ini = optional value (decimal or hex) to which the counter is initialized at the beginning and when the threshold is reached. The default is 0.
- * = stop processing if threshold of the only or second counter is reached.

To reset the INCREASE function, see the "NO INCREASE" command.

INT

Interrupt

Use this command to discontinue the running of CCW chain(s) after the external interrupt button has been pressed twice. A Halt I/O instruction is issued after about five seconds to those I/O devices that are still active. The TIO mode of 4300-FRIEND is reset.

To handle external interruptions normally, see the "NO INT" command.

KEY CAW=k

Use this command to specify CAW key k for the running of the CCW chain. k can be any hex digit 0 to F. The standard key used is 1.

KEY CCW=k,f

Use this command to specify storage key k for the CCW area (for all CCW chains). The standard key is 1 without fetch protection. Specify f to fetch-protect the CCW area.

KEY DATA=k,f

Use this command to specify storage key k for the data area (for the next CCW chains to be entered). 4300-FRIEND increments the data area pointer to the next 2K storage boundary and sets the specified key up through the end of storage. The standard key is 1 without fetch protection. Specify f to fetch-protect the data area.

KEY IDA=k,f

Use this command to specify the storage key k for the IDA area (for all CCW chains). The standard key is 1 without fetch protection. Specify f to fetch-protect the IDA area.

LIST

See the "CCW" Command.

LOAD UCSB

Use this command to load the UCSB buffer of the 3203, 3211, 3262 or 3289 printers (4300-FRIEND requests all necessary load information). The Block Data Check function is set for the printer.

LOOP / LOOP nnn,*

Use this command to specify the number of times to loop the entered CCW chain. Specify the loop number nnn in decimal (the maximum number is 65535). The SIO counter is reset to zero.

If you specify the optional parameter *, the CCW chain is stopped when the specified loop count is reached. You can activate the stopped CCW chains again with the ACT,* command. If you do not specify the parameter * and the CCW chain has looped the specified number of times, 4300-FRIEND stops running all active CCW chains, displays LOOP IS FINISHED ON UNIT xxxx, and requests a new command.

Enter GO to repeat the CCW chain(s). You can display the current loop values (thresholds) with the COUNTER command.

**NO ALARM
NLRM**

Use this command to reset the audible alarm on the operator console.

NO BMPX

Use this command to set block multiplexer mode off (standard if you specify BC mode).

**NO COMPARE
NCMP**

Use this command to reset the compare indication for the last entered chain or for the chain specified in the nn-NOCOMPARE format.

**NO DATA DUMP
NDTDMP**

Use this command to reset the Data Dump command.

**NO DECREASE
NDCR**

Use this command to reset the Decrease command.

NO HALT

Use this command for a no halt after an I/O error occurs.

**NO INCREASE
NINCR**

Use this command to reset the Increase command.

NO INT

Use this command to instruct 4300-FRIEND to handle the external interruptions normally (no interrupt).

NO TEST I/O

Use this command to reset the TIO mode.

**NO TIME DELAY
NTD**

Use this command to instruct 4300-FRIEND to go to wait state after all active UCB devices are started until an I/O interrupt occurs. Devices that do not return a device-end interrupt are not restarted. This mode is recommended, in order to save processor time, if 4300-FRIEND is used in the VM environment.

NO WAIT

Use this command to reset the wait indication for the last entered chain or for the chain specified in the nn-NOWAIT format.

**POINTER CCW=xxx
PTRCCW=xxx**

Use this command to specify the next CCW address (xxx) (must be on doubleword boundary).

**POINTER DATA=xxx
PTRDT=xxx**

Use this command to specify the next CCW data area address (xxx).

**POINTER IDA=xxx
PTRD=xxx**

Use this command to specify the next IDAW address (xxx) (must be on word boundary).

**PRINT SENSE
PRTSNS**

Use this command to display the 32-byte long standard sense area. The TIO mode of 4300-FRIEND is reset.

PSW

Program (PSW) Restart

In execution mode, use this command to request a Clear function without a counter reset.

**QUIT
Q**

Use this command to quit (cancel) a 4300-FRIEND request for console input (for example, DATA=). The last command is ignored, and a new command is requested. The REPLACE function is reset.

**REMOVE=xxx
RMV=xxx**

Use this command to remove all CCW chains for device xxx from the device queue. If you are running several different devices in overlap mode, the complete CCW chain(s) of a device can be removed with this command. To remove a single CCW chain, use the STOP command.

REP nn

Replace CCW

Use this command to replace CCW nn in the last CCW chain entered with the next CCW entered. Use the nn-REP command to modify a specific CCW chain. When you are entering a CCW chain, specifying REP alone replaces the last entered CCW with the next one.

RESET

Use this command to reinitialize 4300-FRIEND. The device queue, CCW area, data area, and IDA areas are zeroed. All references to symbolic I/O areas (\$a to \$z) are reset. A new device address is requested.

RETURN

Use this command to change from card/tape input to operator console input. Otherwise, use the GO or TRACE command.

SCOPE

Use this command to loop on a Start I/O or Test I/O instruction. SCOPE can only be used in single CCW chain mode. If you specify SCOPE after a TEST I/O, do a PSW RESTART to exit SCOPE mode. If you specify SCOPE after a START I/O, use the console REQUEST to exit.

SENSE=xxxx

Use this command to create a sense byte status mask. The two-byte long, hex xxxx field indicates those bits 4300-FRIEND will ignore in the first two bytes of the sense field. You can enter this command anytime during generation of a CCW chain, and you can specify it for each CCW chain entered.

SET FB

Set Fixed-Block Device

Use this command if a device does not store the correct FB ID after a sense I/O.

SIZE

Use this command to display the storage size in hex.

**START READER,xxx,*,nnnn,B
S,xxx**

Use this command to read the CCW chain(s) from either a card reader or a tape drive with address xxx. If the second parameter is *, all records read are displayed. As an optional third parameter, a four-digit test case number can be specified. This number must be located in columns 3 to 6 of the first record of a test case. If a tape is used and a desired test case has been passed, a fourth parameter B for backward read can be used. 4300-FRIEND skips all test cases up to the one specified.

STATUS

Use this command to print all the program indicators normally displayed on line 20.

nn-STOP

Use this command to deactivate CCW chain nn. nn is the UCB number displayed by the LIST= function.



SUBST xxx,yyy

Substitute

Use this command to search all channel programs for device address yyy and then change the device address to xxx. If you want to change the device address in a specific CCW chain, use the nn-DEV=xxx CCW chain control command.

TEST I/O

T

Use this command to repeatedly run the TIO instruction (using the last-entered device address only) and to display the resulting condition code, CSW, and sense bytes. If you specify a loop count for the last entered UCB, the TIO loop can be restricted. To execute the TIO only once, use the EX TIO command. By entering SCOPE instead of GO, the results are not displayed.

Reset TIO mode by pressing the ENTER key twice (if INT feature is active) or by commands NO TEST I/O, PRINT SENSE, or RESET.

TIME

Use this command to get the current time. This is either the time-of-day or the elapsed time since the program was started.

TIME DELAY nn

TMDL nn

Use this command to set the timeout counter (for the running of all CCW chains) to decimal nn seconds. An error message is displayed if 4300-FRIEND does not receive a device end for a CCW chain within the specified time period. Also use this command if an operator console or secondary printer is used as a test device.

For no time delay, see the "NO TIME DELAY" command.

TRACE xxx

TRC

Use this command to start running all active CCW chains and to build up a trace area that contains information about all SIOs and I/O interrupts of all test devices. If you specify an asterisk (*) for device address xxx, the SIOs and TIOs for the operator console and the secondary printer are also traced. If you specify device address xxx, only trace entries for this device are stored in the trace area. You can dump the last entries in the trace area with the DUMPT command.

WAIT nn,n

Use this command to instruct 4300-FRIEND to complete the current CCW chain (device end interrupt) before starting the next CCW chain. If you do not specify nn, 4300-FRIEND starts the next CCW chain when it receives the device end interrupt. Otherwise, it waits for nn milliseconds before starting the next CCW chain. The second parameter (n) is optional and specifies 0.1 milliseconds.

To reset the Wait function, see the "NO WAIT" command.

Changing Existing CCW Chains

During the generation of a CCW chain, all entered commands are related to the current UCB (the number of the current UCB is displayed on the screen). To change an existing CCW chain (UCB), specify the UCB/CCW chain number (get the UCB/CCW chain number by using the CCW= or LIST= commands), a hyphen (-), and then the command.

Example 1

This command changes the loop count for CCW chain 12:

12-loop 5000

Example 2

This command copies CCW chain number 2 to the current UCB by using the same CCWs and data:

2-copy



Change Commands

For more information on these commands, see "4300-FRIEND Commands."

nn-ACTIVATE

Activates UCB/CCW chain number nn.

nn-ADD

Adds a command after CCW chain number nn (see also "nn-SETFB").

nn-CCW

Lists the CCWs of UCB/chain number nn.

nn-COMPARE ...

Specifies/changes COMPARE values.

nn-NO COMPARE

Deactivates COMPARE for CCW chain number nn.

nn-COPY

Copies CCW chain number nn to the current UCB.

nn-COUNTER

Lists the counters of UCB/CCW chain number nn.

nn-CSW=xxxx

Specifies/changes the CSW bits to be ignored.

nn-DATA DUMP

Specifies/changes the DATA DUMP values.

nn-NO DATA DUMP

Deactivates DATA DUMP for CCW chain number nn.

nn-DECREASE ..

Specifies/changes the DECREASE values.

nn-NO DECREASE

Deactivates DECREASE for CCW chain number nn.

nn-DEVICE=

Changes the device address for CCW chain number nn.

nn-FLAG nn,xx

Changes the flag byte in CCW chain number nn.

nn-INCREASE ..

Specifies/changes the INCREASE values.

nn-NO INCREASE

Deactivates INCREASE for CCW chain number nn.

nn-KEY CAW=

Specifies/changes the CAW key.

nn-LIST

Lists the CCWs of UCB/CCW chain number nn.

nn-LOOP

Specifies/changes the LOOP count.

nn-REP nn

Replaces a CCW in CCW chain number nn (see also "nn-SETFB").

nn-SENSE=nxxx

Specifies/changes the sense bits to be ignored.

nn-SETFB

Sets FB type for device (nn-REP and nn-ADD commands require a previous nn-SETFB command for 3370).

nn-STOP

Stops/deactivates UCB/CCW chain number nn.

nn-WAIT nxxx

Specifies/changes WAIT for CCW chain number nn.

nn-NO WAIT

Deactivates WAIT for CCW chain number nn.

CCW Chain Execution Control

Before an SIO is issued, 4300-FRIEND checks the CCW chain and zeros all input areas indicated by the ZERO flag in the CCW.

If an I/O interrupt or condition code 1 or 3 occurs after a Start I/O, 4300-FRIEND analyzes the CSW and issues the specified UCB control commands:

1. Successful completion of a CCW chain (either no error detected or error was masked out by CSW=/SENSE= commands).

- a. Data compare
- b. Data dump
- c. Data ripple or random
- d. Increment or decrement storage field
- e. Compare loop count

2. Unsuccessful execution of a CCW chain (error in CSW after I/O interrupt and CSW status not masked).

- a. Issue sense command if there is a unit check in CSW.
- b. If all the sense bytes are masked and no other error is in CSW, handle it as normal interrupt.
- c. Display error message.
- d. Data dump.
- e. Data ripple or random.
- f. Increment or decrement storage field.
- g. Compare loop count.

3. Condition Code 1 (CSW stored) after Start I/O with unexpected CSW status.

- a. If all the CSW status error bits are masked, handle it as immediate interrupt.
- b. Issue sense command in case of unit check in CSW.
- c. If all the sense bytes are masked and no other error is in CSW, handle it as immediate interrupt.
- d. Display error message.
- e. Increment or decrement storage field.
- f. Retry Start I/O (SIO counter is not incremented). The SIO is not retried if the loop count is one.

4. Condition Code 3 after Start I/O.

- a. Display error message.
- b. Increment or decrement storage field.
- c. Retry Start I/O (SIO counter is not incremented). The SIO is not retried if the loop count is one.

5. Condition Code 2 (busy) after Start I/O.

- If WAIT specified, wait until device end is signaled by device, or stop execution if interrupt not received after about five seconds.
- If WAIT was not specified, start next device (if specified).

6. Test I/O Loop (last entered device address at storage location X'420').

- a. Print condition code.
- b. Increment or decrement storage field.
- c. Compare loop count.

CCW COMMANDS

In general, 4300-FRIEND ignores all vowels, blanks, periods, and asterisks except in requested data. All commands can be entered in either uppercase or lowercase characters.

Following the CCW command, a CCW flag or CCW command modifier can be entered, separated by a comma.

The CCWs that have an *S* following the command are automatically generated with the Suppress Incorrect Length Indicator (SILI) set on. If you do not want the SILI bit set on, specify NOSILI after the CCW command.

For a detailed description of the device CCWs, refer to the *Component Description* manual for that device.

General CCWs

CMD HH *S*

Command Code in Hex

Enter any hex command code. If the last hex digit is odd, data is requested.

HEX HHHHHHHHHHHHHHHH

Complete CCW in Hex

Enter a complete CCW in hex. Sixteen hex characters are packed into an 8-byte CCW and inserted into the CCW chain. The data address in the CCW is changed to point to the next available data area location of 4300-FRIEND (if SKIP bit is not on in CCW flag). Blanks can be inserted to separate fields. No CCW flag or CCW command modifier can be specified.

NOP (X'03') *S*

READ (X'02') *S*

SENSE (X'04') *S*
SNS

Length is always 32 bytes. The standard sense bits (byte zero) are:

- X'80' = Command reject
- X'40' = Intervention required
- X'20' = Bus-out check
- X'10' = Equipment check
- X'08' = Data check
- X'04' = Overrun

SENSE I/O DEVICE (X'E4') *S*
SNSDVC

TIC *-n..n or -n..n (X'08')
TIC *+n..n or +n..n

Transfer in Channel

n..n is the decimal number of bytes for the channel to transfer to (displacement) the * and + or - are optional. If only TIC is entered, *-8 is assumed. If X is the first character of n..n, the following characters are taken as hex displacement.

WRITE (X'01') *S*

Disk CCWs

DIAGNOSTIC LOAD (X'53')
DGL

DIAGNOSTIC WRITE (X'73')
DW

ERASE (X'11') *S*

INIT BUF (X'E3')
NTBF

Initialize Buffer - 2314

MT + CCW

Set multitrack bit for specified CCW

READ BUF (X'E2')

Read Buffer - 2314

READ BUFFERED LOG (X'A4')
RBL

Read Buffered Log - 33XX

READ COUNT (X'12')
RC

READ COUNT KEY DATA (X'1E') *S*
RDCKD

READ DATA (X'06') *S*

READ DIAGNOSTIC STATUS (X'44')
RDDGS

READ HA (X'1A')
RH

Read Home Address

READ IPL (X'02') *S*
RDPL

READ KEY DATA (X'0E') *S*
RKD

READ R0 (X'16') *S*
RR0

Read Record Zero

READ SECTOR (X'22')
RSC

RECALIBRATE (X'13') *S*
RCL

RELEASE (X'94')
RL

Device Release - string switch

RESERVE (X'B4')
RSV

Device Reserve - string switch

RESET BUF (X'C3') *S*
RSTBF

Reset Buffer - 2314

RESTORE (X'17') *S*
RSTR

SEARCH HA EQ (X'39')
SHQ

Search Home Address Equal

SEARCH ID EQ (X'31')
SQD

SEARCH ID HI (X'51')
SDH

SEARCH ID HI EQ (X'71')
SDQH

SEARCH KD EQ (X'2D') *S*
SDT

Search Key and Data Equal

SEARCH KD EQ HI (X'6D') *S*
SKDQH

Search Key/Data Eq/Hi

SEARCH KD HI (X'4D') *S*
SCHKDH

Search Key and Data High

SEARCH KEY EQ (X'29') *S*
SQK

SEARCH KEY EQ HI (X'69') *S*
SKQH

4381
B/M 2676380

MI Seq GG040	PN 6169393 2 of 6	EC A20558 01 Oct 84				
-----------------	----------------------	------------------------	--	--	--	--

© Copyright IBM Corp. 1984



SEARCH KEY HI (X'49') *S*
SKH

SEEK (X'07')
SK

SEEK CYL (X'0B')
SKCL

SEEK HEAD (X'1B')
SKHD

SET FILE MASK (X'1F')
SFM

SET SECTOR (X'23')
SS

SPACE COUNT (X'0F') *S*
SPCNT

WRITE BUF (X'E1')
WBF

Write Buffer - 2314

WRITE COUNT KEY DATA (X'1D')
WCKD

WRITE DATA (X'05')
WD

WRITE HA (X'19')
WH

Write Home Address

WRITE H40 (X'19')
WH40

Write 3340 Home Address

WRITE H50 (X'19')
WH50

Write 3350 Home Address

WRITE KEY DATA (X'0D')
WKD

WRITE R0 (X'15')
WRRO

Write Record Zero

WRITE SPECIAL COUNT KEY DATA (X'01')
WSPCKD

Fixed Block (FB) Commands - 3370

Fixed block (FB) devices are identified during device address specification time (DEV=...). If the device handles FB (depends on SENSE I/O bytes 4 and 5 which must be X'3370'), the DEVICE CHARACTERISTIC is read and saved for later use. If the device does not store the correct FB ID after the sense I/O command, the SET FB command can be used after DEV=.

DEFINE EXTENT (X'63')
DX

(16 bytes)

Requested parameters are:

MASK BYTE= (two hex digits)

PHY.START= (decimal value or up to 8 hex digits preceded by "X").

LOG.START= (decimal value or up to 8 hex digits preceded by "X").

LOG.END= (decimal value or up to 8 hex digits preceded by "X").

If nothing is entered, the defaults are:

First three parameters are all 0.

LOG.END is the value read by the READ DEVICE CHAR command (reduced by 1).

DIAGNOSTIC CONTROL (X'F3')
DCNT

DIAGNOSTIC SENSE (X'C4') *S*
DGSNS

LOCATE (X'43')
LC

(8 bytes)

Requested parameters are:

OP. BYTE =(two hex digits)

REPL. CNT=(decimal value or up to 2 hex digits preceded by "X").

BLCK. CNT=(decimal value or up to 4 hex digits preceded by "X").

BL. OFFS.=(decimal value or up to 8 hex digits preceded by "X").

If nothing is entered the defaults are:

OP. BYTE = X'06'
REPL. CNT= X'00'
BLCK. CNT= X'0001'
BL. OFFS.= X'00000000'

READ BUFFERED LOG (X'A4') *S*
RBL

READ DEVICE CHAR (X'64')
RDDVC

READ FB (X'42') *S*
RFB

READ IPL (X'02') *S*
RDPL

RELEASE (X'94') *S*
RL

Device Release - string switch

RESERVE (X'B4') *S*
RSV

Device Reserve - string switch

SENSE EXTENDED (X'84') *S*
SNSX

WRITE FB (X'41')
WFB

Tape CCWs

BACKSPACE (X'27') *S*
BSR

Backspace Record

BSF (X'2F') *S*

Backspace File

ERG (X'17') *S*

Erase Record Gap

FSF (X'3F') *S*

Forward Space File

FSR (X'37') *S*

Forward Space Record

MODE SET (X'93')
MDST

Mode Set 7-track, 800 bpi

MODE SET 800 (X'CB')
MDST 8

Mode Set 9-track, 800 bpi

MODE SET 1600 (X'C3')
MDST 1

Mode Set 9-track, 1600 bpi

MODE SET 6250 (X'D3')
MDST 6

Mode Set 9-track, 6250 bpi

READ (X'02') *S*
RD

READ BACKWARDS (X'0C') *S*
RDBK

REWIND (X'07') *S*
REW

UNLOAD (X'0F') *S*
RUN

WRITE (X'01') *S*
WRT

WTM (X'1F') *S*
Write Tape Mark

Card Reader/Punch CCWs

PUNCH (X'01') *S*
PCH

2540 punch, feed, select stacker

PUNCH BINARY (X'21') *S*
PNCHBNR

2540 punch binary, feed, select stacker

PUNCH 42 (X'C1') *S*
PNCH42

1442 punch, eject, select stacker 2

PUNCH 42 BINARY (X'E1') *S*
PNCH42BNR

1442 punch binary/eject/select stacker

READ CARD (X'02') *S*
RCD

Printer CCWs

ALLOW DC (X'7B')
LLWDC

Allow Data Check

BLOCK DC (X'73')
BLCKDC

Block Data Check

FOLD (X'43')
FLD

Fold -3211 + 3203-4

GATE LOAD (X'EB')
GTLD

Gate Load - 1403

IMM + CCW command
MM

Immediate - use with SPACE/SKIP commands

LOAD FCB (X'63') *S*
LDFCB

Load Forms Control Buffer

LOAD UCS (X'FB') *S*
LDCS

Load UCS Buffer without Folding

For 1403, a GATE LOAD command must be executed before a LOAD UCS.

LOAD UCS F (X'F3') *S*
LDCSF

Load UCS Buffer and Fold ; not for 3211

PRINT (X'09') *S*
PRT

Print with one Space after

RAISE COVER (X'6B')
RSCVR

READ FCB (X'12') *S*
RFCB

Read FCB 3211

READ PLB (X'02') *S*
RDPLB

Read PLB 3211

READ UCSB (X'0A') *S*
RCSB

Read UCSB 3211

SKIP n *S*
SKPn

Skip to Channel n; n is 1 to 12

SKIP 0 (X'83')
SKP0

Skip to Channel 0 immediate - 3211

SPACE n (X'CC') *S*
SPCn

Print with n Spaces After

n is 1, 2, or 3; command is X'09', X'11', or X'19'; immediate X'0B', X'13', or X'1B'.

UNFOLD (X'23')
NFLD

Unfold [3211 + 3203-4]

WRITE (X'01') *S*

Write without Space Warning: This can destroy printer ribbons.

CRT and Hard-Copy Printer CCWs
(3277/3278-3287)

ERASE ALL U (X'0F') *S*
RSLL

Erase All Unprotected

ERASE/WRITE (X'05') *S*
RSW

ERASE WRITE CRT (X'05') *S*
RSW3277

Erase Write 3277 Data

Instead of DATA= 3277, specific requests are keyed. To end them, enter * after CMD= is keyed. See "Command Table." Do not specify indirect addressing (IDA).

READ BUFFER (X'02') *S*
RBF

READ MODIFIED (X'06') *S*
RMD

SELECT (X'0B') *S*
SLCT

WRITE (X'01') *S*

WRITE CRT (X'01') *S*
W3277

Write 3277 Data Stream

Instead of DATA= 3277 specific requests are typed. To end them, enter * after CMD= is typed. See "Command Table" below. Do not specify indirect addressing (IDA).

Command Table

If you specify WRITE CRT or ERASE WRITE CRT, 4300-FRIEND asks for the 3277 command (buffer control order).

- 'SB' Set Buffer Address (X'11') + address
- 'Sf' Start Field (X'1D') + attribute character
- 'IC' Insert Cursor (X'13')
- 'Pt' Program Tabulator (X'05')
- 'Ra' Repeat to Address (X'3C') + address and 'fill' character (DATA=)
- 'Eu' Erase Unprotected (X'12') + address
- 'EM' End of Message (X'19') - for printer
- 'FF' Forms Feed (X'0C') - for printer
- 'NI' New Line (X'15') - for printer
- '%%' ENTER key = no command
- '*&' end of data stream (no code generated)

4381
B/M 2676380

MI Seq GG040	PN 6169393 4 of 6	EC A20558 01 Oct 84				
-----------------	----------------------	------------------------	--	--	--	--

Teleprocessing CCWs (270x, 370x)

ADPREP (X'1E') *S*
ADP

Address Prepare

BREAK (X'0D') *S*
BRK

CONTROL SCB (X'0B') *S*
CS

(Ctl SCB SDLC -16 bytes)
Address aligned on fullword boundary.

- OFS Enter buffer offset in decimal (default= 2).
- ADR Enter SDLC station address.
- FLG Enter control flag byte in hex:
 X'80' Inactive station (0= active).
 X'40' Datapoll station (0= contact).
 X'20' Send rnr poll (0= rr).
 X'10' Reply rnr to poll (0= rr).
- NSC Enter ns current.
- NSA Enter ns acknowledged.
- NRA Enter nr of next frame to be received.
- IDT Enter four byte identification field in hex.

DIAL (X'29') *S*
DL

Dial, switched line with autocal

DISABLE (X'2F') *S*
DSBL

Disable Line

ENABLE (X'27') *S*
NBL

Enable Line

INHIBIT (X'0A') *S*
NHBT

LISTEN (X'0A') *S*
LSN

SDLC X.21 switched

POLL (X'09') *S*

Poll/Autopoll

POLL SCB (X'09') *S*
PLLS

Poll SCB -SDLC Autopoll
Enter SCBs as for Control SCB command. End command
with answer 'n' after Y-N=.

POLL SDLC (X'0F') *S*
PLLSD

PREPARE (X'06') *S*
PP

READ (X'02') *S*

READ PIU (X'06') *S*
RDP

Read PIU - SDLC

SADn *S*
SDn

SAD n -270x; n is 0, 1, 2, or 3

SET MODE (X'23') *S*

SENSE SCB (X'14') *S*
SNSS

Sense SCB SDLC - 24 bytes

Address aligned on fullword boundary.

WRAP (X'05') *S*
WRP

WRITE (X'01') *S*

WRITE PIU (X'05') *S*
WP

Write PIU - SDLC

CCW FLAGS

You can enter a CCW flag after a CCW command, a CCW modifier, or another CCW flag (separated by a comma). Note that some CCW flags are automatically set by 4300-FRIEND. After the CCW has been specified, you can change these flags with the 4300-FRIEND FLAG command.

DC (X'80')

Data Chaining

Uses address portion of next CCW (command chaining is not turned on)

IDA (X'04')

Indirect Data Addressing

Note: This parameter must be the last one you enter in the CCW command. 4300-FRIEND requests IDA areas for IDAW. Do not specify a CCW command modifier with IDA.

NOSILI (resets X'20')

NSL

Reset Suppress Incorrect Length Indicator

PCI (X'08')

Program Controlled Interrupt

Causes a channel controlled interruption. 4300-FRIEND ignores all interrupts with PCI on in the CSW until device end is posted in the CSW.

SILI (X'20')

Suppress Incorrect Length Indicator

Causes suppression of possible incorrect length indication in CSW.

SKIP (X'10')

Suppresses transfer of information to storage.

CCW COMMAND MODIFIERS

Add the following CCW command modifiers to a CCW command for the indicated reasons. You can combine these modifiers when needed.

CRT or 3277

Requests a special 3277 data stream after WRITE and ERASE WRITE.

FROM

Specifies a symbolic I/O area is to be used.

INTO

Specifies a symbolic I/O area is to be used.

LENGTH

LN

Data Length

4300-FRIEND requests key length and data field length for the file count instead of using the amount of data entered from KEY= and DATA= . For commands which have a fixed data length assigned by 4300-FRIEND, use LENGTH to change the fixed data length.

NEW

Reset CCW indicators.

This modifier resets the disk indicators for:

- TIC required
- Seek argument not required
- Set File Mask required.

RANDOM

RN

Generates random data, bypasses 'home address' and 'count fields'.

RIPPLE

RP

Moves the data area one byte to the left for all write CCWs.

ZERO

ZR

Clears input area of CCW before performing a Start I/O command.

4381
B/M 2676380

MI Seq GG040	PN 6169393 6 of 6	EC A20558 01 Oct 84				
-----------------	----------------------	------------------------	--	--	--	--

© Copyright IBM Corp. 1984



INSTALLATION

INST 001

Contents

Installation Time Guideline	INST 002	Final System Check	INST 061
Processor and Ship Group Checkout	INST 002	Running System Test/4381	INST 061
Power Plug Installation (If Required)	INST 011	Completing the Installation	INST 061
Preparing the Power Cable for Plug	INST 011	Relocation or Discontinuance Procedure	INST 061
Installing the Power Plug	INST 011		
Site and Processor Safety Checkout	INST 012		
Checking the 4381 Processor Power Plug	INST 012		
Checking the Customer Power Receptacle	INST 012		
Measuring the Customer Primary Power	INST 015		
Physical Setup	INST 016		
Processor Location	INST 016		
Channel To Channel Adapter (CTCA) Only	INST 016		
Installing Operator Console	INST 021		
3278-2A	INST 021		
3279-2C	INST 022		
3205 and Operator Control Panel	INST 025		
Installing Remote Support Facility (RSF)	INST 031		
Unpacking the Cable Box	INST 031		
External Cable -- Part 8482931	INST 032		
Set Modem Adapter Card (Canada/U.S.A.)	INST 032		
Set Modem Adapter Card (Japan)	INST 032		
External Cable -- Part 8482930 (External Modem)	INST 035		
External Modem Adapter Card (External Modem)	INST 035		
External Cable -- Part 8482934	INST 036		
Set Modem Adapter Card	INST 036		
External Cable -- Part 8482933	INST 041		
Set Modem Adapter Card (External Modems)	INST 041		
External Cable -- Part 401441	INST 042		
Set Modem Adapter Card	INST 042		
MSS Power-On Checks and Diagnostics	INST 045		
Running MSS Extended Diagnostics	INST 045		
Running Additional MSS Tests	INST 045		
Running PU Diagnostics Based on Initial Install or Relocation	INST 046		
General Instructions	INST 046		
OCP Checkout	INST 046		
Running Cable Wrap Test (CWT)	INST 046		
System Configuration	INST 051		
3279 Display Console Aids	INST 051		
Configuration Aids	INST 051		
Diskette Aids	INST 051		
Remote Support Facility Aids	INST 051		
Patch Aids	INST 051		
Running Channel To Channel Adapter (CTCA) Test	INST 051		
Installing Interface Cables	INST 055		

4381-3
B/M 2676380

MI Seq GH005	PN 6169590 1 of 2	EC A20558 01 Oct 84	EC A20559 03 Dec 84	EC A20560 18 Feb 85	EC A20562 30 Aug 85	
-----------------	----------------------	------------------------	------------------------	------------------------	------------------------	--

Installation Time Guideline

Clock Time	Area
1.0	Processor and Ship Group Checkout Power Plug Installation (If Required) Site and Processor Safety Checkout Physical Setup
.6	Install Operator Console Install RSF
2.0	MSS Power-On Checks and Diagnostics
1.4	System Configuration
1.5	Install Interface Cables
2.0	Final System Checkout

8.5 Hours Total Install Time

Processor and Ship Group Checkout

DANGER
Do not touch any customer power receptacles at the installation site until instructed in the "Site and Processor Safety Checkout" procedure.

Note: If the Remote Support Facility (RSF) feature (B/M 1806885) was ordered, cable and coupler assembly (part 401441) will be installed in gate 01G. Go to "Site and Processor Safety Checkout."

Start here after completing the unpacking instructions.

1. Check the processor for physical damage.
2. Ensure that the processor history matches the features listed on the customer order, and notify your manager of any differences.
3. Ensure that possible last minute processor location changes have not affected I/O cable lengths or power outlets.
4. Unpack the large shipping group package and open the boxes. Ensure that the following items were shipped:
 - Vol A01 thru A08, CO1, Operations Manual, and the PA Guide.
 - RSF phone with hardware (if featured), OCP with OCP cable, coax cable, channel wrap blocks, CTCA interface cables (if featured), module pin alignment template, module pin aligner, leveler assemblies, and terminators.
5. Verify that one DIAG1, two FUNC1, and two FUNC2 diskettes are packed in the storage pocket near the service panel.

6. If the RSF feature other than B/M 1806885 was ordered, verify the correct external RSF cable is part of the ship group. For the correct cable part number, refer to the RSF table shown at **A**.

A

Cable Part Number	Feature Code
8482931	9510
8482934	2837
8382934	2836
8482931	2944/2943
401441	9514
8482930	9511
8482930	2833/2838
8482933	2839

4381-3
B/M 2676380

MI Seq GH005	PN 6169590 2 of 2	EC A20558 01 Oct 84	EC A20559 03 Dec 84	EC A20560 18 Feb 85	EC A20562 30 Aug 85
-----------------	----------------------	------------------------	------------------------	------------------------	------------------------



Power Plug Installation (If Required)

This procedure applies only in countries where the machine is shipped without a plug on the power cable. Because of the various styles of power plugs, *This Procedure is for Reference Only*. The shield must be properly terminated at the plug to ensure proper grounding of the power cable.

Preparing the Power Cable for Plug

Review the figure before starting, and refer to this figure during the procedure.

1. Remove about 65 mm (2-5/8 in) of the cable jacket starting at the plug end of the cable.
2. Unbraid (do not cut), and carefully comb out the shield exposing the cable core.
3. Remove the Mylar separator and cable filler exposing the conductors.
4. Carefully fold the shield back over the cable jacket, and temporarily wrap tape to protect the shield.
5. Install clamp, rubber insulator, and connector shell over the cable core.
6. Remove 14 mm (9/16 in) of insulation from the conductors.

Installing the Power Plug

Note: Nonraised Floor Only. Slide the power cable under the machine frame before connecting the power plug.

The following steps show you how to attach one style of the power plug to the line cord.

1. Remove the tape from the shield, and then loosen and separate the strands.
2. Slide the rubber insulator up against the shield.

Note: Ensure that the ground wire is slightly longer than the adjacent wires.
3. Complete the installation of the power plug by installing the contact assembly to the proper conductors of the power plug. Ensure that the shell makes contact with the shield at all places (360 degrees).

Line Cord Identification

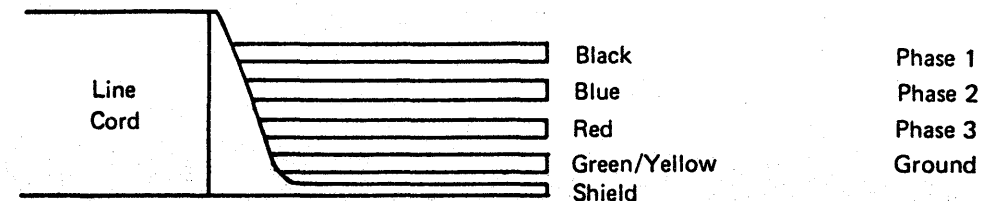

Line Cord Identification

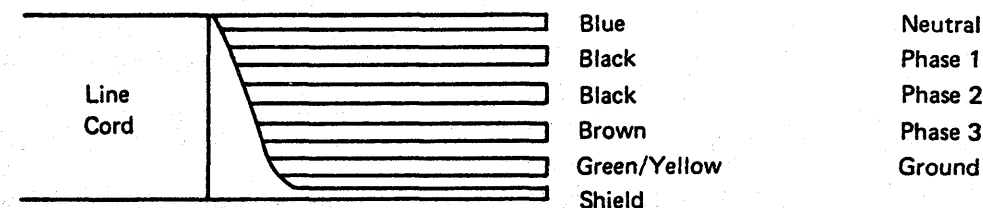

* For 220V wiring, tie the neutral to the line cord.

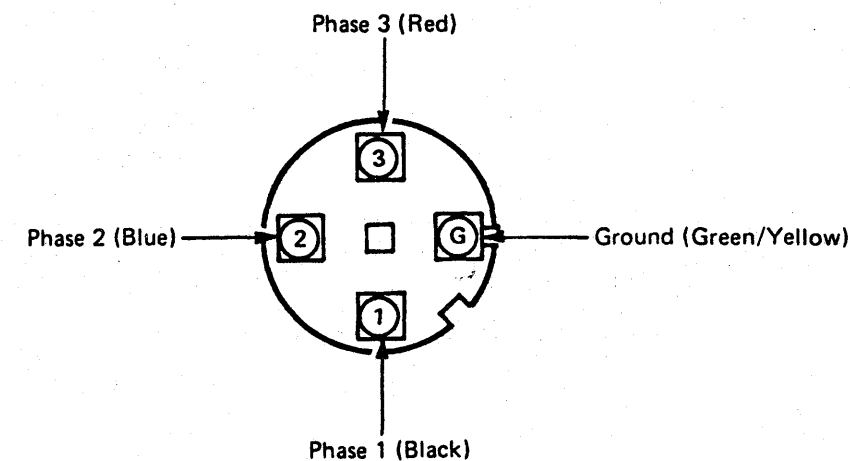
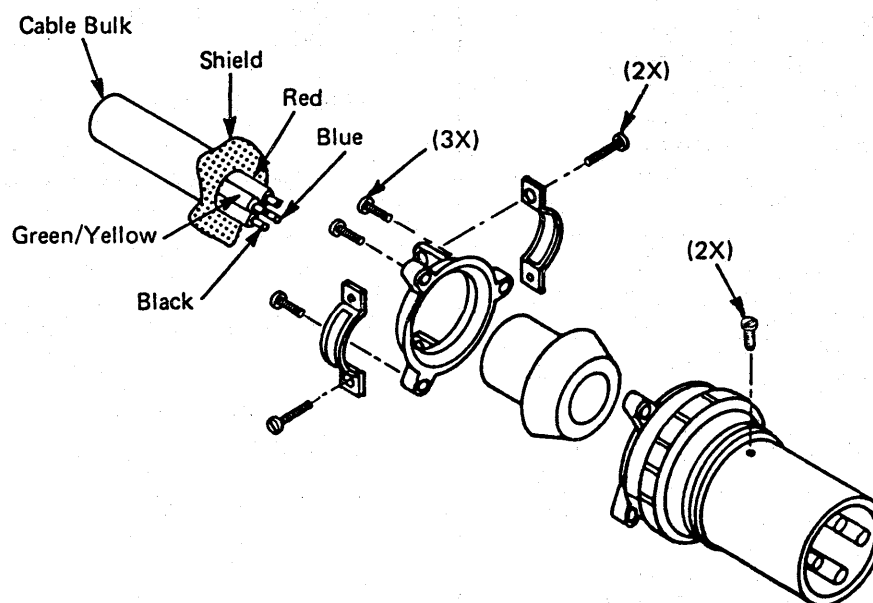
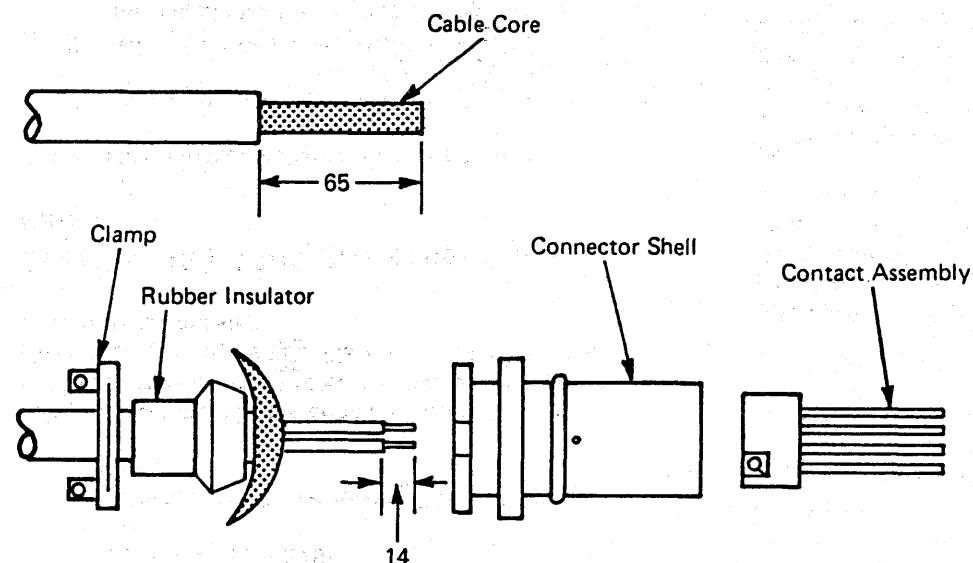

Tools required:

CE Tool Kit

CE Meter (part 8496278)

High Voltage Test Probes (parts 1749249 and 1749250).

This procedure must be performed to ensure that the installation environment is safe. For plug and receptacle pin locations, see figure **A**. Place a CHECK MARK next to each completed step.

Checking the 4381 Processor Power Plug

Repair all IBM product problems if any are found.

- ___ 1. Verify CB1 and CB2 are in the OFF position.
- ___ 2. Make the following resistance measurements; a reading of less than .1 ohm shows a safe grounding conductor.
 - ___ a. Measure the resistance between the ground pin of the processor power plug and the processor frame.
 - ___ b. Measure the resistance between the processor power plug shell and the processor frame. If there is no plug, measure between the green/yellow wire and the processor frame.

Note: If the resistance values are less than .1 ohm, the processor power plug has a safe ground. Continue this procedure.

- ___ 3. Make the following resistance measurements; a value greater than 2000 ohms shows a safe processor power plug.
 - ___ a. Measure the resistance from the phase pins to the processor power plug shell.
 - ___ b. Measure the phase-to-phase resistance of the processor power plug.

Checking the Customer Power Receptacle

If any problems are found:

- Alert the responsible Field Manager.
- Call your Installation Planning Representative (IPR) for assistance.
- Notify the customer of the problem.

DANGER

With the customer branch CB in the OFF position, do not touch the exterior shell of the customer receptacle with anything except the test probes until you have completed step 2.

Power must not be applied to the processor if the building ground cannot be located and verified.

Note: Water pipes, raised floors, and electrical conduit **MAY** be connected to building ground; therefore, provide a usable ground reference. If you are unable to locate building ground, contact your IPR for assistance.

- ___ 1. Ensure that the customer branch CB is in the OFF position.
- ___ 2. Perform the following voltage measurements; all voltage values should be less than 1 Vac.
 - ___ a. Measure the voltage between the exterior shell of the customer receptacle and the building ground.
 - ___ b. Measure the voltage between the ground pin of the customer receptacle and the building ground.
 - ___ c. (World Trade Only) Measure the voltage between the neutral of the customer receptacle (if present) and the building ground.

Note: If the voltage values are less than 1 Vac, the customer receptacle is safe to touch.

- ___ 3. Make the following resistance measurements; a reading of less than 1 ohm shows a safe grounding conductor.
 - ___ a. Measure the resistance between the ground pin of the customer receptacle to the exterior shell.
 - ___ b. Measure the resistance between the ground pin of the customer receptacle to the building ground.

Note: Digital meters may give unstable readings if leakage current is flowing in the building ground circuit. If the reading appears unstable or greater than 1 ohm, use an ECOS 1020, 1023, or equivalent to measure ground impedance only. If the resistance is less than 1 ohm, the customer receptacle has a safe ground.

- ___ 4. Perform the following voltage measurements of the customer receptacle; all voltage values should be less than 1 Vac.
 - ___ a. Measure the phase-to-phase voltage.
 - ___ b. Measure the phase-to-ground voltage.
 - ___ c. (World Trade Only) Measure phase-to-neutral voltage (if present).
 - ___ d. (World Trade Only) Measure neutral-to-ground voltage (if present).

- Notes:**
- 1. If voltage values are less than 1 Vac, continue.
 - 2. Ensure that the language on all safety labels match the country to which the processor is being installed. Refer to "4381 Processor Safety Inspection Guide" for the correct locations and part numbers.

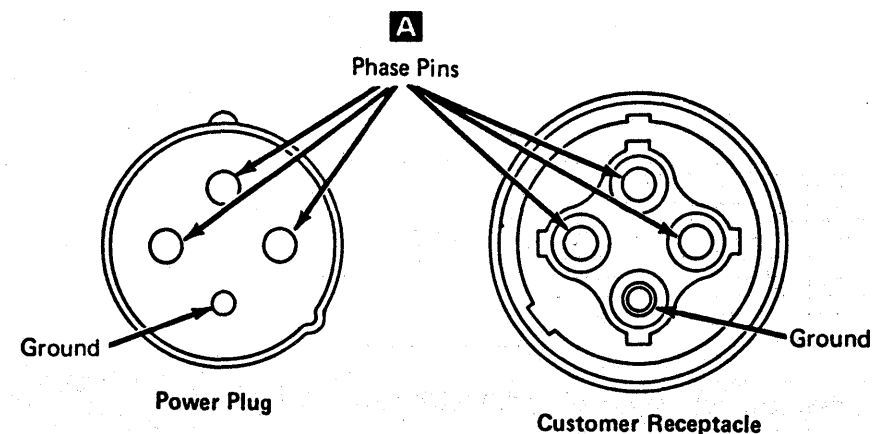

4381-3	MI	PN 6169591	EC A20558	EC A20562			
B/M 2676380	Seq GH010	2 of 2	01 Oct 84	30 Aug 85			

Measuring the Customer Primary Power

DANGER

This procedure must not be performed until you have completed the following procedures.

"Checking the 4381 Processor Power Plug"

"Checking the Customer Power Receptacle"

Do not touch the internal parts of the customer receptacle with anything except the test probes.

- ___ 1. Place the customer branch CB in the ON position.
- ___ 2. Perform the following voltage measurements; all voltage values should be less than 1 Vac.
 - ___ a. Measure the voltage between the exterior shell of the customer receptacle and the building ground.
 - ___ b. Measure the voltage between the ground pin of the customer receptacle and the exterior shell.
 - ___ c. (World Trade only) Measure the voltage between the neutral of the customer receptacle and the building ground.

Note: If the voltage values are less than 1 Vac, the customer receptacle is safe.

- ___ d. **Impedance-grounded neutral power systems only.** Measure the voltage between neutral of the customer receptacle and building ground. If the voltage is greater than 10 Vac, check the phase fault indicator for a phase fault and notify the customer. Do not continue until the phase fault is corrected.
- ___ e. Measure the phase-to-phase voltage of the customer receptacle. Continue only if the voltage values measured meet the requirements as indicated in chart **A**.
- ___ f. Check the voltage label on the cover of the Primary Control Compartment (PCC) box to ensure the processor is correctly wired for the customer outlet. If there is a problem, see Volume C01, "Power Logics" on page YA081 for proper wiring, or invoke your support structure.
- ___ g. Place the customer branch CB in the OFF position.

A 50/60 Hertz Primary Power Voltage

Nominal	Minimum	Maximum
50 Hz		
200	180	220
220	193	238
380	333	410
400	350	432
415	363	448
60 Hz		
200	180	220
208	180	220
220	193	238
240	208	254

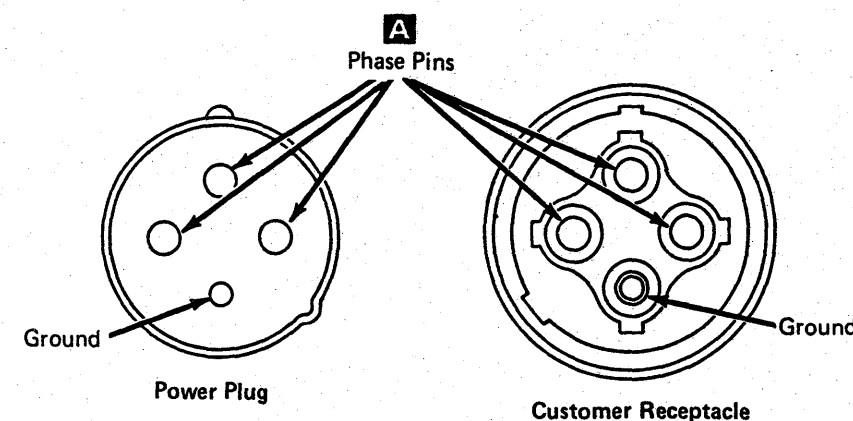

Physical Setup

Processor Location

1. The cable entry and exit holes in the processor frame are shown at **A**. The opening in the subfloor hole must be large enough to accommodate all I/O, Power, and Power Control Interface (PCI) cables.

Note: Excessive cold air on the Air Flow Sensors can cause a power-on failure.

2. Remove the I/O cable cover 01E, and route the power cable through the frame opening.
3. Install two plate assemblies (part 401502) under the frame as shown at **B**. Adjust the levelers until the casters are free to rotate. The levelers will stabilize the processor.

4. For nonraised floor installations only.

- a. Remove two setscrews shown at **C**.
- b. Remove rubber O ring, and slide locking collar away from power plug.
- c. Slide the power plug under the processor frame.
- d. For replacement reverse the procedure.

Note: Ensure that the O ring is seated in the grooved area of the plug.

5. (Japan only). For machines with B/M 1806743, install leveler retainers as shown at **D**.

6. Install cable tie (part 2637668) from the frame support shown at **E** to the cable.

7. Connect the power plug to the customer receptacle.

Channel-To-Channel Adapter (CTCA) Only

For CTCA switch settings, see Volume A06, Service Aids, "CTCA Switch Settings."

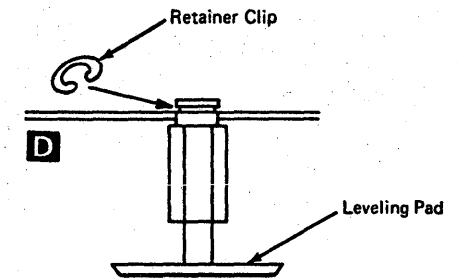
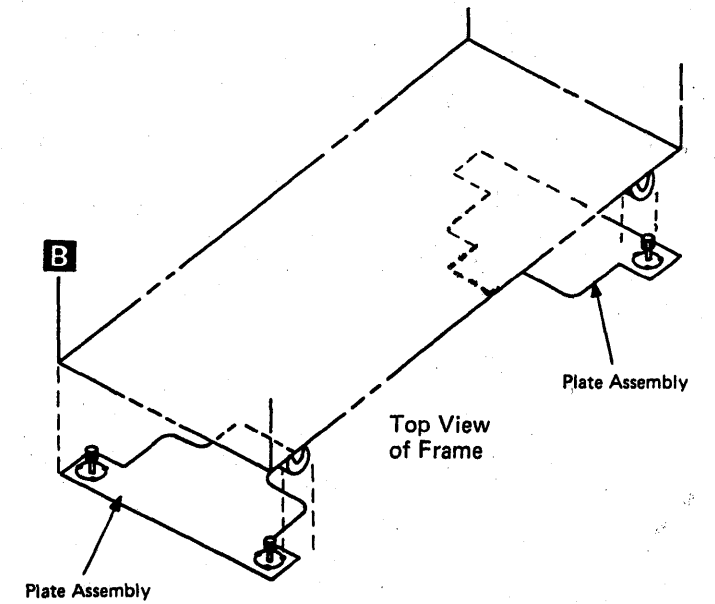
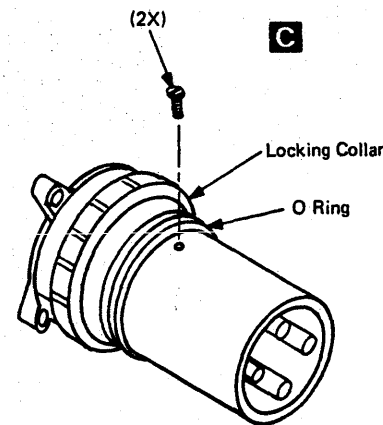
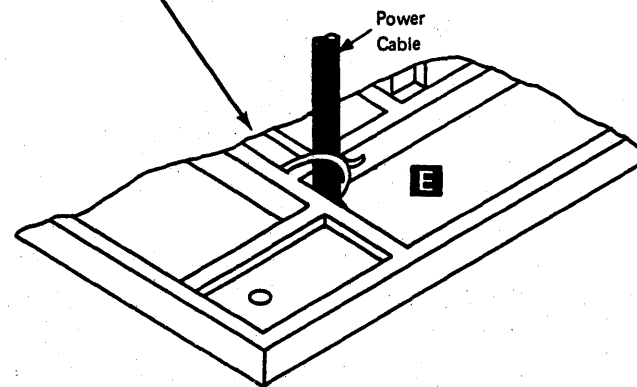
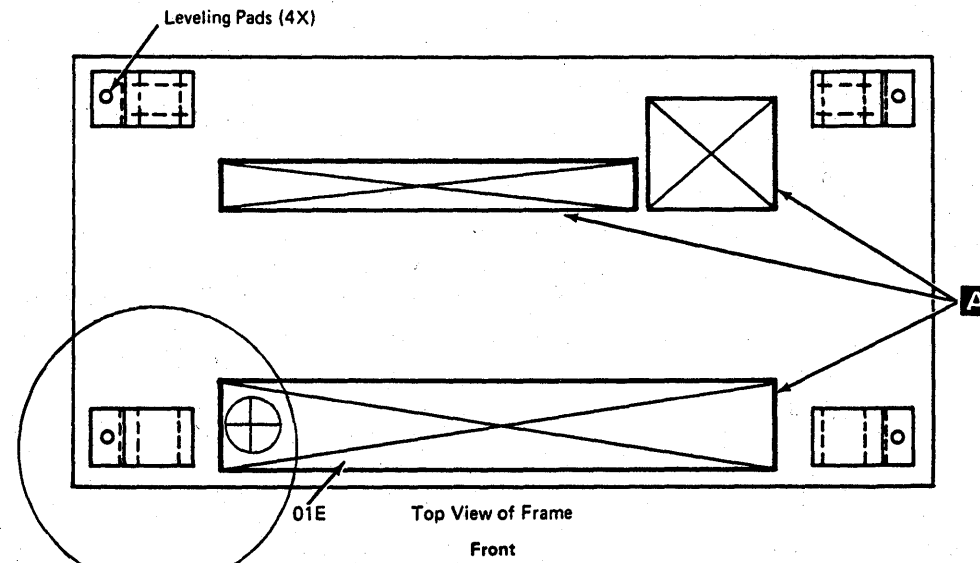

4381	MI	PN 6169592	EC A20558	EC A20559			
B/M 2676380	Seq GH015	2 of 2	01 Oct 84	03 Dec 84			

Installing Operator Console

3278-2A

CAUTION

The weight of the display console is approximately 36 kg (80 lb). Get aid in lifting.

Note: For the correct setup procedures, see 3278-2A Setup Instructions, and follow normal safety practices.

1. The operator console consists of a keyboard with the operator control panel (OCP) and display console unit. This unit is placed on the operator console table.

2. Remove the cover on gate 01F/01H as shown at **A**.

3. Connect the coaxial cable (part 5578477) to the display console, route the cable to gate 01F, and connect to socket 0 as shown at **B**.

Note: If the processor was shipped with a stand-alone OCP, do not use it with the 3278-2A console. Disconnect the the OCP cable (part 401462) from the OCP unit. This cable connects the 3278-2A to the processor. The OCP unit should be left on-site with the customer.

4. Connect the OCP cable (part 401462) to the display console, route the cable to gate 01F, and connect to socket J1 and ground tab as shown at **C**.

5. Install the EMC clamp (part 167338) to the OCP cable, and then fasten the clamp to the grounding stud **D** using a flat washer (part 1622305), lockwasher (part 1622319), and nut (part 1622404).

6. Connect the power cord to the customer-supplied outlet.

Note: If the display has a Security Lock feature, ensure that the key is in the ON position.

7. Replace the cover on gate 01F/01H.

8. Perform the offline test using the 3278 Model 2A Display Console Maintenance Information, Order No. SY27-2546.

9. Connect all optional printers or displays to gate 01F at positions 1, 2, or 3.

10. If RSF is featured on this processor, go to INST 031.

11. If RSF is not featured on this processor, go to INST 045.

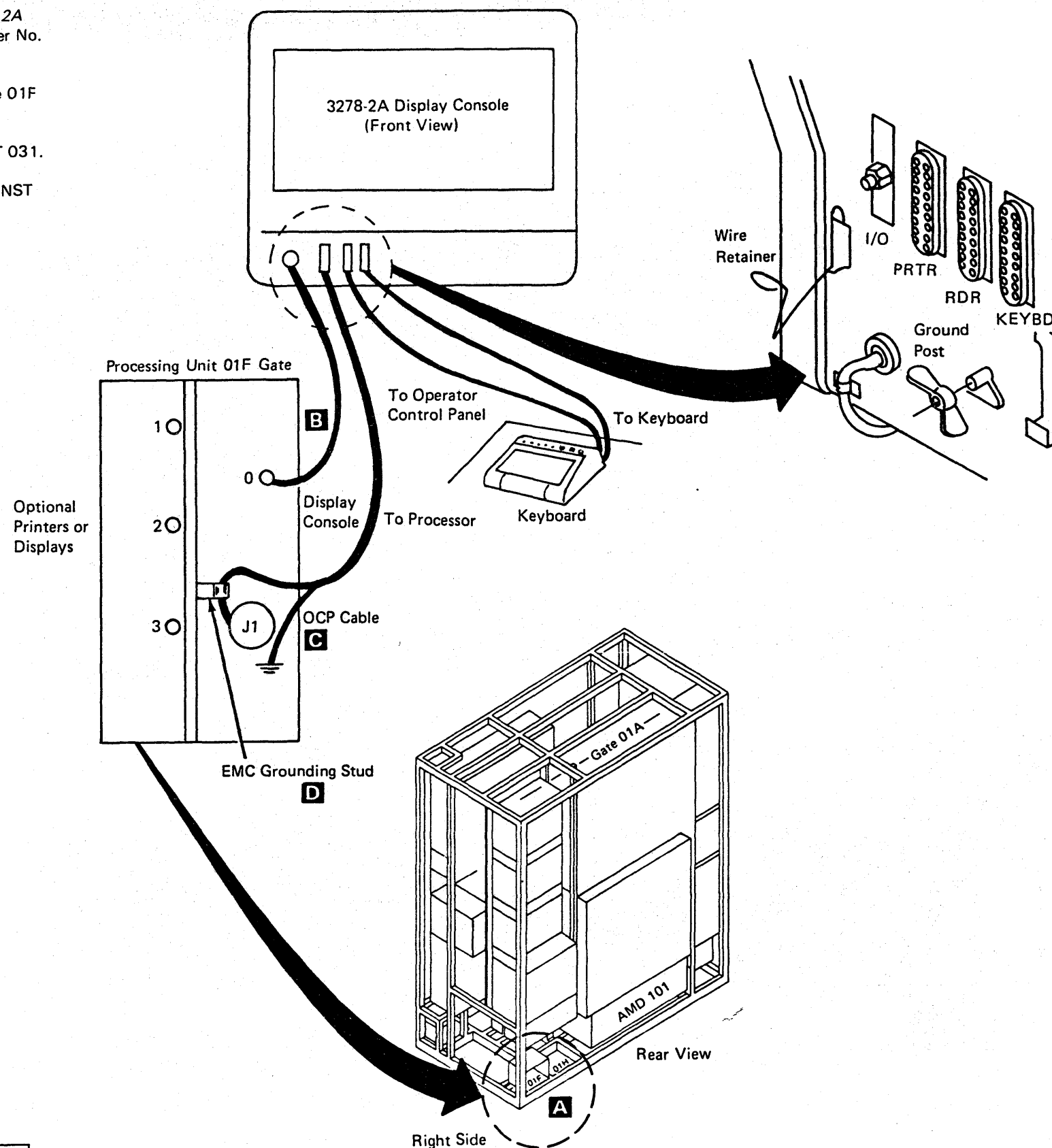

4381-3	MI	PN 6169593	EC A20558	EC A20562		
B/M 2676380	Seq GH020	1 of 2	01 Oct 84	30 Aug 85		

3279-2C

CAUTION

The weight of the display console is approximately 36 kg (80 lb). Get aid in lifting.

Note: For the correct setup procedures, see 3279-2C Setup Instructions, and follow normal safety practices.

1. The operator console consists of a keyboard with the operator control panel (OCP) and display console unit. The unit is placed on the operator console table.

2. Remove the cover on gate 01F/01H as shown at **A**.

3. Connect the coaxial cable (part 5578477) to the display console, route the cable to gate 01F, and connect to socket 0 as shown at **B**.

Note: If the processor was shipped with a stand-alone OCP, do not use it with the 3279-2C console. Disconnect the the OCP cable (part 401462) from the OCP unit. This cable connects the 3279-2C to the processor. The OCP unit should be left on-site with the customer.

4. Connect the OCP cable (part 401462) to the display console, route the cable to gate 01F, and connect to socket J1 and the ground tab shown at **C**.

5. Install the EMC clamp (part 167338) to the OCP cable, and then fasten the clamp to the grounding stud **D** using a flat washer (part 1622305), lockwasher (part 1622319), and nut (part 1622404).

6. Connect the power cord to the customer-supplied outlet.

Note: If the display has a Security Keylock feature, ensure that the key is in the ON position.

7. Replace the cover on gate 01F/01H.

8. Perform the offline test using the 3279 Display Terminal Maintenance Information, Order No. SY33-0069.
9. Connect all optional printers or displays to gate 01F at positions 1, 2, or 3.
10. If RSF is featured on this processor, go to INST 031.
11. If RSF is not featured on this processor, go to INST 045.

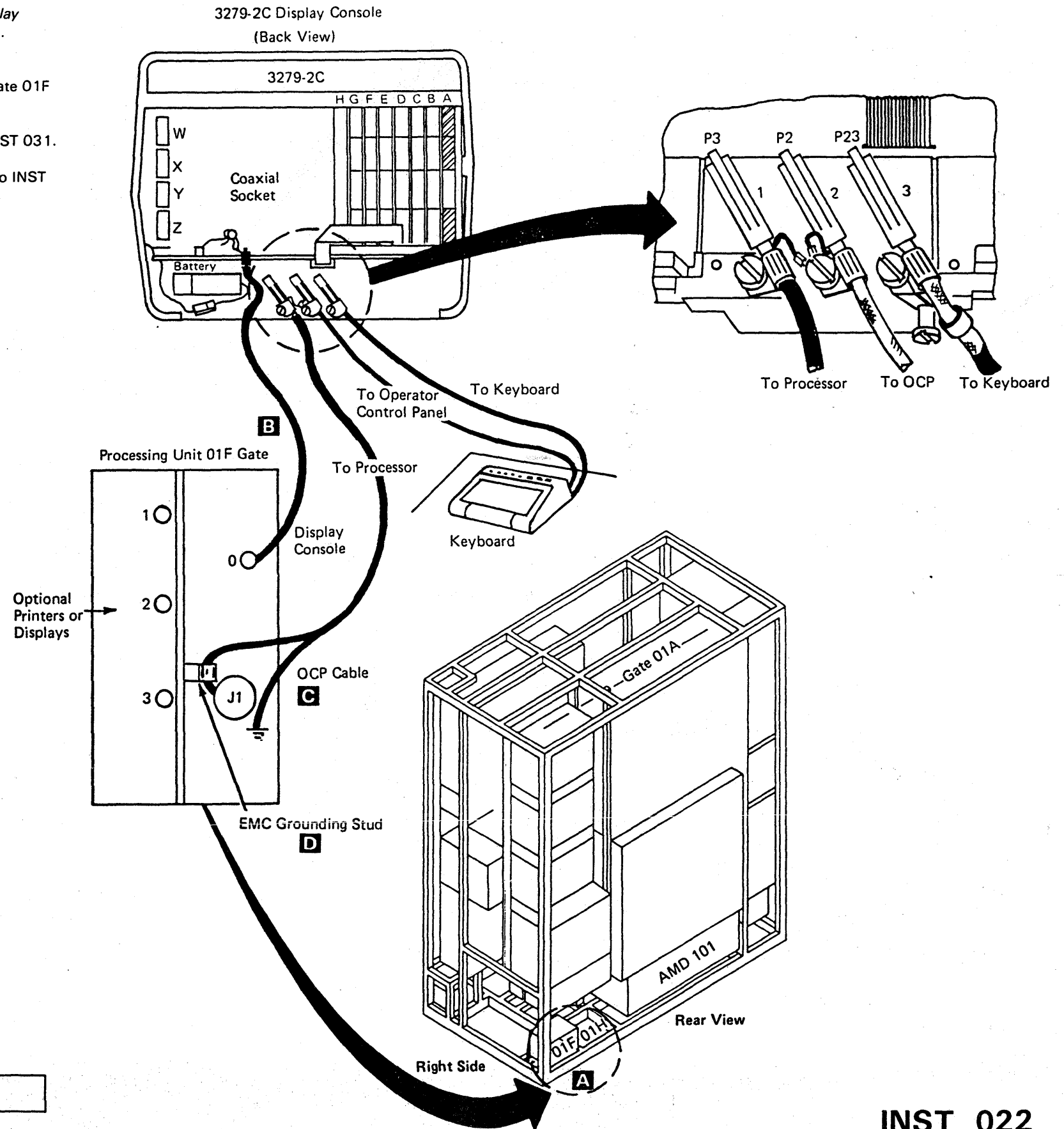

4381-3	MI	PN 6169593	EC A20558	EC A20562			
B/M 2676380	Seq GH020	2 of 2	01 Oct 84	30 Aug 85			

3205 and Operator Console Panel

CAUTION

The weight of the display console is about 20 kg (45 lb). Get aid in lifting.

Note: For the correct setup procedures, see *3205 Color Display Console Maintenance Information*, and follow normal safety practices.

1. The color display console consists of a keyboard, video unit, and logic unit. The OCP is part of the processor ship group.
2. Place the Color Display Console and the OCP on the operator console table.
3. Install OCP plate (part 401345) under the right end of the console base, and place the OCP on top of the plate adjacent to the keyboard as shown **A**.
4. Remove the cover on gate 01F/01H as shown at **B**.
5. Connect the coaxial cable (part 5578477) to the display console, route the cable to gate 01F, and connect to socket O as shown at **C**.
6. Route the OCP cable (part 401462) from the OCP to gate 01F, and connect the cable to J1 position and connect the ground tab shown at **D**.
7. Install the EMC clamp (part 167338) to the OCP cable, and then fasten the clamp to the grounding stud **E** using a flat washer (part 1622305), lockwasher (part 1622319), and nut (part 1622404).
8. Connect the power cord to the customer-supplied outlet.

Note: The display has a Security Keylock feature; ensure that the key is in the ON position.

9. Replace the cover on gate 01F/01H.
10. Connect all optional printers or displays to gate 01F at positions 1, 2, or 3.
11. If RSF is featured on this processor, go to INST 031.
12. If RSF is not featured on this processor, go to INST 045.

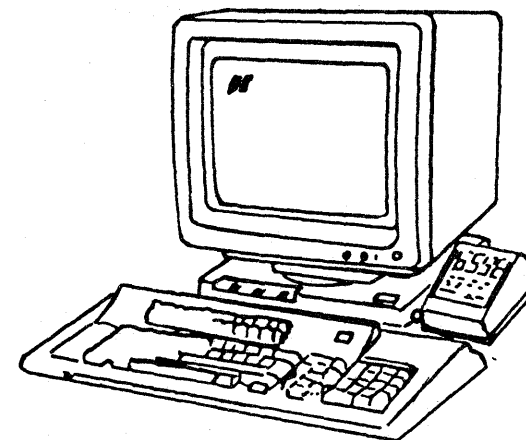

Front View 3205

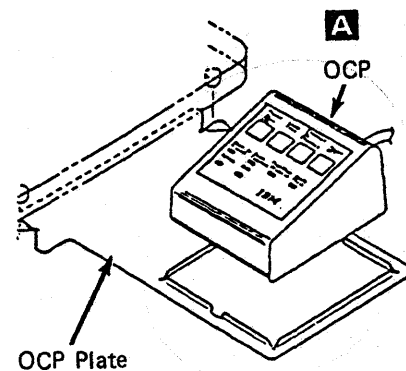
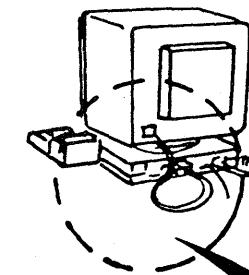

OCP Plate

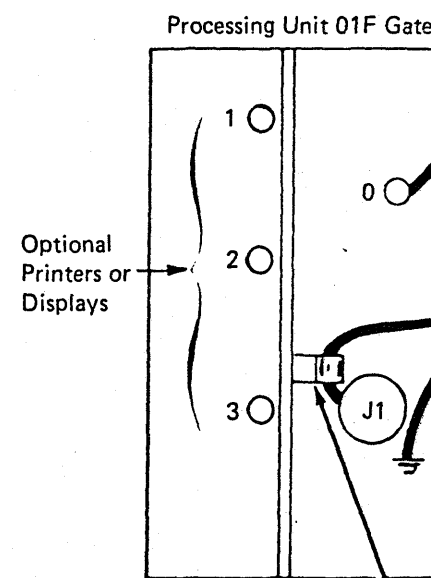

Optional Printers or Displays

OCP Cable

EMC Grounding Stud

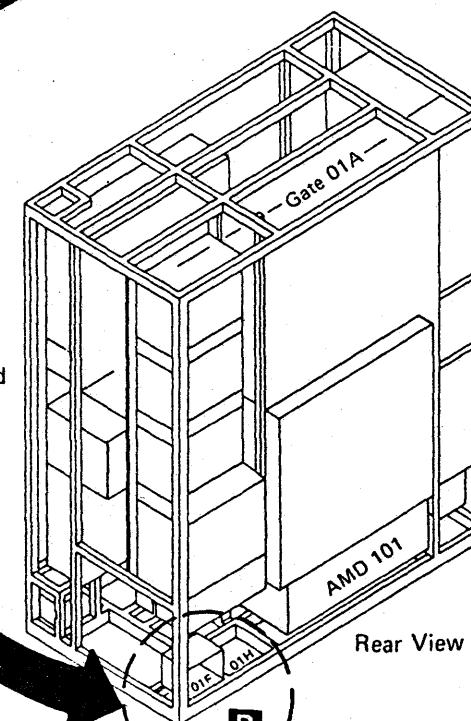

Rear View

Right Side

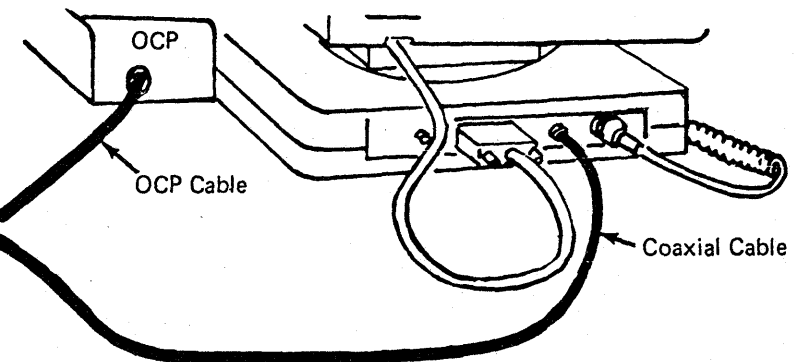

OCP

OCP Cable

Coaxial Cable



Installing Remote Support Facility (RSF)

INST 031

Note: If this installation does not include the Remote Support Facility feature, go to page INST 045.

This section describes the installation of the RSF cable to gate 01G.

Unpacking the Cable Box

If feature B/M 1806885 was ordered, cable assembly (part 401441) is installed in gate 01G; go to page INST 042 to continue the cable installation.

1. For external cable (part 8482931), go to page INST 032.
2. For external cable (part 8482930), go to page INST 035.
3. For external cable (part 8482934), go to page INST 036.
4. For external cable (part 8482933), go to page INST 041.
5. For external cable (part 401441), go to page INST 042.

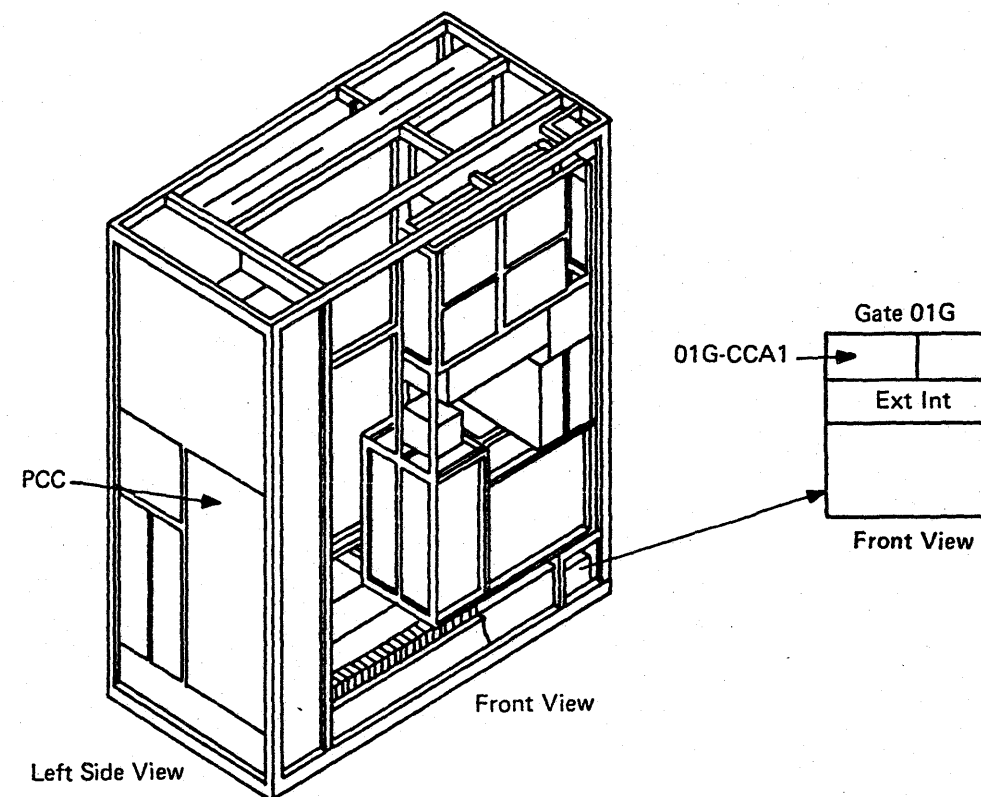

External Cable -- Part 8482931

1. Locate and remove the cover **A** on gate 01G by loosening screws **B** and **C**.
2. Connect RSF external cable **D** to 01G-CCA1 as shown.
3. Connect cable shield **E** to gate 01G (as shown).
4. Route RSF external cable through opening adjacent to gate 01G.
5. Install tie wrap (part 5270166) to the external cable, and fasten it to the adjacent frame support shown at **F** using screw (part 1621230).
6. Reinstall the cover **A** by tightening screws **B** and **C**.
7. Do one of the following to complete the RSF external cable installation:
 - To connect external cable, part 8482931 (Canada/U.S.A.), first connect adapter (part 1853134) and then refer to coupler.
 - To connect external cable, part 8482931 (Japan), see B/M 1864633 contained within B/M 4143541.

Set Modem Adapter Card (Canada/U.S.A.)

1. Remove card (part 8564508) from 01A-A2Q4.
2. Set all rocker switches to the OFF position.
3. Set rocker switch K to the ON position.
4. Use the Transmit DBM chart to match rocker switches A through I to levels specified on the coupler (X=ON).
5. If level is not shown, use the -8 dbm settings.
6. Install the card in 01A-A2Q4.
7. Go to page INST 045.

Set Modem Adapter Card (Japan)

1. Remove card (part 5688021) from 01A-A2Q4.
2. Set all rocker switches to the OFF position.
3. Set rocker switches AA, BB, CC, DD, L, M, and N to the ON position.
4. Use the Transmit DBM chart to match the rocker switch settings A through H and R levels shown on the coupler (X=ON).
5. If no level is shown, use the -8 dbm settings.
6. Install the card in 01A-A2Q4.
7. Go to page INST 045.

Rocker Switches	0	1	2	3	4	5	6	7	8	9	10	11	12	13	14	15	16	17	18
A	X					X					X				X				X
B		X				X				X				X					
C			X			X				X				X					
D				X						X					X				
E				X				X					X				X		
F				X				X				X					X		
G					X	X	X	X	X	X									X
H											X	X	X	X	X	X	X	X	X
I																			X

Rocker Switch Identification	
On	Off
R	H
P	G
N	F
M	E
L	D
K	C
J	B
I	A

Component Side On Off

Rocker Switches	0	1	2	3	4	5	6	7	8	9	10	11	12	13	14	15	16	17	18
A	X						X					X							X
B		X						X					X						
C			X						X					X					
D				X						X					X				
E				X						X				X				X	
F					X					X								X	
G						X	X	X	X	X	X								X
H											X	X	X	X	X	X	X	X	X
R																			X

Rocker Switch Identification	
On	Off
DD	
CC	
BB	
AA	
R	H
P	G
N	F
M	E
L	D
K	C
J	B
I	A

Component Side On Off

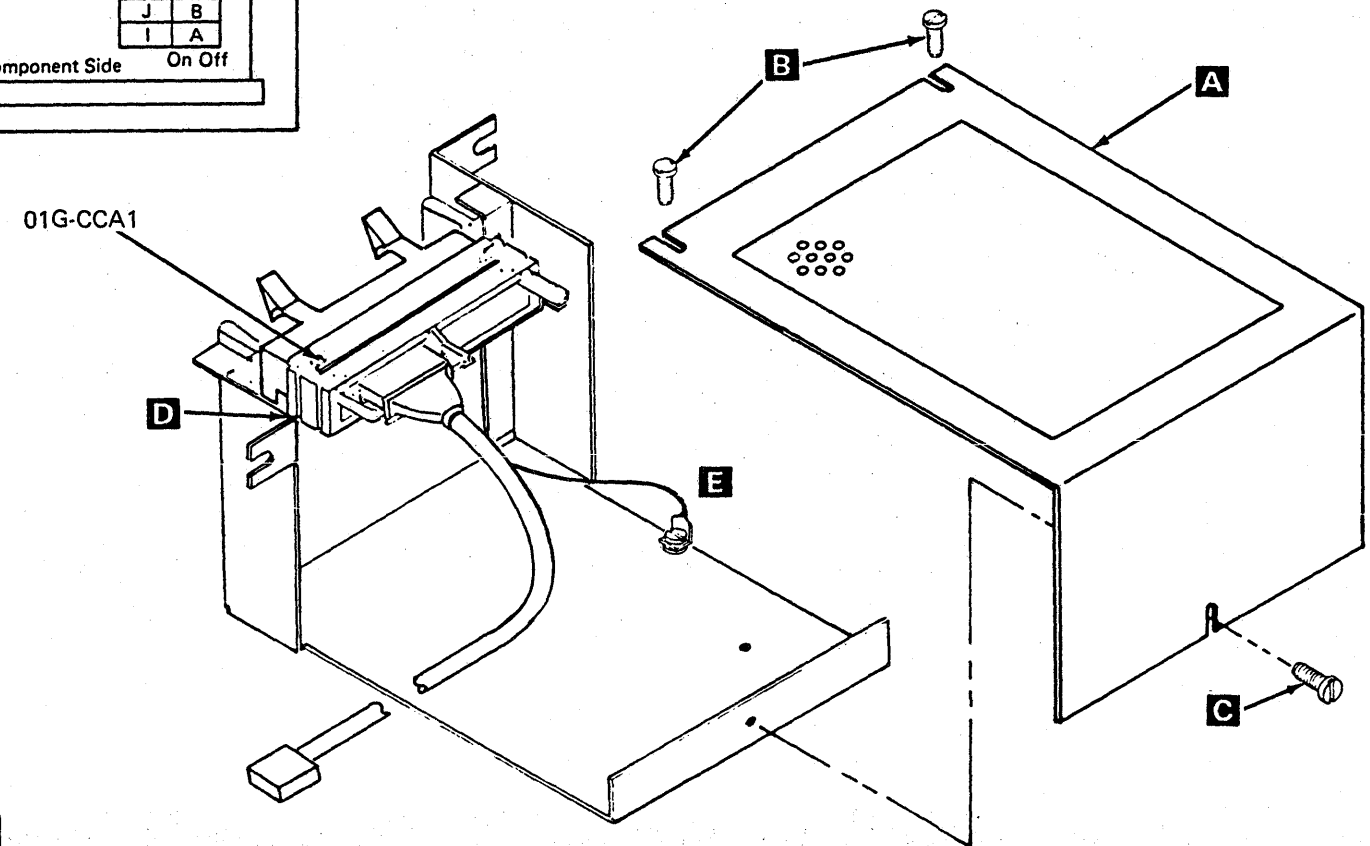
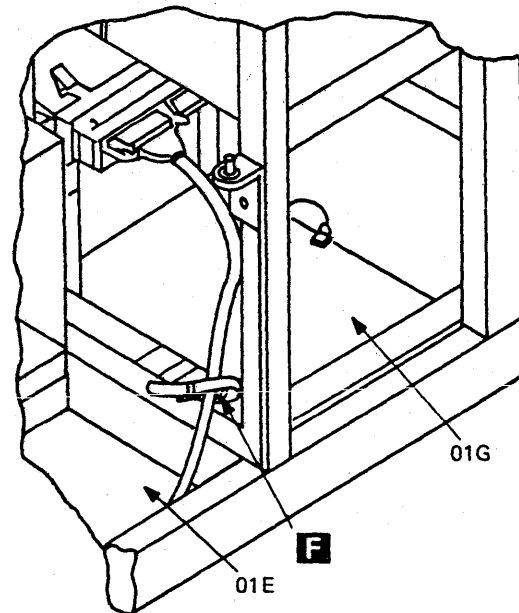

4381-3	MI	PN 6169595	EC A20558	EC A20559	EC A20560		
B/M 2676380	Seq GH030	2 of 2	01 Oct 84	03 Dec 84	18 Feb 85		

**External Cable -- Part 8482930
(External Modem)**

1. Locate and remove the cover **A** on gate 01G by loosening screws **B** and **C**.
2. Connect RSF external cable **D** to 01G-CCA1 position.
3. Connect cable shield **E** to gate 01G as shown.
4. Route RSF external cable through the opening adjacent to gate 01G.
5. Install tie wrap (part 5270166) to the external cable, and fasten it to the adjacent frame support shown at **F** using screw (part 1621230).
6. Reinstall the cover **A** by tightening screws **B** and **C**.
7. Connect external cable connector (part 8482930) **G** to the customer supplied modem.
8. To complete this cable installation, see your modem instructions.

Set Modem Adapter Card (External Modem)

1. Remove card (part 5864668) from 01A-A2Q4.
2. Verify that positions D and F have jumpers installed.
3. Install the card in 01A-A2Q4.
4. Go to page INST 045.

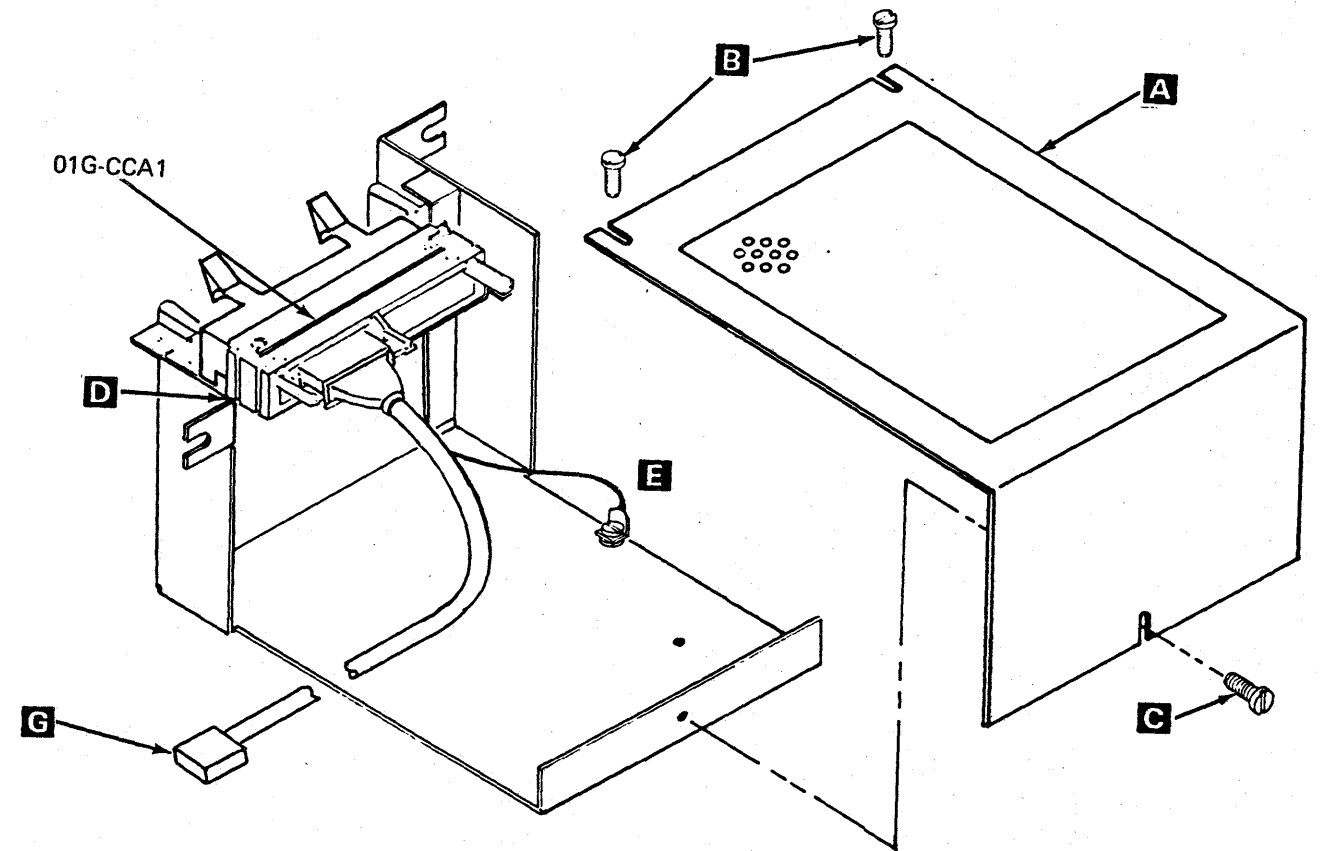
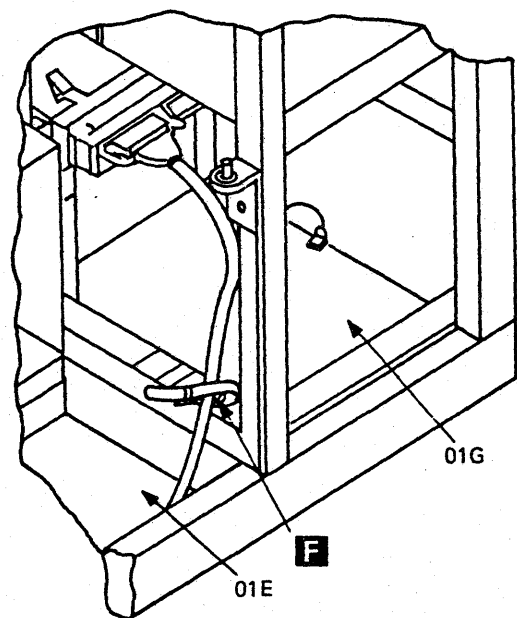
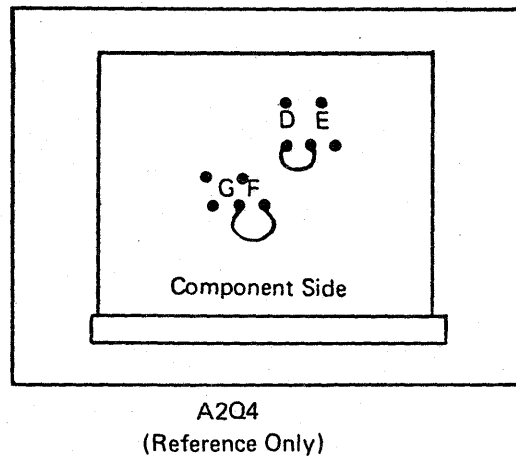

External Cable -- Part 8482934

1. Locate and remove the cover **A** on gate 01G by loosening screws **B** and **C**.
 2. Place foam pad (part 401478) **D** on gate 01G as shown.
 3. Place the RSF external cable assembly **E** on top of the foam pad in gate 01G.
 4. Install retainer bracket (part 401479) **F** using screw (part 1621176).
 5. Install ground wire **G** to housing **H** using screw (part 1621190) and washer (part 1622346).
 6. Install connector **J** to 01G-CCA1.
 7. Route TB1 cable **K** through opening adjacent to gate 01G to location of the telephone coupler.
 8. Install tie wrap (part 5270166) to the external cable and fasten it to the adjacent frame support shown at **L** using screw (part 1621230).
 9. Reinstall the cover **A** by tightening screws **B** and **C**.
- Note:** For a detailed description of TB1 wiring, refer to Volume A06, Service Aids "Line Plate Configuration (World Trade)."
10. To complete the RSF external cable installation, contact your telephone company representative.

Set Modem Adapter Card

1. Remove card (part 5167246) from 01A-A2Q4.
2. Set all rocker switches to the OFF position.
3. Set rocker switches I, J, K, P, and N to the ON position.
4. Use the Transmit DBM chart to match rocker switches A through H and R to levels specified on the coupler (X=ON).
5. If no level is shown, use the -8 dbm settings.
6. Install the card in 01A-A2Q4.
7. Go to page INST 045.

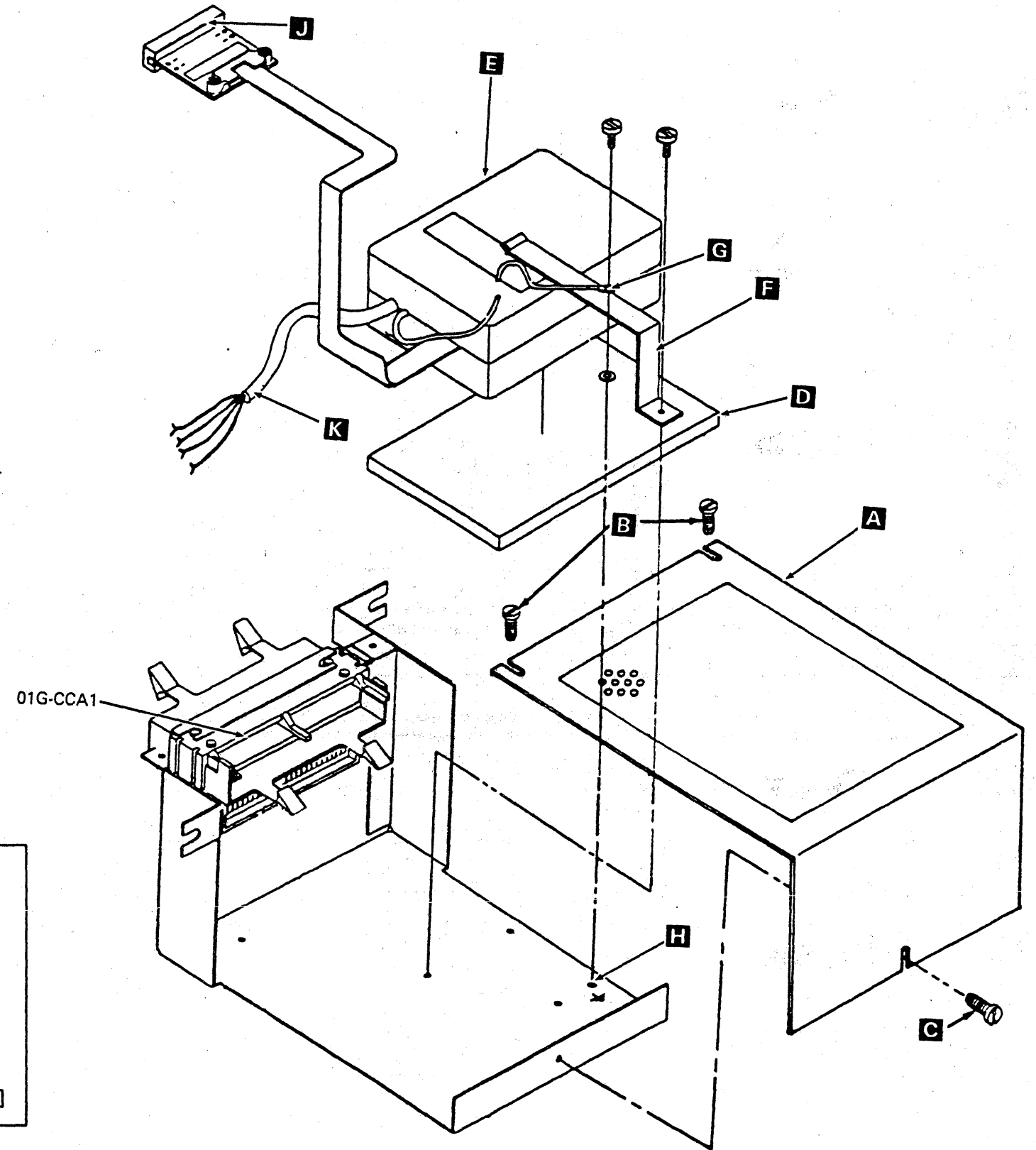
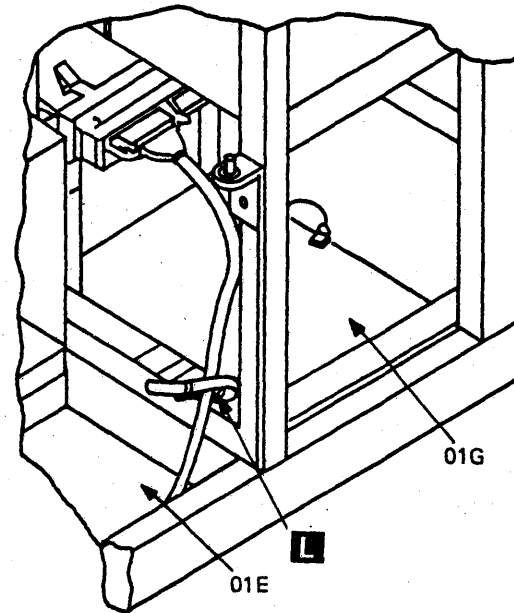

Rocker Switches	Transmit DBM																		
	0	1	2	3	4	5	6	7	8	9	10	11	12	13	14	15	16	17	18
A	X						X						X						X
B		X						X						X					
C			X						X						X				
D				X						X						X			
E					X						X						X		
F						X					X							X	
G							X	X	X	X	X	X							X
H												X	X	X	X	X	X	X	
R																			X

Rocker Switch Identification	
On	Off
R	H
P	G
N	F
M	E
L	D
K	C
J	B
I	A

Component Side On Off

4381-3 MI PN 6169596 EC A20558 EC A20560
 B/M 2676380 Seq GH035 2 of 2 01 Oct 84 18 Feb 85

External Cable -- Part 8482933

1. Locate and remove the cover **A** on gate 01G by loosening screws **B** and **C**.
2. Install the RSF external cable assembly **D** into gate 01G **E**.
3. Route the cable assembly through the opening adjacent to gate 01G and then to the location of telephone coupler.
4. Install the two mounting screws (part 1621176) and the two flat washers (part 1622304) shown at **F**.
5. Connect the cable shield **G** to gate 01G shown at **H**.
6. Connect the ground wire **J** using the screw (part 1621190) and washer (part 162346) **K** to gate 01G shown at **L**.
7. Connect cable **M** to 01G-CCA1.
8. Install tie wrap (part 5270166) to the external cable, and fasten it to the adjacent frame support shown at **N** using screw (part 1621230).
9. Reinstall the cover **A** by tightening screws **B** and **C**.
10. Connect external cable connector (part 8482933) **P** to cable connector (part 1727744) **Q**.
11. To complete this cable installation, see your modem instructions.

Set Modem Adapter Card (External Modems)

1. Remove card (part 5864668) from 01A-A2Q4.
2. Verify that positions D and F have jumpers installed.
3. Install the card in 01A-A2Q4.
4. Go to page INST 045.

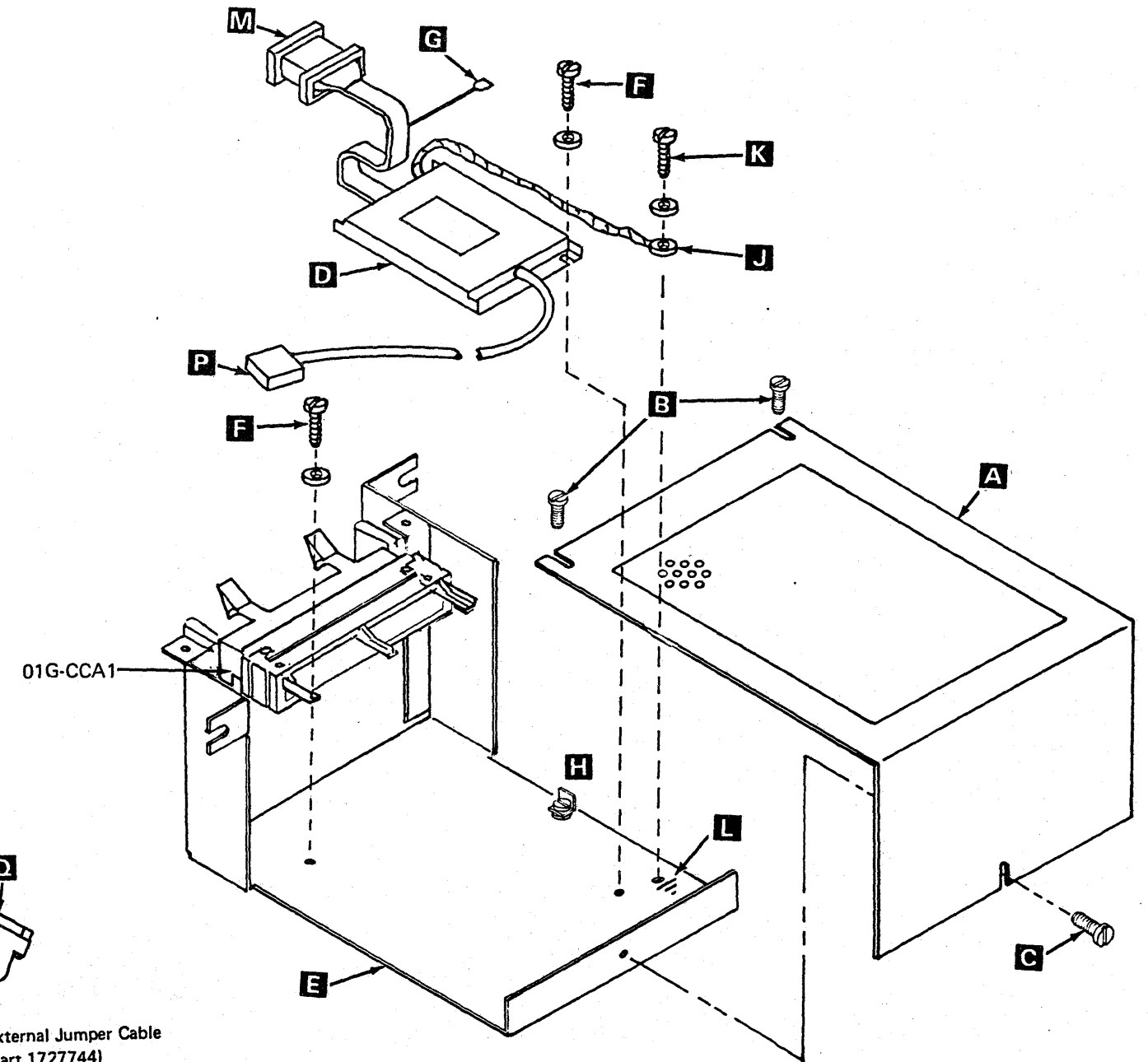
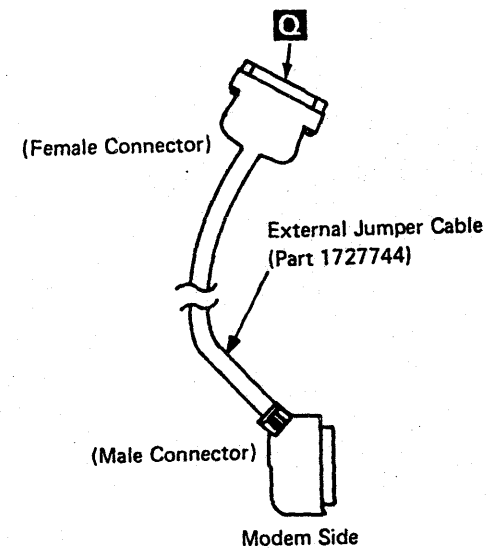
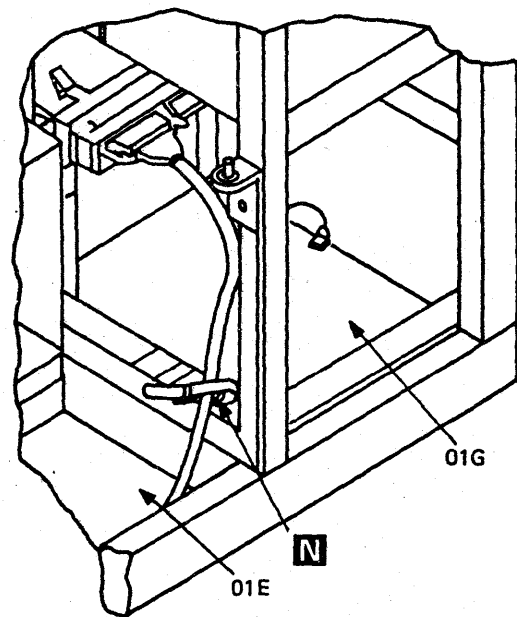
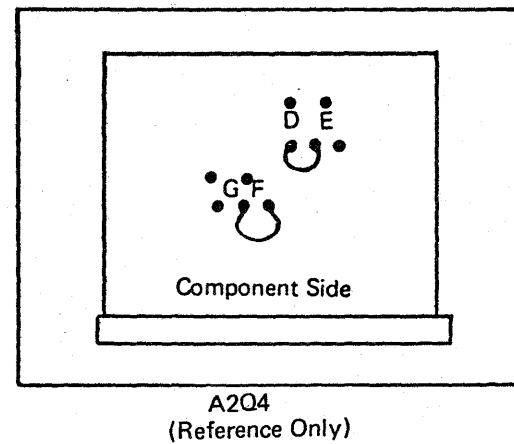

MI Seq GH040	PN 6169597 1 of 2	EC A20558 01 Oct 84	EC A20560 18 Feb 85			
-----------------	----------------------	------------------------	------------------------	--	--	--

External Cable -- Part 401441

1. Locate and remove the cover **A** by loosening screws **B** and **C**.
2. Route cable **D** through the opening adjacent to gate 01G and then to the telephone.
3. Ensure that the 01G-CCA1 connector **E** is properly seated.
4. Reinstall the cover **A** by tightening screws **B** and **C**.

Note: The unpacking, assembly, and connection of the IBM supplied telephone is **TOTALLY** the responsibility of the customer and is **NOT** to be performed by the IBM service representative.

5. Give the customer the box labeled part 4494964, which contains the IBM supplied telephone.

Set Modem Adapter Card

1. Remove card (part 8564508) from 01A-A2Q4.
2. Set all rocker switches to the OFF position.
3. Use the Transmit DBM chart to match rocker switches A through I to the 0 dbm level (X=ON).
4. Set rocker switch J to the ON position.
5. Install the card in 01A-A2Q4.
6. Go to page INST 045.

Rocker Switches	Transmit DBM																		
	0	1	2	3	4	5	6	7	8	9	10	11	12	13	14	15	16	17	18
A	X						X						X					X	
B		X						X							X				
C			X						X							X			
D				X						X						X			
E					X						X						X		
F						X						X						X	
G							X	X	X	X	X	X							
H													X	X	X	X	X	X	X
I																			X

Rocker Switch Identification	
On	Off
R	H
P	G
N	F
M	E
L	D
K	C
J	B
I	A

Component Side On Off

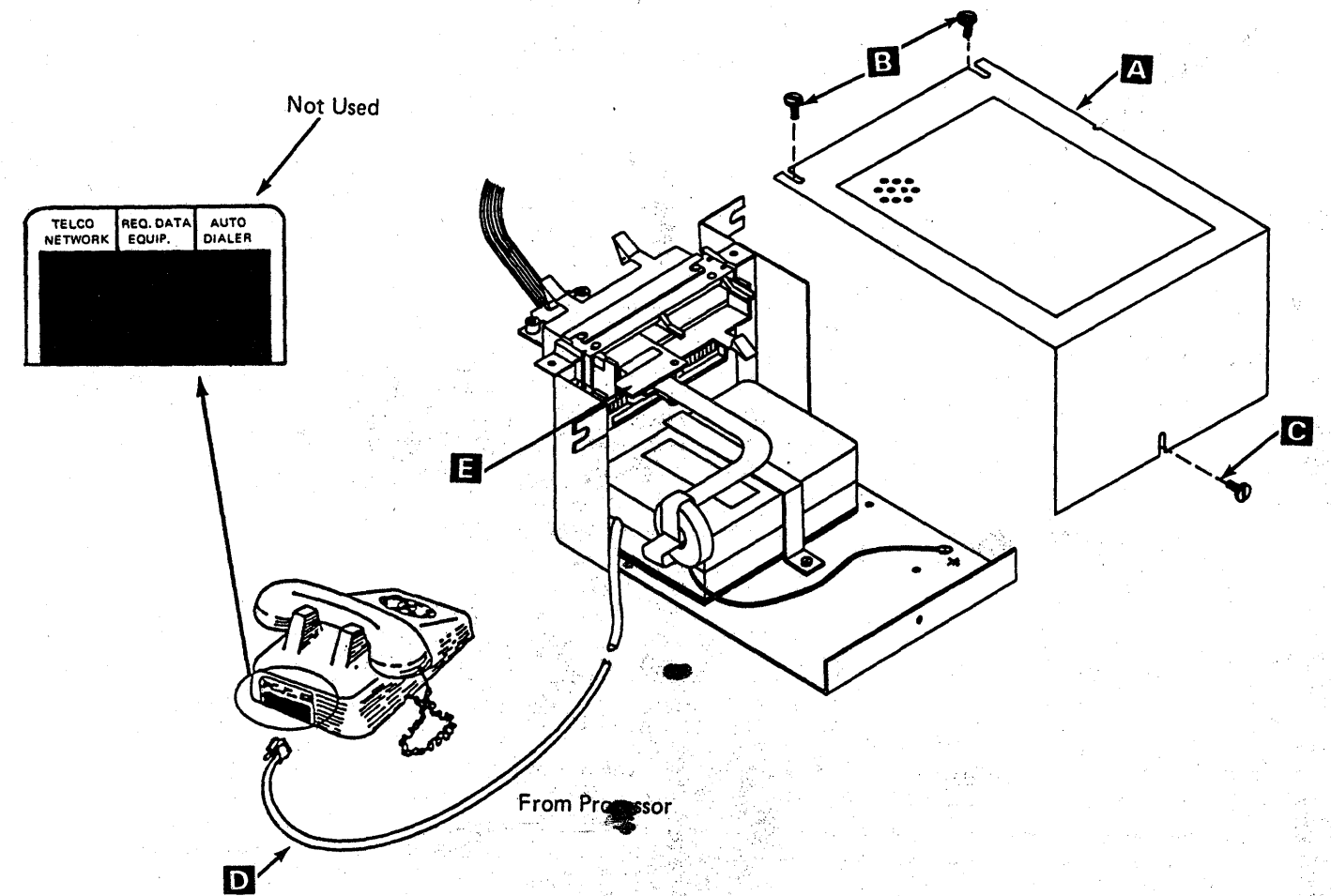

4381-3	MI	PN 6169597	EC A20558	EC A20560			
B/M 2676380	Seq GH040	2 of 2	01 Oct 84	18 Feb 85			

Note: If a processor failure occurs while performing the following instructions, go to Volume A01, "Start Repair Procedure," on page START 001. Once the failure has been corrected, return to the point in the instructions from where you left.

1. Ensure the Unit Emergency Only switch is in the On position and the customer branch CB is in the ON position.
2. Diskette drives 1 and 2 are unloaded.
3. Ensure that the operator console is powered on.
4. Set the CE Mode switch to CE Mode, the Power Off switch to Normal, and verify the following.
 - a. CP1, CB1, and CB2 are in the ON position at the PCC.
 - b. CP2 is in the ON position (all 50 Hz and 60 Hz Japan machines).
 - c. The 5 Volt, 24 Volt, Basic Check, and MBC On indicators are on.
5. Press Power On at the service panel, and verify the following:
 - a. The Power In Process indicator is on.
 - b. After about 30 seconds, 81504 appears in the MSS Code display indicating the SP ROS diagnostics ran error free.
6. Press Lamp Test, and verify that the remaining service panel lights are now on.

Running MSS Extended Diagnostics

1. Set the CE Mode switch to Normal.
2. Set the I/O Power Hold switch to I/O Power Hold.
3. Set the Power Off switch to Power Off.
4. Install the DIAG1 diskette into diskette drive 1.
5. Set the Power Off switch to Normal.
6. Press Power On. The Basic and Extended Diagnostics (FF) start to run.
7. The message MSS EXTENDED DIAGNOSTICS COMPLETED is displayed when the tests are completed.

Note: Errors are indicated by the stop words displayed on the service panel or by a reference code shown on the console.

Running Additional MSS Tests

Note: A error message is displayed on the operator console screen if ports 1, 2, or 3 on gate 01F are unused.

1. Power on all displays/printers, and ensure that all device switches are set to the Normal position.
2. Key in the two-digit code for each selected test, and press ENTER.

3. Follow the instructions displayed on the operator console screen.

Notes:

- a. Run Test A0 against diskette drive 1 and diskette drive 2.
- b. Run test E0 **ONLY** if external cable 8482930 or 8482933 is installed.

MSS Test Selection.

- 90 Run Service Panel diagnostics
- A0 Run DDA/Drive tests
- CE Test all console/printer ports
- D0 Run RSF adapter diagnostics
- E0 Run RSF cable wrap test (EIA interface only)

Note: For additional information, see "Optional MSS Diagnostics," under Diagnostics in this volume.

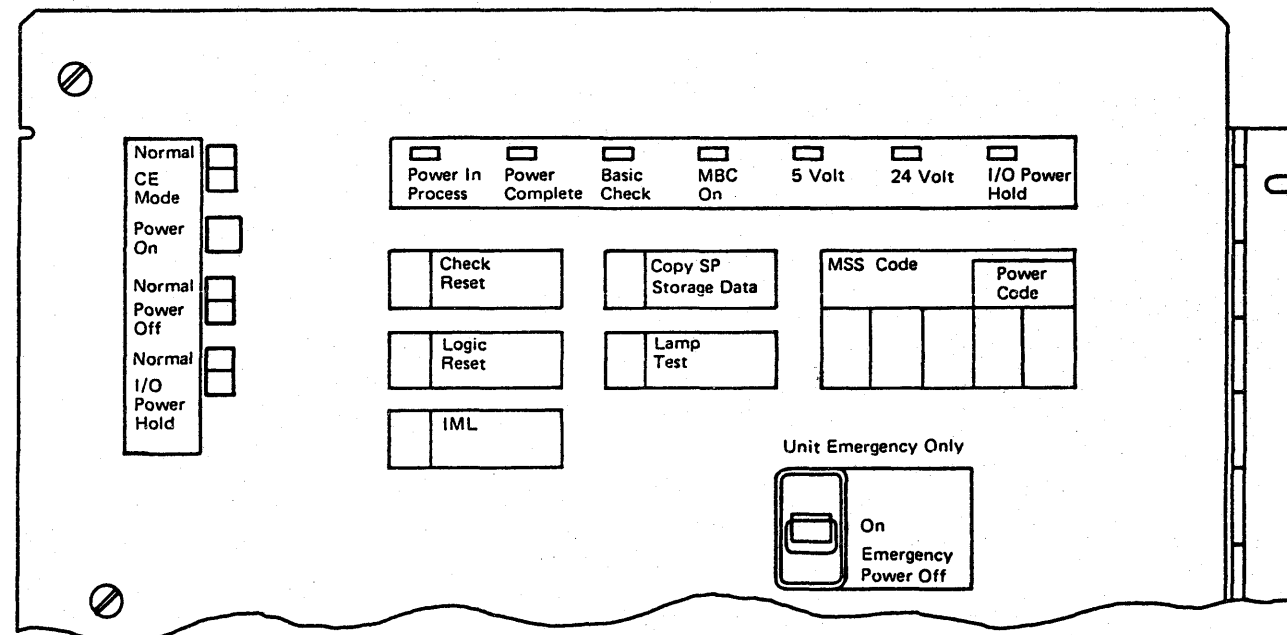

Service Panel (Front View)

4381-3 B/M 2676380	MI Seq GH045	PN 6169598 1 of 2	EC A20558 01 Oct 84	EC A20559 03 Dec 84	EC A20560 18 Feb 85	EC A20562 30 Aug 85	
-----------------------	-----------------	----------------------	------------------------	------------------------	------------------------	------------------------	--

Running PU Diagnostics Based on Initial Install or Relocation

Notes:

1. Ensure that channel 0 is terminated.
2. If a failure should occur, correct the failure and restart this test.
3. Perform Language Configuration first, **only if another keyboard other than the U.S. console keyboard is used.** See Volume A06, Service Aids, "Language Configuration."

General Instructions

1. Set the CE Mode switch to CE Mode.
2. Remove DIAG1 diskette from diskette drive 1.
3. Install FUNC1 diskette into diskette drive 1 and FUNC2 diskette into diskette drive 2.
4. Press IML at the service panel.

Note: Ignore the message "PORT x CONFIG ERROR."

5. Enter date and time.

Note: If the processor that you are installing *DOES NOT* have a printout packaged with the diskettes go to step 8.

6. Go to Volume A06, Service Aids, and perform "System Configuration--Service."

Note: For the correct system configuration information, use the printout packaged with the diskettes.

7. After performing "System Configuration--Service," continue with step 8 on this page.

8. Key in QWW, press ENTER.
 - a. Key in UC, and press ENTER.
9. The Power Complete indicator is now on.
10. Press MODE SEL.
11. Key in QG, and press ENTER to display the Diagnostic Mode PU Diagnostic Selection screen.
12. Select the correct option.

Note: When either option is selected, all available Basic and MSMD diagnostics are run against PU 1 and PU 0 hardware.

a. INITIAL INSTALL—Option T

- 1) Key in T, and press ENTER.
- 2) Key in Y, and press ENTER.

Note: Do not terminate this test.

b. RELOCATION—Option I (Isolate Failure)

Note: If Option T is run at this time and reconfiguration has occurred, a message is displayed on the operator screen indicating that the hardware is reconfigured. Run Option I at this time.

- 1) Key in I, and press ENTER.
- 2) Key in None, and press ENTER.
- 3) Key in Y, and press ENTER.
- 4) To terminate this test, press and hold ALT and then press MODE SEL.

OCP Checkout

1. Set the Power Off switch to Power Off and then back to Normal on the service panel.
2. Set the CE Mode switch to Normal.
3. The indicators on the OCP are not on at this point.
4. Press Power On/IML on the OCP. Enter the needed information on the Time-of-Day screen. Verify that the Power Complete indicator is on.

Note: If this machine has the channel to channel feature, the Chan-Chan Disabled indicator is on or off as the Channel-To-Channel switch is pressed.

5. Press Lamp Test on the OCP, and verify that the Power In Process, Power Complete, Basic Check, System, Wait, and Chan-Chan Disabled (if CTCA is featured) indicators are on.
6. Press Power Off on the OCP, and verify that machine powers down.
7. Set the CE Mode switch to CE Mode. The Basic Check indicator is now on.
8. Press Power On/IML on the OCP, and verify that the processor does not power up.
9. Press Power On on the service panel, the processor will now power up. Key in the needed information on the Time-of-Day screen. When the QWW screen is displayed, enter UC. Verify that power is complete.
10. Press Power On/IML on the OCP. The processor will IML and the General Selection Screen appears.

Running Cable Wrap Test (CWT)

1. Ensure that the CE Mode switch is in CE Mode.
2. Ensure the FUNC1 diskette is in diskette drive 1.
3. Install DIAG1 diskette in diskette drive 2.
4. Key in QG, and press ENTER to display the Diagnostic Mode PU Diagnostic Selection screen.
5. Select Option C, and press ENTER.
6. Select PU side 0.
7. Select 02 for Cable Wrap Test after the Channel Test Selection screen is displayed.
8. Run CWT on all channels attached to PU 0.

Note: Detailed run instructions and test options are displayed on the operator console.

9. Key in option E.
10. Select Option C, and press ENTER.
11. Select PU side 1.
12. Select 02 for Cable Wrap Test after the Channel Test Selection screen is displayed.
13. Run CWT on all channels attached to PU 1.

Note: Detailed run instructions and test options are displayed on the operator console.

14. Key in option E.
15. After completing this test, remove DIAG1 from diskette drive 2, and install FUNC2 in diskette drive 2.

MI Seq GH045	PN 6169598 2 of 2	EC A20558 01 Oct 84	EC A20559 03 Dec 84	EC A20560 18 Feb 85	EC A20562 30 Aug 85	
-----------------	----------------------	------------------------	------------------------	------------------------	------------------------	--

System Configuration

The following procedures are contained in Volume A06, Service Aids. Perform these procedures now.

Note: Perform Language Configuration first, **only if another keyboard other than the U.S. console keyboard is used.**

3279 Display Console Aids

Perform the following procedure if the system has a 3279-2C Display Console attached:

- "3279 Display Console Adjustment."

Configuration Aids

Perform the following configuration procedures at installation:

- "System Configuration--Customer"
- I/O Configuration
 - "I/O Configuration (S/370)" for S/370 mode of operation.
 - "S/370XA Installation" for 370-XA mode of operation.
- "Customer Data and Security Control (Problem Analysis)"

Remote Support Facility Aids

Perform the following RSF procedures at installation:

- "Send Service Information (Problem Analysis)"
- "Remote Operator Console Facility (ROCF)" (if applicable)
- "Data Bank Initialization."

Diskette Aids

Perform the following diskette procedures at installation:

- "Language Configuration" (if required)
- "Module Transfer."

Patch Aids

Perform the following patch procedure at installation:

- "Patch Installation" (if applicable).

Running Channel-To-Channel Adapter (CTCA) Test

Note: Ensure that Channel 0 is terminated.

To run this test, both sides of the CTCA (X and Y) must be cabled to channels on the same processor. Before running this test, verify that the channels are operational. For details on the CTCA tests, see Volume A06, Service Aids, "CTCA Tests."



Installing Interface Cables

INST 055

1. Set the CE Mode switch to Normal, and set the Power Off switch to Power Off.
2. Plug the Power Control Interface (PCI) cables into the 01D I/O rack as shown at **A**.
 - a. Start with position 1 (top left socket) on the PCI panel located at 01D.
 - b. Remove the yellow wire jumper from its plug position.
 - c. Plug the PCI cables in numerical order until all PCI cables are plugged.
 - d. Install the yellow wire jumper next to the last position plugged with the PCI cables.

3. Connect channel cables to gate 01E as shown at **B**.

Notes:

- a. To prevent cable interference, install channel cables in a left-to-right sequence.
 - b. Ensure that **ALL** channels are terminated with 370 type terminators BUS (part 2282675) and TAG (part 2282676).
4. Connect CTCA cables to gate 01H as shown at **C**.
 5. If the processor has an interrupt cable that must be connected to the processor, go to Volume A06, Service Aids, "External Interrupts" for more details.
 6. Reinstall gates 01E and 01F/01H covers.

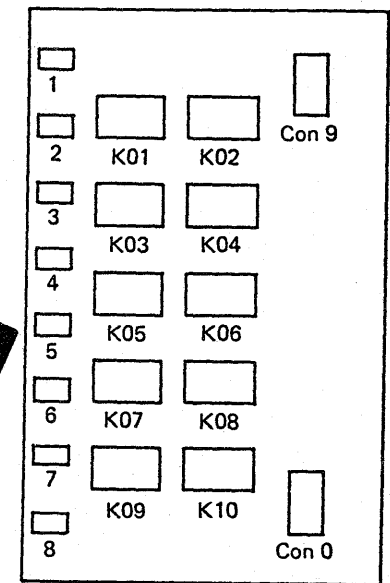
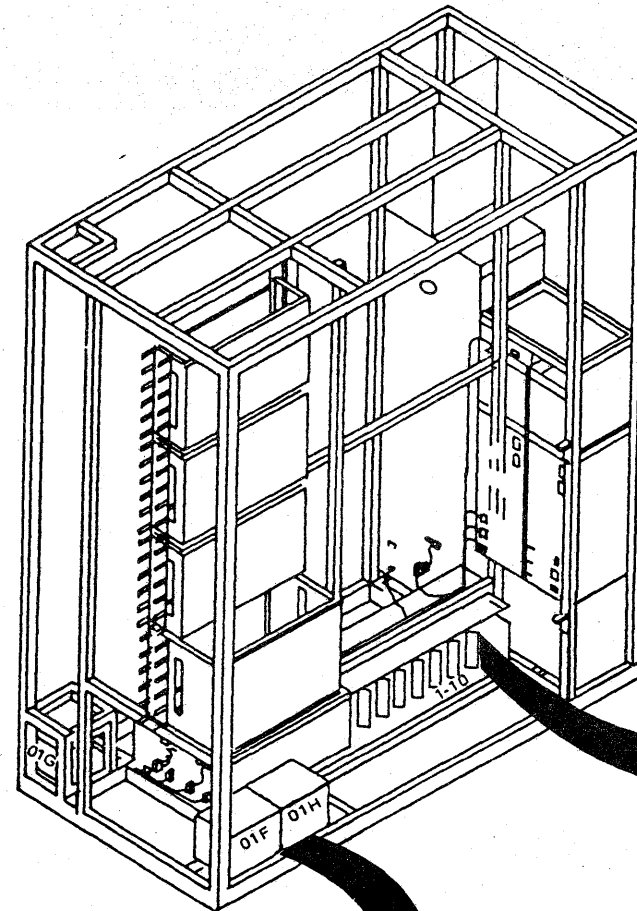
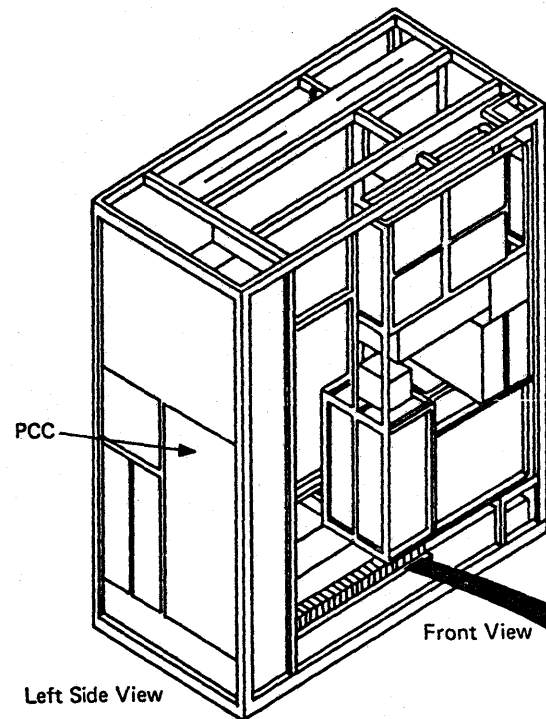

A1	A2	A3	A4	A5	A6	A7	A8
Bus In	Tag In	Bus Out	Tag Out	Bus In	Tag In	Bus Out	Tag Out
X	X	X	X	Y	Y	Y	Y

Gate 01H (CTCA)

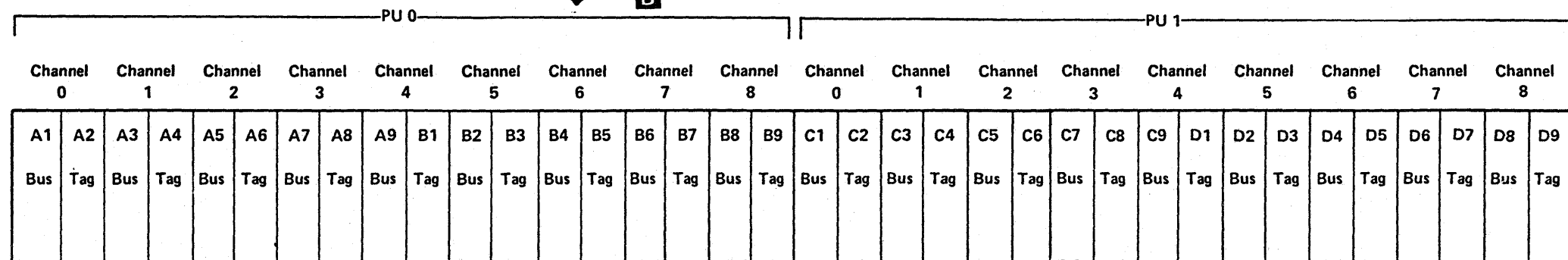

Gate 01E (Channel Interface)

4381-3	MI	PN 6169600	EC A20558	EC A20560			
B/M 2676380	Seq GH055	1 of 1	01 Oct 84	18 Feb 85			



Final System Check

INST 061

Running System Test/4381

System Test/4381 should be run for approximately one hour (2 passes) with all I/O devices connected. For a complete description of System Test/4381, see "System Test/4381" in this volume.

After running System Test/4381, go to Volume A06, Service Aids, and perform "S/370 XA Installation" if this is a XA account. After successfully running System Test/4381, invoke PA Option E (service action complete).

Completing the Installation

1. If you have installed more than one machine, report your time accurately on each machine.
2. File all documents, and complete any associated paperwork.
3. Turn system and the *4381 Processor Operations Manual* over to the customer.

Relocation or Discontinuance Procedure

By using the *Processor Installation* instructions and the *Unpacking Instructions*, you can disconnect the system for equipment location change or discontinuance.

Note: If this system uses the IBM supplied telephone (part 4494964) for RSF transmissions, the telephone is part of the system and must be packaged with the system. The part number is located on bottom of the telephone.

4381-3
B/M 2676380

MI Seq GH060	PN 6169601 1 of 1	EC A20558 01 Oct 84	EC A20562 30 Aug 85			
-----------------	----------------------	------------------------	------------------------	--	--	--

INST 061



4381 PROCESSOR SAFETY INSPECTION GUIDE

INSP 001

Table of Contents

Purpose	INSP 002
Items Needed	INSP 002
Line Cord Ground Check	INSP 003
Frame	INSP 004
External Check	INSP 004
Internal Check	INSP 004
PCC and PS104 Fuses	INSP 005
Line Filter	INSP 006
Safety Labels	INSP 007
Gate 01C	INSP 009
Diskette Drives	INSP 010
Gate 01A	INSP 011
Safety Labels	INSP 011
Console Devices (3205, 3278-2A, 3279-2C)	INSP 013
External Check	INSP 013
Internal Check	INSP 013
Power On/Off Check	INSP 015
Safety Labels	INSP 017

Purpose

To supply a safety inspection procedure for the processor.
This safety inspection should be done:

- When you inspect a processor for an IBM maintenance agreement and there is reason to question the processor's safety.
- When IBM per call service is requested and no service has recently been performed by IBM.
- When an alterations and attachments review is performed.

If the inspection indicates unacceptable safety condition(s), the condition(s) must be corrected before IBM provides service to the machine.

While performing this inspection, special attention must be given to these areas:

- 50 to 60 Hz conversions using IBM or non-IBM parts.
- Feature/model changes and EC upgrades.
- Additions of non-IBM power supplies or attachments.
- Missing safety covers.
- Removed, faded, or painted-over safety labels.
- Primary power parts replacement requirements.
- Other product safety related items.

Items Needed

- CE tool kit
- Fluke* 8060A digital voltmeter (part 8496278) or equivalent.

* Trademark of John Fluke Mfg. Co. Mount Lake Terrace, Washington

4381	MI	PN 6169618	EC A20558				
B/M 2676380	Seq GI005	2 of 2	01 OCT 84				



Line Cord Ground Check

DANGER

Use only test probes to touch the exterior shell of the customer's receptacle until step 9.

- 1. If processor main power connector is unplugged, go to step 8.
- 2. Press Power Off at the operator control panel or the service panel.
- 3. Switch CB1 and CB2 off.
- 4. Have the customer locate and turn off the branch circuit breaker to the processor and all physically attached I/O devices.
- 5. Use Fluke* 8060A meter to check for 0 Vac from the receptacle case **A** to building ground. If voltage is less than 1 Vac, the shell can be touched but not separated.
- 6. Loosen locking device but do not separate connectors.

DANGER

Do not touch connectors to be separated. Wrap connector with electrical tape or wear rubber gloves.

- 7. After taping connector or while wearing rubber gloves, separate connectors.
- 8. Carefully meter from ground pin of receptacle to building ground for 0 Vac. Do not continue if condition is not met.
- 9. Measure from ground pin of receptacle to the case of the receptacle for 0 Vac. Do not continue if condition is not met.
- 10. Measure resistance from ground pin of the customer receptacle to building ground. Reading should be less than 1.0 ohm.

Note: Digital meters may give unstable readings if leakage current is flowing in the building ground circuit. If the reading appears unstable or greater than 1 ohm, use an ECOS 1020, 1023, or equivalent to measure ground impedance only.
- 11. Measure resistance from ground pin of receptacle to receptacle case. Reading should be less than 1.0 ohm.
- 12. Measure resistance from ground pin of disconnected power cord to frame ground. The resistance should be less than .1 ohm.
- 13. Check main power cord for damaged, broken insulation, or arced pins. Ensure the correct locking plug is used.

DO NOT RECONNECT MAIN POWER CONNECTOR UNTIL INSTRUCTED TO DO SO.

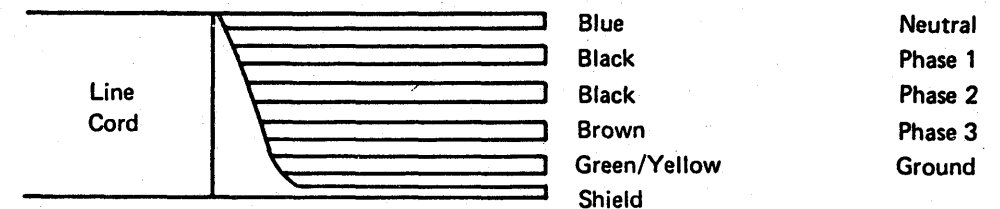
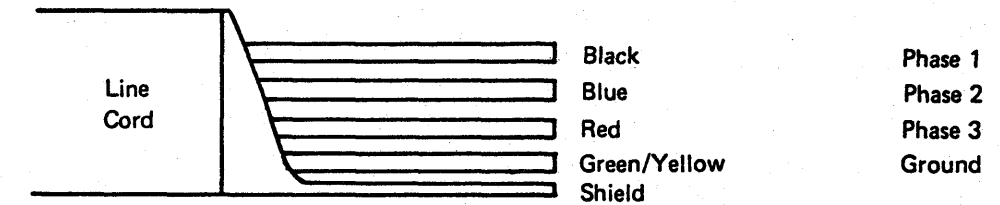
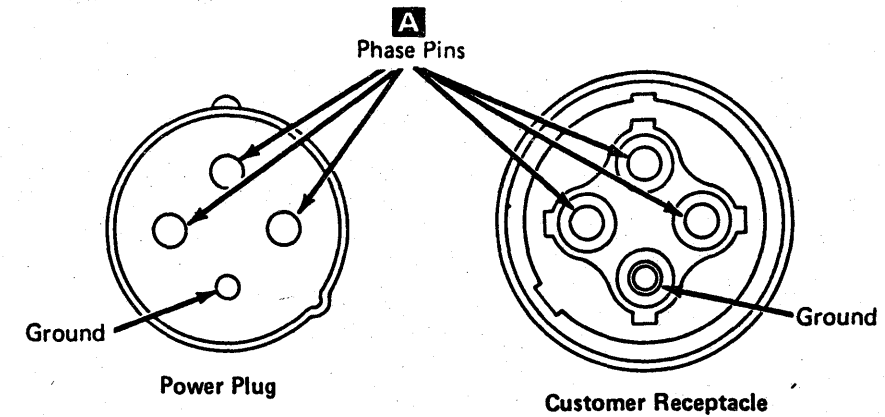

For 220V wiring, tie the neutral to the line cord.

4381-3 B/M 2676380	MI Seq GI010	PN 6169619 1 of 2	EC A20558 01 Oct 84	EC A20559 03 Dec 84	EC A20562 30 Aug 85		
-----------------------	-----------------	----------------------	------------------------	------------------------	------------------------	--	--

Frame

External Check

- ___ 1. Check for damaged or missing external covers.
- ___ 2. Check cover latches for functioning correctly.
- ___ 3. As doors are opened, check the hinges for breakage or corrosion.
- ___ 4. Check covers for sharp edges.

Internal Check

- ___ 1. Check for non-IBM alterations or attachments. If present, complete form R-009, *Non-IBM Alterations/Attachments Survey*.
- ___ 2. Inspect for smoke or water damage and presence of rust or other contaminations.
- ___ 3. Inspect all cables for damage, correct ratings, all needed grommets in place at frame feed-throughs, and tie-downs in place.

DANGER

A shock hazard may exist while plugging or disconnecting inline or Mate-N-Lok connectors because of the connector pin slipping from its socket. Before working with any connectors, ensure power is off.*

- ___ 4. Check that FDS cables are correctly seated and undamaged.
- ___ 5. Check that all covers are correctly installed and no screws or washers missing.

* Trademark of AMP Inc. Harrisburg, Pennsylvania.

4381-3
B/M 2676380

MI Seq GI010	PN 6169619 2 of 2	EC A20558 01 Oct 84	EC A20559 03 Dec 84	EC A20562 30 Aug 85		
-----------------	----------------------	------------------------	------------------------	------------------------	--	--



PCC and PS104 Fuses

The fuses listed below are for the PCC and PS104 only.

Located on the cover of the PCC. **A**

- F1 4 amps 230 Vac
- F2 2.8 amps 240 Vac

Located on PS104 to the left of the PCC. **B**

- F1 15 amps 600 Vac
- F2 15 amps 600 Vac
- F3 15 amps 600 Vac
- F4 15 amps 600 Vac
- F5 6 amps 600 Vac
- F6 6 amps 600 Vac
- F7 6 amps 600 Vac
- F8 6 amps 600 Vac
- F9 1.6 amps 600 Vac

Ensure the following:

1. Green/yellow wire **G** from PCC cover to frame is tight.
2. Green/yellow wire **D** from top rear of PCC to frame is tight. Located near J14.
3. Green/yellow wires **H** at lower rear of PCC are tight.
4. The power strain relief **E** is tight and undamaged.
5. Green/yellow wire **F** in plug J01 is tight.
6. Meter for less than 1 ohm from the convenience outlet ground pin **C** to the frame.

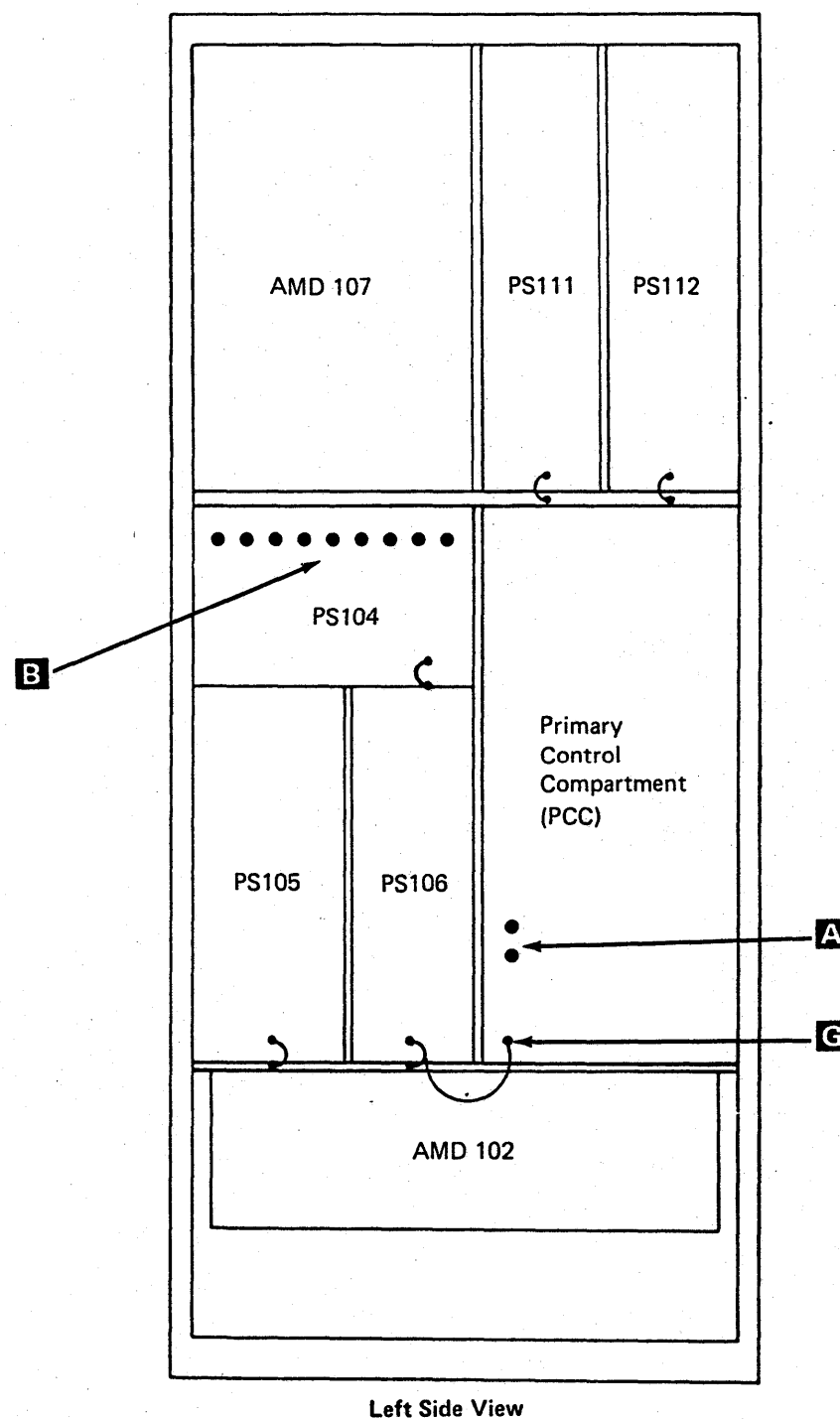

Left Side View

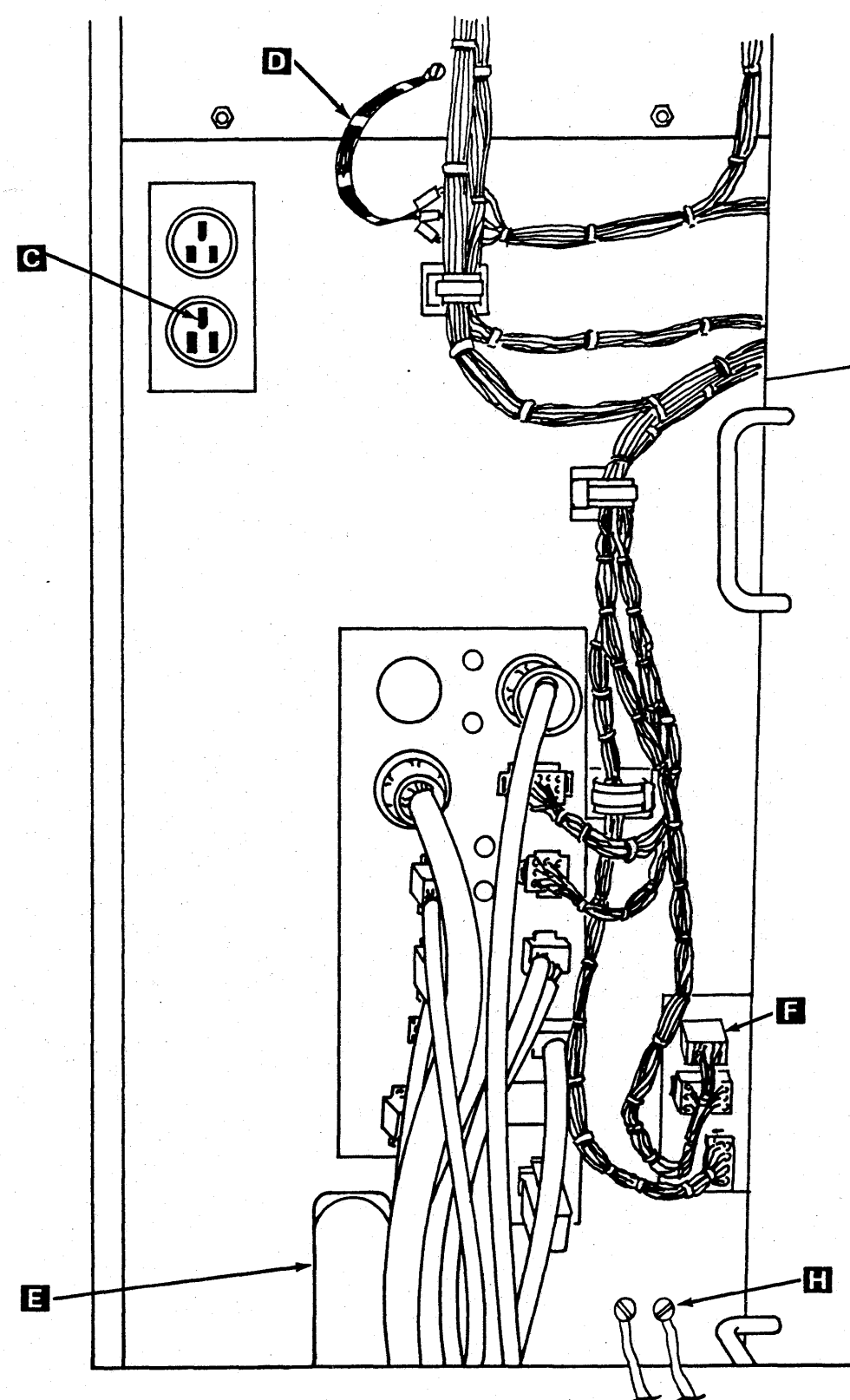

Rear of PCC

Ensure the following:

1. Green/yellow wires from PS104, PS105, PS106, PS111, and PS112 **A** to the frame are tight.
2. Remove the acoustical barrier **B** at AMD 102. Ensure green/yellow wire from motor to frame is tight. This wire is mounted above the motor on the blower mounting frame. Ensure green/yellow wire from the blower mount to the frame and green/yellow wire in plug are tight. Install the acoustical barrier.
3. Open PCC box cover. Ensure safety covers for CP1 **C**, CB1, and CB2 are in place. CB1 is rated for 10 amps; CB2 is rated for 25 amps **D**. Ensure green/yellow wires **E** in all plugs inside the PCC are tight.
4. Green/yellow wires **G** inside of PCC are tight.

Line Filter

Note: Line filter is not installed on machines for Japan.

Remove line filter cover **F**. Ensure all wires at the line filter are tight. Install line filter cover.

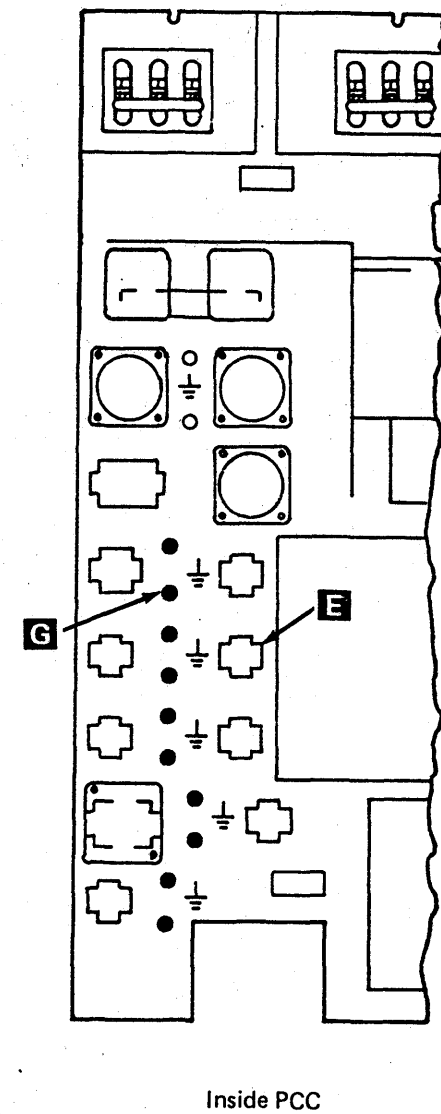
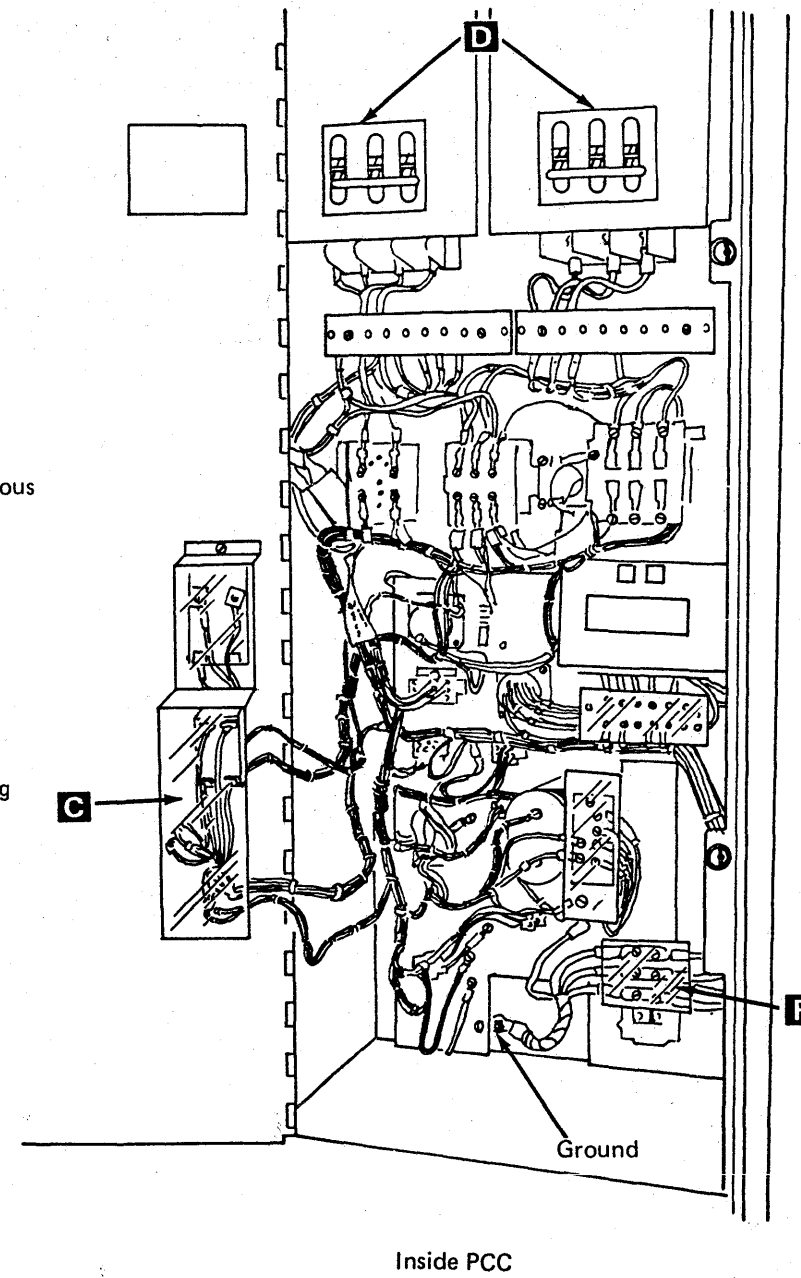
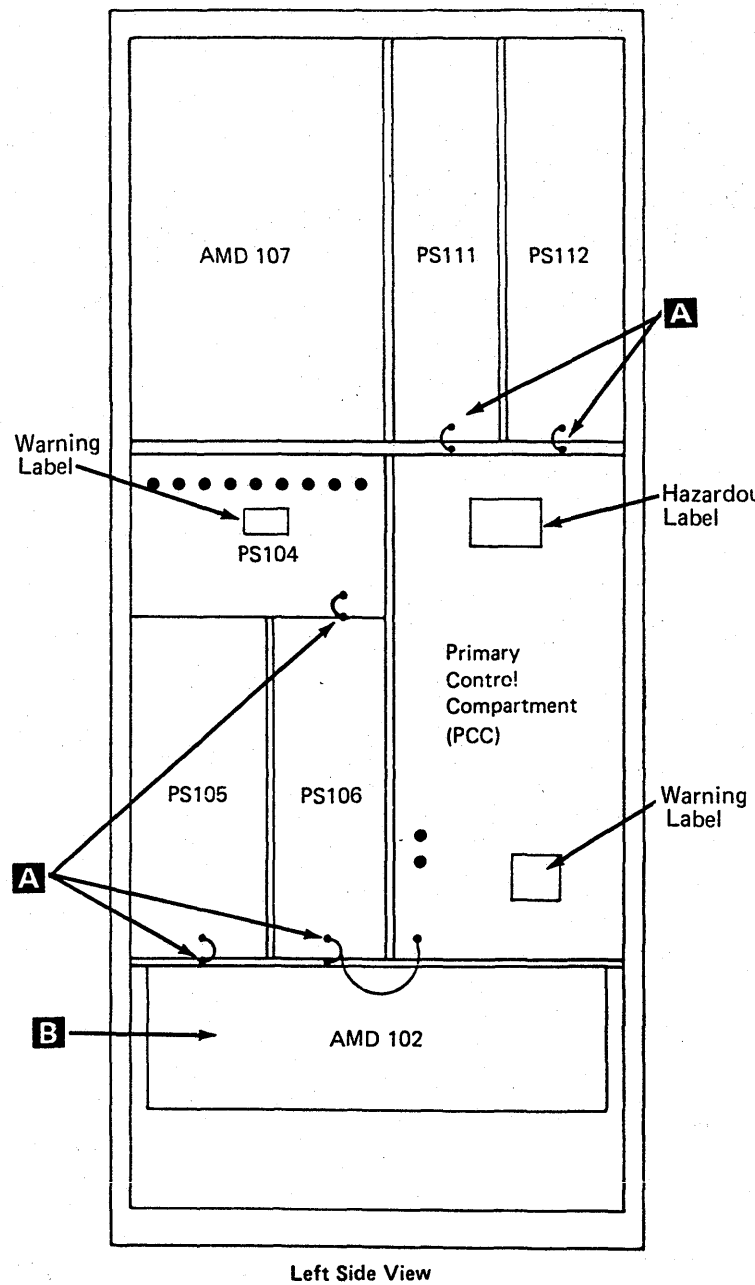

4381	MI	PN 6169620	EC A20558				
B/M 2676380	Seq GI015	2 of 2	01 OCT 84				

Safety Labels

Ensure all safety labels as shown are in place and readable. For safety label part numbers, see page INSP 017.

Item **B** is located between CB1 and CB2 inside the PCC.

Item **D** is located inside the PCC.

Close the cover of the Power Control Compartment (PCC).

A **HAZARDOUS AREA**
TRAINED SERVICE
PERSONNEL ONLY

B **LINE VOLTAGE**
PRESENT WITH
MACHINE POWER OFF

C This unit equipped with line filter circuits. See installation manual for special grounding wire requirements.

WARNING

D High grounding conductor current. Grounding circuit continuity is vital for safe operation of machine. Never operate machine with grounding conductor disconnected.

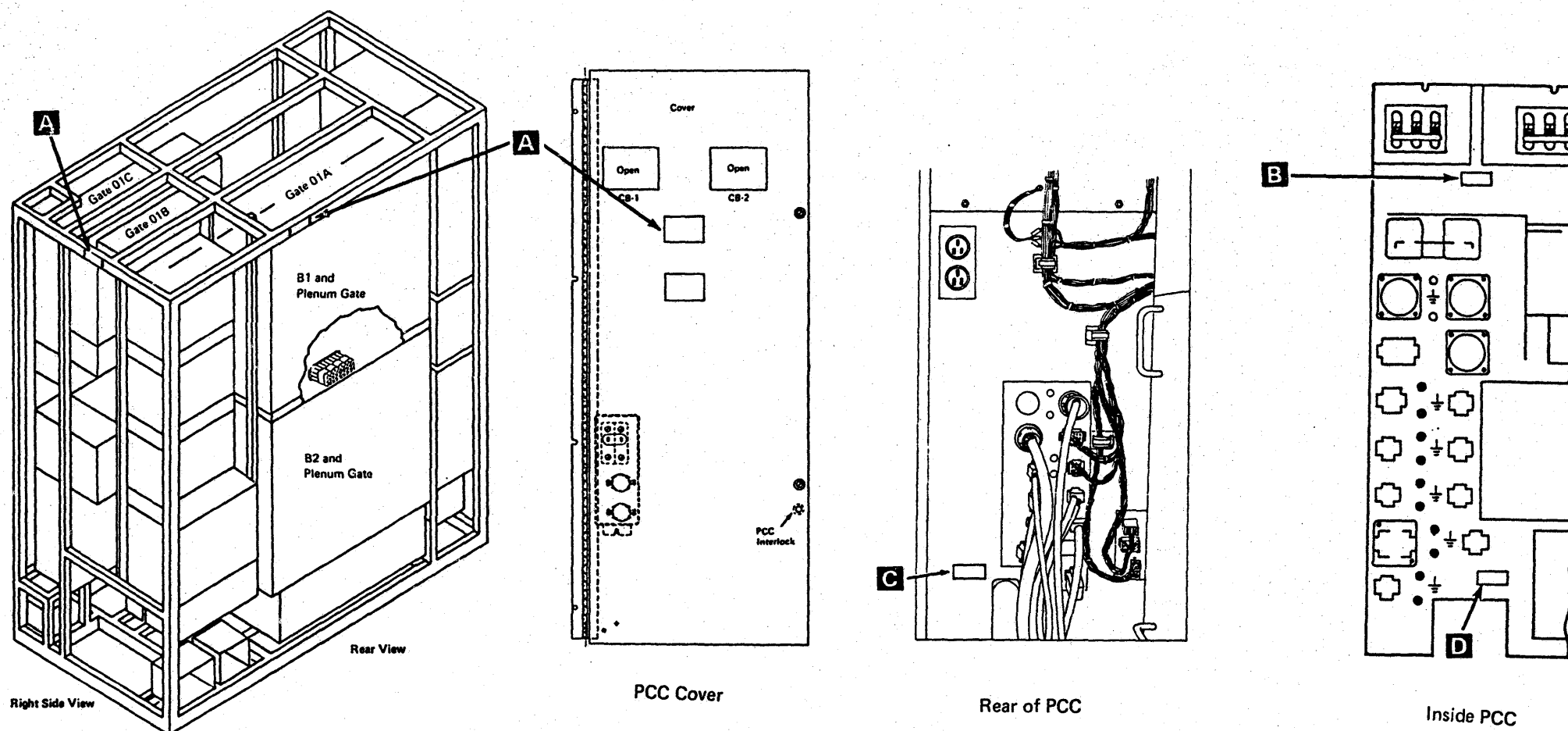

4381	MI	PN 6169621	EC A20558				
B/M 2676380	Seq GI020	1 of 1	01 OCT 84				



Gate 01C

Ensure the following:

- ___ 1. Green/yellow strap **A** from gate 01C to frame is tight.
- ___ 2. Green/yellow strap **B** from PS107, PS108, and PS109 to the frame is tight.
- ___ 3. Remove the acoustical barrier **C** at AMD 105. Ensure green/yellow wire to blower cover, green/yellow wire from motor to blower cover, and green/yellow wire in plug are tight. Install acoustical barrier.
- ___ 4. Green/yellow strap **D** from AMD 105 to the frame is tight.
- ___ 5. Green/yellow strap **E** from PS101, PS102, and PS103 is tight.
- ___ 6. Green/yellow wire in all plugs is tight.
- ___ 7. Green/yellow strap from the service panel to the frame is tight.

Note: Transformers 104A, 104B, 104C, and CP2 are for all 50 Hz and Japan 60 Hz machines. If present, CP2 is mounted on the frame of gate 01C over PS101.

Ensure the following:

- ___ 1. Green/yellow wire in plugs for TR101, TR102, TR103, TR104A, TR104B, and TR104C to transformer case is tight.
- ___ 2. Nuts or screws **F** mounting TR101, TR102, TR103, TR104A, TR104B, and TR104C are tight.
- ___ 3. Check for a 3.2 amp fuse in TR102, a 4.0 amp fuse in TR103, and 15 amp fuses in TR104 if TR104 is installed.
- ___ 4. Ensure the DANGER 550V label is in place for TR101, TR102, and TR103. Label is mounted on the capacitors on the transformers. For safety label part numbers, see page INSP 017.

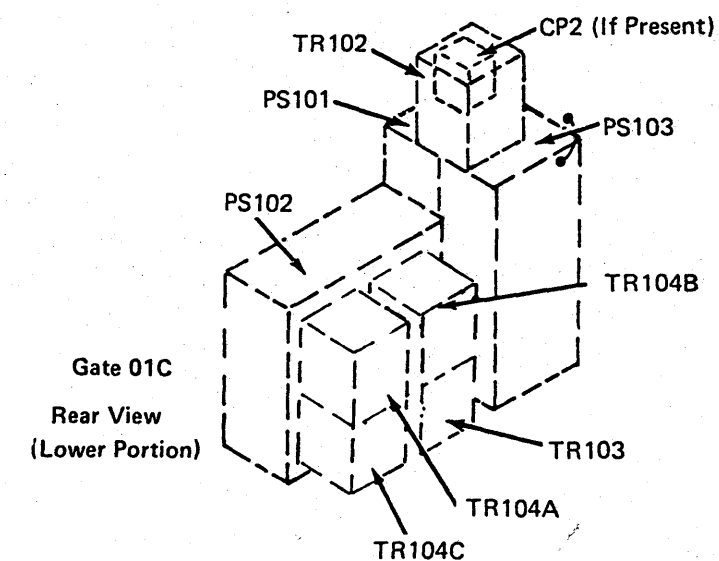
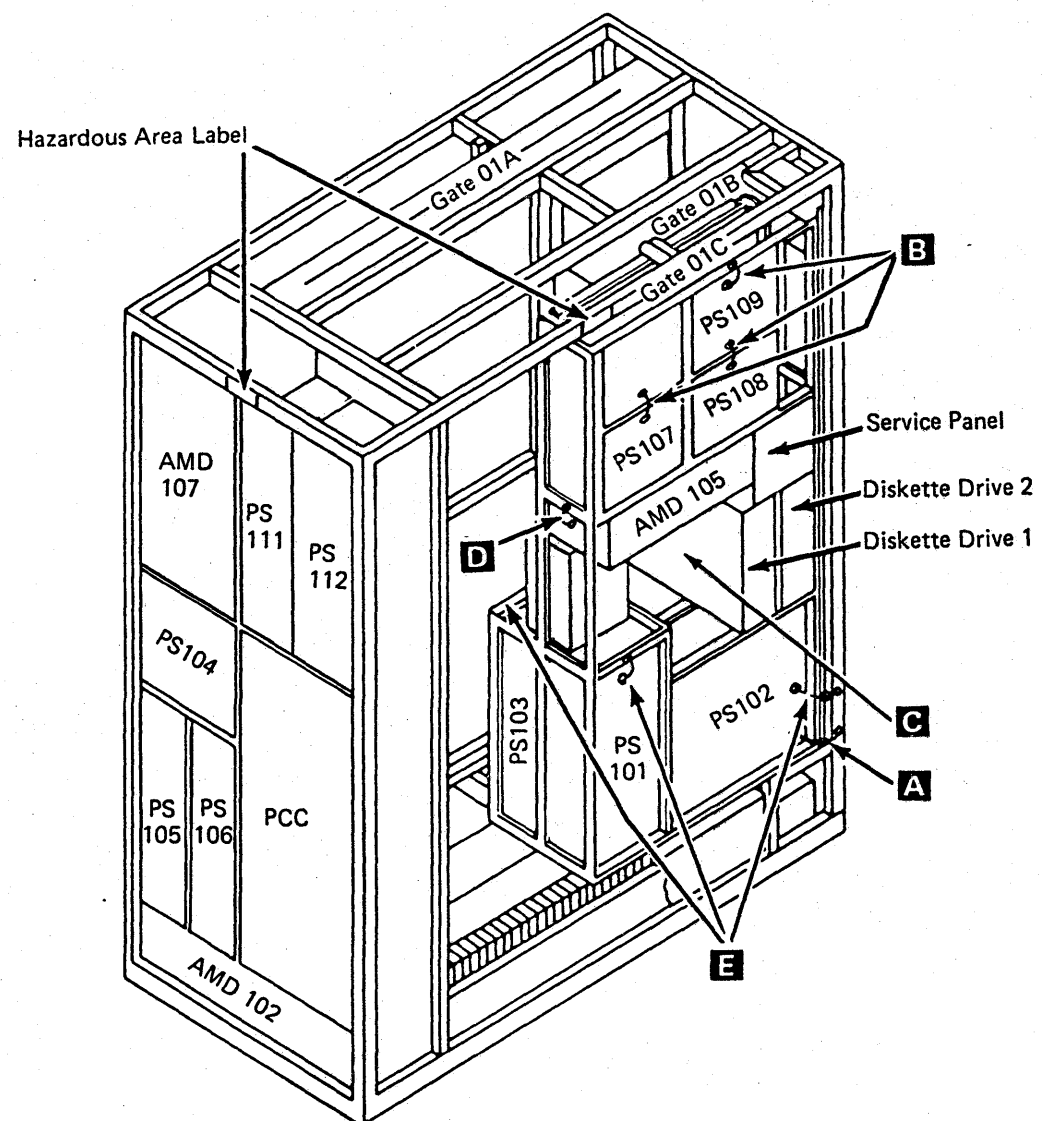
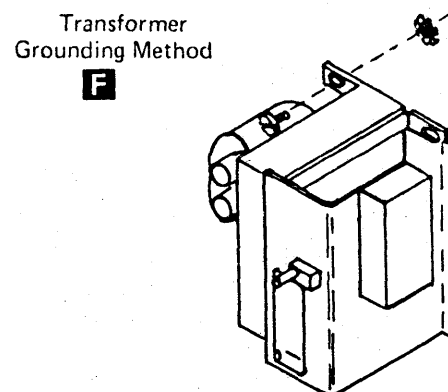

Diskette Drives

Ensure the following:

- ___ 1. Diskette drives are correctly installed.
- ___ 2. Green/yellow wires in plugs for diskette drives are tight.
- ___ 3. Belt safety cover (if installed) is in place.
- ___ 4. Green/yellow wire from both diskette drives **A** to the frame is tight.
- ___ 5. Power cable strain relief for both diskette drives **B** is tight.

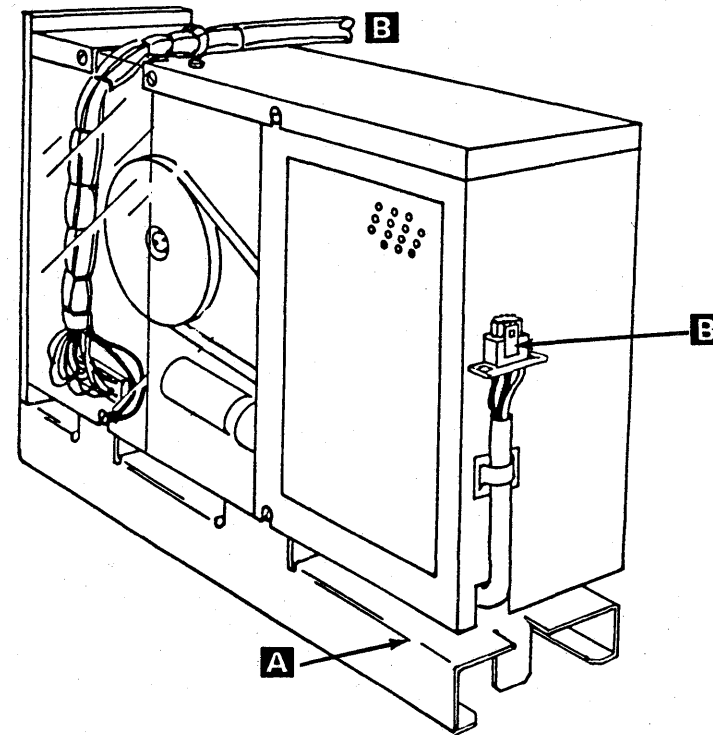

Diskette Drive

4381
B/M 2676380

MI
Seq GI025

PN 6169622
2 of 2

EC A20558
01 OCT 84

© Copyright IBM Corp. 1984

Gate 01A

Ensure the following:

- 1. Green/yellow straps **A** from board 01A-B1 and 01A-B2 plenums to the frame are tight.
- 2. Swing open gate 01C and ensure the green/yellow ground straps for boards 01A-B1 and 01A-B2 are tight. The ground straps are located at the top right corner of the boards.
- 3. Remove acoustical barrier **B** from AMD 101. Ensure green/yellow wire to blower cover and green/yellow wire in plug are tight. Install acoustical barrier.
- 4. Remove acoustical barrier **C** from AMD 103, AMD 104, and AMD 106. (AMD 103 located behind AMD 104). Ensure green/yellow wire to blower cover, green/yellow wire from motor to blower cover, and green/yellow wire in plugs are tight. Install acoustical barrier.
- 5. Ensure the safety cover over the decoupling capacitors **D** are tight. Decoupling capacitors are mounted at top of board 01A-B2 and the cover is mounted over the capacitors.
- 6. Green/yellow wire in plugs at rear of PS104 and PS105 **E** is tight. Gate 01A-B2 must be swung open to see the rear of PS105.

Safety Labels

Ensure safety label **F** is in place and readable. For safety label part numbers, see page INSP 017.

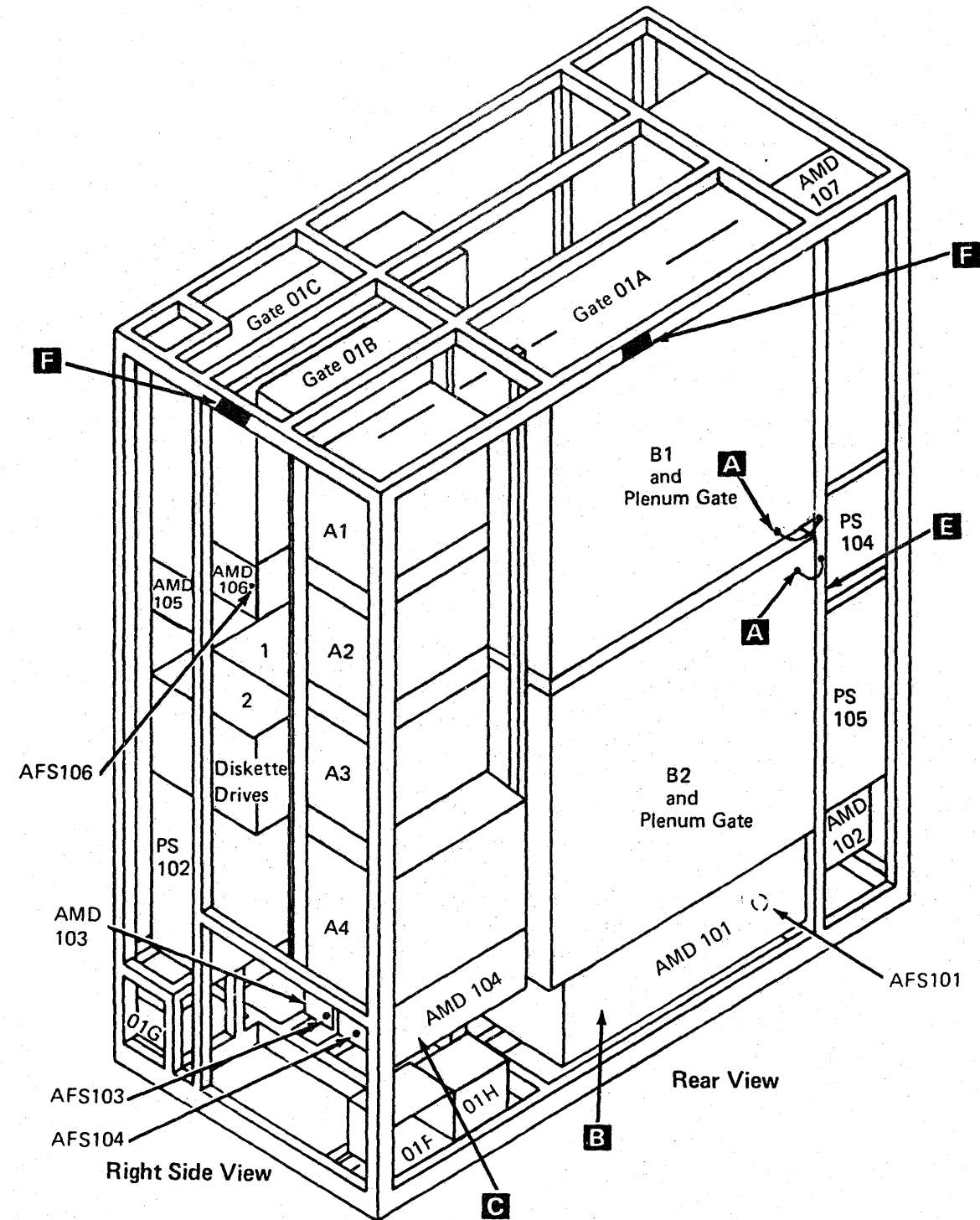
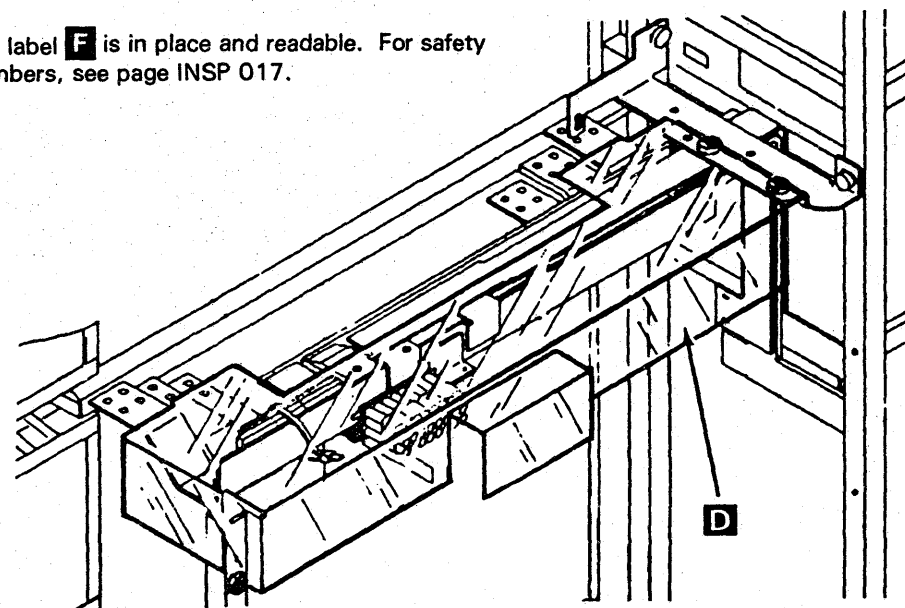

**F HAZARDOUS AREA
TRAINED SERVICE
PERSONNEL ONLY**



Console Devices (3205, 3278-2A, and 3279-2C)

External Check

- ___ 1. Check all covers for correct latching.
- ___ 2. Inspect for sharp edges.
- ___ 3. Ensure all feet are present and undamaged at the base.
- ___ 4. Check CRT for cracks, bubbles, or damage.

Internal Check

- ___ 1. No smoke, water damage, or foreign substances.
- ___ 2. Frayed or broken wiring.
- ___ 3. Terminal board covers undamaged; no screws missing.
- ___ 4. Mate-N-Lok plugs for pushed back pins or wires.
- ___ 5. Rubber boot over filter capacitor is undamaged.
- ___ 6. Correct grounding of CRT yoke **A**.
- ___ 7. All capacitors for damage, expansion, or leakage.
- ___ 8. Verify connections to all capacitors are secure.
- ___ 9. Correct grounding of CRT main power cord **B** to frame.
- ___ 10. Correct grounding of 3205 or 3278-2A or 3279-2C line cord **C**.
- ___ 11. All high voltage, hazardous voltage, fuse size, and any other safety labels are in place and readable. For safety label part numbers, see page INSP 017.

LINE CORD GROUNDING (3279-2C)

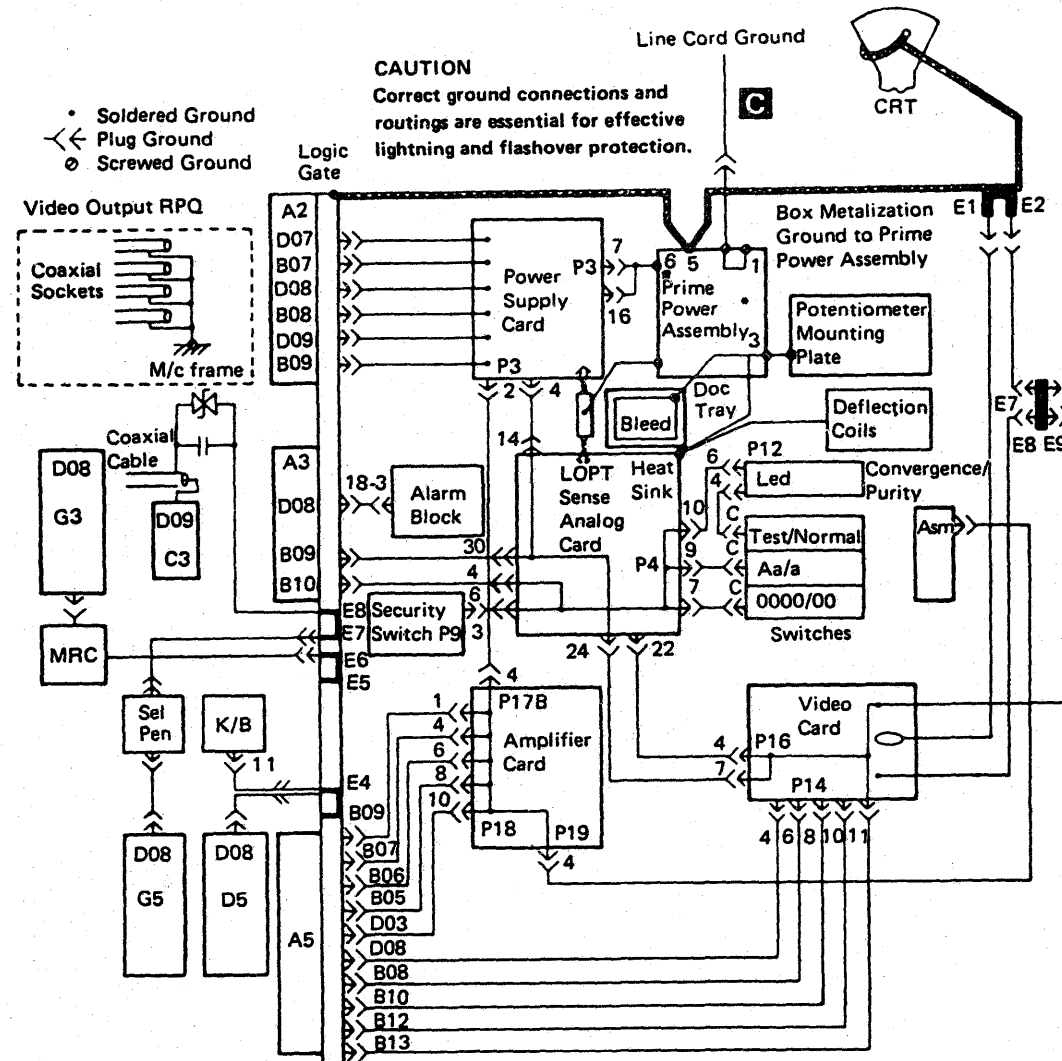

*Wires may be connected to alternative screws

CRT YOKE GROUNDING

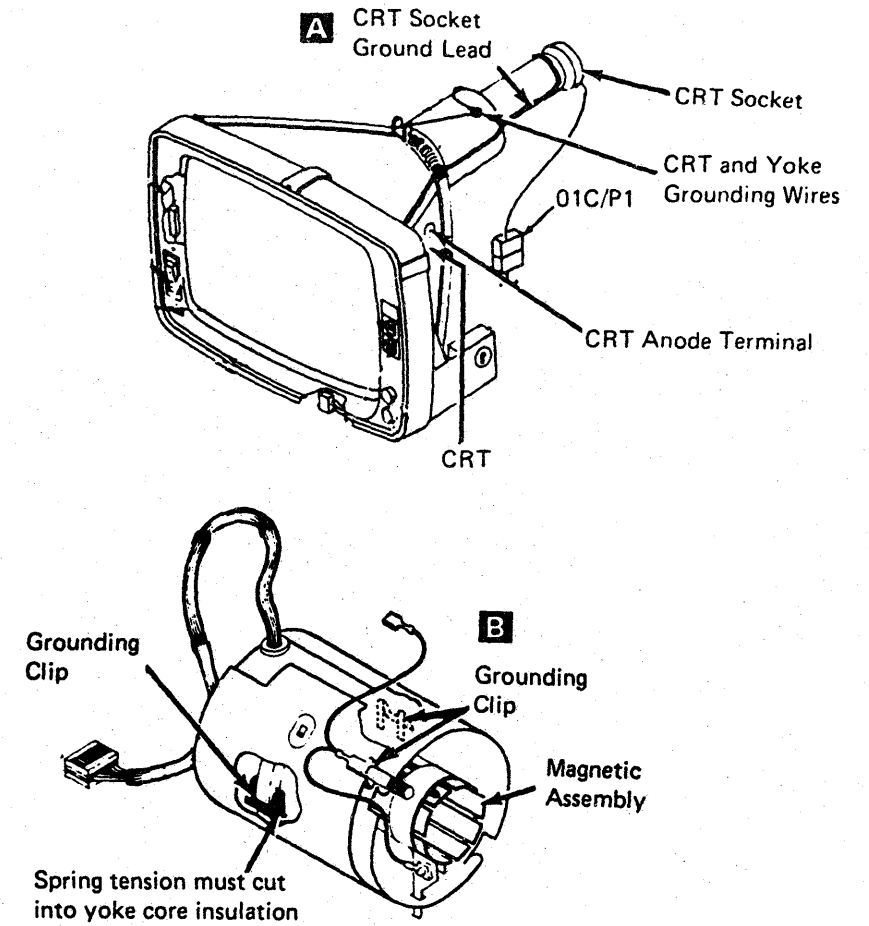

LINE CORD GROUNDING (3278-2A)

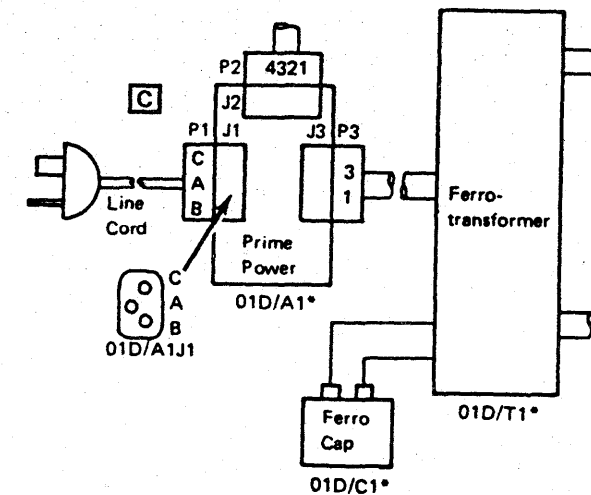

*Grounded only when mounted and fastened in place.



Power On/Off Check

1. Verify the customer's branch circuit breaker is off.
2. Connect the processor power plug to the customer's receptacle.
3. Activate the customer's branch circuit breaker.
4. Activate CB1 and CB2 **B** at the PCC in the processor.
5. Ensure the processor console is powered on.
6. Press Power On **A** on the service panel.
7. At Power Complete **F**, set the Unit Emergency Only switch on the service panel to Emergency Power Off.
8. Ensure that PS104, AMD 102, and AMD 104 are off. If PS104 is still on, reference code 11D1160E is displayed on the system console. If any of these items are on, a safety hazard exists.
9. Set the Power Off switch to Normal at the service panel. Press Power On.

Warning: This condition can only be cleared by tripping CB1 and CB2. These problems can be caused by binding points at K02, K03, or K04, binding relay points in PS101, or a bad card at 01A-A1V2 or 01A-A2D2 and may be intermittent. The 5 Volt, 24 Volt, and MBC On indicators **C** on the service panel will be on if CB1 and CB2 are on with the Power Off switch activated.

10. At Power Complete, switch the Unit Emergency Only switch **E** to Power Off.
 11. Ensure that the 5 Volt, 24 Volt, and MBC On indicators at the service panel are off.
 12. Switch the Unit Emergency Only switch to On.
- Note:** If the switch fails to reset, a retention spring **G** is installed. To reset the switch, push down on the retention spring behind the switch and push up on the Unit Emergency Only switch on the service panel.
13. Press Power On at the service panel. At Power Complete, switch CB1 and CB2 off.
 14. Ensure processing unit power is off and AMDs and diskette drives are not running.
 15. Ensure that the 5 Volt, 24 Volt, and MBC On indicators on the service panel are off.
 16. Switch CB1 and CB2 on.
 17. Press Power On on the service panel.
 18. At Power Complete, switch CP1 off **D**.
 19. Ensure no voltage is present at the convenience outlet.
 20. Switch CP1 on.

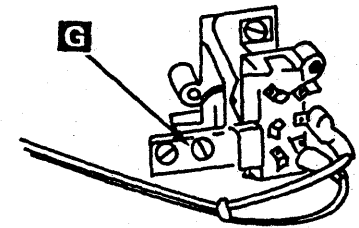
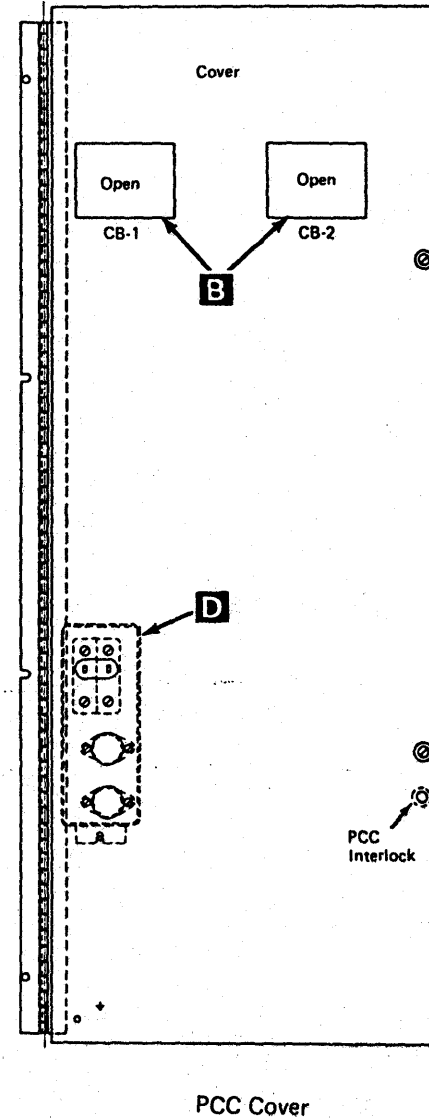

Rear of Unit Emergency Only Switch

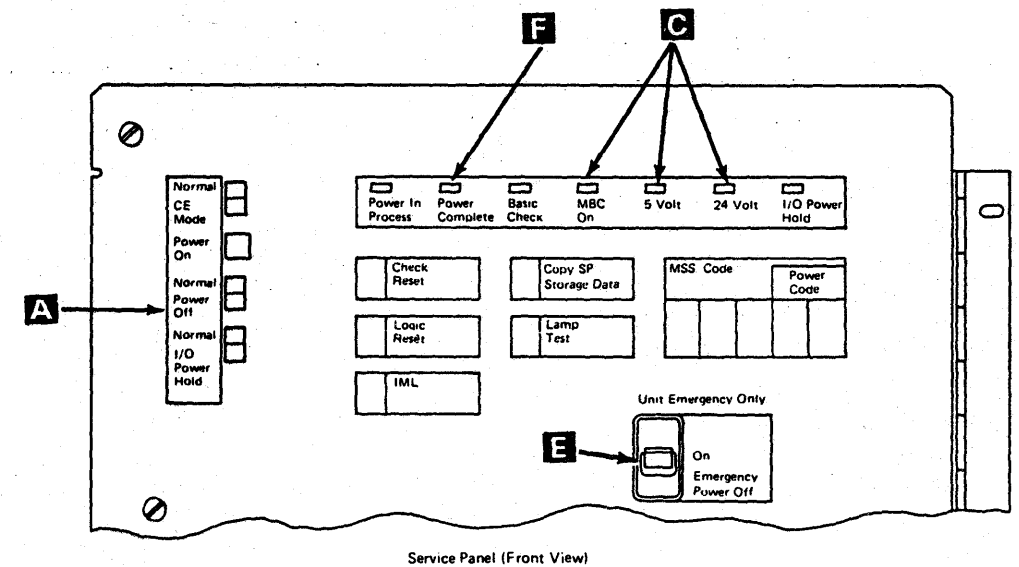

Service Panel (Front View)

MI Seq GI040	PN 6169625 1 of 1	EC A20558 01 OCT 84	EC A35269 29 Aug 85			
-----------------	----------------------	------------------------	------------------------	--	--	--



Safety Label Description and Part Numbers

Description	English	German	Canadian	French	French Dutch	Finnish	Italian
HAZARDOUS AREA TRAINED SERVICE PERSONNEL ONLY	369207	6815193	6815179 and 369207	6815182	6081052	8326801	
LINE VOLTAGE PRESENT WITH MACHINE POWER OFF	138755	6825819	984123	6825828	6121851	6825818	
DANGER 550 VOLTS	8483959	2582954					
WARNING High grounding conductor current. Grounding circuit continuity is vital for safe operation of machine. Never operate machine with grounding conductor disconnected.	5731697	4154584	4154583	6825908	4154587	6825879	
This unit equipped with line filter circuits. See installation manual for special grounding wire requirements.	5397579						

Description	Norwegian	Spanish	Swedish	Brazilian Portuguese	Japanese	Denmark	Dutch
HAZARDOUS AREA TRAINED SERVICE PERSONNEL ONLY	369207	6815180	8551904	6815183	8326797	1806772	369207
LINE VOLTAGE PRESENT WITH MACHINE POWER OFF	138775	4154591	8551903	6815188	6825840	1806773	138775
DANGER 550 VOLTS							
WARNING High grounding conductor current. Grounding circuit continuity is vital for safe operation of machine. Never operate machine with grounding conductor disconnected.		4154589	4154586				5731697
This unit equipped with line filter circuits. See installation manual for special grounding wire requirements.							

