

TABLE OF CONTENTS

0010

NOTICE

I.	INTRODUCTION	0090
A.	Use of Tapes in the AN/FSQ-7	0090
B.	Characteristics of Tape Storage	0090
C.	Block Diagram of Magnetic Tape Element	0100
D.	Statistics (Tapes)	0130
E.	Definitions (Terminology)	0130
F.	Panel Buttons and Lights	0180
G.	Summary Questions	0210
H.	Answers to Summary Questions	0220
I.	NRZI System of Writing on Tapes	0230
J.	Principles of Operation	0270
K.	Summary Questions	0290
L.	Answers to Summary Questions	0290
II.	CHARACTERISTICS (TAPE DRIVE)	0290
A.	Physical	0290
B.	Summary Questions	0480
C.	Answers to Summary Questions	0500

TITLE

D.	Control Line Summarization	0510
E.	Functional Characteristics	0540
F.	Mechanical Characteristics	0550
G.	Electrical Characteristics	0560
H.	Tape	0570
I.	Summary Questions	0630
J.	Answers to Summary Questions	0650
K.	Review of Mechanical Operation	0670
L.	Motor Operation	0680
M.	Power on Reset	0690
III.	DATA PROCESSING MACHINE LOGIC, PLUGGABLE UNITS	0700
	and BASIC CIRCUITS	
A.	⁰⁷¹⁰ DPM Logic, ^{0721-layout} Pluggable Units and Basic Circuits	0700
B.	Summary Questions	1070
C.	Answers to Summary Questions	1080
IV.	TAPE DRIVE INPUT SIGNALS: CIRCUITS AND CIRCUIT ANALYSIS	1090
A.	General	1090
B.	Select and Ready	1090
C.	Read-Write Status	1110
D.	Not in File Area	1130
E.	Tape Break Indication	1130
F.	Starting from Load Point	1150
G.	Rewind to Load Point	1160

TABLE OF CONTENTS (CONT 'D)

<u>TITLE</u>	
H.	Start Stop and Reverse Control 1160
I.	Read Preamplifier 1160
J.	Writing on Tape 1190
K.	<u>Write Echo</u> 1210
L.	Writing a Check Character 1220
M.	Erase 1220
N.	Rewind 1230
O.	File Protection 1230
P.	Forward and Reverse Switch 1250
Q.	Start Button-Mechanically Ready 1250
R.	Reset 1260
S.	Anti-spill Device 1260
T.	Moving Coil Circuit 1270
U.	Forward - Reverse Control 1290
V.	Summary of Moving Coil and Forward - Reverse Magnet . . 1290 Operation
W.	High Speed Rewind Photocell Circuit 1320
X.	Summary Questions 1320
Y.	Answers to Summary Questions 1340
Z.	Tape Drive Logic Circuits Analysis 1340
V.	OPERATIONAL ANALYSIS OF THE TAPE DRIVE 1380
A.	Switch and Relay Function 1380
B.	Summary Questions 1430
C.	Answers to Summary Questions 1430

TABLE OF CONTENTS (CONT'D)

0040

TITLE

D.	Load - Rewind from Low-Speed Area, Mod. III	1440
E.	Another Approach to the Low-Speed, Load-Rewind Mod. III .	1560
	Sequence	
F.	Summary Questions	1570
G.	Answers to Summary Questions	1570
H.	Unload Operation, Mod. III	1580
I.	Summary Questions	1620
J.	Answers to Summary Questions	1630
K.	High Speed Rewind, Mod. III	1630
L.	Summary Questions	1700
M.	Answers to Summary Questions	1710
N.	Purposes of Relay Points and Switches, Mod. III	1710
O.	Summary Questions	1810
P.	Answers to Summary Questions	1830
	•	
VI.	TAPE DRIVE, MOD. II	1840
A.	Differences Between Mod. II and Mod. III	1840
B.	Load-Rewind Operation, Mod. II	1860
C.	Unload Operation, Mod. II	1940
D.	High Speed Rewind, Mod. II	1950
E.	Purposes of Important Relays, Mod. II	2020
F.	Tape Break Circuit, Mod. II	2140
G.	Anti-spill Device, Mod. II	2140

TITLE

VII.	TAPE DRIVE TESTER	2140
A.	Introduction	2140
B.	Description and Electrical Characteristics	2150
C.	Theory of Operation	2190
D.	TDT Block Diagram Analysis	2390
E.	Analysis of TDT Logic.	2420
F.	TDT Power Supply	2500
G.	Installation and Operating Instructions	2550
VIII.	SPECIAL TOOLS AND TEST EQUIPMENT	2610
A.	Test Equipment	2610
B.	Special Tools	2650
IX.	TAPE PROGRAMMING	2670
A.	SEL(11-16)	2670
B.	End of File Operations	2670
C.	PER ₍₇₁₎ -Rewind	2710
D.	PER ₍₇₀₎ -Backspace	2730
E.	BSN ₍₁₁₎ -Sense for Ready	2770
F.	BSN ₍₁₀₎ -Sense for Prepared	2770
G.	PER ₍₆₇₎ -Set Prepared	2780
H.	RDS	2780
I.	WRT	2790
J.	Summary Questions	2800

TABLE OF CONTENTS (CONT'D)

0060

TITLE

K.	Answers to Summary Questions	2800
X.	TAPE ADAPTER UNIT #13 - COMPUTER CONTROL	2820
A.	General	2820
B.	Special Circuits	2840
C.	Summary Questions and Answers	2970
D.	Tape Adapter Control and Transfer Circuits	2970
E.	The Tape Character Reg	2990
F.	Tape Word Register	3010
G.	Word Ring	3020
H.	Tape Drive Selection	3030
I.	The Write Operation	3040
J.	Write Operation, Logic Analysis	3100
K.	Summary Questions	3110
L.	Read Operation	3130
M.	Read Operation, Logic Analysis	3160
N.	Summary Questions	3170
O.	Answers to Summary Questions	3180
XI.	OPERATING PROCEDURES	3190
A.	General	3190
B.	Operating Controls and Indicating Lights	3190
C.	Tape Drive Unit Loading	3190

TABLE OF CONTENTS (CONT'D)

	<u>TITLE</u>	
XII.	TAPE ADAPTER TEST DOOR	3260
	A. Function	3260
	B. Operation	3260
	C. Summary Questions	3320
	D. Answers to Summary Questions	3330
XIII.	TAPES MAINTENANCE PROGRAM	3340
	A. Introduction	3340
	B. Modes of Operation	3350
	C. Description of Routines	3350
	D. Program Write Up	3360
	E. Summary Questions	3360
	F. Answers to Summary Questions	3360
XIV.	UNIT 18 - NON STANDARD POWER SUPPLY	3370
	A. Definitions	3370
	B. Basic Theory of Saturable Reactors	3370
	C. -270 Volt Power Supply	3420
	D. Summary Questions	3450
	E. Answers to Summary Questions	3450
	F. The Remaining Non-Standard Power Supplies	3460
	G. -30 Volt M. C. Power Supply	3460
	H. Control Circuits	3470
	I. Summary of components and Their Function	3490

TABLE OF CONTENTS (CONT'D)

0080

TITLE

J. Summary Questions	3500
K. Answers to Summary Questions	3500
ABBREVIATIONS	3510
GLOSSARY OF TERMS	3520
TAPE DRIVE UNIT, MOD. III. LOGIC AND RELAY DIAGRAM (Sheet 1 of 2)	3530
TAPE DRIVE UNIT, MOD. III. LOGIC AND RELAY DIAGRAM (Sheet 2 of 2)	3540
TAPE DRIVE UNIT, MOD. II. RELAY DIAGRAM	3550
TDT LOGIC AND SWITCHING SCHEMATIC	3560

I. Introduction

A. Use of Tapes in the AN/FSQ-7

1. Operational Program Library
2. Maintenance Program Library
3. Tables and Constants Storage
4. Safe Track Storage
 - a. Friendly flight plans
 - b. Friendly tracks
5. Training and Simulation
6. Proposed that routine accounting data be stored on tapes.
 - a. Payroll records
 - b. Parts inventory

B. Characteristics of Tape Storage

1. Magnetic - Permanent
 - a. Information will not drift away.
2. Non-Destructive Readout
3. Compact and portable.
 - a. One reel can contain 1.2 million computer words.
 - b. Tapes interchangeable between systems.
4. Economical
 - a. Reusable
 - b. Price is approximately \$80 per reel
5. Intermediate speed
 - a. Somewhere between electronic speed of computers and mechanical speed of card machines.
 - b. One word can be written or read in 322 microseconds.
6. Sequential access *Disadvantage*
 - a. Information stored sequentially on tapes as consecutive words.

C. Block Diagram of Magnetic Tape Element

Page 0110

1. Tape Drives

- a. Only four tape drives per computer presently.
- b. Six possible per computer.

- 1) If two added, will be designated units #26 and #40.
- 2) PC1 uses 6 Tape Drives per computer.

2. Tape Adapter (Unit #13)

- a. Translates commands from Central Computer into action in the tape drive.

- 1) Commands from the CC are standard pulses, these are changed into levels and pulses that are used by the tape drives.

Example: A select pulse from CC would be changed into a level to select the specified tape drive.

A RDS pulse from CC would be changed into both a pulse to put the tape drive in read status and a level to tell the tape drive to move tape.

- b. Assists in data transfer between Central Computer and the tape drives.

- 1) Will store bits until a complete computer word is read, then send the word and a break request to the CC.

3. Unit #19 MCD

- a. Supplies standard voltages to Unit #13.
- b. Supplies 3Ø a. c. to unit #13.
- c. Supplies 3Ø a. c. to unit #18, through circuit breakers in unit 13's Z module.

TAPES DRIVES SUPPLY THEIR OWN - 48V

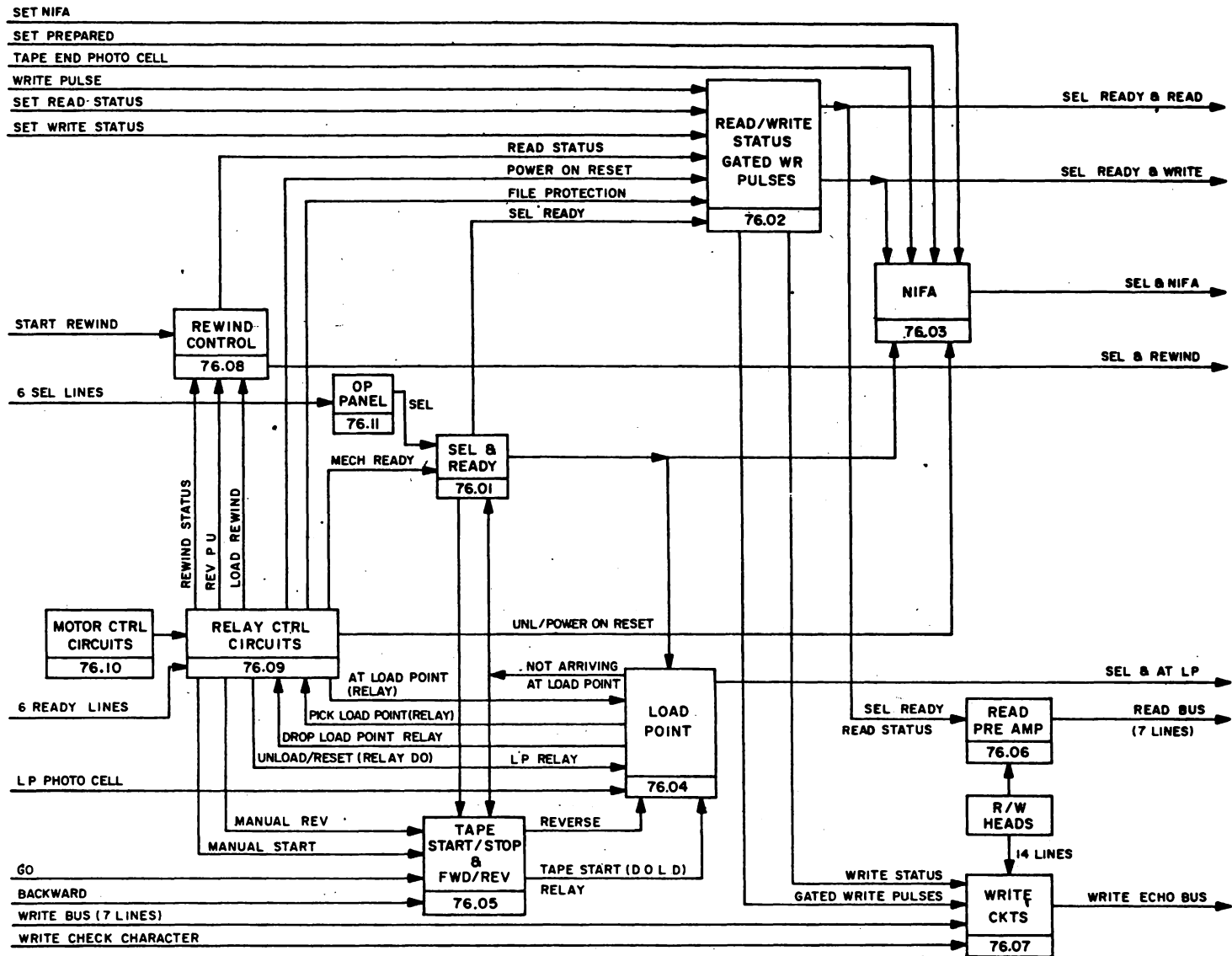

Tape Drive, Block Diagram (76.00)

4. Non-Standard Power Supply Unit 18
- a. Supplies non-standard voltages necessary in the tape drives.
 - b. These voltages are fed through circuit breakers in unit 13.
 - 1) +270V
 - 2) +140V
 - 3) -60V
 - 4) -130V
 - 5) -270V
 - c. Provides means to manually marginal check the non-standard voltages.

D. Statistics

1. Physical characteristics of magnetic tape.
 - a. Width: 0.498 ±0.002 inch
 - b. Thickness: 0.0022 (+0.0003-0.0004) inch
 - c. Base thickness: 0.0015 inch ±10% (*Shiny side of tape*)
 - d. Ferromagnetic material and binder: 0.0006 inch
 - e. Full reel: 2400 feet in length

Note: Three types of tape have been used.

Acetate: Original

Mylar: Replaced acetate because of greater strength and less sensitive to humidity and dryness.

Durexcel Replacing mylar due to improved binder. Otherwise, the same as mylar.

E. Definitions

1. Load Point
 - a. A reflective marker on the front edge of the tape.
 - 1) Indicates, through the use of a light and photocell, the beginning of the useful portion of the tape.
 - 2) Roughly 10' from beginning of the tape.

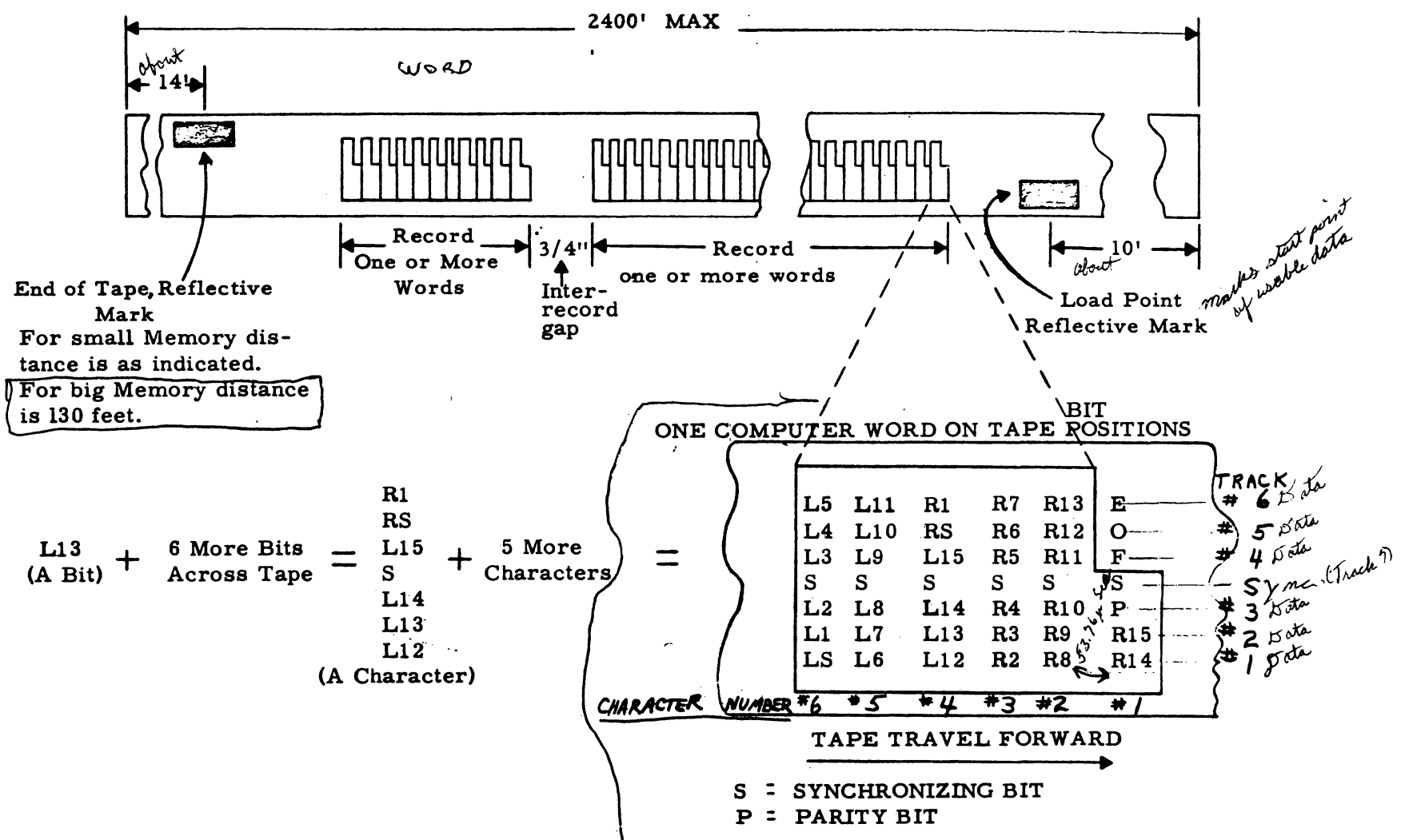

0140

FIGURE - TAPE WORDS

2. End of Tape

a. A reflective marker on the rear edge of the tape.

1) Indicates the physical end of the tape is approaching.

2) Will not interrupt any computer operation already in progress.

3) Roughly 14' from the end of the tape.

*will not stop tape operation**Doesn't permit you to start any more cycles.*

3. Bit

*5-3, 16 μ sec between bits
248 bits/inch*

a. A binary character.

b. Either a one or zero.

c. Smallest unit of intelligence.

4. Character

a. Six information bits plus a sync bits written width of the tape to 0.020 inch from the edge.b. The sync bit, written with each character, defines the area where information is stored.*sync bit*

5. Word

a. 6 characters of 33 bits

1) a) The first character contains only three information bits.

b) The other 5 characters contain six information bits.

c) Each character has a sync bit.

6. Record

*a. A group of consecutively written words.

b. The basic block for reading or writing.

- c. 3/4" unwritten space is left between records to indicate the end of a record.
- d. A record could be a maintenance program.
- e. A record may be one word or any number of words.

7. File

- a. A group of ~~records~~ records
- b. A file could be a group of maintenance programs.

8. End of File *EOF end of related data file*

- a. A one word record denoting the end of a file. *3/4" on both sides of EOF record.*
- b. Only three information bits are written.

- 1) Three ones are written into normally unused portion of first character, track

- c. Six characters are written.

- 1) All zero in the information bit positions.
- 2) A sync bit is written for each character.

9. File Reel

- a. Left hand reel when facing the front of the machine.

10. Machine Reel

- a. Right hand reel when facing the front of the machine.

11. Backspace

- a. Tape moves backwards over one record. *No the start*
- b. Initiated by an operate instruction from Central Computer. *PER70*
will stop at loadpoint if no record is found.

⑫ File Protection

- a. A means of protecting information on a tape from being destroyed by inadvertently writing on it.

- 1) A groove on the back side of the reel is sensed by a pin.

You Can Read anywhere

EOF + Sync bits of EOF Word will be 1 & all data bits will be "0".

- a) If the groove is present, writing cannot take place.
- b) The groove may be filled by a plastic ring. Writing can take place.

13. Not Ready

- a. Mainly a ~~physical~~ condition. Manual intervention always required to make tape drive ready.
- b. Not ready conditions:
 - 1) Reset pushbutton has been depressed.
 - 2) Door open.
 - 3) Tape not in both columns.
 - 4) Fuse blown.
 - 5) Photo light burned out (Note - an exception exists if drive is loaded and tape break light burns out.)
 - 6) Power off
 - 7) Tape broken
 - 8) Start button (Or "Ready I/O Units" or "Master Reset") has not been depressed.

NOT Ready

14. Not Prepared

- a. Mainly an electrical condition. Computer can make a drive prepared.
- b. A tape drive which is not prepared, although ready, cannot be operated from the Central Computer.
- c. Conditions for not prepared:
 - 1) Writing of EOF
 - 2) Reading EOF
 - 3) Sensing the EOT marker
 - 4) During rewind

15. Unload - used mainly for changing reels

- a. Head cover raised.
- b. Tape pulled out of vacuum columns.
- c. Vacuum motor is turned off.

15. Loaded

- a. Tape in vacuum columns
- b. Head cover down

17. Rewind

- a. Tape moves in reverse searching for LP.
 - 1) Tape moves at 500 inches per second average if more than 1/2" tape on the machine reel.
 - 2) Tape moves at 75 inches per second if less than 1/2" tape on the machine reel.
 - 3) Tape stops when LP is sensed.
- b. Tape is not in the columns during H. S. rewind and is loaded during L. S. rewind.
 - 1) If machine starts in H. S. rewind, it will change to L. S. rewind when machine reel tape reaches 1/2".
 - 2) Vacuum remains up during a High speed rewind.
- c. Machine can rewind under computer or manual control.
 - 1) Must be ready for computer control.
 - 2) Must be not ready for manual control.

18. Reading and Writing

- a. Tape drive must be ready and prepared.
- b. Controlled external of the tape drive.
- c. Tape moves forward at 75 inches per second.

F. Panel Buttons and Lights

Fig. A
Page 0190

Located on the reel door of the tape drive are the operating buttons and lights.

1. Select Switch

The select switch is a rotary type, located in the center of the group. It is used to set the tape drive to any one of six addresses associated with an external source.

SEL14 Selects any TDU

decide which SEL instr (11/14) will select that drive, if all TDUs are in same position, all will be selected

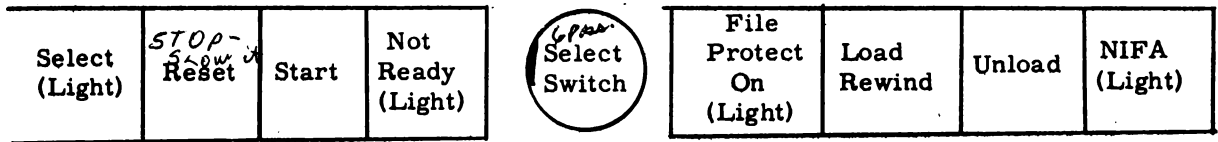

Panel Buttons and Lights

2. SELECT Light

The SELECT light is on when the tape drive is selected by an external source.

- a. When lit, indicates that the drive is selected.
- b. May be selected by the Central Computer.
- c. May be selected by the test door on unit 13 if unit 13 is in test.
- d. May be selected by the tape drive tester.

3. Reset Pushbutton

- a. Takes control away from computer and places tape drive under manual control.
- b. Makes tape drive not ready.
- c. If tape drive is in H. S. rewind, will change status to L. S. rewind.
- d. If tape drive is in L. S. rewind, will stop the tape.

4. Start Pushbutton

- a. Make tape drive ready if all other ready conditions are met. Ready conditions are:
 - 1) Door closed.
 - 2) Tape in both columns.
 - 3) Fuse not blown.
 - 4) Photo lights OK.
 - 5) Power on.
 - 6) Tape not broken.
 - 7) Head cover down.
- b. The START button may be depressed during a load or rewind operation, but the tape drive will not be in the ready status until the above conditions are satisfied.

5. NOT READY Light

The NOT READY light is on when the tape drive is not ready. The not-ready condition is caused by one or more of the following: front door open, tape out of one or both vacuum columns, fuse blown, power off, tape broken, no vacuum in columns, or RESET pushbutton is depressed. Manual operations may be performed when the NOT READY light is on provided only the RESET pushbutton is depressed and the tape is not rewinding or loading.

6. FILE PROTECT ON Light

The FILE PROTECT ON light is conditioned to turn off by mounting an unprotected reel (ring in) on the drive. It is on (a) if no file reel is mounted, (b) during a load and rewind operation, and (c) going into, and in, an unload status.

7. LOAD REWIND Button

Depressing the LOAD REWIND button starts two operations: (a) loading of the tape, and (b) searching for the load point. If the tape has been unloaded manually in the high-speed rewind area of the tape, depressing this button executes a high-speed rewind before the above operation takes place. This button is inoperative unless the tape drive is under manual control.

8. UNLOAD Button

Depressing the UNLOAD button causes the tape to be pulled out of the columns and the upper head assembly raised, regardless of the amount of tape on the two reels. If the tape is not at load point when the operator wishes to change it, a rewind operation should be completed first before the unload operation is started. The UNLOAD button is operative only if the drive is under manual control.

9. NIFA Light

The NIFA light is turned on by (a) sensing the end-of-tape (EOT) reflective spot at the end of a reel of tape or (b) reading or writing a special word known as the end-of-file (EOF) word.

Remove Ring to protect file

Spring is in you CAN write

Unit must be "Not Ready"

EOT LN FILE AREA

The only way to load drive

a. Lights when the Not in File Area FF is set.

b. NIFA FF will be set by:

- 1) Write EOF
- 2) Read EOF
- 3) Sense EOT marker

c. NIFA FF will be cleared by:

- 1) Backspace
- 2) PER 67 (Set prepared)
- 3) An Unload Operation

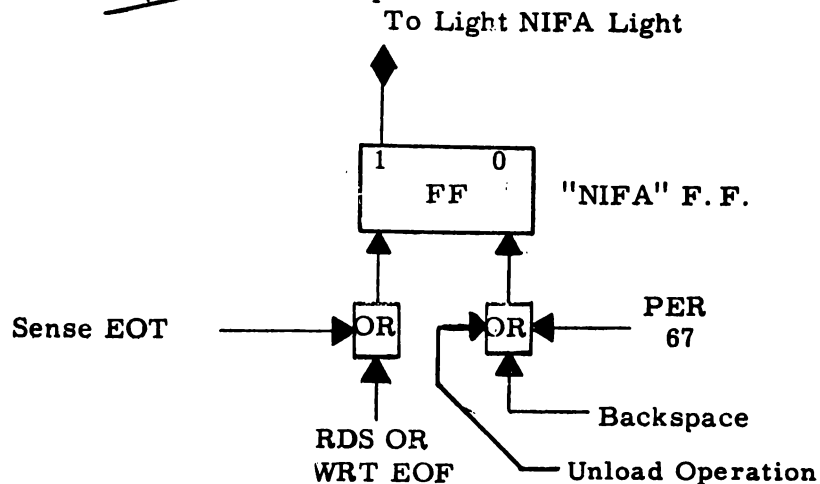

10. Fuse Light and Thermal Light

The fuse light and the thermal light are located on the inside of the door. The fuse light is nearer the door latch and lights when either the a-c or d-c fuse bail trips. This happens only when certain fuses blow. The thermal light lights when the thermal switch at the top of the tube panel transfers (from overheating).

G. Summary Questions

1. Information stored on tape is of a permanent nature. (T/F)
2. One reel of tape is 2400 feet long and can store more than 1 million computer words. (T/F)
3. Unit 19 is the non-standard voltage unit and unit 18 is the standard voltage unit. (T/F)

4. Define each of the following.
 - a. Load Point
 - b. End of Tape
 - c. Character
 - d. Record
 - e. File
 - f. File Protection

5. If the plastic ring is inserted on the tape reel, writing cannot take place on this tape. (T/F)
6. List 5 "Not Ready" conditions.
7. List 3 "Not Prepared" conditions.
8. State the function of the following:
 - a. Select Switch
 - b. Reset pushbutton
 - c. Load Rewind pushbutton
 - d. NIFA light

9. If the Tape Drive is loaded and ready, state condition of the following:
 - a. Tape
 - b. Vacuum Motor
 - c. Head Cover

10. More than one Tape Drive may have the same address. (T/F)

WRT
PROCESS

I. Non-Return to Zero Current System of Writing on Tapes (Abr. NRZI)

1. Magnetic Theory

Page 0250

- a. A magnetic material is one that can be polarized or partially polarized when placed under the influence of a magnetic field. For every magnetic material, a B-H curve can be plotted showing the resultant flux densities in the material when placed under the influence of a varying magnetizing force. If a magnetizing force of ampere-turns (H) is slowly increased in the positive direction, the resultant flux density in a magnetic medium would at first increase rapidly and then slowly attain a steady value of flux. The phenomenon of attaining a steady value of flux density is designated as saturation of the magnetic material. When the ampere-turns are slowly reduced, the flux density also decreases, but at a different rate. This phenomenon is known as the hysteresis effect. When the magnetizing force is again zero, the flux density is not equal to zero, but is equal to some positive value, as point X. The amount of magnetic flux remaining when H is equal to zero, as denoted by the distance X-O is the residual magnetism in the magnetic material.

*When current changes direction,
a 1 is written*

- b. If the ampere-turns are reversed by a reversal in circuit and the current magnitude is increased in the negative direction until saturation is again reached and then once again returned to zero, a negative resultant flux remains (point Y). Thus, by employing suitable circuit techniques, a flux pattern of either positive or negative polarity can be impressed on a magnetic material.
- c. Figure B illustrates the method of storing information. The magnetic circuit consists of a laminated ring, an air gap, a Mylar shim, and the magnetic oxide on tape. The ring is made of mu-metal, which has a high permeability and low retentivity. (Permeability is the measure of the ability of a magnetic material to conduct lines of flux. It is designated by the Greek letter mu (μ) and is numerically equal to the ratio of the flux density to the magnetizing force, $\mu = B \div H$. The mu of air = 1. Retentivity is the capacity of a magnetic material to retain magnetism after the magnetizing force has been removed.) The oxide has a low permeability of approximately 7-9 and a high retentivity. The half-mil gap causes the magnetic lines of flux to diverge away from the head and into the magnetic oxide on the tape. The shim prevents loose oxide from filling the gap.

2. General

The NRZI system of recording binary information is one in which tape is continuously saturated in either the positive or negative direction. Within a given period of time, a change in saturation polarity is called a one, and no change is called a zero.

- a. The process of storing information is called writing, and the process of detecting stored information is called reading.

3. Operation

- a. When switch 1 is closed at time T_1 , current generator E_1 causes the current to flow through the coil as indicated; a flux path is set up as shown.

Fig. A
Page 0250

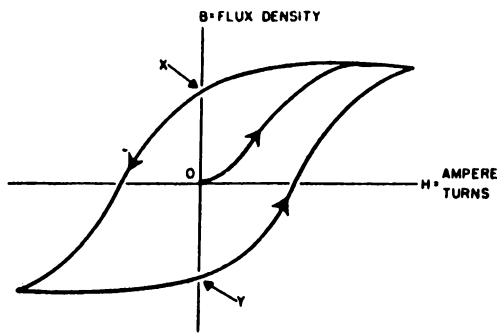

B-H Curve

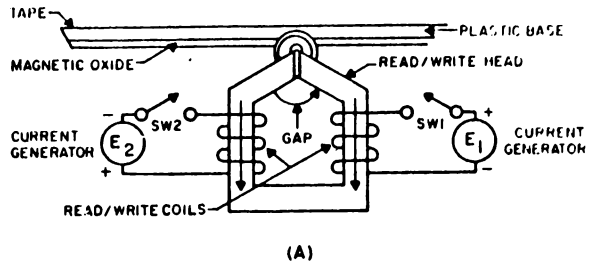

(A)

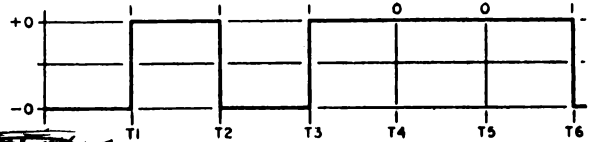

(B)

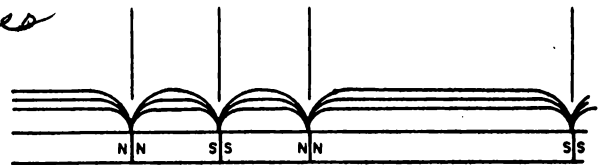

(C)

Method of Storing Information

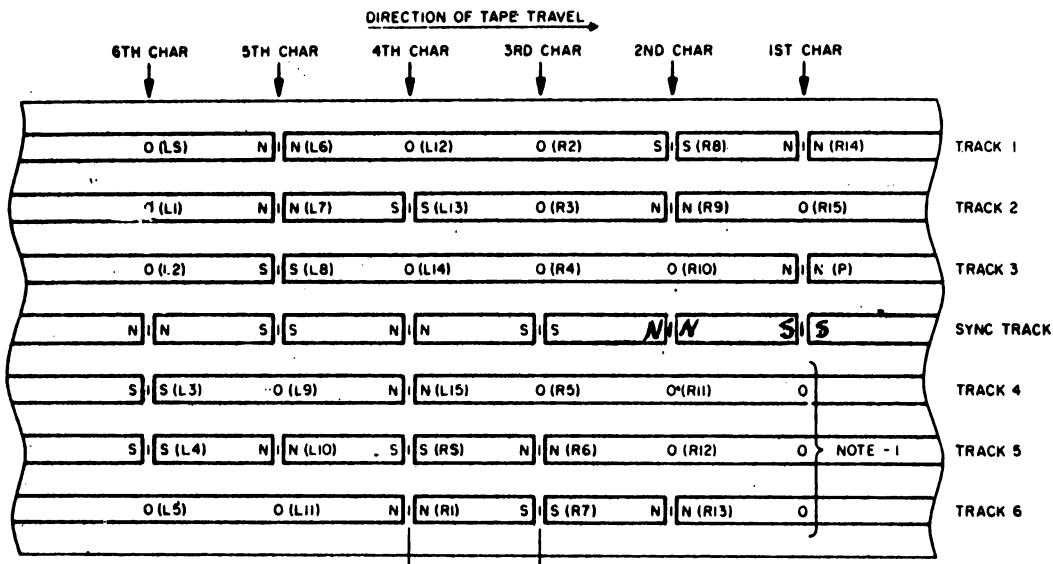

- NOTES:
1. NOT USED EXCEPT WHEN END-OF-FILE RECORD
 2. TRACK 6 IS THE CLOSEST TO THE TAPE DRIVE

NOTE: The Illustrated Tape Word Configuration is viewed looking at the Magnetic side of the Tape. The Tape is loaded oxide face down.

Because this flux path extends into the magnetic oxide on the tape, the oxide particles are magnetized in the direction of the flux path. If the tape is moving at a constant speed of 75 inches per second, all the area passing under the write head becomes magnetized in the same direction.

- b. If, at time T_2 , switch 2 is closed and switch 1 is open, current generator E_2 causes current to flow through the opposite write coil as shown. This causes the flux path to be reversed and the oxide particles to magnetize accordingly. Because the switching time is very short, the tape moves only a minute distance when the reversal takes place. This process constitutes writing a 1 bit on the tape. If, at time T_3 , another reversal is made, then another binary 1 has been written.
- c. If, at time T_4 , no reversal is made, then a binary 0 has been written. Thus, if a reversal in flux is made at any time, a binary 1 is written and, if no reversal is made, a binary 0 is written.
- d. Figure C, illustrates the magnetic material on the tape as being a series of tiny bar magnets placed end to end. Where the change in flux occurs, there are like poles; where no change occurs, there appears to be a long magnet (fig
- e. The reading of a binary 1 makes use of this principle: a voltage is induced in a coil whenever there is change of the flux cutting the turns of the coil. Note: The induced voltage (e) is determined by:
- $$e = -N \frac{di}{dt}$$
- $N =$ No. of turns
- f. A binary 1 is sensed as a voltage pulse at the terminals of the coil. (This pulse is produced by a flux change in either direction.) The absence of a pulse (no change in flux) indicates a binary zero. In reading, a voltage is induced in the coil whenever a flux change occurs. The induced voltage is 35 to 40 millivolts p/p. This is amplified to 18 volts p/p.

- g. The information stored on the tape may be erased by saturating the magnetic material in one direction. This is done by a separate erase head described in 3. 1. 15).

The advantages of the NRZI system are:

- 1) High inherent density. Binary 1's can be written closer together than in a pulse type system.
- 2) High output when reading. A maximum change of flux occurs from minus to plus saturation.
- 3) Simplified erasing technique. Erasing to saturation is simpler than erasing to zero flux.

J. Principles of Operation

1. The 728 Tape Drive Unit has the capabilities of writing, reading, backspacing, erasing, and rewinding. The tape drive operations may be controlled by the Central Computer System via the tape adapter unit, by the tape adapter unit (unit 13) test door controls, and by the tape drive tester.
2. Information is stored on the ferromagnetic or magnetic oxide side of the tape. There are seven tracks across the face of the tape, and it is possible to write information in any of the seven tracks. Each track is independent of every other track and associated with one read-write head.
3. Information is placed on the tape in any configuration of bits desired. The configuration and the interpretation are under control of the external circuitry to which the tape drive is attached.
4. Information is recorded in the form of small magnetized areas on the tape. The method of writing binary information on tapes is known as the NRZI (nonreturn to 0) system. This is a system in which the tape is continuously saturated by a magnetizing force in either the plus or minus direction. A change in saturation polarity is called a 1. No change within a given period of time is called a 0. Writing a series

of 1's would change the polarity of the bits each time a 1 is written. It is the change of polarity that signifies a 1. Thus, if a reversal in flux is made at a specific time, a 1 is written and, if no reversal is made at a specific time, a 0 is written. Information can be written on seven parallel tracks simultaneously in any configuration of bits desired. Bits are written approximately every 53.7 usec. All the tracks on the tape except the middle one contain usable information. The middle track is used as a synchronizing track. Readout is nondestructive, and data may be stored indefinitely. Because the tape can be erased and reused repeatedly, it is an economical storage medium. The information stored on the tape may be erased by saturating the magnetic material all in the same direction. This saturating is done by a separate erase coil.

5. A loop of tape is fed through a vacuum column on each side of the read-write head. The motion of the tape reels is controlled by sensing the loops, which keeps the speed of the tape across the heads constant regardless of the amount of tape on the reel. Because the reels containing the tape are relatively sluggish in action, it would be practically impossible to start and to stop the tape efficiently if it were driven directly from the reels. Therefore, a buffer storage area is provided in the form of vacuum columns below the reels. In each of these columns, a loop of tape is retained. The amount of tape in the columns is sensed by vacuum-operated switches. The tape is driven through the read-write and erase heads by a friction drive and pulley combination. As tape is drawn from one column, it is replenished periodically by the associated reel being rotated in the proper direction. As tape is driven into the opposite column, the associated reel is periodically made to turn in the proper direction to wind up the tape.
6. A reel on which information has been written may be protected from inadvertent writing by removing a circular plastic insert from the back of the file reel. The resulting groove permits a sensing pin to institute circuitry by actuating a sensing arm, which interlocks the writing circuits.

7. Tape is transported from the left, or file reel through the read-write and erase heads to the right, or machine reel. To indicate the beginning of the usable portion of the reel of tape, a small reflective spot is placed on the tape (plastic side) about 10 feet from the physical beginning of tape. The end of the usable portion of the reel of tape is indicated by an identical reflective spot placed on the plastic side at least 14 feet from the physical end of the tape.

K. Summary Questions

1. List three advantages of the NRZI System of reading and writing.
2. How is a "1" bit indicated? How is a "0" bit indicated?

Characteristics

A. Physical

There are two types of 728 Tape Drive Units, model II and Model III. The basic operation of the model II is the same as that of the model III. The description of the model III is covered in this section and the description of the model II in a later section.

The tape drive unit has three of its four sides enclosed with removable covers. A door is mounted on the unit to provide ready access to the front of the tape drive. Manual control buttons and lights are mounted on the door. The door is divided into two sections, which are covered by transparent plastic to allow visual observations of the tape drive operations. The door is interlocked to remove motor power whenever the door is inadvertently opened.

1. Tape Reels

Fig. A
Page 0310

There are two tape reels, each of which has a 2,400-foot capacity and is mounted on a spindle on the upper main plate. The left reel is known as the file reel; the right reel, as the machine reel. Each tape reel is mounted on a hub that protrudes from the upper main plate of the machine. This hub contains an expansion rim that grips the reel tightly when the locking screw in the center of the hub is tightened. The hub is mounted on a shaft controlled by two magnetic powder type clutches: one for forward motion, and one for reverse motion. A third clutch is also provided. Its use will be explained later.

2. Reel Drive Clutches

Fig. C
Page 0310

The innermost part of the magnetic clutch is a rotor that is keyed to the reel shaft. Surrounding the rotor is the clutch housing, mounted on sealed bearings, making it free to turn on the shaft. A coil is embedded within the clutch housing, with its connections brought out to slip rings on one end of the housing. In the space between the rotor and the housing is a mixture of iron powder and graphite.

When current flows through the coil, flux is produced. The flux solidifies the iron and graphite mixture and causes the rotor and housing to be essentially locked together. Although the housing is made to turn continuously through pulley action, the rotor does not move with it unless current is flowing through the coil. As current is caused to flow through the coil, the rotor begins to move with the housing, turning the hub and reel at the front of the machine.

Because of the gradual buildup of current in the coil, due to inductance, the torque transmitted is proportional to the current, producing a smooth acceleration. This smooth acceleration prevents breakage by not shocking the tape into motion. The magnetic powder clutch was selected for its ability to produce smooth acceleration and large torque with small control current. The iron-graphite mixture polishes, but does not wear, the clutch parts. To hold the iron-graphite mixture in the flux gap, a series of ridges was designed into the clutch parts. These ridges assist centrifugal force to keep the powder in the magnetic gap.

*4 felt driven
clutches (2 up
2 down)
2 gear driven
clutches (1
stop clutch)*

Tape Word Configuration

TAPE PULLED ACROSS REWRT HEAD

0310

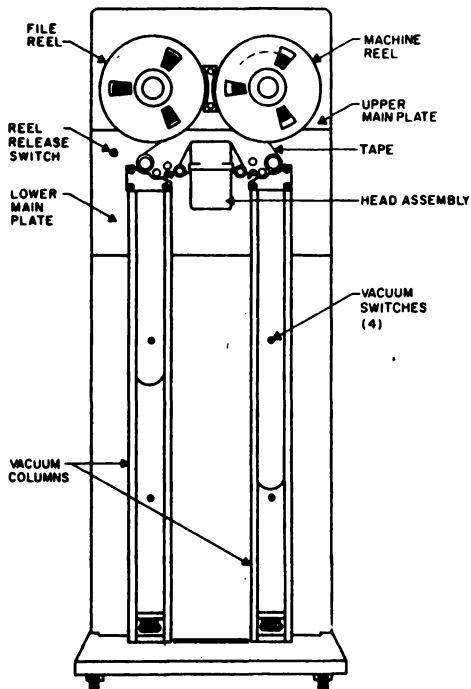

Tape Drive Unit, Model III, Front View

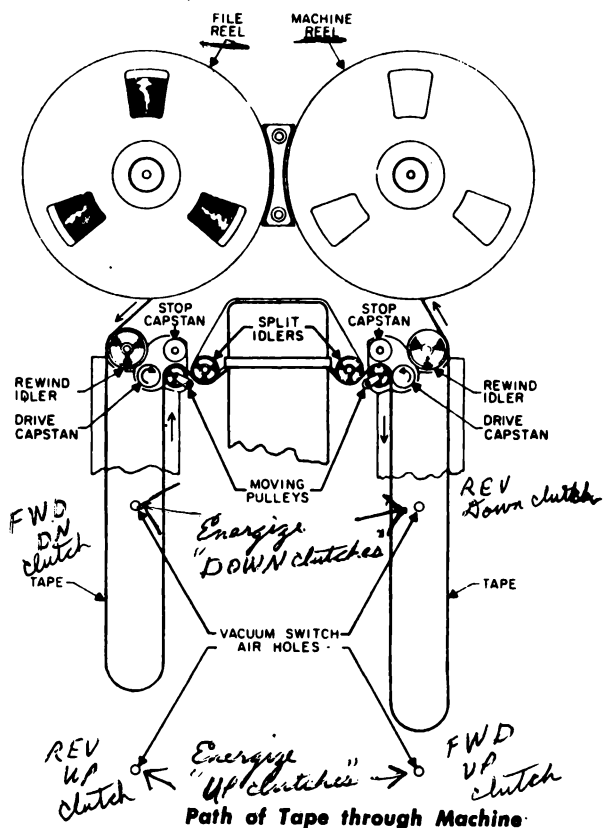

Path of Tape through Machine

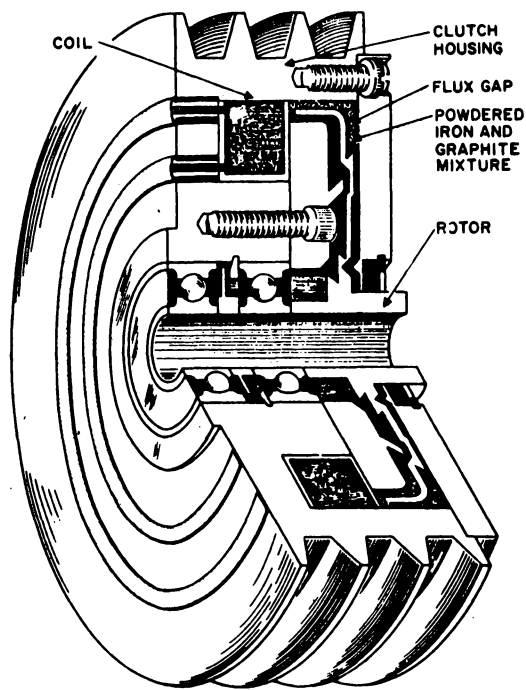

Magnetic Clutch

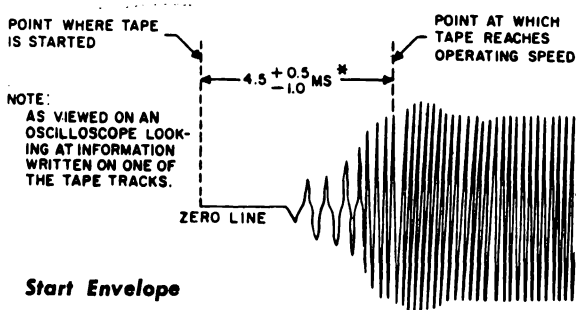

Start Envelope

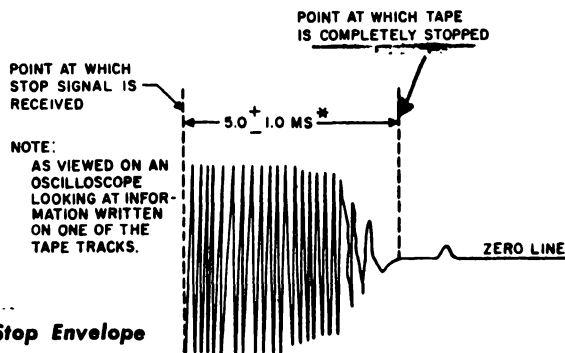

Stop Envelope

up clutch
down clutch sets
Tape from vacuum col.

Three clutches are mounted on each shaft, with all rotors keyed to the shaft. The front clutch has a stationary housing and serves as a brake. The middle clutch housing is driven in a clockwise direction and serves as a forward drive. The rear clutch housing is driven in a counterclockwise direction and serves as a reverse drive. Control of clutch energization is discussed in Chapter 3.

Coast or stop clutch

In the unload status (tape out of both columns, upper head assembly raised, and machine stopped) both brake clutches are energized. Each brake is controlled by the same reel release switch located just below and to the left of the file reel. Depressing this switch will allow the file to machine reels to be rotated by opening the circuit to the stop clutches.

3. Tape Motion

Fig. B
Page 0310

Tape is transported from the file reel past the read-write and erase heads to the machine reel. It would be impossible to start and stop the tape efficiently under control of the reels because the reel drives are relatively sluggish in action. Buffer storage areas are provided in the form of vacuum columns below the reels.

In each of these columns a loop of tape is retained; the tape is drawn past the read-write and erase heads by a friction drive and moving pulley combination. As tape is drawn from one column, it is replenished by the associated reel. As tape is fed into the opposite column, the associated reel winds the tape.

The tape speed across the read-write head is maintained at a constant rate of 75 inches per second. The distance required to get tape up to speed is approximately $3/16$ inch; the distance required to stop the tape is approximately $1/4$ inch. The actual distance traveled before writing is about $1/2$ inch due to a delay built into the external source. The combined distance required to stop, start, and then write is $3/4$ inch.

a. Forward Direction

Fig. B
Page 0310

The right and left drive capstans turn continuously in the direction shown. To draw tape from left to right, the right moving pulley is pivoted to the right, squeezing the tape between the moving pulley and the right drive capstan. At the same time, the left moving pulley is pivoted toward the left drive capstan but does not touch it.

b. Backward Direction

Fig. B
Page 0310

To draw the tape from right to left, the left moving pulley is pivoted to the left, causing the tape to be squeezed between the left moving pulley and the left drive capstan. At the same time, the right moving pulley moves toward the right drive capstan but does not touch it.

*Brake clutch only
clutch used in high
speed rewind. Reels
run by high speed
motor.*

To stop tape motion, the moving pulleys pivot toward the stop capstans, causing the tape to be squeezed between either the right or left moving pulley and the right or left stop capstan, respectively. If the tape is being drawn from left to right, it is stopped by the left stop capstan. If the tape is being drawn from right to left, it is stopped by the right stop capstan.

4. Moving Coil Assembly

Page 0340

a. General

The basic motion is imparted to the moving pulley assemblies by the moving coil. This coil is suspended in the field of a strong permanent magnet. Passing current through the coil causes it to move rapidly either up or down, depending on the direction of current flow.

If the coil is caused to move upward, the start position, the linkage causes both moving pulleys to pivot toward their respective drive capstans. If the coil is caused to move downward, the stop position, both moving pulleys pivot away from their respective drive capstans and toward their respective stop capstans.

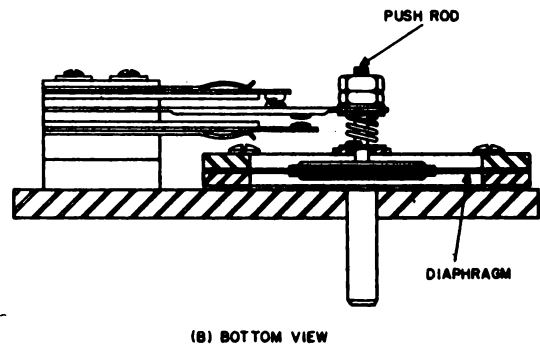
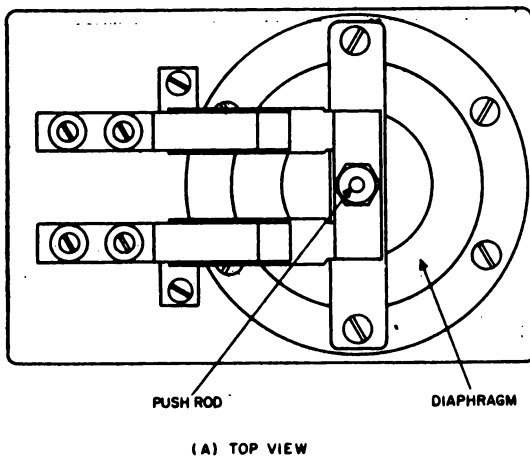
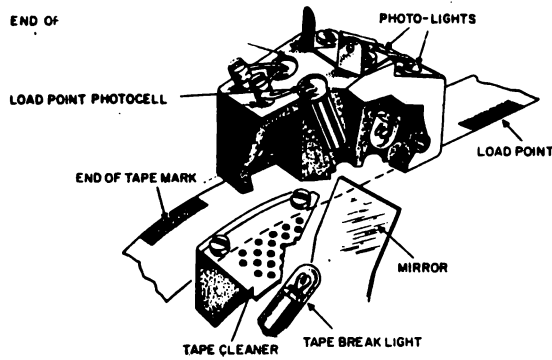
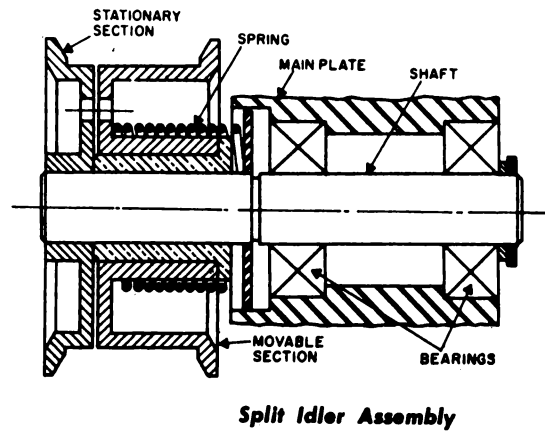
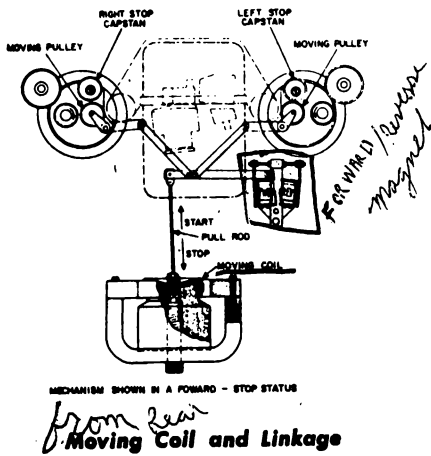

Vacuum Switches

5. Split Idlers - Tape Alignment

Page 0340

Two split idlers are used to assist in maintaining proper alignment of the tape. They are located on the upper head plate to the right and left of the head assembly. These split idlers keep the tape parallel, at a fixed distance, with the front casting. Alignment between machines can be closely controlled. To avoid complex systems, alignment is maintained to one edge of the tape. The front edge of the tape is held at a fixed distance from the front casting by the stationary portion of the idler. The rear portion of the idler is free to slide on the shaft and is held in continual contact with the rear edge of the tape by spring tension. The entire assembly rotates within sleeve bearings in the associated housing.

When the tape expands in width, it spreads the split idler. The track farthest away from the front edge of the tape is most subject to misalignment when the tape expands or contracts laterally between the time of recording and the time of reading. The split idlers are an effective means of keeping to a minimum the time difference between the outside and inside track of the tape (skew) when reading.

6. Head Assembly

Page 0360
&
0370

The head assembly is built on two vertical plates, the lower of which is stationary. The upper plate is built to be moved up and down under power. Located on the lower plate are the read-write head assembly, the tape-break-light assembly, and the tape cleaner. The erase head, load point and end-of-tape photocell assemblies, split idlers, and pressure pad are located on the upper plate.

The upper plate is moved upward about 1 inch from the lower plate in an unload status to allow threading of tape by the operator and to provide free movement of tape during high-speed rewind. During the time tape is being transported through the machine for reading and writing, the upper plate is down, causing the assemblies to be in close contact with the tape. The entire head assembly is removable as a unit; connection to the read-write coils is made through a multi-pin plug at the bottom.

Split Idlers - Tape Alignment

Two split idlers are used to assist in maintaining proper alignment of the tape. They are located on the upper head plate in the left and right of the head assembly. These split idlers keep the tape parallel as it

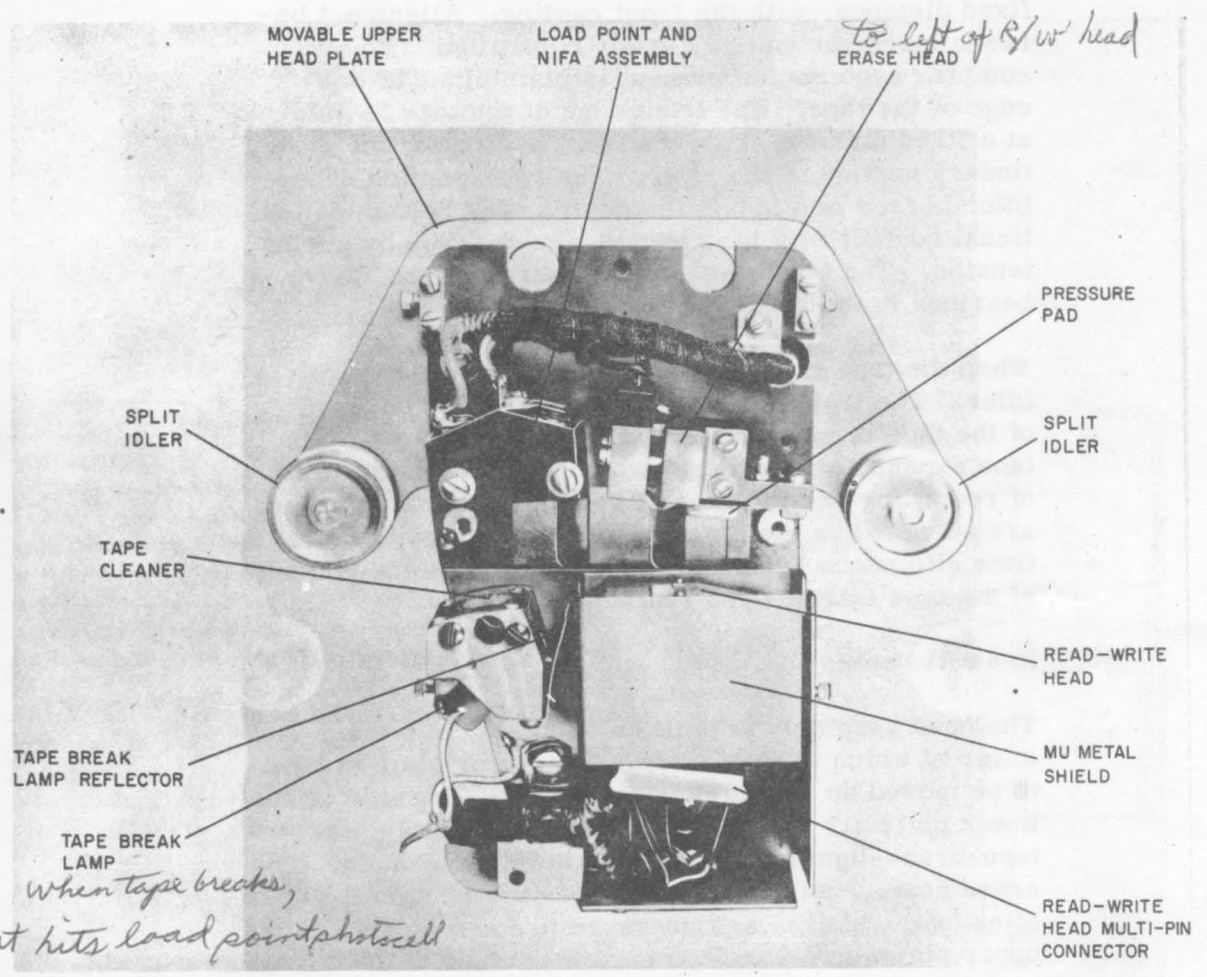

Head Assembly

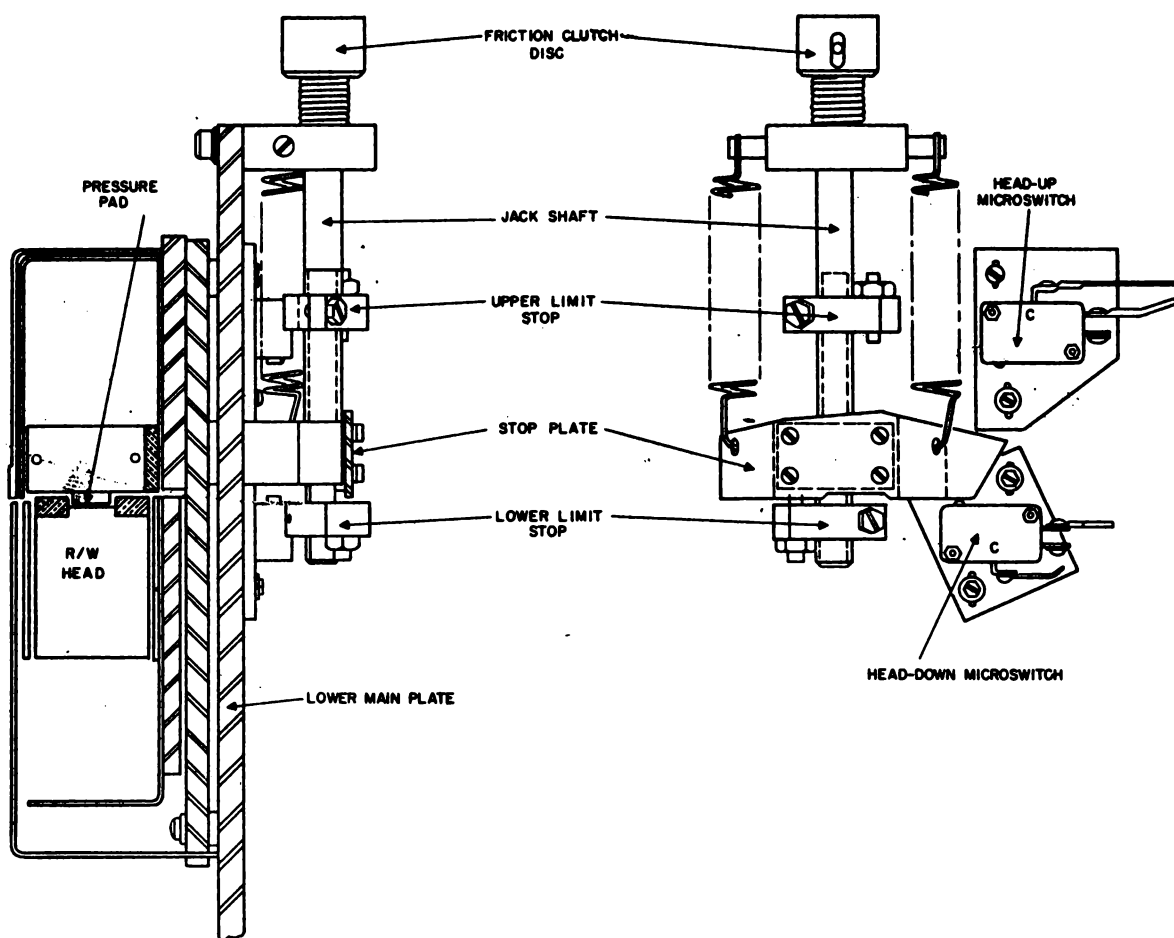

Head Assembly, Cutaway View

a. Read-Write Head Assembly

The read-write head assembly contains the **seven** read-write heads in laminated form, one adjacent to the other. The tape is passed over the head assembly, oxide side down, to complete the flux path of the read-write heads. A pressure pad is used to keep the tape in close contact with the read-write head. The read-write head assembly should not be removed from the lower plate. It is set at the factory. If a read-write head is worn, the entire head assembly should be replaced.

b. Erase Head

The erase head is located above and $3/8$ inch to the left of the read-write head assembly. It consists of one large coil and core covering the entire width of the tape. During writing, all tracks on the tape are magnetized in one direction. The tape is saturated through the backing to the oxide to erase the information previously written. The head is kept close to the tape, ensuring full saturation of the tape.

c. Load-Point Sensing

Page 0340

The load point is a small reflective spot ($3/16$ inch x 1 inch), placed on the plastic side of the tape ($1/32$ inch from the front edge, and 10 feet from the physical beginning of the tape). This reflective spot locates the beginning, or start, of the usable portion of the tape. The 10 feet preceding this spot provide sufficient tape for threading the machine reel.

The load point is used only during a rewind operation; it is sensed by a photocell arrangement. The light from the front bulb is reflected from the spot to the photocell directly to the left of it. Sensing the load point causes the machine to stop.

d. End-of-Tape sensing

An indication that the end of the tape is near, is caused by an identical reflective spot placed approximately 14 feet from the physical end of the tape. This spot is placed on the plastic side of the tape 1/32 inch from the back edge. The rear bulb and photocell sense this reflective spot in the same manner that the load point is sensed. Sensing the end-of-tape mark sets the NIFA trigger and turns on the NIFA light.

e. Tape Break

During a high-speed rewind operation, tape is passed between a light source located on the lower head plate to the left of the read-write head and the load-point photocell. If the tape breaks, the light strikes the load-point photocell, causing the tape drive to stop.

7. Vacuum Columns and Vacuum-Operated Switches

Page 0310

The vacuum columns act as a storage area for the tape, allowing the tape to be moved across the head, at random, without having to turn the reels simultaneously. They also exert tension on the tape, preventing tape buckle at the head during starting and stopping.

&

0340

a. Vacuum Columns

The vacuum columns are of rectangular cross-section. The inside dimensions are 2 1/2 inches x 0.510 inch (+0.002 inch -0.000 inch). The front of the vacuum column is transparent so that tape can be observed. The top of the column is open; the lower end is connected to a manifold leading to a vacuum pump that maintains a vacuum of approximately 8 inches of water with tape in the column. Tape hangs in the columns in such a way as to permit only the sides of the semi-circular loop formed to touch the sides of the column. The vacuum is maintained below the loop, and atmospheric pressure above it.

b. Vacuum-Operated (Diaphragm) Switches

Each column contains two holes: one located about 1/3 of the column length from the top, and the other located about 1/3 of the column length from the bottom. Attached to each hole, via a short tube, is a vacuum-operated switch. As the tape loop is moved past the holes, the change in air pressure is sensed by the switch.

The vacuum column switch is shown in cross-section in figure B . The presence of a vacuum causes the diaphragm to move in a direction to transfer the contacts of the switch. For greater reliability, two sets of contacts are used in parallel.

Page 0340

1) Reel Control - Forward Direction

The tape reel drive clutches are controlled by relay circuitry. As tape is pulled past the read-write head by the right drive capstan, it is pulled out of the left column. When the loop of tape is pulled above the upper vacuum switch in the left column, the file reel forward clutch (left down) is energized and the reel turns in a clockwise direction, causing more tape to be fed into the column. As soon as the loop moves below the upper switch, the left down clutch is de-energized and the brake energized (left stop clutch). This action causes the loop to oscillate about the upper switch of the left column as long as tape is moving past the read-write head in a forward direction.

At the same time, tape is being pushed into the right column by the right drive capstan. When the loop of tape in this column falls below the lower switch, the machine-reel forward clutch (right up) is energized and the reel turns in a clockwise direction to pull tape out of the column by winding it on the reel. As soon as the tape is again above the lower switch, the right up clutch is de-energized and the brake clutch energized.

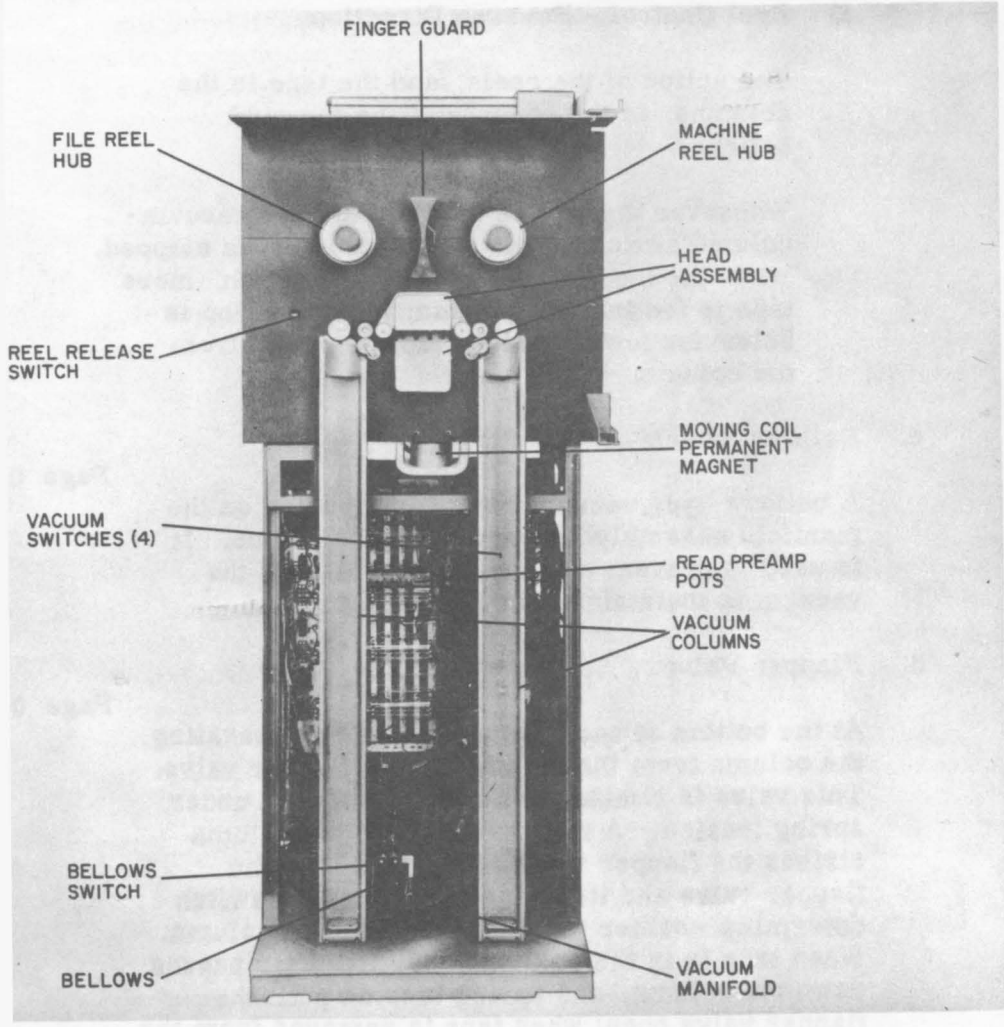

Drive Unit, Model III, Front View without Covers

This action causes the tape loop to oscillate about the lower switch in the right column.

2) Reel Control - Reverse Direction

The action of the reels, and the tape in the columns, is the reverse of the forward action.

Whenever the tape is between the two vacuum-column switches, the associated reel is stopped. When the loop is above the upper switch, more tape is fed into the column; when the loop is below the lower switch, tape is pulled from the column.

c. Bellows Switch

Page 0430

A bellows-type vacuum switch is mounted on the manifold assembly between the two columns. It is used to prevent machine operation until the vacuum is maintained above a certain level.

d. Flapper Valve

Page 0430

At the bottom of each vacuum column, separating the column from the manifold, is a flapper valve. This valve is similar to a door, held open under spring tension. A rush of air down the column strikes the flapper valve and closes it. The flapper valve and its associated mercury switch determine whether tape is in the vacuum column. When tape is in the column, very little air passes down the column, and spring tension pulls the flapper valve open; when tape is removed from the column, or is broken, the rush of air closes the flapper valve and its mercury switch. With tape out of the columns, the flapper valves help maintain sufficient vacuum to keep the bellows switch closed.

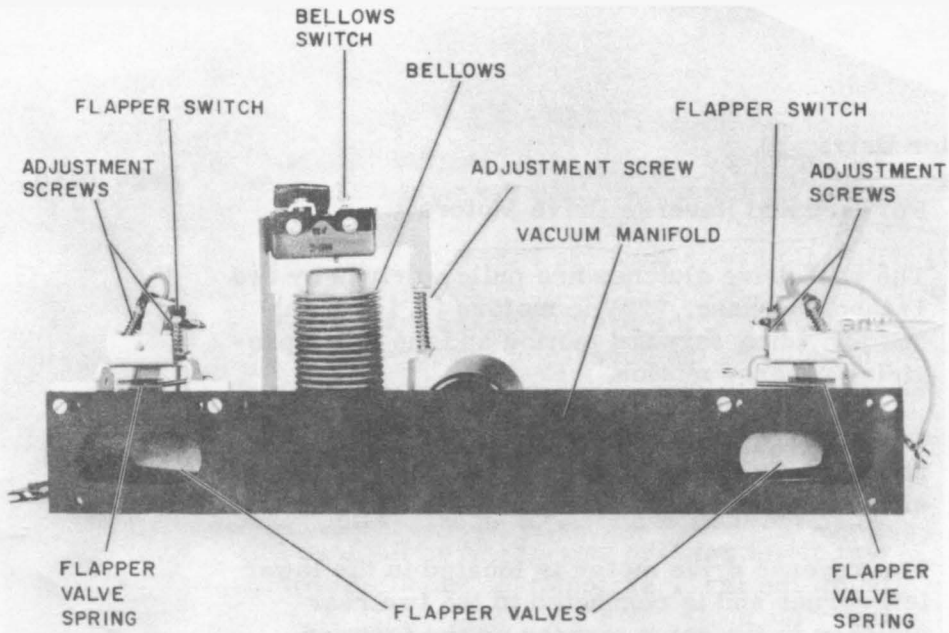

Id Assembly

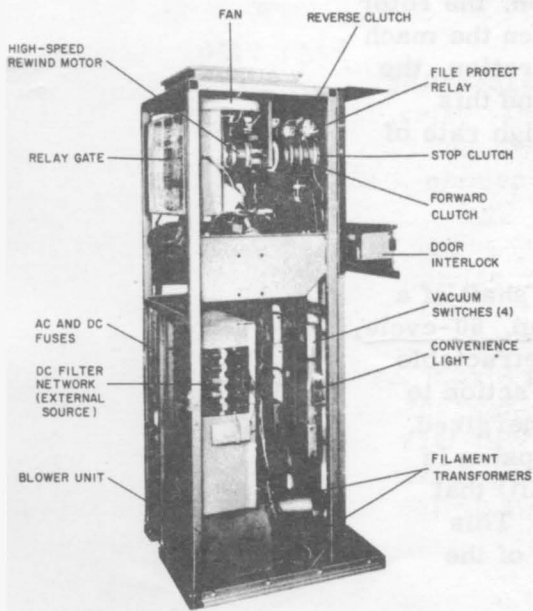

*Tape Drive Unit, Model III,
Left Side View*

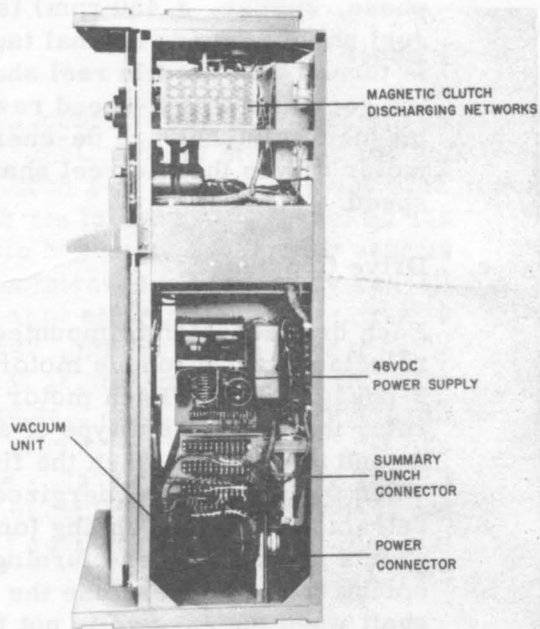

*Tape Drive Unit, Model III,
Right Side View*

8. Motor Drive

Page 0450

a. Forward and Reverse Drive Motors

The reel drive clutches are pulley-driven by two ~~1/4-hp~~, 3-phase, 220Vac motors (1,140 rpm), one providing forward motion and the other providing reverse motion.

The forward drive motor is located in the lower right corner and is connected to the two center clutches by two V-belts adjacent to each other.

The reverse drive motor is located in the lower left corner and is connected to the two rear clutches in the same manner as the forward motor.

b. High-Speed Rewind

To provide fast motion of the reels during high-speed rewind, an additional motor (~~1/12 hp~~, 3-phase, 208Vac, 3,450 rpm) is coupled to the file reel shaft. During normal tape motion, the rotor is turned with the file reel shaft. When the machine goes into a high-speed rewind operation, the magnetic clutches are de-energized and this motor drives the file reel shaft at a high rate of speed.

c. Drive Capstans

Each drive capstan is mounted on the shaft of a reluctance synchronous motor (~~1/20 hp~~, 60-cycle, 3-phase, 208V). Each motor has a retractable rotor that provides a type of solenoid action to extend the capstan when the field is energized. When the field is de-energized, the capstan is retracted by a light spring (on the shaft) that exerts pressure on the turning rotor. This spring does not overcome the friction of the shaft when the capstan is not turning.

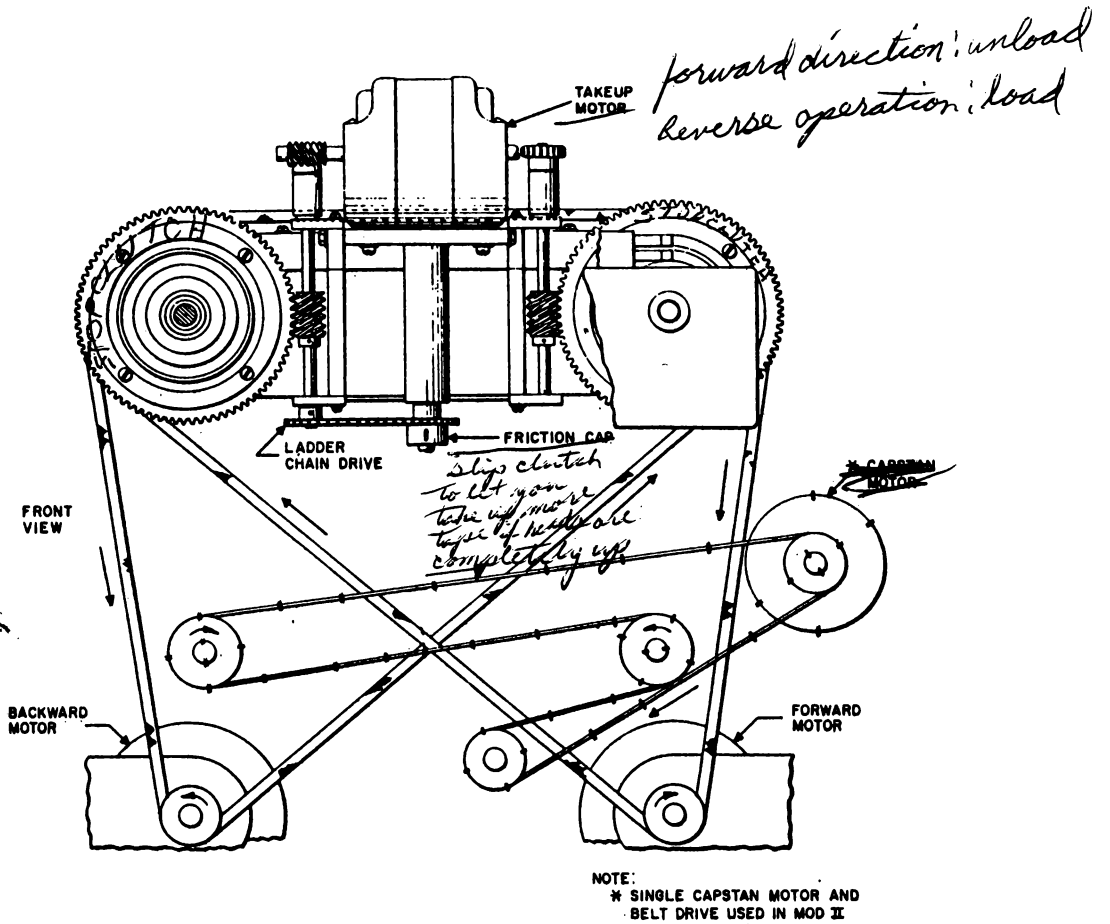

Drive Motor and Pulleys

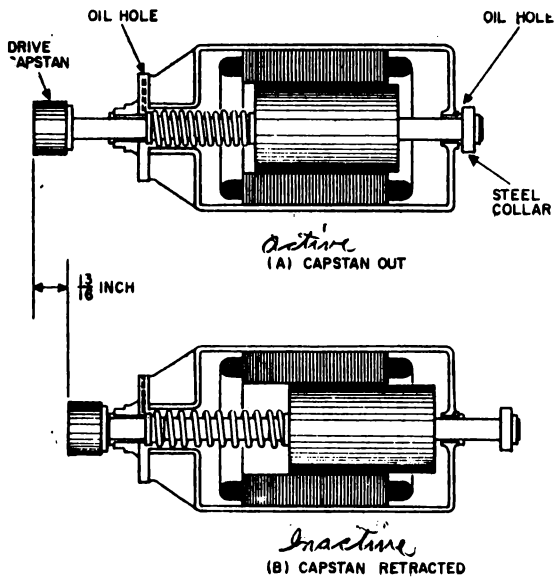

Capstan Drive Motor, Model III

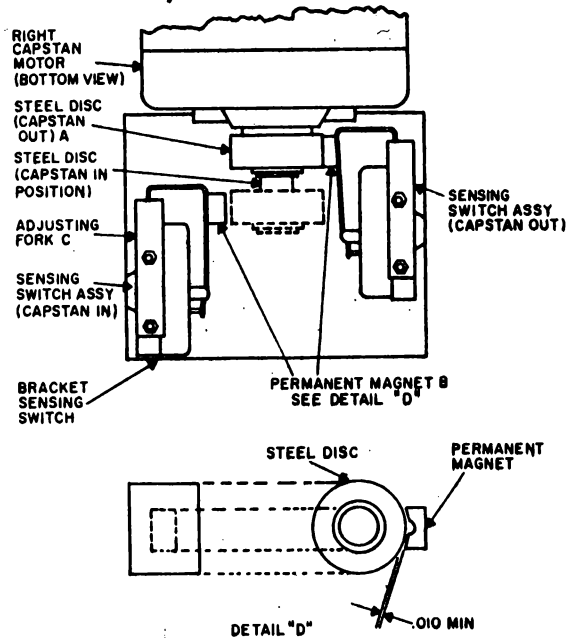

Capstan Sensing Switches, Model III

The position of the capstans, in or out, can be determined by two microswitches located on the rear end of each capstan motor. Each microswitch has a magnet attached to the operating arm that is attracted to a steel collar mounted on the shaft of the rotor.

d. Stop Capstans

There are two stop capstans, each associated with and located above the moving pulleys. The stop capstans are fixed. To stop tape motion, the tape is squeezed between either the right or left moving pulley and the right or left stop capstan, respectively.

9. Time Delay Unit

The time delay unit (motor and microswitch) is located on the relay gate. At the end of a high-speed rewind, this mechanism delays machine operation to allow the reels time to stop before tape is loaded into the columns. When the motor runs, it drives an operating arm by means of a reduction gear train. After a given time, the arm operates the microswitch, referred to as the time delay points. As long as the motor is energized, the operating arm holds the time delay points open. When power is removed, the arm returns to its home position under spring tension. The length of the time delay is set with a calibrated dial on the front of the assembly. It is a 15-second timer, with a dial containing 10 1.5-second divisions.

10. Head-Raising Mechanism

Page 0450

The mechanism that raises the upper plate of the head assembly is directly behind the upper front casting. It consists of a screw shaft, driven from a friction clutch and ladder chain by a 3-phase motor, mounted above and between the two clutch shafts.

When the motor (takeup motor) is operated, the screw shaft turns in a clockwise direction, causing the upper plate to move upward. When two phases are reversed and the motor is operated, the shaft turns counter-clockwise and lowers the plate. Microswitches are used at both limits of travel to determine the position, up or down, of the head cover assembly.

The friction cap permits you to finish a load/unload operation when heads are completely in position desired

TAKE-UP
MOTOR

In addition to operating the screw shaft, the motor is geared to each of the brake clutch housings so that, when the head is being raised, the left stop clutch housing is rotated in a counterclockwise direction and the right stop clutch housing is rotated in a clockwise direction. The brake clutches are energized at this time, and the reels are driven in the same direction as the stop clutch housing. This causes tape to be pulled from both columns. The opposite occurs when the head assembly is lowered and tape is lowered into the columns.

11. Reel Door Interlock

Located in the latch side of the reel door is an interlock switch that is closed when the door is closed or when the operating plunger is pulled out with the door open. When the door is opened, operation of all drive motors is prevented by this switch. A means of closing this switch while the door is open is provided for maintenance.

12. File Protection

For the protection of master files, a device is provided to prevent writing on a reel of tape. A groove is molded in the rear side of each reel; an associated plastic ring may be placed in this groove. The presence or absence of this ring in the file reel determines whether this device is in use. If the ring is not placed in the groove, writing is suppressed but reading is allowed. The reel is then file-protected. If the ring is placed in the groove, both reading and writing may occur.

To sense the presence or absence of the ring, a pin protrudes from the upper front inner cover. The pin is connected to the armature of a duo relay mounted directly behind the cover. If a ring is in the groove of the file reel, the pin is pushed to the rear, moving the relay armature. This action closes a relay contact, energizing the relay, to permit writing. If the groove in the reel is empty, the pin is not actuated and the relay is not energized; writing is prevented.

13. Power Considerations

Power for electronic circuits and drive motors is obtained externally while power for relay circuitry is obtained from a 48V power supply within the unit. The source of external power for the tape unit is through a male cannon plug located at the lower rear left corner of the tape drive. Drive motor operation requires a 3-phase, 208Vac power. One phase of the 3-phase supply is used to operate the 48Vdc and filament power supply located within the tape unit. The 48V is necessary for relay operation. Table lists the fuses used with the 728 Tape Drive, models II and III.

The 270V, 140V, -60V, -130V, and -270V, are brought from unit 18 tape power supply. Neg. 48 volts is also supplied to the drives. It is used only to light a thermal light if the temperature within the unit becomes excessive.

Fig. B

14. High-Speed Rewind Photo-Sensing

Page 0490

A device composed of a photocell and light is used to determine the type of rewind that the tape drive will do. The photocell is located in the lower section of the finger guard; the light is located on the right corner of the top plate. When more than 1/2 inch of tape is on the machine reel, the light path is blocked and the tape drive goes into a high-speed rewind (average, 500 inches per second). When less than 1/2 inch of tape is on the machine reel, the light strikes the photocell, causing the tape drive to go into a low-speed rewind (75 inches per second).

Note

If the bulb burns out, the machine will only perform a slow-speed rewind.

B. Summary Questions

Facing the front of the tape drive:

1. The left reel is call the _____ reel.
2. The right reel is called the _____ reel.

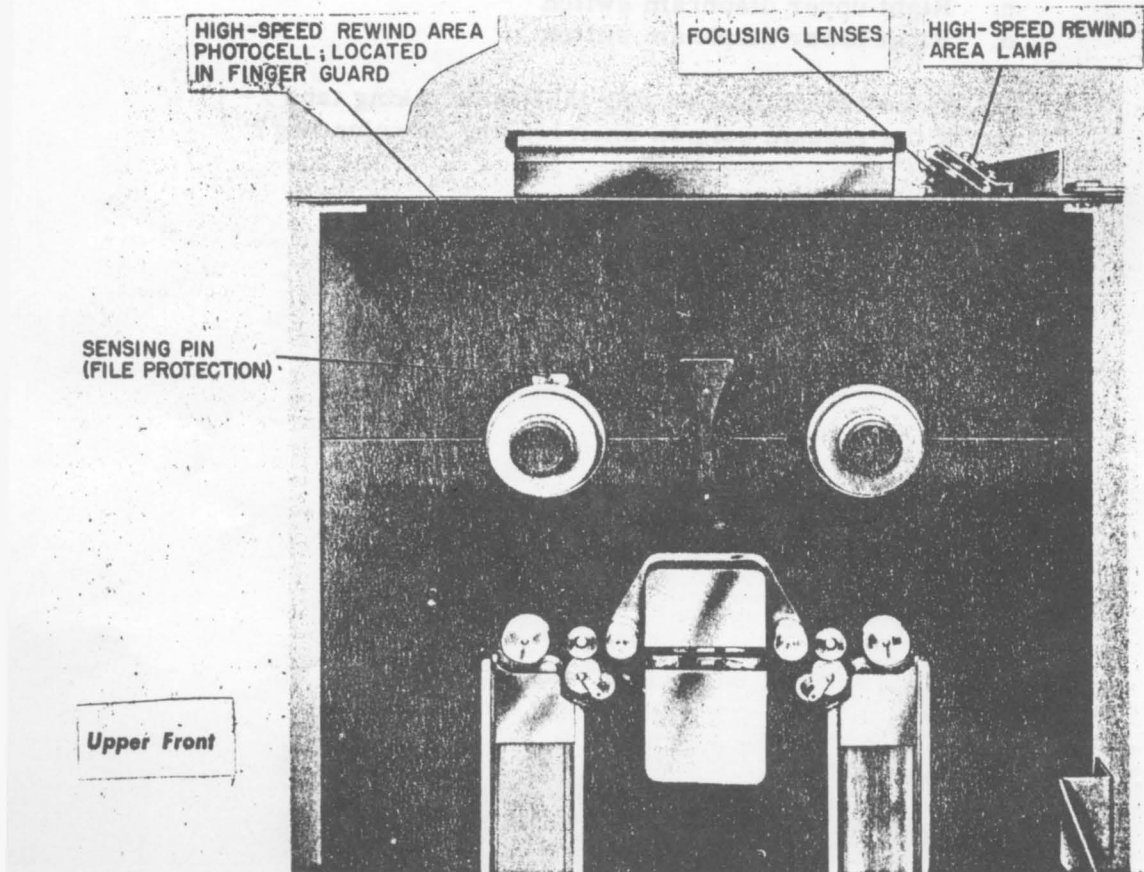
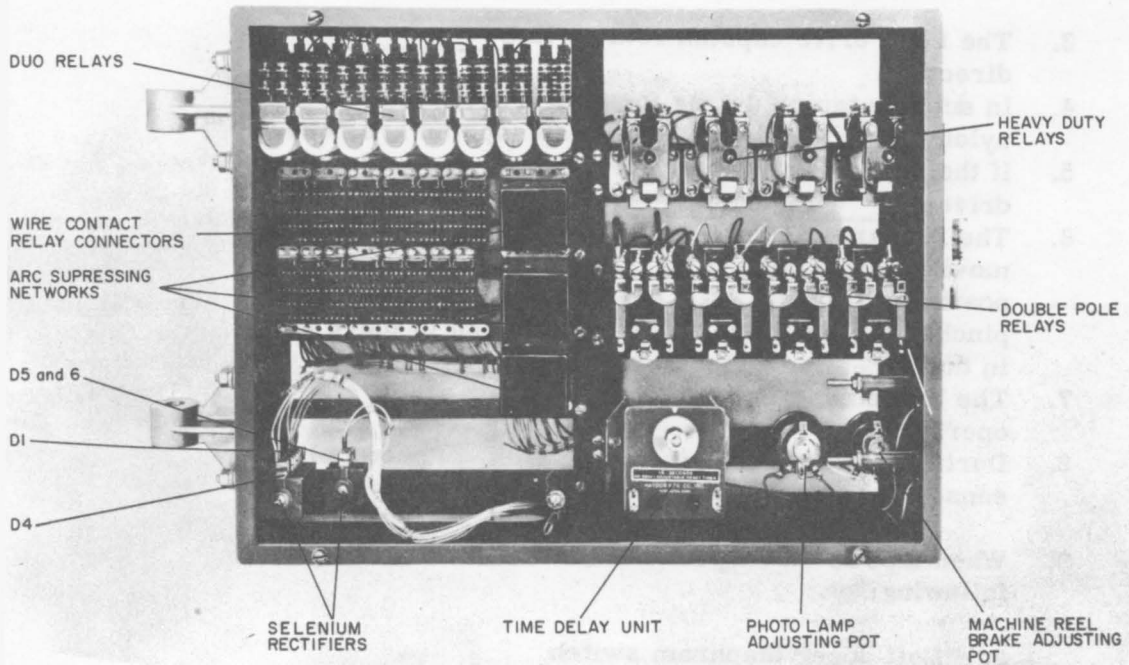

3. The right drive capstan rotates in a _____ direction.
4. In stopping taping during forward travel, the _____ nylon pulley and the _____ stop capstan are used.
5. If the moving coil is moved up, the nylon pulleys are driven _____ to _____ tape.
6. The forward-reverse magnet is reverse position, the moving coil is moved up. The nylon pulleys are positioned _____ so that the left nylon pulley pinches tape with the left drive capstan to move tape in the _____ direction.
7. The erase head is enabled only during a _____ operation.
8. During high speed rewind, the _____ photocell senses for tape breakage.
9. When tape is moving forward, state function of the following:
 - a. Left upper diaphragm switch
 - b. Left lower diaphragm switch
 - c. Right upper diaphragm switch
 - d. Right lower diaphragm switch
10. Which motor controls putting tape in or taking tape out of the vacuum column when loading or unloading?

D. Control Line Summarization

Page 0530

There are two summary punch connectors (wired in parallel) through which the control lines enter and leave the tape drive. A brief description of the function of each control line is given below:

Select lines (six lines)	The select lines are routed from external control. They determine which tape drive is to be selected.	Logic 0.8.1 C.C. Vol. II
Write bus (seven lines)	The seven lines of the write bus transmit the seven bit levels from the external control to condition the seven diode gates.	
Write pulse	This is a line that originates in the external control and over which timed pulses are sent to switch the write triggers through conditioned diode gates.	
Read bus (seven lines)	The read bus consists of seven lines over which the seven bit pulses are transmitted to the external control.	
Write echo bus (seven lines)	Each of these seven lines sends a pulse to the external control when a bit of information is written on its corresponding track.	
Select, ready, and read	This line is an output from the tape drive, indicating that the unit has been selected and is ready to begin reading. The term ready means that the tape drive is in the load status and the machine is mechanically ready (NOT READY light is out).	
Select, ready, and write	This line is also an output of the tape drive, indicating that the unit has been selected and is ready to begin writing.	

Set read	This line is an input from the external control to set the R/W status trigger to the read status.
Set write	This line is an input from the external control to set the R/W status trigger to the write status.
Select and rewind	This line is an output of the tape drive, indicating it has been selected and is rewinding. Reading or writing cannot be performed if this line is up.
Select and at load point	This line indicates to the external control that the selected tape drive is at load point.
Select and not in file area (NIFA)	This output from the tape drive indicates that the selected tape drive is not in a usable portion of tape.
Select and in file area	This output indicates that the selected tape drive is in a usable portion of tape.
Set NIFA	This line, which originates in the external control, sets the NIFA trigger in the selected tape drive.
Set prepared	This line, which originates in the external control, clears the NIFA trigger in the selected tape drive.
Backward	This line also originates in the external control and controls the status of the forward-reverse magnet in the selected unit.
Start rewind	This line, which originates in the external control, initiates rewinding.
Go	This line controls the status of the moving coil. It originates in the external control.

INDICATOR FUSE CHART

PART		208VAC		DC		PART		
334881	1	PH 1	Motors	6A	13	48V Supply output	2A	322784
322784	2	PH 1	48V Supply	2A	14	Duo relays and operating panel 48V return	1A	322895
322899	3	PH 2	48V Supply and motors	7A	15	Wire contact relays 48V return	1A	322895
322784	4	PH 2	Blowers and fan	2A	16	Retracting solenoid FP relay 48V return	1A	322895
322899	5	PH 3	Blowers, fan, and motors	7A	17	Magnetic clutches 48V return	1A	322895
322784	6	PH 1	Rewind motor and pressurizing blower	2A	18	HD & DP relays 48V return	1A	322895
322895	7	PH 1	Time delay motor	1A	19	Dummy fuse		322088
322895	8	PH 2	Takeup motor	1A	20	Dummy fuse		322088
322784	9	PH 2	Capstan drive motor	2A	21	Dummy fuse		322088
322895	10	PH 3	Vacuum motor and takeup motor	1A	22	—60 to 30A FIL transformer center tap	1A	322891
322784	11	PH 3	Capstan drive motor	2A	23	—130 to clutch demagnetizing circuit	1A	322891
322784	12	PH 3	Rewind motor and pressurizing blower	2A	24	140 to relay gate & OP panel	1A	322891

SIGNAL & POWER DISTRIBUTION FROM TAPE
ADAPTER UNIT TO TAPE DRIVES

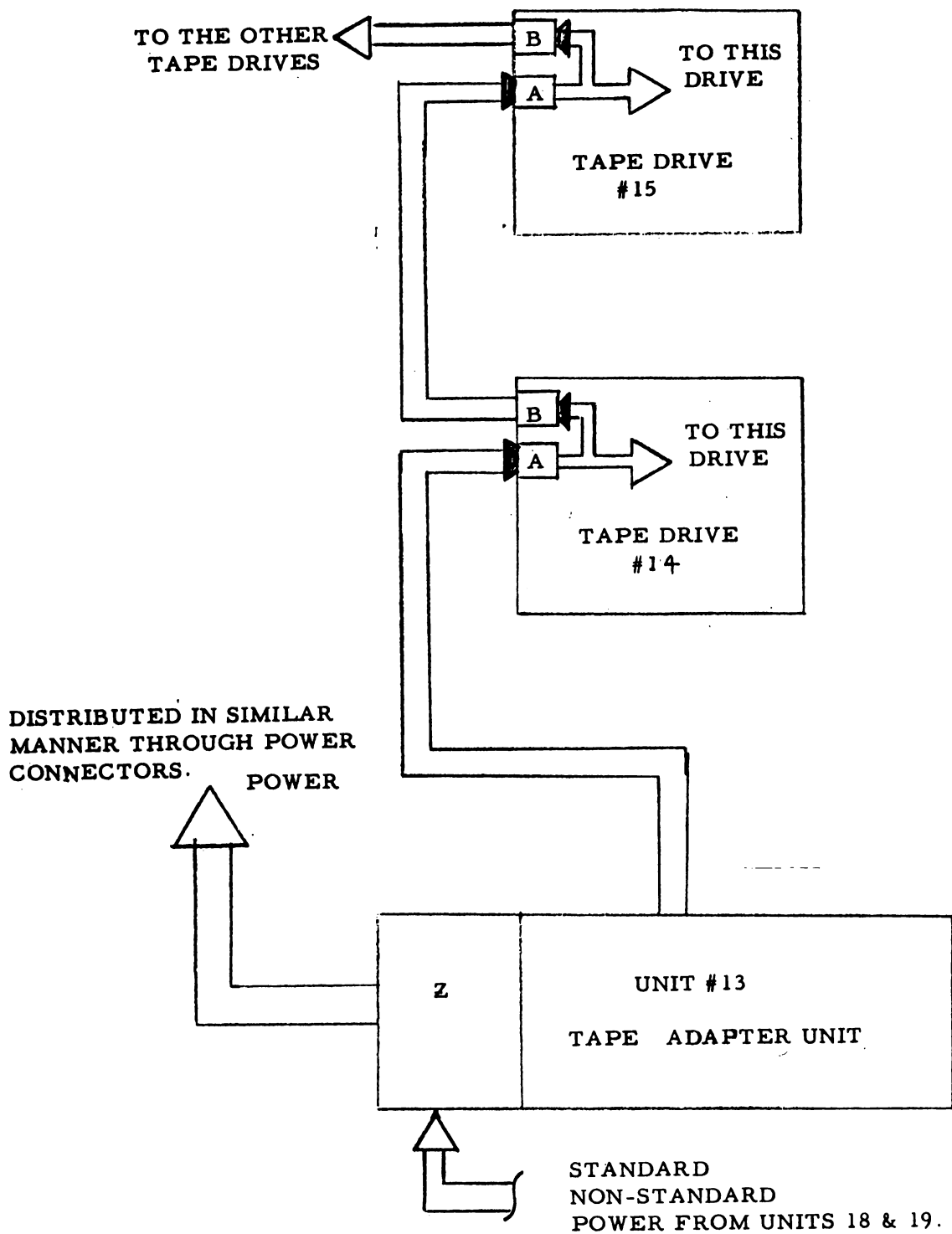

NOTE: SUMMARY PUNCH CONNECTORS INDICATED AS A AND B.

E. Functional Characteristics

1. Machine protection circuits:

- a. The blowing of a bail fuse activates the bail which causes the fuse light to go on and stop the tape drive operation.
- b. Actuating the thermal contact drops the non-standard d-c voltage to the tape drive.

2. Lamps:

- a. **NOT READY** - Lights when the machine is mechanically not ready. This condition remains until tape drive is mechanically ready and **START** button is depressed.
- b. **SELECT** - Lights when the associated select line is at +10V and cut off when the select line is at -30V.
- c. **FILE PROTECT ON** - Lights when a file-protected reel is put on file reel hub of machine. Also when in rewind status, load-rewind, and unload.
- d. **NIFA** - Lights when the special end-of-file (EOF) word is read or written or when the reflective EOT mark on tape operates EOT photocell.

3. Operating buttons:

- a. **UNLOAD** - Operate if in not-ready status. Depression causes upper head assembly to rise and tape to be withdrawn from vacuum column. This is called unload status.
- b. **LOAD REWIND** - Operative if in not-ready status. Depression causes tape to go to load point: through complete high-speed rewind cycle if tape is in high-speed rewind area and slow speed (75 inches per second) only if tape is in low-speed rewind area. Loads machine if in unload status when button is depressed.

- c. **START** - Depression puts unit in a ready status (provided necessary conditions exist), disables manual control buttons, and turns off the NOT READY light.
 - d. **RESET** - Depression resets the tape drive to manual control (turns on NOT READY light). Depression will also simulate the action of the high-speed area sensing device when in high-speed rewind and will stop the tape if in 75-inches-per-second (IPS) rewind.
 - e. **Address selector switch** - Number indicates select line to which tape drive is connected.
 - f. **Reel release switch** - Depression de-energizes reel brake clutches to free reel when loading.
3. **Tape speed:** 75 inches per second.
 4. **Rewind speed:** Average 500 inches per second when in high-speed area, 75 inches per second when in low-speed area.

F. Mechanical Characteristics

The mechanical characteristics of the 728 tape drive are as follows:

1. **Capstans** - Switches are provided to sense whether capstans are in or out.
2. **Tape column guides** - The tape column guides hold the tape square with the back and 1/32 inch further away from the side of the column from which tape is pulled.
3. **Vacuum safety switch** - The vacuum safety switch transfers when the vacuum in the manifold drops below the value required for proper operation.
4. **File protection mechanism** - A reel with an insert depresses the plunger sufficiently for the relay points to make to allow writing on tape.
5. **Reel clutches** - The machine reel brake magnetic clutch is adjusted with the potentiometer on the relay gate so that it is stopped when there is 70 feet (approximately 1/4" or 50 turns) of tape on the reel after rewinding from a full reel of tape. The time delay is adjusted so that it runs for approximately 1½ seconds after the reel has stopped.
6. **Pressure pads** - The pressure pads are adjusted to allow a constant vertical force on the tape.

G. Electrical Characteristics

The electrical characteristics of the 728 tape drive are as follows:

1. Voltage requirements:

- a. Drive motor operation requires 3-phase, 208Vac. One phase of the 3-phase supply is used to operate the 48Vdc and filament power supply located within the tape unit. The 48V is necessary for relay operation.
- b. The d-c service voltages are generated in unit 18: +270V, +140V, -60V, -130V, and -270V.
- c. Input control line voltages are either +10V or -30V.

2. Light sources:

- a. There are two bulbs in the photocell assembly. The total voltage drop across the bulbs, when tape is in the columns, is $6 \pm 0.2V$. This voltage can be adjusted with the photo-lamps potentiometer mounted on the relay gate.
- b. The voltage drop across the bulb in the light source assembly for the photo-sensing high-speed rewind mechanism is $4 + 1, -0.5V$. This voltage can be adjusted with the 400 ohms of resistance (100 ohms of which are variable).

Page 0340

3. Photocells:

- a. The light source assembly for the photo-sensing high-speed rewind mechanism is positioned so that the horizontal slot of light is centered on the photocell located in the guard between the reels. The light beam can be moved by loosening the large ring. It is focused by turning the small ring.
- b. The photo-sensing of load point, NIFA, and tape break operates with bulb voltages of 5V to 6.5V, measured across the combined load point and end-of-tape bulbs when tape is in the columns.

4. Write circuits: The write current is 11 ma ($56V \pm 5V$).
5. Read circuits: The preamplifier gain is set for an 18V peak-to-peak output.

6. Start and stop time:

Page 0310

- a. The start time is $4.5 \begin{matrix} +0.5 \\ -1.0 \end{matrix}$ ms measured to the point at which normal speed is first reached. (The typical start envelope is shown in Fig. D Page 0310)
- b. The stop time is 5.0 ± 1.0 ms measured to the point at which the amplitude of the stop envelope first reaches zero. (The typical stop envelope is shown in Fig. E Page 0310)
- c. The sum of backward stop and forward start should not exceed 9.5 ms for acetate tape and 10 ms for Mylar* tape.

*Trademark of E. I.
DuPont de Nemours &
Co., Inc., Wilmington,
Del.

H. Tape

1. Characteristics

There are three types of tape used; acetate, Mylar, and Durexcel:

- a. Width: 0.498 ± 0.002 inch
- b. Total thickness: $0.0022 (+0.0003, -0.0004)$ inch
- c. Base thickness: 0.0015 inch $\pm 10\%$
- d. Ferromagnetic material and binder: 0.0006 inch
- e. Tensile strength (minimum):

Mylar: 12 pounds

acetate: 8 pounds

Note: Durexcel is replacing Mylar. It has an improved binder.

2. The ferromagnetic material, or magnetic oxide, is the physical medium upon which information is stored.

The tape capacity is as follows:

- a. Tracks - Seven (six information, one sync track).
- b. Character - Generally six information bits plus a synchronizing bit written across the tape. A sync bit is written for every character placed on the tape. In some cases, a character consists of three bits of information and three unused bit positions. The character density is 248 bits per inch.

- c. **Word** - Five full characters plus one character that contains only three information bits (three are unused). The word density (33 bits) is 41.3 words per inch:
 - 1) **Record** - Group of consecutively written words.
 - 2) **File** - Group of consecutively written records. Normally, a file would occupy one reel, but it is possible to write more than one file on a reel.
- d. **Words per reel** (if one continuous record) - 1.2 million approximately.
- e. **Interrecord gap** - 0.75 inch.
- f. **Length of tape on reel** - 2,400 feet.
- g. **Usable tape length** - 2,376 feet. (disregarding tape after EOT)

3. TAPE HANDLING

Because foreign particles can reduce the intensity of reading and recording pulses by increasing the gap between the tape and the head, take the utmost care to protect the magnetic tape from dust and dirt:

- a. Keep tape in dust-proof container whenever not in use on a tape unit. During loading, take tape directly from container; after unloading, place tape directly in container.
- b. While tape is on machine, keep container closed and put it in some location where it is not exposed to dust or dirt.
- c. Store tapes in some type of cabinet elevated from floor and away from sources of paper or card dust. Doing this should minimize the transfer of dust from the outside of the containers to the reel during loading or unloading operations.
- d. Do not use top of tape unit as working area. Placing materials on top of units exposes them to heat and dust from blowers in unit. It might also interfere with cooling of tape unit.
- e. When identifying tape reels, use a material that can be removed without leaving a residue. Adhesive stickers, easily applied and removed, are satisfactory. Usually, they can be prepared beforehand and applied during the loading procedure. Never alter identification by changing labels with an eraser. A card holder has been incorporated in the design of the new reel.

- f. Place load points and reflective spots on tapes with care. Properly align and press them tightly on tape with back of fingernail. It is best to do this while tape is loaded on a unit. If this is done away from unit, keep unrolled end off floor and away from dusty areas.
- g. Inspect containers periodically. Remove any accumulated dust by washing with a regular household detergent.
- h. When necessary to clean tape, gently wipe tape with clean lint-free cloth.
- i. Exercise extreme care while removing file protect ring. Under no circumstances remove ring while tape is loaded in columns.

Recorded information comes within 0.020 inch of the edge of the tape. Proper operation relies on the edge's being free from nicks and kinks. To accomplish this:

- a. Handle reels near hub whenever possible. If difficulty is encountered while removing reel, break bond between reel and hub by placing palm of hands on periphery of reel and rotating. Under no circumstances "rock" reel by grasping outer edge.
- b. Carefully avoid pinching reels or contacting exposed edge of tape.
- c. When mounting, push reels firmly against stop on mounting hub to ensure good alignment.
- d. Always take special precaution to make sure hub has been tightened after reel has been mounted.
- e. When placing tape on takeup reel, carefully align tape to prevent damaging edge on first few turns. If there is a spring, insert tape (without folding back) under spring in direction that reel turns.
- f. When winding tape to load point, rotate machine reel with finger near hub and on reel. Rotating reel with finger in cutout nicks or curls guiding edge of tape.
- g. Always place sponge rubber grommets or special clips on stored reels to prevent free end from unwinding in container.

- h. - If a tape break occurs, divide reel into two smaller reels. Splicing is not recommended. If it is necessary to make a temporary splice to recover information, be sure to use special low cold flow splicing tape (Field Engineering supply item).
- i. Dropping a reel can easily damage both the reel and the tape. General use of a reel and tape after it has been dropped is usually unsatisfactory.
- j. Never throw or mishandle reels, even while they are protected in their containers.
- k. Allow tape drive to complete unload sequence before opening door.

Magnetic tape is sensitive to changes in humidity and temperature. This applies mainly to acetate tape.

Take the following precautions:

- a. If at all possible, store tape where it is to be used; i. e., in maintenance console room. Location of tape storage near tape drives reduces both handling and variations in atmospheric conditions.
- b. Control atmosphere between following limits:
 - 1) Relative humidity: 40% - 60%
 - 2) Temperature: 65°-80°F
- c. If tape must be removed from maintenance console atmosphere, hermetically seal it in a plastic bag. If tape is not hermetically sealed, then before re-use, return to and allow to remain in maintenance console atmosphere for length of time equal to time it was away from room. If tape has been removed for a time greater than 24 hours, 24-hour conditioning is necessary.

When customers ship magnetic tape, the following procedure is advisable:

- a. Pack tape and reel securely in dust-proof container.
- b. Hermetically seal container in plastic bag. (Ordinary plastic bags that can be sealed with a hot iron should be available from local merchants.)
- c. Obtain additional support by enclosing in individual stiff cardboard shipping boxes.

For long-term storage, take the following precautions:

- a. Provide proper mechanical support for reels by using dust-proof containers.
- b. Enclose reel and container in hermetically-sealed moisture-proof plastic bag.
- c. Store in area of constant temperature; either freezing or excessively hot temperatures could harm tape. A temperature between 40° and 120°F is satisfactory.

If a tape reel has been dropped, the reel may be broken or bent (bending is less likely, for a strain sufficient to bend the tape reel will usually break it), the edge of the magnetic tape itself may be crimped, and the magnetic tape may be soiled. The tape should be inspected immediately. Breaking or bending can usually be verified by visual inspection. In addition, bending can be verified by mounting the reel on the hub of the tape frame. If the reel has been bent or broken, it should obviously no longer be used, but the magnetic tape itself may still be perfectly serviceable and can be wound on another reel.

If the edge of the magnetic tape is crimped, what to do with it depends upon whether it contains essential information. If the tape does not contain any essential information, discard the footage with the crimped edge or edges.

Any time a tape reel has been dropped, clean the reel and tape thoroughly. If visual inspection fails to uncover any evidence of breaking or bending of the reel, or crimping or other damage to the magnetic tape, assume that the tape is in good operating condition. If at all possible, make a test to verify that the tape operates properly before using it on subsequent runs.

The following are points of general tape-handling information:

- a. The procedures outlined above apply to handling tape in a SAGE installation.

- b. Field engineers and other IBM personnel should take special precautions to follow the tape-handling recommendations to show, by example, the care required to ensure good tape performance.
- c. Any tape arriving at the customer's installation in an unusable condition should be replaced and the faulty tape returned to the factory. To aid the factory in its inspection, ship the tape according to the shipping instructions outlined above.
- d. Use discretion about smoking in the vicinity of tape because it adds to the dirt problem. A hot ash could cause serious trouble with a reel of tape.

Mylar magnetic tape should be handled in the same manner as acetate tape. However, if Mylar tape is removed from the maintenance console atmosphere for short periods (not in excess of 3 months), it is not necessary to hermetically seal such tape or to recondition it after return to the maintenance console atmosphere. For long-term storage, Mylar tape should be hermetically sealed to guard against dirt, dust, and excessive moisture.

CAUTION

Never store reels of tape near magnetic fields.

4. Humidity Considerations

a. Cellulose Acetate

This plastic material is dimensionally unstable with respect to relative humidity. In the range between 20-percent and 80-percent relative humidity, the width can change as much as 0.0069 inch. When the relative humidity varies over a wide range, the resulting width variations present a problem of storing and using the tape. The accurate guiding of tape to the read-write head depends upon the width of the tape.

b. **Polyester Base**

Du Pont Mylar polyester film is a more stable plastic material than cellulose acetate. In a range between 20-percent to 90-percent relative humidity, the width can vary as much as 0.0023 inch, or 1/3 the variation of cellulose acetate.

Proper storage of a reel of tape is therefore necessary to obtain satisfactory performance. If the tape is stored where the relative humidity ranges between 40 percent and 60 percent, the design tolerances are maintained. If the tape is stored in an atmosphere outside the specifications, the probability of error increases.

Temperature variations are secondary in comparison with humidity. If tape is stored about 70°F, no departure from the specified width should be observed.

Note: It is preferable not to use different types of tape on any one Tape Drive. This may not be possible in practice. If a change is made, it is advisable to clean the tape drive to remove any magnetic oxide before changing to a different type of tape.

Summary Questions

1. Define conditions while loaded - unloaded.

	Loaded	Unloaded
Nylon Pulleys		
Capstans (Drive)		
Head Cover		
Tape		
FWD-REV Motors		
Vacuum Motor		

2. What devices cause tape to move forward over the R/W heads?

3. What devices cause tape to stop?
 - a. Forward stop
 - b. Reverse stop
4. What diaphragm switch controls the file reel when tape is moving forward?
5. Which diaphragm switch controls the machine reel when tape is moving forward?
6. Which diaphragm switches control the tape reels during the time tape is moving backward?
7. What are the advantages of using vacuum columns?
(2)
8. Describe the operation of the flapper switches.
9. What is the function of the flapper switches?
10. What functions does the take up motor perform? (2)
11. What is the purpose of raising the head cover?
12. What components are located on the head cover assembly? (4)
13. What are the functions of the components located on the head cover assembly?
14. Where is the tape break light located?
15. When is the tape break light used?
16. Which pulleys are driven by the forward motor?
17. What is the function of the various clutches?
18. Where is the H. S. Rewind motor located?
19. When is the H. S. Rewind motor used?
20. What determines H. S. or L. S. rewind?

21. What sensing devices are used to determine speed of rewind?
22. What is the condition of the drive capstans while the machine is loaded? Unloaded?
23. Is the head cover up or down while the machine is loaded? Unloaded?
24. What motors are running while the machine is loaded? Unloaded?
25. Is vacuum up or down while the machine is loaded? Unloaded?
26. Is tape in or out of the vacuum columns while the machine is loaded? Unloaded?

21. What speed devices are used to determine speed of
tapes?
22. What is the condition of the drive rollers while the
machine is loaded?
23. Is the head assembly or does while the machine is
loaded?
24. What motors are running while the machine is loaded?

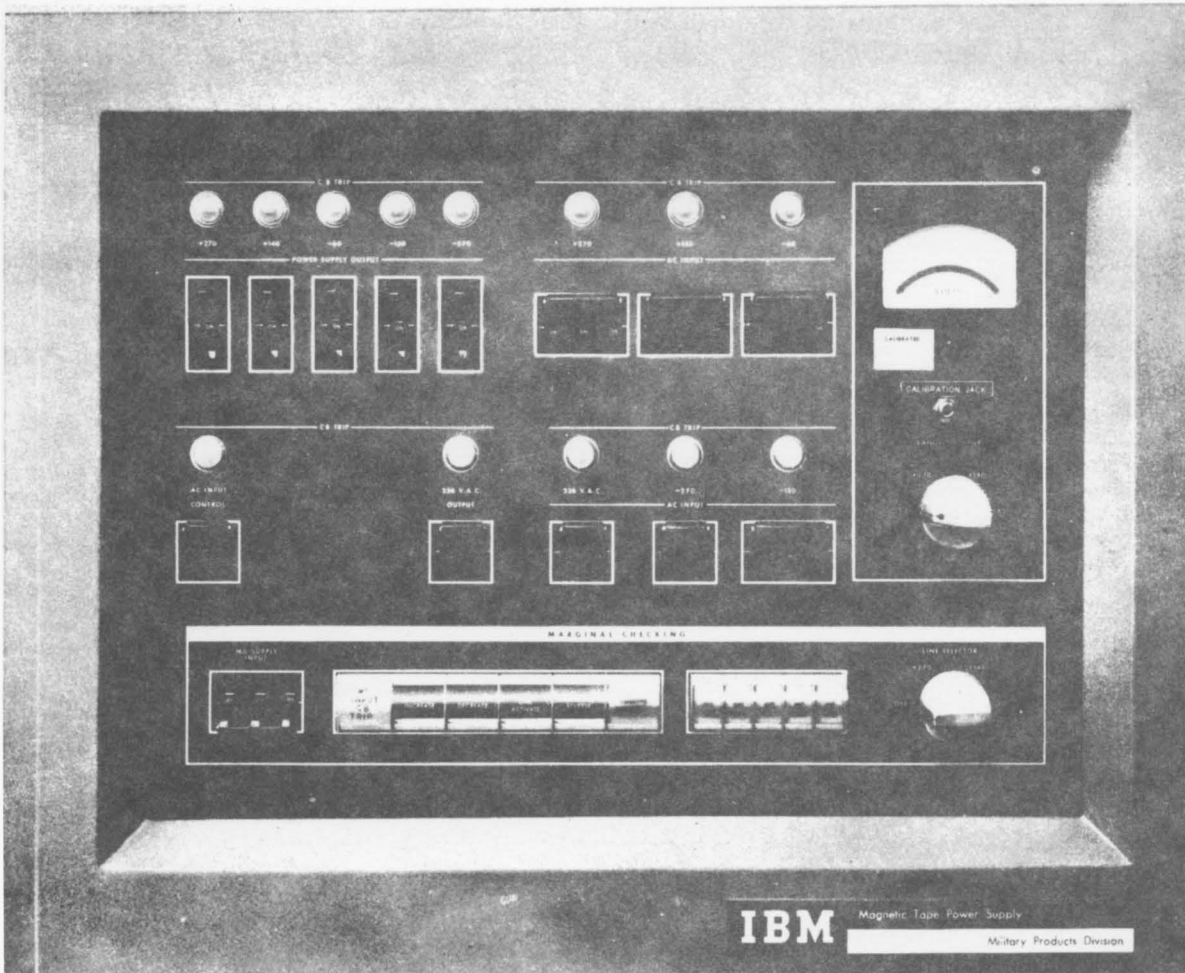

Control Panel, Magnetic Tape Power Supply Unit

K. Review of Mechanical Operations

1. Define loaded and unloaded.

a.	Loaded	Unloaded
Nylon Pulleys	Forward Stop	Forward Start
Capstans	Out & Turning	In & Stopped
Head cover	Down	Up
Tape	In columns	Out of columns
FWD REV Motors	Running	Stopped
Vacuum	Up	Down

2. Which drive capstan drives tape in the forward direction?

a. Right

3. Which motors are running when the tape drive is unloaded and power is up?

- a. 1) Blower
2) Fan

4. Which diaphragm switch controls tape in the right column during the time in which tape is moving forward?

a. Bottom Right

5. What device is used to stop tape?

a. Nylon pulleys and stop capstans.

6. Clutches and Diaphragm Switches

- a. With tape out of columns, stop clutches are under control of the reel release pushbuttons. Up and down clutches are inactive.
- b. During the load and unload operations, partial current is applied to the stop brakes to allow take-up motor to drive the tape reels through the stop clutches.
- c. Take-up motor to drive the tape reels through the stop clutches.

- 1) R-2 & R-1 energized during both load and unload operation.

7. Assume that tape is between the diaphragm switches in both columns and tape is traveling in forward direction.
 - a. Both upper switches not transferred.
 - b. Both lower switches transferred.
 - c. Both left and right stop clutches are energized.
 - d. Tape is pulled out of left column into right column by capstans.
 - e. When tape drops below right bottom diaphragm switch, the switch transfers energizing the right up clutch.
 - f. When tape is pulled above the lower right diaphragm switch, the switch transfers activating the stop clutch.
 - g. When tape is pulled above the upper left diaphragm switch, the left down clutch is energized dropping tape into the column.
 - h. When tape drops below the upper left diaphragm switch, the left stop clutch is energized.
8. Operation of the clutches and diaphragm switches in reverse is the same as forward, except the lower left diaphragm switch controls take up of tape to the file reel and the upper right diaphragm switch controls drop off of tape from the machine reel.

L. Motor Operation

Refer to 76. 10. 02
EDPM.

1. Blower
 - a. Runs with the application of 3Ø A. C.
2. Fan
 - a. Runs with the application of 3Ø A. C.
3. Pressurizing Blower
 - a. Runs with the application of 3Ø A. C.
4. Time Delay
 - a. Runs with the application of 3Ø A. C. and R8 picked.

Page 3530

5. Vacuum Motor
 - a. Runs with the application of 3Ø A.C. and HD-4 picked.
 6. Forward and Reverse Motors
 - a. Runs with the application of 3Ø A.C. and HD-1, HD-2, HD-3 picked.
 7. Rewind Motor
 - a. Runs with the application of 3Ø A.C., HD-1, HD-2, HD-3, and DP-3.
 8. Left and Right Capstan Motors
 - a. Run with the application of 3Ø A.C., HD-1, HD-2, HD-3, and DP-2.
 9. Take-up Motor
 - a. Runs with the application of 3Ø A.C., HD-1, HD-2, HD-3, and DP-4 - Head cover will go up.
 - b. DP-1 reverses the input phase.
 - c. Motor runs in reverse with DP-1 and DP-4 picked - Head cover will go down.
 - d. Reverse causes the head to go down.
- M. Power on Reset
1. R-17 is picked with application of power to the tape drive unit.
 - a. One side tied to +48V.
 - b. Other side returned to ground through voltage interlocks in Unit #18.
 - c. All power must be up to pick R-17.

76.09.05
EDPM
Page 3540

Note: Relay pullers should be used to remove or insert relays. This will prevent bent contact pins.

III. Data Processing Machine Logic, Pluggable Units, and Basic Circuits

A. Data Processing Machine Logic and Pluggable Units

The 728 Tape Drive Unit is a modification of the 727 Tape Drive Unit used with IBM Commercial DPM equipment. The pluggable units are of DPM type, and the logic used with this equipment is DPM logic.

1. Logic Block

Fig. A & B
Page 0710

Logic blocks are used to simplify circuitry. Logic blocks fall into two major classifications: diode circuits and tube circuits. Each type is divided into three sections: the first, top section, contains notations which locate the circuit within a pluggable unit (PU); the second, middle section, contains notations which identify the circuit; the third, bottom section, contains notations which locate the pluggable unit containing the circuit.

The bottom section of each logic block is similar. The first symbol in this section is always "T", designating the tape drive unit. The second symbol (two digits) indicates the column in which the tube is located; column notations run from 01 through 08. The third symbol indicates the row in which the first tube of the pluggable unit is located; this symbol is either A or J.

The middle section serves to identify the specific circuit by means of letters: A for AND circuit, O for an OR circuit, I for an inverter circuit, etc. As part of the symbol for cathode followers, AND, OR's, and diode gates, a resistor value in K OHMS is noted. This value is indicated because the block represents a standard circuit whose component values may vary in accordance with circuit use.

The top section contains notations to further locate the circuit within the pluggable unit. For example, the location of a diode circuit is defined as the end of the resistor to which the diode is connected; this location is a terminal on an island. The first symbol in the top section of a diode logic block identifies the island.

in the pluggable unit upon which the abovementioned terminal is mounted. The second symbol identifies this terminal. Because islands are lettered and terminals are numbered, any component in a pluggable unit can be located. The third symbol identifies the class of diode or diodes used in the circuit.

The top section of the tube circuit logic block also provides additional information to locate the tube within a pluggable unit. The first symbol in the upper section indicates the tube number of that unit (1-8); the second symbol, the front or back portion of the tube used. If the complete tube is used, a hyphen denotes intentional omission of F or B. When more than one tube is used in a block, all tube sections are noted. The 3K block uses both halves of tube 7 and the front half of tube 6. The upper right section is used (mostly in I or K blocks) to denote an output test point. The 4 denotes a panel pin number and is identical with the G4 on the output line. The G notation means that the pin is directly beneath the seventh tube of pluggable unit A.

Special notations that appear in various logic blocks are explained with their circuits.

2. Pluggable Unit

The pluggable unit acts as the carrier for most of the component circuitry (tubes, resistors, capacitors, and so on). The unit has eight tube sockets, although it need not have the full complement of eight tubes. Filament terminals of all tube sockets are wired.

Mounted within the pluggable unit are eight terminal strips, each consisting of 38 solder terminals or lugs. The terminals are numbered 1-19 on the front of the unit and 20-38 on the back. The terminals are initially shorted together and cut open to make the terminals individual. This procedure eliminates the need for jumpers. The terminal strips are called islands and are located by their corresponding positions in the unit (A through H). The circuit components are mounted between these islands.

Fig. A & B
Page 0730
7X. 01. 02

Note: References indicated by "XX.XX.XX" coding will be found Electronic Data Processing Machines Type 728 Magnetic Tape Manual.

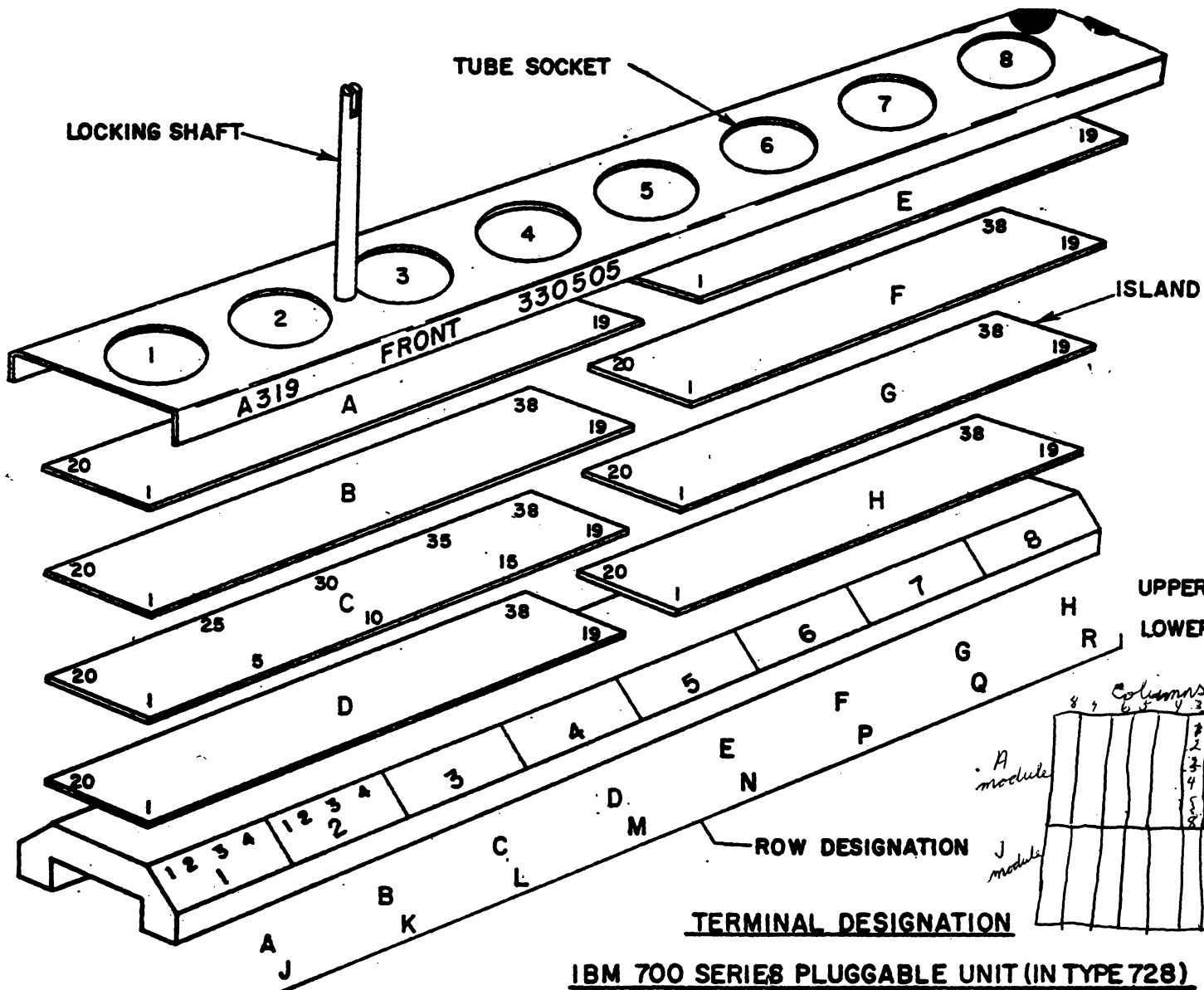

Columns: 8 7 6 5 4 3 2 1

Row of tube pins

1	2	3	4	5	6	7	8
1	2	3	4	5	6	7	8
1	2	3	4	5	6	7	8
1	2	3	4	5	6	7	8
1	2	3	4	5	6	7	8
1	2	3	4	5	6	7	8
1	2	3	4	5	6	7	8
1	2	3	4	5	6	7	8
1	2	3	4	5	6	7	8
1	2	3	4	5	6	7	8

0721

IBM 700 SERIES PLUGGABLE UNIT (IN TYPE 728)

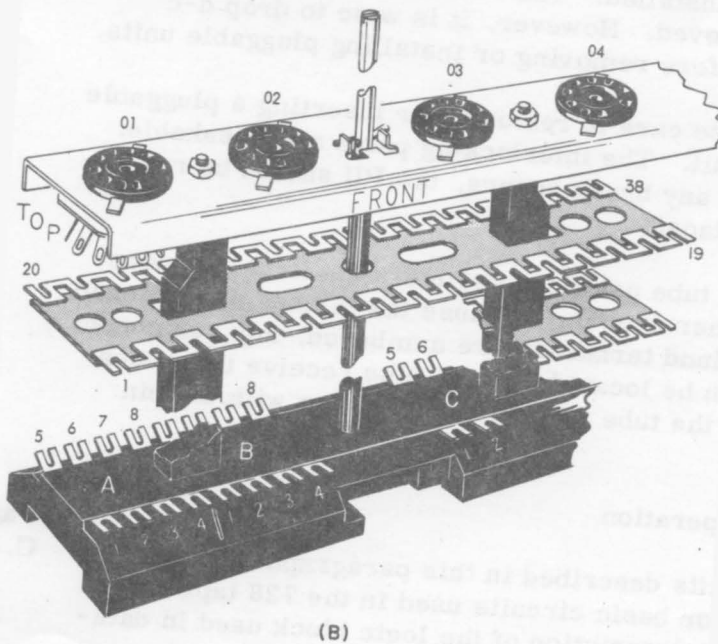
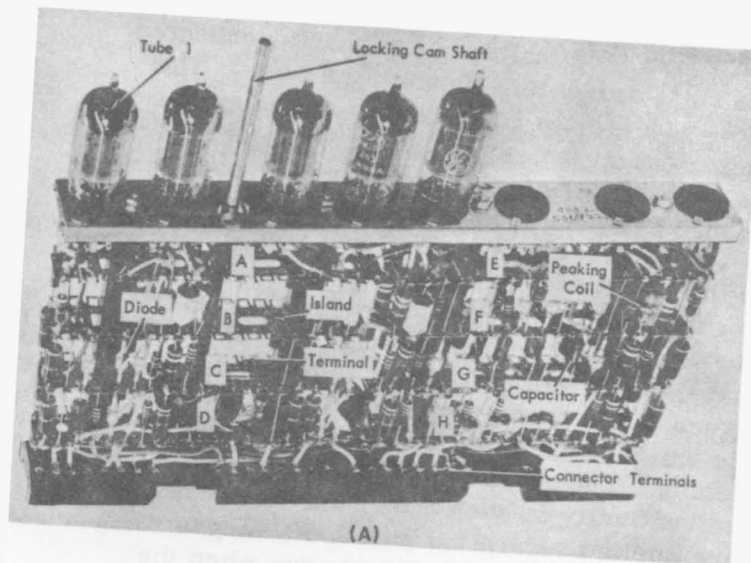

Figure 3-23. DPM Pluggable Unit

Directly beneath each tube position, at the base of the unit, is a group of connector terminals labeled 1 through 8. These terminals are internally connected to the male knife connectors beneath the base. The unit connects to a female receptacle that has solder lugs extending out on the wiring side of the panel (panel pins). There are eight panel pins for each tube position. The panel pins are used for the entry of service wiring (voltage supplies) and signal wiring to the unit.

The locking-cam shaft extends through the unit and is used to seat the unit into its female connector. The unit is aligned to the connector; rotating the shaft with a pluggable unit wrench cams the unit downward to lock it in place. The contacts on the female connector are aligned vertically in such a way that the negative voltages are applied before the positive voltages when the unit is installed. The reverse is true when the unit is removed. However, it is wise to drop d-c voltages before removing or installing pluggable units.

Note: Use care in removing or inserting a pluggable unit. The interlocking parts are breakable. If any break occurs, the PU should be replaced.

With eight tube positions per unit, the first tube location is either A or J. Because the islands are lettered and the island terminals are numbered, any component or unit can be located. Panel pins receive their location from the tube socket that is in line with the pin group.

3. Circuit Operation

The circuits described in this paragraph are the standard or basic circuits used in the 728 tape drive. A detailed description of the logic block used in data-processing machines is also included.

a. Positive AND (-OR) Circuit

The positive AND ensures that both inputs are up before the output comes up, while the -OR gives a minus output as long as any input is down.

Figure A shows the junction point of the diodes and the resistor (R). This point is always used to locate diode circuits within pluggable units. Resistor (R) limits current and controls the rise time of the output. Cs represents the capacity of the circuit being driven and stray wiring capacity.

If both inputs are at -30V, the polarity is correct for both diodes to conduct (fig. B). The resultant current flow through R causes a voltage drop across it to maintain a level of approximately -30V. Because of the diode's forward resistance of 100 ohms, the voltage at the junction will be -29.04V. For practical purposes, the output is -30V and Cs is discharged.

If input 1 changes instantaneously to +10V, diode 1 is cut off because the cathode is more positive than the plate (fig. C). Diode 2, with -30V on its cathode, maintains conduction and the output remains unchanged. There is a small amount of current flowing through diode 2 to the +10V source, but its effect is negligible.

When input 2 changes to +10V, diode 2 is cut off because Cs is momentarily holding the output at -30V (fig. D). Cs has to charge through R to +140V, and this delays the rise of the output level. The voltage level at the junction starts heading for +140V but, as soon as +10V is reached, the diodes go back into conduction. The output is now +10V, and Cs is charged to +10V.

When input 1 falls to -30V, diode 1 conducts harder and discharges Cs, and diode 2 is cut off (fig. E). The output follows the input down to -30V, and Cs is discharged. When input 2 falls to -30V, diode 2 goes back into conduction to help maintain the -30V output.

The action of an AND circuit may be summarized as follows: the output voltage of an AND circuit approximately equals the most negative input voltage. This statement is true regardless of the number of inputs.

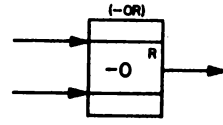
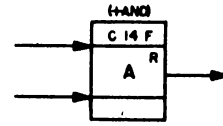
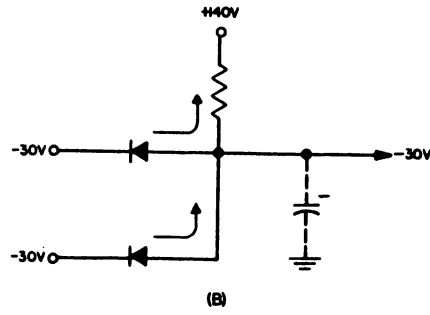
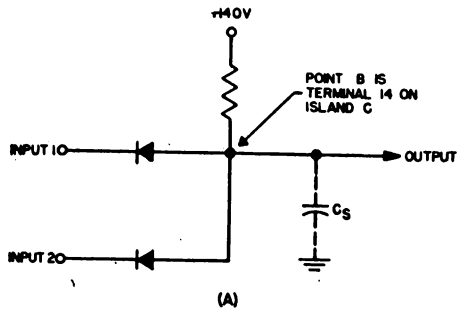

LOGIC BLOCKS

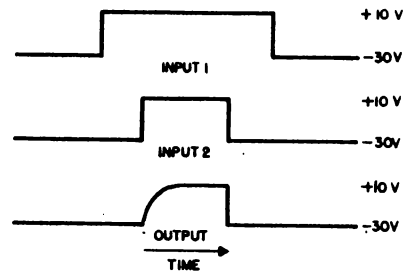
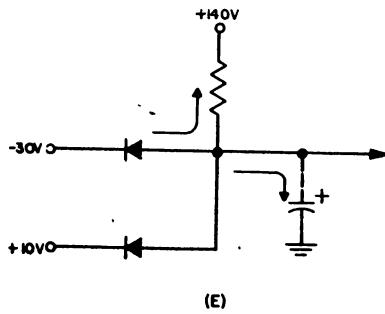
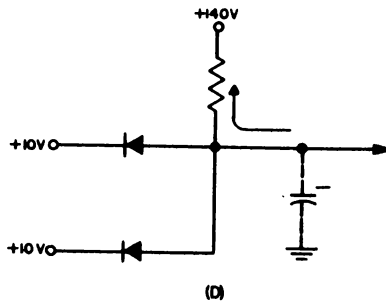
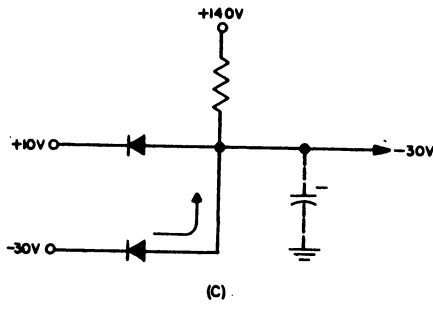

+AND (-OR) Circuit, Logic Diagram and Waveforms

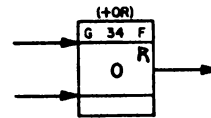
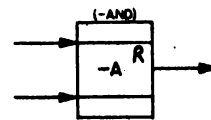
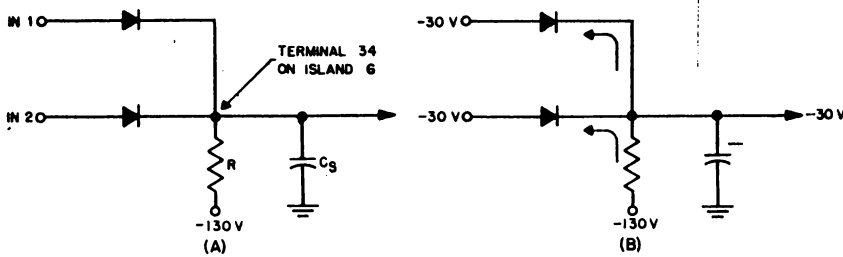

LOGIC BLOCKS

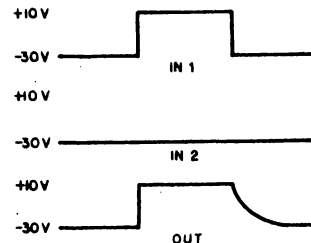
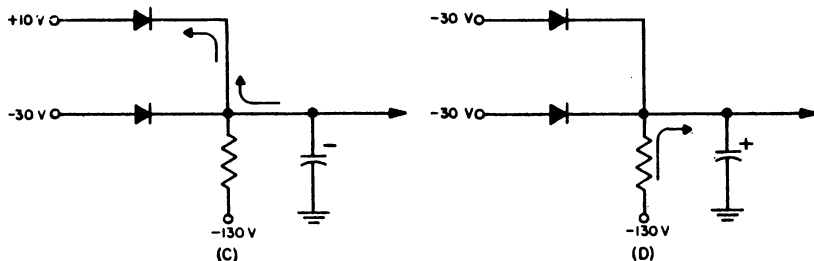

+OR (-AND) Circuit, Logic Diagram and Waveforms

The symbol used for the crystal diode is shown below with plate and cathode labeled.

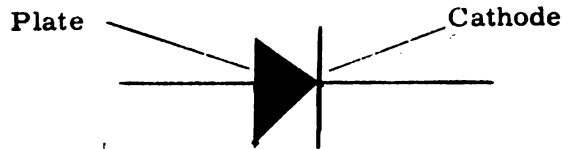

b. Positive OR (-AND) Circuit

Page 0760
C. 06. 04

The positive OR circuit differs from the positive AND circuit in that it needs only one input up to bring the output up.

If both inputs are at $-30V$, the polarity is correct for both diodes to conduct (fig. B). The voltage drop across the limiting resistor sets the output level at approximately $-30V$, and C_s is discharged.

If either input rises to $+10V$, that leg conducts harder and provides a charge path for C_s (fig. C). The other diode cuts off, and the output follows the input in rising to $+10V$. It is normal for only one input to an OR circuit to come up at a time.

When the input that was up at $+10V$ drops to $-30V$, C_s is momentarily still charged to $+10V$, and the input diode is cut off (fig. D). This means that the fall time of the output is delayed because C_s maintains a plus voltage until it is discharged through R . The RC s time constant controls the fall time of the OR output. The input diodes again conduct when the level at the junction reaches a point slightly more plus than $-30V$.

The action of an OR circuit is summarized as follows: the output voltage of an OR circuit approximately equals the most positive input voltage.

An infinity sign in the block means that the return resistor for the OR circuit is in the grid circuit of the trigger.

c. Trigger

Page 0790
C.02.01, Sheet 1

A trigger is a bistable multivibrator; that is, the circuit remains in either of two stable states until an external signal forces it to assume the other state. The forcing action is called triggering or flipping; therefore, another name for the trigger circuit is flip-flop. The bistable property of a trigger allows the circuit to serve several functions; e. g., a storage device, a counter, and a gate-forming circuit.

Because a trigger is said to be on when the left tube is conducting, the left side is called the on-side. The right side is called the off-side. In the on state, the left grid is up, the left plate is down, the right grid is down, and the right plate is up. When a trigger is used to store binary information, a 1 is stored when the circuit is in the on state (left tube conducting), and a zero is stored when the circuit is in the off state (right tube conducting).

Each plate is coupled to the opposite circuit through a compensated voltage divider. High-speed operation is obtained with the aid of plate circuit peaking coils. The plate circuit may contain one resistor or two from which a reduced plate voltage swing may be taken as an output.

If the grid voltage is far below cutoff, a delay in the flipping action can result. To prevent such a condition, the grids are clamped by diodes. The plate of the diode is connected to a -12V source. Hence, a larger negative voltage at the cathode of the diode causes it to conduct, thereby keeping the grid of the tube at -12V. With this arrangement, the grid need rise only a few volts to cause tube conduction.

A neon connected through a 1-megohm resistor to the right plate is used to indicate the state of a trigger. The neon is mounted on the panel and lights when the trigger is on.

We use Divider outputs

ALWAYS "OFF" at LEFT / ON at RIGHT

*-30 to ON side turns "off"
-30 to OFF side turns "on"*

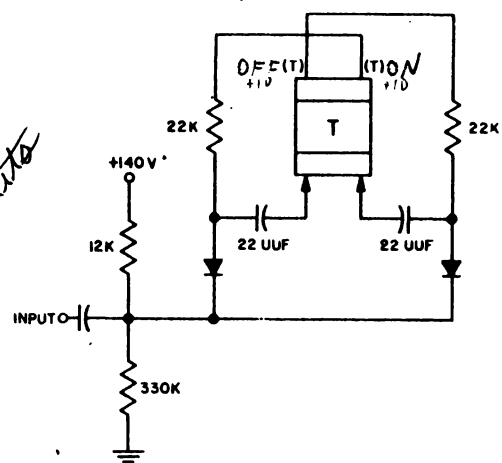

Self-Gated Binary Input, Simplified Circuit Diagram

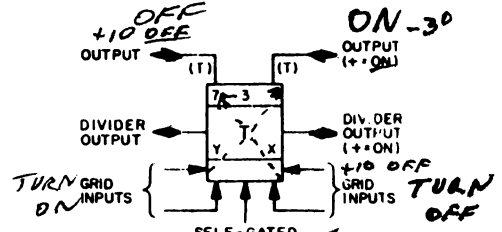
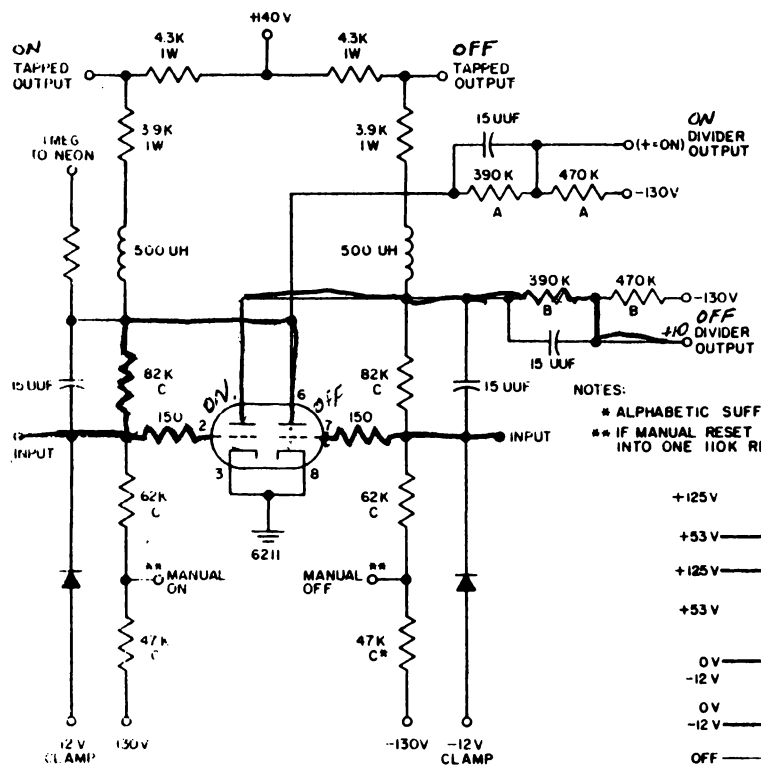

NOTES:
* ALPHABETIC SUFFIX DENOTES THAT RESISTORS ARE TOLERANCE MATCHED
** IF MANUAL RESET IS NOT USED, COMBINE THE 62K AND 47K RESISTORS INTO ONE 110K RESISTOR

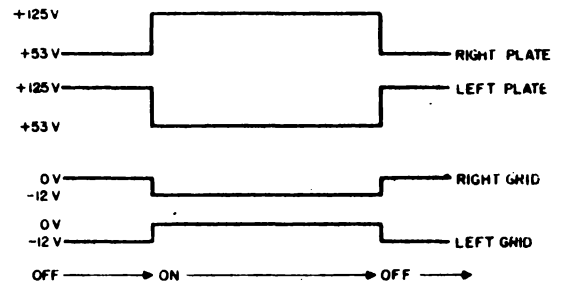

High-Speed Trigger, Logic Diagram and Waveforms

1). Operation

Basically, a trigger circuit resembles two inverter circuits in that each plate output is coupled to the opposite grid. In one stable state, the left tube is in full conduction (approximately 9.5 ma) while the right tube is cut off. In the other state, the right tube is in full conduction while the left tube is cut off. To change from one state to another, an external signal must be applied to a sensitive point in the trigger circuit.

For example, assume that the right tube (fig. Page 0790 B) is conducting (trigger off). The right plate is down; that is, its voltage is considerably less than +140V, while the left plate is up (near +140V). One method of flipping this circuit is to apply a negative pulse to the right grid. Because the right tube is conducting, grid current keeps the grid at about 0V. The negative input pulse causes the right tube to cut off; consequently, the right plate voltage rises. This rise is then coupled through the plate-to-grid voltage divider (cross-coupling circuit) to the left grid, pulling this grid voltage up toward ground. The left tube then begins to conduct, pulling its plate voltage down. This shift at the plate of the left tube is coupled back to the right grid and reinforces the initial action. The cross-coupling circuits speed the regenerative action, and the circuit stabilizes with the right side cut off and the left side in full conduction. The input pulse can now be removed without re-flipping the trigger, because conduction on the left side holds the right side cut off.

The trigger can also be flipped by applying a positive pulse to a nonconducting grid or by lowering the plate voltage of a cutoff side through an external circuit. In any case, an input pulse must initiate a regenerative action to cut off the conducting tube and bring the non-conducting tube into full conduction.

2) Inputs

C.02.01, Sheets 2, 3,
4 of 4.

The binary input is a negative shift input to a trigger and allows it to be flipped regardless of its previous state (unless it is being held by another circuit). A binary input is indicated when the same signal is applied to both the left and right grid (fig). For example, if the trigger is off and it is fed a pulse through a binary input, the trigger is flipped on. If another pulse is then applied to the binary input, the trigger is flipped off.

One grid is initially at ground, and the other is approximately -12V. The negative shift begins at ground and pulls the conducting grid negative. The first 12V of the negative shift cannot affect the cutoff grid because the binary input diode connected to that grid is cut off. By the time this diode is ready to conduct, the regenerative action initiated by the negative shift on the opposite grid produces a positive shift at the formerly cutoff grid.

If the differentiated spike is narrow enough and not excessively large in amplitude, it does not interfere with the positive shift at the formerly cutoff grid. However, if it is too wide, or too large in amplitude, it may interfere with the positive shift, causing the trigger to flip back to its initial state. For this reason, the binary input should not be fed a pulse of very great amplitude.

The most widely used binary input to a trigger is the self-gated binary. It is used when pulse amplitude and width would affect a normal binary input. The circuit is shown in modified block form in figure . When the ordinary binary input exhibits self-gating action for the first 12V of the negative input shift, the self-gated input exhibits this property for the full pulse amplitude because of the different voltage levels maintained at the input diodes.

The voltage at the junction of the 12K and 330K resistors is approximately +135V. When the input is a -30V shift, the voltage at the diode junction is then +105V. Now the potential at the junction of the diode, the 22K resistor and the 22-uuf capacitor of the conducting side of the trigger, is approximately +132V. The potential at this same point on the cutoff side is approximately +94V. Thus, the diode on the cutoff side cannot conduct while the one on the conducting side conducts. The conducting grid is brought down; this side ceases to conduct while the cutoff grid is brought up to ground and starts to conduct.

The driving circuit may be either a standard cathode follower with the minimum load or a standard 6211 inverter tap or trigger tap. The inputs are 25V to 35V negative shifts. The input fall time must be less than 0.25 usec for a 25V input and less than 0.4 usec for a 35V input. Recovery of the input network limits the frequency of operation to 150 kc maximum (with minimum input signal). The trigger output rise time is 0.35 usec; the fall time, including delay, is 0.2 usec.

The following are minimum requirements for flipping a trigger with various inputs:

DC: lower level, -20V to -30V; upper level, +5V to +15V.

Minus shift: 25V minus shift; 60V per usec minimum slope.

Binary input: 25V minus shift; 60V per usec minimum slope.

3) Outputs

There are four types of outputs from a trigger. The full plate swing of either plate may be used, or the plate resistor may be tapped when a smaller swing is needed. Generally, this tapped output is used for feeding binary inputs of other triggers. A standard signal level may be obtained from a voltage

divider connected to either plate. If the divider is not used, it is not wired into the circuit.

4) Reset

Because either side of a trigger can go into conduction when power is first applied, a provision must be made to establish a specific status. The trigger may be reset with the output of the reset cathode follower (Kr) applied at the desired reset point. The reset cathode follower is usually preceded by either the pulse-forming inverter (Ipfi) or a single shot (SS). The reset point is the plate of the -12V clamp diode. The reset cathode follower provides -12V as a clamp voltage and changes to 0V for reset. Bringing the plate of the clamp diode to ground forces a nonconducting grid up; that side of the trigger goes into conduction. The reset pulse lasts long enough to ensure that the regenerative action is complete. The notation of reset is placed in the title section of the logic block (fig B). The notation on the left indicates reset on; that on the right reset off. A trigger may have several resets, but only one takes place at a time.

Page 0790

Triggers may be reset by the output of other triggers; however, in this case, the pullover or flipping is effected through the plate circuit. All triggers with the letter X in either the right or left corner (depending on whether the trigger is to be reset off or on) are set by power on reset through a reset cathode follower.

A manual method of flipping helps to test the trigger circuit. The points in figure marked manual on or manual off are wired to pins on the panel. If a trigger is on and the manual-off pin on the panel is touched by a tweaking probe, the trigger is flipped off. The tweaking probe is merely a line connected through a bypassed, high-impedance resistor

to ground. The ground connection pulls the tweak points (manual points) up toward ground, thus providing a positive shift at the grid to flip the trigger. Tweaking the manual-on point turns the trigger on if it was initially off.

5) Block Representation

A single trigger may have many outputs; it may have different inputs to the same grid or the same type of inputs to opposite grids. A grid input may be shown in either lower corner. A self-gated binary input is indicated merely by a straight line drawn into the middle of the bottom of the block. Diodes closest to the trigger block indicate the polarity of the voltage affecting the trigger.

A tapped output is represented by a line coming out of the top of the block near one side and with a T placed next to the line. Full plate outputs are represented similarly with no T. The divider output is drawn from the side of the block. When the divider is changed to drive a plate level cathode follower, a TD is placed next to the line at the top of the block.

d. Inverter

Page 0870
C.01.01

The standard inverter (I and Ik) is a high-speed circuit which produces a negative shift at its plate when a positive shift is applied to the grid; conversely, a positive shift is produced at the plate when a negative shift is applied to the grid. Therefore, logic conditions can be inverted, such as changing a binary 0 to a binary 1. Also, the inverter is a level setter and pulse shaper because of its amplification properties.

The large resistance in the plate circuit enables a large voltage swing but does not appreciably slow the signal transition. The coil in the plate circuit speeds the rise of the plate voltage. When the tube is cut off, the coil produces a voltage which for a short time makes the plate more positive than it

would be without the coil. Thus, a slight overshoot in the rise of the plate voltage results. This action, however, has practically no effect upon the fall time of the circuit. The effect of this coil on the plate voltage is shown in figure 3-29, F. The lower dotted line represents the voltage without the coil; the upper overshoot represents the voltage produced by the coil. The resultant shape of the voltage shows the tendency to square the rise; this results in a fast-rising voltage at the plate. The 10K resistor and its bypass capacitor are used for grid current limiting when a low impedance driving circuit is used. The inverter has a nominal rise time of 0.2 usec and a fall time of 0.25 usec. An Ik is the same circuit but uses one half of a 5965 tube.

1) Operation

The minimum inverter input requirements are +5V and -13V. Assume that the input voltage is -20V. The tube is well beyond cutoff because cutoff bias is -8.5V for a 6211. The divider output is at +10V because 0.33 ma is flowing through the divider circuit (fig. 3-29, B). The d-c resistance of the coil (25 ohms) is disregarded.

When the input rises to +5V or higher, the tube is in full conduction (fig. 3-29, C). With a load of 6.3K, tube current is found to be about 12.3 ma. Grid current keeps the grid slightly above ground. The current through the plate load causes the plate voltage to drop to +62V. However, the divider circuit is tied to the plate and the +62V level. Divider current drops to 0.23 ma, and this current adds to the tube current through the plate load. The voltage at the plate is lowered to +62V, and the divider output is -30V. The above values are approximate.

The level-setting characteristic of the inverter circuit is shown in figure D. Because the circuit is fully operated by only a portion of the input pulse, the amplification of the tube resets

would be without the coil. Thus, a slight overshoot in the rise of the plate voltage results. This action, however, has practically no effect upon the fall time of the circuit. The effect of this coil on the plate voltage is shown in figure 3-29, F. The lower dotted line represents the voltage without the coil; the upper overshoot represents the voltage produced by the coil. The resultant shape of the voltage shows the tendency to square the rise; this results in a fast-rising voltage at the plate. The 10K resistor and its bypass capacitor are used for grid current limiting when a low impedance driving circuit is used. The inverter has a nominal rise time of 0.2 usec and a fall time of 0.25 usec. An Ik is the same circuit but uses one half of a 5965 tube.

1) Operation

The minimum inverter input requirements are +5V and -13V. Assume that the input voltage is -20V. The tube is well beyond cutoff because cutoff bias is -8.5V for a 6211. The divider output is at +10V because 0.33 ma is flowing through the divider circuit (fig. 3-29, B). The d-c resistance of the coil (25 ohms) is disregarded.

When the input rises to +5V or higher, the tube is in full conduction (fig. 3-29, C). With a load of 6.3K, tube current is found to be about 12.3 ma. Grid current keeps the grid slightly above ground. The current through the plate load causes the plate voltage to drop to +62V. However, the divider circuit is tied to the plate and the +62V level. Divider current drops to 0.23 ma, and this current adds to the tube current through the plate load. The voltage at the plate is lowered to +62V, and the divider output is -30V. The above values are approximate.

The level-setting characteristic of the inverter circuit is shown in figure D. Because the circuit is fully operated by only a portion of the input pulse, the amplification of the tube resets

the levels of the pulse. Pulse shaping is aided by both the amplification and the action of the peaking coil.

2) Compensated Output

The circuit produces a fast rise and fall at the plate. This voltage shift must be fed to the next circuit where stray capacitance acts upon the shift. Figure E illustrates output waveform distortion when C_s is charged through R_1 . However, by adding a compensating capacitor C , the waveform produced by CR_2 adds to the output. Thus, C_s has a fast charge path, and the output more nearly represents the voltage shift at the plate. The compensating capacitor is 8.2 uuf or 15 uuf, depending on the input capacity of the next circuit.

The divider output is high impedance and must feed a cathode follower directly (high-impedance input). The voltage for a tapped plate swings from +139V to +99V, and at the divider output from +10V to -30V.

e. Inverter (Light)

The inverter (light) I_l is used to turn on indicator lamps. The lamp makes up somewhat more than $\frac{1}{2}$ of the inverter load. The lamp will draw somewhere between 40 to 65 ma of current; therefore, a full 5687 tube is needed in parallel to supply this current.

Page 0870
C. 01. 10

f. Tape Erase Circuit

The inverter I_{er} is used in the tape drive unit as a current switch for the erase head. During write operation, the tape is erased before it reaches the read/write head.

Page 0880
C. 01. 09

Write status is plate level, +138V to +50V nominal. When this line is down, the midpoint of the divider is at -157V and the I_{er} is cut off. When write status is up during writing, the divider provides -130V to the I_{er} grids. The I_{er} goes into

Standard Inverter

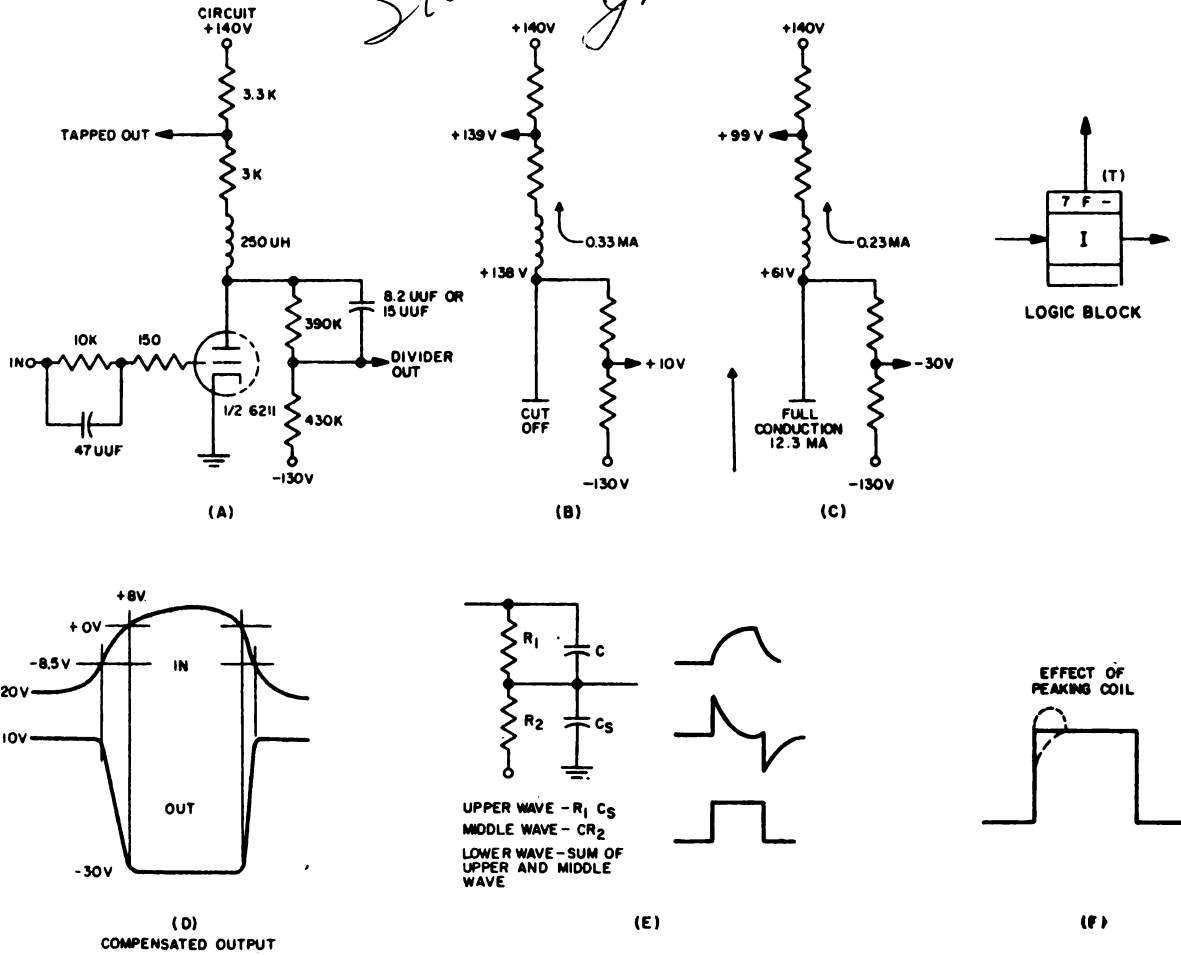

Standard Inverter Circuit, Logic Diagram and Waveforms

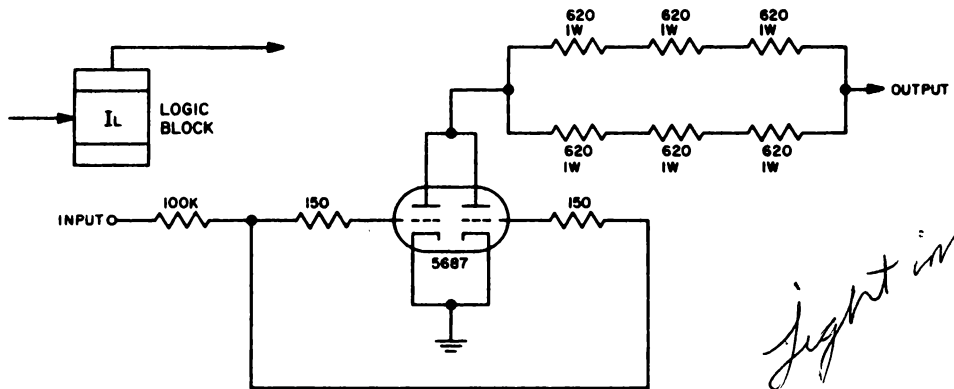

light inverter

Inverter, I₁, Circuit Diagram

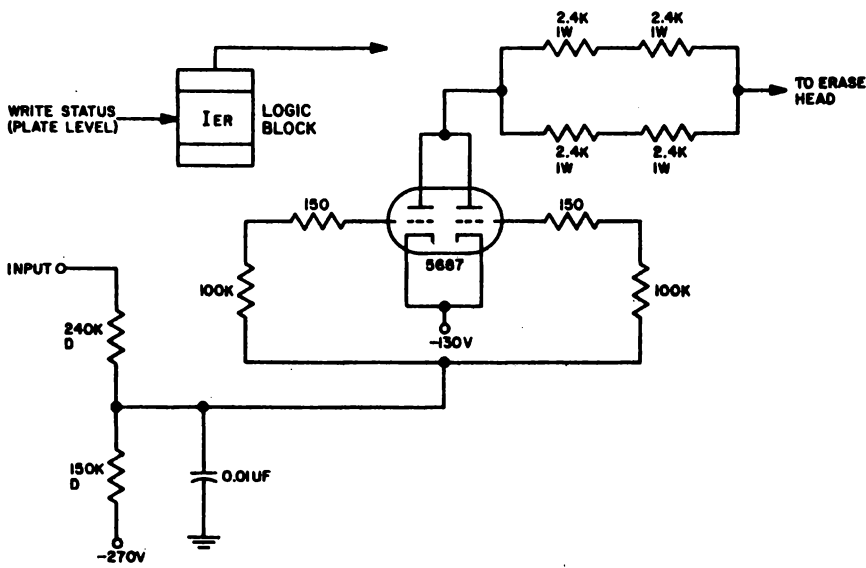

Inverter, I_{ER} , Circuit Diagram

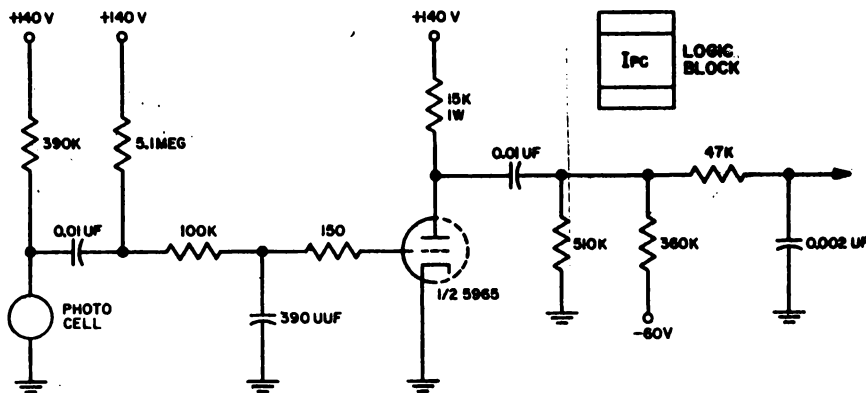

Inverter (Photo Pickup), I_{PC} , Circuit Diagram

*high
output
when
light
felt on
photo cell*

full conduction and 33 ma is fed through the erase coil to ground. While erasing, there is a 17V drop across the erase coil and the Ier plate voltage is approximately -80V.

g. Inverter (Photo Pickup)

IPC

Page 0880
C. 01, 15

The photo pickup inverter Ipc is used to indicate the load point and the presence of end of tape or a break in tape.

When the light to illuminate the photocell is properly adjusted, a photocell of this type produces a change in voltage from 8 to 20V.

The tube is normally conducting heavily. When the photocell conducts, a negative signal is reflected on the control grid of the 5965 tube, causing a decrease in current. The positive output signal is capacitively coupled to the next stage.

h. Tape Write Circuit

Page 0900
C. 01. 07

The tape write circuit TWR, IWR, IG, IS is used in the tape drive unit to provide controlled current to the write coil. Current through the write coil in one direction or the other provides the change in flux that is necessary to write on tape. This method is the NRZI system.

The TWR is a standard trigger with nonstandard outputs. The self-gated binary input allows each negative input shift to change the trigger status. The input to the TWR is a diode gate that samples the write bus every 53.7 usec. The fall of this pulse triggers the TWR. The output levels of the TWR are -30V and -52V, depending on the trigger status. The clamping diode in the output divider circuit prevents that junction point of the divider from rising above ground, thus setting the upper level of -30V.

The Ig is used as an electronic switch to allow conduction through the Iwr only when write status is up. Write status down (+50V) sets the input to the Ig at -147V and the tube is cut off; write status

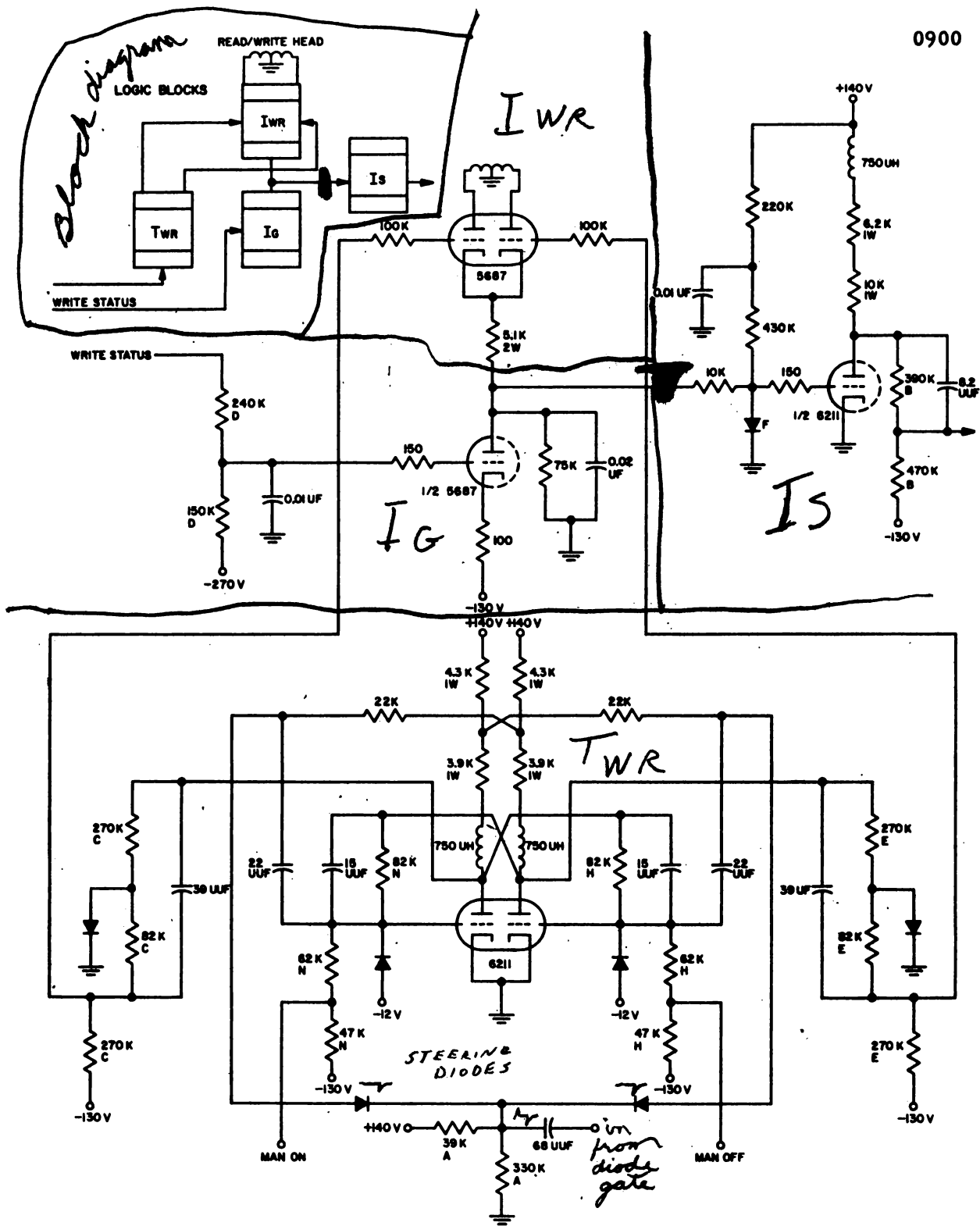

Write Circuit, TWR, IWR, IS, and IS, Circuit Diagram

up (+138V) sets the I_g input at -113V and the tube is able to conduct. The I_g , conducting, produces a -40V cathode voltage for the I_{wr} . With the I_g not conducting, both the plate and the cathode of the I_{wr} are at ground level and no conduction through the write coil is possible. The 75K resistor to ground prevents the I_{wr} cathode and the I_g plate from floating. Thus, the I_g conditions the I_{wr} for conduction, depending, of course, upon the input of the I_{wr} .

The T_{wr} outputs feed both sides of the I_{wr} . If one T_{wr} output is at -30V, then the other is at -52V. Thus, one side of the I_{wr} is able to conduct while the other side is cut off (I_{wr} cathode at -40V). As long as the I_g is conducting and setting the I_{wr} cathode at -40V, all changes in the status of the T_{wr} are reflected as changes in the direction of the current flow through the write coil. When the current flow through the write coil changes direction, a character is written on tape.

Because of the heavy inductive load (the write coil), the I_{wr} cannot switch conduction from one side to the other as fast as the T_{wr} flips. The I_{wr} cuts off for several usec because cutting off the induced voltage from one side lowers the opposite plate voltage sufficiently to prevent conduction even with the grid going up. The I_{wr} cathode, therefore, reflects this as a 17V minus shift during T_{wr} flip time. The negative shift is coupled to the grid of the I_s . The I_s cuts off for about 8-12 usec, and the output pulse (echo pulse) is used for redundancy checking.

i. Cathode Follower

Cathode followers (K) are primarily power amplifiers and, therefore, are used to supply a stable voltage level to drive resistive loads (diode AND and OR circuits) or capacitive loads (wiring capacitance). A high input impedance and low output impedance make this circuit useful for impedance matching and isolation. Cathode followers do not invert a signal, but they do attenuate a signal.

1) Operation

To understand thoroughly the natural actions of a cathode follower, the self-biasing characteristics of the circuit should be understood. The plate, with +140V, is always demanding more current. The controlling grid is calling for more current as long as the effective bias is positive, is neutral when the bias is 0, and completely resists the plate command when the effective bias reaches -3V (-30V on the grid). The grid takes control at 1V bias when the input is +10V. The reason for the different stable points of bias voltage at the two different input levels is readily understood by noting the effective plate voltage in both cases. Because the effective plate voltage is only 129V with +10V on the grid, only 1V bias is needed. With an effective plate voltage of 167V (-30V on the grid), more bias (-3V) is needed to overcome the effect of the plate.

The tube conducts in such a manner as to tend to regulate itself; that is, not to allow an appreciable voltage change from grid to cathode. If the tube current increases, the tube tends to cut itself off as the cathode tends to rise. This cutoff action tends to decrease the current. If, on the other hand, the current tends to decrease, the cathode potential tends to fall, thus increasing the current flow. This type of self-regulation is called inverse voltage feedback.

Current through the tube causes a voltage drop across the 91-ohm dropping resistor. With the input at +10V, this drop should about equal the grid-to-cathode rise, so that the output voltage is also +10V. If the input signal should drop to -30V, then the output voltage will also drop. Note from the tube characteristics that a change in current through the tube, which accompanies the change in voltage across the load, increases the negative grid bias to approximately 3V. With this bias and this current, the drop across the load increases the negative grid bias to approxi-

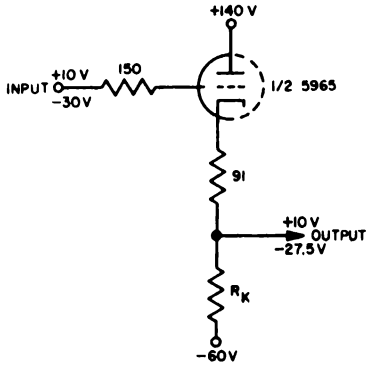

(A) CIRCUIT AND BLOCK

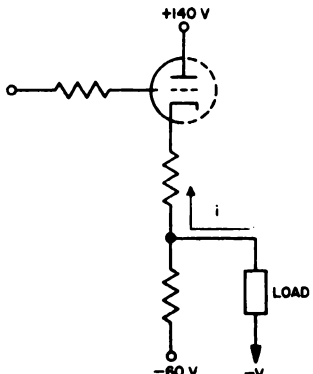
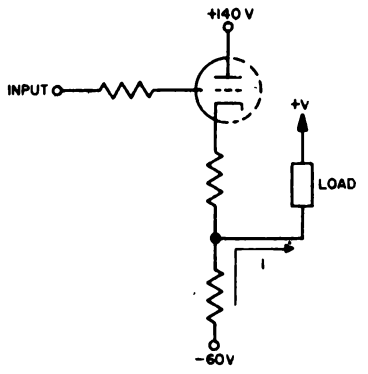
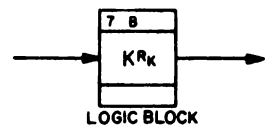

(B) LOADING CONDITIONS

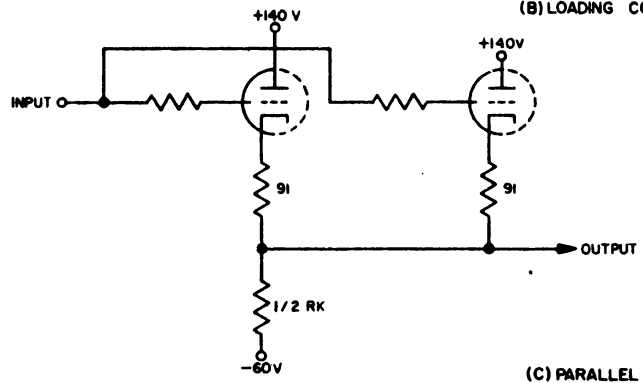
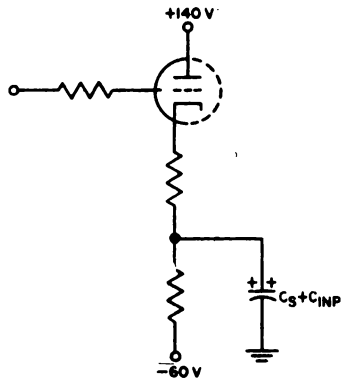

(C) PARALLEL K

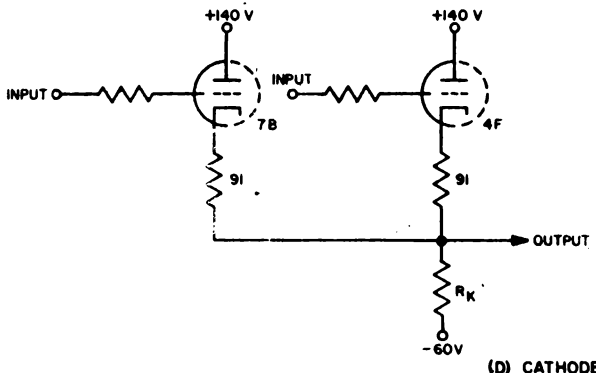
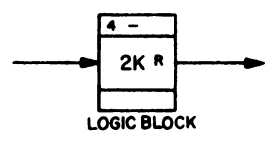

(D) CATHODE FOLLOWER OR CIRCUIT

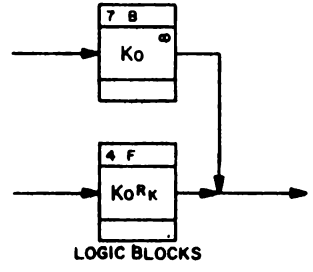

Standard Cathode Follower, Circuit Diagram

mately 3V. With this bias and this current, the drop across the 91-ohm bias resistor changes from the 1V to about $\frac{1}{2}$ V. This means that the drop across the dropping resistor can no longer compensate for the grid-to-cathode rise, and the output will now be more positive than the input. The voltage rise in a cathode follower is about 1/10V per volt change in signal level with the minimum cathode load in the circuit. As the cathode resistor increases, the value of the lower level can be expected to increase also (about 1V per 3K increase in cathode resistor). The gain of a cathode follower operating class A is approximately 0.9V.

2) Resistive Load

Fig. B
Page 0930

If the cathode follower load is resistive and is returned to a positive voltage, the current for the load must be supplied from the -60V supply through the cathode resistor (fig B). Because the tube regulates itself, this load current is taken away from the tube. As load current increases, tube current decreases. Design limits the minimum current through the tube to 1.5 ma. Therefore, a single cathode follower (5965 tube) can supply 10.5 ma without materially affecting the voltage level (low-impedance output).

A load that is returned to a minus supply voltage is effectively paralleled with R_k (fig. B). Therefore, any current demands of the load must be met by the tube. A value of R_k is chosen so that, in parallel with the load, the total impedance is such that both currents together will not exceed 12 ma.

3) Capacitive Load

Assume that a capacitance is connected from the output to ground (fig. B). Because the voltage across the capacitance cannot change suddenly, the cathode is held at +10V while the grid shifts to -30V. The tube is cut off.

The output voltage drops at a rate determined by the RC path of the capacitance and the load resistor. After the voltage has dropped far enough, the tube starts to conduct again. When the input again shifts to +10V, the capacitance is charged by the current through the tube. Usually the input capacitance from succeeding stages is such that the RC time constants encountered are comparable to the rise and fall time of the input. Therefore, the extremes of cutoff and very heavy conduction to charge the capacitance are not encountered, and the output follows the input. If the RC time constant is such as to cause the abovementioned extremes, the output does not follow the input but depends on the RC time constant. This condition appears as output distortion.

j. Parallel Cathode Follower

The use of more than one cathode follower in parallel helps to minimize the voltage rise of the down level through the circuit with a given load. Paralleling the cathode followers also provides more current for the line charging purposes to speed output voltage shifts. In addition, the paralleling lowers effective cathode resistance, allowing faster discharging of line capacitance. Each tube can use one R_k , or the value of R_k can be divided by the number of tubes paralleled. When cathode followers are paralleled, the connections are made at the grid parasitics and the output (Fig. C). The number of half-tubes in parallel precedes the symbol K in the block diagram; thus a whole tube cathode follower is symbolized by 2K. Parallel cathode followers are more susceptible to parasitic oscillation than most of the other circuits or unparallelled cathode followers.

k. Cathode Follower OR Circuit

Frequent use is made of a cathode follower to act in the same manner as a diode input to an OR circuit. Two or more cathode followers are tied together as shown in D of figure . Because they each use the same return resistor, any input rising to +10V causes the output to come up (OR circuit operation). The components of a diode OR circuit

Fig. D
Page 0930

and a separate cathode follower are saved by this method because all input lines to the diode OR circuit would need powering. The block notations of a cathode follower OR circuit are Ko or K with infinity signs (∞) in all blocks but one.

l. Cathode Follower Inputs

Page 0970

Fig. A

C. 05. 01

Figure shows a special input circuit and its logic block notation. Special integrated inputs are used whenever mechanical devices such as relays are used to control voltage levels or activate circuits.

m. Cathode Follower Clamp

Fig. B

Page 0970

The cathode follower clamp (Kc) (fig B) is used to produce the regulated -12V used for clamping trigger grids, and at other points where -12V is desired. The divider on the grid input holds the right grid at -15V. With this grid voltage, the tube draws 3.2 ma and the drop across the cathode resistor is 48V. The output voltage is -12V.

One Kc is designed to clamp a maximum of 10 triggers. The clamp voltage changes approximately 1V from no load to full load.

n. Power Cathode Follower

Fig. C

Page 0970

C. 05. 12

The power cathode follower (Kp) is a cathode follower employing a 5687 tube rather than a 5965. The purpose of this change is to obtain greater power output without going to parallel cathode followers with the danger of parasitic oscillations. The cathode follower Kpo is the use of cathode follower Kp with a common cathode resistor for OR circuit operations.

o. Cathode Follower Reset

Fig. D

Page 0970

C. 05. 13

The cathode follower reset (Kr) is used to reset triggers on or off. It also serves as a -12V clamp. The output of the Kr is connected to the clamp diode at the on-side grid to reset the trigger on.

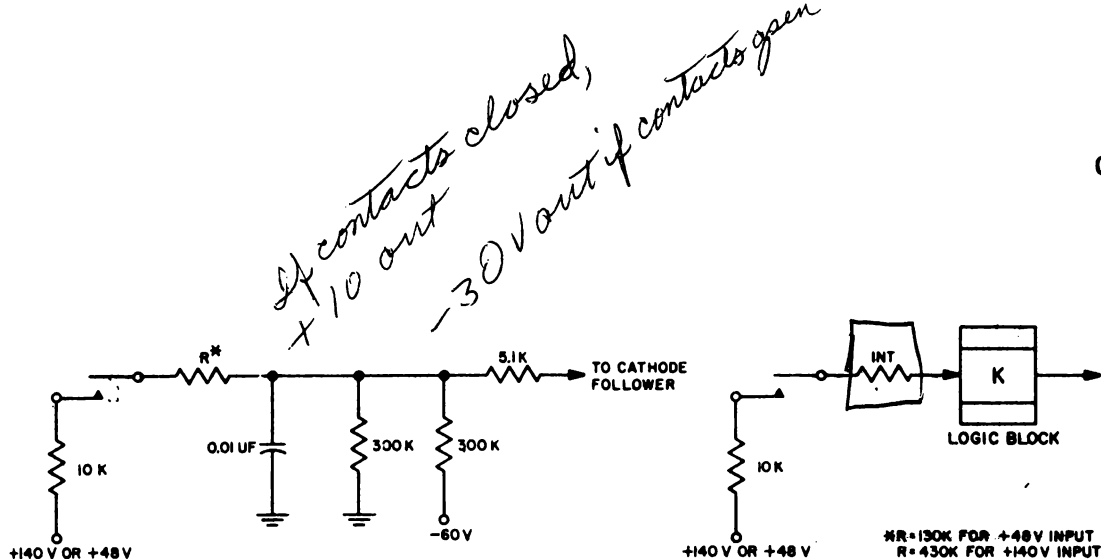

Contact Integrating Input to Cathode Follower, Circuit Diagram

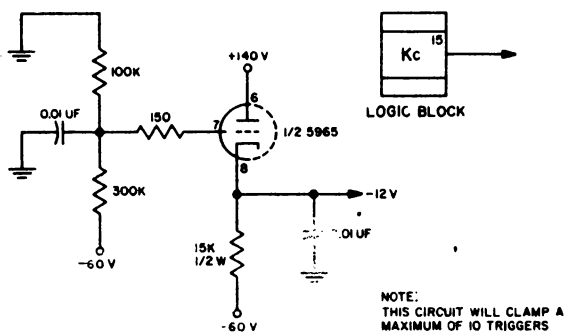

Cathode Follower Clamp, K_c, Circuit Diagram

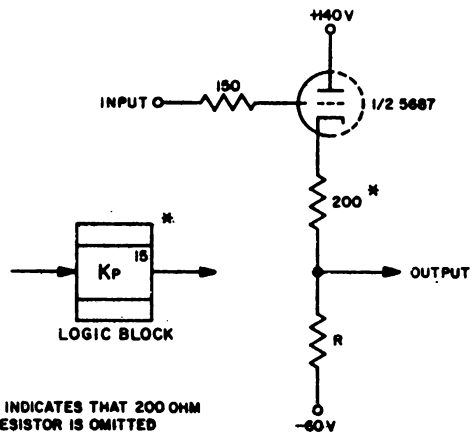
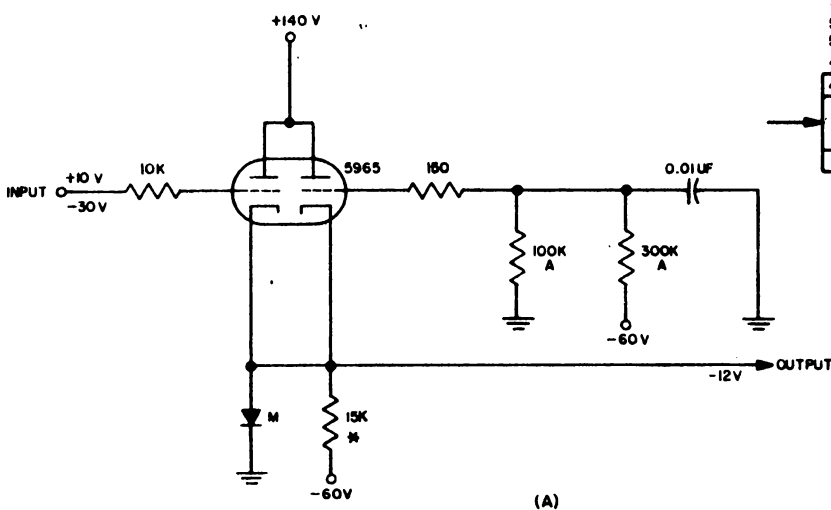
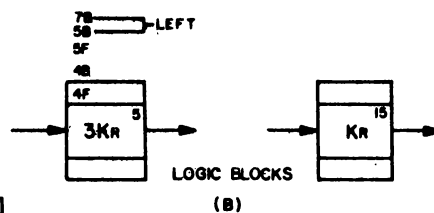

Figure 3-37. Power Cathode Follower, K_p, Circuit Diagram



Cathode Follower Reset, K_r, Circuit Diagram



- NOTES:
1. G DIODE USED IN CERTAIN LIMITED APPLICATIONS.
 2. CIRCUIT IS DESIGNED TO CLAMP AND RESET A MAXIMUM OF 10 TRIGGERS.
 3. HALF TUBE PER 10 TRIGGERS ON CLAMP SIDE AND HALF-TUBE PER 20 TRIGGERS ON RESET SIDE.
 4. WHEN HALF-TUBES ARE PARALLELED, USE 91 OHMS IN EACH CATHODE FOR EQUALIZATION.
 - * R_x = 15 K/N WHERE N IS THE NUMBER OF HALF-TUBES USED ON CLAMP SIDE.

It is connected to the clamp diode on the off-side grid to reset the trigger off.

The right grid of the Kr is at -15V because of the divider on this grid. When the input is down to -30V, the left tube is cut off because the right tube is drawing 3.2 ma and the 48V drop across the 15K load resistor brings the cathode up to -12V. The left grid, therefore, is 18V negative with respect to the cathode. The -12V output serves as a clamping voltage at the trigger to ensure that the grid, to which it is connected, drops no lower than -12V. When the input is brought up to +10V, the cathode comes up as far as ground where it is clamped by the diode to ground. With the cathode at ground, the right tube is cut off because the grid is 15V negative with respect to the cathode. The ground potential at the output of the Kr, tied to a grid of a trigger, causes the tube associated with this grid to conduct. The trigger is set on or off as the case may be.

This circuit is designed to clamp and reset a maximum of 10 triggers with a change of less than 1V in clamp voltage from no load to full load. The Kr is actually two circuits in one: a clamp circuit and a reset circuit. Each half has its own load limitations. The right tube (clamp side) can clamp up to 10 triggers. This means that the Kr can be tied to 20 trigger grids for clamping purposes because only half that number of grids are at -12V at one time. For additional loading, additional half-tubes are paralleled with the right tube.

The left tube (reset side) can reset up to 20 triggers. For additional loading, additional half-tubes are paralleled with the left tube. When half-tubes are paralleled, either on clamp or reset side, 91-ohm resistors are used in the cathodes for load equalization.

The block symbol used is nKr, where n is the number of half-tubes used for the clamp (right) side as above. Thus the 3Kr uses four half-tubes, one half for the reset side and three halves for the clamp side. The value of the cathode resistor is determined

by the formula $15K/n$, where n has the same meaning as above. For multiple numbers of clamps and resets in the same logic block (fig. B), the n states the number of half-tubes used for clamps and the value of R in the logic block is $15K/n$. The reset tubes are identified by a bracket and the word "left."

The duration of the reset condition (up level) should be between 0.5 and 100 usec. To keep the left side cut off, the minimum lower level of input should be -20V.

p. Resistance Gated Diode Driver

Page 1000
C. 05. 14

The resistance gated diode driver (K_s) is used to drive one or more diode gates (D_g) directly or through a cathode follower (K), which in turn drives diode gates. The value of the resistor R in the right grid bias circuit is determined by the output voltage desired. This value is chosen so that the right grid bias is slightly negative with respect to the desired low-level output voltage. When the incoming signal is +10V, the left tube conducts and the right tube is cut off. The output is about +10V, because the bias on the right side is sufficiently negative to cause cutoff. If, however, the input level drops to at least 2V below the desired lower output level, the left side loses control and the right side conducts to give the desired output value.

The K_s circuit may be driven from a trigger or another cathode follower. The K_s drives five triggers located reasonably close together.

q. Cathode Follower

Page 1000
C. 05. 16

The cathode follower (K_x) is merely a cathode follower employing a 6211 tube rather than the 5965, with a resultant saving in power. The filament current is substantially smaller, and the tube also draws a smaller plate current. The cathode follower K_x is simply the use of cathode followers K_x that have a common cathode resistor for OR circuit operation. A retrofit has recently changed the K_x circuits in the 728 to K circuits.

Resistance-Gated Diode Driver, K_S , Circuit Diagram

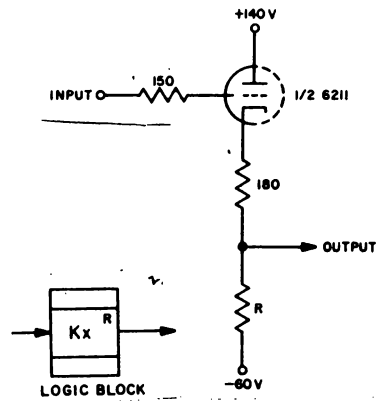
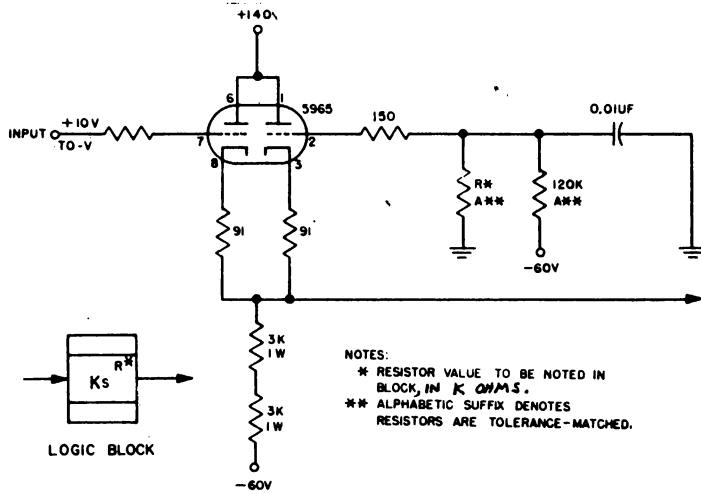

Cathode Follower, K_X , K_{X0} , Circuit Diagram

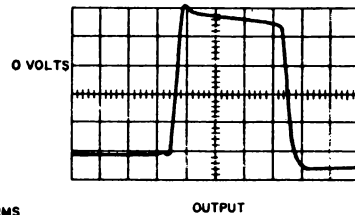
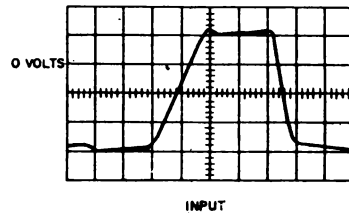
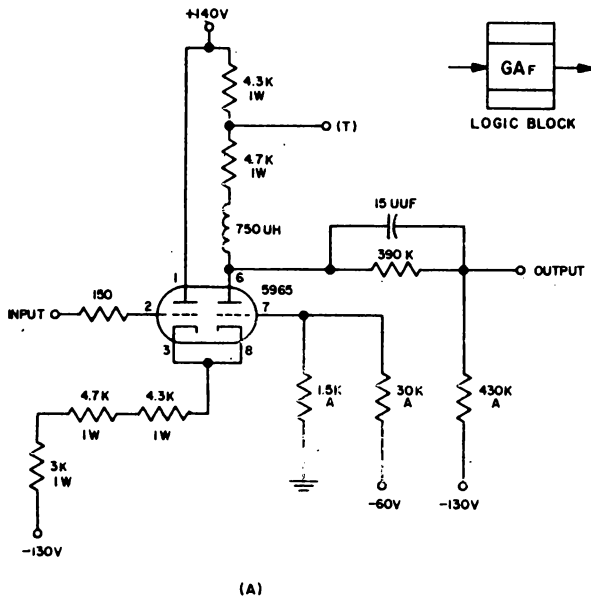

WAVEFORMS
 1 USEC / DIV
 10V / DIV

Grounded Grid Amplifier, GA_X , Logic Diagram and Waveforms

r. Grounded-Grid Amplifier

Page 1000

The grounded-grid amplifier GAf is used as a level C.04.05 setter and pulse shaper. As pulses pass through the machine, their shape and voltage levels deteriorate. The GAf is used to reshape the pulse and feed it to cathode followers. The special down level of -38V permits normal cathode follower down level loss without affecting minimum down level requirements. The GAf does not invert the signal.

1) Operation

The grid of the right tube is held at approximately -3V by the voltage divider network between -60V and ground. With -30V on the left grid, the right tube is conducting approximately 10.5 ma, the cathode is -2.5V, and the right plate is at +45V, resulting in -38V at the divider output. The left tube is cut off.

As the input signal rises, the left tube starts to conduct with approximately -10V on its grid. More current flows through the cathode resistors, and the voltage at the cathode rises. The rising cathode voltage causes the right tube to begin cutoff action because the grid bias is fixed at -3V, and its plate voltage rises toward +140V. The tube characteristics are such that when the input voltage reaches +3V, the cathode is at +3.5V and the right tube is cut off. The divider output is now +10V. Any further rise of the input causes the left tube to conduct harder, and the cathode voltage rises as in a cathode follower. Because the right tube is cut off, the rising cathode voltage has no effect on the right tube or the output voltage.

As the input drops, the previous action is reversed. The right tube starts to conduct when the input is at +3V and is in full conduction when the input falls to -10V. The divider output returns to -38V. There is about a 4-to-1 speedup in rise time and about a 10-to-1 speedup in fall time. The reason for the

difference in speedup of the rise and fall time is the shape of the portion of the input signal that is being used. The leading edge of the input signal is usually sloped much more in the used portion than the trailing edge. Figure 3-41, B, shows a typical input to a GAf and the resultant shaped and level-set output. Minimum input voltage requirements are +5 to -20V. The tapped plate output levels are +138V to +94V nominal.

2) Half-Tube

Sometimes the output of a cathode follower OR circuit needs to be shaped and level-set. One-half tube can be saved by feeding the OR output directly to the cathode of the right tube and deleting the left tube. The rising input to any cathode follower in the OR configuration operates the right tube in the same manner as the GAf. The $\frac{1}{2}$ GAf block uses one-half of a 5965, and the input is at cathode level. All Ko blocks have infinity signs denoting that they are sharing the cathode circuit of the $\frac{1}{2}$ GAf.

s. Diode Gate

Page 1030

The diode gate is similar in action to an AND circuit and is used to flip a trigger. This circuit is used where speed is not essential. Figure A illustrates the circuit, logic symbology, and associated waveforms of a typical diode gate. All waveforms have identical time relationships.

The upper end of the resistor (fig. A) is connected to a circuit (such as a divider output of a trigger) that will supply a nominal +10V to -30V gate pulse. The diode input is the output of a special cathode follower that gives a +10V to -14V pulse. The prerequisite for proper operations is that the gate input overlap the diode input.

Diode gate

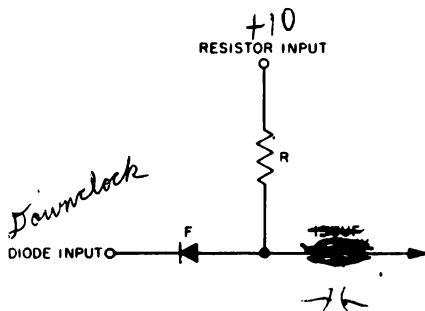

(A) CIRCUIT

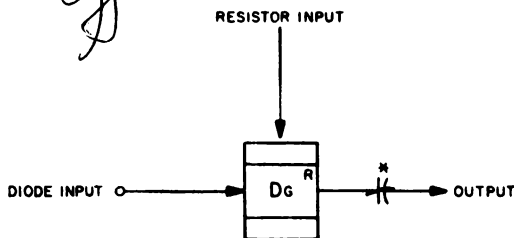

(B) LOGIC BLOCK

* WHERE CAPACITOR IS NOT SHOWN WITH BLOCK SYMBOL, IT IS NOT IN THE CIRCUIT

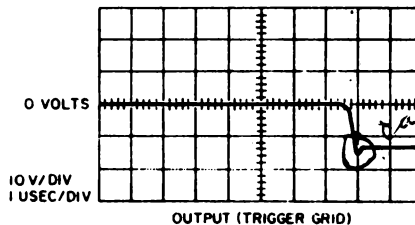
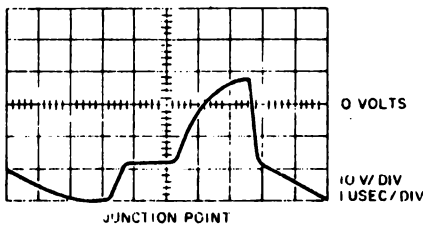
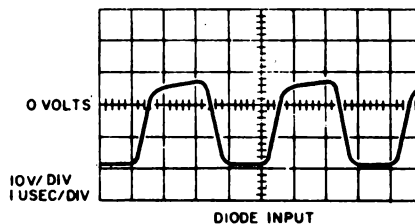
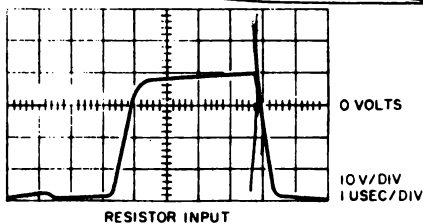

(C) WAVEFORMS

Diode Gate, DG, Logic Diagram and Waveforms

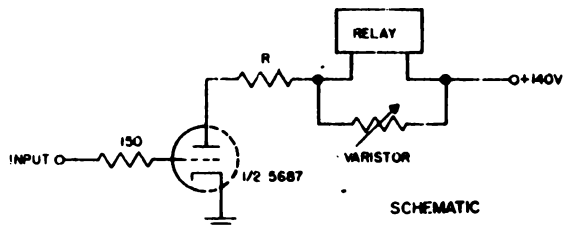
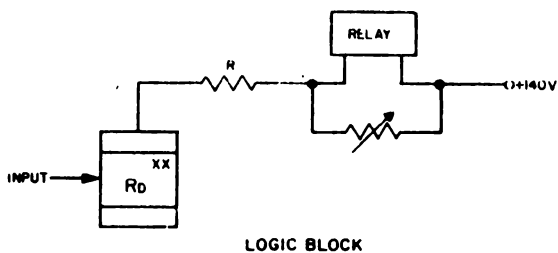

Relay Driver, Rd, Circuit Diagram

Answers to be written

The diode input shows two +8V to -18V pulses (an example of normal circuit variations, hence the use of "nominal"). The gate of +9V to -30V is going to select, or gate, one of the pulses at the diode input. The junction point is initially at about -30V, and the diode is cut off. As the gate rises to +9V, the junction point rises potentially to -18V and is held at that point by the diode's going into conduction. As the diode input rises to +8V, the diode again is cut off and the junction point rises exponentially toward +9V. The capacitor is now charged. When the diode input falls to -18V, the diode's conducting provides a discharge path for the capacitor and the junction point falls sharply to the diode input level of -18V. The diode maintains this voltage level until the gate falls. When the gate falls, the diode cuts off and the junction point falls exponentially to -30V. The sharp fall from +9V to -13V is coupled through the capacitor to the trigger grid. The negative shift forces the grid from 0V to -12V (held by -12 grid clamp) and causes the trigger to flip off. The trigger was turned on by a different circuit.

The above description shows that coincidence of the gate and diode input is necessary for the diode gate to flip the trigger. The exponential rise and fall at the junction point do not affect the trigger.

t. Read Preamplifier

The read-preamplifier AT, DT is used in the tape unit to amplify the signals from the read head. The AT is an RC-coupled amplifier with RC decoupling in the plate circuits. The decoupling decreases interaction between stages and tends to isolate the +270V power supply from circuit variations. Cathode degeneration is used for stability. Degenerative feedback from the third stage back to the first is controlled by the setting of the 50-ohm potentiometer. This procedure sets the gain of the amplifier and stabilizes the output amplitude. The plate-to-ground capacitor at the third stage tends to keep noise pulses out of the output.

Page 1050
C. 04. 04

Input signals, which are taken directly from the read head, are about 35 mv peak to peak. The output signals are 18V (peak to peak) and are ac-coupled to the grid of a cathode follower through a 51K resistor. The d-c level of the K grid is set by a gate-read pulse through the tube diode DT.

With the gate-read pulse down (approximately -25V) the diode conducts through the 51K and 470K resistors to ground; the d-c level at the diode plate is -24V. Any signal or noise will be effectively swamped out because the plate of the diode is not able to go more positive than this level, regardless of the amplitude of the noise passed by the 0.001-uf input capacitor.

With the gate-read pulse up (approximately +11V), the diode is cut off and the diode plate is at ground level through the 51K and 470K resistors. The input signal to the grid of the K varies between +10V and -10V. The output pulse of the K also varies between +10V and -10V.

u. Photocell Single Shot

Page 1050
C.03.05

The photocell single shot (SSt) is used in the tape drive unit to generate a 20-ms gate in the load point, tape break, and end-of-file recognition circuits. The SSt is pulled over by an inverter sharing the SSt left plate circuit. As the reflective spot or tape break is sensed by a photocell, the IPC cuts off and causes the pull-over inverter to conduct. The SSt flips and stays in its quasistable state as long as the RC circuit holds the right grid down. The circuit returns to its stable state as the right tube returns to its conducting status.

The left divider output has a nominal swing from +8V to -36V. The right divider output has a nominal swing from +6V to -32V.

v. Relay Driver

Both the logic symbol and the actual relay driver circuit are shown. This circuit is used to supply the current for operation of relays. The load resistor in series with the relay is chosen so that the total load on the RD is not less than 2,000 ohms. When the input rises above cutoff, the tube conducts and the relay is picked. Conversely, when the input falls below cutoff, the tube stops conducting and the relay opens.

Page 1030
C. 04. 12

B. Summary Questions

1. Explain all designations on this block of tape drive logic.

4	F	3
K		20
T	02	A

2. Match the following EDPM logic designations with the AN/FSQ-7 logic designations.

	<u>EDPM</u>	<u>AN/FSQ-7</u>
_____ a)	RD	(1) CF
_____ b)	T	(2) RHA
_____ c)	AT	(3) VRD
_____ d)	K	(4) FF

3. The trigger circuit is said to be "ON" when the _____ hand tube is conducting.
4. The conditioning level at the resistor input, for a DG is _____ volts.
5. List 4 methods (signal and circuit needed) to trigger a trigger circuit.
6. What are the voltage ranges at the trigger tapped output and divider output?
7. In what state is a trigger said to be on?
8. What is the logic symbol for a read preamplifier?

9. What function does an Int. circuit serve?
10. Tape Relay Drivers must have their plate circuit interrupted before the relay can be de-energized.
11. Phase reversal of the input signal occurs in the GA.
12. What two conditions must be met before a current can be passed through the erase coil from the IER?
13. What are the output voltage ranges of the I from the tap and divider?

Tape Drive Input Signals: Circuits and Circuit Analysis

A. General

The information to be written on the tape is sent from the Central Computer to the tape adapter in the form of a 33-bit word. The computer word is reassembled in the tape adapter frame to form a tape word. The tape word consists of six characters. Each character has seven tracks or channels: six tracks contain information bits, and the remaining track contains the sync bit. The latter is written in the middle track. The first character is composed of three bits plus a sync bit, whereas the remaining five characters each contain six bits plus a sync bit. This constitutes a tape word. The remaining three bits of the first character are used only for a special word termed the end-of-file (EOF) word. For the remainder of the EOF word, 1's are written in the sync track and zero in the remaining bit positions.

Information is placed on tape in any configuration of bits desired.

B. Select and Ready

A tape drive is ready for selection when the following conditions exist: it is in the load status, and the reel door interlock is closed; it is not in the rewind status, and the START button has been depressed. These conditions are indicated by the plus level on the lowest leg to AND circuit A12.

The center leg is always at a plus level, except for 20 ms after the load point has been sensed at the completion of a rewind operation.

Note: The individual circuits are listed as references. Use Fig. 1-1 for the overall logic.

Fig. A
Page 1100

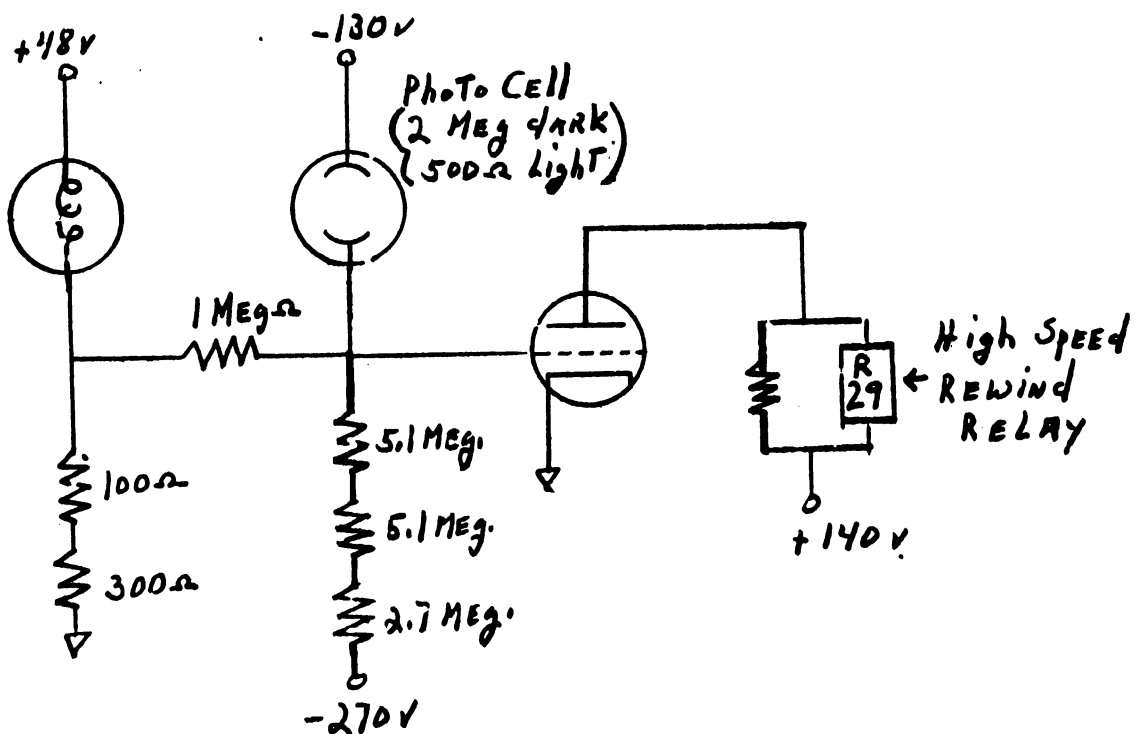
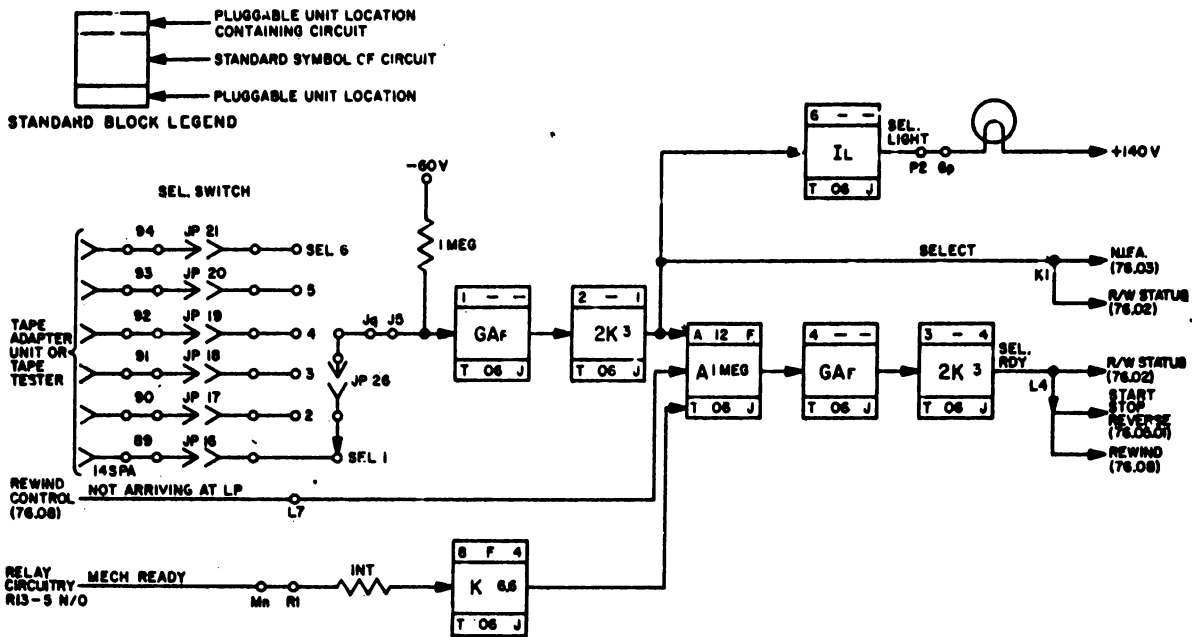

Fig B. High Speed Rewind Photo Cell Circuit

The third input is up when the external select line, corresponding to the setting of the select switch, is up. The output of AND circuit A12 becomes the select-and-ready line. This line must be plus to operate the tape drive from the external control with the exception of the NIFA control.

The select line is plus when the external select line, corresponding to the setting of the select switch, is up regardless of the ready condition. The select line causes the SELECT light to come on through the IL and also conditions the NIFA control.

C. Read-Write Status

Page 1120

1. Set-Read Status

The set-read status is externally generated. It is combined in AND circuit C7 with select and ready, and the resulting positive level turns off the read-write status trigger. This trigger indicates either a read or write status of the tape drive. If the drive is in the read status, the trigger is off. The left output of the read-write status trigger combines with select and ready in AND circuit A35 to bring up select, ready, and read. This line is returned to the external control as an indication that a tape drive is selected, ready, and in the read status.

The read-write status trigger is reset to the read status whenever the tape drive is under manual control or in the rewind status. This is done by the relay reset line. This line is at 48V when either the start relay R13 is down or the rewind relay R12 is up. This 48V level is applied to an integrating network (logic 76.02), where it is converted into the +10V level used to reset off the read-write status trigger.

2. Set-Write Status

The set-write status is externally generated. It combines with select, not file protected, and ready in AND circuit C24, and the resulting positive level turns on the read-write status trigger. The right output of this trigger is combined with not file protection in AND circuit E25; the up level output is combined with select and ready in E18 to produce select, ready, and write.

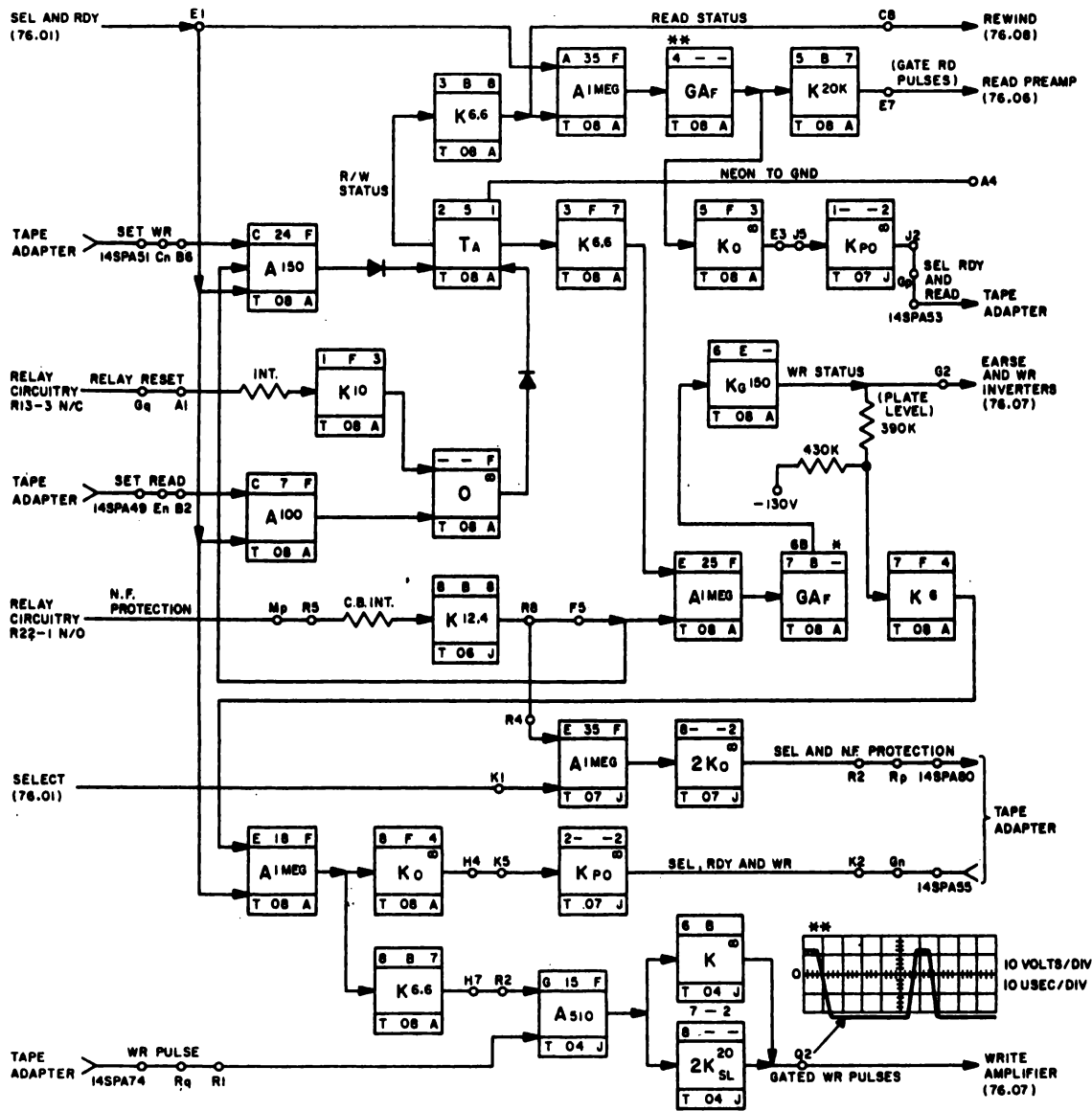

NOTE:
 ** THE WIDTH OF THESE PULSES WILL
 DEPEND ON THE CNTL UNIT.
 * PLATE LOAD 39K 1W
 CATHODE LOAD 43K 1W

Read-Write Status, Simplified Logic Diagram (76.02)

This line is returned to the external control as an indication that a tape is selected, ready, and in the write status. Whenever the output of AND circuit E25 is plus, the write inverters conduct through the write heads, and the erase head conducts. The output of cathode follower 5B goes to the read preamplifier circuit to gate the read pulses.

D. Not in File Area

Page 1140

The NIFA is a trigger that may be used to indicate certain conditions sensed within the tape drive. It may be controlled externally or internally. The trigger is turned on internally by sensing the reflective spot (EOT marker) at the end of a reel of tape, or by reading or writing the EOF word. The rear (EOT) photocell output is ac-coupled to an inverter. The inverter is used to pull over a 20-ms single shot whenever the photocell is illuminated. The plus output of the SST is applied to inverter 3B; as a result, negative output voltage is applied to the off side of the trigger, causing the right tube to be cut off and bringing up the right plate level.

The right output of the NIFA trigger combines with the select level at AND E5 and becomes the select-and-not-in-file area level which returns to external circuitry. The output of the trigger is also applied to an inverter, turning on the NIFA indicator light.

The set-NIFA level is applied from external circuitry whenever the end-of-file word is read from, or written on, the tape. This level combines with the select level at AND C33, resulting in an output which sets or turns on the NIFA trigger.

The end-of-file word indicates that no more usable information is to be recorded (when written) or has been recorded (when read) on the tape even though the physical end of the tape has not been reached. Upon setting the NIFA trigger, the tape unit becomes not prepared.

E. Tape Break Indication

Page 1100

When the tape drive is rewinding at high speed and a tape break occurs, the operation is stopped by the load-point photocell and associated circuitry. A light source is located beneath the tape; it is reflected from a mirrored

surface to the photocell when the tape is broken. This light beam is mechanically aligned to the cell when the upper head assembly is raised to its upper limit.

The photocell output is combined with reverse; this output is used to pick a 20-ms SST which, in turn, picks the load point relay R25. This is a latch pick relay that remains latched until an unload operation is started. (Only an unload operation causes this relay to be latch-tripped for this condition.)

Picking R25 (fig. 1-1, foldout, Sect. 10H) causes R3 to be dropped; R3, in turn, drops R9 (fig. 1-1, Sect. 1K), R2, and 28 (Sec. 1F). Dropping R9 causes R1 and HD1, 2, and 3 to drop because R5 and R6 bypass points are picked (tape out of columns) during a high-speed rewind.

Dropping R1 applies full brake to both reels (fig. 1-1, Sects 6A-B, 8A-B); HD1, 2, and 3 drop the three phases to all the motor circuits, with the exception of the fan, blower, and vacuum motor.

Dropping R28 causes R27 to drop, opening manual start. In this condition, there is no way to bring up the manual start needed to latch-trip R25, after the 20-ms SST times out, except by starting an unload operation. When the UNLOAD button is depressed, the R15-2 points pick R2 and 28 (fig. 1-1, Sect. 1F). The R28-4 points complete a path to R27; manual start is brought up and combined with at load point, allowing R26 to be picked (fig. 1-1, Sect. 7E), latch-tripping R25 (Sect. 1H). The unload operation is now completed.

F. Starting from Load Point

Page 1170

To read or write from the beginning of the tape, start must be brought up. This is done either by go when the tape drive is controlled by the external source (logic 76.05.01) or by manual start when under manual control (CE switch, fig. 1-1), foldout, Sect. 4F).

Start combines with at load point (Sect. 6E) to bring up RDX 5B, picking R26. The R26-1 points close, latch-tripping R25 (Sect. 1H). At load point and select and at load point drop when R25 is dropped. When at load point drops to RDX 5B (logic 76.04), R26 drops. No other load point considerations are made until the tape is returned to load point.

G. Rewind to Load Point

Page 1170

Assume the machine is rewinding. Sensing the load point marker results in a photocell output, which, combining with the rewind-status level at AND-B23, results in an output to the single-shot. The 20-ms positive output from the single-shot combines with the select level at AND-A12, producing the select-and-at-load-point level. This level returns to external circuitry. An output from the single-shot also fires a relay driver, the output being used to pick relay 25. Picking R25 closes the 25-4 N/O points, resulting in the at-load-point level.

The load-point delay is the result of an inverter circuit (not shown). When the positive 20-ms pulse from the single-shot is applied to the inverter, the output is a 20-ms negative pulse which is applied to the select-and-ready circuit, bringing down the select-and-ready level.

H. Start, Stop, and Reverse Control

Page 1180

There are two ways to bring up start. Go, brought up externally, combined with select and ready raises start and drops stop. Also, raising manual start combined with not arriving at load point raises start.

There are two ways to bring up reverse, conditioning the drive to move tape in a reverse direction. Backward, brought up externally, combined with select and ready raises the reverse line (logic 76.05.01). Raising manual reverse (fig. 1-1, foldout, Sect. 6G) brings up reverse.

I. Read Preamplifier

Page 1180

To read from tape, one of the coils of each of seven read-write heads is tapped (logic 76.07) and tied to its respective amplifier circuit (logic 76.06). As bits are read, they are amplified in the AT; the output is capacitively coupled to a Kxo.

The input pulses to the AT should be 35 to 40 mv, peak to peak; the output of the Kxo should be 18V, peak to peak. The output of each track is adjusted by a potentiometer controlling the feedback from the third stage of the AT to the first.

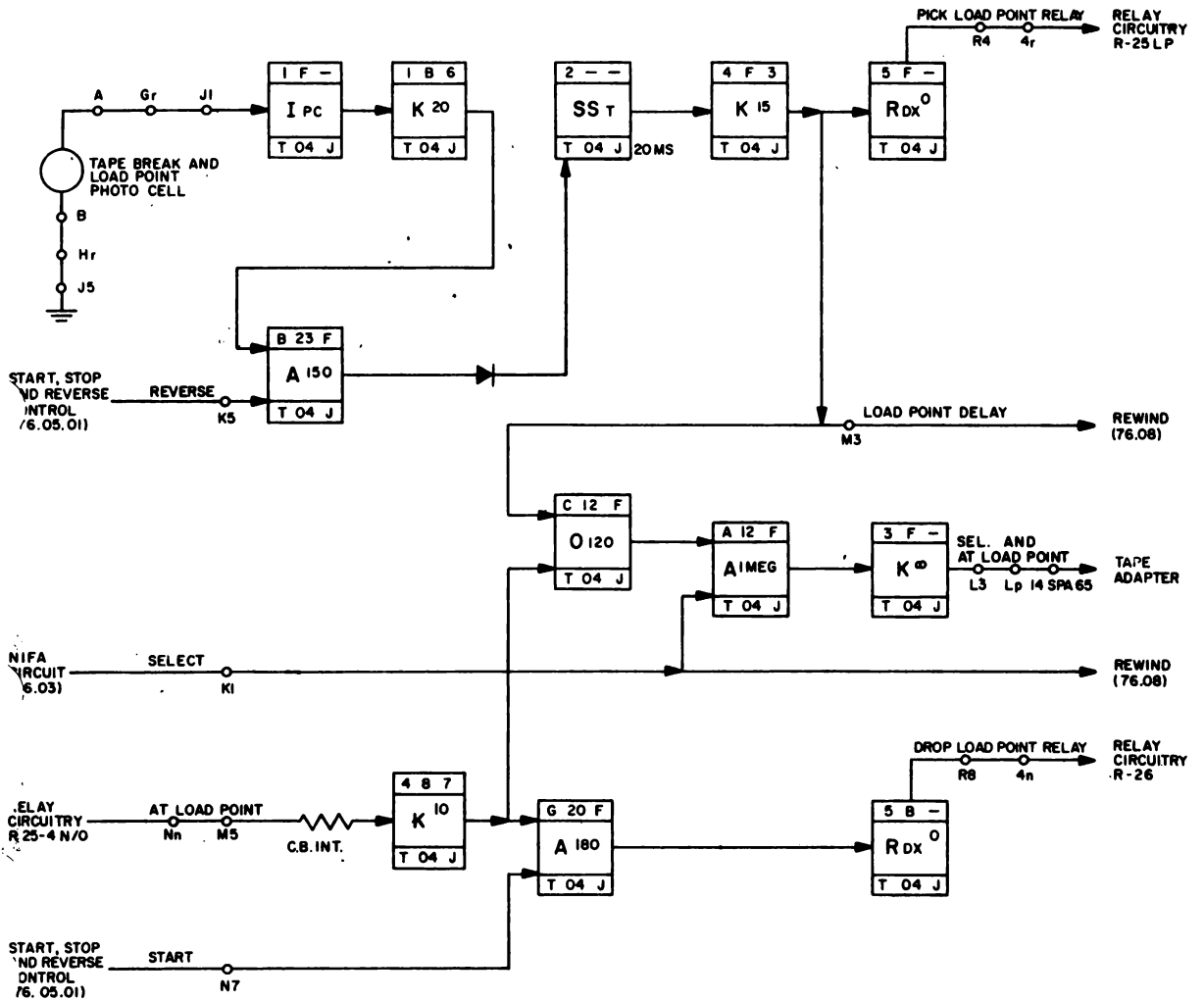

Load Point, Simplified Logic Diagram (76.04)

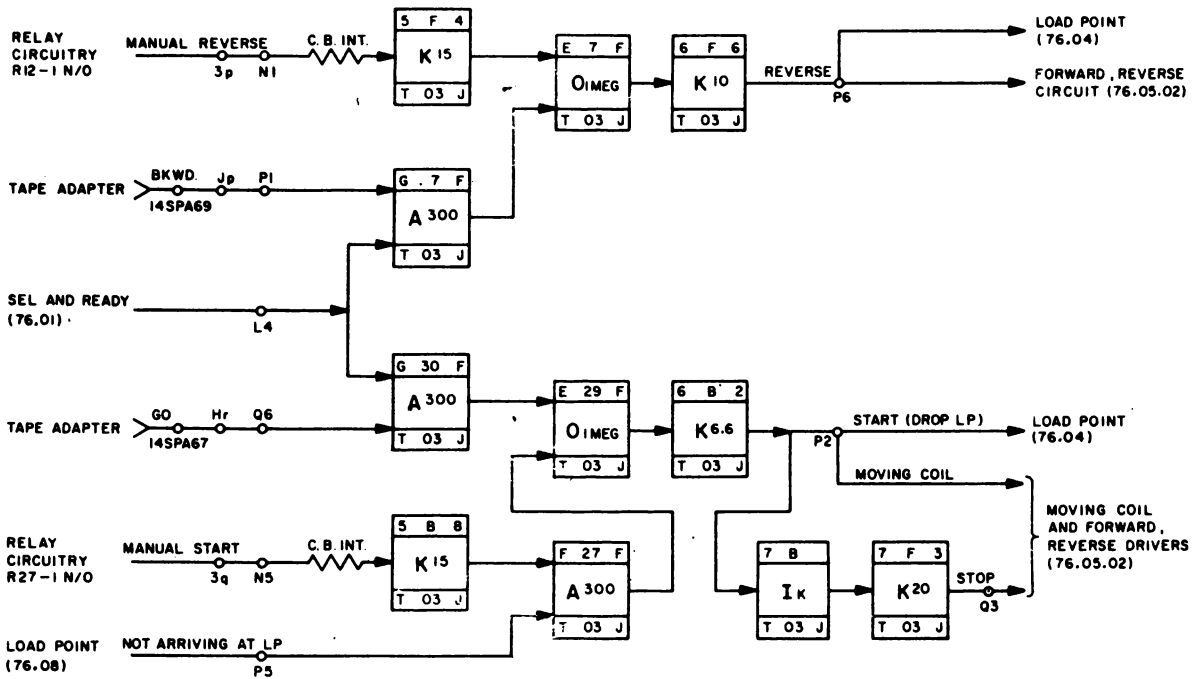
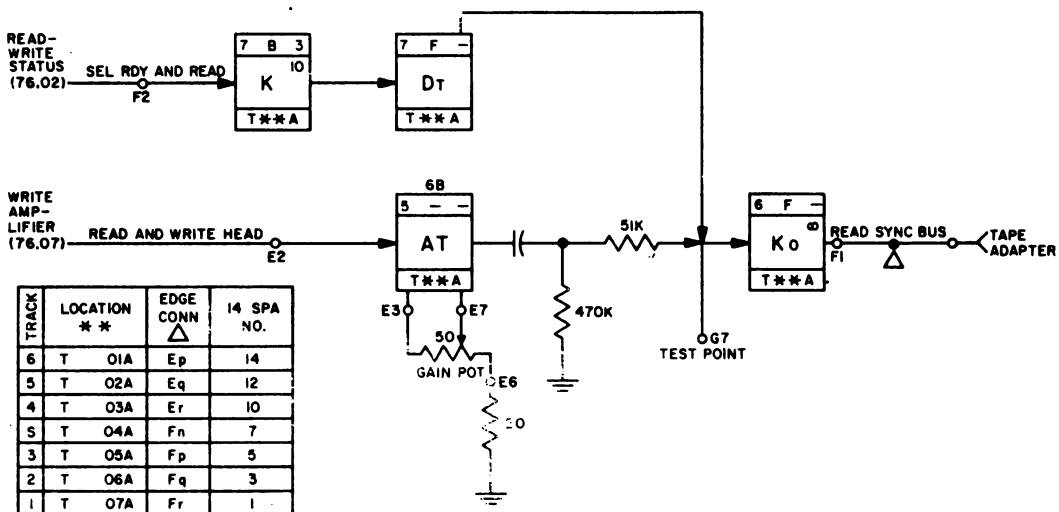

Figure 3-9. Start, Stop, and Reverse Control, Simplified Logic Diagram (76.05.01)



Read Preamp, Simplified Logic Diagram (76.06)

The 18V peak-to-peak signal is imposed on a d-c second level; the signal feeding the Kxo ranges from about +10V to -10V. The input to the Kxo is controlled by select, ready, and read through the DT (diode-tube). The plate and grid of the DT is tied to the input line of the Kxo. If select, ready, and read is down (-30V), the DT conducts heavily, absorbing any noise pulses that may come through the AT.

When select, ready, and read is up (+10V), the diode is cut off, allowing any signal from the AT to be fed to the Kxo.

Either a plus or minus pulse from the read head to the AT's first stage represents a 1 bit. Because of feedback control, the overall gain of the AT is approximately 600; the actual gain of each of the three stages is approximately 9.

J. Writing on Tape (Only 1-Bit Position Considered)

Page 1200

Review the method of storing information. Note that the tape is magnetically saturated in a predetermined direction by passing current through the read-write head in one direction. The flow of current is reversed under control of the write trigger. Current is always flowing through the read-write coil when the tape drive is in the write status with not file protect up (logic 76.07 and C. 01.07).

The right and left outputs of a write trigger are fed to an IWR. The plate loads of this IWR are the two coils making up the R/W head. Because either output of the write trigger is always up, the respective side of the IWR is conducting, causing current to flow in the associated coil.

The write trigger is alternately turned on and off from the negative shift output of a diode gate. This diode gate is conditioned by the write bus that enters from the external control. The level of this bus (+10V or -30) represents the information to be written on the tape. The other input to the diode gate contains timed pulses that flip the trigger. These pulses are routed from read-write circuitry (logic 76.02), where they are a combination of select, ready, and write, and write pulses generated externally. The generated pulses are approximately 53.7 usec apart.

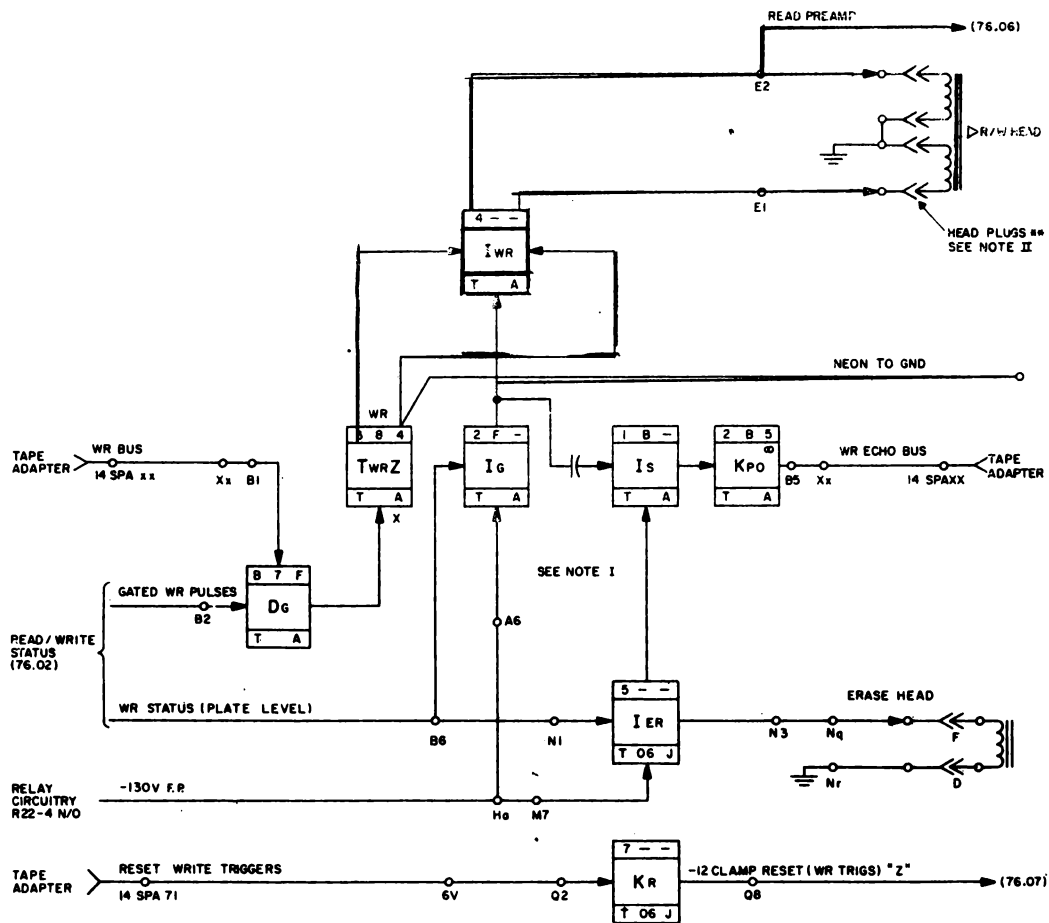

TRACK	LOCATION	WR BUS		READ WRITE	WR ECHO	
		14 SPA **	XX	HEAD PLUG *	14 SPA **	XX
6	TO 01 A	30	An	1	46	Cp
5	TO 02 A	28	Ap	2	44	Cq
4	TO 03 A	26	Aq	3	42	Cr
5	TO 04 A	23	Ar	4	39	Dn
3	TO 05 A	21	Bn	5	37	Dp
2	TO 06 A	19	Bp	6	35	Dq
1	TO 07 A	17	Bq	7	33	Dr

NOTES:

- Z. -12 CLAMP RESET 76.07
- I. USE A SCOPE TO MEASURE WRITE CURRENT BY OBSERVING THE SIGNAL ACROSS THE 5.1K RESISTOR BROUGHT OUT ON TEST POINTS 1-8 AND 1-4. THE RESULTING WAVE FORM UNDER DYNAMIC CONDITIONS WILL SHOW NEGATIVE PULSES WITH THE ZERO LINE DISPLACED 56V ± 5V WHICH CORRESPONDS TO 11MA. ISOLATE THE SCOPE FROM GROUND.
- II. RECONNECT HEAD PLUG WITH RAISED PORTION TO THE FRONT.

Write Amplifier, Simplified Logic Diagram (76.07)

The IWR is further controlled by an IG in the cathode circuit. The IG is allowed to conduct only when the write status is up. This line was generated in the read-write circuit (logic 76.02) from the right output of the read-write status trigger, conditioned by not file protection. Because it is at plate level, a divider is used on the input to the IG on logic 76.07. When the write status is down (indicating read status), the IG is cut off, preventing the IWR from conducting on either side. The file protection device contains a further control on the IG by controlling the cathode voltage. When a file is being file-protected, the -130V is removed from the IG by R22-4 points (fig. 1-1, foldout, Sect. 8L).

There are seven circuits such as the one described above, one for each of the seven tracks,

K. Write Echo

Page 1200

For checking purposes, a write echo pulse for each track is developed, when a bit is written, and sent back to the external control. This pulse, developed at the cathode of the IWR, is ac-coupled to an IS, feeding a KPO that controls the write echo bus.

Assume that the right side of the IWR is conducting and current is flowing through one half of the read-write head. When the write triggers flip, the right side of the IWR is cut off and the left side tries to conduct. However, back electromotive force (emf) is developed in the half of the read-write coil that was conducting. Because of mutual inductance, this collapsing field causes an emf to be developed on the left coil of the read-write head, producing a negative polarity at the plate of the IWR. This negative polarity reduces conduction until the emf has been dissipated.

The voltage level at the cathode of the IWR goes more negative because of the reduced conduction in the left side of the tube (the right side has been cut off). When the left side increases conduction to its maximum, the cathode voltage returns to its original level. Thus, a negative pulse, from -40V to -57V, is developed and coupled to the IS. The duration of the pulse is from 8 to 12 usec, with a nominal value of 10 usec.

L. Writing a Check Character

Since the write trigger for each track is turned alternately on and off to write 1 bits, the state of the trigger at the end of a block of information indicates whether an odd or even number of 1's has been written. If an even number, the write trigger is off; if an odd number, the write trigger is on.

After writing information, all the write triggers receive a reset pulse. Only the triggers that were on will be turned off, thereby writing a 1 on the tape. The character written as a result of resetting the write triggers is called the longitudinal redundancy check character (LRCC). The LRCC is used, during reading of this information from tape, to detect the dropping or picking up of 1 bits in any track.

A line referred to as reset write triggers is routed to the machine from the external control and enters the write amplifier circuit (logic 76.07) to cause a -12V clamp and reset line to rise to ground potential. This is the Z reset for the write triggers.

The check-character feature is not utilized in the AN/FSQ-7, -8 computer as an error-checking circuit. The LRCC's are used as an error-checking scheme when a customer processes a tape with the commercial Tape-Controlled Printer.

M. Erase

Page 1200

The erase head is energized through an IER (logic 76.07) whenever the write status is up. The reset condition of the write triggers (off) causes the R/W head to magnetize the tape in the same direction as the erase head. If the polarity of the erase head is not the same as the read-write heads, errors may occur. It is important that the polarity be checked. The leads to the erase head may be reversed so that its polarity will match that of the read-write heads. The erase head magnetizes the complete width of the tape.

N. Rewind

Page 1240

A rewind operation may be started in two ways. One way is to bring up start rewind from an external source and combine it with select and ready to form rewind PU relay. This line picks R21 to initiate a rewind operation. During the rewind operation, R12 is up and rewind status is brought up (fig. 1-1, foldout, Sect. 1L). This line is combined in AND circuit A17 in logic 76.08 with select to form select and rewind status. This resulting up level is sent back to the external control as an indication that this operation is taking place.

The other way to start a rewind operation is from the LOAD REWIND button on the reel door panel. This button (fig. 1-1, Sect. 4H) bring up manual load rewind which combines with the read status (logic 76.08) to bring up rewind FU relay. The read status is used because, if the drive were in write status, the read-write and erase heads would conduct, destroying information as the tape passed by these heads.

O. File Protection

Page 3200

With a file protection ring placed in the groove of the file reel, the sensing pin is forced to the rear when the reel is mounted. This operates the not-file-protect relay armature; the AL points close, causing the relay coil to be picked (fig. 1-1, foldout, Sect. 2A). The relay will be held as long as the reel is on the machine and the door is closed.

The not-file-protect BL points (Sect. 2F) close to set up a circuit to pick R22, not file protect 2. Because the drive is in the unload status when the reel is mounted, R22 is not picked because the R10-6 points are open. When the tape drive is loaded and not in the rewind status, R22 is picked. The R22-1 points transfer, turning off the FILE PROTECT ON light and bringing up not file protection. This line is combined with the right output of the R/W status trigger (logic 76.02) to bring up the write status.

The R22-4 points (Sect. 6K) close, applying -130V to the erase head inverter and write inverter switch IG.

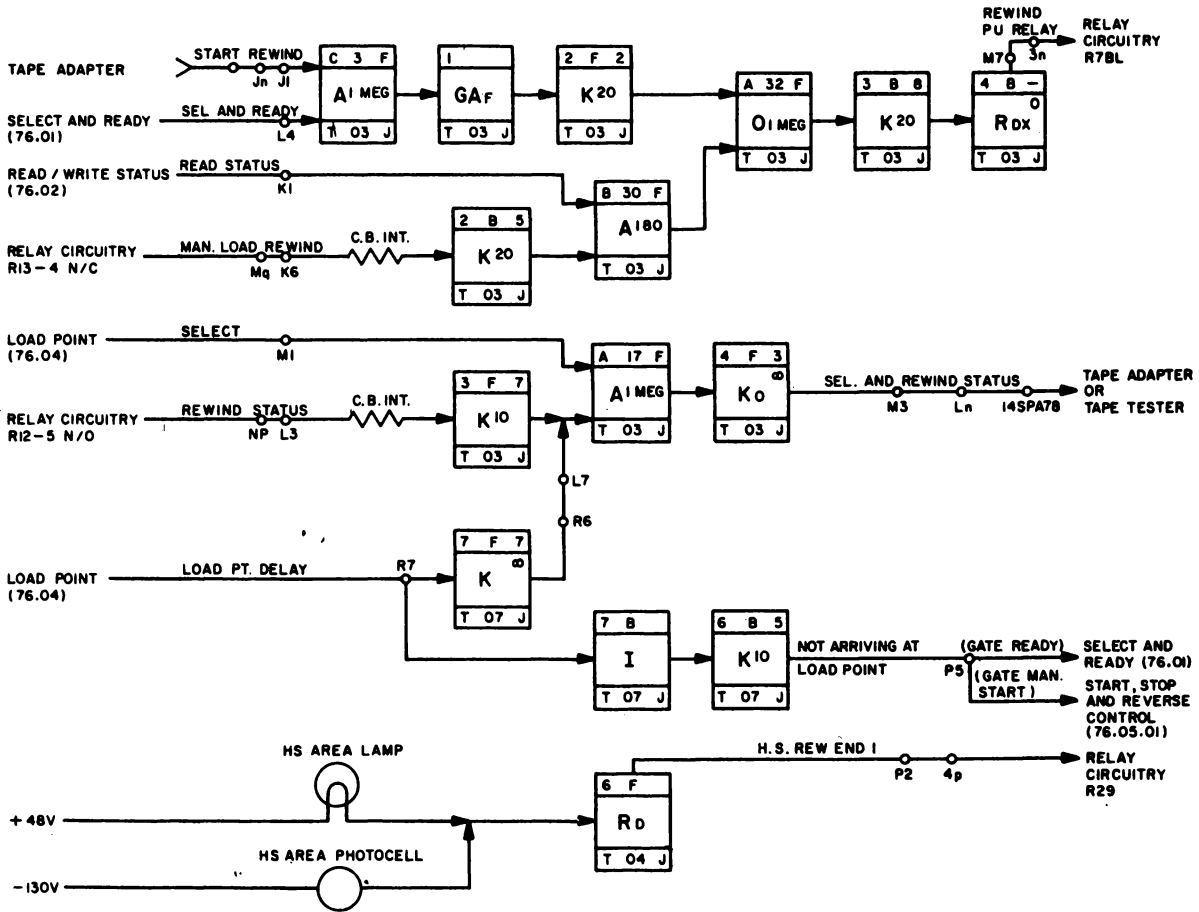

Rewind, Simplified Logic Diagram (76.08)

The file protection device is designed to protect the file reel by dropping R22 during load, unload, and rewind operations.

If the ring is not in the groove of the file reel, R22 will not be picked, thus preventing conduction in the write and erase inverters.

P. FORWARD and Reverse Switch

A customer engineer's tool is provided for manually controlling the forward or reverse motion of tape. The tool consists of two buttons that may be connected, through a cable and Jones plug, to the tape drive (fig. 1-1, foldout, Sect. 4F). When the forward button is depressed, R27 is energized to bring up manual start. Rectifier D5 prevents manual reverse from coming up.

When the reverse button is depressed, both manual reverse and manual start are brought up.

The CE switch shown (Sect. 4F) is a 3-position toggle switch used on the tape drive tester; it may be substituted for the CE portable control keys.

Q. START Button - Mechanically Ready

Page 3540

Mechanically ready is up and the NOT READY light is out if R13 is picked. Depress the START button to obtain this condition (fig. 1-1, foldout, Sect. 2L). When picked, run relay R1 (Sect. 2B) indicates a closed door, no blown fuses or burned out lamps, tape not broken, d-c power available, and sufficient vacuum. Relay R12 down indicates that the tape drive is not rewinding. The R13-5, with R1AU and R12-5, points complete the circuitry to bring up mechanically ready. Mechanically ready, when combined with select and not arriving at load point, brings up select and ready.

The R13-2 points form the holding circuit for R13. R13-4 and 6 open the LOAD REWIND and UNLOAD button circuits, respectively. R13-3 points (Sect. 4J) open relay reset to the R/W status trigger (logic 76.02), allowing the tape drive to go into the write status.

R. Reset

Depressing the RESET button opens the hold circuit to R13, taking the drive out of the ready status (fig. 1-1, foldout).

The RESET button stops any operation that has been started with the exception of the load and unload operations. R13-5, dropping mechanically ready, eliminates most external controls.

The RESET button opens the hold circuit for R12, rewind status, stopping a low-speed rewind operation. If the drive is in a high-speed rewind operation, the RESET button shunts the R29-1 points, high-speed rewind area, causing the drive to load the tape. If the button is held depressed, the drive will stop after the tape has been loaded. R12 cannot be energized after R9 is dropped at the completion of the load-rewind operation.

If the RESET button were depressed and released during a high-speed rewind operation, the drive would cause the tape to load and then start a low-speed rewind operation. The tape will rewind to load point, unless the RESET button is again depressed.

The RESET button does not reset the NIFA trigger.

S. Anti-Spill Device

During the transfer from a high-speed to a low-speed rewind, the time delay allows the reels to coast to a stop before loading the tape. The time delay points are set to close about one second after the reels have stopped when rewinding a full reel of tape. Since not every high-speed rewind will involve a full reel of tape, the reels may stop long before the points close. Because the file reel brake is not applied until the time delay has elapsed, it will be free-wheeling between the times when it has stopped and the brake is applied. This free-wheeling allows the possibility of an improper load operation by dropping tape into either column and allowing it to be drawn to the bottom.

A circuit has been set up to eliminate this condition. Relay R24 is picked at the start of a high-speed rewind by R23 (fig. 1-1, foldout, Sect. 1G) and held through its own points until the time delay points open. The R24-2 points are

transferred, removing the one-half brake from the file reel. The N/O point is brought to the N/C R5BU and R6BU points (Sect. 4B) in parallel. These points are open because tape is out of the columns during high-speed rewind.

If tape should be dropped into either column, the associated N/C points return to normal applying current to the file-reel stop clutch as long as R24 is picked.

T. Moving Coil Circuit

Page 1280

The direction of current flow in the moving coil is controlled by the start and stop lines. When the start line is up, the stop line is down and electrons flow in the moving coil from right to left. This flow produces a magnetic field in the moving coil that opposes the field of the permanent magnet, causing the coil to shift upward. This shift is transferred through linkages to the moving pulley, causing tape to be moved.

The simplified schematic (Page 1300) shows the following operation of the circuit. The start line is fed to IE4 and IF 8, and both tubes begin to conduct. When this line goes up, the output of 4 is fed to IM's 3 and 6. IM 6 is normally biased below cutoff so that the negative shift does not affect it. Tube 3 is driven to cutoff. Tube 8 begins conducting and its plate output is tied to the KA's at 10, which is driven to cutoff. The stop line is down, cutting off tubes 1 and 7. Tube 2 is driven into conduction. Notice that the plate circuit for these two IM tubes is actually a 450-ohm resistor and the moving coil in series with the cathodes at 9. Therefore, electrons flow from ground through tube 2, the 450-ohm resistor, moving coil (right to left), the cathode and plate of tube 9, to +140V. A heavy initial current is needed through the moving coil to produce fast action. This heavy current is obtained with the two IM's at tube 5, which is ac-coupled to the IE at 1. It causes two to three times normal current to flow initially because it provides a parallel circuit with tube 2. The normal current is about 50 ma. The time constant of the input of tube 5 determines the length of time the large current flows, approximately 6 ms.

When the start line goes down, the stop line goes up and electrons flow from left to right through the moving coil.

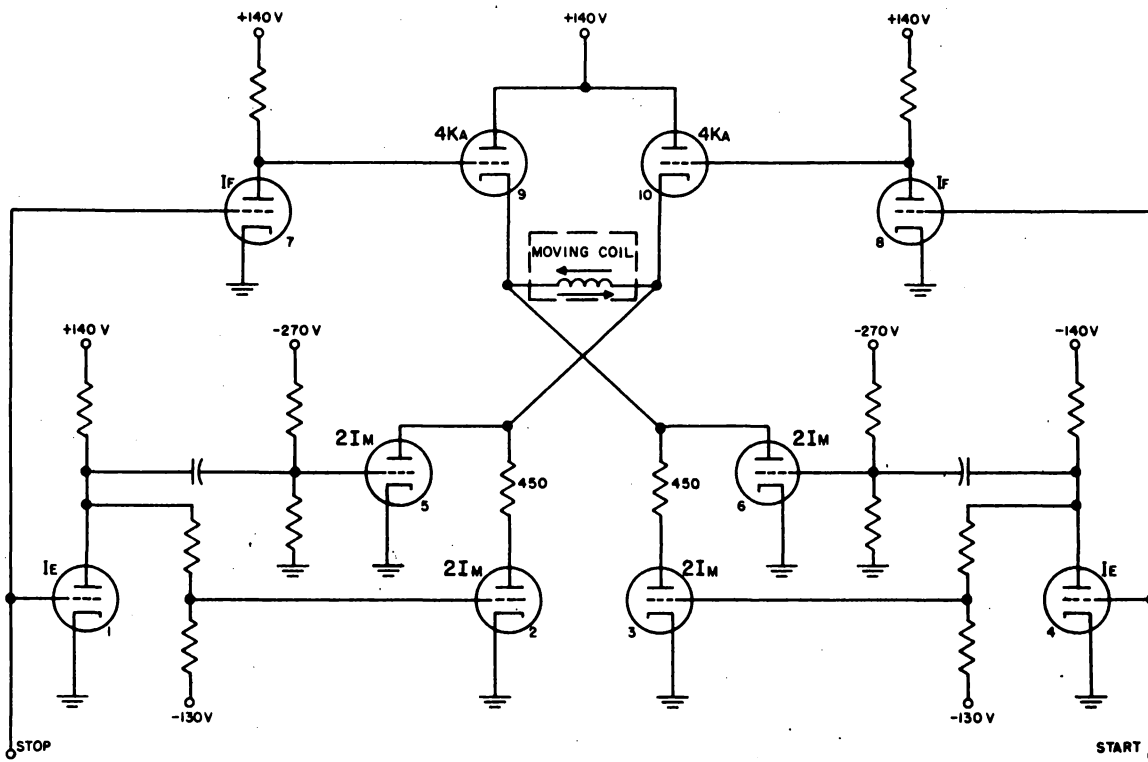

Moving Coil Circuit, Schematic Diagram

This flow causes the moving coil to move downward and the tape to be stopped. The action of the circuit to cause this stopping is the opposite of the start action. In this case, the electron flow is from ground through tube 3, the 450-ohm resistor, moving coil (left to right), the cathode and plate of tube 10, to +140V. The time constant of the input to tube 6 is 6 ms, causing large current flow for that duration.

U. Forward-Reverse Control

The direction of motion of the tape is dependent on the position of the forward-reverse magnet assembly. The magnet control circuit is shown in fig.

If the tape unit is in forward status, the reverse line is down, causing the IB at T02J-6 to be cut off so that no current can flow through the reverse magnet. The divider output of the IB is up and is connected to the IB at T01J-6, which therefore conducts through the forward magnet.

To move the tape backward, the reverse line comes up and the opposite action occurs.

V. Summary of Moving Coil and Forward-Reverse Magnet Operation

1. Forward Reverse Magnet Circuit

- a. +10 input places machine in reverse status.
 - 1) Tubes 1 and 2 conduct through reverse magnet.
 - 2) Control grids of tubes 3 and 4 are at -30V while tubes 1 and 2 conduct.
- b. -30V input places machine in forward status.
 - 1) Tubes 1 and 2 cutoff.
 - 2) With tubes 1 and 2 cutoff, tubes 3 and 4 conduct through forward magnet.
 - a) Control grids at +10V.

Page 1300

C. 01. 03

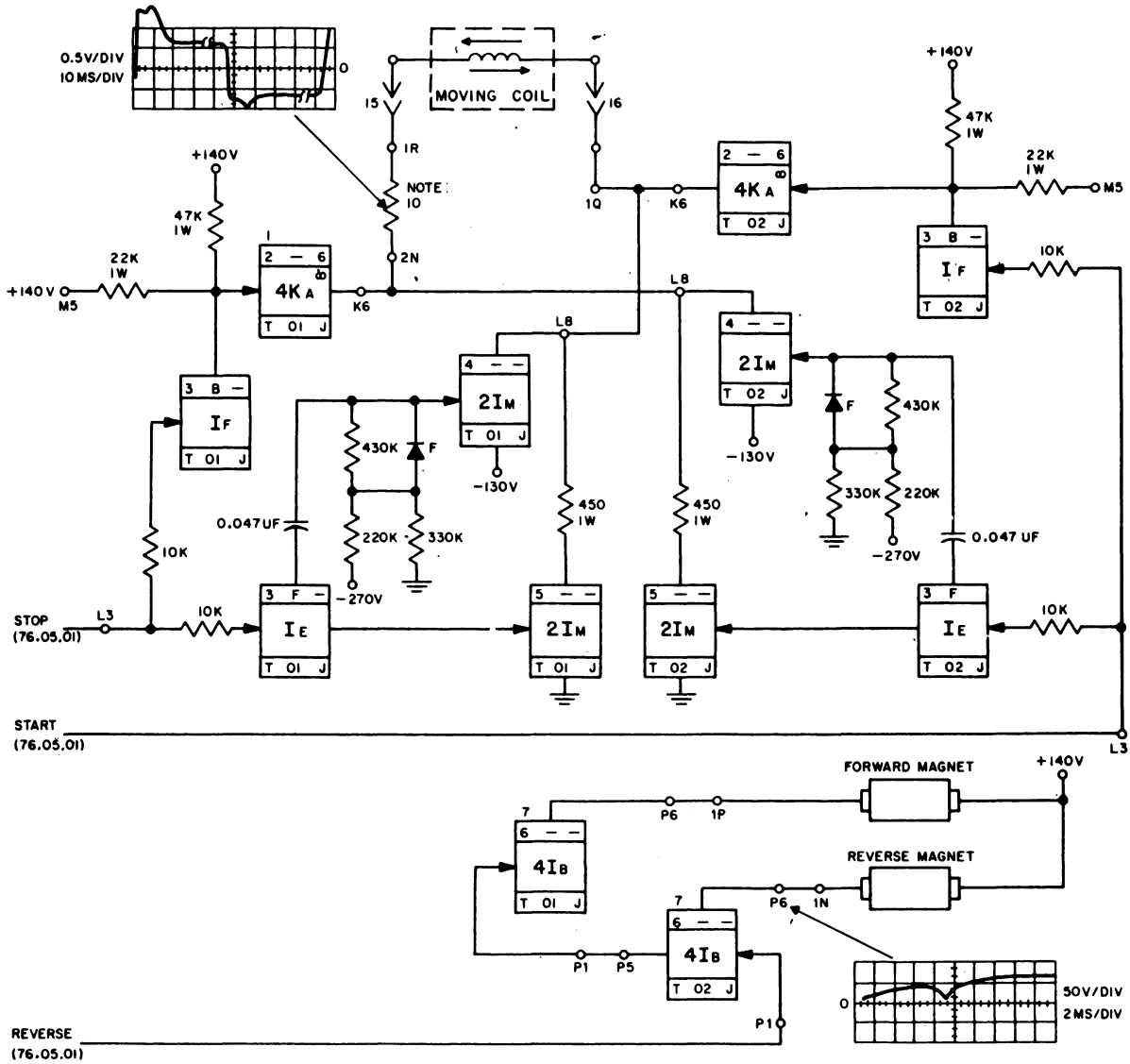

NOTE
 MEASURE MOVING COIL CURRENT
 ACROSS 10 OHM RESISTOR

Moving Coil and Forward-Reverse Drivers, Simplified Logic Diagram (76.05.02)

2. Moving Coil Circuit

Page 1300

- a. +10 applied to the stop line, -30V applied to the start line.

C. 01. 03

- 1) Tubes 1 and 7 conduct.
 - a) Plate voltage of tube 1 equals +35V.
 - 2) Plate voltage of tube 7 equals +35V.
 - 2) Tubes 4 and 8 cutoff.
 - a) Plate voltage of tube 8 equals +100V.
 - (1) Plate voltage does not reach +140V because of grid current from tube 10.
 - 3) Tube 2 cutoff.
 - a) Control grid voltage equals -50V.
 - b) Cathode at ground.
 - c) Plate voltage equals +100V.
 - 4) Tube 3 conducts.
 - a) Control grid voltage equals 0V.
 - b) Cathode at ground.
 - c) Plate voltage equals +60V.
 - 5) Tube 9 cutoff.
 - a) Control grid voltage equals +35V.
 - b) Cathode voltage equals +80V.
 - 6) Tube 10 conducts.
 - a) Control grid voltage equals +100V.
 - b) Cathode voltage equals +100V.
 - 7) Tube 6 conducts until coupling cap charges.
 - a) 85V positive pulse felt on control grid when start line goes to -30V.
- b. Electron flow through the moving coil is from left to right, pulling coil down into stop status.

- 1) Normal moving coil current is 50 ma. The first surge is 2-3 times as much for approximately 6 millisecc.
- c. +10V applied to the start line, -30V applied to stop line.
 - 1) Voltages reversed.
 - 2) Previously cutoff tubes conduct.
 - 3) Previously conducting tubes cutoff.
 - 4) Moving coil is forced up into start status.

W. High Speed Rewind Photocell Circuit

1. When R29 is picked, machine will H. S. rewind.
2. If more than $\frac{1}{2}$ " tape on the machine reel, no light reaches the photocell.
 - a. Potential at the tube control grid is approximately 0V.
 - b. R29 is picked.
3. If less than $\frac{1}{2}$ " tape on the machine reel, light reaches the photocell.
 - a. Potential on the control grid is negative.
 - b. R29 is dropped.
4. Fail Safe Type Circuit
 - a. If the photocell lamp burns out, R29 can never be picked and the machine will only LS rewind.

Page 1100

X. Summary Questions

Refer to EDPM Logic Manual.

1. (76.01) If 14SPA jumper 91 is open, what address is disabled on this tape drive? Will this affect any other tape drive?
2. (76.02) List the function of each:
 - a. AND (A35)
 - b. AND (E25)
 - c. AND (G15)

3. (76.03) List the signals that set the NIFA trigger. Trace the signals to their source and list what each signal is caused by. Give the polarity of the signal as it enters the trigger circuit.
4. (76.04) What is the function of the line labeled, "Load Point Delay"?
5. (76.05.01) Is it necessary for a tape drive to be SEL and RDY in order to put it in manual reverse?
6. (76.05.01) With the conditions of #5, must it be SEL and RDY to put the tape drive in manual reverse start?
7. (76.05.02) The start line = +10V, the stop line is at -30V. The reverse line is at -30 volts. With these given conditions:
 - a. $2I_M$ (T01J-5) is conducting. (T/F)
 - b. $2I_M$ (T01J-4) conducts for approximately 6 ma. (T/F)
 - c. $4K_A$ (T01J-1) is conducting. (T/F)
 - d. Current (electron flow) through the moving coil is from left to right (bottom arrow) (T/F)
 - e. $4I_B$ (T01J-6) is conducting. (T/F)
 - f. The moving coil is in the start position and the FOR-REV magnets are in the forward position. (T/F)
 - g. State the function of the $2I_m$ (T01J-4) and T02J-4) circuits.
8. (76.06) What is the function of the DT circuit block?
9. (76.07) The reset WRT triggers signal will return all WRT trigger to the clear state. (T/F)
10. If the plastic ring is not inserted in the file reel, how will this prevent writing from taking place? Give detailed analysis.

Z. Tape Drive Logic Circuits Analysis

1. Mechanism Ready Line 76.09.07

a. Up when ready relay (R13) in the tape drive is picked.

1) R12 must be dropped.

b. Signals external source that the tape drive is ready.

2. Select Line 76.01

a. +10V when tape drive is selected.

3. Selected and Ready Line 76.01
- a. Output of AND circuit (A12 TO6J)
 - b. Inputs
 - 1) Mechanism ready
 - 2) Selected level
 - 3) Normally +10V output of Load Point SS
 - c. Provides a gate level to other tape drive circuits.
4. Selected and at Load Point Line 76.04
- a. Output of AND circuit (A12 TO4J)
 - b. Inputs
 - 1) At Load Point relay in tape drive and 20 Msec SS (Load Point).
 - 2) Selected level
 - c. Signals external control that tape drive is selected and at Load Point.
5. Selected and Rewind Status Line 76.08
- a. Output of AND circuit (A17 TO3J)
 - b. Inputs
 - 1) Rewind status relay and 20 Msec SS (Load Point)
 - 2) Selected level
 - c. Signal external control that tape drive is selected and in rewind.
- Note: Refer to Fig. 1-1. EDPM references are listed.
6. Forward-Reverse Magnets 76.09.03
- a. Controlled from tape drive and externally. 76.05.01
 - b. Tape drive control is manual reverse line, from tape drive relay circuitry. 76.05.02
 - c. External control is output of AND circuit.

- 1) Inputs
 - a) Selected and ready level
 - b) External backward level

- 7. Moving coil 76.05.01
76.05.02
 - a. Controlled from tape drive and externally.
 - b. Tape drive control is output of AND.
 - 1) Inputs
 - a) Manual start from tape drive relay circuitry.
 - b) Load Point SS
 - c. External control is output of AND circuit.
 - 1) Inputs
 - a) Selected and ready level.
 - b) External go level.

- 8. NIFA FF 76.03
 - a. Controlled from tape drive and externally.
 - b. Tape drive control.
 - 1) Set by EOT.
 - 2) Cleared by Power on Reset.
 - c. External Control
 - 1) Set by set NIFA pulse.
 - 2) Cleared by set prepared pulse.
 - 3) Both pulses gated by selected level.
 - d. Outputs
 - 1) Gated by selected level.
 - 2) Signal external control prepared condition.

- 9. Write Circuit (one of seven) 76.07
 - a. Write current through write head is controlled by a trigger.

- 1) Complementing trigger reverses current through head.
 - 2) Complement input to trigger is through a DCG.
- b. IG is used to disable write circuits during read status.
- 1) Input during read status is +10V.
 - 2) Input during write status is +145V.
- c. Write Pulses
- 1) Arrive every 54 usec. when tape drive is moving forward and in write status.
 - 2) Gated by DCG.
 - a) DCG is conditioned to pass the pulse when a "1" is to be written.
 - b) There are seven WRT Buses; when a one is to be written, the bus will be at +10V.
- d. Is
- 1) Capacity coupled to cathode of IWR.
 - 2) Output occurs when trigger is complement.
 - 3) Output tied to write echo bus for that bit position.
10. Read Circuit
- a. Input to AT capacity coupled to R/W head.
- 
- 1) DT biased to short out signal from AT during write status.

11. R/W Status Trigger

76.02

- a. Controlled from tape drive and externally.
- b. Tape drive control.
 - 1) R/W status reset from tape drive relay circuit brings up read status at beginning of re-wind.

c. External control

- 1) Set read pulse places tape drive in read status.
- 2) Set write pulse places tape drive in write status.
- 3) Pulses gated by selected and ready level.

d. Outputs

1) Read Status

- a) Gates manual load - rewind level to pick rewind relay.
- b) Signal external control that tape drive is in read status.

2) Write Status

- a) Gated by not file protected level.
- b) Signals external control that tape drive is in write status.

- 3) Signals to external control gated by selected and ready level.

12. Selected and Not File Protected Level 76.02

- a. AND circuit combination of not file protected and selected levels.
- b. Signals external control that the selected tape drive is not file protected.

13. Erase Head 76.07

- a. Energized when in write status and not file protected.
 - 1) -130VFP is furnished when R22 is picked.

V. Operational Analysis of Tape Drive

A. Switch and Relay Functions

1. AC and DC FUSE BAIL Switch
 - a. N/C

Fig. 1-1 (Sheet 1
2 of 2)
A/4 Coordinates
Page 3540

- b. OPEN when the fuse bail is moved by a fuse plunger.
 - 1) Blown fuse will prevent tape operation.
- 2. Door interlock switch A/3
 - a. N/O
 - b. Close when the door is closed.
 - 1) Open door will prevent tape operation.
- 3. Bellows switch B/2
 - a. Switch
 - b. Close when vacuum is up.
 - 1) No vacuum will prevent tape operation.
- 4. Left and right caps in switch G/3
 - a. N/O
 - b. Close when the caps are in.
 - 1) Both capstans must be in to start take-up motor.
- 5. Time delay switch G/2
 - a. N/C
 - b. Open approximately 6 seconds after the timer motor is started.
 - 1) Remove nylon pulleys for dropping tape in columns.
- 6. Left and right caps out switch K/3
 - a. N/C
 - b. Open when the caps are out.
- 7. Flapper switches J/1
 - a. N/O
 - b. Close when vacuum is up and tape is out of the column.

8. Head Down switch E/3
- a. N/C
 - b. Opens when the head is down.
9. Head Cover up switch B/3
- a. N/O
 - b. Closes when the head is up.
10. Customer Engineering switch 4/F
- a. Three-position switch on the tape drive tester or two pushbutton box.
 - b. In "Forward Go" position, relay 27 will be picked putting the tape drive in GO status.
 - c. In "Backward Go" position, relay 27 will be picked putting the tape drive in GO status. Also, the manual reverse line is brought up to +10V.
11. R1, Run Relay B/1
- a. Indicates the tape drive is in a run status.
 - b. Will be dropped if fuse bail switches open, loss of vacuum, photocell bulb failure, etc.
12. R2 and R28 clutch status relays
- a. Picks during load or H. S. rewind operations.
13. R3, Load Rewind relay K/1
- a. Picked during load-rewind operations.
14. R4 Low speed rewind area E/1
- a. Picks during load rewind operations when less than $\frac{1}{2}$ " of tape is on the machine reel.
15. R5 Left col. relay J/1
- a. Picks when the left flapper switch is closed.
16. R6 Right col. relay J/1
- a. Picks when the right flapper switch is closed.

17. R7 photolight relay D/4
- a. Is picked through the tape break, load point, and end of tape lamps when +48V is present.
 - b. Will drop R1 if there is a photolight failure.
18. R8 Time Delay Motor Relay E/1
- a. Picks to start the time delay motor.
 - b. If R8 is picked, it will drop the high speed relay rewind relay allowing the tape to coast to a stop.
19. R9 Load Rewind 2 Relay K/1
- a. Is picked when R3 is picked.
20. R10 Unload 2 K/1
- a. Picked when R15 is picked to indicate the drive is unloaded.
21. R12 Rewind Status L/1
- a. Is picked by R21 to indicate the drive is in a re-wind status.
22. R13 Start Relay L/1
- a. Is picked when the start button is depressed if R1 or R9 is picked.
 - b. Will hold until the reset button is pressed or R1 is dropped.
23. R15 Unload C-D/1
- a. A latch pick relay.
 - b. Is latch picked when the unload P. B. is pressed.
 - c. Trips when R21 is picked.
24. R16 Unload Stop C/1
- a. Latch pick relay.
 - b. Latch picked during an unload operation when the head is up and the tape is out of both columns.
 - c. Latch trips when the load rewind button is depressed. (R21 picks)

25. R17 - Power on Reset A/1
- a. Picked when 48V is present.
26. R21 - Rewind Pick-up H/4
- a. Can be picked by pressing the load rewind PB or by a signal from the Central Computer.
27. R22 - Not File Protect F/1
- a. Must be picked before writing can be accomplished.
28. R23 - High Speed Rewind Status B/1
- a. Indicates the high speed rewind motor is running.
29. R24 - High Speed Rewind Interlock H/1 and G/1
- a. Latch Pick relay
 - b. Is picked when R23 is picked.
 - c. Remains picked when R23 is dropped to prevent spilling tape at the end of a H. S. rewind.
 - d. Is tripped at the end of the time delay.
30. R25 - Load Point Relay H/9 and H/1
- a. Latch pick relay.
 - b. Picks when tape reaches load point if the drive is in a rewind status.
 - c. Trips when tape moves away from load point.
31. R26 - Load Point Trip E7
- a. Trips R25
 - b. Is picked when start and at load point levels are up.
32. R27 GO Status Relay G/1
- a. When picked brings up the manual start level to put the moving pulleys in a start status.
33. R29 - High Speed Rewind Area K/5
- a. Picked when in a high speed rewind area.

34. DP1 take-up motor reverse E/1
- a. Switches two phases to the take-up motor causing it to run in reverse.
 - b. Reverse causes the head cover to go down.

Note: The switches and relays under discussion can be related to the EDPM Logic by referring to Pages 7X.06.01; 7X.06.02.

B. Summary Questions

- (T/F) 1. Both the AC and DC fuse bail switches must be transferred to prevent tape drive operation.
- (T/F) 2. Bellows switch indicates whether or not vacuum is sufficiently up.
- (F) 3. R2 and R28 determine when stop clutches are energized or control is turned over to the vacuum switches.
- (T/F) 4. R5 and R6 indicate when tape is in or out of the vacuum columns.
- (T/F) 5. R7, if picked, indicates that the load point, end of tape, and take break lights are OK.
- (F) 6. R13 is the rewind status relay.
- (T/F) 7. R17 is energized whenever the +48 volts is up in the tape drive.
- (F) 8. R22 is not picked when the tape drive is file protected.
- (T/F) 9. R25 indicates that load point is sensed if it is energized.
- (T/F) 10. DP-1 determines whether or not the forward-reverse motors are running.

D. Load-Rewind From Low Speed Area, Model III

Page 1510

1. Define initial conditions.
 - a. Head cover up.
 - b. Capstans retracted.
 - c. Tape out of columns.
 - d. R15 and R16 latch picked.
 - e. R10 picked by R15.
 - f. No vacuum.
 - g. Nylon pulleys in forward start status. (R27 picked)
 - h. R2 and R28 are picked by 15.

2. Define sequence of events for Load-Rewind operation from L. S. Area.
 - a. Push load rewind pushbutton.
 - 1) Nylon pulleys go to reverse status.
 - b. Vacuum comes up.
 - c. Tape drops into columns.
 - d. Head cover comes down.
 - e. Capstans extend.
 - f. Tape moves in reverse direction to LP and stops in a forward stop status.

3. Analysis

Note: Coordinates are for Fig. 1-1.

Assume that the tape drive is unloaded; there is less than $\frac{1}{2}$ inch of tape on the machine reel. Relays 2, 7, 10, 15, 16, 17, 22, 27, and 28 are picked. The nylon pulleys are in Forward-Start. The L. P., E. O. T., and T. B. lights are in series with R7. File reel is not file protected. Following is the:

Low Speed Load-Rewind Sequence

Push the Load-Rewind PB (4H)

MOD III
728

POWER ON SEQUENCE

GIVEN AT START: K-15 AND K-16 LATCHED
DRIVE UNLOADED

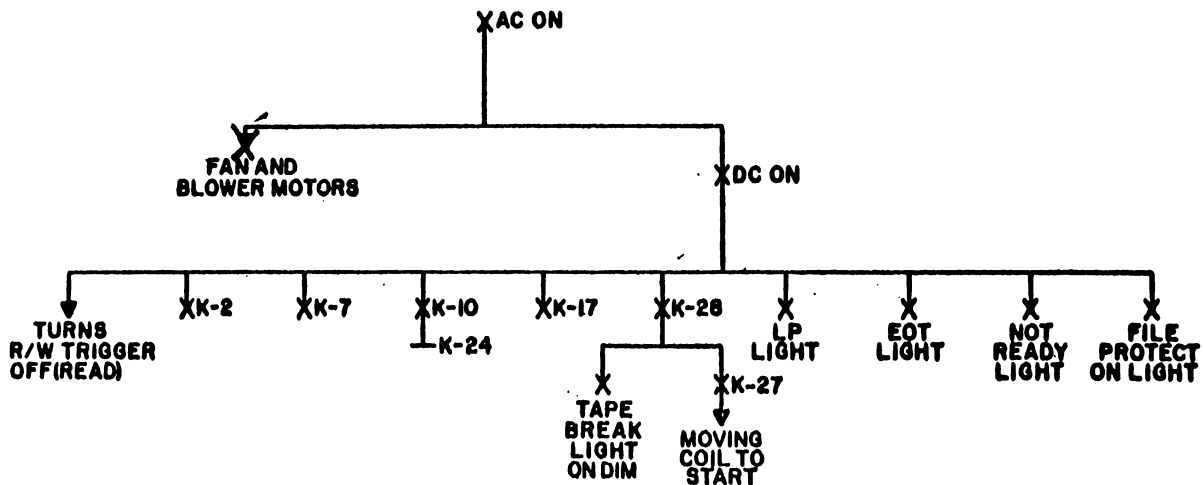

TAPE SEQUENCES- Power On

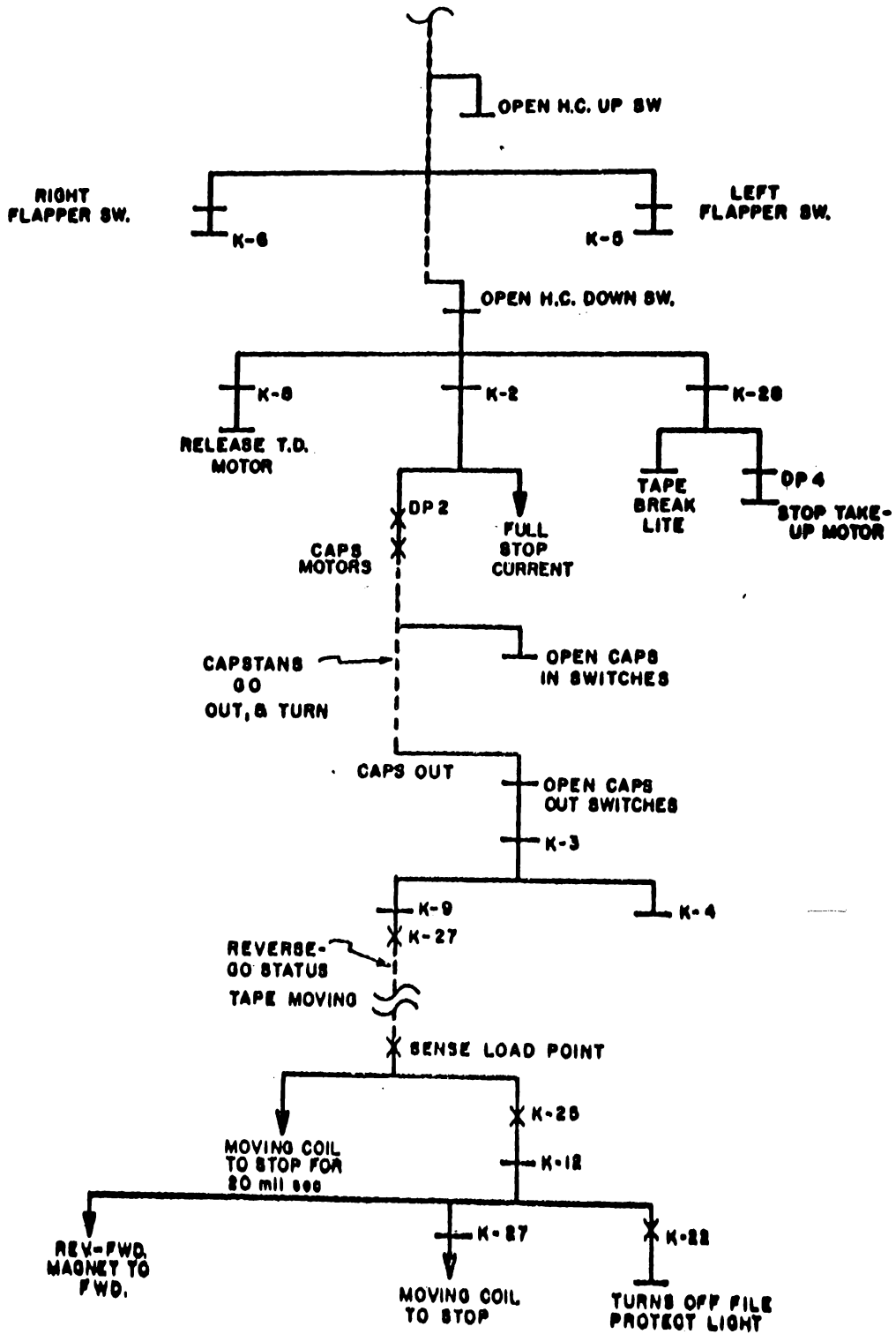

- a. R-21 Rewind Pick-up Relay (Drops when PB is released) (4H)
- | | | | |
|------|-----|---|--|
| 21-1 | pts | - | Pick R-3 (2K) |
| 21-2 | pts | - | Pick R-16 LT (2C) Drop 16 |
| 21-3 | pts | - | Pick R-15 LT (2D) Drop 15 |
| 21-4 | pts | - | Turn on "Not Ready" light; set R/W trigger to read. (3J) |
- b. R-3 Load Rewind 1 Relay
- | | | | |
|------|-----|---|-------------------------|
| 3 AL | pts | - | Pick R-4 and DP-1 (2E) |
| 3 AU | pts | - | Set up pick to R-8 (2E) |
| 3 BL | pts | - | Hold R2 and R-28 (2E) |
| 3 BU | pts | - | Pick R-9 (1K) |
- c. R-15 Unload 1 Relay
- | | | | |
|------|-----|---|--|
| 15-1 | pts | - | (3A) No effect (Shunted by 9-1 pts) |
| 15-2 | pts | - | (3F) No effect (Shunted by 3 BL & Head Down switch.) |
| 15-3 | pts | - | (3K) Drop R-10 |
| 15-4 | pts | - | (2G) Set-up future pick for R-27 |
- d. R-10 Unload 2 Relay
- | | | | |
|------|-----|---|--|
| 10-2 | pts | - | (2L) Set-up future hold for R-12 & R-13 |
| 10-3 | pts | - | (3B) Set-up pick for DP-3 & R-23; Open pick to R16LP |
| 10-5 | pts | - | (5D) N/O - Drops R-15 LT coil |
| 10-5 | pts | - | (5D) NC - Connects Adj. resistor |
- e. R-16 Unload Stop Relay
- | | | | |
|------|-----|---|---|
| 16-1 | pts | - | (3C) Pick HD-4; Drop R16 LT coil |
| 16-2 | pts | - | (2G) Set-up pick to DP-4 |
| 16-3 | pts | - | (2D) Shunts L. P. & E. O. T. lights until R4 picks. |
- f. R-9 Load Rewind Relay
- | | | | |
|-----|-----|---|--|
| 9-1 | pts | - | (3A) Set-up pick for run relays |
| 9-5 | pts | - | (2L) pick R-12 (Nylon pulleys go to reverse-start) |
| 9-6 | pts | - | (1F) Open pick to R-22 |

g. R-12 Rewind Status Relay

12-1	pts	-	(4G) Bring up manual reverse line (See 9-5 pts above)
12-2	pts	-	(2L) Hold R-12 thru 25-3 N/C pts and 10-2 N/C pts.
12-3	pts	-	(4J) Set R/W FF to read status if R-13 is picked; turn on "Not Ready" light.
12-4	pts	-	(2F) Open pick to R-22
12-5	pts-N/O	-	(4G) Bring up rewind status line
	-N/C	-	(4G) Drop "Ready" line; disable C. switch
12-6	pts	-	(2B) Set-up pick to R-23 & DP-3

h. DP-1 Take-up Motor Reverse Relay

- 1) Connects take-up motor to run in reverse.
(Bring head cover down.)

i. HD-4 Vacuum Motor Relay

- 1) Apply AC to vacuum motor. Picked by 16-1
N/C.
- 2) Vacuum comes up.

j. R-4 LOW SPEED REWIND STATUS RELAY

4AU	pts	-	(2E) Pick R-8 thru head cover down switch
4AL	pts	-	(2G) Open pick to DP-4
4BU	pts	-	(2D) Open shunt around L. P. & E. C lights. (Both lights lit)
4BL	pts	-	(3E) Hold R-4 & DP-1 thru 3AL

k. R-8 Time Delay Motor Relay

8AU	pts	(10C)	Start time delay motor
8BU	pts	(2B)	Open pick to R-23 & DP-3

Vacuum up

Flapper switches close (1J) pick R5 & R6

1. R-5 & R-6

5-6	AU	pts	(2A) Open hold to run relays
5-6	AL	pts	(3G) Open pick to R-27 (R-27 still picked 28-4)
5-6	BU	pts	(4B) Set-up pick to R-23 & DP-3
5-6	BL	pts	(2E) Hold R-2 & R-28

Vacuum safety switch closes picking R1; HD-1, 2, 3
(Thru 9-1 pts) (2B)

m. R-1 Run Relay

1AU	pts	-	(4F) Set-up "Ready" line
1AL N/O	pts	-	(1L) Set-up pick to R-13
1BU	pts	-)	(6-8C) Put clutches under control
1BL	pts	-)	of R-2

n. HD 1, 2, 3, Ø1, Ø2, Ø3 Relays (2A-B)

Start Forward-Reverse Motors
Time delay runs out (approx. 6 secs)
Open time delay switch (2G)

o. R-27 Go Status Relay - Now R27 is dropped.

27-1	pts	-	(4F) Drop manuat start line (Nylon pulleys go to Reverse-Stop)
27-2	pts	-	2F Pick DP-4

p. DP-4 Take-up motor start relay (12-13A) relay points
Head cover starts down.

Head up switch opens (No effect at this time) (3B)

Tape starts into columns.

Note: Take-up motor reverse and stop clutches energized cause reels to turn inward so tape is loaded into vacuum columns.

Head down switch opens (3E)
Prepare to drop R-2 & R-28
Tape in both columns
Drop R-5 & R-6 dropping R-2 & R-28 & R-8 and holding the run relays thru 5 & 6 AU N/C points.

q. Drop R-2 Clutch Status 1 Relay

2 U	AU	pts	(1H) Pick DP-2 (Starts capstan rot.
2	AL)		(6B) Put clutches under control
	BU)		(8B) of the dipahragm switches

r. Drop R-28 Clutch status 2 Relay

28-2 pts	-	(2K) prepare to drop R-3
28-3 pts	-	(3D) Turn out T. B. light; turn on L. P & E. O. T. lights
28-4 pts	-	(2G) Drop DP-4

s. R-8 Time Delay Motor Relay

8AU	pts	-	(9C) Stop time delay motor (time dela points close)
8BU	pts	-	(3B) Set-up pick to R-23 & DP-3

t. DP-2 Caps Motor Relay (1H)

Capstans extend (Note: Due to solenoid action of armature & field.)

u. DP-4 Take-up motor stops (13A)

Caps out switches open (3K)

Note: Right caps out N/O pts hold DP-1 to keep torque on take-up motor.

v. R-3 Load Rewind 1 Relay

3AU	pts	-	(2E) Open pick to R 8
3AL	pts	-	(2E) Drop R-4
3BU	pts	-	(1K) Drop R-9

w. R-4 Low Speed Rewind Status Relay

4BL	pts	-	(3E) Set-up pick to R-2 & R-28
4AL	pts	-	(2G) Set-up pick to DP-4
4BU	pts	-	(3D) Set-up shunt around L. P. & E. lights
4AU	pts	-	(2E) Open pick to R-8

x. R-9 Load Rewind Relay

9-1	pts	-	(3A) No effect (Shunted by 5-6 AU)
9-2	pts	-	(1L) No effect (Shunted by 1AL)
9-3	pts	-	(3G) Pick R-27
9-4	pts	-	(2K) No effect
9-5	pts	-	(2L) No effect (Shunted by 12-2, 10-2, and Reset PB)
9-6	pts	-	(1F) Set-up pick to R-22 (Not F. P.)

y. R-27 Go Status Relay

27-1	pts	-	(4F) Bring up manual start line (Nylon pulleys to Reverse-Start.
------	-----	---	--

Tape now moves in reverse until the load point marker is reached.

z. Sense Load Point (6G)

Fire L. P. Single Shot dropping start line for 20 milliseconds. Tape stops. Nylon pulleys to Reverse-Stop - Pick R-25LP (R27 dropped 12-1 opening due to R25 pick which opens 25-3)

aa. R-25 Load Point Relay (10H)

25-1	pts	-	(4G) Open C. E. switch backward line
25-2	pts	-	(2K) Open pick to R-3
25-3	pts	-	(2K) Drop R-12
25-4	pts	-	(4E) Bring up "At Load Point Signal)

bb. R-12 Rewind Status Relay

12-1	pts	-	(4G) Manual Reverse line goes down; also dropping R-27
12-2	pts	-	(2L) Open hold to R-12
12-3	pts	-	(4J) Turn out "Not Ready" light if R-13 is picked.
12-4	pts	-	(2F) Pick R-22 (if not file protected)
12-5	pts	-	(4G) N/O drop rewind status signal. Bring up "Ready" line if R-13 is picked; enable C. E. Sw.
12-6	pts	-	(2B) Open pick to DP-3 & R-23.

- cc. R-27 Go Status Relay (1G)
- | | | |
|----------|---|---|
| 27-1 pts | - | (4F) Drop manual start line (Nylon pulleys to Forward-Stop) |
| 27-2 pts | - | (2F) Set-up pick for DP-4 |
- dd. R-22 File Protect 2 Relay (1F)
- | | | |
|----------|--------|---|
| 22-1 pts | (4H) - | N/O bring up "Not file protect line"
N/C turn out file protect light |
| 22-4 pts | (8L) - | N/C remove gnd from erase inverte
N/O apply -130V to erase inverter |
- ee. R-25 Remains latch picked until tape is started forward.

The tape drive is now loaded and at load point. The tape break light is out; the L. P. & E. O. T. lights are on. The nylon pulleys are in forward stop. Relays NFP, 1, 7, 17, 22, 25; HD-1, 2, 3 & 4; DP-1 & are picked.

PUSH THE START PB (2L)

- ff. R-13 Start Relay (Calculator Interlock) (1L)
- | | | |
|----------|--------|--|
| 13-2 pts | (2L) - | Hold R-13 |
| 13-3 pts | (4J) | Turn out "Not Ready" light |
| 13-4 pts | (4H) | Open manual load-rewind line (Load-rewind PB is now inoperative) |
| 13-5 pts | (5F) | N/O bring up mech. ready signal line |
| 13-6 pts | (2C) | Open pick to R-15 LP (Unload PB is now inoperative) |

Tape drive is now "Ready" and under computer control. If a start RDS or WRT is now given, R-26 will be picked and the start line will come up putting the nylon pulleys in forward-start. Tape will move forward.

- gg. R-26 Load Point Trip Relay (7E)
- | | | |
|----------|--------|--------------|
| 26-1 pts | (1H) - | Pick R-25 LT |
|----------|--------|--------------|
- hh. R-25 Load Point Relay (9H)
- Drop "At Load Point" Signal

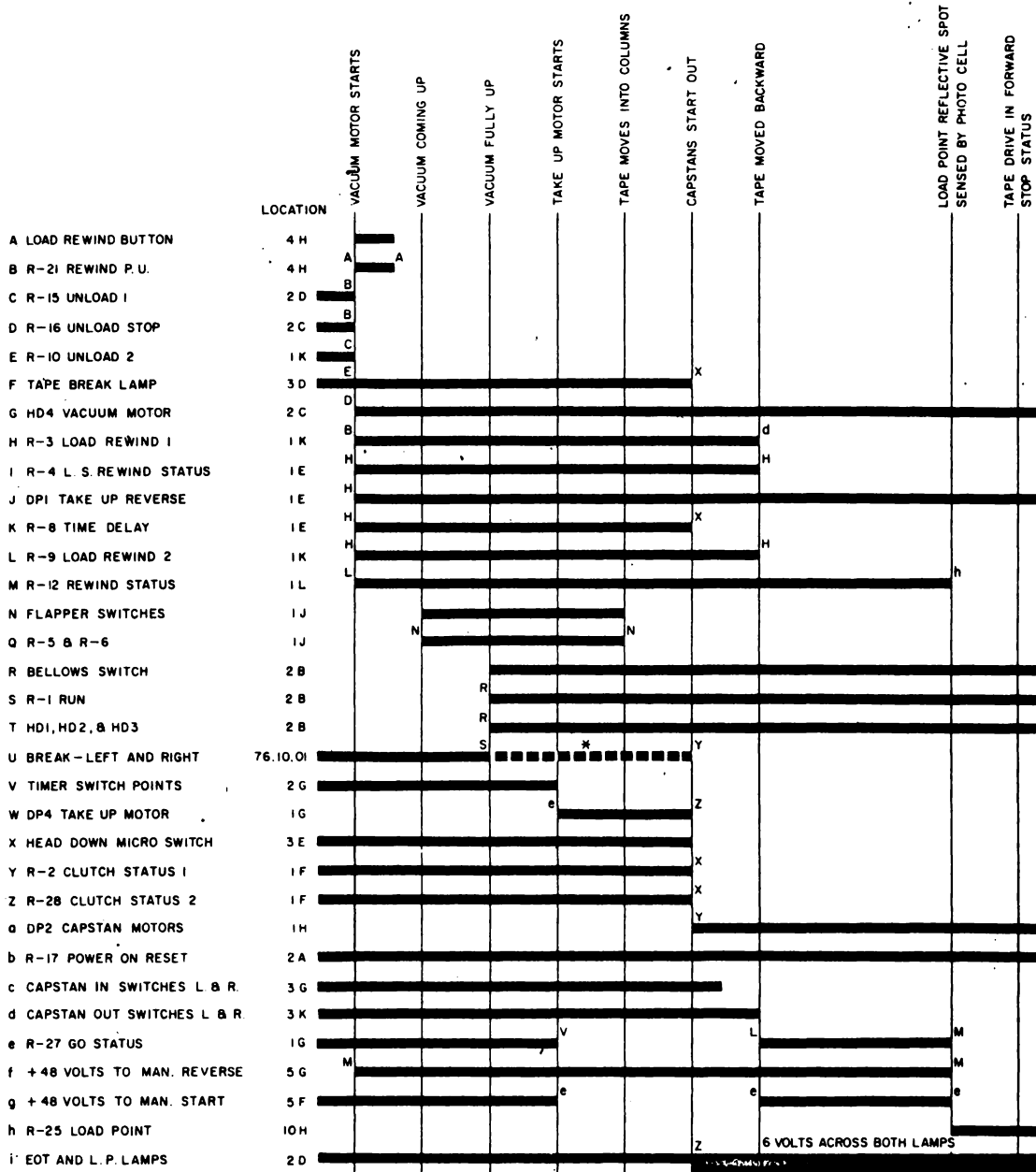

NOTE:
* ■■■■■■ - 1/2 BRAKE

Low-Speed Load Rewind, Model III, Sequence Chart

NOTE:

The following initial conditions exist when external power is first turned on. The 48Vdc supply is energized from phases 1 and 2 of the 3-phase 208Vac supply. The

blower and fan motors are energized from phases 2 and 3, and the filament power is supplied through the filament transformer by the 236V regulated external supply.

LOAD-REWIND OPERATION (LOW-SPEED AREA), MODEL III

LOCATION	SEQUENCE OF OPERATIONS	CONDITIONS	REMARKS
1C	R15, unload 1, and R16, unload stop, are latched.		These relays were latched the last time the machine was unloaded.
1K	Pick R10, unload 2.	R15-3 N/O.	
4D	Pick R7.		Circuit through the load point, EOT, and tape-break lamps.
1F	Pick R2 and R28, clutch status 1 and 2.	R15-2 N/O.	
1G	Pick R27, go status.	R28-4 N/O.	The moving coil will not be energized until d-c power comes up.
6C 7C	Full power to stop clutches.	R1BU N/C and R1BL N/C.	Power to stop clutches is controlled by reel release switch.
4J	High-speed-area lamp on.		Used for high-speed rewind area. After a 5-minute warmup period, d-c supplies are available from the external source.
8D	Reset NIFA trigger.	R17-4 N/C.	After 140V is on before R17 is picked.
2A	Pick R17, power on.	When d-c supplies have been completely sequenced on.	
6K	Reset R/W status trigger to read status.	R13-3 N/C.	Called <i>relay reset</i> .
	Start line up.	R27-1 N/O closed and power on.	R27 has been picked waiting for d-c power to tape drive. The moving pulleys are transferred away from the stop capstans. Thread tape on tape drive.
4H	Depress LOAD REWIND button.		
4H	Pick R21, rewind pickup.	R7BL, read status relay driver logic (76.08).	R21 has no hold. It remains picked as long as button is depressed.
2D	LT R15, unload 1.	R21-3 N/O.	Drop unload status relays.
2C	LT R16, unload stop.	R21-2 N/O.	
1K	Drop R10, unload 2.	R15-3 N/O.	
2C	Pick HD4, vacuum motor.		
1K	Pick R3, load rewind 1.	R21-1 N/O.	Starts load-rewind operation. Used for load operation only.
1E	Pick R4, low-speed rewind status and DP1, takeup motor reverse.	R3AL N/O. R29-1 N/C.	R4 controls low-speed rewind. DP1 prepares takeup motor to run in reverse, to lower head and drop tape in columns.

LOAD-REWIND OPERATION (LOW-SPEED AREA), MODEL III (cont'd)

LOCATION	SEQUENCE OF OPERATIONS	CONDITIONS	REMARKS
1F	R2 and 28 held.	R3BL N/O.	Picked from unload status.
1E	Pick R8, time delay motor.	R3AU N/O. R4AU N/O.	
	Time delay motor starts.	R8AU N/O.	
1K	Pick R9, load rewind 2.	R3BU N/O.	Used with R3 for load operation only. R9-4 points hold R3.
1L	Pick R12, rewind status.	R9-5 N/O.	Used for rewind operation after the load operation.
5G	Manual reverse status to logic 76.05.02.	R12-1 N/O.	Reverse magnet energized.
5G	Rewind status.	R12-5 N/O.	
			The above operations take place with- in a fraction of a second after the LOAD REWIND button is de- pressed.
			When sufficient vacuum is obtained, the flapper and the bellows switches transfer, causing the following ac- tion.
1J	Pick R5 and R6, tape out of left and right columns.	Flapper valves and flapper switches close.	The flapper valves are closed before the bellows. The valves help pro- vide sufficient vacuum to pick the bellows.
2B	Pick R1, run, HD1, HD2, and HD3, phases 1, 2, and 3.	Bellows, R7AL N/O, and R9-1 N/O.	
	One-half power applied to stop clutches.	R1BU N/O, R2AL N/O, R1BL N/O, R2BU N/O.	One-half brake is always applied with R1 and R2 picked.
			The time delay points open.
1G	R27, go status drops.	Time delay points.	
	Manual start drops.	R27-1 N/O.	The moving pulleys move against the stop capstans, pinching the tape.
1G	Pick DP4, takeup motor start.	R27-2 N/C.	
	Start takeup motor.	DP4 points.	Takeup motor goes in reverse. The upper head assembly moves down, and tape goes into columns.
	Head-up microswitch opens.	Head more than 1/4 turn from upper limit.	
			When tape goes in the columns, the flapper valves open, dropping their associated relays.

LOAD-REWIND OPERATION (LOW-SPEED AREA), MODEL III (cont'd)

LOCATION	SEQUENCE OF OPERATIONS	CONDITIONS	REMARKS
1J	Drop R5 and R6, tape is <i>the</i> columns.	Flapper valves open.	
	Head-down microswitch opens.	Head $\frac{1}{4}$ turn from its lower limit.	
1F	Drop R2 and R28, clutch status 1 and 2.	Head-down microswitch points.	
	Tape reels under control of vacuum columns.	R2AL N/C and R2BU N/C.	Tape is adjusted in columns.
1G	Drop DP4, takeup motor start.	R28-2 N/O.	Stop takeup motor.
4D	Tape-break lamp is shunted.	R28-3 N/C.	Not usable when tape drive is loaded.
1H	Pick DP2, capstans motors.	R2AU N/C.	
	Capstans motors start and extend.	DP2 points.	Capstans extend because of solenoid action.
	Capstans-in microswitches open.	Capstans extending.	
	Capstans-out microswitches open.	Capstans fully extended.	
1K	Drop R3, load rewind 1.	R28-2 N/O capstans-out microswitches.	
1K	Drop R9, load rewind 2.	R3BU N/O.	
1E	Drop R4, LS rewind status.	R3AL N/O.	DP1 remains energized through the right capstans-out N/O switch points.
1E	Drop R8, time delay motor.	R3AU N/O.	Time-delay motor has been held energized during the load operation. The load operation is completed. The rewind operation may now be started.
1G	Pick R27, go status.	R9-3 N/C.	
5F	Manual start up.	R27-1 N/O.	The reverse line has been up since R12 was picked. Tape moves in the reverse direction until the load-point photocell senses the load point. As the tape passes under the load-point photocell (6F), the light is reflected by the load-point to the cell, causing the cell to conduct more heavily. The cell output is a negative shift that is applied to an inverter (logic 76.04). The output of this inverter is combined

LOAD-REWIND OPERATION (LOW-SPEED AREA), MODEL III (cont'd)

LOCATION	SEQUENCE OF OPERATIONS	CONDITIONS	REMARKS
			with <i>manual reverse</i> in AND circuit B23. The output of the AND circuit is used to flip a 20-ms SSr.
			The SSr output is fed to inverter 7B, thereby dropping the lower leg of AND circuit F27 (logic 76.05.01). This causes the moving coil to transfer to the stop position, stopping the tape drive in a reverse-stop status. At the same time, the right output of the SSr goes up, allowing the relay driver at 5F (logic 76.04) to conduct, latch-picking R25, load-point relay.
10H	Latch-pick R25.	Photocell.	Tape break and load-point relay.
1L	Drop R12.	R25-3 N/C.	End of rewind operation.
1G	Drop R27.	R12-1 N/O.	
5F	Drop <i>manual start</i> .	R27-1 N/O.	Start line is still deconditioned by the 20-ms SSr.
			The moving coil has been put in a stop status by <i>not arriving at load point</i> . At the end of the 20-ms SSr, the line goes up again. By that time, however, the manual-start line has gone down, keeping the moving coil in a stop status. During the 20-ms period, the status is changed from reverse stop to forward stop.
			At this time, the takeup motor is held in reverse by DP1. With DP4 (the takeup motor start relay) de-energized, there is still a small current supplied to the takeup motor through the head lock capacitors (logic 76.10.02). This produces sufficient torque to hold the upper head assembly in the down position.

E. Another approach to the Low Speed Load-Rewind Mod III Sequence.

1. The LOAD REWIND button starts two distinct operations. (1) loading tape and (2) rewinding the tape to load point. The rewinding operation is conditioned by the depression of the button but will not begin until the last sequence of the load operation is completed.

Page 1510

In this discussion of a load-rewind operation, assume the following initial conditions:

- a. The power cable is connected to an external control that is a source of power. The power is off.
 - b. The tape drive is unloaded (the normal condition with power off); the capstans are in and the head cover is up.
 - c. No reels of tape are on the machine.
2. What follows is a word sequence of bringing up power and load-rewinding:
 - a. Turn on power in unit controlling tape drive. With power on, ac is supplied to the tape drive for the 48Vdc and filament supplies, and to start the blower and fan.
 - b. After a 5-minute warm up period, dc is supplied to the tape drive. A power-on relay picks to indicate the presence of these supplies. The drive may now be operated.
 - c. Mount full reel of tape on file reel, and thread tape past idlers and read-write head assembly over to machine reel. Reel brakes may be released by pressing switch below file reel. Wind several turns of tape on machine reel until load point is well to right of head assembly. Close reel door, and depress LOAD REWIND button.
 - d. Vacuum motor and time-delay motor start turning, and tape drive goes into a reverse status.
 - e. At the end of the time delay (about 6 seconds), the vacuum is at operating strength. The take-up motor starts turning in a reverse direction, lowering the upper head assembly and the tape into each column.

- f. The takeup motor is turned off when three conditions are satisfied: (1) the head cover is all the way down, (2) tape is in the right column, and (3) tape is in the left column. The drive capstans start turning and are extended.
- g. When the capstan-out microswitches indicate that both capstans are fully extended, the machine has completed the load operation. The machine then goes into a start status, and tape is moved in a reverse direction until the load point is sensed. When the START button is depressed, the machine will be in the ready status.

F. Summary Questions

1. Refer to Fig. 1-1. Depressing the load-rewind pushbutton will pick R21. How long is R21 held energized?
2. What relays are interlocked by the "Power On" relay R17?
3. Refer to Fig. 1-1. In a load-rewind operation, assume that DP-1 has an open pick coil. What would be evident to the operator after the load-rewind pushbutton is depressed?
4. Why is it undesirable to rewind tapes while in WRT status?
5. In question #4, what circuit block will prevent a re-wind operation when the drive is in WRT status?

H. Unload Operation, Model III

Page 1590

To remove a reel of tape and mount a new reel, the drive must be in the unload status. Unload status may be obtained by depressing the RESET button and then the UNLOAD button. (Depressing the RESET button is necessary only if the NOT READY light is not lit.) During the unload operation, the capstans are retracted, the upper head assembly is raised, and tape is pulled from the columns. At the end of the operation, all motors, except the fan and blower, are stopped.

Page 3540

Since the tape drive is in the load status, the bellows switch is closed. The following relays are picked: R1, 7, 17, and 25; HD1, 2, 3, and 4; DP1 and DP2. The file protection circuit is not covered in this discussion. (Tape is at load point.)

Unload Operation, Model III

Location	Sequence of Operations	Conditions	Remarks
2C	Depress RESET button. Depress UNLOAD button.	If not ready light is out.	Drops R13. Door must be closed. Latch pick R15.
2D	Latch-pick R15, unload 1.	Unload switch points R13-6 N/C.	R15-1 points for parallel circuit hold R1, HD1, 2, and 3.
1F	Pick R2 and R28, clutch status 1 and 2.	R15-2 N/O.	
1H	Drop DP2, capstan motors.	R2AU N/C.	
1K	Pick R10, unload 2. Reset NIFA trigger (logic 76.03).	R15-3 N/O.	
4D	Tape-break lamp lights. Load point and EOT lamps shunted.	R10-5 N/C, R28-3 N/O.	The tape-break lamp is lighter when going into and in, an unload condition.

MOD III
728

UNLOAD SEQUENCE

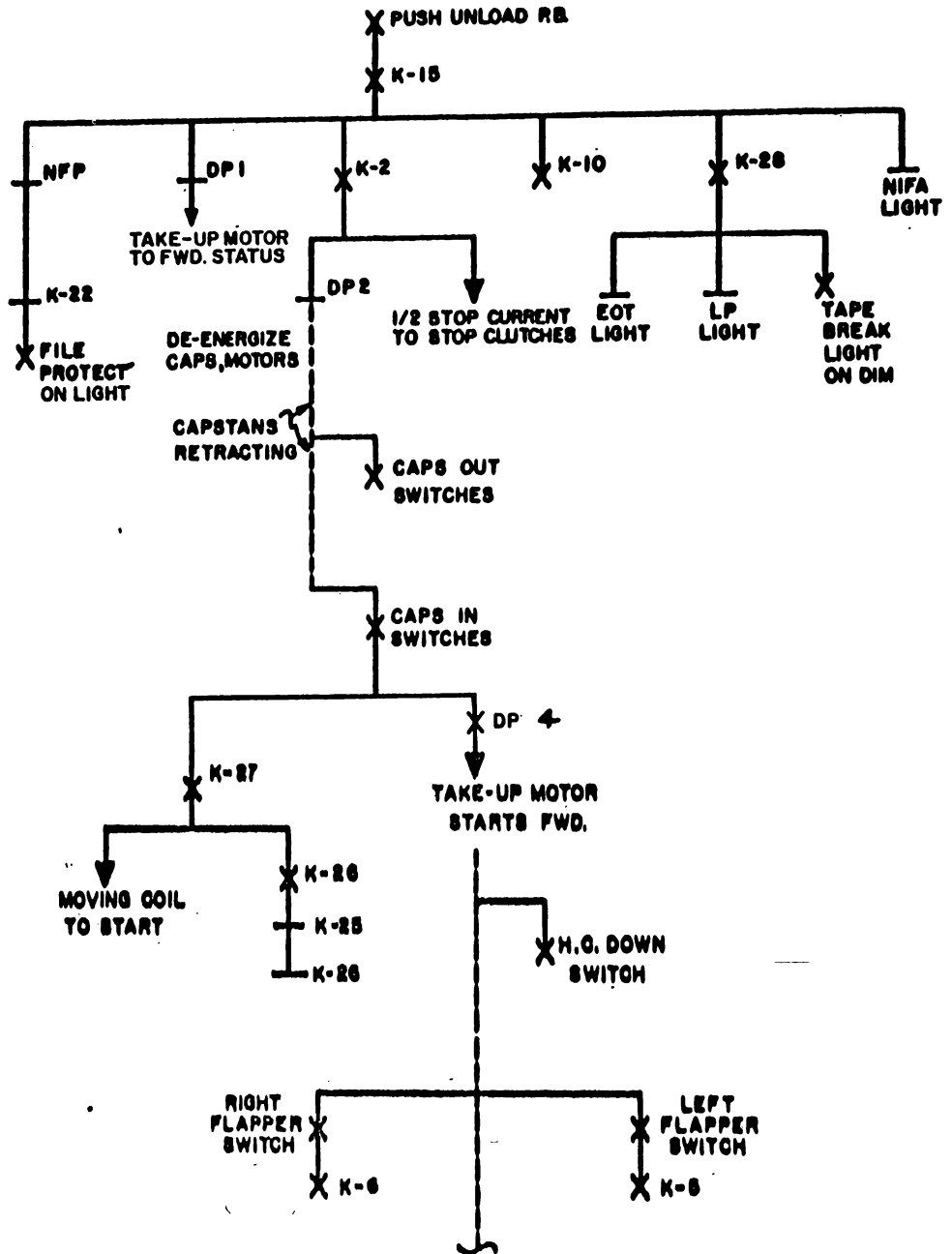

NEXT PAGE

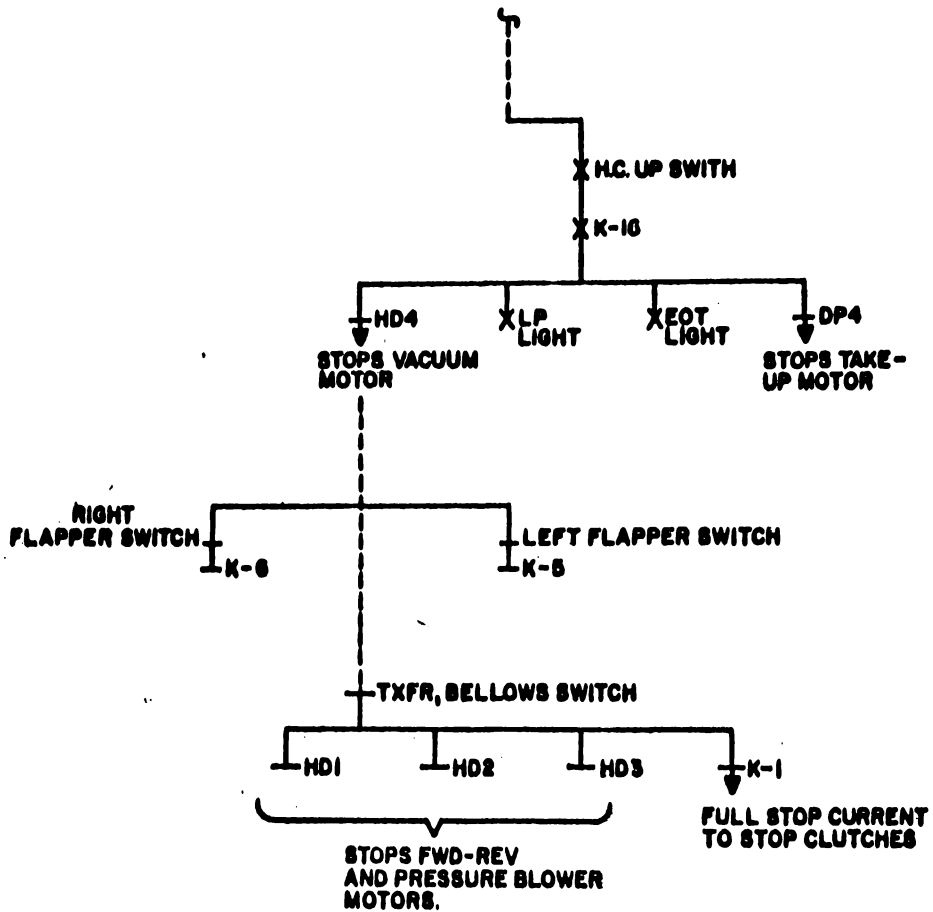

TAPE SEQUENCES- Unload

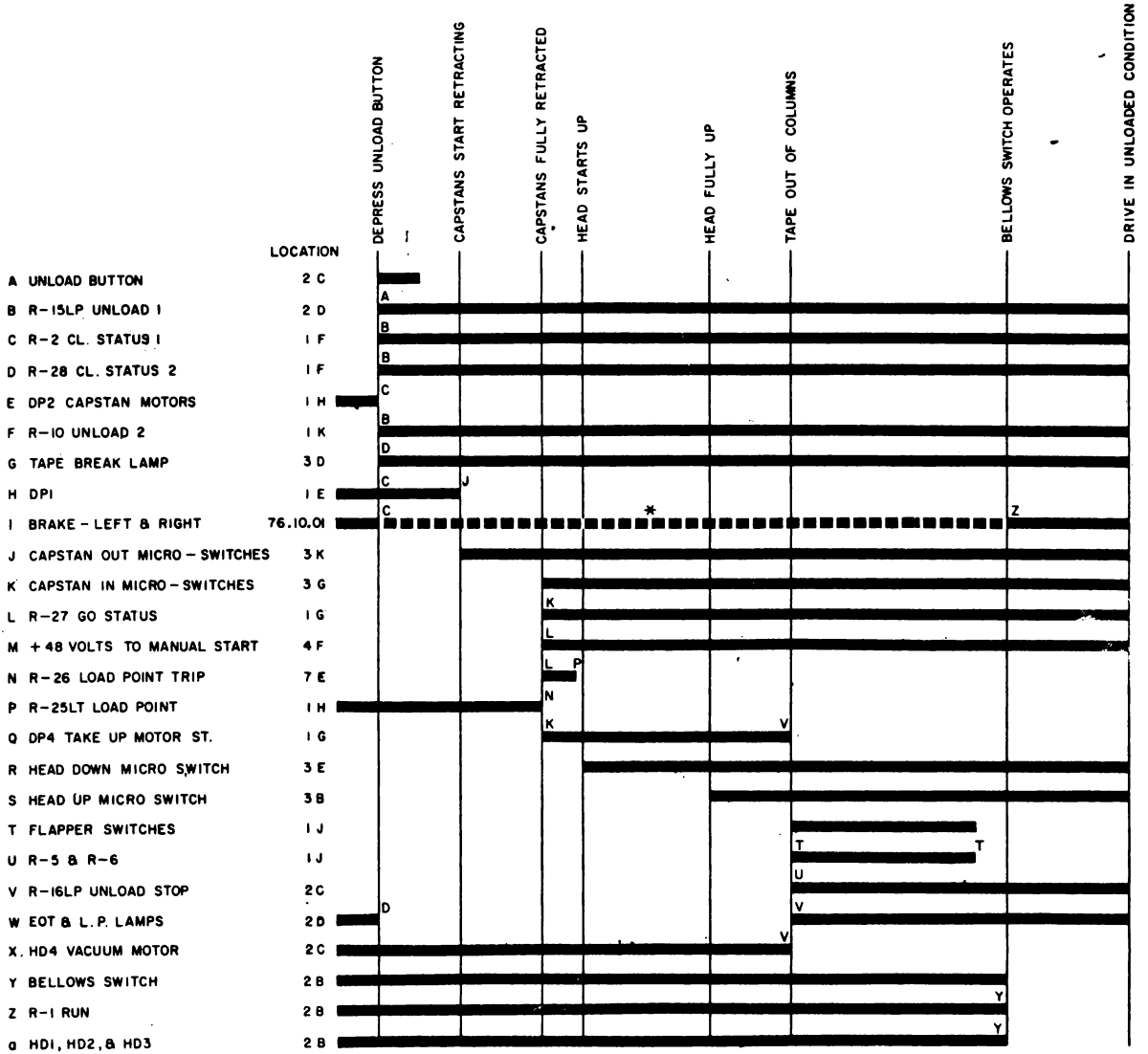

NOTE:
 *■■■■■■■■■ = 1/2 BRAKE.
 RELAY I7 AND 7 UP AND DOOR INTERLOCK
 SWITCH CLOSED THROUGHOUT THIS SEQUENCE.

Unload, Model III, Sequence Chart

Unload Operation, Model III (Cont'd)

Location	Sequence of Operations	Conditions	Remarks
6A, 8A	One-half power is applied to stop clutches.	R1BU N/O, R2AL N/O, R1BL N/O, R2BU N/O.	One-half power is applied when the tape drive is in either a load or unload operation.
1H	Capstans motors stop.	DP2 points out.	Capstans begin retract because of pressure exerted, by a spring, on the rotor.
	Capstans-out microswitches close.	Capstans moving in.	
1E	Drop DP1 takeup motor reverse.	Right capstans-out microswitch transfers.	
	Capstans-in microswitches close.	Capstans fully retracted.	
1G	Pick R27, go status.	Capstans-in microswitches closed.	
5F	Manual start line up (logic 76.05.01).	R27-1 N/O.	Moving pulleys away from stop capstans, in low position since capstans are retracted.
7E	Pick R26, tape break and load-point trip.	R25-4 N/O, manual start (logic 76.04) RDX5B	R26 picked as long as R25 remains picked.
1H	Latch-trip R25, tape break and load point.	R26-1 N/O.	Prepare the tape break and load-point relay for the next load-rewind operation.
1G	Pick DP4, takeup motor start.	Capstans-in microswitches closed.	

Unload Operation, Model III (Cont'd)

Location	Sequence of Operations	Conditions	Remarks
1G	Takeup motor starts.	DP4 points.	Upper head assembly start moving up, and tape is pulled from the columns.
	Head-down microswitch closed.	Head more than 1/4 turn from its lower limit.	
	Head-up microswitch closes.	Head 1/4 turn from its upper limit.	
	Flapper valves close. Flapper switches close.	Tape is pulled from the columns.	
1J	Pick R5 and R6, tape out of left and right columns.	Flapper switches closed.	
2C	Latch-pick R16, unload stop.	R10-3 N/O, head-up microswitch closed, R6BU N/O, R5BU N/O.	Tape must be removed from both columns and the head raised to its upper limit.
3D 2D	Load point and EOT lamps lit.	R16-3 N/C.	All lamps are now lit. If any are burned out, R7 will drop, preventing further operation.
1G	Drop DP4, takeup motor start.	R16-2 N/C.	
2C	Drop HD4, vacuum motor.	R16-1 N/C.	
10A	Vacuum motor stops.	HD4 points.	
	Flapper valves and switches open .	Insufficient vacuum.	
1J	Drop R5 and R6, tape out of left and right columns.	Flapper switches open.	
	Bellows switch opens.	Insufficient vacuum.	

Unload Operation, Model III (Cont'd)

Location	Sequence of Operations	Conditions	Remarks
2B	Drop R1, HD1, 2, and 3.	Bellows switch opens.	The tape drive is now in the unload status. All motors are stopped except the fan and blower motors. The drive remains in this status until the LOAD REWIND button is depressed.

I. Summary Questions

- (T/F)
1. In an unload operation, control is removed from the vacuum switches and transferred to the stop clutches by picking R2 and R28.
 2. Assume tape drive is loaded, selected, at load point, and NOT READY. R28-4 N/O points cannot make contact. What indication of a malfunction would the operator see if the Unload pushbutton is depressed?
 3. The tape drive is loaded and not ready. R10-3 N/O point fails to make. What visual indication occurs if the unload pushbutton is depressed?
 4. With the tape setting at EOT and loaded, the LOAD REWIND switch is depressed. The tape drive becomes unloaded but does not rewind. Trouble could be:
 - a. R4 AU contacts fail to make.
 - b. R24-4 contacts fail to make.
 - c. R21-4 contacts fail to make.
 - d. R3 BU contacts fail to make.
 - e. Head cover up switch fails to break.
 5. Select the false statement(s):
 - a. The vacuum safety switch points close when the vacuum motor stops.
 - b. If the NOT READY light is off, the RESET button must be depressed before the LOAD-REWIND button is effective.

- c. The NIFA flip-flop is set by a PER (71) from central computer.
 - d. R29 is picked only when less than $\frac{1}{2}$ inch tape is present on the machine reel.
6. Select the false statement(s):
- a. The vacuum motor does not stop until tape is removed from the columns during an UNLOAD operation.
 - b. The moving coil will be in the "Start" position and the "Reverse" magnet will be energized during UNLOAD operation.
 - c. The tape drive can become unloaded only if it is in a NOT READY condition.
 - d. Tapes are erased by magnetizing them in such a way that the lines of flux are in one direction.
 - e. Consecutive blank bits on tapes would appear as zero bits if they were to be read.

K. High-Speed Rewind, Model III

Page 1650

Time is of prime importance in the handling of large amounts of tape by the drive. When a tape has been written or read and the bulk of the tape is on the machine reel, it is best to rewind the tape at high speed.

A high-speed rewind may be started when there is at least $\frac{1}{2}$ inch of tape on the machine reel. Refer to figure 1-1, foldout, for relay circuitry.

Assume the tape to be in the load status; i. e., tape in both columns, the head down, the drive capstans extended and turning, and more than $\frac{1}{2}$ inch of tape on the machine reel.

Since the tape drive is in the load status, the bellows switch is closed; the following relays are picked: R1, 7, and 17; HD1, 2, 3, and 4; and DP2 and DP1.

In addition to the above relays, R29 is picked. The high-speed rewind area lamp beam is blocked by the tape on the machine reel. Because this beam cannot strike the high-speed-rewind area photocell, the cell's conduction is light and its plate is at +15V. This +15V level is applied to RD 6F (logic 76.08), picking R29 to allow the tape drive to perform a high-speed rewind. When sufficient tape has been removed from the machine reel, the beam is permitted to strike the photocell, causing heavy conduction. The plate voltage of the cell drops to approximately a -22V level that is applied to the RD. The RD is cut off, causing R29 to drop. Dropping R29 permits a low-speed rewind operation to begin.

The high-speed rewind circuitry is designed for safety. If the RD filaments open or the lamp burns out, the tape cannot perform a high-speed rewind.

High-Speed Rewind, Model III

Location	Sequence of Operations	Conditions	Remarks
4H	Depress LOAD REWIND button.	R13-3 N/C. NOT READY light must be on.	Reset button must be depressed to turn on NOT READY light.
4H	Pick R21, rewind pickup.	R7BL, read status, relay driver (logic 76.08).	R21 has no hold. It remains picked as long as the LOAD REWIND button is depressed.
1K	Pick R3, load rewind 1.	R21-1 N/O.	Starts load-rewind operation. Used for load operation only.

MOD. III
TYPE 728

HIGH SPEED REWIND SEQUENCE
(NOT FILE PROTECTED)

GIVEN: TAPE DRIVE LOADED, AND IN FORWARD-STOP STATUS
K-1, K-7, DP-2 AND HD-1, 2, +3 ARE PICKED.

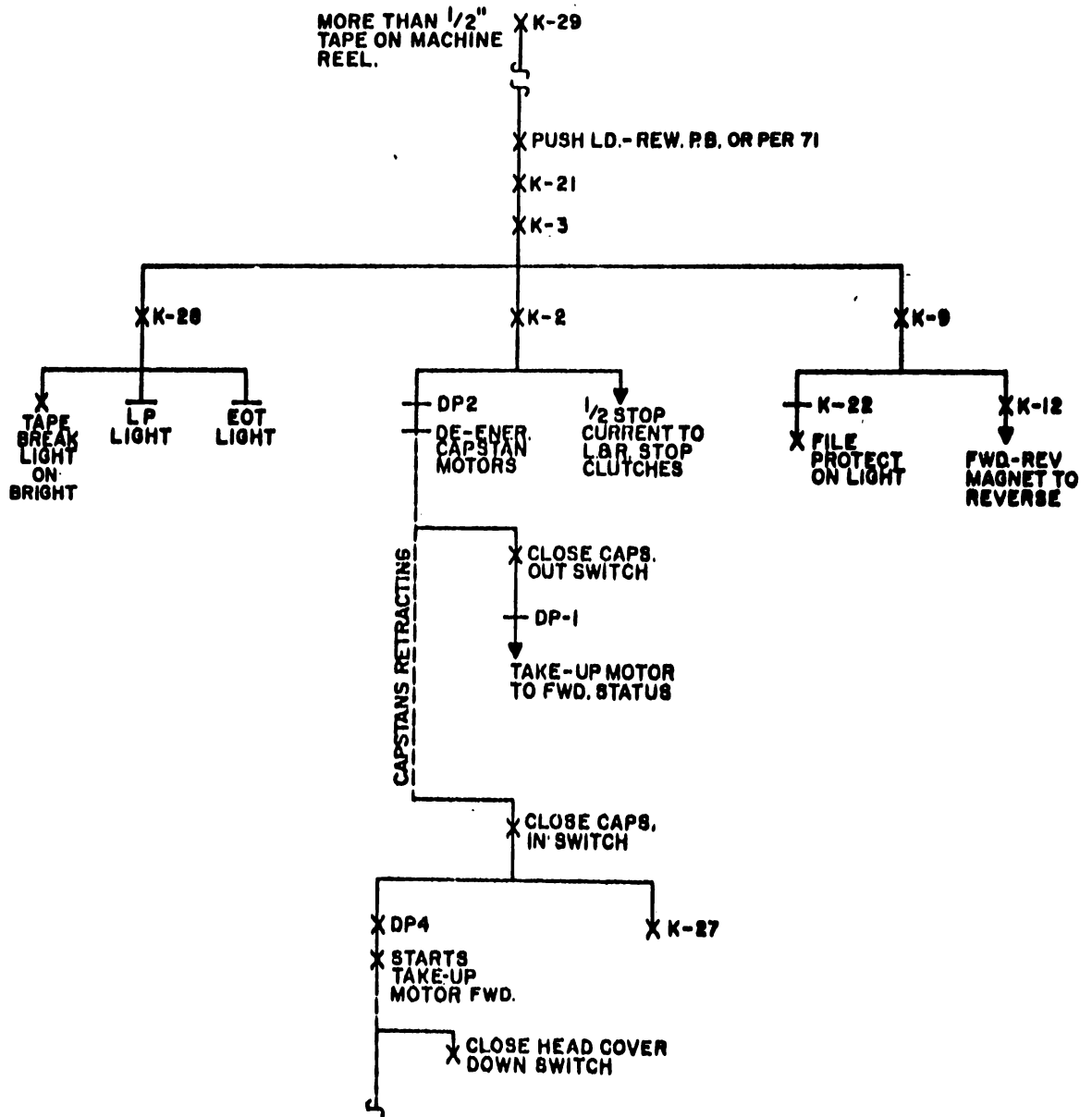

NEXT PAGE

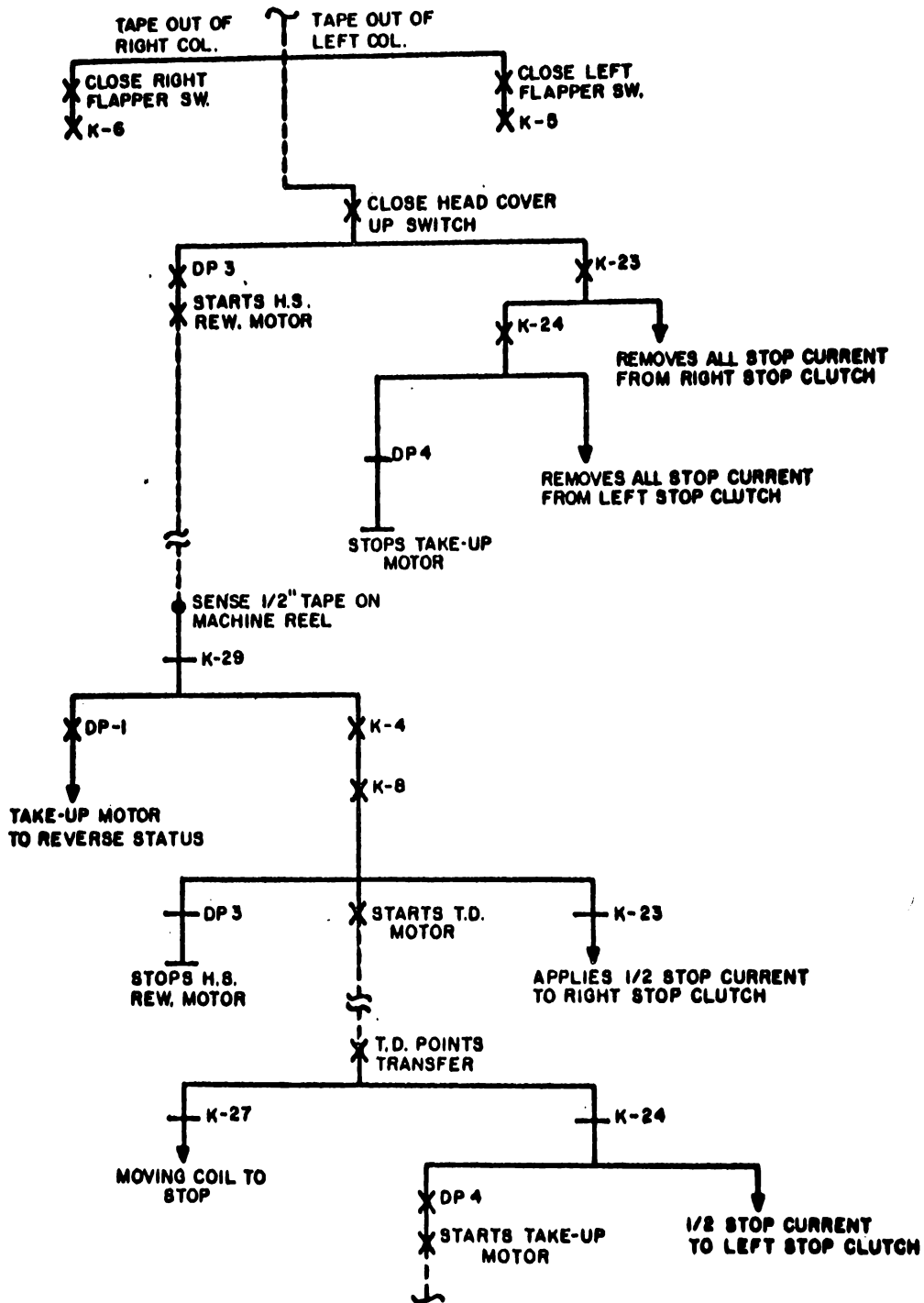

NEXT PAGE

TAPE SEQUENCES- High Speed Rewind

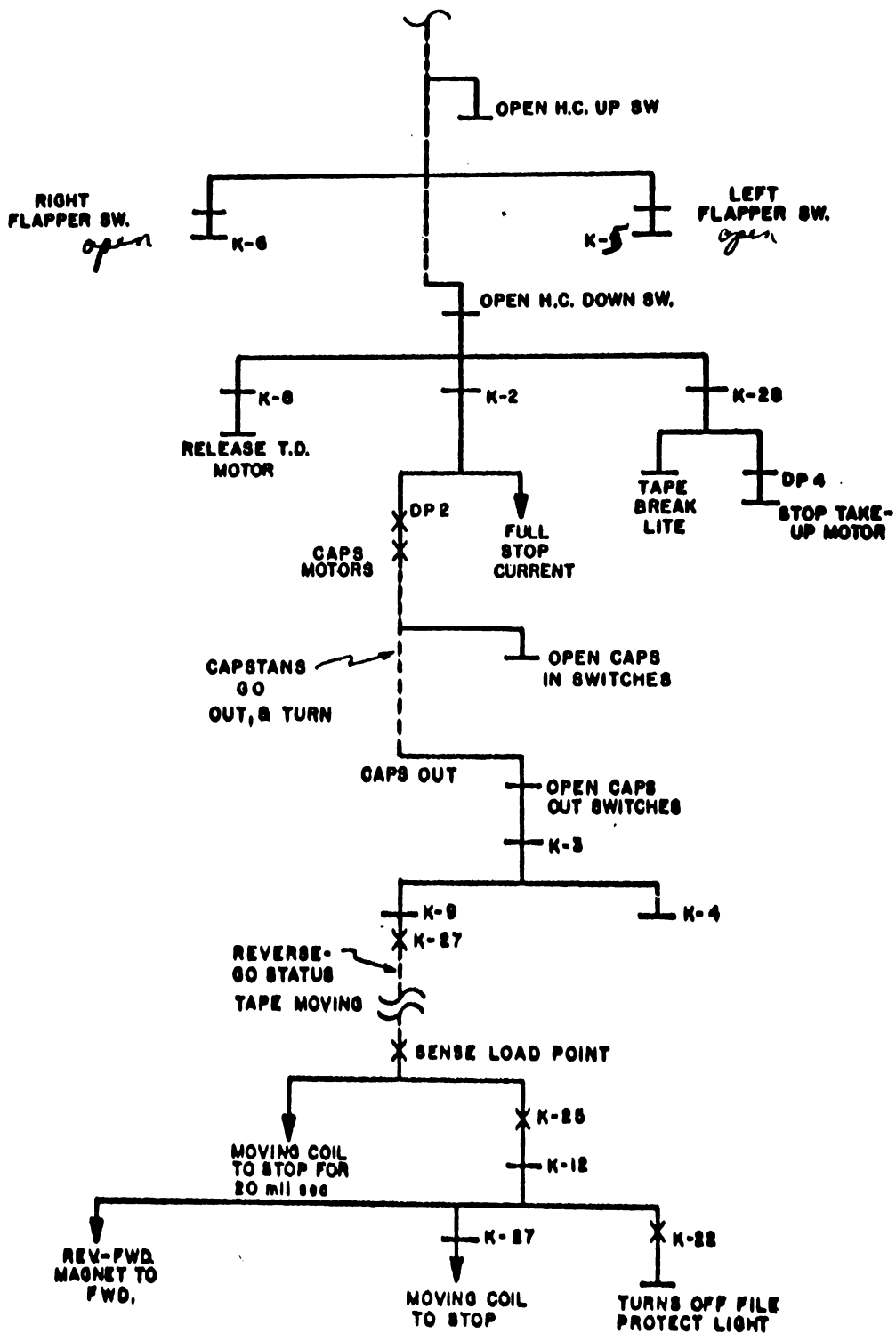

TAPE SEQUENCES- High Speed RewInd

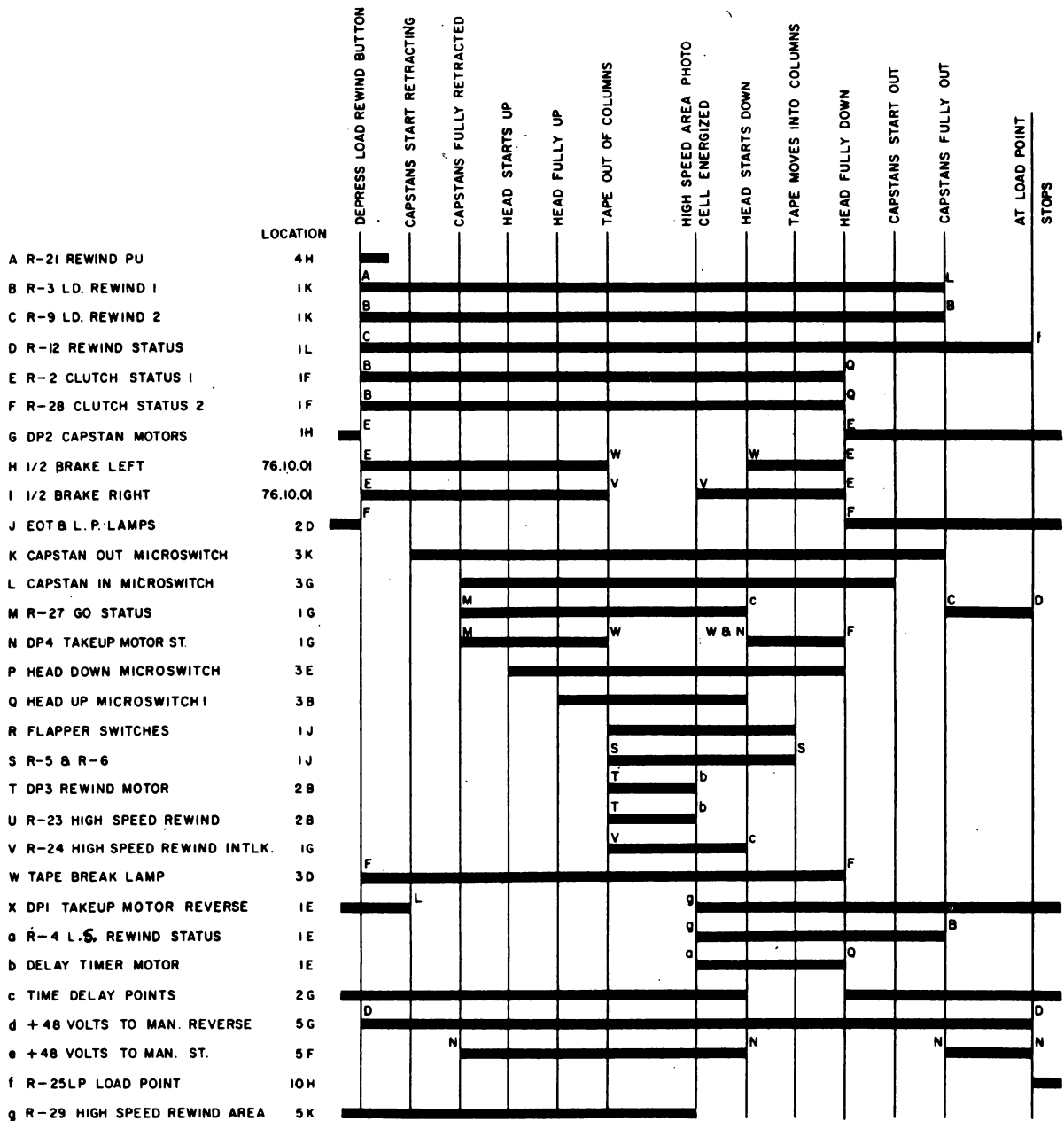

RELAYS UP THROUGHOUT THIS SEQUENCE:
 HD 1, 2, 3, & 4; R-17, R-1, & R-7.
 THE BELLOWS SWITCH AND DOOR INTERLOCK
 SWITCH ARE CLOSED THROUGHOUT THE SEQUENCE.

High-Speed Load Rewind, Model III, Sequence Chart

High-Speed Rewind, Model III (Cont'd)

Location	Sequence of Operations	Conditions	Remarks
1K	Pick R9, load rewind 2.	R3BU N/O.	Used with R3 for load operation only. R4 points hold R3.
1L	Pick R12, rewind status.	R9-5 N/O.	Used for rewind operation after the load operation.
1F	Pick R2 and R28, clutch status 1 and 2.	R3BL N/O and R4B N/C.	
1H	Drop DP2, capstan motors.	R2AU N/C.	
6A	One-half power applied to the left stop clutch.	R1BU N/O, R2AL N/O.	Tape in columns is no under control of the takeup motor, wait to go into the unload condition.
8A	One-half power applied to the right stop clutch.	R1BL N/O, R2BU N/O.	
3D	Shunt load point and EOT lamps. Tape-break lamp lights.	B28-3 N/O.	The tape-break lamp is lit going into, or in, an unload condition.
	Capstan motors stop.	DP2 points open.	Capstans begin retracting because of pressure exerted by a spring, on the roto.
2K	Capstans-out micro-switches close.	Capstans moving in.	
3K	DP1 dropped.	N/O caps out switch.	Takeup motor reverse status removed.
3G	Capstans-in micro-switches close.	Capstans fully retracted.	

High-Speed Rewind, Model III (Cont'd)

cation	Sequence of Operations	Conditions	Remarks
1G	Pick R27, go status.	Capstans-in microswitches closed R28-4 N/O.	-
5F	Manual-start line up (logic 76.05.01).	R27-1 N/O.	Moving pulleys away from stop capstans-in lowest position since capstans are retracted.
1G	Pick DP4, takeup motor start.	Capstans-in microswitches close, R28-4 N/O.	Head starts moving up, and tape is pulled from the columns.
	Takeup motor starts.	DP4 points.	
	Head-down microswitch closes.	Head more than 1/4 turn from its lower limit.	
	Head-up microswitch closes.	Head 1/4 turn from its upper limit.	
	Flapper valves close, closing flapper switches.	Tape is pulled from the columns.	
	Pick R5 and R6, tape out of left and right columns.	Flapper switches closed.	The tape drive is now in the unload condition waiting for the high-speed rewind to start. The takeup motor is stopped at that time.
			The unload condition differs from the unload status in that none of the motors is stopped. An unload condition appears as the unload status, but does not remain so at the end of the high-speed rewind operation

High-Speed Rewind, Model III (Cont'd)

Location	Sequence of Operations	Conditions	Remarks
2B	Pick DP3, rewind motor, and R23, high-speed rewind status.	R5BU N/O, R6 BU N/O, head-up microswitch R8BU N/C.	Indicates tape is out both columns and the head at its upper limit.
8A	One-half power removed from right stop clutch.	R23-1 N/C.	No power to the right stop clutch.
1G	Latch-pick R24, high-speed rewind interlock.	R23-2 N/O.	R24 forms its own circuit.
1G	Drop DP4.	R24-5 N/C.	
1G	Takeup motor stops.	DP4 points.	
6A	One-half power removed from left stop clutch.	R24-2 N/C.	No power to the left stop clutch.
	High-speed rewind motor starts.	DP3-A, B	<p>Tape starts rewinding at high speed, about 500 inches-per-second average.</p> <p>When sufficient tape has been removed from machine reel to permit the beam of the high-speed rewind photo-lamp to strike its photocell, R29 is dropped.</p> <p>Dropping R29 causes the drive to start a slow-speed rewind. The beam of the lamp is adjusted to strike the photocell when $\frac{1}{2}$ inch of tape remains on the machine reel.</p>

High-Speed Rewind, Model III(Cont'd)

Location	Sequence of Operations	Conditions	Remarks
5K	Drop R29, high-speed rewind area.	High-speed rewind area lamp beam strikes its photocell, causing RD6F (logic 76.08) to be cut off.	One-half inch of tape left on the machine reel.
1E	Pick R4, LS rewind status, and DP1, takeup motor reverse.	R29-1 N/C.	
1E	Pick R8, time-delay motor.	R4AU N/O.	
2B	Drop DP3, rewind motor, and R23, high-speed rewind status.	R8BU N/C.	
	Start time delay motor.	R8AU N/O.	The timer is adjusted to allow the reels to coast to a stop before the drive starts the load operation.
	Rewind motor stops.	DP3-A, B	Power removed from rewind motor.
8A	Apply one-half power to the right clutch.	R23-1 N/C.	One-half power is applied to the right clutch to slow the reels down to a stop. The one-half power to the right stop clutch is adjusted so that about 1/16 inch of tape remains on the machine reel when it coasts to a stop.

High-Speed Rewind, Model III (Cont'd)

Location	Sequence of Operations	Conditions	Remarks
2G	Time delay points open.	Microswitch operated by motor.	Set time has elapsed (adjusted to open approximately 1 second after reels have stopped).
1H	Latch-trip R24, high-speed rewind interlock.	Time-delay points.	
6A	One-half power to left stop clutch.	R24-2 N/C.	One-half power needed for the load operation.
1G	Drop R27, go status.	Time-delay points.	
5F	Manual-start line drops.		Pulleys move toward stop capstans, out of the way of the retracted drive capstans. Tape is also pinned against the stop capstan for loading in the column.
1G	Pick DP4, takeup motor start.	R24-5 N/C, R27-2 N/C.	From this point on, sequence of events identical with the speed rewind. Operation ends when the load-point is reached.

L. Summary Questions (Refer to Fig. 1-1)

1. In order for R21, the rewind relay to be picked, the tape drive must be placed in read status. What relay points control this and under what conditions?

2. Fig. 1-1 (5G) If the output of circuit block K T03J 5F remains at -30 volts, what would occur if a low speed rewind operation were initiated?
3. In a H. S. load-rewind sequence, the head cover is raised, tape is removed from the vacuum columns, the nylon pulleys are in REV-start but no H. S. rewind takes place. The most likely cause would be:
 - (1L) a. R12 open coil
 - (3B) b. 6DU N/O points did not make contact.
 - (1E) c. R4 is picked.
 - (1K) d. 17-3 remain open.
 - (4D) e. R7 has open coil.
4. R16 LT coil is open. What would be the symptoms of this trouble as observed by an operator?

N. Purposes of Relay Points and Switches, Model III

For all relay point locations, refer to figure 1-1.

1. Relay 1, the run relay, is picked when the bellows switch closes. It senses failures such as fuse bail operation, loss of vacuum in either column, photo-cell lamp failure, or bellows switch operation during a normal operation:

1AU Completes circuit for +48V to CE switch and ready, drops ready in case of any of the failures mentioned above.

- 1AL Drops R13 (start) for any of the above failures.
 - 1BU Applies full brake to the file reel when normal. N/O points complete a circuit to the R2AL points when R1 is energized.
 - 1BL Same use as R1BU but applied to the machine reel.
2. Relay 2, clutch status relay 1, is picked during re-wind, load, and unload operations. When energized, it allows a circuit to be completed for half-brake on both reels. R2 points also control the energization of the capstan drive motors:
- 2AU N/C points pick DP2 to allow the capstan motors to run only when R2 is down.
 - 2AL Places file reel under control of the left vacuum column switches during normal operation.
 - 2BU Places machine reel under control of the right vacuum column switches during normal operation.
3. Relay 3, load rewind 1, is picked for load operation:
- 3AU Picks R8 to start time delay in slow-speed rewind operation.
 - 3AL Picks R4 (high-speed rewind end 1) and takeup motor reverse relay DP1.
 - 3BU Picks R9 (load-rewind 2).
 - 3BL Holds R2 and R28 when R15 is latch-tripped at start of a load operation in a slow-speed area. It picks R2 and R28 at the start of a high-speed re-wind operation.

4. Relay 4, low-speed rewind area, is picked during load-rewind operations when less than $\frac{1}{2}$ inch of tape is on the machine reel:
 - 4AU Picks R8 (time delay motor) when entering low-speed rewind area from high-speed rewind.
 - 4AL Completes a pick circuit for DP4 to start the takeup motor when R27 is up, at the beginning of a high-speed rewind operation.
 - 4BU Causes the load point and EOT lamps to come on at the start of a low-speed rewind.
 - 4BL Holds R4 and DP1 when entering low-speed rewind from high-speed rewind.

5. Relay 5, flapper switch, is picked when the left flapper-valve switch is operated:
 - 5AU Drops R1 (run) if tape is not in the left column during normal operation.
 - 5AL Drops R27 (go status) if tape is not in left column during a low-speed rewind operation.
 - 5BU N/O, interlock on pick of R23 (high-speed rewind status). Tape must be out of left column before entering high-speed rewind. N/C, anti-spill device, 1/2 brake is applied to file reel if tape goes into the left column at the end of a high-speed rewind and ensures proper load operations if file reel is free-wheeling.
 - 5BL Ensures retention of the capstans until the flapper valves are conditioned.

6. Relay 6, flapper switch, is picked when the right flapper-valve switch is operated:
 - 6AU Drops R1 (run) if tape is not in the right column during normal operation.

- 6AL Drops R27 (go status) if tape is not in the right column during a low-speed rewind operation.
- 6BU N/O, interlock on pick of R23 (high-speed rewind status). Tape must be out of right column before entering high-speed rewind status.
- N/C, same as 5BU N/C, except with reference to the right column.
- 6BL Same as 5BL points.
7. Relay 7, photo-lamp, is picked through the tape break, load point, EOT lamps when +48V is up. It drops as a result of a failure of any of the lamp filaments:
- 7AL Drops R1, HD1, HD2, and HD3 with a photo-lamp failure.
- 7BL Interlocks, prevents picking R21 (rewind PU) when a photo-lamp has failed.
8. Relay 8, time-delay motor, is picked during rewind operations to start the time-delay motor:
- 8AU Completes a circuit from phase 1 through the timer motor to phase 2.
- 8BU Drops R23 when timer starts and prevents picking R23 (high-speed rewind) while timer is running.
9. Relay 9, load-rewind 2, is picked when R3 is picked:
- 9-1 Parallels R5AU and R6AU to pick R1, HD1, HD2, and HD3 during a load-rewind operation.
- 9-2 Allows R13 to be picked before bellows switch operates.
- 9-3 Completes a circuit to R27 (start) during rewind operation.

- 9-4 Hold circuit for R3 during a load operation.
 - 9-5 Picks R12 (rewind status) at the start of a load operation.
 - 9-6 Makes it impossible to write during a load operation by dropping R22.
10. Relay 10, unload 2, is picked when the tape drive starts an unload operation:
- 10-1 Latch-trips R24 high-speed rewind interlock if the UNLOAD button is depressed during a high-speed rewind.
 - 10-2 Prevents R13 from being held during an unload operation.
 - 10-3 N/O, causes R16 to be latch-picked when the tape is out of the columns on unload.

N/C, drops R23 high-speed rewind status if the UNLOAD button is depressed during a high-speed rewind.
 - 10-5 N/C, drops the parallel resistance circuit around the R7 coil, causing the photocell lamps to dim when the drive is unloaded.
11. Relay 12, rewind status, is picked when the LOAD REWIND button is depressed:
- 12-1 Supplies a circuit for +48V to the 9-3 points so R27 can be picked, and a circuit to manual reverse.
 - 12-2 Supplies a hold circuit for R12.
 - 12-3 Furnishes a d-c reset to set the R/W trigger to read status in a rewind operation.
 - 12-4 Keeps not file protect down during rewind operations by dropping R22.
 - 12-5 Drops mechanically ready and bring up rewind status.

- 12-6 Drops high-speed rewind relays when the rewind operation is reset.
12. Relay 13, start relay, is picked when the START button is depressed and holds until the RESET button is depressed:
- 13-2 Hold point R13.
 - 13-3 Drops relay reset so that the R/W trigger can be operated.
 - 13-4 Opens the circuit to the load-rewind switch when the tape drive is under external control.
 - 13-5 Brings up mechanically-ready line.
 - 13-6 Opens the circuit from the unload switch to the latch pick coil of R15. Cannot unload without first depressing the RESET button.
13. Relay 15, unload I latch pick and latch trip, latch-picks when the UNLOAD button is depressed; it latch-trips when R21 is picked for a load-rewind operation:
- 15-1 Drops the NFP relay during an unload operation.
 - 15-2 Picks and holds R2 and R28 when the UNLOAD button is depressed.
 - 15-3 Picks R10 (unload)2) relay.
 - 15-4 Breaks the circuit to R27, dropping R27, go, if the UNLOAD button is depressed while in manual-forward or backward-go operation.
14. Relay 16, unload stop latch pick and latch trip, latch-picks to end an unload operation when the head is up and tape is out of both columns. Latch-trips when the LOAD REWIND button is depressed:
- 16-1 N/C points complete the circuit to HD4 to start vacuum motor.

N/O points supply +48V to the 21-1 points to latch-trip R16 for load rewind.

- 16-2 Drops DP4 to stop the takeup motor at the end of an unload operation.
 - 16-3 Opens the circuit around the load-point and EOT lamps when drive is in the unload status.
15. Relay 17, power on reset, is picked when d-c voltage is up in the external source:
- 17-1 Drops R1, HD1, HD2, and HD3 if d-c voltage drops.
 - 17-2 Prevents picking R21, R25, LP, R26, and R29 until d-c power is up.
 - 17-3 Prevents picking of R3 when d-c power is coming up.
 - 17-4 N/O prevents picking R12 when d-c power is coming up.
- N/C holds NIFA reset off until d-c power comes up.
16. Relay 21, rewind PU, is picked by relay driver T03J4B (logic 76.08):
- 21-1 Completes the circuit to pick R3, starting the load-rewind operation.
 - 21-2 Latch-trips R16 to drop the unload status.
 - 21-3 Latch-trips R15 to drop the unload status.
17. Relay 22, not file protect 2, is picked when file reel is not protected. It allows tape drive to go into the write status:
- 22-1 N/C turns on the FILE PROTECT ON light.
- N/O brings up NOT FILE PROTECT.

- 22-4 Applies -130 voltage to write triggers and the erase head.
18. Relay 23, high-speed rewind status, is picked when the tape is out of both columns and the head is up, during a high-speed rewind operation:
- 23-1 Opens the circuit for 1/2 brake on the machine reel during high-speed rewind.
- 23-2 Picks R24 during the high-speed rewind.
19. Relay 24, high-speed rewind interlock, latch pick, and latch trip, is latch-picked by R23 and latch-tripped when unload button is depressed or when the time-delay points transfer:
- 24-1 Opens the circuit around the tape-break lamp during a high-speed rewind.
- 24-2 Opens the circuit for 1/2 brake on the file reel during high-speed rewind.
- 24-4 Opens the circuit to pick DP4 during high-speed rewind.
20. Relay 25, load point relay, latch pick, and latch trip, is latch-picked when the tape has reached load point during the rewind operation:
- 25-1 Disables the manual-reverse line if the tape is at load point.
- 25-2 Opens the circuit to pick R3 if tape is at load point.
- 25-3 Drops R12 (rewind status) when load point is reached during a rewind operation.
- 25-4 Brings up at load point.
21. Relay 26, load point trip, is picked when start comes up if the tape is at load point with R25 picked:
- 26-1 Completes a circuit to latch-trip R25.

22. Relay 27, go status, is picked during any manual operation: load, rewind, and unload:
- 27-1 Brings up manual start.
 - 27-2 Picks DP4 during the load operation.
23. Relay 28, clutch status 2, is picked during rewind, load, and unload operations:
- 28-2 Forms a hold circuit for R3 (load-rewind 1) at the beginning of a load operation.
 - 28-3 N/C opens circuit around tape-break lamp during load and unload operations.

N/O sets up circuit around load point and EOT lamps during load and unload operations.
 - 28-4 N/O completes circuit to takeup motor during load and unload operations.
24. Relay 29, high-speed rewind area, is picked when the machine reel contains sufficient tape ($\frac{1}{2}$ inch or more) to block the light to the high-speed-rewind area photocell:
- 29-1 Picks low-speed-rewind area relay, R4, to start low-speed rewind.
25. DP1, takeup motor reverse, is picked up during the load operation. DP1 A and B points switch two phases to the takeup motor, allowing it to run in reverse.
26. DP2, capstans motors relay, is picked when tape unit is in load status. DP2 A and B switches two phases to the capstans motors, allowing them to operate.
27. DP3, rewind motor relay, picked during high-speed rewind. DP3 A and B points switch two phases to the rewind motor during high-speed rewind.
28. DP4, takeup motor start, is energized during load and unload operation. DP4 A and B points switch two phases to the takeup motor.

29. HD1, phase 1 relay, is picked when the bellows switch closes. Controls phase 1 of the 3-phase 208Vac supply. Contacts located in systems (logic 76. 10. 02).
30. HD2, phase 2 relay, is picked same time as HD1. Controls phase 2 of the 3-phase 208Vac supply. Contacts located in 10C.
31. HD3, phase 2 relay, is picked same time as HD1. Controls phase 3 of the 3-phase 208Vac supply. Contacts located in 10A.
32. HD4, vacuum motor relay, is energized when R16 is latch-tripped at start of load operation. Contacts (10B) complete circuit to the vacuum motor.
33. NFP, the not file protect 1 relay, is energized by the sense pin which operates its armature, causing the NFP AL points to complete the circuit to the relay coil. This relay is up when a plastic ring is placed in the file reel. When down, this relay prevents writing on tape:

NFP AL Provides circuit to energize the NFP relay coil.

NFP BL Picks R22 not file protect 2.

34. The fuse bail switch points light the fuse light when the fuse bail is moved by a fuse plunger.
35. The door interlock switch points are shown with the door open. When the door is closed, the points transfer to supply +48V to R1, HD1, HD2, and HD3.
36. When sufficient vacuum is up, the bellows is contracted, allowing the bellows switch points to return to the normally closed position.
37. The right and left capstan-in switch points are normally open points of microswitches. When the capstans are in, they are closed.
38. The CE switch is a manually operated, single-pole, 3-position switch. When the switch is set to forward go, R27 is picked. When it is set to backward go, R27 is picked and manual reverse comes up.
39. The left and right capstan-out switch points are normally closed points of microswitches. When the capstans are out, the points are open.
40. The time delay switch points open at the end of a determined number of seconds, set on the dial, after the motor starts. When motor is off, points return to their normal position.

41. The flapper switches are mercury switches. When vacuum is up and tape is out of the columns, the shown points are closed because the rush of air in the columns closed the flapper valves.
42. The UNLOAD switch is a manually operated pushbutton furnishing a circuit to latch-pick R15.
43. The LOAD-REWIND switch is a manually operated pushbutton that applies +48V to manual load-rewind and AND's with the read status, causing R21 to be picked.
44. The head-down switch points are normally closed points that open when the head is 1/4 of a turn from its lower limit.
45. The RESET switch is a manually operated pushbutton which, when depressed, causes R13 to drop.
46. The START button picks R13 when depressed.
47. The head-up switch points are normally open; the points are closed when the head is 1/4 of a turn from its upper limit.

O. Summary Questions

1. How many tape drives per computer are possible?
2. How many bits are written per character in the tape word?
3. How long is the end of record gap?
4. What is the purpose of unit #18?
5. Where is the +48 volts for the tape drives produced?
6. When is the unload pushbutton active?
7. What is an end of file word?
8. What is a record?
9. On tapes, what system of writing is used?
10. What is the purpose of the tape adapter unit #13?
11. If the file protection light is on, what does this indicate?
12. Identify the left and right reels.
13. List three conditions that can make a tape drive "Not Ready."
14. List three conditions that make a tape drive "Not Prepared."
15. Which of the following is a normal high speed rewind?
 - a. Unload and high speed rewind until there were 1/2 inch tape on the machine reel, then load and show speed rewind to load point and remain loaded,

- b. Unload, and high speed rewind until there were $\frac{1}{2}$ inch of tape on the machine reel, then load and slow speed rewind to load point, then unload.
- c. Remain loaded and slow speed rewind to load point.
- d. Unload and high speed rewind to load point.
- e. Unload, high speed rewind, until there were $\frac{1}{2}$ inch of tape on the machine reel, then remain unloaded and slow speed rewind to load point, then load.

16. Match the following switches and lights with their functions:

- | | |
|--|--------------------------------|
| _____ (a) Establishes the tape drive address | (1) "RESET" button |
| _____ (b) Makes the tape drive "READY." | (2) "NIFA" light |
| _____ (c) Lights when EOT marker is sensed. | (3) "FILE PROTECT ON" light |
| _____ (d) Loads the tape drive at load point. | (4) "SELECT" switch |
| _____ (e) Will cause the tape drive to stop if in low speed rewind. | (5) Machine Reel Sensing Light |
| _____ (f) Will cause the tape drive to change from high to low speed rewind. | (6) "LOAD AND REWIND" button |
| _____ (g) Indicates tape can be read but not written on. | (7) "UNLOAD" button |
| | (8) "START" button |

17. Current flow, in one direction, causes the moving coil to move downward and the nylon pulleys move towards their respective _____ capstans. Current in the opposite direction causes the moving coil to move upward and the nylon pulleys move towards their respective _____ capstans.

18. The drive capstan that causes movement of the tape is determined by the _____ magnets.

19. Identify the vacuum switches which control tapes in the column:

a. Tape moves forward:

- 1) Takes tape out of column.
- 2) Supplies tape to column.

b. Tape moves in reverse:

- 1) Takes tape out of column.
- 2) Supplies tape to column.

VI. Tape Drive, Model II

A. Differences Between Model II and Model III

The basic operation of the Model II 728 Tape Drive Unit is the same as that of the Model III. The following are the differences between the two models.

1. Electronic Circuits

The electronic circuitry for model II is logically the same as for model III. The model II relay circuitry is more complex, using more relays than model III to perform the same operations.

The model II tape break circuit is entirely different from the model III. It uses its own relay, R41, and end-of-tape photocell.

2. Mechanical Principles

The magnetic clutch mounting is built of fabricated steel plate. The model II also has an assembly of six magnetic clutches. The clutches are removed as an assembly.

The capstans are spring-extended and solenoid-retracted; the capstans-in and -out microswitches are cam-operated by the retracting mechanism. The capstans are rotated by a motor and pulley arrangement. These are other minor differences which do not alter the basic operation.

3. Comparable Relays

Model II	Names	Model III	Model II	Names	Mode.
DP2	Capstan motor	DP2	DP2	Rewind motor	DF
R13	Clutch status	R2	R40	Rewind pickup	R2'

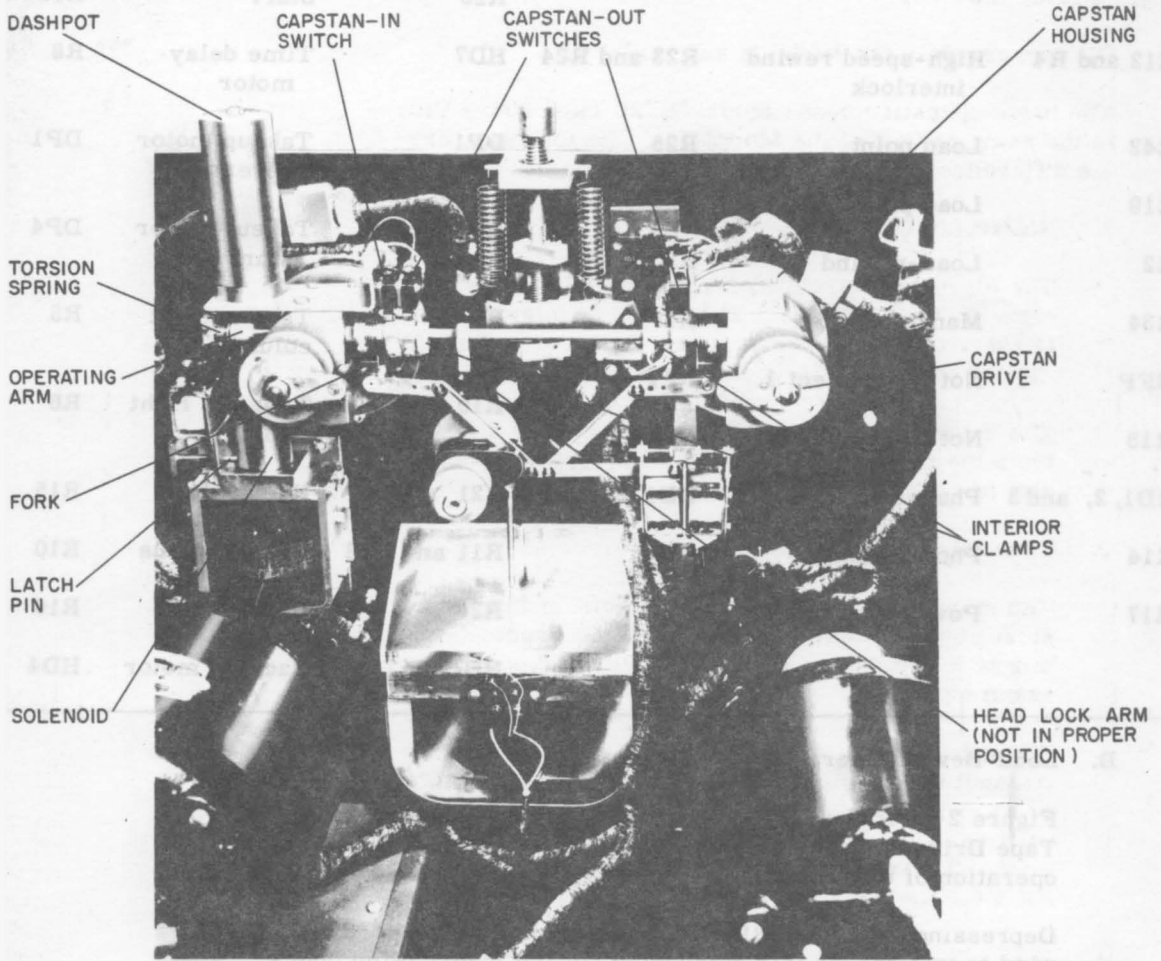

Figure 2-24. Capstan Mechanism, Model II

Model II	Names	Model III	Model II	Names	Mode
R25	High-speed area	R29	R35 and R36	Rewind status	R12
R5 and R6	High-speed rewind end 1	R4	R1 and R18	Run	R1
			R20	Start	R13
R12 and R4	High-speed rewind interlock	R23 and R24	HD7	Time delay motor	R8
R42	Load point	R25	DP1	Takeup motor reverse	DP1
R19	Load point trip	R26			
R2	Load-rewind	R3 and R9	HD5 and 6	Takeup motor start	DP4
R34	Manual start	R27	R9	Tape out left column	R5
NFP	Not file protect 1	NFP			
R15	Not file protect 2	R22	R10	Tape out right column	R6
HD1, 2, and 3	Phases 1, 2, and 3	HD1, 2, and 3	R21	Unload start	R15
R14	Photo-lamps	R7	R11 and R22	Unload status	R10
R17	Power-on reset	R17	R26	Unload stop	R16
			HD4	Vacuum motor	HD4

B. Load-Rewind Operation, Model II

Figure 2-1, foldout, is a relay diagram of the Model II 728 Tape Drive and should be used when following the load-rewind operation of the model II.

Depressing the LOAD REWIND pushbutton starts a load-rewind operation. In this discussion, of the load-rewind operation, assume the following conditions.

1. The power cable is connected to an external control that is a source of power. The power is off.
2. The tape drive is in the unload status; the capstans are retracted and latched; the tape is out of the columns and the head is up.

When external power is first turned on, the 48Vdc supply is energized from phases 1 and 2 of the 3-phase, 208Vac supply. The blower and fan motors are energized from phases 2 and 3 (logic 75.10.02), and the filament power is supplied through the filament transformers (logic 75.10.05) by the 236V regulated external supply.

The following relays can pick with the 48Vdc supply because the tape drive is assumed to be unloaded.

Load-Rewind Operation (Low Speed Area), Model II

Location	Sequence of Operations	Conditions	Remarks
75.09.04. -.05	R21, R26, unload, are latched.		These relays were latched the last time the machine was unloaded.
75.09.05	Pick R11, R22, unload.	R21-4 N/O.	
75.09.01	Pick R14, photo-light.		Circuit through the load point, EOT, and tape-break light.
75.09.05	Pick R8, head not down.	Head-down micro-switch.	
75.09.05	Pick R7, capstans-in.	Capstans-in micro-switch.	
75.10.01	Full power to both stop clutches.	R1AU N/C, R4ALN/C, R1BU N/C, R4BL N/C.	Power to stop clutches can be interrupted by depressing reel release button. After a 5-minute warmup, d-c supplies are available from the external control.
75.09.01	Pick R17, power on.	When d-c supplies have been completely sequenced on.	
75.09.06	Pick HD3, phase 3.	R17-4 N/O.	

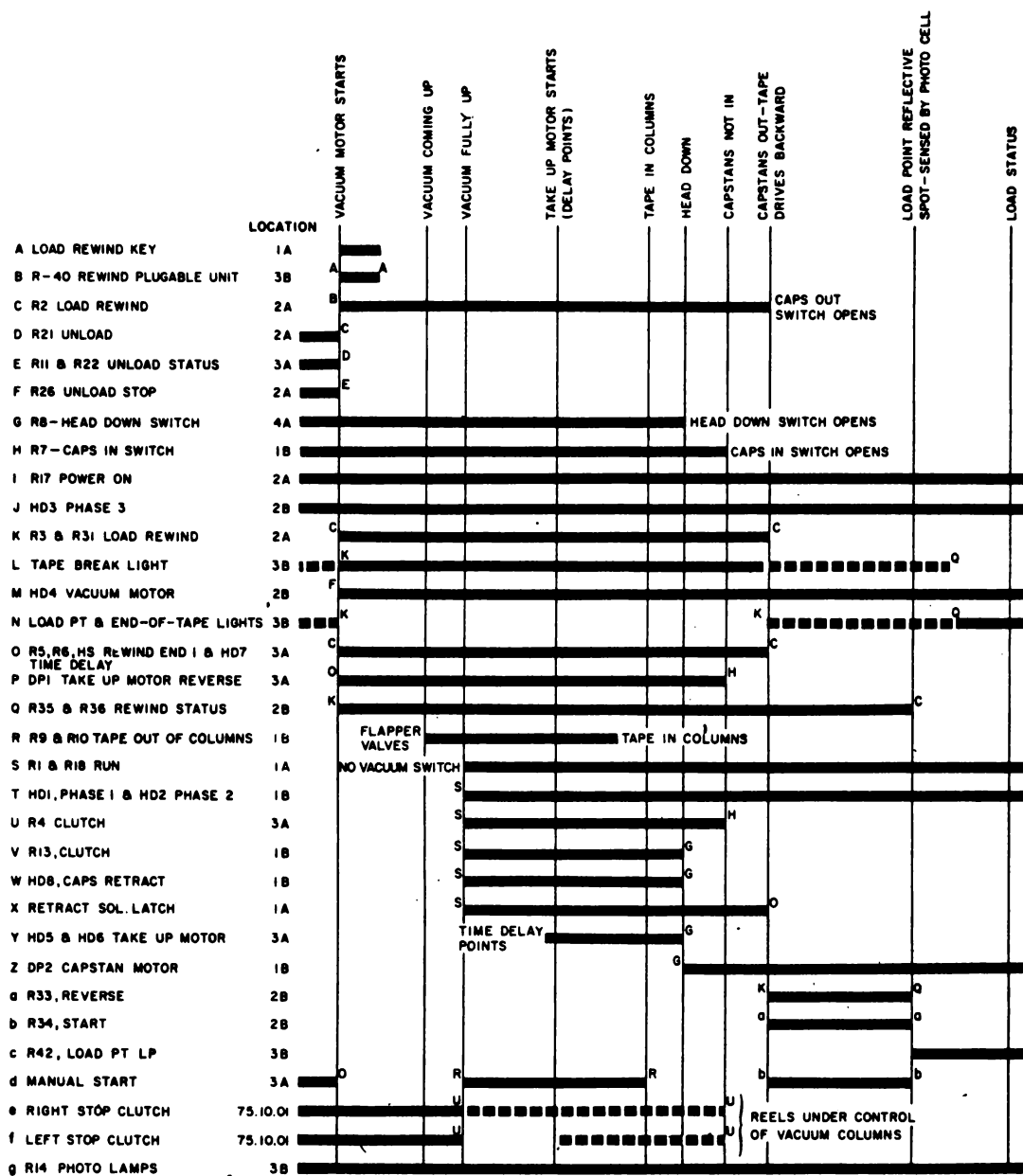

728 Tape Drive, Model II Load-Rewind, Sequence Chart

Load-Rewind Operation (Low-Speed Area), Model II (Cont'd)

Location	Sequence of Operations	Conditions	Remarks
75.09.02	Reset R/W status trigger to read status.	R20-3 N/C.	Positive d-c reset.
75.09.02	Reset NIFA trigger.	R22-4 N/C.	
75.09.02	Manual-start line up.	R7AU N/O, R22-3 N/O, R6BU N/C, R8BL N/O.	The moving pulleys are transferred away from the stop capstans. Thread tape on machine.
75.09.02	Depress LOAD REWIND pushbutton.		
75.09.03	Pick R40, rewind RU.	R42-3 N/C, relay driver (logic 75.08), manual load-rewind line and read status.	R40 has no hold circuit.
75.09.04	Pick R2, load-rewind.	R40-1 N/O, R14BU N/O, R17-3 N/O.	Hold R2 through capstans-out micro-switch, R2AL N/O, R22-7 N/C.
75.09.05	Pick R3, R31, load-rewind, R2BL N/O. LT R21, unload.		
75.09.05	Drop R11, R22, unload	R21-4 N/O.	
75.09.05	LT R26, unload stop.	R22-9 N/O.	
75.10.02	Start vacuum motor.	HD4 point.	
75.09.01	Shunt load point and EOT lights.	R3AU N/O.	
75.09.04	Pick R5, R6, start slow rewind and HD7, time delay.	R2AU N/O high-speed rewind area.	Hold circuit R5AL N/C.
75.10.02	Time delay motor.	HD7 point.	

Load-Rewind Operation (Low-Speed Area), Model II (Cont'd)

Location	Sequence of Operations	Conditions	Remarks
75.09.05	Pick DP1, takeup motor reverse.	R6BL N/O.	Prepare to run takeup motor in reverse.
75.09.01	Pick R35, R36, rewind status.	R31-4 N/O.	Held through R35-1 N/O until load point is reached.
75.09.02	Drop the manual-start line.	R6BU N/C.	The above operations all take place within a fraction of a second after the LOAD REWIND Pushbutton is depressed. When sufficient vacuum is obtained, the flapper valve switches close, causing the no-vacuum switch close.
75.09.05	Pick R9, R10 tape out of columns.	Flapper valve micro-switches.	
75.09.04	Pick R1, R18 run.	No-vacuum switch.	
75.09.06	Pick HD1, phase 1 and HD2, phase 2.	R1AL N/O.	Reel drive motors start.
75.09.04	Pick R4, clutch.	R1BL N/O, R7AL N/O, R21-2 N/C and R2 hold circuit.	
75.10.01	One-half power applied to right stop clutch.	R5BL N/O.	
75.10.01	All power removed from left brake.	R4AL N/O.	

Load-Rewind Operation (Low-Speed Area), Model II (Cont'd)

Location	Sequence of Operations	Conditions	Remarks
09.06	Pick R13, clutch transfer.	R1AL N/O.	
09.06	Pick HD8, retract capstans.	R1AL N/O.	
09.06	Energize capstan retracting solenoid.	HD8 points.	Remove pressure from solenoid latch.
09.06	Energize retracting solenoid latch.	R1AL N/O.	Capstans are prepared to extend when the retracting solenoid is released.
75.09.02	Manual-start line is brought up.	R9BL N/O, R10BL N/O, R31-6 N/O, R8BL N/O.	Manual start is not used at this time. The time-delay point closes.
75.09.06	Pick HD5 and HD6, takeup motor start.	Time delay point.	
75.10.02	Start takeup motor.	HD5 and HD6 points.	
75.10.01	One-half power applied to left stop clutch.	R4AL N/O, R12AL N/C, R7BL N/O time delay point, R7AU N/O.	With one-half power on both stop clutches, the takeup motor spills tape into the columns. When tape gets into either column (assume the left column), its flapper valve opens, dropping R9. The manual-start line goes down (logic 75.09.02), pushing the left moving pulley up against its stop capstan, pinching the tape. The tape then

Load-Rewind Operation (Low-Speed Area), Model II (Cont'd)

Location	Sequence of Operations	Conditions	Remarks
			goes into the other column dropping R10. If tape not pinched by dropping the left column would all the tape spilled from both reels.
75.09.05	Drop R8, head cover not down.	R9BU, R10BU, head-down microswitch opens.	Head cover is down, and tape is in both columns
75.09.05	HD5 and HD6 takeup motor start.	R8BU N/O.	Stop the takeup motor.
75.09.06	Drop R13, clutch transfer.	R8AU N/O.	Vacuum columns now control reel clutches (log 75.10.01).
75.09.06	Drop HD8, retract capstans.	R8AU N/O.	
75.09.06	Pick DP2, capstan motor.	R8AU N/C.	
75.10.02	Start capstan motor.	DP2 points.	Capstans start turning.
75.09.06	Drop capstan retracting solenoid.	HD8 points.	Capstans start to extend.
75.09.05	Drop R7, capstans-in.	Capstans-in microswitch.	
75.09.05	Drop DP1, reverse field.	R7AU N/O.	
75.09.04	Drop R4, clutch.	R7AL N/O.	
75.10.01	Complete circuits to both stop clutches.	R4 points.	
75.09.04	Drop R2, rewind.	Capstans-out microswitches.	Both capstans are fully extended.

Load-Rewind Operation (Low-Speed Area), Model II (Cont'd)

cation	Sequence of Operations	Conditions	Remarks
5. 09.05	Drop R3, R31, rewind.	R2BL N/O.	
. 09.04	Drop R5, R6 start slow rewind and HD7, time delay.	R2AU N/O.	
5. 10. 02	Stop time delay motor.	HD7 point.	Time delay arm returns to start position.
5. 09.06	Drop retracting solenoid latch.	R6AL N/O.	
5. 09.01	Pick R33, reverse.	R31-2 N/C.	
. 09.02	Manual reverse comes up.	R33-2 N/O.	Energize the reverse magnet. De-energize the forward magnet.
5. 09.01	Pick R34, start.	R33-1 N/O.	
. 09.02	Manual start comes up.	R34-1 N/O.	Energize moving coil in the start direction.

Tape moves in the reverse direction until the load point is sensed by the load-point photocell. The photocell output is a negative shift and is applied to an inverter (logic 75. 04). The output of this inverter is again inverted and pulls over a 20-ms SST. The positive output of the SST is fed to an inverter, thereby dropping the lower leg of AND circuit F27 (logic 75. 05. 01). This puts the moving coil in the stop position, stopping the tape in a reverse-stop status.

Load-Rewind Operation (Low-Speed Area), Model II (Cont'd)

Location	Sequence of Operations	Conditions	Remarks
			At the same time, the right output of the SST goes up, allowing the relay driver at 5F (log 75.04) to conduct, latch, picking R42, load point (logic 75.09.03).
75.09.01	Drop R35, R36 rewind status.	R42-1 N/C.	
75.09.01	Drop R33, reverse	R35-2 N/O.	
75.09.01	Drop R34, start.	R33-1 N/O.	
75.09.02	Drop manual-start line.	R34-1 N/O.	
			The moving coil has already been put in a stop position by not arriving at load point. At the end of the 20-ms SST, this line goes up again. By that time, however, MANUAL STOP has gone down, keeping moving coil in a stop position. During the 20-ms period, the status is changed from reverse stop to forward stop.

C. Unload Operation, Model II

To remove a reel of tape and mount a new reel, the drive must be in the unload status. Unload status may be obtained by depressing the RESET pushbutton and then the UNLOAD pushbutton. (Depressing the RESET pushbutton is necessary only if the NOT READY light is not lit.)

During the unload operation, the capstans are retracted, the head is raised, and tape is pulled from the columns.

At the end of the operation, all motors, except the fan and blower, are stopped. The following sequence takes place. Refer to figure 2-1, foldout, for relay diagram.

Because the tape drive is in the load status, the no-vacuum switch is closed and the following relays are picked: R1, R14, R17, and R18; HD1, 2, 3, and 4; DP2. The file protection circuit is not discussed here.

D. High-Speed Rewind, Model II

Time is of prime importance in the handling of large amounts of tape by the drive. When a tape has been written or read and the bulk of the tape is on the machine reel, it is best to rewind the tape at high speed. A high-speed rewind may be started when there is at least $\frac{1}{2}$ inch of tape on the machine reel.

Assume the tape to be in the load status, tape in both columns, the head down, the drive capstans extended and turning, and more than $\frac{1}{2}$ inch of tape on the machine reel. Since the tape drive is in the load status, the no-vacuum switch is closed and the following relays are picked: R1, R14, R17, and R18; HD1, 2, 3, and 4; DP2.

In addition to the above relays, R25, high-speed area, is picked. This relay functions in the same manner as R29 in model III.

Unload Operation, Model II

ation	Sequence of Operations	Conditions	Remarks
05.09.04	Depress UNLOAD push-button. Latch-pick R21, unload.	R20-1 N/C.	Door must be closed. R20 is dropped by the RESET pushbutton. The R21-1 points open the circuit to R20, start, so that machine cannot be placed in a ready status when unloaded. R26-2 points are opened to HD5 and HD6 to prevent arcing. R26 is picked as long as the UNLOAD button is held depressed.

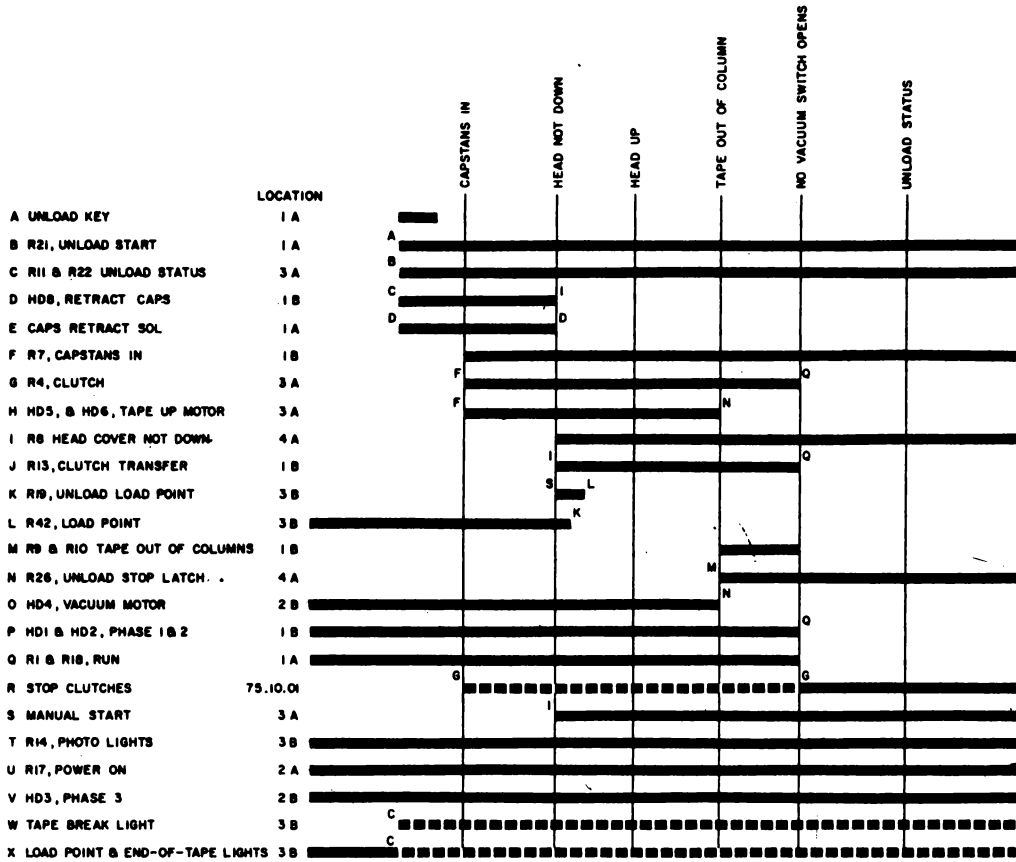

728 Tape Drive, Model II Unload Operation, Sequence Chart

Unload Operation, Model II (Cont'd)

Location	Sequence of Operations	Conditions	Remarks
75.09.05	Pick R11 and R22 unload.	R21-4 N/O	
75.09.04	Form hold circuit for R1 and R18.	R11AL N/O.	
75.09.02	Reset NIFA trigger.	R22-4 N/O.	
75.09.01	Remove shunt from tape-break light.	R22-1 N/C.	
75.09.06	Pick HD8, retract capstans.	R41-3 N/C, R6AU N/C, R22-8 N/O, R8AU N/C, R1AL N/O.	
75.09.06	Capstans retracting solenoid.	HD8 point.	Capstans retract and latch.
75.09.04	Pick R4, clutch.	R1BL N/O, R7AL N/O, R21-2 N/O.	One-half power to both stop clutches (logic 75.10.01) (to left stop through R7BL N/O, R6BL N/C, R7AU N/O).
75.09.05	Pick HD5 and HD6. Takeup motor start.	R7AU N/O.	Takeup motor starts HD5 and HD6 points.
75.09.05	Pick R8, head not down.	Head-down microswitch.	When head is 1/4 turn from lower limit.
75.09.02	Manual start up.	R8BL N/O, R6BL N/C, R22-3 N/O, R7AU N/O.	Moving pulleys move down out of way.
75.09.06	Pick R13.	R8AU N/O.	Condition control of reels from vacuum columns to reel release switch.
75.09.03	Pick R19, drop load point.	At load point and start to AND circuit G20 to condition RD5B (logic 75.04).	If tape was rewound to load point and R42 was picked.

Unload Operation, Model II (Cont'd)

Location	Sequence of Operations	Conditions	Remarks
75.09.03	LT R42, load point.	R19-1 N/O.	
75.09.03	Drop R19, drop load point.	R42-2 N/O drop at load point.	
75.09.06	Drop HD8, retract capstans and DP2, capstan motor.	R8AU N/C.	Stop the capstan motor.
75.09.05	Pick R9 and R10, tape out of columns.	Flapper valve microswitches.	Tape out of both columns
75.09.05	Latch-pick R26, unload stop.	R11AU N/O, head-up microswitch, R10AU N/O, R9AU N/O, R5BL N/C, R6BL N/C, R7AU N/O.	Indicates tape is out of both columns, and head all the way up.
75.09.05	Drop HD5 and HD6 takeup motor start.	R26-2 N/C.	Takeup motor stops.
75.09.06	Drop HD4, vacuum motor.	R26-1 N/C.	Vacuum motor turned off
75.09.04	Drop R1, R18, run.	No-vacuum switch.	Vacuum motor has stop
75.09.06	Drop HD1, HD2 phase 1, phase 2.	R1AL N/O.	Step forward and reverse motors.
75.09.04	Drop R4, clutch,	R1BL N/O.	Full power applied to both stop clutches through the reel release switch.
75.09.06	Drop R13, clutch transfer.	R1AL N/O.	The machine remains in unload status until the LOAD REWIND Button is depressed.

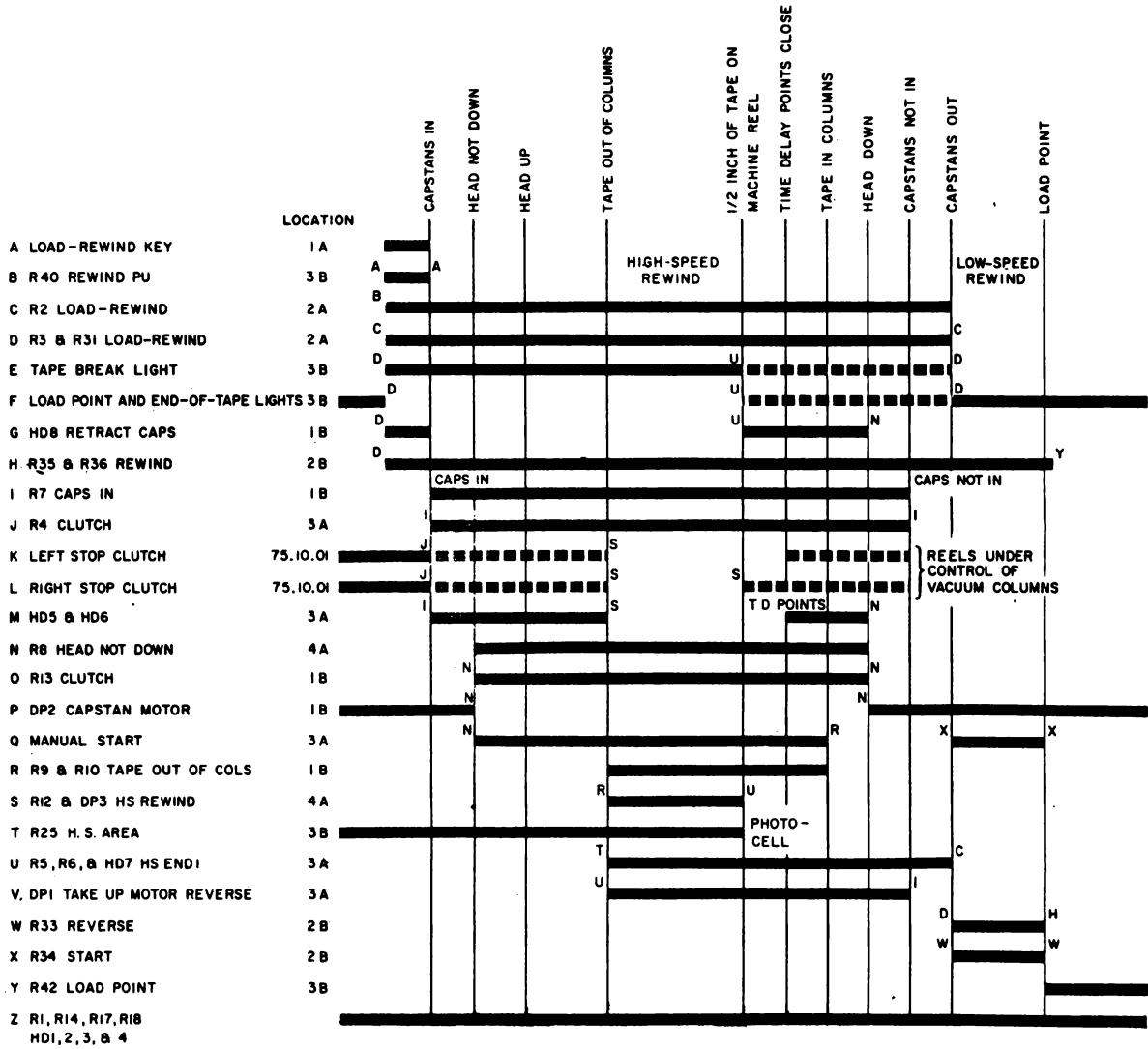

High-Speed Rewind, Model II

Location	Sequence of Operations	Conditions	Remarks
75.09.02	Depress LOAD REWIND pushbutton and pick R40, rewind PU.	R42-3 N/C, relay driver (logic 75.08), manual-load-rewind line, and read status.	Depress RESET pushbutton if NOT READY light is not on.
75.09.04	Pick R2, load-rewind.	R40-1 N/O.	Hold circuit R2AL N/O, R5AL N/C.
75.09.05	Pick R3, R31, load-rewind.	R2BL N/O.	
75.09.04	Hold R1 and R18, run.	R3AL N/O.	
75.09.01	Turn on tape-break light.	R3AU N/C.	Dim the EOT and load-photolights.
75.09.06	Pick HD8, retract capstans.	R3BL N/O, R2BU N/O, R6AU N/C, R7AU N/C.	HD8 points cause retract of the capstans by the retracting solenoid.
75.09.01	Pick R35, R36; rewind status.	R31-4 N/O.	Hold 35-1.
75.09.03	Rewind status up.	R36-1 N/O.	
75.09.05	Pick R7, capstans-in.	Capstans-in micro-switch.	Capstans fully retracted.
75.09.03	Rewind interlock up.	R7BU N/O, R36-1 N/O.	Condition tape-break photocell circuit (logic 75.0) to pick tape break relay.
75.09.04	Pick R4, clutch.	R1BL N/O, R7AL N/O, R2 hold circuit.	One-half power to stop clutches.
75.09.05	Pick HD5 and HD6 take-up motor start.	R26-2 N/C, R5AL N/C, R6BL N/C, R7AU N/O.	Start the takeup motor to raise the head and pull tape from the columns.
75.09.06	Drop HD8.	R7AU N/C.	The capstans remain retracted because of the mechanical latch.

High-Speed Rewind, Model II (Cont'd)

Location	Sequence of Operations	Conditions	Remarks
5.09.05	Pick R8, head not down.	Head-down microswitch.	Head 1/4 turn from its lower limit.
5.09.06	Pick R13.	R8AU N/O.	
5.09.06	Drop DP2, capstan motor.	R8AU N/C.	Stop the capstan motor.
5.09.02	Manual start up.	R8BL N/O, R6BU N/C, R31-6 N/O.	The drive is now in a forward-start status. The moving pulleys are away from the stop capstans.
75.09.05	Pick R9, R10, tape out of columns.	Flapper valve microswitches.	Tape out of both columns.
5.09.05	Pick R12, high-speed, DP3 rewind motor.	R11AU N/C, head-up microswitch, R10AU N/O, R9AU N/O, R5BL N/C, R6BL N/C, R7AU N/O.	Tape out of both columns and head all the way up.
75.09.05	Stop takeup motor.	R12BU N/C.	
5.10.01	Remove power from both stop clutches.	R12AL, BL.	No power on any of the six clutches.
5.10.02	Start the rewind motor.	DP3 A, B.	Rewind tape at high speed until $\frac{1}{2}$ inch of tape is left on machine reel.
75.09.03	Drop R25, HS area.	High-speed area beam strikes its photocell to drop RD 8B (logic 75.08).	
75.09.04	Pick R5, R6, start slow rewind, and HD7, time delay	R25-1 N/C.	Start time delay motor.

High-Speed Rewind, Model II (Cont'd)

Location	Sequence of Operations	Conditions	Remarks
75.09.05	Drop R12, high-speed, and DP3, rewind motor.	R5BL N/C.	Turn off rewind motor.
75.10.01	One-half power to right stop clutch.	R12BL N/C.	Start slowing down. No brake on left stop clutch.
75.09.05	Pick DP1, takeup motor reverse.	R6BL N/O.	Prepare to lower head.
75.09.06	Pick HD8, retract capstans. Pick retracting solenoid latch.	R6AU N/O, R6AL N/O.	Prepare to extend capstans.
75.09.05	HD5 and HD6 takeup motor.	Time delay point.	By this time, tape has been braked to a stop. From this point on, the sequence of events is identical with a slow-speed rewind; the operation ends when the load point is reached.

E. Purpose of Important Relays, Model II

For all relay point locations, refer to figure 2-1, foldout.

1. R1, run, is always picked, except when the drive is in the unload status. When dropped, it indicates a failure in one of the machine interlocks: a blown fuse, tape break, dc-power failure, insufficient vacuum, or a burned-out photo light:

1AU, 1BU When down, they allow full brake to both stop clutches.

1BL These points control phases 1 and 2 a-c power, and DP2, when the tape drive is loaded.

- 1AL** In case of an interlock failure, they drop R4 if it was up, so the 1AU and 1BU points can brake both reels.
- 2. R2, load, rewind, is picked when the LOAD REWIND button is depressed. If this occurs in an unload status or in the high-speed area, R2 holds until both capstans are extended. If the LOAD REWIND button is depressed when the tape drive is loaded and in the slow-speed area, R2 is picked until the button is released:**
- 2AU** They pick R5, R6, and HD7 for a slow-speed rewind.
- 2AL** These are the hold points for R2.
- 2BU** These points form the pick circuit for HD8 in a load-rewind operation.
- 2BL** They pick R3 and R31. They trip R21 and R26 if latched.
- 3. R3, load rewind, is the same as R2:**
- 3AU N/O** These points shunt the load point and EOT lights during high-speed rewind. This makes the tape break light brighter and prevents the end-of-tape mark from causing a false tape-break indication.
- 3AU N/C** These points shunt the tape-break light when the drive is loaded.
- 3AL** These points allow the run relays to hold during load-rewind when tape is not in the columns. It also prevents dropping the run relays if the tape break light burns out during a high-speed rewind.
- 3BL** These points form the pick circuit for HD8 in a load-rewind operation.

4. R4, clutch, is picked when the capstans are retracted. It is used to apply $\frac{1}{2}$ brake to the stop clutches for loading and unloading:

4AL, BL They apply $\frac{1}{2}$ power to the stop clutches.

5. R5 and R6, slow-speed rewind, are picked for a slow-speed rewind, depending upon the amount of tape on the machine reel:

5AU At the start of a load-rewind, from a loaded status, R5AU points determine whether to raise the head.

5AL These points hold R5, R6, and HD7.

5BL These points drop R12 and DP3 when the high-speed area relay, R25, drops.

6AU N/C These points allow the capstans to be retracted when starting a high-speed rewind or unload operation.

6AU N/O These points energize HD8 in preparation for letting capstans out during the load-rewind from an unload status, or during the loading portion of a high-speed rewind.

6AL These points energize the solenoid magnet latch in preparation for extending the capstans.

6BU These points allow a manual start when unloaded.

6BL N/C These points allow the head to be raised during a high-speed rewind and an unload operation.

6BL N/O These points reverse the takeup motor field.

6. **R7, capstans in,** is picked when the capstans are fully retracted:
- 7AU N/C** These points allow HD8 to retract the capstans, starting a high-speed re-wind operation. When the capstans are retracted, this point opens the circuit to HD8.
 - 7AU N/O** These points prevent a manual start while unloading until the capstans are retracted. They also prevent running the takeup motor until the capstans are retracted.
 - 7AL** These points ensure that $\frac{1}{2}$ brake cannot be placed on the reels until the capstans are in.
 - 7BU** These points condition the tape break circuit to pick R41.
 - 7BL** If the tape should go into either column when coasting to a stop following a high-speed rewind, R7BL allows the takeup motor to start without waiting for the time delay point to close. It also applies $\frac{1}{2}$ brake to the left stop clutch.
7. **R8, head not down,** picks R8 when the head is $1/4$ turn from its lower limit. It is held until the head is down and the tape is in both columns:
- 8AU N/C** These points run the capstan motor.
 - 8AU N/O** These points allow the capstans to extend during load-rewind by dropping HD8.
 - 8BU** When lowering tape into the columns during load-rewind, 8BU stops the takeup motor when the holding circuit for R8 is opened.

- 8BL These points allow R34-1 to have complete control of the manual-start line when drive is in the load status.
8. R9, 10 (tape out of columns), R9 is controlled by the left column flapper switch; R10, by the right. When vacuum is up, these relays are picked only when tape is out of their corresponding columns:
- 9, 10AU These points ensure that tape is out of both columns before:
- a. Stopping the vacuum motor when unloading (LP R26).
 - b. Starting the rewind motor for high-speed rewind (DP3, R12).
- 9, 10AL They drop the run relays if tape should break during any operation where tape is being moved by the drive capstans.
- 9, 10BU N/C These points prevent braking the left reel while slowing down from a high-speed rewind.
- 9, 10BU N/O These points hold R8 until tape gets in both columns.
- 9, 10BL These points drop the manual-start line when tape gets into either column. This occurs during load rewind when tape is being lowered to ensure that tape will get into both columns.
9. R11, unload, is picked when R21, unload, is latch-picked.
- 11AU When the head is up and tape is out of both columns, one of two possible conditions exists: (a) unload is completed, (b) it is ready to start the high-speed motor. If R11 is picked, the UNLOAD button has been depressed, so example (a) applies.

- 11AL While unloading, keep the run relays up until the operation is completed.
- 11BL Retract the capstans when an unload operation has been started.
10. R12, high-speed rewind motor, is picked at the start of the high-speed rewind when all conditions are met to start moving tape at high speed. R12 and DP3 drop when the high-speed area relay, R25, drops:
- 12AL, BL Remove $\frac{1}{2}$ power to both stop clutches.
- 12BU Turn off the takeup motor (starting at high-speed rewind from a loaded condition) when tape is out of the columns.
11. R14, photo-light, is always picked when 48V power is on machine. When dropped, it indicates a burned-out photo-light:
- 14AL These points drop the run relays if any photo-light burns out while low-speed rewinding, or if the load point or end-of-tape light burns out while reading or writing.
- 14BL These points prevent starting a load-rewind operation if: (a) unloaded and any photocell is burned out and (b) loaded and the load point or EOT photolight is burned out.
12. R15, not file protect 2, is picked when the not-file-protect ring is mounted on the file reel, and the tape is in the load status and not searching for load point. This relay allows the drive to write on tape:
- 15AL These points bring -130V to the IG and IER (logic 75.07) for a write operation.
- 15BL N/O These points bring up not-file-protect to condition the write circuit.
- 15BL N/C These points turn on the FILE PROTECT ON light.

13. R17, power on reset, is picked when all the d-c supplies are up in the external control and the 48V supply is up in the tape drive:

- 17-1 These points drop the run relays in case of dc-power failure.
- 17-3 These points supply a power-on reset to the NIFA trigger in case power is brought up on a loaded machine.
- 17-4 Phase 3 is picked separately to allow the vacuum motor to run.

R18, run, is the same as R1:

- 18-1 Prevents picking start relay (R20) from external control when door interlock is open.
- 18-2 In case of an interlock failure during low-speed rewind, these points stop tape by dropping the reverse and manual-start relays.
- 18-3, 4 These points ensure that the interlock conditions are satisfied before allowing the ready line to be raised and the READY light to be turned on.

14. R19, load-point reset, is picked whenever the load-point relay, R42, is picked and start is brought up. It is dropped when the load-point relay is dropped. At load point is combined with start in AND circuit G20 (logic 75. 04) to pick R19:

- 19-1 These points latch-trip the load-point relay.

15. R20, start, is picked by depressing the START button if the door is closed and the machine is not unloaded. It holds until the door is opened or until the RESET button is depressed:

- 20-1 N/C These points prevent unloading or load-rewinding a tape drive that is in the ready status, without first depressing the RESET button.

- 20-1 N/O These points are the hold for R20.
- 20-2 These points condition machine ready.
- 20-3 When closed, these points provide a constant reset to the read-write status trigger.
- 20-4 These points condition the NOT READY light.

16. R21, unload pickup, is latch-picked when the UNLOAD button is depressed, if the door is closed and the start relay R20 is not up.

R21 is latch-tripped when a load-rewind operation is started:

- 21-1 These points prevent the start relay R20 from being picked.
- 21-2 N/C These points allow R4 to be picked while load-rewinding.
- 21-2 N/O These points pick R4 during the unload operation.
- 2-3 These points prevent continuous energization of R21LT during load-rewind operation.
- 21-4 These points pick unload relays R11 and R22.

17. R22, unload, is the same as R11:

- 22-1 These points test all three photo-lights, in series with R14, when the drive is in the unload status.
- 22-2 These points give file protection during an unload operation by deconditioning the write circuit.

- 22-3 These points put the moving coil in a start position for ease of handling tape.
- 22-4 N/C These points drop R33 and R34 to stop tape if the UNLOAD button is depressed during a slow-speed rewind operation.
- 22-4 N/O These points reset the NIFA in the unload status.
- 22-6 These points latch-trip the tape break relay when unloading after a tape break.
- 22-7 These points drop R2 if the UNLOAD button is depressed during a load operation.
- 22-8 If the condition existed where the capstans were extended in the unload status, the capstans would be retracted. This set of points also causes the capstan motor to run while retracting.
- 22-9 These points prevent latch-trip of R26 until R21 has been latch-tripped. It is an interlock to prevent latch-picking R21.
- 22-10 These points are part of the interlock circuit mentioned above.
18. R25, high-speed area, is picked when there is more than $\frac{1}{2}$ inch of tape on the machine reel. When picked, it causes the drive to load tape for a high-speed rewind.
19. R26, unload stop, latch-picks at the completion of the unload operation when the head is up and tape is out of both columns. R26 latch-trips when a load rewind operation is started:
- 26-1 These points stop the vacuum motor (HD4).
- 26-2 These points stop the takeup motor HD5 and HD6 when unload operation is completed.

- 26-3 These points prevent continuous energization of R26LT during load-rewind operation.
20. R30, reset, is picked as long as the RESET button is depressed:
- 30-1 These points drop the start relay R20. This takes the machine out of ready status.
- 30-2 These points pick R5, R6, HD7 if the RESET button is depressed during a high-speed rewind. This stimulates dropping of the high-speed area relay R25.
- 30-4 These points drop the rewind status relays R35 and R36. If the RESET button is depressed a short time during a high-speed rewind, the rewind status relays pick again by R31-4 when the RESET button is released.
21. R31, load rewind, is the same as R2:
- 31-2 These points prevent getting a reverse start during the load rewind until both capstans are extended.
- 31-3 These points are used for additional tape file protection when the rewind operation is started.
- 31-4 These points pick the rewind status relays, R35 and R36.
- 31-6 During the load-rewind operation, these points control manual start until the capstans are extended.
22. R33, manual reverse, is picked during the load-rewind operation when R31 drops. This occurs when both capstans are extended. It holds until the load point is reached. The customer engineer's external reverse switch or the reverse switch on the tape tester can also be used to pick R33 when the tape drive is not in rewind status:

- 33-1 These points pick manual start R34.
 - 33-2 These points bring up manual reverse to energize the reverse magnet.
23. R34, manual start, is picked with R33-1. The customer engineer's manual forward switch or the forward switch on the tape tester can also be used to pick R34 when the tape drive is not in rewind status:
- 34-1 These points bring up manual start to energize the moving coil to move tape.
24. R35, R36, rewind status, pick when the LOAD REWIND button is depressed (31-4). They hold until load point is reached:
- 35-1 These points are the hold for R35, R36.
 - 35-2 N/C These points allow the external forward-reverse switch to control R33, R34.
 - 35-2 N/O These points allow a manual reverse at a time determined by R31-2.
 - 35-3 During the rewind operation, the write and erase heads cannot conduct because the not file protect 2, R15, is dropped by these points.
 - 35-4 These points allow the machine to stop when the capstans are extended, if the tape break light has burned out during a high-speed rewind.
 - 36-1 N/C These points prevent the machine from being ready when rewinding.
 - 36-1 N/O These points bring up rewind status and allow R7 BU to control rewind interlock.
 - 36-3 These points ensure that the read-write status trigger is reset off during rewinding operation.

- 36-4 These points prevent the NOT READY light from being on when rewinding.
25. R40, rewind pickup, is picked: (a) by the LOAD REWIND button if the tape is not at load point, the machine is in read status, the start relay R20 is down, and the door is closed, (b) by start rewind from the external control if the tape is not at load point and the tape drive is selected and ready. R40 holds until: (a) the LOAD REWIND button is released, (b) select and ready goes down:
- 40-1 These points pick R2 to start a load-rewind operation if the photolights are good.
- 40-3 These points open HD5 and HD6 circuit to prevent arcing as DP2 is transferred when the LOAD REWIND button is depressed.
26. R41, tape break, latch-picks if tape breaks during a high-speed rewind operation. R41 latch-trips when the UNLOAD button is depressed following a tape break:
- 41-1 These points drop the run relays in case of a tape break.
- 41-2 These points prevent energizing R41LT continuously when in the unload status.
- 41-3 These points prevent continuous energization of HD8 in case tape breaks when slowing down after a high-speed rewind.
27. R42, load point, is latch-picked when the load point passes under the load point photocell. It is latch-tripped when leaving load point or going into an unload operation:
- 42-1 Drop the rewind status relays when load point is reached.
- 42-2 These points: (a) pick R19 when start goes up, (b) allow select and at load point to go plus if tape drive is selected.

- 42-3 These points prevent starting a re-wind operation if the tape is at load point.
- 42-4 Brings up NFP line faster.

F. Tape Break Circuit, Model II

If tape breaks during a high-speed rewind operation, light is reflected into the end-of-tape photocell (logic 75.03), causing a negative shift. This output, inverted, is used to flip a 20-ms SST. The right divider output is fed to two AND circuits, one of which is conditioned. AND circuit E32 is conditioned, during a high-speed rewind, by the re-wind interlock status. It allows the 20-ms pulse to get to the RDX 7B to latch-pick R41.

R41 causes R1 and R18 to drop. R1 drops HD1 and HD2 and also R4. R4 causes full brake to be applied to both reels. With R41 latch-picked, no other operation may take place. R41 is latch-tripped only when going into an unload operation.

G. Anti-Spill Device, Model II

R9BU and R10BU form the anti-spill device in model II. This device prevents tape from falling into the vacuum columns during the period after the reels are stopped and before the tape is loaded, at the end of a high-speed re-wind. If tape should get into one of the columns, the associated points cause the load operation to begin.

VII. Tape Drive Tester (TDT)

A. Introduction

1. Purpose of Equipment

The TDT is designed to provide all the necessary control signals and supply voltages to allow complete off-line testing of the tape drive unit. Thus the TDT facilitates the testings of a new tape drive unit or the performing of lengthy maintenance away from the tape drive area. In addition, the tester is used to perform maintenance checks which cannot be executed from the test door. The mechanical and electrical functions of the tape drive unit may be checked using the TDT.

B. Description and Electrical Characteristics

1. Description

Page 2160

The commercial tape drive tester is manufactured for IBM by an outside vendor. The TDT is designed to test mechanical and electrical functions of the tape drive units. It may also supply power to the tape drive unit.

The tester is 48 inches high, 24 inches wide, 18 inches deep, and is mounted on casters. The tester consists of one pluggable unit, an attached 12-foot signal cable terminated by a summary punch connector, a manual control plug, a power supply, a switch panel, and other associated circuitry. The tester is supplied with a 12-foot power cable.

a. Pluggable Unit

The pluggable unit in the TDT is located in the upper section of the TDT unit. The pluggable unit contains the control logic to generate the necessary output signals to test the tape drive unit. Two conditions must be established in the control logic. First, the nature of the operation to be performed by the TDT, and second, the ready conditions from the tape drive indicating that the tape drive is prepared to accept this operation.

b. Control Panel

The control panel serves as the command center for the TDT; that is, the control of the TDT is established and directed through the setting of switches on the control panel. Information and control levels entering or leaving the TDT are routed through the control panel. Thus the operator is provided with a means of control. Hubs are available on the control panel to observe, with an oscilloscope, the information and control levels.



Front View of Tape Drive Tester

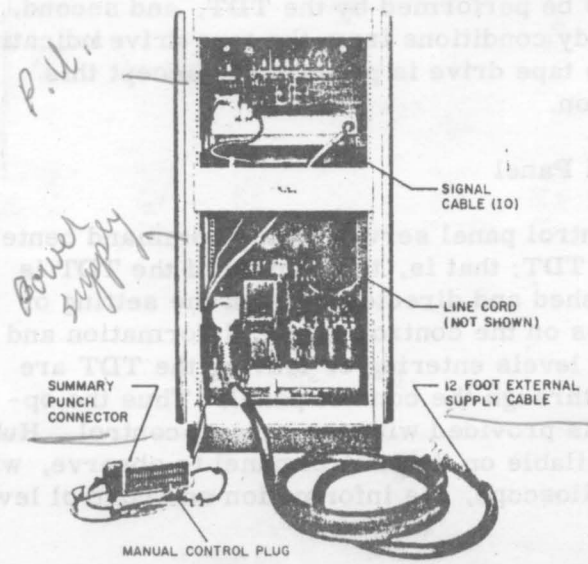

Rear View of Tape Drive Tester

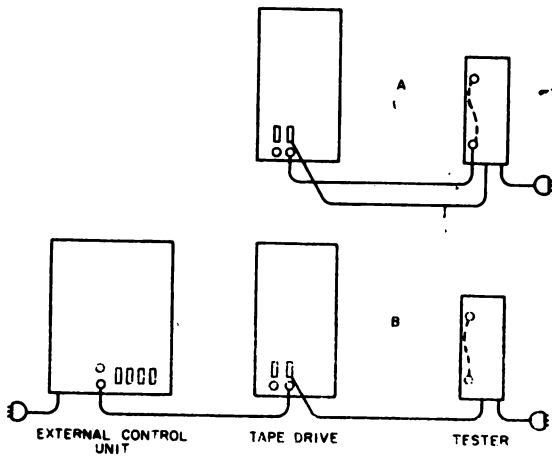

Power Connection Configuration

TABLE | BIT SWITCHES ON TAPE DRIVE TESTER

SWITCH DESIGNATION	TRACK
1	1
2	2
4	3
8	5
A	4
B	5
C	6

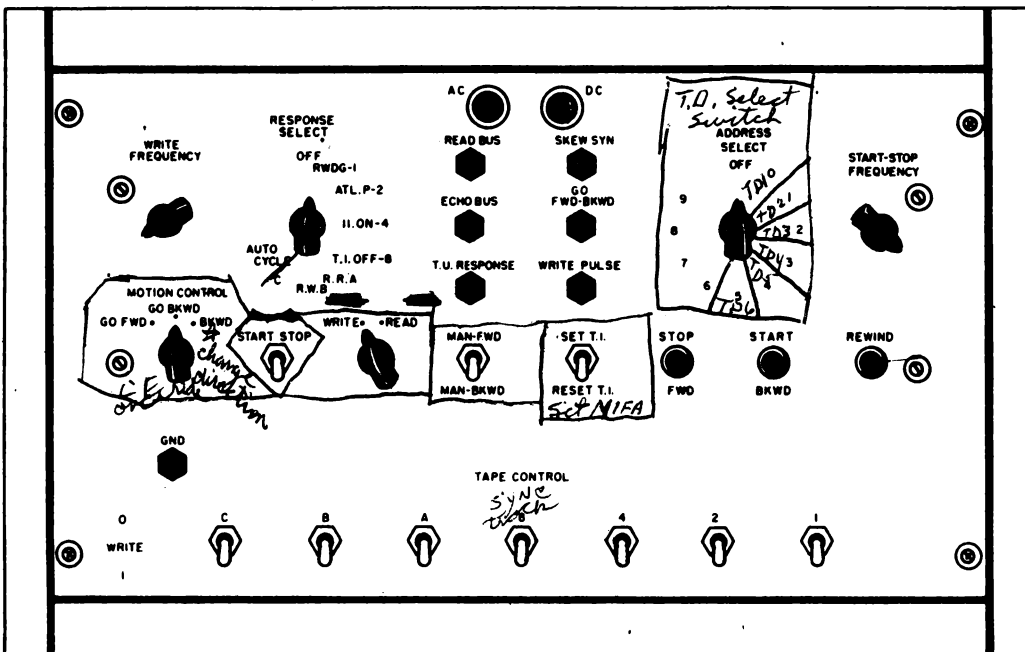

TDT Control Panel
Use + function on P. 2560 - 2590

c. Signal Cable

The signal cable (I/O) extending from the right hand side of the shelf mounted chassis is shown. The signal cable is terminated in a summary punch connector. This summary punch connector is inserted into the summary punch receptacle of the tape drive unit to be tested.

d. Power Supply

The TDT has a self contained power supply located in the lower section of the TDT unit. The power supply receives power through a four-prong, three-phase line cord plug.

A 12-foot power cable which extends from the left side of the power supply may be used to power the tape drive unit being tested.

e. Manual Control Plug

The manual control plug is the black four-prong plug which extends out of the signal cable, several inches away from the summary punch connector. This plug is used to connect the MAN-FWD/MAN-BKWD switch to the tape drive. The four-prong plug is placed into the black receptacle above the summary punch receptacle on the tape drive unit.

2. Electrical Characteristics

The TDT requires 3-phase ac at 208 volts ± 10 percent. The power requirements of the tester are given below. The TDT supplies power at the following voltages: +270, +140, -270, -130, and -60.

Power Requirements

Condition	Power
Supplying only TDT	25 watts (average)
Supplying TDT and tape drive	1, 175 watts (average)
Supplying TDT and tape drive during high-speed rewind	1, 425 watts

C. Theory of Operation

1. Data Processing Machine Logic

The tape drive tester uses commercial data processing machine (DPM) logic. This section will be devoted to explaining the basic DPM circuits as found in the tape drive tester.

a. General Information

The term "tube" may refer to one or both sections of a dual tube, but the term is not used unless the reference is clear in the text. The terms "left tube" and "right tube" refer to the placement of the components on the schematic. They are not to be confused with the terms "front" and "back" that are used to denote the physical placement of the tube socket on the pluggable unit.

b. Pluggable Unit

Page 2200

1) General

The TDT has only one pluggable unit. The layout and general appearance of the type of pluggable unit used in the TDT is shown in figure . Figure A shows a complete pluggable unit with some of the parts labeled. Figure B shows some of the construction details of a pluggable unit, indicates the front and top of a pluggable unit, and shows how terminals and tube sockets are numbered. Note that the front of the pluggable unit faces the observer in both parts of figure

2) Terminal Strips or Islands

Mounted within the pluggable unit are eight terminal strips called islands. The islands are labeled A through H. Islands A through D appear beneath tubes 1 through 4 in the figure, and islands E through H appear beneath tubes (or sockets) 5 through 8. The terminals on the islands are numbered as shown in detail. Terminals 1 through 19 are on the front end of an island, and terminals 20 through 38 are on the back edge.

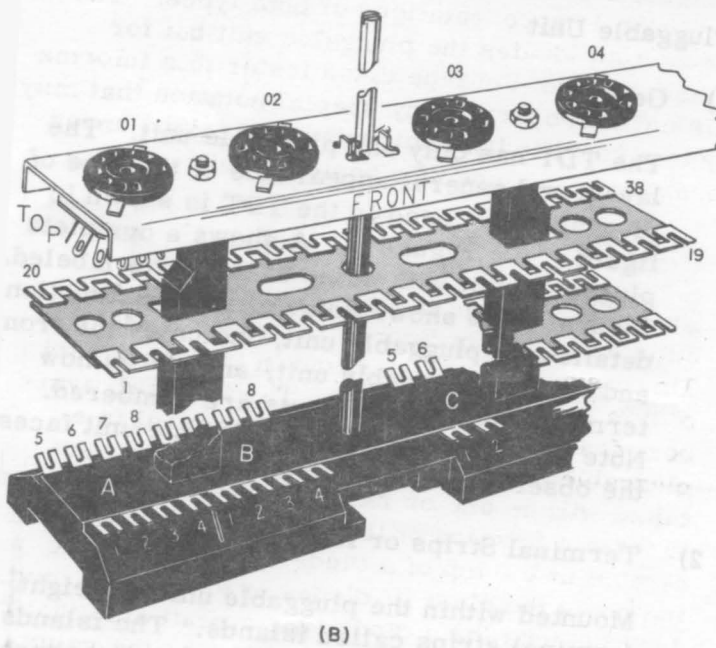
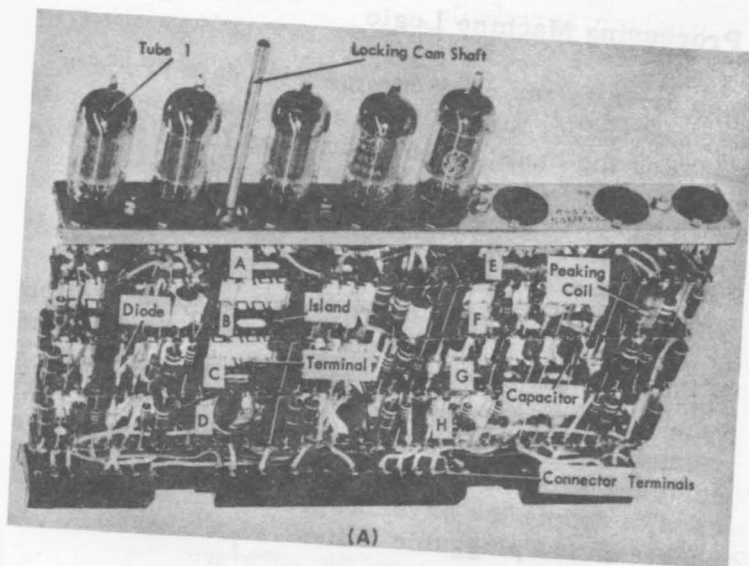

Figure 3-23. DPM Pluggable Unit

3) Connector Terminals

At the bottom of figure B can be seen the arrangement of terminals on a pluggable unit connector. The terminals are divided into eight groups with eight terminals per group. Each group is identified by a letter and the terminals in the group are numbered. The letters run from A through H under tube sockets 1 through 8 respectively. Terminals 1 through 4 of a group are located near the front of the connector, and terminals 5 through 8 are located near the back.

Page 2200

c. Logic Blocks

Page 2220

Logic blocks fall into two major classifications: tube circuits and diode circuits. Figure shows typical representations of both types. The lower section locates the pluggable unit but for this discussion of the tape drive tester this information is not necessary. Any special notation that may apply to a specific basic circuit is explained under the analysis of the specific basic circuit.

1) Diode Circuit Block

Examples of logic blocks for diode type circuits are given in figure , parts A and B. Three symbols will be found in the upper part of this type of logic block. The first two symbols designate an island and a terminal in a pluggable unit. Connected to this island terminal will be one or more diodes and a resistor to form a junction of the circuit. The third symbol at the top of a diode-type logic block indicates the class of diodes used in the circuit. Logic blocks for a diode type circuit also indicate, in units of thousands of ohms, the value of the resistor used in the circuit.

2) Tube Circuit Block

Examples of logic blocks for tube type circuits are given in figure , parts C and D. The first symbol in the upper section of such a logic

DIODE CIRCUITS

Logic Block Notations

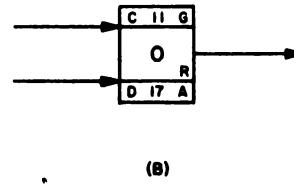
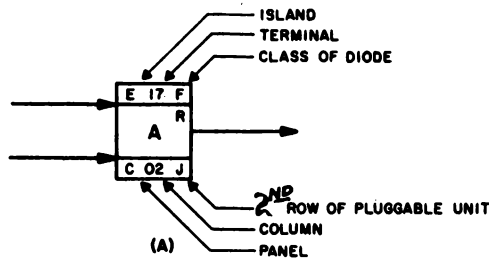

TUBE CIRCUITS

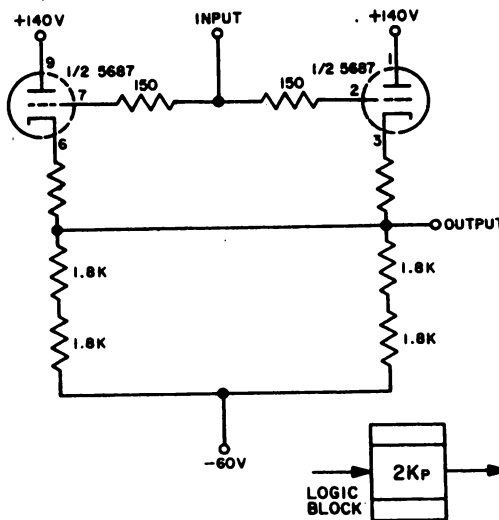
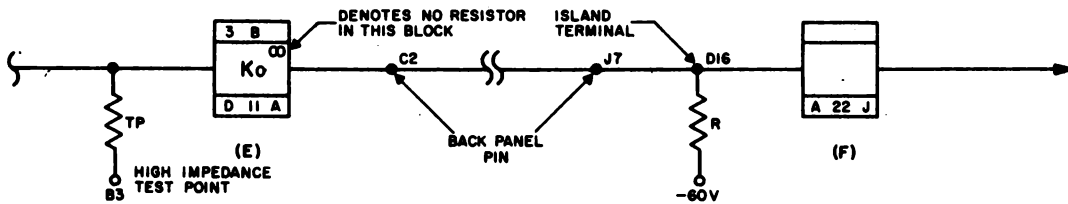
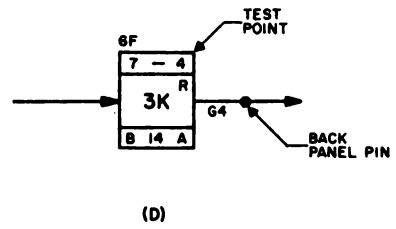
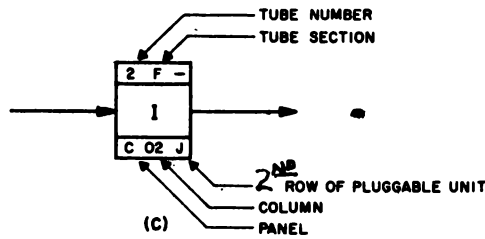

Power Cathode Follower

block indicates the position in the pluggable unit of the tube which is used for the circuit. The second symbol indicates whether the front (F), back (B), or whole tube (-) is used in the circuit. When more than one tube is used in the circuit represented by a block, an additional symbol will be used to designate the position of the second tube. For example, the 3K block shown in figure has the symbol 6F above the upper left hand corner of the logic block. This symbol indicates that the front half of tube 6 is used, and the symbols in the regular position just below the 6F indicate that both halves of tube 7 are used. The upper right hand corner of the block shows a panel pin number for an output test point. The same information is indicated by the G4 on the output line. The G means that the pin is directly beneath the seventh tube in the pluggable unit.

2. Basic Circuit Analysis

a. AND Circuit

Figure shows the logic block and the schematic diagram for the AND circuit. The circuit requires all inputs to be positive levels (+10 volts) to have a positive output level (+10 volts), otherwise the output level will be at -30 volts. The action of an AND circuit may be summarized as follows: the output voltage of an AND circuit approximately equals the most negative input voltage. That is, if there is any negative input level, the output level will be -30 volts.

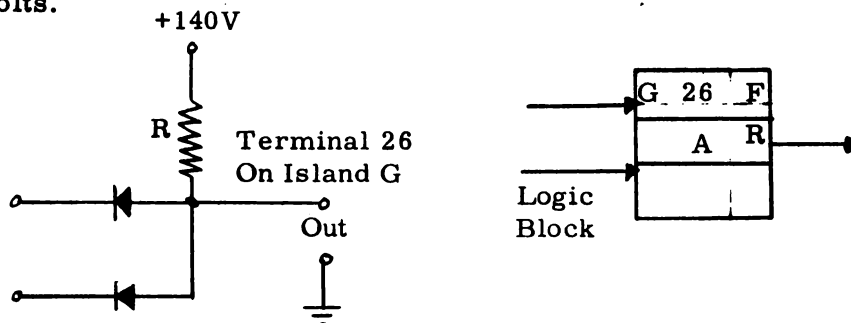

AND Circuit

b. Trigger (Flip-Flop) Circuit

Page 2250

The trigger or flip-flop circuit is a bistable multi-vibrator which remains in either of two stable states until an applied signal forces it to assume the other state. The bistable property of a trigger makes it useful as a storage device.

1) Input-Output Convention for Trigger

In the AN/FSQ-7 and AN/FSQ-8 logic designation system, the conventions established for a flip-flop allow one to know what output will appear, and where it will appear, when a signal is placed at a specific input. In DPM logic the conventions differ slightly; both positive and negative pulses are used as inputs in DPM logic.

In order to determine what output will be present when an input is known, observe the following conventions. An input on the left side of the logic block will go to the grid of the left tube and conversely for the right input. Also, an output shown on the left side of the logic block comes from the left tube and conversely for the right output.

As an example of using the stated convention, assume that a negative pulse is placed on the left input of the trigger logic. This means that the grid of the left tube will be cut off. The left plate voltage will rise; thus, the positive going output level should be observed at the left output.

2) On and Off Convention for Triggers

Because switch terminology on the TDT and the state of the trigger in the TDT are related, it will be necessary to explain the on and off convention. A trigger is said to be on when its left tube is conducting. Therefore, the left side is called the "on-side", and the right side is the "off-side". In the "on" state, the left grid is up, the right plate is up, the right grid is down, and the left plate is down.

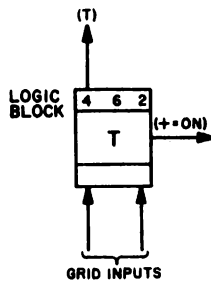
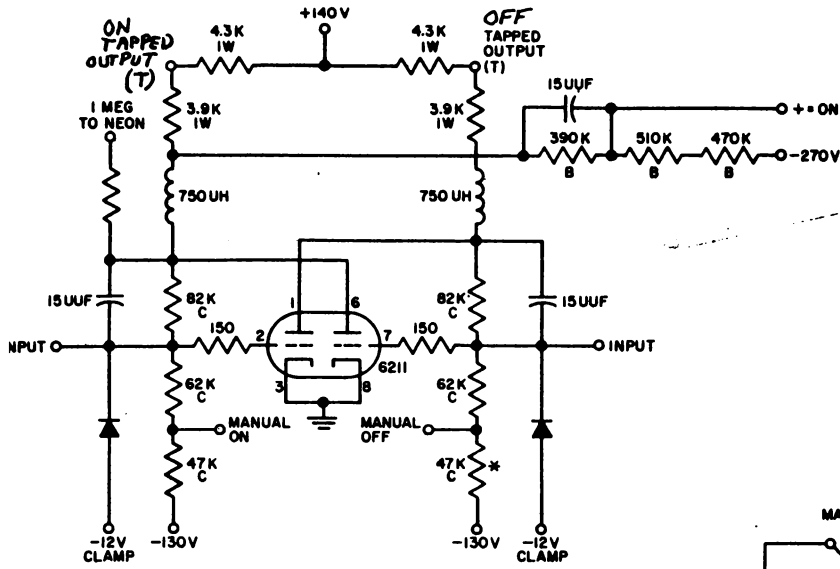

NOTE:
 * LETTERS BELOW RESISTOR VALUES DENOTES THAT RESISTORS ARE TOLERANCE MATCHED

LEGEND
 4 TUBE NUMBER
 6 MANUAL ON PIN
 2 MANUAL OFF PIN

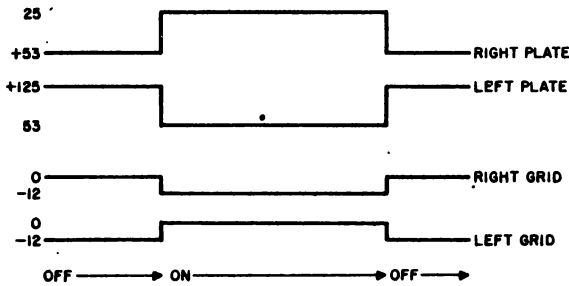

Trigger Circuit

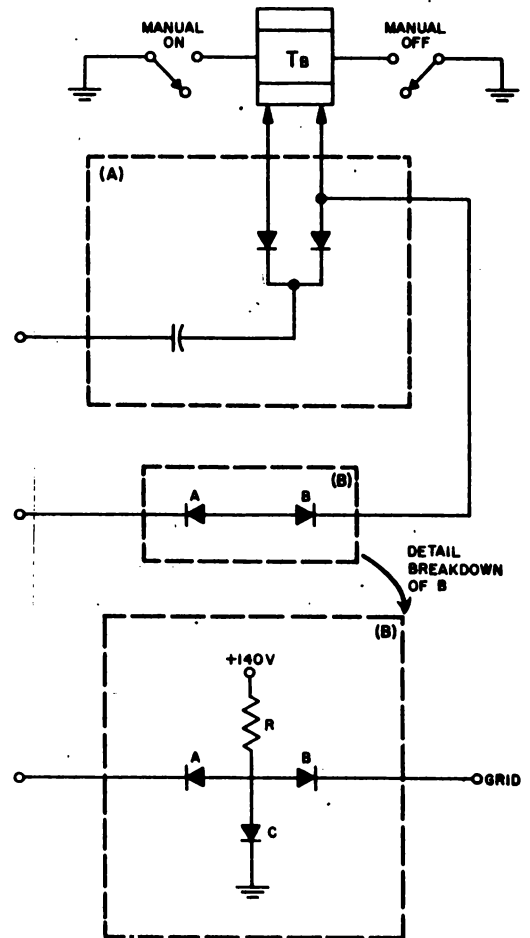

Input Configuration to Trigger

3) Trigger Circuit Operation

Basically, a trigger circuit resembles two inverter circuits in which each plate output is coupled to the opposite grid. In one stable state, the left tube is in full conduction (the current is about 9.5 ma) while the right tube is cut off. In the other state, the right tube is in full conduction while the left tube is cut off. To change from one state to another, an external signal must be applied.

For example, assume that the right tube is conducting (trigger off). The right plate is down; that is, its voltage is considerably less than +140 volts, while the left plate is up (near +140 volts). One method of flipping this circuit is to apply a negative pulse to the right grid. Because the right tube is conducting, grid current keeps the grid at about zero volts. The negative pulse causes the right tube to cut off; consequently, the right plate voltage rises. This rise in voltage is then coupled through the plate-to-grid voltage divider (cross-coupling circuit) to the left grid, pulling this grid voltage up toward ground potential. The left tube then begins to conduct and its plate voltage goes down. This shift at the plate of the left tube is coupled back to the right grid and reinforces the initial action. The cross-coupling circuits speed the regenerative action and the circuit stabilizes with the right side cut off and the left side in full conduction. The input pulse can now be removed without flipping the trigger because conduction on the left side holds the right side cut off.

4) Input Circuits for the Trigger

Unlike the AN/FSQ-7 and AN/FSQ-8 logic designation system, the DPM trigger has many types of input configurations. This discussion will cover the input configuration for the type B tripper used in the TDT.

Complementary Input - The two diodes and a capacitor in the dotted square A of figure represent a complementary input to the trigger. A complementary input feeds both grids of a trigger, thus allowing the trigger to be flipped regardless of its previous state (unless it is being held by another circuit). The capacitor indicates that the input has to be a pulse, not a d-c level. Actually the capacitor is an integral part of the circuit feeding the trigger, but it is placed as shown to indicate that the input is pulsed. In addition, the orientation of the diodes indicate that the pulse input is a negative going pulse. An incoming negative pulse applied to the cathodes of the diodes causes the grids of the trigger to swing between zero and -12 volts. It is obvious that a positive-going pulse would never allow the diodes to conduct and the pulse to get through.

AND Circuit Input - The two diodes shown in the dotted square B of figure represent a one-legged AND circuit. Diode A and resistor R constitute the AND circuit. Diode B indicates that only a positive level will cause the diode to conduct. This is true because the grid swings between zero and -12 volts. Diode C clamps the positive level to ground potential.

Assume that the input is -30 volts and that the grid is non-conductive (-12 volts). The base of the limiting resistor is at -30 volts and diode C is cut off. As the input rises to +10 volts, the base of the resistor rises to zero and is held at that point by the ground clamp diode C. Diode B starts to conduct at -12 volts and continues to conduct, forcing the grid in a positive direction. The tube conducts; the trigger flips and is held in this status by the holding action of the input circuit. When the input drops to -30 volts, the grid stays at zero volts (conducting), diode B cuts off as soon as the input passes zero volts on the fall. Only the holding action has been removed and the trigger does not flip back until pulsed by a different input.

In summary, the AND circuit input to the trigger will accomplish the following: When the AND is up (+10 volts), the right grid will approach zero volts, turning the trigger off. The trigger will be held off as long as the AND is up, due to the holding action of the AND circuit. The trigger may be turned on any time after the AND goes down (-30 volts). This is because the AND no longer has holding action on the trigger.

Manual Off-On Switch Input - The manual off-on switches shown in figure are physically located on the control panel of the TDT. They are respectively the STOP and START push-buttons. Depressing the STOP pushbutton places the right grid of the trigger at ground potential. The right tube will conduct, pulling the right plate voltage down. By definition, when the plate of the right tube is down, the trigger is turned off.

5) Trigger Outputs

The outputs for the trigger are shown in figure . There is an output on the top left side of the logic block. This corresponds to the tapped plate (T) output in the left tube plate circuit of the trigger schematic. This output voltage will swing between +94 volts and +132 volts. The output shown on the right side of the logic block represents the divider output in the plate circuit of the right tube. This voltage will swing between +10 and -30 volts.

c. Diode Gate

Page 2290

The diode gate (DG) is another circuit used in the TDT. The logic block, circuit schematic, and some voltage waveforms for the diode gate are shown in figure . The logic block in the figure shows two diode inputs, but the schematic shows a diode gate circuit with only one diode input. Another way in which the diode gate type of circuit can be varied is to omit the capacitor. The two types of diode gates which are used in the TDT are a diode gate with a capacitor and two diode inputs

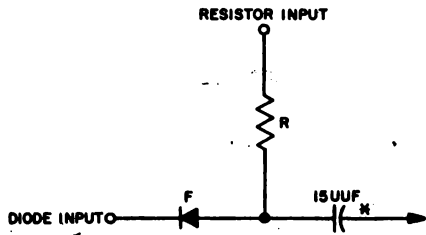

(A) CIRCUIT

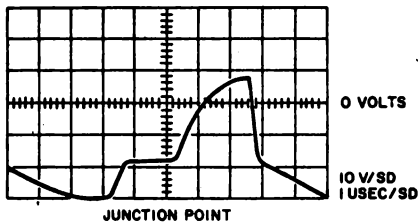
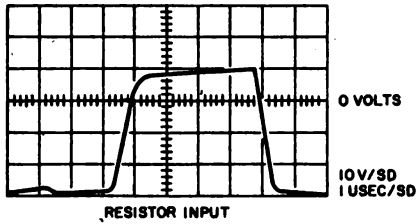

Diode Gate

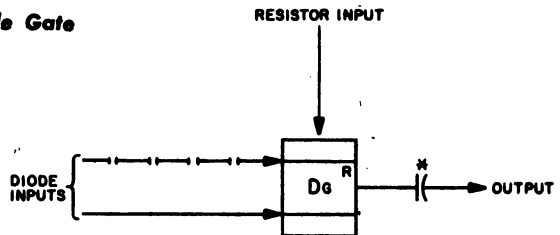

* WHERE CAPACITOR IS NOT SHOWN WITH BLOCK SYMBOL IT IS NOT IN THE CIRCUIT

(B) LOGIC BLOCK

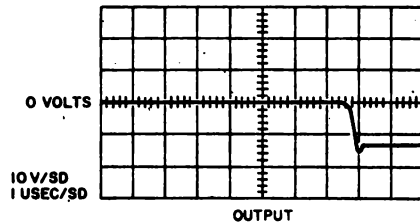
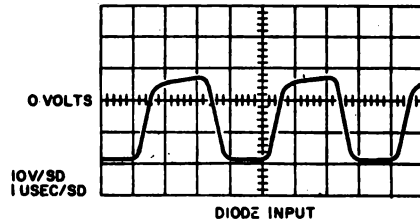

(C) WAVEFORMS

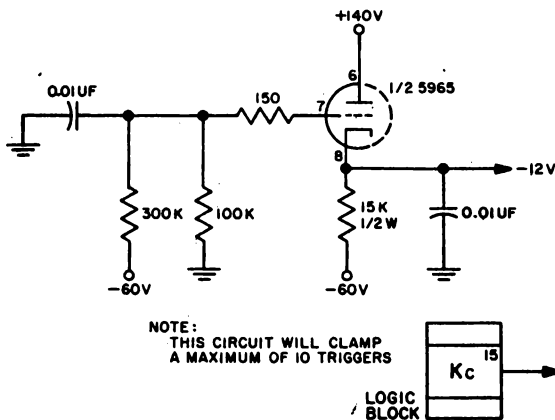

NOTE: THIS CIRCUIT WILL CLAMP A MAXIMUM OF 10 TRIGGERS

Cathode Follower Clamp

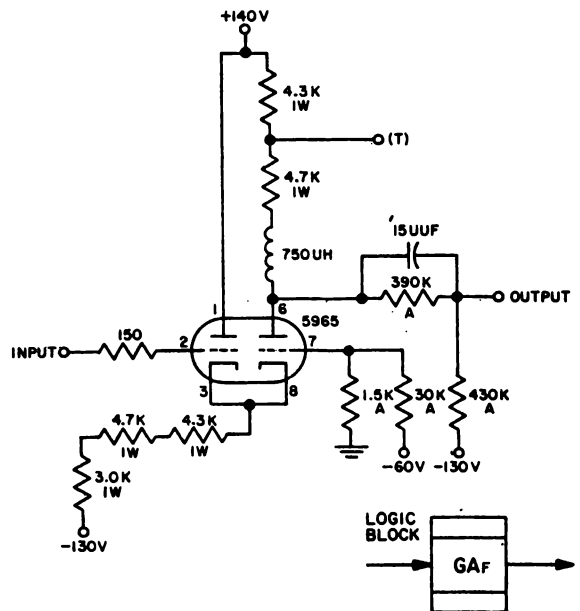

Grounded Grid Amplifier

and a diode gate without the capacitor and only one diode input. Since the diode gate without the capacitor is connected to a single-shot circuit which has a capacitor in the input circuit, this difference in the diode gate circuits can be ignored.

The diode gate circuit performs an AND function. While an AND circuit will have only voltage levels or only pulses as inputs, a gate circuit will have both level and pulse inputs. The voltage level is applied to the resistor input of the diode gate and the pulses arrive at the diode inputs. Since the junction in the diode gate circuit can only be positive when all of the inputs are positive, the circuit does perform an AND function.

The need for having all inputs positive to cause the junction point to be positive is easily seen. If one of the diode inputs is at a negative potential, the junction cannot become positive, because the diode conducts and keeps the junction at a negative potential. If the diode inputs are positive and the resistor input is negative, the diodes will be back biased. With the diodes back biased and a capacitor in the output circuit, there can be no steady current flow through the resistor, and there will be no potential difference across the resistor. Since there will be no potential difference across the resistor, in such a case, the junction will be negative like the resistor input.

The waveforms in figure illustrates the rise and fall times which are possible in the diode gate. The resistor input is shown as going positive for about four usec which is long enough to let one pulse through the circuit. The rise and fall times of the pulses at the diode inputs are about a third of a usec or less. The pulse at the junction, however, has a rise time of over one usec. This relatively poor rise time is not important for the uses of the diode gate in the TDT. A negative voltage step complements a trigger circuit or causes a single-shot to produce a pulse, and the voltage at the junction of the diode gate will closely follow the voltage fall at the end of an input pulse.

The output waveform shown in figure can be misleading if the type of load is not considered. The waveform shows the voltage at the grid of a trigger circuit which is connected to the output of a diode gate. Before the trigger is completed, the input to the trigger is clamped at ground potential. After the negative shift at the junction of the diode gate and the grid of the trigger, the grid is clamped at -12 volts. The characteristic of the trigger circuit as a load depends on the particular state in which the trigger circuit happens to be.

d. Cathode Follower

Page 2290

The cathode follower (K) is primarily a power amplifier and is used to supply a stable voltage level for driving resistive loads such as diode AND and OR circuits or capacitive loads such as wiring capacitance. Their high input impedance and low output impedance make them useful for impedance matching and isolation. They do not invert the signal voltage, but they do attenuate it.

Two types of loading must be considered for a full understanding of the cathode follower; resistive and capacitive.

First, assume a resistive load with +10 volts applied to the input. The tube conducts, tending to regulate itself and not to allow an appreciable voltage difference between the grid and the cathode. If the current increases, the tube tends to cut itself off as the cathode tends to become more positive. This cutoff action tends to decrease the current. Conversely, if the current should tend to decrease, the cathode potential would tend to move in a negative direction, thus increasing the current flow.

Current through the cathode resistor causes a voltage drop across the 91-ohm resistor. With the input at +10 volts, this drop should nearly equal the grid-to-cathode rise, so that output voltage is also +10 volts. If the input signal should drop, say, to -30 volts, then the output voltage would also drop. Characteristics of the tube are such that a change in current through the tube, which

accompanies the change in voltage across the load, increases the grid potential to about 3 volts. With this bias, the current causes a drop across the 91-ohm bias resistor from 1 volt to 0.5 volt. This means that the voltage developed across the bias resistor can no longer compensate for the grid-to-cathode drop, and the output will now be more positive than the input. The voltage rise in a cathode follower is about 0.1 volt-per-volt change in signal level with the minimum cathode load in the circuit. As the cathode resistor is increased, the value of the lower level can be expected to increase also, approximately 1 volt per 3K increase in the cathode resistor. The gain of a cathode follower is about 0.9.

If the loading becomes capacitive, the situation changes somewhat. Assume that a capacitor is connected from the output to ground and that the grid now shifts from +10 to -30 volts. Since the voltage across the capacitor cannot change suddenly, the cathode is held at +10 volts while the grid shifts to -30 volts, cutting the tube off for a time. The output voltage will drop at a rate determined by the RC constants of the load resistance and capacitance. After the voltage has dropped enough, the tube will again start to conduct, and the current flow through the tube will slow the voltage change, and eventually stabilize the output voltage and maintain it at an even level. When the input again shifts to +10 volts, the capacitor will again be charged by the current through the tube. Usually the input capacitance from succeeding stages is such that the RC time constants encountered are comparable to the rise and fall times of the input. Therefore, the extremes of cutoff and very heavy conduction to charge the capacitor are not encountered, and the output will follow the input signal.

e. Power Cathode Follower

Page 2290

The power cathode follower (2KP) is a twin triode; the two sections of which are operated in parallel. The 2KP is used to power the write pulses prior to entering the tape drive.

f. Cathode Follower Clamp

The cathode follower clamp (KC) is used to produce the regulated -12 volts used for clamping trigger grids, and at other points where a -12 volt clamp is desired. The divider at the grid input holds the grid at -15 volts. With this grid voltage, the tube draws 3.2 ma and the drop across the cathode resistor is 48 volts. The output voltage is -12 volts.

g. Grounded Grid Amplifier

Page 2290

The grounded grid amplifier (GAF) is used mainly as a level setter. It also possesses desirable pulse-shaping qualities.

The grid of the right tube is held at approximately -3 volts by the voltage divider network between -60 volts and ground. With no signal on the left tube, the right tube plate current is approximately 10.5 ma. The cathode is at -2.6 volts and the plate at +45 volts. This results in a divider output of -38 volts.

As the input signal rises, the left tube will start to conduct with approximately -10 volts on its grid. More current will be drawn through the cathode resistors as a result, and the cathode goes more positive. The cathode going more positive causes the divider output to rise to +10 volts.

The tube characteristics are such that when the input signal reaches approximately +3 volts, the right tube is cut off and any further rise of the input causes no further rise in the output. This discontinuance of output rise is the reason for the speed-up in the rise and fall times of the output.

h. Single-Shot Circuit

Page 2350

The single-shot circuit (SS) is a mono-stable multivibrator; that is, the circuit has one stable state. When pulsed or triggered, the single-shot changes to its quasi-stable state and returns to its stable condition after a predetermined length of time. These circuits are used to generate gating levels or pulses of specified duration and to provide delays.

1) - Circuit Description

The initial status of the single-shot circuit is with the right tube conducting and the left tube cut-off. This will be the normal state of the circuit because the left grid is clamped by diode G to a negative voltage and the right grid is connected to a positive voltage (the junction of the 100K-82K voltage divider circuit). Consider a -40-volt shift supplied to the negative input. Because the voltage across the capacitor C cannot change instantaneously, a sharp 40-volt drop will occur at the right grid. The tube will be cut-off, the right plate voltage will rise. Since the left grid is coupled to the right plate, the left grid voltage will also rise and the left tube will come out of cut-off. Because the grid of the right tube is coupled to the plate of the left tube, conduction in the left tube will further the action of pulling the right grid down. This essentially is the action taken in the circuit to change it to the quasi-stable state (i. e., left tube conducting, right tube cut-off).

Up to now the right tube has been kept out of conduction by the action of capacitor C holding the grid voltage below cut-off. The RC timing network determines how long it will take capacitor C to discharge through resistor R, thus allowing the right tube to come out of cut-off. When the right tube goes into conduction, its plate voltage goes down, therefore, the left grid voltage goes down. At this point the left tube will be cut-off and the circuit is back to its normal stable condition.

2) Inputs and Outputs

The logic block in figure shows several inputs and outputs. The operation of the circuit has been described for the negative input, because the single-shot circuit is so used in the TDT. The negative input is located at the lower right of the schematic. Negative voltage steps of 15 volts to 20 volts in magnitude at this input will cause the single-shot to generate a pulse. The positive input circuit shown

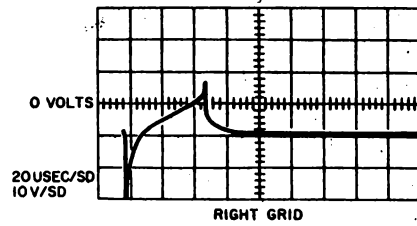
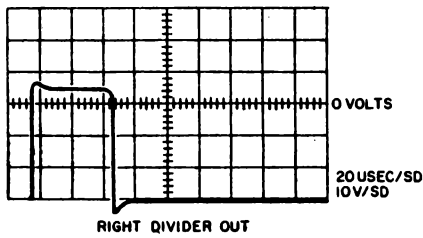
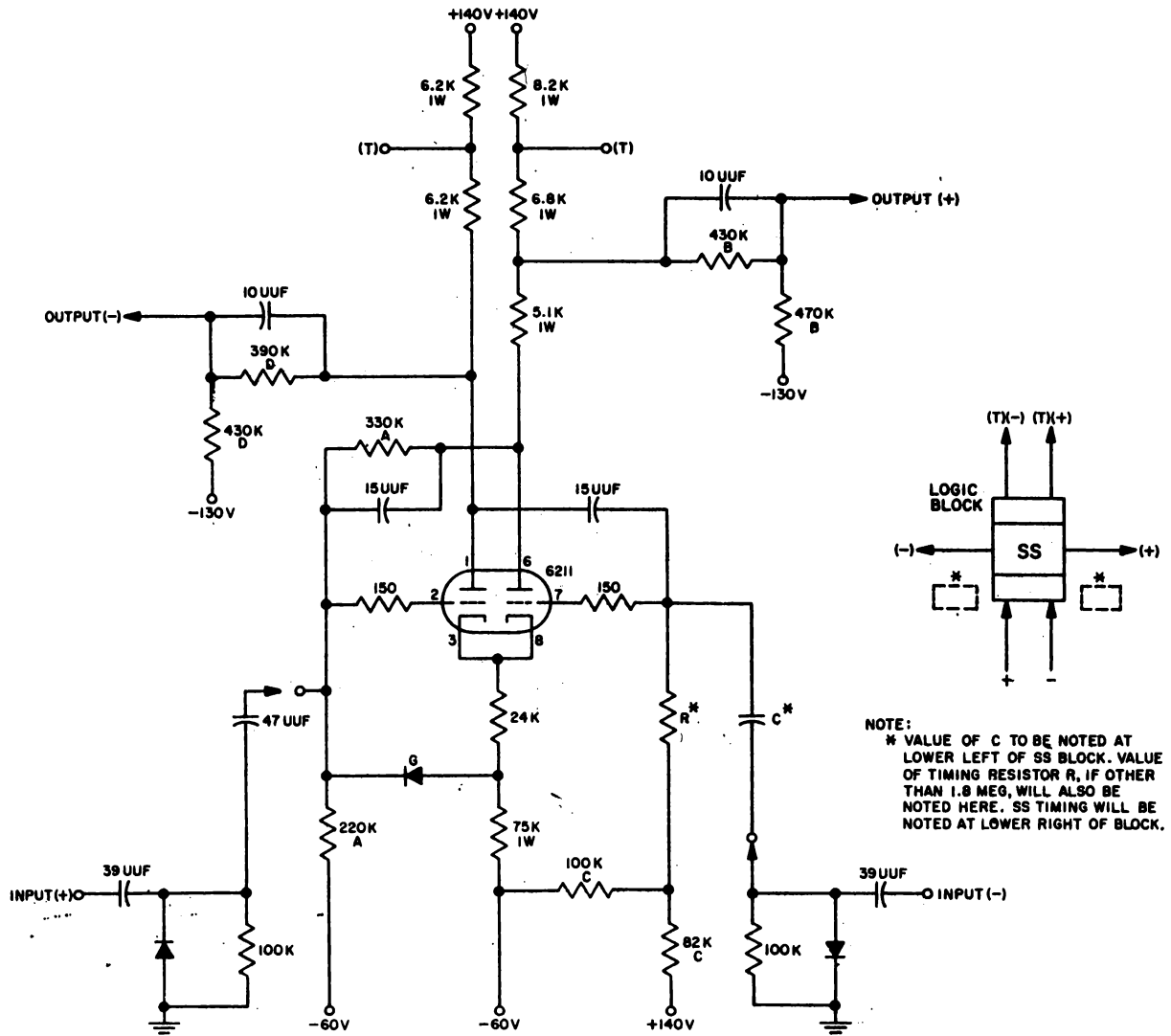

Single Shot

at the lower left of the schematic is not a part of the single-shot circuit used in the TDT. The positive output is taken from a divider network connected to the plate of the right tube. The output is a positive going pulse from -32 volts to +8 volts. The waveform is shown at the bottom left corner of figure

i. **Multivibrator Circuit**

Page 2370

The name multivibrator as used herein refers to a free-running multivibrator (MV), as compared to a bistable (trigger) or quasi-stable (single-shot) multivibrator. Essentially, free-running means once the circuit is activated the output will vary from one state to another without the need of an input to change the output. In the TDT, the MV is a source of timing pulses to control reading and writing operations.

1) **Circuit Description**

Because the TDT allows reading and writing at different frequencies, the timing circuit or MV will be more complex than the basic free-running MV. Figure shows a basic free-running MV to be used for the initial circuit description.

Notice in figure that the plate output of each tube is coupled back to the grid input of the other tube. Since a 180 degree phase shift occurs in one tube, two tubes will produce a 360 degree shift when coupled as described. Thus any change in the output of the first tube will be amplified through the circuit causing a greater change in the same direction in the first tube. To illustrate the operation of a MV, consider tube A non-conducting and tube B conducting. Assume that a transient input to the grid of tube A brings that tube out of cut-off; its plate voltage will fall. Since the voltage across a capacitor cannot change instantaneously, the voltage on the grid of tube B will have to fall. This will cut-off tube B, its plate voltage will rise and further aid the action of pulling up the grid voltage of tube A. It now

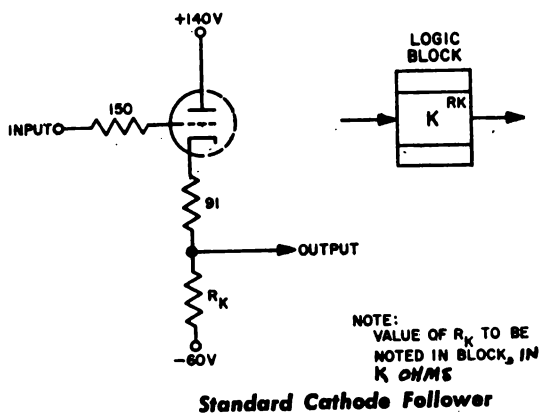

Standard Cathode Follower

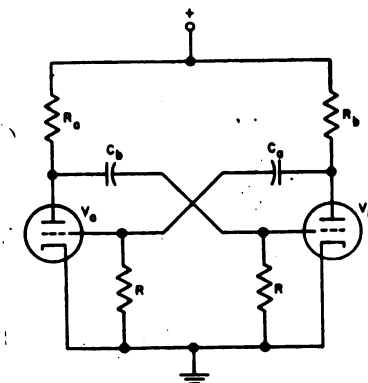

Basic Free Running Multivibrator

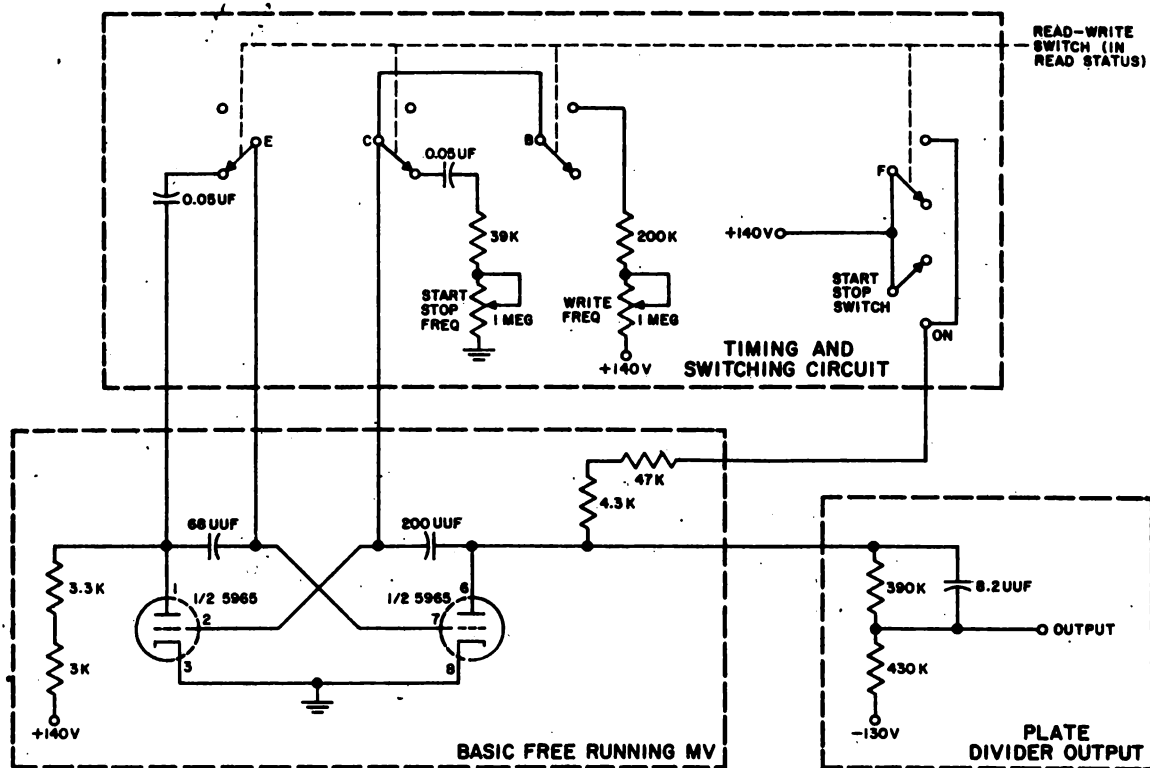

NOTE:
LETTERS INDICATE
TERMINALS OF
READ-WRITE SWITCH

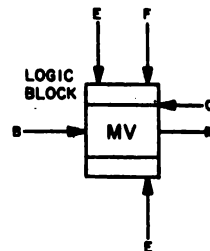

TDT Multivibrator Circuit

can be seen how a change is amplified in phase through the circuit back to the source of the change.

Tube B will be held out of conduction until capacitor C_b discharges through the plate load resistor R_a , thus allowing tube B to come out of cut-off. At this time the plate voltage of tube B falls, capacitor C_a couples this voltage drop back to the grid of tube A and causes tube A to become non-conducting. This completes one cycle of operation for a basic free-running MV. The cycle will start over again as soon as capacitor C_a has had sufficient time to discharge through R_b and thus allow tube A to start conducting again. The timing of the MV is a function essentially of two RC networks ($R_a C_b$ and $R_b C_a$). Any changes to the RC parameters will vary the width of the pulse output accordingly.

2) TDT Multivibrator

Page 2370

The seeming complexity of the circuit is due to the incorporation of components to allow the MV to vary its frequency of operation, and also to allow the MV to be switched as a timing circuit for either reading or writing. Figure reveals three distinct sections: the basic free-running MV, the timing and switching circuitry, and the plate divider output. As indicated, all switch terminals are part of the WRITE-READ switch and the letter by each terminal identifies the terminal on this switch.

3) Inputs and Outputs

The free-running MV requires no external signal input; it operates unaided, once started by transitory conditions. The output is taken from a plate divider network. The voltage will swing from approximately -30 volts to +10 volts at a frequency determined by the timing network. When the MV is in the write status, the output pulse can be varied from 20 to 100 usec, when in the read status it can be varied from 10 to 150 ms.

D. TDT Block Diagram Analysis**Page 2400**

The block diagram shows how the TDT logic operates. The actual TDT consists of one pluggable unit and several switches that route and control the operation of the TDT. The addition of the built-in power supply constitutes the entire TDT.

1. Response Select Switch and Hubs

The RESPONSE SELECT switch and related observation hubs receive all incoming information and control signals from the tape drive being tested. The function of the switch is to allow selection of a specific incoming information or control line to be observed with an oscilloscope at the proper hub (i. e., T. U. response hub, READ BUS hub, etc.). Only the AUTO CYCLE position of the RESPONSE SELECT switch has any command function or ability to control TDT operation. In the AUTO CYCLE position, the end-of-tape mark on a tape will be sensed automatically and the TDT will initiate a rewind to the load point and continue to cycle over and over.

2. Write-Read Switch

The WRITE-READ switch places the TDT in either read or write status. In addition, the WRITE-READ switch places a variable control voltage on the timing circuitry to allow variable read or write frequencies.

3. Timing Circuitry

The timing circuitry is essentially a free-running multivibrator. Under control of the WRITE-READ switch, the multivibrator generates the necessary timing pulses to operate the read-write and write pulse circuitry. By means of two variable resistance networks, the multivibrator can change its frequency of operation to accommodate various rates of either reading or writing.

4. Read-Write Circuitry

The read-write circuitry generates three control levels necessary for a TDT to operate a tape drive. The three control levels are: go, backward, and reset-write-triggers. These control levels are derived from the go backward trigger, which is the key element of the read-

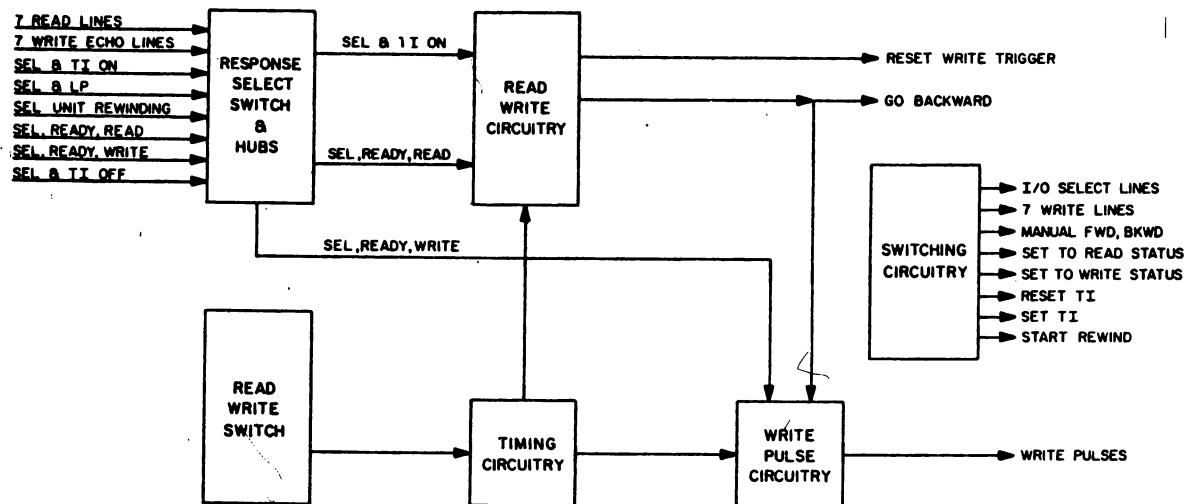

Tape Drive Tester, Block Diagram

INPUTS TO THE TDT FROM THE TAPE DRIVE

INPUTS	FUNCTION
Read bus (seven lines)	The read bus consists of seven d-c lines over which the seven bits are transmitted in parallel to the TDT.
Write Echo bus (seven lines)	These seven lines send the image of the information that is written on the tape back to the TDT where it is used for checking purposes.
Select and TI ON (NIFA)	This output indicates that the selected tape drive has its tape indicator turned on (i.e., tape drive is not in file area).
Select and TI OFF (IFA)	This output indicates that the selected tape drive has its tape indicator turned off (i.e., tape drive is in file area).
Select and at Load Point	This line indicates that the selected tape drive is at load point.
Select and Rewind	This line indicates it has been selected and is rewinding. Reading or writing cannot be performed if this line is up.
Select, Ready, and Write	This line indicates that the unit has been selected and is ready to begin writing. It is a response to the set-write line coming from the TDT.
Select, Ready, and Read	This line indicates that the tape drive has been selected and is ready to begin reading. The term "ready" here means that a tape is loaded into the machine and that the machine is not in rewind status. This is a response to the set-read line coming from the TDT.

OUTPUTS FROM THE TDT TO THE TAPE DRIVE

OUTPUTS	FUNCTION
Select lines (ten lines)	The select lines determine which tape drive is to be selected.
Write bus (seven lines)	The seven d-c lines that comprise the write bus transmit the seven bits to be written in parallel to the tape drive.
Set Read	This line indicates the desire to read from the tape unit. It is preceded by the proper select line indication.
Set Write	This line indicates the desire to write in the selected tape unit.
Set TI (NIFA)	This line turns the tape indicator on in the selected tape drive.
Reset TI (NIFA)	This line turns the tape indicator off in the selected tape drive.
Write Pulse	This line generates gated pulses to switch the write triggers.
Reset Write Triggers	This line generates a pulse that is used to set all the write triggers to the same status prior to writing.
Backward	This line controls the status of the forward-reverse magnet in the selected tape drive.
Start Rewind	This line initiates rewind.
Go	This line controls the status of the moving coil.

write circuitry. The go- and backward-control levels are a direct output of the go backward trigger, and the reset-write-trigger-control level is initiated by the go backward trigger. When the TDT is in read status, the backward-control level allows the tape drive to move in reverse under TDT control. If the TDT is in write status, the reset-write-trigger-control level resets (clears) the tape drive write triggers, and the go-control level allows the tape drive to move forward under TDT control.

5. Write Pulse Circuitry

In the TDT, the output from the write pulse circuitry controls the timing of writing for the tape drive being tested. The write pulse output is derived from a single-shot that is conditioned by three levels: select-read-write, go, and timing.

6. Switching Circuitry

The block labeled switching circuitry in figure contains the remaining switches of the TDT that have not yet been discussed elsewhere. None of these switches has any control on the TDT logic; they merely allow certain control levels to be passed from the TDT to the tape drive being tested.

E. Analysis of TDT Logic

The TDT logic can best be analyzed by examining it in each of its three modes of operation (i. e., reading, writing, and auto cycle). In each mode of operation the following items will be discussed:

1. The information and control levels supplied to the TDT from the tape drive being tested.
2. The information and control levels that the TDT supplies to the tape drive being tested.
3. In addition, how this TDT output is generated by the TDT logic.

Reading Mode

a. Inputs to TDT

All inputs to the TDT entering to the RESPONSE-SELECT switch, regardless of the mode of operation for the TDT are shown in figure . To condition the TDT logic for reading, the select-ready-read level must be up (+10 volts) and the select-and-TI-on level must be down (-30 volts). To observe any of the tracks of information being read from the tape drive being tested, all 7 tracks have read lines entering the RESPONSE-SELECT switch. Selection of any one of the 7 read lines may be made at the RESPONSE-SELECT switch, and observation of that track may be accomplished at the READ BUS hub by using an oscilloscope.

b. TDT Outputs

The following control levels or pulses are supplied to the tape drive being tested, when the TDT is in the read mode: select (1 line), backward, and set-to-read-status.

c. Analysis of TDT Logic In Read Mode

The TDT has two methods of operation in the read mode. One method allows continuous reading until the TDT is stopped manually or until the tape drive reaches the end-of-tape mark. The second means of reading is the start-stop method. The TDT starts to read until stopped automatically by the TDT logic. Reading is initiated automatically again, stopped again, etc. This cycle is repeated over and over continually.

1) Start-Stop Method of Reading

In figure the WRITE-READ switch would be in READ status (shown in WRITE status). In order to read in the start-stop method, the START-STOP switch located above the multi-vibrator MV logic block must be ON. This supplies +140 volts to the plate of the right tube of the MV. Under the above conditions,

Page 3560

Fig. 1-3

the MV is now under control of the variable resistance network labeled START-STOP FREQUENCY. The variable resistance network would be adjusted to give a series of continuous running pulses somewhere in width from 10-150 ms.

The output at the MV is passed through a cathode follower K and becomes one input of the two-input diode gate DG. The other leg of the DG is the set-read-status-control level (+12 volts) coming from the WRITE-READ switch. The gate level for the DG is the select-ready-read level (+12 volts) originating in the tape drive and passed through the RESPONSE-SELECT switch.

The MV pulses are gated through the DG and used to alternately turn the go-backward trigger TB on and off. This is accomplished through the complementary input to the TB (double diode input). The turning off and on of the TB will result in a +10 -30 volt output being fed to the cathode follower K. The output from K (+10 -30 volts) is directed through the MOTION CONTROL switch to the backward and go lines.

As was noted previously, the set-read-status-control level is obtained from the WRITE-READ switch. This level will place the tape drive being tested to read status. The ADDRESS SELECT switch selects the specific tape drive to be tested by furnishing a +12-volt level to its selection circuitry. At this point the tape drive has been selected and readied to read. When the go-backward trigger is turned on, +10 volts on the go line will start the tape drive in motion, thus causing it to read. When the go-backward trigger is turned off, -30 volts on the go line stops the tape drive. The above description indicates how the TDT operates in the start-stop method of reading.

2) Continuous Method of Reading

The TDT will operate the tape drive being tested in a continuous reading manner if the WRITE-READ switch is set to READ status, the START-STOP switch is off, the START pushbutton is depressed to start the read operation. The operation of the TDT logic differs in one aspect for continuous reading as compared to start-stop reading. The difference is the fact that the MV does not function. Turning the START-STOP switch off removes the +140 volts from the plate of the right tube of the MV, thus disabling the MV. The act of depressing the START pushbutton places the left grid of the trigger TB at ground potential; the result is that the TB changes status and is turned on. Turning on the TB (+10 volts) conditions the go line through the MOTION CONTROL switch. All other conditions in the TDT logic remain the same as described for start-stop reading.

2. Writing Mode

a. Inputs to the TDT

In order to condition the TDT for writing, the select-ready write level must be up (+10 volts) and select-and-TI-on level must be down (-30 volts). Observation of information being written is facilitated by the write echo lines entering the RESPONSE SELECT switch. Selection of any one of the 7 write echo lines may be made at the RESPONSE SELECT switch, and observation of that track may be accomplished at the ECHO BUS hub with an oscilloscope.

b. TDT Outputs

The following control levels or pulses are supplied to the tape drive being tested when the TDT is in the write mode; select (1 line), set-to-write-status go, reset-write-triggers, write-pulses, and 7 write lines.

c. Analysis of TDT Logic in Write Mode

Page 3560

To write, the WRITE-READ switch would be placed to the WRITE position and the START pushbutton depressed. At this time the MV is under control of the variable resistance network labeled WRITE FREQUENCY. The variable resistance network should be adjusted to give a series of continuous running pulses, 53.8 usec in width. The output of the MV is passed through a cathode follower K and feeds the single leg diode gate DG.

At this point assume that the START pushbutton has just been depressed. This places the left grid of the trigger TB at ground potential; the result is that the TB changes status and is turned on. Turning the TB on will result in a +10 volt output to the cathode follower K. The output from K (+10 volts) is directed through the MOTION CONTROL switch to the go line. The output from K also feeds one input of the two-input AND circuit. The second input is brought up by the select-ready-write level (+12 volts). The output of the AND circuit (+10 volts) becomes the gating level for the DG.

At this point the go line has been brought up, the AND circuit and the single input DG conditioned. The MV output pulses are gated through the single leg DG thus causing the single-shot SS to produce a series of write pulses 12 usec in duration. The write pulses are passed through a grounded grid amplifier GAF, a double cathode follower 2K, and then enter and condition the write circuitry of the tape drive being tested. The actual information written on each track of the tape is passed through the bit switches of the TDT to the tape drive as either a 1 or 0 bit of information (+12 volts or -30 volts).

The output levels, the set-write-status and the reset-write-triggers levels remain to be discussed. The set-write-status-control level (+12 volts) is obtained from the WRITE-READ switch and is used to condition the tape drive for writing operation. The reset-write-triggers level is generated from

the SS whose input is derived from the T_B . When the START pushbutton is depressed, the T_B produces a negative shift which is applied to the SS. The negative shift produces a 100 usec reset-write-triggers from the SS. This pulse is used to reset all the write triggers to the same status.

3. Auto Cycle

In auto cycle, the TDT causes the tape drive to move forward and write on its tape until the end-of-tape mark is sensed. At this time the TDT initiates a rewind until the load point on the tape is sensed; then writing starts again. This cycle of operation is continued over and over again.

a. Inputs to the TDT

The following control levels enter the TDT from the tape drive being tested: select-and-rewind, select-and-TI-on, and select-ready-write.

b. TDT Outputs

The following control levels or information are supplied to the tape drive being tested when in AUTO CYCLE:

Select (1 line)	Write pulse
Write (7 lines)	Set-to-write-status
Reset-write-triggers	Reset TI
Go	Start rewind

c. Analysis of TDT Logic in Auto Cycle Mode

Since auto cycle is merely a writing operation with the additional feature of automatic rewind, it will only be necessary to explain how automatic rewind is initiated. In order to operate in auto cycle, the RESPONSE SELECT switch is placed to AUTO CYCLE and the WRITE-READ switch is placed to WRITE. When the START pushbutton is depressed, normal writing operation commences. Writing continues until the end-of-tape mark is sensed by the tape drive. At this point the tape indicator trigger (NIFA flip-flop) is turned on, bringing up (+10 volts)

the select-and-TI-on line. Following the select-and-TI-on line through the RESPONSE SELECT switch, notice that this line brings the start-rewind line up (+10 volts). The start-rewind level initiates rewind in the tape drive. When rewind is initiated in the tape drive, the select-and-rewind level is brought up (+10 volts) and returned to the TDT. After this level is routed through the RESPONSE SELECT switch, it will bring up the RESET-TI level (+10 volts). At this point the tape drive is prepared to start writing operation again when load point is reached.

Notice that wafer F of the RESPONSE SELECT switch disconnects the select-and-TI-on level from the TDT logic when in AUTO CYCLE status. Thus the go backward trigger is never turned off in auto cycle. If this were not the case, it would be necessary to manually restart the TDT, for there is no other way to turn the go backward trigger on when the WRITE-READ switch is in the WRITE position.

d. Summary Questions

- 1) List the function of each section of the response select switch: (3A-F)
Sections A, B, C, D, E, and F
 - 2) A set write status signal is sent to the selected tape drive by way of I/O-51(9B). Which switch and switch section controls this signal?
 - 3) When the TDT is not in auto cycle, what switch and section will cause tape to stop when the EOT marker is sensed?
 - 4) There are 2 DG circuit blocks (6C & 6B) on the TDT logic and switching. Explain when each is used, i. e. , for what operations.
- (T/F) 5) A start-stop operation can be performed in read or write operation.

e. Answers to Summary Questions

- 1)
 - a) Section A = To make available to the read bus read information from tracks 1, 2, 3, sync, 4, 5, or 6. The skew sync hub makes track one available for check purposes.
 - b) Section B = Brings a writing indication for tracks 1, 2, 3, sync, 4, 5, or 6 to the echo bus.
 - c) Section C = Makes available to the T. U. response hub the following signals:
 - (1) Selected Unit Rewinding
 - (2) Selected and At Load Point
 - (3) Selected and Tape Indicator ON
 - (4) Selected and Tape Indicator OFF
 - (5) Selected, Ready, and Read
 - (6) Selected, Ready, and WRT
 - d) Section D = For auto cycle operation, it allows the SEL unit rewinding signal to reset the TI preparatory to another write cycle.
 - e) Section E = In auto cycle operation, the SEL & TI on signal produced by EOT will initiate a rewind.
 - f) Section F = In auto cycle, the Go-Backward trigger (TB) is kept on by removing the SEL and TI on signal from the TB clear input.
- 2) The Write-Read switch, section A.
- 3) Response select switch, section F will cause the go line to go down when the EOT marker brings up the SEL and TI on signal.
- 4) DG (6C) is used for start-stop read operation. DG (6D) is used for write operation to generate the write pulses.
- 5) False

F. TDT Power Supply

1. General Description

Page 2510

The power supply for the TDT is located in the lower part of the TDT unit. The only controls for the power supply are the circuit breaker switches located on the lower, vertical, front panel. The circuit breaker switches are arranged in a horizontal line and in two groups of four each. Between the two groups of switches is a pilot light which will be on if the a-c circuit breaker switch is in the on position.

The three switches furthest left are fastened together and act as a gang switch. This switch is the a-c circuit breaker switch and controls the 3-phase a-c input to the TDT unit from the line cord.

The line cord supplies 3-phase, 60-cycle power at 120/208 volts. The line cord also provides a ground connection. The power supply has two outputs: one to the TDT logic circuits, the other to a tape drive unit. The internal supply cable is connected to the chassis in the upper part of the TDT. The large external supply cable is connected to the tape drive unit to be tested. Both of these cables supply the necessary a-c and d-c voltages to operate the equipment to which they are connected.

2. A-C Supplies

Page 2510
&
2520

The symbol for the line cord is located on the left side of the schematic, and the outputs or supply cords and connectors are indicated by the contents of the rectangles on the right side. The rectangles are drawn with dashed lines. The smaller rectangle is for the internal supply cord, and the larger rectangle is for the external supply cord. The numbers inside the rectangles indicate the pin numbers of the connectors for the power cables.

The 3-phase a-c input to the power supply is controlled by a circuit breaker which will not allow a current drain of more than 12 amperes. Three lines carry 3-phase unregulated a-c from the a-c circuit breaker directly to the connector for the external supply cable. The drive motors in a tape drive unit require this 3-phase a-c. The tape drive tester does not use the

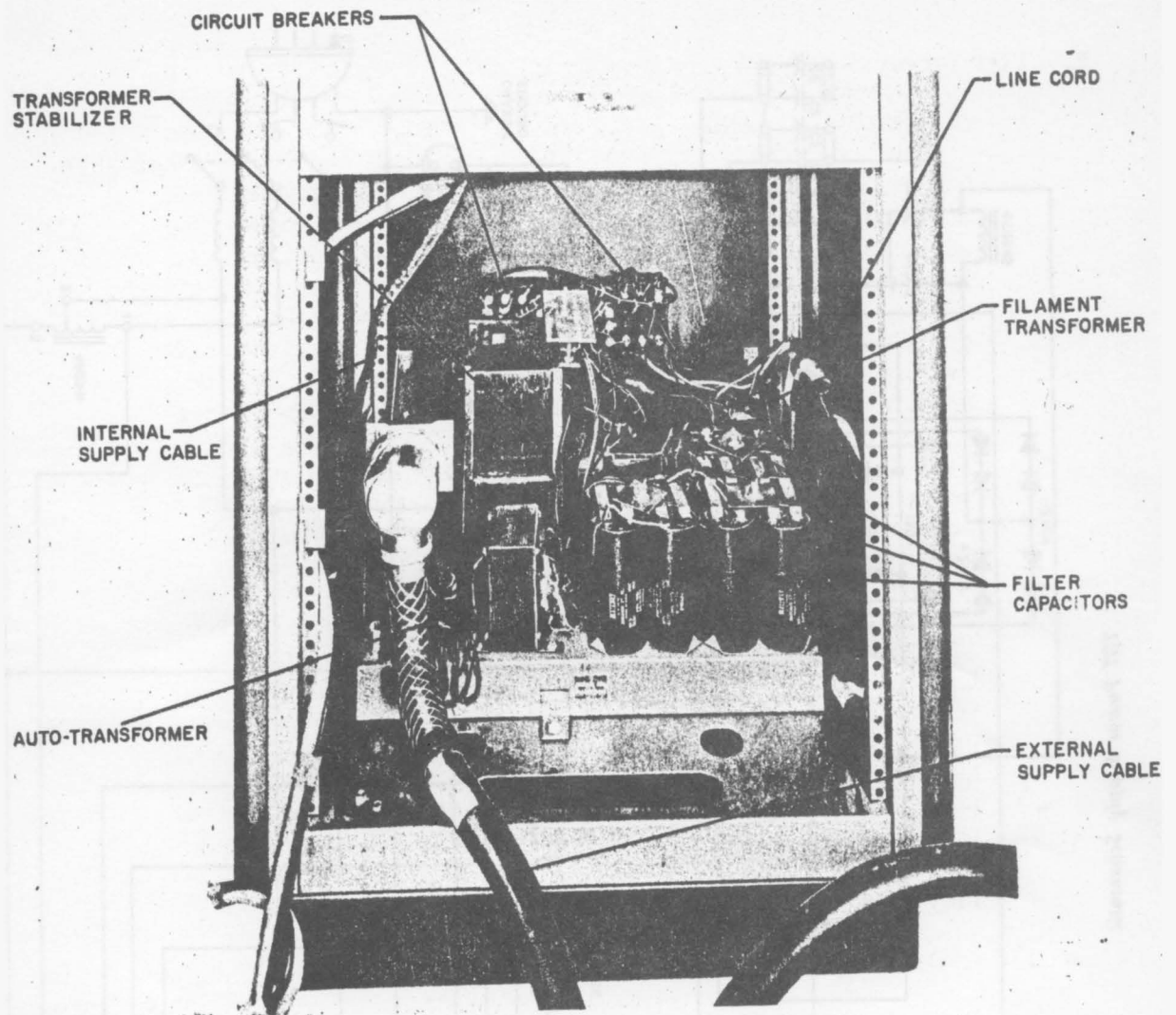

Rear View of Power Supply

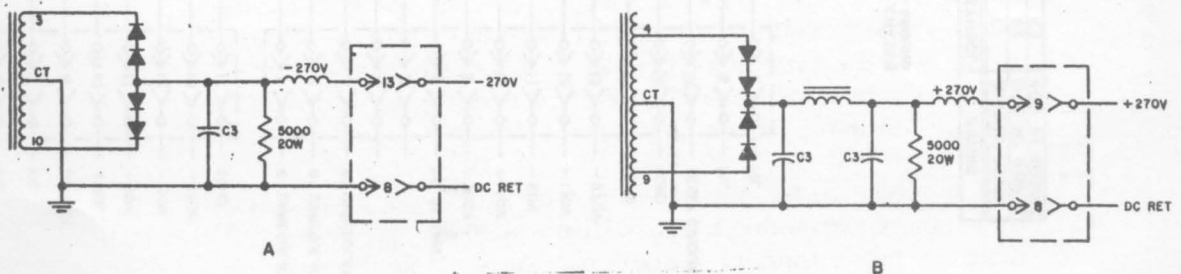

D-C Power Supply Circuits

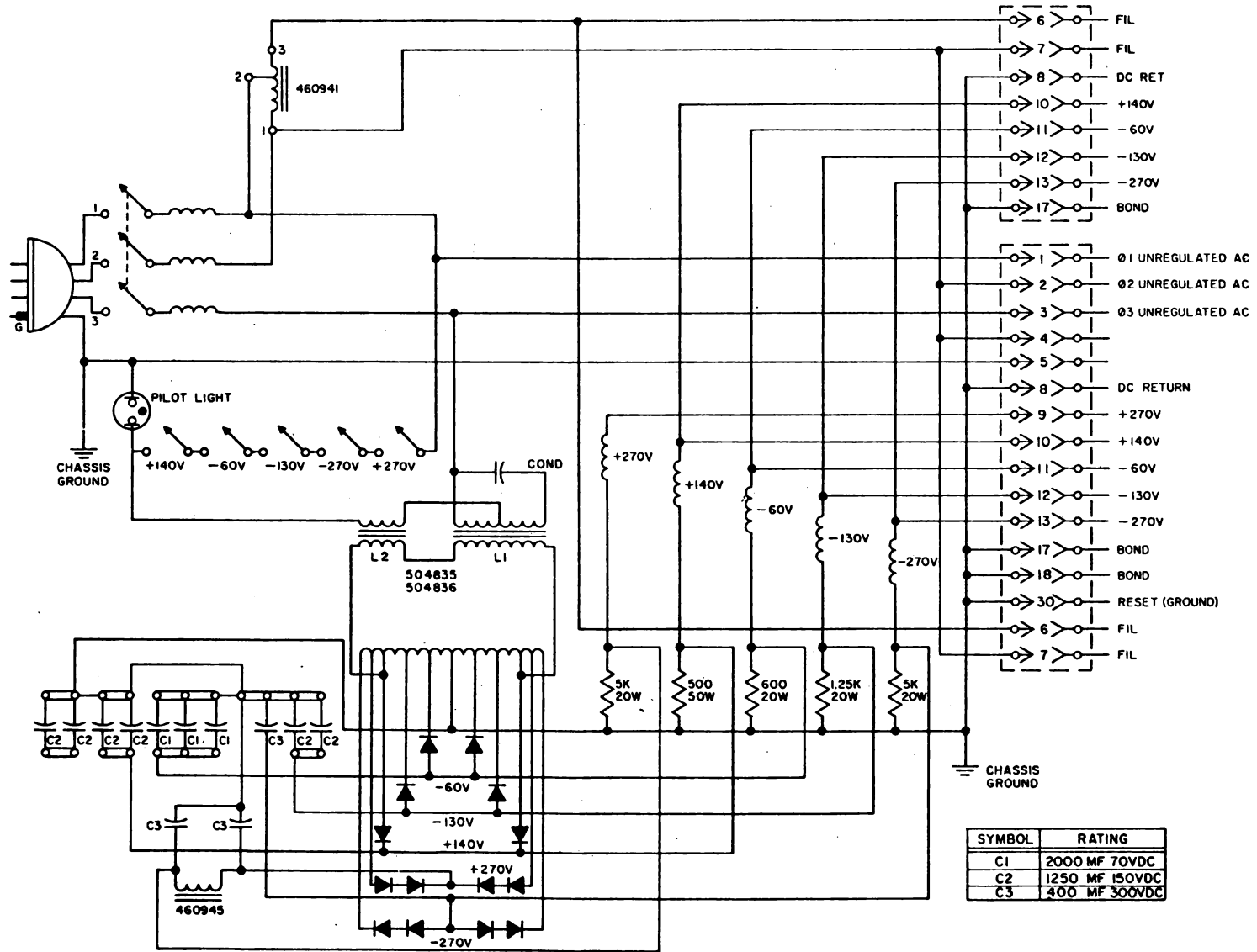

TDT Power Supply Schematic

3-phase a-c; there are no corresponding lines in the internal supply cable.

Between any two of the three lines carrying the 3-phase a-c, there will be a rms potential of 208 volts. Between any one of the three lines and ground there will be a rms of 120 volts.

In addition to the 208 a-c supply, there is a 236 volt a-c supply for the tube heaters. The filament transformer has an input of 208 volts taken from phases 1 and 2 and supplies the desired 236 volts. Both cable connectors are wired to this filament transformer.

It should be noted that neither side of the filament supply is grounded. One of the filament supply lines is connected to the same transformer terminal that is connected to the phase-2 power line. Since the phase-2 voltage has a definite relationship to ground, the filament voltage also has a definite relationship to ground and does not float.

The only part of the a-c circuitry which has not yet been described is the a-c input to the rectifiers of the d-c supplies. The phase-3 supply line is connected directly to one input terminal of the transformer stabilizer (part #504835). The phase-2 supply line is connected to the other input terminal through the series of d-c circuit breaker switches. The transformer stabilizer steps up the 208 volt input to 246 volts. The 246 volts are applied to an auto-transformer which is tapped at different points for inputs to the rectifiers.

The two major loads on the a-c power lines are the filament supply and the d-c supply. These two loads are connected to the power lines using two of the three possible combinations of the 3-phase lines. The third combination, which is not used, is the phase-1 line with the phase-3 line. Since the third combination is not used, the load on the power lines cannot be balanced.

3. D-C Supplies

For purposes of explanation, two of the d-c power supply circuits in the schematic have been redrawn

and are shown separately in figures A and B. These two circuits illustrate all of the principles used in the d-c power supply circuits.

The center-tapped transformer with the diodes form full-wave rectifier circuits. The circuit of figure A allows current (conventional current) to flow out of the transformer at the center tap and to return to the transformer through either terminal 3 or terminal 10. The circuit of figure B allows current to leave the transformer at either terminal 4 or terminal 9 and to return to the transformer through the center tap. The two circuits in figure A&B are high voltage circuits and use pairs of diodes in series where only single diodes are used in a low voltage circuit. The reason for doubling the number of diodes is to halve the peak inverse voltage to which a single diode would be subjected. If the inverse voltage is too high, the diode will break down, allowing too much current to flow in the backward direction.

If only the rectifier circuits were used for d-c power supplies, there would be a large variation in the d-c supply potentials. To reduce the variation in the d-c potential, (minimize ripple) a filter circuit is used with a rectifier circuit.

A shunt-capacitor filter is used in the circuit of figure A. The capacitor will charge to a potential near the peak value of the a-c input. Between the voltage peaks the capacitor will discharge to an extent which depends on the load in parallel with the capacitor. The greater the current drain is, the greater the variation in supply voltage will be. A larger capacitor will store more energy for use during parts of the a-c cycle when little power can be supplied by the a-c power lines. All but one of the d-c power supplies uses a shunt-capacitor filter.

A pi network is used for a filter for the +270 volt d-c supply. The arrangement of the components in the network gives the appearance of the Greek letter π . This particular type of pi network can be called an L-C capacitor-input filter. The capacitors in this circuit perform the same function as the capacitor in the shunt-capacitor filter. The inductance in the circuit tends to keep the current flow constant. Energy is also stored

by the inductor (choke) for use when the a-c power lines cannot supply the required energy. The inductor, like the capacitors, only supplies energy during part of an a-c cycle.

The resistors used in the d-c power supply circuits are bleeder resistors. A bleeder resistor will help prevent any sudden voltage surge on the d-c supply lines when the power supply is first turned on. Another function of a bleeder resistor is to provide a path for the discharge of the filter capacitors when the power supply is turned off and there is no load connected to the supply. However, this safety feature should not be depended upon, for a bleeder resistor can be broken or burned leaving no path for the capacitors to discharge.

The coil symbols in the d-c power supply circuit schematics represent the circuit breaker coils which are connected in series with the ungrounded d-c supply lines. If a d-c supply is overloaded, the corresponding circuit breaker switch will open. Opening one of the d-c circuit breaker switches cuts off the a-c input to the transformer stabilizer, and all of the d-c supplies are turned off. The connections of the circuit breaker switches in the power supply are indicated in the schematic of figure

Figure 1-1 shows a pilot light connected between the phase-2 a-c line and ground when all of the circuit breaker switches are closed. If one or more of the d-c circuit breaker switches is open, the pilot light will be connected between ground and the phase-3 a-c line through the primary winding of the transformer stabilizer. The pilot light will allow only a small current to flow through the primary winding, and an insignificant amount of power will be transferred to the d-c power supplies in this case. Therefore, regardless of the condition of the d-c circuit breaker switches the pilot light will be on if the a-c circuit breaker switches are closed.

Page 3530
Sheet 1 of 2

G. Installation and Operating Instructions

There are no special tools or test equipment necessary to install and operate the tape drive tester.

1. Site Wiring

The TDT tester contains its own power supply. The only requirement for site wiring is that a 208-volt 3-phase outlet capable of delivering 15 amps be available.

2. Cables, Routing and Terminations

There are no cables that permanently attach the TDT to any part of the SAGE System.

3. Power Connections

There are two methods of connecting the power when using the TDT:

- a. The normal method - the TDT supplies power for both itself and the tape drive.
- b. The TDT supplies its own power but an external source supplies the power for the drive.

The figure on Page 2170 illustrates the two power connection configurations.

When the a-c power is applied, wait 30 seconds to allow filaments to heat before turning on the d-c supplies. The d-c switches may be turned on in any order because they are in series with the a-c side of the power supply. All d-c comes up at the same time.

4. Controls

The layout of the TDT control panel is shown on page 2170. At the top of the control panel are the a-c and d-c power indicator lights. The functions of the switches, controls, and hubs are described below.

a. Switches

- 1) ADDRESS SELECT - This switch has 11 positions; 0-9 corresponding to the dial switch on the tape drive and an off position. If the tape drive address selector switch is set to the same address as the TDT address switch, the tape drive is selected by the TDT and the select light is turned on. This permits testing of all select lines to the tape drive.

- 2) **TAPE CONTROL** - These seven switches determine whether ones or zeros are written in the corresponding tracks when the tape is moved in write status. Table gives the **BIT SWITCH** number corresponding with the tape drive track number.
- 3) **MOTION CONTROL** - This switch directs the output of the go-backward trigger (TB) in the TDT to either the go line or the backward line in the tape drive unit.
- 4) **MAN-FWD/MAN-BKWD** - This switch substitutes for the customer engineer's portable forward-reverse switch, and controls forward or backward tape movement.
- 5) **WRITE-READ** - This switch performs several functions. It sets the status of the tape drive to either read or write. When set to **WRITE**, it allows the MV to develop write pulses under control of the **WRITE FREQUENCY** dial. When the **WRITE-READ** switch is set to **READ** with the **START-STOP** switch on, the MV is under control of the **START-STOP FREQUENCY** dial.
- 6) **RESPONSE SELECT** - This dial switch has six wafers. Two are used to select the particular track to be observed at the **READ BUS** or **ECHO BUS** hubs. A third wafer is used to determine the logic line that can be observed at the **TU RESPONSE** hub. These lines are: **select-and-rewind**, **select and**, at **LP**, **select-and-TI-on**, **select-and-TI-off**, **select-ready-and-write**. The last three wafers are used for auto cycle.
- 7) **REWIND** - Depressing this key causes the tape to rewind if the tape drive is selected and ready.
- 8) **START-BKWD** - Depressing this pushbutton turns on the go-backward trigger (TB), to bring up the go and/or backward line.

- 9) **START-STOP** - This switch is used only when the **WRITE-READ** switch is set to **READ**. Turning it on allows pulses, developed by the **MV** (and gated by the **select-ready** and **read level**), to operate the go backward trigger binarily. Therefore, if the **MOTION CONTROL** switch is set to **BKWD**, the forward-reverse magnets alternate.
 - 10) **STOP-FWD** - Depressing this pushbutton turns off the go backward trigger and thus brings down the go line or the backward line depending on the position of the **MOTION CONTROL** switch.
 - 11) **START-STOP FREQUENCY** - This control determines the frequency of the multivibrator, over a range of 10 ms to 150 ms when the **WRITE-READ** switch is set to read.
 - 12) **SET T.I. /RESET T.I.** - This switch directly sets or resets the tape indicator trigger in the tape drive. When the tape indicator is on, neither go nor backward levels may be brought up by the tester. The **select-and-TI-on** level inhibits the go backward trigger. If the **TI** is turned on while writing on tape, the tape unit is stopped.
 - 13) **WRITE FREQUENCY** - This control determines the frequency of the write pulses initiated by the **MV** over a range of a 20- to 00-usec period. It should be set for a period of 53.8 usec using a calibrated oscilloscope.
- b. **Hubs**
- 1) **ECHO BUS** - The write echo of the track selected by the **RESPONSE-SELECT** switch can be observed at this hub.
 - 2) **READ BUS** - The output of the pre-amp selected by the **RESPONSE-SELECT** switch can be observed at this hub.

- 3) **GO BKWD** - This is the output of the go-backward trigger. This hub is used for a scope sync when measuring start-stop time or forward-reverse magnet transfer time.
- 4) **T. U. RESPONSE** - Logical lines from the tape drive, as specified by the **RESPONSE-SELECT** switch, may be observed here.
- 5) **SKEW SYN** - The 1 track output of the read bus is brought here for convenience to sync the scope when measuring skew.
- 6) **WRITE PULSE** - Write pulses are available here when the tape drive is in select-ready-and-write status, and the go backward trigger (TB) is on.

5. Operation

a. Preparation

To operate a tape drive from the TDT, connect the signal and power cables and turn on the power. Load the tape drive in the normal manner. The tape should have a load point and end-of-tape marker. Depress the **START** pushbutton on the tape drive to put it under external control. Select the tape drive by setting the **ADDRESS SELECTOR** switch of both the drive and the TDT to the same address. Set the **START-STOP** switch to off (down position), both the **MAN-FWD/MAN-BKWD** switch and **T. I.** switch to neutral and the **MOTION CONTROL** switch to **GO FWD**.

b. Writing

To write, turn the **WRITE-READ** switch to **WRITE**, set bit switches as desired, and depress the **START** pushbutton. If the tape indicator is not on, the tape moves forward and bits are written on those tracks whose bit switches are set to 1's. Observe write pulses with the scope at the **WRITE PULSE** hub and adjust the **WRITE FREQUENCY** dial for a period of 53.8 usec between pulses. Echo pulses of the track selected by the **RESPONSE SELECT** switch can be observed at the **ECHO PULSE** hub. The

writing operation is stopped by depressing the STOP pushbutton.

When the START pushbutton is depressed, a shift from the go-backward trigger turns on the write-trigger-reset single-shot, sending out a 100-usec reset-write-triggers pulse. At the same time, write pulses (already being developed because the WRITE-READ switch is set to WRITE) are gated to the tape drive. It is possible that the fall of the reset-write-triggers pulse could coincide with the fall of a write pulse because there is no synchronization between them. In this case, some of the write triggers might be turned on and some might be turned off. These triggers would be changing out of step with each other for the rest of that writing period. This condition can be observed at the write trigger neons when the writing is stopped. Usually, however, all triggers are either on or off. The write trigger neons indicate proper operation of the triggers.

c. Reading

To read a tape, set the WRITE-READ switch to READ and depress the START pushbutton. The tape moves forward in read status. The preamp output of the track selected by the RESPONSE SELECT switch can be observed with a scope at the READ BUS hub. The operation is stopped by depressing the STOP pushbutton.

When in READ status, the tape may be read in start-stop fashion if the START-STOP switch is turned on (up position). The START-STOP FREQUENCY knob controls the frequency of the starting and the stopping of the tape. Unless the manual switch is used, the tape cannot be read when the tape indicator is on.

d. Auto Cycle

The function of the auto cycle feature is to write the tape in a forward direction until an EOT reflective spot is sensed. The drive then rewinds the tape back to the load point. Upon reaching the load point, the tape drive starts again and

the cycle is repeated. The auto cycle feature on the TDT may be used to check the following operations of the tape drive: end-of-tape sensing, load-point sensing, high-speed rewind, vacuum switches, and flapper valves.

To put the machine into the auto cycle operation, the RESPONSE SELECT switch is set to AUTO CYCLE and the WRITE-READ switch is set to WRITE. Depressing the START pushbutton then puts the tape drive into auto-cycle operation.

Special Tools and Test Equipment

A. Test Equipment

1. Tape Adapter Test Door

Page 2620

The tape adapter test door is located on the tape adapter unit (unit 13) and is used to simulate the various computer commands to the tape drive unit when in test status. The operation of the controls on the tape adapter test door is discussed in detail in the section on Tape Adapter.

Procedures used for testing with the tape adapter test door are not covered in this section. These procedures are discussed in the Tape Drive Maintenance Handbook (M1-20).

2. Tape Drive Tester

The tape drive tester, is designed to test mechanical and electrical functions of the tape drive unit. The function of the tester is to apply control and functional signals to the tape drive unit, thus causing it to go through various operations. Signals returned from the tape drive unit may be viewed on an oscilloscope through the tape drive tester rather than by connecting the scope directly to the tape drive unit.

The theory of operation and use of the tape drive tester is discussed in the Tape Drive Tester section. The procedure for connecting the tape drive tester to the tape drive unit is covered in the Tape System Maintenance Handbook (M1-20).

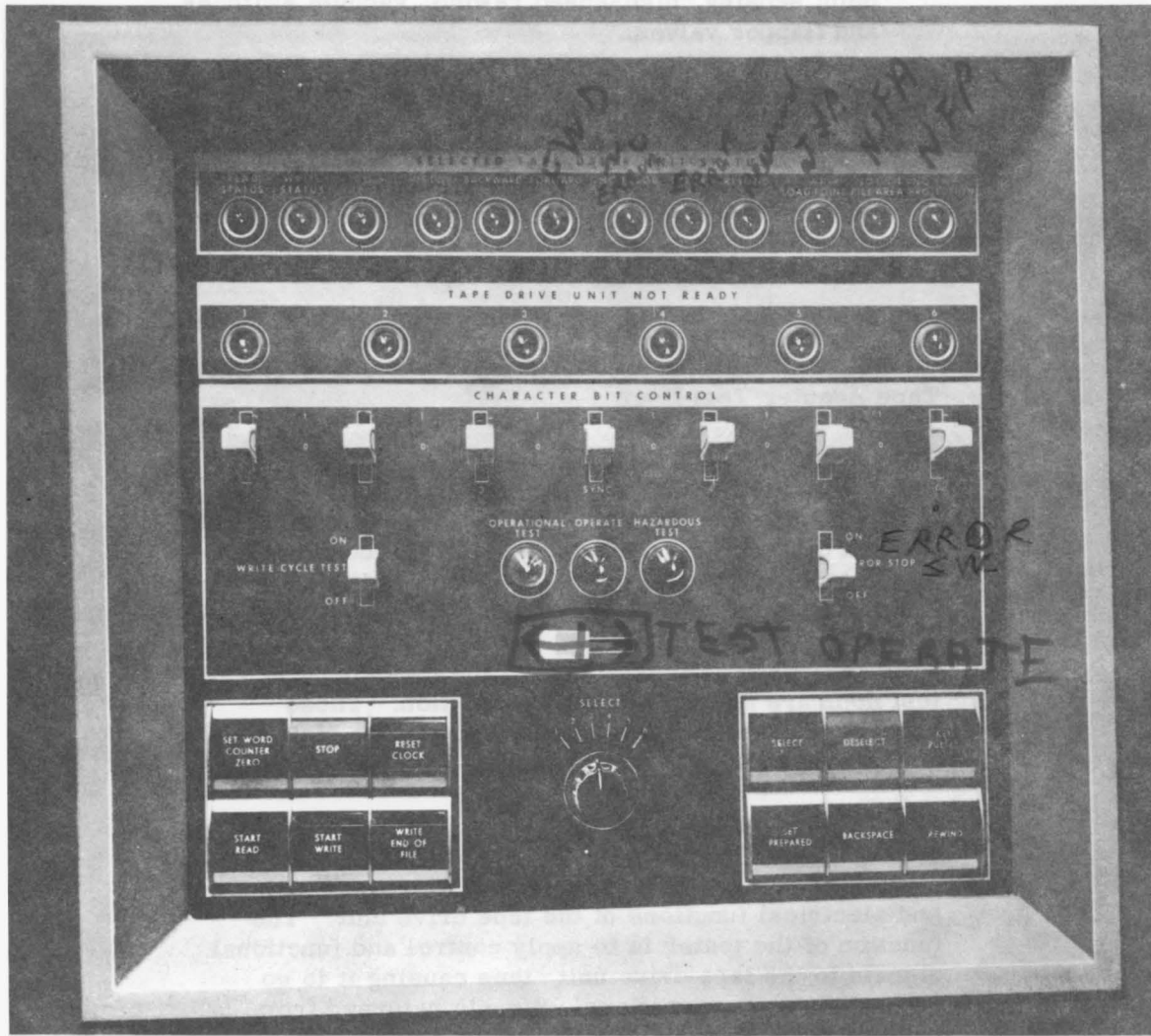

Figure 4-1. Tape Adapter Test Door

3. Master Tape

The master tape, P/N 3034818, is a specially prepared reel of tape, the one and six tracks of which contain continuous 1 bits. This tape is used to measure head skew. The average skew is limited to 1 usec between the 1 bits in the one and six tracks of the same character. Refer to Tape Maintenance Handbook for a discussion of skew adjustment.

4. Oscilloscope

The Oscilloscope Tektronix 545 and 541 is used in conjunction with the tape drive tester for displaying voltage waveforms. The uses of the oscilloscope are covered in the Tape Drive Maintenance Handbook.

5. Signal Junction Box

Page 2640

The signal junction box, P/N 3033375, is used to jumper the signals when a tape drive is removed from its operating position. This box thus serves the same purpose as the second summary punch receptacle on each tape drive. This equipment is required since only one tape adapter is used to control a multiple number of tape drives in series. Where this unit may be used is discussed in the Tape Drive Maintenance Handbook.

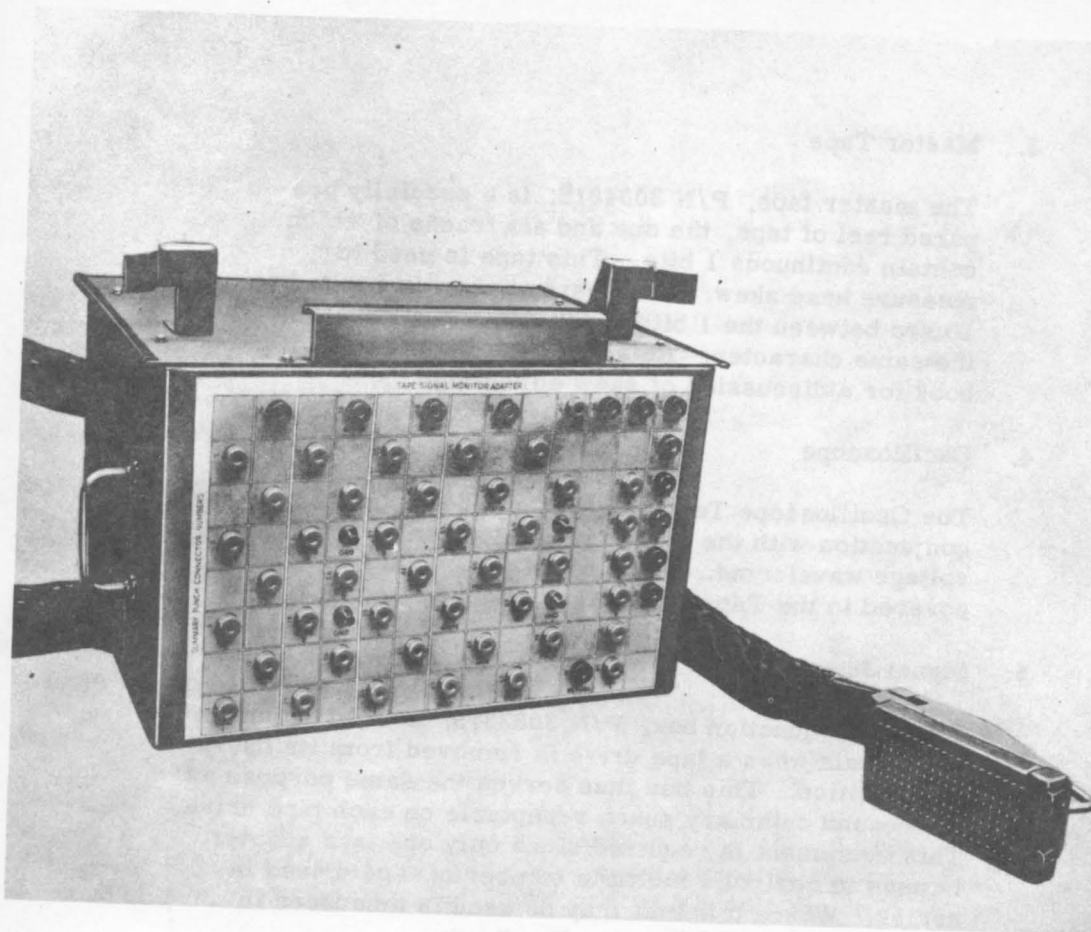

Figure 4-4. Tape Signal Monitor Adapter

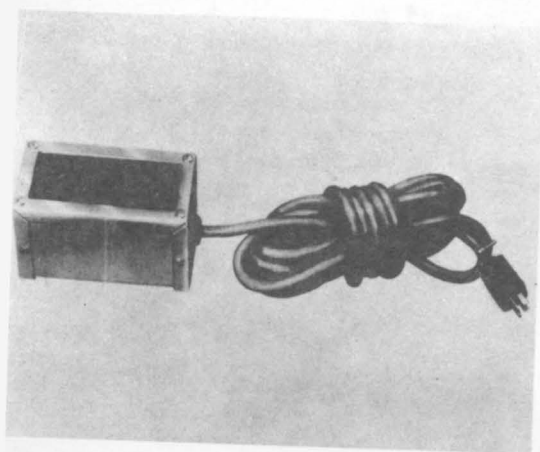

Figure 4-5. Switch Box

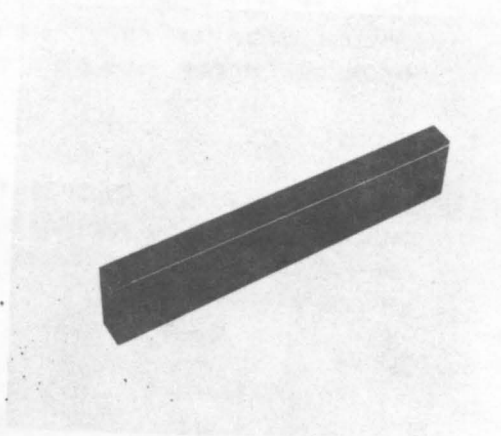

Figure 4-6. Gauge Block

8. Iron Filings.

The iron filings are used when a tape is being developed to check start and stopping distance or erase head polarity. The iron filings are mixed with Tec-solv No. 928, P/N 3034686, to form a suspension. When the tape is run through this mixture, the iron filings adhere to the tape whenever there is a change in magnetic flux. Refer to Tape Drive Maintenance Handbook for tape-developing procedure.

B. Special Tools**Page 2660****1. Gauge Block**

The gauge block, P/N 3033437, is used in adjusting the tape cleaner and photocell assembly. Refer to Tape Maintenance Handbook for tape cleaner and photocell assembly adjustments.

2. Push-Pull Scale (M-II Only)

The push-pull scale, P/N 3033432 is used when the capstan drive belt tension is adjusted. Refer to Tape Maintenance Handbook for the proper capstan drive belt tension adjustment.

3. Reel Latch Gauge (M-II Only)

The reel latch gauge, P/N 3033481, is used when shimming the reel hubs. Refer to Tape Maintenance Handbook for reel-hub-shimming adjustments.

4. Gram Gauge

The gram gauge, P/N 3033415, is used to measure tape tension during pressure pad adjustments. The uses of this tool are covered in the Tape Drive Maintenance Handbook.

5. Dowel Puller

The dowel puller, P/N 3033355, is used to remove dowels. It is screwed onto the threaded portion of the dowel and gently tightened by a wrench. As the threaded portion is screwed into the puller, the dowel is pulled from the hole of the part which holds it.

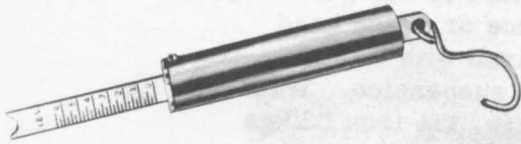

Figure 4-7. Push-Pull Scale

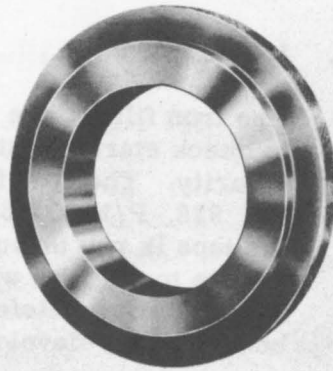

Figure 4-8. Reel Latch Gauge

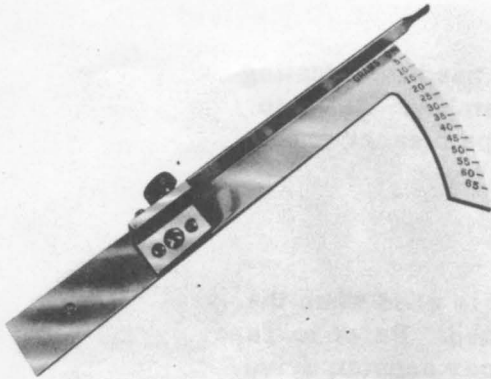

Figure 4-9. Gram Gauge

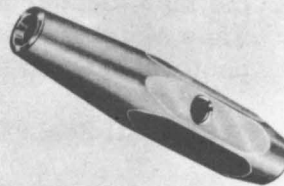

Figure 4-10. Dowel Puller

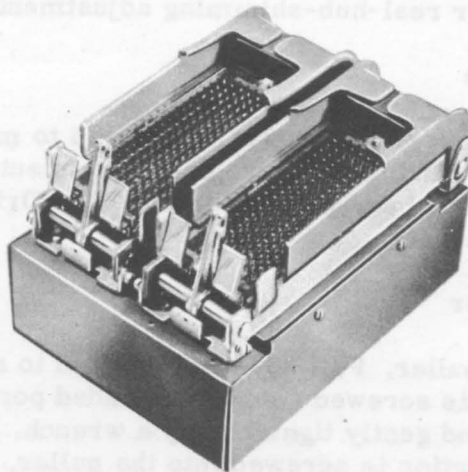

Figure 4-3. Signal Junction Box

6. Main Plate Hinge Kit (M-II Only)

The main plate hinge kit, P/N 3033377, is used when it is necessary to lower the upper main plate. The parts are affixed to the upper and lower main plates, allowing the upper main plate to swing down and to the front of the tape drive unit and thus making the assemblies located on the rear of the upper main plate accessible. The uses of this tool are covered in the Tape Drive Maintenance Handbook.

7. Pluggable Unit Extender

The pluggable unit extender, P/N 3033379, is used to make all parts of a pluggable unit readily accessible without their being disconnected from the actual circuits in which they are used. When the pluggable unit is in its normal position, its components are inaccessible.

8. Pluggable Unit Wrench

The pluggable unit wrench, P/N 3033376, is used to remove and to replace tape drive unit pluggable units. The wrench fits over, and engages, the slotted locking rod, enabling the operator to grip and to turn the rod holding the pluggable units.

Tape Programming**A. SEL (11-16)**

C. C. Vol. 2
0.7.8
0.8.1

1. Selects one of six tape drive units.

a. Should not be followed directly by any instruction pertaining directly to tape operation.

1) Done to allow select level time to rise.

B. End-of-File Operations

Recall that end-of-file is designated with a one-word record having ones in the other three bit positions of character containing bits 31, 32, and 33. Writing the end-of-file record requires the direction of the computer program. Reading the end-of-file record results in setting

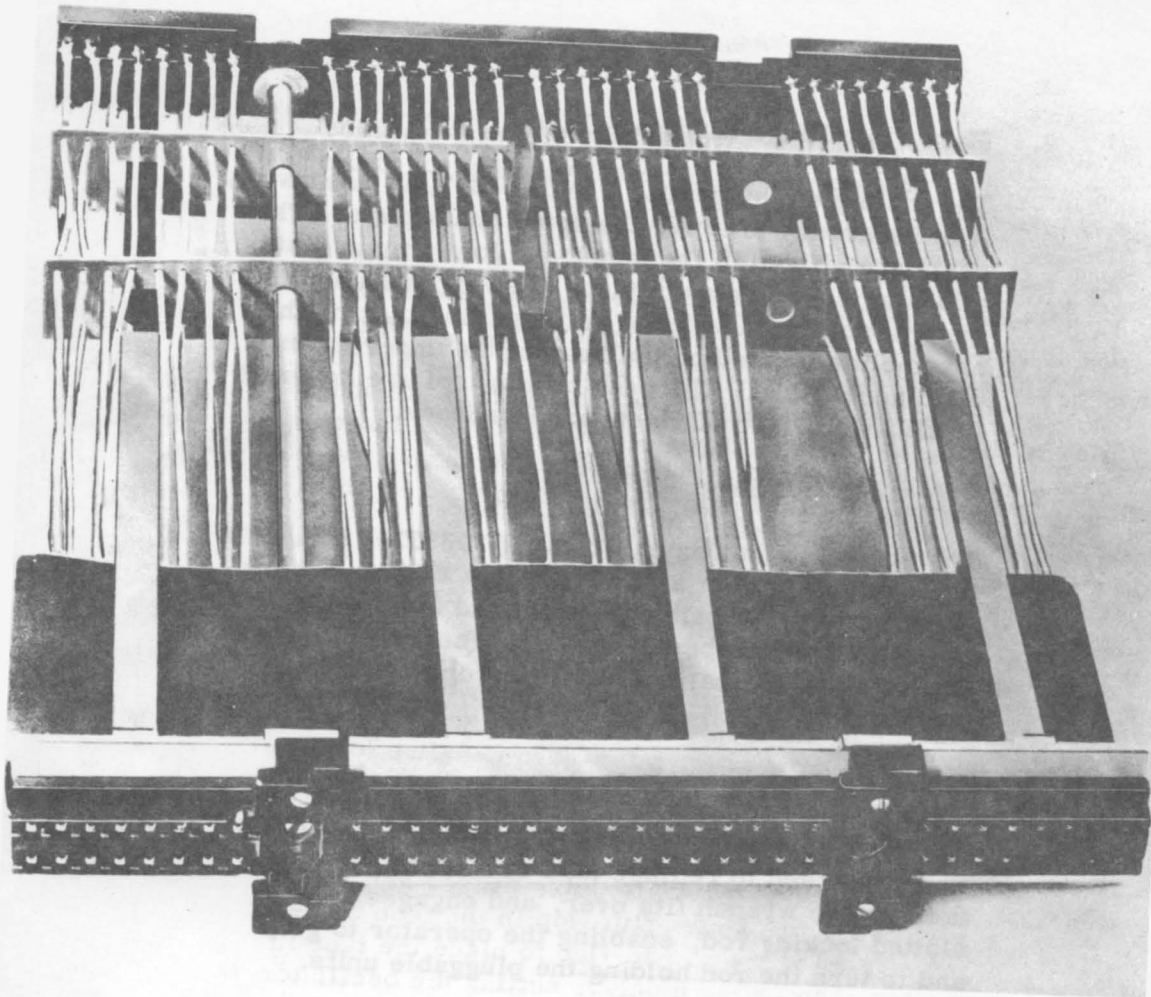

Figure 4-11. Pluggable Unit Extender

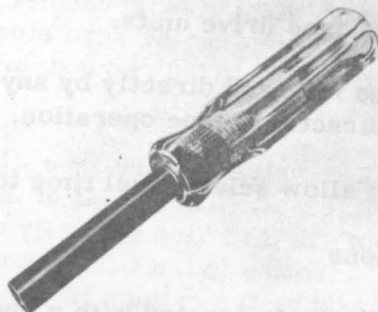

Figure 4-12. Pluggable Unit Wrench

a non-prepared condition. By sensing for this condition the computer program can determine when end-of-file has been reached.

When the end-of-file record is either written or read, a single-shot (selection and status indication logic, 0.8.1) is triggered. The output of the single shot is the set NIFA pulse which is sent to the tape drive to set the not-in-file-area (NIFA) flip-flop. The output from the one side of the NIFA flip-flop (NIFA level) is returned to the tape adapter (0.8.1) where, through an inverter, it removes the prepared level causing the not-prepared condition.

1. Writing End of File

0.7.8
0.8.2

- a. To write the end-of-file bits a PER(72) instruction is used. At OT 9 of the PER instructions a pulse arrives at the tape adapter to set the end-of-file flip-flop and word-counter-zero flip-flop (operation control logic, 0.8.2) and perform the function of a start-write pulse (also 0.8.2).
- b. The function of the write pulse causes setting of the read-write status flip-flop in the tape drive, the setting of the go flip-flop to place the tape in motion, and, after a delay, setting the oscillator gate flip-flop to start the clock.
- c. The clock generates pulses and levels exactly as during a regular write operation except that the request-break pulse will not be generated. (A gate normally conditioned by the zero side of the end-of-file flip-flop blocks the request-break pulse.)
- d. The first character written on the tape will contain the end-of-file bits. The output of the one side of the end-of-file flip-flop partially conditions three AND circuits in the write-word switch in the same manner as the outputs of the individual flip-flops in the word register. The second input to each of those AND circuits is from the word-ring-1 flip-flop. Therefore, when the write pulse is generated during the first clock cycle, the three "1" bits are written on the tape. Since the

word register is clear there is no transfer of bits 31, 32, and 33 to the write bus as one bits. The same is true for the bits in the remaining five characters.

- e. When the word ring is stepped from 5 to 6 the 2nd word-counter-zero flip-flop is set and, consequently, the reset-clock pulse is generated with the word-ring-6 to 1 stepping pulse. The action following the resetting of the clock is the same as for terminating a regular write operation: the absence of the write echo sync pulses allows the output of the MPD to fall generating an end-of-record pulse and after a delay becomes the disconnect pulse.
- f. It can be seen now that the whole write end-of-file operation is effectively started and stopped with the write end-of-file pulse, resulting in the writing of the single-word record.

Note: Special conditions. Tapes must be prepared and ready. If not prepared, a PER 72 (WRT EOF) will cause computer to hang up. The I/O Interlock is set by this instruction.

2. Reading End of File

- a. The end-of-file record is read in the same manner as any other record is read.
- b. The first character read from tape following the RDS instruction will be the one containing the end-of-file bits. When the character register (word transfer logic, 0.8.4) is set, the 4th, 5th, and 6th bit flip-flops will bring up three inputs to a five-way AND circuit. The other two inputs (the sync bit and the not-backward level) are normally up. The output of the AND circuit is applied to a gate that is strobed by the word-ring-1 to 2 pulse. The pulse output from this gate will trigger the 15-microsecond single shot (as occurred during the write end-of-file operation) in the selection and status indication logic, 0.8.1, and also set the end-of-file flip-flop.

- c. The single-shot output becomes the set NIFA pulse which sets the NIFA flip-flop in the tape drive, the output of which is returned to the tape adapter (at 0.8.1). The NIFA level deconditions a gate (through an inverter) which when sensed with a sense-not-prepared instruction following the RDS instruction indicates that the end-of-file record had been read.
- d. Setting of the end-of-file flip-flop resulted in deconditioning the gate which normally allows the request-break to be sent to the IO element. This is done because there is no data in the end-of-file word to be transferred to core memory.
- e. The remaining five character read cycles are performed because the sync bits for these characters were written on the tape when the end-of-file write operation was performed. Following this the absence of sync bits causes the termination of the read operation as already explained.

C. PER (71) - Rewind

- 1. Places tape drive in rewind.
 - a. I/O interlock set for 40 millisecc.
 - b. If tape drive was prepared, it will become not prepared until rewind is complete.
 - c. If tape drive was not prepared, it will remain not prepared.
- 2. Instruction can be performed regardless of condition of I/O interlock or prepared status.
 - a. Must be selected and ready.
 - b. Rewind should be preceded by BSN (10) and BSN (11).
 - c. Rewind should be followed by BSN (14) until I/O interlock goes off, then by BSN (10) to indicate the end of the rewind.
 - d. This disconnect generated after the rewind pulse indicates the tape has begun its rewind.

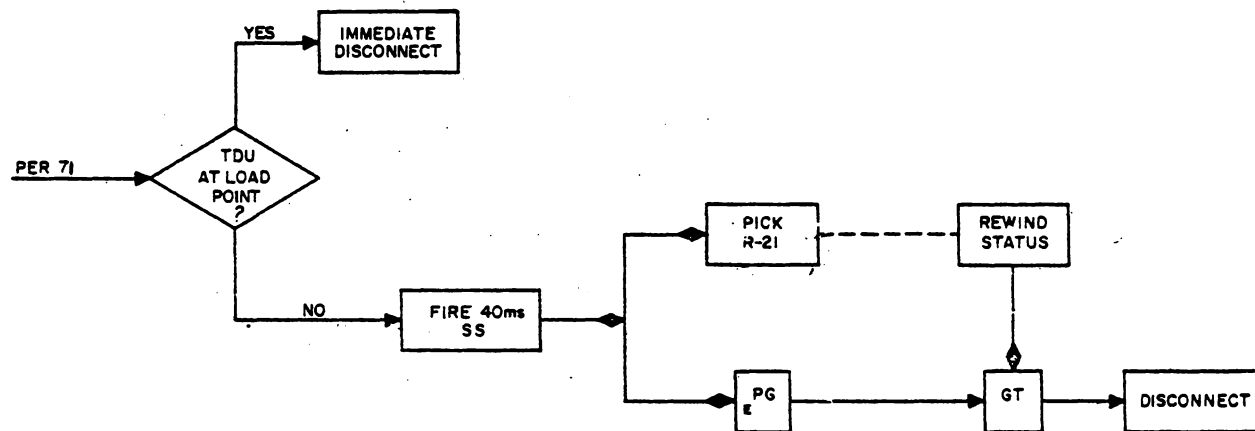

TAPE REWIND OPERATION

3. Rewind - Logic Analysis

0. 7. 8

0. 8. 2

- a. The rewind operation is initiated with a PER(71) instruction. (The tape drive must be selected.) The rewind-tape pulse arrives at the tape adapter and first checks to determine whether the tape is at load point. (The at-load-point level from the tape drive deconditions a gate strobed by the rewind tape pulse.) If the tape is at the load point there is no need to rewind, and accordingly a disconnect pulse is generated immediately.
- b. Assuming the tape is not at the load point the gated rewind-tape pulse triggers a 40-ms single shot. The output of the single shot is sent to the tape drive as a start-rewind pulse. The tape drive returns a select-and rewind level to the tape adapter which is sent to the selection and status indication logic as a rewind status level making the tape not prepared (see 0. 8. 1). The fall in the 40-ms pulse fires a pulse generator, the output of which becomes a disconnect pulse, terminating the computer's action in the rewind operation. The tape drive will continue to rewind the tape until the load point is reached. At this time, the rewind -status level is removed, and if the NIFA level is not present the tape drive is thereby returned to the prepared condition.

Note: When the I/O interlock is cleared 40mil-sec after a PER₇₁ is given, at least 40 mil-sec more must elapse before a PER₇₁ is given to another drive. This is due to the BSS in 13BJ, logic 0. 8. 2

D. PER(70) - Backspace

1. Causes tape to move backwards over one record.
 - a. I/O interlock is set during backspace.
 - b. Selected tape drive must be ready.
 - c. Tape drive becomes a prepared at the start of the backspace.
 - d. Does not check I/O interlock.
2. Special Conditions
 - a. BSN (14) should be used to determine the end of the backspace operation.
 - b. If tape drive was in write status, tape will go forward for 6 millisec before the backspace is started.

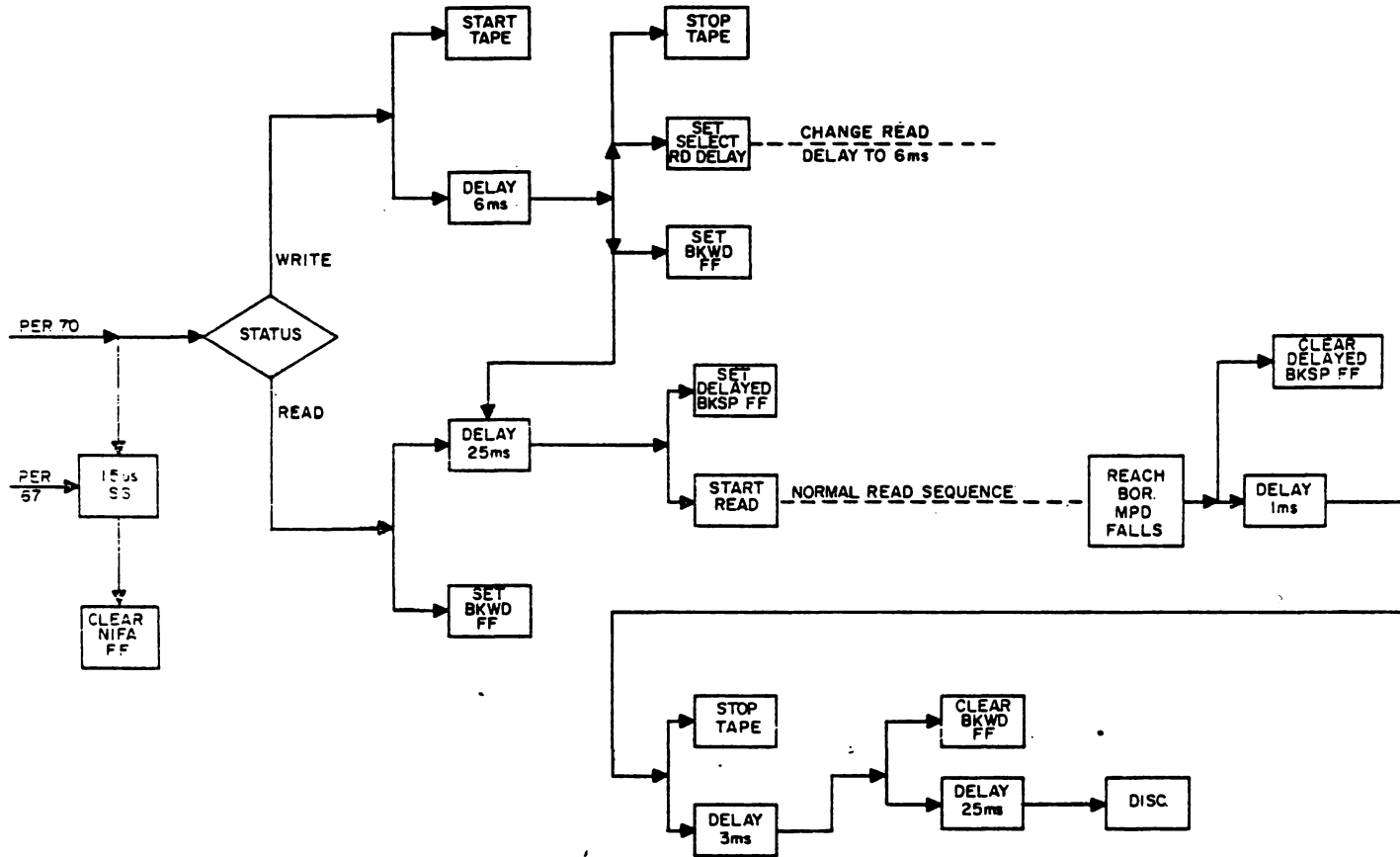

TAPE BACKSPACE OPERATION

- 3. Backspace - Logic Analysis** **0.7.8**
0.8.2
- a. The backspace operation results in moving the tape backward a distance of one record, whatever the length of the record. The operation is initiated by the computer with a PER(70) instruction. Basically, the backspace operation involves a read operation during which the reception of the sync pulses, as in a regular read operation, are applied to the missing pulse detector maintaining the backward motion of the tape. However, the tape is not read for data and there is no transfer to the IO element during the backspace operation. When the beginning of the record is reached the operation is terminated in a manner similar to that when the end of record is reached on a normal read operation.
- b. The backspace operation begins with reception (at the operation control logic, 0.8.2) of the start-backspace pulse which is generated at OT 9 of the PER(70) instruction. The start-backspace pulse first determines whether the tape drive is in the read or write status. If in the write status the tape is moved forward for a distance equivalent to 6 ms. This is done by setting the go flip-flop (with the backspace-go pulse) and with the same pulse triggering the 6-ms single shot. (The backspace-go pulse also sets the normally clear select-read-delay flip-flop. The result of this action is explained below.) The fall in the output of the single shot fires a PG. The output of the PG is the backspace-stop-1 pulse which clears the go flip-flop halting the forward motion of the tape. This slight movement forward is required to move the tape under the read-write head further into the interrecord gap, anticipating the imminent removal of current from the erase head when the read-write status flip-flop is switched to the read side. The removal of current from the erase head will cause a change in magnetic flux, cutting the tape which when read may erroneously indicate a character.
- c. The output of the PG (which generated backspace-stop-1 pulse) triggers a 25-ms SS and sets the backward flip-flop. The output from the one side of the backward flip-flop is sent to the tape drive to prepare the drive mechanism to run in reverse.

- d. The not-backward level (output of zero side of backward flip-flop) is now removed to decondition TPD circuits (0. 8. 3) which generate the request-break and the readout word-register pulses. Also deconditioned is the AND circuit involved with reading the end-of-file bits (0. 8. 4).
- e. The 25-ms SS provides the delay necessary for the tape drive to prepare to be run in reverse. The fall in the output of the 25-ms SS fires a PG, the output of which is the start-read (backspace) pulse. This pulse will cause the same functions to be performed as the normal start-read pulse. Briefly, this involves the clearing of the read-write-status flip-flop in the tape drive (to obtain read-status output), setting of the go flip-flop, and, after a delay, the setting of the delayed-read-write flip-flop. Note that the previous setting of the select-read-delay flip-flop inserts a 6-ms delay into the circuit rather than a 4-ms used for normal read operation. The extra delay is necessary because the tape was repositioned since the start backspace had been initiated with the tape drive in the write status (see above).
- f. The tape will be read backward until the MPD detects absence of sync pulses, at which time it will cause generation of a pulse. This pulse clears the delayed-read-write flip-flop and after being gated by the gate conditioned by the clear side of the delay-backspace flip-flop and delayed 1-ms it becomes the beginning-of-record (BOR) pulse which clears the go flip-flop. The same gated pulse, after a 3-ms delay, clears the backward flip-flop (returning the tape drive mechanism to normal and re-establishing the not-backward level). The pulse at the output of the 3-ms delay is delayed an additional 25 ms before it causes the generation of a disconnect pulse which ends the backspace operation. The delays are required to allow sufficient time for the tape drive mechanical elements to return to normal.

E. BSN(11)

1. Senses ready condition.
2. Branches if not ready.

F. BSN(10)

1. Senses tapes not prepared,
2. Branches if tape drive "Not Prepared."
3. BSN - Logic Analysis

There are two BSN codes which are used to sense for tape conditions: BSN 10, tapes not prepared, and BSN 11, IO unit not ready. (Note that these instructions actually check for the negative condition.) In order for either to be used properly a tape driver must be selected.

In the tape adapter two gates are involved with the sense operation (tape status and indication logic, 0.8.1). One of these is conditioned by either the write-, read-, or rewind-status levels which, by their presense, indicate that the tape drive selected is in the ready condition. The other is conditioned when both the NIFA and rewind-status levels are absent (note the inverter). The absence of these two levels indicates a tape prepared condition.

The two sense flip-flops (sense logic, 0.7.4), the tapes-not-ready flip-flop and the tapes-not-prepared flip-flop, are set at PT 1 of the select instruction. It must be pointed out that if the prepared or ready conditions are present when the BSN instruction is operated, these flip-flops must be cleared in order to properly not indicate the not-ready or not-prepared conditions.

Accordingly with a PT 9 pulse of the BSN (10 or 11) instruction (with tape-operate flip-flop set, tape controls logic, 0.7.8) the two gates (on 0.8.1 and described above) are strobed. If the gates are conditioned (tapes ready and prepared) the output pulses are sent to the sense logic (0.7.4) where the tapes-not-ready and the tapes-not-prepared flip-flops are cleared. At OT 9 of the same BSN instruction, the check for the condition is made (see sense logic 0.7.4) and the two sense flip-flops are again set. If the tapes are

not prepared (or not ready) the PT 9 pulse will not pass the gate on 0. 8. 1 and the not-prepared flip-flop will remain set. When at OT 9 the actual check is made, the not-prepared (or not-ready) condition is detected.

G. PER(67) - Set Prepared

1. Clears NIFA FF in selected tape drive.
2. Does not set the I/O interlock.
3. Is not delayed by the I/O interlock.
4. Set Prepared - Logic Analysis
 - a. In order to perform either the read or write operation the prepared level must be present (see operation control logic, 0. 8. 2). The prepared level exists only if both the NIFA level and the rewind-status level are not up (see status and indication logic 0. 8. 1).
 - b. The tape drive applies the rewind-status level to the tape adapter while the tape is being rewound and removes this level automatically when the rewind is complete.
 - c. The tape drive applies the NIFA level to the tape adapter whenever the end-of-file record is either read or written. However, the NIFA level is removed only as a result of a positive action by the computer program. This positive action is the set-prepared operation (PER 67). At OT 9 of the PER (67) instruction, a 15-microsecond single shot (0. 8. 1) is triggered and the output is sent to the tape drive as a set-prepared pulse. This set-prepared pulse clears the NIFA flip-flop removing the NIFA Level.
 - d. During the backspace operation the 15-microsecond single shot is triggered automatically, thereby eliminating the need for the computer program to issue the set-prepared instruction before backspacing.

H. RDS

1. This instruction causes tape to move forward over one record.
 - a. I/O interlock is set by RDS instruction and cleared at the end of the record.

2. If RDS instruction with number of words specified is less than number contained in the record:
 - a. Number of words specified are transferred.
 - b. When the word counter goes to zero, break requests are generated but are not honored by the computer.
 - c. Tape moves to the end of the record.
 - d. I/O interlock remains on until the end of the record is reached.
 - e. RDS 0 instruction causes one record on the tape to be skipped.
 - 1) Words will be read and transferred to the I/O register but not to memory.
3. RDS instruction with number of words specified is greater than number contained in the record.
 - a. Entire record transferred.
 - b. Tape stops at the end of the record.
 - c. I/O interlock cleared at the end of the record.

I. Write

1. This instruction causes one record to be written.
 - a. The record length will be determined by the number of words specified.
 - b. The I/O interlock is set by the WRT instruction.
 - c. Tape stops at the end of the record.
 - d. The I/O interlock is cleared at the end of the record.
 - e. A WRT instruction when not ready or not prepared hangs up the computer as tape will not be moved and no disconnect pulses will be generated to clear the I/O interlock.
2. WRT 0
 - a. Causes computer to hang up.
 - 1) I/O interlock is set and not cleared.
 - 2) Tape will not start as a start write pulse is never generated. (GT₈, 5FV, Logic 0.7.8).

J. Summary Questions

1. Problem

Starting at load point write 4, 200 word records on TD #4 the first word to be written is in mem. location 1, 000. Then write an end of file record. Backspace to the first record written. Read 200 words of the 1st record. Read 50 words of the 3rd record. Skip the 4th record and read the next.

After this operation is finished, rewind and make sure we are prepared before halting.

2. Answer Yes or No for each item.

	Delayed by I/O Interlock	Sets I/O Interlock	Must be Ready	Must be Prepared	Clears the NIFA FF
Set Prepared PER (67)	no	no	no no	no	yes
Backspace PER (70)	NO	yes	yes	no no	yes
Rewind (PER (71)	no	yes	yes	no	no
Write EOF PER (72)	no yes	yes	yes	yes	no
READS RDS	yes	yes	yes	yes	no
Write WRT	yes	yes	yes	yes	yes

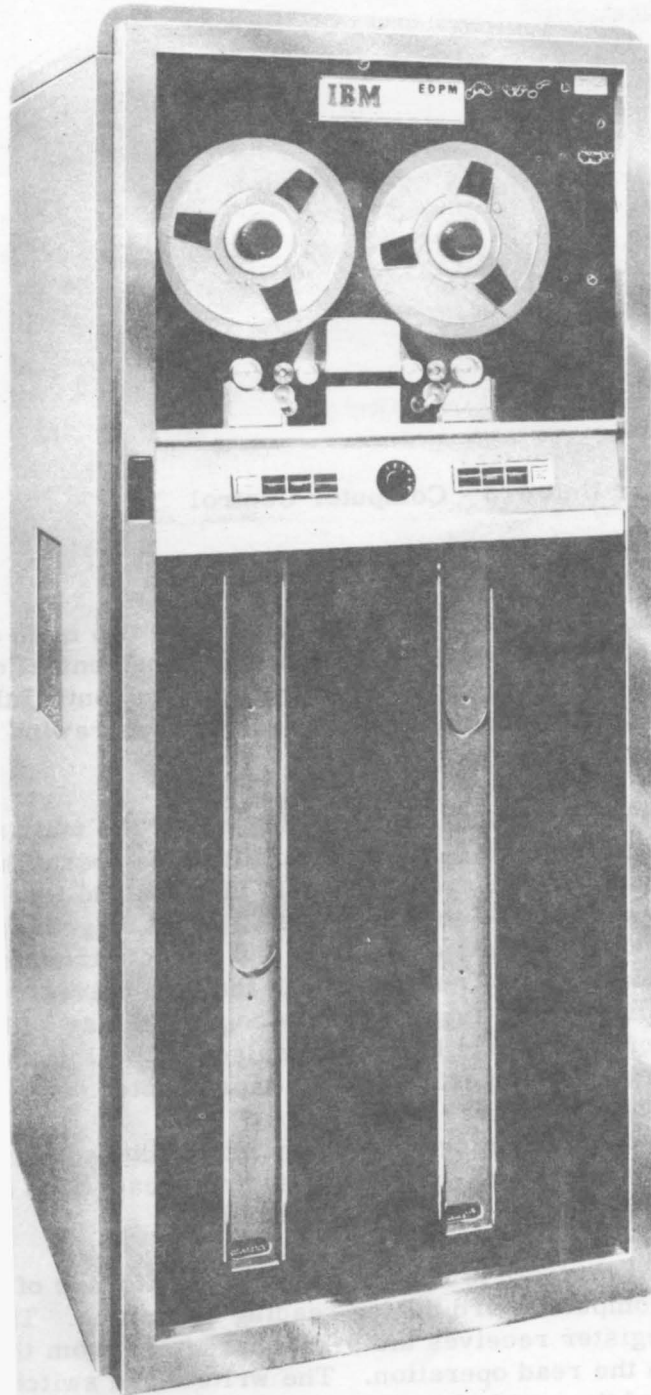

Tape Drive Type 728

X. Tape Adapter Unit #13 - Computer Control

A. General

The tape adapter circuitry is divided into two main areas: one to effect the word transfer between the central computer and the tape drives, and the other to control the word transfers and associated operations such as rewind and backspace.

Page 2830 is an overall block diagram of the main areas of the tape adapter logic involved with tape operations under computer control. (All test circuits and test control signals are ignored in this section.) This diagram shows all the control levels and pulses and the data transfer lines which connect the IO element with the tape drives. A study of this diagram is suggested to become familiar with the names of the various levels and pulses as well as the general principle of operation of the tape adapter.

The word-transfer logic area consists of the word register, character register, write-word switch, read-word switch, word ring, and the end-of-file circuit.

The word register is used for temporary storage of the full 33-bit computer word during reading or writing. The character register receives the 6-bit characters from the tape drive on the read operation. The write-word switch under control of the word ring performs the function of breaking up the 33-bit computer word into 6-bit characters which

2830
1 char. at 1 time

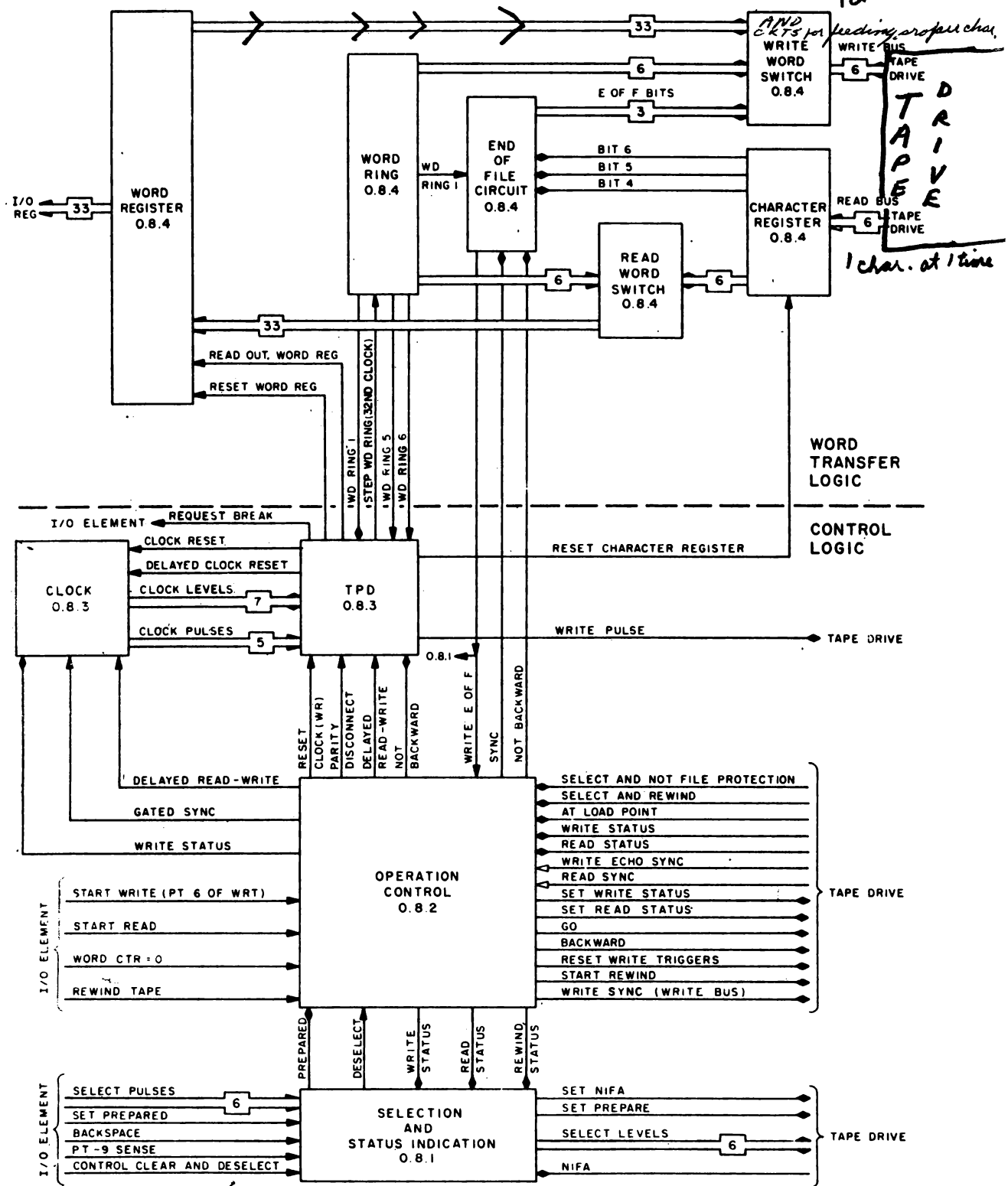

Tape Adapter, Computer-Controlled Operation, Simplified Block Diagram

can be sequentially written on the tape. The read-word switch, also under control of the word ring, transfers the individual 6-bit characters read from the tape and stored in the character register to the proper bit positions in the word register. The word ring controls the word switches in timing with the character reading-writing rate of the tape drive.

The control logic is made up of the selection-and-status-indication circuitry (0. 8. 1), a grouping of circuits which is called operation control (0. 8. 2), a clock which functions as a time-pulse generator (0. 8. 3), and a time-pulse distributor (0. 8. 3).

The main function of the selection-and-status-indication circuitry is to convert the select pulses to select levels and supply these levels to the tape drives. The operation-control logic processes the majority of the control signals from either the computer or the tape drives channeling these control signals to the proper circuits in the tape adapter unit.

The clock is the original source of all timing pulses used in cyclic reading or writing operations. Its output of various levels and pulses is sent to the tape timing-pulse distribution (TPD) circuits.

The tape TPD delivers the timing control pulses to the word transfer logic, the IO element of the computer, and the tape drives to properly sequence the reading or writing operations.

B. Special Circuits

1. Negative "OR"

a. Definition and Description

The negative OR is a logic circuit which furnishes a negative output whenever either of the two input voltages changes in the negative direction.

In Central Computer logic, the negative OR is used in the character register of the tape element. It allows the tape flip-flop to be set either by a pulse read from the tape or by a write echo pulse which appears during the write operation.



Negative OR Circuit, Logic Block Symbol

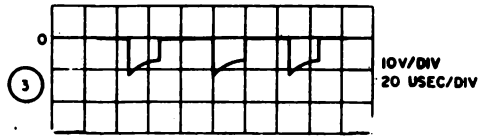
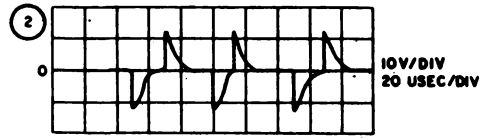
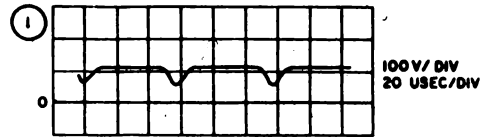
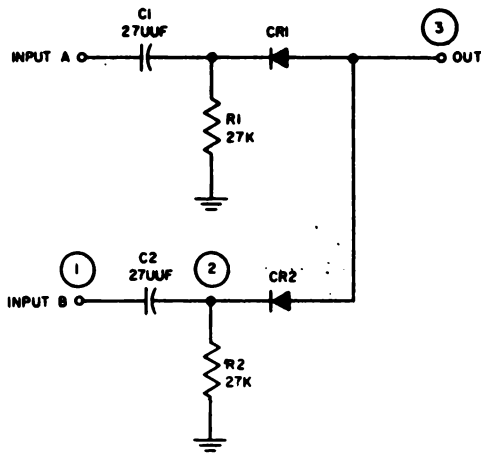

Negative OR Circuit, Schematic Diagram

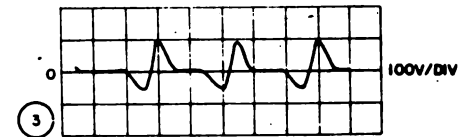
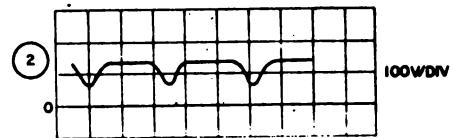
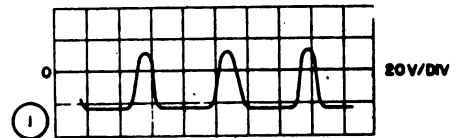
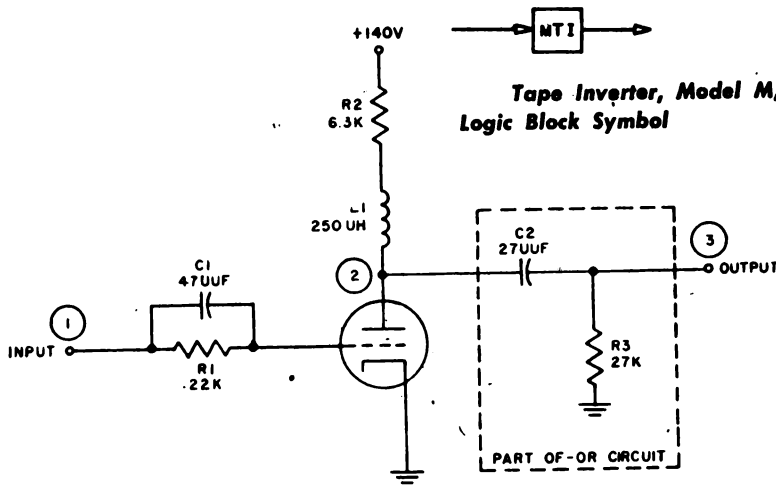

1 = 20 USEC/DIV

Tape Inverter, Model M, Schematic Diagram

The circuit will pass only negative pulses and is insensitive to positive pulses.

b. Principles of Operation

The input signal to the negative OR may be applied to either of the two inputs to the circuit. Only one of the inputs is pulsed at any one time. In the no-signal condition, both inputs are at a high positive level. Capacitors C1 and C2 are charged to a potential equal to the applied voltage, and no current flows through load resistors R1 and R2. When one of the inputs is pulsed, the negative-going edge of the pulse is differentiated by the RC network and passed to the output of the diode.

In a similar manner, the positive-going edge of the input pulse results in a positive voltage across the load resistor associated with that input. The crystal diodes prevent the positive halves of the signals across the resistors from appearing at the output.

2. Tape Shaper, Model A

a. Purpose

- 1) To convert a "1" output of the read head amplifier to a signal which can set a FFF.

b. Circuit blocks making up a tape shaper circuit.

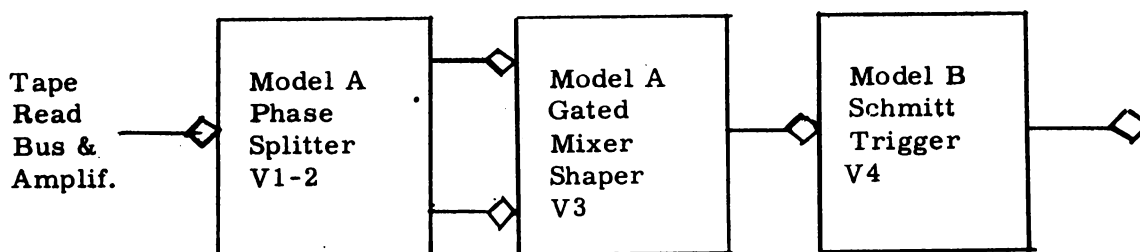

c. Inputs

Fig. A
Page 2890

Fig. A is a series of "1" observed from the sync read bus. The amplitude may vary from 5 to 25 volts p/p for a "1" bit with a signal reference of ground. A zero would be represented by no amplitude. Regardless of the time interval between two "1" bits, the following "1" bit would always be of the opposite polarity to the preceding "1" bit.

There is a gating input to the circuit, +10 volts will enable reading; -30 volts will inhibit reading. The gating signal is called "Read Status."

d. Output of Tape Shaper.

Fig. E
Page 2890

Shown is a nominal output. Exact waveshapes will depend upon input signal and circuit components. Each pulse represents a "1" bit. Each "1" bit signal should set a FFF.

e. Operating Standards for Tape Shaper

- 1) Must reliably pick up all signals 5 volts p/p or greater.
- 2) Must reject all inputs below 2 volts p/p.
- 3) It must reject a 10 volt p/p sine wave at 50ke frequency. This is the criterion established in determining whether noise produced by metal flakes on the tape will set the flip-flop.

f. Circuit Description

Page 2880

The signal frequency is normally 10kc. In the input to V1, it encounters an R-C filter to block 60 c. p. s. noise and a clipping network which will limit signal peaks to +45 volts and -45 volts depending on the input polarity.

Fig. B
Page 2890

The grid of V1 will have a signal of +4.5 volts or -4.5 volts amplitude referenced to ground. V1 is connected in a split load, phase inverter circuit configuration. Tubes V2A and V2B are also split load phase inverters, i. e., a positive signal on the grid will appear as a positive signal on the cathode and an inverted signal on the plate.

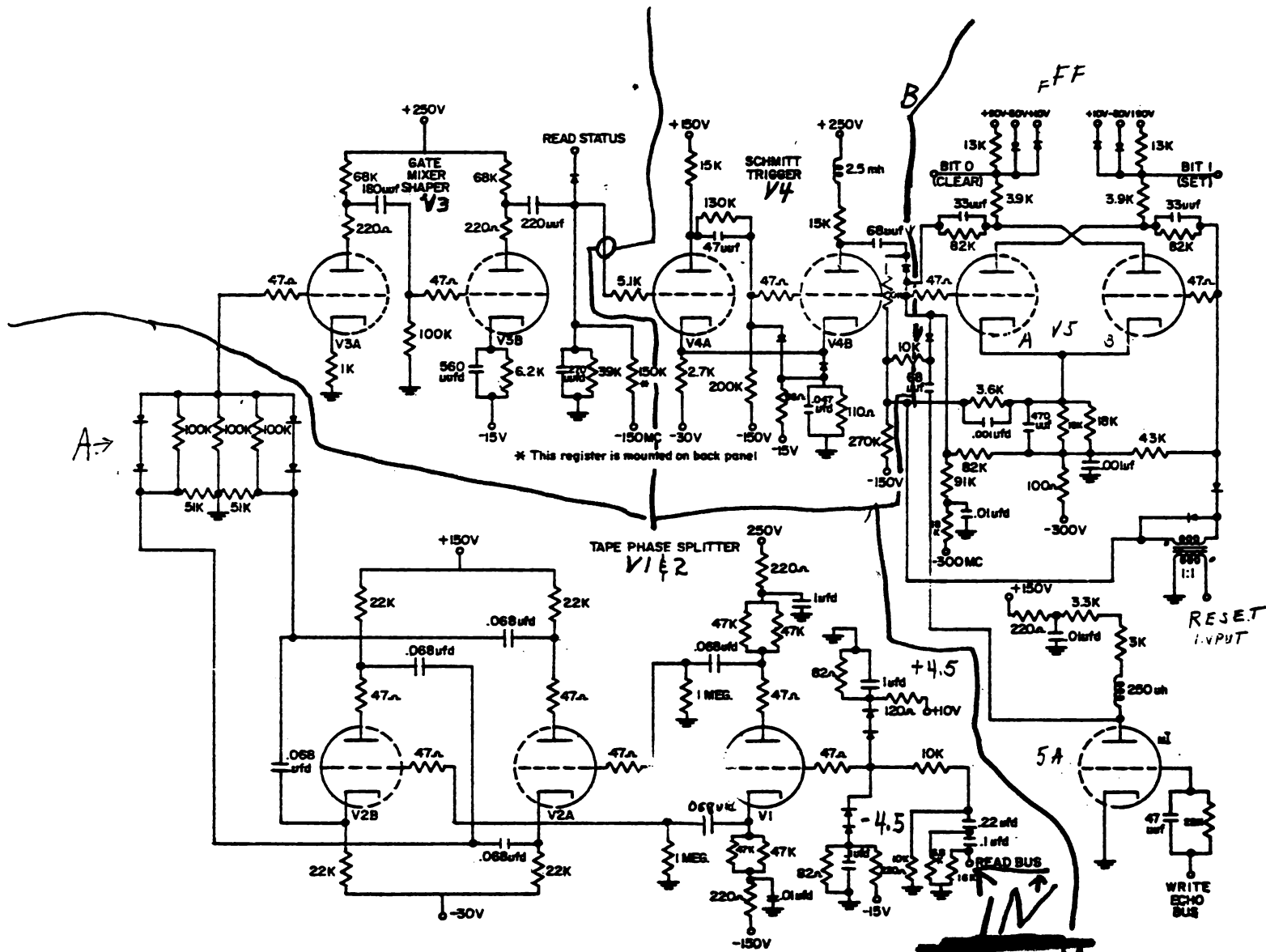

TAPE CHARACTER REGISTER, SCHEMATIC 18VPP

WAVEFORM - TAPE SHAPER CIRCUIT

Fig. A.
 Input from sync track 5 V/CM 20 usec/CM
 @ 0 volts



Fig. B.
 Grid of V1A
 5 V/CM 20 usec/CM @ 0 volts

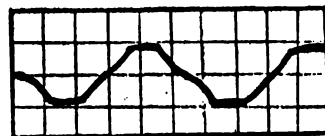

Fig. C.
 Grid of V3A (Output of Mixer)
 2V/CM 20 usec/CM @ 0 volts

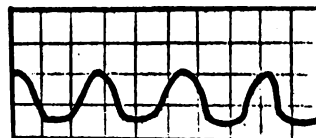

Fig. D.
 Grid of V4A (Schmitt Trigger)
 20 V/CM 20 usec/CM @ -40 volts

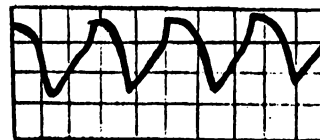

Fig. E.
 Output V4B (Schmitt Trigger).
 50 V/CM 20 usec/CM @ +150 volts.



Note: Figs. A thru G are waveshapes of the Sync Track
 Fig. H. is a track with 100000/000001

Fig. F
 Input to MTI (Write Echo Pulse).
 20 V/CM 20 usec/CM @ -20Volts

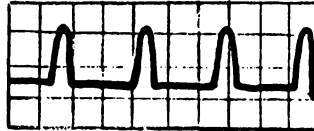

Fig. G.
 Output of MTI
 50 V/CM 20 usecs/CM @ +150 Volts

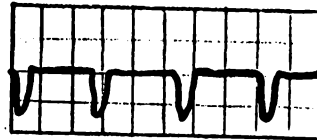
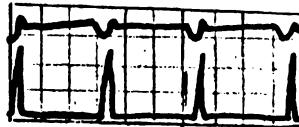

Fig. H
 Diode mixer output (Top Wave)
 Compared to Schmitt Trig. output
 of 100001000001 50 V/CM / 00 usec/CM



Because the cathode and plate load resistors are the same for V1, V2A, and V2B, the signal amplitudes are nominally equal.

Assume a positive signal (+4.5V) on the grid of V1. The cathode of V1 swings positive while the plate swings negative by 4.5 volts. The negative change of the plate of V1 is coupled to the grid of V2A which causes the cathode of V2A to swing negative by 4.5 volts. This negative change is coupled through the capacitor off of the cathode of V2A. During this time, the cathode of V1 will couple a +4.5 volt change to the grid of V2B which causes the plate of V2B to swing negative by 4.5 volts. This negative shift is felt by the capacitor off of the plate of V2B. Thus, the capacitors off the cathode of V2B and the plate of V2A both feel a negative so that the junction of these two capacitors will go negative. This negative change is passed to the grid of V3A through the right hand side of the diode-resistor network (A). A negative signal on the grid of V1 would cause a negative signal to be routed to the grid of V3A through the left side of the diode-resistor network (A). Network (A) is a full wave rectifier. Thus, a positive or negative signal on the grid of V1 will result in a negative swing to the grid of V3A. V3A and V3B are amplifiers so that the output signal of V3B is an in phase but amplified version of the grid signal to V3A.

The negative going signal from the plate of V3B is coupled to the grid of V4A. The grid of V4A is bias such that -11 volts is the cutoff point. Regenerative feedback from the cathode of V4B to the cathode of V4A will speed up the swichover of cutting off V4A when the grid of V4A starts below -11 volts. This -11 volts corresponds closely to the zero axis crossing point of the original signal. Thus, when the grid of V4A goes below -11 volts, the regenerative action quickly cuts off V4A and V4B goes into conduction. The plate of V4B couples a negative signal into the grid of V5A which will cutoff V5A and bring V5B into conduction. The plate of V5A goes positive, thus the FF is set.

- g. In summary, a positive or negative signal 5 volts or greater in amplitude will cause the corresponding FF in the character register to be set.

5. **F^{FF}** - Flip-Flop (V6)

Page 2880

- a. Set input is a negative signal from the **BST** or the **M^{TI}**.
 b. Clear input is a standard pulse.

6. **M^{TI}** - Tape Inverter (V5A)

Page 2880

- a. Input is a positive pulse from the write echo bus.
 b. Output is a negative pulse fed to the **F^{FF}**.
 c. Definition and Description

The model M tape inverter (**M^{TI}**) is a nonlogic circuit which amplifies and inverts the write echo pulses from the tape and feeds them to a negative OR circuit.

d. Principles of Operation

The **M^{TI}** is maintained in a nonconducting state by an externally supplied negative d-c level applied to the grid of V1 through resistor R1. The voltage at the plate of V1 is +140V in this condition. When a write echo pulse (about 30V in amplitude) is applied to the input, V1 goes into conduction and the plate voltage decreases to about +75V. The output of V1, taken from the plate is then fed to part of the negative OR circuit. The short time constant of network C2 and R3 results in peaking of the waveform. C1 and L1 improve the transition time of the circuit.

7. **A^{MPD}** - Missing Pulse Detector

Page 2940

- a. Input is a standard pulse.
 b. Output is at +10 volts as long as the input pulses arrive regularly.
- 1) When 150 usecs elapses from the previous input pulse, the output drops to -30 volts.

Note: Only one input pulse will cause the output to go to +10 volts.

c. Definition and Description

The model A missing-pulse detector (A MPD) is a logic circuit which is used in the magnetic tape system of the Central Computer. The A MPD provides a constant, positive d-c output as long as standard pulses are applied to it. When the pulses are discontinued or occur at a too low rate of repetition, the output falls to a constant negative d-c level.

d. Principles of Operation

With no signal applied, the A MPD maintains an output d-c level of -30V. This condition results from the cutoff bias which is provided to the grid of V1 by a voltage divider between the -300V and -150V supplies. The plate of V1 tries to rise to +150V, but the grid of V3 draws current and clamps the V1 plate, setting its upper limit at approximately ground potential. Since V3 conducts heavily, its plate voltage drops. This causes the voltage level at the output of the A MPD to fall until clamped to -30V by CR2.

Assume that a single standard pulse is applied to the A MPD. This pulse is coupled to the grid of V1, causing the tube to conduct. Capacitor C2, which is normally at ground potential, shorts any quick variation in voltage and consequently charges very rapidly in a negative direction by passing the full conduction current of V1. When C2 has charged to -30V, V2 begins to conduct and passes all the tube current of V1, except for the small current passed by the V1 plate load and the current necessary to keep C2 charged to -30V for the duration of the pulse. When the voltage across C2 falls from ground to -30V, V3A cuts off, its plate voltage rises, and the MPD output level rises until it is clamped at +10V by CR3. V3A remains cut off as long as its grid is more negative than -6V. Since the fall time at V3 is very short, the positive feedback has very little effect in improving the speed of the circuit.



**Missing Pulse Detector, Model A,
Logic Block Symbol**

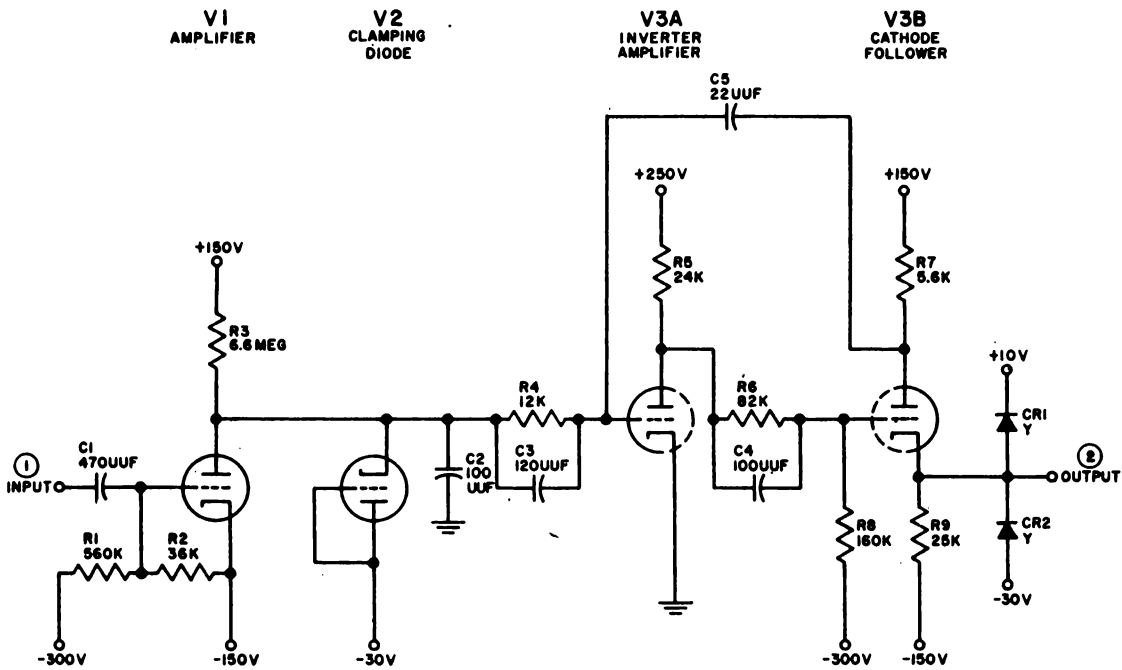

- NOTES:
1. ALL SUPPLY VOLTAGES ARE DECOUPLED IN THE PLUGGABLE UNIT
 2. PARASITIC SUPPRESSORS HAVE BEEN OMITTED

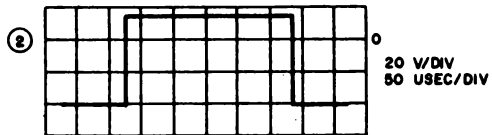
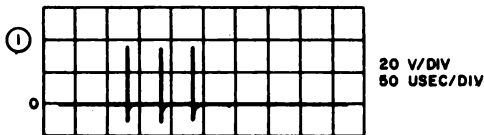

Missing Pulse Detector, Model A, Schematic Diagram

As the input pulse dies, V1 cuts off and C2 begins to charge from -30V toward +150V through R3. When C2 has charged to -6V, V3A begins to conduct. During the first instant of conduction, the plate voltage of V3A is lowered slightly, causing the plate voltage of V3B to rise slightly. This slight rise at V3B plate is coupled to the grid of V3A. Thus, the first instant of conduction in V3A is the trigger that starts the regenerative feedback action. V3A is quickly brought into full conduction and the output falls, returning the circuit to its steady-state condition. C2 offers no opposition to the feedback action. The feedback circuit improves the fall time by a factor of 7.

Now assume that a steady train of standard pulses is applied to the A_{MPD} input. If the time between pulses is less than the delay time as set by the values of R3 and C2, the output will be a steady +10Vdc level since C2 must begin to charge from -30V toward +150V after each pulse. If the pulses occur at such a rate that the time between them is greater than the delay time of the A_{MPD} , the circuit will be allowed to return to its stable state after each pulse.

Missing-Pulse Detector, Model A, Function of Detail Parts

Reference Symbol	Function
R1, R2	Voltage divider
R3	Part of timing circuit in V1 plate load (with C2)
R4	Grid-limiting resistor
R5	V3A plate load and part of voltage divider (with R6, R8)
R6	Part of voltage divider (with R5, R8)
R7	V3B plate load resistor
R8	Part of voltage divider (with R5, R6)

**Missing-Pulse Detector, Model A, Function
of Detail Parts (Cont'd)**

Reference Symbol	Function
R9	V3B cathode output resistor
CR1	Clamping diode for +10V output
CR2	Clamping diode for -30V output
C1	Input coupling capacitor
C2	Part of timing circuit (with R3)
C3	Speedup capacitor
C4	Compensating capacitor
C5	Feedback coupling capacitor

8. Single Shot Delays

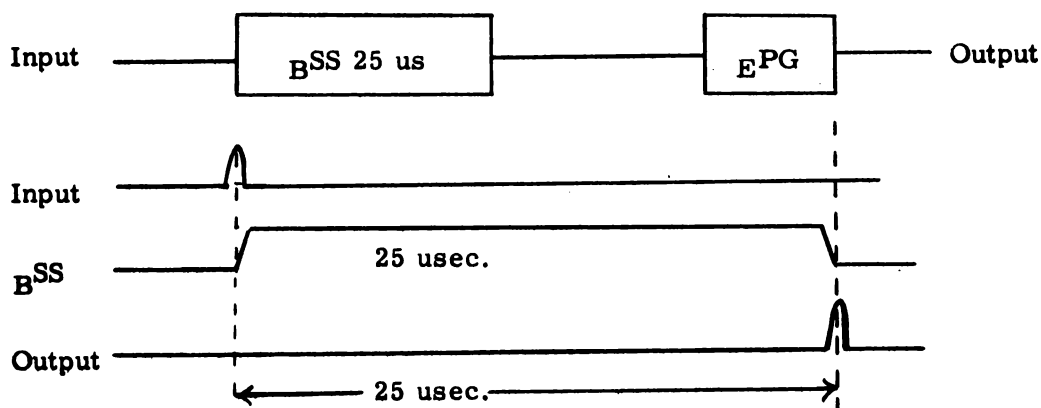

- a. The Model E Pulse Generator is triggered by a negative shift. The output of the E^{PG} is a standard pulse.
- b. The illustration shows a 25 usec delay before the E^{PG} is triggered to send out a pulse.

Note: Single shot delays are used extensively in Unit #13.

C. Summary Questions

1. What is the maximum time between the input pulses that will keep the output of the MPD from falling?
2. How many bit positions are there in the character register?
3. What are the input and output signals of the TPS?
4. What signal will enable the GMS to pass a signal during a read operation?
5. Not including the sync track, how many data bits are read simultaneously from tapes?
6. Where are the data bits stored until the complete computer word is assembled?

D. Tape Adapter Control and Transfer Circuits**1. Clock and Pulse Distributor****C. C. Vol. 2
0.8.2****a. Osc. and Osc. Gate**

- 1) Osc 1190 KC
- 2) Pulses from SH every .84 usec.
- 3) Pulses gated through GT 6 13AC when Osc. Gate FF is set.

b. Freq. Divider

- 1) Halves output frequency of Osc. Gate.
- 2) Output pulses at 1.68 usec.

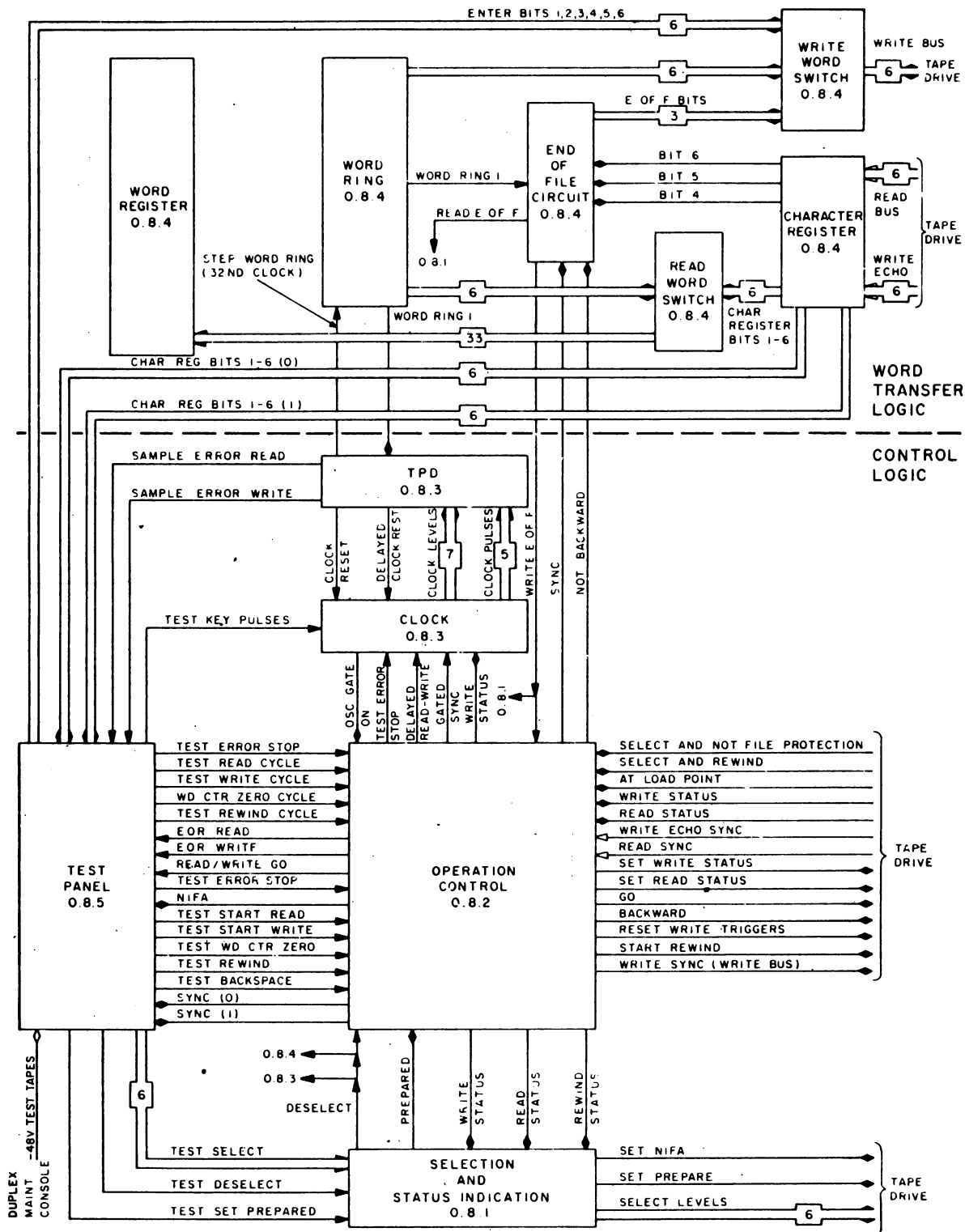

Tape Adapter, Test Operation, Simplified Block Diagram

c. Clock

- 1) 5 stage FF counter
- 2) Cycles in approximately 53.8 usec.

d. Pulse Generation

- 1) Various clock levels brought into 34AG to gate clock pulses.
- 2) Write status clock pulses.
 - a) Clock = 8 (Request break when word ring = 1)
 - b) Clock = 13
 - c) Clock = 24 (Write)
 - d) Clock = 28 (Sample Error)
 - e) Clock = 29
 - f) Clock = 32
- 3) Read Status
 - a) Clock resets at Clock = 16
 - b) Clock pulses
 - (1) Clock = 12 (Sample Error)
 - (2) Clock = 13
 - (3) Clock = 16

Note: During write operation, the clock steps continually from $0_{(10)}$ through $31_{(10)}$ back to $0_{(10)}$... During read operation, the sync bit starts the clock which steps from $0_{(10)}$ through $15_{(10)}$ then the clock stops stepping until the next sync bit starts it again.

E. The Tape Character Register

1. Function

- a. Read Operation - Stores the information read from tape, character by character for transfer to the word register.
- b. Write Operation - Used only for error checking when in test.

C. C. Vol. 2
0.8.4

2. Simplified Logic Diagram

Page 3000

The diagram illustrates the read circuitry.

TAPE CHARACTER REGISTER, LOGIC BLOCKS

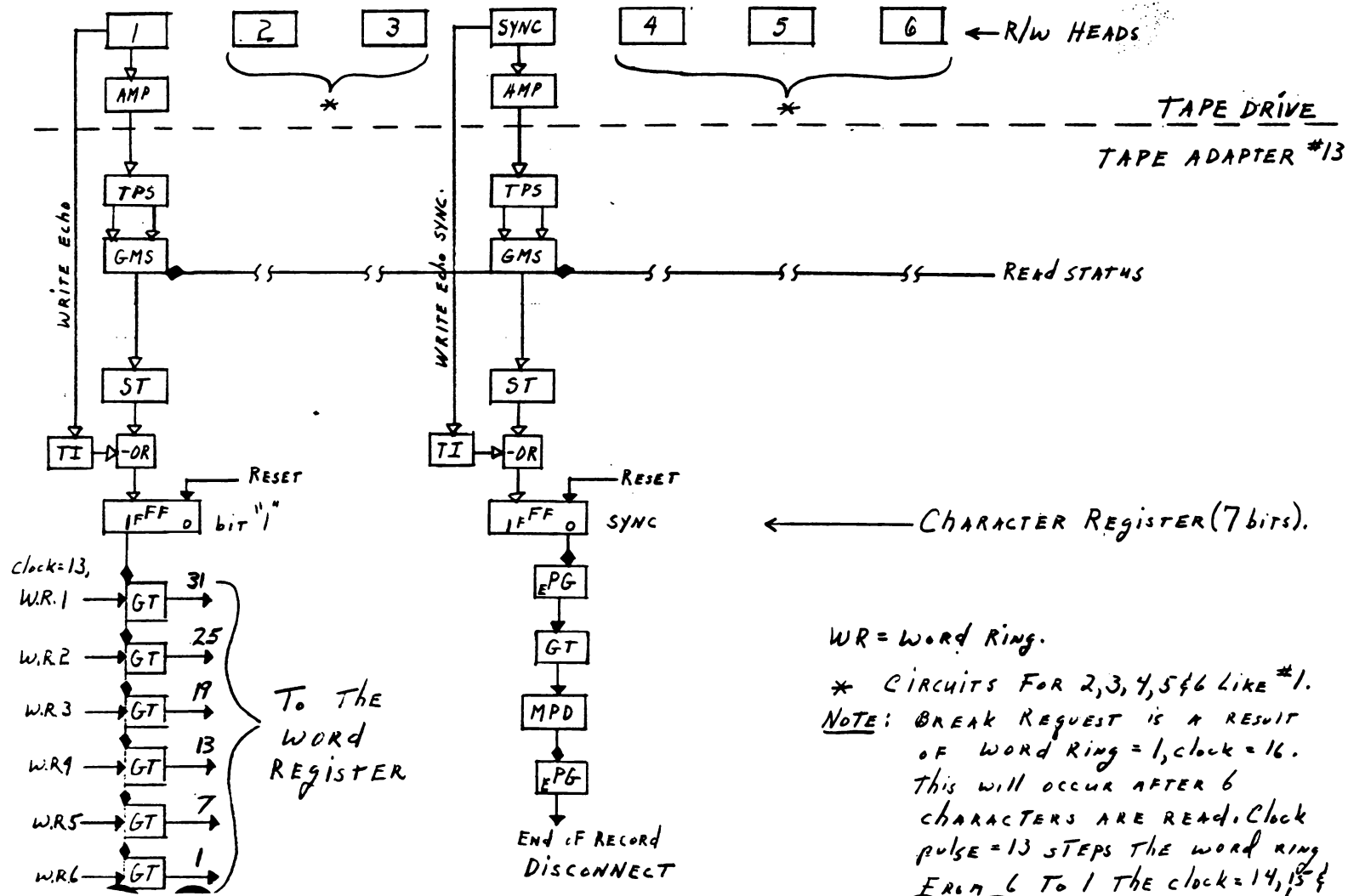

3. Read Operation Analysis of Fig.

- a. Read status level is +10 volts to enable the GMS output.
- b. The R/W head senses a change of flux which induces a sinusoidal voltage in the R/W head.
- c. The amplifier output is 20 volts p/p sine wave.
- d. The TPS converts this to 2 sinusoidal signals, 180° out of phase.
- e. The GMS is triggered by a negative signal and produces a negative signal output.
- f. The ST is triggered by the negative signal to produce a negative shift in its square wave output.
- g. The negative shift of the ST sets the flip-flop in the character register. Thus, information is read into the character register, then transferred into the word register. (Except for sync track.)
- h. When the sync FF is set, the "0" side shifts negative firing the EPG. The EPG output brings the MPD output to +10 and stays there until 150 usecs elapses. If the MPD output falls, the EPG sends a pulse to stop reading.

4. Summary Questions

- a. Is there an MPD circuit for each of the 7 tracks on tape?
- b. Is the character register used in write operation?
- c. What determines to what FF's in the word register the data read will go?
- d. On CC Vol. 2 Logic 0. 8. 3 13ACH1 is open. What effect will this have writing? Reading?

5. Answers to Summary Questions

- a. No, only sync.
- b. Yes, only in test.
- c. The word ring
- d. WRT = no effect. Read = cannot start the clock, thus data is not sent to the word register, no break requests are generated.

F. Tape Word Register

C. C. Vol. 2 0. 8. 4

1. 33 bit register
2. Receives or transfers computer words to or from the IO register.

3. Used as buffer storage.
4. Inputs to the word register:
 - a. Read - character register
 - b. Write - IO register
5. Output of the word register:
 - a. Read - to IO register
 - b. Write - to write bus

G. Word Ring

C.C. Vol. 2 0.8

1. Six FF ring counters
 2. Controls the sequence of transfer.
 3. Write Status
 - a. Reset to 100000
 - b. Break request WR = 1, Clock = 8
 - c. WR = 1, clock = 24 write 1st character.
 - d. Each clock pulse = 32 steps the word ring.
WR = 2, clock = 24 write 2nd character,
WR = 3, clock = 24 write 3rd character,
WR = 4, clock = 24 write 4th character,
WR = 5, clock = 24 write 5th character,
WR = 6, clock = 24 write 6th character.
 4. Read Status
 - a. Word ring stepped by clock pulse = 13. Each word ring stepping pulse transfers the character register contents to the word register.
- Note: Word ring 1, clock = 16 cannot occur at this time because clock = 13 steps WR to 2.
- b. When WR = 6, clock = 13 loads 6th character into the word register and steps the WR to 1. Now WR = 1, clock = 14, 15, then 16. WR = 1, clock = 16 generates break request for transfer of the word register to the IO register.

H. Tape Drive Selection

1. The central computer selects a tape drive with the SEL instruction in which the octal interval code (11-16) specifies the desired tape drive. When the SEL instruction is executed, a control-clear-deselect pulse (at OT 5) from the selection element will clear six select flip-flops in the tape adapter unit (selection and status indication circuitry). At PT 1 of the same SEL instruction, one of the select flip-flops will be set (depending on which octal interval code is specified). The set-output level of the selected flip-flop is applied to the address select switches in each of the tape drives which are electrically connected to the tape adapter.
2. In the tape drive the select level will join with the ready condition level in an AND circuit to produce a select-and-ready level which is distributed throughout the tape drive, preparing it to accept an imminent write, read, backspace, or rewind direction from the tape adapter unit.
3. The selected tape drive is the only tape drive which can be operated by the computer.

Refer to 0. 8. 1
Schematics of C. C.,
Vol. 2

Note: Any tape drive that is addressed to the selected address will be selected. More than one drive may be selected.

4. The deselect pulse, mentioned above, performs a reset operation in several other control circuits in addition to clearing the select flip-flops. These control circuits are listed for convenient reference:
 - a. Clear word-counter-zero flip-flop (0. 8. 2)
 - b. Clear go flip-flop (0. 8. 2)
 - c. Clear end-of-file flip-flop (0. 8. 3)
 - d. Clear delayed-backspace flip-flop (0. 8. 2)
 - e. Clear backward flip-flop (0. 8. 2)
 - f. Clear delayed-read-write flip-flop (0. 8. 2)
 - g. Clear select-read-delay flip-flop (0. 8. 2)
 - h. Set word-ring-1 flip-flop (0. 8. 1)
 - i. Clear word-ring-2 through 6 flip-flops (0. 8. 1)
 - j. Generate reset-word-reg pulse (0. 8. 3)
 - k. Generate clock-reset pulse (0. 8. 3)
 - l. Clear character reg. (0. 8. 3)

I. The Write Operation

Page 3050
&
3120

1. At any time following the execution of the SEL instruction the WRT instruction may be executed to initiate the transfer of data from core memory to the selected magnetic tape. (This is true provided no other select instruction has been given in the meantime.)
2. Within the computer proper, the execution of the WRT instruction causes the setting of the IO interlock and the transfer of the 1's complement of the address portion of the instruction to the IO word counter to specify the number of words to be transferred. At PT 6 of a WRT instruction following a tape SEL instruction a start-write-tapes pulse will be generated in the IO element and delivered to the tape adapter unit (operation control circuitry, 0. 8. 2). When the start-write pulse arrives, a set-write-status level (output of 15-microsecond SS) is generated and sent to the tape drive, provided the prepared and the select-and-not-file-protection levels are present. In the tape drive the set-write-status level sets the read-write-status trigger (flip-flop) to the write-status condition. The write-status output of this trigger is returned to the tape adapter unit (operation control circuitry, 0. 8. 3) where it is distributed throughout the tape adapter to be involved in the generation of control signals for the write operation.
3. The decay in the output of the 15-usec SS which was used to generate the set-write-status level triggers a PG, the output of which will set the go flip-flop and, as a read-write-go pulse, initiate a start-delay pulse. The output of the go flip-flop is sent to the tape drive to start the tape motion. The start-delay pulse enters effective delay circuits (SS's and PG's) to hold up further action in the tape adapter unit (approximately 10 ms) until the tape is moving at operating speed. If the tape was initially at the load point an additional delay period of 40 ms is provided to allow the tape to move past the load point.
4. At the end of the required delay a delayed-read-write pulse sets the oscillator-gate flip-flop (time pulse generator and distribution circuitry, 0. 8. 3) to start the stepping of the clock, and also to become a reset-character-register pulse (word transfer circuitry, 0. 8. 4).

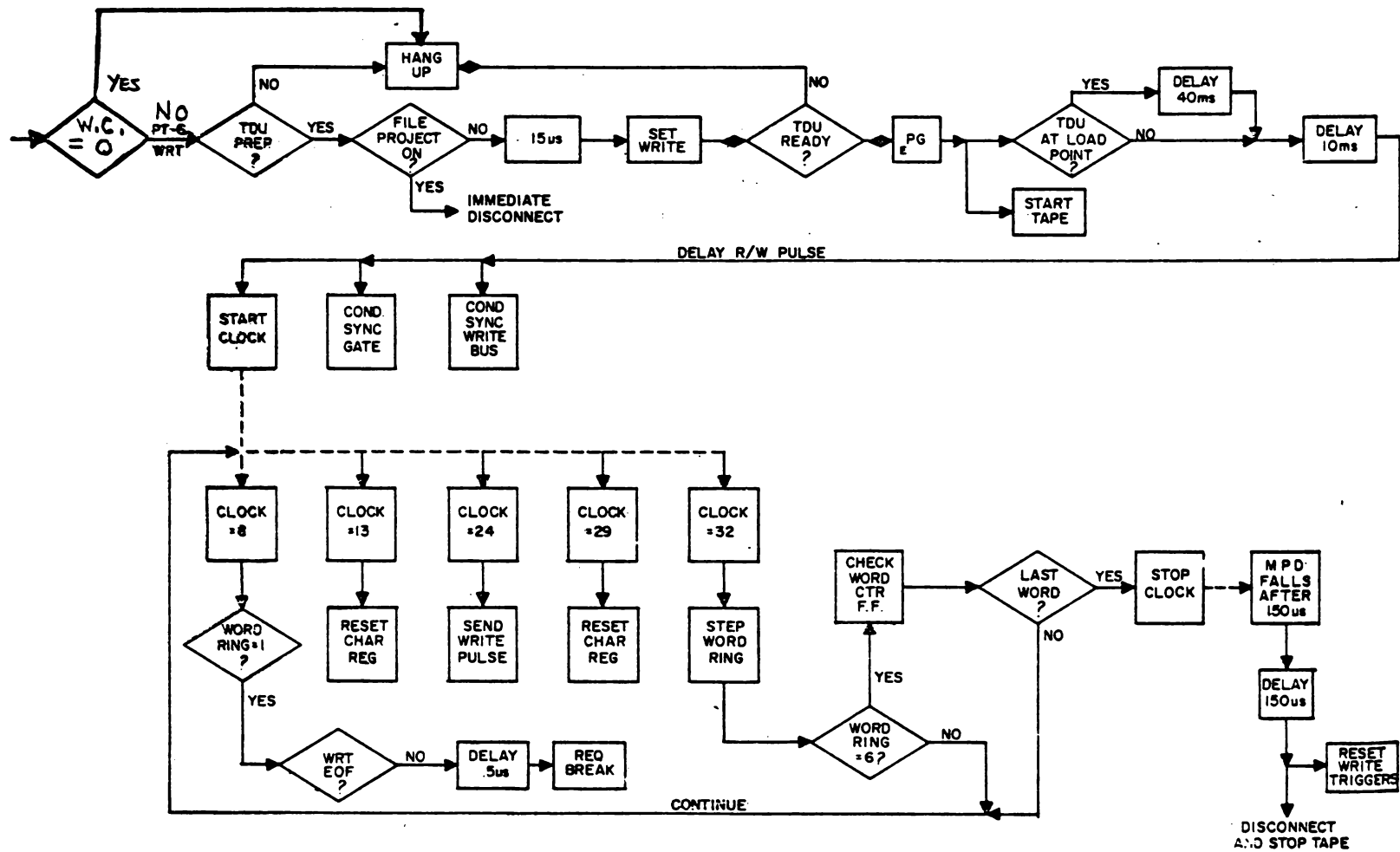

TAPE WRITE OPERATION

5. From this point the clock and TPD (0. 8. 3) will supply most of the control pulses necessary to effect the cyclic write operation.
6. The first control pulse to be generated by the clock for the write operation will be the request-break pulse which was the 8th clock-stepping pulse. It is necessarily generated only once for each full computer word to be written on tape. (A word-ring-1 level, necessary for the request break pulse, ensures this.) The request-break pulse is sent to the IO element. Within a few microseconds the first word to be written on tape will be transferred to the word register (word transfer circuitry, 0. 8. 4) via the IO register. The output of the word register (levels from the one sides of the individual bit flip-flops) is applied to the write word switch (word transfer logic 0. 8. 4). Note that the word ring also supplies levels to the write-word switch.
7. The arrangement of the word-transfer logic is explained for the write operation. The 33 pulse lines from the IO register are shown at the left edge of the logic sheet. These lines are joined in a single heavy line which runs along the bottom of the sheet. The 33 flip-flops that make up the word register are arranged in six vertical columns. The inputs to the word-register flip-flops can be seen being taken off the heavy lines. Refer to 0. 8. 4
8. The level output from the one side of each of the word register flip-flops serves as a condition level for a gate and as one input to a two-way AND circuit. (The gates are used during the read operation.) The other input to each of the AND circuits is from the one side of one of the word-ring flip-flops. These AND circuits constitute the write word switch. Corresponding AND circuits (see table) are joined in OR circuits which are the inputs to the write bus line going to the tape drives.

Corresponding Word-Register Bits and Word-Ring Flip-Flops

Word Ring FF	Bit Positions in Word Register					
1	31	32	33	*	*	*
2	25	26	27	28	29	30
3	19	20	21	22	23	24
4	13	14	15	16	17	18
5	7	8	9	10	11	12
6	1	2	3	4	5	6

*End-of-file bits

9. Only one of the word-ring flip-flops is set at any one time. (Initially the deselect sets the word-ring-1 flip-flop.) As each group of AND circuits is conditioned, a character is written on the tape.

The next control pulse which occurs with the 24th stepping pulse triggers a 15-microsecond SS. The output of the single shot is called the write pulse and is sent to the tape drive where it actuates the write circuits to cause writing the one bits (of the first character) sent over on the write-bus lines. The write bus level for the sync bit, which is written as a one bit for each character, is supplied from an AND circuit (0.8.2), the inputs to which are the write-status level and the level from the one side of the delayed read-write flip-flop.

10. With the 32nd clock stepping pulse the step-word-ring pulse is generated and sent to the word ring. The second flip-flop in the word ring is now set and its output is applied to the second group of AND circuits in the write word switch. The 32nd clock-stepping pulse also leaves all flip-flops in the clock clear, completing the cycle of control pulse generation.

11. The process just explained for the transfer of a character to the tape drive is repeated until the entire word in word register has been transferred. At the completion of the last (sixth) transfer cycle, the step-word-ring pulse will set the word-ring-1 flip-flop. The following 8th clock-stepping pulse will become another request-break pulse, and the next full word to be written on the tape will be sent from the IO element.
12. The write operation is terminated when the word counter (IO element) goes to zero and a word-counter-zero pulse is sent to the tape adapter (0.8.2). The word-counter-zero pulse sets the word-counter-zero flip-flop, the one side of which conditions a gate strobed by the word-ring-5 pulse. When the word-ring-5 pulse (that which steps word ring to six) is generated it sets the 2nd-word-counter-zero flip-flop. The word-ring-6 pulse strobes the gate conditioned by the one side of the 2nd word-counter-zero flip-flop and becomes a reset-clock pulse which clears the oscillator-gate flip-flop, effectively removing the source of clock-stepping pulses.
13. With the clock turned off, the write operation ceases. All that remains is to generate a disconnect pulse which is used to make certain resets in the tape adapter and is sent to the IO element to clear the IO interlock. The explanation of the generation of this pulse follows.
14. During the write operation, certain circuitry connected with the writing of the sync bit was operative, but since it is involved with the termination of the write operation its explanation has been deferred until this point.
15. In the tape drive write circuitry for each of the seven bits an output is generated each time a one bit is to be written and sent to the tape adapter. They are called the write-echo pulses. The write-echo pulses from the data-bit write circuits are used only for test purposes.
16. The write-echo-sync pulse from the tape drive is inverted so that the leading edge of the pulse will set the sync bit flip-flop (0.8.2). (Note that a read sync pulse is connected through the OR circuit to the one side of the sync bit flip-flop. This is explained with the read operation. The sync-bit flip-flop is cleared between

successive write-echo-sync pulses with a gated 13th clock-stepping pulse providing the necessary shift in the output from the zero side (+10 -30 volts) to trigger a pulse generator with the reception of each write-echo pulse.

17. The output pulse from the pulse generator passes a gate conditioned by the one side output of the delayed read-write flip-flop and becomes the input pulse to the missing pulse detector (MPD). The MPD operates in such a manner that its output will remain at the +10 volts as long as a pulse arrives at its input at least once every 150 microseconds. Normally the write-echo pulses arrive approximately every 50 microseconds. When the generation of the write-echo pulses is halted, the output of the MPD will fall to -30V after 150 microseconds and trigger a pulse generator.
18. The output pulse from the PG passes the gate conditioned by the zero side of delayed-backspace flip-flop (which is cleared during write operation) to become the end-of-record pulse. This pulse passes a gate conditioned by the write-status level and fires a 150-microsecond \bar{B} SS. The drop in the level output of the SS triggers a pulse generator, the pulse output of which becomes the end-of-record (write) pulse and which also triggers a 15-microsecond SS generating the reset-write-triggers pulse. The end-of-record (write) pulse passes through an OR circuit to become the disconnect pulse. In addition to being sent to the IO element to clear the IO interlock, the disconnect pulse also:
 - a. Clears the go flip-flop.
 - b. Clears the wd-ctr-0 flip-flop.
 - c. Clears the end-of-file flip-flop.
 - d. Performs some of the functions of a deselect pulse (0. 8. 1) which:
 - 1) Clears the delayed read-write flip-flop.
 - 2) Clears select-read-delay flip-flop.
 - 3) Sets word-ring-1 flip-flop.
 - 4) Clears word-ring-2 through 6 flip-flops.

J. Write Operation, Logic Analysis

C. C. Vol. 2

0. 7. 8

0. 8. 2

1. Start Write Pulse:

- a. Checks prepared GT V9BF
- b. Checks file protection GT V8BF
 - 1) If file protection is on, pulse becomes a gated disconnect.
- c. Fires 15 usec. bSS to place drive into Write Status.
- d. Falling output of 15 usec. bSS fires an EPG.
- e. Pulse sets GO FF and starts delay to allow tape to come up to speed.
 - 1) If not at Load Point, delay is 10 milliseconds.
 - 2) If at Load Point, delay is 50 milliseconds.
 - a) Extra 40 milliseconds is to allow tape to clear Load Point.
- f. At end of delay:
 - 1) Delayed R/W FF is set 0. 8. 2
 - 2) Clock is started, 0. 8. 3
 - 3) Character register is reset. 0. 8. 4
 - 4) Word ring is equal to one. 0. 8. 4
- g. Clock = 8, Word Ring = 1
 - 1) Request break
- h. Clock = 24, Word Ring = 1
 - 1) Write 1st character. 0. 8. 3-0. 8. 4
 - 2) Pulse MPD 0. 8. 2
- i. Clock = 32
 - 1) Step word ring - word ring = 2
- j. Cycle repeats until complete word is written.
 - 1) Word register is reset by word ring 6 pulse. (13DMC1)
0. 8. 3

- k. Break requests continue and information is transferred until word counter goes equal to zero.
- 1) "Word counter equals zero" pulse sets FF7 13 BM. 0. 8. 2
 - 2) Word ring 6 pulse of last word resets clock. 0. 8. 2
 - 3) MPD output falls generating "End of Record" pulse. 0. 8. 2
 - 4) End of Record pulse delayed 150 microseconds and gated as disconnect. 0. 8. 2
 - a) Clears GO FF.
 - b) Clears I/O interlock.

K. Summary Questions

Refer to CC Vol. 2 Logic as indicated.

1. State the purpose of the 15 usec delay provided by BSS V2A, 3 13BF.
2. A start write pulse into (0. 8. 2) 13BFJ1 will be delayed 15 usecs and then 50 msec if the tape drive is at load point. The 50 msec delay is broken up into a 40 msec and 10 msec delay. State the purpose for these delays.
3. What controls the writing of the sync track during a write operation?
4. Identify by clock pulse and/or word ring the following signals:
 - a. Write pulse
 - b. Break Req (WRT)
 - c. Step word ring (WRT)

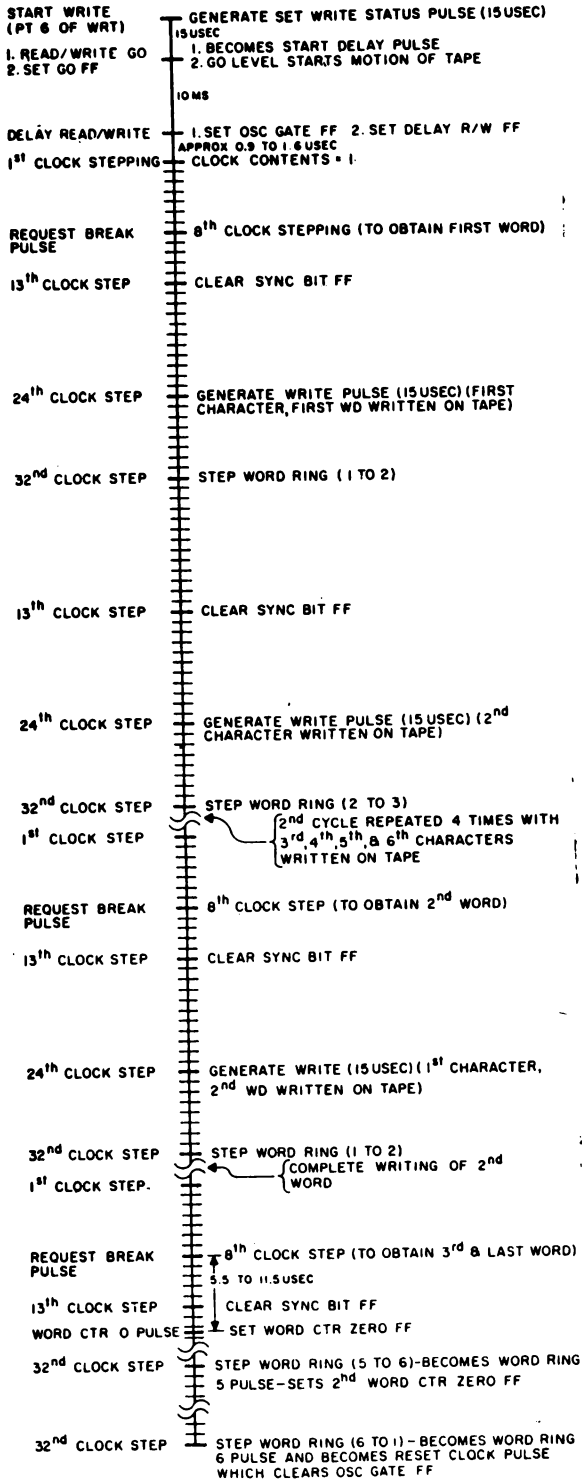

Write Operation, Timing Chart

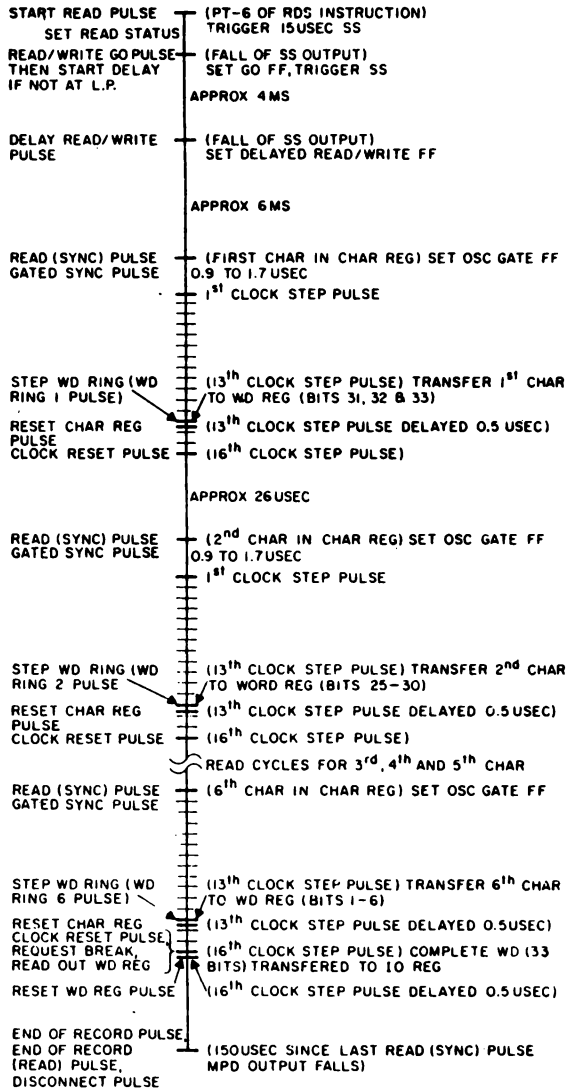

Read Operation, Timing Chart

L. Read Operation

Refer to 0. 8. 2
C. C. Vol. 2

1. Prior to issuing the RDS instruction the computer selects the desired tape drive.
2. At PT 6 of the RDS instruction the start-read pulse is received at the operation control logic, 0. 8. 2. The action of the start-read pulse is identical to that of the start-write pulse except that the read-write-status flip-flop in the tape drive is cleared and a read-status level returned to the tape adapter unit.
3. The fall in the output of the 15 microsecond single shot (source of set-read-status level) causes the generation of the read-write-go pulse and the setting of the go flip-flop. A delay is instituted to allow time for the drive to attain operating speed before setting the delayed read-write-flip-flop. The action by the start-read pulse is completed at this point and it remains now for the tape adapter unit to receive a read (sync) pulse from the tape drive before the read operation continues.
4. The read (sync) pulse will result in the setting of the sync-bit flip-flop just as did the write-echo pulse. When the negative shift occurs the output of the clear side of the sync-bit flip-flop causes the pulse generator to generate a pulse which passes the gate conditioned by the one side of the delayed read-write flip-flops. Throughout the read operation these gated sync pulses will be used to set the oscillator-gate flip-flop since as each character is read the clock is turned off. The gated sync pulses also set the MPD as explained for the write operation.
5. At the same instant the read (sync) pulse is received, the character register (word transfer logic, 0. 8. 4) is set with the data bits in the first character sent from the tape drive on the read bus. The read pulses are shaped by a tape phase splitter (TPS), a gate mixer shaper (GMS) (note the read status level), and a schmitt trigger (ST). The output of the one sides of the individual flip-flops in the character register conditions gates in the read-word switch which will be strobed by the word-ring stepping pulses the contents of the character register thereby being transferred to the appropriate flip-flops in the word register.

Fig.
Page 3120
&
3140

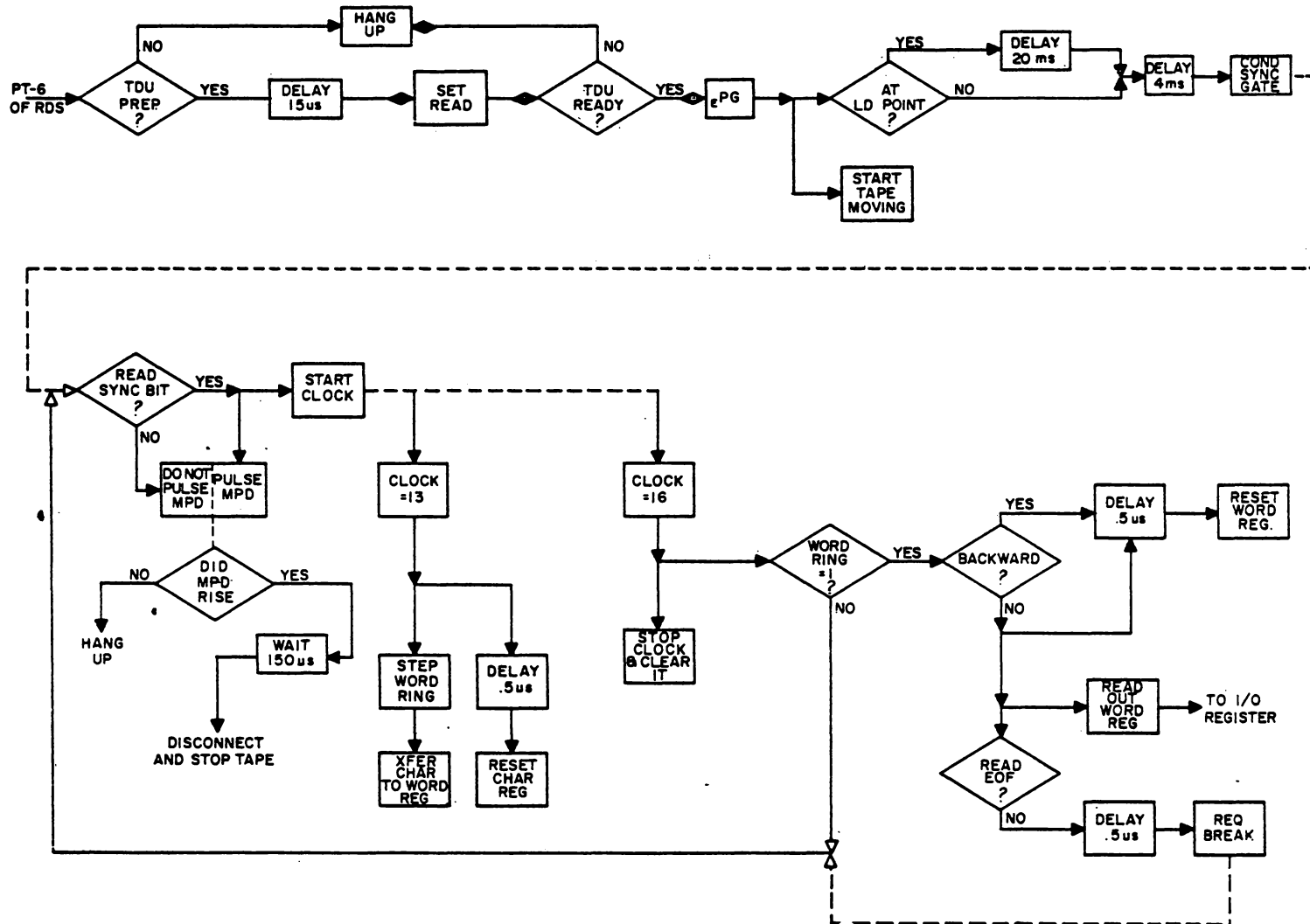

TAPE READ OPERATION

6. The first control pulse to be generated during the first clock cycle is the step-word-ring-1 pulse which will step the word ring from 1 to 2. This is the 13th clock-stepping pulse. The first character is now transferred to the word register. The 13th clock-stepping pulse is delayed 0.5 microsecond to become a reset-character-register pulse which is used to clear the character-register preparing it for reception of the second character. When the 16th clock-stepping pulse is produced a clock-reset pulse is generated which clears the oscillator-gate flip-flop. The individual flip-flops in the clock register and the frequency division flip-flop are cleared with the delayed clock reset pulse.
7. The operation just described will be repeated until all six characters are transferred to the word register.
8. The 16th clock-stepping pulse of the sixth character transfer-clock cycle gated by a word-ring-1 level becomes a request-break pulse. Also with the gated-stepping pulse a read-out-word-register pulse is generated which causes the transfer of the word just read from tape to the IO register. The gated 16th clock-stepping pulse is delayed 0.5 microsecond and is then distributed as a reset-word-register pulse.
9. The read operation is terminated when the end of the record is reached. The end-of-record condition is detected by the MPD as explained in the write operation. As in the write operation a disconnect pulse is generated as a result of the MPD firing a pulse generator.
10. If the RDS instruction specifies fewer words than are in the record that is read, the read operation continues without change, after the word counter goes to zero, until the end of the record is reached. (The word-counter-0 pulse is gated by the write-status level. See 0.8.2.) However, the computer ignores the words coming into the IO register after the word counter reaches zero and they are not stored in core memory.

M. Read Operation - Logic Analysis

1. Instruction pulses start read line.
 - a. Prepared GT checked.
 - b. 15 usec delay started.
 - 1) Rising output of bSS.places drive in read status.
 - c. Delayed pulse
 - 1) Sets GO FF.
 - 2) Starts delay.
 - a) At load point delay is 24 Msec.
 - b) Not at load point delay is 4 Msec.
 - d. End of delay
 - 1) Sets delayed R/W FF.
 - 2) Resets character register.
 - 3) Tape is moving forward.
 - 4) Clock is not running.
 - 5) Word ring equals one.
 - e. When first character passes over R/W head:
 - 1) Sync bit brings up MPD. 0.8.2
 - 2) Data appears in character register. 0.8.4
 - 3) Clock is started.
 - f. Clock = 13
 - 1) Information transferred from character register to word register.
 - 2) Word ring stepped to 2.
 - 3) Character register reset.
 - g. Clock = 16
 - 1) Clock reset and stopped.
 - h. Cycle repeats for each character in the word, starting when a sync bit is read.
 - i. When sixth character is read:

- 1) Clock = 13 pulse steps word ring to 1. 0. 8. 3
- 2) Clock = 16 pulse
 - a) Resets clock.
 - b) Requests break.
 - c) Transfers information to I/O register. 0. 8. 4
- j. Cycle repeats until end of record is reached.
 - 1) Output of MPD falls.
 - a) Delayed R/W FF is cleared.
 - b) Disconnect generated.
 - c) I/O interlock cleared.
 - d) GO FF cleared.
- k. Tape stops.
2. RDS 0 instruction operates in the same manner except that C. C. does not accept break requests.
 - a. Tape drive will read one record.
 - b. No information will be accepted by C. C.
 - c. At the end of record, a disconnect is generated which will clear I/O interlock.

Note: A RDS "0" will move tape whereas a WRT "0" will not move tape. (Logic 0.7.8 due to GTV85FV which will inhibit WRT pulse unless word counter = "0".)

N. Summary Questions

True or False

1. A RDS "0" will not move tape.
2. The delay following a start RDS when the tape drive is not at load point until the clock is started is 4 msec.
3. A RDS "0" will set the I/O interlock.
4. The difference in delay in setting the delayed read-write FF depending upon whether the tape drive is at load point or not is:

RDS = 40 msec.
WRT = 20 msec.

5. During a read operation, clock = 13 pulse will transfer data from the character register to the word register.
6. During a read operation, a break request is produced by word ring = 6, clock = 16.
7. A PER (67) clears the NIFA FF only in the selected tape drives.
8. A PER (72) will send one break request to the central computer.
9. When used with tapes, a WRT 0 instruction generates an immediate tapes disconnect and fails to move tape.
10. A rewind instruction while at load point sets the I/O interlock for 40 milliseconds.
11. The delay before starting the clock following a start write pulse while not at load point is 10 msec.
12. To place a tape drive in rewind status, the tape drive must be ready.
13. To place a tape drive into rewind under computer control, the tape drive must be prepared.

The next two problems are trouble shooting.

14. GT1 in 13DK (0. 8. 2) is open. When would this trouble show up and what indications would be noted?
15. 13CL A3 is open. When would this trouble show up and what indications would be noted?

Operating Procedures

A. General

Functions such as reading, writing, backspacing, and re-winding can be controlled by either manual control operation or computer control operation. Under manual control, the tape drive can be operated by the tape adapter test door or the tape tester. Load and unload operations are manually controlled only by use of the associated button located on the tape drive unit door.

This section contains the procedures necessary to prepare the tape drive(s) for operation. These procedures include loading and unloading and placing the machine under manual or computer control. The operating controls and indicating lights located on the tape drive unit are described in tabular form.

The tape adapter test door operation is discussed in the Tape Adapter section.

B. Operating Controls and Indicating Lights

Tables A and B list the functions of the operating controls and indicating lights, respectively, located on the tape drive door. Figure 1 shows the operating controls and indicating lights.

Pages 3200
&
3210

C. Tape Drive Unit Loading

When the terms load or unload are used concerning the tape drives, it does not necessarily mean the mounting or removal of a reel of tape. The term load, unless otherwise noted, means that tape is in both vacuum columns and the upper head assembly is in the lowermost position. The term unload, unless otherwise noted, means that the upper head assembly is raised to its uppermost position and tape is withdrawn from the vacuum columns.

Two procedures are given for preparing the tape drive unit for operation. The selection of a specific procedure depends entirely upon the status of the tape drive.

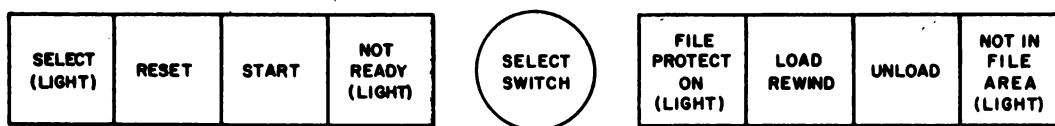

Tape Drive Controls and Indicators

OPERATING CONTROLS AND THEIR FUNCTIONS

CONTROL	TYPE	FUNCTIONS
START	Pushbutton	Depression puts unit in a ready status, disables manual control buttons, and turns off the NOT READY light. Transfers control of the tape drive to computer control.
RESET	Pushbutton	Depression resets the tape drive to manual control (turns on NOT READY light).
UNLOAD	Pushbutton	Depression causes upper head assembly to rise to its upward position and tape to be withdrawn from the vacuum columns.
Address selector	6-position rotary switch	Allows tape drive to be identified by providing it with a specific address.
Reel release	Pushbutton	Releases reel brake clutches to permit manual movement of tape reels.
LOAD REWIND	Pushbutton	When the tape drive is in unload status, depression of the LOAD REWIND button lowers the upper head assembly and rewinds the tape to load point. When the tape drive is in the load status, depressing this button will cause the tape to rewind to load point, if not at load point.

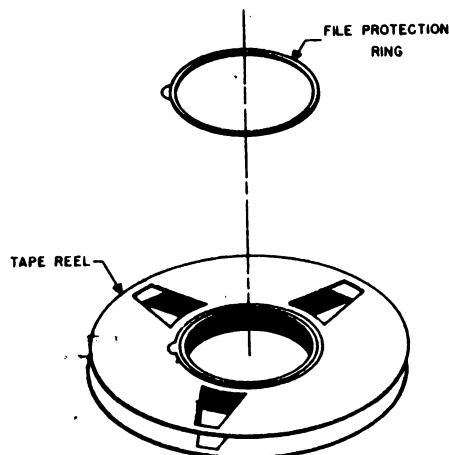

Reel and File Protection Ring

INDICATING LIGHTS AND THEIR FUNCTIONS

INDICATING LIGHT	FUNCTION
SELECT	Indicates when the tape drive unit has been selected for use by an external element.
NOT READY	Indicates that one or more of the following conditions might exist: <ol style="list-style-type: none"> a. Front door open b. Tape out of one or both vacuum columns c. Fuse blown d. Power off e. Tape broken f. No vacuum at columns g. Reset (not started) h. Photo-lights burned out
FILE PROTECT ON	When on, the tape unit is interlocked against writing, indicating one of two conditions: the unit is in rewind status or the reel has its file protection ring removed.
NIFA	Indicates end of file, or end-of-tape marker has been sensed.

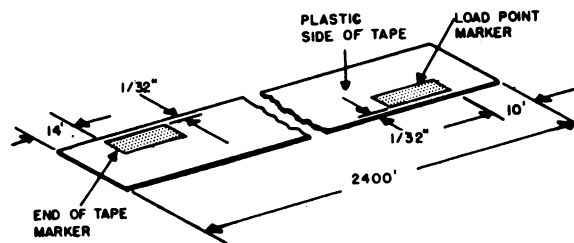

Magnetic Tape

To indicate the usable portion of the tape, markers (reflective spots) of gum-backed tinfoil are placed on the tape at predetermined distances from either end of the tape: the marker at the beginning of the tape is named the load point, and the marker at the end of the tape is named the end of tape (EOT). These markers also serve as control elements, preventing the tape from being completely wound on, or unwound from, the reels. Tape already containing data has both markers in place, whereas a new tape has not.

The use of a new tape requires that the markers be affixed at the correct points. Placement of the load point marker is relatively simple. To affix the end-of-tape marker, however, approximately 2,400 feet of tape must be unwound from the file reel to the machine reel. To expedite this task, the operation is performed with the aid of controls external to the tape drive unit, namely those on the tape adapter test door. The control settings required at that location are included in the preparation procedure for blank tapes.

Note: The operator should be familiar with the procedure on handling tape.

1. Loading Procedures for Marked Tapes

Page 3200

Tapes containing reusable information may be protected from writing and erasing by use of a file protection device. On one side of the tape reel is a groove into which a plastic insert is fitted. This plastic insert is called the file protection ring. Located above the file reel hub is a pin that senses the presence or absence of the file protection ring. If the file protection ring is removed, the reel is then file-protected, thereby inhibiting writing and erasing. Reading, however, is allowed.

In the procedure that follows, it is assumed that no file reel is on the tape drive unit:

- a. Ascertain whether tape is to be file-protected. Remove or place plastic insert at rear of file reel as required.
- b. Open tape drive door, and loosen file-reel-retaining knob to permit insertion of file reel.

- c. Slip reel over retaining knob and onto hub. Push reel firmly against stop on hub to assure good alignment, handling the reel on the center or solid portion whenever possible. Tighten retaining knob securely.
- d. Depress reel release switch, unwind several feet of tape, and thread it.
- e. Wind a few turns of tape around hub of machine reel to secure tape to reel. Be sure to wind tape past load point marker.

Note: If, while loading, the LP marker is to the left of the head assembly, tape will be pulled off of the machine reel.

- f. Close door, and depress LOAD REWIND button to load tape machine. Machine will go into a loaded condition and then into a rewind until load point is reached.
- g. Depress START button to place under computer control.

2. Loading Procedure for New Tape

To prepare a tape drive for operation with a file reel containing tape on which there is no information, proceed as follows:

- a. Check to see that plastic insert is in groove at rear of file reel. If there is none, one should be inserted.
- b. Loosen file-reel-retaining knob to permit insertion of file reel.
- c. Slip reel over retaining knob and onto hub. Push reel firmly against stop on hub to assure good alignment.
- d. Press reel release button, and unwind several feet of tape. Thread it. Wind a few turns of tape around the hub of machine reel to secure tape to reel.
- e. Manually wind approximately 10 feet of tape onto machine reel.
- f. Affix load point marker 1/32-inch from edge of tape on outside and 10 feet from beginning of tape. Load point marker should be placed on plastic side of tape.

- g. Again press reel release switch, and wind tape until load point marker is wound onto machine reel.
- h. Close tape drive door, and depress **LOAD REWIND** button to wind tape to load point.
- i. After load point is reached, depress **START** button to place tape drive under external control.

Note

The controls used in steps j through m are located on the tape adapter test door.

- j. Turn **SELECT** switch on test door so that its setting corresponds to that of **ADDRESS SELECTOR** on tape drive unit.
 - k. Set **TEST-OPERATE** switch at **OPERATIONAL TEST**.
 - l. Depress following pushbuttons in order listed: **DESELECT**, **SELECT**, **SET PREPARED**, and **START WRITE**. When last button is depressed, tape will begin to wind onto machine reel.
 - m. When tape from file reel is almost completely wound on machine reel, depress **STOP** button. The reset of this procedure is completed using the controls at the tape drive unit.
 - n. Depress **RESET** button to bring tape drive under manual control.
 - o. Depress **UNLOAD** button to withdraw tape from vacuum columns.
 - p. Open door, depress reel release switch, and manually unwind 14 to 20 feet from end of tape (fig. 5-2). Affix **EOT** marker 1/32-inch on inside edge and 14 feet from end of tape on plastic side.
 - q. Close door, and depress **LOAD REWIND** button to load machine.
3. **Removing Tape Reel from Machine**

To remove a reel of tape from the machine, it is necessary to place the machine under manual control and to unload the machine. The procedure used to remove a reel of tape is as follows:

- a. Depress **RESET** button to place tape drive under manual control.

- b. If tape has not been wound to load point, depress **LOAD REWIND** button.
 - c. Depress **UNLOAD** button to raise upper head assembly and to free tape from vacuum columns.
 - d. Open machine door, depress reel release switch, and rewind remainder of tape onto file reel manually.
 - e. Refer to Tape Handling section for proper method of storing tape and precautions to be taken when handling tape.
4. **Computer Control**

After a tape is wound to load point, the tape drive can be placed under computer control by depressing the **START** pushbutton. Before doing so, however, check whether the address selector switch has been set to the correct position. Each of the tape drives has a specific address which permits the computer to select a particular tape drive.

When the **START** button is depressed, the **NOT READY** indicator is extinguished and, if the file reel is file-protected, the **FILE PROTECTION ON** indicator lights. When the computer chooses the tape drive for use, the **SELECT** indicator comes on.

During computer control, the tape moves both forward and backward and, at times, remains stationary. Should the tape progress past the point where the written file ends or should it reach the **EOT** marker, the **NIFA** indicator will light. Rewind from either point is usually accomplished by an appropriate instruction from the computer.

5. **Manual Control**

To transfer control of the tape drive from the Central Computer System to the tape drive itself, depress the **RESET** button on the tape drive unit door. This action is accompanied by the lighting of the **NOT READY** indicator, thereby transferring control to the use of the control buttons located on the tape drive door.

XII. Tape Adapter Test Door

Logic - 0.8, 5

C. C. Vol. 2

A. Function

1. Provides a manual method of supplying program pulses to the tape adapter by means of pushbuttons.

picture
Page 2620

B. Operation

0.8.5

1. Test-operate switch, three positions.
 - a. Operate Position (as shown on logic)
 - 1) Complete computer control of the tape drives and tape adapter.
 - 2) 13C1 (K1, K2, K3) are not energized.
 - a) 13C1 (K3) 3 N/C supplies +10 volts to computer control lines.
 - b) 13C1 (K3) 2 N/C supplies -30 volts to the test data bit switches to disable them.
 - c) Operate light should come on -48V through 13C1(K1)2 N/C and 13C1(K2)3 N/C points.
 - b. Operational Test (Transfer 13C1(59))
 - 1) Computer test relay, 1G2(K6) must be picked to supply -48 volts to pick the tape test relays.
 - 2) 13C1(K1) picked by 13C1(59). (Pick and hold coils paralleled.)
 - a) 13C1(K3) picked by 13C1(K1) 4 points. 13C1(K3)3 makes computer control -30 volts. 13C1(K3)2 makes +10 volts available to data bits. 13C1(K3)4 connects A^{PG} to pushbuttons.
 - b) Operational test tapes light comes on.
 - c) Test tapes on maintenance console comes on.
 - 3) If computer is taken out of test, tapes will drop out of test.
 - a) Dropping 1G2(K6) will remove -48 volts.
 - b) 13C1(K1) will drop.
 - c) 13C1(K3) will drop.

Return to operate status.

TABLE A

FUNCTION OF CONTROLS ON TAPE ADAPTER TEST PANEL

CONTROL	FUNCTION
OPERATIONAL TEST/ OPERATE/HAZARDOUS TEST (3-position toggle switch)	With this switch in the OPERATE position, the tape element can be operated by the computer only. In the HAZARDOUS TEST position the tape element can be operated only from the test panel. The OPERATIONAL TEST position permits the tape element to be operated by either the computer or the test panel depending on the setting of the COMPUTER OPERATE/TEST switch on the duplex maintenance console.
CHARACTER BIT CONTROL (toggle switches)	The setting of these switches for the six data bits provides the bit configuration of tape character being written. They are also involved (including SYNC bit switch) with error checking on both reading and writing.
ERROR STOP (toggle switch)	Setting of this switch determines whether the tape will be stopped following an error detection.
WRITE CYCLE (toggle switch)	Using this switch will permit a write operation to be terminated automatically after approximately 100 words are written on the tape. Also, the write operation (after a preset delay) will be restarted automatically following the automatic termination. Repeated write operations are thereby executed with successive 100-word records being written.
SELECT (rotary switch)	Setting of this switch channels the test select pulse generated with SELECT pushbutton to the desired tape drive.
SET WORD COUNTER ZERO (pushbutton)	Simulates word-counter-zero pulse from computer to set word-counter-zero flip-flop.
STOP (pushbutton)	Generates pulse to stop tape motion (clear go flip-flop).
RESET CLOCK (pushbutton)	Clear the tape-clock flip-flops.
START READ (pushbutton)	Simulates start-read pulse from computer.
START WRITE (pushbutton)	Simulates start-write pulse from computer.
WRITE END OF FILE (pushbutton)	Simulates write-end-of-file instruction issued by computer.
SELECT (pushbutton)	Simulates one of select pulses from computer to select tape drive specified by SELECT (rotary switch).
DESELECT (pushbutton)	Performs same functions as the remote deselect pulse generated by DESELECT TAPES pushbutton on duplex maintenance console or the deselect pulse issued by the computer.
KEY PULSES (pushbutton)	Steps tape adapter clock each time depressed. Simulates stepping pulses gated from oscillator output.
SET PREPARED (pushbutton)	Simulates set prepared instruction issued by computer.
BACKSPACE (pushbutton)	Simulates backspace instruction issued by computer.
REWIND (pushbutton)	Simulates rewind instructions issued by computer.

TABLE B FUNCTION OF INDICATORS ON TAPE ADAPTER TEST PANEL

INDICATOR	FUNCTION
OPERATIONAL TEST (lamp) OPERATE (lamp) HAZARDOUS TEST (lamp) TAPE DRIVE UNIT NOT READY (neons; numbered 1 through 6)	Indicates corresponding position of associated switch. Each of neons connected to a line from associated tape drive which will cause neon to glow when not ready.
SELECTED TAPE DRIVE UNIT STATUS (neons)	Each of the 12 lights in this group indicates a condition prevailing in the selective tape drive and the tape adapter.
READ STATUS WRITE STATUS	Actually represents select, ready, and read (or write) status in the tape drive; level supplied from tape drive.
GO	Go flip-flop is set.
STOP	Go flip-flop is cleared.
BACKWARD	Backward flip-flop is set.
FORWARD	Backward flip-flop is clear.
ERROR	Error flip-flop is set.
NO ERROR	Error flip-flop is clear.
REWIND	Selective tape drive is rewinding tape, level supplied from tape drive.
AT LOAD POINT	Tape is at beginning of usable area; level supplied from tape drive.
NOT IN FILE AREA	The not-in-file area flip-flop in tape has been set; level supplied from tape drive.
NO FILE PROTECTION	File protection interlock ring is on file reel; level supplied from tape drive.

- c. Hazardous Test (13C1(59) transferred) 3 and 4 points
- 1) Computer must be in test to pick test relays.
 - 2) 13C1(K2) picked through 13C1(59)4 N/O points. 13C1(K2) held through 13C1(K2)1 points and 13C1(59)3 points which provide -48 volts from Unit 13.
 - a) 13C1(K2)4 picked 13C1(K3).
 - b) 13C1(K3) disables computer control lines.
 - c) 13C1(K3) connects _APG to the pushbuttons.
 - d) Hazardous test tapes lights come on.
 - 3) If computer drops out of test, tapes will remain in test.

2. Summary

- a. Operate - K1, K2, K3 of 13C1 all dropped.
- b. Operational Test - 13C1(K1) & K3 picked only if C.C. is in test and remains in test.
- c. Hazardous Test - 13C1(K2) & (K3) picked only if C.C. in test but will remain picked if C.C. drops out of test.

3. Pushbuttons

- a. Double pole single throw switches.
 - 1) Grounds input to _APG (2 points).
 - 2) Connect output of _APG to proper line.(1 point).
- b. Operates Unit 13 similar to program.
 - 1) Exception - deselect pushbutton must be pushed for any deselect operations.

4. Bit Switches, 7 switches - 1 sync and 6 data.

- a. Apply +10V or -30V to write bus through the write status and circuit. (Bit switch - 4 points)
- b. Connects the "1" or "0" side of the character register trigger FF's to the "Error" OR ckt. (Bit switch - 3 points)

- 1) If the "Error" OR is at +10V when the error sample pulse arrives, the error FF is set.
 - 2) WRT error sample is clock = 28 pulse.
 - 3) RDS error sample is clock = 12 pulse.
 - 4) WRT Ech. pulse loads the character register during WRT.
 - 5) RDS heads load character register during RDS.
- c. Error check will connect "0" side of character register FF to "Error" OR (13BT) for each corresponding "1" bit to be written or read. If a "1" is read or written, the "0" side will be at -30 volts, thus error sample pulse will be stopped at GTV7 13BT.
5. Stop on Error Switch 13C1(58)
- a. OFF in position shown.
 - 1) -30V to GTV8 13BT will inhibit "Stop on Error."
 - b. ON - Transferred position
 - 1) +10V to GTV8 13BT to allow "Stop on Error" pulse to get through. (Clear "Go" FF.)
 - c. 13C1(58)3c enables GTV1 13BT and GTV5 13BS when K3 is picked. (Test)
6. 13C1 (X1 through X4 and X7 through X12) neon indicators for test door.
- X1, 2, 3, 4, 11, and 12 are tape drive indicators.
X7, 8, 9, 10 are Unit 13 indicators.
7. Address Selector Switch 13C1(S14)
- a. Route select pulse to selected tape FF's.
8. Pushbuttons - 13C1 - (Note: 1 points make before 2 points.)
- a. Test key pulses (S11). Single step clock.
 - b. Test Deselect (S12). Clear select FF's, clear control FF's.

- c. Select (S13). Set FF corresponding to select tape drive.
- d. Reset Clock (S15). Return clock to zeroes.
- e. Manual Stop (S16). Clear Go FF - stop tape.
- f. Set word counter zero (S17)
 - 1) WRT status = causes WRT for 40 msec, stop for 40 msec, WRT for 40 msec, etc.
 - 2) RDS status = no effect.
- g. Test Rewind (S18). Simulate computer rewind.
- h. Test Backspace (S19). Simulate computer backspace.
- i. Test Set Prepared (S20). Clears NIFA FF.
- j. Test Write EOF (S21). Sets EOF FF, does not set NIFA FF, does not make tape drive not prepared. Does not start writing operation.
- k. Start Write (S22). Simulates computer WRT.
- l. Test Start Read (S23). Simulates computer RDS.

Note: Both test start read or WRT bypass the prepared condition.

- m. Test Write Cycle (S10). Connect start write pulse to 13BS 40 ms delay.
 - 1) Writing starts normally. 40 msec delay started.
 - 2) At end of 40 msec delay, the word ctr. 0 FF is set.
 - a) Finish writing word in progress.
 - b) Disconnect generated after word is done.
 - 3) End of record pulse starts 40 msec delay.
 - 4) At end of delay, start test WRT cycle, start 40 msec delay.
 - 5) At end of delay, set wrd. ctr. 0 FF.
 - 6) Continue until stopped by pushbutton or tape is run out.

C. Summary Questions

Multiple Choice. Choose most correct answer.

1. (Logic 0. 8. 5) Bit Switch 13C1(S7), the 3 points will not transfer when this bit switch is transferred. The malfunction will be:
 - a. A "1" bit cannot be written in this track.
 - b. A "0" bit cannot be written in this track.
 - c. If the error stop switch is on, an error stop will occur if a "1" or "0" is being written by 13C1(S7).
 - d. An error halt will occur only if a "1" is to be written or read by Bit 1.

2. (Logic 0. 8. 5) Relay 13C1(K1) has an open pick coil. Which of the following cannot occur:
 - a. Operational Test
 - b. Hazardous Test
 - c. Operate
 - d. 13C1(K3) cannot be energized.

3. (Logic 0. 8. 5) If 13C1(K1)2 N/O points do not make contact when K1 is picked, the result will be:
 - a. Noticed in hazardous test, no light indication.
 - b. In operate, both operate and operational test lights on.
 - c. No indication in any setting of test-operate switch.
 - d. In operational test, no operational test lights on.

4. (Logic 0. 8. 5) Open connection at 13BS F1. This will cause a malfunction in test WRT cycle operation, such as:
 - a. No test write operation can occur.
 - b. Only 1 record will be written, then tape is stopped.
 - c. A start write will cause continuous writing until the stop button is used.
 - d. No effect.

5. (Logic 0. 8. 2) 13BJC1 is open. During a test reads:
 - a. Tape will eventually be run off of the file reel.
 - b. An end of record after EOT will start a rewind and then reading will resume.
 - c. Tape will move forward in read and stop when EOT is sensed.
 - d. The test rewind pushbutton is disabled.
6. (Logic 0. 8. 3) What is the function of GTV5 in 13DC?
7. (Logic 0. 8. 5) Depressing the test WRT EOF pushbutton will not start a WRT operation. What prevents tape from moving and writing to take place?
8. Can a test rewind start rewinding tape if tape was at load point prior to pushing the button?
9. (Logic 0. 8. 5) What clock pulse will sample for error during read? WRT?
10. Why is it desirable for section 1 to close before section 2 in the double pole single throw switches, i. e., S18, S19, etc. ?

XIII. Tapes Maintenance Program**A. Introduction****Refer to Program
Writeup.****1. Need for the program.****a. Quantity and quality of superseded programs.**

- 1) There were formerly 17 tape drive programs.
- 2) Many of these programs failed to make the checks they were designed to do.

b. Advantages of Tapes MC 1K

- 1) Has provisions for reliability tests or for automatic M. C. excursions.
- 2) Every necessary tape test in one program.
- 3) Thorough diagnostic checks.

2. Role of the Program**a. Diagnostic**

- 1) Information transfers checks.
- 2) Tape speed variation checks.
- 3) Time checks on rewind, reading, and writing.
- 4) Checks on the stepping of the tape clock.
- 5) Checks the effect of short random number records.
- 6) Checks reading and writing EOF.
- 7) Checks RDS 0.
- 8) Checks reading of more or less than a record.
- 9) Checks file protection circuitry.

b. Availability

- 1) Cards
- 2) Tapes MC 1K essentially the same program, on DCS tape.

3. Testing Routines**a. Routine 1 uses 4 different patterns to check:**

- 1) Writing timing
- 2) Read instruction

- 3) Backspace instruction
- 4) Rewind instruction
- 5) Read/write EOF
- 6) Read zero words
- 7) Read more or less than the number of words contained in one record.
- 8) All information transfers

b. Routine 2 uses a "Random Number" pattern to check:

- 1) Read timing
- 2) Write operation
- 3) Rewind operation
- 4) Stepping of clock
- 5) Tape speed

Routine 3 checks:

- 1) File protection circuitry

B. Modes of Operation

1. Mode A - complete non-marginal run of the program without options.
2. Mode C - complete marginal run of the program without options.

C. Description of Routines

1. Routine 1

a. Four 128_{10} word records

- 1) 1st record = all ones pattern
- 2) 2nd record = all zero pattern
- 3) 3rd record = checkerboard pattern (as it would appear on tape)

1. 24532 1. 12651

- 4) 4th record = 0. 01760 0. 37400
Worst possible pattern. Appears on any one track as 010100.

2. Routine 2

- a. Rewind check first.
- b. 1024 records, each having 13 random numbers.
- c. Rewind
- d. Read all 1024 records.

3. Routine 3

- a. Using a combination of routines 1 and 2.

D. The program write-up is best referred to for printout descriptions, manual intervention, and other necessary information.

E. Summary Questions

True or False - All questions pertain to tapes MC 1K

1. Routine 2 uses four different data patterns.
2. Routine 2 is used primarily to check the rewind instruction.
3. Mode B is a complete non-marginal run of the program without options.
4. In Routine 1, the first record is an all ones pattern.
5. In general, the difference in printouts between a non-marginal check and a marginal check error printout is the marginal check word.
6. Which P. U. would most probably cause error #11?
 - a. 13BC 0. 8. 2
 - b. 13BR 0. 8. 2
 - c. 13BL 0. 8. 2
 - d. 13BD 0. 8. 2
7. List 4 possible troubles that would cause error #7.

V. Unit 18 - Non-Standard Power Supply

A. Definitions

1. Inductance (Henries)

That property whereby a varying current in a circuit produces a voltage in the self-same circuit or in an adjacent circuit.

2. Reactance (ohms)

The opposition (ohms) caused by inductance and/or capacitance in a circuit.

3. Saturation

The state of maximum magnetization.

B. Basic Theory of Saturable Reactors

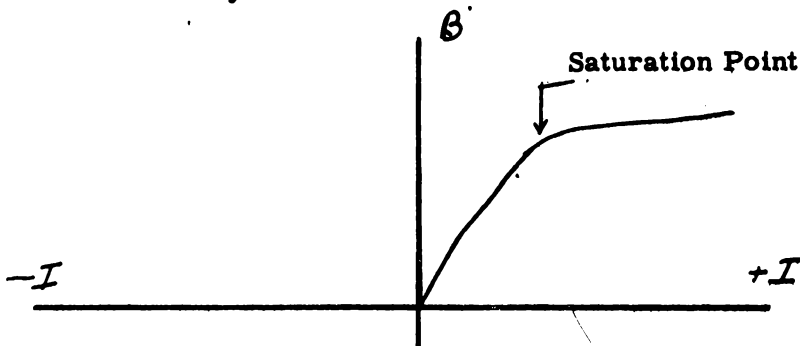

B = Flux density
 I = Current
 The number of turns
 of the coil is constant.

Fig. A

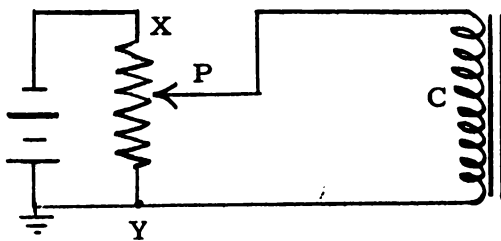

Fig. B

2. Relationship between saturation and current:

Figures A & B on Page

- a. In Fig. B, as the potentiometer is moved toward X, the applied voltage to coil C is increased.
- b. The increasing current through coil C induces a voltage that opposes the applied voltage. The induced voltage limits the change in current flowing through the coil.
- c. Fig. A illustrates the flux density increasing as the current through the coil increases.
- d. Saturation, illustrated in Fig. A, is the point where there is no appreciable change in flux density as the current increases. Beyond this point, an increase in applied voltage cannot produce any significant flux change. Therefore, the reactance of the coil is decreased and the current through the coil is increased.

3. Saturable reactor in series with the load (R) and AC power supply.

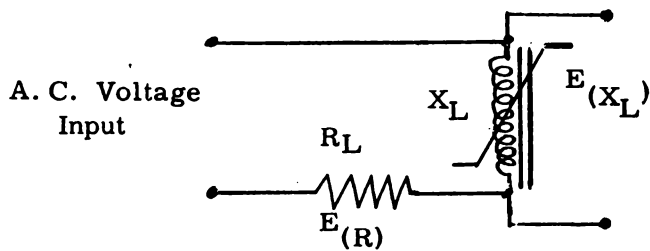

- a. When the reactor is not saturated, the ratio $\frac{R}{X_L}$ is relatively small. The greater voltage drop will be across X_L , the coil, as shown.

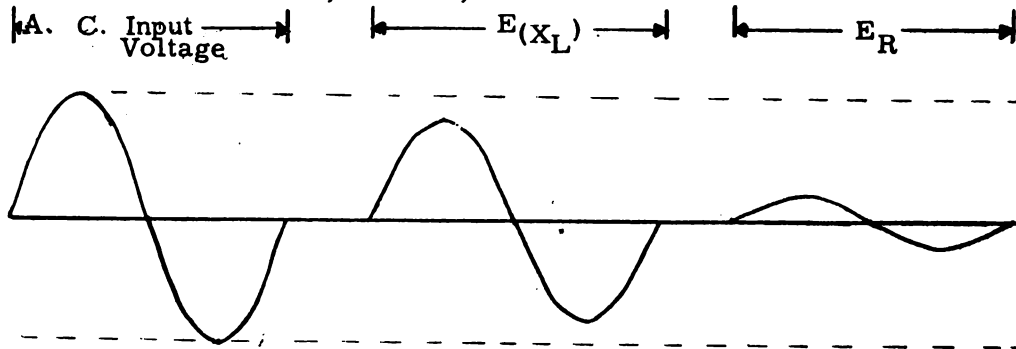

- b. When the reactor is saturated, the reactance of the coil decreases, the ratio $\frac{R}{X_L}$ is relatively greater, thus the voltage drop across R will increase while the voltage drop across XL will decrease.

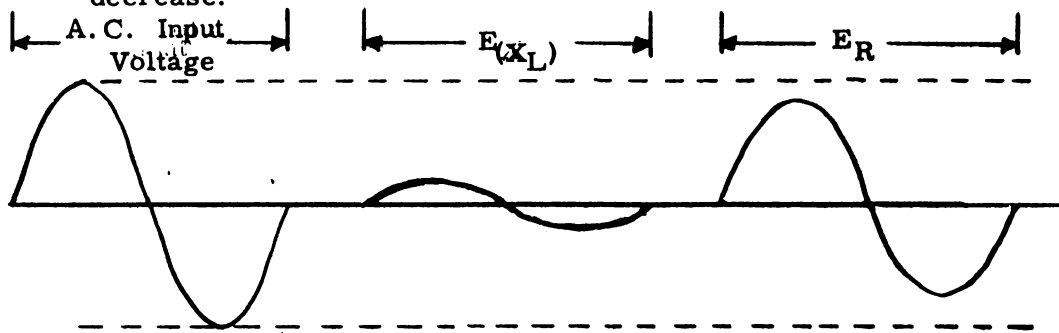

Note: For analogy (b) the reactor stays in the saturated region throughout the input variation.

4. Addition of Bias Winding

- a. The addition of a winding which will carry dc current produces a quiescent flux density that will determine the operating point on the hysteresis curve.
- b. The amplitude of E_R is related to the position of the operating point.
 - 1) If the operating point approaches the saturation point, the amplitude of E_R increases.
- c. The voltage E_R can be filtered to produce DC voltage.

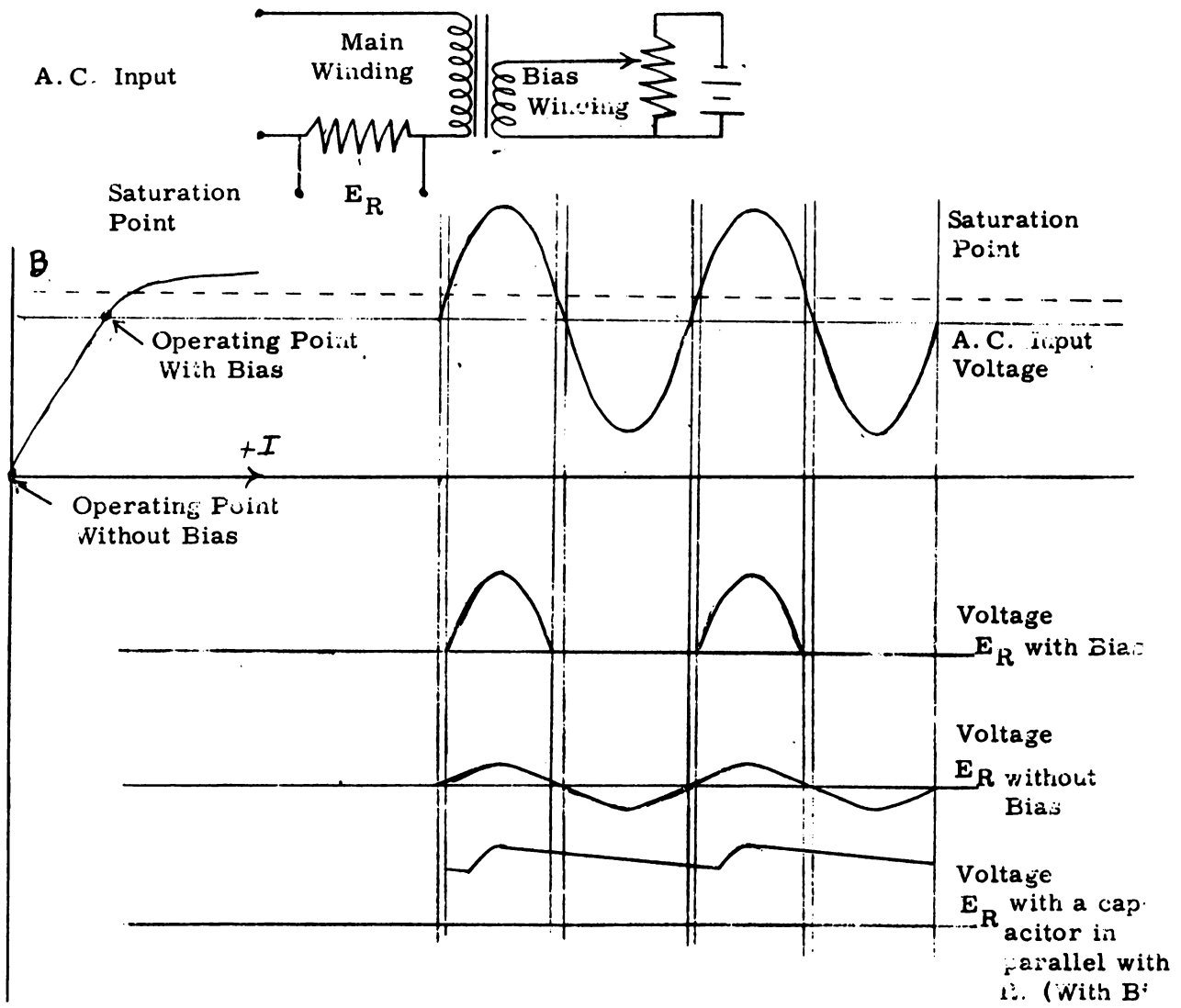

5. Full Wave Rectification

A split main winding and bridge rectifier can be used to give full wave rectified voltage across E_R .

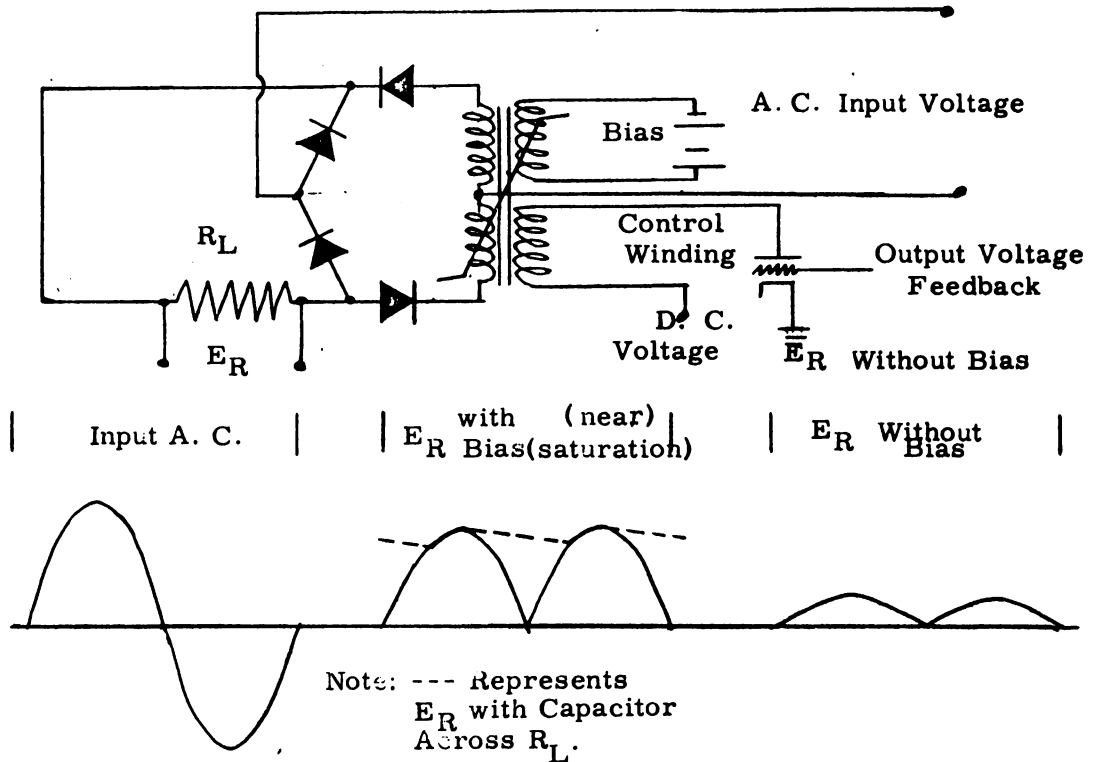

6. Control Winding

- a. To control the output voltage.
- b. Control winding and bias winding current will determine the operating point on the hysteresis curve.
 - 1) An increase in control winding current will move the operating point toward the saturation level, thus increasing the output voltage magnitude.

7. Direction of Current

- a. Load coil current is large so that it would place the reactor well above the saturation level.
- b. Bias current flux opposes that of the load winding. This current is adjusted so that the operating point is below the saturation level.
- c. Control winding current sets up a flux which aids load winding flux. Thus, increasing the current through the control winding will move the operating point toward saturation and increase the voltage

output. The current through the control winding is controlled by the output voltage.

C. -270 Volt Power Supply

Refer to Page 3430

The -270 volt supply is taken as a typical supply. The others will operate in a similar way. (The other supplies utilize 3 phase input transformers.)

Schematics of Power Supply & M. C. Vol. (5. 3. 3. 11 sheet 6)

1. Input (Left upper corner)
 - a. 208 volts ac single phase.
2. Output
 - a. Regulated -270 volts dc.
 - b. Supply is a split main winding and a full wave bridge rectifier.
3. Control Section
 - a. Powered by 462 volts dc power supply. (Left lower corner)
 - b. Bias winding (B)
 - 1) Current - 462 volts across 50K resistor and bias coil.
 - c. Control winding (C)
 - 1) Current controlled by tube 6146 (V1).
 - 2) Output voltage controlled by current through the control winding.
 - 3) Increasing control winding current will move the operating point toward saturation. This will cause an increase in the voltage output.
4. Operation of the Power Supply
 - a. T1 = 462 volts dc supply transformer.
 - b. V3 = Gas diode for constant voltage drop across resistor network 33K, 100K and 47K., to provide a constant bias to left grid of V4. If the -270 volt output changes, the left grid of V4 changes a like amount keeping the bias constant.

TAPE -270V POWER SUPPLY

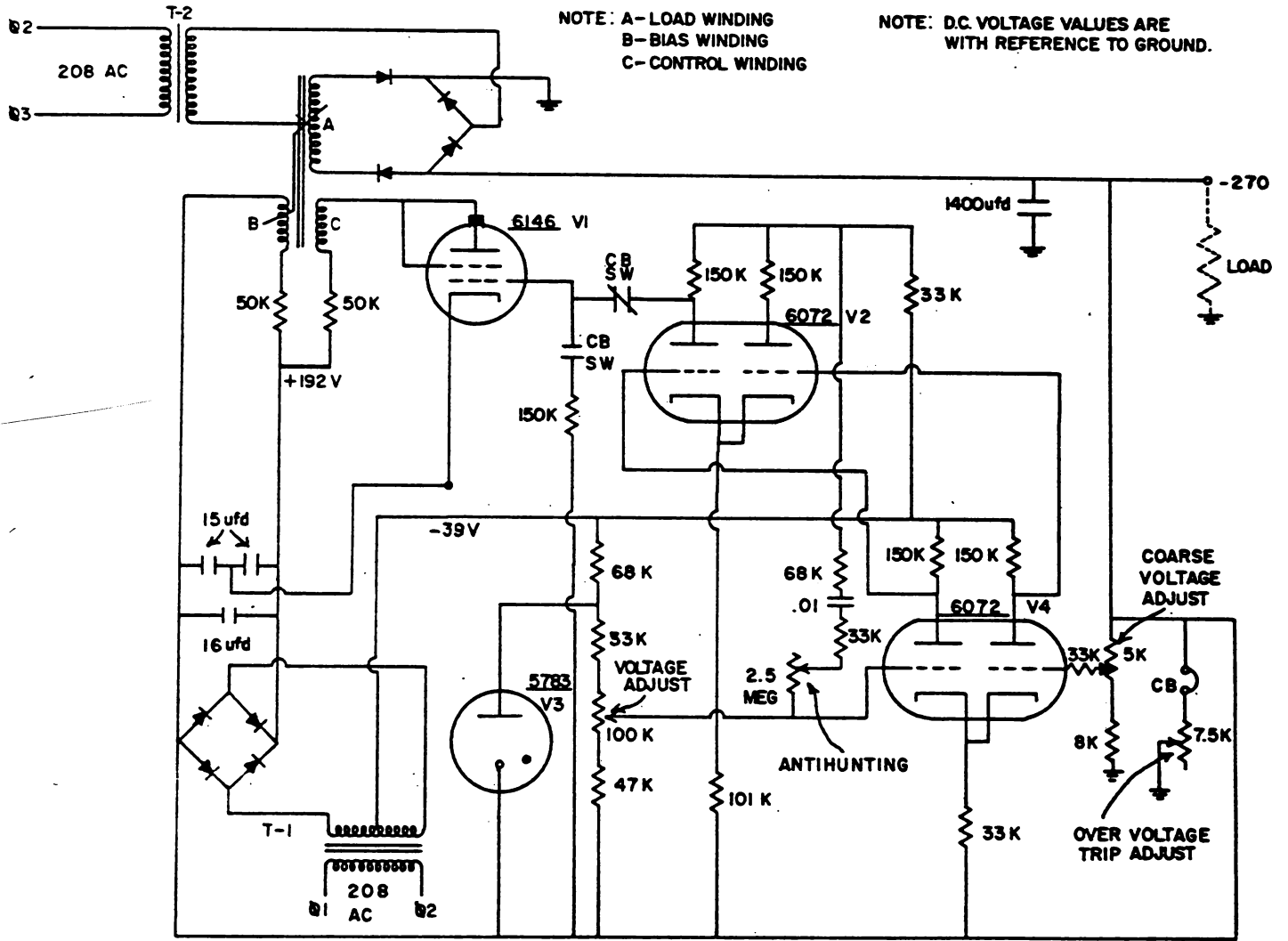

- c. The right grid of V4 samples the -270 volt output.
- d. If the -270 volts attempts to increase (-300), the cathode of V4 feels the full negative increase while the grid of V4 (right) feels a proportion part of the increase. Thus, the right grid effectively has become more positive than the cathode.
- e. The right section of V4 conducts more while the left section of V4 conducts less. The left section of V4 conducts less due to the cathode resistor. The voltage drop across this resistor makes the cathode more positive.
- f. The right grid of V2 becomes more negative while the left grid of V2 becomes more positive.
- g. The left section of V2 conducting harder causes its plate output voltage to decrease.
- h. The grid of V1 becoming more negative will decrease current through the control winding.
- i. The operating point is moved away from saturation.
- j. The output voltage is decreased.

5. Summary

- a. If the output voltage becomes more negative than -270 volts, current through V1 is decreased to decrease the output voltage.
- b. If the output voltage decreases, i. e., becomes more positive than -270, then current through V1 will be increased to increase the output voltage.

6. Controls

- a. Coarse voltage adjust
 - 1) Determines bias on right grid of V4.
 - 2) Determines ratio of voltage output change felt on right grid.
- b. Voltage Adjust
 - 1) Determine bias of left grid on V4.
 - 2) Acts as a fine voltage adjustment for the output voltage.
- c. Over voltage trip adjustment
 - 1) Determines current through the C. B.

- 2) If output voltage should increase beyond a safe value, the C. B. will open. The grid of V1 is driven very negative to cutoff V1 and the output voltage will decrease.

d. Anti-hunting

- 1) Controls the feedback to left grid of V4.
- 2) The relatively long R. C. time will prevent short duration changes from starting any oscillating actions in trying to control the output voltage during rapid changes.

7. 3-phase power supply

- a. Each phase has its own reactor.
- b. The outputs are wired in parallel.
- c. Bias and control windings are the same as a single phase power supply.

D. Summary Questions

1. Explain briefly the effect on the characteristics of an iron core inductor when the core material becomes saturated.
2. Describe the purpose of the bias winding on a saturable reactor.
3. What are the five non-standard voltages that Unit #18 supplies?
4. What is the purpose of the over voltage adjustment and how does it operate?

F. The remaining non-standard power supplies operate in a similar manner as the -270 volts dc supply.

1. +270 volts dc supply
2. +140 volts dc supply
3. -60 volts dc supply
4. -130 volts dc supply

Refer to Power &
M. C. Vol. I
Logic 5. 3. 3
Sheets 2, 3, 4, 5,
and 6.

Note: -270 volt supply uses single phase, while the other supplies use three phase inputs.

G. -30V Marginal Check Power Supply

1. Conventional bridge rectification and filtering.
2. Output variable from 0V to approximately -30V.
 - a. Controlled by motor driven variac in primary of transformer.
 - b. Excursion is manually controlled.
3. Control
 - a. Excursion increase switch
 - 1) Drives motor in forward direction.
 - 2) Increases power supply output voltages.
 - b. Excursion decrease switch
 - 1) Drives motor in reverse direction.
 - 2) Decreases power supply output voltage.
 - c. Limit switches
 - 1) Upper and lower
 - 2) Controls the motor and variac limits.
 - d. 18F(R1)
 - 1) Variable load driven by transformer motor.

5. 3. 3. 11, Sheet 7

5. 3. 3. 11,
Sheets 7 and 8

4. Zero Sensing

5. 3. 3. 11, Sheet 8

- a. Senses for zero voltage from -30V power supply.
- b. Zero sense relay, 18B(K7), is energized when output from power supply is other than zero volts.

- 1) Saturable reactor operating near, but not at, saturation with bias current.
- 2) An output from the -30V power supply drives the reactor into saturation and picks the zero sense relay, 18B(K7).

5. Diodes and lamps are used to maintain a fairly constant voltage drop across the control winding.

- a. Diode resistance decreases with an increase in the applied voltage.
- b. Lamp resistance increases with an increase in the applied voltage.

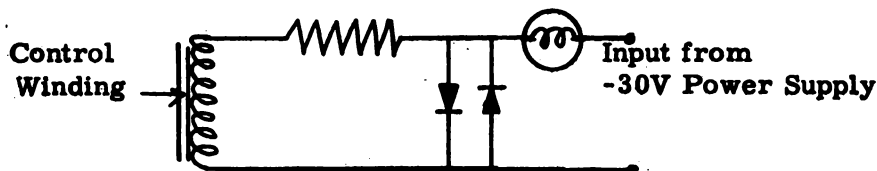

H. Control Circuits

Logic 5. 3. 3. 11
Sheet 1

1. AC Control

- a. AC Circuit Breakers
18A (CB1), (CB3), (CB9), (CB10), (CB12), (CB13), (CB14).
- b. Stabilizer
 - 1) Provide dc reference voltage and filament voltage.
- c. Auto transformer
 - 1) Provide 236 volts AC to Unit 13, Z module, for distribution to the tape drives.

2. MC Controls

Logic 5. 3. 3. 11

Sheets 8 and 9

a. Circuit Selector 18A (S2)

Sections B & C

- 1) Function is to choose a relay which will select the power line which will apply the excursion. The relays selected will be 18B(K9), (K10), (K11), (K12), or (K13).
- 2) 18B(K13) selected if the circuit selector switch is in B7 position (-270 volts). K6 is a hold for K13.
- 3) 18A(CB)14 should be transferred when the -48 volts is available.
- 4) Now, the MC activate switch is enabled provided no excursion is on.
- 5) Pushing the MC activate pushbutton will pick relay 18B(K6) and (K13). K13 will place the -30 volts MC supply in series with the -270 volt line which is selected.
 - a) 18B(K1) is energized by K7 N/O points. Whenever an excursion is on, a hold is established to prevent dropping the selected line until the excursion is returned to zero, even though the selector switch may be switched.
 - b) Point to point path showing the MC supply Refer to Sheet 8 of 9. in series with the -270 volt line 18C(TB4)1 through 18A(CB4) to point A through N/O 18B(K13) points straight up to right to D of N/C 18B(K14) through N/C K14 to E to 18C(TB3)b follow the 0-30 return line to -30 supply and back on the 0-30V line straight across through N/C K14 points, down at point F to F and through K13 N/O to E and right to the -270 volt line output.

b. Polarity Reverse Switch

- 1) By picking 18B(K14) and (K8), the polarity of the -30 volt MC supply is changed. Polarity can be reversed only if 18B(K1) is not picked. K1 is picked when an excursion is on by K7 points.

- c. Meter voltage selection switch 18A(S1) monitors the output voltage. Switch S1 sections B and C switch the voltage to the meter to take care of both positive and negative output voltages.

<u>Switch Positions</u>	<u>Function</u>
B, C5	0-30 volt M. C. Output
B, C3	+270 volt line
B, C1	+140 volt line
B, C11	-60 volt line
B, C9	-130 volt line
B, C7	-270 volt line

d. Features

- 1) A line once selected, activated and in excursion cannot be dropped until the excursion is returned to zero.
- 2) Changing the position of the selector switch when an excursion is on will not change the selection and it will not affect the excursion in progress.

I. Summary of Components and Their Function
(Logic 5.3.11, Sheet 8 and 9)

<u>Relay</u>	<u>Function</u>
18B(K1)	To hold selected line when excursion is ON.
18B(K2) (K9)	Select and hold +270 volt line.
18B(K3) (K10)	Select and hold +140 volt line.
18B(K4) (K11)	Select and hold -60 volt line.
18B(K5) (K12)	Select and hold -130 volt line.
18B(K6) (K13)	Select and hold -270 volt line.
18B(K7)	Zero sense relay, energized when excursion is ON.
18B(K8) (K14)	Energized for positive excursion.
18B(K15)	If energized, drops AC input to Unit 18. Indicates one or more dc voltages not up.
18B(K16)	} Monitor line voltage of Unit 18.
(K17)	
(K18)	
(K19)	
(K20)	

<u>Switches</u>	<u>Function</u>
Excursion Increase	Increase M. C. voltage toward -30 volts.
Excursion Decrease	Decrease M. C. voltage toward 0 volts.
Voltage Selection Switch	Specify the line the meter will monitor.
Circuit Selection Switch	Specify the line the excursion is applied on.
M. C. Activate	Supply initial pick voltage to select relays.
Polarity Reverse	Pick K14 to switch excursion polarity (positive excursion).

<u>Lights</u>	<u>Function</u>
MC Input, CB Trip	Indicate, when lit, -48V not up.
Positive Excursion	Positive excursion, when lit.

J. Summary Questions

1. Vol. I power and MC logic 5. 3. 3. 11, sheet 8. Relay 18B(K20) has an open hold coil. What effect would this have on non-standard dc voltages?
2. The 18BK(K10) relay cannot be picked. Which line cannot be put into an excursion?
3. What would result if 18B(K1) could not be picked?
4. What is the function of the 18B(K2) N/C points in series with the MC activate switch?
5. 18B(K14) cannot be picked. What effect would this have?

POWER PLUG PIN ASSIGNMENTS			
TAPE UNIT		POWER CABLE	
PIN NO.	VOLTAGE OR CONTROL	WIRE SIZE	TYPE
1	UNREG AC ϕ 1 208 V	10	AC
2	UNREG AC ϕ 2 208 V	10	AC
3	UNREG AC ϕ 3 208 V	10	AC
4	AC OUTLET	14	AC
5	AC OUTLET	14	AC
6	REG AC 238 V	10	AC
7	REG AC 238 V	14	AC
8	DC RETURN	10	DC
9	+ 270 V DC	14	DC
10	+ 140 V DC	10	DC
11	- 80 V DC	10	DC
12	- 130 V DC	14	DC
13	- 270 V DC	16	DC
14	SPARE	16	AC
15	SPARE	20	AC
16	THERMAL SWITCH -48V	20	DC
17	BOND	18	AC
18	BOND	18	AC
19	SPARE	20	AC
20	SPARE	20	AC
21	SPARE	18	AC
22	SPARE	20	DC
23	SPARE	20	DC
24	SPARE	20	DC
25	SPARE	20	AC
26	SPARE	20	AC
27	POWER INTERLOCK	18	AC
28	POWER INTERLOCK	18	DC
29	THERM SWITCH RETURN	20	DC
30	POWER ON	20	AC

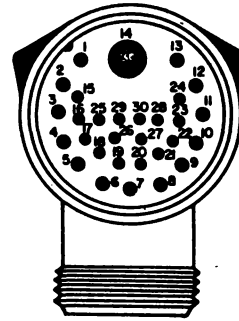

MALE POWER PLUG

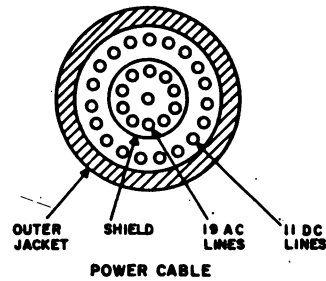

POWER CABLE

Power Plug Pin Assignment

6	GND	7	TAPE READ 8 BIT	8	GND	9	TAPE READ 3 BIT	10	GND	11	TAPE READ 2 BIT	12	GND	13	TAPE READ 1 BIT
16	SPARE	15	GND	14	TAPE READ 6 BIT	13	GND	12	TAPE READ 5 BIT	11	GND	10	TAPE READ 4 BIT	9	GND
24	GND	23	TAPE WR 8 BIT	22	GND	21	TAPE WR 3 BIT	20	GND	19	TAPE WR 2 BIT	18	GND	17	TAPE WR 1 BIT
32	SPARE	31	GND	30	TAPE WR 6 BIT	29	GND	28	TAPE WR 5 BIT	27	GND	26	TAPE WR 4 BIT	25	GND
40	GND	39	WR ECHO 8 BIT	38	GND	37	WR ECHO 3 BIT	36	GND	35	WR ECHO 2 BIT	34	GND	33	WR ECHO 1 BIT
48	SPARE	47	GND	46	WR ECHO 6 BIT	45	GND	44	WR ECHO 5 BIT	43	GND	42	WR ECHO 4 BIT	41	GND
56	GND	55	SEL READY & WR STATUS	54	GND	53	SEL READY & RD STATUS	52	GND	51	SET WR STATUS	50	GND	49	SET READ STATUS
64	SPARE	63	GND	62	NIFA	61	GND	60	SET PREPARED	59	GND	58	SET NIFA	57	GND
72	GND	71	RESET WR TORQ	70	GND	69	BK WD	68	GND	67	GO	66	GND	65	SEL & LOAD PT
80	SEL & NF PROTECT	79	GND	78	REWIND STATUS	77	GND	76	START REWIND	75	GND	74	WR PULSE	73	GND
88	*14 DC RETURN	87	GND	86	GND	85	GND	84	GND	83	GND	82	GND	81	*14 DC RETURN
96	SPARE	95	SPARE	94	SEL TU 6	93	SEL TU 5	92	SEL TU 4	91	SEL TU 3	90	SEL TU 2	89	SEL TU 1
104	READY 6	103	READY 5	102	READY 4	101	READY 3	100	READY 2	99	READY 1	98	SPARE	97	SPARE
112	SPARE	111	SPARE	110	SPARE	109	SPARE	108	SPARE	107	SPARE	106	SPARE	105	REMOTE START

NOTE: Pin Connections 113 through 119 are blank

Summary Punch Connector, Wiring Side

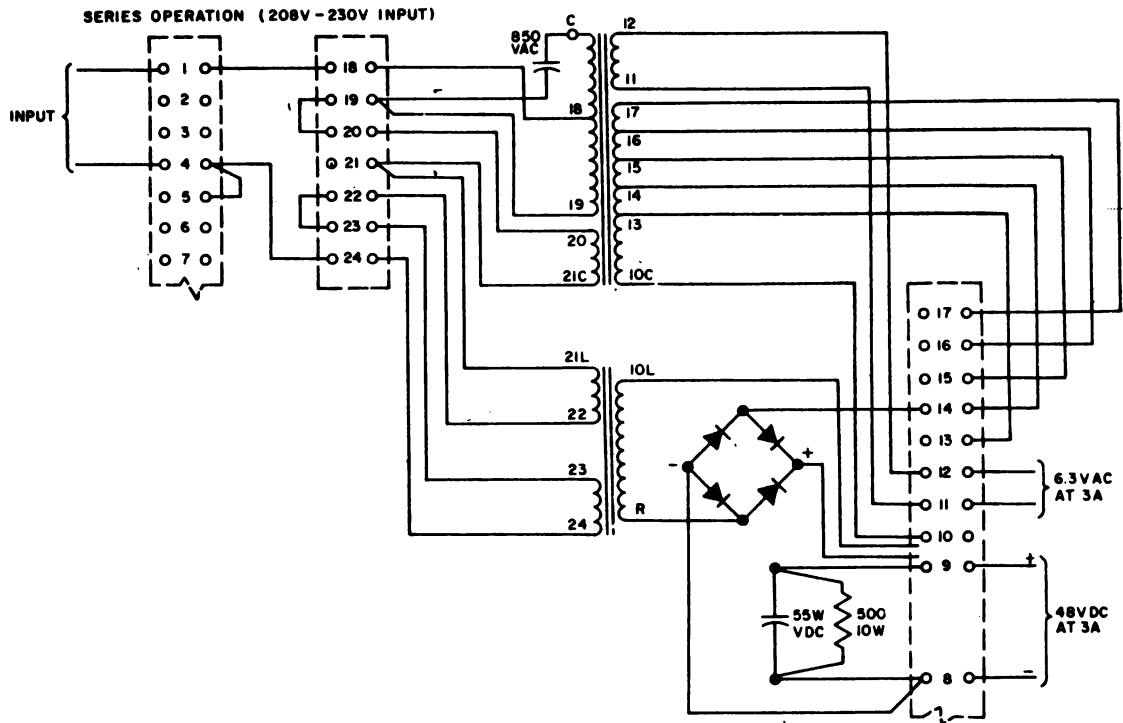

+48 V, 3-Amp Power Supply

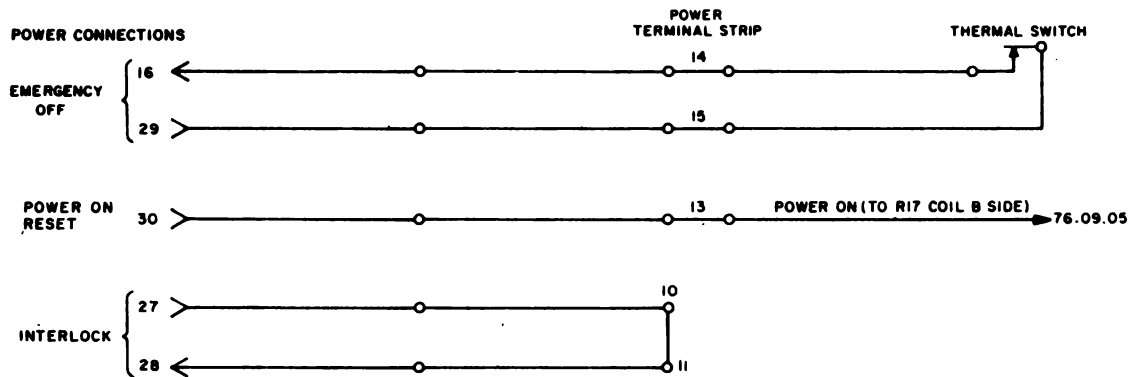

Power-Interlocking (76.10.03)

ABBREVIATIONS

A	AND circuit	LT	Latch trip
AT	Read preamplifier	NFP	Not file protected
B	Motor	NIFA	Not in file area
CAPS	Capstan	NRZI	Nonreturn to zero
CE	Customer Engineer	N/C	Normally closed
DG	Diode gate	N/O	Normally open
DP	Double pole	O	OR circuit
DPM	Data processing machine	PU	Pickup, pluggable unit
EOF	End of file	R	Relay
EOT	End of tape	REV	Reverse
ER	Erase	Rd	Read
FP	File protected	Rd	Relay driver
FWD	Forward	R/W	Read-write
GA	Grounded grid amplifier	SEL	Select
HD	Heavy duty	SPA	Summary punch connector
HP	Horse power	SS	Single shot
HS	High speed	T	Trigger
I	Inverter	TDT	Tape drive tester
INT	Integrating	TGR	Trigger
IPS	Inches per second	TI	Tape indicator
K	Cathode follower	TU	Tape drive unit
LP	Latch pick, load point	WRT	Write
LRCC	Longitudinal redundancy check character		

GLOSSARY OF TERMS

Backspace	An operate instruction which causes the tape to move backward through one record.
Bit	A binary digit (i.e., change in the magnetic flux of the tape representing a 1).
Character	Six data bits plus a synchronizing bit written across the width of the tape.
Drop	To de-energize a relay.
End of file (EOF)	A special word written on the tape to indicate an end of a file. Reading or writing the end-of-file word turns on the NIFA light.
End-of-tape (EOT) marker	A small, reflecting marker placed on top (plastic side) of the tape. This marker is 3/16 inch by 1 inch. It is placed on the rear half of the tape width. It indicates the end of the <i>TAPE IS NEAR</i> .
External control	Exists when the controls on the tape drive unit are inactive and all commands to the machine are through external sources.
File	A group of consecutively written records.
File protection	Indicates tape unit is interlocked to prevent writing.
File reel	The reel located on the left side of the machine.
Interrecord gap	A 3/4-inch gap between records.
Loaded	The status of the machine when power is applied to the machine, the head cover assembly is in the downward position, there is tape in both columns, and capstans are extended and turning.
Load point	A small reflecting marker placed on the top (plastic side) of the tape. This marker is 3/16 inch by 1 inch. It is placed on the front half of the tape width. It indicates the beginning of the usable portion of the tape.
Local control	Exists when the controls on the tape drive unit are active and disconnected from the Central Computer.
Machine reel	The reel located on the right side of the machine.
Not prepared	A condition of the tape drive caused by one or more of the following: the tape adapter unit is in test status, the tape unit is rewinding, the NIFA flip-flop is being set because the EOT marker was passed, or the EOF word has been read or written.
Not ready	A condition of the tape drive caused by one or more of the following: power off, fuse blown, front door open, no vacuum at the columns, tape broken, tape out of one or both vacuum columns, reset, or photo-lights burned out.
Pick	To energize a relay.
Record	A group of consecutively written words.
Reset	To place tape unit under manual control.
Rewind	To move the tape backward.
Set prepared	Clear the NIFA flip-flop.
Unloaded	Condition of the tape drive when head cover is in upward position, power is or is not applied, tape is out of both columns, and capstans are retracted.
Word	Five full characters plus one character containing only three data bits and a synchronizing bit.
Write echo pulse	A write echo pulse for each track is developed, when a bit is written, and sent back to the external control for checking purposes.

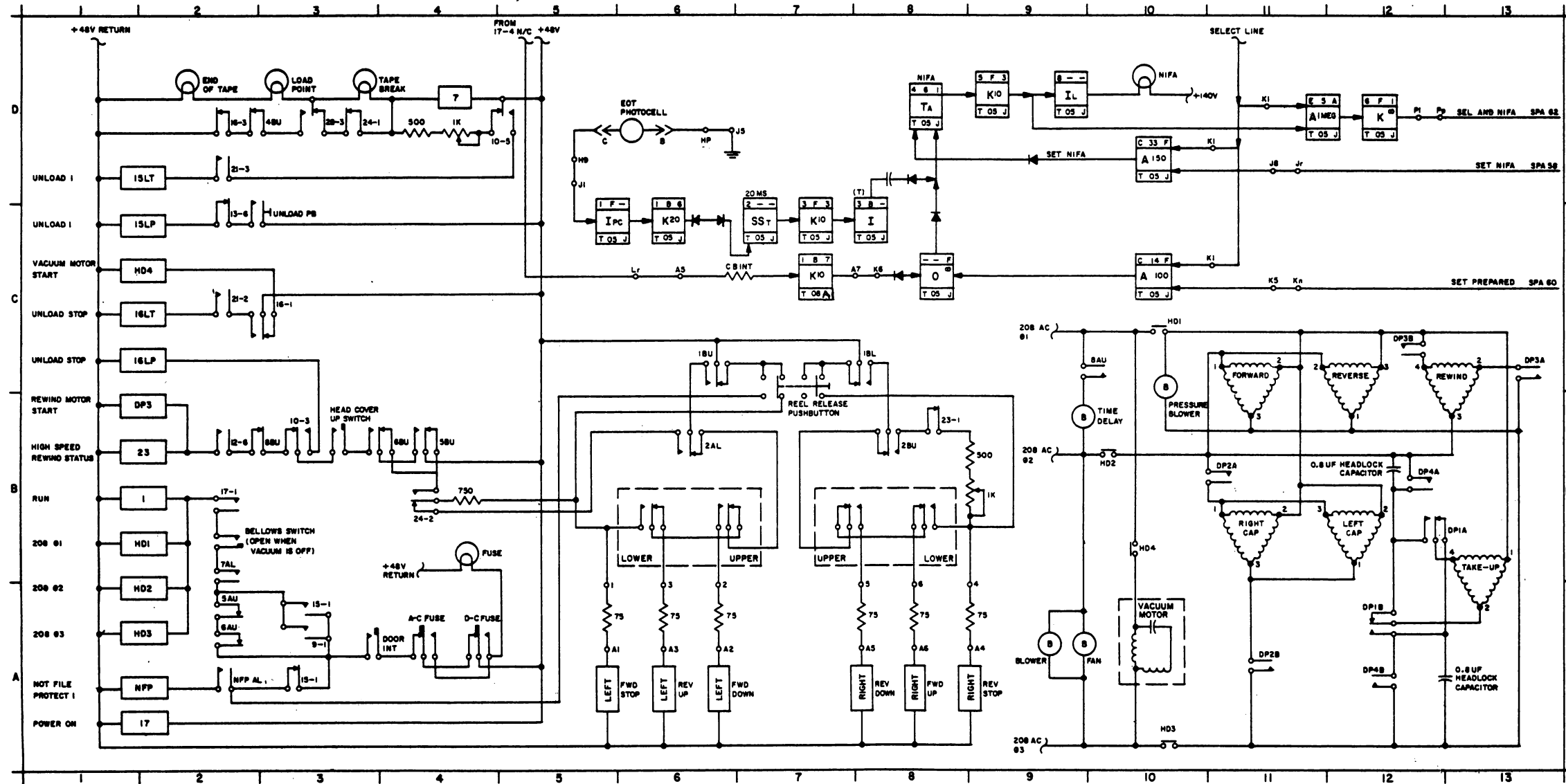

DUO RELAYS					
RELAY NO.	COIL	AU	AL	BU	BL
1	2B	4P	1L	6C	6C
2	1P	1H	6B	6B	-
3	1K	2E	2E	1K	2E
4	1E	2E	2B	2B	2E
5	1J	2A	2B	4B	2F
6	1J	2A	2B	2B	2F
7	4C	-	2B	-	5H
8	1E	6C	-	2B	-
NPP	2A	-	2A	-	2F

WIRE CONTACT RELAYS					
RELAY NO.	COIL	1	2	3	4
9	1K	3A	1L	3B	2K
10	1K	1H	2L	3B	-
12	1L	4G	2L	4J	2F
13	1L	-	2L	4J	4H
15LT	2D	3A	3G	3K	2G
16LP	2C	2C	2G	2D	-
16LT	2C	-	-	-	-
17	2A	2B	7E	1K	3L
21	4H	2K	2C	2D	3J
22	1F	4H	-	-	6L
23	2B	6B	1G	-	-
24LP	1G	3E	4B	2B	1B
24LT	1H	-	-	-	-
25LP	10H	4B	2K	1L	4E
25LT	1H	-	-	-	-
26	7E	1H	-	-	-
27	1F	4F	2B	-	-
28	1F	-	2K	3D	2B
29	5K	3E	-	-	-

HEAVY DUTY RELAYS		DOUBLE POLE RELAYS		
RELAY NO.	COIL	CONTACTS	RELAY NO.	COIL
HD1	2B	10C	DP1	1E
HD2	2B	10B	DP2	1H
HD3	2A	10A	DP3	2B
HD4	2C	10B	DP4	1B

SWITCHES AND CONTACTS		OPERATION	
NAME AND LOCATION			
AC FUSE BAIL	4A	OPEN WHEN AC FUSE BLOWN	
CAPS IN	3G	MAKE WHEN CAPS RETRACTED	
CAPS OUT	3K	BREAK WHEN CAPS EXTENDED	
DOOR INT	3A	BREAK WHEN DOOR OPEN	
DC FUSE BAIL	4A	OPEN WHEN DC FUSE BLOWN	
FLAPPER	1J	MAKE WHEN AIR RUSH DOWN COL.	
HEAD COVER DOWN	3E	BREAK WHEN HC DOWN	
HEAD COVER UP	3B	MAKE WHEN HC UP	
TIME DELAY	2B	BREAK WHEN DROP RELAY NO. 27	
BELLOWS	2B	MAKE WHEN VACUUM PRESENT	

PUSHBUTTONS		LIGHTS	
NAME	LOCATION	NAME	LOCATION
LOAD-REWIND	4H	EDT	2D
RESET	2L	FILE PROT	1H
START	2L	FUSE	4B
UNLOAD	2C	M.S. REWIND	4J
		LOAD POINT	3D
		NIFA	10D
		NOT READY	1J
		SELECT	13B
		TAPE BREAK	3D

728 Tape Drive Unit, Model III, Logic and Relay Diagram (Sheet 1 of 2)

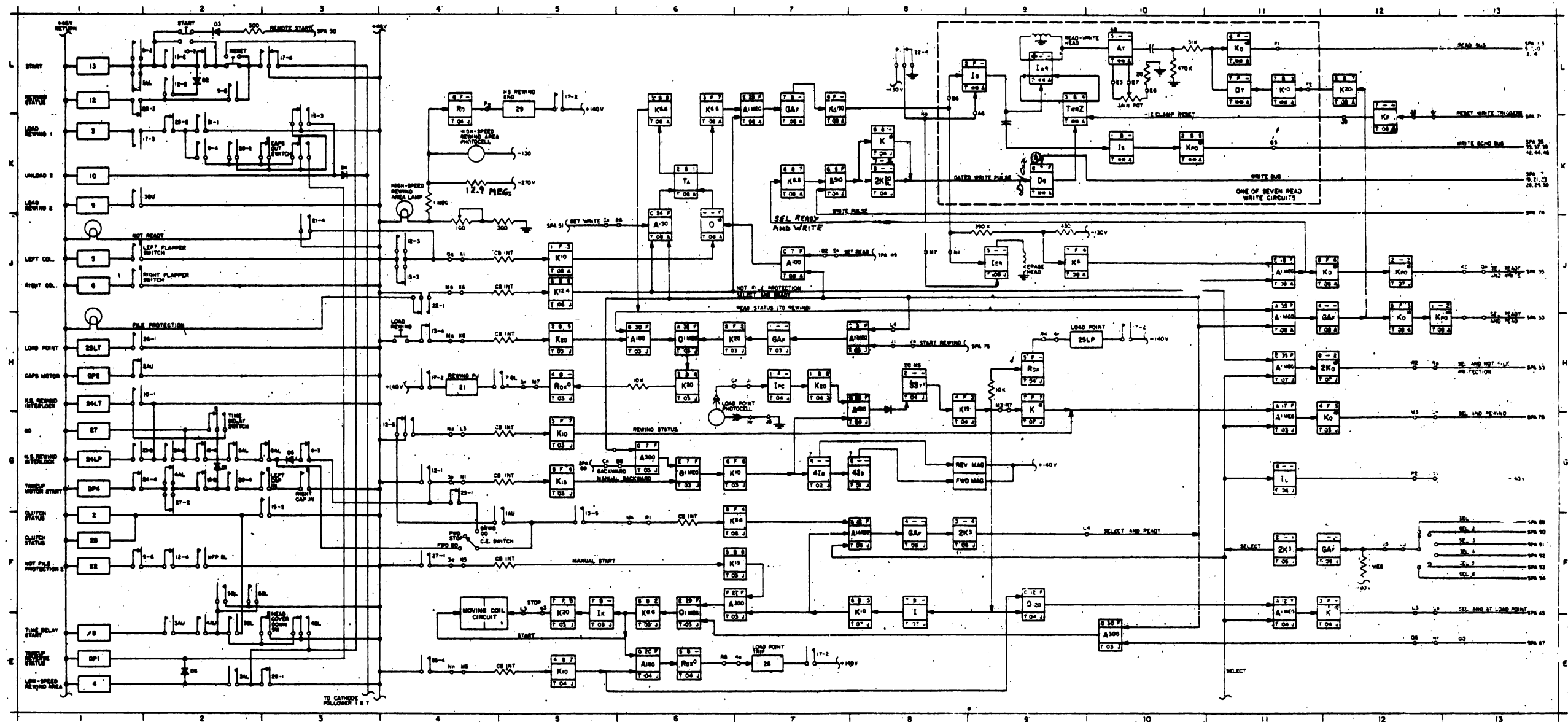

728 Tape Drive Unit, Model III, Logic and Relay Diagram (Sheet 2 of 2)

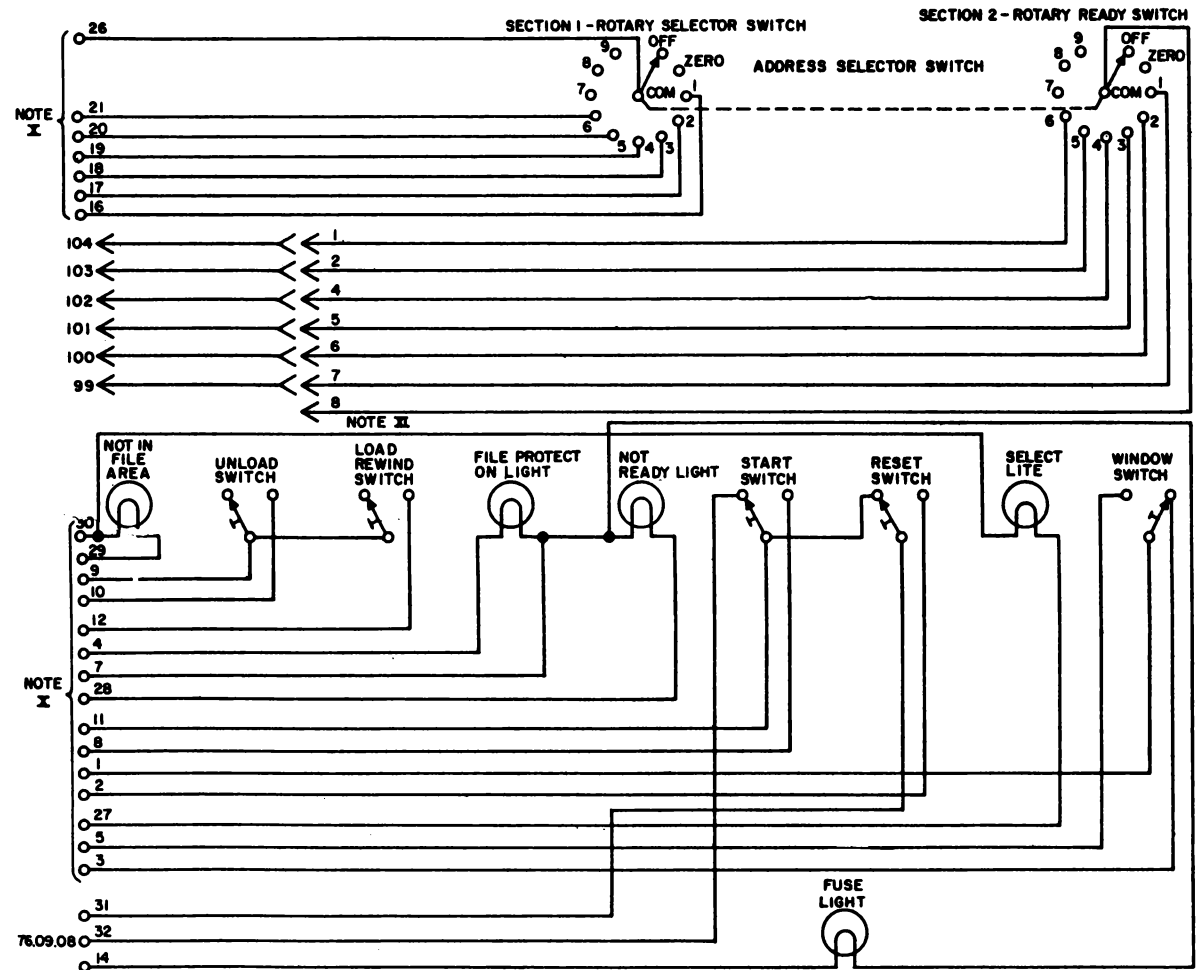

NOTE X - 33 CONTACT CONNECTOR PLUG POSITIONS
 NOT USED - 13, 15, 22, 23, 24, 25
 POSITION 6 IS USED FOR MACHINE BOND

NOTE XI - CONTACT CONNECTOR PLUG POSITION 8 NOT USED.

Control Panel Wiring (76.11)

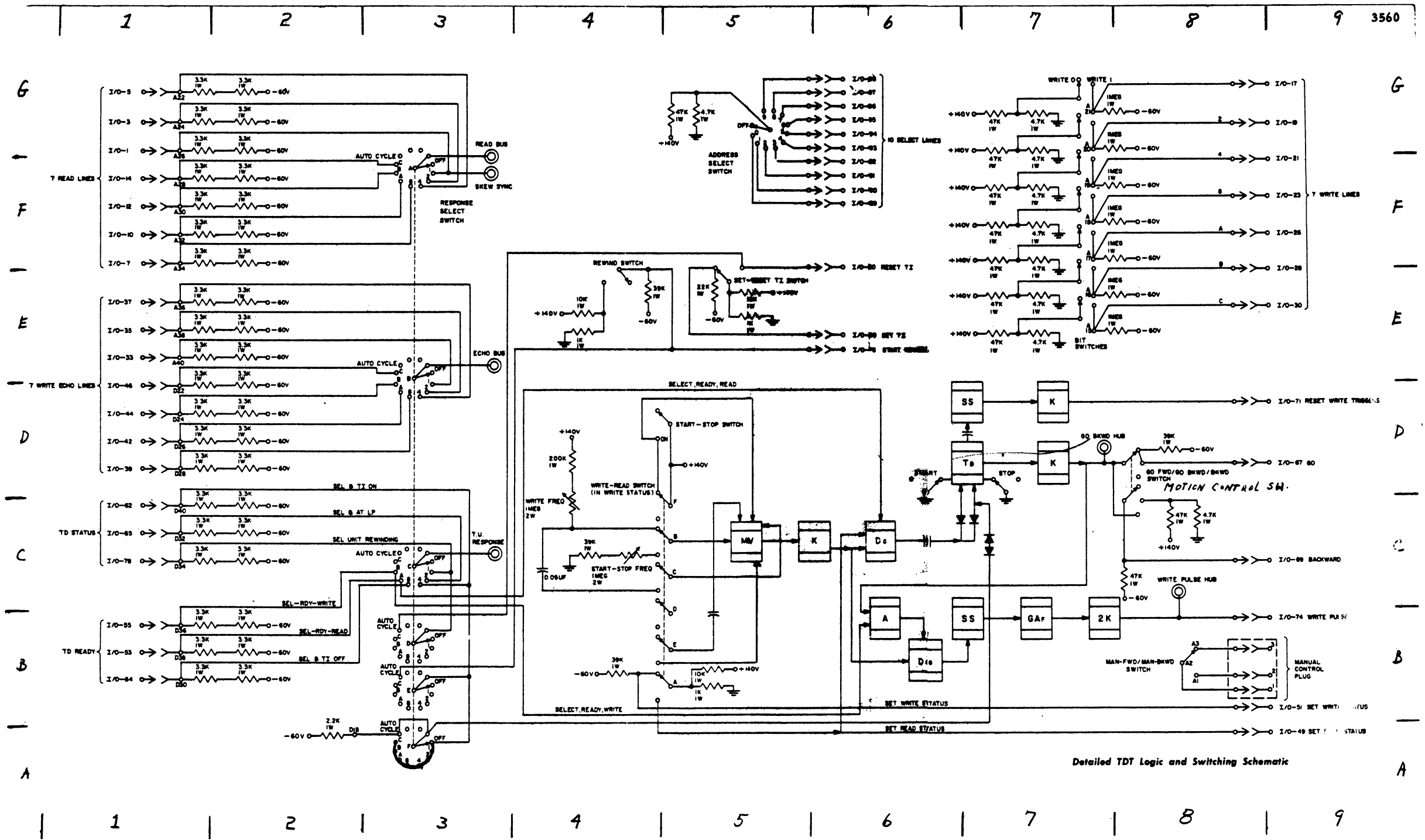

Detailed TDT Logic and Switching Schematic