

GC30-3058-3
File No. S370/4300-30

**Advanced Communications
Function for Network Control
Program, for IBM 3705**

**Advanced Communications
Function for System Support
Programs, for IBM 3705**

Program Product

General Information

IBM

**Advanced Communications
Function for Network Control
Program, for IBM 3705**

**Advanced Communications
Function for System Support
Programs, for IBM 3705**

Program Product

General Information

Program Numbers: 5735-XX1
5735-XX3
5735-XX9
5735-XXA



Fourth Edition (April 1982)

This is a major revision of and makes obsolete GC30-3058-1 and Technical Newsletters GN30-3166 and GN30-3131. The third edition of this publication, GC30-3058-2, was never distributed. This edition applies to Version 1 Releases 2, 2.1, and 3 (Program Number 5735-XX1) and to Version 2 (Program Number 5735-XX9) of the Advanced Communications Function Network Control Program; and to Version 1 Releases 2, 2.1, and 3 (Program No. 5735-XX3) and Version 2 (Program Number 5735-XXA) of the Advanced Communications Function System Support Programs, and to all subsequent programs for Advanced Communications Function for Network Control Program and System Support Programs unless otherwise indicated in new editions or Technical Newsletters.

Changes are made periodically to the information herein; before using this publication in connection with the operation of IBM systems, consult the latest *IBM System/370 and 4300 Processors Bibliography*, GC20-0001 for the editions that are applicable and current.

It is possible that this material may contain reference to, or information about, IBM products (machines and programs), programming, or services that are not announced in your country. Such references or information must not be construed to mean that IBM intends to announce such products, programming, or services in your country.

Publications are not stocked at the address given below; requests for IBM publications should be made to your IBM representative or the IBM branch office serving your locality.

A form for reader's comments is provided at the back of this publication. If the form has been removed, comments may be addressed to the IBM Corporation, Publications Development, Department E02, P. O. Box 12195, Research Triangle Park, North Carolina U. S. A. 27709. IBM may use or distribute any of the information you supply in any way it believes appropriate without incurring any obligation whatever. You may, of course, continue to use the information you supply.

© Copyright International Business Machines Corporation 1978, 1979, 1981, 1982

Preface

This publication describes:

- Advanced Communications Function for the Network Control Program (ACF/NCP)
- The System Support Programs for an ACF/NCP
- How the ACF/NCP interacts with the 3705 Communications Controller

This is an introductory publication for data processing managers and designers who intend to install or enhance a network¹ with an ACF/NCP.

The organization of this publication is as follows:

Chapter 1 describes the purpose of the ACF/NCP and how it interacts with the 3705 Communications Controller and the Advanced Communications Function access methods.

Chapter 2 describes the System Support Programs for the ACF/NCP.

Chapter 3 describes the hardware additions to the 3705 Communications Controller for an ACF/NCP and also the services provided by Version 1 Release 2 of the ACF/NCP.

Chapter 4 describes the services provided by Version 1 Release 2.1 of the ACF/NCP.

Chapter 5 describes the services provided by Version 1 Release 3 of the ACF/NCP.

Chapter 6 describes the services provided by Version 2 of the ACF/NCP.

Chapter 7 describes the installation considerations for end-users who are replacing earlier versions of the network control program with later releases of an ACF/NCP.

Chapter 8 describes a procedure that can be used to plan a network that is to include an ACF/NCP.

Appendix A lists the data processing products that can be attached to a 3705 Communications Controller with Version 1 or Version 2 of the ACF/NCP installed.

Appendix B is a glossary of terms and abbreviations.

¹ The term *network* has at least two meanings. A *public* network is a network established and operated by common carriers or telecommunication Administrations for the specific purpose of providing circuit-switched, packet-switched, and leased-circuit services to the public. A *user-application network* is a configuration of data processing products, such as processors, controllers, and terminals, established and operated by users for the purpose of data processing or information exchange, which may use transport services offered by common carriers or telecommunications Administrations. *Network* as used in this publication, refers to a user-application network.

Prerequisite Publications

Systems Network Architecture Concepts and Products, GC30-3072

Introduction to the IBM 3704 and 3705 Communications Controllers, GA27-3051

ACF/TCAM General Information: Introduction, GC30-3057

ACF/VTAM General Information: Introduction, GC27-0462

Introduction to Advanced Communications Function, GC30-3033

Network Communications Control Facility General Information, GC27-0429

Network Problem Determination Application General Information, GC28-0942

| *Network Logical Data Manager: General Information, SC30-3081*

Contents

Chapter 1. Introduction to the ACF/NCP	1-1
Advanced Communications Function for the Network Control Program Services	1-1
Telecommunication Control	1-2
Control Character Service	1-2
Buffer Service	1-2
Error Recording and Diagnostics	1-2
The Partitioned Emulation Programming Extension	1-3
Block-Handling	1-3
Error Recovery and Diagnostics	1-3
Critical Situation Notification	1-4
Address Trace	1-4
Online Terminal Testing	1-4
Online Line Testing	1-4
Pause-Retry	1-4
Switched Network Backup	1-4
Manual Switched Network Backup	1-4
Channel Attention Delay	1-5
Verification of Identification received from BSC and SDLC Stations	1-5
Multiple Terminal Access	1-5
Manual Dial	1-6
Carriage Return Delay	1-6
Monitor Mode	1-6
Dynamic Control	1-6
Interactions between the ACF/NCP and the 3705 Communications Controller	1-7
Interactions between the ACF/NCP and an Access Method	1-8
Chapter 2. System Support Programs for the ACF/NCP	2-1
The ACF/NCP Generation Procedure	2-1
The ACF/NCP Generation Language	2-1
System Macros	2-2
Configuration Macros	2-2
Block-Handler Macros	2-2
Generation Delimiter Macro	2-3
The OS/VS Generation Procedure	2-3
The VSE Generation Procedure	2-3
Generating Multiple ACF/NCPs	2-4
The 3705 Assembler	2-5
Machine Instructions	2-5
Macro Instructions	2-5
Assembler Instructions	2-5
Uses of the Assembler	2-6
The Utilities	2-6
The Loader Utility	2-6
How the Loader Utility Operates	2-7
The Dump Utility	2-7
The Dump Utility (Under Control of an OS/VS Operating System)	2-7
The Dump Utility (Under control of the VSE system)	2-8
The Dynamic Dump Utility	2-8
The Advanced Communications Function/Trace Analysis Program	2-8
The Configuration Report Program	2-8
Chapter 3. ACF/NCP Version 1 Release 2 Services	3-1
3705 Communications Controller Hardware Additions for Version 1 Release 2	3-1
Communication System Management Services	3-1
Enhanced SDLC Data Link Test	3-2
Intensive Mode Error Recording	3-2
Dynamic Reconfiguration	3-2
Dynamic Display of ACF/NCP Storage	3-3
Chapter 4. ACF/NCP Version 1 Release 2.1 Services	4-1
The Link Problem Determination Aid Modem Test	4-1
The 230.4 Kbps Line Speed Capability of the 3705-II Communications Controller	4-2
Chapter 5. ACF/NCP Version 1 Release 3 Services	5-1
Extended ACF/NCP Interconnection	5-1

Extended Control of an ACF/NCP	5-7
Support of Parallel Data Links between Adjacent ACF/NCPs	5-7
Extended Control of an ACF/NCP	5-7
Expanded Communication System Management Services	5-7
Multiple Routing	5-7
Multiple Priority Level Support	5-8
Transmission Group Services	5-8
Re-routing of Data	5-9
Route Verification	5-10
Flow-Control Enhancements	5-10
Enhanced non-disruptive session recovery	5-10
Chapter 6. ACF/NCP Version 2 Services	6-1
The Network Performance Analyzer	6-1
Generalized Path Information Unit Trace	6-1
Session Trace	6-2
Enhancements for the IBM 3270 Information Display System	6-2
Suppression of the Line Quiet Test	6-3
Address Trace	6-3
Dispatcher Trace	6-3
Link Load of PEP Load Modules	6-3
Chapter 7. Planning for Use of an ACF/NCP	7-1
Communications Controller Hardware Requirements	7-1
Requirements for using an ACF/NCP	7-1
Requirements for Using Multiple ACF/NCPs	7-1
Version 1 Release 2 of the ACF/NCP and an Access Method	7-2
Version 1 Release 3 of the ACF/NCP and an Access Method	7-2
Version 2 of the ACF/NCP and an Access Method	7-2
Version 2 of the ACF/NCP and Another ACF/NCP	7-2
Customer Responsibilities	7-3
Migration of the ACF/NCP	7-3
Program Generation Considerations	7-5
Chapter 8. Planning a Network with an ACF/NCP	8-1
The Objectives for the Network	8-1
The Resources required to Fulfill the Objectives for a Network	8-1
How the Network is to be Controlled	8-2
How the Network is to be Tested	8-2
Requirements for Training End-Users	8-2
The Schedules for the Availability of Network Resources	8-3
Appendix A. Appendix A. Data Processing Products Used with Version 1 and Version 2 of the	
ACF/NCP	A-1
SDLC Control Units and Display Stations	A-1
Binary Synchronous Control Units and Display Stations	A-2
Start-Stop Stations	A-3
Compatible Data Processing Products	A-3
SDLC Control Units and Display Stations	A-3
Binary Synchronous Stations	A-4
Start-Stop Stations	A-4

Glossary X-1

Figures

1-1. Single-Domain Network	1-8
2-1. The OS/VS Generation Procedure	2-4
5-1. Multiple Adjacent ACF/NCPs	5-2
5-2. Cross-Domain Links to ACF/NCPs in Link-Attached 3705s	5-3
5-3. ACF/NCPs in Link-attached 3705s Interacting with Multiple Access Methods Using Cross-Domain Links to Channel-Attached 3705s	5-4
5-4. Example of a Network Controlled by Version 1 Release 2 of the ACF/NCP	5-5
5-5. Example of a Network Controlled by Version 1 Release 3 of the ACF/NCP	5-6
5-6. Two Transmission Groups between ACF/NCPs	5-8
5-7. Sharing of Resources Controlled by an ACF/NCP in a Link-Attached 3705	5-9
7-1. Levels of Access Method and ACF/NCP with which Version 1 Release 2 of the ACF/NCP Can Communicate	7-4
7-2. Levels of Access Method and ACF/NCP with which Version 1 Release 3 of the ACF/NCP Can Interact	7-5

Summary of Amendments

The purpose of this revision is to describe the services included for Version 2 of Advanced Communications Function for the Network Control Program. Portions of Chapter 1, and all of Chapters 2 and 3 have been deleted. The information previously contained in these chapters is in the *SNA Products and Concepts* manual.

The services included for Version 2 are described in Chapter 6. The data processing products that can be attached to a 3705 with Version 1 and Version 2 of an ACF/NCP installed are listed in Appendix A, "Data Processing Products used with Version 2 of the ACF/NCP." Information in the former Appendix B, "ACF/NCP in a Remote Communications Controller" has been added to Chapter 1 in the section *Interactions between the ACF/NCP and the IBM 3705 Communications Controller*. Information in the former Appendix C, "Partitioned Emulation Programming Extension" has been added to Chapter 1 in the section *The Partitioned Emulation Programming Extension*. The former Appendix D, "Glossary of Terms and Abbreviations" is now Appendix B.

Other minor changes, corrections, and clarifications appear throughout this edition.

A change to the text or to an illustration is indicated by a vertical line to the left of the change.

Chapter 1. Introduction to the ACF/NCP

This chapter describes the services provided by Advanced Communications Function for the Network Control Program (ACF/NCP) and how the ACF/NCP interacts with:

- The IBM 3705 Communications Controller
- The Advanced Communications Function access methods

The services that specific releases of the ACF/NCP provide are described in subsequent chapters of this publication. The services provided by each release of the ACF/NCP can be included in each subsequent release.

Advanced Communications Function for the Network Control Program Services

The Advanced Communications Function Network Control Program controls the operation of resources in the network. Some of the services can be performed by any ACF/NCP; other services are provided only in a specific release, and many of the services are optional and may be selected when an ACF/NCP is generated.

The services the ACF/NCP provides are:

- Telecommunication control
- Control character services
- Buffer service
- Enhanced SDLC data link test
- Intensive mode error recording
- Dynamic reconfiguration
- Dynamic display of ACF/NCP storage
- Dynamic dump of ACF/NCP storage
- Extended ACF/NCP Interconnection
- Parallel data links between adjacent 3705s
- Extended control of an ACF/NCP
- Multiple routing
- Multiple priority level support
- Transmission group services
- Route verification
- Flow-control enhancements
- Enhanced non-disruptive session recovery
- Network Performance Analyzer
- Enhancements for the Network Expansion Option Interface
- Enhancements for the IBM 3270 Information Display System
- Address Trace
- Dispatcher Trace
- Link Load of PEP Load Modules

The optional services the ACF/NCP provides are:

- Error recording and diagnostics
- The Partitioned Emulation Programming Extension
- Block handling
- Error recovery and diagnostics
- Channel attention delay
- Verification of identification received from BSC stations

- Multiple terminal access
- Manual dial
- Carriage return delay
- Monitor mode
- Dynamic control
- Link Problem Determination Aid Modem Test
- Session Trace
- Suppression of the Line Quiet Test

The following paragraphs are a general overview of the services in the preceding list that are not described in Chapters 3, 4, 5, and 6.

Telecommunication Control

Telecommunication Control services poll and address stations on nonswitched data links and dial and answer stations over switched data links.

The ACF/NCP automatically translates data from the transmission code used into EBCDIC. Similarly, the ACF/NCP translates EBCDIC data into a transmission code before transmitting the data to a data link.

The speed at which data is to be transferred over a data link is selected when the ACF/NCP is generated. An access method command is used to specify whether the normal (high) or alternate (low) rate is to be used.

Control Character Service

Control Character Service inserts control characters at the beginning of each block of data when data is transmitted to a work station and deletes them when it receives data from a work station.

Buffer Service

Buffer service allocates buffers dynamically from 3705 storage as data is received from either a work station or the host processor. After an entire block of data from a work station is accumulated (the last buffer need not be filled), the ACF/NCP transfers the data to the host processor. The blocking of data received from many points in the network maximizes utilization of the channel attachment to the host processor.

The 3705 link station interrupts the ACF/NCP when either a character arrives over the link or a buffer is filled with characters. The type of communications scanner in the controller determines whether the ACF/NCP is interrupted after each character is received or after the buffer is filled.

Error Recording and Diagnostics

The Error Recording and Diagnostic service maintains several types of error records. For example, the ACF/NCP can record hardware and program checks and transfer a record of that program check to the host processor. The ACF/NCP can also maintain a count of the number of I/O operations executed for each work station in the network and the number of temporary errors that occur for that work station.

If error recovery procedures do not correct a transmission error, the ACF/NCP transfers a record containing information about the error to the host processor.

If the channel adapter has failed when the record is to be transferred, the ACF/NCP attempts to reset the error condition and allows automatic reloading of the 3705.

The operator can dynamically display storage areas, the contents of registers, or control information at the 3705 control panel.

The Partitioned Emulation Programming Extension

The Partitioned Emulation Programming Extension (PEP) is an extension of Advanced Communications Function for the Network Control Program (ACF/NCP). An ACF/NCP with the PEP extension emulates the operation of an IBM 2701 Data Adapter Unit, an IBM 2702 Transmission Control Unit, or an IBM 2703 Transmission Control Unit. Programs such as access method programs and user-written access method programs written for the 2701, 2702, and the 2703 can execute in a 3705 without modification. Programs that involve timing dependencies and that support certain special and custom features may have to be changed.

When the ACF/NCP is defined, program generation parameters indicate whether a data link is to operate in network control mode, emulation mode, or both. The data link always operates in the mode specified.

The principle advantage of the PEP extension is that application programs written for the 2701, 2702, or 2703 can operate concurrently with application programs written to interact with the ACF/NCP. This provides an easier migration path.

Further information on operations in emulation mode, including channel-attachment requirements for the 3705 is given in the *Introduction to the IBM 3704 and 3705 Communications Controllers*.

Block-Handling

Block-handling services process blocks of data received from a host processor or a work station that uses either the binary synchronous or start-stop link protocols, the ACF/NCP can process blocks of data from the host processor or a work station. The ACF/NCP block-handling routines are:

- A date insertion routine
- A time insertion routine
- An editing routine

User-written block handling routines may be included with the ACF/NCP through use of generation macro instructions. User-written routines must be assembled with the 3705 assembler.

Error Recovery and Diagnostics

Error recovery and diagnostic services can be used to determine the origin of problems in the network. The ACF/NCP can include the following error recovery and diagnostic services:

- Critical situation notification (BSC and start-stop stations only)
- Address trace

- Online terminal testing
- Online line testing
- Pause-retry
- Switched network backup
- Manual switched network backup

These services are described in the following paragraphs.

Critical Situation Notification

Critical situation notification services permit the ACF/NCP to send a user-written message to notify work stations when the host processor, channel adapter, or data links become inoperative.

Address Trace

Address trace is a dynamic trace that permits the network operator to enter a controller storage address at the 3705 control panel to request that the ACF/NCP record the contents of four bytes of controller storage or the contents of registers when a certain address in controller storage is accessed.

Online Terminal Testing

The Online Terminal Testing (OLTT) service is a hardware service that sends a test request from a work station to the ACF/NCP. The ACF/NCP acknowledges the test request and executes the appropriate test routine. An OLTT program in the host processor defines the test routine.

Online Line Testing

Online line testing tests data links that use the synchronous data link control (SDLC) link protocol. ACF/NCP test routines are executed in the host processor to test the SDLC data links.

Pause-Retry

The pause-retry service permits the ACF/NCP to retransmit data after a transmission error has occurred. The data is retransmitted after a user-specified time interval has elapsed. The user specifies the maximum number of retries that can be attempted for a work station. This service is included for all work-stations in the network unless the user specifies that no retries are to be made.

Switched Network Backup

The switched network backup service permits the use of an alternate path of data transmission over a switched data link. The alternate path is used if the nonswitched point-to-point data link normally used by a work station encounters an error condition from which recovery procedures cannot recover.

Manual Switched Network Backup

The manual switched network backup service is an extension of the switched network backup service. It permits the network operator to call a workstation after a nonswitched line used by that work station has become inoperative. The operator enters a console message that identifies the work station to be contacted, the response identifies the switched backup line. The operator can then call the work station so that transmission to the station can then resume. Transmission continues to the back-up line until the console operator reestablishes the regular nonswitched line connection.

Manual switched network backup is used when the equipment required for an automatic call is not available.

Channel Attention Delay

The channel attention delay service allows the user to specify the interval during which data arriving from work stations is stored in ACF/NCP buffer pools before it is sent to the host processor. The interval is specified in increments of 100 milliseconds. The ACF/NCP presents attention status to the channel after observing the interval specified. All stored data can then be transferred across the channel with only one interrupt to the host processor.

If no interval is specified, each block of data is transferred as soon as it is processed by the network control program. As a result more frequent interrupts to the host processor are required. Only one interrupt to the host processor is required when an interrupt is specified.

If the ACF/NCP receives enough data to fill all the allocated buffer space in the host processor before the specified interval elapses, it presents attention status and status modifier to the channel immediately.

Verification of Identification received from BSC and SDLC Stations

Verification of identification (ID) received from BSC and SDLC stations permits the user to list the valid IDs for data links on which ID verification is to be used. The ACF/NCP compares the ID received to those in the list and allows the work station to connect to the data link if the ID received matches the one in the list. If no match is found, the ACF/NCP passes the information to the access method in the host processor, or, at the users option, it can break the connection. The ID verification option permits some IDs to be kept in the 3705 (those of more than one active station) and some to be kept in the host processor (those of less active stations). Alternatively, ID verification can be done entirely by the host access method.

Multiple Terminal Access

The multiple terminal access service allows the ACF/NCP to communicate with dissimilar types of terminals over the same switched data link. This service is only available for certain low-speed, start-stop terminals.

If the MTA service is used when a terminal is data link attached to a 3705, the MTA service identifies the type of terminal and the transmission code used. The MTA service can be used with the following:

- IBM 1050 Data Communication System
- IBM 2740 Communications Terminal (Basic)
- IBM 2740 Communications Terminal (Transmit Control)
- IBM 2740 Communications Terminal (Transmit Control with Checking)
- IBM 2740 Communications Terminal (Checking)
- IBM 2741 Communications Terminal
- Terminals using CPT-TWX (models 33 and 35) code (at a line speed of 110, 134.5, and 300 bps)

The terminal types, code combination, and data links to be used for multiple terminal access are specified when the ACF/NCP is generated.

Manual Dial

Manual Dial permits the network operator to call a work station. This service is to be used when automatic calling is not available.

When the access method sends the ACF/NCP a command to contact a station, it returns a message to the access method that instructs the network operator to make the call. After the operator makes the call, he places the data link in data mode. The ACF/NCP can then interact with the work station.

Carriage Return Delay

The carriage return delay service causes the ACF/NCP to pause momentarily before starting a write operation that immediately follows a read operation from a work station. This prevents random printing during the return motion of the station's printing mechanism by allowing time for the printing mechanism to return to the left margin. This service is only available for certain start-stop stations.

Monitor Mode

The monitor mode service permits the ACF/NCP to monitor a data link during input and output operations. The ACF/NCP notifies the access method between receiving an attention interrupt signal or a disconnect signal sent from the work station.

Dynamic Control

Dynamic control permits the use of access method commands to dynamically change certain network parameters. Some dynamic control services are included in the release; others can be specified when the ACF/NCP is generated. The dynamic control services are:

- Activation and deactivation of data links
- Display of any 256 contiguous bytes of 3705 storage
- Requesting the status of a data link
- Replacing ID characters
- Polling and addressing characters for work stations attached to BSC or start-stop data links
- Changing the order in which work stations attached to a BSC or start-stop data link are polled and addressed
- Changing the number of consecutive times work stations on a multipoint data link can respond negatively to polling before the line is rescheduled for other operations
- Altering the sequence of ACF/NCP commands to be routed to a work station
- Changing block-handling routines
- Setting the time and date in the 3705
- Changing the maximum number of data transmissions between the host processor and a work station on a multipoint data link before the ACF/NCP tries to service other work stations attached to the data link
- Turning off the power at a remote 3705 by a command from the access method

Interactions between the ACF/NCP and the 3705 Communications Controller

The 3705 Communications Controller is the control unit in which the Advanced Communications Function Network Control Program (ACF/NCP) is executed to control the links in the network and to route data to and from its destinations.

The 3705 can be channel-attached to a host processor and data link attached to another 3705. Link attachments may be either switched or nonswitched. Nonswitched links are either point-to-point or multipoint. Nonswitched point-to-point links between a 3705 and one or more terminals are multipoint links. Nonswitched multipoint links between a 3705 and one terminal are point-to-point links. Figure 1-1 shows a single-domain network in which terminals are data-link attached to a 3705. The 3705 is channel attached to a host processor.

The 3705 is an interrupt driven control unit; as a result, the ACF/NCP reacts to interrupts that indicate:

- The arrival of control parameters and message data from the access method
- The arrival of data from remote resources in the network
- The occurrence of programmed interruptions
- The occurrence of utility services
- The occurrence of hardware errors

The major program components through which the ACF/NCP controls the internal operation of a 3705 are:

- A system supervisor
- A channel adapter I/O supervisor
- A communications interruption control program
- Error recovery facilities
- Service routines

These program components effectively control data transmission between a host processor and work stations in the network by:

- Establishing a physical path for data transfers
- Initiating sessions
- Using switched network operations
- Executing polling and addressing sequences

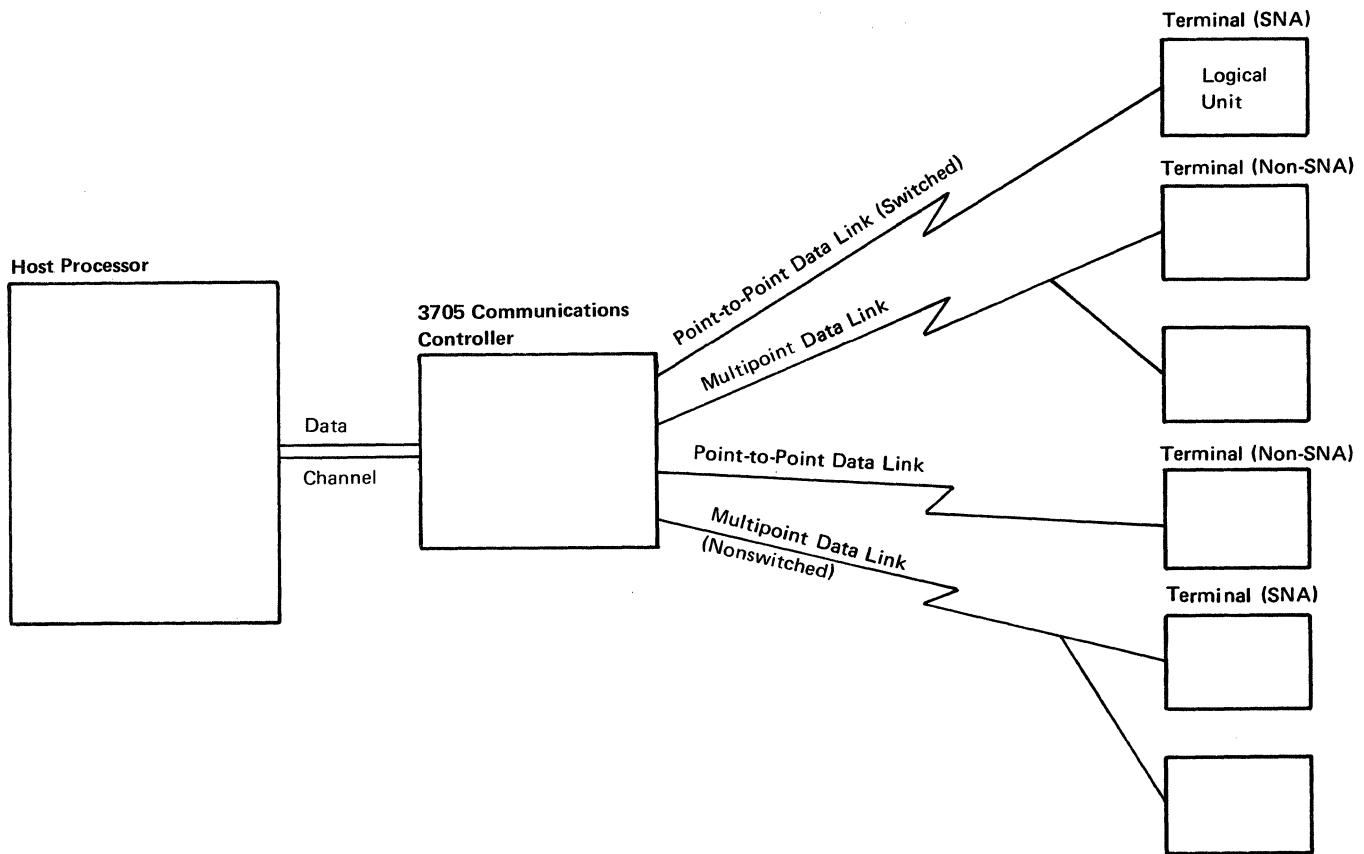

Figure 1-1. Single-Domain Network

Interactions between the ACF/NCP and an Access Method

The access method directs the Advanced Communications Function Network Control Program (ACF/NCP) and the ACF/NCP directs the movement of data in the network. The structure of all resources controlled by the access method is defined when the access method and the ACF/NCP is generated. Functions not performed by the access method can be performed from the 3705 control panel.

The ACF/NCP and the access method communicate by exchanging formatted information. Formatted information consists of control parameters and, optionally, message data. The control parameters direct the ACF/NCP to perform a specific service. The message data is user-defined. When the ACF/NCP receives the information and performs the specific service, the ACF/NCP returns to the access method the control parameters and, if requested, message data. The ACF/NCP also returns the completion status of the operation to the access method.

The ACF/NCP accepts data from the access method as long as the ACF/NCP has buffers available. The ACF/NCP holds the data received in its buffers until it receives a Read command from the access method. When the ACF/NCP has data for the access method, it presents an attention interruption.

If the access method has buffers available, it reads data from the ACF/NCP each time that it writes data to the ACF/NCP. An access method cannot be forced to read data from the ACF/NCP but, when the access method is ready to receive data, it acknowledges the attention interruption by issuing a Read command to the ACF/NCP.

Chapter 2. System Support Programs for the ACF/NCP

This chapter describes the System Support Programs for Advanced Communications Function for the Network Control Program (ACF/NCP). System Support Programs generate the ACF/NCP, dump the contents of 3705 storage, and format various types of trace records from the access method. System Support Programs consist of:

- An assembler program
- A loader utility
- A dump utility
- A dynamic dump utility
- An Advanced Communications Function Trace Analysis Program (ACF/TAP)
- A Configuration Report Program

The assembler program is executed entirely in the host processor. (This need not be the host processor that is to be channel-attached to the 3705 in which the ACF/NCP is to execute.) The utility programs are executed in the host processor and in the 3705. ACF/TAP is executed in the host processor.

The ACF/NCP Generation Procedure

The ACF/NCP generation procedure is either a two-stage or three-stage process that is used to define an ACF/NCP. The generation procedure for an ACF/NCP that is to execute under the control of an OS/VS operating system is a two-stage process. The generation procedure for an ACF/NCP that is to execute under the control of a VSE system is a three-stage process. The procedure is executed as a series of jobs in the host processor and requires the use of:

- The ACF/NCP generation language
- The ACF/NCP library of macro definitions

The ACF/NCP Generation Language

The ACF/NCP generation language is a high-level programming language used to define an ACF/NCP. The programming language consists of four categories of macro instructions:

- System macros
- Configuration macros
- Block handling macros
- A generation delimiter macro

All of the macro operands are keywords; the programmer need not be concerned with the sequence in which the operands are coded. However, the relative order of the macros in the input stream is to some extent fixed. See the *ACF/NCP Logic Manual* for additional information about the macros required to define an ACF/NCP load module.

System Macros

System macros provide information about:

- The type of channel adapters installed
- 3705 hardware features
- The amount of 3705 storage to be used
- Identifiers for the resources in the network
- The size of ACF/NCP buffers
- Optional program services

Configuration Macros

Configuration macros provide the information necessary to construct the tables the ACF/NCP requires to control the flow of data between the host processor and the data link attachments to the 3705.

A configuration macro must be coded for each element in the network and arranged in a specific order in the program. Ordering is required so that a specific data link can be associated with a specific data link group, and a specific work station or physical unit can be associated with a specific data link.

Configuration macros are also used to specify the average block size and the average buffer-unit size to be used to transfer data between the ACF/NCP and the access method.

Block-Handler Macros

Block-handler macros specify the optional processing that the ACF/NCP can perform on a block of data before it is transferred from the ACF/NCP to either the host processor or a work station. These macros can only be used with the binary synchronous or start-stop link protocol. For example, block handler macros can be used to:

- Insert the date and time of day into a block of data
- Edit text entered incorrectly from a work station
- Include user-written block-handling routines in the ACF/NCP
- Define sets of block handlers

Up to three block handler macros can be grouped into a block-handler set. Each block handler macro in a set can be executed at one of three points in time, as follows:

- After the ACF/NCP receives a command from the access method for a work station but *before* the data link is available
- After the ACF/NCP receives a command from the access method for a work station, but *after* the data link is available
- After an input operation on a data link has ended

Each block-handler set may be associated with one or more work stations by coding the name of the set as an operand of the configuration macro used to define the work station.

Generation Delimiter Macro

The generation delimiter macro ends the ACF/NCP generation input stream.

The OS/VS Generation Procedure

The OS/VS generation procedure is a two-stage process. During the first stage, the generation macros (source statements) can be assembled by either the OS/VS assembler or the 3705 assembler. Output from the assembly is a job stream containing the data and control statements necessary to create an ACF/NCP. The job stream is a sequential data set that can be directed to cards, tape, or a direct-access storage unit.

If errors are in the source statements entered as input to stage 1, a diagnostic message is issued for each statement that contains an error. For severe errors, the source statements must be corrected and resubmitted until no severe errors remain.

The second stage of the generation procedure is executed when stage 1 completes. The stage 1 job stream contains the data necessary to select the required program modules and to build the proper tables. Stage 2 first builds the tables then selects and assembles those modules required by the network. The linkage editor combines the appropriate modules into an ACF/NCP load module. The load module is stored on a direct-access storage unit. Figure 2-1 illustrates the ACF/NCP generation procedure under control of an OS/VS operating system.

The VSE Generation Procedure

The VSE generation procedure is a three-stage process. In the first stage, the generation macros (source statements) are assembled by the 3705 assembler. Output from the assembly is a job stream containing the data and control statements necessary to create an ACF/NCP. The job stream is a sequential data set that can be directed to cards, tape, or a direct-access storage unit.

If errors are in the source statements entered as input to stage 1, a diagnostic message is issued for each statement that contains an error. For severe errors, the source statements must be corrected and resubmitted until no severe errors remain.

The second stage of the generation procedure cannot execute until stage 1 completes. The generation procedure selects and assembles the control tables and the program modules required by the network. It then creates job control statements and linkage editor statements for stage 3.

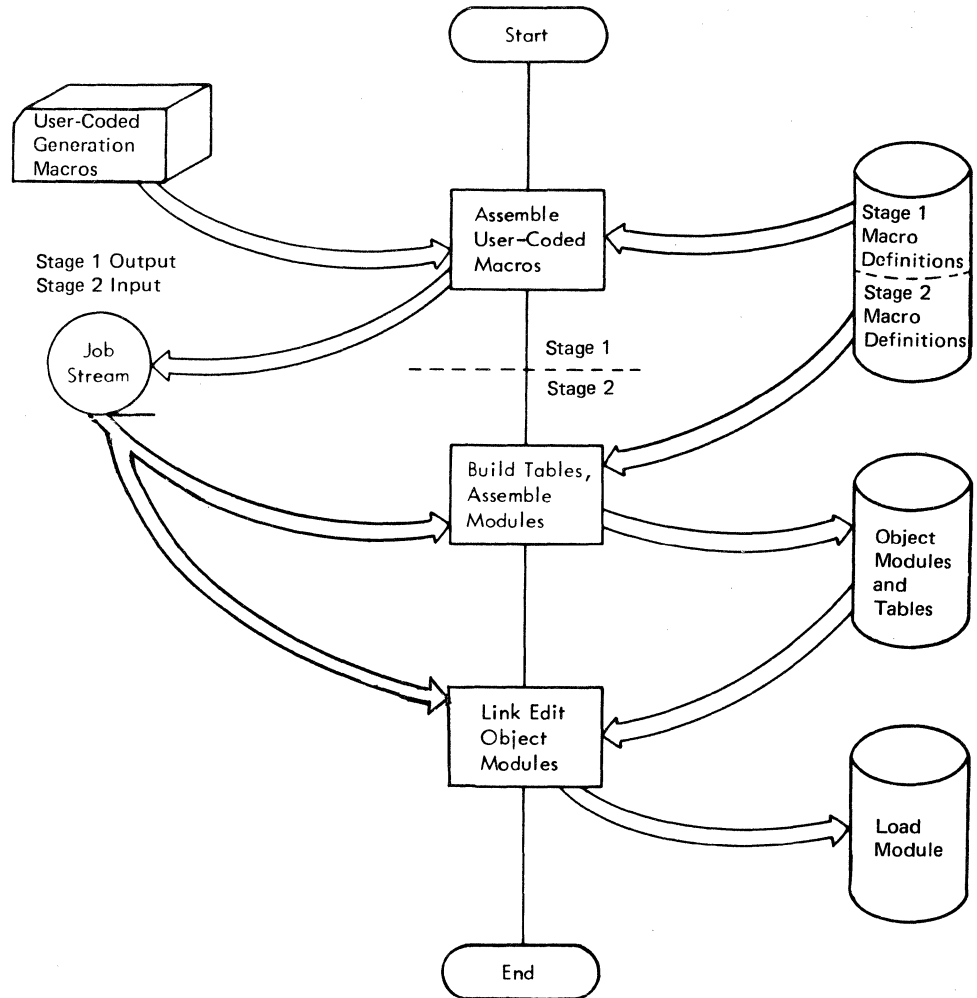

Figure 2-1. The OS/VS Generation Procedure

Stage 3 catalogs the tables and modules assembled in stage 2 and link-edits them into an ACF/NCP load module. A utility named the CSERV utility must then be executed to move the load module to a direct-access data set from which the loader utility may obtain it.

Generating Multiple ACF/NCPs

As many Advanced Communication Function Network Control Program (ACF/NCP) load modules as required can be generated for a network. Each ACF/NCP requires a separate generation, and each must have a different symbolic name so that the loader can identify the load module to be transferred to a 3705.

Multiple load modules are useful for networks that have several distinct applications for the network at varying times. For example, a network that uses only start-stop data links during the day and only binary synchronous data links at night would require a separate ACF/NCP for each configuration. As a result, the

amount of 3705 storage required is reduced and program operation is more efficient.

The 3705 Assembler

The 3705 assembler assembles programs written in 3705 assembler language. In its external structure, it is very similar to the OS/VS and VSE assemblers.

The assembler operates on the following three kinds of instructions:

- Machine instructions
- Macro instructions
- Assembler instructions

These three types of instructions are similar to the types of instructions processed by the OS/VS and VSE assemblers.

The assembler translates both the machine instructions (written in 3705 assembler language notation); and the macro instructions into executable object code. Assembler instructions direct the assembler to perform specific operations during the assembly process but the instructions are not converted into executable code.

Machine Instructions

The instruction set for the 3705 consists of 52 machine instructions. The machine instructions are represented to the assembler by mnemonic operation codes, usually followed by one or more operands. Most of the machine instructions are register-oriented; that is, they represent operations involving two registers, a register and immediate data, or a register and a storage area.

The assembler converts the machine instructions into 2 or 4 bytes of object code, depending on the length assigned to the particular instruction. See the *IBM 3704 and 3705 Principles of Operation* for an explanation of the machine instructions and assembler language statement that corresponds to each.

Macro Instructions

The 3705 macro instructions are an extension of the 3705 controller language. The macro instructions provide a convenient method of generating a desired sequence of assembler language statements in one or more programs. Macro definitions can be coded in assembler-language programs or they can be stored in a macro library at the host and called when needed when the macro instruction executes in the program.

Assembler Instructions

Assembler instructions are assembler pseudo-operation codes that can be written with or without operands. These instructions:

- Delimit the beginning and end of section code
- Define data areas
- Control the format of listings
- Specify base registers

Uses of the Assembler

The 3705 assembler is used to:

- Assemble ACF/NCP generation macros and application-dependent modules during the program generation procedure
- Preassemble user-written block-handling routines

The assembler permits the programmer to augment IBM-supplied ACF/NCP modules with block-handling routines unique to a specific network application. The programmer uses the 3705 assembler language to code the block-handling routines to process data in message blocks going to or coming from a work station. The assembler is also used to create object modules. User-defined object modules are stored in the same library with the IBM-supplied ACF/NCP object modules. Block-handling routines are link-edited to form the ACF/NCP load module during the generation procedure.

The Utilities

System support programs for the Advanced Communications Network Control Program (ACF/NCP) include three utility programs:

- A loader utility
- A dump utility
- A dynamic dump utility

Each utility program is controlled by the appropriate job control statements and control cards.

The Loader Utility

The loader utility has two loading services:

- The transfer of the initial test routine into the 3705
- The transfer of the ACF/NCP from the host processor into the 3705

The initial test routine is a diagnostic routine that tests the hardware for conditions that could result in the failure of the 3705 after the beginning of network operation. When exceptional conditions occur, a hard stop of the 3705 cancels the transfer of the ACF/NCP load module from the host processor. Indicators on the 3705 control panel can assist in isolating the cause of the 3705 failure. The initial-test routine is loaded before the ACF/NCP load module is loaded into the 3705.

The loader utility loads the ACF/NCP load module when the 3705 is started and when the 3705 fails because of some error condition. In either case, the operator starts the loader with the job control statements in the job stream. Whenever the loader is invoked, the initial-test routine is executed automatically unless it is suppressed by a utility control card entered as input to the loader.

The access methods have optional loader routines that may be used instead of the loader utility.

How the Loader Utility Operates

The part of the loader utility that is executed in the host processor reads the ACF/NCP load modules from secondary storage and issues a Write command for each block of code to be transferred to the 3705.

The part of the loader utility that is executed in the 3705 initializes the 3705 to prepare it for the data written from the host processor. It then interacts with the part executing in the host processor to accept blocks of code from the host for positioning in 3705 storage.

The Dump Utility

The dump utility dumps the contents of 3705 storage to help a programmer isolate and correct error conditions. When a dump is requested, the following options can be specified:

- The limits of the 3705 storage area to be printed
- Whether a formatted dump of the ACF/NCP is to be printed

If the limits of the 3705 storage area to be printed are not specified, the dump program provides a printout of all but a small area at the beginning of 3705 storage.

When a formatted dump is requested, the dump program isolates and labels certain control blocks and prints them at the beginning of the dump. Formatted and unformatted dumps contain (1) a hexadecimal representation of 3705 storage, (2) the contents of the general registers, and (3) the EBCDIC representation of all letters and numbers in the dump.

After any dump (whether it be a complete storage dump or a dump of only a portion of storage), the ACF/NCP must be reloaded into the 3705 before network operation can be resumed.

The Dump Utility (Under Control of an OS/VS Operating System)

The OS/VS dump utility consists of two job steps. The first step dumps the entire contents of 3705 storage and the contents of the general registers to a disk data set located at the host processor. This step requires execution of the parts of the dump program that execute in both the host processor and the 3705. The first step then automatically invokes the second step, which executes entirely in the host processor.

Step 2:

- Analyzes the utility control cards.
- Reads the requested contents from the disk data set.
- Translates them into printable hexadecimal characters.
- Writes the requested portion of the dump to an output data set to be printed out.

Step 2 can be executed as many times as desired to produce extra dump printouts or dumps with different formats.

The access method can perform the services provided by step 1 of the dump utility. If the access method instead of the dump utility is used, step 2 must be initiated as an independent job in order to print out the dump.

The Dump Utility (Under control of the VSE system)

The dump utility operating under control of the VSE system is similar to the dump utility operating under control of the OS/VS operating system. Unlike the OS/VS dump utility, however, the VSE dump utility consists of only one job step and uses no intermediate disk data set.

After a dump utility executes, the 3705 remains idle and must be reloaded before it can execute again.

The Dynamic Dump Utility

The dynamic dump utility is an optional utility program that is used only when the ACF/NCP is executed in emulation mode.

The contents of 3705 storage are transferred from the 3705 to the host processor without interrupting operation of the ACF/NCP. In addition, either a full storage dump or a dump of the trace tables as well as portions of storage can be displayed at the operator's console at the host processor.

The Advanced Communications Function/Trace Analysis Program

The Advanced Communications Function/Trace Analysis Program (ACF/TAP) is a service aid that assists in the analysis of trace data produced by the access method and the ACF/NCP. ACF/TAP accepts various types of input data and produces formatted output reports. Error conditions are highlighted.

The Configuration Report Program

The Configuration Report Program is a standalone program that uses one or more stage 1 NCP, EP, or PEP generation decks to produce a detailed report of the resources and resource attributes of a user's network configuration. The report presents information separately for SNA and non-SNA devices. By selecting certain macro instructions for processing, the user can tailor the report to include:

- The resource level: group, line, service (for SNA devices: physical unit, logical unit; for non-SNA devices: cluster, terminal, component)
- The resource name
- The actual network address
- The specified address (as specified in the appropriate macro)
- The type of control unit
- For SNA devices, the physical unit type
- For SNA devices, the data mode (duplex or half-duplex)
- Line type (duplex or half-duplex)
- Line speed
- For non-SNA devices, the resource type (NCP, EP, or PEP)
- For SNA devices, the subarea address
- Clocking (internal or external)
- Line control (for SNA devices: user or SDLC, for non-SNA devices: BSC or SS)
- Dial (yes or no)
- For non-SNA devices, dial number
- For SNA devices: virtual or real status, NRZ or NRZI encoding, PUDRPOOL, LUDRPOOL, LUPOOL, NCPNAU, service order
- Comments and notes

Chapter 3. ACF/NCP Version 1 Release 2 Services

This chapter describes:

- The hardware additions to the 3705-II Communications Controller for Version 1 Release 2 of Advanced Communications Function for the Network Control Program (ACF/NCP).
- The services provided by Version 1 Release 2 of the ACF/NCP.

Version 1 Release 2 of the ACF/NCP program product provides communication system management services.

The access methods with which Version 1 Release 2 of the ACF/NCP can interact are:

- Version 2 Releases 1, 2, or 3 of the Advanced Communications Function for the Telecommunications Access Method (ACF/TCAM)
- Version 1 Releases 2 and 3 of the Advanced Communications Functions for the Virtual Telecommunications Access Method (ACF/VTAM)
- Advanced Communications Function for the Virtual Telecommunications Access Method Extended for the Disk Operating System Extension (ACF/VTAME)

3705 Communications Controller Hardware Additions for Version 1 Release 2

Version 1 Release 2 of the ACF/NCP supports the following hardware additions to the 3705 Communications Controller Models J, K, and L:

- A storage cycle speed of 900 nanoseconds
- The expansion of controller storage to 512K bytes
- A CCITT V.35 local attachment interface for 14.4/57.6 bps links between two ACF/NCPs
- A cycle utilization counter

The cycle utilization counter accumulates statistical data on 3705 cycle utilization for access by the user. The data includes cycles taken for instruction execution, cycle steal operations, and maintenance. Version 1 Release 2 of the ACF/NCP can also provide information on the percentage of buffers available.

See the *Introduction to the IBM 3704 and 3705 Communications Controllers* for more information about the hardware additions to the 3705.

Communication System Management Services

Version 1 Release 2 of the ACF/NCP includes the following communication system management services:

- Enhanced SDLC data link test
- Intensive mode error recording
- Dynamic reconfiguration
- Dynamic display of ACF/NCP storage
- Dynamic dump of ACF/NCP storage

Enhanced SDLC Data Link Test

The Enhanced SDLC Data Link Test pinpoints the cause of errors that occur on data links that use the synchronous data link control (SDLC) link protocol.

The data link test can be initiated by either the network operator or the station operator. When the network operator initiates the link test, it involves only one link station on the data link. As a result, other link stations can continue operation. When the link station operator initiates the link test, the link test allows that operator to determine whether his station is capable of communicating with the host processor.

As directed by the access method, the primary link station sends a test command to a secondary link station. The secondary link station returns the command unchanged if no error occurred on the data link.

Prior to Version 1 Release 2 of the ACF/NCP, link stations on the data link being tested cannot transmit data; the entire link is dedicated to the test. This transmission interruption causes the link tests to be deferred until minimal impact on operations can be expected. For example, at the end of the business day.

The link test does not disrupt transmission for any stations but the one participating in the test. Further, more than one link test can be run at the same time, each involving a different station on the link. After each link test is completed, the result of the test is sent to the requester of the test. As a result, the Release 2 ACF/NCP SDLC link test is most useful when used with nonswitched multipoint data links.

Link testing is important whenever degradation or failure of a data link is suspected. The nondisruptive characteristic of the link test for Version 1 Release 2 of the ACF/NCP enables use of the link test as soon as the problem is suspected. Thus, use of the link test need not be deferred until operations are at a minimum.

Intensive Mode Error Recording

The intensive mode error recording service records detailed information about temporary errors on a data link. ACF/NCP error recovery procedures record the error status information; that is, whether the error is temporary or unrecoverable.

Prior to Version 1 Release 2 of the ACF/NCP the ACF/NCP sent information about temporary errors occurring between the initial and the final error to the host processor. Version 1 Release 2 of the ACF/NCP, however, can provide data about all temporary errors as they occur. When the access method has initiated intensive mode error recording, the error statistics are sent to the host processor after the retry sequence for each error is completed.

The expanded statistics made available by the Intensive Mode Error Recording service used prior to ACF/NCP often precludes the requirement for specific link tests.

Dynamic Reconfiguration

The dynamic reconfiguration service permits network addressable units to be dynamically added to or deleted from the network without requiring a new ACF/NCP generation. The network addressable units that can be added or

deleted dynamically are type 1 and type 2 physical units and logical units. (Type 1 and type 2 physical units are cluster controllers and terminals. Type 1 and type 2 logical units are application programs and terminals.) This service cannot be used with host processor programs, the ACF/NCP, or non-SNA work stations.

Dynamic reconfiguration is not a substitute for the program generation procedure. It simply allows the end-user to make temporary changes in the network configuration during ACF/NCP execution and defers until a more convenient time the program generation required to incorporate the changes permanently.

To prepare for dynamic reconfiguration, the system programmer specifies, in the ACF/NCP generation deck, the dump PU and LU pools to be allocated to the dynamic reconfiguration function. The actual PUs and LUs to be added or deleted are not defined in the generation deck; rather, they are defined later as needed. In addition, the programmer can specify which generation-defined PUs and LUs may later be dynamically deleted. For example, the programmer can specify that a master console be deleted dynamically.

Actual PUs and LUs may be added to SDLC data links any time the ACF/NCP is active. They can be deleted only when they are in the inactive state. Both generation-defined resources and dynamically-added resources may be deleted. When they are deleted, the storage allocated to them is released for use by later dynamic resource additions. Thus, many dynamic reconfigurations can be made with the same PU and LU. Once the pool of dummy PUs and LUs is entirely occupied by actual PUs and LUs a new ACF/NCP generation is necessary. Certain physical limitations also make a new generation necessary; for example, the need to add a new data link and certain parameters specified in the generation deck that limit the number of resources to be associated with a device.

Dynamic reconfiguration is of value to networks because:

- A central site can respond more quickly to user demands for additional or relocated stations because the network need not be shut down to make the change and because no immediate regeneration of the ACF/NCP is necessary.
- A central site can correct certain errors in the network definition without regenerating the ACF/NCP.
- A central site can accommodate a temporary or test configuration without disrupting operation of the network.
- After an SDLC link failure, a new physical connection can be defined for affected LUs without changing the LU names and without adding access-method or ACF/NCP storage.

Dynamic reconfiguration is especially important to networks characterized by large numbers of SNA stations, rapid addition of new stations, frequent configuration changes requiring fast action time, or 24-hour-a-day-operation or any combination of these characteristics.

Dynamic Display of ACF/NCP Storage

The dynamic display of ACF/NCP storage service permits a network operator to display up to 256 contiguous bytes of ACF/NCP storage. The operator can request a display by entering an operator control command at the host processor console. The command specifies the address of the ACF/NCP and the starting address of the ACF/NCP storage to be displayed. After the

command is entered, it is routed to the access method. Network operation is not interrupted when this service is used.

The dynamic display service is of value when operation or performance of the network is incorrect or marginal and the ACF/NCP is suspected of being the cause. For example, an incorrect ACF/NCP generation. This function is especially useful for examining data areas that are static (for example, areas that are associated with an inoperative station) rather than areas that are dynamically changing (as, for example buffer pools or areas that are associated with an operative station). Use of this function is appropriate for users who have considerable knowledge of internal ACF/NCP operations and need to examine ACF/NCP storage when performing problem determination.

Chapter 4. ACF/NCP Version 1 Release 2.1 Services

This chapter describes the services provided by Version 1 Release 2.1 of Advanced Communications Function for the Network Control Program (ACF/NCP):

- The Link Problem Determination Aid (LPDA) Modem Test Service
- The 230.4 Kbps line speed capability of the 3705-II Communications Controller

Additionally, Version 1 Release 2.1 of the ACF/NCP also interacts with the X.25 Packet Switching Interface (X25NPSI). The X25NPSI executes in the 3705 Communications Controller under control of the ACF/NCP and serves as an interface between an ACF/NCP subarea node and remote terminals that communicate with the host processor over a packet-switched data network.

The Link Problem Determination Aid Modem Test

The Link Problem Determination Aid (LPDA) modem test is an optional online modem test service for IBM 3863, 3864, and 3865 modem or the IBM 3867 Link Diagnostic Unit in test mode. Either the binary synchronous or synchronous data link control telecommunication line protocol can be used on data links attached to these modems. These modems have several integrated diagnostic functions that can be used to determine the cause of problems with the link and with the equipment attached to the link.

The ACF/NCP issues LPDA commands to:

- Place a 3863, 3864, or 3865 modem in test mode
- Test the status of the modem and its interface to the attached data terminal equipment (DTE) to determine if the modem, the attached equipment, and the link are operating properly.
- To send quality data and status information about the modems and about the interface between the remote modems and the data terminal equipment (DTE).

Version 1 Release 2.1 of the ACF/NCP requires Release 2 of the Network Problem Determination Application (NPDA).

LPDA commands are issued when:

- The NPDA solicits the data
- The ACF/NCP has data to send to the NPDA for processing

The ACF/NCP automatically sends data to the NPDA when permanent errors occur over the data link or at the link station and also when statistical data records are generated. Control bytes are included with status data to indicate:

- Whether the status was received
- An invalid status of:
 - No response received
 - Bad response received
 - LPDA command execution not attempted

Examples of error conditions that the LPDA modem test service can detect through the appropriate test commands are:

- Loss of data transmission
- Loss of power to a remote modem
- Count of the number of occurrences of random noise on the link that connects the modems

Test commands can also be sent to determine certain characteristics of a modem, such as the features and options with which it is equipped.

LPDA diagnostic services can be performed while the data link affected is carrying on normal data traffic. User sessions are neither aware of nor affected by these operations. More information about the NPDA program product can be found in the *SNA Concepts and Products* manual.

The 230.4 Kbps Line Speed Capability of the 3705-II Communications Controller

The 230.4 Kbps Line Speed Capability of the 3705-II Communications Controller permits data links attached to the 3705-II Communications Controller to operate at data rates of up to ¹ 230 400 bits per second. Such links, when joining two 3705-II Communications Controllers, cannot be used for loading or dumping a 3705-II.

The ACF/NCP line trace service can be used to trace one duplex 230.4 Kbps link or two half-duplex 230.4 Kbps links at once.

¹ In this publication, long numbers are represented in metric style. A space is used, instead of a comma, to separate groups of three digits.

Chapter 5. ACF/NCP Version 1 Release 3 Services

This chapter describes the services provided by Version 1 Release 3 of the Advanced Communications Function Network Control Program (ACF/NCP). Version 1 Release 3 of the ACF/NCP is a program product that executes in a 3705 Communications Controller to provide:

- Extended ACF/NCP Interconnection
- Support of parallel data links between adjacent 3705s
- Extended control of an ACF/NCP
- Multiple routing
- Multiple priority level support
- Transmission group services
- Route verification
- Flow-control enhancements
- Enhanced non-disruptive session recovery

Extended ACF/NCP Interconnection

Extended ACF/NCP interconnection permits the end-user to extend the interconnections between the resources of the network. Thus:

- Adjacent 3705s can be link-attached. See Figure 5-1.
- Cross-domain data links between channel-attached 3705s and link-attached 3705s can be established. See Figure 5-2.
- Link-attached 3705s in one domain can interact with either channel-attached or link-attached ACF/NCPs in another domain. As a result, access methods operating in different domains can share interaction with an ACF/NCP executing in another domain. See Figure 5-3.
- Existing network configurations can be extended and made more flexible by adding link-attached 3705s. Figure 5-4 is an example of a network in which there are three channel-attached 3705s and five link-attached 3705s. Version 1 Release 2 of the ACF/NCP is executing in each 3705. By replacing Version 1 Release 2 of an ACF/NCP with Version 1 Release 3, additional channel attached and link-attached 3705s can be added to the configuration of the network. Figure 5-5 is an example of a network configuration that has been extended so that the data paths within the network are more flexible. One additional link-attached 3705 (connected to an adjacent link-attached 3705), three data links, and three channel-attached 3705s have been added.

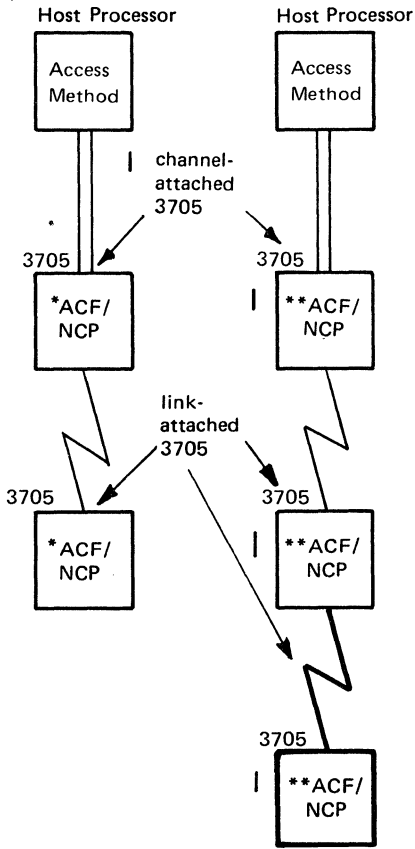

(Maximum of 2 adjacent ACF/NCPs)

(No limit on number of adjacent ACF/NCPs)

ACF/NCP
*Version 1
Release 2

ACF/NCP
**Version 1
Release 3 and
Version 2

Figure 5-1. Multiple Adjacent ACF/NCPs

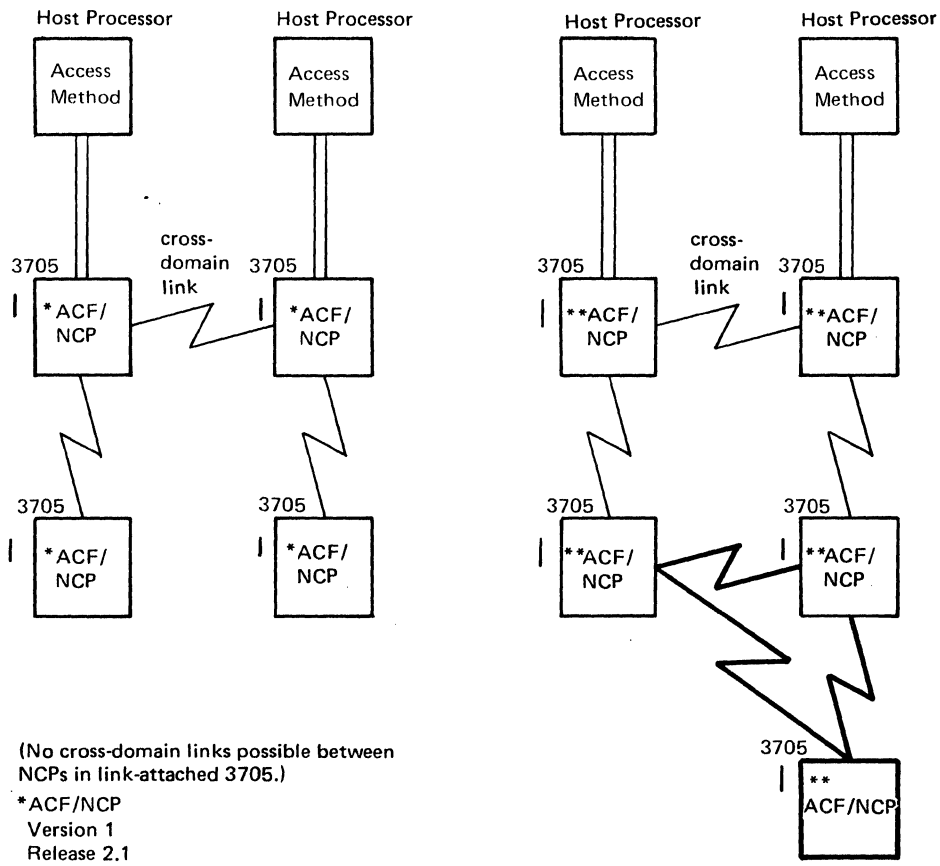
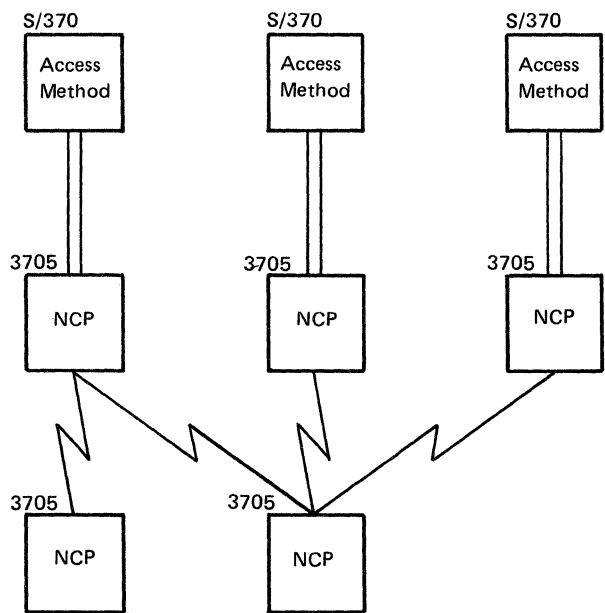

Figure 5-2. Cross Domain Links to ACF/NCPs in Link-Attached 3705s



| Figure 5-3. ACF/NCPs in Link-attached 3705s Interacting with Multiple Access Methods Using Cross-Domain Links to Channel-Attached 3705s

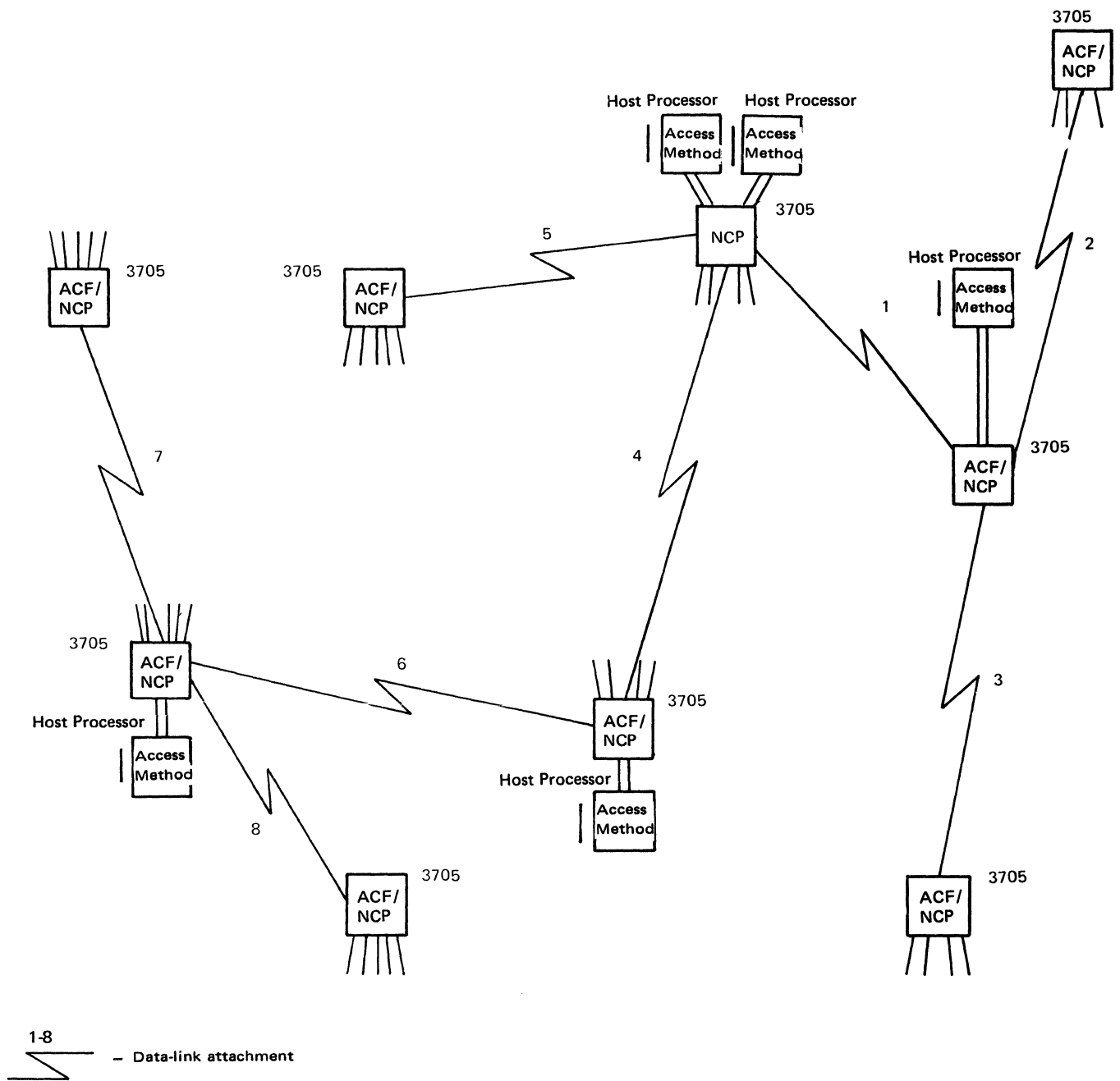
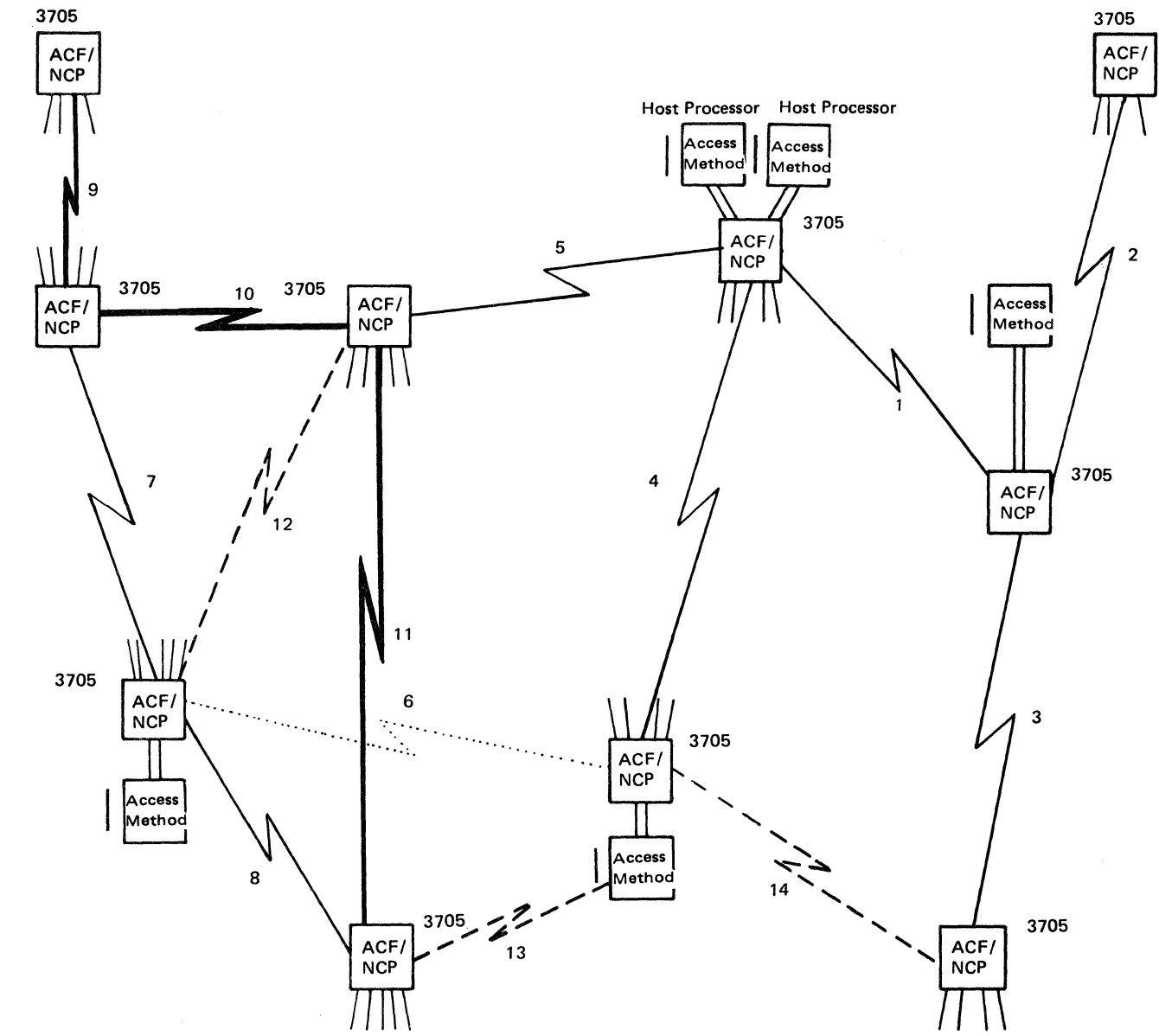

Figure 5-4. Example of a Network Controlled by Version 1 Release 2 of the ACF/NCP



- 1-8 - Data-link attachments
- 9-11 - Data links that can be added to a network because network control programs are Version 1 Release 3 of the ACF/NCP
- 12-14 - Further data links that can be added to network because network control programs are Version 1 Release 3 of the ACF/NCP
- 6 - Former link replaced by combination of existing link 8 and new link 13.

Figure 5-5. Example of a Network Controlled by Version 1 Release 3 of the ACF/NCP

Extended Control of an ACF/NCP

Version 1 Release 3 of the ACF/NCP permits any or all of the System Service Control Points (SSCPs) operating in the host processor to control the data links between multiple 3705s in the network. Control is independent of the distance the ACF/NCP is from the controlling SSCP. Thus several SSCP can activate a data link between 3705s. Each SSCP may deactivate the link when it has no further use for it, however, the link can remain active for use by other SSCP. Only when a Deactivate Link command is received from the last remaining SSCP does the ACF/NCP actually deactivate the data link.

Support of Parallel Data Links between Adjacent ACF/NCPs

Parallel data links between adjacent Advanced Communication Function Network Control Programs (ACF/NCPs) permit data to flow simultaneously over two or more data links between the adjacent ACF/NCPs. The link attachment capabilities of the 3705 determine the number of parallel links that can be operated simultaneously. Distributing data flow among multiple links, permits the end-user to minimize the disruption to sessions caused by failure of a single link or by the need to deactivate a link for reasons such as maintenance. Thus, the reliability and availability of the paths between ACF/NCPs is improved.

Extended Control of an ACF/NCP

Version 1 Release 3 of the ACF/NCP permits any or all of the System Service Control Points (SSCPs) operating in the host processor to control the data links between multiple 3705s in the network. Control is independent of the distance the ACF/NCP is from the controlling SSCP. Thus several SSCP can activate a data link between 3705s. Each SSCP may deactivate the link when it has no further use for it, however, the link can remain active for use by other SSCP. Only when a Deactivate Link command is received from the last remaining SSCP does the ACF/NCP actually deactivate the data link.

Expanded Communication System Management Services

Version 1 Release 3 of the ACF/NCP provides the following expanded communication system management services:

- Multiple routing
- Multiple priority level support
- Transmission group services
- Route verification
- Flow-control enhancements

Multiple Routing

Multiple routing permits the use of several routes for carrying data concurrently between a pair of subareas in the network.

Networks that use prior releases of the ACF/NCP can use only one route to carry data between a pair of subareas. All data sent during sessions established between the subareas must be transmitted over that route. If a physical network element in that route fails, all sessions are interrupted and all data transmission stops until the element is repaired or another element, such as a backup link, is substituted.

Multiple routing permits up to eight physical routes to be established between a pair of subareas. Version 1 Release 3 of the ACF/NCP distributes the sessions between the subareas among the active routes. Data exchanged within a session flows over one route. That is, the session data is not distributed among routes. However, several sessions may be assigned to the same route.

Multiple Priority Level Support

Multiple priority level support permits the end-user to establish up to three levels of priority for the transmission of data within a session. A specific route can be assigned to each priority level so that high-priority traffic can be transmitted over one route while low priority traffic flows over a different route. For example, highly time-dependent interactive transactions can be sent with higher priority than are batches of collected data that only require processing at the end of the day.

Transmission Group Services

Transmission group services permit the logical grouping of multiple data links into a transmission group. The transmission group operates between adjacent ACF/NCPs and appears as a single link connection to the network. Version 1 Release 3 of the ACF/NCP dynamically distributes data traffic among the links in the transmission group. Failure or deactivation of any of the active links in the group (so long as it is not the sole remaining link) results in automatic redistribution of data traffic among the remaining links. Sessions currently in progress over those links are not disrupted. Application programs in the host processor and user sessions are entirely unaware of and are not concerned with any redistribution of traffic within a transmission group resulting from a link becoming inoperative. Figure 5-6 shows five links between adjacent 3705s divided into two transmission groups.

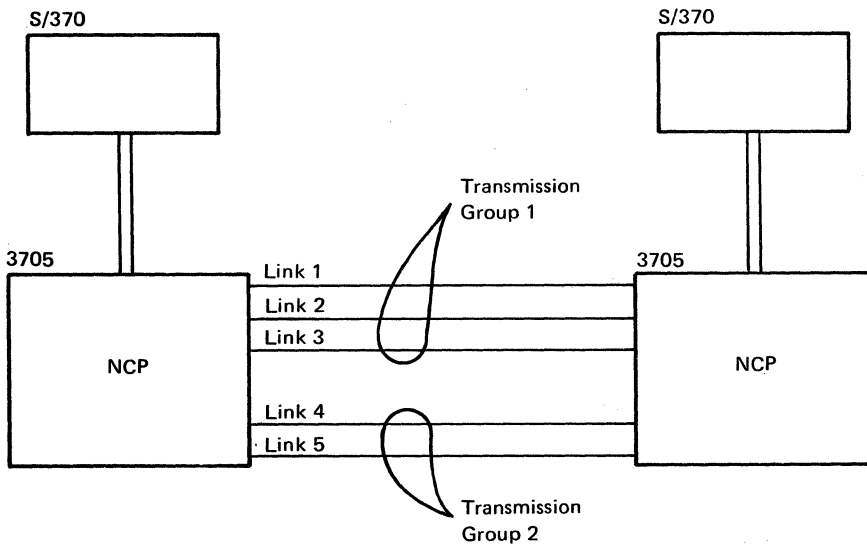

Figure 5-6. Two Transmission Groups between ACF/NCPs

Two 3705s can be joined to up to eight transmission groups. Any single active data link can be assigned to only one transmission group at a time.

Re-routing of Data

An access method can share concurrent interaction with any ACF/NCP executing in the network. Data can be rerouted over an alternate route to simplify access to a network resource. The rerouting of data can occur without disruption of any active cross-domain sessions. See Figure 5-7.

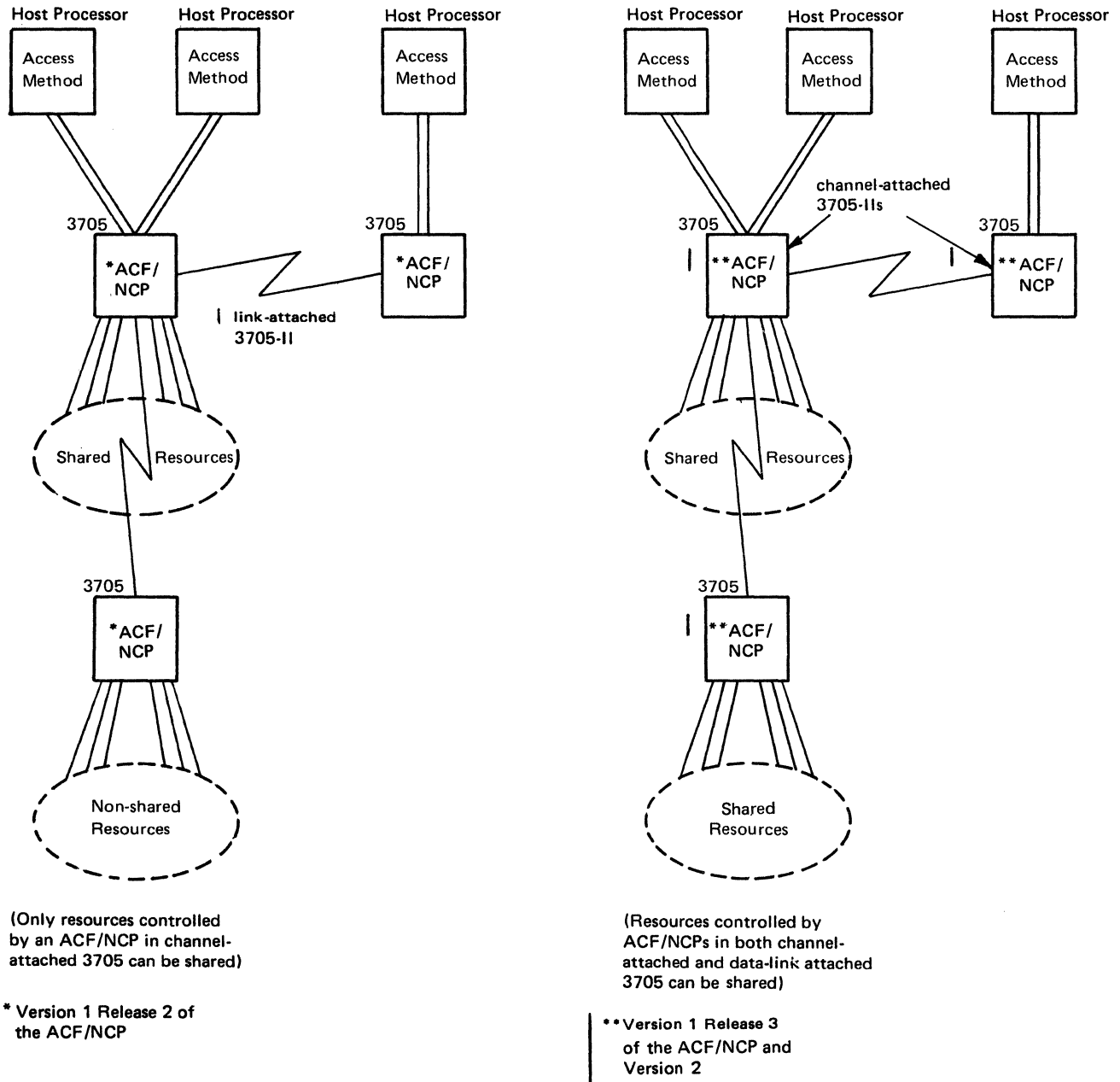

Figure 5-7. Sharing of Resources Controlled by an ACF/NCP in a Link-Attached 3705

Route Verification

Route verification permits a network operator to:

- Verify that a given route is usable for data transmission before assigning it to data traffic.
- Take corrective action for a route that has become inoperative.
- Verify that a route that has been inoperative is once again usable for data transmission after it has been reactivated. The route verification service identifies the physical element in the route that failed and notifies the network operator.

Flow-Control Enhancements

Flow-control enhancements permit the access methods and the ACF/NCP to regulate the flow of data in the ACF/NCP. Through continuous monitoring of data flow and the application of various control mechanisms, the entry of data into the network from logical units is limited to an amount that can be routed through the network and delivered to its destination without delay and without overloading of network resources such as ACF/NCP buffers.

Enhanced non-disruptive session recovery

Enhanced non-disruptive session recovery lessens the disruptive effect caused when logical unit-logical unit (LU-LU) sessions reestablish related system services control point-physical unit (SSCP-PU) or SSCP-LU sessions.

In prior releases of the ACF/NCP, the reestablishment of an SSCP-PU or SSCP-LU session disrupts any active LU-LU sessions involving the corresponding LU. With Version 1 Release 3 of the ACF/NCP, the LU-LU sessions are not disrupted provided the associated physical units can be reactivated without resetting their logical units.

Non-disruptive restart is available only for SNA stations on nonswitched data links. This service does not apply to SNA stations on switched data links.

Chapter 6. ACF/NCP Version 2 Services

Version 2 of the ACF/NCP program product provides the services of Version 1 Release 3, and:

- An integrated Network Performance Analyzer (NPA)
- A Generalized Path Information Unit Trace
- A Session Trace
- Enhancements for the IBM 3270 Information Display System
- Enhancements for the Line Quiet Test
- Enhancements for Address Trace
- A Dispatcher Trace
- Loading PEP Load Modules using Data Links

The access methods with which Version 2 of the ACF/NCP can interact are described in Chapter 7.

The Network Performance Analyzer

The Network Performance Analyzer (NPA) collects operating data from the network for analysis.

Prior releases of the ACF/NCP operated with the field developed program (FDP) that operated in the communications controller called the Network Performance Analyzer. For Version 2 of the ACF/NCP, NPA services have been integrated into the Network Control Program. However, a field developed program (FDP) is still required in the host. The host FDP collects data from every ACF/NCP with which the access method communicates.

NPA can highlight the causes of performance degradation, such as excessive traffic at certain periods, or insufficient line capacity. It may also aid in isolating performance problems induced by high line or cluster error rates caused by temporary errors or wide fluctuations in message rates.

The NPA can collect performance data for the following resources:

- The 3705 Communications Controller
- Switched or non-switched SDLC data links
- Type 1 and type 2 physical units
- Logical units
- BSC links attached to components of the 3270 Information Display System

NPA cannot be included in an Emulation Program; but can be included in a Partitioned Emulation Program. The NPA, therefore, collects data from resources controlled by the ACF/NCP and ignores and is unaffected by resources controlled by an Emulation Program.

Generalized Path Information Unit Trace

The Generalized Path Information Unit Trace (GPT) provides PIU trace records for selected resources in the network. The trace records consist of up to 44 bytes of data that can be used to diagnose and analyze network operating data.

Trace records can be provided for a:

- Boundary Node Logical Unit
- Boundary Node Physical Unit
- BSC data links attached to components of the IBM 3270 Information Display System
- ACF/NCP Physical Unit
- Programmed Physical Unit
- Programmed Logical Unit

The access method activates the GPT trace. The ACF/NCP forwards the trace records associated with ACF/NCP resources to the access method. ACF/TAP, a trace analysis program, can then format, and print the trace records. More information about ACF/TAP may be found in "The ACF/TAP Service Aid" section in Chapter 2.

Session Trace

Session Trace is an ACF/NCP function controlled by the Network Logical Data Manager (NLDM). It records information about the different sessions in the network from both the access method point-of-view and the ACF/NCP point-of-view.

The access method traces PIUs, including the transmission header (TH), the request/response header (RH), and the first 11 bytes of the request/response unit (RU). The ACF/NCP records the last four sequence numbers of the PIUs flowing between ACF/NCP SNA boundary node resources and certain control block fields. The ACF/NCP sends these PIU sequence numbers to NLDM:

- Upon request
- At each session termination (for SNA resources)
- When an abnormal or error condition is detected (for non-SNA resources)

NLDM provides a set of interactive panel displays that allow the user to initiate commands and display data associated with session tracing. These displays provide:

- A list of the names of all network addressable units (NAUs) known to NLDM
- A list of the most recent sessions for a particular NAU name
- A display of session connectivity data
- A formatted display image for session activation requests/responses
- A formatted PIU trace of all supported sessions
- A display of ACF/NCP control block data
- A hexadecimal display of access method PIUs.

The session trace is started for all resources from any Network Communications Control Facility (NCCF) terminal or through the NCCF CLIST facility. It is started when NLDM is initialized, unless the user specifies otherwise. After NLDM is initialized, the user can start and stop session tracing as required.

Enhancements for the IBM 3270 Information Display System

Enhancements for the IBM 3270 Information Display System permit the user to specify non-contiguous addresses for 3270 display stations.

Suppression of the Line Quiet Test

The line quiet test for start-stop lines may be optionally included in this release of the ACF/NCP.

Address Trace

The Address Trace service has been enhanced to permit tracing of either a register address or the address of a main storage location plus a displacement. The displacement entry consists of the address of the previous entry plus the displacement. The range of displacements that can be specified is 256 bytes. Multiple displacements may be specified following an address, and two address or displacement combinations may be traced.

Dispatcher Trace

The dispatcher trace service is a service aid that is continuously active in the ACF/NCP. It continuously records entries in the Dispatcher Trace Table for each QCB task that is dispatched by the ACF/NCP. The QCB regulates the sequential use of a programmer-defined facility among requesting tasks.

Link Load of PEP Load Modules

The ACF/NCP Partitioned Emulation Programming Extension load module can be loaded over a data link to a channel-attached 3705 Communications Controller.

Chapter 7. Planning for Use of an ACF/NCP

This chapter describes installation considerations for end-users who are replacing earlier versions of Advanced Communications Function for the Network Control Program (ACF/NCP) with Version 2.

The following requirements are to be considered:

- Communications Controller hardware requirements
- Requirements for using an ACF/NCP
- Requirements for using multiple ACF/NCPs
- The Access Methods Required
- Customer responsibilities
- Migration paths of the ACF/NCP
- Program generation considerations

Communications Controller Hardware Requirements

Version 1 Release 2 of the ACF/NCP can be executed in:

- A 3705-I Communications Controller
- A 3705-II Communications Controller

The 3705-I must have a minimum of 80K bytes of storage. The 3705-II must have a minimum of 96K bytes of storage.

Version 1 Release 3 and Version 2 of the ACF/NCP can be executed in:

- A 3705-I Communications Controller
- A 3705-II Communications Controller

The 3705-I must have a minimum of 144K bytes of storage. The 3705-II must have a minimum of 128K bytes of storage.

Requirements for using an ACF/NCP

Use of either Version 1 or Version 2 of the Advanced Communications Function/Network Control Program (ACF/NCP) requires the installation of the required release of the operating system. Version 2 of the ACF/NCP can interact with:

- Operating System/Virtual Storage 1
- Operating System/Virtual Storage 2 (MVS SP Versions 1 and 2)
- Multiple Virtual Storage

Requirements for Using Multiple ACF/NCPs

Version 1 and Version 2 of the Advanced Communications Function Network Control Program (ACF/NCP) can interact with other resources in a network over cross-domain or single-domain links.

Version 1 Release 2 of the ACF/NCP and an Access Method

Version 1 Release 2 of Advanced Communications Function for the Network Control Program can interact with:

- Version 1 and Version 2 of Advanced Communications Function for the Telecommunications Access Method (ACF/TCAM)
- Version 1 Releases 1 and 2 of the Advanced Communications Function for the Virtual Telecommunications Access Method (ACF/VTAM)

Version 1 Release 3 of the ACF/NCP and an Access Method

Version 1 Release 3 of Advanced Communications Function for the Network Control Program (ACF/NCP) can interact with:

- Version 1 and Version 2 Releases 1, 2, and 3 of the Advanced Communications Function for the Telecommunication Access Method (ACF/TCAM)
- Version 1 and Version 2 of the Advanced Communications Function for the Virtual Telecommunications Access Method (ACF/VTAM)

Each access method must have the required PTFs included. Optimal utilization of Version 1 Release 3 of the ACF/NCP depends upon its interaction in a network with:

- Version 2 Release 3 of ACF/TCAM
- Release 3 of ACF/VTAM

Version 2 of the ACF/NCP and an Access Method

Version 2 of Advanced Communications Function for the Network Control Program (ACF/NCP) interacts with the following releases of the Advanced Communications Function group of access methods:

- ACF/VTAM
 - Version 1 Release 3
 - Version 2
- ACF/TCAM
 - Version 2 Release 3¹
 - Version 2 Release 4

Version 2 of the ACF/NCP and Another ACF/NCP

| Version 2 of the ACF/NCP can interact with the following releases of another ACF/NCP executing in an adjacent node:

- Version 1 Release 2.1
- Version 1 Release 3

¹ Cannot be used with the Generalized Path Information Unit Trace

Customer Responsibilities

To install and use Advanced Communications Function for the Network Control Program (ACF/NCP), the customer must:

- Design the network in which the ACF/NCP is to be installed.
- Meet the minimum 3705 hardware requirements.
- Order and install all required telecommunications equipment.
- Order, install and generate the ACF/NCP, and the System Support Programs for Version 1 and Version 2, and the operating system required.
- Generate the other programs the configuration of the network requires.
- Load the ACF/NCP load module into the 3705 Communications Controller. Either the loader utility furnished by the ACF/NCP system support programs or the loader facility of the access method that interacts with the ACF/NCP can be used to load the ACF/NCP load module.
- Meet the requirements of the access method that is to interact with the ACF/NCP.

Migration of the ACF/NCP

Advanced Communications Function for the Network Control Program (ACF/NCP) can interact with a non-current release of an access method. Similarly, Version 2 of Advanced Communications Function for the Telecommunication Access Method (ACF/TCAM) and Release 2 and 3 of the Advanced Communications Function for the Virtual Telecommunications Access Method (ACF/VTAM) can interact with non-current releases of the ACF/NCP. As a result, a network can be upgraded a step at a time and the complexity of the upgrading task is reduced.

Permissible combinations of access method programs and ACF/NCPs are listed in the following paragraphs.

Version 1 Release 2 of the ACF/NCP can interact with the following access methods:

- Level 10 of TCAM
- Version 1 of ACF/TCAM
- Version 2 Release 1 of ACF/TCAM
- Version 2 Release 2 of ACF/TCAM
- Version 2 Release 3 of ACF/TCAM
- Version 2 Release 4 of ACF/TCAM
- Level 2 of VTAM (OS/VS1 and OS/VS2 MVS only)
- Release 1 of ACF/VTAM
- Release 2 of ACF/VTAM
- Release 3 of ACF/VTAM

See Figure 7-1.

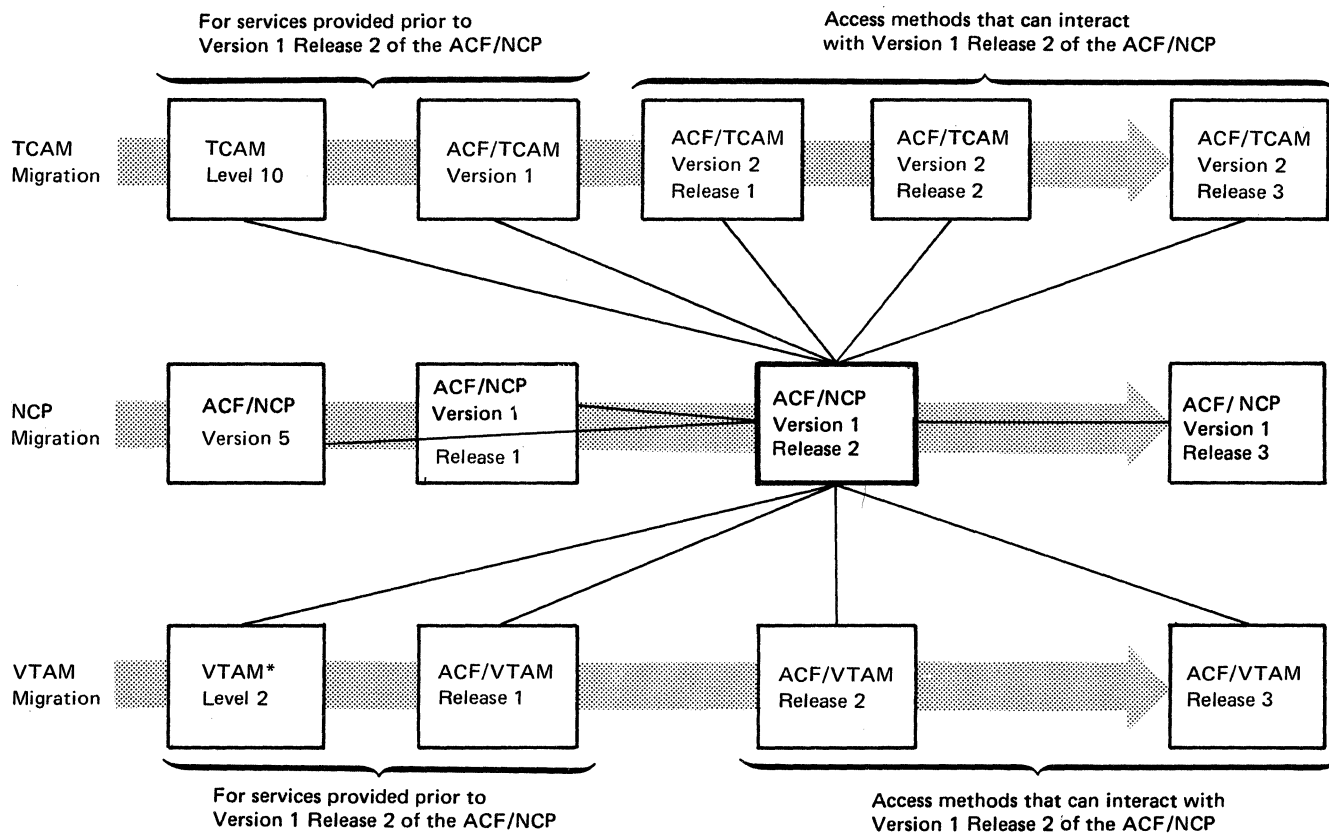

*OS/VS1 and OS/VS2 Only

Figure 7-1. Levels of Access Method and ACF/NCP with which Version 1 Release 2 of the ACF/NCP can Communicate

Version 1 Release 3 of the ACF/NCP can interact with the following access methods if each access method includes the PTFs required.

- Version 1 of ACF/TCAM
- Version 2 Release 1 of ACF/TCAM
- Version 2 Release 2 of ACF/TCAM
- Version 2 Release 3 of ACF/TCAM
- Release 1 of ACF/VTAM
- Release 2 of ACF/VTAM
- Release 3 of ACF/VTAM

See Figure 7-2.

Services provided by Version 1 of the ACF/NCP and the appropriate access method are also provided in Version 2 of the ACF/NCP.

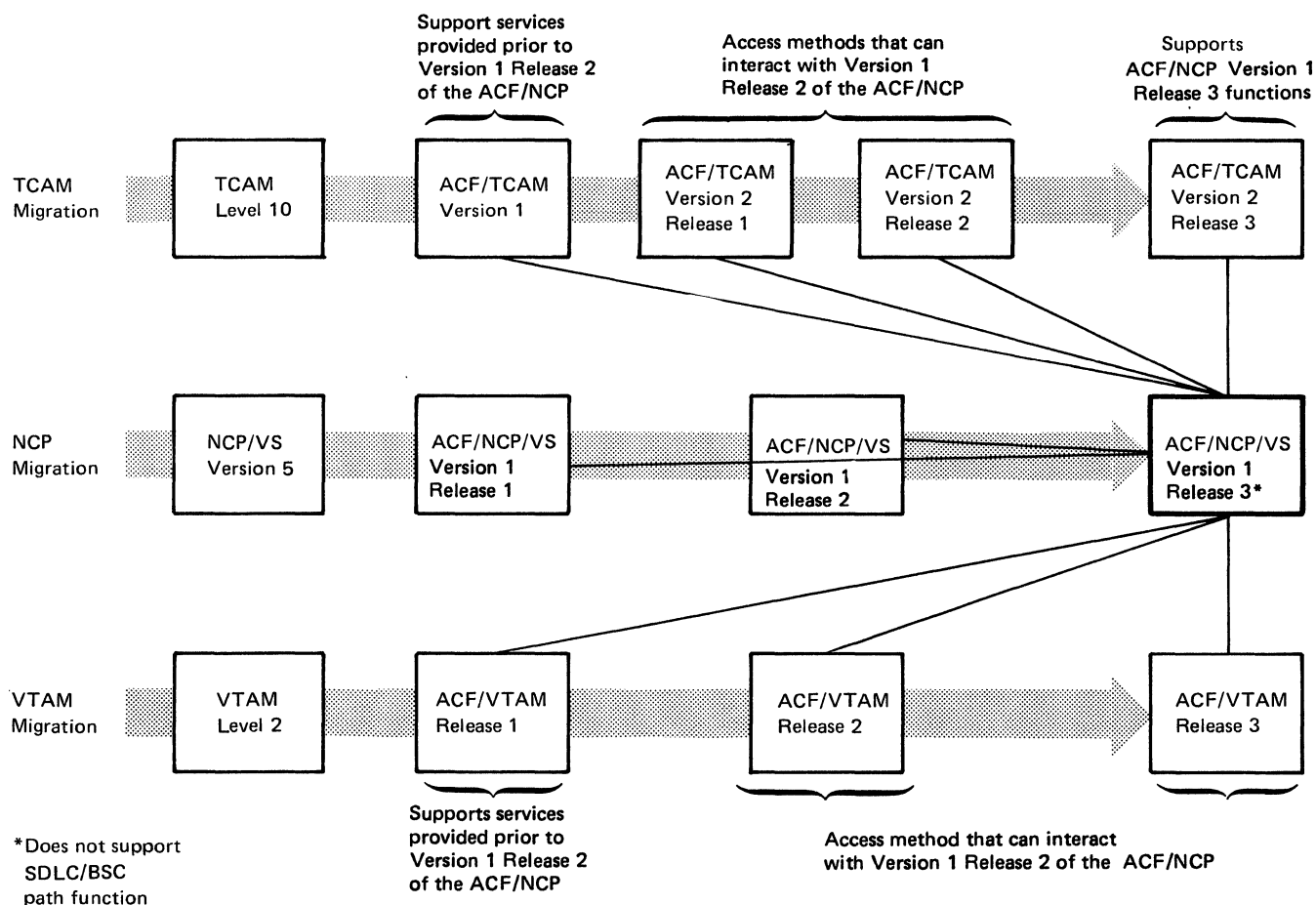

Figure 7-2. Levels of Access Method and ACF/NCP with which Version 1 Release 3 of the ACF/NCP can Interact

Program Generation Considerations

The source statements used to generate a Version 1 Advanced Communications Function for the Network Control Program (ACF/NCP) can be used to generate a Version 2 ACF/NCP. The program generated can be executed as a:

- Version 1 Release 2.1
- Version 1 Release 3
- Version 2

Each subsequent release of an ACF/NCP includes the control blocks and tables required for that release. The access methods required for each release must be installed for interactions with the other resources in the network.

Chapter 8. Planning a Network with an ACF/NCP

This chapter describes a procedure that can be used to plan a network with an Advanced Communications Function Network Control Program. The person responsible for the planning the network should know:

- The objectives for the network
- The resources required to fulfill the objectives for the network
- How the network is to be controlled
- How the network is to be tested
- Requirements for training end-users
- The schedules for the availability of resources to be used

The Objectives for the Network

Before objectives for a network can be defined, the characteristics of the network must be considered. Characteristics such as:

- The configuration of the network
- The applications currently used
- The current requirements for the network
- The performance of the network. For example, the response times provided by the resources during periods of average data flow and during peak periods of data flow.
- The backup plans for various kinds of failures.

These and other pertinent characteristics of the network form the basis of comparison for planning enhancements to the network; for example:

- Are new applications required?
- Do existing application programs need to be enhanced?
- Are existing response times below average?
- Are new resources required?
- Can networks be consolidated to reduce the cost of using the data link?

The Resources required to Fulfill the Objectives for a Network

The resources required to fulfill the objectives for a network can be either permanent or temporary. Permanent resources consist of any new equipment required by the network, for example, host processors, data links, or 3705s. Temporary resources consist of the time the programmer requires to code a new program as well as the additional computer time required to test an upgraded ACF/NCP before it goes into operation.

After the resources for the new network are defined other dependencies for the use the resources required must be considered, for example:

- Will maintenance service be available for the new equipment?
- Are the program resources compatible? For example, will the services provided by the network control program be supported by the access method, the operating system, or by programming subsystems?
- Are service aids or other program products required or desirable for use with new or enhanced program resources.
- Are communication services required?

- Will new personnel be required?
- Will training be required for the use of the new resources?

How the Network is to be Controlled

How the network is to be controlled is a most important aspect of a complex network. The control of multiple domain networks is distributed between two or more of the operators.

Backup and recovery procedures are especially important to the efficient operation of a network. Each possible kind of failure should be anticipated, for example:

- What will be the effect on the network of an equipment or program failure?
- What problem determination procedures will be used?
- What backup resources are available?
- What procedures are required by the network control program operators and users of the network to operate in backup mode? to return to regular operation? to notify network users of changing to backup mode and reverting to regular operation? These procedures should be documented and made available to the individuals who will be affected.

How the Network is to be Tested

Testing is required to ensure that new applications and services work correctly and that existing applications and network services are not impaired. A test plan should be prepared and agreed to by all who may be affected.

The test plan should consider:

- How each new service is to be tested.
- What existing services could be impaired through conflict with an existing service?
- Whether old and new services are to be tested at the same time?

Exceptional conditions as well as normal operations of the network should be tested. Consideration should be given to testing the network under peak traffic loads as well as during periods of normal traffic loads.

Requirements for Training End-Users

Requirements for training end-users depend upon the skills required by the personnel that are to operate the network. For example, terminal operators, computer operators, and network control operators. System programmers and others involved in the development of a service may need to learn about new versions of access methods, network control programs, and other programs to be used in the network being enhanced.

If the Advanced Communications Function Network Control Program (ACF/NCP) is to be modified to meet special needs, the programmers responsible for the modifications must become familiar with the internal logic of the ACF/NCP.

Network operators may require training on new network operating procedures, including those for backup and recovery from various failure conditions.

The Schedules for the Availability of Network Resources

Scheduling for the availability of network resources occurs after all the requirements for the network have been identified. A detailed schedule of events should be developed in cooperation with all responsible individuals affected. The schedule should reflect realistic estimates of the availability of the needed resources, with consideration given to all contingencies.

Some resources take longer to put in place than others. Thus, lead times for new equipment and the installation of communication services, especially, must be considered. Also important is a realistic assessment of the personnel resources involved in developing the network.

When the detailed schedule of events is developed it should be agreed to by all who will be providing resources and by those persons responsible for the operation of the network. The proper review and approval of the schedule should minimize problems in the development process that could arise due to misunderstandings as to priorities and responsibilities involved in the process.

the first of the two... (faint text)

the second of the two... (faint text)

the third of the two... (faint text)

the fourth of the two... (faint text)

the fifth of the two... (faint text)

the sixth of the two... (faint text)

the seventh of the two... (faint text)

the eighth of the two... (faint text)

the ninth of the two... (faint text)

the tenth of the two... (faint text)

the eleventh of the two... (faint text)

the twelfth of the two... (faint text)

Appendix A. Appendix A.Data Processing Products Used with Version 1 and Version 2 of the ACF/NCP

The following data processing products can be attached to a 3705 with either Version 1 or Version 2 of the ACF/NCP installed.

SDLC Control Units and Display Stations

- IBM 3270 Information Display System ¹
- IBM 3271 Control Unit Models 11, 12 ²
- IBM 3274 Control Unit Model C ²
- IBM 3275 Display Station Models 11, 12 ²
- IBM 3276 Control Unit Display Station Models 11, 12, 13, 14
- IBM 3277 Control Unit Models 11, 12 ¹
 - IBM 3284 Printer
 - IBM 3286 Printer
 - IBM 3287 Printer
- IBM 3277 Display Station ¹
- IBM 3276 Control Unit Display Station Models 11, 12, 13, 14
- IBM 3278 Display Station ¹
- IBM 3279 Color Display Station ¹
- IBM 3600 Finance Communication System
 - IBM 3601 Finance Communications Controller
 - IBM 3602 Finance Communications Controller
- IBM 3614 Consumer Transaction Facility ²
- IBM 3624 Consumer Transaction Facility ²
- IBM 3651 Store Controller Models A50, B50
- IBM 3651 Store Controller Models A60, B60 ³
 - IBM 3650 Retail Store System ¹
 - IBM 3660 Supermarket System ¹
- IBM 3661 Store Controller (U.S.A. only) ³
 - IBM 3730 Distributed Office Communications System ¹
- IBM 3760 Dual Key Entry Station (only when attached to an IBM 3790)
- IBM 3767 Communication Terminal Models 1, 2, and 3
- IBM 3770 Data Communications System
 - IBM 3771 Communication Terminal Models 1, 2, 3
 - IBM 3773 Communication Terminal Models 1, 2, 3, P1, P2, P3
 - IBM 3774 Communication Terminal Models 1, 2, P1, P2
 - IBM 3775 Communication Terminal Models 1, P1
 - IBM 3776 Communication Terminal Models 1, 2, 3, 4
 - IBM 3777 Communication Terminal Models 1, 3

¹ Version 2 only

² nonswitched lines only

³ switched lines only

IBM 3791 Communications Controller
IBM 3790 Communication System ⁴
IBM 8100 Information System ⁴

Binary Synchronous Control Units and Display Stations

IBM 1131 Central Processing Unit
IBM 1826 Data Adapter Unit
IBM 2715 Transmission Control Model 2
IBM 2770 Data Communications System (with 2772 Control Unit)
IBM 2772 Multipurpose Control Unit
IBM 2780 Data Transmission Terminal
IBM 2972 General Banking Terminal System (U.S.A. only) ⁵
 IBM 2980 Teller Station Models 1 and 4
 IBM 2980 Administrative Station Model 2
IBM 3270 Information Display System (nonswitched lines only) IBM 3271
Control Unit Models 1, 2 ⁵
 IBM 3284 Printer
 IBM 3286 Printer
 IBM 3287 Printer
IBM 3274 Control Unit Models 1C and 51C
 IBM 3275 Display Station Models 1, 2 ⁵
 IBM 3277 Display Station
IBM 3651 Store Controller Models A50, B50
 IBM 3660 Supermarket System
 IBM 3671 Shared Terminal Control Unit
 IBM 3735 Programmable Buffered Terminal
 IBM 3740 Data Entry System
IBM 3741 Data Station Model 2
IBM 3747 Data Converter
IBM 3750 Switching System (World Trade only) ⁴
IBM 3770 Data Communications Systems
IBM 3780 Data Communication Terminal
IBM 5110 Portable Computer
IBM 5275 Direct Numerical Control Station
IBM 5937 Industrial Terminal
IBM 8100 Information System
IBM System/3
IBM System/360 Model 20
IBM System/360 Models 25, 30, 40, 50, 65, 65MP, 67 (in 65 mode),
 75, 85, 91, 195
IBM System/370 Models 115 - 168MP

⁴ Version 2 only

⁵ nonswitched lines only

Start-Stop Stations

IBM 1050 Data Communication System
IBM 1051 Control Unit
IBM 2740 Communications Terminal Models 1 and 2
IBM 2740 Communications Terminal Model 2⁶
IBM 2741 Communications Terminal
IBM 3101 Display Terminal (operating as ASCII TWX 33/35)
IBM 3767 Communications Terminal Models 1 and 2
(operating as an IBM
2740 Model 1 or 2, or IBM 2741)
AT&T 83B3 line control type (U.S.A. only)⁶
Western Union 115A line control type (U.S.A. only)
CPT-TWX (Models 33, 35) line control type (U.S.A. only)⁷
World Trade teletypewriter (teleprinter) terminals⁶

Compatible Data Processing Products

This section lists compatible data processing products. Functionally equivalent stations operate satisfactorily with an ACF/NCP. The customer must establish equivalency. The compatible data processing products are:

SDLC Control Units and Display Stations

IBM 3274 Control Unit Model 1C defined as a 3791
IBM 3276 Control Unit Display Station Models 1, 2, 3, 4, 11, 12,
13,14 defined as a 3791
IBM 3631 Plant Communication Controller defined as a 3601 or 3602
IBM 3632 Plant Communication Controller defined as a 3601 or 3602
IBM 3771 Communication Terminal Models 1, 2, 3 defined as a 3767
IBM 3773 Communication Terminal Models 1, 2, 3 defined as a 3767
IBM 3774 Communication Terminal Models 1, 2 defined as a 3767
IBM 3775 Communication Terminal Models 1, 2 defined as a 3767
IBM 5937 Industrial Terminal defined as a 3270
IBM 8130 Processor defined as a 3276 Model 11, 12,
13, or 14 or a 3791
IBM 8140 Processor defined as a 3276 Model 11, 12,
13, or 14 or a 3791
IBM System/32 defined as a 3770
IBM System/34 defined as a 3767, 3770, or 3791
IBM System/38 defined as a 3770

⁶ Version 2 only

⁷ nonswitched lines only

Binary Synchronous Stations

IBM 3274 Control Unit (Model 1C defined as a 3271 Model 1 or 2
IBM 3276 Control Unit Display Station Models 1, 2, 3, 4 defined
as a 3271 Model 1 or 2
IBM 3770 Data Communication System terminals as a 2772
IBM 3780 Data Communication Terminal defined as a 2772
IBM 5275 Direct Numerical Control Station defined
as a 3275 Model 1 or 2
IBM 5937 Industrial Terminal defined as a 3270 Model 1 or 2
IBM 8130 Processor defined as a 3271 Model 1 or 2 or a 2772
IBM 8140 Processor defined as a 3271 Model 1 or 2 or a 2772
IBM System/7 Processor Station defined as a System 3
IBM System/32 Batch Work Station defined as a System/3
IBM System/34 defined as a 3767, 3770, or 3791
IBM System/38 defined as a 3770

Start-Stop Stations

IBM 3767 Communication Terminal Models 1 and 2 defined
as a 2740 Model 1 or 2 or a 2741
IBM 3767 Communication Terminal Model 3 defined as a 2740 Model 2
IBM 5100 Portable Computer defined as a 2741
IBM 5110 Portable Computer defined as a 2741
IBM Communicating Magnetic Card Selectric typewriter
defined as a 2741⁸
IBM System/7 Processor Station defined as a 2741

⁸ Version 2 only

Glossary

This glossary includes definitions from:

The *American National Dictionary for Information Processing*, published by the Computer and Business Equipment Manufacturers Association. This material is reproduced from the American National Dictionary for Information Processing, copyright 1977 by the Computer and Business Equipment Manufacturers Association, copies of which may be purchased from the American National Standards Institute at 1430 Broadway, New York, New York 10018. These definitions are identified by an asterisk.

The *ISO Vocabulary of Data Processing*, developed by the International Standards Organization, Technical Committee 97, Subcommittee 1. Definitions from published sections of this vocabulary are identified by the symbol "(ISO)" preceding the definition. Definitions from draft proposals and working papers under development by the ISO/TC97 vocabulary subcommittee are identified by the symbol "(TC97)," indicating that final agreement has not yet been reached among its participating members.

access method. A technique for moving data between main storage and input/output devices.

ACF. Advanced Communication Function.

ACF/NCP. Advanced Communications Function for the Network Control Program

ACF/TCAM. Advanced Communications Function for the Telecommunications Access Access Method.

ACF/VTAM. Advanced Communication Function for the Virtual Telecommunications Access Method.

adjacent NCPs. Network control programs (NCPs) that are connected by subarea links with no intervening NCPs.

Advanced Communication Function (ACF). A group of IBM program products (principally ACF/TCAM, ACF/VTAM, ACF/VTAME, and ACF/NCP) that use the concepts of System Network Architecture (SNA), including distribution of function and resource sharing.

Advanced Communication Function for the Network Control Program (ACF/NCP). A program product that provides communication controller support for single-domain and multiple-domain networks.

application program. (1) A program written for or by a user that applies to the user's work. (2) A program used to connect and communicate with stations in a network, enabling users to perform application-oriented activities.

binary synchronous communication (BSC). (1) Communication using the binary synchronous line discipline. (2) A uniform procedure, using a standardized set of control characters and control character sequences, for synchronous transmission of binary-coded data between stations.

binary synchronous transmission. Data transmission in which synchronization of characters is controlled by timing signals

generated at the sending and receiving stations. See also *start-stop transmission*, *synchronous data link control*.

BSC. Binary synchronous communication.

buffer. An area of storage that is temporarily reserved for use in performing an input/output operation, into which data is read or from which data is written. Synonymous with I/O area.

channel adapter. A communication controller hardware unit used to attach the controller to a System/360 or a System/370 data channel.

channel attached 3705. An IBM 3705 Communications Controller that is attached to a host processor by means of a data channel. Contrast with link-attached 3705.

circuit-switched connection. (TC97) A connection that is established and maintained on demand between two or more data stations in order to allow the exclusive use of a data circuit until the connection is released.

communication controller. A type of communication control unit whose operations are controlled by one or more programs stored and executed in the unit; for example, the IBM 3705 Communications Controller. It manages the details of line control and routing of data through a network.

cross-domain LU-LU session. In SNA, a session between logical units (LUs) in different domains. Contrast with same-domain LU-LU session.

data channel. A device that connects a processor and main storage with I/O control units. Synonymous with input/output channel.

data link. The interconnecting data circuit between two or more equipments operating in accordance with a link protocol; it does not include the data source and the data sink.

Note: A telecommunication line is the physical medium; for example, a telephone wire, a microwave beam. A data link includes the physical medium of transmission, the protocol, and associated devices and programs—it is both logical and physical.

domain. (TC97) in a network, the resources that are under the control of one or more associated host processors.

emulation mode. The function of a network control program that enables it to emulate a transmission control unit. Contrast with network control mode.

emulation program (EP). A control program that allows a local 3704 or 3705 Communications Controller to emulate the function of an IBM 2701 Data Adapter Unit, an IBM 2702 Transmission Control Unit, or an IBM 2703 Transmission Control. See also *network control program*.

end-user. (TC97) A person, process, program, device, or system that employs a user application network for the purpose of data processing and information exchange.

EP. Emulation program.

head. A device that reads, writes, or erases data on a storage medium, for example, a small electromagnet used to read, write, or erase data on a magnetic drum or magnetic tape, or the set of perforating, reading, or marking devices used for punching, reading, or printing on perforated tape.

host processor. (1) In a network, the processing unit in which the access method for the network resides. (2) In an SNA network, the processing unit that contains a system services control point (SSCP).

link. See data link.

link attached 3705. An IBM 3705 Communications Controller that is attached to another 3705 by means of a data link.

link station. In SNA, the combination of hardware and software that allows a node to attach to and provide control for a link.

load module. (ISO) A program unit that is suitable for loading into main storage for execution; it is usually the output of a linkage editor.

logical unit. (1) A port through which a user gains access to the services of a network. (2) In SNA, a port through which an end user accesses the SNA network in order to communicate with another end user and through which the end user accesses the functions provided by system services control points (SSCPs). An LU can support at least two sessions—one with an SSCP and one with another LU—and may be capable of supporting many sessions with other logical units. See also *network addressable unit physical unit, primary logical unit, secondary logical unit, system services control point*.

LU. Logical unit.

LU-LU session. In SNA, a session between two logical units (LUs) in an SNA network. It provides communication between two end users, or between an end user and an LU services component.

multiple-domain network. In SNA, a network with more than one system services control point (SSCP). Contrast with single-domain network.

multipoint link. A link or circuit interconnecting several stations. Synonymous with multidrop line. Contrast with point-to-point link.

network. (1) (TC97) An interconnected group of nodes. (2) The assembly of equipment through which connections are made between data stations.

network addressable unit (NAU). In SNA, a logical unit, a physical unit, or a system services control point; it is the origin or the destination of information transmitted by the path control network. See also *network name, network address, path control (PC) network*.

Note: Each NAU has a network address that represents it to the path control network. (LUs may have multiple addresses for parallel LU-LU sessions.) The path control network and the NAUs together constitute the SNA network.

network control mode. The functions of the network control program that enable it to direct a communication controller to perform activities such as polling, device addressing, dialing, and answering. See also *emulation mode*.

network control program (NCP). A program, generated by the user from a library of IBM-supplied modules, that controls the operation of a communication controller. See also *emulation program*.

network logical data manager (NLDM). A program product that helps a user at a central control point to identify network problems relating to sessions by means of interactive display techniques.

NLDM. network logical data manager.

nonswitched data link. A telecommunication line on which connections do not have to be established by dialing. Contrast with switched line.

OS/VS. Operating System/Virtual Storage.

partitioned emulation programming (PEP) extension. A function of a network control program that enables a communication controller to operate some telecommunication lines in network control mode, while simultaneously operating others in emulation mode.

PEP. Partitioned emulation programming.

physical unit (PU). In SNA, the component that manages and monitors the resources (such as attached links and adjacent link stations) of a node, as requested by an SSCP via an SSCP-SSCP session. See also *peripheral physical unit, physical unit type*.

Note: An SSCP activates a session with the physical unit in order to indirectly manage, through the PU, resources of the node such as attached links and adjacent link stations.

point-to-point connection. A connection established between two data stations for data transmission. The connection may include switching facilities.

point-to-point link. A link that connects a single remote link station to a node; it may be switched or nonswitched. Contrast with multipoint link.

polling. (1) * Interrogation of devices for purposes such as to avoid contention, to determine operational status, or to determine readiness to send or receive data. (2) (TC97) The process whereby stations are invited, one at a time, to transmit.

SCP. System control programming.

SDLC. Synchronous Data Link Control.

session trace. In the Network Logical Data Manager (NLDM), the function that collects session trace data for sessions involving specified resource types or involving a particular resource.

session trace data. Data relating to sessions that is collected by the Network Logical Data Manager (NLDM) whenever a session trace is started and that consists of session activation parameters, access method PIU data, and NCP data.

single-domain network. (1) (TC97) A network that has only one host node. (2) In SNA, a network with one system services control point (SSCP). Contrast with multiple-domain network.

SNA. Systems network architecture.

SNA network. The part of a user-application network that conforms to the formats and protocols of Systems Network Architecture. It enables reliable transfer of data among end users and provides protocols for controlling the resources of various network configurations. The SNA network consists of network addressable units (NAUs), boundary function components, and the path control network.

SSCP. System services control point.

SSCP-LU session. In SNA, a session between a system services control point (SSCP) and a logical unit (LU); the session enables the LU to request the SSCP to help initiate LU-LU sessions.

SSCP-PU session. In SNA, a session between a system services control point (SSCP) and a physical unit (PU); SSCP-PU sessions allow SSCPs to send requests to and receive status information from individual nodes in order to control the network configuration.

start-stop (SS) transmission. (1) (TC97) Asynchronous transmission such that a group of signals representing a character is preceded by a start element and is followed by a stop element. (2) Asynchronous transmission in which a group of bits is preceded by a start bit that prepares the receiving mechanism for the reception and registration of a character and is followed by at least one stop bit that enables the receiving mechanism to come to an idle condition pending the reception of the next character. See also *binary synchronous transmission, synchronous data link control*.

switched line. A telecommunication line in which the connection is established by dialing. Contrast with nonswitched line.

Synchronous Data Link Control (SDLC). A discipline for managing synchronous, code-transparent, serial-by-bit information transfer over a link connection. Transmission exchanges may be duplex or half-duplex over switched or nonswitched links. The configuration of the link connection may be point-to-point, multipoint, or loop. SDLC conforms to subsets of the Advanced Data Communication Control Procedures of the American National Standards Institute and High-level Data Link Control (HDLC) of the International Standards Organization.

system services control point (SSCP). In SNA, a focal point within an SNA network for managing the configuration, coordinating network operator and problem determination requests, and providing directory support and other session services for end users of the network. Multiple SSCPs, cooperating as peers, can divide the network into domains of control, with each SSCP having a hierarchical control relationship to the physical units and logical units within its domain.

systems network architecture (SNA). The description of the logical structure, formats, protocols, and operational sequences for transmitting information units through and controlling the configuration and operation of networks.

Note: The purpose of the layered structure of SNA is to allow the ultimate origins and destinations of information—that is, the end users—to be independent of, and unaffected by, the way in which the specific SNA network services and facilities used for information exchange are provided.

telecommunication line. (1) (TC97) The portion of a data circuit external to a data-circuit terminating equipment (DCE) that connects the DCE to a data switching exchange (DSE), that connects a DCE to one or more other DCEs, or that connects a DSE to another DSE. (2) Any physical medium, such as a wire or microwave beam, that is used to transmit data. (3) Synonymous with data transmission line. (4) Contrast with data link.

TWX. teletypewriter exchange service.



Index

A

access method 1-8, B-1
ACF/NCP
 definition of B-1
 extended control of 5-1
 generation language 2-1
 generation procedure 2-1
 interactions with access method 1-8
 interactions with 3705 1-8
 migration of 7-3
 optional services 1-2
 planning for services of 7-1
 services provided 1-1
 system support program for 2-1
 Version 1 Release 2 services 3-1
 Version 1 Release 2.1 services 4-1
 Version 1 Release 3 services 5-1
 Version 2 services 6-1
ACF/TAP 2-8
address trace 1-4
Advanced Communications Function
 Trace Analysis Program 2-8
assembler instructions 2-5
assembler, uses of 2-6

B

backup, manual switched network 1-4, 1-5
block-handling 1-3
block handler macros 2-2
buffer service 1-2

C

carriage return delay 1-7
channel attention delay 1-5
communication system management services 3-1
configuration macros 2-2
configuration report program 2-8
control character service 1-2
controlling an ACF/NCP network 8-1
critical situation notification 1-4
CSERV utility 2-4

D

data link test 3-2
data processing products A-1
date insertion 1-4
dispatcher trace 6-2
DOS/VSE generation procedure 2-3
dump utility 2-7
dynamic control 1-6
dynamic display of ACF/NCP storage 3-4
dynamic dump utility 2-8
dynamic reconfiguration 3-3

E

editing routine 1-4
enhanced non-disruptive session recovery 5-10
enhancements for the IBM 3270 Information
 Display system 6-2
enhanced SDLC data link test 3-2
error recording and diagnostics 1-2
error recovery and diagnostics 1-3
expanded communication system management services 5-7
extended control of an ACF/NCP 5-7

F

flow-control enhancements 5-10

G

generation delimiter macro 2-3
generation language 2-1, 2-5
generation procedure
 general description 2-1
 OS/VS 2-3
 DOS/VSE 2-3
generalized path information unit trace 6-1

H

hardware additions for Version 1 Release 2 3-1

I

initial test routine 2-6
intensive mode error recording 3-2

L

loader utility 2-6, 2-7
line quiet test, suppression 6-2
link load of PEP load modules 6-2
link problem determination aid modem test 4-1
link station B-3
LPDA modem test 4-1

M

machine instructions 2-5
macro instructions 2-1, 2-5
manual dial 1-6
manual switched network backup 1-5
migration of the ACF/NCP 7-3
modem test 4-1
monitor mode service 1-7
multiple ACF/NCPs 2-4
multiple priority level support 5-8
multiple routing 5-7
multiple terminal access 1-5

N

network control 8-2
network logical data manager 6-2
network objectives 8-1
network performance analyzer 6-1
network testing 8-2

O

objectives, for a network 8-1
online line testing 1-4
online terminal testing 1-4
OS/VS generation procedure 2-3

P

packet-switched data network 4-1
packet-switching interface 4-1
parallel data links between adjacent ACF/NCPs 5-7
partitioned emulation programming extension 1-3
pause retry 1-4
PEP extension 1-3
PEP load modules, link load of 6-2
planning for an ACF/NCP 8-1

R

re-routing of data 5-9
resources 8-1
resource availability 8-3
route verification 5-10

S

session trace 6-1

T

telecommunication control 1-2
testing an ACF/NCP network 8-2
time insertion 1-4

U

utilities
 loader 2-6
 dump 2-6
 dynamic dump 2-6

V

verification of identification received from
 BSC and SDLC stations 1-5
Version 2 services 6-1

X

X.25 packet switching interface

230.4 Kbps line speed 4-2
3270, enhancements for 6-2
3705
 assembler 2-4
 dynamic control of 1-7
 hardware additions for 4-1
 interactions with ACF/NCP 1-8
3863 modem test 4-1
3864 modem test 4-1
3865 modem test 4-1
3867 link diagnostic unit, test for 4-1

Advanced Communications
Function for the Network Control
Program, for the IBM 3705

Advanced Communications
Function for System Support
Programs, for the IBM 3705

General Information

Order No. GC30-30-58-3

**READER'S
COMMENT
FORM**

This form may be used to communicate your views about this publication. They will be sent to the author's department for whatever review and action, if any, is deemed appropriate. Comments may be written in your own language, use of English is not required.

IBM may use or distribute any of the information you supply in any way it believes appropriate without incurring any obligation whatever. You may, of course, continue to use the information you supply.

Note: *Copies of IBM publications are not stocked at the location to which this form is addressed. Please direct any requests for copies of publications, or for assistance in using your IBM system, to your IBM representative or to the IBM branch office serving your locality.*

Possible topics for comment are:

Clarity Accuracy Completeness Organization Coding Retrieval Legibility

Please use pressure sensitive or other gummed tape to seal this form.

Cut or Fold Along This Line

If you would like a reply, complete the following (Please Print):

Your Name _____ Date _____

Company Name _____

Department _____

Street Address _____

City _____ State _____ Zip Code _____

Thank you for your cooperation. No postage stamp is necessary if mailed in the U.S.A. (Elsewhere, an IBM office or representative will be happy to forward your comments.)

ADDITIONAL COMMENTS:

Cut or Fold Along Line

Please Do Not Staple

Fold and Tape

Fold and Tape



NO POSTAGE
NECESSARY
IF MAILED
IN THE
UNITED STATES

BUSINESS REPLY MAIL

FIRST CLASS PERMIT NO. 40 ARMONK, N.Y.

POSTAGE WILL BE PAID BY ADDRESSEE

International Business Machines Corporation
Dept. E02
P.O. Box 12195
Research Triangle Park
North Carolina 27709

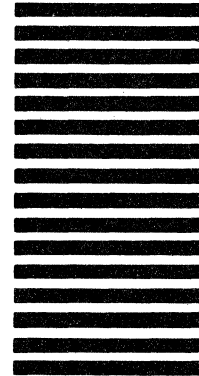

Fold and Tape

Fold and Tape





IBM CORPORATION
ARMONK, N.Y. 10503
U.S.A.

ACF/NCP for IBM 3705; ACF/SSP for IBM 3705, General Information Printed in U.S.A. GC30-3058-3

