

**Program Product**

**Network Problem Determination  
Application: General Information**



## **Program Product**

## **Network Problem Determination Application: General Information**

**Release 2  
Release 2 Enhanced**

**Program Number 5735-XX8  
(DOS/VSE, OS/VS1, OS/VS2 MVS)**



THIRD EDITION (February, 1980)

This edition applies to the Network Problem Determination Application (NPDA) Program Product, 5735-XX8, Release 2 and Release 2 Enhanced, and to all subsequent releases until otherwise indicated in new editions or Technical Newsletters.

This publication is a major revision to GC34-2010-1 (which describes NPDA Release 1 and which can temporarily be obtained as GT34-2010). This new edition reflects technical and editorial changes. Changes and additions to the text and illustrations are indicated by vertical bars to the left of the change. Significant changes are summarized under the "Summary of Amendments" following the figures list.

Changes are continually made to the information herein; before using this publication in connection with the operation of IBM systems, consult the latest IBM System/370 Bibliography, GC20-0001, for the editions that are applicable and current.

It is possible that this material may contain references to, or information about, IBM products (machines and programs), programming, or services that are not announced in your country. Such references or information must not be construed to mean that IBM intends to announce such IBM products, programming, or services in your country.

Publications are not stocked at the address given below; requests for IBM publications should be made to your IBM representative or to the IBM branch office serving your locality.

A form for reader's comments is provided at the back of this publication. If the form has been removed, comments may be addressed to IBM Corporation, Systems Publications, Dept. Z59, P. O. Box 390, Poughkeepsie, NY USA 12602. IBM may use or distribute any of the information you supply in any way it believes appropriate without incurring any obligation whatever. You may, of course, continue to use the information you supply.

This manual provides information needed to plan for the installation and use of the Network Problem Determination Application (NPDA), a program product that allows a user to monitor, record, retrieve, and examine communications error data in an interactive environment. The manual provides a general description of NPDA as well as the initial planning information needed for the installation of this product.

This manual is divided into the following chapters:

- "Introduction" contains a general overview of the NPDA structure, function, and usage.
- "Planning for NPDA" describes the NPDA requirements on the hardware and operating system environments of the installation.
- "Publications Support" describes the publications available for installation and use of NPDA.
- "Glossary" contains definitions of NPDA terminology and abbreviations.

For publications containing additional information about NPDA, and for related publications support, see Chapter 3.



# CONTENTS

Summary of Amendments . . . . .	7
Release 2 . . . . .	7
Release 2 Enhanced . . . . .	7
Chapter 1. Introduction . . . . .	9
NPDA Operating Environment . . . . .	9
Functions . . . . .	11
Data Bases . . . . .	11
NPDA Use . . . . .	12
User Scenario . . . . .	12
Display Screen Format . . . . .	13
Tracking Sequences . . . . .	14
User Action . . . . .	16
Probable Cause . . . . .	17
Commands . . . . .	18
Chapter 2. Planning for NPDA . . . . .	21
Hardware Support . . . . .	21
SNA Mode . . . . .	21
EP Mode . . . . .	21
Local Mode . . . . .	22
Operator Stations . . . . .	22
Programming Requirements . . . . .	23
Storage Estimates . . . . .	23
Chapter 3. Publications Support . . . . .	25
NPDA Publications . . . . .	25
NCCF Publications . . . . .	25
Glossary . . . . .	27
Index . . . . .	29

## FIGURES

Figure 1. NPDA Environment . . . . .	10
Figure 2. Example of an NPDA Display . . . . .	13
Figure 3. First Step in NCP Error Tracking . . . . .	15
Figure 4. Tracking Sequence for 370X/NCP Error Types . . . . .	15
Figure 5. Example of a User Action Display . . . . .	16
Figure 6. Local Probable Cause Definition . . . . .	17

## SUMMARY OF AMENDMENTS

This edition describes the added facilities and changes to NPDA in Release 2 and Release 2 Enhanced.

### RELEASE 2

- Change in the use of the name "NCP" to "SNA" when referencing operating mode and data base.
- Additional displays recommending actions that may assist the user in correcting or bypassing errors.
- Additional displays for error records generated by IBM 386X modems.
- Facilities to monitor link quality and issue operator alerts when error rates exceed preset thresholds.
- Indications of the probable cause for an error record on the 'most recent' SNA category of displays.

### RELEASE 2 ENHANCED

- Additional displays for error records generated by ACF/VTAME and the IBM 4331 Communications Adapter.
- Error record purge from the SNA and the EP/Local data bases of records older than a user-specified date.
- Indications of the probable cause for an error record on the 'most recent' EP and Local category of displays.





Problem determination within a communications network should be an orderly process that helps locate network components that are failing continuously or intermittently, and alerts and offers direction to a user. The Network Problem Determination Application (NPDA) Program Product assists users in performing communications network problem determination by collecting and interpreting records of errors detected within a network and by recommending possible resolutions.

The NPDA user has access, via a terminal, to the accumulated error data and statistics. This data is presented as:

- Error counts associated with communications controllers; BSC, start-stop, and SDLC lines; control units; and terminals in the network. NPDA Release 2 adds error counts and data detected by IBM 386X modems.
- Specific data, an error description, and a probable cause associated with each class of error collected. Recommended actions to resolve the displayed errors are provided with NPDA Release 2.

The cross-domain capability of SNA communication subsystems is used by NPDA to permit displays of errors collected in other network domains that are running equivalent releases of NPDA.

### NPDA OPERATING ENVIRONMENT

NPDA uses system functions provided by the Network Communications Control Facility (NCCF) Program Product to interface with the data base and with communications and display access methods. Refer to NCCF General Information for details about NCCF functions.

NPDA runs as a communications network management command processor under NCCF and can only be invoked by an NCCF-authorized operator at an NCCF-authorized terminal.

The environment under which NPDA operates is shown in Figure 1. Several versions of communications access methods are shown here to delineate the several routings of SNA type error records.

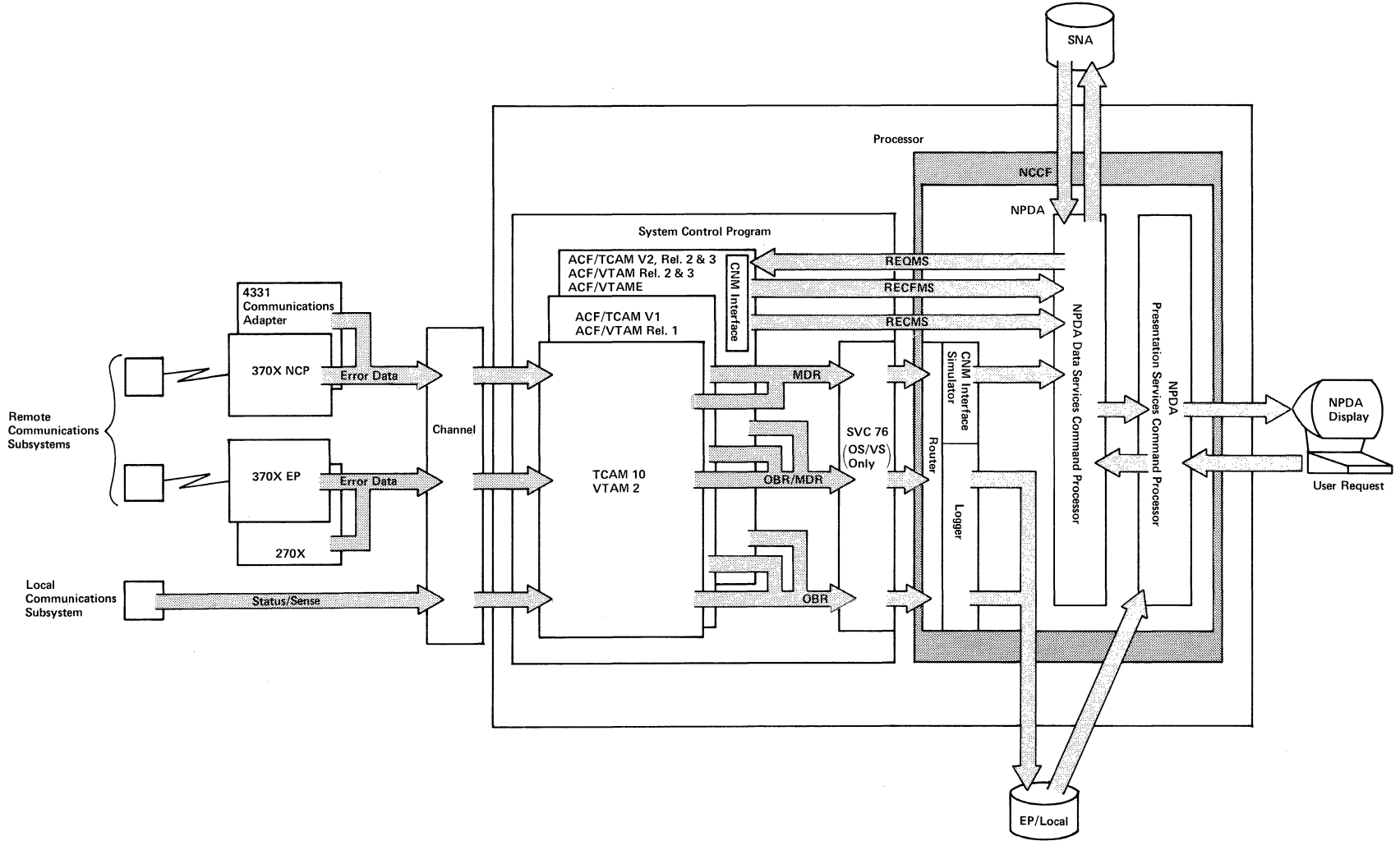

Figure 1. NPDA Environment

## Functions

NPDA is logically composed of three entities, which generally execute in the following order:

- A router/logger, which (executing as a subtask of NCCF) ensures proper routing and recording of error statistics to the EP/Local data base. The router, in conjunction with the CNM interface simulator, also routes error records to the SNA data base (called the NCP data base in NPDA Release 1) from communications subsystems supported by VTAM 2, TCAM 10, ACF/VTAM Release 1, and ACF/TCAM Version 1.

For communications subsystems supported by ACF/VTAM Releases 2 and 3, ACF/TCAM Version 2 Releases 2 and 3, or ACF/VTAME, routing to the SNA data base is via the CNM Interface within the access method.

During error collection, recoverable line error counts are monitored and operator alerts are issued whenever the ratio of errors to traffic exceeds a preset threshold value. This facility is made available in NPDA Release 2.

The router/logger supports the EP/Local data base for OS/VS1 and OS/VS2 MVS only. The router/logger must be included as an NCCF subtask by the user, for details see NPDA Installation.

- Data services command processor (DSCP), which structures requests:
  - To the SNA data base for formatting and recording purposes. For ACF/VTAM Releases 2 and 3, ACF/TCAM Version 2, and ACF/VTAME, the DSCP also structures requests to solicit error statistics for the SNA data base from SNA devices in the communications network.
  - To the SNA data base for data retrieval. The retrieval function is activated when the user enters an NPDA display request at the terminal.
- Presentation services command processor (PSCP), which structures user requests for the formatted display of error statistics (gathered by the data services) and for other NPDA services, at the NPDA user terminal. The PSCP also structures requests for data retrieval from the EP/Local data base.

## Data Bases

NPDA has access to both the EP/Local data base, created by the NPDA router/logger, and the SNA data base, created by the NPDA data services command processor and the NCCF data services manager.

The EP/Local data base is a BDAM-organized file. It contains error incident records from hardware configurations containing 2701, 2702, or 2703 transmission control units; 3704 or 3705 communications controllers running in EP mode; and remote and local VTAM, TCAM, or BTAM-accessed 3270 devices operating in a non-SNA controlled network environment. The EP/Local data

base is supported for use under OS/VS1 and OS/VS2 MVS host systems only; NPDA running under a DOS/VSE system does not support the EP/Local data base.

The SNA data base is a VSAM key-sequenced file. It contains error incident records from a hardware configuration consisting of 3704 or 3705 communications controllers running in NCP mode with SNA and non-SNA devices attached and operating under an SNA-controlled network environment. Error incidents detected by a 4331 Communications Adapter running under ACF/VTAME are also stored and are made available in NPDA Release 2 Enhanced. The SNA data base is supported for use under OS/VS2 (MVS), OS/VS1, and DOS/VSE host systems.

The user has the ability to purge out-of-date error records from the SNA data base by means of an NPDA explicit command that also specifies the cutoff date. This function is also provided for the EP/Local data base as an offline utility and both methods are made available in the enhanced version of NPDA Release 2.

## NPDA USE

This section presents a scenario of NPDA use, an example of an NPDA error display, a description of tracking sequences, an example of a user action display, an explanation of probable cause statements, and a list of NPDA commands.

### User Scenario

The accumulation of error data begins after the system operator starts NCCF. Errors occurring within communications subsystems are written to the EP/Local or SNA data bases and alerts may be issued to the NCCF operator.

If performance degradation occurs or alerts are issued, the user may suspect a problem with a controller, line, or terminal. He should log on to NCCF and invoke NPDA. From an initial menu display, the user may choose the mode in which he wishes to proceed -- EP, SNA, or LOCAL. In NPDA, mode is the category of errors related to the transmission control units, communications controllers, and the controlling disciplines under which the various network components are operating.

After the user chooses an operating mode he enters explicit commands or is prompted through a step-down sequence of NPDA displays for more detailed information, and NPDA processes the requests by retrieving data from the appropriate data base.

For example, in SNA mode the NPDA user can analyze the following error data:

- 3704/3705 errors -- Errors occurring within a communications controller which are due to the channel adapter, communications scanner, NCP instruction exceptions, or NCP miscellaneous interrupts.
- 4331 Communications Adapter errors -- errors detected by the 4331 Communications Adapter and ACF/VTAME are handled by NPDA Release 2 Enhanced.

- Primary-end-of-line errors -- All errors detected at the end of the line that is attached to the communications controller. These errors include both line and station (terminal controller) errors for supported terminal controllers and line errors detected by 386X modems (NPDA Release 2). Recoverable, or temporary, error counts are accumulated and compared to user-established alarm values for the dual purposes of link measurement displays and automatic operator alerts. (NPDA Release 2.)
- Secondary-end-of-line errors -- All errors detected at the end of the line that has a supported terminal controller attached to it.

## Display Screen Format

The NPDA display screen provides both information for problem determination and a means to get additional or more detailed information about an error event. Figure 2 shows the format of a typical screen, in this case the first screen displayed when looking at SNA mode errors.

```

NETWORK COMMUNICATIONS CONTROL FACILITY                                03/16/79 08:16:45
NPDA-370X ALL * TOTAL ERRORS *                                       SNA MODE PAGE 1
FOR ALL 370X/NCPS AND THEIR ATTACHED LINES

NCPNAME: NCPA1

SEL-#
( 1) TOTAL NCP ERRORS: 1 FROM: 03/14 18:04 TO: 03/14 18:04
SECONDARY ERRORS
( 2) LINENAME TRAFFIC PERM-ERRS TEMP-ERRS FROM TO
( 3) LNDET 12570 33 247 03/11 09:12 03/14 09:30
( 4) LNPOK 20100 6 60 03/09 15:05 03/12 10:28 Y
( 5) LNRAL 1250 2 12 03/12 11:10 03/14 12:00
( 6) LNSTL 32604 0 0 03/14 10:32 03/15 09:00 Y
( 7) LNTOL 6200 0 50 03/14 10:20 03/15 13:00
( 8) LNSCHI 0 6 0 03/09 04:00 03/14 11:00
( 9) LSDAL 1200 24 42 03/10 01:20 03/15 16:01
(10) LSDUR 6400 0 10 03/14 10:24 03/15 16:00
(11) LSLAX 4200 0 22 03/14 10:29 03/15 09:00
(11) LSNJY 420 60 50 03/13 14:44 03/15 15:28 Y
** ENTER NPDA OPERATION WORD FOR NEXT PAGE **
ENTER SEL-# OR COMMAND, OR ENTER SEL-# FOLLOWED BY ' S ' TO VIEW SECONDARY ERRORS

NPDA _

```

Figure 2. Example of an NPDA Display

The bottom line of the screen is used for command entry, to get additional information or to view information about other error types in the network.

The user may request an NPDA display by explicit command, or may respond by selecting the information to be displayed. Combinations of these two methods may be used.

## Tracking Sequences

In each operating mode, there is a sequence of displays designed to aid the user in determining the specific cause of a network problem. For any communications controller, line, or terminal controller, the user can get to detailed information about a single error through the error tracking sequence.

Error tracking sequences allow the tracing of error data through several levels of detail:

- Total errors;
  - Total SNA errors -- Total error counts (historical) from the date the data base was last purged (or initialized) until the present.
  - Total EP errors -- Total error counts (historical) from the date the data base was last purged (or initialized) until the present are shown on the Total EP Error display. Total error counts representing only the errors that currently exist on the data base are shown on the EP primary and EP secondary line displays.
  - Total Local errors -- Total error counts (historical) from the date the data base was last purged (or initialized) until the present.
- Most recent errors -- A list of errors retained on the data base and presented in reverse date/time sequence. Totals displayed in this category represent the error counts that currently exist on the data base. Each error event shows an abbreviated error description and probable cause for SNA mode errors (NPDA Release 2) and for EP/Local mode errors (NPDA Release 2 Enhanced).
- Detail errors -- Expanded view of a single error event selected from the list of most recent errors. These displays contain detailed explanations of errors and also identify the network components that most likely caused the error (for the more experienced user).
- User actions -- NPDA Release 2 introduces a series of displays that recommend user actions based on error descriptions and probable cause (for the less experienced user).

In SNA mode, for example, the "Total Errors for All 370X/NCPs and Their Attached Lines" display provides a starting point for each of several more detailed SNA error tracking sequences. The initial display for each of the step-down sequences shows:

- Total 370X/NCP Errors by Type
- Total Primary End-of-Line Errors
- Total Secondary End-of-Line Errors by Controller

Each of these initial displays may be retrieved by means of an explicit command or by entering the proper selection number (see SEL-# heading in Figure 2). The data shown two display lines above the command line always constitutes a prompt designed to guide the user to the next most likely

display, while the line above the prompt describes actions to be taken to view more data on the current display and also serves as an NPDA error/information message line.

Figure 3 shows the initial step in error tracking while operating in SNA mode. This display allows the user to select a more detailed view of error data detected at various points in the network.

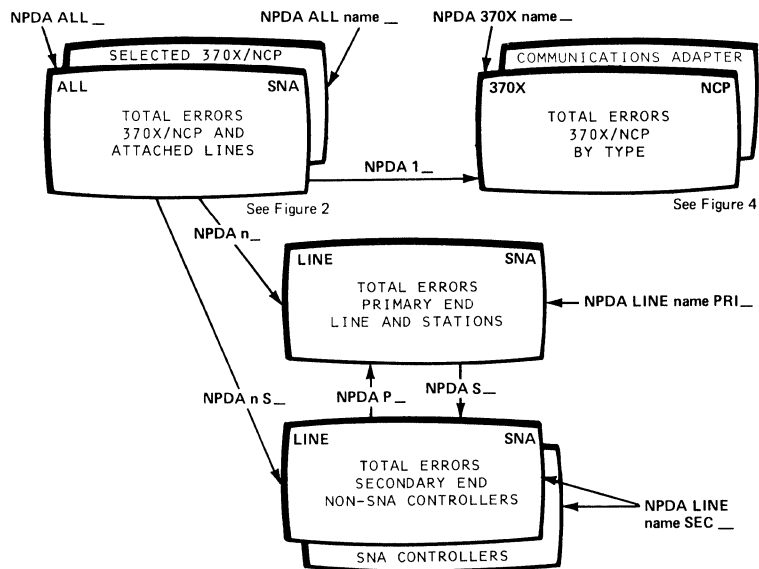

Figure 3. First Step in SNA Error Tracking

Figure 4 continues the tracking example by showing how the user can proceed from the total SNA error count to a specific count of errors for a communications controller, a line, or a terminal controller. To do this, he chooses a selection number on each level of the sequence to proceed to the next more detailed level.

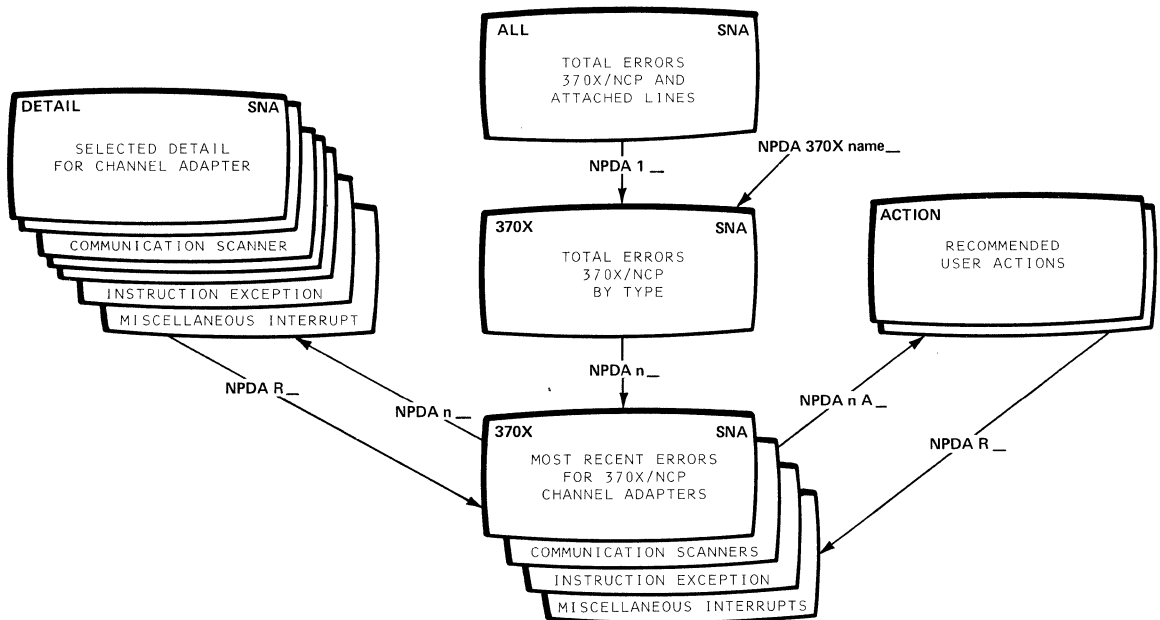

Figure 4. Tracking Sequence for 370X/NCP Error Types



## User Action

In NPDA Release 2, the user has the option (as shown in Figure 4) to retrieve a group of user action displays that are keyed to the error descriptions shown on the most recent displays. These new displays (ACTION displays) are divided into categories of possibly erroneous network activities (for example, user error, improper product installation, or network component failure). Statements shown under each network activity recommend actions that the user might take to either bypass or resolve the error.

These recommended actions include link tests, modem tests, secondary tests, traces, etc., that can be executed by the user, depending on his experience level and the availability of the facilities.

Figure 5 presents an example of a user action display. The indicators (D001, D002, etc.) listed with the activities are references to sections within the NPDA User Action Guide, which provide further details about the execution of recommended user actions.

```
NETWORK COMMUNICATIONS CONTROL FACILITY          08/16/80  08:18:30
NPDA - ACTION  * RECOMMENDED ACTIONS FOR SELECTED EVENT *  PAGE 1

  USER   CAUSED - DEVICE REINITIALIZED DURING TRANSMISSION
           DEVICE POWERED OFF DURING TRANSMISSION
           REMOTE MODEM POWERED OFF DURING TRANSMISSION
           ACTIONS - CORRECT; THEN RETRY (D001)

  INSTALL CAUSED - NCP GEN PARAMETER INCORRECT
                   (REPLYTO)
           ACTIONS - CORRECT GENERATION PROBLEM (D006)

  FAILURE CAUSED - LINE
                   SECONDARY PRODUCT
                   REMOTE MODEM
                   LOCAL MODEM (RECEIVE SIDE)
           ACTIONS - RUN LINE TESTS (D003)
                   RUN SECONDARY TESTS (D004)
                   RUN MODEM TESTS (D002)

ENTER 'R' TO RETURN TO PREVIOUS DISPLAY OR ENTER COMMAND
NPDA _
```

Figure 5. Example of a User Action Display

As an interim measure, the first edition of the NPDA User Action Guide contains significant portions of the NPDA Release 2 user action displays shown as numbered figures. These figures can be located within the publication by means of an error description/probable cause cross-reference table and provide documentation of the user action facility for use with NPDA Release 1.

## Probable Cause

During the tracking of errors, the NPDA user is provided with error descriptions and probable cause statements on the most recent and the detail displays that help him understand which components in a network are experiencing failures. The error descriptions and probable cause statements are derived from an analysis of network error data stored in the NPDA data bases.

The intent of probable cause is to direct the NPDA user to the specific network component that caused the network error. When the accumulated error data is not sufficient to pinpoint the failing network component, the probable cause statement (for example, COMMUNICATION or COMMUNICATION FAILURE) identifies a group of components, one of which probably caused the error. The NPDA user should then examine the available error data and initiate the same procedures that are defined under 'User Action.' When multiple probable causes are identified (for example, HARDWARE/PROGRAM), the NPDA user should examine all probable cause definitions and then initiate the procedures mentioned under 'User Action' to further isolate the failure to the specific component.

Definitions of probable cause in terms of network component failures are provided for all supported network environments.

Figure 6 presents an example of probable cause definitions that apply to a local communications environment with brief explanations of each probable cause.

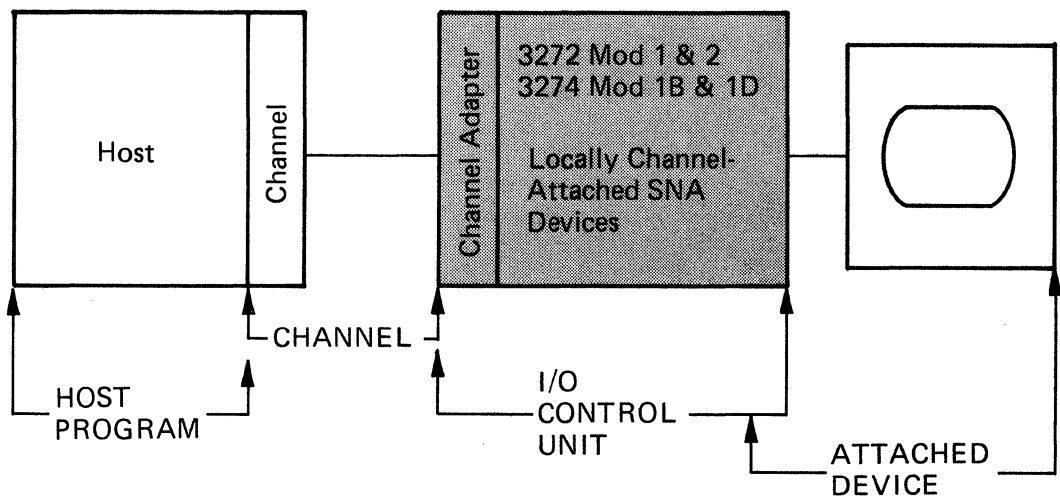

**HOST PROGRAM**  
caused by:  
Host program.

**CHANNEL**  
can be caused by:  
Channel hardware.  
Channel interface cables.

**I/O CONTROL UNIT**  
caused by:  
I/O control unit.

**ATTACHED DEVICE**  
can be caused by:  
I/O control unit receivers  
and drivers.  
Cable.  
Attached device.

Figure 6. Local Probable Cause Definition

## Commands

NPDA commands consist of SNA mode commands, EP mode commands, Local mode commands, and display control commands. SNA mode commands access data in the NCP data base; EP mode commands access EP data in the EP/Local data base using physical device addresses only; Local mode commands access data about local device errors from the EP/Local data base using physical device addresses only. Display control commands move from page to page within a display level, move to different display levels within NPDA, and set or display various control states. Some of these commands, such as the display control commands, may be entered in more than one mode; the function of these general commands, however, varies slightly depending on the mode. Other commands are unique to a particular mode.

Note: EP and Local mode commands do not function for DOS/VSE network operations nor for network cross-domain operations. Certain SNA mode commands also do not function under cross-domain operations. These restrictions are noted under each command on the following list.

### SNA Mode Commands (called NCP mode in Release 1)

- ALERT -- Establishes resources to be scanned for abnormal error rates. (Not functional under cross-domain.) (NPDA Release 2.)
- ALL -- Displays total counts of 3704/3705 errors and primary-end-of-line errors and an indicator of secondary-end-of-line errors.
- CTRL -- Displays most recent error events listed by reverse date/time for the selected 3270 control unit or supporting SNA physical unit.
- DISPLAY DOMAIN -- Displays the current domain ID for a host system in which a specific resource is active.
- DISPLAY WRAP -- Displays the current wrap count for a specified resource. The wrap count is the number of most recent events retained in the SNA data base before deleting the oldest records.
- ID -- Displays a list of symbolic names associated with a specified terminal controller.
- LINE -- Displays total counts for primary- or secondary-end-of-line errors for a line.
- PURGE -- Clears SNA data base of records recorded earlier than a specified date. (Not functional under cross-domain.) (NPDA Release 2 Enhanced.)
- SET DOMAIN -- Establishes the domain in which the user may view error statistics.
- SET WRAP -- Establishes a new wrap count for the specified resource. (Not functional under cross-domain.)
- TERM -- Displays most recent errors listed by reverse date/time for the associated 3270/BSC control unit detected at the secondary end of the line.
- TEST -- Initiates test and displays status and test results for station links or for DTE interface cable. (NPDA Release 2.)
- 370X -- Displays total counts of 3704/3705 errors by error type.

EP Mode Commands (Not functional under DOS/VSE or cross-domain.)

- ALL -- Displays total counts for primary- and secondary-end-of-line errors for all lines in EP mode.
- CTRL -- Displays most recent error events by reverse date/time for the secondary end of the line for a control unit.
- LINE -- Displays total error counts for the primary end of the line and, for remote devices, from the secondary end of the line for each control unit on the line.
- TERM -- Displays most recent error events by reverse date/time for the control unit associated with the specified terminal.

Local Mode Commands (Not functional under DOS/VSE or cross-domain.)

- ALL -- Displays error events by channel address for all channels to which communications devices are attached.
- DEVICE -- Displays most recent error events by reverse date/time for a channel with attached terminal/controllers.

Display Control Commands

- BACK -- Displays the previous page of a multipage display.
- COMMAND -- Displays the syntax of the explicit commands available for the current or specified operating mode.
- END -- Exits from NPDA, while continuing to collect error data on the appropriate data base.
- HELP -- Explains the screen control command options and allows selection of explanations of explicit commands.
- MENU -- Displays the NPDA menu display.
- SNA, EP, or LOCAL -- Displays appropriate command selection display and sets display mode.
- Page forward -- Displays the next sequential page of a multipage display.
- RESUME -- Redisplays the screen of NPDA data being viewed after invoking another communications network management application (used during NPDA session after invoking other NCCF functions).
- RETURN -- Presents the display page from which the current display had been entered.
- TITLE -- Displays the first page of a multipage display.

Details about these commands can be found in NPDA Terminal Use.



This chapter identifies the effect of NPDA upon:

- Hardware support
- Programming support
- Storage estimates

### HARDWARE SUPPORT

NPDA collects hardware errors associated with various IBM devices, depending on the operating mode: SNA, EP, or Local.

#### SNA Mode

For SNA mode, NPDA collects and displays errors for:

- 3704/3705 communications controllers.
- | • IBM 4331 Communications Adapters. (NPDA Release 2 Enhanced.)
- SDLC, BSC, and start-stop lines attached to a 3704/3705 in NCP mode.
- | • 3863, 3864, and 3865 modems. (NPDA Release 2.)
- 3271 Models 1 and 2 control units connected to a 3704/3705 in NCP mode.
- 3274 Model 1C control unit connected to a 3704/3705 in NCP mode.
- 3275 Models 1 and 2 display stations attached via a BSC line to a 3704/3705 in NCP mode.
- 3276 Models 1, 2, 3, 4, 11, 12, 13, and 14 control unit display stations connected to a 3704/3705 in NCP mode.
- 3770 MLU models (3776 Models 3 and 4, 3777 Model 3).

#### EP Mode

For EP mode, NPDA collects and displays errors for:

- BSC and start-stop lines connected to a 2701/2702/2703 or to a 3704/3705 in EP mode.
- 3271 Models 1 and 2 control units connected to a 2701/2702/2703 or to a 3704/3705 in EP mode.

- 3274 Model 1C control unit connected to a 2701/2702/2703 or to a 3704/3705 in EP mode via a BSC line.
- 3275 Models 1 and 2 display stations connected to a 2701/2702/2703 or to a 3704/3705 in EP mode via a BSC line.
- 3276 Models 1 and 2 control unit display stations connected to a 2701/2702/2703 or to a 3704/3705 in EP mode via a BSC line.

## Local Mode

For Local mode, NPDA collects and displays errors for:

- 3272 Models 1 and 2 control units connected directly to a host system channel (for unit check only).
- 3274 Models 1A, 1B, and 1D control units connected directly to a host system channel (for unit check only).
- 3790, as an SNA controller connected directly to a host system channel (for unit check only).
- 3704/3705 communications controllers connected directly to a host system channel (for unit check only).

## Operator Stations

NCCF supports the following devices as NPDA operator stations:

- 3275 Models 2 and 12 display stations.
- 3276 Models 2, 3, 4, 12, 13, and 14 control unit display stations.
- 3277 Model 2 display station.
- 3278 Models 2, 3, 4, and 5 display stations.
- 3279 Models 2A, 2B, 3A, and 3B display stations. (NPDA Release 2 Enhanced.)  
Note: 3279 terminals are supported only in monochrome and base color modes.

## PROGRAMMING REQUIREMENTS

The Network Communications Control Facility (NCCF) Program Product is a prerequisite for NPDA. Refer to NCCF General Information for additional dependencies and prerequisites.

NPDA runs as an application program under NCCF on all IBM processors that meet the minimum requirements for the NCCF program product.

NPDA is provided as a licensed program that runs under NCCF, another licensed program that runs on OS/VS2 MVS Release 3.8 and OS/VS1 Release 6.7 or 7.

NPDA with NCCF also runs with ACF/VTAM Release 2 in a DOS/VSE environment (NPDA Releases 1 and 2) and ACF/VTAME in a DOS/VSE environment (NPDA Release 2 Enhanced).

In a VM/370 environment, NPDA operates with NCCF and ACF/VTAM Release 2 and 3 and ACF/TCAM Version 2 Release 2 and 3 under any of their supported operating systems. NPDA supports only remote controllers/terminals in this environment for collection of problem determination data.

## STORAGE ESTIMATES

The virtual storage requirement for NPDA varies with user options, but is approximately 350K bytes. Direct access space requirements for NPDA data bases depend on the network configurations and user options. Complete storage estimating algorithms for NPDA can be found in NPDA Installation.





## CHAPTER 3. PUBLICATIONS SUPPORT

| The Network Problem Determination Application (NPDA) is supported by both  
| NPDA and NCCF introductory and reference publications.

### | NPDA PUBLICATIONS

| The following publications provide information on how to install, modify,  
| and use NPDA:

Network Problem Determination Application: Terminal Use, SC34-2013,  
describes the NPDA functions and how to use them.

| Network Problem Determination Application: User Action Guide, SC34-2032,  
| provides detailed instructions that help the user to further identify the  
| failing component and possibly correct it or bypass its effect on the  
| network.

| Network Problem Determination Application Reference Summary, SC34-2034,  
| provides quick and easy access to information needed to use NPDA.

Network Problem Determination Application: Messages and Codes, SC34-2012,  
contains explanations of all messages and user completion codes issued by  
NPDA. This information is provided in the format of the OS/VSE and DOS/VSE  
message publications so that it can be filed with other messages  
documentation.

Network Problem Determination Application: Installation, SC34-2011, contains  
information needed to install and verify the operation of NPDA.

Network Problem Determination Application: Logic, LY25-0002, contains  
information needed to maintain or modify NPDA components.

### | NCCF PUBLICATIONS

| The following publications provide information on how to use and install  
| NCCF:

| Network Communications Control Facility: General Information, GC27-0429,  
| provides information on how to plan for the installation and use of NCCF.

| Network Communications Control Facility: Terminal Use, SC27-0432, describes  
| the tasks associated with operating NCCF.

| Network Communications Control Facility: Installation, SC27-0430, provides  
| information about installing and verifying NCCF.

| Network Communications Control Facility: Customization, SC27-0433, provides  
| information about modifying NCCF for your installation's needs.

| Network Communications Control Facility: Messages, SC27-0431, provides  
| explanations of all messages and user completion codes issued by NCCF.



This glossary defines terms and abbreviations that are important in this publication. Additional terms can be found by referring to related publications and to the IBM Data Processing Glossary, GC20-1699.

ACF/NCP/VS. Advanced Communications Function for the Network Control Program/Virtual Storage.

ACF/TCAM. Advanced Communications Function for the Telecommunications Access Method.

ACF/VTAM. Advanced Communications Function for the Virtual Telecommunications Access Method.

ACF/VTAME. Advanced Communications Function for the Virtual Telecommunications Access Method Entry (for DOS/VSE systems running under communications adapters).

CNM. Communications network management.

communications adapter. In NPDA, refers to the hardware feature on the IBM 4331 that performs some of the functions in other IBM communications controllers.

communications network management (CNM). The process of designing, installing, operating, and managing the distribution of information and controls among end users of communications systems.

communications network management application. A combination of the components and elements that comprise the problem determination, operational facilities, and performance functions of CNM. An example is NCCF with added CNM processors.

communications network management interface. The interfaces provided to application programs by the access method for handling data and commands associated with communications systems management.

CNM data and commands are handled across this interface.

communications network management processor. A program that manages one of the functions of a communications system. A CNM processor is executed under control of NCCF and requires NCCF as a prerequisite program.

data services command processor (DSCP). An NCCF component that structures the request for recording and retrieving data in the application program's data base, and also structures the request to solicit data from a network device. NPDA supplies a DSCP for managing problem determination data.

data services manager (DSM). A function in NCCF that provides VSAM services for data storage and retrieval and provides the interface between DSCPs and the CNM interface.

DSCP. Data services command processor.

EP. Emulator Program.

logger/router. An NPDA function that executes as an NCCF subtask to record errors from EP mode and Local mode devices to the EP/Local data base and, for VTAM Level 2, TCAM Level 10, ACF/VTAM Release 1, and ACF/TCAM Version 1, transmits errors from SNA mode devices through the data services command processor and the CNM interface simulator to the SNA data base.

MDR. Miscellaneous data record.

NCCF. Network Communications Control Facility.

NCP. Network Control Program.

Network Communications Control Facility (NCCF). A program consisting of a base for command processors that can monitor, control, and improve the operation of a data communications network.

Network Problem Determination Application (NPDA). A CNM processor that assists the user in identifying communications network problems from a central control point via interactive display techniques.

NPDA. Network Problem Determination Application.

presentation services command processor (PSCP). An NCCF component that processes a user request from a

user terminal and formats displays to be presented at the user terminal. NPDA provides a PSCP for displaying formatted problem determination data.

PSCP. Presentation services command processor.

SNA. Systems network architecture. In NPDA, also specifies an error data category or mode to simplify error tracking.

TCAM. Telecommunications Access Method.

VSAM. Virtual Storage Access Method.

VTAM. Virtual Telecommunications Access Method.

**A**

ACF/TCAM 11, 23  
 ACF/VTAM 11, 23  
 ACF/VTAME 7, 23  
 adapter  
   (see 4331 communications adapter)  
 ALERT command 18  
 alerts 7, 12  
 ALL command 18, 19  
 ALL display 13

**B**

BACK command 19  
 BDAM 11

**C**

CNM interface 11  
 COMMAND command 19  
 command display line 13  
 commands 18  
   display control 19  
   EP mode 18  
   Local mode 19  
   SNA mode 18  
 cross-domain 9, 18  
 CTRL command 18, 19

**D**

data base  
   BDAM 11  
   EP/Local 11  
   purge 7, 12, 14  
   SNA 11, 12  
   VSAM 12  
 data status display line 15  
 detail displays 14  
 DEVICE command 19  
 DISPLAY DOMAIN command 18  
 DISPLAY WRAP command 18  
 displays  
   data  
     commands 13  
     data status 15  
     prompting 15  
   detail 14  
   most recent 14

total 13, 14  
 user action 14, 16  
 DOS/VSE 23  
 DSCP 11

**E**

END command 19  
 environment 10  
 EP  
   commands 18  
   data base 11  
   hardware support 21  
   mode 12  
 error counts 9  
 error description 14  
 error tracking sequence 14, 15  
 estimates, storage 23

**G**

guide, user action 16

**H**

hardware support  
   EP 21  
   Local 22  
   SNA 21  
 HELP command 19

**I**

ID command 18  
 installation 23

**L**

LINE command 18, 19  
 line tests 16  
 link measurement 7, 12  
 Local  
   commands 19  
   data base 11  
   hardware support 22  
   mode 12  
 logger  
   (see router)

logon 12

## M

MENU command 19  
mode 12  
    EP 12  
    Local 12  
    SNA 12  
modem tests 16  
modems  
    (see 386X modems)  
most recent displays 14

## N

NCCF 9  
    logon 12  
    operator stations 22  
    publications 25  
NCP 7  
    (see SNA)  
    (see also 370X communications  
    controllers)  
NPDA  
    commands 18  
    environment 10  
    operator stations 22  
    planning 21  
    publications 25  
    use 12

## O

operating mode 12  
    (see mode)

## P

page forward command 19  
planning for NPDA 21  
probable cause 7, 9, 14, 17  
    definitions 17  
programming requirements 23  
prompt display line 15  
PSCP 11  
publications 25  
purge 7, 12, 14  
PURGE command 18

## R

requirements, programming 23  
restrictions  
    ALERT command 18  
    cross-domain 9, 18  
    DOS/VSE 18  
    EP/Local 18  
    EP/Local 11  
    PURGE command 18  
    router/logger 11  
    SET WRAP command 18  
RESUME command 19  
RETURN command 19  
router 11

## S

scenario 12  
secondary tests 16  
SET DOMAIN command 18  
SET WRAP command 18  
set-mode commands 19  
SNA  
    commands 18  
    data base 12  
    hardware support 21  
    mode 12  
    name 7  
storage estimates 23  
support, publications 25

## T

TERM command 18, 19  
TEST command 18  
tests 16  
TITLE command 19  
total displays 14  
tracking sequence, error 14

## U

user action  
    displays 14, 16  
    general 7, 9, 16  
    guide 16  
user scenario 12

## V

VSAM 12

270X transmission control units	11,	3790 communications system	22
21		386X modems	7, 9, 12, 21
370X, command	18	4331 communications adapter	7, 12,
370X communications controllers	10,	21	
11, 12, 21			





Network Problem Determination  
Application: General Information  
Release 2 and Release 2 Enhanced

GC34-2010-2

READER'S  
COMMENT  
FORM

This manual is part of a library that serves as a reference source for systems analysts, programmers, and operators of IBM systems. This form may be used to communicate your views about this publication. It will be sent to the author's department for whatever review and action, if any, is deemed appropriate. Comments may be written in your own language; use of English is not required.

IBM may use or distribute any of the information you supply in any way it believes appropriate without incurring any obligation whatever. You may, of course, continue to use the information you supply.

Note: *Copies of IBM publications are not stocked at the location to which this form is addressed. Please direct any requests for copies of publications, or for assistance in using your IBM system, to your IBM representative or to the IBM branch office serving your locality.*

Possible topics for comments are:

Clarity    Accuracy    Completeness    Organization    Coding    Retrieval    Legibility

If you wish a reply, give your name and mailing address:

---

---

---

Note: Staples can cause problems with automated mail sorting equipment.  
Please use pressure sensitive or other gummed tape to seal this form.  
Cut or Fold Along Line

What is your occupation? \_\_\_\_\_

Number of latest Technical Newsletter (if any) concerning this publication: \_\_\_\_\_

Thank you for your cooperation. No postage stamp necessary if mailed in the U.S.A. (Elsewhere, an IBM office or representative will be happy to forward your comments.)

Reader's Comment Form

Cut or Fold Along Line

Fold and tape

Please Do Not Staple

Fold and tape



NO POSTAGE  
NECESSARY  
IF MAILED  
IN THE  
UNITED STATES

**BUSINESS REPLY MAIL**  
FIRST CLASS PERMIT NO. 40 ARMONK, N.Y.

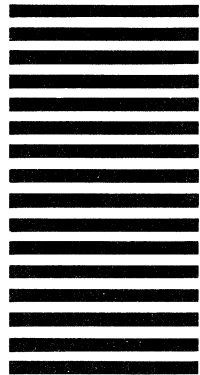

POSTAGE WILL BE PAID BY ADDRESSEE:

International Business Machines Corporation  
Department Z59, Building 931  
P. O. Box 390  
Poughkeepsie, New York 12602

Fold and tape

Please Do Not Staple

Fold and tape

NPPDA: General Information (File No. S370/4300-37)

Printed in U.S.A.

GC34-2010-2



International Business Machines Corporation  
Data Processing Division  
1133 Westchester Avenue, White Plains, N.Y. 10604

IBM World Trade Americas/Far East Corporation  
Town of Mount Pleasant, Route 9, North Tarrytown, N.Y., U.S.A. 10591

IBM World Trade Europe/Middle East/Africa Corporation  
360 Hamilton Avenue, White Plains, N.Y., U.S.A. 10601



International Business Machines Corporation  
Data Processing Division  
1133 Westchester Avenue, White Plains, N.Y. 10604

IBM World Trade Americas/Far East Corporation  
Town of Mount Pleasant, Route 9, North Tarrytown, N.Y., U.S.A. 10591

IBM World Trade Europe/Middle East/Africa Corporation  
360 Hamilton Avenue, White Plains, N.Y., U.S.A. 10601