

OPERATION AND MAINTENANCE MANUAL

for

3300 SERIES DISC DRIVES

Manufactured by

OKIDATA CORPORATION/WESTERN DIVISION
849 Ward Drive
Santa Barbara, California 93111

(805) 964-3535

OKIDATA
WESTERN DIVISION

TABLE OF CONTENTS

	Page	
SECTION I - GENERAL DESCRIPTION		
1.1	General Information	I-1
1.2	Technology	I-1
1.3	Description of Components	I-4
1.4	Specifications	I-9
1.5	Options	I-11
SECTION II - INSTALLATION		
2.2	Equipment Location	II-1
2.3	Cabling Considerations	II-1
2.4	Terminators	II-4
2.5	Transmitters/Receivers	II-4
2.6	Connectors & Cable	II-4
2.7	Power Cable	II-10
2.8	Start Current	II-10
2.9	Running Current & Power	II-11
2.10	Unpacking the Disc Drive	II-11
2.11	Installation Procedure	II-12
SECTION III - OPERATION INTERFACING & FORMATTING		
3.1	Introduction	III-1
3.2	Controls & Indicators	III-2
3.3	Fault Conditions	III-3
3.4	Interface (Data & Control)	III-4
3.5	Interface Signals	III-7
3.6	Data Format & Control Timing	III-19

SECTION IV - PRINCIPLES OF OPERATION

4.0	Introduction	IV-1
4.1	AC Distribution	IV-2
4.2	DC Power Supply	IV-4
4.3	Head Positioning Servo System	IV-6
4.3.1	General	IV-6
4.3.2	Servo Head Signal	IV-8
4.3.3	Servo Signal Processing (Servo Demodulator)	IV-11
4.3.4	Index and Guardband	IV-17
4.3.5	Track Crossing Pulses	IV-17
4.3.6	Illegal Address	IV-17
4.3.7	Seek Cycle Logic	IV-21
4.3.8	Restore Logic	IV-21
4.3.9	Velocity (Coarse) Mode Servo	IV-25
4.3.10	Position (Detent) Mode Servo	IV-26
4.3.11	Servo Power Amplifier	IV-27
4.3.12	Head Positioner Block Diagrams	IV-28
4.3.13	Fault Logic	IV-33
4.3.14	High Ambient Temperature Protection	IV-35
4.4	Data System	IV-36
4.4.1	General	IV-36
4.4.2	Moving Head Preamp and Switch Matrix	IV-36
4.4.3	Fixed Head	IV-42
4.4.4	Data (MFM Encoding)	IV-42
4.4.5	Data (Phase Locked Loop)	IV-45
4.4.6	Read Data Signal Processing	IV-50
4.4.7	Read Data (Decoding to NRZ)	IV-54
4.5	Interface	IV-57
4.5.1	General	IV-57
4.5.2	Transceivers	IV-57
4.5.3	Unit Address Detection	IV-60
4.5.4	Cylinder Addressing	IV-60
4.5.5	Head Addressing	IV-62
4.5.6	Control Functions	IV-63
4.5.7	Moving/Fixed Head Multiplexer	IV-65
4.5.8	Moving/Fixed Head Fault	IV-66
4.5.9	Fault Conditions	IV-66
4.5.10	Write Protect	IV-68
4.5.11	Control Panel Interface	IV-69
4.5.12	Clock Generation	IV-70

SECTION V - MAINTENANCE AND ADJUSTMENTS

5.0	Introduction	V-1
5.1	Precautions	V-2
5.2	Tools and Equipment	V-4
5.3	Power Supply (Set Transformer Taps)	V-6
5.3.1	Power Supply Removal	V-6
5.4	Power Amplifier (Set $\pm 5V$)	V-9
5.4.1	Power Amp. Removal	V-9
5.4.2	Power Transistor Replacement	V-11
5.4.3	Power Amp. PCB Removal	V-12
5.5	PCB Assembly Removal	V-13
5.6	Servo Adjustments	V-14
5.6.1	Up to Speed	V-14
5.6.2	Phase Locked Loop	V-14
5.6.3	Servo AGC	V-15
5.6.4	Servo Offset	V-17
5.6.5	Access Time and Velocity Loop Gain	V-17
5.7	Write Current	V-18
5.7.1	Moving Head	V-19
5.7.2	Fixed Head	V-19
5.8	Data Board	V-20
5.8.1	Threshold Adjust	V-21
5.8.2	Erroneous Zero Crossing Taps	V-21
5.8.3	Delayed Read Pulse Tap	V-23
5.8.4	Delay Corrected Read Pulse Tap	V-23
5.9	Interface Board	V-25
5.9.1	Unit Select Logic Plug	V-25
5.9.2	Sector Logic Plug	V-25
5.10	Clean Air Filters and Blower Ass'y.	V-28
5.11	Breather Filter & Pre-Filter Replacement	V-29
5.12	Blower Spindle Replacement	V-30
5.13	Brake Assembly	V-33
5.13.1	Brake Band Adjustment	V-33
5.13.2	Brake Band Replacement	V-35
5.14	Positioner Motor Replacement	V-38
5.15	Spindle Motor Replacement	V-45
5.16	Drive Belt Tension Adjustments	V-46
5.17	Index Transducer & Spindle Ground Spring	V-48
5.18	Cooling Fan Assembly	V-48
5.19	AC Distribution Assembly	V-50
5.20	Control Panel	V-51
5.21	Troubleshooting	V-54
5.22	Preliminary Checks	V-54
5.23	Troubleshooting Charts	V-55

SECTION VI - SPARE PARTS LIST, SCHEMATICS, and ASSEMBLY DRAWINGS

LIST OF ILLUSTRATIONS

Figure		Page
	3300 Front, Rear View	
	Description of Components	I7, I8
	Cable Connector Locations	II-2
2-1	Star/Daisy Chain Interconnect	II-3
2-2	A & B Cable Line Drivers/Receivers	II-5
2-3	A Cable Transmitters/Receivers	II-6
2-4	B Cable Transmitters/Receivers	II-7
	Power Cable Connector	II-10
	Start Current	II-10
A	Installation Drawing	II-16
	Control Panel	III-2
	CDC 9760 Compatible Interface	III-5, III-6
3-1	Index & Sector Timing	III-14
3-2	Logic Number Select Code & Timing	III-14
3-3	Timing with Address Mark	III-15
3-4	On Cylinder Timing	III-16
3-5	Read Data Timing	III-17
3-6	Write Data & Servo Clock Timing	III-17
3-7	Tag Line & Buss Timing	III-18
3-8	Fixed Sector Format	III-21
3-9	Variable Sector Format	III-22
3-10	Control Timing	III-25
4-1	AC Distribution System	IV-3
4-2	Power Distribution	IV-4
4-3	Transformer Primary Connections	IV-5
4-4	Disc Servo and Data Locations	IV-6
4-5	Moving Head Positions	IV-7
4-6	Positioner Motion During Seek	IV-8
4-7	Servo System Functional Diagram	IV-9
4-8	Servo Head Signal	IV-10
4-9	Servo Head Signal Processing	IV-12
4-10	Phase Lock Timing	IV-13
4-11	Servo Demodulated Signal	IV-14
4-12	Index and Guardband Decoding	IV-18
4-13	Track Crossing Detector	IV-19
4-14	Illegal Address	IV-20

ILLUSTRATIONS (Continued)

4-15	Seek Cycle	IV-22
4-16	Servo Demod. Change of Slope	IV-23
4-17	Restore Cycle	IV-24
4-18	Desired Velocity Generated by DAC	IV-26
4-19	Actual Velocity of Servo Arm	IV-29
4-20	Block Diagram Head Positioning Servo System	IV-29
4-20(a)	Block Diagram (Greater than 64 tracks to go)	IV-30
4-20(b)	Block Diagram (Less than 64 tracks to go)	IV-31
4-20(c)	Block Diagram (Position Mode)	IV-32
4-21	Fault Logic	IV-34
4-22	Data System	IV-37
4-23	Moving Head Preamp and Switch Matrix	IV-38
4-24	Data Head Magnetic Field	IV-39
4-25	Magnetic Field on Media	IV-40
4-26	Fixed Head Select Matrix	IV-41
4-27	MFM Encoding	IV-43
4-28	MFM Timing	IV-44
4-29	Phase Locked Loop Timing	IV-46
4-30	Voltage Controlled Oscillator	IV-47
4-31	Phase Detector	IV-49
4-32	PLL Timing With Data Pattern	IV-51
4-33	Read Data Signal Processing	IV-53
4-34	Erroneous Zero Crossing	IV-55
4-35	Read Data Decoding	IV-56
4-36	Interface Block Diagram	IV-58
5-1	Machine in Service Position	V-2
5-2	Transformer Tap Wiring	V-7
5-3	Power Supply	V-8
5-4	Power Supply Removal	V-8
5-5	Power Amplifier Board	V-10
5-6	Power Amplifier Removal	V-10
5-7	Power Transistors	V-11
5-8	Power Amplifier Board Removal	V-12
5-9	Printed Circuit Boards	V-13
5-10	SVDM Signal	V-16
5-11	Write Current	V-20
5-12	Threshold Adjust	V-22
5-13	Erroneous Zero Crossing Taps	V-22
5-14	Delayed Read Pulse Taps	V-24

ILLUSTRATIONS (Continued)

5-15	Delayed Corrected Read Pulse	V-24
5-16	Address Plug	V-27
5-17	Unit Address Corrections	V-27
5-18	Sector Plug	V-27
5-19	Sector Plug (example)	V-27
5-20	Replacing Pre-Filter Breather	V-29
5-21	Blower Assembly	V-30
5-22	Blower Mounting Plate	V-31
5-23	Blower Fan & Pulley Spacing	V-32
5-24	Brake Adjustment	V-34
5-25	Spindle Brake Assembly	V-35
5-26	Positioner Removal (Machine Orientation)	V-38
5-27	Positioner Motor	V-39
5-28	Positioner Motor Retaining Ring	V-41
5-29	Pulling the Lower End Bell	V-41
5-30	Bellville Washer Location	V-42
5-31	Shimming Shipping Clamp Arm	V-44
5-32	Spindle Drive Belt Tension	V-47
5-33	Cooling Fan	V-49
5-34	AC Distribution Assembly	V-50
5-35	Removing the AC Distribution Assembly	V-52
5-36	AC Distribution Assembly (Repair Position)	V-52
5-37	AC Connector Mounting Plate	V-53
5-38	Replacing Defective Switch	V-53

LIST OF TABLES

Table 1	Available Configurations	I-2
Table 2	Configurations	I-3
	"A" Cable Connections	II-8
	"B" Cable Connections	II-9
4-1	Early/Late Data Strobe	IV-57

INTRODUCTION

This manual describes the 3300 Series of Disc Drives, manufactured by Okidata Corporation, Western Division, 849 Ward Drive, Santa Barbara, California, 93111.

The manual describes installation, operation, interfacing, and maintenance of the 3300 Series of Disc Drives. This information is contained in the first five sections of the manual; Section Six contains schematic diagrams, assembly drawings, and a list of replaceable parts.

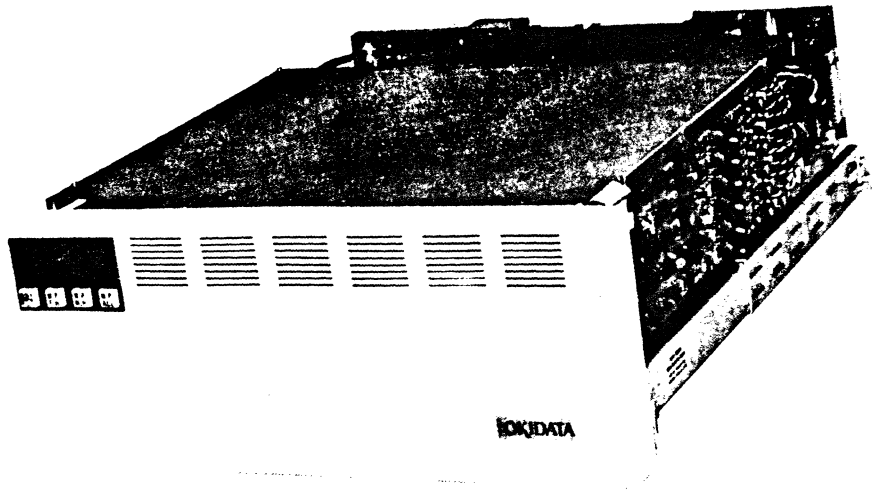

3300 FRONT VIEW

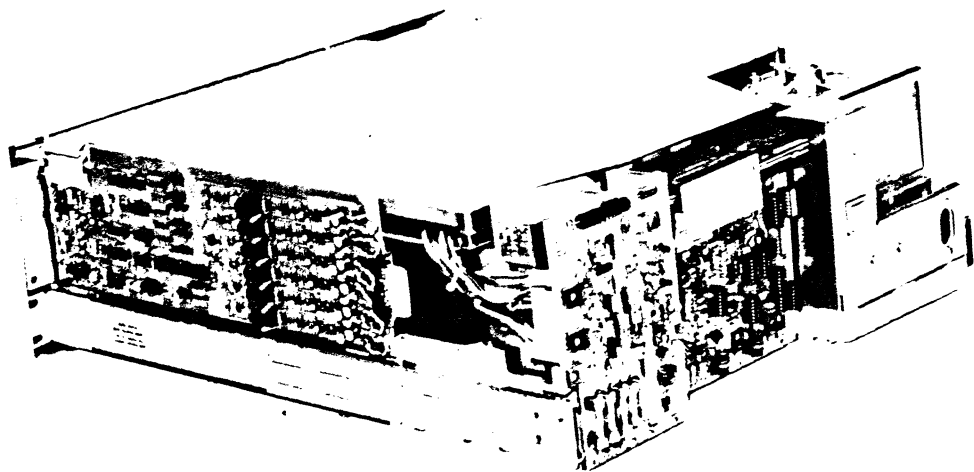

3300 REAR VIEW

SECTION I

GENERAL DESCRIPTION

1.1 GENERAL INFORMATION

The Okidata Model 3300 Series is a family of disc drives which is intended to fill the memory needs of a large variety of minicomputer and medium-scale computer systems. The basic drive mechanism can be configured with one, two, three or four non-removable discs. Up to six surfaces can be used for data accessed by moving head(s), one surface being required for servo information. In addition, fixed heads may be included to provide data storage with minimum access time.

Unformatted capacities range from:

- a) 12.40 to 74.39 Mbyte, moving head.
- b) 0.371 to 2.23 Mbyte, fixed head in increments of 0.371 Mbyte when added to a moving head spindle.
- c) 0.74 to 5.94 Mbyte, fixed head, in increments of 0.371 Mbyte fixed head only.

The eight basic models of the 3300 family and the maximum fixed and/or moving head capacities are shown in Table 1. The disc and head arrangement for each of these models is shown schematically in Table 1-2.

1.2 TECHNOLOGY

The heads and discs used in the 3300 are equivalent to those used in the most advanced, yet field-proven IBM drives, the 3340. To guarantee reliability, every effort has been made to utilize the heads and discs in the same manner as in the 3340. Therefore spindle speeds, bit density, and track density have been made similar to the 3340 drives. This is true also for the optional fixed heads.

Disc rotational speed RPM	2964
Track density fixed heads (tracks/in)	33.3
Track density moving heads (tracks/in)	286
Bit density (inner track) bits/in	5636 approx.

TABLE 1-1
AVAILABLE CONFIGURATIONS

Number of Discs	Model Number	CAPACITY		Moving Head Unformatted Megabytes	Remarks
		Max. Fixed Head Option Unformatted Megabits	Unformatted Megabytes		
1	3301 <i>1ea</i>	5.94	0.74	12.40	1 surface Moving Head
2	3302 <i>2ea</i>	17.82	2.23	24.80	2 surfaces Moving Head
2	3303	5.94	0.74	37.19	3 surfaces Moving Head
3	3304	17.82	2.23	49.59	4 surfaces Moving Head
3	3305	5.94	0.74	61.99	5 surfaces Moving Head
4	3306	5.94	0.74	74.39	6 surfaces Moving Head Max. Capacity
1	3307	23.76	2.97		1 platter Fixed Head Only
2	3308	47.51	5.94		2 platter Fixed Head Only

NOTES: Moving head capacities are a minimum useable with a maximum number of defective tracks.

Fixed head capacities are a minimum useable. One spare addressable track is provided for each group of 20 tracks; however, it may be defective.

All moving head machines have 339 addressable cylinders with two data heads per data surface.

TABLE 1-2 - CONFIGURATIONS

MODEL NUMBER	DISC/HEAD ARRANGEMENT
3301	
3302	
3303	
3304	
3305	
3306	
3307	
3308	

Like IBM's System 32 (which also uses 3340 heads and discs), the 3300 uses a simple, reliable rotary positioner. Like the 3340, the 3300 uses a track following servo and does not require a tachometer. A portion of the lower disc surface contains pre-recorded information allowing for servo positioning directly off the discs, eliminating most temperature and initial adjustment problems associated with high track density recording. Also like the System 32, the discs are contained in a sealed enclosure which allows for recirculation of clean air through an absolute filter.

1.3 DESCRIPTION OF COMPONENTS

DISC ENCLOSURE

The discs, moving heads, fixed heads, and positioner arm are contained in a factory sealed enclosure. This feature, coupled with a recirculating filtration system, results in a clean air environment which virtually eliminates head/disc failures. Components within the enclosure cannot be maintained in the field.

CLEAN AIR PACKAGE

Consisting of a blower, main filter, and breather filter, the clean air system is designed to pass 29 CFM of already clean air through the main filter which is able to stop 99.97% of all particles larger than 0.3 micron in diameter. This results in the clean air in the enclosure being recirculated through the filter up to 60 times per minute. The blower also serves to provide a slight positive pressure to the enclosure so that any small leaks do not result in the intake of contaminated air.

The function of the breather filter is to allow the system to achieve pressure equilibrium regardless of altitude or temperature change without resulting in a negative pressure in the disc enclosure.

The blower spindle and breather filter can be replaced in the field without contaminating the enclosure. The main filter should never need to be replaced.

DECK AND SPINDLE

A rigid, cast aluminum deck is used to mount the disc spindle and positioner motor providing a stiff, dimensionally stable coupling of these two elements without unnecessary bulk or weight.

SPINDLE BRAKE

A brake band is located directly on the disc spindle pulley providing smooth yet rapid deceleration of the disc without creating undue stress on the spindle drive belt.

SPINDLE MOTOR

A capacitor start induction motor is used to achieve rapid yet smooth acceleration of the disc.

AC DISTRIBUTION

Contains spindle motor start components, line filter, and AC fuses.

POWER SUPPLY

All DC power is generated internally. All elements are mounted on a single base plate for easy removal.

HEAT SINK ASSEMBLY

Contains positioner power amplifier and +5 V and -2 V regulators. An easily removable fan provides cooling for the heat sink and printed circuit boards on top of the unit.

PRINTED CIRCUIT BOARDS

All printed circuit boards are mounted such that components and test points are immediately accessible. These boards perform the following functions:

Matrix: Moving head preamps and switching.

Data: Encoding, decoding, and clocking of moving and fixed head data.

Servo/Logic: Derives position servo information and controls machine functions.

Interface: Contains receivers and drivers and gates I/O lines, plus customer options.

Fixed Head Amplifier: Contains fixed head preamps and switching (optional).

Power Amplifier: Contains positioner power amplifier and +5 V and -2 V regulators.

CONTROL PANEL

Contains operator controls.

FIXED HEAD MODULE

Fixed heads are mounted with diodes on a modular plate in groups of 20 heads each up to 80 heads per module. No electronics is contained within the disc enclosure.

POSITIONER MOTOR

Heads are moved from track to track by an arm connected directly to the positioner motor shaft. The positioner motor can be removed from the drive without contaminating the disc enclosure.

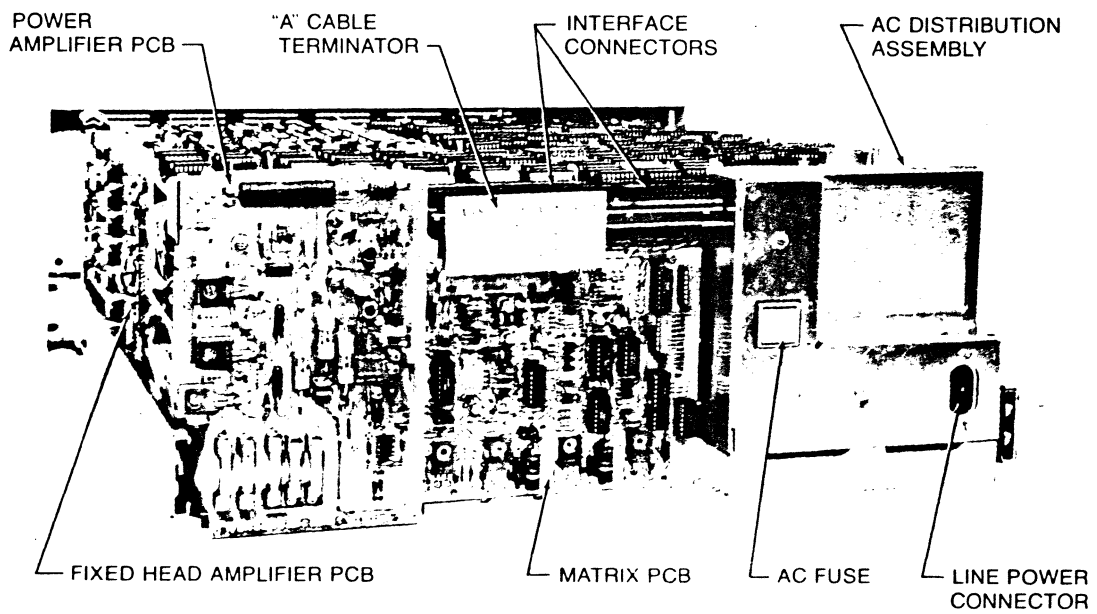
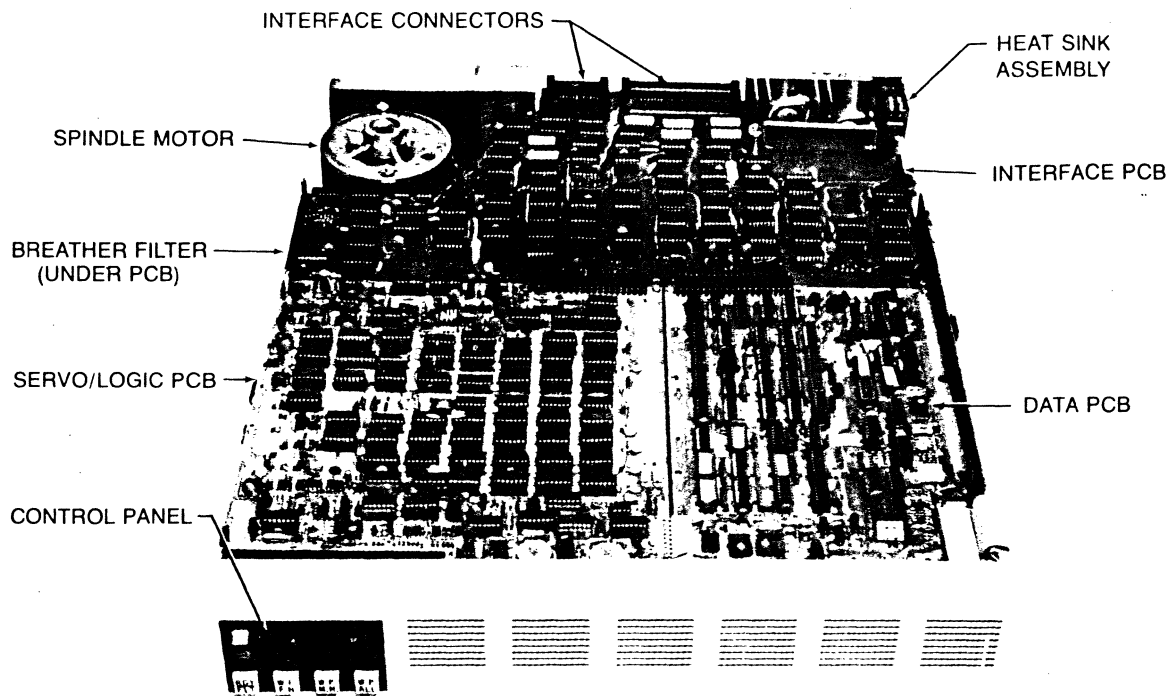

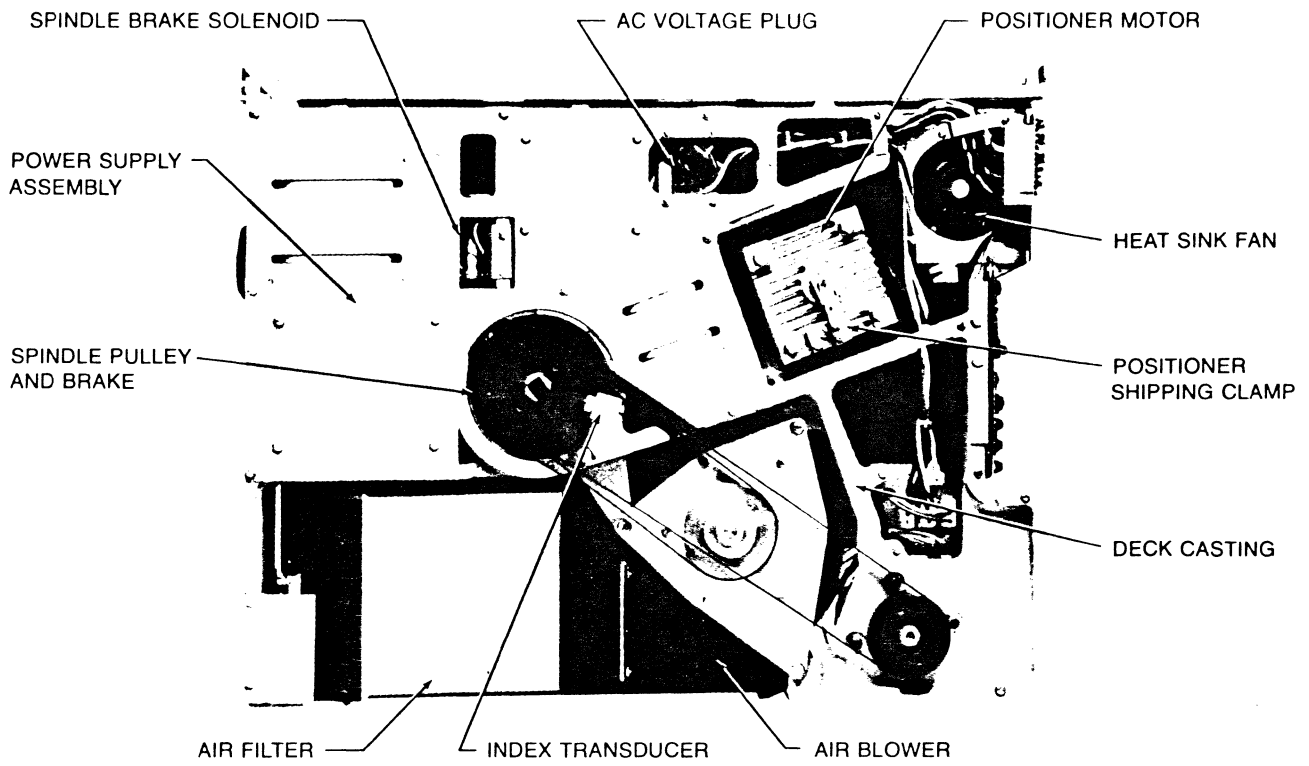

1.4 SPECIFICATIONS

Capacity Ranges	See Table of Available Configurations
Capacity per Track (Unformatted)	18560 Bytes
Addressable Cylinders	339
Heads and Media	IBM (3340) Equivalent
Bit Density (BPI)	5636 Approximately
Track Density (Moving Head) (TPI)	286
Data Tracks per Surface (Moving Head)	678
Track Density (Fixed Head) (TPI)	33.3
Maximum Data Tracks per Surface (Fixed Head)	80
Average Moving Head Position Time (Msec)	38
Maximum Seek (Msec)	75
Single Track Seek (Msec)	10
Average Latency (Msec)	10.12
RPM (Nominal)	2964
Transfer Rate (Megabits/Sec)	7.33
Head Positioner Type	Rotary Motor
Positioner Servo	Track Follow from Dedicated Surface Area
Error Rate (Recoverable)	10^{10} Bits - No Retries or Error Correction
Error Rate (Hard)	10^{13} Bits

Size (Height - Inches x Depth from Mounting Surface - Inches)	7 x 22, 19" Retma Rack Mount
Mounting	Horizontal or Vertical on slides
Weight (Lbs.)	65 Maximum
Air Filtration	0.3 Micron (Absolute Filter) Forced Air - Recirculating @ 29 CFM
Operating Temperature (°C)	10 to 40
Operating Humidity (% R.H.)	20 to 80% (No Condensation)
Power Supply	Built-In Taps for Common Voltages (Pulley Selection Required on Spindle Motor for 50/60 Hz). Spindle Motor Selection Required for 112/225 V.

1.5 OPTIONS

A wide selection of options are available to make the 3300 completely compatible with a wide variety of system requirements. All options except the number of fixed heads are field upgradeable, most by plug-ins in the I/O Board.

1.5.1 FIXED HEADS

Fixed heads can be added to moving head models in groups of 20 heads each up to a maximum capacity as shown in Table 1. Fixed heads can be used in an "overlap seek" mode. (See 3.4)

1.5.2 CONTIGOUS FIXED HEAD ADDRESSING

A PROM can be provided to make all fixed heads addressable by a contiguous set of binary numbers.

1.5.3 VARIABLE SECTORING (ADDRESS MARK)

Read and write address marks can be provided.

1.5.4 WRITE PROTECT

A portion of moving head data, all fixed head data, or the entire drive can be protected from writing with control panel switches.

1.5.5 CDC-9760 COMPATIBLE INTERFACE

The 3300 can be made compatible with the flat cable version of the CDC-9760 (Storage Module)

1.5.6 CHOICE OF TRACK CAPACITY

The number of data bytes per revolution can be varied somewhat to accomodate unique user formats and sector data fields without waste of capacity.

1.5.7 UNIT SELECT SWITCHES

Unit select thumbwheel switches can be provided on the control panel.

SECTION II

INSTALLATION

2.1 INSTALLATION PLANNING

2.2 EQUIPMENT LOCATION

The 3300 Series Disc Drive may be located adjacent to any other electronic data processing equipment provided the temperature, humidity, and other environmental characteristics are within the limits specified in Table . The equipment should not be located in a strong magnetic field, because the head assemblies and other components may become magnetized and thus interfere with the read/write process.

To obtain optimum performance from the equipment the ambient temperature fluctuation should be kept as small as possible and a reasonable clean and dust free environment should be provided. It is also important that a free flow of air is allowed around the equipment and through the rack in which it is mounted.

The Disc Drive should be mounted in a standard 19-inch wide rack cabinet and located on a firm, vibration free surface. The Disc Drive requires 7 inches of vertical rack space. Figure shows mounting dimensions and slide installation details for the Disc Drive.

2.3 CABLING CONSIDERATIONS

All intercomponent cabling within the Disc Drive is completed at the factory, but the interface signal, cabling (both data and control), and primary AC power connections must be completed in the field. A ground strap must be connected between a convenient point on the 3300 deck casting and the power supply DC ground of the controller. Instructions for fabricating the necessary cables are contained below.

It is necessary to fabricate the cables between the Disc Drive and the Controller. Up to four cables are used depending on whether the Drive contains fixed heads, and whether a "Star" or "Daisy Chain" interconnect is used.

"A" cables contain status and control signals. "B" cables contain data and clock signals. "A" cables connect to J 31 and J34 . "B" cables connect to J 32 and J 33 (see Figure 1).

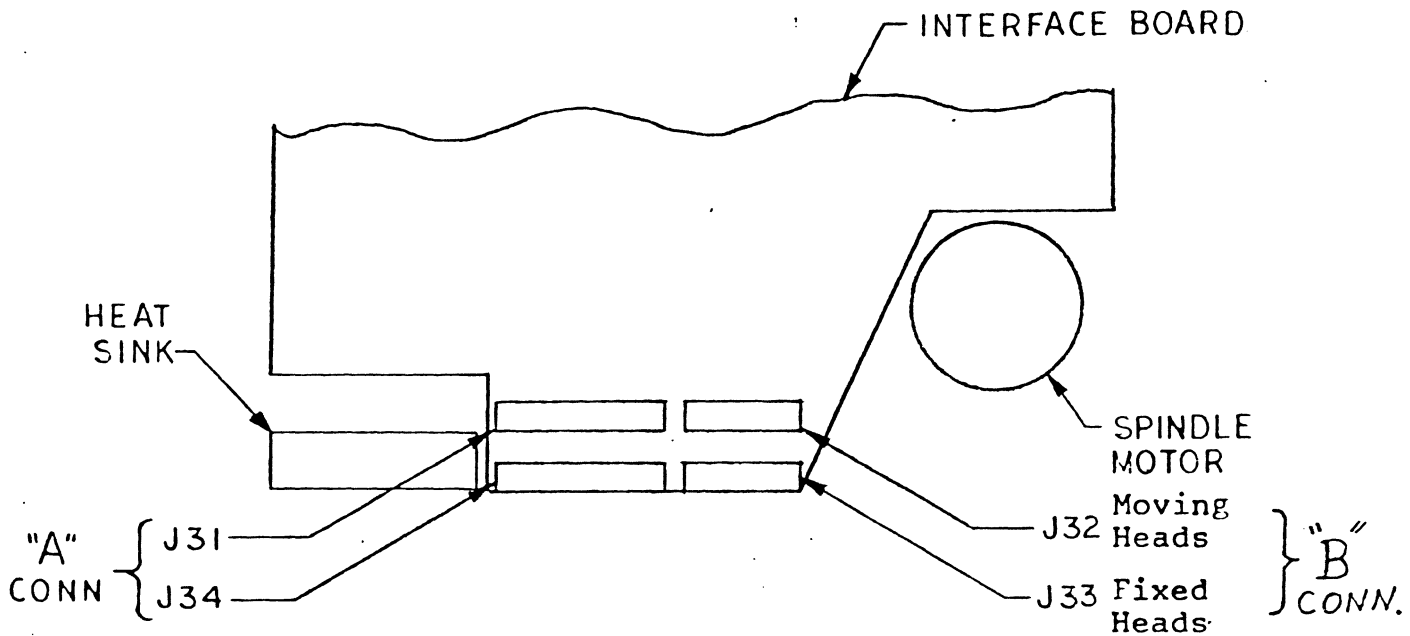

Flat Cable Interface (CDC 9760 Option)

The standard interface accomodates two "A" connectors and one "B" connector. If multiple drives are connected to the same controller, "A" connectors can be either in a "star" or "daisy chain" configuration. "B" connectors must be in a "star" configuration only.

If the drive contains fixed heads a second "B" connector is provided which must also be connected to the controller in a "star" configuration. The same "A" connectors can still be used in either a "star" or "daisy chain" mode. Such arrangements are shown below. The maximum lengths of the cables can be 100 feet cumulative for the "A" cable "daisy chained" and 50 feet for the "B" cable.

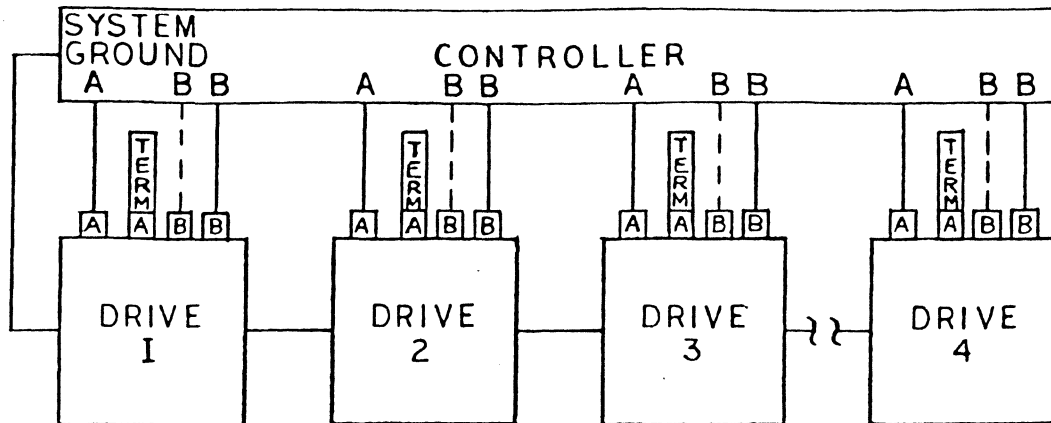

"Star" Interconnect

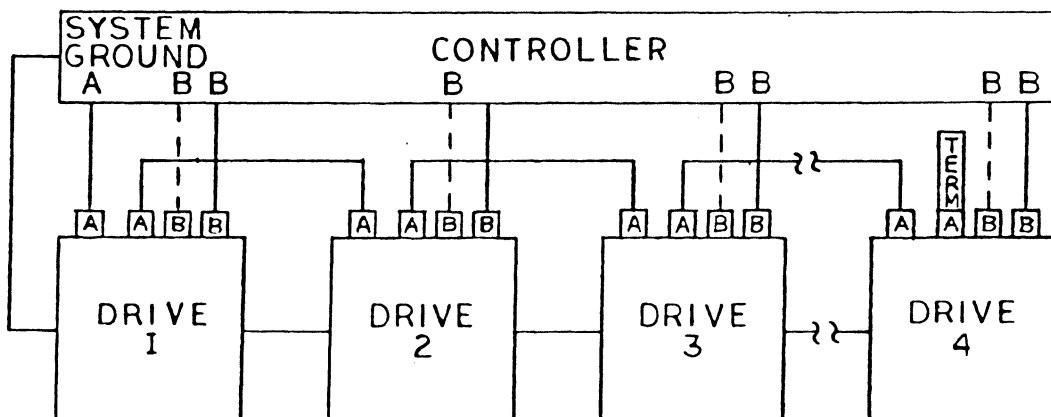

"Daisy Chain" Interconnect

Figure 2-1

2.4 TERMINATORS

Signal line terminating resistors are installed for all "B" connectors on the Interface Board at the factory. An "A" connector terminator assembly Okidata Part Number 30116 must be added as shown depending on whether "Star" or "Daisy Chain" interconnect is used.

Termination resistors as shown in Figures 2, 3 & 4 must be provided at the transmitter and receiver end of each line at the controller.

2.5 TRANSMITTERS AND RECEIVERS

Transmitters and receivers of the industry standard type 75110A and 75108 or equivalent are used to provide a balanced transmission system. Transmitters and receivers used in the controller must be compatible. See Figures 2, 3 & 4.

2.6 CONNECTORS AND CABLE

<u>Description</u>	<u>Amp P/N</u>	<u>3M P/N</u>	<u>Ansley P/N</u>	<u>Spectra Strip P/N</u>
"A" Connector (60 Pin)	88012-2	--	609-6001M	
"A" Cable 30 Pair Twisted 28 awg.				S5-455- 248-60
"B" Connector (26 Pin)	86905-2	3399- 3000	609-2601M	
"B" Cable 26 Line with Ground Plane and Drain Wire		3476-26		

Maximum Cable Length: "A" Cable 100 ft. cumulative
"B" Cable 50 ft.

Ground Strap: Tinned copper braid 7/16 flat width

Power Cable: Size per appropriate current (2.8-2.9)
connector per 2.7

75107B - DUAL LINE RECEIVER

TRUTH TABLE

DIFFERENTIAL INPUTS A-B	STROBES		OUTPUT Y
	G	S	
$V_{ID} \geq 25 \text{ mV}$	L or H	L or H	H
$-25 \text{ mV} < V_{ID} < 25 \text{ mV}$	L or H	L	H
	L	L or H	H
$V_{ID} < -25 \text{ mV}$	H	H	INDETERMINATE
	L or H	L	H
	L	L or H	H
	H	H	L

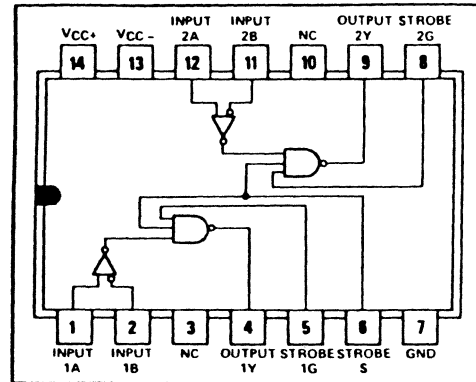

NC—No internal connection

75110 - DUAL LINE DRIVER

TRUTH TABLE

LOGIC INPUTS		INHIBITOR INPUTS		OUTPUTS	
A	B	C	D	Y	Z
L or H	L or H	L	L or H	H	H
L or H	L or H	L or H	L	H	H
L	L or H	H	H	L	H
L or H	L	H	H	L	H
H	H	H	H	H	L

Low output represents the on state
High output represents the off state

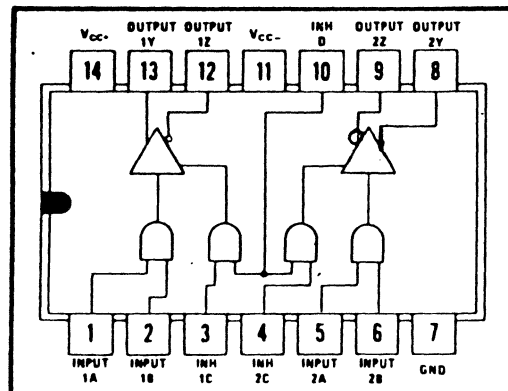

FIGURE 2-2 A AND B CABLE LINE DRIVERS

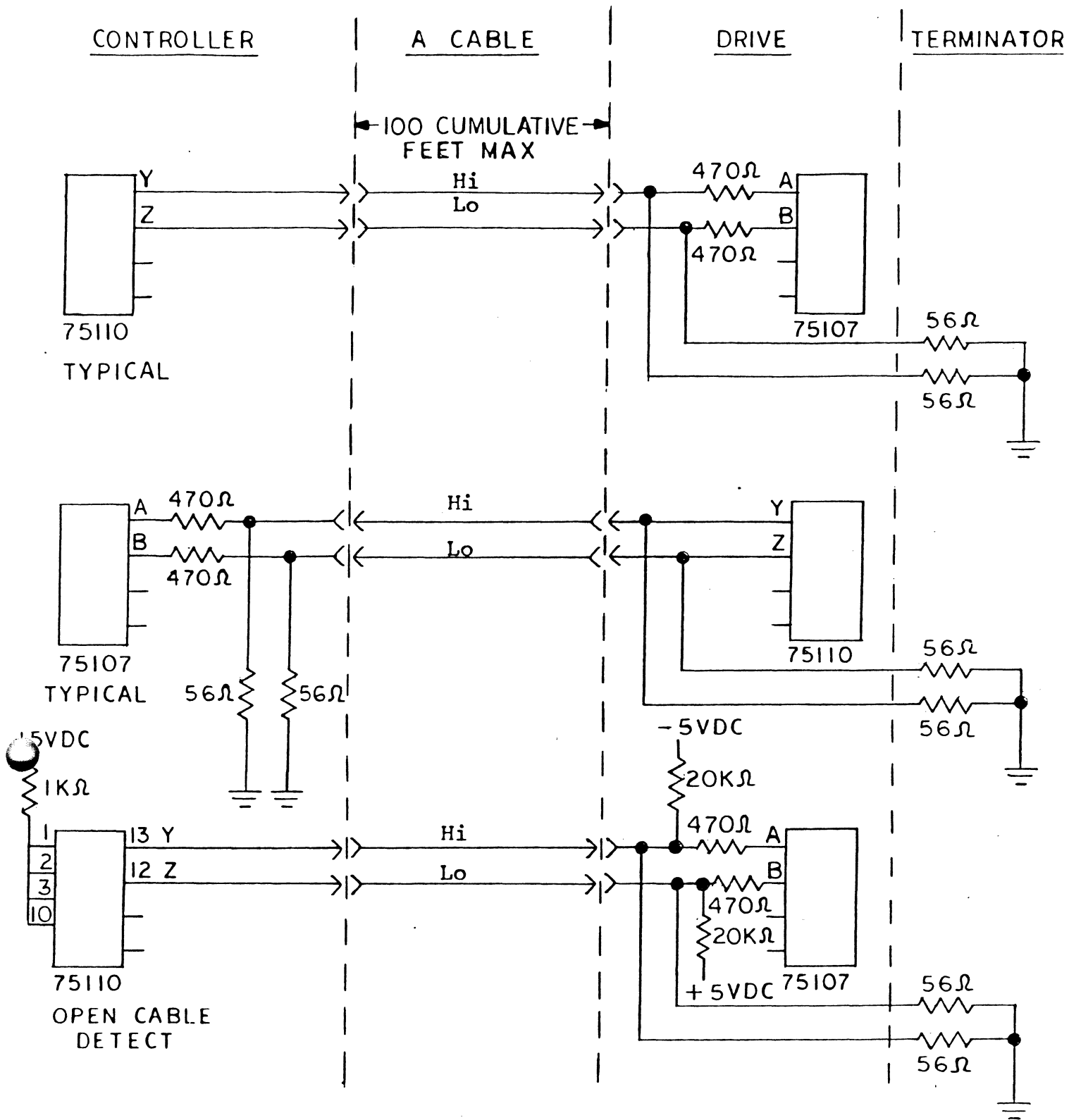

FIGURE 2-3 A CABLE TRANSMITTERS & RECEIVER

"A" CABLE CONNECTIONS
 - FLAT CABLE INTERFACE -

PIN NUMBERS

LO	HI	LINE
22	52	Unit Select Tag
23	53	Unit Select 2 ⁰
24	54	Unit Select 2 ¹
26	56	Unit Select 2 ²
27	57	Unit Select 2 ³
1	31	Tag 1
2	32	Tag 2
3	33	Tag 3
4	34	Bit 0
5	35	Bit 1
6	36	Bit 2
7	37	Bit 3
8	38	Bit 4
9	39	Bit 5
10	40	Bit 6
11	41	Bit 7
12	42	Bit 8
13	43	Bit 9
14	44	Open Cable Detector
18	48	Index
25	55	Sector
15	45	Fault
16	46	Seek Error
17	47	On Cylinder
19	49	Unit Ready
20	50	Address Mark Found
28	58	Write Protected
	29	Power Sequence Pick
	59	Power Sequence Hold
21	51	Busy
30	60	Ground

"B" CABLE CONNECTIONS

PIN NUMBERS		DATA LINE
HI	LO	
14	2	Servo Clock
16	3	Read Data
17	5	Read Clock
19	6	Write Clock
20	8	Write Data
9	22	Unit Selected
23	10	Seek End
24	12	Index (Ungated)
26	13	Sector (Ungated)

Pin numbers 1, 15, 4, 18, 7, 21, 11 & 25 are ground.

2.7 POWER CABLE

The customer must fabricate a power cable consistent with his system's AC distribution and power requirements outlined below. The standard AC connector, located on the rear of the machine, is an internationally approved 3-prong receptacle whose dimensions are shown below:

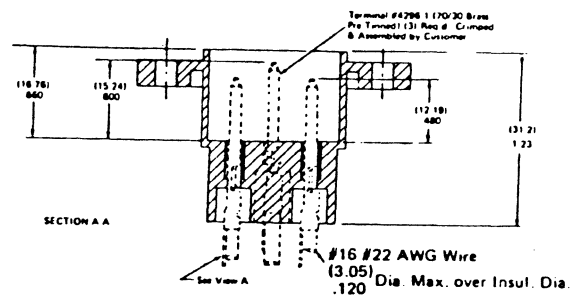
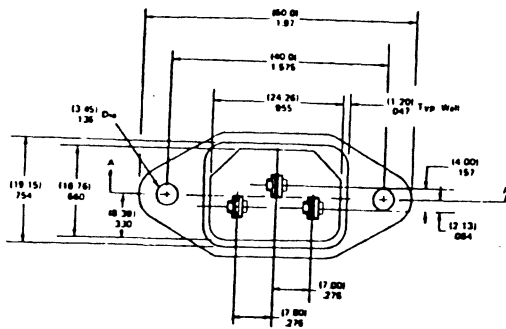

2.8 STARTING CURRENT

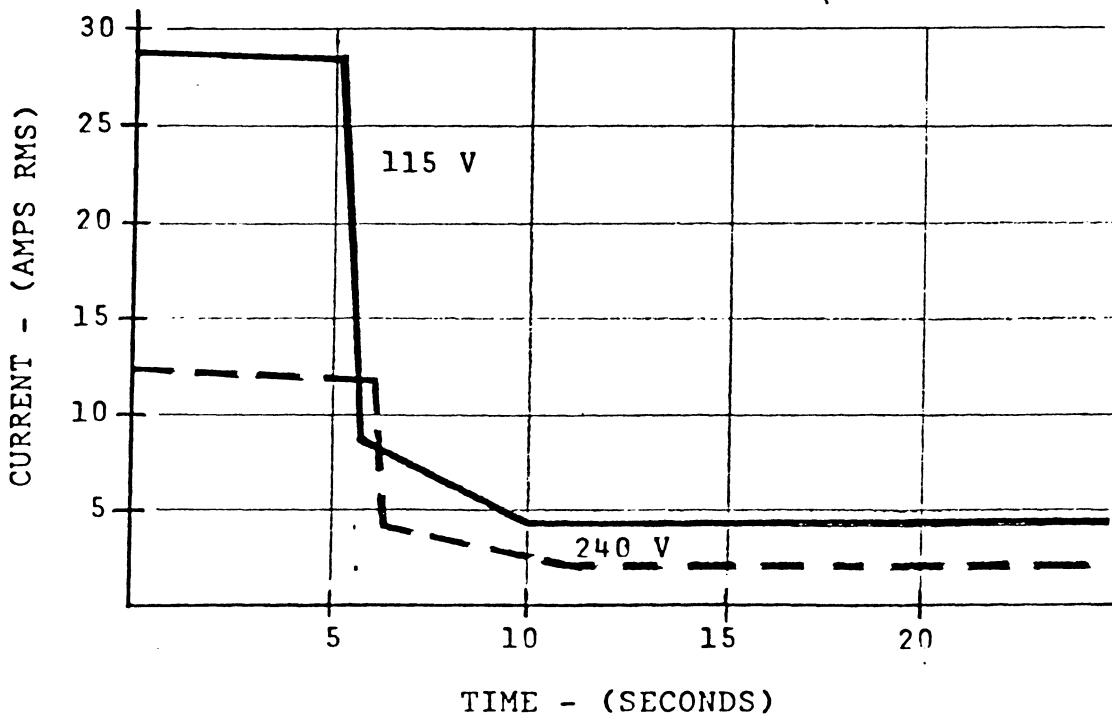

2.9 RUNNING CURRENT AND POWER

The following values are maximum with discs spinning and positioner undergoing a worst case seek:

<u>Voltage</u>	<u>Frequency</u>	<u>Current (Amps)</u>	<u>Power (VA)</u>	<u>Power Factor</u>
115	60	5.2	616	.81
240	50	2.4	575	.85

2.10 UNPACKING THE DISC DRIVE

The Disc Drive is shipped in a special packing case and frame which should be saved if re-shipment of the equipment is planned.

Within the packing case the Disc Drive is mounted on each side to a frame with two bolts. This frame can be used to hold the unit when it is removed and placed on a level surface on either of six sides for inspection or future servicing.

A set of slides, the front panel, and a hardware kit for mounting these parts is contained in the package located beneath the disc drive.

As the equipment is unpacked, care should be exercised to prevent damage to the finished surfaces of the Disc Drive, and all parts should be examined for evidence of damage during shipment (particularly if the inner container has been punctured). If any parts are damaged, advise Okidata Corporation and file a claim with the transfer company. The crated weight of the Disc Drive is approximately 100 pounds.

Inspect all sides of the unit for loose connectors and/or components, and replace where necessary.

2.11 INSTALLATION PROCEDURE (REFER TO FIGURE A)

- a) Extend both of the slides provided and remove the sliding element from the stationary element by depressing the release clip.
- b) Mount the stationary slide elements in a standard 19 inch rack as shown in Figure A . Be sure the width dimension is maintained front to rear across both elements or binding will occur. Both the front and rear mounting brackets must be used to support the weight of the Disc Drive.
- c) Remove the shipping frame from the Disc Drive one side at a time, letting it rest on a level surface which is clean of debris.
- d) Attach the moving element of the slides to each side of the Disc Drive casting as shown in Figure A using the 10-24 screws provided.
- e) Attach the front cover mounting brackets as shown in Detail A with the 10-24 screws provided.

CAUTION

The Disc Drive weighs approximately 65 pounds. The rack into which the Disc Drive is mounted must be of sufficient weight to prevent overturning when the Disc Drive is extended into its service position.

- f) Now carefully lift the Disc Drive and engage the moving slide element attached to the Drive into the stationary element previously mounted to the rack and slide back into the rack until the front cover bracket engages the rack. Should binding occur, the stationary slide element should be adjusted for a constant width front to rear.
- g) Slide the Disc Drive forward until it hits its stops. This is the service position.

- h) Mount the front panel by snapping in place as shown in Detail A.
- i) Now carefully slide the Drive back into the rack being particularly careful that no interference exists between the FHA board and the rack. If interference exists, remove the Drive using the slide release clips and place the Drive on a level surface free of debris. Then move the stationary elements of the slides to increase clearance while maintaining the width dimension front to rear. This same procedure must be followed if interference exists on the top or bottom of the Disc Drive.
- j) Return the unit to the extended service position and remove the front cover.
- k) Attach the interface cables and make sure the unit can slide freely with no binding of cables.
- l) Check again for any loose connections or components.

CAUTION

Be sure the breather filter, Page 9, is clear and unobstructed when the unit is in its operating position within the rack. Serious damage can result to heads and discs if this filter is obstructed.

CAUTION

Serious damage to the spindle motor and start components can result if 100 V is applied to a 200 V machine or vice versa.

- m) Check that the voltage and frequency at the power connector corresponds to those listed on the unit name plate.
- n) Following power supply schematic (30120), determine if the power supply transformer taps can be changed to a voltage close to that of the line to be used. If necessary, change the jumpers in the power supply plug, per sect. 5.3.

- o) Check the fuses. Two AC fuses are located at the rear of the AC distribution box and four DC fuses are located at the lower rear of the heat sink assembly.
- p) Familiarize yourself with the Disc Drive controls by reading Paragraphs 3.1 through 3.3.

IMPORTANT

The head positioner within the Disc Drive is shipped with a shipping clamp which must be loosened before power is applied to the machine.

CAUTION

The shipping clamp arm must not be moved while the discs are at rest or serious damage to heads and discs can result.

- q) Refer to the bottom view of the 3300, Section 1. Remove the positioner shipping clamp screw being careful not to move the shipping clamp arm. Bolt the screw and washer to the casting for possible future use. Remove the spindle shipping clamp from the spindle pulley and rotate into storage position, retaining this hardware for possible future use.

CAUTION

If the machine is to be re-shipped, or removed from the rack, the shipping clamp arm under the head positioner and the spindle shipping clamp must be fastened in place. If not, serious damage to heads and discs will result. When fastening the spindle shipping clamp, rotate spindle only in direction indicated.

CAUTION

NEVER move the shipping clamp arm while the discs are at rest. As part of the power off sequence, the shipping clamp arm should come to rest ready for clamping. If this does not occur, power the drive up and down again.

- r) With the power switch at the control panel in the off position, connect the power cable.

- s) Turn the power switch on. The power switch should illuminate and the Drive should come up to speed. The "Ready" light should come on. Turn the power switch off.
- t) Slide the Drive carefully back into the rack and fasten in place with (2) 10-32 screws. (Figure A)
- u) Snap the front panel into position.

71-II

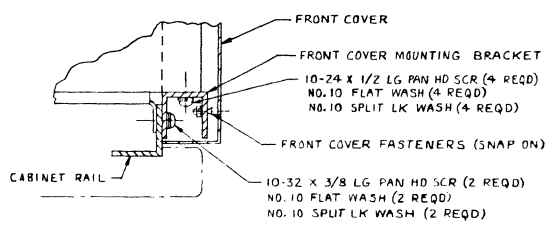
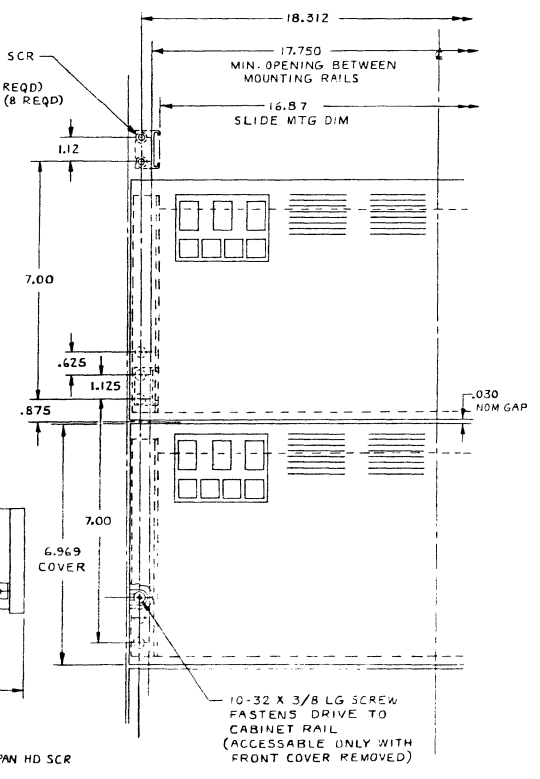
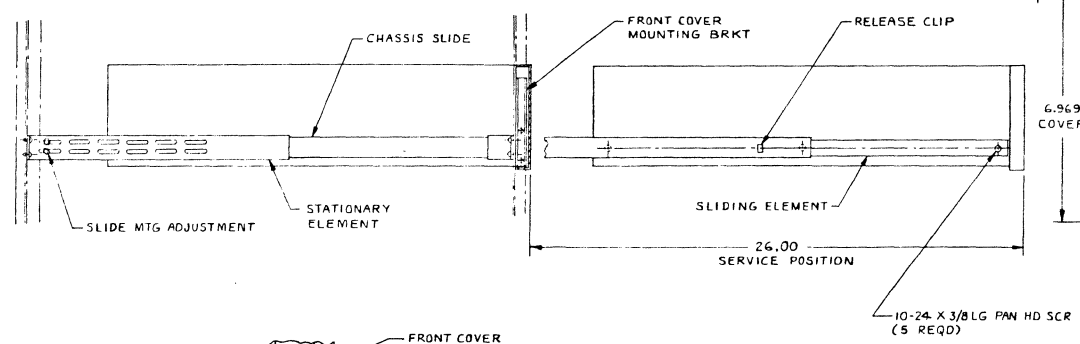
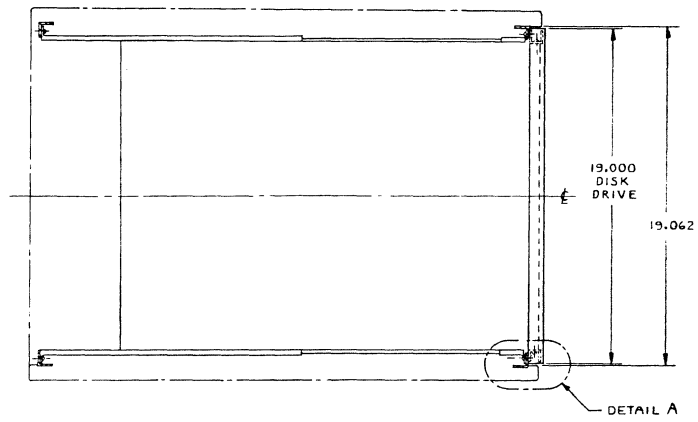

DETAIL A

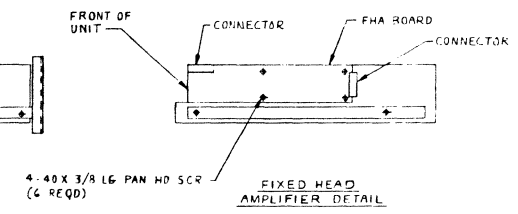
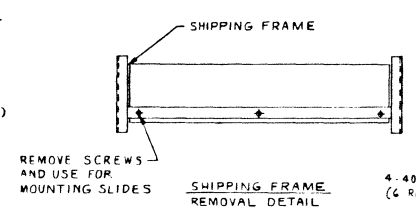

INSTALLATION DRAWING
FIGURE A

SECTION III

OPERATION, INTERFACING AND FORMATTING

3.1 INTRODUCTION

This section contains information on operation, interfacing and formatting the Disc Drive. Operation of the Disc Drive is basically under system control and there is little to be done by the operator other than applying power under normal conditions.

To properly operate, the Disc Drive must be connected to a properly configured controller. This section describes all interface line functions and timing requirements.

Efficient utilization of the Disc Drive capacity and error free performance are heavily dependant on how the Drive is formatted. This section describes format requirements and indicates how to calculate the efficiency of capacity utilization for a given format.

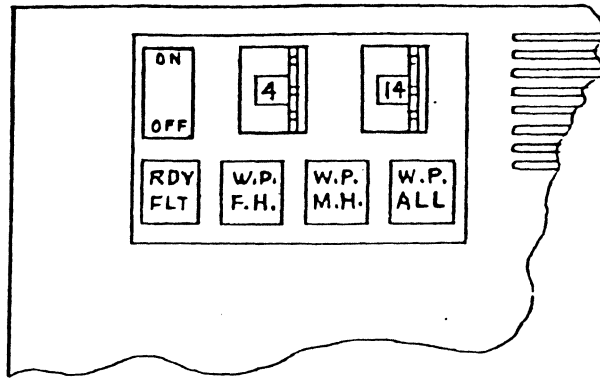

3.2 CONTROLS AND INDICATORS

All controls and indicators are located at the upper left hand corner of the front panel. The following switches and indicator lights are provided as standard:

<u>Name</u>	<u>Function</u>
Power On/Off	Indicator/Switch 'On' initiates the power-up sequence within the drive. 'Off' removes primary power within the Drive initiating the shutdown sequence. The switch is illuminated when primary power is on.
Ready/Fault	Indicator indicates 'Ready' by being constantly illuminated. 'Fault' is indicated by a flashing illumination on and off.

Optional Controls:

<u>Name</u>	<u>Function</u>
Write Protect	Illuminated push button
Fixed Head (W.P.F.H.)	Protects fixed head data only.
Moving Head (W.P.M.H.)	Protects moving head data on one surface only.
All (W.P.ALL)	Protects entire Drive.
Unit Address	Thumbwheel switch (16 position). One or two switches can be provided to accommodate both fixed and moving heads. Positions 14 and 15 are reserved for maintenance only. This switch position should be changed only when the Drive is off line (not selected).

If the Disc Drive is not provided with a Unit Select thumbwheel switch it will be provided with a DIP plug (P/N 30387) on the Interface board at U42 and its unit address will be 0 for moving heads and 1 for fixed heads, if any.

3.3 FAULT CONDITIONS

The 3300 is designed to detect a variety of fault conditions where an internal self-protect feature is executed and external indicators are set for the operator and disc controller. Fault recovery, consisting of an internal restore operation, requires manual intervention in the cases where a fault condition persists and for certain fault types.

Under normal conditions both the Power switch and Ready indicator will be continuously illuminated.

If the Power light and Ready light go off, AC power has failed. Check the fuses and line power.

If the Power light remains on, but the Ready light goes off, or flashes, follow this procedure:

- a) If furnished with thumbwheel unit select switches be sure both unit addresses are not the same.
- b) Wait 15 minutes with power on to see if automatic recovery occurs.
- c) Turn power off, then "on".
- d) If the Ready light does not come on, check fuses.
- e) If the condition persists or quickly recurs, service is required.

3.4 INTERFACE (DATA AND CONTROL)

The Disc Drive interface is compatible with the CDC 9762 (Storage Module), with the following exceptions:

- a) The system must handle the Drive data transfer rate (7.33 Mbits per sec).
- b) The system should transfer and receive data in NRZ (CDC NRZ option).
- c) Up to (12) head addresses are legal, and only track addresses 0 through 339 are legal.

Moving head and fixed head hybrid drives utilize a common interface. Fixed head tracks are addressed using the cylinder address lines (also used for moving heads). Fixed heads will be designated by a unit select address which is different from the moving heads in the same drive. Unit addresses are accomplished with a plug on the interface board, or with optional control panel thumbwheel switches.

Overlap Seek:

The fixed head unit and moving head unit appear to a controller as two independent drives permitting an overlap seek feature where read or write on fixed heads may be enabled while moving heads are undergoing a seek in the same drive. For this purpose, two "B" connectors are provided on drives containing both fixed and moving heads. (See Pages II-2 & III-5).

CDC 9760 COMPATIBLE INTERFACE

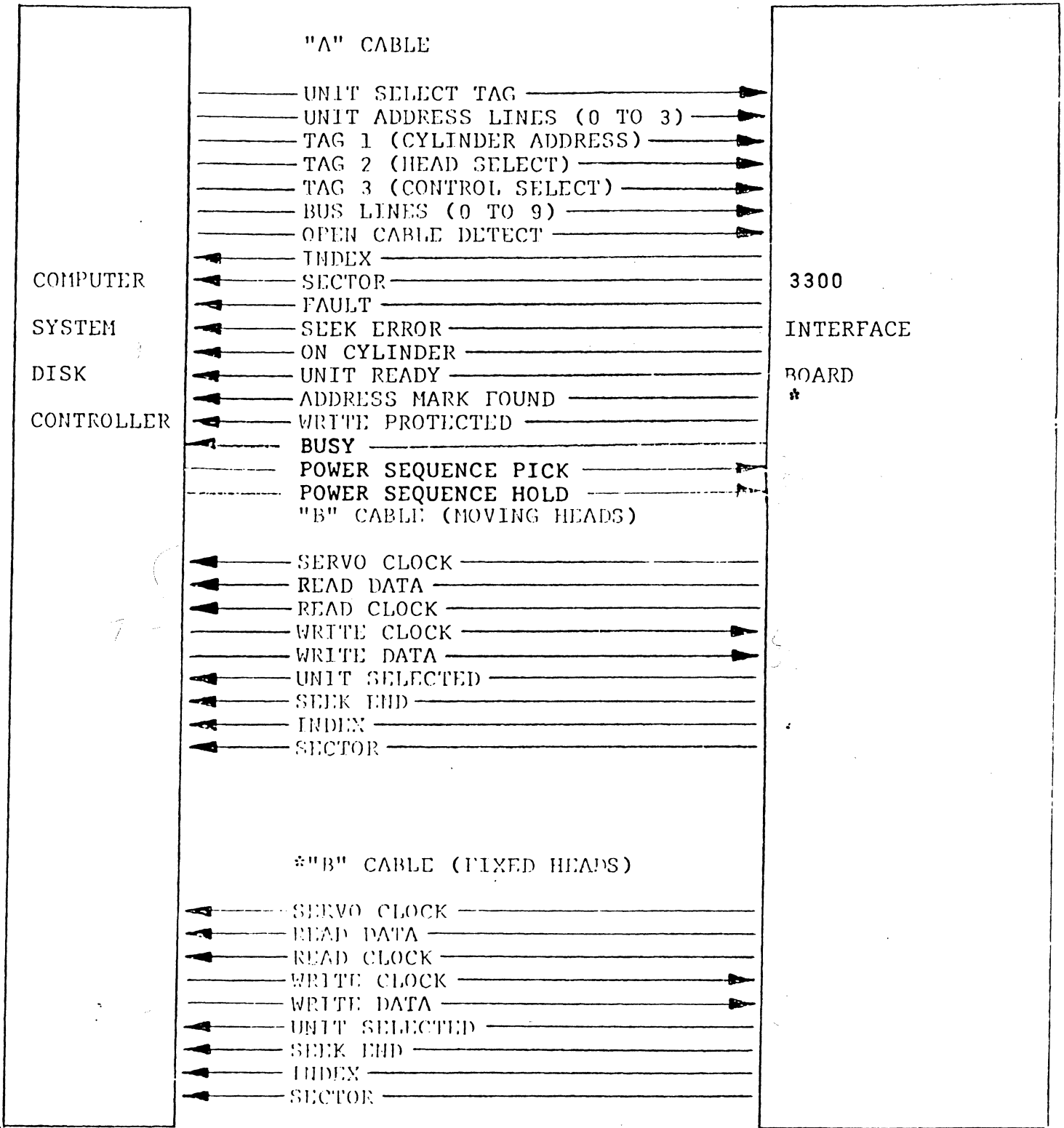

*OPTIONAL

CON'T.

DEFINITION OF "A" CABLE BUS LINES

BUS LINES	TAG 1 (CYLINDER ADR.)	TAG 2 (HEAD ADR.)	TAG 3 (CONTROL FUNCTION)
0	1	1	WRITE ENABLE
1	2	2	READ ENABLE
2	4	4	SERVO OFFSET +
3	8	8	SERVO OFFSET -
4	16	-	FAULT CLEAR
5	32	-	ADDRESS MARK ENABLE*
6	64	-	RESTORE
7	128	-	DATA STROBE EARLY
8	256	-	DATA STROBE LATE
9		-	RELEASE

*OPTIONAL

3.5 INTERFACE SIGNALS (SEE SECTION 2 FOR CABLING)

CABLE "A" SIGNALS (RECEIVED BY THE UNIT):

a) Cylinder Address (Tag 1)

Ten bus lines (Tag 1) are used to carry the cylinder address to the 3300. Since the disc is a direct addressing device, the controller need only place the new address on the lines and strobe the lines with Tag 1 (see Figure 8). The unit must be On Cylinder before Tag 1 is sent. The bus lines should be stable throughout the tag time. Tag 1 must be from 1.0 us to 0.5 ms in duration. Only cylinder addresses from 0 through 338 will be accepted by the drive; greater numbers will result in "Seek Error".

b) Head Select (Tag 2)

This signal is the head address that will be selected by bits 0 through 4. Tag 2 must be from 1.0 us to 0.5 ms in duration.

c) Control Select (Tag 3)

This signal acts as an enable and must be true for the entire control operation.

1. Write Gate (Bit 0)

The Write Gate line enables the write driver. Data is automatically protected by inhibiting the Write Enable in all fault conditions viz:

- A. Fault, line true
- B. On Cylinder, not true
- C. Seek Error, line true
- D. Ready, not true
- E. Open Cable

2. Read Gate (Bit 1)

Enabling of the Read Gate enables digital read data to the transmission lines. The leading edge of Read Gate triggers the read chain to synchronize on an all zeros pattern.

3. Servo Offset Plus (Bit 2)

When this signal is true, the actuator is offset from the nominal On Cylinder position towards the spindle.

4. Servo Offset Minus (Bit 3)

When this signal is true, the actuator is offset from the nominal On Cylinder position away from the spindle.

5. Fault Clear (Bit 4)

A 100 ns minimum pulse sent to the 3300 will clear the fault flip-flop for the selected unit if the fault condition no longer exists.

6. AM Enable (Bit 5) (See Note) (Optional)

The AM (Address Mark) Enable line, in conjunction with Write Gate or Read Gate, allows the writing or recovering of Address Marks (See Figure 3-3). When AM Enable is true while Write Gate is true, the writer will stop toggling and erase the data, creating an Address Mark. Write Fault detection in the unit is inhibited by this signal.

When AM Enable is true while Read Gate is true, an analog voltage comparator detects the absence of read signal. If the duration of the erased area is greater than 16 bits, an Address Mark Found signal will be issued.

NOTE:

If Address Mark is not used, Bit 5 must be held inactive during Control Select functions.

Address Mark should be 3.0 to 3.5 bytes in length with no transitions.

7. RTZ (Bit 6)

A 250 ns minimum, 1.0 ms maximum pulse, sent to the unit will cause the actuator to seek track 0, reset the Head Register and clear the Seek Error flip-flop. For the fixed head unit the Track Address Register will be cleared as opposed to the Head Register.

This seek is significantly longer than a normal seek to track 0, and should only be used for recalibration, not data acquisition.

8. Data Strobe Early (Bit 7)

When this line is true, the PLO Data Separator will strobe the data at a time earlier than nominal. Normal strobe timing will be returned when the line is false.

9. Data Strobe Late (Bit 8)

When this line is true, the PLO Data Separator will strobe the data at a time later than nominal. Normal strobe timing will be returned when the line is false.

NOTE:

The Data Strobe and Servo Offset signals are intended to be used as an aid to recover marginal data. The Servo Offset and Data Strobe position return to nominal when the respective signals go false. A Servo Offset will result in loss of On Cylinder and Seek End for a period of 3.2 ms maximum (see Figure 3-4). The maximum time for the carriage to move from forward to reverse offset or vice versa will not exceed 7 ms; the Servo Offset lines should never be simultaneously on. Data shall not be written while in the offset mode.

10. Release (Bit 9) (Dual Channel Only)

This bit should always be low. It is used for maintenance operations in conjunction with unit addresses 14 or 15.

d) Unit Select Lines (2^0 , 2^1 , 2^2 , 2^3) and Unit Select Tags

The Unit Select Tag signal gates the four Unit Select Lines into the logic number compare circuit. The unit will be selected internally 200 nsec (maximum after leading edge of this signal). For timing see Figure 3-2. The moving head and fixed head unit numbers may be selected by either two thumbwheel switches on the front panel or by one jumper plug on the I/O board. Unit addresses 14 and 15 are reserved for use in field maintenance.

e) Open Cable Detector

Inhibits write gate and unit select when the "A" interface cable is disconnected or controller power is lost.

f) Power Sequence Pick and Hold

The lines are bussed through on the drive to prevent interference with a "daisy chain" of drives which utilize the automatic power sequencing option.

CABLE "A" SIGNALS (TRANSMITTED BY THE UNIT):

a) Sector Mark

Signal derived from the servo track. Any number of sectors can be provided ranging from 2 bytes per sector to 8192 bytes per sector. The number of bytes per sector is selected by a DIP plug (P/N 30388) at U74 on the I/O board. The last sector of the revolution may be longer if necessary.

b) Index

This signal occurs once per revolution, and its leading edge is considered the leading edge of the Sector Zero, typically 2.5 usec. (See Figure 3-1). Timing integrity is retained throughout seek operations.

c) Unit Ready

Indicates that selected unit is up to speed, heads are on a track, and no fault exists.

d) Address Mark Found (Optional)

Address Mark Found is a 9.0 max. usec pulse which is sent to the controller following recognition of at least 16 missing transitions and the first zero of the zeros pattern.

The controller should drop the Address Mark Enable line (Bit 5) upon receiving Address Mark Found (AMF) and valid data will be presented on the I/O lines following the AMF pulse (Figure 3-3).

e) On Cylinder

For moving heads "On Cylinder" indicates that the heads are positioned over a track. For fixed heads, this response is made automatically once a track is selected. This status line is cleared with any seek instruction. For moving heads, a carriage offset will result in loss of "On Cylinder" for a period of 3.2 ms (nominal). See Figure 3-4.

f) Seek Error

Seek Error will be true for moving heads when either Seek Late or Illegal Address (an address greater than the number of data cylinders) occurs. Seek Error will inhibit "On Cylinder" and Write Enable and will only be cleared by performing an RTZ. For fixed heads Seek Error will not be used unless the contiguous track address option is present. In that event Seek Error will be true if an address greater than the number of fixed heads in the drive is requested. "On Cylinder" and Write Enable are disabled in the same fashion as the moving heads.

g) Fault

Fault for the selected unit will be set true for a number of fault conditions and will remain true until the fault condition no longer exists and a Fault Clear pulse is received. Fault conditions are:

1. Multiple Heads Selected
2. Write Protect Violation
3. Multiple Control Tags Received
4. Read or Write Off Cylinder
5. Simultaneous Write and Read Gates
6. Write While Servo Offset
7. Write Current Not On During Write
8. Write Current On During Non-Write
9. Fixed and Moving Head Unit Number Set Equal by Front Panel Switches or by Unit Address Plug.
10. Loss of DC Power

h) Write Protected (Optional)

This signal is true for the selected unit for as long as a Write Protected portion of the drive is addressed. Those portions which may be protected are:

1. Moving Head 0 (all associated tracks)
2. All Fixed Head Tracks
3. Entire Drive (all moving and fixed head tracks)

Attempting to write while protected will cause a fault to be issued.

i) Busy

This line provides compatibility with controllers which utilize the dual port option. Busy is always low to indicate the drive is not currently busy with another controller.

CABLE "B" SIGNALS (RECEIVED BY THE UNIT):

a) Write Clock

This line transmits the Write Clock signal which must be synchronized to the NRZ data as illustrated in Figure 3-6. The Write Clock is the Servo Clock retransmitted to the drive by the controller during a write operation. The received Write Clock is phase-locked again to eliminate any potential transmission distortion. So as not to require a phase-lock startup time, Write Clock should be transmitted continuously.

b) Write Data

Carries data to be recorded on the disc. Data is NRZ, and is clocked onto the disc by the disc drive. See Figure 3-6.

CABLE "B" SIGNALS (TRANSMITTED BY THE UNIT):

a) Servo Clock

Phase-locked 7.33 MHz clock generated from the servo track tribits. It is used to transfer data to the drive. Servo Clock is available at all times (not gated with Unit Select). See Figure 3-6.

b) Read Data

Carries data recovered from the disc. Data is NRZ. See Figure 3-5.

c) Read Clock

The Read Clock defines the beginning of a data cell. It is an internally derived clock signal and is synchronous with the detected data as specified in Figure 3-5. This signal is transmitted continuously, and is in phase sync within 7 us after Read Gate.

d) Seek End

Seek End goes true with either "On Cylinder" or "Seek Error", indicating that a seek operation has terminated. Seek End will remain true so long as the positioner remains on cylinder.

e) Unit Selected

When the four unit select bit lines compare with the jumper plug on the interface board, and when the leading edge of unit select tag is received, the unit selected line becomes true and transmitted to the controller on the "B" cable. Multiple unit selected responses on a daisy-chain system indicate duplicate plugs have been installed. See Figure 3-2.

f) Sector (Optional)

Sector Mark is transmitted continuously, independent of Unit Select, in order to provide look-ahead for the controller.

g) Index (Optional)

Index is transmitted continuously, independent of Unit Select, in order to provide look-ahead for the controller.

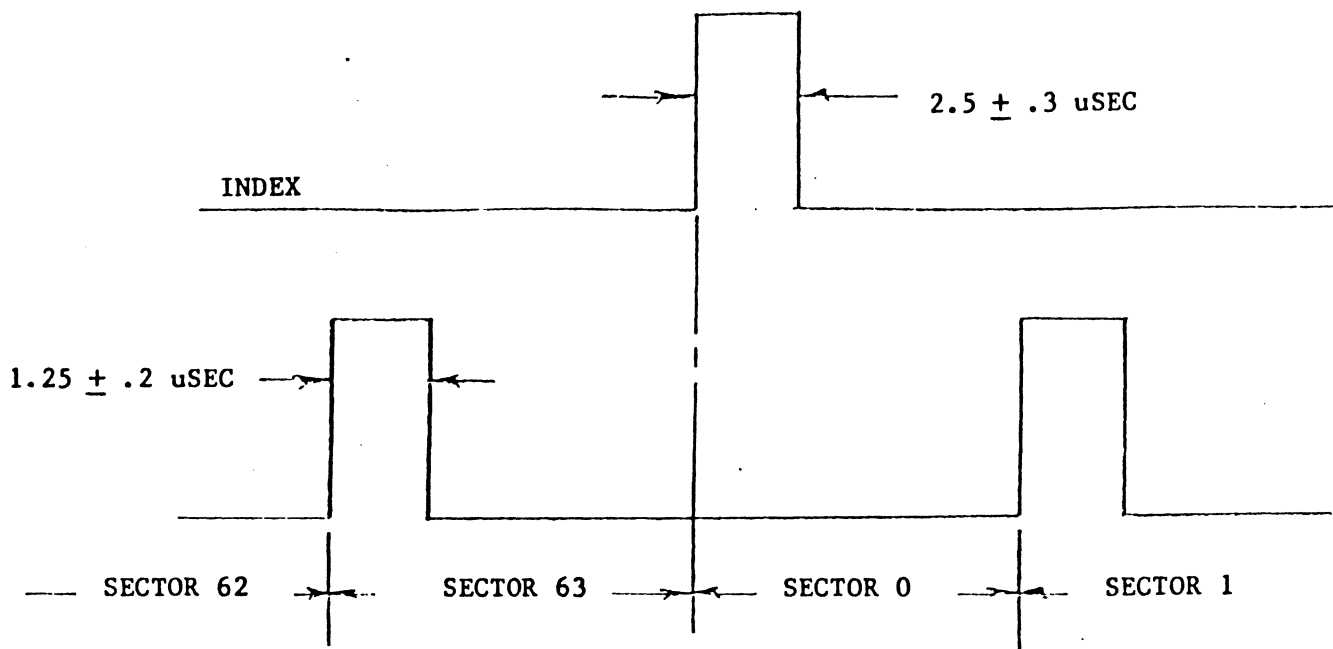

FIGURE 3-1 INDEX AND SECTOR TIMING

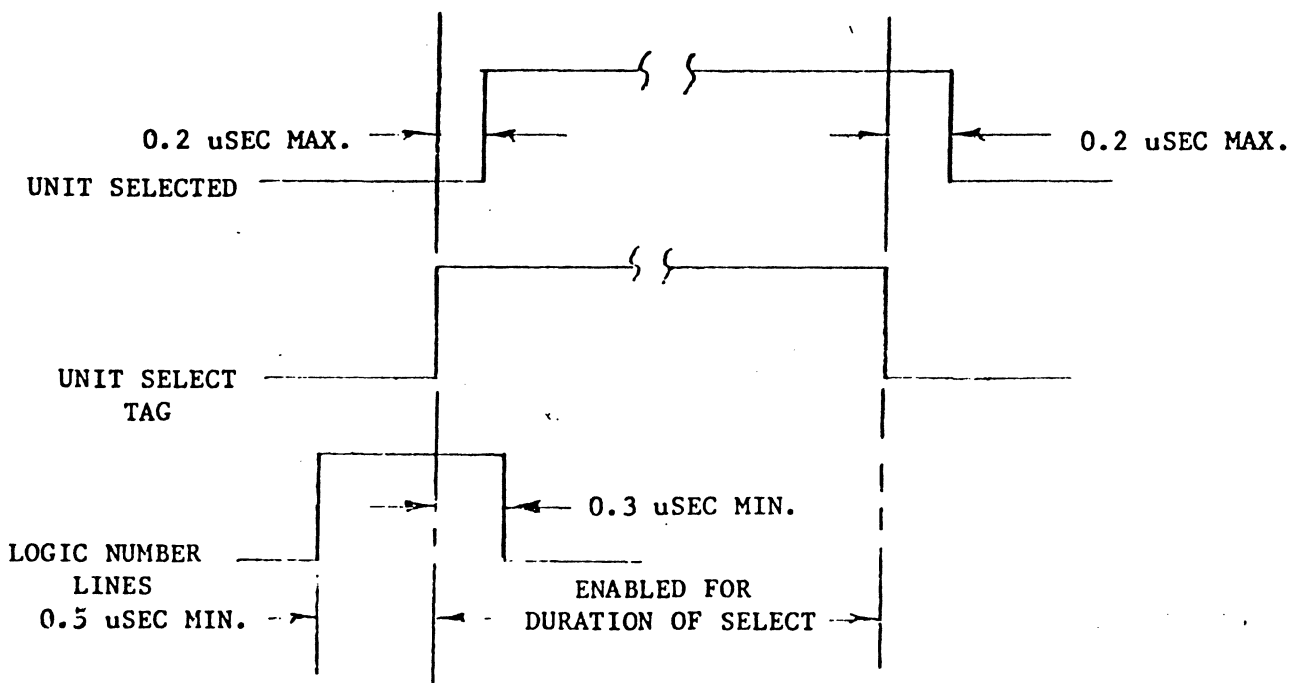
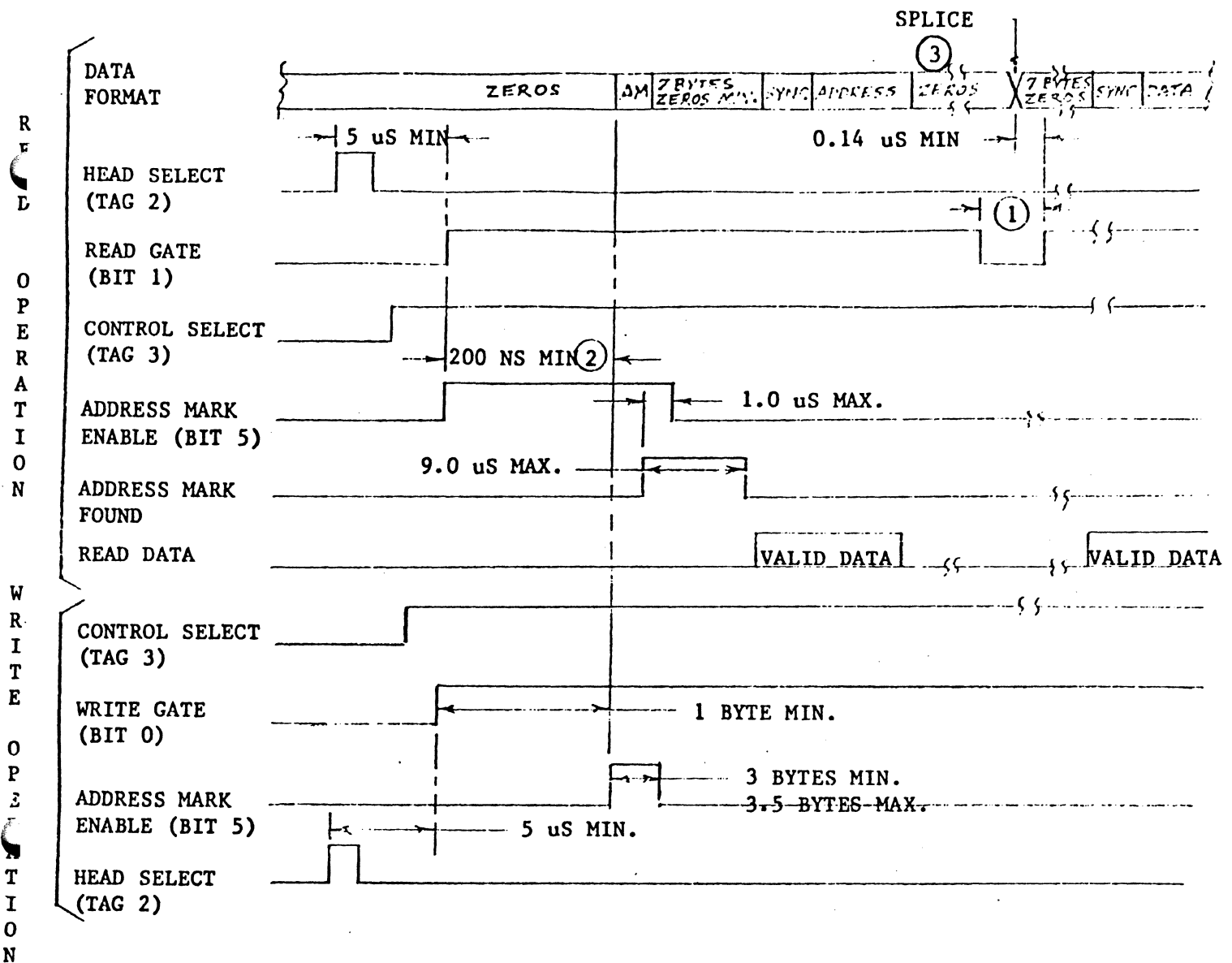

FIGURE 3-2 LOGIC NUMBER SELECT CODE AND TIMING DIAGRAM



- NOTES:
- 1 READ GATE MUST BE DROPPED PRIOR TO THE WRITE SPLICE. IT MUST BE REINITIATED AT LEAST ONE BIT AFTER THE WRITE SPLICE AND WITH AT LEAST 7 BYTES OF ZERO BITS REMAINING IN THE SYNC FIELD.
 - 2 ADDRESS MARK ENABLE SHOULD OCCUR SIMULTANEOUSLY WITH READ ENABLE.
 3. WRITE SPLICE IS DEFINED AS THAT POINT WHERE A WRITE OPERATION IS BEGUN OR TERMINATED. AN ABRUPT PHASE SHIFT IN THE RECORDED SIGNAL USUALLY OCCURS AT THIS POINT.

FIGURE 3-3 TYPICAL TIMING WITH ADDRESS MARK

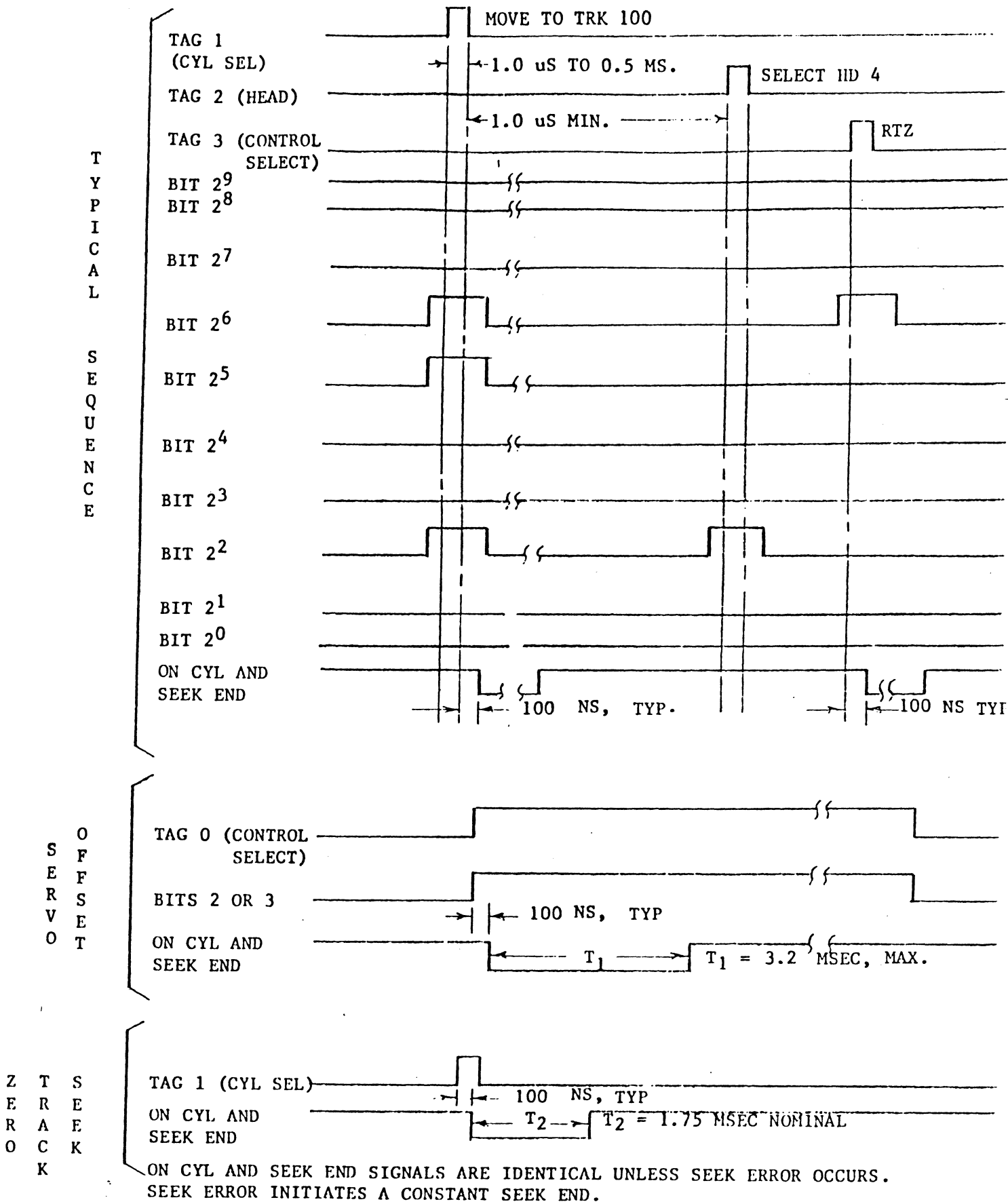
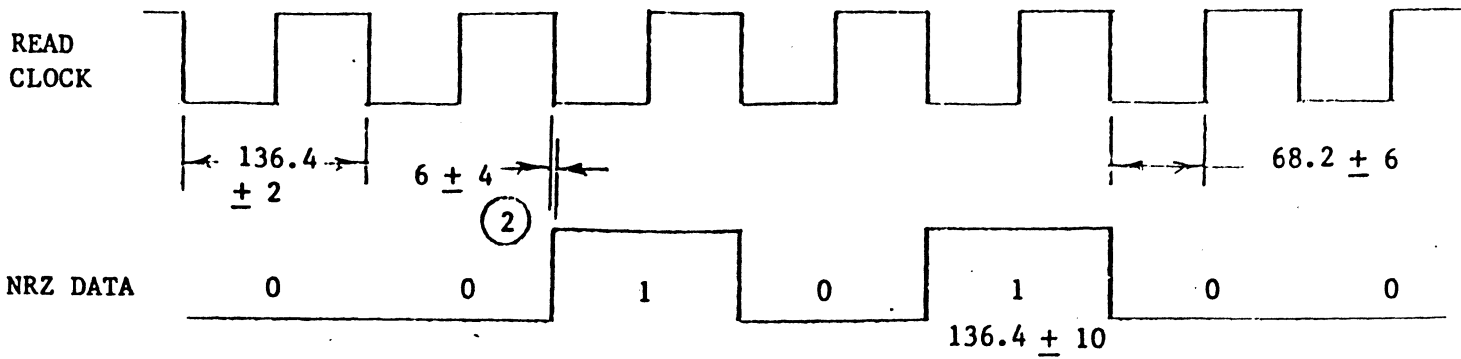

FIGURE 3-4 ON CYLINDER TIMING



NOTES:

1. ALL TIMES IN NSEC.
- ②. NEGATIVE EDGE OF CLOCK PRECEDES SIGNIFICANT EDGE OF DATA AT I/O CONNECTOR.

FIGURE 3-5. READ DATA TIMING

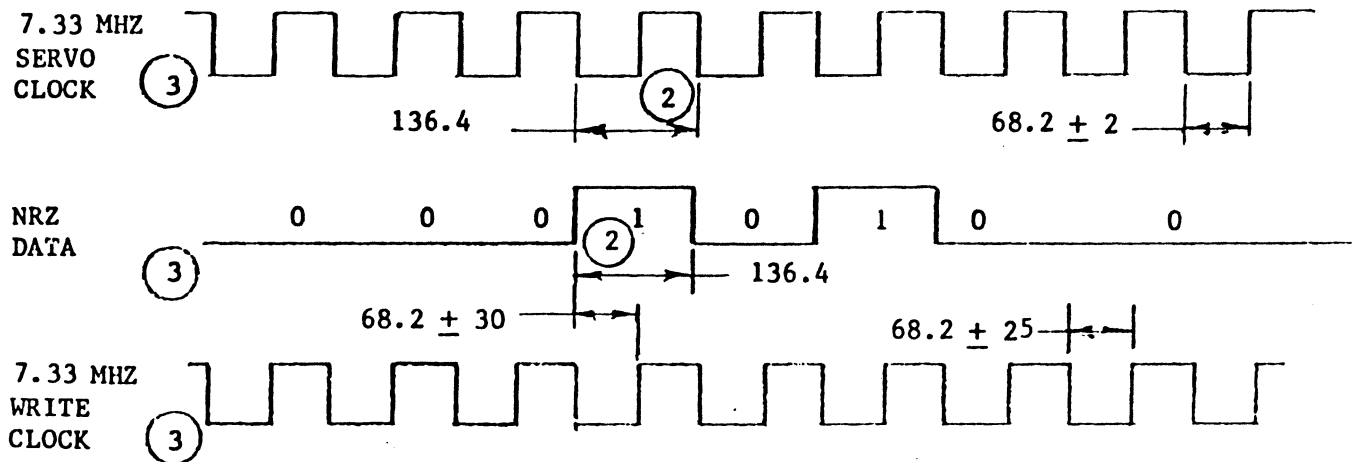

NOTES:

1. ALL TIMES IN NSEC.
- ②. SIMILAR PERIOD SYMMETRY SHALL BE ± 2 NSEC AT I/O CONNECTOR IN DRIVE, SPEED VARIATION TOLERANCE SHALL BE $\pm 5\%$ OF PERIOD WHICH INCLUDES SPINDLE SPEED TOLERANCE AND TRIBIT DROPOUT WHILE CARRIAGE IS MOVING.
- ③. AT I/O CONNECTOR IN CONTROLLER.

FIGURE 3-6 WRITE DATA AND SERVO CLOCK TIMING

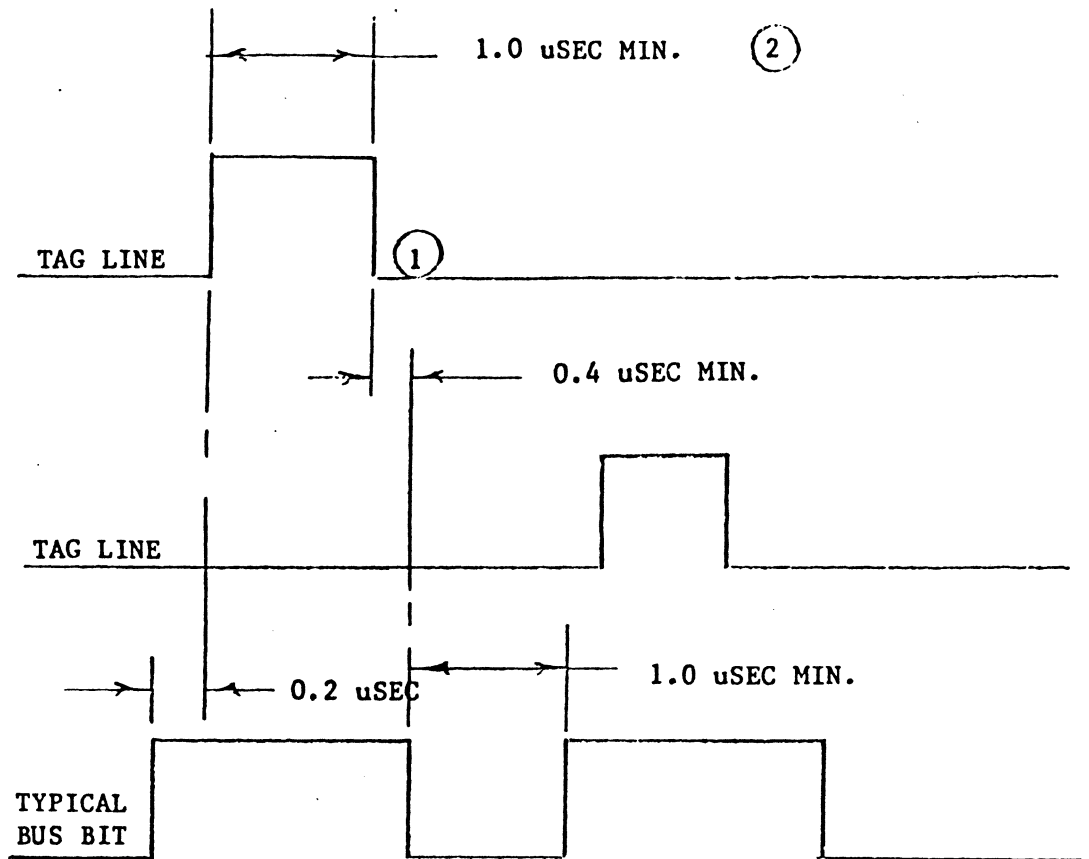

- ① DOES NOT APPLY TO CONTROL SELECT FUNCTIONS.
- ② TAG 1 (CYL SEL) MAX. LENGTH IS 0.5 MSEC.

FIGURE 3-7 TAG LINE AND BUS TIMING TOLERANCE

3.6 DATA FORMAT AND DATA CONTROL TIMING

a) Format Suggestions

The record format on the disc is under control of the controller. The index and sector pulses are available for use by the controller to indicate the beginning of a track or sector. Suggested formats for fixed and variable sector data records are shown in Figures 3-8 & 3-9.

Some hardware oriented constraints must be recognized when designing a format. The following is a list of those format parameters:

1. Beginning-of-Record Tolerance

This tolerance must be provided to allow for worst case conditions of mechanical and circuit tolerances.

This gap must be written with a minimum of 2 bytes of zeros.

NOTE

To allow for head switching between sectors a gap of 7 bytes of zeroes is recommended.

2. Read PLO Synchronization

The synchronization time needed to allow the phase-locked oscillator to synchronize is 7 us of zeros.

3. Sync Pattern

The Sync Pattern consists of a 00000001 pattern indicating the beginning of the address or data area (one "one" bit is the minimum required).

NOTE

In the sample formats (Figures 3-8 & 3-9) the first 7 0's in this pattern are used to augment the PLO sync bytes.

4. Write Splice

The write driver turn-on time is 0.3 usec. Therefore a write splice area must be provided in the format preceeding data. It is recommended 1 byte be provided for this function.

5. End-of-Record Pad

This field is one byte to ensure that the last bit is not distorted or destroyed in an erroneous readback.

6. End-of-Record Tolerance

This tolerance is a two byte pad of zeros.

b) Write Format Procedure

Provisions must be made within the controller to format the disc. The following procedure is recommended for fixed sector formats:

1. Select desired unit, cylinder, head and sector.
2. The controller must provide a 5 us minimum delay between selecting a head and initiating a search for leading edge of sector. This delay will ensure that the unit will be ready to write when the sector leading edge is detected.
3. Search for leading edge of desired sector.
4. Detect leading edge of selected sector.
5. Immediately bring up Write Gate and start writing zeros.
6. Write all zeros for beginning of record and PLO sync areas (13 bytes in sample formats).
7. Write a sync pattern, the address, and the address checkword.
8. Write all zeros for write splice gap and PLO sync field (7 bytes in sample formats).
9. Write a sync pattern, the data field, the two byte data field checkword, and the one byte pad at the end of the checkword. The data field should be written with all ones.
10. The end tolerance gap is the only part of the format where there may be erased areas with no write data.

FIXED SECTOR

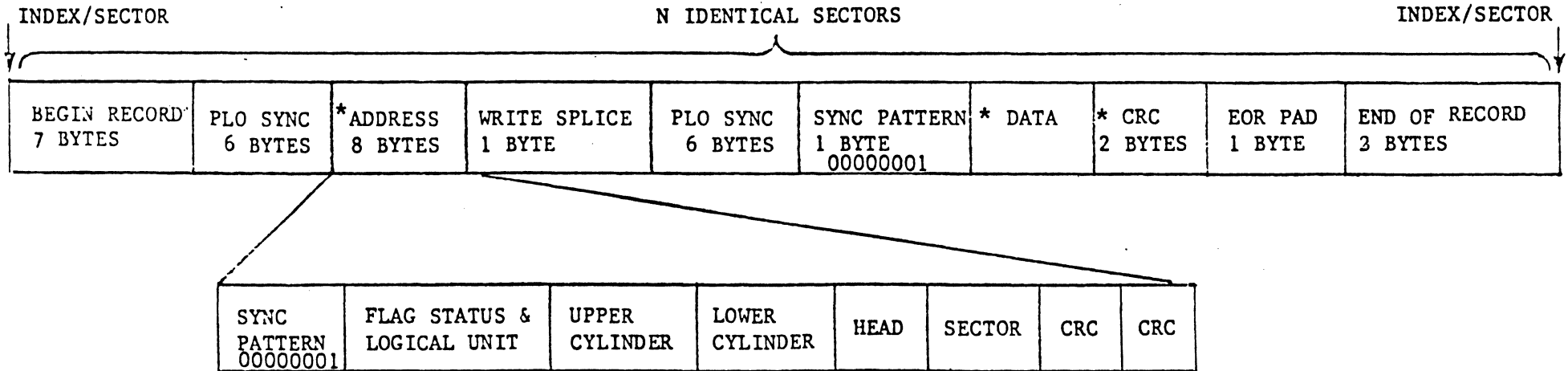

111-21

EXAMPLE NO. 1: WHAT IS DATA FIELD LENGTH USING 64 SECTORS?

$$\text{DATA FIELD} = \frac{\text{TOTAL BYTES/TRACK}}{\text{NUMBER OF SECTORS/TRACK}} - (\text{SYNC FIELDS, TOLERANCE GAPS, AND ADDRESS})$$

$$\text{DATA FIELD} = \frac{18560}{64} - 34 = 256 \frac{\text{BYTES}}{\text{SECTOR}}$$

$$\text{DATA} = 256 \text{ BYTES/SECTOR}$$

$$\% \text{ EFFICIENCY} = \frac{256 \times 64}{18560} \times 100 = 68\%$$

* THESE AREAS ARE EXAMPLES ONLY AND MAY BE STRUCTURED TO SUIT INDIVIDUAL CUSTOMER REQUIREMENTS.

FIGURE 3-8 FIXED SECTOR FORMAT

VARIABLE SECTOR WITH ADDRESS MARKS

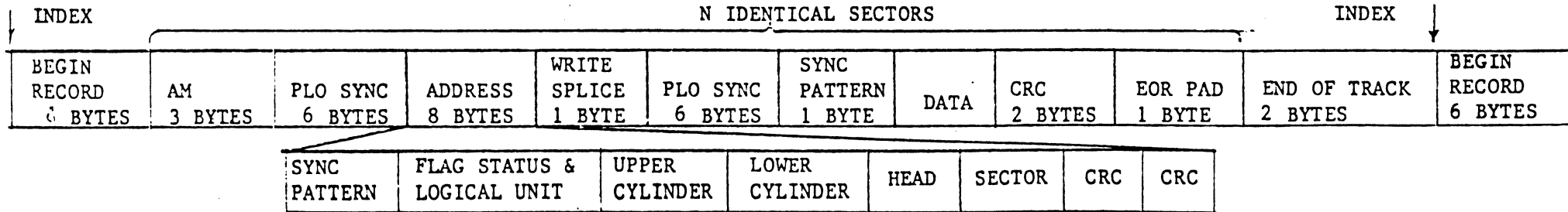

EXAMPLE NO. 1: WHAT IS DATA FIELD LENGTH USING 64 SECTORS?

$$\text{DATA FIELD} = \frac{\text{TOTAL BYTES/TRACK} - \text{MECHANICAL TOLERANCES}}{\text{NUMBER OF SECTORS/TRACK}} - (\text{SYNC FIELDS AND ADDRESS})$$

$$\text{DATA FIELD} = \frac{18560 \frac{\text{BYTES}}{\text{TRACK}} - 8 \frac{\text{BYTES}}{\text{TRACK}}}{64 \frac{\text{SECTORS}}{\text{TRACK}}} - 28 \frac{\text{BYTES}}{\text{SECTOR}} = 261 \frac{\text{BYTES}}{\text{SECTOR}}$$

$$\% \text{ EFFICIENCY} = \frac{261 \times 64}{18560} \times 100 = 90\%$$

EXAMPLE NO. 2: WHAT IS NUMBER OF SECTORS USING 512 DATA BYTES?

$$N \text{ SECTORS} = \frac{18560 - 8}{512 + 28} = 34 \text{ SECTORS}$$

$$\% \text{ EFFICIENCY} = \frac{512 \times 34}{18560} \times 100 = 94\%$$

THESE AREAS ARE EXAMPLES ONLY AND MAY BE STRUCTURED TO SUIT INDIVIDUAL CUSTOMER REQUIREMENTS.

FIGURE 3-0 VARIABLE SECTOR FORMAT

11. If the next sector of the same track is to be formatted and the head is not deselected, the Write Gate may be left on. The controller should write all zeros in the tolerance gap.

c) Control Timing (Figure 3-10)

1. Read

The control line associated with a read command is the Read Gate line.

The leading edge of Read Gate forces the phase-locked oscillator to synchronize on an all zeros pattern. Read Gate also enables the output of the data separator onto the I/O lines after a lock-to-data internal time out. Read Gate must be dropped and raised again after going through a splice area. Read Gate may be enabled 44 clock counts after the leading edge of index or sector to ensure the head is reading the sync field.

The sync pattern search may begin 52 servo clock counts after the leading edge of Read Gate. Head switching and read amplifier stabilization (see Figure 3-10) shows the latest acceptable time at which a head can be selected in order to read the next successive sector.

Data I/O lines may not have valid data until 7 us from leading edge of Read Gate, due to phase-lock synchronizing time.

Ensure that there will be no splice area after Read Gate is brought up.

2. Write Data Field

The control line associated with a write operation is Write Gate.

The sector address must always be read and verified prior to writing the data field, except while formatting.

Writing the data field must always be preceded by writing the PLO sync field and sync pattern.

The controller must provide a three bit internal delay (approximately 0.3 us) between the trailing edge of the Read Gate signal and the leading edge of the Write Gate signal (see Figure 3-10). This

delay will allow for signal propagation tolerances and prevent a possible overlap of the Read and Write Gate in the unit.

Writing the data field must always be followed by writing the checkword and at least an eight bit pad at the end of the checkword.

During formatting, Write Gate is raised immediately upon sensing index or sector. During a record update, Write Gate is raised within two bits of the last bit of an address.

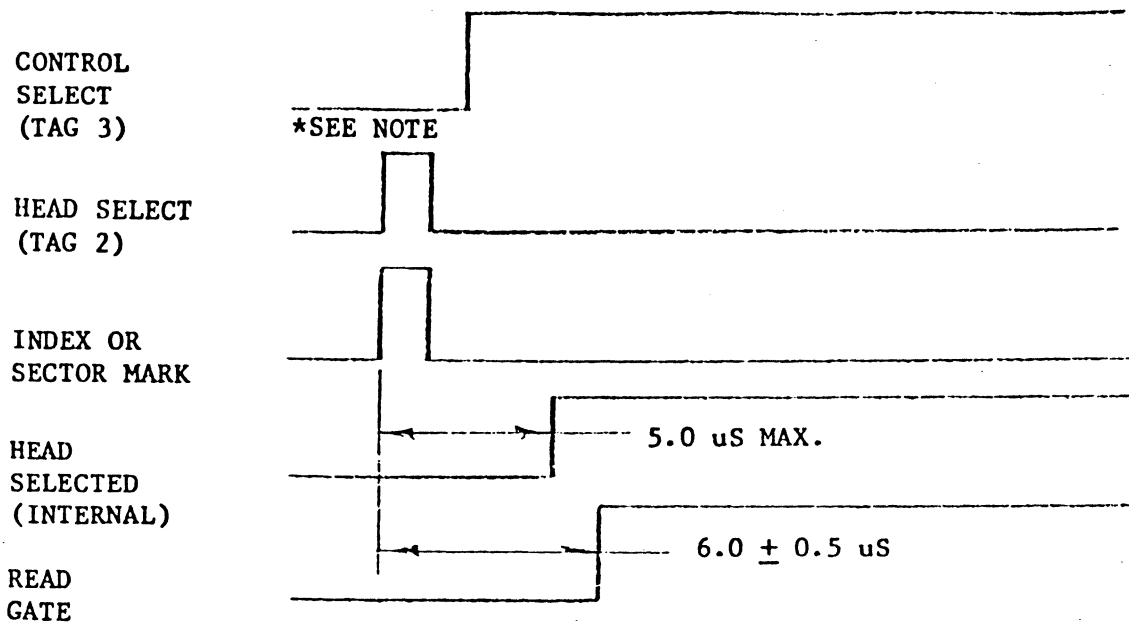

NOTE: READ OPERATION HEAD SELECT MAY NOT OCCUR LATER THAN 6.0 uS AFTER INDEX OR SECTOR.

TYPICAL READ CONTROL TIMING

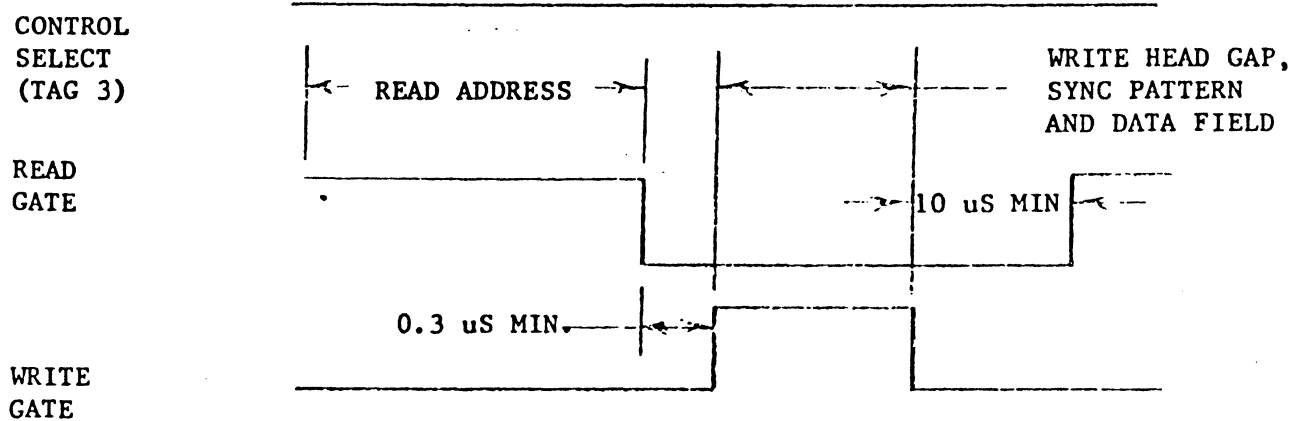

TYPICAL WRITE CONTROL TIMING

FIGURE 3-10 CONTROL TIMING

SECTION IV
PRINCIPLES OF OPERATION

4.0 INTRODUCTION

For ease of understanding the principles of operation of the 3300 disc drive, major functional groups and associated sub-assemblies are described separately. The functional separation of the system relates conveniently to the actual packaging of sub-assemblies. The part number of the sub-assembly and its associated schematic and assembly drawing, are the same. These drawings are contained in Section VI, and should be used in conjunction with this Section to derive complete understanding.

NOTE

Throughout the text, component designators are prefixed with the Page number of the associated schematic, for ease of location of the appropriate circuit. Logic signal polarity is indicated by the presence or absence of a bar above the logic term.

4.011 The following are the major functional groups and associated sub-assemblies in the order in which they are presented:

<u>Functional Group</u>	<u>Sub-Assembly</u>	<u>Part No.</u>
1) A/C Distribution	A/C Distribution	30337
2) Power Supply	Power Supply	30334
	Power Amplifier	30105
3) Head Positioning Servo	Servo/Logic	30103
4) Data	Matrix	30100
	Fixed Head Amp. (optional)	30104
	Data	30102
5) Interface	Interface (optional)	30115

4.1

AC DISTRIBUTION

The AC Distribution system is shown in Figure 4-1. The 120 Volt units differ from the 240 Volt units by different values for the fuses, F1 and F2, the change of spindle motor, motor start relay and motor start capacitor. All of these components are located in assembly P/N 30337. The AC distribution assembly is located at the left rear of the machine (Fig. 5-36). The power On-Off switch also changes from 120V to 240V due to the different lamp voltage required.

When the operator control panel power switch is turned on, the power supply is energized and the control panel light is lit. Now the brake solenoid is energized by the power supply.

The switch on the brake solenoid is closed when the solenoid is energized, closing the spindle motor circuit. The solenoid is powered by the +32V power supply. When the brake band is released, a second switch on the brake band assembly places a dropping resistor in series with the solenoid to reduce solenoid power and to hold the brake disengaged.

After brake disengagement, the spindle motor is energized. A solid state motor start relay connects the start capacitor due to the high current in the run winding. The capacitor and start winding produce a high starting torque and rapidly accelerate the disc. As the disc approaches running speed, the current drops off and the start capacitor is disconnected.

The fan motor is powered by the 115V tap on the power supply transformer for all line voltage and no changes are required to adapt the fan to any selectable line voltage.

A RFI filter is connected to the power line to prevent line induced noise from affecting disc drive operation.

The main input fuse, F1, protects the AC box, spindle motor and RFI filter. A second lower current fuse, F2, is used to protect the power supply from damage.

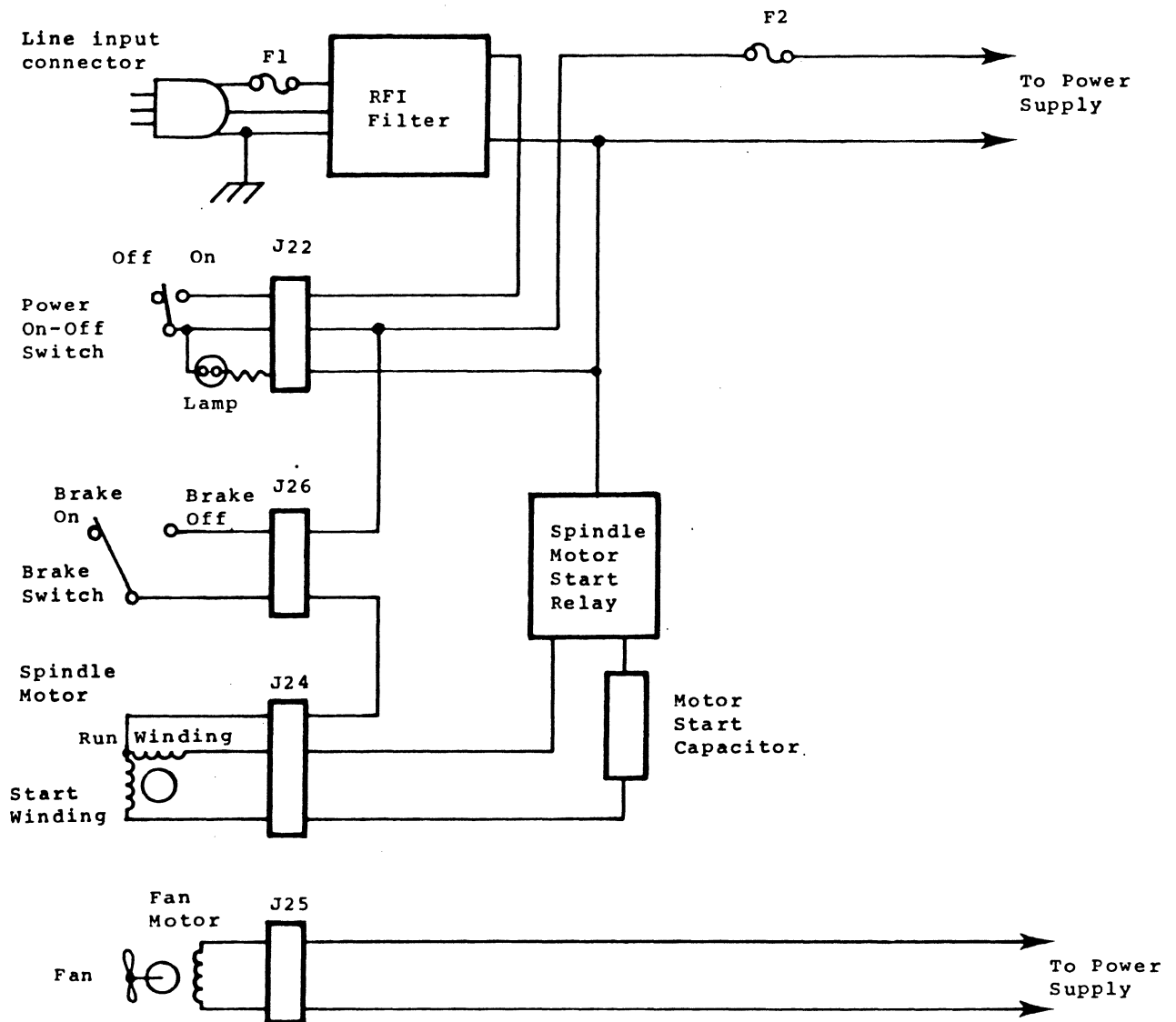

Figure 4-1
A/C Distribution System

D/C POWER SUPPLY

Figure 4-2 shows the power distribution for the 3300 disc drive system. A detailed diagram is located in Section VI (Dwg. 30114).

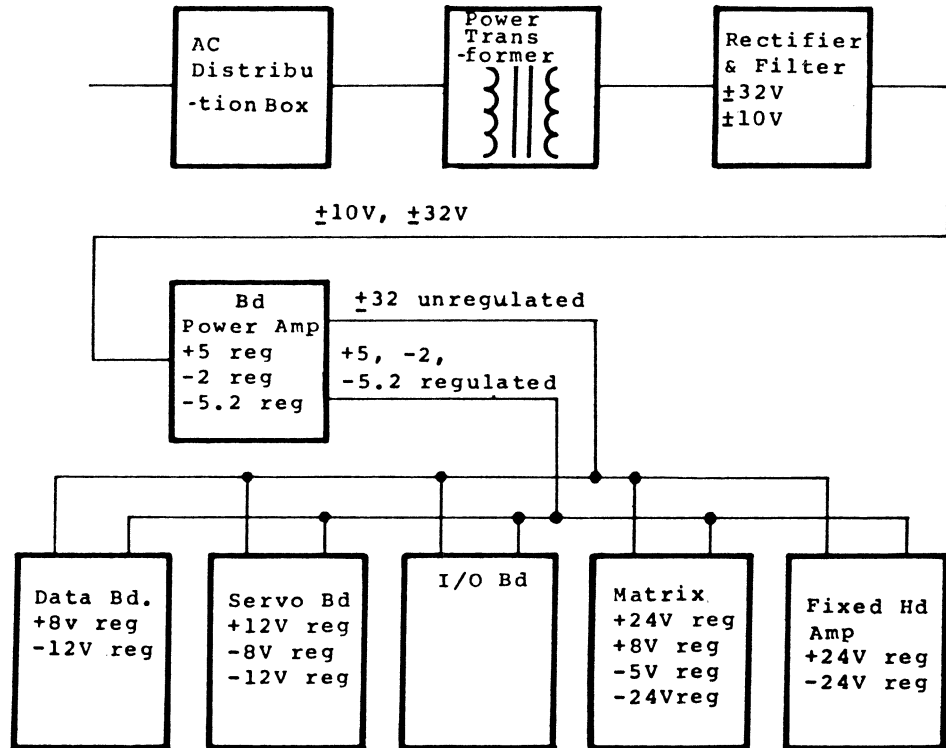

Figure 4-2
Power Distribution

The power transformers, rectifier and filter are located on the bottom plate of the disc drive (Fig. 5-3), and comprise assembly P/N 30334.

Figure 4-3 shows the transformer primary wiring connections required for the 110 vac or 220 vac. The connections for all transformer taps are listed on the power supply schematic. The fan is always

powered by the same windings on the power transformer. The power transformers are used as an Auto transformer to power the fan at the same nominal voltage regardless of input line connections.

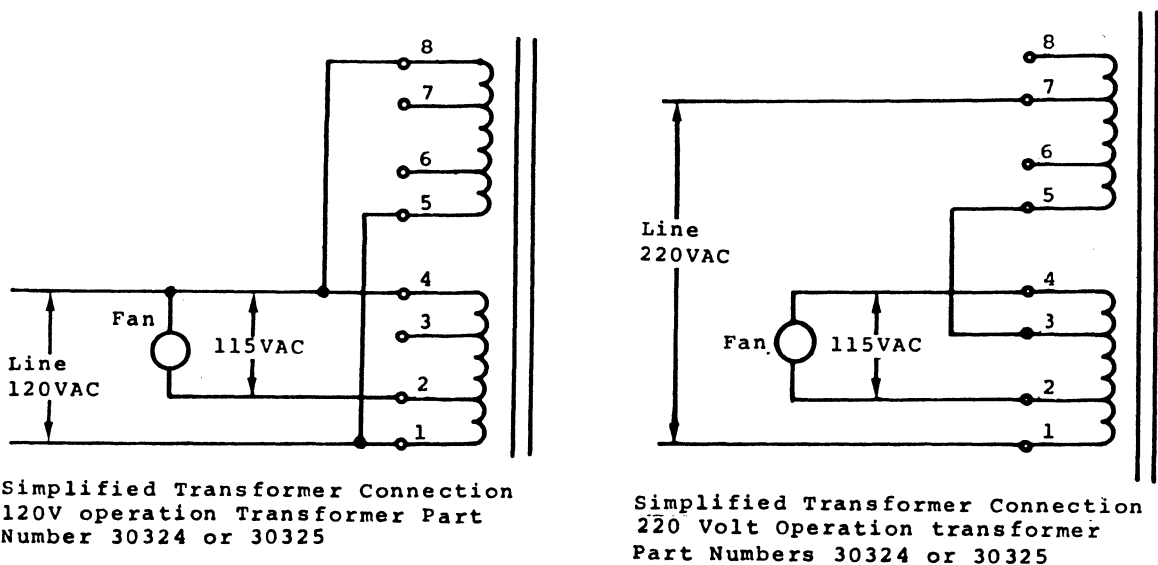

Figure 4-3
Transformer Primary Connections

The transformer secondary is connected as a center tapped full wave bridge circuit. This center tapped circuit produces equal amplitude positive and negative voltages from a single centered tapped secondary. The rectifiers drive a capacitor input filter. Separate transformers are used to produce the nominal ± 10 volts and ± 32 volt unregulated outputs. The power wiring harness from the rectifier-filter connects to the power amplifier board.

The power amplifier board assembly (P/N 30105) is located at the right rear of the drive (Fig. 5-9). It has the series pass regulators for +5 (VDC) -5.2 (VDC) and -2 (VDC) located upon its heat sink.

The control circuitry is on the power amplifier printed circuit board assembly. The +10VDC unregulated is regulated to +5.0VDC, and -10VDC unregulated is regulated to -5.2VDC. The regulated -2VDC is derived from the -5.2VDC. The -2 volt regulator is an Integrated Circuit series pass regulator with all control circuitry in that same package. The (± 32 VDC) unregulated is used to power the position motor via the control transistors located on the power amplifier module. The ± 32 VDC unregulated is distributed to the remaining P.C. cards where it is regulated as required. "3 terminal" regulators, like the -2V regulator, are used with output voltages as required to provide regulated power. See figure 4-2 for power distribution.

4.3 HEAD POSITIONING SERVO SYSTEM

4.3.1 General

In a moving disc drive, the head positioning system serves two primary functions:

- a) Move the data heads from one cylinder to another as demanded at the interface as rapidly as possible.
- b) Maintain the location of the heads on cylinder as accurately as possible.

The 3300 uses a "Track Following" technique to achieve these objectives in which a dedicated servo head is used to generate position information for the system from the pre-recorded servo tracks located on the bottom surface of the lower disc (Fig. 4-4).

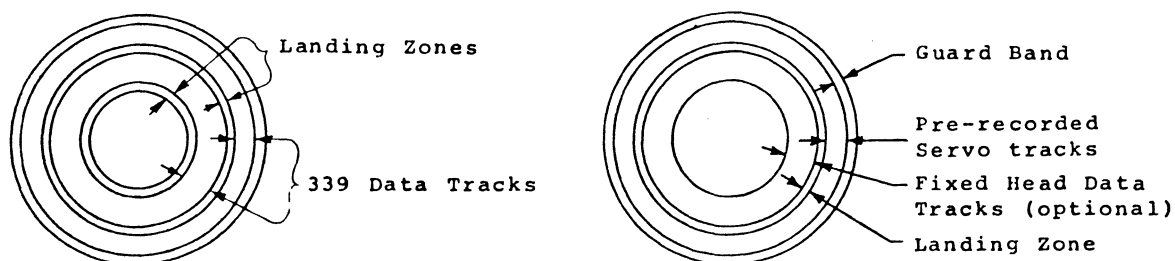

Figure 4-4
Disc Servo and Data Locations

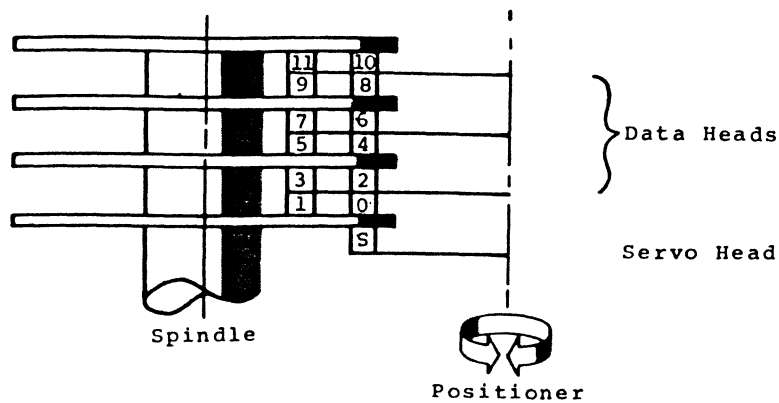

Figure 4-5
Moving Head Positions

As can be seen in Figure 4-5, all the data heads and the servo head are mounted mechanically to a common head mount which is attached to the position arm. Therefore, when the servo head achieves a particular track position, all data heads also achieve a corresponding track position. Depending on the number of heads in the drive, all data tracks accessed for a given servo head comprise a "Cylinder".

To achieve its primary objective, the positioning servo, used in the 3300, operates in two modes:

- a. "Coarse" or velocity feedback mode.
- b. "Detent" or position feedback mode.

The "Coarse" mode is used to locate the heads as rapidly as possible over a desired track location. In this mode, the heads are accelerated as rapidly as possible to high velocity, and at the appropriate position they are rapidly decelerated so that velocity is near zero at the desired track location (Fig. 4-6).

The "Detent" mode is used to position the heads accurately over the track location and keep them there regardless of vibration, thermal effects, etc.

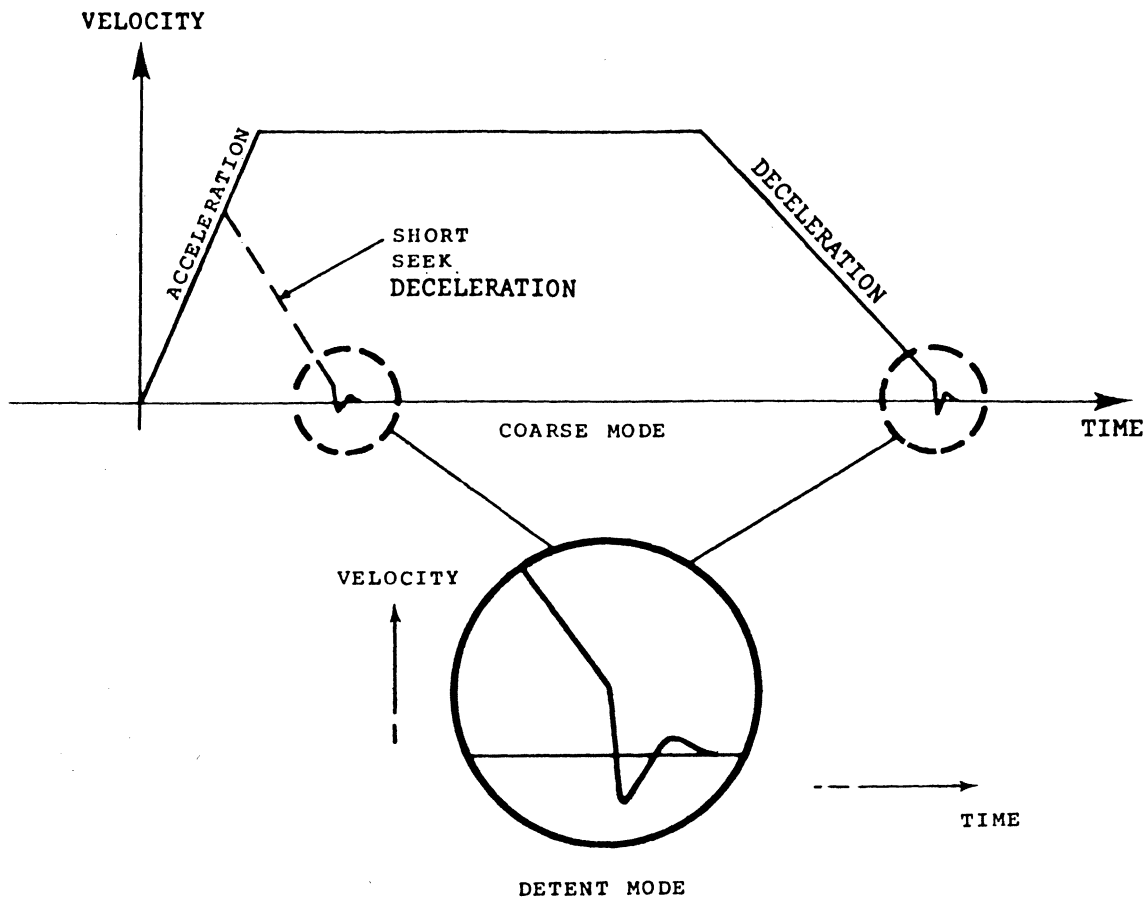

Figure 4-6
Positioner Motion During Seek

The block diagram of Figure 4-7 gives an overview of the basic functional blocks of the servo system. The servo system can be divided into four major blocks: the servo demodulation block, to decode recorded servo information; the arithmetic section, to store and process current and requested track location information; the control section, to execute requested commands; the servo control section, to position the servo and data heads to the requested track location. The circuits associated with these servo functions are located on the Servo/Logic board (P/N 30103).

4.3.2 Servo Head Signal

The servo track information is pre-recorded as shown in Figure 4-8. The servo disc is written in alternating bands of "A" and "B" tracks except in guardband, where a modified "B" track pattern is written. The upper track of Figure 4-8 shows

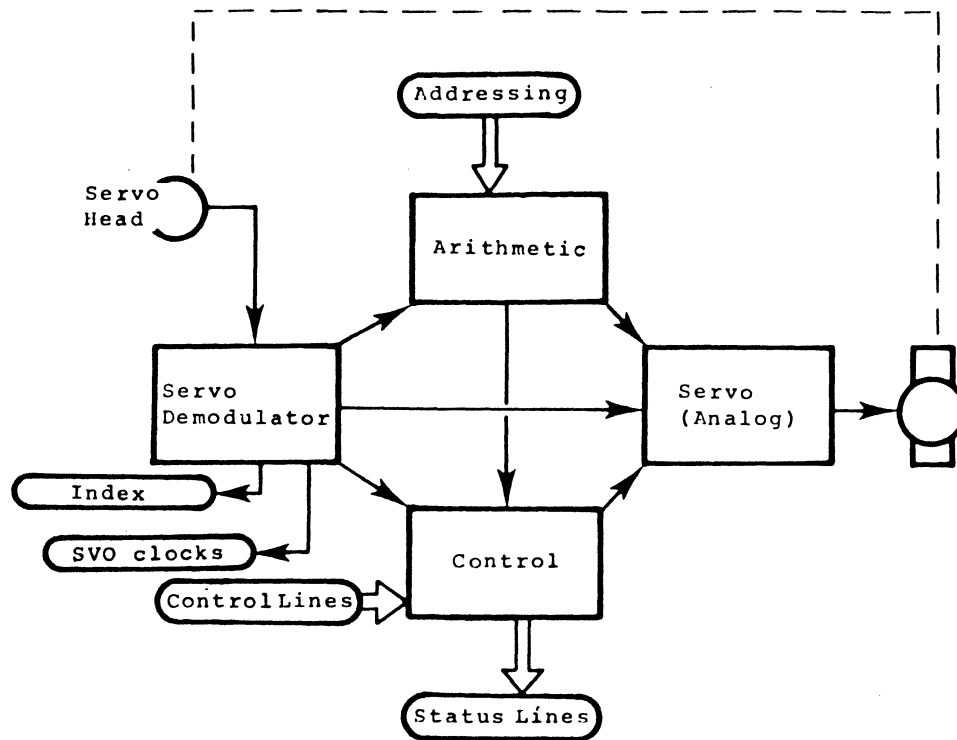

Figure 4-7
Servo System Functional Diagram

the electrical signal when the servo head is directly over an "A" track. The positive going portion of the signal is referred to as a "Sync Pulse"; the negative going portion is referred to as a "servo pulse".

When directly on track "B", the head signal is the same as when on track "A", except for the time relation between the sync and servo pulses. An "A" track servo pulse is about 1/3 of a time period from the sync, whereas the "B" track servo is about 2/3 of a time period from the sync pulse.

Figure 4-8 shows the servo head signal when the head is between an "A" and "B" servo track, and what happens to the signal as the servo head moves toward an "A" or "B" track. The "A" servo bit reduces in amplitude as a "B" track is approached and at the same time, "B" track servo bit increases in amplitude. The opposite occurs as an "A" track is approached.

IV-10

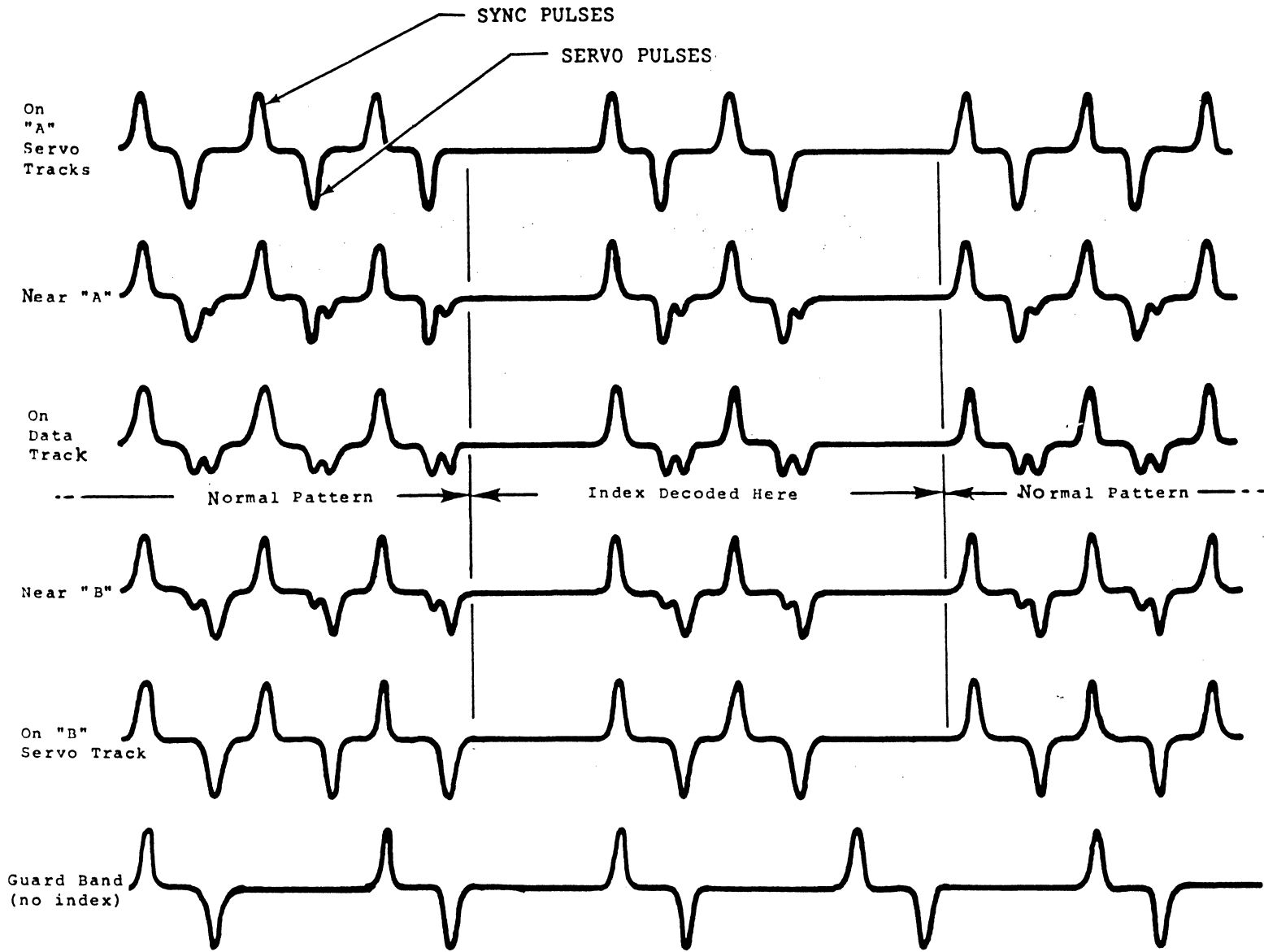

Figure 4-8
Servo Head Signal

The sync bits on "A" and "B" tracks are written in the same time position on both "A" and "B" tracks. When the servo head is moved between an "A" to a "B" track, the signal from the "A" track decreases and the signal from "B" track increases an equal amount, so the servo head signal, which is the sum of the two track signals, stays the same. The servo head signal in guardband consists of a modified "B" signal on every track with alternate bytes dropped. The dropped bytes are decoded to detect the term "GUARDBAND" (Fig. 4-8).

The index pattern is a four byte pattern repeating once per track revolution. This pattern is coded by the deletion of a byte, composed of a sync and servo bit, insertion of two bytes, and deletion of a byte. This pattern is written once per revolution and its angular position is constant, regardless of track location (Fig. 4-8).

The "B" track index pattern is the same as recorded on an "A" track.

4.3.3. Servo Head Signal Processing (Servo Demodulator)

Figure 4-9 shows a block diagram of the process of decoding the servo track information. The head has an "on-board" preamplifier (contained within the disc enclosure) to improve signal-to-noise ratio and reduce noise pickup. The preamplifier requires ground and -8V for power and has a push-pull output signal.

The servo head preamplifier is terminated at the input to the servo board (P/N 30103). Integrated circuit 1U4 and FET 1Q1 form a variable gain amplifier. The variable gain amplifier drives a low pass filter to limit the band width to that required to pass the information recorded on the servo track and reduce the unwanted noise outside the band width of interest.

The filter drives a discrete component amplifier 1U9 and is buffered by emitter follower 1U10, whose output is AC coupled to the sync and servo separator circuits. Transistor 1Q2, 1CR9 let the positive going sync pulses pass and clamp off the servo pulses. Comparator 1U6 threshold detects the sync pulses. Hysteresis is added to prevent triggering due to noise.

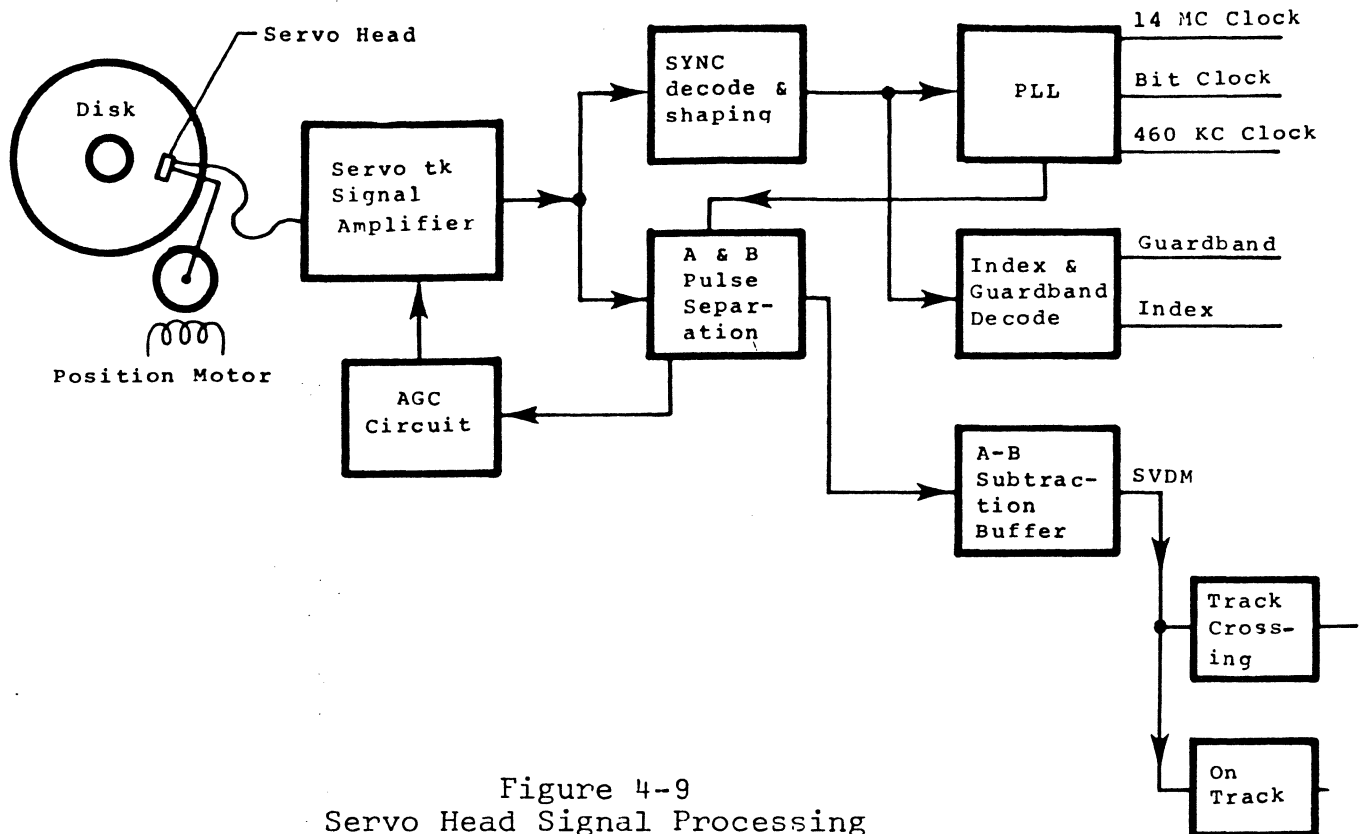

Figure 4-9
 Servo Head Signal Processing
 (Servo Demodulator)

The sync pulses are formed into a squarewave signal by one-shot 1U7 to produce terms SYNC and SYNC. Figure 4-10 shows the timing for servo processing.

The term SVODATA is generated by 1U11. SYNC sets 1U11 and "T" time T_{10} resets 1U11 part 1. ("T" times are generated by a phase locked loop to be covered later.) As shown in Figure 4-10, SVODATA is a waveform whose pulse width is a function of the phase error between sync and time T_{10} . Figure 4-10 shows the waveform SVODATA for normal, early, late and missing SYNC PULSE. SVODATA is used to drive 1U11 part 2, in the absence of a sync pulse, as shown in Figure 4-10. If SVODATA is low, 1U11 part 2 (S0) is clocked by the phase locked loop to record all missing sync pulses as logic level zero's. 1U28 is a four stage shift register. The presence or absence of a sync pulse is shifted through this register. The bit pattern in the four shift registers is monitored to decode index and guardband (refer to 4.3.4).

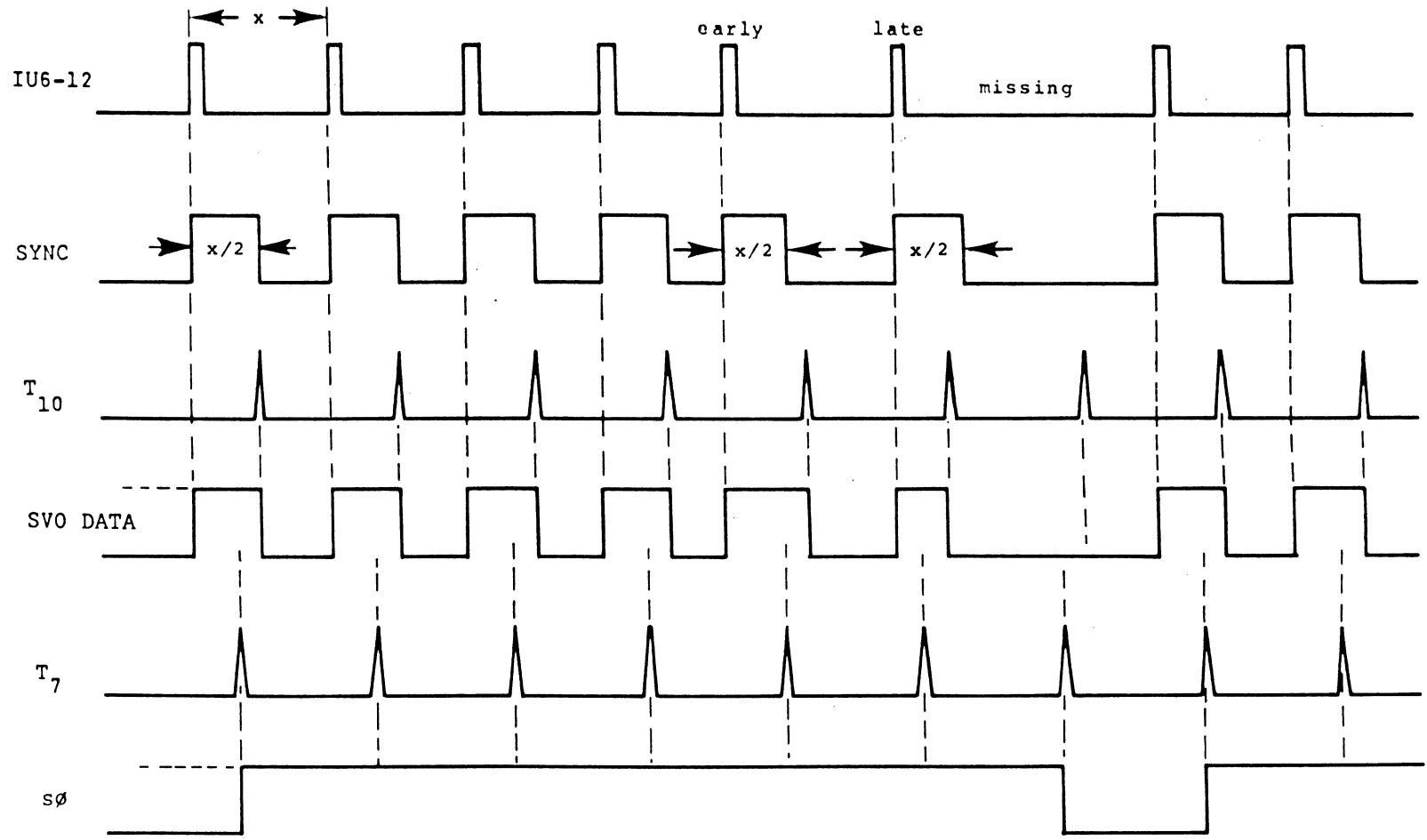

Figure 4-10
Phase Lock Timing

41-14

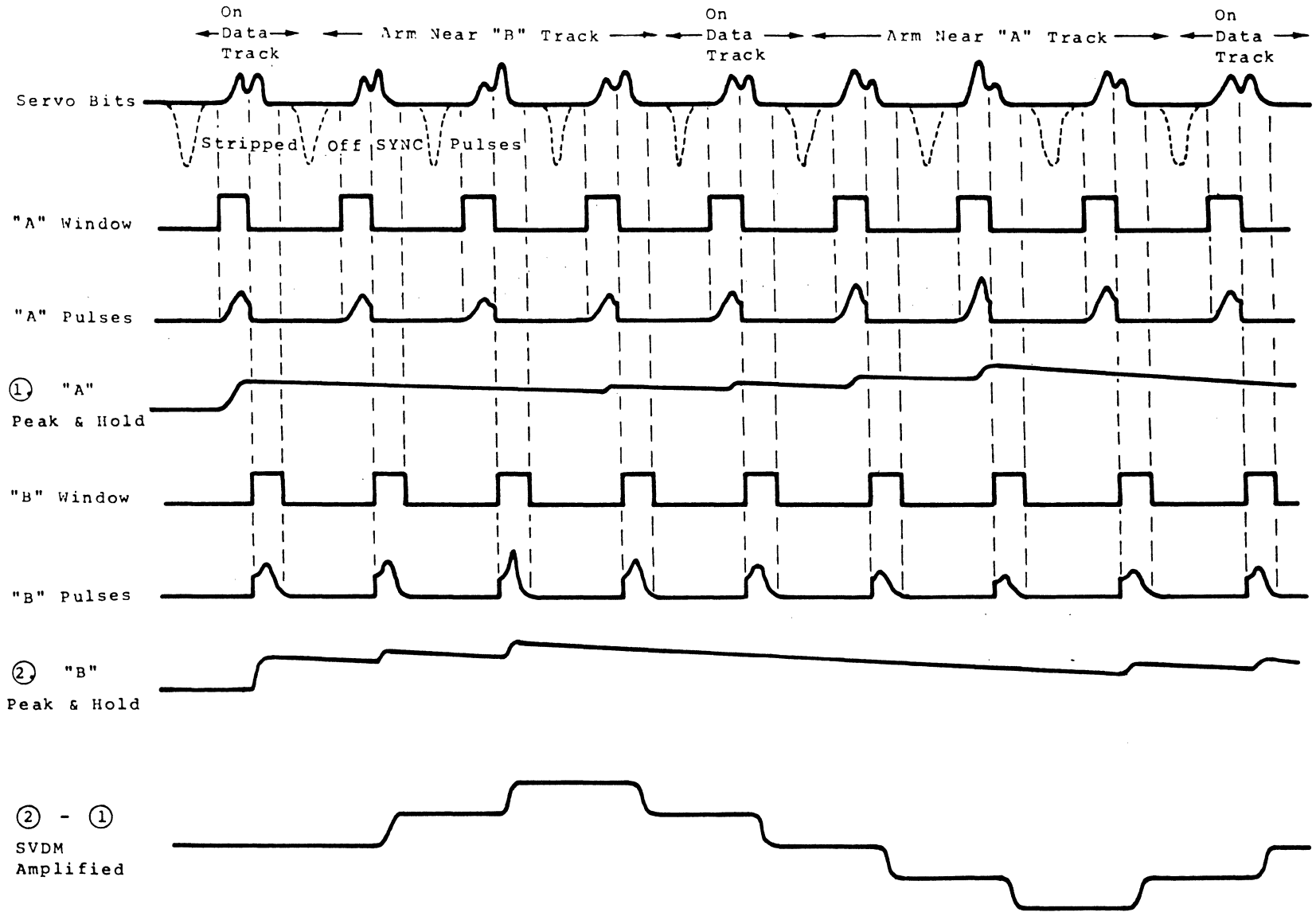

Figure 4-11
Servo Demodulated Signal (SVDM)

The phase locked loop (PLL) is locked to the sync pulses on the servo disc. To avoid disturbance of the PLL during an index or guardband pattern, when sync bytes are deleted, and the possible occurrence of a defect in the media dropping the sync bit, the loss of a sync bit must also result in the loss of a SVODATA bit. As covered above, 1U11 is clocked on by SYNC and off by phase locked loop "T" time T_{10} . (See Fig. 4-10). At the time of the missing sync bit, SVODATA also deletes a bit so both the reference signal 1U29-2 and the variable signal 1U29-6 have the same frequency and phase. This circuit assures that no change in the error amplifier signal and no disturbance for the PLL occur.

The PLL used can lock up in harmonic modes, if not prevented. Diode 1CR11, resistors 1R101 and 1R52 hold the VCO 1U8 frequency high until disc speed, which determines sync pulse frequency, is sufficiently high to allow correct phase lock.

The phase detector 1U29, 1R45, 1R47, 1C22 and 1C23 average the waveforms of SYNC and SVODATA. Any phase error between 1U29 pins 2 and 6 results in unequal amplitudes on 1C22 and 1C23. Capacitors 1C22 and 1C23 amplitudes are subtracted and amplified by error amplifier 1U12. This error signal is fed to voltage controlled oscillator (VCO) 1U8 and the phase is corrected until no phase error exists. The VCO runs at 32 times the sync pulse frequency. The VCO has adjustments to set the minimum and maximum frequency of oscillation.

The flip-flop 1U37 divides the frequency by 2. This signal goes to the divide by 16 counter 1U21. The counter output is decoded by 1U20 and 1U19 to have 16 "t" times lasting 1/16th of the period between sync pulses.

Integrated circuit 3U37 part 2 is used to check for a frequency error between SYNC and SVODATA signals. Any error will disable the positioner motor and set a fault on "Seek Late".

The one-shot 3U47 detects any continuous loss of sync and if faulted, will set "Seek Late" through the phase lock detector, 3U37 part 2.

The servo position information pulses from tracks A and B are separated from the analog the same as were the sync pulses. 1Q3, 1CR10 clamp off the sync pulses.

To separate the "A" pulses from the "B" pulses, the timing signals from the PLL are used, as shown in Fig. 4-11. "A" pulses are recovered by opening a "window" during the time position when "A" pulses are expected. "B" pulses are separated exactly the same way at the "B" time window. Times T2 and T6 open and close the "A" window gate 1U17 pin 12. Times T8, T12 open and close the "B" window gate 1U17 pin 7.

1U16 pin 2, 1U15 sample and hold the peak value of "A" pulses. 1U16 pin 12, 1U14 sample and hold the peak value of "B" pulses.

The sum of the peaks of the "A" and "B" pulses are held at a constant amplitude by the automatic gain control (AGC) circuitry.

The input to 1U1 sums the peak of the "A" and "B" sampled pulse. Potentiometer 1R1 sets the reference level for AGC amplitude, 1CR1 is for temperature compensation.

Any error between the "A" and "B" pulse amplitude sum and the reference potentiometer is amplified by 1U1 and adjusts the gain of the input amplifier by FET 1Q1.

The FET 1Q1 is a variable gain shunting resistor used to adjust the actual signal level produced by the servo head preamplifier.

The peak values of "A" and "B" pulses at any servo head position are subtracted by 1U13 to demodulate the recorded servo information (SVDM). Resistor 1R56, or 1R79 is used to correct for offsets due unequal amplitude "A" and "B" pulses. The servo-demodulated signal (SVDM) is a sinusoidal representation of head position, and is used to derive position, velocity and acceleration feedback for the servo system as well as to count track crossings, etc.

4.3.4 Index and Guardband

Figure 4-12 shows the timing and decoding of index and guardband signals. SVODATA is clocked by time T7 and shifted through shift register S0-S4. A 0110 pattern is for index and is decoded by 1U43 ignoring S4. Gates 1U35, 1U36 decode patterns 01010 and 10101 to produce a nearly continuous high signal in guardband signal and a continuous low signal when out of a guardband.

4.3.5 Track Crossing Pulses (TCP)

The track crossing detectors monitor SVDM to detect motion of the servo head while positioning across servo tracks. Figure 4-13 is a timing diagram of the track crossing detector circuits. SVDM input signal is filtered by 4C131 and 4C132 to prevent noise pulses from triggering the track crossing detectors.

Amplifier 4U89 inverts SVDM to generate $\overline{\text{SVDM}}$. Inverted positive track crossing pulses ($\overline{\text{PTCP}}$) are derived from $\overline{\text{SVDM}}$ and threshold detected by 4U83 pin 4 and inverted by 4U85 to produce inverted positive track crossing pulses ($\overline{\text{PTCP}}$). In the same manner SVDM is used to produce inverted negative track crossing pulses ($\overline{\text{NTCP}}$). Inverted track crossing pulses ($\overline{\text{TCP}}$) are produced by the logical "and" of $\overline{\text{PTCP}}$ and $\overline{\text{NTCP}}$ by 2U47.

"Ontrack" differs from TCP only by the threshold level of the on track detectors (see Fig. 4-13).

4.3.6 Illegal Address

Illegal Address is part of the arithmetic logic section and is used to verify if the demanded address is within range of the disc drive unit. Figure 4-14 is a flow chart of the illegal address section.

Integrated circuits 2U66, 2U65, 2U47 test for valid address, if the address is valid 2U47 gate will be enabled and latches 2U67, 2U76, 2U75 will be receptive to a Seek Strobe. If invalid address present 2U47 gate will not allow Seek Strobe to latch in a new address.

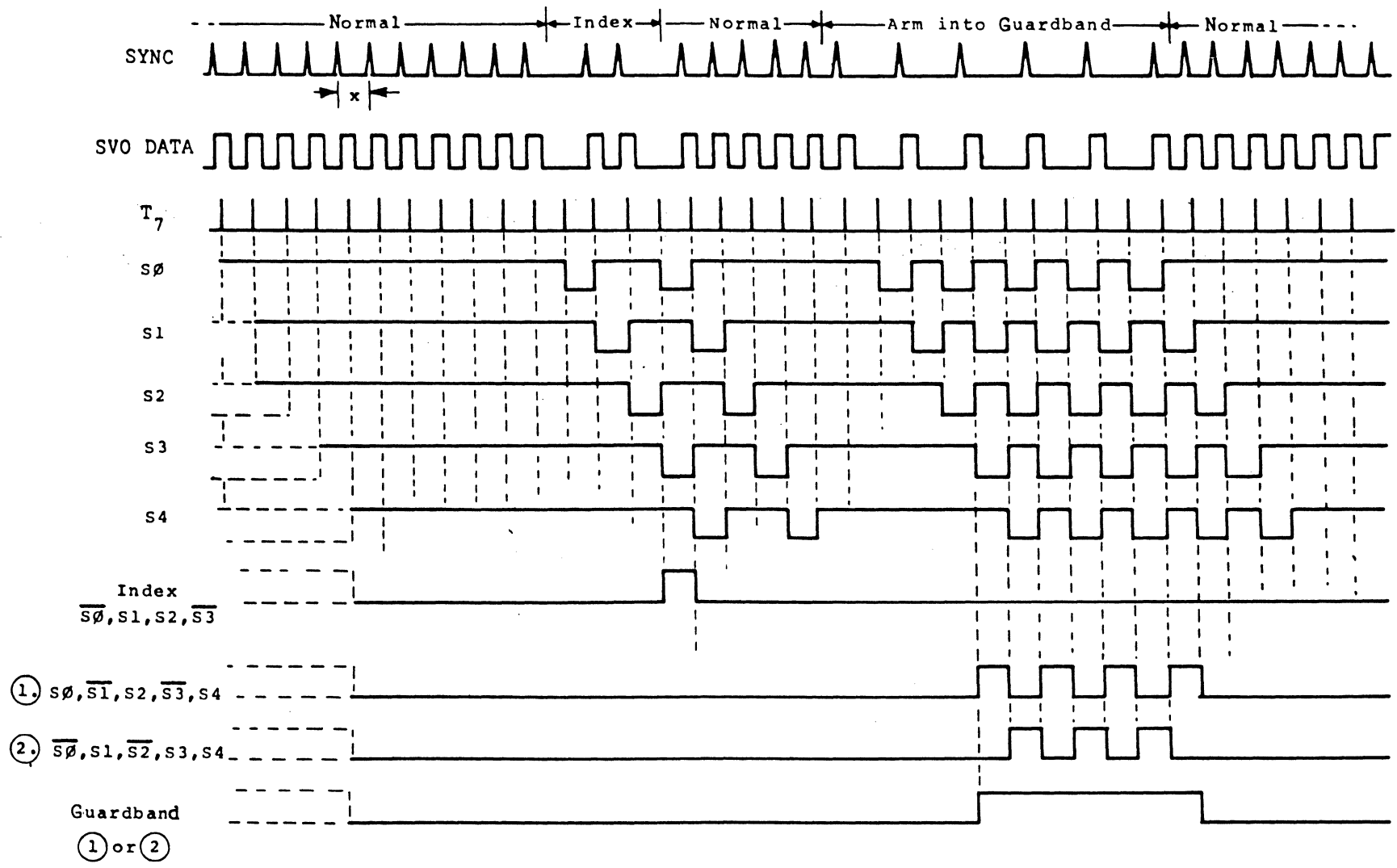

Figure 4-12
Index & Guardband Decoding

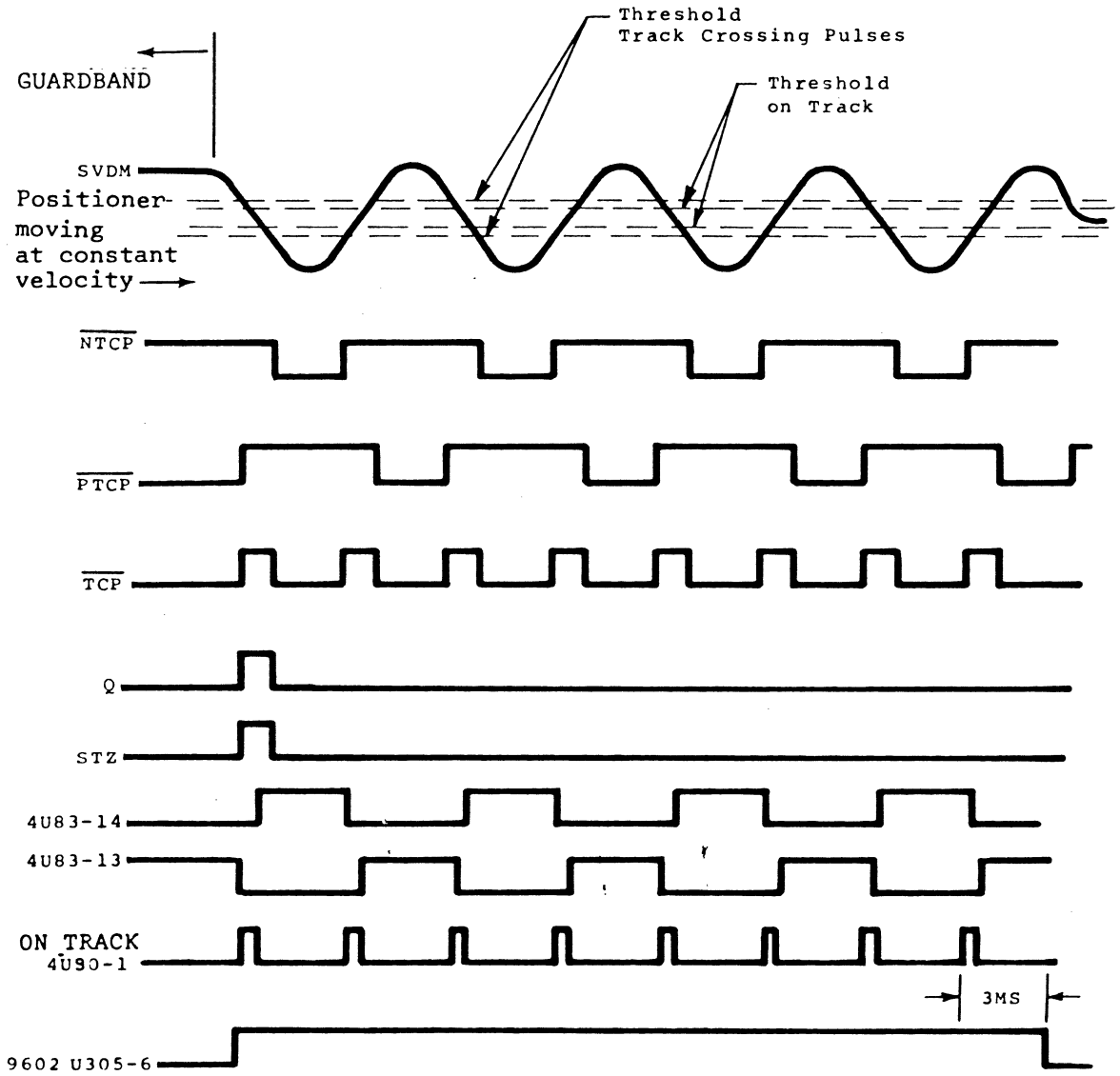

Figure 4-13
Track Crossing Detector

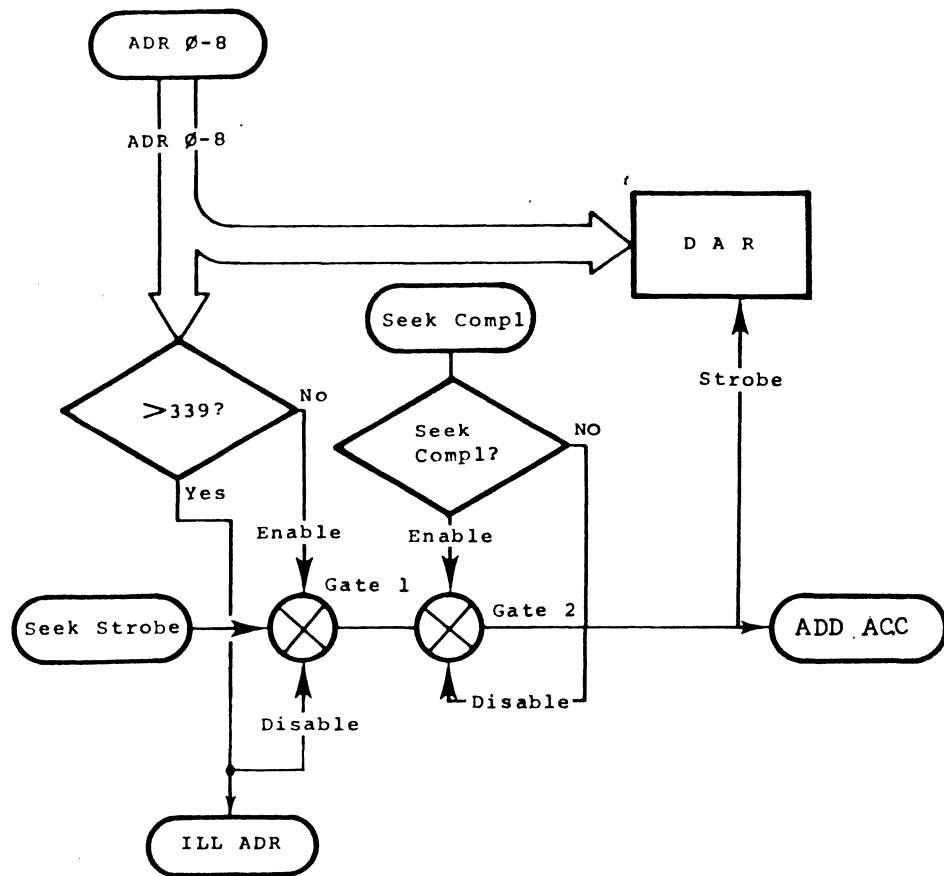

Figure 4-14
Illegal Address

Seek Complete (SEEK COMPL), a term yet to be covered, is false unless the current seek is complete and will disable a new seek strobe until the present seek is complete. See 4.3.7 for complete information on Seek Complete.

In summary, if legal address and seek complete are present a new address is latched in the Demand Address Register (DAR) and is acknowledged by a pulse from 3U31. If either the present seek is not complete or an illegal address is present the strobe to the DAR is blocked. If an illegal address is present during a Seek strobe, 2U69 sets the illegal address line and a restore must be commanded to clear the illegal address status line.

4.3.7 Seek Cycle Logic

Figure 4-15 outlines the flow chart of a seek cycle. The successful strobing of a new demand address starts a new seek cycle. When the DAR does not equal the current address register (CAR), 2U63, 2U55, and 2U72, the servo drops from position mode (Detent) and into velocity mode (Coarse). At the same time, the 1's complement adder, 2U64, 2U56 and 2U73 determines the direction the arm must move. If DAR is greater than CAR, a command is issued to move forward toward disc center, and the CAR is set to count up at each TCP signal. If CAR is greater than DAR, a command is issued to move reverse toward the disc edge, and the CAR is set to count down at each TCP. The CAR is counted up or down until CAR equals DAR, then the difference equals zero gate 2U53, 2U52, 2U65 holds the CAR and changes the servo system to the position mode to detent between servo tracks where data is to be read or written.

To detent, DAR is checked to determine if the DAR was odd or even, the least significant DAR bit determines the sign.

Figure 4-16 shows the SVDM change of sign as a function of odd or even tracks. Even tracks have a negative slope and odd tracks have a positive slope.

Once detent is completed the servo head is held between "A" and "B" servo tracks and ontrack stays true. Inverted on track delayed (ONTRKDLY) one-shot 3U27 times out, clocking seek complete (SEEK COMPL) flip-flop 3U48 and setting SEEK COMPL true.

4.3.8 Restore Logic

The flow diagram for a restore cycle is blocked out in Figure 4-17. When a restore command is issued 3U31 and 3U24 form a restore pulse (RESTOREP). RESTOREP sets 3U58 to the slew mode (SLEW) and 3U59 to inverted Seek Complete inhibit mode (SKCPLI).

Slew is done with the servo system in velocity mode. The velocity is constant and slow. 4R213 sets the slew velocity. Slew moves the servo head to guardband. When guardband is entered 3U50 flip flop is set, starting

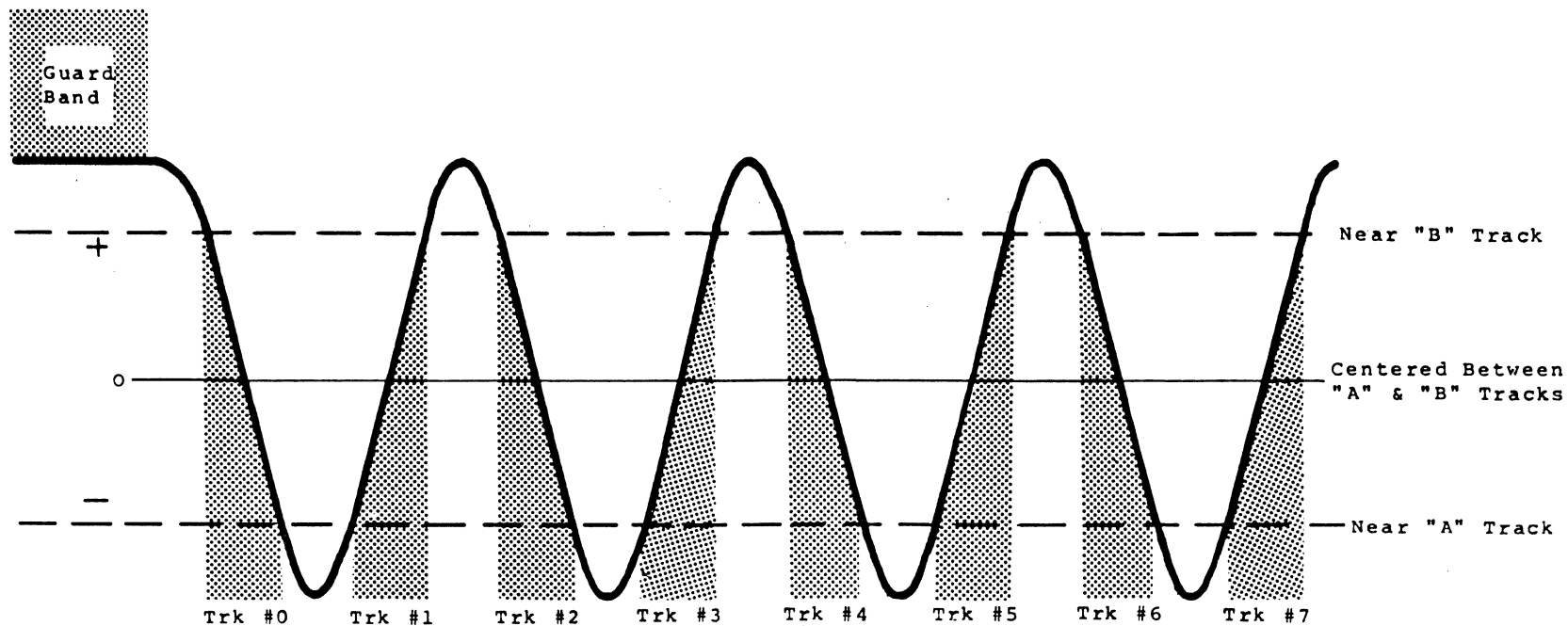

Positive Slope On Odd Track

Negative Slope on Even Track

Figure 4-16
Servo Demod. Change of Slope

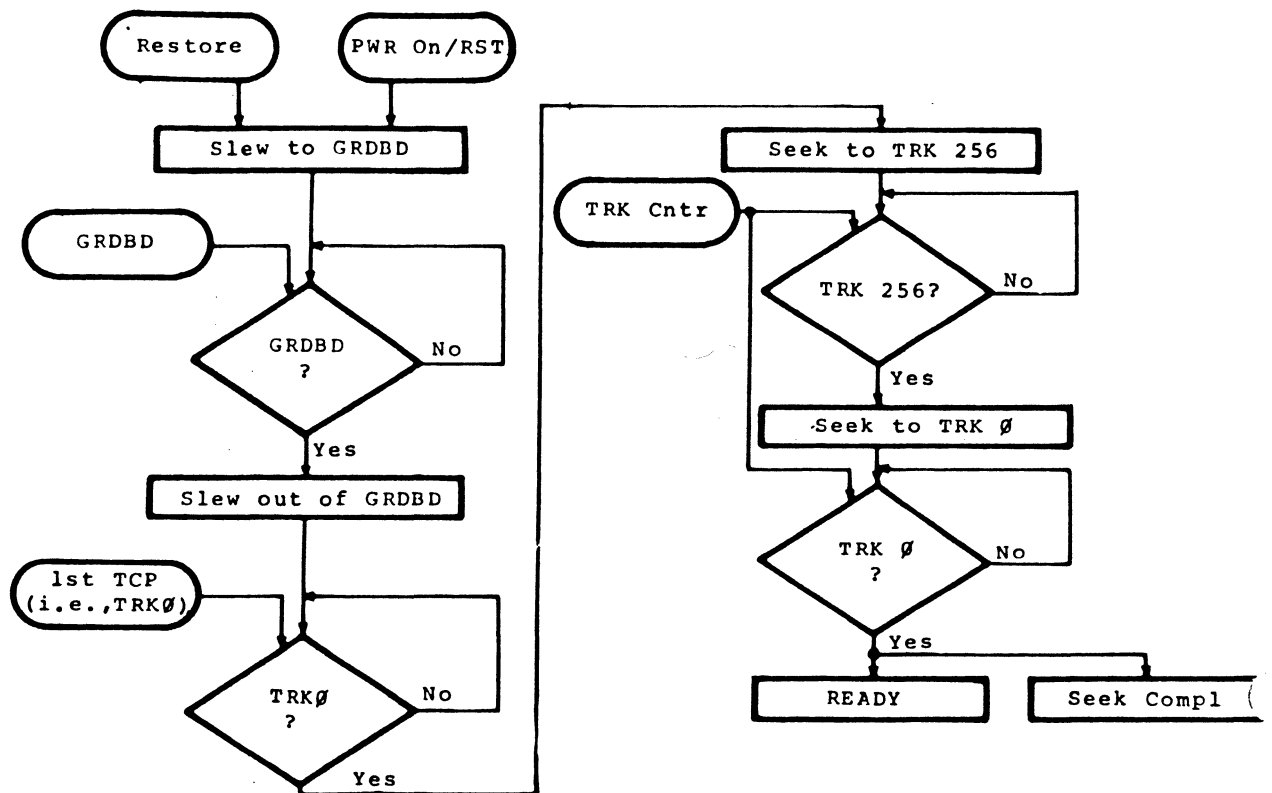

Figure 4-17
Restore Cycle

arm to slew forward out of guardband. Flip flop 3U50 is armed to detect the first PTCP. This is the prime purpose of the guardband signal. When the first PTCP is detected 3U50-11 is set giving an inverted store zero command (STZ). STZ sets both the CAR and DAR to zero. SKCPLI locks a 256 track seek command directly to adder circuitry through 2U60.

A standard seek is done to reach track 256. After detenting on track 256 long enough to time out ONTRKDLY, SKCPLI is set high by ONTRKDLY and 2U60 now feeds DAR bit 8 to the adder circuits. DAR was loaded with zeros by STZ and so the servo does a normal seek to track zero. SEEK COMPL is set true and the ready line is set true.

4.3.9 Velocity (Coarse) Mode Servo

The head velocity is derived from SVDM. SVDM is differentiated by 4C130 and operational amplifier 4U94. Operational amplifiers 4U82 and 4U81 form a full wave rectifier bridge to rectify the rate of change of SVDM. The rectified signal has a value that is proportional to servo head velocity.

When in position mode, the differentiated SVDM represents velocity and is used as a compensation term to cancel the time lag caused by inertia inherent in the system.

Field effect transistors (FETs) are used as switches to select proper terms into the feedback loops. A high level signal, +5v to +12v, will deplete the channel and shut off the device. A voltage near zero will form a channel and allow conduction. FETs 4U93 are FET switches that gate the proper velocity term during velocity and position modes.

Derived velocity is not direction sensitive and direction must be derived from CAR and DAR and the proper sign added. Operational amplifier 4U88 uses a FET switch to control an amplifier whose gain can be either +1 or -1. With the FET switch on a -1 gain amplifier is made. With the FET off a source follower of +1 gain results.

When the servo system is in velocity mode the programmable read-only memory (PROM), 2U61 stores the desired velocity profile as a function of tracks to go as computed from CAR and DAR. Above 64 tracks from the final track destination, all PROM outputs are forced true by 2U25. Upon reaching a track difference of 64 the PROM is active, digitally producing the desired deceleration profile. The digital to analog converter (DAC) 2U70 converts the digital information to the desired analog velocity profile. Access time Pot, 2R157, adjusts the DAC analog output voltage to control actual head velocity in the coarse mode. Desired velocity is constant when more the 64 tracks from desired track and a modified square root function from 64 tracks to go to one track to go. The square root function is used to provide constant deceleration to the desired track. The final velocity is set by last track move resistor 4R205. Figure 4-18 shows the desired head velocity for >64 track moves, at 64 tracks and <64 track moves.

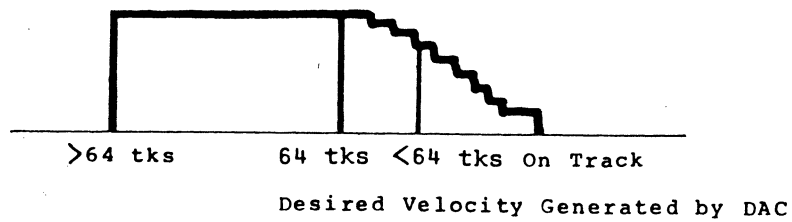

Figure 4-18
Desired Velocity Generated by DAC

Figure 4-19 shows the actual head velocity as a function of tracks to go. The system inertia and the positioner motor protecting current limit prevent instantaneous following of the desired velocity profile. At a large distance from the last track to go, the system is tolerant of large errors in actual velocity. When near the last track to go, the feedback loop is in control and desired velocity is a good match to actual velocity.

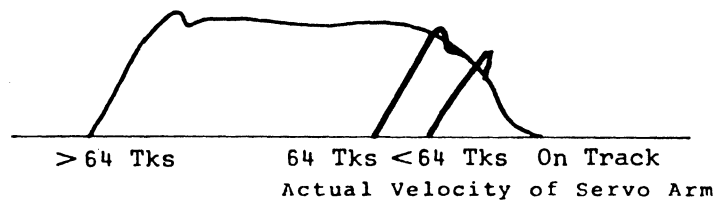

Figure 4-19
Actual Velocity of Servo Arm

4.3.10 Position (Detent) Mode Servo

When the difference between DAR and CAR equals zero, the servo system switches to the position mode and the system proceeds to "detent" on the specified

track. The SVDM signal is summed by the master summing junction, 4U78 input. If SVDM is not zero, an error signal will force the position motor to position the servo head toward half way between the selected "A"- "B" track, and force SVDM to zero volts (Fig. 4-16). From Figure 4-16 it can also be seen that a polarity changing switch is required as a function of odd or even track selection. 4U87 is the operational amplifier used to control polarity.

A velocity signal for position mode is also summed at the master junction. The velocity signal is used to stabilize the system when between "A" and "B" tracks; when the head motion stops, velocity is zero. Velocity compensation is added by FET switches, 4U93 and 4U84.

A bridged twin "T" filter is used to reject resonance centered about 2KHZ and prevents high frequency oscillations. Resistors 4R182, 4R181, 4R207, 4R160 and capacitors 4C115, 4C118, 4C114 are used to form the filter.

Pot 4R172 is used to cancel any offsets in the operational amplifiers 4U87, 4U94, 4U88 or 4U80 by applying a bias current into the junction to correct any offset of the servo head. FET switches 4U84 can introduce intentional offset under I/O control for data recovery. Test point, TP12, can also offset bias the servo head and is used to test servo performance.

4.3.11 Servo Power Amplifier

The positioner motor is driven by the power amplifier located on the power amplifier module (P/N 30105). Feedback is used to make the motor appear to be driven by a current source.

The power amplifier uses complementary darlington power transistors biased so that only one can conduct at a time when driving the position motor. Transistors 1Q8 and 1Q9 are the power transistors. Transistors 1Q1, 1Q2, 1Q3 and 1Q4 are used to drive the power transistors in a closed-loop feedback system. Integrated circuit 1U1 is a differential amplifier used to amplify current loop error signals and reject common-mode noise. The position motor current is sensed by 1R26 on the power amplifier board. Amplifier 4U68 amplifies the voltage developed by resistor 1R26 to develop a voltage at TP10 that is proportional to motor current.

The summing junction for the current feedback loop, 4U91 input, detects any error in current between 4R206 and 4R204. Any error present is amplified by error amplifiers 4U91 and 4U77 to provide a correctional signal to the power amplifiers. This signal in turn increases or decreases the motor current as required to reduce the error to zero. A block diagram of the current loop is shown as part of Figure 4-20. The current loop can be visualized as a block whose output is current to the motor proportional to an input voltage on resistor 4R204.

The maximum current that can be applied to the position motor is limited to prevent position motor demagnetization. Zener diodes 4CR32 and 4CR33 conduct to feed a large error current into the summing junction if the voltage at TP10 is higher than the zener's breakdown voltage. The error amplifier loop reacts by reducing the motor current and voltage at TP10. If the voltage at TP10 is limited, the motor current is limited; since a direct relationship exists between TP10 and motor current.

4.3.12 Head Positioner Servo Block Diagrams

Figures 4-20a, b and c show the signal flow during a seek operation. The dark lines show the signal flow path.

Figure 4-20a is the flow path during a move when there is greater than 64 tracks to go. If DAR is larger than CAR, the FWD is enabled as shown by the solid dark lines. If DAR is smaller than CAR, then REV is enabled as shown by the dashed dark lines.

Figure 4-20b is the same as Figure 1a except that either; the head move has progressed until less than 64 tracks remain to go or the initial move request was for less than 64 tracks.

Figure 4-20c shows the signal flow when the head move is completed and the servo system becomes a position servo to detent on the selected data track.

If detented on odd track, ODD is enabled; solid lines
If detented on even track, EVEN is enabled; dashed lines.

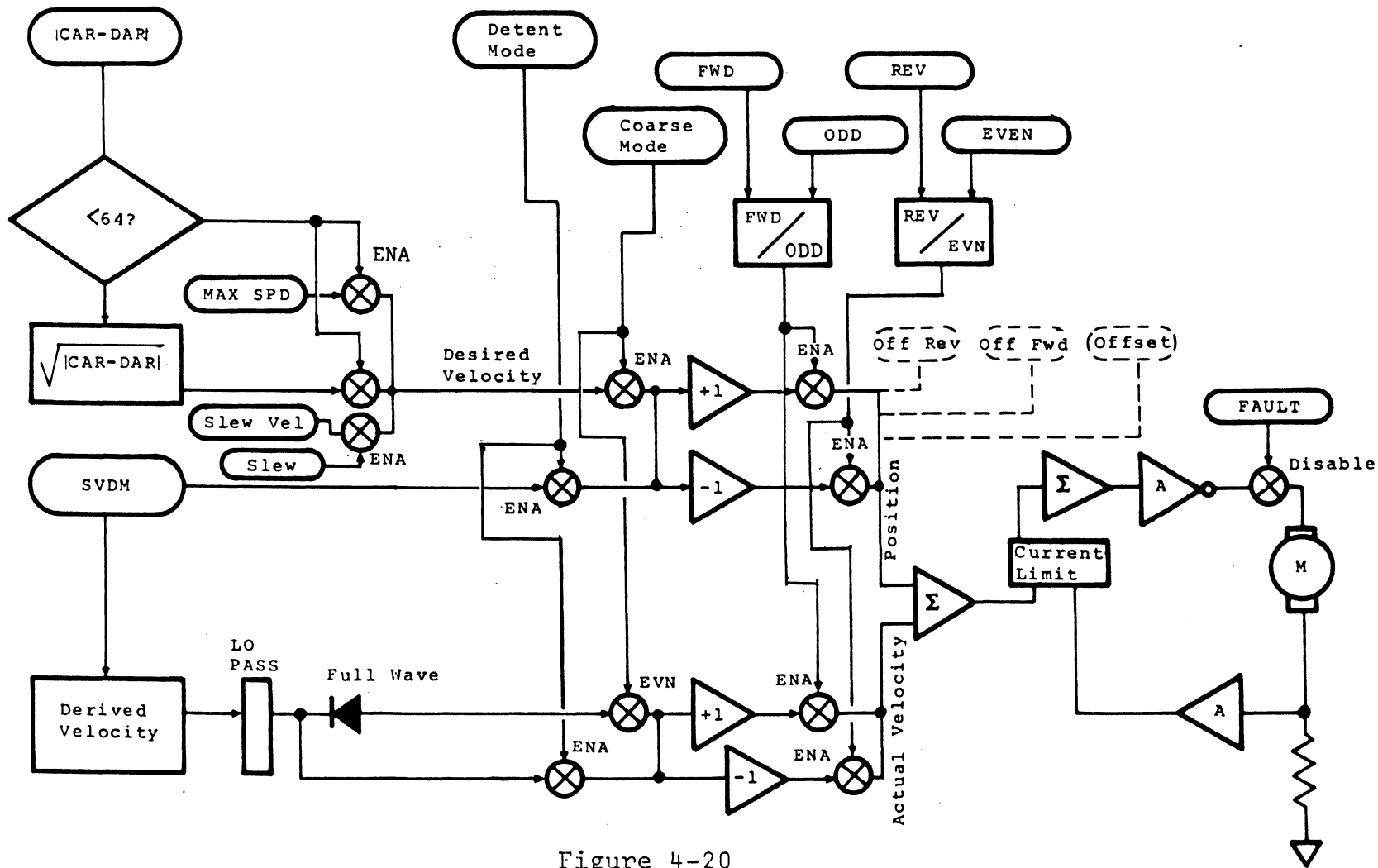

Figure 4-20
Block Diagram Head Positioning Servo System

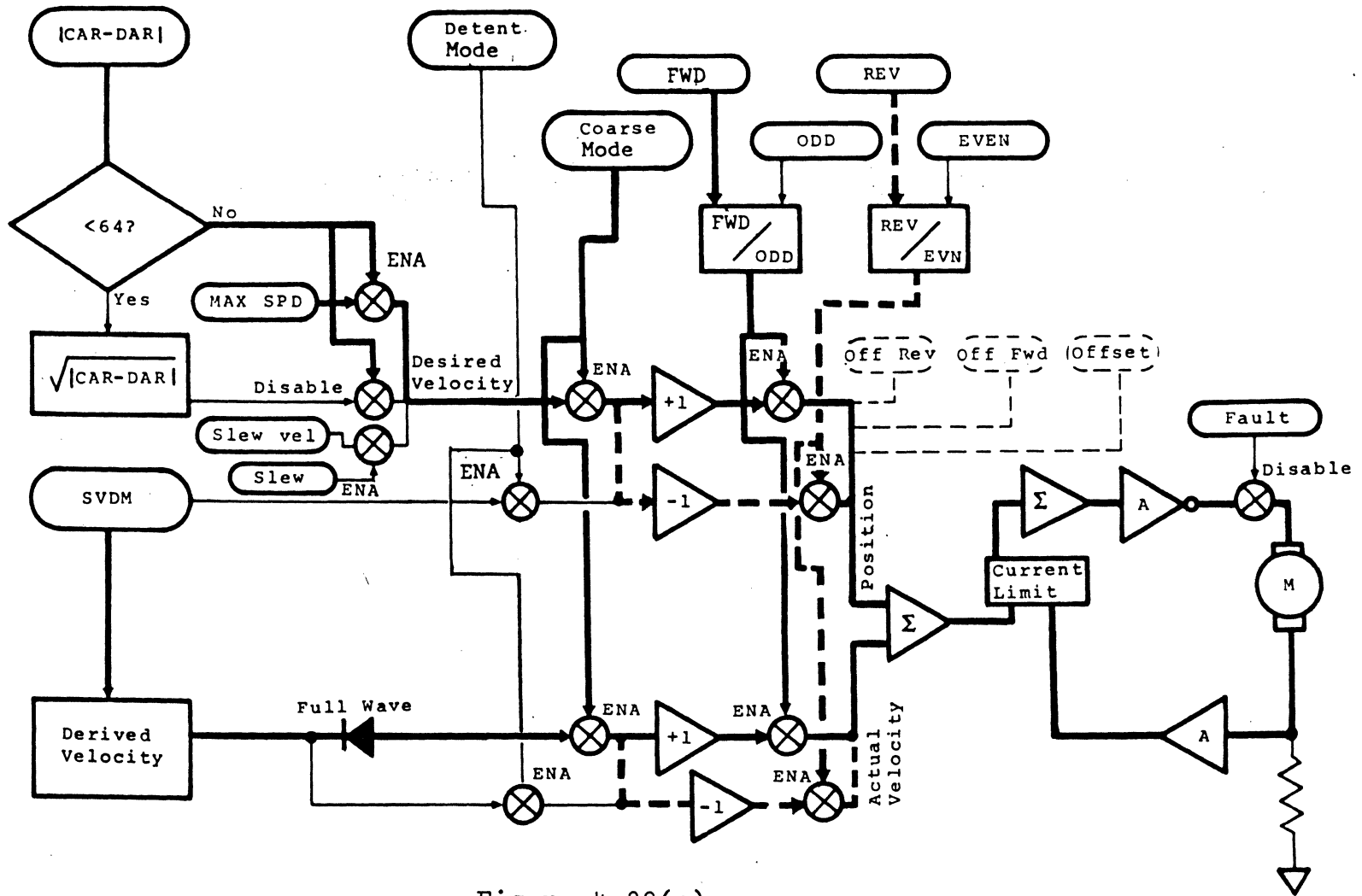

Figure 4-20(a)
 Head Positioning Servo-Velocity Mode
 (Greater Than 64 Tracks to go)

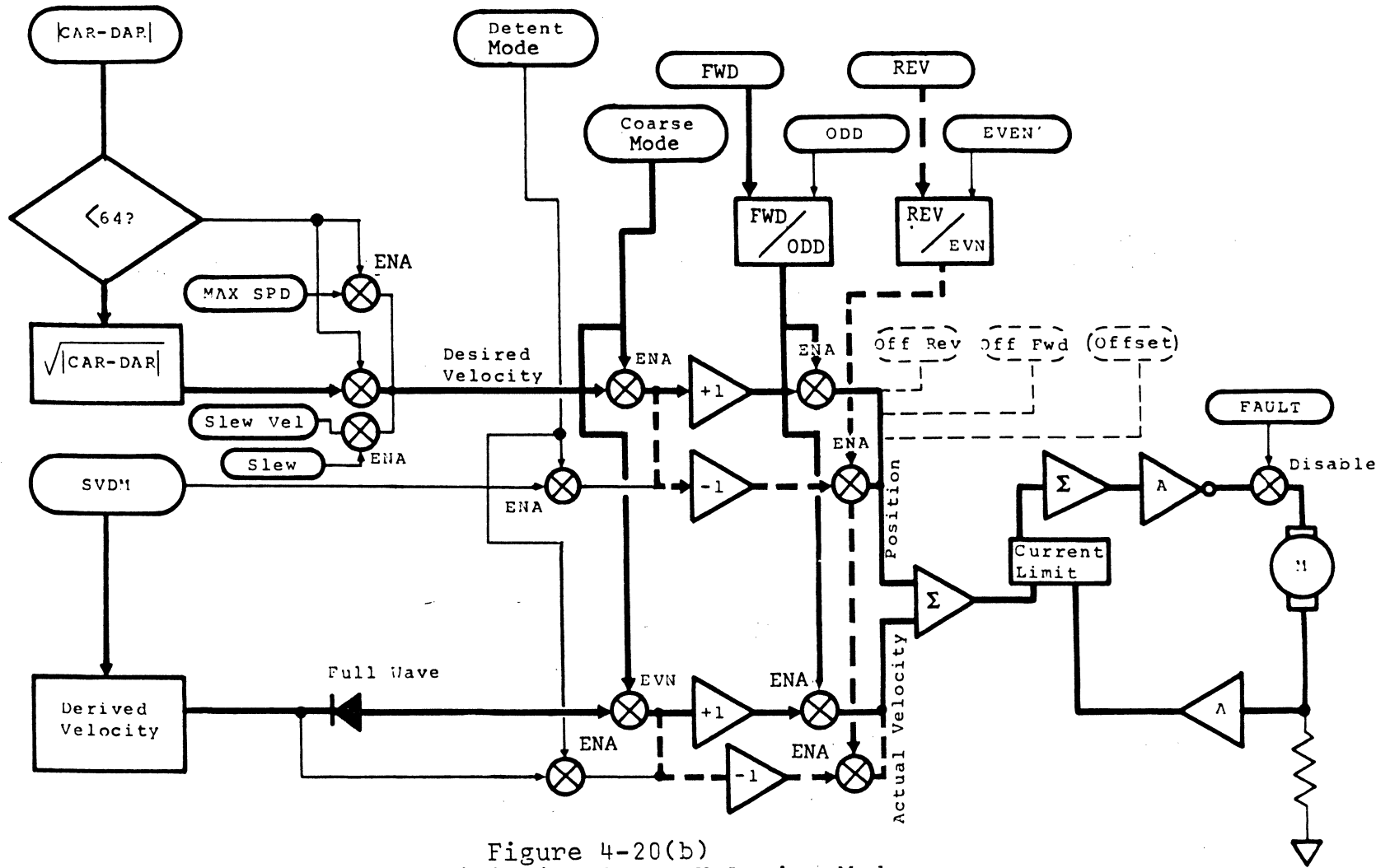

Figure 4-20(b)
 Head Positioning Servo-Velocity Mode
 (Less Than 64 Tracks to go)

4.3.13 Fault Logic

Figure 4-21 is a block diagram of the Servo Logic Board fault lines. Transistor packages 3U30 and 3U23 are connected to monitor the 5 volts, 12 volts, -2 volt, -5.2 volt and -12 volt power supplies. If all monitors are ok the status line power okay (PWR OK) is set true.

The RC network 3R82, 3C52 form a pulse at power turn-on that is amplified by 3U30 and triggers 3U22. Timer 3U22 is an approximate 15 second timer that generates system restore functions at turn on and sets the status line; inverted power restore ($\overline{\text{PWRST}}$).

The system restore signal is used to set or hold Flip-Flops 3U48, 3U33 and 3U59 in the proper state during start up and prior to energizing the positioner motor.

If the power amplifier heatsink should overheat Flip-Flop 3U33 is faulted. This faults the ready line and disables the positioner motor.

If the positioner motor is above approximately 2 amps DC for longer than 1 second the positioner motor current monitor 4U45 sets Flip-Flop 3U33 to a fault condition. This faults the ready line and disables the positioner motor.

A transducer on the spindle pulley generates a pulse for each spindle revolution. The pulse is amplified and triggers retriggerable monostable 3U40. If the spindle slows down the monostable will "time out" and 3U58 will be faulted. This faults the ready line and disables the positioner motor. Also the monostable timing out will set 3U26 and in turn set 3U33 to cause an inverted seek late ($\overline{\text{SKLATE}}$) to disable the positioner motor. A manual restore is required even if the spindle should return to speed.

If the phase locked loop loses phase lock or if sync is lost 3U32 sets 3U26 and sets $\overline{\text{SKLATE}}$ low to disable the positioner motor. A restore is required to clear the system.

The Flip-Flop 3U26 is also used to detect track crossings after detent on a track has been achieved. Crossing tracks after detent means that the positioner arm is lost. If more than two tracks are crossed after detent the $\overline{\text{AMB}}$ is faulted to disable the

4E-34

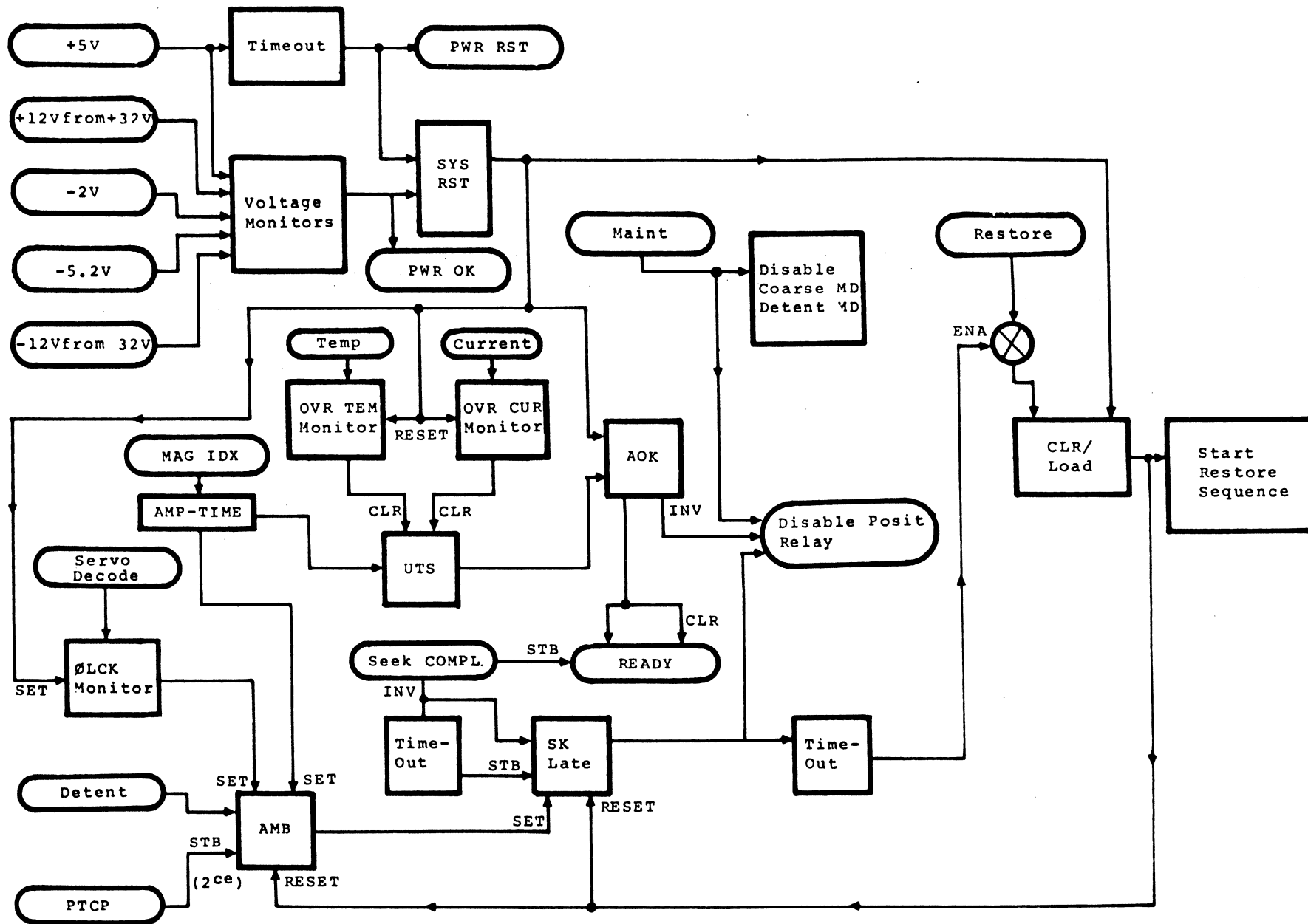

Figure 4-21
Fault Logic

positioner arm. A restore command is required to reset the system. Seek Complete is a term that is set when a successful seek has been completed. On track delay ONTRKDLY normally sets 3U48 to generate the seek complete term. If this time is too long monostable 3U27 times out and sets SKLATE and at the same time disables the positioner arm. When the system is powered on a seek complete follows restore and sets the ready line true.

The loss of "up to speed" (UTS) or SYSRST will fault "all is ok" (AOK) and drop the ready line. The ready line must be reset by a manual system restore for a UTS fault. The completion of a successful restore sequence will reset the ready line true.

A low level on inverted maintenance mode MAINT will disable the FET switches for both velocity and position on the analog circuitry. The low level of MAINT will also hold the positioner arm on magnetic detent and the positioner motor disabled.

The disabling of the position motor relay is controlled by 3U34 and 1Q10 on the power amplifier board. The disabling of the positioner motor applies -32V to the motor through a current limit resistor. This drives the positioner arm in to the head landing zone and against a permanent magnet. The heads are now safely held by the magnetic latch assembly.

The monostable 3U40 times out after a seek late (SKLATE) for a time long enough to allow the positioner arm to return to magnetic detent prior to accepting a restore command. Seek late delayed (SKLTDL) is used to hold 3U31-2 low and prevent a restore from being started.

4.3.14 High Ambient Temperature Protection

To prevent damage to the enclosure internal parts in the event that the disc is operated above its specified ambient temperature while positioning frequently, seek times are allowed to degrade. The thermistor sensor amplifier and bias circuit 4U51 and related components sense the resistance change of a thermistor located inside the enclosure. The circuit controls DAC REF which in turn controls the output magnitude of the DAC 2U70. The DAC output level sets the system access time. As the enclosure warms up to above 120° F. the thermistor starts to lower DAC REF and in turn increases the access time to

reduce position motor heat load in the enclosure. The circuit is designed to reduce positioner heat load enough to prevent the enclosure ambient from exceeding 150° F.

4.4 DATA SYSTEM

4.4.1 General

The disc drive includes as various options 1 to 6 disc surfaces for 2 to 12 moving heads and 1 to 2 disc surfaces for 20 to 120 (actually 126 heads, 120 guaranteed operational) fixed head tracks. The moving heads are positioned to the desired data track by the servo system. Fixed heads, of course, do not move. The first group of up to 40 fixed heads (actually 42 heads, 40 guaranteed operational) share the bottom surface of the bottom disc with the servo head. The servo uses the outer band and the fixed heads the inner band (Fig. 4-4). The second group of up to 80 fixed heads (actually 84 heads, 80 guaranteed operational) occupy the top surface of the top disc. The heads are selected by a diode switching matrix of similar design for both the fixed and moving heads. The same diode switch is used to read or write using the head selected.

Figure 4-22 is a data system block diagram. The moving heads and fixed heads with diode switch matrix are located inside the enclosure. The moving head matrix switch and preamplifier board (P/N 30100) is plugged directly into the rear of the enclosure to minimize head lead length (Fig. 5-6). The fixed head amplifier board (P/N 30104) is located on the side of the disc drive near the fixed head cable outlet (Fig. 5-9). The data board (P/N 30102) is located on the top surface of the disc drive unit (Fig. 5-9). The general signal flow from the selected head to NRZ input or output is covered by Figure 4-22; the operation of each block is covered in the following sections.

4.4.2 Moving Head Preamp and Switch Matrix

Figure 4-23 shows a simplified schematic of the diode switch matrix. The matrix is located with the moving heads inside the enclosure. The control switches S₀---S₁₁ are located on the matrix board. Switches S₀---S₁₁ are integrated circuits 1U11 and 1U14.

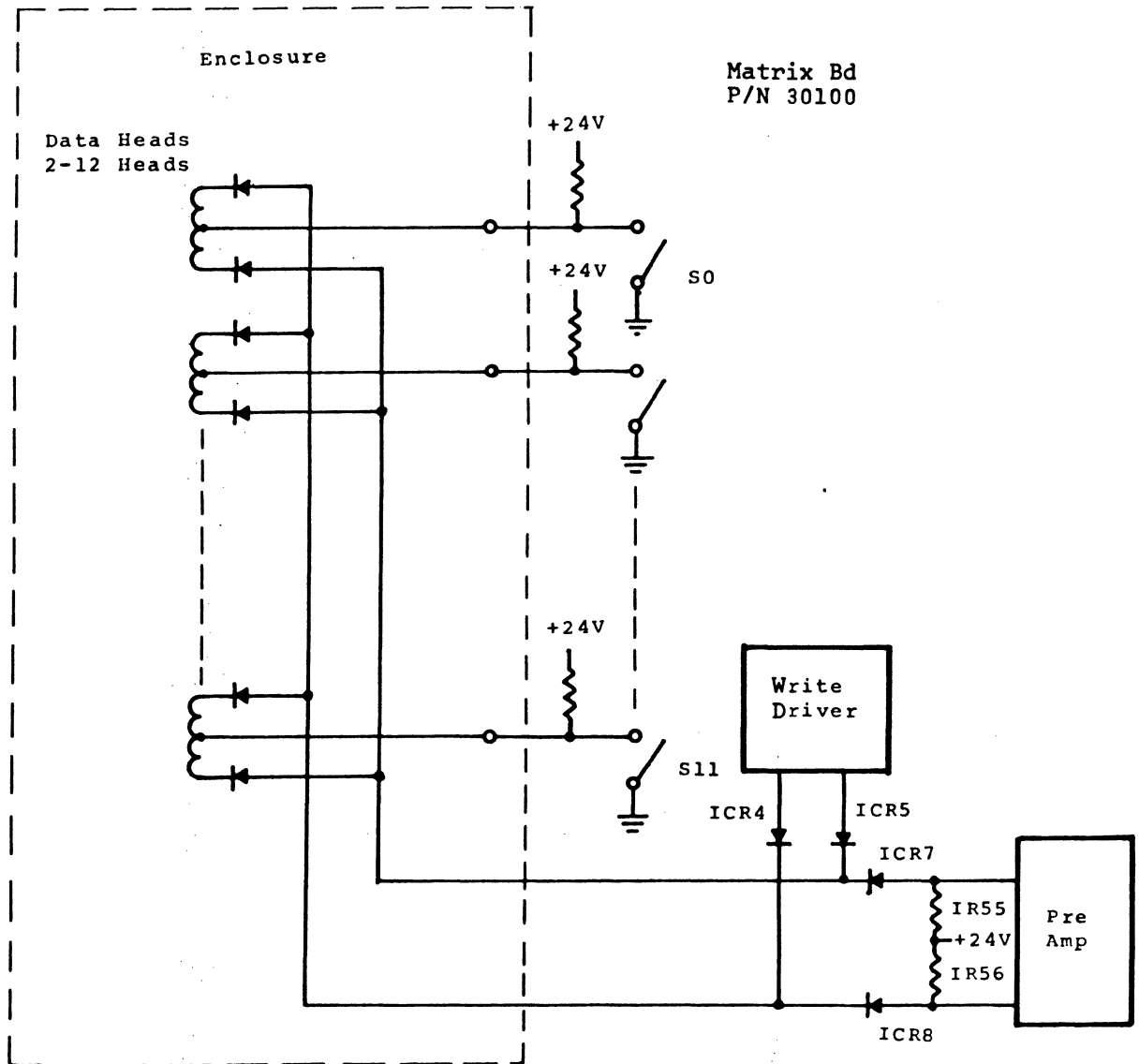

Figure 4-23
Moving Head Preamp and Switch Matrix

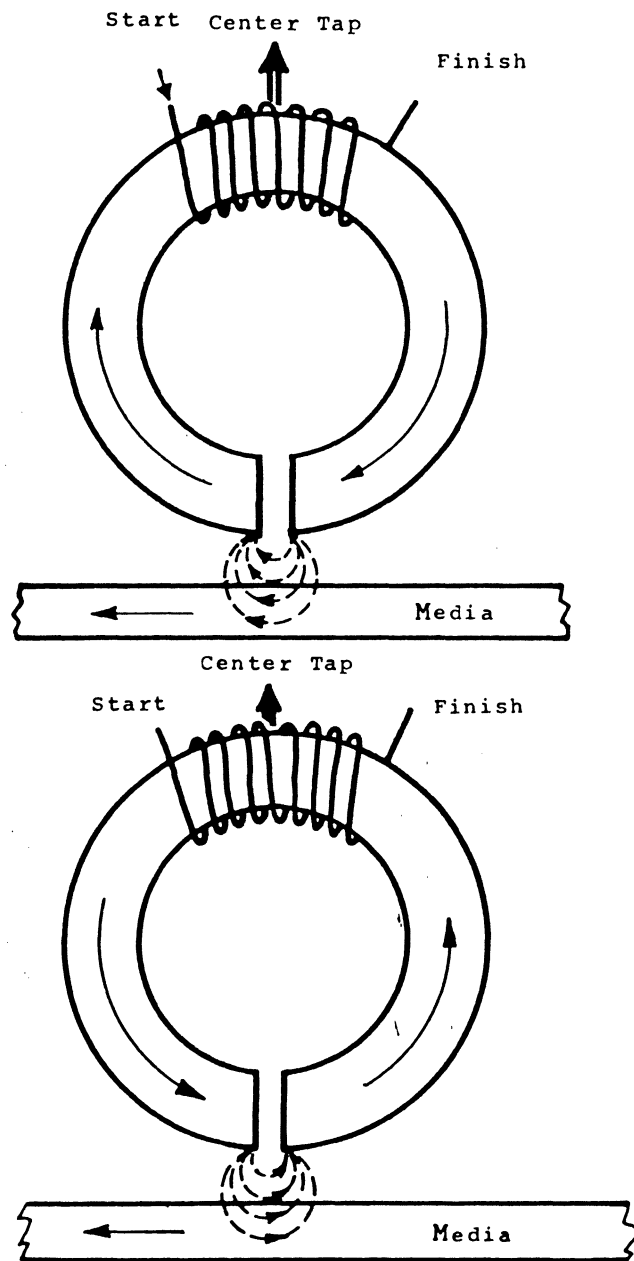

Figure 4-24
Data Head Magnetic Field

U11 decodes heads 0-9 and 1U13, 1U14, and 1U16 decode heads 10,11. Only one switch is closed at a time, and when closed, that head is selected by providing a current path to ground thru current source 1R55, 1R56, turning on 1CR7, 1CR8 and the diodes of the selected head. The "on" diodes have a low resistance and couple head signals to or from the selected head. During Write the write transistors 1Q6 & 1Q5 act as a current switch to steer the current set by current setting resistors 1R17 and 1R25 thru 1CR4 or 1CR5 thru selected head diodes to the head to produce flux reversals, see Figure 4-24 and 4-25. During a "write" diodes 1CR7 and 1CR8 are overridden and 1CR9 and 1CR10 limit the maximum signal into the preamplifier. The matrix board preamplifier is a low noise amplifier using negative feedback. Transistors 1Q7 and 1Q8 set the preamp noise level and are of a low noise design. Integrated circuit transistors and discrete components are used for the remaining preamp circuitry. The design is similar to the Ua733 integrated circuit design. Components 1L₁ -1L₄, 1C₃ and 1C₁₆ form a low pass-phase linear filter. The filter is buffered by emitter follower circuit composed of 1U1 and related components.

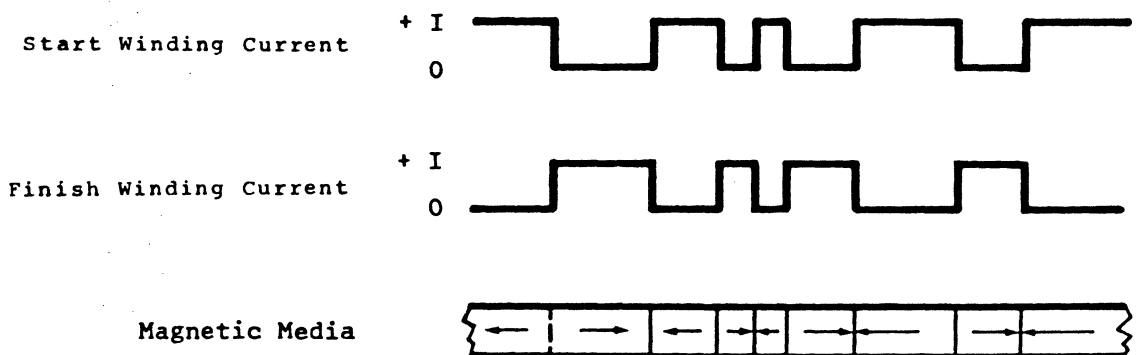

Figure 4-25
Magnetic Field on Media

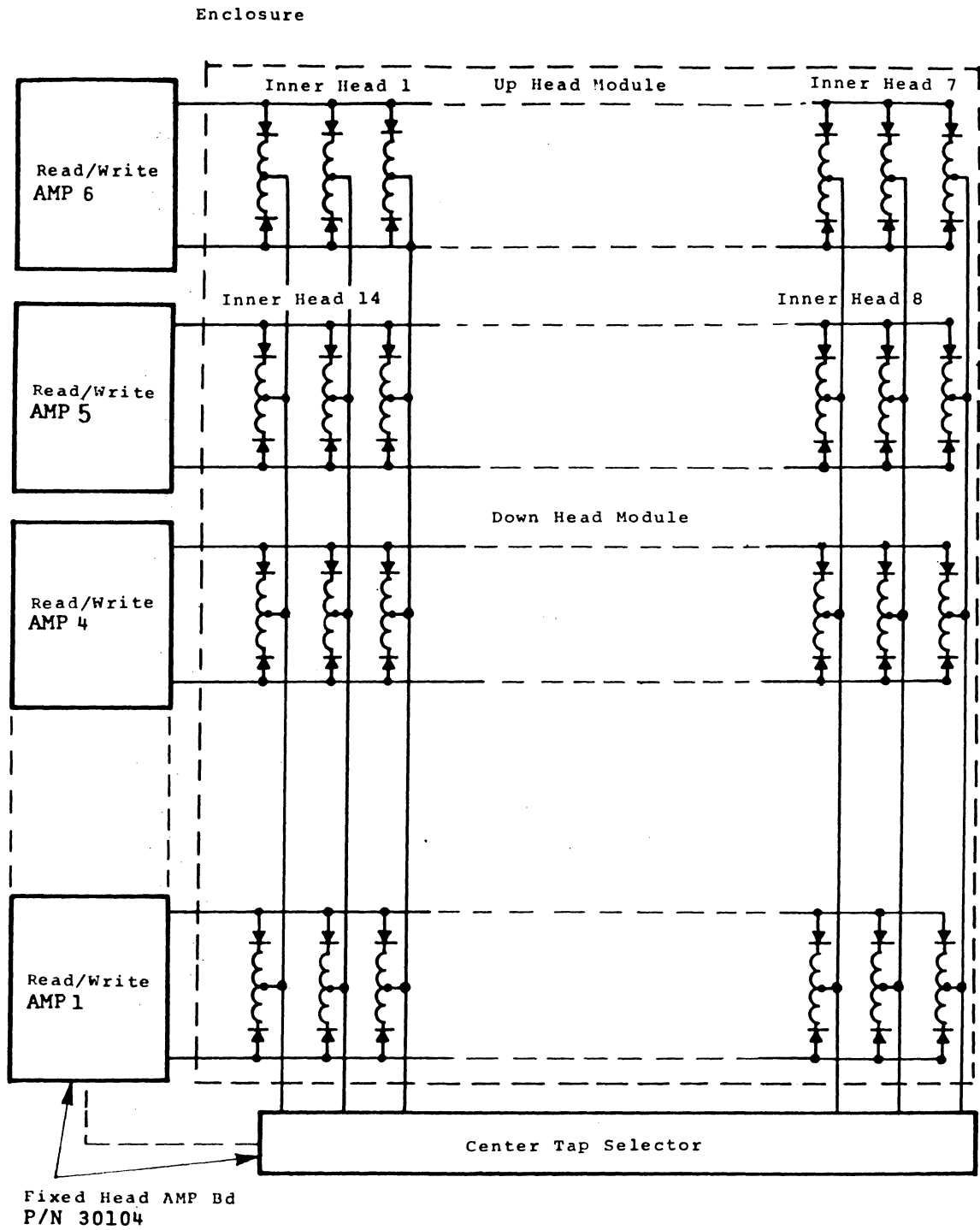

Figure 4-26
Fixed Head Select Matrix

4.4.3 Fixed Head

The fixed head module operation is nearly identical to the moving head module except for a more complex head switching array. Figure 4-26 illustrates the fixed head selection circuitry. One of six read/write amplifier circuits can be selected to service 21 heads. Also one of 21 center taps can be selected on up to 6 banks of heads. When a center tap and a read/write amplifier are selected a definite head is selected.

The fixed head amplifier board preamplifier is an integrated circuit. The higher amplitude output from the fixed heads does not require as low noise preamplifier design as the moving head preamplifier.

The low pass filter and buffer design are the same as the matrix board unit.

The fixed head signal or moving head signal is selected on the data board (P/N 30102) by integrated circuits 1U3 and 1U4. The lower transistors of 1U3 and 1U4 are current sources that can be switched off or on. When the current source is on, the upper portion of that integrated circuit is active and the desired channel is selected. Integrated circuits 1U52 and 1U6 turn on or off the current sources as required.

4.4.4 Data (MFM Encoding)

Data is written on a track by using modified frequency modulation (MFM). A magnetic flux change is written in the center of each "1" cell and between "0" cells. No flux change is written on a "0" cell/"1" cell boundary. See Figure 4-27 for an example of MFM encoded data.

The data board converts NRZ data received to MFM by following MFM encoding rules. The flip flop 2U17 part 1 is connected as a shift register. Write clock is phase locked to the PLL and serves to frame incoming NRZ data and shift it through the shift register. Dual flip flop 2U23 is connected to toggle on each positive going input. The outputs of U23 drive the write drivers

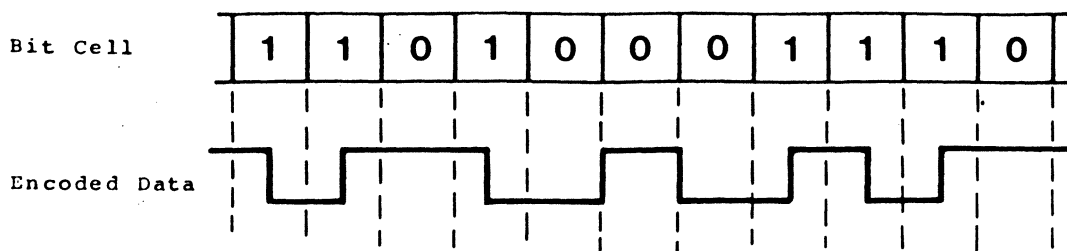

Figure 4-27
MFM Encoding

on the matrix board and fixed head amplifier board. If a "1" is shifted to the second stage of shift register (2U17 part 2) then at time T3 both inputs to 2U14 part 2 are low and 2U14-2 goes high to toggle U23. This causes a change of state on U23 to create a flux change in the center of a "1". If both sections of 2U17 have zero's stored. Gate U14 pins 12 and 13 are low and at time T7 U14 pin 15 will go high to toggle U23. This causes a change of state on U23 to create a flux change between zero's. Fig. 4-28 shows the timing for the MFM data.

The write drive circuitry for the matrix board and fixed head amplifier board are nearly identical. Transistor 1Q1 and 1Q2 on the matrix board and transistors 3Q3 and 3Q4 on the fixed head amplifier board are driven by the MFM generation flip flop U23 on the data board. Transistors 1Q1, 1Q2 on the matrix board and 3Q3, 3Q4 on the fixed head amplifier board in turn drive current steering transistors 1Q5 and 1Q6 on the matrix board and transistor switch banks 2Q102--2Q602 and 2Q103--2Q603 on the fixed head amplifier board. Transistor 2Q101-2Q601 is selected to write on the desired bank. Since either write transistor has a constant emitter voltage regardless of which transistor is turned on by the MFM generation flip flop U23, a constant voltage will result across write current setting resistors 1R17 and 1R25 on the matrix board. Resistors 3R4 and 2R 112--612 have a constant voltage across them and function the same way for the fixed head amplifier board.

A constant voltage across a resistor results in a constant current to the current steering transistors. Resistor 1R17 on the matrix board and resistor 3R4 on the fixed head amplifier board are adjustable to set the write current magnitude. Figure 4-24 shows the resultant magnetic field due to write current and Fig. 4-25 shows the resultant magnetism of a disc for a

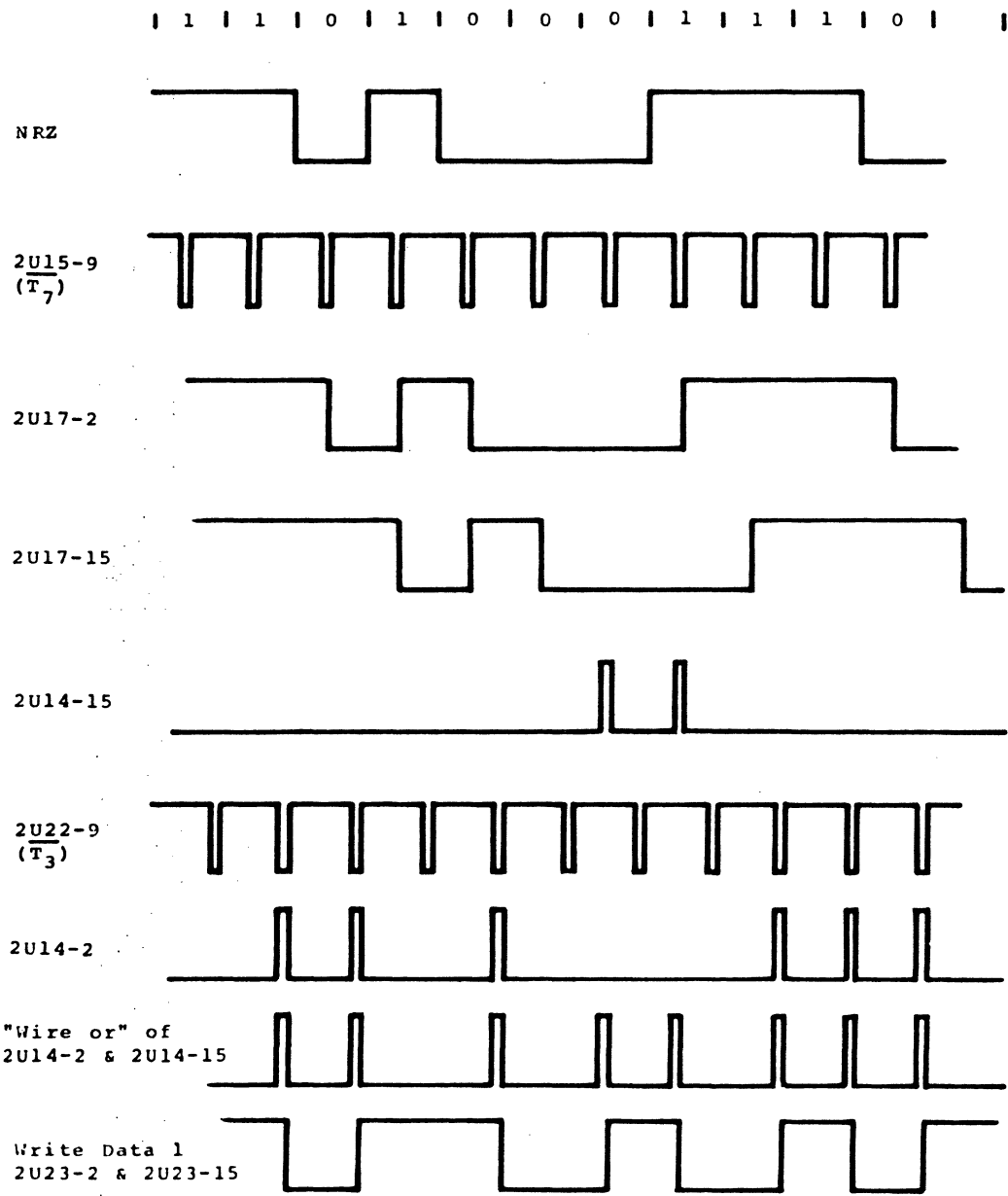

Figure 4-28
MFM Timing
IV-44

given word pattern.

4.4.5 Data (Phase Locked Loop)

The data board flip flops 3U28 and 3U29 and related gates serve to clear and synchronously load shift registers 3U36 and 3U37.

Synchronously loading the shift register reduces the phase error in the phase locked loop to a maximum of 1/8 of a cell time, this minimizes the loop settling time. Figure 4-29 shows the timing of this loop. Important outputs are 3U30-9 which clears the shift register and the wire "or" of 3U31-15 and 3U31-2 which loads the shift register.

The shift register when loaded "shifts" the loaded "1" around the loop continuously to produce a divide by 8 function. A data cell is broken into 8 time intervals. The voltage controlled oscillator (VCO) oscillates at 8 times the cell frequency and is phase locked to the cell frequency by the phase locked loop.

The phase locked loop is similar to the loop used on the servo board. Transistors 3Q1 and 3Q2, and integrated circuit 3U43 and 3U44 plus related components function as the voltage controlled oscillator (VCO). Figure 4-30 shows the ideal waveforms expected by the VCO. Since actual operating frequency (about 56 MHz) approaches the rise and fall times of the gates, the actual waveforms are rounded and somewhat sinusoidal.

The phase detector is made up of individual IC's 3U40, 3U41 and 3U42. Functionally it is similar to the Motorola 4044 IC, except being ECL and therefore faster.

The phase detector is both phase and frequency sensitive and responds only to positive transitions. Wave shapes have no effect on operation. Figure 4-31 shows operation for the four possible states of operation which are:

1. Reference signal (R) with phase lead over the variable (V) signal of the voltage controlled oscillator.

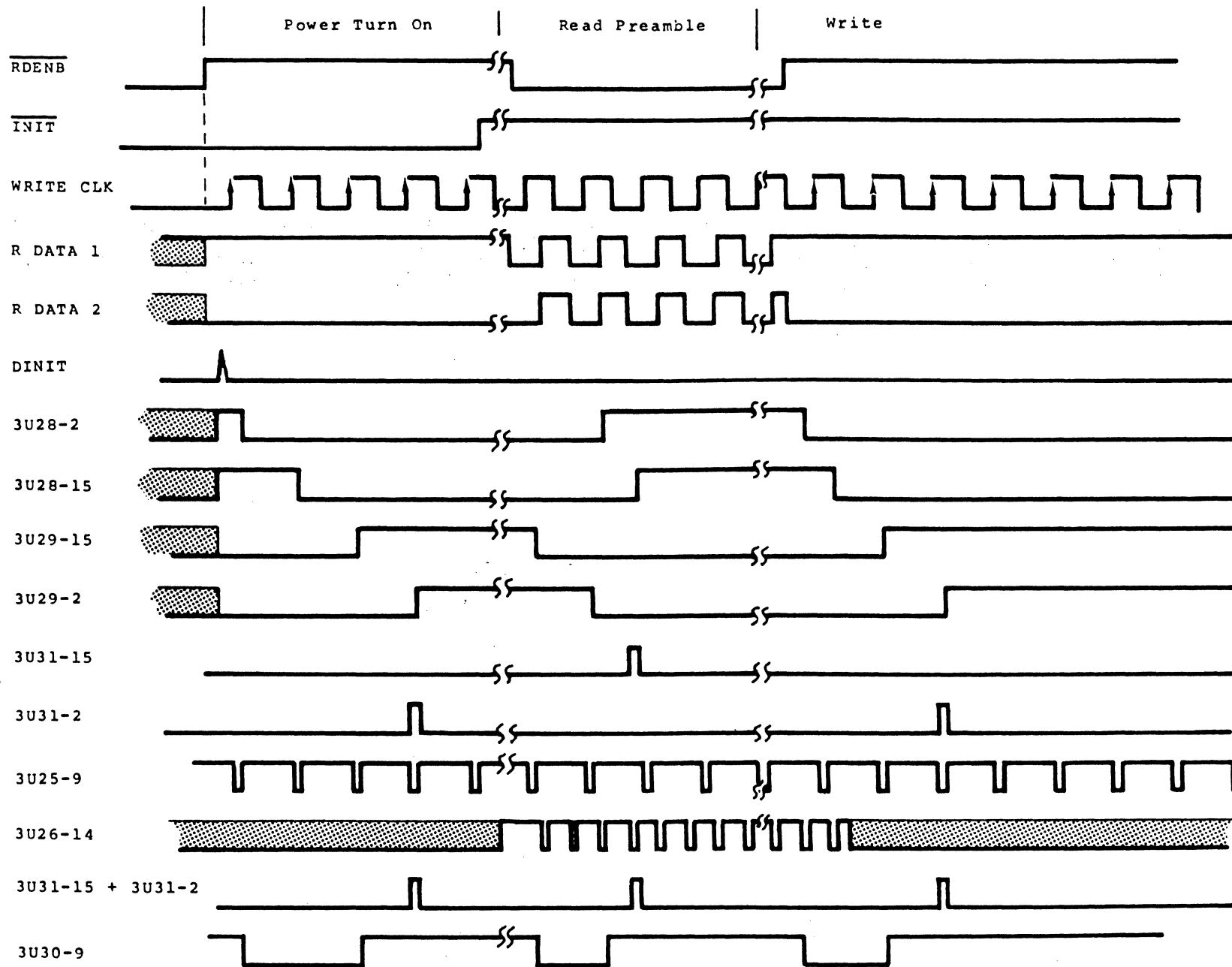

Figure 4-29
Phase Locked Loop Timing

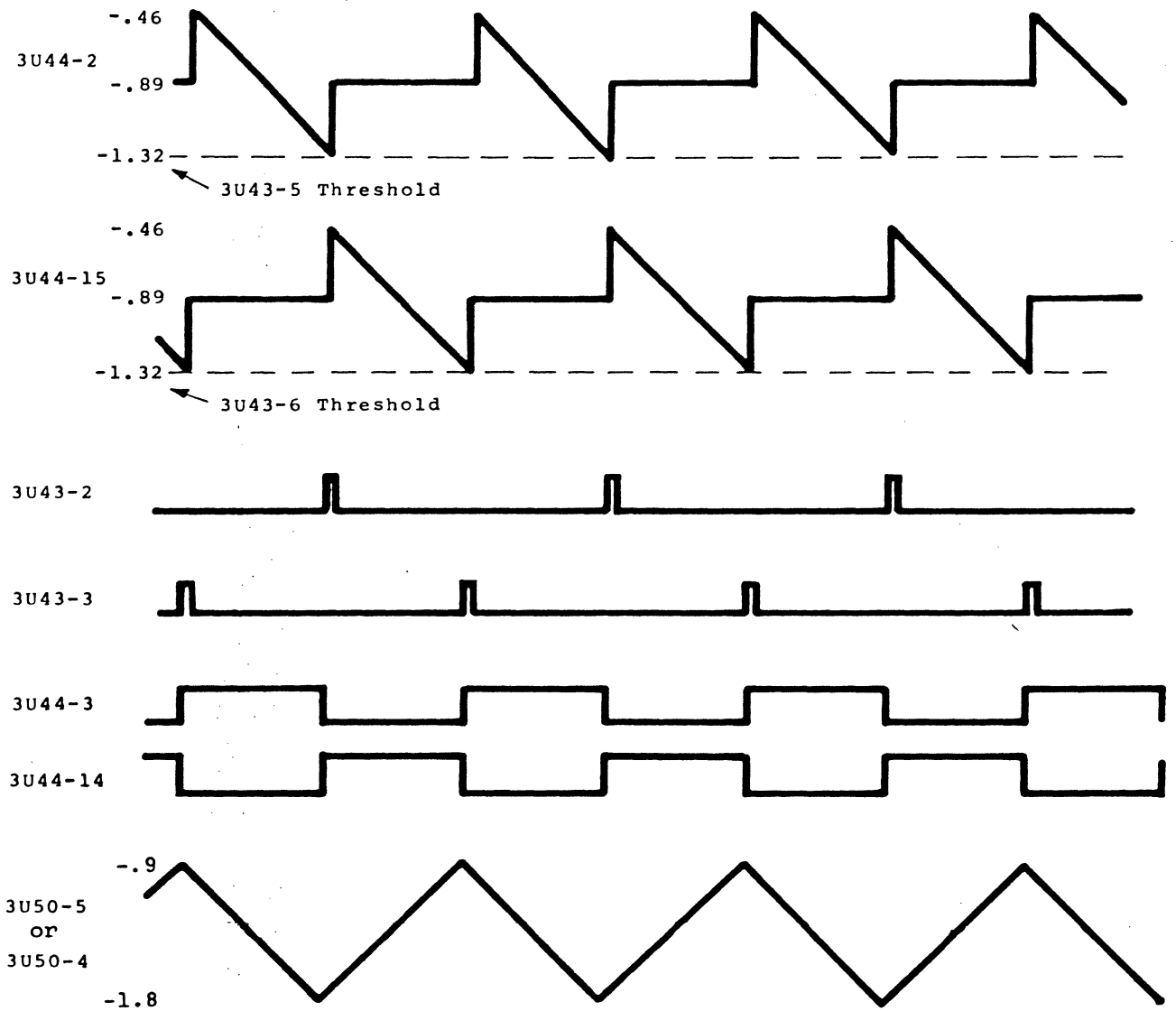

Figure 4-30
Voltage Controlled Oscillator

2. Reference signal with phase lag.
3. Reference signal at a higher frequency than the variable signal from the VCO.
4. Reference signal at a lower frequency than the variable signal from the VCO.

The output pulses from the output up (U) or output down (D) are filtered and subtracted to produce an error signal that is amplified by 3U39 and fed to the VCO to correct the phase or frequency error. Capacitors 3C27, 3C28 and resistors 3R49 and 3R51 stabilize the negative feedback loop and prevent oscillation. Also they add electrical momentum to the PLL, to prevent minor disturbances from affecting frequency of operation.

The VCO oscillates at 8 times the clock frequency. The shift registers 3U36 and 3U37 divide the VCO frequency by 8 and serve as the variable (V) input to the Phase comparator. Either write clock or recovered read clock are used as the reference signal (R).

For finer resolution in setting data recovery and margin windows, phase 1 and 2 of the VCO are split. This allows a PLL running at 8 times the reference frequency to produce 16 time intervals. Integrated circuit 3U51 generates the 1/16 of a cell time intervals required.

During write or standby (not reading) the PLL is synchronized with the write clock. Time T4 is gated to the phase detector through gates 3U34 and 3U35 and is in positive going edge phase lock with write clock.

During a "read" cycle operation of the phaselocked loop becomes more involved. Clocks between cells occur only between "0" cells. During "1" cells clocks occur at the center of each cell. During a "0" cell/"1" cell boundary no clock is received. Provisions must be made to keep both phase and frequency constant to both the (V) and (R) input of the comparator for all of the above cell conditions.

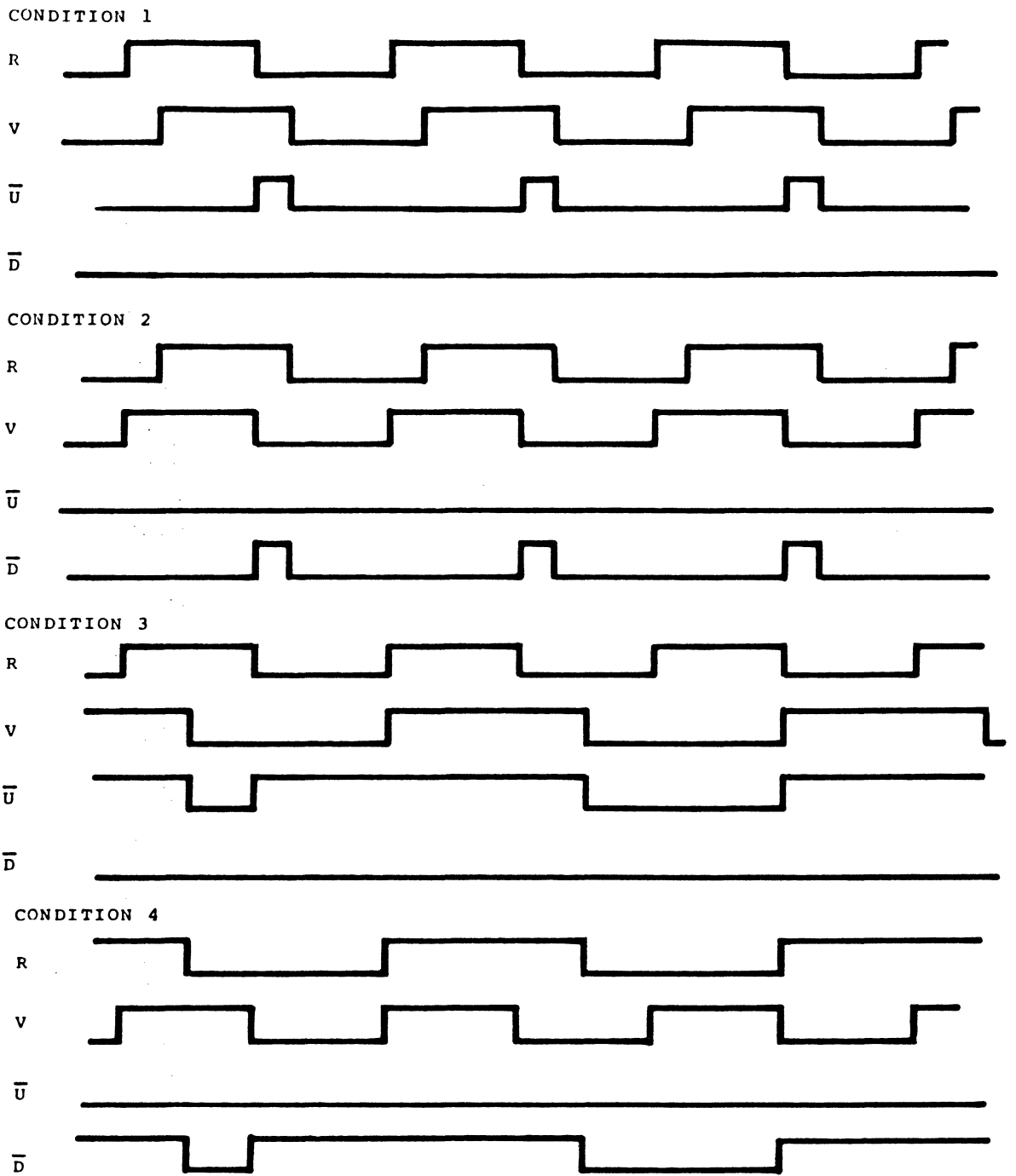

Figure 4-31
Phase Detector

If phase or frequency to the phase comparator is altered, the phase locked loop (PLL) would have a transient error condition. This is undesirable as "window" timing would be altered. Corrections are as listed below.

Correction for phase locking on "1's" versus "0's" is accomplished by altering the "T" time the PLL is locked on for "1's" or "0's". "0's" gate 3U33 part 1 and "1's" gate 3U33 part 2 decode the received data to determine if a "1" or a "0" has been received, the PLL locks to "T" time T4. If a "1" has been received the PLL locks to "T" time T0. The net result is that the PLL is phase locked to a cell boundary regardless of receipt of "1's" or "0's".

The remaining problems of missing transitions on a 1/0 boundary to reference (R) is compensated for by also deleting a transition on variable (V). Since both (R) and (V) have deleted the same transition, no phase or frequency disturbance occurs to the PLL. Figure 4-32 shows the timing of the PLL system upon receipt of a typical data pattern.

Gates 3U35-15 and 3U35-2 feed the V and R signals to the phase comparator during all normal operation. Only during system turn on or test, are gate 3U35-14 and 3U35-3 enabled to allow BCLK reference and T. to be fed directly to the PLL so that initial PLL adjustments can be made.

4.4.6 Read Data Signal Processing

The MFM data from either fixed or moving heads is selected as desired. Desired information is contained in the peaks of the MFM data. By differentiation of the MFM data, peaks become zero crossings and are easier to detect. The MFM low frequency pattern (10101---) may produce erroneous zero crossings which must be corrected for. (A later section covers the operation of the circuit.) A delay line (1DL1) is used to differentiate the MFM data received. Delay line 1DL1 can be thought of as two separate delay lines, each 35 NS in length with the ends shorted. After a time delay of 70 NS (time to end of delay line and back) a signal on the delay line output

4-32

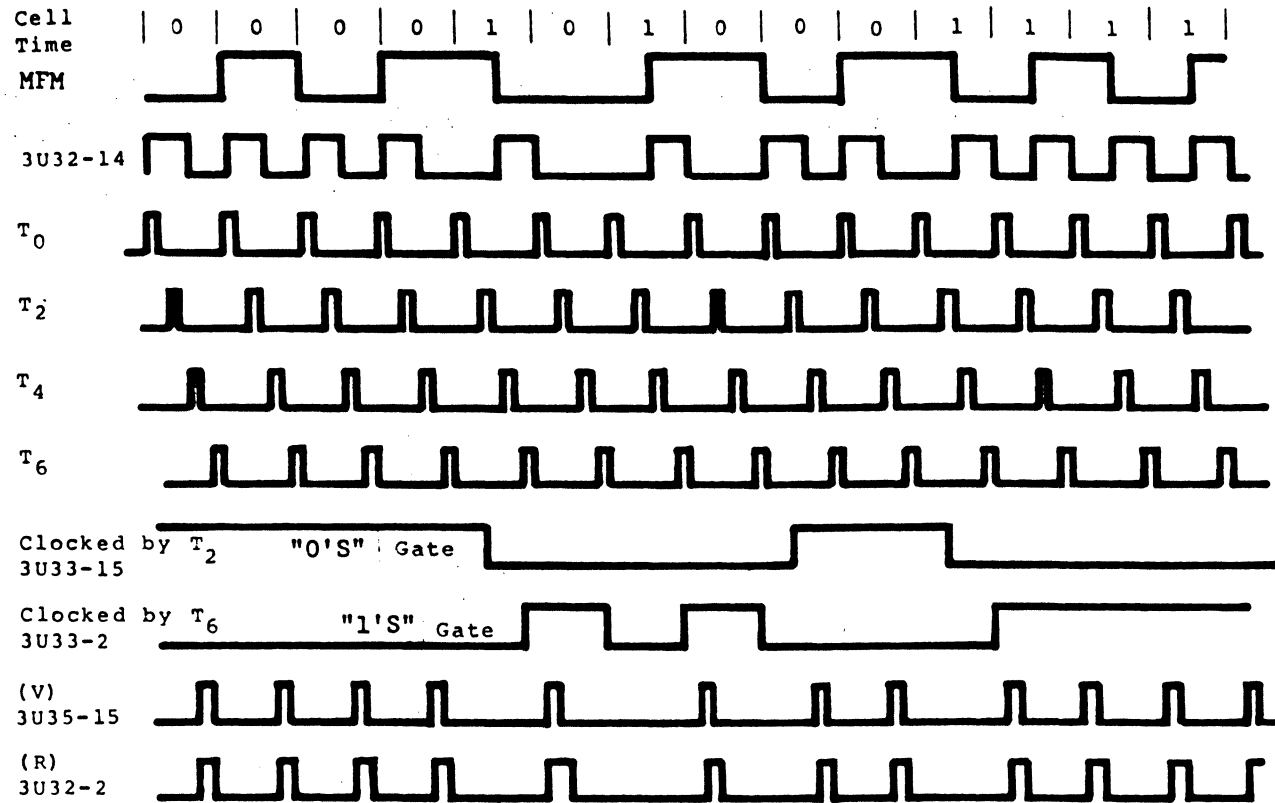

Figure 4-32
PLL Timing With Data Pattern

reflects back as an inverted signal of equal amplitude to cancel the initial signal. Figure 4-33 shows the resultant output signal for inputs produced by an all "0's" or all "1's" pattern or an alternating "1" and "0" pattern.

The output from the delay line drives an emitter follower buffer 1U5. The buffer drives the final Lowpass filter composed of inductors 1L₁ -- 1L₄, capacitors 1C₈₋₉ and related termination resistors. Integrated circuit 1U8 serves to "square up" the signal and convert it to ECL logic levels.

The threshold of the "squaring up" circuit is adjusted by adjustable divider 1R34 so as to "square up" the noise when no input signal is present.

As an option, an automatic threshold adjust circuit; 1U10, 1U11 and related circuitry is installed. Resistors 1R34 and 1R35 are deleted with this option.

The Auto threshold adjust functions on system turn on when the term MINIT is low. At turn on, 460kHz clock is fed to up-down counter 1U10. If 1U8-6 were high and 1U8-7 were low, the counter would start to count up. Integrated Circuit 1U11 and related resistors act as a digital to analog converter. As count up continues, an increasing current is stepped into 1U8-5 until 1U8-6 goes low and 1U8-7 goes high. At this time the counter will start to count down. As soon as a one count down occurs the system will start to count up again oscillating about the point where the "squaring up" circuit is biased to threshold value. When MINIT goes away, Counter clock stops and the counter is locked with the threshold adjust value stored in the counter.

As discussed earlier, the problem of an erroneous zero crossing must be detected and eliminated from the data pattern. The lower frequency pattern known as an "1F" pattern may have enough resolution that the head output voltage due to a flux reversal may return to zero volts prior to another flux reversal. If this happens, the derivative of both the peak output voltage and the zero volts condition could be zero resulting in an extra output. The output, due to the zero volt condition, is erroneous and must be eliminated.

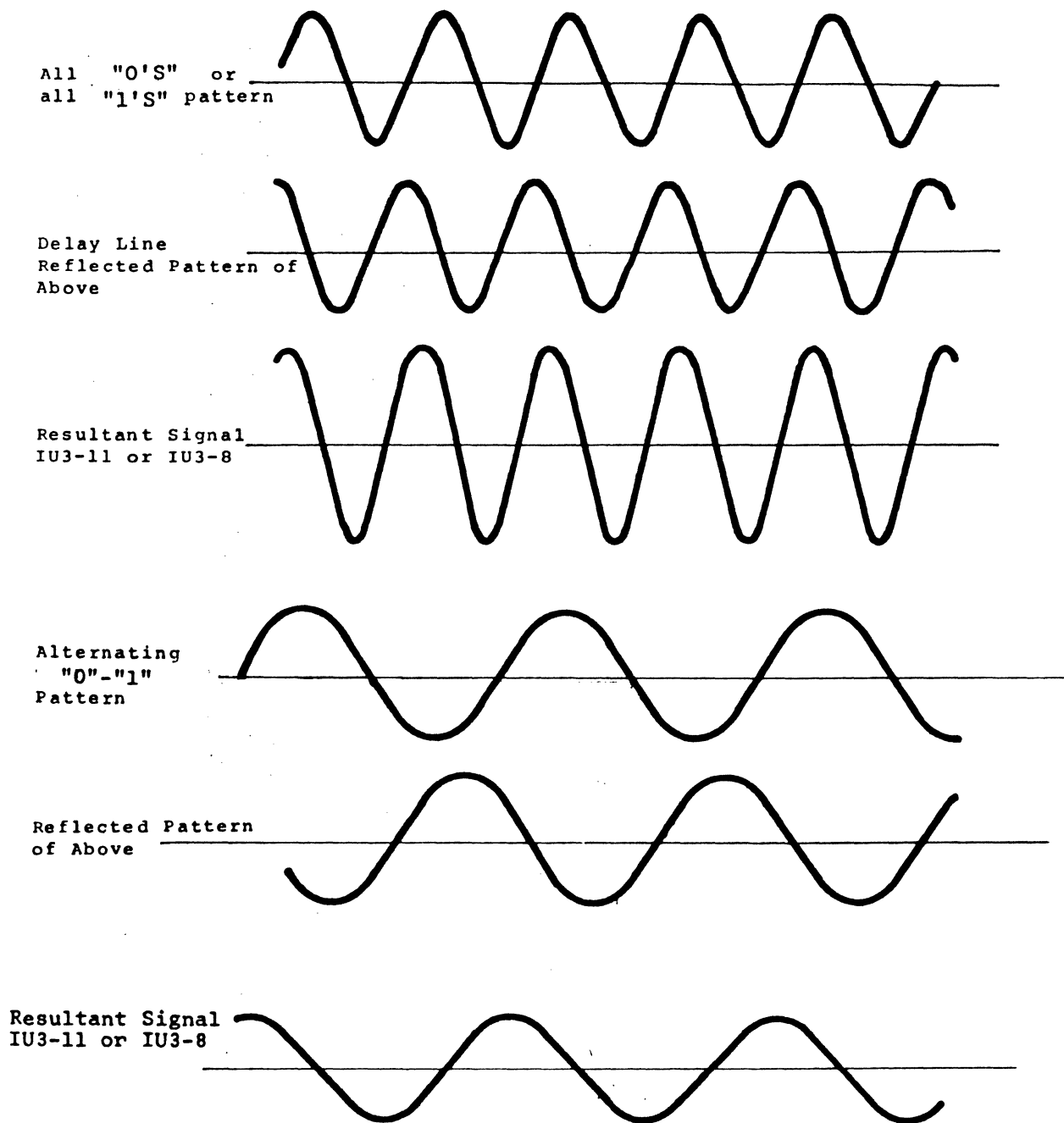

Figure 4-33
Read Data Signal Processing

Figure 4-34 shows the timing of the erroneous zero crossing deletion circuit. Any erroneous signal occurring in the center of the "1F" pattern $\pm 1/4$ of a cell time will be rejected. The timing of 1U12-11 is adjusted by the delay line 1DL2 so that on an all "1's" or all "0's" pattern, known as a "2F" pattern, a pulse is in the center of the cell.

4.4.7 Read Data (Decoding to NRZ)

The conversion of MFM data to NRZ and related read clock is done by 3U45, 3U48 and related circuitry. Figure 4-35 shows the waveforms related to MFM decoding. Signals RDATA1, and RDATA2 are shaped into pulses and "NOR'ed" to produce a negative transition for either a positive or negative MFM transition. Figure 4-35, 3U27-9 show the waveform expected. Times T2 and T6 are derived by the PLL (see Figure 4-32) set and reset 3U45 pins 2 & 3 as shown. Signal DLCORP is a delayed (by delay line 3DL3) and inverted by 3U32-3 signal whose delay time is one half of a cell time. In actual practice the leading edge of DLCORP is adjusted by the delay line 3DL3 to be the center of 3U45-3 waveform on an all "1's" or "0's" pattern. Integrated circuit 3U48 part 2 latches the signal from 3U45-3 as clocked by DLCORP. Integrated circuit 3U48 part 2 forms recovered NRZ "0's" and pulses for NRZ "1's". Integrated circuit 3U48 part 1 shifts data from U48 part 2 to develop recovered NRZ. Integrated circuit 3U49 converts NRZ and Read Clock (RDCLK) to TTL levels for the I/O board interface.

A test mode exists where window timing can be altered to check system margins. Integrated circuits 3U38 and 3U47 are one of 8 decoders. During normal operation control lines A, B and C are all zero and time T2 is gated to S and time T6 is gated to R to form normal windows. Table 4-1 shows the other window timings possible.

Terms STR EARLY and STR LATE move cell boundaries about 9NS early or late, respectively. Term M MODE moves cell boundaries 9NS in on both edges. For combinations of these terms refer to Table 4-1.

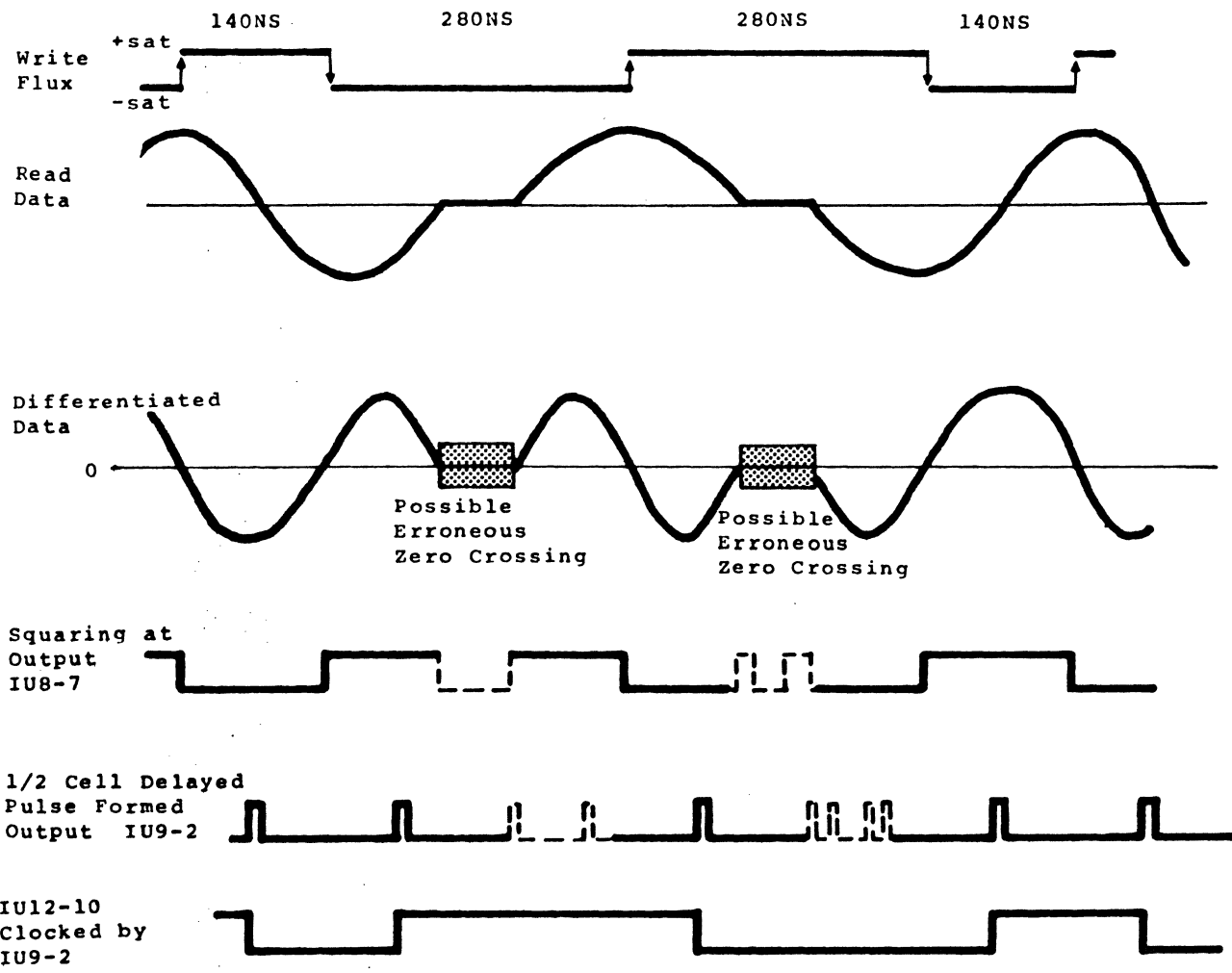

Figure 4-34
Erroneous Zero Crossing

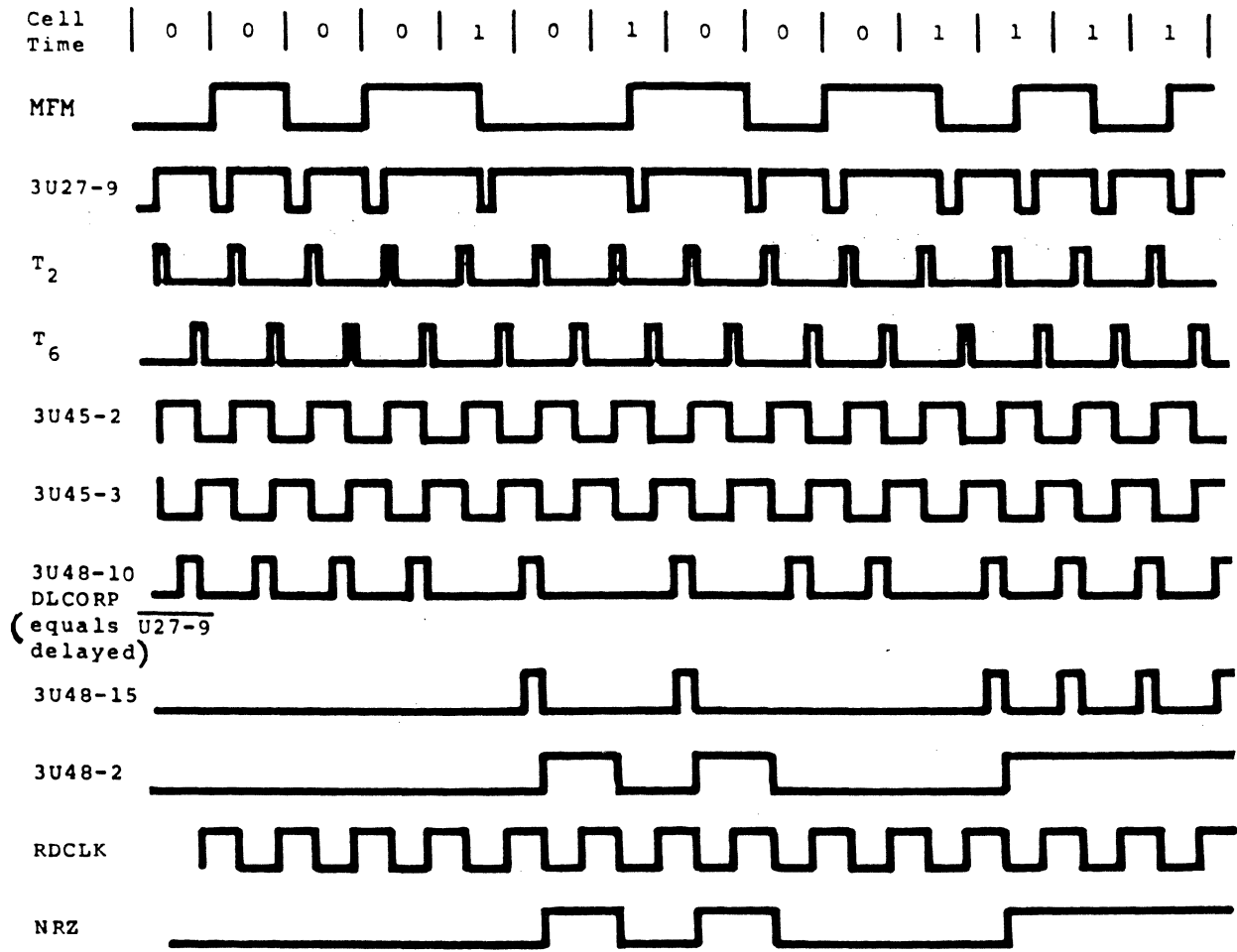

Figure 4-35
Read Data Decoding

Table 4-1
Early/Late Data Strobe

<u>STR-</u> <u>EARLY</u>	<u>STR LATE</u>	<u>M MODE</u>	C	B	A	WINDOW TIMES	
			2 ²	2 ¹	2 ⁰	S	R
1	1	1	0	0	0	T2	T6
0	1	1	0	0	1	T1 Ø2	T5 Ø2
1	0	1	0	1	0	T2 Ø2	T6 Ø2
0	0	1	0	1	1	T2	T6
1	1	0	1	0	0	T2 Ø2	T5 Ø2
0	1	0	1	0	1	T3	T5
1	0	0	1	1	0	T1	T5
0	0	0	1	1	1	T3	T7

4.5 INTERFACE (P/N 30115)

4.5.1 General

The 3300 CDC-9760 compatible I/O Board generates the External CDC Interface (Section 3) from the Internal 3300 Internal Interface (at P11 & P12). The I/O Board is organized into a set of logic modules, see Fig.4-36, which perform the CDC to Internal Interface operation. These modules and their theory of operation are discussed in the following paragraphs. Complete signal timing is covered in Section II.

4.5.2 Transceivers (Refer also to 2.4 and 2.5)

4.5.2.1. A Cable Transceiver

The A-Cable Transceiver consists of differential drivers and receivers which interface to headers J31 and J34. These drivers and receivers are comprised of 75110 and 75107B transmitters and receivers, respectively. The A-Cable receivers 1U59, 1U60, 1U64, 1U69, 1U71, 1U73, 1U75, 1U78, 1U79, 1U80 are disabled to prevent oscillation during

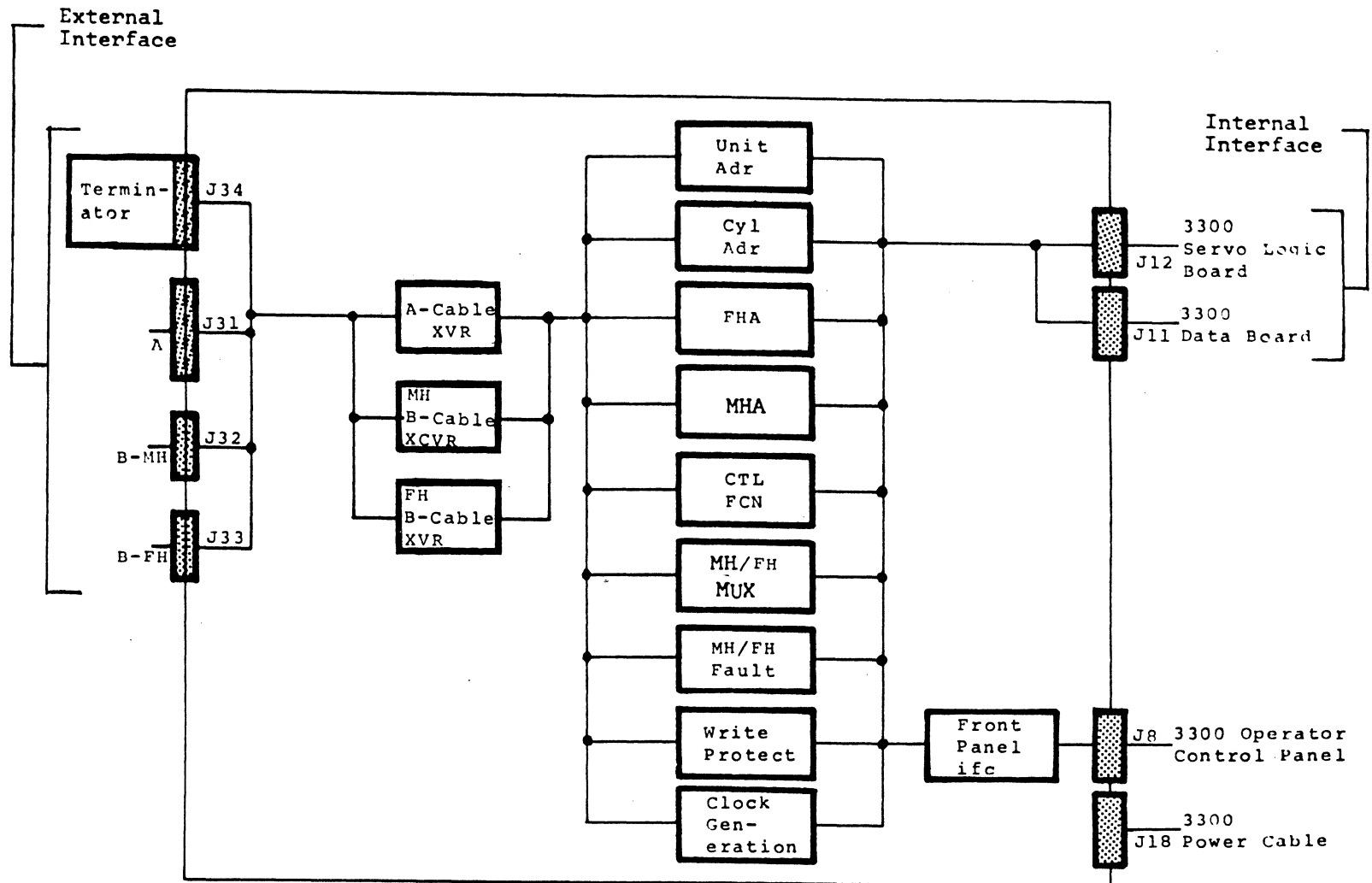

Figure 4-36
Interface Block Diagram

during an open cable condition; this is accomplished by means of terms DSA0 and DSA1, and DSA2 (1U66). The A-Cable transmitters 1U61, 1U65, 1U70, 1U74, 1U77, 1U84 are only enabled when either the moving head or fixed head unit is selected; this is accomplished via signals USEL and USEL2.

4.5.2.2 Differential Signal Characteristics

For a given differential signal pair, only one side of the pair is conducting at a time. The non-conducting side should be at OVDC. The conducting side should be at approximately -0.5VDC.

4.5.2.3 Cable Termination

All the A and B Cables must be terminated. The A-Cable is terminated by a separate board, P/N 30116, which plugs into J34. This terminator board connects each line to ground through 56 ohms except for pins 29 and 59 which are open, and pins 30 and 60 which are ground. The A-Cable may be daisy chained via J34 in which case the terminator is plugged into the last drive of the chain. The B-Cables are terminated to ground through 82 ohms on the I/O board; they may not be daisy chained.

4.5.2.4 Moving Head B-Cable Transceiver

The Moving Head B-Cable Transceiver consists of differential drivers and receivers which interface to header J32. The transmitters (1U83, 1U85, 1U86) are always enabled. The moving head write clock receiver (1U67) is always enabled except during open cable. The moving head write data receiver (1U68) is only enabled when the moving head unit is selected.

4.5.2.5 Fixed Head B-Cable Transceiver

The Fixed Head B-Cable Transceiver section interfaces to J33. The transmitters (1U76, 1U81, 1U84) are always enabled. The receivers for fixed head write data (1U68) and fixed head write clock (1U67) are only enabled when the fixed head unit is selected.

4.5.3 Unit Address Detection

The unit address from the A-Cable (UNIT SEL 0, UNIT SEL 1, UNIT SEL 2), is strobed into a 4-bit latch by UNIT TAG (2U50). The latched address is compared (2U52, 2U63) against a preset moving head address and a preset fixed head address (2U51). The preset unit addresses may be specified by the Unit Address Jumper (2U51) or by front panel hexadecimal thumbwheel switches via J8 in which case the Unit Select Jumper is a terminator to +5VDC. A thumbwheel switch bit is asserted by being connected to switch common; otherwise it is pulled up to +5 volts.

Moving heads selected (MHSEL) is generated with the following: the output of the moving head address comparator (2U52) is high, an open cable condition (OPNCBL) does not exist, and the jumper "MAINT" is not inserted (2U25, 2U26, 2U12). F/M SEL to the Data Board is low when moving heads are selected.

Fixed heads selected (FHSEL) is generated when the output of the fixed head address comparator (2U63) is high, OPNCBL is high and MAINT is high. The fixed head disable jumper, "FHDSA", should only be inserted when the fixed option is absent, where 2U63 is not loaded.

4.5.4 Cylinder Addressing

The Cylinder Address logic module involves the cylinder address lines, cylinder address strobe, servo offset, on cylinder, seek end generation and seek error detection.

4.5.4.1 Cylinder Address Lines

The cylinder address lines are presented to the Servo Board at connector J12 via signals BUS0 thru BUS9 (1U73, 1U64, 1U79, 1U60, 1U59).

4.5.4.2 Cylinder Address Strobe

Seek strobe (SKSTR) is transmitted to the Servo Board when the following conditions are present: moving head unit selected (MHSEL), cylinder address strobe (TAG1), and the unit is ready with no fault condition (URDY) (2U25, 2U22, 2U8).

A test point, TP1, is provided which divides SKSTR by two (2U2).

4.5.4.3 Servo Offset

Servo offset plus (SOFFP) or minus (SOFFM) are generated in conjunction with signals BUS1, BUS2, TAG3, RDY and USEL (3U12, 3U47, 3U33, 3U48). The servo offset is sent to the Servo Board when the moving head unit is selected (MHSEL) and offsets are enabled (TOFFENA) (3U46, 3U30).

4.5.4.4 Track Offset Enable

The track offset enable signal (TOFFENA) is generated by either SOFFP or SOFFM being issued when the servo is on cylinder (ONCYL). TOFFENA is cleared when servo offset is no longer asserted or with seek strobe, moving head restore or power reset (2U13, 2U28, 2U40, 2U57). In addition a pulse (TPULS) is generated with either transition of TOFFENA (2U14, 2U13).

TPULS triggers a 3 msec one-shot (2U38) which is used to suppress on cylinder when the servo arm is moving to/from the track offset.

4.5.4.5 On Cylinder

Moving head on cylinder (MHONCY) is generated when both on cylinder time-outs (2U38) have elapsed, when there is no moving head seek error (MHSKERR) and when seek complete (SKCOMP) is true or when TOFFENA is true (2U13, 2U38, 2U37, 2U28).

Fixed head on cylinder (FHONCY) is generated when the 5 μ s time-out (TMO) has elapsed, and when there is no fixed head seek error (FHSKERR) (2U37, 2U38).

The on cylinder time-outs are triggered by any of the following: seek strobe (SKSTR), fixed head strobe (FHSTR), fixed head restore (FHRTZ), or moving head restore (MHRTZ) (2U22, 2U23, 2U90).

4.5.4.6 Seek End Generation

Seek end is generated for both the moving and fixed heads with either on cylinder or seek error when the seek end time-out has elapsed.

Moving head seek end is generated with either MHSKERR or MHONCYL when the moving head seek end time-out (MHTMO) is not in effect (3U87, 3U89). MHTMO is generated by MHSEL and the 5 μ s on-cylinder time-out (TMO) (2U88).

4.5.4.7 Seek Error Detection

Moving head seek error (MHSKERR) is generated when either seek late (SKLATE) or illegal address (ILL ADD) is detected from the Servo Board (2U9, 2U10, 2U11, 2U14). MHSKERR may only be cleared by power on initialize (PWRRST) or moving head restore (MHRTZ) (2U25).

Fixed head seek error, FHSKERR, is generated when an illegal fixed address (ILLFHA) by the contiguous fixed head address option (2U11, 2U14). FHSKERR may only be cleared by PWRRST or FHRTZ (2U25).

4.5.5 Head Addressing

4.5.5.1 Fixed Head Addressing

The fixed head address presented to the Data Board must be latched on the I/O Board (3U4, 3U18); the fixed head address may also be mapped through a PROM (3U6) to provide contiguous addressing and illegal address detection. In the event a PROM is not used, a replacement jumper must be loaded at U6 to pass the address to the 8-bit latch.

The fixed head address is received via signals "BUS0 thru BUS7" and passed thru the mapping PROM or replacement jumper (3U6) to the 8-bit fixed head address latch (3U4, 3U18). The fixed head address latch is strobed by fixed head address strobe (FHSTR), and is cleared by fixed head restore (FHRTZ). FHSTR is generated with TAG1 when FHSEL is true (3U32).

Illegal fixed head address (ILLFHA) is only supported with the contiguous fixed option. ILLFHA may also be generated in the non-contiguous mode if an illegal fixed head amplifier is selected. ILLFHA is generated when two illegal PROM bits are present with TAG1 and FHSEL (3U6, 3U58).

4.5.5.2 Moving Head Address

The moving head address on signals BUS0 thru BUS3 is strobed in a 4-bit latch (2U5) when TAG2 and MHSEL are present (2U30). This latch is cleared by MHRTZ. The outputs of the moving head address latch are sent to the Data Board and are also used to detect when head 0 is addressed, HD0 (2U23).

4.5.6 Control Functions

The following control functions are initiated via signals BUS0 through BUS9 in conjunction with TAG3: read, write, servo offset, fault clear, address mark, restore, data strobe offset and release which is used in margin mode.

The control functions may pertain to the moving head unit only, the fixed head unit only or both units. The enabling of the particular control functions requires the presence of the following: TAG3; disc ready (RDY) and either MHSEL or FHSEL (3U12, 3U32, 3U30, 3U33, 3U47). A by-product of these control function enable signals are the unit select signals, USEL and USEL2, which are used to enable differential transmitters (1U61, 1U65, 1U74, 1U82, 1U77).

4.5.6.1 Write Control Function

Two write request signals, WTREQ1 and WTREQ2, are generated in response to BUS0 and control function enable (TAG3) (3U19, 3U16, 3U33).

Write enable (WRT ENA) is generated if the write mode signal (WRT MODE) is true and an address mark is not being written (ADRMK) (3U32, 3U33).

The write mode signal (WRT MODE) is generated in response to the WTREQ1 signal in combination with one of three possible conditions. One condition is the presence of margin mode (MMODE) which overrides all interlocks in creating WRTMODE in response to WTREQ1. The second condition is moving head write where the following is required: the unit must be ready with no fault condition (URDY), the moving head unit is selected (MHSEL) and no moving head seek error (MHSKERR) nor moving head fault clear (MHFCL) is present. The third condition is fixed head write

where URDY and FHSEL must be present and FHSKERR and FHFCL must be absent, i.e. logic high (2U35, 2U39, 2U16).

4.5.6.2 Read Control Function

Read enable ($\overline{\text{RDENA}}$) to the Data Board and the read request signal RDREQ are generated in response to BUS1 and control function enable (TAG3). RDENA is suppressed during address mark detect (3U19, 3U33).

4.5.6.3 Servo Offset Control Function

Servo offset plus and minus (SOFFP) and (SOFFM) are generated by BUS2 and BUS3, respectively, in combination with control function enable (TAG3) (3U48). Track offset to the Servo Board is generated in response to SOFFP or SOFFM, MHSEL and TOFFENA (3U30, 3U46); TOFFENA is discussed in paragraph 4.5.4.4.

4.5.6.4 Fault Clear Control Function

Moving head fault clear ($\overline{\text{MHFCL}}$) and fixed head fault clear ($\overline{\text{FHFCL}}$) cause the associated fault latch to be cleared. $\overline{\text{MHFCL}}$ and $\overline{\text{FHFCL}}$ are generated in response to BUS4 in combination with the appropriate control function enable signal (3U19, 3U34).

4.5.6.5 Address Mark Control Function

The address mark control causes address marks to be generated when issued in conjunction with write control function. When the address mark control is issued in conjunction with the read control function, detection of address marks is enabled while $\overline{\text{RDENA}}$ to the Data Board is disabled. The address mark control (ADRMK) is generated in response to BUS5 in combination with the control function enable signal (3U48) TAG3).

4.5.6.5.1 Address Mark Generation

Address marks are written by issuing write address mark ($\overline{\text{WRTADDMK}}$) to the Data Board while write enable ($\overline{\text{WRTENA}}$) is absent. This is accomplished by combining WRTMODE with ADRMK to generate $\overline{\text{WRTADDMK}}$ and $\overline{\text{WRTENA}}$ (3U46, 3U32, 3U33).

4.5.6.5.2 Address Mark Detection

Address mark detection is enabled when address mark control (ADRMK) is present in combination with read request (RDREQ) (3U31). Address mark found (AMKFND) is generated following detection of the address mark gap. If the optional address mark detection circuit is not implemented, AMKFND is grounded.

4.5.6.6 Restore Control Function

Moving head restore (MHRTZ) and fixed head restore (FHRTZ) are generated in response to BUS6 in combination with the appropriate control function enable signal (3U7, 3U34). RESTORE is issued to the Servo Board in response to MHRTZ (3U8).

4.5.6.7 Data Strobe Offset Control Function

Data strobe early (STR EARLY) and data strobe late (STR LATE) are issued to the Data Board in response to BUS7 and BUS8, respectively, in combination with the control function enable signal (3U34).

4.5.6.8 Release Control Function (Margin Mode)

The release control function (RLS) is generated in response to BUS9 in combination with the control function enable signal (3U48).

The release function, normally intended for use with dual port disc drives, is used to generate margin mode (MMODE) when unit addresses 15 or 16 are selected (UNIT SEL1 through UNIT SEL3) (2U58, 2U8). MMODE is issued to the Data Board to cause narrow data windows during read. MMODE is used to override fault conditions and allow write enables.

4.5.7 Moving/Fixed Head Multiplexer

Certain signals from the fixed and moving head unit must be multiplexed onto the A-Cable. These multiplexed signals are as follows: MHSKERR and FHSKERR to SKERR; MHFLT and FHFLT to FLT; and MHONCY and FHONCY to ONCYL (3U72).

Write clock (WRITE CLOCK) and write data (WRITE NRZ) to the Data Board must be multiplexed from moving

head write clock (MHWCLK) and fixed head write clock (FHWCLK) and from moving head write data (MHWDAT) and fixed head write data (FHWDAT) (3U62), respectively. The moving head signals are disabled only when the fixed head unit is selected.

4.5.8 Moving/Fixed Head Fault

Faults are latched for the moving head unit and for the fixed head unit (MHFLT) and (FHFLT) (2U11, 2U9). Unit ready (URDY) for the selected unit indicates that the drive is ready (RDY) and that no fault exists for the selected unit (FLT) (3U32, 3U33).

Faults into the moving head fault latch (2U11) are gated thru an 8-input gate (2U21) whose output is gated to the moving head fault latch only when the moving heads are selected (MHSEL) (2U22, 2U10). Powerfail (PWRFLT) and moving head write current error are enabled to the moving head fault latch at all times (2U10). The moving head fault latch is cleared by power on initialize (PWRRST) or moving head fault clear (MHFCL) (2U11).

Faults into the fixed head fault latch (U11) are gated thru an 8-input gate (2U49) whose output is gated to the fixed head fault latch only when the fixed heads are selected (FHSEL) (2U7, 2U10). PWRFLT and fixed head write current error are enabled to the fixed head fault latch at all times (2U10). The fixed head fault latch is cleared by power on initialize (PWRRST) or fixed head fault clear (FHFCL).

4.5.9 Fault Conditions

There are a number of different fault types which set the moving and fixed head fault latches. These are discussed in the following paragraphs.

4.5.9.1 Control Fault

This fault condition (CTLFLT) is generated if the fixed head unit (FHSEL) and moving head unit (MHSEL) are simultaneously selected (2U40) or if multiple tags (TAG1) (TAG2) (TAG3) are received while either unit is selected (USEL) (2U36, 2U37). This fault condition is monitored by both fault latches only when a unit is selected (2U21, 2U49).

4.5.9.2 Power Fault

This fault condition ($\overline{\text{PWRFLT}}$) is generated when a DC power error (PWROK) occurs not coincident with power on initialize (PWRRST) (2U7). This fault condition is monitored by the fault latches independent of a unit select (2U10).

4.5.9.3 Read While Write Fault

This fault condition is generated when read (RDREQ) and write (WTREQ2) are on simultaneously (2U22). This fault condition is monitored by the fault latches only when a unit is selected (2U49).

4.5.9.4 Write While Track Offset Fault

This fault condition is generated when write (WTREQ2) is attempted during track offset (TROFF). This fault condition is suppressed during margin mode (MMODE) (2U47). Track offset write fault is monitored by both fault latches only when a unit is selected (2U21, 2U49).

4.5.9.5 Read or Write While Off Cylinder Fault

This fault is generated when read (RDREQ) or write (WTREQ) is attempted when the selected unit is not on cylinder (ONCYL) (2U8, 2U6). This condition is monitored by both fault latches only when a unit is selected (2U21, 2U49).

4.5.9.6 Multiple Moving Heads Selected

This fault is generated in response to a Data Board signal (MHD MULTI SEL) (2U16). This condition is only monitored by the moving head fault latch when the moving head unit is selected (2U21).

4.5.9.7 Moving Head Write Current Fault

This fault is generated when moving head write current ($\overline{\text{MHD CUR SENS}}$) is detected and there is no write to the moving heads. It will also be generated if there is a moving head write and no write current is detected (2U3, 2U9, 2U30). Resistor, 2R6, and capacitor, 2C3, filter out the time lag between write enable and current sense. This condition is monitored by the moving head fault latch at all times (2U10).

4.5.9.8 Multiple Fixed Heads Selected

This fault is generated in response to the Data Board (FHD MULTI SEL) (2U16). This condition is only monitored by the fixed head fault latch when the fixed head unit is selected (2U49).

4.5.9.9 Fixed Head Write Current Fault

This fault is generated when fixed head write current (FHD CUR SENS) is detected and there is no write to the fixed heads. It will also be generated if there is a fixed head write and no write current is detected (2U3, 2U9, 2U37). Resistor, 2R7, and capacitor, 2C2, filter out the time lag between write enable and current sense. This condition is monitored by the fixed head fault latch at all times (2U10).

4.5.9.10 Write Fault

Fixed head and moving head write faults are also detected (FHWFLT) and (MHWFLT) (2U41). These conditions are monitored by the moving and fixed head fault latches only when a unit is selected (2U21, 2U49). For a further discussion see paragraph 4.5.11.2.

4.5.10 Write Protect

Write protect consists of reporting when a write protected section of the drive is addressed, WPROT, and of indicating when a moving head or fixed head write fault occurs (MHWFLT) and (FHWFLT). The definition of write protected areas is received from the optional front panel interface section WPH0, WPFH or WPED.

4.5.10.1 Write Protect Status

The write protect status, WPROT, is generated when a write protected section of the drive is selected. Write protected sections are: fixed heads (WPFH), moving head zero (WPH0), or the entire drive (WPED) (2U40, 2U42). This logic (2U42) is optional and may not be loaded. If it is not used, the "WPD1" jumper must be inserted; if it is used, "WPD1" must be removed.

4.5.10.2 Write Fault Detection

Write fault detection (MHWFLT) and (FHWFLT) is determined during a write (WTREQ1) if a write protect violation occurs. This is accomplished by monitoring: the write protect definition signals (WPFH), (WPED) and (WPH0), the write request signal (WTREQ1), and head address zero (HD0) (2U41). A write fault status may be generated during a write but it is only latched into the moving head or fixed head fault latch if the appropriate unit is selected. Write fault detection is optional, and is included in the write protect option. If 2U41 is not loaded jumpers "WPD2" and "WPD3" must be inserted. Conversely, "WPD2" and "WPD3" must be removed if 2U41 is loaded.

4.5.11 Control Panel Interface

The front panel interface connects to header, J8, and receives write protect definitions, controls the write protect displays, receives unit address definitions and controls the ready indicator.

4.5.11.1 Write Protect Interface

The write protect momentary push button switches and indicators are optional and are included in the write protect option. These switches and indicators are labelled: "Write Protect Moving Head Zero", "Write Protect All Fixed Heads", "Write Protect Entire Drive". Each switch input is filtered (2R25, 2R26, 2R27, 2C60, 2C61, 2C62), buffered and levelled (2U53), and latched (2U56, 2U57). The latches, WPH0, WPFH, WPED, are D-type flip-flops which change state each time the associated switch is depressed; all the write protect switches are initialized at power-on to the non-write protect condition.

The outputs of the latches are used in write protect status and in write fault detection. The write protect indicators reflect the state of the associated latch, i.e. if WPH0 is true then the "Write Protect Moving Head Zero" indicator is lit. The write protect indicators are controlled by peripheral interface drivers (2U54, 2U55) which sense the output of the appropriate write protect latch and conditionally provide a current path to ground for the associated 28 volt lamp. 32 VDC is provided to the lamps from the I/O board through J8.

The output of each peripheral driver has a series resistor (2R28, 2R29, 2R31) for current limit and a bleeding resistor (2R32, 2R33, 2R34) to increase lamp life.

4.5.11.2 Unit Select Interface

The front panel may optionally contain a moving head unit address thumbwheel switch and a fixed head unit address thumbwheel switch. These switches are 16 position switches, each with four outputs and a common; for a given output, a true condition is indicated by a connection to the switch common. The switch output lines are terminated by the Unit Address Jumper (2U51) if the unit address option is provided. For further details refer to paragraph 4.5.3.

4.5.11.3 Ready Indicator Interface

The front panel ready indicator provides the operator with the status of the drive. The light remains off until the RDY signal from the Servo Board goes true and no fault exists at which time the light comes on. If RDY drops or a fault condition exists, the light will flash at ten times per second until RDY returns high or the fault is cleared (2U35, 2U8, 2U27). Jumpers "FLT1" and "FLT2" determine which fault conditions may flash the ready light. If only "FLT1" is inserted then either a fixed head or moving head fault will flash the ready light. If only "FLT2" is inserted then only a moving head fault will flash the ready light. Inserting both "FLT1" and "FLT2" is not permitted. The 10Hz oscillator is a free-running oscillator whose output is used to flash the light (2U24, 2U26).

The ready lamp is controlled by a peripheral interface driver (2U55) which provides a path to ground when the lamp is to be on. The ready light is a 28V lamp running on 32V and is switched to ground through a limiting resistor (2R30) when on, and bled by 2R35 when off, to increase the lamp life.

4.5.12 Clock Generation

The following clock signals are derived from Servo Board signals and transmitted to the controller interface: BITCLK, SECT and INDEX.

4.5.13.1 Bit Clock Generation

The double frequency clock signal, 14MHZ, from the Servo Board is used to generate the 7.33 MHZ BITCLK. The signal is terminated by 3R4 and 3R5, Schmidt triggered (3U16) and divided by two (3U2) to become BITCLK.

4.5.13.2 Sector and Index Generation

Transmitted sector marks and index marks are derived from the Servo Board signals, 460KHz and INDEXA. 460KHz is 1/16 the frequency of BITCLK and is used in conjunction with INDEXA to generate sector marks. Each cycle of 460 corresponds to 16 data bits or 2 data bytes; thus the spacing between sector marks is controlled in 2 byte increments. Sector spacing is controlled by a 12 bit down counter (3U29, 3U15, 3U1) which counts down the number of 16 bit words per sector as defined by the Sector Mark Jumper (3U43). Index A is used to resynchronize the sector marks and to derive a skewed index for the controller allowing for an oversized sector at the end of the revolution if the number of sectors do not exactly occupy one data track.

INDEXA is synchronized with 460KHz to cause the 12 bit counter to be preset with the number of words per sector (3U8, 3U47, 3U31, 3U45). Likewise, the carry-out of the 12 bit counter is synchronized with the 460KHz clock to cause the counter to be preset. Each carry-out of the 12-bit counter also triggers two one shots (3U44). However, only one of the one-shots is enabled (3U45) as determined by INDEX-A. The first carry-out after INDEXA becomes INDEX to the controller, all subsequent carry-outs become sector marks, SECT, to the controller.

SECTION V

MAINTENANCE AND ADJUSTMENTS

5.1 INTRODUCTION

Before any 3300 disc drive leaves the factory, each of its components has been thoroughly tested and all adjustments have been made to ensure reliable operation. However, rough handling in transit or the effect of long use may necessitate the replacement of some parts or the adjustment of some components.

This section provides instructions for replacements, readjustments, and trouble shooting that can effectively be done while the disc drive remains installed in the customer's system. Some repairs will require test equipment or tools not normally available in the field. Instructions for repairs of this more complex nature are NOT included in this section.

5.2

PRECAUTIONS

The 3300 uses heads which remain in contact with the disc surface when the discs are not rotating. A "landing zone" is provided on the discs for each head and the head positioner will automatically position the heads to this zone and hold them there with a permanent magnet when power is removed from the drive. (Fig. 4-4.)

The strength of the permanent magnet is such that the disc drive can be removed from its cabinet and placed in its service position (Fig. 5-1) without danger of the heads leaving the "landing zone" providing the machine is not allowed to experience shock or vibration.

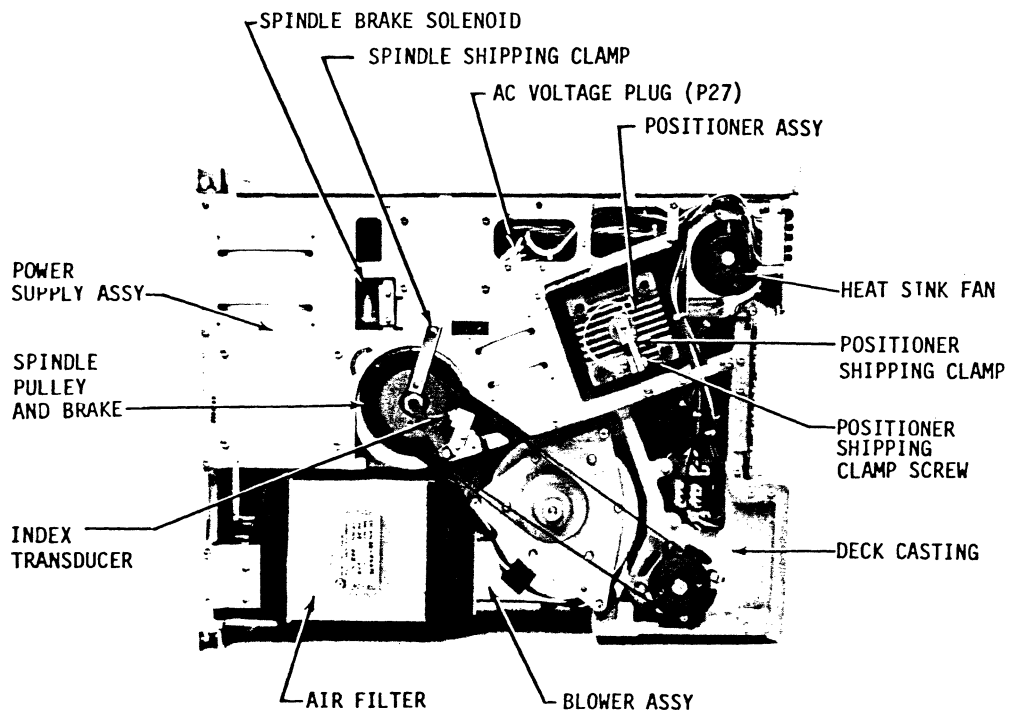

Figure 5-1
Machine in Service Position

NOTE: Serious damage to heads and discs can occur if:
(1) The positioner is moved off of the "landing zone" when the discs are not up to speed.
(2) Discs are rotated counter clockwise as viewed from the bottom at any time.

It is therefore recommended that for any maintenance operation requiring removal of the machine from its rack or enclosure that the positioner shipping clamp and spindle shipping clamp first be fastened (Fig. 5-1).

If the machine is to be shipped to another location these clamps must first be fastened.

5.2

TOOLS AND EQUIPMENT

The following tools and equipment will allow all adjustments and repairs covered in this section to be completed efficiently.

<u>EQUIPMENT</u>	<u>MODEL OR TYPE</u>
Voltmeter	50mv Accuracy
Potentiometer Screwdriver	
Pin Extractor Tool	Molex P/N 11-03-0015
Clip on Jumper Wire	
Oscilloscope	Tektronix 465 or Equiv.
Scope Probes (2)	
Dip Clip	14 Pin & 16 Pin
Soldering Iron	<20W
Phillips Screwdriver	#1 & #2
Spring Scale	Chatillon DPP-5
Hex Driver Set	Bondhus
Silicone Rubber	RTV 162
Steel Scale	18" & 6" 10th & 100ths Grade
Hypodermic Syringe	
Open End Wrench (2)	5/16
Spin Tite	1/4 in
Socket & Ratchet Set	3/8 Drive
Pulley Spanner	Okidata 30244
Pulley Puller	Okidata 30282
Current Probe	Tektronix P6021 with terminator or equivalent

TOOLS AND EQUIPMENT (Continued)

<u>EQUIPMENT</u>	<u>MODEL OR TYPE</u>
Fliers	Needle Nose & Plain
Retaining Ring Pliers	#2 Milbar or Equiv.
Gear Puller	2 Jaw Williams GP-240
Loctite	271
Cotton Swabs	
100% Isopropyl Alcohol	
Shim	.020 & 040 THK.

5.3 POWER SUPPLY (Set Transformer Taps)

- a) Tools Required: Molex P/N 11-03-0015 extractor
- b) The power supply input taps are accessible from bottom of drive. See Fig. 5-1 (A/C Voltage Plug). These taps can be selected to match as nearly as possible the line voltage. Figure 5-2 shows how to select the taps for the line voltage in a given application.

NOTE: Do not switch the transformer taps from 105, 110, 115, 120 to 210, 220, 230, 240 or vice versa. This change requires a spindle motor and AC Distribution Box change (P/N 30337), in addition to the change of transformer taps.

5.3.2 Power Supply Removal

To remove the power supply assembly from the drive the following procedure is to be followed:

- a) Tools Required: #2 phillips screwdriver
- b) Remove drive from cabinet and position vertically on left hand side of drive as shown in Fig. 5-3.
- c) Disconnect AC voltage plug (P27) and power amplifier connector (P15) where shown in Fig. 5-1.
NOTE: Remove cable clamps before removing power amp. connector (P15).
- d) Remove the ten power supply mounting screws circled "A" in Fig. 5-3. The power supply can now be removed from the drive. (Fig. 5-4.)
- e) Re-install power supply assembly in reverse order of removal.
- f) Check to see that no binding or interference with the spindle brake operation exists. Install drive in cabinet.

V-7

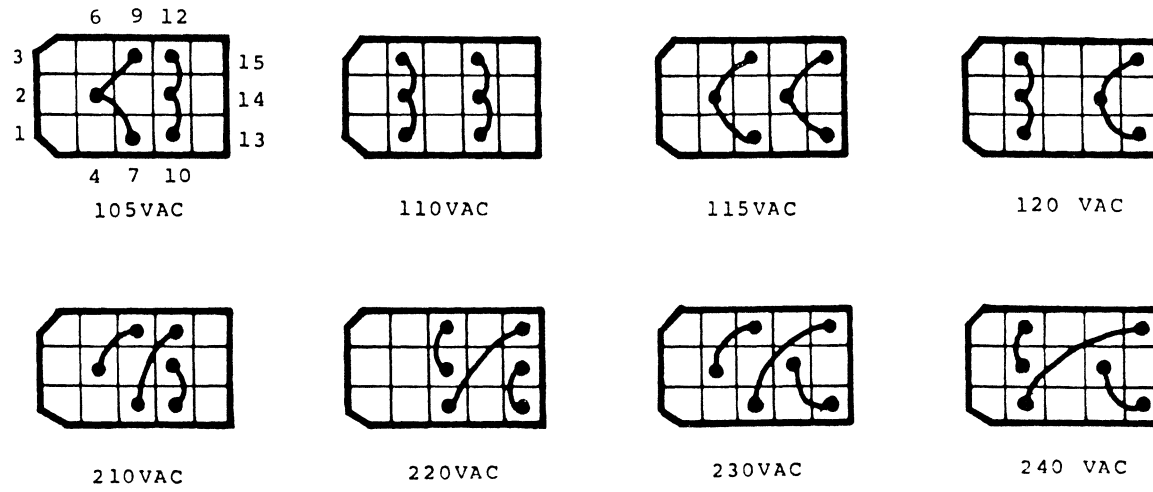

Rear of P27 Shown

Figure 5-2
Transformer Tap Wiring

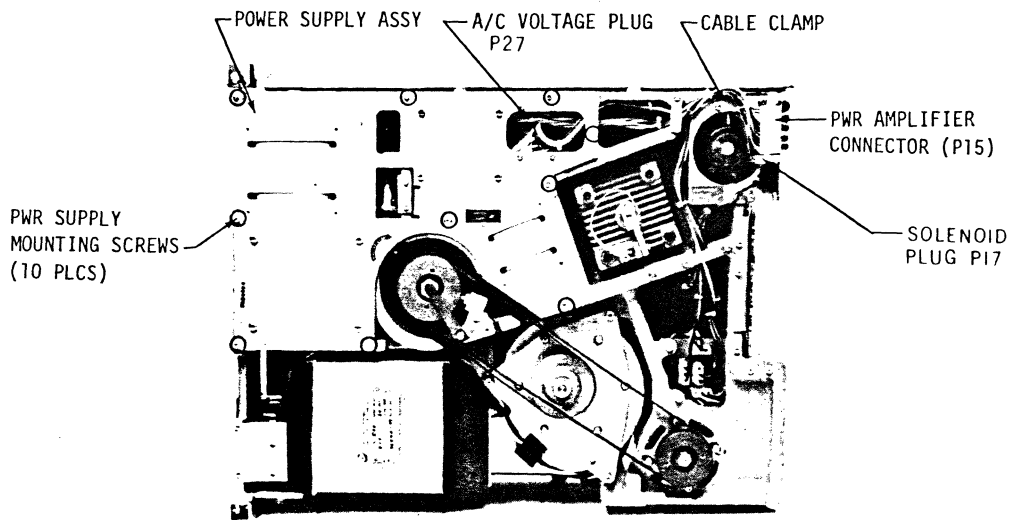

Figure 5-3
Power Supply

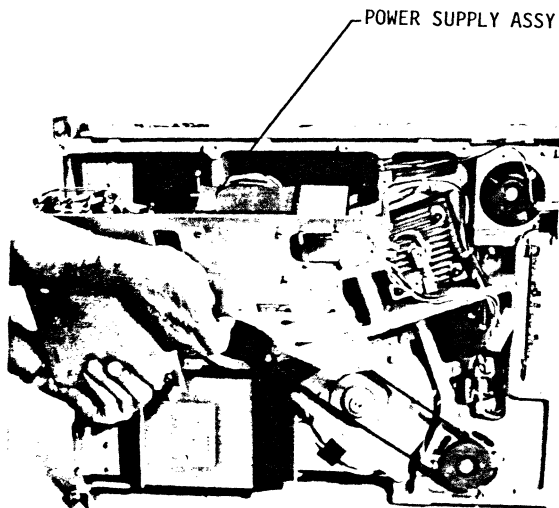

Figure 5-4
Power Supply Removal

5.4

POWER AMPLIFIER (SET $\pm 5V$.)

- a) Tools required: Voltmeter, potentiometer, screwdriver

On the power amplifier and regulator board on the right rear corner of the unit (Fig. 5-9) there are 2 potentiometers 1R30 and 1R35 (Fig. 5-5). 1R30 is an adjustment for the -5.2V, 1R35 for +5.0V. (-2V is set by a 3 terminal regulator I.C., +32V and -32V are unregulated.)

- b) To adjust -5.2V: Put the positive voltmeter lead on 3U48, pin 16 on the data board, the negative lead of the voltmeter on 3U48, pin 8 on the data board. (The reading will be positive voltage.) Set 1R30 so the voltmeter reads +5.2V $\pm 0.05V$. Turning 1R30 clockwise increases the voltage.
- c) To adjust +5.0V: Put the positive voltmeter lead on 2U69, pin 14 on the servo/logic board, negative lead on 2U69, pin 7. Adjust 1R35 so the voltmeter reads +5V $\pm 0.05V$. Turning 1R35 clockwise increases the voltage.

5.4.1 Power Amp Removal

- a) Tools required: #2 phillips screwdriver
Bondhus hex driver set
- b) Pull the drive forward to the slide stops.
- c) Remove the connectors (from bottom of drive) that connect to the power amplifier PCB assembly. Remove the connectors from the right hand side of the power amplifier PCB assembly.
- d) Remove the two socket head screws that mount the power amplifier assembly to the drive deck casting. See Fig. 5-6. The power amplifier assembly can now be removed from the drive.
- e) To re-install the power amplifier assembly follow reverse procedure as outlined above.

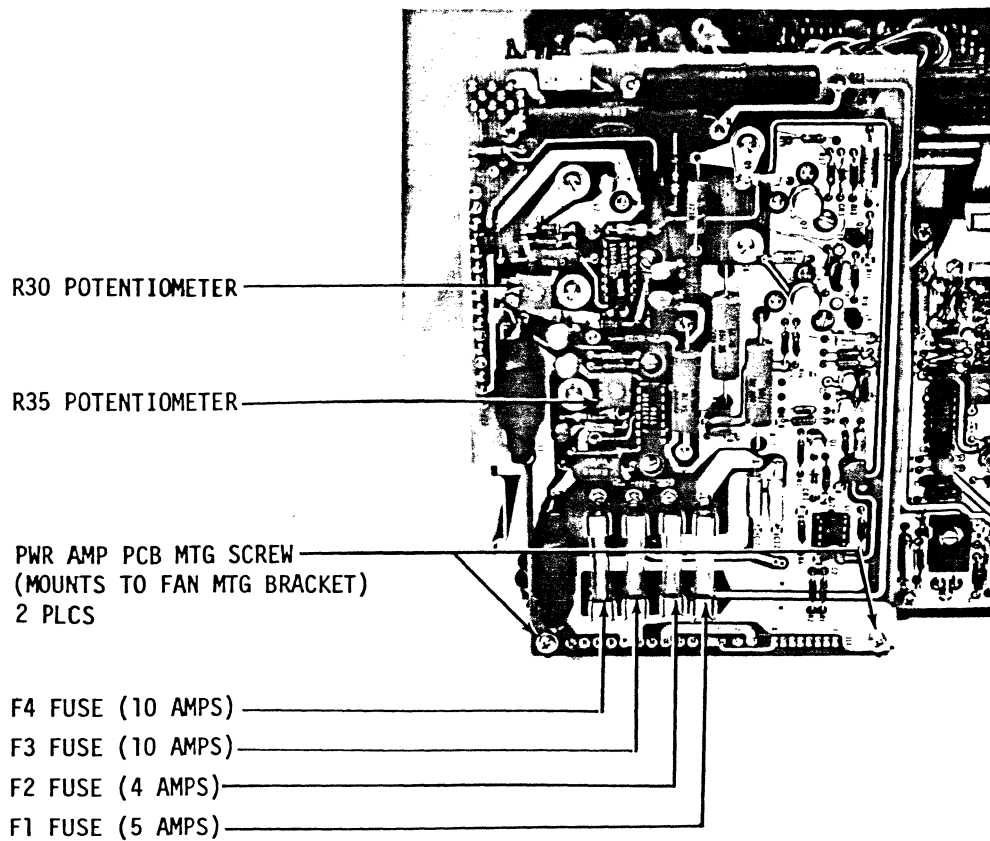

Figure 5-5
Power Amplifier Board

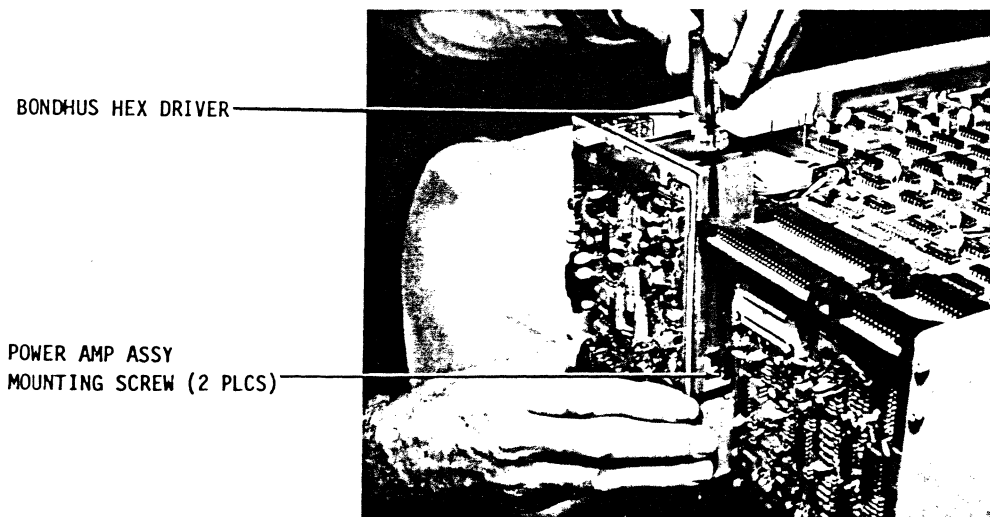

Figure 5-6
Power Amplifier Removal

5.4.2 Power Transistor Replacement

- a) Tools required: #1 phillips screwdriver
Bondhus hex driver set
Kimwipe tissue or equivalent
Silicone heat sink compound
- b) Remove power amplifier assembly from drive per sec. 5.4.1.
- c) To replace a power transistor (1Q8, 1Q9, 1Q12, 1U2) remove the two mounting screws from PCB side of the assembly which removes the defective transistor's mounting plate on the heat sink side of the assembly. See Fig. 5-7. With mounting plate and screws removed, remove the defective transistor.

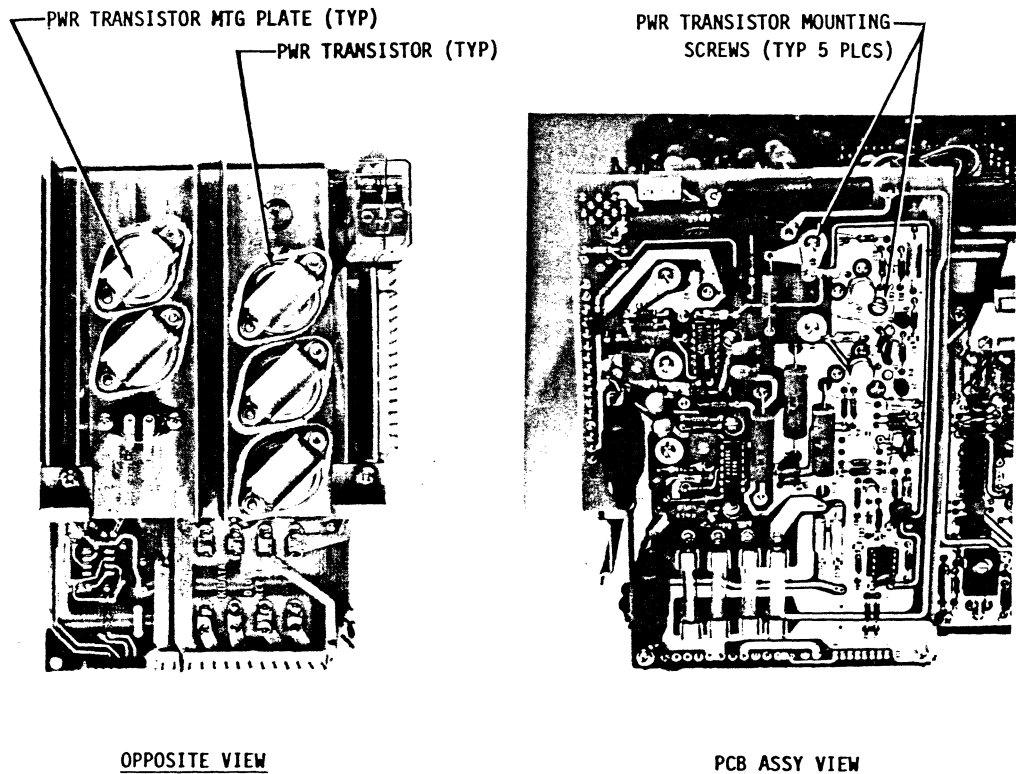

Figure 5-7
Power Transistors

Also remove the mica insulating washer and all silicone grease using the kimwipe tissues.

Install the new mica insulator (Thermalloy part no. 56-03-2AP) after coating both sides with silicone heat sink compound. Install the new transistor into

the sockets in the power amplifier PCB assembly.
NOTE: Make sure the leads on the transistor are straight and not bent. If the leads are not straight they will not line up with sockets in the PCB.

d) Re-install the mounting plate screws previously removed and mount the assembly to the drive deck casting per 5.4.1.

5.4.3 Pwr Amp PCB Removal (P/N 30105) (Fig. 5-8)

a) Tools required: #1 phillips screwdriver

b) Remove the two screws which mount the Pwr amp PCB to the fan mounting bracket. See Fig. 5-5. Disconnect all connectors from PCB.

c) Remove the five screws which are on top of the PCB which mount one end of each power transistor to the heat sink.

NOTE: DO NOT REMOVE OR LOOSEN THE SCREWS WHICH ARE LOCATED BELOW THE PCB AT EACH TRANSISTOR LOCATION.

d) Remove the PCB from heat sink.

e) Re-install in reverse order as noted above.

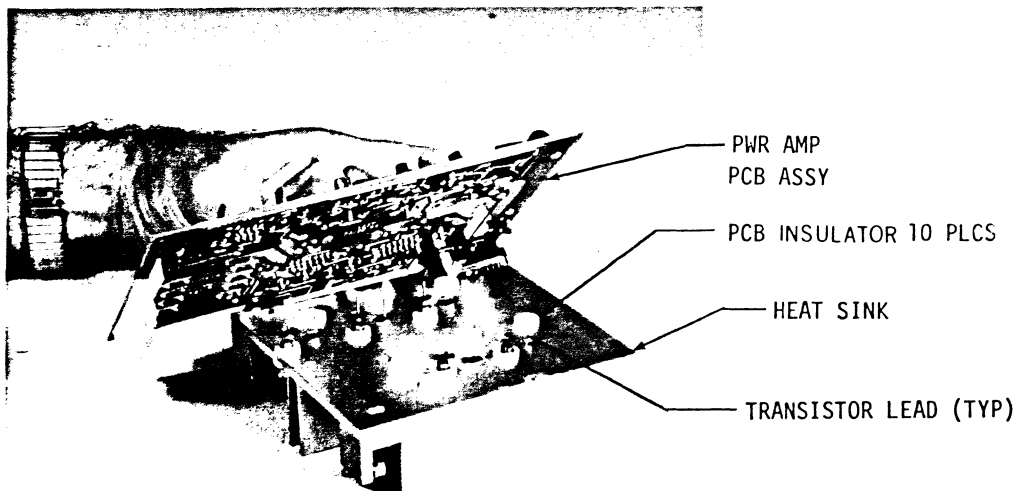

Figure 5-8
Power Amplifier Board Removal

5.5

PCB ASSEMBLY REMOVAL

- a) Tools required: #1 phillips screwdriver
#2 phillips screwdriver
- b) Pull the drive forward out of the cabinet to slide stops. Remove the top cover by removing the five top screws and the two screws on each side of the drive.
- c) With the top cover removed the mounting screws which mount the PCB assemblies are accessible for removal. If the drive has fixed head modules, the FHA PCB assembly is accessible from the right hand side of the drive. To remove the matrix PCB assembly access to the rear of the drive is necessary. This assembly is mounted with four screws.

Removal of the power amplifier PCB assembly is covered in Section 5.4.

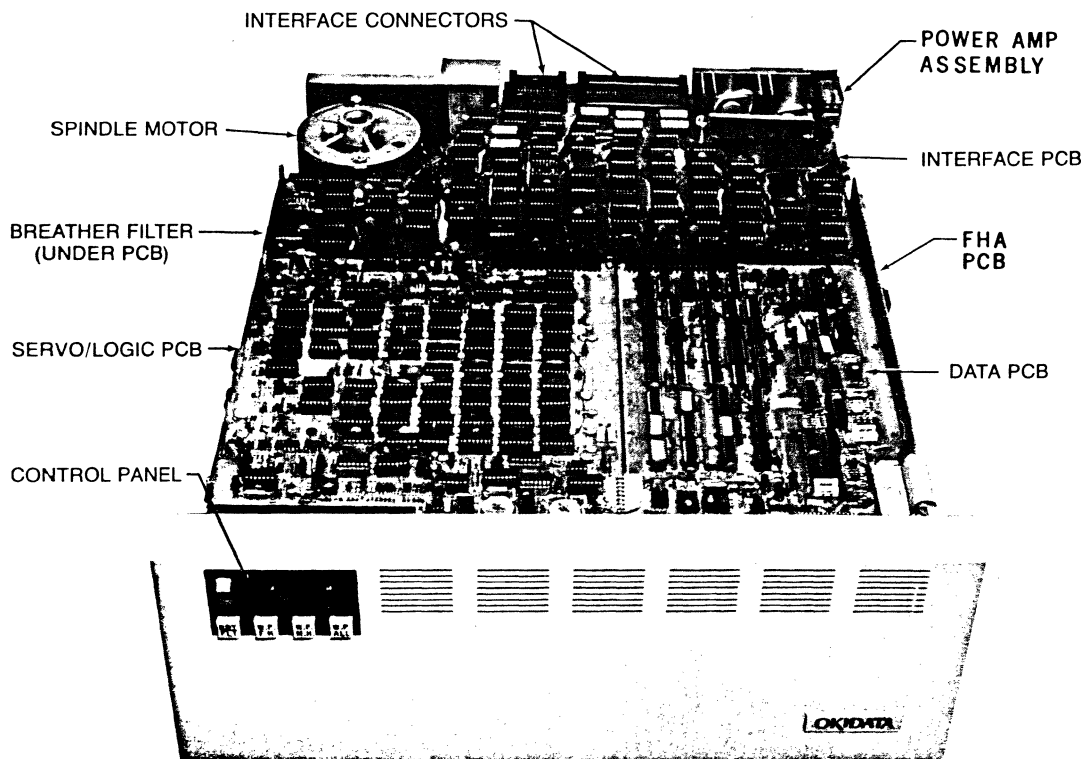

Figure 5-9
Printed Circuit Boards

5.6 SERVO ADJUSTMENTS (P/N 30103)

The servo logic board has six adjustment potentiometers. They are 1R1; Servo AGC, 1R76; Voltage Controlled Oscillator (Low Frequency) Limit, 3R132; Up to Speed, 2R157; Access Time, 4R170; Velocity Loop Gain, and 4R172; Servo Offset. The location of these potentiometers can be found on the assembly drawing in Section 6. 2R157, 4R170, 4R172 require that one can make seeks between tracks 0 and 339. One must take off the top cover to access the servo board (See 5.5.b).

CAUTION

Never attempt to remove 1P16 on the Power Amplifier board with power on. 1P16 drives the positioner motor and high peak currents can occur creating an arc and damage to 1P16, and possibly, the positioner.

5.6.1 R132; Up To Speed

This potentiometer adjusts monostable, 3U40, time-out, to check that the spindle assembly rotation is up to speed.

To adjust: Turn off drive, put oscilloscope probe on 3U40 pin 6. Unplug Position motor plug 1P16 from power amp board. Turn on drive, wait until unit is Up to Speed. Oscilloscope should be at +4VDC (TTL High). Turn 3R132 ccw until low going spikes just appear then turn 3R132 clockwise 1/8 turn. Turn drive off, take off oscilloscope probe. Plug 1P16 back in to power amplifier board.

5.6.2 1C7, 1R76; Phase Locked Loop

5.6.2.1 1C7 is a factory selected capacitor to set the maximum frequency of the voltage controlled oscillator (VCO). 1R76 sets the minimum frequency of the VCO (U8).

To adjust: Turn off drive. Put oscilloscope on 1U18 pin 4. Unplug 1P16 from power amplifier board. Use clip on jumper from 1U18 pin 14 to 1TP7. Turn on drive. After drive is up to speed, one should see high going pulses (TTL High) on scope. Trigger on rising edge. The time between rising edges should be 1.85 μ s to 1.92 μ s. This represents the highest VCO frequency. Adjust 1C7 to meet above timing. 1C7 should range from 0 to 10 pf (picofarads). The larger 1C7, the longer the time.

- 5.6.2.2 When the high limit is set correctly, take the jumper off of 1U18 p 4 and put it on 1U18 p 7 (and 1TP7). Trigger on rising edge and adjust potentiometer 1R76 so that rising edges are $2.84\mu\text{s}$ to $3.00\mu\text{s}$ apart. Turning 1R76 ccw increases the time. This is the low frequency limit.

These adjustments set up the VCO and the phase locked loop correctly. Turn off drive, remove jumper and oscilloscope probe. Plug 1P16 back into power amplifier board.

5.6.3 1R1; Servo AGC

1R1 sets the level of the automatic gain control (AGC) circuitry, hence the amplitude of the demodulated servo signal (SVDM) at 4TP21.

To adjust: Turn off drive. Unplug 1P16 from power amplifier board. Put oscilloscope probe on 4TP21, turn on drive. 4TP21 gives a signal that should vary from +8V to -8V. When drive is up to speed, find the position motor shipping clamp. See Fig. 5-1. The clamp will be used to move the head assembly. The arm should be full ccw, and will travel about 30 degrees clockwise. Note there is a magnetic detent holding the arm in its full ccw position. Pull the shipping clamp, hence the arm, off the magnetic detent. SVDM (TP21) will appear as a sine wave as the arm is moved across the servo tracks. If SVDM does not appear, calibrate the VCO (see 5.6.2). If still no signal, or 2-4 volt noise, replace servo board. At the extreme cw position 4TP21 will go to +9V, this is the guardband. Move the arm back and forth in the outside region (cw). 4TP21 should be $15\text{Vp-p} \pm 1/2\text{V}$. Now move the clamp (and arm) back and forth in the inside (ccw) region. 4TP21 should be about $17\text{Vp-p} \pm 1/2\text{V}$. I.e., the average value of SVDM should be 16Vp-p . Turning 1R1 clockwise increases the signal at 4TP21. This is a critical adjustment and one should check carefully the amplitude at 4TP21 both inside and outside if 1R1 is adjusted. This completes the AGC level setting.

Push the shipping clamp full ccw into the magnetic detent. Turn off drive and remove oscilloscope probe. Plug 1P16 back into Power Amplifier Board.

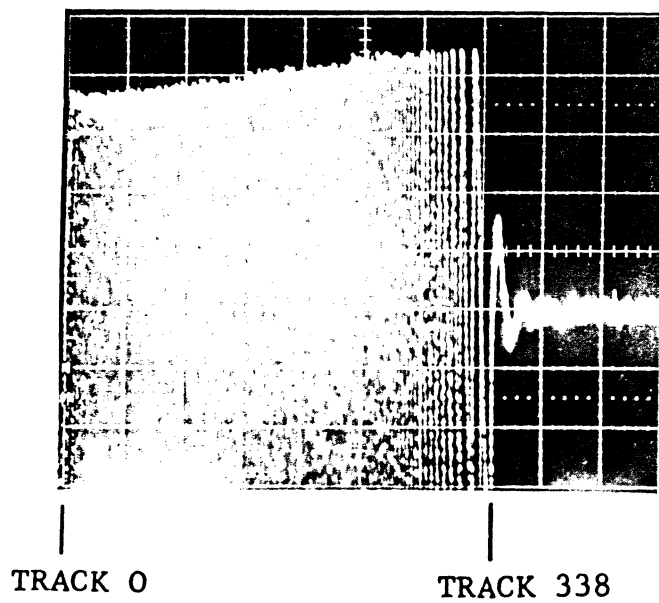
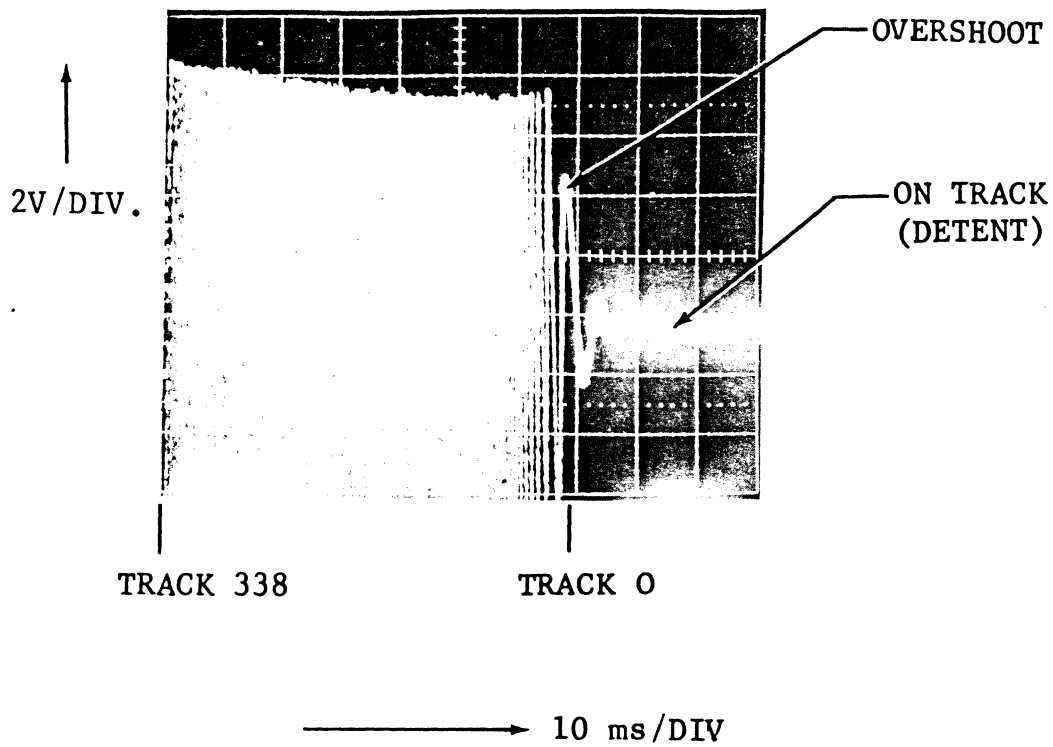

FIGURE 5-10
SERVO DEMODULATED SIGNAL (TP-21)

NOTE

The remaining three potentiometers (2R157, 4R170, 4R172) on the servo logic board affect the performance of the drive as it seeks between cylinders. These potentiometers should NOT be touched unless one can make the drive seek between cylinders 0 and 337. If the facilities are not available to seek between cylinders 0 and 337, and if it has been determined that the servo logic board is defective, replace the servo logic board but do not adjust these potentiometers.

5.6.4 4R172 Servo Offset

4R172 adjusts the voltage for which the system strives, in position (detent) mode, refer to 4.3.10.

To adjust: Seek between tracks 0 and 337. Put one oscilloscope probe on 4TP21 and another oscilloscope probe on TP1 on the interface board, Direction Trigger. Trigger on the rising edge of 2TP1 on the Interface board and view 4TP21. One will see, at a sweep rate of 10ms per square, a very fast sine wave for approximately seven squares. (SVDM during a seek), this will be followed by a signal that is near ground with about 1/2 volt of noise (Fig. 5-10). This second portion of the signal is SVDM during detent. Note its DC level. Trigger on the falling edge of 2TP1 (Interface board). Note the DC level of SVDM (4TP21) during detent. Adjust 4R172 so the levels of SVDM during detent are as near to equal and as near to ground as possible when triggered on both the rising and falling edges of 2TP1 on the Interface Board. This optimizes the servo offset potentiometer.

5.6.5 2R157 Access Time and 4R170 Velocity Loop Gain

2R157 supplies a reference voltage to the DAC (U70). This voltage controls the current that the DAC supplies to the main summing junction, controlling the maximum velocity thereby controlling the seek or access time.

4R170 controls the gain of the servo system. If the gain is too low, the servo system will not have enough signal to control the arm and head assembly. If the gain is too high, the system, the arm in particular, will break into oscillation.

2R157 and 4R170 interact as follows: as 2R157 sets faster access times, more acceleration and deceleration are needed to move faster. The gain of the servo system

needs to be higher to control this acceleration and deceleration. The optimum is to have fast access times with no oscillation.

To adjust: Turn on drive; seek between cylinders 0 and 337, after restore. Set up with one oscilloscope probe on 4TP21 and another on 2TP1 on the Interface board. Trigger on 2TP1 (Interface Board) on whichever of the rising or falling edge that shows 4TP21 to be decreasing in amplitude during the seek (See Fig. 5-10). There should be a small, less than 8 volt, positive bump on 4TP21 just before detent occurs. This bump is overshoot (Fig. 5-10A). Turn 2R157 clockwise to decrease access time so the maximum overshoot is 68ms after the seek starts. If while turning 2R157 clockwise the overshoot exceeds 7V turn 4R170 clockwise (more gain) until the overshoot is less than 4V. When maximum overshoot occurs 64ms after the seek starts, take the probe off of 4TP21 and put it on 3U48 pin 6 (SEEK COMPLETE). The falling edge is the start of seek, the rising edge is the end of seek. Turn 2R157 clockwise until SEEK COMPLETE is low for 70ms. Remove the probe from 3U48 pin 6 and put it back on 4TP21. Turn 4R170 until the maximum overshoot is 4.2V; make 4TP21 look like Fig. 5-10A. Reverse the trigger polarity, 4TP21 amplitude should increase during the seek, see Fig. 5-10B. Maximum overshoot should be about 2V \pm .4V. Take the probe off 4TP21, put it on 3U48 pin 6. Seek complete should be low for 70ms \pm 2ms.

This completes the adjustment for 2R157 and 4R170. Readjust 4R172 if necessary, per (5.6.4).

5.7 WRITE CURRENT

Write current is adjustable on both moving and fixed heads. There exists one potentiometer, 1R17, on the matrix board to adjust the write current of all moving heads and one potentiometer, 3R4, on the fixed head amplifier (FHA) board to adjust the write current for all fixed heads. These potentiometers are identical functionally.

See assembly drawings 30100 and 30104 in Section 6 for potentiometer and current loop locations.

Equipment required: a 60 MHz current probe, an oscilloscope and a controller or the means to write fixed data patterns on to the disc. The fixed data patterns are 01010101... and either all 0's or all 1's. Do NOT touch the write current potentiometers unless all the above equipment is available.

CAUTION

To adjust write current requires putting information on the disc. This operation will write over any data previously written on the disc. Do not perform the write current adjustments without making sure that no data will be overwritten and lost.

5.7.1 To Adjust Moving Head Write Current:

In the upper, right-center of the matrix board exists a twisted pair forming a current loop. Engage both wires into the current probe. Write an 010101... data pattern onto any existing moving head (select the moving head unit), that doesn't overwrite important data. (Any track (sector) on the disc will serve for this adjustment.) Observe waveform as shown in Fig. 5-11. If no signal exists check the troubleshooting guide. If a write protect switch is blocking this head, namely head 0, do not switch write protect off, rather find another permissible track, sector and moving head to perform this adjustment. Adjust R17 so the flat part of the signal, after the overshoot, is 76-80mAp-p. Turning R17 cw increases the write current. Write all 0's or all 1's, peak to peak current should not increase or decrease by more than 5mA. This completes moving head current adjust.

5.7.2 To Adjust Fixed Head Current:

Write an 010101... pattern. Any sector will serve for this adjustment. Put current probe on both wires of one of the six current loops at the rear of the board. Only one loop should have the signal. Try each loop to find signal. Observe signal as in Fig. 5-11.

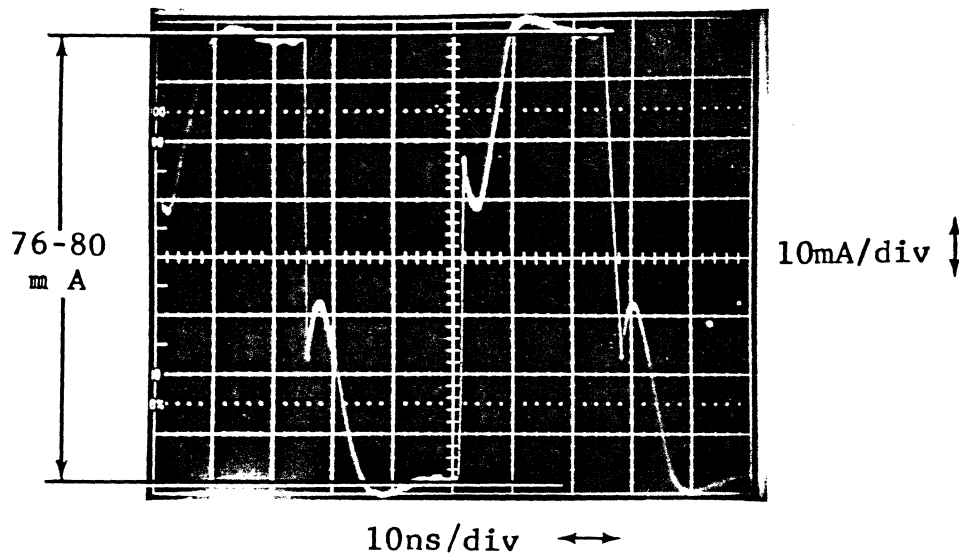

Figure 5-11
Write Current

If no signal exists on any loop, see troubleshooting section. Adjust R4 so the flat section (after the overshoot) is 76-80mA_{p-p}. Turning R4 cw increases current. Write all 1's or all 0's, peak to peak current should not increase or decrease by more than 5mA. This completes the fixed head current adjust.

5.8

DATA BOARD

The data board is adjustable only in the data recovery circuitry. The adjustments are: R34 threshold adjust (Note: adjust may be superseded by an optional automatic threshold circuit), 2 wired-in taps from DL2, the "erroneous zero crossing" adjust, 1 wired-in tap from DL3, Delayed Read Pulse (DLRDP) adjust, and 1 other wired-in tap from DL3, Delay Corrected Read Pulse (DLCORP).

Equipment required: A Tektronix 465 or equivalent oscilloscope, 2 identical 100MHz oscilloscope probes, 1 other oscilloscope probe, a scope hood, a small soldering iron to change taps, and a potentiometer adjustment tool, a controller, and a "jump" wire.

5.8.1 Threshold Adjust

Either 1R34 or 1U10 and 1U11 should be in the board. 1U10 and 1U11 comprise the automatic threshold control. The threshold control sets the level around which the analog read signal moves. This level is just before the clipping amplifiers (1U8) that make the analog read signal into the digital read signal, therefore the threshold level sets the symmetry of the read signal.

To Adjust: Put an oscilloscope probe on 1U12 pin 10, connect jumper from 1U52 pin 10 to 1U52 pin 7. The output levels at 1U12 pin 10 should be -0.9V (ECL High) and -1.8V (ECL low). At full cw on 1R34 the output will be high, and vice versa at full ccw. Near the center of 1R34's travel 1U12 pin 10 should have high frequency oscillation, adjust 1R34 for the maximum amplitude of the oscillation at 1U12 pin 10. Remove jumper from 1U52.

Write an all 1's or 0's pattern, then assert read with the controller. Look at 1U12 pin 10 during a preamble; trigger on read enable (3P11 pin 15 on the Interface board). Set delayed trigger on the rising edge of 1U12 pin 10, with variable sweep set consecutive rising edges on the extremes of the oscilloscope graticule (10 cm apart). The falling edge should be at 5cm \pm 0.1cm, see Fig. 5-12. Adjust 1R34 if necessary. Adjustment of 1R34 should not require more than 1/8 turn from the setting of 1R34 done in the paragraph above; repeat earlier paragraph above if necessary.

5.8.2 Erroneous Zero Crossing (set taps)

These two taps on 1DL2 form a pulse to clock the read data into a flip flop, to eliminate spurious data from detected due to "snaking" effects. See 4.4.6 for a more detailed explanation of this circuit and its function. The hood will be necessary on the oscilloscope.

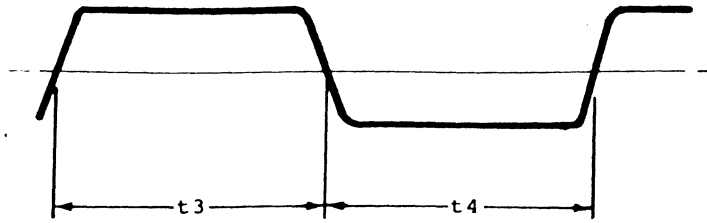

Adjust $t3 = t4 \pm 2ns.$

Figure 5-12
Threshold Adjust

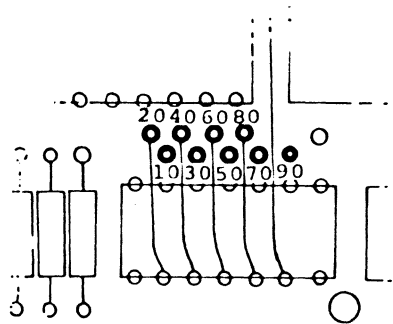

Figure 5-13
Erroneous Zero Crossing Taps

To Adjust: 2 taps are necessary. The first tap should go from "A" to 60 (see Fig. 5-13), the second from "B" to 70. It does not matter if the first goes to "B" and the second tap to "A". Put a probe on U12 p 11 and the other (identical) probe on U12 pin 10. One should see a pulse on pin 11 (10ns wide) that occurs at 65ns with taps at 60 and 70. This pulse is to be in the middle of two transitions at the highest read frequency 7.33 megabits/sec (136 ns is the time between transitions).

5.8.3 DL3, Delayed Read Pulse (DLRDP) (Set Tap)

This tap controls the pulse time of the flip/flop formed by U32. This pulse is used for the reference signal for the data phase locked loop. This tap goes from "C" in Figure 5-14 to a numbered terminal.

NOTE: This tap must be connected to some numbered terminal for the phase-locked loop to work at all. If this tap is missing the drive will neither write nor read.

To Adjust: Put oscilloscope probe on 3U32 pin 14. Assert read with controller. Using the delayed time base look at a section of the preamble where a 3.66MHz pattern will occur. The hood will be necessary for this adjustment. Move tap to make U32 pin 14 symmetrical (equal pulse widths high, and low). Moving a tap to a higher number increases the time 3U32 pin 14 is high (-0.9V). This completes the adjustment of DLDRP.

5.8.4 Delay Corrected Read Pulse (DLCORP) (Set Tap)

This tap controls the timing of the MFM to NRZ decoder circuitry. This tap goes from "D" in Figure 5-14 to a numbered terminal. The hood, and all three probes are necessary for this adjustment.

To Adjust: Use the two identical oscilloscope probes; put one on 3U48 pin 11, the other on 3U48 pin 10. Assert read with controller. Trigger on read enable J11 pin 15 (Interface board). Look in a preamble where a 3.66MHz pattern will occur. Delay from the assertion of read enable at least 10µs for the phase locked loop to settle. See Figure 5-15. Move the tap until the rising edge of the signal on pin 11 is in the middle of the signal on pin 10's high or low level period. Higher numbers (see Fig 5-14) move pin 11

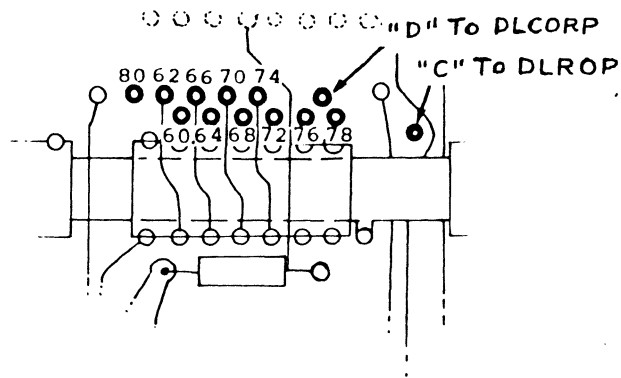

Figure 5-14
 Delayed Read Pulse Tap
 Delay Corrected Read Pulse Tap

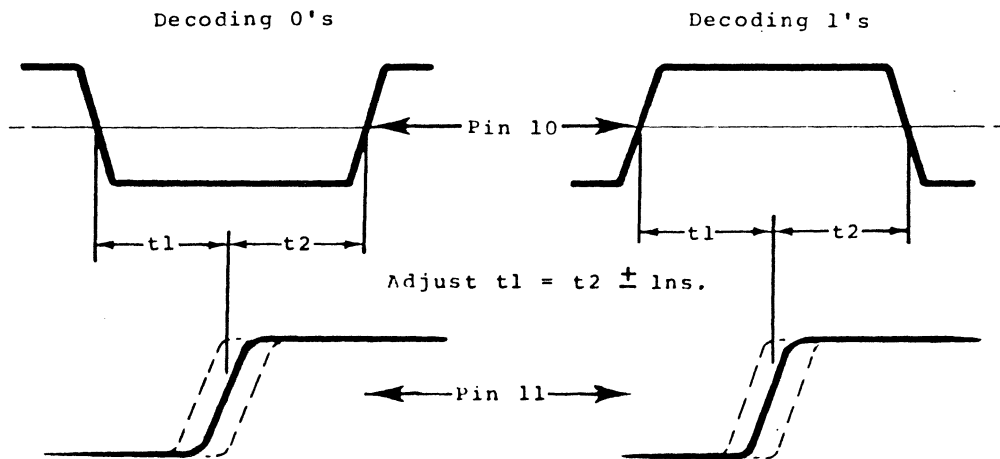

Figure 5-15
 Delay Corrected Read Pulse

to the right. DLCORP and DLDRP may share the same numbered terminal. There may be jitter on pin 11. Adjust the average time to be as shown in Fig. 5-15. If DLCORP is not optimized, sporadic read errors will result. This ends the DLCORP adjustment.

This is the end of Data Board adjustments.

5.9 INTERFACE BOARD (OPTIONAL) P/N 30115

The interface board has no adjustments. However it contains two plug-in headers that affect (1) the unit number of both the moving and fixed head and (2) the number of sectors.

5.9.1 Unit Select Logic Plug (2U51)

This plug is used to select the unit number address of the moving head and fixed head sections of the drive. The moving head and fixed heads are treated as separate units. If both units (fixed and moving) have the same unit address, a fault condition occurs.

The header at 2U51 can be changed, or replaced, so that moving head and/or fixed head sections of the drive respond to a new unit address. If there are thumbwheel switches on the front panel to change the unit numbers, there is no need to change U51 (see Fig. 5-16). The fixed and moving head unit addresses are specified via two 4-bit numbers, pin 12 is the 8's pin to select the fixed head unit number, pin 11 is the 4's pin for fixed heads, etc. These pins are active low; i.e., unit addresses are expressed in one's complement form. For example, if fixed heads are to be unit eleven ($8+2+1$), then pins 12, 10 and 9 are grounded and a pull up resistor is connected to pin 11 (Fig. 5-17). If moving heads are to be unit 4, then pin 15 is grounded, and pins 16, 14, 13 are connected to pull-ups (Fig. 5-17). If moving heads are to be unit 0, then pins 16, 15, 14, 13 are connected to pull-up(s).

5.9.2 The Sector Logic Plug (3U43)

This plug selects the number of 16 bit words per sector and therefore the number of sectors. Reformatting a disc by changing the number of sectors in the field should be a very rare occurrence. This section indicates how sector headers are made.

The numbered pins are active high (see Fig. 5-18). Where the words per sector is specified in normal form the following formula is used to determine the words/sector number:

$$\text{COUNT NO} = \frac{\left(\frac{\# \text{bytes}/2}{\text{track}}\right) - \left(\frac{\text{index}}{\text{overhead}}\right) - \left[\left(\frac{\text{number of}}{\text{sectors}}\right) \times \left(\frac{\text{sector}}{\text{overhead}}\right)]}{\text{number of sectors}}$$

#bytes/2 = words (16 bits)

number of sectors = #S (determined by customer)

$\frac{\# \text{bytes}}{\text{track}} = 18560$ sector overhead = 2 word

index overhead = 2 words

The overhead parameters result from counters being reset and not counting during index and sector times. Filling in the numbers into the words/sector formula yields:

$$\frac{\frac{18560}{2} - 2 - \#S(x2)}{\#S} \quad \text{which reduced is } \frac{9278}{\#S} - 2 = \text{count \#}$$

In example, if one wants 64 sectors, then

$$\frac{9278}{64} - 2 = 144.96 - 2 = 142.96$$

NOTE: The fraction is always dropped. 142.96 = > 142. The decimal number 142 is represented as: 128 + 8 + 4 + 2. See Fig. 5-19. Pins 8(2), 9(4), 10(8) and 13 (128) are connected to the PLUP (pull up) pins (6 & 14). All other pins are connected to the ground pins (3 & 11). The resulting header is illustrated in Fig.5-19.

For some sector numbers the connections for plup and ground must cross, verify that shorts do not exist. This concludes the sector header section and describes the changes that can be made to the I/O board.

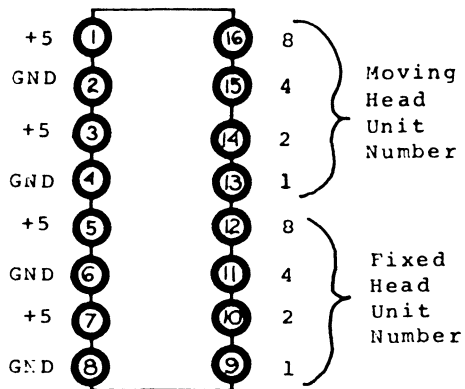

Unit Address Plug
Figure 5-16

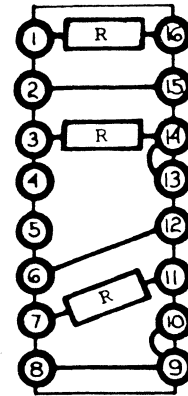

R is 1K Pullup Resistor

Unit Address Plug Connections
Figure 5-17

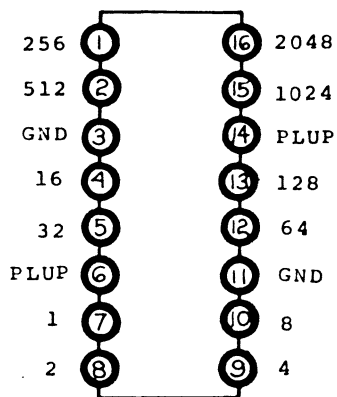

Figure 5-18
Sector Plug

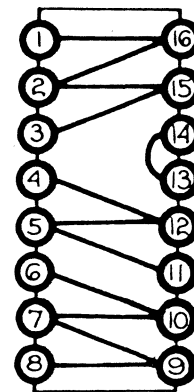

Figure 5-19
Sector Plug (Example)

5.10

CLEAN AIR FILTERS & BLOWER ASSEMBLY

The drive clean air filters comprise a main filter and a make up air breather filter. Figure 5-1 shows the location of the main air filter and the blower assy. The breather filter is mounted on the rear left hand side of the drive (see Fig. 5-20).

The breather filter has a pre-filter which should be checked for dirt buildup periodically depending on the operating environment. A dirty pre-filter should be replaced, and when the filter element is removed, the breather element should be inspected for dirt buildup, and also be replaced if necessary.

5.11

BREATHER FILTER & PRE-FILTER REPLACEMENT

a) Tools required: #2 phillips screwdriver

b) Pull drive forward out of cabinet to slide stops. Remove top cover by removing three screws from each side of drive.

NOTE: To replace pre-filter it is not necessary to remove top cover.

c) To replace pre-filter element remove old element and replace with new element. This part is removed with fingers and requires no tools, as shown in Fig. 5-20.

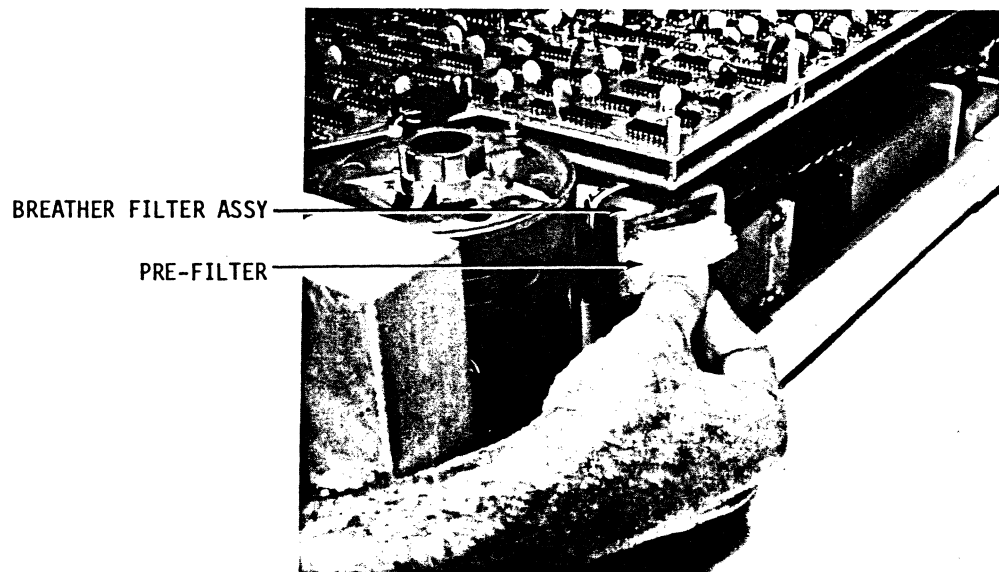

Figure 5-20
Replacing the pre-Filter Breather

d) To replace the pre-filter assembly remove the four filter mounting screws, remove filter and replace with new filter.

NOTE: The breather filter should not be left off the machine for extended periods of time. Remove only when replacement filter is available.

e) Re-install top cover.

5.12

BLOWER SPINDLE REPLACEMENT

NOTE: The blower spindle should not be replaced in an extremely dirty environment, an office cleanliness environment is required.

- a) Tools required: #2 phillips screwdriver
Bondhus hex driver set
RTV 162 silicone rubber
hypodermic syringe
- b) Remove drive from cabinet and position vertically on left hand side of drive as shown in Fig. 5-1.
- c) Remove spindle and blower drive belts per sec. 5.1.6.1.
- d) Remove the three blower assy mounting screws and the six screws which mounts the blower spindle to the blower scroll as shown in Fig. 5-21.

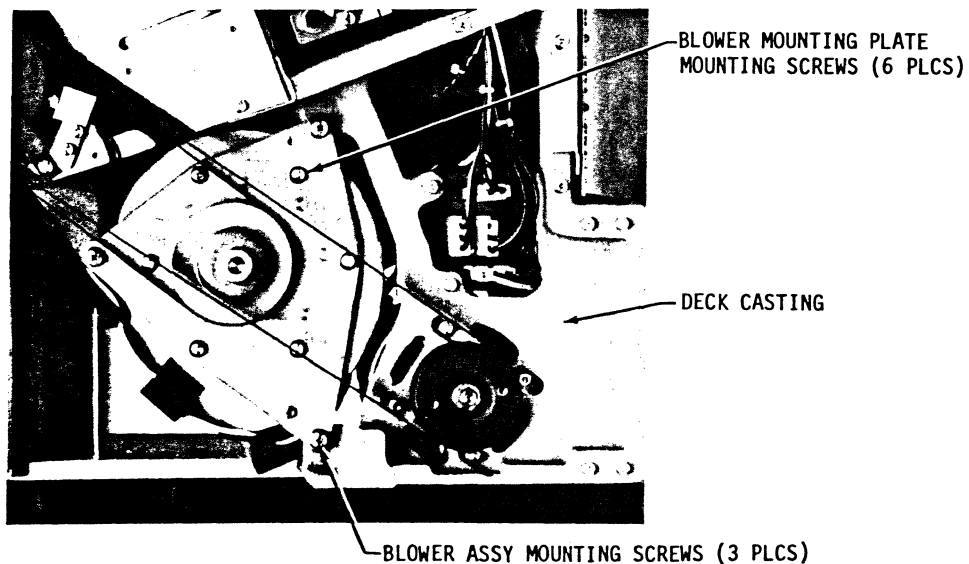
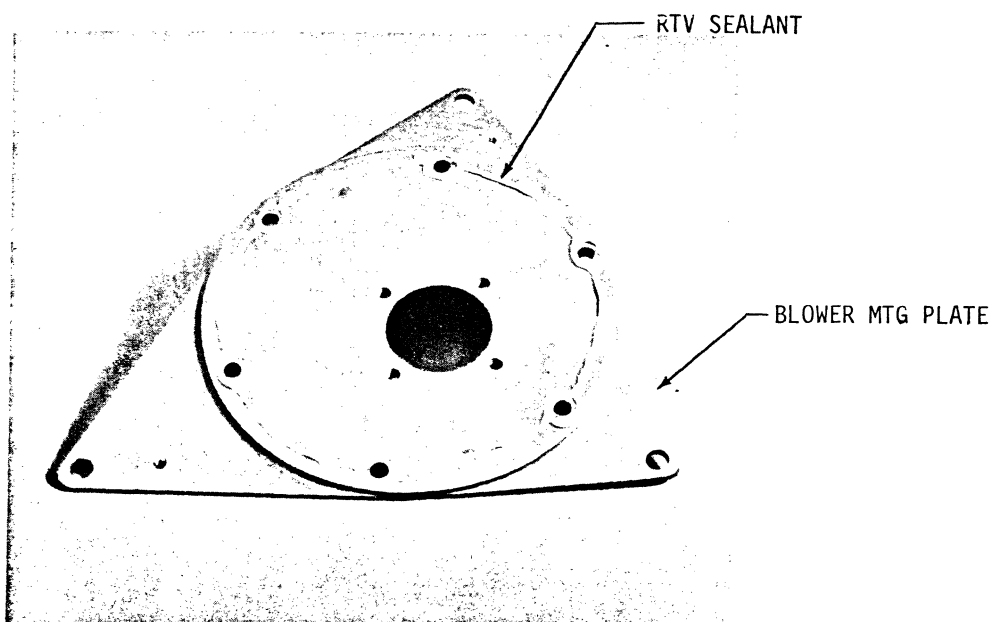

Figure 5-21
Blower Assembly

NOTE: The blower mtg plate is sealed with RTV 162 silicone rubber under the six screws and will require pressure to separate the plate from the blower scroll. Separation is accomplished by lifting upward on the plate at the three corners where the plate attaches to the deck casting. After separation the plate assembly with the blower spindle can be removed. The plate after removal is shown in Fig. 5-22.



NOTE: SPINDLE OMITTED FOR CLARITY

Figure 5-22
Blower Mounting Plate

- e) With assembly removed from the drive, remove the blower pulley and the blower wheel with the appropriate Bondhus hex drivers. Remove the four screws which mounts the blower spindle to the mounting plate. The spindle assembly can now be removed from the mounting plate.

- f) Clean all excess silicone rubber from the blower mounting plate. NOTE: Do not allow loose silicone rubber particles to fall or remain in blower scroll. Apply masking tape over scroll opening to prevent contaminants from entering while replacing blower spindle.
- g) Install new blower spindle to plate using the four screws previously removed. Re-install blower wheel and blower pulley and position to dimensions shown in Fig. 5-23.

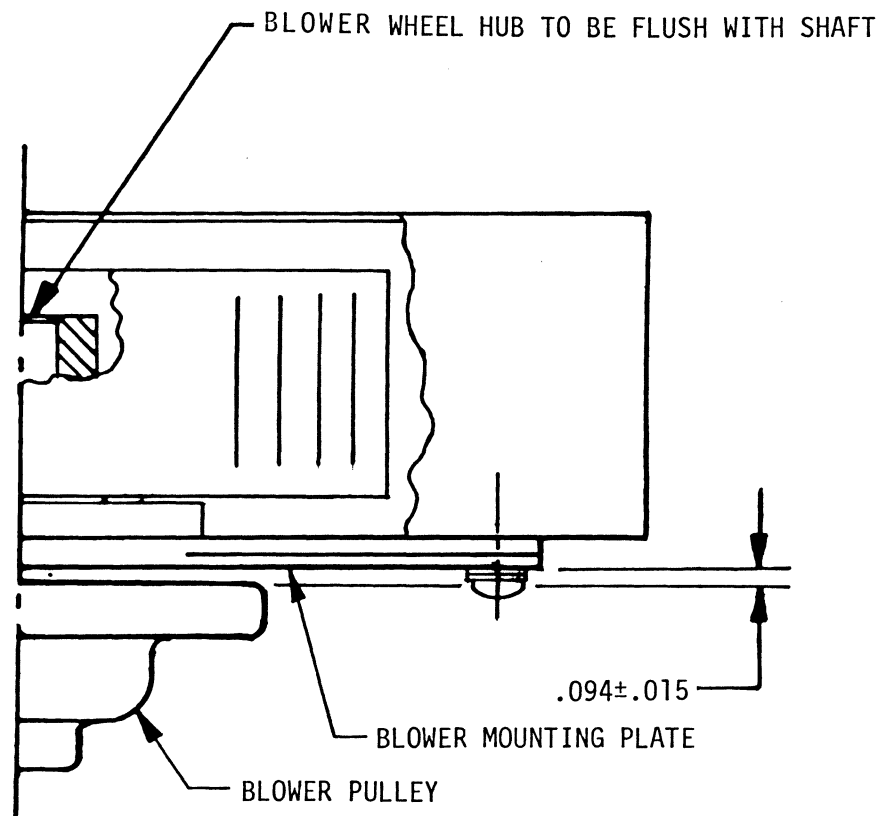

Figure 5-23
Blower Fan and Pulley Spacing

- h) Remove masking tape from scroll and apply bead of RTV 162 silicone rubber around the six screw mounting holes and inside perimeter as shown in Fig. 5-22 . Apply silicone rubber using the hypodermic syringe.

- i) Install mounting plate assembly to scroll using the six screws initially removed. Re-install the three screws which mount the plate assembly to the drive deck casting.
- j) Re-install blower and drive belts.
- k) Install drive into cabinet.

5.13 BRAKE ASSEMBLY

To adjust or replace the brake band the drive must be removed from the cabinet and be positioned vertically on the left hand side of the drive as shown in Fig. 5-13.

5.13.1 Brake Band Adjustment

- a) Tools required: Two 5/16 open end wrenches
- b) With end wrenches loosen nuts on solenoid shaft through opening in power supply mounting plate as shown in Fig. 5-24.

NOTE

Be careful not to rotate solenoid shaft excessively or damage to the metal band will occur.

- c) To decrease disc stopping time move hex nut nearest spring in direction which compresses spring. Move other nut down against nut moved and tighten using the two 5/16 open end wrenches.
- d) Power up and down and check disc stopping time. Disc stopping time from brake on is not to exceed 6 seconds. Repeat above procedure till above specification is met.
- e) Re-install drive in cabinet.

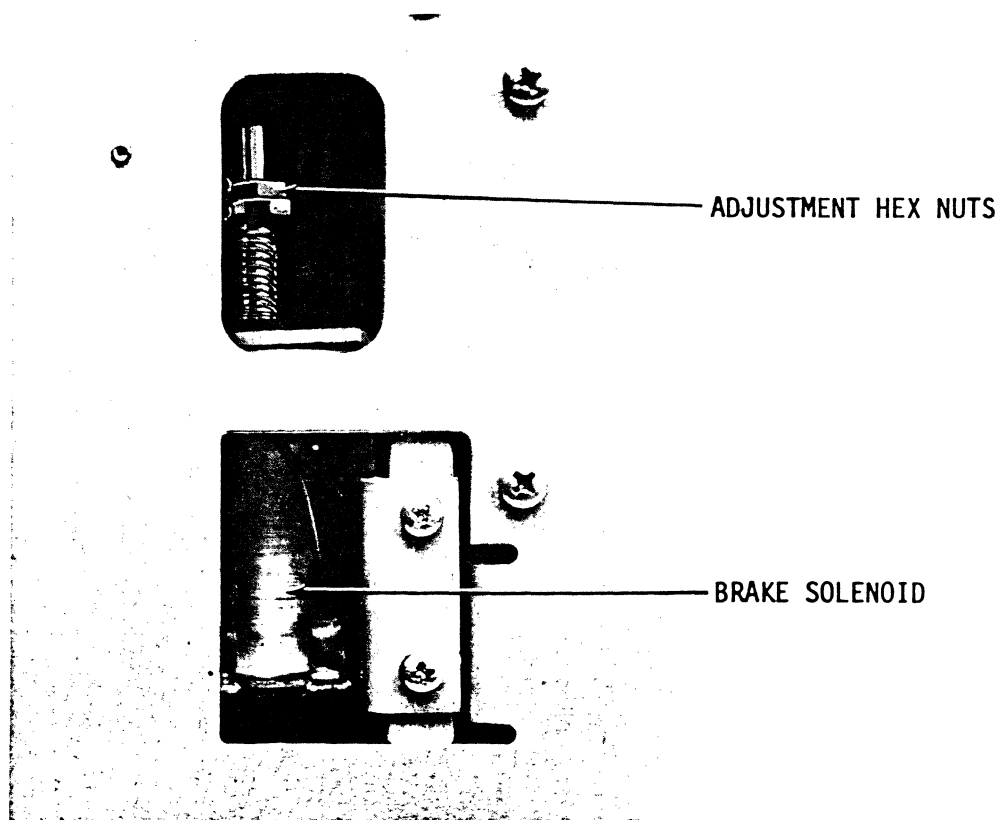

Figure 5-24
Brake Adjustment

5.13.2 Brake Band Replacement

- a) Tools required: #1 & #2 phillips screwdrivers
1/4 inch spintite
3/8 drive hex
Socket & ratchet set (Bonney
No. B-B0308 or equivalent)
Needle nose pliers
- b) Remove power supply assembly per sec 5.3.2.
- c) Remove spindle and blower belts per sec 5.16.
- d) Remove index transducer assembly and spindle
ground by removing three screws as shown
in Fig. 5-25.

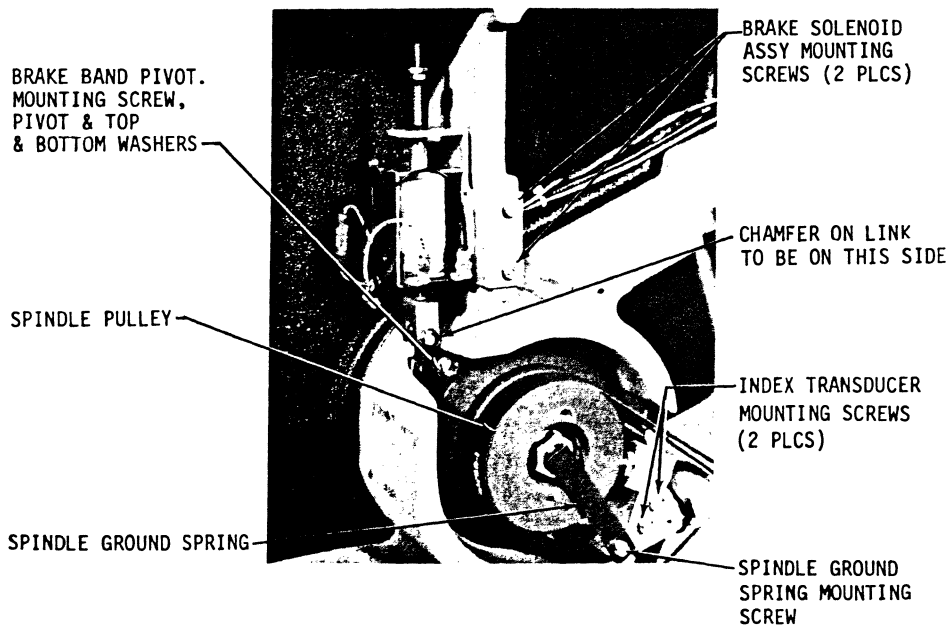

Figure 5-25
Spindle Brake Assembly

- e) Remove brake band pivot screw, top and bottom pivot washers and brake band pivot. See Fig. 5-25.
- f) Remove the brake assembly by removing the two mounting screws shown in Fig. 5-25.

NOTE

Electrical connections to solenoid and solenoid switches do not have to be disconnected unless brake assembly is totally removed from the drive.

With needle nose pliers remove one retaining ring from the link shaft and slide shaft out of link. The brake band is now removed by sliding the band carefully over the spindle pulley.

NOTE

Do not allow spindle to rotate counter-clockwise during this operation.

- g) Before installing new brake band check situation of solenoid switches. Switches should actuate $.06 \pm .02$ from solenoid plunger stop when solenoid is moved in forward direction (against compressor spring). If switches do not operate as outlined above, then loosen switch mounting nuts and adjust switches till the above requirements are met.

- h) Place new brake band in link and replace link shaft. Install new retaining ring.

NOTE

Clean deck casting cavity where brake band seats prior to installing brake assembly.

Place brake assembly in drive and mount with the two mounting screws that were previously removed. Set solenoid mounting bracket in center of slotted holes.

NOTE

Make sure chamfer on brake band link is oriented as shown in Fig. 5-25.

- i) Install brake band pivot, top and bottom washers and retaining screw.
- j) With assembly installed push on end of solenoid shaft and verify that brake band conforms to the machined dia of the deck casting. It is especially important that the brake band conforms to the deck casting at the brake band pivot area.

Solenoid switches should actuate before the brake band seats in the aforementioned machine dia of the deck casting. Re-adjust the solenoid mounting bracket fore or aft till the above requirement is met.

- k) Re-install drive belts.
- l) Re-install power supply per sec. 5.10.
- m) Re-install index transducer and spindle ground spring and adjust transducer gap per sec 5.1.7.
- n) Check stop time adjustment per 5.13.1.
- o) Install drive into cabinet.

5.14

POSITIONER MOTOR REPLACEMENT

NOTE: This operation should not be attempted in the field unless it is done by properly trained personnel.

To replace the positioner motor the drive must have the shipping stands installed and the drive orientated as shown in Fig.5-26 . With power off, remove the positioner power connector (P-16). Power on the drive and, using the positioner shipping clamp, rotate positioner ccw to its stop. Then remove power to drive. This will eliminate possibility of moving positioner when removing motor rotor nut.

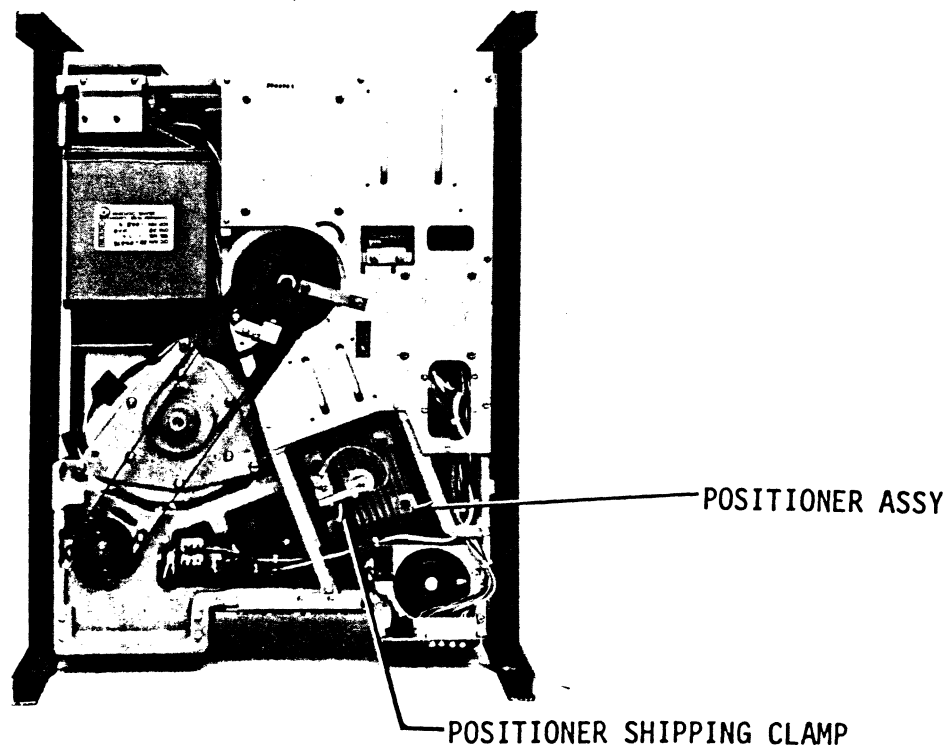

Figure 5-26
Positioner Removal (Machine Orientation)

NOTE: DO NOT MOVE POSITIONER SHAFT AT ANY TIME DURING POSITIONER MOTOR REPLACEMENT.

5.14.1 Positioner Motor Replacement

- a) Tools required: #2 phillips screwdriver
Bondhus hex driver set
No. 2 external retaining ring
pliers (Milbar or equal)
3/8 drive hex socket ratchet
set (Bonney No. B-80308 or equal)
Large pliers
2 jaw puller (Williams No. GP-240
or equal)
Torque wrench (Williams BTW-1RC
or equal)
271 Loctite retaining compound
Cotton-tipped swabs
100% isopropyl alcohol
Lubriplate grease
- b) Remove positioner shipping arm, shipping
bracket & ground strap by removing those
screws noted in Fig.5-27.
- c) Remove four 1/4-20 bolts which holds the
lower end bell. Remove the retaining ring from
the shaft along with the shaft spacers as shown
in Fig. 5-28.

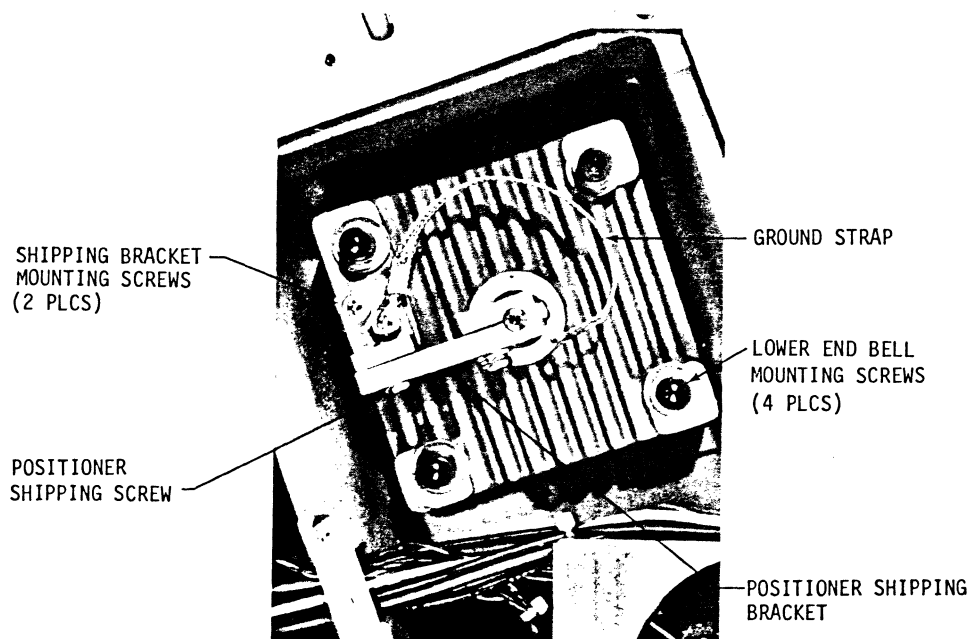

Figure 5-27
Positioner Motor Assembly

d) Place puller onto lower end bell as shown in Fig. 5-29.

NOTE: Make sure that puller is centered and parallel to positioner shaft. Also, apply small amount of lubriplate grease in positioner shaft center prior to mounting puller to lower end bell so that positioner shaft will not rotate.

e) With appropriate socket and ratchet wrench jack lower end bell from positioner shaft and set aside. A sharp breakaway will occur due to the lower bearing locktite giving way. At this point note location of marks on positioner motor rotor and stator. This orientation must be maintained when new positioner motor has been installed. Mark these locations on visible portion of upper end bell with marking pen.

f) Remove 5/16-24 nut which retains the positioner motor rotor with appropriate socket and ratchet wrench. Remove lock washer and positioner motor washer.

With large pliers grasp positioner motor rotor, and remove both positioner rotor and stator together from positioner shaft. NOTE: DO NOT REMOVE POSITIONER MOTOR ROTOR FROM STATOR!

g) Clean positioner shaft using Kimwipe tissues which have been saturated with 100% isopropyl alcohol.

NOTE: DO NOT ROTATE POSITIONER SHAFT AT ANY TIME

h) From lower end bell remove bearing and discard. NOTE: DO NOT USE BRG WHICH WAS REMOVED WITH END BELL. Make sure that Belleville springs do not fall out of lwr end bell when removing bearing. Belleville springs are to be stacked as shown in Fig. 5-30.

i) Install new positioner shaft bearing in end bell. Clean bearing I.D. using cotton swab saturated with alcohol.

NOTE: DO NOT ALLOW ALCOHOL TO ENTER SHIELD IN THE BEARING.

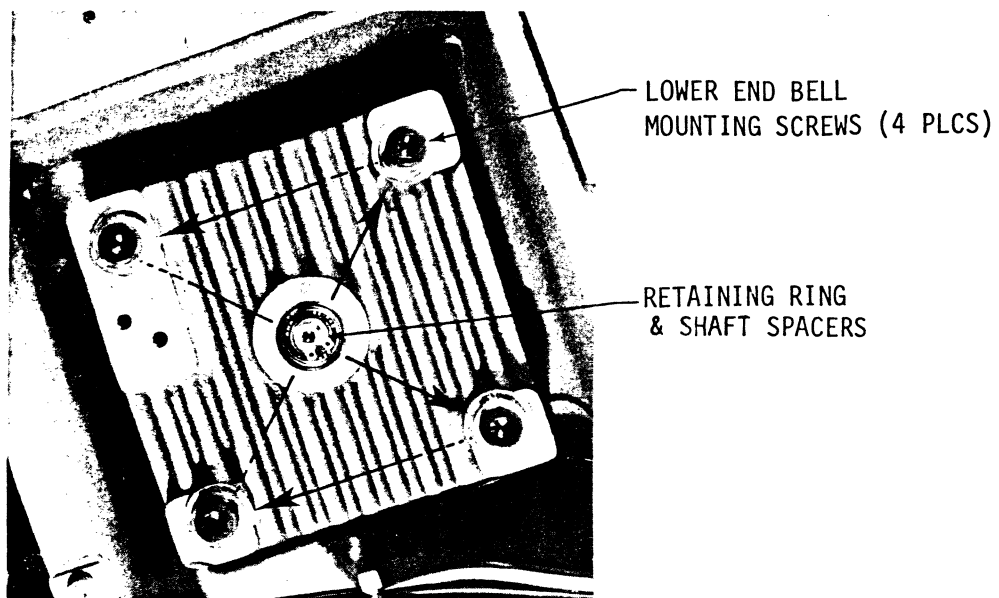

Figure 5-28
Positioner Motor (Retaining Ring)

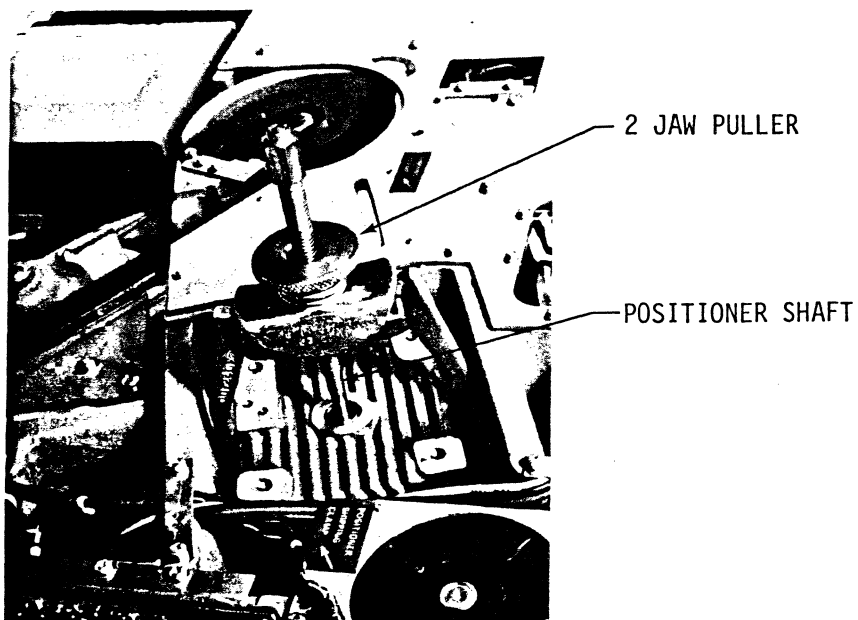

Figure 5-29
Pulling the Lower End Bell

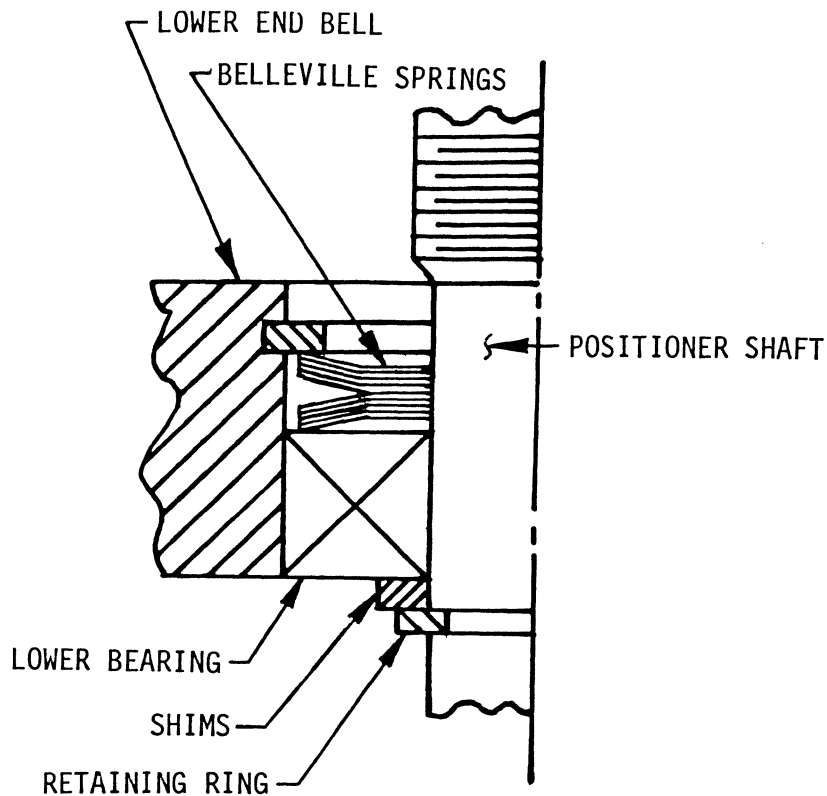

Figure 5-30
Bellville Washer Location

- j) Remove remaining locktite compound from positioner shaft by using .062 thick plastic mtrl. Move plastic mtrl in movements parallel to shaft.

Clean positioner shaft with Kimwipe tissues saturated with alcohol.

NOTE

Do not attempt to scrape locktite material from shaft with any metal object or damage will be done to the shaft.

- k) Install new positioner motor to positioner shaft making sure that marks on motor rotor and stator line up with the marks made previously during motor removal. **NOTE: DO NOT ALLOW MOTOR ROTOR TO EVER BE SEPARATED FROM STATOR! SEPARATION WILL CAUSE DE-MAGNETIZATION OF MOTOR.** Orient marks on rotor and stator as noted in 5.4.1(e).

Re-install positioner motor washer, lock washer and nut. Re-orient drive so that it is upside down. When nut is torqued to 10 ft-lb the shaft will rotate cw until the positioner arm inside the enclosure moves to the magnetic detent position. The shaft should be left in this position for the remainder of this operation. (This is the only time the shaft will rotate.)

- 1) Install lower end bell to positioner shaft making sure bearing does not come out of end bell during installation.

NOTE: Make sure lower end bell is oriented in proper direction as shown in Fig.5-27.

Install 1/4-20 bolts and progressively tighten in sequence shown in Fig. 5-28.

Torque bolts to 60 lb-in.

- m) Add thick (.030) shim washers until retaining ring fails to engage shaft groove while compressing springs under bearing. Remove that shim which prevented retaining ring from engaging shaft groove and replace with thin shim (.010). If retaining ring still fails to engage groove then remove thin shim and snap retaining ring into groove.
- n) Remove retaining ring and shims and the four 1/4-20 bolts and remove lower end bell.
- o) Clean bearing I.D. and shaft where bearing is located with cotton swab immersed in alcohol. Do not allow alcohol to enter bearing.
- p) Apply thin coat of no. 271 Loctite retaining compound to positioner shaft, where bearing mounts, and to I.D. of bearing in lower end bell. Use wooden end of swab to apply compound.

NOTE: DO NOT ALLOW ANY LOCKTITE COMPOUND TO ENTER BEARING!

- q) Install lower end bell to positioner shaft making sure bearing does not come out of end bell during installation.

NOTE: Make sure lower end bell is oriented in proper direction as shown in Fig. 5-27.

Install 1/4-20 bolts and progressively tighten in sequence shown in Fig. 5-28.

Torque bolts to 60 lb-in.

- r) Re-install bearing shims selected per step (m) and install new retaining ring into shaft groove.
- s) Re-install positioner shipping arm, shipping bracket and ground strap previously removed. Set positioner shipping arm .040 from shipping bracket using .040 plastic shim material as shown in Fig. 5-32.

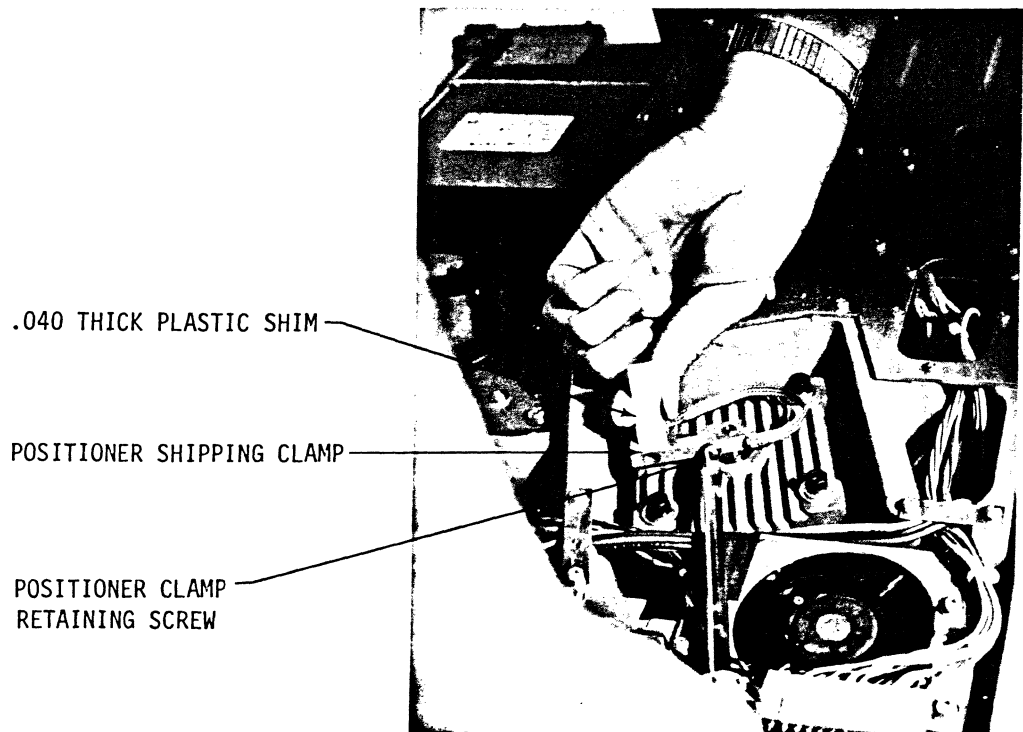

Figure 5-31
Shimming Shipping Clamp Arm

- t) With positioner motor connector (P16) removed, turn on power and rotate shipping arm while checking for freedom of motion. If any binding occurs, remove power and re-assemble motor.
- u) Reconnect positioner motor connector (P-16) to the power amplifier assembly.
- v) Re-install drive in cabinet.

5.15

SPINDLE DRIVE MOTOR REPLACEMENT

- a) Tools required: #2 phillips screwdriver
Bondhus hex driver set
3/8 drive hex socket wrench set
with ratchet (Bonney no.
B-80308 or equal)
Okidata 30244 pulley spanner wrench
Okidata 30282 pulley puller tool
Torque wrench (Williams BWT-1RC
or equal)
- b) Remove drive from cabinet and position vertically on left hand side of drive as shown in Fig.
- c) Remove motor connector (P24) from the connector mounting plate as shown in Fig. 5-37.
- d) Remove spindle drive belt per 5.16. With spanner wrench and appropriate socket remove pulley motor nut. NOTE: This is a left-hand thread - remove by turning cw.

Using pulley puller remove pulley from motor shaft.
- e) Remove the four motor retaining screws using the appropriate hex driver from the Bondhus hex driver set.
- f) Install new motor to drive deck casting. Do not fully tighten motor mounting screws at this time. Install motor pulley but not the nut at this point.

- g) Re-install drive belt and adjust motor position per sec. 5.16. CAUTION: Observe rotation direction as noted by label on drive when installing drive belt.
- h) Tighten pulley nut to 150 in.lbs.
- i) Re-connect motor connector (P24) to connector mounting plate.
- j) Install drive in cabinet.

5.16

DRIVE BELT TENSION ADJUSTMENTS

The spindle drive belt tension should be maintained between 22 and 29 lbs. High belt tension will result in early motor bearing failures and also reduce spindle operating life. Low belt tension will cause excessive belt slippage during drive start and stopping.

The blower drive belt is a semi-elastic type and does not require tension adjustments.

NOTE: Never stretch blower drive belt more than necessary for installation or permanent deformation will occur.

Belt tension adjustments are to be made per the following procedure:

- a) Tools required: Bondhus hex driver set
 #2 phillips screwdriver
 18" steel scale (10ths & 100ths grade)
 Spring scale (Chatillon DPP-5 or equal)
 6" steel scale (10ths & 100ths grade)
- b) Remove drive from cabinet and position vertically on left hand side of drive as shown in Fig. 5-1.
- c) Check belt tension by deflecting belt to .50 inches halfway between motor and spindle pulleys as shown in Fig. 5-32. With spring scale measure force at belt deflection noted above. This force should be 4 ±1/2 lbs.

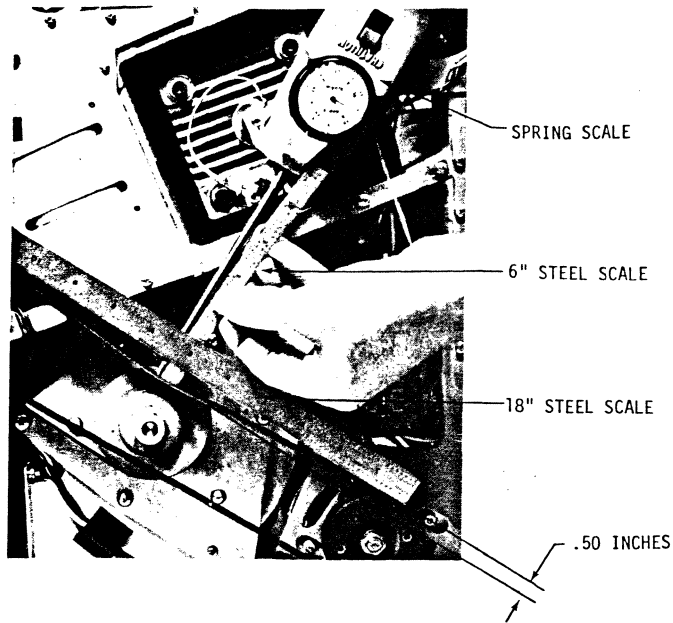

Figure 5-32
Spindle Drive Belt Tension

NOTE

On 50Hz units the motor mounting screws may not be accessible with the pulley installed. On these units perform adjustment steps by loosening pulley and pulling pulley 1/8" forward. This will make the mounting screws accessible. Pulley nut is left thread.

If measured force is not correct, loosen drive motor mounting screws and shift motor to increase or decrease belt tension. Repeat this procedure until the correct tension is obtained. NOTE: It may be useful to remove the spindle drive belt to adjust motor location. This is accomplished in (d) below.

- d) Remove spindle drive belt by pushing solenoid plunger shaft (through opening in power supply mounting plate - see Fig. 5-24) and with upward force on belt rotate spindle in direction until belt is released. NOTE: DO NOT ROTATE CCW OR SERIOUS DAMAGE TO HEADS WILL RESULT.

- e) Re-install belt and check tension as defined in (c) above.
- f) When proper belt tension is achieved re-install drive in cabinet.

5.17 INDEX TRANSDUCER & SPINDLE GROUND SPRING

I. INDEX TRANSDUCER ADJUSTMENT

- a) Tools required: #2 phillips screwdriver
.020 thick plastic shim
- b) Loosen index transducer mounting screws and insert plastic shim between spindle pulley and transducer. Move mounting bracket in against shim and tighten mounting screws. Pull shim out. Index transducer is now set at proper spacing.

II. SPINDLE GROUND SPRING

The spindle ground spring contacts a silver/graphite button which is located in the end of the spindle shaft.

Replacement of the spindle ground spring is accomplished by removing the mounting screw. The spindle ground button in the spindle shaft is now accessible for replacement if necessary.

Add new button and/or ground spring and re-install mounting screw. The ground spring should contact the index transducer bracket to prevent rotation of the ground spring.

5.18 COOLING FAN ASSEMBLY

The cooling fan is located where shown in Fig. 5-33. Under normal conditions the cooling fan need not be replaced over the life span of the drive.

If replacement is necessary then the following procedure is to be followed.

- a) Tools required: #2 phillips screwdriver
- b) Remove drive from cabinet and position vertically on left hand side of drive as shown in Fig.
- c) Remove connectors from power amplifier assembly and two lower screws holding power amplifier PCB assembly to fan mounting bracket.

Disconnect fan connector (P25) from A/C distribution connector plate.

Remove cable clamps and fan mounting bracket screws.

NOTE: Three screws mount the fan assembly to the base casting, two of which also mount cable clamps as shown in Fig. 5-33.

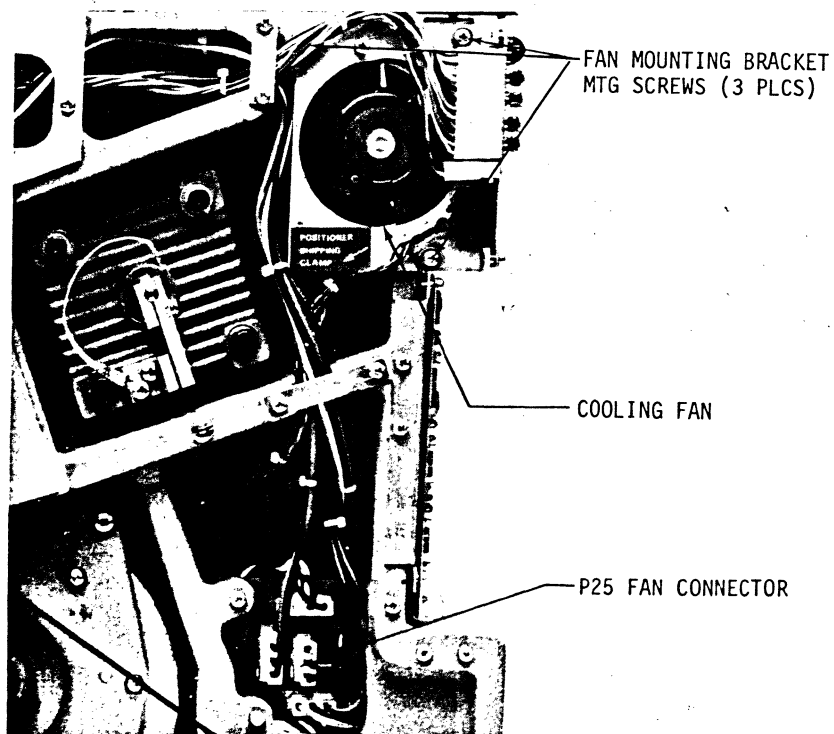

Figure 5-33
Cooling Fan Assembly

- d) Remove defective fan assembly and replace with new assembly. Follow reverse procedure for installation of fan assembly.
- e) Install drive in cabinet.

5.19

A/C DISTRIBUTION ASSY

The A/C distribution assembly is located where shown in Fig. 5-34. The internal harness assembly has a service loop which allows the A/C assembly to fold down and away from the drive for servicing.

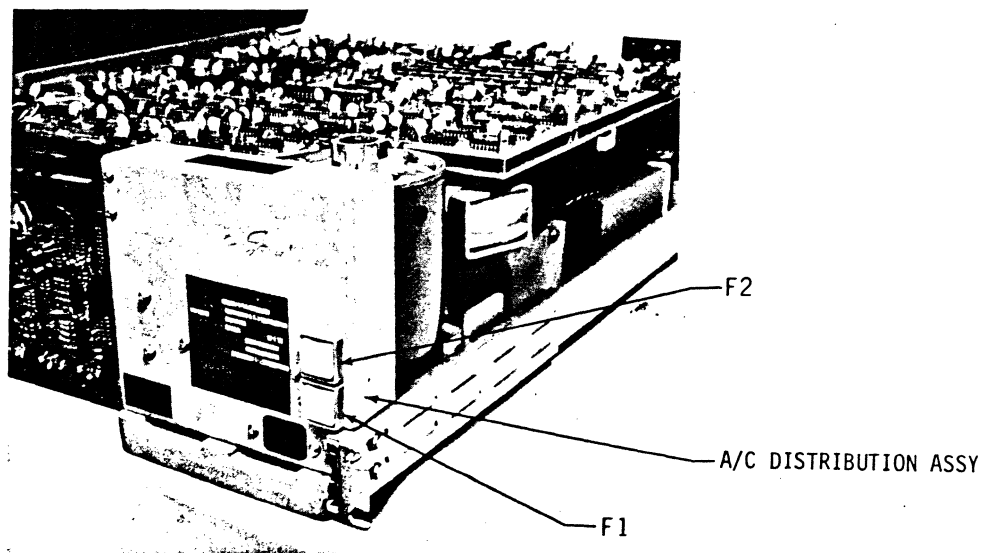

Figure 5-34
AC Distribution Assembly

5.19.1 Removal of A/C Distribution Assembly

- a) Tools required: #2 phillips screwdriver
- b) Remove drive from cabinet and place drive on bench or table with rear of drive overhanging bench as shown in Fig. 5-35. This allows access to the mounting screws on the lower surface of the drive.
- c) Remove the four screws which mount the A/C distribution assembly to the drive deck casting. The A/C distribution assembly can now be folded down and away from the drive for servicing as shown in Fig. 5-36.
- d) Removal of the three screws which mount the A/C connector plate (see Fig. 5-37) will allow the entire A/C distribution assembly to be removed from the drive. NOTE: Before removing screws disconnect connectors from connector mounting plate, and P27 (Fig. 5-3).
- e) After servicing re-install connector mounting plate (if removed) and A/C assembly to deck casting in reverse order as removed as per preceding sections.
- f) Install drive in cabinet.

5.20 CONTROL PANEL

The front panel indicators and switches are replaceable by following the procedure below:

- a) Tools required: #1 phillips screwdriver
- b) Remove the two screws which mount the control panel to the deck casting. This allows access to the rear of the indicator and push button switches.
- c) Push on rear of defective unit until it snaps out of mounting bracket as shown in Fig. 5-38.
- d) Disconnect terminals from assembly and replace with new unit. Snap new assy into bracket hole and replace switch panel mounting bracket to deck casting.

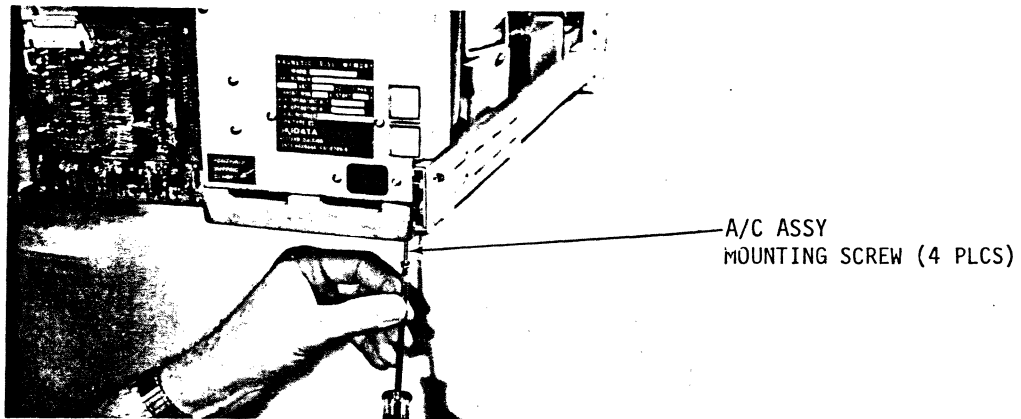

Figure 5-35
Removing the AC Distribution Assembly

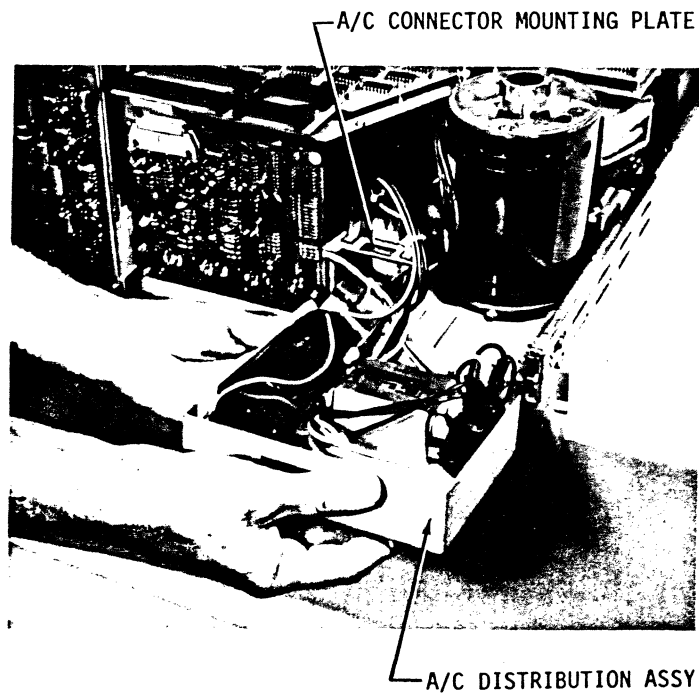
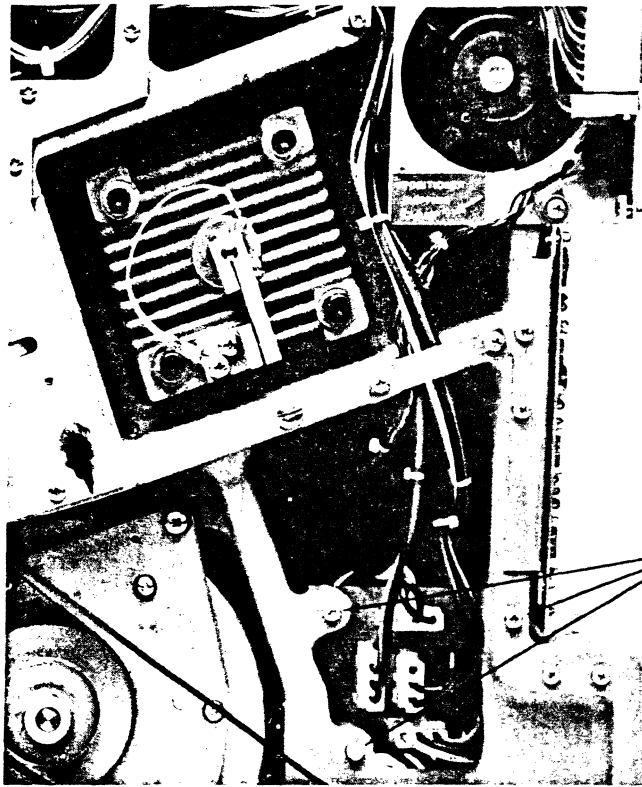

Figure 5-36
AC Distribution Assembly in Repair Position



A/C CONNECTOR MOUNTING
PLATE SCREWS (3 PLCS)

Figure 5-37
AC Connector Mounting Plate

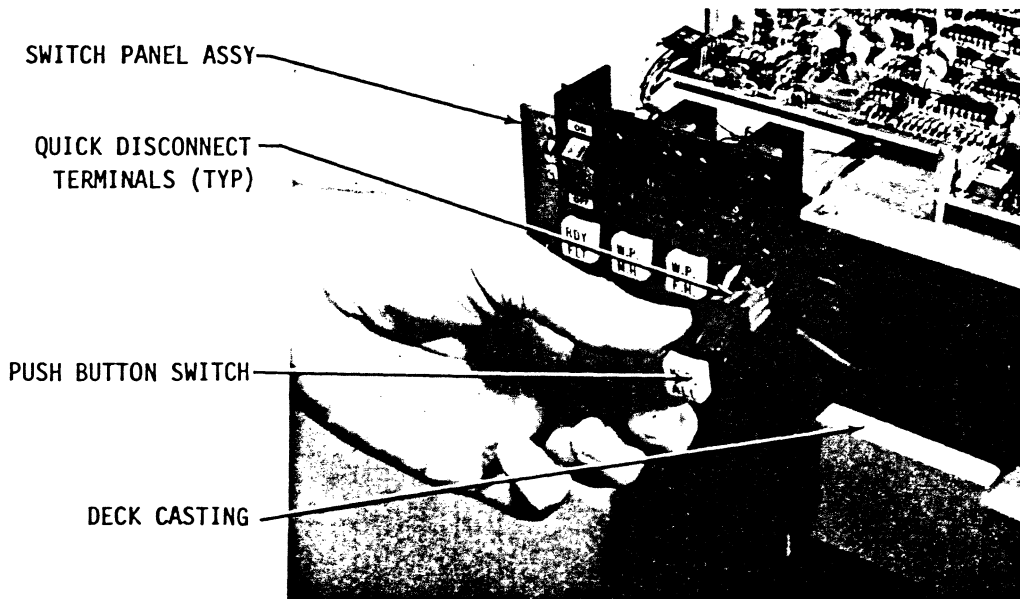

Figure 5-38
Replacing Defective Switch

5.21 TROUBLESHOOTING

Troubleshooting of the Okidata 3300 Disc Drive Units requires a thorough knowledge of the contents of Section 4. Before performing any detailed troubleshooting, the preliminary checks contained in the following paragraph should be performed. If the problem is not corrected by performing the preliminary checks, refer to the paragraphs on system level troubleshooting and to the troubleshooting charts. Note that the troubleshooting procedures do not include checking individual components such as I.C's, capacitors, resistors, etc. Checking of such components is to be done by conventional voltage and resistance tests, with the aid of the schematic and assembly diagrams in Section 6.

5.22 PRELIMINARY CHECKS

Preliminary checks are performed to ascertain that the equipment is connected properly and that the proper operating voltages are present.

- a. Verify that all cables and connectors are in good condition and that connections are made correctly.
- b. Verify that the two A/C fuses on the A/C distribution assembly (P/N 30337) and four DC fuses on the power amp assembly (P/N 30105) are not burned out, and that they are of the specified rating.
- c. Inspect for evidence of broken wires, and overheated components.

An initial check should always include the power supply circuits. Specifically, $\pm 32V$, $\pm 5V$ & $-2V$ should be checked at P21 on the power amp assembly to ensure correct output voltage. Also, eliminate the possibility of external equipment causing the malfunction. If the malfunction is a control function or if all heads are affected, ensure that all inputs to the disc drive are correct.

5.23 TROUBLESHOOTING CHARTS

The system troubleshooting charts are provided to aid the maintenance technician in isolating malfunctions in the disc drive. The troubleshooting charts provide typical symptoms of malfunctions along with probable causes, possible remedies and references to procedures within the manual which may aid the maintenance technician in isolating a fault. These tables should be used in conjunction with the assembly and schematic diagrams in Chapter 6.

TROUBLESHOOTING GUIDE

SYMPTOM	PROBABLE CAUSE	REMEDY	REFERENCE
Turn on switch Switch light not on	Unit not plugged in	Plug in unit	
	AC fuse, F1, blown	See ("AC Fuse, F1, Blows") (Page V-57)	
Spindle motor does not start or does not come up to speed	Defective On-Off Switch	With power disconnected, check continuity between pins 1 & 2; Replace switch	5.20
	Defective Switch light	Check for line voltage between pins 1 & 3; Replace switch	5.20
	AC box connectors loose (P22, P24, P25, P26)	Push in plugs P22, P24, P25, P26 until seated	Fig. 5-38
	Shipping clamp not removed	Remove spindle shipping clamp	Fig. 5-1
	Motor overheated	Let motor cool about 20 minutes to reset internal thermal switch	
	Brake solenoid stuck	Replace or adjust solenoid ass'y	5.13
	Brake microswitch failure or mal-adjustment	With power off, check switch for continuity; adjust or replace microswitch ass'y	5.13
	Motor start relay or motor start capacitor	Replace motor start relay and/or motor start capacitor or AC distribution assy. (P/N 30337)	5.19
	Unit plugged into wrong (AC) voltage	Check for proper line voltage. Look for line voltage sag during start.	5.3

TROUBLESHOOTING GUIDE

SYMPTOM	PROBABLE CAUSE	REMEDY	REFERENCE
Spindle motor does not start or does not come up to speed (cont.)	AC fuse F2 blown	See section "AC Fuse , F2, Blows" (below)	
	+32V Power supply failure	Check J15 pin 3 for +32V±5V; repair or replace power supply assembly	5.3.1
	Connectors loose	Push in plugs P17, P22, P24, P25, P26, & P27 until seated	Fig.5-38 & Fig. 5-3
	Brake band maladjusted	Adjust or replace brake band	5.13.1
	Defective spindle motor	Replace spindle motor	5.15
AC fuse, F1, blows	Wrong fuse installed	Install correct fuse as labelled	Fig. 5-35
	Stuck spindle motor or shorted spindle motor	Remove drive belt if motor does not turn freely, replace spindle motor	5.16d, 5.15
	Short in AC distribution assembly Unit plugged into wrong (AC) voltage	Repair or replace AC distribution assembly Check for proper line voltage	5.19
AC fuse, F2, blows	Wrong fuse installed	Install correct fuse as labelled	Fig. 5-35
	Power supply voltage taps incorrect -OR-	Match tap configuration to line voltage	5.3
	Unit plugged into wrong (AC) voltage	Check for proper line voltage	

V-57

TROUBLESHOOTING GUIDE

SYMPTOM	PROBABLE CAUSE	REMEDY	REFERENCE																			
<p>AC fuse, F2, blows (cont.)</p> <p>Ready light does not turn on 30 seconds after power on</p>	Shorted power supply	Repair or replace power supply assembly	5.3.1																			
	Shorted fan	Replace fan	5.18																			
	Position motor shipping clamp screw not removed	Remove shipping clamp screw	Fig. 5-1																			
	Burnt out ready light	Check for continuity, if open replace light	5.20																			
	Power amplifier thermal switch S1	Connect cables to switch. Check for continuity; if open, replace switch.	5.4.1																			
	Proper voltages on all boards	Check and seat power connectors P1, P3, P5, P8, P10, P18, P20, P21.	Section 6																			
		Check DC fuses F1, F2, F3, F4 and replace if necessary	Fig. 5-5																			
		<p>Check DC voltages on J21 on Power Amp</p> <table border="0" data-bbox="1234 1102 1917 1262"> <tr> <td>Pin 1</td> <td>-2V</td> <td>±.1V</td> <td></td> </tr> <tr> <td>Pin 3</td> <td>-5.2V</td> <td>±.05V</td> <td>spc</td> </tr> <tr> <td>Pin 9</td> <td>+5V</td> <td>±.05V</td> <td>adjust</td> </tr> <tr> <td>Pin 11</td> <td>-32V</td> <td>±5V</td> <td></td> </tr> <tr> <td>Pin 13</td> <td>+32V</td> <td>±5V</td> <td></td> </tr> </table>	Pin 1	-2V	±.1V		Pin 3	-5.2V	±.05V	spc	Pin 9	+5V	±.05V	adjust	Pin 11	-32V	±5V		Pin 13	+32V	±5V	
Pin 1	-2V	±.1V																				
Pin 3	-5.2V	±.05V	spc																			
Pin 9	+5V	±.05V	adjust																			
Pin 11	-32V	±5V																				
Pin 13	+32V	±5V																				
	Signals not applied to servo bd	Check orientation and seat connectors P4, P9, P13; P19 enclosure; P14 power amp	Section 6																			

TROUBLESHOOTING GUIDE

SYMPTOM	PROBABLE CAUSE	REMEDY	REFERENCE
Ready light does not turn on 30 seconds after power on (cont.)	Ready line stays low	Check P12 pin 29 on I/O bd; if TTL low adjust or replace servo bd (P/N 30103), otherwise adjust or replace I/O bd (P/N 30115)	5.6
	Relay, K1, defective on P/N 30105	Check pins 1 & 4 for continuity, if open replace relay	
	Continuous write fault	Check 1U5 pin 9 on matrix bd, if TTL low, replace matrix bd (P/N 30100)	4.4.2
		Check 1U8 pin 1 on optional fixed head amplifier bd, if TTL low replace fixed head amplifier board (P/N 30104)	4.4.3
		If no FHA on drive, check if FLT2 jumper on I/O bd is installed; install if necessary	4.5
		If 1U5 pin 9 on matrix bd, 1U8 pin 1 on FHA are TTL hi and correct "FLT" jumper are installed, replace I/O bd (P/N 30115)	
	Defective servo bd	Adjust or replace servo bd (P/N 30103)	5.6
Defective power amp bd	Replace power amp bd (P/N 30105)	5.4.3	
Defective I/O bd	Replace I/O bd (P/N 30115)		

TROUBLESHOOTING GUIDE

SYMPTOM	PROBABLE CAUSE	REMEDY	REFERENCE
Ready Light flashes	Uncleared fault condition	Momentarily switch off AC power, ready light should turn on within 30 seconds. If ready light again begins to flash, see below	
	Option thumbwheel switches set at same number (unit address)	Set thumbwheel switches to different numbers, as required	5.9.1
	Write fault	Check that optional write protect switches have not been accidentally engaged	4.5
	Invalid interface commands from disc controller	Check connectors P31, P32, P33, P34 or terminator card for proper installation, check interface cables for damage	
	DC power fault	See "proper voltages on all boards", pg.V-58. Check U32 pin 3 on servo bd, if TTL low replace servo bd (P/N 30103)	5.4
	Defective P.C. bd(s)	Various seek, write and/or read problems can result in a fault condition. See "Write Fault", pgV-60 "Does not seek on Command", pgV-61 "Does not Read", pgV-66 "Does not Write", pg.V-65	

TROUBLESHOOTING GUIDE

SYMPTOM	PROBABLE CAUSE	REMEDY	REFERENCE
<p>Does not seek on command (ready light on)</p>	<p>Illegal or invalid address requested</p> <p>No seek strobe asserted</p> <p>Uncleared seek late</p>	<p>Check P31, P34 or terminator card for proper installation, check interface cables for damage</p> <p>Check 2U69 pin 6 (illegal address: ILLADR) on servo bd, if ever TTL high, illegal address was requested, check disc controller and I/O address lines</p> <p>Check J12 pin 31 on I/O bd for high going μs pulse If pulse exists : Is seek complete, 3U42 pin 8 on servo bd, TTL low during pulse? If so, check disc controller timing; replace servo bd (P/N 30103) If no pulse exists at J12 p 31: Check tag 1/2U25 pin 9 on I/O bd if none, check connectors P31,P34 or terminator card and interface cables If tag 1, is moving head unit selected? Is ready line hi (J12 pin 29 on I/O bd) If ready is low, see "Proper Voltages on all Boards", pg. and "Ready Line Stays Low", pg. V-59.</p> <p>Issue "Restore" or momentarily switch power off (controller should issue restore when "Seek Error" is high).</p>	

TROUBLESHOOTING GUIDE

SYMPTOM	PROBABLE CAUSE	REMEDY	REFERENCE
<p>Sporadic missed seeks or relay K1 on power amp bd drops occasionally</p> <p>Continuous data errors (errors common to both write and read)</p>	<p>Defective servo bd</p> <p>Some faulty address lines</p>	<p>Adjust or replace servo bd (P/N 30103)</p> <p>Check P31, P34 or terminator card for proper installation. Check interface cables for damage</p> <p>Replace I/O bd</p>	<p>5.6</p>
	<p>Invalid head selected</p>	<p>Check P31, P32, P33, P34 and/or terminator card for proper installation, check interface cables for damage</p> <p>Check for valid head address on matrix bd, check 1U11 pin 1,2,3, 4, 5, 6,7, 9, 10, 11, 1U14 pin 3, 5. One pin should be TTL low, all others @ +24V.</p> <p>On optional fixed head amplifiers: Check 1U2 pin 1, 2, 3, 4, 5, 6, 7, 9, 1U5 pin 1, 2, 3, 4, 5, 6, 7, 9, 1U7 pin 1, 2, 3, 4, 5, one pin should be TTL low, all others @ +24V AND check 1U10 pin 7, 12, 1U11 pin 7, 12, and 1U12 pin 7, 12, one pin should be -5V, all others @ +24V</p> <p>Check (moving) head address lines and optional fixed head address lines on I/O bd</p>	<p>4.4.2</p> <p>4.4.3</p>

TROUBLESHOOTING GUIDE

SYMPTOM	PROBABLE CAUSE	REMEDY	REFERENCE
<p>Continuous data errors (errors common to both write and read) (cont.)</p>	<p>Neither moving head nor fixed head unit selected</p> <p>Voltage regulators on data bd defective</p> <p>Data bd phase-locked- loop out of lock</p>	<p>Check P31, P32, P33, P34 and/or terminator card for proper installation, check interface cables for damage</p> <p>Check 2U51 on I/O board or optional thumbwheel switches for unit addresses</p> <p>Check 3U39 pin 4 on data board for -12V, U39 pin 7 for +8V; replace data bd (P/N 30102)</p> <p>Check 3U39 pin 6, should be -5VDC to -9VDC w/200mVp-p noise, repair or replace data bd (P/N 30102)</p>	<p>5.9.1</p> <p>4.4.5</p>
<p>Continuous data errors (moving or fixed head only)</p>	<p>Voltage regulators</p>	<p>Moving head: Check matrix bd 1U2, U4, U6, U10 (right-hand most pin on each) for +24V, -24V, -5V, +8V respectively, repair or replace matrix bd (P/N 30100)</p> <p>Optional fixed heads: Check fixed head amplifier bd (FHA bd) 1U3, 1U4, output pin, for +24V, -24V respectively, repair or replace board (P/N 30104)</p>	

TROUBLESHOOTING GUIDE

SYMPTOM	PROBABLE CAUSE	REMEDY	REFERENCE
Continuous data errors (moving or fixed head only) (cont.)	Write Current	Moving heads: Check matrix bd U5 pin 13 Optional fixed heads: Check FHA bd 3U8 pin 1 Should be TTL hi unless moving or fixed head, respectively, is written on, repair or replace board	5.7
	Multi(ple) head(s) select(ed)	Moving heads: Check matrix bd U5 pin 13 Optional fixed heads: Check FHA bd 1U6 pin 12 Should be TTL lo, if not check "Invalid Head Selected", pg. 7, if valid head selected and multihead sel hi, repair or replace board	4.4.2 4.4.3
	Cabling	Moving head: Check P3 data bd and P1 matrix bd (P/N 30100) Optional fixed heads: Check P5 on data bd (P/N 30104)	
	Does not write	Write protected	Check optional write protect switches for accidental protection
Write current fault		See "Write Current", pg. 9, if OK replace I/O bd (P/N 30115)	

TROUBLESHOOTING GUIDE

SYMPTOM	PROBABLE CAUSE	REMEDY	REFERENCE
Does not write (cont.)	No write data (NRZ)	<p>Check P31, P32, P33, P34 and/or terminator card for proper installation, check interface cables for damage</p> <p>Check J11 pin 7 on I/O bd for NRZ data during write. If data exists repair or replace data board (P/N 30102). If all heads bad, Repair or replace matrix board (P/N 30100). If moving heads bad, Repair or replace FHA board (P/N 30104). If no data at J11 pin 7, repair or replace I/O bd (P/N 30115)</p>	
Does not read	<p>Maladjusted write current</p> <p>Read enable not asserted</p>	<p>Adjust matrix or optional FHA board as necessary</p> <p>Check P31, P32, P33, P34 and/or terminator card for proper installation, check interface cables for damage</p> <p>Check J11 pin 15 on I/O bd, should be low during read, if not, check power to I/O board, repair or replace (P/N 30115)</p>	5.7

99-V-66

TROUBLESHOOTING GUIDE

SYMPTOM	PROBABLE CAUSE	REMEDY	REFERENCE
Does not read (cont.)	No read clock and/or no read NRZ data	Check 3U49 pin 13 on data bd, should be 7.33 MHz TTL square wave. If not, check all data board taps are not missing or open. If taps OK repair or replace data board (P/N 30102)	5.8
	Continuous read errors	Does unit write correctly? See "Does not Write", pg.V-64. Moving and optional fixed heads: Adjust or replace data board (P/N 30102), replace I/O board (P/N 30115) Moving heads only: replace matrix board (P/N 30100) Fixed heads only: replace FHA board (P/N 30104) Controller error: tries to read, (1) and write simultaneously; (2) when not on cylinder	5.8
	Sporadic read errors	All heads: adjust or replace data board (P/N 30102) Moving heads only: Check if write current set properly, replace matrix board (P/N 30100) Optional fixed heads only: Check if write current set properly, replace FHA board (P/N 30104)	5.8 4.4.2 & 5.7.1 4.4.3 & 5.7.2

V-67

OKIDATA 3300 DISC DRIVE SPARE PARTS LIST

This list is divided into two sections: (a) Those parts necessary to maintain the drive assembly, and (b) Those parts necessary to repair printed circuit boards.

It is recommended that the customer who services his own drives maintain an inventory of spare parts as indicated in the column, "Depot Recommended Spares for Quantity 100 Drives".

It is also recommended that the customer field service engineers carry an inventory of spare parts as indicated in the column, "Field Service Kit".

No "Field Service Kit" recommendation is made for printed circuit board components since the degree to which a customer repairs printed circuit boards in the field versus depot repair is a function of many variables; i.e. type of customers serviced, degree of training, number of depots, etc.

Only active and precision components are listed, since remaining items on the printed circuit board parts list are readily available resistors and capacitors.

OKIDATA 3300 DISC DRIVE
RECOMMENDED SPARE PARTS LIST

<u>Part No.</u>	<u>Description</u>	<u>Field Service Kit</u>	<u>Depot Recommended Spares for Quantity 100 Disc Drives</u>
30258-1	Belt, Spindle Drive 60 Hz	1	5
30258-2	Belt, Spindle Drive 50 Hz	1	5
30253-3	Belt, Blower	1	5
30244-1	Motor, Spindle Drive-115V, 50/60 Hz	-	2
30244-2	Motor, Spindle Drive-240V, 50/60 Hz	-	2
SU2A1	Fan, Heat Sink	-	4
30205	Filter, Air Breather Assy.	1	10
	Bearing Replacement Kit, Blower Spindle (Contains two bearings & retaining ring)	-	2
	Index Sensor	1	4
30247	Solenoid Assy, Spindle Brake	1	3
30322	Spring, Spindle Brake	1	10
30290	Switch Assy., Spindle Brake	1	5
30226	Brake Band	1	5
LTA 211-TAMB	Switch, On/Off	1	2

<u>Part No.</u>	<u>Description</u>	<u>Field Service Kit</u>	<u>Depot Recommended Spares for Quantity 100 Disc Drives</u>
OT-105	Switch, Pushbutton (Write Protect)	-	2
T-1 3/4	Lamp, Ready or Write Protect)	2	10
R10-ET-W4-V700	Relay, Positioner	1	4
2N6284	Power Transistor	2	5
2N6287	Power Transistor	2	5
	Positioner Motor Kit (Contains Stator, Lower Bearing, Ret. Ring)	-	2
MC1456CPI	Integrated Circuit	-	2
MC7805CP	Integrated Circuit	-	2
MC7905.2CP	Integrated Circuit	-	2
MC7902CP	Integrated Circuit	-	2
MC7908CP	Integrated Circuit	-	2
CA3146	Integrated Circuit	-	3
LM319N	Integrated Circuit	-	7
74221	Integrated Circuit	-	5
LM339N	Integrated Circuit	-	4
74LS04	Integrated Circuit	-	4

<u>Part No.</u>	<u>Description</u>	<u>Field Service Kit</u>	<u>Dept Recommended Spares for Quantity 100 Disc Drives</u>
74S124	Integrated Circuit	-	2
74LS191	Integrated Circuit	-	9
74LS138	Integrated Circuit	-	4
MC4044	Integrated Circuit	-	2
74LS283	Integrated Circuit	-	4
74LS00	Integrated Circuit	-	15
74LS86	Integrated Circuit	-	4
74S288	PROM (must be programmed before use)	-	2
MC3408	Integrated Circuit	-	2
74LS54	Integrated Circuit	-	5
74LS30	Integrated Circuit	-	3
74LS11	Integrated Circuit	-	5
MDA-990-2	Power Supply Rectifier	1	2
	Relay, Spindle Motor Start 115V	1	2
	Relay, Spindle Motor Start 240V	1	2
30102	Data PCB Assy.	1	6

<u>Part No.</u>	<u>Description</u>	<u>Field Service Kit</u>	<u>Depot Recommended Spares for Quantity 100 Disc Drives</u>
30103	Servo Logic PCB Assy.	1	10
30100	Matrix PCB Assy.	1	2
30105	Power Amplifier PCB Assy.	1	2
30104	*Fixed Head Amplifier PCB Assy (.72m Byte)	1	2
	*Interface PCB Assy. (No Options)	1	2
	Fuse, 4 Amp	5	-
	Fuse, 10 Amp	5	-
	Fuse, 2 Amp	5	-
MC10109P	Integrated Circuit	-	2
MC10125P	Integrated Circuit	-	2
MC10164P	Integrated Circuit	-	3
MC10104P	Integrated Circuit	-	8
LM3046N	Integrated Circuit	-	7
LM339N	Integrated Circuit	-	3
7445	Integrated Circuit	-	5

*A number of optional PCB's are available. Consult Okidata for pricing.

EFFECTIVE 3/14/77

<u>Part No.</u>	<u>Description</u>	<u>Field Service Kit</u>	<u>Depot Recommended Spares for Quantity 100 Disc Drives</u>
7406	Integrated Circuit	-	2
75451	Integrated Circuit	-	3
74LS20	Integrated Circuit	-	2
592	Integrated Circuit	-	2
74LS10	Integrated Circuit	-	4
74LS37	Integrated Circuit	-	2
74LS76	Integrated Circuit	-	2
74LS157	Integrated Circuit	-	2
74LS175	Integrated Circuit	-	2
74471	Integrated Circuit	-	2
74LS266	Integrated Circuit	-	3
74LS08	Integrated Circuit	-	10
74LS21	Integrated Circuit	-	5
9602	Integrated Circuit	-	4
74LS74	Integrated Circuit	-	15
MC7812CK	Integrated Circuit	-	2

<u>Part No.</u>	<u>Description</u>	<u>Field Service Kit</u>	<u>Depot Recommended Spares for Quantity 100 Disc Drives</u>
MC7912CK	Integrated Circuit	-	2
CA3046	Integrated Circuit	-	7
74LS14	Integrated Circuit	-	3
7416	Integrated Circuit	-	3
74LS02	Integrated Circuit	-	3
74LS32	Integrated Circuit	-	3
MC1456CP1	Integrated Circuit	-	15
MC1458CP1	Integrated Circuit	-	6
AH5012CN	Integrated Circuit	-	5
NE555V	Integrated Circuit	-	2
MC10141P	Integrated Circuit	-	3
MC10124P	Integrated Circuit	-	4
MC10116P	Integrated Circuit	-	4
MC10113L	Integrated Circuit	-	2
MC10102P	Integrated Circuit	-	7
MC10131P	Integrated Circuit	-	9

<u>Part No.</u>	<u>Description</u>	<u>Field Service Kit</u>	<u>Depot Recommended Spares for Quantity 100 Disc Drives</u>
MC10106P	Integrated Circuit	-	4
MC10105P	Integrated Circuit	-	2
74LS279	Integrated Circuit	-	2
75107B	Integrated Circuit	-	12
75110	Integrated Circuit	-	10
74265	Integrated Circuit	-	2
74S472	PROM (Fixed Head contiguous address option only)	-	2
MC1456CP1	Regulator	-	2
MC7805CP	Regulator	-	2
MC7905.2CP	Regulator	-	2
MC7902CP	Regulator	-	2
MC7908CP	Regulator	-	2
MC7812CK	Regulator	-	2
MC7912CK	Regulator	-	2
MC7803CP	Regulator	-	3

EFFECTIVE 3/14/77

<u>Part No.</u>	<u>Description</u>	<u>Field Service Kit</u>	<u>Depot Recommended Spares for Quantity 100 Disc Drives</u>
MC7912CP	Regulator	-	2
MC7824CP	Regulator	-	3
MC7924CP	Regulator	-	2
MC7905CP	Regulator	-	2
2N2907A	Transistor	-	9
2N2369A	Transistor	-	9
2N2905A	Transistor	-	15
2N3503	Transistor	-	3
MM8006	Transistor	-	3
2N2907A	Transistor	-	3
E109	Transistor	-	2
E177	Transistor	-	3
2N2222A	Transistor	-	4
MPSA56	Transistor	-	2
MPSA06	Transistor	-	3
2N3440	Transistor	-	2

<u>Part No.</u>	<u>Description</u>	<u>Field Service Kit</u>	<u>Depot Recommended Spares for Quantity 100 Disc Drives</u>
2N5415	Transistor	-	2
2N6287	Transistor	-	2
2N6284	Transistor	-	2
2N6330	Transistor	-	2
2N6327	Transistor	-	3
	2.2 Ohm, 2W Power Resistor	-	2
	.05 Ohm, 7W, 3% Power Resistor	-	3
	.05 Ohm, 7W, 1% Power Resistor	-	2
	100 Ohm, 15W Power Resistor	-	3
	50 Ohm, 5W, 1% Power Resistor	-	3
	100 Ohm, 3W, 5% Power Resistor	-	2
	330 Ohm, 3W, 5% Power Resistor	-	2
	200 Ohm, 1W, 1% Power Resistor	-	2
	100 Ohm, 3W, 1% Power Resistor	-	3
	2.4K Ohm, 1W, 5% Power Resistor	-	2

<u>Part No.</u>	<u>Description</u>	<u>Field Service Kit</u>	<u>Depot Recommended Spares for Quantity 100 Disc Drives</u>
593-3-470	Resistor Pack	-	7
399-1-82	Resistor Pack	-	2
430S-101-203	Bournes Resistor Pack	-	5
430S-101-103	Bournes Resistor Pack	-	4
	100 Ohm ECL Term SIP	-	20
3386P (Bournes)	2K Potentiometer	-	3
3386P (Bournes)	1K Potentiometer	-	3
3386P (Bournes)	20K Potentiometer	-	2
3386P (Bournes)	100K Potentiometer	-	2
3386P (Bournes)	10K Potentiometer	-	2
72P (Beckman)	10K Potentiometer	-	2
3386P (Bournes)	100 Ohm Potentiometer	-	2
72P (Beckman)	100 Ohm Potentiometer	-	2
1N5229	Diode	-	2
1N5230	Diode	-	2
1N5242	Diode	-	2

<u>Part No.</u>	<u>Description</u>	<u>Field Service Kit</u>	<u>Depot Recommended Spares for Quantity 100 Disc Drives</u>
1N5241	Diode	-	2
1N4150	Diode	-	20 (40 if F. H. used)
1N5253	Diode	-	2
1N4002	Diode	-	6
LVA56A	Diode	-	2
1N5232B	Diode	-	1

REVISIONS				
REV	SYM	DESCRIPTION	DATE	APP
A		REL COM ECM SETS	11-11-77	<i>M</i>

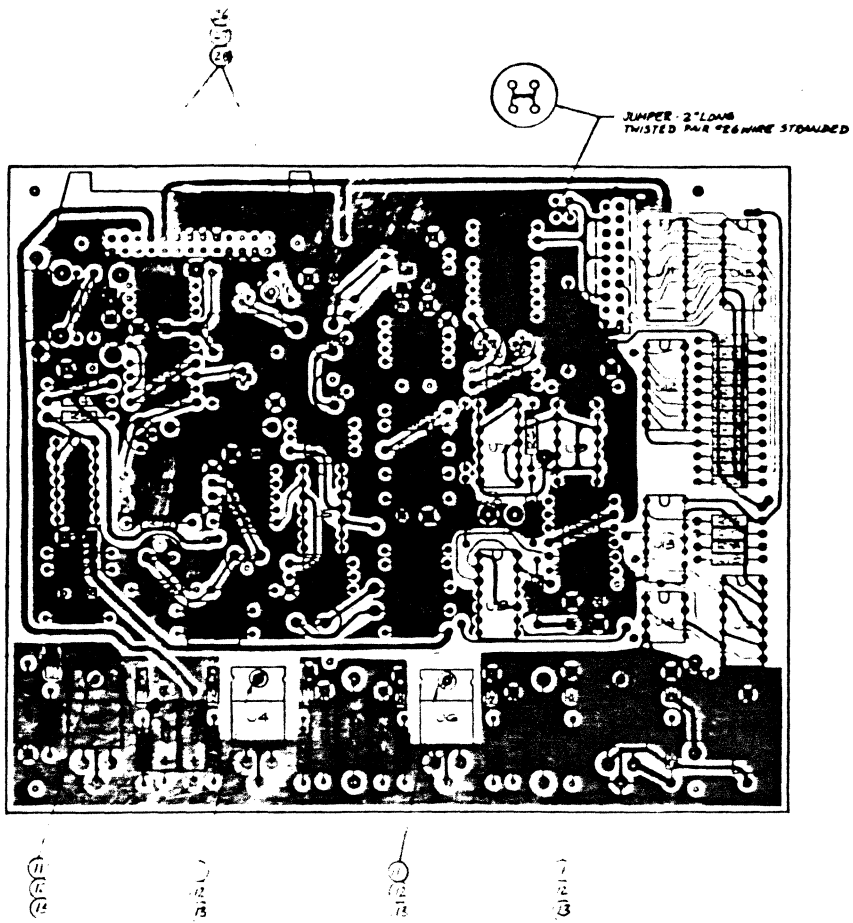

212
 213
 214
 215

REV	SYM	DESCRIPTION	DATE	APP
		PCS		
OKIDATA CORP.				
WESTERN DIVISION • SANTA BARBARA, CALIFORNIA				
ASSEMBLY				
MAI-X				
REV	SYM	DESCRIPTION	DATE	APP
A	D	30100	AS	1-1

REVISIONS			
NO.	DESCRIPTION	DATE	BY
1	REVISED	12-77	JL
2	REVISED	12-77	JL
B	ECN	5-31-77	
C	ECN	5-31-77	

INSTALL INSULATION STRIP & MINI BUS, PRIOR TO IC INSTALLATION.
 INSULATION STRIP NOT REQD WITH FABRICATED BUS.
 CHECK ALL MINI BUSES FOR SHORTS PRIOR TO IC INSTALLATION.

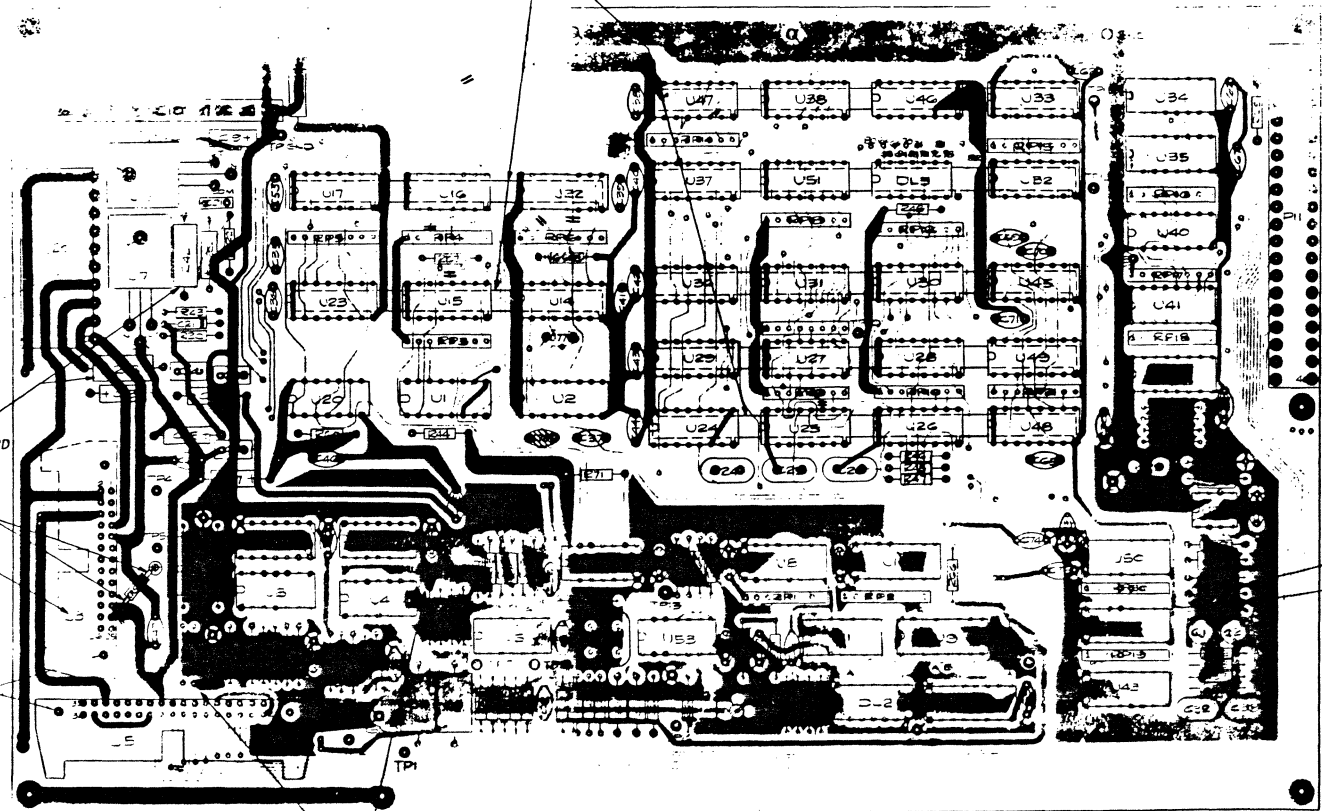

SPACE
 R18 & R42
 1/8" FROM BOARD
 & AWAY FROM
 C13 & C20

USE #22 TEFLON
 SLEEVING

INSTALL J3
 ON FAR SIDE OF
 BOARD

- ①
 - ②
 - ③
- TRACS

CONNECT AS SHOWN
 USE #30 WW WIRE

C31 NOT USED
 CR3 & CR4

DATE	BY	APPROVED	OKIDATA CORP. WESTERN DIVISION - SANTA BARBARA, CALIFORNIA
DATE	BY	APPROVED	
REWORK ASSEMBLY DATA BOARD			
DATE	BY	APPROVED	

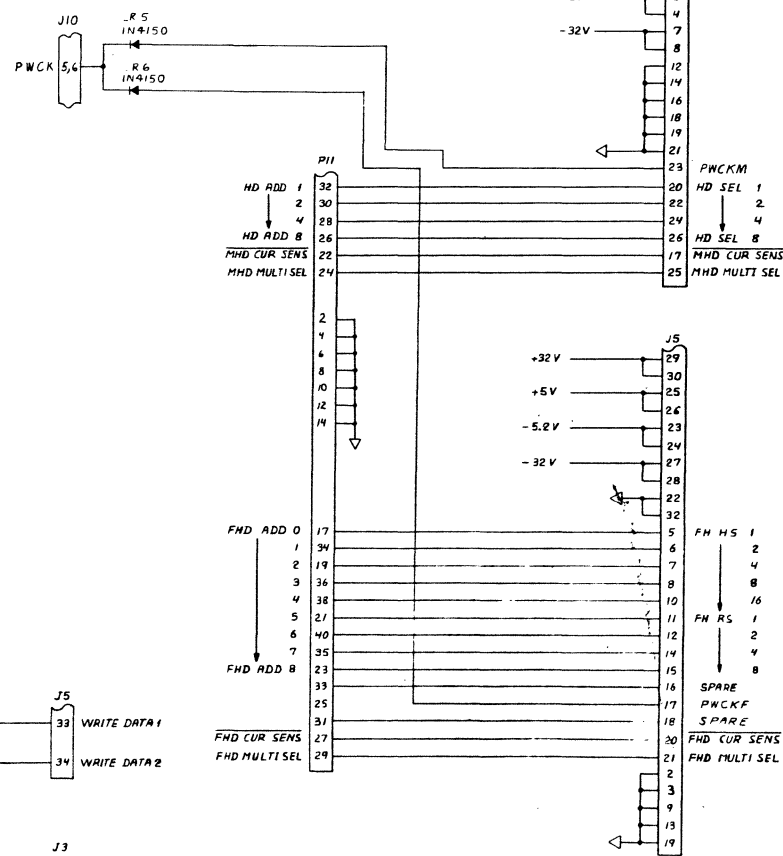
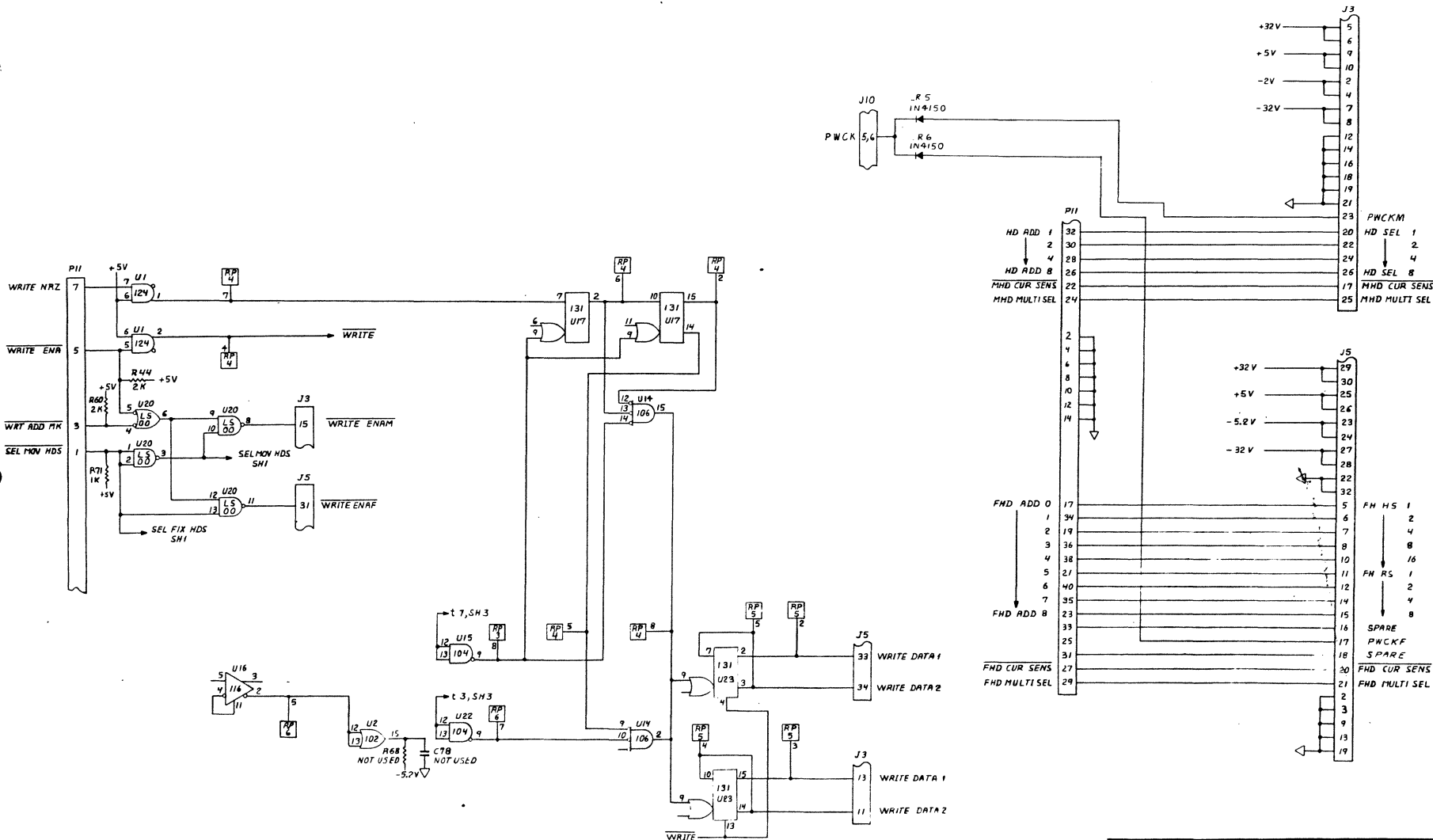

SCALE	TOLERANCES	DATE	H.B.	OKIDATA CORP. WESTERN DIVISION • SANTA BARBARA, CALIFORNIA DATA ELECTRONICS (WRITE ENCODER)			
MATERIAL	CHECKED	DATE	2/22/76				
DESIGNED	DATE	DATE	5/8/76				
APPROVED	DATE	DATE	7/27/76				
REV	DATE	REV	DATE	REV			
1		1		1	30102	2	3

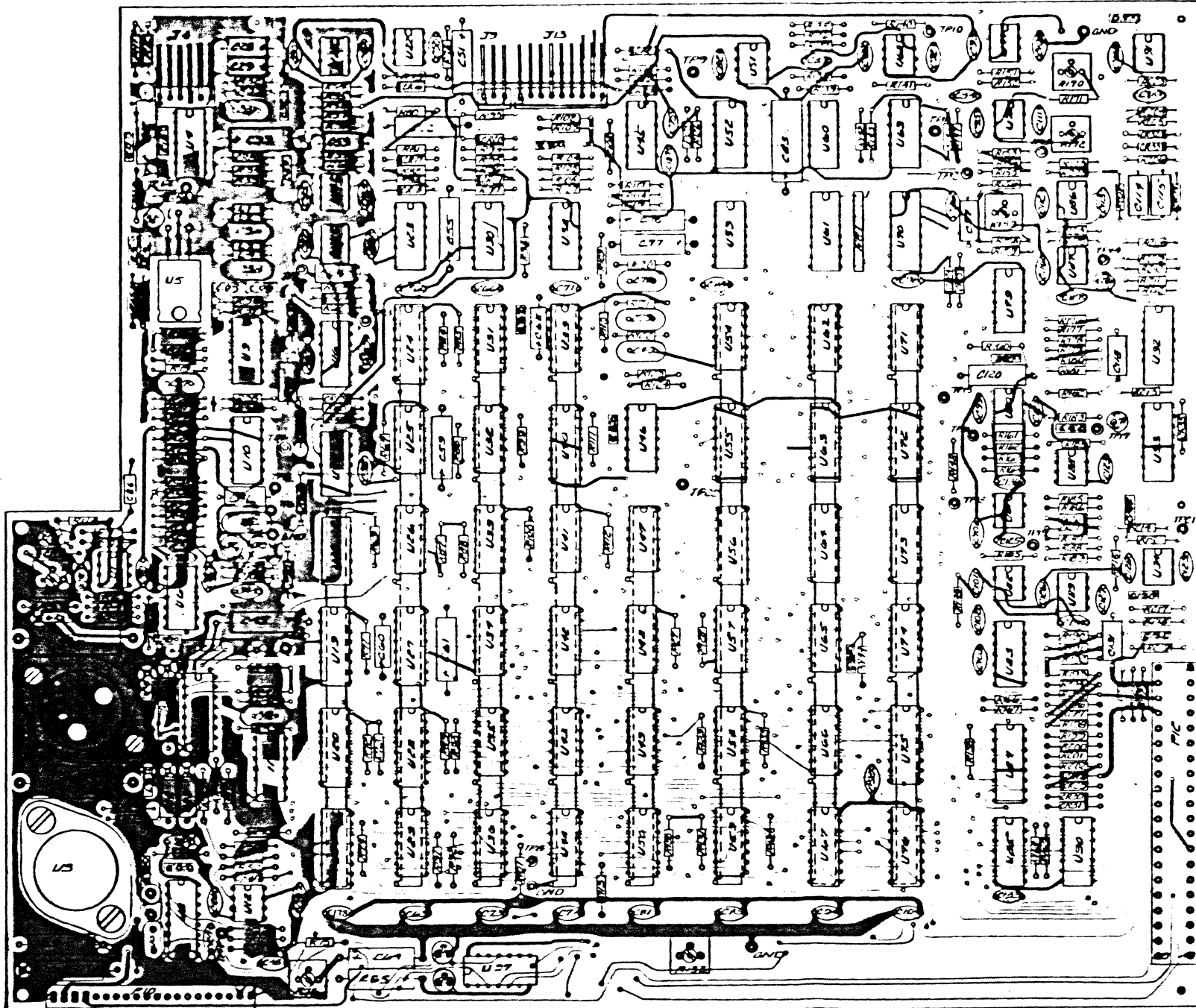

UT 51M 2 PLS

INSTALL CR12 AS SHOWN

OK! DATA	
—U1	—
—U5-77	—
ASSEMBLY	
SEMIC-LOGIC BOARD	

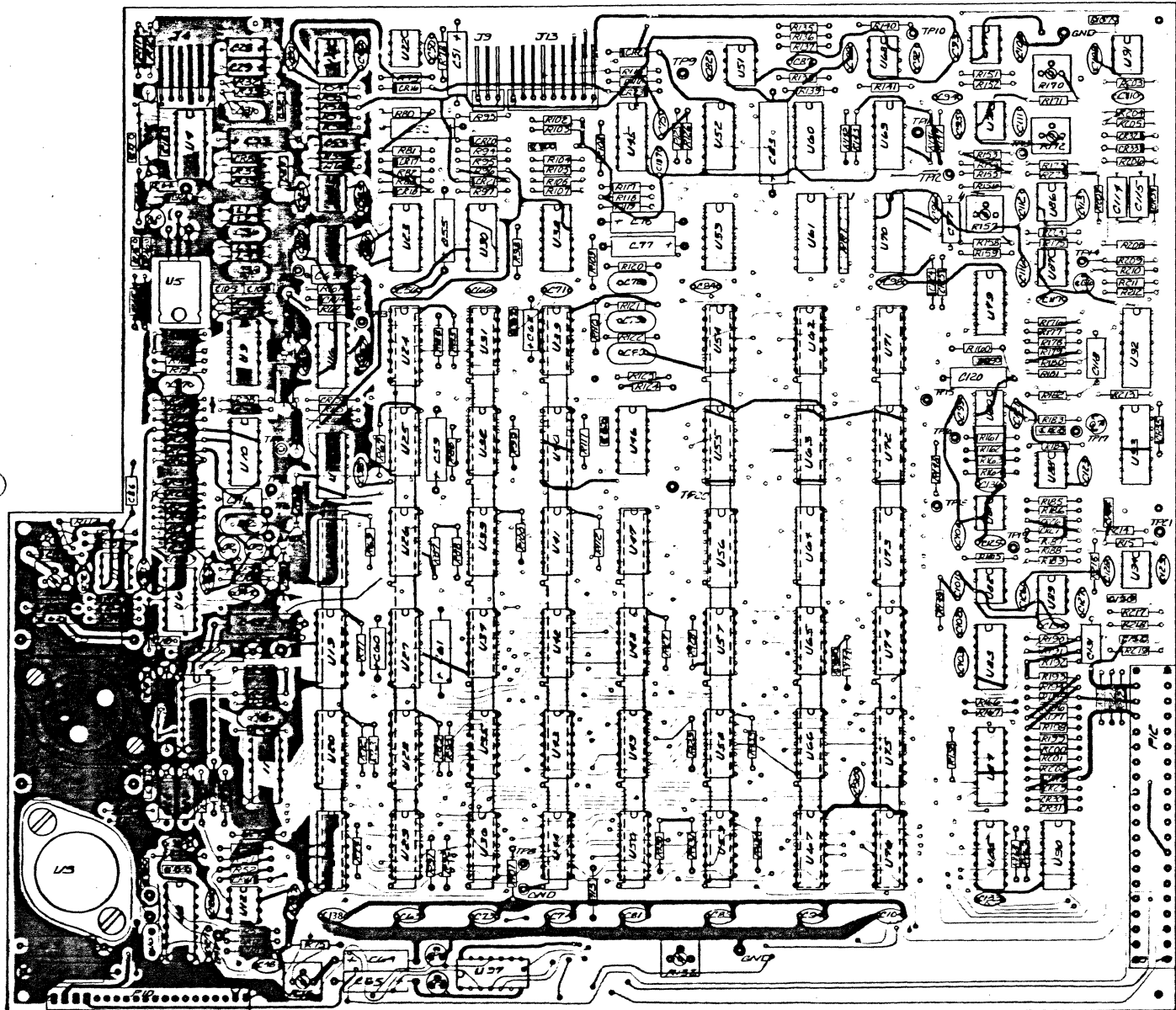

CUT ETCH 2 PLCS

INSTALL CR12 AS SHOWN

OKIDATA	
REV 1	REV 1
6-5-77	REV N
ASSEMBLY	
SEMO-LOGIC BOARD	30103

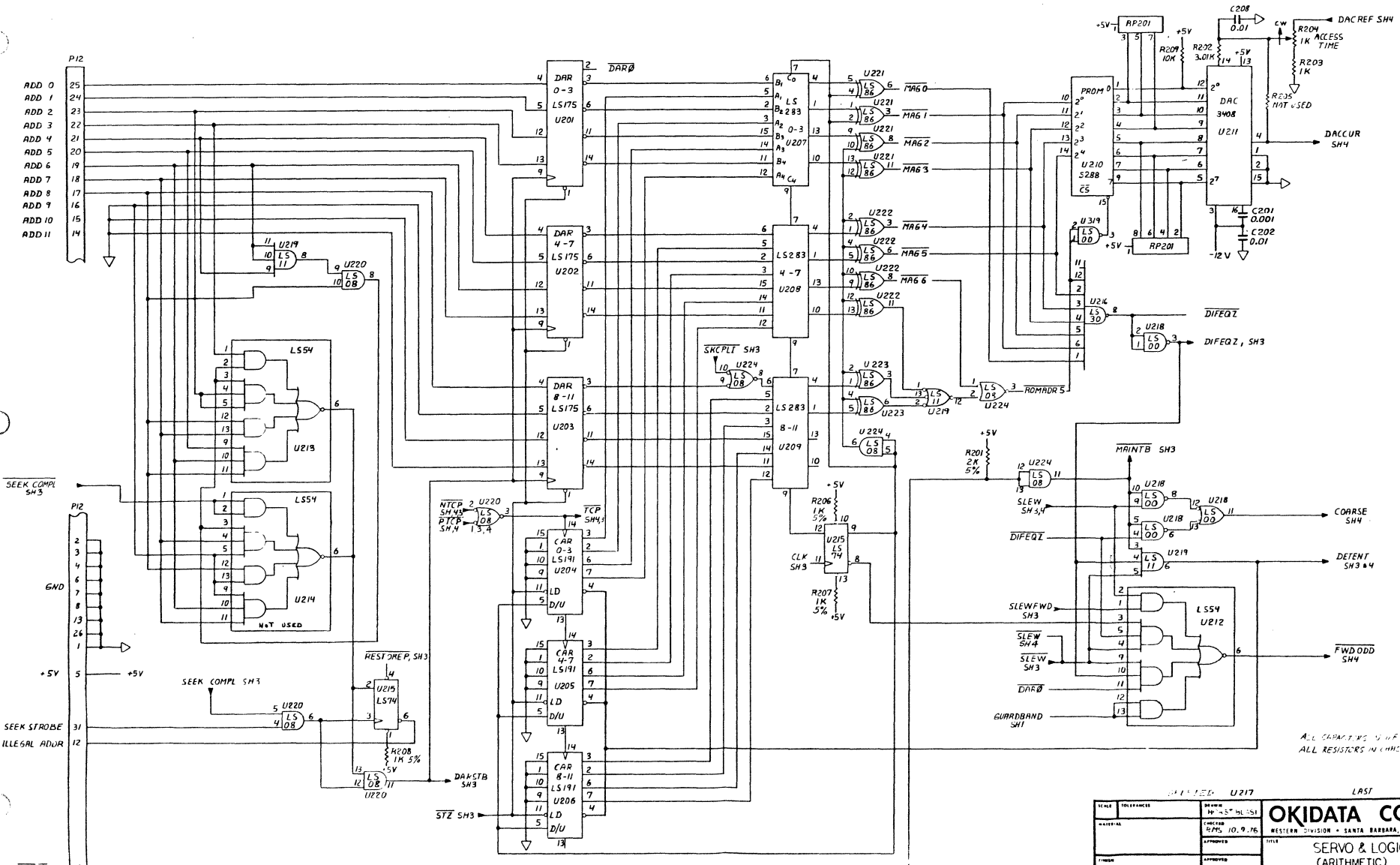

ALL CAPACITORS IN μ F
 ALL RESISTORS IN Ω 1%
 RP201
 U224
 C208
 R209

REVISIONS		DATE	BY	CHK	APP	REV	DATE	BY	CHK	APP

OKIDATA CORP.
 WESTERN DIVISION - SANTA BARBARA, CALIFORNIA
 SERVO & LOGIC
 (ARITHMETIC)

30103 SC 2-4

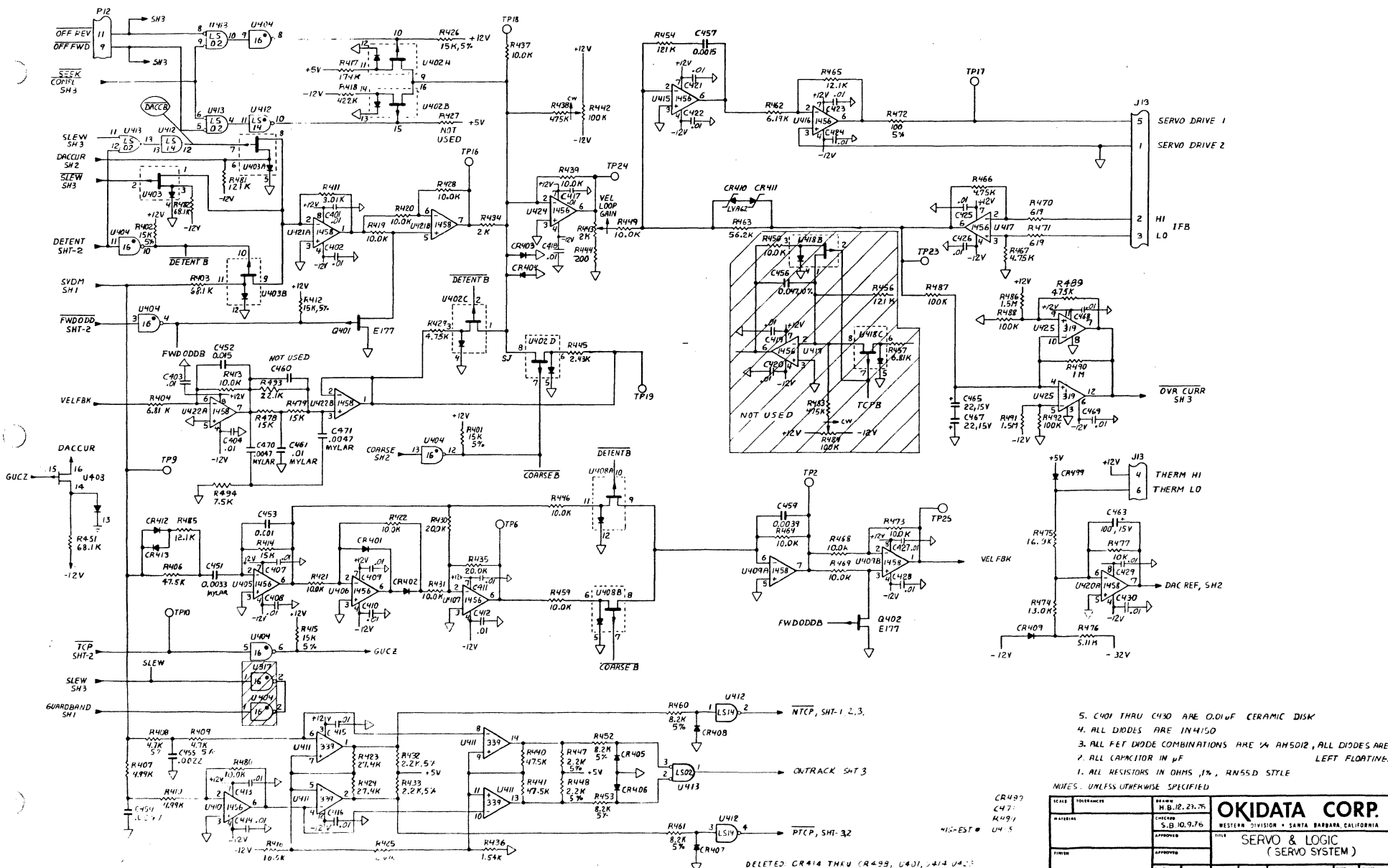

- 5. C401 THRU C430 ARE 0.01µF CERAMIC DISK
- 4. ALL DIODES ARE 1N4150
- 3. ALL FET DIODE COMBINATIONS ARE 1/4 AM5012, ALL DIODES ARE LEFT FLOATING.
- 2. ALL CAPACITORS IN µF
- 1. ALL RESISTORS IN OHMS, 1%, RN55D STYLE

NOTES: UNLESS OTHERWISE SPECIFIED

SCALE	TOLERANCES	REV	M.B. 12, 23, 75
MATERIAL	APPROVED	DATE	S.B. 0, 9, 76
FINISH	APPROVED	DATE	WESTERN DIVISION - SANTA BARBARA, CALIFORNIA
			OKIDATA CORP.
			SERVO & LOGIC (SERVO SYSTEM)
DATE	REV	BY	30103 SC 4-4

DELETED: CR414 THRU CR499, U401, U414, U425, R405, R455, R458, R406, U417, U418, U419, U420, U421, U422, U423, U424, U426, U427, U428, U429, U430, U431, U432, U433, U434, U435, U436, U437, U438, U439, U440, U441, U442, U443, U444, U445, U446, U447, U448, U449, U450, U451, U452, U453, U454, U455, U456, U457, U458, U459, U460, U461, U462, U463, U464, U465, U466, U467, U468, U469, U470, U471, U472, U473, U474, U475, U476, U477, U478, U479, U480, U481, U482, U483, U484, U485, U486, U487, U488, U489, U490, U491, U492, U493, U494, U495, U496, U497, U498, U499, U500, U501, U502, U503, U504, U505, U506, U507, U508, U509, U510, U511, U512, U513, U514, U515, U516, U517, U518, U519, U520, U521, U522, U523, U524, U525, U526, U527, U528, U529, U530, U531, U532, U533, U534, U535, U536, U537, U538, U539, U540, U541, U542, U543, U544, U545, U546, U547, U548, U549, U550, U551, U552, U553, U554, U555, U556, U557, U558, U559, U560, U561, U562, U563, U564, U565, U566, U567, U568, U569, U570, U571, U572, U573, U574, U575, U576, U577, U578, U579, U580, U581, U582, U583, U584, U585, U586, U587, U588, U589, U590, U591, U592, U593, U594, U595, U596, U597, U598, U599, U600, U601, U602, U603, U604, U605, U606, U607, U608, U609, U610, U611, U612, U613, U614, U615, U616, U617, U618, U619, U620, U621, U622, U623, U624, U625, U626, U627, U628, U629, U630, U631, U632, U633, U634, U635, U636, U637, U638, U639, U640, U641, U642, U643, U644, U645, U646, U647, U648, U649, U650, U651, U652, U653, U654, U655, U656, U657, U658, U659, U660, U661, U662, U663, U664, U665, U666, U667, U668, U669, U670, U671, U672, U673, U674, U675, U676, U677, U678, U679, U680, U681, U682, U683, U684, U685, U686, U687, U688, U689, U690, U691, U692, U693, U694, U695, U696, U697, U698, U699, U700, U701, U702, U703, U704, U705, U706, U707, U708, U709, U710, U711, U712, U713, U714, U715, U716, U717, U718, U719, U720, U721, U722, U723, U724, U725, U726, U727, U728, U729, U730, U731, U732, U733, U734, U735, U736, U737, U738, U739, U740, U741, U742, U743, U744, U745, U746, U747, U748, U749, U750, U751, U752, U753, U754, U755, U756, U757, U758, U759, U760, U761, U762, U763, U764, U765, U766, U767, U768, U769, U770, U771, U772, U773, U774, U775, U776, U777, U778, U779, U780, U781, U782, U783, U784, U785, U786, U787, U788, U789, U790, U791, U792, U793, U794, U795, U796, U797, U798, U799, U800, U801, U802, U803, U804, U805, U806, U807, U808, U809, U810, U811, U812, U813, U814, U815, U816, U817, U818, U819, U820, U821, U822, U823, U824, U825, U826, U827, U828, U829, U830, U831, U832, U833, U834, U835, U836, U837, U838, U839, U840, U841, U842, U843, U844, U845, U846, U847, U848, U849, U850, U851, U852, U853, U854, U855, U856, U857, U858, U859, U860, U861, U862, U863, U864, U865, U866, U867, U868, U869, U870, U871, U872, U873, U874, U875, U876, U877, U878, U879, U880, U881, U882, U883, U884, U885, U886, U887, U888, U889, U890, U891, U892, U893, U894, U895, U896, U897, U898, U899, U900, U901, U902, U903, U904, U905, U906, U907, U908, U909, U910, U911, U912, U913, U914, U915, U916, U917, U918, U919, U920, U921, U922, U923, U924, U925, U926, U927, U928, U929, U930, U931, U932, U933, U934, U935, U936, U937, U938, U939, U940, U941, U942, U943, U944, U945, U946, U947, U948, U949, U950, U951, U952, U953, U954, U955, U956, U957, U958, U959, U960, U961, U962, U963, U964, U965, U966, U967, U968, U969, U970, U971, U972, U973, U974, U975, U976, U977, U978, U979, U980, U981, U982, U983, U984, U985, U986, U987, U988, U989, U990, U991, U992, U993, U994, U995, U996, U997, U998, U999, U1000

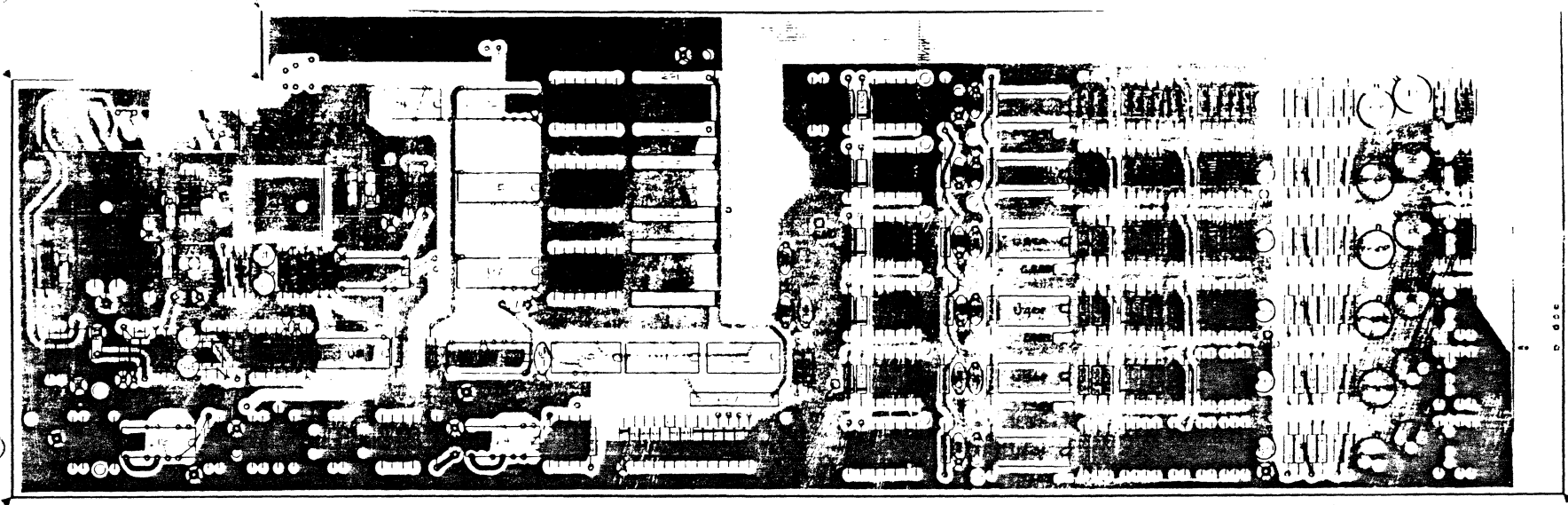

DATE	DESCRIPTION	REVISION	OKIDATA CORP.			
			BY: [illegible] DATE: [illegible]			
			30104			
			REV	DATE	BY	APP
			1		D	

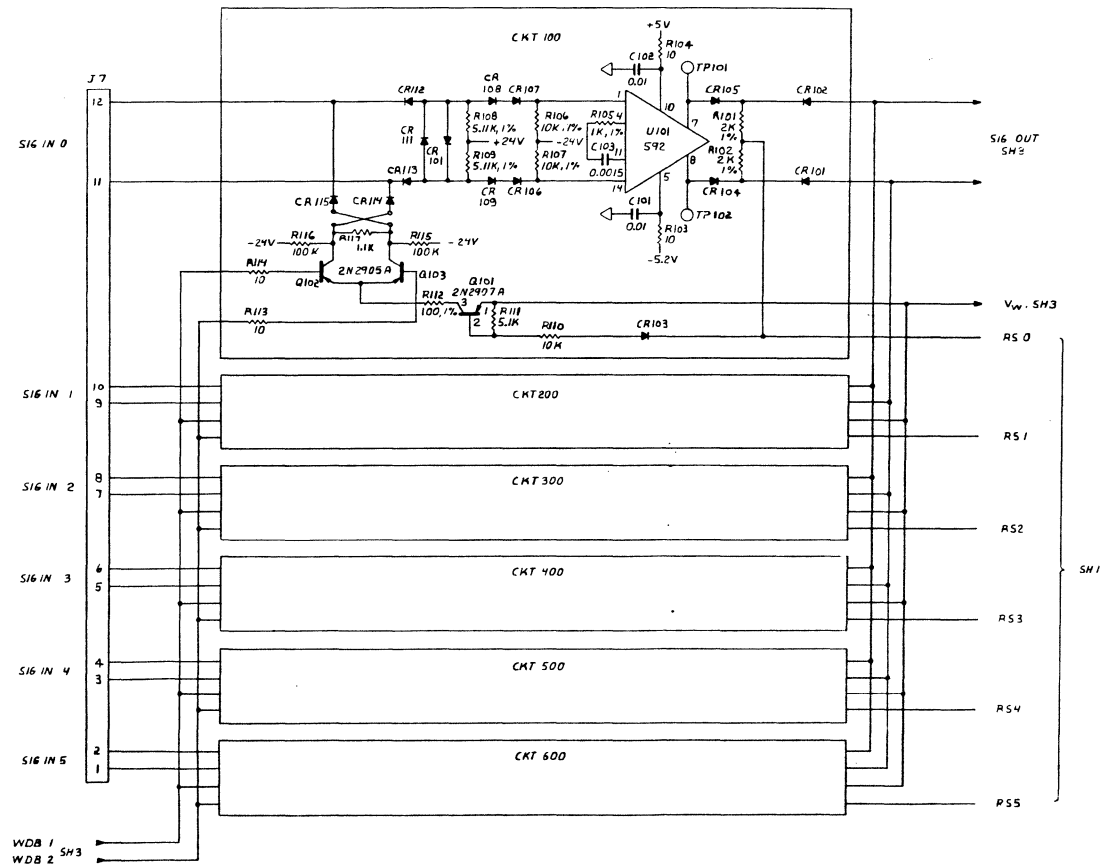

2. COMPONENTS IN EACH CIRCUIT HAVE 10%, 20, -1% TOLERANCE TO THEIR PART NUMBERS

NOTES 1. ALL DIMS IN INCHES

SCALE	TOLERANCES	BY DRAW	OKIDATA CORP. WESTERN DIVISION - SANTA BARBARA CALIFORNIA
		M.E. 3-6-77	
MATERIAL		DATE	FIXED HEAD AMPLIFIER
		3/25/77	
FINISH		APPROVED	
		DATE	REV
		1-1-77	0
		SIZE	D
		REV NO	30104
		DATE	2-73

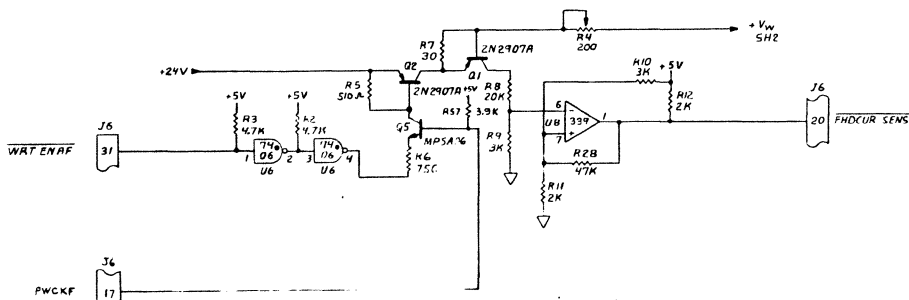
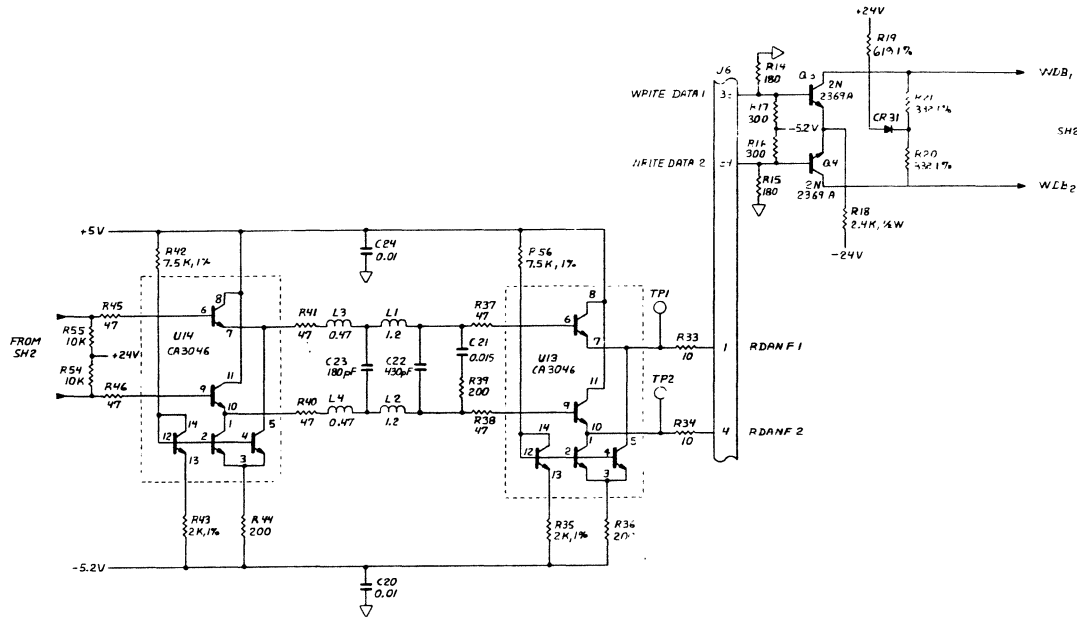

NOTE: L: INDUCTOR VALUE IN μ H

OKIDATA CORP.			
SCALE:	APPROVED BY:	DRAWN BY: H. B.	
DATE: 12/1/75		REVISED: 5-2-78 (75)	
FIXED HEAD AMPLIFIER			
Sheet 3 of 3			30104

REVISIONS				
REV	SYM	DESCRIPTION	DATE	APPR
B		REV 0526	12/77	

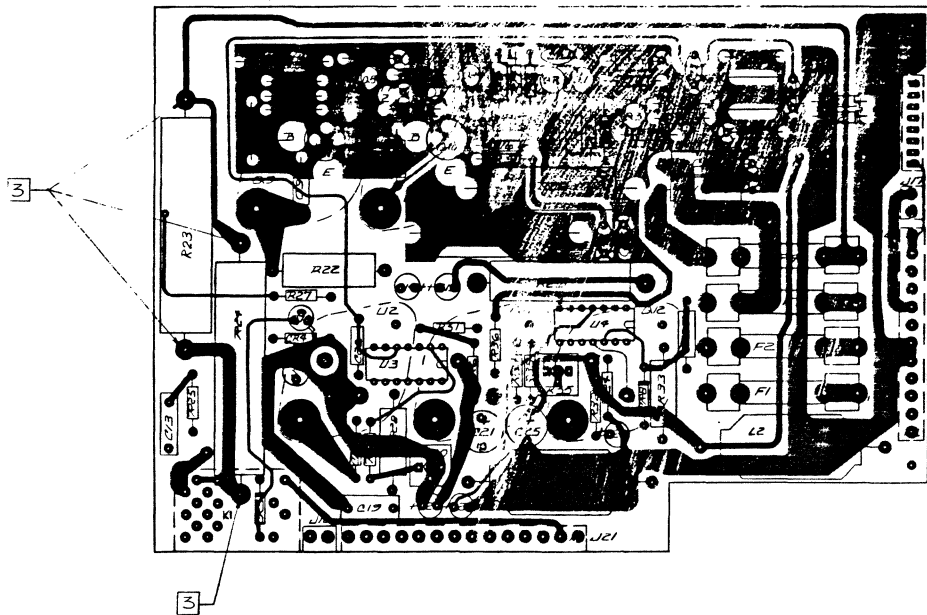

- 3] INSTALL ITEM 79 TERMINAL USE (1) No. 1119 B (1) No. 1119 C USING SWAGE TOOL (1) No. 1119 D (1) No. 1119 E
- 2] FASTEN R23, R24 TO TOP OF BOARD USING SWAGE TOOL (1) No. 1119 D AT LEAST .150 CLEARANCE BETWEEN BOARD & RESISTORS
- 1] R20, R21, & R26 TO BE RAISED 1/8" ABOVE BOARD SURFACE
- NOTES—UNLESS OTHERWISE SPECIFIED

SCALE	DESCRIPTION	DATE	OKIDATA CORP.	
		12-2-77	WESTERN DIVISION • SANTA BARBARA, CALIFORNIA	
			TITLE	
			ASSEMBLY	
			POWER AMPLIFIER	
			REV	DATE
			B	D 3005

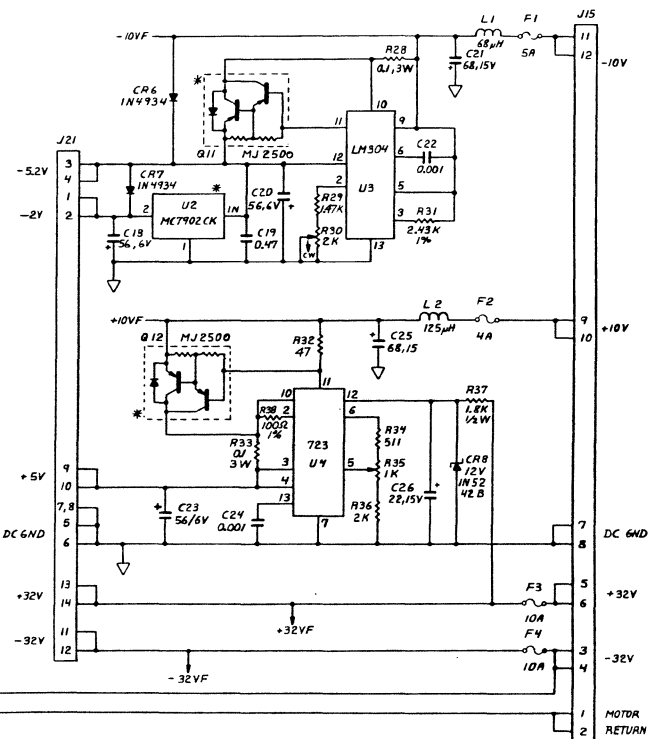
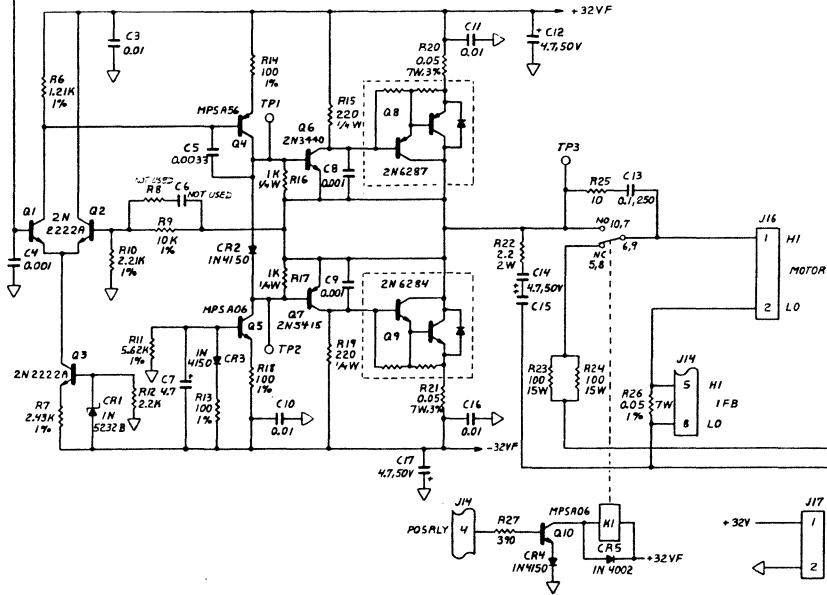
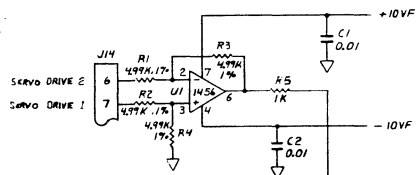

- 4. * TO BE INSULATED FROM GROUND
 - 3. ALL 1% RESISTORS ARE RNSSD
 - 2. CAPACITORS IN μ F
 - 1. RESISTOR $\frac{E}{7}$ $\frac{V}{W}$
- NOTES: UNLESS OTHERWISE SPECIFIED

DESIGN	H. B.	OKIDATA CORP.
CHECKED	C. J.	
APPROVED	J. J.	WESTERN DIVISION • SANTA BARBARA CALIFORNIA
DATE	REV	POWER AMP & REGULATOR
1	1	30105

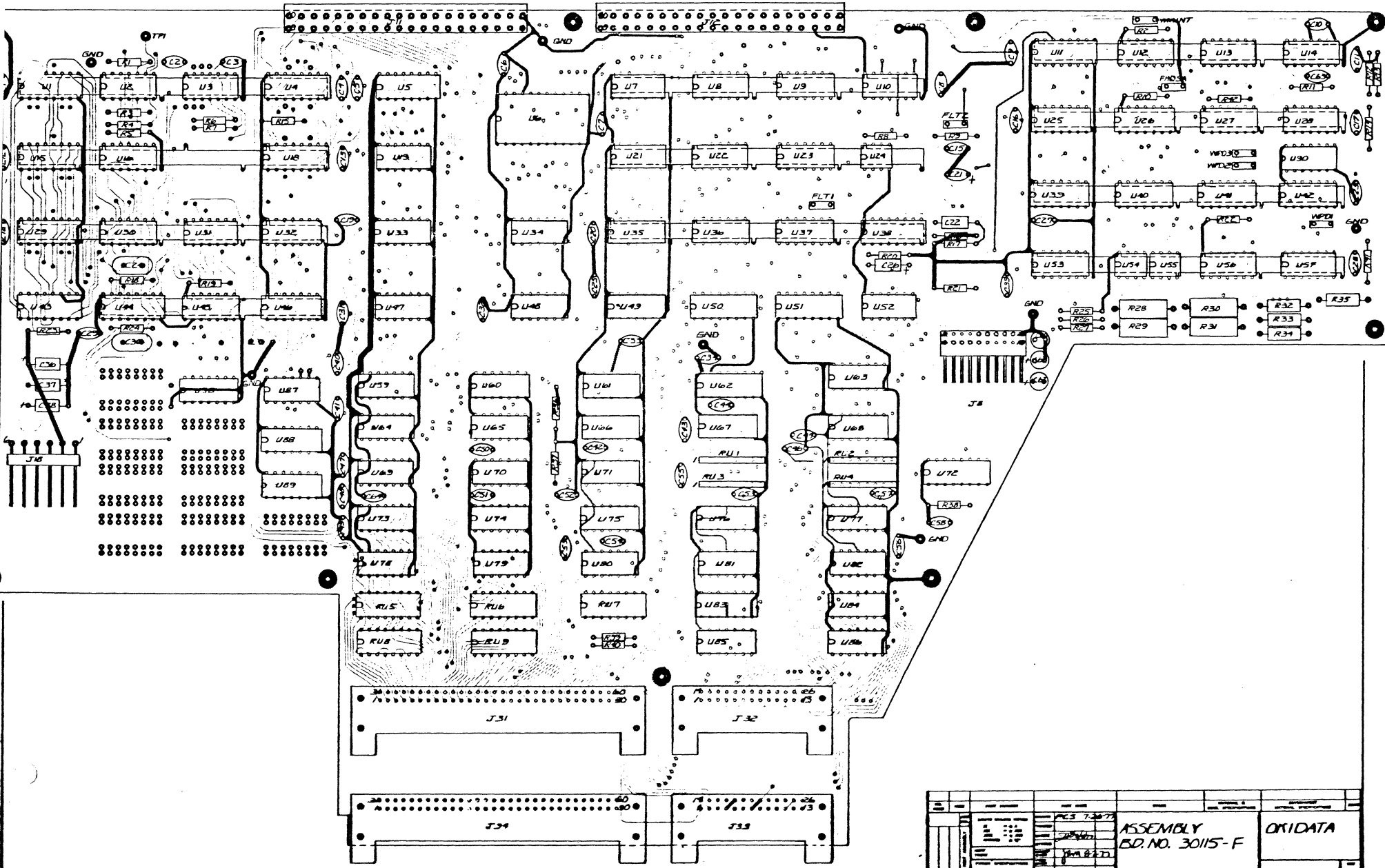

REV	DATE	BY	CHKD	APPROV	PCS 7-2077	ASSEMBLY	OKIDATA
					7-2077	BD. NO. 3015-F	
					7-2077		
							F

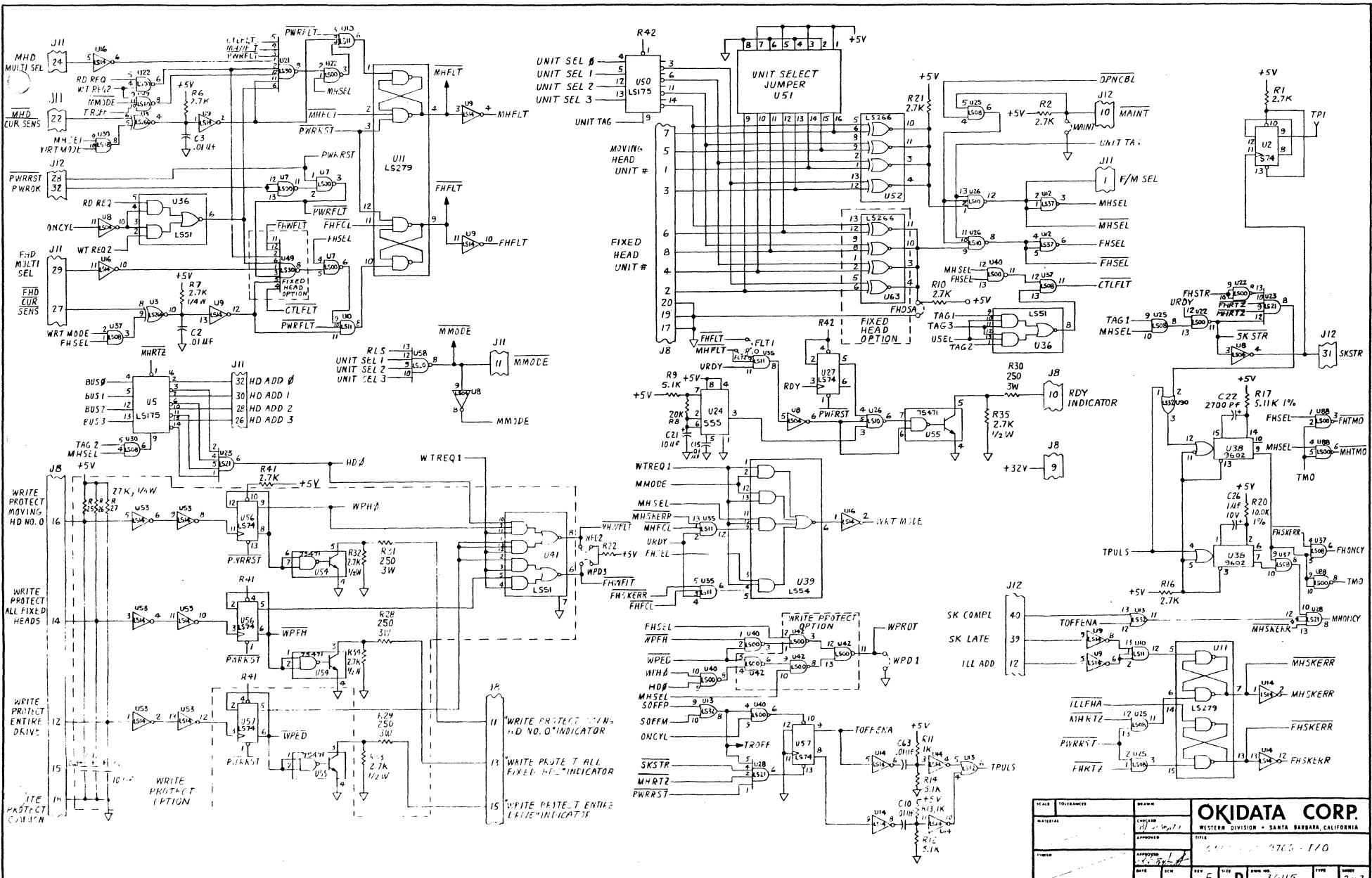

SCALE TOLERANCES		DRAWN		OKIDATA CORP.	
RESISTORS	1% 5% 10% 20%	DATE	REV	WESTERN DIVISION • SANTA BARBARA, CALIFORNIA	
CAPACITORS	1% 5% 10% 20%	APPROVED	DATE	TITLE	
INDUCTORS	1% 5% 10% 20%	DATE	REV	36115	
TRANSISTORS	1% 5% 10% 20%	DATE	REV	PAGE 2 OF 3	

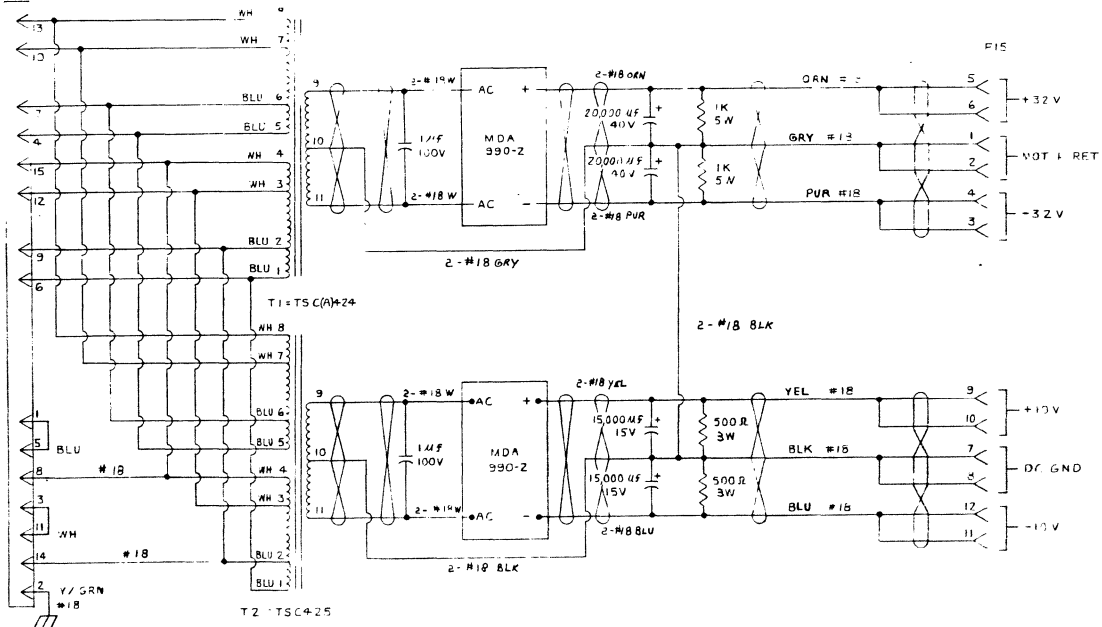

- PRIMARY**
- USE TYPE 1015 WIRE FOR ALL PRIMARY WIRING
 - USE SLEEVING ON ALL PRIMARY TRANSFORMER SQUARE LUGS
- SECONDARY**
- USE TYPE 1061 WIRE FOR ALL SECONDARY WIRING
- NOTE!**

IN	VOLT	PIN
1	0V	5
2	10V	6
3	110V	7
4	130V	8
T1 AND T2		

P27

1	4	7	10	13
2	5	8	11	14
3	6	9	12	15

FRONT OF ACK

P27 TOLERANCE

LINE VOLTAGE	IMPEDANCE	WIRE GAUGE
100	5-7-9, 11-9-12	
110	5-7-9, 11-9-12	
120	5-7-9, 11-9-12	
130	5-7-9, 11-9-12	
200	5-3, 11-10	
220	5-6, 4-11, 11-10	
240	5-9, 7-5, 11-13	
260	5-6, 4-15, 11-12	

30120

B

SCALE	TOLERANCE	DRW	CSB PLO	OKIDATA CORP. WESTERN DIVISION • SANTA BARBARA, CALIFORNIA TITLE: <i>Comp. P.S. 100, FINDER - 1/2/74</i>
MATERIAL		CHECKED	APPROVED	
FORM		APPROVED		
DATE	REV	DES	APP'D	
2-4-77	8	D	3120	REV 1

REVISIONS				
REV	SYM	DESCRIPTION	DATE	APP'R
A		PLS. PRD REL.	5-4-77	
B		2 M 3:15	5-4-77	
C		KCH 5476	7-27-77	
D		ECN 5431	8-30-77	

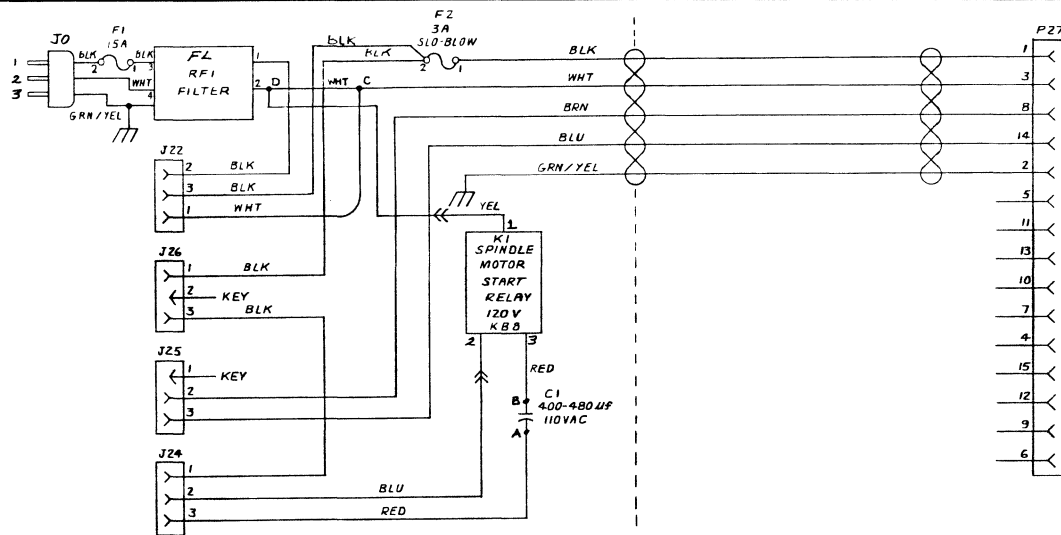

AC DISTRIBUTION BOX 100 V-130V

TABLE A

NOMINAL LINE	P27 PIN CONNECTIONS	
100	5-7 & 9	11-10 & 12
110	5-4 & 6	11-10 & 12
120	5-7 & 9	11-13 & 15
130	5-4 & 6	11-13 & 15

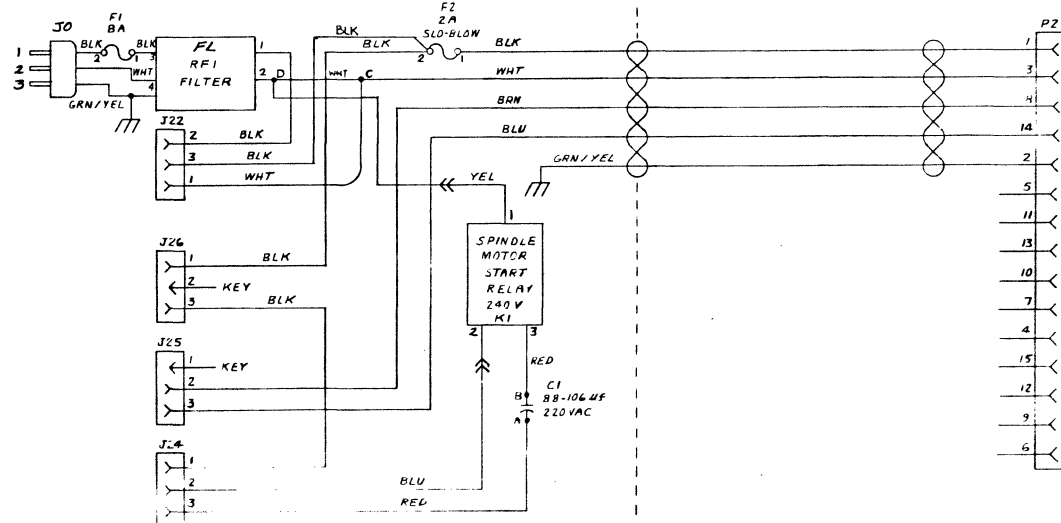

AC DISTRIBUTION BOX 200 V-260V

TABLE B

NOMINAL LINE	P27 PIN CONNECTIONS		
200	5-9	12-7	11-10
220	5-6	12-4	11-10
240	5-9	15-7	11-13
260	5-6	15-4	11-13

30390
D

Z- FOR AC WIRE SEE 30317.
1- ALL WIRE # 18 AWG TYPE 1017
NOTES: UNLESS OTHERWISE SPECIFIED

REVISED BY	DATE	OKIDATA CORP. WESTERN DIVISION - SANTA BARBARA, CALIFORNIA TITLE: SCHEMATIC, AC DISTRIBUTION BOX
APPROVED BY	DATE	
DESIGNED BY	DATE	DRAWING NO. 30390 SHEET 1 OF 1