

CONTROL MEMORY TEST

This program tests the ability of the control memory section to accept and retain various bit configurations. This is accomplished by loading and evaluating a series of patterns which range in complexity from the simplest to two patterns generating the maximum amount of noise in the core sense windings. These patterns included worst pattern, a complement worst pattern, a random number generator, a read/write test, and a pattern test consisting of hold 1's, hold 0's, alternate 1's and 0's and alternate 0's and 1's. Each pattern is loaded and evaluated within a subroutine which is under the control of an executive routine. In addition, a Hammer Test is included which is also under control of the executive.

The Control Memory Test is written from either a 128 or 256 word control memory. The Control Memory Size table shows the appropriate size index that must be entered into AL before the program is initiated.

CONTROL MEMORY SIZE TABLE

Control Memory Size	Set AL bits 2-0 to
128	0
256	1

The operator has the option of selecting either or both a computer console error display or an error timeout. If PROGRAM STOP 0 is set and an error is detected, the test will stop and display the correct pattern in AU and the incorrect pattern in AL. Upon restarting, the test will stop with the failing address in AL. If PROGRAM SKIP 4 is not set Timeout Subroutines will provide the operator with a timeout of the status of the Control Memory Test. If an error is detected, and PROGRAM SKIP 4 is not set, the failing address and the correct and incorrect patterns will be buffered out. All messages are buffered out in field data code via channel 0.

The Control Memory Test may be run separately or as a part of the Integrated Memory test. If it is run separately PROGRAM SKIP 2 must be set to remain in the CONTROL MEMORY TEST. The following is the operating procedure for the CONTROL MEMORY TEST.

- a. Disconnect the RTC.

- b. Load the CONTROL MEMORY TEST PROGRAM or the INTEGRATED MEMORY TEST PROGRAM. The jumps and stops for this program are as shown in the following table:

PROGRAM SWITCH	PROGRAM ACTION
PROGRAM SKIP 0	Set to recycle a failing test sub-routine
PROGRAM SKIP 2	Set to remain in the Control Memory test
PROGRAM SKIP 4	Set to suppress timeouts
PROGRAM STOP 0	Set to computer console error display
PROGRAM STOP 1	Set to end test after current cycle
PROGRAM STOP 2	Set to stop after error timeout
PROGRAM STOP 3	Set to end test after a selected number (the number -1 in address NUMB) of cycles of the Control Memory Test. This stop is used with timeouts only.

- c. Set PROGRAM SKIPS and STOPS as desired according to the above table.
- d. Master Clear the Computer.
- e. Set AL bits 2-0 to the appropriate size index as found in the Control Memory Size table.
- f. Set the 1232/1532 channel number in AL bits 6 to 3.
- g. Set AL bit 8 if the I/O Console is a 1532.
- h. Set AL bits 17-15 as follows:
- Set bit 17 if computer is in 1218 normal mode
 - Set bit 16 if computer is in 1218 NTDS mode
 - Set bit 15 if computer is in 1219 normal mode
- i. Insert (if necessary) the plug-in printed wiring assembly 7104010 in the location specified as follows:
- A4A1J5G if computer is in 1218 normal mode
 - A4A1J5F if computer is in 1218 NTDS mode
 - A4A1J4G if computer is in 1219 normal mode
- j. Set P=3700.
- k. Start the Computer.

PROGRAM DATA PAGE

SHEET 668

REVISION

SPECIFICATION SYMBOL

SB-10163

TITLE: SIZE - CONTROL MEMORY SIZE DETERMINATIONDECK IDENTIFIER: FACTCS-1 LABEL: SIZE KEY: _____ IS LABEL DUPLICATE? NoPROGRAMMER: H W M modified by TLR DATE: 8 Dec. 67NUMBER OF L₄ OUTPUT INSTRUCTIONS: 26

DESCRIPTION:

This routine, SIZE, takes a size index that is manually entered into AL and uses it to set the upper limit of control memory and to initialize the routine, CHECK, that checks for the areas of main memory that are not to be tested.

This routine stores the 1232/1532 channel number in all I/O instructions. Also, the terminal BCW's for output and external function instructions are setup for either N or N+1 termination.

This routine is run only once and is not referenced by subsequent routines.

SIZE saves the index in AL then adds the index to the base address for the control memory size. This modified address is used to enter the appropriate value for control memory size into AL and store it at address PAR1. A similar procedure is used to store the appropriate instruction in routine CHEK.

TITLE: SIZE - CONTROL MEMORY SIZE DETERMINATION

INPUT PARAMETERS (Listed Sequentially):

AL is entered manually before initialing program

OUTPUT PARAMETERS (Listed Sequentially):

PAR1
CHEK4

ABNORMAL EXITS (Listed Sequentially):

NEXT LEVEL PROCEDURES OR SUBROUTINES (Keys of Duplicate Labels Specified):

TYPE
IOSET
CRANK

SYSTEM DATA REFERENCES:

ALARMS AND/OR REMARKS:

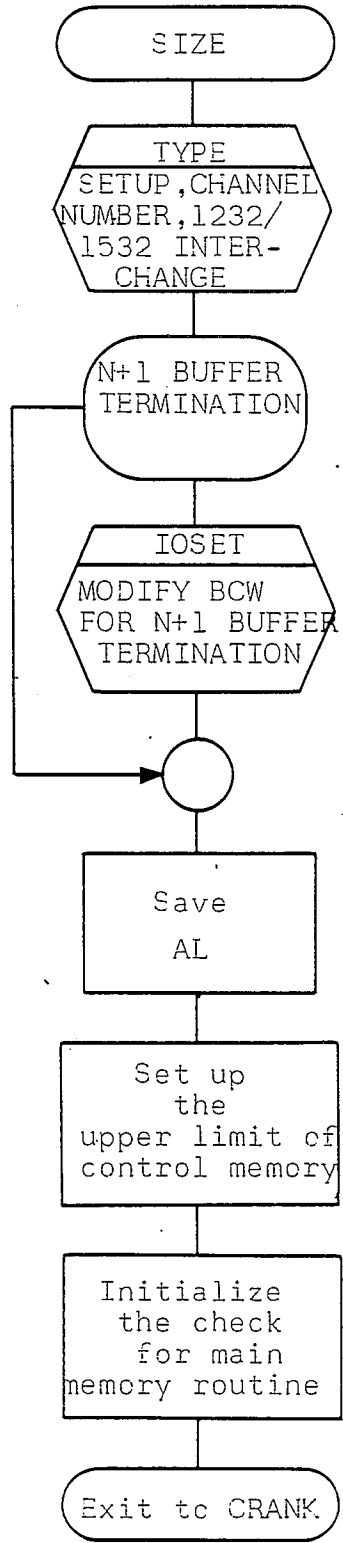

SIZE

PROGRAM DATA PAGE

SHEET

671

REVISION

1

SPECIFICATION SYMBOL

SB-10163

TITLE: CRANK - 1219B CONTROL MEMORY TEST MONITORDECK IDENTIFIER: FACTCS-1 LABEL: CRANK KEY: _____ IS LABEL DUPLICATE? NOPROGRAMMER: HWM modified by CRB DATE: 23 Jan. 69NUMBER OF L₄ OUTPUT INSTRUCTIONS: 34

DESCRIPTION:

This routine, CRANK, monitors the 1219B Control Memory Test.

CRANK is referenced by routines TEST and FLUSH.

PROGRAM SKIP 4 is referenced when CRANK is entered. If not set, the I/O console is turned on and CONTROL MEMORY TEST is typed. It then exits to TRACK. If SKIP 4 is set, TRACK is entered. The number of cycles completed by Control Memory Test is referenced. If 10 cycles are not completed, the program exits to TEST. If 10 cycles are completed, the count is cleared and PROGRAM SKIP 4 is referenced. If set, the program continues without typeouts. If SKIP 4 is not set, a flag is checked to determine if any errors occurred during the test. If no errors occurred, OK, END CYCLES is printed and the program continues. If errors occurred, RECYCLE is printed, the error flag is cleared, and the program continues. PROGRAM STOP 3 is referenced. If it is set, TEST has ended. If it is not set, PROGRAM SKIP 2 is referenced. If it is set, exit to TRACK. If it is not set, exit to INTEGRATED EXECUTIVE.

PROGRAM DATA PAGE (Cont)

SHEET 672

REVISION

SPECIFICATION SYMBOL

SB-10163

TITLE: CRANK - 1219B CONTROL MEMORY TEST MONITOR

INPUT PARAMETERS (Listed Sequentially):

BAER

OUTPUT PARAMETERS (Listed Sequentially):

BUFFER PC
BUFFER MEM-MEMO+3
BUFFER END-END+5
BUFFER BUN-BUN+3

ABNORMAL EXITS (Listed Sequentially):

NEXT LEVEL PROCEDURES OR SUBROUTINES (Keys of Duplicate Labels Specified):

TEST
TYPI

SYSTEM DATA REFERENCES:

ALARMS AND/OR REMARKS:

PROGRAM SKIP 4- set to suppress typecuts
PROGRAM STOP 3- set to end test
PROGRAM SKIP 2- set to remain in the Control Memory Test

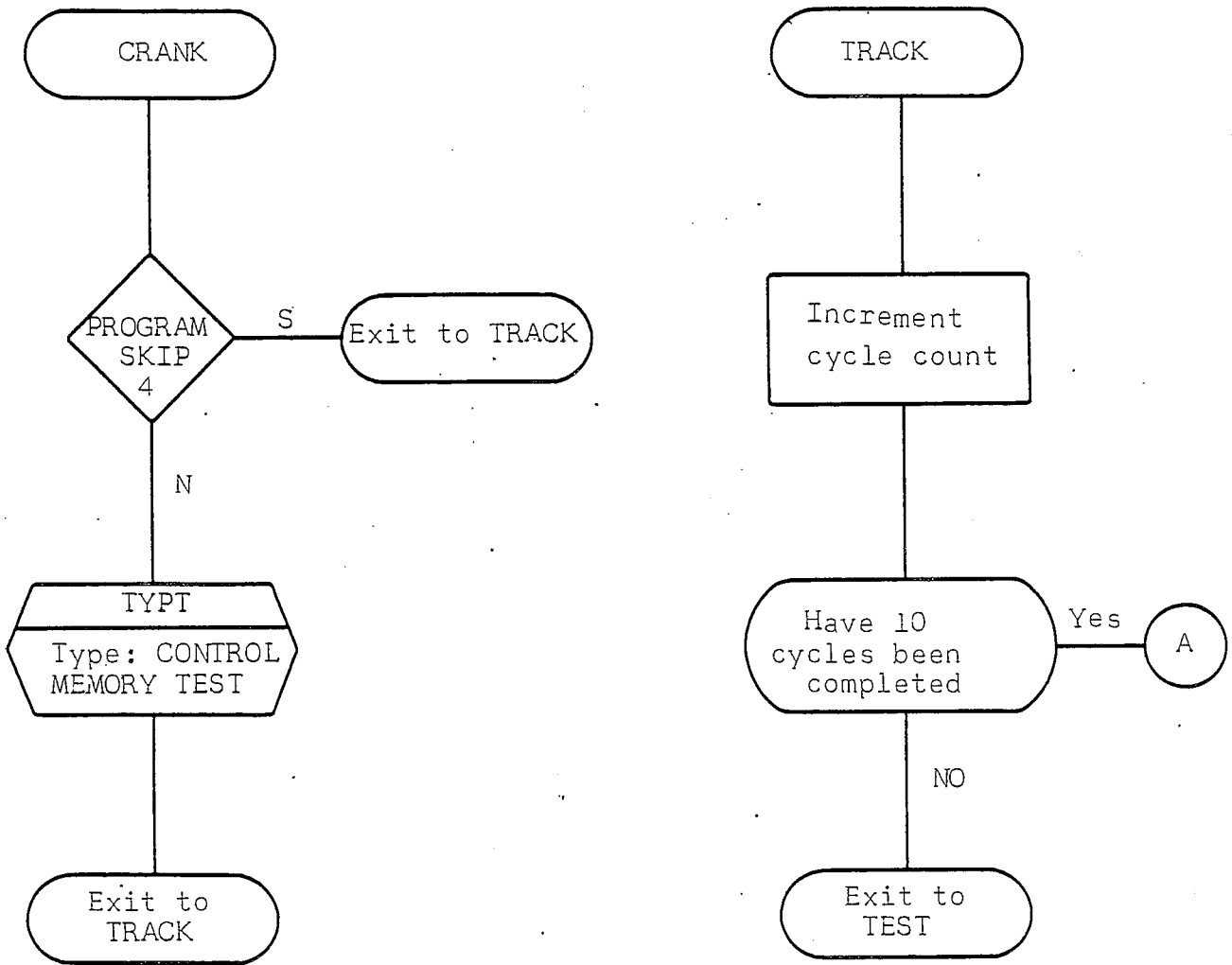

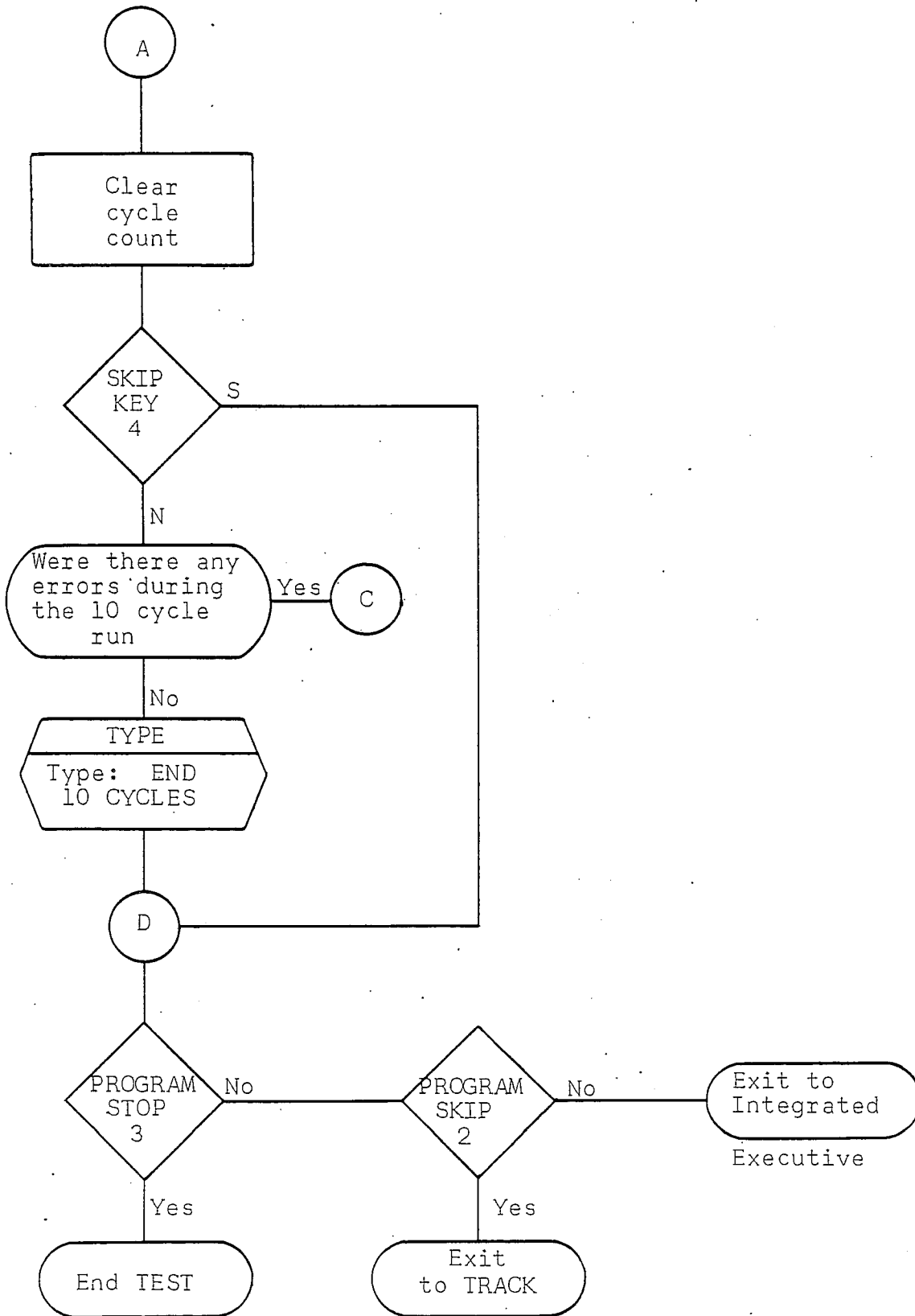

SPECIFICATION SYMBOL SB-10163

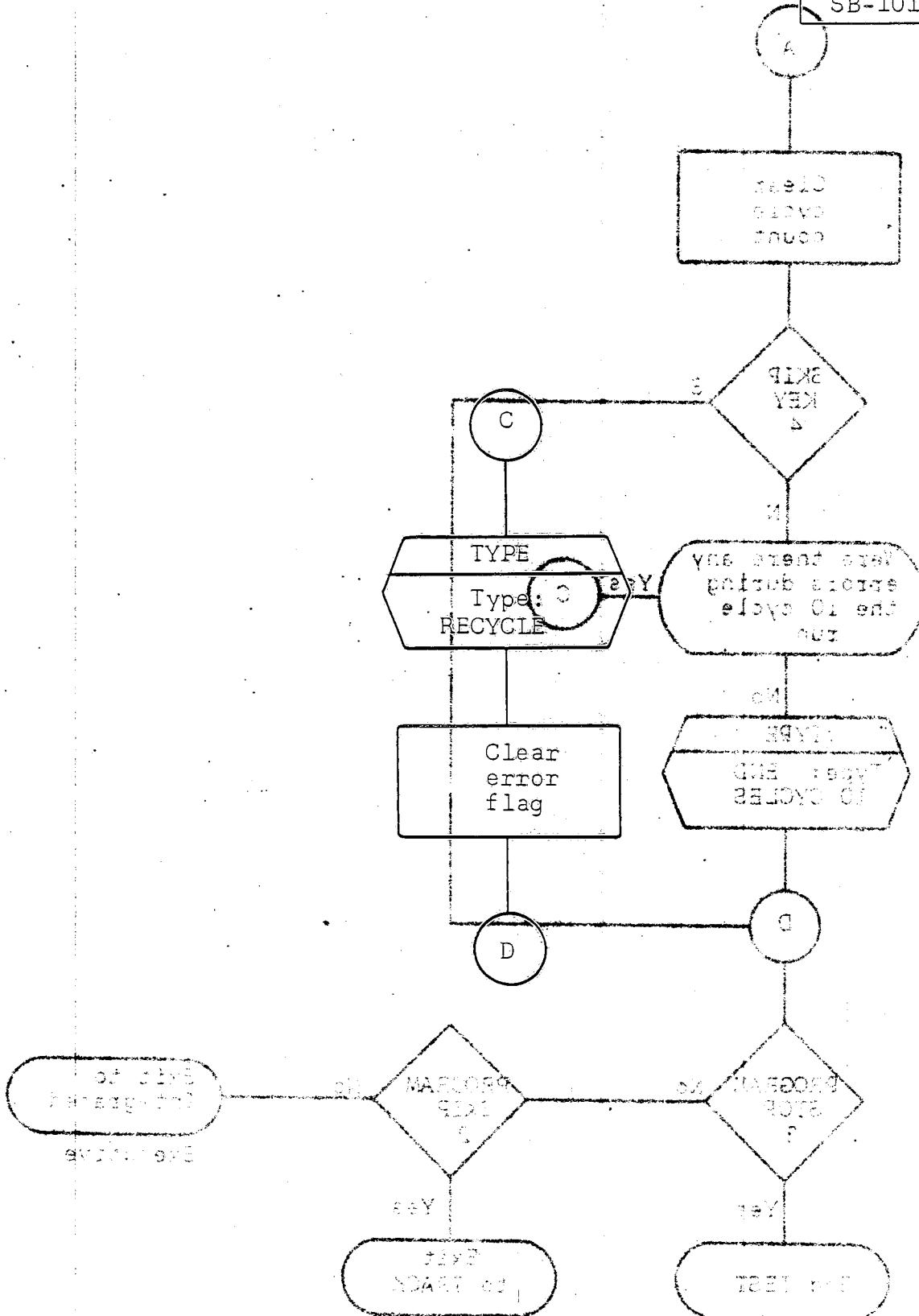

SPECIFICATION SYMBOL
SB-10163

TITLE: ERROUT - ERROR TYPEOUT

DECK IDENTIFIER: FACT

CS-1 LABEL: ERROUT KEY: _____ IS LABEL DUPLICATE? No

PROGRAMMER: H W M modified by TLR DATE: 8. Dec. 67

NUMBER OF 1 OUTPUT INSTRUCTIONS: 35

DESCRIPTION:

This subroutine, ERROUT, types out the following error indication:

ERROR

1st ADDRESS	LAST ADDRESS	CORRECT	INCORRECT
XXXXXX	XXXXXX	XXXXXX	XXXXXX

After the typeout PROGRAM STOP 2 is referenced for the end of the Control Memory test. This routine, ERROUT, is referenced by the following routines: PROOF, WPI, CWP1, and RW.

Upon entering ERROUT the current ICR is stored and reset to 2. Then the contents B2 and the output buffer locations are stored. An error flag is set. The typeout is completed in the format shown above and PROGRAM STOP 2 is referenced for end of test. The ICR, B2, and the output buffer locations are restored and an exit is made from ERROUT.

TITLE: ERROUT - ERROT TYPEOUT

INPUT PARAMETERS (Listed Sequentially):

HERE
THERE
DIP
DIP+1

OUTPUT PARAMETERS (Listed Sequentially):

BUFFER RUE - TRUE+11
BAER
BUFFER BUN - BUN+3
DIP
DIP+1

ABNORMAL EXITS (Listed Sequentially):

NEXT LEVEL PROCEDURES OR SUBROUTINES (Keys of Duplicate Labels Specified):

TYPT
CRANK

SYSTEM DATA REFERENCES:

ALARMS AND/OR REMARKS:

PROGRAM STOP 2 - set to stop after error typeout

PROGRAM DATA PAGE

SHEET 679

REVISION —

SPECIFICATION SYMBOL

SB-10163

TITLE: TYPE - SETUP CHANNEL NUMBER, 1232/1532 INTERCHANGE

DECK IDENTIFIER: FACT

CS-1 LABEL: TYPE KEY: _____ IS LABEL DUPLICATE? No

PROGRAMMER: _____ TLR _____ DATE: 8 December 1967

NUMBER OF L₄ OUTPUT INSTRUCTIONS: 43

DESCRIPTION:

This subroutine inserts the 1232/1532 channel number in all I/O instructions. It also modifies the TYPT and TYPC sub-routines so as to accept either 1232 or 1532 coded data.

SPECIFICATION SYMBOL
SB-10163

TITLE: _____ TYPE _____

INPUT PARAMETERS (Listed Sequentially):

ALPARM - Initial AL input parameter.

OUTPUT PARAMETERS (Listed Sequentially):

I\$1 T\$\$1
I\$2 T\$\$2
I\$3 T\$\$3
I\$4 T\$\$4

} I/O instructions with channel number inserted

RNOOP

{ RJP - CONVER if 1232 selected.
ADDALK -.40 if 1532 selected.

ABNORMAL EXITS (Listed Sequentially):

NEXT LEVEL PROCEDURES OR SUBROUTINES (Keys of Duplicate Labels Specified):

SYSTEM DATA REFERENCES:

ALARMS AND/OR REMARKS:

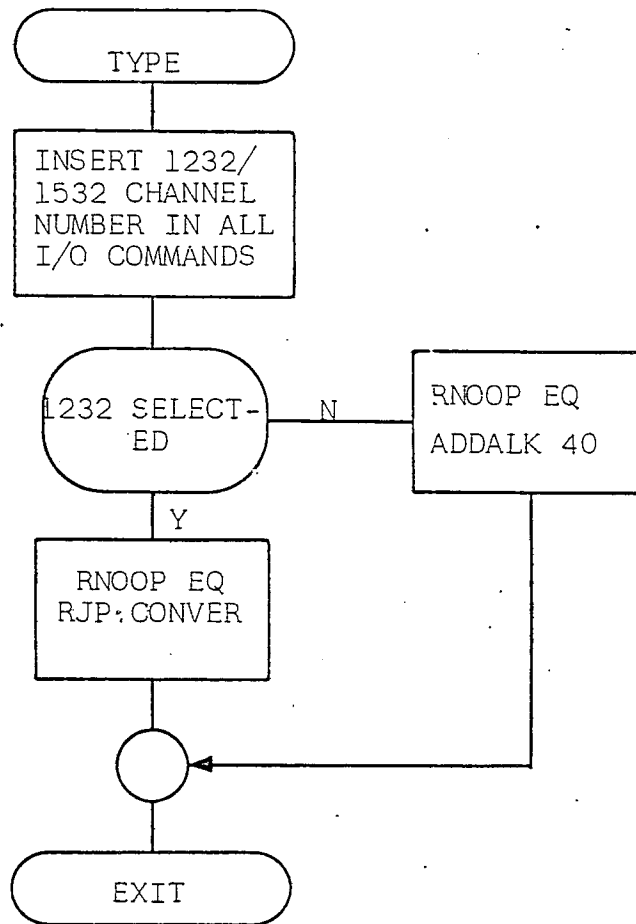

SHEET 682

REVISION —

SPECIFICATION SYMBOL

SB-10163

TITLE: IOSET

DECK IDENTIFIER: IOSET

CS-1 LABEL: IOSET KEY: IS LABEL DUPLICATE? No

PROGRAMMER: TLR DATE: 8 December 1967

NUMBER OF L₄ OUTPUT INSTRUCTIONS: 14

DESCRIPTION:

This subroutine modifies output and external function buffer for N+1 termination.

PROGRAM DATA PAGE (Cont)

SHEET 683

REVISION

SPECIFICATION SYMBOL
SB-10163

TITLE: IOSET

INPUT PARAMETERS (Listed Sequentially):

IS1+2
IS2+2

OUTPUT PARAMETERS (Listed Sequentially):

OS1+1
OS2+1

ABNORMAL EXITS (Listed Sequentially):

NEXT LEVEL PROCEDURES OR SUBROUTINES (Keys of Duplicate Labels Specified):

SYSTEM DATA REFERENCES:

ALARMS AND/OR REMARKS:

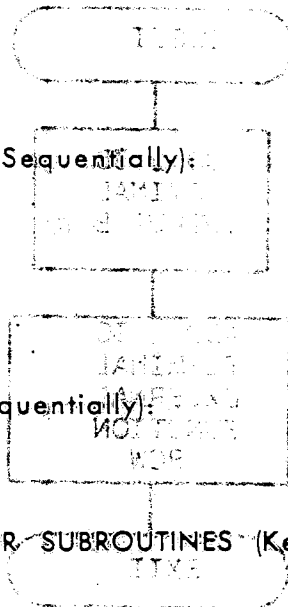

SPECIFICATION SYMBOL
SB-10163

IOSET

ADD 1 TO
TERMINAL
OUTPUT BCW

ADD 1 TO
TERMINAL
EXTERNAL
FUNCTION
BCW

EXIT

NEXT LEVEL PROCEDURES OR SUBROUTINES (or of Duplicate Label Specified)

SYSTEM DATA REFERENCES

ALARM AND/OR REMARKS

PROGRAM DATA PAGE

SHEET 685

REVISION —

SPECIFICATION SYMBOL

SB-10163

TITLE: CHEK - CHECK FOR MAIN MEMORYDECK IDENTIFIER: FACTCS-1 LABEL: CHEK KEY: _____ IS LABEL DUPLICATE? NoPROGRAMMER: H W M modified by TLR DATE: 8 Dec. 67NUMBER OF L₄ OUTPUT INSTRUCTIONS: 20

DESCRIPTION:

This subroutine, CHEK, checks the address to be tested, the current value of PAR, to determine if it is in main memory. If it is in main memory appropriate modifications are made on the address (PAR) and an exit is made from this subroutine, CHEK.

This subroutine, CHEK, is referenced by the following routines: PROOF, TEST, HD1, HALT HALTO, WP1, CWP1, RW1 and FLUSH1.

If CHEK has been modified for the 128 Control Memory size the current address, PAR, is compared to 177_g. If not equal an exit is made from CHEK. If equal, PAR is decremented by 100_g and an exit is made from CHEK. If CHEK has not been modified for 128 Control Memory PAR is compared to 577_g. If equal, PAR is decremented by 100_g and an exit is made from CHEK. If not equal, PAR is compared to 377_g. If equal, PAR is decremented by 100_g and an exit is made from CHEK. If not equal PAR is compared to 177_g. If not equal an exit is made from CHEK. If equal, PAR is decremented by 100_g and an exit is made from CHEK.

TITLE: CHEK - CHECK FOR MAIN MEMORY

INPUT PARAMETERS (Listed Sequentially):

PAR

CHEK 4

OUTPUT PARAMETERS (Listed Sequentially):

PAR

ABNORMAL EXITS (Listed Sequentially):

NEXT LEVEL PROCEDURES OR SUBROUTINES (Keys of Duplicate Labels Specified):

SYSTEM DATA REFERENCES:

ALARMS AND/OR REMARKS:

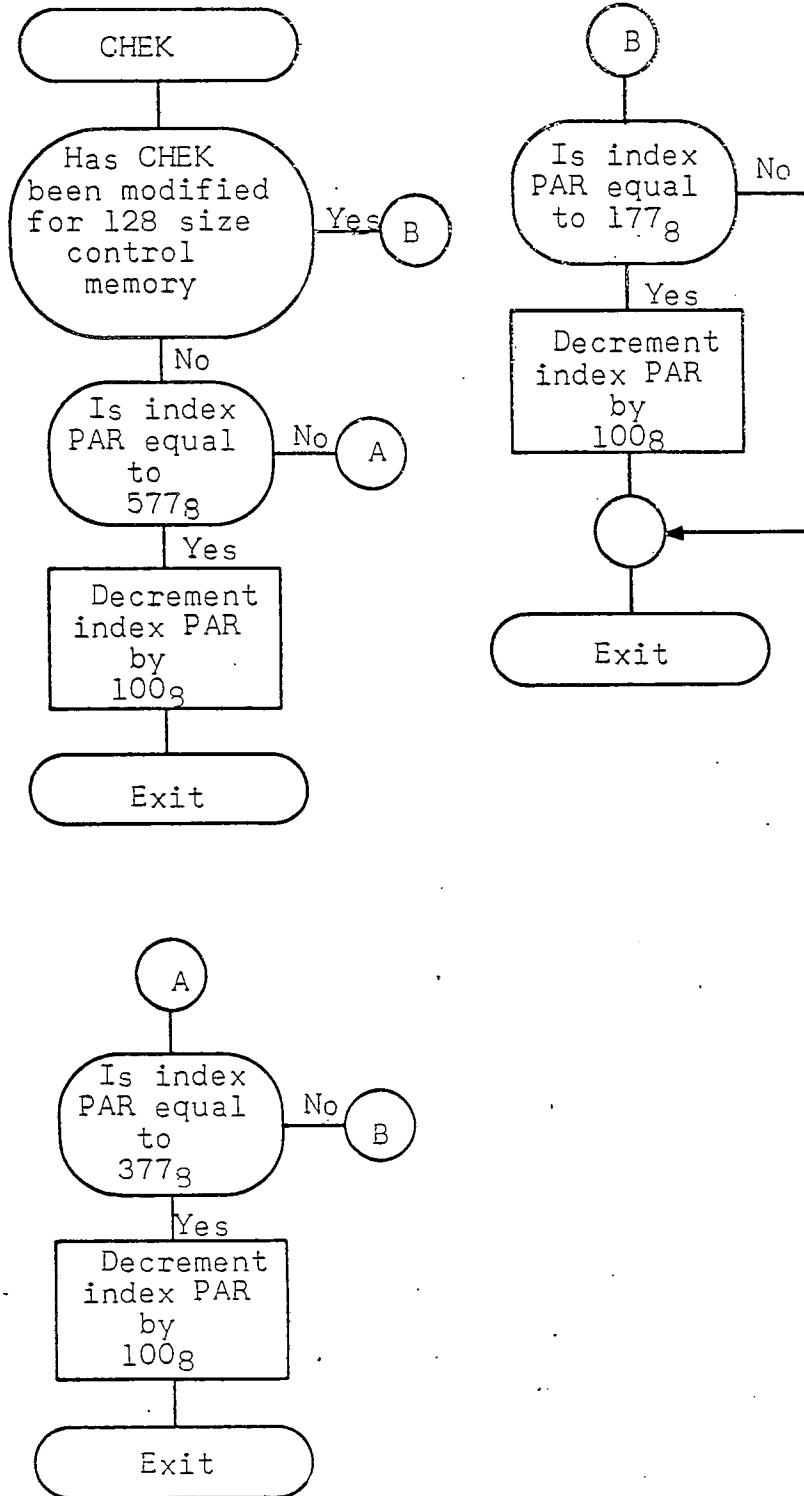

CHEK- CHECK FOR MAIN MEMORY

TITLE: PROOF - CONTINUE ERROR CHECK, TYPEOUTDECK IDENTIFIER: FACTCS-1 LABEL: PROOF KEY: _____ IS LABEL DUPLICATE? NoPROGRAMMER: H W M modified by TLF DATE: 8 Dec. 67NUMBER OF L₄ OUTPUT INSTRUCTIONS: 14

DESCRIPTION:

This subroutine, PROOF, continues the error check and initiates the error typeout whenever an error typeout is wanted in routines TEST, HD1, HALT and HALTO.

Whenever an error occurs in any of the higher level routines and an error typeout is wanted this routine, PROOF, continues to check the following addresses for incorrect contents. It then indicates an error typeout indicating the correct and incorrect test pattern and the inclusive consecutive addresses that contain incorrect test patterns. Upon completion of the error typeout, control is returned to the referencing routine.

SPECIFICATION SYMBOL

SB-10163

TITLE: PROOF - CONTINUE ERROR CHECK, TYPEOUT

INPUT PARAMETERS (Listed Sequentially):

PAR

OUTPUT PARAMETERS (Listed Sequentially):

THERE

ABNORMAL EXITS (Listed Sequentially):

NEXT LEVEL PROCEDURES OR SUBROUTINES (Keys of Duplicate Labels Specified):

ERROUT
CHEK

SYSTEM DATA REFERENCES:

ALARMS AND/OR REMARKS:

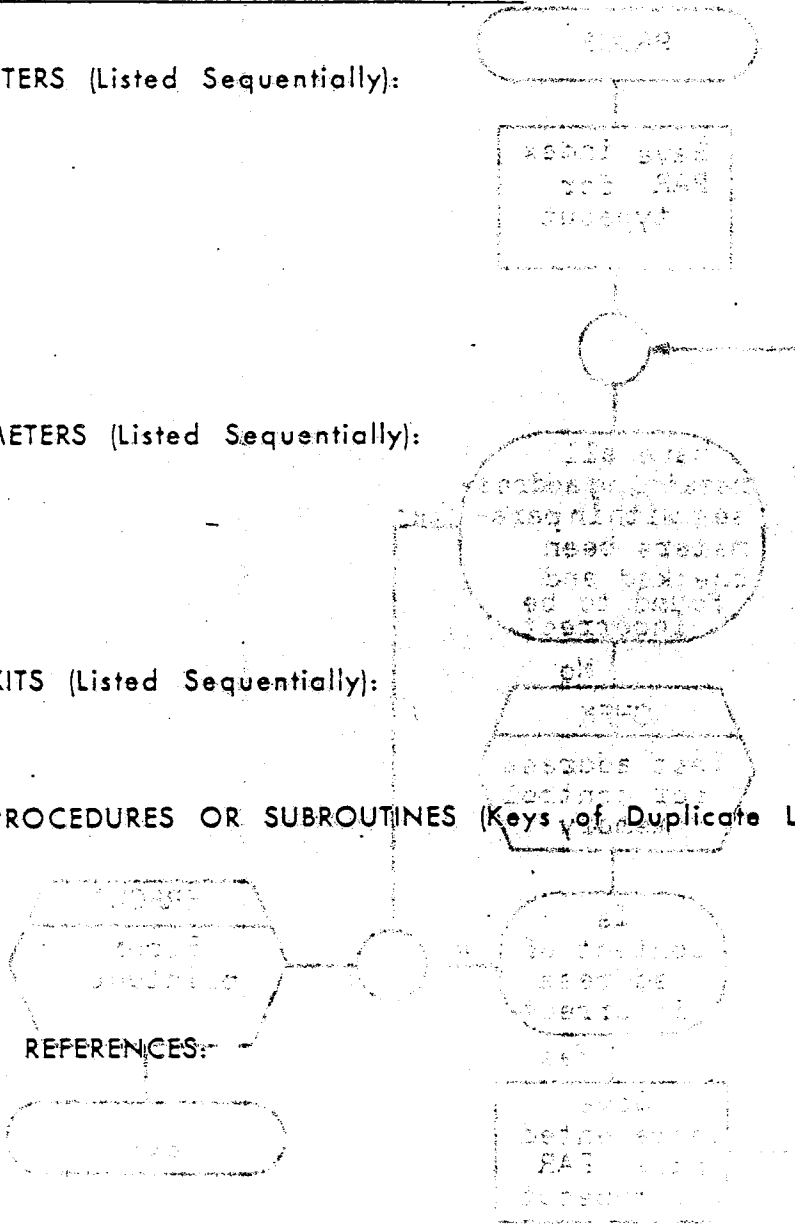

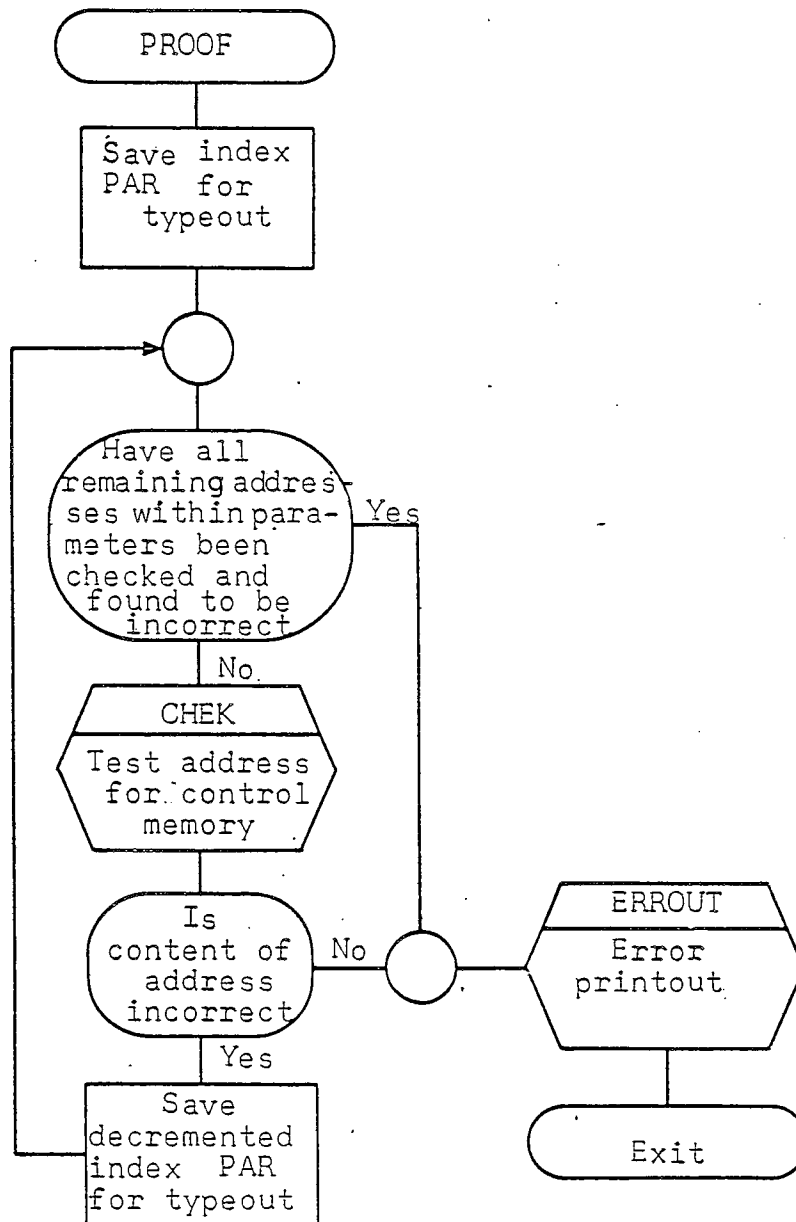

PROOF - CONTINUE ERROR CHECK, TYPEOUT

TITLE: TEST - HOLD ZEROES TESTDECK IDENTIFIER: FACTCS-1 LABEL: TEST KEY: _____ IS LABEL DUPLICATE? NoPROGRAMMER: H W M modified by TLR DATE: 8 Dec. 67NUMBER OF L₄ OUTPUT INSTRUCTIONS: 33

DESCRIPTION:

This routine, TEST, checks the ability of control memory to hold zeroes.

This routine is referenced by routines CRANK and FLUSH.

Control memory is cleared to all 0's. At the completion of the clearing, the content of each address is entered into AL and checked. If AL contains all 0's the next sequential address is checked. If it contains any improper information, the incorrect information is entered into AL, AU remains cleared which is the correct information. If PROGRAM STOP 0 is set the routine stops and the display may be evaluated. Upon restarting with PROGRAM STOP 0 set, the failing address will be displayed in AL and the routine stops. If PROGRAM STOP 0 is not set, or upon restarting, PROGRAM SKIP 4 is referenced. If it is not set an error timeout will occur. After the timeout, or if PROGRAM SKIP 4 is set, PROGRAM SKIP 0 is checked. If set, the test for holding zeroes will recycle; if not set, the test will continue. Upon successful completion of the test an exit is made to routine HD1.

TITLE: TEST - HOLD ZEROES TEST

INPUT PARAMETERS (Listed Sequentially):

PAR1

TEST PATTERN
PAT 000000

OUTPUT PARAMETERS (Listed Sequentially):

PAR
DIP
DIP+1
HERE

ABNORMAL EXITS (Listed Sequentially):

NEXT LEVEL PROCEDURES OR SUBROUTINES (Keys of Duplicate Labels Specified):

CHEK
PROOF
HD1

SYSTEM DATA REFERENCES:

ALARMS AND/OR REMARKS:

ERROR DISPLAYS

1st PROGRAM STOP 0 - correct information in AU (cleared) incorrect
information in AL
2nd PROGRAM STOP 0 - failing address in AL
PROGRAM SKIP 4 - not set for error typeout
set to suppress typeout
PROGRAM SKIP 0 - set to recycle hold zeroes test
not set to continue test

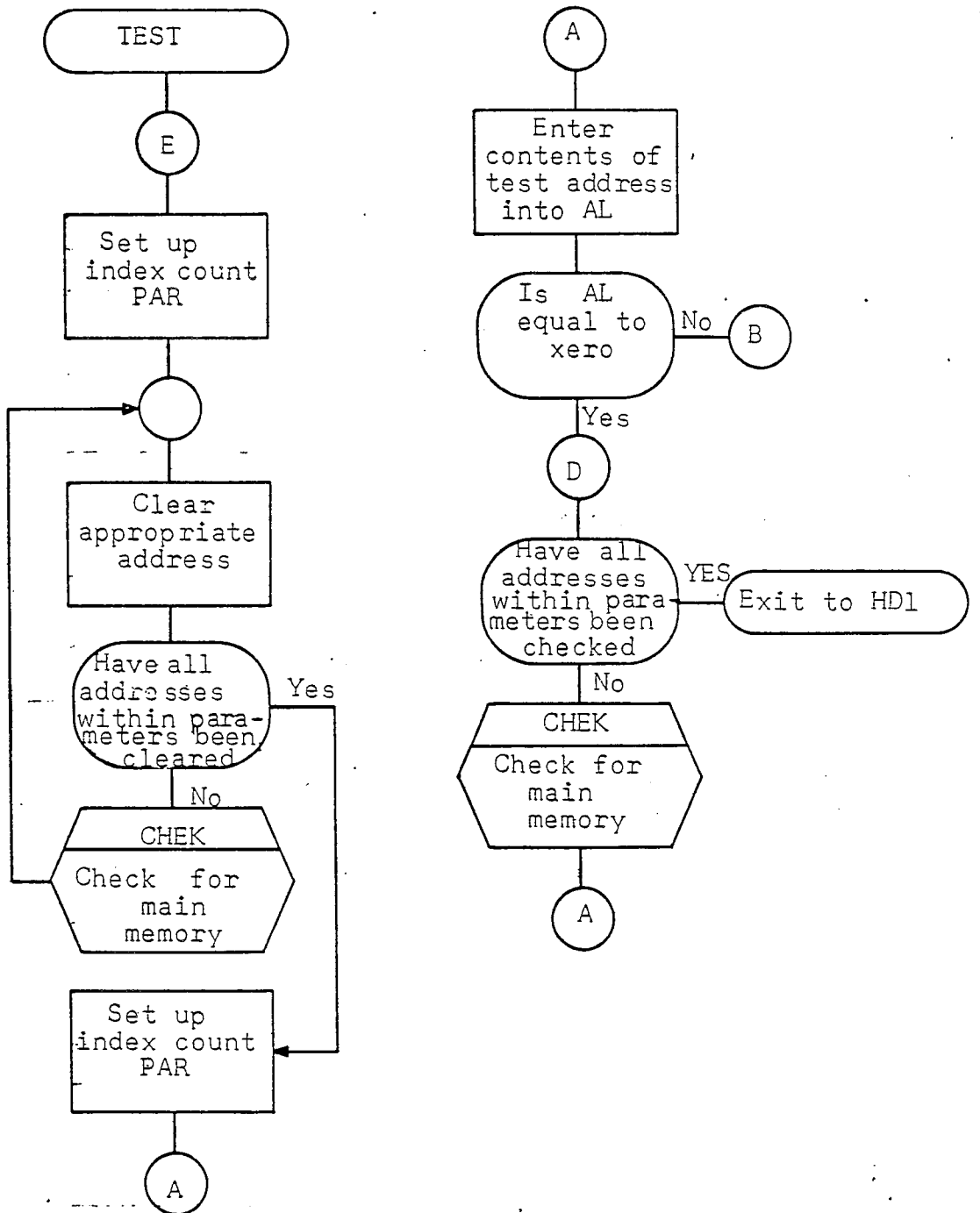

TEST

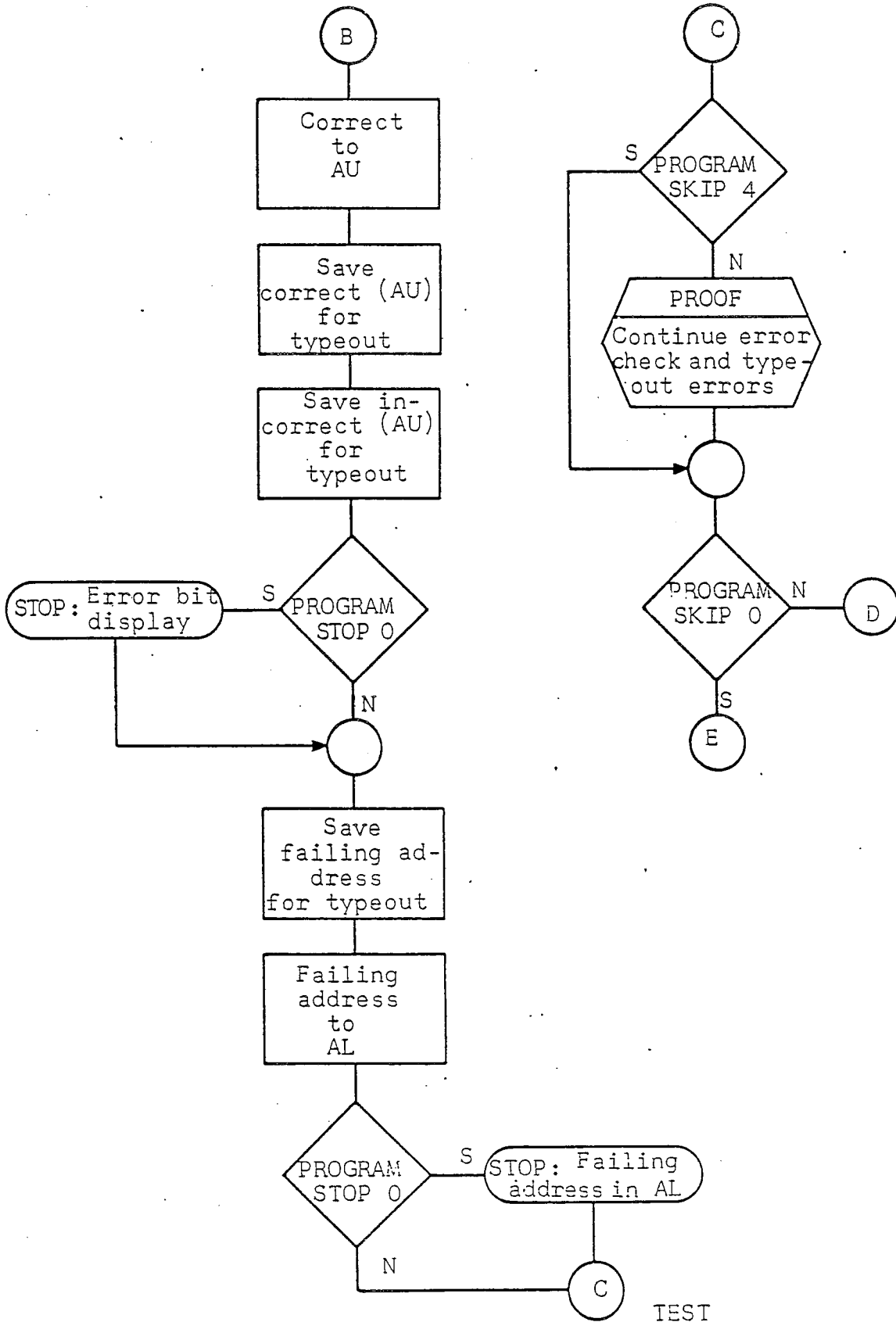

TEST

PROGRAM DATA PAGE

SHEET 695

REVISION —

SPECIFICATION SYMBOL

SB-10163

TITLE: HD1 - HOLD ONES

DECK IDENTIFIER: FACT

CS-1 LABEL: HD1 KEY: IS LABEL DUPLICATE? No

PROGRAMMER: H W M modified by FLR DATE: 8 Dec. 67

NUMBER OF L₄ OUTPUT INSTRUCTIONS: 35

DESCRIPTION:

This routine, HD1, checks the ability of the control memory to receive and retain all ones.

This routine is entered from routine TEST.

Control memory is loaded with all ones (777777). When the load is completed, the content of each sequential address is entered into AL and checked for validity. If the contents are incorrect, AU is entered with the correct information (the incorrect being in AL) and PROGRAM STOP 0 is checked. If set, the subroutine stops and the display may be evaluated. Upon restarting, AL is entered with the failing address and, if PROGRAM STOP 0 is still set, the subroutine stops for the address display. If PROGRAM STOP 0 is not set, or upon restarting, PROGRAM SKIP 4 is referenced. If it is not set an error timeout will occur. After the timeout, or if PROGRAM SKIP 4 is set, PROGRAM SKIP 0 is checked. If set, HD1 will recycle; if not set, the test will continue. Upon successful completion of HD1, an exit is made to routine HALT.

PROGRAM DATA PAGE (Cont)

SHEET 696

REVISION —

SPECIFICATION SYMBOL
SB-10163

TITLE: HD1 - HOLD ONES

INPUT PARAMETERS (Listed Sequentially):

PAR1	TEST PATTERN
PAR	PAT1 777777

OUTPUT PARAMETERS (Listed Sequentially):

DIP
DIP+1
HERE

ABNORMAL EXITS (Listed Sequentially):

NEXT LEVEL PROCEDURES OR SUBROUTINES (Keys of Duplicate Labels Specified):

CHEK
PROOF
HALT

SYSTEM DATA REFERENCES:

ALARMS AND/OR REMARKS:

ERROR DISPLAYS

1st PROGRAM STOP 0 - correct information in AU (777777) incorrect
information in AL
2nd PROGRAM STOP 0 - failing address displayed in AL
PROGRAM SKIP 4 - not set for error typeout
set to suppress error typeout
PROGRAM SKIP 0 - not set to continue routine HD1
set to recycle routine HD1

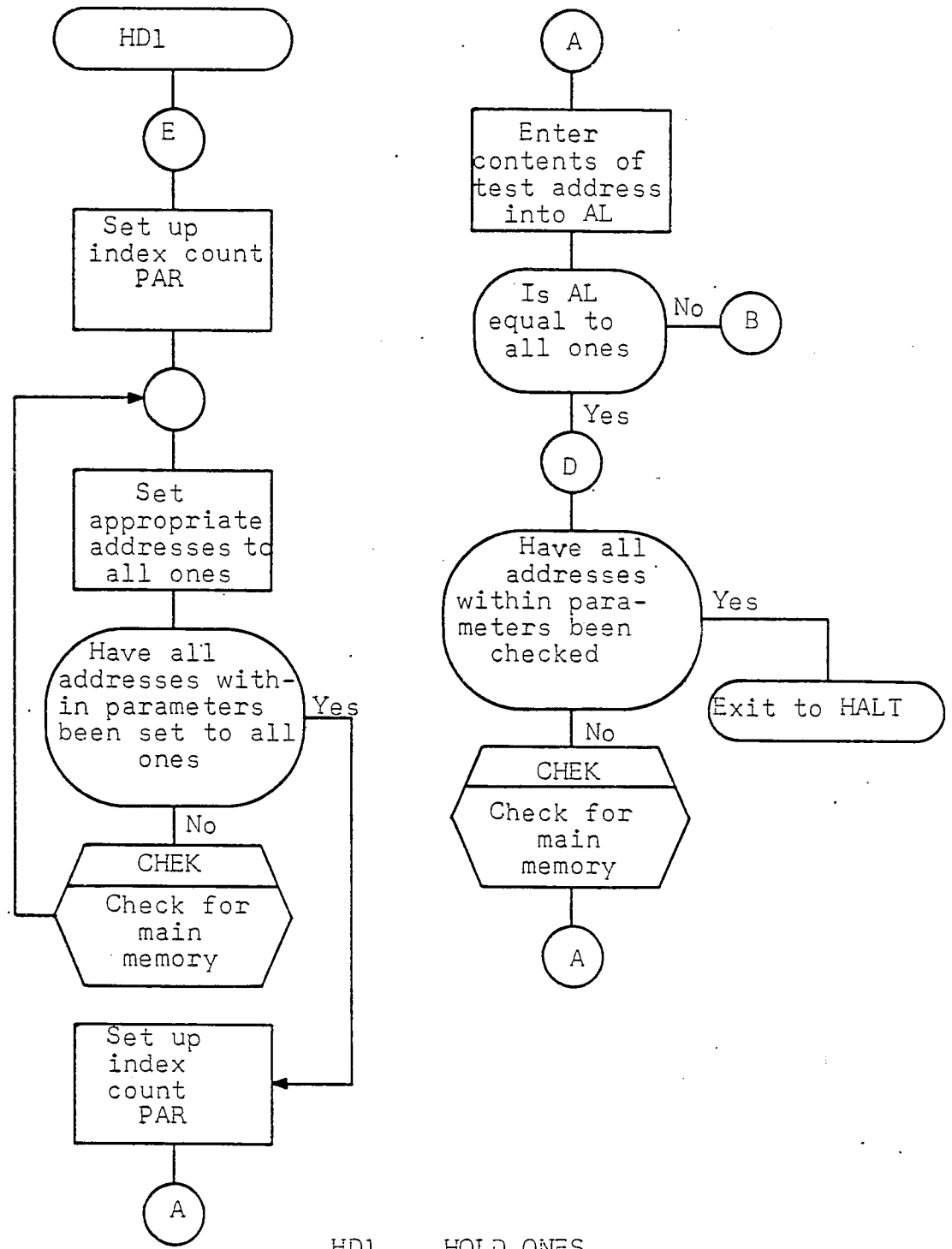

HD1.- HOLD ONES

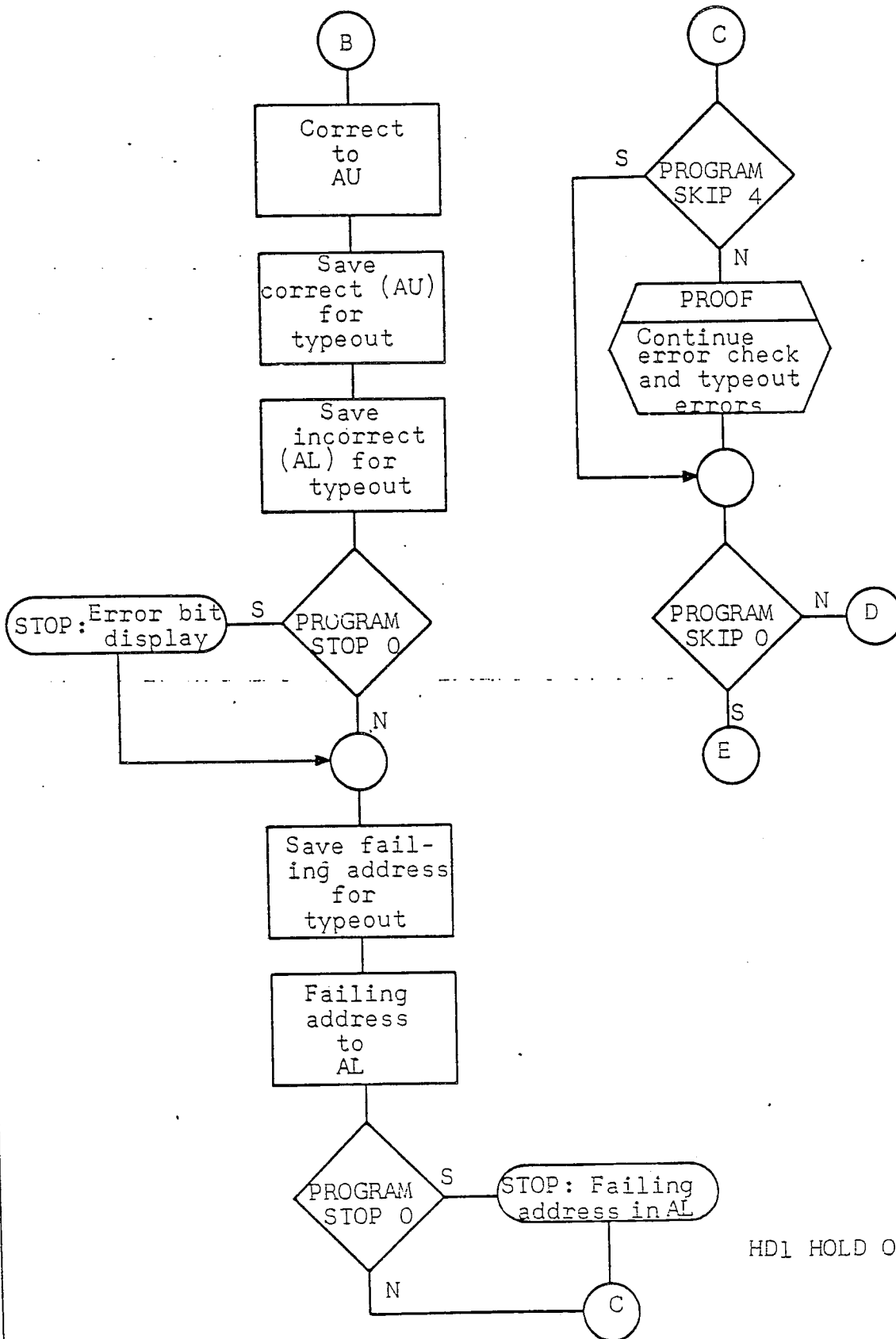

HD1 HOLD ONES

PROGRAM DATA PAGE

SHEET 699

REVISION

SPECIFICATION SYMBOL

SR-10163

TITLE: HALT - HOLD ALTERNATE ONES AND ZEROESDECK IDENTIFIER: FACTCS-1 LABEL: HDI KEY: IS LABEL DUPLICATE? NoPROGRAMMER: H W M modified by TLR DATE: 8 Dec. 67NUMBER OF L₄ OUTPUT INSTRUCTIONS: 35

DESCRIPTION:

This routine, HALT, checks the ability of the control memory to receive and retain a pattern of alternate ones and zeroes (525252).

This routine is entered from routine HD1.

Control memory is loaded with alternate ones and zeroes (525252). When the load is completed, the content of each sequential address is entered into AL and checked for validity. If the contents are incorrect AU is entered with the correct information (the incorrect being in AL) and PROGRAM STOP 0 is checked. If set, the subroutine stops and the display may be evaluated. Upon restarting, AL is entered with the failing address and, if PROGRAM STOP 0 is still set, the subroutine stops for address display. If PROGRAM STOP 0 is not set, or upon restarting, PROGRAM SKIP 4 is referenced. If it is not set an error typeout will occur. After the typeout, if PROGRAM SKIP 4 is set, PROGRAM SKIP 0 is checked. If set, HALT will recycle; if not set, the test will continue. Upon successful completion of HALT, an exit is made to routine HALTO.

TITLE: HALT - HOLD ALTERNATE ONES AND ZEROES

INPUT PARAMETERS (Listed Sequentially):

PAR	TEST PATTERN
PAR1	525252

OUTPUT PARAMETERS (Listed Sequentially):

DIP
DIP+1
HERE

ABNORMAL EXITS (Listed Sequentially):

NEXT LEVEL PROCEDURES OR SUBROUTINES (Keys of Duplicate Labels Specified):

CHEK
PROOF
HALTO

SYSTEM DATA REFERENCES:

ALARMS AND/OR REMARKS:

ERROR DISPLAYS

1st PROGRAM STOP 0 - correct information in AU (525252) incorrect
information in AL
2nd PROGRAM STOP 0 - failing address displayed in AL
PROGRAM SKIP 4 - not set for error typeout
set to suppress error typeout
PROGRAM SKIP 0 - not set to continue routine HALT
set to recycle routine HALT

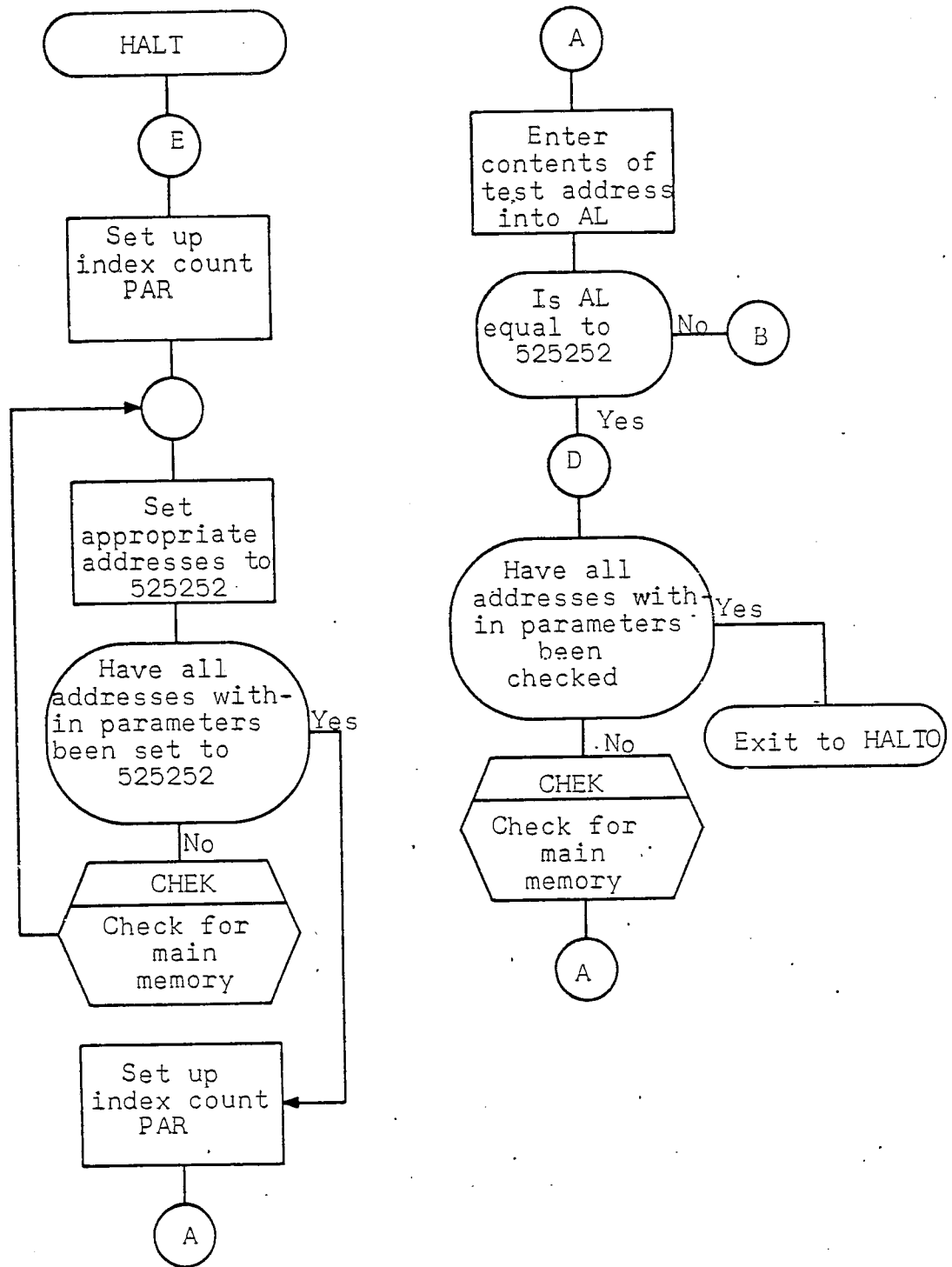

HALT - Hold alternate ones and zeroes

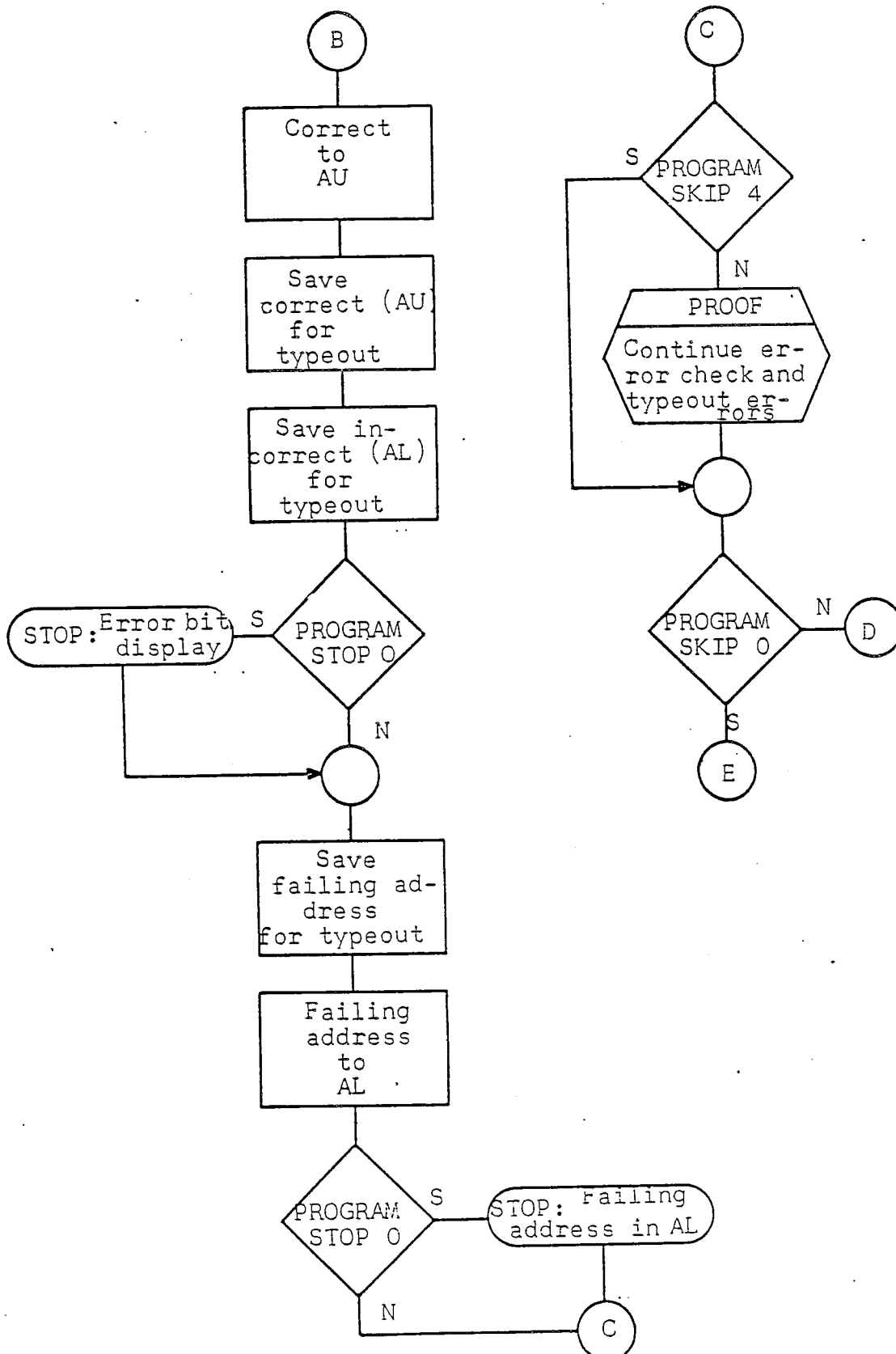

HALT - Hold alternate ones and zeroes

TITLE: HALTO - HOLD ALTERNATE ZEROES AND ONESDECK IDENTIFIER: FACTCS-1 LABEL: HALTO KEY: _____ IS LABEL DUPLICATE? NoPROGRAMMER: H W M modified by TLR DATE: 8 Dec. 67NUMBER OF L₄ OUTPUT INSTRUCTIONS: 35

DESCRIPTION:

This routine, HALTO, checks the ability of the control memory to receive and retain a pattern of alternate zeroes and ones (252525).

This routine is entered from routine HALT.

Control memory is loaded with alternate zeroes and ones (252525). When the load is completed, the content of each sequential address is entered into AL and checked for validity. If the contents are incorrect, AU is entered with the correct information (the incorrect being in AL) and PROGRAM STOP 0 is checked. If set, the routine stops and the display may be evaluated. Upon restarting, AL is entered with the failing address and, if PROGRAM STOP 0 is still set, the subroutine stops for address display. If PROGRAM STOP 0 is not set, or upon restarting, PROGRAM SKIP 4 is referenced. If it is not set an error typeout will occur. After the typeout, or if PROGRAM SKIP 4 is set, PROGRAM SKIP 0 is checked. If set, HALTO will recycle, if not set, the test will continue. Upon successful completion of HALTO, an exit is made to routine WPl.

TITLE: HALTO - HOLD ALTERNATE ZEROES AND ONES

INPUT PARAMETERS (Listed Sequentially):

PAR TEST PATTERN
PAR1 252525

OUTPUT PARAMETERS (Listed Sequentially):

DIP
DIP+1
HERE

ABNORMAL EXITS (Listed Sequentially):

NEXT LEVEL PROCEDURES OR SUBROUTINES (Keys of Duplicate Labels Specified):

CHEK
PROOF
WPL

SYSTEM DATA REFERENCES:

ALARMS AND/OR REMARKS:

ERROR DISPLAYS

- 1st PROGRAM STOP 0 - correct information in AU (252525) incorrect information in AL
- 2nd PROGRAM STOP 0 - failing address displayed in AL
- PROGRAM SKIP 4 - not set for error typeout
set to suppress error typeout
- PROGRAM SKIP 0 - not set to continue routine HALTO
set to recycle routine HALT 0

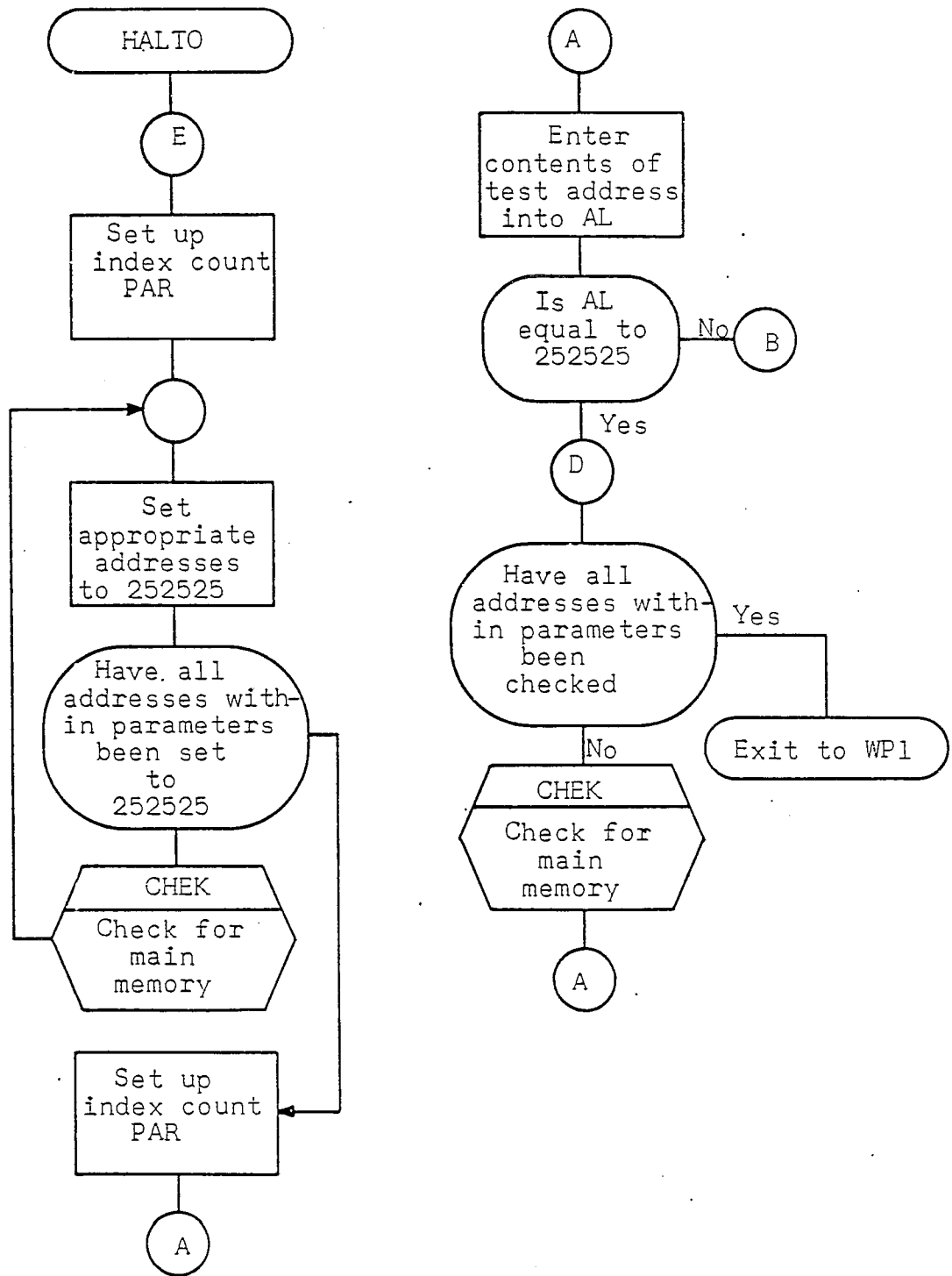

HALTO - Hold alterante zeroes and ones

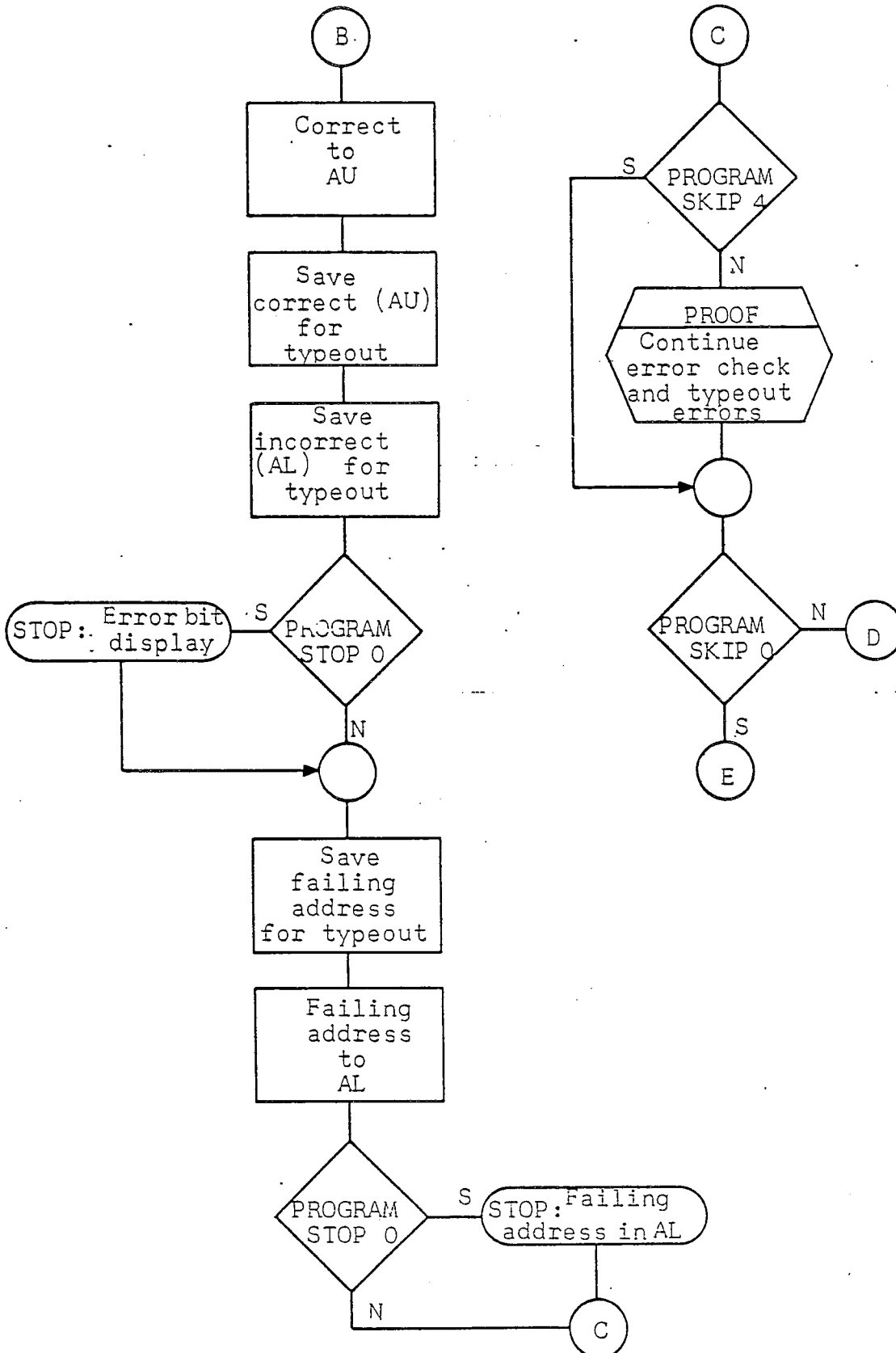

HALTO - Hold alternate zeroes and ones

SHEET 707

REVISION —

SPECIFICATION SYMBOL
SB-10163TITLE: WP1 - WORST PATTERNDECK IDENTIFIER: FACTCS-1 LABEL: WP1 KEY: _____ IS LABEL DUPLICATE? NoPROGRAMMER: H W M modified by TLR DATE: 8 Dec. 67NUMBER OF L_4 OUTPUT INSTRUCTIONS: 59

DESCRIPTION:

This routine, WP1, tests the ability of the control memory to accept and retain the worst pattern.

This routine is entered from routine HALTO.

The worst pattern causes maximum cross-talk noise. The following arrangement produces the maximum noise. The address storage selection is attained by utilizing an address parity mask of 000100. If upon checking, parity is found to be odd, all ones are loaded; if even the complement or all zeroes are loaded. After the control memory is loaded the content of each sequential address is entered into AL and checked for validity. If it is incorrect an exit is made to the error display routine AIR, upon completion of the error check, subroutine FLUSH, is utilized to set the tested control memory to all ones then to all zeroes. Then an exit is made to the next test routine CWP1.

TITLE: WP1 - WORST PATTERN

INPUT PARAMETERS (Listed Sequentially):

PAR
PAR1

TEST PATTERNS

CKWP 13 000000
CKWP 14 777777

OUTPUT PARAMETERS (Listed Sequentially):

ABNORMAL EXITS (Listed Sequentially):

NEXT LEVEL PROCEDURES OR SUBROUTINES (Keys of Duplicate Labels Specified):

CHEK
AIR
FLUSH1
CWP1

SYSTEM DATA REFERENCES:

ALARMS AND/OR REMARKS:

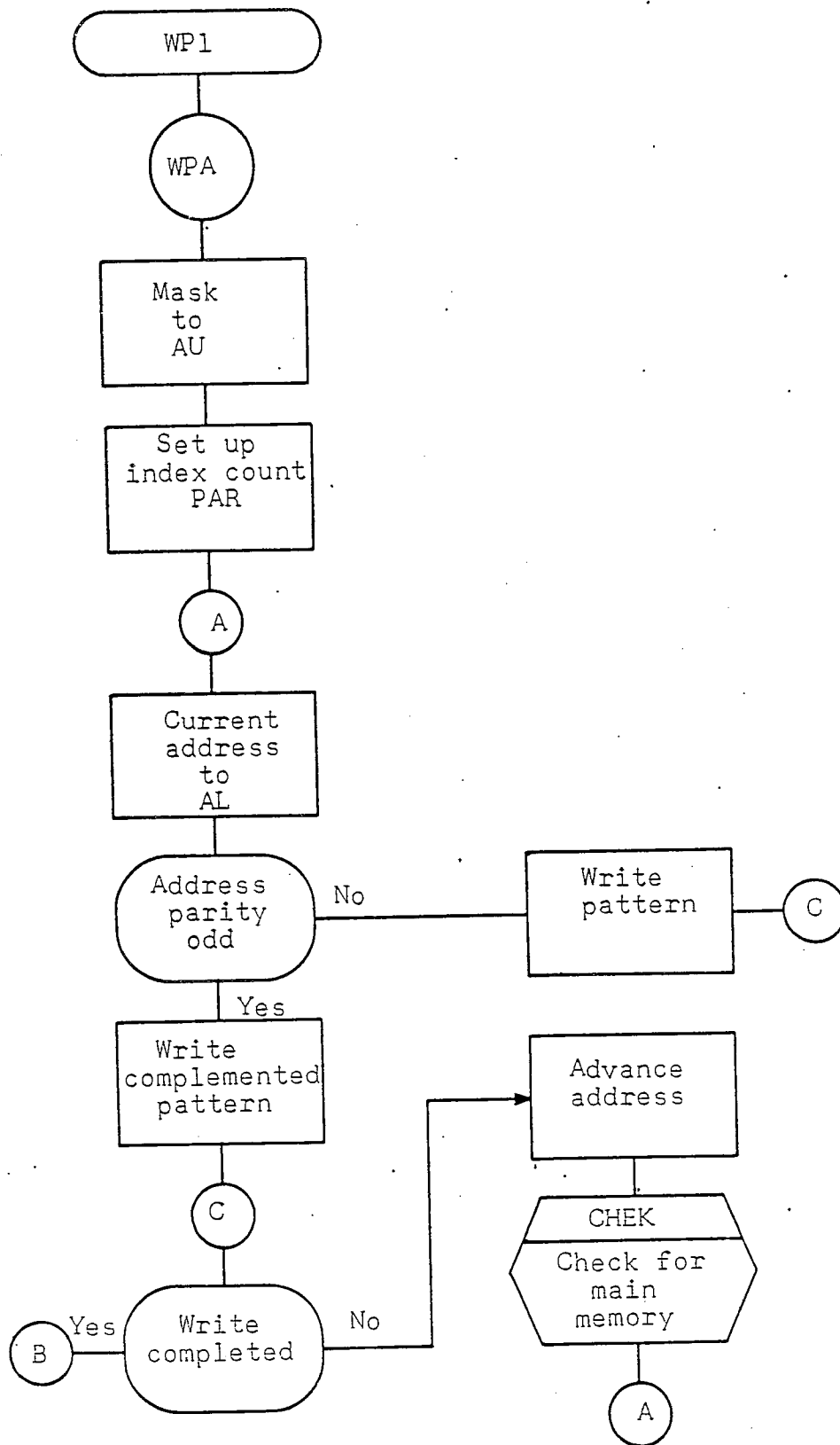

WP1 - Worst Pattern

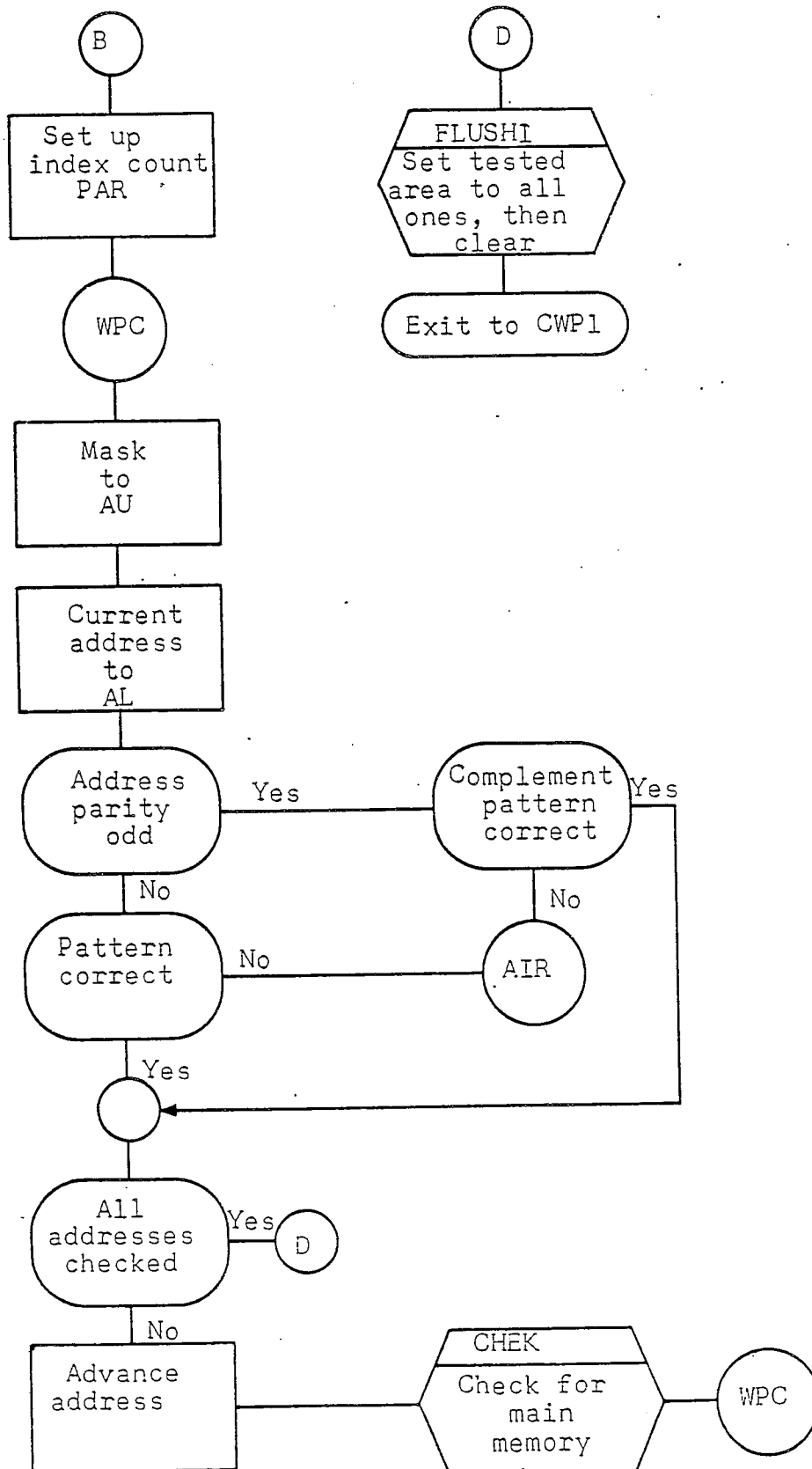

WP1 - Worst Pattern

TITLE: AIR - WORST PATTERN ERROR DISPLAY

DECK IDENTIFIER: FACT

CS-1 LABEL: AIR KEY: IS LABEL DUPLICATE? No

PROGRAMMER: H W M modified by TLF DATE: 8 Dec. '67

NUMBER OF L₄ OUTPUT INSTRUCTIONS: 34

DESCRIPTION:

This routine, AIR, is the error display for the worst pattern routine, WP1.

Should an error be detected by the validity check in the WP1 routine, an entry is made to this routine, AIR.

When AIR is entered, AU is entered with the correct information and AL is entered with the incorrect, then AU and AL are saved for the error typeout and PROGRAM STOP 0 is checked. If PROGRAM STOP 0 is set the subroutine stops and the display may be evaluated. Upon restarting, the failing address is entered into AL then stored for the error typeout and PROGRAM STOP 0 is checked. If it is set the routine stops and the operator may note the failing address. Upon restarting, or if PROGRAM STOP 0 is not set, PROGRAM SKIP 4 is checked. If it is not set an error typeout will occur. After the typeout, or if PROGRAM SKIP 4 is set, PROGRAM SKIP 0 is checked. If set, WP1 will recycle, if not set the error check in WP1 will continue.

SPECIFICATION SYMBOL SR-10163

TITLE: AIR - WORST PATTERN ERROR DISPLAY

INPUT PARAMETERS (Listed Sequentially):

TEST PATTERNS

CKWP13	000000
CKWP14	777777

OUTPUT PARAMETERS (Listed Sequentially):

HERE
THERE
DIP
DIP+1

ABNORMAL EXITS (Listed Sequentially):

NEXT LEVEL PROCEDURES OR SUBROUTINES (Keys of Duplicate Labels Specified):

ERROUT
WP1

SYSTEM DATA REFERENCES:

ALARMS AND/OR REMARKS:

ERROR DISPLAYS

1st PROGRAM STOP 0 - correct information in AU incorrect information
in AL

2nd PROGRAM STOP 0 - failing address displayed in AL

PROGRAM SKIP 4 - not set for error timeout
set to suppress error timeout

PROGRAM SKIP 0 - not set to continue routine WP1
set to recycle routine WP1

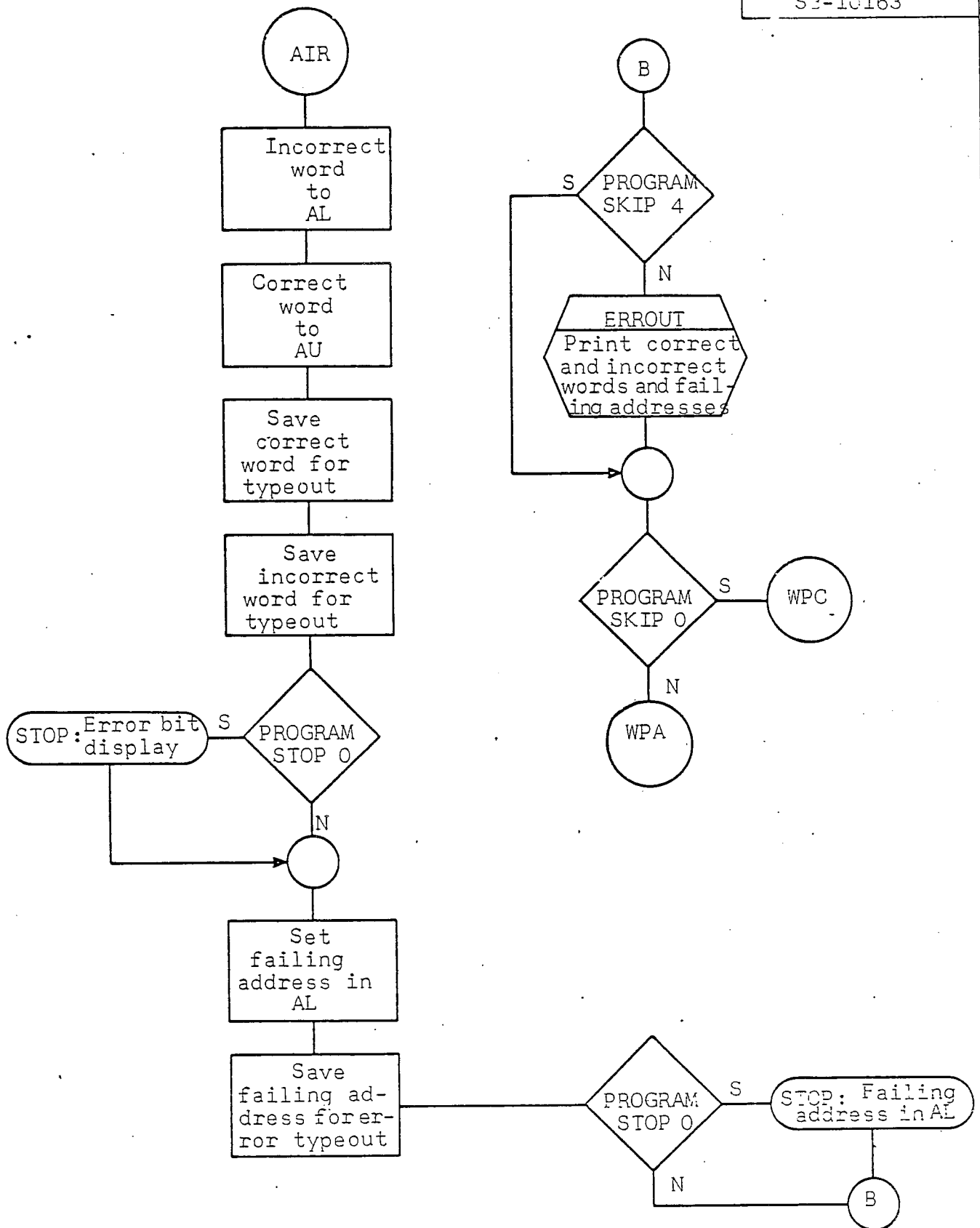

AIR - Worst Pattern Error Display

SHEET 714

REVISION

SPECIFICATION SYMBOL

SB-10163

TITLE: CWPI - COMPLEMENT WORST PATTERNDECK IDENTIFIER: FACTCS-1 LABEL: CWPI KEY: _____ IS LABEL DUPLICATE? NoPROGRAMMER: H W M modified by FLR DATE: 8 Dec. 67NUMBER OF L₄ OUTPUT INSTRUCTIONS: 58

DESCRIPTION:

This routine, CWPI, tests the ability of the control memory to accept and retain the worst pattern.

This routine is entered from routine WPI.

The complement worst pattern causes maximum cross-talk noise. The following arrangement produces the maximum noise. The address storage selection is attained by utilizing an address parity mask of 000100. If upon checking, parity is found to be even, all ones are loaded; if odd the complement or all zeroes are loaded. After the control memory is loaded the content of each sequential address is entered into AL and checked for validity. If it is incorrect an exit is made to the error display routine CAIR; upon completion of the error check, subroutine FLUSH, is utilized to set the tested control memory to all ones then to all zeroes. Then an exit is made to the next test routine RW.

PROGRAM DATA PAGE (Cont)

SHEET 715

REVISION

SPECIFICATION SYMBOL

SP-10163

TITLE: CWPI - COMPLEMENT WORST PATTERN

INPUT PARAMETERS (Listed Sequentially):

PAR	TEST PATTERNS
PAR1	CKWP14 777777
	CKWP13 000000

OUTPUT PARAMETERS (Listed Sequentially):

ABNORMAL EXITS (Listed Sequentially):

NEXT LEVEL PROCEDURES OR SUBROUTINES (Keys of Duplicate Labels Specified):

CHEK
CAIR
FLUSH1
RW

SYSTEM DATA REFERENCES:

ALARMS AND/OR REMARKS:

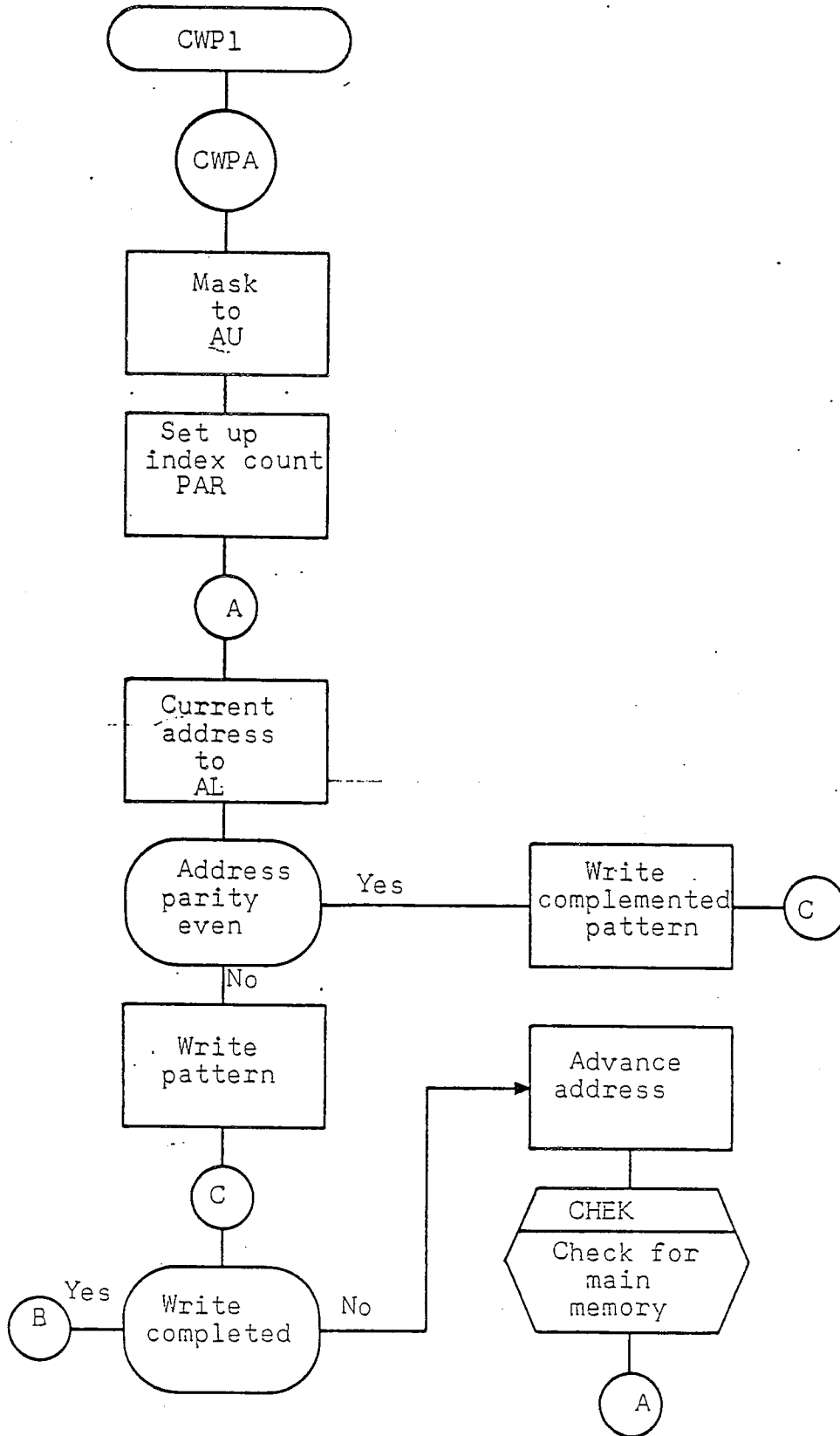

--- CWP1 - Complement Worst Pattern

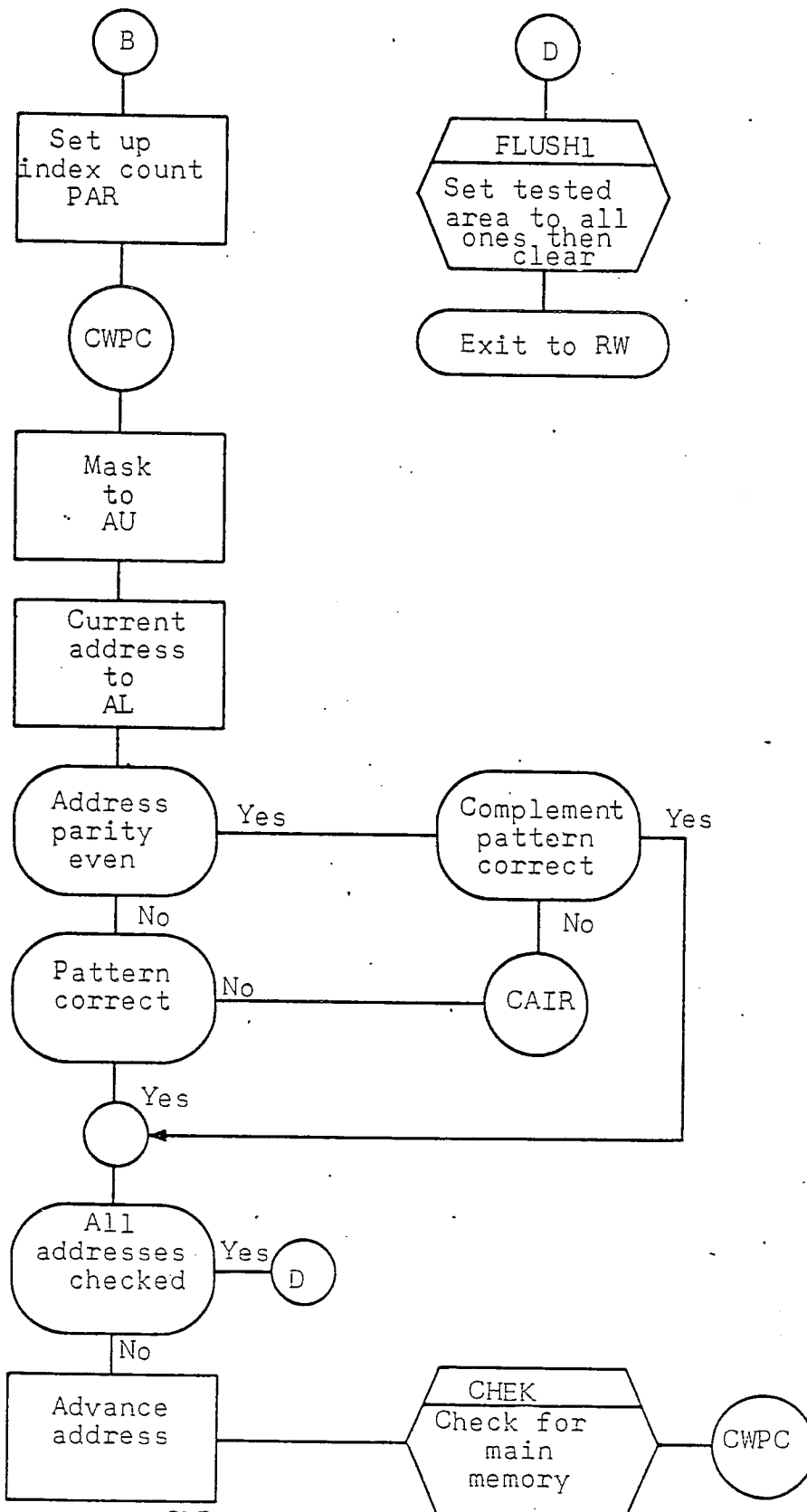

CWPC1 - Complement Worst Pattern

TITLE: CAIR - COMPLEMENT WORST PATTERN ERROR DISPLAYDECK IDENTIFIER: FACT.CS-1 LABEL: CAIR KEY: _____ IS LABEL DUPLICATE? NoPROGRAMMER: H W M modified by TLR DATE: 8 Dec. 67NUMBER OF L₄ OUTPUT INSTRUCTIONS: 32

DESCRIPTION:

This routine, CAIR, is the error display for the complement worst pattern routine, CWPl.

Should an error be detected by the validity check in the CWPl routine, an entry is made to this routine, CAIR.

When CAIR is entered, AU is entered with the correct information and AL is entered with the incorrect, then AU and AL are saved for the error typeout and PROGRAM STOP 0 is checked. If PROGRAM STOP 0 is set the subroutine stops and the display may be evaluated. Upon restarting, the failing address is entered into AL then stored for the error typeout and PROGRAM STOP 0 is checked. If it is set the routine stops and the operator may note the failing address. Upon restarting, or, if PROGRAM STOP 0 is not set, PROGRAM SKIP 4 is checked. If it is not sent an error typeout will occur. After the typeout, or if PROGRAM SKIP 4 is set, PROGRAM SKIP 0 is checked. If set, CWPl will recycle; if not set, the error check in CWPl will continue.

PROGRAM DATA PAGE (Cont)

SHEET 719

REVISION —

SPECIFICATION SYMBOL

SR-10163

TITLE: CAIR - COMPLEMENT WORST PATTERN ERROR DISPLAY

INPUT PARAMETERS (Listed Sequentially):

TEST PATTERNS

CKWP14 777777
CKWP13 000000

OUTPUT PARAMETERS (Listed Sequentially):

HERE
THERE
DIP
DIP+1

ABNORMAL EXITS (Listed Sequentially):

NEXT LEVEL PROCEDURES OR SUBROUTINES (Keys of Duplicate Labels Specified):

ERROUT
CWPI

SYSTEM DATA REFERENCES:

ALARMS AND/OR REMARKS:

ERROR DISPLAYS

- 1st PROGRAM STOP 0 - Correct information in AU incorrect information in AL.
- 2nd PROGRAM STOP 0 - Failing address displayed in AL
- PROGRAM SKIP 4 - Not set for error typeout
Set to suppress error typeout
- PROGRAM SKIP 0 - Not set to continue routine CWPI
Set to recycle routine CWPI

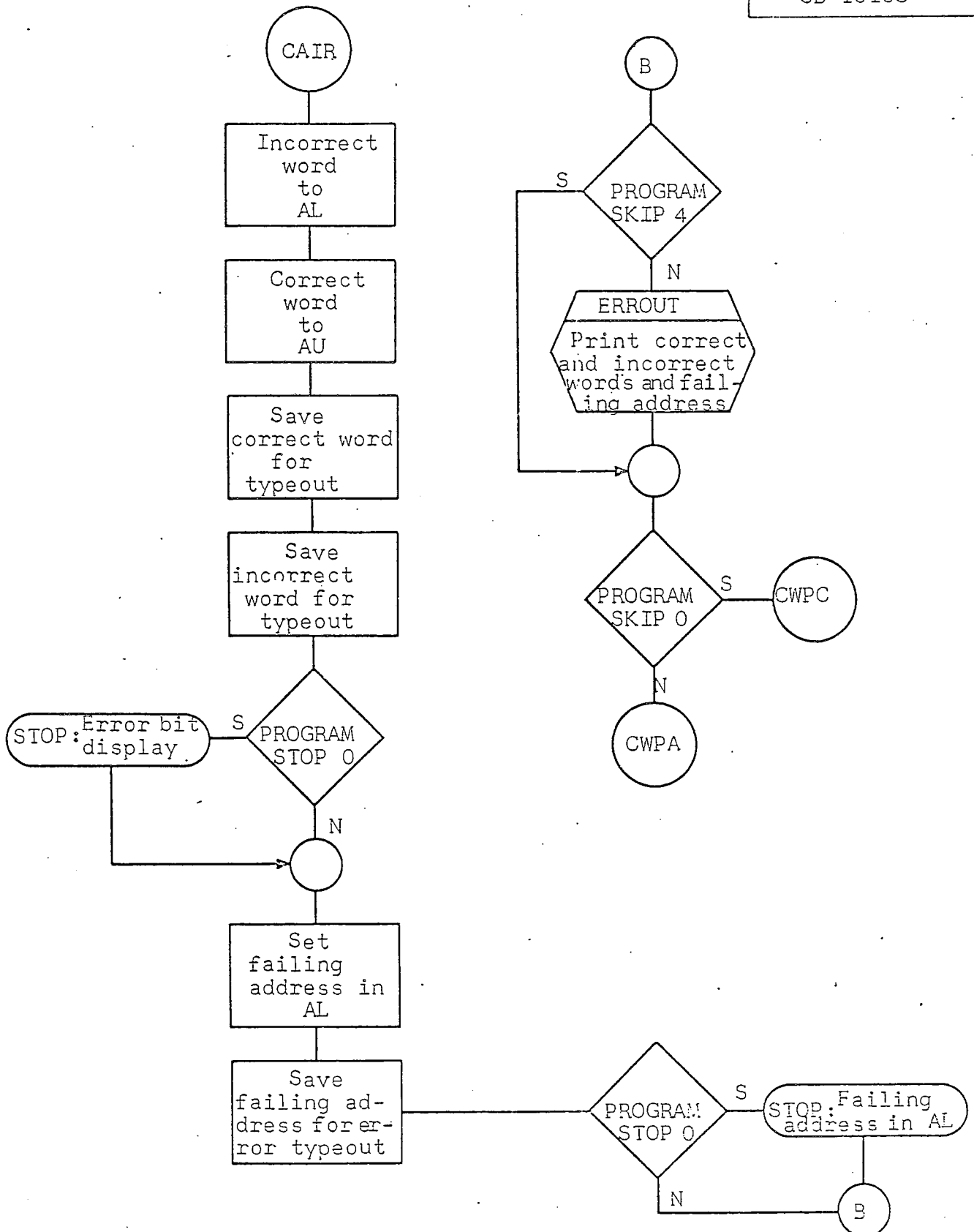

CAIR - Complement Worst Pattern Error Display

PROGRAM DATA PAGE

SHEET 721

REVISION SPECIFICATION SYMBOL
SB-10163TITLE: RW - READ/WRITE RANDOM WORD TEST

DECK IDENTIFIER: _____

CS-1 LABEL: RW KEY: _____ IS LABEL DUPLICATE? NoPROGRAMMER: H W M modified by TLR DATE: 8 Dec. 67NUMBER OF L_4 OUTPUT INSTRUCTIONS: 70

DESCRIPTION:

This routine, RW, tests the ability of the control memory to accept and retain numbers and accomplish a fast read/write.

This routine is entered from routine CWPL.

This routine RW takes numbers generated by the random-number-generator subroutine (RAN) and stores them in the control memory. Simultaneously, a second store is made at another set of addresses to set up an image of the information being stored. This enables verification of the storages by comparing the two information cells at the completion of the fast read. For the fast read/write each address under test is read repeatedly 40 times. When the addresses have been read 40 times their contents are checked for validity. If the comparison with the image addresses does not check, the incorrect information is entered into AL, the correct is entered into AU, then AU and AL are saved for the error typeout, and PROGRAM STOP 0 is checked. If PROGRAM STOP 0 is set, the routine stops and the display may be evaluated. Upon restarting, or if PROGRAM STOP 0 is not set, the failing address is entered into AL, then AL is stored for the error typeout and PROGRAM STOP 0 is checked. If set the routine stops and the operator may note the failing address. Upon restarting or if PROGRAM STOP 0 is not set, PROGRAM SKIP 4 is checked. If not set an error typeout will occur. After the typeout, or if PROGRAM SKIP 4 is set, PROGRAM SKIP 0 is checked. If set RW will recycle, if not set RW will continue. After the completion of RW an exit is made to routine LCON.

SPECIFICATION SYMBOL
SB-10163TITLE: RW - READ/WRITE RANDOM TEST

INPUT PARAMETERS (Listed Sequentially):

PAR
PAR1

OUTPUT PARAMETERS (Listed Sequentially):

HERE
THERE
DIP
DIP+1

ABNORMAL EXITS (Listed Sequentially):

NEXT LEVEL PROCEDURES OR SUBROUTINES (Keys of Duplicate Labels Specified):

RAN
CHEK
ERROUT
LCON

SYSTEM DATA REFERENCES:

ALARMS AND/OR REMARKS:

ERROR DISPLAYS

- 1st PROGRAM STOP 0 - Correct information in AU incorrect in AL
- 2nd PROGRAM STOP 0 - Failing address displayed in AL
- PROGRAM SKIP 4 - Not set for error typeout
Set to suppress error typeout
- PROGRAM SKIP 0 - Not set to continue routine RW
Set to continue routine RW

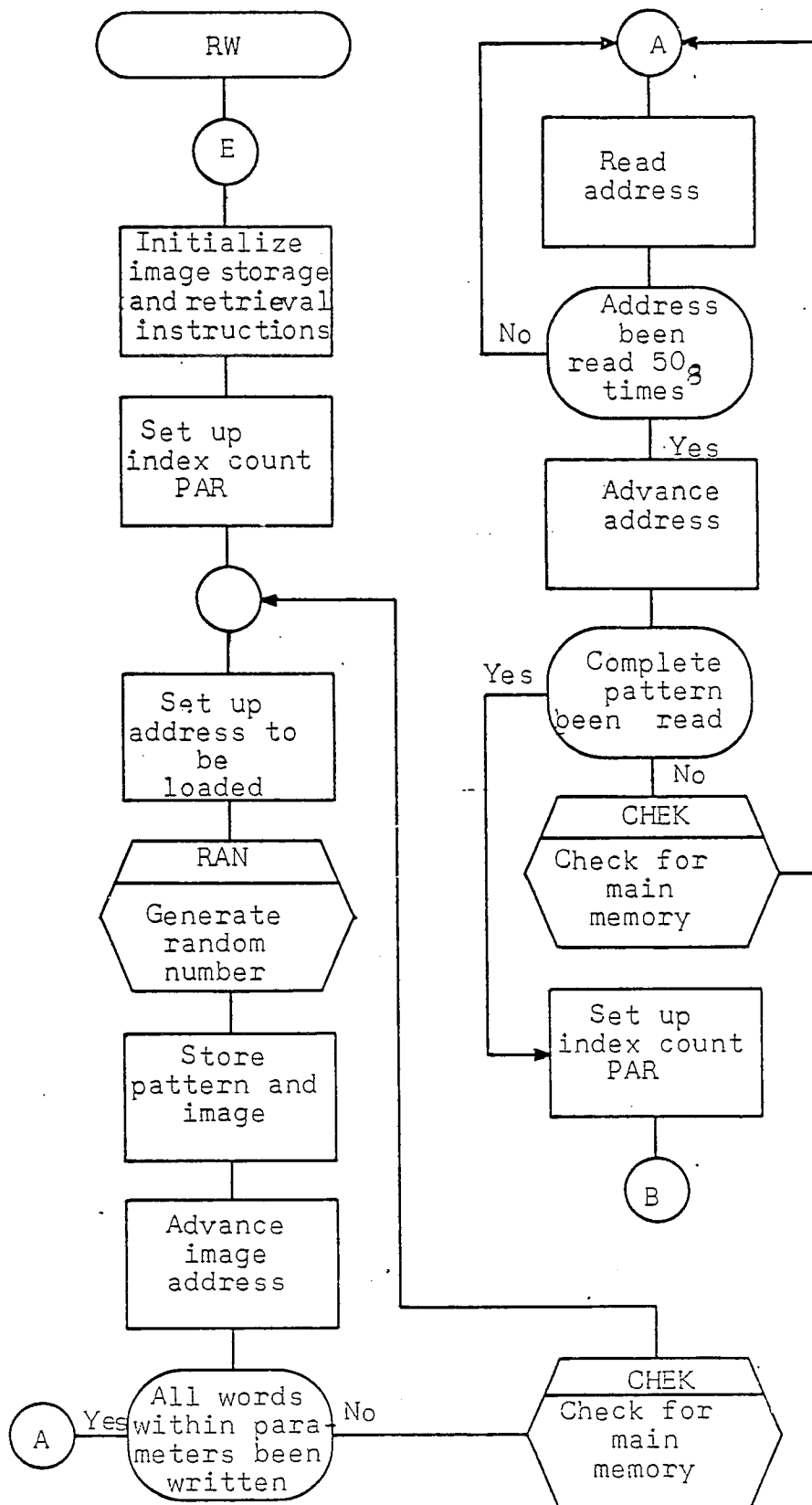

RW - Read/Write Random Word Test

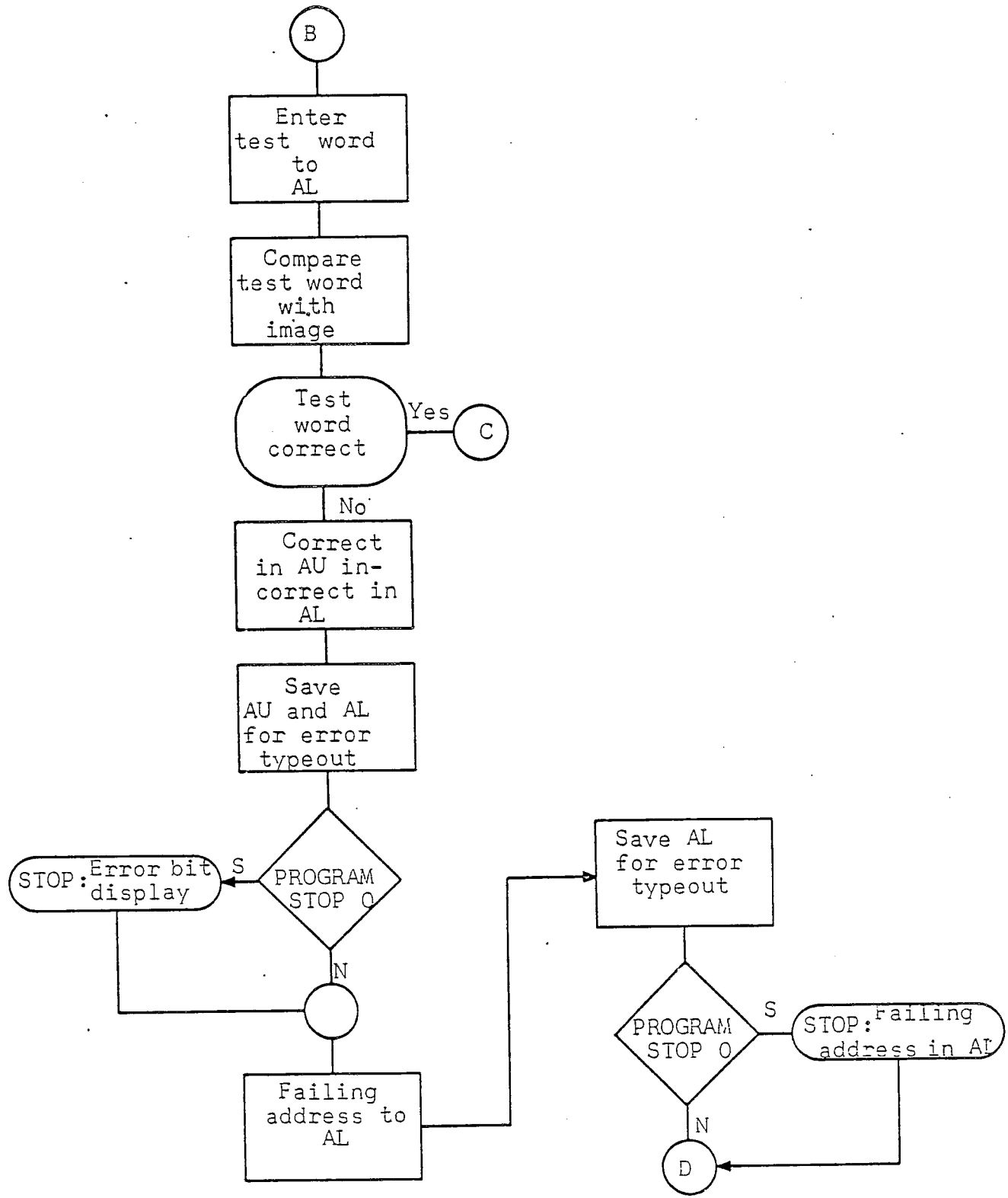

RW - Read/Write Random Word Test

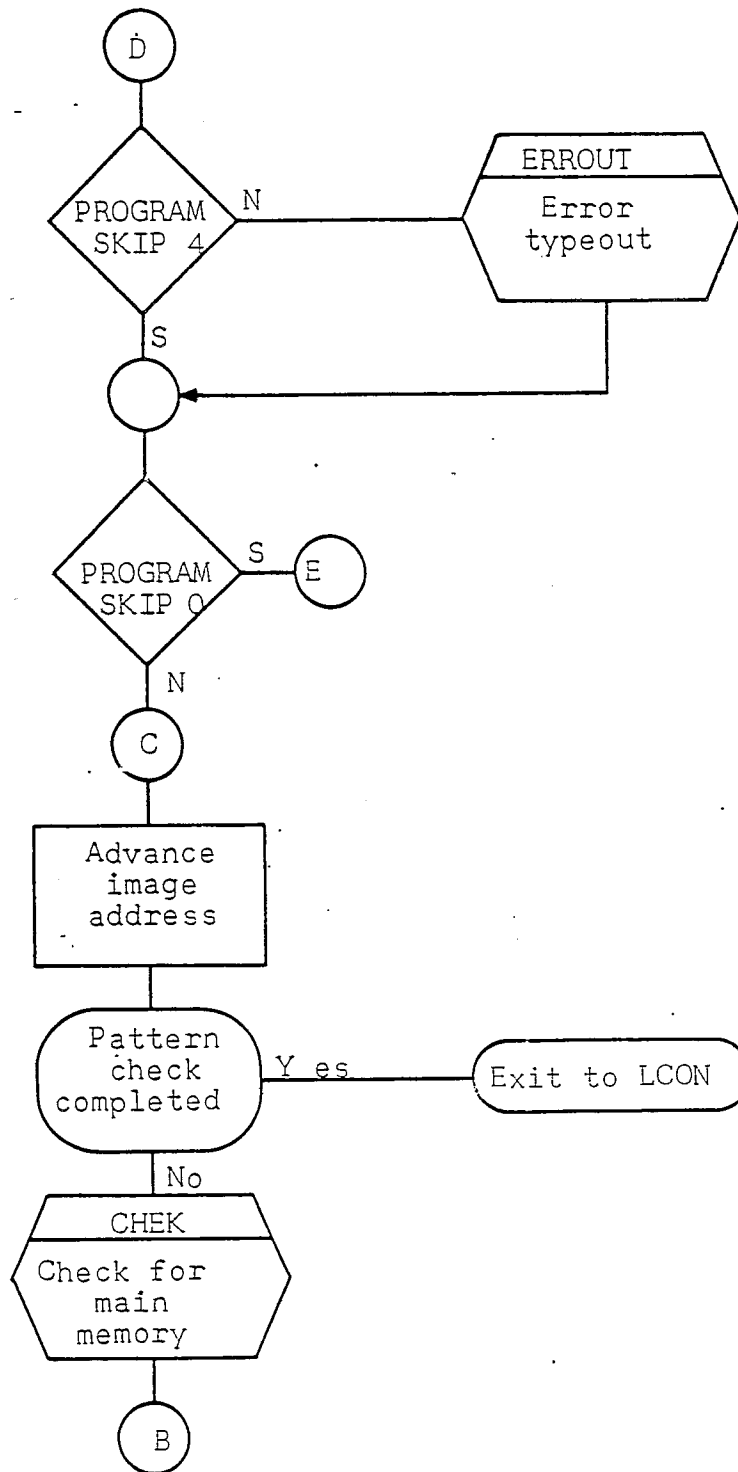

RW - Read/Write Random Word Test

SHEET 726

REVISION

SPECIFICATION SYMBOL
SB-10163TITLE: RAN - RANDOM NUMBER GENERATORDECK IDENTIFIER: FACTCS-1 LABEL: RAN KEY: _____ IS LABEL DUPLICATE? NoPROGRAMMER: P.H.C. modified by TLR DATE: 8 Dec. 67NUMBER OF L_4 OUTPUT INSTRUCTIONS: 11

DESCRIPTION:

This subroutine generates a series of random numbers which are used by the read/write test, RW. Two basic constants are used: 0007031 (RAN2) and 377775 (RAN3). RAN2 is entered into AU and multiplied by itself. At the completion of the multiply, the contents of A are divided by RAN3 (377775) and AU is checked. If AU is not equal to zero the contents of AU are stored at RAN2. If AU is equal to zero the contents of AL are stored at RAN2, thereby setting a new constant for the next generation of a random number. An exit is then made to the referencing subroutine, P.W.

PROGRAM DATA PAGE (Cont)

SHEET 727 REVISION 1

NO. 10163 TITLE: RAN - RANDOM NUMBER GENERATOR SPECIFICATION SYMBOL: SR-10163

TITLE: RAN - RANDOM NUMBER GENERATOR

INPUT PARAMETERS (Listed Sequentially):

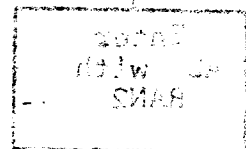

OUTPUT PARAMETERS (Listed Sequentially):

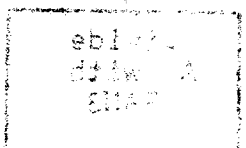
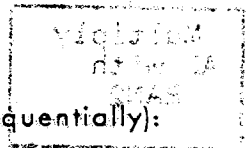

ABNORMAL EXITS (Listed Sequentially):



NEXT LEVEL PROCEDURES OR SUBROUTINES (Keys of Duplicate Labels Specified):

RW

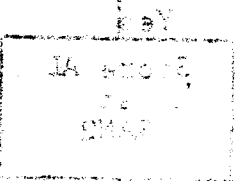

SYSTEM DATA REFERENCES:

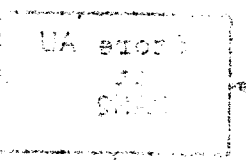

ALARMS AND/OR REMARKS:

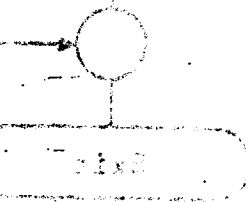

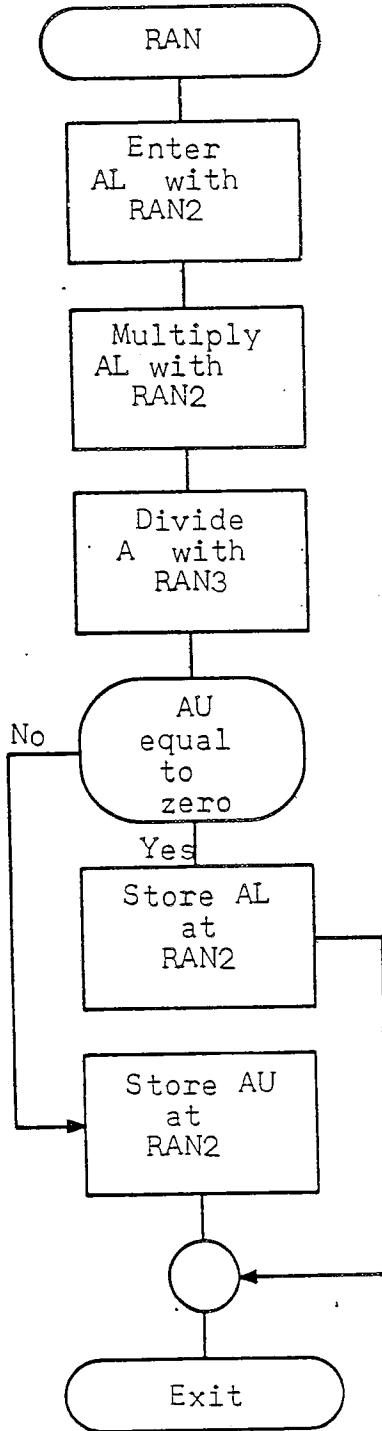

RAN - Random Number Generator

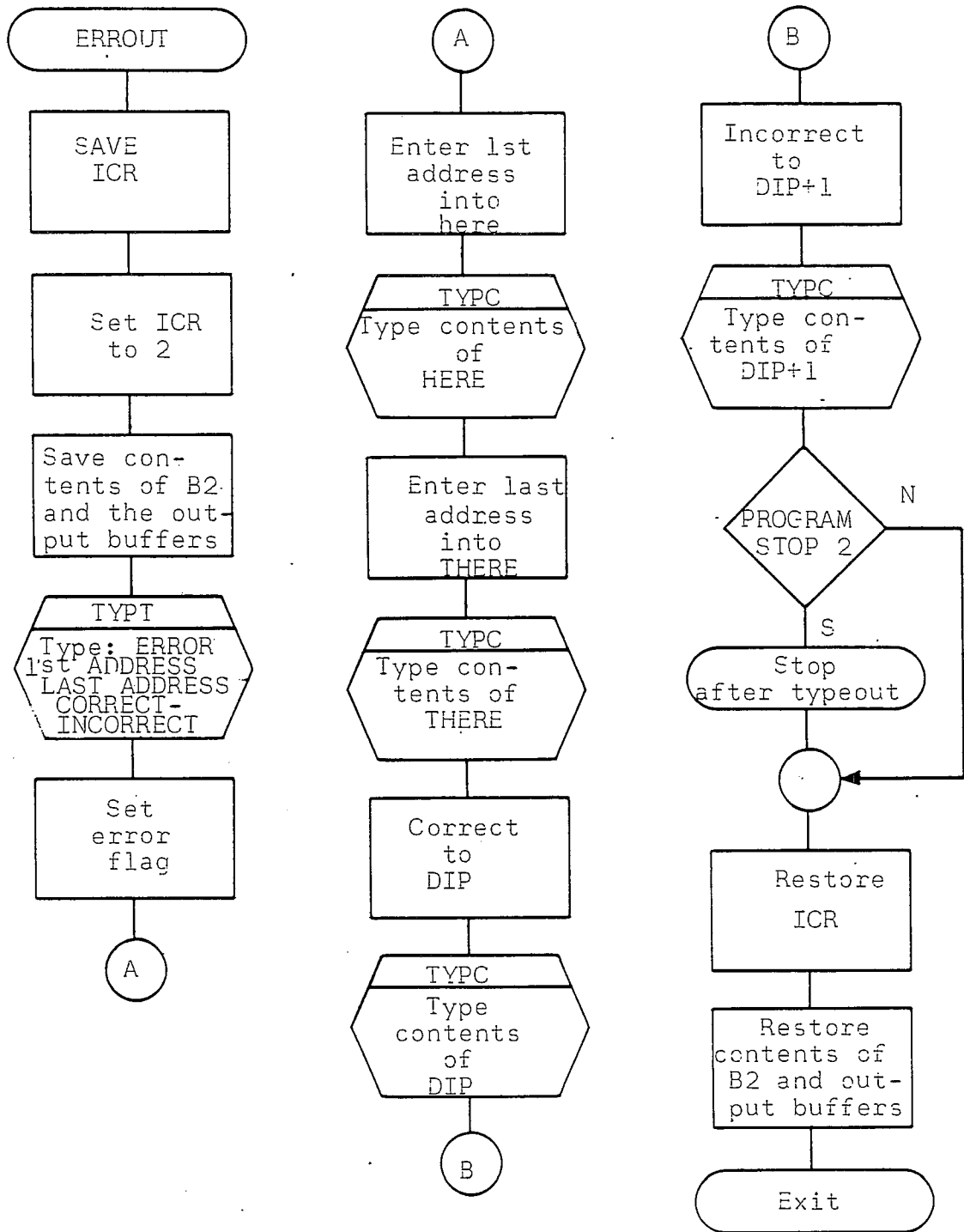

ERRROUT

PROGRAM DATA PAGE

SHEET 728.1

REVISION

✓

SPECIFICATION SYMBOL
SB-10163

LABEL: LCON

TITLE AND/OR PURPOSE: LCON, the Hammer Test, Hammers a value into a cell located within control memory to see if any other control memory cell changes value as a result..

INPUT PARAMETERS:

None

OUTPUT PARAMETERS:

None

DESCRIPTION:

All cells within control memory are set to zero and then the first cell (address 20) is changed to the value 677 by hammering this value into the cell 10 times. The entire control memory is then checked to see if it was left unchanged by this action. If an error is detected and PROGRAM SKIP 4 is not set, a message is typed to display the error.

All cells are again set to zero and the hammering action for value 677 takes place into address 21. Following the error check, the procedure is repeated for each address within control memory.

When the last address within control memory has been tested by the procedure with value 677, the entire test cycle, starting again with address 20, is repeated. The one difference is that all cells will initially be set to 777777 each time instead of zero.

At the end of this cycle, an exit is made to routine FLUSH.

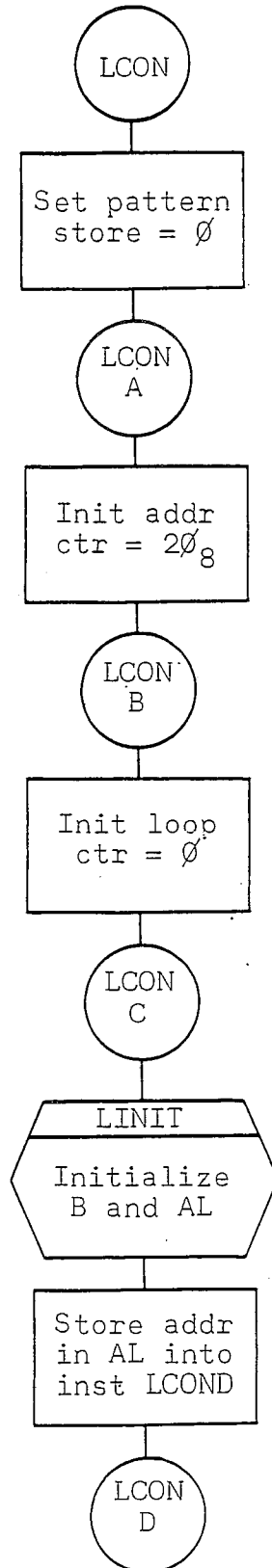

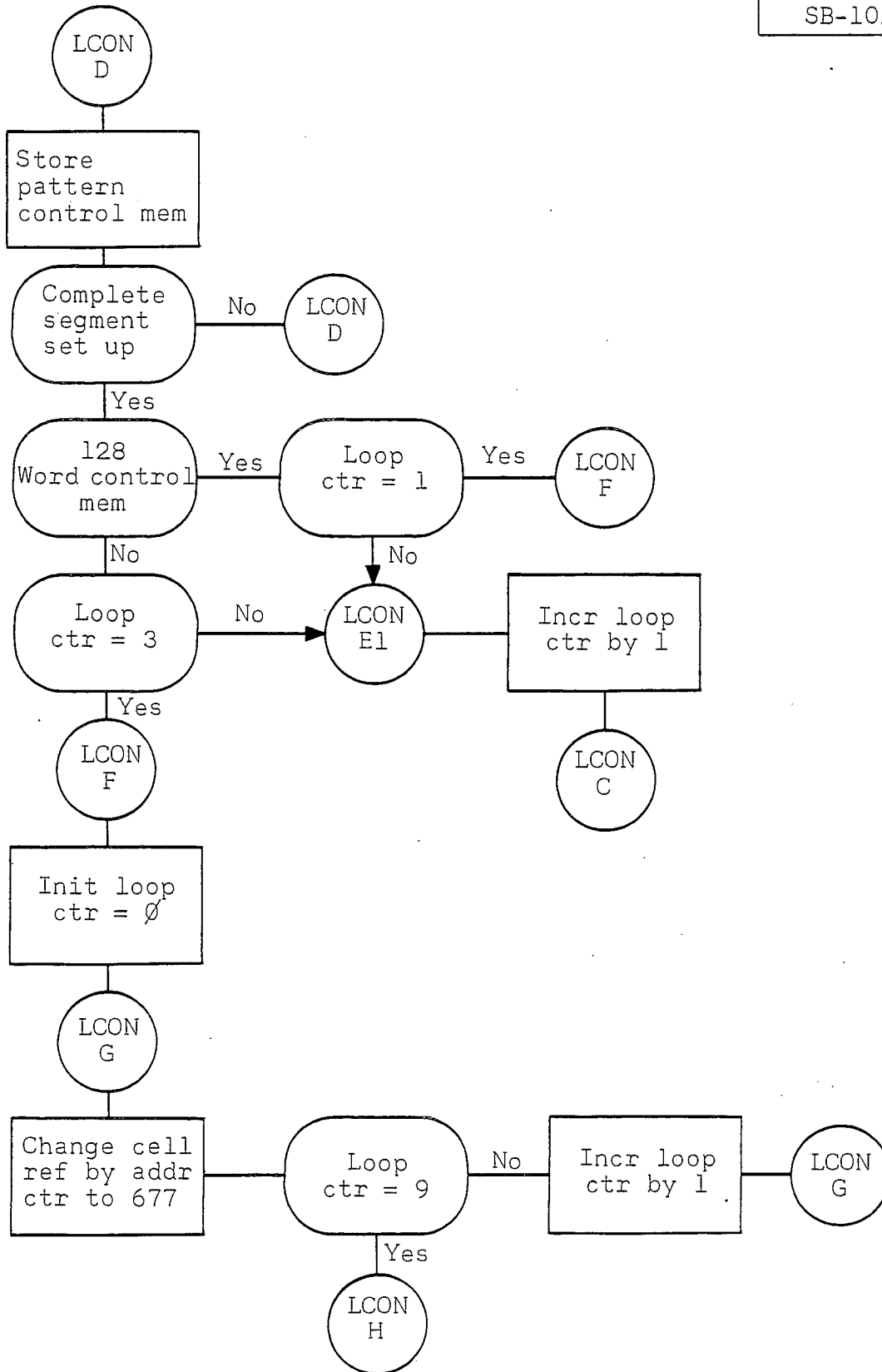

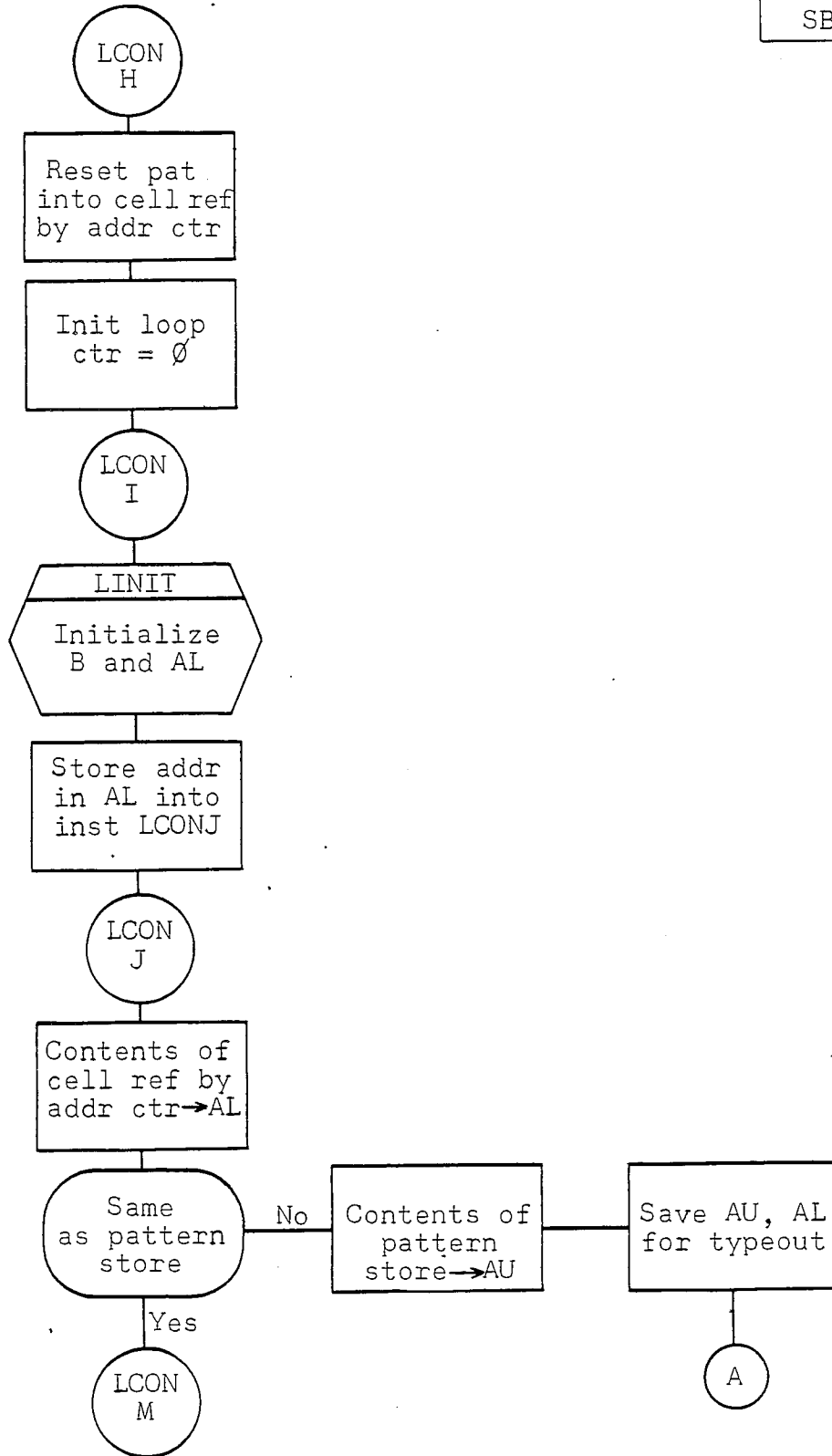

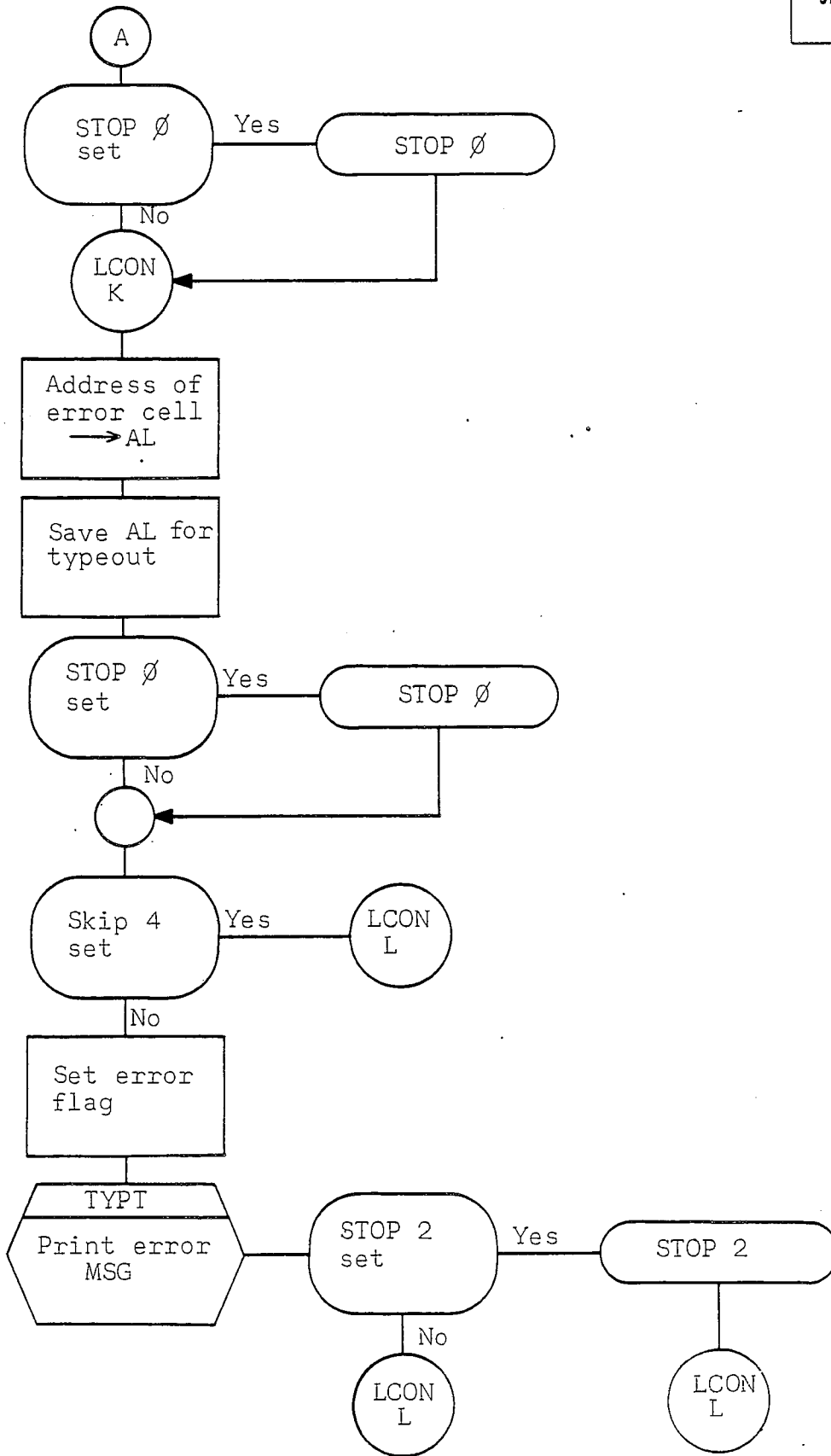

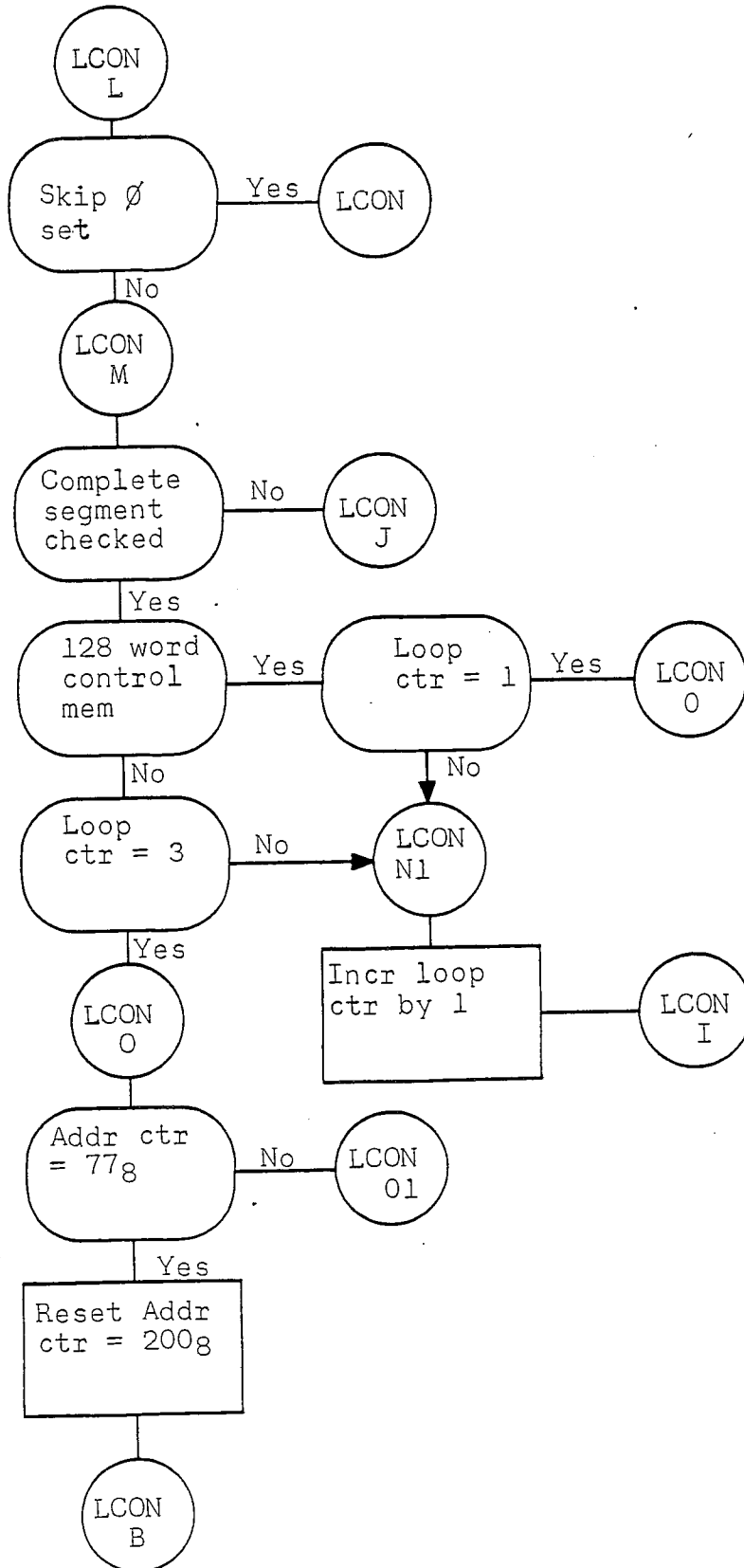

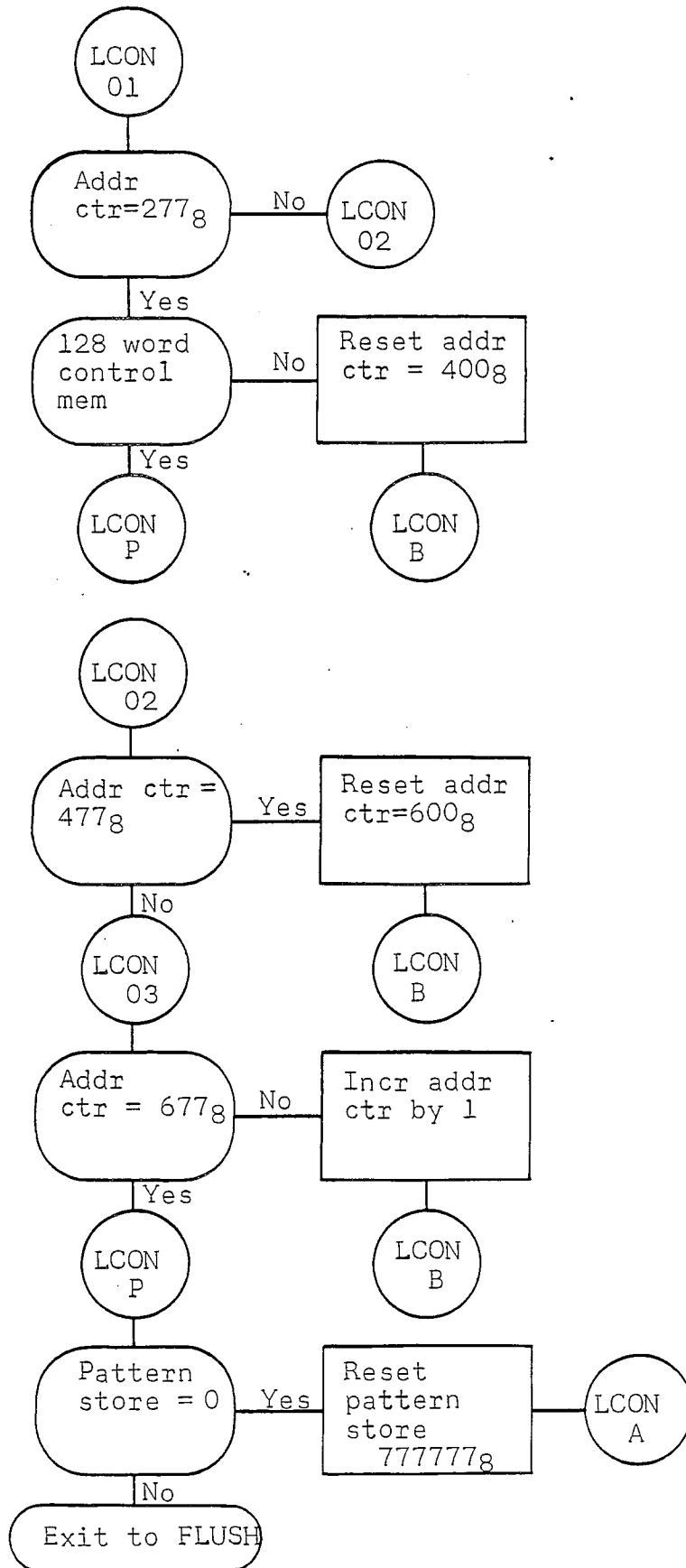

PROGRAM DATA PAGE

SHEET 728.8

REVISION

SPECIFICATION SYMBOL
SB-10163

LABEL: LINIT

TITLE AND/OR PURPOSE: Initialize B and set AL with the segment initial address.

INPUT PARAMETERS:

None

OUTPUT PARAMETERS:

B set to an address bias
AL set to a base address

DESCRIPTION:

The loop counter (LOOP) is referenced to see which segment of control memory is next for a store operation or about to be checked. The initial address of the segment is set into AL and an address bias is set into B before the exit as follows:

- a. If LOOP = 0, AL is set to 0 and B is set to 20 octal
- b. If LOOP = 1, AL is set to 200 octal and B is set to 0
- c. If LOOP = 2, AL is set to 400 octal and B is set to 0
- d. If LOOP = 3, AL is set to 600 octal and B is set to 0

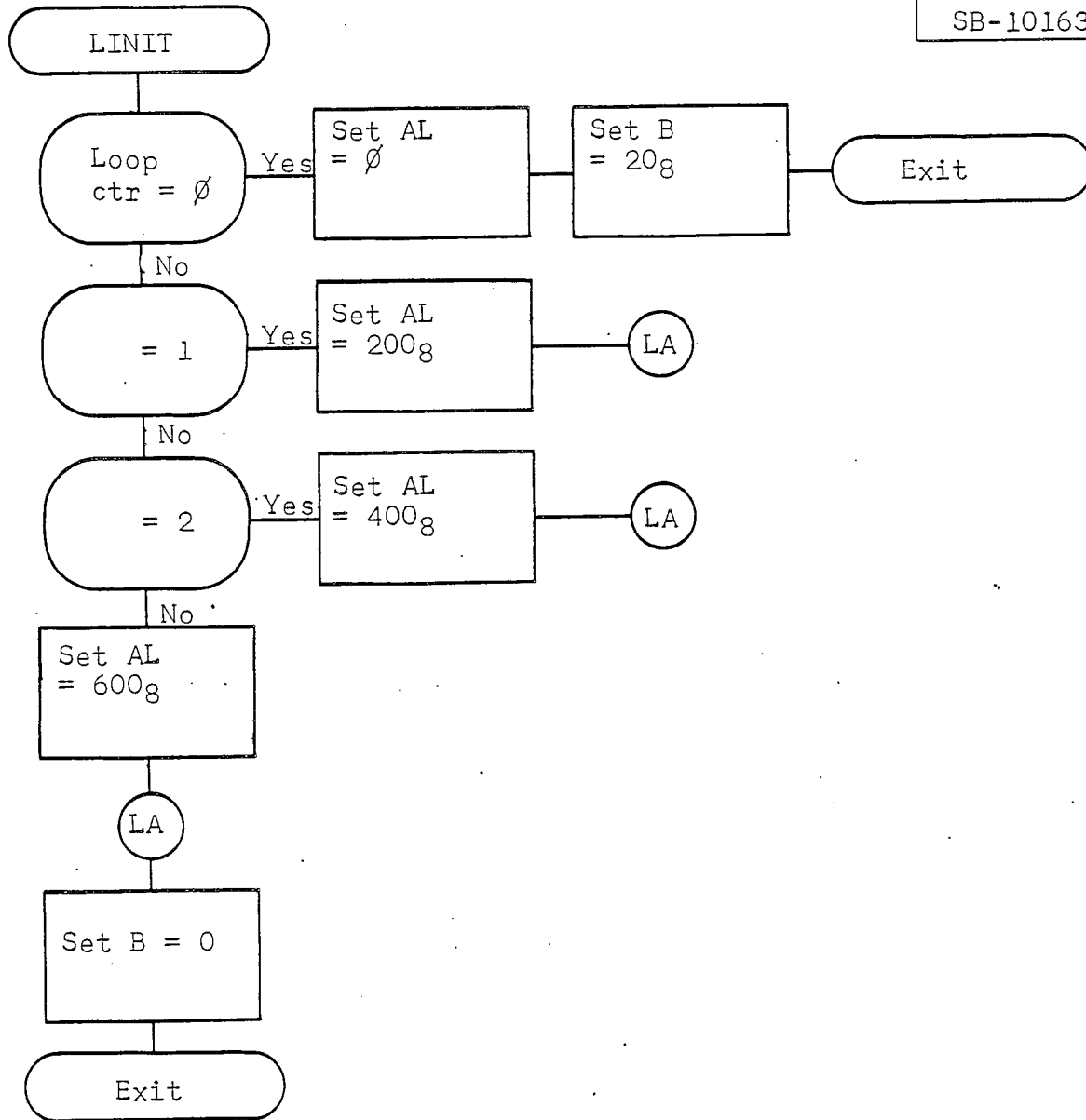

PROGRAM DATA PAGE

SHEET 729

REVISION —

SPECIFICATION SYMBOL

SP-10163

TITLE: FLUSH1- FLUSH CONTROL MEMORYDECK IDENTIFIER: FACTCS-1 LABEL: FLUSH1 KEY: _____ IS LABEL DUPLICATE? NoPROGRAMMER: H W M modified by TLR DATE: 8 Dec. 67NUMBER OF L₄ OUTPUT INSTRUCTIONS: 22

DESCRIPTION:

This subroutine, FLUSH1, normalizes the control memory.

This subroutine is referenced by routines WP1, CWP1, and FLUSH.

The cells of control memory are first set to all ones (777777) then all the cells are cleared to zero (000000). An exit is then made to the referencing routine.

SPECIFICATION SYMBOL
SB-10163

TITLE: FLUSH1 - FLUSH CONTROL MEMORY

INPUT PARAMETERS (Listed Sequentially):

TEST PATTERNS
PAT1 -777777

OUTPUT PARAMETERS (Listed Sequentially):

ABNORMAL EXITS (Listed Sequentially):

NEXT LEVEL PROCEDURES OR SUBROUTINES (Keys of Duplicate Labels Specified):

CHEK

SYSTEM DATA REFERENCES:

ALARMS AND/OR REMARKS:

SHEET 731	REVISION
-----------	----------

SPECIFICATION SYMBOL SB-10163

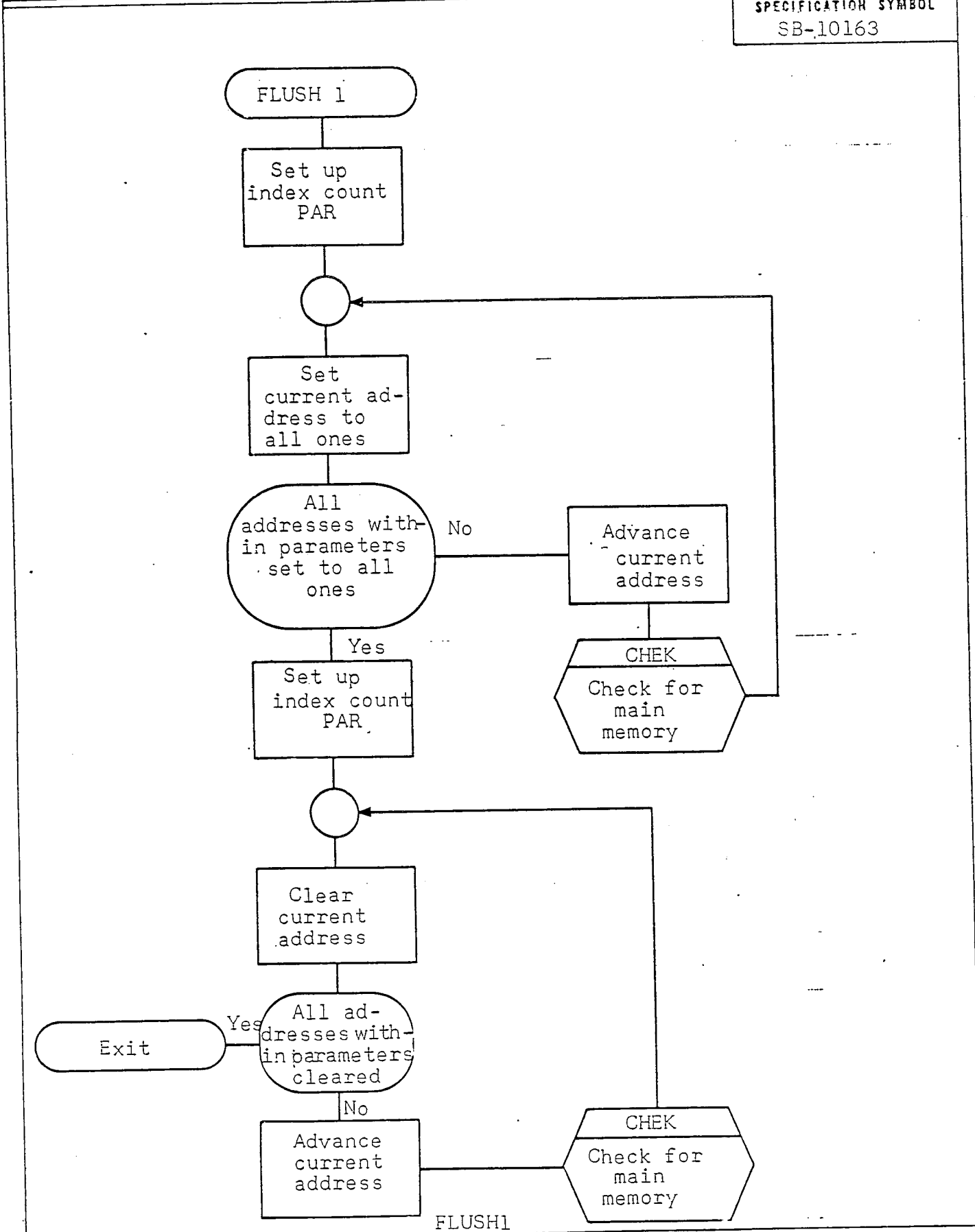

TITLE: FLUSH - FLUSH CONTROL MEMORY, STOP, RECYCLEDECK IDENTIFIER: FACTCS-1 LABEL: FLUSH KEY: _____ IS LABEL DUPLICATE? NoPROGRAMMER: H W M modified by TLR DATE: 8 Dec. 67NUMBER OF L₄ OUTPUT INSTRUCTIONS: 5

DESCRIPTION:

This routine, FLUSH, normalizes control memory, checks PROGRAM STOP 1 for the end of the Control Memory test, and checks PROGRAM SKIP 4 for recycle conditions.

This routine is entered from routine LCON

FLUSH return jumps to FLUSH1 to flush control memory, then checks PROGRAM STOP 1. If set, the Control Memory test is terminated. If not set, or upon restarting, PROGRAM SKIP 4 is checked. If set the Control Memory test is recycled without typeouts. If not set the Control Memory test is recycled with typeouts.

TITLE: FLUSH - FLUSH CONTROL MEMORY, STOP, RECYCLE

INPUT PARAMETERS (Listed Sequentially):

OUTPUT PARAMETERS (Listed Sequentially):

ABNORMAL EXITS (Listed Sequentially):

NEXT LEVEL PROCEDURES OR SUBROUTINES (Keys of Duplicate Labels Specified):

FLUSH1
HEAD+6 in routine CRANK
TEST

SYSTEM DATA REFERENCES:

ALARMS AND/OR REMARKS:

PROGRAM STOP 1 - set for end of Control Memory test
PROGRAM SKIP 4 - set to recycle Control Memory test without typeouts
 not set to recycle Control Memory test with typeouts

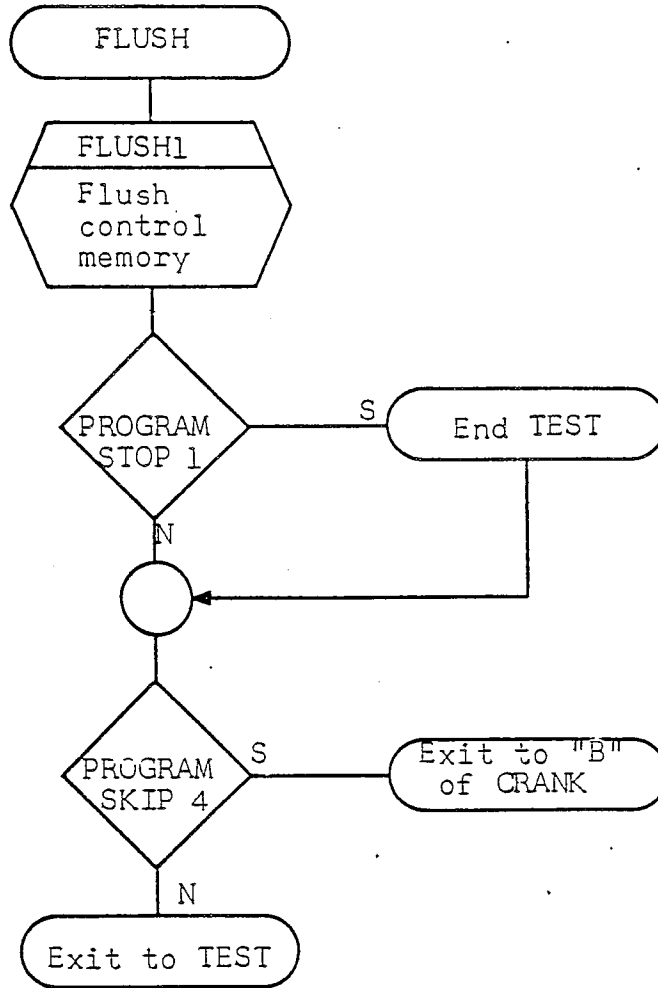

FLUSH

PROGRAM DATA PAGE

SHEET 735	REVISION
SPECIFICATION SYMBOL CB-10163	

TITLE: PAR - STORAGE, TEST PATTERNS

DECK IDENTIFIER: FACT.

CS-1 LABEL: PAR KEY: IS LABEL DUPLICATE? No

PROGRAMMER: H W M modified by TLR DATE: '8 Dec. 67

NUMBER OF L₄ OUTPUT INSTRUCTIONS: 10

DESCRIPTION:

This program contains test patterns and storage for parameters used in the Control Memory test.

UNIVAC

DIVISION OF SPERRY AND CORPORATION

SPECIFICATION SHEET

PROGRAM DATA PAGE (Cont)

SHEET 736

REVISION

SPECIFICATION SYMBOL

SB-10163

TITLE: PAR - STORAGE, TEST PATTERNS

INPUT PARAMETERS (Listed Sequentially):

PAR
PAR1
DIP
DIP+1
HERE
THERE

OUTPUT PARAMETERS (Listed Sequentially):

ABNORMAL EXITS (Listed Sequentially):

NEXT LEVEL PROCEDURES OR SUBROUTINES (Keys of Duplicate Labels Specified):

SYSTEM DATA REFERENCES:

ALARMS AND/OR REMARKS: