

WANG

DISK PROCESSING UNIT

Model: 2280

**Customer Engineering
Product Maintenance Manual**

741-0971

PREFACE

The purpose of this manual is to provide the Wang-trained Customer Engineer (CE) with instructions to operate, troubleshoot and repair the Disk Processing Unit Model 2280.

Second Edition (August 1984)

This edition is the converted number for and obsoletes document number 729-0971. It also incorporates Publication Update Bulletin (PUB), 729-0971-1. This edition of the manual may be used only for the purpose stated in the Preface. Updates and /or changes to this document will be published as Publication Update Bulletins (PUB's) or subsequent editions.

This document is the property of Wang Laboratories, Inc. All information contained herein is considered company proprietary, and its use is restricted solely to the purpose of assisting the Wang-trained CE in servicing this Wang product. Reproduction of all or any part of this document is prohibited without the prior consent of Wang Laboratories, Inc.

© Copyright WANG Labs., Inc. 1981, 1984

PUBLICATION UPDATE BULLETIN

DATE: 3/19/84

This PUB: 729-0971-1

Class Code: 3107

Base Document: 729-0971

Previous Notice(s):None

REASON FOR CHANGE:

This PUB corrects a previous error by reversing the photos in figures 2-8, and 2-9 for the proper sequence, enhancing figures 2-12 and 2-13, and adding figures 2-12A and 2-13A.

INSTRUCTIONS:

Remove pages and insert attached pages as follows:

	REMOVE	INSERT
1.	2-11, 2-12	2-11, 2-12
2.	2-15, 2-16	2-15, 2-16
3.	2-17, 2-18	2-17, 2-17A
4.		2-17B
5.		2-17D, 2-18
6.		
7.		
8.		
9.		
10.		

This page is to be used as a permanent record of revisions; place it directly following the title page.

This document is the property of Wang Laboratories, Inc. Information contained herein is considered company proprietary information and its use is restricted solely to the purpose of assisting you in servicing Wang products. Reproduction of all or any part of this document is prohibited without the prior consent of Wang Laboratories.

© Copyright Wang Labs, Inc. 1984

TABLE OF CONTENTS

Section		Page
1	GENERAL DESCRIPTION	1-1
	1.1 Purpose and Scope	1-1
	1.2 Related Publications	1-1
	1.3 Functional Description	1-1
	1.4 Specifications	1-3
2	INSTALLATION	2-1
	2.1 Site Preparation	2-1
	2.2 Pre-Unpacking Inspection	2-1
	2.3 Unpacking Instructions	2-1
	2.4 Pre-Installation Inspection	2-1
	2.5 Initial Setup	2-2
	2.5.1 Motherboard AC Input Voltage Selection Jumpers	2-2
	2.5.2 Circuit Boards	2-4
	2.5.3 Motherboard/PCB Layout	2-4
	2.5.4 Input/Output Cable Connections	2-15
	2.5.5 Device Address Plug (on Phoenix Disk Drive)	2-15
	2.5.6 Shielded Cable Connections	2-18
	2.6 Installation Procedure	2-22
3	OPERATION	3-1
4	MAINTENANCE	4-1
	4.1 Recommended Test Equipment/Tool List	4-1
	4.2 Diagnostics	4-1
	4.3 Preventive Maintenance	4-1
	4.4 Power Supply Voltage Adjustment	4-2
	4.5 Removal/Replacement Procedures	4-3
	4.5.1 Top Cover	4-3
	4.5.2 Bottom Cover	4-3
	4.6 Disk Error Codes	4-7
5	THEORY OF OPERATION	5-1
	5.1 Block Level	5-1
	5.1.1 WL No. 210-7423-A RAM/PROM Control Board	5-1
	5.1.2 WL No. 210-7421-A ALU/MUX Interface Board	5-5
	5.1.3 WL No. 210-7424 I/O Controller Board	5-8
	5.1.4 WL No. 210-7422 ECC/Device Interface Board	5-10
	5.1.5 WL No. 210-L567 Regulator Board	5-13
	5.2 Read/Write Data Flow	5-14
	5.2.1 Write Data Flow	5-14
	5.2.2 Read Data Flow	5-14
	5.3 Microprogram Flowcharts	5-14
A	Disk Error Codes	A-1
B	Disk Sector Layout	B-1
C	Bill Of Materials	C-1
D	Schematics	D-1

LIST OF ILLUSTRATIONS

Figure		Page
1-1	2200/2280 System Configuration	1-2
2-1	AC Input Voltage Selection Jumpers	2-3
2-2	WL No. 210-7415 Prime Circuit Card	2-5
2-3	WL No. 210-7421-A ALU/MUX Interface Card	2-6
2-4	WL No. 210-7422 ECC/Device Interface Board	2-7
2-5	WL No. 210-7423-A RAM/PROM Control Board	2-8
2-6	WL No. 210-7424 I/O Controller Board	2-9
2-7	WL No. 210-7715 2280 MUX Disk Controller Board	2-10
2-8	WL No. 210-7717 2280 MUX Master Board	2-11
2-9	WL No. 210-7718 2280 MUX Slave Board	2-12
2-10	Circuit Board Loading	2-13
2-11	WL No. 210-7716 Motherboard	2-14
2-12	System Interconnection Diagram with One DPU	2-16
2-12A	System Interconnection Diagram with Two DPU's	2-17
2-13	MUX System Interconnection Diagram with One DPU	2-17A
2-13A	System Interconnection Diagram with Two DPU's	2-17B
2-14	Shielded Cable Installation	2-19
2-15	DPU Mounted in Bottom of Stand	2-23
4-1	WL No. 210-L567 Regulator Board Potentiometers	4-4
4-2	Top Cover Removal	4-5
4-3	Bottom Cover Removal	4-6
5-1	WL No. 210-7423-A RAM/PROM Control Block Diagram	5-2
5-2	Timing Chart	5-3
5-3	WL No. 210-7421-A ALU/MUX Interface Block Diagram	5-6
5-4	WL No. 210-7424 I/O Controller Block Diagram	5-9
5-5	WL No. 210-7422 WCC/Device Interface Block Diagram	5-11
5-6	ECC Code Handling Flowchart	5-12
5-7	Write Data Flow	5-15
5-8	Read Data Flow	5-16
5-9	2280 DPU Microprogram Flowchart	5-17
5-10	2280 DPU Microprogram Flowchart - Read Data	5-19
5-11	2280 DPU Microprogram Flowchart - Format	5-20
5-12	2280 DPU Microprogram Flowchart - Verify	5-21
5-13	2280 DPU Microprogram Flowchart - Write/Start MSW/Stop MSW	5-22
5-14	2280 DPU Microprogram Flowchart - Compare	5-23
5-15	2280 DPU Microprogram Flowchart - Power-On Diagram/Begin	5-24

LIST OF TABLES

Table		Page
2-1	Voltage Selection Jumpers	2-2
4-1	DC Voltage Specifications	4-3

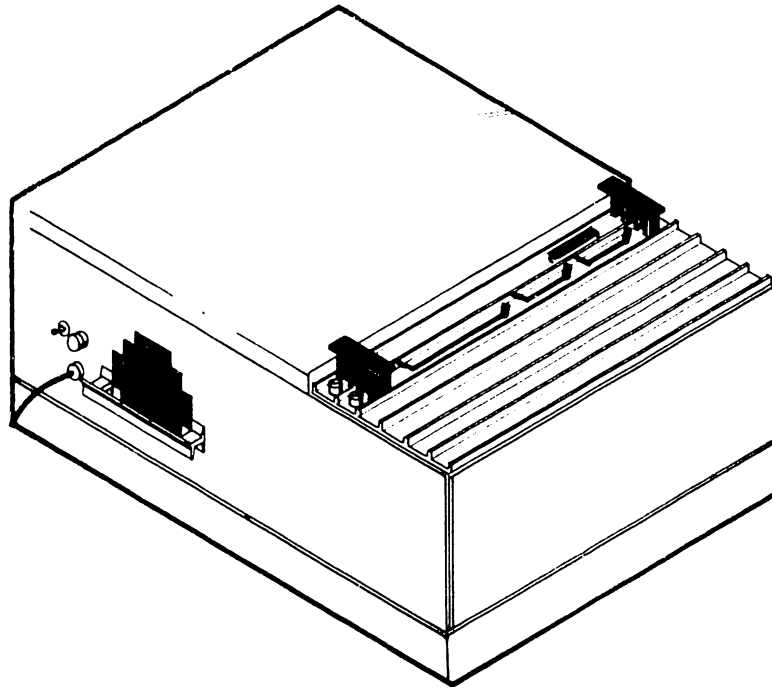

SECTION

1

GENERAL

DESCRIP-

TION

SECTION 1

INTRODUCTION

1.1 PURPOSE AND SCOPE

The purpose of this Product Maintenance Manual (PMM) is to provide sufficient information for the Wang CE to install and maintain the Model 2280 Disk Processor. The information is presented as follows:

<u>Section</u>	<u>Title</u>
1	INTRODUCTION
2	INSTALLATION
3	OPERATION
4	MAINTENANCE
5	THEORY OF OPERATION
Appendix A	DISK ERROR CODES
Appendix B	DISK SECTOR LAYOUT
Appendix C	BILL OF MATERIAL
Appendix D	SCHEMATICS

1.2 RELATED PUBLICATIONS

Following is a list of documentation categories referenced by this PMM. Documentation from these other categories is required for the performance of certain installation/maintenance tasks.

Phoenix Disk Drive -- III.A.7
 Disk Diagnostics -- IV.C.1
 2280 DPU-to-2280 DPU/MUX Conversion -- I.B.2
 22C03, 22C11, 22C32 Disk I/O Controllers -- IV.B.1

1.3 FUNCTIONAL DESCRIPTION

The 2280 DPU (Disk Processing Unit) controls all disk drive operations (such as reading, writing, and head positioning) for the CDC Model 9448 Cartridge Module Disk Drive (CMD)--commonly called the "Phoenix"--when the drive is a component in a 2200VP/LVP/MVP/SVP Computer System. The DPU permits two Phoenix drives to be daisy-chained, providing up to 162 megabytes (approximate) of on-line storage. The 2280 processor (WL No. 187-2200-80) consists of nine printed circuit boards and a motherboard contained in a 2200S chassis. This chassis is housed (located) in the bottom of the Phoenix cabinet/stand. All printed circuit boards are defined in section 2.5.2.

The 2280 DPU connects to a 22C03, 22C11, or 22C32 disk I/O controller in the CPU via a 12-ft (3.6-m) twisted pair cable. The processor connects to the disk drive via two 15-ft (4.5-m) ribbon cables. Figure 1-1 shows a dual disk drive 2200/2280 system configuration.

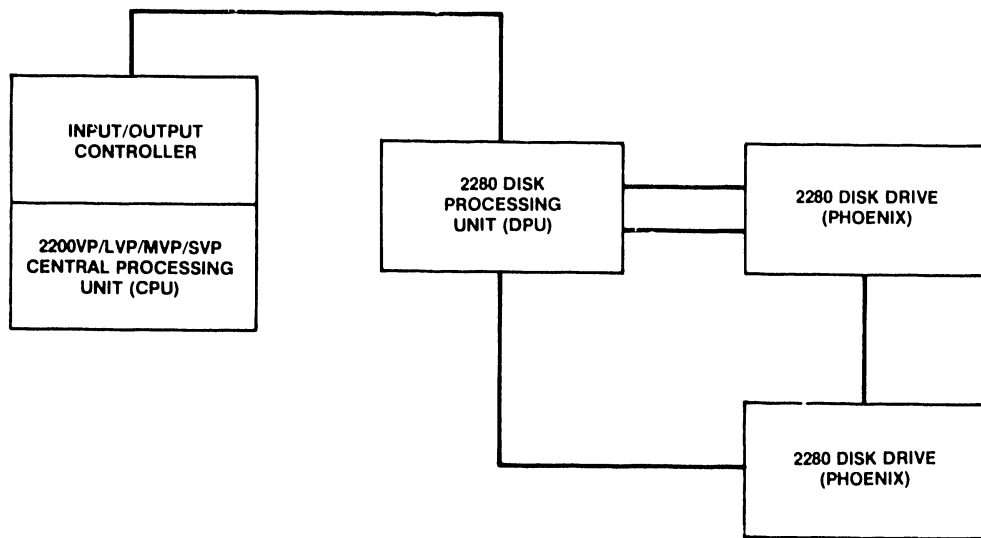

Figure 1-1. 2200/2280 System Configuration

1.4 SPECIFICATIONS

The specifications for the 2280 DPU system are listed below as follows:

Physical Dimensions

Height - 9 in. (23 cm)
Width - 16 in. (41 cm)
Depth - 21 in. (53 cm)

Power Requirements

115 or 230 Vac $\pm 10\%$
50 or 60 Hz ± 1.0 Hz
230 Watts

Fuses

3.0 A (SB) for 115 Vac
1.5 A (SB) for 230 Vac

Operating Environment

Temperature - 60°F to 80°F (15°C to 27°C)
Relative Humidity - 40% to 60% (noncondensing)

Heat Output

787 BTU/hr (197 Kcal/hr)

Cables

Power - 10 ft (3.0 m)
Data - 15 ft (4.5 m)

SECTION

2

INSTAL-

LATION

SECTION 2
INSTALLATION

2.1 SITE PREPARATION

For information concerning preinstallation site planning and preparations, refer to the corporate "Customer Site Planning Guide" WL No. 700-5978, its updates, and CE documentation category I.A.7.

2.2 PRE-UNPACKING INSPECTION

Before unpacking the 2280 DPU, check the packing slip to ensure that the proper equipment has been delivered. After checking the slip, visually inspect the container carefully for any indications of possible shipping damage (crushed edges or corners, puncture holes, tears, etc.). If any damage is noted, file an appropriate claim promptly with the carrier involved and notify the WLI Distribution Center (Department 90), Quality Assurance Department, of the nature and extent of the damage, making arrangements for equipment replacement, if necessary.

2.3 UNPACKING INSTRUCTIONS

- a. Using an x-acto knife, cut the tape securing the shipping carton cover.
- b. Open the box and remove the instapack covering the top of the unit.
- c. Remove the unit from the carton.
- d. Save the shipping carton and protective padding for use when reshipping the unit.

2.4 PRE-INSTALLATION INSPECTION

- a. Remove the top cover from the unit (see section 4.5).
- b. Inspect the DPU chassis for damaged or loosened assemblies. Also check for loose hardware or debris. If any damage is noted, notify the WLI Distribution Center (Department 90), Quality Assurance Department, of the nature and extent of the damage, making arrangements for equipment replacement, if necessary.
- c. Thoroughly clean the unit. Use a soft bristle brush and a vacuum cleaner to remove dust from the inside of the unit. Use a mild detergent and a soft cloth or sponge to remove dirt and grime from the chassis. Do not use abrasive or corrosive materials.

2.5 INITIAL SETUP

This section consists of:

- a. ac input voltage selection information
- b. photographs of the circuit boards giving all pertinent information concerning each board (if applicable) along with motherboard loading
- c. an explanation of system interconnection cabling.
- d. device address selection information.

Section 2.6 (Installation Procedure) helps link together the various information items contained in this section.

2.5.1 Motherboard AC Input Voltage Selection Jumpers

Jumper wires are provided on the motherboard for ac input voltage selection (115V or 230V). Two jumpers are installed for 115Vac and one jumper for 230Vac. Figure 2-1 shows the positions of these jumpers. Be certain the jumper configuration is correct for the supplied ac voltage (see table 2-1).

TABLE 2-1 Voltage Selection Jumpers

JUMPER	115VAC	230VAC
A	IN	OUT
B	OUT	IN
C	IN	OUT

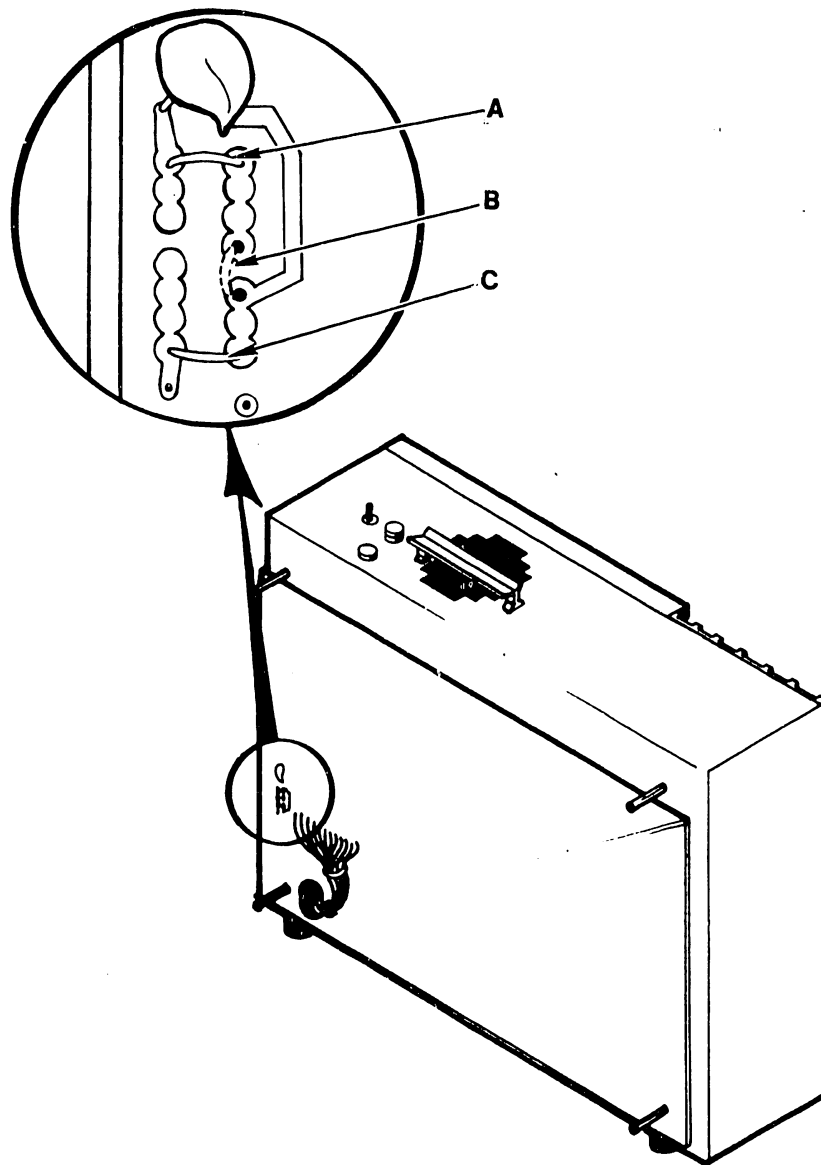

Figure 2-1. AC Input Voltage Selection Jumpers

2.5.2 Circuit Boards

Figures 2-2 through 2-9, 2-11, and 4-1 illustrate the individual printed circuit boards that comprise the 2280 DPU. The specific reference to each figure is as follows:

<u>WL Number</u>	<u>Nomenclature</u>	<u>Figure</u>
210-7415	Prime Circuit Board	2-2
210-7421-A	ALU/MUX Interface Board	2-3
210-7422	ECC/Device Interface Board	2-4
210-7423-A	RAM/PROM Control Board	2-5
210-7424	I/O Controller Board	2-6
210-7715	2280 MUX Disk Controller	2-7
210-7716	Motherboard	2-11
210-7717	2280 MUX Master	2-8
210-7718	2280 MUX Slave	2-9
210-L567	Regulator Board	4-1

2.5.3 Motherboard/PCB Layout

The locations of the 2280 DPU circuit boards in relation to the motherboard/chassis are shown in figures 2-10 and 2-11. Ensure that all fingerboard connectors are clean prior to installing the boards in the DPU. (An ink eraser should be used to clean the pins if necessary.)

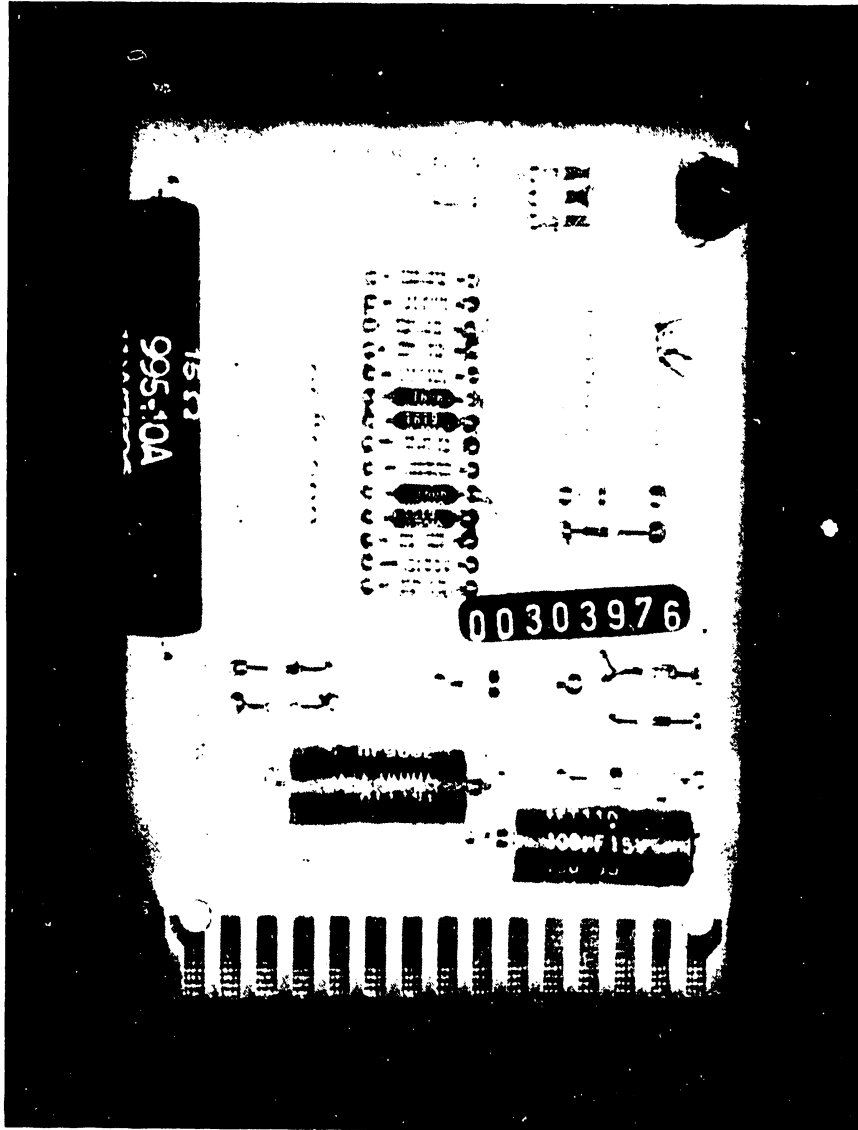

Figure 2-2. WL No. 210-7415 Prime Circuit Board

J1 - CONNECTS TO I/O CONTROLLER
IN CPU VIA 220-0105-2 CABLE

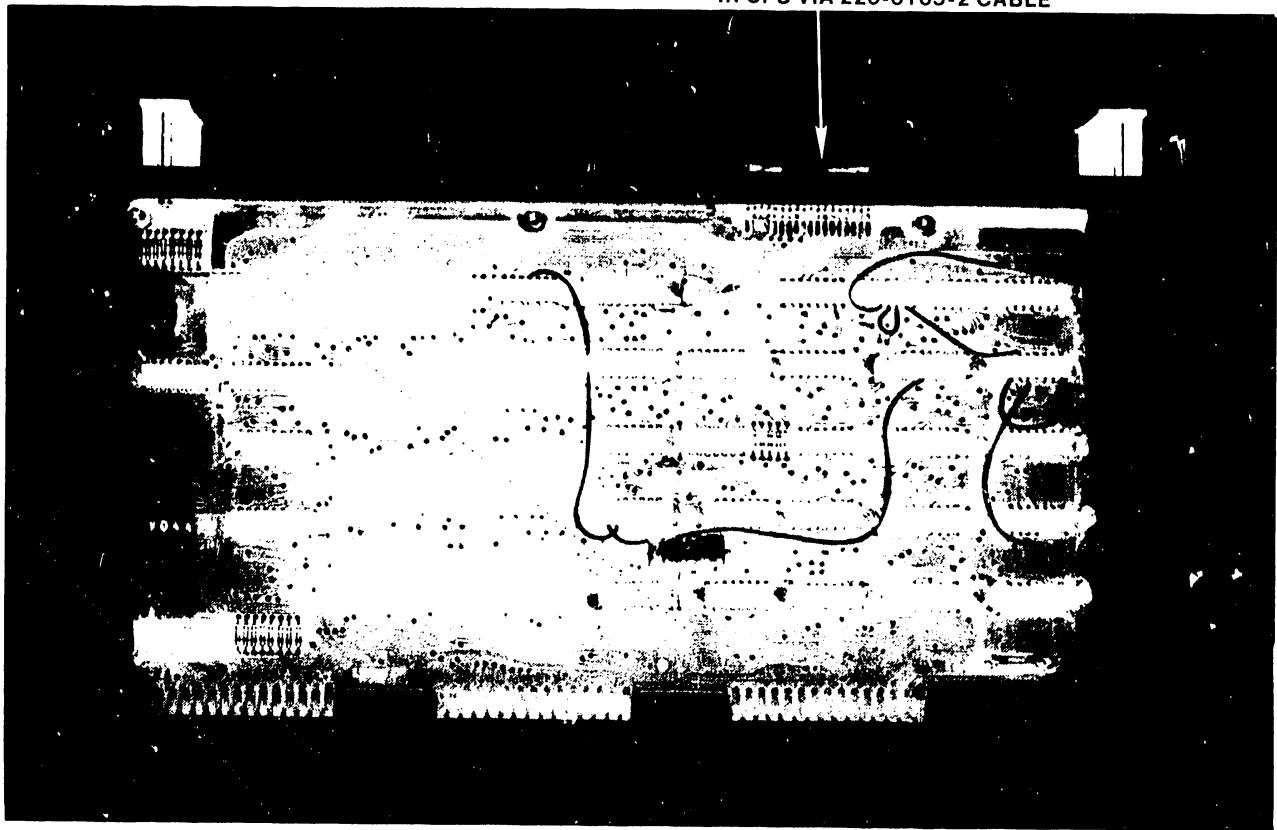
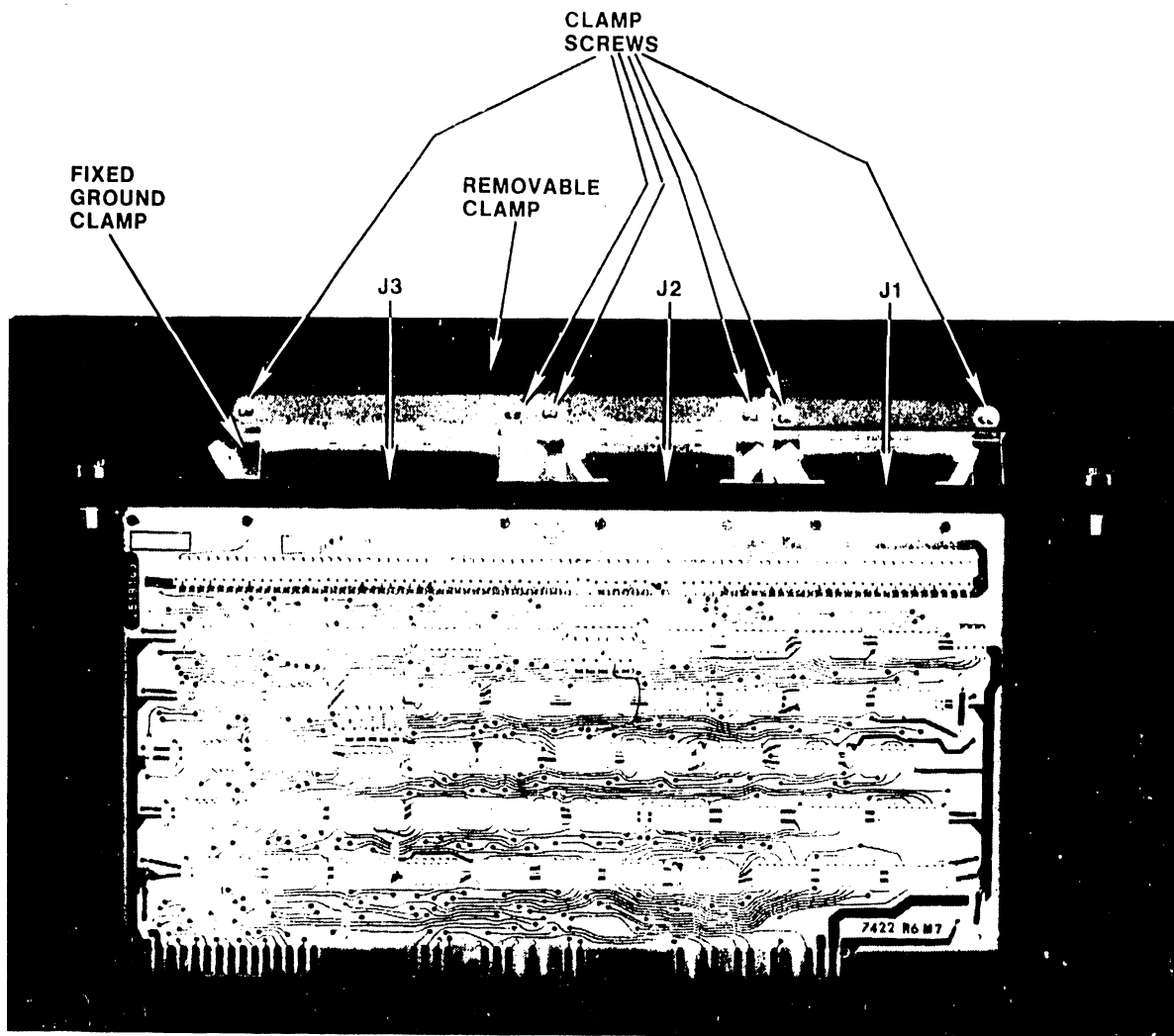

Figure 2-3. WL No. 210-7421-A ALU/MUX Interface Board



J1 AND J2 CONNECT TO PHOENIX EM2
BOARDS VIA 220-3033-36 CABLE

J3 CONNECT TO PHOENIX EM1 BOARD
VIA 220-3041-22 CABLE

Figure 2-4. WL No. 210-7422 ECC/Device Interface Board

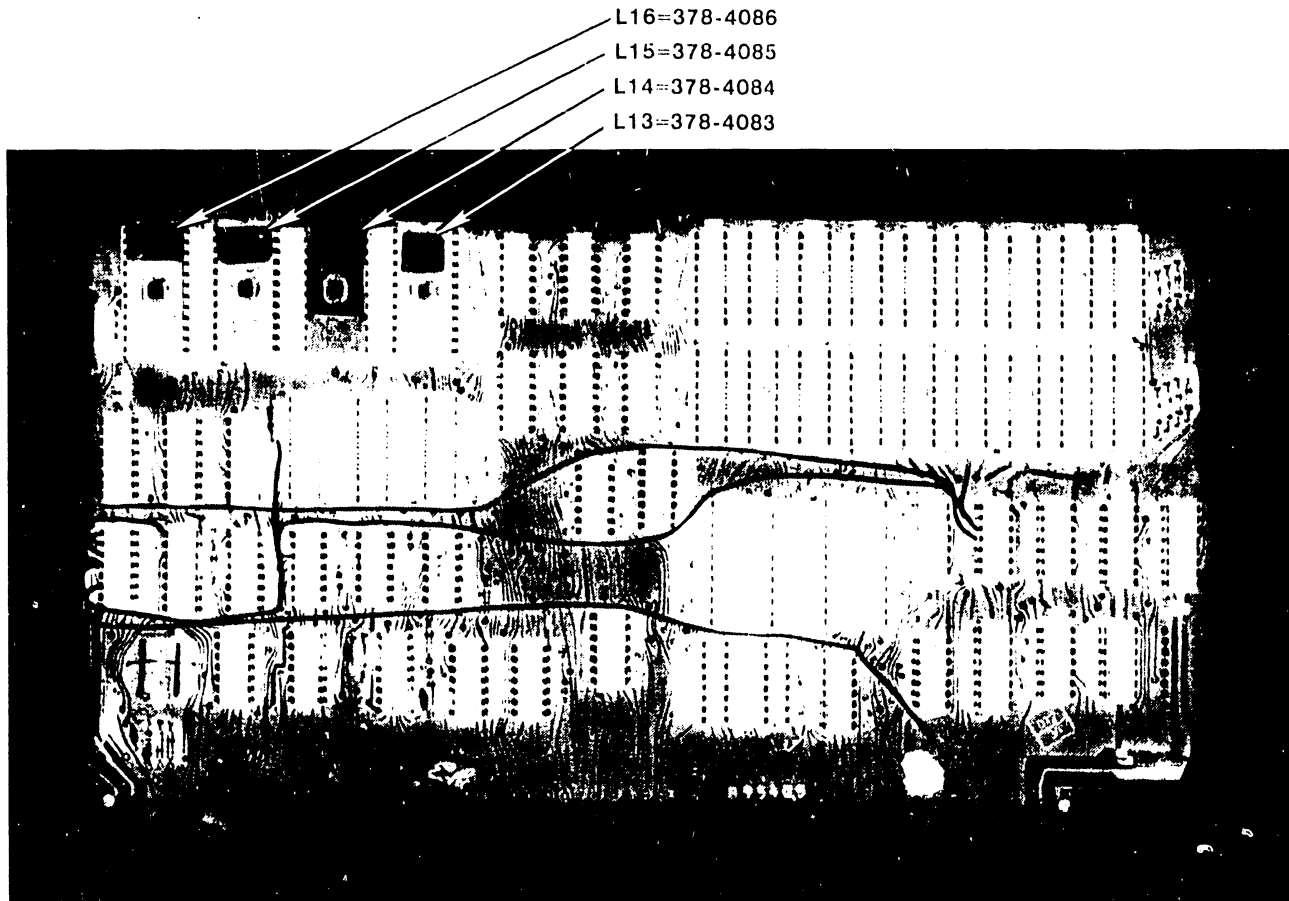

Figure 2-5. WL No. 210-7423-A RAM/PROM Control Board

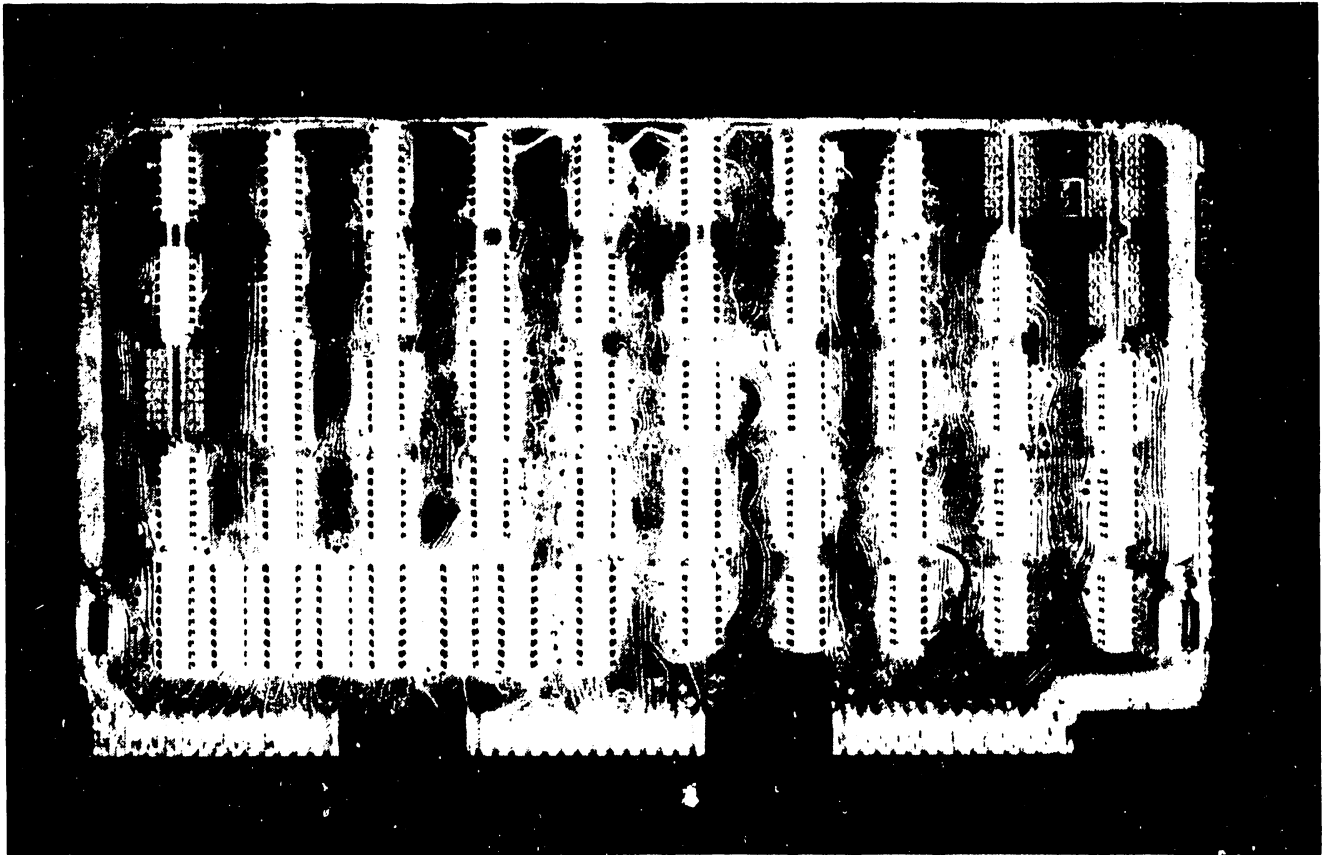

Figure 2-6. WL No. 210-7424 I/O Controller Board

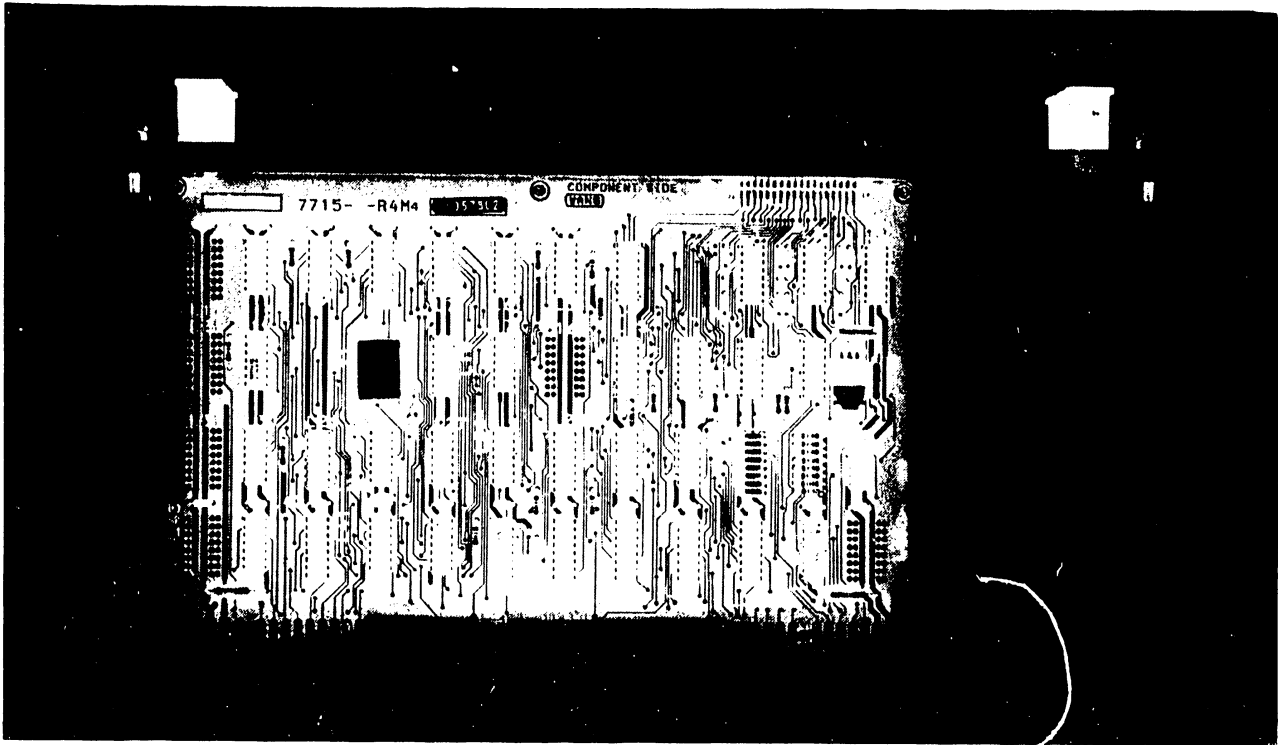
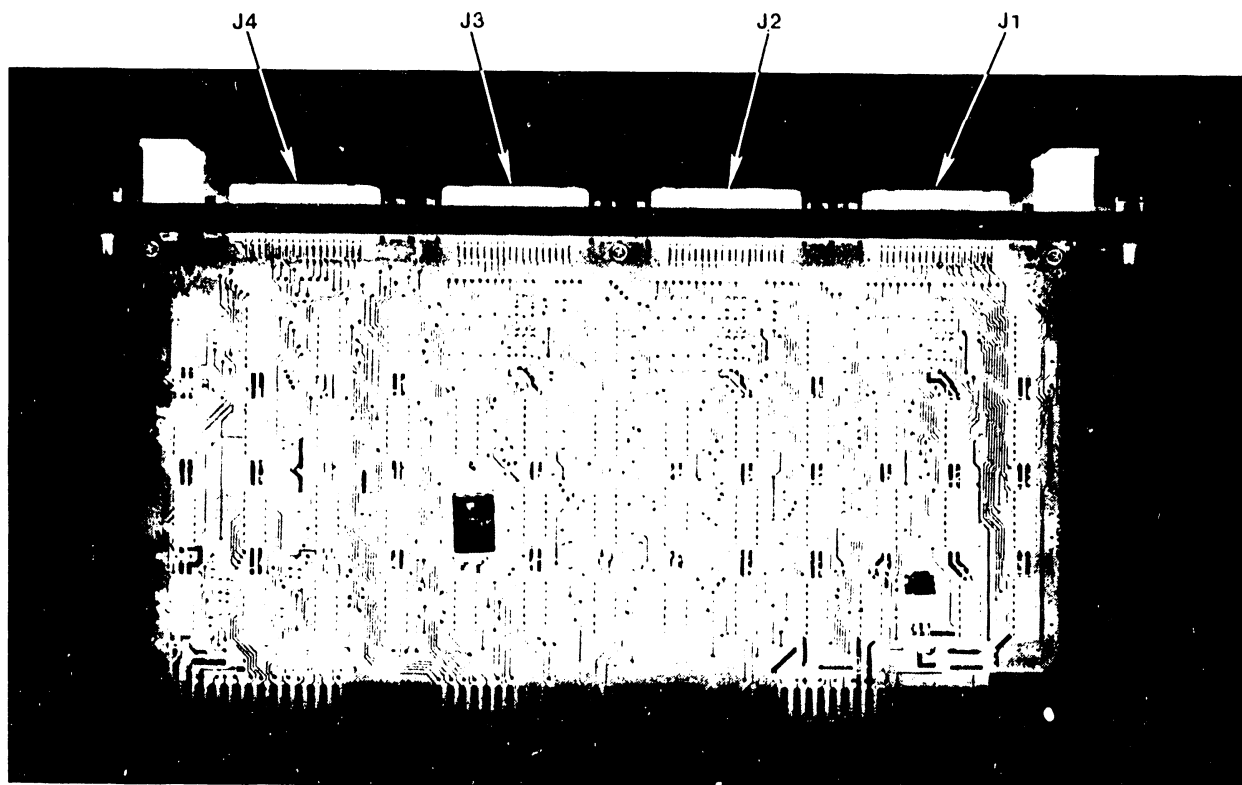
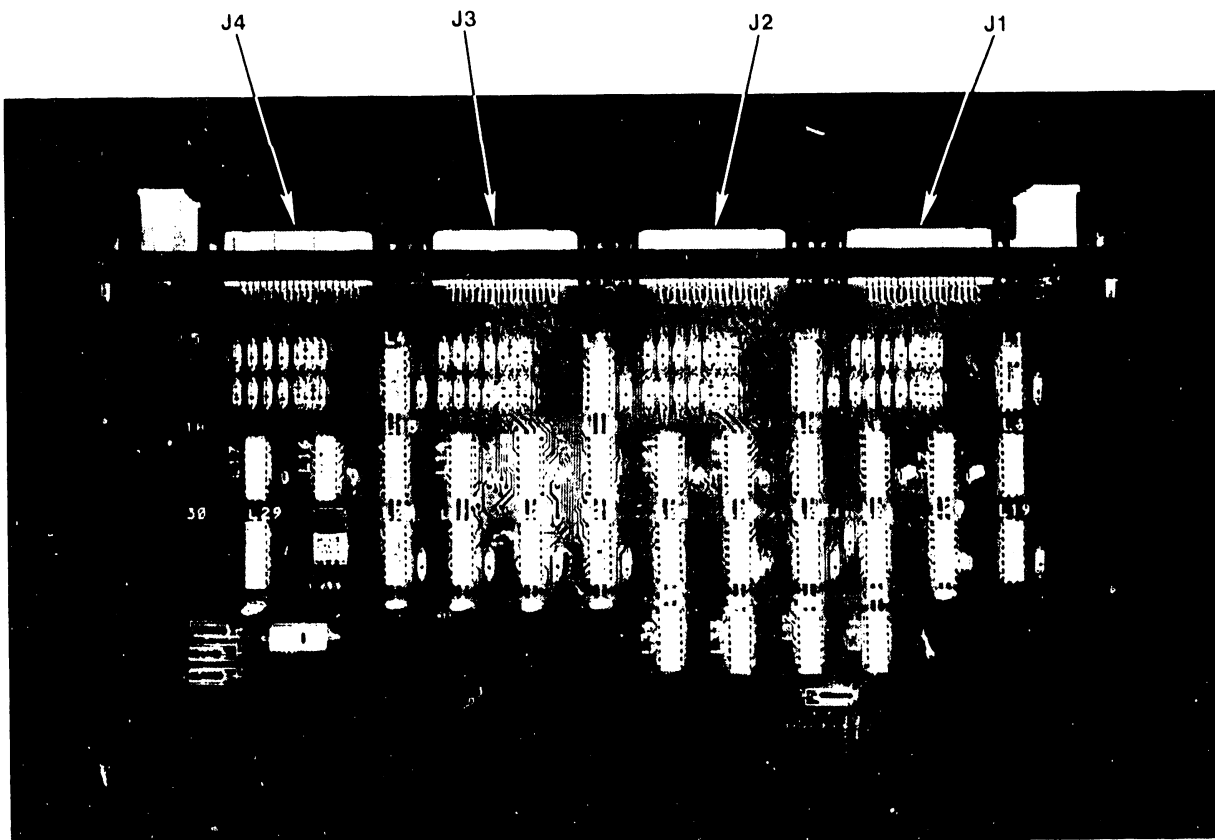

Figure 2-7. WL No. 210-7715 2280 MUX Disk Controller Board



J1 THROUGH J4 ARE EACH CONNECTED
TO THE 7715 PCB IN THEIR RESPECTIVE
CPU VIA 220-0365 CABLE

Figure 2-8. WL No. 210-7717 2280 MUX Master Board



1. J1,J2,AND J3 ARE EACH CONNECTED TO THE 7715 PCB IN THEIR RESPECTIVE CPU VIA 220-0365 CABLE
2. J4 IS CONNECTED TO THE 7421 PCB IN ITS RESPECTIVE CPU VIA 220-0360 CABLE

Figure 2-9. WL No. 210-7718 MUX Slave Board

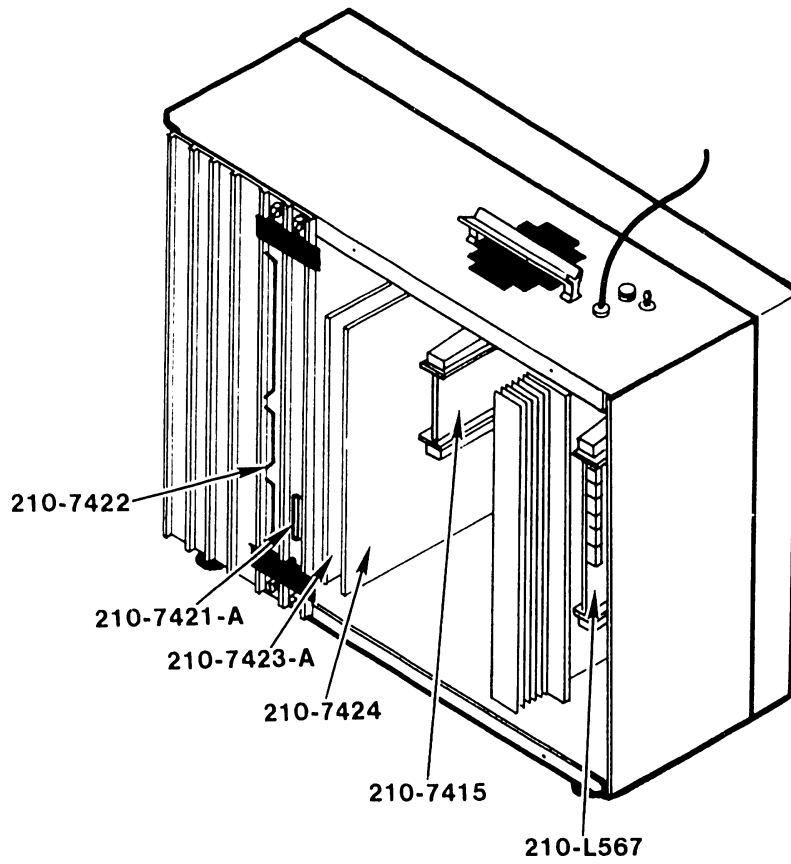

Figure 2-10. Circuit Board Loading

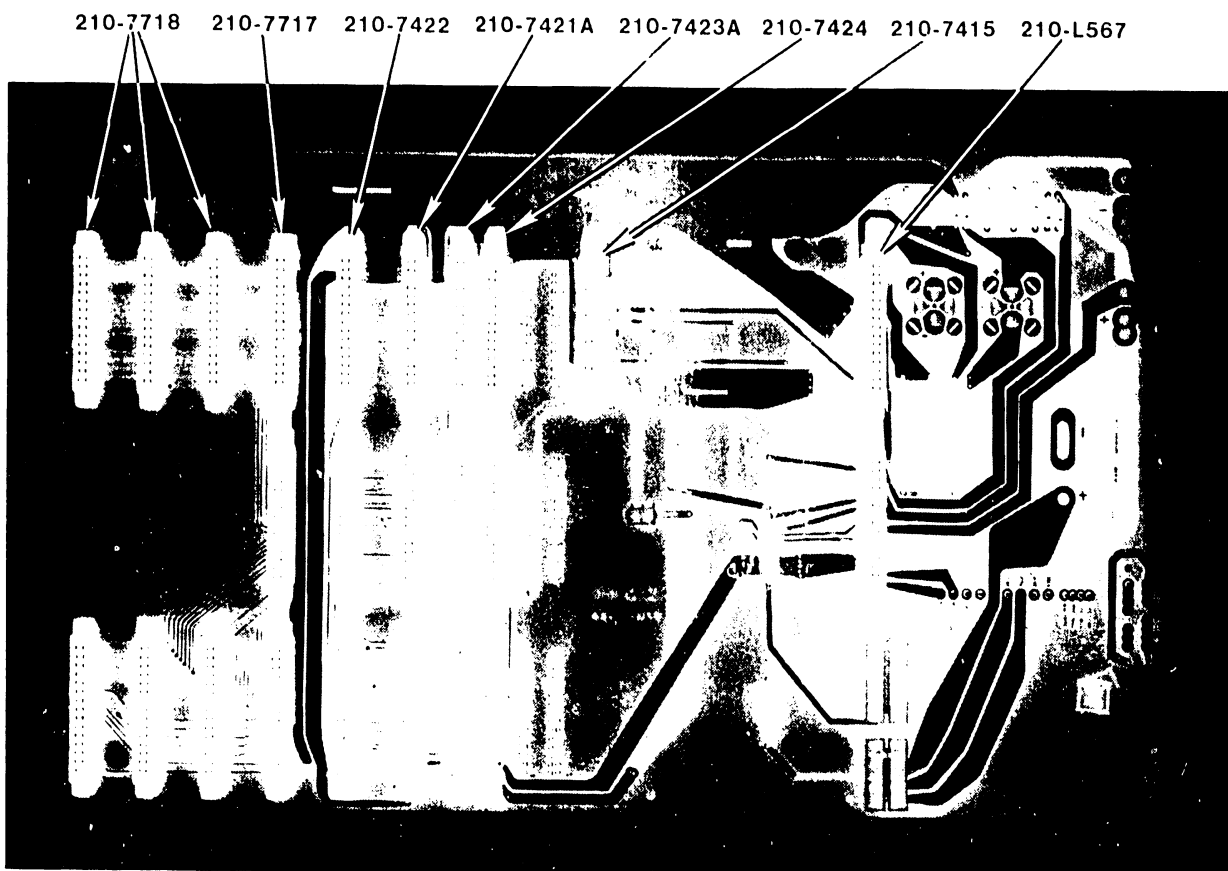

Figure 2-11. WL No. 210-7716 Motherboard

2.5.4 Input/Output Cable Connections (see figure 2-12)

Refer to documentation category 3105 for Phoenix disk drive connection locations.

CAUTION:

Since the "A" the "B" cables are not keyed, carefully check the routing of the cables (following steps) to ensure that pin 1 on the drive connector receiving the cable connects to pin 1 on the appropriate DPU interface connector. Pin 1 of the cables is designated on the connectors of the cable by an embossed triangle. Pin 1 is also recognized by the black strand of the ribbon cable that is attached to that pin.

A 36-pin I/O cable (WL No. 220-0365) connects J1 on the 210-7421-A board in the DPU (see figure 2-3) to the appropriate jack on the I/O controller in the CPU.

A 60-pin "A" cable (WL No. 220-3041-22) connects J3 on the 210-7422 board in the DPU (see figure 2-4) to J1 on I/O logic board EM1 in the Phoenix drive.

A 26-pin "B" cable (WL No. 220-3033-36) connects J2 (Device No. 1 connector) on the 210-7422 board in the DPU (see figure 2-4) to J3 on Control/Mux logic board E 2 in the Phoenix drive.

If only one disk drive is connected to the DPU, a terminator board (WL No. 726-5790) is installed in J2 on I/O logic board EM1 in the Phoenix drive; otherwise, the terminator is installed in the same location in the second drive.

If two disk drives are connected to the DPU, the following cable connections are also required.

A 60-pin "A" cable (WL No. 220-3041-7) connects J2 on the I/O logic board EM1 in the first Phoenix drive to J1 on I/O logic board EM1 in the second Phoenix drive.

A 26-pin "B" cable (WL No. 220-3033-21) connects J1 (Device No. 2 connector) on the 210-7422 board in the DPU (see figure 2-4) to J3 on Control/Mux logic board EM2 in the second Phoenix drive.

2.5.5 Device Address Plug (on Phoenix disk drive)

A device address plug must be inserted into the socket at the left of the START/STOP indicator switch on the front panel of each disk drive. The address plug must correspond with the device number assigned to the 210-7422 connector receiving the "B" cable from the given drive. That is, install a "1" device address plug in the disk drive whose "B" cable is attached to connector J2 (Device No. 1) on the 210-7422 board in the DPU, and install a "2" plug in the drive whose "B" cable is attached to connector J1 (Device No. 2) on the 210-7422 board.

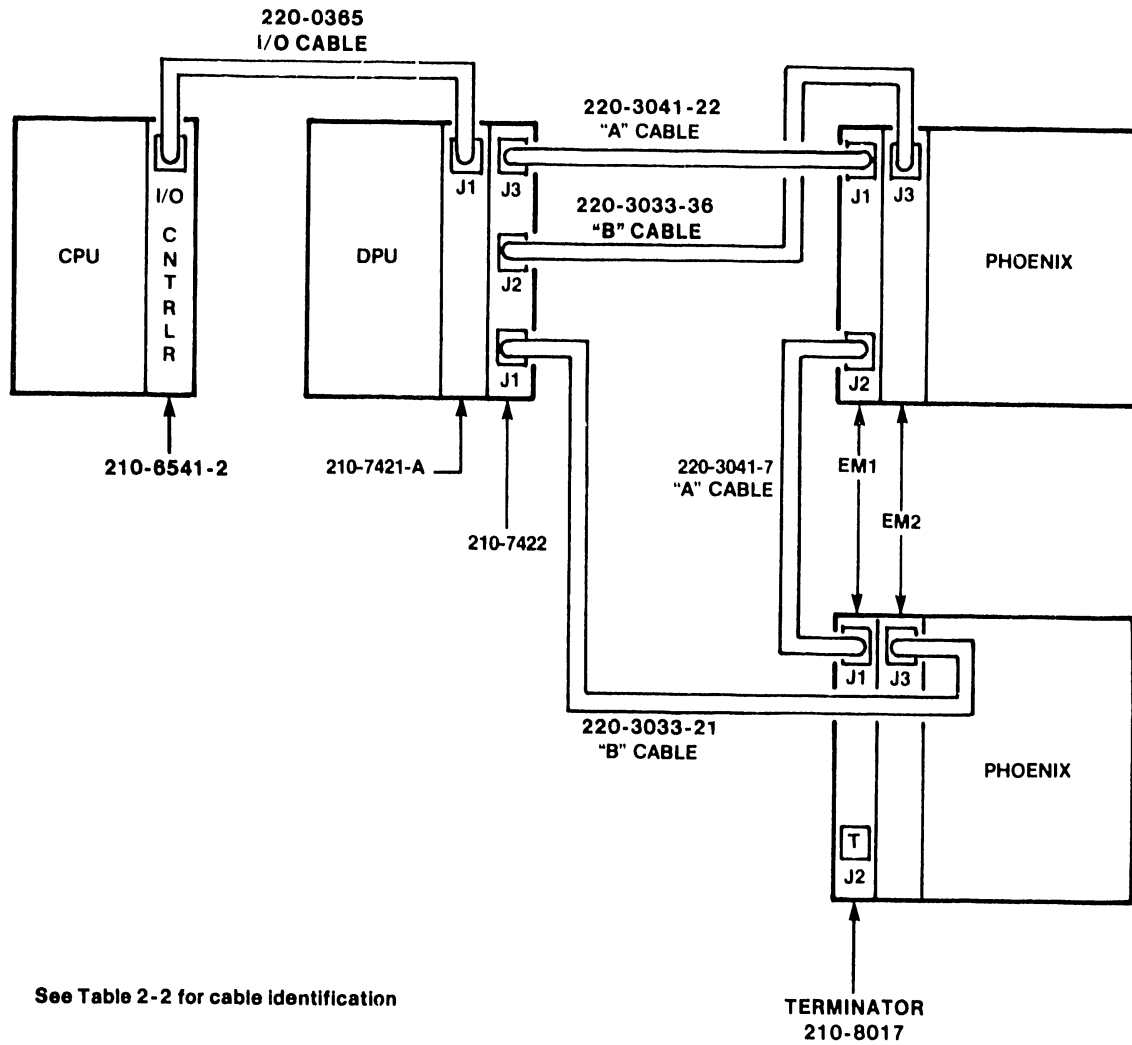
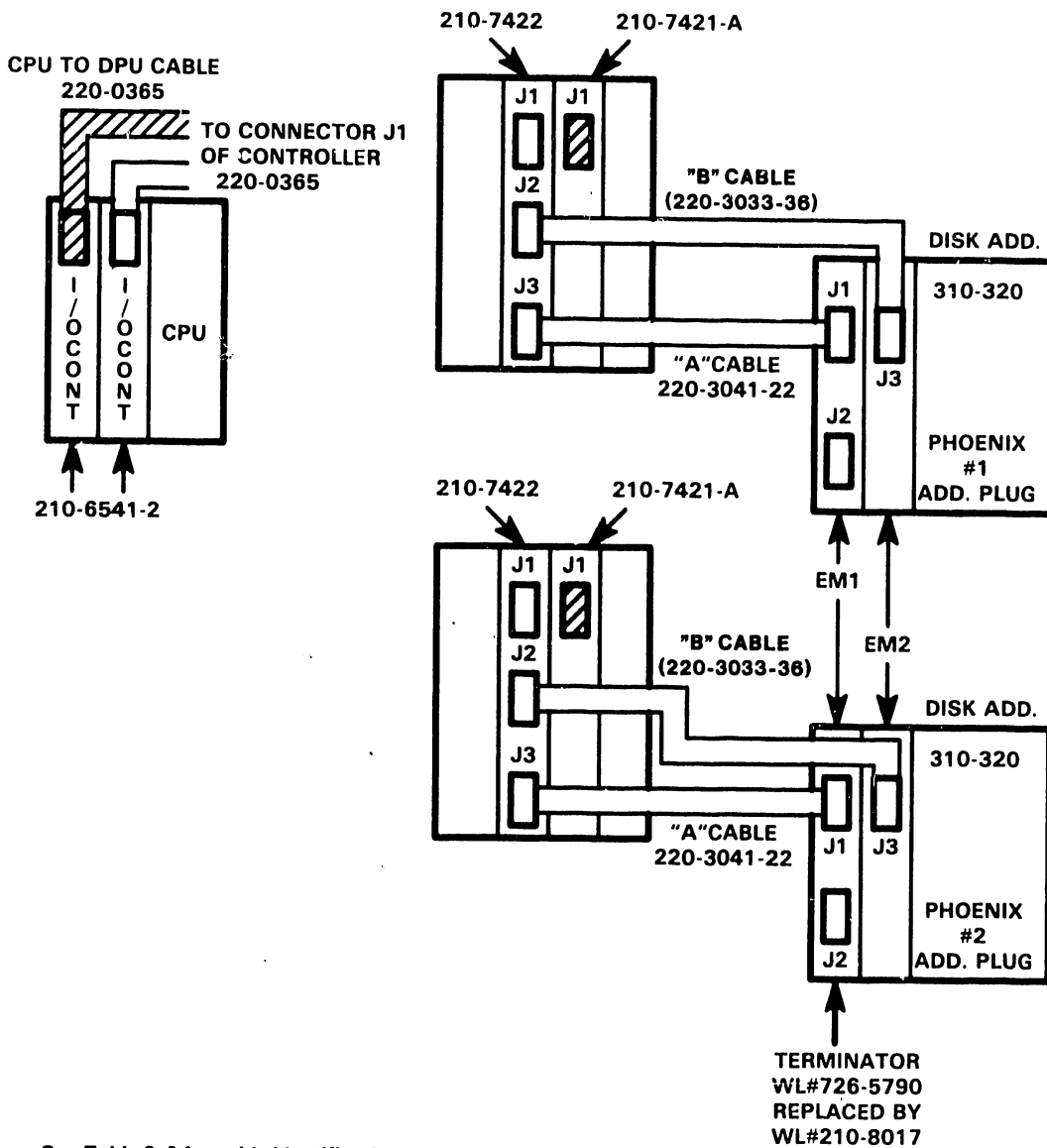
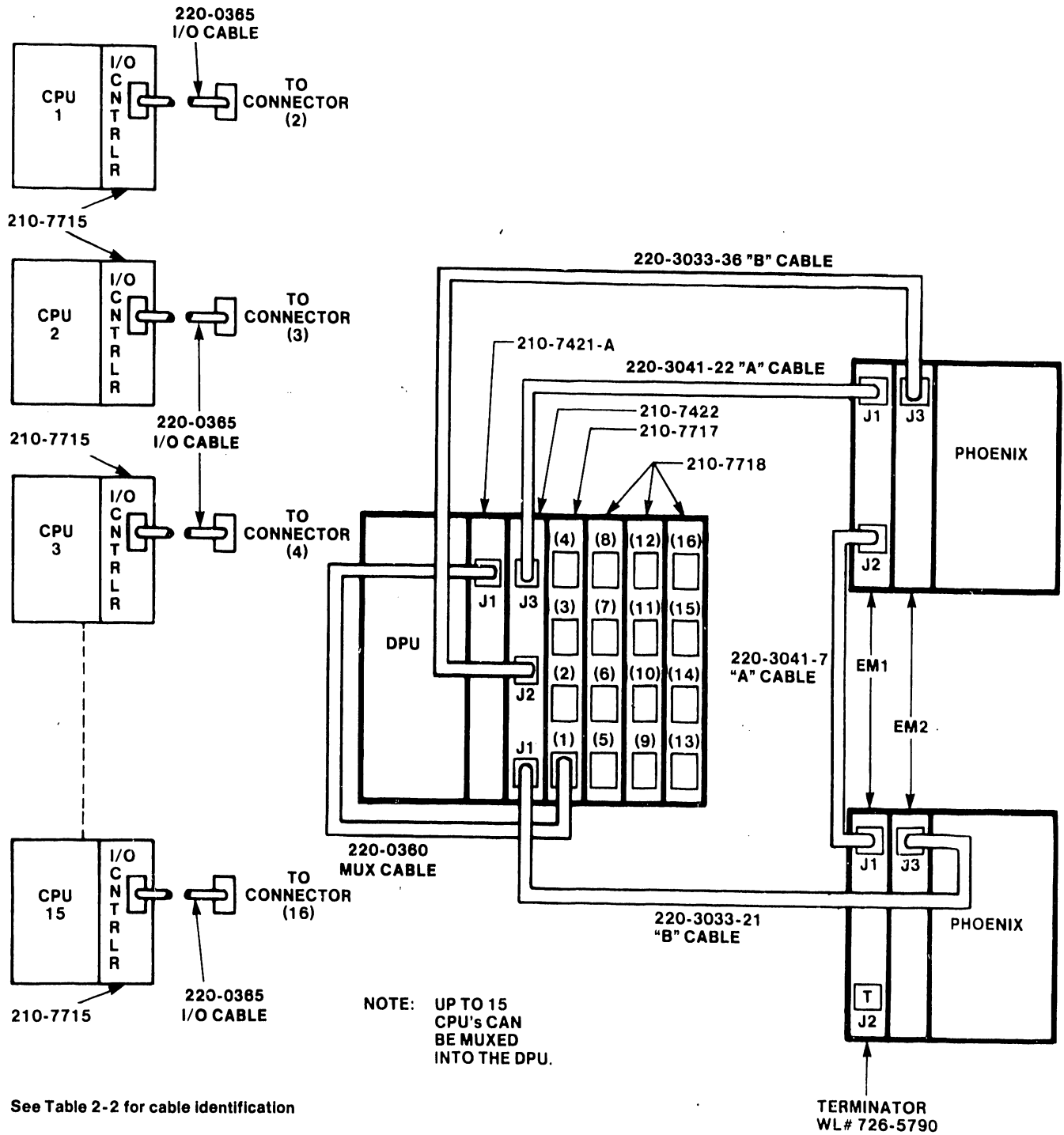

FIGURE 2-12 SYSTEM INTERCONNECTION DIAGRAM WITH ONE DPU



See Table 2-2 for cable identification.

FIGURE 2-12A SYSTEM INTERCONNECTION DIAGRAM WITH TWO DPU'S



See Table 2-2 for cable identification

FIGURE 2-13 MUX SYSTEM INTERCONNECTION DIAGRAM WITH ONE DPU

TABLE 2-2. CABLES AND TERMINATOR PART NUMBERS

FIGURES 2-12 & 2-12A

CABLE NAMES	CONNECTS	STANDARD	SPECIAL
CPU to DPU Cable	CPU I/O Controller to J1 of 210-7421-A	220-0365 9 ft	N/A
"A" Cable	J3 of DPU's 210- 7422 to J1 of Phoenix #1	220-3041-22	N/A
"A" Cable	J2 of Phoenix #1 to J1 of Phoenix #2	N/A	220-3041-7
"B" Cable	J1 of 210-7422 to J3 of EM2 Phoenix #2	220-3308-21	220-3033-36*
"B" Cable	J2 of DPU's 210- 7422 to J3 of Phoenix #1	220-3033-36	N/A
Terminator	J2 EM1 Phoenix #2	726-5790	210-8017

FIGURES 2-13 & 2-13A

CPU to DPU Cable	210-7715 to either 210-7717 or 210-7718	220-0365 9 ft	
"A" Cable	DPU's J3 to Phoenix's J1	220-3041-22	N/A
"A" Cable	Phoenix #1's J2 to Phoenix #2's J1	N/A	220-3041-7
"B" Cable	J1 of 210-7422 to J3 EM2 Phoenix #2	220-3308-21	220-3033-36*
"B" Cable	J2 of 210-7422 to Phoenix #1's J3	220-3033-36	N/A
Terminator	J2 EM1 Phoenix #2	726-5790	210-8017

*For Daisy Chain Configuration Only.

2.5.6 Shielded Cable Connections

The ribbon cable connecting the 210-7422 PCB to the disk drive is copper clad for good shielding. To ensure proper contact, install the DPU cable clamp at the 210-7422 PCB as follows:

- a. Loosen and remove the clamp screws that secure the two halves of the DPU cable clamp to the 210-7422 PCB (see figure 2-4).
- b. Remove the removable half of the cable clamp from the 210-7422 board.
- c. Connect the ribbon cable to the fixed half of the DPU cable clamp by inserting the grounding clip (only) between the copper shield and the outer cable jacket of the ribbon cable (see figure 2-14, A).
- d. Push the ribbon cable onto the clamp; fully inserting the grounding clip (see figure 2-14, B).
- e. Install the removable clamp in the same manner (see figure 2-14, C).
- f. Assemble and secure the two halves of the clamp: tighten the two clamp screws evenly, ensuring that the copper shield remains in good contact with both grounding clips (see figure 2-14, D).

CAUTION

Do not overtighten the clamp screws which secure the two halves of the clamp; otherwise, damage to the cable may result.

- g. All three ribbon cables are secure in the same fashion (refer to figure 2-14, E).

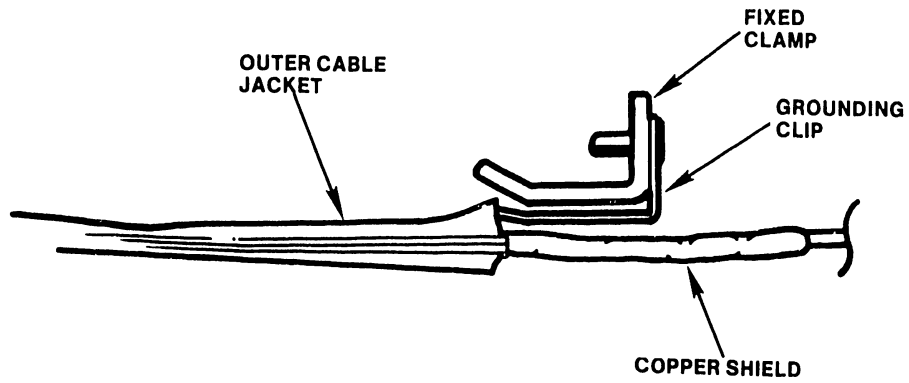

A

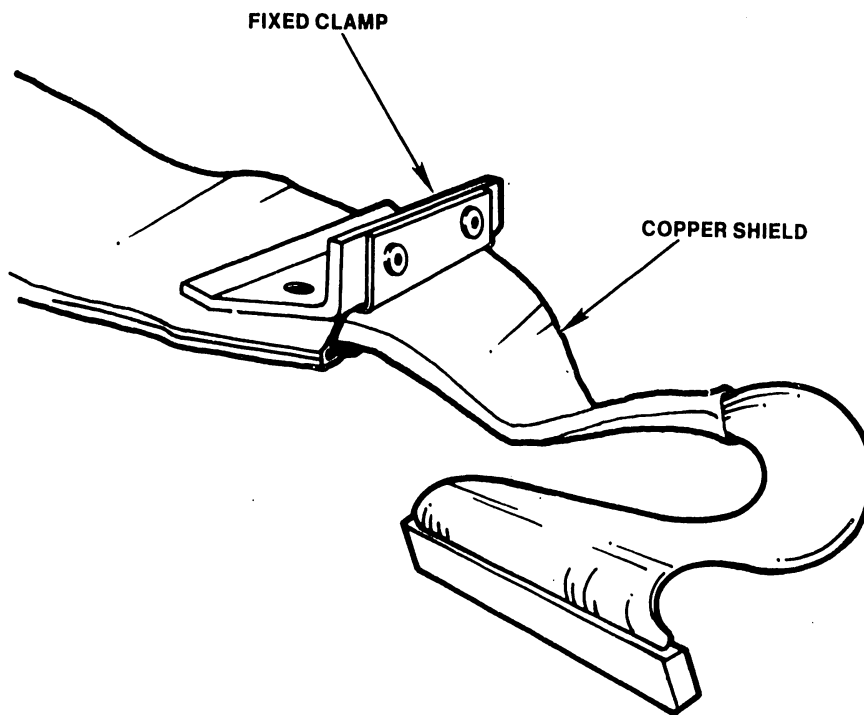

B

Figure 2-14. Shielded Cable Installation (Sheet 1 of 3)

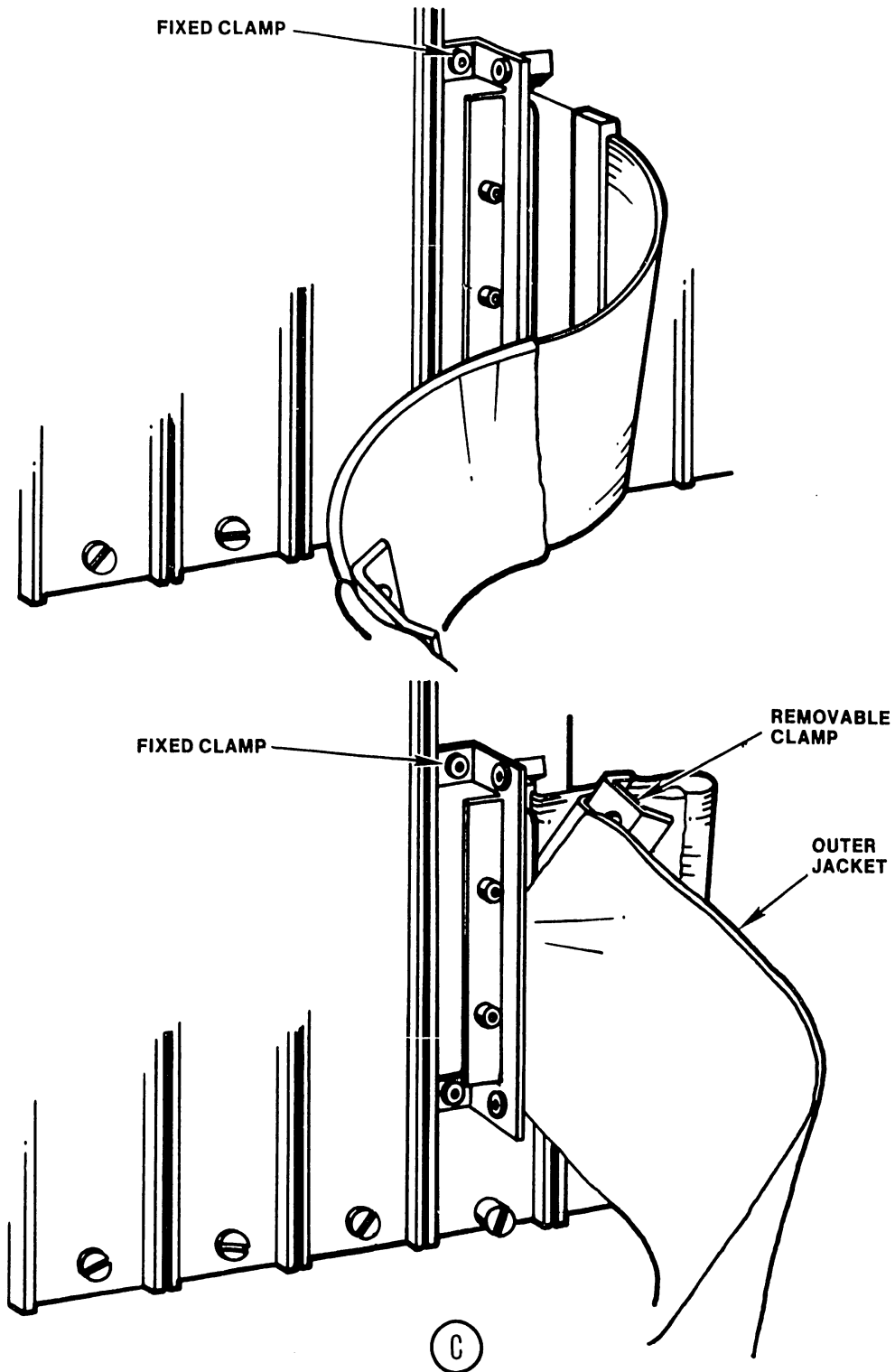

Figure 2-14. Shielded Cable Installation (Sheet 2 of 3)

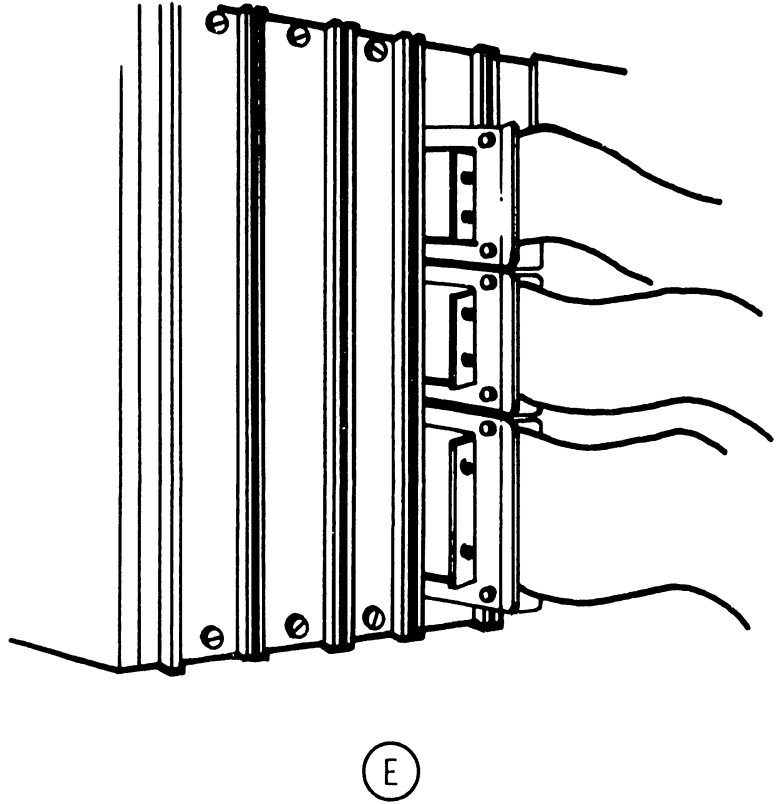
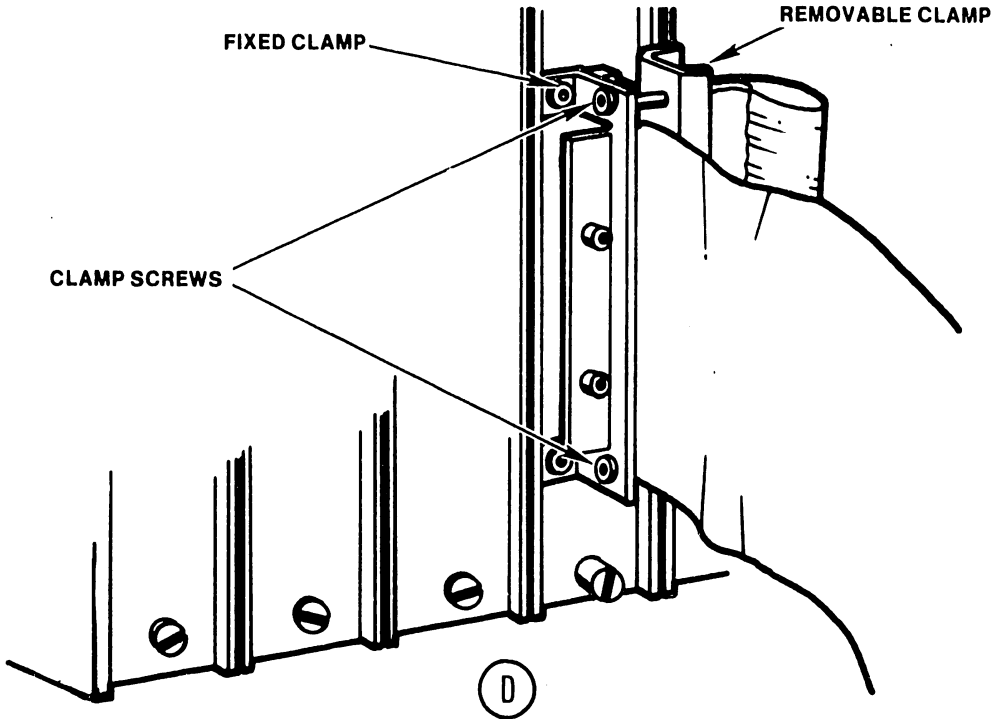

Figure 2-14. Shielded Cable Installation (Sheet 3 of 3)

2.6 INSTALLATION PROCEDURE

- a. Ensure that the ac input voltage selection jumpers on the motherboard are positioned correctly for the supplied voltage (see section 2.5.1).
- b. Check to see that all circuit boards are properly seated in the appropriate locations (see section 2.5.3).
- c. Attach all system interconnection cables (see section 2.5.4) ensuring that the cable shields are properly connected (see section 2.5.6).
- d. Check to see that the appropriate device address plug is in the disk drive (see section 2.5.5).
- e. Be certain the ac power switch is OFF, and then plug the ac power cord in.
- f. Set the ac power switch ON, then check and adjust, if necessary, all power supply voltages (see section 4.4).
- g. Run all appropriate 2280 disk diagnostics to confirm proper operation of the system (see section 4.2).
- h. Replace the unit cover(s) and place the DPU in the disk drive stand as shown in figure 2-15.
- i. The system is now ready for customer use.

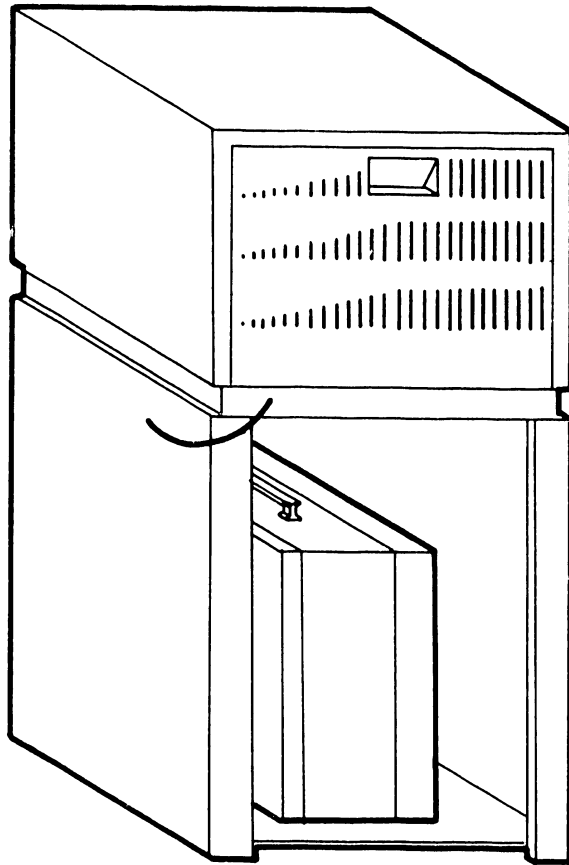

Figure 2-15. DPU Mounted In Bottom Of Stand

SECTION

3

OPERA-

TION

SECTION 3

OPERATION

For information concerning operation/programming of the 2280 Disk System (Phoenix drive and DPU) refer to Wang BASIC-2 Disk Reference Manual, WL No. 700-4081F (III.A.0), and Model 2280 Disk Drive User Manual, WL No. 700-5216 (III.A.10).

SECTION

4

**MAINT-
ENANCE**

SECTION 4
MAINTENANCE

4.1 RECOMMENDED TEST EQUIPMENT/TOOL LIST

- a. Digital voltmeter--(acceptable type/equivalent: Fluke No. 8000A).
- b. Oscilloscope--(acceptable type/equivalent: Tektronix No. 465).
- c. Heavy duty screw driver with insulated handle (WL No. 726-9411).
- d. Small slot screwdriver with insulated handle (WL No. 726-9406).

4.2 DIAGNOSTICS

Refer to documentation category IV.C.1 for information concerning disk diagnostics.

4.3 PREVENTIVE MAINTENANCE

To ensure trouble-free operation, the 2280 DPU must have periodic preventive maintenance, consisting of inspection, cleaning, and adjustments. The following preventive maintenance routine should be performed once every six months. This maintenance schedule assumes a clean operating environment and a normal operating time during the standard five-day, 40-hour weeks. A dusty environment or any substantial increase in system operating time will require that the preventive maintenance be scheduled at closer intervals. In addition, this preventive maintenance routine should be performed during each unscheduled service call.

- a. Check the unit cooling fan for proper operation.
- b. Set the DPU ac power switch OFF.
- c. Remove the screws securing the top cover and remove the cover (see Section 4.5).
- d. Remove each circuit board from the DPU and clean the finger connectors with an ink eraser.
- e. Check to see that all circuit boards are at the latest electronic revision (E-REV). Refer to Mandatory Update Bulletin in documentation category I.B.0 for ECO implementation procedures.

- f. Use a soft-bristle brush and a vacuum cleaner (WL No. 726-9518) to remove dust from the inside of the DPU.
- g. Reinstall all circuit boards in the appropriate locations (see section 2.5.3).
- h. Set the ac power switch ON.

NOTES:

- 1. Before making any adjustment, be certain the measuring instrument is properly calibrated.
- 2. Electrical adjustments should be performed only when the parameter measured is out of tolerance. Do not make electrical adjustments indiscriminately.
- i. Check and adjust, if necessary, the DPU power supply voltages according to the procedure given in section 4.4.
- j. Run the 2280 disk diagnostics (see section 4.2) to confirm proper operation of the DPU and then replace the top cover.
- k. Use a mild detergent and a soft cloth or sponge to remove dirt and grime from the DPU chassis. Do not use abrasive or corrosive chemicals.

4.4 POWER SUPPLY VOLTAGE ADJUSTMENT

- a. Set the ac power switch OFF.
- b. Remove the top cover of the unit. (see section 4.5).
- c. Set the ac power switch ON.
- d. Check the dc voltages with a digital voltmeter for the values listed in table 4-1. (The test points for monitoring the voltages are also given in table 4-1.) Adjust the trimpots where indicated in figure 4-1 to obtain correct voltage levels where necessary.

NOTE:

Be sure to connect the common lead of the voltmeter to a +0V connection, NOT the chassis or I/O controller rail. Erroneous readings will result if chassis ground is used as the voltmeter reference. The oscilloscope ground clip should also be connected to +0V, NOT chassis ground.

- e. Using an oscilloscope with the vertical sensitivity set at 1V/cm and a X1 probe, measure the ripple at the points indicated in table 4-1. AC ripple must not exceed the limits specified.

TABLE 4-1 DC VOLTAGE SPECIFICATIONS

VOLTAGE	L567 TEST POINT	L567 ADJUST	LIMITS	
			VOLTAGE	RIPPLE
+5VRM	Pin 1 ₁	R17	+4.90 to +5.10	15 mv p-p
+5VRL	Pin 2 ₁	R2	+4.90 to +5.10	15 mv p-p
+8VR	Pin 12 ₁	R13	+8.50 to +8.80	20 mv p-p
+12VR	Pin 15 ₁	R30	+11.80 to +12.20	15 mv p-p
-12VR	Pin 5 ₂	R34	-11.80 to -12.20	15 mv p-p
-15VR	Pin 6 ₂	R40	-14.80 to -15.20	25 mv p-p

4.5 REMOVAL/REPLACEMENT PROCEDURES

4.5.1 Top Cover

Remove the four screws that secure the top cover (see figure 4-2) and remove the cover from the unit.

4.5.2 Bottom Cover

Remove the four screws that secure the bottom cover (see figure 4-3) and remove the cover from the unit.

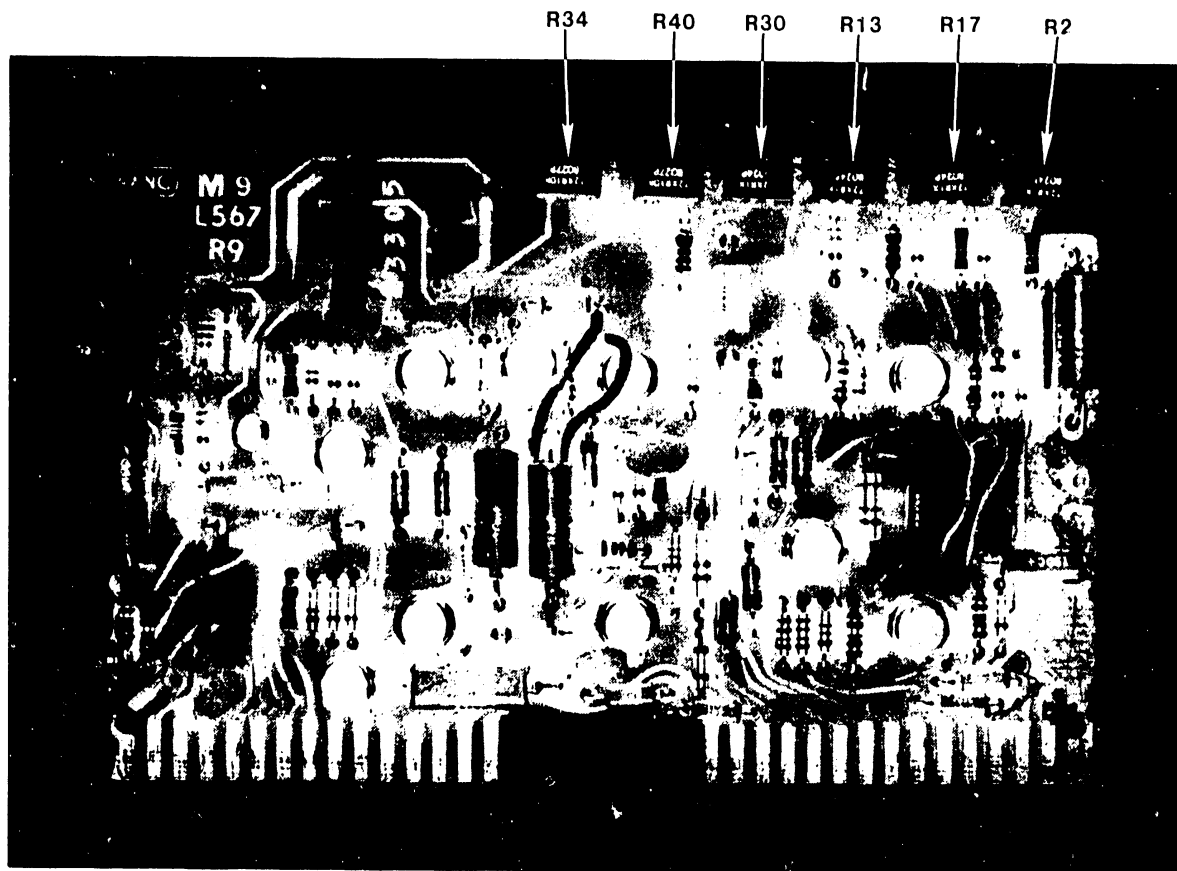

Figure 4-1. WL No. 210-L567 Regulator Board Potentiometers

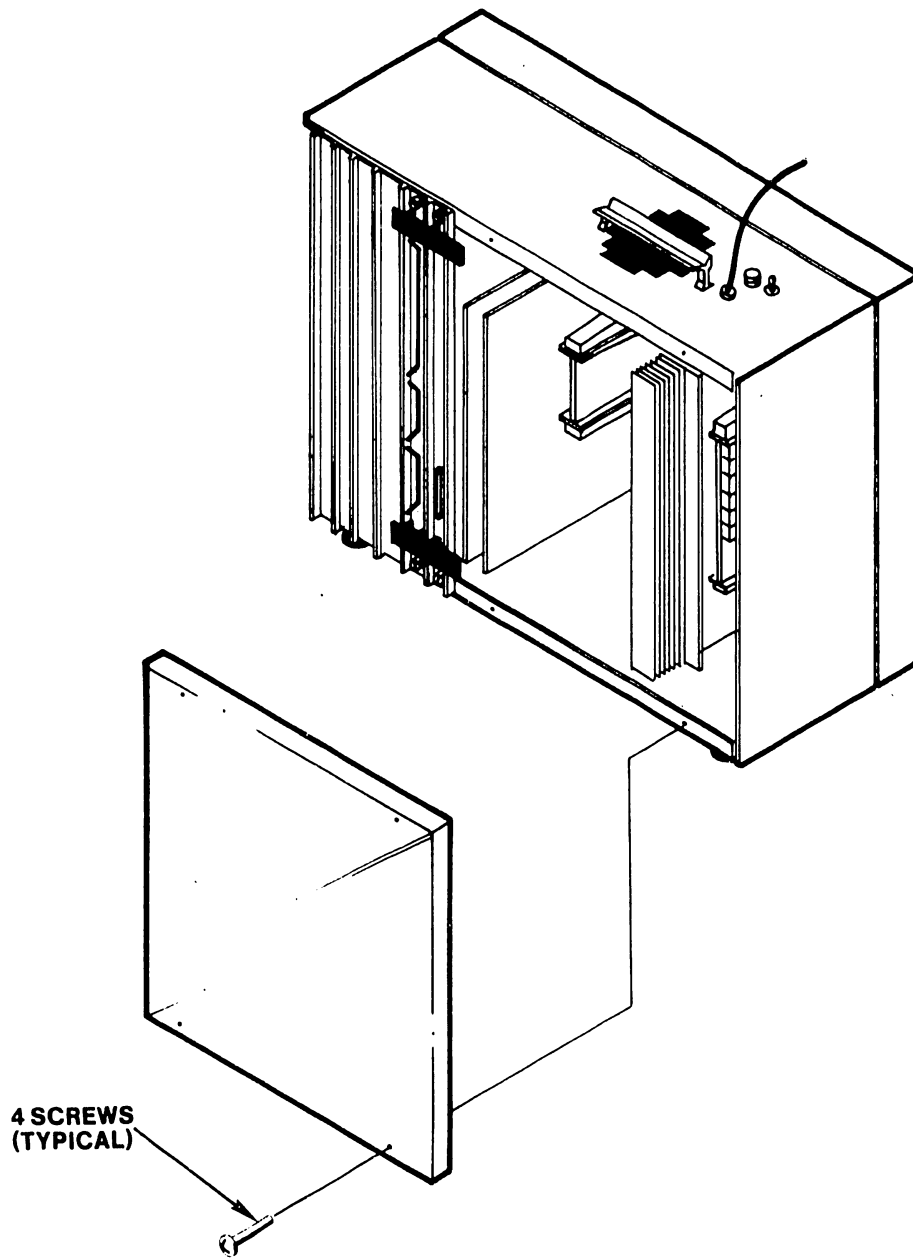

Figure 4-2. Top Cover Removal

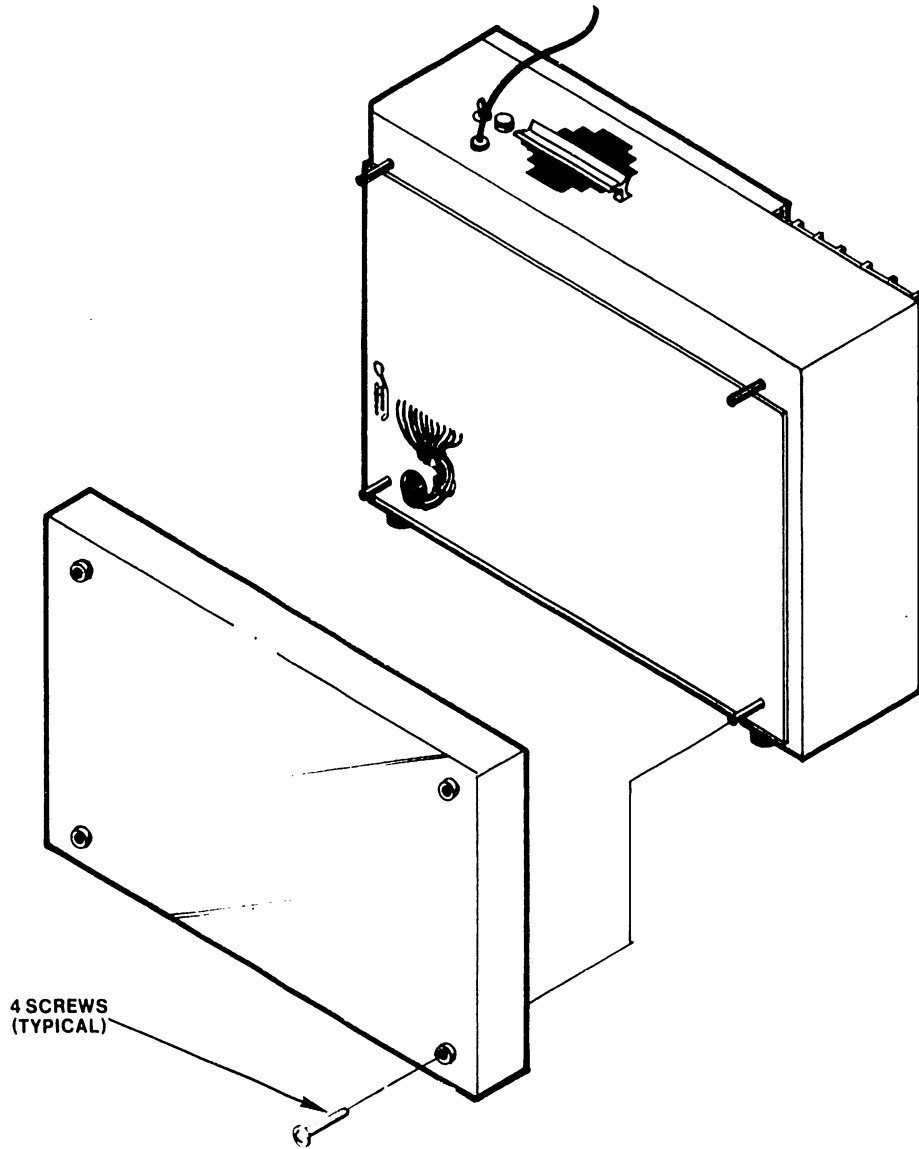

Figure 4-3. Bottom Cover Removal

4.6 DISK ERROR CODES

ERR I90 -- Disk Hardware Error

The disk did not properly respond to the system at the beginning of a read or write operation.

ERR I91 -- Disk Hardware Error

The disk is not in a "ready" condition.

ERR I92 -- Timeout Error

The disk did not respond to the system in the proper amount of time during a read or write operation.

ERR I93 -- Format Error

The disk media is not properly formatted.

ERR I94 -- Format Key Engaged

Not applicable for the 2280 DPU.

ERR I95 -- Seek Error

The specified sector could not be found on the disk.

ERR I96 -- Cyclic Redundancy Check Error

The data in a sector was read (or written) incorrectly.

ERR I97 -- Longitudinal Redundancy Error

The data was not transmitted to the CPU correctly during a read operation.

ERR I98 -- Illegal Sector Address

The sector address is greater than that allowed for the specific disk capacity.

ERR I99 -- Read After Write Error

The data read did not compare to that that was written during a read after write operation.

SECTION

5

THEORY

OF

OPERA-

TION

CHAPTER 5

THEORY OF OPERATION

5.1 BLOCK LEVEL

This section consists of a brief explanation of the circuitry that comprises the four major logic boards in the DPU. The section is divided into five subsections--one for each logic board.

5.1.1 WL No. 210-7423-A RAM/PROM Control Board (see figure 5-1)

5.1.1.1 Clock (see timing chart, figure 5-2) -- The clock circuit produces 16 clock cycles, each 100 nsec in duration. This results in a machine-cycle speed of 1.6 usec (1600 nsec). The clock cycles are applied to a bcd-to-decimal (4-to-10) decoder which generates 8 clock pulses that are used in the DPU. These clock pulses and the events that occur at that specific time are listed below.

T0 - Clocks instruction through Rom Bit Latch as R_{0-15} .
Clocks Status Register 0.

T2 - Clocks data into the A and K Registers.

T3 - Clocks data into Memory Register.

T4 - Clocks Instruction Counter.
Loads/clears Memory Address Register.
Generates A and K Register Strokes.
Combines with CNTRL-1 to generate CNTRL14 which--
Clocks Read/Write/Format Latch.
Fires Strobe One-Shot.
Sets/resets Busy F/F.
Clocks ECC Shift Register.
Combines with CNTRL-3 to generate CNTRL34 which--
Clocks Tag Latches.
Clocks Select Latches.

T5 - Increments/decrements Memory Address Register.

T8 - Clocks Carry F/F.
Clocks Equal F/F.

T9 - Strokes data from RAM through Memory Register.

T2-5 - Generates RAM write pulse.

5.1.1.2 Programmable Read Only Memory (PROM) -- The PROM contains the microprogram that controls the operations of the DPU. The 2280 DPU utilizes four INTEL 2716 PROM chips. Each PROM contains a 2K x 8-bit matrix. Since the DPU instruction set requires 16-bit words, two PROM's are selected at the same time to provide the instruction. With this requirement, the total read only memory capacity is 4096 words or instructions.

The PROM output bits are clocked through D-type latches at time T0 as ROM bits R_{0-15} .

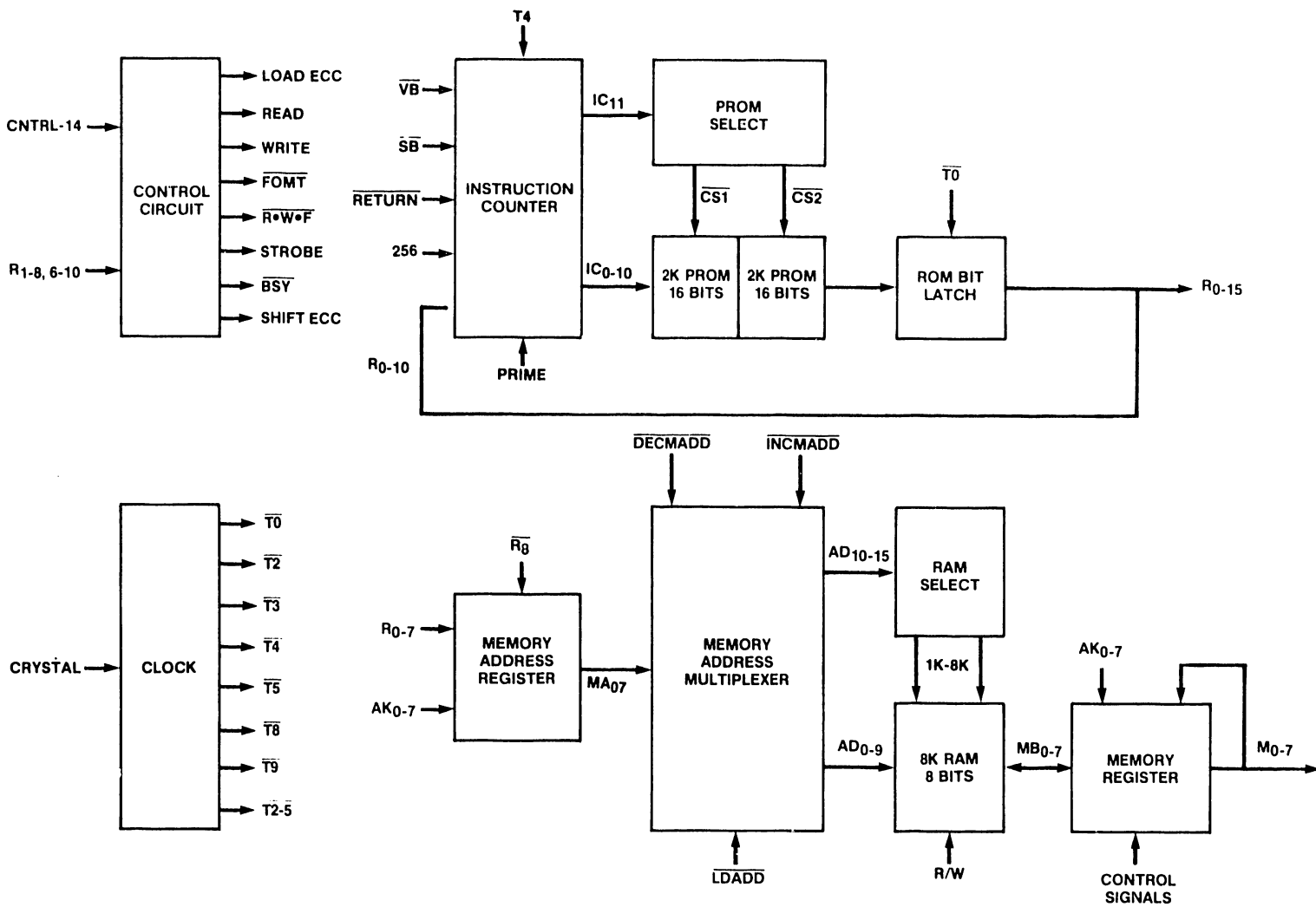

Figure 5-1. WL No. 210-7423-A RAM/PROM Control Block Diagram

10 MHz CLK T=100 nSEC

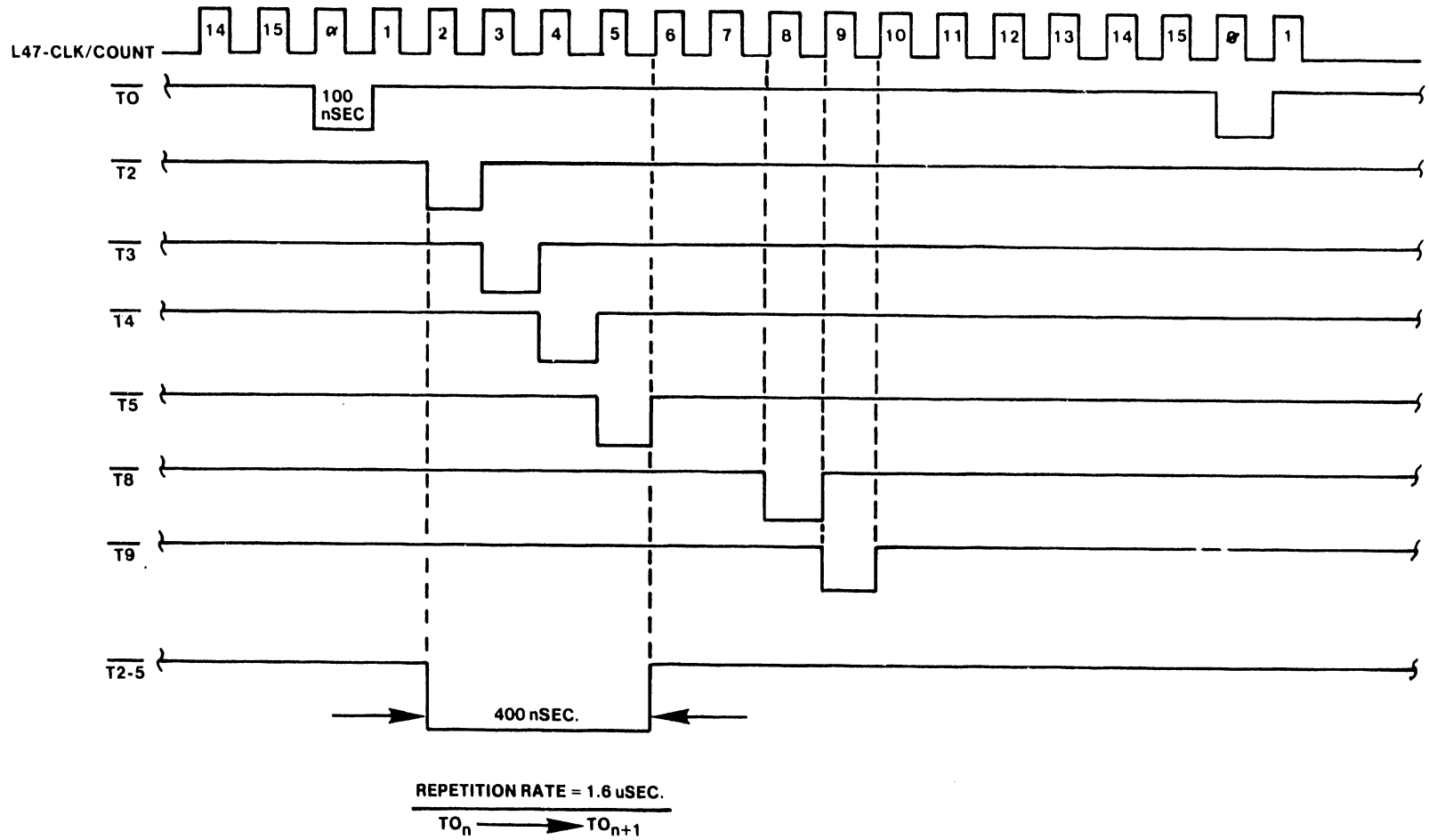

Figure 5-2. Timing Chart

The PROM is addressed by an Instruction Counter composed of three AM2911 microprogram sequencer chips. Twelve bits (IC₀₋₁₁) are applied to the PROM by the instruction counter; IC₀₋₁₀ provide the addressing and IC₁₁ produces the appropriate chip select (CS₁₋₂) signal. CS₁ selects the lower 2K of PROM and CS₂ selects the higher 2K. The PROM space is allocated as follows.

0K-2K = main body of microprogram
 2K-3K = alternate sector routine, copy write error routine, error correction routine, and diagnostics
 3K-4K = diagnostics

Normally the instruction counter increments by one at time T4. However, during execution of the microprogram, it is necessary to jump (branch) to a location other than that immediately following. Three signals are provided to accomplish the jump (branch): UB--Unconditional Branch, SB--Subroutine Branch, and 256--256 step branch.

5.1.1.3 Random Access Memory (RAM) -- The RAM is used to store flags, pointers, and status information required for execution of the microprogram as well as the data that is to be exchanged between disk and CPU. The RAM consists of eighteen 2114-L integrated circuits with a capacity of 1024 x 4 bits resulting in a total storage capacity of 9,216 bytes.

The Memory Address Register (MAR) provides 16 bits (AD₀₋₁₅) for the addressing of the RAM. AD₀₋₉ supply the actual RAM address while AD₁₀₋₁₅ generate the appropriate chip select (1K-8K) signal. The MAR increments or decrements at time T5. It can also be loaded (preset to a certain address) or cleared (reset to an address of zero) at time T4. The address to which the MAR can be loaded is provided through the Memory Address Multiplexer (MA₀₋₇). The inputs to the multiplexer that can be selected to provide the address are either ROM bits 0-7 (R₀₋₇) or the A and K Register bus (AK₀₋₇).

Data is transferred to/from RAM through the Memory Register (MB₀₋₇). The 2280 DPU utilizes two AM2905 Bus Transceiver chips for the MAR. Data that is to be written into RAM is input to the Memory Register from the A bus or the Memory Register bus (M₀₋₇). Data that is read from RAM is applied to the Memory Register bus (M₀₋₇). RAM space is allocated as follows.

1st 1/4K (256 bytes) = flags and pointers
 Next 2K = cache for read
 Next 4K = cache for multi-sector write
 Next 8K = read/write buffer for COPY
 2nd page of last 'K' = alternate sector RAM

READ -- 256-1K-1K
 WRITE -- 256-1K-1K-1K-1K
 COPY -- 256-1K-1K-1K-1K-1K-1K-1K

The Error Check Circuitry (ECC) in the RAM functions as a 35-shift polynomial in a similar manner as that found in the OIS/VS systems.

5.1.1.4 Control Circuit -- Refer to section 5.3 (Instruction Set) for information concerning the control circuitry on the 210-742-A board.

5.1.2 WL No. 210-7421-A ALU/MUX Interface Board (see figure 5-2)

5.1.2.1 Arithmetic/Logic Unit (ALU) -- Two 74181 integrated circuits, designed to perform specific arithmetic or logical operations as directed by the microprogram, comprise the ALU.

The ALU data inputs are referred to as the A-bus and the B-bus. The A-bus inputs are from the A or K Registers (AK_{0-7}). The B-bus is the output of a multiplexer, incorporating memory (M_{0-7}) and ROM bits (R_{0-7}) as selectable inputs.

The ALU output is the C-bus (C_{0-7}). Data on this bus can be input to the A Register or K Register.

5.1.2.2 A Register -- The general purpose A-Register stores data from: 1) the CPU, 2) Status Register 0, 3) the ECC Shift Register, or 4) the ALU. The contents of the A-Register can be processed by the ALU, stored in memory, or input to the Track, Head, or Sector Registers (THS_{0-7}).

5.1.2.3 K-Register -- The general purpose K-Register stores data from the ALU or acts as Status Register 1. The contents of the K-Register can be processed by the ALU or stored in memory.

5.1.2.4 Status Register 0 (STO) -- STO stores seven CPU/DPU conditions which can be input to the A-Register, via the BO_{0-7} bus, for monitoring or testing. The conditions are as follows:

*REQ (Bit 0)	--	When active, indicates the Output Bus Buffer has received a byte of data from the CPU.
*CAB (Bit 1)	--	When active, indicates a carry resulted from a preceding ALU arithmetic operation or from the execution of a "Set Carry" instruction.
*GKBD (Bit 2)	--	When active, indicates the CPU is ready to receive input from the DPU.
REINIT (Bit 3)	--	When active, indicates the CPU is sending address information next. When inactive, indicates the CPU is sending data next.
DN #3 (Bit 4)	--	When active, indicates that selection of drive 2 in a daisy-chain configuration is desired.
A=B (Bit 5)	--	When active, indicates the data on the ALU A-bus is equal to that on the B-bus.
AD7 (Bit 6)	--	The eighth ($2^8 = 128$) RAM address bit.

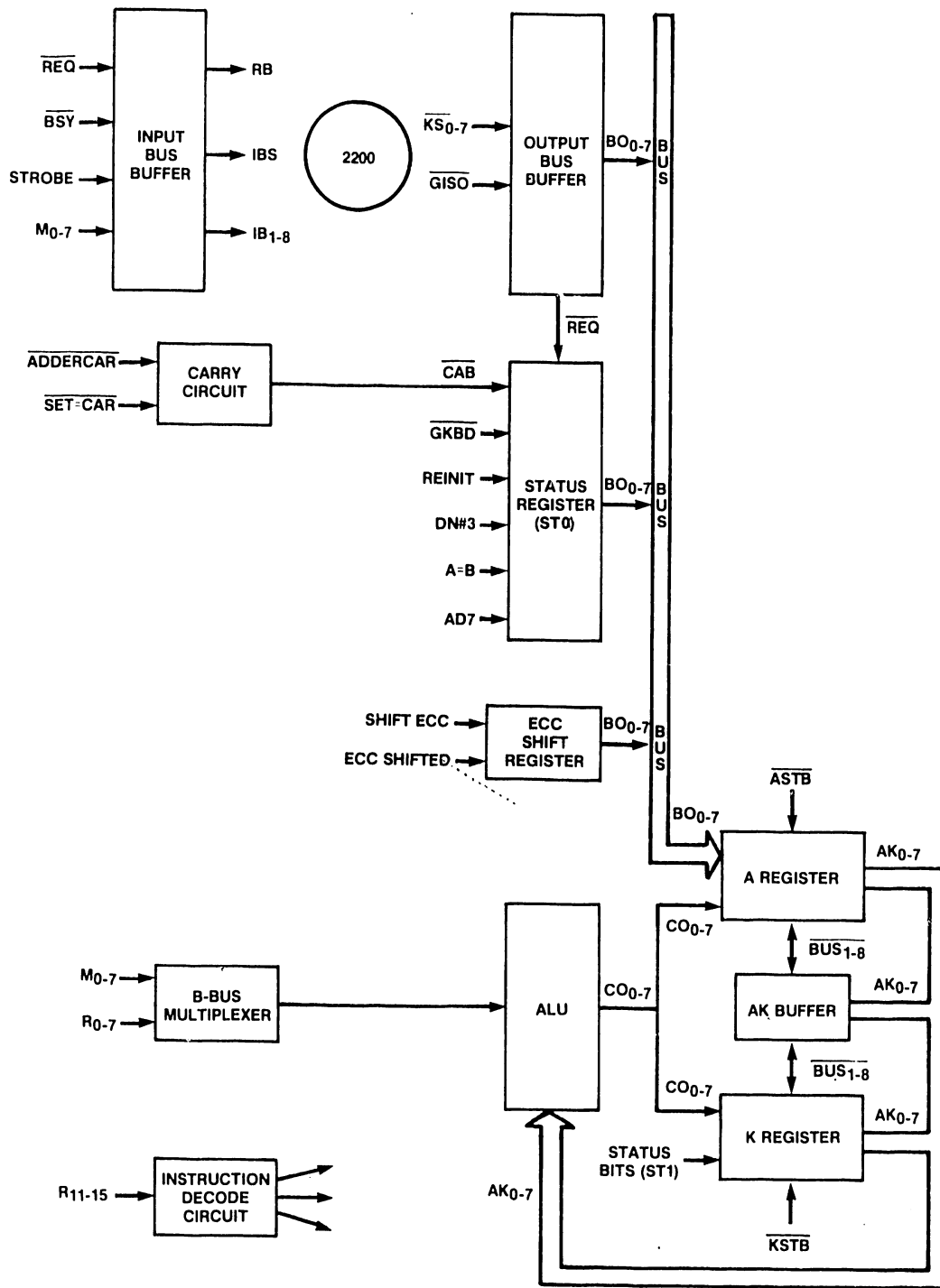

Figure 5-3. WL No. 210-7421-A ALU/MUX Interface Block Diagram

5.1.2.5 Status Register 1 (ST1) -- The K-Register acts as ST1. Seven bits representing DPU/disk drive conditions can be selected as inputs to the K-Register. Once in the register, the bits can be tested for the various conditions. The bit representation is as follows:

W/P (Bit 1)	--	When active, indicates the disk drive is write protected.
ERROR (Bit 2)	--	When active, indicates an address error was detected.
DERROR (Bit 3)	--	When active, indicates a disk drive fault occurred or a seek error was detected by the disk drive.
*DONE (Bit 4)	--	When active, indicates 256 bytes of data have been transferred to/from the disk.
*NULL (Bit 5)	--	(Not Used)
READY (Bit 6)	--	When active, indicates the disk drive is "on cylinder" and "ready".
SECTOR (Bit 7)	--	When active, indicates the sector counter is equal to the desired sector, which is present on the THS (<u>T</u> rack/ <u>H</u> ead/ <u>S</u> ector) bus.

5.1.2.6 Input Bus Buffer -- The Input Bus Buffer provides the interface for data being sent to the CPU from the DPU. Data is input to the buffer from the Memory Register (M₀₋₇).

5.1.2.7 Output Bus Buffer -- The Output Bus Buffer provides the interface for data being sent to the DPU from the CPU. Data is output from the buffer to the A-Register via BO₀₋₇. When the buffer receives a byte of data, it generates a request (REQ) signal. REQ is monitored by the DPU, and when the signal is active, the microprogram causes the hardware to read in the data.

5.1.2.8 Instruction Decode Circuit -- ROM bits R₁₁₋₁₅ are applied to a 74154 one-of-sixteen decoder which produces the control signals necessary for execution of the microinstructions by the hardware.

5.1.3 WL No. 210-7424 I/O Controller Board (see figure 5-4)

5.1.3.1 Track Register -- The Track Register holds the desired track (cylinder) address as input from the AK bus. The address is output to a buffer, via the THS bus, from where it is sent to the disk drive.

5.1.3.2 Head Register -- The Head Register holds the desired head number and volume select bit as input from the AK bus. The head/volume select information is output to a buffer, via the THS bus, from where it is sent to the disk drive.

5.1.3.3 Sector Register -- The Sector Register holds the desired sector number as input from the AK bus. The number is output to the Sector Comparator, via the THS bus, where it is checked against the output of the Sector Counter.

5.1.3.4 Command Register -- The Command Register holds the disk drive control select bits (for example, write gate, read gate, and return to zero). The control information is output to a differential buffer to be sent to the disk drive.

5.1.3.5 Bit/Byte Counter -- The Bit/Byte Counter keeps track of the number of bytes of data transferred between DPU and disk. The counter generates certain control signals depending on the number of bits/bytes that have been counted.

5.1.3.6 Serial-to-Parallel, Parallel-to-Serial (SP/PS) Converter -- The SP/PS accepts eight parallel bits of data from the Memory Register (M_{0-7}) and converts the information to serial and adds clock pulses between data bits. The serial data is then transmitted to the disk drive.

The converter also accepts serial Read Data and changes it to eight parallel bits of data. If the data that is read is address information, it is input to the Address Comparator; otherwise, the data is sent to memory.

5.1.3.7 Address Comparator -- The Address Comparator checks the address read from the disk with the desired address that is present on the THS bus. If the two are not the same, the comparator flags an error.

5.1.3.8 Control Circuit -- Refer to section 5.3 (Instruction Set) for information concerning the control circuitry on the WL No. 210-7424 board.

Figure 5-4. WIL No. 210-7424 I/O Controller Block Diagram

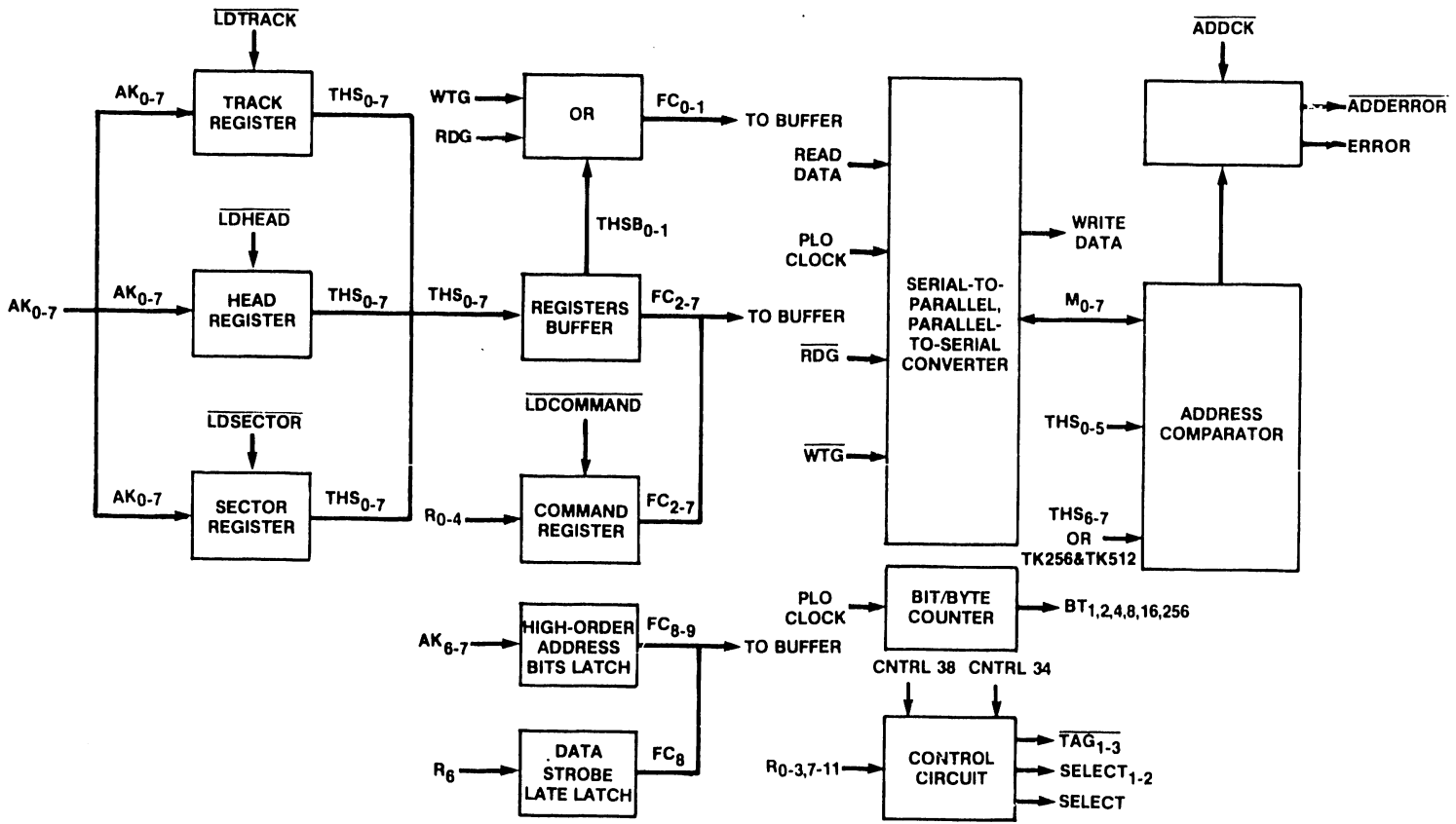

5.1.4 WL No. 210-7422 ECC/Device Interface Board (see figure 5-5)

5.1.4.1 Differential Buffers -- The Differential Buffers provide the interface between DPU and disk drive. The buffers convert TTL voltage levels to differential voltage levels and vice versa.

5.1.4.2 Sector Counter -- The Sector Counter increments every time a sector mark pulse is received from the disk drive. It is reset (cleared) when the index pulse is received.

5.1.4.3 Sector Comparator -- The Sector Comparator checks the desired sector number that is present on the THS bus against the count from the sector counter. When the two are equal, indicating the correct disk sector is under the read/write head, an EQUAL signal is generated to inform the microprogram.

5.1.4.4 ECC -- The Error Correction Circuit along with an ECC routine in the microcode is responsible for detecting and correcting any single-bit errors that occur during a read operation. Figure 5-6 is a detailed flowchart illustrating the ECC code handling routine.

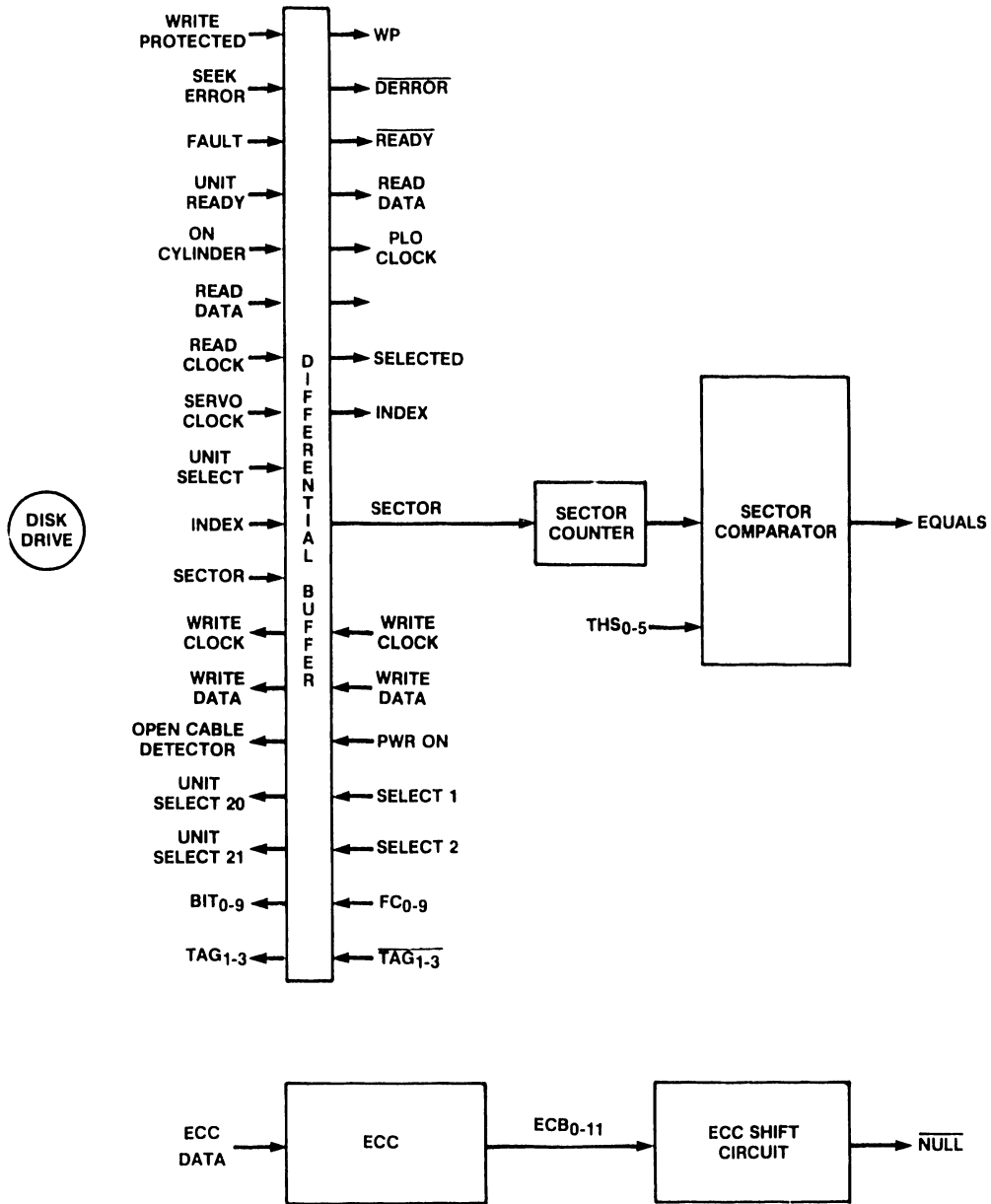

Figure 5-5. WL No. 210-7422 ECC/Device Interface Block Diagram

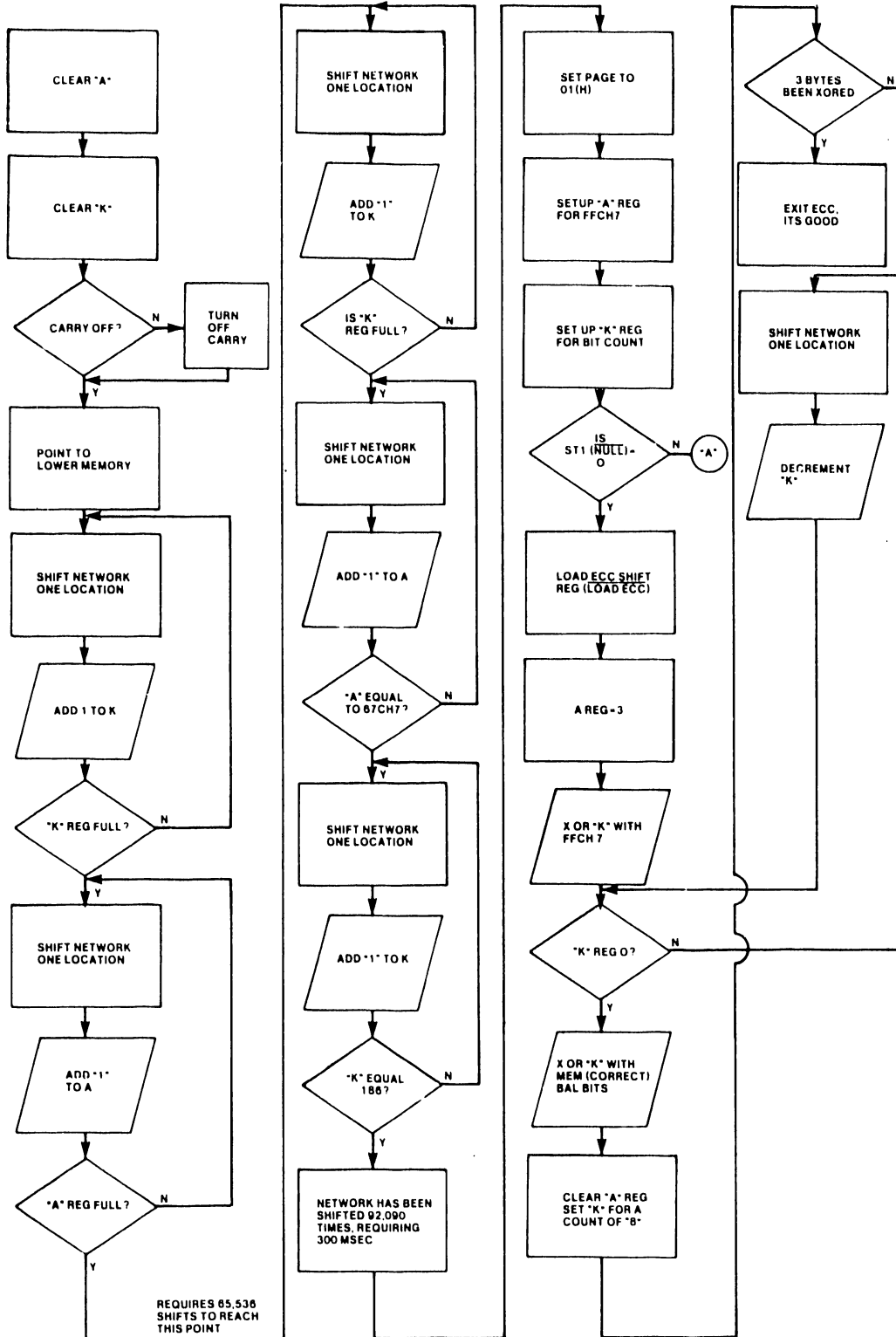

Figure 5-6. ECC Code Handling Flowchart

5.1.5 WL No. 210-L567 Regulator Board (see schematic)

There are six regulated voltages in the DPU power supply, each independently variable. All six supplies are of the series pass variety, each controlled by an IC voltage regulator. There are four transformer generated, full wave unregulated supplies which provide the necessary voltages for the regulators.

The six regulated supplies are +5VRL for the TTL logic and +5VRM, +8VR, +12VR, -12VR, and -15VR for the PROM's and RAM's. As all regulators operate in the same manner, only the +5VRL supply is discussed here.

The heart of the regulated supply is the voltage regulator (L4). Unregulated +14V is applied to L4 pin 8 to provide the operating voltage for the IC. Pin 4 of the regulator is the output from a reference amplifier in the IC. The output of this amplifier is applied to the voltage divider network R1, R2, and R3. The reference amplifier contains a current source and temperature compensator to prevent drifting.

The voltage present at the wiper of potentiometer R2 is applied to the non-inverting input of the error amplifier (regulator pin 3). By varying the voltage at the non-inverting input, the output voltage changes.

Since the IC regulator cannot supply large output currents, external circuitry must be provided for this purpose. Pin 7 of the regulator is the collector output of the internal series pass transistor which provides the necessary drive for transistor Q5. Q5 provides the necessary current for driver X8, which in turn controls the series pass transistors X6 and X7.

The error amplifier constantly monitors the regulated output voltage by sampling the output voltage at the inverting input (regulator pin 2). Voltage regulation is performed as follows.

If the output voltage tries to go more positive, the inverting input (pin 2) also follows positive. This results in a more negative input to the internal series pass transistor, causing it to conduct less thus increasing the positive voltage at pin 7. (The voltage drop across R4 is less due to the decrease in current; hence Q5 base tends toward +14V.) Q5 conducts less, driver Q8 controlled by Q5 conducts less, and finally the series pass transistors conduct less, decreasing the output voltage. In a similar manner, the output voltage is increased when a negative output change is detected. Note that no regulation can take place unless there is a change in the output voltage to initiate a correction; therefore, the regulation is less than perfect.

The regulators also employ foldback current limiting as follows.

Resistors R5, R7, and R8 form the external current sensing network. As the current in the external circuit increases, the voltage drop across the sensing network changes, until the internal current limiter transistor is turned off. The output voltage drops to zero and the output current remains at a safe value when the output current exceeds the predetermined value.

Capacitor C8 compensates the internal error amplifier to avoid instability. As mentioned previously, all other regulator circuits operate in the same manner.

Diode D2 connected between L5 pin 1 and L1 pin 1 prevents the +5VRM supply from ever becoming more positive than the +8VR supply. This is necessary to prevent damage to the memory. Also diode D1 prevents the +8VR supply from rising above +14.2V, again to prevent damage to the memory.

5.2 READ/WRITE DATA FLOW

5.2.1 Write Data Flow

Figure 5-5 is a write data flow diagram illustrating the hardware involved when data is read from the 2200, processed through the 2280 DPU, and written onto the disk. The following theory references schematic diagrams located in Appendix D at the end of this document.

Parallel write data enters the 2280 DPU at 7421-2 (KS₀₋₇ to BO₀₋₇) where it goes through the A register as AK₀₋₇. The data is sent via 7423-2 to L40 and L41 (M₀₋₇) and to the RAM. From the RAM the data goes through L40 and L41 (M₀₋₇) to 7424-1 and to L47 (serializer/de-serializer). The data goes out as WDATA to 7424-2 through L32 and L42 and emerges as WRITE DATA (serial) and to the drive.

5.2.2 Read Data Flow

Figure 5-6 is a read data flow diagram illustrating the hardware involved when data is read from the disk, processed through the 2280 DPU, and written into the 2200. The theory discription presented below references schematic diagrams located in Appendix D at the end of this document.

Serial read data from the disk drive enters the 2280 DPU at 7424-1 where is is applied to L47 (serializer/de-serialaizer). The parallel data output from the serializer/de-serializer is sent via 7423-2 to L40 and L41 and to the RAM. From the RAM, it goes to L40 and L41 and to 7421-1. It is now sent via L4 and L11 to the 2200 as IB₀₋₇.

5.3 MICROPROGRAM FLOWCHARTS

Figures 5-9 thru 5-15 are flowcharts of each individual microprogram sequence for the 2280 DPU functional modes of operation.

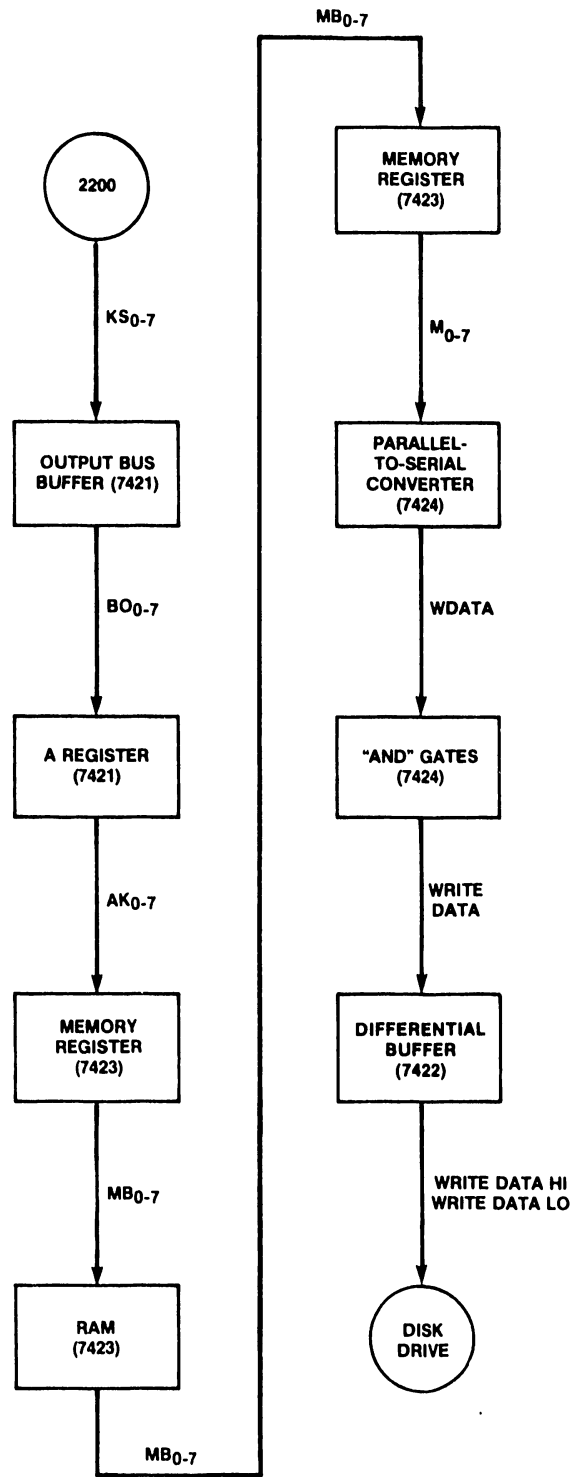

Figure 5-7. Write Data Flow

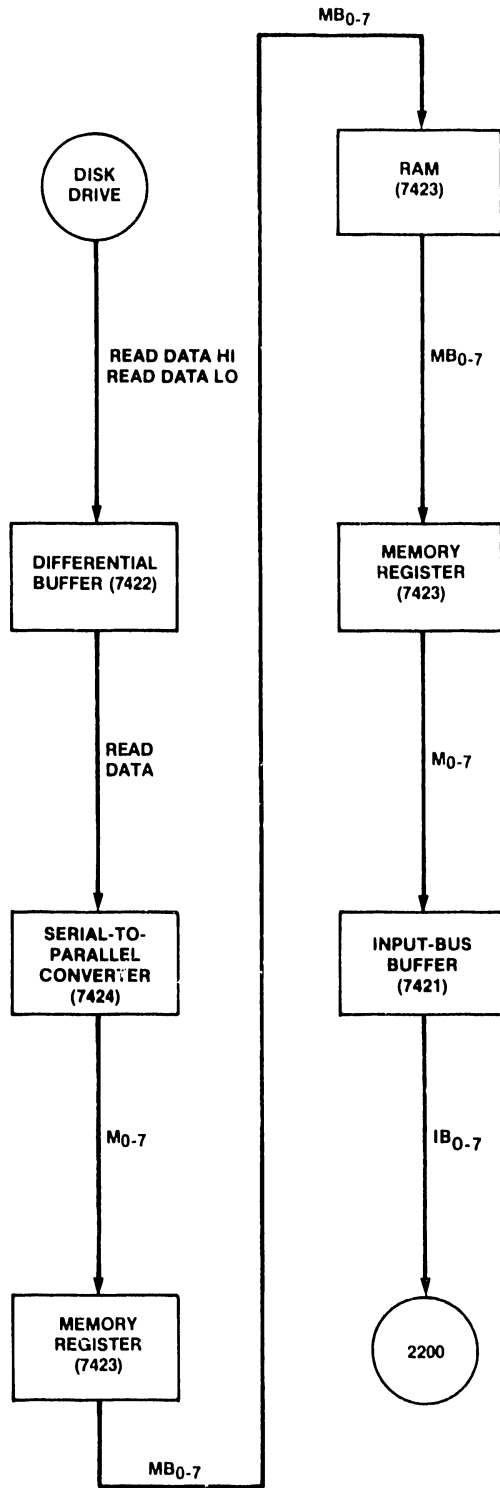

Figure 5-8. Read Data Flow

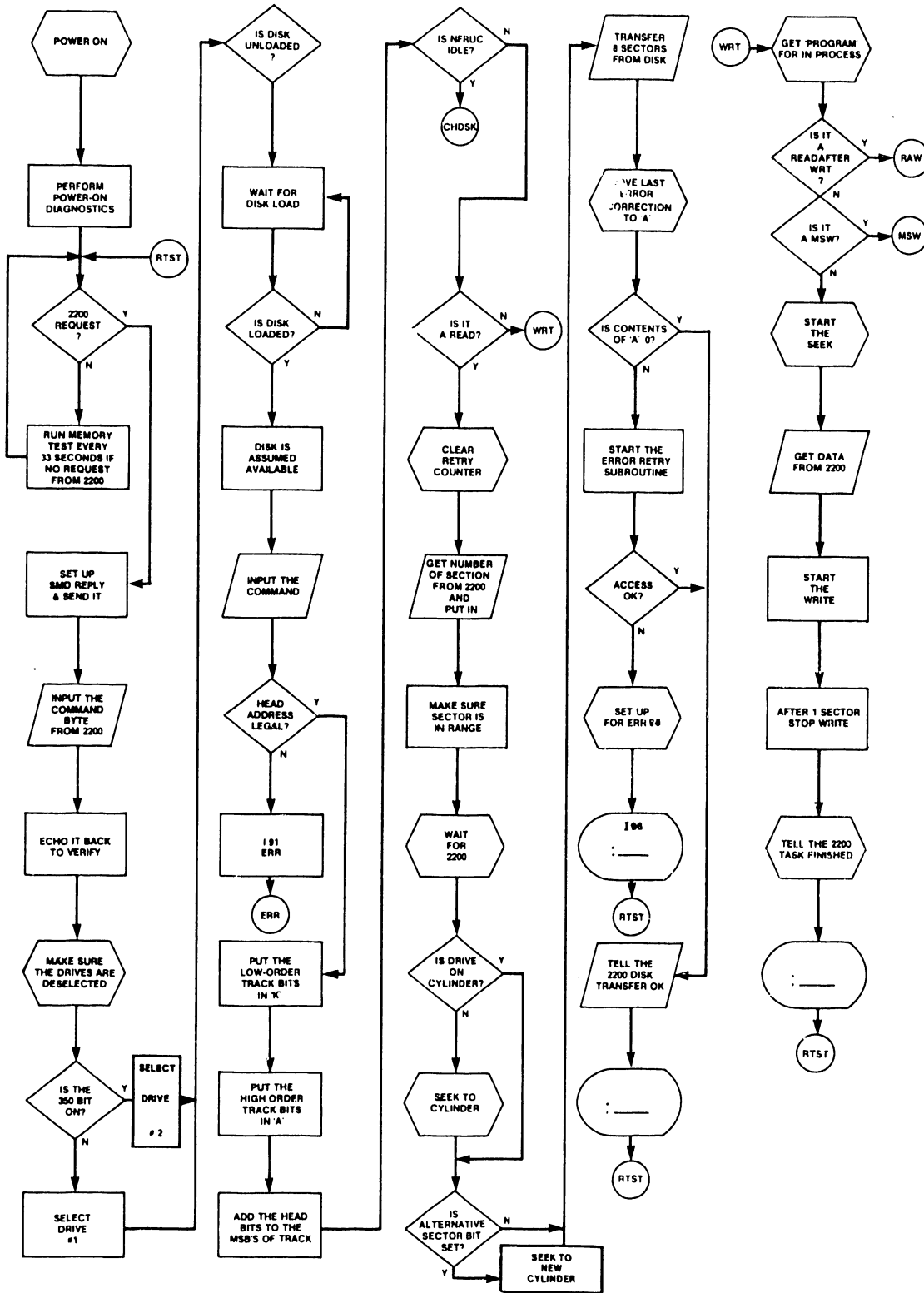

Figure 5-9. 2280 DPU Microprogram Flowchart (Sheet 1 of 2)

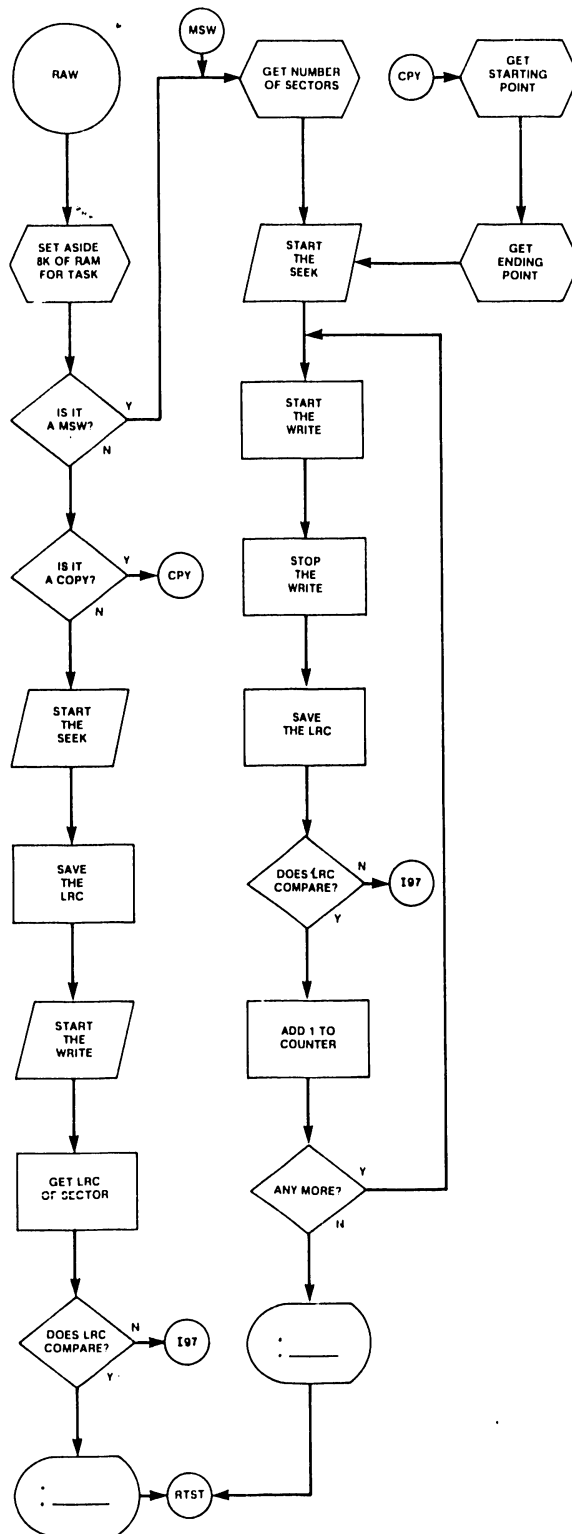

Figure 5-9. 2280 DPU Microprogram Flowchart (Sheet 2 of 2)

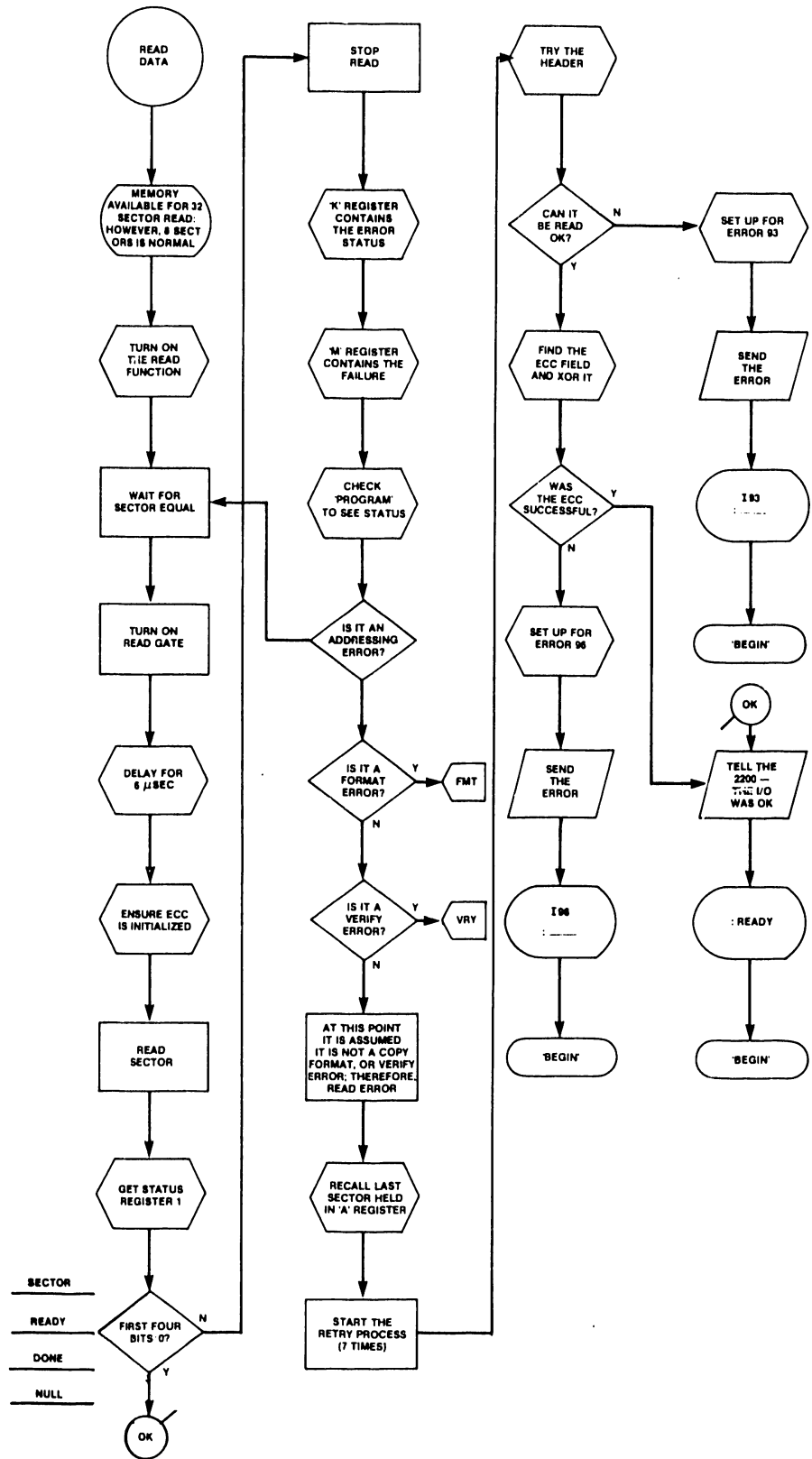

Figure 5-10. 2280 DPU Microprogram Flowchart - Read Data

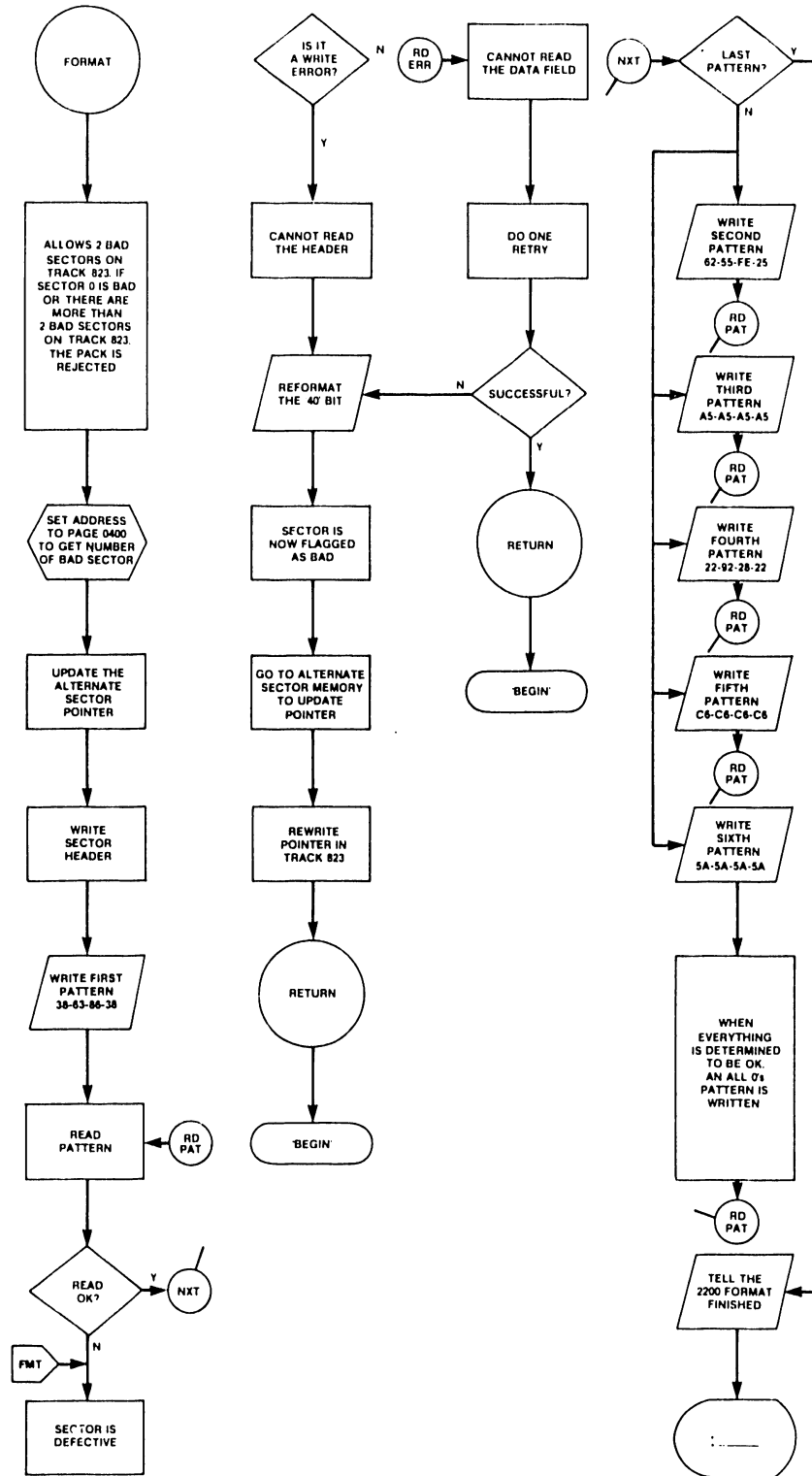

Figure 5-11. 2280 DPU Microprogram Flowchart - Format

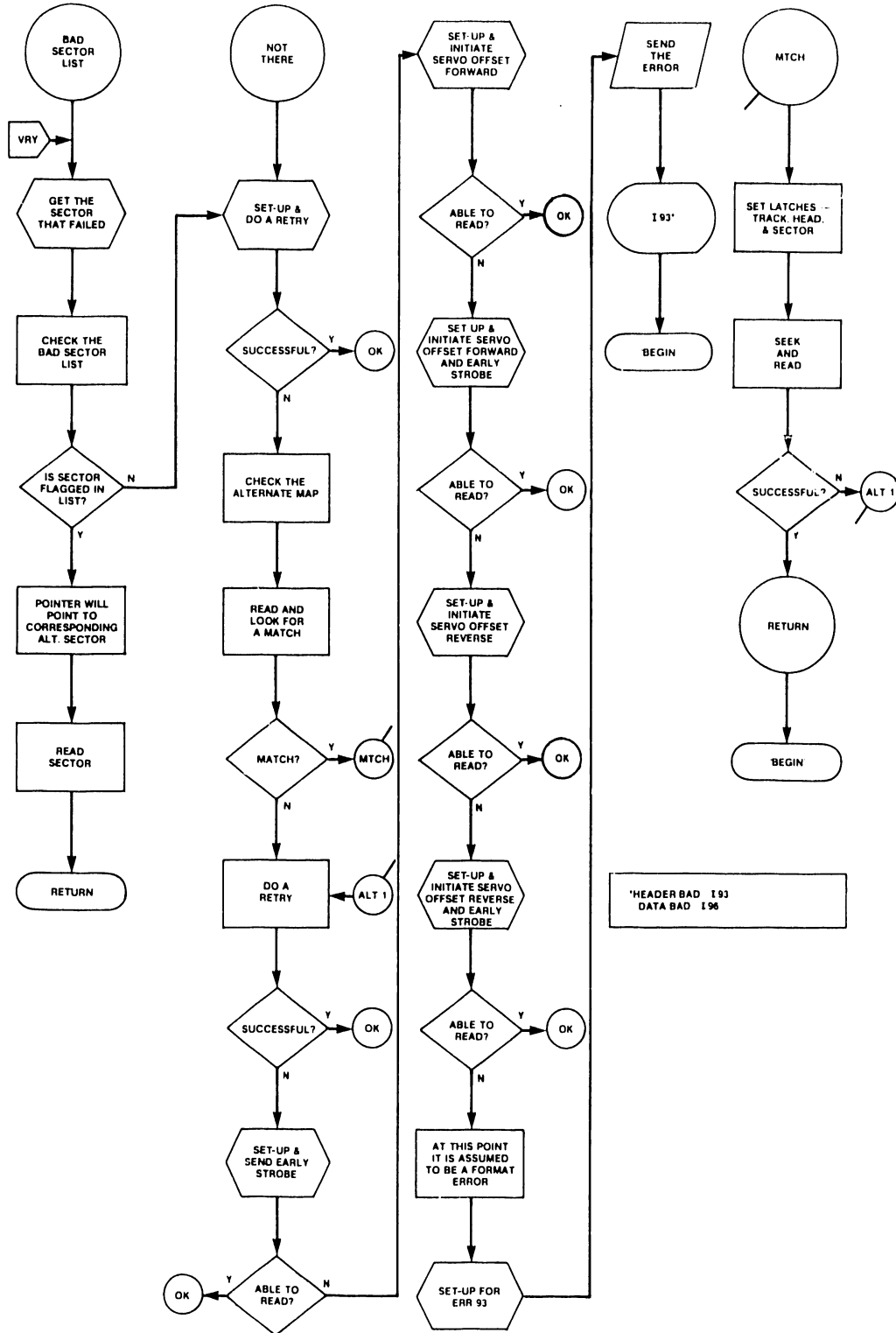

Figure 5-12. 2280 DPU Microprogram Flowchart - Verify

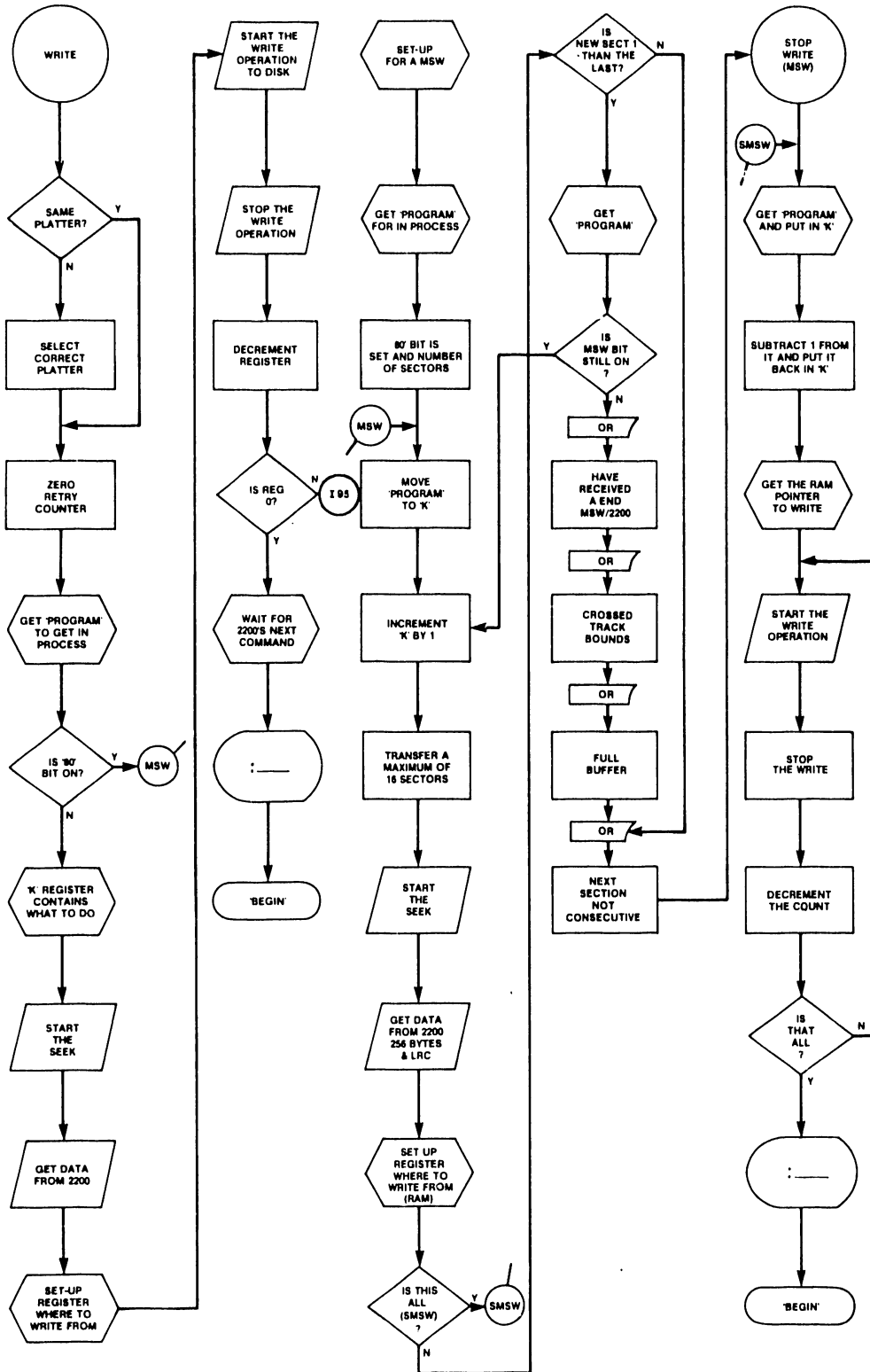

Figure 5-13. 2280 DPU Microprogram Flowchart - Write/Start MSW/Stop MSW

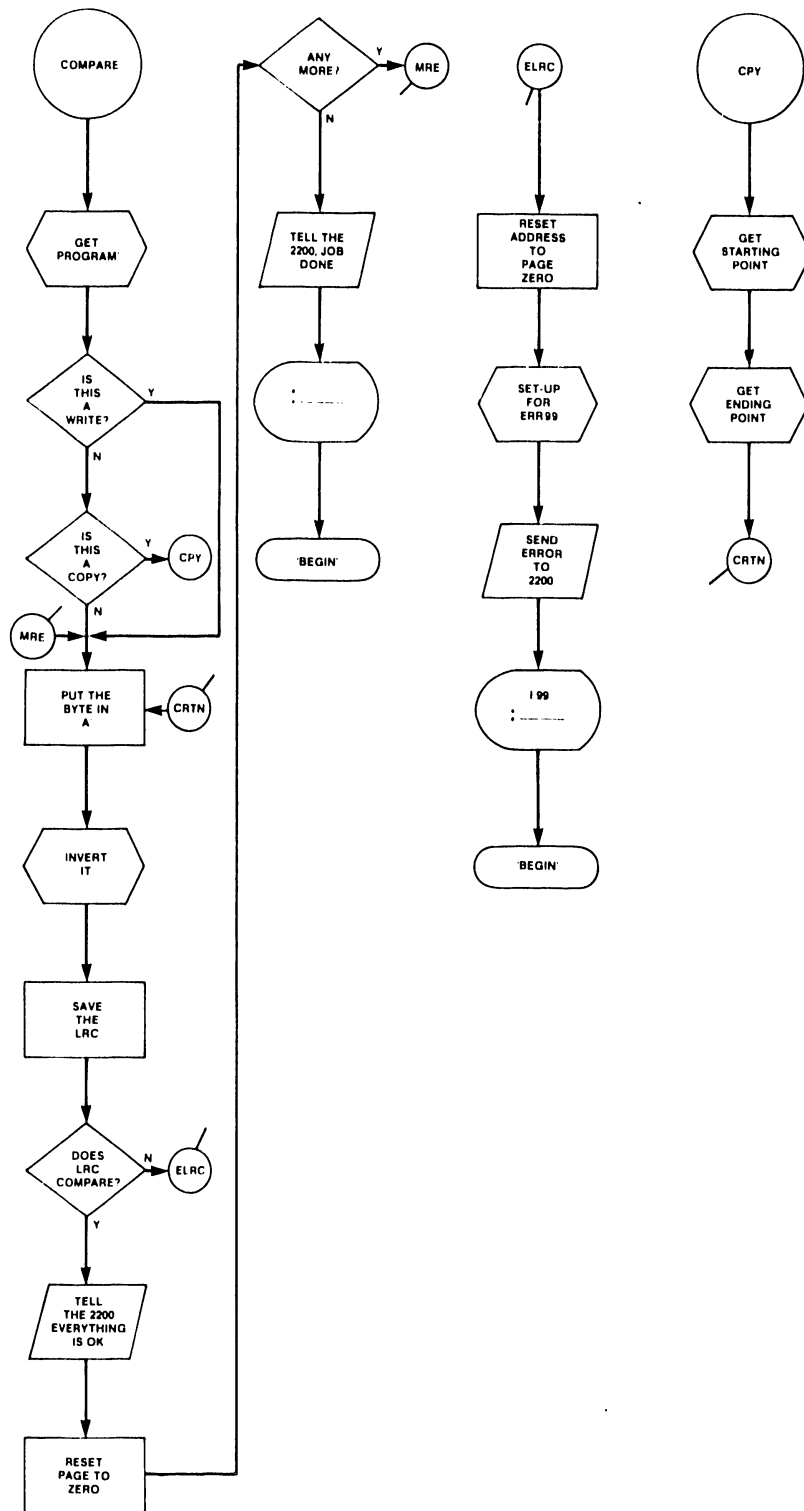

Figure 5-14. 2280 DPU Microprogram Flowchart - Compare

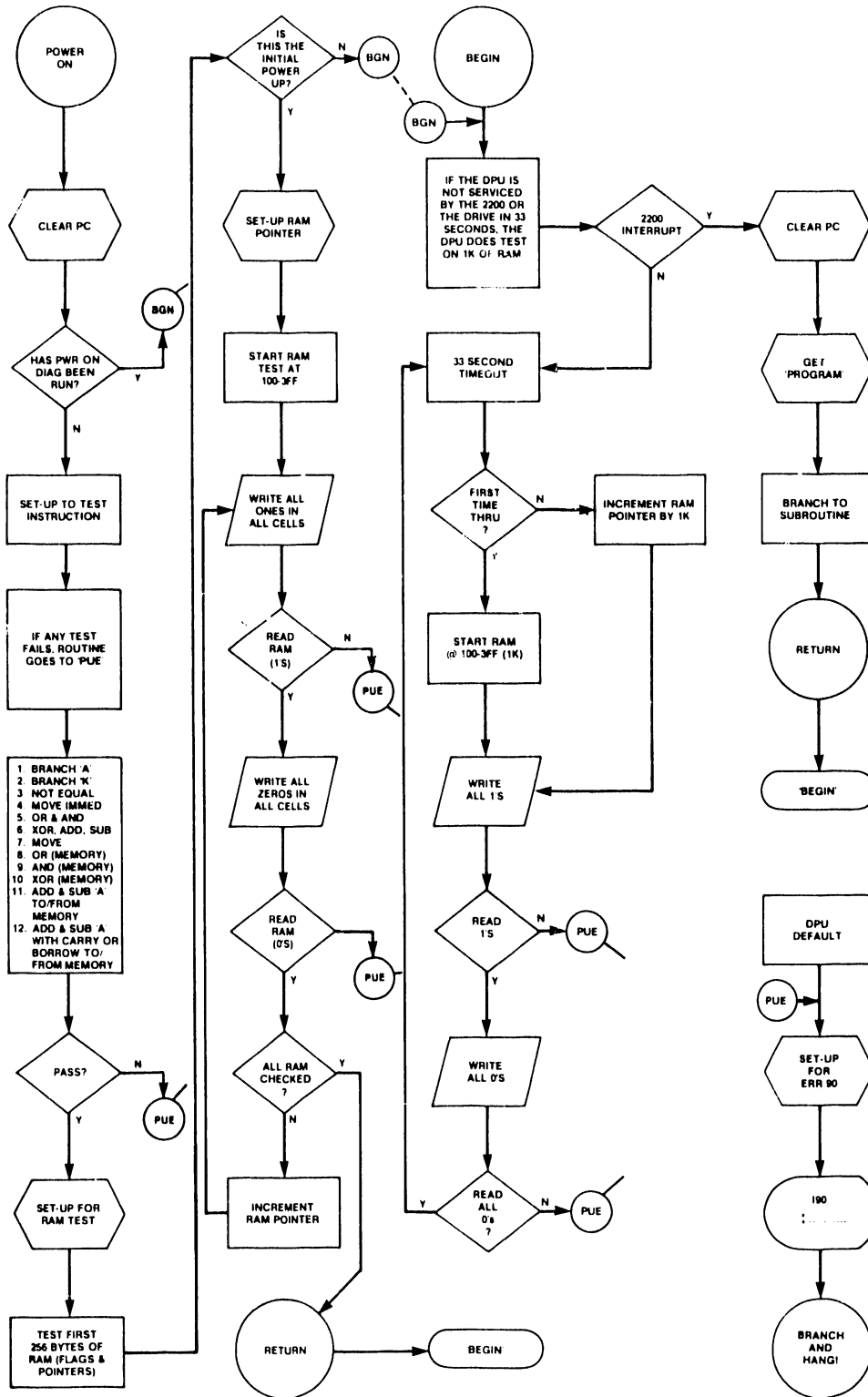

Figure 5-15. 2280 DPU Microprogram Flowchart - Power-On Diagram/Begin

APPENDIX

A

DISK

ERROR

CODES

APPENDIX A
DISK ERROR CODES

ERR D80

Error: File Not Open

Cause: The file was not opened.

Recovery: Open the file before attempting to read from it or write to it.

ERR D81

Error: File Full

Cause: The file is full; no more information may be written into the file.

Recovery: Correct the program, or use MOVE to move the file to another platter and reserve additional space for it.

ERR D82

Error: File not in Catalog

Cause: A non-existing file name was specified, or an attempt was made to load a data file as a program file.

Recovery: Make sure the correct file name is being used, the proper disk is mounted, and that the proper disk drive is being accessed.

ERR D83

Error: File Already Cataloged

Cause: An attempt was made to catalog a file with a name that already exists in the Catalog Index.

Recovery: Use a different name, or catalog the file on a different platter.

ERR D84

Error: File Not Scratched

Cause: An attempt was made to rename, or write over a file that has not been scratching.

Recovery: Scratch the file before renaming it.

ERR D85

Error: Catalog Index Full

Cause: There is no more room in the Catalog Index for a new name.

Recovery: Scratch any unwanted files and compress the catalog using a MOVE statement, or mount a new disk platter and create a new catalog.

ERR D86

Error: Catalog End Error

Cause: The end of the catalog area is defined to fall within the catalog index, or an attempt has been made to move the end of the catalog area to fall within the area already occupied by cataloged files (with MOVE END), or there is not room left in the Catalog Area to store more information.

Recovery: Correct the SCRATCH DISK or MOVE END statement, or increase the size of the Catalog Area with MOVE END, or scratch unwanted files and compress the catalog with MOVE, or open a new catalog on a separate platter.

ERR D87

Error: No End of File

Cause: No end-of-file record was recorded in the file (with DATASAVE DC END or DATASAVE DA END), and therefore none could be found by the DSKIP END statement.

Recovery: Correct the file by writing an end-of-file trailer after the last data record.

ERR D88

Error: Wrong Record Type

Cause: A program record was encountered when a data record was expected, or vice versa.

Recovery: Correct program. Be sure the proper platter is mounted and be sure the proper drive is being accessed.

ERR D89

Error: Sector Address Beyond End of File

Cause: The sector address being accessed by the DATALOAD DC or DATASAVE DC operation is beyond the end-of-file. This error can be caused by a bad disk platter.

Recovery: Run the program again. If error persists, use a different platter or reformat the platter. If error still exists, contact your Wang Service Representative.

ERR I90

Error: Disk Hardware Error

Cause: The disk did not recognize or properly respond to the System at the beginning of a read or write operation (the read or write has not been performed).

Recovery: Run the program again. If error persists, contact your Wang Service Representative.

ERR I91

Error: Disk Hardware Error

Cause: A disk hardware error occurred, e.g., the disk is not in file-ready position. This could occur, for example, if the disk is in LOAD mode or power is not turned on.

Recovery: Ensure disk is turned on and properly set up for operation. Set the disk into LOAD mode and then back into RUN mode with the RUN/LOAD selection switch. The check light should then go out. If error persists, call your Wang Service Representative. (Note: disk must never be left in LOAD mode when turned on.)

ERR I92

Error: Time-out Error

Cause: The disk did not respond to the system during a read or write operation in the proper amount of time (time-out).

Recovery: Run program again. If error persists, reinitialize disk - if error still occurs, contact your Wang Service Representative.

III.A.10 M-2

ERR I93

Error: Disk Format Error

Cause: A disk format error was detected during a disk read or write. The disk is not properly formatted. The error can be either in the disk platter or the disk hardware.

Recovery: Format the disk again; if error persists, call your Wang Service Representative.

ERR I94

Error: Format Key Engaged

Cause: The disk format key is engaged (the key should be engaged only when formatting a disk).

Recovery: Turn off the format key.

ERR I95

Error: Seek Error, or Platter Protected

Cause: A disk-seek error occurred; the specified sector could not be found on the disk. This error may indicate a bad format, or it may result from an attempt to write to a protected platter.

Recovery: Run program again. If error persists, reinitialize (reformat) the disk. If error still occurs, call your Wang Service Representative.

ERR I96

Error: Cyclic Read Error

Cause: A cyclic redundancy check (CRC) error occurred during a disk read operation; the sector being addressed has never been written to or was incorrectly written.

Recovery: If not formatted, format the disk. If the disk was formatted, rewrite the bad sector. If error persists, use a different disk platter. If error persists on a fixed platter, call your Wang Service Representative.

ERR I97

Error:

LRC Error

Cause:

A disk longitudinal redundancy check (LRC) error occurred when reading a sector. This usually indicates a data transmission error occurred when the sector was read or written.

Recovery:

If error persists, rewrite the sector. If the error still persists, call your Wang Service Representative.

ERR I98

Error:

Illegal Sector Address or Platter Not Mounted

Cause:

The disk sector being addressed is not on the disk or the disk platter is not mounted. (Maximum Legal sector address depends upon the model of disk used.)

Recovery:

Correct the program statement in error, or mount a platter in the specified drive.

ERR I99

Error:

Read After Write Error

Cause:

The comparison of read after write to a disk sector failed, indicating that the information was not written properly. This error usually indicates a bad disk platter.

Recovery:

Write the information again. If error persists, try a new platter; if error still persists, call your Wang Service Representative.

APPENDIX

B

DISK

SECTOR

LAYOUT

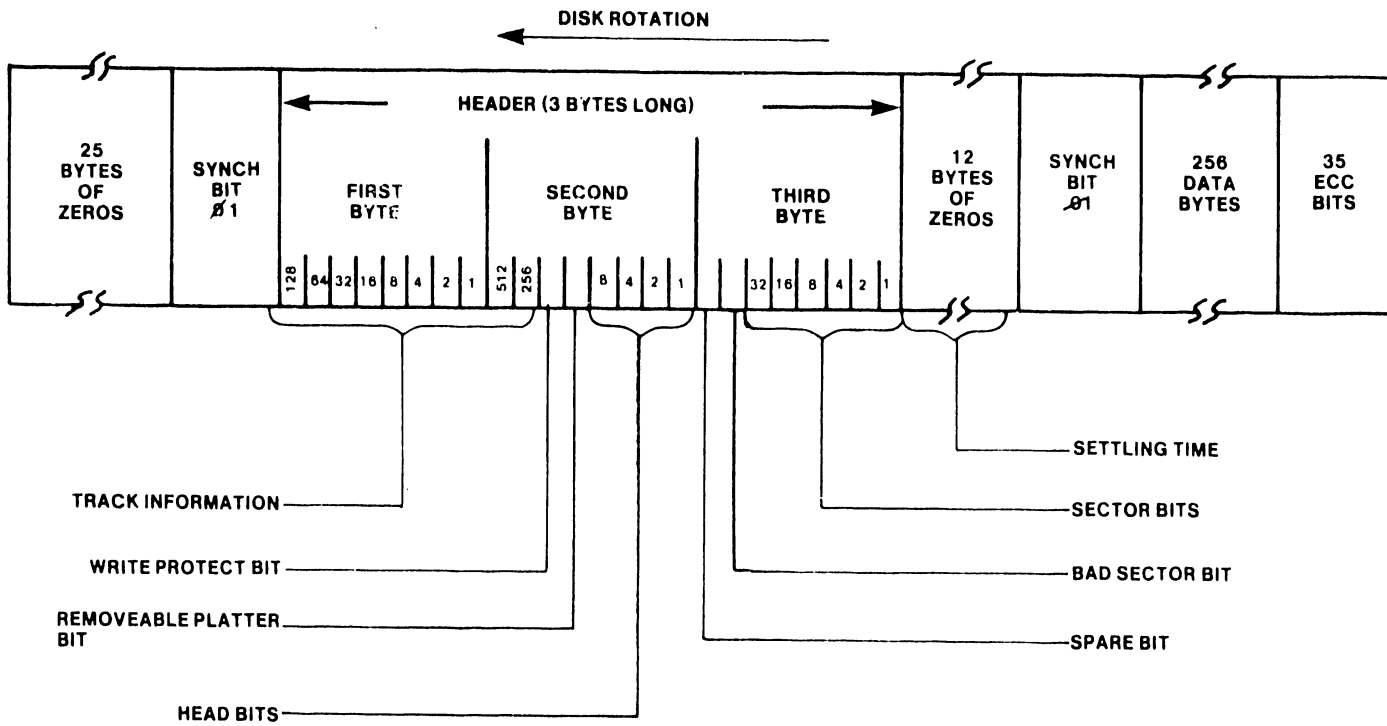

B-1

DISK SECTOR LAYOUT

APPENDIX B

APPENDIX

C

BILL

OF

MATER-

IALS

APPENDIX C

BILL OF MATERIALS

A Bill of Materials for the 2280 DPU starts on the following page.

ASSEMBLY PART NUMBER 177-2200-90 -

LEGEND

ASSEMBLY DESCRIPTION 0259 DISK PROCESSOR UNIT

1: PHENANICM; 2: ITEM MASTER DELY CODE; 3: *TAGGED OUT OF KIT(PROD STR)

POSITION IN STRUCTURE	LEGEND			COMPONENT PART NUMBER	DESCRIPTION	E C N	QUANTITY PER ASSY	L/P	L/T
	1	2	3						
1		IN		187-2200-90 -	MFI 2280 DISK TO VP/MVP INTREC		1.0000	EACH	00010
2		IN		000-0005- -	LABOR PRODUCTION SYSTEMS		2.4610		00000
2		IN		000-0011- -	LABOR QUALITY CONTROL		.4920		00000
2		IN		210-L567- -	FCA 2200A/R/C/S/T PS REGULATOR		1.0000	EACH	00023
3		IN		000-0003- -	LABOR CALCULATING SYSTEMS		1.0000		00000
3		IN		000-0011- -	LABOR QUALITY CONTROL		.2000		00000
3		IN		000-0099- -	OTHER DIRECT COST		14.3880	EACH	00000
3		IN		300-1082- -	CAP 82 PF 10% 500 V CERAMIC DISC		1.0000	EACH	
3		IN		300-1100- -	CAP 100 PF 10% 500 V CERAMIC DISC		1.0000	EACH	
3		IN		300-1906- -	CAP .001 UF 10% 500 V CERAMIC DISC		2.0000	EACH	
3		FS		300-4000-R -	CAP 1.0 UF 35V 10% TANT AXIAL T&R E15765		11.0000	EACH	
3		FS		300-4001-R -	CAP .47 UF 35V 10% TANT AXIAL T&R E15765		2.0000	EACH	
3		FS		300-4002-R -	CAP .1 UF 35V 10% TANT AXIAL T&R E15765		1.0000	EACH	
3		FS		300-4013-R -	CAP 1.2 UF 35V 10% TANT AXIAL T&R E15765		1.0000	EACH	
3		FS		300-4014-R -	CAP 2.2 UF 20V 10% TANT AXIAL T&R E15765		1.0000	EACH	
3		FS		300-4018-R -	CAP 18.0 UF 15V 10% TANT AXIAL T&R E15765		1.0000	EACH	
3		IN		300-4019- -	CAP 33.0 UF 15 V 10% TANT AXIAL		1.0000	EACH	
3		IN		300-4020- -	CAP 47.0 UF 15 V 10% TANT AXIAL		1.0000	EACH	
3		IN		300-4032- -	CAP 10.0 UF 35 V 10% TANT AXIAL		4.0000	EACH	
3		FS		330-1027- -	RFS 27 OHM 1/4W 10% FIXED CCMP E15765		2.0000	EACH	
3		FS		330-2010- -	RES 100 OHM 1/4W 10% FIXED CCMP E15765		1.0000	EACH	
3		FS	*	330-2022- -	RFS 220 OHM 1/4W 10% FIXED CCMP		4.0000	EACH	
3		FS		330-2033- -	RES 330 OHM 1/4W 10% FIXED CCMP E15765		1.0000	EACH	
3		FS		330-2047- -	RES 470 OHM 1/4W 10% FIXED CCMP E15765		2.0000	EACH	
3		FS		330-2056- -	RES 560 OHM 1/4W 10% FIXED CCMP E15765		2.0000	EACH	
3		FS		330-2068- -	RFS 680 OHM 1/4W 10% FIXED CCMP E15765		2.0000	EACH	
3		FS	*	330-3010- -	RES 1K OHM 1/4W 10% FIXED CCMP E15765		8.0000	EACH	
3		FS	*	330-3015- -	RES 1.5K OHM 1/4W 10% FIXED CCMP		7.0000	EACH	
3		FS	*	330-3022- -	RFS 2.2K OHM 1/4W 10% FIXED COMP E16778		2.0000	EACH	
3		FS		330-3033- -	RFS 3.3K OHM 1/4W 10% FIXED CCMP E16778		2.0000	EACH	
3		FS		330-3047- -	RFS 4.7K OHM 1/4W 10% FIXED CCMP E15765		2.0000	EACH	
3		FS		330-3068- -	RFS 6.8K OHM 1/4W 10% FIXED CCMP E15765		1.0000	EACH	
3		FS		330-3083- -	RFS 8.2K OHM 1/4W 5% FIXED CCMP E15765		2.0000	EACH	
3		FS		330-4012- -	RES 12K OHM 1/4W 10% FIXED CCMP E15765		1.0000	EACH	
3		FS		330-4015- -	RFS 15K OHM 1/4W 10% FIXED CCMP E15765		1.0000	EACH	
3		FS		330-4040- -	RFS 39K OHM 1/4W 5% FIXED CCMP E15765		1.0000	EACH	
3		FS		331-0010-R -	RFS 1 OHM 1/2W 10% FIXD CCMP T&R E15765		1.0000	EACH	
3		FS		331-2015-R -	RES 150 OHM 1/2W 10% FIXD CCMP T&R E15765		1.0000	EACH	
3		FS		333-0053-R -	RES 2.37K OHM 1/4W 1% FIX FILM T&R E15765		2.0000	EACH	
3		IN		336-1014- -	RFS 1K OHM VAR TRIM SIDE ADJ SQ		4.0000	EACH	
3		IN		336-1015- -	RES 10K OHM VAR TRIM SIDE ADJ SQ FC4859		2.0000	EACH	
3		IN		775-0017- -	TSTR 2N3014 360MW 40V SH NPN S E2		1.0000	EACH	
3		IN		775-0018- -	TSTR 2N4037 1.0W 40V S PNP S		5.0000	EACH	
3		IN		775-9001- -	TRANSIPAD 89778P7-1 LARGE		5.0000	EACH	
3		IN		775-9004- -	TRANSIPAD TO-1P (SMALL)		1.0000	EACH	
3		IN		776-0006- -	IC 723 VOLTAGE REGULATOR		4.0000	EACH	
3		IN		776-0134- -	IC LM304 NEG VOLTAGE REGULATOR		2.0000	EACH	
3		FS		380-1001-R -	0035 SIL DIODE 70V, 100MA AT 1V T&R E15765		2.0000	EACH	
3		FS	*	380-1004-R -	0035 SIL DIODE 40V, 250MA AT 1V -P		3.0000	EACH	
3		FS		380-2033-R -	D1D ZFN 1N746A 3.3V 400MW SD07 T&R E15765		1.0000	EACH	
3		IN		380-3005- -	1N5823 / MB05300		1.0000	EACH	
3		IN		510-L567- -	PCB 2200A/R/C/S/T PS REGULATOR		1.0000	EACH	

ASSEMBLY PART NUMBER 177-2200-80- -
 ASSEMBLY DESCRIPTION 2280 DISK PROCESSOR UNIT

LEGEND
 1: P=PHANTOM; 2: ITEM MASTER DELY CCDE; 3: *=TAGGED OUT OF KIT(PROD STR)

POSITION IN STRUCTURE	LEGEND			COMPONENT PART NUMBER	DESCRIPTION	E C N	QUANTITY PER ASSY	U/M	L/T
	1	2	3						
3	P	FS		600-1002-	WIRE 22 GA RED	E16826	.3333	FEET	
4		FS		600-1009-	WIRE 22 GA WHITE		1.0000	FEET	
3	P	FS		600-7000-	16 GA BLACK STRANDED WIRE	E16826	.0833	FEET	
4		FS		600-7005-	16 GA WHITE STRANDED WIRE		1.0000	FEET	
2		IN		210-7415-	PCA 2200SMD PRIME CIRCUIT		1.0000	EACH	00023
3		IN		000-0001-	LABOR CIRCUIT SYSTEMS		.6890		00000
3		IN		000-0005-	LABOR PRODUCTION SYSTEMS		1.6680		00000
3		IN		000-0011-	LABOR QUALITY CONTROL		.4150		00000
3		IN		300-1931-	1 UF CERAMIC CAPACITOR(HIGH FREQ)		2.0000	EACH	
3		IN		300-4021-	CAP 100.0 UF 15 V 10% TANT AXIAL		2.0000	EACH	
3		FS		330-3022-	RES 2.2K OHM 1/4W 10% FIXED COMP		1.0000	EACH	
3		FS		331-2010-R	RES 100 OHM 1/2W 10% FIXED COMP T&R	E15690	2.0000	EACH	
3		FS		333-0060-R	RFS 4.02K OHM 1/8W 1% FIX FL T+R	E15690	4.0000	EACH	
3		IN		333-0061-	RFS 9.09K OHM 1/8W 1% FIXED FILM		2.0000	EACH	
3		IN		333-0069-	RFS 6.19K OHM 1/8W 1% FIXED FILM		2.0000	EACH	
3		FS		333-0050-R	RES 10 K OHM 1/8W 1% FIX FILM T+R	E15690	6.0000	EACH	
3		IN		334-0002-	15 OHM 11W FIXED RESISTOR		1.0000	EACH	
3		IN		374-0002-	IC REG UA 7905 -5V 10-220		1.0000	EACH	
3		IN		376-0240-	IC LM339 4 COMPARATOR		1.0000	EACH	
3		FS		380-1001-	0035 SIL DIODE 30V 100 MA AT 1V T&R		3.0000	EACH	
3		FS		380-2062-R	DD ZFN 1N753A 6.2V 400MW SDC7 T+R	E15690	2.0000	EACH	
3		IN		510-7415-	PCB 2200SMD PRIME CIRCUIT		1.0000	EACH	
3		FS		650-3007-	SCR 6-32 1/4 PAN SLOT MS NYL	E12099	1.0000	EACH	
3		FS		652-3002-	NUT 6-32UNC HEX REG PAT NYLON	E12099	1.0000	EACH	
2		IN		210-7421-A	PCA 2200SMD ALU/MUX INTERFACE		1.0000	EACH	00023
3		IN		000-0005-	LABOR PRODUCTION SYSTEMS		.2740		00000
3		IN		000-0011-	LABOR QUALITY CONTROL		.0550		00000
3	P	IN		209-7421-	PCA 2200SMD ALU/MUX INTERFACE		1.0000	EACH	
4		IN		000-0001-	LABOR CIRCUIT SYSTEMS		2.1260		00000
4		IN		000-0011-	LABOR QUALITY CONTROL		.4250		00000
4		IN		300-1100-	CAP 100 PF 10% 500 V CERAMIC DISC	E10435	1.0000	EACH	
4		IN		300-1150-	CAP 150 PF 10% 500 V CERAMIC DISC	18091	1.0000	EACH	
4		FS		300-1966-	CAP .047 UF 50V+80-20% CERAMIC MLD	E13726	20.0000	EACH	
4		IN		300-3011-	CAP 100 UF 16V -10+75% ELECT AXIAL		1.0000	EACH	
4		FS		300-4022-R	CAP 15.0 UF 20V 10% TANT AXIAL T&R	E15690	2.0000	EACH	
4		FS		330-2025-	RES 240 OHM 1/4W 5% FIXED COMP	E15690	1.0000	EACH	
4		FS		330-2033-	RFS 330 OHM 1/4W 10% FIXED COMP	E12553	5.0000	EACH	
4		FS		330-2039-	RFS 390 OHM 1/4W 10% FIXED COMP	E15690	8.0000	EACH	
4		FS		330-2047-	RFS 470 OHM 1/4W 10% FIXED COMP	18091	1.0000	EACH	
4		FS		330-3110-	RFS 1K OHM 1/4W 10% FIXED COMP	18091	9.0000	EACH	
4		FS		330-5010-	RES 100K OHM 1/4W 10% FIXED COMP	E15690	1.0000	EACH	
4		FS		333-0057-R	RFS 16.9K OHM 1/8W 1% FIX FILM T+R	E15690	1.0000	EACH	
4		IN		350-2006-	CONN RECEPT.36 SLD CUP W/O FLOAT	E12101	1.0000	EACH	
4		IN		376-0002-	IC 7420N 4 2 IN POS NAND GATE		1.0000	EACH	
4		IN		376-0003-	IC 7413N 3 3 IN POS NAND GATE		1.0000	EACH	
4		IN		376-0006-	IC 7474N 2 D EDGE TRIG FLIP-FLOP	E12101	1.0000	EACH	
4		IN		376-0007-	IC 7476N 2 JK MA-CLV F/F PRST CLEAR		1.0000	EACH	
4		IN		376-0010-	IC 7404N HEX INVERTER	E12079	1.0000	EACH	
4		IN		376-0012-	IC 7451N EXP 2 W 2 IN AND OR INV GT		1.0000	EACH	

ASSEMBLY PART NUMBER: MPD-00000-000-0
ASSEMBLY DESCRIPTION: LOW POWER PROCESSOR UNIT

LEGEND

1: REPHANTOM; 2: ITEM MASTER DELY CODE; 3: *TAGGED OUT OR REFERRED (TR)

POSITION IN STRUCTURE	IN LEGEND	COMPONENT PART NUMBER	DESCRIPTION	F O C N	QUANTITY PER ASSY	U/M	L/T
4	IN	376-0016-	IC 7402N 4 2 IN POS NOR GATE		1.0000	EACH	
4	IN	376-0044-	IC 74154 1 OF 16 DECODER DEMX E7758	E12101	1.0000	EACH	
4	IN	376-0091-	IC 74181 ARITHMETIC LOGIC UNITS	E12101	1.0000	EACH	
4	IN	376-0092-	IC 74S412 MULTI-MODE BUFFRD LATCH	E12101	1.0000	EACH	
4	IN	376-0093-	IC 7410N 3 3 IN POS NAND GATE	E10865	1.0000	EACH	
4	IN	376-0096-	IC 7402N 4 2 IN POS NOR GATE		1.0000	EACH	
4	IN	376-0098-	IC 7412 4 2 IN OR GATE		3.0000	EACH	
4	IN	376-0104-	IC 9321 2 1 OF 4 DECODER		1.0000	EACH	
4	IN	376-0139-	IC 9602 2 RETRIG RESET MONOSTBL MVH	E10439	1.0000	EACH	
4	IN	376-0153-	IC 7414 HEX SCHMITT TRIGGER	E12079	5.0000	EACH	
4	IN	376-0154-	IC 74LS76P HEX BUS DRIVER 3 STATE		2.0000	EACH	
4	IN	376-0286-	IC 7411 3 3 IN POS AND GATE	PATREL	1.0000	EACH	
4	IN	376-0286-	IC 74LS174 8 LATCHES W/TR ST OUTP		1.0000	EACH	
4	IN	376-0297-	IC 74LS240 OCTAL BUF/LINE DR/LN REC	PATREL	1.0000	EACH	
4	IN	376-0303-	IC 74LS299 SCHOTTKY 8 BIT UNIV RES		1.0000	EACH	
4	IN	376-9003-	IC 24 PIN SOCKET BURNDY	E12101	8.0000	EACH	
4	IN	376-9005-	IC 16 PIN SOCKET CAMBION	E12101	1.0000	EACH	
4	IN	376-9008-	IC 16 PIN TEKNA #4330	E12101	1.0000	EACH	
4	FS	380-1001-R	DIODE SIL DIODE 30V, 100MA AT 1V T&R	E15690	1.0000	EACH	
4	IN	449-0247-	HANDLE,FACEPLATE R6415-123	E11116	2.0000	EACH	
4	IN	452-2095-36-	PC FACE PLATE (16 PIN) C6422-354	E11039	1.0000	EACH	
4	IN	461-3140-	SCREW CAP R-32 R6422-231	E11039	2.0000	EACH	
4	IN	461-3141-	SCREW CAP HOUSING R6422-233	E11039	2.0000	EACH	
4	IN	462-0091-	STANDOFF,MALE/FEMALE P4815-56	E11039	2.0000	EACH	
4	IN	510-7421-	PCB 2200SMD ALU/MUX INTERFACE		1.0000	EACH	
4	FS	650-2120-	4-40 X 3/8 PAN HD PHL MS SS SEMS	E12101	3.0000	EACH	
4	FS	651-0070-	SCREW,SELF TAP T-R #4X1/2"NL FAMD PH	E12101	4.0000	EACH	
4	FS	653-2000-	NO. 4 FLAT WASHER	E12101	3.0000	EACH	
4	FS	653-3002-	WASH 6 .141ID .250OD .062 FL NYL	E12553	3.0000	EACH	
3	IN	376-0090-	IC 74154 1 OF 16 DECODER DEMX E7758	E12101	1.0000	EACH	
3	IN	376-0099-	IC 74181 ARITHMETIC LOGIC UNITS	E12101	1.0000	EACH	
3	IN	376-0320-	IC 74 S412 MULTI-MODE BUFFRD LATCH	E12101	1.0000	EACH	
3	IN	377-0353-	AM2905 LOW PWR SCHOTTKY BUS TRNSCVR		4.0000	EACH	
2	IN	210-7422-	PCA 2200SMD ECC/DEVICE INTERFACE		1.0000	EACH	00023
3	IN	000-0001-	LABOR CIRCUIT SYSTEMS		1.9460		00000
3	IN	000-0005-	LABOR PRODUCTION SYSTEMS		2.2640		00000
3	IN	000-0011-	LABOR QUALITY CONTROL		.8430		00000
3	FS	300-1966-	CAP .047 UF 50V+80-20% CERAMIC MLD	E13726	18.0000	EACH	
3	FS	300-4022-R	CAP 15.0 UF 20V 10% TANT AXIAL T&R	E15690	3.0000	EACH	
3	FS	330-1056-	RES 56 OHM 1/4W 10% FIXED CCMP	E12648	96.0000	EACH	
3	FS	330-2068-	RES 680 OHM 1/4W 10% FIXED CCMP	E15690	2.0000	EACH	
3	FS	330-3010-	RES 1K OHM 1/4W 10% FIXED CCMP	E15690	2.0000	EACH	
3	FS	330-3022-	RES 2.2K OHM 1/4W 10% FIXED CCMP	E15476	5.0000	EACH	
3	FS	330-4021-	RES 20K OHM 1/4W 5% FIXED CCMP	E15690	2.0000	EACH	
3	IN	350-0057-	60P 90 DEG HDR ASSY PCB LK & EJECT	E10865	1.0000	EACH	
3	IN	350-0058-	26P 90 DEG HDR CONN ASSY PCB LK EJT	E10865	2.0000	EACH	
3	IN	376-0002-	IC 7400N 4 2 IN POS NAND GATE	E10865	3.0000	EACH	
3	IN	376-0003-	IC 7410N 3 3 IN POS NAND GATE	E12648	1.0000	EACH	
3	IN	376-0004-	IC 7420N 2 4 IN POS NAND GATE	E12648	1.0000	EACH	
3	IN	376-0010-	IC 7404N HEX INVERTER	E10865	2.0000	EACH	
3	IN	376-0016-	IC 7402N 4 2 IN POS NOR GATE		1.0000	EACH	
3	IN	376-0031-	IC 7430 8 1 POS NAND GATE	E10865	3.0000	EACH	

ASSEMBLY PART NUMBER 177-2200-40- -
 ASSEMBLY DESCRIPTION 1240 DISK PROCESSOR UNIT

LEGEND

1: P-PHANTOM; 2: ITEM MASTER DELY CODE; 3: *-TAGGED OUT OF KIT(PROD STR)

POSITION IN STRUCTURE	LEGEND	COMPONENT PART NUMBER	DESCRIPTION	E C N	QUANTITY PER ASSY	U/M	L/T
3	IN	376-0036-	IC 7486N 4 2 IN EXCLUSIVE OR GATE		4.0000	EACH	
3	IN	376-0041-	IC 7408 4 2 IN POS AND GATE		2.0000	EACH	
3	IN	376-0042-	IC 74157 4 2 IN MX		1.0000	EACH	
3	IN	376-0094-	IC 74161 SYNCHRONOUS 4 BIT COUNTER		4.0000	EACH	
3	IN	376-0094-	IC 74174 HEX D TYPE FLIP FLOP	PATREL	2.0000	EACH	
3	IN	376-0119-	IC 74175 4 D TYPE EDGE TRIG F/F		6.0000	EACH	
3	IN	376-0202-	IC 74S74 2 D TYPE F F W PRESET CLER		1.0000	EACH	
3	IN	376-0205-	IC 74S32 4 2 IN POS OR GATE		1.0000	EACH	
3	IN	376-0206-	IC 74S260 2 5 IN POS NOR GATE		1.0000	EACH	
3	IN	376-0238-	IC 74S10 3 3 IN POS NAND GATE		1.0000	EACH	
3	IN	376-0255-	IC 75110 2 LINE DRIVER	PATREL	2.0000	EACH	
3	IN	376-0274-	IC MC3453L4 LINE DRIVER		5.0000	EACH	
3	IN	376-0275-	IC MC3450P 4 LINE RECEIVER		6.0000	EACH	
3	IN	376-0303-	IC 74LS299 SCHOTTKY 8 BIT UNIV RES		2.0000	EACH	
3	IN	376-0317-	IC 25LS2521 8-BIT EQUAL TO CMPRTR		2.0000	EACH	
3	IN	449-0247-	HANDLE,FACEPLATE H6F15-123	E11770	2.0000	EACH	
3	IN	452-2095-35-	FACE PLATE 2200 PHOENIX D6422-34P	E10865	1.0000	EACH	
3	IN	461-3140-	SCREW CAP 8-32 B6422-231	E10865	2.0000	EACH	
3	IN	461-3141-	SCREW CAP HOUSING B6422-233	E10865	2.0000	EACH	
3	IN	510-7422-	PCB 2200SMD ECC/DEVICE INTERFACE		1.0000	EACH	
3	FS	650-1120-	SCR 3-4P 3/8 SLOT PH MS SS	E10865	1.0000	EACH	
3	FS	650-1160-	SCR 3-4R 1/2 SLOT PH MS SS	F10865	6.0000	EACH	
3	FS	651-0110-	SCREW,SELF TAP T-R #4X1/2*ML FNHC PH	E12648	4.0000	EACH	
2	IN	210-7423-A	PCA 2200SMD RAM/PROM CNTL		1.0000	EACH	00023
3	IN	000-0005-	LABOR PRODUCTION SYSTEMS		2.5730		00000
3	IN	000-0011-	LABOR QUALITY CONTROL		.5150		00000
3	P IN	209-7423-	PCA 2200SMD RAM/PROM CNTL		1.0000	EACH	
4	IN	000-0001-	LABOR CIRCUIT SYSTEMS		1.2760		00000
4	IN	000-0011-	LABOR QUALITY CONTROL		.2550		00000
4	IN	300-1010-	CAP 10 PF 10% 500 V CERAMIC DISC		1.0000	EACH	
4	IN	300-1220-	CAP 220 PF 1% 500 V CERAMIC DISC	E11204	1.0000	EACH	
4	IN	300-1906-	CAP .001 UF 10% 500 V CERAMIC DISC		1.0000	EACH	
4	FS	300-1966-	CAP .047 UF 50V+80-20% CERAMIC MLD	E13726	24.0000	EACH	
4	FS	300-4022-R	CAP 15.0 UF 20V 10% TANT AXIAL TRR	E15690	4.0000	EACH	
4	IN	321-0008-	CRYSTAL 10.0 5 % QUARTZ FC-18/U		1.0000	EACH	
4	FS	330-2022-	RES 220 OHM 1/4W 10% FIXED CCMP	20200	1.0000	EACH	
4	FS	330-2033-	RES 330 OHM 1/4W 10% FIXED CCMP	E15690	1.0000	EACH	
4	FS	330-2047-	RES 470 OHM 1/4W 10% FIXED CCMP	20200	8.0000	EACH	
4	FS	330-3018-	RES 1.8K OHM 1/4W 10% FIXED COMP	F15690	1.0000	EACH	
4	FS	330-3022-	RES 2.2K OHM 1/4W 10% FIXED COMP	F12634	6.0000	EACH	
4	FS	333-01F1-R	RFS 16.2K OHM 1/4W 1% FIX FL T+R	F15690	1.0000	EACH	
4	IN	376-0002-	IC 7400N 4 2 IN POS NAND GATE		1.0000	EACH	
4	IN	376-0006-	IC 7474N 2 D EDGE TRIG FLIP-FLOP	E10675	2.0000	EACH	
4	IN	376-0006-	IC 7442N 4 LINE-16 LINE DECODER	F12634	1.0000	EACH	
4	IN	376-0010-	IC 7404N HEX INVERTER		3.0000	EACH	
4	IN	376-0012-	IC 7451N FXP 2 W 2 IN AND OR INV GT		1.0000	EACH	
4	IN	376-0016-	IC 7402N 4 2 IN POS NOR GATE	F10675	1.0000	EACH	
4	IN	376-0044-	IC 74153 2 4-1 LINE DATA SEL MX		1.0000	EACH	
4	IN	376-0053-	IC 74193 SYN 4 BIT UP DOWN COUNTER	F10675	4.0000	EACH	
4	IN	376-0061-	IC 7408 4 2 IN POS AND GATE		2.0000	EACH	
4	IN	376-0082-	IC 74157 4 2 IN MX	E10679	2.0000	EACH	

ASSEMBLY PART NUMBER 177-2200-40-

LEGEND

ASSEMBLY DESCRIPTION 2200 DISK PROCESSOR UNIT

1: PHANTOM; 2: ITEM MASTER DILY CODE; 3: *TAGGED OUT OF KIT(PROD CTR)

POSITION IN STRUCTURE	LEGEND		COMPONENT PART NUMBER	DESCRIPTION	F C N	QUANTITY PFR ASSY	U/M	L/T
	1	2						
4	IN		376-0093-	IC 7432 4 2 IN OR GATE	E10679	5.0000	EACH	
4	IN		376-0096-	IC 9321 2 1 OF 4 DECODER		1.0000	EACH	
4	IN		376-0097-	IC 74195 4 BIT PAR ACCESS SHIFT REG	E12634	1.0000	EACH	
4	IN		376-0098-	IC 74174 HEX C TYPE FLIP FLOP		3.0000	EACH	
4	IN		376-0104-	IC 9602 2 RETRIG RESFT MONOSTPL MVR		1.0000	EACH	
4	IN		376-0125-	IC 7427 3 3 IN NOR GATE		1.0000	EACH	
4	IN		376-0139-	IC 7414 HEX SCHMITT TRIGGER	E10679	1.0000	EACH	
4	IN		376-0191-	IC 74160 SYN 4 BIT CTR	E10679	1.0000	EACH	
4	IN		376-0294-	IC 74LS13A 3-A LINE DECODER/MPX	E10679	1.0000	EACH	
4	IN		376-9002-	IC 16 PIN SOCKET BURNDY	E10679	2.0000	EACH	
4	IN		376-9003-	IC 24 PIN SOCKET BURNDY	E10679	6.0000	EACH	
4	IN		376-9014-	IC 18 PIN SOCKET	E10679	18.0000	EACH	
4	IN		376-9020-	IC 20PIN SOCKET DIL LOW PROFILE	E10679	3.0000	EACH	
4	IN		510-7423-	PCB 2200SMD RAM/PROM CNTL		1.0000	EACH	
3	IN		377-0341-L	2114L 1KX4 STATIC RAM 450NS L PWR	E11118	18.0000	EACH	
3	IN		377-0347-	2911 BIPOLAR MICROPRGRM SEQUENCES		3.0000	EACH	
3	IN		377-0353-	AM2905 LOW PWR SCHOTTKY BUS TRNSCVR		2.0000	EACH	
3	FS		378-4083-R7-	2280 CPU MICROCODE CHIP #4 L13	18418	1.0000	EACH	00003
4	IN		377-0348-	TMS2716 2KX8 EPROM 12V		1.0000	EACH	
3	FS		378-4084-R7-	2280 DPU MICROCODE CHIP #3 L14	18418	1.0000	EACH	00003
4	IN		377-0348-	TMS2716 2KX8 EPROM 12V		1.0000	EACH	
3	FS		378-4085-R7-	2280 DPU MICROCODE CHIP #1 L15	18418	1.0000	EACH	00003
4	IN		377-0348-	TMS2716 2KX8 EPROM 12V		1.0000	EACH	
3	FS		378-4086-R7-	2280 CPU MICROCODE CHIP #2 L16	18418	1.0000	EACH	00003
4	IN		377-0348-	TMS2716 2KX8 EPROM 12V		1.0000	EACH	
2	IN		210-7424-	PCA 2200SMD I/O CONTROLLER		1.0000	EACH	00023
3	IN		000-0001-	LABOR CIRCUIT SYSTEMS		.9510		00000
3	IN		000-0005-	LABOR PRODUCTION SYSTEMS		1.4020		00000
3	IN		000-0011-	LABOR QUALITY CONTROL		.6710		00000
3	IN		300-1220-	CAP 220 PF 10% 500 V CERAMIC DISC	E12563	1.0000	EACH	
3	IN		300-1470-	CAP 470 PF 10% 500 V CERAMIC DISC	E12231	3.0000	EACH	
3	FS		300-1966-	CAP .047 UF 50V+80-20% CERAMIC MLD	E13726	17.0000	EACH	
3	FS		300-4022-R	CAP 15.0 UF 20V 10% TANT AXIAL TRR	E15690	2.0000	EACH	
3	FS		330-3022-	RES 2.2K OHM 1/4W 10% FIXED COMP	E15690	3.0000	EACH	
3	IN		376-0002-	IC 7400N 4 2 IN POS NAND GATE		2.0000	EACH	
3	IN		376-0004-	IC 7420N 2 4 IN POS NAND GATE	F12490	2.0000	EACH	
3	IN		376-0006-	IC 7474A 2 D EDGE TRIG FLIP-FLOP		6.0000	EACH	
3	IN		376-0110-	IC 7404N HEX INVERTER	18094	3.0000	EACH	
3	IN		376-0012-	IC 7451N EXP 2 W 2 IN AND OR INV GT		4.0000	EACH	
3	IN		376-0016-	IC 7402N 4 2 IN POS NOR GATE	E12563	2.0000	EACH	
3	IN		376-0053-	IC 74193 SYN 4 BIT UP DOWN COUNTER		3.0000	EACH	
3	IN		376-0081-	IC 7408 4 2 IN POS AND GATE		5.0000	EACH	
3	IN		376-0093-	IC 7432 4 2 IN OR GATE	E12563	2.0000	EACH	
3	IN		376-0056-	IC 9321 2 1 OF 4 DECODER		2.0000	EACH	
3	IN		376-0139-	IC 7414 HEX SCHMITT TRIGGER	18094	1.0000	EACH	
3	IN		376-0154-	IC 7411 3 3 IN POS AND GATE		4.0000	EACH	
3	IN		376-0238-	IC 74S10 3 3 IN POS NAND GATE	E10725	2.0000	EACH	

ASSEMBLY PART NUMBER 177-2200-H0- -
 ASSEMBLY DESCRIPTION 2200 DISK PROCESSOR UNIT

LFGFND
 1: P=PHANTOM; 2: ITEM MASTER DELY CODE; 3: *-TAGGED OUT OF KIT(PROD STR)

POSITION IN STRUCTURE	LEGEND			COMPONENT PART NUMBER	DESCRIPTION	F C N	QUANTITY PER ASSY	U/M	L/T
	1	2	3						
3		IN		376-0286- - -	IC 74LS374 8 LATCHES W/TR ST OUTP		4.0000	EACH	
3		IN		376-0288- - -	IC 74LS244 OCTUAL BUF/LINE DR 3 OUT		1.0000	EACH	
3		IN		376-0298- - -	IC 74S138 3 TO 8 LINE DECODER/MPX		1.0000	EACH	
3		IN		376-0303- - -	IC 74LS299 SCHOTTKY 8 BIT UNIV RES		1.0000	EACH	
3		IN		376-0317- - -	IC 25LS2521 8-BIT EQUAL TO CMPRTR		1.0000	EACH	
3		IN		376-0318- - -	IC 74276 QUAD J-K FLIP FLOPS		3.0000	EACH	
3		IN		510-7424- - -	PCB 22005MD I/O CONTROLLER		1.0000	EACH	
3		FS		600-9012- - -	24 GA YELLOW SOLID TEFLON WIRE	17991	.1042	FEET	
2		IN		220-0138- - -	12*EXTENSION CABLE(36C)B6482-16		1.0000	EACH	00010
3		IN		000-0004- - -	LABOR SUB-SYSTEMS		.6980	EACH	00000
3		IN		000-0011- - -	LABOR QUALITY CONTROL		.1400		00000
3		IN		350-2082- - -	CONN 18-36 CABLE TO PANEL PLLG	EC6407	2.0000	EACH	
3		IN		350-4228-G - -	STRAIN RELIEF CVR 36 POS 180DEG GRV	EC8484	2.0000	EACH	
3		IN		350-4228-Y - -	STRAIN RELIEF CVR 36 POS 180DEG TNG	EC8484	2.0000	EACH	
3		IN		350-4234- - -	4-40X3/8 CAPT SCR FOR SCR MT CONNS.	EC6407	4.0000	EACH	
3		FS		420-0054- - -	36 COND 26 GA SHIELDED CABLE	EC6407	13.0000	FEET	
3		IN		458-0361- - -	GROUND STRAP C6R15-2R	EC6407	2.0000	EACH	
3		IN		605-1011- - -	TY-WRAP IDENT MARKER	E15816	1.0000	EACH	
2		IN		220-3032- - -	30 PAIR FLAT CA ASSY(5*) D6482-188		1.0000	EACH	00010
3		IN		000-0004- - -	LABOR SUB-SYSTEMS		.2370	EACH	00000
3		IN		000-0011- - -	LABOR QUALITY CONTROL		.0470		00000
3		IN		350-0414- - -	30-60 RECEPT CONN .100	EC8371	2.0000	EACH	
3		IN		350-4120- - -	PULL TAB FOR FLAT CABLE	EC8371	2.0000	EACH	
3		FS		420-0070- - -	30 TWISTED PAIR/FLAT RIBBON CABLE		5.0000	FEET	
3		FS		660-0196- - -	GLUE,HOTMFLT(.750DX1.375LG)	EC8371	.0100	EACH	
2		IN		220-3033-5 - -	26 COND.SHIELDED FLT CRLE C6482-189		1.0000	EACH	00010
3		IN		000-0004- - -	LABOR SUB-SYSTEMS		.4770	EACH	00000
3		IN		000-0011- - -	LABOR QUALITY CONTROL		.0950		00000
3		IN		350-0413- - -	13-26 RECEPT CONN .100		2.0000	EACH	
3		IN		350-4119- - -	PULL TAB FOR FLAT CABLE		1.0000	EACH	
3		FS		420-0069- - -	26 COND FLAT CABLE W/GRND PLANE		5.0000	FEET	
3		FS		660-0195- - -	HOT MFLT GLUE	E13142	.0400	LB	
2		IN		270-0575- - -	PHCENIX DR INTTRFC TO VPA/MVPA 2200		1.0000	EACH	00010
3		IN		000-0004- - -	LABOR SUB-SYSTEMS		3.0000	EACH	00000
3		IN		000-0005- - -	LABOR PRODUCTION SYSTEMS		.1210		00000
3		IN		000-0011- - -	LABOR QUALITY CONTROL		.6240		00000
3		IN		210-7416- - -	PCA 2200 SMD MOTHERBOARD	E15193	1.0000	EACH	00023
4		IN		000-0004- - -	LABOR SUB-SYSTEMS		1.3300	EACH	00000
4		IN		000-0011- - -	LABOR QUALITY CONTROL		.2660		00000
4		IN		300-4032- - -	CAP 10.0 UF 35 V 10% TANT AXIAL	E11283	1.0000	EACH	
4		IN		300-4041- - -	CAP 10.0 UF 35 V 5% TANT AXIAL	E12060	1.0000	EACH	
4		FS		331-3010-R - -	RFS 1K OHM 1/2W 10% FIXD COMP TRR	E16370	4.0000	EACH	
4		IN		332-2010- - -	RFS 100 OHM 1W 10% FIXED COMP		1.0000	EACH	
4		IN		334-0014- - -	1 OHM 2.5W 5% FIXED RESISTOR		1.0000	EACH	
4		IN		334-0016- - -	.6 OHM 4W 5% FIXED RESISTOR		2.0000	EACH	
4		IN		334-0023- - -	.15 OHM 12W 5% RESISTOR	PATREFL	3.0000	EACH	
4		IN		350-0011- - -	225-21521-110 PC CONN SOLDER TYPE	E11215	15.0000	EACH	
4		IN		360-3002- - -	DIO 1N4719 50V 1A RECT S C60		4.0000	EACH	

ASSEMBLY PART NUMBER 177-2200-00-

LEGEND

ASSEMBLY DESCRIPTION 2000 DISK PROCESSOR UNIT

1=PHANTOM; 2: ITEM MASTER DELY CODE; 3: *TAGGED OUT OF KIT(PROD STR)

POSITION IN STRUCTURE	LEGEND 1 2 3	COMPONENT PART NUMBER	DESCRIPTION	E C N	QUANTITY PER ASSY	U/M	L/T
4	IN	510-7416-	PCB 2200 SMD MOTHERBOARD		1.0000	EACH	
4	IN	654-1172-	12 POS PIN HEADER ASSY AMP 350213-1 E11683		1.0000	EACH	
4	IN	654-1177-	14 POS PC PIN HEADER ASY AMP3502141 E11683		1.0000	EACH	
4	IN	654-1158-	2 POS PIN HEADER ASSY AMP 350209-1 E11683		1.0000	EACH	
3	IN	270-0256-	2200S HEAT SINK ASSY 6527-8		1.0000	EACH	00000
4	IN	000-0000-	LABOR PRODUCTION SYSTEMS		.3750		00000
4	IN	000-0111-	LABOR QUALITY CONTROL		.0750		00000
4	IN	000-9999-	OTHER DIRECT COST		13.1490	EACH	00000
4	IN	270-3043-	2200S HEAT SINK HARNESS		1.0000	EACH	00010
5	IN	000-0004-	LABOR SUB-SYSTEMS		.4960	EACH	00000
5	IN	000-0011-	LABOR QUALITY CONTROL		.0990		00000
5	P FS	600-0000-	WIRE 18 GA BLACK UL		.5800	FEET	
6	FS	600-0009-	WIRE 18 GA WHITE UL		1.0000	FEET	
5	P FS	600-0001-	WIRE 18 GA BROWN UL		.5800	FEET	
6	FS	600-0009-	WIRE 18 GA WHITE UL		1.0000	FEET	
5	P FS	600-0002-	WIRE 18 GA RED UL		1.4200	FEET	
6	FS	600-0009-	WIRE 18 GA WHITE UL		1.0000	FEET	
5	P FS	600-0003-	WIRE 18 GA ORANGE UL		1.1700	FEET	
6	FS	600-0009-	WIRE 18 GA WHITE UL		1.0000	FEET	
5	P FS	600-0004-	WIRE 18 GA YELLOW UL		1.1700	FEET	
6	FS	600-0009-	WIRE 18 GA WHITE UL		1.0000	FEET	
5	P FS	600-0005-	WIRE 18 GA GREEN UL		.6700	FEET	
6	FS	600-0009-	WIRE 18 GA WHITE UL		1.0000	FEET	
5	P FS	600-0006-	WIRE 18 GA PLUF UL		1.1700	FEET	
6	FS	600-0009-	WIRE 18 GA WHITE UL		1.0000	FEET	
5	P FS	600-0007-	WIRE 18 GA VIOLET UL		.6700	FEET	
6	FS	600-0009-	WIRE 18 GA WHITE UL		1.0000	FEET	
5	FS	600-0009-	WIRE 18 GA WHITE UL		.5800	FEET	
5	P FS	600-0050-	WIRE 18 GA WH/BLK		1.0000	FEET	
6	FS	600-0009-	WIRE 18 GA WHITE UL		1.0000	FEET	
5	P FS	600-0052-	18 GA WIRE WH/RED	ECP399	1.0400	FEET	
6	FS	600-0009-	WIRE 18 GA WHITE UL		1.0000	FEET	
5	P FS	600-2005-	WIRE 24 GA GREEN UL	W/CFF-76	1.0000	FEET	
6	FS	600-2009-	WIRE 24 GA WHITE UL		1.0000	FEET	
5	FS	600-2009-	WIRE 24 GA WHITE UL		1.1700	FEET	
5	P FS	600-2050-	WIRE 24 GA WH/BLK UL		.5800	FEET	
6	FS	600-2009-	WIRE 24 GA WHITE UL		1.0000	FEET	
5	P FS	600-2051-	WIRE 24 GA WH/BRN UL		.5800	FEET	
6	FS	600-2009-	WIRE 24 GA WHITE UL		1.0000	FEET	

ASSEMBLY PART NUMBER 177-2200-40-

LEGEND

ASSEMBLY DESCRIPTION 2200 DISK PROCESSOR UNIT

1: P=PHANTOM; 2: ITEM MASTER DELY CODE; 3: *TAGGED OUT OF KIT(PROD STR)

POSITION IN STRUCTURE	LEGEND 1 2 3	COMPONENT PART NUMBER	DESCRIPTION	E C N	QUANTITY PER ASSY	U/M	L/T
5	P	FS 607-2052-	WIRE 24 GA WH/RED UL	ECR399	1.1700	FEET	
5	F	FS 600-2009-	WIRE 24 GA WHITE UL		1.0000	FEET	
5	P	FS 600-2093-	WIRE 24 GA WH/ORN UL		1.1700	FEET	
5	F	FS 600-2009-	WIRE 24 GA WHITE UL		1.0000	FEET	
5	P	FS 600-2094-	WIRE 24 GA WH/YEL UL	RF2285	1.0400	FEET	
5	F	FS 600-2009-	WIRE 24 GA WHITE UL		1.0000	FEET	
5	P	FS 600-2095-	WIRE 24 GA WH/GRN UL		.6700	FEET	
5	F	FS 600-2009-	WIRE 24 GA WHITE UL		1.0000	FEET	
5	P	FS 600-2097-	WIRE 24 GA WH/VIO UL		.6700	FEET	
5	F	FS 600-2009-	WIRE 24 GA WHITE UL		1.0000	FEET	
5	P	FS 600-7002-	16 GA RED STRANDED WIRE		.9200	FEET	
5	F	FS 600-7009-	16 GA WHITE STRANDED WIRE		1.0000	FEET	
5	P	FS 600-7003-	16 GA ORANGE STRANDED WIRE		1.1700	FEET	
5	F	FS 600-7009-	16 GA WHITE STRANDED WIRE		1.0000	FEET	
5	P	FS 600-7006-	16 GA BLUE STRANDED WIRE		1.7500	FEET	
5	F	FS 600-7009-	16 GA WHITE STRANDED WIRE		1.0000	FEET	
5	FS *	605-1004-	CABLE TIE, PAN-TY PLTIM-M		15.0000	EACH	
5	IN	606-3043-	3/4" DIA WHT SHRINK BLK NU 270-3043	E12R26	1.0000	EACH	00001
5	FS *	654-1143-R	SOCKET 20-14 GA (REEL) AMP 61117-4		16.0000	EACH	
5	FS *	654-1145-R	SOCKET 30-22 GA (REEL) AMP 350078-4		10.0000	EACH	
5	IN	654-1171-	12 POS SOCKET HOUSING AMP 1-4802870		1.0000	EACH	
5	IA	654-1174-	16 POS SOCKET HOUSING AMP 1480438-0		1.0000	EACH	
4	IN	375-1008-	40251 / MJ2801 TRANSISTOR	EC9826	1.0000	EACH	
4	IA	375-1022-	40250 / 2N4231A PWR TRANSISTOR		6.0000	EACH	
4	IN	375-1030-	2N5956 TRANSISTOR		2.0000	EACH	
4	IN	375-1072-	TRANSISTOR 2N5685 300W S NPN TO-3	FC9826	1.0000	EACH	
4	IN	375-9014-	INSULATOR XTOR MOUNT WECKERSSER TM-1	10C280	3.0000	EACH	
4	IN	375-9015-	INSULATOR XTOR MOUNT WECKERSSER TM-2		8.0000	EACH	
4	IN	375-9019-	MICA WSHR (SMALL) FOR POWER XISTORS	EC6584	8.0000	EACH	
4	IA	375-9020-	MICA WSHR (LARGE) FOR POWER XISTORS	EC6584	3.0000	EACH	
4	IN	380-3000-	DIO 1N1200A 100V 12A RECT S D04		2.0000	EACH	
4	IA	380-4003-	M-7110 MDA 970-1 RECTIFIER		1.0000	EACH	
4	IN	380-9002-	MICA WSHR .191DX.630DX.003THK(3000)	E150R2	2.0000	EACH	
4	IN	478-0275-	HEATSINK, (2200S)D6627-11		1.0000	EACH	
4	P	FS 600-0097-	18 GA WIRE WH/VIOLET		.5100	FEET	
5	F	FS 600-0009-	WIRE 18 GA WHITE UL		1.0000	FEET	
4	FS *	600-9015-	WIRE 14 GA TINNED COPPER BUS (UL)		.2100	FEET	
4	FS *	600-9018-	WIRE 18 GA TINNED COPPER BUS (UL)		.6100	FEET	
4	FS *	605-0006-	TUPING NRR 12 CLEAR		.0800	FEET	
4	FS *	605-0109-	TUPING NO 6 CLEAR		.1600	FEET	
4	FS *	650-2160-	4-40 X 1/2 PAN HD PHL MS SS SEMS		1.0000	EACH	

ASSEMBLY PART NUMBER 177-2200-00- -
 ASSEMBLY DESCRIPTION (204) DISK PROCESSOR UNIT

LEGEND
 1: P-PHANTOM; 2: ITEM MASTER DELY CODE; 3: *-TAGGED OUT OF KIT(PROG STR)

POSITION IN STRUCTURE	LEGEND		COMPONENT PART NUMBER	DESCRIPTION	F C N	QUANTITY PER ASSY	U/M	L/T
	1	2						
4	FS		650-3160-	6-32 X 1/2 PAN HD PHL MS SS SEMS	E10280	22.0000	EACH	
4	FS		652-3004-	NUT 6-32UNC HEX SMALL PAT	SS E10280	22.0000	EACH	
4	FS		652-6700-	NUT 10-32UNC HEX REG PAT	SS E15082	2.0000	EACH	
4	FS		653-3000-	WASH 6 .149ID .375OD .016 FL	SS E10280	23.0000	EACH	
4	FS		653-3701-	WASH 6 .150ID .280OD INT T	ST E10280	11.0000	EACH	
4	FS		653-6700-	WASH 10 .203ID .438OD .032 FL	SS E15082	2.0000	EACH	
4	FS		653-6701-	WASH 10 .204ID .381OD INT T	ST E15082	2.0000	EACH	
4	IN		654-1191-	SOLDER GROUND LUG DO-4	E15082	2.0000	EACH	
4	IN		654-1706-	#6 GROUND LUG	E10280	11.0000	EACH	
4	IN		654-1319-	SHOULDER PUSHING DO-4	E15082	2.0000	EACH	
3	IN		300-3019-	6000 UF 25V ELECTROLYTIC CAPACITOR		2.0000	EACH	
3	IN		300-3049-	77000 UF 15V ELECTROLYTIC CAPACITOR		1.0000	EACH	
3	IN		300-3068-	9.2K UF 25V ELECTROLYTIC CAP		2.0000	EACH	
3	IN		300-9009-	CAP CLAMP 1 1/4 INCH 2 LUG CMC-22		2.0000	EACH	
3	IN		300-9022-	CAP CLAMP 2 1/16 INCH 3 LUG		1.0000	EACH	
3	IN		325-0023-	DPST TOGGLE SW 15 A 125V CH 7561K4		1.0000	EACH	
3	IN		360-0000-	FUSE HOLDER 90 DEGREE CONTACT		1.0000	EACH	
3	IN		360-9000-	RUBBER WSHR FOR 360-1000 / 360-0001		1.0000	EACH	
3	IN		360-9002-	HEX NLT FOR 360-1000 / 360-0001		1.0000	EACH	
3	IN		360-9003-	LOCK WSHR LF#90523(FOR 360-0000/1)		1.0000	EACH	
3	IN		380-5000-	130 VOLT VARISTOR V130LA10	E11580	1.0000	EACH	
3	IN		400-1009-	FAN W/WHISPER(SKELETON) ROTRON WR2A2	E17208	1.0000	EACH	
3	IN		410-0098-	XFMR LNP MDL 220S/220SE C5068-99		1.0000	EACH	
3	IN		420-1005-	POWER CORD ROTRON FAN 16415		1.0000	EACH	
3	IN		420-1096-	POWER CORD, 10 FT 18AWG		1.0000	EACH	
3	IN		451-1085-	2200S CPU & PWR SUPPLY CHAS E6627-6		1.0000	EACH	
3	IN		451-2100-	2200S MOTHER BOARD COVER D6627-10		1.0000	EACH	
3	IN		458-0196-	2217 CARD HOLD DOWN (T-1)C5300-1060	E11212	4.0000	EACH	
3	IN		461-0132-	PLATE NUT (MODIFIED) C6P00-113	E11837	2.0000	EACH	
3	IN		462-0105-	SPCR 4-4UNC .250 OD .250 L FX B	E12303	6.0000	EACH	
3	IN		462-0141-	SPCR, PHENOLIC CURRENT 4-250	E12303	1.0000	EACH	
3	IN		462-0243-	SPCR, HEX 6-32 X 1 3/4 E6R00-110		4.0000	EACH	
3	P FS		600-0000-	WIRE 18 GA BLACK UL		1.1700	FEET	
4	FS		600-0009-	WIRE 18 GA WHITE UL		1.0000	FEET	
3	FS		600-9018-	WIRE 18 GA TINNED COPPER BUS (UL)		.2100	FEET	
3	FS		605-0010-	TUBING PVC #2 CLEAR	E16875	.1600	FEET	
3	FS		605-0015-	#3 CLEAR TUBING		2.3400	FEET	
3	FS		605-0103-	TUBING 3/8 BLACK		.8300	FEET	00000
3	FS		605-0109-	TUBING NO 6 CLEAR		.2100	FEET	
3	FS		605-0124-	TEFLON TUBING #20 PENNTUBE#1-E116	E11814	.0030	ROLL	
3	FS		605-1004-	CABLE TIE, PAN-TY PLT/M-M	E16875	3.0000	EACH	
3	FS		650-2121-	SCR 4-40 3/8 PHIL FLAT F MS SS	E11837	4.0000	EACH	
3	FS		650-2240-	4-40 X 3/4 PAN HD PHL MS SS SEMS	E16875	18.0000	EACH	
3	FS		650-3080-	6-32 X 1/4 PAN HD PHL MS SS SEMS		7.0000	EACH	
3	FS		650-3160-	6-32 X 1/2 PAN HD PHL MS SS SEMS		8.0000	EACH	
3	FS		650-3207-	SCR 6-32X5/8 PAN HD PHL SFMS MS SS	E16875	3.0000	EACH	
3	FS		650-3560-	SCR 6-32 1 3/4 SLOT PH MS SS	E16875	4.0000	EACH	
3	FS		650-4160-	8-32 X 1/2 PAN HD PHL MS SS SEMS		4.0000	EACH	
3	FS		650-5161-	SCR 10-24 1/2 PHIL PH MS SS		2.0000	EACH	

ASSEMBLY PART NUMBER 177-2200-00 -
 ASSEMBLY DESCRIPTION 2200 DISK PROCESSOR UNIT

LFGENO
 1: PEPHANTCM; 2: ITEM MASTER DFLY CCDE; 3: *TAGGED OUT OF KIT(PROD STR)

POSITION IN STRUCTURE	LEGEND	COMPONENT PART NUMBER	DESCRIPTION	F C A	QUANTITY PER ASSY	U/M	L/T
3	FS	650-6160-	10-32 X 1/2 PAN HD PHL MS SS SEMS	E16875	10.0000	EACH	
3	FS	652-0029-	R-32 LOCK-NUT KEPS 511-081800-50		4.0000	EACH	
3	FS	652-0032-	E-32 LOCK-NUT KEPS 511-061800-00		3.0000	EACH	
3	FS	652-2002-	4-40 SQUARE NUT	E16875	4.0000	EACH	
3	FS	652-2005-	4-40 LOCK-NUT KEPS SS	E16875	15.0000	EACH	
3	IN	652-3000-	NUT 6-32UNC HEX REG PAT	SS	1.0000	EACH	
3	FS	653-0003-	WASHER, NO.4 NYLON 1/8 ID X 3/8 OD	E16875	8.0000	EACH	
3	FS	653-2000-	NO. 4 FLAT WASHER		2.0000	EACH	
3	FS	653-2001-	NO. 4 FLAT WSHR 1/8ID 1/4OD	E16875	12.0000	EACH	
3	FS	653-2002-	WASH 4 .123ID .2650D INT T	ST	2.0000	EACH	
3	FS	653-3000-	WASH 6 .149ID .3750D .016 FL	SS E16875	4.0000	EACH	
3	FS	653-3001-	WASH 6 .150ID .2880D INT T	ST	8.0000	EACH	
3	FS	653-3003-	WASH 6 .141ID .2530D SPLIT	SS	1.0000	EACH	
3	FS	653-4000-	WASH 8 .174ID .3750D .016 FL	SS	4.0000	EACH	
3	FS	653-6001-	WASH 10.204ID .3810D INT T	ST	2.0000	EACH	
3	IN	654-1006-	#6 GROUND LUG		1.0000	EACH	
3	IN	654-1010-	#10 GROUND LUG		6.0000	EACH	
3	IN	654-1238-	HEYCO STRAIN RELIEF SR5P-4		1.0000	EACH	
3	IN	654-1245-	SNAP RUSHING,HEYCO SR-1507-21		1.0000	EACH	
3	IN	655-0119-	2200 PS HANDLE R6422-10R		1.0000	EACH	
3	IN	655-0203-	FFET PLACK GREENE BH 2096		4.0000	EACH	
3	IN	655-0208-	FFET WHITE GREENE BH-21R4		4.0000	EACH	
2	IN	449-0056-	FACE PLATE,P.C.PLANK C6422-305	E15007	3.0000	EACH	
2	IN	449-0273-	PLANK FACE PLATE R 2200 D6884-1029	E15007	1.0000	EACH	
2	IN	450-0904-	WANG NAME TAG C6815-97		1.0000	EACH	
2	IN	451-2101-	2200S CPU COVER (6 1/2) C6627-9		1.0000	EACH	
2	FS	650-4165-	SCR 8-32 1/2 SLOT PH MS SS		8.0000	EACH	
2	FS	650-4480-	SCR 8-32 1 1/2 PHIL PH MS SS		4.0000	EACH	
2	FS	650-0058-	NEOPRENE SPONGE TP GREENE 2218 3/8"		1.0000	FEE I	
2	IN	690-0312-	#6 SHIPPING BAG	E11690	3.0000	EACH	
1	IN	290-0015-	SHPG PKG BOM:F/R-DISK-DRIVE	18250	1.0000	EACH	00010
2	IN	685-0014-	TAPE 3" PAPER GUMMED NON-ASPT REINF		.0000	ROLL	
2	IN	685-0017-	STRAPPING STEEL .50 WD .015 THK		.0000	ROLL	
2	IN	685-0019-	PUCKLE #41 METAL .50 WIDE	18783	2.0000	EACH	
2	IN	685-0100-	EDGE PRCTR 21/2X21/2X3 L-BOARD .06		4.0000	EACH	
2	IN	685-0266-	PALLET 40 X 32 CUSHIONED		1.0000	EACH	
2	IN	685-0287-	HSC 500# DW 39 1/4 X 32 1/4 X 25		1.0000	EACH	
2	IN	685-0307-	RSC 20 X 20 X 22 DW275	20010	.0000	EACH	
2	IN	685-0332-	FOAM-IN-PLACE "A" CHEMICAL .5 PCF	20010	.0000	EACH	
2	IN	685-0333-	FOAM-IN-PLACE "R" CHEMICAL .5 PCF	20010	.0000	EACH	

END OF REPORT MB0080-A

APPENDIX

D

SCHE-

MATICS

APPENDIX D

SCHEMATICS

This appendix contains all of the pertinent schematics relating to the 2280 DPU. These are listed below as follows:

<u>WL Number</u>	<u>Nomenclature</u>
210-7415	Prime Circuit Board
210-7416	Motherboard
210-7421	ALU/MUX Interface Board
210-7422	ECC/Device Interface Board
210-7423	RAM/PROM Control Board
210-7424	I/O Controller Board
210-7715	2280 MUX Disk Controller
210-7716	Motherboard
210-7717	2280 MUX Master
210-7718	2280 MUX Slave
210-L567	Regulator Board

THIS DRAWING AND THE DATA SHOWN THERE ON ARE THE CONFIDENTIAL PROPERTY OF, AND ARE PROPRIETARY TO WANG LABORATORIES, INC. THIS DRAWING AND THE DATA SHOWN THEREON MAY NOT BE MADE PUBLIC WITHOUT THE WRITTEN CONSENT OF WANG LABORATORIES, INC. IF FOR ANY REASON THIS DRAWING IS PERMITTED BY WANG TO LEAVE THE PHYSICAL CUSTODY OF THE COMPANY, IT IS RETURNABLE UPON THE DEMAND OF WANG LABORATORIES, INC.

DO NOT SCALE

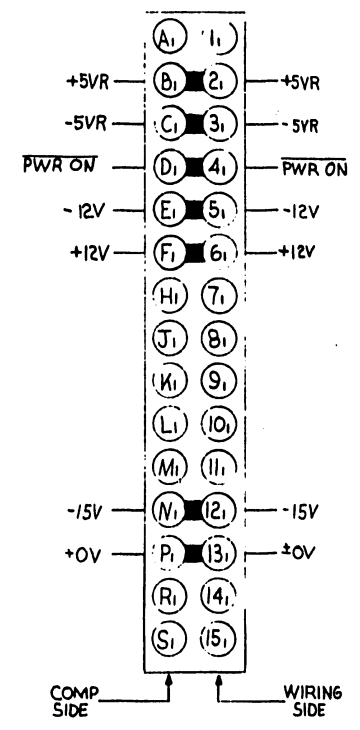
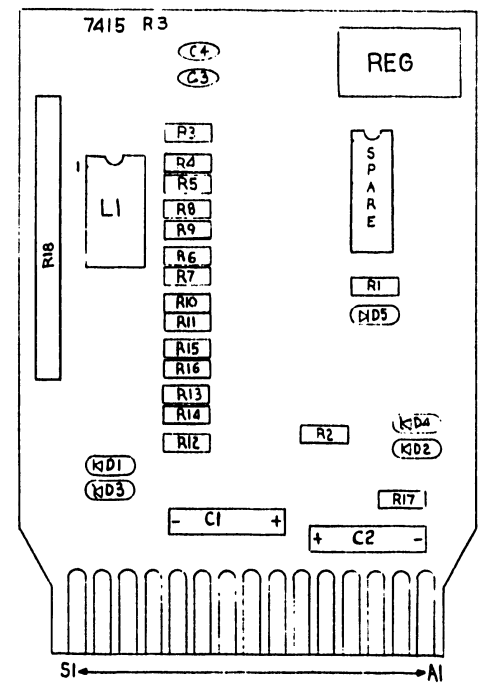
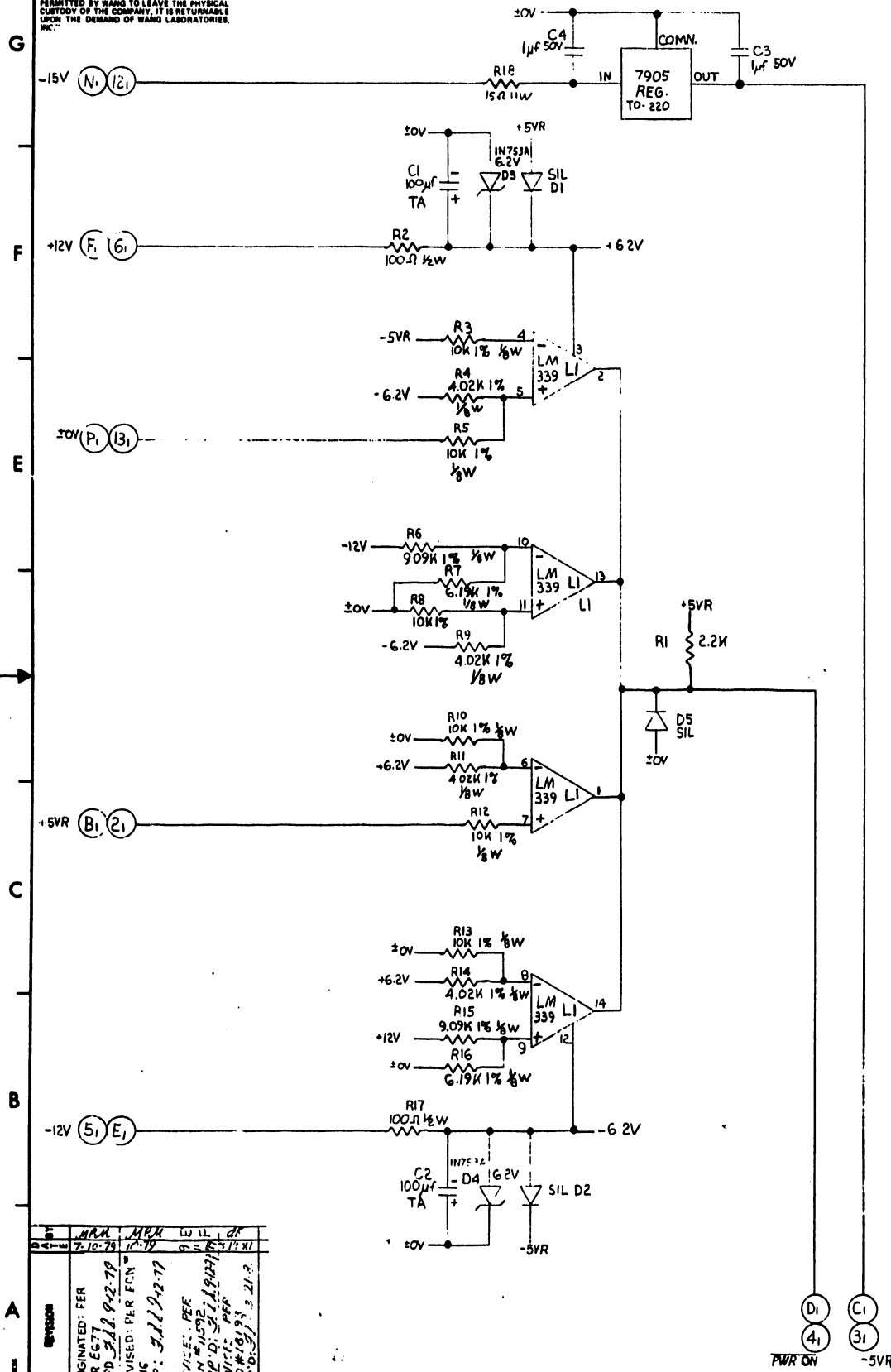

COMPONENT	WLI #	TYPE
R1	330-3022	2.2K 1/8W 10%
R2,17	331-2010	100-Ω 1/8W 10%
R3,5,8,10,12,13	333-0090	10K 1% 1/8W
R4,9,11,14	333-0060	4.02K 1% 1/8W
R6,15	333-0061	9.09K 1% 1/8W
R7,16	333-0069	6.19K 1% 1/8W
R18	334-0002	15-Ω 11W
C1,2	300-4021	100μF 15V (T)
C3,4	300-1931	1μF 50V CER
D1,2,5	380-1001	SIL DIODE
D3,4	380-2062	6.2V ZEN IN753A
REG	374-0002	μA 7905

LOCATION	WLI PART NO.	TYPE
L1	376-0240	LM339
L2	SPARE	

REV	DATE	BY	CHK	APP	REASON
1	7-10-75	MAM			ORIGINATED: FER
2	9-2-79				DWR EGT
3	11-7-79				APPD JAL
4	11-7-79				REVISED: P.L.R. FCN
5	3-11-77				APP: JAL
6	3-11-77				FCN: PEF
7	3-11-77				FCN: PEF
8	3-11-77				APP: JAL
9	3-11-77				REVISED: PEF
10	3-11-77				ECO: PEF
11	3-11-77				APP: JAL

WANG LABORATORIES, INC. LOWELL, MASS. U.S.A.		BY	DATE	APPROVED BY	DATE
MODEL NO. 2280		DWN	7-2-79	E ENGR M. GREER	7-12-79
SEE ENGR. SPECIFICATIONS		CHR	9-2-79	M ENGR	
TITLE		PRIME CIRCUIT			
FINISH		101 EE AS NOTED			
SCALE		1:1			
WANG PART NUMBER		210-7415			
DRAWING NUMBER		D			
REV		E			

D 7415

E-REV
O

THIS DRAWING AND THE DATA SHOWN THERE ON ARE THE CONFIDENTIAL PROPERTY OF, AND ARE PROPRIETARY TO WANG LABORATORIES, INC. THIS DRAWING AND THE DATA SHOWN THEREIN MAY NOT BE REPRODUCED WITHOUT THE WRITTEN CONSENT OF WANG LABORATORIES, INC. IF FOR ANY REASON THIS DRAWING IS PERMITTED BY WANG TO LEAVE THE PHYSICAL CUSTODY OF THE COMPANY, IT IS RETURNABLE UPON THE DEMAND OF WANG LABORATORIES, INC.

SIGNAL	INTERFACE 74-22	ADU/ADUX 74-21	RAM/PRDM/IO CONTROL 74-23	SPARE	REGULATOR 6-39	J1	J2	J3	SPARE
AK0		I12	I12						
AK1		I02	I02						
AK2		R2	R2						
AK3		92	92						
AK4		I22	I22						
AK5		33	33						
AK6		43	43						
AK7		I52	I52						
AD7		F3	F3						
BD SECTOR		42							
BSY		I41	I41						
CAOM		53	53						
CNTR-1		K2	K2						
CNTR-2		M2							
CNTR-3		P2							
CRESET		D1	D1						
C100		J1	J1						
C700		42	42						
DERROR		Z2	E3						
DONE		R2	I42						
DONE		N1	K9						
ECB0		93	J3						
ECC SHIFTED		71							
ECC DATA		I32							
EQUALS		F3							
ERROR		73							
FC0		H3							
FC1		K3							
FC2		L3							
FC4		N3							
FC5		I03							
FC6		53							
FC7		H1							
FC8		B2							
FC9		N2							
FC9		S1							
FONT		C2							
INIT		D2							
LAUX		I11							
LOADELL		22							
M0		52							
M1		I21							
M2		I01							
M3		B3							
M4		151							
M5		I41							
M6		K1							
M7		S2							
NULL		A2							
PLO CLOCK		I31							
PRIME		N2							
PWR ON		L1							
RA0		C3							
RDG		D3							
READ		F1							
READ DATA		M3							
READ DATA		93							
READY		32							
RETURN		I3							
RTM-CMP		F2							
RTG-WTG		H1							
RWF		81							
R0		I51							
R1		I13							
R2		I15							
R3		I13							
R4		F2							
R5		H1							
R6		81							
R7		I151							
R8		I13							
R9		E1							
R10		41							
R11		62							
R12		72							
R13		H2							
R14		71							
R15		I2							
SB		J2							
SECTOR		S2							
SELECT		62							
SELECT1		H2							
SELECT2		72							
SHIFT ECC		M3							
SORT		42							
STROBE		I23							
T0		H3							
T2		I32							
T2-5		N3							
T4		B2							
T8		A3							
TAG1		J2							
TAG-2		K2							
TAG-3		E2							
THS 0		G3							
THS 1		23							
THS 2		D3							
THS 3		E3							
THS 4		C3							
THS 5		B3							
UB		L2							
W/P		J1							
WRITE DATA		51							

NO.	REVISION
1	SEC 3/17/54

WANG LABORATORIES, INC. LORAIN, MASS. U.S.A.		BY DWN	DATE 7-25-79	APPROVED BY T ENGR	DATE
MATERIAL	MODEL NO. 2200 SMD	TITLE MOTHER BOARD			
SEE ENGR'S SPECIFICATIONS		MFG ENGR			
FINISH	TOL EN. AS NOTED	210-7416	D	7416	4
FINISH		MFG PART NUMBER		SIZE	DRAWING NUMBER

44

11 10 9 8 7 5 4 3 2 1

DO NOT SCALE

THIS DRAWING AND THE DATA SHOWN THERE ON ARE THE CONFIDENTIAL PROPERTY OF AND ARE PROPRIETARY TO WANG LABORATORIES, INC. THIS DRAWING AND THE DATA SHOWN THEREON MAY NOT BE MADE PUBLIC WITHOUT THE WRITTEN CONSENT OF WANG LABORATORIES, INC. IF FOR ANY REASON THIS DRAWING IS PERMITTED BY WANG TO LEAVE THE PHYSICAL CUSTODY OF THE COMPANY, IT IS RETURNABLE UPON THE DEMAND OF WANG LABORATORIES.

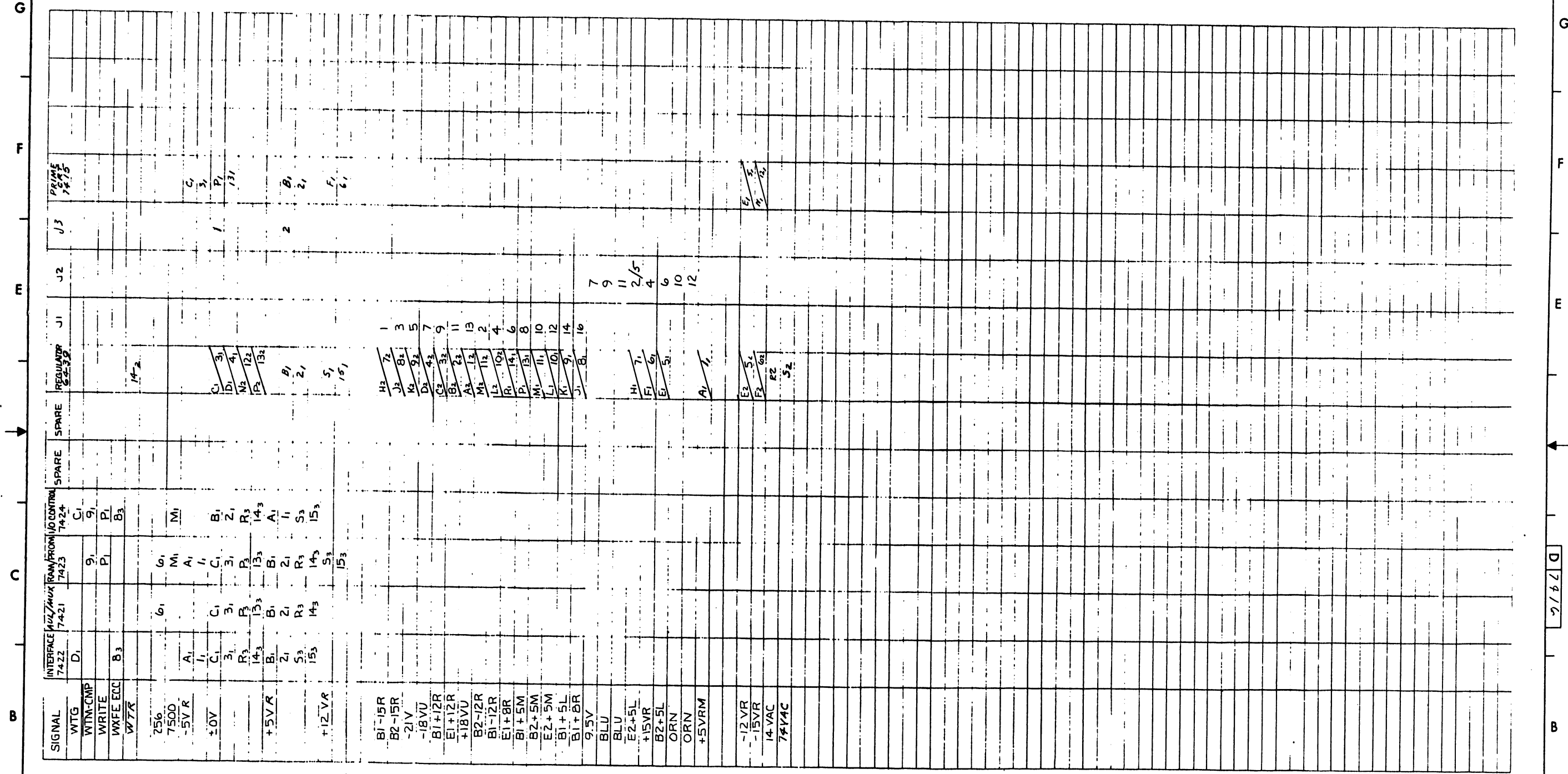

NO.	REVISION
	SEE SMT 9

WANG LABORATORIES, INC. LOWELL, MASS. U.S.A.		BY DWN E J L	DATE 7 25 77	APPROVED BY M ENGR	DATE
MATERIAL	MODEL NO. 2200SMD SEE ENGR SPECIFICATIONS	CHK	M ENGR	MFG ENGR	
FINISH	TOL ER AS NOTED XX ± PAK ± XXX ± ANG ± FINISH	TITLE MOTHERBOARD		210-746 D	7416 4
	SCALE 1/8" = 1"	SHT 2 OF 4		WANG PART NUMBER	SIZE DRAWING NUMBER REV

2167C

45

THIS DRAWING AND THE DATA SHOWN THERE ON ARE THE CONFIDENTIAL PROPERTY OF AND ARE PROPRIETARY TO WANG LABORATORIES, INC. THIS DRAWING AND THE DATA SHOWN THEREON MAY NOT BE MADE PUBLIC WITHOUT THE WRITTEN CONSENT OF WANG LABORATORIES, INC. IF FOR ANY REASON THIS DRAWING IS PERMITTED BY WANG TO LEAVE THE PHYSICAL CUSTODY OF THE COMPANY, IT IS RETURNABLE UPON THE DEMAND OF WANG LABORATORIES, INC.

DO NOT SCALE

NOTE:
LOAD 115/230 VAC
JUMPERS/VARISTERS
FOR APPROPRIATE
115/230 VAC OPERATION

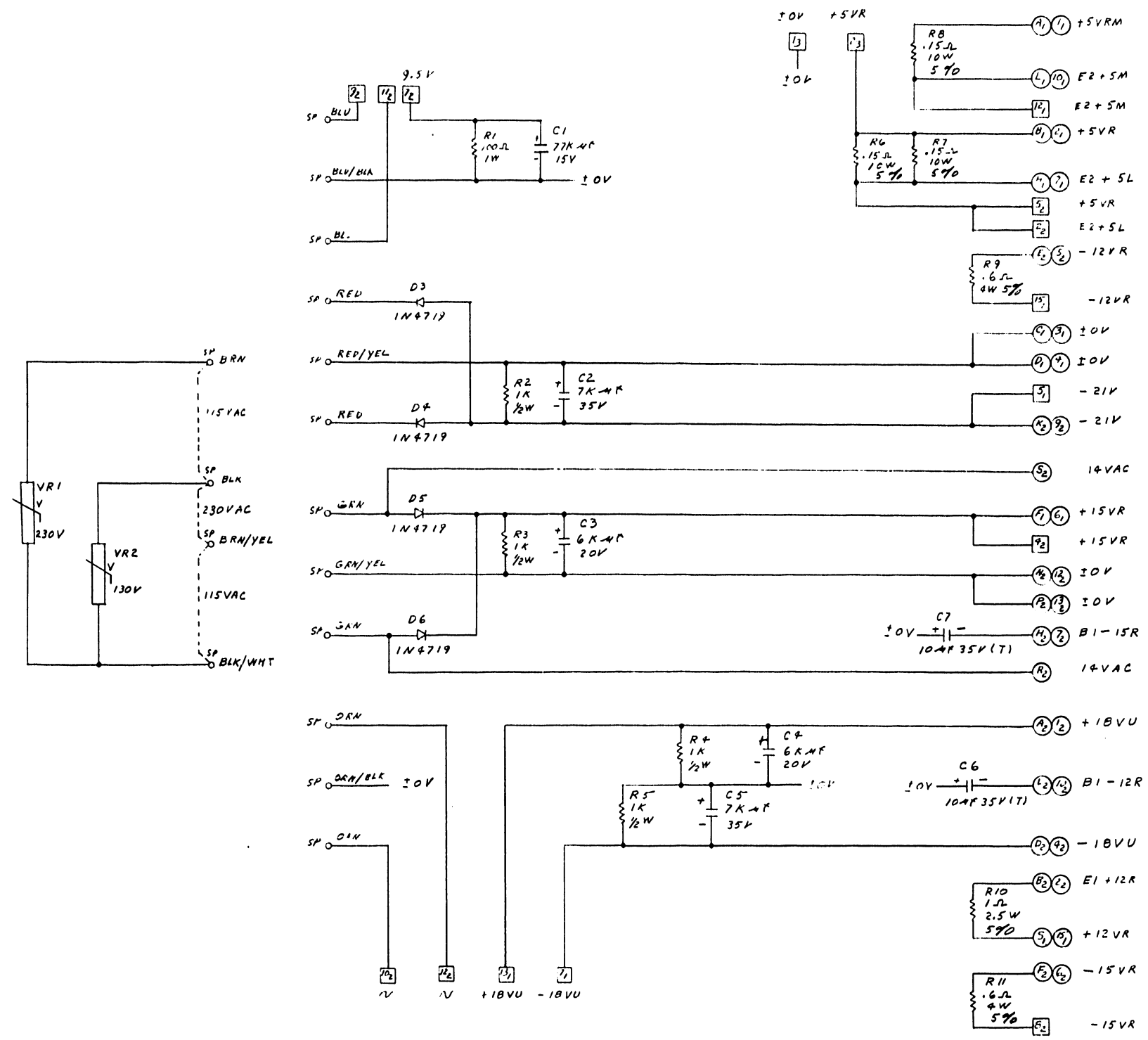

REV	DATE	BY	APP
1			
2			

REVISION SEE INT 4

WANG LABORATORIES, INC. LOWELL, MASS. U.S.A.		BY: DWH	DATE: 1/2/80	APPROVED BY: E ENGR	DATE:
MATERIAL:		CHK:		M ENGR	
MODEL NO: 2200SMD		TITLE: MOTHERBOARD		MFG ENGR:	
FINISH:		TOL: ±	115 ±	115 ±	FINISH
SCALE: 1/8" = 1"		SIZE: 210-7416 D	7416	WANG PART NUMBER:	DRAWING NUMBER: 7416

56

11 10 9 8 7 5 4 3 2 1

DO NOT SCALE

"THIS DRAWING AND THE DATA SHOWN THERE ON ARE THE CONFIDENTIAL PROPERTY OF, AND ARE PROPRIETARY TO, WANG LABORATORIES, INC. THIS DRAWING AND THE DATA SHOWN THEREON MAY NOT BE MADE PUBLIC WITHOUT THE WRITTEN CONSENT OF WANG LABORATORIES, INC. IF FOR ANY REASON THIS DRAWING IS PERMITTED BY WANG TO LEAVE THE PHYSICAL CUSTODY OF THE COMPANY, IT IS RETURNABLE UPON THE DEMAND OF WANG LABORATORIES, INC."

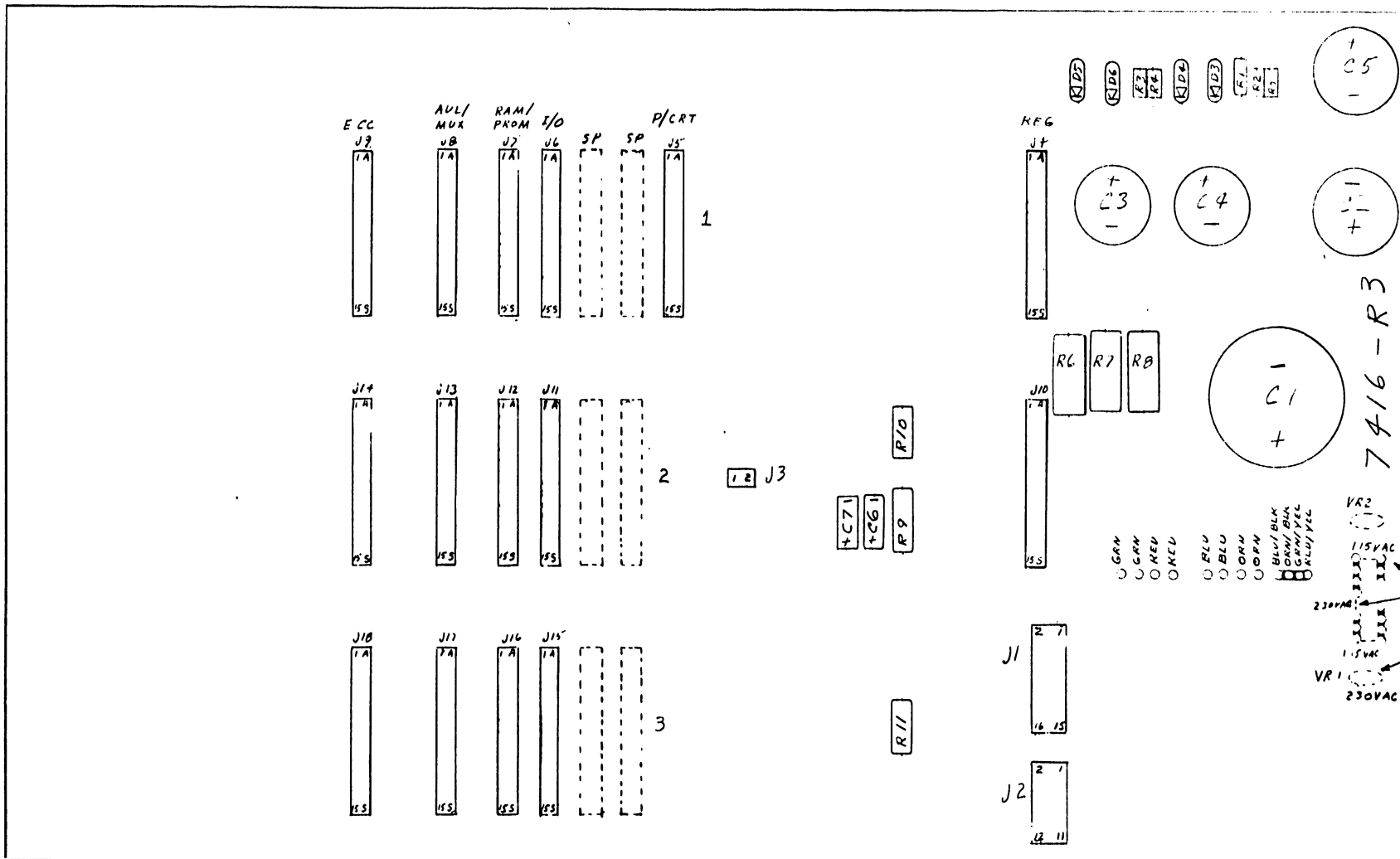

COMP.	W.L. PART NO	TYPE
R2,3,4,5	331-3010	1K 12W 10%T
R1	332-2010	100Ω 1W 10%T
R6,7,8	334-0023	15Ω 10W 5%T
R10	334-0014	1Ω 2.5W 5%T
R9,11	334-0015	6.24W 5%T
C1	301-3049	77KMF5V (E)
C2,5	301-3049	77KMF35V (E)
C3,4	301-3049	77KMF20V (E)
C7	301-3049	10KMF35V 5%T (E)
J1	054-1177	16 PIN HEADER
J2	054-1172	12 PIN HEADER
J3	054-198	2 PIN HEADER
J9-18	350-10	
VR1	380-5051	250V VARISTOR
VR2	380-5051	130V VARISTOR
D3,4,5,6	380-3002	1N4749 ZENER
C6	300-4032	10MF 35V 10%T

MOUNT 115/230VAC JUMPERS/VARISTOR ON CIRCUIT SIDE FOR APPROPRIATE 115/230VAC OPERATION

VR1 AND 115/230VAC JUMPER MOUNTED ON CIRCUIT SIDE

E-REV
2

NO.	REVISION	DATE	BY
1	REVISED PER ECN # 12, 13	1-27-70	WANG
2	REVISED PER ECN # 12, 13	1-27-70	WANG
3	REVISED PER ECN # 12, 13	1-27-70	WANG
4	REVISED PER ECN # 12, 13	1-27-70	WANG
5	REVISED PER ECN # 12, 13	1-27-70	WANG
6	REVISED PER ECN # 12, 13	1-27-70	WANG
7	REVISED PER ECN # 12, 13	1-27-70	WANG
8	REVISED PER ECN # 12, 13	1-27-70	WANG
9	REVISED PER ECN # 12, 13	1-27-70	WANG
10	REVISED PER ECN # 12, 13	1-27-70	WANG
11	REVISED PER ECN # 12, 13	1-27-70	WANG

WANG LABORATORIES, INC. LOWELL, MASS. U.S.A.		BY DWN	DATE 1-27-70	APPROVED BY E ENGR	DATE 1-27-70
MATERIAL	MODEL NO. 22005MD	TITLE MOTHERBOARD			
FINISH	101 ± AS NOTED 111 ± FRAC ± 121 ± ANG ± SCALE 1/8" = 1"	210-710	D	7416	4
WANG PART NUMBER		SIZE	DRAWING NUMBER	REV	

11 10 9 8 7 5 4 3 2 1

THIS DRAWING AND THE DATA SHOWN THERE ON ARE THE CONFIDENTIAL PROPERTY OF, AND ARE PROPRIETARY TO WANG LABORATORIES, INC. THIS DRAWING AND THE DATA SHOWN THEREIN MAY NOT BE MADE PUBLIC WITHOUT THE WRITTEN CONSENT OF WANG LABORATORIES, INC. IF FOR ANY REASON THIS DRAWING IS PERMITTED BY WANG TO LEAVE THE PHYSICAL CUSTODY OF THE COMPANY, IT IS RETURNABLE UPON THE DEMAND OF WANG LABORATORIES, INC.

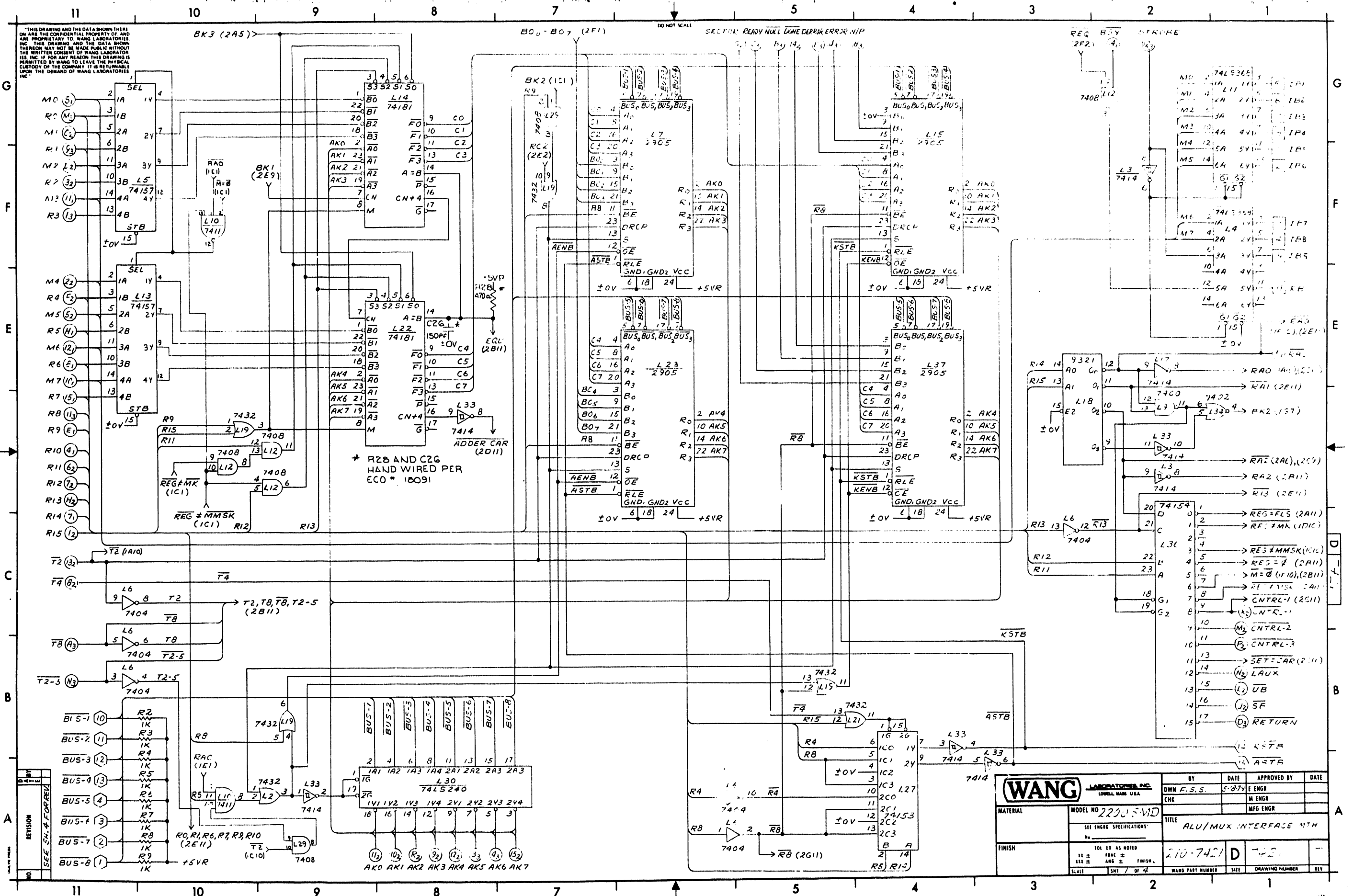

WANG LABORATORIES, INC. LOWELL, MASS. U.S.A.		BY DWM F.S.S.	DATE 5-8-79	APPROVED BY M ENGR	DATE
MATERIAL	MODEL NO 2290-5-MID	CHK		MFG ENGR	
FINISH	SEE ENGR SPECIFICATIONS	TITLE ALU/MUX INTERFACE 9TH			
	101 LT AS NOTED				
	11 ± 100 ±				
	111 ± ANG ± FINISH				
DATE	SMT / OF 4	WANG PART NUMBER	SIZE	DRAWING NUMBER	REV

16	1A	74154	1	→ RA0 (2E1)
17	2A	74154	2	→ RA1 (2E11)
18	3A	74154	3	→ RA2 (2A11)
19	4A	74154	4	→ RA3 (2E11)
20	5A	74154	5	→ REG # FLS (2A11)
21	6A	74154	6	→ REG # FMK (1D1C)
22	7A	74154	7	→ REG # MMSK (101C)
23	8A	74154	8	→ REG # Y (2A11)
24	9A	74154	9	→ REG # YSR (2A11)
25	10A	74154	10	→ CNTRL-1 (2E11)
26	11A	74154	11	→ (A2) CNTRL-1
27	12A	74154	12	→ (M2) CNTRL-2
28	13A	74154	13	→ (P2) CNTRL-3
29	14A	74154	14	→ SET-CAR (2E11)
30	15A	74154	15	→ (M2) LAUX
31	16A	74154	16	→ (L2) UB
32	17A	74154	17	→ (J2) SF
33	18A	74154	18	→ (D2) RETURN

78

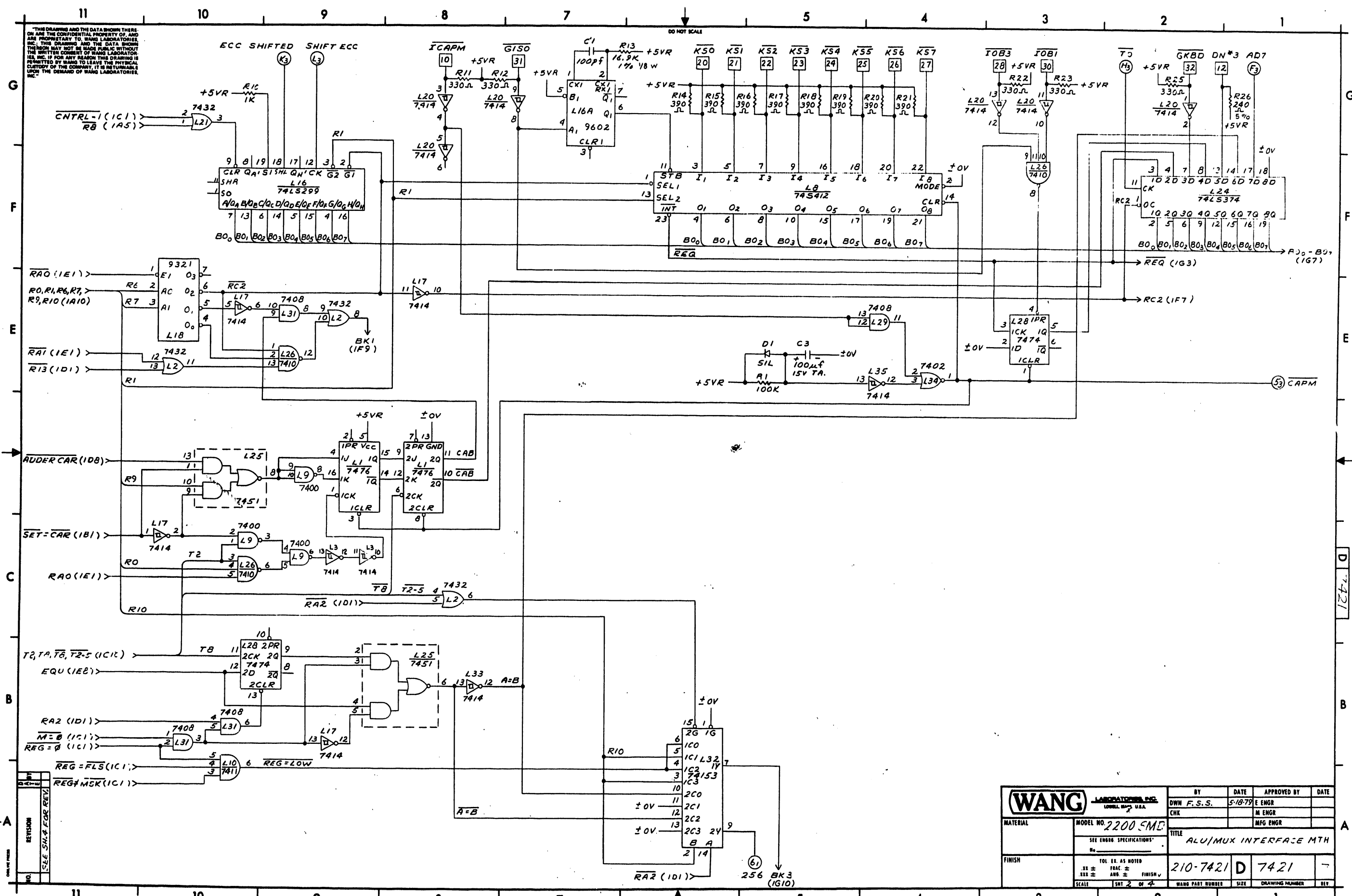

THIS DRAWING AND THE DATA SHOWN THERE ON ARE THE CONFIDENTIAL PROPERTY OF WANG LABORATORIES, INC. THIS DRAWING AND THE DATA SHOWN THEREON MAY NOT BE MADE PUBLIC WITHOUT THE WRITTEN CONSENT OF WANG LABORATORIES, INC. IF FOR ANY REASON THIS DRAWING IS REPRODUCED BY WANG TO LEAVE THE PHYSICAL CUSTODY OF THE COMPANY, IT IS RETURNABLE UPON THE DEMAND OF WANG LABORATORIES, INC.

DO NOT SCALE

WANG LABORATORIES, INC. LOWELL, MASS. U.S.A.		BY DWN F.S.S.	DATE 5-18-79	APPROVED BY E ENGR	DATE
MATERIAL	MODEL NO. 2200 SMD	CHK		M ENGR	
SEE ENGR SPECIFICATIONS		TITLE ALU/MUX INTERFACE MTH			
FINISH	TOL. AS NOTED XXX ±	210-7421		D 7421	
	SCALE 1/8" = 1"	INT. 2 OF 4	WANG PART NUMBER	SIZE	DRAWING NUMBER

11 10 9 8 7 5 4 3 2 1

DO NOT SCALE

THIS DRAWING AND THE DATA SHOWN THEREON ARE THE CONFIDENTIAL PROPERTY OF AND ARE PROPRIETARY TO WANG LABORATORIES, INC. THIS DRAWING AND THE DATA SHOWN THEREON MAY NOT BE MADE PUBLIC WITHOUT THE WRITTEN CONSENT OF WANG LABORATORIES, INC. IF FOR ANY REASON THIS DRAWING IS PERMITTED BY WANG TO LEAVE THE PHYSICAL CUSTODY OF THE COMPANY, IT IS RETURNABLE UPON THE DEMAND OF WANG LABORATORIES, INC.

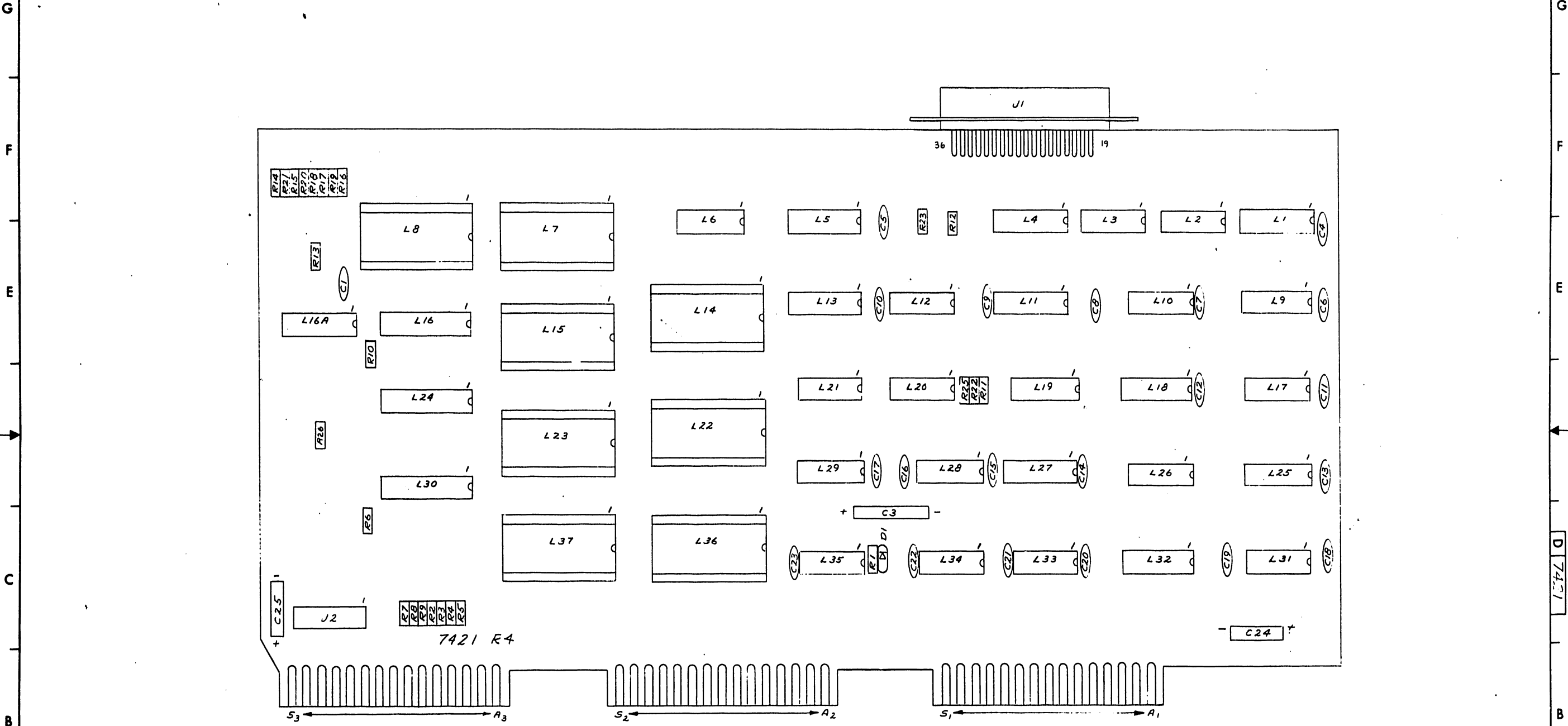

NO.	REVISION
	SEE SH. 4 FOR REV.

WANG LABORATORIES, INC. LOWELL, MASS. U.S.A.		BY DWN F. S. S.	DATE 5/19/79	APPROVED BY E ENGR	DATE
MATERIAL		MODEL NO. 2200 SMD		TITLE ALU/MUX INTERFACE M7H	
FINISH		SEE ENGR. SPECIFICATIONS		210-7421 D 7421 7	
SCALE		TOL. EX. AS NOTED XX ± FRACTION XXX ± ANG. ± FINISH		WANG PART NUMBER SIZE DRAWING NUMBER REV.	

D10

"THIS DRAWING AND THE DATA SHOWN THERE ON ARE THE CONFIDENTIAL PROPERTY OF, AND ARE PROPRIETARY TO, WANG LABORATORIES, INC. THIS DRAWING AND THE DATA SHOWN THEREON MAY NOT BE MADE PUBLIC WITHOUT THE WRITTEN CONSENT OF WANG LABORATORIES, INC. IF FOR ANY REASON THIS DRAWING IS PERMITTED BY WANG TO LEAVE THE PHYSICAL CUSTODY OF THE COMPANY, IT IS RETURNABLE UPON THE DEMAND OF WANG LABORATORIES, INC."

I.C. LOCATION	TYPE	W.L. NO.
L1	7476	376-0007
L2,19,21	7432	376-0093
L6	7404	376-0010
L4,11	74LS368	376-0193
L5,13	74157	376-0082
L7,15,23,37	AM2905	377-0353
L8	74S412	376-0320
L9	7400	376-0002
L10	7411	376-C194
L12,29,31	7408	376-0081
L14,22	74181	376-0099
L16	74LS299	376-0303
L16A	96C2	376-C104
L3,17,20,33,35	7414	376-C135
L18	9321	376-0096
L24	74LS374	376-0286
L25	7451	376-0012
L26	7410	376-0003
L27,32	74153	376-0048
L28	7474	376-0006
L30	74LS240	376-0297
L34	7402	376-0016
L36	74154	376-0090
L7,8,14,15,22,23,36,37	24 PIN SKT.	376-9003

COMPONENT	TYPE	W.L. NO.
R1	100K, 1/4W, 10%	330-5010
R2-10	1K, 1/4W, 10%	330-3010
R11,12,22,23,25	330Ω, 1/4W, 10%	330-2033
R13	1K, 9K, 1/4W, 10%	333-0097
R14-21	390Ω, 1/4W, 10%	330-2039
R26	240Ω, 1/4W, 5%	330-2025
R28	470Ω, 1/4W, 10%	330-2047
C1	100PF 500V	300-1100
C3	100μF, 16V(E)	300-3011
C4-23	.05μF, 12V	300-1506
C24,25	15μF, 20V TA	300-4022
C26	150PF 500V	300-1150
D1	SIL.	380-1001
J1	36 PIN CONN.	350-2096
J2	16 PIN SKT.	376-9005

MNEMONIC	COORD.
AD7	2G1
AK0-AK7	1A8
ASTB	1A1
BUS-1-BUS-8	1B11
BSY	1G2
CAPM	2E1
CTRL-1,2,3	1C1
DERROR	1G5
DONE	1G5
DN*3	2G2
ECC SHIFTED	2G9
ERROR	1G5
GIS0	2G7
GKBD	2G2
IB1-IB8	1G1
IBS	1F1
ICAPM	2G8
IOB1, IOB3	2G3
K50-K57	2G6
KSTB	1B1
LAUX	1B1
MO-M7	1G11
NULL	1G5

MNEMONIC	COORD.
RO-R15	1G11
RA0	1E1
RB	1E1
READY	1G5
RETURN	1B1
SB	1B1
SECTOR	1G5
SHIFT ECC	2G9
STROBE	1G2
T0	2G2
T2, T4, T8, T2-5	1C11
UB	1B1
WIP	1G4
256	2A5

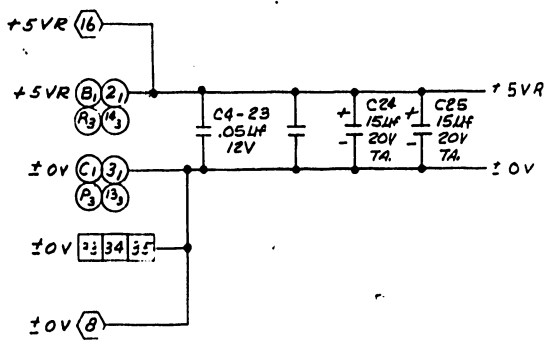

I.C. LOCATION	TYPE	SPARES
L3	1414	2
L16 A	96C2	1
L17	7414	1
L21	7432	2
L29	7408	1
L31		1
L34	7402	2
L35	7414	5

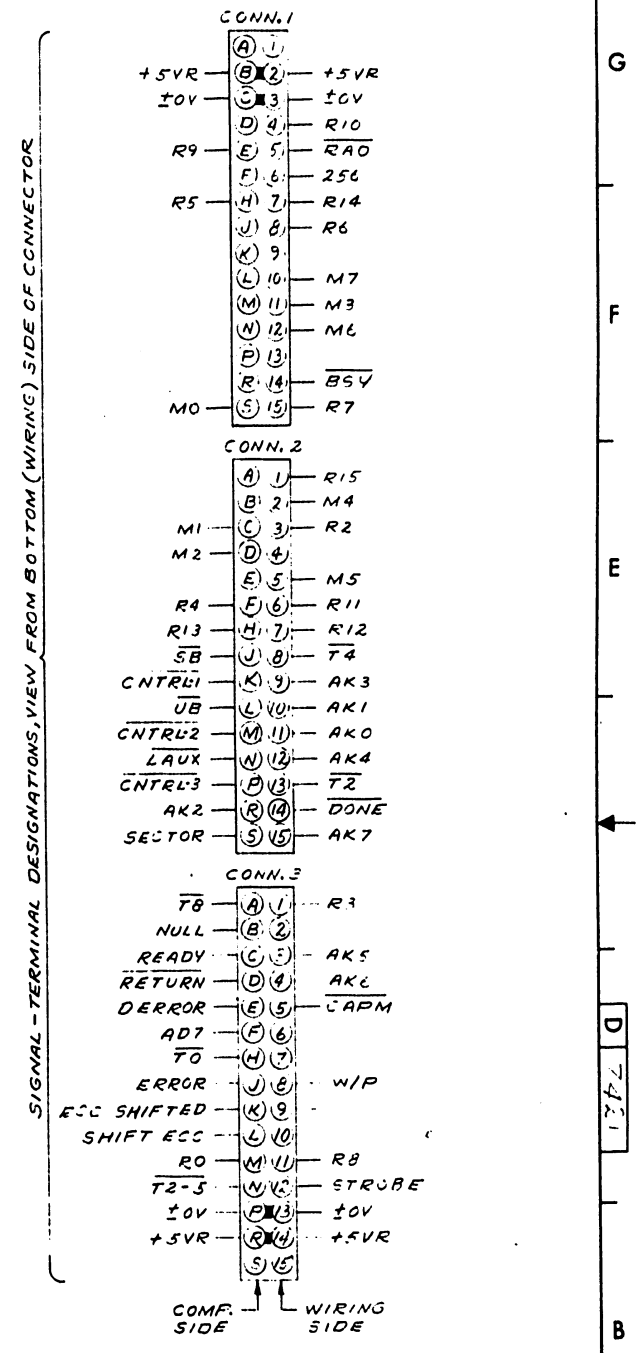
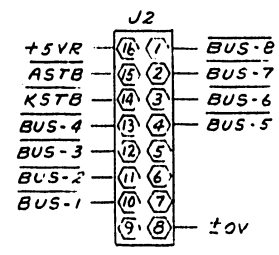
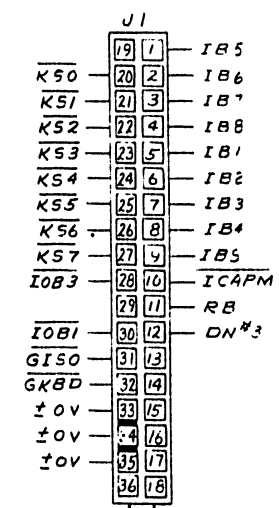

NO.	REVISION	DATE	BY	APPROVED BY	DATE
1	REVISED PER...
2	REVISED PER...
3	REVISED PER...
4	REVISED PER...
5	REVISED PER...
6	REVISED PER...
7	REVISED PER...
8	REVISED PER...
9	REVISED PER...

WANG LABORATORIES, INC. LOWELL, MASS. U.S.A.

MODEL NO. 2200 SMD

SEE ENGR. SPECIFICATIONS

TITLE: ALU/MUX INTERFACE MTH

210-7421 D 7421 7

SCALE: 1 SHT of 4

WANG PART NUMBER: 210-7421 D 7421 7

BY: DWN F.S.E. DATE: 5-21-79 APPROVED BY: E ENGR DATE: 5-21-79

CHK: MFG ENGR DATE: 5-21-79

A11

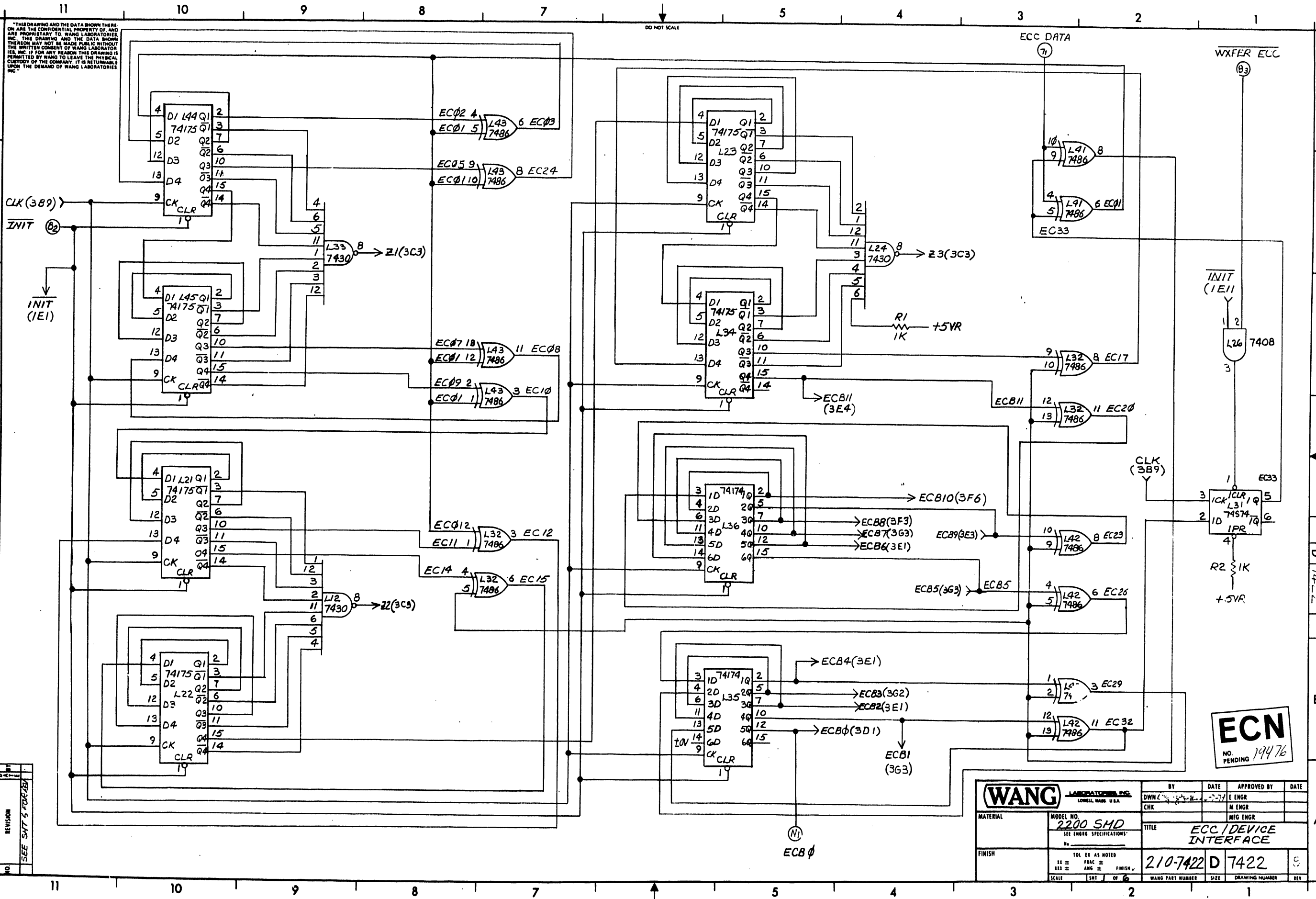

THIS DRAWING AND THE DATA SHOWN THERE ON ARE THE CONFIDENTIAL PROPERTY OF AND ARE PROPRIETARY TO WANG LABORATORIES, INC. THIS DRAWING AND THE DATA SHOWN THEREON MAY NOT BE MADE PUBLIC WITHOUT THE WRITTEN CONSENT OF WANG LABORATORIES, INC. IF FOR ANY REASON THIS DRAWING IS PERMITTED BY WANG TO LEAVE THE PHYSICAL POSSESSION OF THE COMPANY, IT IS RETURNABLE UPON THE DEMAND OF WANG LABORATORIES, INC.

NO.	REVISION	DATE	BY	CHK

SEE SAT 5 FOR REV

ECN
NO. PENDING 19476

WANG LABORATORIES, INC. LOWELL, MASS. U.S.A.		BY	DATE	APPROVED BY	DATE
MODEL NO. 2200 SMD SEE ENGRG SPECIFICATIONS		DWN	2-27-77	E ENGR	
FINISH		CHK		M ENGR	
TOL. EX. AS NOTED				MFG ENGR	
210-7422 D 7422		TITLE		ECC / DEVICE INTERFACE	
SCALE		WANG PART NUMBER		SIZE DRAWING NUMBER	

D12

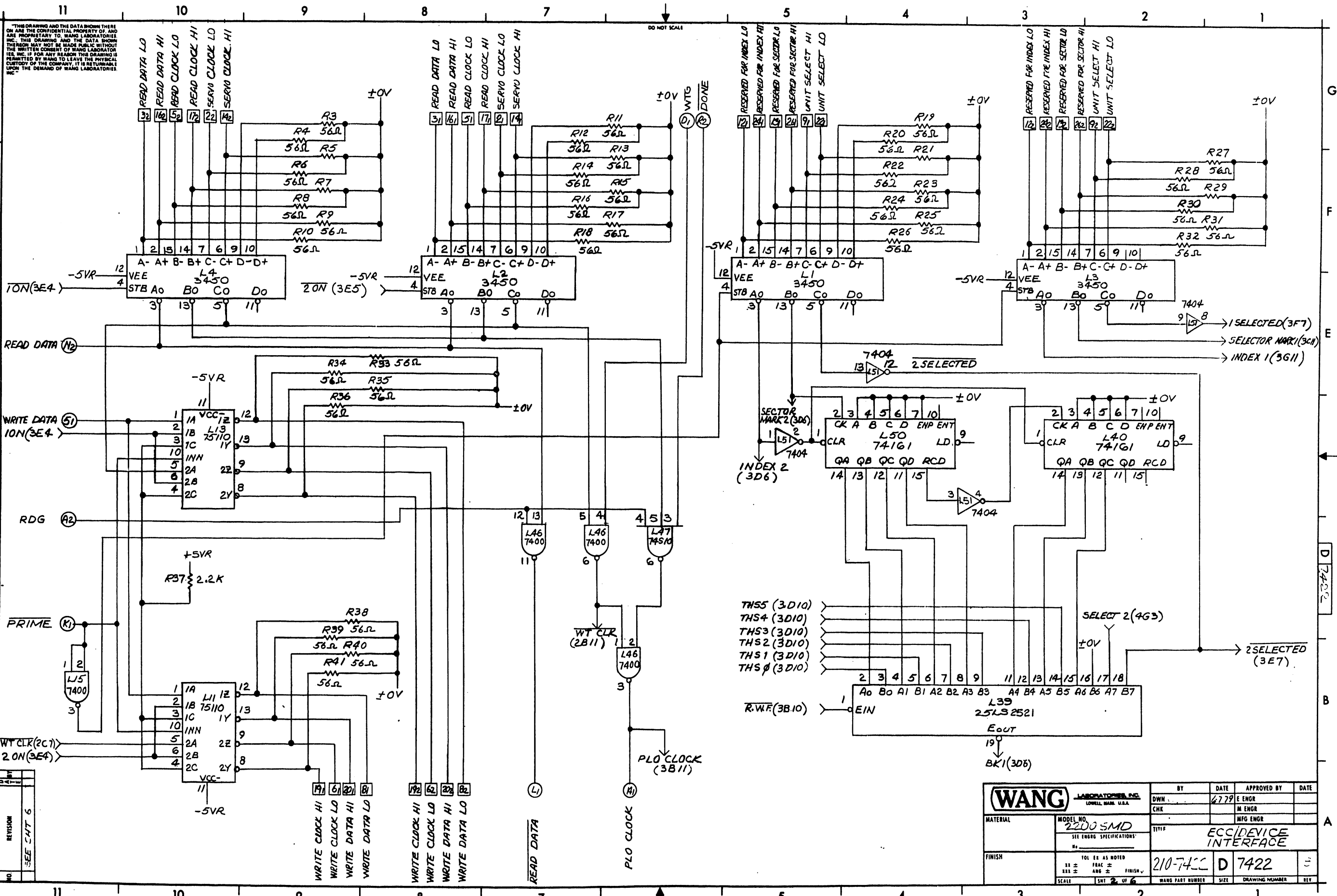

THIS DRAWING AND THE DATA SHOWN THERE ON ARE THE CONFIDENTIAL PROPERTY OF, AND ARE PROPRIETARY TO, WANG LABORATORIES, INC. THIS DRAWING AND THE DATA SHOWN THEREON MAY NOT BE MADE PUBLIC WITHOUT THE WRITTEN CONSENT OF WANG LABORATORIES, INC. IF FOR ANY REASON THIS DRAWING IS PERMITTED BY WANG TO LEAVE THE PHYSICAL CUSTODY OF THE COMPANY, IT IS RETURNABLE UPON THE DEMAND OF WANG LABORATORIES, INC.

DO NOT SCALE

REV	REVISION
1	SEE CAT 6

WANG LABORATORIES, INC. LOWELL, MASS. U.S.A.		BY: DWN	DATE: 6/77	APPROVED BY: E ENGR	DATE:
MATERIAL:	MODEL NO: 2200 SMD	CHK:		M ENGR:	
FINISH:	TOL ER AS NOTED XX ± FRAC ± FINISH XXX ± ANG ±	TITLE: ECC/DEVICE INTERFACE		MFG ENGR:	
SCALE: INT 2 OF 6	WANG PART NUMBER: 210-7422	SIZE: D	DRAWING NUMBER: 7422	REV: 1	

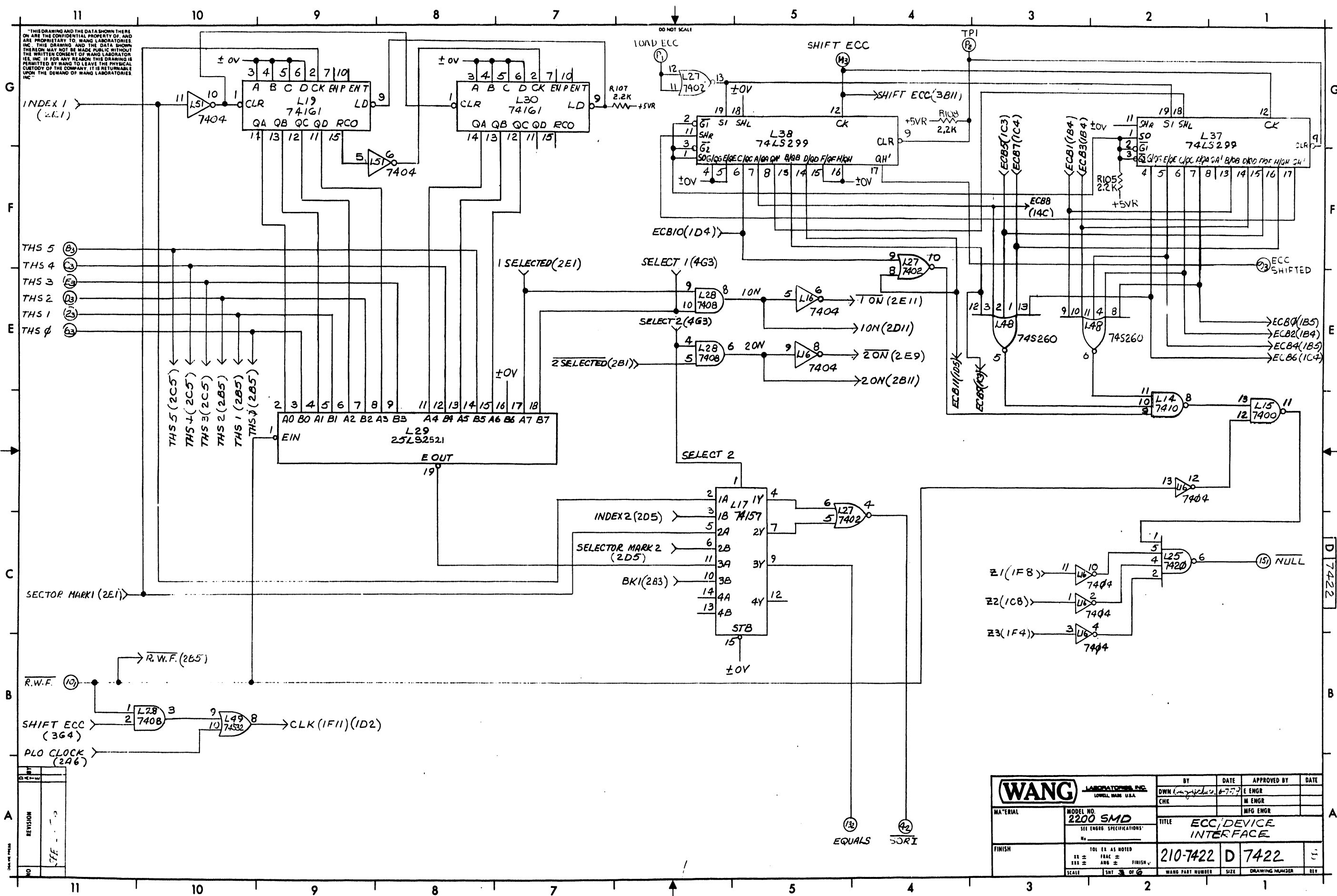

THIS DRAWING AND THE DATA SHOWN THERE ON ARE THE CONFIDENTIAL PROPERTY OF, AND ARE PROPRIETARY TO, WANG LABORATORIES, INC. THIS DRAWING AND THE DATA SHOWN THEREON MAY NOT BE MADE PUBLIC WITHOUT THE WRITTEN CONSENT OF WANG LABORATORIES, INC. IF FOR ANY REASON THIS DRAWING IS PERMITTED BY WANG TO LEAVE THE PHYSICAL CUSTODY OF THE COMPANY, IT IS RETURNABLE UPON THE DEMAND OF WANG LABORATORIES, INC.

THS 5 (2C5)
 THS 4 (2C5)
 THS 3 (2C5)
 THS 2 (2C5)
 THS 1 (2B5)
 THS 0 (2B5)

SECTOR MARK 1 (2E1)

R.W.F. (2E5)

SHIFT ECC (3G4) → CLK (1F1) (1D2)

PLO CLOCK (2A6)

NO	REVISION

WANG LABORATORIES, INC. LOWELL, MASS. U.S.A.		BY	DATE	APPROVED BY	DATE
MODEL NO. 2200 SMD SEE ENGR. SPECIFICATIONS		DWN	6-7-72	E ENGR	
FINISH		CHK		M ENGR	
TITLE		ECC/DEVICE INTERFACE			
210-7422 D 7422					
SCALE	1/8" = 1"	WANG PART NUMBER	SIZE	DRAWING NUMBER	REV

214

THIS DRAWING AND THE DATA SHOWN THERE ON ARE THE CONFIDENTIAL PROPERTY OF AND ARE PROPRIETARY TO WANG LABORATORIES, INC. THIS DRAWING AND THE DATA SHOWN THEREON MAY NOT BE MADE PUBLIC WITHOUT THE WRITTEN CONSENT OF WANG LABORATORIES, INC. IF FOR ANY REASON THIS DRAWING IS PERMITTED BY WANG TO LEAVE THE PHYSICAL CUSTODY OF THE COMPANY, IT IS RETURNABLE UPON THE DEMAND OF WANG LABORATORIES, INC.

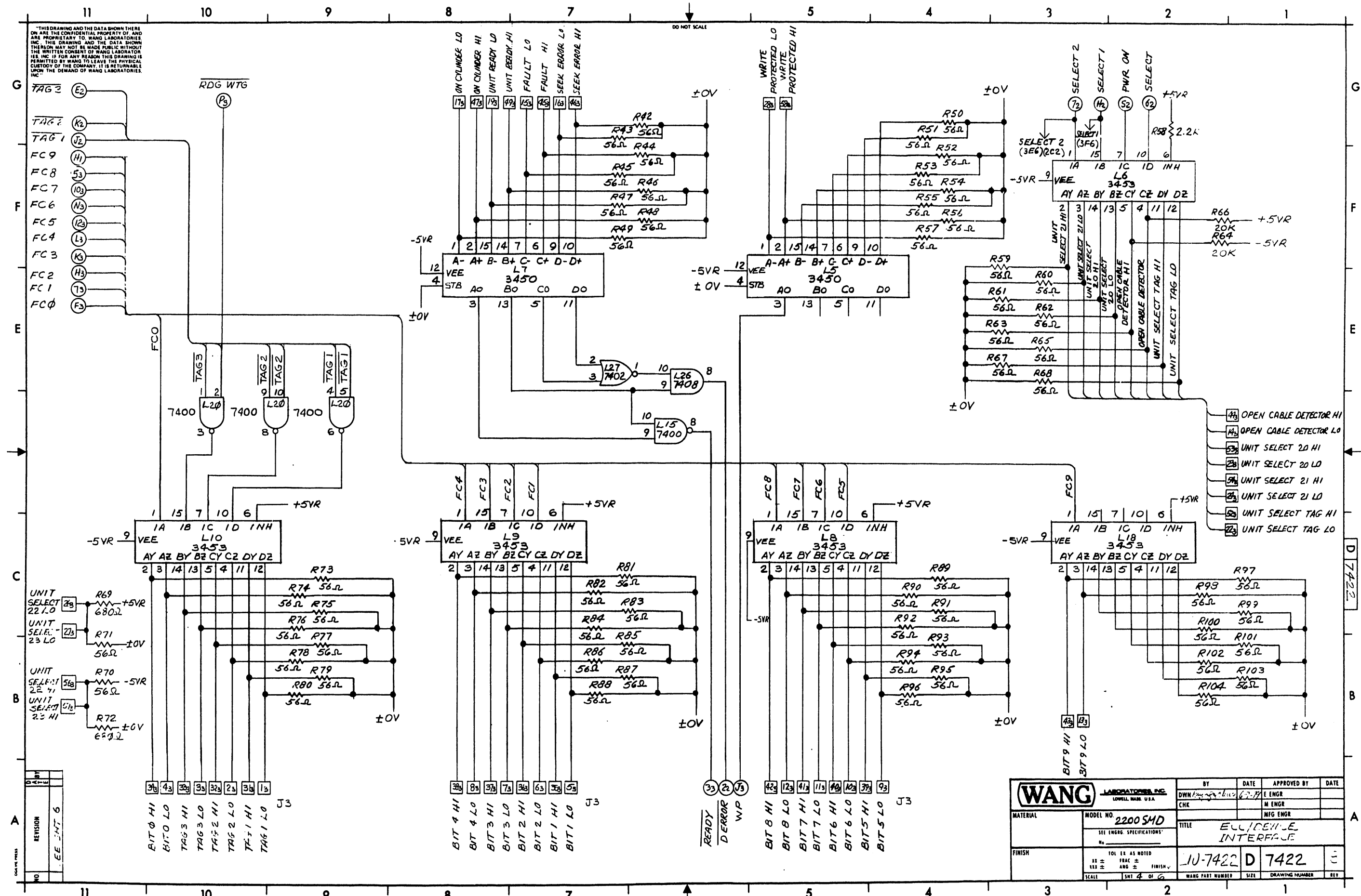

- G TAG 3 (E2)
- TAG 2 (K2)
- TAG 1 (J2)
- FC 9 (H1)
- FC 8 (53)
- FC 7 (103)
- FC 6 (N3)
- FC 5 (123)
- FC 4 (L3)
- FC 3 (K3)
- FC 2 (H3)
- FC 1 (T3)
- FC 0 (F3)

- UNIT SELECT 22 LO (R69)
- UNIT SELECT 23 LO (R71)
- UNIT SELECT 22 HI (R70)
- UNIT SELECT 23 HI (R72)

- OPEN CABLE DETECTOR HI (M3)
- OPEN CABLE DETECTOR LO (M2)
- UNIT SELECT 20 HI (N3)
- UNIT SELECT 20 LO (N2)
- UNIT SELECT 21 HI (P3)
- UNIT SELECT 21 LO (P2)
- UNIT SELECT TAG HI (Q3)
- UNIT SELECT TAG LO (Q2)

REVISION	DATE	BY
1	EE INT 6	

WANG LABORATORIES, INC. LOWELL, MASS. U.S.A.		BY	DATE	APPROVED BY	DATE
MATERIAL	MODEL NO. 2200 SMD	CHK	ENGR		
FINISH	TOL. AS NOTED		MFG ENGR		
	10 ±				
	FRAC ±				
	100 ±				
	AND ±				
	FINISH				
SCALE	SHT 4 OF 6	TITLE	ECC/DEVICE INTERFACE		
		10-7422 D	7422		
		WANG PART NUMBER	SIZE	DRAWING NUMBER	REV

11 10 9 8 7 6 5 4 3 2 1

THIS DRAWING AND THE DATA SHOWN THEREON ARE THE CONFIDENTIAL PROPERTY OF, AND ARE PROPRIETARY TO, WANG LABORATORIES, INC. THIS DRAWING AND THE DATA SHOWN THEREON MAY NOT BE MADE PUBLIC WITHOUT THE WRITTEN CONSENT OF WANG LABORATORIES, INC. IF FOR ANY REASON THIS DRAWING IS PERMITTED BY WANG TO LEAVE THE PHYSICAL CUSTODY OF THE COMPANY, IT IS RETURNABLE UPON THE DEMAND OF WANG LABORATORIES, INC.

DO NOT SCALE

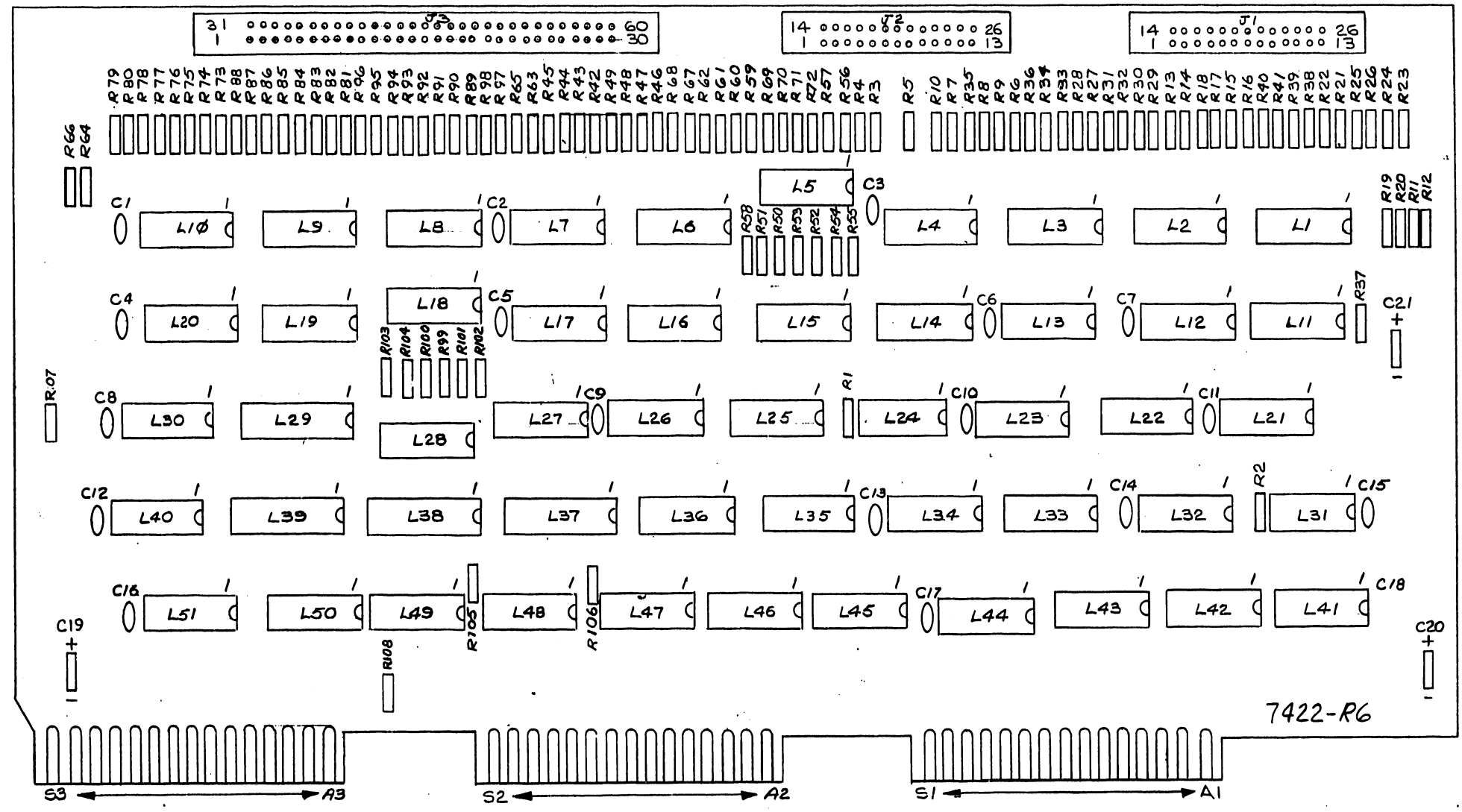

REV	DATE	BY	CHK
1			
2			
3			
4			
5			
6			

REV. 6
SEE CHIT. 6

WANG LABORATORIES, INC. LOWELL, MASS. U.S.A.		BY DWN	DATE 6-7-77	APPROVED BY E ENGR	DATE
MATERIAL	MODEL NO. 2200 SMD SEE ENGR. SPECIFICATIONS	CHK		M ENGR	
FINISH	101. EE. AS NOTED 112 ± FRAC. ± 113 ± ANG. ± FINISH	TITLE ECC/DEVICE INTERFACE		MFG ENGR	
SCALE 1/8" = 1"	SHEET 5 OF 6	210-7422	D	7422	3
		WANG PART NUMBER	SIZE	DRAWING NUMBER	REV.

516

"THIS DRAWING AND THE DATA SHOWN THERE ON ARE THE CONFIDENTIAL PROPERTY OF, AND ARE PROPRIETARY TO, WANG LABORATORIES, INC. THIS DRAWING AND THE DATA SHOWN THEREON MAY NOT BE MADE PUBLIC WITHOUT THE WRITTEN CONSENT OF WANG LABORATORIES, INC. IF FOR ANY REASON THIS DRAWING IS PERMITTED BY WANG TO LEAVE THE PHYSICAL CUSTODY OF THE COMPANY, IT IS RETURNABLE UPON THE DEMAND OF WANG LABORATORIES, INC."

LOC. LOCATION	TYPE	W.L. NO.
L1,2,3,4,5,7	3450	376-0275
L6,8,9,10,18	3453	376-0274
L11,13	75110	376-0255
L12,24,33	7430	376-0031
L14	7410	376-0003
L15,20,46	7400	376-0002
L16,51	7404	376-0010
L17	74157	376-0082
L19,30,40,50	74161	376-0094
L21,22,23,34	74175	376-0119
L44,45		
L25	7420	376-0004
L26,28	7408	376-0081
L27	7402	376-0016
L29,39	25452521	376-0317
L31	74574	376-0202
L32,41,42,43	7486	376-0036
L35,36	74174	376-0098
L37,38	745299	376-0303
L47	74510	376-0238
L48	745260	376-0206
L49	74532	376-0205

COMPONENT	TYPE	W.L. NO.
R1,R2	1K, 1/4 10%	330-3010
R37,58,105,106,107,108	2.2K 1/4W 10%	330-3022
R64,66	20K 1/4W 10%	330-4020
R69,72	180Ω 1/4W 10%	330-2068
R8-36		
R38-57, R59-C3	56Ω	330-1056
65,67,68,70,71,73-104	114W 10%	
C1-C18	.047UF, 50V	300-1966
C19,21	15UF 20VTA	300-4022
J1,2	26 PIN CONN	350-0058
J3	60 PIN CONN	350-0057

LOCATION	TYPE	SPARES
L1	3450	1
L2	3450	1
L3	3450	1
L4	3450	1
L5	3450	3
L14	7410	2
L15	7400	1
L20	7400	1
L25	7420	1
L26	7408	2
L27	7402	1
L28	7408	1
L31	74574	1
L41	7486	2
L46	7400	1
L47	74510	2
L49	74532	3

MNEMONIC	COORD
BIT 0-9 LO	4A7
BIT 0-9 HI	4A7
DONE	2G6
ERROR	4A6
ECB 0	1A5
ECC DATA	1G3
ECC SHIFTED	3E1
EQUALS	3A4
FAULT HI	4G7
FAULT LO	4G7
FC 0-FC 9	4F11
INIT	1F11
NULL	3C1
LOAD ECC	3G5
NULL	3C1
ON CYLINDER HI	4G8
ON CYLINDER LO	4G8
OPEN CABLE DETECTOR HI	4D1
OPEN CABLE DETECTOR LO	4D1
PLO CLOCK	2A6
PRIME	2C11
PWR ON	4G2
RDG	2C11
RDG-WTG	4G10
READ CLOCK HI	2G7,2G10
READ CLOCK LO	2G8,2G10
READ DATA	2A7
READ DATA HI	2E11
READ DATA LO	2G8,2G10
READY	4A6
RESERVED FOR INDEX HI	2G5

MNEMONIC	COORD
RESERVED FOR INDEX LO	2G5
R.W.F	3B11
RESERVED FOR SECTOR HI	2G3,2G5
RESERVED FOR SECTOR LO	2G3,2G5
SEEK ERROR HI	4G7
SEEK ERROR LO	4G7
SELECT	4G2
SELECT 1,2	4G2
SERVO CLOCK HI	2G7,2G10
SERVO CLOCK LO	2G7,2G10
SHIFT ECC	3G4
SHIFTED	2G8
SORT	3A4
TAG 1-3	4G11
TAG 1-3 HI	4A10
TAG 1-3 LO	4A10
THS 0-5	3E11
TPI	3G3
UNIT SELECT 20-21 HI, LO	4D2
UNIT SELECT 22,23 HI, LO	4D11
UNIT SELECT TAG HI, LO	4D1
UNIT READY HI, LO	4G8
WXFER ECC	1G1
WRITE CLOCK HI	2A8,2A9
WRITE CLOCK LO	2A8,2A9
WRITE DATA	2D11
WRITE DATA HI	2A8
WRITE DATA LO	2A8
WRITE PROTECTED HI, LO	4G5
WP	4A6
WTG	2G6

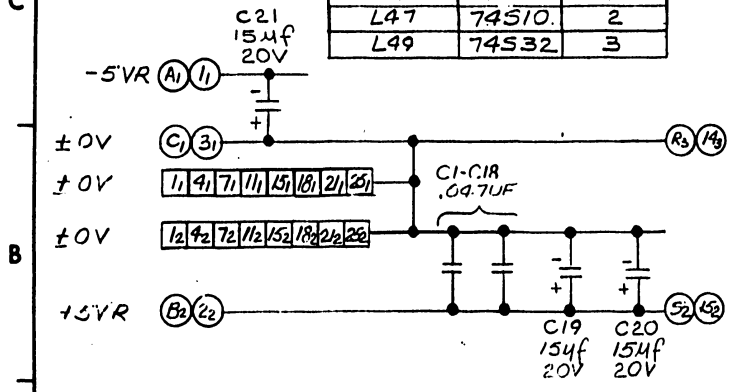
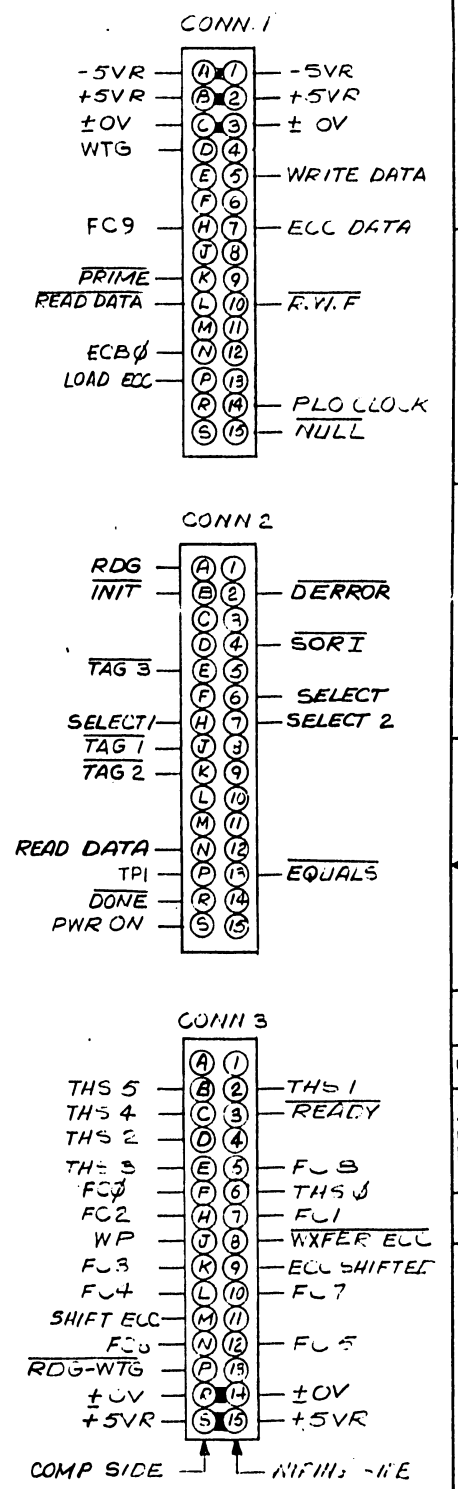
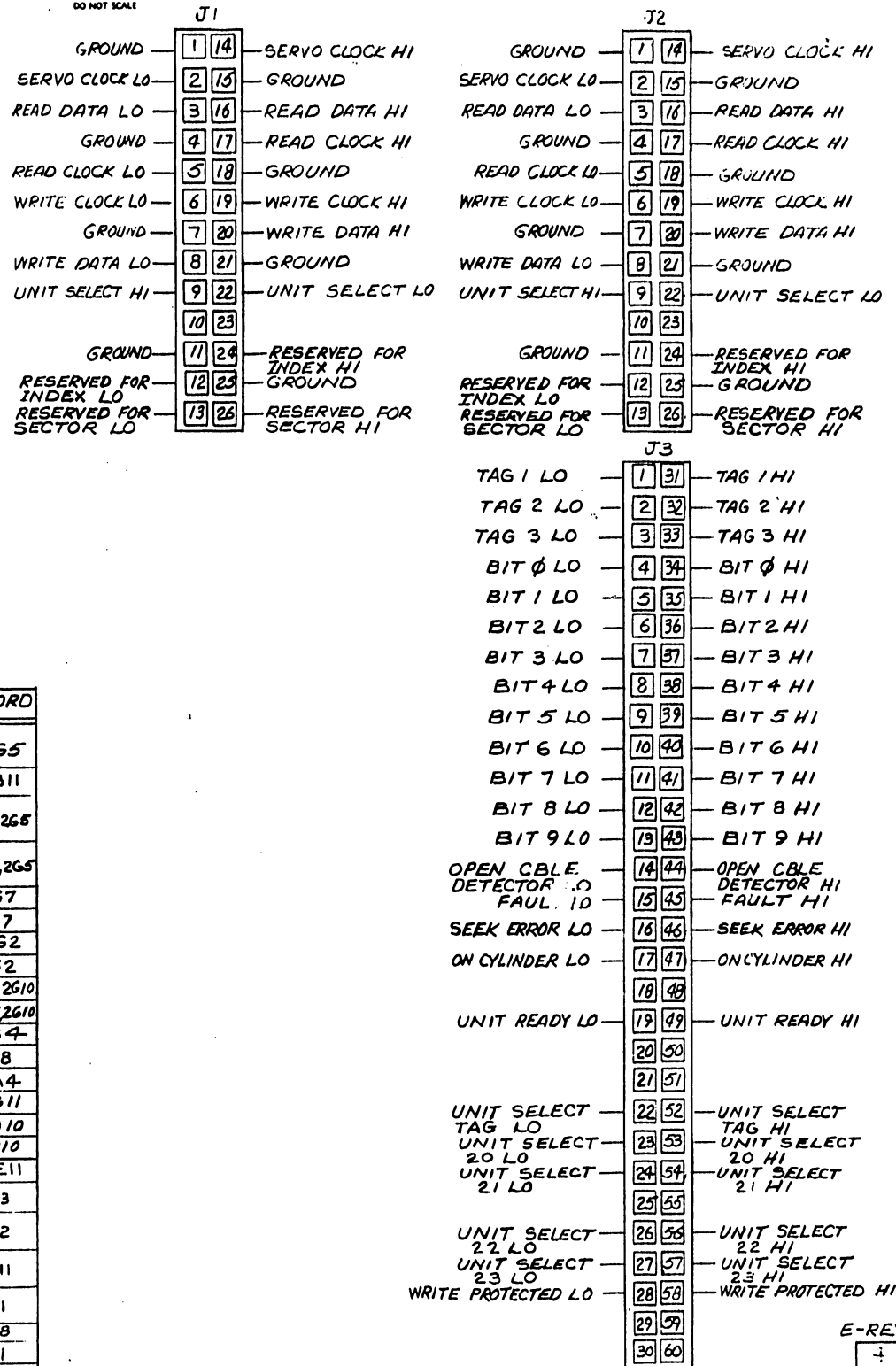

REV	DATE	BY	REASON
1	6-7-78	RC	ORIGINATED PER DWG E-549 APP'D JLL/177
2	6-7-78	RC	REVISED PER ECN #10964 APP'D C.E./117
3	6-7-78	RC	REVISED PER ECN #11170 APP'D C.E./117
4	6-7-78	RC	REVISED PER ECN #11623 APP'D JLL/177
5	6-7-78	RC	REVISED PER ECN #11589 APP'D JLL/177
6	6-7-78	RC	REVISED PER ECN #12283 APP'D JLL/177
7	6-7-78	RC	REVISED PER ECN #14564 APP'D JLL/177
8	6-7-78	RC	REVISED PER ECN #15100 APP'D JLL/177
9	6-7-78	RC	REVISED PER ECN #15100 APP'D JLL/177
10	6-7-78	RC	REVISED PER ECN #15100 APP'D JLL/177

WANG LABORATORIES, INC.
LOWELL, MASS. U.S.A.

BY: [Signature] DATE: 7-2-78 APPROVED BY: [Signature] DATE: 7-2-78

MATERIAL: 2200 SMD MODEL NO. SEE ENG'G SPECIFICATIONS

TITLE: ECC DEVICE IN LRA FILE

FINISH: 101 EE AS NOTED 110 ± 120 ± ANG ± FINISH

SCALE: 210-7422 D 7422

WANG PART NUMBER: 210-7422 SIZE: D DRAWING NUMBER: 7422 REV: 3

THIS DRAWING AND THE DATA SHOWN THEREON ARE THE CONFIDENTIAL PROPERTY OF, AND ARE PROPRIETARY TO WANG LABORATORIES, INC. THIS DRAWING AND THE DATA SHOWN THEREON MAY NOT BE MADE PUBLIC WITHOUT THE WRITTEN CONSENT OF WANG LABORATORIES, INC. IF FOR ANY REASON THIS DRAWING IS PERMITTED BY WANG TO LEAVE THE PHYSICAL CUSTODY OF THE COMPANY, IT IS RETURNABLE UPON THE DEMAND OF WANG LABORATORIES, INC.

DO NOT SCALE

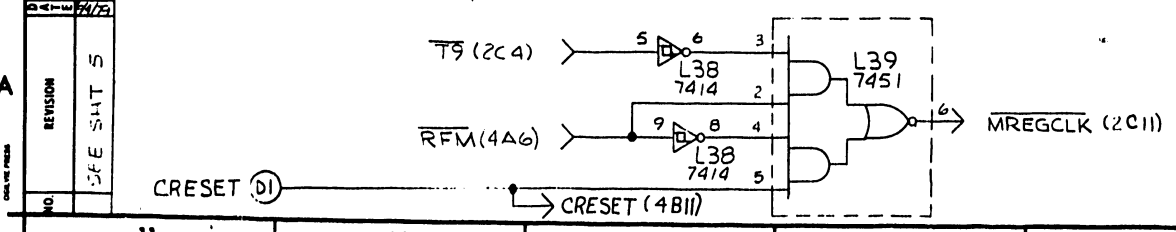
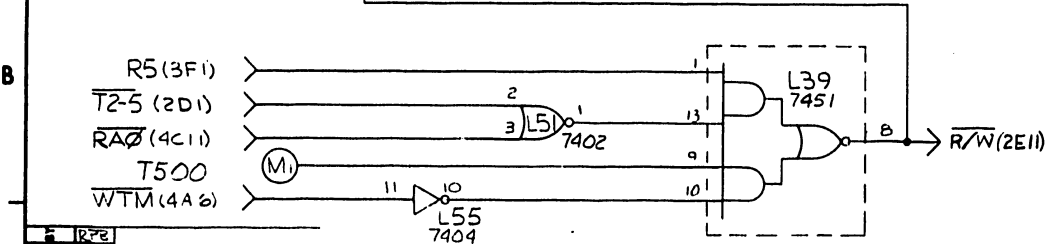
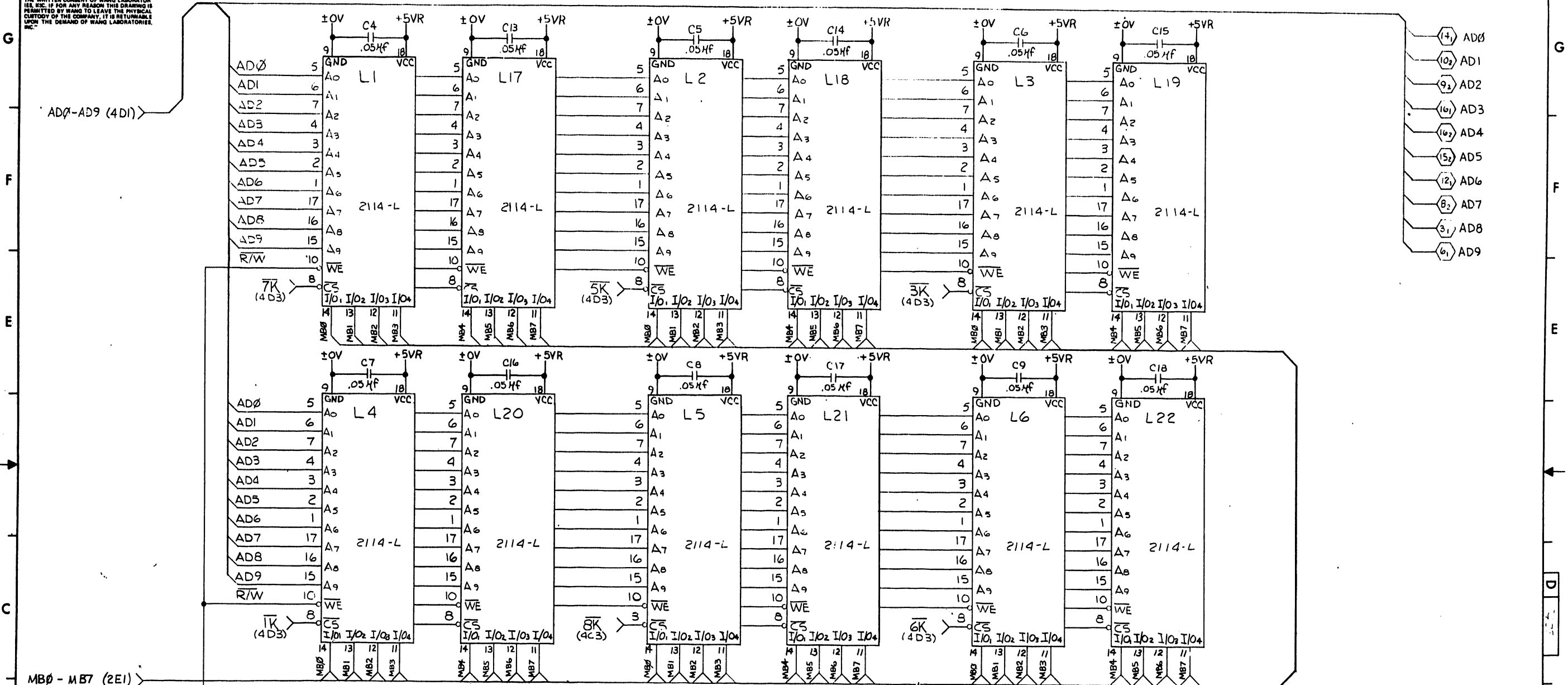

- (1) AD0
- (2) AD1
- (3) AD2
- (4) AD3
- (5) AD4
- (6) AD5
- (7) AD6
- (8) AD7
- (9) AD8
- (10) AD9

REV	DATE	BY	CHK	APPROVED BY	DATE
1					

WANG LABORATORIES, INC. LOWELL, MASS. U.S.A.		BY	DATE	APPROVED BY	DATE
		DWN R.P.B.	7/1/79	E ENGR	
MATERIAL		MODEL NO.	TITLE		
---		2220SMD	RAM/PRGM CONTROL		
FINISH		SEE ENGR SPECIFICATIONS	MFG ENGR		
---		SEE CHART	D 7423		
SCALE		1/1	WANG PART NUMBER	SIZE	DRAWING NUMBER
		OF 5			

THIS DRAWING AND THE DATA SHOWN THEREON ARE THE CONFIDENTIAL PROPERTY OF AND ARE PROPRIETARY TO WANG LABORATORIES, INC. THIS DRAWING AND THE DATA SHOWN THEREON MAY NOT BE MADE PUBLIC WITHOUT THE WRITTEN CONSENT OF WANG LABORATORIES, INC. IF FOR ANY REASON THIS DRAWING IS PERMITTED BY WANG TO LEAVE THE PHYSICAL CUSTODY OF THE COMPANY, IT IS RETURNABLE UPON THE DEMAND OF WANG LABORATORIES, INC.

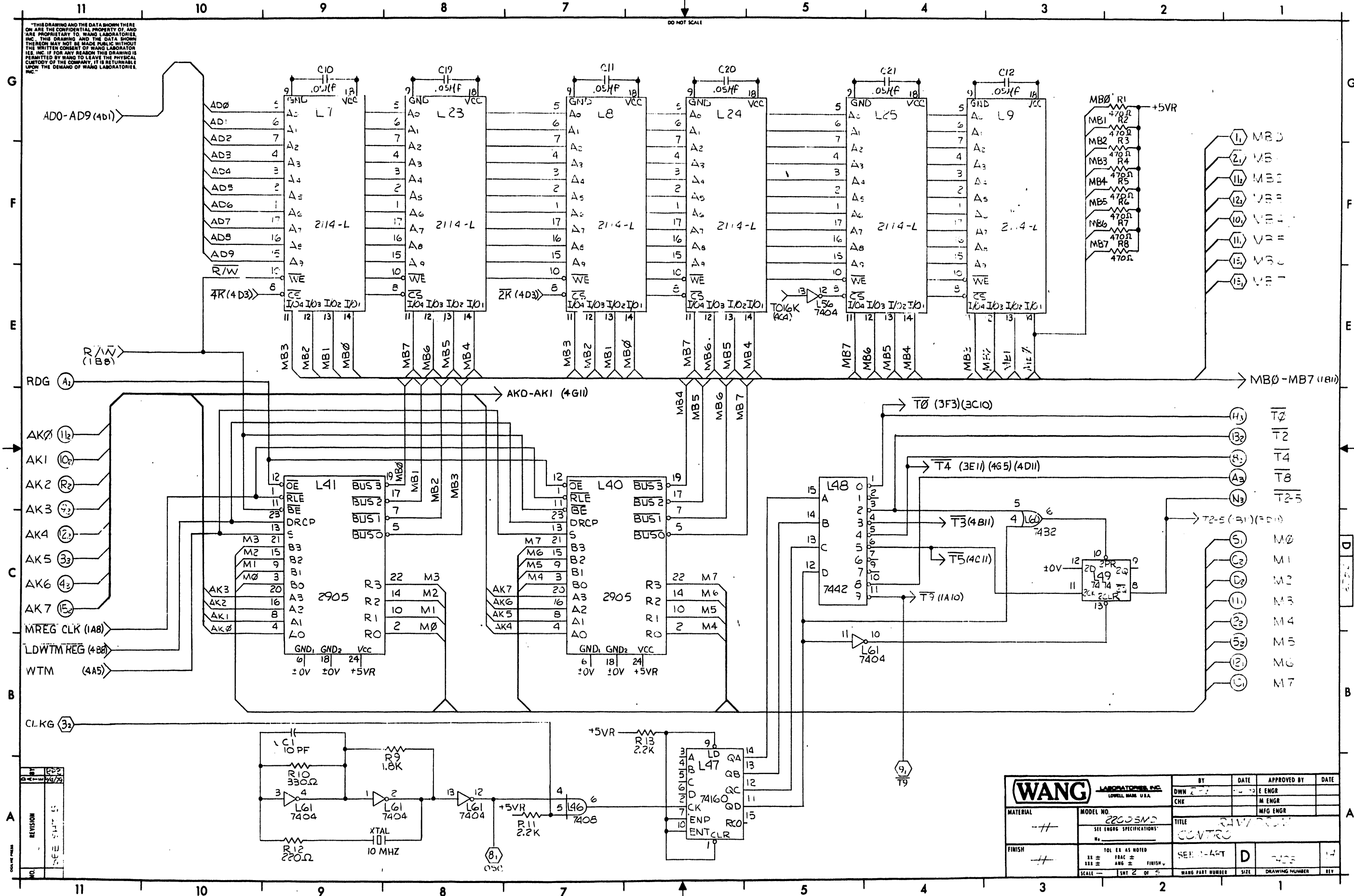

REV	DATE	BY	CHK
1	11/17/72		
2			

WANG LABORATORIES, INC. LOWELL, MASS. U.S.A.		BY	DATE	APPROVED BY	DATE
MATERIAL	---	DWN	11-17-72	E ENGR	
FINISH	---	CHK		M ENGR	
				MFG ENGR	
MODEL NO. 22035M2 SEE ENGR SPECIFICATIONS		TITLE: R/W CONTROL			
SCALE: 1:1		SEE PART	D	WDS	14
WANG PART NUMBER		SIZE	DRAWING NUMBER	REV	

119

THIS DRAWING AND THE DATA SHOWN THERE ON ARE THE CONFIDENTIAL PROPERTY OF, AND ARE PROPRIETARY TO, WANG LABORATORIES, INC. THIS DRAWING AND THE DATA SHOWN THEREON MAY NOT BE MADE PUBLIC WITHOUT THE WRITTEN CONSENT OF WANG LABORATORIES, INC. IF FOR ANY REASON THIS DRAWING IS PERMITTED BY WANG TO LEAVE THE PHYSICAL CUSTODY OF THE COMPANY, IT IS RETURNABLE UPON THE DEMAND OF WANG LABORATORIES, INC.

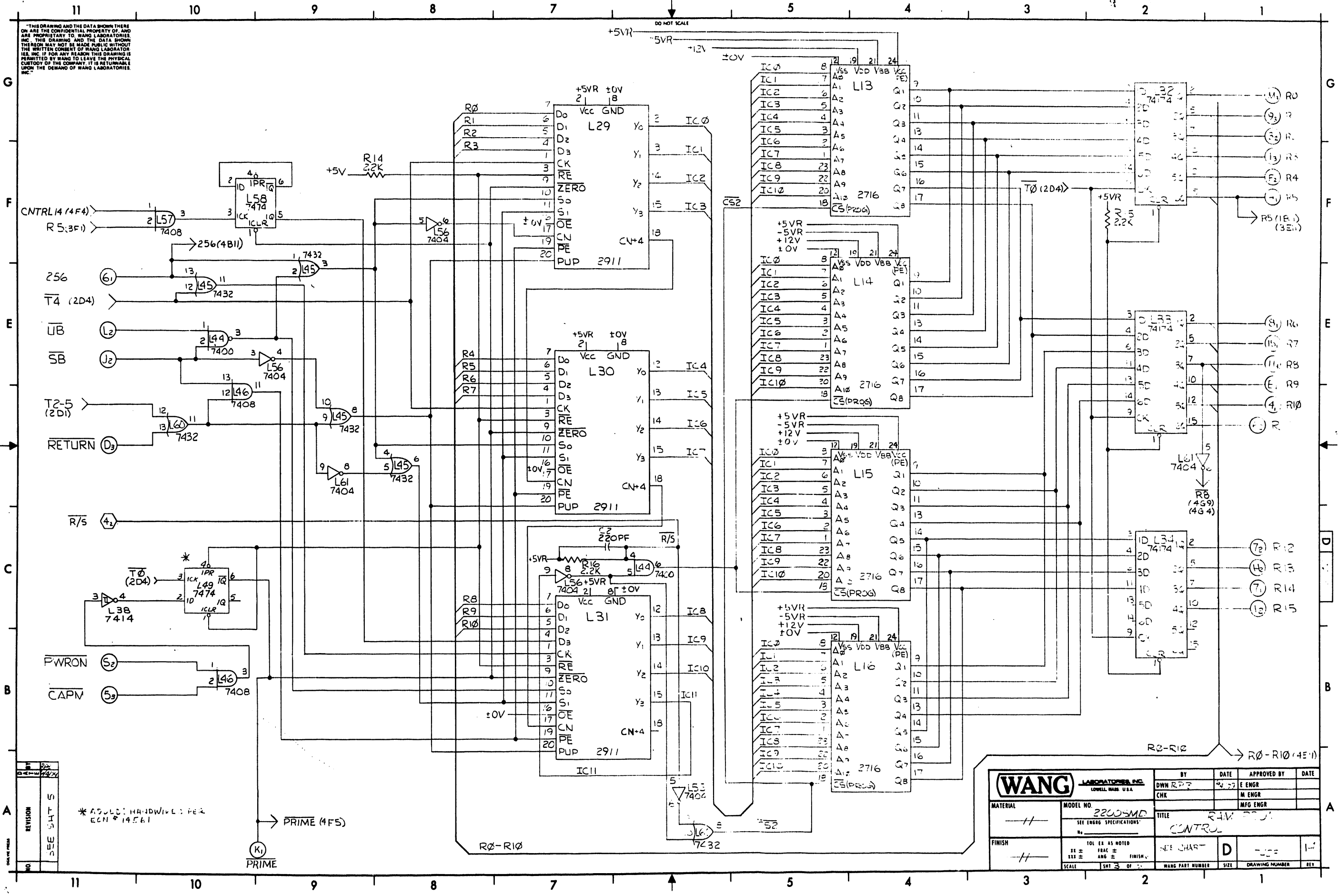

REV	DATE	BY	CHK	APP'D
1	11/14/74	W		
2	11/14/74	W		

* ADD'D. HANDWRT. PER ECN # 14561

WANG LABORATORIES, INC. LOWELL, MASS. U.S.A.		BY DWN RDP	DATE 11/14/74	APPROVED BY E ENGR	DATE
MATERIAL //	MODEL NO. 2200-MD SEE ENGR. SPECIFICATIONS	CHK		M ENGR	
FINISH //	TOL EX AS NOTED FRAC ± ANG ± FINISH ±	TITLE RAM PUP CONTROL		MFG ENGR	
SCALE	SHT 3 OF 3	WANG PART NUMBER	SIZE	DRAWING NUMBER	REV

D20

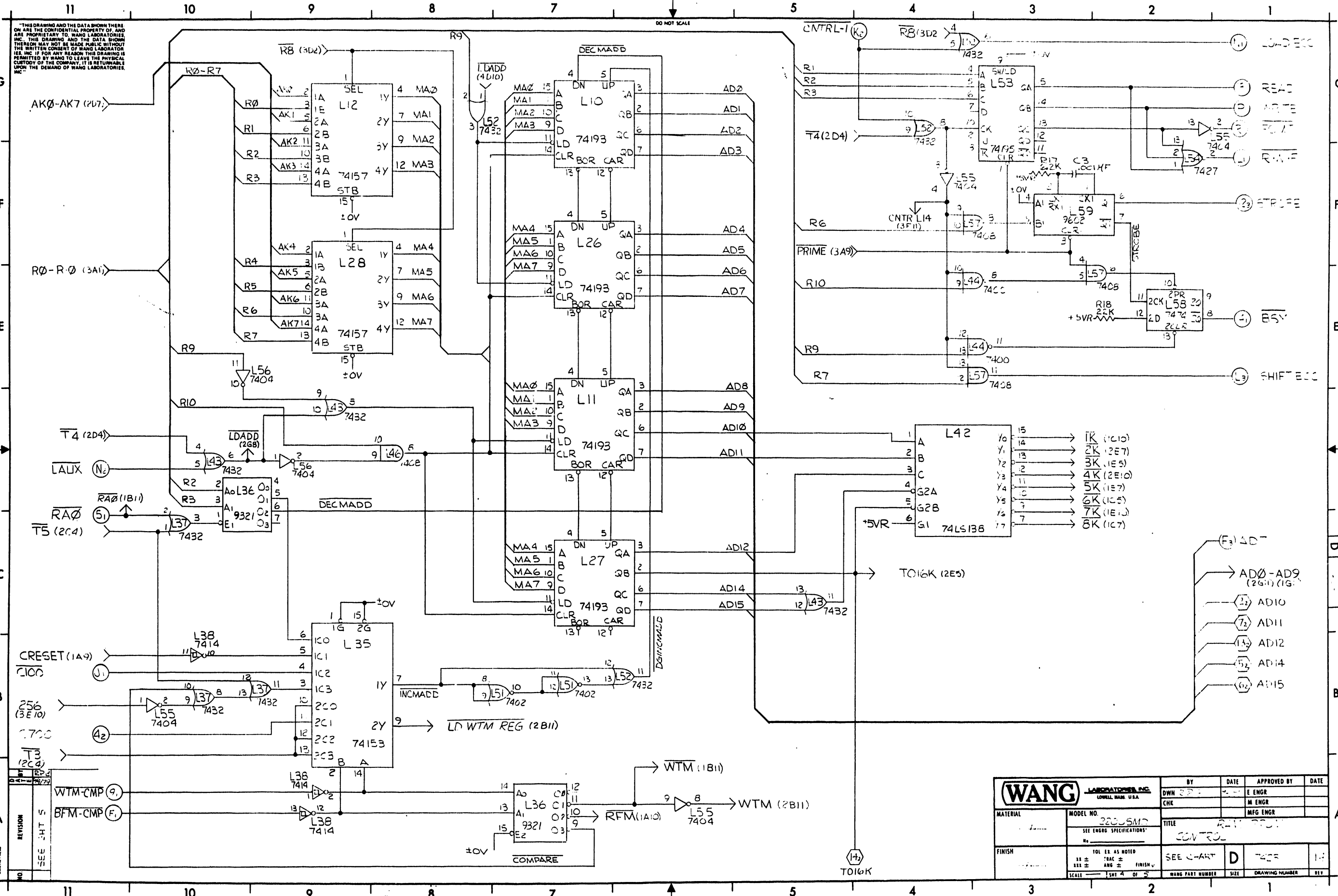

THIS DRAWING AND THE DATA SHOWN THERE ON ARE THE CONFIDENTIAL PROPERTY OF, AND ARE PROPRIETARY TO WANG LABORATORIES, INC. THIS DRAWING AND THE DATA SHOWN THEREON MAY NOT BE MADE PUBLIC WITHOUT THE WRITTEN CONSENT OF WANG LABORATORIES, INC. IF FOR ANY REASON THIS DRAWING IS PERMITTED BY WANG TO LEAVE THE PHYSICAL CUSTODY OF THE COMPANY, IT IS RETURNABLE UPON THE DEMAND OF WANG LABORATORIES, INC.

REVISION	DATE	BY	CHKD	APPROVED BY	DATE
1					
2					
3					
4					
5					

WANG LABORATORIES, INC. LOWELL, MASS. U.S.A.		BY	DATE	APPROVED BY	DATE
MATERIAL		DOWN		E ENGR	
MODEL NO. 20005MD SEE ENGR. SPECIFICATIONS		CHK		M ENGR	
FINISH		TITLE		MFG ENGR	
101 EX AS NOTED		CONTROL			
SEE CHART		SEE CHART	D	DATE	11
SCALE 1/8" = 1"		WANG PART NUMBER	SIZE	DRAWING NUMBER	REV

J 21

THIS DRAWING AND THE DATA SHOWN THERE ON ARE THE CONFIDENTIAL PROPERTY OF, AND ARE PROPRIETARY TO, WANG LABORATORIES, INC. THIS DRAWING AND THE DATA SHOWN THEREON MAY NOT BE MADE PUBLIC WITHOUT THE WRITTEN CONSENT OF WANG LABORATORIES, INC. IF FOR ANY REASON THIS DRAWING IS PERMITTED BY WANG TO LEAVE THE PHYSICAL CUSTODY OF THE COMPANY, IT IS RETURNABLE UPON THE DEMAND OF WANG LABORATORIES, INC.

210-2091-378 OR 379					
210	229	L13	L14	L15	L16
7433A DI4 MICRO CODE	7423	378-4083-R7	378-4084-R7	378-4085-R7	378-4086-R7

COMPONENT	WLI NO.	TYPE
C1	300-1220	100PF 500V CER
C2	300-1220	220PF 500V CER
C3	300-1900	304F 500V CER
C4-C27	300-1900	054F 2V CER
C28-C31	300-4022	151F 20V TA
XTAL	52-0008	CM-8
R1-R8	330-2047	470Ω 1/4W 10%
R9	330-3015	1.8K 1/4W 10%
R10	330-2033	330Ω 1/4W 10%
R11-R12	330-3022	3.3K 1/4W 10%
R12	330-2022	220Ω 1/4W 10%
R17	333-0051	16.2K 1/4W 1%

LOCATION	WL PART NO	TYPE
L1-L9, L17-L25	376-0041 L	2114-L
L10, L11, L26-L27	376-0053	74193
L12-L28	376-0052	74157
L13-L16	SEE CHART	2716
L29, L30, L31	377-0047	2911
L32, L33, L34	376-0098	74174
L35	376-0048	74153
L36	376-0090	9331
L37, L43, L45, L52, L53	376-0093	7432
L38	376-0039	7414
L39	376-0002	7451
L40-L41	377-0053	2905
L42	376-0294	74LS138
L44	376-0002	7400
L46, L57	376-0081	7408
L47	376-0191	74160
L48	376-0009	7442
L49, L58	376-0006	7474
L51	376-0016	7402
L53	376-0097	74195
L54	376-0125	7427
L55, L56, L61	376-0010	7404
L57	376-0104	9602
L50		SPARE
L1-9, 17-25	376-9014	18 PIN SKT.
L13-16, 40-41	376-9030	24 PIN SKT.
L29-31	376-9020	20 PIN SKT.

TYPE	LOCATION	SPARES
7432	-L37	-1
7432	-L43	-1
7432	-L60	-1
7402	-L51	-1
7427	-L54	-2
9602	-L59	-1

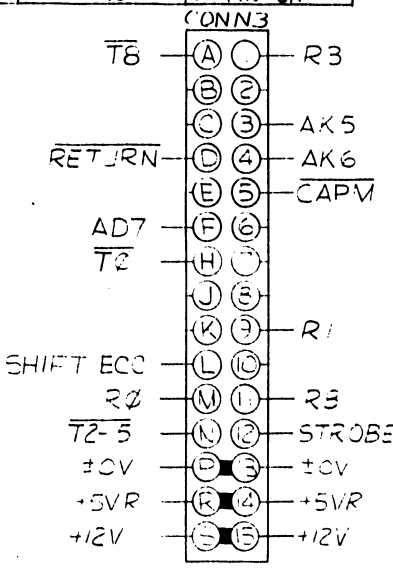
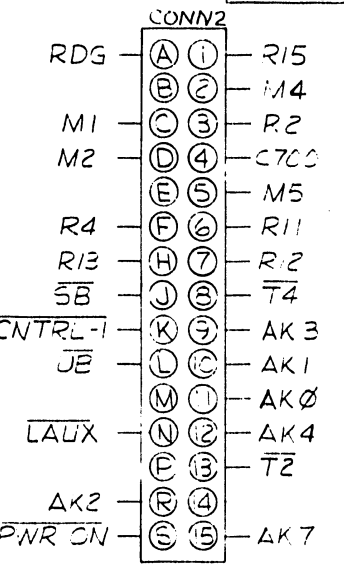
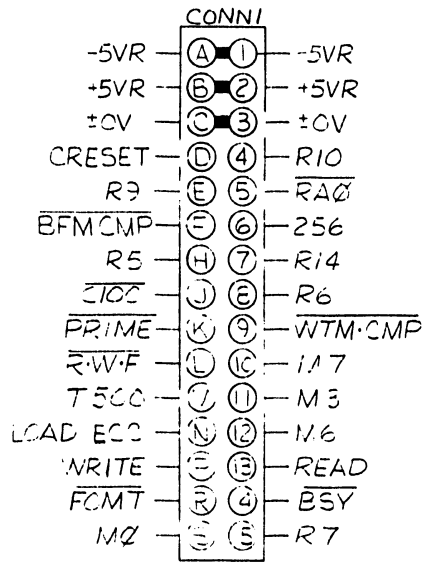
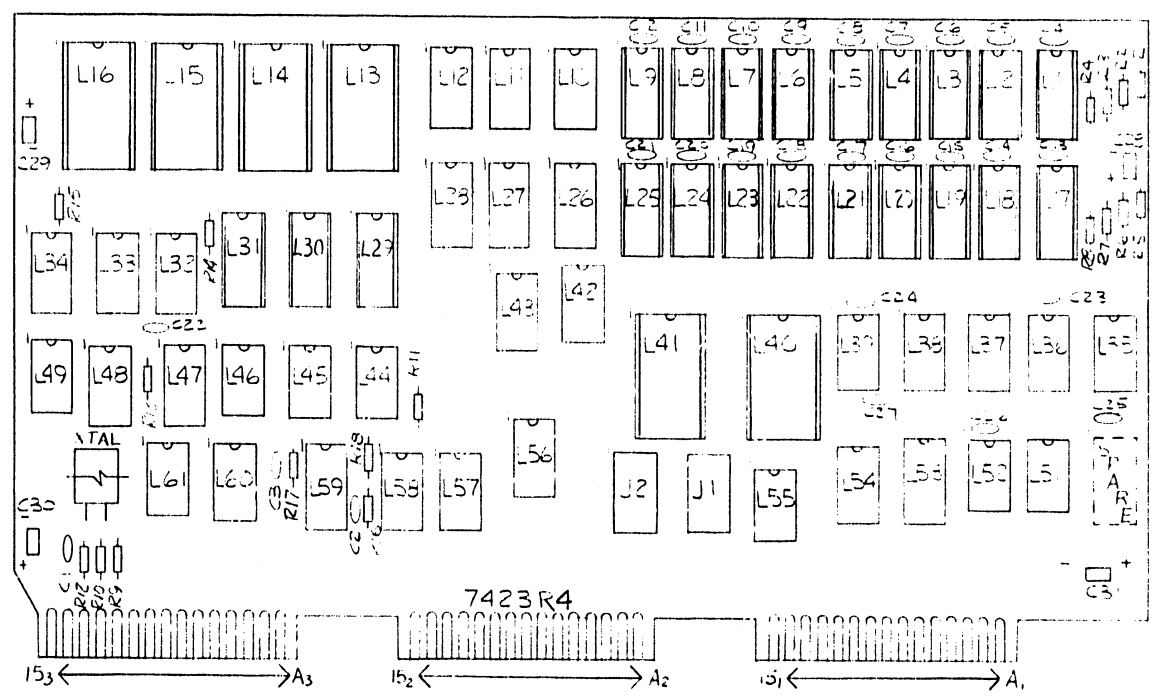

MNEMONIC	COORDINATE
AD7	1C1
AK0-AK7	2C11
BFM CMP	4A11
BSY	4E1
CAPM	3B11
CTRL-T	4G4
CRESET	1A11
C700	4B11
C700	4B11
FCMT	4G1
LAUX	4D11
LOAD ECC	4G1
M0-M7	2C1
PRIME	5A10
PWR ON	3B11
RA0	4C11
RDS	2D11
READ	4G1
RETURN	3D11
RWF	4F1
AD0-AD12, 14, 15	1C1
CLKG	2B11
MB0-MB7	2F1
OSC	2A8

MNEMONIC	COORDINATE
R0-R15	3E1
SB	3E11
SHIFT ECC	4E1
STROBE	4F1
T500	1B1
T0, T2, T2-5	2D1
T4, T8	2D1
T016K	4A5
T9	2A4
R15	3C11
SB	3E11
WRITE	4G1
WTM CMP	4A11
Z5B	3E11

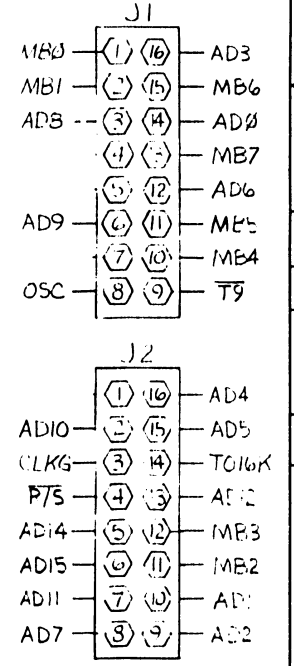

REV	DATE	BY	DESCRIPTION
1	11/17/77
2	11/17/77
3	11/17/77
4	11/17/77
5	11/17/77
6	11/17/77
7	11/17/77
8	11/17/77
9	11/17/77
10	11/17/77
11	11/17/77
12	11/17/77
13	11/17/77
14	11/17/77
15	11/17/77

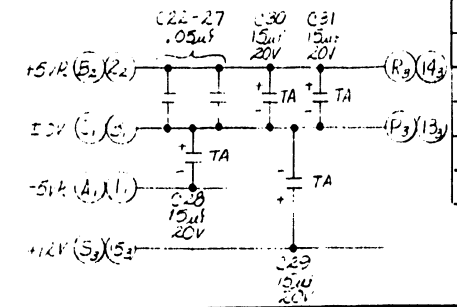

WANG LABORATORIES, INC. LOWELL, MASS. U.S.A.		BY	DATE	APPROVED BY	DATE
MATERIAL		DOWN RTR	6-1-77	E. ENGRA, KEER	7/1/77
MODEL NO. 223-5MD		CHR	ES	M ENGR	
SEE ENGR SPECIFICATIONS		TITLE RAM PROM CONTROL			
FINISH		SCALE 1:1			
101 IS AS NOTED		D			
FRAC ±		WANG PART NUMBER			
ANG ±		SIZE			
FINISH		DRAWING NUMBER			
SCALE 1:1		SHT 5 OF 5			

THIS DRAWING AND THE DATA SHOWN THERE ON ARE THE CONFIDENTIAL PROPERTY OF, AND ARE PROPRIETARY TO WANG LABORATORIES, INC. THIS DRAWING AND THE DATA SHOWN THEREON MAY NOT BE MADE PUBLIC WITHOUT THE WRITTEN CONSENT OF WANG LABORATORIES, INC. IF FOR ANY REASON THIS DRAWING IS PERMITTED BY WANG TO LEAVE THE PHYSICAL CUSTODY OF THE COMPANY, IT IS RETURNABLE UPON THE DEMAND OF WANG LABORATORIES, INC.

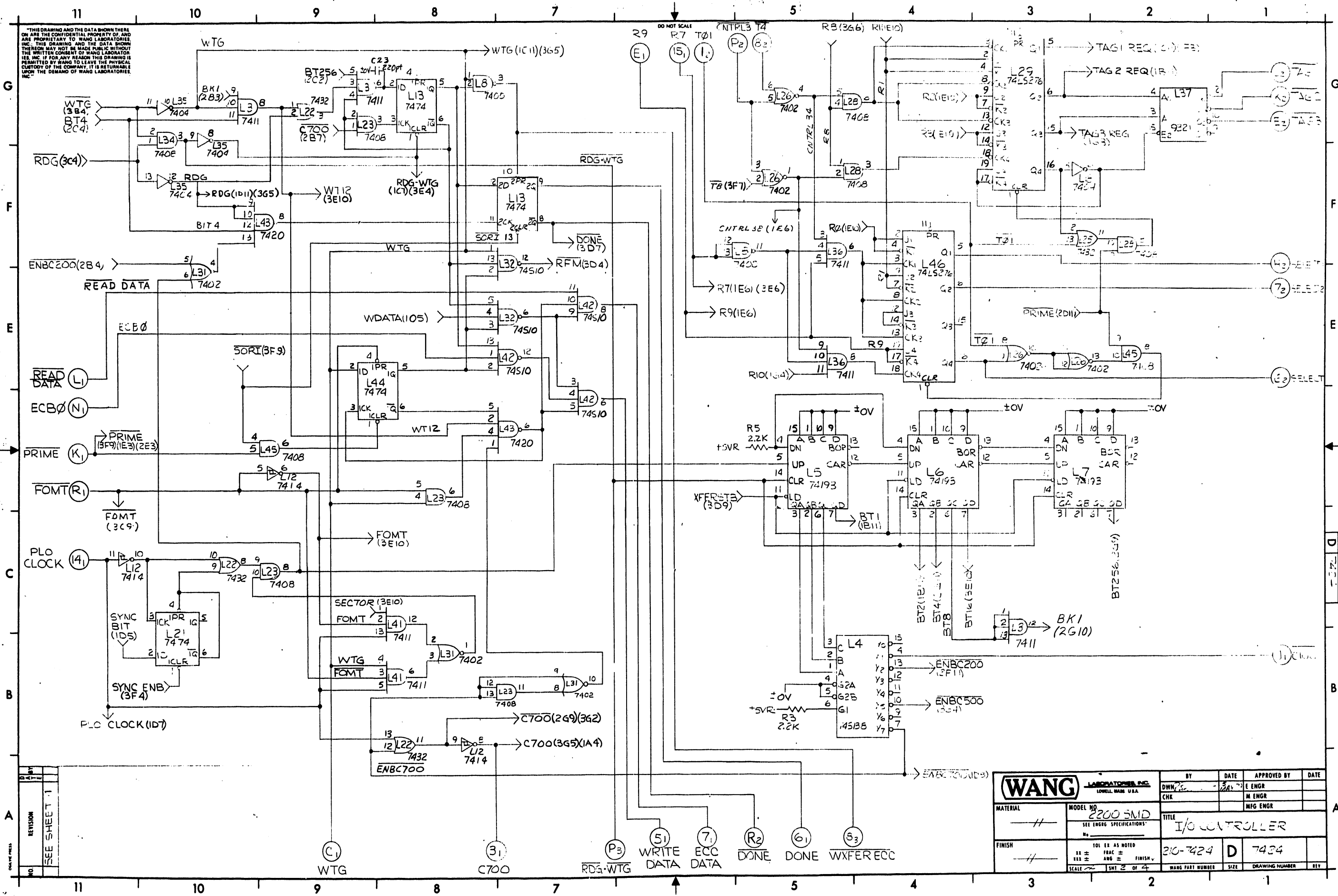

REVISION	DATE	BY	APPROVED BY

WANG LABORATORIES, INC. LOWELL, MASS. U.S.A.		BY: <i>DWN</i>	DATE: <i>2/2/74</i>	APPROVED BY: <i>E ENGR</i>	DATE: <i>2/2/74</i>
		MATERIAL: <i>//</i>			CHK: <i>E ENGR</i>
MODEL NO: 2200 SMD		TITLE: I/O CONTROLLER			
FINISH: <i>//</i>		SCALE: <i>1/16"</i>		SIZE: D	DRAWING NUMBER: 7424
SEE ENGR SPECIFICATIONS		WANG PART NUMBER: 210-7424			
FOR USE AS NOTED		SIZE: D			
FRAC =		DRAWING NUMBER: 7424			
ANG =		BY: <i>E ENGR</i>			
FINISH =		DATE: <i>2/2/74</i>			
SCALE =		PAGE: 2 OF 4			

THIS DRAWING AND THE DATA SHOWN THEREON ARE THE CONFIDENTIAL PROPERTY OF, AND ARE PROPRIETARY TO, WANG LABORATORIES, INC. THIS DRAWING AND THE DATA SHOWN THEREON MAY NOT BE MADE PUBLIC WITHOUT THE WRITTEN CONSENT OF WANG LABORATORIES, INC. IF FOR ANY REASON THIS DRAWING IS PERMITTED BY WANG TO LEAVE THE PHYSICAL CUSTODY OF THE COMPANY, IT IS RETURNABLE UPON THE DEMAND OF WANG LABORATORIES, INC.

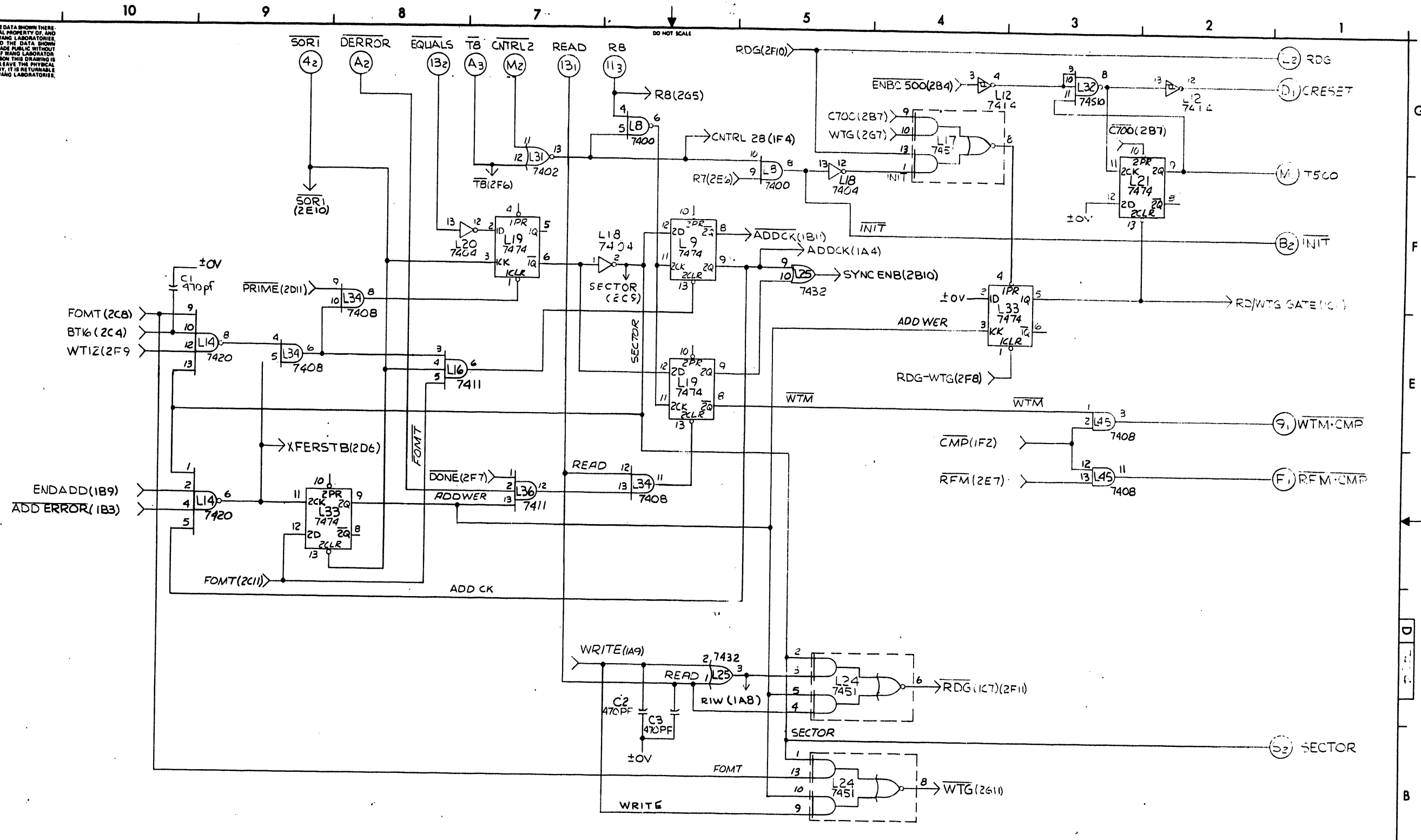

NO.	REVISION
1	SEE SHEET 1

WANG LABORATORIES, INC. LOWELL, MASS. U.S.A.		BY DWN	DATE 12/11/72	APPROVED BY E ENGR	DATE
MATERIAL //	MODEL NO. 230USMD SEE ENGR SPECIFICATIONS	CHK		M ENGR	
FINISH //	101 EX AS NOTED XXX ± FRAC ± FINISH SCALE 1/8" = 1" SH 3 OF 4	TITLE I/O CONTROLLER		MFG ENGR	
	20-7224	D	7224		
		WANG PART NUMBER	SIZE	DRAWING NUMBER	SHEET

1725

"THIS DRAWING AND THE DATA SHOWN THERE ON ARE THE CONFIDENTIAL PROPERTY OF AND ARE PROPRIETARY TO WANG LABORATORIES, INC. THIS DRAWING AND THE DATA SHOWN THEREON MAY NOT BE MADE PUBLIC WITHOUT THE WRITTEN CONSENT OF WANG LABORATORIES, INC. IF FOR ANY REASON THIS DRAWING IS PERMITTED BY WANG TO LEAVE THE PHYSICAL CUSTODY OF THE COMPANY, IT IS RETURNABLE UPON THE DEMAND OF WANG LABORATORIES, INC."

11 10 9 8 7 6 5 4 3 2 1

COMPONENT	WLI NO.	TYPE
C23	300-1220	220pf, 500v
C1, C2, C3	300-1470	470 pf, 500V
C4 - C20	300-1900	.054F, 12VDC
C21, C22	300-4022	154F, 20V
R1, R2, R3	330-3022	2.2K, 1/4W 10%

LOCATION	WL PART NO	TYPE
L3, L16, L36, L41	376-0194	7411
L4	376-0298	745138
L5, L6, L7	376-0053	74193
L10, L17, L15, L24	376-0012	7451
L8, L20, L35	376-0010	7404
L9, L13, L19, L21, L33, L44	376-0006	7474
L14, L43	376-0004	7420
L12	376-0139	7414
L22, L25	376-0093	7432
L23, L34, L39, L45	376-0081	7408
L26, L31	376-0016	7402
L27, L29, L46	376-0318	74276
L32, L42	376-0238	74510
L37, L40	376-0096	9321
L8, L38	376-0002	7400
L47	376-0303	74LS299
L48	376-0317	25LS2521
L49, L50, L51, L53	376-0286	74LS374
L52	376-0288	74LS244
L1, L2, L11, L30	SPARE	

TYPE	LOCATION	SPARES
7432	L22	1
7414	L12	1
7408	L39	2
7411	L41	1
7474	L44	1

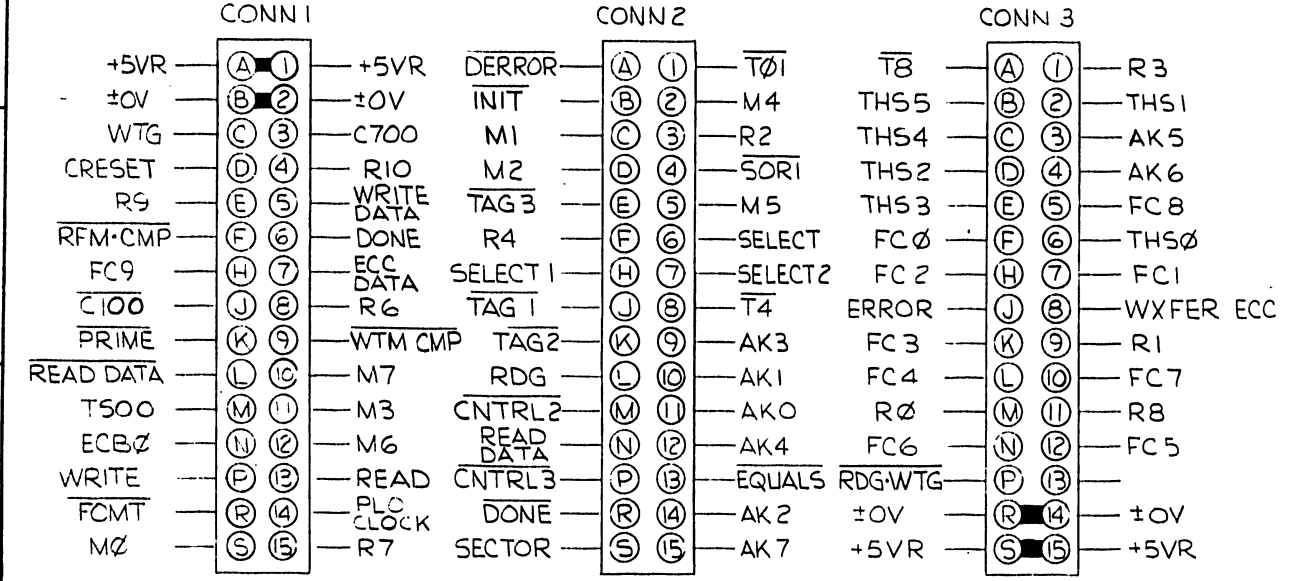
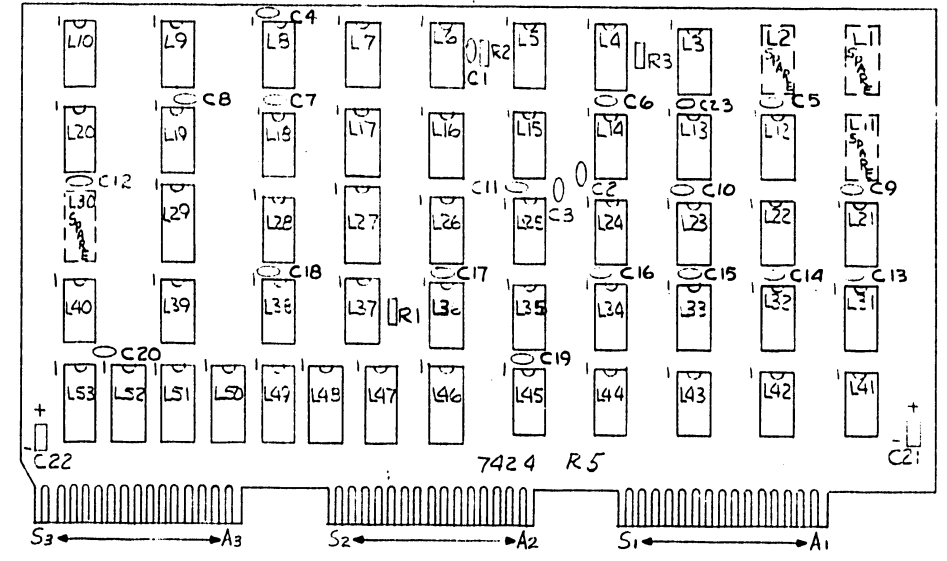
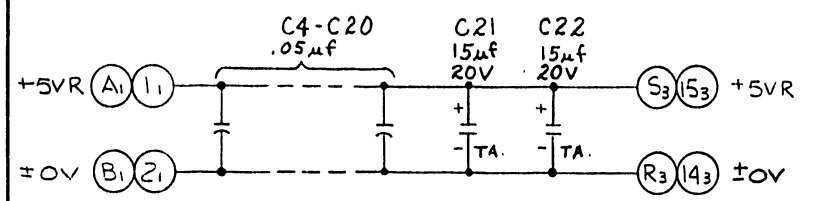

MNEMONIC	COORDINATE
AK0-AK7	1F11
CNTRL2	3G7
CNTRL3	2G5
CRESET	3G1
C100	2B1
C700	2A7
DERROR	3G8
DONE	2A5
DONE	2A5
ECB0	2D11
ECC DATA	2A6
EQUALS	3G8
ERROR	1B1
FC0-FC9	1E1
FOMT	2D11
INIT	3F1
M0-M7	1D1
PLO CLOCK	2C11
PRIME	2D11
RDG	3G1
RDG-WTG	2A6
READ	3G7
READ DATA	1G8
READ DATA	2E11
R0-R9, R6	1E11
RFM-CMP	3D1
R7	2G6
R8	3G6
R9	2G6

MNEMONIC	COORDINATE
R10	1G4
SECTOR	3B1
SELECT-SELECT 2	2E1
SORI	3G9
TAG1-TAG3	2G1
THS0-THS5	1C1
T500	3G1
T01	2G6
T4	2G5
T8	3G7
WRITE	1B11
WRITE DATA	2A6
WTG	2A9
WTM-CMP	3E1
WXFER ECC	2A4

REV	DATE	BY	APP'D.	REVISION
1	11-17-79	ORIGINAL PER LWF
2	11-17-79	REVISED PER APP'D. 5/11/80
3	11-17-79	REVISED PER APP'D. 5/11/80
4	11-17-79	REVISED PER APP'D. 5/11/80
5	11-17-79	REVISED PER APP'D. 5/11/80
6	11-17-79	REVISED PER APP'D. 5/11/80
7	11-17-79	REVISED PER APP'D. 5/11/80
8	11-17-79	REVISED PER APP'D. 5/11/80
9	11-17-79	REVISED PER APP'D. 5/11/80
10	11-17-79	REVISED PER APP'D. 5/11/80
11	11-17-79	REVISED PER APP'D. 5/11/80

WANG LABORATORIES, INC.
LOWELL, MASS. U.S.A.

BY: [Signature] DATE: 11/17/79 APPROVED BY: E. ENGR M. GREER DATE: 11/17/79

CHK: [Signature] DATE: 11/17/79 MFG ENGR

TITLE: I/O CONTROLLER

WANG PART NUMBER: 210-7424 SIZE: D DRAWING NUMBER: 7424 SHEET 4 OF 4

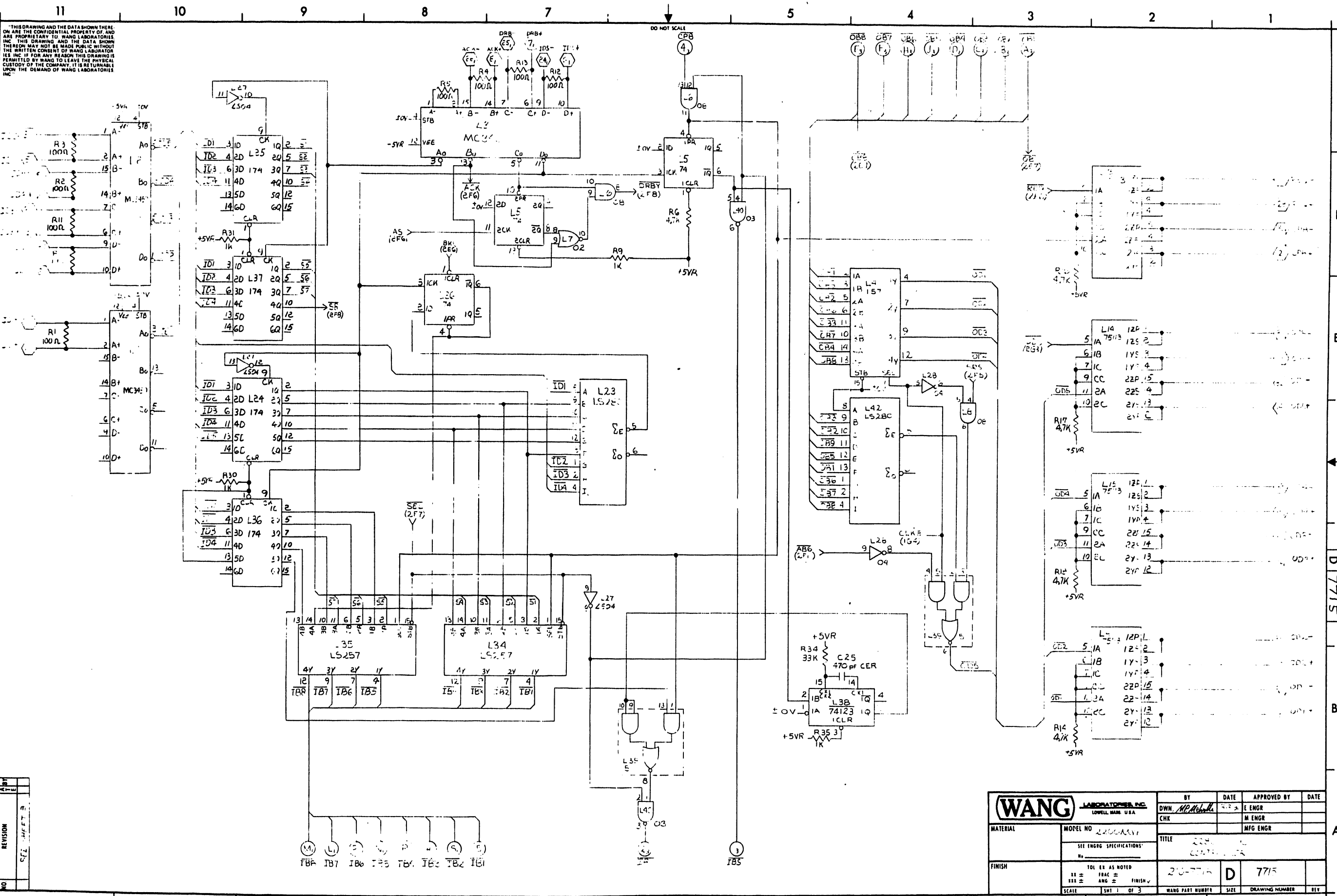

THIS DRAWING AND THE DATA SHOWN THEREON ARE THE CONFIDENTIAL PROPERTY OF AND ARE PROPRIETARY TO WANG LABORATORIES, INC. THIS DRAWING AND THE DATA SHOWN THEREON MAY NOT BE MADE PUBLIC WITHOUT THE WRITTEN CONSENT OF WANG LABORATORIES, INC. IF FOR ANY REASON THIS DRAWING IS PERMITTED BY WANG TO LEAVE THE PHYSICAL CUSTODY OF THE COMPANY, IT IS RETURNABLE UPON THE DEMAND OF WANG LABORATORIES, INC.

NO.	REVISION	DATE	BY

WANG LABORATORIES, INC. LOWELL, MASS. U.S.A.		BY DWN. MPA/ML	DATE 9-2-68	APPROVED BY E ENGR	DATE
MATERIAL	MODEL NO. 200-7715	CHK		M ENGR	
SEE ENGRG SPECIFICATIONS		TITLE CENTRAL CONTROL			
FINISH	TOL. AS NOTED XX ± XXX ±	200-7715	D	7715	
SCALE	1/8" = 1"	WANG PART NUMBER	SIZE	DRAWING NUMBER	REV.

D27

THIS DRAWING AND THE DATA SHOWN THERE ON ARE THE CONFIDENTIAL PROPERTY OF AND ARE PROPRIETARY TO WANG LABORATORIES, INC. THIS DRAWING AND THE DATA SHOWN THEREON MAY NOT BE MADE PUBLIC WITHOUT THE WRITTEN CONSENT OF WANG LABORATORIES, INC. IF FOR ANY REASON THIS DRAWING IS PERMITTED BY WANG TO LEAVE THE PHYSICAL CUSTODY OF THE COMPANY, IT IS RETURNABLE UPON THE DEMAND OF WANG LABORATORIES, INC.

DO NOT SCALE

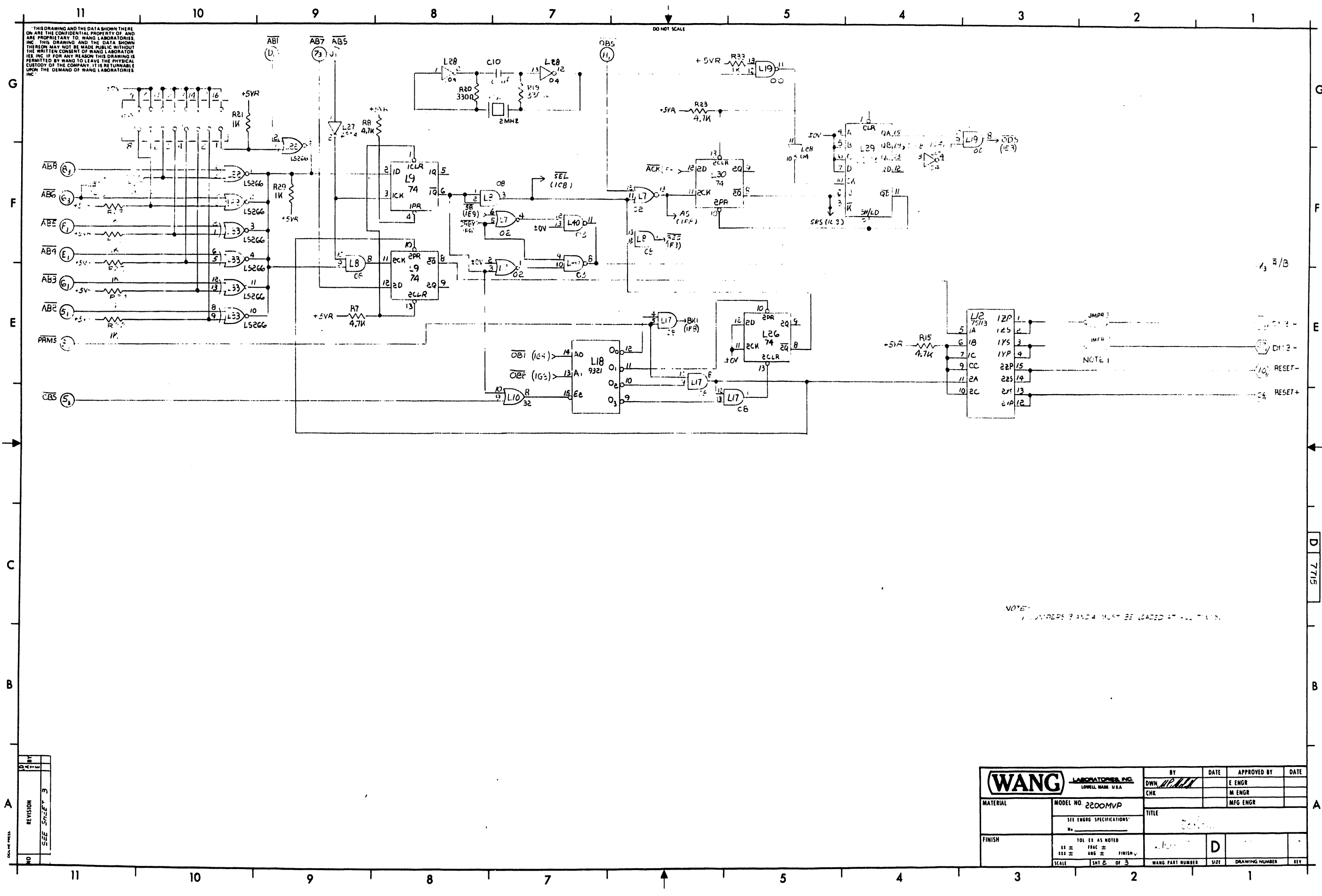

NO.	REVISION	BY	DATE
	SEE SHEET 3		

WANG LABORATORIES, INC. LOWELL, MASS. U.S.A.		BY	DATE	APPROVED BY	DATE
		DWN. <i>[Signature]</i>		E ENGR	
MATERIAL: MODEL NO. 2200MVP SEE ENGR. SPECIFICATIONS		CHK		M ENGR	
				MFG ENGR	
FINISH		TITLE		SCALE	
101 ER AS NOTED 101 ± 10% ± 102 ± 5% ± 103 ± 5% ± 104 ± 5% ± 105 ± 5% ± 106 ± 5% ± 107 ± 5% ± 108 ± 5% ± 109 ± 5% ± 110 ± 5% ± 111 ± 5% ± 112 ± 5% ± 113 ± 5% ± 114 ± 5% ± 115 ± 5% ± 116 ± 5% ± 117 ± 5% ± 118 ± 5% ± 119 ± 5% ± 120 ± 5% ± 121 ± 5% ± 122 ± 5% ± 123 ± 5% ± 124 ± 5% ± 125 ± 5% ± 126 ± 5% ± 127 ± 5% ± 128 ± 5% ± 129 ± 5% ± 130 ± 5% ± 131 ± 5% ± 132 ± 5% ± 133 ± 5% ± 134 ± 5% ± 135 ± 5% ± 136 ± 5% ± 137 ± 5% ± 138 ± 5% ± 139 ± 5% ± 140 ± 5% ± 141 ± 5% ± 142 ± 5% ± 143 ± 5% ± 144 ± 5% ± 145 ± 5% ± 146 ± 5% ± 147 ± 5% ± 148 ± 5% ± 149 ± 5% ± 150 ± 5% ± 151 ± 5% ± 152 ± 5% ± 153 ± 5% ± 154 ± 5% ± 155 ± 5% ± 156 ± 5% ± 157 ± 5% ± 158 ± 5% ± 159 ± 5% ± 160 ± 5% ± 161 ± 5% ± 162 ± 5% ± 163 ± 5% ± 164 ± 5% ± 165 ± 5% ± 166 ± 5% ± 167 ± 5% ± 168 ± 5% ± 169 ± 5% ± 170 ± 5% ± 171 ± 5% ± 172 ± 5% ± 173 ± 5% ± 174 ± 5% ± 175 ± 5% ± 176 ± 5% ± 177 ± 5% ± 178 ± 5% ± 179 ± 5% ± 180 ± 5% ± 181 ± 5% ± 182 ± 5% ± 183 ± 5% ± 184 ± 5% ± 185 ± 5% ± 186 ± 5% ± 187 ± 5% ± 188 ± 5% ± 189 ± 5% ± 190 ± 5% ± 191 ± 5% ± 192 ± 5% ± 193 ± 5% ± 194 ± 5% ± 195 ± 5% ± 196 ± 5% ± 197 ± 5% ± 198 ± 5% ± 199 ± 5% ± 200 ± 5% ±		TITLE: <i>[Handwritten]</i>		SCALE: 1:1	
WANG PART NUMBER: <i>[Handwritten]</i>		SIZE: D		DRAWING NUMBER: <i>[Handwritten]</i>	

D 7715

A

528

NO	REVISION
1	SEE SHIT 5

DATE PLOT

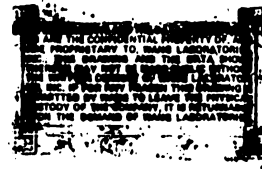

WANG LABORATORIES, INC. LAWRENCEVILLE, MASS. U.S.A.	
MODEL NO. 2280	TITLE MUX MOTHER BOARD
DATE AS ORDERED 210-7716	SIZE D 7716
DATE PLOT 1-23-80	SIZE D 7716

BY	DATE	APPROVED BY	DATE
DWN RB	1-23-80	E ENGR	
CHE		M ENGR	
		MFG ENGR	

SIGNAL	INTFC 7422	AUX/AUX RAM/PRM 7421	IO CONT 7424	SPARE	REGULATOR 6439	J1	J2	J3	PRIME CRT 7415	MASTER	SLAVE 1	SLAVE 2	SLAVE 3
ACK2-1									D3		63		
ACK2-2									C3		F3		
ACK2-3									A3		73		
ACK2-4									B3		H3		
ACK3-1									J3			63	
ACK3-2									H3		F3		
ACK3-3									E3		73		
ACK3-4									F3		H3		
ACK4-1									S3			63	
ACK4-2									L3		F3		
ACK4-3									K3		73		
ACK4-4									M3		H3		
AK0		112	112										
AK1		102	102										
AK2		R2	R2										
AK3		92	92										
AK4		122	122										
AK5		33	33										
AK6		43	43										
AK7		152	152										
AD7		F3	F3										
BSY		141	141										
BS2													
BS3													
BS4													
CADM		53	53										
CLK													
CTRL-1		K2	K2										
CTRL-2		M2	M2										
CTRL-3		P2	P2										
CYPB													
C50													
C51													
CRESET		D1	D1										
C100		J1	J1										
C700		42	31										
DERROR		E3	A2										
DOD1													
DOD2													
DOD3													
DOD4													
DS													
DN3													
DONE		R2	142										
ECBO		N1	N1										
ECC SHIFTED		93	K3										
ECC DATA		71	71										
EQUALS		132	132										
ERROR		J3	J3										
FC0		F3	F3										
FC1		73	73										
FC2		H3	H3										
FC3		K3	K3										
FC4		L3	L3										
FC5		123	123										
FC6		N3	N3										
FC7		103	103										
FC8		53	53										
FC9		H1	H1										
FOMT		R1	R1										
INIT		B2	B2										
IOB7													
IB7													
IB2													
IB3													
IB4													
IB5													
IB6													
IB7													
IB8													
LAUX		N2	N2										
LOAD ECC		P1	P1										
MD		S1	S1										
M1		C2	C2										
M2		D2	D2										
M3		111	111										
M4		22	22										
M5		52	52										
M6		121	121										
M7		101	101										
NULL		151	B3										
ND													
OBS													
PLO CLOCK		141	141										
PRIME		K1	K1										
PWR ON		S2	S2										
RA0		51	51										
RB													
RDG		A2	A2										
READ		131	131										
READ DATA		N2	N2										

9111 D

430

11 10 9 8 7 5 4 3 2 1

DO NOT SCALE

G F E C B A

	11	10	9	8	7	6	5	4	3	2	1
FUNCTION	READY	READY	READY	READY	READY	READY	READY	READY	READY	READY	READY
DESCRIPTION	READY	READY	READY	READY	READY	READY	READY	READY	READY	READY	READY
LOCATION	U3	U2	U1	U1	U1	U1	U1	U1	U1	U1	U1
QUANTITY	1	1	1	1	1	1	1	1	1	1	1
MARKING	U3	U2	U1	U1	U1	U1	U1	U1	U1	U1	U1
DATE	11/15/68	11/15/68	11/15/68	11/15/68	11/15/68	11/15/68	11/15/68	11/15/68	11/15/68	11/15/68	11/15/68
BY	RB	RB	RB	RB	RB	RB	RB	RB	RB	RB	RB
CHECKED											
APPROVED											

9/1/68

WANG LABORATORIES, INC. LYELL, MASS. U.S.A.

MODEL NO. 2280

SITE ENG'G SPECIFICATIONS

TITLE MUX MOTHER BOARD

DATE 11-23-68

BY DWN RB

CHE M ENGR

APPROVED BY

DATE

DATE

DATE

DATE

DATE

"THIS DRAWING AND THE DATA SHOWN THEREON ARE THE CONFIDENTIAL PROPERTY OF AND ARE PROPRIETARY TO WANG LABORATORIES, INC. THIS DRAWING AND THE DATA SHOWN THEREON MAY NOT BE REPRODUCED OR TRANSMITTED IN ANY FORM OR BY ANY MEANS, IN WRITING OR ORALLY, WITHOUT THE WRITTEN CONSENT OF WANG LABORATORIES, INC. FOR ANY REASON. THIS DRAWING IS PERMITTED BY WANG TO LEAVE THE PHYSICAL POSSESSION OF THE CUSTOMER. IT IS RETURNABLE TO WANG UPON DEMAND OF WANG LABORATORIES, INC."

NO. 11

REL. 11-23-68

SEE SMT 11

11 10 9 8 7 5 4 3 2 1

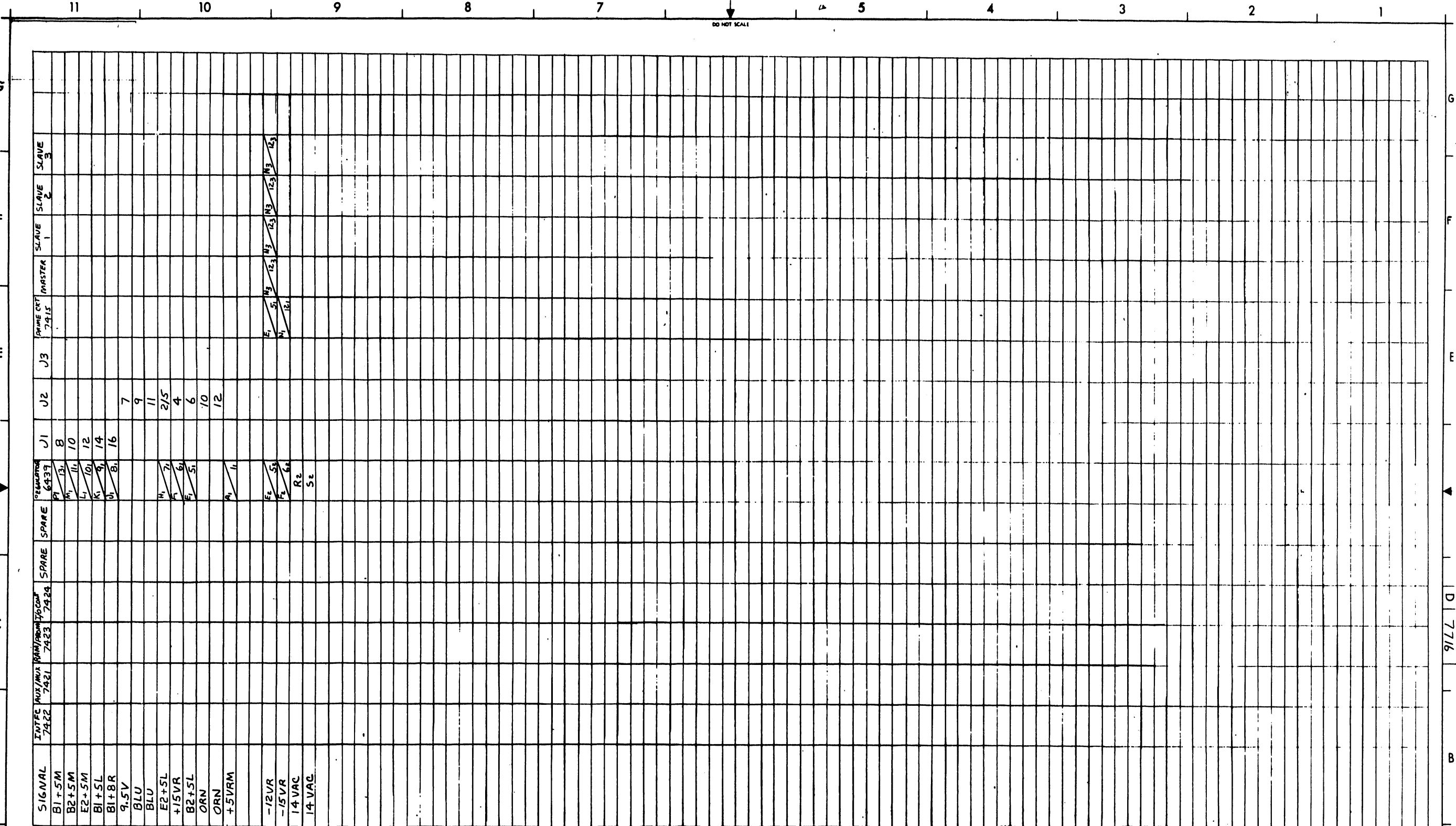

NO	REVISION
1	SEE SMT 5

THIS DRAWING AND THE DATA SHOWN THEREON ARE THE CONFIDENTIAL PROPERTY OF WANG LABORATORIES, INC. THE DRAWING AND THE DATA SHOWN THEREON MAY NOT BE MADE PUBLIC WITHOUT THE WRITTEN CONSENT OF WANG LABORATORIES, INC. IF FOR ANY REASON THIS DRAWING IS PERMITTED BY YOU TO LEAVE THE PHYSICAL CUSTODY OF THE COMPANY, IT IS RETURNABLE UPON THE DEMAND OF WANG LABORATORIES, INC.

WANG LABORATORIES, INC. LUNEL, MASS. U.S.A.		BY DWN A.B.	DATE 1-23-80	APPROVED BY E ENGR	DATE
MATERIAL		TITLE MUX MOTHERBOARD			
MODEL NO. 2280		MFG ENGR			
SEE ENGR SPECIFICATIONS		SIZE D 7716			
FINISH		DRAWING NUMBER 2			
10L ± AS NOTED R2 ± FRAC ± ANG ± FINISH ±		WANG PART NUMBER			
SCALE		SHEET 3 OF 5			

W 32

11 10 9 8 7 5 4 3 2 1

"THIS DRAWING AND THE DATA SHOWN THEREON ARE THE CONFIDENTIAL PROPERTY OF, AND ARE PROPRIETARY TO, WANG LABORATORIES, INC. THIS DRAWING AND THE DATA SHOWN THEREON MAY NOT BE MADE PUBLIC WITHOUT THE WRITTEN CONSENT OF WANG LABORATORIES, INC. IF FOR ANY REASON THIS DRAWING IS PERMITTED BY WANG TO LEAVE THE PHYSICAL CUSTODY OF THE COMPANY, IT IS RETURNABLE UPON THE DEMAND OF WANG LABORATORIES, INC."

DO NOT SCALE

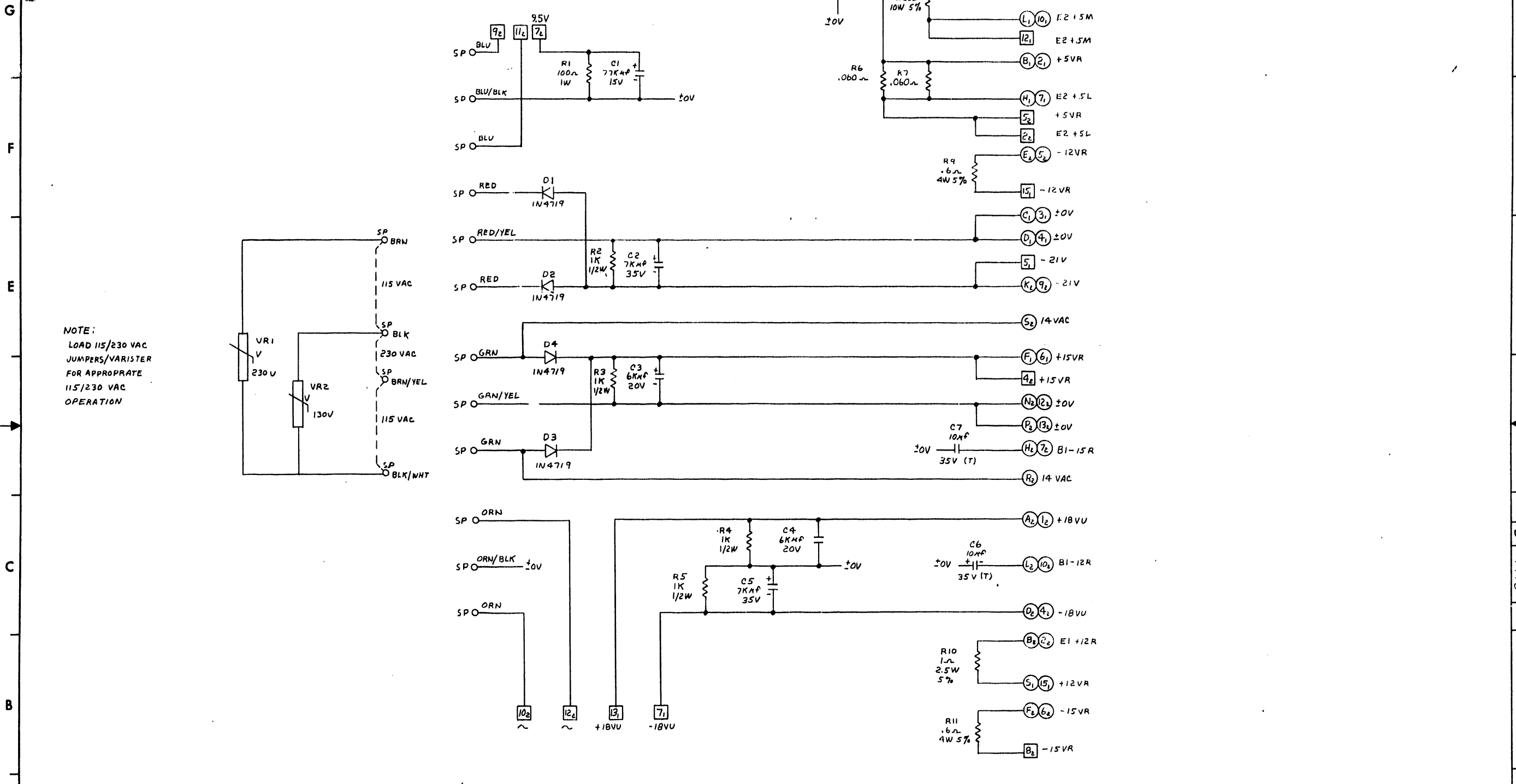

NOTE:
LOAD 115/230 VAC
JUMPERS/VARISTER
FOR APPROPRIATE
115/230 VAC
OPERATION

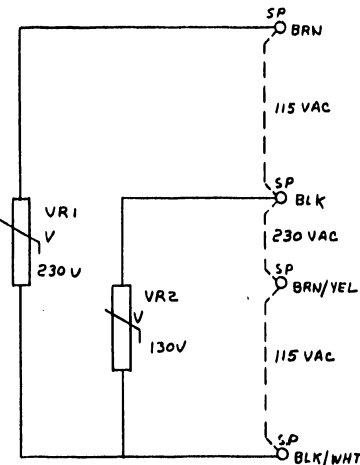

NO.	REVISION
	SEE SHT. 5

WANG LABORATORIES, INC. LOWELL, MASS. U.S.A.		BY DWN AB	DATE 1-23-60	APPROVED BY E ENGR	DATE
MATERIAL	MODEL NO. 2280	CNK		MFG ENGR	
FINISH	SEE ENGR SPECIFICATIONS	TITLE MUX MOTHERBOARD			
	TOL EX AS NOTED XX ± FRACTION ± XXX ± ANG ± FINISH	210-7716	D	7716	2
	SCALE	SHT 2 OF 5	WANG PART NUMBER	SIZE	DRAWING NUMBER

7716

11 10 9 8 7 6 5 4 3 2 1

"THIS DRAWING AND THE DATA SHOWN THERE ON ARE THE CONFIDENTIAL PROPERTY OF, AND ARE PROPRIETARY TO, WANG LABORATORIES, INC. THIS DRAWING AND THE DATA SHOWN THEREON MAY NOT BE MADE PUBLIC WITHOUT THE WRITTEN CONSENT OF WANG LABORATORIES, INC. IF FOR ANY REASON THIS DRAWING IS PERMITTED BY WANG TO LEAVE THE PHYSICAL CUSTODY OF THE COMPANY, IT IS RETURNABLE UPON THE DEMAND OF WANG LABORATORIES, INC."

G F E C B A

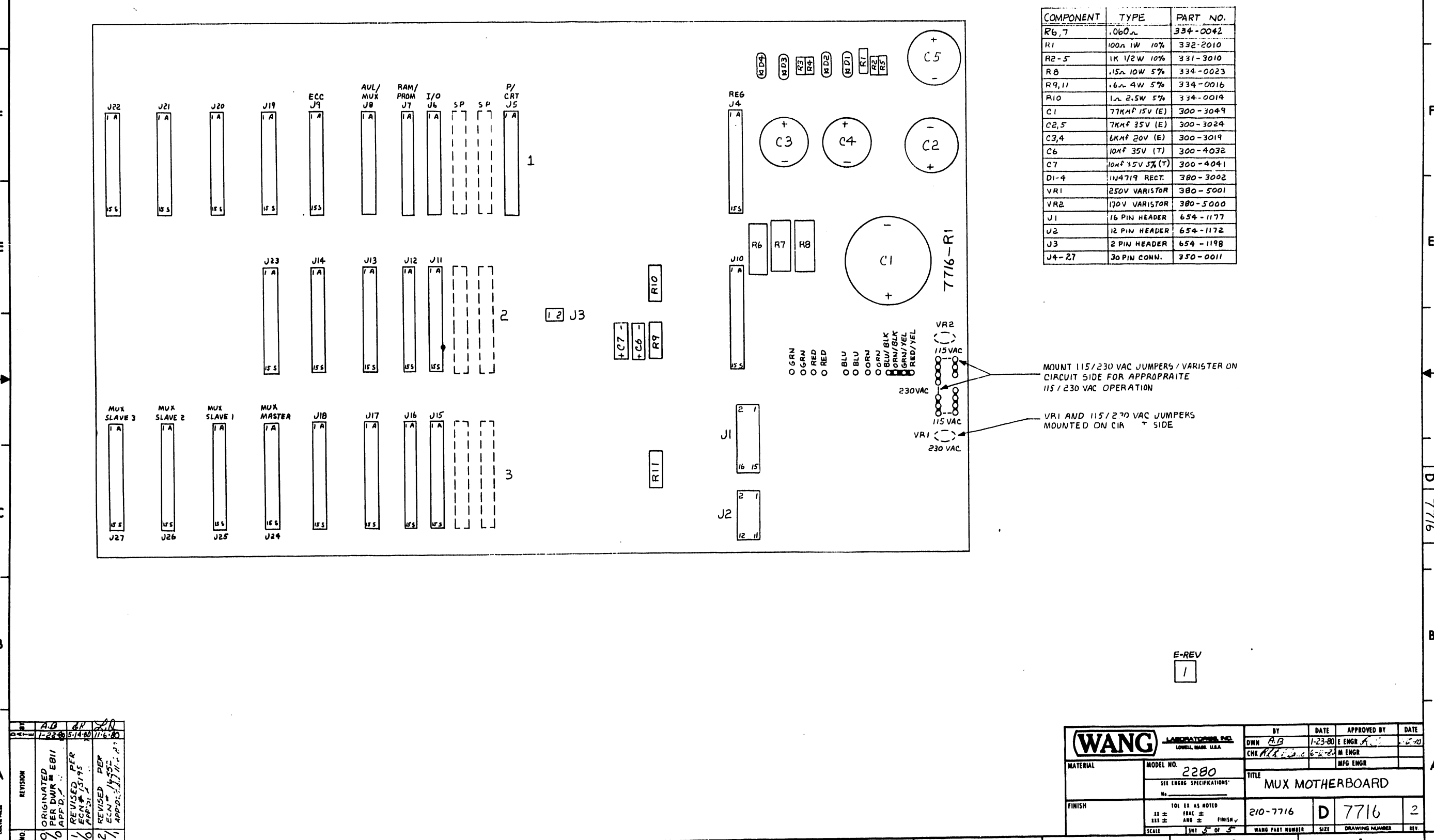

5-31

THIS DRAWING AND THE DATA SHOWN THERE ON ARE THE CONFIDENTIAL PROPERTY OF, AND ARE PROPRIETARY TO WANG LABORATORIES, INC. THIS DRAWING AND THE DATA SHOWN THEREON MAY NOT BE MADE PUBLIC WITHOUT THE WRITTEN CONSENT OF WANG LABORATORIES, INC. IF FOR ANY REASON THIS DRAWING IS PERMITTED BY WANG TO LEAVE THE PHYSICAL CUSTODY OF THE COMPANY, IT IS RETURNABLE UPON THE DEMAND OF WANG LABORATORIES, INC.

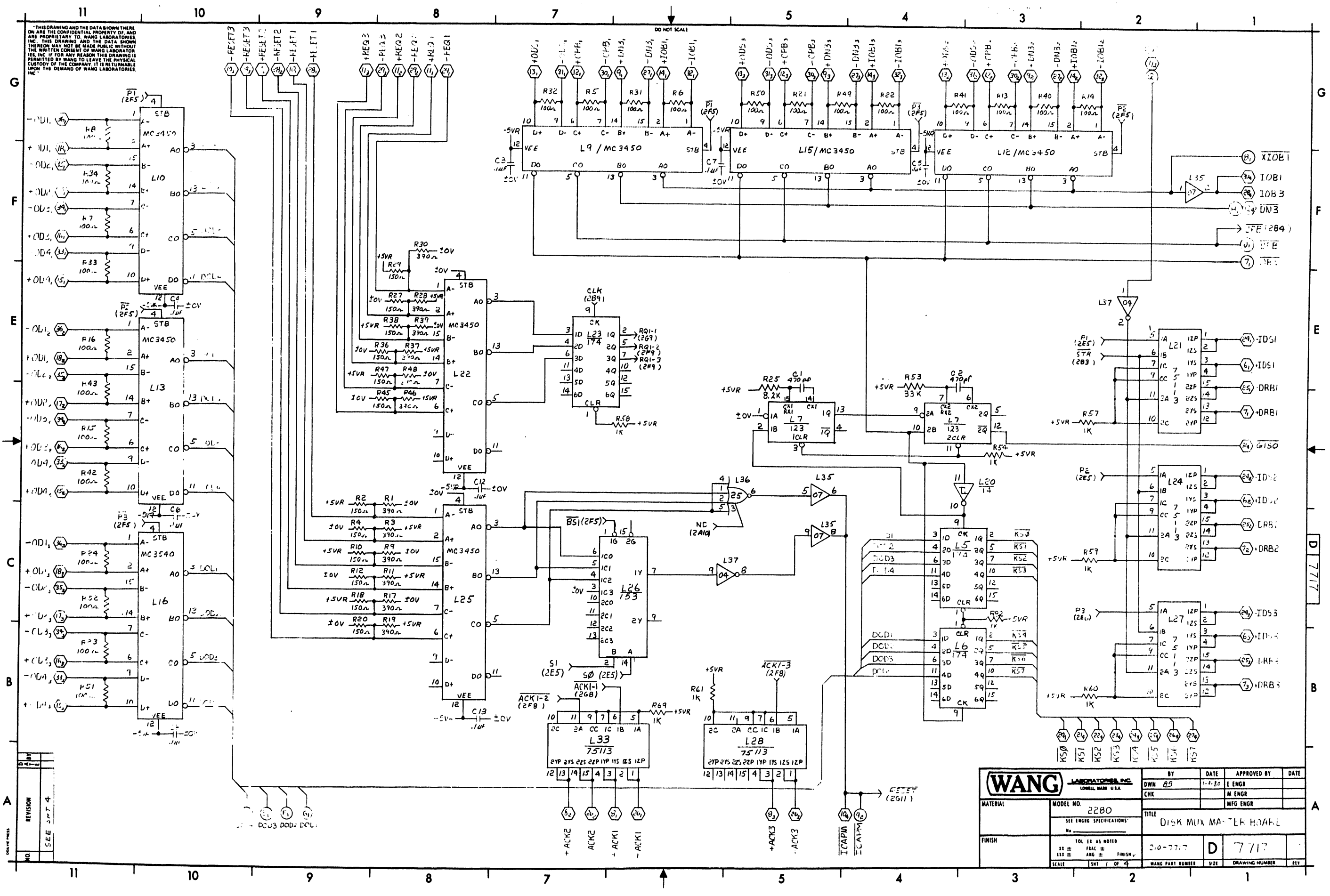

NO.	REVISION
1	SEE SHT 4

WANG LABORATORIES, INC.		BY	DATE	APPROVED BY	DATE
LOWELL, MASS. U.S.A.		DWN	1-7-80	E ENGR	
MATERIAL		CHR		M ENGR	
MODEL NO. 2280				MFG ENGR	
SEE ENGR SPECIFICATIONS		TITLE			
		DISK MUX MASTER BOARD			
FINISH		SCALE		SIZE	
101 EE AS NOTED		3:0-7:7		D 7717	
111 ±		SHT 1 OF 4		WANG PART NUMBER	
112 ±				SIZE	
113 ±				DRAWING NUMBER	
				REV	

35

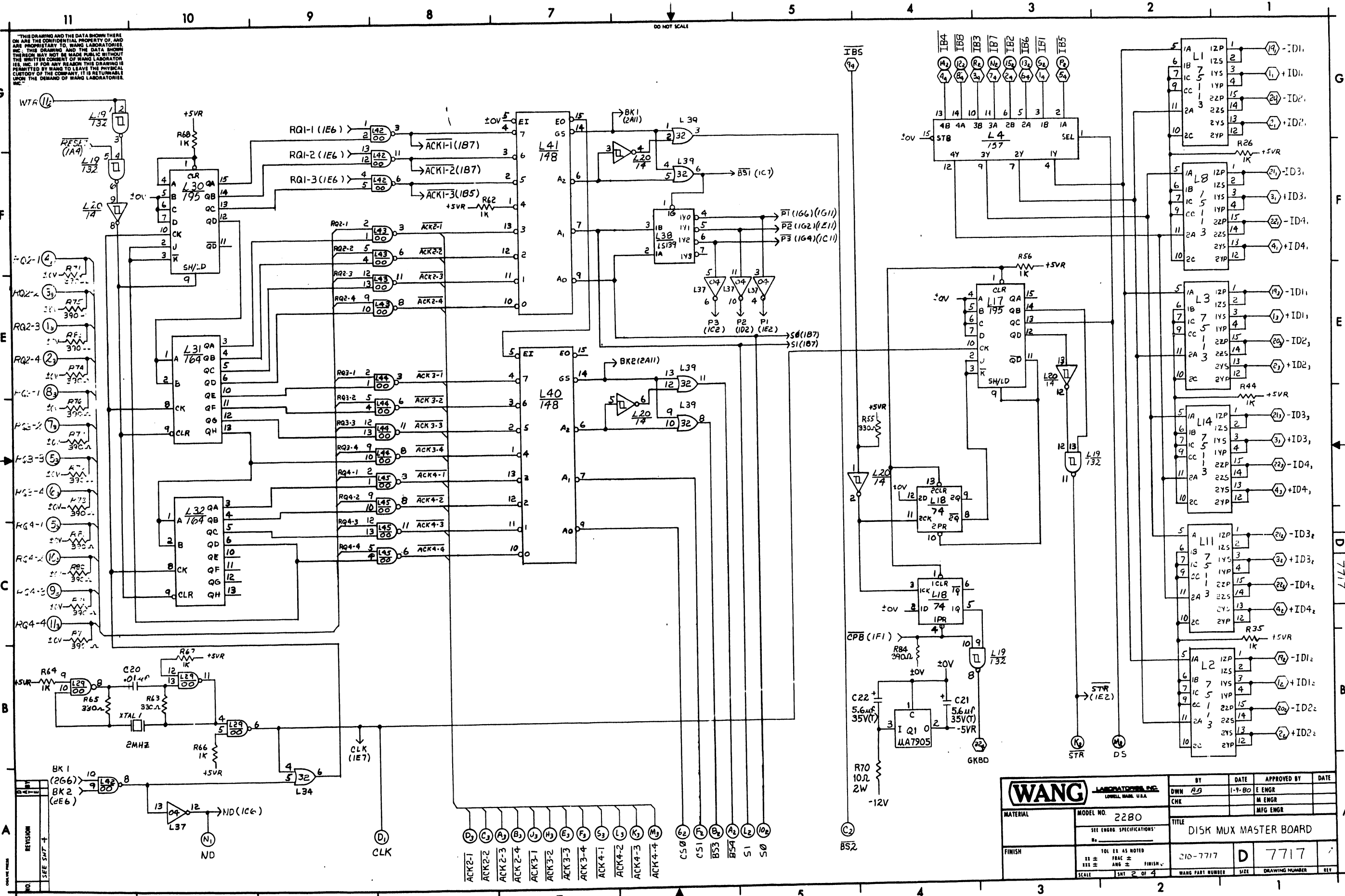

THIS DRAWING AND THE DATA SHOWN THERE ON ARE THE CONFIDENTIAL PROPERTY OF, AND ARE PROPRIETARY TO, WANG LABORATORIES, INC. THIS DRAWING AND THE DATA SHOWN THEREIN MAY NOT BE MADE PUBLIC WITHOUT THE WRITTEN CONSENT OF WANG LABORATORIES, INC. IF FOR ANY REASON THIS DRAWING IS PERMITTED BY WANG TO LEAVE THE PHYSICAL CUSTODY OF THE COMPANY, IT IS RETURNABLE UPON THE DEMAND OF WANG LABORATORIES, INC.

NO.	REVISION	DATE	BY	APPROVED BY
1	SEE SMT			

WANG LABORATORIES, INC. LOWELL, MASS. U.S.A.		BY	DATE	APPROVED BY	DATE
MODEL NO. 2280		DWN	1-9-80	E ENGR	
SEE ENGR SPECIFICATIONS		CHK		M ENGR	
TITLE				MFG ENGR	
DISK MUX MASTER BOARD					
FINISH		TOL EX AS NOTED		210-7717	
		101 ±		D	
		101 ±		7717	
		101 ±		2 OF 4	
		101 ±		SIZE	
		101 ±		DRAWING NUMBER	
		101 ±		REV	

THIS DRAWING AND THE DATA SHOWN THEREON ARE THE CONFIDENTIAL PROPERTY OF, AND ARE PROPRIETARY TO, WANG LABORATORIES, INC. THIS DRAWING AND THE DATA SHOWN THEREON MAY NOT BE MADE PUBLIC WITHOUT THE WRITTEN CONSENT OF WANG LABORATORIES, INC. IF FOR ANY REASON THIS DRAWING IS PERMITTED BY WANG TO LEAVE THE PHYSICAL CUSTODY OF THE COMPANY, IT IS RETURNABLE UPON THE DEMAND OF WANG LABORATORIES, INC.

DO NOT SCALE

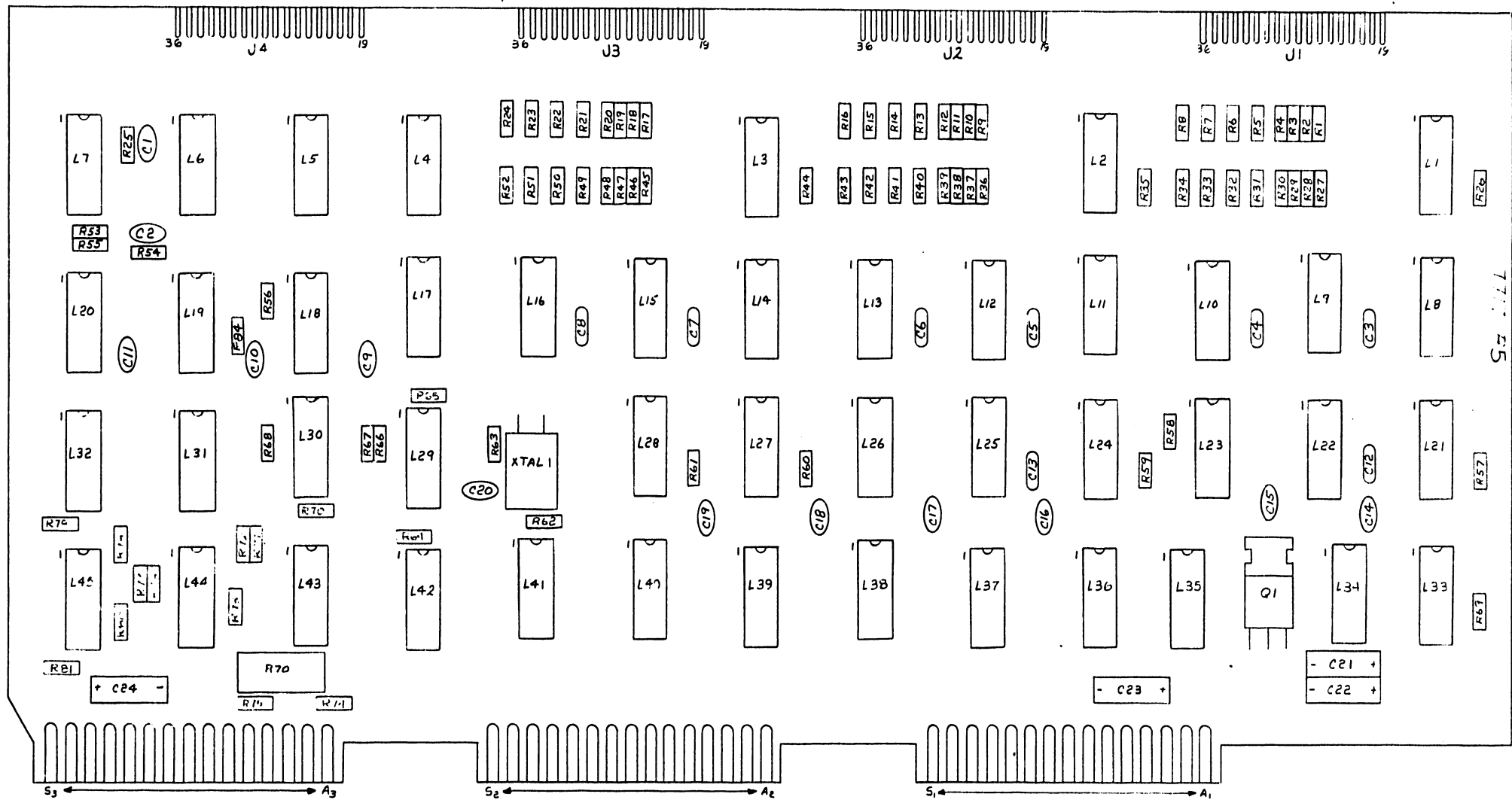

NO.	REVISION
1	SEE SHEET 4

WANG LABORATORIES, INC. LOWELL, MASS. U.S.A.		BY DWN R.G.	DATE 3-29-65	APPROVED BY E ENGR	DATE
MATERIAL	MODEL NO 2280 SEE ENGR SPECIFICATIONS	TITLE DISK MUX MASTER P.C.B.			
FINISH	101 EE AS NOTED XX ± FRAC ± XXX ± ANG ± FINISH	3-D-7717	D	7717	
SCALE SMT 3 OF 4		WANG PART NUMBER	SIZE	DRAWING NUMBER	REV

D 57

THIS DRAWING AND THE DATA SHOWN THEREON ARE THE CONFIDENTIAL PROPERTY OF WANG LABORATORIES, INC. THIS DRAWING AND THE DATA SHOWN THEREON MAY NOT BE MADE PUBLIC WITHOUT THE WRITTEN CONSENT OF WANG LABORATORIES, INC. IF FOR ANY REASON THIS DRAWING IS PERMITTED BY WANG TO LEAVE THE PHYSICAL CUSTODY OF THE COMPANY, IT IS RETURNABLE UPON THE DEMAND OF WANG LABORATORIES, INC.

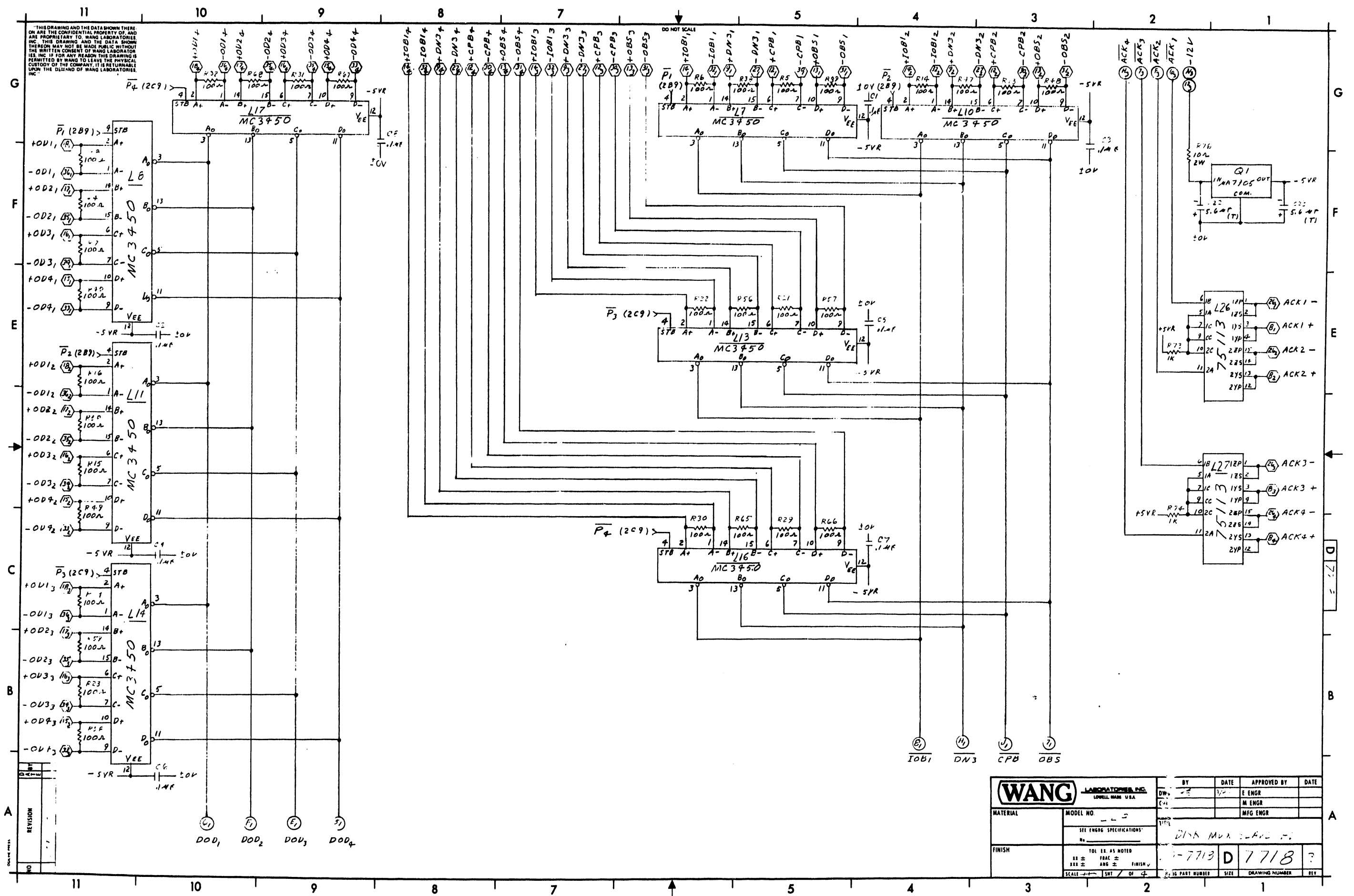

REV	DESCRIPTION

WANG LABORATORIES, INC. LOWELL, MASS. U.S.A.		BY	DATE	APPROVED BY	DATE
MATERIAL	MODEL NO.	DW	3/7	E ENGR	
SEE ENGR. SPECIFICATIONS				M ENGR	
FINISH		DINA MUX BOARD		MFG ENGR	
TOL. UNLESS NOTED					
±0.005	±0.005				
±0.005	±0.005				
SCALE	SMT / OF 4				

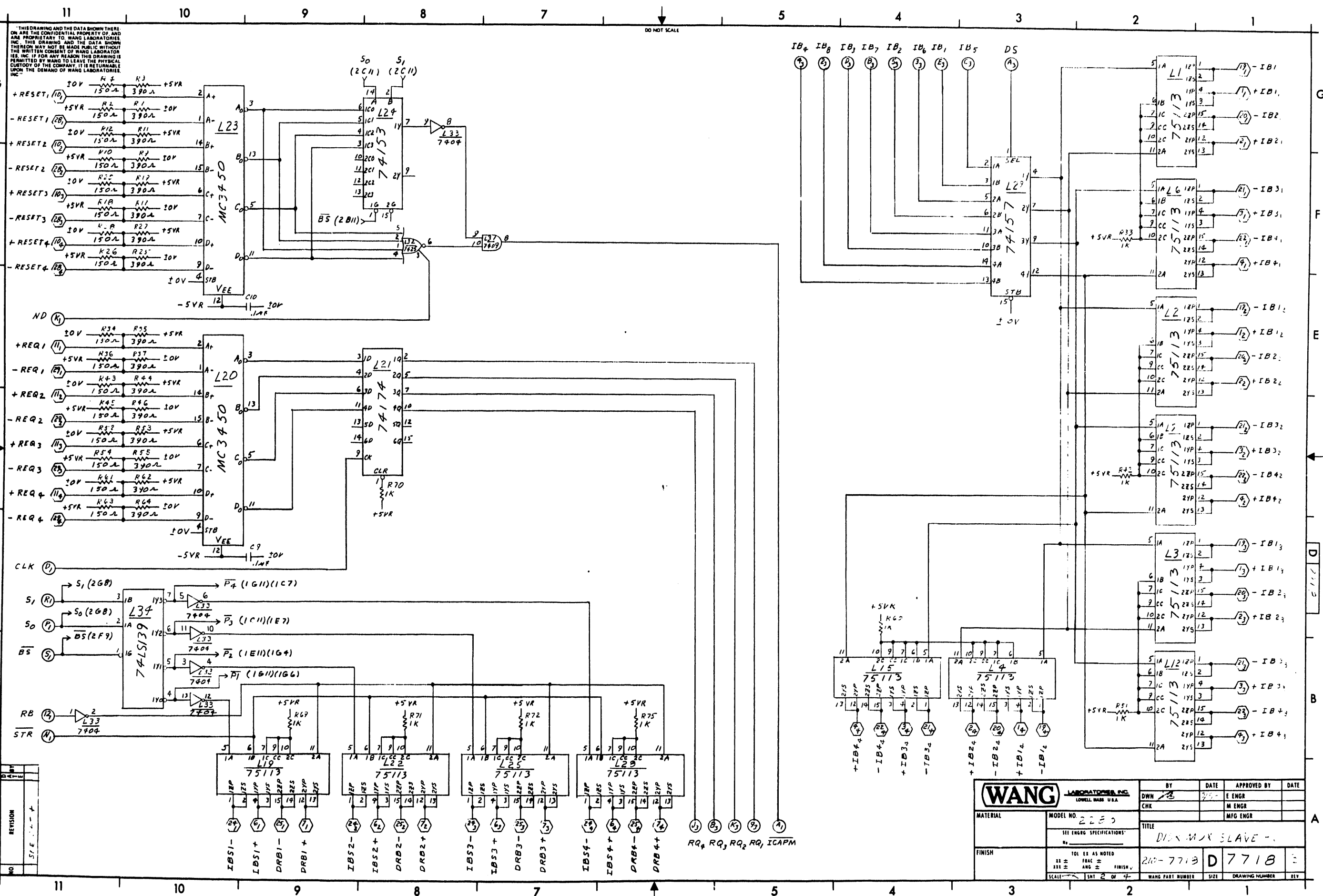

THIS DRAWING AND THE DATA SHOWN THEREON ARE THE CONFIDENTIAL PROPERTY OF AND ARE PROPRIETARY TO WANG LABORATORIES, INC. THIS DRAWING AND THE DATA SHOWN THEREON MAY NOT BE MADE PUBLIC WITHOUT THE WRITTEN CONSENT OF WANG LABORATORIES, INC. IF FOR ANY REASON THIS DRAWING IS PERMITTED BY WANG TO LEAVE THE PHYSICAL CUSTODY OF THE COMPANY, IT IS RETURNABLE UPON THE DEMAND OF WANG LABORATORIES, INC.

NO.	REVISION	DATE	BY	APPROVED BY
1	1			
2	1			

WANG LABORATORIES, INC. LOWELL, MASS. U.S.A.		BY: DWN	DATE: 7/64	APPROVED BY: E ENGR	DATE:
MATERIAL:	MODEL NO. 2283	CHK:		M ENGR:	
FINISH:	SIT ENGR SPECIFICATIONS	TITLE: DIN MAX SLAVE		MFG ENGR:	
TOL EX AS NOTED		240-7718	D 7718		
SCALE: 1/8" = 1"		WANG PART NUMBER:	SIZE:	DRAWING NUMBER:	REV:

D40

THIS DRAWING AND THE DATA SHOWN THERE ON ARE THE CONFIDENTIAL PROPERTY OF, AND ARE PROPRIETARY TO, WANG LABORATORIES, INC. THIS DRAWING AND THE DATA SHOWN THEREON MAY NOT BE MADE PUBLIC WITHOUT THE WRITTEN CONSENT OF WANG LABORATORIES, INC. IF FOR ANY REASON THIS DRAWING IS PERMITTED BY WANG TO LEAVE THE PHYSICAL CUSTODY OF THE COMPANY, IT IS RETURNABLE UPON THE DEMAND OF WANG LABORATORIES, INC.

DO NOT SCALE

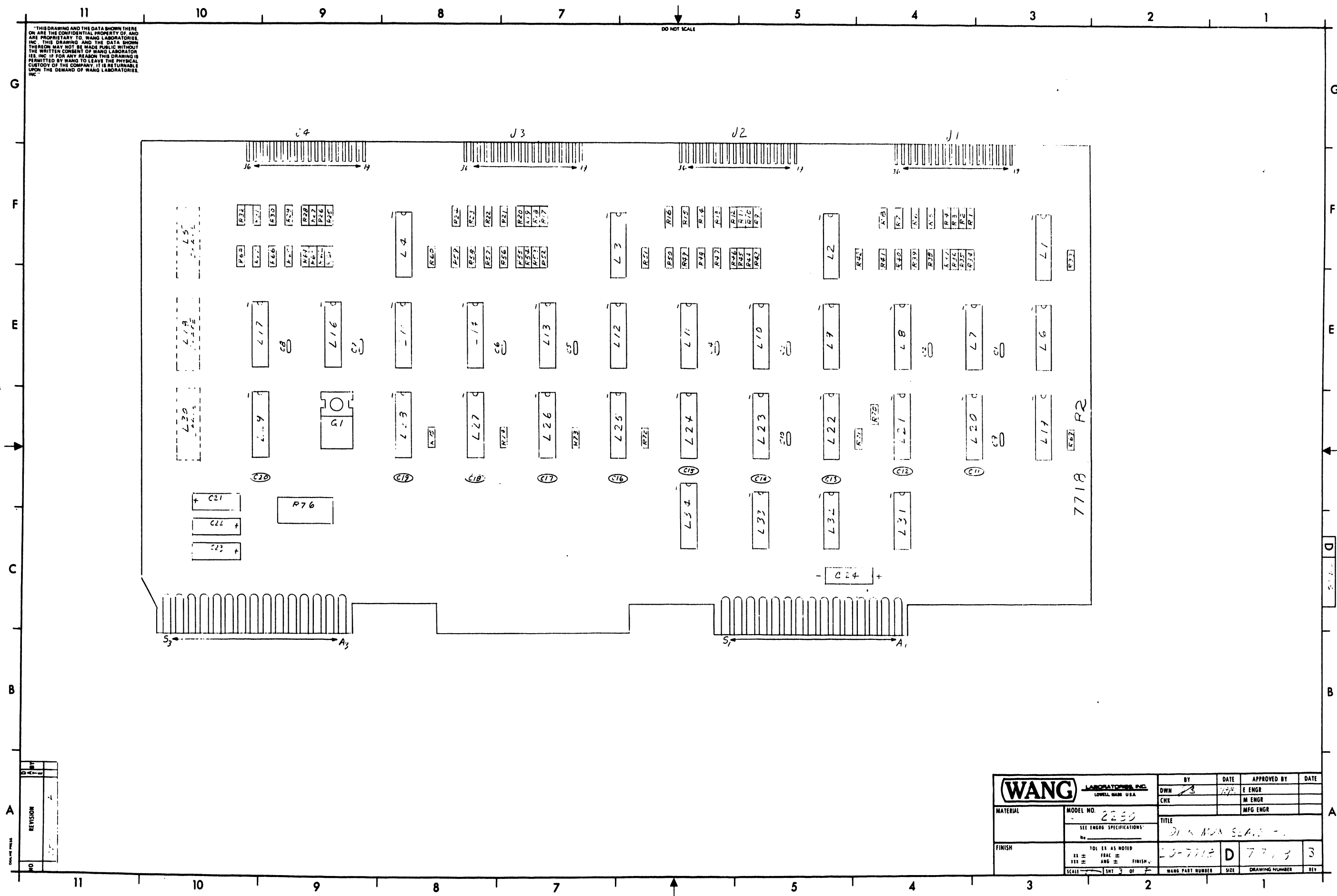

NO	REVISION

WANG LABORATORIES, INC. LOWELL, MASS. U.S.A.		BY DWN	DATE 1/78	APPROVED BY E ENGR	DATE
MATERIAL	MODEL NO. 2230	CHK		M ENGR	
	SEE ENGR'S SPECIFICATIONS	TITLE DIN A MCA SLA. 7718			
FINISH	101 EX AS NOTED	20-7718	D	7718	3
	11 ± FRAC ±	WANG PART NUMBER	SIZE	DRAWING NUMBER	REV
	100 ± ANG ± FINISH				
	SCALE 1/8" = 1" SMT 3 OF 7				

741

THIS DRAWING AND THE DATA SHOWN THERE ON ARE THE CONFIDENTIAL PROPERTY OF AND ARE PROPRIETARY TO WANG LABORATORIES, INC. THIS DRAWING AND THE DATA SHOWN THEREON MAY NOT BE MADE PUBLIC WITHOUT THE WRITTEN CONSENT OF WANG LABORATORIES, INC. IF FOR ANY REASON THIS DRAWING IS PERMITTED BY WANG TO LEAVE THE PHYSICAL CUSTODY OF THE COMPANY, IT IS RETURNABLE UPON THE DEMAND OF WANG LABORATORIES, INC.

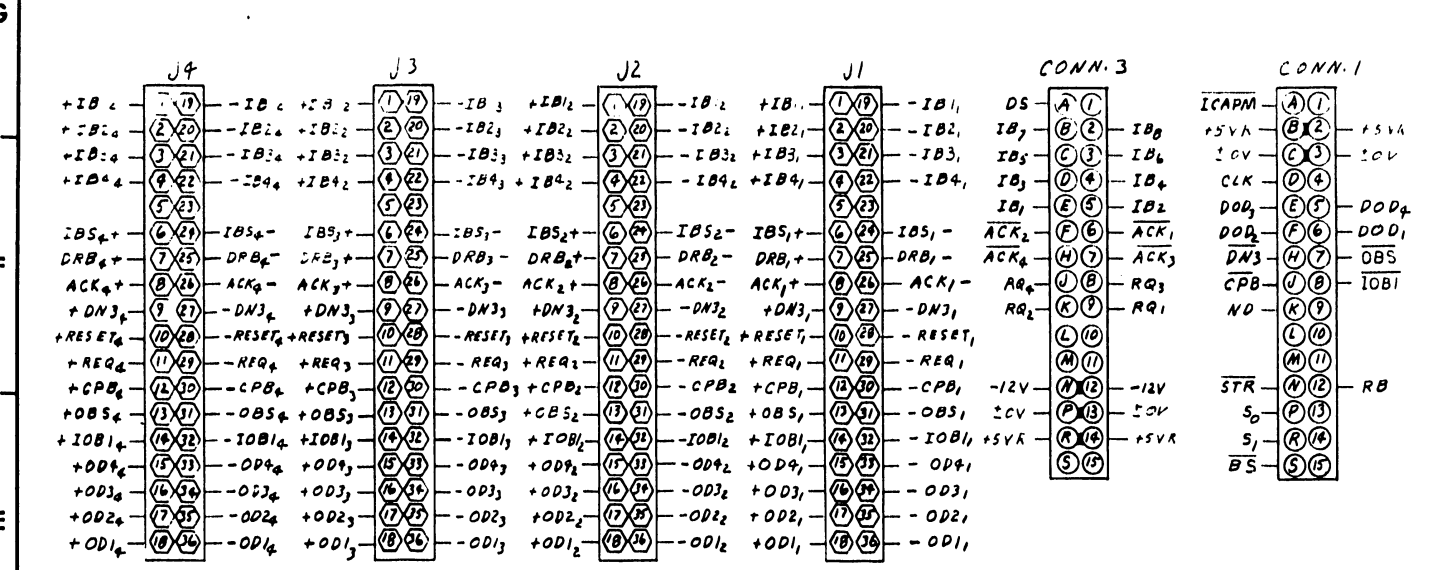

QTY	TYPE	LOCATION	SPARES
7	409	L31	3
7	425	L32	1
7	4LS139	L34	1

LOCATION	WL PART No	TYPE
L1-4, 6, 9, 12, 15, 18, 23, 25-28	376-0256	75113
L5, 18, 30		SPARE
L7, 8, 10, 11, 13, 14, 16, 17, 20, 23	376-0275	MC3450
L21	376-0098	74174
L24	376-0098	74153
L29	376-0082	74157
L31	376-0085	7409
L32	376-0092	7425
L33	376-0010	7404
L34	376-0226	74LS139

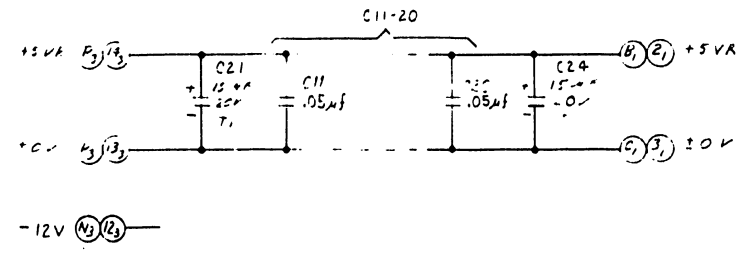

MNEMONIC	COORDINATE
RB	2 B 11
+RESET ₁ THRU +RESET ₄	2 G 11
-RESET ₁ THRU -RESET ₄	2 G 11
+REQ ₁ THRU +REQ ₄	2 D 11
-REQ ₁ THRU -REQ ₄	2 D 11
RQ ₁ - RQ ₄	2 A 5
S ₀ , S ₁	2 C 11
STR	2 B 11

COMPONENT	WL PART No	TYPE
R1, 3, 9, 11, 17, 19, 25, 27, 35, 37, 44, 46, 53, 55, 62, 64	330-2039	330 Ω 1/4 W 10%
R2, 4, 10, 12, 18, 20, 26, 28, 34, 36, 43, 45, 52, 54, 61, 63	330-2015	150 Ω 1/4 W 10%
R5-8, 13-16, 21-24, 29-32, 38-41, 47-50, 56-58, 65-68	330-2010	100 Ω 1/4 W 10%
R39, 42, 51, 69, 70-75	330-3010	1K 1/4 W 10%
R76	337-1010	10 Ω 2 W 10%
C1-10	300-1930	.1 μF 50V 5%T
C11-20	300-1900	.05 μF 12V 5%T
C21, 24	300-4022	15 μF 20V 17%
C22, 23	300-4025	5.6 μF 35V 17%
Q1	374-0002	7905

MNEMONIC	COORDINATE
+IB ₃ ₁ +IB ₄ ₁	2 F 1
-IB ₃ ₁ -IB ₄ ₁	2 F 1
+IB ₃ ₂ +IB ₄ ₂	2 D 1
-IB ₃ ₂ -IB ₄ ₂	2 D 1
+IB ₃ ₃ +IB ₄ ₃	2 B 1
-IB ₃ ₃ -IB ₄ ₃	2 B 1
+IB ₃ ₄ +IB ₄ ₄	2 B 4
-IB ₃ ₄ -IB ₄ ₄	2 B 4
IBS ₁ +	2 A 7
IBS ₁ -	2 A 9
IBS ₂ +	2 A 8
IBS ₂ -	2 A 9
IBS ₃ +	2 A 7
IBS ₃ -	2 A 8
IBS ₄ +	2 A 6
IBS ₄ -	2 A 7
ICAPM	2 A 5
IOB ₁	1 B 4
+IOB ₁	1 G 6
-IOB ₁	1 G 6
+IOB ₂	1 G 4
-IOB ₂	1 G 4
+IOB ₃	1 G 7
-IOB ₃	1 G 7
+IOB ₄	1 G 8
-IOB ₄	1 G 8
NP	2 E 11
OBS	1 B 3
+OBS ₁	1 G 5
-OBS ₁	1 G 5
+OBS ₂	1 G 3
-OBS ₂	1 G 3
+OBS ₃	1 G 6
-OBS ₃	1 G 6
+OBS ₄	1 G 7
-OBS ₄	1 G 7
+OD ₁ THRU +OD ₄	1 F 11
-OD ₁ THRU -OD ₄	1 F 11
+OD ₂ THRU +OD ₄	1 D 11
-OD ₂ THRU -OD ₄	1 D 11
+OD ₃ THRU +OD ₄	1 B 11
-OD ₃ THRU -OD ₄	1 B 11
+OD ₁ THRU +OD ₄	1 G 10
-OD ₁ THRU -OD ₄	1 G 10

MNEMONIC	COORDINATE
ACK ₁ - ACK ₄	1 G 2
ACK ₁ - ACK ₂ -	1 E 1
ACK ₁ + ACK ₂ +	1 E 1
ACK ₃ - ACK ₄ -	1 D 1
ACK ₃ + ACK ₄ +	1 D 1
BS	2 B 11
CLK	2 C 11
CPB	1 B 3
+CPB ₁	1 G 5
-CPB ₁	1 G 5
+CPB ₂	1 G 3
-CPB ₂	1 G 3
+CPB ₃	1 G 7
-CPB ₃	1 G 7
+CPB ₄	1 G 8
-CPB ₄	1 G 8
DN ₃	1 B 4
+DN ₃	1 G 6
-DN ₃	1 G 5
+DN ₃	1 G 4
-DN ₃	1 G 3
+DN ₃	1 G 7
-DN ₃	1 G 7
+DN ₃	1 G 8
-DN ₃	1 G 8
DOD ₁ - DOD ₄	1 A 10
DRB ₁ +	2 A 9
DRB ₁ -	2 A 9
DRB ₂ +	2 A 8
DRB ₂ -	2 A 8
DRB ₃ +	2 A 7
DRB ₃ -	2 A 7
DRB ₄ +	2 A 6
DRB ₄ -	2 A 6
DS	2 G 3
IB ₁ - IB ₈	2 G 4
+IB ₁ ₁ +IB ₂ ₁	2 G 1
-IB ₁ ₁ -IB ₂ ₁	2 G 1
+IB ₂ ₂ +IB ₂ ₂	2 E 1
-IB ₂ ₂ -IB ₂ ₂	2 E 1
+IB ₁ ₃ +IB ₂ ₃	2 C 1
-IB ₁ ₃ -IB ₂ ₃	2 C 1
+IB ₁ ₄ +IB ₂ ₄	2 B 3
-IB ₁ ₄ -IB ₂ ₄	2 B 3

REV	DATE	BY	CHKD	APPD
1	9/2/71	JL		
2				
3				

WANG LABORATORIES, INC. LOWELL, MASS. U.S.A.		BY DWN	DATE 9/2/71	APPROVED BY E ENGR	DATE 9/2/71
MATERIAL	MODEL NO. 2180	CHKD CHR	TITLE DATA M.A. PLATE		
FINISH	TOL. IS AS NOTED UNLESS OTHERWISE SPECIFIED	SCALE 1:1		DRAWING NUMBER D 77183	
SCALE 1:1		SHEET NO. OF 4		WANG PART NUMBER	

D42

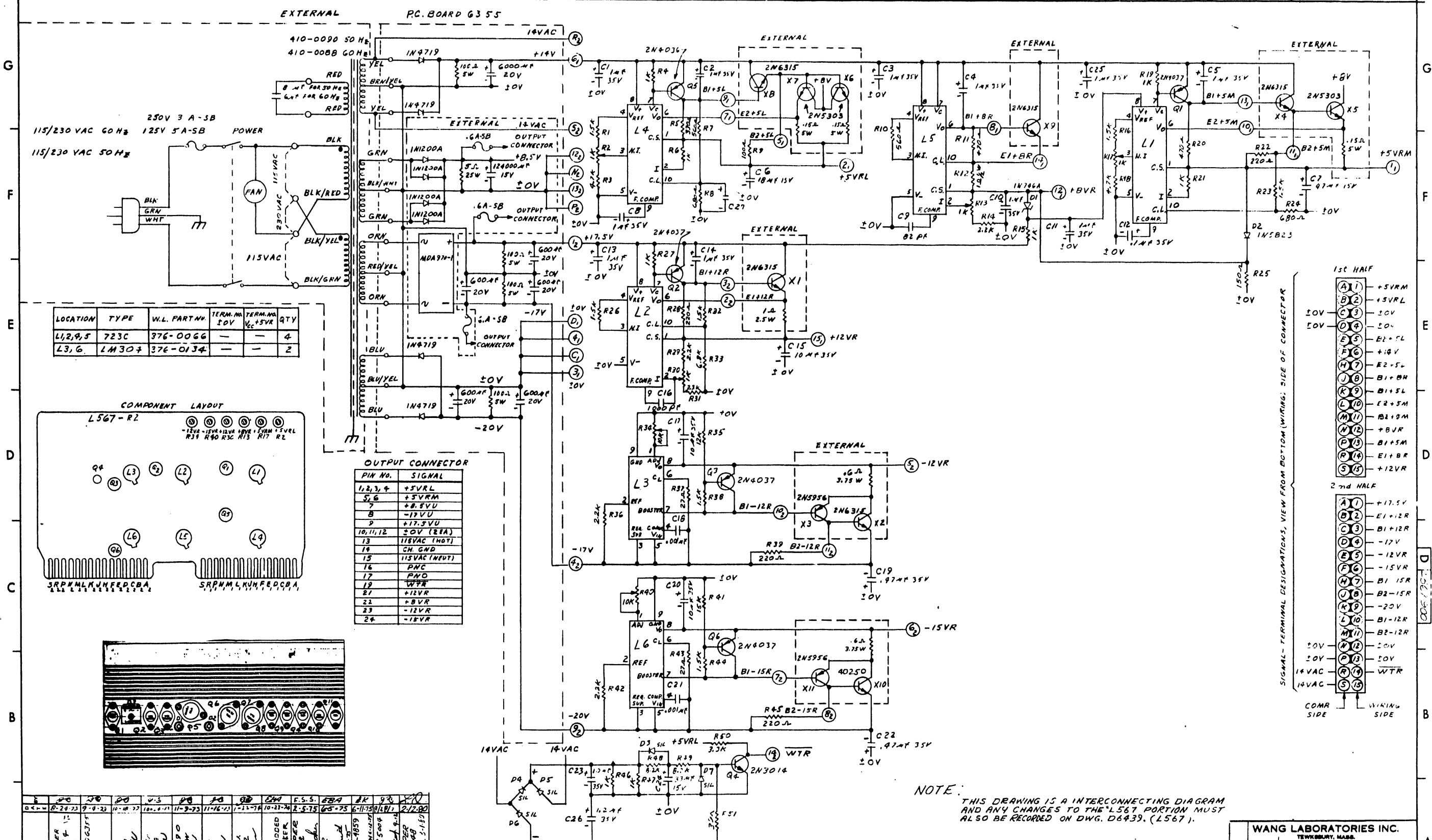

LOCATION	TYPE	WL. PART NO.	TERM. NO. 1-5	TERM. NO. 6-15	QTY
L1,2,4,5	723C	376-0066	-	-	4
L3,6	LM304	376-0134	-	-	2

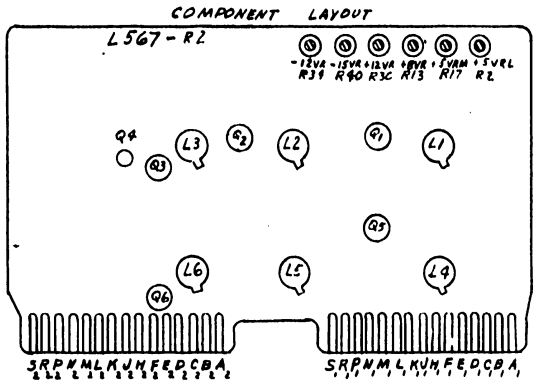

PIN NO.	SIGNAL
1,2,3,4	+5VRL
5,6	+5VRLM
7	+8.5VU
8	-17.5VU
9	+17.5VU
10,11,12	±0V (2EA)
13	115VAC (HOT)
14	CH. GND
15	115VAC (NEUT)
16	PNC
17	PND
18	WTR
21	+12VR
22	+8VR
23	-12VR
24	-15VR

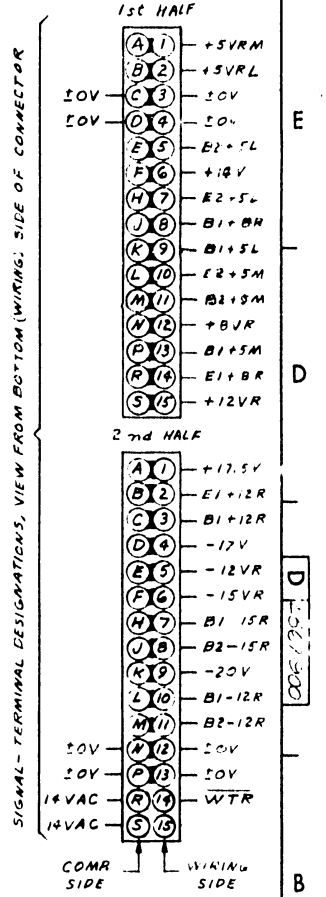

NOTE: THIS DRAWING IS AN INTERCONNECTING DIAGRAM AND ANY CHANGES TO THE LS67 PORTION MUST ALSO BE RECORDED ON DWG. D6439. (LS67).

REV.	DATE	BY	CHKD.	DESCRIPTION
1	8-29-73	W	W	REVISED PER APP. 0354
2	9-9-73	W	W	ADDED HC EDG JST
3	10-18-73	W	W	OUTLINE APP. 1 B.08
4	10-18-73	W	W	REVISED PER APP. 0354
5	10-18-73	W	W	REVISED PER APP. 0354
6	11-9-73	W	W	REVISED PER APP. 0354
7	11-16-73	W	W	REVISED PER APP. 0354
8	11-16-73	W	W	REVISED PER APP. 0354
9	12-11-73	W	W	REVISED PER APP. 0354
10	1-5-75	W	W	REVISED PER APP. 0354
11	6-5-75	W	W	REVISED PER APP. 0354
12	6-11-75	W	W	REVISED PER APP. 0354
13	11-17-75	W	W	REVISED PER APP. 0354
14	1-17-76	W	W	REVISED PER APP. 0354
15	2-2-76	W	W	REVISED PER APP. 0354
16	2-2-76	W	W	REVISED PER APP. 0354

WANG LABORATORIES INC.
 WENDEBURY, MASS.
 MODEL NO. 2200 DRAWN 3-15-73 APP. 4-14-73
 TITLE INTERCONNECTION DIAG 2200 POWER SUPPLY
 SHEET 1 OF 1 DWG. NO. 2567-900

54344

END