

Three
Rivers
Computer
PERQ



The definitive graphics workstation

The definitive graphics workstation

People think and communicate visually. That's why we depend in so many circumstances on graphs, maps, drawings, models and plans to represent, display and communicate information.

The problem with putting information into a visual form is the time and effort that can often be involved, especially when a high level of accuracy is demanded—not only in preparing the original display but also in carrying out amendments, experimenting with variations and extracting new data.

Today, we are all familiar with the profound way that computers can save time and boost productivity in such areas as data processing and mathematical computation.

The development of PERQ[®] has created a self-sufficient graphics workstation of unprecedented power and flexibility, available to a single user for tasks that involve the visualization of information—in all sectors of engineering and construction, architecture and education, research and development, print production and software design.



PERQ is in a class of its own. It has the work capacity and processing speed of an expensive mini-computer and a graphics capability that far exceeds that of any microcomputer system.



*PERQ is a trademark of Three Rivers Computer Corporation

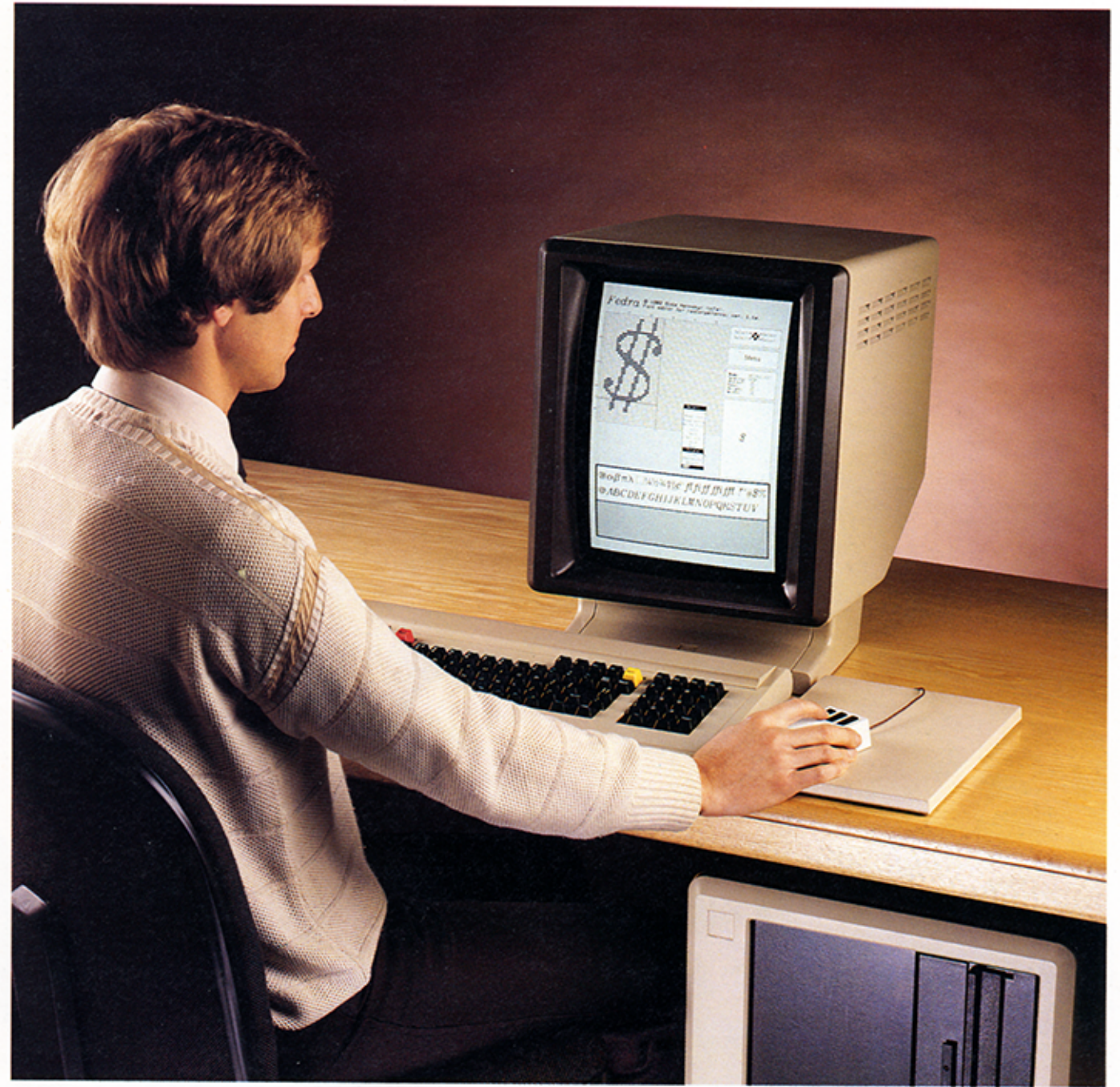

Consider PERQ's remarkable list of features:

- A screen resolution that has to be seen to be believed.
- A speed of operation and memory capacity to solve the most complex problems.
- The flexibility to be used as either a self-sufficient workstation or in conjunction with other computers and peripherals in a distributed network.
- The ability to function as a dedicated specialist system with the use of suitable applications software.

A breakthrough in computer development

The introduction of PERQ has extended the horizons of computing.

Before PERQ, most sophisticated graphics systems depended on a mainframe time-sharing arrangement that meant expensive initial investment, and that could also be impractical and inconvenient in operation.

What is more, even with such a machine, you still could not achieve the superior graphics capability provided today by PERQ.

The development of PERQ represents, in effect, a new approach to computing. PERQ is not an adaptation of an existing system but an original design concept created specifically to increase efficiency in all areas where visualization is a fundamental need.

Elegant and compact, the PERQ design enables the four main components (the processor, display, keyboard and graphics tablet) to fit around an ordinary desk. The floor mounted processor cabinet contains the main electronics, including the main memory, a fixed disk with mass local storage and a floppy disk drive for software back-up and program transportation.

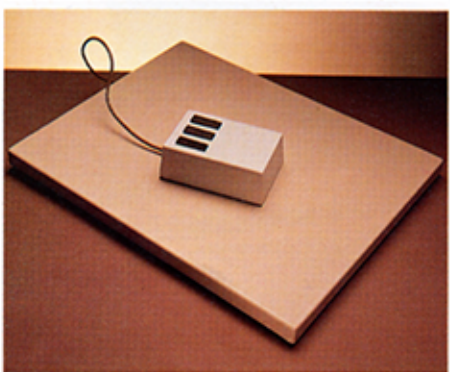
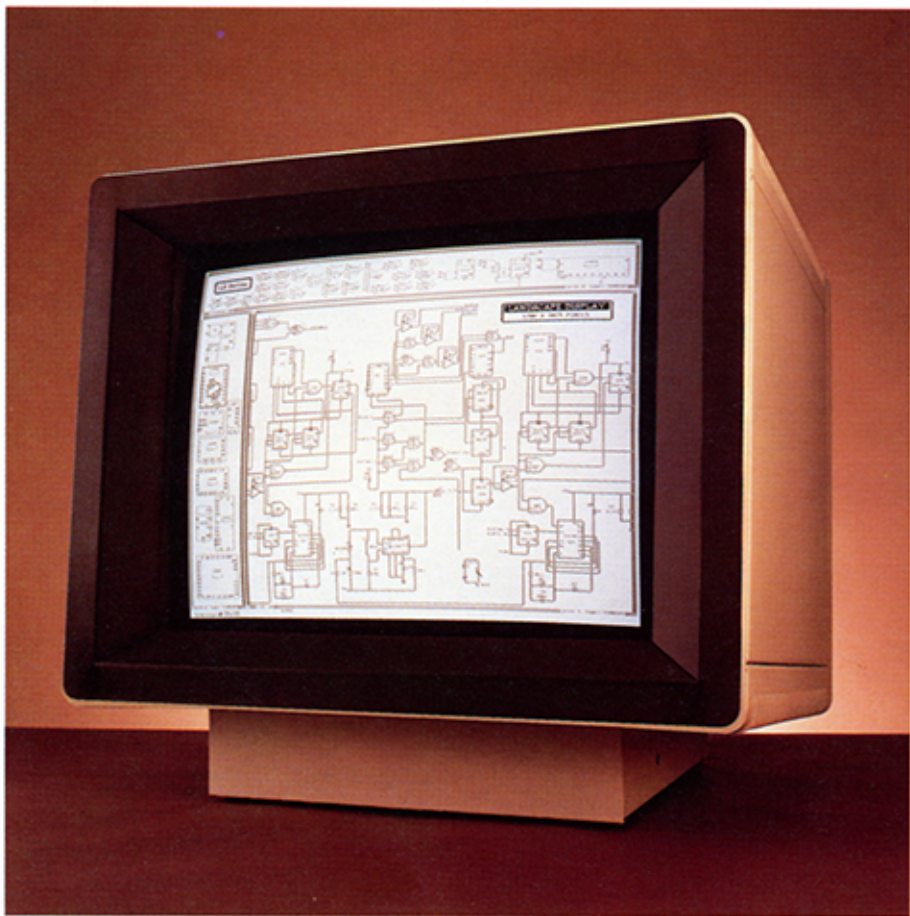

PERQ has been jointly developed by Three Rivers Computer Corporation in the USA and ICL—the leading computer company in Europe. Both companies are recognized as leaders in computing technology, and are committed to carry on the development of PERQ to maintain its leading edge position.

Three Rivers' and ICL's joint involvement means that the system is supported worldwide, an important consideration when it comes to maintenance and software support services.

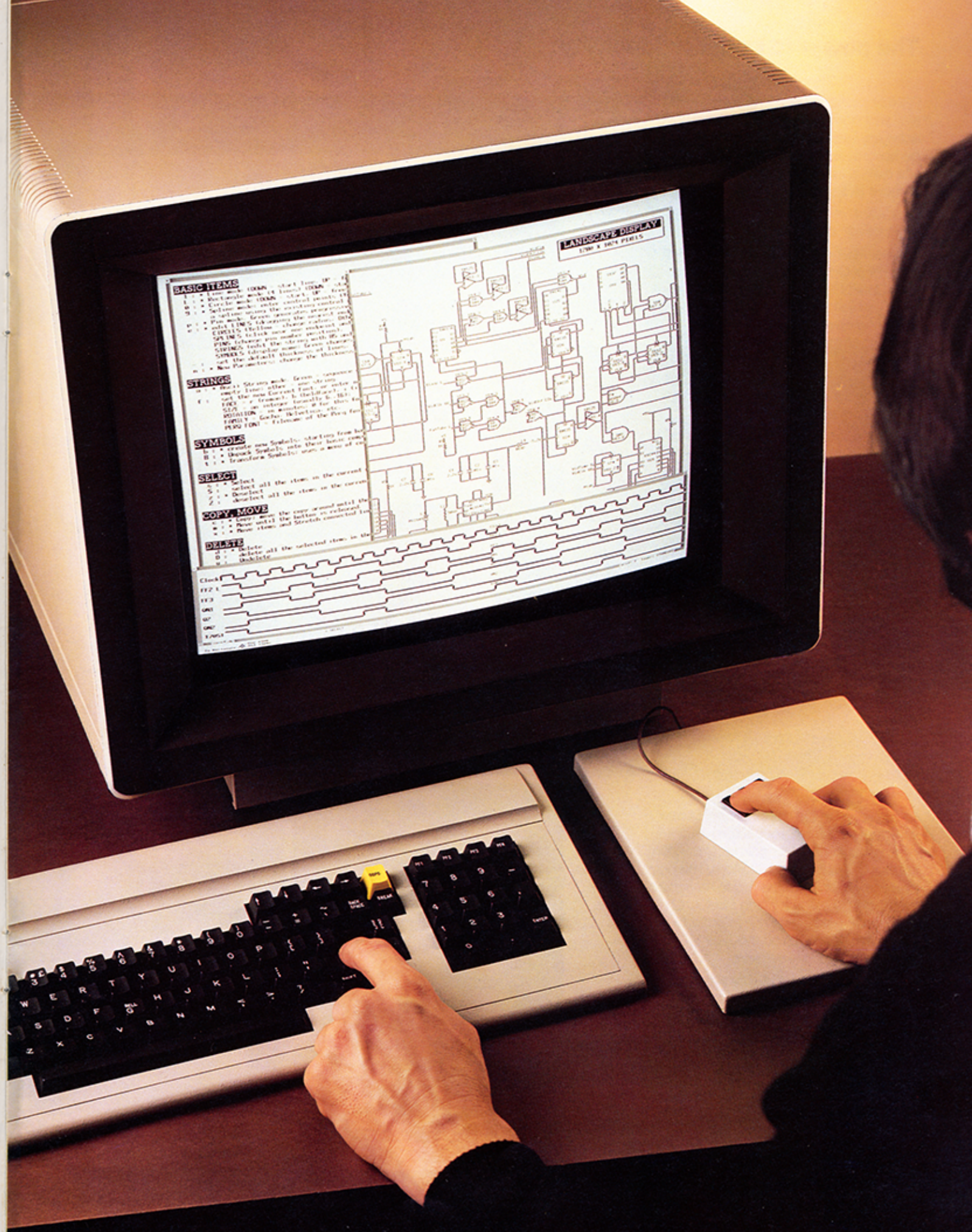

The power to boost productivity

PERQ has the capability to change the way you work, to free you from repetitive activities. Tasks that took hours can now be accomplished in minutes, allowing you to give full rein to your expertise and creative skills.

In practical terms, the key to this leap in productivity is software.

The backbone of the system's software is the PNX Operating System (derived from Unix™ System III under licence from AT&T), which provides a multi-tasking operating environment. As an established industry system, PNX provides a standardized core of utilities, languages and tools with which you can develop your own personalized applications programs.

There is also scope for acquiring a wide range of software already developed for other Unix systems.

In addition to PNX, PERQ has its own native operating system capable of supporting Pascal and FORTRAN 77 programs and providing a range of graphics tools and a number of applications packages.

General software packages and applications systems will be available to you from a number of sources, including:

- Software houses.
- Academic institutions.
- Other PERQ users.

To keep you fully informed on the software products available to PERQ users, a regularly updated software catalogue is produced and distributed worldwide.

To assist you in the development of new software, be it small specialized routines or major applications packages, you can access a Writable Control Store. This powerful facility enables you to maximize the efficiency of the existing PERQ microcode (instruction set) in order to obtain even faster throughput of development or live systems.

As well as providing industry with a graphics computer of unprecedented flexibility, the development of PERQ also represents a breakthrough in terms of value, with the cost of a single system marking a new low entry price into the era of visual computing.

‘Being able to produce high quality layouts and generate original typefaces makes PERQ ideal for use in the design and production of all kinds of documents.’

‘For the designer and architect, PERQ makes it possible to build up diagrams and plans from libraries of shapes and design routines and then to carry out with great ease such complex tasks as rotation and the creation of new projections and perspectives.’

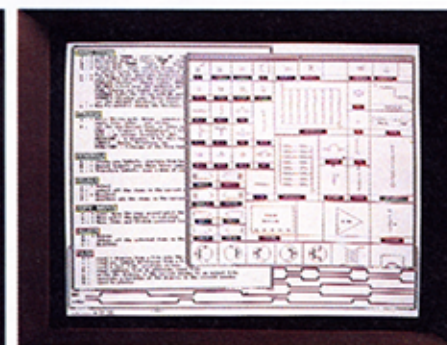
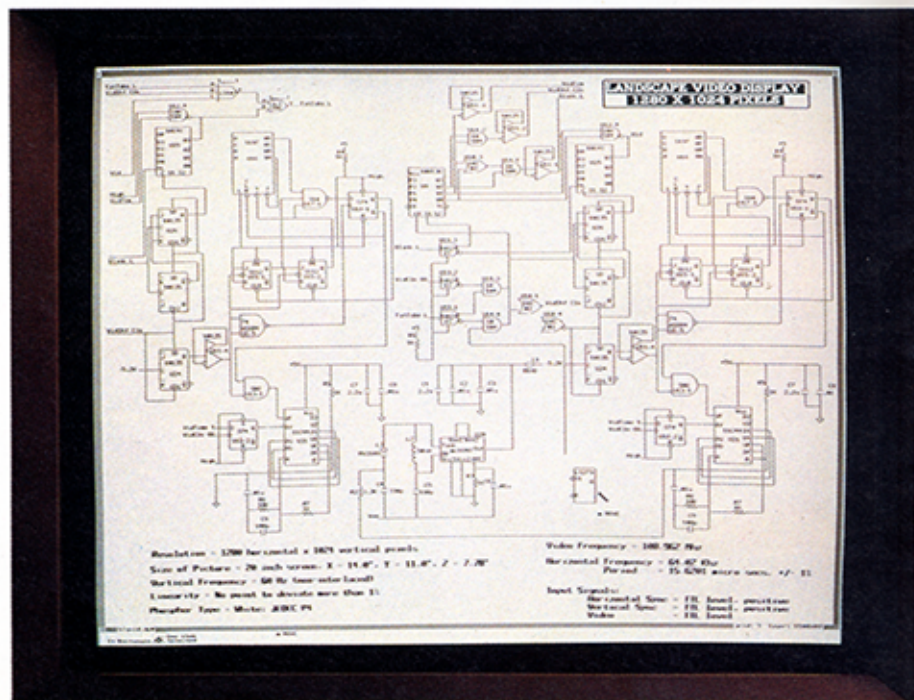
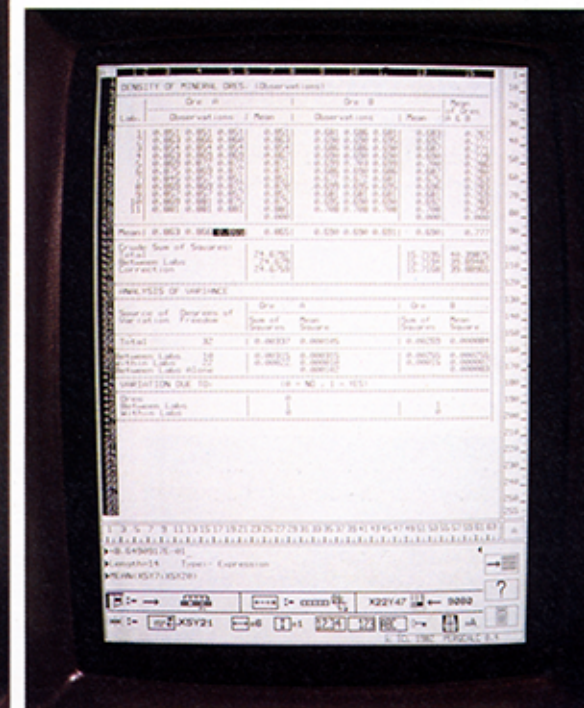
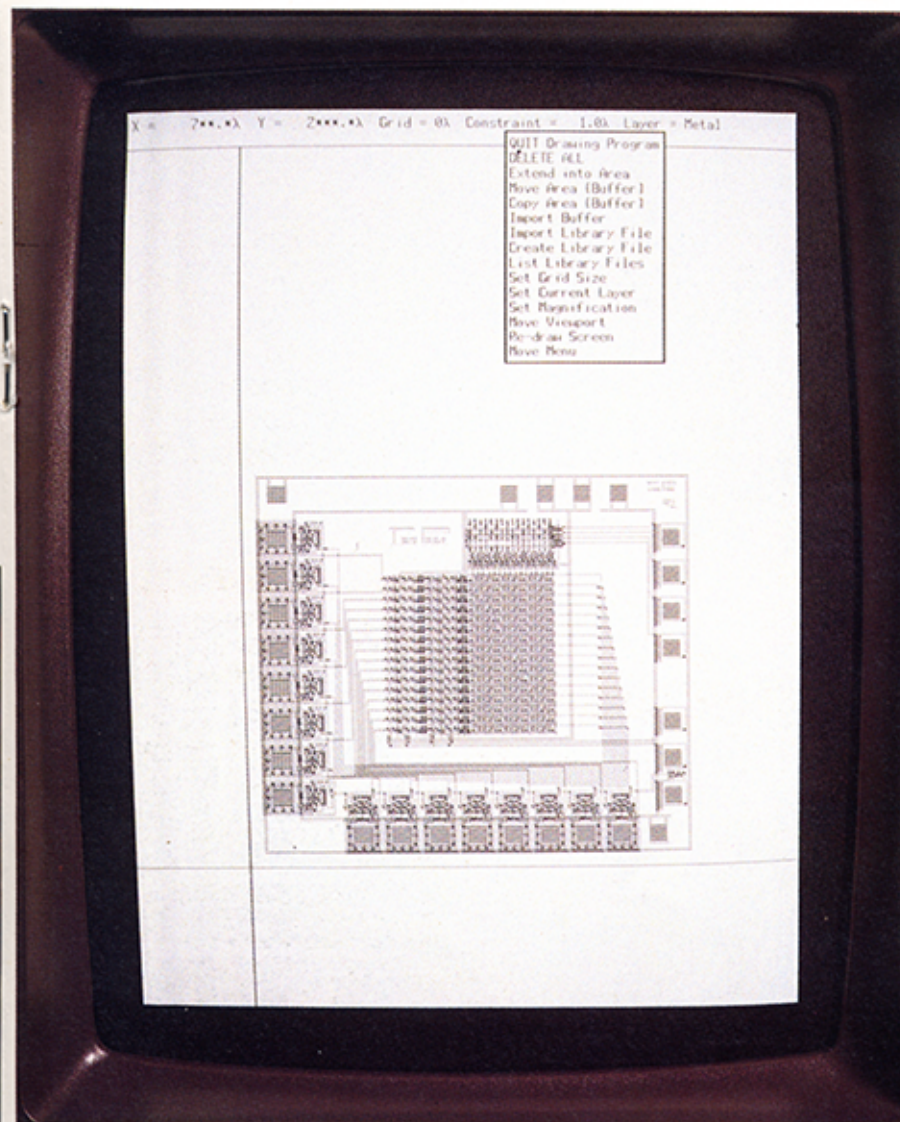
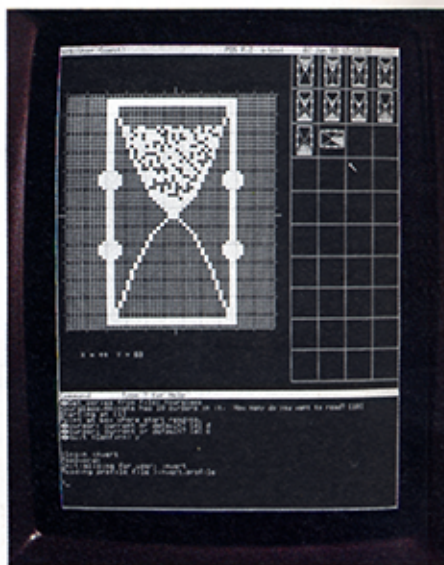
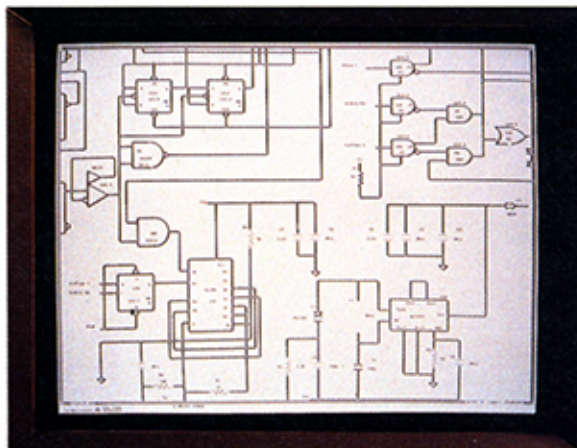

‘The applications open to PERQ in engineering are almost endless—from CAD/CAM and modelling to circuit design and simulation. The only limit, in fact, is the ingenuity of the user.’

‘With its industry-standard multi-processing operating system and allied range of programming facilities, PERQ can dramatically reduce the time required to develop advanced software applications.’

The PERQ experience

From the moment power is up (PERQ can be installed and operating within an hour of delivery), you realize that you have a system of enormous potential at your fingertips.

The system's superior graphics facilities result from a design approach and set of technical specifications that separate PERQ from its competitors.

The high resolution screen contains almost 100 dots per inch, each of which has its own location in a bit-map held in main memory. The provision of special hardware eliminates the delays usually associated with bit-mapped displays, and makes it possible to change all or part of the display with a single instruction. Coupled with this capability is a central processor that is able to operate at the rate of one million instructions per second. This power, together with other high performance characteristics, enables the whole screen to be refreshed, flicker-free, 60 times a second (at least twice as fast as a television screen), ensuring fast screen updating.



With any computer, the efficiency of the man-machine interface is a controlling factor in productivity attainment. Because PERQ has been designed for use by people who are more familiar with pen and paper than with computer keyboards, and because it is natural to point at a particular item you wish to amend or select, the main method of interaction with PERQ is with a graphics tablet and pointing device.

Using the pointing device, you can select items from an on-screen menu, construct drawings from library shapes, manipulate complex diagrams and maps, and design your own character fonts—all with exceptional ease.



Taken together, these attributes endow PERQ with an exceptional range of features:

- The screen can display any combination of graphics and text.
- Items can be erased and drawn almost instantly.
- You can scroll, pan and zoom across technical drawings highlighting any desired area.
- You can create life-like animated sequences.
- You can draw free-hand designs.
- Scientific models can be simulated and manipulated with ease.
- You can arrange page layouts for business and technical reports and books.

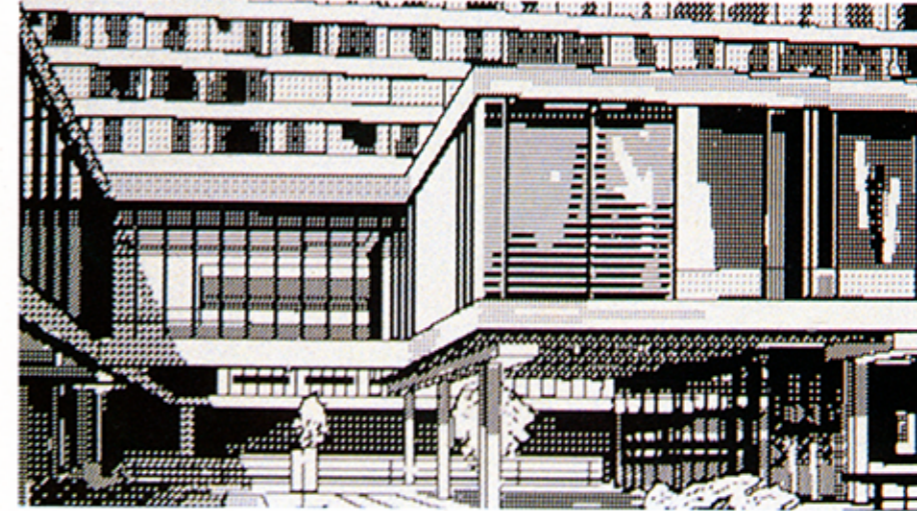
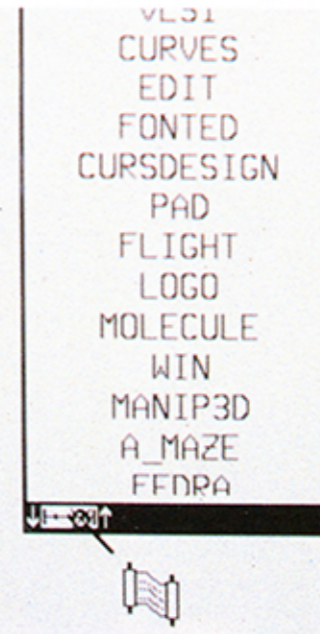

- You can generate typefaces of any design, creating your own fonts by building up each character pixel-by-pixel.
- The screen can be divided into separate 'windows', each of which can be thought of as a screen in its own right, capable of containing a different concurrent operation. These windows can be enlarged, reduced, overlaid and brought forward, making it possible to manipulate them as if they were papers on your desk.
- Because of the system's high processing rate, you can display, process and analyze laboratory data in real time.

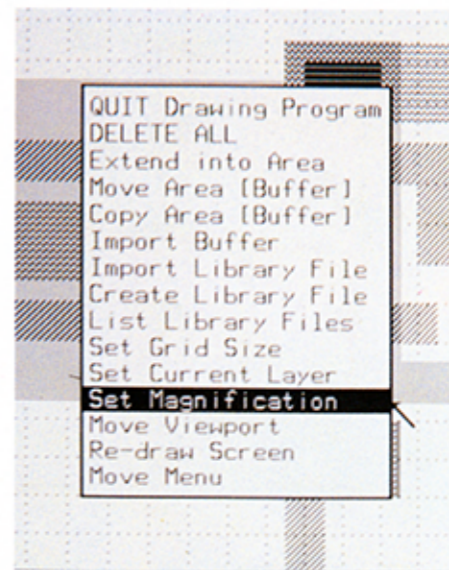

13 15 17 19 21 23 25 27 29 31 33 35 37 39 41 43

PIC HOR MIRROR ROT L
PART VER MIRROR ROT RI
H PIC n/a INVE
H PART n/a n/a

404 0211-482044

WINDOW

Read Selections
Move
Move next to
Grow/Shrink
Put on top
Put on bottom
Kill
Make Invisible

er Strings

with different fonts
and styles
and directions a

board

Puck providing Cursor Cont
with different
and

You and PERQ

An exceptional man-machine partnership

All the right connections

As well as being able to function as a stand-alone system, PERQ can also operate within a Local Area Network.

This makes it possible to:

- Communicate with other PERQ users.
- Transmit data between PERQs at speeds comparable to disk data transfer rates.
- Share data bases and exchange software.
- Share expensive peripherals such as laser printers and mass storage devices.
- Connect with other computer systems and devices that support the new international industry networking standard—Ethernet™ Local Area Network.

A distributed network provides you with a more resilient approach to computing because even if one (or more) of the devices involved fails, the other elements in the network continue to function unaffected, and communications are not broken.

In addition to networking, two standard interfaces are provided:

- The General Purpose Instrumentation Bus (GPIB) provides an easy means of interfacing with medium-speed peripherals and laboratory equipment. The connections can be made in parallel to allow a number of devices to be used simultaneously while remaining uniquely identified.

- A standard serial port (RS232) allows communications to take place at slow to medium data rates to other computer systems or peripherals.

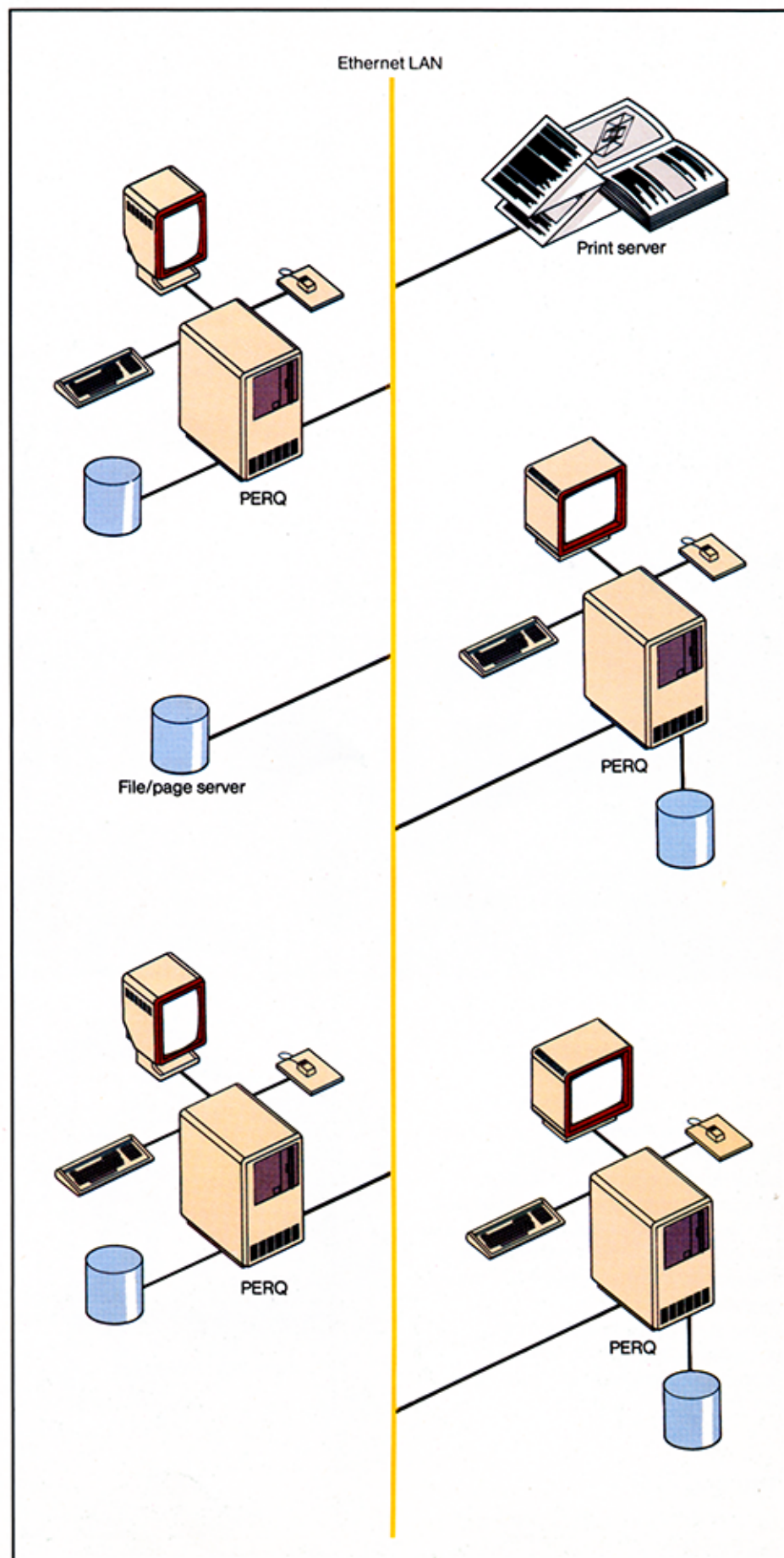

Ethernet™ is a trademark of Xerox Corporation

Three Rivers Computer Corporation gratefully acknowledges the co-operation of Ove Arup Partnership, Queen Mary College of the University of London, the University of Bath and the University of Tromsø, in the preparation of screen data for this document.



For further information contact

PERQ Systems Corporation
27281 Las Ramblas Suite 200
Mission Viejo, CA 92691
(714) 643-0782

Three Rivers
Computer Corporation
720 Gross Street
Pittsburgh Pennsylvania 15224
412/621-6250 TWX 710-664-4490

Three Rivers Computer Corporation endeavours to ensure that the information in this document is correct and fairly stated, but does not accept liability for any error or omission.

The development of Three Rivers' products and services is continuous and published information may not be up to date. It is important to check the current position with Three Rivers Computer Corporation. This document is not part of a contract or licence save insofar as may be expressly agreed.

© Three Rivers Computer Corporation 1983

P1436X Printed in England. 10M/2.83/HP