

Thermovision® 900 Series

USERS' MANUAL

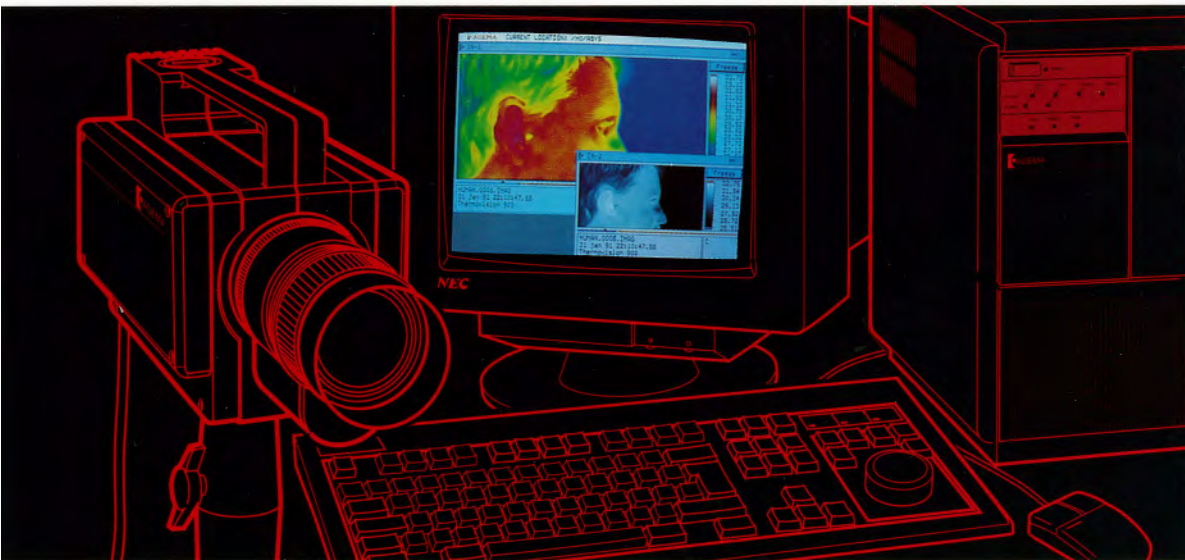

Preface

This is the user's guide for the installation and operation of Thermovision® 900 with

Software version ERIKA 3.00
(valid from September 1992).

Publication No. 556 960, Ed. 1, (Eng.).

This manual is subject to change without notice.



Copyright

(c) by AGEMA Infrared Systems AB, 1990, 1991, 1992. All rights reserved worldwide. No parts of the software including listings may be reproduced, transmitted, transcribed or translated into any language or computer language in any form or by any means, electronic, magnetic, optical, manual or otherwise, without the prior written permission of AGEMA Infrared Systems AB, Box 3, S-182 11 Danderyd, Sweden.

This manual is copyrighted and all rights are reserved. This document may not, in whole or part, be copied, photocopied, reproduced, translated or reduced to any electronic medium or machine readable form without prior consent, in writing, from AGEMA Infrared Systems AB.

Guarantee conditions

AGEMA Infrared System's computer software is supplied on the basis that it is complete and the Company accepts no responsibility or liability and makes no warranties whatsoever whether expressly or implied with regard to the same, including but not limited to its quality, performance, merchantability or fitness for any particular purpose.

AGEMA takes no responsibility for personal injuries, damage, to property loss or loss of profit or any other indirect damage unless it is proved that we have been guilty of gross negligence.

For further information on guarantee conditions, please refer to AGEMA general Guarantee Conditions.

Warning

This equipment generates, uses and can radiate radio frequency energy and if not installed and used in accordance with the instructions manual, may cause interference to radio communications. It has been tested and found to comply with the limits for a Class A computing device pursuant to Subpart J of Part 15 of FCC Rules, which are designed to provide reasonable protection against such interference when operated in a commercial environment.

Operation of this equipment in a residential area is likely to cause interference in which case the user at his own expense will be required to take whatever measures may be required to correct the interference.

Thermovision® is a registered trademark of AGEMA Infrared Systems AB.

X-Window System™ is a registered trademark of MIT Massachusetts Institute of Technology.

Ethernet™ is a registered trademark of Xerox Inc.

OS9 is a trademark of Microware Systems Corporation.

Thermovision®900 System Hardware Manual

C

C

C

C



Contents

1.	INTRODUCTION	
1.1.	AGEMA - The Company	1-3
1.2.	Thermovision® 900 System	1-5
1.3.	System Controller	1-6
1.4.	Scanners	1-7
1.5.	Lenses	1-8
1.6.	Accessories	1-9
1.7.	System Specifications	1-10
2.	UNPACKING AND INSPECTION	
2.1.	General	2-3
2.2.	Unpacking	2-4
2.3.	Inspection	2-5
2.4.	Assembly	2-8
2.5.	Interconnection	2-9
2.6.	Power Supplies	2-11
3.	INITIAL START-UP	
3.1.	General	3-3
3.2.	Scanner preparation	3-4
3.3.	Switch on	3-6
4.	DETAILED DESCRIPTION	
4.1.	Introduction	4-3
4.2.	System Controller	4-4
4.2.1.	General	4-4
4.2.2.	Processor unit	4-4
4.2.3.	Monitor, keyboard and mouse	4-7
4.2.4.	Accessories	4-10
4.3.	Scanners	4-11
4.3.1.	General	4-11
4.3.2.	Scanner 900 LW	4-16
4.3.3.	Scanner 900 SW	4-17
4.3.4.	Scanner 900SW-TE	4-19

- 5. TROUBLESHOOTING
 - 5.1. Introduction 5-3

- 6. THERMAL MEASUREMENT TECHNIQUES
 - 6.1. Introduction 6-3
 - 6.2. Correction for the influence of atmosphere and object emissivity 6-4
 - 6.3. Compensation for the radiation emitted from the scanner 6-5
 - 6.4. Calibration function 6-6
 - 6.5. Object parameters 6-8
 - 6.5.1. Emissivity 6-8
 - 6.5.2. Efficient atmospheric transmission 6-10
 - 6.5.3. Object distance and relative humidity .. 6-11
 - 6.5.4. Atmospheric temperature 6-11
 - 6.5.5. Reflected ambient temperature 6-11
 - 6.5.6. Estimated transmission 6-12
 - 6.5.7. Relative humidity 6-12

- 7. INTRODUCTION TO THE THEORY OF THERMOGRAPHY
 - 7.1. Introduction 7-3
 - 7.2. The Electromagnetic Spectrum 7-4
 - 7.3. Blackbody Radiation 7-6
 - 7.4. Photon Emission 7-10
 - 7.5. Non-blackbody emitters 7-12
 - 7.6. Infrared semi-transparent materials . 7-15
 - 7.7. Infrared optical materials 7-16
 - 7.8. IR detectors 7-18
 - 7.9. Infrared scanners 7-20
 - 7.10. Origins of modern radiation theory . 7-21

1. Introduction

1.1.	AGEMA - The Company	1-3
1.2.	Thermovision® 900 System	1-5
1.3.	System Controller	1-6
1.4.	Scanners	1-7
1.5.	Lenses	1-8
1.6.	Accessories	1-9
1.7.	System Specifications	1-12



1.1. AGEMA - The Company

AGEMA Infrared Systems AB, the producer of the Thermovision® 900 System, has been the world leader in the civil use of infrared thermography since the introduction of the first Thermovision® in the mid-sixties. Since then several thousand systems have been installed in almost every country in the world. A vast amount of experience of IR technology has been gained by AGEMA over the years and this has been used as the basis for the design of the Thermovision® 900 System. AGEMA's expertise is in thermal measurement but our know-how encompasses other fields such as electronics, optics, precision engineering and electro-optics.

AGEMA headquarters and production facilities are housed in a modern purpose designed building at Danderyd, 15 km north of Stockholm. Here approximately 150 people are involved in the design, development, manufacturing and marketing of thermography equipment. Thermovision®, Thermoprofile® and Thermopoint® are all trade names of AGEMA products.

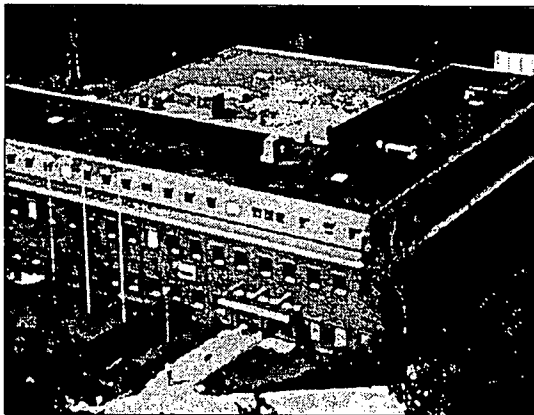
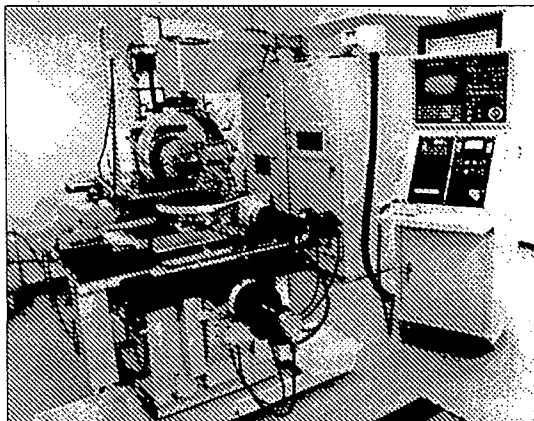

Fig 1-1
AGEMA headquarters



*Fig 1-2
AGEMA Calibration department*



*Fig 1-3
The Diamond turning machine
installed at AGEMA*

Thermovision® 900 uses an optical scanning system which requires highly sophisticated production technology. The tolerances relating to deviations in optical surface measurements are extremely small. AGEMA have therefore invested in a diamond turning machine, one of the first to be installed in Europe. With this machine optical surfaces can be manufactured in metal and germanium with far greater accuracy than with conventional techniques. Thanks to this investment AGEMA has retained full control of a very important part of scanner production.

The sales, installation and servicing of AGEMA products are carried out through a worldwide organisation of AGEMA subsidiaries and specially trained representatives. They are experts in their field and can give specialised training in various aspects of thermal image analysis and also provide factory-authorised service. Fast repair and return to operation of a system is the goal of our service organisation.

1.2. Thermovision® 900 System

The Thermovision®900 System is the sixth generation of infrared scanning systems produced by AGEMA Infrared Systems AB. It offers improved accuracy and resolution with greater image definition. The use of state of the art technology has enabled AGEMA to reduce the size of the scanners and incorporate all controls and analysis features into a specially designed system controller working in a menu driven windows environment. The Thermovision® 900 system controller is a true dual channel microprocessor based controller.

The system is designed for static use in laboratory or industrial situations but can, when necessary, become mobile using a specially designed workstation. The following sections give a brief description of the different units and accessories of the system and their respective specifications.

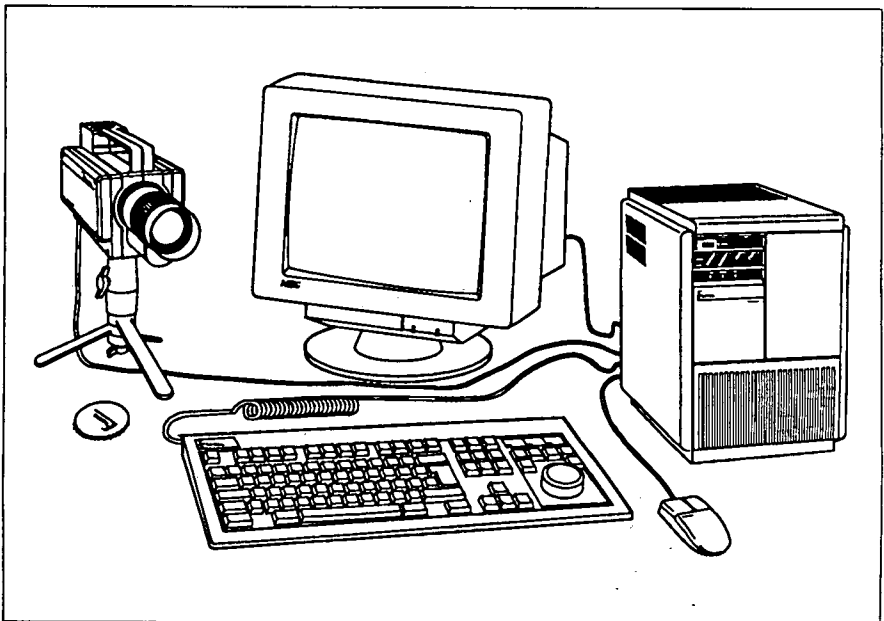
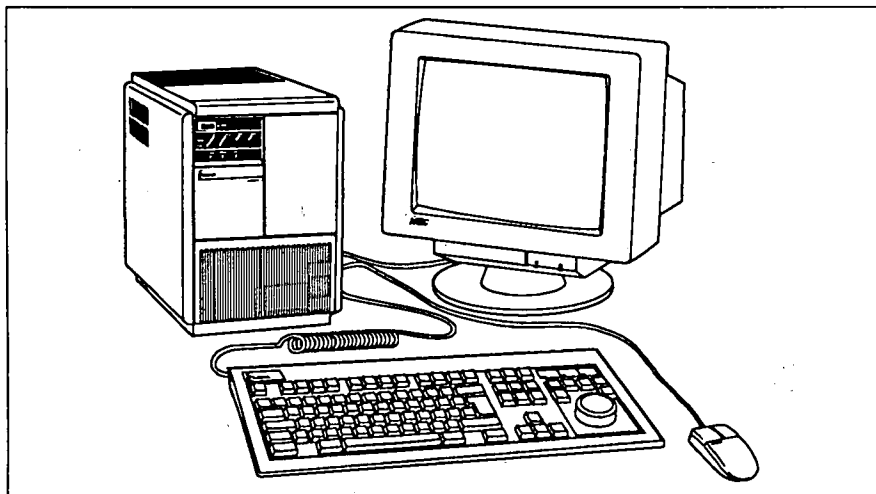

Fig 1-4
Thermovision®900 System

1.3. System Controller

The System controller is a purpose built microcomputer based on the industry standard VME bus. It has been designed specifically for use with the Thermovision[®]900 System Scanners and has the following features:

- OS9 operating system
- Two 68020 processors
- Menu driven X-Window System™ environment with mouse
- Enhanced keyboard with specialized built-in controls for image handling
- VGA Monitor
- Standard 3 1/2" floppy disk drive
- High speed 100 or 500 Mb hard disk drive
- 4 + 8 Mb of Dynamic RAM (DRAM)
- Readily expandable



*Fig 1-5
System controller processor unit,
Monitor, Keyboard and Mouse*

1.4. Scanners

The Thermovision®900 System Scanners are compact, lightweight scanners designed to operate in the Long and Short Wavebands. The scanners have the following features:

- Microprocessor control of all servo-motors
- Microprocessor controlled image handling
- 12 bit A/D conversion of scanner signals
- Digital output from scanner to system controller
- Patented diamond turned optical system
- Four range settings for different sensitivities
- Interchangeable filter cassette
- Interchangeable lenses
- Remote focusing controlled from the System controller keyboard
- All scanner functions remotely controlled

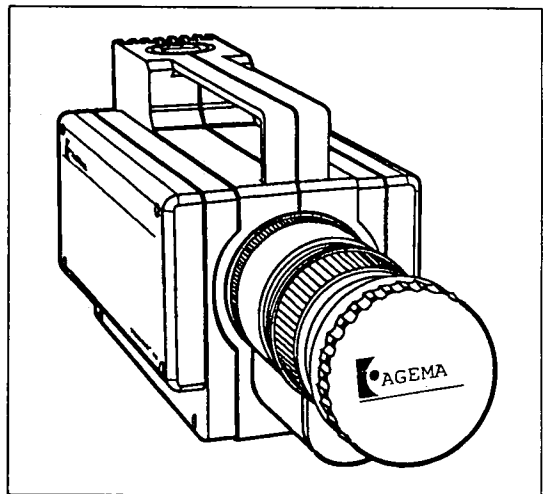

Fig 1-6
Thermovision®900 Scanner

1.5. Lenses

Five different interchangeable lenses are available for the Thermovision® 900 system.

900/LN2 and ST	900 TE	
• 2.5° x 1.25°	• 2.5° x 1.55°	FOV
• 5° x 2.5°	• 5° x 3.13°	FOV
• 10° x 5°	• 10° x 6.25°	FOV
• 20° x 10°	• 20° x 12.5°	FOV
• 40° x 20°	• 40° x 25°	FOV

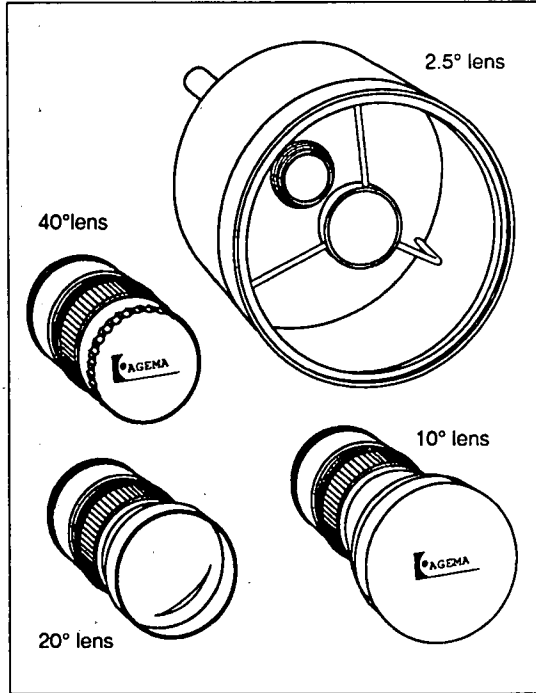

Fig 1-7
Thermovision®900 Lenses

1.6. Accessories

The Thermovision® 900 system can be interfaced with a range of accessories as follows:

- Video Cassette Recorder (VCR)
- RGB Video Printer for high resolution printed output
- Text Printer
- Burst recording unit
- Fibre optic link and scanner power supply for long distance transmission
- Mobile workstation
- Microscope lens
- DAT recorder, hard disk or magneto-optical disk (MO disk)

1.7. System Specifications

System controller

Processor	2 x 68020
Memory	4 + 8 Mb of dynamic RAM, 100 Mb Winchester disk
Bus system	32 bit VME bus, 2 x 16 bit IR busses
Inputs/Outputs	2 x Scanner connectors 2 x RS-232-C serial connectors External input/output connector Ethernet interface connector Monitor connector Mouse connector Keyboard connector Composite video output connector
Power Supplies	
Mains input	100 - 250 VAC, 48 - 65 Hz, 300 VA approx.
Scanner output	+5 V, ± 12 VDC

Scanners

Scanner SW, thermo-electrically cooled

Detector type	2 x SPRITE, serial scanning
Spectral response	2 - 5.4 micron
Temperature range	-10 to +500°C (+2000 with filter)
Sensitivity	0.1°C at 30°C
Accuracy	$\pm 1^\circ\text{C}$ (range 1), $\pm 1\%$ (ranges 2-4)
Repeatability	$\pm 0.5^\circ\text{C}$ (range 1), $\pm 0.5\%$ (ranges 2-4)
Spatial resolution	140 elements per line (50% modulation)
IR-line frequency	3.5 kHz
Frame freq.	20 Hz/30 Hz
IR-lines per frame	128 (86 at 30 Hz)
Samples per line	204

Scanner SW, LN₂ or Stirling cooled

Detector type	2 x InSb, serial scanning
Spectral response	2 - 5.6 micron
Temperature range	-20 to +500°C (+2000 with filter)
Sensitivity	0.1°C at 30°C
Accuracy	$\pm 1^\circ\text{C}$ (range 1), $\pm 1\%$ (ranges 2-4)
Repeatability	$\pm 0.5^\circ\text{C}$ (range 1), $\pm 0.5\%$ (ranges 2-4)
Spatial resolution	200 elements per line (50% modulation)
IR-line frequency	2.5 kHz
Frame freq.	15 Hz/30 Hz
IR-lines per frame	136 (68 at 30 Hz)
Samples per line	272

Scanner LW, LN₂ or Stirling cooled

Detector type	MCT
Spectral response	8 - 12 micron
Temperature range	-30 to +1500°C (+2000 with filter)
Sensitivity	0.08°C at 30°C
Accuracy	±1°C (range 1), ±1% (ranges 2-4)
Repeatability	±0.5°C (range 1), ±0.5% (ranges 2-4)
Spatial resolution	230 elements per line (50% modulation)
IR-line frequency	2.5 kHz
Frame freq.	15 Hz/30 Hz
IR-lines per frame	136
Samples per line	272

Power supplies +5 Vdc, ±12 Vdc

Vibration, operating,
acc. to IEC 68-2-6
Test 5-2000 Hz 5 G or max. ±2.5 mm

Shock, operating,
acc. to IEC 68-2-29
Test Eb Pulse
duration 7 ms 5 G or max. ±2.5 mm

Operating temperature -15 to +55°C

Storage temperature -40 to +70°C

Dimensions

Width	120 mm
Height	155 mm
Depth	250 mm

Weight 3.5 kg

Lenses

2.5°	Minimum focus	20 m
	Geometric resolution	0.19 mrad LW
		0.22 mrad SW
5°	Minimum focus	4 m
	Geometric resolution	0.38 mrad LW
		0.44 mrad SW
10°	Minimum focus	1.2 m
	Geometric resolution	0.76 mrad LW
		0.87 mrad SW
20°	Minimum focus	0.6 m
	Geometric resolution	1.5 mrad LW
		1.7 mrad SW
40°	Minimum focus	0.3 m
	Geometric resolution	3.0 mrad LW
		3.5 mrad SW
		4.9 mrad TE

No lens (macro)

<u>Type</u>	<u>Focus (mm)</u>	<u>fov</u>	<u>Resolution (mrad)</u>
TE	45.7	32.7 x 20.5	0.24
SW/cryo	45.7	32 x 16	0.16
LW/cryo	43.3	30.6 x 15.3	0.14

2. Unpacking and Inspection

2.1.	General	2-3
2.2.	Unpacking	2-4
2.3.	Inspection	2-5
2.4.	Assembly	2-8
2.5.	Interconnection	2-9
2.6.	Power Supplies	2-11



2.1. General

The Thermovision® 900 System contains one or two scanners, system controller with monitor, keyboard and mouse, and operating manuals. Hardware and software options will have been incorporated before delivery of the system and the necessary cables will be packed with the system. This section deals with the unpacking, inspection, assembly and preparation of the system prior to initial switch-on.

2.2. Unpacking

The Thermovision® 900 system is supplied in three or four cases depending on whether a single or dual scanner system is ordered. The scanners are supplied in standard transport cases while the system controller, monitor, keyboard and mouse are packed in standard re-usable cartons which should be retained for use when transporting the system. The separate items are distributed as follows:

Case type 1 - Standard transport case containing:

- 1 Scanner without fitted lens
- 1 10° Lens (if ordered)
- 1 20° Lens (if ordered)
- 1 Funnel, for liquid nitrogen

The optional extension cable for the scanner will be packed in this case, if ordered.

Case type 2 - Re-usable carton containing:

- 1 System controller processor unit
- 1 Cable, Mains input
- 1 Cable, Mains, Monitor
- 1 Keyboard
- 1 Mouse
- 1 Manual set
- 1 Diskette set

Case type 3 - Re-usable carton containing:

- 1 Monitor
- 1 Cable, signal, Monitor
- 1 Manual, Monitor

On receipt of the Thermovision®900 System carefully remove each item from its packing and check the part and serial numbers of the components against the delivery note. Inspect the components for obvious damage which may have occurred during transportation and report any such damage immediately to your local AGEMA representative.

2.3. Inspection

Scanner

Carefully examine the scanner cable and connector for signs of damage such as split insulation or bent pins.

Remove the lens cover and ensure that the fixed front lens of the scanner is not scratched or damaged. Check that the bayonet connector is in good condition.

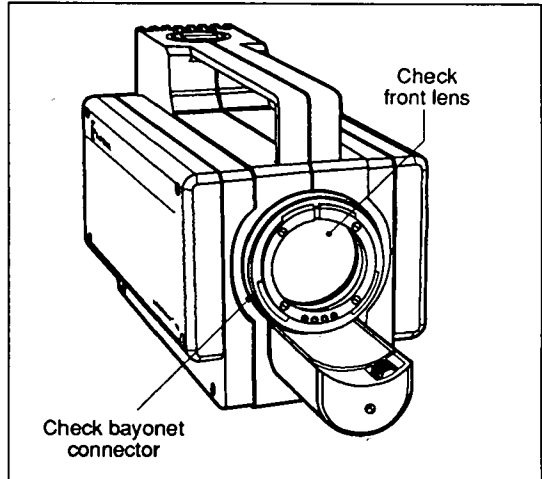

Fig 2-1
Checking the Scanner

Check that the detachable lenses included with the scanner are in good condition. Examine the focusing attachment for any damage to the drive mechanism.

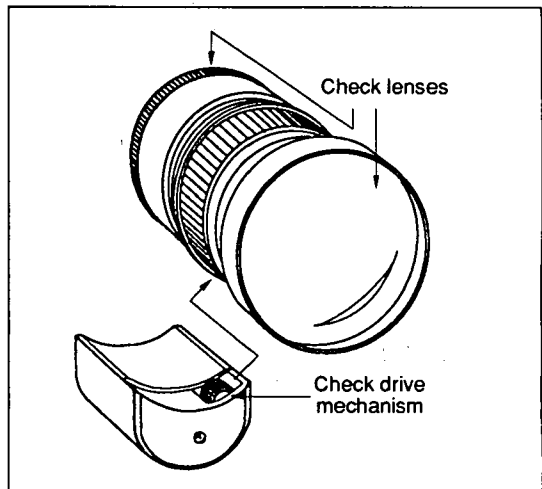

Fig 2-2
Checking the Lenses

Check the scanner and lens bayonet connections by fitting a lens to the scanner. Align the white dots on the lens and carefully push the lens against the bayonet fitting on the scanner. Turn the lens locking ring clockwise approximately one quarter turn or until resistance is felt. Check that the lens is secure before using the scanner.

System controller processor unit

Check all cables supplied with the system controller for obvious damage to insulation or connectors. Carefully examine the system controller for signs of damage to the unit panels and rear panel connectors. Remove the floppy disk protection card from the 3½" drive.

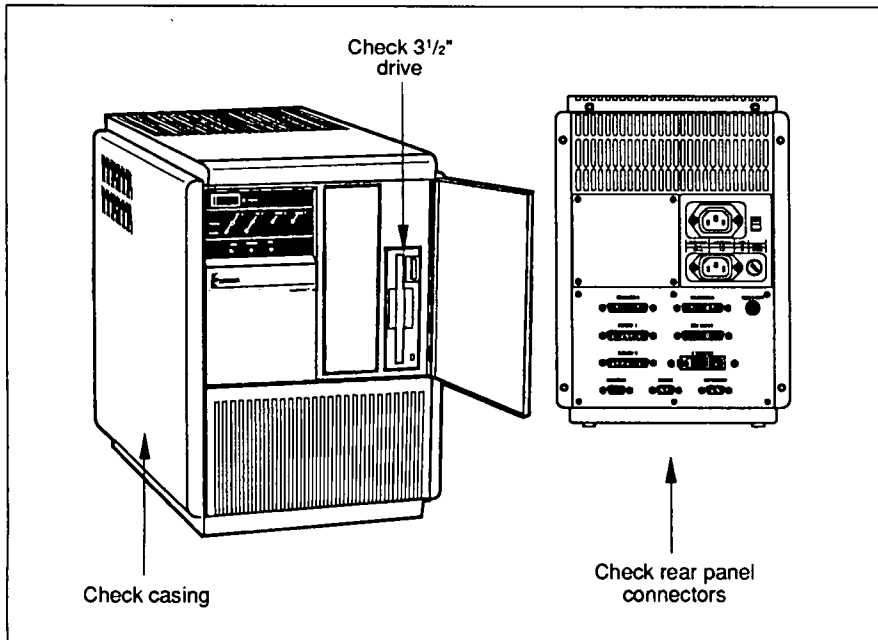

Fig 2-3
Checking the System controller processor unit

Monitor

Examine the monitor cables for signs of damage to the insulation and connectors. Check the casing for any signs of damage which may have occurred in transit.

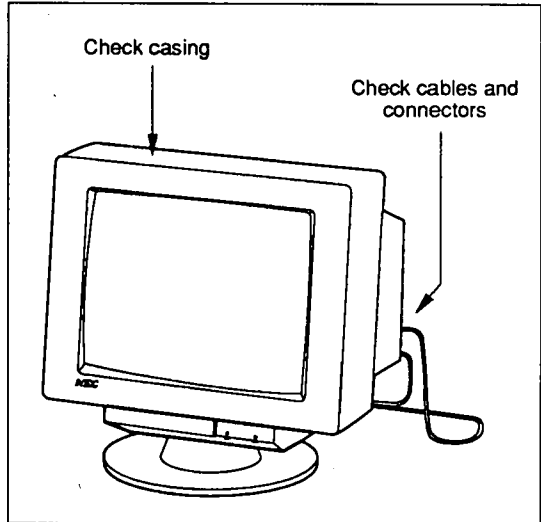

Fig 2-4
Checking the Monitor

Keyboard and Mouse

Examine the keyboard and mouse cables for signs of damage to the insulation and connectors. Check the keyboard and the mouse for any signs of damage to the casing and keys that may have occurred in transit.

2.4. Assembly

The Thermovision®900 System is designed for use as a stationary installation in laboratory or industrial situations. The scanner is mounted on a fixed tripod and the System controller processor unit, monitor, keyboard and mouse on a desk or table top. The standard cable length is 3 metres but an optional extension of 7 metres can be added for a maximum separation, between the scanner and System controller, of 10 metres. This separation can be greatly increased by using the optional scanner power supply and fibre optic link.

The system can be mounted on a mobile workstation. The scanner is mounted on a stand secured to the workstation or can be removed and operated separately using the tripod. The workstation has positions for mounting the System controller processor unit, monitor, keyboard, mouse and an extra shelf for locating a video printer or other accessories.

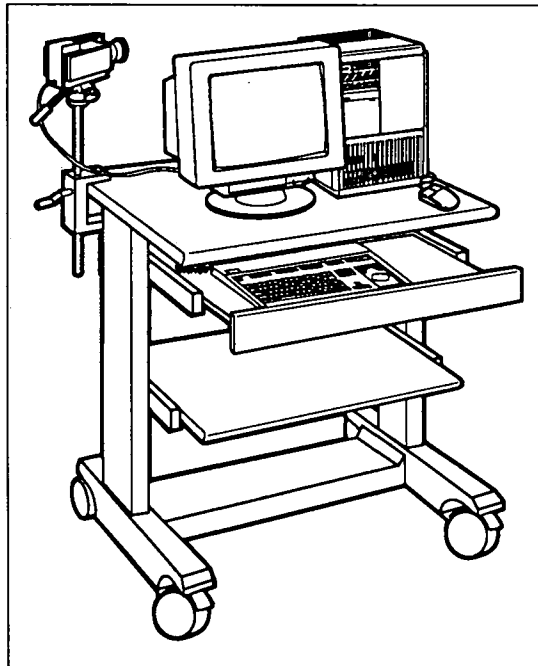

Fig 2-5
Mobile workstation

2.5. Interconnection

All the components of the system are connected to the System controller processor unit at its rear panel. Figure 2-6 shows the location of the rear panel connectors.

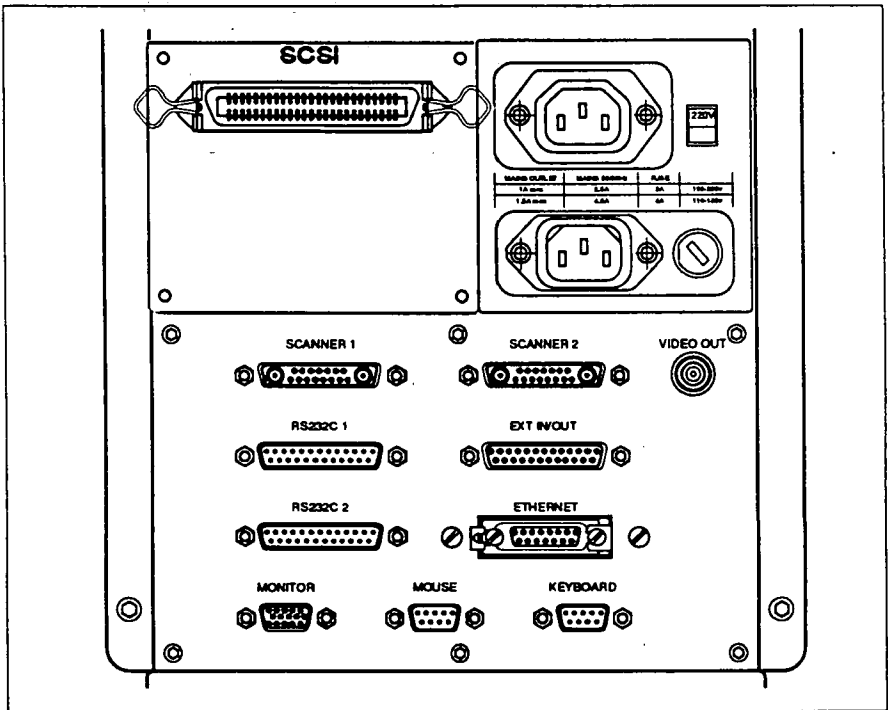

Fig 2-6

System controller processor unit
rear panel connectors

The Scanners have fixed cables terminating in D-type connectors which mate directly with the rear panel sockets marked SCANNER 1 and SCANNER 2. In the case of a single scanner system the scanner must be connected to the SCANNER 1 socket.

The VGA Monitor is connected to the System controller via two fixed cables, one for the mains supply and the other for the video signals. The mains supply cable terminates in a plug which connects with the MAINS OUT socket. The video cable terminates in a D-type connector and this mates with the MONITOR socket.

The keyboard and mouse both have fixed cables which terminate in plugs and mate with the KEYBOARD and MOUSE sockets respectively.

Before connecting the System controller processor unit to the mains supply ensure that the rear panel switch is set to the correct voltage. Check that the fuse is correct for the local supply voltage. The recommended fuse values are shown on the rear panel. Check that the mains supply setting on the monitor is set to the correct voltage.

Ensure that all connections are secure by carefully tightening the screws on the cable connectors and checking that all mains connectors are pushed fully home.



2.6. Power Supplies

The power requirements of the system are as follows:

Supply voltage	100 - 250 VAC, 48 - 65 Hz
Power consumption	250 VA approx.
Fuses	120V 4A 220V 2A

The System controller processor unit provides the power supplies for the other components of the system as follows

Scanner	+5 V, ± 12 VDC via the scanner connectors
Monitor	100 - 250 VAC, 48 - 65 Hz



3. Initial Start-up

3.1.	General	3-3
3.2.	Scanner preparation	3-4
3.3.	Switch on	3-6

C

C

C

C

3.1. General

The Thermovision® 900 System software is installed prior to delivery. All calibration data for the scanners, lenses and filters included in the system has already been loaded. It is not necessary for the user to input any data prior to using the equipment.

Ensure that the system has been inspected and assembled as detailed in the previous section. The cryogenically cooled scanner is prepared as detailed in the following paragraphs prior to switching on the system.

3.2. Scanner preparation



CAUTION: *Some safety precautions should be observed when using liquid nitrogen. These are detailed in the following paragraphs*

1. Never store the liquid in sealed containers. LN_2 and other cryogenic liquids are always stored in Dewar flasks or the equivalent, which allow the gases to vent without building up dangerous pressures.
2. Never come into direct contact with liquid nitrogen. Serious frostbite injury (similar to a burn) can result if the liquid is allowed to splash into the eyes or onto the skin.
3. Prior to filling the scanner Dewar chamber it is advisable to transfer some LN_2 from the main Dewar to a small portable Dewar.

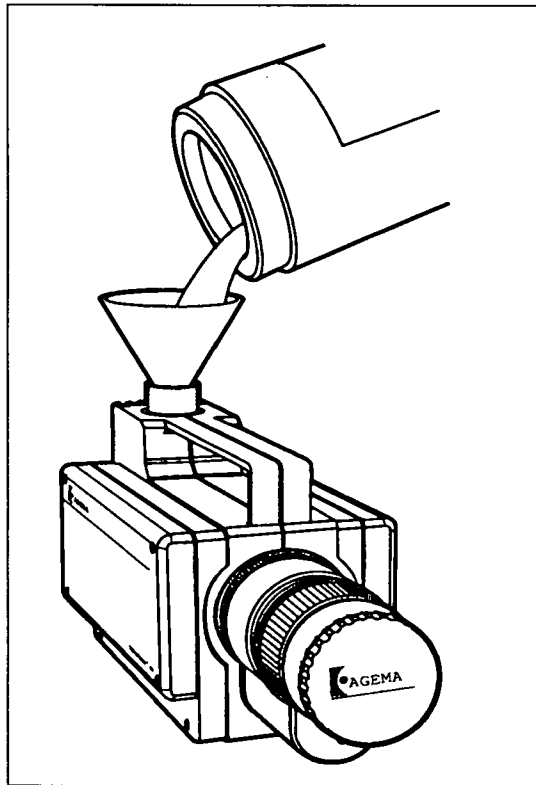

*Fig. 3-1
Filling the scanner Dewar chamber*

The scanner Dewar is filled as follows:

4. Unscrew the filler cap from the top of the scanner body.



WARNING: *Under NO circumstances look down into the Scanner Dewar or the funnel during the filling operation. Trapped air in the Dewar can cause the liquid nitrogen to be expelled with considerable force.*

5. Using a funnel pour a small amount of LN_2 into the scanner Dewar chamber and wait until the boiling ceases (refer to Fig. 3-1). This is to reduce the temperature of the Dewar to that of the liquid nitrogen to prevent excess spillage. It may require several minutes and repeated amounts of liquid nitrogen to reduce the temperature sufficiently.
6. When the temperature has been reduced, continue to fill the Dewar. Extreme caution must be exercised on completing the filling operation as the LN_2 will overflow.
7. Replace the filler cap on the scanner.
8. After an initial filling or replenishment of liquid nitrogen, the system will require some time to stabilize before thermal measurement can be accurately achieved.

If the Thermovision®900 scanner is being used for periods in excess of four hours it is advisable to ensure that the liquid nitrogen does not completely evaporate. Lack of liquid nitrogen in the Dewar will result in measurement inaccuracy or total loss of image.

A warning will appear on the screen that the liquid nitrogen level is low and the scanner status LED will turn red. The operator should immediately replenish the liquid nitrogen if measurement is to continue. With the LW scanner the image will disappear shortly after the warning is given. A SW scanner image will disappear a few minutes after the warning.

3.3. Switch on

Prior to switching on the system ensure that all cables are correctly connected and that the voltage selector at the rear of the System controller is set to the correct voltage for the local supply. Check that the fuse is correct for the local supply voltage. The recommended fuse values are shown on the rear panel. Check that the mains supply setting on the monitor is correct for the local supply voltage.

1. Ensure the scanner has been correctly prepared and has the required lens fitted, with the lens cap removed. Set up the scanner on a tripod or on the workstation pointing at a "test" object, i.e. any object that will give a range of temperature readings.
2. Set the POWER switch on the System controller front panel to ON and check that the power indicator LED is lit.
3. Switch on the monitor and check that the power indicator is lit.
4. Check that the scanner motors are running (the scanner is automatically started up when the system controller is switched on).
5. Check that after a short period the monitor shows the ERIKA copyright notice and that the IR1 window is then opened with a live scanner image. The image should be shown in the IRONBOW colour palette and be auto-scaled. This is the normal case as long as you have not changed the start-up procedure.

The system is now ready for normal operation. Any failure at this point must be reported immediately to your AGEMA representative.

Refer to the Tutorial manual for instructions on how to proceed, using the software to open and close windows, store, retrieve and analyse images and the mouse and keyboard to achieve the desired image parameters.

4. Detailed Description

4.1.	Introduction	4-3
4.2.	System Controller	4-4
4.2.1.	General	4-4
4.2.2.	Processor unit	4-4
4.2.3.	Monitor, keyboard and mouse	4-7
4.2.4.	Accessories	4-10
4.3.	Scanners	4-12
4.3.1.	General	4-12
4.3.2.	Scanner 900 LW	4-17
4.3.3.	Scanner 900 SW	4-18
4.3.4.	Scanner 900SW-TE	4-20

C

C

C

C

4.1. Introduction

Thermovision® 900 is a complete infrared imaging system with a purpose built microcomputer designed to handle the digital data from two scanners simultaneously and display the images in real-time on a VGA monitor. This section gives a detailed description of the various items that make up a Thermovision® 900 system and also describes the options and accessories that can be used with the system.

4.2. System Controller

4.2.1. General

The System Controller is a dedicated microcomputer designed specifically for the Thermovision® 900 system. It consists of a modular design, microprocessor based processor unit in a compact desktop housing, a VGA monitor, a mouse and an enhanced keyboard with specialized system controls. The system uses X Window System™ running under the OS9 operating system giving an easy to use, menu driven, real-time environment.

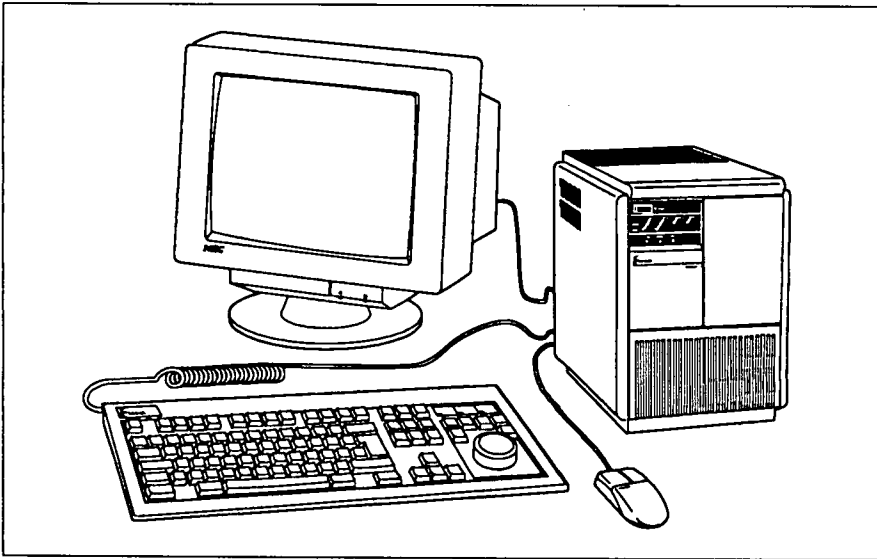

Fig. 4-1
Thermovision® 900 System
controller

4.2.2. Processor unit

The processor unit contains the processor and interface boards, system busses, disk drives and the power supplies required for both the processor unit and the scanners. Three main busses are used in the processor unit, two IR busses for scanner interfacing and an industry standard VME 32 bit system bus. For a basic single or dual scanner system the processor unit uses three of the five available board slots, one for each of the processor, scanner interface and display interface boards.

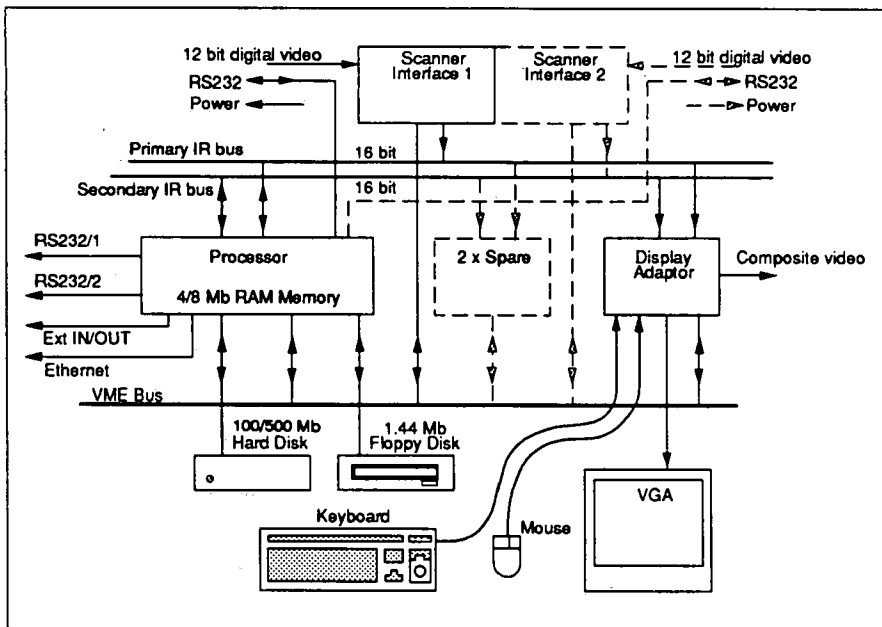

Fig. 4-2
*System controller simplified block
 schematic*

The data input from the scanner is in 12 bit digital format giving high resolution over the complete temperature range. Level and span settings are not required prior to recording an image. The image data is stored in 12 bit format so later analysis can be performed with the same accuracy as real-time analysis. Sequential recording up to all images can be performed, saving the images to the hard disk. The recording rate is dependent on hard disk speed and the amount of images in the actual directory. A Burst Recording option has to be installed if all images are to be saved to hard disk or to RAM.

The system software is stored on a 100/500 Mb Winchester disk fitted inside the system controller. A 3 1/2" floppy disk drive is also fitted for the transfer of image data and for input of additional software or calibration data. The system can also be controlled from and exchange data with a remote "host" computer connected via one of the two RS-232-C connectors or the Ethernet interface.

Front panel LEDs give an indication of the status of the system (refer to Table 4-1).

Power	Green	Mains power switched ON
IR 1/2	Green	IR channel 1/2 state is good
Status	Green	Channel state is good
	Red	Channel has a fault
IR 1/2 Alarm		For future use
Scan 1/2		
Status	Green	Scanner state is good
	Red	Scanner has a fault. In the case of the LN ₂ cooled scanner this indication is given when the detector temperature is too high, i.e. the liquid nitrogen needs topping up.
HDD	Green	Indicates that the Hard disk is in use (writing or reading)
Remote	Green	For future use
VGA	Green	Indicates that the system is running in VGA mode - high resolution non-interlaced mode

Table 4-1.
Key to Front panel LED indicators

The processor unit connectors are located on two panels at the rear of the unit. A mains supply panel contains the mains input connector, input fuse, voltage selector switch and mains output supply connector for the monitor. All other connectors are located on the separate interface connector panel.

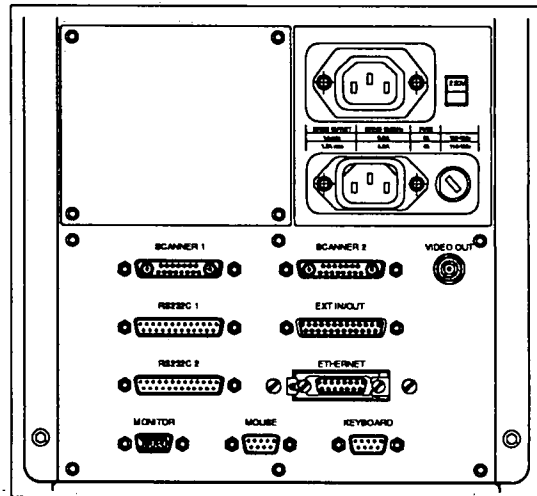

Fig. 4-3
System controller rear panel connectors

SCANNER 1 and 2	Contain power, an RS-232-C serial port and image data (serial) connections.
RS232C 1 and 2	Two standard RS-232-C ports for connection of peripheral equipment.
EXT IN/OUT	Contains 4 opto-isolated inputs for triggers and 4 relay outputs for alarms or equipment control.
ETHERNET	A standard Ethernet network connector.
MONITOR	Standard 15 pin D-type connector for display adaptor output to the monitor.
MOUSE	A standard 9 pin D-type connector for the Microsoft mouse.
KEYBOARD	A standard 9 pin D-type connector for the enhanced keyboard.
VIDEO OUT	A BNC connector carrying composite video signals for a VCR or television monitor.

Table 4-2.
Rear panel connectors

Customer defined connectors can be located on the blank panel alongside the mains supply panel.

4.2.3. Monitor, keyboard and mouse

A standard 14" VGA monitor is connected to the processor unit. The display driver in the processor unit uses an 8 bit system giving a maximum of 256 colours on screen. The display area is 240 x 180 mm.

The windows environment allows two real-time IR images to be displayed on the screen at the same time as other operator actions are being performed via the menus. It is not necessary to use two scanners in order to make use of the two IR windows. An image from a single scanner can be displayed in one window with one set of image parameters and in the other window with a different set of parameters. A real-time image can be compared with a pre-recorded image viewed with a different range or filter setting.

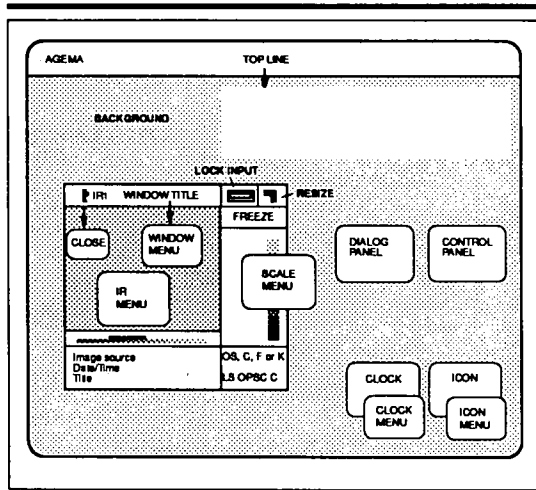

Fig. 4-4.

Schematic representation of image window and pop-up menu locations

Each IR window contains the image, a presentation of the image scale as set by the level and span controls and a text box containing the source of the image, the date/time for the image displayed and the first line of the comment attached to the image. The values and limits of any active isotherms are also displayed under the image. Directly under the image is a graphic representation of the actual temperature values compared with the scaling set by the level and span controls. This uses the same palette as selected for the image. Autoscaling of the level and span sets these parameters to display a selectable percentage of the object temperatures in the image. The default value is 100%.

The IR image can be presented in two sizes, e.g. for 900 LW it is 136 x 272 pixels (1:1 presentation) or 272 x 544 pixels (2:1 presentation). When both IR windows are using the 2:1 presentation only one window can be displayed fully, the other window sits behind and must be moved to the front to be displayed. Full analysis can be performed in both IR windows. Pop-up menus and dialog panels contain the system commands for selection of the different windows, analysis functions and system handling options. Different menus are opened at different locations on the screen or window. For a full explanation of the windows environment refer to the Tutorial or Software Reference manuals.

The mains supply for the monitor comes via the mains supply panel of the processor unit and is controlled by the processor unit power ON/OFF switch.

The keyboard is a specially modified enhanced keyboard. The numeric keypad has been replaced with the controls for level and span, and isotherms while the majority of the function keys have been dedicated to specific tasks. The main keyboard uses the US standard layout.

Level (the centre value of the scaling) and span (the width of the temperature scale) are adjusted from the keyboard. Level or Span is selected by pressing the relevant key and the rotary knob is then used to change the settings. The levels of isotherms 1 and 2 are adjusted in the same way. Two further keys, Aux1 and 2, are for future use. Each of the six keys around the rotary knob has an LED to indicate which function has been selected. Two LEDs in the indicator panel above the rotary knob section of the keyboard indicate the IR window to which the enhanced keypad is connected.

Fifteen function keys are located along the top of the keyboard, eight of which are dedicated to specific functions.

Freeze 1, 2	Used to freeze the image in IR windows 1 or 2. The keys are pressed a second time to unfreeze the image.
Auto adjust 1, 2	Automatically sets the level and span of the image in IR windows 1 or 2 to display 100% of the object temperatures from the image.
Trig A, B	Provide manual trigger inputs.
Focus -, +	Used in conjunction with IR window selection to remotely adjust the focus of the scanner lens.
F1, F2	Show scanner in IR 1/2.

Table 4-3.
Function key definition

The mouse is a standard Microsoft mouse or compatible. It is connected to the Mouse connector at the rear of the processor unit.

4.2.4. Accessories

A number of accessories and options can be connected to the System Controller. A 5¹/₄" standard unit can be fitted inside the processor unit giving the option of extra data storage. This can be in the form of a DAT recorder, a further hard disk or a magneto-optical disk unit.

High quality hard copy of image displays can be achieved by connecting a video printer to the monitor output from the System Controller. A video printer is necessary in order to retain the high resolution (colour and grey-scale) of the system. The monitor is connected via the video printer when the video printer is in use.

A separate scanner power supply is used when the distance between the scanner and System Controller exceeds 30 metres. However, if the distance exceeds 10 metres, which is the maximum without any amplification of the signal, then the cable, which in the case can be up to 50 metres, will be equipped with an amplifier. When using the scanners at longer distances from the System Controller a fibre optic link can be used to connect the System Controller to the scanner. The scanner power supply used at the remote location also powers the opto-electronic interface unit at the scanner. The opto-electronic interface at the System Controller receives its power from the scanner connector on the System Controller.

A video cassette recorder can be connected to the composite video output (VIDEO OUT) of the processor unit to record images for later playback on a standard television monitor. There is no facility for playback of video recordings through Thermovision® 900.

Before video recording can take place the function **Interlace on** in the System Menu - **Equipment menu** has to be selected. This will give an interlaced image on the VGA screen, which is not as good as the normal VGA image, but it is necessary for the video recording. When the video recording is finished, the function **Interlace off** in the same menu will

restore the VGA quality image on the screen.

A text printer can be connected to the RS232 output number 2 if hard copy of text files and directory contents is required.

4.3. Scanners

4.3.1. General

The Thermovision® 900 scanners are compact and lightweight, modular design units. All the optical and electronic modules are located on and around a machined aluminium chassis that forms the base plate of the scanner. The centre structure incorporating the carrying handle, and the two side covers form a protective enclosure that is completely removable.

The purpose of the scanner unit is to convert infrared radiation into digital signals that can be interpreted by the System controller and used to display an image of the object in either colour or grey-scale. The infrared radiation is converted in the scanner to a 12 bit digital signal which is passed via an interconnecting cable or fibre-optic link to the processor unit. The scanner is comprised of an optical scanning module LK4, detector module incorporating signal amplification and analog-to-digital conversion, microprocessor board and servomotor control board. The scan is non-interlaced and can take place at two different frame rates.

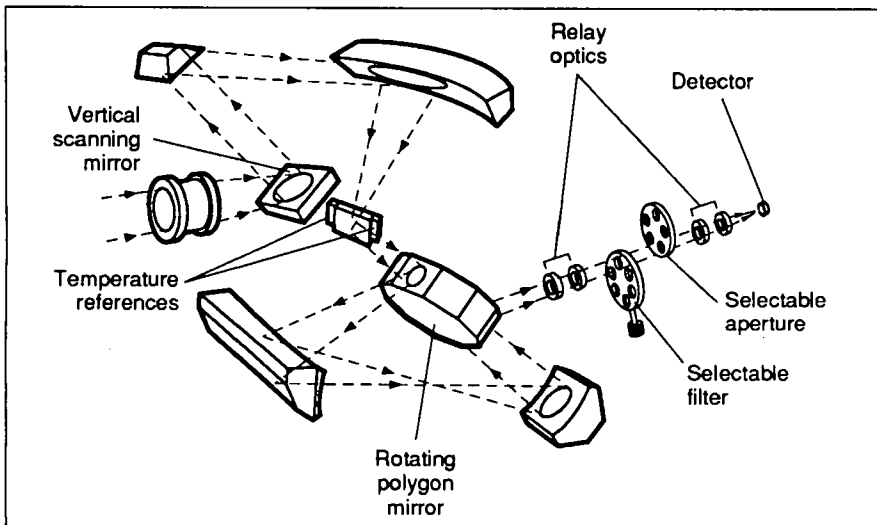

Fig 4-5.

*Exploded view of the scanner
optical path*

The scanner has a fixed lens which focuses the radiation onto the first scanning mirror in the optical scanning module. This mirror is oscillated in the vertical plane by a dc torque motor. The beam from the oscillating mirror is focused by three fixed mirrors onto a rotating horizontal mirror polygon. Both the oscillating mirror and the rotating polygon mirror are controlled from the servo-motor control board. These mirrors are synchronized by means of fibre optic position sensor output signals which are also used to produce the video clamping signals. The scan of the polygon mirror also encompasses two temperature references, a high temperature reference maintained at 110°C and a low temperature reference at the internal temperature. These references are located either side of the third fixed mirror.

The reflected beam from the rotating polygon mirror is focused by two further fixed mirrors onto the opposite side of the polygon, then passed through a set of relay optics that include selectable aperture and filter wheels and finally focused onto the detector.

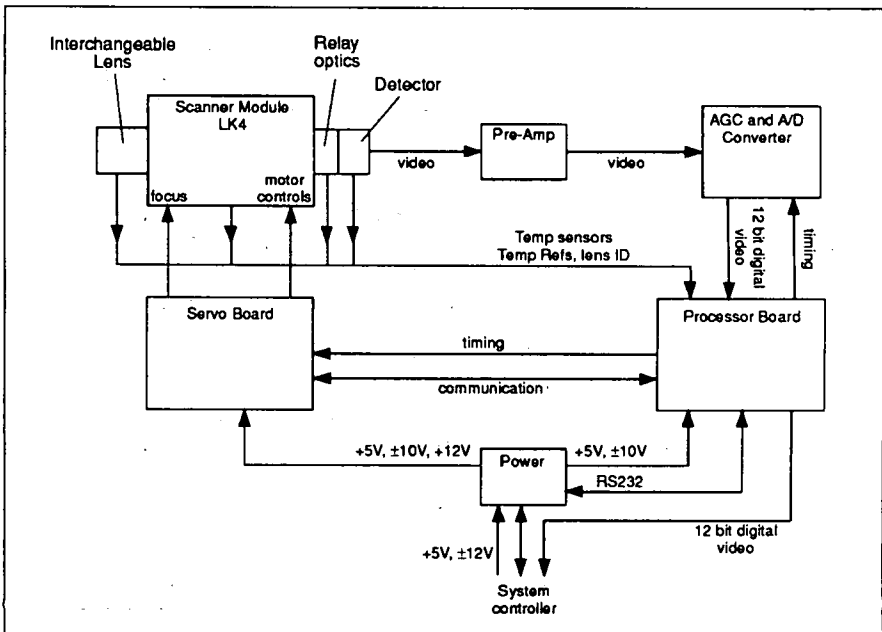

Fig. 4-6.
Scanner simplified block
schematic

The detector output is passed through pre-amplification and gain control circuits to the analog to digital converter. From there the 12 bit signal passes to the processor board where it is converted from parallel to serial format for transmission to the System controller.

The scanner is fitted with three separate temperature sensors and two temperature references in order to compensate for the radiation emitted by the scanner. Temperature sensors are located behind the lens, in the relay optics behind the aperture and filter wheels and at the detector. The sensor at the detector is also used to give an indication of the temperature state of the detector, i.e. whether the temperature is correct for accurate image presentation. The two references are those located in the scanning module. A further temperature sensor located in each interchangeable lens is used by the scanner processor to compensate for radiation from the lens unit itself.

Range and filter selection

The different range and filter selections are made remotely via the keyboard of the System controller. Four range and five filter settings are available.

The ranges are selected so that object temperatures covering the range -30 to +1500°C (LW) and -20 to 500°C (SW) can be measured without the use of filters. At start up the range setting is at its most sensitive, i.e. Range 1.

The system can handle more than one filter cassette. Each cassette has six positions for various filters. Normally a system has only one cassette, of which the 1st position is the NOF, i.e. No Filter, position. The standard filters which can be delivered with the scanners are listed in Table 4-4.

Besides the standard filters, AGEMA delivers a large range of filters according to customer specifications.

Longwave filters

Long pass Used to prevent energy shorter than 7.5 μm being detected

CO₂ Laser Used to limit the sensitivity to energy emitted by a 10.6 μm CO₂ laser.

Shortwave filters

High temp.

HT1 Used when measuring hot objects through flames, e.g. as used in a furnace or as a high temperature damping filter for objects between 0 and 2000°C.

Atmospheric Used when measuring objects hotter than 200 to 300°C from a distance.

Sun Reflex Used for suppressing reflected short wave radiation below 3.4 μm , e.g. from the sun, received at a peak of 1.7 μm .

Glass Used when measuring the temperature of glass to suppress short wave radiation below 4.8 μm

Table 4-4.
Standard filters

The curves for the filters are shown in Figures 4-7 and 4-8.

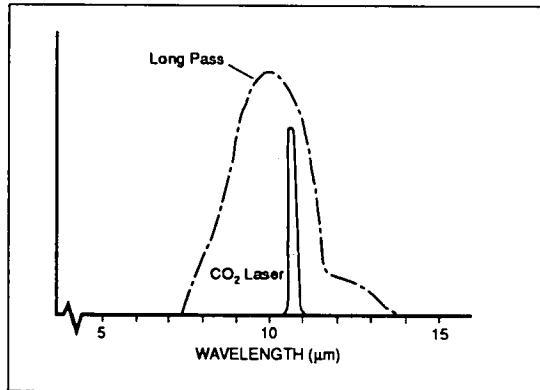

Fig. 4-7.
Relative system response using
standard longwave filters

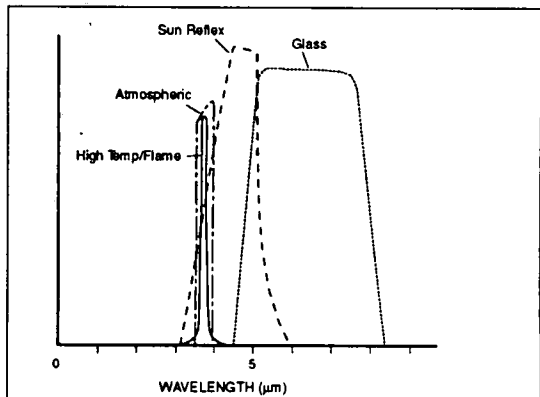

Fig. 4-8.
Relative system response using
standard shortwave filters

Filter cassette replacement

The filter cassette fitted to the scanner can be replaced with another cassette containing other filters. The procedure for replacement is as follows:

1. Remove the circular cover in the bottom plate of the scanner.
2. Unscrew the filter cassette retaining screw and carefully remove the cassette (refer to Figure 4-9)

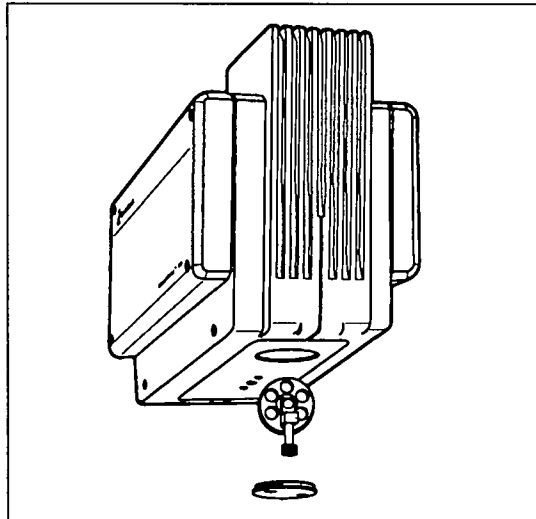

Fig. 4-9.
Filter cassette replacement

3. Align the new filter cassette and carefully locate it in the scanner ensuring the wheel and drive mesh correctly.
4. Tighten the retaining screw and replace the circular cover.
5. Place the unloaded cassette in a safe location. Do NOT attempt to remove any of the filters from their positions in the cassette wheel or to swap filters between cassettes. The filter calibration constants are related directly to their position in specific cassettes and any misplacement will cause incorrect constants to be used by the System controller with a consequent loss of accuracy.

6. At the System controller select the scanner control panel (on screen) and set the filter type required. This should also be done if the same filter cassette, as was removed, is replaced, since the filter wheel position may have been displaced. Selecting the required filter allows the scanner to align the filter wheel eliminating errors due to incorrect filter positioning.

Interchangeable Lenses

Five standard lenses are available for use with Thermovision® 900 scanners. They are detailed in Table 4-5.

*Table 4-5.
Standard Lenses for use with
Thermovision® 900 LW/SW
scanners*

Lens FOV	Minimum focus (metres)	Geometric resolution (mrad)	
2.5° x 1.25°	20 m	0.19 LW	0.22 SW
x 2.5°	5 m	0.38 LW	0.44 SW
10° x 5°	1.2 m	0.76 LW	0.87 SW
20° x 10°	0.6 m	1.5 LW	1.7 SW
40° x 20°	0.3 m	3.0 LW	3.5 SW

A remote focusing attachment fitted to the scanner is used for the 5°, 10° and 20° lenses while the 2.5° lens has the remote focusing built-in to the lens. A cable connects this focusing drive to the scanner connector. With these remote drives the lenses can be focused using dedicated keys on the System controller keyboard. The lenses can also be focused by hand if required.

4.3.2. Scanner 900 LW

The Thermovision® 900 LW scanner is designed to operate in the 8 - 12 μm band of the infrared spectrum. However, there is also some response outside this spectral range. The scanner uses cooled Mercury Cadmium Telluride (MCT) detector, an LN_2 or Stirling. The temperature sensor at the detector gives an indication at the System controller of when the detector temperature increases above the level required to maintain the specified accuracy (scanner status indication).

The optical scanning unit synchronization gives a scan rate of 15 Hz and an image resolution of 200 elements by 136 lines. This is interpreted in the processor to provide an image of 272 pixels per line. A 30 Hz scan rate gives a reduced number of lines per frame.

The temperature range of the scanner can be changed remotely by the selection of different range settings at the System controller. These are achieved in the scanner by both gain control and aperture wheel setting. The temperature measurement ranges are given in Table 4-6.

Table 4-6.
Thermovision® 900 LW scanner temperature ranges

Range 1	-30°C - 80°C	Full gain Aperture 1
Range 2	0°C - 250°C	Reduced gain Aperture 1
Range 3	100°C - 600°C	Aperture 2
Range 4	300°C - 1500°C 2000°C with filter	Aperture 3

4.3.3. Scanner 900 SW

The Thermovision® 900 SW scanner is designed to operate in the 2 - 5.6 μm band of the infrared spectrum. However, there is also some response outside this spectral range. The scanner uses 2 LN₂ or Stirling cooled indium antimonide (InSb) detectors. The operating time available and scanner status indication are the same as the Thermovision® 900 LW scanner.

The temperature range of the scanner can be changed remotely as in the LW scanner. The temperature measurement ranges are given in Table 4-7.

Table 4-7.
Thermovision® 900 SW scanner temperature ranges

Range 1	-20°C - 80°C	Full gain Aperture 1
Range 2	0°C - 150°C	Reduced gain Aperture 1
Range 3	50°C - 250°C	Aperture 2
Range 4	100°C - 500°C 2000°C with filter	Aperture 3

4.3.4. Scanner 900SW-TE

The Thermovision® 900 SW-TE scanner is designed to operate in the 2 - 5.4 μm band of the infrared spectrum. However, there is also some response outside this spectra range. The scanner uses 2 thermo-electrically cooled SPRITE (Signal Processing In The Element) detectors maintained at a temperature of -70°C.

The optical scanning unit synchronization gives a scan rate of 20 Hz and an image resolution of 140 elements per line. This is interpreted in the processor to provide an image of 204 pixels by 128 lines. A 30 Hz scan rate gives a reduced number of lines per frame.

The temperature range of the scanner can be changed remotely as in the cryogenically cooled scanners. The temperature measurement ranges are given in Table 4-8. The standard lenses for use with the thermo-electrically cooled scanner are given in Table 4-9.

Table 4-8.
Thermovision® 900 SW-TE
scanner temperature ranges

Range 1	-10°C - 80°C	Full gain Aperture 1
Range 2	0°C - 150°C	Reduced gain Aperture 1
Range 3	50°C - 250°C	Aperture 2
Range 4	100°C - 500°C 2000°C with filter	Aperture 3

Table 4-9.
Standard Lenses for use with
Thermovision® 900 SW-TE
scanner

Lens FOV	Minimum focus (metres)	Geometric resolution (mrad)
2.5° x 1.55°	20 m	0.31
5° x 3.13°	5 m	0.62
10° x 6.25°	1.2 m	1.25
20° x 12.5°	0.6 m	2.5
40° x 25°	0.3 m	4.9

C

O

O

O

5. Troubleshooting

5.1. Introduction 5-3



5.1. Introduction

The following guide lists operational faults that may occur during the use of the Thermovision® 900 system. It has been assumed that the equipment is connected to the correct ac supply and the POWER switch is set to ON.

The guide is divided into two sections which deal with problems arising during switch-on and while operating the equipment. Faults that may occur in accessories are not included. In such cases please refer to the local representative or to the relevant separate information sheets.

[Faint, illegible text, likely bleed-through from the reverse side of the page]



6. Thermal Measurement Techniques

6.1.	Introduction	6-3
6.2.	Correction for the influence of atmosphere and object emissivity	6-4
6.3.	Compensation for the radiation emitted from the scanner	6-5
6.4.	Calibration function	6-6
6.5.	Object parameters	6-8
6.5.1	Emissivity	6-8
6.5.2.	Reflected ambient temperature	6-10
6.5.3.	Atmospheric temperature	6-10
6.5.4.	Object distance	6-10
6.5.5.	Computed transmittance	6-11
6.5.6	Estimated transmission	6-12
6.5.7.	Relative humidity	6-12

6.1. Introduction

The Thermovision®900 infrared scanners measure infrared radiation within certain spectral ranges. The calibration function, which describes the scanner output as a function of blackbody temperature, is used to transform measured radiation into object temperature. The radiation received by the scanner detector consists of radiation emitted not only from the object but also from the surroundings, from the atmosphere and from the scanner optics (refer to Fig. 6-1). The radiation is also attenuated by the atmosphere and the scanner optics. All of these factors have to be included in the object temperature calculation.

The compensation methods and calibration function are explained in the following sections. Object parameters are also explained in section 6.5.

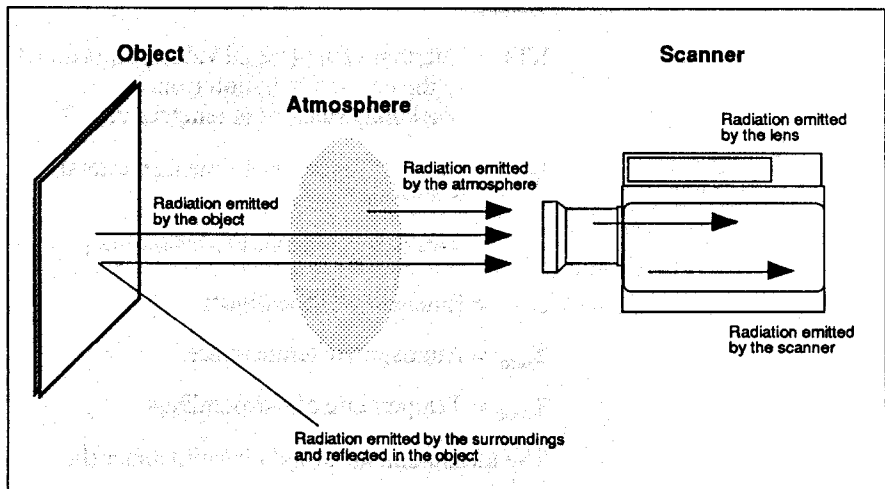

Figure 6-1.

Radiation contributions to the general measurement situation.

6.2. Correction for the influence of atmosphere and object emissivity

The incident radiation onto the imager consists not only of radiation from the object attenuated by the atmosphere but also radiation from the surroundings that has been reflected in the object and attenuated by the atmosphere and radiation emitted from the atmosphere itself. The object radiation intensity is also a function of the emissivity since no object is a perfect blackbody. The corresponding measurement formula is given below and is implemented in the ERIKA software for the System controller.

Measurement formula:

$$I_m = I(T_{obj}) \cdot \tau \cdot \epsilon + \tau \cdot (1 - \epsilon) \cdot I(T_{amb}) + (1 - \tau) \cdot I(T_{atm})$$

object radiation	reflected radiation from surroundings	atmospheric radiation
---------------------	------------------------------------------	--------------------------

Where

$I(T)$ = Thermal value (signal value proportional to the emitted radiation from a blackbody radiator at temperature T)

I_m = Thermal value for the measured total radiation

τ = Efficient atmospheric transmission

ϵ = Emissivity of the object

T_{atm} = Atmospheric temperature

T_{amb} = Temperature of surroundings

The measurement formula is valid under the following assumptions:

- Opaque object
- Lambertian surface
- Constant spectral emissivity (grey body)

This measurement formula is automatically used by the Thermovision[®]900. However, the operator has to type in the object parameters (emissivity, object distance, relative humidity, atmospheric temperature and reflected ambient temperature) for the present measurement situation.

6.3. Compensation for the radiation emitted from the scanner

The compensation for the scanner temperature dependent radiation emitted from the scanner and its own optics is performed automatically in Thermovision®900 (refer to Fig.6-1).

This is performed by a microprocessor controlled system using two blackbody temperature references, that are scanned, and four temperature sensors that measure the scanner and lens temperatures. This includes a temperature sensor in the lens which compensates for the radiation from the lens.

6.4. Calibration function

The calibration function expresses the non-linear relationship between blackbody temperature and signal output of the scanner.

Each lens, filter and range combination has its own calibration function. The constants for these functions are stored in the scanner and the system automatically chooses the correct constants for the combination used.

The calibration function could be calculated using Planck's Law and the spectral response of the scanner and filter, however, a much more accurate result is achieved by measurement. This is done during calibration when a number of blackbody sources are measured with the scanner. A curve-fitting program is then used to compute the constants (R, B, F) that give the best fit for the mathematical function describing the calibration. This procedure is then repeated for every lens, filter and measurement range combination and the result is then stored in memory in the scanner.

The calibration function used by Thermovision[®] 900 is given below and is partly built on Planck's Law and partly empirical:

$$I = R/(\exp(B/T)-F)$$

where

I = Thermal value

R = Response factor

B = Spectral factor

F = Shape factor

T = Object temperature (K)

One of the assumptions under which the measurement formula is valid is that the output signal of the scanner is proportional to the received radiation. Since the response of the detector is slightly non-linear a correction function with a fourth calibration constant has been added in the Thermovision®900 to rectify this small non-linearity error. The non-linearity correction is performed in a look-up table before the image is stored or otherwise manipulated.

When "object signal" is chosen as the presentation measurement unit, the signal that is displayed is that after non-linearity compensation, i.e. the signal proportional to the photon radiation.

6.5. Object parameters

A set of object parameters describe a certain measurement situation and include all parameters that the software requires for correction for object emissivity and atmospheric influence (refer to para. 6.2.), prior to the transformation of radiation into object temperature. A set of object parameters can be stored and recalled just as the actual measurement situation was itself stored. The object parameters include the emission factor, the atmospheric temperature, the reflected ambient temperature, the object distance, the relative humidity and the efficient atmospheric transmission. These are explained in more detail in the following sections.

6.5.1 Emissivity

Actual objects are seldom "black". The emissivity factor must therefore often be taken into account in infrared temperature measurement as detailed in the measurement formulæ. Individual object emissivity can be measured or can be found in tables.

Ordinarily, object materials and surface treatments exhibit emissivities ranging from approximately 0.1 to 0.95. A highly polished (mirror) surface falls below 0.1, while an oxidised or painted surface has greatly increased emissivity. Oil-based paint, regardless of colour in the visible spectrum, has an emissivity over 0.9 in the infrared. Human skin exhibits an emissivity close to 1. The values for ϵ obtained by using Thermovision[®]900 are, in effect, the average of ϵ_λ occurring over the infrared wavelength interval used by Thermovision[®]. If ϵ_λ varies with the wavelength, ϵ (the average value) will be dependent on the object temperature.

Non-oxidised metals represent an extreme case of almost perfect opacity and high specular reflectivity, which does not vary greatly with wavelength. Consequently, the emissivity of metals is low – only increasing with temperature. For non-metals, emissivity tends to be high, and decreases with temperature.

Typical emissivities for a variety of common materials at short wavelengths are listed in Tables 6-1. The values are meant to be used only as a guide, however, because they depend upon the spectral response of the instrument used to obtain them. For this reason, Thermovision® measurement may result in emissivities which vary somewhat from these, so verification is recommended in each case.

Metals and their oxides	Wavelength (Microns)	Temp. (°C)	Emissivity(ϵ)
Aluminium:			
foil (bright)		20	0.04
weathered	SW	20	0.83 - 0.94
Copper:			
polished	3	100	0.05
heavily oxidized		20	0.78
Iron:			
cast, oxidized		100	0.64
sheet, heavily rusted	SW	20	0.69 - 0.96
Nickel:			
electroplated, polished		20	0.05
Stainless Steel (type 18-8):			
polished		20	0.16
oxidized		60	0.85
Steel:			
polished		100	0.07
oxidized		200	0.79
Other materials	Wavelength (Microns)	Temp. (°C)	Emissivity(ϵ)
Brick: common red		20	0.93
Carbon candle soot		20	0.95
Concrete: dry	5	35	0.95
Glass: chemical ware	5	35	0.97
Oil: lubricating		17	0.87
film thickness 0.03 mm		20	0.27
film thickness 0.13 mm		20	0.72
thick coating		20	0.82
Paint, oil:			
average of 16 colours		20	0.94
Paper: white	SW	20	0.07 - 0.90
Plaster	SW	20	0.86 - 0.90
Rubber: black	5	20	0.95
Skin: human		32	0.98
Soil:			
dry		20	0.92
saturated with water		20	0.95
Water:			
distilled		20	0.96
frost crystals		-10	0.98
snow		-10	0.85
Wood: planed oak		20	0.90

Table 6-1

Emissivities of common materials

6.5.2. Reflected ambient temperature

The reflectivity factor of an opaque object can be written as $\rho = 1 - \epsilon$

A low emissivity factor indicates therefore that not only the emission from the object is lower than that from a blackbody of the same temperature, but also that undesired radiation from the surroundings is reflected in the object and then into the scanner. The measurement formula corrects for this radiation. This correction is based on the "reflected ambient temperature" which is the mean value of the temperature of the object's surroundings. In most cases the values for the "atmospheric temperature" and "reflected ambient temperature" are considered to be the same.

6.5.3. Atmospheric temperature

The "atmospheric temperature" is the temperature of the atmosphere between the object and the scanner. In the case where the temperature over the path varies the mean temperature should be used.

6.5.4. Object distance

The "object distance" is the distance between the object and the front lens of the scanner.

This parameter is used in the computation of the efficient atmospheric transmission described in section 6.5.5.

6.5.5. Computed transmittance

Certain constituents of the atmosphere absorb infrared radiation in the spectral bands being used. The most important gases are water vapour and carbon dioxide. This absorption will attenuate the infrared radiation from the object to the instrument.

This atmospheric attenuation effect is compensated by the measurement formula. The measurement formula uses the constant τ (efficient atmospheric transmission), which is the mean atmospheric transmission between the object and the front lens for radiation within the spectral range.

The value of τ could either be calculated by the software (τ calculated) as a function of object distance, atmospheric temperature and relative humidity or entered direct (τ estimated) if the value of τ has been found by measurement or from advanced atmospheric models such as LOWTRAN. If the value τ is entered by the operator (τ estimated) it will override the value computed by the software (τ calculated).

The formula that is used by the software for the calculation of efficient atmospheric transmission is empirical.

$$\tau = X \cdot \exp(-d \cdot (\alpha_1 + \beta_1 \cdot W)) + (1 - X) \cdot \exp(-d \cdot (\alpha_2 + \beta_2 \cdot W))$$

where

- τ = efficient atmospheric transmission
- X = Weight factor
- α_1, α_2 = attenuation coefficients
- β_1, β_2 = attenuation coefficients for the water vapour related attenuation
- d = the distance between the scanner front lens and the object
- W = equivalent water content (computed by the software as a function of relative humidity and the temperature of the atmosphere)

The atmospheric constants X, a_1, a_2, b_1, b_2 have been computed for best fit to the algorithm above to a computed τ versus object distance and water vapour function. The LOWTRAN atmospheric model was used to derive the τ values for this computation, carried out by AGEMA for all spectra defined by the Thermovision[®]900 scanners and standard filters in a typical atmosphere. All these atmospheric constants are contained in the scanner and automatically loaded when a new filter is chosen.

6.5.6 Estimated transmission

Sometimes the measurement conditions can be tricky and the normal algorithms for calculation of the transmission through the atmosphere may not be applicable. In such a case it is possible to override the automatically calculated Atmospheric transmission by setting a value into the column Estimated transmission. This can be the case, e.g. when there is a sapphire window in the measurement path. Such a window can have a transmission of 0.87, which should be multiplied by the calculated transmission for the distance.

Estimated transmission should normally have no value at all. Do not put 0 into its place!

6.5.7 Relative humidity

The "relative humidity" is the relative humidity of the atmosphere between the object and the scanner.

This parameter is used in the computation of the efficient atmospheric transmission described in section 6.5.5.

7. Introduction to the Theory of Thermography

7.1.	Introduction	7-3
7.2.	The Electromagnetic Spectrum	7-4
7.3.	Blackbody Radiation	7-6
7.4.	Photon Emission	7-10
7.5.	Non-blackbody emitters	7-12
7.6.	Infrared semi-transparent materials	7-15
7.7.	Infrared optical materials	7-16
7.8.	IR detectors	7-18
7.9.	Infrared scanners	7-20
7.10.	Origins of modern radiation theory .	7-22



7.1. Introduction

The subject of infrared radiation and the related technique of thermography are still new to many who are in a position to make use of Thermovision®. In this section the theory behind thermography will be given and the basic outline of the history and the men who invented the technique will be explored.

7.2. The Electromagnetic Spectrum

The electromagnetic spectrum is divided arbitrarily into a number of wavelength regions, called "bands", distinguished by the methods utilised to produce and detect the radiation. There is no fundamental difference between radiation in the different bands of the electromagnetic spectrum, however, they are all governed by the same laws and the only differences are those due to differences in wavelength.

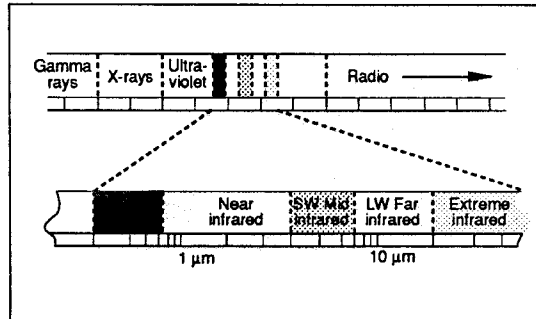

Fig 7-1
The Electromagnetic Spectrum

Thermography makes use of the infrared spectral band. At the short-wavelength end the boundary lies at the limit of visual perception, in the deep red. At the long-wavelength end it merges with the 'microwave' radio wavelengths, in the millimetre range.

The infrared band is commonly further subdivided into four lesser bands, the boundaries of which are also arbitrarily chosen. They include: the "near infrared" (0.75 - 3 μm), the "middle infrared" (3 - 6 μm), the "far infrared" (6 - 15 μm) and the "extreme infrared" (15 - 100 μm). Although the wavelengths are given in μm (micrometres), other units are often still utilised to measure wavelength in this spectral region, e.g. microns(μ), nanometres (nm) and Ångströms (Å). the relationships between the different wavelength measurements is

$$10,000 \text{ \AA} = 1,000 \text{ nm} = 1\mu = 1 \mu\text{m}$$

Some confusion has existed in the past concerning the term infrared photography, as contrasted with thermography. The distinction is one of wavelength - conventional "infrared

film" photographic emulsions are sensitive to wavelengths no longer than 1.2 μm . For this reason, astronomers call the wavelength span 0.75 - 1.2 μm the "photographic infrared spectrum". Beyond the 2 μm wavelength lies the so called "thermal infrared". Infrared photography exploits the differences in the absorptive and emissive properties of surfaces. It depends upon the reflection of very short infrared wavelengths generated by outside sources such as the sun, or lamps, which are much hotter than the object.

7.3. Blackbody Radiation

A blackbody is defined as an object which absorbs all radiation that impinges on it at any wavelength. The apparent misnomer "black" relating to an object emitting radiation is explained by Kirchhoff's Law, which states that a body capable of absorbing all radiation at any wavelength is equally capable in the emission of radiation.

The construction of a blackbody source is very simple in principle. The radiative characteristics of an aperture in an isotherm cavity made of an opaque absorbing material represents almost exactly the property of a blackbody. A practical application of the principle to the construction of a perfect absorber of radiation consists of a box that is light tight except for an aperture in one of the sides. Any radiation which then enters the hole is scattered and absorbed by repeated reflections so only an infinitesimal fraction can possibly escape. The blackness which is obtained at the aperture is nearly equal to a blackbody and almost perfect for all wavelengths.

By providing such an isothermal cavity with a suitable heater it becomes what is termed a "cavity radiator". An isothermal cavity heated to a uniform temperature generates blackbody radiation, the characteristics of which are determined solely by the temperature of the cavity. Such cavity radiators are commonly utilised as sources of radiation in temperature reference standards in the laboratory for calibrating thermographic instruments, such as Thermovision[®]900 for example.

If the temperature of blackbody radiation increases to over 525°C, the source begins to be visible so that it appears to the eye no longer black. This is the incipient red heat temperature of the radiator, which then becomes orange or yellow as the temperature increases further. In fact, the definition of the so-called "colour temperature" of an object is the temperature to which a blackbody would have to be heated to have the same appearance.

Now consider three expressions that describe the radiation emitted from a blackbody.

a) **Planck's law.** Max Planck was able to describe the spectral distribution of the radiation from a blackbody by means of the following formula:

$$W\lambda_b = \frac{2hc^2}{\lambda^5(ehc/\lambda kT - 1)} \times 10^{-6} \text{ [Watts/m}^2\mu\text{m]}$$

where

$W\lambda_b$ = the blackbody spectral radiant emittance at wavelength λ

c = the velocity of light = 3×10^8 m/sec.

h = Planck's constant = 6.6×10^{-34} Joule sec.

k = Boltzmann's constant = 1.4×10^{-23} Joule/K.

T = the absolute temperature (K) of a blackbody.

λ = wavelength (m)

Note: The factor 10^{-6} is used since spectral emittance in the curves is expressed in Watts/m²μm. If the factor is excluded, the dimension will be Watts/m²m.

Planck's formula, when plotted graphically for various temperatures, produces a family of curves. Following any particular Planck curve, the spectral emittance is zero at $\lambda = 0$, then increases rapidly to a maximum at a wavelength λ_{\max} and after passing it approaches zero again at very long wavelengths. The higher the temperature, the shorter the wavelength at which maximum occurs.

Fig. 7-2
Blackbody spectral radiant emittance according to Planck's law, plotted for various absolute temperatures

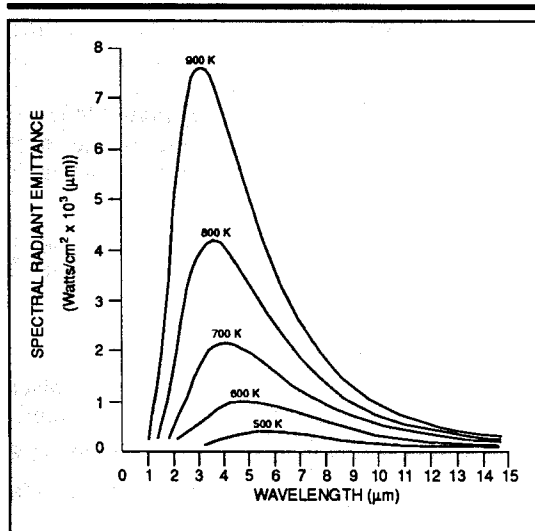

b) **Wien's displacement law.** By differentiating Planck's formula with respect to λ , and finding the maximum, we have:

$$\lambda_{\max} = \frac{2898}{T} [\mu\text{m}]$$

This is Wien's formula, which expresses mathematically the common observation that colours vary from red to orange or yellow as the temperature of a thermal radiator increases. The wavelength of the colour is the same as the wavelength calculated for λ_{\max} . A good approximation of the value of λ_{\max} for a given blackbody temperature is obtained by applying the rule-of-thumb (3000K). Thus, a very hot star such as Sirius (11,000K), emitting bluish-white light, radiates with the peak of spectral radiant emittance occurring within the invisible ultraviolet spectrum, at wavelength 0.27 μm . The sun (approx. 6,000K) emits yellow light, peaking at about 0.5 μm in the middle of the visible light spectrum. At room temperature (300K) the peak of radiant emittance lies at 9.7 μm , in the far infrared, while at the temperature of liquid nitrogen (77K) the maximum of the almost insignificant amount of radiant emittance occurs at 38 μm , in the extreme infrared wavelengths.

c) **The Stefan-Boltzmann law.** By integrating Planck's formula from $\lambda = 0$ to $\lambda = \infty$, we obtain the total radiant emittance (W_b) of a blackbody:

$$W_b = \sigma T^4 \text{ [Watts/m}^2\text{]}$$

where

$$\sigma = \text{the Stefan-Boltzmann constant} = 5.7 \times 10^{-8} \text{ Watts/m}^2.$$

This is the Stefan-Boltzmann formula, which states that the total emissive power of a blackbody is proportional to the fourth power of its absolute temperature. Graphically, W_b represents the area under the Planck curve for a particular temperature. It can be shown that the radiant emittance in the interval $\lambda = 0$ to λ_{\max} is only 25 percent of the total, which represents about the amount of the sun's radiation which lies inside the visible light spectrum.

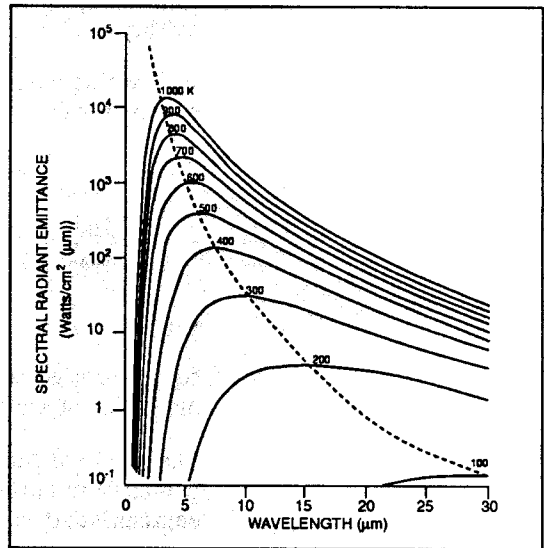

Fig. 7-3
Planckian curves plotted on semi-log scales from 100 to 1000K. The dotted line represents the locus of maximum radiant emittance at each temperature as described by Wien's displacement law.

Using the Stefan-Boltzmann formula to calculate the power radiated by the human body, at a temperature of 300K and an external surface area of approx. 2m^2 , we obtain 1 kilowatt. This power loss could not be sustained if it were not for the compensating absorption of radiation from surrounding surfaces, at room temperatures which do not vary too drastically from the temperature of the body – or, of course, the addition of clothing.

7.4. Photon Emission

The energy emitted by a thermal radiator is not transferred as a continuous flow, as Max Planck proved. The radiation occurs as discrete energy "jumps", or quanta - called photons. The energy of a photon (Q) is given by

$$Q = \frac{hc}{\lambda} \text{ [Joule]}$$

from which it is seen that photon energy is inversely proportional to the wavelength of the radiation.

The three radiation laws given earlier, which describe the radiation of a blackbody, were all concerned with the energy of the radiation. They can, however, be modified to deal with a number of photons (N_b) rather than the energy. This is of interest where photon detectors rather than energy detectors are utilised, as in the case of Thermovision.

By dividing Planck's formula by hc/λ , the energy of one photon, we obtain

$$\begin{aligned} N_{\lambda b} &= \frac{\lambda}{hc} W_{\lambda b} \\ &= \frac{2hc}{\lambda^4(e^{hc/\lambda kT} - 1)} \times 10^{-6} \text{ [photons/sec m}^2 \text{ }\mu\text{m]} \end{aligned}$$

where

$N_{\lambda b}$ = the spectral photon emittance for a blackbody at wavelength λ .

The family of curves for the spectral photon emittance resembles the former spectral radiant emittance curves, but has a less abrupt maximum; and the peaks are shifted toward the long-wavelength side.

The Wien formula for calculating the wavelength of peak photon emission for a given absolute temperature becomes

$$\lambda_{\max} = \frac{3663}{T} \text{ [}\mu\text{m]}$$

The wavelength at which the maximum occurs is about 25 percent greater for photon emission than for energy emission. Thus, for $T = 300\text{K}$, we get $\lambda_{\text{max}} = 12.2 \mu\text{m}$ instead of the value $9.7 \mu\text{m}$ obtained if the energy emission is considered.

The Stefan-Boltzmann formula, written to express the total number of photons emitted from a blackbody at a specific temperature, becomes

$$N_b = \frac{0.37\sigma T^3}{k} \text{ [photons/sec m}^2\text{]}$$

This alternative form of the Stefan-Boltzmann formula states that the total photon emission of a blackbody is proportional only to the third power of its absolute temperature.

7.5. Non-blackbody emitters

So far, only blackbody radiators and blackbody radiation have been discussed. However, real objects almost never comply with these laws over an extended wavelength region - although they may approach the blackbody behaviour in certain spectral intervals. For example, white paint appears perfectly "white" in the visible light spectrum, but becomes distinctly "grey" at about 2 μm , and beyond 3 μm it is almost "black".

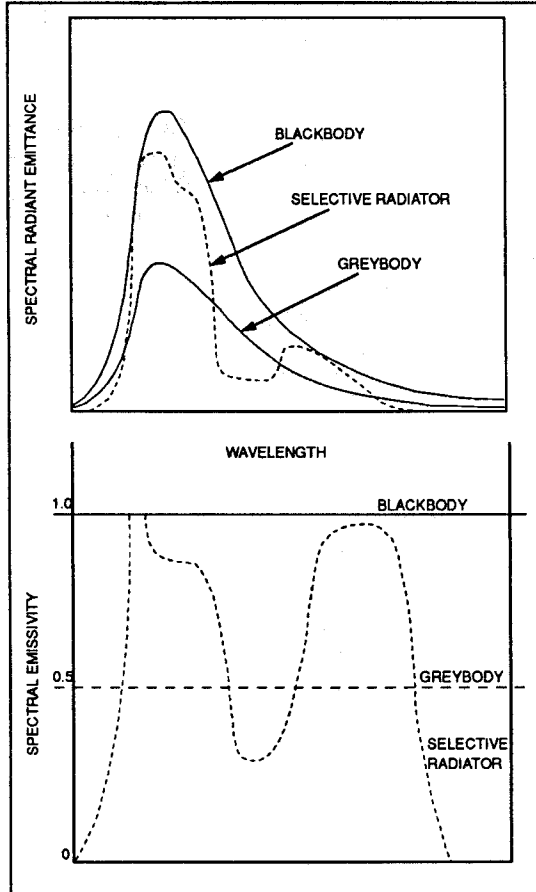

Fig. 7-4
Spectral radiant emittance and spectral emissivity of three types of radiators.

There are three processes which can occur that prevent a real object from acting like a blackbody: a fraction of the incident radiation α may be absorbed, a fraction ρ may be reflected, and a fraction τ may be transmitted. Since all of

these factors are more-or-less wavelength dependent, the subscript λ is used to imply the spectral dependence of their definitions. Thus:

The spectral absorptance α_λ = the ratio of the spectral radiant power absorbed by an object to that incident upon it.

The spectral reflectance ρ_λ = the ratio of the spectral radiant power reflected by an object to that incident upon it.

The spectral transmittance τ_λ = the ratio of the spectral radiant power transmitted through an object to that incident upon it.

The sum of these three factors must always add up to the whole at any wavelength, so we have the relation

$$\alpha_\lambda + \rho_\lambda + \tau_\lambda = 1$$

For opaque materials $\tau_\lambda = 0$, and the relation simplifies to

$$\alpha_\lambda + \rho_\lambda = 1$$

Another factor, called the emissivity, is required to describe the fraction ϵ of the radiant emittance of a blackbody produced by an object at a specific temperature. Thus, we have the definition:

The spectral emissivity ϵ_λ = the ratio of the spectral radiant power from an object to that from a blackbody at the same temperature and wavelength.

Expressed mathematically, this can be written as the ratio of the spectral emittance of the object to that of a blackbody as follows:

$$\epsilon_\lambda = \frac{W_{\lambda o}}{W_{\lambda b}}$$

Generally speaking, there are three types of radiation source, distinguished by the ways in which the spectral emittance of each varies with wavelength.

- a) A blackbody, for which $e_1 = e = 1$.
- b) A greybody, for which $e_1 = e = \text{constant}$ less than 1.
- c) A selective radiator, for which e varies with wavelength.

According to Kirchhoff's Law, for any material the spectral emissivity and spectral absorptance of a body are equal to any specified temperature and wavelength. That is: $\epsilon_\lambda = \alpha_\lambda$.

From this we obtain, for an opaque material (since $\alpha_\lambda + \rho_\lambda = 1$):

$$\epsilon_\lambda + \rho_\lambda = 1$$

For highly polished materials ϵ_λ approaches zero, so that for a perfect reflecting material (= a perfect mirror) we have

$$\rho_\lambda = 1$$

Taking into account for a greybody radiator, the Stefan-Boltzmann formula becomes

$$W = \epsilon \sigma T^4 \text{ [Watts/m}^2\text{]}$$

This states that the total emissive power of a greybody is the same as a blackbody at the same temperature reduced in proportion to the value of ϵ from the greybody.

7.6. Infrared semi-transparent materials

Consider now a non-metallic, semi-transparent body – for simplicity, in the form of a thick flat plate of plastic material. When the plate is heated, radiation generated within its volume must work its way toward the surfaces through the material in which it is partially absorbed. Moreover, when it arrives at the surface, some of it is reflected back into the interior. The back-reflected radiation is again partially absorbed, but some of it arrives at the other surface, through which it mostly escapes; part of it is reflected back again. Although the progressive reflections become weaker and weaker they must all be added up when the total emittance of the plate is sought. When the resulting geometrical series is summed, the effective emissivity of a semi-transparent plate is obtained as

$$\varepsilon_{\lambda} = \frac{(1 - \rho_{\lambda})(1 - \tau_{\lambda})}{1 - \rho_{\lambda}\tau_{\lambda}}$$

This formula represents a generalisation of Kirchhoff's law, which reduces when the plate becomes opaque ($\tau_{\lambda} = 0$) to the single form

$$\varepsilon_{\lambda} = 1 - \rho_{\lambda}$$

This last relation is a particularly convenient one, because it is often easier to measure reflectance than to measure emissivity directly.

7.7. Infrared optical materials

There are also very useful materials which are transparent to the infrared. These are not necessarily transparent in the visible region of the spectrum, of course. For instance, while silicon and germanium are opaque in the visible wavelengths they are transparent in parts of the infrared spectrum. Some infrared transmitting materials and their IR-refractive indices (n) are listed in Table 7-1, together with their transmission cut-off wavelengths.

Table 7-1
IR-optical materials

Material	n at $\lambda = 2 \mu\text{m}$	λ cut-off (approx.)
Germanium (Ge)	4.0	50
Silicon (Si)	3.4	40
Arsenic Trisulphide glass (As ₂ S ₃)	2.4	12
Irtan 2 (ZnS)	2.2	14
Sapphire (Al ₂ O ₃)	1.8	7
Irtan 1 (MgF ₂)	1.3	8

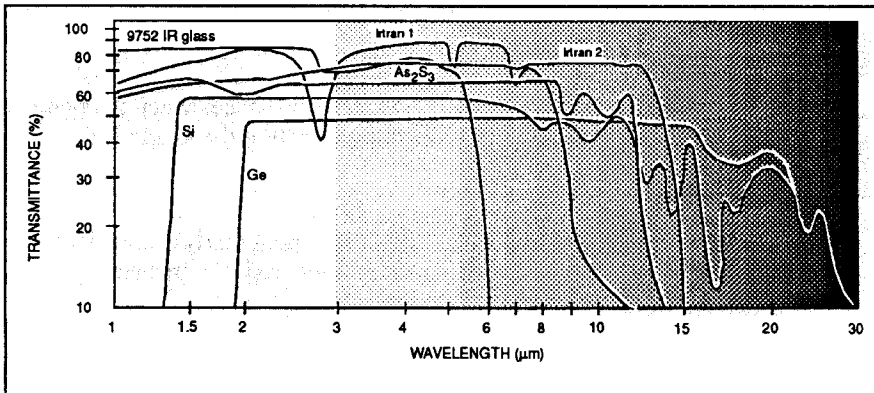

Fig. 7-5

The spectral transmittance of some preferred infrared optical materials, thickness 2 mm.

A high value of n is advantageous in lens design, but on the other hand it is a fact that materials with high refractive indexes have rather low transmittances. The relation between transmittance and refractive index for non-absorbing materials can be shown to be

$$\tau = \frac{2n}{n^2 + 1}$$

For germanium ($n = 4$), τ becomes 0.47. Each germanium element in an IR-scanner lens system should thus reduce the transmittance by a factor of 2.

These high reflective losses can be eliminated, however, by anti-reflection coatings which can raise the transmittance to as high as 95 – 99 percent for a given wavelength interval. The wavelength interval is determined by the thickness of the coating. With multi-layer coatings, the transmission interval can be increased over a wide wavelength band.

7.8. IR detectors

We have no difficulty detecting infrared energy when standing in front of an open fire or lying on the beach in the sun. But to produce an infrared picture at normal temperatures of the objects around us, we are dealing with such exceedingly small radiant powers that one of the principal problems in infrared technology has been the search for adequate IR detectors.

An infrared detector is a converter that absorbs IR energy and converts it to a signal, usually an electrical voltage or current. The detector types used in today's Thermovision are so-called photon detectors.

There is a variety of different kinds of photon (or "quantum") detectors. They show distinctly different spectral responses between types – characterised by a sharp cut-off in the long-wavelength range. All photon detectors are composed of semiconductor material, in which the release or transfer of charge carriers (e.g. electrons) is directly associated with photon absorption. The energy of the photon is inversely proportional to the wavelength associated with it and the disappearance of photoelectric activity at wavelengths longer than the "cut-off" wavelength (λ_c) indicates the energy of the photons to be insufficient to set electrons free. That is, the photons must exceed the so-called "forbidden energy gap" (E_g) in the semiconductor material. This cut-off wavelength is:

$$\lambda_c = \frac{hc}{E_g} \text{ [m]}$$

where E_g is expressed in Joules.

In general, the width of the forbidden energy gap is increased by cooling, so that the cut-off wavelength is decreased when the detector is cooled.

Two principal types of photon detector are of particular interest today: the "photoconductive" and the "photovoltaic" detectors. In a photoconductive detector the gap energy is determined by the nature of the material itself,

and the effect of photon absorption is to free the electrons and thereby increase the detector's conductivity.

In photovoltaic detectors the gap energy is also determined by the material, but the radiation-generated charge carriers are swept away by the electric field in a p-n junction, thereby directly producing a voltage rather than a change in conductivity.

High-speed scanning of necessity requires a detector with a very short response time. The advantage of photon detectors is that they are more sensitive, and have a much shorter response time than thermal detectors but they have a limited spectral response, and require cooling for optimum sensitivity – generally to the temperature of liquid nitrogen (77K). However, the SPRITE detector produces excellent results at a working temperature of 200K.

In the case of an ideal thermal detector which has a perfectly flat spectral response curve, it is sufficient to state a single value of detectivity (D^*). However, the situation is more complicated with photon detectors, whose spectral response is not flat, and typically drops off to zero at the long-wavelength cut-off point. The D^* is therefore wavelength dependent and consequently bears the usual subscript, $D^* \lambda$. $D^* \lambda_{\max}$ is noted at the peak of the spectral response curve.

The ultimate limit on detectivity is set by the "radiation noise" signal which is generated in a detector, resulting from the statistical fluctuation of the radiation received and re-emitted by the detector itself. The noise signal is characterised by its random fluctuations in amplitude, frequency and phase. The result due to noise on the Thermovision display is the familiar TV "snow" on the picture screen. A detector where this noise sets the limit of detectivity is said to be "background limited".

7.9. Infrared scanners

It is possible to obtain an infrared picture using infrared sensitive film loaded into a regular camera. Contrary to the passive technique used with an infrared scanning head the film uses active methods described previously.

The film emulsion is only sensitive between 0.7 μm and 1.2 μm in the electromagnetic spectrum. This technique is very useful for airborne inspections of forests and agricultural areas. In medicine it will show arteries and veins (darker) in a picture, however it does not give any information regarding temperature distribution over a surface. This is carried out in the longer wavelengths usually above the 2 μm to 12 μm band and using a measuring function for temperature evaluation.

It is not possible to obtain, with passive techniques, a single frame shot using a camera. In order to do this the surface has to be scanned and the temperature identified and measured point by point (horizontal scan) and along a number of lines (vertical scan). The infrared image is built up like a TV picture. Therefore it is easy to understand that an infrared element must be extremely sensitive together with a short response time if a thermographic image is to be presented in real time, i.e. 15-30 images per second. To be sensitive not only to higher temperatures but also to both ambient and lower temperatures and to eliminate electrical noise, the detector is normally cooled by liquid nitrogen.

Today very satisfactory results can be obtained without the necessity of liquid nitrogen cooling. With the development of more sophisticated detectors and the advantage obtained using Peltier elements, detectable voltages corresponding to the heat radiated by an object can be measured without cooling to cryogenic temperatures.

7.10. Origins of modern radiation theory

Since the English physicist William Herschel discovered, in 1800, thermal radiation outside the deep red in the visible spectrum, later called 'infrared', one of the major problems facing physicists during the second half of the nineteenth century was to explain the energy distribution in the spectrum of thermal radiation. Common experience had shown that objects seem to absorb more or less heat depending on how "dark" or "light" their surfaces colouration appears to be. Gustav Kirchhoff sought to eliminate this arbitrariness from theoretical considerations by proposing the term "blackbody" to describe an object which absorbs all incident radiation energy. In 1860 he introduced a law that states, in effect, that a good thermal absorber is also a good radiator. As a consequence of Kirchhoff's Law, then the blackbody provides the standard of comparison for radiation sources: it is the ultimate thermal radiator with which we can compare any other thermal radiation source.

In 1879, Josef Stefan concluded from experimental measurements that the total amount of energy radiated from a blackbody is proportional to the fourth power of its absolute temperature, a conclusion which was also reached via theoretical thermodynamic relationships by Ludwig Boltzmann in 1884. This important formula has since come to be known as the Stefan-Boltzmann law.

In the meantime, the physicist Clark Maxwell had predicted the theoretical existence of electromagnetic waves (1865) and proposed their identity with light waves. Heinrich Hertz, confirming Maxwell's prediction, produced electromagnetic waves in his laboratory in Germany in 1887, and showed that they propagate with the same velocity as light waves.

It was the German physicist, Max Planck, who finally recognised that it was necessary to depart from the classical approach. He was forced to the conclusion that the proper distribution of energy among the elementary oscillators comprising the blackbody radiator

can be obtained only if one abandons the concept that the energy is continuously divisible. The postulate of discontinuous, quantised exchange of radiant energy, which he introduced, appeared to him to be the only alternative leading to a correct theory that would be in agreement with experimental evidence. In 1900 he finally produced a derivation of the law of radiation, which bears his name, which precisely describes the spectral distribution of the radiation from a blackbody.

The assumptions behind Planck's Law were radical ones, and Planck himself resisted accepting them for many years. The concepts, when they finally gained acceptance, resulted in the formal discipline of "quantum mechanics" and today the mechanics of classical physics are regarded as merely the special case of quantum mechanics that is successful in the realm of engineering but is inadequate to describe processes at atomic level.

Thermovision®900 Tutorial

Contents

1.	INTRODUCTION	
2.	OPERATING PRINCIPLES AND SCREEN LAYOUT	
2.1.	System Controls	2-3
2.1.1.	Mouse Controls	2-3
2.1.2.	Pointers	2-5
2.1.3.	Keyboard	2-6
2.2.	Windows, Menus and Panels	2-10
2.2.1	System menu	2-10
2.2.2.	Window Menus and Window Title Bar	2-11
2.2.3.	IR Window Menus	2-12
2.2.4.	Scanner Control panel	2-13
2.2.5.	Dialog panels	2-13
2.2.6.	Warning panels	2-14
2.2.6.	Warning panels	2-14
2.2.7	Result table menu	2-14
2.2.8	Measurement functions menu	2-14
2.2.9	Histogram menu	2-15
2.2.10	Profile menu	2-15
2.2.11	Plot menu	2-15
2.2.12	Top line menu	2-15
2.2.13	Clock menu	2-15
2.2.14	Company label menu	2-15
2.3.	Directory structure	2-16
3.	GETTING STARTED	
3.1.	Setting the Date and Time	3-3
3.2.	Creating the right image	3-5
4.	IMAGES	
4.1.	Level adjustment	4-3
4.2.	Span adjustment	4-4
4.3.	Image information	4-5

5.	SAVE AND RETRIEVE	
5.1.	Freeze image	5-6
5.2.	Store image	5-7
5.3.	Retrieve image	5-8
5.3.	Store sequence	5-10
5.4.	Recall sequence	5-13
6.	ANALYSIS	
6.1.	Spotmeters	6-3
6.2.	Areas	6-4
6.3.	Line	6-6
6.4.	Isotherms	6-8
7.	MANIPULATION	
7.1.	Show other IR window	7-3
7.2.	Show other manipulated;	
	Time process control	7-4
7.2.1.	Recursive filtering	7-4
7.2.2.	Averaging	7-5
7.3.	Show other manipulated;	
	Display process control	7-6
7.3.1.	Mirroring	7-6
7.3.2.	Rotating	7-6
7.3.3.	View	7-7
7.3.4.	Swcopy	7-7
7.4.	Align and Subtraction control	7-8
7.4.1.	Align	7-8
8.	TEXT FILE FACILITIES	
8.1.	Editing text files	8-3
8.2.	Editing commands	8-4

1. Introduction



This tutorial gives a basic introduction to using the Thermovision®900 system. It begins by describing the operating principles and content of the various menus and windows that appear on the screen and then goes on into the initial system start up after checking and installation. System operation details are covered in the final chapters of the manual.

It is recommended that the complete tutorial is worked through step by step so that system operation is fully understood. For those new to Thermovision® it is recommended that the complete tutorial is worked through step by step so that system operation is fully understood.

The initial checking and installation of the system and all the details of the hardware are contained in the System Hardware Manual. Chapters 2 and 3 of that manual cover unpacking, inspection and start-up and must be read prior to using this tutorial.

An alphabetical listing of all the available functions is contained in the Software Reference Manual with concise details of how each function operates.

The Thermovision®900 system also contains an extensive "On-line Help" facility which can be used in conjunction with this tutorial and the reference manual.

The first part of the tutorial covers the basic concepts of the course. It includes a brief overview of the course objectives and the structure of the tutorial. The second part of the tutorial discusses the importance of the course and the role of the student. The third part of the tutorial discusses the importance of the course and the role of the student.

The fourth part of the tutorial discusses the importance of the course and the role of the student. The fifth part of the tutorial discusses the importance of the course and the role of the student. The sixth part of the tutorial discusses the importance of the course and the role of the student.

The seventh part of the tutorial discusses the importance of the course and the role of the student. The eighth part of the tutorial discusses the importance of the course and the role of the student. The ninth part of the tutorial discusses the importance of the course and the role of the student.

The tenth part of the tutorial discusses the importance of the course and the role of the student. The eleventh part of the tutorial discusses the importance of the course and the role of the student. The twelfth part of the tutorial discusses the importance of the course and the role of the student.

The thirteenth part of the tutorial discusses the importance of the course and the role of the student. The fourteenth part of the tutorial discusses the importance of the course and the role of the student. The fifteenth part of the tutorial discusses the importance of the course and the role of the student.

The sixteenth part of the tutorial discusses the importance of the course and the role of the student. The seventeenth part of the tutorial discusses the importance of the course and the role of the student. The eighteenth part of the tutorial discusses the importance of the course and the role of the student.

The nineteenth part of the tutorial discusses the importance of the course and the role of the student. The twentieth part of the tutorial discusses the importance of the course and the role of the student. The twenty-first part of the tutorial discusses the importance of the course and the role of the student.

The twenty-second part of the tutorial discusses the importance of the course and the role of the student. The twenty-third part of the tutorial discusses the importance of the course and the role of the student. The twenty-fourth part of the tutorial discusses the importance of the course and the role of the student.

The twenty-fifth part of the tutorial discusses the importance of the course and the role of the student. The twenty-sixth part of the tutorial discusses the importance of the course and the role of the student. The twenty-seventh part of the tutorial discusses the importance of the course and the role of the student.

2. Operating principles and screen layout

2.1.	System Controls	2-3
2.1.1.	Mouse Controls	2-3
2.1.2.	Pointers	2-5
2.1.3.	Keyboard	2-6
2.2.	Windows, Menus and Panels	2-10
2.2.1	System menu	2-10
2.2.2.	Window Menus and Window Title Bar	2-11
2.2.3.	IR Window Menus	2-12
2.2.4.	Scanner Control panel	2-13
2.2.5.	Dialog panels	2-13
2.2.6.	Warning panels	2-14
2.2.7	Result table menu	2-14
2.2.8	Measurement functions menu	2-14
2.2.9	Histogram menu	2-15
2.2.10	Profile menu	2-15
2.2.11	Plot menu	2-15
2.2.12	Top line menu	2-15
2.2.13	Clock menu	2-15
2.2.14	Company label menu	2-15
2.3.	Directory structure	2-16

The purpose of this chapter is to introduce you to the menu driven, window based structure used by the Thermovision[®]900 system. The key elements of the screen layout and their functionality are also explained.

2.1. System Controls

Everything that you need to do with the system can be done using a combination of the mouse pointer on the screen, the mouse buttons, the keyboard keys and special controls.

2.1.1. Mouse Controls

There are three basic mouse techniques used within the system:

- Pointing
- Clicking
- Dragging

The mouse controls the pointer on the screen. The pointer is moved by moving the mouse over the desk top in the direction the pointer is required to move. Moving the mouse slowly results in small movements of the pointer, while moving the mouse faster produces larger pointer movements.

Clicking means pressing and quickly releasing a mouse button. By pointing at a window or menu option on the screen and then clicking a mouse button you can open menus or select menu options.

Dragging means holding down a mouse button and moving the pointer. In this way you can move objects around the screen or change the size of windows.

Menus are opened and selections made by positioning the mouse pointer and clicking the **left** mouse button. Dragging within a window uses the **right** mouse button. Releasing the mouse button completes the action.

Both mouse buttons are used when moving window scroll bars to view text or lists.

Use the **RIGHT** button to scroll to the **LEFT** or **UPWARDS**.

Use the **LEFT** button to scroll to the **RIGHT** or **DOWNWARDS**.

The further to the right/down you click, the larger the steps will become.

A window or icon that is partially hidden behind other windows can be brought to the front by positioning the pointer on the window title bar or icon and clicking Ctrl + the right mouse button.













By clicking and dragging on the title bar using the right button the window is both moved to a new position and brought to the front.

By clicking and dragging on a measurement label using the right button the position of the measurement function is changed.

Menus opened in error can be cancelled by positioning the pointer outside the menu box or in the menu title and clicking either mouse button.

2.1.2. Pointers

The following pointer symbols are used:

-  Background pointer
-  Window pointer.
-  Button pointer
-  Button pointer - in title bar
-  Menu pointer
-  Version window appearing
-  Please wait!
-  Cross-hairs - Used to locate Spots and start and end points of Lines and Areas within IR image
-  Move pointer - Used when moving or resizing a window
-  Text Editor symbol - Used to show that text (or a value) is to be entered
-  Window selection symbol. Used when moving windows to the front or back and when removing windows
-  Remove symbol - used when removing a window

2.1.3. Keyboard

The keyboard is a specially modified enhanced keyboard. The main part of the keyboard is standard and uses the US layout for the keys. The numeric keypad has been replaced with the controls for level and span, and isotherms while the majority of the function keys, of which there are fifteen, have been dedicated to specific tasks.

The keyboard layout is shown on the opposite page.

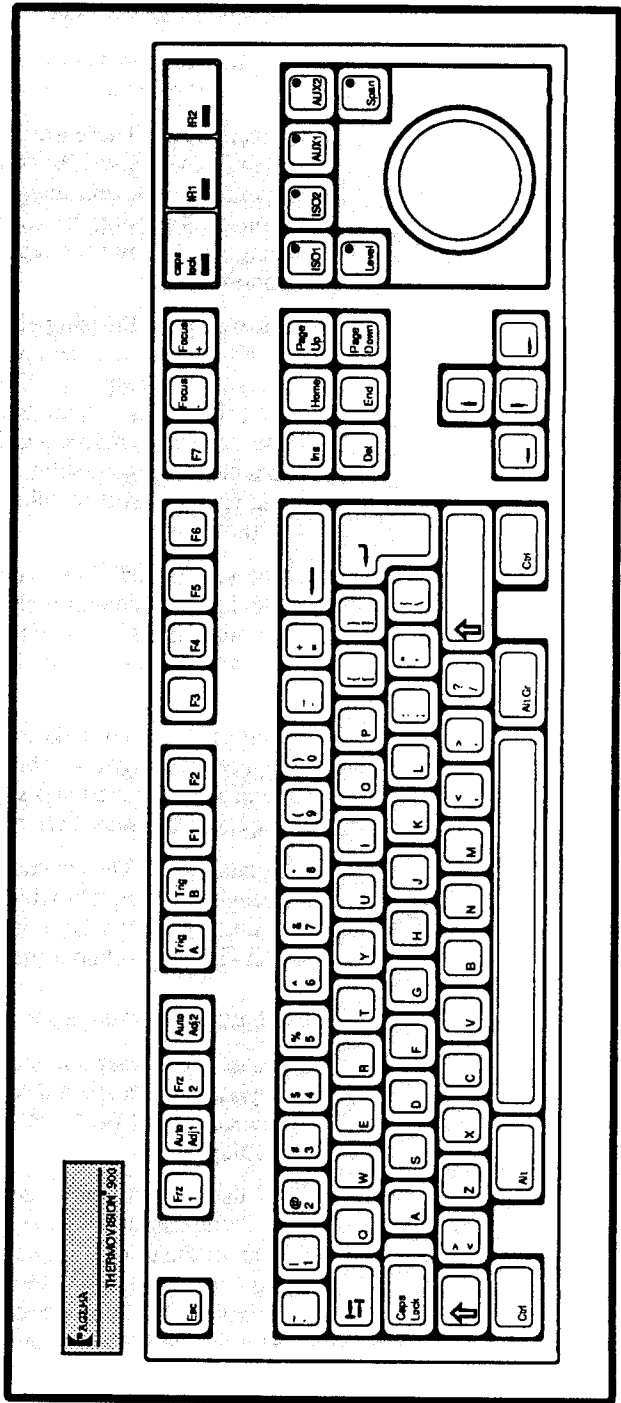

Special function keys

Eight of the function keys along the top of the keyboard have special functions:

Freeze 1, 2 These are used to freeze the image in the IR windows. Pressing either Freeze 1 or 2 freezes the relevant image at that precise moment. Pressing the key again unfreezes the image and allows the real time display to continue.

Auto adj 1, 2 Pressing either of these two keys automatically sets the level and span of the image in the respective IR window to 100% of the full level and span data coming from the source. They provide a quick means of returning to a basic image display after using the level and span controls to enhance particular aspects of the image.

The value 100% can be changed either in the file .login by changing the environment variable for auto adjust or by using the function Auto adjust in the Level and Span menu on the scale area.

Trig A, B These keys provide manual trigger inputs to the system. They could, for example, be used as the start and stop triggers when a sequence of images are recorded.

Focus -, + The scanner lens has a remote focusing attachment which allows you to control the focus from the keyboard. Use the + and -keys to obtain a sharp image on the screen.

Rotary knob and associated keys

Instead of having a numeric keypad the keyboard has a special section that gives you fine control of isotherm and image temperature displays.

By using the mouse to select either IR window 1 or 2 you can then change both the level and span of the temperatures displayed in the image. You can check which IR window is selected by looking at the LED panel above the rotary knob. The selected IR window LED will be lit. When you select a function to adjust, by pressing the

appropriate key, an LED in the key is lit. The rotary knob drives an encoder so that there are no limits to its rotation, and also you do not need to reset the knob to any particular position when selecting any of the other functions.

F1 Executes the command Show Scanner in IR-1

F2 Executes the command Show Scanner in IR-2

2.2. Windows, Menus and Panels

The pop-up menus used to select the different functions that are available within the system are located in particular areas on the screen.

They are grouped either in the background (the area of the screen that is fixed) or within the windows that are opened.

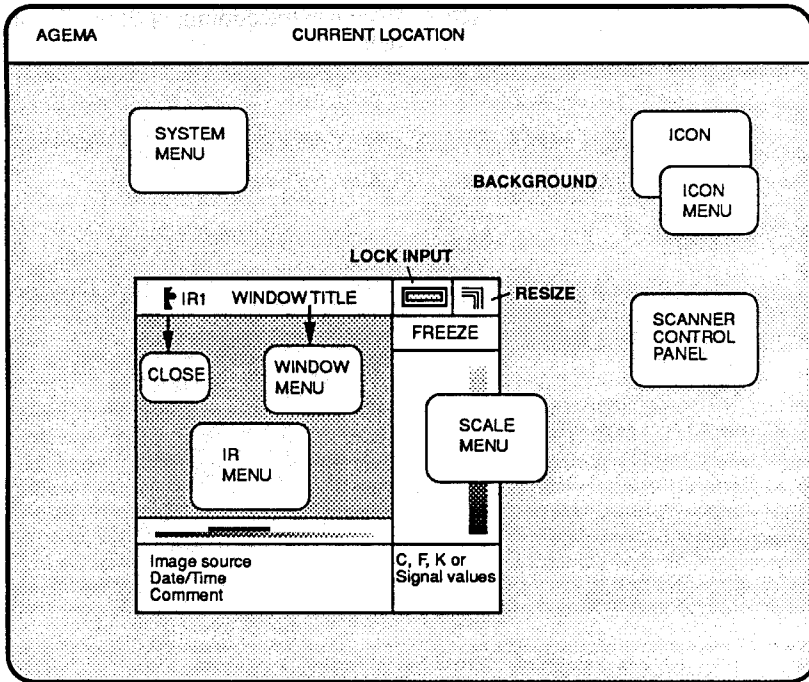

To change something on the screen first try clicking on it with either of the mouse buttons. Then a menu or a dialog panel or an editor etc might appear.

2.2.1 System menu

The SYSTEM menu is the top level menu. All of the windows that can be created are derived from the options available in this menu. You can bring this menu up by clicking with the mouse anywhere in the background, i.e. positioning the cross symbol in the background

and clicking the left mouse button. The basic system management functions are also accessed via this menu.

2.2.2. Window Menus and Window Title Bar

When any window is opened, a window menu and other window handling functions can be accessed from within the window itself. As soon as the mouse pointer is moved to within the window boundary that window becomes active. All other windows on the screen are then dormant.

The pop-up menu for that window can be displayed by positioning the pointer in the centre section of the title bar and clicking the mouse button. Window handling options, allowing the window to be moved, resized, closed or removed, can then be selected.

The window can also be resized by positioning the pointer in the extreme right hand box of the title bar and dragging the pointer with the mouse. The new window size is outlined on the screen. Once the window size is correct all that is needed is to release the mouse button.

To the left of the resize corner of the window title bar is the lock input selection (shown as a small keyboard icon). Clicking on this symbol locks the window in the active state. No other window can be selected, irrespective of the mouse pointer position, until the locked window has been unlocked. The Unlock Input option can be found in the System menu - Window handling.

An alternative way of moving windows (or icons) is to place the pointer in the middle of the title bar and drag it by pressing the right mouse button.

The window can be closed by clicking on the small AGEMA logo at the left hand end of the title bar. The window is reduced to an icon and remains on the screen.

A window is removed from the screen by selecting the remove option in the window menu.

Icons

When a window is closed it reduces to an icon representing the window. Clicking within the icon boundary brings up the icon menu. The icon can then be moved or the window re-opened.

2.2.3. IR Window Menus

Three specific menus are opened from within the IR window.

IR menu

This menu is opened by positioning the pointer within the image boundary and then clicking the mouse button. You can then open other sub-windows, change the image size and use the analysis functions on the image.

Scale menu

The scale used in the image is displayed at the right of the image. The scale menu can be opened by clicking within the scale section of the IR window. Different palettes can then be selected, the object parameters can be changed and the level and span of the image can be set.

In the IR window you can also click on special areas. If you click on

- status corner (lower right corner of the window) Start the IR status window
- title line: will start the Edit comment window

Isotherm Menu

Each isotherm menu is opened by positioning the pointer either on ISO1 and/or the ISO2 part of the isotherm line.

The isotherms must first be started by pressing the ISO1/2 buttons and then moving the Level/ Span rotary knob slightly.

2.2.4. Scanner Control panel

At switch on or when a scanner is selected the Scanner Control panel automatically appears in the foreground. From this panel you can control the scanner motors, select filters and change temperature ranges.

This window will always be open when the scanner is selected as the image source. If it is violently removed it will come back after a few seconds. If another image source is selected this window will disappear automatically.

2.2.5. Dialog panels

When you select some menu options a dialog panel opens requesting additional information or requesting that a further selection be made.

These further selections will normally be presented as text with a "button" alongside or with the selection appearing on the "button".

The selection is made by pressing the button, i.e. positioning the mouse pointer over the button and clicking.

The button then becomes dark. The buttons have different symbols on them depending on the kind of choice you have to make. For information about this, please refer to the Software Reference Manual.

If the dialog panel requires that text be entered then a text editor pointer appears within the boundary of the dialog panel and the arrow keys are used to select the text entry point...

Pressing the Enter key after having entered text into the bottom input field is equivalent to clicking on OK.

Pressing the ESC key during dialogue panel text input is equivalent to clicking on CANCEL.

If the dialog panel requires that text be entered then the text editor pointer is positioned within the boundary of the dialog panel and the arrow keys used to select the text entry point (shown by the cursor position). One of the cases when this is necessary is when you perform any file management actions, such as storing, moving or recalling files.

2.2.6. Warning panels

At any time during the operation of the system you may receive information concerning errors or warnings. These are displayed in the form of panels stating the location of the error or warning and giving you information as to the cause of the error or the system function that requires attention.

You are recommended to take note of any error panel that appears. Clicking on the CONFIRM button acknowledges that you have noted the problem. You can also ask for help by clicking on the HELP button.

2.2.7 Result table menu

When you have selected Analyze image there will be a result window opened. In this window there will be one line for each activated measurement function. There is one menu on the first line of the result table and other menus on the next lines.

2.2.8 Measurement functions menu

When you have started analysis functions (spots, lines and/areas) you can open the spot menu, line menu and/or area menu by clicking on the appropriate measurement label, e.g. SP01, in the image.

2.2.9 Histogram menu

When you click on the left part of the histogram (=the scale area) you will find the histogram menu.

2.2.10 Profile menu

By clicking in the profile window the Profile menu is produced. The cursor must not be activated simultaneously.

2.2.11 Plot menu

When the plot function has been activated and the plot window has been opened you will find the plot menu with the left mouse button.

2.2.12 Top line menu

By clicking on the top line with the left mouse button the Top line menu is activated.

2.2.13 Clock menu

The clock window is opened by selecting in the System menu - Create window - Analog/Digital clock. This will in both cases open a window which does not have the normal top line. However, by clicking anywhere on the clock window the clock menu is activated.

The window can be moved by clicking, holding and dragging the right button in the window.

2.2.14 Company label menu

The Company label window is opened by selecting the function in the System menu - Create window - Company label. This window does not have any top line, but by clicking anywhere in the Company label window the Company label menu is called up.

The window can be moved by clicking, holding and dragging the right button in the window.

2.3. Directory structure

In order to know where the various files and directories are located it is important that you have a basic understanding of the structure of the directory tree that is used by the system. A simplified diagram of the structure is shown below.

The top level or "Root" directory is /h0. All the

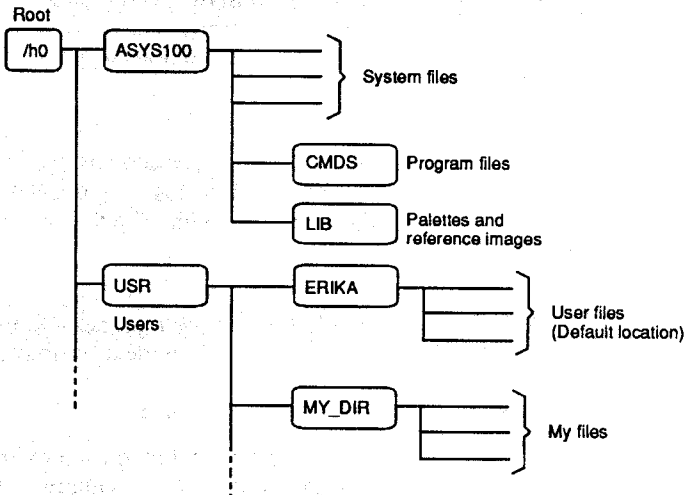

system directories are then sub-directories of /h0.

All the system and program files are in the sub-directories of ASYS.

When you store (save) any images, comments or object parameters these files are created in the default user sub-directory ERIKA unless you specify otherwise. You can if you wish create your own user sub-directory under USR. Refer to the Software Reference Manual for details.

It is a good rule not to store files in any other location than locations under /H0/USR or lower, e.g. /H0/USR/MYTEST.

At any time you can see your current location in the structure by looking in the top line of the screen.

the structure by looking in the top line of the screen.

Similar directory systems can be introduced to other devices, such as /d0, which denotes a diskette under OS9, or /DOS, which denotes a diskette where the information is stored in DOS format.

If more than one hard disk is connected to the system, the second hard disc will be called /h1 etc.

3. Getting started

- 3.1. Setting the Date and Time 3-3
- 3.2. Creating the right image 3-5

This chapter explains the few steps you need to follow before you can begin to use the Thermovision[®]900 system.

At this point you should have already installed and started the system. If not you should read chapters 2 and 3 of the System Hardware Manual.

On the screen you have an image from the scanner that has been auto-adjusted for level and span. The SCANNER CONTROL panel is also open in the foreground.

3.1. Setting the Date and Time

First you should set the system clock to the correct date and time. This is important as all the files you create contain the date and time. If this is not correct it will lead to confusion when you return to the system and want to analyse a particular image.

This will also get you used to moving the pointer about the screen and selecting menu options.

Move the mouse slowly to locate the pointer on the screen. Once you have located the pointer move it around the screen and note how the pointer changes when it crosses from within a window into the background area. You can find a description of the various pointers in chapter 2.

Move the pointer into the background area, click with the left mouse button and the SYSTEM MENU appears at the point where you clicked. The pointer has changed from a cross into the menu pointer.

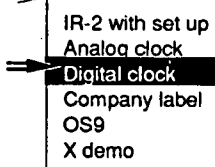
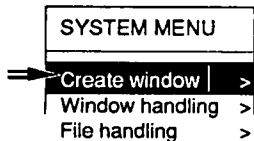
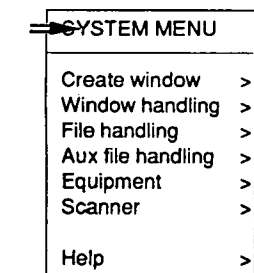

Date: YY:MM:DD
Time: HH:MM:SS_

Move the pointer on the menu until it is above the CREATE WINDOW option and click with the mouse. The CREATE WINDOW option is highlighted to show that it has been selected.

Another menu appears with the window options. There are two clocks available, one analog clock, which displays a clock-like image, and a digital clock, which shows time and date in digits.

Select the DIGITAL CLOCK and click with the mouse. The DIGITAL CLOCK option is highlighted, the menus are cleared and the clock appears.

Now to set the time and date.

Move the pointer over the clock and click with the mouse. The CLOCK menu appears at the pointer location. Select the SET TIME & DATE option and a small dialog panel opens in the centre of the screen.

This panel shows the time and date that are set into the system.

Use the **BACKSPACE** key to erase the date and type in the correct date in the format - **YY:MM:DD**. Press the **ENTER** key to move the cursor to the time text box. Erase the time shown in this box with the **BACKSPACE** key and type in the correct time in the format **HH:MM:SS**.

It is not necessary to enter the seconds as the system will assume they are set to 00.



Place the pointer on the **OK** button and click. The date and time are now entered into the system.

If you make a mistake with the date or time format an error panel will appear reminding you of the correct format.

3.2. Creating the right image

With the correct date and time now set you can turn your attention to the IR window, the image and the Scanner Control Panel.

Focusing

Check the image on screen. It will very probably be out of focus.

You can focus the scanner lens using the FOCUS + and FOCUS - keys on the keyboard. Pressing either of these keys rotates the lens focusing ring. Releasing the key stops the focusing ring.

Adjust the focus of the lens using these two keys until you have a sharp image in the IR window.

Selecting the palette



Position the pointer anywhere in the Scale section of the IR window and click. In the SCALE menu click on SELECT COLOUR PALETTE and then select COL RAINBOW from the menu that appears.

The image in the IR window will change to display the temperature measurements in the full 112 colours.

You may at this point want to try some of the other colour palettes or the grey scale palette to see what the differences are within the image.

Scanner Control Panel

From the Scanner Control panel you can change the range and filter selections and also control the scanner motors.

The filters available for selection will be those delivered with the scanner that is connected to IR channel 1. The selection at switch-on will be NOF (no filter). If different filter cassettes were delivered with the scanner they are also selectable at this panel. Selecting a different filter cassette requires that it first be fitted to the scanner (refer to the System Hardware Manual for instructions).

Four different range settings can be selected from the Scanner Control panel. At switch-on range 1 will be selected.



Click on one of the filter selection buttons (other than NOF). The temperature ranges displayed in the range selection buttons and the image will change. Depending on the filter selected the image may disappear altogether.



Select the NOF filter button and the image will return to its original state. The temperature ranges on the range buttons also change back.



Click on the Scanner Control panel title bar and the window menu will appear. Select REMOVE from this menu. The Scanner Control panel is then removed from the screen. This scanner window will now automatically re-appear after few seconds.

The image will be refreshed and the Scanner Control Panel will re-appear. The normal way is to iconify the Scanner Control window when the scanner setting is finished.

Removing and re-opening the window

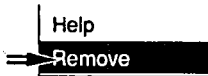

Click in the IR window title bar and the window menu will appear. Select REMOVE from this menu and the IR window and Scanner Control panel will be removed from the screen. Only the clock will remain.

Position the pointer anywhere within the background and click. The System menu will appear at the pointer location.

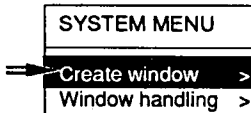

Select CREATE WINDOW from this menu and a further menu appears.

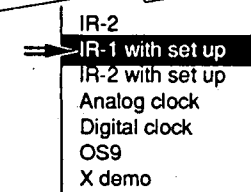

Select IR-1 WITH SET UP. A dialog panel appears showing the different measurement scale selections.



Temperature



Click on the TEMPERATURE and CELSIUS buttons and then click on the OK button.

The dialog panel is removed.

The IR window appears on the screen and the scale to the right of the image will be in Celsius. The image will be a default image recalled from a file stored on the hard disk.

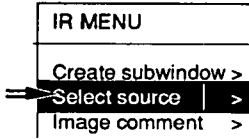

Click anywhere within the image and the IR menu appears. Select SELECT SOURCE from this menu and then select SHOW SCANNER from the sub-menu that appears. A quicker way to start showing the scanner is just to press the F1 key. (Similarly the F2 key will show the other scanner, if any, in window 2.)

The Scanner will be started and the Scanner Control panel will appear. The image will change to the real-time image supplied by the scanner.

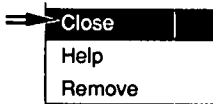

Click in the Scanner Control panel title bar and select CLOSE from the window menu that appears or click on the AGEMA logo.

The Scanner Control panel will be reduced to an icon. You can move this icon out of the way by clicking on the icon and selecting MOVE from the menu that appears or by placing the cursor on the icon and pressing the right button. The pointer changes to the Move symbol. Move this pointer to where you want the icon to be located (an outline of the icon follows the pointer) and click. You can also move the icon by clicking on it with the **right** mouse button and dragging it to a new location.

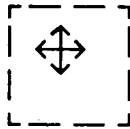

In the next chapter more details of image settings are explained.



4. Images

4.1.	Level adjustment	4-3
4.2.	Span adjustment	4-4
4.3.	Image information	4-5

Adjusting the level and span controls changes the image on screen to display what you, the operator, wants to see. At switch-on the image is auto-adjusted to display a span of 100% of the temperature measurement information coming from the source. This provides you with a recognizable image in the IR window. However, you may only want to display certain temperatures in a specific band. To do this you must adjust the level and span controls on the keyboard.



4.1. Level adjustment



Before adjusting the level control you should check that the correct IR window is selected by positioning the pointer within the window boundary.

Look at the three LEDs at the right hand end of the keyboard and check that IR1 is lit. Since there is only one IR window open this should be the case.

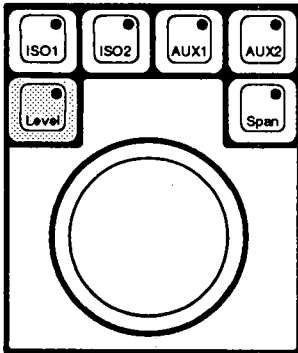

Press the LEVEL key to the left of the rotary knob. The built-in LED lights to show that this is the function adjusted by the rotary knob.

Slowly turn the rotary knob counter-clockwise and note what happens in the scale section of the IR window. The temperature values decrease as you lower the level setting. The image loses the higher temperature details.

Note also what happens to the small graphic scale under the image. It shows which span you are looking at. The upper scale indicates where to find the image. The lower scale moves slowly to the left.

Slowly turn the rotary knob clockwise and note that the values in the scale section increase and the scale bar under the window moves to the right.



Press the AUTO ADJ 1 key. The image, scale, and scale bar return to their original setting of 100%.

Try also the SET, SET VIA SCALE AND THE AUTO ADJUST functions in the Level and Span menu in the Scale menu.

4.2. Span adjustment

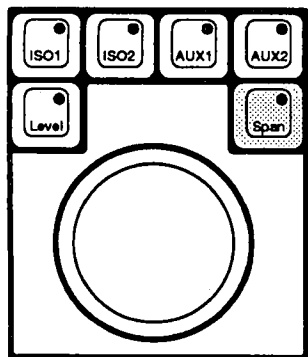

Press the SPAN key to the right of the rotary knob. The built-in LED lights to show that this is the function adjusted by the rotary knob.

Slowly turn the rotary knob counter-clockwise and note what happens in the scale section of the IR window. The high and low temperature values converge on the centre value. The image loses the higher and lower temperature details.

Note also what happens to the small graphic scale under the image and shows which span you are looking at. The upper scale indicates where to find the image. The lower scale contracts about its centre point.

Slowly turn the rotary knob clockwise and note that the values in the scale section diverge from the centre value and the scale bar under the window expands about its centre point.

Press the AUTO ADJ 1 key. The image, scale, and scale bar return to their original setting of 100%.

By using the level and span keys, the rotary knob and the values in the scale section of the IR window you can set a specific temperature measurement span centred around a particular temperature level.

There is a low limit of the span built into the system, which you cannot pass.

Try also the SET, SET VIA SCALE AND THE AUTO ADJUST functions in the Level and Span menu in the Scale menu.

4.3. Image information

Having set the image level and span to the required values you may wish to note important points concerning the image. These notes are incorporated in the image information so that when you later store and recall the file for analysis all the salient points concerning the image will be available.

Adding a comment

Click anywhere within the IR image and the IR menu appears. Select IMAGE COMMENT from this menu and a further submenu appears.

A short-cut is to click on the line at the bottom of the IR-window.

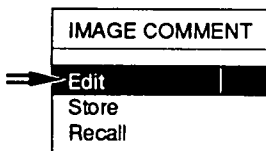

Select EDIT from this menu. A text editing window appears on the screen. Type your notes into this window using the text editing commands listed in chapter 7. You can type up to a maximum of 2000 characters. Make sure that the mouse pointer is placed within the text editing window before typing.



When the notes are complete click on OK and the comment is added to the image. The first 30 characters of the comment will be displayed under the image source and date/time information of the IR window.

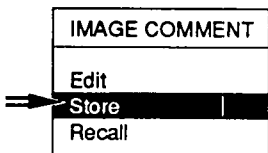

You can also store/recall the comment as a separate file for printout purposes to be used as a prewritten comment.

Saving and recalling image files are explained in the next chapter.

Location:

Name:





5. Store and recall

5.1.	Freeze image	5-6
5.2.	Store image	5-7
5.3.	Recall image	5-8
5.3.	Store sequence	5-10
5.4.	Recall sequence	5-13

With the level and span adjusted and your notes added to the image in the form of a comment the next step may be to save the image for analysis at a later stage.

Location

The word location denotes a place in the OS9 directory tree.

Example: /H0/USR/ERIKA

/H0 is the device name of the system hard disk. USR and ERIKA are directories on that disk.

Sample device names:

/H0 the system hard disk

/H1 /H2 extra hard disks

/DOS the floppy disk, formatted for DOS

/D0 the floppy disk, formatted for OS9

/MT0 a magnetic tape drive, if any.

/BO a burst recording disk, if any.

Current location means the directory where you happen to be.

This is in the dialog panels denoted as . after which there is usually a slash / for sub-directories.

.. (two points) refer to the directory superior to the one, in which you are.

The location name must consist of alphanumerical characters, of which the first must be a letter.

Name

Name is the name of the file, which is going to be used. The file name can have a length of maximum 29 alphanumerical letters plus an extension of three letters.

Examples: MYFILE.HIS
THE_LAST_TEST_ON_JUNE_28.TXT etc

Many functions add the extension themselves. When you e.g. store an image under the name XYZ it automatically gets the name XYZ.IMG, which is recognized by the system as an image.

In many functions there is a possibility to use a so-called wild card.

This word is frequently used in many dialog panels, for example COPY FILES. Wild card, which in ERIKA is either an asterisk (*) or a question mark (?) can be used in the following way:

- * replaces any possible letter or digit combination irrespective of how many there are of them.
- ? replaces any possible letter or digit in the position where the question mark stands.

Examples: file.* can mean file.abc, file.947, file.a6h etc

*.IMG means all files with extension .IMG in the current location.

file.?ab can stand for file.aab or file.lab etc

fi?e.abc can mean file.abc but also fi7e.abc etc

It is also possible to specify a list of file names and/or wild cards separated by commas.

Example: nice.txt, a*, b*.IMG, c??

Handling DOS files in ERIKA

The floppy disk drive is called /DOS when working with DOS-formatted diskettes.

It is possible to translate ERIKA files, i.e. OS-9 files, into DOS file format and vice versa. However, the DOS diskettes have to be formatted outside ERIKA.

As the OS-9 operating system is not optimized for handling DOS files, any operations in DOS will take quite some time. If you have never tried any operations on DOS files before, do so in order to get a full understanding of the time frame. Listings may take more time than the operator might be used to, so be patient.

An OS-9 file name can contain up to 29 characters, but in DOS, a file name only can contain 8+3 characters. Copying and moving file handling functions are equipped with a DOS-rename button. If this option is selected, files will be renamed automatically, if needed. The new name will become unique.

It is also to recommend to check that the format of data types like float and double remain unchanged after the transformation from OS-9 to DOS, as the standards might differ. If so, the translation has to take place before further processing.

ERIKA files with legal extensions will be converted correctly when using DOS copy file(s) or DOS convert file(s). Files not known to ERIKA can be forced to conversion.

The following text file extensions are recognized by ERIKA:

.AST .BAK .BIT .CLG .CMT .FLT .HIS .HLP .INI
.MAC .OPR .OPT .PAL .PLT .PRI .PRF .TXT .SYS

The following binary file extensions are recognized by ERIKA:

.BIN .CAL .GIF .PCX .TIF

The following image file extensions are recognized by ERIKA:

.IMD .IMG .SEQ

Note that the extension of a file may change as a result of the conversion between DOS and OS-9.

5.1. Freeze image

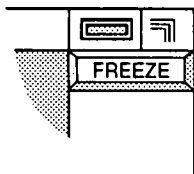

When storing an image e.g. of a moving target and this image is coming from the scanner in real-time it is not easy to ensure that the image stored is the one that you wanted. So prior to storing an image it may be better to first freeze the image at the required moment and then store the frozen image, but it is not necessary to freeze the image before storing an image.

The image can be frozen by pressing the FREEZE 1 key on the keyboard at the correct moment in time. The image will remain frozen until this key is pressed again.

There is also a FREEZE button at the side of the image in the IR window. Clicking on this button has the same effect as pressing the key on the keyboard. After freezing the image using this button or the FREEZE 1 key the legend in the button changes to UNFREEZE.

The keyboard and IR window freeze functions are interchangeable. The image can be frozen with the FREEZE 1 key and unfrozen with the button in the window and vice versa.

5.2. Store image

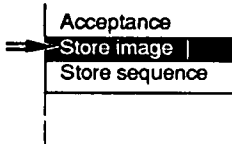

Location:

Name:



Overwrite

Freeze the image by pressing the FREEZE 1 key. However, this is not necessary.

Click anywhere in the IR image to obtain the IR menu. Select the STORE IMAGE option from this menu.

A dialog panel opens on the screen requesting the LOCATION and NAME of the file to be stored.

The LOCATION can be left as it appears with just a full stop indicating the current location (default). Press the DOWN arrow on the keyboard or Carriage return to move the cursor to the NAME field. The extension .IMG is automatically added to the file name so it is not necessary for you to type this. Click on the OK button to store the image. It is recommended to store all your images and other files under location /H0/USR or any subdirectory under that.

If the file location and name are already in use you will be informed about this. If you click on the OVERWRITE button (button down) the existing file will be overwritten. **But you should use this option with care.** You may inadvertently overwrite a file that was important and once overwritten there is no way to retrieve the data.

5.3. Recall image

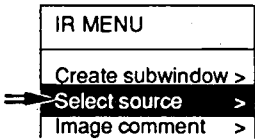
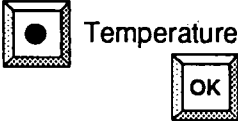
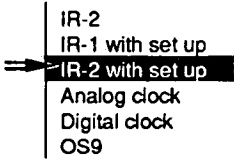

Location:

Name:



Position the pointer anywhere in the background and click with the mouse. Select **CREATE WINDOW** from the System menu and then select **IR-2 WITH SET UP**.

Click on the **TEMPERATURE** and **CELSIUS** buttons in the IR-2 dialog panel and then click on **OK**.

The IR2 window opens with a default image. Position the pointer in the IR2 window title bar and, using the **right** mouse button, drag the window to a position where you can view both IR windows.

Click in the IR2 image and select **SELECT SOURCE** from the IR menu.

Select **RECALL IMAGE** from the menu that appears.

A dialog panel then appears requesting the **LOCATION** and **NAME** of the file to recall.

The **LOCATION** can be left as it appears with just a full stop indicating the current location (default). Press the **DOWN** arrow on the keyboard to move the cursor into the **NAME** field. All that remains is to type in the name of the file that you have just stored.

Assuming that you already have forgotten the name of the image, you might want to have the names of the possible choices displayed on the screen. This can be done by pressing the **LIST** button.

A window with two tables will appear with your file name in the left column. Click on the name to transfer it to the **NAME** field of the **RECALL** image panel. The **LIST** window will then disappear.

Click on the **OK** button and the image that you stored will be recalled into the IR2 window.

The image will be loaded with level and span values from the time of its storage.



If you now set the level and span of window IR2 to the same as that for IR1 the two images will be identical (you could use the auto adjust keys). You can select IR2 by moving the pointer to within the IR2 window boundary.

Position the pointer in the IR1 window title bar and click with the RIGHT mouse button. The IR1 window will be moved to the front.

Press the FREEZE1 key on the keyboard to unfreeze the image.

5.3. Store sequence



Instead of storing one image at a time you may wish to store a complete sequence of images to record a particular event.

Click anywhere in the IR image to obtain the IR menu. Select the STORE SEQUENCE option from this menu.

A large dialog panel opens requesting first the LOCATION and NAME of the file to be stored. This is completed in the same way as before with STORE IMAGE.

Now move down the dialog panel to the next item.

This is where you tell the system when to start recording images for the sequence.



In the field alongside the START button the default action "NOW" is shown. This means that the system will start recording as soon as the OK button is clicked.

Click repeatedly on the START button and the other options will be displayed in turn. For further details on each of these options refer to the Software Reference Manual.

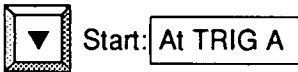

Keep clicking on the START button until AT TRIG A is displayed in the field. This means you will use the TRIG A key to start the recording.

Next you must select how you want the system to record the images; at highest speed, at intervals or on command.

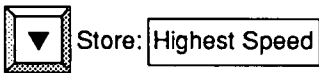

In the field alongside the STORE button the default method "HIGHEST SPEED" is shown. This means that the images will be recorded at two or more per second.

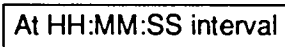

Click repeatedly on the STORE button to view the other options. This time select the AT HH:MM:SS INTERVAL option.

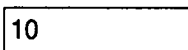

Use the arrow keys to move the cursor into the text field under the option field and type in "10". This means that an image will be recorded

every 10 seconds. It is not necessary to type in the hours and minutes unless you require such a long interval between stored images.

Now you must tell the system when to stop recording.



In the field alongside the UNTIL button the default action "FOREVER" is shown. This means the system will record images until the storage limit is reached (this depends on the space available on the hard disk).

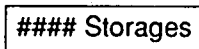

Click repeatedly on the UNTIL button to view the other options. Select the "#### STORAGES" option.



Use the arrow keys to move the cursor into the text field under the option field and type in "20".

You should now have the options that will start the system recording when you press the TRIG A key, and record an image every 10 seconds until 20 images have been recorded.

The KEEP text field displays the default "ALL". This field allows you to tell the system how many of the most recent images to retain in long sequences. Leave this field as it is.

There are three further buttons which at this point should not be selected. These are the OVERWRITE EXISTING and APPEND TO EXISTING sequence and the IMAGES IN ONE FILE (.SEQ) buttons. See the Software Reference Manual for further details on these three options.



Click on the OK button at the bottom of the panel and the store sequence action is started.

A status window opens giving you the name of the file, details of the options you have selected and showing a small panel with the results of the images stored or lost.



Press the TRIG A key once and the recording will start.

Every 10 seconds you will note the STORED quantity is incremented by one. This will continue until 20 images have been stored.

If any images are missed for any reason they will be accounted for in the LOST field.

At the end of the sequence of 20 images the window will be removed. The 20 images are now stored in separate files with file names in the format NAME_0001.IMG, or, if you pressed the Images in one file-button, in the format NAME.SEQ.

5.4. Recall sequence

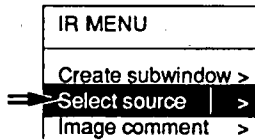

Position the pointer in the IR2 Window title bar and click with the right mouse button to bring that window to the front.

Click in the IR2 image and select **SELECT SOURCE** from the IR menu.

Select **RECALL SEQUENCE** from the menu that appears.

A dialog panel then appears requesting the **LOCATION** and **NAME** of the sequence file to recall.

Location:

Name:

The **LOCATION** can be left as it appears with just a full stop indicating the current location (default). Press the **DOWN** arrow on the keyboard to move the cursor into the **NAME** field. All that remains is to type in the name of the sequence that you have just stored.



Click on the **OK** button and the sequence that you stored will be recalled into the IR2 window.

A dialog panel resembling the keys on a video cassette recorder will then appear. These keys allow you to replay the sequence in a number of different ways. The keys are "pressed" by clicking on them.

- **STOP** key - Stops the replay of the sequence when "pressed".
- ▶ **PLAY FORWARD** - replays from the present image to the final image of the sequence. Replay is at approximately one image per second.
- ◀ **PLAY BACKWARD** - replays from the present image to the first image of the sequence. Replay is at approximately one image per second.

-
- ▶▶ **FAST FORWARD** - replays from the present image to the last image of the sequence at high speed.
 - ◀◀ **FAST BACKWARD** - replays from the present image to the first image of the sequence at high speed.
 - >> **TO END** - Displays the last image of the sequence.
 - << **TO BEGINNING** - Displays the first image of the sequence.
 - + **STEP FORWARD** - Steps forward one image at a time.
 - + ▶ **STEP TO END** - Replays from the present image to the last image of the sequence and at the same time it calculates the results of any analysis functions for each image.
 - **STEP BACKWARD** - Steps backward one image at a time.
 - ◀ - **STEP TO BEGINNING** - Replays from the present image to the last image of the sequence and at the same time it calculates the results of any analysis functions for each image.

Now try pressing a few buttons!

This panel will also show up if you select **RECALL IMAGE(S)** stating more than one image (using wildcards).

6. Analysis

6.1. Spotmeters	6-3
6.2. Areas	6-4
6.3. Line	6-6
6.4. Isotherms	6-8

Having now set up the image, stored both a single image and a sequence, and recalled images from file, now is the time to introduce you to the analysis functions available. There are six different analysis functions that can be used in the image: Spotmeters, Line, Box, Area, Circle and Ellipse.



6.1. Spotmeters

This function gives you the temperature measurement at single points in the image.

Position the pointer in the IR1 window title bar and click with the RIGHT mouse button. The IR1 window will be moved to the front.

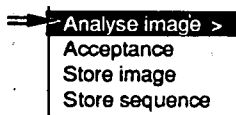

Click anywhere in the IR1 image to obtain the IR menu. Select ANALYSE IMAGE from this menu. Then select ADD SPOT/LINE/AREA/CIRCLE/ELLIPSE.

The text field under the image is replaced with a set of selection buttons. Alongside the buttons in a separate text field appears the instruction "Press ADD".



Click on the ADD button and a short menu appears. Select the SPOTS option from this menu.



The pointer changes to a crosshair symbol. Move this symbol into the image and position it over a point, the temperature of which you want to know, and click.

Select as many points as you like (up to a maximum of 99) within the image and note that the image coordinates for each spot are displayed in the text field as you position it.

If you hold down the mouse button while moving the crosshair, then the image coordinates are displayed in the text field.



You can move a wrongly positioned spot by clicking on EDIT and selecting MOVE from the menu that appears. Then drag the spot to the new position. Releasing the mouse button completes the MOVE action. A simpler way to do this is to click on the spot identification key, label, with the right button and drag the spot to the wanted place.



If you decide that you want to remove the last spot placed, click on the UNDO button.



Once you have positioned all the spots that you require, click on the OK button. You may create areas and lines too before clicking on OK. All the spots have an identification flag added to them.

The result window opens displaying the spot identification number (as shown on the flag), the temperature at that point and the image coordinates of each spot.



Click on any one of the identification flags.

A short menu opens giving you the choice of moving the spot, bringing it to the front or sending it to the back, or removing it altogether.

Click in the IR1 image to obtain the IR menu and select ANALYSE IMAGE from the menu.

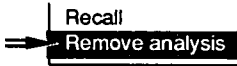

Select REMOVE ANALYSIS from the menu that appears. All the spots will disappear from the image and the results window will be removed.

6.2. Areas

With this function the temperatures contained within an area can be analysed.

Select ANALYSE IMAGE from the IR menu. Then press the ADD button.

This time select the AREA option from the menu that appears after clicking on the ADD button.

An empty results window will open.

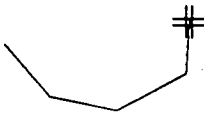

Move the crosshair symbol into the image and position it at a corner of the area that you want to analyse. Click with the mouse and then move the crosshairs to the next corner. Click again and a straight line will join the two points selected. If you hold down the mouse button while moving the crosshairs the line moves with it.

Continue selecting the corners until you have the area defined. It is not necessary to join the first and last corners. As you select the corners their coordinates are displayed.



Click on the **COMPLETE** button and the first and last corners will be joined automatically. The area will not be completed if the last line crosses part of the area selected. In that case "Crossing" appears in the text field and you should select a further corner.

At this point you can adjust the shape of the area by clicking on the **EDIT** button and selecting **RESHAPE** from the menu that appears. Instructions then appear in the text field.

Clicking on the **OK** button changes the area outline from colour and adds an identification flag to it.

In the results window an area identification number will now be shown.



Click on the identification flag and select **RESULTS** from the menu that appears.

A dialog panel appears with the analysis selections available: **Extremes**, **Statistics**, **Histogram** and **Metric size**.



Click on all four selection buttons and then click on the **OK** button

The result window is updated to include the extremes, statistics and the size of the object in metric units. A further window opens to display a histogram of the measurement points within the area.

Click in the IR1 image to obtain the IR menu and select **ANALYSE IMAGE** from the menu.



Select **REMOVE ANALYSIS** from the menu that appears. The area will disappear from the image and the results windows will be removed.

6.3. Line

With this function the temperatures along a line can be analysed.

Select **ANALYSE IMAGE** from the **IR** menu. Then press the **ADD** button and select **LINE** from the **ADD** menu.

Move the crosshair symbol into the image and select the first point of the line that you want to analyse. Click with the mouse and then move the crosshairs to the next point in the line. Click again and a straight line will join the two points.



Continue selecting points until the line is defined. Click on the **COMPLETE** and then the **OK** buttons. The line changes colour and an identification flag is added.



Before clicking on **OK** you can move or reshape the line.

In the already opened results window there will now be a line identification number.



Click on the identification flag and select **RESULTS** from the menu that appears.

This time just select **PROFILE** and **LENGTH** and click on the **OK** button.

In the results window the length of the line will be shown in metric units and a window opens showing the temperature profile along the line.



Click on the **CURSOR** button and select **ADD** from the menu that appears.

The pointer becomes an arrow. Move the arrow into the profile window and position it at a point of interest on the profile.

Click with the mouse button and a vertical line will appear at that point.

This cursor line can be repositioned by clicking at another point on the profile or by dragging the line to a new position.

Click on the OK button and the line changes to a cross. A cross also appears at the corresponding position on the line in the image. The temperature measurement at that point and the image coordinates are displayed in a text field under the profile.



Click on the EXPAND button and select x 4 from the menu that appears.

Note what happens to the profile. The profile can be viewed by clicking with the left and right mouse buttons in the scroll bar under the profile.

The cursor can be moved or removed by selecting the appropriate option from the menu that appears after clicking on the CURSOR button.

Click on the identification flag of the line in the IR image and select CURSOR ADD/MOVE. Now you can reposition the line cursor in the IR image. Press OK when finished.

Click in the IR1 image to obtain the IR menu and select ANALYSE IMAGE from the menu.



Select REMOVE ANALYSIS from the menu that appears. The line will disappear from the image and the results and profile windows will be removed.

6.4. Isotherms

This function allows you to highlight specific temperature bands within the image.

There are two ways to activate the isotherms, either select ISOTHERM HANDLING in the ANALYSE IMAGE menu or press the buttons ISO1 and ISO2 on the keyboard. First try the menu.

Select ISOTHERM HANDLING from the ANALYSE IMAGE menu.

A dialog panel opens from which you control the two available isotherms.

Each isotherm has three selectable options. You can highlight all areas with a temperature higher than a value that you set, all areas with a temperature lower than that set, or all areas with a temperature that falls in a specific band below a set value.



Highlight interval



ON



Enter a temperature value into the ISOTHERM VALUE text field for ISOTHERM 1 that is at approximately the mid-point of the values displayed in the IR1 window scale.

Click on the HIGHLIGHT INTERVAL button and enter a value into the text field alongside the button (Do not enter too high a value).

Click on the ON/OFF button to switch the isotherm on.

Make your own selection for ISOTHERM 2 and switch that isotherm on.

Click on the OK button and the isotherms will appear in the image. Isotherm 1 uses green to highlight the temperature and Isotherm 2 uses yellow.

Press the ISO 1 key on the keyboard and turn the rotary knob first in one direction and then the other. The areas highlighted in the image will change and the isotherm values displayed under the image will also change. The representation of the isotherm under the image will move.

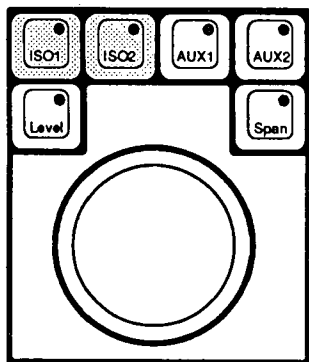

Press ISO 2 on the keyboard and adjust that isotherm value. The effects noted in the display will depend on the selection you made.



Select ISOTHERM HANDLING from the ANALYSE IMAGE menu and switch off the two isotherms by clicking on the two ON/OFF buttons.



Click on the OK button and the isotherms are then removed from the image.

The isotherm function is, however, more easily started by just pressing the ISO buttons on the keyboard. Having done that let the isotherm highlight the corresponding areas by turning the rotary knob. If you press the ISO buttons once again the isotherm width can be changed by turning the rotary knob.

Delete the isotherm by clicking in the green and yellow markers below the IR image. Select Remove, and the isotherm disappears.



7. Manipulation

- 7.1. Show other IR window 7-3
- 7.2. Show other manipulated;
Time process control 7-4
 - 7.2.1. Recursive filtering 7-4
 - 7.2.2. Averaging 7-5
- 7.3. Show other manipulated;
Display process control 7-6
 - 7.3.1. Mirroring 7-6
 - 7.3.2. Rotating 7-6
 - 7.3.3. View 7-7
 - 7.3.4. Swcopy 7-7
- 7.4. Align and Subtraction control 7-8
 - 7.4.1. Align 7-8

Any of the text files stored in the system can be edited. This chapter gives a brief explanation of how to open a text file and the commands that are used within the text edit function.



7.1 Show other IR window

With this function you can display the same image in both IR windows and apply different parameters to the two images.

Make sure that the IR2 window is opened.

Click anywhere in the IR2 image to obtain the IR menu. Select **SELECT SOURCE** and **SHOW OTHER IR WINDOW** from the menus that appear.

The same image, auto-adjusted, as is displayed in the IR1 window appears in the IR2 window.

Now try applying different settings to the two windows.

7.2 Show other manipulated Time process control

With this function you take the image in IR-1 and filter it over to the IR-2 or vice versa. The resulting image is manipulated. Make sure that IR-1 is opened with a live image in it.

Click anywhere in the IR2 image to obtain the IR menu. Select SELECT SOURCE from the menu that appears.

Then under SHOW OTHER MANP'D select Time process control.

The following 'filters' are implemented under that menu:

Recursive filtering

Averaging

Maxmin

Named

7.2.1 Recursive filtering

Select Recurs in the dialog panel and click on the figure 2 below.

This '2' figure will change to 4 etc up to 32 when it starts from 2 again.

Select 4 and click on SET.

Recursive filtering 4 means e.g. that 1/4 of the latest image is added to 3/4 of the image, which is already in the IR-2. The sum of this is the new image.

Recursive filtering is a software implemented function the speed of which varies slightly with the load on the system.

7.2.2 Averaging

Select Average in the dialog panel by clicking on the button beside the 'Recurs' text.

This will step forward to next function, which is Averaging.

Then select 8, meaning 8 images will be averaged. Averaging is a means to bring the noise down by the square root of the number of averaged images.

The filter picks up 8 images from IR-1 at a rate governed by the load on the system, adds them together and shows them in IR-2.

You can see that it updates the filtered image approximately once a second.

Also try other averaging numbers like e.g. 4 or 16.

7.3 Show other manipulated

Display process control

7.3.1 Mirroring

The first function in this menu is Mirroring. Mirroring means that the filtered image is the same as the image in IR-1 but as seen in a mirror. Mirroring possibilities are to mirror it in the X or Y axis or in an XY axis, i.e. turning upside down and right to left simultaneously.

Try XY. This function can correct the image if the scanner is looking at the object via a mirror.

7.3.2 Rotating

This function shows the filtered image as a 180 degrees tilted image from IR-1.

7.3.3 View

There are three options of this filter, 4, 9 or 16. Select 4 for example.

If you have a live image in IR-1, then there will be 4 1/4-sized continuously running images displayed in IR-2. The latest image is taken in at the lower right corner, then it is shifted to the lower left corner and the next image is taken in at the lower right.

The images will now keep running.

Shift to 16 and see the difference.

If a sequence is taken in into IR-1, then this is a nice way to look at the contents of the sequence.

7.3.4 Swcopy

This is the same type of copying from IR-1 to IR-2 as in Show other IR window, but in this case it is done via software. Different colour scales and object parameter sets can be applied as in the hardware case.

7.4 Align and Subtraction Control

7.4.1 Align

Click on Align in the Align & Sub Ctrl panel. It takes a few seconds to start this function. You will get two spot meters in each window. This function can be used for the alingment of two images with another.

But this little exercise will show something else.

Press the button Keep IR-1 as reference.

Find an interesting part in the live image in IR-1. Put the two spot meters on each side of the object. Click in the spotmeter to the wanted place.

Then in IR-2 put the spotmeter with the double distance between them. Then click on SET.

See the result. Move one of the spots in IR-2 and click on SET again.

8. Text file facilities

8.1.	Editing text files	8-3
8.2.	Editing commands	8-4

Any of the text files stored in the system can be edited. This chapter gives a brief explanation of how to open a text file and the commands that are used within the text edit function.



8.1. Editing text files

Select EDIT TEXT FILE from the FILE HANDLING menu. This brings up a dialog panel requesting the LOCATION and NAME of the file to be edited.

The LOCATION can be left as it appears with just a full stop indicating the current location or a new location can be typed. The file name is then typed into the NAME field.

Clicking on the LIST button brings up a window listing the directories and files available. In order to list the available files the required file extension (or an asterisk * meaning all files) must be typed into the SELECT field in the LIST dialog panel. Selecting a directory and file from the list or clicking the OK button loads this information into the location and name fields.

Clicking on the OK button selects the file.

A new window opens showing the contents of the file selected.

8.2. Editing commands

Text can be input or edited using the following keys and commands:

Insert Toggles between Insert and Overwrite modes. When **Insert mode** is on characters are inserted under the cursor and the original text moves to the right.

When **Overwrite mode** is on the character under the cursor is replaced with the character typed.

Delete In **Insert mode** the character under the cursor is erased and the characters to the right of the cursor move to the left.

In **Overwrite mode** the character under the cursor is replaced with a blank and the cursor moves to the right.

Backspace In **Insert mode** the character to the left of the cursor is erased and the characters to the right of the cursor move to the left.

In **Overwrite mode** the character to the left of the cursor is replaced with a blank and the cursor moves to the left.

Home Moves the cursor to the beginning of the line.

End Moves the cursor to the last character of the line.

PageUp The preceding page is moved into the window.

PageDn The next page is moved into the window.

Return Inserts a line feed at the position of the cursor. All characters to the right of the cursor and the character under the cursor are moved to a new line.

Left Arrow Cursor is moved one character to the left.

Right Arrow Cursor is moved one character to the right.

Down arrow Cursor is moved to the corresponding character in the line below.

Up arrow Cursor is moved to the corresponding character in the line above.

Ctrl + Home In Insert mode all the characters from the beginning of the line to the cursor are erased.

In Overwrite mode all the characters from the beginning of the line to the cursor are replaced with blanks.

Ctrl + End In Insert mode all the characters from the cursor to the end of the line are erased.

In Overwrite mode all the characters from the cursor to the end of the line are replaced with blanks.

Ctrl + PageUp The cursor is moved to the first character of the first line.

Ctrl + PageDn The cursor is moved to the last character of the last line.

O

C

C

C