

REVISIONS				
LTR.	DESCRIPTION	CHECK	DATE	APPV.
C	REVISED	Helen Sacks	5-4-83	Ed McAvoy

P Dataproducts

TITLE

B600 PRODUCT DESCRIPTION

SIZE A	CODE IDENT NO. 19790	DRAWING NO. B-600-PD	REV. C
SCALE		PAGE 1A	OF 44



TABLE OF CONTENTS

		Page
1.0	INTRODUCTION.....	3
1.1	Scope.....	3
1.2	Product Description.....	3
1.3	Summary Characteristics.....	4
2.0	PERFORMANCE CHARACTERISTICS.....	6
2.1	Print Bands.....	6
2.2	Print Rate.....	6
2.3	Print Quality.....	10
2.4	Form Types.....	10
2.5	Ribbon.....	13
2.6	Acoustics.....	13
2.7	Protective Devices.....	13
2.8	Electrostatic Discharge Susceptibility.....	13
2.9	Product Safety and FCC Compliance (RFI).....	14
3.0	CONTROLS AND INDICATORS.....	14
3.1	Cabinet Mounted.....	14
3.2	Operator Panel (Externally Accessible).....	14
3.3	Operator Panel (Internally Accessible).....	15
3.4	Mechanism Controls.....	16
3.5	Maintenance Aids.....	16
3.6	Documentation.....	16
4.0	FUNCTIONAL DESCRIPTION.....	16
4.1	Font Carrier.....	18
4.2	Band Drive System.....	18
4.3	Ribbon System.....	18
4.4	Paper Feed System.....	19
4.5	Hammer System.....	20
4.6	Power Supply.....	21
4.7	Electronics Assembly.....	21
5.0	PROGRAMMING RESTRICTIONS.....	23
6.0	PRINTER/USER SYSTEM INTERFACE.....	23
6.1	Standard Interface Signals.....	25
6.2	Optional Interface Signals.....	25
6.3	Interface Handshaking.....	27
6.4	Interface Circuits.....	31
6.5	Printer Connectors.....	31
6.5.1	AC Power Connector.....	31
6.5.2	Interface Connector.....	31

DRAWING NO. B-600 - PD	REV C
SHEET 1 OF 44 SHEETS	

TABLE OF CONTENTS

		Page
7.0	OPTIONS.....	33
7.1	Automatic Line Feed.....	33
7.2	Character Sets.....	33
7.2.1	Font Styles.....	33
7.2.2	Multiple Band Sensing.....	33
7.2.3	Additional Bands.....	33
7.2.4	Additional Band Image Proms & Automatic Foldover.....	33
7.3	Elapsed Time Meters.....	33
7.4	Format Control.....	34
7.4.1	Fixed Form Length.....	34
7.4.2	Print to Bottom of Form.....	34
7.4.3	Fixed Perforation Skipover Length.....	34
7.4.4	Form Length Selector Switch.....	34
7.4.5	12 Channel Direct Access Vertical Format Unit.....	35
7.4.6	12 Channel Tape Controlled Vertical Format Unit.....	35
7.5	Ground Isolation.....	36
7.6	Paint.....	36
7.7	Interfaces.....	36
7.7.1	Custom Interfaces.....	36
7.7.2	Long-Line Interface.....	37
7.7.3	Serial Interface.....	37
7.7.4	Centronics Interface.....	37
7.7.5	Low True Interface.....	37
7.7.6	Buffer Clear Invert.....	37
7.7.7	Pull Up/Pull Down.....	37
7.7.8	Winchester Connector.....	37
7.8	Master Support & Logistics Manual.....	39
7.9	Parity Error Detect.....	39
7.10	Power Supply - Universal.....	39
7.11	Pedestal.....	39
7.12	Acoustic Cabinet.....	39
7.13	136 Column Option.....	40
8.0	RELIABILITY/MAINTAINABILITY.....	40
8.1	Design Workload.....	40
8.2	Mean Time Between Service Calls (MTBSC).....	40
8.3	Mean Time To Repair (MTTR).....	41
8.4	Preventative Maintenance (PM).....	41
9.0	SHIPAWAY KIT.....	41
10.0	PHYSICAL CHARACTERISTICS.....	41
11.0	REFERENCE DOCUMENTS & APPLICATION NOTES.....	44
11.1	Reference Documents.....	44
11.2	Application Notes (BAPN).....	44

DRAWING NO. B-600 - PD	REV C
SHEET 2 OF 44 SHEETS	

PRODUCT DESCRIPTION

B600 LINE PRINTER

1.0 INTRODUCTION

1.1 SCOPE

This document describes the Dataproducts Corporation Model B-600 Line Printer.

It contains detailed information on the unit's performance and a functional description of the operation of each major subsystem. Data concerning physical characteristics, reliability, maintainability, optional features and environmental requirements is also provided.

1.2 PRODUCT DEFINITION

The B-600 Line Printer is a general-purpose, solid font impact printer designed as an output device for use on electronic information-processing systems, such as small business computing, data communications/data entry terminals, text processing and dedicated mini-computer based systems where reliable above average operation with minimal preventative maintenance is required.

The standard B-600 is a compact, horizontal font, 132 column impact printer designed to provide a throughput of 600 LPM in a typical printing application using a 64 character ASCII set.

The basic printer is a pedestal mounted configuration (it can optionally be operated on a modified table top) and consists of a steel band font carrier, a single column spanning Mark V hammer system, a stepper motor activated paper feed system, ribbon transport, microprogrammed control logic, power supply, full line buffer and interface.

A variety of options are available to efficiently configure the printer to meet specific application requirements. A description of the options is provided in Section 7.0 of this document.

The B-600 has been designed with both the end user and the OEM in mind. Operator controls are minimized and located according to their frequency and mode of operation. The loading of expendibles (ribbon and paper) is facilitated by the use of a cartridge ribbon system, horizontal and vertical forms alignment scales and a wide opening through which paper is loaded. Automatic motor control, paper low and paper jam detectors, ribbon motion detector, high-speed slew rate and a large viewing window are just a few of the features which make the unit attractive to the end user.

DRAWING NO. B-600 - PD		REV C
SHEET	3	OF 44 SHEETS

In addition to the end user features, OEM customers will be interested in the technological advances and serviceability of the B-600. The Mark V Hammer is an evolutionary design based upon the field proven voice coil actuated Mark IV device. When used in conjunction with new magnet materials, the Mark V provides for multi-copy capability with extremely low power consumption. Integrated circuit hammer drivers and microprogrammed control minimize the number of printed circuit boards, maximize the printer's reliability and result in a low cost of ownership over the B-600's useful service life. A built-in self test capability and diagnostic display will reduce the number of unnecessary service calls and result in lower field maintenance expense. The features and benefits of the B-600 truly distinguish it as the "printer designed for people."

1.3 SUMMARY CHARACTERISTICS

Throughput (Lines/Minute)

ASCII CHARACTER SET SIZE	PRINT THROUGHPUT AT 10 CPI
48 Character	646 LPM
64 Character Utility	646 LPM
96 Character Upper/Lower Case	543 LPM

For details refer to Application Note BAPN-001. Typically, 75% of characters are low usage; 25% high usage.

Characters Per Line	132 (136 Optional)
Character Spacing Horizontal (characters/inch)	10 cpi
Vertical (lines/inch)	6/8 operator switch selectable.
Line Advance Time	25 milliseconds (Maximum)
Paper Slew Speed	15 inches/second (Minimum)

DRAWING NO. B-600 - PD		REV C
SHEET	4 OF 44 SHEETS	

Electrical Characteristics

	<u>STANDARD</u>	<u>OPTIONAL</u>
Voltage	90 - 132 VAC	90 - 132 VAC 180 - 250 VAC
Frequency	60 ± 1 HZ	50, 60 ± 2 HZ
Phase	Single	Single
Stand Alone Version:		
Nominal Power - Standby	225 Watts	275 Watts
- Printing	375 Watts	425 Watts
Heat Generation	1150 BTU/Hr.	1320 BTU/Hr.
Acoustic Cabinet:		
Nominal Power - Standby	325 Watts	375 Watts
- Printing	475 Watts	525 Watts
Heat Generation	1465 BTU/Hr. Max	1630 BTU/Hr. Max.

Physical Characteristics

(Refer to Section 10.0)

	<u>STAND ALONE</u>	<u>ACOUSTIC CABINET</u>
Dimensions:	Height: 38 CM (14.9 inches)	113 CM (44.5 inches)
	Width : 77 CM (30.3 inches)	87 CM (34.3 inches)
	Depth : 64 CM (25.2 inches)	75.5 CM (29.7 inches)
Weight :	72.5 Kg (160 pounds)	159 Kg (350 pounds)
	86 Kg (190 pounds) shipping	195 Kg (430 pounds) shipping
Color :	Two standard color combinations are available: Warm Tone - Brown and Tan (B600-SPS-1) Cool Tone - Light Gray and Charcoal (B600-SPS-2)	

DRAWING NO. B-600 - PD		REV C
SHEET	5	OF 44 SHEETS

Environmental Characteristics

	<u>OPERATING</u>	<u>STORAGE</u>	<u>TRANSIT</u>
Temperature:	10°C (50°F) to 38°C (100°F)	-10°C (14°F) to 50°C (127°F)	-40°C (-40°F) to 71°C (160°F)
*Humidity:	20% to 80%	10% to 90%	95% Maximum
Altitude :	0 to 3000M (0 Ft. to 9842 Ft.)	0 to 3000M (0 Ft. to 9842 Ft.)	0 to 10,000M (0 Ft. to 32,808 Ft.)
*Non-Condensating			

2.0 PERFORMANCE CHARACTERISTICS

2.1 PRINT BANDS

The standard B-600 print band contains 416 characters arranged on 0.1125 inch centers. Each character is typically 0.095 inches high by 0.064 inches wide. Custom character sets are available upon request.

Band characters are rated for 30,000,000 impacts per character when printing all possible characters on a minimum paper weight of 56 gms (15 lb.) and using DpC standard ink. After 30×10^6 impacts, the characters may appear wider and less defined.

The basic printer will be equipped with the 64 utility character band. Upon request, 48, 96, and 128 sets are available. Refer to the B-Series Character Set document for full font style and character set information. Additional, non-standard character sets are available for special applications.

Tables 2 and 3 define the character/code relationship of the three standard character sets.

2.2 PRINT RATE

The print speed of the B-600 is a function of band speed, band character pitch and paper advance time. These are fixed parameters. Variables that affect print rate include the number of times each character appears on a print band, the character content of printed lines and the time taken to load each new line into the printer memory from the user system.

DRAWING NO. B-600 - PD	REV C
SHEET 6 OF 44 SHEETS	

Table 1 provides print rate details on two band arrangements:

TABLE 1

BAND	MAXIMUM (LPM)	MINIMUM (LPM)
64 Character Utility	650	600
96 Character U/L Case	650	506

Refer to Application Note BAPN-001 for additional print speed information. These print speeds assume the standard band speed of 126.6 IPS.

DRAWING NO. B-600 - PD	REV C
SHEET 7 OF 44 SHEETS	

TABLE 2

US ASCII CHARACTER SET (48 CHARACTER)

b7 b6 b5	0 0 0	0 1 0	0 1 1	1 0 0	1 0 1
b4 b3 b2 b1					
0 0 0 0		SPACE	0	@	P
0 0 0 1		!	1	A	Q
0 0 1 0			2	B	R
0 0 1 1		#	3	C	S
0 1 0 0		\$	4	D	T
0 1 0 1		%	5	E	U
0 1 1 0		&	6	F	V
0 1 1 1			7	G	W
1 0 0 0			8	H	X
1 0 0 1			9	I	Y
1 0 1 0	LF	*		J	Z
1 0 1 1				K	
1 1 0 0	FF	,		L	
1 1 0 1	CR	-		M	
1 1 1 0		.		N	
1 1 1 1		/	?	O	

Note: Characters not in the 48 Character Set print as spaces.

DRAWING NO. B-600 - PD				REV C
SHEET	8	OF	44	SHEETS

2.3 PRINT QUALITY

The following best describes print quality and assumes a properly set up machine fitted with the recommended Dataproducts ribbon, and using the stated paper weights.

A. Registration - Using 56 gms (15 lb.) single part paper.

Vertical - The vertical registration spread of characters on a printed line will not exceed 0.3mm (0.012 inch). Registration may be beyond these limits when printing the last 7.6cm (3 in.) of paper following detection of end of form set.

Horizontal - Horizontal character registration will be within $\pm 0.2\text{mm}$ (.008 in.) of a line drawn vertically through the mean of two adjacent columns. Registration may be beyond these limits when printing the last 7.6cm (3 in.) of paper following detection of end of form set.

B. Character Ghosting - Using 56 gms (15 lb.) single part paper.

Character ghosting is defined as marking from an adjacent character to the character being printed. There shall be no character ghosting, unless very wet ribbons (greater than 20% ink content) are used, on single-part forms up to 74 gms (20 lb.) weight. On multipart forms or heavy card stock, ghosting may be observed but will not impair legibility.

C. Multipart Print Through

This parameter is very paper and carbon sensitive. On smooth paper with 30gms (8 lb.) carbon, having a stock thickness of less than 0.43mm (.017 in.), the last copy of six part will be legible. Hammer face blocking may appear on the last copy, but there will be no difficulty in reading text.

2.4 FORM TYPES

Some recommendations regarding forms which can be used in the printer are listed in Table 4.

The B-600 is designed to utilize pin feed, continuous fan fold forms from single to six part.

For satisfactory system performance, the forms used should be within the following limits:

DRAWING NO. B-600 - PD		REV C
SHEET	10 OF	44 SHEETS

- Length - The standard Top of Form spacing is set for 11 inches at 6 or 8 lines/inch with a 3 line perforation skipover. A 12 inch fixed form length and alternate skipover facilities are available optionally. If variable form lengths (3 to 14 inches) are a requirement, the optional 12-channel Direct Access, Tape Controlled Vertical Format Unit, or Form Length Selector Switch can be used. Refer to Section 7.4 for a description of the Format Control Options.
- Width - Forms widths from 7.62cm to 40.64cm (3 to 16 inches) are acceptable. Refer to Figure 1 for margin detail.
- Thickness - The minimum paper weight is 56gms (15 pound bond). Thinner forms are subject to embossing, paper handling difficulties and reduced printer life. The maximum form set thickness is 0.5mm (0.020 inches).

While multipart forms up to six part (original plus 5 copies and 5 carbon sheets) may be used, the quality of multipart printout is dependent on the quality and weight of the forms. Typical forms consisting of 12 pound bond and 6 to 8 pound carbons produce acceptable print quality.

Forms with large cut to uncut perforation ratios may become caught in the hammer bank mask or suffer perforation bursting. Use of such forms is not encouraged. Restacking of forms after exiting the printer is dependent upon gravity and memory of the folds and is somewhat related to humidity conditions. Printing on the folds will degrade paper stacking.

TABLE 4

PRINTABLE FORMS

The following form data is recommended to assure acceptable print quality and reliable forms movement in the printer. Various other forms construction is possible and should be tested by the user to assure adequate printer performance.

The values are shown in grams/meter²(GMS) and pounds and represent maximum paper weights. Lower weight forms may be used in all cases as long as the paper weight is no less than 56/15 for single part or 37/10 for multipart. It is recommended that all multipart forms are tested prior to quantity ordering.

DRAWING NO. B-600 - PD		REV C
SHEET	11	OF 44 SHEETS

BOND PAPER WITH CARBON USING 30GMS (8 LB.) SINGLE SHOT CARBON

FORM							FORMS THICKNESS	
	1	2	3	4	5	6	MM	(MILS)
2 PT	56/15	56/15					.15	(6)
3 PT	56/15	45/12	56/15				.23	(9)
4 PT	56/15	45/12	45/12	56/15			.33	(13)
5 PT	56/15	45/12	45/12	45/12	56/15		.40	(16)
6 PT	56/15	45/12	45/12	45/12	45/12	56/15	.50	(20)

For proper paper handling, adequate tension strength of the perforation at the fold is required. The ratio of cut to uncut sections in the perforation should not exceed 2:1.

Fastening such as crimping, stitching, or gluing should be used to fasten forms together. Fastening must occur on the right-hand margin as a minimum.

Carbons may be attached by gluing in narrow width carbon or by using unattached full width carbon with margin holes.

Multiple part forms in which individual parts vary in size must be tested prior to quantity ordering.

Forms should be fastened in the margins only, avoiding any hard fastening such as staples.

Maximum thickness of the form set should not exceed 0.5 mm (.020 in.) If inadequate fastening of forms is used, print quality and paper refolding may deteriorate.

FIGURE 1.

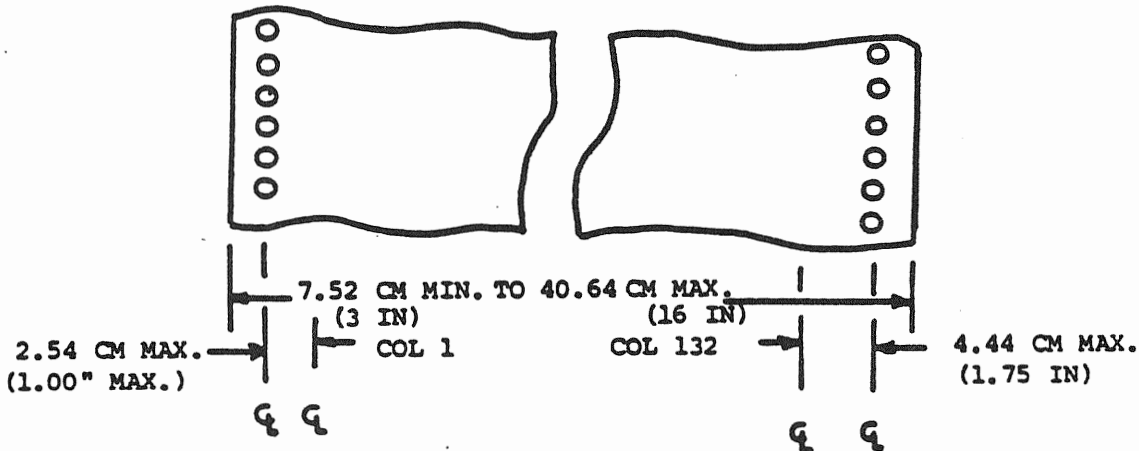

DRAWING NO. B-600 - PD		REV C
SHEET	12	OF 44 SHEETS

2.5 RIBBON

The printer uses a ribbon cartridge containing a 45m (50 yard) continuous loop of 2.54cm (1 in.) wide nylon ribbon. Ribbon changes can be easily accomplished by the operator in less than 1 minute.

Ribbon life is defined as the number of characters that may be printed before: 1) removing enough ink from the ribbon to make printout illegibly light, 2) destroying the ribbon fiber or 3) separation of the ribbon at the weld. Ribbon life is dependent upon print patterns, print density, paper used, ribbon thickness and ink characteristics.

An average ribbon life of 250,000 lines of print will be obtained with the standard ribbon when used in a normal on-line print mode. It is recommended that 0.005" thick nylon ribbons be used on the product.

Ribbons vary markedly from one supplier to another relative to ink type and content, thread count, etc. Tests should be run to insure adequate performance in the printer prior to ordering large quantities of ribbons.

2.6 ACOUSTICS

Acoustic damping materials in the standard B-600 enclosure allow the printer to produce an average sound pressure reading of 70 dba. (Average of readings from four sides taken per Application Note BAPN-006). An optional 60 dba cabinet is available and described in Section 7.12.

2.7 PROTECTIVE DEVICES

Protective devices are provided to prevent printer operation in the event of certain component failures or improper operator procedure. A band cover interlock is provided to inhibit band motion if the band cover is raised. Fuses and a circuit breaker are employed to protect against current overload conditions and airflow is continuously monitored. Paper low, ribbon motion, ribbon jam, and paper motion devices sense the readiness of the unit for printing. Should a fault be detected, a unique fault code as well as an alarm light will be displayed on the control panel which allows the operator to identify the fault and take appropriate corrective action.

2.8 ELECTROSTATIC DISCHARGE SUSCEPTIBILITY

When tested to Dataproducts' procedures, the printer will withstand 12KV* of electrostatic discharge on external operator contactable surfaces without causing the unit to malfunction. Using these same procedures, the printer will withstand 25KV* of electrostatic discharge on external operator contactable surfaces without causing

DRAWING NO. B-600 - PD	REV C
SHEET 13 OF 44 SHEETS	

damage to the printer. Refer to Application Note BAPN-007 for detail test methods.

*Using the Andy Hish, Model 255 ESD Test Unit.

2.9 PRODUCT SAFETY AND FCC COMPLIANCE (RFI)

The printer is Underwriters Laboratories UL/478 approved and Canadian Standard Association C22.2 No. 154 certified. The requirements of International Electrical Commission (IEC 435) 1979 edition were implemented in the product design. The standard B-600 complies with the requirements in Part 15 of FCC rules for a Class A operating device, and VDE EMI/RFI requirements (VDE 0871, Class A limit).

3.0 CONTROLS AND INDICATORS

3.1 CABINET MOUNTED

On/Off Switch A switch which allows A/C line voltage to be applied to the internal printer electronics.

3.2 OPERATOR PANEL (Externally Accessible)

Power On An indicator which is illuminated when primary power is on.

On/Off Line A pushbutton/indicator which is illuminated when the printer is in the READY condition and the ON/OFF LINE switch has been actuated to the ON LINE condition. The interface is active only in the ON LINE condition. Depressing the switch will alternately place the printer ON LINE and OFF LINE.

NOTE: If the SELF TEST switch is active, depressing the ON/OFF LINE switch will alternately place the printer in and out of the self test mode. The ON/OFF LINE indicator will be illuminated when the printer is in the self test mode; however, the DEMAND and ON LINE interface signals will be inactive.

Alarm/Clear A pushbutton/indicator that illuminates during power up and on the occurrence of a fault condition. The specific ALARM condition is identified by the diagnostic display (refer to Section 3.3). Depressing the ALARM/CLEAR switch master clears the printer logic.

DRAWING NO. B-600 - PD	REV C
SHEET 14 OF 44 SHEETS	

Paper Step A momentary pushbutton that can be used to advance the form one line if the printer is in an OFF LINE condition. This switch is disabled during tape load of the optional VFU or when the printer is ON LINE or printing in SELF TEST mode.

Top of Form A momentary pushbutton that can be used to advance the form to the Top of Form (TOF) position on the next form if the printer is in an OFF LINE condition. This switch is disabled during tape load of the optional VFU or when the printer is ON LINE or printing in SELF TEST mode.

Phasing Control The phasing potentiometer is used to maintain equal print density on the left and right side of the characters. The normal position is centered.

3.3 OPERATOR PANEL (Internally Accessible)

6/8 Lines Per Inch A two-position switch which allows the operator to select either six (6) or eight (8) lines per inch spacing. Any change in the switch position is ignored unless the printer is OFF LINE and at TOF.

Self Test A three-position switch which provides a means for exercising the printer OFF LINE. When in the SELF TEST mode, the operator can cause either a 132 column sliding or single character pattern to be printed followed by a single line feed. The single character is factory set in PROM and is normally "H".

Penetration Control A potentiometer which varies hammer energy to optimize print quality when printing on forms of various thicknesses. The lower possible leftmost setting that provides the desired print density should be used to maximize ribbon, band and hammer face life.

Diagnostic Display Digital readouts that indicate printer status. This feature enables the operator to quickly identify the nature of a fault and determine if it can be corrected locally, thus eliminating many unnecessary service calls.

When technical assistance is required, the diagnostic display aids the field engineer to quickly isolate the problem area and initiate corrective action. Refer to the Operator's Guide for detail on all status conditions.

DRAWING NO.		REV
B-600 - PD		C
SHEET	15 OF	44 SHEETS

3.4 MECHANISM CONTROLS

- Hammer Bank Latch A lever which separates the hammer bank and print band to facilitate paper loading. An unlatched condition causes a display of status and inhibits the READY, ON LINE, and DEMAND signals.
- Vertical Forms Positioning Vertical forms alignment is provided by a control knob located on the paper feed mechanism. A locking device enables the operator to release the positioning knob and reposition the paper. Character line location is indicated by a reference scale on the hammer bank face plate.
- Horizontal Forms Positioning Left & right spockets may be independently located horizontally to provide for various width forms and to allow proper positioning of left- and right-hand margins. A reference scale indicates horizontal location of individual column positions on the forms.
- Band Release A lever which allows the operator to release and reset tension on the print band during band changing.

3.5 MAINTENANCE AIDS

- Print Inhibit A switch located on the timing and status board which prevents hammers from firing in a maintenance mode. When "ON", this switch causes the ON LINE signal to go inactive at the interface. Print Inhibit status is indicated on the diagnostic display if this mode is selected.
- Self Test See Section 3.3 for details.

3.6 DOCUMENTATION

Each printer, when shipped, will have an accompanying Operator's Guide and Maintenance Guide. The latter contains information necessary to enable a technician to properly install the unit and maintain it in the field, using an assembly level repair philosophy. Detailed component level troubleshooting information is contained in the optional Master Support & Logistics Manual.

4.0 FUNCTIONAL DESCRIPTION

The B-600 printer consists of seven major modules and associated subsystems. The relationship between the subsystems is shown in block diagram form in Figure 2.

DRAWING NO. B-600 - PD	REV C
SHEET 16 OF 44 SHEETS	

FIGURE 2
MAJOR SUBSYSTEMS

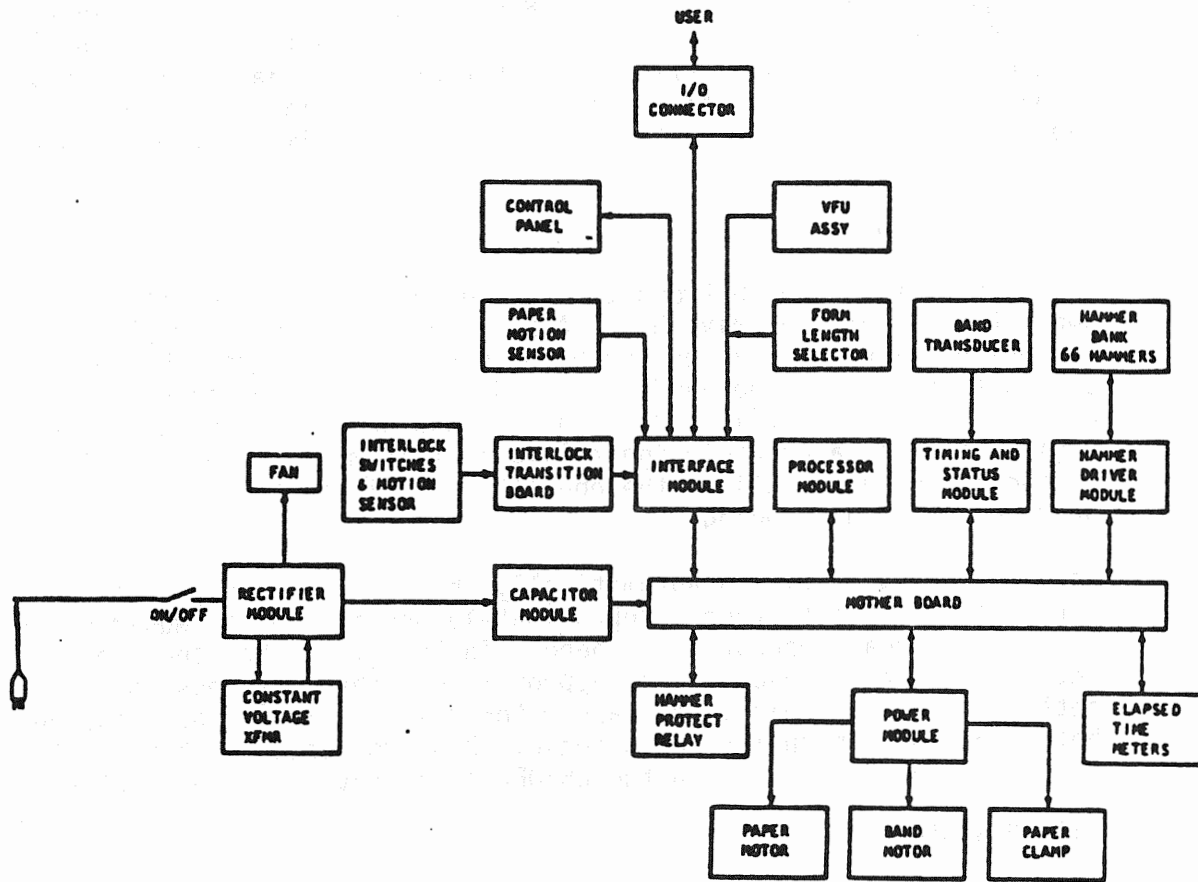

DRAWING NO. B-600 - PD		REV C
SHEET	17	OF 44 SHEETS

The following paragraphs contain a functional description of each of the major subsystems.

4.1 FONT CARRIER

The operator changeable font carrier consists of an etched steel band containing 416 characters spaced 0.1125 inches apart.

Maximum stress relief has been provided by perforating the band above and between each character, giving the top edge of the band a scalloped appearance. Character clocks, index and band identification information is extracted from the band by a variable reluctance pick off. This information is made available to the processor module via the timing and status module. The printer, when equipped with the appropriate PROMS, is capable of recognizing and accepting the presence of up to three different bands configured in one of the following arrays: 48 character, 64 character utility, or 96 character. Refer to Section 7.2.2 for multiband sensing capability. NOTE: For Centronics Interface, maximum character band size is 95 character.

4.2 BAND DRIVE SYSTEM

The band is tensioned between two tapered pulleys mounted at opposite ends of the drive bed. A DC motor is directly coupled to the drive pulley and causes the band to rotate counterclockwise at a constant velocity. The band is biased downward by the tapered pulleys until contact is made with two edge guides. Vertical band registration is accurately controlled in this manner. An eccentric on the idler pulley allows the operator to release tension on the band during band changing.

Band motion is initiated automatically whenever data is transmitted across the user interface. Approximately one second is required for the band to reach operational speed. In the event that the user interface remains inactive for approximately three seconds (other settings are available), the band motor drive will turn off causing both band and ribbon motion to cease. Band motion or lack thereof does not have any effect on the ON/OFF line status of the printer.

4.3 RIBBON SYSTEM

The use of a ribbon cassette containing a continuous loop of ribbon provides for easy ribbon changing and maximum simplicity in the ribbon system. The rectangular cartridge snaps onto the band drive casting and a capstan/pinch wheel assembly bears directly on the ribbon fabric to provide ribbon motion. The capstan is coupled to the band drive motor, thus causing band and ribbon motion to occur concurrently. The ribbon path is skewed across the print station to insure maximum utilization of the ribbon. A motion sensing device monitors ribbon motion. If a failure appears, the printer will go OFF LINE and display the appropriate status.

DRAWING NO. B-600 - PD	REV C
SHEET 18 OF 44 SHEETS	

4.4 PAPER FEED SYSTEM

Paper loading is from the bottom of the printer, through a paper entry door, directly in line with the print station. A lever is provided to separate the hammer bank from the font carrier to facilitate paper loading.

Two paper feed sprockets above the print station enable the paper to be moved through the hammer bank area, turned and directed through a guide to the paper exit at the rear of the printer. A tensioner located below the print station provides vertical forms tensioning, while a stepper motor coupled to the sprocket shaft by a timing belt supplies motive power. A solenoid actuated paper clamp located below the print station minimizes multipart "blousing" and prevents lateral movement of the paper during printing. The clamp is energized prior to printing and released prior to the execution of paper motion commands. Carriage return (CR) commands do not result in paper movement or release of the clamps.

The vertical position of the form is established by placing the form in the sprocket set and initiating a manual TOP OF FORM operation. The first line to be printed is then positioned with respect to the forms alignment scale by rotating the form advance knob located on the sprocket drive shaft.

Horizontal form position is established by the lateral positioning of the individual sprockets. A column indicator scale designates where each column will be printed.

A paper motion detector is located in the left hand sprocket. Detection of loss of motion for a maximum of eight lines will cause the printer to go OFF LINE after completion of the current line.

A paper low sensor is located below the print station. Detection of a paper low condition causes the printer to go OFF LINE after completion of the current line being printed. Additional lines may then be printed in the single line step mode (17 lines at 6 LPI or 23 lines at 8 LPI).

The paper feed system is capable of advancing paper (one to six-part forms) in either single line or multiple line (slew) modes. Maximum single line rate is 25 milliseconds. Minimum slew rate is 380/mm (15 inches)/second.

Forms are advanced as a result of operator controls or interface commands.

The manual operator controls are:

Paper Step	Causes the form to advance one line.
Top of Form	Causes the form to advance to the next TOF position.

DRAWING NO. B-600 - PD	REV C
SHEET 19 OF 44 SHEETS	

The operator/format controls are inhibited when the printer is ON LINE, in SELF TEST mode, or when VFU is being loaded.

The coded interface commands are as follows:

- Line Feed (LF) The octal 012 code terminates the load cycle, initiates the print cycle and causes the paper to advance on line.
- Form Feed (FF) The octal 014 code terminates the load cycle, initiates the print cycle and causes the paper to advance to the next Top of Form position.
- Carriage Return (CR) The octal 015 code terminates the load cycle initiates the print cycle, results in no paper advance, and does not release paper clamps.

Multiple line advances can be accomplished by issuing successive LF commands. The CR command is not required in conjunction with either the LF or FF commands, although CR/LF, LF/CR, CR/FF or FF/CR can be received without degrading print speed. A CR command is required only for overprinting.

The Top of Form position is set for 11 inches with 3 line automatic perforation skipover. Forms control may be augmented by an optional 12-inch fixed Top of Form length, the 12-channel VFU, Form Length Selector switch as described in Section 7.4 (Format Control), or the optional Fixed Perforation Skipover settings.

The switch selectable line-to-line spacing is $N (0.167) \pm 0.010$ inches (6 lines per inch), or $N (0.125) \pm 0.010$ inches (8 lines per inch) where N equals the number of lines advanced. These measurements are made from mean lines through printed lines being considered.

4.5 HAMMER SYSTEM

The B-600 uses one print hammer for each print position. The print hammers are located in the hammerbank and are arranged in two rows. The upper row prints all even numbered columns while the lower row prints all odd numbered print columns.

When interleaved between permanent magnets, the Mark V hammer provides the impact energy necessary for multicopy printing while using a low coil current. Each hammer's flight time is controlled by the position of an associated backstop screw.

Two hammer driver cards located in dedicated slots in the electronics cage contain the power drivers for all 132 hammers.

DRAWING NO. B-600 - PD		REV C
SHEET	20 OF	44 SHEETS

The standard B600 provides 132 print positions at a pitch of 10 characters per inch (CPI). As an optional feature, the printer can be provided with 136 columns at 10 CPI.

4.6 POWER SUPPLY

A constant voltage transformer allows the printer to operate on incoming power ranging from 90 through 132 volts AC and a frequency of 60 ± 1 Hz. An optional universal power supply module allows and provides for selectable use of the full voltage and frequency range for international operation. Refer to Section 7.10 for further details.

The equipment will suffer no component failure if the input voltage varies $\pm 10\%$ of rated voltage and ± 3 Hz of rated frequency. Voltage spikes on the primary power line up to 1000 volts for 1 microsecond maximum may cause printer malfunction but no component failures.

A circuit breaker provides protection on the primary side of the transformer. Rectified secondary voltages are as follows:

- a) +38v DC Used by hammers, band motor, paper clamp, paper stepper motor and distributed to the +12v DC regulator.

- b) + 9v DC Used by the paper stepper motor and distributed to the +5v DC regulator.

- c) - 9v DC Distributed to various operational amplifiers throughout the printer.

4.7 ELECTRONICS ASSEMBLY

The B-600 electronics assembly consists of six major printed circuit boards which connect via dual edge connectors into a mother board. All boards, with the exception of the hammer driver boards, are mounted in a bus fashion to facilitate troubleshooting by allowing boards to be placed in the rearmost position. The function of each board is as follows:

a) Processor Module

This module, which consists of low power Schottky and standard TTL and MSI devices, provides the total computing power for the B-600 printer. The module was custom designed using a bit slice approach to provide the speed, reliability and flexibility required to control the printer. It is structured in a manner which causes other printer modules (hammer driver, paper feed system, etc.) to appear as peripheral devices.

DRAWING NO. B-600 - PD		REV C
SHEET	21	OF 44 SHEETS

b) Timing and Status Module

This module provides the fault monitoring circuits and generates the time base necessary for print operation. Other functions of this module include:

- 1) Generate power up & power down sequence.
- 2) Shut down printer logic following detection of air flow loss, 5 volt fault or system clock fault.
- 3) Generate the time base necessary for electrical/mechanical system synchronization.
- 4) Detect band ident pulses.

The print inhibit switch located on this module assists the technician when troubleshooting the unit.

c) Power Module

The power module handles the majority of the high power elements of the printer. They include the +5 volt and +12 volt DC regulators and voltage clamp to control the constant current hammer drivers. Band drive, paper feed motor, paper clamp and control circuitry plus the hammer bank isolation relay drive circuit are contained in this module.

d) Hammer Driver Modules (2)

These modules use custom integrated circuit constant current hammer driver power amplifiers to control hammer firing. Each I.C. contains the circuitry to drive 2 hammers. A total of 33 (optionally 34) hammer drive I.C.'s are contained on each module.

e) Interface Module

This board contains circuitry to interface the processor module to the user Input/Output, control panel, printer interlocks and most optional features. It also contains the circuitry necessary for VFU (Optional) operation and ribbon motion sensing.

DRAWING NO. B-600 - PD	REV C
SHEET 22 OF 44 SHEETS	

Configuration switches allow a printer to be functionally adapted to suit individual requirements. Features which can be implemented via the switches include: various amounts of perforation skipover, automatic line feed after carriage return, 11 or 12 inch form length, automatic print to bottom of form on paper low or single step on paper low, 7 or 8 bit data, buffer clear, high or low true interface, automatic VFU skipover, and step count truncate.

5.0 PROGRAMMING RESTRICTIONS

No programming restrictions other than the normal interface handshaking (reference Section 6.3) are placed upon the user.

Issuing multiple Top of Form (TOF) commands may affect the ability of paper to stack properly upon exiting the printer.

It is recommended that a Top of Form (TOF) command be issued or the TOF pushbutton be depressed before commencing a print run. This will ensure that the paper assumes the correct vertical tension.

A standard B600 will accept eight printing operations on a print line without paper movement. Attempts to cause further overprints will result in a diagnostic status error and the assumption of an off line condition.

6.0 PRINTER/USER SYSTEM INTERFACE

An ASCII 7 bit parallel interface is provided in the standard B-600. The demand/response timing allows the user system to control the data transfer rate up to a maximum of 500 KHZ (500,000 characters/second). A maximum load window of 5 msec for a line of data must be used in order to guarantee full print speed. If an optional feature or special interface is utilized, the transfer rate may be reduced.

The interface lines between the printer and the user system are listed below. Interface levels are undefined during POWER ON and POWER OFF phases.

6.1 STANDARD INTERFACE SIGNALS

READY A PRINTER generated signal which indicates that the printer is ready to be put ON LINE by the printer operator.

DRAWING NO. B-600 - PD		REV C
SHEET	23	OF 44 SHEETS

When READY is true, the following are true:

- A. Power and DC voltage are on.
- B. All interlocks are closed.
- C. Paper has been loaded.
- D. No printer fault exists.
- E. The Alarm light is off.

ON LINE

A PRINTER generated signal which indicates that the printer has been put ON LINE. When ON LINE is true, the following are true:

- A. The Alarm light is off.
- B. The printer operator has depressed the ON LINE switch.
- C. The printer is ready to accept data from the user.
- D. The print inhibit switch is off.

DEMAND LINE

A PRINTER generated signal which synchronizes data transmission between the printer and the user system. The DEMAND LINE signal requests a character from the user and remains active until the DATA STROBE is received. After the data character has been loaded into the printer, the DEMAND LINE will never be active unless ON LINE is active. (For exception: Refer to Section 3.5). User must follow handshaking timing as described in Section 6.3.

DATA STROBE

A USER generated signal which defines when information on the data lines is stable and may be stored in the printer buffer. Each time a DATA STROBE occurs, the printer samples the data lines. After the data lines have been sampled, the DEMAND LINE signal will go inactive. STROBE should be held active until DEMAND goes inactive. Once a format control character has been transferred to the printer, the DEMAND LINE will remain inactive until printing is complete. Handshaking for the format control character and for print data is identical. User must follow handshaking timing as described in Section 6.3

DRAWING NO. B-600 - PD		REV C
SHEET	24 OF	44 SHEETS

DATA LINES Seven (7) USER generated data lines which carry print data codes and format control codes. That data is transferred to the print memory when the STROBE signal is high. An additional data line is used if parity data is sent along with the data code.

I/F VERIFICATION Two interface connector pins are jumpered together to allow the user to verify that the interface connector is plugged into the printer.

IDENT 0 & IDENT 1 These lines indicate to the user system the characteristic of the band installed into the printer. These lines are valid only if READY is active. Coding is as follows:

IDENT 1	IDENT 0	BAND TYPE
0	0	EDP B300 only
0	1	64 Set (Utility)
1	0	96 U/L Case
1	1	48 or 128 character set

6.2 OPTIONAL INTERFACE SIGNALS

PARITY BIT (Odd Parity) This USER generated signal is used when the parity option is present. The standard machine checks parity over a maximum of eight data bits plus parity. If a parity error is detected, the parity error line to the USER will become active and remain so until either buffer clear or a control character is received by the printer. If the USER opts to transmit a control character, then a space will be left in the column for which the parity error was detected. Transmission of BUFFER CLEAR followed by re-transmission of the line of data is recommended following a parity error report.

DRAWING NO. B-600 - PD	REV C
SHEET 25 OF 44 SHEETS	

8 BIT I/O The printer may be configured for 8 Bit data transfer.

VFU VERIFY An I/O test loop available to the user to determine if the machine is fitted with the optional Vertical Format Unit. Loop is open circuit if VFU is present.

VFU READY This PRINTER generated signal, when true, indicates to the user that the VFU memory is loaded and no VFU fault exists.

BUFFER CLEAR
(LOW TRUE STD) This USER generated signal, when active, will clear the printer buffer and allow a new line of data to be loaded. If the Parity Error option is installed, the BUFFER CLEAR signal will reset the Parity Error signal.

NOTE:

For details on the application and timing considerations of this signal, refer to Application Note BAPN-005.

PAPER INSTRUCTION This USER generated signal informs the printer that information on the data lines is to be treated as format data. This signal can only be used when the TCVFU or DAVFU option is installed. The ASCII LF, FF, and CR control characters will still be recognized by machines fitted with VFU facilities.

NOTE:

The PAPER INSTRUCTION signal is looked at only when the DEMAND LINE is active and a strobe received.

DRAWING NO. B-600 - PD		REV C
SHEET	26 OF	44 SHEETS

BOTTOM OF FORM This PRINTER generated signal is active whenever the bottom of form position has been reached. The B.O.F. position is determined by the forms length as provided in the standard printer, or as dictated by the FLS, the TCVFU or the DAVFU data when these options are installed. The B.O.F. signal will be true before the first demand request for the Bottom of Form line.

TOP OF FORM Same as above except top of form position is transmitted.

PAPER MOVING This PRINTER generated signal is active when the paper is moving.

6.3 INTERFACE HANDSHAKING

Interface timing restrictions are shown in Figure 3. Interface signals operate in handshake rather than a pulsed mode. If the printer is READY, ON LINE and able to load data, handshaking operation is as follows (Ref: Figure 3)

- A) If the STROBE signal is inactive, the DEMAND LINE will go active to request data from the user and will remain active until the STROBE signal is received.
- B) The STROBE signal may go active only if the DEMAND LINE is active and the data lines are stable. Once the STROBE signal goes active, it must stay active while the DEMAND LINE signal is active.
- C) When the data lines have been sampled, the DEMAND LINE will go inactive.
- D) When the user detects that the DEMAND LINE is inactive, the STROBE signal can then go inactive.
- E) When the printer detects the inactive STROBE signal, the next DEMAND LINE signal will be generated.

DRAWING NO. B-600 - PD		REV C
SHEET	27	OF 44 SHEETS

FIGURE 3
INTERFACE TIMING (500 KHZ)

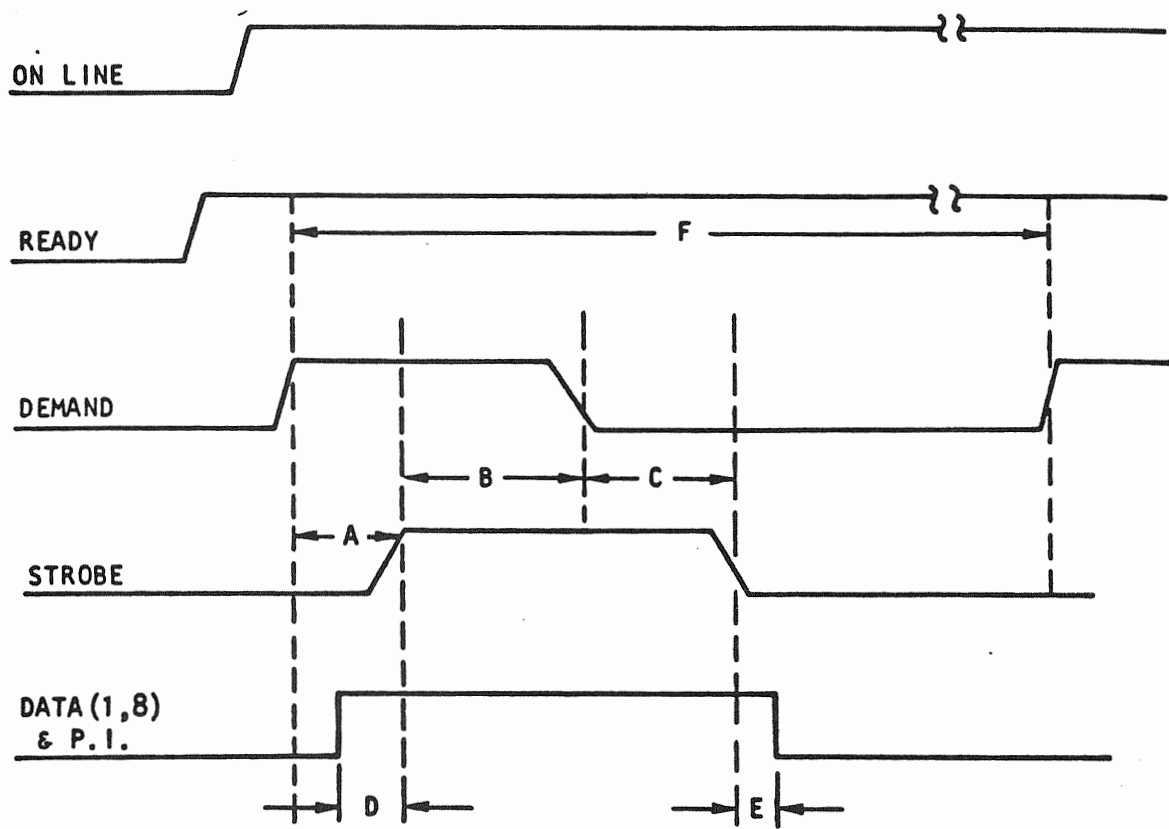

	MAX	MIN
A. STROBE PRESENT AFTER DEMAND PRESENT	250 NS	50 NS
B. DEMAND REMOVED AFTER STROBE PRESENT	143 NS	N/A
C. STROBE REMOVED AFTER DEMAND REMOVED	800 NS	50 NS
D. SETTLING TIME	N/A	50 NS
E. DATA HOLD TIME	N/A	50 NS
F. CHARACTER TRANSFER	N/A	1.95 μ S

FIGURE 3A FURTHER DEFINES THIS TIMING.
THIS TIMING MUST BE FOLLOWED TO GUARANTEE 500 KHZ TRANSFER RATE.
DIRECT ACCESS VFU IS LOADED AT 125 KHZ TRANSFER RATE MAXIMUM.

DRAWING NO. B-600 - PD		REV C
SHEET 28	OF 44	SHEETS

FIGURE 3A

DEFINITIONS OF INTERFACE TIMING

- A This is the time range the user may take to raise strobe following the leading edge of the demand, to guarantee the maximum transfer rate.
- B This is the time the printer will take to drop the demand after the leading edge to the strobe.
- C This is the time range the user may take to remove strobe following the trailing edge of the demand, to guarantee the maximum transfer rate.
- D This is the minimum data settling time the user must guarantee prior to raising the strobe.
- E This is the minimum data hold time the user must guarantee after removal of the strobe.
- F Minimum character transfer period if timing is specified in items A through D are met.

DRAWING NO. B-600 - PD	REV C
SHEET 29 OF 44 SHEETS	

FIGURE 4

INTERFACE HARDWARE - SHORT LINE

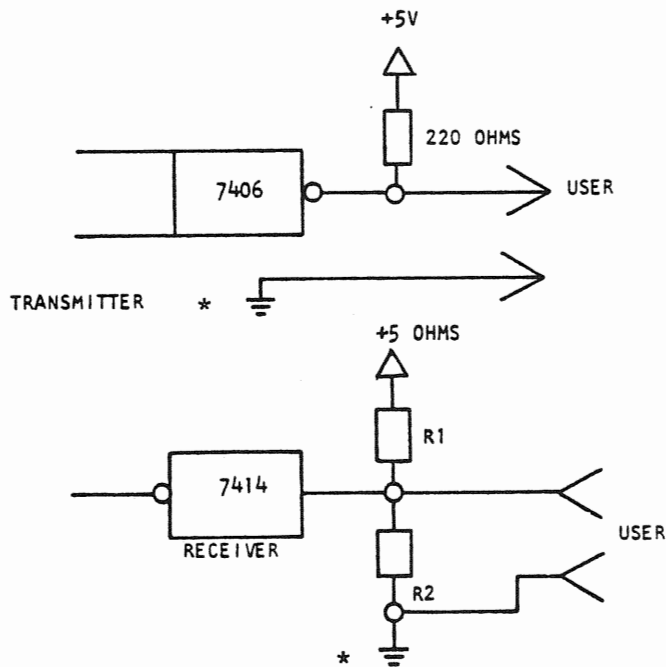

INTERFACE DRIVER
TERMINATIONS (Standard)

Interface drive active lines are terminated by 220 resistors to +5V.

INTERFACE RECEIVER
TERMINATIONS (Optional)

R1 and R2 are 200 minimum termination resistors provided only upon customer request. When both R1 and R2 are installed, 470 is the optimum value of each resistor.

*Interface signal return lines are common to logic '0' volt and safety ground in standard configuration.

The user interface circuits must be capable of providing the following levels at the printer I/O connector:

- A Logic '1' Must be greater than +2.4 VDC and less than +5.0 VDC.
- A Logic '0' Must be greater than 0.0 VDC and less than +0.4 VDC.

Interface signals are active when in the Logic '1' state except Buffer Clear which is normally active in the Logic '0' state.

DRAWING NO. B-600 - PD		REV C
SHEET	30 OF	44 SHEETS

6.4 INTERFACE CIRCUITS

Signals between the user and printer are transmitted over twisted pair wires by signal receivers and transmitters in the printer. The maximum recommended cable length is 15 meters (49 feet). A Long Line interface option is available for distances up to 150 meters (492 feet). Refer to Option Section 7.8.2 for description of the Long Line feature. The standard receiver and transmitter characteristics are shown in Figure 4.

6.5 PRINTER CONNECTORS

Both the AC Power and signal interface connectors are located at the rear of the printer. The former is on the right side and the latter is on the left side when viewed from the front.

6.5.1 AC Power Connector

The AC Power connector is attached to the end of a permanently mounted 4 meter power cord. A NEMA 5-15P connector is used for units equipped with the standard 90-132 VAC/60HZ power supply. Refer to Section 7.10 for optional power supply details.

6.5.2 Interface Connector

The Interface Connector is a 50 pin clamp type AMP connector, Part Number 205740-1. A mating connector, AMP Part Number 205212-1, and 50 crimp type pins, Part Number 66506-9, are provided with each printer. This connector is not compatible with the one used on the 2200 Series equipment. A twisted pair is recommended for each signal.

CONNECTOR PIN ASSIGNMENTS

SIGNAL	PIN	SIGNAL	PIN
READY	22	DATA 1	19
RTN	6	RTN	3
ON LINE	21	DATA 2	20
RTN	5	RTN	4
DEMAND	23	DATA 3	1
RTN	7	RTN	2
PARITY ERROR**	27	DATA 4	41
RTN	11	RTN	40
BOTTOM OF FORM	25	DATA 5	34
RTN	9	RTN	18

DRAWING NO. B-600 - PD	REV C
SHEET 31 OF 44 SHEETS	

<u>SIGNAL</u>	<u>PIN</u>	<u>SIGNAL</u>	<u>PIN</u>
PAPER MOVING (STD)*** RTN	26 10	DATA 6 RTN	43 42
PAPER MOVING (OPTION) RTN	48 17	DATA 7 RTN	36 35
TOP OF FORM RTN	24 8	DATA 8 (OPTION) RTN	28 44
VFU VERIFY* RTN	47 33	PARITY (OPTION) RTN	29 13
		PAPER INSTRUCTION* RTN	30 14
INTERFACE CONNECT VERIFY RTN	46 45	DATA STROBE RTN	38 37
IDENT 0 RTN	50 32	BUFFER CLEAR (OPTION) RTN	31 15
IDENT 1 RTN	49 16	+5V (TEST ONLY) RTN	12 39

* This signal is related to the optional VFU feature.

** This signal is related to the optional parity feature.

*** Optionally VFU Ready may be reported on this line.

Pins 26 & 48 are internally connected on the I/O connector.

DRAWING NO. B-600 - PD		REV C
SHEET	32 OF	44 SHEETS

7.0 OPTIONS

7.1 AUTOMATIC LINE FEED

When implemented, allows a line feed to occur automatically upon detection of a carriage return (CR) code at the interface. A line feed (LF) code will also cause a single line advance. Any data in the line buffer will be printed prior to the line feed operation.

7.2 CHARACTER SETS AND BAND IMAGE PROMS

7.2.1 Font Styles

A variety of special characters and font styles are available. Unique characters may be designed upon customer request. All standard bands are defined in the B-Series Character Set Manual.

7.2.2 Additional Band Image PROMS

An automatic array recognition capacity (up to three) is available for those requirements where various bands are likely to be used on the same printer to suit special application needs. For example, a machine may be fitted with band sensing enabling usage of 48, 64 and upper and lower case 96 character bands. Bands and PROMS are uniquely paired by an address; care must be exercised when defining additional band image PROMS. Note that machines cannot be equipped with more than one PROM for any one band.

7.2.3 Additional Bands

Up to two additional bands may be ordered to ship with a printer unit. Where more than one type of band is to be used on a unit, the additional band image PROM option is incurred.

7.2.4 Automatic Foldover

In the event that 96 character ASCII codes for lower case characters are sent to a printer with only a 64 character band, this feature automatically "folds-over" the lower case codes to print the appropriate upper case character. This option is only available with the 64 character utility band sequences.

7.3 ELAPSED TIME METERS

Dual elapsed time meters of the chemical type enable measure of both "POWER ON" and "PRINT TIME" within $\pm 10\%$ accuracy. These are intended for historical recording purposes only and are not in the operator viewing area. Power on time is measured with a 0-10,000 hours meter and print time with a 0-1000 hours meter.

DRAWING NO. B-600 - PD		REV C
SHEET	33	OF 44 SHEETS

7.4 FORMAT CONTROL

7.4.1 Fixed Form Length

The standard 11 inch Top of Form length may be modified and set for 12 inch to suit international requirements. Other form length requirements can be met by use of the Form Length Selector Switch or Vertical Format Unit options.

7.4.2 Print to Bottom of Form

When provided; this facility permits the printer to automatically print to the bottom of the last form following detection of paper low instead of going into single-step-to-bottom of form as it normally does on a paper low condition. If the optional VFU is present, a stop in Channel 12 is interpreted as Bottom of Form. A maximum of 17 lines at 6 line/inch or 23 lines at 8 line/inch will be printed before the printer goes off line following detection of paper low.

7.4.3 Fixed Perforation Skipover Length

The standard three-line perforation skipover distances may be modified to a 0, 4 or 6 line skipover. Skipover is activated on detection of Bottom of Form (BOF).

Presence of either Vertical Format Unit transfers control of the skipover distance to the BOF and TOF data contained in the VFU memory. No skipover will occur unless the VFU memory is loaded with a BOF stop (Channel 12).

7.4.4 Form Length Selector Switch

The Form Length Selector (FLS) consists of dual thumbwheel switches which allow the operator to conveniently handle a variety of commonly used form lengths and advance paper the appropriate number of lines to Top of Form under pushbutton or code control. Each switch may be set independently to any of its designated positions. The combined settings of the two switches define the length of form the printer will handle. Switch designations are as follows:

Switch #1 (inches): 3, 4, 5, 6, 7, 8, 9, 10, 11, 12, 13, 14

Switch #2 (fractions of an inch): 0, 1/4, 1/3, 1/2, 2/3, 3/4

Should a form length be selected that is not divisible by the selected line pitch (6 or 8 lpi), a status check will be raised on the diagnostic display. Where a DAVFU and/or TCVFU is fitted, a switch is provided to allow operator selection of either the FLS or VFU facilities. The maximum selectable form length is 14 inches.

DRAWING NO. B-600 - PD		REV C
SHEET	34 OF	44 SHEETS

7.4.5 12 Channel Direct Access Vertical Format Unit (Standard Interface)

The Direct Access Vertical Format Unit (DAVFU) is offered as an option to enable handling of a variety of form lengths and allow, under host system control, paper slewing within a form in a manner identical to the Tape Controlled Vertical Format Unit (Section 7.4.6).

Rather than loading the memory from tape loop, the DAVFU provides for direct loading from the controller via the printer interface lines.

Presenting a start code of octal 156 with the Paper Instruction line active will initiate a load DAVFU sequence. The least significant 6 data lines are now used to transmit a tape image. The 6 least significant bits of the first character transferred load memory locations that correspond to Channels 1-6. The next character will load memory locations that correspond to Channels 7-12. This first channel 1 through 12 (two characters) load should contain the Top of Form channel 1 stop. DAVFU load will continue with each pair of 6 bit characters detailing channel stop information for each line on the associated form. A maximum of 143 lines (286 DAVFU characters) can be accommodated. On completion of the tape image load, a stop code of octal 157 with PI active is sent to the printer causing the DAVFU routine to be exited.

Once the memory has been loaded via the interface, DAVFU controlled paper motion instructions and operation are identical to those of the TCVFU.

Once the DAVFU is loaded, the Perforation Skipover feature (refer to Section 7.4.3) is disabled. Optionally VFU controlled skipover may be selected. Skipover will occur whenever BOF is detected and will stop when TOF is detected. Further information is contained in BAPN-003.

7.4.6 12 Channel Tape Controlled Vertical Format Unit

The B-600 Tape Controlled Vertical Format Unit (TCVFU), consisting of an optical tape reader and associated electronics, is offered as an option to enable handling of a variety of form lengths and allow rapid paper slewing within individual forms. The reader utilizes 12 channel IBM paper tape (IBM P/N 429754) or equivalent.

The maximum tape length is 144 lines (24 inches @ 6 lpi; 18 inches @ 8 lpi). Each tape loop should have only one hole punched in the least significant channel (LSC) corresponding to Top of Form. If the format is short, multiple forms may be punched into one tape if, and only if, each repetition of the format pattern is identical to all other format patterns on that tape.

DRAWING NO. B-600 - PD		REV C
SHEET	35	OF 44 SHEETS

The VFU tape is calibrated in lines, not inches; therefore, a given tape will yield different dimensional formats at 6 and 8 lpi. Special tape preparation methods are not required for 8 lpi operation.

Data is read from tape during a LOAD TAPE mode and stored in memory. The memory load will start when a hole is detected in the least significant tape channel (left-most) and continues until a hole is again detected in this channel.

The LOAD TAPE operation will be initiated automatically on power up or any time that the operator depresses the LOAD TAPE switch located on the tape reader assembly. VFU memory loading must be initiated following any tape change or following the detection of a VFU error. At the end of the operation, indicated by the tape coming to a stop, the tractors will be synchronized with the memory at the Top of Form position.

Once the memory has been loaded, the reader turns off and all mechanical activity ceases. TCVFU instructions are transmitted to the printer by activating the PAPER INSTRUCTION at the same time that coded instructions are presented on the data lines. By holding data line 5 true, it is possible to slew a specified number of lines (up to 16 maximum). By holding it false, a channel may be selected under program control.

As paper is advanced, a "current line" count is incremented in synchronism as a tape loop would be rotated in a purely mechanical system. The inherent advantage of the B-600 TCVFU is the total lack of mechanical motion after the initial memory load sequence. Machines provided with this option may also be operated in the DAVFU mode.

Turning power off will result in loss of synchronization between form and TCVFU.

7.5 GROUND ISOLATION

The standard printer will be shipped with logic and frame grounds tied together. ISOLATED GROUND configuration is optionally available.

7.6 PAINT

Special paint colors for the exterior skins of the printer may be specified as an option at the time of order. Refer to BAPN-002 for description of standard paint schemes.

7.7 INTERFACES

7.7.1 Custom Interfaces

Custom interface requirements can be implemented upon special request. Centronics compatible, Dataprinter compatible, Pertec

DRAWING NO. B-600 - PD		REV C
SHEET	36	OF 44 SHEETS

compatible, as well as a number of different Serial interface protocols, are also available upon request. Detail specifications of these interfaces are available and should be reviewed prior to purchase.

7.7.2 Long Line Interface

This option allows the interface lines to be extended from the standard 15 meters (49 feet) to 150 meters (492 feet). Integrated circuit differential transmitters and receivers of the DM 8830/8820 class are used. The inclusion of this option requires the user to supply similar long-line devices at the controller end.

7.7.3 Serial Interface

This option allows operation on certain RS232 or current loop interfaces, with or without VFU, through the use of a front-ended board in the spare slot. Refer to Section 11.1 for detail document numbers.

7.7.4 Centronics Interface

This option permits the operation on most Centronics-compatible controllers. VFU option is standard with this interface. Maximum character set size is 95 characters. (Note: Octal 177 is a delete code). Refer to Section 11.1 for detail document numbers.

7.7.5 Low True Interface

Allows all interface signals (except Buffer Clear) -- both received and transmitted -- to be inverted.

7.7.6 Buffer Clear Invert

Allows the standard Low Active Buffer Clear to be made High Active.

7.7.7 Pull Up/Pull Downs

Custom termination resistor values on the receiver lines may be provided upon special request. Minimum acceptable values are 200 ohms. Transmitter lines are always pulled up with 220 ohms to +5 volts.

7.7.8 Winchester Connector

An optional 50 pin Winchester Connector (Part Number MRA 50SD5J), a mating connector (Winchester Part Number MRAC 50 PJTDH8) and 50 crimp type pins (P/N 100-1024P) can be provided with each printer in lieu of the AMP connector, described in Section 6.5.2. This connector is the same used on all 2200 Series equipment. A twisted pair is used for each signal. The pin assignments for this connector are shown below:

DRAWING NO. B-600 - PD		REV C
SHEET	37	OF 44 SHEETS

WINCHESTER CONNECTOR PIN ASSIGNMENTS

<u>SIGNAL</u>	<u>PIN</u>	<u>SIGNAL</u>	<u>PIN</u>
READY RTN	<u>CC</u> <u>EE</u>	DATA 1 RTN	<u>B</u> <u>D</u>
ON LINE RTN	<u>y</u> <u>AA</u>	DATA 2 RTN	<u>F</u> <u>J</u>
DEMAND RTN	<u>E</u> <u>C</u>	DATA 3 RTN	<u>L</u> <u>N</u>
PARITY ERROR (OPTION) RTN	<u>r</u> <u>t</u>	DATA 4 RTN	<u>R</u> <u>T</u>
BOTTOM OF FORM RTN	<u>M</u> <u>P</u>	DATA 5 RTN	<u>V</u> <u>X</u>
PAPER MOVING (STD)* RTN	<u>W</u> <u>Y</u>	DATA 6 RTN	<u>Z</u> <u>b</u>
PAPER MOVING (OPTION) RTN	<u>FF</u> <u>DD</u>	DATA 7 RTN	<u>n</u> <u>k</u>
TOP OF FORM RTN	<u>S</u> <u>U</u>	DATA 8 (OPTION) RTN	<u>u</u> <u>w</u>
VFU VERIFY (OPTION)	<u>e</u> <u>h</u>	PARITY (OPTION) RTN	<u>z</u> <u>BB</u>
PAPER INSTRUCTION (OPTION) RTN	<u>p</u> <u>s</u>	DATA STROBE RTN	<u>j</u> <u>m</u>
INTERFACE CONNECT VERIFY	<u>v</u> <u>x</u>	BUFFER CLEAR (OPTION) RTN	<u>A</u> <u>H</u>
IDENT 0 RTN	<u>d</u> <u>f</u>	+5V (Test Only) RTN	<u>HH</u> <u>K</u>
IDENT 1 RTN	<u>a</u> <u>c</u>		

*Optionally, VFU READY may be reported on this line. W & FF are internally connected on the I/O connector.

DRAWING NO. B-600 - PD	REV C
SHEET 38 OF 44 SHEETS	

7.8 MASTER SUPPORT & LOGISTICS MANUAL

This manual contains schematics, a detailed theory of operation, and a detailed illustrated parts breakdown.

7.9 PARITY ERROR DETECT

Parity circuitry will check for the presence of odd or even parity. When an error is detected, the character in error is converted to a space and a parity error line (Pin 27) will be raised to alert the host. The line will remain true until operation of the CLEAR pushbutton or the receipt of either a format control character or a buffer clear signal (Pin 31) (reference Section 6.2).

7.10 POWER SUPPLY - UNIVERSAL

This supply provides for those applications requiring a printer capable of operating on any of the following voltages & frequencies:

Voltage	90 to 132, 180 to 250 VAC
Frequency	50 or 60 hz \pm 2 hz

Changing from one voltage or frequency range to another is easily accomplished in the field by changing the position of internal plug connectors. When shipped with this supply, the AC line connector will be NEMA 5-15P for 110V or NEMA L6-15P for 220V operation.

7.11 PEDESTAL

A pedestal is standard on the B-600. For those applications requiring a table-top configuration, the printer can be so treated. The pedestal is shipped separate from the printer in a disassembled state to reduce shipping costs and storage space requirements.

A shelf which attaches to the rear of the pedestal provides for passive stacking of paper which has exited the printer.

NOTE: Printers may be used on a modified or standard table. Where a standard table is used it is necessary to ensure stability by bolting the printer down using the M6 thread holes normally reserved for the pedestal. Refer to Application Note BAPN-004 for details.

7.12 ACOUSTIC CABINET

The B-600 printer can be supplied in an optional Acoustic Cabinet which fully encloses the printer's electro-mechanical assembly. This provides excellent acoustic performance with db levels of 59 dba in standby and 60 dba while printing when measurements are taken in accordance with Application Note BAPN-006.

DRAWING NO. B-600 - PD		REV C
SHEET	39	OF 44 SHEETS

B600 printers mounted in the acoustic cabinet have a combination on/off switch and circuit breaker instead of separate power switch and circuit breakers. This combination on/off switch and circuit breaker is mounted in the rear of the cabinet on the left-hand side (when viewed from the rear of the printer).

Acoustic cabinet B600's have a detachable power cord which is shipped in a box inside the rear doors of the cabinet.

Also inside the rear doors is access to a plenum panel which houses the receptacle for the detachable power cord and provides routing for the I/O cable. The plenum panel is open at the bottom so that the I/O cable and power cord can route through the floor. The left panel inside the rear doors is removable to allow easy handling. The I/O cable can be dressed through the interior of the cabinet to the I/O connector which is mounted on the power supply cover.

The Acoustic Cabinet comes complete with a paper puller mechanism and an adjustable paper stacking shelf. NOTE: The paper puller operates continuously when the printer is in a POWER ON condition.

The Acoustic Cabinet can be ordered with an optional Rear Window mounted on the right rear door. This allows for viewing of the paper stack height. See Summary Characteristics Section 1.3 for electrical power size and weight characteristics.

7.13 136 COLUMN OPTION

This option allows printing of a full 136 columns at 10 cpi. The standard printer is configured for 132 columns.

8.0 RELIABILITY/MAINTAINABILITY

8.1 DESIGN WORKLOAD

The printer is designed for a normal workload of eight hours/day, five days/week at a 40% printing duty cycle (duty cycle = print time/power on time) which will typically generate 60,000 original pages per month. A 60% line and 60% column density is assumed.

8.2 MEAN TIME BETWEEN SERVICE CALLS (MTBSC)

The MTBSC which is realized in the field is a function of the design, use and maintenance of the printer. A field MTBSC design goal of six months is based upon the design workload specified in Paragraph 8.1. The printer can be used for higher workloads; however, the MTBSC will be reduced accordingly. Service calls to complete PM procedures are not included in this goal.

DRAWING NO. B-600 - PD		REV C
SHEET	40	OF 44 SHEETS

8.3 MEAN TIME TO REPAIR (MTTR)

An MTTR of less than thirty (30) minutes is achieved by the use of functional packaging and modular design. The enclosure is completely removable to provide easy access to all areas of the printer. Troubleshooting is facilitated by the presence of the self test and diagnostic display indicators. In addition to design features inherent to the printer, the realization of MTTR objectives requires adequate service training and proper spares provisioning.

8.4 PREVENTATIVE MAINTENANCE (PM)

Preventative Maintenance should be provided twice per year based upon the printer being used in accordance with the design workload. Normal operator actions such as paper and ribbon loading, forms tape replacement, band cleaning and general cleaning are not considered to be in the PM schedule.

The maintenance guide contains a list of recommended PM activities.

9.0 SHIPAWAY KIT

The standard shipaway kit will include the following items:

<u>Quantity</u>	<u>Description</u>
1	AMP Connector
50	Crimp Pins (66506-9)
1	Operator's Guide
1	Maintenance Guide
1	Nylon Ribbon (50 yd x 5 mil. thickness)
1	Print Samples (1 & 6 part forms)

10.0 PHYSICAL CHARACTERISTICS

Figures 5 & 6 contain dimensional data relevant to printer installation requirements.

When the printer is ordered for use with a customer-supplied pedestal or table, it is important that the printer be securely fastened to the supporting structure. It may also be necessary to provide an opening in the structure to allow paper to smoothly enter the printer. Refer to Application Note BAPN-004.

DRAWING NO. B-600 - PD		REV C
SHEET	41	OF 44 SHEETS

FIGURE 5

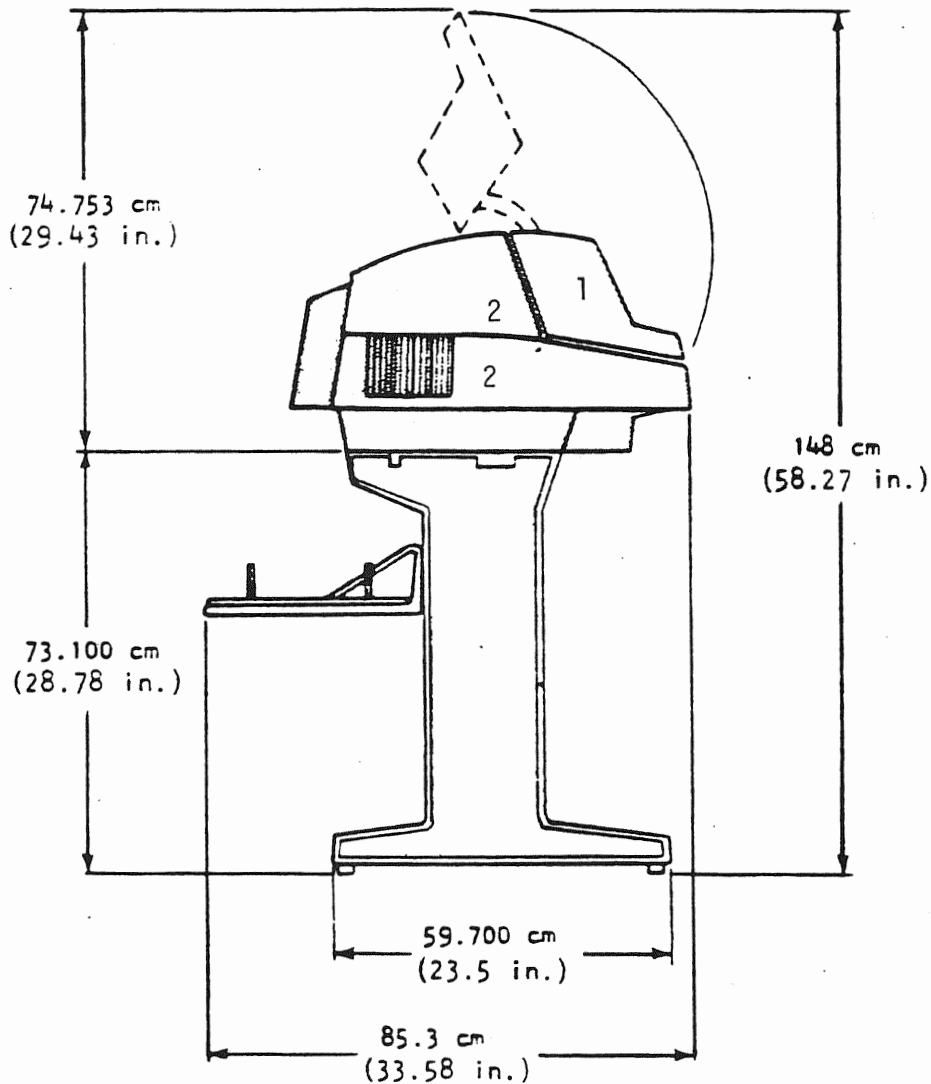

Preferred Color Combinations:

Dataproduct Standards

Area 1: (Dark Color) - Operator Hood

Area 2: (Light Color) - Top Cover

'Warm Tone' - DpC Brown + DpC Tan

'Cool Tone' - DpC Charcoal + DpC Light Gray

DRAWING NO. B-600 - PD			REV C
SHEET	42	OF 44	SHEETS

FIGURE 6

Interface Connector
Rear Left

Power Cord
Rear Right

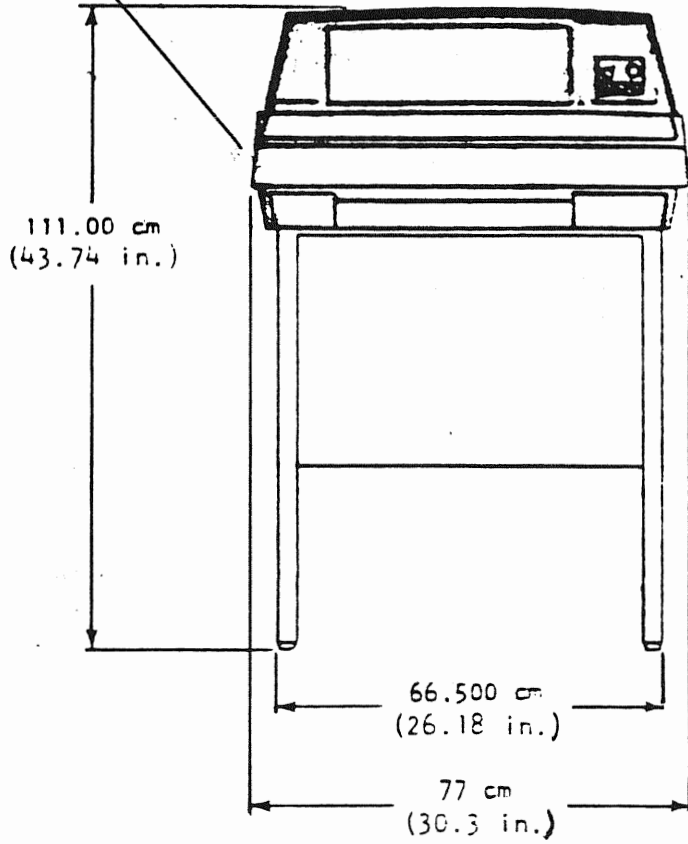

Note: Printer shown with Standard Pedestal

DRAWING NO. B-600 - PD	REV C
SHEET 43 OF 44 SHEETS	

11.0 REFERENCE DOCUMENTS & APPLICATION NOTES

11.1 REFERENCE DOCUMENTS

Master Support & Logistics Manual	267726
B300/B600 Operator's Guide	255136
B-Series Line Printer w/Acoustic Cabinet Operator Guide	267720
B300/B600 Maintenance Guide	255137
300 LPM/600 LPM Acoustic Cabinet L/P Maintenance Guide	267714
B-Series Band Printer Character Sets	250213
Dataproducts Front Ended Serial I/F Specification	263012
Dataproducts Centronics Compatible I/F Specification	251981
Dataproducts Dataprinter Compatible I/F Specification	267328

11.2 APPLICATION NOTES (BAPN)

B-Series Print Speed	BAPN- 001
Paint Specifications	BAPN- 002
Direct Access VFU Option	BAPN- 003
Table Top Mounting	BAPN- 004
Buffer Clear	BAPN- 005
Acoustic Measurement	BAPN- 006
Electrostatic Discharge	BAPN- 007
Outline of FCC Compliance Testing	BAPN- 008

DRAWING NO. B-600 - PD		REV C
SHEET	44	OF 44 SHEETS