

HP C2244/45/46/47 3.5-inch SCSI-2 Disk Drive

Technical Reference Manual



HP Part No. 5960-8346
Printed in U.S.A. September 1992

Edition 3



Printed on
Recycled Paper

Printing History

This manual will be revised without notice in order to reflect the latest version of the product it describes. New editions are complete revisions of the manual. The dates on the title page change only when a new edition is published.

Many product updates do not require manual changes and, conversely, manual corrections may be done without accompanying product changes.

Edition 1	December 1991
Edition 2	April 1992
Edition 3	September 1992

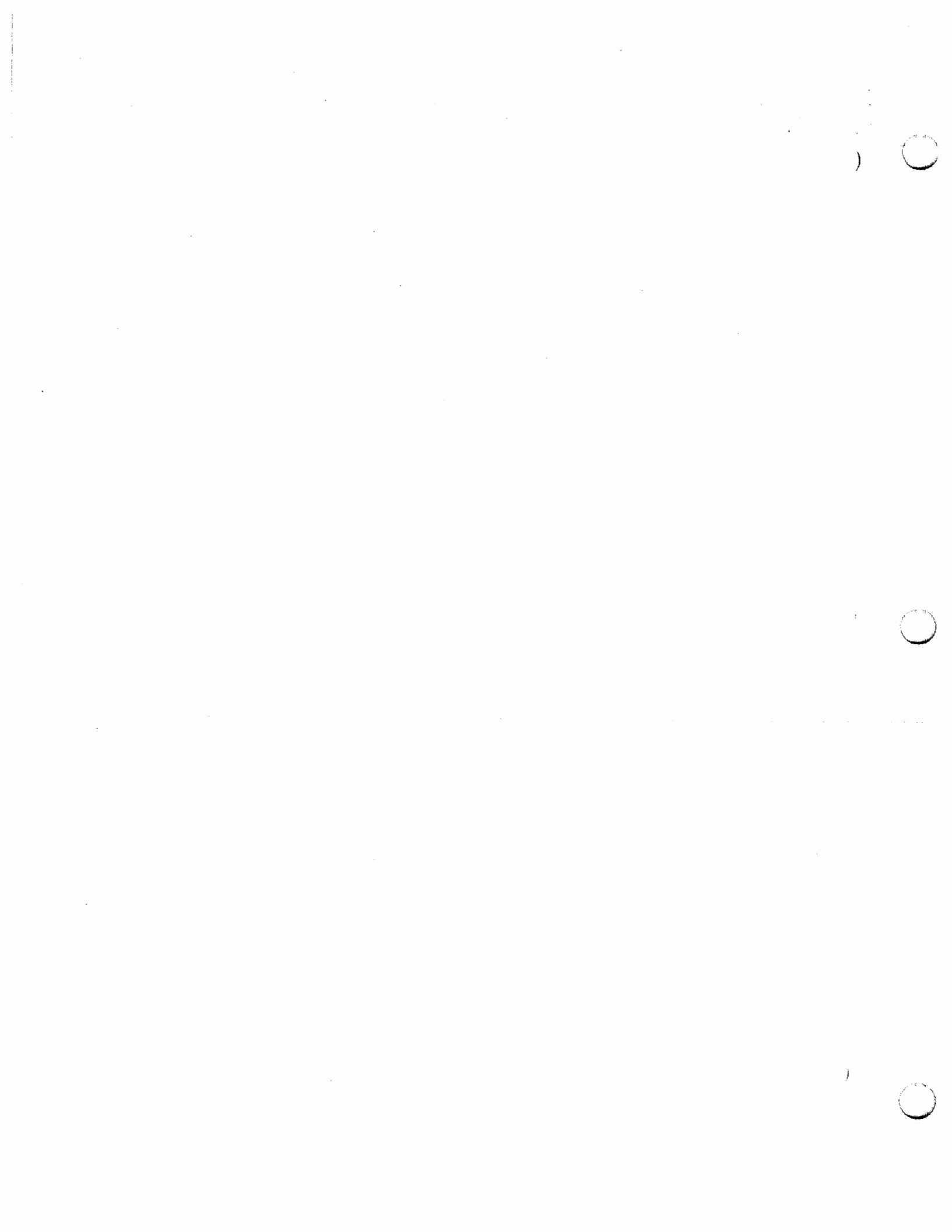

Contents

1. Product Specifications	
Product Description	1-1
Key Features	1-1
Interface Options	1-2
Specials	1-2
Related Documentation	1-2
Disk Drive Capacities	1-4
Operating Specifications	1-5
DC Power Characteristics	1-8
Environmental Requirements	1-9
2. Product Installation	
Introduction	2-1
Handling Guidelines	2-1
Protection From Mechanical Shock	2-1
Protection from Electrostatic Discharge (ESD)	2-1
Unpacking the Disk Drive	2-2
Inspecting the Shipping Container	2-2
Inspecting the Disk Drive	2-2
Recording the Serial Number	2-2
Disk Drive Returns	2-2
Return Shipment Addresses	2-2
Vendor Purchases	2-2
Hewlett-Packard Direct Purchases	2-2
Re-Packing For Shipment	2-3
Mounting Information	2-5
Safety/Regulatory Compliance	2-5
Chassis Dimensions and Mounting Screw Locations	2-5
Physical Mounting	2-5
Airflow Requirements	2-5
Front Panel LED Indicator	2-6
Address and Configuration Pin-Set Set-ups	2-6
Drive To Interface Connections	2-8
Interface Connectors and Cables	2-9
Connector Dimensions and Locations	2-9
SCSI Connector	2-9
DC Power Connector	2-9
Mating Connector Requirements	2-9
Cabling Requirements	2-10
Single-ended Cable	2-10
Differential Cable	2-10

3. Product Features	
Introduction	3-1
Functional Description	3-1
Disk Format	3-1
Sector Format	3-1
Addressing Structure	3-1
Error Correction Code	3-1
Cyclic Redundancy Check (CRC)	3-2
Track Sparing	3-2
Look Ahead Reads	3-2
Head Alignments	3-3
Head Alignment States	3-3
Head Alignment Modes	3-3
Typical Head Alignment Times	3-4
Command Queuing	3-4
Error Recovery	3-6
Synchronized Spindle Operation	3-6
Assembly Descriptions	3-6
Head/Disk Assembly	3-6
Disks	3-6
Heads	3-7
Actuator and Latch Assembly	3-7
Head Interface Electronics	3-7
Atmospheric Controls	3-7
Vibration Isolators	3-7
Spindle Assembly	3-7
Block Diagram	3-8
SCSI Interface	3-8
RAM Buffer	3-8
Disk Controller	3-8
Data Encoder/Decoder	3-8
Microcontroller	3-8
Servo Processor	3-9
Data Head Interface	3-9
Actuator Driver	3-9
Servo Timing	3-9
Spindle Motor Driver	3-9
Power Distribution	3-9
4. SCSI Interface	
Introduction	4-1
Supported Functions	4-1
Status Byte	4-6
SCSI Message Support	4-7
Target Error Conditions	4-8
Message Out Phase Parity Error	4-8
Command or Data Out Phase Parity Error	4-8
Illegal Messages	4-8
Reselection Timeout	4-9

A. SCSI Command Descriptions

Command Descriptions	A-1
Command Details	A-1
Control Byte	A-2
Change Definition	A-6
Format Unit	A-7
Inquiry	A-11
Mode Select, Mode Sense	A-15
Read	A-31
Read Buffer	A-32
Read Capacity	A-33
Read Defect Data	A-34
Read Long	A-36
Reassign Blocks	A-37
Receive Diagnostic Results	A-39
Release	A-41
Request Sense	A-42
Reserve	A-48
Rezero Unit	A-49
Seek	A-50
Send Diagnostic	A-51
Start/Stop Unit	A-53
Synchronize Cache	A-54
Test Unit Ready	A-55
Verify	A-56
Write	A-57
Write And Verify	A-59
Write Buffer	A-60
Write Long	A-62
Write Same	A-63

B. Vendor Unique Command Descriptions

Command Descriptions	B-1
Access Log	B-2
Change SCSI ID	B-7
Change Wide SCSI ID	B-8
Execute Data	B-9
Interface Control	B-10
Manage Primary	B-11
Media Test	B-16
Read Full	B-18
Read Headers	B-20
Reformat Track	B-21
Write Full	B-22

C. Vendor Unique Status Codes

D. Reference

E. Narrow, Single-Ended Drive Configurations
Terminator Power Source Options E-4

F. Narrow, Differential Drive Configurations

G. Wide, Differential Drive Configurations

Index

Figures

1-1. Disk Drive Major Components	1-3
2-1. Single-Unit Packaging	2-3
2-2. Ten-Unit Packaging	2-4
3-1. Disk Drive Addressing Structure	3-10
3-2. Formatted Physical Sector Allocation	3-13
3-3. Disk Drive Block Diagram	3-14
E-1. Narrow, Single-Ended: Disk Drive Dimensions and Mounting Locations	E-1
E-2. Narrow, Single-Ended: Interface, Address and Option Connectors	E-2
E-3. Narrow, Single-Ended: Connector Dimensions	E-5
E-4. Narrow, Single-Ended: Operating Temperatures	E-6
F-1. Narrow, Differential: Disk Drive Dimensions and Mounting Locations	F-1
F-2. Narrow, Differential: Interface, Address and Option Connectors	F-2
F-3. Narrow, Differential: Connector Dimensions	F-4
F-4. Narrow, Differential: Operating Temperatures	F-5
G-1. Wide, Differential: Disk Drive Dimensions,	G-1
G-2. Wide, Differential: Interface, Address and Option Connectors	G-2
G-3. Wide, Differential: Connector Dimensions	G-4
G-4. Wide, Differential: Operating Temperatures	G-5

Tables

1-1. HP C2244/45/46/47 SCSI Disk Drive Capacities	1-4
1-2. HP C2244/45/46/47 Operating Specifications	1-5
1-3. HP C2244/45/46/47 DC Power Characteristics	1-8
1-4. HP C2244/45/46/47 Environmental Requirements	1-9
2-1. Address/Configuration Pin-Set Information Locations	2-6
2-2. Address/Configuration Option Descriptions	2-7
2-3. Recommended Mating Connectors	2-9
3-1. C2244/45/46/47 Cylinder Allocation	3-11
4-1. HP C2244/45/46/47 Supported SCSI Commands	4-4
A-1. Supported SCSI-2 Commands	A-3
B-1. Vendor Unique Commands	B-1
C-1. Vendor Unique DERROR Status Codes	C-1
D-1. Reference Appendix Contents	D-1
E-1. Narrow, Single-Ended: Address and Option Connector Configurations	E-3
E-2. Narrow, Single-Ended: On-Board Terminator Power (TermPwr) Sources	E-4
E-3. Narrow, Single-Ended: SCSI Connector Pin Assignments	E-5
F-1. Narrow, Differential: Address and Option Connector Configurations	F-3
F-2. Narrow, Differential: SCSI Connector Pin Assignments	F-4
G-1. Wide, Differential: Address and Option Connector Configurations	G-3
G-2. Wide, Differential: SCSI Connector Pin Assignments	G-4

Product Specifications

Product Description

The HP C2244/45/46/47 single-ended and differential disk drives are reliable, low cost, high capacity, high performance, random access mass storage devices. Each product utilizes sputtered thin-film 3.5-inch (95 mm) disks as storage media. The disk drive electrical interface is compatible with the new industry standard Small Computer System Interface (SCSI-2). Figure 1-1 shows the major components of the disk drive.

These drives incorporate an advanced Digital Signal Processor (DSP) hybrid servo design that provides the flexibility and performance of a dedicated servo system and the dynamic head alignment of an embedded servo system. High capacity and fast average transfer rates are achieved with Multiple Zone Recording.

The product specifications are listed in the following tables:

Capacities	Table 1-1
Operating Specifications	Table 1-2
DC Power Characteristics	Table 1-3
Environmental Requirements	Table 1-4

Key Features

- High reliability (300,000 hours MTBF).
- Synchronous data transfer rate of up to 20 megabytes per second.
- Digital Signal Processor (DSP) hybrid servo system.
- High performance HP-designed balanced actuator.
- Industry standard 3.5-inch form factor and voltage requirements.
- Fast and Wide Embedded SCSI-2 controller.
- Powerful HP-designed Reed-Solomon ECC.

Interface Options

The following interface options are available:

Interface Option	Description	Reference Appendix
001	SCSI-2 Fast, Narrow, Single-Ended	E
002	SCSI-2 Fast, Narrow, Differential	F
012	SCSI-2 Fast, Wide, Differential	G

Specials

For customer needs that differ from the products described in this manual, Hewlett-Packard can provide specially modified products. These modifications are ordered, defined, engineered, and manufactured under "special" contract negotiations.

Related Documentation

The following documentation provides information related to the operation of the HP C2244/45/46/47 disk drives:

- *Small Computer Systems Interface: ANSI XT39.2/86-109 (Rev 10h), XT39/89-042*
- *Common Command Set (CCS) of the Small Computer System Interface (SCSI): ANSI XT39.2/85-52 (Rev 4B)*

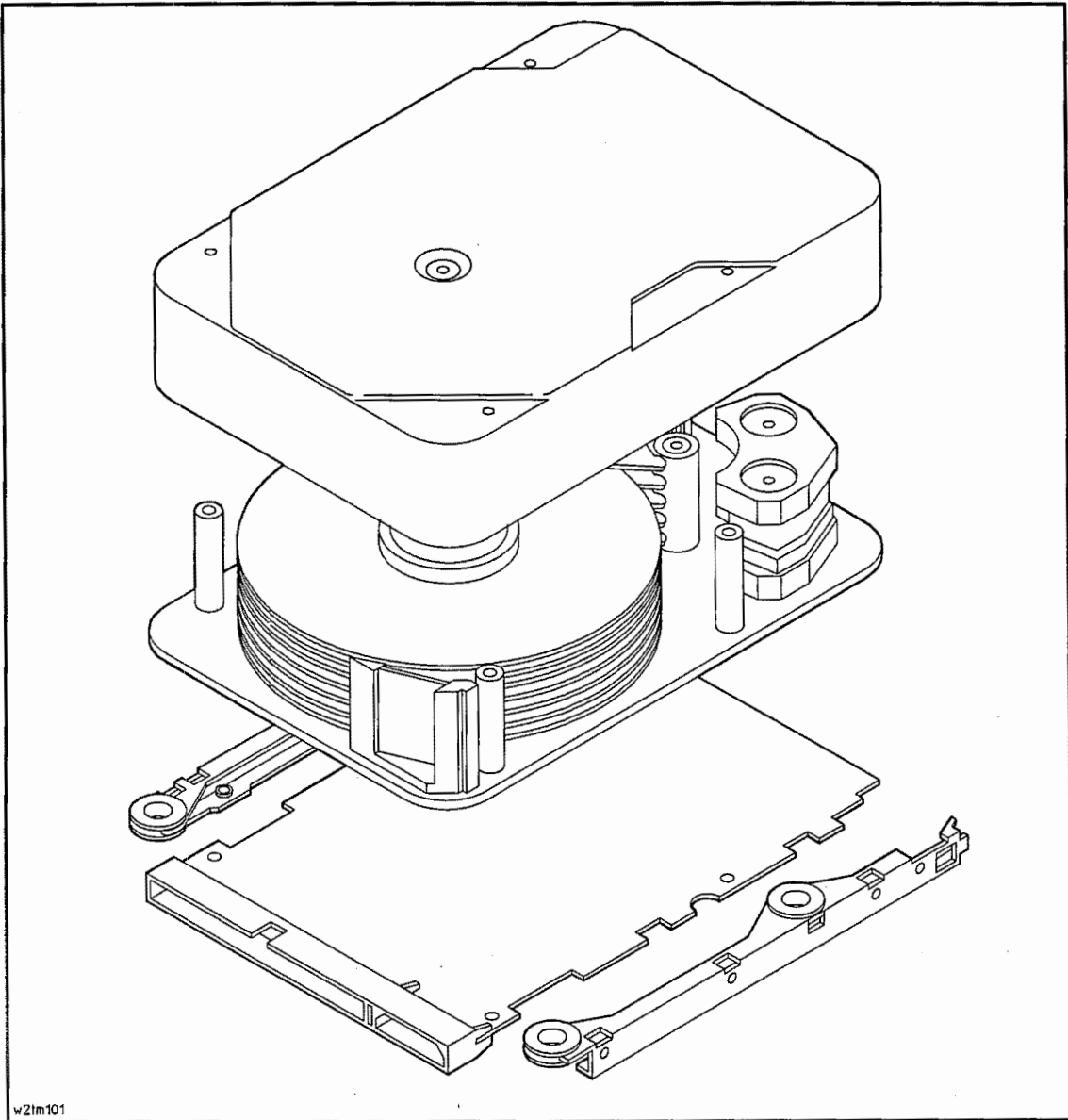

w21m101

Figure 1-1. Disk Drive Major Components

Disk Drive Capacities

Table 1-1. HP C2244/45/46/47 SCSI Disk Drive Capacities

These numbers are for comparison only. Capacities are calculated using a 512-byte sector. When other sector sizes are used, formatted capacities will change. Unformatted capacities are given in parenthesis ().								
	Zone 0 (Outer)	Zone 1	Zone 2	Zone 3	Zone 4	Zone 5	Zone 6	Zone 7 (Inner)
Data Tracks per Surface:	533	192	136	144	138	318	268	252
Data Sectors per Track:	96	92	88	84	80	72	64	56
Data Bytes per Track:	49,152 (58,899)	47,104 (56,338)	45,056 (53,968)	43,008 (51,440)	40,960 (49,034)	36,864 (44,079)	32,768 (39,351)	28,672 (34,391)
Data Sectors per Cylinder:								
C2244	672	644	616	588	560	504	448	392
C2245	864	828	792	756	720	648	576	504
C2246	1,056	1,012	968	924	880	792	704	616
C2247	1,248	1,196	1,144	1,092	1,040	936	832	728
Data Bytes per Cylinder:								
C2244	344,064 (412,293)	329,728 (394,366)	315,392 (377,776)	301,056 (360,080)	286,720 (343,238)	258,048 (308,553)	229,376 (275,457)	200,704 (240,737)
C2245	442,368 (530,091)	423,936 (507,042)	405,504 (485,712)	387,072 (462,960)	368,640 (441,306)	331,776 (396,711)	294,912 (354,159)	258,048 (309,519)
C2246	540,672 (647,889)	518,144 (619,718)	495,616 (593,648)	473,088 (565,840)	450,560 (539,374)	405,504 (484,869)	360,448 (432,861)	315,392 (378,301)
C2247	638,976 (765,687)	612,352 (732,394)	585,728 (701,584)	559,104 (668,720)	532,480 (637,442)	479,232 (573,027)	425,984 (511,563)	372,736 (447,083)
	C2244	C2245	C2246	C2247				
Data Surfaces per Drive:	7	9	11	13				
Data Bytes per Sector:	512 (610)	512 (610)	512 (610)	512 (610)				
Data Sectors per Surface:	158,096	158,096	158,096	158,096				
Data Bytes per Surface:	80,945,152	80,945,152	80,945,152	80,945,152				
Data Cylinders per Drive:¹	1,981	1,981	1,981	1,981				
Data Sectors per Drive:	1,106,288	1,422,480	1,738,672	2,054,864				
Data Bytes per Drive:	566,419,456 (678,438,799)	728,309,760 (872,345,769)	890,200,064 (1,066,252,739)	1,052,090,368 (1,260,159,709)				
Notes:								
1. There are 2051 total cylinders per drive, allocated as follows: 1981 data cylinders, 69 spare cylinders, and 1 cylinder reserved for logs and maintenance information. Partial cylinders have been rounded to the next whole number. Refer to Chapter 3, Table 3-1 for a complete cylinder allocation list.								

Operating Specifications

Table 1-2. HP C2244/45/46/47 Operating Specifications

Note: The HP C2244/45/46/46 disk drives must be operated within the Disk Drive Environmental Requirements specified in Table 1-4 in order for them to function properly.

Interface Industry Standard SCSI-2

Controller:

Overhead time < 500 microseconds
Buffer size 256 kbytes
Buffer type Dual-ported
Sector size 180 - 744 Data Field Bytes
Interleave 1:1

Seek Times (includes settling time)

Track to Track Seek 2.5 milliseconds
Head Switch Time < 1 millisecond
Average Random Seek
 Reads 10.2 milliseconds
 Writes 11.2 milliseconds
Maximum Seek 22 milliseconds

Notes:

Seek time is defined as the time from when the actuator begins to move until the head has settled over the target track. It does not include any controller overhead time or any initiator overhead time. The values above are derived from a representative sample of disk drives measured under normal temperature and voltage conditions.

Track to track seek time is the mean value of all seek times measured when performing all possible single track seeks.

Average random seek time is the time to do all possible seeks divided by the number of seeks possible.

Maximum seek time is the time it takes to seek 2051 physical cylinders.

Spin-up Time

From Power-On to Ready for Access
 Typical: 14 seconds

From Power-On to SCSI Bus Selection
 Typical: 3 seconds
 Maximum: 5 seconds

Disk Rotating Speed 5400 rpm \pm 0.5%

Rotational Latency (Average time) 5.56 milliseconds \pm 0.5%

Internal Data Transfer Rates (Controller/Disk)

Burst Rates (for single sector transfers):

 Inner Zone to Outer Zone 3.1 to 5.3 Mbytes (24.8 to 42.4 Mbits) per second

Sustained Rates: (for continuous transfers; excludes controller overhead)

 Inner Zone to Outer Zone 2.1 to 3.7 Mbytes (17.1 to 29.5 Mbits) per second

Table 1-2. HP C2244/45/46/47 Operating Specifications (continued)

External Data Transfer Rate (Host/Controller)

Narrow Single-Ended/Differential	
Asynchronous	2.5 Mbytes per second
Synchronous	up to 10.0 Mbytes per second
Wide Differential	
Asynchronous	5.0 Mbytes per second
Synchronous	up to 20.0 Mbytes per second

Recoverable Data Error Rate

Less than ten (10) errors in 10^{13} bits transferred when the disk drive is operated within the specified environmental limits.

Note: A recoverable data error occurs when a read or write operation successfully completes with the execution of a recovery algorithm. The recovery action is reported to the host with a Sense Key of 1. (Refer to the Request Sense command in Appendix A.) Mode pages *must* be in the factory default states.

Unrecoverable Data Error Rate

Less than ten (10) errors in 10^{15} bits transferred when the disk drive is operated within the specified environmental limits.

Note: An un-recoverable data error occurs when a read or write operation does not successfully complete with the execution of a recovery algorithm. The unsuccessful operation is reported to the host with a Sense Key of 3. (Refer to the Request Sense command in Appendix A.) Mode pages *must* be in the factory default states.

Seek Error Rate

Less than ten (10) seek errors in 10^7 seeks when the drive is operated within the specified environmental limits.

Note: A seek error occurs when the drive does not successfully locate the desired cylinder and head.

Recording Density

Bit Density:	1968 bits per mm (49,987 bits per inch)
Track Density:	91 tracks per mm (2304 tracks per inch)

Coding System 1,7 Run Length Limited (RLL) Code

Electromagnetic Emissions

Current Electromagnetic Compatibility (EMC) regulations do not specify or require testing at the component (standalone) level since EMC is highly dependent upon the characteristics of the system in which the product is installed.

Although regulatory testing is not required, these products have been characterized as individual components using Hewlett-Packard standardized tests.

Table 1-2. HP C2244/45/46/47 Operating Specifications (continued)

Acoustical Noise: Typical values measured as average sound pressure at one meter per ISO 7779; converted to average sound power (in bels) per ISO 7779.

Idling:

A-Weighted Sound Pressure: 35 db(A)
Sound Power: 4.6 bels

Seeking:

A-Weighted Sound Pressure: 37 db(A)
Sound Power: 4.8 bels

Safety

This product will be evaluated as a component (incomplete in nature) to the following specifications. A complete test and evaluation program should be performed on the end use application.

IEC 950, 1st Edition, Amendments 1 and 2
UL 1950, 1st Edition
CSA C22.2 No. 950-M89
EN 60950, 1988
TUV EN 60950, 1988; DIN VDE 0805/05.90
DEMKO EMKO-TUE (74-SEC) 203/91

Physical Characteristics

Unit Weight 1.0 kg (2.2 lbs)
Shipping Weight (Single-Unit Package) 1.6 kg (3.5 lbs)
Shipping Weight (Ten-Unit Package) 11.5 kg (25 lbs)

Dimensions:

Length 146.1 mm (5.75 in.)
Width 101.6 mm (4.00 in.)
Height 41.3 mm (1.63 in.)

(Dimensions exclude front bezel. Additional information is provided in Chapter 2.)

DC Power Characteristics

All values assume input voltages are within limits specified under *Input Power Requirements* in Table 1-4.

Table 1-3. HP C2244/45/46/47 DC Power Characteristics

	Start-Up Typ/Max	Running Typ/Max (Note 1)	Seeking Typ/Max (Note 2)
+5 Vdc Current			
Narrow, Single-Ended	0.93 A / 1.03 A	0.93 A / 1.03 A	0.93 A / 1.03 A
Narrow, Differential (Idle)	1.3 A / 1.44 A	1.3 A / 1.44 A	1.3 A / 1.44 A
Narrow, Differential (Active) ^{Note 3}	1.8 A / 1.94 A	1.8 A / 1.94 A	1.8 A / 1.94 A
Wide, Differential (Idle)	1.4 A / 1.55 A	1.4 A / 1.55 A	1.4 A / 1.55 A
Wide, Differential (Active) ^{Note 3}	2.4 A / 2.55 A	2.4 A / 2.55 A	2.4 A / 2.55 A
+12 Vdc (ave) Current ^{Note 4}			
All		0.54 A / 0.57 A	0.82 A / 0.85 A
+12 Vdc (peak) Current ^{Notes 4, 5}			
All	2.45 A / 2.50 A		1.20 A / 1.50 A
Power			
Narrow, Single-Ended	34.1 W / 36.9 W	11.1 W / 12.6 W	14.4 W / 16.1 W
Narrow, Differential	35.9 W / 39.1 W	13.0 W / 14.7 W	16.3 W / 18.8 W
Wide, Differential	36.4 W / 39.6 W	13.5 W / 15.3 W	16.8 W / 18.8 W
Notes:			
1. Spindle up to speed and actuator is track following.			
2. Assuming random seeks with an average latency between seeks.			
3. Differential trancievers transmitting and receiving.			
4. Typical +12 Vdc currents are for sustained drive operation at 25° ambient temperature. Maximum +12 Vdc currents (running and seeking) are for initial drive turn-on at 0° C ambient temperature.			
5. Peak values shown are for occurrences greater than 5 milliseconds duration.			

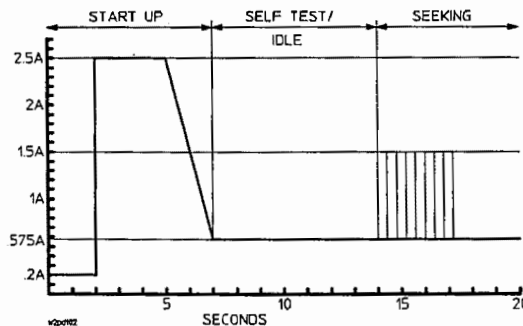

Typical +12V Current

Environmental Requirements

The environmental requirements for proper operation of the HP C2244/45/46/46 Disk Drive are listed in Table 1-4.

Table 1-4. HP C2244/45/46/47 Environmental Requirements

Input Power

Voltages +5 V, +12 V

Regulation $\pm 5\%$

($\pm 10\%$ tolerance allowed for +12V during start-up.)

Ripple and Noise:

+5 V $< 100 \text{ mV}_{\text{p-p}}$

+12 V $< 200 \text{ mV}_{\text{p-p}}$

Ambient Air Temperature

Operating 5°C to 50°C (41°F to 122°F)

Nonoperating -40°C to 65°C (-40°F to 149°F)

(Maximum rate of change shall not exceed 20°C (36°F) per hour.)

Airflow Requirements

Narrow, Single-Ended Drives 3 to 5 cfm

Narrow, Differential Drives 3 to 5 cfm

Wide, Differential Drives 4 to 6 cfm

For more information:

General installation guidelines refer to Chapter 2

Narrow, Single-Ended Drives refer to Appendix E

Narrow, Differential Drives refer to Appendix F

Wide, Differential Drives refer to Appendix G

Relative Humidity

Operating 8% to 80% with wet bulb limit of 28°C

Nonoperating (storage and shipping) 5% to 90% with wet bulb limit of 28°C

(Excludes all conditions which can cause condensation in or on the disk drive.)

Altitude

Operating - 305 m (- 1,000 ft) to 3,048 m (10,000 ft) above sea level.

Nonoperating - 305 m (- 1,000 ft) to 15,240 m (50,000 ft) above sea level.

Tilt

The disk drive will meet all performance specifications on any of the major mounting axes.
Refer to Chapter 2 for mounting instructions.

Table 1-4. HP C2244/45/46/47 Environmental Requirements (continued)

Shock

Operating:

Applied Acceleration (half sine)3.0 g (peak), 11 milliseconds
The drive meets recoverable and unrecoverable data error rate specifications (refer to Table 1-2) with no recoverable or unrecoverable hardware faults. Mode pages *must* be in factory default state.

Applied Acceleration (half sine) 10.0 g (peak), 11 milliseconds
The drive meets unrecoverable data error rate specifications (refer to Table 1-2) with no unrecoverable hardware faults. Mode pages *must* be in factory default state.

Nonoperating:

Applied Acceleration (half sine) 50 g (peak), 11 milliseconds
The drive meets recoverable and unrecoverable data error rate specifications (refer to Table 1-2) with no recoverable or unrecoverable hardware faults and no damage to the mechanism. Mode pages *must* be in factory default state.

Notes:

A recoverable hardware fault occurs when the drive detects a hardware error, such as a seek or track following error, and successfully completes the operation with the execution of a recovery algorithm. The recovery action is reported to the host with a Sense Key of 1. (Refer to the Request Sense command in Appendix A.) Mode pages *must* be in the factory default states.

An un-recoverable hardware fault occurs when the drive detects a hardware error, such as a seek or track following error, and does not successfully complete the operation with the execution of a recovery algorithm. The unsuccessful operation is reported to the host with a Sense Key of 4. (Refer to the Request Sense command in Appendix A.) Mode pages *must* be in the factory default states.

Swept Sine Vibration

Operating:

Applied Acceleration 0.25 g (peak), 5 to 500 Hz
The drive meets recoverable and unrecoverable data error rate specifications (refer to Table 1-2) with no recoverable or unrecoverable hardware faults. Mode pages *must* be in factory default state.

Applied Acceleration0.5 g (peak), 5 to 500 Hz
The drive meets unrecoverable data error rate specifications (refer to Table 1-2) with no unrecoverable hardware faults. Mode pages *must* be in factory default state.

Nonoperating:

Applied Acceleration2.0 g (peak), 5 to 500 Hz
The drive meets recoverable and unrecoverable data error rate specifications (refer to Table 1-2) with no recoverable or unrecoverable hardware faults and no damage to the mechanism. Mode pages *must* be in factory default state.

Table 1-4. HP C2244/45/46/47 Environmental Requirements (continued)

Electromagnetic Compatibility (EMC)

Current EMC regulations do not specify or require testing at the component (standalone) level since EMC is highly dependent upon the characteristics of the system in which the product is installed.

Although regulatory testing is not required, these products have been characterized as individual components using Hewlett-Packard standardized tests. These tests are summarized below.

Electromagnetic Susceptibility

Radiated < 3V/m from 14 kHz to 1 GHz

Conducted

+5 V < 200 mVp-p from 100 kHz to 250 MHz

+12 V < 400 mVp-p from 100 kHz to 250 MHz

Magnetic < 4 gauss, 47.5 to 198 Hz



Product Installation

Introduction

This chapter provides information for the mechanical and electrical installation of the disk drive.

Handling Guidelines

The purpose of a correct installation is to provide an optimum environment for the disk drive. Continually subjecting the disk drive to the extremes of the environmental specifications results in stress on the product and can result in early failure or less reliable operation. All possible combinations of stresses have not been tested and the results of simultaneously applying worst case extremes of several environment parameters are unpredictable.

Protection From Mechanical Shock

Before installation, the disk drive is susceptible to damage from excessive shock and vibration during shipping and handling.

Caution



Always handle the disk drive carefully to reduce the danger of losing control and setting it down too hard or dropping it.

Always place the drive top side up on a flat surface when it is unmounted.

Always install a grounded cushioning pad on hard surfaces such as tables and storage racks used for handling and storing disk drives.

Never stack drives on top of each other.

Protection from Electrostatic Discharge (ESD)

The electronic components in these products can be permanently destroyed or suffer latent (hidden) damage by the currents generated from the normal static electricity that resides on hands and table surfaces.

Caution



Never handle the drive outside its anti-static bag unless the surrounding surfaces and the operator are grounded and the outside of the anti-static bag is first discharged to the surroundings.

Always put the drive inside the anti-static bag or other approved container before it is handled by a non-grounded person, before moving it away from a grounded (ESD safe) work area, and before it is to be stored.

Unpacking the Disk Drive

Note



The disk drive is shipped in a reusable shipping container. Retain the shipping container and all packing material for re-shipment.

Inspecting the Shipping Container

When your shipment arrives, ensure that it is complete as specified by the carrier's bill of lading. Inspect the shipping container immediately upon receipt for evidence of mishandling during transit. If the container is damaged or water stained, request that the carrier's agent be present when the container is unpacked.

Inspecting the Disk Drive

Remove the disk drive from the shipping container and inspect it for any mechanical damage that may have occurred during shipment. If any damage is observed, immediately notify Hewlett-Packard and file a claim with any carrier involved.

Recording the Serial Number

Each drive carries an individual serial number. Keep a record of all serial numbers and dates of purchase. If your drive is lost or stolen, this information is often necessary for tracing and recovery, as well as for any insurance claims.

Disk Drive Returns

Return Shipment Addresses

Vendor Purchases

Return the drive(s) to the vendor from which it was purchased. Refer to your original ordering information for that address.

Hewlett-Packard Direct Purchases

If you purchased your drive(s) directly from Hewlett-Packard, contact your Hewlett-Packard sales representative for instructions.

Re-Packing For Shipment

Use the original container and packaging material supplied with the drive for any shipments. If the original packaging material is not available, contact your Hewlett-Packard sales representative for replacements. Figure 2-1 illustrates the single-unit packaging and Figure 2-2 illustrates the ten-unit packaging.

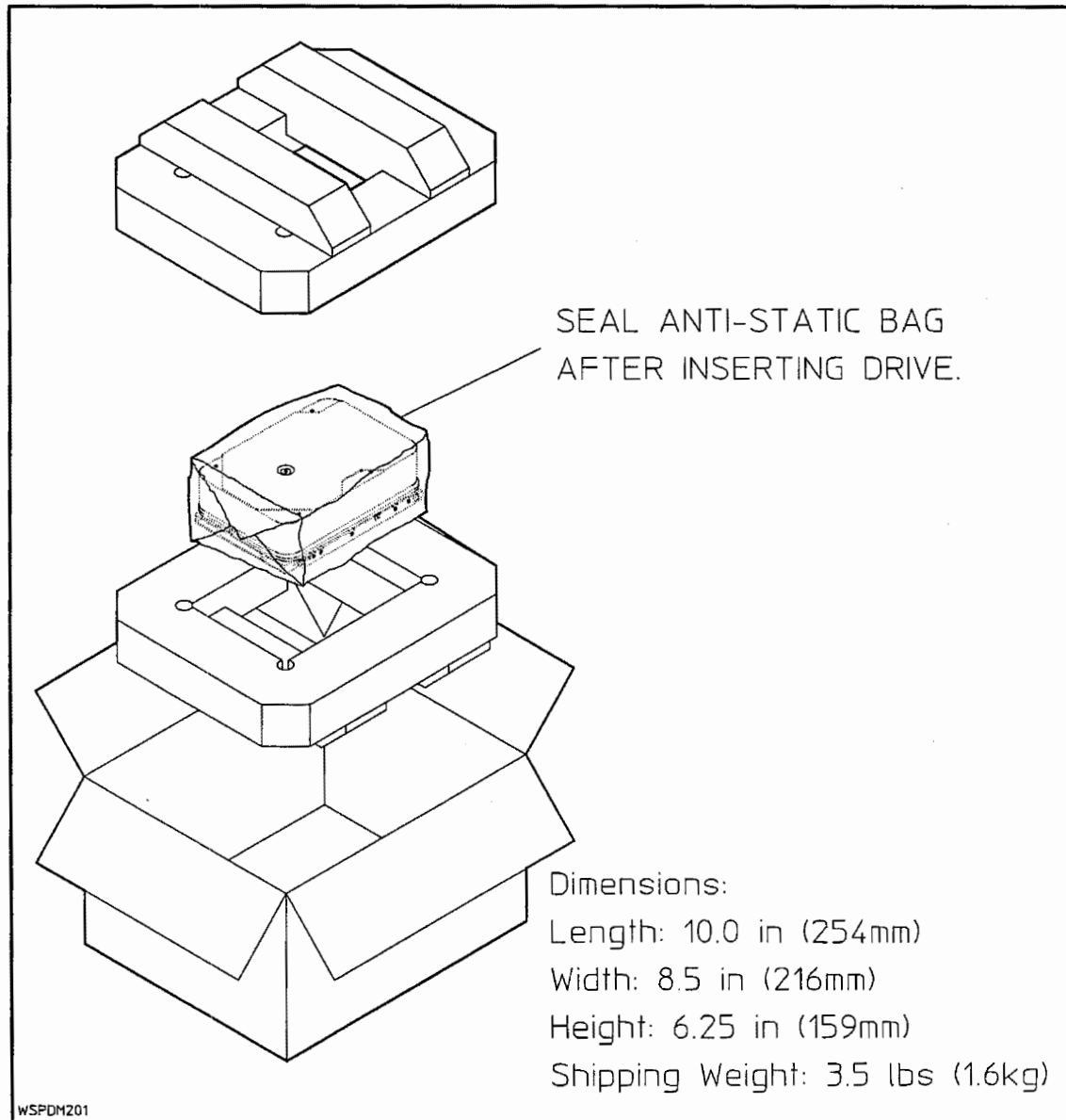

Figure 2-1. Single-Unit Packaging

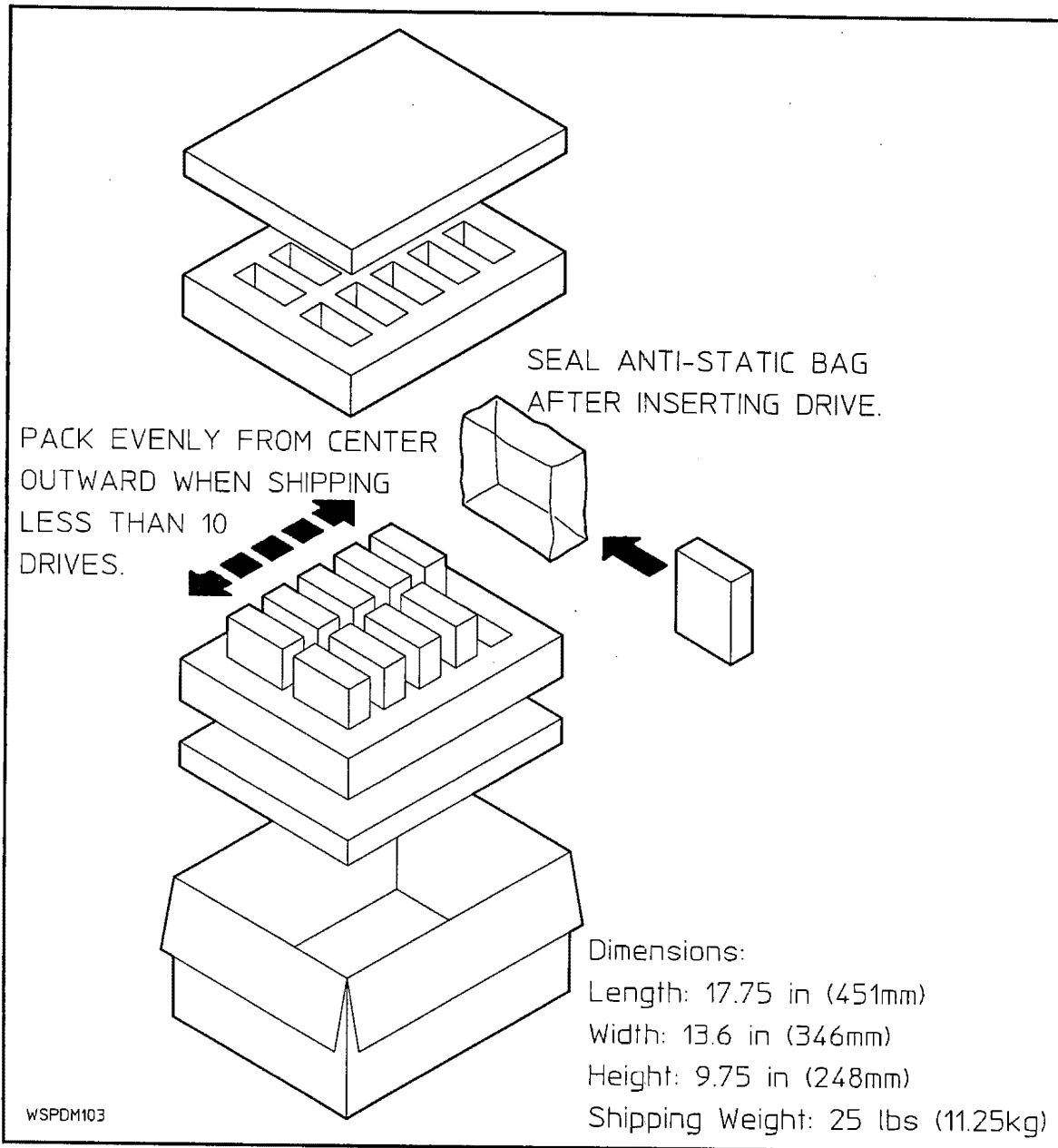

Figure 2-2. Ten-Unit Packaging

Mounting Information

The disk drive can be mounted in any of the major mounting axes.

Safety/Regulatory Compliance

- When installing the HP C2244/45/46/47 Disk Drives into an end use product, safety and regulatory Conditions of Acceptability *must* be considered. Contact your sales/service representative for a copy of the Hewlett-Packard Conditions of Acceptability.
- If the front bezel option has been installed, it should be evaluated in the intended end use application.
- If installing an HP C2244/45/46/47 Disk Drive with an adaptor mounting frame, the complete installation should be evaluated in the intended end use application.

Chassis Dimensions and Mounting Screw Locations

The physical dimensions and mounting screw locations for each interface option are shown in the respective appendices for each option. The length dimensions shown are for the chassis only and do not include clearances for power and interface connectors.

Physical Mounting

There are twelve (12) threaded mounting holes (for no. 6-32 screws) on the disk drive: four on each side, and four on the bottom (see Figure 2-3). Use the mounting guidelines listed in the respective appendices for each option.

Airflow Requirements

The disk drive must be installed so that the ambient air temperature surrounding the disk drive is maintained within the limits specified under *Environmental Requirements* in Chapter 1.

Airflow is required to maintain disk drive performance and reliability. For best results, the drive should be operated as cool as possible. The airflow requirements for each interface option are listed in Table 1-4. The majority of the air should flow across the PCA. This is a function of the specific airflow pattern inside the cabinet where the disk drive is installed.

The airflow pattern around the drive should be adjusted to prevent the temperature measuring points on the HDA and the PCA from exceeding the maximum limits shown in the respective appendix for each interface option.

All temperature measurements should be made under worst case operating conditions. These conditions should be maintained for at least one hour to allow the drive to reach equilibrium before making any measurements.

Front Panel LED Indicator

The light emitting diode (LED) on the front of the disk drive is an activity light that indicates the operational status of the drive from power-on, through the self-test diagnostics, and into normal operation.

1. **On**

At Power-On, the LED turns on until the Power-On sequence is complete and then turns off.

If the Auto-SpinUp option jumper is installed, the Power-On sequence includes execution of the SpinUp sequence, calibrating the head positioning electronics, and testing the read/write system.

If the Auto-SpinUp option is not installed, the Power-On sequence includes execution of the SpinUp sequence only.
2. **Flashing**

A flashing LED (approximately 1 Hz) indicates that the controller has failed all or a portion of the internal diagnostic tests.
3. **Intermittent**

After the power-on diagnostics have completed, the LED functions as an activity light and will go on any time the disk drive is executing a command, reading, or writing. If the LED is off, the drive is idle.

Address and Configuration Pin-Set Set-ups

The location and set-up of the address and configuration pin-sets depends upon the drive interface option and its associated PCA. The information for each interface option is contained in its own appendix to this manual. *Save any removed shorting jumpers for future use.*

- Table 2-1 lists the currently supported interface options, their associated electronics/controller PCAs, and the appendices that provide configuration details for each PCA.
- Table 2-2 lists the currently supported configuration options and provides a brief explanation of each.

Table 2-1. Address/Configuration Pin-Set Information Locations

Interface Option	Interface PCA	Appendix
001	SCSI-2, Fast, Narrow, Single-Ended	Appendix E
002	SCSI-2, Fast, Narrow, Differential	Appendix F
012	SCSI-2, Fast, Wide, Differential	Appendix G

Table 2-2. Address/Configuration Option Descriptions

Configuration Option	Description
Auto Spin Up	When shorted, the disk drive will automatically spin up at power on. If open, the drive will not spin up until the Initiator sends a Start Unit command. When not in the auto spin up mode the drive will return "Not Ready" to all commands except REQUEST SENSE, INQUIRY, RESERVE, RELEASE, and START UNIT until the drive is ready for access.
Parity	When shorted, the disk drive checks parity on commands and data. When open, the disk drive does not check for parity. Parity bits are generated whether this pin-set is open or shorted.
SCSI-1/SCSI-2	When open, the drive checks Mode Page 09, byte 8, bit 4 and responds accordingly. The default is SCSI-2. When shorted the drive is forced to respond as a SCSI-1 device.
SCSI Address Selection	Narrow SCSI drives are shipped from the factory with shorting jumpers across all three pin-sets which sets up a SCSI Address of 7. Wide SCSI drives are shipped from the factory with shorting jumpers across all four pin-sets which sets up a SCSI Address of 15.
Synchronized Spindle	<p>These pinsets control the routing of the Synchronized Spindle signals. They have no effect if the Synchronous Spindle Mode is disabled. The C2244/45/46/47 disk drives support the Stand Alone, Slave, and Master modes, but not the Master Control mode. The power-on default for all drives is the Stand Alone Mode. Refer to the Mode Sense/Mode Select command page 04 information in Appendix A for more details about implementing these functions, including positional offset from the input sync signal.</p> <ul style="list-style-type: none"> ■ When the drive is in the <i>Stand Alone</i> mode: <ul style="list-style-type: none"> It does not transmit a sync signal. It does not sync to any externally sourced slave sync inputs. ■ When the drive is set to the <i>Slave</i> mode: <ul style="list-style-type: none"> It does not transmit a sync signal. It will sync to an externally sourced slave sync signal. ■ When the drive is set to the <i>Master</i> mode: <ul style="list-style-type: none"> It transmits a sync signal on the <i>sync</i> pin. It syncs internally to the same signal.
Synchronous Data Transfer Request (SDTR)	When shorted, the drive will initiate an SDTR message at power-on and RESET. When open, the drive will not initiate an SDTR message. The drive will respond to a host-initiated SDTR message whether this pin-set is open or shorted.
Termination Power Source	Determines the power source and routing for the on-board terminators.
Unit Attention	Controls the Unit Attention function: Shorted = disabled; Open = enabled.
Write Protect	When shorted, the entire drive is forced into the media Write Protect mode. When open, the Write Protect function can be controlled with the Mode Select command. The default is NOT write protected. Refer to the Mode Select/Mode Sense explanation in Appendix A for more details.

Drive To Interface Connections

You should be aware of the following considerations when connecting the drive to the SCSI bus.

- Static Damage
- Stub Length
- Terminator Power
- Resistive/Capacitive Loading
- "Glitch" Generation

Caution



1. Avoid static damage to all components of a bus system by observing proper handling and grounding procedures.

When plugging a drive into an active or inactive bus, connect the drive's ground to the system ground **before** connecting the SCSI connector.

When unplugging a drive from an active or inactive bus, disconnect the SCSI connector **before** disconnecting the power connector.

2. The active terminators must have terminator power (TermPwr) applied at all times; either from the SCSI bus pin 26, or from the drive, or both.

The effects of connecting a drive to the SCSI bus are as follows:

■ Drive powered off:

1. Connecting or removing a powered-off drive to/from an inactive bus will have no effect.
2. Connecting or removing a powered-off drive to/from an active bus will have no effect if the bus is loaded and terminated according to the ANSI specification.
3. The SCSI bus will operate properly with one or more drives connected but powered-off.
4. Applying power to a powered-off drive connected to the bus will have no effect if the bus is loaded and terminated according to the ANSI specification.

■ Drive powered on:

1. Connecting or removing a powered-on drive to/from an inactive bus will have no effect.
2. Connecting or removing a powered-on drive to/from an active bus will have no effect if the bus is loaded and terminated according to the ANSI specification.
3. Removing power from a powered-on drive connected to the bus will have no effect if the bus is loaded and terminated according to the ANSI specification.

Interface Connectors and Cables

Connector Dimensions and Locations

The physical locations and dimensions of the interface connectors are shown in the respective appendices for each interface PCA. Refer to Table 2-1 for a list of these appendices.

SCSI Connector

The SCSI device connector is a nonshielded 50-pin (narrow drives) or a 68-pin (wide drives) connector. The physical construction and pin assignments for the connectors conform to SCSI specifications. Mating connector information is listed in Table 2-3. The connector pin assignments are listed in the respective appendices for each interface PCA (refer to Table 2-1).

DC Power Connector

Power requirements for the disk drive are listed in Chapter 1. Pin assignments for the dc power connector are shown in the respective appendices for each interface PCA (refer to Table 2-1). Mating connector information is listed in Table 2-3.

Mating Connector Requirements

Table 2-3. Recommended Mating Connectors

Connector/Function	Recommended Mating Connector
Equivalents may be used.	
SCSI Connector (narrow: single-ended and differential)	3M® 3425-6600
SCSI Connector (wide: differential)	AMP® 786090-7
DC Power	AMP® 1-480424-0
Synchronized Spindle Connector	AMP® Housing 4-87456-9 ¹
Shorting jumpers (2.0 mm spacing)	2x1 shorting jumper: Dupont® 86730-001 (HP p/n 1258-0209) 2x2 connector housing: Dupont® 69307-004 ² 2x3 connector housing: Dupont® 69307-006 ² 2x5 connector housing: Dupont® 69307-010 ²
Notes: 1. Contact insert required; refer to vendor documentation to select the proper contact set for the installed wire size. (For AWG 20-24 wire, use AMP® 1-87309-4.) 2. Contact inserts required; refer to vendor documentation to select the proper contact set for the installed wire size. (For AWG 26-30 wire, use Dupont® 77138-101; for AWG 32-36 wire, use Dupont® 77139-101.)	

Cabling Requirements

The disk drive adheres to the cabling requirements and limitations set forth in the ANSI SCSI specifications. Refer to the SCSI specifications for additional details.

- Cables with a characteristic impedance of 100 ohms $\pm 10\%$ are recommended for unshielded flat or twisted pair ribbon cable.
- Cables with a characteristic impedance of 90 ohms $\pm 10\%$ are preferred for shielded cables.
- To minimize discontinuities and signal reflections, do not use cables with different impedances on the same bus.
- A minimum wire size of 28 AWG should be used to minimize noise effects and ensure proper distribution of termination power. *Note:* because of physical size limitations of current connector designs, a wire size of 30 AWG should be used for wide differential cabling.
- Cables must be properly terminated.

Single-ended Cable

- A 50-conductor flat cable or 25-signal twisted-pair cable should be used. Cable length should be equal to or less than 6.0 meters. This refers to internal and external cable length (except stubs).
- A stub length of no more than 0.1 meter is allowed off the main line interconnection within any connected device.

Differential Cable

- For narrow differential drives, a 50-conductor flat cable or 25-signal twisted-pair cable should be used. For wide differential drives, a 68-conductor flat cable or 34-signal twisted pair cable should be used. Twisted pair cabling is preferred to minimize noise. Cable length should be equal to or less than 25 meters. This refers to internal and external cable length (except stubs).
- A stub length of no more than 0.2 meter is allowed off the main line interconnection within any connected device.

Product Features

Introduction

This chapter provides an overall functional description, major assembly descriptions, and a block diagram description.

Functional Description

This section provides a functional description of the HP C2244/45/46/47 SCSI disk drives.

Disk Format

The head/disk assembly (HDA) contains the magnetic disks (see Figure 3-1). Table 3-1 lists the physical allocation of the cylinders. Each physical sector can store 512 bytes of user data in the standard format. The user can choose to format the drives using other physical sector sizes (from 180-744 bytes in increments of 2 bytes). The user can choose logical block sizes which are 1, 2, 4, or 8 times as large as the physical sector size.

Sector Format

The smallest directly addressable storage area on a data surface is a sector. Accessing a sector is accomplished when the controller specifies the address of the cylinder, head, and sector. The formatted sector bytes are allocated as shown in figure 3-2.

Addressing Structure

All addressing between the disk drive and the host is logical. The drive's embedded controller converts the logical block address into the appropriate physical address (i.e. cylinder, head, sector), allowing for any sparing operations that have been performed. To support logical blocks larger than the physical sector size, the drive automatically blocks and deblocks the physical sectors into the currently specified logical block size.

Error Correction Code

The HP C2244/45/46/47 disk drives use a Reed-Solomon error correction code (ECC) for detection and correction of data errors. During a write operation, the ECC function generates 18 bytes of ECC information, and writes the information into the ECC field as the sector is written. During a read operation, the controller generates an 18-byte code from the data field being read, and compares it to the ECC field created during the write operation. If the 18-byte code differs from the ECC field, a data error is detected and the ECC field is used to correct the data.

The ECC function is enabled or disabled via the DCR (Disable Correction) bit in parameter page 01H of the MODE SELECT command. When enabled, the ECC algorithm divides a sector's data field into three interleaves, or rows, with a selectable correction factor of one, two, or three bytes per interleave. Mathematically, this converts to a maximum burst size of 72 bits per sector. However, the maximum number of bits that is guaranteed to fit into nine contiguous bytes is 65. Therefore, if an error burst longer than 65 bits falls exactly within the boundaries of nine contiguous bytes, it will be corrected. If it spreads across more than nine contiguous bytes, it will be flagged as unrecoverable after the error correction algorithm has been executed (i.e. read retry count, recalibrations, read with offset, reseek, etc.).

The number of bytes that will be corrected in an interleave is selectable via the Correction Span field in parameter page 01h of the MODE SELECT command. The Correction Span field value is stated in bits-per-sector. The ECC algorithm converts this value to bytes-per-interleave by dividing it by 24 (8-bits per byte times three interleaves) and rounding it up to the nearest byte value.

Cyclic Redundancy Check (CRC)

ECC is aided by a 2-byte cyclic redundancy check (CRC) to decrease the probability of error miscorrection. With the correction span set to 72 bits, if a random error distribution is assumed, the calculated probabilities of error misdetection and miscorrection are as follows:

- Probability of misdetection (an error exists, but ECC does not recognize it) is less than 1×10^{-79} .
- Probability of miscorrection (an error is detected, but is improperly corrected) with CRC is less than 1×10^{-47} .

Track Sparing

Refer to Table 3-1 for a complete track allocation list. The spare cylinders are divided into eight "pools", one located at the inside diameter of each zone. If all of the spare cylinders in a given zone have been used, the drive will use the spare cylinders in the adjacent zones nearer to the outer diameter.

Track sparing is implemented for any defect within the track. Defects causing a spare operation may exist in the header, data field, or any other area within the physical sector.

During a Format operation, "Slip Track Sparing" is used: defective tracks are passed over, and the logical volume is slipped one track into the spare pool. During subsequent reads, the defective track is passed over and the read continues at the next logical track.

For a Reassign Block operation, "Skip Track Sparing" is used: the data in the defective track is reassigned to an alternate track located in the spare pool. The "new" location is maintained in a RAM look-up table and supplied to the servo system prior to seeking. When the drive encounters the defective track, it will seek to the alternate location, read the data, and return to the original track to continue the read.

Look Ahead Reads

The Look Ahead Read capability can improve the performance of a drive doing sequential READs by preloading the track buffer with the data most likely to be requested with the next READ command. After a READ command is received by the controller, the drive seeks to the proper track and loads the requested data into the buffer. While that data is being transferred to the host, the Look Ahead Read function continues to read the remainder of the current

track into the buffer. If in subsequent READ requests, the host asks for the following blocks on the same track, they will already be in the buffer, and the data will be returned to the host without the delay of a media access. However, the controller is optimized to return any requested data to the host as fast as possible.

If a new READ command requests data not contained in the buffer while the drive is performing a Look Ahead Read, the process is aborted, and the drive will immediately seek to the new track with no effect on access or transfer performance. Filling the track buffer with unrequested data has a lower priority than delivering requested data. Other conditions that may affect completing a full-track READ before receiving the next READ command are: head position relative to the requested data, transfer size, and the host transfer rate.

Head Alignments

The drive executes periodic head alignments to maintain proper track following tolerances. During the Power-On sequence, the drive executes a complete calibration and head alignment for all heads. For subsequent operation, there are two modes for head alignments: the automatic mode, and the Initiator-controlled mode. In the automatic (default) mode, the drive automatically implements single head alignments in Seek, Read, and Write commands. In the Initiator-controlled mode, head alignments are executed upon receipt of a Rezero Unit command.

Head Alignment States

The drive will enter either a head alignment *needed* or *critical* state according to changes in temperature since the last head alignment, or the elapsed time since the last head alignment.

Temperature Considerations	Elapsed Time Considerations
<p>If a temperature change exceeds the first of two factory defined thresholds, the drive enters the head alignment <i>needed</i> state. If a head alignment occurs the drive cancels the <i>needed</i> state. If the temperature change exceeds the second (higher) threshold before a head alignment is accomplished, the drive enters the <i>critical</i> state.</p>	<p>Under normal conditions, the drive schedules head alignment calibrations at preset intervals after spin-up. The drive enters the <i>needed</i> state at these intervals. If a head alignment occurs the drive cancels the <i>needed</i> state. If twice the expected time interval passes without a calibration, the drive enters the <i>critical</i> state. The time periods between head alignments are pre-defined at the factory to assure reliable operation under start-up and long term conditions.</p>

Head Alignment Modes

The Mode Select command (page 09H, byte 8, bits 6 and 7), allows the Initiator to control the head alignment function as follows:

Drive State	Automatic Mode (bit 6 = 0)	Initiator Controlled Mode (bit 6 = 1)
<i>Normal</i>	Perform no automatic head alignments. Rezero Unit behavior: bit 7 = 0: align current head on next Rezero Unit command bit 7 = 1: align all heads on next Rezero Unit Command	Disable automatic head alignments. Rezero Unit behavior: bit 7 = 0: align current head on next Rezero Unit command bit 7 = 1: align all heads on next Rezero Unit Command
<i>Needed:</i>	Embed single-head alignments in Seek, Read, and Write commands. Rezero Unit behavior: bit 7 = 0: align current head on next Rezero Unit command bit 7 = 1: align all heads on next Rezero Unit command	Disable automatic head alignments. Execute alignments upon receipt of Rezero commands. Rezero Unit behavior: bit 7 = 0: align current head on next Rezero Unit command bit 7 = 1: align all heads on next Rezero Unit command
<i>Critical:</i>	Write Protect until alignment occurs on next Seek, Read, or Write command. Rezero Unit behavior: bit 7 = 0: align current head on next Rezero Unit command bit 7 = 1: align all heads on next Rezero Unit command	Disable automatic head alignments except for a write to a head that needs alignment. Write Protect until alignment occurs on next write. Rezero Unit behavior: bit 7 = 0: align current head on next Rezero Unit command bit 7 = 1: align all heads on next Rezero Unit command

Typical Head Alignment Times

The time requirements for head alignments will vary according to how they are executed. Some *typical* values are listed below:

Single Head Alignment:110 milliseconds
All-Heads Alignment:
13 data heads820 milliseconds

Command Queuing

The HP C2244/45/46/47 of disk drives support the following SCSI command queuing operations:

- **Head of Queue Tag.** Instructs the Target to put the command that follows at the front of the command queue and execute it immediately following the command currently being executed. A command in the process of being executed will not be pre-empted. The Target executes multiple Head-of-Queue commands in last-in, first-out order.
- **Simple Queue Tag.** Instructs the Target to put the command that follows at the end of the command queue. The Target executes multiple Simple-Queue commands in any order that will enable it to minimize actuator seek times to block locations if the queue algorithm modifier allows it.
- **Ordered Queue Tag.** Instructs the Target to put the command that follows at the end of the command queue. The Target executes Ordered-Queue commands in the order they were received. All Simple-Queue commands received prior to an Ordered-Queue command are

executed before the Ordered-Queue command. All Simple-Queue commands received after an Ordered-Queue command are executed after the Ordered-Queue command.

- **Clear Queue Message.** Clears from the queue all I/O processes from all initiators in the queue for the specified logical unit (LUN). All active I/O processes for that LUN are terminated. All pending status and data for that LUN are cleared. No status or message is sent for any of the I/O processes. A Unit Attention condition is generated for all other initiators with I/O processes that either were active or were queued for that target. The device goes to the Bus Free phase following successful receipt of this message. The additional sense code for the Unit Attention is: *Commands Cleared by Another Initiator*.
- **Abort Tag Message.** Instructs the target to abort a tagged command. The target clears the current I/O process. If the target has already started execution of the I/O process, the execution is halted. Any pending status or data for the I/O process is cleared and no status or ending message is sent to the initiator. Pending status, data, and commands for other active or queued I/O processes are not affected.

Command queuing is activated by the Target when the Initiator precedes a command with a one-byte queue tag message that specifies the type of command queuing, followed by a one-byte queue tag value that uniquely defines the I/O process. The queue tag message values are:

- 20H = Head of Queue Tag
- 21H = Simple Queue Tag
- 22H = Ordered Queue Tag

A queue tag value can be any hex value from 00h to FFh. An Initiator can assign 256 queue tags to a LUN. A queue tag value becomes available for reassignment after the I/O process it is assigned to is completed. If more than one command with the same queue tag value is sent to a LUN, all commands are aborted for that initiator.

The Clear Queue and Abort Tag operations are activated by one-byte messages with no follow-on values. These message formats are:

- 0EH = Clear Queue
- 0DH = Abort Tag

If an Initiator sends a tagged command to a Target when the command queue is full, the Target will send a Queue Full status to the Initiator. The Initiator should wait a period of time, and then send the command again.

Untagged commands are also accepted by the C2244/45/46/47 with the following restrictions:

- An untagged command sent by an Initiator will not be accepted if there are any other commands (tagged or untagged) in the queue that were sent by the same Initiator.
- A tagged command sent by an Initiator will not be accepted if there is an untagged command already in the queue that was sent by the same Initiator.

The C2244/45/46/47 will clear the queue in either case.

Note

Error recovery is an exception to the above restrictions because the Initiator is required to send an untagged REQUEST SENSE command if an error occurs while a Target is executing a command.

Error Recovery

If an error occurs while a Target is executing a queued command, the following error recovery sequence is performed to ensure proper handling of any commands still in the queue:

1. Target sends a Check Condition status to the current Initiator.
2. A Contingent Allegiance condition is established for the current Initiator. This means all commands in the queue are suspended until the next command is received from the current Initiator (normally a REQUEST SENSE command). Commands received from other Initiators will be queued normally.
3. If QErr=1 in the Control Mode Parameter Page 0Ah (refer to the Mode Select and Mode Sense commands), all commands in the queue are aborted upon receipt of a command to clear which clears the Contingent Allegiance condition. A Unit Attention condition with an Additional Sense Key of Tagged Commands Cleared by Another Initiator is established for all other Initiators that had commands in the queue.
4. Current Initiator sends the next command. If the next command is an untagged REQUEST SENSE, it is executed immediately by the Target. If the next command is any command other than an untagged REQUEST SENSE, error recovery is terminated and the command is queued or rejected according to normal queuing procedures.
5. The Contingent Allegiance condition is removed, and any commands still in the queue are executed by the Target in a normal manner.

Synchronized Spindle Operation

Synchronized spindle operation (Master or Slave modes) is enabled via Mode Page 04H. Refer to Table 2-2 (Chapter 2), and the Mode Sense/Mode Select command information (Appendix A), for more details about implementing these functions.

Assembly Descriptions

The assemblies in the disk drive include the head/disk assembly (HDA) and the drive electronics/controller printed-circuit assembly (PCA). The sealed HDA contains the mechanical and electromechanical assemblies of the disk drive. The drive electronics/controller PCA provides the SCSI interface and all electronic control over the HDA. The following paragraphs describe the major functional components of each assembly.

Head/Disk Assembly

The head/disk assembly (HDA) contains disks, heads, an actuator assembly, head interface circuits, atmospheric controls, vibration isolators, and a spindle assembly. A stainless steel baseplate and cover provide the supporting structure for these parts. The entire assembly is sealed and is not field repairable.

Disks

The disks are 3.5-inch (95 mm) diameter aluminum substrates with sputtered thin-film surfaces. Data is stored on both surfaces of all disks except for one surface reserved for servo information.

Heads

Thin film data heads in the HDA write and read user data. An additional thin film head in each unit is used to recover the servo information.

Actuator and Latch Assembly

A rotary actuator positions the heads. A shipping latch captures the actuator arm at the inside diameter of the disks (away from user data) whenever power is removed from the disk drive. This prevents the heads from moving over data until power is applied and the disks are spinning, causing the heads to fly at a safe distance above the disk surfaces. During the power-up sequence, the processor releases the latch, allowing normal movement of the heads.

Head Interface Electronics

The head interface circuits (located inside the HDA), process the data signals transferred between the read/write heads and the drive electronics/controller PCA. These circuits include write drivers which provide the necessary current to the heads during write operations, and read preamplifiers that amplify data read from the disk before transferring it to the read/write circuit on the drive electronics/controller PCA. Additional functions performed by the head interface include head selection and write control.

Atmospheric Controls

The atmospheric controls in the HDA consist of a breather filter and a recirculating filter. The breather filter equalizes air pressure within the HDA to ambient air pressure and prevents contaminants from entering the HDA. The recirculating filter maintains the internal cleanliness of the HDA.

Vibration Isolators

The HDA is mounted on vibration isolators to protect it from high frequency external vibrations.

Spindle Assembly

The spindle assembly provides the mechanical mounting for the disks. The spindle rotates on a bearing system and is driven by an "in hub" brushless dc motor. The drive current for the motor is supplied by the spindle driver circuit on the drive electronics/controller PCA. Three Hall-effect sensors, mounted on the spindle assembly, provide feedback signals to the spindle control electronics for speed and phase switching control.

Block Diagram

Refer to figure 3-3. The drive electronics/controller PCA controls the operation of the drive, including head positioning, data transfer, spindle speed, and power distribution.

SCSI Interface

The SCSI interface is the direct electrical interface between the SCSI channel and the drive electronics. It handles all SCSI timing and protocol, and transfer of commands, status and configuration information.

The SCSI interface handles SCSI protocol without intervention from the microprocessor, and is capable of automatically controlling the proper sequence of bus phases involved in each transaction. Full arbitration and disconnect/reselection are implemented by the SCSI interface.

RAM Buffer

The RAM buffer contains 256-kilobytes of static RAM. All data transferred between the host and the disk must pass through the RAM buffer.

Disk Controller

The disk controller coordinates the flow of data by interleaving RAM accesses between the SCSI interface and the disk controller. It contains a DMA section which controls the transfer of data between the SCSI interface, the buffer RAM and the disk controller. The DMA accesses the 256-kilobyte static RAM buffer to match the transfer speeds of the SCSI interface and the disk controller.

The disk controller also performs error checking on data being transferred from the disk to the RAM buffer and generates ECC on data transferred from the RAM buffer to the disk. The data controller also does header verification during read/write operations.

Data Encoder/Decoder

The primary function of the Data Encoder/Decoder is to convert between the NRZ (Non Return to Zero) data/clock present on the SCSI channel and RLL (Run Length Limited, 1,7) data transferred to and from the disk surface. This includes sector length and content information provided by the host during format operations as well as data transfers during normal Read and Write operations.

Microcontroller

The microcontroller used on the drive electronics/controller PCA is a single-chip device. The microcontroller is responsible for decoding incoming SCSI commands, controlling the servo processor and the read/write circuitry, and managing the head alignment function.

Servo Processor

The servo processor provides index and start-of-sector timing signals, and controls actuator movement, motor spin-up and speed control, and synchronized spindle operation. Actuator movement control consists of track-to-track seeks, track following, and correction for both DC and repeatable AC errors. Motor spin-up and speed control consists of regulated drive motor current modified by information derived from the dedicated servo surface. Synchronized spindle control is derived from an external sync input that is compared to position information from the disk surface.

Data Head Interface

The data head interface processes the data signals transferred between the read/write heads and the data encoder/decoder. This includes head selection, providing analog write current to the heads, and amplification and conversion of impulses from the heads to RLL data.

Actuator Driver

The actuator driver provides the current necessary to operate the actuator assembly. The driver amplifies the control information provided by the servo processor, and outputs the resultant current to the actuator.

Servo Timing

The function of the servo timing circuit is to amplify and convert impulses from the servo head into position and rotation speed information for the servo processor.

Spindle Motor Driver

The spindle motor driver provides 3-phase current to start, drive, and control the speed of the in-hub spindle motor. Hall-effect sensors mounted on the spindle assembly provide feedback for phase switching control.

Power Distribution

The +5 and +12 voltages provided by an external dc power supply are distributed to the spindle motor driver, actuator driver, analog amplifiers, and digital circuitry. A reset output alerts the other circuits when power-on occurs and when power is lost. Each circuit responds in a predefined manner to the reset condition.

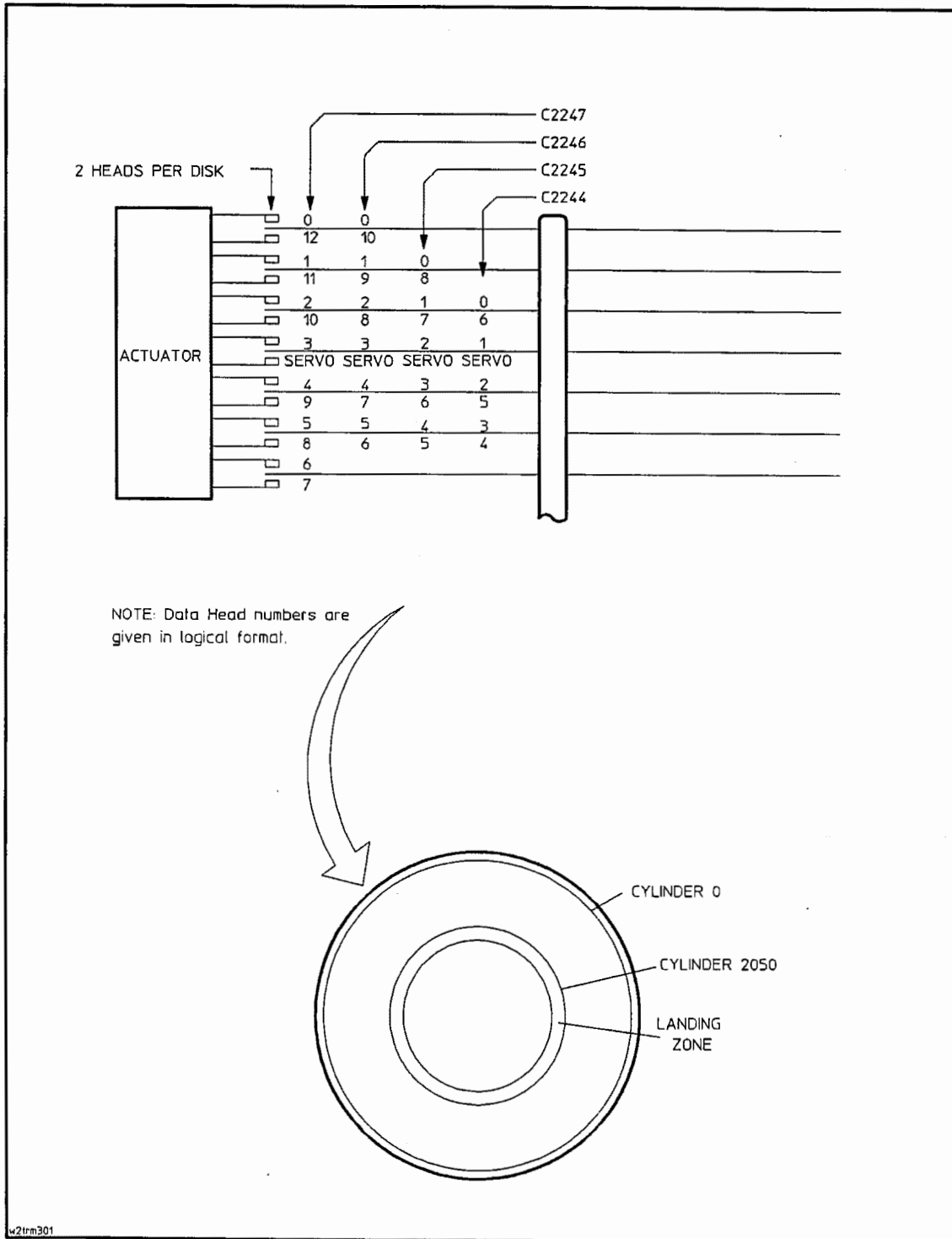

Figure 3-1. Disk Drive Addressing Structure

Table 3-1. C2244/45/46/47 Cylinder Allocation

Function	Product	Cylinder(s) ¹	Head(s) ²
Zone 0 (Outer Zone)			
Defect List	C2244/45/46/47	0	0, 1, 2
Logs, Mode Pages	C2244/45/46/47	0	3
Maintenance	C2244	0 1	4 thru 6 0 thru 3
	C2245	0 1	4 thru 8 0 thru 3
	C2246	0 1	4 thru 10 0 thru 3
	C2247	0 1	4 thru 12 0 thru 3
User Data	C2244	1 2 thru 533	4 thru 6 0 thru 6
	C2245	1 2 thru 533	4 thru 8 0 thru 8
	C2246	1 2 thru 533	4 thru 10 0 thru 10
	C2247	1 2 thru 533	4 thru 12 0 thru 12
Spares	C2244	534 thru 558 (25 ea)	0 thru 6
	C2245	534 thru 558 (25 ea)	0 thru 8
	C2246	534 thru 558 (25 ea)	0 thru 10
	C2247	534 thru 558 (25 ea)	0 thru 12
Zone 1			
User Data	C2244	559 thru 750	0 thru 6
	C2245	559 thru 750	0 thru 8
	C2246	559 thru 750	0 thru 10
	C2247	559 thru 750	0 thru 12
Spares	C2244	751 thru 760 (10 ea)	0 thru 6
	C2245	751 thru 760 (10 ea)	0 thru 8
	C2246	751 thru 760 (10 ea)	0 thru 10
	C2247	751 thru 760 (10 ea)	0 thru 12
Zone 2			
User Data	C2244	761 thru 896	0 thru 6
	C2245	761 thru 896	0 thru 8
	C2246	761 thru 896	0 thru 10
	C2247	761 thru 896	0 thru 12
Spares	C2244	897 thru 901 (5 ea)	0 thru 6
	C2245	897 thru 901 (5 ea)	0 thru 8
	C2246	897 thru 901 (5 ea)	0 thru 10
	C2247	897 thru 901 (5 ea)	0 thru 12
Notes: 1. Cylinder references are given in physical format. 2. Head references are given in logical format.			
(continued on next page)			

Table 3-1. C2244/45/46/47 Cylinder Allocation (continued)

Function	Product	Cylinder(s) ¹	Head(s) ²
Zone 3			
User Data	C2244	902 thru 1045	0 thru 6
	C2245	902 thru 1045	0 thru 8
	C2246	902 thru 1045	0 thru 10
	C2247	902 thru 1045	0 thru 12
Spares	C2244	1046 thru 1051 (6 ea)	0 thru 6
	C2245	1046 thru 1051 (6 ea)	0 thru 8
	C2246	1046 thru 1051 (6 ea)	0 thru 10
	C2247	1046 thru 1051 (6 ea)	0 thru 12
Zone 4			
User Data	C2244	1052 thru 1189	0 thru 6
	C2245	1052 thru 1189	0 thru 8
	C2246	1052 thru 1189	0 thru 10
	C2247	1052 thru 1189	0 thru 12
Spares	C2244	1190 thru 1193 (4 ea)	0 thru 6
	C2245	1190 thru 1193 (4 ea)	0 thru 8
	C2246	1190 thru 1193 (4 ea)	0 thru 10
	C2247	1190 thru 1193 (4 ea)	0 thru 12
Zone 5			
User Data	C2244	1194 thru 1511	0 thru 6
	C2245	1194 thru 1511	0 thru 8
	C2246	1194 thru 1511	0 thru 10
	C2247	1194 thru 1511	0 thru 12
Spares	C2244	1512 thru 1519 (8 ea)	0 thru 6
	C2245	1512 thru 1519 (8 ea)	0 thru 8
	C2246	1512 thru 1519 (8 ea)	0 thru 10
	C2247	1512 thru 1519 (8 ea)	0 thru 12
Zone 6			
User Data	C2244	1520 thru 1787	0 thru 6
	C2245	1520 thru 1787	0 thru 8
	C2246	1520 thru 1787	0 thru 10
	C2247	1520 thru 1787	0 thru 12
Spares	C2244	1788 thru 1793 (6 ea)	0 thru 6
	C2245	1788 thru 1793 (6 ea)	0 thru 8
	C2246	1788 thru 1793 (6 ea)	0 thru 10
	C2247	1788 thru 1793 (6 ea)	0 thru 12
Zone 7 (Inner Zone)			
User Data	C2244	1794 thru 2045	0 thru 6
	C2245	1794 thru 2045	0 thru 8
	C2246	1794 thru 2045	0 thru 10
	C2247	1794 thru 2045	0 thru 12
Spares	C2244	2046 thru 2050 (5 ea)	0 thru 6
	C2245	2046 thru 2050 (5 ea)	0 thru 8
	C2246	2046 thru 2050 (5 ea)	0 thru 10
	C2247	2046 thru 2050 (5 ea)	0 thru 12
Notes:			
1. Cylinder references are given in physical format.			
2. Head references are given in logical format.			

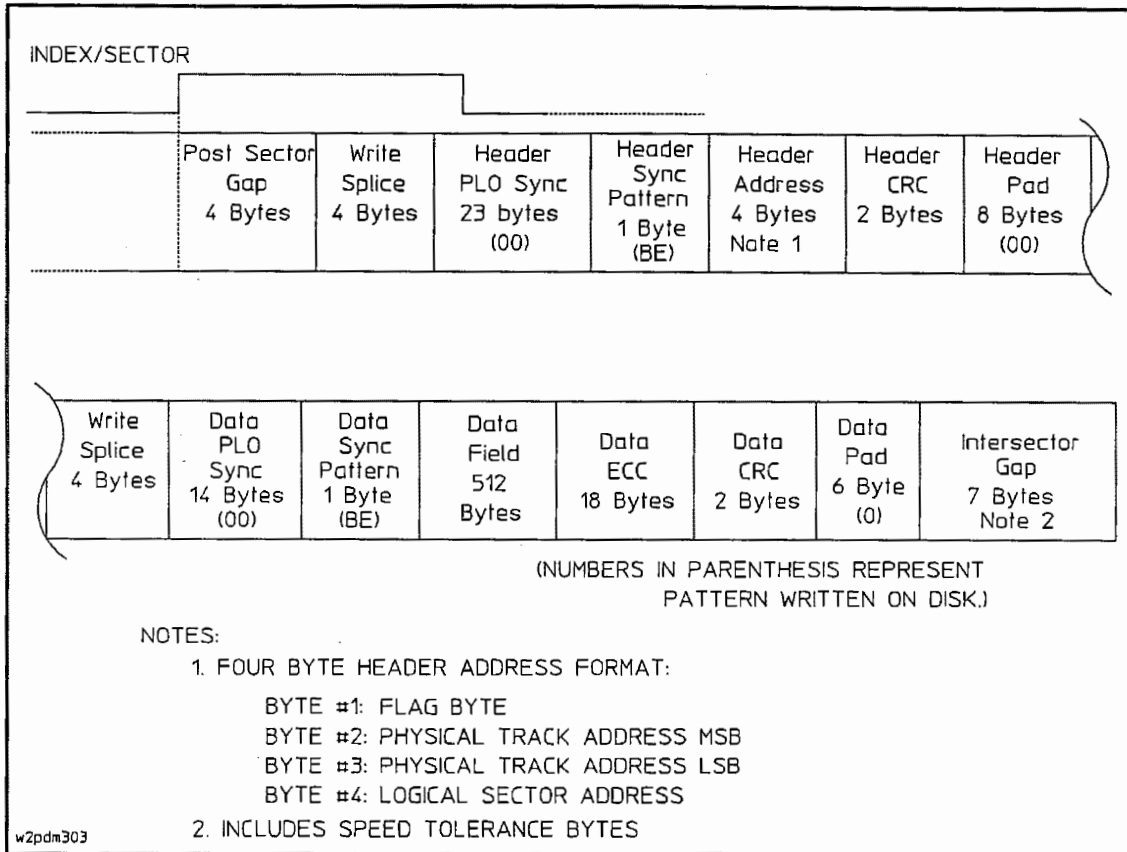

Figure 3-2. Formatted Physical Sector Allocation

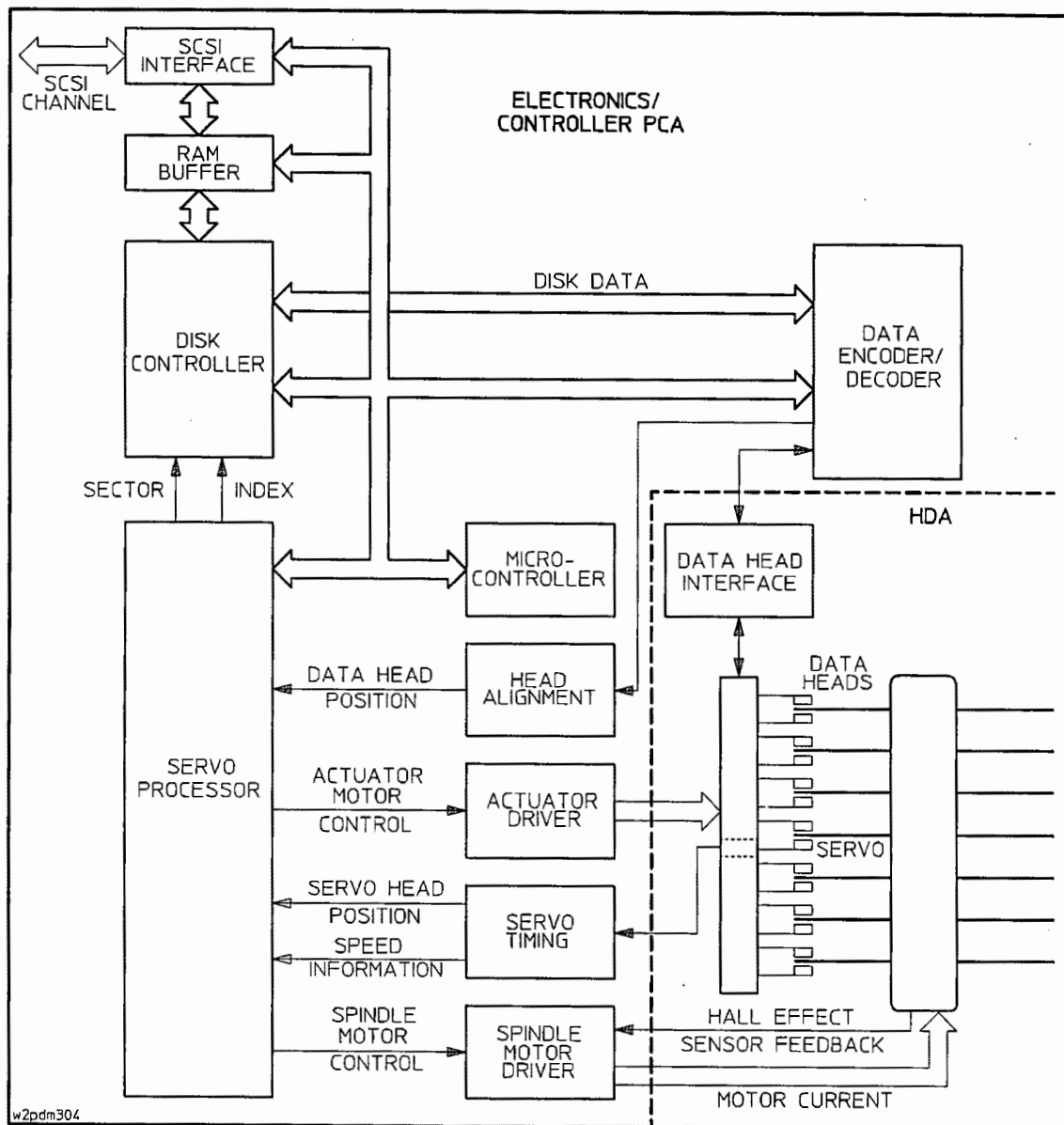

Figure 3-3. Disk Drive Block Diagram

SCSI Interface

Introduction

This chapter describes the implementation of the Small Computer System Interface, SCSI on the HP C2244/45/46/47 disk drives. The information includes an overview of the SCSI features, options, and commands supported by these products. Any operating characteristics relevant to SCSI implementation are also discussed. In this manual the term Target refers to the HP C2244/45/46/47 Disk Drives.

Table 1-1 provides a list of all the commands supported by the Target and identifies which commands are SCSI implementations and which commands are Vendor Unique implementations.

Appendix A provides detailed descriptions of the SCSI commands supported by the Target. These descriptions are in alphabetical order and include Command Descriptor Block (CDB) formats, data formats, and all device specific information involved in command execution. For further command specific details, refer to the ANSI SCSI Specification.

Appendix B provides descriptions of the Vendor Unique commands supported by the Target. These descriptions include Command Descriptor Block (CDB) formats, data formats, and all device specific information involved in command execution.

Supported Functions

The Target support the following:

- **Command Queuing.** Command queuing is supported.
- **Write Cache.** Write caching is supported.
- **Arbitration.** Full arbitration is supported.
- **Disconnect.** If allowed, the Target may disconnect after a command is received, and for any significant delay occurring during a data transfer operation.
- **Linked Commands.** Command linking is supported.

■ **Power-On Sequence Sequence.** At Power-on, the Target performs the following:

- Turn on LED
- Microprocessor Self Test
- Microprocessor RAM Test
- Data Controller Test
- ECC Verification Test
- Buffer RAM Test, first 64 bytes
- Test and Initialize Servo Processor
- Initialize SCSI interface

If Auto Spin-Up *is not enabled*:

- turn off LED and wait for a command

If Auto Spin-Up *is enabled*:

- begin spin-up sequence:
 - Start spindle motor (See **Note** below)
 - Test buffer RAM while spindle is gaining speed
 - Settle heads on track and calibrate servo system
 - Perform head alignments
 - Write/Read Test
 - Initialize Spare Table
 - Initialize Logs
 - Initialize Saved Pages Information
 - Turn off LED and wait for a command

Note: While the spindle motor is spinning up, the drive will respond to all commands (except REQUEST SENSE and INQUIRY) with a status byte of *Check Condition*. The subsequent REQUEST SENSE command will return a Sense Key Code of *Not Ready*.

■ **Data Head Alignment.** These drives incorporate the capability to perform periodic data head alignments. A full head alignment is executed at power-on. Subsequent head alignments may be executed relative to temperature changes and/or elapsed time since power-on.

■ **Bus Reset.** In response to a SCSI bus reset or Bus Device Reset message, the Target will perform the following:

- Turn on LED
- Abort Any Command in Progress (reads/writes are aborted at sector boundaries)
- Initialize SCSI interface
- Initialize Controller
- Initialize Spare Table
- Initialize Logs
- Initialize Saved Pages Information
- Turn off LED and wait for a command

■ **SCSI Messages.** The following SCSI messages are supported:

Code (hex)	Length (bytes)	Message	Direction ¹
00	1	Command Complete	In
01	2 ²	Extended Message to Follow	In/Out
The following extended message is supported:			
01	3*	Request for SDTR	In/Out
03	2*	Wide Data Transfer Request * added length in bytes	In/Out
00	1	Abort Tag	Out
02	1	Save Data Pointers	In
04	1	Disconnect	In
05	1	Initiator Detected Error	Out
06	1	Abort	Out
07	1	Message Reject	In/Out
08	1	No Operation	Out
09	1	Message Parity error	Out
0A	1	Linked Command Complete	In
0B	1	Linked Command Complete With Flag	In
0C	1	Bus Device Reset	Out
0D	1	Abort Tag	Out
0E	1	Clear Queue	Out
20	2	Simple Queue Tag	In/Out
21	2	Head of Queue Tag	Out
22	2	Ordered Queue Tag	Out
80-FF	1	Identify	In/Out

Notes:

1. In = Target to Initiator; Out = Initiator to Target.
2. 2nd byte indicates additional length of extended message.

■ **Status Codes.** The following status byte codes are supported:

Code (hex)	Status
00	Good
02	Check Condition
08	Busy
10	Intermediate
18	Reservation Conflict
28	Queue Full

Table 4-1. HP C2244/45/46/47 Supported SCSI Commands

Command Name	Opcode (hex)	SCSI Command (Appendix A)	Vendor Unique Command (Appendix B)
Access Log	F2		*
Change Definition	40	*	
Change SCSI ID	C1		*
Change Wide SCSI ID	C2		*
Execute Data	FE		*
Format Unit	04	*	
Inquiry	12	*	
Interface Control	EF		*
Manage Primary	FD		*
Media Test	F1		*
Mode Select (6-byte)	15	*	
Mode Select (10-byte)	55	*	
Mode Sense (6-byte)	1A	*	
Mode Sense (10-byte)	5A	*	
Read (6-byte)	08	*	
Read (10-byte)	28	*	
Read Buffer	3C	*	
Read Capacity	25	*	
Read Defect Data	37	*	
Read Full	FO		*
Read Headers	EE		*
Read Long	3E	*	
Reassign Blocks	07	*	
Receive Diagnostic Results	1C	*	
Reformat Track	ED		*
Release	17	*	
Request Sense	03	*	
Reserve	16	*	
Rezero Unit	01	*	

Table 4-1. HP C2244/45/46/47 Supported SCSI Commands (continued)

Command Name	Opcode (hex)	SCSI Command (Appendix A)	Vendor Unique Command (Appendix B)
Seek (6-byte)	0B	*	
Seek (10-byte)	2B	*	
Send Diagnostic	1D	*	
Start/Stop Unit	1B	*	
Synchronize Cache	35	*	
Test Unit Ready	00	*	
Verify	2F	*	
Write (6-byte)	0A	*	
Write (10-byte)	2A	*	
Write and Verify	2E	*	
Write Buffer	3B	*	
Write Full	FC		*
Write Long	3F	*	
Write Same	41	*	

Status Byte

A status byte is sent from the Target to the Initiator during the Status phase at the termination of each command as specified, unless the command is cleared by an *Abort* message, by a *Bus Device Reset* message, or by a "hard" *Reset* condition. The status byte format, code values, and code descriptions are shown below.

Status Byte Format

Byte	Bit							
	7	6	5	4	3	2	1	0
00	Reserved		Status Byte Code					Reserved

Status Byte Code Descriptions

Value	Status	Description
5 4 3 2 1		
0 0 0 0 0	Good	Indicates that Target has successfully completed the command.
0 0 0 0 1	Check Condition	Caused by any error, exception, or abnormal condition that causes sense data to be set. The REQUEST SENSE command should be issued following a <i>Check Condition</i> status to determine the nature of the condition.
0 0 1 0 0	Busy	The Target is busy. This status is returned whenever a Target is unable to accept a command from an Initiator. The normal Initiator recovery action is to issue the command again at a later time.
0 1 0 0 0	Intermediate	This status is returned for every command in a series of linked commands (except the last GOOD command), unless an error, exception, or abnormal condition causes a <i>Check Condition</i> status to be set. If this status is not returned, the chain of linked commands is broken; no further commands in the series will be requested.
0 1 1 0 0	Reservation Conflict	This status is returned whenever a SCSI device attempts to access a logical unit that is reserved to another SCSI device.
1 0 1 0 0	Queue Full	This status is returned when a <i>Simple Queue Tag</i> , <i>Ordered Queue Tag</i> , or <i>Head of Queue Tag</i> message is received and the command queue is full. The I/O process is not placed in the command queue.

SCSI Message Support

The disk drive supports messages received from the Initiator in the following manner:

- Multiple byte message out phases are allowed.
- Any message out may be prefixed with an optional Identify byte.
- An optional number of No-Op message bytes may be embedded in the message out received by the disk drive prior to the final message byte.
- Only one message type (other than the Identify prefix and the optional No-Op bytes) will be accepted per message out phase. If more than one type is received, the message will be treated as an illegal message.
- A maximum of 16-message out bytes will be accepted by the disk drive. If the ATN line is still set after 16 bytes have been received, the disk drive will treat this as an illegal message type, except that the disk drive will always terminate in a Bus Free state.

The following message types are supported:

Message Parity Error Initiator Detected Error	If either of these messages is received from the Initiator, the disk drive will abort the command in process and set the sense key to <i>Aborted Command</i> with the sense code set to <i>Initiator Detected Error</i> . If a valid LUN has been received in an Identify or CDB, and a status phase has not yet begun, then the command will be terminated with a <i>Check Condition</i> status; otherwise the Target will go to the Bus Free state.
Abort	This message will cause the disk drive to abort the command in process, clear the Initiator's status and go to the Bus Free state.
Reset	This message will cause the disk drive to abort the command in process, reset to Power On conditions for all Initiators, and go to the Bus Free state.
No-Op	This message will be treated as an illegal message type if not followed by some legal message byte, except when the No-Op message type is received immediately following a Re-select attempt by the Target. In this case, the Target will attempt to proceed with the interrupted re-select phase.
Message Reject	<p>If a <i>Message Reject</i> message is received from the Initiator it will normally be treated like an Illegal Message. Only if the Target is in the Message In phase and attempting to send one of the following messages will it be treated differently.</p> <p>Disconnect Message In, Save Data Pointer Message In. The Target will not disconnect and will proceed with the command in process. This will not prevent the disk drive from attempting to disconnect from the Initiator at a later time.</p> <p>Synchronous Data Transfer Message In. The Target will assume that an asynchronous transfer is expected. This will affect all later data transfer phases.</p>

Extended SDTR Message	The SDTR (Synchronous Data Transfer Request) message type will only be accepted prior to the Command phase, and only prior to the first Command phase in a linked command set. At any other time it will be treated as an illegal message type. If the negotiation process is started by the Initiator, the drive will respond with its SDTR message. If the Initiate SDTR Message Option is enabled, the drive will initiate an SDTR message at Power On and Reset.
Extended WDTR Message	The WDTR (Wide Data Transfer Request) message type will only be accepted prior to the Command phase, and only prior to the first Command phase in a linked command set. At any other time it will be treated as an illegal message type. The negotiation process must be started by the Initiator. The drive will respond with its WDTR message. A WDTR message will reset all synchronous parameters previously established by an SDTR message.

Target Error Conditions

Under some error conditions the Target may proceed to the Bus Free phase without terminating the command (i.e. no *Disconnect* or *Command Complete* message sent to the host). In this case, the Target will not attempt to re-connect with the Initiator. The Initiator should consider this as a catastrophic error. Information regarding the cause of this abnormal response can be recovered by the Initiator with the REQUEST SENSE command.

Message Out Phase Parity Error

If parity checking is enabled and a message out parity error is detected the disk drive will abort the command in process and set the sense key to *Aborted Command* with the sense code set to *Parity Error*. If a valid LUN has been received in an identify or in the CDB, and status phase has not yet begun, then the command will be terminated with a *Check Condition* status; otherwise, the Target will go to the Bus Free state.

Command or Data Out Phase Parity Error

If parity checking is enabled and a Command or Data Out phase parity error is detected then disk drive will terminate the command in process with a *Check Condition* status. The sense information will have the sense key set to *Aborted Command* with the sense code set to *Parity Error*.

Illegal Messages

If an illegal or unexpected message out is received from the Initiator, the disk drive will abort the command in process and set the sense key to *Aborted Command* with the sense code set to *Inappropriate/Illegal Message*. If a valid LUN has been received in an identify or in the CDB, and the status phase has not yet begun, then the command will be terminated with a *Check Condition* status; otherwise the Target will go to the BUS FREE phase.

Reselection Timeout

If the Target attempts to reselect the Initiator and the Initiator does not respond within a *Selection Timeout Delay*, the Target will attempt to reselect a second time. If the second attempt fails, the Target will abort the command in process and make no further attempts to reselect the host. The sense information will be set with a sense key of *Hardware Error* and a sense code of *Select/Reselect Failed*.

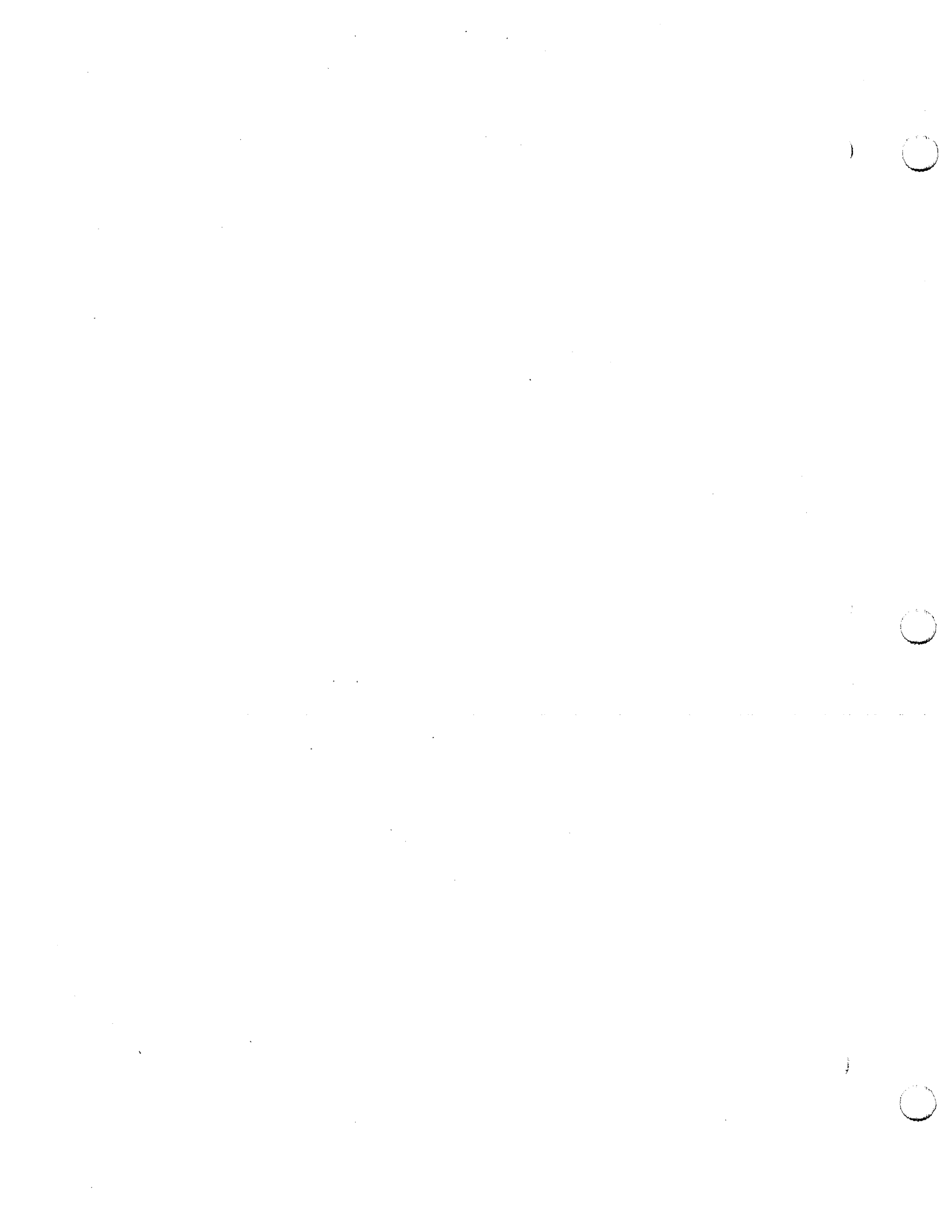

SCSI Command Descriptions

This appendix provides descriptions of the SCSI commands supported by the Target. Table A-1 is a list of the SCSI commands supported by the Target with brief descriptions included for each command.

Command Descriptions

Detailed descriptions of the SCSI commands supported by the Target are provided in the following pages. These descriptions include Command Descriptor Block (CDB) formats, data formats, and all device-specific information involved in command execution.

Command Details

The following information applies to all commands:

- The abbreviations “MSB” and “LSB” in the CDB and other descriptor blocks refer to the most significant byte and least significant byte, respectively.
- The Target only supports a single Logical Unit Number (LUN). All commands must be addressed to LUN 0, except an INQUIRY command which may be directed to any LUN.
- All reserved fields in each command must be set to 0.
- All reserved and vendor-unique fields in each command are tested for proper values (normally 0).

Control Byte

The control byte is the last byte of every Command Descriptor Block (CDB).

Control Byte Format

	Bit							
Byte	7	6	5	4	3	2	1	0
Last	Vend Unq = 0		Reserved				Flag	Link

Link. Command linking is supported. A Link bit set to one (1) indicates that the Initiator desires an automatic link to the next command upon successful completion of the current command. After successful completion of the current command, the Target will return a status of INTERMEDIATE and will then send one of the messages defined by the FLAG bit.

Flag. Typically, the FLAG bit is used to cause an interrupt in the Initiator between linked commands.

When LINK = 0 (zero), then FLAG will = 0 (zero).

When LINK = 1 (one), and FLAG = 0 (zero), the Target will return a LINKED COMMAND COMPLETE message when the command completes successfully,

When LINK = 1 (one), and FLAG = 1 (one), the Target will return a LINKED COMMAND COMPLETE (WITH FLAG) message when the command completes successfully,

Note



For the Mode Select command only, bit 7 of the control byte is used to enable (1) or disable (0) the Write Protect mode. The WP bit in the Mode Sense parameter list header reports the Write Protect status:

- 1 = enabled
 - 0 = disabled.
-

Table A-1. Supported SCSI-2 Commands

Command	Opcode (hex)	Use Before Spinup	Use When WP ¹ Enabled	Description
Change Definition	40	No	No	Requests the Target to change to the specified operating definition. Supported definitions are SCSI (CCS) and SCSI-2.
Format Unit	04	No	No	Formats Target media into Initiator addressable logic blocks. Defect sources include P, D, and G lists (no C list). When formatting, it is recommended that the Initiator not include a D list (FMTDAT=0). However, if the Initiator does include a D list, it must be in the physical sector or bytes from index format. The Target uses an interleave of 1 regardless of the value in Interleave field.
Inquiry	12	Yes	Yes	Requests that information regarding Target be sent to the Initiator. Target returns 36 bytes of SCSI Standard Product Data. Additional Vital Product Data (VPD) may be supplied if requested by the Initiator.
Mode Select (6-byte) (10-byte)	15 55	No ²	Yes	Provides a means for Initiator to specify media, logical unit, or drive parameters to Target. The following values are supported: <ul style="list-style-type: none"> ■ Media Type: 0 ■ Density Code: 0 ■ Number of Blocks: 0 ■ Block Length: 512, 1024, 2048, or 4096 bytes ■ Page Codes (hex): 01, 02, 03, 04, 08, 09, 0A Use of the following is supported: <ul style="list-style-type: none"> ■ Disable Correction (DCR) ■ Data Termination on Error (DTE) ■ Post Error (PER) ■ Transfer Block (TB) ■ Retry Count ■ Recovery Limit (converts to Retry Count)
Mode Sense (6-byte) (10-byte)	1A 5A	No ²	Yes	Provides a means for Target to report its media, logical unit, or drive parameters to Initiator. The following CDB values are supported: <ul style="list-style-type: none"> ■ Page Control Field: 00 (current values); 01 (changeable values); 10 (default values); 11 (saved values) ■ Page Codes (hex): 01, 02, 03, 04, 08, 09, 0A The Target default block size is 512 bytes. Default page parameters are listed in the MODE SENSE command description.
Read (6-byte) (10-byte)	08 28	No	Yes	Requests Target to transfer data to Initiator. Both 6-byte and 10-byte (extended) command formats are supported.
Read Buffer	3C	No	Yes	Used with WRITE BUFFER command to test the Target's data buffer. Recommend executing RESERVE command to guarantee data integrity.
Notes: 1. WP = Write Protect 2. Mode Select and Mode Sense commands that do not involve saved pages may be used before spinup.				

Table A-1. Supported SCSI-2 Commands (continued)

Command	Opcode (hex)	Use Before Spinup	Use When WP ¹ Enabled	Description
Read Capacity	25	No	Yes	Enables Initiator to request information regarding capacity of logical unit. Use of PMI bit supported. Relative Addressing not supported (REL=0).
Read Defect Data	37	No	Yes	Requests Target to transfer media defect data to Initiator. Target returns P, G, or P+G lists in physical sector or bytes from index format.
Read Long	3E	No	Yes	Requests Target to return the header, data field and ECC bytes of one physical sector.
Reassign Blocks	07	No	No	Requests Target to reassign defective logical blocks to an area on logical unit reserved for this purpose. It is recommended that the defect list contain only one defect location per command.
Receive Diagnostic Results	1C	No	Yes	Requests the target to send the results of a previous Send Diagnostic command to the initiator.
Release	17	Yes	Yes	Releases previously reserved logical units. Unit and Third-Party Release supported. Extent Release not supported.
Request Sense	03	Yes	Yes	Only the Extended Sense Data Format is supported. The Bit Pointer and Field Pointer fields are not used.
Reserve	16	Yes	Yes	Unit and Third-Party Reservations are supported. Extent Reservations are not supported.
Rezero Unit	01	No	Yes	Requests Target to perform a recalibrate and then to seek to logical address 0.
Seek (6-byte) (10-byte)	0B 2B	No	Yes	Requests Target to seek to a specified address. Both 6-byte and 10-byte (extended) formats are supported. Target returns GOOD status when seek is complete.
Send Diagnostic	1D	No	Yes	Self-test (Power-On) and Translate Address are supported. If self-test fails, CHECK CONDITION status indicates that results are available via REQUEST SENSE command.
Start/Stop Unit	1B	Yes	Yes	Both modes are supported.
Synchronize Cache	35	No	No	Ensures that specified logical blocks in the cache memory have their most recent data value recorded on the media.
Test Unit Ready	00	Yes	Yes	Checks Target spindle for proper speed. Target returns GOOD status if drive is up to speed.
Verify	2F	No	No	Requests Target to verify the data written on the media by performing a selectable ECC check or a byte compare. Relative addressing not supported. (REL=0).
<p>Notes:</p> <p>1. WP = Write Protect</p> <p>2. Mode Select and Mode Sense commands that do not involve saved pages may be used before spinup.</p>				

Table A-1. Supported SCSI-2 Commands (continued)

Command	Opcode (hex)	Use Before Spinup	Use When WP ¹ Enabled	Description
Write (6-byte) (10-byte)	0A 2A	No	No	Requests Target to write the data transferred by the Initiator to the media. Both 6-byte and 10-byte (extended) formats are supported.
Write And Verify	2E	No	No	The Target performs a write followed by an ECC verify pass or a byte compare. Relative addressing not supported. (REL=0).
Write Buffer	3B	No	No	May be used to test Target's data buffer or download code. To avoid possible data corruption, it is recommended that a RESERVE command be executed prior to the WRITE BUFFER command.
Write Long	3F	No	No	Allows Initiator to write one complete physical sector, including header, data, and ECC fields.
Write Same	41	No	No	Requests the Target to write the supplied block of data to the media a specified number of times.
Notes: 1. WP = Write Protect 2. Mode Select and Mode Sense commands that do not involve saved pages may be used before spinup.				

Change Definition

The CHANGE DEFINITION command requests the Target to change to the operating definition specified in the Definition Parameter field for all further interaction with subsequent Initiators.

Change Definition Command Description Block (CDB)

Byte	Bit							
	7	6	5	4	3	2	1	0
00	Opcode = 40H							
01	Logical Unit Number				Reserved			
02	Reserved							Save
03	Reserved	Definition Parameter						
04—07	Reserved							
08	Parameter List Length = 0							
09	Control Byte							

Save. This bit is ignored by the Target. The Target will save the new operating definition regardless of the state of the Save bit. No error will be declared based on the state of this bit.

Definition Parameter. This field indicates the new operating definition the Target is to use after the command is implemented. Any value other than those listed below will result in a status of *Check Condition* and a sense key of *Illegal Request*.

Field Value (hex)	Operating Definition
00	The current Operating Definition is not changed
01	SCSI X3.131-1986 ¹
02	SCSI (CCS) ¹
03	SCSI-2 X3.131-19xx

1. The implementation of SCSI X3.131-1986 and SCSI (CCS) is identical in these products.

Parameter List Length. Any value other than 0 (zero) will be rejected with a Status of CHECK CONDITION and a Sense Key of ILLEGAL REQUEST.

Format Unit

The FORMAT UNIT command formats the Target media into Initiator-addressable logical blocks according to Initiator defined options. During execution of the FORMAT UNIT command, the Target may perform a media defect management algorithm (which can be controlled by the Initiator using optional forms of the command). Defect management instructions (if any) are contained in the Defect List supplied to the Target in the Data Out phase of the command.

The FORMAT UNIT command ensures that the media is formatted so that all data blocks can be accessed. **Any data residing on the media before this command is issued will be lost.** Any log information will be cleared by the format operation. The current Mode Select operating parameters will become the saved values if the DSP bit in the defect list header is zero (0).

There are four possible sources of defect location information during execution of the FORMAT UNIT command:

Plist (Primary Defect List). The list of permanent defects supplied by the original manufacturer. The Plist is stored outside of the Initiator-accessible logical block space. The Plist is accessible by the Target (to reference while formatting), but is not normally accessible by the Initiator except through the READ DEFECT command. Once created, the original Plist is not subject to change. The Format Unit command does not affect the Plist.

Glist (Target Certification List). This list includes defects detected by the Target during an optional certification process executed during the FORMAT UNIT command. This list will be added to the Glist.

Dlist (Data Defect List). Supplied by the Initiator in the Data Out phase of the FORMAT UNIT command.

Glist (Grown Defect List.) Maintained by the Target and includes all defects sent to the Target from the Initiator (the Dlist), any defects identified by the Target during previous and current FORMAT UNIT operations, and any defects identified by a REASSIGN BLOCKS command. The Glist does NOT include the Plist.

Format Unit Command Descriptor Block (CDB)

Byte	Bit							
	7	6	5	4	3	2	1	0
00	Opcode = 04H							
01	Logical Unit Number			FMTDTA	CMLPST	Defect List Format		
02	Vendor Unique							
03—04	(MSB=03)			Interleave		(LSB=04)		
05	Control Byte							

FMTDTA (Format Data). Indicates whether the Initiator will send additional defect information (Dlist) to the Target. If set to zero (0),

there will be no Data Out phase,
 the Target will not receive a new Dlist,
 all previous defect information (Glist) is retained,
 and the CMLPST bit and the Defect List Format field will have no effect.

Format Unit

If set to one (1), a new Dlist will be supplied by the Initiator and the CMPLST bit and the Defect List Format field will provide additional parameters.

CMPLST (Complete List). Determines whether or not existing defects in the Glist will be retained during the format. If set to zero (0), the Glist is retained and the Dlist is appended to it. If set to 1, the defects in the Dlist are used to create a new Glist which replaces the old Glist.

Defect List Format. The supported field values are:

Field Value	Description
0 0 0	Block format (defect list length of zero)
0 0 1	Reserved
0 1 0	Reserved
0 1 1	Reserved
1 0 0	Bytes from index format
1 0 1	Physical sector format (recommended)
1 1 0	Reserved
1 1 1	Reserved

FORMAT UNIT Defect Sources

FMTDTA	CMPLST	Defect List Format Field	Defect List Supplied	Target Instructions
0 ¹	X	X X X	No	<ul style="list-style-type: none"> ■ No Data Out Phase. ■ No Dlist supplied by Initiator. ■ Retain current Glist².
1	0	1 0 1 or 1 0 0 or 0 0 0 ³	Yes	<ul style="list-style-type: none"> ■ New Dlist supplied by Initiator. ■ Retain current Glist². ■ Append new Dlist to current Glist.
1	1	1 0 1 or 1 0 0 or 0 0 0 ³	Yes	<ul style="list-style-type: none"> ■ New Dlist supplied by Initiator. ■ Build new Glist from supplied Dlist. ■ Replace old Glist with new Glist.

Notes:

1. The preferred option is FMTDTA = 0.
2. The Format Unit command always leaves the Plist unaltered.
3. Defect list length of zero only.

Vendor Unique Byte. This byte must contain all zeros.

Interleave. These bytes specify the order in which logical blocks are related to physical blocks. Any interleave value will be accepted, but the Target will always use its default interleave value of (1) so that logical blocks are placed in consecutive physical order.

Defect List

The defect list consists of a 4-byte header followed by zero or more 8-byte defect descriptors. Each descriptor consists of an 8-byte physical address or bytes from index address. Each address is bounds-checked by the Target. If any address is out of bounds, an **ILLEGAL REQUEST** Sense Key is generated, and the format operation is discontinued.

FORMAT UNIT Defect List Header Format

	Bit							
Byte	7	6	5	4	3	2	1	0
00	Reserved							
01	FOV	DPRY	DCRT	STPF	IP=0	DSP	IMED=0	VU=0
02-03	(MSB=02) Defect List Length				(LSB=03)			

FOV (Format Options Valid). If the FOV bit is set to one (1), the drive will accept a DPRY (Disable Primary), DCRT (Disable Certification), STPF (Stop Format) and/or DSP (Disable Saving Parameter) bit(s) set to one (1). All other options must be set to zero (0).

DPRY (Disable Primary). A DPRY bit of zero (0) indicates that Target will not use portions of the media identified as defective in the Plist for Initiator addressable logic blocks. If the Target cannot locate the Plist or it cannot determine if a Plist exists, it will perform the action specified by the STPF bit. A DPRY bit of one (1) indicates that the target will not use the Plist to identify defective areas of the media. The Plist is not deleted.

DCRT (Disable Certification). A DCRT bit of zero (0) indicates that the Target will perform a media certification operation to generate a Clist. A DCRT bit of one (1), indicates that the target will not perform any media certification process or format verification operation while executing the **FORMAT UNIT** command.

STPF (Stop Format). The STPF bit controls the behavior of the Target when one of the following events occurs:

1. The Target has requested the use of the Plist (DPRY is set to zero), or the Glist (CMPLST is set to zero) and the Target cannot locate the list or determine whether the list exists.
2. The target has been requested to use the Plist (DPRY is set to zero) or the Glist (CMPLST is set to zero), and the Target encounters an error while accessing the Dlist.

A STPF bit of zero (0) indicates that, if one or both of the above conditions occurs, the Target will continue to execute the **FORMAT UNIT** command. The Target will return **CHECK CONDITION** status at the completion of the **FORMAT UNIT** command. The Sense Key will be set to **RECOVERED ERROR** and the Additional Sense Code will be set to either **DEFECT LIST NOT FOUND** if condition 1 described above occurs, or **DEFECT LIST ERROR** if condition 2 occurs.

A STPF bit of one (1) indicates that, if one or both of the above conditions occurs, the Target will terminate the **FORMAT UNIT** command with a status of **CHECK CONDITION**, a Sense Key of **MEDIA ERROR**, and an Additional Sense Code of either **DEFECT LIST NOT FOUND** if condition 1 occurred, or **DEFECT LIST ERROR** if condition 2 occurred.

IP (Initialization Pattern). The IP bit must be set to zero (0), indicating that no Initialization Pattern will be sent. The Target will use its default initialization pattern when it formats the media.

Format Unit

DSP (Disable Saving Parameter). A DSP bit of one (1) specifies that the Target will not save the MODE SELECT parameters.

VU (Vendor Unique). This bit must be set to zero (0).

Defect List Length. This field specifies the total length in bytes of the defect descriptor that follows. A sector number of FFFFFFFFH indicates that the entire track will be reallocated.

Defect Descriptor Format

Byte	Bit							
	7	6	5	4	3	2	1	0
00—02	(MSB=00) Cylinder Number Of Defect				(LSB=02)			
03	Head Number Of Defect							
04—07	(MSB=04) Defect Bytes From Index Or Defective Sector Number				(LSB=07)			

Each defect descriptor specifies the location of a defect. Each descriptor is comprised of the cylinder number of the defect, the head number of the defect, and either the number of bytes from index to the defect, or the defective sector number. The Target will return CHECK CONDITION if the defect descriptors are not in ascending order. The most significant part of the address is the cylinder number. The least significant part of the address is either the number of bytes from index to the defect, or the defective sector number, depending on the format chosen. More than one block may be affected by each defect descriptor.

A defect bytes from index of defective sector number of FFFFFFFF(h) indicates that the entire track will be reallocated.

Inquiry

The INQUIRY command requests that information regarding parameters of the Target be sent to the Initiator.

The INQUIRY command will return a CHECK CONDITION status only when the Target cannot return the requested Inquiry data. Inquiry data will be returned even though the peripheral device may not be ready for other commands. The INQUIRY command will execute even if the drive is reserved to another Initiator.

If an INQUIRY command is received from an Initiator with a pending UNIT ATTENTION condition (before the Target reports CHECK CONDITION status), the Target will execute the INQUIRY command and will not clear the UNIT ATTENTION condition.

Note



An INQUIRY command directed to an invalid LUN ($\neq 0$) will return a Peripheral Device Type of 7FH (Logical Unit Not Present) in byte 0 of the parameter list. This condition is not considered an error. The INQUIRY command will be executed with no error reported even if the Target is reserved by/to a different Initiator.

Inquiry Command Descriptor Block (CDB)

Byte	Bit							
	7	6	5	4	3	2	1	0
00	Opcode = 12H							
01	LUN (Logical Unit Number)				Reserved			EVPD
02	VPD Page Code							
03	Reserved							
04	Allocation Length							
05	Control Byte							

EVPD (Enable Vital Product Data) and VPD Identifier. The status of the EVPD bit and the VPD Identifier field determine the information to be returned to the Initiator. The supported combinations are:

EVPD bit	VPD Page Code	Target Will Return:
0	00H	Standard Inquiry Parameter Page
1	00H	Supported VPD Page List
1	80H	Unit Serial Number VPD Page
1	E0H	Manufacturing Information VPD Page

If EVPD is set to 0 (zero), and the VPD Page Code is set to 1 (one), the Target will return:

Status: CHECK CONDITION
Sense Key: ILLEGAL REQUEST
Additional Sense Code: INVALID FIELD IN CDB.

Allocation Length. This field specifies the number of bytes that the Initiator has allocated for returned Inquiry data. An Allocation Length of zero indicates that no INQUIRY data will be transferred. This condition will not be considered as an error. Any other value indicates the

Inquiry

maximum number of bytes that will be transferred. The Target will terminate the DATA IN phase when the specified number of bytes have been transferred or when all available Inquiry data have been transferred to the Initiator, whichever is less.

Standard Inquiry Parameter Page Format

Byte	Bit							
	7	6	5	4	3	2	1	0
00	Peripheral Qualifier (bits 7 - 5) / Peripheral Device Type (bits 4 - 0) all zero's = requested LUN is supported 7FH = requested LUN is not supported							
01	RMB=0	Device Type Modifier = 0						
02	ISO VER = 0		ECMA VER = 0			ANSI VER = 2		
03	AENC	TRMIOP=0	Reserved		Response Data Format = 2			
04	Additional Parameter Length (n=1Fh)							
05-06	Reserved							
07	RELADR = 1	WBUS32 = 0	WBUS16 Note 1	SYNC = 1	LINKED = 1	Reserved = 0	CMDQUE = 1	SOFTR = 0
08-15	Vendor Identification Bytes (ASCII)							
08	= H (ASCII)							
09	= P (ASCII)							
10-15	= ASCII Spaces							
16-31	Product Identification Bytes (ASCII)							
16	= C (ASCII)							
17	= 2 (ASCII)							
18	= 2 (ASCII)							
19	= 4 (ASCII)							
20	= C2244: = 4 (ASCII) = C2245: = 5 (ASCII) = C2246: = 6 (ASCII) = C2247: = 7 (ASCII)							
21	Product ID (ASCII)							
22	Product ID (ASCII)							
23	Product ID (ASCII)							
24	Product ID (ASCII)							
25-31	= ASCII Spaces							
32-35	(MSB=32)		Product Revision Number (ASCII)			(LSB=35)		
Notes:								
1. For narrow drives, WBUS16 = 0; for wide drives, WBUS16 = 1								

Page Code 00H: Supported VPD Page List Format

Byte	Bit							
	7	6	5	4	3	2	1	0
00	Peripheral Qualifier (bits 7 - 5) / Peripheral Device Type (bits 4 - 0) all zero's = requested LUN is supported 7FH = requested LUN is not supported							
01	Page Code = 00H							
02	Reserved							
03	Page Length = 3							
04	Page Code 00H, Supported VPD Page List							
05	Page Code 80H, Unit Serial Number							
06	Page Code E0H, Manufacturing Information							

Page Code 80H: Unit Serial Number VPD Page Format

Byte	Bit							
	7	6	5	4	3	2	1	0
00	Peripheral Qualifier (bits 7 - 5) / Peripheral Device Type (bits 4 - 0) all zero's = requested LUN is supported 7FH = requested LUN is not supported							
01	VPD Identifier = 80H							
02	Reserved							
03	VPD ASCII Data Length = 0AH							
04—17	Product Serial Number (ASCII)							

Inquiry

Page Code E0H: Manufacturing Information VPD Page Format

Byte	Bit							
	7	6	5	4	3	2	1	0
00	Peripheral Qualifier (bits 7 - 5) / Peripheral Device Type (bits 4 - 0) all zero's = requested LUN is supported 7FH = requested LUN is not supported							
01—04	Reserved							
05	VPD Identifier = E0H							
06	Reserved							
07	VPD ASCII Data Length = 50H							
08—17	Manufacturing Product Code							
08	= C (ASCII)							
09	= 2 (ASCII)							
10	= 2 (ASCII)							
11	= 4 (ASCII)							
12	= C2244: = 4 (ASCII) = C2245: = 5 (ASCII) = C2246: = 6 (ASCII) = C2247: = 7 (ASCII)							
13	= ASCII Space							
14—16	Option Indicator (ASCII)							
17	ASCII Space							
18—27	HDA Serial Number							
28—37	SCSI Firmware Revision Number							
38—47	ESDI Firmware Revision Number							
	Option Pin-set Configurations (0 = open; 1 = shorted)							
48	Unit Attention							
49	SDTR							
50	Parity							
51	Auto Spin Up							
52—54	SCSI Address byte 52 = bit 2 byte 53 = bit 1 byte 54 = bit 0							
55	Write Protect							
56	SCSI-1/SCSI-2							
57	ASCII Space							
58	Note 1							
59—87	ASCII Spaces							
Notes:								
1. For wide differential drives, byte 58 = SCSI Address bit 3; for all other drives, byte 58 = ASCII space								

Mode Select, Mode Sense

The MODE SELECT command provides a means for the Initiator to specify media, logical unit, or peripheral device parameters to the Target.

The MODE SENSE command provides a means for a Target to report its media, logical unit, or peripheral device parameters to the Initiator. It is a complementary command to the MODE SELECT command.

Mode Select Command Description

If a MODE SELECT modifies operating parameters that are common to other Initiators, the Target will report CHECK CONDITION status and UNIT ATTENTION Sense Key with Additional Sense Code of MODIFIED PARAMETERS when next accessed by other Initiators but not by the Initiator issuing the MODE SELECT command. This rule does NOT override the normal first access rule for each Initiator, nor does it override the normal rules for INQUIRY and REQUEST SENSE.

Mode Select (6-Byte) Command Descriptor Block (CDB)

	Bit							
Byte	7	6	5	4	3	2	1	0
00	Opcode = 15H							
01	Logical Unit Number			PF	Reserved			SP
02—03	(MSB=02)			Reserved		(LSB=03)		
04	Parameter List Length							
05	Control Byte							

Mode Select (10-Byte) Command Descriptor Block (CDB)

	Bit							
Byte	7	6	5	4	3	2	1	0
00	Opcode = 55H							
01	Logical Unit Number			PF	Reserved			SP
02—06	(MSB=02)			Reserved		(LSB=06)		
07—08	(MSB=07)			Parameter List Length		(LSB=08)		
09	Control Byte							

Note



Bit 7 of the Mode Select control byte will enable (1) or disable (0) the Write Protect mode. The WP bit in the Mode Sense parameter list header reports the Write Protect status: 1 = enabled, 0 = disabled.

Mode Select, Mode Sense

PF (Page Format) A PF bit set to one (1) indicates that the data is sent in the SCSI-2 page format. When set to zero (0), the data is sent in the vendor unique format. For this product both formats are the same and the PF bit is ignored.

SP (Save Page) This bit indicates that the Target should save any savable pages sent with this command. If the SP bit is set to one (1), the current block size will also be saved.

Parameter List Length This field specifies the length in bytes of the MODE SELECT parameter list that will be transferred during the Data Out phase. A parameter list length of zero indicates that no data will be transferred. This condition is not considered as an error. If non-zero, the parameter length must contain a header and optionally a Block Descriptor (if Block Descriptor Length is 8) and optional Parameter Pages.

The currently supported Mode Select Pages are:

<u>Page Codes</u>	<u>Parameter Pages</u>
01H	Read Write Error Recovery Parameters
02H	Device Disconnect/Reconnect Parameters
03H	Direct Access Device Format Parameters
04H	Rigid Disk Drive Geometry Parameters
08H	Cache Control Parameters
09H	Peripheral Device Parameters
0AH	Control Mode Parameters

The minimum page length accepted is 2 bytes (page code plus length). The Page Length field must exactly match the values supplied in the Mode Sense data. Illegal parameter lengths will result in a Status of CHECK CONDITION, a Sense Key of ILLEGAL REQUEST, and an Additional Sense Key of INVALID FIELD IN CDB.

Mode Sense Command Description

Mode Sense (6-Byte) Command Descriptor Block (CDB)

Byte	Bit							
	7	6	5	4	3	2	1	0
00	Opcode = 1AH							
01	Logical Unit Number			Reserved	DBD	Reserved		
02	PC			Page Code				
03	Reserved							
04	Allocation Length							
05	Control Byte							

Mode Sense (10-Byte) Command Descriptor Block (CDB)

byte	Bit								
	7	6	5	4	3	2	1	0	
00	Opcode = 5AH								
01	Logical Unit Number			Reserved	DBD	Reserved			
02	PC			Page Code					
03—06	Reserved								
07—08	(MSB=07)			Allocation Length				(LSB=08)	
09	Control Byte								

Mode Select, Mode Sense

DBD (Disable Block Descriptors). This field indicates whether or not the target will return any block descriptors. A DBD bit of zero (0) indicates that zero or more block descriptors will be returned. A DBD bit of one (1) indicates that no block descriptors will be returned.

PC (Page Control). This field defines the Parameter Page type to be returned. The supported values for this field are:

00 = Report Current Values: Returns the parameters set in the last successful MODE SELECT command; or the saved values if a MODE SELECT command has not been executed since the last Power On, Hard Reset, or Bus Device Reset; or the default values if saved values are not available.

01 = Report Changeable Values: The changeable values are listed in the Parameter Values table that follows each of the page format tables.

10 = Report Default Values: The default values are listed in the Parameter Values table that follows each of the page format tables.

11 = Report Saved Values: Returns the saved values of the requested Parameter Pages. (Savable Pages are indicated in the following table and in the title block for each page format table.) The Save Block size is reported in the Block Length field of the Block Descriptor.

Page Code. This field specifies which page(s) are to be returned to the initiator. The target supports the following Mode Sense page codes:

<u>Page Code</u>	<u>Description</u>	<u>Savable</u>
00H	Return No Pages	n/a
01H	Error Recovery Parameters	Yes
02H	Device Disconnect/Reconnect Parameters	Yes
03H	Direct Access Device Format Parameters	Yes
04H	Rigid Disk Drive Geometry Parameters	No
08H	Cache Control Parameters	Yes
09H	Peripheral Device Parameters	Yes
0AH	Control Mode Parameters	Yes
3FH	Return All Pages	n/a

Allocation Length. This field specifies the number of bytes that the initiator has allocated for returned MODE SENSE data. An Allocation Length of zero indicates that no MODE SENSE data will be transferred. This condition is not considered an error. Any other value indicates the maximum number of bytes that will be transferred. The target will terminate the Data In phase when the specified number of bytes have been transferred or when all available MODE SENSE data have been transferred to the initiator, whichever is less.

Six-Byte Parameter Formats

The 6-byte parameter format contains a 4-byte header followed by an optional Block Descriptor, followed by the requested page.

6-Byte Parameter List Header Format

	Bit							
Byte	7	6	5	4	3	2	1	0
00	Sense Data Length							
01	Media Type = 0							
02	WP	Reserved		DPOFUA	Reserved			
03	Block Descriptor Length							

6-Byte Block Descriptor Format (Optional)

	Bit							
Byte	7	6	5	4	3	2	1	0
04	Density Code = 0							
05—07	(MSB=05)		Number Of Blocks = 0			(LSB=07)		
08	Reserved							
09—11	(MSB=09)		Block Length			(LSB=11)		

Parameter List Page Format

	Bit							
Byte	7	6	5	4	3	2	1	0
00	PS	Reserved	Page Code					
01	Page Length in Bytes							
02—nn	Page Parameters Refer to the Parameter Specification Tables that follow.							

Mode Select, Mode Sense

Ten-Byte Parameter Formats

The 10-byte parameter formats contains an 8-byte header followed by an optional Block Descriptor, followed by the requested page.

10-Byte Parameter List Header Format

	Bit							
Byte	7	6	5	4	3	2	1	0
00—01	(MSB=00) Sense Data Length				(LSB=01)			
02	Media Type = 0							
03	WP	Reserved		DPOFUA	Reserved			
04—05	Reserved							
06—07	(MSB=06) Block Descriptor Length				(LSB=07)			

10-Byte Block Descriptor Format (Optional)

	Bit							
Byte	7	6	5	4	3	2	1	0
08	Density Code = 0							
09—11	(MSB=09) Number Of Blocks = 0				(LSB=11)			
12	Reserved							
13—15	(MSB=13) Block Length				(LSB=15)			

Parameter List Page Format

	Bit							
Byte	7	6	5	4	3	2	1	0
00	PS	Reserved	Page Code					
01	Page Length in Bytes							
02—nn	Page Parameters Refer to the Parameter Specification Tables that follow.							

Mode Select, Mode Sense

Sense Data Length. This field specifies the length in bytes of the page data to be returned during the Data In phase. The Sense Data Length field does not include itself nor does it include the Block Descriptor length.

Media Type. Set to all zeros to indicate fixed disk.

WP (Write Protect). Indicates whether the drive is in the write protect mode: zero (0) = write protect disabled; one (1) = write protect enabled. The write protect mode is enabled or disabled with bit 7 in the Mode Select command control byte: zero (0) = write protect disabled; one (1) = write protect enabled.

DPOFUA. Indicates whether the target supports the cache control bits DPO (Disable Page Out) and FUA (Force Unit Access) in the extended READ command. The target always reports a one (1) indicating that only the FUA bit is supported.

Device Specific Parameters. Not used. Set to all zeros.

Block Descriptor Length. This field specifies the length in bytes of the Block Descriptor, and does not include the Parameter Pages. The block descriptor length will be either 0 or 8. The Block Descriptor specifies the media characteristics for the entire Logical Unit.

Density Code. Not used. Set to zeros.

Number of Blocks. Set to all zeros indicating that all blocks are set to same size.

Block Length. Indicates logical block size. Set to user configuration.

PS (Page Save). Indicates savable Mode Sense page when set to one (1). Ignored for Mode Select.

Page Length. Indicates number of bytes remaining in specified page after Page Length field.

Parameter Specifications for Supported Pages

The following tables list the parameter formats for all supported pages, their respective default values, and indicates whether the field values are changeable or non-changeable with the Mode Select command. If a field is changeable, the allowable range is given. In addition, the title block for each page indicates whether the page is savable.

Mode Select, Mode Sense

Page Code 01H, Read/Write Error Recovery Parameters (Savable Page)

Byte	Bit								
	7	6	5	4	3	2	1	0	
00	PS	Reserved	Page Code = 01H						
01	Page Length in Bytes: SCSI (CCS) = 06; SCSI-2 = 0A								
02	AWRE	ARRE	TB	RC	EER	PER	DTE	DCR	
03	SCSI (CCS): Retry Count; SCSI-2: Read Retry Count								
04	Correction Span								
05	Head Offset Count								
06	Data Strobe Offset Count								
07	SCSI (CCS): Recovery time Limit (last byte)								
SCSI-2 Bytes Follow									
07	Reserved								
08	Write Retry Count								
09	Reserved								
10—11	(MSB=10)		Recovery Time Limit				(LSB=11)		

Page 01H Parameter Values

Parameter	Default Values (hex)	Changeable Values	Allowable Ranges
AWRE (Automatic Write Reallocation)	0	Yes	0 = Disable; 1 = Enable
ARRE (Automatic Read Reallocation)	0	Yes	0 = Disable; 1 = Enable
TB (Transfer Block)	0	Yes	0 = Disable; 1 = Enable transfer of errored data
RC (Read Continuous)	0	No	n/a
EER (Enable Early Recovery)	0	No	n/a
PER (Post Error)	1	Yes	0 = Disable; 1 = Enable posting of recovered errors
DTE (Disable Transfer on Error)	0	Yes	1 = Disable; 0 = Enable transfer on recovered errors
DCR (Disable Correction)	0	Yes	1 = Disable; 0 = Enable error correction
Read Retry Count	08	Yes	Maximum allowable retries = 255 (FFH)
Correction Span (Bits per Sector)	48	Yes	0, 24 (18H), 72 (48H)
Head Offset Count	0	No	n/a
Data Strobe Offset Count	0	No	n/a
Write Retry Count (SCSI-2 only)	8	Yes	0 to 255
Recovery Time Limit: SCSI (CCS)	FF	No	SCSI (CCS): FF = maximum number of retrys allowed.
Recovery Time Limit: SCSI-2	0000	Yes	SCSI-2: 0000 = use defaults (i.e. Retry Counts).

Page Code 02H, Disconnect/Reconnect Parameters (Savable Page)

	Bit								
Byte	7	6	5	4	3	2	1	0	
00	PS	Reserved	Page Code = 02H						
01	Page Length in Bytes; SCSI (CCS): = 0AH; SCSI-2: = 0EH								
02	Buffer Full Ratio								
03	Buffer Empty Ratio								
04—05	(MSB=04)		Bus Inactivity Limit			(LSB=05)			
06—07	(MSB=06)		Disconnect Time Limit			(LSB=07)			
08—09	(MSB=08)		Connect Time Limit			(LSB=09)			
10—11	SCSI (CCS): Reserved (last bytes)								
SCSI-2 Bytes Follow									
10—11	(MSB=10)		Maximum Burst Size			(LSB=11)			
12	Reserved						DTDC		
13—15	Reserved								

Page 02H Parameter Values

Parameter	Default Values (hex)	Changeable Values	Allowable Range
Buffer Full Ratio	C0	Yes	00 to FF
Buffer Empty Ratio	C0	Yes	00 to FF
Bus Inactivity Limit	0004	Yes	0000 to FFFF
Disconnect Time Limit	0000	Yes	0000 to FFFF (ignored)
Connect Time Limit	0000	Yes	0000 = No limit
Maximum Burst Size (SCSI-2 only)	0000	Yes	0000 to FFFF
DTDC (SCSI-2 only; Data Transfer Disconnect Control)	00	Yes	<ul style="list-style-type: none"> ■ 00B = Disconnect as controlled by ratios ■ 01B = No disconnect during data transfer ■ 11B = No disconnect once data transfer started until command complete ■ 10B = Reserved

Mode Select, Mode Sense

Page Code 03H, Direct Access Device Format (Savable Page)

Byte	Bit								
	7	6	5	4	3	2	1	0	
00	PS	Reserved	Page Code = 03H						
01	Page Length In Bytes: 16H								
02—03	(MSB=02)		Tracks per Zone			(LSB=03)			
04—05	(MSB=04)		Alternate Sectors per Zone			(LSB=05)			
06—07	(MSB=06)		Alternate Tracks per Zone			(LSB=07)			
08—09	(MSB=08)		Alternate Tracks per Logical Unit			(LSB=09)			
10—11	(MSB=10)		Sectors per Track			(LSB=11)			
12—13	(MSB=12)		Data Bytes per Physical Sector			(LSB=13)			
14—15	(MSB=14)		Interleave			(LSB=15)			
16—17	(MSB=16)		Track Skew Factor			(LSB=17)			
18—19	(MSB=18)		Cylinder Skew Factor			(LSB=19)			
20	SSEC	HSEC	RMB	SURF	Reserved				
21—23	Reserved								

Page 03H Parameter Values

Parameter	Default Value (hex)	Changeable Value	Allowable Range
Tracks per Zone: C2244	0E8F	No	n/a
Tracks per Zone: C2245	12B9	No	n/a
Tracks per Zone: C2246	16E3	No	n/a
Tracks per Zone: C2247	1B0D	No	n/a
Alternate Sectors per Zone: all	0000	No	n/a
Alternate Tracks per Zone: C2244	00AF	No	n/a
Alternate Tracks per Zone: C2245	00E1	No	n/a
Alternate Tracks per Zone: C2246	0113	No	n/a
Alternate Tracks per Zone: C2247	0145	No	n/a
Alternate Tracks per Logical Unit: C2244	01E3	No	n/a
Alternate Tracks per Logical Unit: C2245	026D	No	n/a
Alternate Tracks per Logical Unit: C2246	02F7	No	n/a
Alternate Tracks per Logical Unit: C2247	0381	No	n/a
Sectors per Track: all	0060	No	n/a
Data Bytes per Physical Sector: all	0200	Yes	Per customer requirement. From 180 (B4H) bytes to 744 (2E8H) bytes in increments of 2 bytes.
Interleave: all	0001	No	n/a
Track Skew Factor: all	000E	No	n/a
Cylinder Skew Factor: all	0020	No	n/a
SSEC (Soft Sector)	0	No	n/a
HSEC (Hard Sector)	1	No	n/a
RMB (Removable Media)	0	No	n/a
SURF (Surface Mode Addressing)	0	No	n/a

Mode Select, Mode Sense

Page Code 04H, Rigid disk Drive Geometry Parameters (Non-Savable Page)

Byte	Bit								
	7	6	5	4	3	2	1	0	
00	PS	Reserved	Page Code = 04H						
01	Page Length In Bytes: SCSI (CCS) = 12H; SCSI-2 = 16H								
02—04	(MSB=02)		Number Of Cylinders			(LSB=04)			
05	(MSB=02)		Number Of Heads			(LSB=042)			
06—08	(MSB=06)		Starting Cylinder, Write Precomp			(LSB=08)			
09—11	(MSB=09)		Starting Cylinder, Reduced Write Current			(LSB=11)			
12—13	(MSB=12)		Drive Step Rate			(LSB=13)			
14-16	(MSB=14)		Landing Zone Cylinder			(LSB=16)			
17-19	SCSI (CCS): Reserved (last bytes)								
SCSI-2 Bytes Follow									
17	Reserved						RPL		
18	Rotational Offset								
19	Reserved								
20—21	(MSB=20)		Media Rotation Rate			(LSB=21)			
22—23	Reserved								

Page 04H Parameter Values

Parameter	Default Values (hex)	Changeable Values	Allowable Range
Number Of Cylinders	0803	No	n/a
Number Of Heads: C2244	07	No	n/a
Number Of Heads: C2245	09	No	n/a
Number Of Heads: C2246	0B	No	n/a
Number Of Heads: C2247	0D	No	n/a
Starting Cylinder: Write Precomp (Not Used)	000000	No	n/a
Starting Cylinder: Reduced Write Current (Not Used)	000000	No	n/a
Drive Step Rate	0000	No	n/a
Landing Zone Cylinder	000000	No	n/a
RPL (SCSI-2 only; Rotational Position Locking)	00	Yes	<ul style="list-style-type: none"> ■ 00 = No locking ■ 01 = Slave ■ 10 = Master
Rotational Offset (from input sync signal; SCSI-2 only)	00	Yes	0 - 255 (Note: each unit represents 1/256th revolution of the disk.)
Media Rotation Rate (SCSI-2 only)	1518	No	n/a

Page Code 08H, Cache Control Parameters (Savable Page)

	Bit							
Byte	7	6	5	4	3	2	1	0
00	PS	Reserved	Page Code = 08H					
01	Page Length In Bytes = 12H							
02	IC	APBF	CAP	DISC	SIZE	WCE	MF	RCD
03	Demand Read Retention Priority				Write Retention Priority			
04—05	(MSB=04) Disable Pre-Fetch Transfer Length				(LSB=05)			
06—07	(MSB=06) Minimum Pre-Fetch				(LSB=07)			
08—09	(MSB=08) Maximum Pre-Fetch				(LSB=09)			
10—11	(MSB=10) Maximum Pre-Fetch Ceiling				(LSB=11)			
12	FSW	Reserved	DRA	Reserved				
13	Number of Cache Segments							
14—15	(MSB=14) Cache Segment Size				(LSB=15)			
16	Reserved							
17—19	(MSB=17) Non-Cache Segment Size				(LSB=19)			

Mode Select, Mode Sense

Page 08H Parameter Values

Parameter	Default Values (HEX)	Changeable Values	Allowable Range
IC (Initiator Control)	0	Yes	ignored 1 = Use number of cache segments to control caching algorithm 0 = Use adaptive algorithm
ABPF (Abort Pre-Fetch)	0	No	n/a
CAP (Caching Analysis Permitted)	1	Yes	ignored 1 = Enable Caching Analysis 0 = Disable Caching Analysis
DISC (Discontinuity)	1	No	n/a
SIZE (Size Enable)	0	No	n/a
WCE (Write Cache Enable)	0	Yes	0 = Disable; 1 = Enable
MF (Multiplier Factor)	0	No	n/a
RCD (Read Cache Disable)	0	Yes	1 = Disable; 0 = Enable Track Caching
Demand Read Retention Priority	0	No	n/a
Write Retention Priority	0	No	n/a
Disable Pre-Fetch Transfer Length	FFFF	Yes	0000 - FFFF (ignored)
Minimum Pre-Fetch	0000	Yes	0000 - FFFF logical blocks
Maximum Pre-Fetch	0080	Yes	0000 - FFFF logical blocks
Maximum Pre-Fetch Ceiling	0080	Yes	0000 - FFFF (ignored)
FSW (Force Sequential Write)	0	No	n/a
DRA (Disable Read-Ahead)	0	Yes	0 = Enable; 1 = Disable
Number of Cache Segments	2	Yes	1, 2, 4, 8, or 16
Cache Segment Size	FFFF	Yes	Depends upon Number of Cache Segments field and size of RAM buffer in bytes
Non-Cache Segment Size	000000	No	n/a

Page Code 09H, Peripheral Device Parameters (Savable Page)

Byte	Bit								
	7	6	5	4	3	2	1	0	
00	PS	Reserved	Page Code = 09H						
01	Page Length In Bytes = 0AH								
02—03	(MSB=02)		Interface Identifier			(LSB=03)			
04—07	Reserved								
08—10	(MSB=08)		Interface Specific Parameters			(LSB=10)			
11	Reserved								

Page 09H Parameter Values

Parameter	Default Values (HEX)	Changeable Values	Allowable Range
Interface Identifier	8000	No	8000 = SCSI
Interface Specific Parameters	000000	Yes	<ul style="list-style-type: none"> ■ If Interface Identifier = 8000 (SCSI): □ Byte 8, bit 4: <ul style="list-style-type: none"> 0 = SCSI-2 mode 1 = SCSI (CCS) mode □ Byte 8, bit 5: <ul style="list-style-type: none"> 0 = copy drive error and fault log from RAM to media on error only 1 = do not copy log; log contents will be lost on power cycle or bus reset □ Byte 8, bit 6: Auto-head alignment control <ul style="list-style-type: none"> 0 = enable automatic head alignments 1 = disable automatic head alignments and execute them on Rezero Unit commands, check bit 7 □ Byte 8, bit 7: Rezero Unit command head alignment control <ul style="list-style-type: none"> 0 = align current head 1 = always align all heads regardless of bit 6 state □ All other bit positions are reserved and should be set to zero (0)

Mode Select, Mode Sense

Page Code 0AH, Control Mode Parameters (Savable Page)

Byte	Bit							
	7	6	5	4	3	2	1	0
00	PS	Reserved	Page Code = 0AH					
01	Page Length In Bytes = 06H							
02	Reserved							RLEC
03	Queue Algorithm Modifier				Reserved		QErr	DQue
04	EECA	Reserved			RAENP	UAAENP	EAENP	
05	Reserved							
06—07	Ready AEN Holdoff Period							

Page 0AH Parameter Values (Savable)

Parameter	Default Values (HEX)	Changeable Values	Allowable Range
RLEC (Report Log Exceptions)	0	Yes	0 = Disable; 1 = Enable reporting of Log Exception Conditions
Queue Algorithm Modifier	1	Yes	0 = Restricted reordering; 1 = Unrestricted reordering
QErr (Queue Error Management)	0	Yes	0 = Continue; 1 = Abort
DQue (Disable Queuing)	0	No	n/a
EECA (Enable Extended Contingent Allegiance)	0	No	n/a
RAENP (Ready AEN Permission) ¹	0	No	n/a
UAAENP (Unit Attention AEN Permission) ¹	0	No	n/a
EAENP (Error AEN Permission) ¹	0	No	n/a
Ready AEN Holdoff Period ¹	0000	No	n/a
Notes:			
1. AEN = Asynchronous Event Notification			

Read

The READ command requests that the Target transfer data to the Initiator. The Target accepts both the non-extended (6-byte) and extended (10-byte) CDB formats.

Read (6-Byte) Command Descriptor Block (CDB)

Byte	Bit							
	7	6	5	4	3	2	1	0
00	Opcode = 08H							
01	Logical Unit Number			Logical Block Address (MSB)				
02—03	(MSB=02)			Logical Block Address		(LSB=03)		
04	Transfer Length							
05	Control Byte							

Read (10-Byte) Command Descriptor Block (CDB)

Byte	Bit							
	7	6	5	4	3	2	1	0
00	Opcode = 28H							
01	Logical Unit Number			DPO=0	FUA	Reserved		RelAdr
02—05	(MSB=02)			Logical Block Address		(LSB=05)		
06	Reserved							
07—08	(MSB=07)			Transfer Length		(LSB=08)		
09	Control Byte							

Logical Block Address. This field specifies the logical block at which the read operation will begin.

DPO (Disable Page Out). Not supported. Must be set to 0 (zero).

FUA (Forced Unit Access). A 0 (zero) instructs the target to satisfy data demand from cache; a 1 (one) instructs the target to satisfy data demand from the media.

RelAdr (Relative Address). A one (1) indicates that the logical block address field is a two's complement displacement. This negative or positive displacement is to be added to the logical block address last accessed on the logical unit to form the logical block address for this command. This feature is only available when linking commands. The feature requires that a previous command in the linked group has accessed a block of data on the logical unit.

A RelAdr bit of zero (0) indicates that the logical block address field specifies the first logical block of the range of logical blocks to be operated on by this command.

Transfer Length. This field specifies the number of contiguous logical blocks of data to be transferred. When using the non extended (6-byte) CDB format, a Transfer Length of zero indicates that 256 logical blocks will be transferred. When using the extended (10-byte) CDB format, a Transfer Length of zero indicates that no logical blocks will be transferred. This condition is not considered an error (no SEEK occurs, and no data is transferred).

The most recent data value written in the addressed logical block(s) will be returned.

Read Buffer

The READ BUFFER command is used in conjunction with the WRITE BUFFER command as a diagnostic tool for testing Target memory and the SCSI bus integrity. This command does not alter the media or the buffer. The data returned by the READ BUFFER command contains a 4-byte header, followed by the buffer data.

Read Buffer Command Descriptor Block (CDB)

Byte	Bit							
	7	6	5	4	3	2	1	0
00	Opcode = 3CH							
01	Logical Unit Number			Reserved			Mode	
02	Buffer ID = 0							
03—05	(MSB=03)			Buffer Offset = 0		(LSB=05)		
06—08	(MSB=06)			Allocation Length		(LSB=08)		
09	Control Byte							

Mode. Modes 0 (000b) and 3 (011b) are supported. Mode 0 returns a 4-byte header followed by the data bytes, and Mode 3 returns only the 4-byte header.

Buffer ID. This field is not supported and should be set to zero (0).

Buffer Offset. This field is not supported and should be set to zero (0).

Allocation Length. This field specifies the number of bytes that the initiator has allocated for returned data. An allocation length of zero specifies that no data be transferred and is not considered an error. The target will terminate the Data Phase when the specified number of bytes or when all available buffer data has been transferred, whichever is less.

Read Buffer Header Format

Byte	Bit							
	7	6	5	4	3	2	1	0
00	Reserved							
01—03	(MSB=01)			Available Length		(LSB=03)		

Available Length. This field may contain up to 262,144 bytes (1's-based 256K). An Available Length of zero indicates that no data transfer will take place. If the Allocation Length of the CDB is too small to allow all of the Available Length, the Available Length field is NOT adjusted to reflect the truncation.

The data in the buffer may have been altered since the last WRITE BUFFER command. It is recommended that the Target be placed in reserve or that the WRITE BUFFER command and subsequent READ BUFFER command be linked to ensure that the initiator can reliably test the Target's data buffer.

If any command has been executed by the controller between the execution of the WRITE BUFFER command and the READ BUFFER command, a status of CHECK CONDITION will be returned. In this case, the sense information will have a Sense Key of MISCOMPARE set. The amount of requested buffer data will be returned regardless of the MISCOMPARE error status, but the contents should be suspect.

Read Capacity

The READ CAPACITY command provides a means for the Initiator to request information regarding the capacity of the logical unit.

Read Capacity Command Descriptor Block (CDB)

Byte	Bit							
	7	6	5	4	3	2	1	0
00	Opcode = 25H							
01	Logical Unit Number				Reserved			RelAdr=0
02—05	(MSB=02)		Logical Block Address				(LSB=05)	
06—07	Reserved							
08	Reserved							PMI
09	Control Byte							

PMI (Partial Media Indicator). A PMI bit of zero (0) indicates that the information returned in the READ CAPACITY Data phase will be the logical block address and block length (in bytes) of the last logical block of the logical unit. The Logical Block Address field in the CDB must be set to zero for this option. If the PMI bit is zero (0) and the logical block address is not zero, the Target will return a Status of CHECK CONDITION, a Sense Key of ILLEGAL REQUEST, and an Additional Sense Code of ILLEGAL FIELD IN CDB.

A PMI bit of one (1) indicates that the information returned in the Data phase will be the logical block address and block length (in bytes) of the last logical block address after which a substantial delay in data transfer will be encountered. This logical block address shall be greater than or equal to the logical block address specified in the CDB. (Implementor's Note: This function is intended to assist storage management software in determining whether there is sufficient space on the current track, cylinder, etc. to contain a frequently accessed data structure such as a file directory or file index without incurring an access delay. The address returned will normally be the last block on the addressed track.)

Read Capacity Data Format

The format of the information returned by the Target during the Data In phase of the command is as follows:

Byte	Bit							
	7	6	5	4	3	2	1	0
00—03	(MSB=00)		Logical Block Address				(LSB=03)	
04—07	(MSB=04)		Block Length				(LSB=07)	

Read Defect Data

The READ DEFECT DATA command requests that the Target transfer the media defect data to the Initiator.

Read Defect Data Command Descriptor Block (CDB)

Byte	Bit							
	7	6	5	4	3	2	1	0
00	Opcode = 37H							
01	Logical Unit Number			Reserved				
02	Reserved			PLIST	GLIST	Defect List Format		
03—06	Reserved							
07—08	(MSB=07)			Allocation Length		(LSB=08)		
09	Control Byte							

PLIST (Primary Defect List), GLIST (Grown Defect List). A PLIST bit of one (1) indicates the Initiator requests a primary list of defects be returned. A GLIST bit of one (1) indicates that the Initiator requests the grown list of defects. If both bits are one (1), the combination of both lists is requested. If both bits are zero (0), only the header will be returned.

Defect List Format. This field indicates the preferred format for the returned defect list. The bit states are as defined by the FORMAT UNIT command. The Target will return the list in the physical sector format (5) or bytes from index (4) format. If any other format is requested, the list will be returned in the bytes from index format and the target will return:

Status: CHECK CONDITION
Sense Key RECOVERED ERROR
Additional Sense Code DEFECT LIST NOT FOUND

Allocation Length. This field specifies the number of bytes that the Initiator has allocated for returned data. An Allocation Length of zero indicates that no data should be transferred and should not be considered an error. Any other value indicates the maximum number of bytes that shall be transferred. The Target shall terminate the data phase when either the allocation length or all available READ DEFECT DATA has been sent, whichever is less.

Read Defect Data Defect List Header Format

	Bit							
Byte	7	6	5	4	3	2	1	0
00	Reserved							
01	Reserved			PLIST	GLIST	Defect List Format		
02—03	(MSB=02)			Defect List Length		(LSB=03)		

Defect List Descriptor Format

	Bit							
Byte	7	6	5	4	3	2	1	0
00—02	(MSB=00)			Cylinder Number Of Defect		(LSB=02)		
03	Head Number of Defect							
04—07	(MSB=04)			Sector Number Of Defect (Physical Sector Format)			(LSB=07)	
	Byte Index of Defect (Bytes from Index Format)							

The data returned by the READ DEFECT DATA command contains a four-byte Header, followed by zero or more Defect Descriptors

Defect List Length. This Header field specifies the total length of the following Defect Descriptors in bytes. If the Allocation Length field of the CDB is less than the length of the available defect list data, the Defect List Length is NOT adjusted to reflect the truncation. The defect descriptors are in ascending address order. Ascending address order for physical sector format is defined as cylinder most-significant and sector least-significant. A sector number of all ones (FFFFFFFFH) indicates that the entire track has been spared.

The defect data is supplied in such a manner that the list can be issued in a FORMAT command to restore the current media reassignment mapping without re-ordering. If the list cannot be read from the media, the Target will return:

Status: CHECK CONDITION
 Sense Key: MEDIUM ERROR
 Additional Sense Code: DEFECT LIST ERROR

Read Long

The READ LONG command requests the Target to transfer a specific block of data to the Initiator. The data transferred will include all header, data, and ECC (Error Correction Code) bytes.

Read Long Command Descriptor Block (CDB)

Byte	Bit							
	7	6	5	4	3	2	1	0
00	Opcode = 3EH							
01	Logical Unit Number			Reserved			CORRCT	RelAdr=0
02—05	(MSB=02)		Logical Block Address				(LSB=05)	
06	Reserved							
07—08	(MSB=07)		Byte Transfer Length				(LSB=08)	
09	Control Byte							

CORRCT (Corrected). A CORRCT bit of one (1) instructs the Target to correct the data by ECC before transferring it to the Initiator. A CORRCT bit of zero (0) causes the logical block to be read and transferred without any error detection or correction.

Logical Block Address. This field specifies the starting address for the Read Long operation. The operation will continue for the length specified by the Byte Transfer Length field.

Byte Transfer Length. This field should specify exactly the number of bytes available for transfer. A value of zero in this field indicates that no data bytes will be transferred. This condition is not considered an error.

If the number of bytes specified matches exactly the available data length, the most recent data written in the specified logical block will be transferred. If a requested transfer length value does not match exactly the available data length, the Target will truncate to the total transfer length available.

Reassign Blocks

The REASSIGN BLOCKS command requests the Target to reassign the defective logical blocks to an area on the logical unit reserved for this purpose and to record the defective logical blocks to the Grown Defect list (Glist). More than one physical or logical block may be relocated by each defect descriptor sent by the Initiator. This command does not alter the contents or location of the Primary Defect List (Plist).

Reassign Blocks Command Descriptor Block CDB)

Byte	Bit							
	7	6	5	4	3	2	1	0
00	Opcode = 07H							
01	Logical Unit Number				Reserved			
02—04	(MSB=02)			Reserved		(LSB=04)		
05	Control Byte							

The Initiator transfers a defect list that contains the logical block addresses to be reassigned. The Target reassigns the physical media used for each logical block address in the list. The data contained in the logical blocks specified in the defect list will be lost, but the data in all other logical blocks on the media shall be preserved.

A specific logical block address may be reassigned more than once; thus, over the life the media, a logical block can be assigned to multiple physical addresses (until no more spare locations remain on the media).

Note



The REASSIGN BLOCKS command is intended to be used to reassign a single block defect. The provision to handle multiple defects in a single command is made to allow recovery from a situation where multiple defects occur on a single track. Therefore, the maximum length defect list that will be accepted by the Target is 96. Duplicate entries in the defect list result in a single spare operation.

Reassign Blocks Defect List Header Format

Byte	Bit							
	7	6	5	4	3	2	1	0
00—01	Reserved							
02—03	(MSB=02)			Defect List Length		(LSB=03)		

The REASSIGN BLOCKS defect list contains a 4-byte header followed by one or more defect descriptors. The length of each defect descriptor is four bytes.

Defect List Length. This field specifies the total length in bytes of the defect descriptors that follow. The Defect List Length is equal to four times the number of defect descriptors and does not include the Defect Header length.

Reassign Blocks

Defect List Descriptor Format

	Bit								
Byte	7	6	5	4	3	2	1	0	
00—03	(MSB=00)				Defect Logical Block Address				(LSB=03)

The Defect Descriptor specifies a 4-byte Defect Logical Block Address that contains the defect. The defect descriptors shall be in ascending order.

If the logical unit has insufficient capacity to reassign all of the logical blocks specified in the defect descriptors, the command shall terminate with a CHECK CONDITION status and the Sense Key will be set to MEDIUM ERROR. The additional Sense Code will be NO DEFECT SPARE LOCATION AVAILABLE (32H). The logical block address of the first logical block not reassigned shall be returned in the Information Bytes of the sense data.

During a reassign operation, all data residing on the track with the specified defective block(s), except that contained within the defective block(s), is moved to a new physical track. If the Target is unable to recover data from any of these block(s) affected by the operation but *not* contained in the defect descriptor list, the command is terminated with CHECK CONDITION status and a Sense Key of MEDIUM ERROR. The additional Sense Code will be set to UNRECOVERED READ ERROR (11H), and the information bytes will contain the logical block address of the new defect. These additional defect(s) should be added to the reassignment defect list and the command reissued.

All blocks affected by the reassignment operation but *not* included in the defect descriptor list, are verified following the reassignment. If the verification fails, the data will be reassigned to another physical location. If this second reassignment operation fails, the command is terminated with CHECK CONDITION status, a Sense Key of MEDIUM ERROR, and an additional sense code of SPARE OPERATION FAILED. In this case, the media configuration remains as it was prior to the command. The spare track on which the original verify failed is marked as bad. This allows a reissue of the same Reassign Blocks command to step through spare tracks if consecutive spare tracks are defective. Multiple failures of this command probably indicate a hardware failure.

Receive Diagnostic Results

Requests the target to send the results of a previous Send Diagnostic command to the initiator.

Receive Diagnostic Results Command Descriptor Block (CDB)

Byte	Bit							
	7	6	5	4	3	2	1	0
00	Opcode = 1CH							
01	Logical Unit Number			Reserved				
02	Reserved							
03—04	(MSB=03)			Allocation Length		(LSB=04)		
05	Control Byte							

Allocation Length. Specifies the maximum number of bytes the Initiator has allocated for returned data. A value of 0 (zero) indicates that no data will be transferred (not considered an error). The Target will terminate the DATA IN phase when the specified number of bytes have been transferred or when all available diagnostic data bytes have been returned.

The target supports the following pages:

00H	Supported Diagnostic Pages
40H	Translate Address Page

Receive Diagnostic Results

Page 00H: Supported Diagnostic Page

Byte	Bit							
	7	6	5	4	3	2	1	0
00	Page Code = 00H							
01	Reserved							
02—03	(MSB=02)		Page Length: = 0002				(LSB=03)	
04	Supported Page List: 00H							
05	Translate Address Page: 40H							

Page 40H: Translate Address Page

Byte	Bit							
	7	6	5	4	3	2	1	0
00	Pagecode = 40H							
01	Reserved							
02—03	(MSB=02)		Page Length				(LSB=03)	
04	Reserved					Supplied Format		
05	RAREA	ALTSEC=0	ALTRK=0	Reserved		Translated Format		
06—13	(MSB=06)		Translated Address 1				(LSB=13)	
14—21	(MSB=14)		Translated Address 2 (if required)				(LSB=21)	
22—nn	(MSB=14)		Translated Address n (if required)				(LSB=nn)	

Supplied Format/ Translated Format. Contains the value from the SEND DIAGNOSTIC command Supplied Format field.

RAREA (Reserved Area). Supported when Translated Format field is set to Logical Block Addressing. The bit indications are:

- 1 All or part of the translated address is within a reserved area of the media. The returned Translated Address is FFFF with the remaining bytes filled with zeros.
- 0 No part of the translated address is within a reserved area of the media.

ALTSEC (Alternate Sector), and ALTRK (Alternate Track). Not Supported. Will be set to 0 (zero).

Translated Address. Contains the address(s) the Target translated from the address supplied in the SEND DIAGNOSTIC command. The data will be in the format specified in the SEND DIAGNOSTIC Translate Format field.

■ If the Logical Block Format is specified:

the block address will be in the first four bytes of the field,
and the remaining bytes will be set to 0 (zero).

■ If the Physical or Logical Sector Formats are specified, and the address to be translated covers more than one address after translation:

the target will return all possible addresses contained in the area specified in the SEND DIAGNOSTIC Address To Translate field.

Release

The RELEASE command is used to release previously reserved logical units. It is not an error for an Initiator to attempt to release a reservation that is not currently active. In this case, the Target returns GOOD status without altering any other reservation. A third-party release option for the RELEASE command allows an Initiator to release a logical unit that was previously reserved using the third-party reservation option.

Release Command Descriptor Block (CDB)

Byte	Bit							
	7	6	5	4	3	2	1	0
00	Opcode = 17H							
01	Logical Unit Number			3RDPTY	Third Party Device ID			XTNT=0
02	Reservation Identification = 00							
03—04	(MSB=03)			Reserved		(LSB=04)		
05	Control Byte							

3RDPTY (Third-Party). If the 3RDPTY bit is set to one (1), the Target shall release the specified logical unit, but only if the reservation was made using the third-party reservation option by the same Initiator for the same SCSI device as specified in the Third-Party Device ID field. If the 3RDPTY bit is set to zero (0), the third-party release option is not requested.

Request Sense

The REQUEST SENSE command requests that the Target transfer sense data to the Initiator. Only the extended sense data format is supported.

Request Sense Command Descriptor Block (CDB)

Byte	Bit							
	7	6	5	4	3	2	1	0
00	Opcode = 03H							
01	Logical Unit Number				Reserved			
02—03	Reserved							
04	Allocation Length							
05	Control Byte							

The returned Request Sense data is valid for a CHECK CONDITION status returned on the prior command. This data is preserved by the Target for the Initiator until retrieved by the REQUEST SENSE command or until the receipt of any other command for the same logical unit from the Initiator that issued the command resulting in the CHECK CONDITION status. Sense data is cleared upon receipt of any subsequent command to the logical unit from the Initiator receiving the CHECK CONDITION status. In the case of the single Initiator option, the Target will assume that the REQUEST SENSE command is from the same Initiator. Sense information will be cleared by the REQUEST SENSE command following the transfer of the data.

Allocation Length. This field specifies the number of bytes that the Initiator has allocated for returned sense data. In the SCSI (CCS) mode, an allocation length of zero (0) indicates that four bytes of sense data will be transferred. In the SCSI-2 mode, an allocation length of zero (0) indicates that no data will be returned. Any other value indicates the maximum number of bytes that will be transferred. The Target will terminate the Data In phase when the specified number of bytes have been transferred or when all available sense data has been transferred to the Initiator, whichever is less. The drive will return a maximum of 22 bytes (SCSI-CCS) or 28 bytes (SCSI-2) of sense data. Refer to the REQUEST SENSE Extended Data Format descriptions.

The REQUEST SENSE command will return the CHECK CONDITION status only to report fatal errors for the REQUEST SENSE command. The REQUEST SENSE command will be executed even if the drive is reserved to another Initiator.

If any nonfatal error occurs during the execution of the REQUEST SENSE command, the Target will return the sense data with GOOD status. When a fatal error occurs on a REQUEST SENSE command, the returned sense data may be invalid.

After the Sense Data is returned, all conditions are cleared except for a UNIT ATTENTION Sense Key if Power-On verification failed. In this case, the HARDWARE ERROR Sense Key is set by the Target for the first REQUEST SENSE, and UNIT ATTENTION is set for the subsequent command. This is done to insure that diagnostic failures and "Reset Conditions" are observed.

SCSI (CCS) Request Sense Extended Data Format

	Bit							
Byte	7	6	5	4	3	2	1	0
00	Valid	Error Class=7			Reserved			Error Code
01	Segment Number = 0							
02	FM=0	EOM=0	ILI=0	Reserved	Sense Key			
03—06	(MSB=03) Information Bytes			(LSB=06)				
07	Additional Sense Length = 0EH							
08—11	Command Specific Information							
12	Additional Sense Code							
13	Reserved							
14	Field Replaceable Unit Code = 0							
15	FPV=0	C/D=0	Vendor Unique=0	BPV=0	Bit Pointer=0			
16—17	(MSB=16) Field Pointer = 00			(LSB=17)				
Device Error Field Follows: (Bytes 18—21)								
18	Vendor Unique DERROR Status Code							
19	ESDI Status Byte							
20-21	SCSI Status Bytes							

SCSI-2 Request Sense Extended Data Format

	Bit							
Byte	7	6	5	4	3	2	1	0
00	Valid	Error Class = 7			Reserved			Error Code
01	Segment Number = 0							
02	FM = 0	EOM = 0	ILI = 0	Reserved	Sense Key			
03—06	(MSB=03) Information Bytes			(LSB=06)				
07	Additional Sense Length = 14H							
08—11	Command Specific Information							
12	Additional Sense Code							
13	Additional Sense Code Qualifier							
14	Field Replaceable Unit Code = 0							
15	SKSV=0	Sense Key Specific						
16—17	Sense Key Specific							
18	Retry=0	Reassign=0	HRDERR=0	Reserved				
19—23	Reserved							
Device Error Field Follows: (Bytes 24—27)								
24	Vendor Unique DERROR Status Code							
25	ESDI Status Byte							
26—27	SCSI Status Bytes							

Request Sense

SCSI-2 Error Code. A bit value of 0 (zero) specifies current error; a bit value of 1 (one) specifies deferred error.

Error Class. This field is always equal to 7.

Valid. When set to 1, the VALID bit indicates that the Information Bytes field contains valid information. The exact significance of the Information Bytes depends on the status of the Sense Key field.

Segment Number. Set to zero (0). Used for Copy and Search commands; not supported in this product.

FM (File Mark), EOM (End of Media), ILI (Incorrect Length Indicator). All set to zero (0).

Sense Key. This field is used to indicate the type of error that has occurred, and the recovery action that should be taken by the initiator. It is the primary piece of information available to the Initiator for making decisions based on errors detected by the Target. The Sense Key codes are:

Value (hex)	Description
0	No Sense. Indicates that there is no specific sense key information to be reported for the designated logical unit.
1	Recovered Error. Indicates that the last command completed successfully with some recovery action performed by the Target. Details may be determinable by examining the additional sense bytes and the information bytes.
2	Not Ready. Indicates that the logical unit addressed cannot be accessed.
3	Media Error. Indicates that the command terminated with a nonrecovered error condition that was probably caused by a flaw in the media or an error in the recorded data.
4	Hardware Error. Indicates that the Target detected a nonrecoverable hardware failure (for example, controller failure, device failure, parity error, etc.) while performing the command or during a self test.
5	Illegal Request. Indicates that there was an illegal parameter in the command descriptor block or in the additional parameters supplied as data for some commands.
6	Unit Attention. Indicates that the Target has been reset or there has been a power on.
7	Data Protect. Indicates that a command that reads or writes the media was attempted on a block that is protected from this operation. The read or write operation is not performed.
B	Aborted Command. Indicates that the Target aborted the command due to Initiator request/action.
E	Miscompare. Indicates data in buffer may have been corrupted between READ BUFFER and WRITE BUFFER commands, or a MISCOMPARE occurred during a VERIFY (with BYTCK enabled).

Additional Sense Code. This field is specific for each sense code and provides additional information about the cause of that particular Sense Key.

Additional Sense Codes

Value (hex)	Description
00	No Additional Sense Information
01	No Index/Sector signal
02	No Seek Complete
03	Write Fault
04	Drive Not Ready
05	Logical Unit Does Not Respond to Selection
08	Logical Unit Communication Failure
09	Servo lost while track following
10	ID CRC or ECC Error
11	Unrecovered Read Error of Data Blocks
14	No Record Found
15	Seek Positioning Error
17	Recovered Read Data with Target's Read Retries (Not with ECC)
18	Recovered Read Data with Target's ECC Correction (Not with retries)
19	Defect List Error
1A	Parameter Overrun
1B	Synchronous Transfer Error
1D	Compare Error
20	Invalid Command Operation Code
21	Illegal Logical Block Address. Address greater than the maximum LBA returned by the READ CAPACITY data with PMI not set.
24	Illegal Field in CDB
25	Invalid LUN
26	Invalid Field in Parameter List
27	Write Protected
29	Power On or Reset or Bus Device Reset Occurred
2A	Mode Select Parameters Changed
2C	Command Sequence Error
2F	Commands Cleared by Another Initiator
31	Media Format Corrupted
32	No Defect Spare Location Available
33	Spare Operation Failed
3D	Invalid Bits in Identify Message
3E	Invalid Microcode
3F	Target Operating Conditions Have Changed

(continued on next page)

Request Sense

Additional Sense Codes (continued)

Value (hex)	Description
40	RAM Failure
41	Data Path Diagnostic Failure
42	Power-On Diagnostic Failure
43	Message Reject Error
44	Internal Controller Error
45	Select/Reselect Failed
46	Unsuccessful Soft Reset
47	SCSI Interface Parity Error
48	Initiator Detected Error
49	Inappropriate/Illegal Message
4C	Microcode Programming Failed
4E	Overlapped Commands Attempted

Information Bytes. Contain information relative to specific commands and specific devices.

Additional Sense Length. Specifies the number of additional Sense data bytes to follow. Set to 14 for SCSI (CCS) or 20 for SCSI-2.

Command Specific Information. Contains information dependent upon the command that was executed. Specific details are included in appropriate command explanations.

Additional Sense Code Qualifier. Not supported, reported as zeros.

Failed Field Replaceable Unit (FRU). Refers to the Field Replaceable Unit (FRU) that caused the current error reported in this Sense Key. This field will be set to 0 since FRU specific error detection is not supported.

SKSV (Sense Key Specific Valid). Not supported, reported as zeros.

Device Error Field. Indicates device unique error codes designed to aid service personnel in more detailed analysis of any drive faults. This field consists of four bytes, with the byte positions determined by the interface version in use:

SCSI (CCS) Byte	SCSI-2 Byte	Description
18	24	Vendor Unique DERROR Status Codes: listed in Appendix C
19	25	ESDI Status Byte
20-21	26-27	SCSI Status Bytes

- The contents of the Vendor Unique DERROR Status Code bytes are listed in Appendix C.
- The contents of the ESDI and SCSI status bytes are listed in the tables that follow.

SCSI (CCS) = Byte 19
SCSI-2 = Byte 25
ESDI Status Byte Contents

Bit	Description
7	Spindle Motor Stopped
6	Command Data Parity Fault
5	Interface Fault
4	Invalid Command Fault
3	Seek Fault
2	Write Gate with Track Offset Fault
1	Vendor Unique DERROR Status Available; SCSI (CCS)=byte 18, SCSI-2=byte 24
0	Write Fault

SCSI (CCS) = Bytes 20, 21
SCSI-2 = Bytes 26, 27
SCSI Status Bytes Contents

Bit	Description
Byte 20: SCSI (CCS); Byte 26: SCSI-2	
7	BPF: Buffer parity fault
6	UOF: PHLEA FIFO underflow/overflow
5	SNR: Status not read
4	DNC: Data not complete
3	ATN: ESDI/device attention
2	SNC: Status not complete
1	CTO: Command Timeout
0	EOS: End of sector
Byte 21: SCSI (CCS); Byte 27: SCSI-2	
7	SIL: Error would have been silent
6	DE3: Data ECC3 error
5	DE1: Data ECC1 error
4	HE1: Header ECC1 error
3	DSF: Data sync fault
2	HSF: Header sync fault
1	HTC: Header track miscompare
0	HSC: Header sector miscompare

Reserve

The RESERVE command is used to reserve logical units for the use of the Initiator. With third-party reservation, the logical units may be reserved for another specified SCSI device. The RESERVE and RELEASE commands provide the basic mechanism for contention resolution in multiple-Initiator systems.

Reserve Command Descriptor Block (CDB)

Byte	Bit							
	7	6	5	4	3	2	1	0
00	Opcode = 16H							
01	Logical Unit Number			3RDPTY	Third Party Device ID			XTNT = 0
02	Reservation Identification = 00							
03—04	(MSB=03)		Extent List Length = 00			(LSB=04)		
05	Control Byte							

3RDPTY (Third-Party). A 3RDPTY bit set to one (1) indicates that the reservation is being made on behalf of another bus device (the third party). When 3RDPTY is set to zero (0), third-party reservation is not requested.

Third Party Device ID. This field indicates the identity of the third party. The reservation can only be released by the party that made the reservation.

When a third-party reservation is made, the mode parameters of the reserving Initiator will be copied to the mode parameters of the third party. This will cause Unit Attention to the third party with a Sense Key of UNIT ATTENTION (6) and an Additional Sense Code of MODE SELECT PARAMETERS CHANGED (2AH).

XTNT (Extent Reservation). With the XTNT bit set to zero (0), this command will request that the entire logical unit be reserved for the exclusive use of the Initiator until the reservation is superseded by another valid RESERVE command from the same Initiator that made the reservation or until released by a RELEASE command from the same Initiator, by a BUS DEVICE RESET message from any Initiator, or by a "hard" RESET condition. A logical unit reservation will not be granted if the logical unit is reserved by another Initiator. It will be permissible for an Initiator to reserve a logical unit that is currently reserved by that Initiator. With XTNT set to zero (0), The Reservation Identification and the Extent List Length fields will be ignored.

If the logical unit is reserved for another Initiator, the target will respond by returning a RESERVATION CONFLICT status.

Once a reservation is installed, the reserved logical unit is available only to the Initiator that issued the RESERVE command, or a specified optional third party. If any other Initiator attempts to perform a command on the reserved logical unit the command will be rejected with RESERVATION CONFLICT status. Exceptions are the RELEASE command, which will be ignored by the target, and the INQUIRY command, which will be executed.

Rezero Unit

The REZERO UNIT command causes the Target to perform a recalibrate operation and then seek to logical address zero. The status of the seek is reported as the status of this command. This command may be used to control head alignments. Refer to Chapter 3 for additional operational details.

Rezero Unit Command Descriptor Block (CDB)

Byte	Bit							
	7	6	5	4	3	2	1	0
00	Opcode = 01H							
01	Logical Unit Number				Reserved			
02—04	Reserved							
05	Control Byte							

Seek

The SEEK command requests the logical unit to seek to the specified logical block address. The target accepts both the 6-byte and 10-byte (extended) command formats. Status will be returned as GOOD when the seek is complete. This command will return a CHECK CONDITION status with a Sense Key of HARDWARE ERROR if unable to complete. The NOT READY Sense Key will be returned if the drive has not yet spun up.

Seek (6-Byte) Command Descriptor Block (CDB)

Byte	Bit							
	7	6	5	4	3	2	1	0
00	Opcode = OBH							
01	Logical Unit Number			Logical Block Address (MSB)				
02—03	Logical Block Address (LSB=03)							
04	Reserved							
05	Control Byte							

Seek (10-Byte) Command Descriptor Block (CDB)

Byte	Bit							
	7	6	5	4	3	2	1	0
00	Opcode = 2BH							
01	Logical Unit Number			Reserved				
02—05	(MSB=02)		Logical Block Address				(LSB=05)	
06—08	Reserved							
09	Control Byte							

Logical Block Address. This field specifies the logical block address for the seek.

Send Diagnostic

The SEND DIAGNOSTIC command requests the Target to execute the specified diagnostic test(s) upon itself. When successfully completed, the SEND DIAGNOSTIC command will be terminated with a GOOD status. The results of a SEND DIAGNOSTIC command are reported with the RECEIVE DIAGNOSTIC RESULTS command.

Send Diagnostic Command Descriptor Block (CDB)

Byte	Bit							
	7	6	5	4	3	2	1	0
00	Opcode = 1DH							
01	Logical Unit Number			PF	Reserved	S/TEST	DEVOFL	UNTOFL
02	Reserved							
03—04	(MSB=03) Parameter List Length			(LSB=04)				
05	Control Byte							

Activity Qualifiers. These bits tell the Target what diagnostics are allowed. If the selected diagnostic cannot be executed in its entirety, it will not be executed at all.

UNTOFL Unit Offline: Ignored by the Target.

DEVOFL Device Offline: Ignored by the Target.

S/TEST Self-Test: If set to one (1), the PF bit will be ignored, the Parameter List Length field must be 0, and the Target will execute the Default Self-Test. If set to zero (0), no self-test will be executed.

PF Page Format: Must be set to 1 (one) for the Target to recognize any following pages. Note: If S/TEST is set to 1 (one), the Target will ignore the PF bit.

Parameter List Length. Specifies the length in bytes of the parameter pages to be transferred to the Target. A value of zero indicates that no data will be transferred. The target supports the following pages:

00H Supported Diagnostic Pages (Length = 0004H)

40H Translate Address Page (Length = 000EH)

Refer to the following pages for parameter page formats. If the Initiator sends a parameter length that does not match the supported page lengths, the target will terminate the command with:

Status: Check Condition
 Sense Key: Illegal Request
 Additional Sense Code: Invalid Field in CDB

Send Diagnostic

Page 00H: Supported Diagnostic Pages

Byte	Bit							
	7	6	5	4	3	2	1	0
00	Page Code = 00H							
01	Reserved							
02—03	(MSB=02)		Page Length: 0000				(LSB=03)	

Page 40H: Translate Address Page

Byte	Bit							
	7	6	5	4	3	2	1	0
00	Pagecode = 40H							
01	Reserved							
02—03	(MSB=02)		Page Length 000A				(LSB=03)	
04	Reserved				Supplied Format			
05	Reserved				Translated Format			
Address to Translate: Logical Block Address Format								
06—09	Logical Block Address							
10—13	Filled With Zeros							
Address to Translate: Physical Sector Format								
06—08	(MSB=06)		Physical Cylinder Number				(LSB=08)	
09	Logical Head Number							
10—13	Physical Sector Number							
Address to Translate: Logical Sector Format								
06—08	(MSB=06)		Physical Cylinder Number				(LSB=08)	
09	Logical Head Number							
10—13	Logical Sector Number							

Supplied Format/Translated Format. The supported formats are:

00H Logical Block Address format
 05H Physical Sector format
 06H Logical Sector format

Address To Translate. These bytes contain the single address the Initiator is requesting the Target to translate. The contents will be determined by the Supplied Format/Translate Format fields.

Start/Stop Unit

The START/STOP UNIT command requests the Target to enable or disable the logical unit for further operations.

Start/Stop Unit Command Descriptor Block (CDB)

Byte	Bit							
	7	6	5	4	3	2	1	0
00	Opcode = 1BH							
01	Logical Unit Number			Reserved				IMMED
02—03	Reserved							
04	Reserved						Start	
05	Control Byte							

IMMED (Immediate). If the IMMED bit is set to one (1), status will be returned as soon as the operation is initiated. The Target will respond to all commands received prior to the completion of the spin-up sequence with a status of CHECK CONDITION. The response to a Request Sense command will be a Sense Key of NOT READY. If IMMED is set to zero (0), status will be returned after the operation is completed.

Start. A START bit of one (1) requests the logical unit be made ready for use. A START bit of zero (0) requests that the logical unit be made not ready for use by stopping the spindle motor until the next START UNIT command is sent.

Synchronize Cache

If a more recent logical block within the specified range exists in cache memory than on the physical medium, the SYNCHRONIZE CACHE command requests the target to write that logical block to the medium.

Synchronize Cache Command Descriptor Block (CDB)

Byte	Bit							
	7	6	5	4	3	2	1	0
00	Opcode = 35H							
01	Logical Unit Number			Reserved			Immed=0	RelAdr=0
02—05	(MSB=02)		Logical Block Address				(LSB=05)	
06	Reserved							
07—08	(MSB=07)		Number of Blocks			(LSB=08)		
09	Control Byte							

Immed (Immediate). The target will return status after the operation is completed.

Note: If Immed is not supported, the target will terminate the command with:

Status: CHECK CONDITION
Sense Key: ILLEGAL REQUEST
Additional Sense Code: INVALID FIELD IN CDB

Logical Block Address. Specifies the address of the first logical block in the range.

Number of Blocks. Specifies the total number of contiguous logical blocks within the range. If set to 0 (zero), all remaining logical blocks on the logical unit are within the range.

Test Unit Ready

The TEST UNIT READY command provides a means to check if the logical unit is ready. This is not a request for a self test. If the logical unit is up to speed and ready for media access, this command will return a GOOD status. This does not assure that media access will be successful. If the drive is not up to speed, this command will return a status of CHECK CONDITION. A REQUEST SENSE command will return a Sense Key of NOT READY and an Additional Sense Code of DRIVE NOT READY.

Test Unit Ready Command Descriptor Block (CDB)

Byte	Bit							
	7	6	5	4	3	2	1	0
00	Opcode = 00H							
01	Logical Unit Number				Reserved			
02—04	Reserved							
05	Control Byte							

Verify

The VERIFY command requests that the Target verify the data written on the media.

Verify Command Descriptor Block (CDB)

Byte	Bit							
	7	6	5	4	3	2	1	0
00	Opcode = 2FH							
01	Logical Unit Number			DPO=0	Reserved		BYTCK	RelAdr=0
02—05	(MSB=02)		Logical Block Address			(LSB=05)		
06	Reserved							
07—08	(MSB=07)		Verification Length			(LSB=08)		
09	Control Byte							

BYTCK (Byte Check). If the BYTCK bit is set to zero (0), a media verification is performed with no data comparison. If BYTCK is set to one (1), the drive will request data from the Initiator and do a byte-by-byte comparison of this data with the data read from the media. If the data does not compare with that on the media, a Status of CHECK CONDITION will be returned. The Sense Key will be set to MISCOMPARE with a Sense Code of COMPARE ERROR. If the data cannot be read from the media, a MEDIUM ERROR will be returned.

Logical Block Address. This field specifies the logical block at which the VERIFY operation will begin.

Verification Length. This field specifies the number of contiguous logical blocks of data that will be verified. A length of zero indicates that no logical blocks will be verified. This condition is not considered an error. Any other value indicates the number of logical blocks that will be verified. If the BYTCK bit is set to one (1), the total number of bytes to be verified must not exceed 32,768 or the following will be returned:

Status: CHECK CONDITION
Sense Key: ILLEGAL REQUEST
Sense Code: ILLEGAL FIELD IN CDB.

Write

The WRITE command requests that the Target write the data transferred by the Initiator to the media. The Target accepts both the non-extended (6-byte) and extended (10-byte) CDB formats.

Write (6-Byte) Command Descriptor Block (CDB)

Byte	Bit							
	7	6	5	4	3	2	1	0
00	Opcode = 0AH							
01	Logical Unit Number			Logical Block Address (MSB)				
02—03	Logical Block Address (LSB=03)							
04	Transfer Length							
05	Control Byte							

Write (10-Byte) Command Descriptor Block (CDB)

Byte	Bit							
	7	6	5	4	3	2	1	0
00	Opcode = 2AH							
01	Logical Unit Number			DPO=0	FUA	Reserved		RelAdr
02—05	(MSB=02)			Logical Block Address		(LSB=05)		
06	Reserved							
07—08	(MSB=07)			Transfer Length		(LSB=08)		
09	Control Byte							

Logical Block Address. This field specifies the logical block at which the write operation will begin.

FUA (Forced Unit Access). If the FUA bit is set to one (1), the WRITE command will not return GOOD Status until the logical blocks have actually been written on the media. If the FUA bit is set to zero (0), logical blocks may be transferred directly to cache memory, and GOOD Status may be returned to the Initiator prior to writing the logical blocks to the media if the WCE bit in Mode page 08H, byte 02 is set. Any error which occurs after the GOOD Status is returned as a deferred error and information regarding the error is not reported until a subsequent command.

RelAdr (Relative Address). A one (1) indicates that the logical block address field is a two's complement displacement. This negative or positive displacement is to be added to the logical block address last accessed on the logical unit to form the logical block address for this command. This feature is available only when linking commands. The feature requires that a previous command in the linked group has accessed a block of data on the logical unit.

A RelAdr bit of zero (0) indicates that the logical block address field specifies the first logical block of the range of logical blocks to be operated on by this command.

Transfer Length. This field specifies the number of contiguous logical blocks of data to be transferred. When using the non-extended (6-byte) CDB format, a Transfer Length of zero indicates that 256 logical blocks will be transferred. When using the extended (10-byte) CDB

Write

format, a Transfer Length of zero indicates that no logical blocks will be transferred. This condition shall not be considered an error (it is functionally equivalent to a SEEK command).

Write And Verify

The WRITE AND VERIFY command requests the Target to write the data transferred by the Initiator to the media, and then verify the data that was written.

Write And Verify Command Descriptor Block (CDB)

Byte	Bit							
	7	6	5	4	3	2	1	0
00	Opcode = 2EH							
01	Logical Unit Number			DPO=0	Reserved		BYTCK	RelAdr=0
02—05	(MSB=02)			Logical Block Address		(LSB=05)		
06	RESERVED							
07—08	(MSB=07)			Transfer Length		(LSB=08)		
09	Control Byte							

BYTCK (Byte Check). If the BYTCK bit is set to zero (0), an ECC verification of the data written is performed with no data comparison. If BYTCK is set to one (1), the drive will do a byte-by-byte comparison of the data written to the data read from the media. If the data does not compare with that on the media, a Status of CHECK CONDITION will be returned. The Sense Key will be set to MISCOMPARE with a Sense Code of COMPARE ERROR. If the data cannot be read from the media, a MEDIUM ERROR will be returned.

Logical Block Address. This field specifies the logical block at which the WRITE AND VERIFY operations will begin.

Transfer Length. This field specifies the number of contiguous logical blocks of data to be transferred. A Transfer Length of zero indicates that no logical blocks shall be transferred. This condition shall not be considered an error (it is functionally equivalent to a SEEK command). If the BYTCK bit is set to one (1), the total number of bytes to be written and verified must not exceed 32,768 or the following will be returned:

Status: CHECK CONDITION
Sense Key: ILLEGAL REQUEST
Sense Code: ILLEGAL FIELD IN CDB

Write Buffer

The WRITE BUFFER command puts data into the Target's buffer RAM without writing to the disk. An Initiator can use this command in conjunction with the READ BUFFER command to check the SCSI interface and the buffer RAM. Only mode 0 (zero) of the WRITE BUFFER command is used for this purpose.

The download microcode function is implemented with modes 4 and 5.

Mode 4 writes a partial segment of the microcode without attempting to execute that microcode. Mode 4 is useful for Initiators which do not have a large enough buffer size to download microcode in one segment.

Mode 5 is used for the last (or only) segment of the microcode. The Target executes its Power-On sequence after writing microcode in mode 5.

Caution



The WRITE BUFFER download microcode mode command allows the Initiator to execute code that may cause damaging results. It should only be performed when no data retention is required. Use of this command should be restricted to development or other highly controlled environments. Development of the code for this command should be carefully coordinated with the product's support team. Execution of this command with code not approved by Hewlett-Packard may be deemed a violation of warranty.

Write Buffer Command Descriptor Block (CDB)

Byte	Bit							
	7	6	5	4	3	2	1	0
00	Opcode = 3BH							
01	Logical Unit Number			Reserved			Mode	
02-05	Reserved							
06-08	(MSB=06)			Byte Transfer Length			(LSB=08)	
09	Control Byte							

Mode. Modes 0, 4, and 5 are supported:

Mode 0 (000b): Write combined header and data.

Mode 4 (100b): Download microcode.

Mode 5 (101b): Download microcode and save.

Byte Transfer Length. This field specifies the number of bytes to be transferred to the Target during the data phase. The transfer length includes the number of bytes to be written to the data buffer plus four (4) for the header. (The four header bytes are ignored by the Target and not written to the buffer.) A transfer length of zero indicates that no data transfer will take place and will not be considered an error. It is not considered an error to request a transfer length smaller than the Target data buffer size.

If the transfer length is greater than the maximum size of the Target's data buffer, the data phase will not be performed. The Target progresses immediately to the Status phase with CHECK CONDITION, ILLEGAL REQUEST Sense Key.

Write Buffer

To avoid the possibility of causing data buffer corruption between a WRITE BUFFER and a subsequent READ BUFFER, it is recommended that the Target be placed in Reserve or that the commands be linked to ensure that the Initiator can reliably test the Target's data buffer.

Write Long

The WRITE LONG command requests the Target to write the data transferred by the Initiator to the media. The data transferred is implementation specific, but will include the header, data bytes, and the ECC bytes. The READ LONG command is usually issued before issuing a WRITE LONG command. The WRITE LONG data should be the same length and in the same order as the data returned by the READ LONG command.

Write Long Command Description Block (CDB)

Byte	Bit							
	7	6	5	4	3	2	1	0
00	Opcode = 3FH							
01	Logical Unit Number			Reserved				REL=0
02—05	(MSB=02)		Logical Block Address			(LSB=05)		
06	Reserved							
07—08	(MSB=07)		Byte Transfer Length			(LSB=08)		
09	Control Byte							

Logical Block Address. This field specifies the logical block address where the write operation will begin.

Byte Transfer Length. This field specifies the number of data bytes the Target would return for the READ LONG command. A transfer length of zero indicates that no bytes will be transferred. This condition is not considered an error.

If a non-zero byte transfer length does not exactly match the data length the Target would return for the READ LONG command, the Target will terminate the command with a CHECK CONDITION status and a Sense Key of ILLEGAL REQUEST, and an Additional Sense Code of INVALID FIELD IN CDB. The ILI and VALID bits will be set to one (1), and the information bytes will be set to the difference (residue) of the requested length minus the actual length in bytes. Negative numbers will be indicated by two's complement notation.

If the Byte Transfer Length field matches exactly the length that the Target would return for the READ LONG command, the Target will write the data to the specified address.

Write Same

Requests the Target to write the single block of data transferred by the Initiator to the media the number of times specified in the Number of Blocks field.

Write Same Command Descriptor Block (CDB)

Byte	Bit							
	7	6	5	4	3	2	1	0
00	Opcode = 41H							
01	Logical Unit Number			Reserved		PBdata	LBdata	RelAdr=0
02—05	(MSB=02)			Logical Block Address		(LSB=05)		
06	Reserved							
07—08	(MSB=07)			Number of Blocks		(LSB=08)		
09	Control Byte							

LBdata (Logical Block Data). If LBdata equals one (1), the Target will replace the first four bytes of the data to be written to the current logical block with the logical block address of the block currently being written.

PBdata (Physical Block Data). If PBdata equals one (1), the Target will replace the first eight bytes of the data to be written to the current physical sector with the physical address of the sector currently being written using the physical sector format.

Note: If both LBdata and PBdata equal one (1), the target will terminate the command with a Status of CHECK CONDITION, a Sense Key of ILLEGAL REQUEST, and an Additional Sens Code of ILLEGAL FIELD IN CDB.

Logical Block Address. Specifies the address of the first logical block to be written.

Number of Blocks. Specifies the number of contiguous logical blocks to be written. If set to zero (0), the target will write the supplied data to all remaining logical blocks on the media.



Vendor Unique Command Descriptions

This section provides descriptions of the Vendor Unique commands supported by the Target. Table B-1 is a list of the Vendor Unique commands supported by the Target with brief descriptions included for each command.

Command Descriptions

Detailed descriptions of the Vendor Unique commands supported by the Target are provided at the end of this chapter. These descriptions include the Control Byte format, Command Descriptor Block (CDB) formats, data formats, and all device-specific information involved in command execution.

Table B-1. Vendor Unique Commands

Command	Opcode (hex)	Use Before Spinup	Use When WP ¹ Enabled	Description
Access Log	F2	No	Yes	Used to retrieve information from the Target's maintenance log.
Change SCSI ID	C1	No	Yes	Instructs the Target to change to the supplied address.
Execute Data	FE	No	No	Executes special code downloaded via the WRITE BUFFER command.
Interface Control	EF	No	No	Allows the ESDI commands to be sent to the disk drive processor.
Manage Primary	FD	No	No	Used to manage the primary defect list (P list).
Media Test	F1	No	No	Used to test the integrity of the disk media.
Read Headers	EE	No	Yes	Requests Target to read all the headers on the addressed track and return the requested number of bytes of header information.
Read Full	F0	No	Yes	Requests Target to return the header, data field, and ECC bytes of one physical sector.
Reformat Track	ED	No	No	Formats a single track. If HS bit is 0, then it uses normal default header information. If the HS bit is 1, the supplied header information is used for the track logical address and flag bytes.
Write Full	FC	No	No	Allows Initiator to write one complete physical sector, including header, data, and ECC fields.

Access Log

The ACCESS LOG command allows the Initiator to read the entries contained in the disk drive's maintenance log. This information is available for maintenance purposes. The log information is maintained in a RAM table which is initialized from the disk log on power-on, reset, or Format Unit. It is only posted to the disk when an error entry is added. The ACCESS LOG command will always return this information from the RAM log; there is no disk access.

Access Log Command Descriptor Block (CDB)

Byte	Bit							
	7	6	5	4	3	2	1	0
00	Opcode = F2H							
01	Logical Unit Number			Reserved			Clear	PHYS
02—06	(MSB=02)		Reserved		(LSB=06)			
07—08	(MSB=07)		Allocation Length		(LSB=08)			
09	Control Byte							

Clear. A CLEAR bit of one (1) allows the Initiator to clear all the current log entries after reading them.

PHYS (Physical Address). A PHYS bit of zero (0) causes all addresses and block counts to be in terms of logical blocks. Any addresses that are outside the user data space are set to addresses higher than the maximum block address when logical block references are requested. If PHYS is set to one (1), all addresses and block counts are in terms of physical sectors.

Allocation Length. This field specifies the number of bytes that the Initiator has allocated for returned ACCESS LOG data. An Allocation Length of zero indicates that no ACCESS LOG data will be transferred. This condition shall not be considered as an error. Any other value indicates the maximum number of bytes that shall be transferred. The Target will terminate the Data In phase when the specified number of bytes have been transferred, or when all available ACCESS LOG data have been transferred to the Initiator, whichever is less.

Access Log Data Header Format

The log information is preceded by a 4-byte header.

Byte	Bit							
	7	6	5	4	3	2	1	0
00—01	Reserved							
02—03	(MSB=02)				Available Length		(LSB=03)	

Available Length. This field defines the number of bytes following the header. This length does not include the 4-byte header itself. The header is followed by zero or more log entries. Each log entry begins with a 2-byte header identifying the type and length (excluding the header) of the following entry. The log types are defined as follows:

- 00H - No information
- 01H - Usage log entry
- 02H - Data Error log entry
- 03H - Hardware Error log entry

Usage Log Entry

The Usage log entry conveys usage information about the entire device. The length of this entry is 12 bytes.

Usage Log Entry Header Format

Byte	Bit							
	7	6	5	4	3	2	1	0
00	Log Entry Type = 01H							
01	Log Entry Length = 0CH							

Usage Log Entry Data Format

Byte	7	6	5	4	3	2	1	0
02	Reporting Area = FFH							
03	Reserved				Access Count			
04—09	(MSB=04)				Blocks Read Count		(LSB=09)	
10—11	(MSB=10)				First Retry Count		(LSB=11)	
12—13	(MSB=12)				Multiple Retry Count		(LSB=13)	

Reporting Area. This field is set to FFH, indicating that the entry refers to the entire device.

Access Log

Access Count. This field indicates the number of media positionings since the last hardware error occurred. This field is reset to zero each time a Hardware Error log entry is added to the log. If no Hardware Error log entries are included in the ACCESS LOG data, this field reflects the total number of media accesses. If Hardware Error log entries are included, this field and the values in corresponding Access Count fields in those entries must be combined to yield the total number of media accesses. The number of accesses represented by the Access Count field are as follows:

Access Count Range Values

Value (HEX)	Minimum of Access Range	Maximum of Access Range	Value (HEX)	Minimum of Access Range	Maximum of Access Range
0	No Accesses	No Accesses	8	500,001	1,000,000
1	1	1	9	1,000,001	5,000,000
2	2	10	A	5,000,001	10,000,000
3	11	100	B	10,000,001	50,000,000
4	101	1,000	C	50,000,001	100,000,000
5	1,001	10,000	D	100,000,001	500,000,000
6	10,001	100,000	E	500,000,001	1,000,000,000
7	100,001	500,000	F	1,000,000,001	>1,000,000,001

Blocks Read Count. This field is the count of the blocks read over the entire disk drive. If the PHYS bit in the CDB is set to zero (0), the count represents logical blocks. If PHYS is set to one (1), the count represents physical blocks.

First Retry Count. This field indicates the number of instances when the data error recovery algorithm was forced to perform data read retries and the data was recovered on the first retry.

Multiple Retry Count. This field indicates the number of times data was not recovered on the first retry. Note that this count is incremented only once per complete recovery action, not once for each retry within one recovery action.

Data Error Log Entry

This 6-byte entry is used to convey data error information about a specific data block.

Data Error Log Entry Header Format

	Bit							
Byte	7	6	5	4	3	2	1	0
00	Log Entry Type = 02H							
01	Log Entry Length = 06H							

Data Error Log Entry Data Format

Byte	7	6	5	4	3	2	1	0
02—05	(MSB=02)		Block Address				(LSB=05)	
06	Data Error Code							
07	Occurrence Count							

Block Address. This field contains the block address of the data block that encountered multiple read retries during one or more data error recovery attempts. If the PHYS bit in the CDB is set to zero (0), the field contains the logical block address. If PHYS is set to one (1), the field contains the physical block address in the following format:

- Byte 2: Cylinder Address (MSB)
- Byte 3: Cylinder Address (LSB)
- Byte 4: Head Address
- Byte 5: Sector Address

Data Error Code. This byte is bit-significant, and multiple errors at the same location will have their respective bits merged into the reported byte as follows:

- Bit 7: Unclassifiable error
- Bit 6: Error occurred in header field
- Bit 5: Error occurred in data field
- Bit 4: Unrecoverable error
- Bit 3: Error recovered with ECC
- Bit 2: Error recovered with retries
- Bit 1: Write fault
- Bit 0: Reserved

Occurrence Count. This field is incremented each time the specified block is uncorrectable or requires multiple read retries in a given transaction. This field is incremented only once for each data recovery.

Access Log

Hardware Error Log Entry

This 8-byte entry conveys hardware fault information.

Hardware Error Log Entry Header Format

Byte	Bit							
	7	6	5	4	3	2	1	0
00	Log Entry Type = 03H							
01	Log Entry Length = 08H							

Hardware Error Log Entry Data Format

Byte	7	6	5	4	3	2	1	0
02—05	(MSB=02) Block Address				(LSB=05)			
06	Internal Device Status							
07	Vendor Unique Status							
08	Field Replaceable Unit (FRU) = 0							
09	Reserved				Access Count			

Block Address. This field contains the block address the disk drive was attempting to access when the error occurred. If the PHYS bit in the CDB is set to zero (0), this is a logical block address. If PHYS is set to one (1), this is a physical block address. The address format is similar to that described for the Data Error Log entry.

Internal Device Status. This byte contains an error code corresponding to the Additional Sense code returned by the REQUEST SENSE command. If the error was recoverable, the most significant bit will be set (1). If the error was unrecoverable, the most significant bit will be zero (0).

Vendor Unique Status. The vendor unique status codes are listed in Appendix C.

Field Replaceable Unit (FRU). Returned as zeros.

Access Count. This field contains access information as defined in the Usage log entry.

Change SCSI ID

The CHANGE SCSI ID command instructs the Target to change its address to that supplied in the SCSI ID field. The Target will accept the command at any time, but will not change the ID until a SCSI bus reset is performed. This allows the Initiator to change the ID's of up to seven targets without duplication.

If power is lost, the Target's SCSI ID source will revert to the address pinsets when power is restored.

Rezero Unit Command Descriptor Block (CDB)

Byte	Bit							
	7	6	5	4	3	2	1	0
00	Opcode = C1H							
01	Logical Unit Number				Reserved			
02—03	Reserved							
04	Reserved				IDCF	SCSI ID		
05	Control Byte							

IDCF (ID Control Field).

If IDCF = 0: The SCSI ID field is ignored and the drive obtains its ID from the address pinsets at the next bus reset.

If IDCF = 1: The drive obtains its ID from the SCSI ID field in byte 4 at the next bus reset.

SCSI ID. Provides the new SCSI address: MSB = bit 2; LSB = bit 0.

Change Wide SCSI ID

The CHANGE WIDE SCSI ID command instructs the Target to change its address to that supplied in the SCSI ID field. The Target will accept the command at any time, but will not change the ID until a SCSI bus reset is performed. This allows the Initiator to change the ID's of up to seven targets without duplication.

If power is lost, the Target's SCSI ID source will revert to the address pinsets when power is restored.

Rezero Unit Command Descriptor Block (CDB)

Byte	Bit							
	7	6	5	4	3	2	1	0
00	Opcode = C2H							
01	Logical Unit Number			Reserved				
02—03	Reserved							
04	Reserved			IDCF	SCSI ID			
05	Control Byte							

IDCF (ID Control Field).

If IDCF = 0: The SCSI ID field is ignored and the drive obtains its ID from the address pinsets at the next bus reset.

If IDCF = 1: The drive obtains its ID from the SCSI ID field in byte 4 at the next bus reset.

SCSI ID. Provides the new SCSI address: MSB = bit 3; LSB = bit 0.

Execute Data

The EXECUTE DATA command allows the Initiator to instruct the Target to execute special firmware utilities, thus providing functions not available in the standard command set. This command causes parameter bytes, sent by the Initiator to the data buffer via a WRITE BUFFER command, to be used by those firmware utilities.

Caution



The EXECUTE DATA command allows the Initiator to execute code that may cause damaging results. It should only be performed when no data retention is required. Use of this command should be restricted to development or other highly controlled environments. Execution of these firmware utilities with parameters not approved by Hewlett-Packard may be deemed a violation of warranty.

EXECUTE DATA Command Descriptor Block (CDB)

Byte	Bit							
	7	6	5	4	3	2	1	0
00	Opcode = FEH							
01	Logical Unit Number			0	0	RST	0	EXE
02	0	0	0	0	0	Page		
03	0	0	0	0	Jump Entry			
04-08	Reserved							
09	Control Byte							

RST (Restart). This bit instructs the target to re-execute the firmware utility where it stopped due to a reported error condition, Data In phase, etc. *Note:* If RST is set on a firmware utility that doesn't support it, the command will fail with:

Status: CHECK CONDITION
Sense Key: ILLEGAL REQUEST
Additional Sense Code: ILLEGAL FIELD IN CDB

EXE (Execute). This bit instructs the Target to execute the firmware utility at the specified *Page* and *Jump Entry* locations. A WRITE BUFFER command which includes any required firmware utility parameters should precede the EXECUTE DATA command.

Page (ROM Page). This field indicates the location in ROM of the firmware utility. The currently supported *Page* values are **06H** and **07H**.

If the specified *Page* value is not supported, the command will fail with:

Status: CHECK CONDITION
Sense Key: ILLEGAL REQUEST
Additional Sense Code: ILLEGAL FIELD IN CDB

Jump Entry. This field indicates the specific firmware utility on the selected *Page* to execute or re-start. The currently supported *Jump Entry* values are 0 to 15 (0000 to 1111).

Interface Control

The INTERFACE CONTROL command allows the Initiator to send an ESDI command directly to the disk drive ESDI interface. If this command returns a *Check Condition* status, the subsequent Request Sense command will, in most cases, return a Sense Key of 01, and an additional Sense Code of 44H, whether or not the command completed correctly. However, the Vendor Unique DERROR status code will be valid.

Interface Control Command Descriptor Block (CDB)

Byte	Bit							
	7	6	5	4	3	2	1	0
00	Opcode = EFH							
01	Logical Unit Number			Reserved				Status
02—03	(MSB=02) Command			(LSB=03)				
04—08	(MSB=04) Reserved			(LSB=08)				
09	Control Byte							

Status. If this byte is set to one (1), two (2) bytes of ESDI status information will be received from the disk drive and returned to the Initiator in addition to the interface status byte described below.

Note



There is no interface timeout on this command. It is the Initiator's responsibility to issue valid commands and to set the STAT bit only for commands which will normally return status information.

A single byte will be returned to the Initiator when the disk controller completes its operation. The byte has the following bit definitions:

- Bit 0 - Disk drive selected
- Bit 1 - Command complete
- Bit 2 - Ready
- Bit 3 - Attention
- Bits 4-7 - Undefined

Command. This field is the ESDI command for the disk drive.

Manage Primary

The MANAGE PRIMARY command is used to manage the Primary Defect list (Plist). The command has three options: *delete* the current Plist, *append* defects to the current Plist, or *replace* the current Plist with a new Plist. When appending or replacing the Plist, this command causes the specified physical blocks to be reassigned as primary defects and added to the Plist.

The delete and replace options are implemented by performing a full device format, which will cause the loss of all user data and log information. **Any data residing on the media before these options are implemented will be lost.** Any existing Grown Defect List (Glist) defect information will also be lost. The current operating MODE SELECT parameters will become the saved parameters following this command.

The append option will only update the list of Plist entries. The media will not be reinitialized, but the mapping to user data will be altered such that data resident on the media prior to the append operation will be lost.

The operation of the MANAGE PRIMARY command is similar to the FORMAT UNIT command.

Caution



The MANAGE PRIMARY command allows the Target to overwrite any or all of the Initiator-addressable data space. This command should be performed only when no data retention is required.

Use of this command should be restricted to development or other highly controlled environments. Any use of this command other than at Hewlett-Packard approved sites may be deemed a violation of warranty.

There are three possible sources of defect location information during execution of the MANAGE PRIMARY command:

Plist (Primary Defect List). The list of permanent defects supplied by the original manufacturer. The Plist is located outside of the Initiator-accessible logical block space. The Plist is accessible by the Target (to reference while formatting), but is not normally accessible by the Initiator except through the READ DEFECT command.

Dlist (Data Defect List). Supplied by the Initiator in the Data Out phase of the MANAGE PRIMARY command.

Glist (Grown Defect List.) Maintained by the Target and includes all defects sent to the Target from the Initiator (the Dlist), any defects identified by the Target during previous and current MANAGE PRIMARY operations, and any defects identified by a REASSIGN BLOCKS command. The Glist does NOT include the Plist. Any execution of the MANAGE PRIMARY command will delete the current Glist (if present).

Manage Primary

Manage Primary Command Descriptor Format (CDB)

Byte	Bit							
	7	6	5	4	3	2	1	0
00	Opcode = FDH							
01	Logical Unit Number			FMTDTA	CMPLST	Defect List Format		
02—08	(MSB=02)			Reserved		(LSB=08)		
09	Control Byte							

FMTDTA (Format Data). Indicates whether the Initiator will send additional defect information (Dlist) to the Target. If set to zero (0):

- there will be no Data Out phase,
- the Target will not receive a new Dlist,
- the current Plist is **not** retained,
- the current Glist is **not** retained,
- and the CMPLST bit and the Defect List Format field will have no effect.

If set to 1 (one), a new Dlist will be supplied by the Initiator and the CMPLST bit and the Defect List Format field will provide additional parameters.

CMPLST (Complete List). If set to zero (0), the Plist is retained and the Dlist is appended to it. Note: this option will only format tracks found within the Dlist. If set to 1 (one), the defects in the Dlist are used to create a new Plist which replaces the old Plist.

Defect List Format. The supported field values are:

Field Value	Description
0 0 0	Block format (defect list length of zero)
0 0 1	Reserved
0 1 0	Reserved
0 1 1	Reserved
1 0 0	Bytes from index format
1 0 1	Physical sector format (recommended)
1 1 0	Reserved
1 1 1	Reserved

Manage Primary Defect Sources

FMTDTA	CMPLST	Defect List Format Field	Defect List Supplied	Target Instructions
0 ¹	X	X X X	No	Delete Option: <ul style="list-style-type: none"> ■ No Data Out Phase. ■ Delete current Plist. ■ Delete current Glist (if present).
1	0	1 0 1 or 1 0 0 or 0 X X ²	Yes	Append Option: <ul style="list-style-type: none"> ■ New Dlist supplied by Initiator. ■ Retain current Plist. ■ Append new Dlist to current Plist. ■ Delete current Glist (if present).
1	1	1 0 1 or 1 0 0 or 0 X X ²	Yes	Replace Option: <ul style="list-style-type: none"> ■ New Dlist supplied by Initiator. ■ Build new Plist from supplied Dlist. ■ Replace old Plist with new Plist. ■ Delete current Glist (if present).
<p>Notes:</p> <p>1. The preferred option is FMTDTA = 0. 2. Defect list length of zero only.</p>				

Manage Primary

Defect List Header

This header indicates the total number of bytes in the set of descriptors to follow. Each descriptor consists of an 8-byte physical sector address or bytes from index address. Each address is bounds checked by the Target. If any address is out of bounds an ILLEGAL REQUEST Sense Key is generated, and the format operation is discontinued.

Manage Primary Defect List Header Format

	Bit							
Byte	7	6	5	4	3	2	1	0
00	Reserved							
01	Vendor Unique = 0							
02-03	(MSB=02)		Defect List Length				(LSB=03)	

Defect List Length. Specifies the total length in bytes of the defect descriptors that follow and does not include the initialization pattern, if used. The length of the defect descriptors varies with the format of the defect list. The length of the defect list with n descriptors is $8n$ bytes.

Defect Descriptors (if any)

	Bit							
Byte	7	6	5	4	3	2	1	0
00 to 07	Defect Descriptor 1 (see specific table for length)							
:								
$n-1*8$ to $n-1*8+7$	Defect Descriptor n (see specific table for length)							

Defect Descriptor - Bytes from Index Format

Byte	Bit							
	7	6	5	4	3	2	1	0
00—02	(MSB=00)		Cylinder Number Of Defect				(LSB=02)	
03	Head Number Of Defect							
04—07	(MSB=04)		Defect Bytes From Index				(LSB=07)	

Each defect descriptor for the Bytes from Index Format specifies the beginning of an 8-byte defect location on the media. Each defect descriptor contains the cylinder, head, and the offset in bytes from index of the defect.

The defect descriptors within a defect list will be sorted in ascending order as follows:

- Primary Key: cylinder
- Secondary Key: head number
- Tertiary Key: bytes from index

More than one physical or logical block may be relocated by each defect descriptor.

Defect Descriptor - Physical Sector Format

Byte	Bit							
	7	6	5	4	3	2	1	0
00—02	(MSB=00)		Cylinder Number Of Defect				(LSB=02)	
03	Head Number Of Defect							
04—07	(MSB=04)		Defective Sector Number				(LSB=07)	

Each physical sector defect descriptor specifies the location of a defect that is the length of a sector. Each defect descriptor contains the cylinder, head, and the sector location of the defect.

The defect descriptors within a defect list will be sorted in ascending order as follows:

- Primary Key: cylinder
- Secondary Key: head number
- Tertiary Key: sector number

More than one physical or logical block may be relocated by each defect descriptor.

A defective sector number of FFFFFFFFH indicates that the entire track is considered defective.

Media Test

The MEDIA TEST command instructs the Target to automatically perform testing over a specified area of the media.

Media Test Command Descriptor Block (CDB)

Byte	Bit							
	7	6	5	4	3	2	1	0
00	Opcode = F1H							
01	Logical Unit Number			WRT	PHYS	INT	RND	RST
02—05	(MSB=02) Address				(LSB=05)			
06—08	(MSB=06) Transfer Length				(LSB=08)			
09	Control Byte							

WRT (Write). This bit defines the type of test to be performed on the specified media area. If WRT is set to zero (0), the Target performs a read; if WRT is set to one (1), the Target performs a write operation.

PHYS (Physical Address). If PHYS is set to zero (0), the address is assumed to be a logical address. If the PHYS bit is set to one (1), the address field is interpreted as a physical address in the following format:

- Byte 2: Physical Cylinder Address (MSB)
- Byte 3: Physical Cylinder Address (LSB)
- Byte 4: Head Address
- Byte 5: Physical Sector Address

The Initiator can specify the test area as follows:

If the values of the specified physical address (cylinder, head, sector) are within the physical boundaries of the drive under test, it will seek to that location and begin the test.

If any of the values of the specified physical address are greater than the drive boundaries, it will perform the test on the following area:

Out-Of-Bound Value(s)			Test Area
Cylinder	Head	Sector	
Outside	Inside	Outside	The entire surface of the addressed head
Inside	Outside	Outside	The entire addressed cylinder
Inside	Inside	Outside	The entire track relative to the addressed head and cylinder
Outside	Outside	Outside	The entire volume

INT (Internal Pattern). This bit selects the source of the data pattern used when a write test is selected. If INT is set to one (1), the Target uses an internally generated worst-case data pattern (6DBH). If INT is set to zero (0), the current contents of the first logical block of the Target's data buffer is used for the write pattern. Therefore, immediately preceding a MEDIA TEST command with INT set to zero (0), the Initiator should perform a WRITE BUFFER command (of at least one block length) which loads the desired data pattern into the data buffer. If WRT is set to zero (0), INT must also be set to zero (0).

Media Test

RND (Random). This bit selects either random or sequential addressing. The media testing begins with the logical block address specified in the CDB. If RND is set to zero (0), the test proceeds sequentially from the specified logical block. Logical block zero follows the last logical block on the media when using sequential addressing. If RND is set to one (1), the next address is generated randomly from any block on the media.

RST (Reset Seed). This bit is used only when RND is set to one (1). When RST is set to one (1), the Target initializes its random number seed using the specified block address. This capability provides a method to enable a repeatable sequence of random addresses for pairs of MEDIA TEST commands (i.e., a write followed by a read). If RND is set to one (1) and RST is set to zero (0), the random number seed is not reset. If RND is set to zero (0), RST must also be set to zero (0).

Address. This field specifies the media test area; refer to the previous explanation for the PHYS bit.

Transfer Length. This field indicates the number of blocks to be tested, unless terminated by an error. An unrecoverable error terminates the MEDIA TEST command and generates CHECK CONDITION status with the appropriate sense information. If only recoverable errors occur, the media test will run to completion and return a CHECK CONDITION status with sense information set for the last recoverable error which occurred. Information on any additional errors can be obtained from the drive error log. A transfer length of zero shall not cause any media transfer to occur and shall not be considered an error.

On a sequential media test, if the Transfer Length is greater than the length remaining from the start address to the maximum block address, the test will continue to run from address zero (0) after the maximum block address is reached. This is not considered an error. This "wrap around" may occur more than once during a long test.

For random tests, only single block operations are performed. The transfer length field indicates the number of these operations to be performed.

Read Full

The READ FULL command allows the Initiator to request all available information fields for the specified logical or physical block. This information includes the header, data, and ECC field contents. The Target returns to the Initiator a complete image of one physical block. Included with the contents of the physical block is a header that defines the amount and type of data available.

Note

For this command to succeed, the header of the sector prior to the requested sector *must* be readable.



Read Full Command Descriptor Block (CDB)

Byte	Bit							
	7	6	5	4	3	2	1	0
00	Opcode = FOH							
01	Logical Unit Number			Reserved				PHYS
02—05	(MSB=02) Address			(LSB=05)				
06	Reserved							
07—08	(MSB=07) Allocation Length			(LSB=08)				
09	Control Byte							

Address. This field specifies which block to return.

PHYS (Physical Address). The interpretation of the address is determined by the state of the PHYS bit. If PHYS is set to zero (0), the Address field is treated as a logical block address per normal conventions and all normal position verifications are performed. The first *physical* block in the specified *logical* block is returned. To access all physical blocks, the Initiator must use the MODE SELECT command to set the logical block size equal to the physical block size (normally 512 bytes). Otherwise, only the first physical block in each logical block is accessible.

If PHYS is set to one (1), the Address field is treated as a physical block address with the Address field defined as follows:

- Byte 2: Physical Cylinder Address (MSB)
- Byte 3: Physical Cylinder Address (LSB)
- Byte 4: Head Address
- Byte 5: Physical Sector Address

Allocation Length.

This field specifies the number of bytes the Initiator is prepared to accept. If the number of bytes available from the Target is greater than that specified in the CDB, the data will be truncated to the Allocation Length value. The typical allocation length for a device formatted with a 512 byte data field is 548.

Read Full Header Format

The physical block returned by the Target is preceded by a 10-byte header.

Byte	Bit							
	7	6	5	4	3	2	1	0
00	Total Available Length (MSB) = 02H							
01	Total Available Length (MSB) = 22H							
02	Field Descriptor = 001				Field Length (MSB) = 00H			
03	Field Length (LSB) = 06H							
04	Field Descriptor = 010				Field Length (MSB) = 02H			
05	Field Length (LSB) = 00H							
06	Field Descriptor = 100				Field Length (MSB) = 00H			
07	Field Length (LSB) = 14H							
08	Field Descriptor = 000				Field Length (MSB) = 00H			
09	Field Length (LSB) = 00H							

Read Full Physical Block Contents

Byte	Bit							
	7	6	5	4	3	2	1	0
10—15	Header Bytes/Header CRC							
16—527	Data Bytes							
528—547	ECC Bytes/Data CRC							

Total Available Length. This field contains the number of bytes that the device can return for this command. The length does not include itself but does include the remaining eight bytes of the header. If the Allocation Length field in the CDB is smaller than the Total Available Length, the Total Available length is not adjusted to show the truncation.

Field Descriptor. The bit code values are defined as follows:

- 001 - Physical Block Header Field
- 010 - User Data Field
- 100 - Error Correction/Detection Field
- 000 - End Fields Mark

Field Length. The individual fields define the number of bytes to follow them in the associated field. The Field Length for the End Fields Mark is set to zero.

The physical block consists of 538 bytes: 6 bytes of header, 512 (maximum) bytes of data, and 20 bytes of data ECC. No error correction is applied to the data bytes returned.

Read Headers

The READ HEADERS command will read all the headers on the track specified by the Address field and return the requested number of bytes. The header information will always be returned starting from physical sector 0 of the addressed track regardless of the addressed block or sector.

READ HEADERS Command Descriptor Block (CDB)

	Bit							
Byte	7	6	5	4	3	2	1	0
00	Opcode = EEH							
01	Logical Unit Number			Reserved				PHYS
02—05	(MSB=02)			Address		(LSB=05)		
06	Reserved							
07—08	(MSB=07)			Allocation Length		(LSB=08)		
09	Control Byte							

PHYS (Physical Address). If the PHYS bit is set to one (1), the address field is interpreted as a physical address in the following format:

- Byte 2: Cylinder Address (MSB)
- Byte 3: Cylinder Address (LSB)
- Byte 4: Head Address
- Byte 5: Sector Address (Ignored)

If PHYS is set to zero (0), the address is assumed to be a logical address.

Address. This field specifies which track to read.

Allocation Length. A value of zero (0) in this field will cause a seek to the addressed track with the header information read from the disk but no data transfer to the Initiator.

Reformat Track

The REFORMAT TRACK command will cause the addressed track on the disk drive to be formatted according to the setting of the Transfer Length field.

Caution



REFORMAT TRACK will cause the loss of all user data on the specified track. Use of this command should be restricted to development or other highly controlled environments. Improper use of this command may cause the reformatted tracks to become unusable, or other user tracks to become inaccessible. Loss of defect information may also result. Any use of this command other than at Hewlett-Packard approved sites and by HP approved methods may be deemed a violation of warranty.

Reformat Track Command Descriptor Block (CDB)

Byte	Bit							
	7	6	5	4	3	2	1	0
00	Opcode = EDH							
01	Logical Unit Number			Reserved				
02—05	(MSB=02)			Physical Block Address		(LSB=05)		
06—08	Reserved							
09	Control Byte							

Physical Block Address. This field selects the physical block address of the track to be reformatted. The Address field is defined as follows:

- Byte 2: Cylinder Address (MSB)
- Byte 3: Cylinder Address (LSB)
- Byte 4: Head Address
- Byte 5: Sector Address (Ignored)

Write Full

The WRITE FULL command allows the Initiator to request the Target to write the specified logical or physical block with the exact block formatting information included with the command. This information may include the header, data, and ECC field contents.

Caution



The WRITE FULL command allows the Initiator to directly control the formatting of a physical block of media. Use of this command should be restricted to development or other highly controlled environments. The use of this command may adversely affect the reliability of data recovery and proper device operation at media addresses other than the one specified. This command is intended strictly to test Target and Initiator reaction to certain induced media errors. Any use of this command other than at Hewlett-Packard approved sites and by Hewlett-Packard approved methods may be deemed a violation of warranty.

Write Full Command Descriptor Block (CDB)

Byte	Bit							
	7	6	5	4	3	2	1	0
00	Opcode = FCH							
01	Logical Unit Number			Reserved				Phys
02—05	(MSB=02)			Address		(LSB=05)		
06	Reserved							
07—08	(MSB=07, 02H)		Byte Transfer Length			(LSB=08, 1AH)		
09	Control Byte							

Note



For this command to succeed, the header of the sector prior to the requested sector must be readable.

Using the WRITE FULL command, the Initiator transfers to the Target the complete information to write one physical block. A WRITE FULL command is usually preceded by a READ FULL command, which returns the entire contents (548 bytes) of a specified block. The Initiator receives the complete READ FULL data, strips off the 10-byte header, and modifies the block contents as required. The resultant 538 bytes constitute the data phase of the WRITE FULL command. The WRITE FULL command and the preceding READ FULL command should both address the same block; thus ensuring that the modified data is returned to its original location.

Write Full

PHYS (Physical Address). The interpretation of the address is determined by the state of the PHYS bit. If PHYS is set to zero (0), the Address field is treated as a logical block address per normal conventions and all normal position verifications are performed. The first *physical* block in the specified *logical* block is written. To access all physical blocks, the Initiator must use the MODE SELECT command to set the logical block size equal to the physical block size (normally 512 bytes). Otherwise, only the first physical block in each logical block is accessible.

If PHYS is set to one (1), the Address field is treated as a physical block address with the Address field defined as follows:

Byte 2: Cylinder Address (MSB)

Byte 3: Cylinder Address (LSB)

Byte 4: Head Address

Byte 5: Sector Address

Address. This field specifies which block to write.

Byte Transfer Length. This field specifies the number of bytes to be transferred in the data phase. This field is set to 021AH (538 decimal) indicating the full physical block length. Setting this field to any other value will generate an ILLEGAL REQUEST sense key.

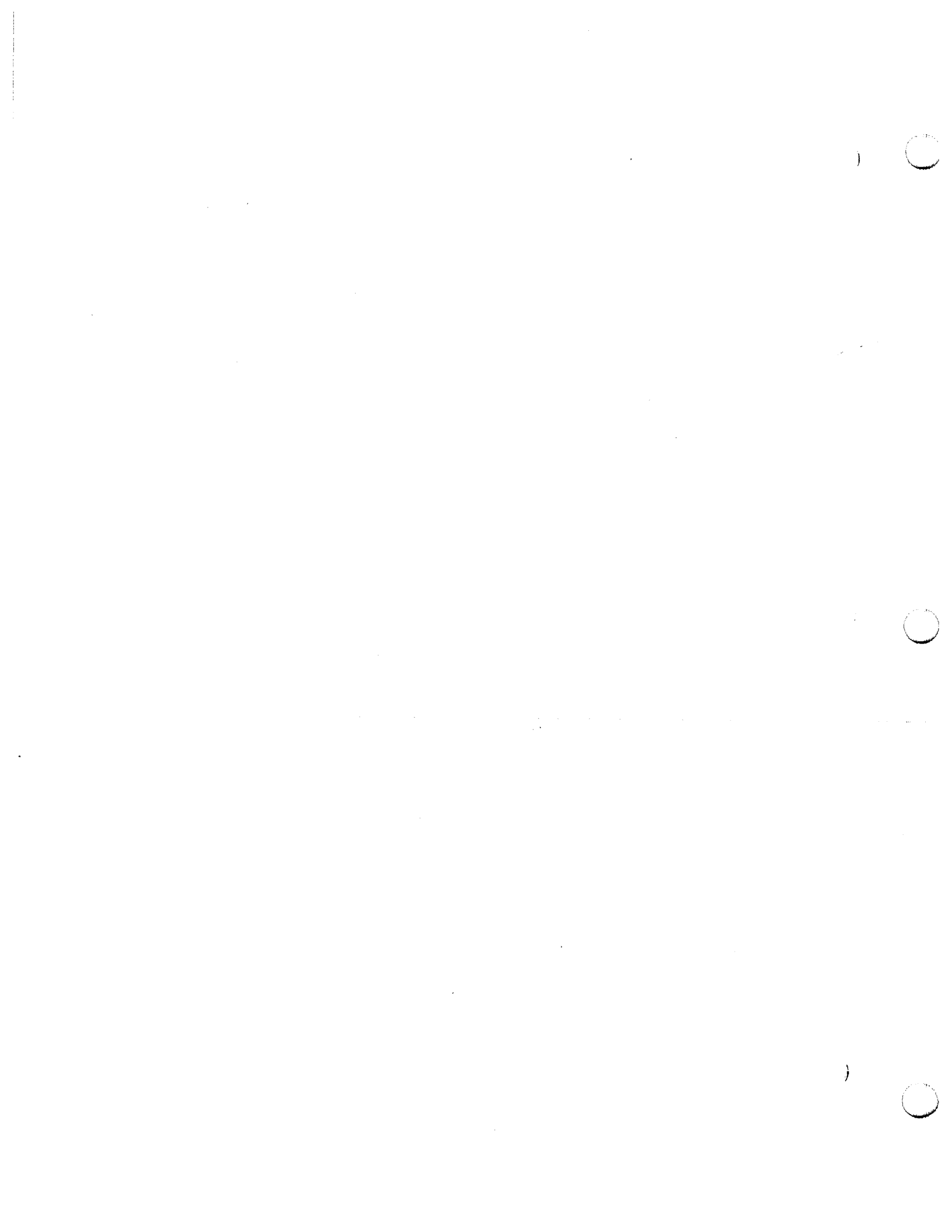

Vendor Unique Status Codes

Table C-1. Vendor Unique DERROR Status Codes

Error Code Hex(Dec)	Description
00(0)	Not an error condition.
01(1)	Power-On condition.
02(2)	Reserved.
03(3)	Timed out waiting for DSP to complete Power On Self-Test.
04(4)	After power-on, DSP became Command Ready without Finished being asserted.
05(5)	DSP reported a revision value incompatible with this firmware version.
06(6)	Power-On DSP RAM test failed.
07(7)	Parity error on command received.
08(8)	Reserved.
09(9)	Reserved.
0A(10)	Received illegal command.
0B(11)	Address of Seek command was outside legal address space.
0C(12)	An attempt was made to set an illegal EEPROM address.
0D(13)	Reserved.
0E(14)	Timed out waiting for EEPROM write to complete.
0F(15)	DSP did not spinup after a spinup command was executed.
10(16)	Timed out waiting for DSP to become ready for a short term command.
11(17)	Timed out waiting for DSP to become ready for a long term command.
12(18)	A Seek was attempted when either the spindle was not spun up or the servo PLL was not locked.
13(19)	The DSP did not end up in tracking mode after a Recalibrate command was executed.
14(20)	Bounds test of Track Offset command failed.
15(21)	A fault is still set after clearing Gate Array fault latches.
16(22)	Retries were exhausted while trying to verify position during a Recalibrate.
17(23)	The DC bias adaptation failed to null NPES within the maximum iteration limit.
18(24)	Maximum iteration limit reached during head alignment SPES null.
19(25)	DSP sync lost during head alignment SPES measurement.
1A(26)	The drive has entered the Head Alignment Needed state.
1B(27)	The drive has entered the Head Alignment Critical state.
1C(28)	The maximum total (AC+DC) head alignment correction limit was exceeded.
1D(29)	Reserved
1E(30)	DSP failed to complete a Read Track Number command in allotted time.
1F(31)	DSP failed to complete a Spin Down command in allotted time.
20(32)	Reserved.
21(33)	DSP failed to complete a Spin Up command in allotted time.
22(34)	DSP failed to complete a Recalibrate command in allotted time.
23(35)	DSP failed to complete an Introduce Tracking Offset command in allotted time.
24(36)	DSP failed to complete a Seek command in allotted time.
25(37)	DSP failed to complete a Measure Alignment Band command in allotted time.
26(38) thru 29(41)	Reserved.

Table C-1. Vendor Unique DERROR Status Codes (continued)

Error Code Hex(Dec)	Description
2A(42)	HDA EEPROM test byte is not 55H.
2B(43)	HDA EEPROM checksum result not equal to 00.
2C(44)	PCA EEPROM test byte is not 55H.
2D(45)	PCA EEPROM checksum result not equal to 00.
2E(46)	Computed read/write setting is out of range.
2F(47)	Reserved.
thru	
31(49)	
32(50)	The long term DSP command completed with Alert signal set in status register.
33(51)	The DSP Alert signal was set when attempting to send a command to the DSP.
34(52)	Request Status logged a Servo Fault from the fault register.
35(53)	DSP failure code indicates other than Reset at power-on.
36(54)	Reserved.
37(55)	Reserved.
38(56)	Maximum DC head alignment correction capability was exceeded.
39(57)	Maximum AC head alignment correction capability was exceeded.
3A(58)	Maximum iteration limit was exceeded in calibrating the NPES gain.
3B(59)	SPES gain not within acceptable level.
3C(60)	Reserved.
3D(61)	Reserved.
3E(62)	Write current unsafe.
3F(63)	Command requires a special test enable to be executed.
40(64)	Unknown write fault.
41(65)	Write during loss of servo timing sync.
42(66)	Write during momentary spindle off-speed indication.
43(67)	Write during momentary actuator off-track indication.
44(68)	Write during a seek operation.
45(69)	Write after settle or tracking failure.
46(70)	Write following aggressive settle.
47(71)	Not defined.
48(72)	Write was attempted while ESDI attention was asserted.
49(73)	Write was attempted while an illegal head was selected.
4A(74)	Write was attempted while a recalibrate was in process.
4B(75)	Write was attempted on a head that was in the head alignment critical state.
4C(76)	Write was attempted while a head alignment was in process.
4D(77)	Write was attempted after a fatal head alignment occurred.
4E(78)	Write was attempted while spun down or after a recalibrate failure.
4F(79)	Reserved.
thru	
7F(127)	

Table C-1. Vendor Unique DERROR Status Codes (continued)

Error Code Hex(Dec)	Description
Note: The remaining codes (80H thru FFH) are servo processor DERROR codes.	
80(128)	No failure detected.
81(129)	Unsupported command.
82(130)	Illegal command sequence.
83(131)	Servo heartbeat time out.
84(132)	Spindle stuck.
85(133)	Spindle couldn't reach full speed.
86(134)	Servo PLL didn't lock.
87(135)	Index pattern fault.
88(136)	TMR2 Alignment failure.
89(137)	Servo PLL came unlocked.
8A(138)	Bad hard track number.
8B(139)	Settle failure.
8C(140)	Alignment Band AGC voltage not within legal range.
8D(141)	Heroics invoked during spin up.
8E(142)	DSP reset detected.
8F(143)	Minimum spindle speed could not be maintained.
90(144)	Tracking failure after a successful settle to a new setpoint.
91(145)	Reserved.
thru	
C0(192)	
C1(193)	PLL came unlocked in Slow Acceleration Phase.
C2(194)	Seek timed out in Slow Acceleration Phase.
C3(195)	Velocity too high in Slow Acceleration Phase.
C4(196)	Unassigned seek fault in Slow Acceleration Phase.
thru	
C8(200)	
C9(201)	PLL came unlocked in Fast Acceleration Phase.
CA(202)	Seek timed out in Fast Acceleration Phase.
CB(203)	Velocity too high in Fast Acceleration Phase.
CC(204)	Unassigned seek fault in Fast Acceleration Phase.
thru	
D0(208)	
D1(209)	PLL came unlocked in the Coasting Phase.
D2(210)	Seek timed out in the Coasting Phase.
D3(211)	Velocity too high in the Coasting Phase.
D4(212)	Unassigned seek fault in the Coasting Phase.
thru	
D8(216)	
D9(217)	PLL came unlocked in Fast Deceleration Phase.
DA(218)	Seek timed out in Fast Deceleration Phase.
DB(219)	Velocity too high in Fast Deceleration Phase.
DC(220)	Unassigned seek fault in Fast Deceleration Phase.
thru	
E0(224)	

Table C-1. Vendor Unique DERROR Status Codes (continued)

Error Code Hex(Dec)	Description
E1(225)	PLL came unlocked in Slow Deceleration Phase
E2(226)	Seek timed out in Slow Deceleration Phase
E3(227)	Velocity too high in Slow Deceleration Phase
E4(228) thru E8(232)	Unassigned seek fault in Slow Deceleration Phase.
E9(233) thru F0(240)	Unassigned seek fault.
F1(241)	PLL came unlocked in the Gross Settle Phase.
F2(242)	Seek timed out in the Gross Settle Phase.
F3(243)	Velocity too high in the Gross Settle Phase.
F4(244) thru F9(249)	Unassigned seek fault in the Gross Settle Phase.
FA(250)	Seek timed out in the Fine Settle Phase.
FB(251)	Velocity too high in the Fine Settle Phase.
FC(252) thru FF(255)	Unassigned seek fault in the Fine Settle Phase.

D

Reference

This appendix contains information pertaining to previous or special versions of the product. The following table lists the material contained herein.

Table D-1. Reference Appendix Contents

Item	Title

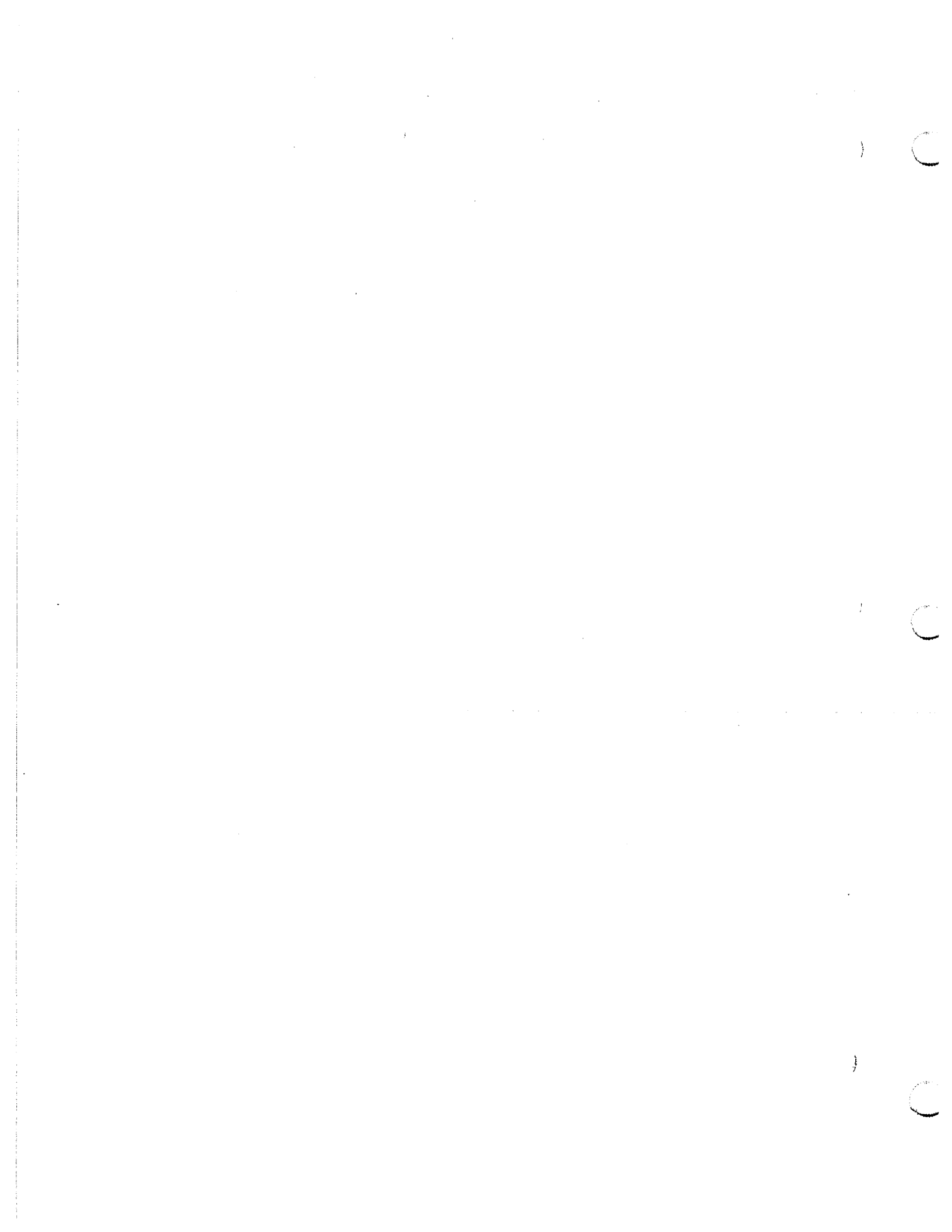

Narrow, Single-Ended Drive Configurations

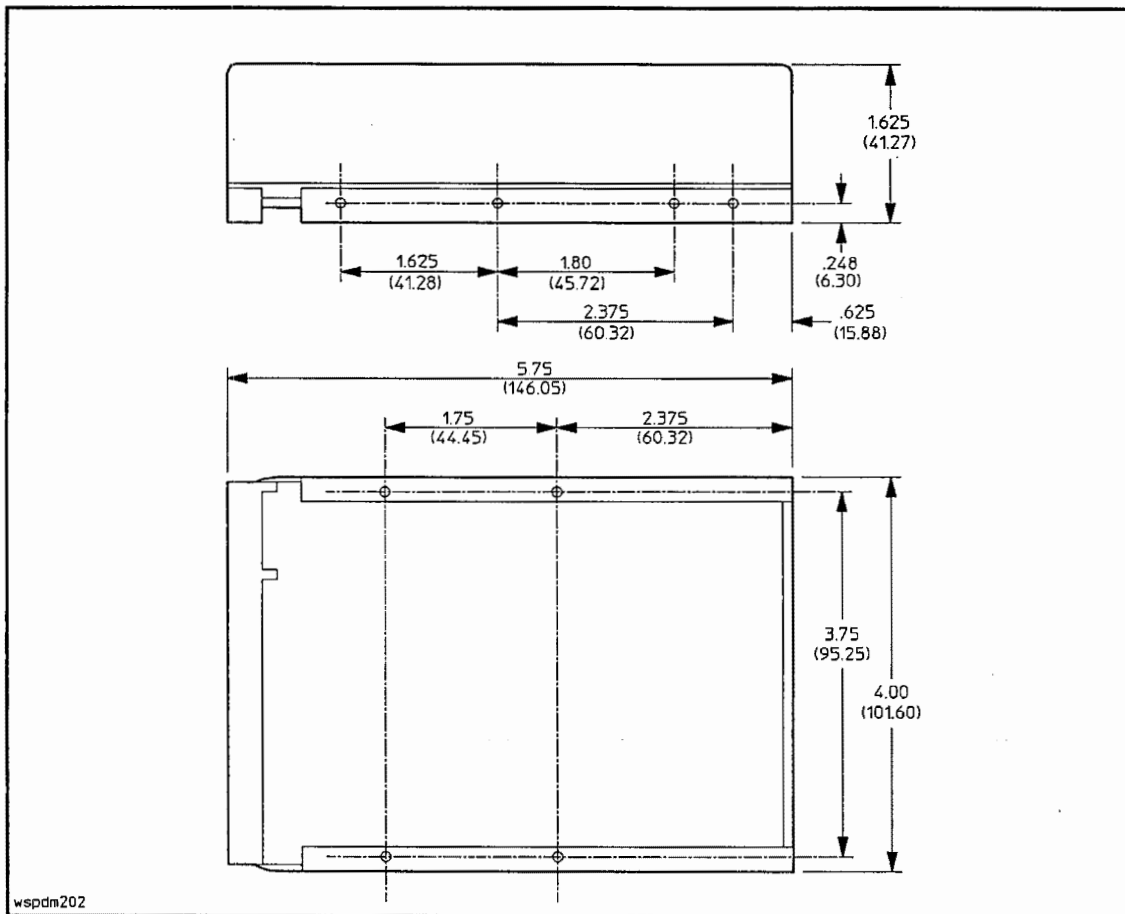

Figure E-1. Narrow, Single-Ended: Disk Drive Dimensions and Mounting Locations

Mounting Guidelines:

1. Values given in inches and (millimeters).
2. Maintain a minimum clearance of 0.06 in. (1.5 mm) between any system structure and the top and all four sides of the disk drive. Insure that the system structure contacts only the drive mounting frames and clears the drive HDA by at least 0.06 in. (1.5 mm).
3. Maintain a minimum clearance of 0.04 in. (1.0 mm) between any system structure and any PCA component.
4. Use 6-32 UNC screws with flat washers under the heads and torque them to 15 inch-pounds.
5. When mounded, the screws should not protrude more than 0.12 in. (3 mm) beyond the inside of the disk drive mounting frame.

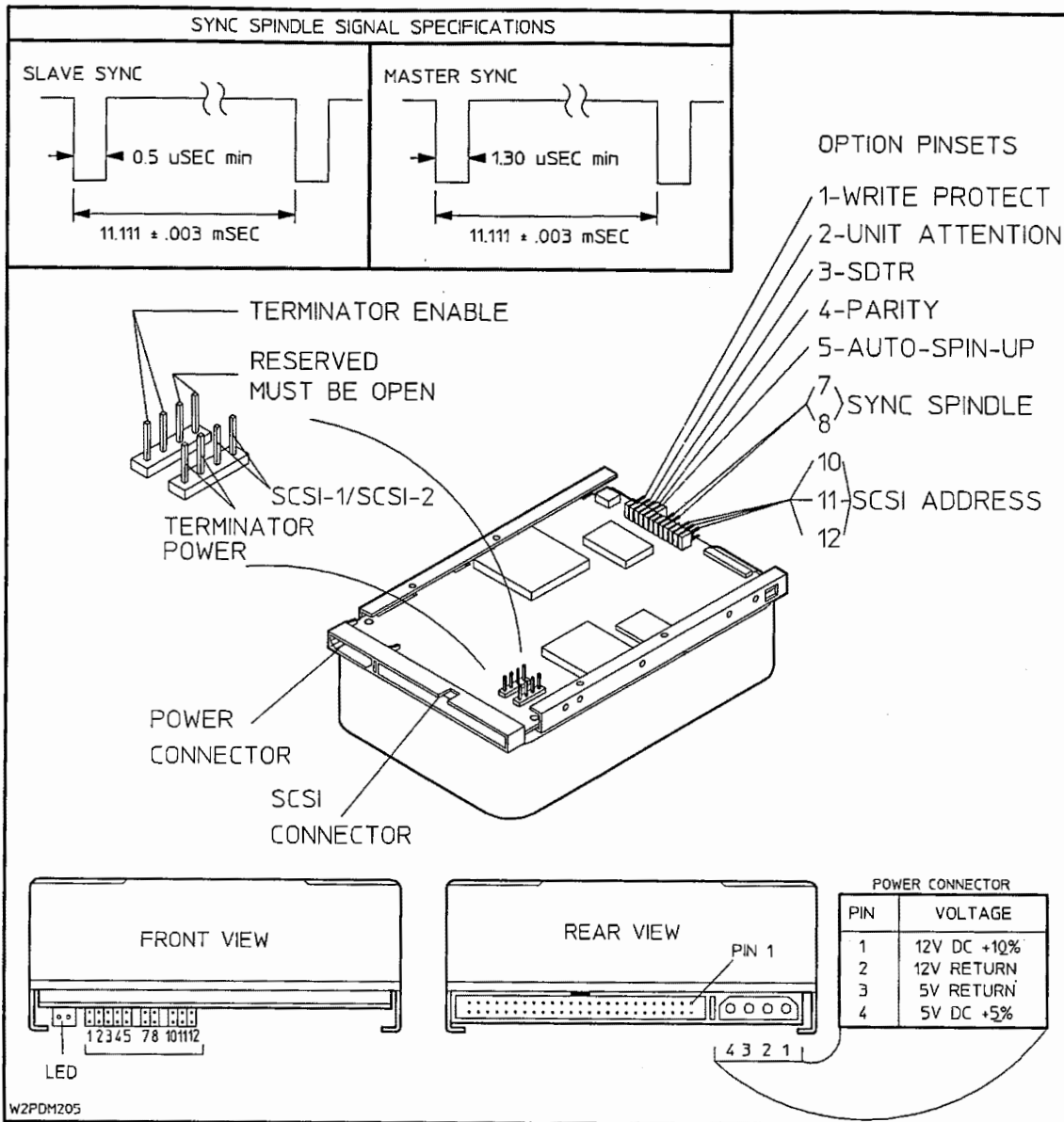

Figure E-2. Narrow, Single-Ended: Interface, Address and Option Connectors

**Table E-1.
Narrow, Single-Ended: Address and Option Connector Configurations**

Refer to Figure E-2 front view for pinset locations.			
Pinset	Function		Configuration
	Upper Pin	Lower Pin	
1 (left)	Write Protect	Gnd	Open: Drive looks at Mode Page header and responds accordingly; default = NOT write protected. Shorted: Drive is forced into the Write Protect mode.
2	Unit Attention	Gnd	Open: Enable Unit Attention. Shorted: Inhibit Unit Attention.
3	SDTR	Gnd	Open: Inhibit drive initiation of SDTR message. Shorted: Enable drive initiation of SDTR message at Power-On and Reset.
4	Parity	Gnd	Open: Inhibit parity checking. Shorted: Enable parity checking.
5	Auto Spin-Up	Gnd	Open: Drive will not spin up until Initiator sends Start Unit Command. Shorted: Drive will spin up automatically at Power-On.
6	Key: No pins.		
7	SCSI pin 29	Gnd	<p>Note: Pinsets 7 and 8 have no effect if Sync Spindle Mode is disabled. Refer to Mode Page 04H.</p> <p>7 Open, 8 Open: <i>Not Allowed.</i></p> <p>7 Open, 8 Shorted: Connects Sync Spindle line to SCSI pin 29. When pinset 8 is shorted, pinset 7 <i>must</i> be open.</p> <p>7 Shorted, 8 Open: Connects SCSI pin 29 to ground. Upper pin of pinset 8 is sync output in Master mode, or sync input in Slave mode. When pinset 7 is shorted, pinset 8 <i>must</i> be open.</p> <p>7 Shorted, 8 Shorted: <i>Not Allowed.</i></p>
8	Sync Spindle	SCSI pin 29	
9	Key: No pins.		
10	Unit Select 3	Gnd	<p>0 = Open, S = Shorted</p> <p>SCSI Address 0: 10 = 0, 11 = 0, 12 = 0</p> <p>SCSI Address 1: 10 = 0, 11 = 0, 12 = S</p> <p>SCSI Address 2: 10 = 0, 11 = S, 12 = 0</p> <p>SCSI Address 3: 10 = 0, 11 = S, 12 = S</p> <p>SCSI Address 4: 10 = S, 11 = 0, 12 = 0</p> <p>SCSI Address 5: 10 = S, 11 = 0, 12 = S</p> <p>SCSI Address 6: 10 = S, 11 = S, 12 = 0</p> <p>SCSI Address 7: 10 = S, 11 = S, 12 = S</p>
11	Unit Select 2	Gnd	
12 (right)	Unit Select 1	Gnd	
SCSI-1/SCSI-2		<p>Open: Drive looks at Mode Page 09, byte 8, bit 4 and responds accordingly; default = SCSI-2.</p> <p>Shorted: Drive is forced to respond as a SCSI-1 device.</p>	

Terminator Power Source Options

The single-ended drive is shipped with active terminator integrated circuits installed. When installing multiple drives on the SCSI channel, the terminators must be disabled on all but the last drive in the chain. When the Terminator *Enable* jumper is installed, the terminators are connected to the SCSI connector; when removed, the terminators are disconnected from the SCSI connector. Refer to Figure E-2 for the Terminator *Enable* jumper location.

Active terminators should be powered by Terminator voltage (TermPwr) whenever the drive is connected to an active SCSI bus to avoid exceeding the bus high-state input current specification. The Terminator *Power* jumper determines the TermPwr source as listed below. Refer to Figure E-2 for the Terminator *Power* jumper location.

Table E-2.
Narrow, Single-Ended: On-Board Terminator Power (TermPwr) Sources

Note: Terminator Enable jumper <i>must</i> be installed to connect the active terminators to the SCSI connector.	
■ Terminator Enable = open	■ On-board active terminators disabled. Terminators not connected to SCSI Connector.
■ Terminator Enable = shorted	■ On-board active terminators enabled and connected to SCSI bus. TermPwr source determined by placement of Terminator Power pinset jumper.
■ Terminator Power = open	■ TermPwr for on-board terminators provided by the drive only. Drive TermPwr is <i>not</i> connected to SCSI connector pin 26.
■ Terminator Power = shorted	■ TermPwr for on-board terminators provided by the drive, and drive TermPwr <i>is</i> connected to SCSI connector pin 26.

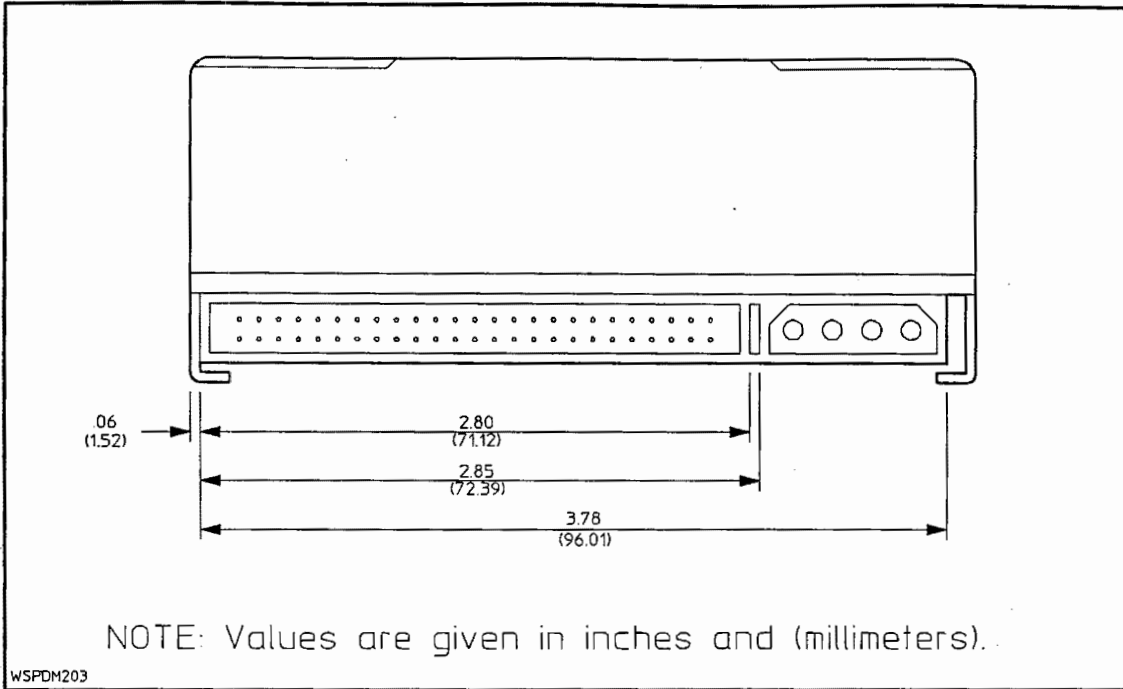

Figure E-3. Narrow, Single-Ended: Connector Dimensions

Table E-3. Narrow, Single-Ended: SCSI Connector Pin Assignments

Pin	Signal	Pin	Signal	Pin	Signal	Pin	Signal
2	-Data Bit 0	16	-Data Bit 7	28	Ground	40	-RST
4	-Data Bit 1	18	-Data Bit P	30	Ground	42	-MSG
6	-Data Bit 2	20	Ground	32	-ATN	44	-SEL
8	-Data Bit 3	22	Ground	34	Ground	46	-C/D
10	-Data Bit 4	24	Ground	36	-BSY	48	-REQ
12	-Data Bit 5	26	TERMPWR	38	-ACK	50	-I/O
14	-Data Bit 6						

Notes:

- All odd numbered pins, except pins 25 and 29, must be connected to ground. Pin 25 should be left open. Pin 29 can be used for Synchronized Spindle operation. Refer to Table E-1 and Figure E-2.
- Pin 26 is reserved for terminator resistor power source.

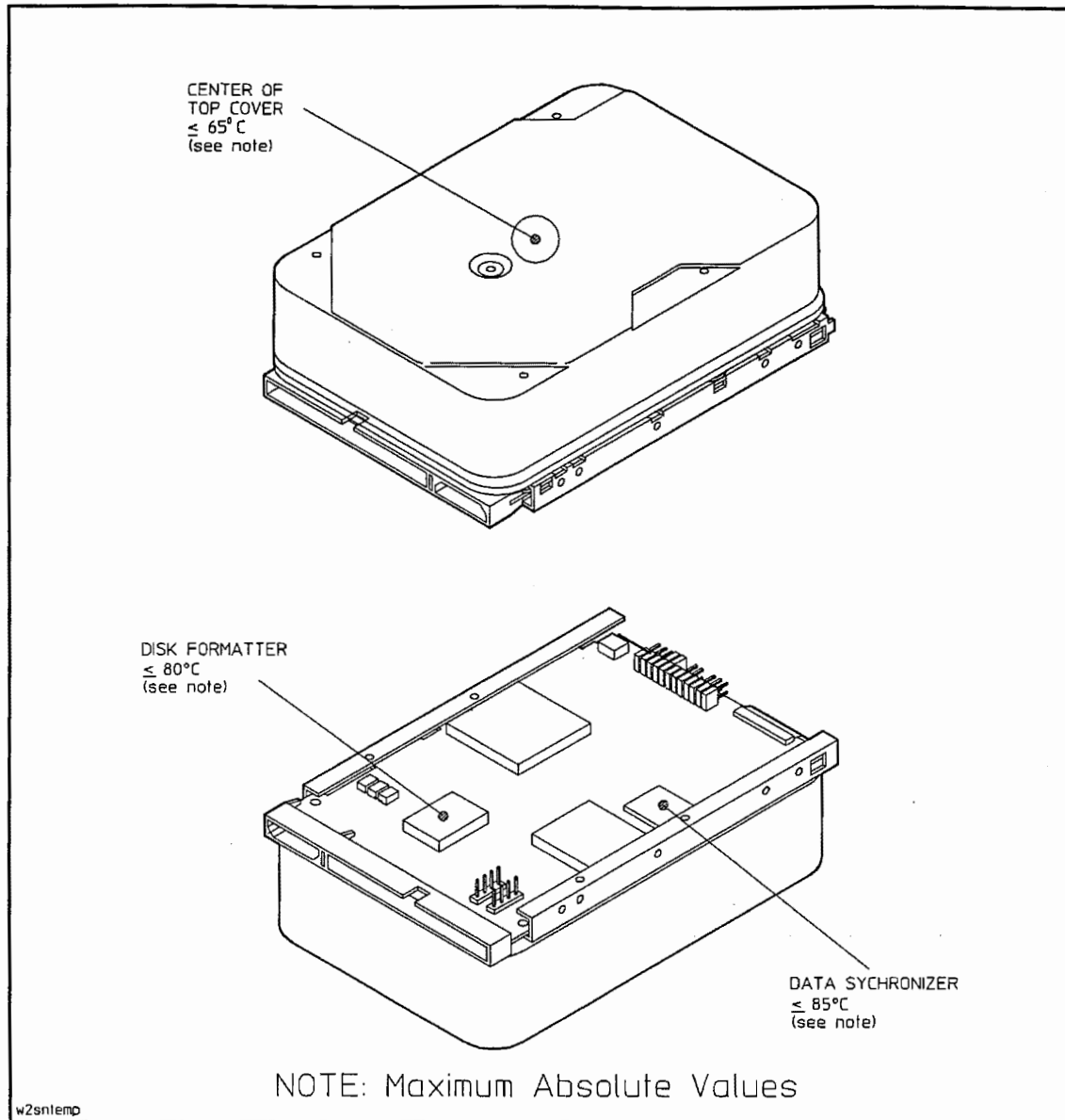

Figure E-4. Narrow, Single-Ended: Operating Temperatures

Operating Temperature Guidelines

The temperatures at the above locations represent the *maximum operating limits* for extended reliable operation. Ambient air temperature and airflow must be properly balanced to maintain drive performance and reliability.

Operating Temperature Considerations

The operating ambient air temperature specification is 5°C to 50°C (41°F to 122°F).

Adjust the ambient air temperature to prevent the temperature at each location from exceeding the stated limit.

Airflow Considerations

The recommended air flow to maintain the component temperatures is 3 to 5 CFM (cubic feet per minute) with most of the air flowing across the printed circuit board.

Adjust the air flow to prevent the temperature at each location from exceeding the stated limit.

E-6 Narrow, Single-Ended Drive Configurations

Narrow, Differential Drive Configurations

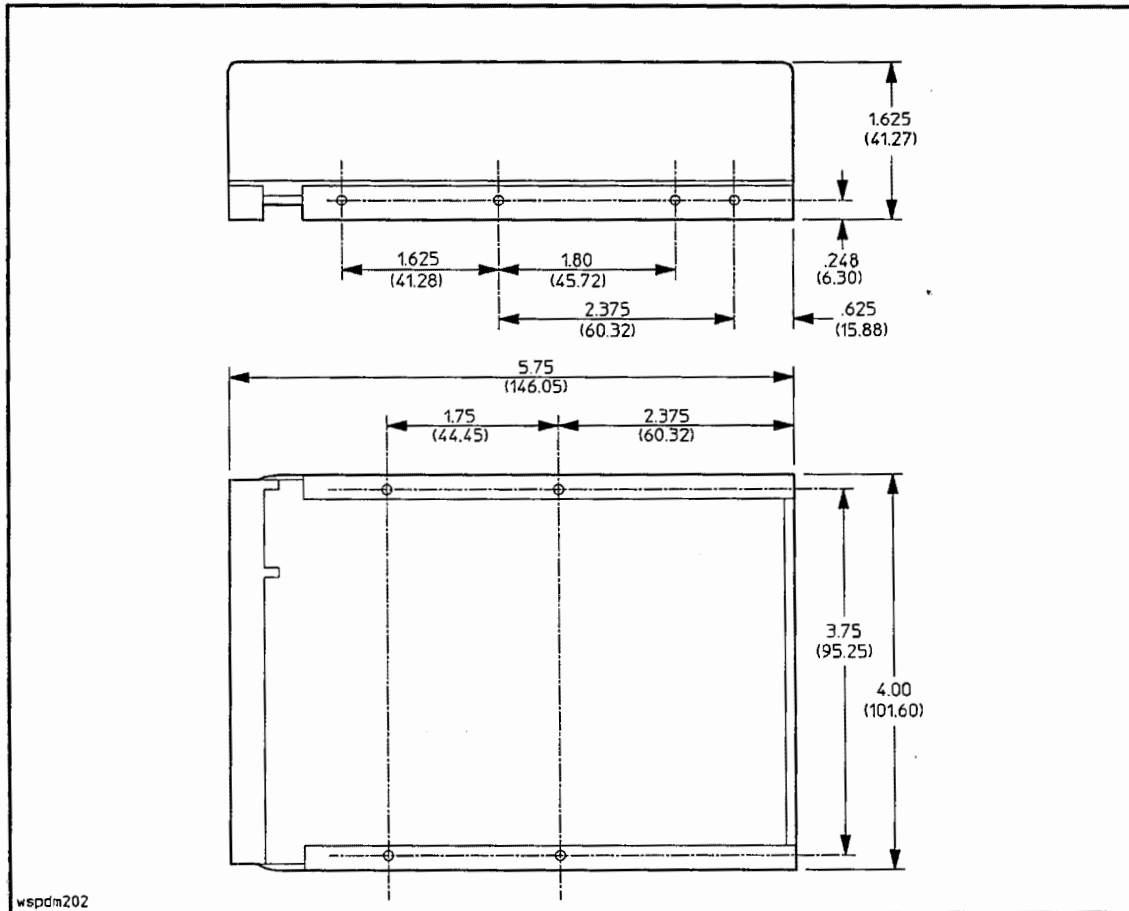

Figure F-1. Narrow, Differential: Disk Drive Dimensions and Mounting Locations

Mounting Guidelines:

1. Values given in inches and (millimeters).
2. Maintain a minimum clearance of 0.06 in. (1.5 mm) between any system structure and the top and all four sides of the disk drive. Insure that the system structure contacts only the drive mounting frames and clears the drive HDA by at least 0.06 in. (1.5 mm).
3. Maintain a minimum clearance of 0.04 in. (1.0 mm) between any system structure and any PCA component.
4. Use 6-32 UNC screws with flat washers under the heads and torque them to 15 inch-pounds.
5. When mounded, the screws should not protrude more than 0.12 in. (3 mm) beyond the inside of the disk drive mounting frame.

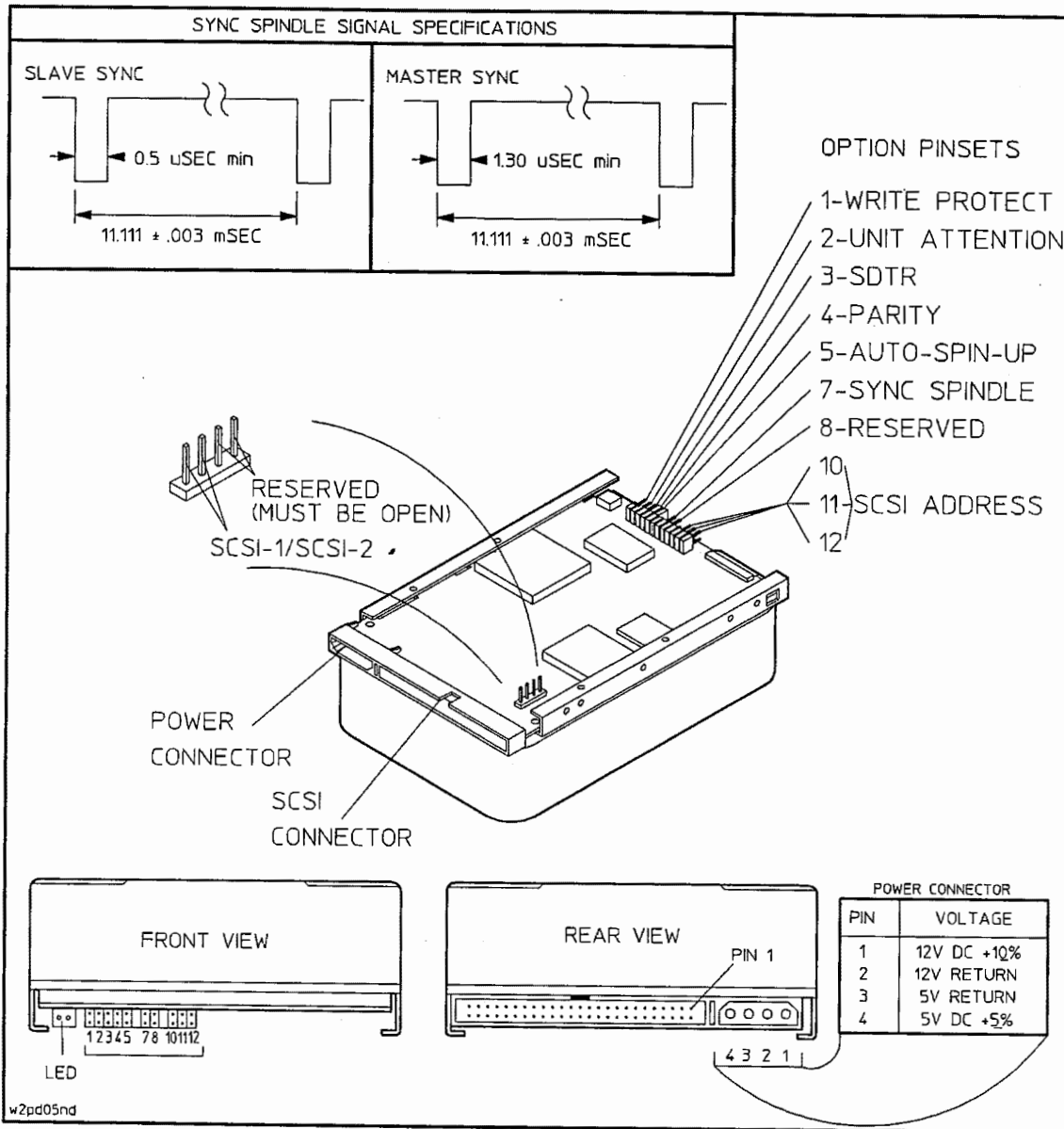

Figure F-2. Narrow, Differential: Interface, Address and Option Connectors

**Table F-1.
Narrow, Differential: Address and Option Connector Configurations**

Refer to Figure F-2 front view for pinset locations.			
Pinset	Function		Configuration
	Upper Pin	Lower Pin	
1 (left)	Write Protect	Gnd	<p>Open: Drive looks at Mode Page header and responds accordingly; default = NOT write protected.</p> <p>Shorted: Drive is forced into the Write Protect mode.</p>
2	Unit Attention	Gnd	<p>Open: Enable Unit Attention.</p> <p>Shorted: Inhibit Unit Attention.</p>
3	SDTR	Gnd	<p>Open: Inhibit drive initiation of SDTR message.</p> <p>Shorted: Enable drive initiation of SDTR message at Power-On and Reset.</p>
4	Parity	Gnd	<p>Open: Inhibit parity checking.</p> <p>Shorted: Enable parity checking.</p>
5	Auto Spin-Up	Gnd	<p>Open: Drive will not spin up until Initiator sends Start Unit Command.</p> <p>Shorted: Drive will spin up automatically at Power-On.</p>
6	Key: No pins.		
7	Sync Spindle	Gnd	<p>Pinset 7 has no effect if Sync Spindle Mode is disabled. Refer to Mode Page 04H.</p> <p>Upper pin is sync output in Master mode, or sync input in Slave mode.</p> <p><i>Do not</i> short this pinset. The purpose of the lower pin is to provide a ground for external cabling.</p>
8	Reserved		
9	Reserved		
10	Unit Select 3	Gnd	<p>0 = Open, S = Shorted</p> <p>SCSI Address 0: 10 = 0, 11 = 0, 12 = 0</p> <p>SCSI Address 1: 10 = 0, 11 = 0, 12 = S</p> <p>SCSI Address 2: 10 = 0, 11 = S, 12 = 0</p> <p>SCSI Address 3: 10 = 0, 11 = S, 12 = S</p> <p>SCSI Address 4: 10 = S, 11 = 0, 12 = 0</p> <p>SCSI Address 5: 10 = S, 11 = 0, 12 = S</p> <p>SCSI Address 6: 10 = S, 11 = S, 12 = 0</p> <p>SCSI Address 7: 10 = S, 11 = S, 12 = S</p>
11	Unit Select 2	Gnd	
12 (right)	Unit Select 1	Gnd	
SCSI-1/SCSI-2		<p>Open: Drive looks at Mode Page 09, byte 8, bit 4 and responds accordingly; default = SCSI-2.</p> <p>Shorted: Drive is forced to respond as a SCSI-1 device.</p>	

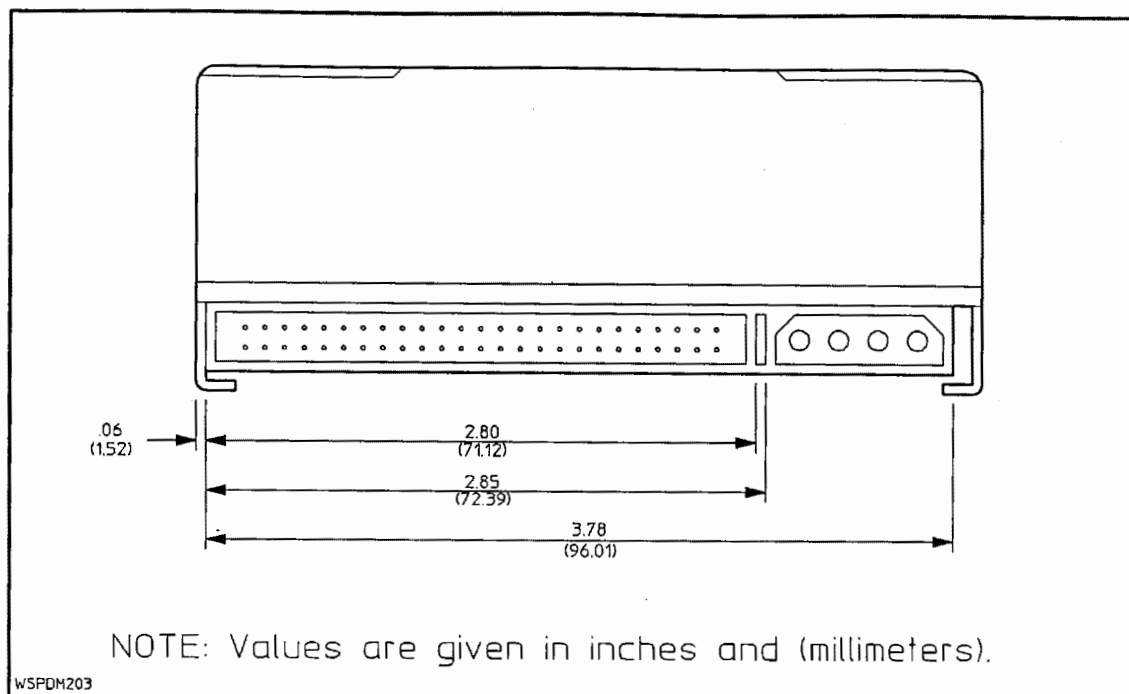

Figure F-3. Narrow, Differential: Connector Dimensions

Table F-2. Narrow, Differential: SCSI Connector Pin Assignments

Pin	Signal	Pin	Signal	Pin	Signal	Pin	Signal
1	Shield GND	14	-DB(5)	27	Ground	39	+MSG
2	Ground	15	+DB(6)	28	Ground	40	-MSG
3	+DB(0)	16	-DB(6)	29	+ATN	41	+SEL
4	-DB(0)	17	+DB(7)	30	-ATN	42	-SEL
5	+DB(1)	18	-DB(7)	31	Ground	43	+C/D
6	-DB(1)	19	+DB(P)	32	Ground	44	-C/D
7	+DB(2)	20	-DB(P)	33	+BSY	45	+REQ
8	-DB(2)	21	DIFFSENS	34	-BSY	46	-REQ
9	+DB(3)	22	Ground	35	+ACK	47	+I/O
10	-DB(3)	23	Ground	36	-ACK	48	-I/O
11	+DB(4)	24	Ground	37	+RST	49	Ground
12	-DB(4)	25	TERMPWR	38	-RST	50	Ground
13	+DB(5)	26	TERMPWR				

Note: SHIELD GND is optional on some cables. (Implementors note: Some shielded flat ribbon cables use pin 1 as a connection to the shield.)

F-4 Narrow, Differential Drive Configurations

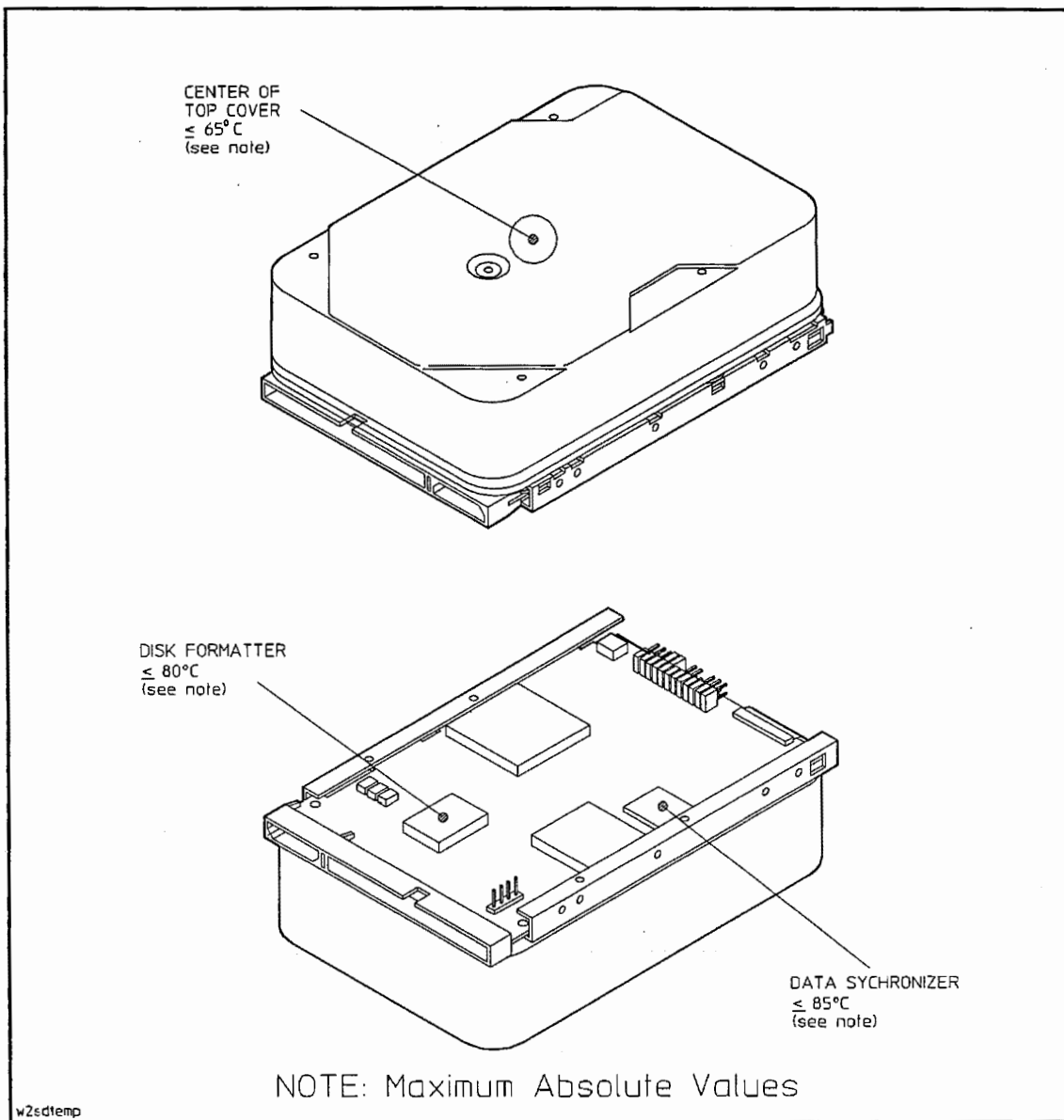

Figure F-4. Narrow, Differential: Operating Temperatures

Operating Temperature Guidelines

The temperatures at the above locations represent the *maximum operating limits* for extended reliable operation. Ambient air temperature and airflow must be properly balanced to maintain drive performance and reliability.

Operating Temperature Considerations

The operating ambient air temperature specification is 5°C to 50°C (41°F to 122°F).

Adjust the ambient air temperature to prevent the temperature at each location from exceeding the stated limit.

Airflow Considerations

The recommended air flow to maintain the component temperatures is 3 to 5 CFM (cubic feet per minute) with most of the air flowing across the printed circuit board.

Adjust the air flow to prevent the temperature at each location from exceeding the stated limit.

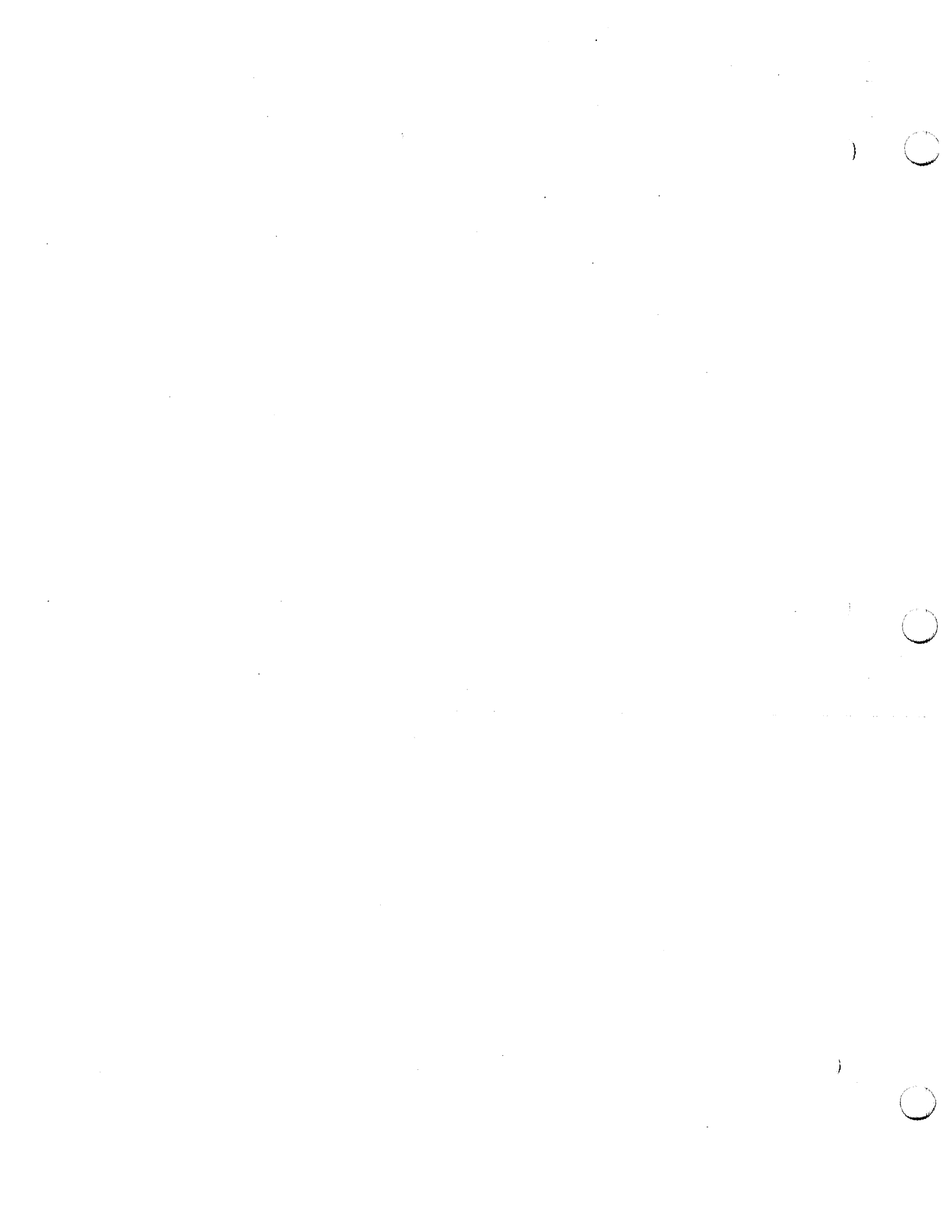

Wide, Differential Drive Configurations

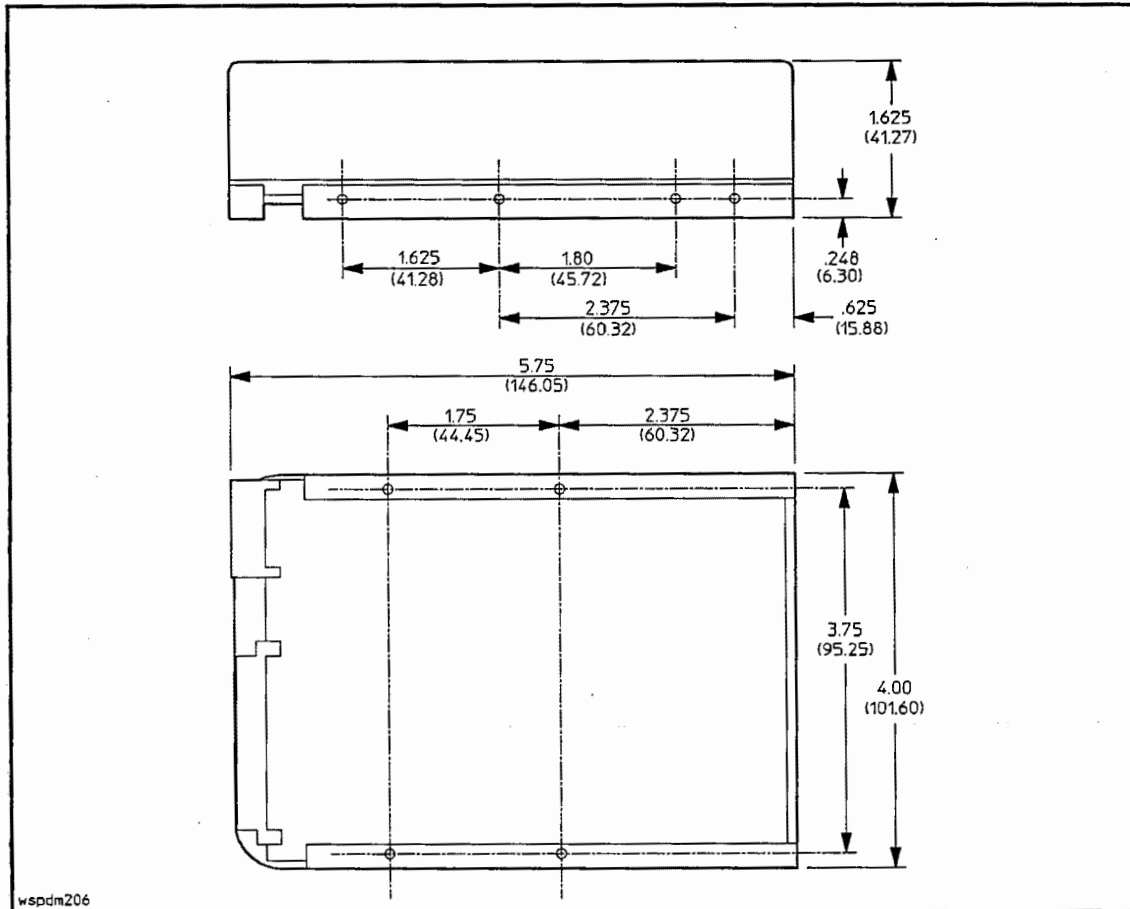

Figure G-1. Wide, Differential: Disk Drive Dimensions,

Mounting Guidelines:

1. Values given in inches and (millimeters).
2. Maintain a minimum clearance of 0.06 in. (1.5 mm) between any system structure and the top and all four sides of the disk drive. Insure that the system structure contacts only the drive mounting frames and clears the drive HDA by at least 0.06 in. (1.5 mm).
3. Maintain a minimum clearance of 0.04 in. (1.0 mm) between any system structure and any PCA component.
4. Use 6-32 UNC screws with flat washers under the heads and torque them to 15 inch-pounds.
5. When mounded, the screws should not protrude more than 0.12 in. (3 mm) beyond the inside of the disk drive mounting frame.

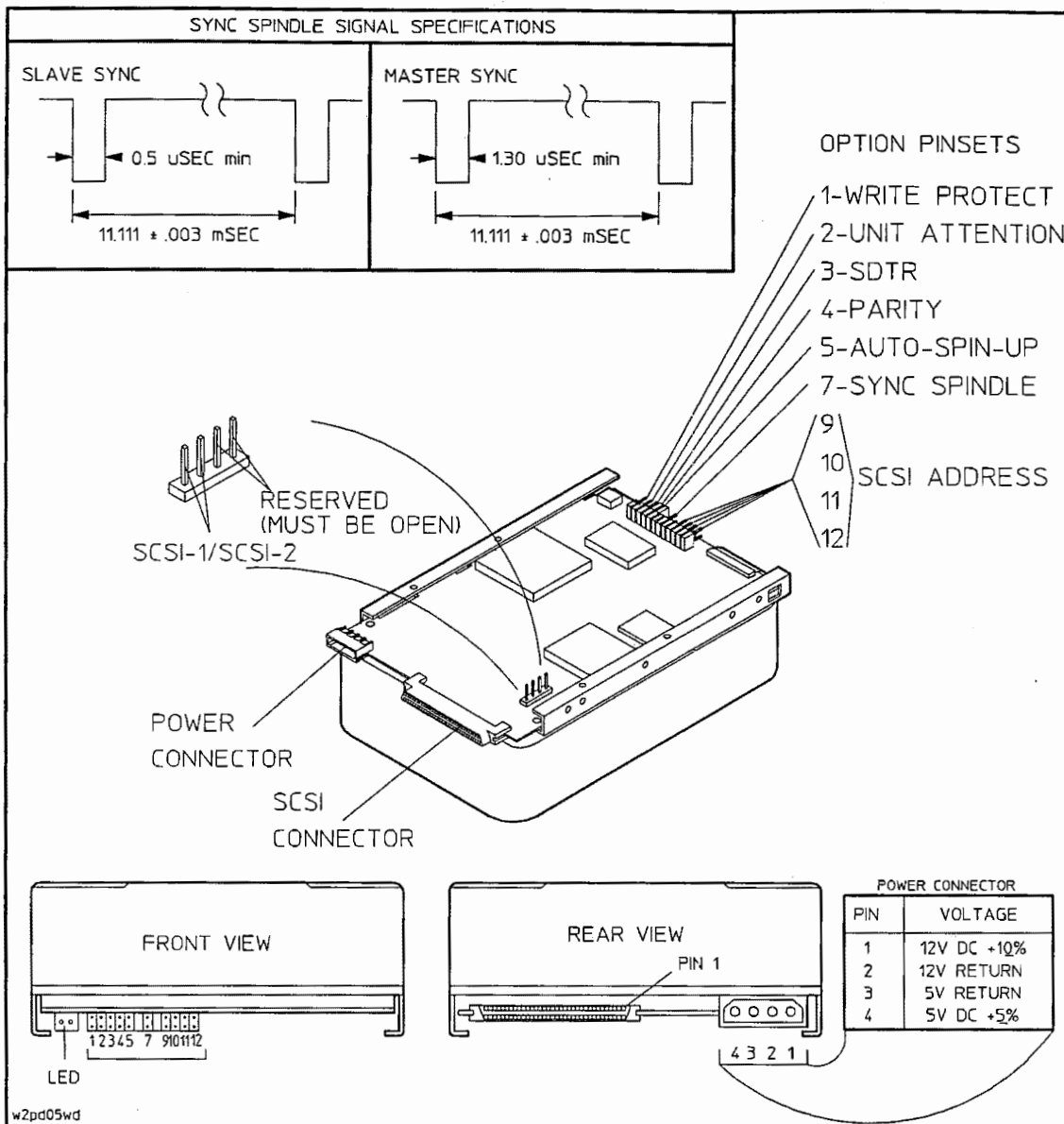

Figure G-2. Wide, Differential: Interface, Address and Option Connectors

Table G-1. Wide, Differential: Address and Option Connector Configurations

Refer to Figure G-2 front view for pinset locations.			
Pinset	Function		Configuration
	Upper Pin	Lower Pin	
1 (left)	Write Protect	Gnd	<p>Open: Drive looks at Mode Page header and responds accordingly; default = NOT write protected.</p> <p>Shorted: Drive is forced into the Write Protect mode.</p>
2	Unit Attention	Gnd	<p>Open: Enable Unit Attention.</p> <p>Shorted: Inhibit Unit Attention.</p>
3	SDTR	Gnd	<p>Open: Inhibit drive initiation of SDTR message.</p> <p>Shorted: Enable drive initiation of SDTR message at Power-On and Reset.</p>
4	Parity	Gnd	<p>Open: Inhibit parity checking.</p> <p>Shorted: Enable parity checking.</p>
5	Auto Spin-Up	Gnd	<p>Open: Drive will not spin up until Initiator sends Start Unit Command.</p> <p>Shorted: Drive will spin up automatically at Power-On.</p>
6	Key: No pins.		
7	Sync Spindle	Gnd	<p>Pinset 7 has no effect if Sync Spindle Mode is disabled. Refer to Mode Page 04H.</p> <p>Upper pin is sync output in Master mode, or sync input in Slave mode.</p> <p><i>Do not</i> short this pinset. The purpose of the lower pin is to provide a ground for external cabling.</p>
8	Key: No pins.		
9	Unit Select 4	Gnd	<p>0 = Open, S = Shorted</p> <p>SCSI Address 0: 12 = 0, 11 = 0, 10 = 0, 9 = 0</p> <p>SCSI Address 1: 12 = 0, 11 = 0, 10 = 0, 9 = S</p> <p>SCSI Address 2: 12 = 0, 11 = 0, 10 = S, 9 = 0</p> <p>SCSI Address 3: 12 = 0, 11 = 0, 10 = S, 9 = S</p> <p>SCSI Address 4: 12 = 0, 11 = S, 10 = 0, 9 = 0</p> <p>SCSI Address 5: 12 = 0, 11 = S, 10 = 0, 9 = S</p> <p>SCSI Address 6: 12 = 0, 11 = S, 10 = S, 9 = 0</p> <p>SCSI Address 7: 12 = 0, 11 = S, 10 = S, 9 = S</p> <p>SCSI Address 8: 12 = S, 11 = 0, 10 = 0, 9 = 0</p> <p>SCSI Address 9: 12 = S, 11 = 0, 10 = 0, 9 = S</p> <p>SCSI Address 10: 12 = S, 11 = 0, 10 = S, 9 = 0</p> <p>SCSI Address 11: 12 = S, 11 = 0, 10 = S, 9 = S</p> <p>SCSI Address 12: 12 = S, 11 = S, 10 = 0, 9 = 0</p> <p>SCSI Address 13: 12 = S, 11 = S, 10 = 0, 9 = S</p> <p>SCSI Address 14: 12 = S, 11 = S, 10 = S, 9 = 0</p> <p>SCSI Address 15: 12 = S, 11 = S, 10 = S, 9 = S</p>
10	Unit Select 3	Gnd	
11	Unit Select 2	Gnd	
12	Unit Select 1	Gnd	
SCSI-1/SCSI-2			

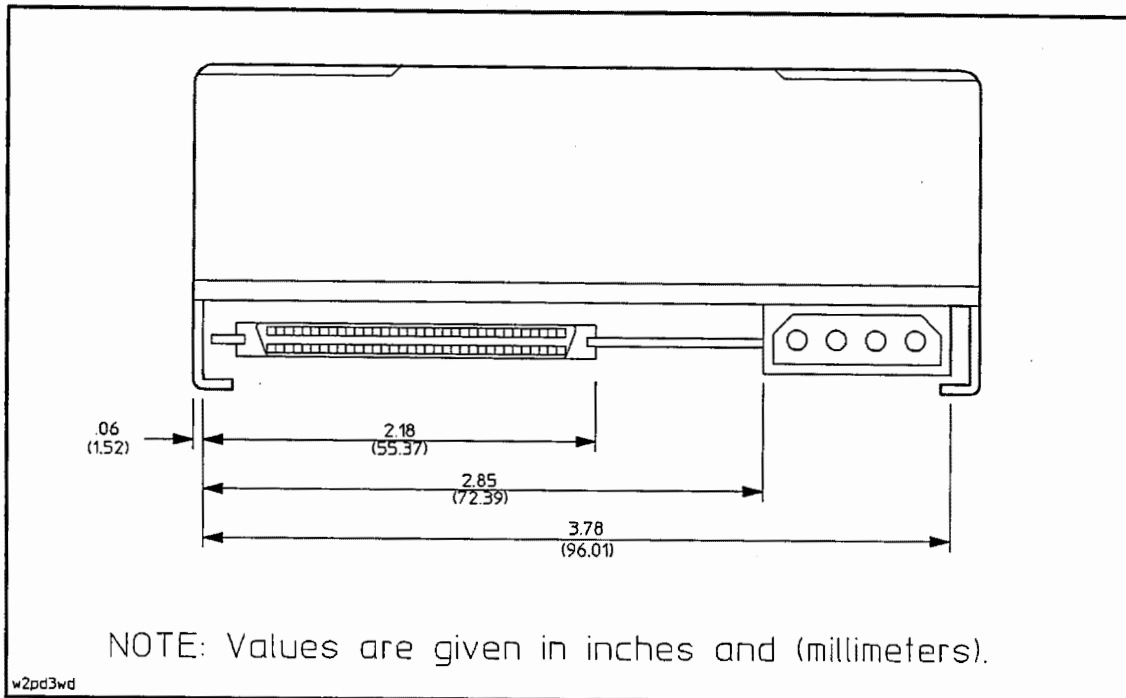

Figure G-3. Wide, Differential: Connector Dimensions

Table G-2. Wide, Differential: SCSI Connector Pin Assignments

Pin	Signal	Pin	Signal	Pin	Signal	Pin	Signal
1	+DB(12)	18	TermPwr	35	-DB(12)	52	TermPwr
2	+DB(13)	19	Reserved	36	-DB(13)	53	Reserved
3	+DB(14)	20	+ATN	37	-DB(14)	54	-ATN
4	+DB(15)	21	Ground	38	-DB(15)	55	Ground
5	+DB(P1)	22	+BSY	39	-DB(P1)	56	-BSY
6	Ground	23	+ACK	40	Ground	57	-ACK
7	+DB(0)	24	+RST	41	-DB(0)	58	-RST
8	+DB(1)	25	+MSG	42	-DB(1)	59	-MSG
9	+DB(2)	26	+SEL	43	-DB(2)	60	-SEL
10	+DB(3)	27	+C/D	44	-DB(3)	61	-C/D
11	+DB(4)	28	+REQ	45	-DB(4)	62	-REQ
12	+DB(5)	29	+I/O	46	-DB(5)	63	-I/O
13	+DB(6)	30	Ground	47	-DB(6)	64	Ground
14	+DB(7)	31	+DB(8)	48	-DB(7)	65	-DB(8)
15	+DB(P)	32	+DB(9)	49	-DB(P)	66	-DB(9)
16	DiffSens	33	+DB(10)	50	Ground	67	-DB(10)
17	TermPwr	34	+DB(11)	51	TermPwr	68	-DB(11)

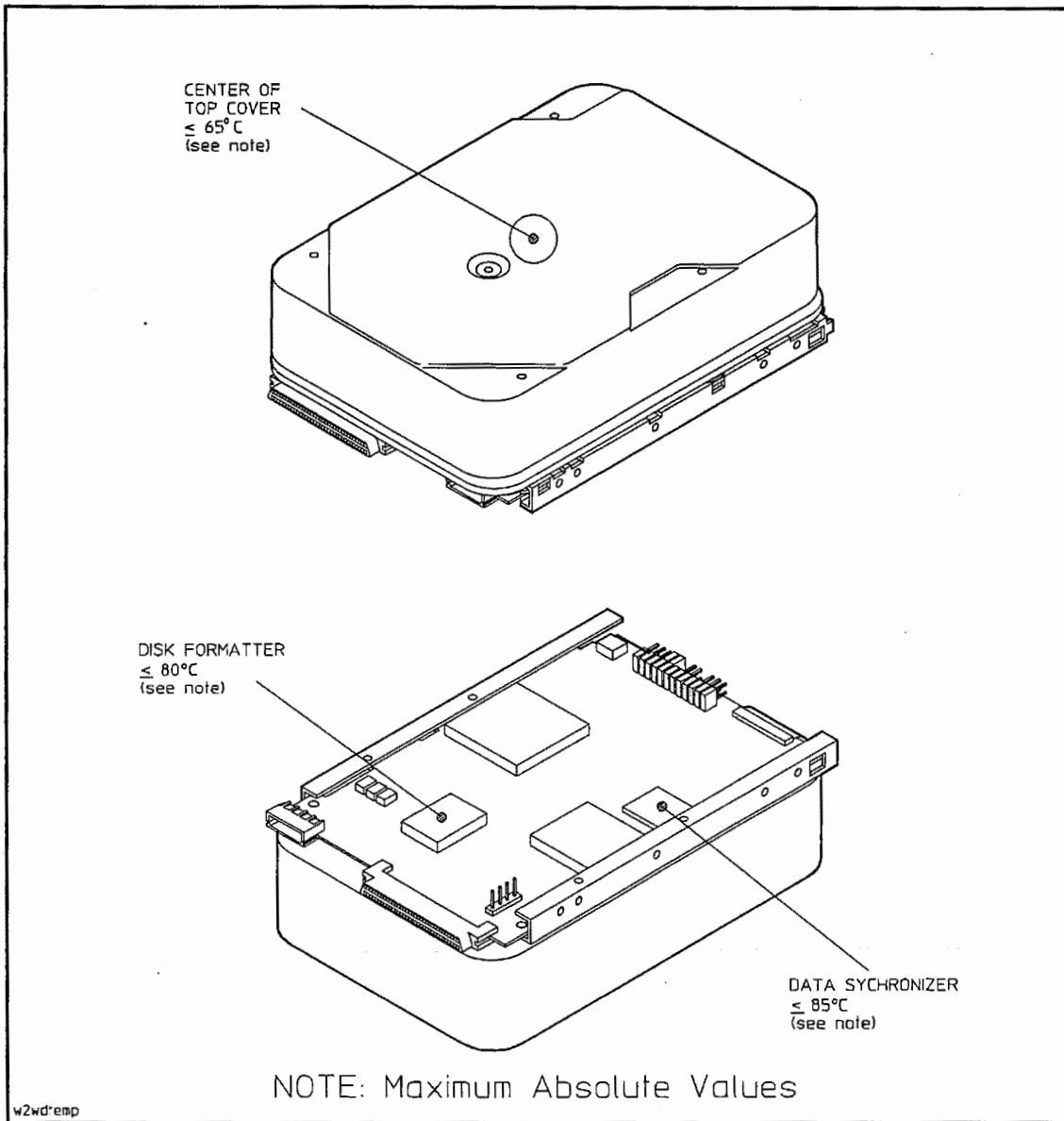

Figure G-4. Wide, Differential: Operating Temperatures

Operating Temperature Guidelines

The temperatures at the above locations represent the *maximum operating limits* for extended reliable operation. Ambient air temperature and airflow must be properly balanced to maintain drive performance and reliability.

Operating Temperature Considerations

The operating ambient air temperature specification is 5°C to 50°C (41°F to 122°F).

Adjust the ambient air temperature to prevent the temperature at each location from exceeding the stated limit.

Airflow Considerations

The recommended air flow to maintain the component temperatures is 4 to 6 CFM (cubic feet per minute) with most of the air flowing across the printed circuit board.

Adjust the air flow to prevent the temperature at each location from exceeding the stated limit.

