

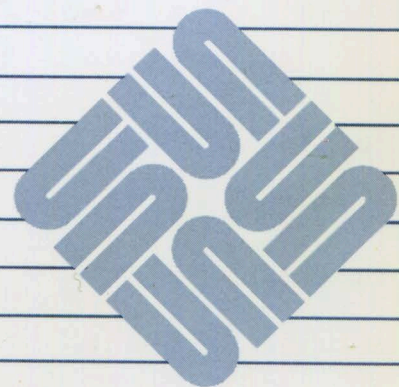

# Sun™ Rackmountable Fileservers Installation Manual





---

# Sun™ Rackmountable Fileservers Installation Manual

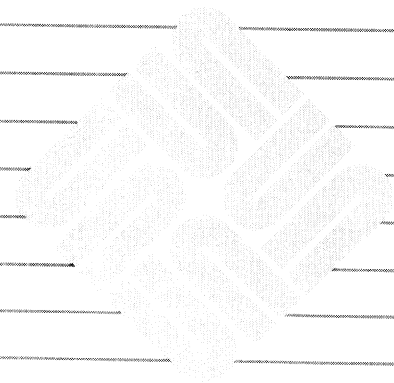

# Credits and Trademarks

**Multibus** is a trademark of Intel Corporation.

**Sun Microsystems** and **Sun Workstation** are registered trademarks of Sun Microsystems, Incorporated. **Sun-2**, **Sun-2/xxx**, **Sun-3/xxx**, **Deskside**, **SunStation**, **SunCore**, **SunWindows**, and **DVMA** are trademarks of Sun Microsystems, Incorporated.

**UNIX** is a trademark of AT&T Bell Laboratories.

This equipment generates, uses, and can radiate radio frequency energy and if not installed and used in accordance with the instructions manual, may cause interference to radio communications. It has been tested and found to comply with the limits for a Class A computing device pursuant to Subpart J of Part 15 of FCC Rules, which are designed to provide reasonable protection against such interference when operated in a commercial environment. Operation of this equipment in a residential area is likely to cause interference in which case the user at his own expense will be required to take whatever measures may be required to correct the interference.

## WARNING

The CPU board installed in this enclosure may have an on-board Lithium Battery Component (BBCV2), Matsushita Electric Type No. BR2325. This battery is not a customer replaceable part. The battery will be marked as follows: "Warning - Replace battery with MATSUSHITA ELECTRIC or PANASONIC part No. BR2325 only. Use of another battery may present a risk of fire or explosion." The battery may explode if mistreated. Do not dispose of in fire, attempt to recharge, or disassemble the battery.

Copyright © 1988 by Sun Microsystems, Inc.

This publication is protected by Federal Copyright Law, with all rights reserved. No part of this publication may be reproduced, stored in a retrieval system, translated, transcribed, or transmitted, in any form, or by any means manual, electric, electronic, electro-magnetic, mechanical, chemical, optical, or otherwise, without prior explicit written permission from Sun Microsystems.

---

# Contents

Preface .....	iii
<b>Chapter 1 The Sun Rackmountable Fileserver .....</b>	<b>3</b>
1.1. Introduction .....	3
1.2. Rack Requirements .....	3
<b>Chapter 2 Installation .....</b>	<b>7</b>
2.1. Unpacking and Inspection .....	7
2.2. Tools Needed .....	7
2.3. Installation .....	8
2.4. External Connections .....	13
2.5. Power Controller Cabling .....	13





---

## Figures

Figure 2-1 Typical Rack Installation .....	8
Figure 2-2 Support Bracket Installation .....	10
Figure 2-3 Support Rail Installation .....	11
Figure 2-4 Fileserver Installation .....	12
Figure 2-5 Connections to the 115V Power Supply .....	13
Figure 2-6 Connections to the 230V Power Controller .....	14
Figure 2-7 Connections to the 240V Power Controller .....	14





---

## Preface

**Purpose of the Manual.** This manual is written for field service personnel and users of Sun Rackmountable Fileservers. It contains information about installing a rackmountable fileserver in a Sun or user supplied rack.

**Applicable Sun Documents.** Documents which contain information necessary or helpful for the installation and operation of the rackmountable fileserver are listed below.

1. *Cardcage Slot Assignments and Backplane Configuration Procedures.*
2. *Installing UNIX on the Sun Workstation.*
3. *System Administration for the Sun Workstation.*
4. *System Managers Manual for the Sun Workstation.*
5. *Installation Manual for the Sun 12-Slot Deskside Logic Enclosure.*
6. *Installation and Service Manual for the Sun-3/180 Tape Drive Option.*
7. *Installation and Service Manual for the Sun-3 Small Computer System Interface Circuit Card Option.*
8. *Installation Manual for the Sun Full-Height Rack System..*

Your rackmount system will also be shipped with an installation document that is specifically for the CPU board you ordered.

**CAUTION** Springfingers are metal strips that are installed between the edge of the PC board and the outer panel to reduce RFI emissions. Serrated metal "fingers" protrude from either side of the strip.

If a board WITH springfingers is installed next to a board WITHOUT spring fingers, the insulator shield on the outside of the fingers **MUST** be present to prevent possible shorting of component leads to the spring fingers. Installation of a board WITHOUT springfingers may affect RFI emissions and may therefore affect FCC compliance. Sun will no longer be responsible for FCC compliance if non-springfingered boards are added to a system originally shipped WITH springfingers and FCC approval.



**In the case of a logic enclosure containing boards WITH and WITHOUT springfingers use the following guidelines:**

- Before removing a board WITHOUT springfingers, remove the board to the left if it is equipped WITH springfingers and an outer insulator shield.
- Replace any filler panel equipped WITH springfingers by pulling out the air restrictor panel far enough to allow the springfingers to lay against the panel. Push both units into place simultaneously and fasten with the appropriate fasteners. This procedure makes replacement of the filler panels easier, and reduces the chance of damage to the springfingers.
- Always install a board WITHOUT springfingers first, and then replace the board WITH springfingers and insulator shield in the slot on the left.

**If a board with springfingers is installed next to a board or filler panel also equipped with springfingers, the outside insulator shields should be removed.**

**Ensure that the insulator strip between the inner side of the springfingers and the PC board is intact at all times.**

**When removing and replacing boards with spring fingers, check the condition of the insulator strip/shield(s) and replace if damaged.**

**Call 800 USA-4SUN with any questions, or for information on how to obtain additional insulator strips or shields.**

**Some of the devices on Sun boards are very sensitive to electro-static discharge, that can be built up in the human body and discharge when you touch the board. Before handling any board, make sure that you have placed your hand on a conductive surface that is grounded to a common earth ground, (such as the metal screws on an AC receptacle cover) to discharge any static electricity present in your body.**

---

# The Sun Rackmountable Fileserver

The Sun Rackmountable Fileserver .....	3
1.1. Introduction .....	3
1.2. Rack Requirements .....	3

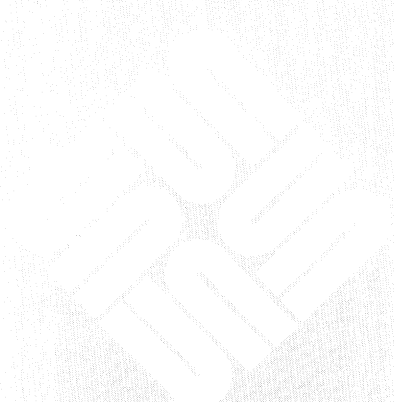



---

# The Sun Rackmountable Fileserver

## 1.1. Introduction

This installation manual describes the installation procedures for rackmountable file servers. It is meant to be used **in addition to** the *Installation Manual for the Sun Full-Height Rack System*, and in tandem with the CPU board installation document shipped with the system.

## 1.2. Rack Requirements

*NOTE* The fileserver assembly **must be mounted in a rack enclosure**. The fileserver will be damaged by blocked cooling if located on a flat surface.

The fileserver may be installed in a Sun rack, assembly number 595-1346-01. The Sun rack is equipped with an AC power controller, exhaust fans, keyswitch, and blank filler panels. The rack is furnished with front, center, and rear standard (RETMA) rails. Sun rack dimensions are shown below.

Outside: 77-1/2" high x 35" deep x 25-1/2" wide.

Inside: 70" high x 34" deep x 19" wide.

The fileserver may be installed in a user-supplied 19-inch commercial electronic rack with front and rear RETMA rails. The minimum rack height is 36 inches for the fileserver assembly alone. Minimum rack depth is 34 inches if the Fujitsu disk drives are to be installed. The user-supplied rack must be equipped with stabilizer bars if the half-inch tape drive option or the disk drive option is to be installed.



---

# Installation

Installation .....	7
2.1. Unpacking and Inspection .....	7
2.2. Tools Needed .....	7
2.3. Installation .....	8
2.4. External Connections .....	13
2.5. Power Controller Cabling .....	13





---

## Installation

This chapter contains information for unpacking and installing the rackmountable fileserver assembly.

**CAUTION** Before installing any equipment in the rack, or performing any maintenance, insure that the rack is unplugged from its AC source.

### 2.1. Unpacking and Inspection

The fileserver assembly is shipped in a cardboard carton. The assembly is protected by foam side caps.

Inspect the shipping carton for evidence of exterior damage. Notify the shipping carrier and your Sun service representative if damage is observed.

Locate the packing list. Remove shipping bands and tape from the shipping cartons. Open the carton's top flaps.

**CAUTION** The fileserver weighs approximately 115 pounds. A minimum of two people are required to unpack and install the fileserver.

Invert the carton and lift away from the fileserver assembly. Carefully remove the foam end caps. Inspect the assembly for physical damage and loose or missing parts. Notify the shipping carrier if concealed damage is found.

Before proceeding with the installation, it is necessary to pry off the front panel of the fileserver, which is secured by snap-on ball screws. Set it aside, and remove the two aluminum support braces that are attached to the mounting brackets on the front of the fileserver. Unscrew the five 10mm length screws that retain each brace, and set them aside. The braces are for protection during shipping and are not used for the installation.

### 2.2. Tools Needed

The following tools will be needed to install the rackmountable fileserver.

- wire cutter — to cut tie wraps
- flat blade screwdriver
- Philips #2 screwdriver
- flashlight — may be needed to view interior of the rack
- torque wrench capable of up to 50 inch-pounds with blade and Phillips #2 screwdriver fittings



2.3. Installation

A typical fileserver location in a Sun rack installation is shown in figure 2-1.

*NOTE* The fileserver assembly requires a minimum of 3-1/2 inches of cooling air clearance at the bottom and a minimum of 1-3/4 inches of clearance at the top.

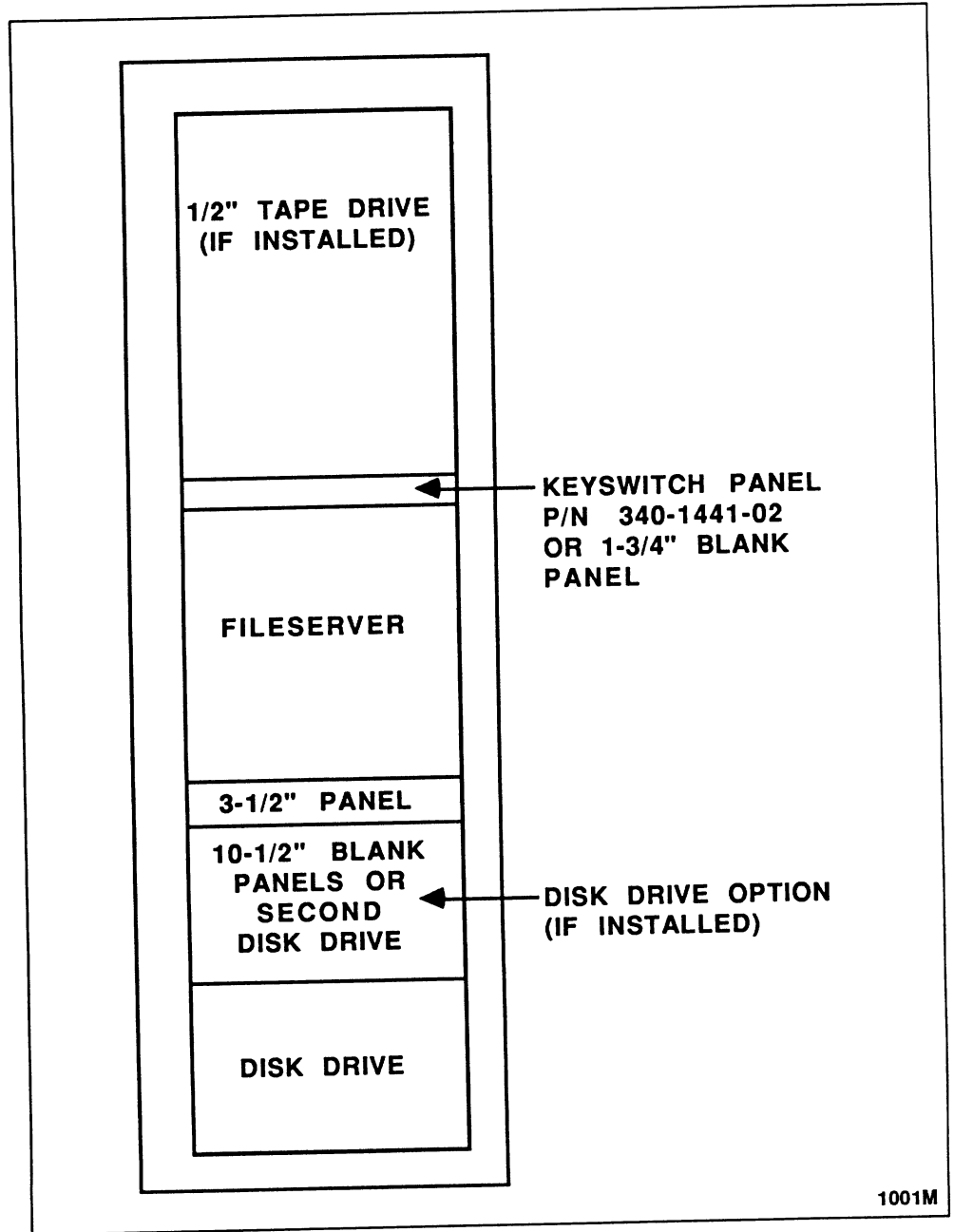

Figure 2-1 Typical Rack Installation

Perform the following procedure to install the mounting hardware, fileserver assembly, and panels. The procedure is tailored for a Sun rack, use similar measurements for a user-supplied commercial rack.

1. Install the four support brackets on the front and rear RETMA rails as shown in figure 2-2 (Sun rack). Locate the brackets so that their upper edges are raised 24 1/2" from the bottom of the RETMA rails. Install screws from inside the RETMA rail and torque to 20 inch-pounds.
2. Secure the two support rails (right and left) to the support brackets as shown in figure 2-3, using the nuts and bolts provided. Install the four slotted hex-head bolts and locknuts in each support rail. Position the support rails so their upper edges are flush with the upper edges of the brackets and their forward edges are flush with the front RETMA rails. Torque the bolts to 36 inch-pounds.
3. *Option Step.* Perform this step if the cartridge tape drive option is to be installed in the fileserver. Install the cartridge tape drive option following the instructions in *Installation and Service Manual for the Sun-3/180 Tape Drive Option*.
4. Remove the keyswitch panel from the rack, and the 3 1/2" panel below the fileserver location (if installed) and set aside.

**CAUTION**

**The Sun rack base stabilizer bars must be fully extended, with the feet adjusted, before attempting to install the fileserver or extend any other equipment from the front of the rack. Failure to extend and correctly level the bars may allow the rack to fall forward, resulting in personal injury and equipment damage. The stabilizer bars are located at the extreme bottom of the front of the Sun rack.**

5. Slide the fileserver into the rack on the support rails. Verify that fileserver mounting holes are aligned with holes in RETMA rail. Adjust the height of support rails if necessary.
6. Secure fileserver in rack with eight 10-32 x 1/2 screws (figure 2-4).
7. Place fileserver front panel over front of assembly and snap in place.
8. Route the AC power cord from the fileserver, down the righthand RETMA rail, as viewed from the rear of the rack. Connect the AC cord to the power controller outlet as shown in figure 2-5.
9. Reinstall the two panels removed from the front of the rack in step 4.
10. If disk and/or tape drives are installed in the rack, connect their respective data and command cables to the fileserver as shown in the installation manual(s) shipped with the drive(s).
11. Route the cables installed in the previous step down the lefthand rear RETMA rail (as viewed from the rear of the rack).

**NOTE**

*These cables should be routed so that there is enough slack to allow for servicing of the other boards in the cardcage without having to disconnect them.*

**CAUTION** Do NOT route the data and command cables down the same side of the rack as the AC power cables. Data integrity may be adversely affected if these cables are not routed separately.

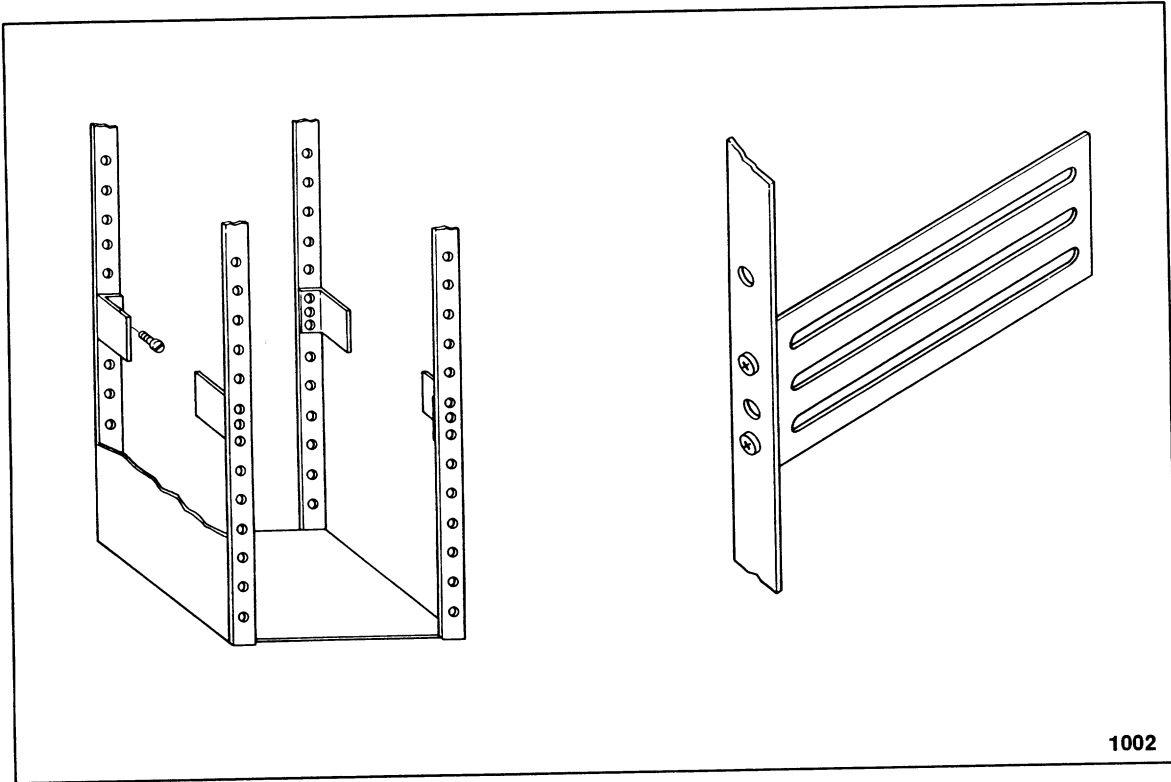

Figure 2-2 *Support Bracket Installation*

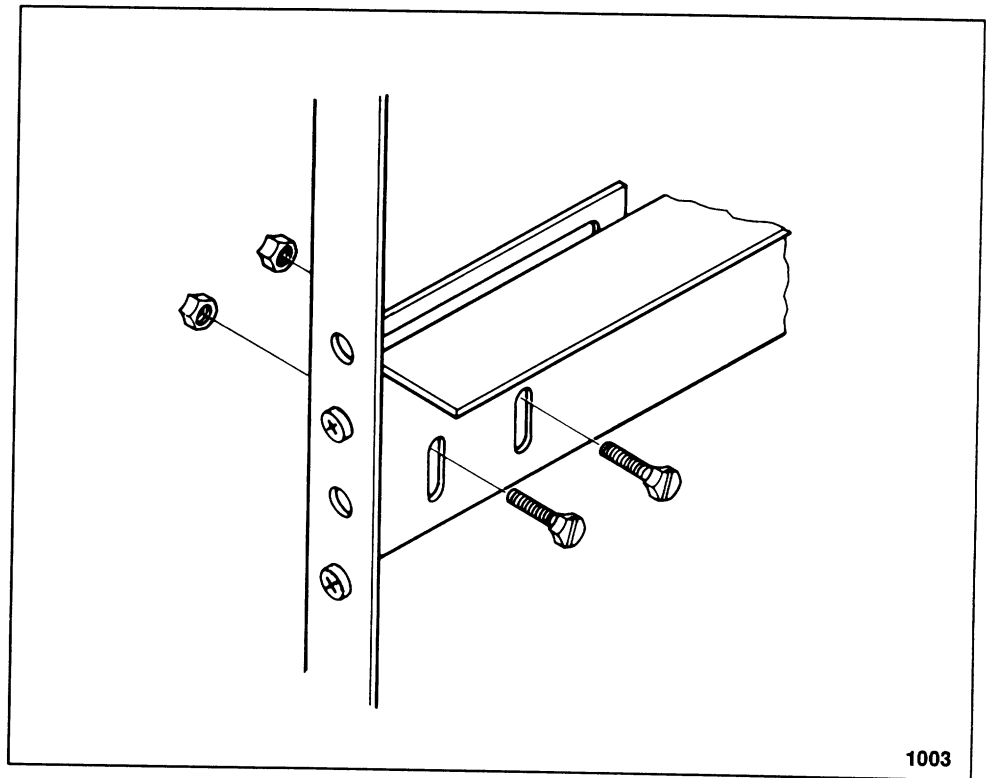

Figure 2-3 *Support Rail Installation*

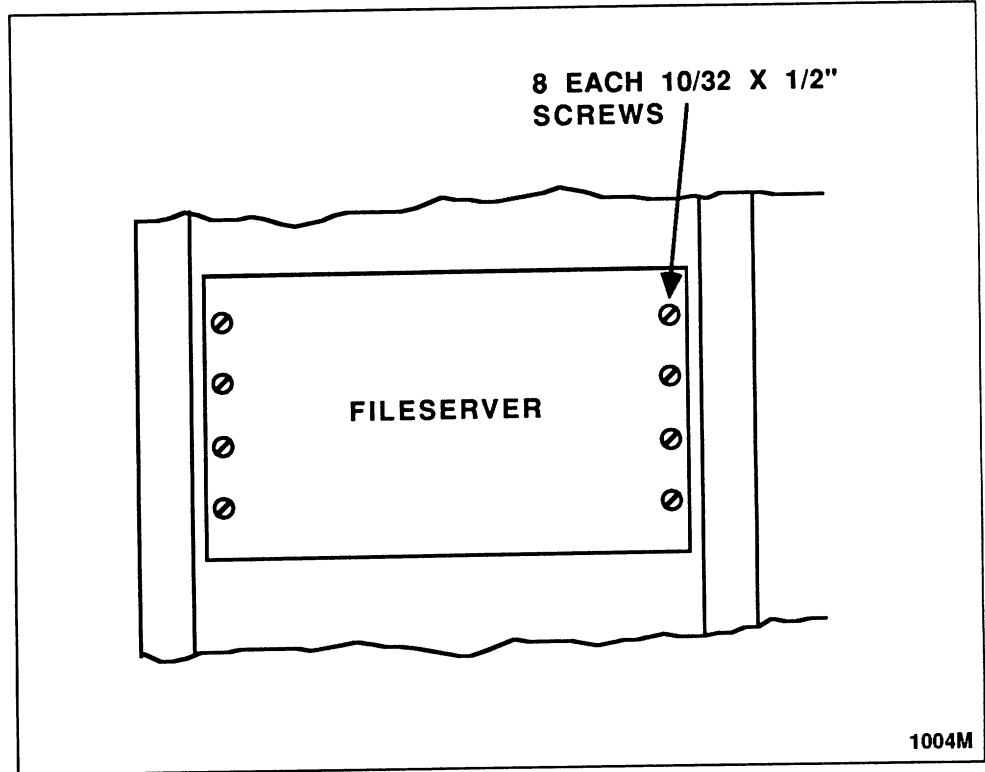

Figure 2-4 *Fileserver Installation*

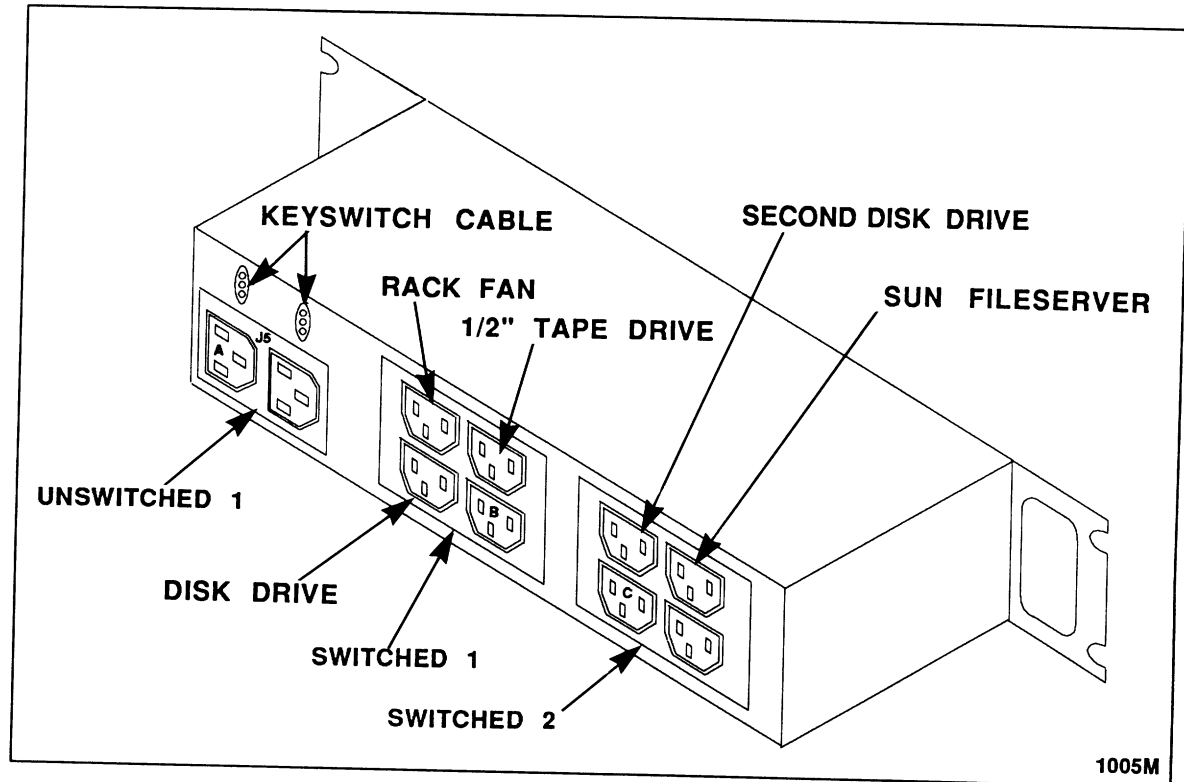

Figure 2-5 Connections to the 115V Power Supply

## 2.4. External Connections

Keyboard, and peripheral equipment connections are discussed in the CPU board installation document shipped with your system. Additional useful information regarding Ethernet connections can be found in the *Installation Manual for the Sun 12-Slot Logic Enclosure*.

The line power cord will come with one of three plugs, dependent upon whether the supply voltage is 115, 230 or 240VAC. The required plug-receptacle combinations are listed below:

- 115VAC (North American operation) - NEMA L5-30
- 230VAC (North American operation) - NEMA L6-30
- 240VAC (European operation) - IEC 309

## 2.5. Power Controller Cabling

In order to reduce the power-up load on the AC line, a *power controller* has been designed into the Sun Full-height Rack. The controller has the following features:

- powers the components up in a controlled sequence, and
- provides noise and transient protection.

Figure 2-5 illustrates the correct arrangement of equipment connections for a 115V power controller. Figures 2-6 and 2-7 illustrate the correct connections for

230V and 240V power controllers, respectively.

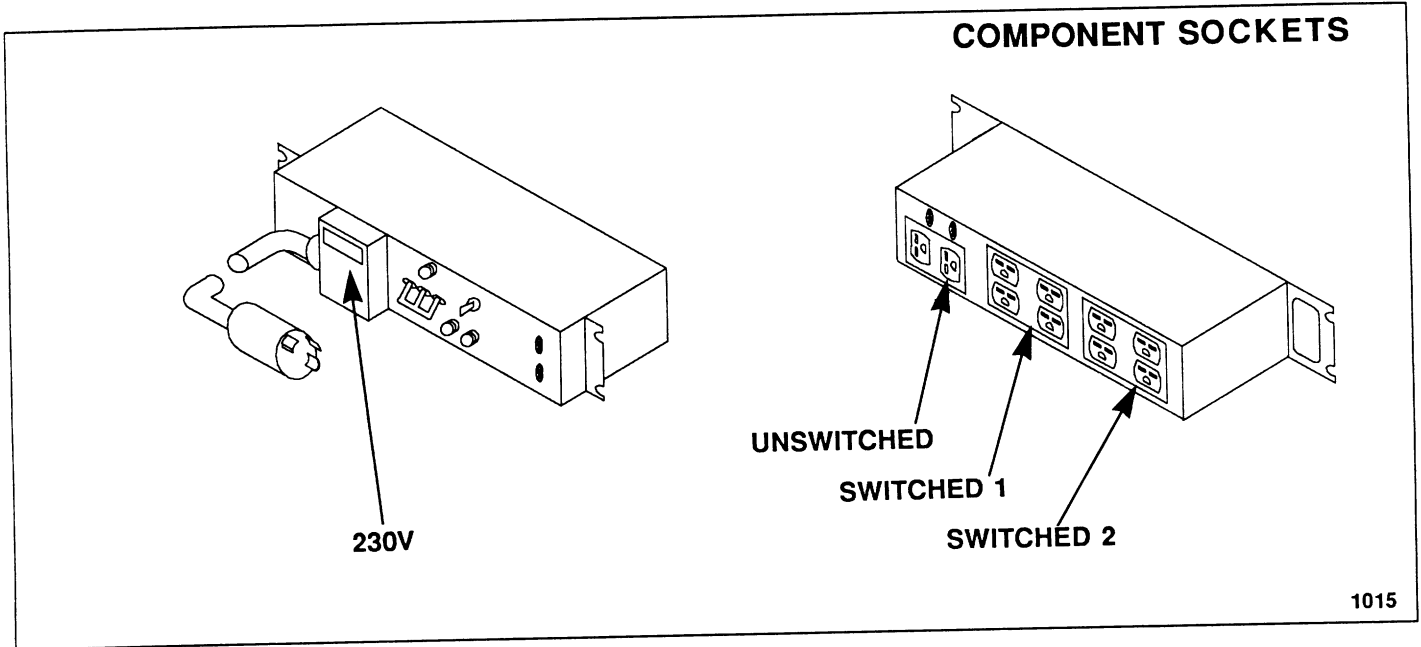

Figure 2-6 Connections to the 230V Power Controller

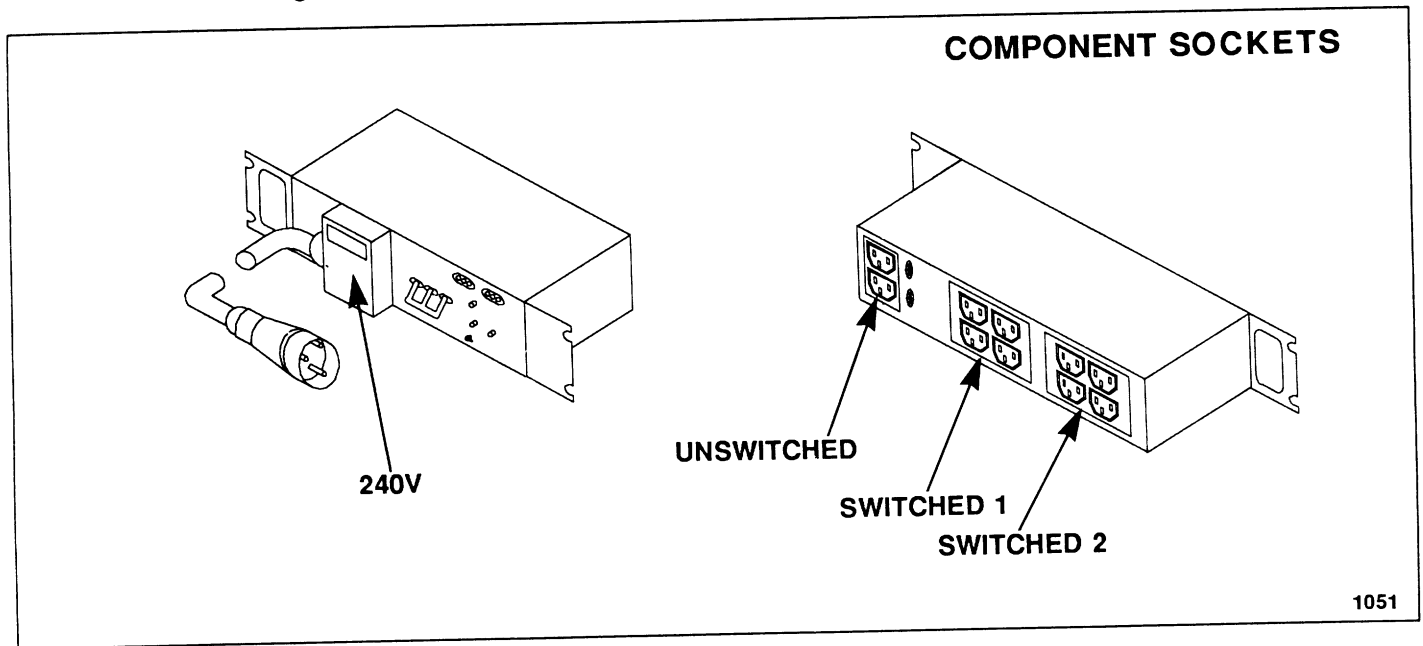

Figure 2-7 Connections to the 240V Power Controller

---

## Revision History

Revision	Date	Comments
01-50	14 June 1986	Review draft of this Installation Manual.
05-A	17 July 1986	Production release of this manual.
06-A	11 March 1988	Edited to incorporate power controller cabling data from errata 800-2266-01.







---



## READER COMMENT SHEET

Dear Customer,

We who work at Sun Microsystems wish to provide the best possible documentation for our products. To this end, we solicit your comments on this manual. We would appreciate your telling us about errors in the content of the manual, and about any material that you feel should be there but isn't. Comments on the *Installation Manual for Sun Rackmountable Fileservers* (800-1676-XX) are:

### Typographical Errors

Please list typographical errors by page number and actual text of the error.

### Technical Errors

Please list errors in technical accuracy by page number and actual text of the error.

**Content**

Did this guide meet your needs? If not, please indicate what you think should be added or deleted in order to do so. Please comment on any material that you feel should be present but is not. Is there material found in other manuals that would be more convenient if it were in this manual?

**Layout and Style**

Did you find the organization of this guide useful? If not, how would you rearrange things? Do you find the style of this manual pleasing or irritating? What would you like to see different?

Send comments to:

Sun Microsystems,  
Inc., Attn. Technical  
Publications Mgr.  
2550 Garcia Avenue,  
Mountain View, CA  
94043



**Corporate Headquarters**  
Sun Microsystems, Inc.  
2550 Garcia Avenue  
Mountain View, CA 94043  
415 960-1300  
TLX 37-29639  
**For U.S. Sales Office**  
**locations, call:**  
800 821-4643  
In CA: 800 821-4642

**European Headquarters**  
Sun Microsystems Europe, Inc.  
Sun House  
31-41 Pembroke Broadway  
Camberley  
Surrey GU15 3XD  
England  
0276 62111  
TLX 859017

**Australia:** (02) 436 4699  
**Canada:** 416 477-6745  
**France:** (1) 46 30 23 24  
**Germany:** (089) 95094-0  
**Japan:** (03) 221-7021  
**Nordic Countries:** (08) 764 78 10  
**Switzerland:** (1) 82 89 555  
**The Netherlands:** 02155 24888  
**UK:** 0276 62111

**Europe, Middle East, and Africa,**  
**call European Headquarters:**  
0276 62111

**Elsewhere in the world,**  
**call Corporate Headquarters:**  
415 960-1300  
Intercontinental Sales

